

ETSI TS 136 101 V13.18.0 (2020-02)



LTE;
Evolved Universal Terrestrial Radio Access (E-UTRA);
User Equipment (UE) radio transmission and reception
(3GPP TS 36.101 version 13.18.0 Release 13)



ReferenceRTS/TSGR-0436101vD10

KeywordsLTE

ETSI

650 Route des Lucioles
F-06921 Sophia Antipolis Cedex - FRANCE

Tel.: +33 4 92 94 42 00 Fax: +33 4 93 65 47 16

Siret N° 348 623 562 00017 - NAF 742 C
Association à but non lucratif enregistrée à la
Sous-Préfecture de Grasse (06) N° 7803/88

Important notice

The present document can be downloaded from:

<http://www.etsi.org/standards-search>

The present document may be made available in electronic versions and/or in print. The content of any electronic and/or print versions of the present document shall not be modified without the prior written authorization of ETSI. In case of any existing or perceived difference in contents between such versions and/or in print, the prevailing version of an ETSI deliverable is the one made publicly available in PDF format at www.etsi.org/deliver.

Users of the present document should be aware that the document may be subject to revision or change of status.

Information on the current status of this and other ETSI documents is available at

<https://portal.etsi.org/TB/ETSIDeliverableStatus.aspx>

If you find errors in the present document, please send your comment to one of the following services:

<https://portal.etsi.org/People/CommitteeSupportStaff.aspx>

Copyright Notification

No part may be reproduced or utilized in any form or by any means, electronic or mechanical, including photocopying and microfilm except as authorized by written permission of ETSI.

The content of the PDF version shall not be modified without the written authorization of ETSI.

The copyright and the foregoing restriction extend to reproduction in all media.

© ETSI 2020.

All rights reserved.

DECT™, **PLUGTESTS™**, **UMTS™** and the ETSI logo are trademarks of ETSI registered for the benefit of its Members.

3GPP™ and **LTE™** are trademarks of ETSI registered for the benefit of its Members and of the 3GPP Organizational Partners.

oneM2M™ logo is a trademark of ETSI registered for the benefit of its Members and of the oneM2M Partners.

GSM® and the GSM logo are trademarks registered and owned by the GSM Association.

Intellectual Property Rights

Essential patents

IPRs essential or potentially essential to normative deliverables may have been declared to ETSI. The information pertaining to these essential IPRs, if any, is publicly available for **ETSI members and non-members**, and can be found in ETSI SR 000 314: "*Intellectual Property Rights (IPRs); Essential, or potentially Essential, IPRs notified to ETSI in respect of ETSI standards*", which is available from the ETSI Secretariat. Latest updates are available on the ETSI Web server (<https://ipr.etsi.org/>).

Pursuant to the ETSI IPR Policy, no investigation, including IPR searches, has been carried out by ETSI. No guarantee can be given as to the existence of other IPRs not referenced in ETSI SR 000 314 (or the updates on the ETSI Web server) which are, or may be, or may become, essential to the present document.

Trademarks

The present document may include trademarks and/or tradenames which are asserted and/or registered by their owners. ETSI claims no ownership of these except for any which are indicated as being the property of ETSI, and conveys no right to use or reproduce any trademark and/or tradename. Mention of those trademarks in the present document does not constitute an endorsement by ETSI of products, services or organizations associated with those trademarks.

Legal notice

This Technical Specification (TS) has been produced by the ETSI 3rd Generation Partnership Project (3GPP).

The present document may refer to technical specifications or reports using their 3GPP identities. These shall be interpreted as being references to the corresponding ETSI deliverables.

The cross reference between 3GPP and ETSI identities can be found under <http://webapp.etsi.org/key/queryform.asp>.

Modal verbs terminology

In the present document "**shall**", "**shall not**", "**should**", "**should not**", "**may**", "**need not**", "**will**", "**will not**", "**can**" and "**cannot**" are to be interpreted as described in clause 3.2 of the [ETSI Drafting Rules](#) (Verbal forms for the expression of provisions).

"**must**" and "**must not**" are **NOT** allowed in ETSI deliverables except when used in direct citation.

Contents

Intellectual Property Rights	2
Legal notice	2
Modal verbs terminology.....	2
Foreword.....	25
1 Scope	26
2 References	26
3 Definitions, symbols and abbreviations	26
3.1 Definitions	26
3.2 Symbols.....	28
3.3 Abbreviations	31
4 General	32
4.1 Relationship between minimum requirements and test requirements	32
4.2 Applicability of minimum requirements	32
4.3 Void.....	33
4.3A Applicability of minimum requirements (CA, UL-MIMO, ProSe, Dual Connectivity, UE category 0, UE category M1, UE category NB1).....	33
4.4 RF requirements in later releases	34
5 Operating bands and channel arrangement.....	34
5.1 General	34
5.2 Void.....	34
5.3 Void.....	34
5.4 Void.....	34
5.5 Operating bands.....	34
5.5A Operating bands for CA	36
5.5B Operating bands for UL-MIMO	46
5.5C Operating bands for Dual Connectivity.....	46
5.5D Operating bands for ProSe.....	48
5.5E Operating bands for UE category 0 and UE category M1	49
5.5F Operating bands for category NB1	49
5.6 Channel bandwidth.....	49
5.6.1 Channel bandwidths per operating band.....	50
5.6A Channel bandwidth for CA.....	52
5.6A.1 Channel bandwidths per operating band for CA.....	54
5.6B Channel bandwidth for UL-MIMO	73
5.6B.1 Void	73
5.6C Channel bandwidth for Dual Connectivity.....	73
5.6C.1 Void	73
5.6D Channel bandwidth for ProSe.....	73
5.6D.1 Channel bandwidths per operating band for ProSe.....	73
5.6F Channel bandwidth for category NB1	74
5.7 Channel arrangement.....	75
5.7.1 Channel spacing	75
5.7.1A Channel spacing for CA.....	75
5.7.1F Channel spacing for category NB1	76
5.7.2 Channel raster	76
5.7.2A Channel raster for CA.....	76
5.7.2F Channel raster for category NB1	76
5.7.3 Carrier frequency and EARFCN.....	76
5.7.3F Carrier frequency and EARFCN for category NB1	78
5.7.4 TX–RX frequency separation	78
5.7.4A TX–RX frequency separation for CA	79
5.7.4E TX–RX frequency separation for category M1	79
5.7.4F TX–RX frequency separation for category NB1	79

6	Transmitter characteristics	80
6.1	General	80
6.2	Transmit power	80
6.2.1	Void	80
6.2.2	UE maximum output power	80
6.2.2A	UE maximum output power for CA	82
6.2.2B	UE maximum output power for UL-MIMO	84
6.2.2C	Void	86
6.2.2D	UE maximum output power for ProSe	86
6.2.2E	UE maximum output power for Category M1 UE	86
6.2.2F	UE maximum output power for category NB1	87
6.2.3	UE maximum output power for modulation / channel bandwidth	88
6.2.3A	UE Maximum Output power for modulation / channel bandwidth for CA	89
6.2.3B	UE maximum output power for modulation / channel bandwidth for UL-MIMO	90
6.2.3D	UE maximum output power for modulation / channel bandwidth for ProSe	91
6.2.3E	UE maximum output power for modulation / channel bandwidth for category M1	91
6.2.3F	UE maximum output power for modulation / channel bandwidth for category NB1	92
6.2.4	UE maximum output power with additional requirements	92
6.2.4A	UE maximum output power with additional requirements for CA	102
6.2.4A.1	A-MPR for CA_NS_01 for CA_1C	104
6.2.4A.2	A-MPR for CA_NS_02 for CA_1C	104
6.2.4A.3	A-MPR for CA_NS_03 for CA_1C	105
6.2.4A.4	A-MPR for CA_NS_04	106
6.2.4A.5	A-MPR for CA_NS_05 for CA_38C	107
6.2.4A.6	A-MPR for CA_NS_06	108
6.2.4A.7	A-MPR for CA_NS_07	109
6.2.4A.8	A-MPR for CA_NS_08	110
6.2.4B	UE maximum output power with additional requirements for UL-MIMO	111
6.2.4D	UE maximum output power with additional requirements for ProSe	112
6.2.4E	UE maximum output power with additional requirements for category M1 UE	112
6.2.4F	UE maximum output power with additional requirements for category NB1 UE	114
6.2.5	Configured transmitted power	114
6.2.5A	Configured transmitted power for CA	128
6.2.5B	Configured transmitted power for UL-MIMO	130
6.2.5C	Configured transmitted power for Dual Connectivity	131
6.2.5D	Configured transmitted power for ProSe	132
6.2.5F	Configured transmitted Power for category NB1	134
6.3	Output power dynamics	135
6.3.1	(Void)	135
6.3.2	Minimum output power	135
6.3.2.1	Minimum requirement	135
6.3.2A	UE Minimum output power for CA	135
6.3.2A.1	Minimum requirement for CA	135
6.3.2B	UE Minimum output power for UL-MIMO	136
6.3.2B.1	Minimum requirement	136
6.3.2C	Void	136
6.3.2D	UE Minimum output power for ProSe	136
6.3.2F	UE Minimum output power for category NB1	136
6.3.3	Transmit OFF power	137
6.3.3.1	Minimum requirement	137
6.3.3A	UE Transmit OFF power for CA	137
6.3.3A.1	Minimum requirement for CA	137
6.3.3B	UE Transmit OFF power for UL-MIMO	137
6.3.3B.1	Minimum requirement	138
6.3.3D	Transmit OFF power for ProSe	138
6.3.3F	Transmit OFF power for category NB1	138
6.3.4	ON/OFF time mask	138
6.3.4.1	General ON/OFF time mask	138
6.3.4.2	PRACH and SRS time mask	139
6.3.4.2.1	PRACH time mask	139
6.3.4.2.2	SRS time mask	140
6.3.4.3	Slot / Sub frame boundary time mask	140

6.3.4.4	PUCCH / PUSCH / SRS time mask.....	141
6.3.4A	ON/OFF time mask for CA	142
6.3.4B	ON/OFF time mask for UL-MIMO	142
6.3.4D	ON/OFF time mask for ProSe.....	142
6.3.4D.1	General time mask for ProSe	143
6.3.4D.2	PSSS/SSSS time mask	143
6.3.4D.3	PSSS / SSSS / PSBCH time mask.....	144
6.3.4D.4	PSSCH / SRS time mask.....	145
6.3.4F	ON/OFF time mask for category NB1	145
6.3.4F.1	General ON/OFF time mask	145
6.3.4F.2	NPRACH time mask.....	145
6.3.5	Power Control.....	146
6.3.5.1	Absolute power tolerance.....	146
6.3.5.1.1	Minimum requirements	146
6.3.5.2	Relative Power tolerance.....	146
6.3.5.2.1	Minimum requirements	146
6.3.5.3	Aggregate power control tolerance	147
6.3.5.3.1	Minimum requirement.....	148
6.3.5A	Power control for CA.....	148
6.3.5A.1	Absolute power tolerance.....	148
6.3.5A.1.1	Minimum requirements	148
6.3.5A.2	Relative power tolerance	148
6.3.5A.2.1	Minimum requirements	148
6.3.5A.3	Aggregate power control tolerance	149
6.3.5A.3.1	Minimum requirements	149
6.3.5B	Power control for UL-MIMO	149
6.3.5D	Power Control for ProSe.....	150
6.3.5D.1	Absolute power tolerance.....	150
6.3.5E	Power control for category M1	150
6.3.5E.1	Absolute power tolerance.....	150
6.3.5E.2	Relative Power tolerance.....	150
6.3.5E.3	Aggregate power control tolerance	150
6.3.5E.3.1	Minimum requirement.....	150
6.3.5F	Power Control for category NB1	151
6.3.5F.1	Absolute power tolerance.....	151
6.3.5F.2	Relative power tolerance.....	152
6.3.5F.3	Aggregate power control tolerance for category NB1	152
6.3.5F.3.1	Minimum requirement.....	152
6.4	Void.....	153
6.5	Transmit signal quality	153
6.5.1	Frequency error.....	153
6.5.1A	Frequency error for CA.....	153
6.5.1B	Frequency error for UL-MIMO	153
6.5.1D	Frequency error for ProSe.....	153
6.5.1E	Frequency error for UE category M1	153
6.5.1F	Frequency error for UE category NB1.....	153
6.5.2	Transmit modulation quality.....	154
6.5.2.1	Error Vector Magnitude	154
6.5.2.1.1	Minimum requirement.....	154
6.5.2.2	Carrier leakage	155
6.5.2.2.1	Minimum requirements	155
6.5.2.3	In-band emissions	155
6.5.2.3.1	Minimum requirements	155
6.5.2.4	EVM equalizer spectrum flatness	156
6.5.2.4.1	Minimum requirements	156
6.5.2A	Transmit modulation quality for CA.....	157
6.5.2A.1	Error Vector Magnitude	158
6.5.2A.2	Carrier leakage for CA.....	158
6.5.2A.2.1	Minimum requirements.....	158
6.5.2A.3	In-band emissions	158
6.5.2A.3.1	Minimum requirement for CA.....	158
6.5.2B	Transmit modulation quality for UL-MIMO	160

6.5.2B.1	Error Vector Magnitude	161
6.5.2B.2	Carrier leakage	161
6.5.2B.3	In-band emissions	161
6.5.2B.4	EVM equalizer spectrum flatness for UL-MIMO	161
6.5.2D	Transmit modulation quality for ProSe	161
6.5.2D.1	Error Vector Magnitude	161
6.5.2D.2	Carrier leakage	161
6.5.2D.3	In-band emissions	162
6.5.2D.4	EVM equalizer spectrum flatness for ProSe	162
6.5.2E	Transmit modulation quality for category M1	162
6.5.2E.1	Error Vector Magnitude	162
The Error Vector Magnitude is defined in section 6.5.2.1.		162
6.5.2E.2	Carrier leakage	162
6.5.2E.2.1	Minimum requirements	162
6.5.2E.3	In-band emissions	162
6.5.2E.3.1	Minimum requirements	162
6.5.2F	Transmit modulation quality for Category NB1	163
6.5.2F.1	Error Vector Magnitude	163
6.5.2F.2	Carrier leakage	163
6.5.2F.3	In-band emissions	163
6.6	Output RF spectrum emissions	164
6.6.1	Occupied bandwidth	165
6.6.1A	Occupied bandwidth for CA	165
6.6.1B	Occupied bandwidth for UL-MIMO	165
6.6.1F	Occupied bandwidth for category NB1	166
6.6.2	Out of band emission	166
6.6.2.1	Spectrum emission mask	166
6.6.2.1.1	Minimum requirement	166
6.6.2.1A	Spectrum emission mask for CA	166
6.6.2.2	Additional spectrum emission mask	167
6.6.2.2.1	Minimum requirement (network signalled value "NS_03", "NS_11", "NS_20", and "NS_21") ..	168
6.6.2.2.2	Minimum requirement (network signalled value "NS_04")	168
6.6.2.2.3	Minimum requirement (network signalled value "NS_06" or "NS_07")	169
6.6.2.2A	Additional Spectrum Emission Mask for CA	169
6.6.2.2A.1	Minimum requirement (network signalled value "CA_NS_04")	169
6.6.2.3	Adjacent Channel Leakage Ratio	170
6.6.2.3.1	Minimum requirement E-UTRA	170
6.6.2.3.1A	Void	171
6.6.2.3.1Aa	Void	171
6.6.2.3.2	Minimum requirements UTRA	171
6.6.2.3.2A	Minimum requirement UTRA for CA	172
6.6.2.3.3A	Minimum requirements for CA E-UTRA	173
6.6.2.4	Void	175
6.6.2.4.1	Void	175
6.6.2A	Void	175
6.6.2B	Out of band emission for UL-MIMO	175
6.6.2C	Void	175
6.6.2D	Out of band emission for ProSe	175
6.6.2F	Out of band emission for category NB1	175
6.6.2F.1	Spectrum emission mask	175
6.6.2F.2	Void	176
6.6.2F.3	Adjacent Channel Leakage Ratio for category NB1	176
6.6.3	Spurious emissions	176
6.6.3.1	Minimum requirements	177
6.6.3.1A	Minimum requirements for CA	177
6.6.3.2	Spurious emission band UE co-existence	178
6.6.3.2A	Spurious emission band UE co-existence for CA	184
6.6.3.3	Additional spurious emissions	191
6.6.3.3.1	Minimum requirement (network signalled value "NS_05")	191
6.6.3.3.2	Minimum requirement (network signalled value "NS_07")	191
6.6.3.3.3	Minimum requirement (network signalled value "NS_08")	192
6.6.3.3.4	Minimum requirement (network signalled value "NS_09")	192

6.6.3.3.5	Minimum requirement (network signalled value "NS_12")	192
6.6.3.3.6	Minimum requirement (network signalled value "NS_13")	193
6.6.3.3.7	Minimum requirement (network signalled value "NS_14")	193
6.6.3.3.8	Minimum requirement (network signalled value "NS_15")	193
6.6.3.3.9	Minimum requirement (network signalled value "NS_16")	193
6.6.3.3.10	Minimum requirement (network signalled value "NS_17")	194
6.6.3.3.11	Minimum requirement (network signalled value "NS_18")	194
6.6.3.3.12	Minimum requirement (network signalled value "NS_19")	194
6.6.3.3.13	Minimum requirement (network signalled value "NS_11")	194
6.6.3.3.14	Minimum requirement (network signalled value "NS_20")	195
6.6.3.3.15	Minimum requirement (network signalled value "NS_21")	195
6.6.3.3.16	Minimum requirement (network signalled value "NS_22")	195
6.6.3.3.17	Minimum requirement (network signalled value "NS_23")	196
6.6.3.3.18	Void	196
6.6.3.3.19	Minimum requirement (network signalled value "NS_04")	196
6.6.3.3.20	Minimum requirement (network signalled value "NS_24")	197
6.6.3.3.21	Minimum requirement (network signalled value "NS_25")	197
6.6.3.3.22	Minimum requirement (network signalled value "NS_26")	197
6.6.3.3.23 - 6.6.3.3.27	Void	198
6.6.3.3.28	Minimum requirement (network signalled value "NS_36")	198
6.6.3.3A	Additional spurious emissions for CA	198
6.6.3.3A.1	Minimum requirement for CA_1C (network signalled value "CA_NS_01")	198
6.6.3.3A.2	Minimum requirement for CA_1C (network signalled value "CA_NS_02")	198
6.6.3.3A.3	Minimum requirement for CA_1C (network signalled value "CA_NS_03")	199
6.6.3.3A.4	Minimum requirement for CA_38C (network signalled value "CA_NS_05")	199
6.6.3.3A.5	Minimum requirement for CA_7C (network signalled value "CA_NS_06")	199
6.6.3.3A.6	Minimum requirement for CA_39C and CA_39C-41A (network signalled value "CA_NS_07")	200
6.6.3.3A.7	Minimum requirement for CA_42C (network signalled value "CA_NS_08")	200
6.6.3.3A.8	Minimum requirement for CA_41C (network signalled value "CA_NS_04")	201
6.6.3A	Void	201
6.6.3B	Spurious emission for UL-MIMO	201
6.6.3C	Void	201
6.6.3D	Spurious emission for ProSe	201
6.6.3F	Spurious emission for category NB1	201
6.6A	Void	202
6.6B	Void	202
6.7	Transmit intermodulation	202
6.7.1	Minimum requirement	202
6.7.1A	Minimum requirement for CA	202
6.7.1B	Minimum requirement for UL-MIMO	203
6.7.1F	Minimum requirement for category NB1	203
6.8	Void	204
6.8.1	Void	204
6.8A	Void	204
6.8B	Time alignment error for UL-MIMO	204
6.8B.1	Minimum Requirements	204
7	Receiver characteristics	204
7.1	General	204
7.2	Diversity characteristics	205
7.3	Reference sensitivity power level	205
7.3.1	Minimum requirements (QPSK)	205
7.3.1A	Minimum requirements (QPSK) for CA	221
7.3.1B	Minimum requirements (QPSK) for UL-MIMO	251
7.3.1D	Minimum requirements (QPSK) for ProSe	251
7.3.1E	Minimum requirements (QPSK) for UE category 0 and M1	253
7.3.1F	Minimum requirements for UE category NB1	257
7.3.1F.1	Reference sensitivity for UE category NB1	257
7.3.1F.2	Void	257
7.3.2	Void	258
7.4	Maximum input level	258

7.4.1	Minimum requirements.....	258
7.4.1A	Minimum requirements for CA	258
7.4.1B	Minimum requirements for UL-MIMO	259
7.4.1D	Minimum requirements for ProSe	259
7.4.1F	Minimum requirements for category NB1	259
7.4A	Void.....	260
7.4A.1	Void	260
7.5	Adjacent Channel Selectivity (ACS).....	260
7.5.1	Minimum requirements.....	260
7.5.1A	Minimum requirements for CA	261
7.5.1B	Minimum requirements for UL-MIMO	264
7.5.1D	Minimum requirements for ProSe	264
7.5.1F	Minimum requirements for category NB1	265
7.6	Blocking characteristics	266
7.6.1	In-band blocking.....	266
7.6.1.1	Minimum requirements.....	266
7.6.1.1A	Minimum requirements for CA.....	267
7.6.1.1D	Minimum requirements for ProSe.....	270
7.6.1.1F	Minimum requirements for category NB1	271
7.6.2	Out-of-band blocking.....	272
7.6.2.1	Minimum requirements	272
7.6.2.1A	Minimum requirements for CA.....	273
7.6.2.1D	Minimum requirements for ProSe.....	277
7.6.2.1F	Minimum requirements for category NB1	277
7.6.3	Narrow band blocking	278
7.6.3.1	Minimum requirements.....	278
7.6.3.1A	Minimum requirements for CA.....	279
7.6.3.1D	Minimum requirements for ProSe.....	280
7.6A	Void.....	280
7.6B	Blocking characteristics for UL-MIMO	280
7.7	Spurious response.....	281
7.7.1	Minimum requirements.....	281
7.7.1A	Minimum requirements for CA	281
7.7.1B	Minimum requirements for UL-MIMO	282
7.7.1D	Minimum requirements for ProSe	283
7.7.1F	Minimum requirements for UE category NB1.....	283
7.8	Intermodulation characteristics	284
7.8.1	Wide band intermodulation.....	284
7.8.1.1	Minimum requirements.....	284
7.8.1A	Minimum requirements for CA	284
7.8.1B	Minimum requirements for UL-MIMO	287
7.8.1D	Minimum requirements for ProSe	287
7.8.1F	Minimum requirements for category NB1	288
7.8.2	Void	288
7.9	Spurious emissions	288
7.9.1	Minimum requirements.....	289
7.9.1A	Minimum requirements.....	289
7.10	Receiver image	289
7.10.1	Void	289
7.10.1A	Minimum requirements for CA	289
8	Performance requirement	290
8.1	General	290
8.1.1	Receiver antenna capability	290
8.1.1.1	Simultaneous unicast and MBMS operations.....	291
8.1.1.2	Dual-antenna receiver capability in idle mode.....	291
8.1.2	Applicability of requirements	291
8.1.2.1	Applicability of requirements for different channel bandwidths.....	291
8.1.2.2	Definition of CA capability.....	291
8.1.2.2A	Definition of dual connectivity capability.....	294
8.1.2.3	Applicability and test rules for different CA configurations and bandwidth combination sets.....	295

8.1.2.3A	Applicability and test rules for different dual connectivity configuration and bandwidth combination set	297
8.1.2.3B	Applicability and test rules for different TDD-FDD CA configurations and bandwidth combination sets.....	298
8.1.2.4	Test coverage for different number of component carriers	300
8.1.2.5	Applicability of performance requirements for Type B receiver	301
8.1.2.6	Applicability of performance requirements for 4Rx capable UEs	301
8.1.2.6.1	Applicability rule and antenna connection for single carrier tests with 2Rx	301
8.1.2.6.2	Applicability rule and antenna connection for CA and DC tests with 2Rx	302
8.1.2.6.3	Applicability rule and antenna connection for single carrier tests with 4Rx	303
8.1.2.6.4	Applicability rule for 256QAM tests	303
8.1.2.7	Applicability of Enhanced Downlink Control Channel Performance Requirements	303
8.1.2.8	Applicability of performance requirements for CDM-multiplexed DM RS with interfering simultaneous transmission (FRC) with multiple CSI-RS configurations	304
8.1.2.8A	Applicability of performance requirements for UE supporting coverage enhancement	304
8.1.3	UE category and UE DL category	304
8.2	Demodulation of PDSCH (Cell-Specific Reference Symbols)	305
8.2.1	FDD (Fixed Reference Channel)	305
8.2.1.1	Single-antenna port performance	305
8.2.1.1.1	Minimum Requirement	305
8.2.1.1.2	Void	310
8.2.1.1.3	Void	310
8.2.1.1.4	Minimum Requirement 1 PRB allocation in presence of MBSFN.....	310
8.2.1.2	Transmit diversity performance	310
8.2.1.2.1	Minimum Requirement 2 Tx Antenna Port	310
8.2.1.2.2	Minimum Requirement 4 Tx Antenna Port	311
8.2.1.2.3	Minimum Requirement 2 Tx Antenna Port (demodulation subframe overlaps with aggressor cell ABS).....	312
8.2.1.2.3A	Minimum Requirement 2 Tx Antenna Ports (demodulation subframe overlaps with aggressor cell ABS and CRS assistance information are configured)	314
8.2.1.2.4	Enhanced Performance Requirement Type A - 2 Tx Antenna Ports with TM3 interference model	316
8.2.1.2.5	Enhanced Performance Requirement Type B - 2 Tx Antenna Ports with TM2 interference model	318
8.2.1.2.6	Enhanced Performance Requirement Type B - 2 Tx Antenna Ports with TM9 interference model	319
8.2.1.3	Open-loop spatial multiplexing performance.....	320
8.2.1.3.1	Minimum Requirement 2 Tx Antenna Port	320
8.2.1.3.1B	Enhanced Performance Requirement Type C -2Tx Antenna Ports	324
8.2.1.3.1C	Enhanced Performance Requirement Type C - 2 Tx Antenna Ports with TM1 interference	325
8.2.1.3.2	Minimum Requirement 4 Tx Antenna Port	326
8.2.1.3.3	Minimum Requirement 2 Tx Antenna Port (demodulation subframe overlaps with aggressor cell ABS)	326
8.2.1.3.4	Minimum Requirement 2 Tx Antenna Port (demodulation subframe overlaps with aggressor cell ABS and CRS assistance information are configured)	330
8.2.1.4	Closed-loop spatial multiplexing performance	332
8.2.1.4.1	Minimum Requirement Single-Layer Spatial Multiplexing 2 Tx Antenna Port.....	332
8.2.1.4.1A	Minimum Requirement Single-Layer Spatial Multiplexing 4 Tx Antenna Port.....	333
8.2.1.4.1B	Enhanced Performance Requirement Type A - Single-Layer Spatial Multiplexing 2 Tx Antenna Port with TM4 interference model	333
8.2.1.4.1C	Minimum Requirement Single-Layer Spatial Multiplexing 2 Tx Antenna Ports (demodulation subframe overlaps with aggressor cell ABS and CRS assistance information are configured).....	335
8.2.1.4.1D	Enhanced Performance Requirement Type B - Single-layer Spatial Multiplexing 2 Tx Antenna Port with TM4 interference model	337
8.2.1.4.1E	Minimum Requirement Single-Layer Spatial Multiplexing 2 Tx Antenna Ports with CRS assistance information	339
8.2.1.4.2	Minimum Requirement Multi-Layer Spatial Multiplexing 2 Tx Antenna Port	340
8.2.1.4.2A	Enhanced Performance Requirement Type C - Multi-layer Spatial Multiplexing 2Tx Antenna Ports.....	340
8.2.1.4.3	Minimum Requirement Multi-Layer Spatial Multiplexing 4 Tx Antenna Port	341
8.2.1.4.3A	Minimum Requirement Multi-Layer Spatial Multiplexing 4 Tx Antenna Port for dual connectivity	345

8.2.1.5	MU-MIMO.....	346
8.2.1.6	[Control channel performance: D-BCH and PCH]	346
8.2.1.7	Carrier aggregation with power imbalance	346
8.2.1.7.1	Minimum Requirement	347
8.2.1.8	Intra-band non-contiguous carrier aggregation with timing offset.....	347
8.2.1.8.1	Minimum Requirement	348
8.2.2	TDD (Fixed Reference Channel).....	348
8.2.2.1	Single-antenna port performance	349
8.2.2.1.1	Minimum Requirement	349
8.2.2.1.2	Void	353
8.2.2.1.3	Void	353
8.2.2.1.4	Minimum Requirement 1 PRB allocation in presence of MBSFN.....	353
8.2.2.2	Transmit diversity performance	354
8.2.2.2.1	Minimum Requirement 2 Tx Antenna Port	354
8.2.2.2.2	Minimum Requirement 4 Tx Antenna Port	354
8.2.2.2.3	Minimum Requirement 2 Tx Antenna Port (demodulation subframe overlaps with aggressor cell ABS)	355
8.2.2.2.3A	Minimum Requirement 2 Tx Antenna Ports (demodulation subframe overlaps with aggressor cell ABS and CRS assistance information are configured)	357
8.2.2.2.4	Enhanced Performance Requirement Type A – 2 Tx Antenna Ports with TM3 interference model	359
8.2.2.2.5	Minimum Requirement 2 Tx Antenna Port (when <i>EIMTA-MainConfigServCell-r12</i> is configured)	361
8.2.2.2.6	Enhanced Performance Requirement Type B - 2 Tx Antenna Ports with TM2 interference model	361
8.2.2.2.7	Enhanced Performance Requirement Type B - 2 Tx Antenna Ports with TM9 interference model	363
8.2.2.3	Open-loop spatial multiplexing performance.....	364
8.2.2.3.1	Minimum Requirement 2 Tx Antenna Port	364
8.2.2.3.1A	Soft buffer management test	366
8.2.2.3.1B	Enhanced Performance Requirement Type C - 2Tx Antenna Ports	367
8.2.2.3.1C	Enhanced Performance Requirement Type C - 2 Tx Antenna Ports with TM1 interference	367
8.2.2.3.2	Minimum Requirement 4 Tx Antenna Port	368
8.2.2.3.3	Minimum Requirement 2Tx antenna port (demodulation subframe overlaps with aggressor cell ABS)	369
8.2.2.3.4	Minimum Requirement 2 Tx Antenna Port (demodulation subframe overlaps with aggressor cell ABS and CRS assistance information are configured)	373
8.2.2.4	Closed-loop spatial multiplexing performance	375
8.2.2.4.1	Minimum Requirement Single-Layer Spatial Multiplexing 2 Tx Antenna Port.....	375
8.2.2.4.1A	Minimum Requirement Single-Layer Spatial Multiplexing 4 Tx Antenna Port.....	376
8.2.2.4.1B	Enhanced Performance Requirement Type A – Single-Layer Spatial Multiplexing 2 Tx Antenna Port with TM4 interference model	376
8.2.2.4.1C	Minimum Requirement Single-Layer Spatial Multiplexing 2 Tx Antenna Ports (demodulation subframe overlaps with aggressor cell ABS and CRS assistance information are configured).....	378
8.2.2.4.1D	Enhanced Performance Requirement Type B - Single-layer Spatial Multiplexing 2 Tx Antenna Port with TM4 interference model	380
8.2.2.4.1E	Minimum Requirement Single-Layer Spatial Multiplexing 2 Tx Antenna Ports with CRS assistance information	382
8.2.2.4.2	Minimum Requirement Multi-Layer Spatial Multiplexing 2 Tx Antenna Port	383
8.2.2.4.2A	Enhanced Performance Requirement Type C Multi-Layer Spatial Multiplexing 2 Tx Antenna Port	384
8.2.2.4.3	Minimum Requirement Multi-Layer Spatial Multiplexing 4 Tx Antenna Port	385
8.2.2.4.3A	Minimum Requirement Multi-Layer Spatial Multiplexing 4 Tx Antenna Port for dual connectivity	388
8.2.2.4.4	Void	390
8.2.2.5	MU-MIMO.....	390
8.2.2.6	[Control channel performance: D-BCH and PCH]	390
8.2.2.7	Carrier aggregation with power imbalance	390
8.2.2.7.1	Minimum Requirement	390
8.2.2.8	Intra-band contiguous carrier aggregation with minimum channel spacing.....	391
8.2.2.8.1	Minimum Requirement	391
8.2.3	TDD FDD CA (Fixed Reference Channel).....	392

8.2.3.1	Single-antenna port performance	393
8.2.3.1.1	Minimum Requirement for FDD PCell	393
8.2.3.1.2	Minimum Requirement for TDD PCell	396
8.2.3.2	Open-loop spatial multiplexing performance 2Tx Antenna port.....	398
8.2.3.2.1	Minimum Requirement for FDD PCell	398
8.2.3.2.1A	Soft buffer management test for FDD PCell	401
8.2.3.2.2	Minimum Requirement for TDD PCell	402
8.2.3.2.2A	Soft buffer management test for TDD PCell	405
8.2.3.3	Closed-loop spatial multiplexing performance 4Tx Antenna Port.....	406
8.2.3.3.1	Minimum Requirement for FDD PCell	406
8.2.3.3.2	Minimum Requirement for TDD PCell	409
8.2.3.4	Minimum Requirement for Closed-loop spatial multiplexing performance 4Tx Antenna Port for dual connectivity	412
8.2.4	LAA.....	414
8.2.4.1	Closed-loop spatial multiplexing performance 4Tx Antenna Port.....	414
8.2.4.1.1	FDD PCell (FDD single carrier).....	414
8.2.4.1.2	TDD PCell (TDD single carrier)	416
8.3	Demodulation of PDSCH (User-Specific Reference Symbols).....	419
8.3.1	FDD	419
8.3.1.1	Single-layer Spatial Multiplexing	420
8.3.1.1A	Enhanced Performance Requirement Type A – Single-layer Spatial Multiplexing with TM9 interference model.....	421
8.3.1.1B	Single-layer Spatial Multiplexing (demodulation subframe overlaps with aggressor cell ABS and CRS assistance information are configured).....	423
8.3.1.1C	Enhanced Performance Requirement Type B – Single-layer Spatial Multiplexing with TM9 interference model.....	425
8.3.1.1D	Enhanced Performance Requirement Type B – Single-layer Spatial Multiplexing with CRS interference model.....	427
8.3.1.1E	Enhanced Performance Requirement Type B – Single-layer Spatial Multiplexing with TM3 interference model.....	428
8.3.1.1F	Enhanced Performance Requirement Type B – Single-layer Spatial Multiplexing with TM10 serving cell configuration and TM9 interference model	429
8.3.1.1G	Single-layer Spatial Multiplexing (CRS assistance information is configured).....	431
8.3.1.1H	Single-layer Spatial Multiplexing (With Enhanced DMRS table configured)	433
8.3.1.2	Dual-Layer Spatial Multiplexing	434
8.3.1.2A	Enhanced Performance Requirement Type C - Dual-Layer Spatial Multiplexing	436
8.3.1.3	Performance requirements for DCI format 2D and non Quasi Co-located Antenna Ports	437
8.3.1.3.1	Minimum requirement with Same Cell ID (with single NZP CSI-RS resource).....	437
8.3.1.3.2	Minimum requirements with Same Cell ID (with multiple NZP CSI-RS resources).....	439
8.3.1.3.3	Minimum requirement with Different Cell ID and Colliding CRS (with single NZP CSI-RS resource)	441
8.3.1.3.4	Minimum requirement with Different Cell ID and non-colliding CRS (with single NZP CSI-RS resource and CRS assistance information is configured).....	443
8.3.1.3.5	Minimum requirements with different Cell ID and non-colliding CRS (with multiple NZP CSI-RS resources and CRS assistance information is configured).....	445
8.3.2	TDD.....	447
8.3.2.1	Single-layer Spatial Multiplexing	448
8.3.2.1A	Single-layer Spatial Multiplexing (with multiple CSI-RS configurations)	450
8.3.2.1B	Enhanced Performance Requirement Type A – Single-layer Spatial Multiplexing with TM9 interference model.....	452
8.3.2.1C	Single-layer Spatial Multiplexing (demodulation subframe overlaps with aggressor cell ABS and CRS assistance information are configured)	454
8.3.2.1D	Enhanced Performance Requirement Type B – Single-layer Spatial Multiplexing with TM9 interference.....	456
8.3.2.1E	Enhanced Performance Requirement Type B – Single-layer Spatial Multiplexing with CRS interference model.....	458
8.3.2.1F	Enhanced Performance Requirement Type B – Single-layer Spatial Multiplexing with TM3 interference.....	460
8.3.2.1G	Enhanced Performance Requirement Type B – Single-layer Spatial Multiplexing with TM10 serving cell configuration and TM9 interference model	461
8.3.2.1H	Single-layer Spatial Multiplexing (CRS assistance information is configured).....	463
8.3.2.1I	Single-layer Spatial Multiplexing (With Enhanced DMRS table configured)	465

8.3.2.2	Dual-Layer Spatial Multiplexing	466
8.3.2.2A	Enhanced Performance Requirement Type C - Dual-Layer Spatial Multiplexing	467
8.3.2.3	Dual-Layer Spatial Multiplexing (with multiple CSI-RS configurations)	468
8.3.2.4	Performance requirements for DCI format 2D and non Quasi Co-located Antenna Ports	469
8.3.2.4.1	Minimum requirement with Same Cell ID (with single NZP CSI-RS resource).....	469
8.3.2.4.2	Minimum requirements with Same Cell ID (with multiple NZP CSI-RS resources).....	471
8.3.2.4.3	Minimum requirement with Different Cell ID and Colliding CRS (with single NZP CSI-RS resource)	473
8.3.2.4.4	Minimum requirement with Different Cell ID and non-Colliding CRS (with single NZP CSI-RS resource and CRS assistance information is configured).....	475
8.3.2.4.5	Minimum requirements with different Cell ID and non-colliding CRS (with multiple NZP CSI-RS resources and CRS assistance information is configured).....	477
8.3.3	LAA	479
8.3.3.1	Dual-Layer Spatial Multiplexing with DM-RS	479
8.3.3.1.1	FDD PCell (FDD single carrier).....	479
8.3.3.1.2	TDD Pcell (TDD single carrier)	482
8.4	Demodulation of PDCCH/PCFICH	485
8.4.1	FDD	485
8.4.1.1	Single-antenna port performance	486
8.4.1.2	Transmit diversity performance	486
8.4.1.2.1	Minimum Requirement 2 Tx Antenna Port	486
8.4.1.2.2	Minimum Requirement 4 Tx Antenna Port	486
8.4.1.2.3	Minimum Requirement 2 Tx Antenna Port (demodulation subframe overlaps with aggressor cell ABS)	487
8.4.1.2.4	Minimum Requirement 2 Tx Antenna Port (demodulation subframe overlaps with aggressor cell ABS and CRS assistance information are configured)	491
8.4.1.2.5	Enhanced Downlink Control Channel Performance Requirement Type A - 2 Tx Antenna Port under Asynchronous Network	495
8.4.1.2.6	Enhanced Downlink Control Channel Performance Requirement Type A - 2 Tx Antenna Port with Non-Colliding CRS Dominant Interferer	496
8.4.1.2.7	Enhanced Downlink Control Channel Performance Requirement Type B - 2 Tx Antenna Port with Colliding CRS Dominant Interferer.....	497
8.4.1.2.8	Enhanced Downlink Control Channel Performance Requirement Type B - 2 Tx Antenna Port with Non-Colliding CRS Dominant Interferer	498
8.4.2	TDD	499
8.4.2.1	Single-antenna port performance	500
8.4.2.2	Transmit diversity performance	500
8.4.2.2.1	Minimum Requirement 2 Tx Antenna Port	500
8.4.2.2.2	Minimum Requirement 4 Tx Antenna Port	501
8.4.2.2.3	Minimum Requirement 2 Tx Antenna Port (demodulation subframe overlaps with aggressor cell ABS)	501
8.4.2.2.4	Minimum Requirement 2 Tx Antenna Port (demodulation subframe overlaps with aggressor cell ABS and CRS assistance information are configured)	505
8.4.2.2.5	Enhanced Downlink Control Channel Performance Requirement Type A - 2 Tx Antenna Port with Colliding CRS Dominant Interferer.....	509
8.4.2.2.6	Enhanced Downlink Control Channel Performance Requirement Type A - 2 Tx Antenna Port with Non-Colliding CRS Dominant Interferer	510
8.4.2.2.7	Enhanced Downlink Control Channel Performance Requirement Type B - 2 Tx Antenna Port with Colliding CRS Dominant Interferer.....	511
8.4.2.2.8	Enhanced Downlink Control Channel Performance Requirement Type B - 2 Tx Antenna Port with Non-Colliding CRS Dominant Interferer	512
8.4.3	LAA	513
8.4.3.1	Transmit diversity performance	513
8.4.3.1.1	FDD Pcell (FDD single carrier).....	513
8.4.3.1.2	TDD Pcell (TDD single carrier)	514
8.5	Demodulation of PHICH.....	515
8.5.1	FDD	516
8.5.1.1	Single-antenna port performance	516
8.5.1.2	Transmit diversity performance	516
8.5.1.2.1	Minimum Requirement 2 Tx Antenna Port	516
8.5.1.2.2	Minimum Requirement 4 Tx Antenna Port	517
8.5.1.2.3	Minimum Requirement 2 Tx Antenna Port (demodulation subframe overlaps with aggressor cell ABS)	517

8.5.1.2.4	Minimum Requirement 2 Tx Antenna Port (demodulation subframe overlaps with aggressor cell ABS and CRS assistance information are configured)	519
8.5.1.2.5	Enhanced Downlink Control Channel Performance Requirement Type A - 2 Tx Antenna Ports under Asynchronous Network	521
8.5.1.2.6	Enhanced Downlink Control Channel Performance Requirement Type A - 2 Tx Antenna Ports with Non-Colliding CRS Dominant Interferer	522
8.5.1.2.7	Enhanced Downlink Control Channel Performance Requirement Type B - 2 Tx Antenna Ports with Colliding CRS Dominant Interferer	523
8.5.1.2.8	Enhanced Downlink Control Channel Performance Requirement Type B - 2 Tx Antenna Ports with Non-Colliding CRS Dominant Interferer	524
8.5.2	TDD	525
8.5.2.1	Single-antenna port performance	526
8.5.2.2	Transmit diversity performance	526
8.5.2.2.1	Minimum Requirement 2 Tx Antenna Port	526
8.5.2.2.2	Minimum Requirement 4 Tx Antenna Port	527
8.5.2.2.3	Minimum Requirement 2 Tx Antenna Port (demodulation subframe overlaps with aggressor cell ABS)	527
8.5.2.2.4	Minimum Requirement 2 Tx Antenna Port (demodulation subframe overlaps with aggressor cell ABS and CRS assistance information are configured)	529
8.5.2.2.5	Enhanced Downlink Control Channel Performance Requirement Type A - 2 Tx Antenna Ports with Colliding CRS Dominant Interferer	531
8.5.2.2.6	Enhanced Downlink Control Channel Performance Requirement Type A - 2 Tx Antenna Ports with Non-Colliding CRS Dominant Interferer	532
8.5.2.2.7	Enhanced Downlink Control Channel Performance Requirement Type B - 2 Tx Antenna Ports with Colliding CRS Dominant Interferer	533
8.5.2.2.8	Enhanced Downlink Control Channel Performance Requirement Type B - 2 Tx Antenna Ports with Non-Colliding CRS Dominant Interferer	534
8.6	Demodulation of PBCH	535
8.6.1	FDD	535
8.6.1.1	Single-antenna port performance	535
8.6.1.2	Transmit diversity performance	536
8.6.1.2.1	Minimum Requirement 2 Tx Antenna Port	536
8.6.1.2.2	Minimum Requirement 4 Tx Antenna Port	536
8.6.1.2.3	Minimum Requirement 2 Tx Antenna Port under Time Domain Measurement Resource Restriction with CRS Assistance Information	536
8.6.2	TDD	538
8.6.2.1	Single-antenna port performance	538
8.6.2.2	Transmit diversity performance	538
8.6.2.2.1	Minimum Requirement 2 Tx Antenna Port	538
8.6.2.2.2	Minimum Requirement 4 Tx Antenna Port	538
8.6.2.2.3	Minimum Requirement 2 Tx Antenna Port under Time Domain Measurement Resource Restriction with CRS Assistance Information	539
8.7	Sustained downlink data rate provided by lower layers	540
8.7.1	FDD (single carrier and CA)	540
8.7.2	TDD (single carrier and CA)	546
8.7.3	FDD (EPDCCH scheduling)	549
8.7.4	TDD (EPDCCH scheduling)	551
8.7.5	TDD FDD CA	553
8.7.5.1	Minimum Requirement FDD PCell	554
8.7.5.2	Minimum Requirement TDD PCell	558
8.7.6	FDD (DC)	562
8.7.7	TDD (DC)	567
8.7.8	TDD FDD (DC)	570
8.7.9	Void	573
8.7.10	Void	573
8.7.11	Void	574
8.7.11.1	Void	574
8.8	Demodulation of EPDCCH	574
8.8.1	Distributed Transmission	574
8.8.1.1	FDD	574
8.8.1.1.1	Void	575
8.8.1.2	TDD	575

8.8.1.2.1	Void.....	576
8.8.2	Localized Transmission with TM9	576
8.8.2.1	FDD.....	576
8.8.2.1.1	Void.....	577
8.8.2.1.2	Void.....	578
8.8.2.2	TDD	578
8.8.2.2.1	Void.....	580
8.8.2.2.2	Void.....	580
8.8.3	Localized transmission with TM10 Type B quasi co-location type.....	580
8.8.3.1	FDD.....	580
8.8.3.2	TDD	582
8.8.4	Enhanced Downlink Control Channel Performance Requirements Type A - Localized Transmission with CRS Interference Model	584
8.8.4.1	FDD.....	584
8.8.4.2	TDD	585
8.8.5	Enhanced Downlink Control Channel Performance Requirements Type A - Distributed Transmission with TM9 Interference Model	587
8.8.5.1	TDD	587
8.8.6	Enhanced Downlink Control Channel Performance Requirements Type A - Distributed Transmission with TM3 Interference Model	588
8.8.6.1	FDD.....	588
8.9	Demodulation (single receiver antenna).....	589
8.9.1	PDSCH	589
8.9.1.1	FDD and half-duplex FDD (Fixed Reference Channel).....	589
8.9.1.1.1	Transmit diversity performance (Cell-Specific Reference Symbols)	589
8.9.1.1.2	Closed-loop spatial multiplexing performance (Cell-Specific Reference Symbols)	590
8.9.1.1.3	Closed-loop spatial multiplexing performance (User-Specific Reference Symbols)	591
8.9.1.2	TDD (Fixed Reference Channel)	592
8.9.1.2.1	Transmit diversity performance (Cell-Specific Reference Symbols)	592
8.9.1.2.2	Closed-loop spatial multiplexing performance (Cell-Specific Reference Symbols)	593
8.9.1.2.3	Closed-loop spatial multiplexing performance (User-Specific Reference Symbols)	594
8.9.2	PHICH	595
8.9.2.1	FDD and half-duplex FDD.....	595
8.9.2.1.1	Transmit diversity performance.....	595
8.9.2.2	TDD	595
8.9.2.2.1	Transmit diversity performance.....	595
8.9.3	PBCH.....	595
8.9.3.1	FDD and half-duplex FDD.....	595
8.9.3.1.1	Transmit diversity performance.....	595
8.9.3.2	TDD	596
8.9.3.2.1	Transmit diversity performance.....	596
8.10	Demodulation (4 receiver antenna ports)	596
8.10.1	PDSCH	596
8.10.1.1	FDD (Fixed Reference Channel).....	596
8.10.1.1.1	Transmit diversity performance with 2Tx Antenna Ports (Cell-Specific Reference Symbols)	597
8.10.1.1.1A	Transmit diversity performance with Enhanced Performance Requirement Type A - 2 Tx Antenna Ports with TM3 interference model.....	597
8.10.1.1.2	Open-loop spatial multiplexing performance with 2Tx Antenna Ports (Cell-Specific Reference Symbols).....	599
8.10.1.1.3	Closed-loop spatial multiplexing Enhanced Performance Requirements Type A - Single-Layer Spatial Multiplexing 2 Tx Antenna Port with TM4 interference model (Cell-Specific Reference Symbols).....	599
8.10.1.1.4	Closed-loop spatial multiplexing performance, Dual-Layer Spatial Multiplexing 4 Tx Antenna Port (Cell-Specific Reference Symbols)	600
8.10.1.1.5	Enhanced Performance Requirement Type A – Single-layer Spatial Multiplexing with TM9 interference model (User-Specific Reference Symbols).....	601
8.10.1.1.5A	Single-layer Spatial Multiplexing (User-Specific Reference Symbols)	603
8.10.1.1.5B	Single-layer Spatial Multiplexing (With Enhanced DMRS table configured)	604
8.10.1.1.6	Dual-Layer Spatial Multiplexing (User-Specific Reference Symbols)	605
8.10.1.1.7	Open-loop spatial multiplexing, 3 Layer Multiplexing with 4 Tx Antenna Ports (Cell-Specific Reference Symbols).....	607

8.10.1.1.8	Closed-loop spatial multiplexing performance, 4 Layers spatial multiplexing 4 Tx antennas (Cell-Specific Reference Symbols)	607
8.10.1.1.9	4 Layer Spatial Multiplexing (User-Specific Reference Symbols)	608
8.10.1.2	TDD (Fixed Reference Channel)	609
8.10.1.2.1	Transmit diversity performance with 2Tx Antenna Ports (Cell-Specific Reference Symbols)	610
8.10.1.2.1A	Transmit diversity performance with Enhanced Performance Requirement Type A – 2 Tx Antenna Ports with TM3 interference model.....	611
8.10.1.2.2	Open-loop spatial multiplexing performance with 2Tx Antenna Ports (Cell-Specific Reference Symbols).....	612
8.10.1.2.3	Closed-loop spatial multiplexing Enhanced Performance Requirements Type A - Single-Layer Spatial Multiplexing 2 Tx Antenna Port with TM4 interference model (Cell-Specific Reference Symbols).....	612
8.10.1.2.4	Closed-loop spatial multiplexing performance, Dual-Layer Spatial Multiplexing 4 Tx Antenna Ports (Cell-Specific Reference Symbols).....	613
8.10.1.2.5	Enhanced Performance Requirement Type A – Single-layer Spatial Multiplexing with TM9 interference model (User-Specific Reference Symbols).....	614
8.10.1.2.5A	Single-layer Spatial Multiplexing (with multiple CSI-RS configurations).....	616
8.10.1.2.5B	Single-layer Spatial Multiplexing (With Enhanced DMRS table configured)	617
8.10.1.2.6	Dual-Layer Spatial Multiplexing (User-Specific Reference Symbols)	618
8.10.1.2.7	Open-loop spatial multiplexing, 3 Layer Multiplexing with 4 Tx Antenna Ports (Cell-Specific Reference Symbols).....	620
8.10.1.2.8	Closed-loop spatial multiplexing performance, 4 Layers spatial multiplexing 4 Tx antennas	620
8.10.1.2.9	4 Layer Spatial Multiplexing (User-Specific Reference Symbols)	621
8.10.2	PDCCH/PCFICH.....	622
8.10.2.1	FDD.....	622
8.10.2.1.1	Single-antenna port performance.....	623
8.10.2.1.2	Transmit diversity performance with 2 Tx Antenna Ports	623
8.10.2.1.3	Transmit diversity performance with 4 Tx Antenna Ports	623
8.10.2.2	TDD	624
8.10.2.2.1	Single-antenna port performance.....	624
8.10.2.2.2	Transmit diversity performance with 2 Tx Antenna Ports	624
8.10.2.2.3	Transmit diversity performance with 4 Tx Antenna Ports	625
8.10.3	PHICH	625
8.10.3.1	FDD.....	625
8.10.3.1.1	Single Tx Antenna Port performance	626
8.10.3.1.2	Transmit diversity performance with 2 Tx Antenna Ports	626
8.10.3.1.3	Transmit diversity performance with 4 Tx Antenna Ports	626
8.10.3.2	TDD	626
8.10.3.2.1	Single Tx Antenna Port performance	627
8.10.3.2.2	Transmit diversity performance with 2 Tx Antenna Ports	627
8.10.3.2.3	Transmit diversity performance with 4 Tx Antenna Ports	628
8.10.4	ePDCCH	628
8.10.4.1	Distributed Transmission with 4Rx.....	628
8.10.4.1.1	FDD	628
8.10.4.1.2	TDD.....	629
8.10.4.2	Localized Transmission with TM9 and 4Rx	630
8.10.4.2.1	FDD	630
8.10.4.2.2	TDD.....	631
8.11	Demodulation (UE supporting coverage enhancement)	633
8.11.1	PDSCH	633
8.11.1.1	FDD and half-duplex FDD (Fixed Reference Channel).....	633
8.11.1.1.1	Closed-loop spatial multiplexing performance (Cell-Specific Reference Symbols)	633
8.11.1.1.2	Closed-loop spatial multiplexing performance (User-Specific Reference Symbols)	635
8.11.1.1.3	Transmit diversity performance (Cell-Specific Reference Symbols)	636
8.11.1.2	TDD (Fixed Reference Channel)	638
8.11.1.2.1	Closed-loop spatial multiplexing performance (Cell-Specific Reference Symbols)	639
8.11.1.2.2	Closed-loop spatial multiplexing performance (User-Specific Reference Symbols)	641
8.11.1.2.3	Transmit diversity performance (Cell-Specific Reference Symbols)	643
8.11.2	MPDCCH	645
8.11.2.1	FDD and half-duplex FDD.....	645
8.11.2.1.1	CE Mode A.....	646
8.11.2.1.2	CE Mode B.....	647

8.11.2.2	TDD	648
8.11.2.2.1	CE Mode A	649
8.11.2.2.2	CE Mode B	650
8.11.3	PBCH	650
8.11.3.1	FDD and half-duplex FDD	651
8.11.3.1.1	Transmit diversity performance	651
8.11.3.2	TDD	651
8.11.3.2.1	Transmit diversity performance	651
8.12	Demodulation of Narrowband IoT	652
8.12.1	NPDSCH	652
8.12.1.1	Half-duplex FDD	652
8.12.1.1.1	Minimum Requirements for In-band	652
8.12.1.1.2	Minimum Requirements for Standalone/Guard-band	653
8.12.2	NPDCCH	654
8.12.2.1	Half-duplex FDD	654
8.12.2.1.1	Single-antenna performance	655
8.12.2.1.2	Transmit diversity performance	655
8.12.3	Demodulation of NPBCH	655
8.12.3.1	HD-FDD	656
8.12.3.1.1	Single-antenna port performance with single NPBCH TTI	656
8.12.3.1.2	Transmit diversity performance	656
9	Reporting of Channel State Information	657
9.1	General	657
9.1.1	Applicability of requirements	657
9.1.1.1	Applicability of requirements for different channel bandwidths	657
9.1.1.2	Applicability and test rules for different CA configurations and bandwidth combination sets	657
9.1.1.2A	Applicability and test rules for different TDD-FDD CA configurations and bandwidth combination sets	658
9.1.1.3	Test coverage for different number of component carriers	659
9.1.1.4	Applicability of performance requirements for 4Rx capable UEs	659
9.1.1.4.1	Applicability rule and antenna connection for single carrier tests with 2Rx	659
9.1.1.4.2	Applicability rule and antenna connection for CA tests with 2Rx	661
9.1.1.4.3	Applicability rule and antenna connection for single carrier tests with 4Rx	662
9.1.1.5	Applicability of requirements for UEs supporting coverage enhancement	662
9.2	CQI reporting definition under AWGN conditions	662
9.2.1	Minimum requirement PUCCH 1-0 (Cell-Specific Reference Symbols)	662
9.2.1.1	FDD	662
9.2.1.2	TDD	663
9.2.1.3	FDD (CSI measurements in case two CSI subframe sets are configured)	664
9.2.1.4	TDD (CSI measurements in case two CSI subframe sets are configured)	666
9.2.1.5	FDD (CSI measurements in case two CSI subframe sets are configured and with CRS assistance information)	668
9.2.1.6	TDD (CSI measurements in case two CSI subframe sets are configured and with CRS assistance information)	670
9.2.1.7	FDD (Modulation and TBS index Table 2 and 4-bit CQI Table 2 are used)	672
9.2.1.8	TDD (Modulation and TBS index Table 2 and 4-bit CQI Table 2 are used)	673
9.2.2	Minimum requirement PUCCH 1-1 (Cell-Specific Reference Symbols)	673
9.2.2.1	FDD	673
9.2.2.2	TDD	674
9.2.3	Minimum requirement PUCCH 1-1 (CSI Reference Symbols)	675
9.2.3.1	FDD	675
9.2.3.1A	FDD (With <i>channelMeasRestriction</i> configured)	676
9.2.3.2	TDD	677
9.2.3.2A	TDD (With <i>channelMeasRestriction</i> configured)	678
9.2.4	Minimum requirement PUCCH 1-1 (With Single CSI Process)	679
9.2.4.1	FDD	680
9.2.4.1A	FDD (With <i>interferenceMeasRestriction</i> configured)	682
9.2.4.2	TDD	684
9.2.4.2A	TDD (With <i>interferenceMeasRestriction</i> configured)	686
9.2.5	Minimum requirement PUCCH 1-1 (when <i>csi-SubframeSet -r12</i> and <i>EIMTA-MainConfigServCell-r12</i> are configured)	688

9.2.6	Minimum requirement PUSCH 3-0 (Cell-Specific Reference Symbols).....	690
9.2.6.1	Frame structure type 3 with FDD Pcell.....	690
9.2.6.2	Frame structure type 3 with TDD Pcell.....	692
9.2.7	Minimum requirement PUSCH 3-1 (CSI Reference Symbol).....	694
9.2.7.1	Frame structure type 3 with FDD Pcell.....	694
9.2.7.2	Frame structure type 3 with TDD Pcell.....	696
9.3	CQI reporting under fading conditions.....	700
9.3.1	Frequency-selective scheduling mode	700
9.3.1.1	Minimum requirement PUSCH 3-0 (Cell-Specific Reference Symbols).....	700
9.3.1.1.1	FDD	700
9.3.1.1.2	TDD.....	701
9.3.1.1.3	FDD (CSI measurements in case two CSI subframe sets are configured and with CRS assistance information)	702
9.3.1.1.4	TDD (CSI measurements in case two CSI subframe sets are configured and with CRS assistance information)	705
9.3.1.1.5	TDD (when <i>csi-SubframeSet-r12</i> is configured)	707
9.3.1.2	Minimum requirement PUSCH 3-1 (CSI Reference Symbol)	709
9.3.1.2.1	FDD	709
9.3.1.2.2	TDD.....	710
9.3.1.2.3	FDD (Modulation and TBS index Table 2 and 4-bit CQI Table 2 are used).....	712
9.3.1.2.4	TDD (Modulation and TBS index Table 2 and 4-bit CQI Table 2 are used).....	713
9.3.1.2.5	Void.....	714
9.3.1.2.6	TDD (when <i>csi-SubframeSet-r12</i> is configured with one CSI process).....	714
9.3.2	Frequency non-selective scheduling mode	717
9.3.2.1	Minimum requirement PUCCH 1-0 (Cell-Specific Reference Symbol).....	717
9.3.2.1.1	FDD	717
9.3.2.1.2	TDD.....	719
9.3.2.2	Minimum requirement PUCCH 1-1 (CSI Reference Symbol).....	721
9.3.2.2.1	FDD	721
9.3.2.2.2	TDD.....	722
9.3.3	Frequency-selective interference	724
9.3.3.1	Minimum requirement PUSCH 3-0 (Cell-Specific Reference Symbol)	724
9.3.3.1.1	FDD	724
9.3.3.1.2	TDD.....	725
9.3.3.2	Void.....	726
9.3.3.2.1	Void.....	726
9.3.3.2.2	Void.....	726
9.3.4	UE-selected subband CQI.....	726
9.3.4.1	Minimum requirement PUSCH 2-0 (Cell-Specific Reference Symbols).....	726
9.3.4.1.1	FDD	726
9.3.4.1.2	TDD.....	727
9.3.4.2	Minimum requirement PUCCH 2-0 (Cell-Specific Reference Symbols)	728
9.3.4.2.1	FDD	728
9.3.4.2.2	TDD.....	730
9.3.5	Additional requirements for enhanced receiver Type A	732
9.3.5.1	Minimum requirement PUCCH 1-0 (Cell-Specific Reference Symbol).....	732
9.3.5.1.1	FDD	732
9.3.5.1.2	TDD.....	733
9.3.5.2	Minimum requirement PUCCH 1-1 (CSI Reference Symbol).....	735
9.3.5.2.1	FDD	735
9.3.5.2.2	TDD.....	737
9.3.6	Minimum requirement (With multiple CSI processes).....	739
9.3.6.1	FDD.....	739
9.3.6.2	TDD	743
9.3.7	Minimum requirement PUSCH 3-2	746
9.3.7.1	FDD.....	746
9.3.7.2	TDD	747
9.3.8	Additional requirements for enhanced receiver Type B	749
9.3.8.1	Minimum requirement PUCCH 1-1 (Cell-Specific Reference Symbols)	749
9.3.8.1.1	FDD	749
9.3.8.1.2	TDD.....	750
9.3.8.2	Minimum requirement PUCCH 1-1 (CSI Reference Symbols)	752

9.3.8.2.1	FDD	752
9.3.8.2.2	TDD	754
9.3.8.3	Minimum requirement with CSI process	756
9.3.8.3.1	FDD	756
9.3.8.3.2	TDD	758
9.4	Reporting of Precoding Matrix Indicator (PMI).....	760
9.4.1	Single PMI	761
9.4.1.1	Minimum requirement PUSCH 3-1 (Cell-Specific Reference Symbols).....	761
9.4.1.1.1	FDD	761
9.4.1.1.2	TDD	762
9.4.1.2	Minimum requirement PUCCH 2-1 (Cell-Specific Reference Symbols)	763
9.4.1.2.1	FDD	763
9.4.1.2.2	TDD	764
9.4.1.3	Minimum requirement PUSCH 3-1 (CSI Reference Symbol)	766
9.4.1.3.1	FDD	766
9.4.1.3.2	TDD	767
9.4.1.3.3	FDD (with Class A 12Tx codebook).....	769
9.4.1.3.4	TDD (with Class A 12Tx codebook).....	771
9.4.1.4	Minimum requirement PUCCH 1-1 (CSI Reference Symbol).....	773
9.4.1.4.1	FDD (with 4Tx enhanced codebook)	773
9.4.1.4.2	TDD (with 4Tx enhanced codebook)	775
9.4.1.4.3	FDD (with Class B alternative codebook for one CSI-RS resource configured).....	777
9.4.1.4.4	TDD (with Class B alternative codebook for one CSI-RS resource configured)	779
9.4.1a	Void	781
9.4.1a.1	Void.....	781
9.4.1a.1.1	Void	781
9.4.1a.1.2	Void	781
9.4.2	Multiple PMI	781
9.4.2.1	Minimum requirement PUSCH 1-2 (Cell-Specific Reference Symbols).....	781
9.4.2.1.1	FDD	781
9.4.2.1.2	TDD	782
9.4.2.2	Minimum requirement PUSCH 2-2 (Cell-Specific Reference Symbols).....	783
9.4.2.2.1	FDD	783
9.4.2.2.2	TDD	784
9.4.2.3	Minimum requirement PUSCH 1-2 (CSI Reference Symbol)	785
9.4.2.3.1	FDD	785
9.4.2.3.2	TDD	787
9.4.2.3.3	FDD (with 4Tx enhanced codebook)	789
9.4.2.3.4	TDD (with 4Tx enhanced codebook).....	791
9.4.2.3.5	FDD (with Class A 16Tx codebook).....	793
9.4.2.3.6	TDD (with Class A 16Tx codebook).....	795
9.4.3	Void	797
9.4.3.1	Void.....	797
9.4.3.1.1	Void	797
9.4.3.1.2	Void	797
9.5	Reporting of Rank Indicator (RI)	797
9.5.1	Minimum requirement (Cell-Specific Reference Symbols).....	797
9.5.1.1	FDD.....	797
9.5.1.2	TDD	798
9.5.2	Minimum requirement (CSI Reference Symbols)	799
9.5.2.1	FDD.....	799
9.5.2.2	TDD	801
9.5.3	Minimum requirement (CSI measurements in case two CSI subframe sets are configured).....	803
9.5.3.1	FDD.....	803
9.5.3.2	TDD	805
9.5.4	Minimum requirement (CSI measurements in case two CSI subframe sets are configured and CRS assistance information are configured)	807
9.5.4.1	FDD.....	807
9.5.4.2	TDD	809
9.5.5	Minimum requirement (with CSI process)	811
9.5.5.1	FDD.....	812
9.5.5.2	TDD	814

9.6	Additional requirements for carrier aggregation	816
9.6.1	Periodic reporting on multiple cells (Cell-Specific Reference Symbols)	816
9.6.1.1	FDD.....	816
9.6.1.2	TDD	820
9.6.1.3	TDD-FDD CA with FDD PCell.....	823
9.6.1.4	TDD-FDD CA with TDD PCell.....	826
9.7	CSI reporting (Single receiver antenna)	829
9.7.1	CQI reporting definition under AWGN conditions	829
9.7.1.1	FDD and half-duplex FDD.....	829
9.7.1.2	TDD	830
9.7.2	CQI reporting under fading conditions	831
9.7.2.1	FDD and half-duplex FDD.....	831
9.7.2.2	TDD	832
9.8	CSI reporting (UE supporting coverage enhancement)	833
9.8.1	CQI reporting definition under AWGN conditions	833
9.8.1.1	FDD and half-duplex FDD.....	833
9.8.1.2	TDD	834
9.8.2	UE-selected subband CQI.....	835
9.8.2.1	FDD and half-duplex FDD.....	835
9.8.2.2	TDD	838
9.9	CSI reporting for 4Rx UE	840
9.9.1	CQI reporting definition under AWGN conditions	840
9.9.1.1	Minimum requirement PUCCH 1-0 with Rank 1 (Cell-Specific Reference Symbols)	840
9.9.1.1.1	FDD	840
9.9.1.1.2	TDD.....	841
9.9.1.2	Minimum requirement PUCCH 1-1 with Rank 2 (CSI Reference Symbols).....	842
9.9.1.2.1	FDD	842
9.9.1.2.2	TDD.....	843
9.9.1.3	Minimum requirement PUCCH 1-1 with Rank 4 (Cell-Specific Reference Symbols)	844
9.9.1.3.1	FDD	845
9.9.1.3.2	TDD.....	845
9.9.1.4	Minimum requirement PUCCH 1-1 with Rank 3 (CSI Reference Symbols).....	846
9.9.1.4.1	FDD	846
9.9.1.4.2	TDD.....	847
9.9.2	CQI reporting definition under fading conditions.....	848
9.9.2.1	Minimum requirement PUCCH 1-0 (Cell-Specific Reference Symbol) for enhanced receiver Type A	848
9.9.2.1.1	FDD	849
9.9.2.1.2	TDD.....	850
9.9.2.2	Minimum requirement PUCCH 1-1 (CSI Reference Symbol) for enhanced receiver Type A	852
9.9.2.2.1	FDD	852
9.9.2.2.2	TDD.....	854
9.9.3	Reporting of Precoding Matrix Indicator (PMI) for 4Rx UE.....	856
9.9.3.1	Minimum requirement PUSCH 3-1 (CSI Reference Symbol)	856
9.9.3.1.1	TDD.....	856
9.9.4	Reporting of Rank Indicator (RI).....	858
9.9.4.1	Minimum requirement (Cell-Specific Reference Symbols).....	858
9.9.4.1.1	FDD	858
9.9.4.1.2	TDD.....	860
9.9.4.2	Minimum requirement (CSI Reference Symbols).....	861
9.9.4.2.1	FDD	861
9.9.4.2.2	TDD.....	863
9.10	Reporting of CSI-RS Resource Indicator (CRI).....	865
9.10.1	Minimum requirement (PUSCH 3-1)	865
9.10.1.1	FDD.....	865
9.10.1.2	TDD	867
10	Performance requirement (MBMS).....	869
10.1	FDD (Fixed Reference Channel).....	869
10.1.1	Minimum requirement	869
10.2	TDD (Fixed Reference Channel).....	870
10.2.1	Minimum requirement	870

11	Performance requirement (ProSe Direct Discovery).....	871
11.1	General	871
11.1.1	Applicability of requirements	871
11.1.2	Reference DRX configuration	872
11.2	Demodulation of PSDCH (single link performance).....	872
11.2.1	FDD (in-coverage).....	872
11.2.2	TDD (in-coverage).....	873
11.2.3	FDD (out-of-coverage)	874
11.3	Power imbalance performance with two links.....	874
11.3.1	FDD	874
11.3.2	TDD.....	875
11.4	Multiple timing reference test	876
11.4.1	FDD	877
11.5	Maximum Sidelink processes test	878
11.5.1	FDD	878
11.5.2	TDD.....	879
12	Performance requirement (ProSe Direct Communication)	881
12.1	General	881
12.1.1	Applicability of requirements	881
12.1.1.1	Applicability of requirements for different channel bandwidths.....	881
12.1.1.2	Test coverage for different number of component carriers	881
12.1.1.3	Applicability and test rules for different CA configurations and bandwidth combination sets.....	881
12.1.2	Reference DRX configuration	882
12.2	Demodulation of PSSCH.....	882
12.2.1	FDD	882
12.3	Demodulation of PSCCH	883
12.3.1	FDD	884
12.4	Demodulation of PSBCH	885
12.4.1	FDD	885
12.5	Power imbalance performance with two links.....	885
12.5.1	FDD	885
12.6	Multiple timing reference test	887
12.6.1	FDD	887
12.7	Maximum Sidelink processes test	889
12.7.1	FDD	889
12.8	Sustained downlink data rate with active Sidelink	890
Annex A (normative): Measurement channels.....		893
A.1	General	893
A.2	UL reference measurement channels	893
A.2.1	General	893
A.2.1.1	Applicability and common parameters	893
A.2.1.2	Determination of payload size	893
A.2.1.3	Overview of UL reference measurement channels	894
A.2.2	Reference measurement channels for FDD.....	906
A.2.2.1	Full RB allocation.....	906
A.2.2.1.1	QPSK	906
A.2.2.1.2	16-QAM.....	908
A.2.2.1.3	64-QAM.....	909
A.2.2.2	Partial RB allocation.....	909
A.2.2.2.1	QPSK	910
A.2.2.2.2	16-QAM.....	912
A.2.2.2.3	64-QAM.....	914
A.2.2.3	Void	915
A.2.3	Reference measurement channels for TDD.....	915
A.2.3.1	Full RB allocation.....	915
A.2.3.1.1	QPSK	915
A.2.3.1.2	16-QAM.....	917
A.2.3.1.3	64-QAM.....	918
A.2.3.2	Partial RB allocation.....	918

A.2.3.2.1	QPSK	919
A.2.3.2.2	16-QAM	921
A.2.3.2.3	64-QAM	923
A.2.3.3	Void	924
A.2.4	Reference measurement channels for UE category NB1	924
A.3	DL reference measurement channels	925
A.3.1	General	925
A.3.1.1	Overview of DL reference measurement channels	925
A.3.2	Reference measurement channel for receiver characteristics	943
A.3.3	Reference measurement channels for PDSCH performance requirements (FDD)	965
A.3.3.1	Single-antenna transmission (Common Reference Symbols)	965
A.3.3.2	Multi-antenna transmission (Common Reference Symbols)	970
A.3.3.2.1	Two antenna ports	970
A.3.3.2.2	Four antenna ports	974
A.3.3.3	Reference Measurement Channel for UE-Specific Reference Symbols	976
A.3.3.3.0	Two antenna ports (no CSI-RS)	976
A.3.3.3.1	Two antenna port (CSI-RS)	977
A.3.3.3.2	Four antenna ports (CSI-RS)	979
A.3.3.3.2A	Eight antenna ports (CSI-RS)	983
A.3.3.3.3	Twelve antenna port (CSI-RS)	984
A.3.3.3.4	Sixteen antenna port (CSI-RS)	985
A.3.4	Reference measurement channels for PDSCH performance requirements (TDD)	987
A.3.4.1	Single-antenna transmission (Common Reference Symbols)	987
A.3.4.2	Multi-antenna transmission (Common Reference Signals)	995
A.3.4.2.1	Two antenna ports	995
A.3.4.2.2	Four antenna ports	1002
A.3.4.3	Reference Measurement Channels for UE-Specific Reference Symbols	1004
A.3.4.3.1	Single antenna port (Cell Specific)	1004
A.3.4.3.2	Two antenna ports (Cell Specific)	1005
A.3.4.3.3	Two antenna ports (CSI-RS)	1007
A.3.4.3.4	Four antenna ports (CSI-RS)	1009
A.3.4.3.5	Eight antenna ports (CSI-RS)	1014
A.3.4.3.6	Twelve antenna ports (CSI-RS)	1017
A.3.4.3.7	Sixteen antenna ports (CSI-RS)	1018
A.3.5	Reference measurement channels for PDCCH/PCFICH performance requirements	1020
A.3.5.1	FDD	1020
A.3.5.2	TDD	1020
A.3.5.3	LAA	1020
A.3.6	Reference measurement channels for PHICH performance requirements	1021
A.3.7	Reference measurement channels for PBCH performance requirements	1022
A.3.8	Reference measurement channels for MBMS performance requirements	1022
A.3.8.1	FDD	1022
A.3.8.2	TDD	1024
A.3.9	Reference measurement channels for sustained downlink data rate provided by lower layers	1026
A.3.9.1	FDD	1026
A.3.9.2	TDD	1029
A.3.9.3	FDD (EPDCCH scheduling)	1036
A.3.9.4	TDD (EPDCCH scheduling)	1037
A.3.10	Reference Measurement Channels for EPDCCH performance requirements	1038
A.3.10.1	FDD	1038
A.3.10.2	TDD	1038
A.3.11	Reference Measurement Channels for MPDCCH performance requirements	1039
A.3.11.1	FDD and half-duplex FDD	1039
A.3.11.2	TDD	1039
A.3.12	Reference measurement channels for NPDSCH performance requirements	1040
A.3.12.1	In-band	1040
A.3.12.1.1	Two-antenna transmission	1040
A.3.12.2	Standalone/Guard-band	1041
A.3.12.3.1	Single-antenna transmission	1041
A.3.13	Reference measurement channels for NPDCCH performance requirements	1041
A.3.13.1	Half-duplex FDD	1041

A.3.14	Reference measurement channels for NPBCH performance requirements for Cat NB1 UEs.....	1042
A.3.15	Reference Measurement Channels for LAA SCell with frame structure Type-3	1042
A.3.15.1	Multi-antenna transmission (Common Reference Symbols)	1042
A.3.15.1.1	Four antenna ports.....	1042
A.3.15.2	Reference Measurement Channel for UE-Specific Reference Symbols	1043
A.3.15.2.1	Two antenna ports (CSI-RS).....	1043
A.4	CSI reference measurement channels.....	1043
A.5	OFDMA Channel Noise Generator (OCNG)	1053
A.5.1	OCNG Patterns for FDD	1053
A.5.1.1	OCNG FDD pattern 1: One sided dynamic OCNG FDD pattern	1053
A.5.1.2	OCNG FDD pattern 2: Two sided dynamic OCNG FDD pattern	1054
A.5.1.3	OCNG FDD pattern 3: 49 RB OCNG allocation with MBSFN in 10 MHz	1054
A.5.1.4	OCNG FDD pattern 4: One sided dynamic OCNG FDD pattern for MBMS transmission	1055
A.5.1.5	OCNG FDD pattern 5: One sided dynamic 16QAM modulated OCNG FDD pattern	1055
A.5.1.6	OCNG FDD pattern 6: dynamic OCNG FDD pattern when user data is in 2 non-contiguous blocks....	1056
A.5.1.8	OCNG FDD pattern 8: Dynamic OCNG FDD pattern for TM10 transmission.....	1057
A.5.2	OCNG Patterns for TDD	1058
A.5.2.1	OCNG TDD pattern 1: One sided dynamic OCNG TDD pattern.....	1058
A.5.2.2	OCNG TDD pattern 2: Two sided dynamic OCNG TDD pattern	1059
A.5.2.3	OCNG TDD pattern 3: 49 RB OCNG allocation with MBSFN in 10 MHz	1060
A.5.2.4	OCNG TDD pattern 4: One sided dynamic OCNG TDD pattern for MBMS transmission	1060
A.5.2.5	OCNG TDD pattern 5: One sided dynamic 16QAM modulated OCNG TDD pattern.....	1061
A.5.2.6	OCNG TDD pattern 6: dynamic OCNG TDD pattern when user data is in 2 non-contiguous blocks ...	1062
A.5.2.8	OCNG TDD pattern 8: Dynamic OCNG TDD pattern for TM10 transmission	1063
A.5.3	OCNG Patterns for Narrowband IoT	1064
A.5.3.1	Narrowband IoT OCNG pattern 1	1065
A.5.4	OCNG Patterns for frame structure type 3	1065
A.5.4.1	OCNG FS3 pattern 1: One sided dynamic OCNG frame structure type 3 pattern.....	1065
A.5.4.2	OCNG FS3 pattern 2: Two sided dynamic OCNG frame structure 3 pattern.....	1066
A.6	Sidelink reference measurement channels.....	1067
A.6.1	General	1067
A.6.1.1	Overview of ProSe reference measurement channels	1067
A.6.2	Reference measurement channel for receiver characteristics	1068
A.6.3	Reference measurement channels for PSDCH performance requirements	1070
A.6.4	Reference measurement channels for PSCCH performance requirements.....	1071
A.6.5	Reference measurement channels for PSSCH performance requirements	1071
A.6.6	Reference measurement channels for PSBCH performance requirements.....	1072
A.7	Sidelink reference resource pool configurations	1073
A.7.1	Reference resource pool configurations for ProSe Direct Discovery demodulation tests	1073
A.7.1.1	FDD	1073
A.7.1.2	TDD.....	1076
A.7.2	Reference resource pool configurations for ProSe Direct Communication demodulation tests.....	1078
A.7.2.1	FDD	1078
Annex B (normative):	Propagation conditions.....	1084
B.1	Static propagation condition.....	1084
B.1.1	UE Receiver with 2Rx.....	1084
B.1.2	UE Receiver with 4Rx.....	1084
B.2	Multi-path fading propagation conditions	1085
B.2.1	Delay profiles	1085
B.2.2	Combinations of channel model parameters	1086
B.2.3	MIMO Channel Correlation Matrices	1086
B.2.3.1	Definition of MIMO Correlation Matrices	1086
B.2.3.2	MIMO Correlation Matrices at High, Medium and Low Level.....	1088
B.2.3A	MIMO Channel Correlation Matrices using cross polarized antennas	1092
B.2.3A.1	Definition of MIMO Correlation Matrices using cross polarized antennas	1092
B.2.3A.2	Spatial Correlation Matrices using cross polarized antennas at eNB and UE sides.....	1093
B.2.3A.2.1	Spatial Correlation Matrices at eNB side	1093

B.2.3A.2.2	Spatial Correlation Matrices at UE side	1093
B.2.3A.4	Beam steering approach.....	1096
B.2.3B	MIMO Channel Correlation Matrices using two-dimension cross polarized antennas at eNB and cross polarized antennas at UE.....	1096
B.2.3B.1	Definition of MIMO Correlation Matrices using two-dimension cross polarized antennas at eNB and cross polarized antennas at UE	1097
B.2.3B.2	Spatial Correlation Matrices using two-dimension cross polarized antennas at eNB and cross polarized antennas at UE	1098
B.2.3B.2.1	Spatial Correlation Matrices at eNB side	1098
B.2.3B.2.2	Spatial Correlation Matrices at UE side.....	1098
B.2.3B.3	MIMO Correlation Matrices using two-dimension cross polarized antennas at eNB and cross polarized antennas at UE	1098
B.2.3B.4	Beam steering approach.....	1101
B.2.4	Propagation conditions for CQI tests.....	1102
B.2.4.1	Propagation conditions for CQI tests with multiple CSI processes.....	1102
B.2.5	Void.....	1102
B.2.6	MBSFN Propagation Channel Profile	1102
B.3	High speed train scenario	1103
B.4	Beamforming Model	1104
B.4.1	Single-layer random beamforming (Antenna port 5, 7, or 8).....	1104
B.4.1A	Single-layer random beamforming (Antenna port 7, 8, 11 or 13 with enhanced DMRS table configured)	1105
B.4.2	Dual-layer random beamforming (antenna ports 7 and 8).....	1106
B.4.3	Generic beamforming model (antenna ports 7-14).....	1106
B.4.4	Random beamforming for EPDCCH distributed transmission (Antenna port 107 and 109).....	1107
B.4.5	Random beamforming for EPDCCH localized transmission (Antenna port 107, 108, 109 or 110).....	1107
B.4.6	Beamforming model for CRI test	1107
B.5	Interference models for enhanced performance requirements Type-A	1109
B.5.1	Dominant interferer proportion	1109
B.5.2	Transmission mode 3 interference model.....	1109
B.5.3	Transmission mode 4 interference model.....	1109
B.5.4	Transmission mode 9 interference model.....	1110
B.6	Interference models for enhanced performance requirements Type-B	1110
B.6.1	Transmission mode 2 interference model.....	1110
B.6.2	Transmission mode 3 interference model.....	1111
B.6.3	Transmission mode 4 interference model.....	1111
B.6.4	Transmission mode 9 interference model.....	1111
B.6.5	CRS interference model	1112
B.6.6	Random interference model	1112
B.7	Interference models for enhanced downlink control channel performance requirements Type A and B	1113
B.7.1	PDCCH, PCFICH and PHICH interference model	1113
B.8	Burst transmission models for Frame structure type 3	1114
B.8.1	Burst transmission model for one LAA SCell.....	1114
Annex C (normative):	Downlink Physical Channels.....	1115
C.1	General	1115
C.2	Set-up	1115
C.3	Connection	1115
C.3.1	Measurement of Receiver Characteristics	1115
C.3.2	Measurement of Performance requirements.....	1116
C.3.3	Aggressor cell power allocation for Measurement of Performance Requirements when ABS is Configured.....	1117
C.3.4	Power Allocation for Measurement of Performance Requirements when Quasi Co-location Type B: same Cell ID.....	1118
C.3.5	Simplified CA testing method	1118
C.3.6	Measurement of Receiver Characteristics for Narrowband IoT	1119

Annex D (normative):	Characteristics of the interfering signal	1120
D.1	General	1120
D.2	Interference signals.....	1120
Annex E (normative):	Environmental conditions	1121
E.1	General	1121
E.2	Environmental	1121
E.2.1	Temperature	1121
E.2.2	Voltage	1121
E.2.3	Vibration.....	1122
Annex F (normative):	Transmit modulation.....	1123
F.1	Measurement Point.....	1123
F.2	Basic Error Vector Magnitude measurement	1123
F.3	Basic in-band emissions measurement.....	1124
F.4	Modified signal under test.....	1124
F.5	Window length	1126
F.5.1	Timing offset.....	1126
F.5.2	Window length	1126
F.5.3	Window length for normal CP	1126
F.5.4	Window length for Extended CP.....	1127
F.5.5	Window length for PRACH	1127
F.5.F	Window length for category NB1	1128
F.6	Averaged EVM	1128
F.6.F	Averaged EVM for category NB1	1129
F.7	Spectrum Flatness	1129
Annex G (informative):	Reference sensitivity level in lower SNR.....	1130
G.1	General	1130
G.2	Typical receiver sensitivity performance (QPSK)	1130
G.3	Reference measurement channel for REFSENSE in lower SNR.....	1134
Annex H (normative):	Modified MPR behavior.....	1137
H.1	Indication of modified MPR behavior.....	1137
Annex I (informative):	Change history	1138
History	1171

Foreword

This Technical Specification (TS) has been produced by the 3rd Generation Partnership Project (3GPP).

The contents of the present document are subject to continuing work within the TSG and may change following formal TSG approval. Should the TSG modify the contents of the present document, it will be re-released by the TSG with an identifying change of release date and an increase in version number as follows:

Version x.y.z

Where:

- x the first digit:
 - 1 presented to TSG for information;
 - 2 presented to TSG for approval;
 - 3 or greater indicates TSG approved document under change control.
- y the second digit is incremented for all changes of substance, i.e. technical enhancements, corrections, updates, etc.
- z the third digit is incremented when editorial only changes have been incorporated in the document.

1 Scope

The present document establishes the minimum RF characteristics and minimum performance requirements for E-UTRA User Equipment (UE).

2 References

The following documents contain provisions which, through reference in this text, constitute provisions of the present document.

- References are either specific (identified by date of publication, edition number, version number, etc.) or non-specific.
- For a specific reference, subsequent revisions do not apply.
- For a non-specific reference, the latest version applies. In the case of a reference to a 3GPP document (including a GSM document), a non-specific reference implicitly refers to the latest version of that document *in the same Release as the present document*.

- [1] 3GPP TR 21.905: "Vocabulary for 3GPP Specifications".
- [2] ITU-R Recommendation SM.329-10, "Unwanted emissions in the spurious domain"
- [3] ITU-R Recommendation M.1545: "Measurement uncertainty as it applies to test limits for the terrestrial component of International Mobile Telecommunications-2000".
- [4] 3GPP TS 36.211: "Physical Channels and Modulation".
- [5] 3GPP TS 36.212: "Multiplexing and channel coding".
- [6] 3GPP TS 36.213: "Physical layer procedures".
- [7] 3GPP TS 36.331: " Requirements for support of radio resource management ".
- [8] 3GPP TS 36.307: " Requirements on User Equipments (UEs) supporting a release-independent frequency band".
- [9] 3GPP TS 36.423: "X2 application protocol (X2AP) ".
- [10] 3GPP TS 23.303: "Technical Specification Group Services and System Aspects; Proximity-based services (ProSe); Stage 2".
- [11] 3GPP TS36.300: "Evolved Universal Terrestrial Radio Access (E-UTRA) and Evolved Universal Terrestrial Radio Access Network (E-UTRAN); Overall description; Stage 2".

3 Definitions, symbols and abbreviations

3.1 Definitions

For the purposes of the present document, the terms and definitions given in TR 21.905 [1] and the following apply in the case of a single component carrier. A term defined in the present document takes precedence over the definition of the same term, if any, in TR 21.905 [1].

Aggregated Channel Bandwidth: The RF bandwidth in which a UE transmits and receives multiple contiguously aggregated carriers.

Aggregated Transmission Bandwidth Configuration: The number of resource block allocated within the aggregated channel bandwidth.

Carrier aggregation: Aggregation of two or more component carriers in order to support wider transmission bandwidths.

Carrier aggregation band: A set of one or more operating bands across which multiple carriers are aggregated with a specific set of technical requirements.

Carrier aggregation bandwidth class: A class defined by the aggregated transmission bandwidth configuration and maximum number of component carriers supported by a UE.

Carrier aggregation configuration: A combination of CA operating band(s) and CA bandwidth class(es) supported by a UE.

Channel edge: The lowest and highest frequency of the carrier, separated by the channel bandwidth.

Channel bandwidth: The RF bandwidth supporting a single E-UTRA RF carrier with the transmission bandwidth configured in the uplink or downlink of a cell. The channel bandwidth is measured in MHz and is used as a reference for transmitter and receiver RF requirements.

Composite spectrum emission mask: Emission mask requirement for intraband non-contiguous carrier aggregation which is a combination of individual sub-block spectrum emissions masks.

Composite spurious emission requirement: Spurious emission requirement for intraband non-contiguous carrier aggregation which is a combination of individual sub-block spurious emission requirements.

Contiguous carriers: A set of two or more carriers configured in a spectrum block where there are no RF requirements based on co-existence for un-coordinated operation within the spectrum block.

Contiguous resource allocation: A resource allocation of consecutive resource blocks within one carrier or across contiguously aggregated carriers. The gap between contiguously aggregated carriers due to the nominal channel spacing is allowed.

Contiguous spectrum: Spectrum consisting of a contiguous block of spectrum with no sub-block gaps.

Enhanced downlink control channel performance requirements type A: This defines performance requirements for downlink control channel assuming as baseline receiver reference symbol based linear minimum mean square error interference rejection combining plus CRS interference cancellation.

Enhanced downlink control channel performance requirements type B: This defines performance requirements for downlink control channel assuming as baseline receiver reference symbol based enhanced linear minimum mean square error interference rejection combining plus CRS interference cancellation.

Enhanced performance requirements type A: This defines performance requirements assuming as baseline receiver reference symbol based linear minimum mean square error interference rejection combining.

Enhanced performance requirements type B: This defines performance requirements assuming as baseline receiver using network assisted interference cancellation and suppression.

Enhanced performance requirements type C: This defines performance requirements assuming as baseline receiver inter-stream interference cancellation.

Inter-band carrier aggregation: Carrier aggregation of component carriers in different operating bands.

NOTE: Carriers aggregated in each band can be contiguous or non-contiguous.

Intra-band contiguous carrier aggregation: Contiguous carriers aggregated in the same operating band.

Intra-band non-contiguous carrier aggregation: Non-contiguous carriers aggregated in the same operating band.

Lower sub-block edge: The frequency at the lower edge of one sub-block. It is used as a frequency reference point for both transmitter and receiver requirements.

Category NB1 stand-alone operation: a category NB1 is operating standalone when it utilizes its own spectrum, for example the spectrum used by GERAN systems as a replacement of one or more GSM carriers, as well as scattered spectrum for potential IoT deployment.

Category NB1 guard band operation: category NB1 is operating in guard band when it utilizes the unused resource block(s) within a E-UTRA carrier's guard-band.

Category NB1 in-band operation: category NB1 is operating in-band when it utilizes the resource block(s) within a normal E-UTRA carrier.

Non-contiguous spectrum: Spectrum consisting of two or more sub-blocks separated by sub-block gap(s).

ProSe-enabled UE: A UE that supports ProSe requirements and associated procedures.

NOTE: As defined in TS 23.303 [10].

ProSe Direct Communication: A communication between two or more UEs in proximity that are ProSe-enabled.

NOTE: As defined in TS 23.303 [10].

ProSe Direct Discovery: A procedure employed by a ProSe-enabled UE to discover other ProSe-enabled UEs in its vicinity.

NOTE: As defined in TS 23.303 [10].

Sub-block: This is one contiguous allocated block of spectrum for transmission and reception by the same UE. There may be multiple instances of sub-blocks within an RF bandwidth.

Sub-block bandwidth: The bandwidth of one sub-block.

Sub-block gap: A frequency gap between two consecutive sub-blocks within an RF bandwidth, where the RF requirements in the gap are based on co-existence for un-coordinated operation.

Synchronized operation: Operation of TDD in two different systems, where no simultaneous uplink and downlink occur.

Unsynchronized operation: Operation of TDD in two different systems, where the conditions for synchronized operation are not met.

Upper sub-block edge: The frequency at the upper edge of one sub-block. It is used as a frequency reference point for both transmitter and receiver requirements.

3.2 Symbols

For the purposes of the present document, the following symbols apply:

BW_{Channel}	Channel bandwidth
$BW_{\text{Channel,block}}$	Sub-block bandwidth, expressed in MHz. $BW_{\text{Channel,block}} = F_{\text{edge,block,high}} - F_{\text{edge,block,low}}$.
$BW_{\text{Channel_CA}}$	Aggregated channel bandwidth, expressed in MHz.
BW_{GB}	Virtual guard band to facilitate transmitter (receiver) filtering above / below edge CCs.
E_{RS}	Transmitted energy per RE for reference symbols during the useful part of the symbol, i.e. excluding the cyclic prefix, (average power normalized to the subcarrier spacing) at the eNode B transmit antenna connector
\hat{E}_s	The averaged received energy per RE of the wanted signal during the useful part of the symbol, i.e. excluding the cyclic prefix, at the UE antenna connector; average power is computed within a set of REs used for the transmission of physical channels (including user specific RSs when present), divided by the number of REs within the set, and normalized to the subcarrier spacing
F	Frequency
$F_{\text{agg_alloc_low}}$	Aggregated Transmission Bandwidth Configuration. The lowest frequency of the simultaneously transmitted resource blocks.
$F_{\text{agg_alloc_high}}$	Aggregated Transmission Bandwidth Configuration. The highest frequency of the simultaneously transmitted resource blocks.
$F_{\text{Interferer (offset)}}$	Frequency offset of the interferer

$F_{\text{Interferer}}$	Frequency of the interferer
F_{C}	Frequency of the carrier centre frequency
$F_{\text{C,agg}}$	Aggregated Transmission Bandwidth Configuration. Center frequency of the aggregated carriers.
$F_{\text{C,block,high}}$	Center frequency of the highest transmitted/received carrier in a sub-block.
$F_{\text{C,block,low}}$	Center frequency of the lowest transmitted/received carrier in a sub-block.
$F_{\text{C,low}}$	The centre frequency of the <i>lowest carrier</i> , expressed in MHz.
$F_{\text{C,high}}$	The centre frequency of the <i>highest carrier</i> , expressed in MHz.
$F_{\text{DL,low}}$	The lowest frequency of the downlink operating band
$F_{\text{DL,high}}$	The highest frequency of the downlink operating band
$F_{\text{UL,low}}$	The lowest frequency of the uplink operating band
$F_{\text{UL,high}}$	The highest frequency of the uplink operating band
$F_{\text{edge,block,low}}$	The lower sub-block edge, where $F_{\text{edge,block,low}} = F_{\text{C,block,low}} - F_{\text{offset}}$.
$F_{\text{edge,block,high}}$	The upper sub-block edge, where $F_{\text{edge,block,high}} = F_{\text{C,block,high}} + F_{\text{offset}}$.
$F_{\text{edge,low}}$	The <i>lower edge</i> of aggregated channel bandwidth, expressed in MHz.
$F_{\text{edge,high}}$	The <i>higher edge</i> of aggregated channel bandwidth, expressed in MHz.
F_{offset}	Frequency offset from $F_{\text{C,high}}$ to the <i>higher edge</i> or $F_{\text{C,low}}$ to the <i>lower edge</i> .
$F_{\text{offset,block,low}}$	Separation between lower edge of a sub-block and the center of the lowest component carrier within the sub-block
$F_{\text{offset,block,high}}$	Separation between higher edge of a sub-block and the center of the highest component carrier within the sub-block
$F_{\text{offset,NS}_23}$	Frequency offset in MHz needed if NS_23 is used
F_{OOB}	The boundary between the E-UTRA out of band emission and spurious emission domains.
I_o	The power spectral density of the total input signal (power averaged over the useful part of the symbols within the transmission bandwidth configuration, divided by the total number of RE for this configuration and normalised to the subcarrier spacing) at the UE antenna connector, including the own-cell downlink signal
I_{or}	The total transmitted power spectral density of the own-cell downlink signal (power averaged over the useful part of the symbols within the transmission bandwidth configuration, divided by the total number of RE for this configuration and normalised to the subcarrier spacing) at the eNode B transmit antenna connector
\hat{I}_{or}	The total received power spectral density of the own-cell downlink signal (power averaged over the useful part of the symbols within the transmission bandwidth configuration, divided by the total number of RE for this configuration and normalised to the subcarrier spacing) at the UE antenna connector
I_{ot}	The received power spectral density of the total noise and interference for a certain RE (average power obtained within the RE and normalized to the subcarrier spacing) as measured at the UE antenna connector
L_{CRB}	Transmission bandwidth which represents the length of a contiguous resource block allocation expressed in units of resources blocks
L_{Ctone}	Transmission bandwidth which represents the length of a contiguous sub-carrier allocation expressed in units of tones
N_{cp}	Cyclic prefix length
N_{DL}	Downlink EARFCN
N_{oc}	The power spectral density of a white noise source (average power per RE normalised to the subcarrier spacing), simulating interference from cells that are not defined in a test procedure, as measured at the UE antenna connector
N_{oc1}	The power spectral density of a white noise source (average power per RE normalized to the subcarrier spacing), simulating interference in non-CRS symbols in ABS subframe from cells that are not defined in a test procedure, as measured at the UE antenna connector.
N_{oc2}	The power spectral density of a white noise source (average power per RE normalized to the subcarrier spacing), simulating interference in CRS symbols in ABS subframe from all cells that are not defined in a test procedure, as measured at the UE antenna connector.
N_{oc3}	The power spectral density of a white noise source (average power per RE normalised to the subcarrier spacing), simulating interference in non-ABS subframe from cells that are not defined in a test procedure, as measured at the UE antenna connector

N_{oc}'	The power spectral density (average power per RE normalised to the subcarrier spacing) of the summation of the received power spectral densities of the strongest interfering cells explicitly defined in a test procedure plus N_{oc} , as measured at the UE antenna connector. The respective power spectral density of each interfering cell relative to N_{oc}' is defined by its associated DIP value, or the respective power spectral density of each interfering cell relative to N_{oc} is defined by its associated E_s/N_{oc} value.
$N_{\text{Offs-DL}}$	Offset used for calculating downlink EARFCN
$N_{\text{Offs-UL}}$	Offset used for calculating uplink EARFCN
N_{otx}	The power spectral density of a white noise source (average power per RE normalised to the subcarrier spacing) simulating eNode B transmitter impairments as measured at the eNode B transmit antenna connector
N_{RB}	Transmission bandwidth configuration, expressed in units of resource blocks
N_{RB_agg}	The number of the aggregated RBs within the fully allocated Aggregated Channel bandwidth.
N_{RB_alloc}	Total number of simultaneously transmitted resource blocks in Channel bandwidth or Aggregated Channel Bandwidth.
$N_{RB,c}$	The transmission bandwidth configuration of component carrier c , expressed in units of resource blocks
$N_{RB,largest\ BW}$	The largest transmission bandwidth configuration of the component carriers in the bandwidth combination, expressed in units of resource blocks
N_{RX}	Number of receiver antennas
N_{tone}	Transmission bandwidth configuration for category NB1, expressed in units of tones.
$N_{tone\ 3.75kHz}$	Transmission bandwidth configuration for category NB1 with 3.75 kHz sub-carrier spacing, expressed in units of tones.
$N_{tone\ 15kHz}$	Transmission bandwidth configuration for category NB1 with 15 kHz sub-carrier spacing, expressed in units of tones.
N_{UL}	Uplink EARFCN.
R_{av}	Minimum average throughput per RB.
P_{CMAX}	The configured maximum UE output power.
$P_{CMAX,c}$	The configured maximum UE output power for serving cell c .
P_{EMAX}	Maximum allowed UE output power signalled by higher layers. Same as IE $P\text{-Max}$, defined in [7].
$P_{EMAX,c}$	Maximum allowed UE output power signalled by higher layers for serving cell c . Same as IE $P\text{-Max}$, defined in [7].
$P_{Interferer}$	Modulated mean power of the interferer
$P_{PowerClass}$	$P_{PowerClass}$ is the nominal UE power (i.e., no tolerance).
P_{UMAX}	The measured configured maximum UE output power.
P_{uw}	Power of an unwanted DL signal
P_w	Power of a wanted DL signal
RB_{start}	Indicates the lowest RB index of transmitted resource blocks.
RB_{end}	Indicates the highest RB index of transmitted resource blocks.
Δf_{OOB}	Δ Frequency of Out Of Band emission.
$\Delta R_{IB,c}$	Allowed reference sensitivity relaxation due to support for inter-band CA operation, for serving cell c .
$\Delta R_{IB,4R}$	Reference sensitivity adjustment due to support for 4 antenna ports.
$\Delta T_{IB,c}$	Allowed maximum configured output power relaxation due to support for inter-band CA operation, for serving cell c .
ΔT_C	Allowed operating band edge transmission power relaxation.
$\Delta T_{C,c}$	Allowed operating band edge transmission power relaxation for serving cell c .
ΔT_{ProSe}	Allowed operating band transmission power relaxation due to support of E-UTRA ProSe on an operating band.
ρ_A	According to Clause 5.2 in TS 36.213 [6]
ρ_B	According to Clause 5.2 in TS 36.213 [6]
σ	Test specific auxiliary variable used for the purpose of downlink power allocation, defined in Annex C.3.2.
W_{gap}	Sub-block gap size

3.3 Abbreviations

For the purposes of the present document, the abbreviations given in TR 21.905 [1] and the following apply. An abbreviation defined in the present document takes precedence over the definition of the same abbreviation, if any, in TR 21.905 [1].

ABS	Almost Blank Subframe
ACLR	Adjacent Channel Leakage Ratio
ACS	Adjacent Channel Selectivity
A-MPR	Additional Maximum Power Reduction
AWGN	Additive White Gaussian Noise
BS	Base Station
CA	Carrier Aggregation
CA_X	Intra-band contiguous CA of component carriers in one sub-block within Band X where X is the applicable E-UTRA operating band
CA_X-X	Intra-band non-contiguous CA of component carriers in two sub-blocks within Band X where X is the applicable E-UTRA operating band
CA_X-Y	Inter-band CA of component carrier(s) in one sub-block within Band X and component carrier(s) in one sub-block within Band Y where X and Y are the applicable E-UTRA operating band
CA_X-X-Y	CA of component carriers in two sub-blocks within Band X and component carrier(s) in one sub-block within Band Y where X and Y are the applicable E-UTRA operating bands
CC	Component Carriers
CG	Carrier Group
CPE	Customer Premise Equipment
CPE_X	Customer Premise Equipment for E-UTRA operating band X
CW	Continuous Wave
DC	Dual Connectivity
DC_X-Y	Inter-band DC of component carrier(s) in one sub-block within Band X and component carrier(s) in one sub-block within Band Y where X and Y are the applicable E-UTRA operating band
DL	Downlink
DIP	Dominant Interferer Proportion
EARFCN	E-UTRA Absolute Radio Frequency Channel Number
EPRE	Energy Per Resource Element
E-UTRA	Evolved UMTS Terrestrial Radio Access
EUTRAN	Evolved UMTS Terrestrial Radio Access Network
EVM	Error Vector Magnitude
FDD	Frequency Division Duplex
FRC	Fixed Reference Channel
HD-FDD	Half-Duplex FDD
MCS	Modulation and Coding Scheme
MCG	Master Cell Group
MOP	Maximum Output Power
MPR	Maximum Power Reduction
MSD	Maximum Sensitivity Degradation
OCNG	OFDMA Channel Noise Generator
OFDMA	Orthogonal Frequency Division Multiple Access
OOB	Out-of-band
PA	Power Amplifier
PCC	Primary Component Carrier
P-MPR	Power Management Maximum Power Reduction
ProSe	Proximity-based Services
PSBCH	Physical Sidelink Broadcast CHannel
PSCCH	Physical Sidelink Control CHannel
PSDCH	Physical Sidelink Discovery CHannel
PSS	Primary Synchronization Signal
PSS_RA	PSS-to-RS EPRE ratio for the channel PSS
PSSCH	Physical Sidelink Shared CHannel
PSSS	Primary Sidelink Synchronization Signal
RE	Resource Element
REFSENS	Reference Sensitivity power level
r.m.s	Root Mean Square

SCC	Secondary Component Carrier
SCG	Secondary Cell Group
SINR	Signal-to-Interference-and-Noise Ratio
SNR	Signal-to-Noise Ratio
SSS	Secondary Synchronization Signal
SSS_RA	SSS-to-RS EPRE ratio for the channel SSSSSSS Secondary Sidelink Synchronization Signal
TDD	Time Division Duplex
UE	User Equipment
UL	Uplink
UL-MIMO	Up Link Multiple Antenna transmission
UMTS	Universal Mobile Telecommunications System
UTRA	UMTS Terrestrial Radio Access
UTRAN	UMTS Terrestrial Radio Access Network
xCH_RA	xCH-to-RS EPRE ratio for the channel xCH in all transmitted OFDM symbols not containing cell-specific RS
xCH_RB	xCH-to-RS EPRE ratio for the channel xCH in all transmitted OFDM symbols containing cell-specific RS

4 General

4.1 Relationship between minimum requirements and test requirements

The Minimum Requirements given in this specification make no allowance for measurement uncertainty. The test specification TS 36.521-1 Annex F defines Test Tolerances. These Test Tolerances are individually calculated for each test. The Test Tolerances are used to relax the Minimum Requirements in this specification to create Test Requirements.

The measurement results returned by the Test System are compared - without any modification - against the Test Requirements as defined by the shared risk principle.

The Shared Risk principle is defined in ITU-R M.1545 [3].

4.2 Applicability of minimum requirements

- a) In this specification the Minimum Requirements are specified as general requirements and additional requirements. Where the Requirement is specified as a general requirement, the requirement is mandated to be met in all scenarios
- b) For specific scenarios for which an additional requirement is specified, in addition to meeting the general requirement, the UE is mandated to meet the additional requirements.
- c) The reference sensitivity power levels defined in subclause 7.3 are valid for the specified reference measurement channels.
- d) NOTE: Receiver sensitivity degradation may occur when:
 - 1) The UE simultaneously transmits and receives with bandwidth allocations less than the transmission bandwidth configuration (see Figure 5.6-1), and
 - 2) Any part of the downlink transmission bandwidth is within an uplink transmission bandwidth from the downlink center subcarrier.
- e) The spurious emissions power requirements are for the long term average of the power. For the purpose of reducing measurement uncertainty it is acceptable to average the measured power over a period of time sufficient to reduce the uncertainty due to the statistical nature of the signal.
- f) The requirements in this specification for TDD operating bands apply for downlink and uplink operations using Frame Structure Type 2 [4] except for Band 46 operating with Frame Structure Type 3.

4.3 Void

4.3A Applicability of minimum requirements (CA, UL-MIMO, ProSe, Dual Connectivity, UE category 0, UE category M1, UE category NB1)

The requirements in clauses 5, 6 and 7 which are specific to CA, UL-MIMO, ProSe, Dual Connectivity, UE category 0, UE category M1, and UE category NB1 are specified as suffix A, B, C, D, E, and F where;

- a) Suffix A additional requirements need to support CA
- b) Suffix B additional requirements need to support UL-MIMO
- c) Suffix C additional requirements need to support Dual Connectivity
- d) Suffix D additional requirements need to support ProSe
- e) Suffix E additional requirements need to support UE category 0 and category M1
- f) Suffix F additional requirements need to support UE category NB1

A terminal which supports the above features needs to meet both the general requirements and the additional requirement applicable to the additional subclause (suffix A, B, C, D, E and F) in clauses 5, 6 and 7. Where there is a difference in requirement between the general requirements and the additional subclause requirements (suffix A, B, C, D, E and F) in clauses 5, 6 and 7, the tighter requirements are applicable unless stated otherwise in the additional subclause.

A terminal which supports more than one feature (CA, UL-MIMO, ProSe, Dual Connectivity, UE category 0, UE category M1 and UE category NB1) in clauses 5, 6 and 7 shall meet all of the separate corresponding requirements.

For a terminal supporting CA, compliance with minimum requirements for non-contiguous intra-band carrier aggregation in any given operating band does not imply compliance with minimum requirements for contiguous intra-band carrier aggregation in the same operating band.

For a terminal supporting CA, compliance with minimum requirements for contiguous intra-band carrier aggregation in any given operating band does not imply compliance with minimum requirements for non-contiguous intra-band carrier aggregation in the same operating band.

A terminal which supports a DL CA configuration shall support all the lower order fallback DL CA combinations and it shall support at least one bandwidth combination set for each of the constituent lower order DL combinations containing all the bandwidths specified within each specific combination set of the upper order DL combination.

A terminal which supports CA, for each supported CA configuration, shall support Pcell transmissions in each of the aggregated Component Carriers unless indicated otherwise in clause 5.6A.1.

Terminal supporting Dual Connectivity configuration shall meet the minimum requirements for corresponding CA configuration (suffix A), unless otherwise specified.

For a terminal that supports ProSe Direct Communication and/or ProSe Direct Discovery, the minimum requirements are applicable when

- the UE is associated with a serving cell on the ProSe carrier, or
- the UE is not associated with a serving cell on the ProSe carrier and is provisioned with the preconfigured radio parameters for ProSe Direct Communications and/or ProSe Direct Discovery that are associated with known Geographical Area, or
- the UE is associated with a serving cell on a carrier different than the ProSe carrier, and the radio parameters for ProSe Direct Discovery on the ProSe carrier are provided by the serving cell, or

- the UE is associated with a serving cell on a carrier different than the ProSe carrier, and has a non-serving cell selected on the ProSe carrier that supports ProSe Direct Discovery and/or ProSe Direct Communication.

When the ProSe UE is not associated with a serving cell on the ProSe carrier, and the UE does not have knowledge of its geographical area, or is provisioned with preconfigured radio parameters that are not associated with any Geographical Area, ProSe transmissions are not allowed, and the requirements in Section 6.3.3D apply.

A terminal that supports simultaneous E-UTRA ProSe sidelink transmissions and E-UTRA uplink transmissions for the inter-band E-UTRA ProSe/E-UTRA bands specified in Table 5.5D-2, shall meet the minimum requirements for the corresponding inter-band UL CA configuration (suffix A), unless otherwise specified. For transmitter characteristics specified in clause 6, the terminal is required to meet the conformance tests for the corresponding inter-band UL CA configuration and is not required to be retested with simultaneous E-UTRA ProSe sidelink and E-UTRA uplink transmissions.

4.4 RF requirements in later releases

The standardisation of new frequency bands and carrier aggregation configurations (downlink and uplink aggregation) may be independent of a release. However, in order to implement a UE that conforms to a particular release but supports a band of operation or a carrier aggregation configuration that is specified in a later release, it is necessary to specify some extra requirements. TS 36.307 [8] specifies requirements on UEs supporting a frequency band or a carrier aggregation configuration that is independent of release.

NOTE: For UEs conforming to the 3GPP release of the present document, some RF requirements of later releases may be mandatory independent of whether the UE supports the bands specif or carrier aggregation configurations ied in later releases or not. The set of RF requirements of later releases that is also mandatory for UEs conforming to the 3GPP release of the present document is determined by regional regulation.

5 Operating bands and channel arrangement

5.1 General

The channel arrangements presented in this clause are based on the operating bands and channel bandwidths defined in the present release of specifications.

NOTE: Other operating bands and channel bandwidths may be considered in future releases.

5.2 Void

5.3 Void

5.4 Void

5.5 Operating bands

E-UTRA is designed to operate in the operating bands defined in Table 5.5-1.

Table 5.5-1 E-UTRA operating bands

E-UTRA Operating Band	Uplink (UL) operating band BS receive UE transmit		Downlink (DL) operating band BS transmit UE receive		Duplex Mode
	F _{UL_low}	F _{UL_high}	F _{DL_low}	F _{DL_high}	
1	1920 MHz	– 1980 MHz	2110 MHz	– 2170 MHz	FDD
2	1850 MHz	– 1910 MHz	1930 MHz	– 1990 MHz	FDD
3	1710 MHz	– 1785 MHz	1805 MHz	– 1880 MHz	FDD
4	1710 MHz	– 1755 MHz	2110 MHz	– 2155 MHz	FDD
5	824 MHz	– 849 MHz	869 MHz	– 894 MHz	FDD
6 ¹	830 MHz	– 840 MHz	875 MHz	– 885 MHz	FDD
7	2500 MHz	– 2570 MHz	2620 MHz	– 2690 MHz	FDD
8	880 MHz	– 915 MHz	925 MHz	– 960 MHz	FDD
9	1749.9 MHz	– 1784.9 MHz	1844.9 MHz	– 1879.9 MHz	FDD
10	1710 MHz	– 1770 MHz	2110 MHz	– 2170 MHz	FDD
11	1427.9 MHz	– 1447.9 MHz	1475.9 MHz	– 1495.9 MHz	FDD
12	699 MHz	– 716 MHz	729 MHz	– 746 MHz	FDD
13	777 MHz	– 787 MHz	746 MHz	– 756 MHz	FDD
14	788 MHz	– 798 MHz	758 MHz	– 768 MHz	FDD
15	Reserved		Reserved		FDD
16	Reserved		Reserved		FDD
17	704 MHz	– 716 MHz	734 MHz	– 746 MHz	FDD
18	815 MHz	– 830 MHz	860 MHz	– 875 MHz	FDD
19	830 MHz	– 845 MHz	875 MHz	– 890 MHz	FDD
20	832 MHz	– 862 MHz	791 MHz	– 821 MHz	FDD
21	1447.9 MHz	– 1462.9 MHz	1495.9 MHz	– 1510.9 MHz	FDD
22	3410 MHz	– 3490 MHz	3510 MHz	– 3590 MHz	FDD
23	2000 MHz	– 2020 MHz	2180 MHz	– 2200 MHz	FDD
24	1626.5 MHz	– 1660.5 MHz	1525 MHz	– 1559 MHz	FDD
25	1850 MHz	– 1915 MHz	1930 MHz	– 1995 MHz	FDD
26	814 MHz	– 849 MHz	859 MHz	– 894 MHz	FDD
27	807 MHz	– 824 MHz	852 MHz	– 869 MHz	FDD
28	703 MHz	– 748 MHz	758 MHz	– 803 MHz	FDD
29	N/A		717 MHz	– 728 MHz	FDD ²
30	2305 MHz	– 2315 MHz	2350 MHz	– 2360 MHz	FDD
31	452.5 MHz	– 457.5 MHz	462.5 MHz	– 467.5 MHz	FDD
32	N/A		1452 MHz	– 1496 MHz	FDD ²
33	1900 MHz	– 1920 MHz	1900 MHz	– 1920 MHz	TDD
34	2010 MHz	– 2025 MHz	2010 MHz	– 2025 MHz	TDD
35	1850 MHz	– 1910 MHz	1850 MHz	– 1910 MHz	TDD
36	1930 MHz	– 1990 MHz	1930 MHz	– 1990 MHz	TDD
37	1910 MHz	– 1930 MHz	1910 MHz	– 1930 MHz	TDD
38	2570 MHz	– 2620 MHz	2570 MHz	– 2620 MHz	TDD
39	1880 MHz	– 1920 MHz	1880 MHz	– 1920 MHz	TDD
40	2300 MHz	– 2400 MHz	2300 MHz	– 2400 MHz	TDD
41	2496 MHz	– 2690 MHz	2496 MHz	– 2690 MHz	TDD
42	3400 MHz	– 3600 MHz	3400 MHz	– 3600 MHz	TDD
43	3600 MHz	– 3800 MHz	3600 MHz	– 3800 MHz	TDD
44	703 MHz	– 803 MHz	703 MHz	– 803 MHz	TDD
45	1447 MHz	– 1467 MHz	1447 MHz	– 1467 MHz	TDD
46	5150 MHz	– 5925 MHz	5150 MHz	– 5925 MHz	TDD ^{8,9}
...					
64	Reserved				
65	1920 MHz	– 2010 MHz	2110 MHz	– 2200 MHz	FDD
66	1710 MHz	– 1780 MHz	2110 MHz	– 2200 MHz	FDD ⁴
67	N/A		738 MHz	– 758 MHz	FDD ²
68	698 MHz	– 728 MHz	753 MHz	– 783 MHz	FDD

NOTE 1: Band 6 is not applicable
NOTE 2: Restricted to E-UTRA operation when carrier aggregation is configured. The downlink operating band is paired with the uplink operating band (external) of the

	carrier aggregation configuration that is supporting the configured Pcell.
NOTE 3:	A UE that complies with the E-UTRA Band 65 minimum requirements in this specification shall also comply with the E-UTRA Band 1 minimum requirements.
NOTE 4:	The range 2180-2200 MHz of the DL operating band is restricted to E-UTRA operation when carrier aggregation is configured.
NOTE 5:	A UE that supports E-UTRA Band 66 shall receive in the entire DL operating band
NOTE 6:	A UE that supports E-UTRA Band 66 and CA operation in any CA band shall also comply with the minimum requirements specified for the DL CA configurations CA_66B, CA_66C and CA_66A-66A.
NOTE 7:	A UE that complies with the E-UTRA Band 66 minimum requirements in this specification shall also comply with the E-UTRA Band 4 minimum requirements.
NOTE 8:	This band is an unlicensed band restricted to licensed-assisted operation using Frame Structure Type 3
NOTE 9:	In this version of the specification, restricted to E-UTRA DL operation when carrier aggregation is configured.

5.5A Operating bands for CA

E-UTRA carrier aggregation is designed to operate in the operating bands defined in Tables 5.5A-1, 5.5A-2, 5.5A-2a, 5.5A-2b and 5.5A-3.

Table 5.5A-1: Intra-band contiguous CA operating bands

E-UTRA CA Band	E-UTRA Band	Uplink (UL) operating band		Downlink (DL) operating band		Duplex Mode
		BS receive / UE transmit		BS transmit / UE receive		
		F _{UL_low}	F _{UL_high}	F _{DL_low}	F _{DL_high}	
CA_1	1	1920 MHz	1980 MHz	2110 MHz	2170 MHz	FDD
CA_2	2	1850 MHz	1910 MHz	1930 MHz	1990 MHz	FDD
CA_3	3	1710MHz	1785MHz	1805MHz	1880MHz	FDD
CA_5	5	824 MHz	849 MHz	869 MHz	894 MHz	FDD
CA_7	7	2500 MHz	2570 MHz	2620 MHz	2690 MHz	FDD
CA_8	8	880 MHz	915 MHz	925 MHz	960 MHz	FDD
CA_12	12	699 MHz	716 MHz	729 MHz	746 MHz	FDD
CA_23	23	2000 MHz	2020 MHz	2180 MHz	2200 MHz	FDD
CA_27	27	807 MHz	824 MHz	852 MHz	869 MHz	FDD
CA_38	38	2570 MHz	2620 MHz	2570 MHz	2620 MHz	TDD
CA_39	39	1880 MHz	1920 MHz	1880 MHz	1920 MHz	TDD
CA_40	40	2300 MHz	2400 MHz	2300 MHz	2400 MHz	TDD
CA_41	41	2496 MHz	2690 MHz	2496 MHz	2690 MHz	TDD
CA_42	42	3400 MHz	3600 MHz	3400 MHz	3600 MHz	TDD
CA_66	66	1710 MHz	1780 MHz	2110 MHz	2200 MHz	FDD

Table 5.5A-2: Inter-band CA operating bands (two bands)

E-UTRA CA Band	E-UTRA Band	Uplink (UL) operating band		Downlink (DL) operating band		Duplex Mode		
		BS receive / UE transmit		BS transmit / UE receive				
		F _{UL_low} – F _{UL_high}	F _{DL_low} – F _{DL_high}					
CA_1-3	1	1920 MHz	–	1980 MHz	2110 MHz	–	2170 MHz	FDD
	3	1710 MHz	–	1785 MHz	1805 MHz	–	1880 MHz	
CA_1-3-3	1	1920 MHz	–	1980 MHz	2110 MHz	–	2170 MHz	FDD
	3	1710 MHz	–	1785 MHz	1805 MHz	–	1880 MHz	
CA_1-5	1	1920 MHz	–	1980 MHz	2110 MHz	–	2170 MHz	FDD
	5	824 MHz	–	849 MHz	869 MHz	–	894 MHz	
CA_1-7	1	1920 MHz	–	1980 MHz	2110 MHz	–	2170 MHz	FDD
	7	2500 MHz	–	2570 MHz	2620 MHz	–	2690 MHz	
CA_1-8	1	1920 MHz	–	1980 MHz	2110 MHz	–	2170 MHz	FDD
	8	880 MHz	–	915 MHz	925 MHz	–	960 MHz	
CA_1-11	1	1920 MHz	–	1980 MHz	2110 MHz	–	2170 MHz	FDD
	11	1427.9 MHz	–	1447.9 MHz	1475.9 MHz	–	1495.9 MHz	
CA_1-18	1	1920 MHz	–	1980 MHz	2110 MHz	–	2170 MHz	FDD
	18	815 MHz	–	830 MHz	860 MHz	–	875 MHz	
CA_1-19	1	1920 MHz	–	1980 MHz	2110 MHz	–	2170 MHz	FDD
	19	830 MHz	–	845 MHz	875 MHz	–	890 MHz	
CA_1-20	1	1920 MHz	–	1980 MHz	2110 MHz	–	2170 MHz	FDD
	20	832 MHz	–	862 MHz	791 MHz	–	821 MHz	
CA_1-21	1	1920 MHz	–	1980 MHz	2110 MHz	–	2170 MHz	FDD
	21	1447.9 MHz	–	1462.9 MHz	1495.9 MHz	–	1510.9 MHz	
CA_1-26	1	1920 MHz	–	1980 MHz	2110 MHz	–	2170 MHz	FDD
	26	814 MHz	–	849 MHz	859 MHz	–	894 MHz	
CA_1-28	1	1920 MHz	–	1980 MHz	2110 MHz	–	2170 MHz	FDD
	28	703 MHz	–	748 MHz	758 MHz	–	803 MHz	
CA_1-40	1	1920 MHz	–	1980 MHz	2110 MHz	–	2170 MHz	FDD
	40	2300 MHz	–	2400 MHz	2300 MHz	–	2400 MHz	TDD
CA_1-41	1	1920 MHz	–	1980 MHz	2110 MHz	–	2170 MHz	FDD
	41	2496 MHz	–	2690 MHz	2496 MHz	–	2690 MHz	TDD
CA_1-42	1	1920 MHz	–	1980 MHz	2110 MHz	–	2170 MHz	FDD
	42	3400 MHz	–	3600 MHz	3400 MHz	–	3600 MHz	TDD
CA_1-46	1	1920 MHz	–	1980 MHz	2110 MHz	–	2170 MHz	FDD
	46	5150 MHz	–	5925 MHz	5150 MHz	–	5925 MHz	TDD
CA_2-4	2	1850 MHz	–	1910 MHz	1930 MHz	–	1990 MHz	FDD
	4	1710 MHz	–	1755 MHz	2110 MHz	–	2155 MHz	
CA_2-4-4	2	1850 MHz	–	1910 MHz	1930 MHz	–	1990 MHz	FDD
	4	1710 MHz	–	1755 MHz	2110 MHz	–	2155 MHz	
CA_2-5	2	1850 MHz	–	1910 MHz	1930 MHz	–	1990 MHz	FDD
	5	824 MHz	–	849 MHz	869 MHz	–	894 MHz	
CA_2-2-5	2	1850 MHz	–	1910 MHz	1930 MHz	–	1990 MHz	FDD
	5	824 MHz	–	849 MHz	869 MHz	–	894 MHz	
CA_2-7	2	1850 MHz	–	1910 MHz	1930 MHz	–	1990 MHz	FDD
	7	2500 MHz	–	2570 MHz	2620 MHz	–	2690 MHz	
CA_2-12	2	1850 MHz	–	1910 MHz	1930 MHz	–	1990 MHz	FDD
	12	699 MHz	–	716 MHz	729 MHz	–	746 MHz	
CA_2-2-12	2	1850 MHz	–	1910 MHz	1930 MHz	–	1990 MHz	FDD
	12	699 MHz	–	716 MHz	729 MHz	–	746 MHz	
CA_2-13	2	1850 MHz	–	1910 MHz	1930 MHz	–	1990 MHz	FDD
	13	777 MHz	–	787 MHz	746 MHz	–	756 MHz	
CA_2-2-13	2	1850 MHz	–	1910 MHz	1930 MHz	–	1990 MHz	FDD
	13	777 MHz	–	787 MHz	746 MHz	–	756 MHz	
CA_2-17	2	1850 MHz	–	1910 MHz	1930 MHz	–	1990 MHz	FDD
	17	704 MHz	–	716 MHz	734 MHz	–	746 MHz	
CA_2-28	2	1850 MHz	–	1910 MHz	1930 MHz	–	1990 MHz	FDD
	28	703 MHz	–	748 MHz	758 MHz	–	803 MHz	
CA_2-29	2	1850 MHz	–	1910 MHz	1930 MHz	–	1990 MHz	FDD

	29	N/A		717 MHz	–	728 MHz		
CA_2-30	2	1850 MHz	–	1910 MHz	1930 MHz	–	1990 MHz	FDD
	30	2305 MHz	–	2315 MHz	2350 MHz	–	2360 MHz	
CA_2-46	2	1850 MHz	–	1910 MHz	1930 MHz	–	1990 MHz	FDD
	46	5150 MHz	–	5925 MHz	5150 MHz	–	5925 MHz	TDD
CA_3-5	3	1710 MHz	–	1785 MHz	1805 MHz	–	1880 MHz	FDD
	5	824 MHz	–	849 MHz	869 MHz	–	894 MHz	
CA_3-3-5	3	1710 MHz	–	1785 MHz	1805 MHz	–	1880 MHz	FDD
	5	824 MHz	–	849 MHz	869 MHz	–	894 MHz	
CA_3-7	3	1710 MHz	–	1785 MHz	1805 MHz	–	1880 MHz	FDD
	7	2500 MHz	–	2570 MHz	2620 MHz	–	2690 MHz	
CA_3-8	3	1710 MHz	–	1785 MHz	1805 MHz	–	1880 MHz	FDD
	8	880 MHz	–	915 MHz	925 MHz	–	960 MHz	
CA_3-3-8	3	1710 MHz	–	1785 MHz	1805 MHz	–	1880 MHz	FDD
	8	880 MHz	–	915 MHz	925 MHz	–	960 MHz	
CA_3-19	3	1710 MHz	–	1785 MHz	1805 MHz	–	1880 MHz	FDD
	19	830 MHz	–	845 MHz	875 MHz	–	890 MHz	
CA_3-20	3	1710 MHz	–	1785 MHz	1805 MHz	–	1880 MHz	FDD
	20	832 MHz	–	862 MHz	791 MHz	–	821 MHz	
CA_3-26	3	1710 MHz	–	1785 MHz	1805 MHz	–	1880 MHz	FDD
	26	814 MHz	–	849 MHz	859 MHz	–	894 MHz	
CA_3-27	3	1710 MHz	–	1785 MHz	1805 MHz	–	1880 MHz	FDD
	27	807 MHz	–	824 MHz	852 MHz	–	869 MHz	
CA_3-28	3	1710 MHz	–	1785 MHz	1805 MHz	–	1880 MHz	FDD
	28	703 MHz	–	748 MHz	758 MHz	–	803 MHz	
CA_3-31	3	1710 MHz	–	1785 MHz	1805 MHz	–	1880 MHz	FDD
	31	452.5 MHz	–	457.5 MHz	462.5 MHz	–	467.5 MHz	
CA_3-38	3	1710 MHz	–	1785 MHz	1805 MHz	–	1880 MHz	FDD
	38	2570 MHz	–	2620 MHz	2570 MHz	–	2620 MHz	TDD
CA_3-40	3	1710 MHz	–	1785 MHz	1805 MHz	–	1880 MHz	FDD
	40	2300 MHz	–	2400 MHz	2300 MHz	–	2400 MHz	TDD
CA_3-41	3	1710 MHz	–	1785 MHz	1805 MHz	–	1880 MHz	FDD
	41	2496 MHz	–	2690 MHz	2496 MHz	–	2690 MHz	TDD
CA_3-42	3	1710 MHz	–	1785 MHz	1805 MHz	–	1880 MHz	FDD
	42	3400 MHz	–	3600 MHz	3400 MHz	–	3600 MHz	TDD
CA_3-46	3	1710 MHz	–	1785 MHz	1805 MHz	–	1880 MHz	FDD
	46	5150 MHz	–	5925 MHz	5150 MHz	–	5925 MHz	TDD
CA_4-5	4	1710 MHz	–	1755 MHz	2110 MHz	–	2155 MHz	FDD
	5	824 MHz	–	849 MHz	869 MHz	–	894 MHz	
CA_4-4-5	4	1710 MHz	–	1755 MHz	2110 MHz	–	2155 MHz	FDD
	5	824 MHz	–	849 MHz	869 MHz	–	894 MHz	
CA_4-7	4	1710 MHz	–	1755 MHz	2110 MHz	–	2155 MHz	FDD
	7	2500 MHz	–	2570 MHz	2620 MHz	–	2690 MHz	
CA_4-4-7	4	1710 MHz	–	1755 MHz	2110 MHz	–	2155 MHz	FDD
	7	2500 MHz	–	2570 MHz	2620 MHz	–	2690 MHz	
CA_4-12	4	1710 MHz	–	1755 MHz	2110 MHz	–	2155 MHz	FDD
	12	699 MHz	–	716 MHz	729 MHz	–	746 MHz	
CA_4-4-12	4	1710 MHz	–	1755 MHz	2110 MHz	–	2155 MHz	FDD
	12	699 MHz	–	716 MHz	729 MHz	–	746 MHz	
CA_4-13	4	1710 MHz	–	1755 MHz	2110 MHz	–	2155 MHz	FDD
	13	777 MHz	–	787 MHz	746 MHz	–	756 MHz	
CA_4-4-13	4	1710 MHz	–	1755 MHz	2110 MHz	–	2155 MHz	FDD
	13	777 MHz	–	787 MHz	746 MHz	–	756 MHz	
CA_4-17	4	1710 MHz	–	1755 MHz	2110 MHz	–	2155 MHz	FDD
	17	704 MHz	–	716 MHz	734 MHz	–	746 MHz	
CA_4-27	4	1710 MHz	–	1755 MHz	2110 MHz	–	2155 MHz	FDD
	27	807 MHz	–	824 MHz	852 MHz	–	869 MHz	
CA_4-28	4	1710 MHz	–	1755 MHz	2110 MHz	–	2155 MHz	FDD
	28	703 MHz	–	748 MHz	758 MHz	–	803 MHz	
CA_4-29	4	1710 MHz	–	1755 MHz	2110 MHz	–	2155 MHz	FDD

	29	N/A		717 MHz	–	728 MHz	
CA_4-4-29	4	1710 MHz	–	1755 MHz	2110 MHz	–	2155 MHz
	29	N/A		717 MHz	–	728 MHz	FDD
CA_4-30	4	1710 MHz	–	1755 MHz	2110 MHz	–	2155 MHz
	30	2305 MHz	–	2315 MHz	2350 MHz	–	2360 MHz
CA_4-4-30	4	1710 MHz	–	1755 MHz	2110 MHz	–	2155 MHz
	30	2305 MHz	–	2315 MHz	2350 MHz	–	2360 MHz
CA_4-46	4	1710 MHz	–	1755 MHz	2110 MHz	–	2155 MHz
	46	5150 MHz	–	5925 MHz	5150 MHz	–	5925 MHz
CA_5-7	5	824 MHz	–	849 MHz	869 MHz	–	894 MHz
	7	2500 MHz	–	2570 MHz	2620 MHz	–	2690 MHz
CA_5-12	5	824 MHz	–	849 MHz	869 MHz	–	894 MHz
	12	699 MHz	–	716 MHz	729 MHz	–	746 MHz
CA_5-13	5	824 MHz	–	849 MHz	869 MHz	–	894 MHz
	13	777 MHz	–	787 MHz	746 MHz	–	756 MHz
CA_5-17	5	824 MHz	–	849 MHz	869 MHz	–	894 MHz
	17	704 MHz	–	716 MHz	734 MHz	–	746 MHz
CA_5-25	5	824 MHz	–	849 MHz	869 MHz	–	894 MHz
	25	1850 MHz	–	1915 MHz	1930 MHz	–	1995 MHz
CA_5-29	5	824 MHz	–	849 MHz	869 MHz	–	894 MHz
	29	N/A		717 MHz	–	728 MHz	FDD
CA_5-30	5	824 MHz	–	849 MHz	869 MHz	–	894 MHz
	30	2305 MHz	–	2315 MHz	2350 MHz	–	2360 MHz
CA_5-38	5	824 MHz	–	849 MHz	869 MHz	–	894 MHz
	38	2570 MHz	–	2620 MHz	2570 MHz	–	2620 MHz
CA_5-40	5	824 MHz	–	849 MHz	869 MHz	–	894 MHz
	40	2300 MHz	–	2400 MHz	2300 MHz	–	2400 MHz
CA_7-8	7	2500 MHz	–	2570 MHz	2620 MHz	–	2690 MHz
	8	880 MHz	–	915 MHz	925 MHz	–	960 MHz
CA_7-12	7	2500 MHz	–	2570 MHz	2620 MHz	–	2690 MHz
	12	699 MHz	–	716 MHz	729 MHz	–	746 MHz
CA_7-20	7	2500 MHz	–	2570 MHz	2620 MHz	–	2690 MHz
	20	832 MHz	–	862 MHz	791 MHz	–	821 MHz
CA_7-22	7	2500 MHz	–	2570 MHz	2620 MHz	–	2690 MHz
	22	3410 MHz	–	3490 MHz	3510 MHz	–	3590 MHz
CA_7-28	7	2500 MHz	–	2570 MHz	2620 MHz	–	2690 MHz
	28	703 MHz	–	748 MHz	758 MHz	–	803 MHz
CA_7-40	7	2500 MHz	–	2570 MHz	2620 MHz	–	2690 MHz
	40	2300 MHz	–	2400 MHz	2300 MHz	–	2400 MHz
CA_7-42	7	2500 MHz	–	2570 MHz	2620 MHz	–	2690 MHz
	42	3400 MHz	–	3600 MHz	3400 MHz	–	3600 MHz
CA_7-42-42	7	2500 MHz	–	2570 MHz	2620 MHz	–	2690 MHz
	42	3400 MHz	–	3600 MHz	3400 MHz	–	3600 MHz
CA_7-46	7	2500 MHz	–	2570 MHz	2620 MHz	–	2690 MHz
	46	5150 MHz	–	5925 MHz	5150 MHz	–	5925 MHz
CA_8-11	8	880 MHz	–	915 MHz	925 MHz	–	960 MHz
	11	1427.9 MHz	–	1447.9 MHz	1475.9 MHz	–	1495.9 MHz
CA_8-20	8	880 MHz	–	915 MHz	925 MHz	–	960 MHz
	20	832 MHz	–	862 MHz	791 MHz	–	821 MHz
CA_8-40	8	880 MHz	–	915 MHz	925 MHz	–	960 MHz
	40	2300 MHz	–	2400 MHz	2300 MHz	–	2400 MHz
CA_8-41	8	880 MHz	–	915 MHz	925 MHz	–	960 MHz
	41	2496 MHz	–	2690 MHz	2496 MHz	–	2690 MHz
CA_8-42	8	880 MHz	–	915 MHz	925 MHz	–	960 MHz
	42	3400 MHz	–	3600 MHz	3400 MHz	–	3600 MHz
CA_11-18	11	1427.9 MHz	–	1447.9 MHz	1475.9 MHz	–	1495.9 MHz
	18	815 MHz	–	830 MHz	860 MHz	–	875 MHz
CA_12-25	12	699 MHz	–	716 MHz	729 MHz	–	746 MHz
	25	1850 MHz	–	1915 MHz	1930 MHz	–	1995 MHz
CA_12-30	12	699 MHz	–	716 MHz	729 MHz	–	746 MHz

	30	2305 MHz	–	2315 MHz	2350 MHz	–	2360 MHz	
CA_18-28	18	815 MHz	–	830 MHz	860 MHz	–	875 MHz	FDD
	28	703 MHz	–	733 MHz ¹	758 MHz	–	788 MHz ¹	
CA_19-21	19	830 MHz	–	845 MHz	875 MHz	–	890 MHz	FDD
	21	1447.9 MHz	–	1462.9 MHz	1495.9 MHz	–	1510.9 MHz	
CA_19-28	19	830 MHz	–	845 MHz	875 MHz	–	890 MHz	FDD
	28	718 MHz ¹	–	748 MHz	773 MHz ¹	–	803 MHz	
CA_19-42	19	830 MHz	–	845 MHz	875 MHz	–	890 MHz	FDD
	42	3400 MHz	–	3600 MHz	3400 MHz	–	3600 MHz	TDD
CA_20-31	20	832 MHz	–	862 MHz	791 MHz	–	821 MHz	FDD
	31	452.5 MHz	–	457.5 MHz	462.5 MHz	–	467.5 MHz	
CA_20-32	20	832 MHz	–	862 MHz	791 MHz	–	821 MHz	FDD
	32	N/A			1452 MHz	–	1496 MHz	
CA_20-38	20	832 MHz	–	862 MHz	791 MHz	–	821 MHz	FDD
	38	2570 MHz	–	2620 MHz	2570 MHz	–	2620 MHz	TDD
CA_20-40	20	832 MHz	–	862 MHz	791 MHz	–	821 MHz	FDD
	40	2300 MHz	–	2400 MHz	2300 MHz	–	2400 MHz	TDD
CA_20-42	20	832 MHz	–	862 MHz	791 MHz	–	821 MHz	FDD
	42	3400 MHz	–	3600 MHz	3400 MHz	–	3600 MHz	TDD
CA_20-42-42	20	832 MHz	–	862 MHz	791 MHz	–	821 MHz	FDD
	42	3400 MHz	–	3600 MHz	3400 MHz	–	3600 MHz	TDD
CA_20-67	20	832 MHz	–	862 MHz	791 MHz	–	821 MHz	FDD
	67	N/A			738 MHz	–	758 MHz	
CA_21-42	21	1447.9 MHz	–	1462.9 MHz	1495.9 MHz	–	1510.9 MHz	FDD
	42	3400 MHz	–	3600 MHz	3400 MHz	–	3600 MHz	TDD
CA_23-29	23	2000 MHz	–	2020 MHz	2180 MHz	–	2200 MHz	FDD
	29	N/A			717 MHz	–	728 MHz	
CA_25-26	25	1850 MHz	–	1915 MHz	1930 MHz	–	1995 MHz	FDD
	26	814 MHz	–	849 MHz	859 MHz	–	894 MHz	
CA_25-41	25	1850 MHz	–	1915 MHz	1930 MHz	–	1995 MHz	FDD
	41	2496 MHz	–	2690 MHz	2496 MHz	–	2690 MHz	TDD
CA_26-41	26	814 MHz	–	849 MHz	859 MHz	–	894 MHz	FDD
	41	2496 MHz	–	2690 MHz	2496 MHz	–	2690 MHz	TDD
CA_28-40	28	703 MHz	–	748 MHz	758 MHz	–	803 MHz	FDD
	40	2300 MHz	–	2400 MHz	2300 MHz	–	2400 MHz	TDD
CA_28-41	28	703 MHz	–	748 MHz	758 MHz	–	803 MHz	FDD
	41	2496 MHz	–	2690 MHz	2496 MHz	–	2690 MHz	TDD
CA_28-42	28	703 MHz	–	748 MHz	758 MHz	–	803 MHz	FDD
	42	3400 MHz	–	3600 MHz	3400 MHz	–	3600 MHz	TDD
CA_29-30	29	N/A			717 MHz	–	728 MHz	FDD
	30	2305 MHz	–	2315 MHz	2350 MHz	–	2360 MHz	
CA_38-40	38	2570 MHz	–	2620 MHz	2570 MHz	–	2620 MHz	TDD
	40	2300 MHz	–	2400 MHz	2300 MHz	–	2400 MHz	
CA_39-41	39	1880 MHz	–	1920 MHz	1880 MHz	–	1920 MHz	TDD
	41	2496 MHz	–	2690 MHz	2496 MHz	–	2690 MHz	
CA_41-42	41	2496 MHz	–	2690 MHz	2496 MHz	–	2690 MHz	TDD
	42	3400 MHz	–	3600 MHz	3400 MHz	–	3600 MHz	
CA_41-46	41	2496 MHz	–	2690 MHz	2496 MHz	–	2690 MHz	TDD
	46	5150 MHz	–	5925 MHz	5150 MHz	–	5925 MHz	
CA_42-46	42	3400 MHz	–	3600 MHz	3400 MHz	–	3600 MHz	TDD
	46	5150 MHz	–	5925 MHz	5150 MHz	–	5925 MHz	

NOTE 1: The frequency range in band 28 is restricted for this CA band combination.

Table 5.5A-2a: Inter-band CA operating bands (three bands)

E-UTRA CA Band	E-UTRA Band	Uplink (UL) operating band		Downlink (DL) operating band		Duplex Mode
		BS receive / UE transmit		BS transmit / UE receive		
		F _{UL_low}	F _{UL_high}	F _{DL_low}	F _{DL_high}	
CA_1-3-5	1	1920 MHz	– 1980 MHz	2110 MHz	– 2170 MHz	FDD
	3	1710 MHz	– 1785 MHz	1805 MHz	– 1880 MHz	
	5	824 MHz	– 849 MHz	869 MHz	– 894 MHz	
CA_1-3-7	1	1920 MHz	– 1980 MHz	2110 MHz	– 2170 MHz	FDD
	3	1710 MHz	– 1785 MHz	1805 MHz	– 1880 MHz	
	7	2500 MHz	– 2570 MHz	2620 MHz	– 2690 MHz	
CA_1-3-8	1	1920 MHz	– 1980 MHz	2110 MHz	– 2170 MHz	FDD
	3	1710 MHz	– 1785 MHz	1805 MHz	– 1880 MHz	
	8	880 MHz	– 915 MHz	925 MHz	– 960 MHz	
CA_1-3-19	1	1920 MHz	– 1980 MHz	2110 MHz	– 2170 MHz	FDD
	3	1710 MHz	– 1785 MHz	1805 MHz	– 1880 MHz	
	19	830 MHz	– 845 MHz	875 MHz	– 890 MHz	
CA_1-3-20	1	1920 MHz	– 1980 MHz	2110 MHz	– 2170 MHz	FDD
	3	1710 MHz	– 1785 MHz	1805 MHz	– 1880 MHz	
	20	832 MHz	– 862 MHz	791 MHz	– 821 MHz	
CA_1-3-26	1	1920 MHz	– 1980 MHz	2110 MHz	– 2170 MHz	FDD
	3	1710 MHz	– 1785 MHz	1805 MHz	– 1880 MHz	
	26	814 MHz	– 849 MHz	859 MHz	– 894 MHz	
CA_1-3-28	1	1920 MHz	– 1980 MHz	2110 MHz	– 2170 MHz	FDD
	3	1710 MHz	– 1785 MHz	1805 MHz	– 1880 MHz	
	28	703 MHz	– 748 MHz	758 MHz	– 803 MHz	
CA_1-3-40	1	1920 MHz	– 1980 MHz	2110 MHz	– 2170 MHz	FDD
	3	1710 MHz	– 1785 MHz	1805 MHz	– 1880 MHz	
	40	2300 MHz	– 2400 MHz	2300 MHz	– 2400 MHz	TDD
CA_1-3-42	1	1920 MHz	– 1980 MHz	2110 MHz	– 2170 MHz	FDD
	3	1710 MHz	– 1785 MHz	1805 MHz	– 1880 MHz	
	42	3400 MHz	– 3600 MHz	3400 MHz	– 3600 MHz	TDD
CA_1-5-7	1	1920 MHz	– 1980 MHz	2110 MHz	– 2170 MHz	FDD
	5	824 MHz	– 849 MHz	869 MHz	– 894 MHz	
	7	2500 MHz	– 2570 MHz	2620 MHz	– 2690 MHz	
CA_1-5-40	1	1920 MHz	– 1980 MHz	2110 MHz	– 2170 MHz	FDD
	5	824 MHz	– 849 MHz	869 MHz	– 894 MHz	
	40	2300 MHz	– 2400 MHz	2300 MHz	– 2400 MHz	TDD
CA_1-7-8	1	1920 MHz	– 1980 MHz	2110 MHz	– 2170 MHz	FDD
	7	2500 MHz	– 2570 MHz	2620 MHz	– 2690 MHz	
	8	880 MHz	– 915 MHz	925 MHz	– 960 MHz	
CA_1-7-20	1	1920 MHz	– 1980 MHz	2110 MHz	– 2170 MHz	FDD
	7	2500 MHz	– 2570 MHz	2620 MHz	– 2690 MHz	
	20	832 MHz	– 862 MHz	791 MHz	– 821 MHz	
CA_1-7-28	1	1920 MHz	– 1980 MHz	2110 MHz	– 2170 MHz	FDD
	7	2500 MHz	– 2570 MHz	2620 MHz	– 2690 MHz	
	28	703 MHz	– 748 MHz	758 MHz	– 803 MHz	
CA_1-8-11	1	1920 MHz	– 1980 MHz	2110 MHz	– 2170 MHz	FDD
	8	880 MHz	– 915 MHz	925 MHz	– 960 MHz	
	11	1427.9 MHz	– 1447.9 MHz	1475.9 MHz	– 1495.9 MHz	
CA_1-8-40	1	1920 MHz	– 1980 MHz	2110 MHz	– 2170 MHz	FDD
	8	880 MHz	– 915 MHz	925 MHz	– 960 MHz	
	40	2300 MHz	– 2400 MHz	2300 MHz	– 2400 MHz	TDD
CA_1-11-18	1	1920 MHz	– 1980 MHz	2110 MHz	– 2170 MHz	FDD
	11	1427.9 MHz	– 1447.9 MHz	1475.9 MHz	– 1495.9 MHz	
	18	815 MHz	– 830 MHz	860 MHz	– 875 MHz	
CA_1-18-28	1	1920 MHz	– 1980 MHz	2110 MHz	– 2170 MHz	FDD
	18	815 MHz	– 830 MHz	860 MHz	– 875 MHz	
	28	703 MHz	– 733 MHz ¹	758 MHz	– 788 MHz ¹	
CA_1-19-21	1	1920 MHz	– 1980 MHz	2110 MHz	– 2170 MHz	FDD

	19	830 MHz	–	845 MHz	875 MHz	–	890 MHz	
	21	1447.9 MHz	–	1462.9 MHz	1495.9 MHz	–	1510.9 MHz	
CA_1-19-28	1	1920 MHz	–	1980 MHz	2110 MHz	–	2170 MHz	FDD
	19	830 MHz	–	845 MHz	875 MHz	–	890 MHz	
	28	718 MHz ¹	–	748 MHz	773 MHz ¹	–	803 MHz	
CA_1-19-42	1	1920 MHz	–	1980 MHz	2110 MHz	–	2170 MHz	FDD
	19	830 MHz	–	845 MHz	875 MHz	–	890 MHz	
	42	3400 MHz	–	3600 MHz	3400 MHz	–	3600 MHz	TDD
CA_1-21-42	1	1920 MHz	–	1980 MHz	2110 MHz	–	2170 MHz	FDD
	21	1447.9 MHz	–	1462.9 MHz	1495.9 MHz	–	1510.9 MHz	
	42	3400 MHz	–	3600 MHz	3400 MHz	–	3600 MHz	TDD
CA_2-4-5	2	1850 MHz	–	1910 MHz	1930 MHz	–	1990 MHz	FDD
	4	1710 MHz	–	1755 MHz	2110 MHz	–	2155 MHz	
	5	824 MHz	–	849 MHz	869 MHz	–	894 MHz	
CA_2-2-4-5	2	1850 MHz	–	1910 MHz	1930 MHz	–	1990 MHz	FDD
	4	1710 MHz	–	1755 MHz	2110 MHz	–	2155 MHz	
	5	824 MHz	–	849 MHz	869 MHz	–	894 MHz	
CA_2-4-4-5	2	1850 MHz	–	1910 MHz	1930 MHz	–	1990 MHz	FDD
	4	1710 MHz	–	1755 MHz	2110 MHz	–	2155 MHz	
	5	824 MHz	–	849 MHz	869 MHz	–	894 MHz	
CA_2-4-7	2	1850 MHz	–	1910 MHz	1930 MHz	–	1990 MHz	FDD
	4	1710 MHz	–	1755 MHz	2110 MHz	–	2155 MHz	
	7	2500 MHz	–	2570 MHz	2620 MHz	–	2690 MHz	
CA_2-4-12	2	1850 MHz	–	1910 MHz	1930 MHz	–	1990 MHz	FDD
	4	1710 MHz	–	1755 MHz	2110 MHz	–	2155 MHz	
	12	699 MHz	–	716 MHz	729 MHz	–	746 MHz	
CA_2-4-13	2	1850 MHz	–	1910 MHz	1930 MHz	–	1990 MHz	FDD
	4	1710 MHz	–	1755 MHz	2110 MHz	–	2155 MHz	
	13	777 MHz	–	787 MHz	746 MHz	–	756 MHz	
CA_2-4-29	2	1850 MHz	–	1910 MHz	1930 MHz	–	1990 MHz	FDD
	4	1710 MHz	–	1755 MHz	2110 MHz	–	2155 MHz	
	29	N/A			717 MHz	–	728 MHz	
CA_2-4-30	2	1850 MHz	–	1910 MHz	1930 MHz	–	1990 MHz	FDD
	4	1710 MHz	–	1755 MHz	2110 MHz	–	2155 MHz	
	30	2305 MHz	–	2315 MHz	2350 MHz	–	2360 MHz	
CA_2-5-12	2	1850 MHz	–	1910 MHz	1930 MHz	–	1990 MHz	FDD
	5	824 MHz	–	849 MHz	869 MHz	–	894 MHz	
	12	699 MHz	–	716 MHz	729 MHz	–	746 MHz	
CA_2-2-5-12	2	1850 MHz	–	1910 MHz	1930 MHz	–	1990 MHz	FDD
	5	824 MHz	–	849 MHz	869 MHz	–	894 MHz	
	12	699 MHz	–	716 MHz	729 MHz	–	746 MHz	
CA_2-5-13	2	1850 MHz	–	1910 MHz	1930 MHz	–	1990 MHz	FDD
	5	824 MHz	–	849 MHz	869 MHz	–	894 MHz	
	13	777 MHz	–	787 MHz	746 MHz	–	756 MHz	
CA_2-5-29	2	1850 MHz	–	1910 MHz	1930 MHz	–	1990 MHz	FDD
	5	824 MHz	–	849 MHz	869 MHz	–	894 MHz	
	29	N/A			717 MHz	–	728 MHz	
CA_2-5-30	2	1850 MHz	–	1910 MHz	1930 MHz	–	1990 MHz	FDD
	5	824 MHz	–	849 MHz	869 MHz	–	894 MHz	
	30	2305 MHz	–	2315 MHz	2350 MHz	–	2360 MHz	
CA_2-7-12	2	1850 MHz	–	1910 MHz	1930 MHz	–	1990 MHz	FDD
	7	2500 MHz	–	2570 MHz	2620 MHz	–	2690 MHz	
	12	699 MHz	–	716 MHz	729 MHz	–	746 MHz	
CA_2-12-30	2	1850 MHz	–	1910 MHz	1930 MHz	–	1990 MHz	FDD
	12	699 MHz	–	716 MHz	729 MHz	–	746 MHz	
	30	2305 MHz	–	2315 MHz	2350 MHz	–	2360 MHz	
CA_2-29-30	2	1850 MHz	–	1910 MHz	1930 MHz	–	1990 MHz	FDD
	29	N/A			717 MHz	–	728 MHz	
	30	2305 MHz	–	2315 MHz	2350 MHz	–	2360 MHz	
CA_3-5-40	3	1710 MHz	–	1785 MHz	1805 MHz	–	1880 MHz	FDD

	5	824 MHz	–	849 MHz	869 MHz	–	894 MHz	
	40	2300 MHz	–	2400 MHz	2300 MHz	–	2400 MHz	TDD
CA_3-7-8	3	1710 MHz	–	1785 MHz	1805 MHz	–	1880 MHz	FDD
	7	2500 MHz	–	2570 MHz	2620 MHz	–	2690 MHz	
	8	880 MHz	–	915 MHz	925 MHz	–	960 MHz	
CA_3-7-20	3	1710 MHz	–	1785 MHz	1805 MHz	–	1880 MHz	FDD
	7	2500 MHz	–	2570 MHz	2620 MHz	–	2690 MHz	
	20	832 MHz	–	862 MHz	791 MHz	–	821 MHz	
CA_3-7-28	3	1710 MHz	–	1785 MHz	1805 MHz	–	1880 MHz	FDD
	7	2500 MHz	–	2570 MHz	2620 MHz	–	2690 MHz	
	28	703 MHz	–	748 MHz	758 MHz	–	803 MHz	
CA_3-8-40	3	1710 MHz	–	1785 MHz	1805 MHz	–	1880 MHz	FDD
	8	880 MHz	–	915 MHz	925 MHz	–	960 MHz	
	40	2300 MHz	–	2400 MHz	2300 MHz	–	2400 MHz	
CA_3-19-42	3	1710 MHz	–	1785 MHz	1805 MHz	–	1880 MHz	FDD
	19	830 MHz	–	845 MHz	875 MHz	–	890 MHz	
	42	3400 MHz	–	3600 MHz	3400 MHz	–	3600 MHz	
CA_3-7-38	3	1710 MHz	–	1785 MHz	1805 MHz	–	1880 MHz	FDD
	7	N/A			2620 MHz	–	2690 MHz	
	38	N/A			2570 MHz	–	2620 MHz	
CA_3-28-40	3	1710 MHz	–	1785 MHz	1805 MHz	–	1880 MHz	FDD
	28	703 MHz	–	748 MHz	758 MHz	–	803 MHz	
	40	2300 MHz	–	2400 MHz	2300 MHz	–	2400 MHz	
CA_3-41-42	3	1710 MHz	–	1785 MHz	1805 MHz	–	1880 MHz	FDD
	41	2496 MHz	–	2690 MHz	2496 MHz	–	2690 MHz	
	42	3400 MHz	–	3600 MHz	3400 MHz	–	3600 MHz	
CA_4-5-12	4	1710 MHz	–	1755 MHz	2110 MHz	–	2155 MHz	FDD
	5	824 MHz	–	849 MHz	869 MHz	–	894 MHz	
	12	699 MHz	–	716 MHz	729 MHz	–	746 MHz	
CA_4-4-5-12	4	1710 MHz	–	1755 MHz	2110 MHz	–	2155 MHz	FDD
	5	824 MHz	–	849 MHz	869 MHz	–	894 MHz	
	12	699 MHz	–	716 MHz	729 MHz	–	746 MHz	
CA_4-5-13	4	1710 MHz	–	1755 MHz	2110 MHz	–	2155 MHz	FDD
	5	824 MHz	–	849 MHz	869 MHz	–	894 MHz	
	13	777 MHz	–	787 MHz	746 MHz	–	756 MHz	
CA_4-5-29	4	1710 MHz	–	1755 MHz	2110 MHz	–	2155 MHz	FDD
	5	824 MHz	–	849 MHz	869 MHz	–	894 MHz	
	29	N/A			717 MHz	–	728 MHz	
CA_4-5-30	4	1710 MHz	–	1755 MHz	2110 MHz	–	2155 MHz	FDD
	5	824 MHz	–	849 MHz	869 MHz	–	894 MHz	
	30	2305 MHz	–	2315 MHz	2350 MHz	–	2360 MHz	
CA_4-4-5-30	4	1710 MHz	–	1755 MHz	2110 MHz	–	2155 MHz	FDD
	5	824 MHz	–	849 MHz	869 MHz	–	894 MHz	
	30	2305 MHz	–	2315 MHz	2350 MHz	–	2360 MHz	
CA_4-7-12	4	1710 MHz	–	1755 MHz	2110 MHz	–	2155 MHz	FDD
	7	2500 MHz	–	2570 MHz	2620 MHz	–	2690 MHz	
	12	699 MHz	–	716 MHz	729 MHz	–	746 MHz	
CA_4-12-30	4	1710 MHz	–	1755 MHz	2110 MHz	–	2155 MHz	FDD
	12	699 MHz	–	716 MHz	729 MHz	–	746 MHz	
	30	2305 MHz	–	2315 MHz	2350 MHz	–	2360 MHz	
CA_4-4-12-30	4	1710 MHz	–	1755 MHz	2110 MHz	–	2155 MHz	FDD
	12	699 MHz	–	716 MHz	729 MHz	–	746 MHz	
	30	2305 MHz	–	2315 MHz	2350 MHz	–	2360 MHz	
CA_4-29-30	4	1710 MHz	–	1755 MHz	2110 MHz	–	2155 MHz	FDD
	29	N/A			717 MHz	–	728 MHz	
	30	2305 MHz	–	2315 MHz	2350 MHz	–	2360 MHz	
CA_4-4-29-30	4	1710 MHz	–	1755 MHz	2110 MHz	–	2155 MHz	FDD
	29	N/A			717 MHz	–	728 MHz	
	30	2305 MHz	–	2315 MHz	2350 MHz	–	2360 MHz	
CA_7-8-20	7	2500 MHz	–	2570 MHz	2620 MHz	–	2690 MHz	FDD

	8	880 MHz	–	915 MHz	925 MHz	–	960 MHz	
	20	832 MHz	–	862 MHz	791 MHz	–	821 MHz	
CA_7-20-38	7	N/A			2620 MHz	–	2690 MHz	FDD
	20	832 MHz	–	862 MHz	791 MHz	–	821 MHz	
	38	N/A			2570 MHz	–	2620 MHz	TDD
CA_19-21-42	19	830 MHz	–	845 MHz	875 MHz	–	890 MHz	FDD
	21	1447.9 MHz	–	1462.9 MHz	1495.9 MHz	–	1510.9 MHz	
	42	3400 MHz	–	3600 MHz	3400 MHz	–	3600 MHz	TDD
NOTE 1: The frequency range in band 28 is restricted for this CA band combination.								

Table 5.5A-2b: Inter-band CA operating bands (four bands)

E-UTRA CA Band	E-UTRA Band	Uplink (UL) operating band		Downlink (DL) operating band		Duplex Mode
		BS receive / UE transmit		BS transmit / UE receive		
		F _{UL_low}	F _{UL_high}	F _{DL_low}	F _{DL_high}	
CA_1-3-5-40	1	1920 MHz	– 1980 MHz	2110 MHz	– 2170 MHz	FDD
	3	1710 MHz	– 1785 MHz	1805 MHz	– 1880 MHz	
	5	824 MHz	– 849 MHz	869 MHz	– 894 MHz	
	40	2300 MHz	– 2400 MHz	2300 MHz	– 2400 MHz	TDD
CA_1-3-7-8	1	1920 MHz	– 1980 MHz	2110 MHz	– 2170 MHz	FDD
	3	1710 MHz	– 1785 MHz	1805 MHz	– 1880 MHz	
	7	2500 MHz	– 2570 MHz	2620 MHz	– 2690 MHz	
	8	880 MHz	– 915 MHz	925 MHz	– 960 MHz	
CA_1-3-7-28	1	1920 MHz	– 1980 MHz	2110 MHz	– 2170 MHz	FDD
	3	1710 MHz	– 1785 MHz	1805 MHz	– 1880 MHz	
	7	2500 MHz	– 2570 MHz	2620 MHz	– 2690 MHz	
	28	703 MHz	– 748 MHz	758 MHz	– 803 MHz	
CA_1-3-8-40	1	1920 MHz	– 1980 MHz	2110 MHz	– 2170 MHz	FDD
	3	1710 MHz	– 1785 MHz	1805 MHz	– 1880 MHz	
	8	880 MHz	– 915 MHz	925 MHz	– 960 MHz	
	40	2300 MHz	– 2400 MHz	2300 MHz	– 2400 MHz	TDD
CA_1-3-19-42	1	1920 MHz	– 1980 MHz	2110 MHz	– 2170 MHz	FDD
	3	1710 MHz	– 1785 MHz	1805 MHz	– 1880 MHz	
	19	830 MHz	– 845 MHz	875 MHz	– 890 MHz	
	42	3400 MHz	– 3600 MHz	3400 MHz	– 3600 MHz	TDD
CA_1-19-21-42	1	1920 MHz	– 1980 MHz	2110 MHz	– 2170 MHz	FDD
	19	830 MHz	– 845 MHz	875 MHz	– 890 MHz	
	21	1447.9 MHz	– 1462.9 MHz	1495.9 MHz	– 1510.9 MHz	
	42	3400 MHz	– 3600 MHz	3400 MHz	– 3600 MHz	TDD
CA_2-4-5-12	2	1850 MHz	– 1910 MHz	1930 MHz	– 1990 MHz	FDD
	4	1710 MHz	– 1755 MHz	2110 MHz	– 2155 MHz	
	5	824 MHz	– 849 MHz	869 MHz	– 894 MHz	
	12	699 MHz	– 716 MHz	729 MHz	– 746 MHz	
CA_2-4-5-29	2	1850 MHz	– 1910 MHz	1930 MHz	– 1990 MHz	FDD
	4	1710 MHz	– 1755 MHz	2110 MHz	– 2155 MHz	
	5	824 MHz	– 849 MHz	869 MHz	– 894 MHz	
	29	N/A		717 MHz	– 728 MHz	
CA_2-4-5-30	2	1850 MHz	– 1910 MHz	1930 MHz	– 1990 MHz	FDD
	4	1710 MHz	– 1755 MHz	2110 MHz	– 2155 MHz	
	5	824 MHz	– 849 MHz	869 MHz	– 894 MHz	
	30	2305 MHz	– 2315 MHz	2350 MHz	– 2360 MHz	
CA_2-4-7-12	2	1850 MHz	– 1910 MHz	1930 MHz	– 1990 MHz	FDD
	4	1710 MHz	– 1755 MHz	2110 MHz	– 2155 MHz	
	7	2500 MHz	– 2570 MHz	2620 MHz	– 2690 MHz	
	12	699 MHz	– 716 MHz	729 MHz	– 746 MHz	
CA_2-4-12-30	2	1850 MHz	– 1910 MHz	1930 MHz	– 1990 MHz	FDD
	4	1710 MHz	– 1755 MHz	2110 MHz	– 2155 MHz	
	12	699 MHz	– 716 MHz	729 MHz	– 746 MHz	
	30	2305 MHz	– 2315 MHz	2350 MHz	– 2360 MHz	
CA_2-4-29-30	2	1850 MHz	– 1910 MHz	1930 MHz	– 1990 MHz	FDD
	4	1710 MHz	– 1755 MHz	2110 MHz	– 2155 MHz	
	29	N/A		717 MHz	– 728 MHz	
	30	2305 MHz	– 2315 MHz	2350 MHz	– 2360 MHz	

Table 5.5A-3: Intra-band non-contiguous CA operating bands (with two sub-blocks)

E-UTRA CA Band	E-UTRA Band	Uplink (UL) operating band			Downlink (DL) operating band			Duplex Mode
		BS receive / UE transmit			BS transmit / UE receive			
		F _{UL_low}	–	F _{UL_high}	F _{DL_low}	–	F _{DL_high}	
CA_2-2	2	1850 MHz	–	1910 MHz	1930 MHz	–	1990 MHz	FDD
CA_3-3	3	1710 MHz	–	1785 MHz	1805 MHz	–	1880 MHz	FDD
CA_4-4	4	1710 MHz	–	1755 MHz	2110 MHz	–	2155 MHz	FDD
CA_5-5	5	824 MHz	–	849 MHz	869 MHz	–	894 MHz	FDD
CA_7-7	7	2500 MHz	–	2570 MHz	2620 MHz	–	2690 MHz	FDD
CA_23-23	23	2000 MHz	–	2020 MHz	2180 MHz	–	2200 MHz	FDD
CA_25-25	25	1850 MHz	–	1915 MHz	1930 MHz	–	1995 MHz	FDD
CA_40-40	40	2300 MHz	–	2400 MHz	2300 MHz	–	2400 MHz	TDD
CA_41-41	41	2496 MHz	–	2690 MHz	2496 MHz	–	2690 MHz	TDD
CA_42-42	42	3400 MHz	–	3600 MHz	3400 MHz	–	3600 MHz	TDD
CA_66-66	66	1710 MHz	–	1780 MHz	2110 MHz	–	2200 MHz	FDD

5.5B Operating bands for UL-MIMO

E-UTRA UL-MIMO is designed to operate in the operating bands defined in Table 5.5B-1.

Table 5.5B-1: Void

5.5C Operating bands for Dual Connectivity

E-UTRA dual connectivity is designed to operate in the operating bands defined in Table 5.5C-1.

Table 5.5C-1: Inter-band dual connectivity operating bands (two bands)

E-UTRA DC Band	E-UTRA Band	Uplink (UL) operating band			Downlink (DL) operating band			Duplex Mode
		BS receive / UE transmit			BS transmit / UE receive			
		F _{UL_low}	–	F _{UL_high}	F _{DL_low}	–	F _{DL_high}	
DC_1-3	1	1920 MHz	–	1980 MHz	2110 MHz	–	2170 MHz	FDD
	3	1710 MHz	–	1785 MHz	1805 MHz	–	1880 MHz	
DC_1-5	1	1920 MHz	–	1980 MHz	2110 MHz	–	2170 MHz	FDD
	5	824 MHz	–	849 MHz	869 MHz	–	894 MHz	
DC_1-7	1	1920 MHz	–	1980 MHz	2110 MHz	–	2170 MHz	FDD
	7	2500 MHz	–	2570 MHz	2620 MHz	–	2690 MHz	
DC_1-8	1	1920 MHz	–	1980 MHz	2110 MHz	–	2170 MHz	FDD
	8	880 MHz	–	915 MHz	925 MHz	–	960 MHz	
DC_1-19	1	1920 MHz	–	1980 MHz	2110 MHz	–	2170 MHz	FDD
	19	830 MHz	–	845 MHz	875 MHz	–	890 MHz	
DC_1-21	1	1920 MHz	–	1980 MHz	2110 MHz	–	2170 MHz	FDD
	21	1447.9 MHz	–	1462.9 MHz	1495.9 MHz	–	1510.9 MHz	
DC_1-42	1	1920 MHz	–	1980 MHz	2110 MHz	–	2170 MHz	FDD
	42	3400 MHz	–	3600 MHz	3400 MHz	–	3600 MHz	
DC_2-4	2	1850 MHz	–	1910 MHz	1930 MHz	–	1990 MHz	FDD
	4	1710 MHz	–	1755 MHz	2110 MHz	–	2155 MHz	
DC_2-5	2	1850 MHz	–	1910 MHz	1930 MHz	–	1990 MHz	FDD
	5	824 MHz	–	849 MHz	869 MHz	–	894 MHz	
DC_2-12	2	1850 MHz	–	1910 MHz	1930 MHz	–	1990 MHz	FDD
	12	699 MHz	–	716 MHz	729 MHz	–	746 MHz	
DC_2-13	2	1850 MHz	–	1910 MHz	1930 MHz	–	1990 MHz	FDD
	13	777 MHz	–	787 MHz	746 MHz	–	756 MHz	
DC_3-5	3	1710 MHz	–	1785 MHz	1805 MHz	–	1880 MHz	FDD
	5	824 MHz	–	849 MHz	869 MHz	–	894 MHz	
DC_3-7	3	1710 MHz	–	1785 MHz	1805 MHz	–	1880 MHz	FDD
	7	2500 MHz	–	2570 MHz	2620 MHz	–	2690 MHz	
DC_3-8	3	1710 MHz	–	1785 MHz	1805 MHz	–	1880 MHz	FDD
	8	880 MHz	–	915 MHz	925 MHz	–	960 MHz	
DC_3-19	3	1710 MHz	–	1785 MHz	1805 MHz	–	1880 MHz	FDD
	19	830 MHz	–	845 MHz	875 MHz	–	890 MHz	
DC_3-20	3	1710 MHz	–	1785 MHz	1805 MHz	–	1880 MHz	FDD
	20	832 MHz	–	862 MHz	791 MHz	–	821 MHz	
DC_3-26	3	1710 MHz	–	1785 MHz	1805 MHz	–	1880 MHz	FDD
	26	814 MHz	–	849 MHz	859 MHz	–	894 MHz	
DC_4-5	4	1710 MHz	–	1755 MHz	2110 MHz	–	2155 MHz	FDD
	5	824 MHz	–	849 MHz	869 MHz	–	894 MHz	
DC_4-7	4	1710 MHz	–	1755 MHz	2110 MHz	–	2155 MHz	FDD
	7	2500 MHz	–	2570 MHz	2620 MHz	–	2690 MHz	
DC_4-12	4	1710 MHz	–	1755 MHz	2110 MHz	–	2155 MHz	FDD
	12	699 MHz	–	716 MHz	729 MHz	–	746 MHz	
DC_4-13	4	1710 MHz	–	1755 MHz	2110 MHz	–	2155 MHz	FDD
	13	777 MHz	–	787 MHz	746 MHz	–	756 MHz	
DC_4-17	4	1710 MHz	–	1755 MHz	2110 MHz	–	2155 MHz	FDD
	17	704 MHz	–	716 MHz	734 MHz	–	746 MHz	
DC_5-7	5	824 MHz	–	849 MHz	869 MHz	–	894 MHz	FDD
	7	2500 MHz	–	2570 MHz	2620 MHz	–	2690 MHz	
DC_5-12	5	824 MHz	–	849 MHz	869 MHz	–	894 MHz	FDD
	12	699 MHz	–	716 MHz	729 MHz	–	746 MHz	
DC_5-17	5	824 MHz	–	849 MHz	869 MHz	–	894 MHz	FDD
	17	704 MHz	–	716 MHz	734 MHz	–	746 MHz	
DC_7-20	7	2500 MHz	–	2570 MHz	2620 MHz	–	2690 MHz	FDD
	20	832 MHz	–	862 MHz	791 MHz	–	821 MHz	
DC_7-28	7	2500 MHz	–	2570 MHz	2620 MHz	–	2690 MHz	FDD
	28	703 MHz	–	748 MHz	758 MHz	–	803 MHz	
DC_19-21	19	830 MHz	–	845 MHz	875 MHz	–	890 MHz	FDD

	21	1447.9 MHz	–	1462.9 MHz	1495.9 MHz	–	1510.9 MHz	
DC_39-41	39	1880 MHz	–	1920 MHz	1880 MHz	–	1920 MHz	TDD
	41	2496 MHz	–	2690 MHz	2496 MHz	–	2690 MHz	

Table 5.5C-2: Inter-band dual connectivity operating bands (three bands)

E-UTRA DC Band	E-UTRA Band	Uplink (UL) operating band			Downlink (DL) operating band			Duplex Mode
		BS receive / UE transmit			BS transmit / UE receive			
		F _{UL_low}	–	F _{UL_high}	F _{DL_low}	–	F _{DL_high}	
DC_1-3-19	1	1920 MHz	–	1980 MHz	2110 MHz	–	2170 MHz	FDD
	3	1710 MHz	–	1785 MHz	1805 MHz	–	1880 MHz	
	19	830 MHz	–	845 MHz	875 MHz	–	890 MHz	
DC_1-19-21	1	1920 MHz	–	1980 MHz	2110 MHz	–	2170 MHz	FDD
	19	830 MHz	–	845 MHz	875 MHz	–	890 MHz	
	21	1447.9 MHz	–	1462.9 MHz	1495.9 MHz	–	1510.9 MHz	

5.5D Operating bands for ProSe

E-UTRA ProSe is designed to operate in the operating bands defined in Table 5.5D-1.

Table 5.5D-1 E-UTRA ProSe operating band

E-UTRA ProSe Band	E-UTRA Operating Band	ProSe UE transmit		ProSe UE receive		ProSe Duplex Mode	ProSe Direct	
		F _{UL_low}	– F _{UL_high}	F _{DL_low}	– F _{DL_high}		Disc.	Comm.
2	2	1850 MHz	– 1910 MHz	1850 MHz	– 1910 MHz	HD	Yes	
3	3	1710 MHz	– 1785 MHz	1710 MHz	– 1785 MHz	HD	Yes	Yes
4	4	1710 MHz	– 1755 MHz	1710 MHz	– 1755 MHz	HD	Yes	
7	7	2500 MHz	– 2570 MHz	2500 MHz	– 2570 MHz	HD	Yes	Yes
14	14	788 MHz	– 798 MHz	788 MHz	– 798 MHz	HD	Yes	Yes
20	20	832 MHz	– 862 MHz	832 MHz	– 862 MHz	HD	Yes	Yes
26	26	814 MHz	– 849 MHz	814 MHz	– 849 MHz	HD	Yes	Yes
28	28	703 MHz	– 748 MHz	703 MHz	– 748 MHz	HD	Yes	Yes
31	31	452.5 MHz	– 457.5 MHz	452.5 MHz	– 457.5 MHz	HD	Yes	Yes
41	41	2496 MHz	– 2690 MHz	2496 MHz	– 2690 MHz	HD	Yes	
68	68	698 MHz	– 728 MHz	698 MHz	– 728 MHz	HD	Yes	Yes

E-UTRA ProSe is designed to operate concurrent with E-UTRA uplink/downlink on the operating bands combinations listed in Table 5.5D-2.

Table 5.5D-2 Inter-band E-UTRA ProSe / E-UTRA operating bands

E-UTRA ProSe Band ^{Note 1}	E-UTRA band / E-UTRA CA band ^{Note 2}
2	4
	CA_2-4 ^{Note 3}
28	1
	CA_1-28 ^{Note 3}
NOTE 1: As specified in Table 5.5D-1 NOTE 2: As specified in Table 5.5-1 and Table 5.5A-2 NOTE 3: Applies when E-UTRA uplink is assigned to one E-UTRA band and ProSe operation is restricted to the uplink frequencies paired with either PCC or SCC. NOTE 4: The concurrency for E-UTRA ProSe Direct Discovery with E-UTRA uplink/downlink applies after allowing for any transmission and/or reception gap requested by the UE.	

5.5E Operating bands for UE category 0 and UE category M1

UE category 0 is designed to operate in the E-UTRA operating bands 2, 3, 4, 5, 8, 13, and 20 in both half duplex FDD mode and full-duplex FDD mode and in bands 39 and 41 in TDD mode. The E-UTRA bands are defined in Table 5.5-1.

UE category M1 is designed to operate in the E-UTRA operating bands 1, 2, 3, 4, 5, 7, 8, 11, 12, 13, 18, 19, 20, 21, 26, 27, 28, and 31 in both half duplex FDD mode and full-duplex FDD mode, and in bands 39 and 41 in TDD mode. The E-UTRA bands are defined in Table 5.5-1.

5.5F Operating bands for category NB1

Category NB1 is designed to operate in the E-UTRA operating bands 1, 2, 3, 5, 8, 12, 13, 17, 18, 19, 20, 26, 28, 66 which are defined in Table 5.5-1. Category NB1 system operates in HD-FDD duplex mode.

5.6 Channel bandwidth

Requirements in present document are specified for the channel bandwidths listed in Table 5.6-1.

Table 5.6-1: Transmission bandwidth configuration N_{RB} in E-UTRA channel bandwidths

Channel bandwidth $BW_{Channel}$ [MHz]	1.4	3	5	10	15	20
Transmission bandwidth configuration N_{RB}	6	15	25	50	75	100

Figure 5.6-1 shows the relation between the Channel bandwidth ($BW_{Channel}$) and the Transmission bandwidth configuration (N_{RB}). The channel edges are defined as the lowest and highest frequencies of the carrier separated by the channel bandwidth, i.e. at $F_C \pm BW_{Channel} / 2$.

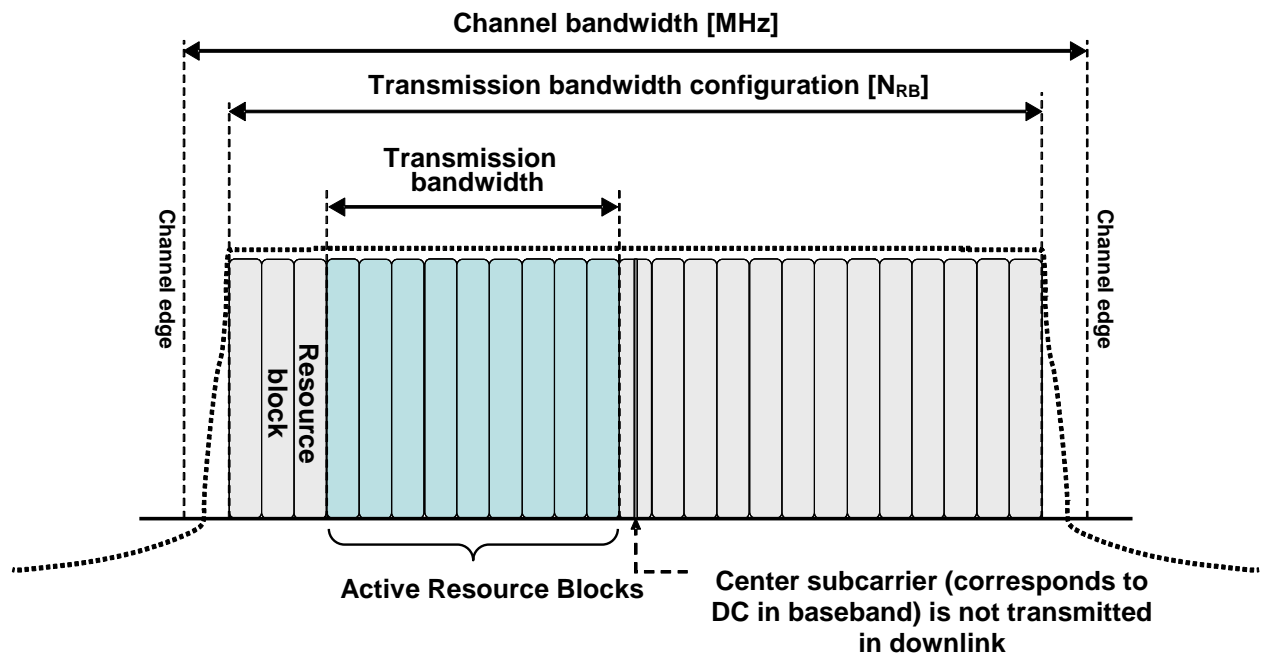

Figure 5.6-1: Definition of channel bandwidth and transmission bandwidth configuration for one E-UTRA carrier

5.6.1 Channel bandwidths per operating band

a) The requirements in this specification apply to the combination of channel bandwidths and operating bands shown in Table 5.6.1-1. The transmission bandwidth configuration in Table 5.6.1-1 shall be supported for each of the specified channel bandwidths. The same (symmetrical) channel bandwidth is specified for both the TX and RX path.

Table 5.6.1-1: E-UTRA channel bandwidth

E-UTRA band / Channel bandwidth						
E-UTRA Band	1.4 MHz	3 MHz	5 MHz	10 MHz	15 MHz	20 MHz
1			Yes	Yes	Yes	Yes
2	Yes	Yes	Yes	Yes	Yes ¹	Yes ¹
3	Yes	Yes	Yes	Yes	Yes ¹	Yes ¹
4	Yes	Yes	Yes	Yes	Yes	Yes
5	Yes	Yes	Yes	Yes ¹		
6			Yes	Yes ¹		
7			Yes	Yes	Yes ³	Yes ^{1,3}
8	Yes	Yes	Yes	Yes ¹		
9			Yes	Yes	Yes ¹	Yes ¹
10			Yes	Yes	Yes	Yes
11			Yes	Yes ¹		
12	Yes	Yes	Yes ¹	Yes ¹		
13			Yes ¹	Yes ¹		
14			Yes ¹	Yes ¹		
...						
17			Yes ¹	Yes ¹		
18			Yes	Yes ¹	Yes ¹	
19			Yes	Yes ¹	Yes ¹	
20			Yes	Yes ¹	Yes ¹	Yes ¹
21			Yes	Yes ¹	Yes ¹	
22			Yes	Yes	Yes ¹	Yes ¹
23	Yes	Yes	Yes	Yes	Yes ¹	Yes ¹
24			Yes	Yes		
25	Yes	Yes	Yes	Yes	Yes ¹	Yes ¹
26	Yes	Yes	Yes	Yes ¹	Yes ¹	
27	Yes	Yes	Yes	Yes ¹		
28		Yes	Yes	Yes ¹	Yes ¹	Yes ^{1,2}
30			Yes	Yes ¹		
31	Yes	Yes ¹	Yes ¹			
...						
33			Yes	Yes	Yes	Yes
34			Yes	Yes	Yes	
35	Yes	Yes	Yes	Yes	Yes	Yes
36	Yes	Yes	Yes	Yes	Yes	Yes
37			Yes	Yes	Yes	Yes
38			Yes	Yes	Yes ³	Yes ³
39			Yes	Yes	Yes ³	Yes ³
40			Yes	Yes	Yes	Yes
41			Yes	Yes	Yes	Yes
42			Yes	Yes	Yes	Yes
43			Yes	Yes	Yes	Yes
44		Yes	Yes	Yes	Yes	Yes
45			Yes	Yes	Yes	Yes
46						Yes
...						
64	Reserved					
65	Yes	Yes	Yes	Yes	Yes	Yes
66	Yes	Yes	Yes	Yes	Yes	Yes
68			Yes	Yes	Yes ⁴	
NOTE 1:	¹ refers to the bandwidth for which a relaxation of the specified UE receiver sensitivity requirement (subclause 7.3) is allowed.					
NOTE 2:	² For the 20 MHz bandwidth, the minimum requirements are specified for E-UTRA UL carrier frequencies confined to either 713-723 MHz or 728-738 MHz					
NOTE 3:	³ refers to the bandwidth for which the uplink transmission bandwidth can be restricted by the network for some channel assignments in FDD/TDD co-existence scenarios in order to meet unwanted emissions requirements (Clause 6.6.3.2).					
NOTE 4:	⁴ For the 15 MHz bandwidth, the minimum requirements are specified for E-UTRA UL carrier frequencies confined to either 705.5 MHz or 710.5-720.5 MHz					

b) The use of different (asymmetrical) channel bandwidth for the TX and RX is not precluded and is intended to form part of a later release.

5.6A Channel bandwidth for CA

For intra-band contiguous carrier aggregation *Aggregated Channel Bandwidth*, *Aggregated Transmission Bandwidth Configuration* and *Guard Bands* are defined as follows, see Figure 5.6A-1.

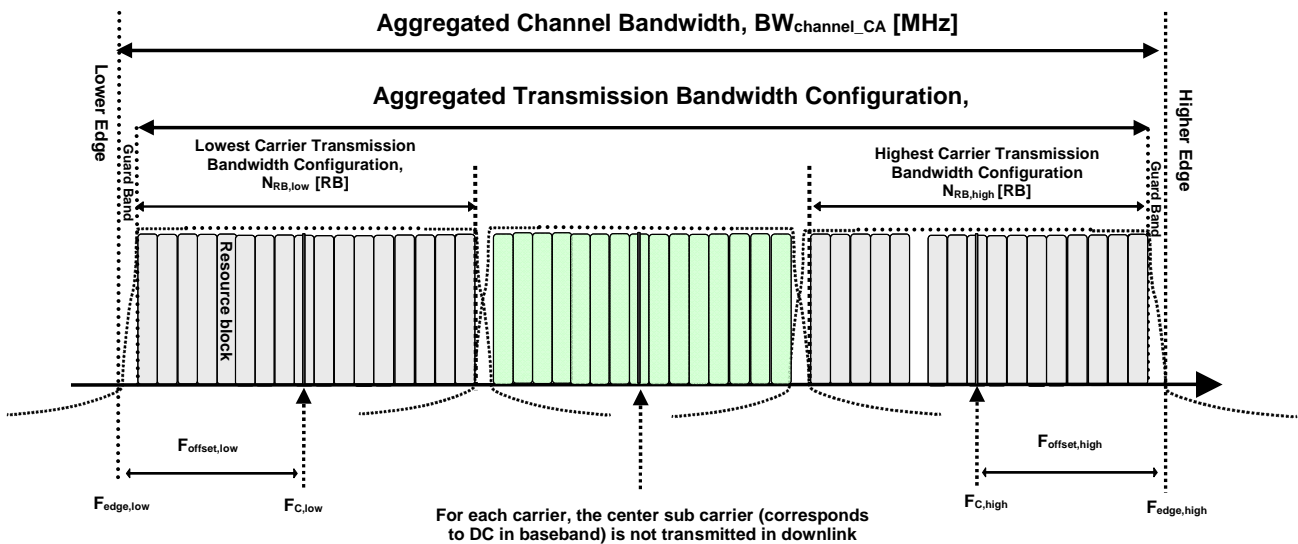

Figure 5.6A-1. Definition of Aggregated channel bandwidth and aggregated channel bandwidth edges

The *aggregated channel bandwidth*, $BW_{\text{Channel_CA}}$, is defined as

$$BW_{\text{Channel_CA}} = F_{\text{edge,high}} - F_{\text{edge,low}} \text{ [MHz]}.$$

The lower bandwidth edge $F_{\text{edge,low}}$ and the upper bandwidth edge $F_{\text{edge,high}}$ of the aggregated channel bandwidth are used as frequency reference points for transmitter and receiver requirements and are defined by

$$F_{\text{edge,low}} = F_{C,\text{low}} - F_{\text{offset,low}}$$

$$F_{\text{edge,high}} = F_{C,\text{high}} + F_{\text{offset,high}}$$

The lower and upper frequency offsets depend on the transmission bandwidth configurations of the lowest and highest assigned edge component carrier and are defined as

$$F_{\text{offset,low}} = (0.18N_{\text{RB,low}} + \Delta f_1)/2 + BW_{\text{GB}} \text{ [MHz]}$$

$$F_{\text{offset,high}} = (0.18N_{\text{RB,high}} + \Delta f_1)/2 + BW_{\text{GB}} \text{ [MHz]}$$

where $\Delta f_1 = \Delta f$ for the downlink with Δf the subcarrier spacing and $\Delta f_1 = 0$ for the uplink, while $N_{\text{RB,low}}$ and $N_{\text{RB,high}}$ are the transmission bandwidth configurations according to Table 5.6-1 for the lowest and highest assigned component carrier, respectively. BW_{GB} denotes the *Nominal Guard Band* and is defined in Table 5.6A-1, and the factor 0.18 is the PRB bandwidth in MHz.

NOTE: The values of $BW_{\text{Channel_CA}}$ for UE and BS are the same if the lowest and the highest component carriers are identical.

Aggregated Transmission Bandwidth Configuration is the number of the aggregated RBs within the fully allocated Aggregated Channel bandwidth and is defined per CA Bandwidth Class (Table 5.6A-1).

For intra-band non-contiguous carrier aggregation *Sub-block Bandwidth* and *Sub-block edges* are defined as follows, see Figure 5.6A-2.

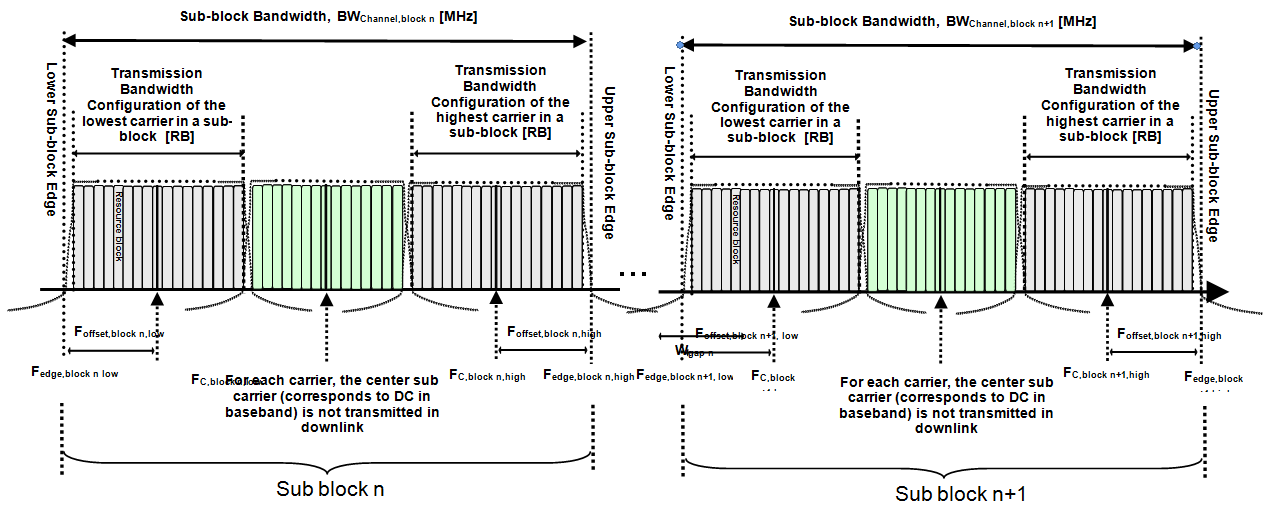

Figure 5.6A-2. Non-contiguous intraband CA terms and definitions

The lower sub-block edge of the Sub-block Bandwidth ($BW_{Channel,block}$) is defined as

$$F_{edge,block,low} = F_{C,block,low} - F_{offset,block,low}$$

The upper sub-block edge of the Sub-block Bandwidth is defined as

$$F_{edge,block,high} = F_{C,block,high} + F_{offset,block,high}$$

The Sub-block Bandwidth, $BW_{Channel,block}$, is defined as follows:

$$BW_{Channel,block} = F_{edge,block,high} - F_{edge,block,low} \text{ [MHz]}$$

The lower and upper frequency offsets $F_{offset,block,low}$ and $F_{offset,block,high}$ depend on the transmission bandwidth configurations of the lowest and highest assigned edge component carriers within a sub-block and are defined as

$$F_{offset,block,low} = (0.18N_{RB,low} + \Delta f_1)/2 + BW_{GB} \text{ [MHz]}$$

$$F_{offset,block,high} = (0.18N_{RB,high} + \Delta f_1)/2 + BW_{GB} \text{ [MHz]}$$

where $\Delta f_1 = \Delta f$ for the downlink with Δf the subcarrier spacing and $\Delta f_1 = 0$ for the uplink, while $N_{RB,low}$ and $N_{RB,high}$ are the transmission bandwidth configurations according to Table 5.6-1 for the lowest and highest assigned component carrier within a sub-block, respectively. BW_{GB} denotes the *Nominal Guard Band* and is defined in Table 5.6A-1, and the factor 0.18 is the PRB bandwidth in MHz.

The sub-block gap size between two consecutive sub-blocks W_{gap} is defined as

$$W_{gap} = F_{edge,block\ n+1,low} - F_{edge,block\ n,high} \text{ [MHz]}$$

Table 5.6A-1: CA bandwidth classes and corresponding nominal guard bands

CA Bandwidth Class	Aggregated Transmission Bandwidth Configuration	Number of contiguous CC	Nominal Guard Band BW_{GB}
A	$N_{RB,agg} \leq 100$	1	$a_1 BW_{Channel(1)} - 0.5\Delta f_1$ (NOTE 2)
B	$25 < N_{RB,agg} \leq 100$	2	$0.05 \max(BW_{Channel(1)}, BW_{Channel(2)}) - 0.5\Delta f_1$
C	$100 < N_{RB,agg} \leq 200$	2	$0.05 \max(BW_{Channel(1)}, BW_{Channel(2)}) - 0.5\Delta f_1$
D	$200 < N_{RB,agg} \leq 300$	3	$0.05 \max(BW_{Channel(1)}, BW_{Channel(2)}, BW_{Channel(3)}) - 0.5\Delta f_1$
E	$300 < N_{RB,agg} \leq 400$	4	$0.05 \max(BW_{Channel(1)}, BW_{Channel(2)}, BW_{Channel(3)}, BW_{Channel(4)}) - 0.5\Delta f_1$
F	$400 < N_{RB,agg} \leq 500$	5	NOTE 3
I	$700 < N_{RB,agg} \leq 800$	8	NOTE 3
NOTE 1: $BW_{Channel(j)}$, $j = 1, 2, 3, 4$ is the channel bandwidth of an E-UTRA component carrier according to Table 5.6-1 and $\Delta f_1 = \Delta f$ for the downlink with Δf the subcarrier spacing while $\Delta f_1 = 0$ for the uplink.			
NOTE 2: $a_1 = 0.16/1.4$ for $BW_{Channel(1)} = 1.4$ MHz whereas $a_1 = 0.05$ for all other channel bandwidths.			
NOTE 3: Applicable for later releases.			

The channel spacing between centre frequencies of contiguously aggregated component carriers is defined in subclause 5.7.1A.

5.6A.1 Channel bandwidths per operating band for CA

The requirements for carrier aggregation in this specification are defined for carrier aggregation configurations with associated bandwidth combination sets. For inter-band carrier aggregation, a *carrier aggregation configuration* is a combination of operating bands, each supporting a carrier aggregation bandwidth class. For intra-band contiguous carrier aggregation, a carrier aggregation configuration is a single operating band supporting a carrier aggregation bandwidth class.

For each carrier aggregation configuration, requirements are specified for all bandwidth combinations contained in a *bandwidth combination set*, which is indicated per supported band combination in the UE radio access capability. A UE can indicate support of several bandwidth combination sets per band combination.

Requirements for intra-band contiguous carrier aggregation are defined for the carrier aggregation configurations and bandwidth combination sets specified in Table 5.6A.1-1. Requirements for inter-band carrier aggregation are defined for the carrier aggregation configurations and bandwidth combination sets specified in Table 5.6A.1-2, Table 5.6A.1-2a, and Table 5.6A.1-2b. Requirements for intra-band non-contiguous carrier aggregation are defined for the carrier aggregation configurations and bandwidth combination sets specified in Table 5.6A.1-3.

The DL component carrier combinations for a given CA configuration shall be symmetrical in relation to channel centre unless stated otherwise in Table 5.6A.1-1, Table 5.6A.1-2, Table 5.6A.1-2a and Table 5.6A.1-2b.

Table 5.6A.1-1: E-UTRA CA configurations and bandwidth combination sets defined for intra-band contiguous CA

E-UTRA CA configuration	E-UTRA CA configuration / Bandwidth combination set						
	Uplink CA configurations (NOTE 3)	Component carriers in order of increasing carrier frequency				Maximum aggregated bandwidth [MHz]	Bandwidth combination set
		Channel bandwidths for carrier [MHz]	Channel bandwidths for carrier [MHz]	Channel bandwidths for carrier [MHz]	Channel bandwidths for carrier [MHz]		
CA_1C	CA_1C	15	15			40	0
		20	20				
CA_2C		5	20			40	0
		10	15, 20				
		15	10, 15, 20				
		20	5, 10, 15, 20				
CA_3C	CA_3C	5, 10, 15	20			40	0
		20	5, 10, 15, 20				
CA_5B		5, 10	10			20	0
		10	5				
CA_7B		15	5			20	0
CA_7C	CA_7C	15	15			40	0
		20	20				
		10	20			40	1
		15	15, 20				
		20	10, 15, 20			40	2
		15	10, 15				
20	15, 20						
CA_8B	CA_8B	5,10	10			20	0
		10	5				
CA_12B	-	5	5, 10			15	0
CA_23B	-	10	10			20	0
		5	15				
CA_27B	-	1.4, 3, 5	5			13	0
		1.4, 3	10				
CA_38C	CA_38C	15	15			40	0
		20	20				
CA_39C	CA_39C	5,10,15	20			35	0
		20	5, 10, 15				
CA_40C	CA_40C	10	20			40	0
		15	15				
		20	10, 20				
		10, 15	20			40	1
		15	15				
		20	10, 15, 20				
CA_40D	CA_40C	10, 15, 20	20	20		60	0
		20	10, 15	20			
		20	20	10, 15			
CA_41C	CA_41C	10	20			40	0

		15	15, 20			40	1		
		20	10, 15, 20						
		5, 10	20						
		15	15, 20						
				20	5, 10, 15, 20			40	2
		10	15, 20						
		15	10, 15, 20						
				20	10, 15, 20			40	3
		10	20						
				20	20			60	0
CA_41D	CA_41C	10	20	15					
		10	15, 20	20					
		15	20	10, 15					
		15	10, 15, 20	20					
		20	15, 20	10					
		20	10, 15, 20	15, 20					
CA_42C	CA_42C	5, 10, 15, 20	20			40	0		
		20	5, 10, 15						
		10, 15, 20	20			40	1		
		20	10, 15						
CA_42D	CA_42C	5,10,15,20	20	20		60	0		
		20	20	5,10,15					
CA_42E	CA_42C	5,10,15,20	20	20	20	80	0		
		20	20	20	5,10,15				
CA_66B	-	5	5, 10, 15			20	0		
		10	5, 10						
		15	5						
CA_66C	-	5	20			40	0		
		10	15, 20						
		15	10, 15, 20						
		20	5, 10, 15, 20						

NOTE 1: The CA configuration refers to an operating band and a CA bandwidth class specified in Table 5.6A-1 (the indexing letter). Absence of a CA bandwidth class for an operating band implies support of all classes.

NOTE 2: For the supported CC bandwidth combinations, the CC downlink and uplink bandwidths are equal.

NOTE 3: Uplink CA configurations are the configurations supported by the present release of specifications.

Table 5.6A.1-2: E-UTRA CA configurations and bandwidth combination sets defined for inter-band CA (two bands)

E-UTRA CA configuration / Bandwidth combination set										
E-UTRA CA Configuration	Uplink CA configurations (NOTE 4)	E-UTRA Bands	1.4 MHz	3 MHz	5 MHz	10 MHz	15 MHz	20 MHz	Maximum aggregated bandwidth [MHz]	Bandwidth combination set
CA_1A-3A	CA_1A-3A	1			Yes	Yes	Yes	Yes	40	0
		3			Yes	Yes	Yes	Yes		
CA_1A-3C	-	1			Yes	Yes	Yes	Yes	60	0
		3	See CA_3C Bandwidth Combination Set 0 in Table 5.6A.1-1							
CA_1A-5A	CA_1A-5A	1				Yes			20	0
		5				Yes				
		1			Yes	Yes	Yes	Yes	30	1
		5			Yes	Yes				
CA_1A-7A	CA_1A-7A	1			Yes	Yes	Yes	Yes	40	0
		7				Yes	Yes	Yes		
CA_1A-7C	-	1			Yes	Yes	Yes	Yes	60	0
		7	See CA_7C Bandwidth Combination Set 2 in Table 5.6A.1-1							
CA_1A-8A	CA_1A-8A	1			Yes	Yes	Yes	Yes	30	0
		8			Yes	Yes				
		1			Yes	Yes			20	1
		8			Yes	Yes				
		1			Yes	Yes	Yes	Yes	30	2
8		Yes	Yes	Yes						
CA_1A-11A	-	1			Yes	Yes	Yes	Yes	30	0
		11			Yes	Yes				
CA_1A-18A	CA_1A-18A	1			Yes	Yes	Yes	Yes	35	0
		18			Yes	Yes	Yes			
		1			Yes	Yes			20	1
		18			Yes	Yes				
CA_1A-19A	CA_1A-19A	1			Yes	Yes	Yes	Yes	35	0
		19			Yes	Yes	Yes			
CA_1A-20A	-	1			Yes	Yes	Yes	Yes	40	0
		20			Yes	Yes	Yes	Yes		
CA_1A-21A	CA_1A-21A	1			Yes	Yes	Yes	Yes	35	0
		21			Yes	Yes	Yes			
CA_1A-26A	CA_1A-26A	1			Yes	Yes	Yes	Yes	35	0
		26			Yes	Yes	Yes			
		1			Yes	Yes			20	1
		26			Yes	Yes				
CA_1A-28A	CA_1A-28A	1			Yes	Yes	Yes	Yes	40	0
		28			Yes	Yes	Yes	Yes		
		1			Yes	Yes			20	1
		28			Yes	Yes				
CA_1A-40A	-	1			Yes	Yes	Yes	Yes	40	0
		40			Yes	Yes	Yes	Yes		
CA_1A-41A ⁶	-	1			Yes	Yes	Yes	Yes	40	0
		41			Yes	Yes	Yes	Yes		
CA_1A-41C ⁶	-	1			Yes	Yes	Yes	Yes	60	0
		41	See CA_41C Bandwidth Combination Set 1 in Table 5.6A.1-1							
CA_1A-42A	CA_1A-42A	1			Yes	Yes	Yes	Yes	40	0
		42			Yes	Yes	Yes	Yes		
CA_1A-42C	-	1			Yes	Yes	Yes	Yes	60	0
		42	See CA_42C Bandwidth Combination Set 0 in Table 5.6A.1-1							
CA_1A-46A	-	1			Yes	Yes	Yes	Yes	40	0
		46						Yes		

CA_2A-4A	CA_2A-4A	2	Yes	Yes	Yes	Yes	Yes	Yes	40	0
		4			Yes	Yes	Yes	Yes		
		2			Yes	Yes			20	1
		4			Yes	Yes				
		2			Yes	Yes	Yes	Yes	40	2
4			Yes	Yes	Yes	Yes				
CA_2A-2A-4A	-	2	See CA_2A-2A Bandwidth Combination Set 0 in Table 5.6A.1-3					60	0	
		4			Yes	Yes	Yes			Yes
CA_2A-4A-4A	-	2			Yes	Yes	Yes	Yes	60	0
		4	See CA_4A-4A Bandwidth Combination Set 0 in Table 5.6A.1-3							
CA_2A-2A-4A-4A	-	2	See CA_2A-2A Bandwidth Combination Set 0 in Table 5.6A.1-3					80	0	
		4	See CA_4A-4A Bandwidth Combination Set 0 in Table 5.6A.1-3							
CA_2A-5A	CA_2A-5A	2			Yes	Yes	Yes	Yes	30	0
		5			Yes	Yes				
		2			Yes	Yes			20	1
		5			Yes	Yes				
CA_2A-2A-5A	-	2	See CA_2A-2A Bandwidth Combination Set 0 in Table 5.6A.1-3					50	0	
		5			Yes	Yes				
CA_2C-5A	-	2	See CA_2C Bandwidth combination set 0 in Table 5.6A.1-1					50	0	
		5			Yes	Yes				
CA_2A-7A	-	2			Yes	Yes	Yes	Yes	40	0
		7			Yes	Yes	Yes	Yes		
CA_2A-12A	CA_2A-12A	2			Yes	Yes	Yes	Yes	30	0
		12			Yes	Yes				
		2			Yes	Yes	Yes	Yes	30	1
		12		Yes	Yes	Yes				
		2			Yes	Yes			20	2
12			Yes	Yes						
CA_2A-2A-12A	-	2	See CA_2A-2A Bandwidth Combination Set 0 in Table 5.6A.1-3					50	0	
		12			Yes	Yes				
CA_2A-12B	-	2			Yes	Yes	Yes	Yes	35	0
		12	See CA_12B Bandwidth Combination Set 0 in Table 5.6A.1-1							
CA_2A-2A-12B	-	2	See CA_2A-2A Bandwidth combination set 0 in Table 5.6A.1-3					55	0	
		12	See CA_12B Bandwidth Combination Set 0 in Table 5.6A.1-1							
CA_2C-12A	-	2	See CA_2C Bandwidth combination set 0 in Table 5.6A.1-1					50	0	
		12			Yes	Yes				
CA_2A-13A	CA_2A-13A	2			Yes	Yes	Yes	Yes	30	0
		13				Yes				
		2			Yes	Yes			20	1
		13				Yes				
CA_2A-2A-13A	-	2	See CA_2A-2A Bandwidth Combination Set 0 in Table 5.6A.1-3					50	0	
		13				Yes				
CA_2A-17A	-	2			Yes	Yes			20	0
		17			Yes	Yes				
CA_2A-28A	-	2			Yes	Yes	Yes	Yes	40	0
		28			Yes	Yes	Yes	Yes		
CA_2A-29A	-	2			Yes	Yes			20	0
		29		Yes	Yes	Yes				
		2			Yes	Yes			20	1
		29			Yes	Yes				
		2			Yes	Yes	Yes	Yes	30	2

		29			Yes	Yes				
CA_2C-29A	-	2	See CA_2C Bandwidth Combination Set 0 in table 5.6A.1-1						50	0
		29			Yes	Yes				
CA_2A-30A	-	2			Yes	Yes	Yes	Yes	30	0
		30			Yes	Yes				
CA_2C-30A	-	2	See CA_2C Bandwidth combination set 0 in Table 5.6A.1-1						50	0
		30			Yes	Yes				
CA_2A-46A	-	2			Yes	Yes	Yes	Yes	40	0
		46						Yes		
CA_3A-5A	CA_3A-5A	3				Yes	Yes	Yes	30	0
		5			Yes	Yes				
		3				Yes				
		5			Yes	Yes				
		3			Yes	Yes	Yes	Yes		
		5			Yes	Yes				
		3			Yes	Yes	Yes	Yes		
CA_3C-5A	-	3	See CA_3C Bandwidth Combination Set 0 in Table 5.6A.1-1						50	0
		5			Yes	Yes				
CA_3A-7A	CA_3A-7A	3			Yes	Yes	Yes	Yes	40	0
		7				Yes	Yes	Yes		
		3			Yes	Yes	Yes	Yes		
		7			Yes	Yes	Yes	Yes		
CA_3A-7B	-	3			Yes	Yes	Yes	Yes	40	0
		7	See CA_7B bandwidth combination set 0 in table 5.6A.1-1							
CA_3A-7C	CA_3A-7A CA_7C	3			Yes	Yes	Yes	Yes	60	0
		7	See CA_7C Bandwidth combination set 1 in table 5.6A.1-1							
		3			Yes	Yes	Yes	Yes		
		7	See CA_7C Bandwidth combination set 2 in table 5.6A.1-1							
CA_3C-7A	CA_3A-7A CA_3C	3	See CA_3C Bandwidth Combination Set 0 in table 5.6A.1-1						60	0
		7			Yes	Yes	Yes	Yes		
CA_3C-7C	-	3	See CA_3C Bandwidth Combination Set 0 in Table 5.6A.1-1						80	0
		7	See CA_7C Bandwidth Combination Set 2 in Table 5.6A.1-1							
CA_3A-8A	CA_3A-8A	3				Yes	Yes	Yes	30	0
		8			Yes	Yes				
		3				Yes				
		8			Yes	Yes				
		3			Yes	Yes	Yes	Yes		
		8		Yes	Yes	Yes				
		3			Yes	Yes	Yes	Yes		
CA_3A-3A-8A	-	3	See CA_3A-3A Bandwidth Combination Set 0 in table 5.6A.1-3						50	0
		8			Yes	Yes				
		3	See CA_3A-3A Bandwidth Combination Set 1 in table 5.6A.1-3							
		8			Yes	Yes				
CA_3A-19A	CA_3A-19A	3			Yes	Yes	Yes	Yes	35	0
		19			Yes	Yes	Yes			
CA_3A-20A	CA_3A-20A	3			Yes	Yes	Yes	Yes	30	0
		20			Yes	Yes				
		3			Yes	Yes	Yes	Yes		
		20			Yes	Yes	Yes	Yes		
CA_3A-26A	CA_3A-26A	3			Yes	Yes	Yes	Yes	35	0

		26			Yes	Yes	Yes			
		3			Yes	Yes				
		26			Yes	Yes			20	1
CA_3A-27A	-	3			Yes	Yes	Yes	Yes	30	0
		27			Yes	Yes				
CA_3A-28A	-	3			Yes	Yes	Yes	Yes	40	0
		28			Yes	Yes	Yes	Yes		
CA_3C-28A	-	3	See CA_3C Bandwidth Combination Set 0 in Table 5.6A.1-1						60	0
		28			Yes	Yes	Yes	Yes		
CA_3A-31A	-	3			Yes	Yes	Yes	Yes	25	0
		31		Yes	Yes					
CA_3A-38A	-	3			Yes	Yes	Yes	Yes	40	0
		38			Yes	Yes	Yes	Yes		
CA_3A-40A	-	3			Yes	Yes	Yes	Yes	40	0
		40			Yes	Yes	Yes	Yes		
CA_3A-40C	-	3			Yes	Yes	Yes	Yes	60	0
		40	See CA_40C Bandwidth Combination Set 1 in Table 5.6A.1-1							
CA_3A-41A	-	3			Yes	Yes	Yes	Yes	40	0
		41			Yes	Yes	Yes	Yes		
CA_3A-41C	-	3			Yes	Yes	Yes	Yes	60	0
		41	See CA_41C Bandwidth Combination Set 0 in Table 5.6A.1-1							
CA_3A-42A	-	3			Yes	Yes	Yes	Yes	40	0
		42			Yes	Yes	Yes	Yes		
CA_3A-42C	-	3			Yes	Yes	Yes	Yes	60	0
		42	See CA_42C Bandwidth Combination Set 0 in Table 5.6A.1-1							
CA_3A-46A	-	3			Yes	Yes	Yes	Yes	40	0
		46						Yes		
CA_4A-5A	CA_4A-5A	4			Yes	Yes			20	0
		5			Yes	Yes				
		4			Yes	Yes	Yes	Yes	30	1
		5			Yes	Yes				
CA_4A-4A-5A	-	4	See CA_4A-4A Bandwidth Combination Set 0 in table 5.6A.1-3						50	0
		5			Yes	Yes				
CA_4A-7A	CA_4A-7A	4			Yes	Yes			30	0
		7			Yes	Yes	Yes	Yes		
		4			Yes	Yes	Yes	Yes	40	1
		7			Yes	Yes	Yes	Yes		
CA_4A-4A-7A	-	4			Yes	Yes			40	0
		4			Yes	Yes				
		7			Yes	Yes	Yes	Yes		
		4			Yes	Yes	Yes	Yes	60	1
		4			Yes	Yes	Yes	Yes		
		7			Yes	Yes	Yes	Yes		
CA_4A-12A	CA_4A-12A	4	Yes	Yes	Yes	Yes			20	0
		12			Yes	Yes				
		4	Yes	Yes	Yes	Yes	Yes	Yes	30	1
		12			Yes	Yes				
		4			Yes	Yes	Yes	Yes	30	2
		12		Yes	Yes	Yes				
		4			Yes	Yes			20	3
		12			Yes	Yes				
		4			Yes	Yes	Yes	Yes	30	4
		12			Yes	Yes				
		4			Yes	Yes	Yes		20	5
		12			Yes					
CA_4A-4A-12A	-	4	See CA_4A-4A Bandwidth Combination Set 0 in Table 5.6A.1-3						50	0

		12			Yes	Yes				
CA_4A-12B	-	4			Yes	Yes	Yes	Yes		
		12	See CA_12B Bandwidth Combination Set 0 in Table 5.6A.1-1						35	0
CA_4A-13A	CA_4A-13A	4			Yes	Yes	Yes	Yes		
		13				Yes				
		4			Yes	Yes				
CA_4A-4A-13A	-	13				Yes				
		4	See CA_4A-4A Bandwidth Combination Set 0 in Table 5.6A.1-3						50	0
CA_4A-17A	CA_4A-17A	4			Yes	Yes				
		17			Yes	Yes				
CA_4A-27A	-	4			Yes	Yes	Yes	Yes		
		27		Yes	Yes	Yes				
CA_4A-28A	-	4			Yes	Yes	Yes	Yes		
		28			Yes	Yes	Yes	Yes		
CA_4A-29A	-	4			Yes	Yes				
		29		Yes	Yes	Yes				
		4			Yes	Yes				
		29			Yes	Yes				
		4			Yes	Yes	Yes	Yes		
CA_4A-4A-29A	-	29			Yes	Yes				
		4	See CA_4A-4A Bandwidth combination set 0 in Table 5.6A.1-3						50	0
CA_4A-30A	-	4			Yes	Yes	Yes	Yes		
		30			Yes	Yes				
CA_4A-4A-30A	-	4			Yes	Yes				
		30			Yes	Yes				
CA_4A-46A	-	4			Yes	Yes	Yes	Yes		
		46							Yes	
CA_5A-7A	CA_5A-7A	5	Yes	Yes	Yes	Yes				
		7				Yes	Yes	Yes		
		5			Yes	Yes				
CA_5A-12A	CA_5A-12A	7				Yes	Yes	Yes		
		5			Yes	Yes				
CA_5A-12B	-	12			Yes	Yes				
		5	See CA_12B Bandwidth Combination Set 0 in Table 5.6A.1-1						25	0
CA_5A-13A	-	5			Yes	Yes				
		13				Yes				
CA_5A-17A	CA_5A-17A	5			Yes	Yes				
		17			Yes	Yes				
CA_5A-25A	-	5			Yes	Yes				
		25			Yes	Yes	Yes	Yes		
CA_5A-29A	-	5			Yes	Yes				
		29			Yes	Yes				
CA_5A-30A	-	5			Yes	Yes				
		30			Yes	Yes				
CA_5A-38A	-	5			Yes	Yes				
		38			Yes	Yes	Yes	Yes		
CA_5A-40A	-	5			Yes	Yes				
		40			Yes	Yes	Yes	Yes		
		5		Yes	Yes	Yes				
CA_5A-40C	-	40			Yes	Yes	Yes	Yes		
		5	See CA_40C Bandwidth Combination Set 1 in Table 5.6A.1-1						50	0
		5		Yes	Yes	Yes				

		40	See CA_40C Bandwidth Combination Set 1 in Table 5.6A.1-1							
CA_7A-8A	-	7			Yes	Yes	Yes	30	0	
		8		Yes	Yes	Yes				
		7			Yes	Yes	Yes	30	1	
		8			Yes	Yes				
CA_7A-12A	-	7			Yes	Yes	Yes	30	0	
		12			Yes	Yes				
CA_7A-20A	CA_7A-20A	7			Yes	Yes	Yes	30	0	
		20			Yes	Yes				
		7			Yes	Yes	Yes			
CA_7A-22A	-	20			Yes	Yes	Yes	40	1	
		7			Yes	Yes	Yes			
CA_7A-22A	-	7			Yes	Yes	Yes	40	0	
		22			Yes	Yes	Yes			
CA_7A-28A	CA_7A-28A	7			Yes	Yes	Yes	35	0	
		28			Yes	Yes	Yes			
		7			Yes	Yes	Yes			
CA_7A-28A	-	28			Yes	Yes	Yes	40	1	
		7			Yes	Yes	Yes			
CA_7B-28A	-	7	See CA_7B bandwidth combination set 0 in table 5.6A.1-1						40	0
		28			Yes	Yes	Yes	Yes		
CA_7C-28A	-	7	See CA_7C bandwidth combination set 2 in table 5.6A.1-1						60	0
		28			Yes	Yes	Yes	Yes		
CA_7A-40A	-	7			Yes	Yes	Yes	40	0	
		40			Yes	Yes	Yes			
CA_7A-40C	-	7			Yes	Yes	Yes	60	0	
		40	See CA_40C Bandwidth Combination Set 1 in Table 5.6A.1-1							
CA_7A-42A	-	7			Yes	Yes	Yes	40	0	
		42			Yes	Yes	Yes			
CA_7A-42A-42A	-	7			Yes	Yes	Yes	60	0	
		42	See CA_42A-42A Bandwidth Combination Set 0 in Table 5.6A.1-3							
CA_7A-46A	-	7			Yes	Yes	Yes	40	0	
		46					Yes			
CA_8A-11A	-	8			Yes	Yes		20	0	
		11			Yes	Yes				
CA_8A-20A	-	8			Yes	Yes		20	0	
		20			Yes	Yes				
		8		Yes	Yes	Yes				
CA_8A-20A	-	20			Yes	Yes		20	1	
		8			Yes	Yes				
CA_8A-40A	-	8			Yes	Yes		30	0	
		40			Yes	Yes	Yes			
CA_8A-40A	-	8		Yes	Yes	Yes		30	1	
		40			Yes	Yes	Yes			
CA_8A-41A	-	8	Yes	Yes	Yes	Yes		30	0	
		41				Yes	Yes			
CA_8A-41C	-	8	Yes	Yes	Yes	Yes		50	0	
		41	See CA_41C bandwidth combination set 3 in table 5.6A.1-1							
CA_8A-42A	-	8	Yes	Yes	Yes	Yes		30	0	
		42			Yes	Yes	Yes			
CA_8A-42C	-	8	Yes	Yes	Yes	Yes		50	0	
		42	See CA_42C Bandwidth Combination Set 0 in Table 5.6A.1-1							
CA_11A-18A	-	11			Yes	Yes		25	0	
		18			Yes	Yes	Yes			
CA_12A-25A	-	12			Yes	Yes		30	0	
		25			Yes	Yes	Yes			
CA_12A-30A	-	12			Yes	Yes		20	0	
		30			Yes	Yes				

CA_18A-28A	CA_18A-28A	18			Yes	Yes	Yes		25	0
		28			Yes	Yes				
CA_19A-21A	CA_19A-21A	19			Yes	Yes	Yes		30	0
		21			Yes	Yes	Yes			
CA_19A-28A	-	19			Yes	Yes	Yes		25	0
		28			Yes	Yes				
CA_19A-42A	-	19			Yes	Yes	Yes		35	0
		42			Yes	Yes	Yes	Yes		
CA_19A-42C	-	19			Yes	Yes	Yes		55	0
		42	See CA_42C Bandwidth Combination Set 0 in Table 5.6A.1-1							
CA_20A-31A	-	20			Yes	Yes	Yes	Yes	25	0
		31		Yes	Yes					
CA_20A-32A	-	20			Yes	Yes			30	0
		32			Yes	Yes	Yes	Yes		
CA_20A-38A	-	20			Yes	Yes	Yes	Yes	40	0
		38			Yes	Yes	Yes	Yes		
CA_20A-40A	-	20			Yes	Yes	Yes	Yes	40	0
		40			Yes	Yes	Yes	Yes		
CA_20A-42A	-	20			Yes	Yes	Yes	Yes	40	0
		42			Yes	Yes	Yes	Yes		
CA_20A-42A-42A	-	20			Yes	Yes	Yes	Yes	60	0
		42	See CA_42A-42A Bandwidth Combination Set 0 in Table 5.6A.1-3							
CA_20A-67A	-	20			Yes	Yes	Yes	Yes	40	0
		67			Yes	Yes	Yes	Yes		
CA_21A-42A	-	21			Yes	Yes	Yes		35	0
		42			Yes	Yes	Yes	Yes		
CA_21A-42C	-	21			Yes	Yes	Yes		55	0
		42	See CA_42C Bandwidth Combination Set 0 in Table 5.6A.1-1							
CA_23A-29A	-	23			Yes	Yes	Yes	Yes	30	0
		29		Yes	Yes	Yes				
		23			Yes	Yes			20	1
		29		Yes	Yes	Yes				
CA_25A-26A	-	25		Yes	Yes	Yes	Yes	Yes	35	0
		26	Yes	Yes	Yes	Yes	Yes			
		25		Yes	Yes	Yes			20	1
		26		Yes	Yes	Yes				
		25			Yes	Yes			20	2
		26			Yes	Yes				
CA_25A-41A ⁶	-	25			Yes	Yes	Yes	Yes	40	0
		41			Yes	Yes	Yes	Yes		
CA_25A-41C ⁶	-	25			Yes	Yes	Yes	Yes	60	0
		41	See CA_41C Bandwidth Combination Set 1 in Table 5.6A.1-1							
CA_25A-41D ⁶	-	25			Yes	Yes	Yes	Yes	80	0
		41	See CA_41D Bandwidth Combination Set 0 in Table 5.6A.1-1							
CA_26A-41A	-	26			Yes	Yes	Yes		35	0
		41			Yes	Yes	Yes	Yes		
CA_26A-41C	-	26			Yes	Yes	Yes		55	0
		41	See CA_41C Bandwidth Combination Set 1 in Table 5.6A.1-1							
CA_28A-40A	-	28			Yes	Yes	Yes	Yes	40	0
		40			Yes	Yes	Yes	Yes		
CA_28A-40C	-	28			Yes	Yes	Yes	Yes	60	0
		40	See CA_40C Bandwidth Combination set 1 in Table 5.6A.1-1							
CA_28A-40D	-	28			Yes	Yes	Yes	Yes	80	0
		40	See CA_40D Bandwidth Combination Set 0 in Table 5.6A.1-1							

CA_28A-41A	-	28			Yes	Yes			30	0
		41			Yes	Yes	Yes	Yes		
CA_28A-41C		28			Yes	Yes			50	0
		41	See CA_41C Bandwidth Combination set 0 in Table 5.6A.1-1							
CA_28A-42A	-	28			Yes	Yes	Yes	Yes	40	0
		42			Yes	Yes	Yes	Yes		
CA_28A-42C	-	28			Yes	Yes	Yes	Yes	60	0
		42	See CA_42C Bandwidth combination set 0 in Table 5.6A.1-1							
CA_29A-30A	-	29			Yes	Yes			20	0
		30			Yes	Yes				
CA_38A-40A	-	38				Yes		Yes	40	0
		40				Yes		Yes		
CA_38A-40A-40A	-	38				Yes		Yes	60	0
		40	See CA_40A-40A Bandwidth Combination Set 0 in Table 5.6A.1-3							
CA_38A-40C	-	38				Yes		Yes	60	0
		40	See CA_40C Bandwidth Combination Set 0 in Table 5.6A.1-1							
CA_39A-41A	CA_39A-41A	39				Yes	Yes	Yes	40	0
		41						Yes		
CA_39A-41C	CA_41C CA_39A-41A CA_39A-41C	39				Yes	Yes	Yes	60	0
		41						Yes		
		41						Yes		
CA_39A-41D	CA_41C CA_39A-41A	39				Yes	Yes	Yes	80	0
		41						Yes		
		41						Yes		
		41						Yes		
CA_39C-41A	CA_39C CA_39A-41A CA_39C-41A	39	See CA_39C Bandwidth Combination Set 0 in Table 5.6A.1-1						55	0
		41						Yes		
CA_39C-41C	CA_39C CA_41C CA_39A-41A	39	See CA_39C Bandwidth Combination Set 0 in Table 5.6A.1-1						75	0
		41						Yes		
		41						Yes		
CA_41A-42A	-	41				Yes	Yes	Yes	40	0
		42				Yes	Yes	Yes		
CA_41A-42C	-	41				Yes	Yes	Yes	60	0
		42	See CA_42C Bandwidth Combination Set 1 in Table 5.6A.1-1							
CA_41C-42A	-	41	See CA_41C Bandwidth Combination Set 0 in Table 5.6A.1-1						60	0
		42				Yes	Yes	Yes		
CA_41C-42C	-	41	See CA_41C Bandwidth Combination Set 0 in Table 5.6A.1-1						80	0
		42	See CA_42C Bandwidth Combination Set 1 in Table 5.6A.1-1							
CA_41A-46A	-	41			Yes	Yes	Yes	Yes	40	0
		46						Yes		
CA_42A-46A	-	42			Yes	Yes	Yes	Yes	40	0
		46						Yes		

NOTE 1: The CA Configuration refers to a combination of an operating band and a CA bandwidth class specified in Table 5.6A-1 (the indexing letter). Absence of a CA bandwidth class for an operating band implies support of all classes.

NOTE 2: For each band combination, all combinations of indicated bandwidths belong to the set.

NOTE 3: For the supported CC bandwidth combinations, the CC downlink and uplink bandwidths are equal.

NOTE 4: Uplink CA configurations are the configurations supported by the present release of specifications.

NOTE 5: For TDD inter-band Carrier Aggregation only non-simultaneous Rx/Tx uplink CA configurations can be supported by UE supporting corresponding DL CA configuration without simultaneous Rx/Tx.

NOTE 6: For the corresponding CA configuration, UE may not support Pcell transmissions in this E-UTRA band.

Table 5.6A.1-2a: E-UTRA CA configurations and bandwidth combination sets defined for inter-band CA (three bands)

E-UTRA CA configuration / Bandwidth combination set												
E-UTRA CA Configuration	Uplink CA configurations (NOTE 5)	E-UTRA Bands	1.4 MHz	3 MHz	5 MHz	10 MHz	15 MHz	20 MHz	Maximum aggregated bandwidth [MHz]	Bandwidth combination set		
CA_1A-3A-5A	CA_1A-3A CA_1A-5A ⁶ CA_3A-5A	1			Yes	Yes	Yes	Yes	50	0		
		3			Yes	Yes	Yes	Yes				
		5			Yes	Yes						
		CA_1A-3A-7A	-	1			Yes	Yes	Yes	Yes	60	0
				3			Yes	Yes	Yes	Yes		
7						Yes	Yes	Yes				
CA_1A-3A-7C	-	1			Yes	Yes	Yes	Yes	80	0		
		3				Yes	Yes	Yes				
		7	See CA_7C Bandwidth Combination Set 2 in Table 5.6A.1-1									
CA_1A-3A-8A	CA_1A-3A CA_1A-8A ⁶ CA_3A-8A ⁶	1			Yes	Yes	Yes	Yes	50	0		
		3			Yes	Yes	Yes	Yes				
		8		Yes	Yes	Yes						
		CA_1A-3A-8A	CA_1A-3A CA_1A-8A ⁶ CA_3A-8A ⁶	1			Yes	Yes	Yes	Yes	40	1
				3			Yes	Yes	Yes	Yes		
				8		Yes	Yes	Yes				
				1			Yes	Yes	Yes		40	2
		3			Yes	Yes	Yes					
		8		Yes	Yes	Yes						
		CA_1A-3A-8A	CA_1A-3A CA_1A-8A ⁶ CA_3A-8A ⁶	1			Yes	Yes	Yes	Yes	50	3
3					Yes	Yes	Yes	Yes				
8					Yes	Yes						
8					Yes	Yes						
CA_1A-3A-19A	CA_1A-3A CA_1A-19A ⁶ CA_3A-19A	1			Yes	Yes	Yes	Yes	55	0		
		3			Yes	Yes	Yes	Yes				
		19			Yes	Yes	Yes					
CA_1A-3A-26A	-	1			Yes	Yes	Yes	Yes	50	0		
		3			Yes	Yes	Yes	Yes				
		26			Yes	Yes						
CA_1A-3A-20A	-	1			Yes	Yes	Yes	Yes	60	0		
		3			Yes	Yes	Yes	Yes				
		20			Yes	Yes	Yes	Yes				
CA_1A-3A-28A	-	1			Yes	Yes	Yes	Yes	60	0		
		3			Yes	Yes	Yes	Yes				
		28			Yes	Yes	Yes	Yes				
CA_1A-3A-40A	-	1			Yes	Yes	Yes	Yes	60	0		
		3			Yes	Yes	Yes	Yes				
		40			Yes	Yes	Yes	Yes				
CA_1A-3A-42A	-	1			Yes	Yes	Yes	Yes	60	0		
		3			Yes	Yes	Yes	Yes				
		42			Yes	Yes	Yes	Yes				
CA_1A-3A-42C	-	1			Yes	Yes	Yes	Yes	80	0		
		3			Yes	Yes	Yes	Yes				
		42	See CA_42C Bandwidth combination set 0 in Table 5.6A.1-1									
CA_1A-5A-40A	-	1			Yes	Yes	Yes	Yes	50	0		
		5			Yes	Yes						
		40				Yes	Yes	Yes				
CA_1A-5A-7A	CA_1A-5A ⁶ CA_1A-7A CA_5A-7A ⁶	1			Yes	Yes			40	0		
		5			Yes	Yes						
		7				Yes	Yes	Yes				
		1			Yes	Yes	Yes	Yes	50	1		
		5			Yes	Yes						
7				Yes	Yes	Yes						
CA_1A-7A-8A	-	1			Yes	Yes	Yes	Yes	50	0		

		7			Yes	Yes	Yes			
		8			Yes	Yes				
CA_1A-7A-20A	-	1			Yes	Yes	Yes	Yes	50	0
		7			Yes	Yes	Yes	Yes		
CA_1A-7A-28A	-	20			Yes	Yes			55	0
		1			Yes	Yes	Yes	Yes		
		7			Yes	Yes	Yes	Yes		
		28			Yes	Yes	Yes			
		1			Yes	Yes	Yes	Yes		
CA_1A-7A-28A	-	7			Yes	Yes	Yes	Yes	60	1
		1			Yes	Yes	Yes	Yes		
		28			Yes	Yes	Yes			
CA_1A-7C-28A	-	1			Yes	Yes	Yes	Yes	80	0
		7	See CA_7C Bandwidth Combination Set 2 in Table 5.6A.1-1							
		28			Yes	Yes	Yes			
CA_1A-8A-11A	-	1			Yes	Yes	Yes	Yes	40	0
		8			Yes	Yes				
CA_1A-8A-40A	-	11			Yes	Yes			50	0
		1			Yes	Yes	Yes	Yes		
		8		Yes	Yes	Yes				
CA_1A-11A-18A	-	40			Yes	Yes	Yes	Yes	45	0
		1			Yes	Yes	Yes	Yes		
		11			Yes	Yes				
		18			Yes	Yes	Yes			
		1			Yes	Yes	Yes	Yes		
CA_1A-18A-28A	CA_1A-18A ⁶ CA_1A-28A CA_18A-28A	11			Yes	Yes			40	1
		18			Yes	Yes	Yes			
		1			Yes	Yes	Yes	Yes		
		11			Yes	Yes				
		18			Yes	Yes				
CA_1A-18A-28A	CA_1A-18A ⁶ CA_1A-28A CA_18A-28A	1			Yes	Yes	Yes	Yes	45	0
		18			Yes	Yes	Yes			
		28			Yes	Yes				
		1			Yes	Yes	Yes	Yes		
CA_1A-19A-21A	CA_1A-19A ⁶ CA_1A-21A CA_19A-21A ⁶	18			Yes	Yes			40	1
		28			Yes	Yes				
		1			Yes	Yes	Yes	Yes		
CA_1A-19A-21A	CA_1A-19A ⁶ CA_1A-21A CA_19A-21A ⁶	19			Yes	Yes	Yes		50	0
		21			Yes	Yes	Yes			
		1			Yes	Yes	Yes	Yes		
CA_1A-19A-28A	-	19			Yes	Yes	Yes		45	0
		28			Yes	Yes				
		1			Yes	Yes	Yes	Yes		
CA_1A-19A-42A	-	19			Yes	Yes	Yes		55	0
		42			Yes	Yes	Yes	Yes		
		1			Yes	Yes	Yes	Yes		
CA_1A-19A-42C	-	19			Yes	Yes	Yes		75	0
		42	See CA_42C Bandwidth combination set 0 in Table 5.6A.1-1							
CA_1A-21A-42A	-	1			Yes	Yes	Yes	Yes	55	0
		21			Yes	Yes	Yes			
		42			Yes	Yes	Yes	Yes		
CA_1A-21A-42C	-	1			Yes	Yes	Yes	Yes	75	0
		21			Yes	Yes	Yes			
		42	See CA_42C Bandwidth combination set 0 in Table 5.6A.1-1							
CA_2A-4A-5A	-	2			Yes	Yes	Yes	Yes	50	0
		4			Yes	Yes	Yes	Yes		
		5			Yes	Yes				
CA_2A-2A-4A-5A	-	2	See CA_2A-2A Bandwidth Combination Set 0 in Table 5.6A.1-3						70	0
		4			Yes	Yes	Yes	Yes		
		5			Yes	Yes				
CA_2A-4A-7A	.	2			Yes	Yes	Yes	Yes	60	0
		4			Yes	Yes	Yes	Yes		
		7			Yes	Yes	Yes	Yes		

CA_2A-4A-4A-5A	-	2			Yes	Yes	Yes	Yes	70	0
		4	See CA_4A-4A Bandwidth Combination Set 0 in Table 5.6A.1-3							
		5			Yes	Yes				
CA_2A-4A-12A	CA_2A-4A CA_4A-12A	2			Yes	Yes	Yes	Yes	50	0
		4			Yes	Yes	Yes	Yes		
		12			Yes	Yes				
CA_2A-2A-4A-12A	-	2	See CA_2A-2A Bandwidth Combination Set 0 in Table 5.6A.1-3						70	0
		4			Yes	Yes	Yes	Yes		
		12			Yes	Yes				
CA_2A-4A-4A-12A	-	2			Yes	Yes	Yes	Yes	70	0
		4	See CA_4A-4A Bandwidth Combination Set 0 in Table 5.6A.1-3							
		12			Yes	Yes				
CA_2A-4A-13A	-	2			Yes	Yes	Yes	Yes	50	0
		4			Yes	Yes	Yes	Yes		
		13				Yes				
CA_2A-4A-29A	-	2			Yes	Yes	Yes	Yes	50	0
		4			Yes	Yes	Yes	Yes		
		29			Yes	Yes				
CA_2A-4A-30A	-	2			Yes	Yes	Yes	Yes	50	0
		4			Yes	Yes	Yes	Yes		
		30			Yes	Yes				
CA_2A-5A-12A	-	2			Yes	Yes	Yes	Yes	40	0
		5			Yes	Yes				
		12			Yes	Yes				
CA_2A-2A-5A-12A	-	2	See CA_2A-2A Bandwidth Combination Set 0 in Table 5.6A.1-3						60	0
		5			Yes	Yes				
		12			Yes	Yes				
CA_2A-5A-12B	-	2			Yes	Yes	Yes	Yes	45	0
		5			Yes	Yes				
		12	See CA_12B Bandwidth Combination Set 0 in Table 5.6A.1-1							
CA_2A-5A-13A	CA_2A-13A ⁶	2			Yes	Yes	Yes	Yes	40	0
		5			Yes	Yes				
		13				Yes				
CA_2A-5A-29A	-	2			Yes	Yes	Yes	Yes	40	0
		5			Yes	Yes				
		29			Yes	Yes				
CA_2A-5A-30A	-	2			Yes	Yes	Yes	Yes	40	0
		5			Yes	Yes				
		30			Yes	Yes				
CA_2C-5A-30A	-	2	See CA_2C Bandwidth combination set 0 in Table 5.6A.1-1						60	0
		5			Yes	Yes				
		30			Yes	Yes				
CA_2A-7A-12A	-	2			Yes	Yes	Yes	Yes	50	0
		7			Yes	Yes	Yes	Yes		
		12			Yes	Yes				
CA_2A-12A-30A	-	2			Yes	Yes	Yes	Yes	40	0
		12			Yes	Yes				
		30			Yes	Yes				
CA_2C-12A-30A	-	2	See CA_2C Bandwidth combination set 0 in Table 5.6A.1-1						60	0
		12			Yes	Yes				
		30			Yes	Yes				
CA_2A-29A-30A	-	2			Yes	Yes	Yes	Yes	40	0
		29			Yes	Yes				
		30			Yes	Yes				
CA_2C-29A-	-	2	See CA_2C Bandwidth Combination set 0						60	0

30A		in Table 5.6A.1-1								
		29		Yes	Yes					
CA_3A-5A-40A	-	3		Yes	Yes	Yes	Yes	50	0	
		5		Yes	Yes					
		40			Yes	Yes	Yes			
CA_3A-7A-8A	-	3		Yes	Yes	Yes		40	0	
		7			Yes	Yes				
		8		Yes	Yes					
		3		Yes	Yes	Yes	Yes	50	1	
		7			Yes	Yes	Yes			
		8		Yes	Yes					
CA_3A-7A-20A	CA_3A-7A CA_3A-20A CA_7A-20A ⁶	3		Yes	Yes	Yes	Yes	60	0	
		7			Yes	Yes	Yes			
		20		Yes	Yes	Yes	Yes			
CA_3A-7A-28A	CA_3A-7A CA_7A-28A	3		Yes	Yes	Yes	Yes	60	0	
		7		Yes	Yes	Yes	Yes			
		28		Yes	Yes	Yes	Yes			
CA_3A-7C-28A	-	3			Yes	Yes	Yes	80	0	
		7	See CA_7C Bandwidth Combination Set 2 in Table 5.6A.1-1							
		28			Yes	Yes	Yes			
CA_3C-7A-28A	-	3	See CA_3C Bandwidth Combination Set 0 in Table 5.6A.1-1						80	0
		7			Yes	Yes	Yes			
		28			Yes	Yes	Yes			
CA_3C-7C-28A	-	3	See CA_3C Bandwidth Combination Set 0 in Table 5.6A.1-1						100	0
		7	See CA_7C Bandwidth Combination Set 2 in Table 5.6A.1-1							
		28			Yes	Yes	Yes			
CA_3A-7A-38A ⁷	-	3		Yes	Yes	Yes	Yes	60	0	
		7			Yes	Yes	Yes			
		38		Yes	Yes	Yes	Yes			
CA_3A-8A-40A	-	3		Yes	Yes	Yes	Yes	50	0	
		8	Yes	Yes	Yes					
		40		Yes	Yes	Yes	Yes			
CA_3A-19A-42A	-	3		Yes	Yes	Yes	Yes	55	0	
		19		Yes	Yes	Yes				
		42		Yes	Yes	Yes	Yes			
CA_3A-19A-42C	-	3		Yes	Yes	Yes	Yes	75	0	
		19		Yes	Yes	Yes				
		42	See CA_42C Bandwidth combination set 0 in Table 5.6A.1-1							
CA_3A-28A-40A	-	3		Yes	Yes	Yes	Yes	60	0	
		28		Yes	Yes	Yes	Yes			
		40		Yes	Yes	Yes	Yes			
CA_3A-28A-40C	-	3		Yes	Yes	Yes	Yes	80	0	
		28		Yes	Yes	Yes	Yes			
		40	See CA_40C Bandwidth combination set 0 in Table 5.6A.1-1							
CA_3A-41A-42A	-	3		Yes	Yes	Yes	Yes	60	0	
		41			Yes	Yes	Yes			
		42			Yes	Yes	Yes			
CA_4A-5A-12A	-	4		Yes	Yes	Yes	Yes	40	0	
		5		Yes	Yes					
		12		Yes	Yes					
CA_4A-4A-5A-12A	-	4	See CA_4A-4A Bandwidth Combination Set 0 in Table 5.6A.1-3						60	0
		5		Yes	Yes					
		12		Yes	Yes					
CA_4A-5A-13A	CA_4A-13A ⁶	4		Yes	Yes	Yes	Yes	40	0	

		5			Yes	Yes				
		13				Yes				
CA_4A-5A-29A	-	4			Yes	Yes	Yes	Yes	40	0
		5			Yes	Yes				
		29			Yes	Yes				
CA_4A-5A-30A	-	4			Yes	Yes	Yes	Yes	40	0
		5			Yes	Yes				
		30			Yes	Yes				
CA_4A-4A-5A-30A	-	4	See CA_4A-4A Bandwidth Combination Set 0 in Table 5.6A.1-3						60	0
		5			Yes	Yes				
		30			Yes	Yes				
CA_4A-7A-12A	-	4			Yes	Yes			40	0
		7			Yes	Yes	Yes	Yes		
		12			Yes	Yes				
		4			Yes	Yes	Yes	Yes	50	1
		7			Yes	Yes	Yes	Yes		
		12			Yes	Yes				
CA_4A-12A-30A	-	4			Yes	Yes	Yes	Yes	40	0
		12			Yes	Yes				
		30			Yes	Yes				
CA_4A-4A-12A-30A	-	4	See CA_4A-4A Bandwidth Combination Set 0 in Table 5.6A.1-3						60	0
		12			Yes	Yes				
		30			Yes	Yes				
CA_4A-29A-30A	-	4			Yes	Yes	Yes	Yes	40	0
		29			Yes	Yes				
		30			Yes	Yes				
CA_4A-4A-29A-30A	-	4	See CA_4A-4A Bandwidth combination set 0 in Table 5.6A.1-3						60	0
		29			Yes	Yes				
		30			Yes	Yes				
CA_7A-8A-20A	-	7				Yes	Yes	Yes	40	0
		8	Yes	Yes	Yes					
		20			Yes	Yes				
CA_7A-20A-38A ⁸	-	7				Yes	Yes	Yes	60	0
		20			Yes	Yes	Yes	Yes		
		38			Yes	Yes	Yes	Yes		
CA_19A-21A-42A	-	19			Yes	Yes	Yes		50	0
		21			Yes	Yes	Yes			
		42			Yes	Yes	Yes	Yes		
CA_19A-21A-42C	-	19			Yes	Yes	Yes		70	0
		21			Yes	Yes	Yes			
		42	See CA_42C Bandwidth combination set 0 in Table 5.6A.1-1							

NOTE 1: The CA Configuration refers to a combination of an operating band and a CA bandwidth class specified in Table 5.6A-1 (the indexing letter). Absence of a CA bandwidth class for an operating band implies support of all classes.

NOTE 2: For each band combination, all combinations of indicated bandwidths belong to the set.

NOTE 3: For the supported CC bandwidth combinations, the CC downlink and uplink bandwidths are equal.

NOTE 4: A terminal which supports a DL CA configuration shall support all the lower order fallback DL CA combinations and it shall support at least one bandwidth combination set for each of the constituent lower order DL combinations containing all the bandwidths specified within each specific combination set of the upper order DL combination.

NOTE 5: Uplink CA configurations are the configurations supported by the present release of specifications.

NOTE 6: If the UE supports any uplink CA configuration for corresponding downlink CA configuration it shall support this uplink CA configuration.

NOTE 7: UL carrier shall be supported in Band 3 only. Power imbalance between downlink carriers on Band 7 and Band 38 is assumed to be within [6dB].

NOTE 8: UL carrier shall be supported in Band 20 only. Power imbalance between downlink carriers on Band 7 and Band 38 is assumed to be within [6dB].

Table 5.6A.1-2b: E-UTRA CA configurations and bandwidth combination sets defined for inter-band CA (four bands)

E-UTRA CA configuration / Bandwidth combination set											
E-UTRA CA Configuration	Uplink CA configurations (NOTE 5)	E-UTRA Bands	1.4 MHz	3 MHz	5 MHz	10 MHz	15 MHz	20 MHz	Maximum aggregated bandwidth [MHz]	Bandwidth combination set	
CA_1A-3A-5A-40A	-	1			Yes	Yes	Yes	Yes	70	0	
		3			Yes	Yes	Yes	Yes			
		5			Yes	Yes					
		40				Yes	Yes	Yes			
CA_1A-3A-7A-8A	-	1			Yes	Yes	Yes	Yes	70	0	
		3			Yes	Yes	Yes	Yes			
		7				Yes	Yes	Yes			
		8			Yes	Yes					
CA_1A-3A-7A-28A	-	1			Yes	Yes	Yes	Yes	80	0	
		3				Yes	Yes	Yes			
		7				Yes	Yes	Yes			
		28				Yes	Yes	Yes			
CA_1A-3A-7C-28A	-	1			Yes	Yes	Yes	Yes	100	0	
		3				Yes	Yes	Yes			
		7	See CA_7C Bandwidth Combination Set 2 in Table 5.6A.1-1								
		28				Yes	Yes	Yes			
CA_1A-3A-8A-40A	-	1			Yes	Yes	Yes	Yes	70	0	
		3			Yes	Yes	Yes	Yes			
		8		Yes	Yes	Yes					
		40			Yes	Yes	Yes	Yes			
CA_1A-3A-19A-42A	-	1			Yes	Yes	Yes	Yes	75	0	
		3			Yes	Yes	Yes	Yes			
		19			Yes	Yes	Yes				
		42			Yes	Yes	Yes	Yes			
CA_1A-3A-19A-42C	-	1			Yes	Yes	Yes	Yes	95	0	
		3			Yes	Yes	Yes	Yes			
		19			Yes	Yes	Yes	Yes			
		42	See CA_42C Bandwidth combination set 0 in Table 5.6A.1-1								
CA_1A-19A-21A-42A	-	1			Yes	Yes	Yes	Yes	70	0	
		19			Yes	Yes	Yes				
		21			Yes	Yes	Yes				
		42			Yes	Yes	Yes	Yes			
CA_1A-19A-21A-42C	-	1			Yes	Yes	Yes	Yes	90	0	
		19			Yes	Yes	Yes				
		21			Yes	Yes	Yes				
		42	See CA_42C Bandwidth combination set 0 in Table 5.6A.1-1								
CA_2A-4A-5A-12A	-	2			Yes	Yes	Yes	Yes	60	0	
		4			Yes	Yes	Yes	Yes			
		5			Yes	Yes					
		12			Yes	Yes					
CA_2A-4A-5A-29A	-	2			Yes	Yes	Yes	Yes	60	0	
		4			Yes	Yes	Yes	Yes			
		5			Yes	Yes					
		29			Yes	Yes					
CA_2A-4A-5A-30A	-	2			Yes	Yes	Yes	Yes	60	0	
		4			Yes	Yes	Yes	Yes			
		5			Yes	Yes					
		30			Yes	Yes					
CA_2A-4A-7A-12A	-	2			Yes	Yes	Yes	Yes	70	0	
		4			Yes	Yes	Yes	Yes			
		7			Yes	Yes	Yes	Yes			
		12			Yes	Yes					
CA_2A-4A-12A-30A	-	2			Yes	Yes	Yes	Yes	60	0	
		4			Yes	Yes	Yes	Yes			

		12			Yes	Yes				
		30			Yes	Yes				
CA_2A-4A-29A-30A	-	2			Yes	Yes	Yes	Yes	60	0
		4			Yes	Yes	Yes	Yes		
		29			Yes	Yes				
		30			Yes	Yes				

NOTE 1: The CA Configuration refers to a combination of an operating band and a CA bandwidth class specified in Table 5.6A-1 (the indexing letter). Absence of a CA bandwidth class for an operating band implies support of all classes.

NOTE 2: For each band combination, all combinations of indicated bandwidths belong to the set.

NOTE 3: For the supported CC bandwidth combinations, the CC downlink and uplink bandwidths are equal.

NOTE 4: A terminal which supports a DL CA configuration shall support all the lower order fallback DL CA combinations and it shall support at least one bandwidth combination set for each of the constituent lower order DL combinations containing all the bandwidths specified within each specific combination set of the upper order DL combination.

NOTE 5: Uplink CA configurations are the configurations supported by the present release of specifications.

Table 5.6A.1-3: E-UTRA CA configurations and bandwidth combination sets defined for non-contiguous intra-band CA (with two sub-blocks)

E-UTRA CA configuration / Bandwidth combination set							
E-UTRACA configuration	Uplink CA configurations (NOTE 1)	Component carriers in order of increasing carrier frequency				Maximum aggregated bandwidth [MHz]	Bandwidth combination set
		Channel bandwidths for carrier [MHz]	Channel bandwidths for carrier [MHz]	Channel bandwidths for carrier [MHz]	Channel bandwidths for carrier [MHz]		
CA_2A-2A	-	5, 10, 15, 20	5, 10, 15, 20			40	0
CA_3A-3A	-	5, 10, 15, 20	5, 10, 15, 20			40	0
		5, 10	5, 10, 15, 20			30	1
CA_4A-4A	CA_4A-4A	5, 10, 15, 20	5, 10, 15, 20			40	0
		5, 10	5, 10			20	1
CA_5A-5A	-	5,10	5,10			20	0
CA_7A-7A	-	5	15			40	0
		10	10, 15				
		15	15, 20				
		20	20				
		5, 10, 15, 20	5, 10, 15, 20			40	1
CA_23A-23A	-	5	10			15	0
CA_25A-25A	-	5, 10	5, 10			20	0
		5, 10, 15, 20	5, 10, 15, 20			40	1
CA_40A-40A	-	10, 20	10, 20			40	0
CA_41A-41A	-	10, 15, 20	10, 15, 20			40	0
		5, 10, 15, 20	5, 10, 15, 20			40	1
CA_41A-41C	-	5, 10, 15, 20	See CA_41C Bandwidth Combination Set 1 in Table 5.6A.1-1			60	0
		See CA_41C Bandwidth Combination Set 1 in Table 5.6A.1-1		5, 10, 15, 20			
CA_41A-41D	CA_41C	5, 10, 15, 20	See CA_41D Bandwidth Combination Set 0 in Table 5.6A.1-1			80	0
		See CA_41D Bandwidth Combination Set 0 in Table 5.6A.1-1			5, 10, 15, 20		
CA_41C-41C	CA_41C	See CA_41C Bandwidth Combination Set 0 in Table 5.6A.1-1		See CA_41C Bandwidth Combination Set 0 in Table 5.6A.1-1		80	0
CA_42A-42A	-	5, 10, 15, 20	5, 10, 15, 20			40	0
CA_42A-42C	-	5, 10, 15, 20	See CA_42C Bandwidth Combination Set 0 in Table 5.6A.1-1			60	0
		See CA_42C Bandwidth Combination Set 0 in Table 5.6A.1-1		5, 10, 15, 20			
CA_42A-42D	-	5, 10, 15, 20	See CA_42D Bandwidth Combination Set 0 in Table 5.6A.1-1			80	0
		See CA_42D Bandwidth Combination Set 0 in Table 5.6A.1-1			5, 10, 15, 20		
CA_42C-42C	-	See CA_42C Bandwidth		See CA_42C Bandwidth		80	0

CA_66A-66A	-	Combination Set 0 in Table 5.6A.1-1		Combination Set 0 in Table 5.6A.1-1		40	0
		5, 10, 15, 20	5, 10, 15, 20				
NOTE 1: Uplink CA configurations are the configurations supported by the present release of specifications.							

5.6B Channel bandwidth for UL-MIMO

The requirements specified in subclause 5.6 are applicable to UE supporting UL-MIMO.

5.6B.1 Void

5.6C Channel bandwidth for Dual Connectivity

For E-UTRA DC bands specified in 5.5C, the corresponding E-UTRA CA configurations in 5.6A.1, i.e., dual uplink inter-band carrier aggregation with uplink assigned to two E-UTRA bands, are applicable to Dual Connectivity.

NOTE 1: Requirements for the dual connectivity configurations are defined in the section corresponding E-UTRA uplink CA configurations, unless otherwise specified.

NOTE 2: For TDD inter-band dual connectivity configurations, requirements are applicable only for synchronous operation.

5.6C.1 Void

Table 5.6C.1-1: Void

Table 5.6C.1-2: Void

5.6D Channel bandwidth for ProSe

5.6D.1 Channel bandwidths per operating band for ProSe

The ProSe combination of channel bandwidths and operating bands is shown in Table 5.6D.1-1 and Table 5.6D.1-2. The transmission bandwidth configuration in Table 5.6D.1-1 and Table 5.6D.1-2 shall be supported for each of the specified channel bandwidths. The same (symmetrical) channel bandwidth is specified for both the TX and RX path.

Table 5.6D.1-1 ProSe Direct Discovery channel bandwidth

E-UTRA ProSe band / ProSe channel bandwidth						
E-UTRA ProSe Band	1.4 MHz	3 MHz	5 MHz	10 MHz	15 MHz	20 MHz
2			Yes	Yes	Yes	Yes
3			Yes	Yes	Yes	Yes
4			Yes	Yes	Yes	Yes
7			Yes	Yes	Yes	Yes
14			Yes	Yes		
20			Yes	Yes	Yes	Yes
26			Yes	Yes	Yes	
28			Yes	Yes	Yes	Yes
31			Yes			
41			Yes	Yes	Yes	Yes
68			Yes	Yes	Yes	

Table 5.6D.1-2 ProSe Direct Communication channel bandwidth

E-UTRA ProSe band / ProSe channel bandwidth						
E-UTRA ProSe Band	1.4 MHz	3 MHz	5 MHz	10 MHz	15 MHz	20 MHz
3				Yes		
7				Yes		
14				Yes		
20				Yes		
26				Yes		
28				Yes		
31			Yes			
68			Yes	Yes		

5.6F Channel bandwidth for category NB1

Channel bandwidth for Category NB1 is 200 kHz.

For category NB1, requirements in present document are specified for the channel bandwidth listed in Table 5.6F-1.

Table 5.6F-1: Transmission bandwidth configuration N_{RB} , $N_{tone\ 15kHz}$ and $N_{tone\ 3.75kHz}$ in NB1 channel bandwidth

Channel bandwidth $BW_{Channel}$ [kHz]	200
Transmission bandwidth configuration N_{RB}	1
Transmission bandwidth configuration $N_{tone\ 15kHz}$	12
Transmission bandwidth configuration $N_{tone\ 3.75kHz}$	48

Figure 5.6F-1 shows the relation between the Category NB1 channel bandwidth ($BW_{Channel}$) and the Category NB1 transmission bandwidth configuration (N_{tone}). The channel edges are defined as the lowest and highest frequencies of the carrier separated by the channel bandwidth, i.e. at $F_C \pm BW_{Channel} / 2$.

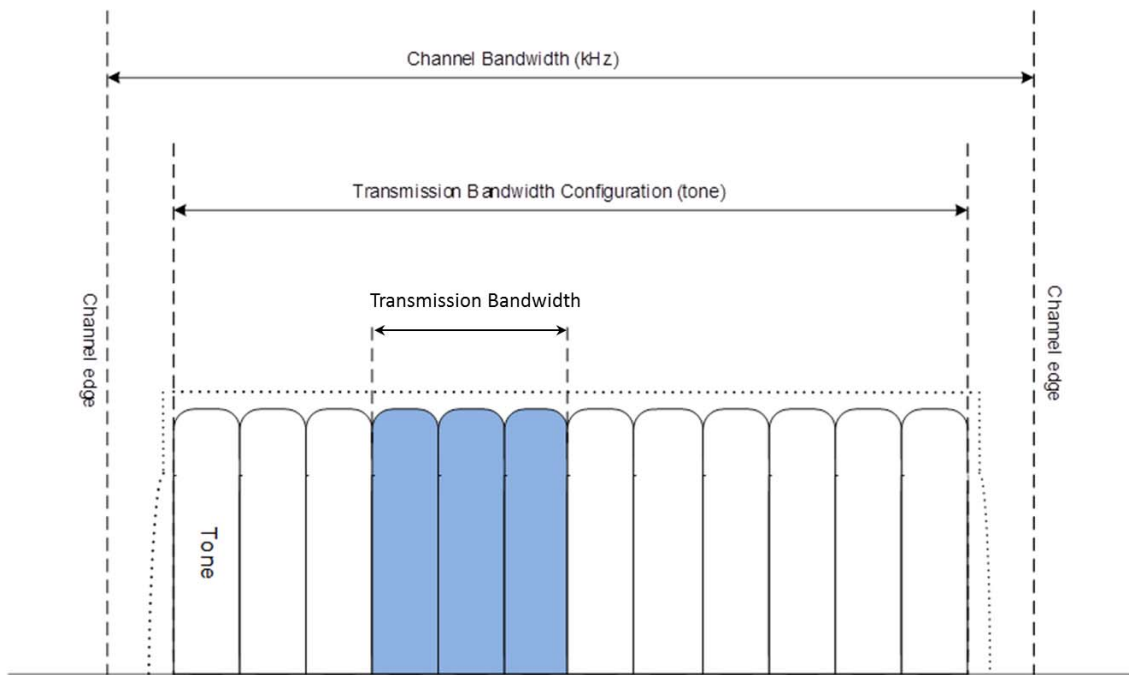

Figure 5.6F-1 Definition of Channel Bandwidth and Transmission Bandwidth configuration

5.7 Channel arrangement

5.7.1 Channel spacing

The spacing between carriers will depend on the deployment scenario, the size of the frequency block available and the channel bandwidths. The nominal channel spacing between two adjacent E-UTRA carriers is defined as following:

$$\text{Nominal Channel spacing} = (BW_{\text{Channel}(1)} + BW_{\text{Channel}(2)})/2$$

where $BW_{\text{Channel}(1)}$ and $BW_{\text{Channel}(2)}$ are the channel bandwidths of the two respective E-UTRA carriers. The channel spacing can be adjusted to optimize performance in a particular deployment scenario.

5.7.1A Channel spacing for CA

For intra-band contiguous carrier aggregation with two or more component carriers, the nominal channel spacing between two adjacent E-UTRA component carriers is defined as the following unless stated otherwise:

$$\text{Nominal channel spacing} = \left\lceil \frac{BW_{\text{Channel}(1)} + BW_{\text{Channel}(2)} - 0.1|BW_{\text{Channel}(1)} - BW_{\text{Channel}(2)}|}{0.6} \right\rceil 0.3 \text{ [MHz]}$$

where $BW_{\text{Channel}(1)}$ and $BW_{\text{Channel}(2)}$ are the channel bandwidths of the two respective E-UTRA component carriers according to Table 5.6-1 with values in MHz. The channel spacing for intra-band contiguous carrier aggregation can be adjusted to any multiple of 300 kHz less than the nominal channel spacing to optimize performance in a particular deployment scenario.

For intra-band contiguous carrier aggregation with two or more component carriers in Band 46, the requirements apply for both 19.8 MHz and 20.1 MHz nominal carrier spacing.

For intra-band non-contiguous carrier aggregation the channel spacing between two E-UTRA component carriers in different sub-blocks shall be larger than the nominal channel spacing defined in this subclause.

5.7.1F Channel spacing for category NB1

Nominal channel spacing for UE category NB1 in stand-alone mode is 200 kHz. For in-band and guard-band cases the nominal channel spacing between two adjacent category NB1 carriers is 180 kHz.

5.7.2 Channel raster

The channel raster is 100 kHz for all bands, which means that the carrier centre frequency must be an integer multiple of 100 kHz.

5.7.2A Channel raster for CA

For carrier aggregation the channel raster is 100 kHz for all bands, which means that the carrier centre frequency must be an integer multiple of 100 kHz.

5.7.2F Channel raster for category NB1

Channel raster for category NB1 in-band, guard-band and standalone operation is 100 kHz.

5.7.3 Carrier frequency and EARFCN

The carrier frequency in the uplink and downlink is designated by the E-UTRA Absolute Radio Frequency Channel Number (EARFCN) in the range 0 – 262143. The relation between EARFCN and the carrier frequency in MHz for the downlink is given by the following equation, where F_{DL_low} and $N_{Offs-DL}$ are given in Table 5.7.3-1 and N_{DL} is the downlink EARFCN.

$$F_{DL} = F_{DL_low} + 0.1(N_{DL} - N_{Offs-DL})$$

The relation between EARFCN and the carrier frequency in MHz for the uplink is given by the following equation where F_{UL_low} and $N_{Offs-UL}$ are given in Table 5.7.3-1 and N_{UL} is the uplink EARFCN.

$$F_{UL} = F_{UL_low} + 0.1(N_{UL} - N_{Offs-UL})$$

Table 5.7.3-1: E-UTRA channel numbers

E-UTRA Operating Band	Downlink			Uplink		
	F _{DL_low} (MHz)	N _{Offs-DL}	Range of N _{DL}	F _{UL_low} (MHz)	N _{Offs-UL}	Range of N _{UL}
1	2110	0	0 – 599	1920	18000	18000 – 18599
2	1930	600	600 – 1199	1850	18600	18600 – 19199
3	1805	1200	1200 – 1949	1710	19200	19200 – 19949
4	2110	1950	1950 – 2399	1710	19950	19950 – 20399
5	869	2400	2400 – 2649	824	20400	20400 – 20649
6	875	2650	2650 – 2749	830	20650	20650 – 20749
7	2620	2750	2750 – 3449	2500	20750	20750 – 21449
8	925	3450	3450 – 3799	880	21450	21450 – 21799
9	1844.9	3800	3800 – 4149	1749.9	21800	21800 – 22149
10	2110	4150	4150 – 4749	1710	22150	22150 – 22749
11	1475.9	4750	4750 – 4949	1427.9	22750	22750 – 22949
12	729	5010	5010 – 5179	699	23010	23010 – 23179
13	746	5180	5180 – 5279	777	23180	23180 – 23279
14	758	5280	5280 – 5379	788	23280	23280 – 23379
...						
17	734	5730	5730 – 5849	704	23730	23730 – 23849
18	860	5850	5850 – 5999	815	23850	23850 – 23999
19	875	6000	6000 – 6149	830	24000	24000 – 24149
20	791	6150	6150 – 6449	832	24150	24150 – 24449
21	1495.9	6450	6450 – 6599	1447.9	24450	24450 – 24599
22	3510	6600	6600 – 7399	3410	24600	24600 – 25399
23	2180	7500	7500 – 7699	2000	25500	25500 – 25699
24	1525	7700	7700 – 8039	1626.5	25700	25700 – 26039
25	1930	8040	8040 – 8689	1850	26040	26040 – 26689
26	859	8690	8690 – 9039	814	26690	26690 – 27039
27	852	9040	9040 – 9209	807	27040	27040 – 27209
28	758	9210	9210 – 9659	703	27210	27210 – 27659
29 ²	717	9660	9660 – 9769	N/A		
30	2350	9770	9770 – 9869	2305	27660	27660 – 27759
31	462.5	9870	9870 – 9919	452.5	27760	27760 – 27809
32 ²	1452	9920	9920 – 10359	N/A		
33	1900	36000	36000 – 36199	1900	36000	36000 – 36199
34	2010	36200	36200 – 36349	2010	36200	36200 – 36349
35	1850	36350	36350 – 36949	1850	36350	36350 – 36949
36	1930	36950	36950 – 37549	1930	36950	36950 – 37549
37	1910	37550	37550 – 37749	1910	37550	37550 – 37749
38	2570	37750	37750 – 38249	2570	37750	37750 – 38249
39	1880	38250	38250 – 38649	1880	38250	38250 – 38649
40	2300	38650	38650 – 39649	2300	38650	38650 – 39649
41	2496	39650	39650 – 41589	2496	39650	39650 – 41589
42	3400	41590	41590 – 43589	3400	41590	41590 – 43589
43	3600	43590	43590 – 45589	3600	43590	43590 – 45589
44	703	45590	45590 – 46589	703	45590	45590 – 46589
45	1447	46590	46590 – 46789	1447	46590	46590 – 46789
46 ⁴	5150	46790	46790 – 54539	5150	46790	46790 – 54539
...						
64	Reserved					
65	2110	65536	65536 – 66435	1920	131072	131072 – 131971
66 ⁵	2110	66436	66436 – 67335	1710	131972	131972 – 132671
67 ²	738	67336	67336 – 67535	N/A		
68	753	67536	67536 – 67835	698	132672	132672 – 132971

NOTE 1: The channel numbers that designate carrier frequencies so close to the operating band edges that the carrier extends beyond the operating band edge shall not be used. This implies that the first 7, 15, 25, 50, 75 and 100 channel numbers at the lower operating band edge and the last 6, 14, 24, 49, 74 and 99 channel numbers at the upper operating band edge shall not be used for channel bandwidths of 1.4, 3, 5, 10, 15 and 20 MHz respectively.

NOTE 2: Restricted to E-UTRA operation when carrier aggregation is configured.

NOTE 3: For ProSe the corresponding UL channel number are also specified for the DL for the associated ProSe operating bands i.e. ProSe_F_{UL} = F_{UL} and ProSe_F_{DL} = F_{UL}.

NOTE 4: Requirements for uplink operations are not specified in this version of the specification.

NOTE 5: The range 2180-2200 MHz of the DL operating band is restricted to E-UTRA operation when carrier aggregation is configured.

5.7.3F Carrier frequency and EARFCN for category NB1

The carrier frequency of category NB1 in the downlink is designated by the E-UTRA Absolute Radio Frequency Channel Number (EARFCN) in the range 0 – 262143 and the Offset of category NB1 Channel Number to EARFCN in the range {-10,-9,-8,-7,-6,-5,-4,-3,-2,-1,-0.5,0,1,2,3,4,5,6,7,8,9}. The relation between EARFCN, Offset of category NB1 Channel Number to EARFCN and the carrier frequency in MHz for the downlink is given by the following equation, where F_{DL} is the downlink carrier frequency of category NB1, F_{DL_low} and $N_{Offs-DL}$ are given in table 5.7.3-1, N_{DL} is the downlink EARFCN, M_{DL} is the Offset of category NB1 Channel Number to downlink EARFCN.

$$F_{DL} = F_{DL_low} + 0.1(N_{DL} - N_{Offs-DL}) + 0.0025*(2M_{DL}+1)$$

The carrier frequency of category NB1 in the uplink is designated by the E-UTRA Absolute Radio Frequency Channel Number (EARFCN) in the range 0 – 262143 and the Offset of category NB1 Channel Number to EARFCN in the range {-10,-9,-8,-7,-6,-5,-4,-3,-2,-1,0,1,2,3,4,5,6,7,8,9}. The relation between EARFCN, Offset of category NB1 Channel Number to EARFCN and the carrier frequency in MHz for the uplink is given by the following equation, where F_{UL} is the uplink carrier frequency of category NB1, F_{UL_low} and $N_{Offs-UL}$ are given in table 5.7.3-1, N_{UL} is the uplink EARFCN, M_{UL} is the Offset of category NB1 Channel Number to uplink EARFCN.

$$F_{UL} = F_{UL_low} + 0.1(N_{UL} - N_{Offs-UL}) + 0.0025*(2M_{UL})$$

NOTE 1: For category NB1, N_{DL} or N_{UL} is different than the value of EARFCN that corresponds to E-UTRA downlink or uplink carrier frequency for in-band and guard band operation.

NOTE 2: For stand-alone operation, only $M_{DL} = -0.5$ and $M_{UL} = 0$ are applicable. $M_{DL} = -0.5$ is not applicable for in-band and guard band operation.

NOTE 3: For the carrier including NPSS/NSSS for in-band and guard band operation, M_{DL} is selected from {-2,-1,0,1}.

5.7.4 TX–RX frequency separation

a) The default E-UTRA TX channel (carrier centre frequency) to RX channel (carrier centre frequency) separation is specified in Table 5.7.4-1 for the TX and RX channel bandwidths defined in Table 5.6.1-1

Table 5.7.4-1: Default UE TX-RX frequency separation

E-UTRA Operating Band	TX – RX carrier centre frequency separation
1	190 MHz
2	80 MHz
3	95 MHz
4	400 MHz
5	45 MHz
6	45 MHz
7	120 MHz
8	45 MHz
9	95 MHz
10	400 MHz
11	48 MHz
12	30 MHz
13	-31 MHz
14	-30 MHz
17	30 MHz
18	45 MHz
19	45 MHz
20	-41 MHz
21	48 MHz
22	100 MHz
23	180 MHz
24	-101.5 MHz
25	80 MHz
26	45 MHz
27	45 MHz
28	55 MHz
30	45 MHz
31	10 MHz
65	190 MHz
66	400 MHz
68	55 MHz

b) The use of other TX channel to RX channel carrier centre frequency separation is not precluded and is intended to form part of a later release.

5.7.4A TX–RX frequency separation for CA

For intra-band contiguous carrier aggregation, the same TX-RX frequency separation as specified in Table 5.7.4-1 is applied to PCC and SCC, respectively.

5.7.4E TX–RX frequency separation for category M1

For the category M1 TX-RX frequency separation is flexible within the assigned channel bandwidth of E-UTRA carrier with the TX-RX frequency separation of the E-UTRA carriers as specified in Table 5.7.4-1.

5.7.4F TX–RX frequency separation for category NB1

For in-band and guard-band operation mode, the category NB1 TX-RX frequency separation is flexible within the assigned channel bandwidth of E-UTRA carrier with the TX-RX frequency separation of the E-UTRA carriers as specified in Table 5.7.4-1. For stand-alone operation mode the TX-RX frequency separation is the same as Table 5.7.4-1.

6 Transmitter characteristics

6.1 General

Unless otherwise stated, the transmitter characteristics are specified at the antenna connector of the UE with a single or multiple transmit antenna(s). For UE with integral antenna only, a reference antenna with a gain of 0 dBi is assumed.

6.2 Transmit power

6.2.1 Void

6.2.2 UE maximum output power

The following UE Power Classes define the maximum output power for any transmission bandwidth within the channel bandwidth for non CA configuration unless otherwise stated. The period of measurement shall be at least one sub frame (1ms).

Table 6.2.2-1: UE Power Class

EUTRA band	Class 1 (dBm)	Tolerance (dB)	Class 2 (dBm)	Tolerance (dB)	Class 3 (dBm)	Tolerance (dB)	Class 4 (dBm)	Tolerance (dB)
1					23	±2		
2					23	±2 ²		
3					23	±2 ²		
4					23	±2		
5					23	±2		
6					23	±2		
7					23	±2 ²		
8					23	±2 ²		
9					23	±2		
10					23	±2		
11					23	±2		
12					23	±2 ²		
13					23	±2		
14	31	+2/-3			23	±2		
17					23	±2		
18					23	±2 ⁵		
19					23	±2		
20					23	±2 ²		
21					23	±2		
22					23	+2/-3.5 ²		
23					23 ⁶	±2 ⁶		
24					23	±2		
25					23	±2 ²		
26					23	±2 ²		
27					23	±2		
28					23	+2/-2.5		
30					23	±2		
31					23	±2		
...								
33					23	±2		
34					23	±2		
35					23	±2		
36					23	±2		
37					23	±2		
38					23	±2		
39					23	±2		
40					23	±2		
41					23	±2 ²		
42					23	+2/-3		
43					23	+2/-3		
44					23	+2/[-3]		
45					23	±2		
...								
65					23	±2		
66					23	±2		
68					23	±2		

NOTE 1: Void
 NOTE 2: ² refers to the transmission bandwidths (Figure 5.6-1) confined within F_{UL_low} and $F_{UL_low} + 4$ MHz or $F_{UL_high} - 4$ MHz and F_{UL_high} , the maximum output power requirement is relaxed by reducing the lower tolerance limit by 1.5 dB
 NOTE 3: For the UE which supports both Band 11 and Band 21 operating frequencies, the tolerance is FFS.
 NOTE 4: $P_{PowerClass}$ is the maximum UE power specified without taking into account the tolerance
 NOTE 5: For a UE that supports both Band 18 and Band 26, the maximum output power requirement is relaxed by reducing the lower tolerance limit by 1.5 dB for transmission bandwidths confined within 815 MHz and 818 MHz.
 NOTE 6: When NS_20 is signalled, the total output power within 2000-2005 MHz shall be limited to 7 dBm.

The default power class for an operating band is Power Class 3 unless otherwise stated.

6.2.2A UE maximum output power for CA

The following UE Power Classes define the maximum output power for any transmission bandwidth within the aggregated channel bandwidth.

The maximum output power is measured as the sum of the maximum output power at each UE antenna connector. The period of measurement shall be at least one sub frame (1ms).

For inter-band carrier aggregation with one uplink component carrier assigned to one E-UTRA band the requirements in subclause 6.2.2 apply. For inter-band carrier aggregation with two uplink contiguous component carrier assigned to one E-UTRA band the requirements specified in Table 6.2.2A-1 apply for that band.

For inter-band carrier aggregation with uplink assigned to two E-UTRA bands, UE maximum output power shall be measured over all component carriers from different bands. If each band has separate antenna connectors, maximum output power is measured as the sum of maximum output power at each UE antenna connector. The maximum output power is specified in Table 6.2.2A-0.

Table 6.2.2A-0: UE Power Class for uplink interband CA (two bands)

E-UTRA CA Configuration	Class 1 (dBm)	Tolerance (dB)	Class 2 (dBm)	Tolerance (dB)	Class 3 (dBm)	Tolerance (dB)	Class 4 (dBm)	Tolerance (dB)
CA_1A-3A					23	+2/-3 ²		
CA_1A-5A					23	+2/-3		
CA_1A-7A					23	+2/-3 ²		
CA_1A-8A					23	+2/-3 ²		
CA_1A-18A					23	+2/-3 ⁵		
CA_1A-19A					23	+2/-3		
CA_1A-21A					23	+2/-3		
CA_1A-26A					23	+2/-3 ²		
CA_1A-28A					23	+2/-3		
CA_1A-42A					23	+2/-3		
CA_2A-4A					23	+2/-3 ²		
CA_2A-5A					23	+2/-3 ²		
CA_2A-12A					23	+2/-3 ²		
CA_2A-13A					23	+2/-3 ²		
CA_3A-5A					23	+2/-3 ²		
CA_3A-7A					23	+2/-3 ²		
CA_3A-8A					23	+2/-3 ²		
CA_3A-19A					23	+2/-3 ²		
CA_3A-20A					23	+2/-3 ²		
CA_3A-26A					23	+2/-3 ²		
CA_4A-5A					23	+2/-3		
CA_4A-7A					23	+2/-3 ²		
CA_4A-12A					23	+2/-3 ²		
CA_4A-13A					23	+2/-3		
CA_4A-17A					23	+2/-3		
CA_5A-7A					23	+2/-3 ²		
CA_5A-12A					23	+2/-3 ²		
CA_5A-17A					23	+2/-3		
CA_7A-20A					23	+2/-3 ²		
CA_7A-28A					23	+2/-3 ²		
CA_18A-28A					23	+2/-3		
CA_19A-21A					23	+2/-3		
CA_39A-41A					23	+2/-3 ²		
CA_39A-41C					23	+2/-3 ²		
CA_39C-41A					23	+2/-3 ²		

NOTE 1: Void
NOTE 2: ² refers to the transmission bandwidths (Figure 5.6-1) confined within F_{UL_low} and $F_{UL_low} + 4$ MHz or $F_{UL_high} - 4$ MHz and F_{UL_high} , the maximum output power requirement is relaxed by reducing the lower tolerance limit by 1.5 dB
NOTE 3: $P_{PowerClass}$ is the maximum UE power specified without taking into account the tolerance
NOTE 4: For inter-band carrier aggregation the maximum power requirement should apply to the total transmitted power over all component carriers (per UE).
NOTE 5: For a UE that supports both Band 18 and Band 26, the maximum output power requirement is relaxed by reducing the lower tolerance limit by 1.5 dB for transmission bandwidths confined within 815 MHz and 818 MHz.

For intra-band contiguous carrier aggregation the maximum output power is specified in Table 6.2.2A-1.

Table 6.2.2A-1: CA UE Power Class for intraband contiguous CA

E-UTRA CA Configuration	Class 1 (dBm)	Tolerance (dB)	Class 2 (dBm)	Tolerance (dB)	Class 3 (dBm)	Tolerance (dB)	Class 4 (dBm)	Tolerance (dB)
CA_1C					23	+2/-2		
CA_3C					23	+2/-2 ²		
CA_7C					23	+2/-2 ²		
CA_8B					23	+2/-2 ²		
CA_38C					23	+2/-2		
CA_39C					23	+2/-2		
CA_40C					23	+2/-2		
CA_41C					23	+2/-2 ²		
CA_42C					23	+2/-3		

NOTE 1: Void
NOTE 2: If all transmitted resource blocks (Figure 5.6A-1) over all component carriers are confined within F_{UL_low} and $F_{UL_low} + 4$ MHz or/and $F_{UL_high} - 4$ MHz and F_{UL_high} , the maximum output power requirement is relaxed by reducing the lower tolerance limit by 1.5 dB
NOTE 3: $P_{PowerClass}$ is the maximum UE power specified without taking into account the tolerance
NOTE 4: For intra-band contiguous carrier aggregation the maximum power requirement should apply to the total transmitted power over all component carriers (per UE).

For intra-band non-contiguous carrier aggregation with one uplink carrier on the PCC, the requirements in subclause 6.2.2 apply. For intra-band non-contiguous carrier aggregation with two uplink carriers the maximum output power is specified in Table 6.2.2A-2.

Table 6.2.2A-2: UE Power Class for intraband non-contiguous CA

E-UTRA CA Configuration	Class 1 (dBm)	Tolerance (dB)	Class 2 (dBm)	Tolerance (dB)	Class 3 (dBm)	Tolerance (dB)	Class 4 (dBm)	Tolerance (dB)
CA_4A-4A					23	+2/-2		

NOTE 1: For transmission bandwidths (Figure 5.6-1) confined within F_{UL_low} and $F_{UL_low} + 4$ MHz or $F_{UL_high} - 4$ MHz and F_{UL_high} , the maximum output power requirement is relaxed by reducing the lower tolerance limit by 1.5 dB
NOTE 2: $P_{PowerClass}$ is the maximum UE power specified without taking into account the tolerance
NOTE 3: For intra-band non-contiguous carrier aggregation the maximum power requirement should apply to the total transmitted power over all component carriers (per UE).

6.2.2B UE maximum output power for UL-MIMO

For UE with two transmit antenna connectors in closed-loop spatial multiplexing scheme, the maximum output power for any transmission bandwidth within the channel bandwidth is specified in Table 6.2.2B-1. The requirements shall be met with the UL-MIMO configurations specified in Table 6.2.2B-2. For UE supporting UL-MIMO, the maximum output power is measured as the sum of the maximum output power at each UE antenna connector. The period of measurement shall be at least one sub frame (1ms).

Table 6.2.2B-1: UE Power Class for UL-MIMO in closed loop spatial multiplexing scheme

EUTRA band	Class 1 (dBm)	Tolerance (dB)	Class 2 (dBm)	Tolerance (dB)	Class 3 (dBm)	Tolerance (dB)	Class 4 (dBm)	Tolerance (dB)
1					23	+2/-3		
2					23	+2/-3 ²		
3					23	+2/-3 ²		
4					23	+2/-3		
5					23	+2/-3		
6					23	+2/-3		
7					23	+2/-3 ²		
8					23	+2/-3 ²		
9					23	+2/-3		
10					23	+2/-3		
11					23	+2/-3		
12					23	+2/-3 ²		
13					23	+2/-3		
14					23	+2/-3		
...								
17					23	+2/-3		
18					23	+2/-3		
19					23	+2/-3		
20					23	+2/-3 ²		
21					23	+2/-3		
22					23	+2/-4.5 ²		
...								
23					23	+2/-3		
24					23	+2/-3		
25					23	+2/-3 ²		
26					23	+2/-3 ²		
27					23	+2/-3		
28					23	+2/[-3]		
30					23	+2/-3		
31					23	+2/-3		
...								
33					23	+2/-3		
34					23	+2/-3		
35					23	+2/-3		
36					23	+2/-3		
37					23	+2/-3		
38					23	+2/-3		
39					23	+2/-3		
40					23	+2/-3		
41					23	+2/-3 ²		
42					23	+2/-4		
43					23	+2/-4		
44					23	+2/[-3]		
45					23	+2/-3		
...								
65					23	+2/-3		
66					23	+2/-3		
68					23	+2/-3		
<p>NOTE 1: Void</p> <p>NOTE 2: ² refers to the transmission bandwidths (Figure 5.6-1) confined within F_{UL_low} and $F_{UL_low} + 4$ MHz or $F_{UL_high} - 4$ MHz and F_{UL_high}, the maximum output power requirement is relaxed by reducing the lower tolerance limit by 1.5 dB</p> <p>NOTE 3: For the UE which supports both Band 11 and Band 21 operating frequencies, the tolerance is FFS.</p> <p>NOTE 4: $P_{PowerClass}$ is the maximum UE power specified without taking into account the tolerance</p>								

The default power class for an operating band is Power Class 3 unless otherwise stated.

Table 6.2.2B-2: UL-MIMO configuration in closed-loop spatial multiplexing scheme

Transmission mode	DCI format	Codebook Index
Mode 2	DCI format 4	Codebook index 0

If UE is configured for transmission on single-antenna port, the requirements in subclause 6.2.2 apply.

6.2.2C Void

<reserved for future use>

6.2.2D UE maximum output power for ProSe

When UE is configured for simultaneous E-UTRA ProSe sidelink and E-UTRA uplink transmissions for inter-band E-UTRA ProSe / E-UTRA bands specified in Table 5.5D-2, the UE maximum output power shall be as specified in Table 6.2.2A-0 in subclause 6.2.2A for the corresponding inter-band aggregation with uplink assigned to two bands.

If UE is configured to operate on single E-UTRA ProSe sidelink band or E-UTRA uplink band specified in Table 5.5D-1, the requirements in subclause 6.2.2 apply.

6.2.2E UE maximum output power for Category M1 UE

The following UE Power Classes define the maximum output power for any transmission bandwidth within the channel bandwidth for non CA configuration and UL-MIMO unless otherwise stated. The period of measurement shall be at least one sub frame (1ms).

Table 6.2.2E-1: UE Power Class

EUTRA band	Class 3 (dBm)	Tolerance (dB)	Class 5 (dBm)	Tolerance (dB)
1	23	± 2	20	± 2
2	23	$\pm 2^2$	20	$\pm 2^2$
3	23	$\pm 2^2$	20	$\pm 2^2$
4	23	± 2	20	± 2
5	23	± 2	20	± 2
7	23	$\pm 2^2$	20	$\pm 2^2$
8	23	$\pm 2^2$	20	$\pm 2^2$
11	23	± 2	20	± 2
12	23	$\pm 2^2$	20	$\pm 2^2$
13	23	± 2	20	± 2
18	23	$\pm 2^5$	20	$\pm 2^5$
19	23	± 2	20	± 2
20	23	$\pm 2^2$	20	$\pm 2^2$
21	23	± 2	20	± 2
26	23	$\pm 2^2$	20	$\pm 2^2$
27	23	± 2	20	± 2
28	23	$+2/-2.5$	20	$+2/-2.5$
31	23	± 2	20	± 2
...				
39	23	± 2	20	± 2
41	23	$\pm 2^2$	20	$\pm 2^2$
NOTE 1: Void				
NOTE 2: ² refers to the transmission bandwidths (Figure 5.6-1) confined within F_{UL_low} and $F_{UL_low} + 4$ MHz or $F_{UL_high} - 4$ MHz and F_{UL_high} , the maximum output power requirement is relaxed by reducing the lower tolerance limit by 1.5 dB				
NOTE 3: For the UE which supports both Band 11 and Band 21 operating frequencies, the tolerance is FFS.				
NOTE 4: $P_{PowerClass}$ is the maximum UE power specified without taking into account the tolerance				
NOTE 5: For a UE that supports both Band 18 and Band 26, the maximum output power requirement is relaxed by reducing the lower tolerance limit by 1.5 dB for transmission bandwidths confined within 815 MHz and 818 MHz.				
NOTE 6: Void				

6.2.2F UE maximum output power for category NB1

Category NB1 UE Power Classes are specified in Table 6.2.2F-1 and define the maximum output power for any transmission bandwidth within the category NB1 channel bandwidth. For 3.75 kHz sub-carrier spacing the maximum output power is defined as mean power of measurement which period is at least one slot (2ms) excluding the 2304Ts gap when UE is not transmitting. For 15kHz sub-carrier spacing the maximum output power is defined as mean power of measurement which period is at least one sub-frame (1ms).

Table 6.2.2F-1: UE Power Class

EUTRA band	Class 3 (dBm)	Tolerance (dB)	Class 5 (dBm)	Tolerance (dB)
1	23	±2	20	±2
2	23	±2	20	±2
3	23	±2	20	±2
5	23	±2	20	±2
8	23	±2	20	±2
12	23	±2	20	±2
13	23	±2	20	±2
17	23	±2	20	±2
18	23	±2	20	±2
19	23	±2	20	±2
20	23	±2	20	±2
26	23	±2	20	±2
28	23	±2	20	±2
66	23	±2	20	±2

6.2.3 UE maximum output power for modulation / channel bandwidth

For UE Power Class 1 and 3, the allowed Maximum Power Reduction (MPR) for the maximum output power in Table 6.2.2-1 due to higher order modulation and transmit bandwidth configuration (resource blocks) is specified in Table 6.2.3-1.

Table 6.2.3-1: Maximum Power Reduction (MPR) for Power Class 1 and 3

Modulation	Channel bandwidth / Transmission bandwidth (N_{RB})						MPR (dB)
	1.4 MHz	3.0 MHz	5 MHz	10 MHz	15 MHz	20 MHz	
QPSK	> 5	> 4	> 8	> 12	> 16	> 18	≤ 1
16 QAM	≤ 5	≤ 4	≤ 8	≤ 12	≤ 16	≤ 18	≤ 1
16 QAM	> 5	> 4	> 8	> 12	> 16	> 18	≤ 2
64 QAM	≤ 5	≤ 4	≤ 8	≤ 12	≤ 16	≤ 18	≤ 2
64 QAM	> 5	> 4	> 8	> 12	> 16	> 18	≤ 3

For PRACH, PUCCH and SRS transmissions, the allowed MPR is according to that specified for PUSCH QPSK modulation for the corresponding transmission bandwidth.

For each subframe, the MPR is evaluated per slot and given by the maximum value taken over the transmission(s) within the slot; the maximum MPR over the two slots is then applied for the entire subframe.

For transmissions with non-contiguous resource allocation in single component carrier, the allowed Maximum Power Reduction (MPR) for the maximum output power in table 6.2.2-1, is specified as follows

$$MPR = \text{CEIL} \{M_A, 0.5\}$$

Where M_A is defined as follows

$$M_A = 8.00 - 10.12A \quad ; 0.00 < A \leq 0.33$$

$$5.67 - 3.07A \quad ; 0.33 < A \leq 0.77$$

$$3.31 \quad ; 0.77 < A \leq 1.00$$

Where

$$A = N_{RB_alloc} / N_{RB}$$

CEIL $\{M_A, 0.5\}$ means rounding upwards to closest 0.5dB, i.e. $MPR \in [3.0, 3.5, 4.0, 4.5, 5.0, 5.5, 6.0, 6.5, 7.0, 7.5, 8.0]$

For the UE maximum output power modified by MPR, the power limits specified in subclause 6.2.5 apply.

6.2.3A UE Maximum Output power for modulation / channel bandwidth for CA

For inter-band carrier aggregation with one uplink component carrier assigned to one E-UTRA band, the requirements in subclause 6.2.3 apply. For inter-band carrier aggregation with two uplink contiguous component carrier assigned to one E-UTRA band the requirements specified in this clause for intra-band contiguous carrier aggregation apply for that band.

For inter-band carrier aggregation with one component carrier per operating band and the uplink active in two E-UTRA bands, the requirements in subclause 6.2.3 apply for each uplink component carrier.

For intra-band contiguous carrier aggregation the allowed Maximum Power Reduction (MPR) for the maximum output power in Table 6.2.2A-1 due to higher order modulation and contiguously aggregated transmit bandwidth configuration (resource blocks) is specified in Table 6.2.3A-1. In case the modulation format is different on different component carriers then the MPR is determined by the rules applied to higher order of those modulations.

Table 6.2.3A-1: Maximum Power Reduction (MPR) for Power Class 3

Modulation	CA bandwidth Class B and C / Smallest Component Carrier Transmission Bandwidth Configuration				MPR (dB)
	25 RB	50 RB	75 RB	100 RB	
QPSK	> 8 and ≤ 25	> 12 and ≤ 50	> 16 and ≤ 75	> 18 and ≤ 100	≤ 1
QPSK	> 25	> 50	> 75	> 100	≤ 2
16 QAM	≤ 8	≤ 12	≤ 16	≤ 18	≤ 1
16 QAM	> 8 and ≤ 25	> 12 and ≤ 50	> 16 and ≤ 75	> 18 and ≤ 100	≤ 2
16 QAM	> 25	> 50	> 75	> 100	≤ 3
64 QAM	≤ 8 and allocation wholly contained within a single CC	≤ 12 and allocation wholly contained within a single CC	≤ 16 and allocation wholly contained within a single CC	≤ 18 and allocation wholly contained within a single CC	≤ 2
64 QAM	> 8 or allocation extends across two CC's	> 12 or allocation extends across two CC's	> 16 or allocation extends across two CC's	> 18 or allocation extends across two CC's	≤ 3

For PUCCH and SRS transmissions, the allowed MPR is according to that specified for PUSCH QPSK modulation for the corresponding transmission bandwidth.

For intra-band contiguous carrier aggregation bandwidth class C with non-contiguous resource allocation, the allowed Maximum Power Reduction (MPR) for the maximum output power in Table 6.2.2A-1 is specified as follows

$$\text{MPR} = \text{CEIL} \{ \min(M_A, M_{IM5}), 0.5 \}$$

Where M_A is defined as follows

$$M_A = \begin{cases} 8.2 & ; 0 \leq A < 0.025 \\ 9.2 - 40A & ; 0.025 \leq A < 0.05 \\ 8 - 16A & ; 0.05 \leq A < 0.25 \\ 4.83 - 3.33A & ; 0.25 \leq A \leq 0.4, \\ 3.83 - 0.83A & ; 0.4 \leq A \leq 1, \end{cases}$$

and M_{IM5} is defined as follows

$$M_{IM5} = 4.5 \quad ; \Delta_{IM5} < 1.5 * \text{BW}_{\text{Channel_CA}}$$

$$6.0 \quad ; 1.5 * BW_{\text{Channel_CA}} \leq \Delta_{\text{IM5}} < BW_{\text{Channel_CA}}/2 + F_{\text{OOB}}$$

$$M_A \quad ; \Delta_{\text{IM5}} \geq BW_{\text{Channel_CA}}/2 + F_{\text{OOB}}$$

For intra-band contiguous carrier aggregation bandwidth class B with non-contiguous resource allocation, the allowed Maximum Power Reduction (MPR) for the maximum output power in Table 6.2.2A-1 is specified as follows

$$\text{MPR} = \text{CEIL} \{ M_A, 0.5 \}$$

Where M_A is defined as follows

$$M_A = 10.5 - 17.5A \quad ; 0 \leq A < 0.2$$

$$8.5 - 7.5A \quad ; 0.2 \leq A < 0.6$$

$$5.5 - 2.5A \quad ; 0.6 \leq A \leq 1$$

Where

$$A = N_{\text{RB_alloc}} / N_{\text{RB_agg}}$$

$$\Delta_{\text{IM5}} = \max(| F_{\text{C_agg}} - (3 * F_{\text{agg_alloc_low}} - 2 * F_{\text{agg_alloc_high}}) |, | F_{\text{C_agg}} - (3 * F_{\text{agg_alloc_high}} - 2 * F_{\text{agg_alloc_low}}) |)$$

$$F_{\text{C_agg}} = (F_{\text{edge_high}} + F_{\text{edge_low}}) / 2$$

$\text{CEIL}\{M_A, 0.5\}$ means rounding upwards to closest 0.5dB, i.e. $\text{MPR} \in [3.0, 3.5, 4.0, 4.5, 5.0, 5.5, 6.0, 6.5, 7.0, 7.5, 8.0, 8.5]$.

For intra-band non-contiguous carrier aggregation with one uplink carrier, the requirements in subclause 6.2.3 apply.

For intra-band non-contiguous carrier aggregation with two uplink carriers MPR is specified for E-UTRA CA configurations with a maximum possible $W_{\text{GAP}} \leq 35$ MHz; the allowed MPR is

$$\text{MPR} = \text{CEIL} \{ M_N, 0.5 \}$$

where M_N is defined as follows

$$M_N = -0.125 N + 18.25 \quad ; 2 \leq N \leq 50$$

$$-0.0333 N + 13.67 \quad ; 50 < N \leq 200$$

where $N = N_{\text{RB_alloc}}$ is the number of allocated resource blocks. Clause 6.2.3 does not apply in addition. E-UTRA CA configurations with a maximum possible $W_{\text{gap}} > 35$ MHz and their corresponding MPR are intended to form part of a later release.

For intra-band carrier aggregation, the MPR is evaluated per slot and given by the maximum value taken over the transmission(s) on all component carriers within the slot; the maximum MPR over the two slots is then applied for the entire subframe.

For combinations of intra-band and inter-band carrier aggregation with three uplink component carriers (up to two contiguously aggregated carriers per band), the requirements specified in subclause 6.2.3 apply for the E-UTRA band supporting one component carrier, and for the E-UTRA band supporting two contiguous component carriers the requirements specified in subclause 6.2.3A apply.

For the UE maximum output power modified by MPR, the power limits specified in subclause 6.2.5A apply.

6.2.3B UE maximum output power for modulation / channel bandwidth for UL-MIMO

For UE with two transmit antenna connectors in closed-loop spatial multiplexing scheme, the allowed Maximum Power Reduction (MPR) for the maximum output power in Table 6.2.2B-1 is specified in Table 6.2.3-1. The requirements shall be met with UL-MIMO configurations defined in Table 6.2.2B-2. For UE supporting UL-MIMO, the maximum output power is measured as the sum of the maximum output power at each UE antenna connector.

For the UE maximum output power modified by MPR, the power limits specified in subclause 6.2.5B apply.

If UE is configured for transmission on single-antenna port, the requirements in subclause 6.2.3 apply.

6.2.3D UE maximum output power for modulation / channel bandwidth for ProSe

When UE is configured for E-UTRA ProSe sidelink transmissions non-concurrent with E-UTRA uplink transmissions for E-UTRA ProSe operating bands specified in Table 5.5D-1, this subclause specifies the allowed Maximum Power Reduction (MPR) power for ProSe physical channels and signals due to higher order modulation and transmit bandwidth configuration (resource blocks).

The allowed MPR for the maximum output power for ProSe physical channels PSDCH, PSCCH, PSSCH, and PSBCH shall be as specified in subclause 6.2.3 for PUSCH for the corresponding modulation and transmission bandwidth.

The allowed MPR for the maximum output power for ProSe physical signal PSSS shall be as specified in subclause 6.2.3 for PUSCH QPSK modulation for the corresponding transmission bandwidth.

The allowed MPR for the maximum output power for ProSe physical signal SSSS is specified in Table 6.2.3D-1.

Table 6.2.3D-1: Maximum Power Reduction (MPR) for SSSS for Power Class 1 and 3

Channel bandwidth	MPR for SSSS (dB)
1.4 MHz	
3.0 MHz	
5.0 MHz	≤ 4
10 MHz	≤ 4
15 MHz	≤ 4
20 MHz	≤ 4

When UE is configured for simultaneous E-UTRA ProSe sidelink and E-UTRA uplink transmissions for inter-band E-UTRA ProSe / E-UTRA bands specified in Table 5.5D-2, the requirements in subclause 6.2.3D apply for ProSe transmission and the requirements in subclause 6.2.3 apply for uplink transmission.

6.2.3E UE maximum output power for modulation / channel bandwidth for category M1

For UE Power Class 3 and 5, the allowed Maximum Power Reduction (MPR) for the maximum output power specified in Table 6.2.2E-1 due to higher order modulation and transmit bandwidth configuration (resource blocks) is specified in Table 6.2.3E-1 and 6.2.3E-2 respectively.

Table 6.2.3E-1: Maximum Power Reduction (MPR) for Power Class 3

Modulation	Channel bandwidth / Transmission bandwidth (N_{RB})						MPR (dB)
	1.4 MHz	3.0 MHz	5 MHz	10 MHz	15 MHz	20 MHz	
QPSK	>2	>2	>1	>4	-	-	≤ 1
QPSK	>5	>5	-	-	-	-	≤ 2
16 QAM	≤ 2	≤ 2	>1	>3	-	-	≤ 1
16QAM	>2	>2	>3	>5	-	-	≤ 2

Table 6.2.3E-2: Maximum Power Reduction (MPR) for Power Class 5

Modulation	Channel bandwidth / Transmission bandwidth (N_{RB})						MPR (dB)
	1.4 MHz	3.0 MHz	5 MHz	10 MHz	15 MHz	20 MHz	

QPSK	>2	>2	>3	>5	-	-	≤ 1
QPSK	>5	>5	-	-	-	-	≤ 2
16 QAM	≤ 2	≤ 2	>3	>5	-	-	≤ 1
16QAM	>2	>2	>5	-	-	-	≤ 2

For PRACH, PUCCH and SRS transmissions, the allowed MPR is according to that specified for PUSCH QPSK modulation for the corresponding transmission bandwidth.

For each subframe, the MPR is evaluated per slot and given by the maximum value taken over the transmission(s) within the slot; the maximum MPR over the two slots is then applied for the entire subframe.

For the UE maximum output power modified by MPR, the power limits specified in subclause 6.2.5 apply.

No other MPR requirement than those specified in tables 6.2.3E-1 and Table 6.2.3E-2 applies to category M1 UE.

6.2.3F UE maximum output power for modulation / channel bandwidth for category NB1

For UE category NB1 power class 3 and 5 the allowed Maximum Power Reduction (MPR) for the maximum output power given in Table 6.2.2F-1 is specified in Table 6.2.3F-1.

Table 6.2.3F-1: Maximum Power Reduction (MPR) for UE category NB1 Power Class 3 and 5

Modulation	QPSK		
	Tone positions for 3 Tones allocation	0-2	3-5 and 6-8
MPR	≤ 0.5 dB	0 dB	≤ 0.5 dB
Tone positions for 6 Tones allocation	0-5 and 6-11		
MPR	≤ 1 dB	≤ 1 dB	
Tone positions for 12 Tones allocation	0-11		
MPR	≤ 2 dB		

For the UE maximum output power modified by MPR, the power limits specified in sub-clause 6.2.5F apply.

6.2.4 UE maximum output power with additional requirements

Additional ACLR and spectrum emission requirements can be signalled by the network to indicate that the UE shall also meet additional requirements in a specific deployment scenario. To meet these additional requirements, Additional Maximum Power Reduction (A-MPR) is allowed for the output power as specified in Table 6.2.2-1. Unless stated otherwise, an A-MPR of 0 dB shall be used.

For UE Power Class 1 and 3 the specific requirements and identified subclauses are specified in Table 6.2.4-1 along with the allowed A-MPR values that may be used to meet these requirements. The allowed A-MPR values specified below in Table 6.2.4.-1 to 6.2.4-15 are in addition to the allowed MPR requirements specified in subclause 6.2.3.

Table 6.2.4-1: Additional Maximum Power Reduction (A-MPR)

Network Signalling value	Requirements (subclause)	E-UTRA Band	Channel bandwidth (MHz)	Resources Blocks (N_{RB})	A-MPR (dB)
NS_01	6.6.2.1.1	Table 5.5-1	1.4, 3, 5, 10, 15, 20	Table 5.6-1	N/A
NS_03	6.6.2.2.1	2, 4, 10, 23, 25, 35, 36, 66	3	>5	≤ 1
			5	>6	≤ 1
			10	>6	≤ 1
			15	>8	≤ 1
20	>10	≤ 1			
NS_04	6.6.2.2.2, 6.6.3.3.19	41	5, 10, 15, 20	Table 6.2.4-4	
NS_05	6.6.3.3.1	1	10, 15, 20	≥ 50 (NOTE1)	≤ 1 (NOTE1)
			15, 20	Table 6.2.4-18 (NOTE2)	
		65 (NOTE 3)	10, 15, 20	≥ 50	≤ 1 (NOTE 1)
			15, 20	Table 6.2.4-18 (NOTE 2)	
NS_06	6.6.2.2.3	12, 13, 14, 17	1.4, 3, 5, 10	Table 5.6-1	N/A
NS_07	6.6.2.2.3 6.6.3.3.2	13	10	Table 6.2.4-2	
NS_08	6.6.3.3.3	19	10, 15	> 44	≤ 3
NS_09	6.6.3.3.4	21	10, 15	> 40	≤ 1
				> 55	≤ 2
NS_10		20	15, 20	Table 6.2.4-3	
NS_11	6.6.2.2.1 6.6.3.3.13	23	1.4, 3, 5, 10, 15, 20	Table 6.2.4-5	
NS_12	6.6.3.3.5	26	1.4, 3, 5, 10, 15	Table 6.2.4-6	
NS_13	6.6.3.3.6	26	5	Table 6.2.4-7	
NS_14	6.6.3.3.7	26	10, 15	Table 6.2.4-8	
NS_15	6.6.3.3.8	26	1.4, 3, 5, 10, 15	Table 6.2.4-9 Table 6.2.4-10	
NS_16	6.6.3.3.9	27	3, 5, 10	Table 6.2.4-11, Table 6.2.4-12, Table 6.2.4-13	
NS_17	6.6.3.3.10	28	5, 10	Table 5.6-1	N/A
NS_18	6.6.3.3.11	28	5	≥ 2	≤ 1
			10, 15, 20	≥ 1	≤ 4
NS_19	6.6.3.3.12	44	10, 15, 20	Table 6.2.4-14	
NS_20	6.2.2 6.6.2.2.1 6.6.3.3.14	23	5, 10, 15, 20	Table 6.2.4-15	
NS_21	6.6.2.2.1 6.6.3.3.15	30	5, 10	Table 6.2.4-16	
NS_22	6.6.3.3.16	42, 43	5, 10, 15, 20	Table 6.2.4-17	
NS_23	6.6.3.3.17	42, 43	5, 10, 15, 20	N/A	
NS_24	6.6.3.3.20	65 (NOTE 4)	5, 10, 15, 20	Table 6.2.4-19	
NS_25	6.6.3.3.21	65 (NOTE 4)	5, 10, 15, 20	Table 6.2.4-20	
NS_26	6.6.3.3.22	68	10, 15	Table 6.2.4-21	
...					
NS_32	-	-	-	-	-
NS_36	6.6.3.3.28	68	5, 10, 15	Table 6.2.4-27	
NOTE 1	Applicable when the lower edge of the assigned E-UTRA UL channel bandwidth frequency is larger than or equal to the upper edge of PHS band (1915.7 MHz) + 4 MHz + the channel BW assigned, where channel BW is as defined in subclause 5.6. A-MPR for operations below this frequency is not covered in this version of specifications except for the channel assignments in NOTE2 as the emissions requirement in 6.6.3.3.1 may not be met. For 10MHz channel bandwidth whose carrier frequency is larger than or equal to 1945 MHz or 15 MHz channel bandwidth whose carrier frequency is larger than or equal to 1947.5 MHz, no A-MPR applies.				
NOTE 2	Applicable when carrier frequency is 1932.5 MHz for 15MHz channel bandwidth or 1930 MHz for 20MHz channel bandwidth case.				
NOTE 3:	Applicable when the E-UTRA carrier is within 1920-1980 MHz.				
NOTE 4:	Applicable when the upper edge of the channel bandwidth frequency is greater than 1980MHz.				

Table 6.2.4-2: A-MPR for "NS_07"

Parameters	Region A		Region B		Region C
RB _{start}	0 - 12		13 – 18	19 – 42	43 – 49
L _{CRB} [RBs]	6-8	1 to 5 and 9-50	≥8	≥18	≤2
A-MPR [dB]	≤ 8	≤ 12	≤ 12	≤ 6	≤ 3
NOTE 1; RB _{start} indicates the lowest RB index of transmitted resource blocks					
NOTE 2; L _{CRB} is the length of a contiguous resource block allocation					
NOTE 3; For intra-subframe frequency hopping between two regions, notes 1 and 2 apply on a per slot basis.					
NOTE 4; For intra-subframe frequency hopping between two regions, the larger A-MPR value of the two regions may be applied for both slots in the subframe.					

Table 6.2.4-3: A-MPR for "NS_10"

Channel bandwidth [MHz]	Parameters	Region A
15	RB _{start}	0 – 10
	L _{CRB} [RBs]	1 -20
	A-MPR [dB]	≤ 2
20	RB _{start}	0 – 15
	L _{CRB} [RBs]	1 -20
	A-MPR [dB]	≤ 5
NOTE 1: RB _{start} indicates the lowest RB index of transmitted resource blocks		
NOTE 2: L _{CRB} is the length of a contiguous resource block allocation		
NOTE 3: For intra-subframe frequency hopping which intersects Region A, notes 1 and 2 apply on a per slot basis		
NOTE 4: For intra-subframe frequency hopping which intersect Region A, the larger A-MPR value may be applied for both slots in the subframe		

Table 6.2.4-4: A-MPR requirements for "NS_04" with bandwidth >5MHz

Channel bandwidth [MHz]	Parameters						
5	F _c [MHz]	≤ 2499.5				> 2499.5	
	RB _{start}	0 - 8		9 – 24	0 - 24		
	L _{CRB} [RBs]	> 0		> 0		> 0	
	A-MPR [dB]	≤ 2		0		0	
10	F _c [MHz]	≤ 2504				> 2504	
	RB _{start}	0 - 8		9 - 35	36 - 49	0 - 49	
	L _{CRB} [RBs]	≤ 15	> 15 and < 25	≥ 25	N/A	> 0	> 0
	RB _{start} + L _{CRB} [RBs]	N/A	N/A	N/A	≥ 45	N/A	N/A
	A-MPR [dB]	≤ 3	≤ 1	≤ 2	≤ 1	0	0
15	F _c [MHz]	≤ 2510.8				> 2510.8	
	RB _{start}	0 - 13		14 – 59	60 – 74	0 - 74	
	L _{CRB} [RBs]	≤ 18 or ≥ 36	> 18 and < 36	N/A	> 0	> 0	
	RB _{start} + L _{CRB} [RBs]	N/A	N/A	≥ 62	N/A	N/A	
	A-MPR [dB]	≤ 3	≤ 1	≤ 1	0	0	
20	F _c [MHz]	≤ 2517.5				> 2517.5	
	RB _{start}	0 – 22		23 – 76	77 – 99	0 - 99	
	L _{CRB} [RBs]	≤ 18 or ≥ 40	> 18 and < 40	N/A	> 0	> 0	
	RB _{start} + L _{CRB} [RBs]	N/A	N/A	≥ 86	N/A	N/A	
	A-MPR [dB]	≤ 3	≤ 1	≤ 1	0	0	

NOTE 1: RB_{start} indicates the lowest RB index of transmitted resource blocks
 NOTE 2: L_{CRB} is the length of a contiguous resource block allocation
 NOTE 3: For intra-subframe frequency hopping which intersects regions, notes 1 and 2 apply on a per slot basis
 NOTE 4: For intra-subframe frequency hopping which intersects regions, the larger A-MPR value may be applied for both slots in the subframe

Table 6.2.4-5: A-MPR for "NS_11"

Channel Bandwidth [MHz]	Parameters						
3	F _c [MHz]	<2004		≥2004			
	L _{CRB} [RBs]	1-15		>5			
	A-MPR [dB]	≤5		≤1			
5	F _c [MHz]	<2004		2004 ≤ F _c <2007		≥2007	
	L _{CRB} [RBs]	1-25		1-6 & 15-25	8-12	>6	
	A-MPR [dB]	≤7		≤4	0	≤1	
10	F _c [MHz]	2005 ≤ F _c <2015			2015		
	RB _{start}	0-49			0-49		
	L _{CRB} [RBs]	1-50			1-50		
	A-MPR [dB]	≤12			0		
15	F _c [MHz]	<2012.5					
	RB _{start}	0-4	5-21		22-56		57-74
	L _{CRB} [RBs]	≥1	7-50	0-6 & ≥50	≤25	>25	>0
	A-MPR [dB]	≤15	≤7	≤10	0	≤6	≤15
	F _c [MHz]	2012.5					
	RB _{start}	0-12	13-39		40-65		66-74
	L _{CRB} [RBs]	≥1	≥30	<30	≥(69 – RB _{start})		≥1
	A-MPR [dB]	≤10	≤6	0	≤2	≤6.5	
20	F _c [MHz]	2010					
	RB _{start}	0-12	13-29		30-68		69-99
	L _{CRB} [RBs]	≥1	10-60	1-9 & >60	1-24	≥25	≥1
	A-MPR [dB]	≤15	≤7	≤10	0	≤7	≤15

Table 6.2.4-6: A-MPR for "NS_12"

Channel bandwidth [MHz]	Parameters	Region A		Region B
1.4	RB _{start}	0		1-2
	LCRB [RBs]	≤3	≥4	≥4
	A-MPR [dB]	≤3	≤6	≤3
3	RB _{start}	0-3		4-5
	LCRB [RBs]	1-15		≥9
	A-MPR [dB]	≤4		≤3
5	RB _{start}	0-6		0-9
	LCRB [RBs]	≤8		≥9
	A-MPR [dB]	≤5		≤3
10	RB _{start}	0-15		0-22
	LCRB [RBs]	≤18		≥20
	A-MPR [dB]	≤4		≤2
15	RB _{start}	0-30		0-30
	LCRB [RBs]	≤30		≥32
	A-MPR [dB]	≤4		≤3

Table 6.2.4-7: A-MPR for "NS_13"

Channel bandwidth [MHz]	Parameters	Region A	
5	RB _{start}	0-2	
	LCRB [RBs]	≤5	≥18
	A-MPR [dB]	≤3	≤2

Table 6.2.4-8: A-MPR for "NS_14"

Channel bandwidth [MHz]	Parameters	Region A	
10	RB _{start}	0	
	LCRB [RBs]	≤5	≥50
	A-MPR [dB]	≤3	≤1
15	RB _{start}	≤8	
	LCRB [RBs]	≤16	≥50
	A-MPR [dB]	≤3	≤1

Table 6.2.4-9: A-MPR for "NS_15" for E-UTRA highest channel edge > 845 MHz and ≤ 849 MHz

Channel bandwidth [MHz]	Parameters	Region A	Region B	Region C
1.4	RB _{end} [RB]			4-5
	A-MPR [dB]			≤3
3	RB _{end} [RB]	0-1	8-12	13-14
	LCRB [RB]	≤2	≥8	>0
	A-MPR [dB]	≤4	≤4	≤9
5	RB _{end} [RB]	0-4	12-19	20-24
	LCRB [RB]	≤2	≥8	>0
	A-MPR [dB]	≤4	≤5	≤9
10	RB _{end} [RB]	0-12	23-36	37-49
	LCRB [RB]	≤2	≥15	>0
	A-MPR [dB]	≤4	≤6	≤9
15	RB _{end} [RB]	0-20	26-53	54-74
	LCRB [RB]	≤2	≥20	>0
	A-MPR [dB]	≤4	≤5	≤9

Table 6.2.4-10: A-MPR for "NS_15" for E-UTRA highest channel edge ≤ 845 MHz

Channel bandwidth [MHz]	Parameters	Region A	Region B	Region C
5	RB _{end} [RB]			19-24
	LCRB [RB]			≥18
	A-MPR [dB]			≤2
10	RB _{end} [RB]	0-4	29-44	45-49
	LCRB [RB]	≤2	≥24	>0
	A-MPR [dB]	≤4	≤4	≤9
15	RB _{end} [RB]	0-12	44-61	62-74
	LCRB [RB]	≤2	≥20	>0
	A-MPR [dB]	≤4	≤5	≤9

Table 6.2.4-11: A-MPR for "NS_16" with channel lower edge at ≥807 MHz and <808.5 MHz

Channel bandwidth [MHz]	Parameter	Region A	Region B	Region C	Region D	Region E
3 MHz	RB _{start}	0	1-2			
	LCRB [RBs]	≥12	12			
	A-MPR [dB]	≤2	≤1			
5 MHz	RB _{start}	0-1	2	2-9	2-5	
	LCRB [RBs]	1 - 25	12	15-18	20	
	A-MPR [dB]	≤5	≤1	≤2	≤3	
10 MHz	RB _{start}	0 - 8	0-14		15-20	15-24
	LCRB [RBs]	1 - 12	15-20	≥24	≥30	24-27
	A-MPR [dB]	≤5	≤3	≤7	≤3	≤1

Table 6.2.4-12: A-MPR for "NS_16" with channel lower edge at ≥ 808.5 MHz and < 812 MHz

Channel bandwidth [MHz]	Parameter	Region A	Region B	Region C	Region D	Region E
5 MHz	RB _{start}	0	0-1	1-5		
	LCRB [RBs]	16-20	≥ 24	16-20		
	A-MPR [dB]	≤ 2	≤ 3	≤ 1		
10 MHz	RB _{start}	0-6		0-10	0-14	11-20
	LCRB [RBs]	1-12	15-20	24-32	≥ 36	24-32
	A-MPR [dB]	≤ 5	≤ 2	≤ 4	≤ 5	≤ 1

Table 6.2.4-13: A-MPR for "NS_16" with channel lower edge at ≥ 812 MHz

Channel bandwidth [MHz]	Parameter	Region A	Region B	Region C	Region D
10 MHz	RB _{start}	0 - 9	0	1-14	0-5
	LCRB [RBs]	27-32	36-40	36-40	≥ 45
	A-MPR [dB]	≤ 1	≤ 2	≤ 1	≤ 3

Table 6.2.4-14: A-MPR for "NS_19"

Channel bandwidth [MHz]	Parameters	Region A		Region B
10	RB _{start}			0-6
	LCRB [RBs]			≥ 40
	A-MPR [dB]			≤ 1
15	RB _{start}	0-6		7-20
	LCRB [RBs]	≤ 18	≥ 36	≥ 42
	A-MPR [dB]	≤ 2	≤ 3	≤ 2
20	RB _{start}	0-14		15-30
	LCRB [RBs]	≤ 40	≥ 45	≥ 50
	A-MPR [dB]	≤ 2	≤ 3	≤ 2

Table 6.2.4-15: A-MPR for "NS_20"

Channel Bandwidth [MHz]	Parameters							
	FC [MHz]	< 2007.5		2007.5 ≤ Fc < 2012.5		2012.5 ≤ Fc ≤ 2017.5		
5	RB _{start}	≤24		0-3	4-6	≤24		
	LCRB [RBs]	>0	15-19	≥20	≥18	1-25		
	A-MPR [dB]	≤17		≤1	≤4	≤2	≤0	
	FC [MHz]	2005						
10	RB _{start}	0-25		26-34		35-49		
	LCRB [RBs]	>0	8-15	>15	>0			
	A-MPR [dB]	≤16		≤2	≤5	≤6		
	FC [MHz]	2015						
	RB _{start}	0-5			6-10			
	LCRB [RBs]	≥32			≥40			
	A-MPR [dB]	≤4			≤2			
	FC [MHz]	2012.5						
15	RB _{start}	0-14		15-24		25-39	61-74	
	LCRB [RBs]	1-9 & 40-75	10-39	24-29	≥30	≥36	≤6	
	A-MPR [dB]	≤11	≤6	≤1	≤7	≤5	≤6	
	FC [MHz]	2010						
20	RB _{start}	0-21	22-31		32-38	39-49	50-68	69-99
	LCRB [RBs]	>0	1-9 & 31-75	10-30	≥15	≥24	≥25	>0
	A-MPR [dB]	≤17	≤12	≤6	≤9	≤7	≤5	≤16
	FC [MHz]	2010						

NOTE 1: When NS_20 is signaled the minimum requirements for the 10 MHz bandwidth are specified for E-UTRA UL carrier center frequencies of 2005 MHz or 2015 MHz.

NOTE 2: When NS_20 is signaled the minimum requirements for the 15 MHz channel bandwidth are specified for E-UTRA UL carrier center frequency of 2012.5 MHz.

Table 6.2.4-16: A-MPR for "NS_21"

Channel Bandwidth [MHz]	Parameters	Region A		Region B	
		Region A	Region A	Region B	Region B
10	RB _{start}	0 – 6	0 – 6	N/A	N/A
	RB _{end}	N/A	N/A	43 – 49	43 – 49
	LCRB [RBs]	1 – 2	3 – 12, 32 - 50	1 – 2	3 – 12, 32 - 50
	A-MPR [dB]	≤ 4	≤ 3	≤ 4	≤ 3

Table 6.2.4-17: A-MPR for "NS_22"

Channel bandwidth [MHz]	Parameters	Region A	Region B	Region C	Region D
5	No A-MPR is needed for 5 MHz channel bandwidth				
10	RB _{start}	0-13	0-17	≤ 6	≥ 12
	LCRB [RBs]	> 36	33-36	≤ 32	≤ 32
	RB _{start} + LCRB [RBs]	N/A	N/A	N/A	≥ 44
	A-MPR [dB]	≤ 4	≤ 3	≤ 3	≤ 3
15	RB _{start}	0-24	0-38	≤ 14	≥ 23
	LCRB [RBs]	> 50	37-50	≤ 36	≤ 36
	RB _{start} + LCRB [RBs]	N/A	N/A	N/A	≥ 59
	A-MPR [dB]	≤ 5	≤ 4	≤ 3	≤ 3
20	RB _{start}	0-35	0-51	≤ 21	≥ 31
	LCRB [RBs]	> 64	49-64	≤ 48	≤ 48
	RB _{start} + LCRB [RBs]	N/A	N/A	N/A	≥ 79
	A-MPR [dB]	≤ 5	≤ 4	≤ 3	≤ 3

NOTE 1; RB_{start} indicates the lowest RB index of transmitted resource blocks
 NOTE 2; LCRB is the length of a contiguous resource block allocation
 NOTE 3; For intra-subframe frequency hopping between two regions, notes 1 and 2 apply on a per slot basis.
 NOTE 4; For intra-subframe frequency hopping between two regions, the larger A-MPR value of the two regions may be applied for both slots in the subframe.

Table 6.2.4-18: A-MPR for "NS_05"

Channel Bandwidth [MHz]	Parameters							
15	Fc [MHz]	1932.5						
	RB _{start}	0-7	8 – 66			67-74		
	LCRB [RBs]	≥ 1	≤ 30	31 – 54	> 54	≤ 6	> 6	
	A-MPR [dB]	≤ 11	0	≤ 3	≤ 5	≤ 5	≤ 1	
20	Fc [MHz]	1930						
	RB _{start}	0-23	24-75			76-99		
	LCRB [RBs]	≥ 1	≤ 24	25 – 40	41 – 50	> 50	≤ 6	> 6
	A-MPR [dB]	≤ 11	0	≤ 3	≤ 5	≤ 10	≤ 5	≤ 1

Table 6.2.4-19: A-MPR for "NS_24"

Channel Bandwidth [MHz]	Parameters							
5	Fc [MHz]	Fc > [1987.5]						
	RB _{start}	0 - 24						
	LCRB [RBs]	0 - 24						
	A-MPR [dB]	≤ 10						
10	Fc [MHz]	1975 < Fc ≤ 1985					1985 < Fc ≤ 1995	Fc > 1995
	RB _{start}	0 - 1	2 - 14	15 - 26	36 - 49		0 - 49	0 - 49
	LCRB [RBs]	> 10	≥ 35	N/A	≤ 2	> 11	0 - 49	0 - 49
	RB _{end}	N/A	N/A	> 48	N/A	N/A	N/A	N/A
A-MPR [dB]	≤ 2	≤ 2	1	≤ 3	≤ 1	≤ 9	≤ 17	
15	Fc [MHz]	1972.5 < Fc ≤ 1987.5					Fc > 1987.5	
	RB _{start}	0 - 11			12 - 74		0 - 74	
	LCRB [RBs]	≤ 45		> 45		> 3		0 - 74

	RB _{end}	N/A	N/A	≥ 45	N/A
	A-MPR [dB]	≤ 2	≤ 8	≤ 7	≤ 17
20	Fc [MHz]	Fc > 1970			
	RB _{start}	0 - 99			
	L _{CRB} [RBs]	0 - 99			
	A-MPR [dB]	≤ 17			

Table 6.2.4-20: A-MPR for "NS_25"

Channel Bandwidth [MHz]	Parameters									
5	Fc [MHz]	Fc > [1997.5]								
	RB _{start}	0 - 9				10 - 24				
	L _{CRB} [RBs]	> 12				N/A				
	RB _{end}	N/A				≥ 22				
	A-MPR [dB]	≤ 5				≤ 2				
10	Fc [MHz]	1975 < Fc ≤ 1985		1985 < Fc ≤ 1995			Fc > 1995			
	RB _{start}	0-1	2-49	0	1 - 18	19-49	0-6	7-15	16-49	
	L _{CRB} [RBs]	> 10	N/A	≤ 25	> 25	> 25	N/A	N/A	> 20	N/A
	RB _{end}	N/A	> 48	N/A	N/A	N/A	> 42	N/A	N/A	> 35
	A-MPR [dB]	≤ 1	≤ 1	≤ 1	≤ 5	≤ 5	≤ 1	≤ 10	≤ 7	≤ 11
15	Fc [MHz]	1972.5 < Fc ≤ 1987.5						Fc > 1987.5		
	RB _{start}	0 - 4	5 - 30	31 - 62	63 - 74	0 - 74				
	L _{CRB} [RBs]	≥ 15	≥ 45	N/A	N/A	0 - 74				
	RB _{end}	N/A	N/A	> 71	N/A	N/A				
	A-MPR [dB]	≤ 4	≤ 3	≤ 1	≤ 1	≤ 13				
20	Fc [MHz]	1970 < Fc ≤ 1990						Fc > 1990		
	RB _{start}	0 - 13	14 - 40	41 - 99	0 - 99					
	L _{CRB} [RBs]	N/A	≥ 32	N/A	0 - 99					
	RB _{end}	N/A	N/A	> 72	N/A					
	A-MPR [dB]	≤ 11	≤ 11	≤ 13	≤ 13					

Table 6.2.4-21: A-MPR for "NS_26"

Bandwidth (MHz)	RB _{start}	L _{crb}	A-MPR
10	0 - 10	≥ 1	≤ 1
15	0 - 17	≥ 1	≤ 1

Table 6.2.4-27: A-MPR for “NS_36”

Channel Bandwidth [MHz]	Parameters				
5 MHz	F _c [MHz]	700.5 ≤ F _c < 705.5			
	RB _{start}	0		1-4	
	LCRB [RBs]	1	≥ 15	≥ 15	24
	A-MPR [dB]	≤ 2	≤ 4	≤ 1	≤ 3
10 MHz	F _c [MHz]	703 ≤ F _c < 708			
	RB _{start}	0 - 8	9 - 12	13 - 39	40 - 43
	LCRB [RBs]	> 0	> 12	> 16	> 0
	A-MPR [dB]	≤ 10	≤ 8	≤ 6	≤ 6
15 MHz	F _c [MHz]	F _c = 705.5			
	RB _{start}	0 - 16	17 - 23	24 - 56	57 - 60
	LCRB [RBs]	> 0	> 12	> 20	< 6
	A-MPR [dB]	≤ 10	≤ 9	≤ 7	≤ 6
NOTE 1: RB _{start} indicates the lowest RB index of transmitted resource blocks					
NOTE 2: LCRB is the length of a contiguous resource block allocation					
NOTE 3: For intra-subframe frequency hopping between two regions, notes 1 and 2 apply on a per slot basis.					
NOTE 4: For intra-subframe frequency hopping between two regions, the larger A-MPR value of the two regions may be applied for both slots in the subframe.					

For PRACH, PUCCH and SRS transmissions, the allowed A-MPR is according to that specified for PUSCH QPSK modulation for the corresponding transmission bandwidth.

For each subframe, the A-MPR is evaluated per slot and given by the maximum value taken over the transmission(s) within the slot; the maximum A-MPR over the two slots is then applied for the entire subframe.

For the UE maximum output power modified by A-MPR, the power limits specified in subclause 6.2.5 apply.

6.2.4A UE maximum output power with additional requirements for CA

Additional ACLR, spectrum emission and spurious emission requirements for carrier aggregation can be signalled by the network to indicate that the UE shall also meet additional requirements in a specific deployment scenario. To meet these additional requirements, Additional Maximum Power Reduction (A-MPR) is allowed for the CA Power Class as specified in Table 6.2.2A-1.

If for intra-band carrier aggregation the UE is configured for transmissions on a single serving cell, then subclauses 6.2.3 and 6.2.4 apply with the Network Signaling value indicated by the field *additionalSpectrumEmission*.

For intra-band contiguous aggregation with the UE configured for transmissions on two serving cells, the maximum output power reduction specified in Table 6.2.4A-1 is allowed for all serving cells of the applicable uplink CA configurations according to the CA network signalling value indicated by the field *additionalSpectrumEmissionSCell-r10*. Then clause 6.2.3A does not apply, i.e. the carrier aggregation MPR = 0dB, unless the value indicated is CA_NS_31. For uplink 64QAM, the applied maximum output power reduction is obtained by taking the maximum value of MPR requirements specified in Table 6.2.3A-1 and A-MPR requirements specified in Table 6.2.4A-1.

Table 6.2.4A-1: Additional Maximum Power Reduction (A-MPR) for intra-band contiguous CA

CA Network Signalling value	Requirements (subclause)	Uplink CA Configuration	A-MPR [dB] (subclause)
CA_NS_01	6.6.3.3A.1	CA_1C	6.2.4A.1
CA_NS_02	6.6.3.3A.2	CA_1C	6.2.4A.2
CA_NS_03	6.6.3.3A.3	CA_1C	6.2.4A.3
CA_NS_04	6.6.2.2A.1, 6.6.3.3A.8	CA_41C	6.2.4A.4
CA_NS_05	6.6.3.3A.4	CA_38C	6.2.4A.5
CA_NS_06	6.6.3.3A.5	CA_7C	6.2.4A.6
CA_NS_07	6.6.3.3A.6	CA_39C	6.2.4A.7
CA_NS_08	6.6.3.3A.7	CA_42C	6.2.4A.8
...			
CA_NS_31	NOTE 1	Table 5.6A.1-1 (NOTE 1)	N/A
CA_NS_32	Reserved		
NOTE 1: Applicable for uplink CA configurations listed in Table 5.6A.1-1 for which none of the additional requirements in subclauses 6.6.2.2A or 6.6.3.3A apply.			
NOTE 2: The index of the sequence CA_NS corresponds to the value of <i>additionalSpectrumEmissionSCell-r10</i> .			

If for intra-band non-contiguous carrier aggregation the UE is configured for transmissions on a single serving cell, then subclauses 6.2.3 and 6.2.4 apply with the Network Signaling value indicated by the field *additionalSpectrumEmission*.

For intra-band non-contiguous carrier aggregation with the UE configured for transmissions on two serving cells, the maximum output power reduction specified in Table 6.2.4A-2 is allowed for all serving cells of the applicable uplink CA configurations according to the CA network signalling value indicated by the field *additionalSpectrumEmissionSCell-r10*. MPR as specified in subclause 6.2.3A is not allowed in addition, unless A-MPR is N/A.

Table 6.2.4A-2: Additional Maximum Power Reduction (A-MPR) for intra-band non-contiguous CA

CA Network Signalling value	Additional requirements for sub-blocks in order of increasing uplink carrier frequency		Uplink CA Configuration	A-MPR for sub-blocks in order of increasing uplink carrier frequency
	Requirements (subclause)	Requirements (subclause)		A-MPR [dB] (subclause)
CA_NC_NS_01	6.6.2.2.1 (NS_03)	6.6.2.2.1 (NS_03)	CA_4A-4A	N/A
...				
CA_NC_NS_31	NOTE 1	NOTE 1	Table 5.6A.1-3 (NOTE 1)	N/A
CA_NC_NS_32	Reserved			
NOTE 1: Applicable for uplink CA configurations listed in Table 5.6A.1-3 for which the additional requirements in subclause 6.6.2.1.1 (indicated by NS_01) applies in each sub-block.				
NOTE 2: The index of the sequence CA_NC_NS corresponds to the value of <i>additionalSpectrumEmissionSCell-r10</i> .				

If for inter-band carrier aggregation the UE is configured for transmissions on a single serving cell, then subclauses 6.2.3 and 6.2.4 apply with the Network Signaling value indicated by the field *additionalSpectrumEmission*.

For inter-band carrier aggregation with the UE configured for transmissions on two serving cells the maximum output power reduction specified in Table 6.2.4-1 is allowed for each serving cell of the applicable uplink CA configuration according to the Network Signaling value indicated by the field *additionalSpectrumEmission* for the PCC and the CA network signalling value indicated by the field *additionalSpectrumEmissionSCell-r10* for the SCC. The value of *additionalSpectrumEmissionSCell-r10* is equal to that of *additionalSpectrumEmission* configured on the SCC. MPR as specified in subclause 6.2.3A is allowed in addition.

For PUCCH and SRS transmissions, the allowed A-MPR is according to that specified for PUSCH QPSK modulation for the corresponding transmission bandwidth.

For intra-band carrier aggregation, the A-MPR is evaluated per slot and given by the maximum value taken over the transmission(s) on all component carriers within the slot; the maximum A-MPR over the two slots is then applied for the entire subframe.

For combinations of intra-band and inter-band carrier aggregation with the UE configured for transmission on three serving cells (up to two contiguously aggregated carriers per band), the maximum output power reduction is specified as follows. For the band supporting one serving cell the maximum output power reduction specified in Table 6.2.4-1 is allowed according to the Network Signaling value indicated by the field *additionalSpectrumEmission* for the PCC and the CA network signalling value indicated by the field *additionalSpectrumEmissionSCell-r10* for the SCC. The value of *additionalSpectrumEmissionSCell-r10* is equal to that of *additionalSpectrumEmission* configured on the SCC. MPR as specified in subclause 6.2.3A is allowed in addition. For the band supporting intra-band contiguous aggregation with the UE configured for transmissions on two serving cells, the maximum output power reduction specified in Table 6.2.4A-1 is allowed for all serving cells of the applicable uplink CA configurations according to the CA network signalling value indicated by the field *additionalSpectrumEmissionSCell-r10*. Then clause 6.2.3A does not apply, i.e. the carrier aggregation MPR = 0dB, unless the value indicated is CA_NS_31. For uplink 64QAM, the applied maximum output power reduction is obtained by taking the maximum value of MPR requirements specified in Table 6.2.3A-1 and A-MPR requirements specified in Table 6.2.4A-1.

For the UE maximum output power modified by A-MPR specified in table 6.2.4A-1, the power limits specified in subclause 6.2.5A apply.

6.2.4A.1 A-MPR for CA_NS_01 for CA_1C

If the UE is configured to CA_1C and it receives IE CA_NS_01 the allowed maximum output power reduction applied to transmissions on the PCC and the SCC for contiguously aggregated signals is specified in table 6.2.4A.1-1.

Table 6.2.4A.1-1: Contiguous allocation A-MPR for CA_NS_01

CA_1C: CA_NS_01	RB _{start}	L _{CRB} [RBs]	RB _{start} + L _{CRB} [RBs]	A-MPR for QPSK, 16-QAM and 64-QAM [dB]
100 RB / 100 RB	0 – 23 and 176 – 199	> 0	N/A	≤ 12.0
	24 – 105	> 64	N/A	≤ 6.0
	106 – 175	N/A	> 175	≤ 5.0
75 RB / 75 RB	0 – 6 and 143 – 149	0 < L _{CRB} ≤ 10	N/A	≤ 11.0
		> 10	N/A	≤ 6.0
	7 – 90	> 44	N/A	≤ 5.0
	91 – 142	N/A	> 142	≤ 2.0
NOTE 1: RB _{start} indicates the lowest RB index of transmitted resource blocks				
NOTE 2: L _{CRB} is the length of a contiguous resource block allocation				
NOTE 3: For intra-subframe frequency hopping which intersects regions, notes 1 and 2 apply on a per slot basis				
NOTE 4: For intra-subframe frequency hopping which intersects regions, the larger A-MPR value may be applied for both slots in the subframe				

If the UE is configured to CA_1C and it receives IE CA_NS_01 the allowed maximum output power reduction applied to transmissions on the PCell and the SCell with non-contiguous resource allocation is defined as follows

$$A\text{-MPR} = \text{CEIL} \{M_A, 0.5\}$$

Where M_A is defined as follows

$$M_A = \begin{cases} -22.5 A + 17 & ; 0 \leq A < 0.20 \\ -11.0 A + 14.7 & ; 0.20 \leq A < 0.70 \\ -1.7 A + 8.2 & ; 0.70 \leq A \leq 1 \end{cases}$$

Where $A = N_{\text{RB_alloc}} / N_{\text{RB_agg}}$.

6.2.4A.2 A-MPR for CA_NS_02 for CA_1C

If the UE is configured to CA_1C and it receives IE CA_NS_02 the allowed maximum output power reduction applied to transmission on the PCC and the SCC for contiguously aggregated signals is specified in Table 6.2.4A.2-1.

Table 6.2.4A.2-1: Contiguous allocation A-MPR for CA_NS_02

CA_1C: CA_NS_02	RB _{end}	L _{CRB} [RBs]	A-MPR for QPSK, 16-QAM and 64-QAM [dB]
100 RB / 100 RB	0 – 20	> 0	≤ 4 dB
	21 – 46	> 0	≤ 3 dB
	47 – 99	> RB _{end} - 20	≤ 3 dB
	100 – 184	> 75	≤ 6 dB
	185 – 199	> 0	≤ 10 dB
75 RB / 75 RB	0 – 48	> 0	≤ 2 dB
	49 – 80	> RB _{end} - 20	≤ 3 dB
	81 – 129	> 60	≤ 5 dB
	130 – 149	> 84	≤ 6 dB
	130 – 149	1 – 84	≤ 2 dB

If the UE is configured to CA_1C and it receives IE CA_NS_02 the allowed maximum output power reduction applied to transmissions on the PCell and the SCell with non-contiguous resource allocation is defined as follows:

$$\text{A-MPR} = \text{CEIL} \{M_A, 0.5\}$$

Where M_A is defined as follows

$$M_A = \begin{cases} -22.5 A + 17 & ; 0 \leq A < 0.20 \\ -11.0 A + 14.7 & ; 0.20 \leq A < 0.70 \\ -1.7 A + 8.2 & ; 0.70 \leq A \leq 1 \end{cases}$$

Where $A = N_{\text{RB_alloc}} / N_{\text{RB_agg}}$.

6.2.4A.3 A-MPR for CA_NS_03 for CA_1C

If the UE is configured to CA_1C and it receives IE CA_NS_03 the allowed maximum output power reduction applied to transmission on the PCC and the SCC for contiguously aggregated signals is specified in Table 6.2.4A.3-1.

Table 6.2.4A.3-1: Contiguous allocation A-MPR for CA_NS_03

CA_1C: CA_NS_03	RB _{end}	L _{CRB} [RBs]	A-MPR for QPSK, 16-QAM and 64-QAM [dB]
100 RB / 100 RB	0 – 26	> 0	≤ 10 dB
	27 – 63	≥ RB _{end} - 27	≤ 6 dB
	27 – 63	< RB _{end} - 27	≤ 1 dB
	64 – 100	> RB _{end} - 20	≤ 4 dB
	101 – 171	> 68	≤ 7 dB
	172 – 199	> 0	≤ 10 dB
75 RB / 75 RB	0 – 20	> 0	≤ 10 dB
	21 – 45	> 0	≤ 4 dB
	46 – 75	> RB _{end} - 13	≤ 2 dB
	76 – 95	> 45	≤ 5 dB
	96 – 149	> 43	≤ 8 dB
	120 – 149	1 - 43	≤ 6 dB

If the UE is configured to CA_1C and it receives IE CA_NS_03 the allowed maximum output power reduction applied to transmissions on the PCell and the SCell with non-contiguous resource allocation is defined as follows:

$$\text{A-MPR} = \text{CEIL} \{M_A, 0.5\}$$

Where M_A is defined as follows

$$M_A = \begin{cases} -23.33A + 17.5 & ; 0 \leq A < 0.15 \\ -7.65A + 15.15 & ; 0.15 \leq A \leq 1 \end{cases}$$

Where $A = N_{\text{RB_alloc}} / N_{\text{RB_agg}}$.

6.2.4A.4 A-MPR for CA_NS_04

If the UE is configured to CA_41C or any uplink inter-band CA configuration containing CA_41C and it receives IE CA_NS_04 the allowed maximum output power reduction applied to transmission on two component carriers for contiguously aggregated signals is specified in Table 6.2.4A.4-1.

Table 6.2.4A.4-1: Contiguous Allocation A-MPR for CA_NS_04

CA Bandwidth Class C	RB _{Start}	L _{CRB} [RBs]	RB _{Start} + L _{CRB} [RBs]	A-MPR for QPSK [dB]	A-MPR for 16QAM and 64QAM [dB]
25 RB / 100 RB	0 – 34 and 90 – 124	>0	N/A	≤3dB	≤3.5dB
	35 – 89	N/A	>90	≤1dB	≤2.5dB
50RB / 100 RB	0 – 44 and 105 – 149	>0	N/A	≤4dB	≤4dB
	45 – 104	N/A	>105	≤3dB	≤4dB
75 RB / 75 RB	0 – 44 and 105 – 149	>0	N/A	≤4dB	≤4dB
	45 – 104	N/A	>105	≤4dB	≤4dB
100 RB / 75 RB	0 – 49 and 125 – 174	>0	N/A	≤4dB	≤4dB
	50 - 124	N/A	>125	≤3dB	≤4dB
100 RB / 100 RB	0 – 59 and 140 – 199	>0	N/A	≤3dB	≤4dB
	60– 139	N/A	>140	≤3dB	≤4dB

NOTE 1: RB_{start} indicates the lowest RB index of transmitted resource blocks
NOTE 2: L_{CRB} is the length of a contiguous resource block allocation
NOTE 3: For intra-subframe frequency hopping which intersects regions, notes 1 and 2 apply on a per slot basis
NOTE 4: For intra-subframe frequency hopping which intersects regions, the larger A-MPR value may be applied for both slots in the subframe

If the UE is configured to CA_41C or any uplink inter-band CA configuration containing CA_41C and it receives IE CA_NS_04 the allowed maximum output power reduction applied to transmissions on two serving cells assigned to Band 41 with non-contiguous resource allocation is defined as follows

$$A\text{-MPR} = \text{CEIL} \{M_A, 0.5\}$$

Where M_A is defined as follows

$$\begin{aligned}
M_A &= 11, & 0 \leq A < 0.05 \\
&= -55.0A + 13.75, & 0.05 \leq A < 0.15 \\
&= -4.0A + 6.10, & 0.15 \leq A < 0.40 \\
&= -0.83A + 4.83, & 0.40 \leq A \leq 1
\end{aligned}$$

Where $A = N_{\text{RB_alloc}} / N_{\text{RB_agg}}$.

6.2.4A.5 A-MPR for CA_NS_05 for CA_38C

If the UE is configured to CA_38C and it receives IE CA_NS_05 the allowed maximum output power reduction applied to transmission on the PCC and the SCC for contiguously aggregated signals is specified in Table 6.2.4A.5-1.

Table 6.2.4A.5-1: Contiguous Allocation A-MPR for CA_NS_05

CA_38C	RB _{end}	L _{CRB} [RBs]	A-MPR for QPSK, 16-QAM and 64-QAM [dB]
100RB/100RB	0 – 12	>0	≤ 5 dB
	13 – 79	> RB _{end} – 13	≤ 2 dB
	80 – 180	>60	≤ 6 dB
	181 – 199	> 0	≤ 11 dB
75RB/75RB	0 – 70	> max (0, RB _{end} -10)	≤ 2 dB
	71- 108	> 60	≤ 5 dB
	109 – 139	>0	≤ 5 dB
	140 – 149	≤ 70	≤ 2 dB
	140 – 149	>70	≤ 6 dB
NOTE 1: RB _{end} indicates the highest RB index of transmitted resource blocks			
NOTE 2: L _{CRB} is the length of a contiguous resource block allocation			
NOTE 3: For intra-subframe frequency hopping which intersects regions, notes 1 and 2 apply on a per slot basis			
NOTE 4: For intra-subframe frequency hopping which intersects regions, the larger A-MPR value may be applied for both slots in the subframe			

If the UE is configured to CA_38C and it receives IE CA_NS_05 the allowed maximum output power reduction applied to transmissions on the PCell and the SCell with non-contiguous resource allocation is defined as follows

$$A\text{-MPR} = \text{CEIL} \{M_A, 0.5\}$$

Where MA is defined as follows

$$M_A = -14.17 A + 16.50 \quad ; 0 \leq A < 0.60$$

$$-2.50 A + 9.50 \quad ; 0.60 \leq A \leq 1$$

Where $A = N_{\text{RB_alloc}} / N_{\text{RB_agg}}$.

6.2.4A.6 A-MPR for CA_NS_06

If the UE is configured to CA_7C and it receives IE CA_NS_06 the allowed maximum output power reduction applied to transmission on the PCC and the SCC for contiguously aggregated signals is specified in Table 6.2.4A.6-1.

Table 6.2.4A.6-1: Contiguous Allocation A-MPR for CA_NS_06

CA Bandwidth Class C	RB _{end}	L _{CRB} [RBs]	A-MPR for QPSK, 16-QAM and 64-QAM [dB]
100RB/100RB	0 – 22	>0	≤ 4 dB
	23 – 99	> max(0, RB _{end} – 25)	≤ 2 dB
	100 – 142	> 75	≤ 3 dB
	143 – 177	>70	≤ 5 dB
	178 – 199	> 0	≤ 10 dB
75RB/75RB	0 – 7	>0	≤ 5 dB
	8- 74	> max(0, RB _{end} – 10)	≤ 2 dB
	75 – 109	>64	≤ 2 dB
	110 – 144	>35	≤ 6 dB
	145 – 149	>0	≤ 10 dB
50RB/100RB and 100RB/50RB	0 – 10	> 0	≤ 5 dB
	11 – 75	> max(0, RB _{End} – 25)	≤ 2 dB
	76 – 103	> 50	≤ 3 dB
	104 – 144	> 25	≤ 6 dB
	145 – 149	> 0	≤ 10 dB
75RB/100RB and 100RB/75RB	0 – 15	> 0	≤ 5 dB
	16 – 75	> max(0, RB _{End} – 15)	≤ 2 dB
	76 – 120	> 50	≤ 3 dB
	121 – 160	> 50	≤ 6 dB
	161 – 174	> 0	≤ 10 dB

If the UE is configured to CA_7C and it receives IE CA_NS_06 the allowed maximum output power reduction applied to transmissions on the PCell and the SCell with non-contiguous resource allocation is defined as follows:

$$A\text{-MPR} = \text{CEIL} \{M_A, 0.5\}$$

Where M_A is defined as follows

$$M_A = \begin{cases} -13.33A + 17.5 & ; 0 \leq A < 0.15 \\ -6.47A + 16.47 & ; 0.15 \leq A \leq 1 \end{cases}$$

Where $A = N_{RB_alloc} / N_{RB_agg}$.

6.2.4A.7 A-MPR for CA_NS_07

If the UE is configured to CA_39C or any uplink inter-band CA configuration containing CA_39C and it receives IE CA_NS_07 the allowed maximum output power reduction applied to transmission on two component carriers for contiguously aggregated signals is specified in Table 6.2.4A.7-1.

Table 6.2.4A.7-1: Contiguous Allocation A-MPR for CA_NS_07

CA_39C: CA_NS_07	RB _{start}	L _{CRB} [RBs]	A-MPR for QPSK, 16-QAM and 64-QAM[dB]
75 RB / 100 RB and 100 RB / 75 RB	0 – 13	> 0	≤ 11
	14 – 50	≤ 60	≤ 3
	14 – 100	> 60	≤ 7
	101 – 155	> max(155 - RB _{start} , 0)	≤ 2
	156 – 174	> 0	≤ 5
50 RB / 100 RB and 100 RB / 50 RB	0 – 5	> 0	≤ 11
	6 – 42	≤ 25	≤ 3
		> 25	≤ 6
	43 – 80	> 50	≤ 5
	81 – 138	> 20	≤ 2
139 – 149	> 0	≤ 5	
25 RB / 100 RB and 100 RB / 25 RB	0 – 32	≥ 84	≤ 6
		< 84	≤ 4
	33 – 60	> 50	≤ 3
61 – 124	> 20	≤ 3	

If the UE is configured to CA_39C or any uplink inter-band CA configuration containing CA_39C and it receives IE CA_NS_07 the allowed maximum output power reduction applied to transmissions on two serving cells assigned to Band 39 with non-contiguous resource allocation is defined as follows

$$A\text{-MPR} = \text{CEIL} \{M_A, 0.5\}$$

Where M_A is defined as follows

$$M_A = -16.25A + 21 \quad ; 0 \leq A < 0.80$$

$$-2.50A + 10.00 \quad ; 0.80 \leq A \leq 1$$

Where $A = N_{RB_alloc} / N_{RB_agg}$

6.2.4A.8 A-MPR for CA_NS_08

If the UE is configured to CA_42C and it receives IE CA_NS_08 the allowed maximum output power reduction applied to transmission on the PCC and the SCC for contiguously aggregated signals is specified in Table 6.2.4A.8-1.

Table 6.2.4A.8-1: Contiguous Allocation A-MPR for CA_NS_08

CA_42C: CA_NS_08	RBstart	Condition	RBend	L _{CRB} [RBs]	A-MPR for QPSK and 16- QAM[dB]
100RB / 100RB	≤ 21	Or	≥ 178	≤ 25	≤ 12
	≥ 0	N/A	N/A	> 25 and ≤ 80	≤ 6
	> 21 and ≤ 58	Or	≥ 141 and < 178	> 80 and ≤ 172	≤ 8
	> 21	And	< 178	> 172	≤ 9
100RB / 75RB And 75RB / 100RB	≤ 12	Or	≥ 162	< 48	≤ 3
	≥ 0	N/A	N/A	≥ 48 and ≤ 80	≤ 4
	> 12 and ≤ 49	Or	≥ 125 and < 162	≤ 25	≤ 12
	> 12	And	< 162	> 25 and ≤ 75	≤ 6
	> 49	And	< 125	> 75 and < 172	≤ 8
75RB / 75RB and 100RB / 50RB And 50RB / 100RB	≤ 5	Or	≥ 144	≥ 172	9
	≥ 0	N/A	N/A	< 54	≤ 3
	> 5	And	< 144	≥ 54 and ≤ 75	≤ 5
	> 5 and ≤ 41	Or	≥ 108 and < 144	≥ 36 and < 54	≤ 2
100RB / 25RB And 25RB / 100RB	≤ 31	Or	≥ 92	≤ 16	≤ 12
	≥ 0	N/A	N/A	> 16 and ≤ 61	≤ 6
				> 61	≤ 8
			≥ 36 and ≤ 61	≤ 5	
			< 36	≤ 3	
			≤ 34	≤ 4	
			> 34 and ≤ 44	≤ 5	
			> 44	≤ 8	

NOTE 1: RB_{start} indicates the lowest RB index of transmitted resource blocks
NOTE 2: L_{CRB} is the length of a contiguous resource block allocation
NOTE 3: RB_{end} indicates the highest RB index of transmitted resource blocks
NOTE 4: If condition is "and" both RB_{start} and RB_{end} constraints need to be met. If condition is "or" either RB_{start} or RB_{end} constraints need to be met
NOTE 5: For intra-subframe frequency hopping which intersects regions, notes 1, 2, 3 and 4 apply on a per slot basis
NOTE 6: For intra-subframe frequency hopping which intersects regions, the larger A-MPR value may be applied for both slots in the subframe

If the UE is configured to CA_42C and it receives IE CA_NS_08 the allowed maximum output power reduction applied to transmissions on the PCell and the SCell with non-contiguous resource allocation is defined as follows

$$A\text{-MPR} = \text{CEIL} \{M_A, 0.5\}$$

Where MA is defined as follows

$$M_A = \begin{cases} 20 & 0 \leq A < 0.025 \\ 23 - 120A & 0.025 \leq A < 0.05 \\ 17.53 - 10.59A & 0.05 \leq A \leq 0.9 \\ 8 & 0.9 \leq A \leq 1 \end{cases}$$

Where $A = N_{\text{RB_alloc}} / N_{\text{RB_agg}}$.

6.2.4B UE maximum output power with additional requirements for UL-MIMO

For UE with two transmit antenna connectors in closed-loop spatial multiplexing scheme, the A-MPR values specified in subclause 6.2.4 shall apply to the maximum output power specified in Table 6.2.2B-1. The requirements shall be met with the UL-MIMO configurations specified in Table 6.2.2B-2. For UE supporting UL-MIMO, the maximum output power is measured as the sum of the maximum output power at each UE antenna connector. Unless stated otherwise, an A-MPR of 0 dB shall be used.

For the UE maximum output power modified by A-MPR, the power limits specified in subclause 6.2.5B apply.

If UE is configured for transmission on single-antenna port, the requirements in subclause 6.2.4 apply.

6.2.4D UE maximum output power with additional requirements for ProSe

When UE is configured for E-UTRA ProSe sidelink transmissions non-concurrent with E-UTRA uplink transmissions for E-UTRA ProSe operating bands specified in Table 5.5D-1, the allowed A-MPR for the maximum output power for ProSe physical channels PSDCH, PSCCH, PSSCH, and PSBCH shall be as specified in subclause 6.2.4 for PUSCH for the corresponding modulation and transmission bandwidth.

The allowed A-MPR for the maximum output power for ProSe physical signal PSSS and SSSS shall be as specified in subclause 6.2.4 for PUSCH QPSK modulation for the corresponding transmission bandwidth.

When UE is configured for simultaneous E-UTRA ProSe sidelink and E-UTRA uplink transmissions for inter-band E-UTRA ProSe / E-UTRA bands specified in Table 5.5D-2, the requirements in subclause 6.2.4D apply for ProSe transmission and the requirements in subclause 6.2.4 apply for uplink transmission.

6.2.4E UE maximum output power with additional requirements for category M1 UE

Additional ACLR and spectrum emission requirements can be signalled by the network to indicate that the UE shall also meet additional requirements in a specific deployment scenario. To meet these additional requirements, Additional Maximum Power Reduction (A-MPR) is allowed for the output power as specified in Table 6.2.2E-1. Unless stated otherwise, an A-MPR of 0 dB shall be used.

For UE Power Class 3 and 5 the specific requirements and identified subclauses are specified in Table 6.2.4E-1 along with the allowed A-MPR values that may be used to meet these requirements. The allowed A-MPR values specified below in Table 6.2.4E-1 and from 6.2.4-2 to 6.2.4-15 are in addition to the allowed MPR requirements specified in subclause 6.2.3E.

Table 6.2.4E-1: Additional Maximum Power Reduction (A-MPR) for category M1 UE

Network Signalling value	Requirements (subclause)	E-UTRA Band	Resources Blocks (N_{RB})	A-MPR (dB)
NS_01	6.6.2.1.1	Table 5.5-1	Table 5.6-1	N/A
NS_03	6.6.2.2.1	2, 4	Table 5.6-1	N/A
NS_04	6.6.2.2.2	41	Table 6.2.4E-3	
NS_05	6.6.3.3.1	1	Table 5.6-1	N/A
NS_06	6.6.2.2.3	12, 13	Table 5.6-1	N/A
NS_07	6.6.2.2.3 6.6.3.3.2	13	Table 6.2.4E-4	
NS_08	6.6.3.3.3	19	Table 5.6-1	N/A
NS_09	6.6.3.3.4	21	Table 5.6-1	N/A
NS_10		20	Table 5.6-1	N/A
NS_12	6.6.3.3.5	26	Table 6.2.4E-5	
NS_13	6.6.3.3.6	26	Table 5.6-1	N/A
NS_14	6.6.3.3.7	26	Table 5.6-1	N/A
NS_15	6.6.3.3.8	26	Table 6.2.4-9	
NS_16	6.6.3.3.9	27	Table 5.6-1	N/A
NS_17	6.6.3.3.10	28	Table 5.6-1	N/A
NS_18	6.6.3.3.11	28	Table 5.6-1	N/A
NS_32	-	-	-	-

No other A-MPR requirement than those specified in tables 6.2.4E-1 applies to category M1 UE.

Table 6.2.4E-2: Void

Table 6.2.4E-3: A-MPR for "NS_04" for Cat-M1

Channel bandwidth [Hz]	Parameters	Region
------------------------	------------	--------

5	Fc [MHz]	≤ 2500.5			
	(NB _{index} , RB _{start})	(0, 0-5)		(1, 0-1)	
	LCRB [RBs]	> 0			
	A-MPR [dB]	≤ 2			
10	Fc [MHz]	≤ 2504			
	(NB _{index} , RB _{start})	(0, 0-5)		(1, 0-1)	
	LCRB [RBs]	>0			
	A-MPR [dB]	≤ 3			
15	Fc [MHz]	≤ 2510.8			
	(NB _{index} , RB _{start})	(0, 0-5)		(1, 0-5)	
	LCRB [RBs]	>0			
	A-MPR [dB]	≤ 3			
20	Fc [MHz]	≤ 2517.5			
	(NB _{index} , RB _{start})	(0, 0-5)	(1, 0-5)	(2, 0-5)	(3, 0-2)
	LCRB [RBs]	>0			
	A-MPR [dB]	≤ 3			
NOTE 1: RB _{start} indicates the lowest RB index of transmitted resource blocks					
NOTE 2: LCRB is the length of a contiguous resource block allocation					
NOTE 3: For intra-subframe frequency hopping which intersects regions, notes 1 and 2 apply on a per slot basis					
NOTE 4: For intra-subframe frequency hopping which intersects regions, the larger A-MPR value may be applied for both slots in the subframe					
NOTE 5: For CAT-M1 device, the NB index is the starting index allocated from DCI[6], the RB _{start} is indexed within the NB allocated to cat-M1 device.					

Table 6.2.4E-4: A-MPR for "NS_07" for Cat-M1

BW [MHz]	5				10		
	(NB _{index} , RB _{start})	(0, <6)	(0, <6)	(3, <6)	(3, <6)	(0, <6)	(7, <6)
LCRB	>4 and <7	>1 and ≤4	>4 and <7	>1 and ≤4	>2 and <7	>2 and <7	
AMPR [dB]		2	1	2	1	1	1
NOTE 1: NB _{index} is the narrowband index that is defined in 6.2.7 in [4]. The resource block assignment is defined within the narrowband as defined in 5.3.3.1.12 and 5.3.3.1.13 in [5].							

Table 6.2.4E-5: A-MPR for "NS_12" for Cat-M1

Channel bandwidth [MHz]	Parameters	Region		
1.4	(NB _{index} , RB _{start})	(0,0)		(0,1-2)
	LCRB [RBs]	≤3	≥4	≥4
	A-MPR [dB]	≤3	≤6	≤3
3	(NB _{index} , RB _{start})	(0,0-2)		
	LCRB [RBs]	>0		
	A-MPR [dB]	≤4		
5	(NB _{index} , RB _{start})	(0, 0-5)		
	LCRB [RBs]	>0		
	A-MPR [dB]	≤5		
10	(NB _{index} , RB _{start})	(0, 0-5)	(1, 0-5)	(2,0-2)
	LCRB [RBs]	>0		
	A-MPR [dB]	≤4		
15	(NB _{index} , RB _{start})	(0-5,0-5)		
	LCRB [RBs]	>0		
	A-MPR [dB]	≤4		

6.2.4F UE maximum output power with additional requirements for category NB1 UE

Additional ACLR and spectrum emission requirements can be signalled by the network to indicate that the UE shall also meet additional requirements in a specific deployment scenario. To meet these additional requirements, Additional Maximum Power Reduction (A-MPR) is allowed for the output power are specified. For the agreed E-UTRA bands for category NB1 UE an A-MPR of 0 dB shall be allowed unless specified otherwise.

6.2.5 Configured transmitted power

The UE is allowed to set its configured maximum output power $P_{\text{CMAX},c}$ for serving cell c . The configured maximum output power $P_{\text{CMAX},c}$ is set within the following bounds:

$P_{\text{CMAX}_L,c} \leq P_{\text{CMAX},c} \leq P_{\text{CMAX}_H,c}$ with

$$P_{\text{CMAX}_L,c} = \text{MIN} \{ P_{\text{EMAX},c} - \Delta T_{C,c}, P_{\text{PowerClass}} - \text{MAX}(MPR_c + A\text{-MPR}_c + \Delta T_{\text{IB},c} + \Delta T_{C,c} + \Delta T_{\text{ProSe}}, P\text{-MPR}_c) \}$$

$$P_{\text{CMAX}_H,c} = \text{MIN} \{ P_{\text{EMAX},c}, P_{\text{PowerClass}} \}$$

where

- $P_{\text{EMAX},c}$ is the value given by IE *P-Max* for serving cell c , defined in [7];
- $P_{\text{PowerClass}}$ is the maximum UE power specified in Table 6.2.2-1 without taking into account the tolerance specified in the Table 6.2.2-1;
- MPR_c and $A\text{-MPR}_c$ for serving cell c are specified in subclause 6.2.3 and subclause 6.2.4, respectively;
- $\Delta T_{\text{IB},c}$ is the additional tolerance for serving cell c as specified in Table 6.2.5-2; $\Delta T_{\text{IB},c} = 0$ dB otherwise;
- $\Delta T_{C,c} = 1.5$ dB when NOTE 2 in Table 6.2.2-1 applies;
- $\Delta T_{C,c} = 0$ dB when NOTE 2 in Table 6.2.2-1 does not apply;
- $\Delta T_{\text{ProSe}} = 0.1$ dB when the UE supports ProSe Direct Discovery and/or ProSe Direct Communication on the corresponding E-UTRA ProSe band; $\Delta T_{\text{ProSe}} = 0$ dB otherwise.

$P\text{-MPR}_c$ is the allowed maximum output power reduction for

- a) ensuring compliance with applicable electromagnetic energy absorption requirements and addressing unwanted emissions / self desense requirements in case of simultaneous transmissions on multiple RAT(s) for scenarios not in scope of 3GPP RAN specifications;
- b) ensuring compliance with applicable electromagnetic energy absorption requirements in case of proximity detection is used to address such requirements that require a lower maximum output power.

The UE shall apply $P\text{-MPR}_c$ for serving cell c only for the above cases. For UE conducted conformance testing $P\text{-MPR}$ shall be 0 dB

NOTE 1: $P\text{-MPR}_c$ was introduced in the $P_{\text{CMAX},c}$ equation such that the UE can report to the eNB the available maximum output transmit power. This information can be used by the eNB for scheduling decisions.

NOTE 2: $P\text{-MPR}_c$ may impact the maximum uplink performance for the selected UL transmission path.

For each subframe, the $P_{\text{CMAX}_L,c}$ for serving cell c is evaluated per slot and given by the minimum value taken over the transmission(s) within the slot; the minimum $P_{\text{CMAX}_L,c}$ over the two slots is then applied for the entire subframe. $P_{\text{PowerClass}}$ shall not be exceeded by the UE during any period of time.

The measured configured maximum output power $P_{\text{UMAX},c}$ shall be within the following bounds:

$$P_{\text{CMAX}_L,c} - \text{MAX}\{T_{L,c}, T(P_{\text{CMAX}_L,c})\} \leq P_{\text{UMAX},c} \leq P_{\text{CMAX}_H,c} + T(P_{\text{CMAX}_H,c}).$$

where the tolerance $T(P_{\text{CMAX},c})$ for applicable values of $P_{\text{CMAX},c}$ is specified in Table 6.2.5-1, and Table 6.2.5-1A. The tolerance $T_{L,c}$ is the absolute value of the lower tolerance for the applicable operating band as specified in Table 6.2.2-1.

Table 6.2.5-1: P_{CMAX} tolerance

$P_{\text{CMAX},c}$ (dBm)	Tolerance $T(P_{\text{CMAX},c})$ (dB)
$23 < P_{\text{CMAX},c} \leq 33$	2.0
$21 \leq P_{\text{CMAX},c} \leq 23$	2.0
$20 \leq P_{\text{CMAX},c} < 21$	2.5
$19 \leq P_{\text{CMAX},c} < 20$	3.5
$18 \leq P_{\text{CMAX},c} < 19$	4.0
$13 \leq P_{\text{CMAX},c} < 18$	5.0
$8 \leq P_{\text{CMAX},c} < 13$	6.0
$-40 \leq P_{\text{CMAX},c} < 8$	7.0

Table 6.2.5-1A: P_{CMAX} tolerance for power class 5

$P_{\text{CMAX},c}$ (dBm)	Tolerance $T(P_{\text{CMAX},c})$ (dB)
$P_{\text{CMAX},c} = 20$	2.0
$19 \leq P_{\text{CMAX},c} < 20$	3.5
$18 \leq P_{\text{CMAX},c} < 19$	4.0
$13 \leq P_{\text{CMAX},c} < 18$	5.0
$8 \leq P_{\text{CMAX},c} < 13$	6.0
$-40 \leq P_{\text{CMAX},c} < 8$	7.0

For the UE which supports inter-band carrier aggregation configurations with the uplink assigned to one or two E-UTRA bands the $\Delta T_{\text{IB},c}$ is defined for applicable bands in Table 6.2.5-2, Table 6.2.5-3 and Table 6.2.5-4.

Table 6.2.5-2: $\Delta T_{IB,c}$ (two bands)

Inter-band CA Configuration	E-UTRA Band	$\Delta T_{IB,c}$ [dB]
CA_1A-3A	1	0.3
	3	0.3
CA_1A-3C	1	0.3
	3	0.3
CA_1A-5A	1	0.3
	5	0.3
CA_1A-7A	1	0.5
	7	0.6
CA_1A-7C	1	0.5
	7	0.6
CA_1A-8A	1	0.3
	8	0.3
CA_1A-11A	1	0.3
	11	0.3
CA_1A-18A	1	0.3
	18	0.3
CA_1A-19A	1	0.3
	19	0.3
CA_1A-20A	1	0.3
	20	0.3
CA_1A-21A	1	0.3
	21	0.3
CA_1A-26A	1	0.3
	26	0.3
CA_1A-28A	1	0.3
	28	0.6
CA_1A-40A	1	0.5
	40	0.5
CA_1A-41A ⁸	1	0.5
	41	0.5
CA_1A-41C ⁸	1	0.5
	41	0.5
CA_1A-42A	1	0.3
	42	0.8
CA_1A-42C	1	0.3
	42	0.8
CA_1A-46A	1	0
CA_2A-4A	2	0.5
	4	0.5
CA_2A-2A-4A	2	0.5
	4	0.5
CA_2A-4A-4A	2	0.5
	4	0.5
CA_2A-2A-4A-4A	2	0.5
	4	0.5
CA_2A-5A	2	0.3
	5	0.3
CA_2A-2A-5A	2	0.3
	5	0.3
CA_2C-5A	2	0.3
	5	0.3
CA_2A-7A	2	0.5
	7	0.5
CA_2A-12A	2	0.3
	12	0.3
CA_2A-2A-12A	2	0.3
	12	0.3
CA_2A-2A-12B	2	0.3
	12	0.3
CA_2A-12B	2	0.3
	12	0.3

CA_2C-12A	2	0.3
	12	0.3
CA_2A-13A	2	0.3
	13	0.3
CA_2A-2A-13A	2	0.3
	13	0.3
CA_2A-17A	2	0.3
	17	0.8
CA_2A-28A	2	0.3
	28	0.3
CA_2A-29A	2	0.3
CA_2C-29A	2	0.3
CA_2A-30A	2	0.5
	30	0.3
CA_2C-30A	2	0.5
	30	0.3
CA_2A-46A	2	0
CA_3A-5A	3	0.3
	5	0.3
CA_3C-5A	3	0.3
	5	0.3
CA_3A-7A	3	0.5
	7	0.5
CA_3A-7B	3	0.5
	7	0.5
CA_3A-7C	3	0.5
	7	0.5
CA_3C-7A	3	0.5
	7	0.5
CA_3C-7C	3	0.5
	7	0.5
CA_3A-8A	3	0.3
	8	0.3
CA_3A-3A-8A	3	0.3
	8	0.3
CA_3A-19A	3	0.3
	19	0.3
CA_3A-20A	3	0.3
	20	0.3
CA_3A-26A	3	0.3
	26	0.3
CA_3A-27A	3	0.3
	27	0.3
CA_3A-28A	3	0.3
	28	0.3
CA_3C-28A	3	0.3
	28	0.3
CA_3A-31A	3	0.3
	31	0.6
CA_3A-38A	3	0.5
	38	0.5
CA_3A-40A	3	0.5
	40	0.5
CA_3A-40C	3	0.5
	40	0.5
CA_3A-41A	3	0.5
	41	0.3 ¹⁰
CA_3A-41C	3	0.5
	41	0.3 ¹⁰
CA_3A-42A	3	0.6
	42	0.8
CA_3A-42C	3	0.6
	42	0.8

CA_3A-46A	3	0
CA_4A-5A	4	0.3
	5	0.3
CA_4A-4A-5A	4	0.3
	5	0.3
CA_4A-7A	4	0.5
	7	0.5
CA_4A-4A-7A	4	0.5
	7	0.5
CA_4A-12A	4	0.3
	12	0.8
CA_4A-4A-12A	4	0.3
	12	0.8
CA_4A-12B	4	0.3
	12	0.8
CA_4A-13A	4	0.3
	13	0.3
CA_4A-4A-13A	4	0.3
	13	0.3
CA_4A-17A	4	0.3
	17	0.8
CA_4A-27A	4	0.3
	27	0.3
CA_4A-28A	4	0.3
	28	0.6
CA_4A-29A	4	0.3
CA_4A-4A-29A	4	0.3
CA_4A-30A	4	0.5
	30	0.3
CA_4A-4A-30A	4	0.5
	30	0.3
CA_4A-46A	4	0
CA_5A-7A	5	0.3
	7	0.3
CA_5A-12A	5	0.8
	12	0.4
CA_5A-12B	5	0.8
	12	0.4
CA_5A-13A	5	0.5
	13	0.5
CA_5A-17A	5	0.8
	17	0.4
CA_5A-25A	5	0.3
	25	0.3
CA_5A-29A	5	0.5
CA_5A-30A	5	0.3
	30	0.3
CA_5A-38A	5	0.3
	38	0.3
CA_5A-40A	5	0.3
	40	0.3
CA_5A-40C	5	0.3
	40	0.3
CA_7A-8A	7	0.3
	8	0.6
CA_7A-12A	7	0.3
	12	0.3
CA_7A-20A	7	0.3
	20	0.3
CA_7A-22A	7	0.5
	22	0.8
CA_7A-28A	7	0.3
	28	0.3
CA_7B-28A	7	0.3
	28	0.3

CA_7C-28A	7	0.3
	28	0.3
CA_7A-40A	7	0.5
	40	[0.6]
CA_7A-40C	7	0.5
	40	[0.6]
CA_7A-42A	7	0.5
	42	0.8
CA_7A-42A-42A	7	0.5
	42	0.8
CA_7A-46A	7	0
CA_8A-11A	8	0.3
	11	0.4
CA_8A-20A	8	0.4
	20	0.4
CA_8A-40A	8	0.3
	40	0.3
CA_8A-41A	8	0.3
	41	0.3
CA_8A-41C	8	0.3
	41	0.3
CA_8A-42A	8	0.6
	42	0.8
CA_8A-42C	8	0.6
	42	0.8
CA_11A-18A	11	0.3
	18	0.3
CA_12A-25A	12	0.3
	25	0.3
CA_12A-30A	12	0.3
	30	0.3
CA_18A-28A ⁹	18	0.5
	28	0.5
CA_19A-21A	19	0.3
	21	0.4
CA_19A-28A ⁹	19	0.5
	28	0.5
CA_19A-42A	19	0.3
	42	0.8
CA_19A-42C	19	0.3
	42	0.8
CA_20A-31A	20	0.5
	31	0.5
CA_20A-32A	20	0.3
CA_20A-38A	20	0.3
	38	0.3
CA_20A-40A	20	0.3
	40	0.3
CA_20A-42A	20	0.6
	42	0.8
CA_20A-42A-42A	20	0.6
	42	0.8
CA_20A-67A	20	0.5
CA_21A-42A	21	0.4
	42	0.8
CA_21A-42C	21	0.4
	42	0.8
CA_23A-29A	23	0.3
CA_25A-26A	25	0.3
	26	0.3
CA_25A-41A ⁸	25	0.5
	41	0.5
CA_25A-41C ⁸	25	0.5
	41	0.5
CA_25A-41D ⁸	25	0.5

	41	0.5
CA_26A-41A	26	0.3
	41	0.3
CA_26A-41C	26	0.3
	41	0.3
CA_28A-40A	28	0.3
	40	0.3
CA_28A-40C	28	0.3
	40	0.3
CA_28A-40D	28	0.3
	40	0.3
CA_28A-41A	28	0.3
	41	0.3
CA_28A-41C	28	0.3
	41	0.3
CA_28A-42A	28	0.5
	42	0.8
CA_28A-42C	28	0.5
	42	0.8
CA_29A-30A	30	0.3
CA_38A-40A	38	0 ⁴
	40	0 ⁴
CA_38A-40A-40A	38	0 ⁴
	40	0 ⁴
CA_38A-40C	38	0 ⁴
	40	0 ⁴
CA_39A-41A	39	0 ⁴
	41	0 ⁴
CA_39A-41A	39	0.5 ⁷
	41	0.5 ⁷
CA_39A-41C	39	0 ⁴
	41	0 ⁴
CA_39A-41C	39	0.5 ⁷
	41	0.5 ⁷
CA_39A-41D	39	0 ⁴
	41	0 ⁴
CA_39C-41A	39	0 ⁴
	41	0 ⁴
CA_39C-41A	39	0.5 ⁷
	41	0.5 ⁷
CA_39C-41C	39	0 ⁴
	41	0 ⁴
CA_41A-42A	41	0 ⁴
	42	0.5 ⁴
CA_41A-42C	41	0 ⁴
	42	0.5 ⁴
CA_41C-42A	41	0 ⁴
	42	0.5 ⁴
CA_41C-42C	41	0 ⁴
	42	0.5 ⁴
CA_41A-46A	41	0
CA_42A-46A	42	[0.5]

NOTE 1: The above additional tolerances are only applicable for the E-UTRA operating bands that belong to the supported inter-band carrier aggregation configurations

NOTE 2: The above additional tolerances also apply in non-aggregated operation for the supported E-UTRA operating bands that belong to the supported inter-band carrier aggregation configurations

NOTE 3: In case the UE supports more than one of the above 2DL inter-band carrier aggregation configurations and a E-UTRA operating band belongs to more than one 2DL inter-band carrier aggregation configurations then:

- When the E-UTRA operating band frequency range is ≤ 1 GHz, the applicable additional tolerance shall be the average of the 2DL tolerances above, truncated to one decimal place for that operating band among the supported 2DL CA configurations. In case there is a harmonic relation

<p>between low band UL and high band DL, then the maximum tolerance among the different supported 2DL carrier aggregation configurations involving such band shall be applied</p> <ul style="list-style-type: none"> - When the E-UTRA operating band frequency range is >1GHz, the applicable additional 2DL tolerance shall be the maximum tolerance above that applies for that operating band among the supported 2DL CA configurations <p>NOTE 4: Only applicable for UE supporting inter-band carrier aggregation with uplink in one E-UTRA band and without simultaneous Rx/Tx.</p> <p>NOTE 5: Unless otherwise specified, in case the UE supports more than one of the above 3DL inter-band carrier aggregation configurations and a E-UTRA operating band belongs to more than one 3DL inter-band carrier aggregation configurations then:</p> <ul style="list-style-type: none"> - When the E-UTRA operating band frequency range is ≤ 1GHz and the tolerances are the same, the value applies to the band. If the tolerances are different, the applicable additional 3DL tolerance is FFS. In case there is a harmonic relation between low band UL and high band DL, then the maximum tolerance among the different supported 3DL carrier aggregation configurations involving such band shall be applied - When the E-UTRA operating band frequency range is >1GHz, the applicable additional 3DL tolerance shall be the maximum tolerance above that applies for that operating band among the supported 3DL CA configurations. <p>NOTE 6: The above additional tolerances applicable for the E-UTRA operating bands that belong to the supported highest order inter-band carrier aggregation configuration, also applies to the same E-UTRA operating bands that belong to a supported lower order CA configuration.</p> <p>NOTE 7: Applicable for UE supporting inter-band carrier aggregation without simultaneous Rx/Tx.</p> <p>NOTE 8: Only applicable for UE supporting inter-band carrier aggregation with the uplink active in the FDD band.</p> <p>NOTE 9: For Band 28, the requirements only apply for the restricted frequency range specified for this CA configuration (Table 5.5A-2).</p> <p>NOTE 10: The requirement is applied for UE transmitting on the frequency range of 2545-2690MHz.</p> <p>NOTE 11: The requirement is applied for UE transmitting on the frequency range of 2496-2545MHz.</p> <p>NOTE 12: For UE supporting E-UTRA band 65 and CA configurations including Band 1, the Band 65 $\Delta T_{IB,c}$ is the $\max(\text{Band 65 } \Delta T_{IB,c}, \text{Band 1 } \Delta T_{IB,c})$</p>
--

NOTE: The above additional tolerances do not apply to supported UTRA operating bands with frequency range below 1 GHz that correspond to the E-UTRA operating bands that belong to the supported inter-band carrier aggregation configurations when such bands are belonging only to band combination(s) where one band is <1GHz and another band is >1.7GHz and there is no harmonic relationship between the low band UL and high band DL. Otherwise the above additional tolerances also apply to supported UTRA operating bands that correspond to the E-UTRA operating bands that belong to the supported inter-band carrier aggregation configurations.

NOTE: To meet the $\Delta T_{IB,c}$ requirements for CA_3A-7A with state-of-the-art technology, an increase in power consumption of the UE may be required. It is also expected that as the state-of-the-art technology evolves in the future, this possible power consumption increase can be reduced or eliminated.

Table 6.2.5-3: $\Delta T_{IB,c}$ (three bands)

Inter-band CA Configuration	E-UTRA Band	$\Delta T_{IB,c}$ [dB]
CA_1A-3A-7A	1	0.6
	3	0.6
	7	0.6
CA_1A-3A-7C	1	0.6
	3	0.6
	7	0.6
CA_1A-3A-8A	1	0.3
	3	0.3
	8	0.3
CA_1A-3A-5A	1	0.3
	3	0.3
	5	0.3
CA_1A-3A-19A	1	0.3
	3	0.3
	19	0.3
CA_1A-3A-20A	1	0.3
	3	0.3
	20	0.3
CA_1A-3A-26A	1	0.3
	3	0.3
	26	0.3
CA_1A-3A-28A	1	0.3
	3	0.3
	28	0.6
CA_1A-3A-40A	1	0.5
	3	0.5
	40	0.5
CA_1A-3A-42A	1	0.6
	3	0.6
	42	0.8
CA_1A-3A-42C	1	0.6
	3	0.6
	42	0.8
CA_1A-5A-7A	1	0.5
	5	0.3
	7	0.6
CA_1A-5A-40A	1	0.5
	5	0.3
	40	0.5
CA_1A-7A-8A	1	0.5
	7	0.6
	8	0.6
CA_1A-7A-20A	1	0.5
	7	0.6
	20	0.3
CA_1A-7A-28A	1	0.5
	7	0.6
	28	0.6
CA_1A-7C-28A	1	0.5
	7	0.6
	28	0.6
CA_1A-8A-11A	1	0.3
	8	0.3
	11	0.4
CA_1A-8A-40A	1	0.5
	8	0.3
	40	0.5
CA_1A-11A-18A	1	0.3
	11	0.4
	18	0.3
CA_1A-18A-28A	1	0.3

	18	0.5
	28	0.5
CA_1A-19A-21A	1	0.3
	19	0.3
	21	0.4
CA_1A-19A-28A	1	0.3
	19	0.5
	28	0.5
CA_1A-19A-42A	1	0.3
	19	0.3
	42	0.8
CA_1A-19A-42C	1	0.3
	19	0.3
	42	0.8
CA_1A-21A-42A	1	0.3
	21	0.4
	42	0.8
CA_1A-21A-42C	1	0.3
	21	0.4
	42	0.8
CA_2A-2A-4A-12A	2	0.5
	4	0.5
	12	0.8
CA_2A-4A-5A	2	0.5
	4	0.5
	5	0.3
CA_2A-2A-4A-5A	2	0.5
	4	0.5
	5	0.3
CA_2A-4A-4A-5A	2	0.5
	4	0.5
	5	0.3
CA_2A-4A-7A	2	0.5
	4	0.5
	7	0.5
CA_2A-4A-12A	2	0.5
	4	0.5
	12	0.8
CA_2A-4A-4A-12A	2	0.5
	4	0.5
	12	0.8
CA_2A-4A-13A	2	0.5
	4	0.5
	13	0.3
CA_2A-4A-29A	2	[0.5]
	4	0.5
CA_2A-4A-30A	2	0.5
	4	0.5
	30	0.3
CA_2A-5A-12A	2	0.3
	5	0.8
	12	0.4
CA_2A-2A-5A-12A	2	0.3
	5	0.8
	12	0.4
CA_2A-5A-12B	2	0.3
	5	0.8
	12	0.4
CA_2A-5A-13A	2	0.3
	5	0.5
	13	0.5
CA_2A-5A-29A	2	0.3
	5	0.5
CA_2A-5A-30A	2	0.5
	5	0.3

	30	0.3
CA_2C-5A-30A	2	0.5
	5	0.3
	30	0.3
CA_2A-7A-12A	2	0.5
	7	0.5
	12	0.3
CA_2A-12A-30A	2	0.5
	12	0.3
	30	0.3
CA_2C-12A-30A	2	0.5
	12	0.3
	30	0.3
CA_2A-29A-30A	2	0.5
	30	0.3
CA_2C-29A-30A	2	0.5
	30	0.3
	30	0.3
CA_3A-5A-40A	3	0.5
	5	0.3
	40	0.5
CA_3A-7A-8A	3	0.5
	7	0.5
	8	0.6
CA_3A-7A-20A	3	0.5
	7	0.5
	20	0.3
CA_3A-7A-28A	3	0.5
	7	0.5
	28	0.3
CA_3A-7C-28A	3	0.5
	7	0.5
	28	0.3
CA_3C-7A-28A	3	0.5
	7	0.5
	28	0.3
CA_3C-7C-28A	3	0.5
	7	0.5
	28	0.3
CA_3A-7A-38A	3	0.5
	7	0.5
	38	0.5
CA_3A-8A-40A	3	0.5
	8	0.3
	40	0.5
CA_3A-19A-42A	3	0.6
	19	0.3
	42	0.8
CA_3A-19A-42C	3	0.6
	19	0.3
	42	0.8
CA_3A-28A-40A	3	0.5
	28	0.3
	40	0.5
CA_3A-28A-40C	3	0.5
	28	0.3
	40	0.5
CA_3A-41A-42A ⁸	3	1
	41	$0.3^5/0.8^6$
	42	0.8
CA_4A-5A-12A	4	0.3
	5	0.8
	12	0.8
CA_4A-4A-5A-12A	4	0.3
	5	0.8
	12	0.8

CA_4A-5A-13A	4	0.3
	5	0.5
	13	0.5
CA_4A-5A-29A	4	0.3
	5	0.5
CA_4A-5A-30A	4	0.5
	5	0.3
	30	0.3
CA_4A-4A-5A-30A	4	0.5
	5	0.3
	30	0.3
CA_4A-7A-12A	4	0.5
	7	0.5
	12	0.8
CA_4A-12A-30A	4	0.5
	12	0.8
	30	0.3
CA_4A-4A-12A-30A	4	0.5
	12	0.8
	30	0.3
CA_4A-29A-30A	4	0.5
	30	0.3
CA_4A-4A-29A-30A	4	0.5
	30	0.3
CA_7A-8A-20A	7	0.3
	8	0.6
	20	[0.6]
CA_7A-20A-38A	7	0.3
	20	0.3
	38	0.3
CA_19A-21A-42A	19	0.3
	21	0.4
	42	0.8
CA_19A-21A-42C	19	0.3
	21	0.4
	42	0.8
NOTE 1: The above additional tolerances are only applicable for the E-UTRA operating bands that belong to the supported inter-band carrier aggregation configurations		
NOTE 2: The above additional tolerances also apply in non-aggregated operation for the supported E-UTRA operating bands that belong to the supported inter-band carrier aggregation configurations		
NOTE 3: Unless otherwise specified, in case the UE supports more than one of the above 3DL inter-band carrier aggregation configurations and a E-UTRA operating band belongs to more than one 3DL inter-band carrier aggregation configurations then:		
- When the E-UTRA operating band frequency range is \leq 1GHz and the tolerances are the same, the value applies to the band. If the tolerances are different, the applicable additional 3DL tolerance is FFS. In case there is a harmonic relation between low band UL and high band DL, then the maximum tolerance among the different supported 3DL carrier aggregation configurations involving such band shall be applied		
- When the E-UTRA operating band frequency range is >1GHz, the applicable additional 3DL tolerance shall be the maximum tolerance above that applies for that operating band among the supported 3DL CA configurations		
NOTE 4: The above additional tolerances applicable for the E-UTRA operating bands that belong to the supported highest order inter-band carrier aggregation configuration, also applies to the same E-UTRA operating bands that belong to a supported lower order CA configuration.		
NOTE 5: The requirement is specified for the frequency range of 2545-2690MHz.		
NOTE 6: The requirement is specified for the frequency range of 2496-		

2545MHz.

NOTE 7: For UE supporting E-UTRA band 65 and CA configurations including Band 1, the Band 65 $\Delta T_{IB,c}$ is the max(Band 65 $\Delta T_{IB,c}$, Band 1 $\Delta T_{IB,c}$)

NOTE 8: Applicable for UE supporting inter-band carrier aggregation without simultaneous Rx/Tx among TDD bands.

Table 6.2.5-4: $\Delta T_{IB,c}$ (four bands)

Inter-band CA Configuration	E-UTRA Band	$\Delta T_{IB,c}$ [dB]
CA_1A-3A-5A-40A	1	0.5
	3	0.5
	5	0.3
	40	0.5
CA_1A-3A-7A-8A	1	0.6
	3	0.6
	7	0.6
	8	0.6
CA_1A-3A-7A-28A	1	0.6
	3	0.6
	7	0.6
	28	0.6
CA_1A-3A-7C-28A	1	0.6
	3	0.6
	7	0.6
	28	0.6
CA_1A-3A-8A-40A	1	0.5
	3	0.5
	8	0.3
	40	0.5
CA_1A-3A-19A-42A	1	0.6
	3	0.6
	19	0.3
	42	0.8
CA_1A-3A-19A-42C	1	0.6
	3	0.6
	19	0.3
	42	0.8
CA_1A-19A-21A-42A	1	0.3
	19	0.3
	21	0.4
	42	0.8
CA_1A-19A-21A-42C	1	0.3
	19	0.3
	21	0.4
	42	0.8
CA_2A-4A-5A-12A	2	0.5
	4	0.5
	5	0.8
	12	0.8
CA_2A-4A-5A-29A	2	0.5
	4	0.5
	5	0.5
CA_2A-4A-5A-30A	2	0.5
	4	0.5
	5	0.3
	30	0.3
CA_2A-4A-7A-12A	2	0.5
	4	0.5
	7	0.5
	12	0.8
CA_2A-4A-12A-30A	2	0.5
	4	0.5
	12	0.8
	30	0.3
CA_2A-4A-29A-30A	2	0.5
	4	0.5
	30	0.3

NOTE 1: The above additional tolerances are only applicable for the E-UTRA operating bands that belong to the supported inter-band carrier aggregation configurations.

NOTE 2:	The above additional tolerances also apply in non-aggregated operation for the supported E-UTRA operating bands that belong to the supported inter-band carrier aggregation configurations.
NOTE 3:	Tolerances for a UE supporting multiple 4DL inter-band CA configurations are FFS.
NOTE 4:	The above additional tolerances applicable for the E-UTRA operating bands that belong to the supported highest order inter-band carrier aggregation configuration, also applies to the same E-UTRA operating bands that belong to a supported lower order CA configuration.
NOTE 5:	For UE supporting E-UTRA band 65 and CA configurations including Band 1, the Band 65 $\Delta T_{IB,c}$ is the $\max(\text{Band 65 } \Delta T_{IB,c}, \text{Band 1 } \Delta T_{IB,c})$

NOTE: The above additional tolerances do not apply to supported UTRA operating bands with frequency range below 1 GHz that correspond to the E-UTRA operating bands that belong to the supported inter-band carrier aggregation configurations when such bands are belonging only to band combination(s) where one band is <1GHz and other bands are >1.7GHz and there is no harmonic relationship between the low band UL and high band DL. Otherwise the above additional tolerances also apply to supported UTRA operating bands that correspond to the E-UTRA operating bands that belong to the supported inter-band carrier aggregation configurations.

6.2.5A Configured transmitted power for CA

For uplink carrier aggregation the UE is allowed to set its configured maximum output power $P_{CMAX,c}$ for serving cell c and its total configured maximum output power P_{CMAX} .

The configured maximum output power $P_{CMAX,c}$ on serving cell c shall be set as specified in subclause 6.2.5.

For uplink inter-band carrier aggregation, MPR_c and $A-MPR_c$ apply per serving cell c and are specified in subclause 6.2.3 and subclause 6.2.4, respectively. $P-MPR_c$ accounts for power management for serving cell c . $P_{CMAX,c}$ is calculated under the assumption that the transmit power is increased independently on all component carriers.

For uplink intra-band contiguous and non-contiguous carrier aggregation, $MPR_c = MPR$ and $A-MPR_c = A-MPR$ with MPR and $A-MPR$ specified in subclause 6.2.3A and subclause 6.2.4A respectively. There is one power management term for the UE, denoted $P-MPR$, and $P-MPR_c = P-MPR$. $P_{CMAX,c}$ is calculated under the assumption that the transmit power is increased by the same amount in dB on all component carriers.

The total configured maximum output power P_{CMAX} shall be set within the following bounds:

$$P_{CMAX_L} \leq P_{CMAX} \leq P_{CMAX_H}$$

For uplink inter-band carrier aggregation with one serving cell c per operating band,

$$P_{CMAX_L} = \min \left\{ 10 \log_{10} \sum \min \left[p_{EMAX,c} / (\Delta t_{C,c}), p_{PowerClass} / (mpr_c \cdot a-mpr_c \cdot \Delta t_{C,c} \cdot \Delta t_{IB,c} \cdot \Delta t_{ProSe}), p_{PowerClass} / pmpr_c \right], P_{PowerClass} \right\}$$

$$P_{CMAX_H} = \min \{ 10 \log_{10} \sum p_{EMAX,c}, P_{PowerClass} \}$$

where

- $p_{EMAX,c}$ is the linear value of $P_{EMAX,c}$ which is given by IE *P-Max* for serving cell c in [7];
- $P_{PowerClass}$ is the maximum UE power specified in Table 6.2.2A-1 without taking into account the tolerance specified in the Table 6.2.2A-1; $p_{PowerClass}$ is the linear value of $P_{PowerClass}$;
- mpr_c and $a-mpr_c$ are the linear values of MPR_c and $A-MPR_c$ as specified in subclause 6.2.3 and subclause 6.2.4, respectively;
- $pmpr_c$ is the linear value of $P-MPR_c$;
- $\Delta t_{C,c}$ is the linear value of $\Delta T_{C,c}$. $\Delta t_{C,c} = 1.41$ when NOTE 2 in Table 6.2.2-1 applies for a serving cell c , otherwise $\Delta t_{C,c} = 1$;
- $\Delta t_{IB,c}$ is the linear value of the inter-band relaxation term $\Delta T_{IB,c}$ of the serving cell c as specified in Table 6.2.5-2; otherwise $\Delta t_{IB,c} = 1$;

- ΔT_{ProSe} is the linear value of ΔT_{ProSe} and applies as specified in subclause 6.2.5.

For uplink intra-band contiguous and non-contiguous carrier aggregation,

$$P_{CMAX_L} = \text{MIN}\{10 \log_{10} \sum p_{EMAX,c} - \Delta T_C, P_{PowerClass} - \text{MAX}(MPR + A\text{-MPR} + \Delta T_{IB,c} + \Delta T_C + \Delta T_{ProSe}, P\text{-MPR})\}$$

$$P_{CMAX_H} = \text{MIN}\{10 \log_{10} \sum p_{EMAX,c}, P_{PowerClass}\}$$

where

- $p_{EMAX,c}$ is the linear value of $P_{EMAX,c}$ which is given by IE *P-Max* for serving cell c in [7];
- $P_{PowerClass}$ is the maximum UE power specified in Table 6.2.2A-1 without taking into account the tolerance specified in the Table 6.2.2A-1;
- MPR and A-MPR are specified in subclause 6.2.3A and subclause 6.2.4A respectively;
- $\Delta T_{IB,c}$ is the additional tolerance for serving cell c as specified in Table 6.2.5-2;
- P-MPR is the power management term for the UE;
- ΔT_C is the highest value $\Delta T_{C,c}$ among all serving cells c in the subframe over both timeslots. $\Delta T_{C,c} = 1.5$ dB when NOTE 2 in Table 6.2.2A-1 applies to the serving cell c , otherwise $\Delta T_{C,c} = 0$ dB;
- ΔT_{ProSe} applies as specified in subclause 6.2.5.

For combinations of intra-band and inter-band carrier aggregation with UE configured for transmission on three serving cells (up to two contiguously aggregated carriers per operating band),

$$P_{CMAX_L} = \text{MIN}\{10 \log_{10} \sum (P_{CMAX_L, Bi}), P_{PowerClass}\}$$

$$P_{CMAX_H} = \text{MIN}\{10 \log_{10} \sum p_{EMAX,c}, P_{PowerClass}\}$$

where

- $p_{EMAX,c}$ is the linear value of $P_{EMAX,c}$ which is given by IE *P-Max* for serving cell c in [7];
- $P_{PowerClass}$ is the maximum UE power specified in Table 6.2.2A-0 without taking into account the tolerance specified in the Table 6.2.2A-0; $p_{PowerClass}$ is the linear value of $P_{PowerClass}$;
- $P_{CMAX_L, Bi}$ is the linear values of P_{CMAX_L} as specified in corresponding operating band. $P_{CMAX_L,c}$ specified for single carrier in subclause 6.2.5 applies for operating band supporting one serving cell. P_{CMAX_L} specified for uplink intra-band contiguous carrier aggregation in subclause 6.2.5A applies for operating band supporting two contiguous serving cells.

For each subframe, the P_{CMAX_L} is evaluated per slot and given by the minimum value taken over the transmission(s) within the slot; the minimum P_{CMAX_L} over the two slots is then applied for the entire subframe. $P_{PowerClass}$ shall not be exceeded by the UE during any period of time.

If the UE is configured with multiple TAGs and transmissions of the UE on subframe i for any serving cell in one TAG overlap some portion of the first symbol of the transmission on subframe $i+1$ for a different serving cell in another TAG, the UE minimum of P_{CMAX_L} for subframes i and $i+1$ applies for any overlapping portion of subframes i and $i+1$. $P_{PowerClass}$ shall not be exceeded by the UE during any period of time.

In case PC2 and uplink intra-band contiguous CA capable UE receives $p_{EMAX,c}$ in Scell then that applies both to Scell and Pcell once the Scell is activated.

The measured maximum output power P_{UMAX} over all serving cells shall be within the following range:

$$P_{CMAX_L} - \text{MAX}\{T_L, T_{LOW}(P_{CMAX_L})\} \leq P_{UMAX} \leq P_{CMAX_H} + T_{HIGH}(P_{CMAX_H})$$

$$P_{UMAX} = 10 \log_{10} \sum p_{UMAX,c}$$

where $p_{\text{UMAX},c}$ denotes the measured maximum output power for serving cell c expressed in linear scale. The tolerances $T_{\text{LOW}}(P_{\text{CMAX}})$ and $T_{\text{HIGH}}(P_{\text{CMAX}})$ for applicable values of P_{CMAX} are specified in Table 6.2.5A-1 and Table 6.2.5A-2 for inter-band carrier aggregation and intra-band carrier aggregation, respectively. The tolerance T_L is the absolute value of the lower tolerance for applicable E-UTRA CA configuration as specified in Table 6.2.2A-0, Table 6.2.2A-1 and Table 6.2.2A-2 for inter-band carrier aggregation, intra-band contiguous carrier aggregation and intra-band non-contiguous carrier aggregation, respectively.

Table 6.2.5A-1: P_{CMAX} tolerance for uplink inter-band CA (two bands)

P_{CMAX} (dBm)	Tolerance $T_{\text{LOW}}(P_{\text{CMAX}})$ (dB)	Tolerance $T_{\text{HIGH}}(P_{\text{CMAX}})$ (dB)
$P_{\text{CMAX}} = 23$	3.0	2.0
$22 \leq P_{\text{CMAX}} < 23$	5.0	2.0
$21 \leq P_{\text{CMAX}} < 22$	5.0	3.0
$20 \leq P_{\text{CMAX}} < 21$	6.0	4.0
$16 \leq P_{\text{CMAX}} < 20$	5.0	
$11 \leq P_{\text{CMAX}} < 16$	6.0	
$-40 \leq P_{\text{CMAX}} < 11$	7.0	

Table 6.2.5A-2: P_{CMAX} tolerance

P_{CMAX} (dBm)	Tolerance $T_{\text{LOW}}(P_{\text{CMAX}})$ (dB)	Tolerance $T_{\text{HIGH}}(P_{\text{CMAX}})$ (dB)
$21 \leq P_{\text{CMAX}} \leq 23$	2.0	
$20 \leq P_{\text{CMAX}} < 21$	2.5	
$19 \leq P_{\text{CMAX}} < 20$	3.5	
$18 \leq P_{\text{CMAX}} < 19$	4.0	
$13 \leq P_{\text{CMAX}} < 18$	5.0	
$8 \leq P_{\text{CMAX}} < 13$	6.0	
$-40 \leq P_{\text{CMAX}} < 8$	7.0	

6.2.5B Configured transmitted power for UL-MIMO

For UE supporting UL-MIMO, the transmitted power is configured per each UE.

The definitions of configured maximum output power $P_{\text{CMAX},c}$, the lower bound $P_{\text{CMAX}_L,c}$, and the higher bound $P_{\text{CMAX}_H,c}$ specified in subclause 6.2.5 shall apply to UE supporting UL-MIMO, where

- $P_{\text{PowerClass}}$ and $\Delta T_{C,c}$ are specified in subclause 6.2.2B;
- MPR_{c} is specified in subclause 6.2.3B;
- A-MPR_{c} is specified in subclause 6.2.4B.

The measured configured maximum output power $P_{\text{UMAX},c}$ for serving cell c shall be within the following bounds:

$$P_{\text{CMAX}_L,c} - \text{MAX}\{T_L, T_{\text{LOW}}(P_{\text{CMAX}_L,c})\} \leq P_{\text{UMAX},c} \leq P_{\text{CMAX}_H,c} + T_{\text{HIGH}}(P_{\text{CMAX}_H,c})$$

where $T_{\text{LOW}}(P_{\text{CMAX}_L,c})$ and $T_{\text{HIGH}}(P_{\text{CMAX}_H,c})$ are defined as the tolerance and applies to $P_{\text{CMAX}_L,c}$ and $P_{\text{CMAX}_H,c}$ separately, while T_L is the absolute value of the lower tolerance in Table 6.2.2B-1 for the applicable operating band.

For UE with two transmit antenna connectors in closed-loop spatial amultiplexing scheme, the tolerance is specified in Table 6.2.5B-1. The requirements shall be met with UL-MIMO configurations specified in Table 6.2.2B-2.

Table 6.2.5B-1: $P_{\text{CMAX},c}$ tolerance in closed-loop spatial multiplexing scheme

$P_{\text{CMAX},c}$ (dBm)	Tolerance $T_{\text{LOW}}(P_{\text{CMAX}_L,c})$ (dB)	Tolerance $T_{\text{HIGH}}(P_{\text{CMAX}_H,c})$ (dB)
$P_{\text{CMAX},c} = 23$	3.0	2.0
$22 \leq P_{\text{CMAX},c} < 23$	5.0	2.0
$21 \leq P_{\text{CMAX},c} < 22$	5.0	3.0
$20 \leq P_{\text{CMAX},c} < 21$	6.0	4.0
$16 \leq P_{\text{CMAX},c} < 20$	5.0	
$11 \leq P_{\text{CMAX},c} < 16$	6.0	
$-40 \leq P_{\text{CMAX},c} < 11$	7.0	

If UE is configured for transmission on single-antenna port, the requirements in subclause 6.2.5 apply.

6.2.5C Configured transmitted power for Dual Connectivity

For inter-band dual connectivity with one uplink serving cell per CG, the UE is allowed to set its configured maximum output power $P_{\text{CMAX},c(i),i}$ for serving cell $c(i)$ of CG i , $i = 1, 2$, and its total configured maximum output power P_{CMAX} .

The configured maximum output power $P_{\text{CMAX},c(i),i}(p)$ in subframe p of serving cell $c(i)$ on CG i shall be set within the following bounds:

$$P_{\text{CMAX}_L,c(i),i}(p) \leq P_{\text{CMAX},c(i),i}(p) \leq P_{\text{CMAX}_H,c(i),i}(p)$$

where $P_{\text{CMAX}_L,c(i),i}(p)$ and $P_{\text{CMAX}_H,c(i),i}(p)$ are the limits for a serving cell $c(i)$ of CG i as specified in subclause 6.2.5.

The total UE configured maximum output power $P_{\text{CMAX}}(p,q)$ in a subframe p of CG 1 and a subframe q of CG 2 that overlap in time shall be set within the following bounds for synchronous and asynchronous operation unless stated otherwise:

$$P_{\text{CMAX}_L}(p,q) \leq P_{\text{CMAX}}(p,q) \leq P_{\text{CMAX}_H}(p,q)$$

with

$$P_{\text{CMAX}_L}(p,q) = \text{MIN} \{ 10 \log_{10} [p_{\text{CMAX}_L,c(1),1}(p) + p_{\text{CMAX}_L,c(2),2}(q)], P_{\text{PowerClass}} \}$$

$$P_{\text{CMAX}_H}(p,q) = \text{MIN} \{ 10 \log_{10} [p_{\text{CMAX}_H,c(1),1}(p) + p_{\text{CMAX}_H,c(2),2}(q)], P_{\text{PowerClass}} \}$$

where $p_{\text{CMAX}_L,c(i),i}$ and $p_{\text{CMAX}_H,c(i),i}$ are the respective limits $P_{\text{CMAX}_L,c(i),i}(p)$ and $P_{\text{CMAX}_H,c(i),i}(p)$ expressed in linear scale.

If the UE is configured in Dual Connectivity and synchronous transmissions of the UE on subframe p for a serving cell in one CG overlaps some portion of the first symbol of the transmission on subframe $q+1$ for a different serving cell in the other CG, the UE minimum of P_{CMAX_L} between subframes pairs (p, q) and $(p+1, q+1)$ respectively applies for any overlapping portion of subframes (p, q) and $(p+1, q+1)$. $P_{\text{PowerClass}}$ shall not be exceeded by the UE during any period of time.

The measured total maximum output power P_{UMAX} over both CGs is

$$P_{\text{UMAX}} = 10 \log_{10} [p_{\text{UMAX},c(1),1} + p_{\text{UMAX},c(2),2}],$$

where $p_{\text{UMAX},c(i),i}$ denotes the measured output power of serving cell $c(i)$ of CG i expressed in linear scale.

If the UE is configured in Dual Connectivity and synchronous transmissions

$$P_{\text{CMAX}_L}(p, q) - T_{\text{LOW}}(P_{\text{CMAX}_L}(p, q)) \leq P_{\text{UMAX}} \leq P_{\text{CMAX}_H}(p, q) + T_{\text{HIGH}}(P_{\text{CMAX}_H}(p, q))$$

where $P_{\text{CMAX}_L}(p,q)$ and $P_{\text{CMAX}_H}(p,q)$ are the limits for the pair (p,q) and with the tolerances $T_{\text{LOW}}(P_{\text{CMAX}})$ and $T_{\text{HIGH}}(P_{\text{CMAX}})$ for applicable values of P_{CMAX} specified in Table 6.2.5C-1. P_{CMAX_L} may be modified for any overlapping portion of subframes (p, q) and $(p+1, q+1)$.

If the UE is configured in Dual Connectivity and asynchronous transmissions, the subframes of the leading CG are taken as reference subframes for the measurement of the total configured output power P_{UMAX} . If subframe p of CG 1 and subframe q of CG 2 overlap in time in their respective slot 0 and

1. if p leads in time over q , then p is the reference subframe and the (p,q) and $(p,q-1)$ pairs are considered for determining the P_{CMAX} tolerance
2. if q leads in time over p , then q is the reference subframe and the $(p-1,q)$ and (p,q) pairs are considered for determining the P_{CMAX} tolerance;

for the reference subframe p duration (when subframe p in CG 1 leads):

$$P'_{\text{CMAX}_L} = \text{MIN} \{P_{\text{CMAX}_L}(p,q), P_{\text{CMAX}_L}(p,q-1)\}$$

$$P'_{\text{CMAX}_H} = \text{MAX} \{P_{\text{CMAX}_H}(p,q), P_{\text{CMAX}_H}(p,q-1)\}$$

while for the reference subframe q duration (when subframe q in CG 2 leads):

$$P'_{\text{CMAX}_L} = \text{MIN} \{P_{\text{CMAX}_L}(p-1,q), P_{\text{CMAX}_L}(p,q)\}$$

$$P'_{\text{CMAX}_H} = \text{MAX} \{P_{\text{CMAX}_H}(p-1,q), P_{\text{CMAX}_H}(p,q)\}$$

where P_{CMAX_L} and P_{CMAX_H} are the applicable limits for each overlapping subframe pairs (p,q) , $(p, q-1)$ and $(p-1,q)$. The measured total configured maximum output power P_{UMAX} shall be within the following bounds:

$$P'_{\text{CMAX}_L} - T_{\text{LOW}}(P'_{\text{CMAX}_L}) \leq P_{\text{UMAX}} \leq P'_{\text{CMAX}_H} + T_{\text{HIGH}}(P'_{\text{CMAX}_H})$$

with the tolerances $T_{\text{LOW}}(P_{\text{CMAX}})$ and $T_{\text{HIGH}}(P_{\text{CMAX}})$ for applicable values of P_{CMAX} specified in Table 6.2.5C-1.

Table 6.2.5C-1: P_{CMAX} tolerance for inter-band Dual Connectivity

$P_{\text{CMAX}}(\text{dBm})$	Tolerance $T_{\text{LOW}}(P_{\text{CMAX}_L})(\text{dB})$	Tolerance $T_{\text{HIGH}}(P_{\text{CMAX}_H})(\text{dB})$
$P_{\text{CMAX}} = 23$	3.0	2.0
$22 \leq P_{\text{CMAX}} < 23$	5.0	2.0
$21 \leq P_{\text{CMAX}} < 22$	5.0	3.0
$20 \leq P_{\text{CMAX}} < 21$	6.0	4.0
$16 \leq P_{\text{CMAX}} < 20$	5.0	
$11 \leq P_{\text{CMAX}} < 16$	6.0	
$-40 \leq P_{\text{CMAX}} < 11$	7.0	

6.2.5D Configured transmitted power for ProSe

When UE is configured for E-UTRA ProSe sidelink transmissions non-concurrent with E-UTRA uplink transmissions for E-UTRA ProSe operating bands specified in Table 5.5D-1, the configured maximum output power $P_{\text{CMAX},c}$ and power boundary requirement specified in subclause 6.2.5 shall apply to UE supporting ProSe, where

- MPR_c is specified in subclause 6.2.3D;
- A-MPR_c is specified in subclause 6.2.4D;
- $\Delta T_{\text{ProSe}} = 0.1$ dB.

For $P_{\text{CMAX},\text{PSSCH}}$ and $P_{\text{CMAX},\text{PSCCH}}$, $P_{\text{EMAX},c}$ is the value given by IE $P\text{-Max}$ for serving cell c , defined by [7], when present. $P_{\text{EMAX},c}$ is the value given by IE maxTxPower , defined by [7], when the UE is not associated with a serving cell on the ProSe carrier.

For $P_{\text{CMAX},\text{PSDCH}}$, $P_{\text{EMAX},c}$ is the value given by the IE discMaxTxPower in [7].

For $P_{\text{CMAX},\text{PSBCH}}$, $P_{\text{EMAX},c}$ is the value given by the IE maxTxPower in [7] when the ProSe UE is not associated with a serving cell on the ProSe carrier. When the UE is associated with a serving cell, then $P_{\text{EMAX},c}$ is the value given by the IE $P\text{-Max}$ when PSBCH/SLSS transmissions is triggered for ProSe Direct communication as specified in [7], and is the value given by the IE discMaxTxPower in [7] otherwise.

For $P_{\text{CMAX,SSSS}}$, the value is as calculated for $P_{\text{CMAX,PSBCH}}$ and applying the MPR for SSSS as specified in Section 6.2.3D.

When a UE is configured for simultaneous E-UTRA ProSe sidelink and E-UTRA uplink transmissions for inter-band E-UTRA ProSe / E-UTRA bands specified in Table 5.5D-2, the UE is allowed to set its configured maximum output power $P_{\text{CMAX,c,E-UTRA}}$ and $P_{\text{CMAX,c,ProSe}}$ for the configured E-UTRA uplink carrier and the configured E-UTRA ProSe carrier, respectively, and its total configured maximum output power $P_{\text{CMAX,c}}$.

The configured maximum output power $P_{\text{CMAX,c,E-UTRA}}(p)$ in subframe p for the configured E-UTRA uplink carrier shall be set within the bounds:

$$P_{\text{CMAX,L,c,E-UTRA}}(p) \leq P_{\text{CMAX,c,E-UTRA}}(p) \leq P_{\text{CMAX,H,c,E-UTRA}}(p)$$

where $P_{\text{CMAX,L,c,E-UTRA}}$ and $P_{\text{CMAX,H,c,E-UTRA}}$ are the limits for a serving cell c as specified in subclause 6.2.5.

The configured maximum output power $P_{\text{CMAX,c,ProSe}}(q)$ in subframe q for the configured E-UTRA ProSe carrier shall be set within the bounds:

$$P_{\text{CMAX,c,ProSe}}(q) \leq P_{\text{CMAX,H,c,ProSe}}(q)$$

where $P_{\text{CMAX,H,c,ProSe}}$ is the limit as specified in subclause 6.2.5D.

The total UE configured maximum output power $P_{\text{CMAX}}(p,q)$ in a subframe p of an E-UTRA uplink carrier and a subframe q of an E-UTRA ProSe sidelink that overlap in time shall be set within the following bounds for synchronous and asynchronous operation unless stated otherwise:

$$P_{\text{CMAX,L}}(p,q) \leq P_{\text{CMAX}}(p,q) \leq P_{\text{CMAX,H}}(p,q)$$

with

$$P_{\text{CMAX,L}}(p,q) = P_{\text{CMAX,L,c,E-UTRA}}(p)$$

$$P_{\text{CMAX,H}}(p,q) = \text{MIN} \{ 10 \log_{10} [p_{\text{CMAX,H,c,E-UTRA}}(p) + p_{\text{CMAX,H,c,ProSe}}(q)], P_{\text{PowerClass}} \}$$

where $p_{\text{CMAX,H,c,ProSe}}$ and $p_{\text{CMAX,H,c,E-UTRA}}$ are the limits $P_{\text{CMAX,H,c,ProSe}}(q)$ and $P_{\text{CMAX,H,c,E-UTRA}}(p)$ expressed in linear scale.

The measured total maximum output power P_{UMAX} over both the E-UTRA uplink and E-UTRA ProSe carriers is

$$P_{\text{UMAX}} = 10 \log_{10} [p_{\text{UMAX,c,E-UTRA}} + p_{\text{UMAX,c,ProSe}}],$$

where $p_{\text{UMAX,c,E-UTRA}}$ denotes the measured output power of serving cell c for the configured E-UTRA uplink carrier, and $p_{\text{UMAX,c,ProSe}}$ denotes the measured output power for the configured E-UTRA ProSe carrier expressed in linear scale.

When a UE is configured for synchronous ProSe and uplink transmissions,

$$P_{\text{CMAX,L}}(p,q) - T_{\text{LOW}}(P_{\text{CMAX,L}}(p,q)) \leq P_{\text{UMAX}} \leq P_{\text{CMAX,H}}(p,q) + T_{\text{HIGH}}(P_{\text{CMAX,H}}(p,q))$$

where $P_{\text{CMAX,L}}(p,q)$ and $P_{\text{CMAX,H}}(p,q)$ are the limits for the pair (p,q) and with the tolerances $T_{\text{LOW}}(P_{\text{CMAX}})$ and $T_{\text{HIGH}}(P_{\text{CMAX}})$ for applicable values of P_{CMAX} specified in Table 6.2.5C-1. $P_{\text{CMAX,L}}$ may be modified for any overlapping portion of subframes (p,q) and $(p+I,q+I)$.

When a UE is configured for asynchronous ProSe and uplink transmissions, the carrier configured for uplink transmission is taken as the reference. If subframe p for the E-UTRA uplink carrier and subframe q for the E-UTRA ProSe carrier overlap in time and

1. if uplink carrier leads in time over q , then p is the reference subframe and, the (p,q) and $(p,q-1)$ pairs are considered for determining the P_{CMAX} tolerance
2. if ProSe carrier leads in time over p , then p is the reference subframe and, the (p,q) and $(p,q+1)$ pairs are considered for determining the P_{CMAX} tolerance

For the reference subframe p duration when uplink carrier leads:

$$P'_{\text{CMAX,L}} = P_{\text{CMAX,L,c,E-UTRA}}(p)$$

$$P'_{\text{CMAX}_H} = \text{MAX} \{ P_{\text{CMAX}_H}(p, q-1), P_{\text{CMAX}_H}(p, q) \}$$

For the reference subframe p duration when ProSe carrier leads:

$$P'_{\text{CMAX}_L} = P_{\text{CMAX}_{L,cE-UTRA}}(p)$$

$$P'_{\text{CMAX}_H} = \text{MAX} \{ P_{\text{CMAX}_H}(p, q), P_{\text{CMAX}_H}(p, q+1) \}$$

where $P_{\text{CMAX}_{L,cE-UTRA}}(p)$ and P_{CMAX_H} are the applicable limits for each overlapping subframe pairs (p, q) , $(p, q+1)$, $(p, q-1)$. The measured total configured maximum output power P_{UMAX} shall be within the following bounds:

$$P'_{\text{CMAX}_L} - T_{\text{LOW}}(P'_{\text{CMAX}_L}) \leq P_{\text{UMAX}} \leq P'_{\text{CMAX}_H} + T_{\text{HIGH}}(P'_{\text{CMAX}_H})$$

with the tolerances $T_{\text{LOW}}(P_{\text{CMAX}})$ and $T_{\text{HIGH}}(P_{\text{CMAX}})$ for applicable values of P_{CMAX} specified in Table 6.2.5C-1.

6.2.5F Configured transmitted Power for category NB1

For each slot i the category NB1 UE is allowed to set its configured maximum output power $P_{\text{CMAX},c}$. The configured maximum output power $P_{\text{CMAX},c}$ is set within the following bounds:

$$P_{\text{CMAX}_{L,c}} \leq P_{\text{CMAX},c} \leq P_{\text{CMAX}_{H,c}}$$

Where

- $P_{\text{CMAX}_{L,c}} = \text{MIN} \{ P_{\text{EMAX},c}, P_{\text{PowerClass}} - \text{MPR}_c - \text{A-MPR}_c \}$
- $P_{\text{CMAX}_{H,c}} = \text{MIN} \{ P_{\text{EMAX},c}, P_{\text{PowerClass}} \}$
- $P_{\text{EMAX},c}$ is the value given to IE $P\text{-Max}$, defined in [7]
- $P_{\text{PowerClass}}$ is the maximum category NB1 UE power specified in Table 6.2.2F-1 without taking into account the associated tolerance
- MPR_c is specified in subclause 6.2.3F
- $\text{A-MPR}_c = 0\text{dB}$ unless otherwise stated.

The measurement period for $P_{\text{UMAX},c}$ is at least one sub-frame (1ms) for 15 KHz channel spacing, and at least a 2ms slot (excluding the 2304Ts gap when UE is not transmitting) respectively for the 3.75 KHz channel spacing. The measured maximum output power $P_{\text{UMAX},c}$ shall be within the following bounds:

$$P_{\text{CMAX}_{L,c}} - T(P_{\text{CMAX}_{L,c}}) \leq P_{\text{UMAX},c} \leq P_{\text{CMAX}_{H,c}} + T(P_{\text{CMAX}_{H,c}})$$

Where $T(P_{\text{CMAX}})$ is defined by the tolerance table below and applies to $P_{\text{CMAX}_{L,c}}$ and $P_{\text{CMAX}_{H,c}}$ separately.

Table 6.2.5F-1: P_{CMAX} tolerance for power class 3

P_{CMAX} (dBm)	Tolerance $T(P_{\text{CMAX}})$ (dB)
$21 \leq P_{\text{CMAX}} \leq 23$	2.0
$20 \leq P_{\text{CMAX}} < 21$	2.5
$19 \leq P_{\text{CMAX}} < 20$	3.5
$18 \leq P_{\text{CMAX}} < 19$	4.0
$13 \leq P_{\text{CMAX}} < 18$	5.0
$8 \leq P_{\text{CMAX}} < 13$	6.0
$-40 \leq P_{\text{CMAX}} < 8$	7.0

Table 6.2.5F-2: P_{CMAX} tolerance for power class 5

$P_{\text{CMAX},c}$ (dBm)	Tolerance $T(P_{\text{CMAX},c})$ (dB)
$18 \leq P_{\text{CMAX}} \leq 20$	2.0
$17 \leq P_{\text{CMAX},c} < 18$	2.5
$16 \leq P_{\text{CMAX},c} < 17$	3.5
$15 \leq P_{\text{CMAX},c} < 16$	4.0
$10 \leq P_{\text{CMAX},c} < 15$	5.0
$5 \leq P_{\text{CMAX},c} < 10$	6.0
$-40 \leq P_{\text{CMAX},c} < 5$	7.0

6.3 Output power dynamics

6.3.1 (Void)

6.3.2 Minimum output power

The minimum controlled output power of the UE is defined as the broadband transmit power of the UE, i.e. the power in the channel bandwidth for all transmit bandwidth configurations (resource blocks), when the power is set to a minimum value.

6.3.2.1 Minimum requirement

The minimum output power is defined as the mean power in one sub-frame (1ms). The minimum output power shall not exceed the values specified in Table 6.3.2.1-1.

Table 6.3.2.1-1: Minimum output power

	Channel bandwidth / Minimum output power / Measurement bandwidth					
	1.4 MHz	3.0 MHz	5 MHz	10 MHz	15 MHz	20 MHz
Minimum output power	-40 dBm					
Measurement bandwidth	1.08 MHz	2.7 MHz	4.5 MHz	9.0 MHz	13.5 MHz	18 MHz

6.3.2A UE Minimum output power for CA

For inter-band carrier aggregation with uplink assigned to two E-UTRA bands and intra-band contiguous and non-contiguous carrier aggregation, the minimum controlled output power of the UE is defined as the transmit power of the UE per component carrier, i.e., the power in the channel bandwidth of each component carrier for all transmit bandwidth configurations (resource blocks), when the power on both component carriers are set to a minimum value.

6.3.2A.1 Minimum requirement for CA

For inter-band carrier aggregation with uplink assigned to two E-UTRA bands, the minimum output power is defined per carrier and the requirement is specified in subclause 6.3.2.1. If two contiguous component carriers are assigned to one E-UTRA band, the requirements in subclause 6.3.2A.1 apply for those component carriers.

For intra-band contiguous and non-contiguous carrier aggregation the minimum output power is defined as the mean power in one sub-frame (1ms). The minimum output power shall not exceed the values specified in Table 6.3.2A.1-1.

Table 6.3.2A.1-1: Minimum output power for intra-band contiguous and non-contiguous CA UE

	CC Channel bandwidth / Minimum output power / Measurement bandwidth					
	1.4 MHz	3.0 MHz	5 MHz	10 MHz	15 MHz	20 MHz
Minimum output power	-40 dBm					
Measurement bandwidth			4.5 MHz	9.0 MHz	13.5 MHz	18 MHz

6.3.2B UE Minimum output power for UL-MIMO

For UE supporting UL-MIMO, the minimum controlled output power is defined as the broadband transmit power of the UE, i.e. the sum of the power in the channel bandwidth for all transmit bandwidth configurations (resource blocks) at each transmit antenna connector, when the UE power is set to a minimum value.

6.3.2B.1 Minimum requirement

For UE with two transmit antenna connectors in closed-loop spatial multiplexing scheme, the minimum output power is defined as the sum of the mean power at each transmit connector in one sub-frame (1ms). The minimum output power shall not exceed the values specified in Table 6.3.2B.1-1.

Table 6.3.2B.1-1: Minimum output power

	Channel bandwidth / Minimum output power / Measurement bandwidth					
	1.4 MHz	3.0 MHz	5 MHz	10 MHz	15 MHz	20 MHz
Minimum output power	-40 dBm					
Measurement bandwidth	1.08 MHz	2.7 MHz	4.5 MHz	9.0 MHz	13.5 MHz	18 MHz

If UE is configured for transmission on single-antenna port, the requirements in subclause 6.3.2 apply.

6.3.2C Void

<reserved for future use>

6.3.2D UE Minimum output power for ProSe

When UE is configured for E-UTRA ProSe sidelink transmissions non-concurrent with E-UTRA uplink transmissions for E-UTRA ProSe operating bands specified in Table 5.5D-1, the requirements in subclause 6.3.2 apply for ProSe transmission.

When UE is configured for simultaneous E-UTRA ProSe sidelink and E-UTRA uplink transmissions for inter-band E-UTRA ProSe / E-UTRA bands specified in Table 5.5D-2, the requirements in subclause 6.3.2A apply as specified for the corresponding inter-band aggregation with uplink assigned to two bands.

6.3.2F UE Minimum output power for category NB1

For category NB1 UE the single-tone and multi-tone transmission minimum output power requirement for the channel bandwidth is -40 dBm. For 3.75kHz sub-carrier spacing the minimum output power is defined as mean power in one slot (2ms) excluding the 2304Ts gap when UE is not transmitting. For 15kHz sub-carrier spacing the minimum output power is defined as mean power in one sub-frame (1ms).

6.3.3 Transmit OFF power

Transmit OFF power is defined as the mean power when the transmitter is OFF. The transmitter is considered to be OFF when the UE is not allowed to transmit or during periods when the UE is not transmitting a sub-frame. During DTX and measurements gaps, the UE is not considered to be OFF.

6.3.3.1. Minimum requirement

The transmit OFF power is defined as the mean power in a duration of at least one sub-frame (1ms) excluding any transient periods. The transmit OFF power shall not exceed the values specified in Table 6.3.3.1-1.

Table 6.3.3.1-1: Transmit OFF power

	Channel bandwidth / Transmit OFF power / Measurement bandwidth					
	1.4 MHz	3.0 MHz	5 MHz	10 MHz	15 MHz	20 MHz
Transmit OFF power	-50 dBm					
Measurement bandwidth	1.08 MHz	2.7 MHz	4.5 MHz	9.0 MHz	13.5 MHz	18 MHz

6.3.3A UE Transmit OFF power for CA

For inter-band carrier aggregation with uplink assigned to two E-UTRA bands and intra-band contiguous and non-contiguous carrier aggregation, transmit OFF power is defined as the mean power per component carrier when the transmitter is OFF on all component carriers. The transmitter is considered to be OFF when the UE is not allowed to transmit or during periods when the UE is not transmitting a sub-frame. During measurements gaps, the UE is not considered to be OFF.

6.3.3A.1 Minimum requirement for CA

For inter-band carrier aggregation with uplink assigned to two E-UTRA bands, transmit OFF power requirement is defined per carrier and the requirement is specified in subclause 6.3.3.1. If two contiguous component carriers are assigned to one E-UTRA band, the requirements in subclause 6.3.3A.1 apply for those component carriers.

For intra-band contiguous and non-contiguous carrier aggregation the transmit OFF power is defined as the mean power in a duration of at least one sub-frame (1ms) excluding any transient periods. The transmit OFF power shall not exceed the values specified in Table 6.3.3A.1-1.

Table 6.3.3A.1-1: Transmit OFF power for intra-band contiguous and non-contiguous CA UE

	CC Channel bandwidth / Transmit OFF power / Measurement bandwidth					
	1.4 MHz	3.0 MHz	5 MHz	10 MHz	15 MHz	20 MHz
Transmit OFF power	-50 dBm					
Measurement bandwidth			4.5 MHz	9.0 MHz	13.5 MHz	18 MHz

6.3.3B UE Transmit OFF power for UL-MIMO

For UE supporting UL-MIMO, the transmit OFF power is defined as the mean power at each transmit antenna connector when the transmitter is OFF at all transmit antenna connectors. The transmitter is considered to be OFF when the UE is not allowed to transmit or during periods when the UE is not transmitting a sub-frame. During DTX and measurements gaps, the UE is not considered to be OFF.

6.3.3B.1 Minimum requirement

The transmit OFF power is defined as the mean power at each transmit antenna connector in a duration of at least one sub-frame (1ms) excluding any transient periods. The transmit OFF power at each transmit antenna connector shall not exceed the values specified in Table 6.3.3B.1-1.

Table 6.3.3B.1-1: Transmit OFF power per antenna port

	Channel bandwidth / Transmit OFF power/ Measurement bandwidth					
	1.4 MHz	3.0 MHz	5 MHz	10 MHz	15 MHz	20 MHz
Transmit OFF power	-50 dBm					
Measurement bandwidth	1.08 MHz	2.7 MHz	4.5 MHz	9.0 MHz	13.5 MHz	18 MHz

6.3.3D Transmit OFF power for ProSe

When UE is configured for E-UTRA ProSe sidelink transmissions non-concurrent with E-UTRA uplink transmissions for E-UTRA ProSe operating bands specified in Table 5.5D-1, the ProSe UE shall meet the Transmit OFF power at all times when the UE is not associated with a serving cell on the ProSe carrier and does not have knowledge of its geographical area or is provisioned with pre-configured radio parameters that are not associated with any known Geographical Area.

The requirements specified in subclause 6.3.3 shall apply to UE supporting ProSe when

- the UE is associated with a serving cell on the ProSe carrier, or
- the UE is not associated with a serving cell on the ProSe carrier and is provisioned with the preconfigured radio parameters for ProSe Direct Communications and/or ProSe Direct Discovery that are associated with known Geographical Area, or
- the UE is associated with a serving cell on a carrier different than the ProSe carrier, and the radio parameters for ProSe Direct Discovery on the ProSe carrier are provided by the serving cell, or
- the UE is associated with a serving cell on a carrier different than the ProSe carrier, and has a non-serving cell selected on the ProSe carrier that supports ProSe Direct Discovery and/or ProSe Direct Communication.

When UE is configured for simultaneous E-UTRA ProSe sidelink and E-UTRA uplink transmissions for inter-band E-UTRA ProSe / E-UTRA bands specified in Table 5.5D-2, transmit OFF power is defined as the mean power per component carrier when the transmitter is OFF on all component carriers. During measurement gaps and transmission/reception gaps for ProSe, the UE is not considered to be OFF. Transmit OFF power requirement as specified in subclause 6.3.3 apply per carrier.

6.3.3F Transmit OFF power for category NB1

For category NB1 UE the transmit OFF power requirement for the channel bandwidth is -50 dBm. For 3.75kHz sub-carrier spacing the transmit OFF power is defined as mean power in one slot (2ms) excluding the 2304Ts gap when UE is not transmitting. For 15kHz sub-carrier spacing the transmit OFF power is defined as mean power in one sub-frame (1ms).

6.3.4 ON/OFF time mask

6.3.4.1 General ON/OFF time mask

The General ON/OFF time mask defines the observation period between Transmit OFF and ON power and between Transmit ON and OFF power. ON/OFF scenarios include; the beginning or end of DTX, measurement gap, contiguous, and non contiguous transmission

The OFF power measurement period is defined in a duration of at least one sub-frame excluding any transient periods. The ON power is defined as the mean power over one sub-frame excluding any transient period.

There are no additional requirements on UE transmit power beyond that which is required in subclause 6.2.2 and subclause 6.6.2.3

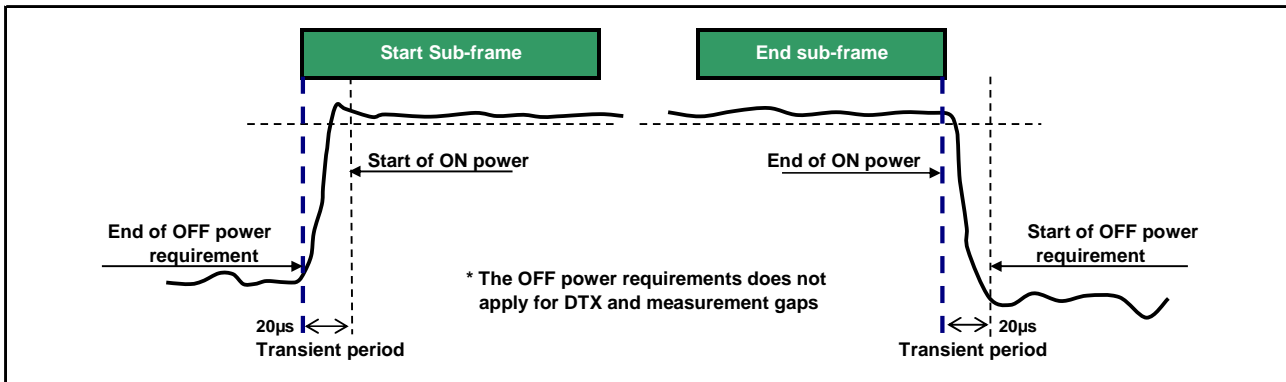

Figure 6.3.4.1-1: General ON/OFF time mask

6.3.4.2 PRACH and SRS time mask

6.3.4.2.1 PRACH time mask

The PRACH ON power is specified as the mean power over the PRACH measurement period excluding any transient periods as shown in Figure 6.3.4.2-1. The measurement period for different PRACH preamble format is specified in Table 6.3.4.2-1.

There are no additional requirements on UE transmit power beyond that which is required in subclause 6.2.2 and subclause 6.6.2.3

Table 6.3.4.2-1: PRACH ON power measurement period

PRACH preamble format	Measurement period (ms)
0	0.9031
1	1.4844
2	1.8031
3	2.2844
4	0.1479

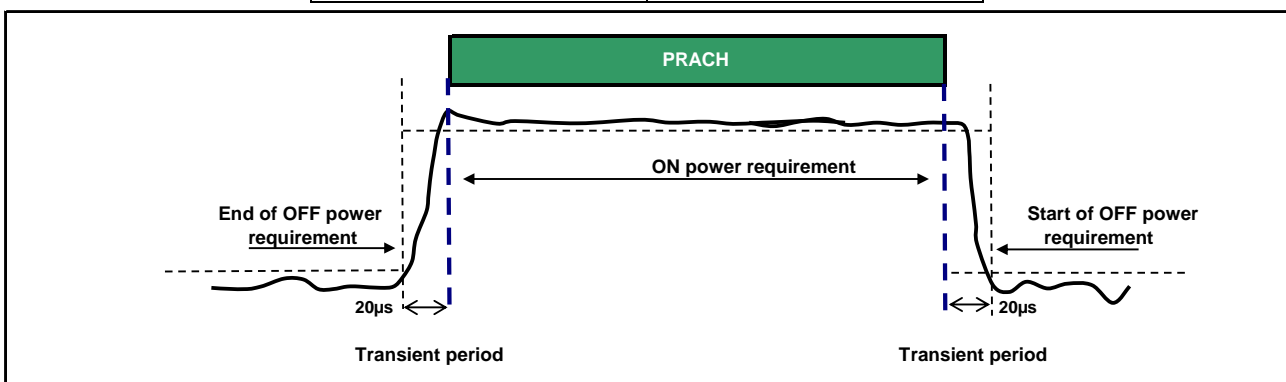

Figure 6.3.4.2-1: PRACH ON/OFF time mask

6.3.4.2.2 SRS time mask

In the case a single SRS transmission, the ON power is defined as the mean power over the symbol duration excluding any transient period. Figure 6.3.4.2.2-1

In the case a dual SRS transmission, the ON power is defined as the mean power for each symbol duration excluding any transient period. Figure 6.3.4.2.2-2

There are no additional requirements on UE transmit power beyond that which is required in subclause 6.2.2 and subclause 6.6.2.3

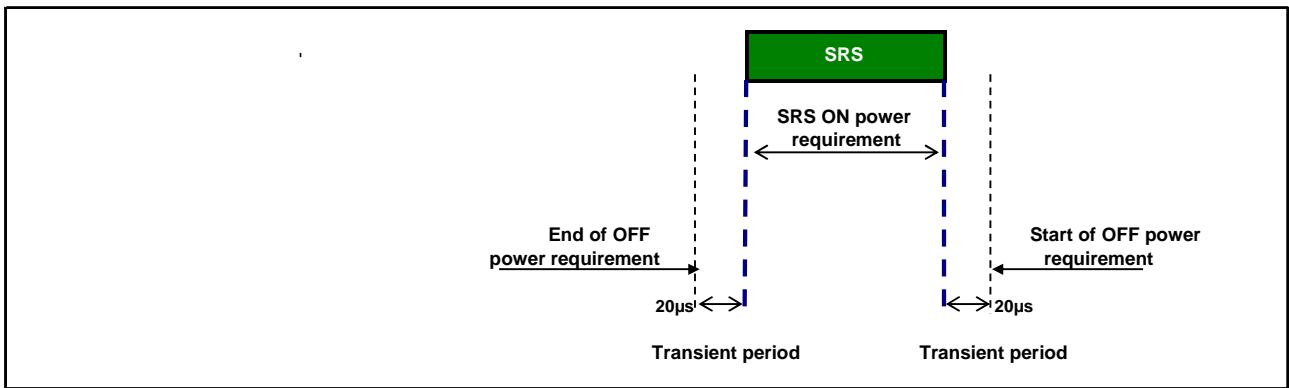

Figure 6.3.4.2.2-1: Single SRS time mask

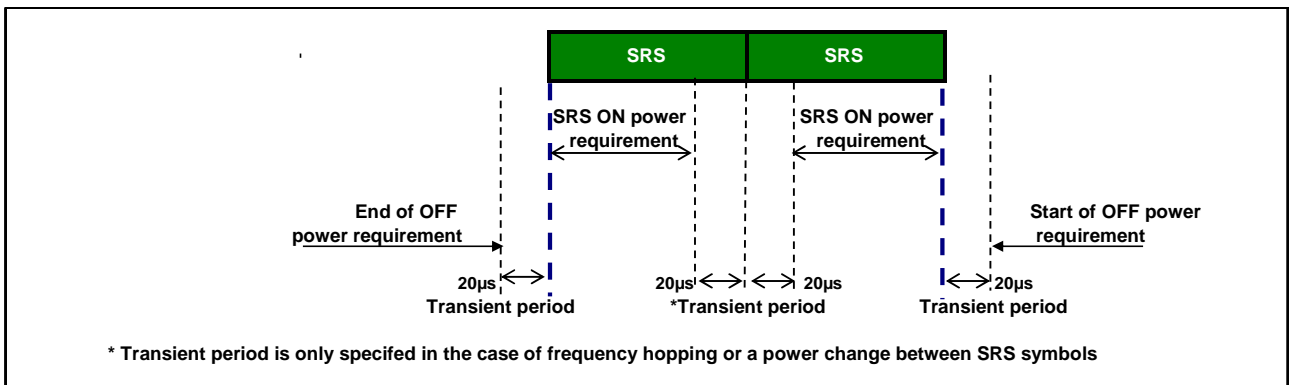

Figure 6.3.4.2.2-2: Dual SRS time mask for the case of UpPTS transmissions

6.3.4.3 Slot / Sub frame boundary time mask

The sub frame boundary time mask defines the observation period between the previous/subsequent sub-frame and the (reference) sub-frame. A transient period at a slot boundary within a sub-frame is only allowed in the case of Intra-sub frame frequency hopping. For the cases when the subframe contains SRS the time masks in subclause 6.3.4.4 apply.

There are no additional requirements on UE transmit power beyond that which is required in subclause 6.2.2 and subclause 6.6.2.3

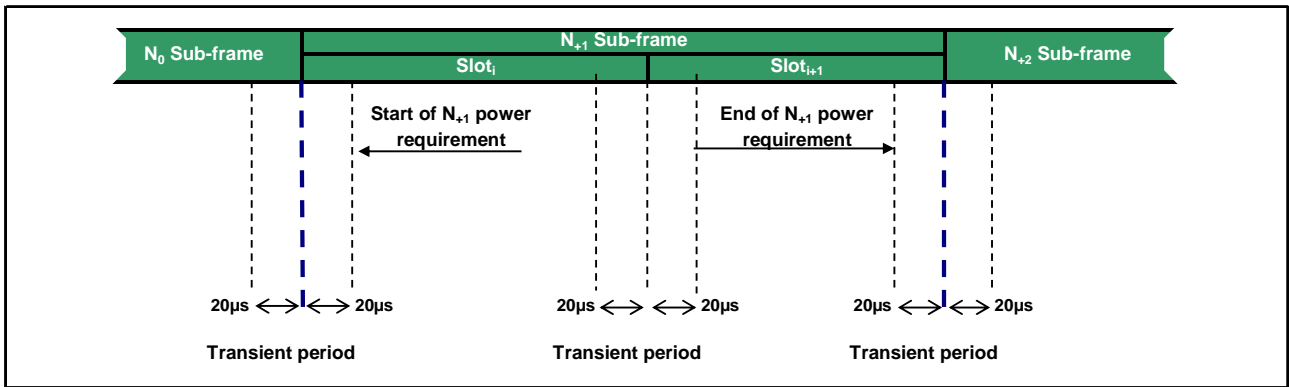

Figure 6.3.4.3-1: Transmission power template

6.3.4.4 PUCCH / PUSCH / SRS time mask

The PUCCH/PUSCH/SRS time mask defines the observation period between sounding reference symbol (SRS) and an adjacent PUSCH/PUCCH symbol and subsequent sub-frame.

There are no additional requirements on UE transmit power beyond that which is required in subclause 6.2.2 and subclause 6.6.2.3

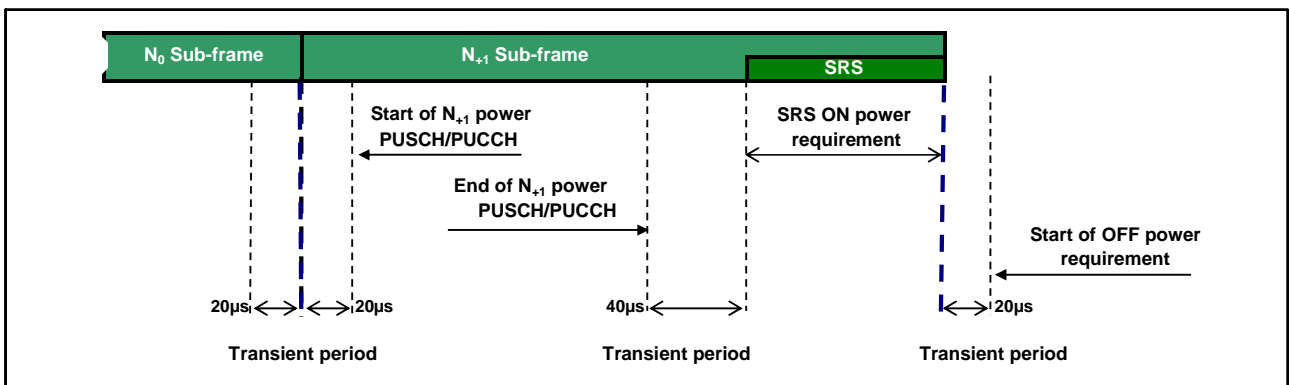

Figure 6.3.4.4-1: PUCCH/PUSCH/SRS time mask when there is a transmission before SRS but not after

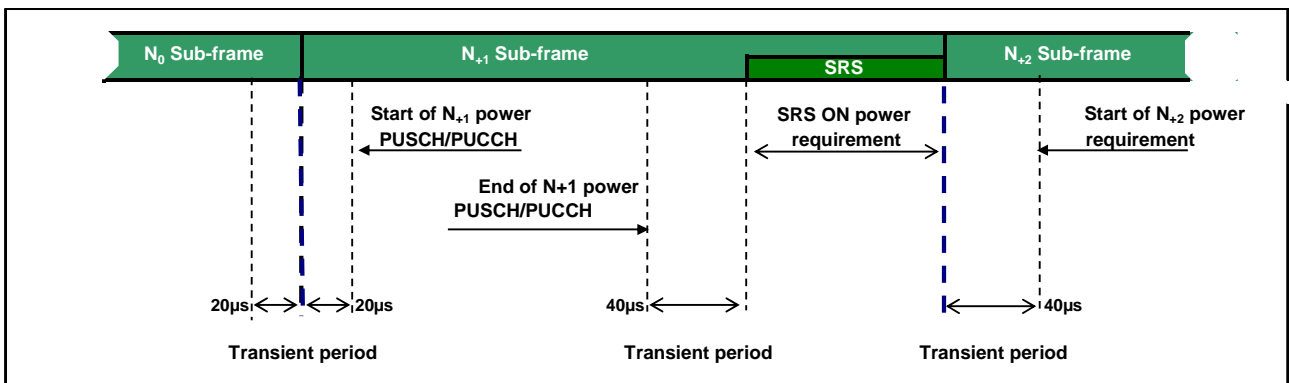

Figure 6.3.4.4-2: PUCCH/PUSCH/SRS time mask when there is transmission before and after SRS

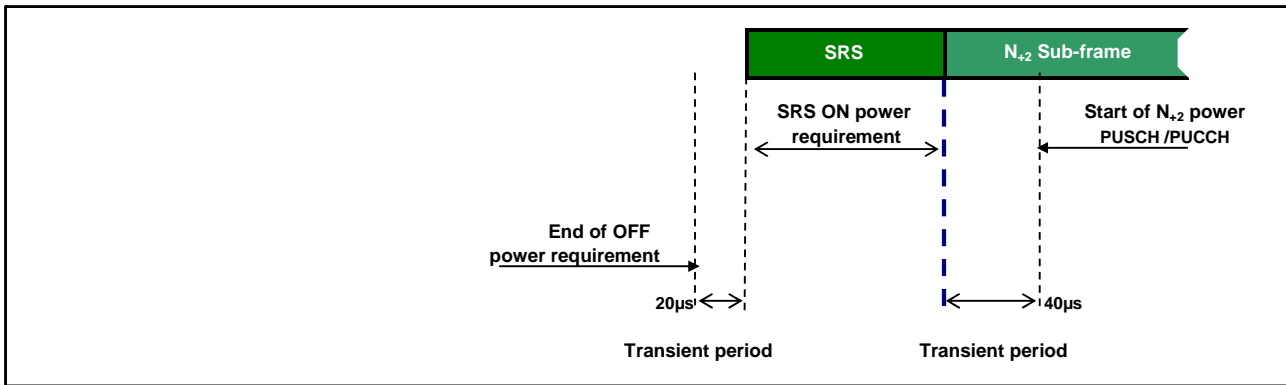

Figure 6.3.4.4-3: PUCCH/PUSCH/SRS time mask when there is a transmission after SRS but not before

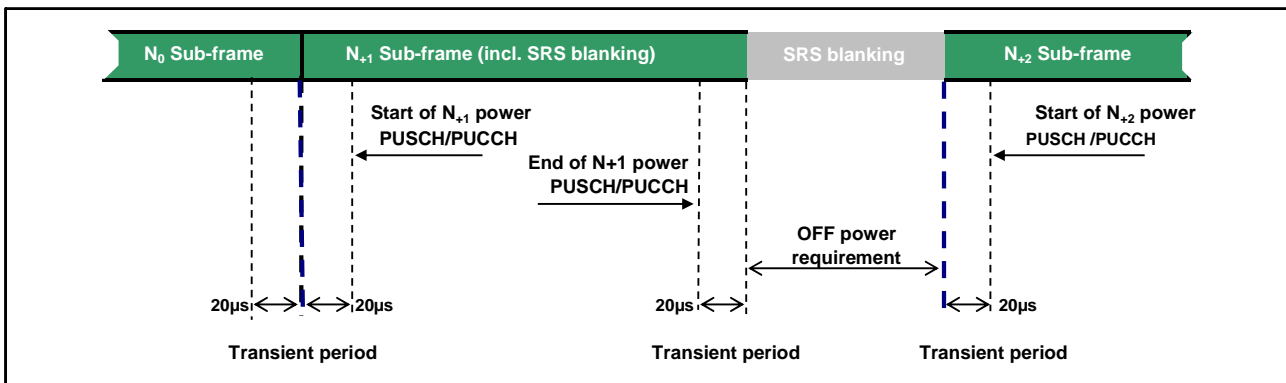

Figure 6.3.4.4-4: SRS time mask when there is FDD SRS blanking

6.3.4A ON/OFF time mask for CA

For inter-band carrier aggregation with uplink assigned to two E-UTRA bands and intra-band contiguous and non-contiguous carrier aggregation, the general output power ON/OFF time mask specified in subclause 6.3.4.1 is applicable for each component carrier during the ON power period and the transient periods. The OFF period as specified in subclause 6.3.4.1 shall only be applicable for each component carrier when all the component carriers are OFF.

6.3.4B ON/OFF time mask for UL-MIMO

For UE supporting UL-MIMO, the ON/OFF time mask requirements in subclause 6.3.4 apply at each transmit antenna connector.

For UE with two transmit antenna connectors in closed-loop spatial multiplexing scheme, the general ON/OFF time mask requirements specified in subclause 6.3.4.1 apply to each transmit antenna connector. The requirements shall be met with the UL-MIMO configurations specified in Table 6.2.2B-2.

If UE is configured for transmission on single-antenna port, the requirements in subclause 6.3.4 apply.

6.3.4D ON/OFF time mask for ProSe

For ProSe Direct Discovery and ProSe Direct Communications, additional requirements on ON/OFF time masks for ProSe physical channels and signals are specified in this clause.

When UE is configured for simultaneous E-UTRA ProSe sidelink and E-UTRA uplink transmissions for inter-band E-UTRA ProSe / E-UTRA bands specified in Table 5.5D-2, the requirements in subclause 6.3.4D apply for ProSe transmission and the requirements in subclause 6.3.4 apply for uplink transmission.

6.3.4D.1 General time mask for ProSe

The General ON/OFF time mask defines the observation period between the Transmit OFF and ON power and between Transmit ON and OFF power for PSDCH, PSCCH, and PSSCH transmissions in a subframe wherein the last symbol is punctured to create a guard period.

There are no additional requirements on UE transmit power beyond that which is required in subclause 6.2.2 and subclause 6.6.2.3.

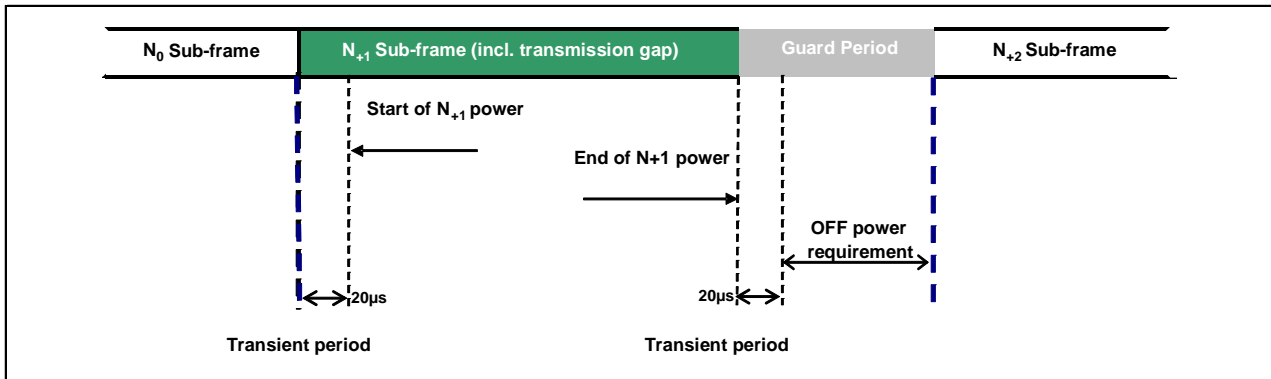

Figure 6.3.4D.1-1: PSDCH/PSCCH/PSSCH time mask

6.3.4D.2 PSSS/SSSS time mask

The PSSS time mask / SSSS time mask defines the observation period between the Transmit OFF and ON power and between Transmit ON and OFF power for PSSS/SSSS transmissions in a subframe when not multiplexed with PSBCH in that subframe.

There are no additional requirements on UE transmit power beyond that which is required in subclause 6.2.2 and subclause 6.6.2.3.

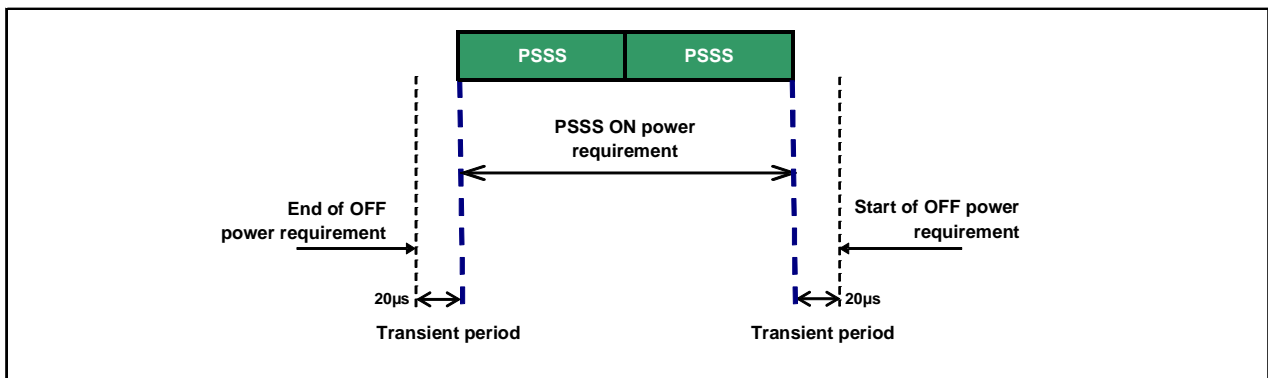

Figure 6.3.4D.2-1: PSSS time mask for normal CP transmission (when not time-multiplexed with PSBCH)

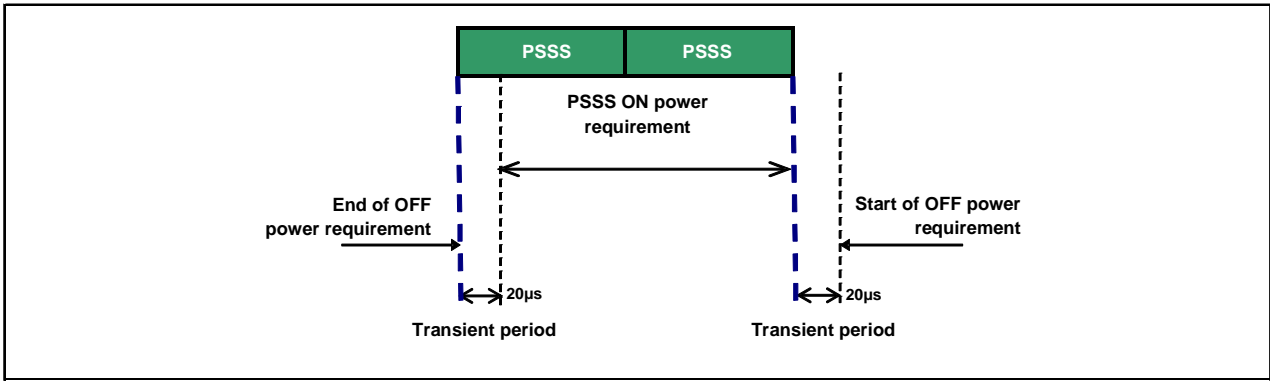

Figure 6.3.4D.2-2: PSSS time mask for extended CP transmission (when not time-multiplexed with PSBCH)

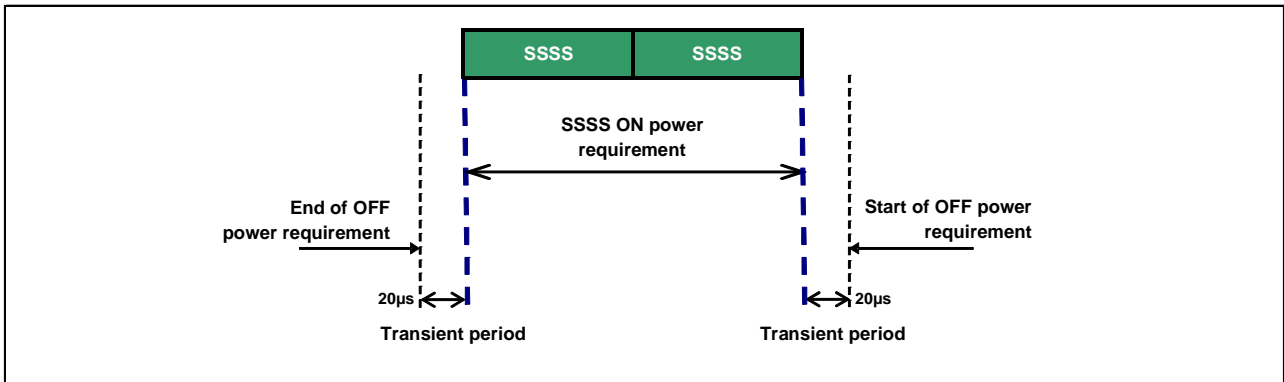

Figure 6.3.4D.2-3: SSSS time mask (when not time-multiplexed with PSBCH)

6.3.4D.3 PSSS / SSSS / PSBCH time mask

The PSSS/SSSS/PSBCH time mask defines the observation period between SSSS and adjacent PSSS/PSBCH symbols in a subframe, with last symbol punctured to create a guard period.

There are no additional requirements on UE transmit power beyond that which is required in subclause 6.2.2 and subclause 6.6.2.3.

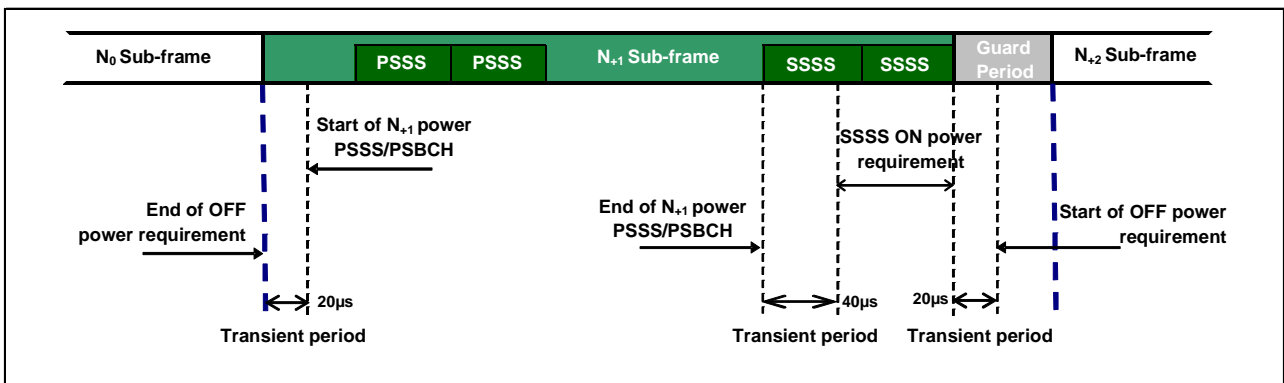

Figure 6.3.4D.3-1: PSSS/SSSS/PSBCH time mask for normal CP transmission

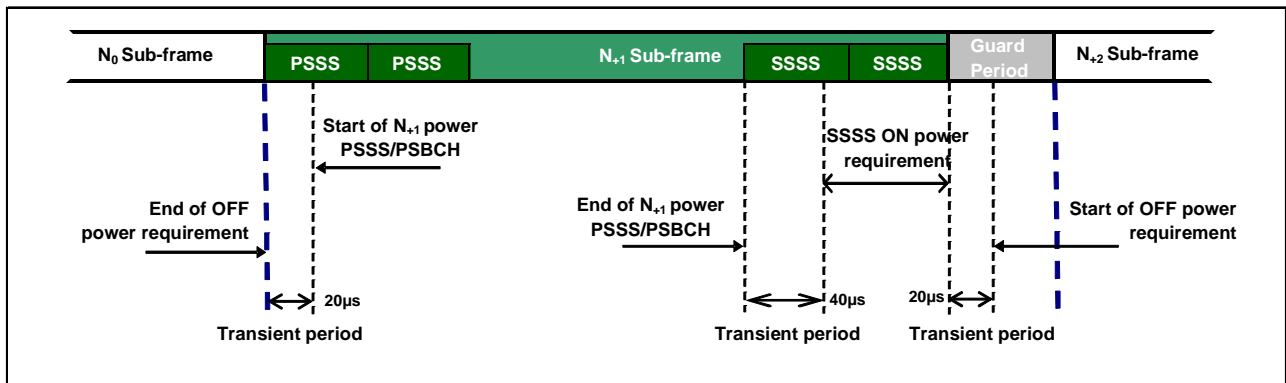

Figure 6.3.4D.3-2: PSSS/SSSS/PBCH time mask for extended CP transmission

6.3.4D.4 PSSCH / SRS time mask

The PSSCH/SRS time mask defines the observation period between sounding reference symbol (SRS) and an adjacent PSSCH symbol and subsequent sub-frame.

There are no additional requirements on UE transmit power beyond that which is required in subclause 6.2.2 and subclause 6.6.2.3.

The PSSCH/SRS time mask shall follow the PUSCH/PUCCH/SRS time mask as specified in subclause 6.3.4.4.

6.3.4F ON/OFF time mask for category NB1

6.3.4F.1 General ON/OFF time mask

E-UTRA general ON/OFF time mask in subclause 6.3.4.1 applies for category NB1 UE with an exception that for 3.75kHz sub-carrier spacing the transmit OFF power is defined as mean power in one slot (2ms) and for 15kHz sub-carrier spacing the transmit OFF power is defined as mean power in one sub-frame (1ms), excluding any transient periods. The ON power is defined as the mean power over one RU excluding any transient periods.

6.3.4F.2 NPRACH time mask

The NPRACH ON power is specified as the mean power over the NPRACH measurement period excluding any transient periods as shown in Figure 6.3.4F.2-1. The measurement period for different NPRACH preamble format is specified in Table 6.3.4F.2-1.

There are no additional requirements on UE transmit power beyond that which is required in subclause 6.2.2F and subclause 6.6.2.3F.

Table 6.3.4F.2-1: NPRACH ON power measurement period

NPRACH preamble format	Measurement period (ms)
0	5.6
1	6.4

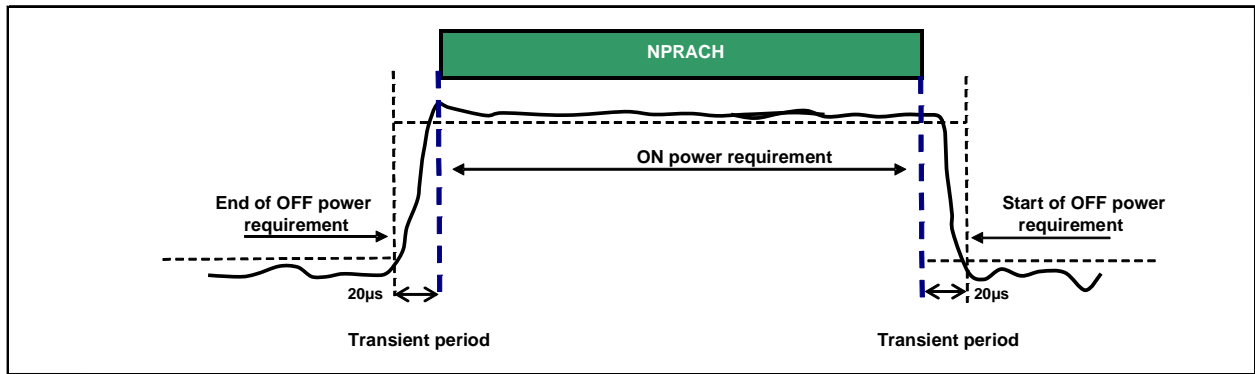

Figure 6.3.4F.2-1: NPRACH ON/OFF time mask

6.3.5 Power Control

6.3.5.1 Absolute power tolerance

Absolute power tolerance is the ability of the UE transmitter to set its initial output power to a specific value for the first sub-frame at the start of a contiguous transmission or non-contiguous transmission with a transmission gap larger than 20ms. This tolerance includes the channel estimation error (the absolute RSRP accuracy requirement specified in subclause 9.1 of TS 36.133)

In the case of a PRACH transmission, the absolute tolerance is specified for the first preamble. The absolute power tolerance includes the channel estimation error (the absolute RSRP accuracy requirement specified in subclause 9.1 of TS 36.133).

6.3.5.1.1 Minimum requirements

The minimum requirement for absolute power tolerance is given in Table 6.3.5.1.1-1 over the power range bounded by the Maximum output power as defined in subclause 6.2.2 and the Minimum output power as defined in subclause 6.3.2.

For operating bands under NOTE 2 in Table 6.2.2-1, the absolute power tolerance as specified in Table 6.3.5.1.1-1 is relaxed by reducing the lower limit by 1.5 dB when the transmission bandwidth is confined within F_{UL_low} and $F_{UL_low} + 4$ MHz or $F_{UL_high} - 4$ MHz and F_{UL_high} .

Table 6.3.5.1.1-1: Absolute power tolerance

Conditions	Tolerance
Normal	± 9.0 dB
Extreme	± 12.0 dB

6.3.5.2 Relative Power tolerance

The relative power tolerance is the ability of the UE transmitter to set its output power in a target sub-frame relatively to the power of the most recently transmitted reference sub-frame if the transmission gap between these sub-frames is ≤ 20 ms.

For PRACH transmission, the relative tolerance is the ability of the UE transmitter to set its output power relatively to the power of the most recently transmitted preamble. The measurement period for the PRACH preamble is specified in Table 6.3.4.2-1.

6.3.5.2.1 Minimum requirements

The requirements specified in Table 6.3.5.2.1-1 apply when the power of the target and reference sub-frames are within the power range bounded by the Minimum output power as defined in subclause 6.3.2 and the measured PUMAX as

defined in subclause 6.2.5 (i.e, the actual power as would be measured assuming no measurement error). This power shall be within the power limits specified in subclause 6.2.5.

To account for RF Power amplifier mode changes 2 exceptions are allowed for each of two test patterns. The test patterns are a monotonically increasing power sweep and a monotonically decreasing power sweep over a range bounded by the requirements of minimum power and maximum power specified in subclauses 6.3.2 and 6.2.2. For these exceptions the power tolerance limit is a maximum of ± 6.0 dB in Table 6.3.5.2.1-1

Table 6.3.5.2.1-1 Relative power tolerance for transmission (normal conditions)

Power step ΔP (Up or down) [dB]	All combinations of PUSCH and PUCCH transitions [dB]	All combinations of PUSCH/PUCCH and SRS transitions between sub- frames [dB]	PRACH [dB]
$\Delta P < 2$	± 2.5 (NOTE 3)	± 3.0	± 2.5
$2 \leq \Delta P < 3$	± 3.0	± 4.0	± 3.0
$3 \leq \Delta P < 4$	± 3.5	± 5.0	± 3.5
$4 \leq \Delta P \leq 10$	± 4.0	± 6.0	± 4.0
$10 \leq \Delta P < 15$	± 5.0	± 8.0	± 5.0
$15 \leq \Delta P$	± 6.0	± 9.0	± 6.0
NOTE 1: For extreme conditions an additional ± 2.0 dB relaxation is allowed NOTE 2: For operating bands under NOTE 2 in Table 6.2.2-1, the relative power tolerance is relaxed by increasing the upper limit by 1.5 dB if the transmission bandwidth of the reference sub-frames is confined within F_{UL_low} and $F_{UL_low} + 4$ MHz or $F_{UL_high} - 4$ MHz and F_{UL_high} and the target sub-frame is not confined within any one of these frequency ranges; if the transmission bandwidth of the target sub-frame is confined within F_{UL_low} and $F_{UL_low} + 4$ MHz or $F_{UL_high} - 4$ MHz and F_{UL_high} and the reference sub-frame is not confined within any one of these frequency ranges, then the tolerance is relaxed by reducing the lower limit by 1.5 dB. NOTE 3: For PUSCH to PUSCH transitions with the allocated resource blocks fixed in frequency and no transmission gaps other than those generated by downlink subframes, DwPTS fields or Guard Periods for TDD: for a power step $\Delta P \leq 1$ dB, the relative power tolerance for transmission is ± 1.0 dB.			

The power step (ΔP) is defined as the difference in the calculated setting of the UE Transmit power between the target and reference sub-frames with the power setting according to subclause 5.1 of [TS 36.213]. The error is the difference between ΔP and the power change measured at the UE antenna port with the power of the cell-specific reference signals kept constant. The error shall be less than the relative power tolerance specified in Table 6.3.5.2.1-1.

For sub-frames not containing an SRS symbol, the power change is defined as the relative power difference between the mean power of the original reference sub-frame and the mean power of the target subframe not including transient durations. The mean power of successive sub-frames shall be calculated according to Figure 6.3.4.3-1 and Figure 6.3.4.1-1 if there is a transmission gap between the reference and target sub-frames.

If at least one of the sub-frames contains an SRS symbol, the power change is defined as the relative power difference between the mean power of the last transmission within the reference sub-frame and the mean power of the first transmission within the target sub-frame not including transient durations. A transmission is defined as PUSCH, PUCCH or an SRS symbol. The mean power of the reference and target sub-frames shall be calculated according to Figures 6.3.4.1-1, 6.3.4.2-1, 6.3.4.4-1, 6.3.4.4-2 and 6.3.4.4-3 for these cases.

6.3.5.3 Aggregate power control tolerance

Aggregate power control tolerance is the ability of a UE to maintain its power in non-contiguous transmission within 21 ms in response to 0 dB TPC commands with respect to the first UE transmission, when the power control parameters specified in TS 36.213 are constant. For HD-FDD UEs that support coverage enhancement (CE), the requirements on aggregate power control tolerance in 6.3.5E.3 apply.

6.3.5.3.1 Minimum requirement

The UE shall meet the requirements specified in Table 6.3.5.3.1-1 for aggregate power control over the power range bounded by the minimum output power as defined in subclause 6.3.2 and the maximum output power as defined in subclause 6.2.2.

Table 6.3.5.3.1-1: Aggregate power control tolerance

TPC command	UL channel	Aggregate power tolerance within 21 ms
0 dB	PUCCH	±2.5 dB
0 dB	PUSCH	±3.5 dB
NOTE: The UE transmission gap is 4 ms. TPC command is transmitted via PDCCH 4 subframes preceding each PUCCH/PUSCH transmission.		

6.3.5A Power control for CA

The requirements apply for one single PUCCH, PUSCH or SRS transmission of contiguous PRB allocation per component carrier with power setting in accordance with Clause 5.1 of [6].

6.3.5A.1 Absolute power tolerance

The absolute power tolerance is the ability of the UE transmitter to set its initial output power to a specific value for the first sub-frame at the start of a contiguous transmission or non-contiguous transmission with a transmission gap on each active component carriers larger than 20ms. The requirement can be tested by time aligning any transmission gaps on the component carriers.

6.3.5A.1.1 Minimum requirements

For inter-band carrier aggregation with uplink assigned to two E-UTRA bands, the absolute power control tolerance is specified on each component carrier exceed the minimum output power as defined in subclause 6.3.2A and the total power is limited by maximum output power as defined in subclause 6.2.2A. The requirements defined in Table 6.3.5.1.1-1 shall apply on each component carrier with all component carriers active. The requirements can be tested by time aligning any transmission gaps on all the component carriers.

For intra-band contiguous carrier aggregation bandwidth class B and C and intra-band non-contiguous carrier aggregation the absolute power control tolerance per component carrier is given in Table 6.3.5.1.1-1.

6.3.5A.2 Relative power tolerance

6.3.5A.2.1 Minimum requirements

For inter-band carrier aggregation with uplink assigned to two E-UTRA bands, the relative power tolerance is specified when the power of the target and reference sub-frames on each component carrier exceed the minimum output power as defined in subclause 6.3.2A and the total power is limited by P_{UMAX} as defined in subclause 6.2.5A. The requirements shall apply on each component carrier with all component carriers active. The UE transmitter shall have the capability of changing the output power independently on all component carriers in the uplink and:

- the requirements for all combinations of PUSCH and PUCCH transitions per component carrier is given in Table 6.3.5.2.1-1.
- for SRS the requirements for combinations of PUSCH/PUCCH and SRS transitions between subframes given in Table 6.3.5.2.1-1 apply per component carrier when the target and reference subframes are configured for either simultaneous SRS or simultaneous PUSCH.
- for RACH the requirements apply for the primary cell and are given in Table 6.3.5.2.1-1.

For intra-band contiguous carrier aggregation bandwidth class B and C and intra-band non-contiguous carrier aggregation, the requirements apply when the power of the target and reference sub-frames on each component carrier

exceed -20 dBm and the total power is limited by P_{UMAX} as defined in subclause 6.2.5A. For the purpose of these requirements, the power in each component carrier is specified over only the transmitted resource blocks.

The UE shall meet the following requirements for transmission on both assigned component carriers when the average transmit power per PRB is aligned across both assigned carriers in the reference sub-frame:

- a) for all possible combinations of PUSCH and PUCCH transitions per component carrier, the corresponding requirements given in Table 6.3.5.2.1-1;
- b) for SRS transitions on each component carrier, the requirements for combinations of PUSCH/PUCCH and SRS transitions given in Table 6.3.5.2.1-1 with simultaneous SRS of constant SRS bandwidth allocated in the target and reference subframes;
- c) for RACH on the primary component carrier, the requirements given in Table 6.3.5.2.1-1 for PRACH.

For a) and b) above, the power step ΔP between the reference and target subframes shall be set by a TPC command and/or an uplink scheduling grant transmitted by means of an appropriate DCI Format.

For a), b) and c) above, two exceptions are allowed for each component carrier for a power per carrier ranging from -20 dBm to $P_{UMAX,c}$ as defined in subclause 6.2.5. For these exceptions the power tolerance limit is ± 6.0 dB in Table 6.3.5.2.1-1.

6.3.5A.3 Aggregate power control tolerance

Aggregate power control tolerance is the ability of a UE to maintain its power in non-contiguous transmission within 21 ms in response to 0 dB TPC commands with respect to the first UE transmission, when the power control parameters specified in [6] are constant on all active component carriers.

6.3.5A.3.1 Minimum requirements

For inter-band carrier aggregation with uplink assigned to two E-UTRA bands, the aggregate power tolerance is specified on each component carrier exceed the minimum output power as defined in subclause 6.3.2A and the total power is limited by maximum output power as defined in subclause 6.2.2A. The requirements defined in Table 6.3.5.3.1-1 shall apply on each component carrier with all component carriers active. The requirements can be tested by time aligning any transmission gaps on both the component carriers.

For intra-band contiguous carrier aggregation bandwidth class B and C and intra-band non-contiguous carrier aggregation, the aggregate power tolerance per component carrier is given in Table 6.3.5.3.1-1 with either simultaneous PUSCH or simultaneous PUCCH-PUSCH (if supported by the UE) configured. The average power per PRB shall be aligned across both assigned carriers before the start of the test. The requirement can be tested with the transmission gaps time aligned between component carriers.

6.3.5B Power control for UL-MIMO

For UE supporting UL-MIMO, the power control tolerance applies to the sum of output power at each transmit antenna connector.

The power control requirements specified in subclause 6.3.5 apply to UE with two transmit antenna connectors in closed-loop spatial multiplexing scheme. The requirements shall be met with UL-MIMO configurations specified in Table 6.2.2B-2, wherein

- The Maximum output power requirements for UL-MIMO are specified in subclause 6.2.2B
- The Minimum output power requirements for UL-MIMO are specified in subclause 6.3.2B
- The requirements for configured transmitted power for UL-MIMO are specified in subclause 6.2.5B.

If UE is configured for transmission on single-antenna port, the requirements in subclause 6.3.5 apply.

6.3.5D Power Control for ProSe

When UE is configured for simultaneous E-UTRA ProSe sidelink and E-UTRA uplink transmissions for inter-band E-UTRA ProSe / E-UTRA bands specified in Table 5.5D-2, the requirements in subclause 6.3.5D apply for ProSe transmission and the requirements in subclause 6.3.5 apply for uplink transmission.

6.3.5D.1 Absolute power tolerance

For ProSe transmissions, the absolute power tolerance requirements specified in subclause 6.3.5.1 shall apply for each ProSe transmission.

6.3.5E Power control for category M1

6.3.5E.1 Absolute power tolerance

The absolute power tolerance requirements specified in subclause 6.3.5.1 apply, wherein

- The Maximum output power requirements are specified in subclause 6.2.2E
- The Minimum output power requirements are specified in subclause 6.3.2
- The requirements for configured transmitted power are specified in subclause 6.2.5.

6.3.5E.2 Relative Power tolerance

The relative power tolerance requirements specified in subclause 6.3.5.2 apply, wherein

- The Maximum output power requirements are specified in subclause 6.2.2E
- The Minimum output power requirements are specified in subclause 6.3.2
- The requirements for configured transmitted power are specified in subclause 6.2.5.

6.3.5E.3 Aggregate power control tolerance

Aggregate power control tolerance is the ability of a UE to maintain its power in non-contiguous transmission in response to 0 dB TPC commands with respect to the first UE transmission, when the power control parameters specified in TS 36.213 are constant.

For category M1 TDD and FD-FDD UEs, the aggregate power control tolerance requirements specified in Table 6.3.5E.3.1-0 apply. For category M1 HD-FDD UEs and for continuous uplink transmissions of duration ≤ 64 ms, the aggregate power control tolerance requirements specified in Table 6.3.5E.3.1-0 apply.

For category M1 HD-FDD UEs and for continuous uplink transmissions of duration > 64 ms, the aggregate power control tolerance requirements specified in Table 6.3.5E.3.1-1 apply.

6.3.5E.3.1 Minimum requirement

The category M1 TDD and FD-FDD UEs shall meet the requirements specified in Table 6.3.5E.3.1-0 for aggregate power control over the power range bounded by the minimum output power as defined in subclause 6.3.2, the maximum output power as defined in subclause 6.2.2E, and the requirements for configured transmitted power are specified in subclause 6.2.5.

The category M1 HD-FDD UEs and for continuous uplink transmissions of duration ≤ 64 ms, shall meet the requirements specified in Table 6.3.5E.3.1-0 for aggregate power control over the power range bounded by the minimum output power as defined in subclause 6.3.2, the maximum output power as defined in subclause 6.2.2E, and the requirements for configured transmitted power are specified in subclause 6.2.5.

Table 6.3.5E.3.1-0: Aggregate power control tolerance

TPC command	UL channel	Aggregate power tolerance within 21 ms ²
0 dB	PUCCH	±2.5 dB
0 dB	PUSCH	±3.5 dB
NOTE 1: The UE transmission gap is 4 ms for full-duplex FDD and TDD. For UE of half-duplex FDD with the channel bandwidth 5 MHz / 10 MHz / 15 MHz / 20 MHz, the transmission gap is 1 ms after subframe #4 and 7 ms after subframe #6. For UE of half-duplex FDD with the CBW 1.4 / 3 MHz, the transmission gap is 9 ms. TPC command is transmitted via MPDCCH 4 subframes preceding each PUCCH/PUSCH transmission.		
NOTE 2: For UE of half-duplex FDD with the CBW 1.4 / 3 MHz, the test interval is 41 ms.		

The category M1 HD-FDD UE and for continuous uplink transmissions of duration > 64 ms shall meet the requirements specified in Table 6.3.5E.3.1-1 for aggregate power control over the power range bounded by the minimum output power as defined in subclause 6.3.2 and the maximum output power as defined in subclause 6.2.2E.

Table 6.3.5E.3.1-1: Aggregate power control tolerance

TPC command	UL channel	Aggregate power tolerance within 129 ms
0 dB	PUCCH	±2.5 dB
0 dB	PUSCH	±3.5 dB
NOTE: The UE transmission gap is 5 ms. TPC command is transmitted via MPDCCH 4 subframes preceding each PUCCH/ PUSCH transmission.		

6.3.5F Power Control for category NB1

Power control requirements in this clause apply for category NB1 UE.

6.3.5F.1 Absolute power tolerance

The minimum requirement for absolute power tolerance is given in Table 6.3.5F.1-1 over the power range bounded by the Maximum output power as defined in subclause 6.2.2F and the Minimum output power as defined in subclause 6.3.2F.

Table 6.3.5F.1-1: Absolute power tolerance - I

Conditions	Tolerance
Normal	± 9.0 dB
Extreme	±12.0 dB

In case of $-15 \text{ dB} \leq \hat{E}_s/I_{ot} < -6 \text{ dB}$, the absolute power tolerance given in Table 6.3.5F.1-2 applies if the UE transmit power is not mandated to be $P_{\text{CMAX},c}$ according to the UE uplink power control procedure or random access procedure in Section 16 of [6] (e.g. the lowest configured repetition level is used for NPRACH transmission or the number of repetitions of the allocated NPUSCH RUs is no more than 2).

Table 6.3.5F.1-2: Absolute power tolerance - II

Conditions	Tolerance
Normal	± 13.3 dB
Extreme	± 16.3 dB

6.3.5F.2 Relative power tolerance

Category NB1 UE relative power control requirement is defined for NPRACH power step values of 0, 2, 4 and 6 dB. For NPRACH transmission, the relative tolerance is the ability of the UE transmitter to set its output power relatively to the power of the most recently transmitted preamble. The measurement period for the NPRACH preamble is specified in Table 6.3.4F.2-1.

The requirements specified in Table 6.3.5F.2-1 apply when the power of the target and reference sub-frames are within the power range bounded by the Minimum output power as defined in subclause 6.3.2F and the maximum output power as defined in subclause 6.2.2F.

Table 6.3.5F.2-1: Relative power tolerance for category NB1 NPRACH transmission (normal conditions)

Power step ΔP [dB]	NPRACH [dB]
$\Delta P = 0$	± 1.5
$\Delta P = 2$	± 2.0
$\Delta P = 4$	± 3.5
$\Delta P = 6$	± 4.0
NOTE: For extreme conditions an additional ± 2.0 dB relaxation is allowed.	

The power step (ΔP) is defined as the difference in the calculated setting of the UE transmit power between the target and reference sub-frames. The error is the difference between ΔP and the power change measured at the UE antenna port with the power of the cell-specific reference signals kept constant. The error shall be less than the relative power tolerance specified in Table 6.3.5F.2-1.

6.3.5F.3 Aggregate power control tolerance for category NB1

Category NB1 aggregate power control tolerance is the ability of a UE to maintain its output power in non-contiguous transmission with respect to the first UE transmission, when the uplink power control parameters as defined in TS 36.213 are constant and α is set to 0.

6.3.5F.3.1 Minimum requirement

The UE shall meet the requirements specified in Table 6.3.5F.3.1-1 for aggregate power control over the power range bounded by the minimum output power as defined in subclause 6.3.2F and the maximum output power as defined in subclause 6.2.2F.

Table 6.3.5F.3.1-1: Aggregate power control tolerance

UL channel	Aggregate power tolerance	
	15 kHz / 12 tones within 53 ms	15 kHz / 1 tone within 104 ms
NPUSCH	± 3.5 dB	
NOTE: For five consecutive UE transmissions the transmission gaps are 12 ms for 12 tone and 16 ms for single tone transmissions. Uplink scheduling grant is transmitted via NPDCCH eight subframes before NPUSCH transmission.		

6.4 Void

6.5 Transmit signal quality

6.5.1 Frequency error

The UE modulated carrier frequency shall be accurate to within ± 0.1 PPM observed over a period of one time slot (0.5 ms) compared to the carrier frequency received from the E-UTRA Node B

6.5.1A Frequency error for CA

For inter-band carrier aggregation with uplink assigned to two E-UTRA bands, the frequency error requirements defined in subclause 6.5.1 shall apply on each component carrier with all component carriers active.

For intra-band contiguous carrier aggregation the UE modulated carrier frequencies per band shall be accurate to within ± 0.1 PPM observed over a period of one timeslot compared to the carrier frequency of primary component carrier received from the E-UTRA in the corresponding band.

For intra-band non-contiguous carrier aggregation the requirements in Section 6.5.1 applies per component carrier.

6.5.1B Frequency error for UL-MIMO

For UE(s) supporting UL-MIMO, the UE modulated carrier frequency at each transmit antenna connector shall be accurate to within ± 0.1 PPM observed over a period of one time slot (0.5 ms) compared to the carrier frequency received from the E-UTRA Node B.

6.5.1D Frequency error for ProSe

The UE modulated carrier frequency for ProSe sidelink transmissions shall be accurate to within ± 0.1 PPM observed over a period of one time slot (0.5 ms) compared to the carrier frequency received from the synchronization source. The synchronization source can be E-UTRA Node B or a ProSe UE transmitting sidelink synchronization signals.

When UE is configured for simultaneous E-UTRA ProSe sidelink and E-UTRA uplink transmissions for inter-band E-UTRA ProSe / E-UTRA bands specified in Table 5.5D-2, the requirements in subclause 6.5.1D apply for ProSe transmission and the requirements in subclause 6.5.1 apply for uplink transmission.

6.5.1E Frequency error for UE category M1

For category M1 TDD UEs and FD-FDD UEs, the frequency error requirements in Clause 6.5.1 apply.

For category M1 HD-FDD UEs and for continuous uplink transmissions of duration ≤ 64 ms, the frequency error requirements in Clause 6.5.1 apply.

For category M1 HD-FDD UEs and for continuous uplink transmissions of duration > 64 ms, the UE modulated carrier frequency shall be accurate to within the limits in Table 6.5.1E-1 observed over a period of one time slot (0.5 ms) compared to the carrier frequency received from the E-UTRA Node B.

Table 6.5.1E-1: Frequency error requirement for HD-FDD UE category M1

Carrier frequency [GHz]	Frequency error [ppm]
≤ 1	± 0.2
> 1	± 0.1

6.5.1F Frequency error for UE category NB1

For UE category NB1, the UE modulated carrier frequency shall be accurate to within the following limits

Table 6.5.1F-1: Frequency error requirement for UE category NB1

Carrier frequency [GHz]	Frequency error [ppm]
≤1	±0.2
>1	±0.1

Observed over a period of one time slot (0.5 ms for 15 kHz sub-carrier spacing and 2 ms excluding the 2304Ts gap for 3.75 kHz sub-carrier spacing) and averaged over $72/L_{Ctone}$ slots (where $L_{Ctone} = \{1, 3, 6, 12\}$ is the number of sub-carriers used for the transmission), compared to the carrier frequency received from the E-UTRA Node B.

6.5.2 Transmit modulation quality

Transmit modulation quality defines the modulation quality for expected in-channel RF transmissions from the UE. The transmit modulation quality is specified in terms of:

- Error Vector Magnitude (EVM) for the allocated resource blocks (RBs)
- EVM equalizer spectrum flatness derived from the equalizer coefficients generated by the EVM measurement process
- Carrier leakage
- In-band emissions for the non-allocated RB

All the parameters defined in subclause 6.5.2 are defined using the measurement methodology specified in Annex F.

6.5.2.1 Error Vector Magnitude

The Error Vector Magnitude is a measure of the difference between the reference waveform and the measured waveform. This difference is called the error vector. Before calculating the EVM the measured waveform is corrected by the sample timing offset and RF frequency offset. Then the carrier leakage shall be removed from the measured waveform before calculating the EVM.

The measured waveform is further modified by selecting the absolute phase and absolute amplitude of the Tx chain. The EVM result is defined after the front-end IDFT as the square root of the ratio of the mean error vector power to the mean reference power expressed as a %.

The basic EVM measurement interval in the time domain is one preamble sequence for the PRACH and is one slot for the PUCCH and PUSCH in the time domain.. When the PUSCH or PUCCH transmission slot is shortened due to multiplexing with SRS, the EVM measurement interval is reduced by one symbol, accordingly. The PUSCH or PUCCH EVM measurement interval is also reduced when the mean power, modulation or allocation between slots is expected to change. In the case of PUSCH transmission, the measurement interval is reduced by a time interval equal to the sum of 5 μ s and the applicable exclusion period defined in subclause 6.3.4, adjacent to the boundary where the power change is expected to occur. The PUSCH exclusion period is applied to the signal obtained after the front-end IDFT. In the case of PUCCH transmission with power change, the PUCCH EVM measurement interval is reduced by one symbol adjacent to the boundary where the power change is expected to occur.

6.5.2.1.1 Minimum requirement

The RMS average of the basic EVM measurements for 10 sub-frames excluding any transient period for the average EVM case, and 60 sub-frames excluding any transient period for the reference signal EVM case, for the different modulations schemes shall not exceed the values specified in Table 6.5.2.1.1-1 for the parameters defined in Table 6.5.2.1.1-2. For EVM evaluation purposes, [all PRACH preamble formats 0-4 and] all PUCCH formats 1, 1a, 1b, 2, 2a and 2b are considered to have the same EVM requirement as QPSK modulated.

Table 6.5.2.1.1-1: Minimum requirements for Error Vector Magnitude

Parameter	Unit	Average EVM Level	Reference Signal EVM Level
QPSK or BPSK	%	17.5	17.5
16QAM	%	12.5	12.5
64QAM	%	8	8

Table 6.5.2.1.1-2: Parameters for Error Vector Magnitude

Parameter	Unit	Level
UE Output Power	dBm	≥ -40
Operating conditions		Normal conditions

6.5.2.2 Carrier leakage

Carrier leakage is an additive sinusoid waveform that has the same frequency as a modulated waveform carrier frequency. The measurement interval is one slot in the time domain.

6.5.2.2.1 Minimum requirements

The relative carrier leakage power is a power ratio of the additive sinusoid waveform and the modulated waveform. The relative carrier leakage power shall not exceed the values specified in Table 6.5.2.2.1-1.

Table 6.5.2.2.1-1: Minimum requirements for relative carrier leakage power

Parameters	Relative limit (dBc)	Applicable frequencies
Output power >10 dBm	-28	Carrier center frequency < 1 GHz
	-25	Carrier center frequency ≥ 1 GHz
0 dBm \leq Output power ≤ 10 dBm	-25	
-30 dBm \leq Output power ≤ 0 dBm	-20	
-40 dBm \leq Output power < -30 dBm	-10	

6.5.2.3 In-band emissions

The in-band emission is defined as the average across 12 sub-carrier and as a function of the RB offset from the edge of the allocated UL transmission bandwidth. The in-band emission is measured as the ratio of the UE output power in a non-allocated RB to the UE output power in an allocated RB.

The basic in-band emissions measurement interval is defined over one slot in the time domain. When the PUSCH or PUCCH transmission slot is shortened due to multiplexing with SRS, the in-band emissions measurement interval is reduced by one SC-FDMA symbol, accordingly.

6.5.2.3.1 Minimum requirements

The relative in-band emission shall not exceed the values specified in Table 6.5.2.3.1-1.

Table 6.5.2.3.1-1: Minimum requirements for in-band emissions

Parameter description	Unit	Limit (NOTE 1)		Applicable Frequencies
General	dB	$\max \left\{ -25 - 10 \cdot \log_{10} (N_{RB} / L_{CRB}), \right.$ $20 \cdot \log_{10} EVM - 3 - 5 \cdot (\Delta_{RB} - 1) / L_{CRB},$ $\left. -57 \text{ dBm} / 180 \text{ kHz} - P_{RB} \right\}$		Any non-allocated (NOTE 2)
IQ Image	dB	-28	Image frequencies when carrier center frequency < 1 GHz and Output power > 10 dBm	Image frequencies (NOTES 2, 3)
		-25	Image frequencies when carrier center frequency < 1 GHz and Output power ≤ 10 dBm	
		-25	Image frequencies when carrier center frequency ≥ 1 GHz	
Carrier leakage	dBc	-28	Output power > 10 dBm and carrier center frequency < 1 GHz	Carrier frequency (NOTES 4, 5)
		-25	Output power > 10 dBm and carrier center frequency ≥ 1 GHz	
		-25	0 dBm ≤ Output power ≤ 10 dBm	
		-20	-30 dBm ≤ Output power ≤ 0 dBm	
		-10	-40 dBm ≤ Output power < -30 dBm	
<p>NOTE 1: An in-band emissions combined limit is evaluated in each non-allocated RB. For each such RB, the minimum requirement is calculated as the higher of $P_{RB} - 30$ dB and the power sum of all limit values (General, IQ Image or Carrier leakage) that apply. P_{RB} is defined in NOTE 10.</p> <p>NOTE 2: The measurement bandwidth is 1 RB and the limit is expressed as a ratio of measured power in one non-allocated RB to the measured average power per allocated RB, where the averaging is done across all allocated RBs.</p> <p>NOTE 3: The applicable frequencies for this limit are those that are enclosed in the reflection of the allocated bandwidth, based on symmetry with respect to the centre carrier frequency, but excluding any allocated RBs.</p> <p>NOTE 4: The measurement bandwidth is 1 RB and the limit is expressed as a ratio of measured power in one non-allocated RB to the measured total power in all allocated RBs.</p> <p>NOTE 5: The applicable frequencies for this limit are those that are enclosed in the RBs containing the DC frequency if N_{RB} is odd, or in the two RBs immediately adjacent to the DC frequency if N_{RB} is even, but excluding any allocated RB.</p> <p>NOTE 6: L_{CRB} is the Transmission Bandwidth (see Figure 5.6-1).</p> <p>NOTE 7: N_{RB} is the Transmission Bandwidth Configuration (see Figure 5.6-1).</p> <p>NOTE 8: EVM is the limit specified in Table 6.5.2.1.1-1 for the modulation format used in the allocated RBs.</p> <p>NOTE 9: Δ_{RB} is the starting frequency offset between the allocated RB and the measured non-allocated RB (e.g. $\Delta_{RB} = 1$ or $\Delta_{RB} = -1$ for the first adjacent RB outside of the allocated bandwidth).</p> <p>NOTE 10: P_{RB} is the transmitted power per 180 kHz in allocated RBs, measured in dBm.</p>				

6.5.2.4 EVM equalizer spectrum flatness

The zero-forcing equalizer correction applied in the EVM measurement process (as described in Annex F) must meet a spectral flatness requirement for the EVM measurement to be valid. The EVM equalizer spectrum flatness is defined in terms of the maximum peak-to-peak ripple of the equalizer coefficients (dB) across the allocated uplink block. The basic measurement interval is the same as for EVM.

6.5.2.4.1 Minimum requirements

The peak-to-peak variation of the EVM equalizer coefficients contained within the frequency range of the uplink allocation shall not exceed the maximum ripple specified in Table 6.5.2.4.1-1 for normal conditions. For uplink allocations contained within both Range 1 and Range 2, the coefficients evaluated within each of these frequency ranges shall meet the corresponding ripple requirement and the following additional requirement: the relative difference between the maximum coefficient in Range 1 and the minimum coefficient in Range 2 must not be larger than 5 dB, and the relative difference between the maximum coefficient in Range 2 and the minimum coefficient in Range 1 must not be larger than 7 dB (see Figure 6.5.2.4.1-1).

The EVM equalizer spectral flatness shall not exceed the values specified in Table 6.5.2.4.1-2 for extreme conditions. For uplink allocations contained within both Range 1 and Range 2, the coefficients evaluated within each of these frequency ranges shall meet the corresponding ripple requirement and the following additional requirement: the relative difference between the maximum coefficient in Range 1 and the minimum coefficient in Range 2 must not be larger than 6 dB, and the relative difference between the maximum coefficient in Range 2 and the minimum coefficient in Range 1 must not be larger than 10 dB (see Figure 6.5.2.4.1-1).

Table 6.5.2.4.1-1: Minimum requirements for EVM equalizer spectrum flatness (normal conditions)

Frequency range	Maximum ripple [dB]
$F_{UL_Meas} - F_{UL_Low} \geq 3$ MHz and $F_{UL_High} - F_{UL_Meas} \geq 3$ MHz (Range 1)	4 (p-p)
$F_{UL_Meas} - F_{UL_Low} < 3$ MHz or $F_{UL_High} - F_{UL_Meas} < 3$ MHz (Range 2)	8 (p-p)
NOTE 1: F_{UL_Meas} refers to the sub-carrier frequency for which the equalizer coefficient is evaluated	
NOTE 2: F_{UL_Low} and F_{UL_High} refer to each E-UTRA frequency band specified in Table 5.5-1	

Table 6.5.2.4.1-2: Minimum requirements for EVM equalizer spectrum flatness (extreme conditions)

Frequency range	Maximum Ripple [dB]
$F_{UL_Meas} - F_{UL_Low} \geq 5$ MHz and $F_{UL_High} - F_{UL_Meas} \geq 5$ MHz (Range 1)	4 (p-p)
$F_{UL_Meas} - F_{UL_Low} < 5$ MHz or $F_{UL_High} - F_{UL_Meas} < 5$ MHz (Range 2)	12 (p-p)
NOTE 1: F_{UL_Meas} refers to the sub-carrier frequency for which the equalizer coefficient is evaluated	
NOTE 2: F_{UL_Low} and F_{UL_High} refer to each E-UTRA frequency band specified in Table 5.5-1	

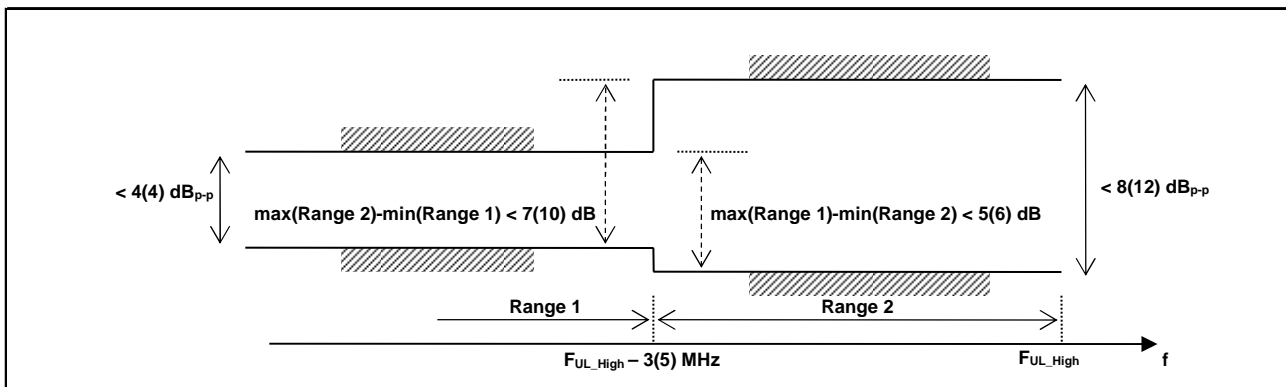

Figure 6.5.2.4.1-1: The limits for EVM equalizer spectral flatness with the maximum allowed variation of the coefficients indicated (the ETC minimum requirement within brackets).

6.5.2A Transmit modulation quality for CA

For inter-band carrier aggregation with uplink assigned to two E-UTRA bands, the requirements shall apply on each component carrier as defined in clause 6.5.2 with all component carriers active. If two contiguous component carriers are assigned to one E-UTRA band, the requirements in subclauses 6.5.2A.1, 6.5.2A.2, and 6.5.2A.3 apply for those component carriers.

The requirements in this clause apply with PCC and SCC in the UL configured and activated: PCC with PRB allocation and SCC without PRB allocation and without CSI reporting and SRS configured.

6.5.2A.1 Error Vector Magnitude

For the intra-band contiguous and non-contiguous carrier aggregation, the Error Vector Magnitude requirement should be defined for each component carrier. Requirements only apply with PRB allocation in one of the component carriers. Similar transmitter impairment removal procedures are applied for CA waveform before EVM calculation as is specified for non-CA waveform in sub-section 6.5.2.1.

When a single component carrier is configured Table 6.5.2.1.1-1 apply.

The EVM requirements are according to Table 6.5.2A.1-1 if CA is configured in uplink.

Table 6.5.2A.1-1: Minimum requirements for Error Vector Magnitude

Parameter	Unit	Average EVM Level per CC	Reference Signal EVM Level
QPSK or BPSK	%	17.5	17.5
16QAM	%	12.5	12.5
64QAM	%	8	8

6.5.2A.2 Carrier leakage for CA

Carrier leakage is an additive sinusoid waveform that is confined within the aggregated transmission bandwidth configuration. The carrier leakage requirement is defined for each component carrier and is measured on the component carrier with PRBs allocated. The measurement interval is one slot in the time domain.

6.5.2A.2.1 Minimum requirements

The relative carrier leakage power is a power ratio of the additive sinusoid waveform and the modulated waveform. The relative carrier leakage power shall not exceed the values specified in Table 6.5.2A.2.1-1.

Table 6.5.2A.2.1-1: Minimum requirements for Relative Carrier Leakage Power

Parameters	Relative Limit (dBc)
Output power >0 dBm	-25
-30 dBm ≤ Output power ≤ 0 dBm	-20
-40 dBm ≤ Output power < -30 dBm	-10

6.5.2A.3 In-band emissions

6.5.2A.3.1 Minimum requirement for CA

For intra-band contiguous carrier aggregation bandwidth class B and C, the requirements in Table 6.5.2A.3.1-1 and 6.5.2A.3.1-2 apply within the aggregated transmission bandwidth configuration with both component carrier (s) active and one single contiguous PRB allocation of bandwidth L_{CRB} at the edge of the aggregated transmission bandwidth configuration.

The inband emission is defined as the interference falling into the non allocated resource blocks for all component carriers. The measurement method for the inband emissions in the component carrier with PRB allocation is specified in annex F. For a non allocated component carrier a spectral measurement is specified.

For intra-band non-contiguous carrier aggregation the requirements for in-band emissions should be defined for each component carrier. Requirements only apply with PRB allocation in one of the component carriers according to Table 6.5.2.3.1.

Table 6.5.2A.3.1-1: Minimum requirements for in-band emissions (allocated component carrier)

Parameter	Unit	Limit	Applicable Frequencies	
General	dB	$\max \left\{ -25 - 10 \cdot \log_{10} (N_{RB} / L_{CRB}), \right.$ $20 \cdot \log_{10} EVM - 3 - 5 \cdot (\Delta_{RB} - 1) / L_{CRB},$ $\left. -57 \text{ dBm} / 180 \text{ kHz} - P_{RB} \right\}$	Any non-allocated (NOTE 2)	
IQ Image	dB	-25	Exception for IQ image (NOTE 3)	
Carrier leakage	dBc	-25	Exception for Carrier frequency (NOTE 4)	
		Output power > 0 dBm		
		-30 dBm ≤ Output power ≤ 0 dBm		
		-10	-40 dBm ≤ Output power < -30 dBm	
<p>NOTE 1: An in-band emissions combined limit is evaluated in each non-allocated RB. For each such RB, the minimum requirement is calculated as the higher of $P_{RB} - 30$ dB and the power sum of all limit values (General, IQ Image or Carrier leakage) that apply. P_{RB} is defined in NOTE 9. The limit is evaluated in each non-allocated RB.</p> <p>NOTE 2: The measurement bandwidth is 1 RB and the limit is expressed as a ratio of measured power in one non-allocated RB to the measured average power per allocated RB, where the averaging is done across all allocated RBs</p> <p>NOTE 3: Exceptions to the general limit are allowed for up to $L_{CRBs} + 1$ RBs within a contiguous width of $L_{CRBs} + 1$ non-allocated RBs. The measurement bandwidth is 1 RB.</p> <p>NOTE 4: Exceptions to the general limit are allowed for up to two contiguous non-allocated RBs. The measurement bandwidth is 1 RB and the limit is expressed as a ratio of measured power in the non-allocated RB to the measured total power in all allocated RBs.</p> <p>NOTE 5: L_{CRB} is the Transmission Bandwidth (see Figure 5.6-1) not exceeding $\lfloor N_{RB} / 2 - 1 \rfloor$</p> <p>NOTE 6: N_{RB} is the Transmission Bandwidth Configuration (see Figure 5.6-1) of the component carrier with RBs allocated.</p> <p>NOTE 7: EVM is the limit specified in Table 6.5.2.1.1-1 for the modulation format used in the allocated RBs.</p> <p>NOTE 8: Δ_{RB} is the starting frequency offset between the allocated RB and the measured non-allocated RB (e.g. $\Delta_{RB} = 1$ or $\Delta_{RB} = -1$ for the first adjacent RB outside of the allocated bandwidth).</p> <p>NOTE 9: P_{RB} is the transmitted power per 180 kHz in allocated RBs, measured in dBm.</p>				

Table 6.5.2A.3.1-2: Minimum requirements for in-band emissions (not allocated component carrier)

Parameter	Unit	Meas BW NOTE 1	Limit	remark	Applicable Frequencies	
General	dB	BW of 1 RB (180KHz rectangular)	$\max \left\{ -25 - 10 \cdot \log_{10} (N_{RB} / L_{CRB}), \right.$ $20 \cdot \log_{10} EVM - 3 - 5 \cdot (\Delta_{RB} - 1) / L_{CRB},$ $\left. -57 \text{ dBm} / 180 \text{ kHz} - P_{RB} \right\}$	The reference value is the average power per allocated RB in the allocated component carrier	Any RB in the non allocated component carrier. The frequency raster of the RBs is derived when this component carrier is allocated with RBs	
IQ Image	dB	BW of 1 RB (180KHz rectangular)	-25 NOTE 2	The reference value is the average power per allocated RB in the allocated component carrier	The frequencies of the L_{CRB} contiguous non-allocated RBs are unknown. The frequency raster of the RBs is derived when this component carrier is allocated with RBs	
Carrier leakage	dBc	BW of 1 RB (180KHz rectangular)	NOTE 3		The reference value is the total power of the allocated RBs in the allocated component carrier	The frequencies of the up to 2 non-allocated RBs are unknown. The frequency raster of the RBs is derived when this component carrier is allocated with RBs
			-25	Output power > 0 dBm		
			-20	-30 dBm ≤ Output power ≤ 0 dBm		
			-10	-40 dBm ≤ Output power < -30 dBm		
NOTE 1: Resolution BWs smaller than the measurement BW may be integrated to achieve the measurement bandwidth.						
NOTE 2: Exceptions to the general limit is are allowed for up to $L_{CRB} + 1$ RBs within a contiguous width of $L_{CRB} + 1$ non-allocated RBs.						
NOTE 3: Two Exceptions to the general limit are allowed for up to two contiguous non-allocated RBs						
NOTE 4: NOTES 1, 5, 6, 7, 8, 9 from Table 6.5.2A.3.1-1 apply for Table 6.5.2A.3.1-2 as well.						
NOTE 5: Δ_{RB} for measured non-allocated RB in the non allocated component carrier may take non-integer values when the carrier spacing between the CCs is not a multiple of RB.						

6.5.2B Transmit modulation quality for UL-MIMO

For UE supporting UL-MIMO, the transmit modulation quality requirements are specified at each transmit antenna connector.

If UE is configured for transmission on single-antenna port, the requirements in subclause 6.5.2 apply.

The transmit modulation quality is specified in terms of:

- Error Vector Magnitude (EVM) for the allocated resource blocks (RBs)
- EVM equalizer spectrum flatness derived from the equalizer coefficients generated by the EVM measurement process
- Carrier leakage (caused by IQ offset)
- In-band emissions for the non-allocated RB

6.5.2B.1 Error Vector Magnitude

For UE with two transmit antenna connectors in closed-loop spatial multiplexing scheme, the Error Vector Magnitude requirements specified in Table 6.5.2.1.1-1 which is defined in subclause 6.5.2.1 apply at each transmit antenna connector. The requirements shall be met with the UL-MIMO configurations specified in Table 6.2.2B-2.

6.5.2B.2 Carrier leakage

For UE with two transmit antenna connectors in closed-loop spatial multiplexing scheme, the Relative Carrier Leakage Power requirements specified in Table 6.5.2.2.1-1 which is defined in subclause 6.5.2.2 apply at each transmit antenna connector. The requirements shall be met with the UL-MIMO configurations specified in Table 6.2.2B-2.

6.5.2B.3 In-band emissions

For UE with two transmit antenna connectors in closed-loop spatial multiplexing scheme, the In-band Emission requirements specified in Table 6.5.2.3.1-1 which is defined in subclause 6.5.2.3 apply at each transmit antenna connector. The requirements shall be met with the uplink MIMO configurations specified in Table 6.2.2B-2.

6.5.2B.4 EVM equalizer spectrum flatness for UL-MIMO

For UE with two transmit antenna connectors in closed-loop spatial multiplexing scheme, the EVM Equalizer Spectrum Flatness requirements specified in Table 6.5.2.4.1-1 and Table 6.5.2.4.1-2 which are defined in subclause 6.5.2.4 apply at each transmit antenna connector. The requirements shall be met with the UL-MIMO configurations specified in Table 6.2.2B-2.

6.5.2D Transmit modulation quality for ProSe

The requirements in this clause apply to ProSe sidelink transmissions.

When UE is configured for simultaneous E-UTRA ProSe sidelink and E-UTRA uplink transmissions for inter-band E-UTRA ProSe / E-UTRA bands specified in Table 5.5D-2, the requirements in subclause 6.5.2D apply for ProSe transmission and the requirements in subclause 6.5.2 apply for uplink transmission.

6.5.2D.1 Error Vector Magnitude

For ProSe sidelink physical channels PSDCH, PSCCH, PSSCH, and PSBCH, the Error Vector Magnitude requirements shall be as specified for PUSCH in subclause 6.5.2.1 for the corresponding modulation and transmission bandwidth. When ProSe transmissions are shortened due to transmission gap of 1 symbol at the end of the subframe, the EVM measurement interval is reduced by one symbol, accordingly.

For PSBCH the duration over which EVM is averaged shall be 24 subframes.

This requirement is not applicable for ProSe physical signals PSSS and SSSS.

6.5.2D.2 Carrier leakage

The requirements of subcaluse 6.5.2.2 shall apply for ProSe transmissions.

6.5.2D.3 In-band emissions

For ProSe sidelink physical channels PSDCH, PSCCH, PSSCH, and PSBCH, the In-band emissions requirements shall be as specified for PUSCH in subclause 6.5.2.3 for the corresponding modulation and transmission bandwidth. When ProSe transmissions are shortened due to transmission gap of 1 symbol at the end of the subframe, the In-band emissions measurement interval is reduced by one symbol, accordingly.

6.5.2D.4 EVM equalizer spectrum flatness for ProSe

The requirements of subcaluse 6.5.2.4 shall apply for ProSe transmissions.

6.5.2E Transmit modulation quality for category M1

For UE of UL Category M1, the requirements shall apply as defined in clause 6.5.2.

6.5.2E.1 Error Vector Magnitude

The Error Vector Magnitude is defined in section 6.5.2.1.

6.5.2E.2 Carrier leakage

Carrier leakage is an additive sinusoid waveform that has the same frequency as a modulated waveform carrier frequency. For UE of UL Category M1, the sinusoid waveform may alternatively lie at the center of the 6 RB narrowband assigned for transmission. The measurement interval is one slot in the time domain.

6.5.2E.2.1 Minimum requirements

The relative carrier leakage power is a power ratio of the additive sinusoid waveform and the modulated waveform. The relative carrier leakage power at the center of the channel bandwidth or the 6 RB narrowband assigned for transmission shall not exceed the values specified in Table 6.5.2.2.1-1.

6.5.2E.3 In-band emissions

The in-band emission is defined in clause 6.5.2.3.

6.5.2E.3.1 Minimum requirements

The relative in-band emission when center carrier frequency is at the center of channel bandwidth or when at the 6RB narrowband assigned for transmission shall not exceed the values specified in Table 6.5.2E.3.1-1

Table 6.5.2E.3.1-1: Minimum requirements for in-band emissions

Parameter description	Unit	Limit (NOTE 1)		Applicable Frequencies
General	dB	$\max \left\{ -25 - 10 \cdot \log_{10} (N_{RB} / L_{CRB}), \right.$ $20 \cdot \log_{10} EVM - 3 - 5 \cdot (\Delta_{RB} - 1) / L_{CRB},$ $\left. -57 \text{ dBm} / 180 \text{ kHz} - P_{RB} \right\}$		Any non-allocated (NOTE 2)
IQ Image	dB	-28	Image frequencies when carrier center frequency < 1 GHz and Output power > 10 dBm	Image frequencies (NOTES 2, 3)
		-25	Image frequencies when carrier center frequency < 1 GHz and Output power ≤ 10 dBm	
		-25	Image frequencies when carrier center frequency ≥ 1 GHz	
Carrier leakage	dBc	-28	Output power > 10 dBm and carrier center frequency < 1 GHz	Carrier frequency (NOTES 4, 5)
		-25	Output power > 10 dBm and carrier center frequency ≥ 1 GHz	
		-25	0 dBm ≤ Output power ≤ 10 dBm	
		-20	-30 dBm ≤ Output power ≤ 0 dBm	

	-10	-40 dBm ≤ Output power < -30 dBm	
NOTE 1:	An in-band emissions combined limit is evaluated in each non-allocated RB. For each such RB, the minimum requirement is calculated as the higher of $P_{RB} - 30$ dB and the power sum of all limit values (General, IQ Image or Carrier leakage) that apply. P_{RB} is defined in NOTE 10.		
NOTE 2:	The measurement bandwidth is 1 RB and the limit is expressed as a ratio of measured power in one non-allocated RB to the measured average power per allocated RB, where the averaging is done across all allocated RBs.		
NOTE 3:	The applicable frequencies for this limit are those that are enclosed in the reflection of the allocated bandwidth, based on symmetry with respect to the centre carrier frequency, but excluding any allocated RBs. For UE of UL Category M1, applicable frequencies shall alternatively include those found by reflection on the center of the assigned 6 RB narrowband, but excluding any allocated RBs.		
NOTE 4:	The measurement bandwidth is 1 RB and the limit is expressed as a ratio of measured power in one non-allocated RB to the measured total power in all allocated RBs.		
NOTE 5:	The applicable frequencies for this limit are those that are enclosed in the RBs containing the DC frequency if N_{RB} is odd, or in the two RBs immediately adjacent to the DC frequency if N_{RB} is even, but excluding any allocated RB. For UE of UL Category M1, the applicable frequencies shall alternatively be the centre frequency of the supported 6RBs.		
NOTE 6:	L_{CRB} is the Transmission Bandwidth (see Figure 5.6-1).		
NOTE 7:	N_{RB} is the Transmission Bandwidth Configuration (see Figure 5.6-1).		
NOTE 8:	EVM is the limit specified in Table 6.5.2.1.1-1 for the modulation format used in the allocated RBs.		
NOTE 9:	Δ_{RB} is the starting frequency offset between the allocated RB and the measured non-allocated RB (e.g. $\Delta_{RB} = 1$ or $\Delta_{RB} = -1$ for the first adjacent RB outside of the allocated bandwidth).		
NOTE 10:	P_{RB} is the transmitted power per 180 kHz in allocated RBs, measured in dBm.		

6.5.2F Transmit modulation quality for Category NB1

6.5.2F.1 Error Vector Magnitude

The RMS average of the basic EVM measurements for $240/L_{Ctone}$ slots excluding any transient period for the average EVM case, where $L_{Ctone} = \{1, 3, 6, 12\}$ is the number of subcarriers for the category NB1 transmission, for the different modulations schemes shall not exceed the values specified in Table 6.5.2.1.1-1 for the parameters defined in Table 6.5.2.1.1-2. For EVM evaluation purposes, both NPRACH formats are considered to have the same EVM requirement as QPSK modulated.

6.5.2F.2 Carrier leakage

Carrier leakage is an additive sinusoid waveform that has the same frequency as a modulated waveform carrier frequency. The measurement interval is one slot in the time domain. The relative carrier leakage power is a power ratio of the additive sinusoid waveform and the modulated waveform. The relative carrier leakage power of category NB1 UE shall not exceed the values specified in Table 6.5.2F.2-1.

Table 6.5.2F.2-1: Minimum requirements for relative carrier leakage power

Parameters	Relative limit (dBc)
$0 \text{ dBm} \leq \text{Output power}$	-25
$-30 \text{ dBm} \leq \text{Output power} \leq 0 \text{ dBm}$	-20
$-40 \text{ dBm} \leq \text{Output power} < -30 \text{ dBm}$	-10

6.5.2F.3 In-band emissions

The in-band emission is defined as a function of the tone offset from the edge of the allocated UL transmission tone(s) within the transmission bandwidth configuration. The in-band emission is measured as the ratio of the UE output power in a non-allocated tone to the UE output power in an allocated tone. The basic in-band emissions measurement interval is defined over one slot in the time domain.

The category NB1 UE relative in-band emission shall not exceed the values specified in Table 6.5.2F.3-1.

Table 6.5.2F.3-1: Minimum requirements for in-band emissions

Parameter description	Unit	Limit (NOTE 1)		Applicable Frequencies
General	dB	$\max \left\{ -15 - 10 \cdot \log_{10} (N_{tone} / L_{Ctone}), \right.$ $-18 - 5 \cdot (\Delta_{tone} - 1) / L_{Ctone},$ $\left. -57 \text{ dBm} / (3.75 \text{ kHz or } 15 \text{ kHz}) - P_{tone} \right\}$		Any non-allocated (NOTE 2)
IQ Image	dB	-25		Image frequencies (NOTES 2, 3)
Carrier leakage	dBc	-25	$0 \text{ dBm} \leq \text{Output power}$	Carrier frequency (NOTES 4, 5)
		-20	$-30 \text{ dBm} \leq \text{Output power} \leq 0 \text{ dBm}$	
		-10	$-40 \text{ dBm} \leq \text{Output power} < -30 \text{ dBm}$	

NOTE 1: An in-band emissions combined limit is evaluated in each non-allocated tone. For each such tone, the minimum requirement is calculated as the higher of $P_{tone} - 30 \text{ dB}$ and the power sum of all limit values (General, IQ Image or Carrier leakage) that apply. P_{tone} is defined in NOTE 9.

NOTE 2: The measurement bandwidth is 1 tone and the limit is expressed as a ratio of measured power in one non-allocated tone to the measured average power per allocated tone, where the averaging is done across all allocated tones.

NOTE 3: The applicable frequencies for this limit are those that are enclosed in the reflection of the allocated bandwidth, based on symmetry with respect to the centre carrier frequency, but excluding any allocated tones.

NOTE 4: The measurement bandwidth is 1 tone and the limit is expressed as a ratio of measured power in one non-allocated tone to the measured total power in all allocated tones.

NOTE 5: The applicable frequencies for this limit are those that are enclosed in the tones containing the DC frequency if N_{tone} is odd, or in the two tones immediately adjacent to the DC frequency if N_{tone} is even, but excluding any allocated tone.

NOTE 6: L_{Ctone} is the Transmission Bandwidth (tones).

NOTE 7: N_{tone} is the Transmission Bandwidth Configuration (tones).

NOTE 8: Δ_{tone} is the starting frequency offset between the allocated tone and the measured non-allocated tone. (e.g. $\Delta_{tone} = 1$ or $\Delta_{tone} = -1$ for the first adjacent tone outside of the allocated bandwidth).

NOTE 9: P_{tone} is the transmitted power per 3.75 kHz or 15 kHz in allocated tones, measured in dBm.

6.6 Output RF spectrum emissions

The output UE transmitter spectrum consists of the three components; the emission within the occupied bandwidth (channel bandwidth), the Out Of Band (OOB) emissions and the far out spurious emission domain.

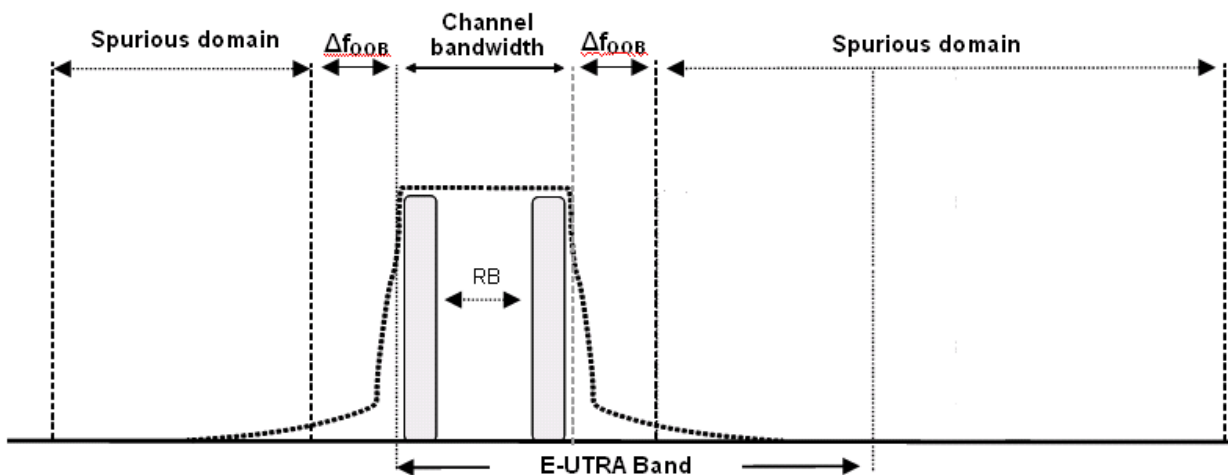

Figure 6.6-1: Transmitter RF spectrum

6.6.1 Occupied bandwidth

Occupied bandwidth is defined as the bandwidth containing 99 % of the total integrated mean power of the transmitted spectrum on the assigned channel. The occupied bandwidth for all transmission bandwidth configurations (Resources Blocks) shall be less than the channel bandwidth specified in Table 6.6.1-1

Table 6.6.1-1: Occupied channel bandwidth

	Occupied channel bandwidth / Channel bandwidth					
	1.4 MHz	3.0 MHz	5 MHz	10 MHz	15 MHz	20 MHz
Channel bandwidth (MHz)	1.4	3	5	10	15	20

6.6.1A Occupied bandwidth for CA

For inter-band carrier aggregation with one component carrier per operating band and the uplink active in two E-UTRA bands the occupied bandwidth is defined per component carrier. Occupied bandwidth is the bandwidth containing 99 % of the total integrated mean power of the transmitted spectrum on assigned channel bandwidth on the component carrier. The occupied bandwidth shall be less than the channel bandwidth specified in Table 6.6.1-1.

For intra-band contiguous carrier aggregation the occupied bandwidth is a measure of the bandwidth containing 99 % of the total integrated power of the transmitted spectrum. The OBW shall be less than the aggregated channel bandwidth defined in subclause 5.6A.

For intra-band non-contiguous carrier aggregation sub-block occupied bandwidth is defined as the bandwidth containing 99 % of the total integrated mean power of the transmitted spectrum on the sub-block. In case the sub-block consist of one component carrier the occupied bandwidth of the sub-block shall be less than the channel bandwidth specified in Table 6.6.1-1.

For combinations of intra-band and inter-band carrier aggregation with three uplink component carriers (up to two contiguously aggregated carriers per band), the occupied bandwidth is the bandwidth containing 99 % of the total integrated mean power of the transmitted spectrum on each E-UTRA band. The OBW shall be less than the channel bandwidth as specified in Table 6.6.1-1 for the E-UTRA band supporting one component carrier. The OBW shall be less than the aggregated channel bandwidth as specified in subclause 5.6A for the E-UTRA band supporting two contiguous component carriers.

6.6.1B Occupied bandwidth for UL-MIMO

For UE supporting UL-MIMO, the requirements for occupied bandwidth is specified at each transmit antenna connector. The occupied bandwidth is defined as the bandwidth containing 99 % of the total integrated mean power of the transmitted spectrum on the assigned channel at each transmit antenna connector.

For UE with two transmit antenna connectors in closed-loop spatial multiplexing scheme, the occupied bandwidth at each transmitter antenna shall be less than the channel bandwidth specified in Table 6.6.1B-1. The requirements shall be met with the UL-MIMO configurations specified in Table 6.2.2B-2.

Table 6.6.1B-1: Occupied channel bandwidth

	Occupied channel bandwidth / Channel bandwidth					
	1.4 MHz	3.0 MHz	5 MHz	10 MHz	15 MHz	20 MHz
Channel bandwidth (MHz)	1.4	3	5	10	15	20

If UE is configured for transmission on single-antenna port, the requirements in subclause 6.6.1 apply.

6.6.1F Occupied bandwidth for category NB1

The occupied bandwidth is defined as the bandwidth containing 99 % of the total integrated mean power of the transmitted spectrum on the assigned channel at the transmit antenna connector. Occupied bandwidth shall be less than the channel bandwidth of category NB1 specified in Section 5.6F.

6.6.2 Out of band emission

The Out of band emissions are unwanted emissions immediately outside the assigned channel bandwidth resulting from the modulation process and non-linearity in the transmitter but excluding spurious emissions. This out of band emission limit is specified in terms of a spectrum emission mask and an Adjacent Channel Leakage power Ratio.

6.6.2.1 Spectrum emission mask

The spectrum emission mask of the UE applies to frequencies (Δf_{OoB}) starting from the \pm edge of the assigned E-UTRA channel bandwidth. For frequencies greater than (Δf_{OoB}) as specified in Table 6.6.2.1.1-1 the spurious requirements in subclause 6.6.3 are applicable.

6.6.2.1.1 Minimum requirement

The power of any UE emission shall not exceed the levels specified in Table 6.6.2.1.1-1 for the specified channel bandwidth.

Table 6.6.2.1.1-1: General E-UTRA spectrum emission mask

Spectrum emission limit (dBm)/ Channel bandwidth							
Δf_{OoB} (MHz)	1.4 MHz	3.0 MHz	5 MHz	10 MHz	15 MHz	20 MHz	Measurement bandwidth
$\pm 0-1$	-10	-13	-15	-18	-20	-21	30 kHz
$\pm 1-2.5$	-10	-10	-10	-10	-10	-10	1 MHz
$\pm 2.5-2.8$	-25	-10	-10	-10	-10	-10	1 MHz
$\pm 2.8-5$		-10	-10	-10	-10	-10	1 MHz
$\pm 5-6$		-25	-13	-13	-13	-13	1 MHz
$\pm 6-10$			-25	-13	-13	-13	1 MHz
$\pm 10-15$				-25	-13	-13	1 MHz
$\pm 15-20$					-25	-13	1 MHz
$\pm 20-25$						-25	1 MHz

NOTE: As a general rule, the resolution bandwidth of the measuring equipment should be equal to the measurement bandwidth. However, to improve measurement accuracy, sensitivity and efficiency, the resolution bandwidth may be smaller than the measurement bandwidth. When the resolution bandwidth is smaller than the measurement bandwidth, the result should be integrated over the measurement bandwidth in order to obtain the equivalent noise bandwidth of the measurement bandwidth.

6.6.2.1A Spectrum emission mask for CA

For inter-band carrier aggregation with one component carrier per operating band and the uplink active in two E-UTRA bands, the spectrum emission mask of the UE is defined per component carrier while both component carriers are active and the requirements are specified in subclauses 6.6.2.1 and 6.6.2.2. If for some frequency spectrum emission masks of component carriers overlap then spectrum emission mask allowing higher power spectral density applies for that frequency. If for some frequency a component carrier spectrum emission mask overlaps with the channel bandwidth of another component carrier, then the emission mask does not apply for that frequency.

For intra-band contiguous carrier aggregation the spectrum emission mask of the UE applies to frequencies (Δf_{OoB}) starting from the \pm edge of the aggregated channel bandwidth (Table 5.6A-1) For intra-band contiguous carrier aggregation the bandwidth class B and C, the power of any UE emission shall not exceed the levels specified in Table 6.6.2.1A-0 and Table 6.6.2.1A-1 for the specified channel bandwidth.

Table 6.6.2.1A-0: General E-UTRA CA spectrum emission mask for Bandwidth Class B

Spectrum emission limit [dBm]/BW _{Channel_CA}			
Δf_{OOB} (MHz)	25RB+50RB (14.95 MHz)	50RB+50RB (19.9 MHz)	Measurement bandwidth
± 0-1	-20	-21	30 kHz
± 1-5	-10	-10	1 MHz
± 5-14.95	-13	-13	1 MHz
± 14.95-19.90	-25	-13	1 MHz
± 19.90-19.95	-25	-25	1 MHz
± 19.95-24.90		-25	1 MHz

Table 6.6.2.1A-1: General E-UTRA CA spectrum emission mask for Bandwidth Class C

Spectrum emission limit [dBm]/BW _{Channel_CA}							
Δf_{OOB} (MHz)	25RB+100RB (24.95MHz)	50RB+75RB (24.75 MHz)	50RB+100RB (29.9 MHz)	75RB+75RB (30 MHz)	75RB+100RB (34.85 MHz)	100RB+100RB (39.8 MHz)	Measurement bandwidth
± 0-1	-22	-22	-22.5	-22.5	-23.5	-24	30 kHz
± 1-5	-10	-10	-10	-10	-10	-10	1 MHz
± 5-24.75	-13	-13	-13	-13	-13	-13	1 MHz
± 24.75- 24.95	-13	-25	-13	-13	-13	-13	1 MHz
± 24.95- 29.75	-25	-25	-13	-13	-13	-13	1 MHz
± 29.75-29.9	-25		-13	-13	-13	-13	1 MHz
± 29.9-29.95	-25		-25	-13	-13	-13	1 MHz
± 29.95-30			-25	-13	-13	-13	1 MHz
± 30-34.85			-25	-25	-13	-13	1 MHz
± 34.85-34.9			-25	-25	-25	-13	1 MHz
± 34.9-35				-25	-25	-13	1 MHz
± 35-39.8					-25	-13	1 MHz
± 39.8-39.85					-25	-25	1 MHz
± 39.85-44.8						-25	1 MHz

For intra-band non-contiguous carrier aggregation transmission the spectrum emission mask requirement is defined as a composite spectrum emissions mask. Composite spectrum emission mask applies to frequencies up to $\pm \Delta f_{\text{OOB}}$ starting from the edges of the sub-blocks. Composite spectrum emission mask is defined as follows

- Composite spectrum emission mask is a combination of individual sub-block spectrum emissions masks
- In case the sub-block consist of one component carrier the sub-lock general spectrum emission mask is defined in subclause 6.6.2.1.1
- If for some frequency sub-block spectrum emission masks overlap then spectrum emission mask allowing higher power spectral density applies for that frequency
- If for some frequency a sub-block spectrum emission mask overlaps with the sub-block bandwidth of another sub-block, then the emission mask does not apply for that frequency.

For combinations of intra-band and inter-band carrier aggregation with three uplink component carriers (up to two contiguously aggregated carriers per band), the spectrum emission mask of the UE is defined per E-UTRA band while all component carriers are active. For the E-UTRA band supporting one component carrier the requirements in subclauses 6.6.2.1 and 6.6.2.2 apply. For the E-UTRA band supporting two contiguous component carriers the requirements specified in subclause 6.6.2.1A apply. If for some frequency spectrum emission masks of single component carrier and two contiguous component carriers overlap then spectrum emission mask allowing higher power spectral density applies for that frequency. If for some frequency spectrum emission masks of single component carrier or two contiguous component carriers overlap then the emission mask does not apply for that frequency.

6.6.2.2 Additional spectrum emission mask

This requirement is specified in terms of an "additional spectrum emission" requirement.

6.6.2.2.1 Minimum requirement (network signalled value "NS_03", "NS_11", "NS_20", and "NS_21")

Additional spectrum emission requirements are signalled by the network to indicate that the UE shall meet an additional requirement for a specific deployment scenario as part of the cell handover/broadcast message.

When "NS_03", "NS_11", "NS_20" or "NS_21" is indicated in the cell, the power of any UE emission shall not exceed the levels specified in Table 6.6.2.2.1-1.

Table 6.6.2.2.1-1: Additional requirements

Δf_{OoB} (MHz)	Spectrum emission limit (dBm)/ Channel bandwidth						Measurement bandwidth
	1.4 MHz	3.0 MHz	5 MHz	10 MHz	15 MHz	20 MHz	
$\pm 0-1$	-10	-13	-15	-18	-20	-21	30 kHz
$\pm 1-2.5$	-13	-13	-13	-13	-13	-13	1 MHz
$\pm 2.5-2.8$	-25	-13	-13	-13	-13	-13	1 MHz
$\pm 2.8-5$		-13	-13	-13	-13	-13	1 MHz
$\pm 5-6$		-25	-13	-13	-13	-13	1 MHz
$\pm 6-10$			-25	-13	-13	-13	1 MHz
$\pm 10-15$				-25	-13	-13	1 MHz
$\pm 15-20$					-25	-13	1 MHz
$\pm 20-25$						-25	1 MHz

NOTE: As a general rule, the resolution bandwidth of the measuring equipment should be equal to the measurement bandwidth. However, to improve measurement accuracy, sensitivity and efficiency, the resolution bandwidth may be smaller than the measurement bandwidth. When the resolution bandwidth is smaller than the measurement bandwidth, the result should be integrated over the measurement bandwidth in order to obtain the equivalent noise bandwidth of the measurement bandwidth.

6.6.2.2.2 Minimum requirement (network signalled value "NS_04")

Additional spectrum emission requirements are signalled by the network to indicate that the UE shall meet an additional requirement for a specific deployment scenario as part of the cell handover/broadcast message.

When "NS_04" is indicated in the cell, the power of any UE emission shall not exceed the levels specified in Table 6.6.2.2.2-1.

Table 6.6.2.2.2-1: Additional requirements

Δf_{OoB} (MHz)	Spectrum emission limit (dBm)/ Channel bandwidth				Measurement bandwidth
	5 MHz	10 MHz	15 MHz	20 MHz	
$\pm 0-1$	-15	-18	-20	-21	30 kHz
$\pm 1-2.5$	-10	-10	-10	-10	1 MHz
$\pm 2.5-2.8$	-10	-10	-10	-10	1 MHz
$\pm 2.8-5$	-10	-10	-10	-10	1 MHz
$\pm 5-6$	-13	-13	-13	-13	1 MHz
$\pm 6-9$	-25	-13	-13	-13	1 MHz
$\pm 9-10$	-25	-25	-13	-13	1 MHz
$\pm 10-13.5$		-25	-13	-13	1 MHz
$\pm 13.5-15$		-25	-25	-13	1 MHz
$\pm 15-18$			-25	-13	1 MHz
$\pm 18-20$			-25	-25	1 MHz
$\pm 20-25$				-25	1 MHz

NOTE: As a general rule, the resolution bandwidth of the measuring equipment should be equal to the measurement bandwidth. However, to improve measurement accuracy, sensitivity and efficiency, the resolution bandwidth may be smaller than the measurement bandwidth. When the resolution bandwidth is smaller than the measurement bandwidth, the result should be integrated over the measurement bandwidth in order to obtain the equivalent noise bandwidth of the measurement bandwidth.

6.6.2.2.3 Minimum requirement (network signalled value "NS_06" or "NS_07")

Additional spectrum emission requirements are signalled by the network to indicate that the UE shall meet an additional requirement for a specific deployment scenario as part of the cell handover/broadcast message.

When "NS_06" or "NS_07" is indicated in the cell, the power of any UE emission shall not exceed the levels specified in Table 6.6.2.2.3-1.

Table 6.6.2.2.3-1: Additional requirements

Δf_{OoB} (MHz)	Spectrum emission limit (dBm)/ Channel bandwidth				
	1.4 MHz	3.0 MHz	5 MHz	10 MHz	Measurement bandwidth
$\pm 0-0.1$	-13	-13	-15	-18	30 kHz
$\pm 0.1-1$	-13	-13	-13	-13	100 kHz
$\pm 1-2.5$	-13	-13	-13	-13	1 MHz
$\pm 2.5-2.8$	-25	-13	-13	-13	1 MHz
$\pm 2.8-5$		-13	-13	-13	1 MHz
$\pm 5-6$		-25	-13	-13	1 MHz
$\pm 6-10$			-25	-13	1 MHz
$\pm 10-15$				-25	1 MHz

NOTE: As a general rule, the resolution bandwidth of the measuring equipment should be equal to the measurement bandwidth. However, to improve measurement accuracy, sensitivity and efficiency, the resolution bandwidth may be smaller than the measurement bandwidth. When the resolution bandwidth is smaller than the measurement bandwidth, the result should be integrated over the measurement bandwidth in order to obtain the equivalent noise bandwidth of the measurement bandwidth.

6.6.2.2A Additional Spectrum Emission Mask for CA

This requirement is specified in terms of an "additional spectrum emission" requirement.

6.6.2.2A.1 Minimum requirement (network signalled value "CA_NS_04")

Additional spectrum emission requirements are signalled by the network to indicate that the UE shall meet an additional requirement for a specific deployment scenario as part of the cell handover/broadcast message.

When "CA_NS_04" is indicated in the cell, the power of any UE emission shall not exceed the levels specified in Table 6.6.2.2A.1-1.

Table 6.6.2.2A.1-1: Additional requirements

Δf_{OoB} (MHz)	Spectrum emission limit [dBm]/ $BW_{\text{Channel_CA}}$						Measurement bandwidth
	50+75RB (24.75 MHz)	25+100RB (24.95 MHz)	50+100RB (29.9 MHz)	75+75RB (30 MHz)	75+100RB (34.85 MHz)	100+100RB (39.8 MHz)	
$\pm 0-1$	-22	-22	-22.5	-23	-23.5	-24	30 kHz
$\pm 1-5$	-10	-10	-10	-10	-10	-10	1 MHz
$\pm 5-22.95$	-13	-13	-13	-13	-13	-13	1 MHz
$\pm 22.95-23.25$	-13	-25	-13	-13	-13	-13	1 MHz
$\pm 23.25-27.9$	-25	-25	-13	-13	-13	-13	1 MHz
$\pm 27.9-28.5$	-25	-25	-25	-13	-13	-13	1 MHz
$\pm 28.5-29.75$	-25	-25	-25	-25	-13	-13	1 MHz
$\pm 29.75-29.95$		-25	-25	-25	-13	-13	1 MHz
$\pm 29.95-32.85$			-25	-25	-13	-13	1 MHz
$\pm 32.85-34.9$			-25	-25	-25	-13	1 MHz
$\pm 34.9-35$				-25	-25	-13	1 MHz
$\pm 35-37.8$					-25	-13	1 MHz
$\pm 37.8-39.85$					-25	-25	1 MHz
$\pm 39.85-44.8$						-25	1 MHz

NOTE: As a general rule, the resolution bandwidth of the measuring equipment should be equal to the measurement bandwidth. However, to improve measurement accuracy, sensitivity and efficiency, the resolution bandwidth may be smaller than the measurement bandwidth. When the resolution bandwidth is smaller than the measurement bandwidth, the result should be integrated over the measurement bandwidth in order to obtain the equivalent noise bandwidth of the measurement bandwidth.

6.6.2.3 Adjacent Channel Leakage Ratio

Adjacent Channel Leakage power Ratio (ACLR) is the ratio of the filtered mean power centred on the assigned channel frequency to the filtered mean power centred on an adjacent channel frequency. ACLR requirements for one E-UTRA carrier are specified for two scenarios for an adjacent E-UTRA and /or UTRA channel as shown in Figure 6.6.2.3-1.

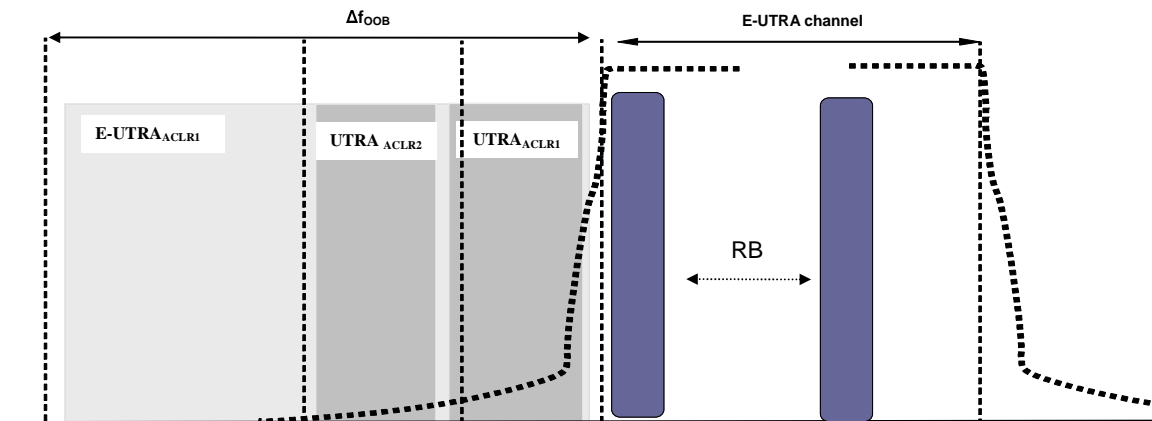

Figure 6.6.2.3-1: Adjacent Channel Leakage requirements for one E-UTRA carrier

6.6.2.3.1 Minimum requirement E-UTRA

E-UTRA Adjacent Channel Leakage power Ratio ($E-UTRA_{ACLR}$) is the ratio of the filtered mean power centred on the assigned channel frequency to the filtered mean power centred on an adjacent channel frequency at nominal channel spacing. The assigned E-UTRA channel power and adjacent E-UTRA channel power are measured with rectangular filters with measurement bandwidths specified in Table 6.6.2.3.1-1 and Table 6.6.2.3.1-2. If the measured adjacent channel power is greater than -50dBm then the $E-UTRA_{ACLR}$ shall be higher than the value specified in Table 6.6.2.3.1-1 and Table 6.6.2.3.1-2.

Table 6.6.2.3.1-1: General requirements for $E-UTRA_{ACLR}$

	Channel bandwidth / $E-UTRA_{ACLR1}$ / Measurement bandwidth					
	1.4 MHz	3.0 MHz	5 MHz	10 MHz	15 MHz	20 MHz
$E-UTRA_{ACLR1}$	30 dB	30 dB	30 dB	30 dB	30 dB	30 dB
E-UTRA channel Measurement bandwidth	1.08 MHz	2.7 MHz	4.5 MHz	9.0 MHz	13.5 MHz	18 MHz
Adjacent channel centre frequency offset [MHz]	+1.4 / -1.4	+3.0 / -3.0	+5 / -5	+10 / -10	+15 / -15	+20 / -20

Table 6.6.2.3.1-2: Additional E-UTRA_{ACL}R requirements for Power Class 1

	Channel bandwidth / E-UTRA _{ACL} R1 / Measurement bandwidth					
	1.4 MHz	3.0 MHz	5 MHz	10 MHz	15 MHz	20 MHz
E-UTRA _{ACL} R1			37 dB	37 dB		
E-UTRA channel Measurement bandwidth			4.5 MHz	9.0 MHz		
Adjacent channel centre frequency offset [MHz]			+5 / -5	+10 / -10		
NOTE 1: E-UTRA _{ACL} R1 shall be applicable for >23dBm						

6.6.2.3.1A Void

6.6.2.3.1Aa Void

6.6.2.3.2 Minimum requirements UTRA

UTRA Adjacent Channel Leakage power Ratio (UTRA_{ACL}R) is the ratio of the filtered mean power centred on the assigned E-UTRA channel frequency to the filtered mean power centred on an adjacent(s) UTRA channel frequency.

UTRA Adjacent Channel Leakage power Ratio is specified for both the first UTRA adjacent channel (UTRA_{ACL}R1) and the 2nd UTRA adjacent channel (UTRA_{ACL}R2). The UTRA channel power is measured with a RRC bandwidth filter with roll-off factor $\alpha = 0.22$. The assigned E-UTRA channel power is measured with a rectangular filter with measurement bandwidth specified in Table 6.6.2.3.2-1. If the measured UTRA channel power is greater than -50 dBm then the UTRA_{ACL}R shall be higher than the value specified in Table 6.6.2.3.2-1.

Table 6.6.2.3.2-1: Requirements for UTRAA_{ACLR1/2}

	Channel bandwidth / UTRAA _{ACLR1/2} / Measurement bandwidth					
	1.4 MHz	3.0 MHz	5 MHz	10 MHz	15 MHz	20 MHz
UTRA _{ACLR1}	33 dB	33 dB	33 dB	33 dB	33 dB	33 dB
Adjacent channel centre frequency offset [MHz]	$0.7+BW_{UTRA/2}$ / $-0.7-BW_{UTRA/2}$	$1.5+BW_{UTRA/2}$ / $-1.5-BW_{UTRA/2}$	$+2.5+BW_{UTRA/2}$ / $-2.5-BW_{UTRA/2}$	$+5+BW_{UTRA/2}$ / $-5-BW_{UTRA/2}$	$+7.5+BW_{UTRA/2}$ / $-7.5-BW_{UTRA/2}$	$+10+BW_{UTRA/2}$ / $-10-BW_{UTRA/2}$
UTRA _{ACLR2}	-	-	36 dB	36 dB	36 dB	36 dB
Adjacent channel centre frequency offset [MHz]	-	-	$+2.5+3*BW_{UTRA/2}$ / $-2.5-3*BW_{UTRA/2}$	$+5+3*BW_{UTRA/2}$ / $-5-3*BW_{UTRA/2}$	$+7.5+3*BW_{UTRA/2}$ / $-7.5-3*BW_{UTRA/2}$	$+10+3*BW_{UTRA/2}$ / $-10-3*BW_{UTRA/2}$
E-UTRA channel Measurement bandwidth	1.08 MHz	2.7 MHz	4.5 MHz	9.0 MHz	13.5 MHz	18 MHz
UTRA 5MHz channel Measurement bandwidth (NOTE 1)	3.84 MHz	3.84 MHz	3.84 MHz	3.84 MHz	3.84 MHz	3.84 MHz
UTRA 1.6MHz channel measurement bandwidth (NOTE 2)	1.28 MHz	1.28 MHz	1.28 MHz	1.28MHz	1.28MHz	1.28MHz
NOTE 1: Applicable for E-UTRA FDD co-existence with UTRA FDD in paired spectrum.						
NOTE 2: Applicable for E-UTRA TDD co-existence with UTRA TDD in unpaired spectrum.						

6.6.2.3.2A Minimum requirement UTRA for CA

For inter-band carrier aggregation with one component carrier per operating band and the uplink active in two E-UTRA bands, the UTRA Adjacent Channel Leakage power Ratio (UTRA_{ACLR}) is the ratio of the filtered mean power centred on the assigned channel bandwidth on the component carrier to the filtered mean power centred on an adjacent channel frequency. The UTRA Adjacent Channel Leakage power Ratio is defined per carrier and the requirement is specified in subclause 6.6.2.3.2.

For intra-band contiguous carrier aggregation the UTRA Adjacent Channel Leakage power Ratio (UTRA_{ACLR}) is the ratio of the filtered mean power centred on the aggregated channel bandwidth to the filtered mean power centred on an adjacent(s) UTRA channel frequency.

For intra-band non-contiguous carrier aggregation when all sub-blocks consist of one component carrier the UTRA Adjacent Channel Leakage power Ratio (UTRA_{ACLR}) is the ratio of the sum of the filtered mean powers centered on the assigned sub-block frequencies to the filtered mean power centred on an adjacent(s) UTRA channel frequency. UTRAA_{ACLR1/2} requirements are applicable for all sub-blocks and are specified in Table 6.6.2.3.2A-2. UTRAA_{ACLR1} is required to be met in the sub-block gap when the gap bandwidth W_{gap} is $5\text{MHz} \leq W_{gap} < 15\text{MHz}$. Both UTRAA_{ACLR1} and UTRAA_{ACLR2} are required to be met in the sub-block gap when the gap bandwidth W_{gap} is $15\text{MHz} \leq W_{gap}$.

For combinations of intra-band and inter-band carrier aggregation with three uplink component carriers (up to two contiguously aggregated carriers per band), the UTRA Adjacent Channel Leakage power Ratio (UTRA_{ACLR}) is defined as follows. For the E-UTRA band supporting one component carrier, the UTRA Adjacent Channel Leakage power Ratio (UTRA_{ACLR}) is the ratio of the filtered mean power centred on the assigned channel bandwidth of the component carrier to the filtered mean power centred on an adjacent(s) UTRA channel frequency and the requirements specified in subclause 6.6.2.3.2 apply. For the E-UTRA band supporting two contiguous component carriers the UTRA Adjacent Channel Leakage power Ratio (UTRA_{ACLR}) is the ratio of the filtered mean power centred on the aggregated channel bandwidth to the filtered mean power centred on an adjacent(s) UTRA channel frequency and the requirements specified in subclause 6.6.2.3.2A apply.

UTRA Adjacent Channel Leakage power Ratio is specified for both the first UTRA adjacent channel ($UTRA_{ACLR1}$) and the 2nd UTRA adjacent channel ($UTRA_{ACLR2}$). The UTRA channel power is measured with a RRC bandwidth filter with roll-off factor $\alpha = 0.22$. The assigned aggregated channel bandwidth power is measured with a rectangular filter with measurement bandwidth specified in Table 6.6.2.3.2A-1 for intraband contiguous carrier aggregation or 6.6.2.3.2A-2 for intraband non-contiguous carrier aggregation. If the measured UTRA channel power is greater than -50 dBm then the $UTRA_{ACLR}$ shall be higher than the value specified in Table 6.6.2.3.2A-1 for intraband contiguous carrier aggregation or 6.6.2.3.2A-2 for intraband non-contiguous carrier aggregation.

Table 6.6.2.3.2A-1: Requirements for $UTRA_{ACLR1/2}$

	CA bandwidth class / $UTRA_{ACLR1/2}$ / measurement bandwidth
	CA bandwidth class B and C
$UTRA_{ACLR1}$	33 dB
Adjacent channel centre frequency offset (in MHz)	$\frac{+ BW_{Channel_CA} / 2 + BW_{UTRA} / 2}{- BW_{Channel_CA} / 2 - BW_{UTRA} / 2}$
$UTRA_{ACLR2}$	36 dB
Adjacent channel centre frequency offset (in MHz)	$\frac{+ BW_{Channel_CA} / 2 + 3 * BW_{UTRA} / 2}{- BW_{Channel_CA} / 2 - 3 * BW_{UTRA} / 2}$
CA E-UTRA channel Measurement bandwidth	$BW_{Channel_CA} - 2 * BW_{GB}$
UTRA 5MHz channel Measurement bandwidth (NOTE 1)	3.84 MHz
UTRA 1.6MHz channel measurement bandwidth (NOTE 2)	1.28 MHz
NOTE 1: Applicable for E-UTRA FDD co-existence with UTRA FDD in paired spectrum.	
NOTE 2: Applicable for E-UTRA TDD co-existence with UTRA TDD in unpaired spectrum.	

Table 6.6.2.3.2A-2: Requirements for intraband non-contiguous CA $UTRA_{ACLR1/2}$

	$UTRA_{ACLR1/2}$ / measurement bandwidth
$UTRA_{ACLR1}$	33 dB
Adjacent channel centre frequency offset (in MHz)	$\frac{+ F_{edge,block,high} + BW_{UTRA} / 2}{- F_{edge,block,low} - BW_{UTRA} / 2}$
$UTRA_{ACLR2}$	36 dB
Adjacent channel centre frequency offset (in MHz)	$\frac{+ F_{edge,block,high} + 3 * BW_{UTRA} / 2}{- F_{edge,block,low} - 3 * BW_{UTRA} / 2}$
Sub-block measurement bandwidth	$BW_{Channel,block} - 2 * BW_{GB}$
UTRA 5 MHz channel Measurement bandwidth (NOTE 1)	3.84 MHz
UTRA 1.6 MHz channel measurement bandwidth (NOTE 2)	1.28 MHz
NOTE 1: Applicable for E-UTRA FDD co-existence with UTRA FDD in paired spectrum.	
NOTE 2: Applicable for E-UTRA TDD co-existence with UTRA TDD in unpaired spectrum.	

6.6.2.3.3A Minimum requirements for CA E-UTRA

For intra-band contiguous carrier aggregation the carrier aggregation E-UTRA Adjacent Channel Leakage power Ratio (CA E- $UTRA_{ACLR}$) is the ratio of the filtered mean power centred on the aggregated channel bandwidth to the filtered mean power centred on an adjacent aggregated channel bandwidth at nominal channel spacing. The assigned aggregated channel bandwidth power and adjacent aggregated channel bandwidth power are measured with rectangular filters with

measurement bandwidths specified in Table 6.6.2.3.3A-1. If the measured adjacent channel power is greater than –50dBm then the E-UTRA_{ACLR} shall be higher than the value specified in Table 6.6.2.3.3A-1.

Table 6.6.2.3.3A-1: General requirements for CA E-UTRA_{ACLR}

	CA bandwidth class / CA E-UTRA _{ACLR} / Measurement bandwidth
	CA bandwidth class B and C
CA E-UTRA _{ACLR}	30 dB
CA E-UTRA channel Measurement bandwidth	$BW_{\text{Channel_CA}} - 2 * BW_{\text{GB}}$
Adjacent channel centre frequency offset (in MHz)	$+ BW_{\text{Channel_CA}}$ / $- BW_{\text{Channel_CA}}$

For inter-band carrier aggregation with one component carrier per operating band and the uplink active in two E-UTRA bands, E-UTRA Adjacent Channel Leakage power Ratio (E-UTRA_{ACLR}) is the ratio of the filtered mean power centred on the assigned channel bandwidth on a component carrier to the filtered mean power centred on an adjacent channel frequency. The E-UTRA Adjacent Channel Leakage power Ratio is defined per carrier and the requirement is specified in subclause 6.6.2.3.1.

For intra-band non-contiguous carrier aggregation when all sub-blocks consist of one component carrier the E-UTRA Adjacent Channel Leakage power Ratio (E-UTRA_{ACLR}) is the ratio of the sum of the filtered mean powers centred on the assigned sub-block frequencies to the filtered mean power centred on an adjacent channel frequency at nominal channel spacing. In case the sub-block gap bandwidth W_{gap} is smaller than of the sub-block bandwidth then for that sub-block no E-UTRA_{ACLR} requirement is set for the gap. In case the sub-block gap bandwidth W_{gap} is smaller than either of the sub-block bandwidths then no E-UTRA_{ACLR} requirement is set for the gap. The assigned E-UTRA sub-block power and adjacent E-UTRA channel power are measured with rectangular filters with measurement bandwidths specified in Table 6.6.2.3.3A-2. If the measured adjacent channel power is greater than –50dBm then the E-UTRA_{ACLR} shall be higher than the value specified in Table 6.6.2.3.3A-2.

Table 6.6.2.3.3A-2: General requirements for non-contiguous intraband CA E-UTRA_{ACLR}

	CC and adjacent channel bandwidth / E-UTRA _{ACLR} / Measurement bandwidth					
	1.4 MHz	3 MHz	5 MHz	10 MHz	15 MHz	20 MHz
E-UTRA _{ACLR1}	30 dB	30 dB	30 dB	30 dB	30 dB	30 dB
CC and adjacent channel measurement bandwidth [MHz]	1.08	2.7	4.5	9	13.5	18
Adjacent channel centre frequency offset [MHz]	+ 1.4 / - 1.4	+ 3 / - 3	+ 5 / - 5	+ 10 / - 10	+ 15 / - 15	+ 20 / - 20

For combinations of intra-band and inter-band carrier aggregation with three uplink component carriers (up to two contiguously aggregated carriers per band), the E-UTRA Adjacent Channel Leakage power Ratio (E-UTRA_{ACLR}) is defined as follows. For the E-UTRA band supporting one component carrier, the E-UTRA Adjacent Channel Leakage power Ratio (UTRA_{ACLR}) is the ratio of the filtered mean power centred on the assigned channel bandwidth of the component carrier to the filtered mean power centred on an adjacent channel frequency and the requirements in subclause 6.6.2.3.1 apply. For the E-UTRA band supporting two contiguous component carriers the E-UTRA Adjacent Channel Leakage power Ratio (E-UTRA_{ACLR}) is the ratio of the filtered mean power centred on the aggregated channel bandwidth to the filtered mean power centred on an adjacent(s) aggregated channel bandwidth at nominal channel spacing and the requirements of CA E-UTRA_{ACLR} specified in subclause 6.6.2.3.3A apply.

6.6.2.4 Void

6.6.2.4.1 Void

6.6.2A Void

<reserved for future use>

6.6.2B Out of band emission for UL-MIMO

For UE supporting UL-MIMO, the requirements for Out of band emissions resulting from the modulation process and non-linearity in the transmitters are specified at each transmit antenna connector.

For UEs with two transmit antenna connectors in closed-loop spatial multiplexing scheme, the requirements in subclause 6.6.2 apply to each transmit antenna connector. The requirements shall be met with the UL-MIMO configurations specified in Table 6.2.2B-2.

If UE is configured for transmission on single-antenna port, the requirements in subclause 6.6.3 apply.

6.6.2C Void

<reserved for future use>

6.6.2D Out of band emission for ProSe

When UE is configured for E-UTRA ProSe sidelink transmissions non-concurrent with E-UTRA uplink transmissions for E-UTRA ProSe operating bands specified in Table 5.5D-1, the requirements in subclause 6.6.2 apply.

When UE is configured for simultaneous E-UTRA ProSe sidelink and E-UTRA uplink transmissions for inter-band E-UTRA ProSe / E-UTRA bands specified in Table 5.5D-2, the requirements in subclause 6.6.2 apply per E-UTRA ProSe sidelink and E-UTRA uplink transmission as specified for the corresponding inter-band aggregation with uplink assigned to two bands.

6.6.2F Out of band emission for category NB1

6.6.2F.1 Spectrum emission mask

The spectrum emission mask of the category NB1 UE applies to frequencies (Δf_{OOB}) starting from the \pm edge of the assigned category NB1 channel bandwidth. For frequencies greater than (Δf_{OOB}) as specified in Table 6.6.2F.1-1 the spurious requirements in subclause 6.6.3 are applicable.

The power of any category NB1 UE emission shall not exceed the levels specified in Table 6.6.2F.1-1. The spectrum emission limit between each Δf_{OOB} is linearly interpolated.

Table 6.6.2F.1-1: category NB1 UE spectrum emission mask

Δf_{OOB} (kHz)	Emission limit (dBm)	Measurement bandwidth
± 0	26	30 kHz
± 100	-5	30 kHz
± 150	-8	30 kHz
± 300	-29	30 kHz
$\pm 500-1700$	-35	30 kHz

In addition to the spectrum emission mask requirement in Table 6.6.2F.1-1 a category NB1 UE shall also meet the applicable E-UTRA spectrum emission mask requirement in sub-clause 6.6.2. E-UTRA spectrum emission requirement applies for frequencies that are Foffset away from edge of NB1 channel edge as defined in Table 6.6.2F.1-2.

Table 6.6.2F.1-2: Foffset for category NB1 UE spectrum emission mask

Channel BW (MHz)	Foffset [kHz]
1.4	165
3	190
5	200
10	225
15	240
20	245

Note: Foffset in Table 6.6.2F.1-2 is used to guarantee co-existence for guard-band operation.

6.6.2F.2 Void

<reserved for future use>

6.6.2F.3 Adjacent Channel Leakage Ratio for category NB1

Adjacent Channel Leakage power Ratio is the ratio of the filtered mean power centred on the assigned channel frequency to the filtered mean power centred on an adjacent channel frequency. The assigned category NB1 channel power and adjacent channel power are measured with filters and measurement bandwidths specified in Table 6.6.2F.3-1. If the measured adjacent channel power is greater than -50 dBm then the category NB1 UE ACLR shall be higher than the value specified in Table 6.6.2F.3-1. GSM_{ACLR} requirement is intended for protection of GSM system. $UTRA_{ACLR}$ requirement is intended for protection of UTRA and E-UTRA systems.

Table 6.6.2F.3-1: category NB1 UE ACLR requirements

	GSM_{ACLR}	$UTRA_{ACLR}$
ACLR	20 dB	37 dB
Adjacent channel center frequency offset from category NB1 Channel edge	± 200 kHz	± 2.5 MHz
Adjacent channel measurement bandwidth	180 kHz	3.84 MHz
Measurement filter	Rectangular	RRC-filter $\alpha=0.22$
Category NB1 channel measurement bandwidth	180 kHz	180 kHz
Category NB1 channel Measurement filter	Rectangular	Rectangular

6.6.3 Spurious emissions

Spurious emissions are emissions which are caused by unwanted transmitter effects such as harmonics emission, parasitic emissions, intermodulation products and frequency conversion products, but exclude out of band emissions unless otherwise stated. The spurious emission limits are specified in terms of general requirements inline with SM.329 [2] and E-UTRA operating band requirement to address UE co-existence.

To improve measurement accuracy, sensitivity and efficiency, the resolution bandwidth may be smaller than the measurement bandwidth. When the resolution bandwidth is smaller than the measurement bandwidth, the result should

be integrated over the measurement bandwidth in order to obtain the equivalent noise bandwidth of the measurement bandwidth.

6.6.3.1 Minimum requirements

Unless otherwise stated, the spurious emission limits apply for the frequency ranges that are more than F_{OOB} (MHz) in Table 6.6.3.1-1 from the edge of the channel bandwidth. The spurious emission limits in Table 6.6.3.1-2 apply for all transmitter band configurations (NRB) and channel bandwidths.

NOTE: For measurement conditions at the edge of each frequency range, the lowest frequency of the measurement position in each frequency range should be set at the lowest boundary of the frequency range plus $MBW/2$. The highest frequency of the measurement position in each frequency range should be set at the highest boundary of the frequency range minus $MBW/2$. MBW denotes the measurement bandwidth defined for the protected band.

Table 6.6.3.1-1: Boundary between E-UTRA out of band and spurious emission domain

Channel bandwidth	1.4 MHz	3.0 MHz	5 MHz	10 MHz	15 MHz	20 MHz
OOB boundary F_{OOB} (MHz)	2.8	6	10	15	20	25

Table 6.6.3.1-2: Spurious emissions limits

Frequency Range	Maximum Level	Measurement bandwidth	NOTE
$9 \text{ kHz} \leq f < 150 \text{ kHz}$	-36 dBm	1 kHz	
$150 \text{ kHz} \leq f < 30 \text{ MHz}$	-36 dBm	10 kHz	
$30 \text{ MHz} \leq f < 1000 \text{ MHz}$	-36 dBm	100 kHz	
$1 \text{ GHz} \leq f < 12.75 \text{ GHz}$	-30 dBm	1 MHz	
$12.75 \text{ GHz} \leq f < 5^{\text{th}}$ harmonic of the upper frequency edge of the UL operating band in GHz	-30 dBm	1 MHz	1
NOTE 1: Applies for Band 22, Band 42 and Band 43			

6.6.3.1A Minimum requirements for CA

This clause specifies the spurious emission requirements for carrier aggregation.

NOTE: For measurement conditions at the edge of each frequency range, the lowest frequency of the measurement position in each frequency range should be set at the lowest boundary of the frequency range plus $MBW/2$. The highest frequency of the measurement position in each frequency range should be set at the highest boundary of the frequency range minus $MBW/2$. MBW denotes the measurement bandwidth defined for the protected band.

For inter-band carrier aggregation with one component carrier per operating band and the uplink active in two E-UTRA bands, the spurious emission requirement Table 6.6.3.1-2 apply for the frequency ranges that are more than F_{OOB} as defined in Table 6.6.3.1-1 away from edges of the assigned channel bandwidth on a component carrier. If for some frequency a spurious emission requirement of individual component carrier overlaps with the spectrum emission mask or channel bandwidth of another component carrier then it does not apply.

NOTE: For inter-band carrier aggregation with uplink assigned to two E-UTRA bands the requirements in Table 6.6.3.1-2 could be verified by measuring spurious emissions at the specific frequencies where second and third order intermodulation products generated by the two transmitted carriers can occur; in that case, the requirements for remaining applicable frequencies in Table 6.6.3.1-2 would be considered to be verified by the measurements verifying the one uplink inter-band CA spurious emission requirement.

For intra-band contiguous carrier aggregation the spurious emission limits apply for the frequency ranges that are more than F_{OOB} (MHz) in Table 6.6.3.1A-1 from the edge of the aggregated channel bandwidth (Table 5.6A-1). For frequencies Δf_{OOB} greater than F_{OOB} as specified in Table 6.6.3.1A-1 the spurious emission requirements in Table 6.6.3.1-2 are applicable.

Table 6.6.3.1A-1: Boundary between E-UTRA out of band and spurious emission domain for intra-band contiguous carrier aggregation

CA Bandwidth Class	OOB boundary F_{OOB} (MHz)
A	Table 6.6.3.1-1
B	$BW_{Channel_CA} + 5$
C	$BW_{Channel_CA} + 5$

For intra-band non-contiguous carrier aggregation transmission the spurious emission requirement is defined as a composite spurious emission requirement. Composite spurious emission requirement applies to frequency ranges that are more than F_{OOB} away from the edges of the sub-blocks. Composite spurious emission requirement is defined as follows

- a) Composite spurious emission requirement is a combination of individual sub-block spurious emission requirements
- b) In case the sub-block consist of one component carrier the sub-block spurious emission requirement and F_{OOB} are defined in subclause 6.6.3.1
- c) If for some frequency an individual sub-block spurious emission requirement overlaps with the general spectrum emission mask or the sub-block bandwidth of another sub-block then it does not apply

For combinations of intra-band and inter-band carrier aggregation with three uplink component carriers (up to two contiguously aggregated carriers per band), the spurious emission requirement is defined as follows. For the E-UTRA band supporting one component carrier the requirements in Table 6.6.3.1-2 apply for frequency ranges that are more than F_{OOB} (MHz) from the edges of assigned channel bandwidth as defined in Table 6.6.3.1-1. For the E-UTRA band supporting two contiguous component carriers the requirements in Table 6.6.3.1-2 apply for frequency ranges that are more than F_{OOB} (MHz) from the edges of assigned aggregated channel bandwidth as defined in Table 6.6.3.1A-1. If for some frequency a spurious emission requirement of a single component carrier or two contiguous component carriers overlap with the spurious emission requirement or channel bandwidth of another component carrier or two contiguously aggregated carriers then it does not apply.

6.6.3.2 Spurious emission band UE co-existence

This clause specifies the requirements for the specified E-UTRA band, for coexistence with protected bands.

- NOTE: For measurement conditions at the edge of each frequency range, the lowest frequency of the measurement position in each frequency range should be set at the lowest boundary of the frequency range plus $MBW/2$. The highest frequency of the measurement position in each frequency range should be set at the highest boundary of the frequency range minus $MBW/2$. MBW denotes the measurement bandwidth defined for the protected band.

Table 6.6.3.2-1: Requirements

E-UTRA Band	Spurious emission						
	Protected band	Frequency range (MHz)			Maximum Level (dBm)	MBW (MHz)	NOTE
1	E-UTRA Band 1, 3, 5, 7, 8, 11, 18, 19, 20, 21, 22, 26, 27, 28, 31, 32, 38, 40, 41, 42, 43, 44, 45, 65, 67, 68	F _{DL_low}	-	F _{DL_high}	-50	1	
	E-UTRA Band 34	F _{DL_low}	-	F _{DL_high}	-50	1	15
	Frequency range	1880	-	1895	-40	1	15, 27
	Frequency range	1895		1915	-15.5	5	15, 26, 27
	Frequency range	1915		1920	+1.6	5	15, 26, 27, 39
2	E-UTRA Band 4, 5, 10, 12, 13, 14, 17, 23, 24, 26, 27, 28, 29, 30, 41, 42, 66	F _{DL_low}	-	F _{DL_high}	-50	1	
	E-UTRA Band 2, 25	F _{DL_low}	-	F _{DL_high}	-50	1	15
	E-UTRA Band 43	F _{DL_low}	-	F _{DL_high}	-50	1	2
3	E-UTRA Band 1, 5, 7, 8, 11, 18, 19, 20, 21, 26, 27, 28, 31, 32, 33, 34, 38, 39, 40, 41, 43, 44, 45, 65, 67, 68	F _{DL_low}	-	F _{DL_high}	-50	1	
	E-UTRA Band 3	F _{DL_low}	-	F _{DL_high}	-50	1	15
	E-UTRA Band 22, 42	F _{DL_low}	-	F _{DL_high}	-50	1	2
	Frequency range	1884.5	-	1915.7	-41	0.3	
4	E-UTRA Band 2, 4, 5, 7, 10, 12, 13, 14, 17, 23, 24, 25, 26, 27, 28, 29, 30, 41, 43, 66	F _{DL_low}	-	F _{DL_high}	-50	1	
	E-UTRA Band 42	F _{DL_low}	-	F _{DL_high}	-50	1	2
5	E-UTRA Band 1, 2, 3, 4, 5, 7, 8, 10, 12, 13, 14, 17, 23, 24, 25, 28, 29, 30, 31, 34, 38, 40, 42, 43, 45, 65, 66	F _{DL_low}	-	F _{DL_high}	-50	1	
	E-UTRA Band 26	859	-	869	-27	1	
	E-UTRA Band 41	F _{DL_low}	-	F _{DL_high}	-50	1	2
	E-UTRA Band 18, 19	F _{DL_low}	-	F _{DL_high}	-40	1	38
	E-UTRA Band 11, 21	F _{DL_low}	-	F _{DL_high}	-50	1	38
	Frequency range	1884.5	-	1915.7	-41	0.3	8, 38
6	E-UTRA Band 1, 9, 11, 34	F _{DL_low}	-	F _{DL_high}	-50	1	
	Frequency range	860	-	875	-37	1	
	Frequency range	875	-	895	-50	1	
	Frequency range	1884.5	-	1919.6	-41	0.3	7
		1884.5	-	1915.7			8
7	E-UTRA Band 1, 2, 3, 4, 5, 7, 8, 10, 12, 13, 14, 17, 20, 22, 26, 27, 28, 29, 30, 31, 32, 33, 34, 40, 42, 43, 65, 66, 67, 68	F _{DL_low}	-	F _{DL_high}	-50	1	
	Frequency range	2570	-	2575	+1.6	5	15, 21, 26
	Frequency range	2575	-	2595	-15.5	5	15, 21, 26
	Frequency range	2595	-	2620	-40	1	15, 21
8	E-UTRA Band 1, 20, 28, 31, 32, 33, 34, 38, 39, 40, 45, 65, 67, 68	F _{DL_low}	-	F _{DL_high}	-50	1	
	E-UTRA band 3, 7, 22, 41, 42, 43	F _{DL_low}	-	F _{DL_high}	-50	1	2
	E-UTRA Band 8	F _{DL_low}	-	F _{DL_high}	-50	1	15
	E-UTRA Band 11, 21	F _{DL_low}	-	F _{DL_high}	-50	1	23
	Frequency range	860	-	890	-40	1	15, 23
	Frequency range	1884.5	-	1915.7	-41	0.3	8, 23
9	E-UTRA Band 1, 3, 11, 18, 19, 21, 26, 28, 34	F _{DL_low}	-	F _{DL_high}	-50	1	
	E-UTRA Band 42	F _{DL_low}	-	F _{DL_high}	-50	1	2
	Frequency range	945	-	960	-50	1	
	Frequency range	1884.5	-	1915.7	-41	0.3	8
	Frequency range	2545	-	2575	-50	1	
Frequency range	2595	-	2645	-50	1		

10	E-UTRA Band 2, 4, 5, 10, 12, 13, 14, 17, 23, 24, 25, 26, 27, 28, 29, 30, 41, 43, 66	F_{DL_low}	-	F_{DL_high}	-50	1	
	E-UTRA Band 22, 42	F_{DL_low}	-	F_{DL_high}	-50	1	2
11	E-UTRA Band 1, 3, 11, 18, 19, 21, 28, 34, 42, 65	F_{DL_low}	-	F_{DL_high}	-50	1	
	Frequency range	945	-	960	-50	1	
	Frequency range	1884.5	-	1915.7	-41	0.3	8
	Frequency range	2545	-	2575	-50	1	
	Frequency range	2595	-	2645	-50	1	
12	E-UTRA Band 2, 5, 13, 14, 17, 23, 24, 25, 26, 27, 30, 41	F_{DL_low}	-	F_{DL_high}	-50	1	
	E-UTRA Band 4, 10, 66	F_{DL_low}	-	F_{DL_high}	-50	1	2
	E-UTRA Band 12	F_{DL_low}	-	F_{DL_high}	-50	1	15
13	E-UTRA Band 2, 4, 5, 10, 12, 13, 17, 23, 25, 26, 27, 29, 41, 66	F_{DL_low}	-	F_{DL_high}	-50	1	
	E-UTRA Band 14	F_{DL_low}	-	F_{DL_high}	-50	1	15
	E-UTRA Band 24, 30	F_{DL_low}	-	F_{DL_high}	-50	1	2
	Frequency range	769	-	775	-35	0.00625	15
	Frequency range	799	-	805	-35	0.00625	11, 15
14	E-UTRA Band 2, 4, 5, 10, 12, 13, 14, 17, 23, 24, 25, 26, 27, 29, 30, 41, 66	F_{DL_low}	-	F_{DL_high}	-50	1	
	Frequency range	769	-	775	-35	0.00625	12, 15
	Frequency range	799	-	805	-35	0.00625	11, 12, 15
17	E-UTRA Band 2, 5, 13, 14, 17, 23, 24, 25, 26, 27, 30, 41	F_{DL_low}	-	F_{DL_high}	-50	1	
	E-UTRA Band 4, 10, 66	F_{DL_low}	-	F_{DL_high}	-50	1	2
	E-UTRA Band 12	F_{DL_low}	-	F_{DL_high}	-50	1	15
18	E-UTRA Band 1, 3, 11, 21, 34, 42, 65	F_{DL_low}	-	F_{DL_high}	-50	1	
	Frequency range	758	-	799	-50	1	
	Frequency range	799	-	803	-40	1	15
	Frequency range	860	-	890	-40	1	
	Frequency range	945	-	960	-50	1	
	Frequency range	1884.5	-	1915.7	-41	0.3	8
	Frequency range	2545	-	2575	-50	1	
19	E-UTRA Band 1, 3, 11, 21, 28, 34, 42, 65	F_{DL_low}	-	F_{DL_high}	-50	1	
	Frequency range	945	-	960	-50	1	
	Frequency range	1884.5	-	1915.7	-41	0.3	8
	Frequency range	2545	-	2575	-50	1	
	Frequency range	2595	-	2645	-50	1	

20	E-UTRA Band 1, 3, 7, 8, 22, 31, 32, 33, 34, 40, 43, 65, 67, 68	F _{DL_low}	-	F _{DL_high}	-50	1	
	E-UTRA Band 20	F _{DL_low}	-	F _{DL_high}	-50	1	15
	E-UTRA Band 38, 42	F _{DL_low}	-	F _{DL_high}	-50	1	2
	Frequency range	758	-	788	-50	1	
21	E-UTRA Band 1, 3, 18, 19, 28, 34, 42, 65	F _{DL_low}	-	F _{DL_high}	-50	1	
	Frequency range	945	-	960	-50	1	
	Frequency range	1884.5	-	1915.7	-41	0.3	8
	Frequency range	2545	-	2575	-50	1	
22	E-UTRA Band 1, 3, 7, 8, 20, 26, 27, 28, 31, 32, 33, 34, 38, 39, 40, 43, 65, 67, 68	F _{DL_low}	-	F _{DL_high}	-50	1	
	Frequency range	3510	-	3525	-40	1	15
	Frequency range	3525	-	3590	-50	1	
23	E-UTRA Band 4, 5, 10, 12, 13, 14, 17, 23, 24, 26, 27, 29, 30, 41, 66	F _{DL_low}	-	F _{DL_high}	-50	1	
24	E-UTRA Band 2, 4, 5, 10, 12, 13, 14, 17, 23, 24, 25, 26, 29, 30, 41, 66	F _{DL_low}	-	F _{DL_high}	-50	1	
25	E-UTRA Band 4, 5, 10, 12, 13, 14, 17, 23, 24, 26, 27, 28, 29, 30, 41, 42, 66	F _{DL_low}	-	F _{DL_high}	-50	1	
	E-UTRA Band 2	F _{DL_low}	-	F _{DL_high}	-50	1	15
	E-UTRA Band 43	F _{DL_low}	-	F _{DL_high}	-50	1	2
26	E-UTRA Band 1, 2, 3, 4, 5, 10, 11, 12, 13, 14, 17, 18, 19, 21, 23, 24, 25, 26, 29, 30, 31, 34, 39, 40, 42, 43, 65, 66	F _{DL_low}	-	F _{DL_high}	-50	1	
	E-UTRA Band 41	F _{DL_low}	-	F _{DL_high}	-50	1	2
	Frequency range	703	-	799	-50	1	
	Frequency range	799	-	803	-40	1	15
	Frequency range	945	-	960	-50	1	
27	E-UTRA Band 1, 2, 3, 4, 5, 7, 10, 12, 13, 14, 17, 23, 25, 26, 27, 29, 30, 31, 38, 40, 41, 42, 43, 65, 66	F _{DL_low}	-	F _{DL_high}	-50	1	
	E-UTRA Band 28	F _{DL_low}	-	790	-50	1	
	Frequency range	799	-	805	-35	0.00625	
	E-UTRA Band 1, 4, 10, 22, 32, 42, 43, 65, 66	F _{DL_low}	-	F _{DL_high}	-50	1	2
	E-UTRA Band 1	F _{DL_low}	-	F _{DL_high}	-50	1	19, 25
28	E-UTRA Band 2, 3, 5, 7, 8, 18, 19, 20, 25, 26, 27, 31, 34, 38, 40, 41	F _{DL_low}	-	F _{DL_high}	-50	1	
	E-UTRA Band 11, 21	F _{DL_low}	-	F _{DL_high}	-50	1	19, 24
	Frequency range	470	-	694	-42	8	15, 35
	Frequency range	470	-	710	-26.2	6	34
	Frequency range	662	-	694	-26.2	6	15
	Frequency range	758	-	773	-32	1	15
	Frequency range	773	-	803	-50	1	
	Frequency range	1884.5	-	1915.7	-41	0.3	8, 19
30	E-UTRA Band 2, 4, 5, 7, 10, 12, 13, 14, 17, 23, 24, 25, 26, 27, 29, 30, 38, 41, 66	F _{DL_low}	-	F _{DL_high}	-50	1	
31	E-UTRA Band 1, 5, 7, 8, 20, 22, 26, 27, 28, 31, 32, 33, 34, 38, 40, 42, 43, 65, 67, 68	F _{DL_low}	-	F _{DL_high}	-50	1	
	E-UTRA Band 3	F _{DL_low}	-	F _{DL_high}	-50	1	2
	Frequency range	470	-	694	-42	8	
...							
33	E-UTRA Band 1, 7, 8, 20, 22, 28, 31, 32, 34, 38, 40, 42, 43, 65, 67	F _{DL_low}	-	F _{DL_high}	-50	1	5
	E-UTRA Band 3	F _{DL_low}	-	F _{DL_high}	-50	1	15
34	E-UTRA Band 1, 3, 7, 8, 11, 18, 19, 20, 21, 22, 26, 28, 31, 32, 33, 38, 39, 40, 41, 42, 43, 44, 45, 65, 67	F _{DL_low}	-	F _{DL_high}	-50	1	5
	Frequency range	1884.5	-	1915.7	-41	0.3	8
35							
36							
37							
38	E-UTRA Band 1, 2, 3, 4, 5, 8, 10, 12, 13,	F _{DL_low}	-	F _{DL_high}	-50	1	

	14, 17, 20, 22, 27, 28, 29, 30, 31, 32, 33, 34, 40, 42, 43, 65, 66, 67, 68						
	Frequency range	2620	-	2645	-15.5	5	15, 22, 26
	Frequency range	2645	-	2690	-40	1	15, 22
39	E-UTRA Band 1, 8, 22, 26, 34, 40, 41, 42, 44, 45	F _{DL_low}	-	F _{DL_high}	-50	1	
	Frequency range	1805		1855	-40	1	33
	Frequency range	1855		1880	-15.5	5	15,26,33
40	E-UTRA Band 1, 3, 5, 7, 8, 20, 22, 26, 27, 28, 31, 32, 33, 34, 38, 39, 41, 42, 43, 44, 45, 65, 67, 68	F _{DL_low}	-	F _{DL_high}	-50	1	
41	E-UTRA Band 1, 2, 3, 4, 5, 8, 10, 12, 13, 14, 17, 23, 24, 25, 26, 27, 28, 29, 30, 34, 39, 40, 42, 44, 45, 65, 66	F _{DL_low}	-	F _{DL_high}	-50	1	
	E-UTRA Band 9, 11, 18, 19, 21	F _{DL_low}	-	F _{DL_high}	-50	1	30
	Frequency range	1884.5		1915.7	-41	0.3	8, 30
42	E-UTRA Band 1, 2, 3, 4, 5, 7, 8, 10, 11, 18, 19, 20, 21, 25, 26, 27, 28, 31, 32, 33, 34, 38, 40, 41, 44, 45, 65, 66, 67, 68	F _{DL_low}	-	F _{DL_high}	-50	1	
	Frequency range	1884.5	-	1915.7	-41	0.3	8
43	E-UTRA Band 1, 2, 3, 4, 5, 7, 8, 10, 20, 25, 26, 27, 28, 31,32, 33, 34, 38, 40, 65, 66, 67, 68	F _{DL_low}	-	F _{DL_high}	-50	1	
44	E-UTRA Band 1, 40, 42, 45	F _{DL_low}	-	F _{DL_high}	-50	1	2
	E-UTRA Band 3, 5, 8, 34, 39, 41	F _{DL_low}	-	F _{DL_high}	-50	1	
45	E-UTRA Band 1, 3, 5, 8, 34, 39, 40, 41, 42,44	F _{DL_low}	-	F _{DL_high}	-50	1	
65	E-UTRA Band 1, 3, 7, 8, 20, 22, 28, 31, 32, 38, 40, 42, 43, 65, 68	F _{DL_low}	-	F _{DL_high}	-50	1	
	E-UTRA Band 5, 11, 18, 19, 21, 26, 27, 41	F _{DL_low}	-	F _{DL_high}	-50	1	
	E-UTRA Band 34	F _{DL_low}	-	F _{DL_high}	-50	1	36
	Frequency range	1884.5	-	1915.7	-41	0.3	37
	Frequency range	1900	-	1915	-15.5	5	15, 26, 27
	Frequency range	1915	-	1920	+1.6	5	15, 26, 27
66	E-UTRA Band 2, 4, 5, 7, 10, 12, 13, 14, 17, 23, 24, 25, 26, 27, 28, 29, 30, 38, 41, 43, 66	F _{DL_low}	-	F _{DL_high}	-50	1	
	E-UTRA Band 42	F _{DL_low}	-	F _{DL_high}	-50	1	2
68	E-UTRA Band 3, 7, 8, 20, 22, 28, 31, 38, 40, 42, 43, 65	F _{DL_low}	-	F _{DL_high}	-50	1	
	E-UTRA Band 1	F _{DL_low}	-	F _{DL_high}	-50	1	2
NOTE 1: F _{DL_low} and F _{DL_high} refer to each E-UTRA frequency band specified in Table 5.5-1							
NOTE 2: As exceptions, measurements with a level up to the applicable requirements defined in Table 6.6.3.1-2 are permitted for each assigned E-UTRA carrier used in the measurement due to 2 nd , 3 rd , 4 th [or 5 th] harmonic spurious emissions. Due to spreading of the harmonic emission the exception is also allowed for the first 1 MHz frequency range immediately outside the harmonic emission on both sides of the harmonic emission. This results in an overall exception interval centred at the harmonic emission of (2MHz + N x L _{CRB} x 180kHz), where N is 2, 3, 4, [5] for the 2 nd , 3 rd , 4 th [or 5 th] harmonic respectively. The exception is allowed if the measurement bandwidth (MBW) totally or partially overlaps the overall exception interval.							
NOTE 3: N/A							
NOTE 4: N/A							
NOTE 5: For non synchronised TDD operation to meet these requirements some restriction will be needed for either the operating band or protected band							
NOTE 6: N/A							
NOTE 7: Applicable when co-existence with PHS system operating in 1884.5-1919.6MHz.							
NOTE 8: Applicable when co-existence with PHS system operating in 1884.5 -1915.7MHz.							
NOTE 9: N/A							
NOTE 10: N/A							
NOTE 11: Whether the applicable frequency range should be 793-805MHz instead of 799-805MHz is TBD							
NOTE 12: The emissions measurement shall be sufficiently power averaged to ensure a standard deviation < 0.5 dB							
NOTE 13: N/A							
NOTE 14: N/A							
NOTE 15: These requirements also apply for the frequency ranges that are less than F _{OOB} (MHz) in Table 6.6.3.1-1 and Table 6.6.3.1A-1 from the edge of the channel bandwidth.							
NOTE 16: N/A							

- NOTE 17: N/A
- NOTE 18: N/A
- NOTE 19: Applicable when the assigned E-UTRA carrier is confined within 718 MHz and 748 MHz and when the channel bandwidth used is 5 or 10 MHz.
- NOTE 20: N/A
- NOTE 21: This requirement is applicable for any channel bandwidths within the range 2500 - 2570 MHz with the following restriction: for carriers of 15 MHz bandwidth when carrier centre frequency is within the range 2560.5 - 2562.5 MHz and for carriers of 20 MHz bandwidth when carrier centre frequency is within the range 2552 - 2560 MHz the requirement is applicable only for an uplink transmission bandwidth less than or equal to 54 RB.
- NOTE 22: This requirement is applicable for any channel bandwidths within the range 2570 - 2615 MHz with the following restriction: for carriers of 15 MHz bandwidth when carrier centre frequency is within the range 2605.5 - 2607.5 MHz and for carriers of 20 MHz bandwidth when carrier centre frequency is within the range 2597 - 2605 MHz the requirement is applicable only for an uplink transmission bandwidth less than or equal to 54 RB.
For carriers with channel bandwidth overlapping the frequency range 2615 - 2620 MHz the requirement applies with the maximum output power configured to +19 dBm in the IE *P-Max*.
- NOTE 23: This requirement is applicable only for the following cases:
- for carriers of 5 MHz channel bandwidth when carrier centre frequency (F_c) is within the range $902.5 \text{ MHz} \leq F_c < 907.5 \text{ MHz}$ with an uplink transmission bandwidth less than or equal to 20 RB
 - for carriers of 5 MHz channel bandwidth when carrier centre frequency (F_c) is within the range $907.5 \text{ MHz} \leq F_c \leq 912.5 \text{ MHz}$ without any restriction on uplink transmission bandwidth.
 - for carriers of 10 MHz channel bandwidth when carrier centre frequency (F_c) is $F_c = 910 \text{ MHz}$ with an uplink transmission bandwidth less than or equal to 32 RB with $RB_{\text{start}} > 3$.
- NOTE 24: As exceptions, measurements with a level up to the applicable requirement of -38 dBm/MHz is permitted for each assigned E-UTRA carrier used in the measurement due to 2nd harmonic spurious emissions. An exception is allowed if there is at least one individual RB within the transmission bandwidth (see Figure 5.6-1) for which the 2nd harmonic totally or partially overlaps the measurement bandwidth (MBW).
- NOTE 25: As exceptions, measurements with a level up to the applicable requirement of -36 dBm/MHz is permitted for each assigned E-UTRA carrier used in the measurement due to 3rd harmonic spurious emissions. An exception is allowed if there is at least one individual RB within the transmission bandwidth (see Figure 5.6-1) for which the 3rd harmonic totally or partially overlaps the measurement bandwidth (MBW).
- NOTE 26: For these adjacent bands, the emission limit could imply risk of harmful interference to UE(s) operating in the protected operating band.
- NOTE 27: This requirement is applicable for any channel bandwidths within the range 1920 - 1980 MHz with the following restriction: for carriers of 15 MHz bandwidth when carrier centre frequency is within the range 1927.5 - 1929.5 MHz and for carriers of 20 MHz bandwidth when carrier centre frequency is within the range 1930 - 1938 MHz the requirement is applicable only for an uplink transmission bandwidth less than or equal to 54 RB.
- NOTE 28: N/A
- NOTE 29: N/A
- NOTE 30: This requirement applies when the E-UTRA carrier is confined within 2545-2575MHz or 2595-2645MHz and the channel bandwidth is 10 or 20 MHz
- NOTE 31: N/A
- NOTE 32: Void
- NOTE 33: This requirement is only applicable for carriers with bandwidth confined within 1885-1920 MHz (requirement for carriers with at least 1RB confined within 1880 - 1885 MHz is not specified). This requirement applies for an uplink transmission bandwidth less than or equal to 54 RB for carriers of 15 MHz bandwidth when carrier center frequency is within the range 1892.5 - 1894.5 MHz and for carriers of 20 MHz bandwidth when carrier center frequency is within the range 1895 - 1903 MHz.
- NOTE 34: This requirement is applicable for 5 and 10 MHz E-UTRA channel bandwidth allocated within 718-728MHz. For carriers of 10 MHz bandwidth, this requirement applies for an uplink transmission bandwidth less than or equal to 30 RB with $RB_{\text{start}} > 1$ and $RB_{\text{start}} < 48$.
- NOTE 35: This requirement is applicable in the case of a 10 MHz E-UTRA carrier confined within 703 MHz and 733 MHz, otherwise the requirement of -25 dBm with a measurement bandwidth of 8 MHz applies.
- NOTE 36: This requirement is applicable for E-UTRA channel bandwidth allocated within 1920-1980 MHz.
- NOTE 37: Applicable when the upper edge of the channel bandwidth frequency is greater than 1980MHz.
- NOTE 38: Applicable only for UE category M1 and NB1.
- NOTE 39: For category NB1 UE when carrier centre frequency is 1920.1 MHz, in case of single-tone uplink transmission the requirement is applicable only for sub-carrier index > 2 .

NOTE: The restriction on the maximum uplink transmission to 54 RB in Notes 21, 22, and 27 of Table 6.6.3.2-1 and the restriction on the single-tone uplink transmission to sub-carrier index > 2 in Note 39 of Table 6.6.3.2-1 are intended for conformance testing and may be applied to network operation to facilitate coexistence when the aggressor and victim bands are deployed in the same geographical area. The applicable spurious emission requirement of -15.5 dBm/5MHz is a least restrictive technical condition for FDD/TDD coexistence and may have to be revised in the future.

6.6.3.2A Spurious emission band UE co-existence for CA

This clause specifies the requirements for the specified carrier aggregation configurations for coexistence with protected bands.

NOTE: For measurement conditions at the edge of each frequency range, the lowest frequency of the measurement position in each frequency range should be set at the lowest boundary of the frequency range plus $MBW/2$. The highest frequency of the measurement position in each frequency range should be set at the highest boundary of the frequency range minus $MBW/2$. MBW denotes the measurement bandwidth defined for the protected band.

For inter-band carrier aggregation with the uplink assigned to two E-UTRA bands, the requirements in Table 6.6.3.2A-0 apply on each component carrier with all component carriers are active.

NOTE: For inter-band carrier aggregation with uplink assigned to two E-UTRA bands the requirements in Table 6.6.3.2A-0 could be verified by measuring spurious emissions at the specific frequencies where second and third order intermodulation products generated by the two transmitted carriers can occur; in that case, the requirements for remaining applicable frequencies in Table 6.6.3.2A-0 would be considered to be verified by the measurements verifying the one uplink inter-band CA UE to UE co-existence requirements.

Table 6.6.3.2A-0: Requirements for uplink inter-band carrier aggregation (two bands)

E-UTRA CA Configuration	Spurious emission						
	Protected band	Frequency range (MHz)		Maximum Level (dBm)	MBW (MHz)	NOTE	
CA_1A-3A	E-UTRA Band 1, 5, 7, 8, 11, 18, 19, 20, 21, 26, 27, 28, 31, 32, 38, 40, 41, 43, 44, 65, 67	F _{DL_low}	-	F _{DL_high}	-50	1	
	E-UTRA band 3, 34	F _{DL_low}	-	F _{DL_high}	-50	1	3
	E-UTRA band 22, 42	F _{DL_low}	-	F _{DL_high}	-50	1	2
	Frequency range	1884.5	-	1915.7	-41	0.3	7
	Frequency range	1880		1895	-40	1	3,12
	Frequency range	1895		1915	-15.5	5	3, 12, 13
	Frequency range	1915		1920	+1.6	5	3, 12, 13
CA_1A-5A	E-UTRA Band 1, 5, 7, 8, 22, 28, 31, 38, 40, 42, 43, 65	F _{DL_low}	-	F _{DL_high}	-50	1	
	E-UTRA band 3,34	F _{DL_low}	-	F _{DL_high}	-50	1	3
	E-UTRA band 26	859	-	869	-27	1	
	E-UTRA band 41	F _{DL_low}	-	F _{DL_high}	-50	1	2
CA_1A-7A	E-UTRA Band 1, 5, 7, 8, 20, 22, 26, 27, 28, 31,32, 40, 42, 43, 65, 67	F _{DL_low}	-	F _{DL_high}	-50	1	
	E-UTRA band 3, 34	F _{DL_low}	-	F _{DL_high}	-50	1	3
	Frequency range	1880		1895	-40	1	3,12
	Frequency range	1895		1915	-15.5	5	3, 12, 13
	Frequency range	1915		1920	+1.6	5	3, 12, 13
	Frequency range	2570	-	2575	+1.6	5	3, 13, 14
	Frequency range	2575	-	2595	-15.5	5	3, 13, 14
CA_1A-8A	E-UTRA Band 1, 20, 28, 31, 32, 38, 40, 65, 67	F _{DL_low}	-	F _{DL_high}	-50	1	
	E-UTRA band 3	F _{DL_low}	-	F _{DL_high}	-50	1	2,3
	E-UTRA band 7, 22, 41, 42, 43	F _{DL_low}	-	F _{DL_high}	-50	1	2
	E-UTRA Band 8, 34	F _{DL_low}	-	F _{DL_high}	-50	1	3
	E-UTRA band 11, 21	F _{DL_low}	-	F _{DL_high}	-50	1	11
	Frequency range	860	-	890	-40	1	3, 11
	Frequency range	1884.5	-	1915.7	-41	0.3	7, 11
	Frequency range	1880		1895	-40	1	3,12
	Frequency range	1895		1915	-15.5	5	3, 12, 13
CA_1A-18A	E-UTRA Band 1, 3, 11, 21, 42, 65	F _{DL_low}	-	F _{DL_high}	-50	1	
	E-UTRA Band 34	F _{DL_low}	-	F _{DL_high}	-50	1	3
	Frequency range	758	-	799	-50	1	
	Frequency range	799	-	803	-40	1	3
	Frequency range	860	-	890	-40	1	
	Frequency range	945	-	960	-50	1	
	Frequency range	1884.5	-	1915.7	-41	0.3	3, 7
	Frequency range	2545	-	2575	-50	1	
CA_1A-19A	E-UTRA Band 1, 3, 11, 21, 28, 42, 65	F _{DL_low}	-	F _{DL_high}	-50	1	
	E-UTRA Band 34	F _{DL_low}	-	F _{DL_high}	-50	1	3
	Frequency range	860	-	890	-40	1	3, 8
	Frequency range	945	-	960	-50	1	
	Frequency range	1884.5	-	1915.7	-41	0.3	3, 7
	Frequency range	2545	-	2575	-50	1	
	Frequency range	2595	-	2645	-50	1	
CA_1A-21A	E-UTRA Band 11	F _{DL_low}	-	F _{DL_high}	-35	1	3, 16
	E-UTRA Band 1, 3, 18, 19, 28, 34, 42, 65	F _{DL_low}	-	F _{DL_high}	-50	1	
	E-UTRA Band 21	F _{DL_low}	-	F _{DL_high}	-50	1	16
	Frequency range	1884.5	-	1915.7	-41	0.3	7

	Frequency range	945	-	960	-50	1		
	Frequency range	2545	-	2575	-50	1		
	Frequency range	2595	-	2645	-50	1		
CA_1A-26A	E-UTRA Band 1, 3, 5, 7, 11, 18, 19, 20, 21, 22, 26, 27, 31, 38, 40, 42, 43, 44, 65	F_{DL_low}	-	F_{DL_high}	-50	1		
	Frequency range	1880	-	1895	-40	1	3, 12	
	Frequency range	1895	-	1915	-15.5	5	3, 12, 13	
	Frequency range	1915	-	1920	+1.6	5	3, 12, 13	
	Frequency range	1884.5	-	1915.7	-41	0.3	7	
	Frequency range	945	-	960	-50	1		
	E-UTRA Band 41	F_{DL_low}	-	F_{DL_high}	-50	1	2	
	E-UTRA Band 34	F_{DL_low}	-	F_{DL_high}	-50	1	3	
	Frequency range	703	-	799	-50	1		
			799	-	803	-40	1	3
	CA_1A-28A	E-UTRA Band 3, 5, 7, 8, 18, 19, 20, 26, 27, 31, 32, 38, 40, 41	F_{DL_low}	-	F_{DL_high}	-50	1	
E-UTRA Band 22, 42, 43		F_{DL_low}	-	F_{DL_high}	-50	1	2	
E-UTRA Band 34		F_{DL_low}	-	F_{DL_high}	-50	1	3	
E-UTRA Band 11, 21		F_{DL_low}	-	F_{DL_high}	-50	1	5, 21	
E-UTRA Band 1, 65		F_{DL_low}	-	F_{DL_high}	-50	1	5, 6	
Frequency range		470	-	694	-42	8	3, 22	
Frequency range		470	-	710	-26.2	6	23	
Frequency range		758	-	773	-32	1	3	
Frequency range		773	-	803	-50	1		
Frequency range		662	-	694	-26.2	6	3	
Frequency range		1880	-	1895	-40	1	3, 12	
Frequency range		1895	-	1915	-15.5	5	3, 12, 13	
Frequency range		1915	-	1920	+1.6	5	3, 12, 13	
Frequency range		1884.5	-	1915.7	-41	0.3	5, 7	
CA_1A-42A		E-UTRA Band 1, 3, 5, 7, 8, 11, 18, 19, 20, 21, 26, 27, 28, 31, 32, 38, 40, 41, 44, 65, 67	F_{DL_low}	-	F_{DL_high}	-50	1	
	E-UTRA Band 34	F_{DL_low}	-	F_{DL_high}	-50	1	3	
	Frequency range	1880	-	1895	-40	1	3, 12	
	Frequency range	1895	-	1915	-15.5	5	3, 12, 13	
	Frequency range	1915	-	1920	+1.6	5	3, 12, 13	
	Frequency range	1884.5	-	1915.7	-41	0.3	3, 7	
CA_2A-4A	E-UTRA Band 4, 5, 10, 12, 13, 14, 17, 22, 23, 24, 26, 27, 28, 29, 30, 41, 66	F_{DL_low}	-	F_{DL_high}	-50	1		
	E-UTRA Band 2, 25	F_{DL_low}	-	F_{DL_high}	-50	1	3	
	E-UTRA Band 42, 43	F_{DL_low}	-	F_{DL_high}	-50	1	2	
CA_2A-5A	E-UTRA Band 4, 5, 10, 12, 13, 14, 17, 23, 24, 28, 29, 30, 42, 66	F_{DL_low}	-	F_{DL_high}	-50	1		
	E-UTRA Band 2, 25	F_{DL_low}	-	F_{DL_high}	-50	1	3	
	E-UTRA Band 26	859	-	869	-27	1		
	E-UTRA Band 41, 43	F_{DL_low}	-	F_{DL_high}	-50	1	2	
CA_2A-12A	E-UTRA Band 5, 13, 14, 17, 23, 24, 26, 27, 30, 41	F_{DL_low}	-	F_{DL_high}	-50	1		
	E-UTRA Band 2, 12, 25	F_{DL_low}	-	F_{DL_high}	-50	1	3	
	E-UTRA Band 4, 10, 66	F_{DL_low}	-	F_{DL_high}	-50	1	2	
CA_2A-13A	E-UTRA Band 4, 5, 10, 12, 13, 17, 22, 23, 26, 27, 29, 41, 42, 66	F_{DL_low}	-	F_{DL_high}	-50	1		
	E-UTRA Band 2, 14, 25	F_{DL_low}	-	F_{DL_high}	-50	1	3	
	E-UTRA Band 24, 30, 43	F_{DL_low}	-	F_{DL_high}	-50	1	2	
	Frequency range	769	-	775	-35	0.00625	3	
	Frequency range	799	-	805	-35	0.00625	3, 9	
CA_3A-5A	E-UTRA Band 1, 5, 7, 8, 22, 28, 31, 38, 40, 42, 43, 65	F_{DL_low}	-	F_{DL_high}	-50	1		
	E-UTRA band 3, 34	F_{DL_low}	-	F_{DL_high}	-50	1	3	
	E-UTRA band 26	859	-	869	-27	1		
CA_3A-7A	E-UTRA Band 1, 5, 7, 8, 20, 26, 27, 28, 31, 32, 33, 34, 40, 43, 44,	F_{DL_low}	-	F_{DL_high}	-50	1		

	65, 67						
	E-UTRA band 3	F _{DL_low}	-	F _{DL_high}	-50	1	3
	E-UTRA band 22, 42	F _{DL_low}	-	F _{DL_high}	-50	1	2
	Frequency range	2570	-	2575	+1.6	5	3, 13, 14
	Frequency range	2575	-	2595	-15.5	5	3, 13, 14
	Frequency range	2595	-	2620	-40	1	3, 14
CA_3A-8A	E-UTRA Band 1, 20, 28, 31, 32, 33, 34, 38, 39, 40, 44, 65, 67	F _{DL_low}	-	F _{DL_high}	-50	1	
	E-UTRA band 3, 8	F _{DL_low}	-	F _{DL_high}	-50	1	2, 3
	E-UTRA band 11, 21	F _{DL_low}	-	F _{DL_high}	-50	1	11
	E-UTRA band 7, 22, 41, 42, 43	F _{DL_low}	-	F _{DL_high}	-50	1	2
	Frequency range	1884.5	-	1915.7	-41	0.3	4, 11
	Frequency range	860	-	890	-40	1	3,11,17
CA_3A-19A	E-UTRA Band 1, 11, 21, 28, 65	F _{DL_low}	-	F _{DL_high}	-50	1	
	E-UTRA Band 34	F _{DL_low}	-	F _{DL_high}	-50	1	3
	E-UTRA Band 42	F _{DL_low}	-	F _{DL_high}	-50	1	2
	Frequency range	860	-	890	-40	1	3, 8
	Frequency range	945	-	960	-50	1	
	Frequency range	1884.5	-	1915.7	-41	0.3	3, 4
	Frequency range	2545	-	2575	-50	1	
	Frequency range	2595	-	2645	-50	1	
CA_3A-20A	E-UTRA Band 1, 7, 8, 31, 32, 33, 34, 40, 43, 65, 67	F _{DL_low}	-	F _{DL_high}	-50	1	
	E-UTRA Band 3, 20	F _{DL_low}	-	F _{DL_high}	-50	1	3
	E-UTRA Band 22, 38, 42	F _{DL_low}	-	F _{DL_high}	-50	1	2
	Frequency range	758	-	788	-50	1	
CA_3A-26A	E-UTRA Band 1, 5, 7, 11, 18, 19, 21, 26, 34, 39, 40, 43, 65	F _{DL_low}	-	F _{DL_high}	-50	1	
	E-UTRA band 3	F _{DL_low}	-	F _{DL_high}	-50	1	3
	E-UTRA band 22, 41, 42	F _{DL_low}	-	F _{DL_high}	-50	1	2
	Frequency range	1884.5	-	1915.7	-41	0.3	4, 10
	Frequency range	703	-	799	-50	1	
	Frequency range	799	-	803	-40	1	3
	Frequency range	851	-	859	-53	0.00625	15
Frequency range	945	-	960	-50	1		
CA_4A-5A	E-UTRA Band 2, 4, 5, 7, 10, 12, 13, 14, 17, 23, 24, 25, 28, 29, 30, 43, 66	F _{DL_low}	-	F _{DL_high}	-50	1	
	E-UTRA Band 26	859	-	869	-27	1	
	E-UTRA band 41, 42	F _{DL_low}	-	F _{DL_high}	-50	1	2
CA_4A-7A	E-UTRA Band 2, 4, 5, 7, 10, 12, 13, 14, 17, 26, 27, 28, 29, 30, 43, 66	F _{DL_low}	-	F _{DL_high}	-50	1	
	E-UTRA band 42	F _{DL_low}	-	F _{DL_high}	-50	1	2
	Frequency range	2570	-	2575	+1.6	5	3, 13, 14
	Frequency range	2575	-	2595	-15.5	5	3, 13, 14
	Frequency range	2595	-	2620	-40	1	3, 14
CA_4A-12A	E-UTRA Band 2, 5, 7,13, 14, 17, 22, 23, 24, 25, 26, 27, 30, 41, 43	F _{DL_low}	-	F _{DL_high}	-50	1	
	E-UTRA Band 4, 10, 42, 66	F _{DL_low}	-	F _{DL_high}	-50	1	2
	E-UTRA Band 12	F _{DL_low}	-	F _{DL_high}	-50	1	3
CA_4A-13A	E-UTRA Band 2,4, 5, 7, 10,12,13,17, 22, 23,25, 26, 27, 29, 41, 43, 66	F _{DL_low}	-	F _{DL_high}	-50	1	
	E-UTRA Band 14	F _{DL_low}	-	F _{DL_high}	-50	1	3
	E-UTRA Band 24, 30, 42	F _{DL_low}	-	F _{DL_high}	-50	1	2
	Frequency range	769	-	775	-35	0.00625	3
	Frequency range	799	-	805	-35	0.00625	3, 9
CA_4A-17A	E-UTRA Band 2, 5, 7,13, 14, 17, 22, 23, 24, 25, 26, 27, 30, 41, 43	F _{DL_low}	-	F _{DL_high}	-50	1	
	E-UTRA Band 4, 10, 42, 66	F _{DL_low}	-	F _{DL_high}	-50	1	2
	E-UTRA Band 12	F _{DL_low}	-	F _{DL_high}	-50	1	3
CA_5A-7A	E-UTRA Band 1, 2, 3, 4, 5, 7, 8,	F _{DL_low}	-	F _{DL_high}	-50	1	

	10, 12, 13, 14, 17, 22, 28, 29, 30, 31, 40, 42, 43, 65, 66						
	E-UTRA band 26	859	-	869	-27	1	
	Frequency range	2570	-	2575	+1.6	5	3, 13, 14
	Frequency range	2575	-	2595	-15.5	5	3, 13, 14
	Frequency range	2595	-	2620	-40	1	3, 14
CA_5A-12A	E-UTRA Band 2, 5, 13, 14, 17, 22, 23, 24, 25, 30, 31, 42, 43	F _{DL_low}	-	F _{DL_high}	-50	1	
	E-UTRA band 4, 10, 41, 66	F _{DL_low}	-	F _{DL_high}	-50	1	2
	E-UTRA band 26	859	-	869	-27	1	
	E-UTRA band 12	F _{DL_low}	-	F _{DL_high}	-50	1	3
CA_5A-17A	E-UTRA Band 2, 5, 13, 14, 17, 22, 23, 24, 25, 30, 31, 42, 43	F _{DL_low}	-	F _{DL_high}	-50	1	
	E-UTRA band 4, 10, 41, 66	F _{DL_low}	-	F _{DL_high}	-50	1	2
	E-UTRA band 26	859	-	869	-27	1	
	E-UTRA band 12	F _{DL_low}	-	F _{DL_high}	-50	1	3
CA_7A-20A	E-UTRA Band 1,3, 7, 8, 22, 28, 31, 32, 33, 34, 40, 43, 65, 67	F _{DL_low}	-	F _{DL_high}	-50	1	
	E-UTRA Band 20	F _{DL_low}	-	F _{DL_high}	-50	1	3
	E-UTRA Band 42	F _{DL_low}	-	F _{DL_high}	-50	1	2
	Frequency range	2570	-	2575	+1.6	5	3, 13, 14
	Frequency range	2575	-	2595	-15.5	5	3, 13, 14
	Frequency range	2595	-	2620	-40	1	3, 14
CA_7A-28A	E-UTRA Band 2, 3, 5, 7, 8, 20, 26, 27, 31, 34, 40	F _{DL_low}	-	F _{DL_high}	-50	1	
	E-UTRA Band 1, 4, 10, 22, 32, 42, 43, 65, 66	F _{DL_low}	-	F _{DL_high}	-50	1	2
	E-UTRA Band 1	F _{DL_low}	-	F _{DL_high}	-50	1	5, 6
	Frequency range	758	-	773	-32	1	3
	Frequency range	773	-	803	-50	1	
	Frequency range	2570	-	2575	+1.6	5	3, 13, 14
	Frequency range	2575	-	2595	-15.5	5	3, 13, 14
	Frequency range	2595	-	2620	-40	1	3, 14
CA_18A-28A	E-UTRA Band 11, 21	F _{DL_low}	-	F _{DL_high}	-50	1	5, 21
	E-UTRA Band 1, 65	F _{DL_low}	-	F _{DL_high}	-50	1	5, 6
	E-UTRA Band 42, 43	F _{DL_low}	-	F _{DL_high}	-50	1	2
	E-UTRA Band 3, 34	F _{DL_low}	-	F _{DL_high}	-50	1	
	Frequency range	470	-	710	-26.2	6	23
	Frequency range	758	-	773	-32	1	3
	Frequency range	773	-	799	-50	1	
	Frequency range	799	-	803	-40	1	3
	Frequency range	860	-	890	-40	1	
	Frequency range	945	-	960	-50	1	3
	Frequency range	1884.5	-	1915.7	-41	0.3	4
	Frequency range	2545	-	2575	-50	1	
	Frequency range	2595	-	2645	-50	1	
CA_19A-21A	E-UTRA Band 1, 18, 19, 28, 34, 42, 65	F _{DL_low}	-	F _{DL_high}	-50	1	
	E-UTRA Band 11	F _{DL_low}	-	F _{DL_high}	-50	1	3, 16
	E-UTRA Band 21	F _{DL_low}	-	F _{DL_high}	-50	1	16
	Frequency range	860	-	890	-40	1	3, 8
	Frequency range	945	-	960	-50	1	
	Frequency range	1884.5	-	1915.7	-41	0.3	4
	Frequency range	2545	-	2575	-50	1	
	Frequency range	2595	-	2645	-50	1	
CA_39A-41A	E-UTRA Band 1, 8, 26, 34, 40, 42, 44	F _{DL_low}	-	F _{DL_high}	-50	1	
	Frequency range	1805	-	1855	-40	1	20
	Frequency range	1855	-	1880	-15.5	5	3, 13, 20
CA_39A-41C	E-UTRA Band 1, 8, 26, 34, 40, 42, 44	F _{DL_low}	-	F _{DL_high}	-50	1	
	Frequency range	1805	-	1855	-40	1	20
	Frequency range	1855	-	1880	-15.5	5	3, 13, 20

CA_39C-41A	E-UTRA Band 34, 40, 42, 44	F_{DL_low}	-	F_{DL_high}	-50	1
NOTE 1:	F_{DL_low} and F_{DL_high} refer to each E-UTRA frequency band specified in Table 5.5-1					
NOTE 2:	As exceptions, measurements with a level up to the applicable requirements defined in Table 6.6.3.1-2 are permitted for each assigned E-UTRA carrier used in the measurement due to 2 nd , 3 rd , 4 th [or 5 th] harmonic spurious emissions. In case the exceptions are allowed due to spreading of the harmonic emission the exception is also allowed for the first 1 MHz frequency range immediately outside the harmonic emission on both sides of the harmonic emission. This results in an overall exception interval centred at the harmonic emission of $(2\text{MHz} + N \times L_{CRB} \times 180\text{kHz})$, where N is 2, 3 or 4 for the 2 nd , 3 rd or 4 th harmonic respectively. The exception is allowed if the measurement bandwidth (MBW) totally or partially overlaps the overall exception interval.					
NOTE 3:	These requirements also apply for the frequency ranges that are less than F_{OOB} (MHz) in Table 6.6.3.1-1 and Table 6.6.3.1A-1 from the edge of the aggregated channel bandwidth.					
NOTE 4:	Applicable when co-existence with PHS system operating in 1884.5 -1915.7MHz.					
NOTE 5:	Applicable when the assigned E-UTRA carrier is confined within 718 MHz and 748 MHz and when the channel bandwidth used is 5 or 10 MHz.					
NOTE 6:	As exceptions, measurements with a level up to the applicable requirement of -36 dBm/MHz is permitted for each assigned E-UTRA carrier used in the measurement due to 3 rd harmonic spurious emissions. An exception is allowed if there is at least one individual RB within the transmission bandwidth (see Figure 5.6-1) for which the 3 rd harmonic totally or partially overlaps the measurement bandwidth (MBW).					
NOTE 7:	Applicable when NS_05 in section 6.6.3.3.1 is signalled by the network.					
NOTE 8:	Applicable when NS_08 in subclause 6.6.3.3.3 is signalled by the network					
NOTE 9:	Whether the applicable frequency range should be 793-805MHz instead of 799-805MHz is TBD.					
NOTE10:	N/A					
NOTE 11:	This requirement is applicable only for the following cases: <ul style="list-style-type: none"> - for carriers of 5 MHz channel bandwidth when carrier centre frequency (F_c) is within the range $902.5 \text{ MHz} \leq F_c < 907.5 \text{ MHz}$ with an uplink transmission bandwidth less than or equal to 20 RB - for carriers of 5 MHz channel bandwidth when carrier centre frequency (F_c) is within the range $907.5 \text{ MHz} \leq F_c \leq 912.5 \text{ MHz}$ without any restriction on uplink transmission bandwidth. - for carriers of 10 MHz channel bandwidth when carrier centre frequency (F_c) is $F_c = 910 \text{ MHz}$ with an uplink transmission bandwidth less than or equal to 32 RB with $RB_{start} > 3$. 					
NOTE 12:	This requirement is applicable for any channel bandwidths within the range 1920 - 1980 MHz with the following restriction: for carriers of 15 MHz bandwidth when carrier centre frequency is within the range 1927.5 - 1929.5 MHz and for carriers of 20 MHz bandwidth when carrier centre frequency is within the range 1930 - 1938 MHz the requirement is applicable only for an uplink transmission bandwidth less than or equal to 54 RB.					
NOTE13:	For these adjacent bands, the emission limit could imply risk of harmful interference to UE(s) operating in the protected operating band.					
NOTE 14:	This requirement is applicable for any channel bandwidths within the range 2500 - 2570 MHz with the following restriction: for carriers of 15 MHz bandwidth when carrier centre frequency is within the range 2560.5 - 2562.5 MHz and for carriers of 20 MHz bandwidth when carrier centre frequency is within the range 2552 - 2560 MHz the requirement is applicable only for an uplink transmission bandwidth less than or equal to 54 RB.					
NOTE 15:	Applicable when NS_15 in subclause 6.6.3.3.8 is signalled by the network.					
NOTE 16:	Applicable when NS_09 in subclause 6.6.3.3.4 is signalled by the network					
NOTE 17:	This requirement is applicable only when Band 3 transmission frequency is less than or equal to 1765 MHz.					
NOTE 18:	This requirement applies when the E-UTRA carrier is confined within 2545-2575MHz or 2595-2645MHz and the channel bandwidth is 10 or 20 MHz					
NOTE 19:	Void					
NOTE 20:	This requirement is only applicable for carriers with bandwidth confined within 1885-1920 MHz (requirement for carriers with at least 1RB confined within 1880 - 1885 MHz is not specified). This requirement applies for an uplink transmission bandwidth less than or equal to 54 RB for carriers of 15 MHz bandwidth when carrier center frequency is within the range 1892.5 - 1894.5 MHz and for carriers of 20 MHz bandwidth when carrier center frequency is within the range 1895 - 1903 MHz.					
NOTE 21:	As exceptions, measurements with a level up to the applicable requirement of -38 dBm/MHz is permitted for each assigned E-UTRA carrier used in the measurement due to 2 nd harmonic spurious emissions. An exception is allowed if there is at least one individual RB within the transmission bandwidth (see Figure 5.6-1) for which the 2 nd harmonic totally or partially overlaps the measurement bandwidth (MBW).					
NOTE 22:	This requirement is applicable in the case of a 10 MHz E-UTRA carrier confined within 703 MHz and 733 MHz, otherwise the requirement of -25 dBm with a measurement bandwidth of 8 MHz applies.					
NOTE 23:	This requirement is applicable for 5 and 10 MHz E-UTRA channel bandwidth allocated within 718-728MHz. For carriers of 10 MHz bandwidth, this requirement applies for an uplink transmission bandwidth less than or equal to 30 RB with $RB_{start} > 1$ and $RB_{start} < 48$.					

Table 6.6.3.2A-1: Requirements for intraband carrier aggregation

E-UTRA CA Configuration	Spurious emission						
	Protected band	Frequency range (MHz)		Maximum Level (dBm)	MBW (MHz)	NOTE	
CA_1C	E-UTRA Band 1, 7, 8, 11, 18, 19, 20, 21, 22, 26, 27, 28, 31, 32, 38, 40, 41, 42, 43, 44, 65, 67	F _{DL_low}	-	F _{DL_high}	-50	1	
	E-UTRA Band 3	F _{DL_low}	-	F _{DL_high}	-50	1	10
CA_3C	E-UTRA Band 1, 7, 8, 20, 26, 27, 28, 31, 32, 33, 34, 38, 41, 43, 44, 65, 67	F _{DL_low}	-	F _{DL_high}	-50	1	
	E-UTRA Band 3	F _{DL_low}	-	F _{DL_high}	-50	1	10
	E-UTRA Band 22, 42	F _{DL_low}	-	F _{DL_high}	-50	1	2
CA_7C	E-UTRA Band 1, 3, 7, 8, 20, 22, 27, 28, 29, 30, 31, 32, 33, 34, 40, 42, 43, 65, 67	F _{DL_low}	-	F _{DL_high}	-50	1	
CA_8B	E-UTRA Band 1, 20, 28, 31, 32, 33, 34, 38, 39, 40	F _{DL_low}	-	F _{DL_high}	-50	1	
	E-UTRA band 3	F _{DL_low}	-	F _{DL_high}	-50	1	2
	E-UTRA band 7	F _{DL_low}	-	F _{DL_high}	-50	1	2
	E-UTRA Band 8	F _{DL_low}	-	F _{DL_high}	-50	1	10
	E-UTRA Band 22, 41, 42, 43	F _{DL_low}	-	F _{DL_high}	-50	1	2
CA_38C	E-UTRA Band 1, 3, 8, 20, 22, 27, 28, 29, 30, 31, 32, 33, 34, 40, 42, 43, 65, 67	F _{DL_low}	-	F _{DL_high}	-50	1	
CA_39C	E-UTRA Band 22, 34, 40, 41, 42, 44	F _{DL_low}	-	F _{DL_high}	-50	1	
CA_40C	E-UTRA Band 1, 3, 7, 8, 20, 22, 26, 27, 32, 33, 34, 38, 39, 41, 42, 43, 44, 65, 67	F _{DL_low}	-	F _{DL_high}	-50	1	
CA_41C	E-UTRA Band 1, 2, 3, 4, 5, 8, 10, 12, 13, 14, 17, 23, 24, 25, 26, 27, 28, 29, 30, 34, 39, 40, 42, 44, 65, 66	F _{DL_low}	-	F _{DL_high}	-50	1	
CA_42C	E-UTRA Band 1, 2, 3, 4, 5, 7, 8, 10, 11, 18, 19, 20, 21, 25, 26, 27, 28, 31, 32, 33, 34, 38, 40, 41, 44, 65, 66, 67	F _{DL_low}	-	F _{DL_high}	-50	1	
	Frequency range	1884.5	-	1915.7	-41	0.3	
NOTE 1: FDL_low and FDL_high refer to each E-UTRA frequency band specified in Table 5.5-1							
NOTE 2: As exceptions, measurements with a level up to the applicable requirements defined in Table 6.6.3.1-2 are permitted for each assigned E-UTRA carrier used in the measurement due to 2 nd , 3 rd , 4 th [or 5 th] harmonic spurious emissions. Due to spreading of the harmonic emission the exception is also allowed for the first 1 MHz frequency range immediately outside the harmonic emission on both sides of the harmonic emission. This results in an overall exception interval centred at the harmonic emission of (2MHz + N x L _{CRB} x 180kHz), where N is 2, 3, 4, [5] for the 2 nd , 3 rd , 4 th [or 5 th] harmonic respectively. The exception is allowed if the measurement bandwidth (MBW) totally or partially overlaps the overall exception interval							
NOTE 3: To meet these requirements some restriction will be needed for either the operating band or protected band							
NOTE 4: N/A							
NOTE 5: N/A							
NOTE 6: N/A							
NOTE 7: N/A							
NOTE 8: N/A							
NOTE 9: N/A							
NOTE 10: The requirement also applies for the frequency ranges that are less than F _{OOB} (MHz) in Table 6.6.3.1-1 and Table 6.6.3.1A-1 from the edge of the aggregated channel bandwidth.							
NOTE 11: N/A							
NOTE 12: N/A							
NOTE 13: N/A							
NOTE 14: N/A							

Table 6.6.3.2A-2: Requirements for intraband non-contiguous CA

E-UTRA CA Configuration	Spurious emission						
	Protected band	Frequency range (MHz)		Maximum Level (dBm)	MBW (MHz)	NOTE	
CA_4A-4A	E-UTRA Band 2, 4, 5, 7, 10, 12, 13, 14, 17, 22, 23, 24, 25, 26, 27, 28, 29, 30, 41, 43, 66	F _{DL_low}	-	F _{DL_high}	-50	1	
	E-UTRA Band 42	F _{DL_low}	-	F _{DL_high}	-50	1	2
NOTE 1: F _{DL_low} and F _{DL_high} refer to each E-UTRA frequency band specified in Table 5.5-1							
NOTE 2: As exceptions, measurements with a level up to the applicable requirements defined in Table 6.6.3.1-2 are permitted for each assigned E-UTRA carrier used in the measurement due to 2nd or 3rd harmonic spurious emissions. Due to spreading of the harmonic emission the exception is also allowed for the first 1 MHz frequency range immediately outside the harmonic emission on both sides of the harmonic emission. This results in an overall exception interval centred at the harmonic emission of (2MHz + N x LCRB x 180kHz), where N is 2 or 3 for the 2nd or 3rd harmonic respectively. The exception is allowed if the measurement bandwidth (MBW) totally or partially overlaps the overall exception interval.							

6.6.3.3 Additional spurious emissions

These requirements are specified in terms of an additional spectrum emission requirement. Additional spurious emission requirements are signalled by the network to indicate that the UE shall meet an additional requirement for a specific deployment scenario as part of the cell handover/broadcast message.

NOTE: For measurement conditions at the edge of each frequency range, the lowest frequency of the measurement position in each frequency range should be set at the lowest boundary of the frequency range plus MBW/2. The highest frequency of the measurement position in each frequency range should be set at the highest boundary of the frequency range minus MBW/2. MBW denotes the measurement bandwidth defined for the protected band.

6.6.3.3.1 Minimum requirement (network signalled value "NS_05")

When "NS_05" is indicated in the cell, the power of any UE emission shall not exceed the levels specified in Table 6.6.3.3.1-1. This requirement also applies for the frequency ranges that are less than FOOB (MHz) in Table 6.6.3.1-1 from the edge of the channel bandwidth.

Table 6.6.3.3.1-1: Additional requirements (PHS)

Frequency band (MHz)	Channel bandwidth / Spectrum emission limit (dBm)				Measurement bandwidth	NOTE
	5 MHz	10 MHz	15 MHz	20 MHz		
$1884.5 \leq f \leq 1915.7$	-41	-41	-41	-41	300 KHz	1

Table 6.6.3.3.1-2: Void

6.6.3.3.2 Minimum requirement (network signalled value "NS_07")

When "NS_07" is indicated in the cell, the power of any UE emission shall not exceed the levels specified in Table 6.6.3.3.2-1. This requirement also applies for the frequency ranges that are less than FOOB (MHz) in Table 6.6.3.1-1 from the edge of the channel bandwidth.

Table 6.6.3.3.2-1: Additional requirements

Frequency band (MHz)	Channel bandwidth / Spectrum emission limit (dBm)		Measurement bandwidth
	10 MHz		
$769 \leq f \leq 775$	-57		6.25 kHz
NOTE: The emissions measurement shall be sufficiently power averaged to ensure standard standard deviation < 0.5 dB.			

6.6.3.3.3 Minimum requirement (network signalled value "NS_08")

When "NS 08" is indicated in the cell, the power of any UE emission shall not exceed the levels specified in Table 6.6.3.3.3-1. This requirement also applies for the frequency ranges that are less than F_{OOB} (MHz) in Table 6.6.3.1-1 from the edge of the channel bandwidth.

Table 6.6.3.3.3-1: Additional requirement

Frequency band (MHz)	Channel bandwidth / Spectrum emission limit (dBm)			Measurement bandwidth
	5MHz	10MHz	15MHz	
$860 \leq f \leq 890$	-40	-40	-40	1 MHz

6.6.3.3.4 Minimum requirement (network signalled value "NS_09")

When "NS 09" is indicated in the cell, the power of any UE emission shall not exceed the levels specified in Table 6.6.3.3.4-1. This requirement also applies for the frequency ranges that are less than F_{OOB} (MHz) in Table 6.6.3.1-1 from the edge of the channel bandwidth.

Table 6.6.3.3.4-1: Additional requirement

Frequency band (MHz)	Channel bandwidth / Spectrum emission limit (dBm)			Measurement bandwidth
	5MHz	10MHz	15MHz	
$1475.9 \leq f \leq 1510.9$	-35	-35	-35	1 MHz

NOTE 1: Void.

NOTE 2: To improve measurement accuracy, A-MPR values for NS_09 specified in Table 6.2.4-1 in subclause 6.2.4 are derived based on 100 kHz RBW.

6.6.3.3.5 Minimum requirement (network signalled value "NS_12")

When "NS 12" is indicated in the cell, the power of any UE emission shall not exceed the levels specified in Table 6.6.3.3.5-1. This requirement also applies for the frequency ranges that are less than F_{OOB} (MHz) in Table 6.6.3.1-1 from the edge of the channel bandwidth.

Table 6.6.3.3.5-1: Additional requirements

Frequency band (MHz)	Channel bandwidth / Spectrum emission limit (dBm)		Measurement bandwidth
	1.4 MHz, 3 MHz, 5 MHz, 10 MHz, 15 MHz		
$806 \leq f \leq 813.5$	-42		6.25 kHz
NOTE 1: The requirement applies for E-UTRA carriers with lower channel edge at or above 814.2 MHz.			
NOTE 2: The emissions measurement shall be sufficiently power averaged to ensure a standard deviation < 0.5 dB.			

6.6.3.3.6 Minimum requirement (network signalled value “NS_13”)

When “NS 13” is indicated in the cell, the power of any UE emission shall not exceed the levels specified in Table 6.6.3.3.6-1. This requirement also applies for the frequency ranges that are less than F_{OOB} (MHz) in Table 6.6.3.1-1 from the edge of the channel bandwidth.

Table 6.6.3.3.6-1: Additional requirements

Frequency band (MHz)	Channel bandwidth / Spectrum emission limit (dBm)	Measurement bandwidth
	1.4, 3, 5 MHz	
$806 \leq f \leq 816$	-42	6.25 kHz
NOTE 1: The requirement applies for E-UTRA carriers with lower channel edge at or above 819 MHz. NOTE 2: The emissions measurement shall be sufficiently power averaged to ensure a standard deviation < 0.5 dB.		

6.6.3.3.7 Minimum requirement (network signalled value “NS_14”)

When “NS 14” is indicated in the cell, the power of any UE emission shall not exceed the levels specified in Table 6.6.3.3.7-1. This requirement also applies for the frequency ranges that are less than F_{OOB} (MHz) in Table 6.6.3.1-1 from the edge of the channel bandwidth.

Table 6.6.3.3.7-1: Additional requirements

Frequency band (MHz)	Channel bandwidth / Spectrum emission limit (dBm)	Measurement bandwidth
	10 MHz, 15 MHz	
$806 \leq f \leq 816$	-42	6.25 kHz
NOTE 1: The requirement applies for E-UTRA carriers with lower channel edge at or above 824 MHz. NOTE 2: The emissions measurement shall be sufficiently power averaged to ensure a standard deviation < 0.5 dB.		

6.6.3.3.8 Minimum requirement (network signalled value “NS_15”)

When “NS 15” is indicated in the cell, the power of any UE emission shall not exceed the levels specified in Table 6.6.3.3.8-1. This requirement also applies for the frequency ranges that are less than F_{OOB} (MHz) in Table 6.6.3.1-1 from the edge of the channel bandwidth.

Table 6.6.3.3.8-1: Additional requirements

Frequency band (MHz)	Channel bandwidth / Spectrum emission limit (dBm)	Measurement bandwidth
	1.4 MHz, 3 MHz, 5 MHz, 10 MHz, 15 MHz	
$851 \leq f \leq 859$	-53	6.25 kHz
NOTE 1: The emissions measurement shall be sufficiently power averaged to ensure a standard deviation < 0.5 dB.		

6.6.3.3.9 Minimum requirement (network signalled value “NS_16”)

When “NS_16” is indicated in the cell, the power of any UE emission shall not exceed the levels specified in Table 6.6.3.3.9-1. This requirement also applies for the frequency ranges that are less than F_{OOB} (MHz) in Table 6.6.3.1-1 from the edge of the channel bandwidth.

Table 6.6.3.3.9-1: Additional requirements

Frequency band (MHz)	Channel bandwidth / Spectrum emission limit (dBm)	Measurement bandwidth	NOTE
	1.4, 3, 5, 10 MHz		
$790 \leq f \leq 803$	-32	1 MHz	

6.6.3.3.10 Minimum requirement (network signalled value "NS_17")

When "NS_17" is indicated in the cell, the power of any UE emission shall not exceed the levels specified in Table 6.6.3.3.10-1. This requirement also applies for the frequency ranges that are less than F_{OOB} (MHz) in Table 6.6.3.3.1-1 from the edge of the channel bandwidth.

Table 6.6.3.3.10-1: Additional requirements

Frequency band (MHz)	Channel bandwidth / Spectrum emission limit (dBm)	Measurement bandwidth	NOTE
	5, 10 MHz		
$470 \leq f \leq 710$	-26.2	6 MHz	1
NOTE 1: Applicable when the assigned E-UTRA carrier is confined within 718 MHz and 748 MHz and when the channel bandwidth used is 5 or 10 MHz.			

6.6.3.3.11 Minimum requirement (network signalled value "NS_18")

When "NS_18" is indicated in the cell, the power of any UE emission shall not exceed the levels specified in Table 6.6.3.3.11-1. This requirement also applies for the frequency ranges that are less than F_{OOB} (MHz) in Table 6.6.3.1-1 from the edge of the channel bandwidth.

Table 6.6.3.3.11-1: Additional requirements

Frequency band (MHz)	Channel bandwidth / Spectrum emission limit (dBm)	Measurement bandwidth	NOTE
	5, 10, 15, 20 MHz		
692-698	-26.2	6 MHz	

6.6.3.3.12 Minimum requirement (network signalled value "NS_19")

When "NS_19" is indicated in the cell, the power of any UE emission shall not exceed the levels specified in Table 6.6.3.3.12-1. This requirement also applies for the frequency ranges that are less than F_{OOB} (MHz) in Table 6.6.3.1-1 from the edge of the channel bandwidth.

Table 6.6.3.3.12-1: Additional requirements

Frequency band (MHz)	Channel bandwidth / Spectrum emission limit (dBm)	Measurement bandwidth	NOTE
	3, 5, 10, 15, 20 MHz		
$662 \leq f \leq 694$	-25	8 MHz	

6.6.3.3.13 Minimum requirement (network signalled value "NS_11")

When "NS_11" is indicated in the cell, the power of any UE emission shall not exceed the levels specified in Table 6.6.3.3.13-1. These requirements also apply for the frequency ranges that are less than F_{OOB} (MHz) in Table 6.6.3.1-1 and Table 6.6.3.1A-1 from the edge of the channel bandwidth.

Table 6.6.3.3.13-1: Additional requirements

Frequency band (MHz)	Channel bandwidth / Spectrum emission limit (dBm)	Measurement bandwidth
	1.4, 3, 5, 10, 15, 20 MHz	
E-UTRA Band 2	-50	1 MHz
$1998 \leq f \leq 1999$	-21	1 MHz
$1997 \leq f < 1998$	-27	1 MHz
$1996 \leq f < 1997$	-32	1 MHz
$1995 \leq f < 1996$	-37	1 MHz
$1990 \leq f < 1995$	-40	1 MHz

6.6.3.3.14 Minimum requirement (network signalled value "NS_20")

When "NS_20" is indicated in the cell, the power of any UE emission shall not exceed the levels specified in Table 6.6.3.3.14-1. These requirements also apply for the frequency ranges that are less than F_{OOB} (MHz) in Table 6.6.3.1-1 and Table 6.6.3.1A-1 from the edge of the channel bandwidth.

Table 6.6.3.3.14-1: Additional requirements

Frequency band (MHz)	Channel bandwidth / Spectrum emission limit (dBm)	Measurement bandwidth
	5, 10, 15, 20 MHz	
$1990 \leq f < 1999$	-40	1 MHz
$1999 \leq f \leq 2000$	-40	NOTE 1
NOTE 1: The measurement bandwidth is 1% of the applicable E-UTRA channel bandwidth.		

6.6.3.3.15 Minimum requirement (network signalled value "NS_21")

When "NS_21" is indicated in the cell, the power of any UE emission shall not exceed the levels specified in Table 6.6.3.3.15-1. These requirements also apply for the frequency ranges that are less than F_{OOB} (MHz) in Table 6.6.3.1-1 and Table 6.6.3.1A-1 from the edge of the channel bandwidth.

Table 6.6.3.3.15-1: Additional requirements

Frequency band (MHz)	Channel bandwidth / Spectrum emission limit (dBm)	Measurement bandwidth
	5, 10 MHz	
$2200 \leq f < 2288$	-40	1 MHz
$2288 \leq f < 2292$	-37	1 MHz
$2292 \leq f < 2296$	-31	1 MHz
$2296 \leq f < 2300$	-25	1 MHz
$2320 \leq f < 2324$	-25	1 MHz
$2324 \leq f < 2328$	-31	1 MHz
$2328 \leq f < 2332$	-37	1 MHz
$2332 \leq f \leq 2395$	-40	1 MHz

6.6.3.3.16 Minimum requirement (network signalled value "NS_22")

When "NS_22" is indicated in the cell, the power of any UE emission shall not exceed the levels specified in Table 6.6.3.3.16-1. This requirement also applies for the frequency ranges that are less than F_{OOB} (MHz) in Table 6.6.3.1-1 from the edge of the channel bandwidth.

Table 6.6.3.3.16-1: Additional requirement

Frequency band (MHz)	Channel bandwidth / Spectrum emission limit (dBm)	MBW
	5, 10, 15, 20 MHz	
3400 ≤ f ≤ 3800	-23 (NOTE 1, NOTE 3)	5 MHz
	-40 (NOTE 2)	1 MHz
<p>NOTE 1: This requirement applies within an offset between 5 MHz and 25 MHz from the lower and from the upper edge of the channel bandwidth, whenever these frequencies overlap with the specified frequency band.</p> <p>NOTE 2: This requirement applies from 3400 MHz to 25 MHz below the lower E-UTRA channel edge and from 25 MHz above the upper E-UTRA channel edge to 3800 MHz.</p> <p>NOTE 3: This emission limit might imply risk of harmful interference to UE(s) operating in the protected operating band</p>		

6.6.3.3.17 Minimum requirement (network signalled value "NS_23")

When "NS 23" is indicated in the cell, the power of any UE emission shall not exceed the levels specified in Table 6.6.3.3.17-1. This requirement also applies for the frequency ranges that are less than F_{OoB} (MHz) in Table 6.6.3.1-1 from the edge of the channel bandwidth.

Table 6.6.3.3.17-1: Additional requirement

Frequency band (MHz)	Channel bandwidth / Spectrum emission limit (dBm)	MBW
	5, 10, 15, 20 MHz	
3400 ≤ f ≤ 3800	-23 (NOTE 1, NOTE 4)	5 MHz
	-40 (NOTE 2)	1 MHz
<p>NOTE 1: This requirement applies within an offset between 5 MHz + $F_{offset_NS_23}$ and 25 MHz + $F_{offset_NS_23}$ from the lower and from the upper edges of the channel bandwidth, whenever these frequencies overlap with the specified frequency band.</p> <p>NOTE 2: This requirement applies from 3400 MHz to 25 MHz + $F_{offset_NS_23}$ below the lower E-UTRA channel edge and from 25 MHz + $F_{offset_NS_23}$ above the upper E-UTRA channel edge to 3800 MHz.</p> <p>NOTE 3: $F_{offset_NS_23}$ is: 0 MHz for 5 MHz channel BW, 5 MHz for 10 MHz channel BW, 9 MHz for 15 MHz channel BW and 12 MHz for 20 MHz channel BW.</p> <p>NOTE 4: This emission limit might imply risk of harmful interference to UE(s) operating in the protected operating band</p>		

6.6.3.3.18 Void

Table 6.6.3.3.18-1: Void

6.6.3.3.19 Minimum requirement (network signalled value "NS_04")

When "NS 04" is indicated in the cell, the power of any UE emission shall not exceed the levels specified in Table 6.6.3.3.19-1. This requirement also applies for the frequency ranges that are less than F_{OoB} (MHz) in Table 6.6.3.1-1 from the edge of the channel bandwidth.

Table 6.6.3.3.19-1: Additional requirements

Frequency band	Channel bandwidth / Spectrum emission limit (dBm)	Measurement bandwidth
	5, 10, 15, 20 MHz	
$2490.5 \text{ MHz} \leq f < 2496 \text{ MHz}$	-13	1 MHz
$9 \text{ kHz} < f < 2490.5 \text{ MHz}$	-25	1 MHz

6.6.3.3.20 Minimum requirement (network signalled value "NS_24")

When "NS_24" is indicated in the cell, the power of any UE emission shall not exceed the levels specified in Table 6.6.3.3.20-1. This requirement also applies for the frequency ranges that are less than F_{OoB} (MHz) in Table 6.6.3.1-1 from the edge of the channel bandwidth.

Table 6.6.3.3.20-1: Additional requirements

Frequency band (MHz)	Channel bandwidth / Spectrum emission limit (dBm)	Measurement bandwidth
	5 MHz, 10 MHz, 15 MHz, 20 MHz	
Band 34	-50	MHz
NOTE 1: This requirement applies at a frequency offset equal or larger than 5 MHz from the upper edge of the channel bandwidth, whenever these frequencies overlap with the specified frequency band.		

6.6.3.3.21 Minimum requirement (network signalled value "NS_25")

When "NS_25" is indicated in the cell, the power of any UE emission shall not exceed the levels specified in Table 6.6.3.3.21-1. This requirement also applies for the frequency ranges that are less than F_{OoB} (MHz) in Table 6.6.3.1-1 from the edge of the channel bandwidth.

Table 6.6.3.3.21-1: Additional requirements

Frequency band (MHz)	Channel bandwidth / Spectrum emission limit (dBm)	Measurement bandwidth
	5 MHz, 10 MHz, 15 MHz, 20 MHz	
Band 34	-40	MHz
NOTE 1: This requirement applies at a frequency offset equal or larger than 5 MHz from the upper edge of the channel bandwidth, whenever these frequencies overlap with the specified frequency band.		

6.6.3.3.22 Minimum requirement (network signalled value "NS_26")

When "NS_26" is indicated in the cell, the power of any UE emission shall not exceed the levels specified in Table 6.6.3.3.22-1. This requirement also applies for the frequency ranges that are less than F_{OoB} (MHz) in Table 6.6.3.1-1 from the edge of the channel bandwidth.

Table 6.6.3.3.22-1: Additional requirements

Frequency band (MHz)	Channel bandwidth / Spectrum emission limit (dBm)	Measurement bandwidth
	5 MHz, 10 MHz, 15 MHz	
$686 \leq f \leq 694$	-25	8MHz

6.6.3.3.23 - 6.6.3.3.27 Void

6.6.3.3.28 Minimum requirement (network signalled value "NS_36")

When "NS_36" is indicated in the cell, the power of any UE emission shall not exceed the levels specified in Table 6.6.3.3.28-1. This requirement also applies for the frequency ranges that are less than F_{OOB} (MHz) in Table 6.6.3.1-1 from the edge of the channel bandwidth.

Table 6.6.3.3.28-1: Additional requirements

Frequency band (MHz)	Channel bandwidth / Spectrum emission limit (dBm)	Measurement bandwidth
	5 MHz, 10 MHz and 15 MHz	
$470 \leq f \leq 694$	-42	8MHz
NOTE: For a 5 MHz E-UTRA carrier confined within 698MHz and 703MHz, this requirement shall be met in normal conditions only. The requirement is relaxed to -30dBm in extreme conditions.		

6.6.3.3A Additional spurious emissions for CA

These requirements are specified in terms of an additional spectrum emission requirement. Additional spurious emission requirements are signalled by the network to indicate that the UE shall meet an additional requirement for a specific deployment scenario as part of the cell reconfiguration message.

NOTE: For measurement conditions at the edge of each frequency range, the lowest frequency of the measurement position in each frequency range should be set at the lowest boundary of the frequency range plus MBW/2. The highest frequency of the measurement position in each frequency range should be set at the highest boundary of the frequency range minus MBW/2. MBW denotes the measurement bandwidth defined for the protected band.

6.6.3.3A.1 Minimum requirement for CA_1C (network signalled value "CA_NS_01")

When "CA_NS_01" is indicated in the cell, the power of any UE emission shall not exceed the levels specified in Table 6.6.3.3A.1-1. This requirement also applies for the frequency ranges that are less than F_{OOB} (MHz) in Table 6.6.3.1A-1 from the edge of the aggregated channel bandwidth.

Table 6.6.3.3A.1-1: Additional requirements (PHS)

Protected band	Frequency range (MHz)			Maximum Level (dBm)	MBW (MHz)	NOTE
E-UTRA band 34	FDL_low	-	FDL_high	-50	1	
Frequency range	1884.5	-	1915.7	-41	0.3	1
NOTE 1: Applicable when the aggregated channel bandwidth is confined within frequency range 1940 – 1980 MHz						

6.6.3.3A.2 Minimum requirement for CA_1C (network signalled value "CA_NS_02")

When "CA_NS_02" is indicated in the cell, the power of any UE emission shall not exceed the levels specified in Table 6.6.3.3A.2-1. This requirement also applies for the frequency ranges that are less than F_{OOB} (MHz) in Table 6.6.3.1A-1 from the edge of the aggregated channel bandwidth.

Table 6.6.3.3A.2-1: Additional requirements

Protected band	Frequency range (MHz)			Maximum Level (dBm)	MBW (MHz)	NOTE
E-UTRA band 34	F _{DL_low}	-	F _{DL_high}	-50	1	
Frequency range	1900	-	1915	-15.5	5	1, 2
Frequency range	1915	-	1920	+1.6	5	1, 2
NOTE 1: The requirement also applies for the frequency ranges that are less than F _{OOB} (MHz) in Table 6.6.3.1-1 and Table 6.6.3.1A-1 from the edge of the channel bandwidth.						
NOTE 2: For these adjacent bands, the emission limit could imply risk of harmful interference to UE(s) operating in the protected operating band.						

6.6.3.3A.3 Minimum requirement for CA_1C (network signalled value "CA_NS_03")

When "CA_NS_03" is indicated in the cell, the power of any UE emission shall not exceed the levels specified in Table 6.6.3.3A.3-1. This requirement also applies for the frequency ranges that are less than F_{OOB} (MHz) in Table 6.6.3.1A-1 from the edge of the aggregated channel bandwidth.

Table 6.6.3.3A.3-1: Additional requirements

Protected band	Frequency range (MHz)			Maximum Level (dBm)	MBW (MHz)	NOTE
E-UTRA band 34	F _{DL_low}	-	F _{DL_high}	-50	1	
Frequency range	1880	-	1895	-40	1	
Frequency range	1895	-	1915	-15.5	5	1, 2
Frequency range	1915	-	1920	+1.6	5	1, 2
NOTE 1: The requirement also applies for the frequency ranges that are less than F _{OOB} (MHz) in Table 6.6.3.1-1 and Table 6.6.3.1A-1 from the edge of the channel bandwidth.						
NOTE 2: For these adjacent bands, the emission limit could imply risk of harmful interference to UE(s) operating in the protected operating band.						

6.6.3.3A.4 Minimum requirement for CA_38C (network signalled value "CA_NS_05")

When "CA_NS_05" is indicated in the cell, the power of any UE emission shall not exceed the levels specified in Table 6.6.3.3A.4-1. This requirement also applies for the frequency ranges that are less than F_{OOB} (MHz) in Table 6.6.3.1A-1 from the edge of the aggregated channel bandwidth. This requirement is applicable for carriers with aggregated channel bandwidths confined in 2570 - 2615 MHz.

Table 6.6.3.3A.4-1: Additional requirements

Protected band	Frequency range (MHz)			Maximum Level (dBm)	MBW (MHz)	NOTE
Frequency range	2620	-	2645	-15.5	5	1, 2, 3
Frequency range	2645	-	2690	-40	1	1, 3
NOTE 1: The requirement also applies for the frequency ranges that are less than F _{OOB} (MHz) in Table 6.6.3.1-1 and Table 6.6.3.1A-1 from the edge of the channel bandwidth.						
NOTE 2: For these adjacent bands, the emission limit could imply risk of harmful interference to UE(s) operating in the protected operating band.						
NOTE 3: This requirement is applicable for carriers with aggregated channel bandwidths confined in 2570-2615 MHz.						

6.6.3.3A.5 Minimum requirement for CA_7C (network signalled value "CA_NS_06")

When "CA_NS_06" is indicated in the cell, the power of any UE emission shall not exceed the levels specified in Table 6.6.3.3A.5-1. This requirement also applies for the frequency ranges that are less than F_{OOB} (MHz) in Table 6.6.3.1A-1 from the edge of the aggregated channel bandwidth.

Table 6.6.3.3A.5-1: Additional requirements

Protected band	Frequency range (MHz)			Maximum Level (dBm)	MBW (MHz)	NOTE
Frequency range	2570	-	2575	+1.6	5	1, 2
Frequency range	2575	-	2595	-15.5	5	1, 2
Frequency range	2595	-	2620	-40	1	
NOTE 1: The requirement also applies for the frequency ranges that are less than F _{OOB} (MHz) in Table 6.6.3.1-1 and Table 6.6.3.1A-1 from the edge of the channel bandwidth.						
NOTE 2: For these adjacent bands, the emission limit could imply risk of harmful interference to UE(s) operating in the protected operating band.						

6.6.3.3A.6 Minimum requirement for CA_39C and CA_39C-41A (network signalled value "CA_NS_07")

When "CA_NS_07" is indicated in the cell, the power of any UE emission shall not exceed the levels specified in Table 6.6.3.3A.6-1. This requirement also applies for the frequency ranges that are less than F_{OOB} (MHz) in Table 6.6.3.1A-1 from the edge of the aggregated channel bandwidth.

Table 6.6.3.3A.6-1: Additional requirements

Protected band	Frequency range (MHz)			Maximum Level (dBm)	MBW (MHz)	NOTE
Frequency range	1805	-	1855	-40	1	1
Frequency range	1855	-	1880	-15.5	5	1, 2, 3
NOTE 1: This requirement is applicable for carriers with aggregated channel bandwidths confined in 1885-1920 MHz.						
NOTE 2: The requirement also applies for the frequency ranges that are less than F _{OOB} (MHz) in Table 6.6.3.1-1 and Table 6.6.3.1A-1 from the edge of the channel bandwidth.						
NOTE 3: For these adjacent bands, the emission limit could imply risk of harmful interference to UE(s) operating in the protected operating band.						

6.6.3.3A.7 Minimum requirement for CA_42C (network signalled value "CA_NS_08")

When "CA_NS_08" is indicated in the cell, the power of any UE emission shall not exceed the levels specified in Table 6.6.3.3A.7-1. This requirement also applies for the frequency ranges that are less than F_{OOB} (MHz) in Table 6.6.3.1A-1 from the edge of the aggregated channel bandwidth.

Table 6.6.3.3A.7-1: Additional requirements

Frequency band (MHz)	Aggregated bandwidth / Spectrum emission limit (dBm)	MBW
	25, 30, 35, 40 MHz (Note 1)	
3400 ≤ f ≤ 3800	-23 (Note 2, Note 4)	5 MHz
	-40 (Note 3)	1 MHz
NOTE 1: Possible aggregated bandwidth for CA_42C as specified in Table 5.6A.1-1.		
NOTE 2: This requirement applies within an offset between 5 MHz and 25 MHz from the lower and from the upper edge of the channel bandwidth, whenever these frequencies overlap with the specified frequency band.		
NOTE 3: This requirement applies from 3400 MHz to 25 MHz below the lower E-UTRA channel edge and from 25 MHz above the upper E-UTRA channel edge to 3800 MHz.		
NOTE 4: This emission limit might imply risk of harmful interference to UE(s) operating in the protected operating band.		

6.6.3.3A.8 Minimum requirement for CA_41C (network signalled value "CA_NS_04")

When "CA_NS_04" is indicated in the cell, the power of any UE emission shall not exceed the levels specified in Table 6.6.3.3A.8-1. This requirement also applies for the frequency ranges that are less than F_{OOB} (MHz) in Table 6.6.3.1A-1 from the edge of the aggregated channel bandwidth.

Table 6.6.3.3A.8-1: Additional requirements

Frequency band	Spectrum emission limit (dBm)	Measurement bandwidth
$2490.5 \text{ MHz} \leq f < 2495 \text{ MHz}$	-13	1 MHz
$9 \text{ kHz} < f < 2490.5 \text{ MHz}$	-25	1 MHz

6.6.3A Void

<reserved for future use>

6.6.3B Spurious emission for UL-MIMO

For UE supporting UL-MIMO, the requirements for Spurious emissions which are caused by unwanted transmitter effects such as harmonics emission, parasitic emissions, intermodulation products and frequency conversion products are specified at each transmit antenna connector.

For UEs with two transmit antenna connectors in closed-loop spatial multiplexing scheme, the requirements in subclause 6.6.3 apply to each transmit antenna connector. The requirements shall be met with the UL-MIMO configurations specified in Table 6.2.2B-1.

If UE is configured for transmission on single-antenna port, the general requirements in subclause 6.6.3 apply.

6.6.3C Void

<reserved for future use>

6.6.3D Spurious emission for ProSe

When UE is configured for E-UTRA ProSe sidelink transmissions non-concurrent with E-UTRA uplink transmissions for E-UTRA ProSe operating bands specified in Table 5.5D-1, the requirements in subclause 6.6.3 apply.

When UE is configured for simultaneous E-UTRA ProSe sidelink and E-UTRA uplink transmissions for inter-band E-UTRA ProSe / E-UTRA bands specified in Table 5.5D-2, the UE co-existence requirements in Table 6.6.3.2A-0 in subclause 6.6.3.2A apply as specified for the corresponding inter-band aggregation with uplink assigned to two bands.

6.6.3F Spurious emission for category NB1

When UE is configured for category NB1 uplink transmissions the requirements in subclause 6.6.3 apply with an exception that boundary between category NB1 out of band and spurious emission domain shall be $F_{\text{OOB}} = 1.7 \text{ MHz}$.

6.6A Void

6.6B Void

6.7 Transmit intermodulation

The transmit intermodulation performance is a measure of the capability of the transmitter to inhibit the generation of signals in its non linear elements caused by presence of the wanted signal and an interfering signal reaching the transmitter via the antenna.

6.7.1 Minimum requirement

User Equipment(s) transmitting in close vicinity of each other can produce intermodulation products, which can fall into the UE, or eNode B receive band as an unwanted interfering signal. The UE intermodulation attenuation is defined by the ratio of the mean power of the wanted signal to the mean power of the intermodulation product when an interfering CW signal is added at a level below the wanted signal at each of the transmitter antenna port with the other antenna port(s) if any is terminated. Both the wanted signal power and the intermodulation product power are measured through E-UTRA rectangular filter with measurement bandwidth shown in Table 6.7.1-1.

The requirement of transmitting intermodulation is prescribed in Table 6.7.1-1.

Table 6.7.1-1: Transmit Intermodulation

BW Channel (UL)	5MHz		10MHz		15MHz		20MHz	
Interference Signal Frequency Offset	5MHz	10MHz	10MHz	20MHz	15MHz	30MHz	20MHz	40MHz
Interference CW Signal Level	-40dBc							
Intermodulation Product	-29dBc	-35dBc	-29dBc	-35dBc	-29dBc	-35dBc	-29dBc	-35dBc
Measurement bandwidth	4.5MHz	4.5MHz	9.0MHz	9.0MHz	13.5MHz	13.5MHz	18MHz	18MHz

6.7.1A Minimum requirement for CA

User Equipment(s) transmitting in close vicinity of each other can produce intermodulation products, which can fall into the UE, or eNode B receive band as an unwanted interfering signal. The UE intermodulation attenuation is defined by the ratio of the mean power of the wanted signal to the mean power of the intermodulation product on both component carriers when an interfering CW signal is added at a level below the wanted signal at each of the transmitter antenna port with the other antenna port(s) if any is terminated. Both the wanted signal power and the intermodulation product power are measured through rectangular filter with measurement bandwidth shown in Table 6.7.1A-1.

For inter-band carrier aggregation with one component carrier per operating band and the uplink active in two E-UTRA bands, the requirement is specified in Table 6.7.1-1 which shall apply on each component carrier with both component carriers active.

For intra-band contiguous carrier aggregation the requirement of transmitting intermodulation is specified in Table 6.7.1A-1.

Table 6.7.1A-1: Transmit Intermodulation

CA bandwidth class(UL)	B and C	
Interference Signal Frequency Offset	$BW_{\text{Channel_CA}}$	$2 \cdot BW_{\text{Channel_CA}}$
Interference CW Signal Level	-40dBc	
Intermodulation Product	-29dBc	-35dBc
Measurement bandwidth	$BW_{\text{Channel_CA}} - 2 \cdot BW_{\text{GB}}$	

For combinations of intra-band and inter-band carrier aggregation with three uplink component carriers (up to two contiguously aggregated carriers per band) transmit intermodulations is defined as follows. For the E-UTRA band supporting one component carrier the requirement specified in Table 6.7.1-1 apply. For the E-UTRA band supporting two contiguous component carriers the requirements specified in Table 6.7.1A-1 apply.

6.7.1B Minimum requirement for UL-MIMO

For UE supporting UL-MIMO, the transmit intermodulation requirements are specified at each transmit antenna connector and the wanted signal is defined as the sum of output power at each transmit antenna connector.

For UEs with two transmit antenna connectors in closed-loop spatial multiplexing scheme, the requirements in subclause 6.7.1 apply to each transmit antenna connector. The requirements shall be met with the UL-MIMO configurations specified in Table 6.2.2B-2.

If UE is configured for transmission on single-antenna port, the requirements in subclause 6.7.1 apply.

6.7.1F Minimum requirement for category NB1

The UE category NB1 transmitter intermodulation attenuation is defined by the ratio of the mean power of the wanted signal to the mean power of the intermodulation product as defined in Table 6.7.1F-1 when an interfering CW signal is added at a level below the wanted signal at the transmitter antenna port. Both the wanted signal power and the intermodulation product power are measured through rectangular filter with measurement bandwidth shown in Table 6.7.1F-1.

Table 6.7.1F-1: UE category NB1 transmitter IM requirement

Parameters for transmitter intermodulation		
BW Channel (UL)	15 kHz (1 tone at sub-carrier 5 or 6)	
Interference Signal Frequency Offset	180 kHz	360 kHz
Interference CW Signal Level	-40dBc	
Intermodulation Product	-20 dBc	-39 dBc
Measurement bandwidth	30 kHz	30 kHz

6.8 Void

6.8.1 Void

6.8A Void

6.8B Time alignment error for UL-MIMO

For UE(s) with multiple transmit antenna connectors supporting UL-MIMO, this requirement applies to frame timing differences between transmissions on multiple transmit antenna connectors in the closed-loop spatial multiplexing scheme.

The time alignment error (TAE) is defined as the average frame timing difference between any two transmissions on different transmit antenna connectors.

6.8B.1 Minimum Requirements

For UE(s) with multiple transmit antenna connectors, the Time Alignment Error (TAE) shall not exceed 130 ns.

7 Receiver characteristics

7.1 General

Unless otherwise stated the receiver characteristics are specified at the antenna connector(s) of the UE. For UE(s) with an integral antenna only, a reference antenna(s) with a gain of 0 dBi is assumed for each antenna port(s). UE with an integral antenna(s) may be taken into account by converting these power levels into field strength requirements, assuming a 0 dBi gain antenna. For UEs with more than one receiver antenna connector, identical interfering signals shall be applied to each receiver antenna port if more than one of these is used (diversity).

The levels of the test signal applied to each of the antenna connectors shall be as defined in the respective sections below.

With the exception of subclause 7.3, the requirements shall be verified with the network signalling value NS_01 configured (Table 6.2.4-1).

All the parameters in clause 7 are defined using the UL reference measurement channels specified in Annexes A.2.2 and A.2.3, the DL reference measurement channels specified in Annex A.3.2 and using the set-up specified in Annex C.3.1.

For the additional requirements for intra-band non-contiguous carrier aggregation of two sub-blocks, an in-gap test refers to the case when the interfering signal is located at a negative offset with respect to the assigned lowest channel frequency of the highest sub-block and located at a positive offset with respect to the assigned highest channel frequency of the lowest sub-block.

For the additional requirements for intra-band non-contiguous carrier aggregation of two sub-blocks, an out-of-gap test refers to the case when the interfering signal(s) is (are) located at a positive offset with respect to the assigned channel frequency of the highest carrier frequency, or located at a negative offset with respect to the assigned channel frequency of the lowest carrier frequency.

For the additional requirements for intra-band non-contiguous carrier aggregation of two sub-blocks with channel bandwidth larger than or equal to 5 MHz, the existing adjacent channel selectivity requirements, in-band blocking requirements (for each case), and narrow band blocking requirements apply for in-gap tests only if the corresponding interferer frequency offsets with respect to the two measured carriers satisfy the following condition in relation to the sub-block gap size W_{gap} for at least one of these carriers $j = 1, 2$, so that the interferer frequency position does not change the nature of the core requirement tested:

$$W_{\text{gap}} \geq 2 \cdot |f_{\text{Interferer (offset)}_j} - \text{BWChannel}_j|$$

where $F_{\text{Interferer (offset),j}}$ for a sub-block with a single component carrier is the interferer frequency offset with respect to carrier j as specified in subclause 7.5.1, subclause 7.6.1 and subclause 7.6.3 for the respective requirement and $BW_{\text{Channel}(j)}$ the channel bandwidth of carrier j . $F_{\text{Interferer (offset),j}}$ for a sub-block with two or more contiguous component carriers is the interference frequency offset with respect to the carrier adjacent to the gap is specified in subclause 7.5.1A, 7.6.1A and 7.6.3A. The interferer frequency offsets for adjacent channel selectivity, each in-band blocking case and narrow-band blocking shall be tested separately with a single in-gap interferer at a time.

For a ProSe UE that supports both ProSe Direct Discovery and ProSe Direct Communication, the receiver characteristics specified in clause 7 for ProSe Direct Communication shall apply.

For ProSe Direct Discovery and ProSe Direct Communication on E-UTRA ProSe operating bands that correspond to TDD E-UTRA operating bands as specified in subclause 5.5D, the only additional requirement for ProSe specified in subclause 7.4.1D is applicable.

7.2 Diversity characteristics

The requirements in Section 7 assume that the receiver is equipped with two Rx port as a baseline. These requirements apply to all UE categories unless stated otherwise. Additional requirements apply for UE(s) equipped with four Rx ports. These additional requirements also apply for supported band combinations for which the UE can operate using up to four Rx ports while configured with carrier aggregation. With the exception of subclause 7.9 all requirements shall be verified by using both (all) antenna ports simultaneously.

NOTE: for an operating band in which the UE can operate using up to four Rx ports, it suffices to verify for conformance the additional requirements applicable for four Rx ports [except for REFSENS].

NOTE: Implementation of 4 antenna ports for all operating bands supported by the UE is not mandated.

For a category 0, a category [M 1] and category NB1 UE the requirements in Section 7 assume that the receiver is equipped with single Rx port.

7.3 Reference sensitivity power level

The reference sensitivity power level REFSENS is the minimum mean power applied to each one of the UE antenna ports for all UE categories except category 0 and category [M1], or to the single antenna port for UE category 0 and UE category [M1], at which the throughput shall meet or exceed the requirements for the specified reference measurement channel.

The throughput for the REFSENS test is measured based on the Transmission Mode 1 unless specified otherwise.

7.3.1 Minimum requirements (QPSK)

The throughput shall be $\geq 95\%$ of the maximum throughput of the reference measurement channels as specified in Annexes A.2.2, A.2.3 and A.3.2 (with one sided dynamic OCNG Pattern OP.1 FDD/TDD for the DL-signal as described in Annex A.5.1.1/A.5.2.1) with parameters specified in Table 7.3.1-1 and Table 7.3.1-2

Table 7.3.1-1: Reference sensitivity QPSK P_{REFSENS}

E-UTRA Band	Channel bandwidth						Duplex Mode
	1.4 MHz (dBm)	3 MHz (dBm)	5 MHz (dBm)	10 MHz (dBm)	15 MHz (dBm)	20 MHz (dBm)	
1			-100	-97	-95.2	-94	FDD
2	-102.7	-99.7	-98	-95	-93.2	-92	FDD
3	-101.7	-98.7	-97	-94	-92.2	-91	FDD
4	-104.7	-101.7	-100	-97	-95.2	-94	FDD
5	-103.2	-100.2	-98	-95			FDD
6			-100	-97			FDD
7			-98	-95	-93.2	-92	FDD
8	-102.2	-99.2	-97	-94			FDD
9			-99	-96	-94.2	-93	FDD
10			-100	-97	-95.2	-94	FDD
11			-100	-97			FDD
12	-101.7	-98.7	-97	-94			FDD
13			-97	-94			FDD
14			-97	-94			FDD
...							
17			-97	-94			FDD
18			-100 ⁷	-97 ⁷	-95.2 ⁷		FDD
19			-100	-97	-95.2		FDD
20			-97	-94	-91.2	-90	FDD
21			-100	-97	-95.2		FDD
22			-97	-94	-92.2	-91	FDD
23	-104.7	-101.7	-100	-97	-95.2	-94	FDD
24			-100	-97			FDD
25	-101.2	-98.2	-96.5	-93.5	-91.7	-90.5	FDD
26	-102.7	-99.7	-97.5 ⁶	-94.5 ⁶	-92.7 ⁶		FDD
27	-103.2	-100.2	-98	-95			FDD
28		-100.2	-98.5	-95.5	-93.7	-91	FDD
30			-99	-96			FDD
31	-99.0	-95.7	-93.5				FDD
...							
33			-100	-97	-95.2	-94	TDD
34			-100	-97	-95.2		TDD
35	-106.2	-102.2	-100	-97	-95.2	-94	TDD
36	-106.2	-102.2	-100	-97	-95.2	-94	TDD
37			-100	-97	-95.2	-94	TDD
38			-100	-97	-95.2	-94	TDD
39			-100	-97	-95.2	-94	TDD
40			-100	-97	-95.2	-94	TDD
41			-98	-95	-93.2	-92	TDD
42			-99	-96	-94.2	-93	TDD
43			-99	-96	-94.2	-93	TDD
44		[-100.2]	[-98]	[-95]	[-93.2]	[-92]	TDD
45			-100	-97	-95.2	-94	TDD
...							
65	-104.2	-101.2	-99.5	-96.5	-94.7	-93.5	FDD
66	-104.2	-101.2	-99.5	-96.5	-94.7	-93.5	FDD
68			-98.5	-95.5	-93.7		FDD

NOTE 1: The transmitter shall be set to P_{UMAX} as defined in subclause 6.2.5
NOTE 2: Reference measurement channel is A.3.2 with one sided dynamic OCNG Pattern OP.1 FDD/TDD as described in Annex A.5.1.1/A.5.2.1

NOTE 3:	The signal power is specified per port
NOTE 4:	For the UE which supports both Band 3 and Band 9 the reference sensitivity level is FFS.
NOTE 5:	For the UE which supports both Band 11 and Band 21 the reference sensitivity level is FFS.
NOTE 6:	⁶ indicates that the requirement is modified by -0.5 dB when the carrier frequency of the assigned E-UTRA channel bandwidth is within 865-894 MHz.
NOTE 7:	For a UE that support both Band 18 and Band 26, the reference sensitivity level for Band 26 applies for the applicable channel bandwidths.

For UE(s) equipped with 4 antenna ports, the minimum requirement for reference sensitivity in Table 7.3.1-1 shall be modified by the amount given in $\Delta R_{IB,4R}$ in Table 7.3.1-1a for the applicable E-UTRA bands.

Table 7.3.1-1a: $\Delta R_{IB,4R}$

E-UTRA Band	$\Delta R_{IB,4R}$ [dB]
1, 2, 3, 7, 20, 39, 41	- 2.7
42	- 2.2

The reference receive sensitivity (REFSENS) requirement specified in Table 7.3.1-1 (two antenna ports) and Table 7.3.1-1a (four antenna ports) shall be met for an uplink transmission bandwidth less than or equal to that specified in Table 7.3.1-2.

NOTE: Table 7.3.1-2 is intended for conformance tests and does not necessarily reflect the operational conditions of the network, where the number of uplink and downlink allocated resource blocks will be practically constrained by other factors. Typical receiver sensitivity performance with HARQ retransmission enabled and using a residual BLER metric relevant for e.g. Speech Services is given in the Annex G (informative). For the UE which supports inter-band carrier aggregation configuration with the uplink in one or two E-UTRA bands, the minimum requirement for reference sensitivity in Table 7.3.1-1 and Table 7.3.1-1a shall be increased by the amount given in $\Delta R_{IB,c}$ in Table 7.3.1-1A, Table 7.3.1-1B and Table 7.3.1-1C for the applicable E-UTRA bands.

Table 7.3.1-1A: $\Delta R_{IB,c}$ (two bands)

Inter-band CA Configuration	E-UTRA Band	$\Delta R_{IB,c}$ [dB]
CA_1A-3A	1	0
	3	0
CA_1A-3C	1	0
	3	0
CA_1A-5A	1	0
	5	0
CA_1A-7A	1	0
	7	0
CA_1A-7C	1	0
	7	0
CA_1A-8A	1	0
	8	0
CA_1A-11A	1	0
	11	0
CA_1A-18A	1	0
	18	0
CA_1A-19A	1	0
	19	0
CA_1A-20A	1	0
	20	0
CA_1A-21A	1	0
	21	0
CA_1A-26A	1	0
	26	0
CA_1A-28A	1	0
	28	0.2
CA_1A-40A	1	0
	40	0
CA_1A-41A ⁸	1	0
	41	0
CA_1A-41C ⁸	1	0
	41	0
CA_1A-42A	1	0
	42	0.5
CA_1A-42C	1	0
	42	0.5
CA_1A-46A	1	0
CA_2A-4A	2	0.3
	4	0.3
CA_2A-2A-4A	2	0.3
	4	0.3
CA_2A-4A-4A	2	0.3
	4	0.3
CA_2A-2A-4A-4A	2	0.3
	4	0.3
CA_2A-5A	2	0
	5	0
CA_2A-2A-5A	2	0
	5	0
CA_2C-5A	2	0
	5	0
CA_2A-7A	2	0
	7	0
CA_2A-12A	2	0
	12	0
CA_2A-2A-12A	2	0
	12	0
CA_2A-2A-12B	2	0
	12	0
CA_2A-12B	2	0
	12	0

CA_2C-12A	2	0
	12	0
CA_2A-13A	2	0
	13	0
CA_2A-2A-13A	2	0
	13	0
CA_2A-17A	2	0
	17	0.5
CA_2A-28A	2	0
	28	0
CA_2A-29A	2	0
CA_2C-29A	2	0
CA_2A-30A	2	0.4
	30	0.5
CA_2A-46A	2	0
CA_2C-30A	2	0.4
	30	0.5
CA_3A-5A	3	0
	5	0
CA_3C-5A	3	0
	5	0
CA_3A-7A	3	0
	7	0
CA_3A-7B	3	0
	7	0
CA_3A-7C	3	0
	7	0
CA_3C-7A	3	0
	7	0
CA_3C-7C	3	0
	7	0
CA_3A-8A	3	0
	8	0
CA_3A-3A-8A	3	0
	8	0
CA_3A-19A	3	0
	19	0
CA_3A-20A	3	0
	20	0
CA_3A-26A	3	0
	26	0
CA_3A-27A	3	0
	27	0
CA_3A-28A	3	0
	28	0
CA_3C-28A	3	0
	28	0
CA_3A-31A	3	0
	31	0.2
CA_3A-38A	3	0
	38	0
CA_3A-40A	3	0
	40	0
CA_3A-40C	3	0
	40	0
CA_3A-41A	3	0
	41	0 ¹⁰
CA_3A-41C	3	0.5 ¹¹
	41	0
CA_3A-42A	3	0 ¹⁰
	42	0.5 ¹¹
CA_3A-42C	3	0.2
	42	0.5

CA_3A-46A	3	0
CA_4A-5A	4	0
	5	0
CA_4A-4A-5A	4	0
	5	0
CA_4A-7A	4	0.5
	7	0.5
CA_4A-4A-7A	4	0.5
	7	0.5
CA_4A-12A	4	0
	12	0.5
CA_4A-12B	4	0
	12	0.5
CA_4A-4A-12A	4	0
	12	0.5
CA_4A-13A	4	0
	13	0
CA_4A-4A-13A	4	0
	13	0
CA_4A-17A	4	0
	17	0.5
CA_4A-27A	4	0
	27	0
CA_4A-28A	4	0
	28	0.2
CA_4A-29A	4	0
CA_4A-4A-29A	4	0
CA_4A-30A	4	0.4
	30	0.5
CA_4A-4A-30A	4	0.4
	30	0.5
CA_4A-46A	4	0
CA_5A-7A	5	0
	7	0
CA_5A-12A	5	0.5
	12	0.3
CA_5A-12B	5	0.5
	12	0.3
CA_5A-13A	5	0
	13	0
CA_5A-17A	5	0.5
	17	0.3
CA_5A-25A	5	0
	25	0
CA_5A-29A	5	0
CA_5A-30A	5	0
	30	0
CA_5A-38A	5	0
	38	0
CA_5A-40A	5	0
	40	0
CA_5A-40C	5	0
	40	0
CA_7A-8A	7	0
	8	0.2
CA_7A-12A	7	0
	12	0
CA_7A-20A	7	0
	20	0
CA_7A-22A	7	0
	22	0.5
CA_7A-28A	7	0
	28	0
CA_7B-28A	7	0
	28	0

CA_7C-28A	7	0
	28	0
CA_7A-40A	7	0
	40	0.5
CA_7A-40C	7	0
	40	0.5
CA_7A-42A	7	0
	42	0.5
CA_7A-42A-42A	7	0
	42	0.5
CA_7A-46A	7	0
CA_8A-11A	8	0
	11	0
CA_8A-20A	8	0
	20	0
CA_8A-40A	8	0
	40	0
CA_8A-41A	8	0
	41	0
CA_8A-41C	8	0
	41	0
CA_8A-42A	8	0.2
	42	0.5
CA_8A-42C	8	0.2
	42	0.5
CA_11A-18A	11	0
	18	0
CA_12A-25A	12	0
CA_12A-30A	12	0
	30	0
CA_18A-28A ⁹	18	0
	28	0
CA_19A-21A	19	0
	21	0
CA_19A-28A ⁹	19	0
	28	0
CA_19A-42A	19	0
	42	0.5
CA_19A-42C	19	0
	42	0.5
CA_20A-31A	20	0
	31	0
CA_20A-32A	20	0
CA_20A-38A	20	0
	38	0
CA_20A-40A	20	0
	40	0
CA_20A-42A	20	0
	42	0.5
CA_20A-42A-42A	20	0
	42	0.5
CA_20A-67A	20	0
CA_21A-42A	21	0
	42	0.5
CA_21A-42C	21	0
	42	0.5
CA_23A-29A	23	0
CA_25A-26A	25	0
	26	0
CA_25A-41A ⁸	25	0
	41	0
CA_25A-41C ⁸	25	0
	41	0
CA_25A-41D ⁸	25	0

	41	0
CA_26A-41A	26	0
	41	0
CA_26A-41C	26	0
	41	0
CA_28A-40A	28	0
	40	0
CA_28A-40C	28	0
	40	0
CA_28A-40D	28	0
	40	0
CA_28A-41A	28	0
	41	0
CA_28A-41C	28	0
	41	0
CA_28A-42A	28	0.2
	42	0.5
CA_28A-42C	28	0.2
	42	0.5
CA_29A-30A	30	0
CA_38A-40A	38	0.5 ⁴
	40	0.5 ⁴
CA_38A-40A-40A	38	0.5 ⁴
	40	0.5 ⁴
CA_38A-40C	38	0.5 ⁴
	40	0.5 ⁴
CA_39A-41A	39	0.2 ⁴
	41	0.2 ⁴
CA_39A-41A	39	0.2 ⁷
	41	0.2 ⁷
CA_39A-41C	39	0.2 ⁴
	41	0.2 ⁴
CA_39A-41C	39	0.2 ⁷
	41	0.2 ⁷
CA_39A-41D	39	0.2 ⁴
	41	0.2 ⁴
CA_39C-41A	39	0.2 ⁴
	41	0.2 ⁴
CA_39C-41A	39	0.2 ⁷
	41	0.2 ⁷
CA_39C-41C	39	0.2 ⁴
	41	0.2 ⁴
CA_41A-42A	41	0.4 ⁴
	42	0.5 ⁴
CA_41A-42C	41	0.4 ⁴
	42	0.5 ⁴
CA_41C-42A	41	0.4 ⁴
	42	0.5 ⁴
CA_41C-42C	41	0.4 ⁴
	42	0.5 ⁴
CA_41A-46A	41	0
CA_42A-46A	42	[0]

NOTE 1: The above additional tolerances are only applicable for the E-UTRA operating bands that belong to the supported inter-band carrier aggregation configurations

NOTE 2: The above additional tolerances also apply in intra-band and non-aggregated operation for the supported E-UTRA operating bands that belong to the supported inter-band carrier aggregation configurations

NOTE 3: In case the UE supports more than one of the above 2DL inter-band carrier aggregation configurations and a E-UTRA operating band belongs to more than one 2DL inter-band carrier aggregation configurations then:

- When the E-UTRA operating band frequency range is ≤ 1 GHz, the applicable additional tolerance shall be the average of the 2DL tolerances in Table 7.3.1-1A, truncated to one decimal place that would apply for that operating band among the supported 2DL CA configurations. In case there

is a harmonic relation between low band UL and high band DL, then the maximum tolerance among the different supported 2DL carrier aggregation configurations involving such band shall be applied

- When the E-UTRA operating band frequency range is >1GHz, the applicable additional tolerance shall be the maximum 2DL tolerance in Table 7.3.1-1A that would apply for that operating band among the supported 2DL CA configurations

NOTE 4: Only applicable for UE supporting inter-band carrier aggregation with uplink in one E-UTRA band and without simultaneous Rx/Tx.

NOTE 5: Unless otherwise specified, in case the UE supports more than one of the above 3DL inter-band carrier aggregation configurations and a E-UTRA operating band belongs to more than one 3DL inter-band carrier aggregation configurations then:

- When the E-UTRA operating band frequency range is ≤ 1 GHz and the tolerances are the same, the value applies to the band. If the tolerances are different, the applicable additional 3DL tolerance is FFS. In case there is a harmonic relation between low band UL and high band DL, then the maximum tolerance among the different supported 3DL carrier aggregation configurations involving such band shall be applied
- When the E-UTRA operating band frequency range is >1GHz, the applicable additional 3DL tolerance shall be the maximum tolerance above that applies for that operating band among the supported 3DL CA configurations.

NOTE 6: The above additional tolerances applicable for the E-UTRA operating bands that belong to the supported highest order inter-band carrier aggregation configuration, also applies to the same E-UTRA operating bands that belong to a supported lower order CA configuration.

NOTE 7: Applicable for UE supporting inter-band carrier aggregation without simultaneous Rx/Tx.

NOTE 8: Only applicable for UE supporting inter-band carrier aggregation with the uplink active in the FDD band.

NOTE 9: For Band 28, the requirements only apply for the restricted frequency range specified for this CA configuration (Table 5.5A-2).

NOTE 10: The requirement is applied for UE transmitting on the frequency range of 2545-2690MHz.

NOTE 11: The requirement is applied for UE transmitting on the frequency range of 2496-2545MHz.

Table 7.3.1-1B: $\Delta R_{IB,c}$ (three bands)

Inter-band CA Configuration	E-UTRA Band	$\Delta R_{IB,c}$ [dB]
CA_1A-3A-5A	1	0
	3	0
	5	0
CA_1A-3A-7A	1	0
	3	0
	7	0
CA_1A-3A-7C	1	0
	3	0
	7	0
CA_1A-3A-8A	1	0
	3	0
	8	0
CA_1A-3A-19A	1	0
	3	0
	19	0
CA_1A-3A-20A	1	0
	3	0
	20	0
CA_1A-3A-26A	1	0
	3	0
	26	0
CA_1A-3A-28A	1	0
	3	0
	28	0.2
CA_1A-3A-40A	1	0
	3	0
	40	0
CA_1A-3A-42A	1	0.2
	3	0.2
	42	0.5
CA_1A-3A-42C	1	0.2
	3	0.2
	42	0.5
CA_1A-5A-7A	1	0
	5	0
	7	0
CA_1A-5A-40A	1	0
	5	0
	40	0
CA_1A-7A-8A	1	0
	7	0
	8	0.2
CA_1A-7A-20A	1	0
	7	0
	20	0
CA_1A-7A-28A	1	0
	7	0
	28	0.2
CA_1A-7C-28A	1	0
	7	0
	28	0.2
CA_1A-8A-11A	1	0
	8	0
	11	0
CA_1A-8A-40A	1	0
	8	0
	40	0
CA_1A-11A-18A	1	0
	11	0
	18	0
CA_1A-18A-28A	1	0

	18	0
	28	0
CA_1A-19A-21A	1	0
	19	0
	21	0
CA_1A-19A-28A	1	0
	19	0
	28	0
CA_1A-19A-42A	1	0
	19	0
	42	0.5
CA_1A-19A-42C	1	0
	19	0
	42	0.5
CA_1A-21A-42A	1	0
	21	0
	42	0.5
CA_1A-21A-42C	1	0
	21	0
	42	0.5
CA_2A-2A-4A-12A	2	0.3
	4	0.3
	12	0.5
CA_2A-4A-5A	2	0.3
	4	0.3
	5	0
CA_2A-2A-4A-5A	2	0.3
	4	0.3
	5	0
CA_2A-4A-4A-5A	2	0.3
	4	0.3
	5	0
CA_2A-4A-7A	2	0.3
	4	0.5
	7	0.5
CA_2A-4A-12A	2	0.3
	4	0.3
	12	0.5
CA_2A-4A-4A-12A	2	0.3
	4	0.3
	12	0.5
CA_2A-4A-13A	2	0.3
	4	0.3
	13	0
CA_2A-4A-29A	2	0.3
	4	0.3
CA_2A-4A-30A	2	0.4
	4	0.4
	30	0.5
CA_2A-5A-12A	2	0
	5	0.5
	12	0.3
CA_2A-2A-5A-12A	2	0.3
	5	0.5
	12	0.3
CA_2A-5A-12B	2	0
	5	0.5
	12	0.3
CA_2A-5A-13A	2	0
	5	0
	13	0
CA_2A-5A-29A	2	0
	5	0
CA_2A-5A-30A	2	0.4
	5	0

	30	0.5
CA_2C-5A-30A	2	0.4
	5	0
	30	0.5
CA_2A-7A-12A	2	0
	7	0
	12	0
CA_2A-12A-30A	2	0.4
	12	0
	30	0.5
CA_2C-12A-30A	2	0.4
	12	0
	30	0.5
CA_2A-29A-30A	2	0.4
	30	0.5
CA_2C-29A-30A	2	0.4
	30	0.5
CA_3A-5A-40A	1	0
	5	0
	40	0
CA_3A-7A-8A	3	0
	7	0
	8	0.2
CA_3A-7A-20A	3	0
	7	0
	20	0
CA_3A-7A-28A	3	0
	7	0
	28	0
CA_3A-7C-28A	3	0
	7	0
	28	0
CA_3C-7A-28A	3	0
	7	0
	28	0
CA_3C-7C-28A	3	0
	7	0
	28	0
CA_3A-7A-38A	3	0
	7	0
	38	0.2
CA_3A-8A-40A	3	0
	8	0
	40	0
CA_3A-19A-42A	3	0.2
	19	0
	42	0.5
CA_3A-19A-42C	3	0.2
	19	0
	42	0.5
CA_3A-28A-40A	3	0
	28	0
	40	0
CA_3A-28A-40C	3	0
	28	0
	40	0
CA_3A-41A-42A ⁷	3	0.5
	41	0 ⁵ /0.5 ⁶
	42	0.5
CA_4A-5A-12A	4	0
	5	0.5
	12	0.5
CA_4A-4A-5A-12A	4	0
	5	0.5
	12	0.5

CA_4A-5A-13A	4	0
	5	0
	13	0
CA_4A-5A-29A	4	0
	5	0
CA_4A-5A-30A	4	0.4
	5	0
	30	0.5
CA_4A-4A-5A-30A	4	0.4
	5	0
	30	0.5
CA_4A-7A-12A	4	0.5
	7	0.5
	12	0.5
CA_4A-12A-30A	4	0.4
	12	0.5
	30	0.5
CA_4A-4A-12A-30A	4	0.4
	12	0.5
	30	0.5
CA_4A-29A-30A	4	0.4
	30	0.5
CA_4A-4A-29A-30A	4	0.4
	30	0.5
CA_7A-8A-20A	7	0
	8	0.2
	20	[0.2]
CA_7A-20A-38A	7	0
	20	0
	38	0.2
CA_19A-21A-42A	19	0
	21	0
	42	0.5
CA_19A-21A-42C	19	0
	21	0
	42	0.5
<p>NOTE 1: The above additional tolerances are only applicable for the E-UTRA operating bands that belong to the supported inter-band carrier aggregation configurations.</p> <p>NOTE 2: The above additional tolerances also apply in intra-band and non-aggregated operation for the supported E-UTRA operating bands that belong to the supported inter-band carrier aggregation configurations.</p> <p>NOTE 3: Unless otherwise specified, in case the UE supports more than one of the above 3DL inter-band carrier aggregation configurations and a E-UTRA operating band belongs to more than one 3DL inter-band carrier aggregation configurations then:</p> <ul style="list-style-type: none"> - When the E-UTRA operating band frequency range is ≤ 1GHz and the tolerances are the same, the value applies to the band. If the tolerances are different, the applicable additional 3DL tolerance is FFS. In case there is a harmonic relation between low band UL and high band DL, then the maximum tolerance among the different supported 3DL carrier aggregation configurations involving such band shall be applied - When the E-UTRA operating band frequency range is >1GHz, the applicable additional 3DL tolerance shall be the maximum tolerance above that applies for that operating band among the supported 3DL CA configurations. <p>NOTE 4: The above additional tolerances applicable for the E-UTRA operating bands that belong to the supported highest order inter-band carrier aggregation configuration, also applies to the same E-UTRA operating bands that belong to a supported lower order CA configuration.</p> <p>NOTE 5: The requirement is specified for the frequency range of 2545-2690MHz.</p> <p>NOTE 6: The requirement is specified for the frequency range of 2496-2545MHz.</p> <p>NOTE 7: Applicable for UE supporting inter-band carrier aggregation without simultaneous Rx/Tx among TDD bands.</p>		

Table 7.3.1-1C: $\Delta R_{IB,c}$ (four bands)

Inter-band CA Configuration	E-UTRA Band	$\Delta R_{IB,c}$ [dB]
CA_1A-3A-5A-40A	1	0
	3	0
	5	0
	40	0
CA_1A-3A-7A-8A	1	0
	3	0
	7	0
	8	0.2
CA_1A-3A-7A-28A	1	0
	3	0
	7	0
	28	0.2
CA_1A-3A-7C-28A	1	0
	3	0
	7	0
	28	0.2
CA_1A-3A-8A-40A	1	0
	3	0
	8	0
	40	0
CA_1A-3A-19A-42A	1	0.2
	3	0.2
	19	0
	42	0.5
CA_1A-3A-19A-42C	1	0.2
	3	0.2
	19	0
	42	0.5
CA_1A-19A-21A-42A	1	0
	19	0
	21	0
	42	0.5
CA_1A-19A-21A-42C	1	0
	19	0
	21	0
	42	0.5
CA_2A-4A-5A-12A	2	0.3
	4	0.3
	5	0.5
	12	0.5
CA_2A-4A-5A-29A	2	0.3
	4	0.3
	5	0
CA_2A-4A-5A-30A	2	0.4
	4	0.4
	5	0
	30	0.5
CA_2A-4A-7A-12A	2	0.3
	4	0.3
	7	0.5
	12	0.5
CA_2A-4A-12A-30A	2	0.4
	4	0.4
	12	0.5
	30	0.5
CA_2A-4A-29A-30A	2	0.4
	4	0.4
	30	0.5

NOTE 1: The above additional tolerances are only applicable for the E-UTRA operating bands that belong to the supported inter-band carrier aggregation configurations.

<p>NOTE 2: The above additional tolerances also apply in intra-band and non-aggregated operation for the supported E-UTRA operating bands that belong to the supported inter-band carrier aggregation configurations.</p> <p>NOTE 3: Tolerances for a UE supporting multiple 4DL inter-band CA configurations are FFS.</p> <p>NOTE 4: The above additional tolerances applicable for the E-UTRA operating bands that belong to the supported highest order inter-band carrier aggregation configuration, also applies to the same E-UTRA operating bands that belong to a supported lower order CA configuration.</p>

NOTE : The above additional tolerances do not apply to supported UTRA operating bands with frequency range below 1 GHz that correspond to the E-UTRA operating bands that belong to the supported inter-band carrier aggregation configurations when such bands are belonging only to band combination(s) where one band is <1GHz and other bands are >1.7GHz and there is no harmonic relationship between the low band UL and high band DL. Otherwise the above additional tolerances also apply to supported UTRA operating bands that correspond to the E-UTRA operating bands that belong to the supported inter-band carrier aggregation configurations.

Table 7.3.1-2: Uplink configuration for reference sensitivity

E-UTRA Band / Channel bandwidth / N _{RB} / Duplex mode							
E-UTRA Band	1.4 MHz	3 MHz	5 MHz	10 MHz	15 MHz	20 MHz	Duplex Mode
1			25	50	75	100	FDD
2	6	15	25	50	50 ¹	50 ¹	FDD
3	6	15	25	50	50 ¹	50 ¹	FDD
4	6	15	25	50	75	100	FDD
5	6	15	25	25 ¹			FDD
6			25	25 ¹			FDD
7			25	50	75	75 ¹	FDD
8	6	15	25	25 ¹			FDD
9			25	50	50 ¹	50 ¹	FDD
10			25	50	75	100	FDD
11			25	25 ¹			FDD
12	6	15	20 ¹	20 ¹			FDD
13			20 ¹	20 ¹			FDD
14			15 ¹	15 ¹			FDD
...							
17			20 ¹	20 ¹			FDD
18			25	25 ¹	25 ¹		FDD
19			25	25 ¹	25 ¹		FDD
20			25	20 ¹	20 ³	20 ³	FDD
21			25	25 ¹	25 ¹		FDD
22			25	50	50 ¹	50 ¹	FDD
23	6	15	25	50	75	100	FDD
24			25	50			FDD
25	6	15	25	50	50 ¹	50 ¹	FDD
26	6	15	25	25 ¹	25 ¹		FDD
27	6	15	25	25 ¹			FDD
28		15	25	25 ¹	25 ¹	25 ¹	FDD
30			25	25 ¹			FDD
31	6	5 ⁴	5 ⁴				FDD
...							
33			25	50	75	100	TDD
34			25	50	75		TDD
35	6	15	25	50	75	100	TDD
36	6	15	25	50	75	100	TDD
37			25	50	75	100	TDD
38			25	50	75	100	TDD
39			25	50	75	100	TDD
40			25	50	75	100	TDD
41			25	50	75	100	TDD
42			25	50	75	100	TDD
43			25	50	75	100	TDD
44		15	25	50	75	100	TDD
45			25	50	75	100	TDD
...							
65	6	15	25	50	75	100	FDD
66	6	15	25	50	75	100	FDD
68			25	25 ¹	25 ¹		FDD

NOTE 1: ¹ refers to the UL resource blocks shall be located as close as possible to the downlink operating band but confined within the transmission bandwidth configuration for the channel bandwidth (Table 5.6-1).

NOTE 2:	For the UE which supports both Band 11 and Band 21 the uplink configuration for reference sensitivity is FFS.
NOTE 3:	³ refers to Band 20; in the case of 15MHz channel bandwidth, the UL resource blocks shall be located at RB _{start} 11 and in the case of 20MHz channel bandwidth, the UL resource blocks shall be located at RB _{start} 16
NOTE 4:	⁴ refers to Band 31; in the case of 3 MHz channel bandwidth, the UL resource blocks shall be located at RB _{start} 9 and in the case of 5 MHz channel bandwidth, the UL resource blocks shall be located at RB _{start} 10.

Unless given by Table 7.3.1-3, the minimum requirements specified in Tables 7.3.1-1, 7.3.1-1a and 7.3.1-2 shall be verified with the network signalling value NS_01 (Table 6.2.4-1) configured.

Table 7.3.1-3: Network signalling value for reference sensitivity

E-UTRA Band	Network Signalling value
2	NS_03
4	NS_03
10	NS_03
12	NS_06
13	NS_06
14	NS_06
17	NS_06
19	NS_08
21	NS_09
23	NS_03
25	NS_03
30	NS_21
66	NS_03

7.3.1A Minimum requirements (QPSK) for CA

For inter-band carrier aggregation with one component carrier per operating band and the uplink assigned to one E-UTRA band the throughput shall be $\geq 95\%$ of the maximum throughput of the reference measurement channels as specified in Annexes A.2.2, A.2.3 and A.3.2 (with one sided dynamic OCNG Pattern OP.1 FDD/TDD for the DL-signal as described in Annex A.5.1.1/A.5.2.1) with parameters specified in Table 7.3.1-1, Table 7.3.1-1a and Table 7.3.1-2. The reference sensitivity is defined to be met with all downlink component carriers active and one of the uplink carriers active. The uplink resource blocks shall be located as close as possible to the primary downlink operating band but confined within the transmission bandwidth configuration for the channel bandwidth (Table 5.6-1). The primary downlink operating band is the downlink band of the active uplink operating band. The UE shall meet the requirements specified in subclause 7.3.1 with the following exceptions.

For the bands supporting 4 antenna ports which are in Table 7.3.1-1a, the minimum requirements for reference sensitivity in the reference sensitivity exception tables shall be modified by the amount given in $\Delta R_{IB,4R}$ in Table 7.3.1-1a for the applicable E-UTRA bands unless otherwise specified.

For the UE that supports any of the E-UTRA CA configurations given in Table 7.3.1A-0a, exceptions to the aforementioned requirements are allowed when the uplink is active in a lower-frequency band and is within a specified frequency range such that transmitter harmonics fall within the downlink transmission bandwidth assigned in a higher band as noted in Table 7.3.1A-0a. For these exceptions, the UE shall meet the requirements specified in Table 7.3.1A-0a and Table 7.3.1A-0b.

Table 7.3.1A-0a: Reference sensitivity for carrier aggregation QPSK $P_{\text{REFSENS, CA}}$ (exceptions due to harmonic issue)

EUTRA CA Configuration	Channel bandwidth							Duplex mode
	EUTRA band	1.4 MHz (dBm)	3 MHz (dBm)	5 MHz (dBm)	10 MHz (dBm)	15 MHz (dBm)	20 MHz (dBm)	
CA_1A-3A-7A-8A ⁴	1			N/A	N/A	N/A	N/A	FDD
	3			N/A	N/A	N/A	N/A	
	7				N/A	N/A	N/A	
	8			N/A	N/A			
CA_1A-3A-7A-8A ^{4,5,6}	1			-100	-97	-95.2	-94	FDD
	3			-97	-94	-92.2	-91	
	7 ²¹				-87.4	-87	-86.7	
	8			-96.8	-93.8			
CA_1A-3A-7A-28A ^{5,6}	1 ²¹			-89.8	-89.4	-89	-88.7	FDD
	3				-94	-92.2	-91	
	7				-95	-93.2	-92	
	28				-95.3	-93.5	-90.8	
CA_1A-3A-8A ⁴	1			N/A	N/A	N/A	N/A	FDD
	3			N/A	N/A	N/A	N/A	
	8		N/A	N/A	N/A			
CA_1A-3A-8A-40A ⁴	1			N/A	N/A	N/A	N/A	FDD
	3			N/A	N/A	N/A	N/A	
	8		N/A	N/A	N/A			
	40			N/A	N/A	N/A	N/A	TDD
CA_1A-3A-19A-42A ^{9,10}	1			-99.8	-96.8	-95	-93.8	FDD
	3			-96.8	-93.8	-92	-90.8	
	19			-100	-97	-95.2		
	42 ²¹			-71.7	-71.7	-71.7	-71.7	TDD
CA_1A-3A-19A-42A ¹¹	1			-99.8	-96.8	-95	-93.8	FDD
	3			-96.8	-93.8	-92	-90.8	
	19			-100	-97	-95.2		
	42 ²¹			-97.1	-94.7	-93.2	-92.5	TDD
CA_1A-3A-28A	1 ²¹			-89.8	-89.4	-89	-88.7	FDD
	3			-97	-94	-92.2	-91	
	28			-98.3	-95.3	-93.5	-90.8	
CA_1A-3A-42A ^{9,10}	1			-99.8	-96.8	-95	-93.8	FDD
	3			-96.8	-93.8	-92	-90.8	
	42 ²¹			-71.7	-71.7	-71.7	-71.7	
CA_1A-3A-42A ¹¹	1			-99.8	-96.8	-95	-93.8	FDD
	3			-96.8	-93.8	-92	-90.8	
	42 ²¹			-97.1	-94.7	-93.2	-92.5	
CA_1A-7A-8A ^{5,6}	1			-100	-97	-95.2	-94	FDD
	7 ²¹				-87.4	-87	-86.7	
	8			-96.8	-93.8			
CA_1A-7A-28A ^{5,6}	1 ²¹			-89.8	-89.4	-89	-88.7	FDD
	7				-95	-93.2	-92	
	28			-98.3	-95.3	-93.5	-90.8	
CA_1A-18A-28A ¹⁴	1			N/A	N/A	N/A	N/A	FDD
	18			N/A	N/A	N/A		
	28			N/A	N/A			
CA_1A-19A-28A ¹⁴	1			N/A	N/A	N/A	N/A	FDD
	19			N/A	N/A	N/A		
	28			N/A	N/A			
CA_1A-28A ^{5,6,14}	1 ²¹			-89.8	-89.4	-89	-88.7	FDD
	28			-98.3	-95.3	-93.5	-90.8	
CA_2A-4A-12A ^{5,6}	2			-97.7	-94.7	-92.9	-91.7	FDD

	4			-90	-89.5	-89	-88.5	
	12			-96.5	-93.5			
CA_2A-4A-5A-12A ^{5,6}	2			-97.7	-94.7	-92.9	-91.7	FDD
	4			-90	-89.5	-89	-88.5	
	5			-97.5	-94.5			
	12			-96.5	-93.5			
CA_2A-4A-7A-12A ^{5,6}	2			-97.7	-94.7	-92.9	-91.7	FDD
	4			-90	-89.5	-89	-88.5	
	7			-97.5	-94.5	-92.7	-91.5	
	12			-96.5	-93.5			
CA_2A-4A-12A-30A ^{5,6}	2			-97.6	-94.6	-92.8	-91.6	FDD
	4			-90	-89.5	-89	-88.5	
	12			-96.5	-93.5			
	30			-98.5	-95.5			
CA_3A-7A-8A ⁴	3			N/A	N/A	N/A	N/A	FDD
	7				N/A	N/A	N/A	
	8			N/A	N/A			
CA_3A-7A-8A ^{4,5,6}	3			-97	-94	-92.2	-91	FDD
	7 ²¹				-87.4	-87	-86.7	
	8			-96.8	-93.8			
CA_3A-8A ⁴	3			N/A	N/A	N/A	N/A	FDD
	8		N/A	N/A	N/A			
CA_3A-8A-40A ⁴	3			N/A	N/A	N/A	N/A	FDD
	8		N/A	N/A	N/A			
	40			N/A	N/A	N/A	N/A	
CA_3A-19A-42A ^{9,10}	3			-96.8	-93.8	-92	-90.8	FDD
	19			-100	-97	-95.2		
	42 ²¹			-71.7	-71.7	-71.7	-71.7	
CA_3A-19A-42A ¹¹	3			-96.8	-93.8	-92	-90.8	FDD
	19			-100	-97	-95.2		
	42 ²¹			-97.1	-94.7	-93.2	-92.5	
CA_3A-28A-40A ^{15,16}	3			-97	-94	-92.2	-91	FDD
	28			-60.7	-60.7	-60.7	-60.7	
	40			-100	-97	-95.2	-94	
CA_3A-31A ^{12,13}	3 ²¹			-86.9	-86.4	-86	-85.6	FDD
	31		-95.5	-93.3				
CA_3A-42A ^{9,10}	3			-96.8	-93.8	-92	-90.8	FDD
	42 ²¹			-71.7	-71.7	-71.7	-71.7	
CA_3A-42A ¹¹	3			-96.8	-93.8	-92	-90.8	FDD
	42 ²¹			-97.1	-94.7	-93.2	-92.5	
CA_4A-5A-12A ^{5,6}	4			-90	-89.5	-89	-88.5	FDD
	5			-97.5	-94.5			
	12			-96.5	-93.5			
CA_4A-7A-12A ^{5,6}	4			-90	-89.5	-89	-88.5	FDD
	7			-97.5	-94.5			
	12			-96.5	-93.5			
CA_4A-12A ^{5,6}	4	-89.2	-89.2	-90	-89.5	-89	-88.5	FDD
	12		-98.2	-96.5	-93.5			
CA_4A-12A-30A ^{5,6}	4			-90	-89.5	-89	-88.5	FDD
	12			-96.5	-93.5			
	30			-98.5	-95.5			
CA_4A-17A ^{5,6}	4			-90	-89.5			FDD
	17			-96.5	-93.5			
CA_4A-28A ^{5,6}	4			-89.8	-89.4	-89	-88.7	FDD
	28			-98.3	-95.3	-93.5	-90.8	
CA_5A-38A ¹⁹	5			N/A	N/A			FDD
	38			N/A	N/A	N/A	N/A	
CA_7A-8A ^{5,6}	7 ²¹				-87.4	-87	-86.7	FDD
	8		-99	-96.8	-93.8			

CA_7A-8A-20A ^{5,6}	7 ²¹				-87.4	-87	-86.7	FDD
	8		-99	-96.8	-93.8			
	20			[-96.8]	[-93.8]			
CA_7A-20A-38A ¹⁹	7				N/A	N/A	N/A	FDD
	20			N/A	N/A	N/A	N/A	FDD
	38			N/A	N/A	N/A	N/A	TDD
CA_8A-41A ⁸	8	N/A	N/A	N/A	N/A	N/A	N/A	FDD
	41				N/A	N/A	N/A	TDD
CA_8A-42A ^{12,13}	8	-102	-99	-96.8	-93.8			FDD
	42 ²¹			-84.8	-84.7	-84.6	-84.5	TDD
CA_20A-38A ¹⁹	20			N/A	N/A	N/A	N/A	FDD
	38			N/A	N/A	N/A	N/A	TDD
CA_20A-40A ^{15,16}	20 ²¹			-60.7	-60.7	-60.7	-60.7	FDD
	40			-100	-97	-95.2	-94	TDD
CA_20A-42A ^{12,13} , CA_20A-42A-42A ^{12,13}	20			-97	-94	-91.2	-90	FDD
	42 ²¹			-84.8	-84.7	-84.6	-84.5	TDD
CA_26A-41A ^{8, 19}	26			N/A	N/A	N/A	N/A	FDD
	41			N/A	N/A	N/A	N/A	TDD
CA_28A-40A ^{15,16}	28			-60.7	-60.7	-60.7	-60.7	FDD
	40			-100	-97	-95.2	-94	TDD
CA_28A-42A ^{17,18}	28			-98.3	-95.3	-93.5	-92.3	FDD
	42 ²¹			-85.7	-85.4	-85.1	-84.9	TDD

NOTE 1: The transmitter shall be set to P_{UMAX} as defined in subclause 6.2.5A.

NOTE 2: Reference measurement channel is A.3.2 with one sided dynamic OCNG Pattern OP.1 FDD/TDD as described in Annex A.5.1.1/A.5.2.1

NOTE 3: The signal power is specified per port

NOTE 4: No requirements apply when there is at least one individual RE within the uplink transmission bandwidth of the low band for which the 2nd transmitter harmonic is within the downlink transmission bandwidth of the high band. The reference sensitivity is only verified when this is not the case (the requirements specified in clause 7.3.1 apply unless otherwise specified).

NOTE 5: These requirements apply when there is at least one individual RE within the uplink transmission bandwidth of a low band for which the 3rd transmitter harmonic is within the downlink transmission bandwidth of a high band.

NOTE 6: The requirements should be verified for UL EARFCN of a low band (superscript LB) such that $f_{UL}^{LB} = \lfloor f_{DL}^{HB} / 0.3 \rfloor 0.1$ in MHz and $F_{UL_low}^{LB} + BW_{Channel}^{LB} / 2 \leq f_{UL}^{LB} \leq F_{UL_high}^{LB} - BW_{Channel}^{LB} / 2$ with f_{DL}^{HB} the carrier frequency of a high band in MHz and $BW_{Channel}^{LB}$ the channel bandwidth configured in the low band.

NOTE 7: Void.

NOTE 8: No requirements apply when there is at least one individual RE within the uplink transmission bandwidth of the low band for which the 3rd transmitter harmonic is within the downlink transmission bandwidth of the high band. The reference sensitivity is only verified when this is not the case (the requirements specified in clause 7.3.1 apply).

NOTE 9: These requirements apply when there is at least one individual RE within the uplink transmission bandwidth of the aggressor (lower) band for which the 2nd transmitter harmonic is within the downlink transmission bandwidth of a victim (higher) band and a range ΔF_{HD} above and below the edge of this downlink transmission bandwidth. The value ΔF_{HD} depends on the E-UTRA configuration: $\Delta F_{HD} = 10$ MHz for CA_3A-42A, CA_1A-3A-42A, CA_3A-19A-42A, and CA_1A-3A-19A-42A.

NOTE 10: The requirements should be verified for UL EARFCN of the aggressor (lower) band (superscript LB) such that $f_{UL}^{LB} = \lfloor f_{DL}^{HB} / 0.2 \rfloor 0.1$ in MHz and $F_{UL_low}^{LB} + BW_{Channel}^{LB} / 2 \leq f_{UL}^{LB} \leq F_{UL_high}^{LB} - BW_{Channel}^{LB} / 2$ with f_{DL}^{HB} carrier frequency in the victim (higher) band in MHz and $BW_{Channel}^{LB}$ the channel bandwidth configured in the lower band.

NOTE 11: The requirements are only applicable to channel bandwidths with a carrier frequency at $\pm (20 + BW_{Channel}^{HB} / 2)$ MHz offset from $2f_{UL}^{LB}$ in the victim (higher) band) with

$$F_{UL_low}^{LB} + BW_{Channel}^{LB} / 2 \leq f_{UL}^{LB} \leq F_{UL_high}^{LB} - BW_{Channel}^{LB} / 2, \text{ where } BW_{Channel}^{LB} \text{ and } BW_{Channel}^{HB} \text{ are the channel bandwidths configured in the aggressor (lower) and victim (higher) bands in MHz, respectively.}$$

NOTE 12: These requirements apply when there is at least one individual RE within the uplink transmission bandwidth of a low band for which the 4th transmitter harmonic is within the downlink transmission bandwidth of a high band.

NOTE 13: The requirements should be verified for UL EARFCN of a low band (superscript LB) such that

$$f_{UL}^{LB} = \lfloor f_{DL}^{HB} / 0.4 \rfloor 0.1 \text{ in MHz and } F_{UL_low}^{LB} + BW_{Channel}^{LB} / 2 \leq f_{UL}^{LB} \leq F_{UL_high}^{LB} - BW_{Channel}^{LB} / 2 \text{ with } f_{DL}^{HB} \text{ the carrier frequency of a high band in MHz and } BW_{Channel}^{LB} \text{ the channel bandwidth configured in the low band.}$$

NOTE 14: For the UE that supports CA_1A-18A-28A or CA_1A-19A-28A, no requirements apply when there is at least one individual RE within the uplink transmission bandwidth of the low band for which the 3rd

transmitter harmonic is within the downlink transmission bandwidth of the high band. The reference sensitivity should only be verified when this is not the case (the requirements specified in clause 7.3.1 apply).

NOTE 15: These requirements apply when there is at least one individual RE within the downlink transmission bandwidth of the victim (lower) band for which the 3rd harmonic is within the uplink transmission bandwidth or the uplink adjacent channel's transmission bandwidth of an aggressor (higher) band.

NOTE 16: The requirements should be verified for UL EARFCN of the aggressor (higher) band (superscript HB) such

that $f_{DL}^{LB} = \left\lfloor f_{UL}^{HB} / 0.3 \right\rfloor 0.1$ in MHz and $F_{UL_low}^{LB} + BW_{Channel}^{LB} / 2 \leq f_{UL}^{LB} \leq F_{UL_high}^{LB} - BW_{Channel}^{LB} / 2$ with

f_{DL}^{LB} the carrier frequency in the victim (lower) band and $BW_{Channel}^{HB}$ the channel bandwidth configured in the higher band.

NOTE 17: These requirements apply when there is at least one individual RE within the uplink transmission bandwidth of a low band for which the 5th transmitter harmonic is within the downlink transmission bandwidth of a high band.

NOTE 18: The requirements should be verified for UL EARFCN of a low band (superscript LB) such that

$f_{UL}^{LB} = \left\lfloor f_{DL}^{HB} / 0.5 \right\rfloor 0.1$ in MHz and $F_{UL_low}^{LB} + BW_{Channel}^{LB} / 2 \leq f_{UL}^{LB} \leq F_{UL_high}^{LB} - BW_{Channel}^{LB} / 2$ with f_{DL}^{HB} the carrier frequency of a high band in MHz and $BW_{Channel}^{LB}$ the channel bandwidth configured in the low band.

NOTE 19: No requirements apply for the case that there is at least one individual RE within the uplink transmission bandwidth of the relative higher band and when the frequency range of relative higher band's uplink channel bandwidth or uplink 1st adjacent channel bandwidth is fully or partially overlapped with the 3 times of the frequency range of the relative lower band's downlink channel bandwidth. The reference sensitivity is only verified when this is not the case (the requirements specified in clause 7.3.1 apply).

NOTE 20: Void.

NOTE 21: Applicable for the operations with 2 or 4 antenna ports supported in the band with carrier aggregation configured.

Table 7.3.1A-0b: Uplink configuration for the low band (exceptions due to harmonic issue)

E-UTRA Band / Channel bandwidth of the high band / N _{RB} / Duplex mode								
EUTRA CA Configuration	UL band	1.4 MHz	3 MHz	5 MHz	10 MHz	15 MHz	20 MHz	Duplex mode
CA_1A-3A-7A-8A	8				16	25	25	FDD
CA_1A-3A-7A-28A	28				16	25	25	FDD
CA_1A-3A-19A-42A	3			12	25	36	50	FDD
CA_1A-3A-28A	28			8	16	25	25	FDD
CA_1A-3A-42A	3			12	25	36	50	FDD
CA_1A-7A-8A	8				16	25	25	FDD
CA_1A-7A-28A	28			8	16	25	25	FDD
CA_1A-28A	28			8	16	25	25	FDD
CA_2A-4A-12A	12			8	16	20	20	FDD
CA_2A-4A-5A-12A	12			8	16	20	20	FDD
CA_2A-4A-7A-12A	12			8	16	20	20	FDD
CA_2A-4A-12A-30A	12			8	16	20	20	FDD
CA_3A-7A-8A	8				16	25	25	FDD
CA_3A-19A-42A	3			12	25	36	50	FDD
CA_3A-28A-40A	40			25	50	75	100	TDD
CA_3A-31A	31			5	5	5	5	FDD
CA_3A-42A	3			12	25	36	50	FDD
CA_4A-5A-12A	12			8	16	20	20	FDD
CA_4A-7A-12A	12			8	16	20	20	FDD
CA_4A-12A	12	2	5	8	16	20	20	FDD
CA_4A-12A-30A	12			8	16	20	20	FDD
CA_4A-17A	17			8	16			FDD
CA_4A-28A	28			[8]	[16]	[25]	[25]	FDD
CA_7A-8A	8				16	25	25	FDD
CA_7A-8A-20A	8				16	25	25	FDD
CA_8A-42A	8			8	16	25	25	FDD
CA_20A-40A ³	40			25	50	75	100	TDD
CA_20A-42A, CA_20A-42A-42A	20			8	16	25	25	FDD
CA_28A-40A	40			25	50	75	100	TDD
CA_28A-42A	28			5	10	15	20	FDD
NOTE 1: refers to the UL resource blocks, which shall be centred within the transmission bandwidth configuration for the channel bandwidth.								
NOTE 2: the UL configuration applies regardless of the channel bandwidth of the low band unless the UL resource blocks exceed that specified in Table 7.3.1-2 for the uplink bandwidth in which case the allocation according to Table 7.3.1-2 applies.								
NOTE 3: ³ refers to the UL resource blocks shall be located between 2373-2400MHz.								

For the UE that supports any of the E-UTRA CA configurations given in Table 7.3.1A-0bA, exceptions are allowed when the uplink is active within a specified frequency range as noted in Table 7.3.1A-0bA. For these exceptions, the UE shall meet the requirements specified in Table 7.3.1A-0bA and Table 7.3.1A-0bB.

Table 7.3.1A-0bA: Reference sensitivity for carrier aggregation QPSK $P_{REFSENS, CA}$ (exceptions for two bands due to close proximity of UL to DL channel)

Channel bandwidth								
EUTRA CA Configuration	EUTRA band	1.4 MHz (dBm)	3 MHz (dBm)	5 MHz (dBm)	10 MHz (dBm)	15 MHz (dBm)	20 MHz (dBm)	Duplex mode
CA_1A-3A ⁴	1			-100	-97	-95.2	-94	FDD
	3 ⁹			-94	-91.5	-90	-89	
CA_1A-3A ⁵	1			-100	-97	-95.2	-94	FDD
	3			-97	-94	-92.2	-91	
CA_1A-3C ⁴	1			-100	-97	-95.2	-94	FDD
	3 ⁹			-94	-91.5	-90	-89	
CA_1A-3C ⁵	1			-100	-97	-95.2	-94	FDD
	3			-97	-94	-92.2	-91	
CA_18A-28A ⁶	18			-100	-97	-95.2		FDD
	28			-94	-92.5			
CA_19A-28A ⁷	19			-100	-97	-95.2		FDD
	28			-94	-92			
<p>NOTE 1: The transmitter shall be set to P_{UMAX} as defined in subclause 6.2.5A.</p> <p>NOTE 2: Reference measurement channel is A.3.2 with one sided dynamic OCNG Pattern OP.1 FDD/TDD as described in Annex A.5.1.1/A.5.2.1</p> <p>NOTE 3: The signal power is specified per port</p> <p>NOTE 4: These requirements apply when the uplink is active in Band 1 and the separation between the lower edge of the uplink channel in Band 1 and the upper edge of the downlink channel in Band 3 is < 60 MHz. For each channel bandwidth in Band 3, the requirement applies regardless of channel bandwidth in Band 1.</p> <p>NOTE 5: These requirements apply when the uplink is active in Band 1 and the separation between the lower edge of the uplink channel in Band 1 and the upper edge of the downlink channel in Band 3 is \geq 60 MHz. For each channel bandwidth in Band 3, the requirement applies regardless of channel bandwidth in Band 1.</p> <p>NOTE 6: These requirements apply when the uplink is active in Band 18 and the downlink channels in Band 28 are confined within the restricted frequency range specified for this CA configuration (Table 5.5A-2). For each channel bandwidth in Band 28, the requirement applies regardless of channel bandwidth in Band 18.</p> <p>NOTE 7: These requirements apply when the uplink is active in Band 19 and the downlink channels in Band 28 are allocated at the middle of the restricted frequency range specified for this CA configuration (Table 5.5A-2). For each channel bandwidth in Band 28, the requirement applies regardless of channel bandwidth in Band 19.</p> <p>NOTE 8: Void</p> <p>NOTE 9: Applicable for the operations with 2 or 4 antenna ports supported in the band with carrier aggregation configured.</p>								

Table 7.3.1A-0bB: Uplink configuration for the uplink band (exceptions for two bands due to close proximity of UL to DL channel)

E-UTRA Band / Channel bandwidth of the affected DL band / N_{RB} / Duplex mode								
EUTRA CA Configuration	UL band	1.4 MHz	3 MHz	5 MHz	10 MHz	15 MHz	20 MHz	Duplex mode
CA_1A-3A ^{1,2}	1			25	25	25	25	FDD
CA_1A-3A ^{1,3}	1			25	45	45	45	FDD
CA_1A-3C ^{1,2}	1			25	25	25	25	FDD
CA_1A-3C ^{1,3}	1			25	45	45	45	FDD
CA_18A-28A ⁴	18			18	18			FDD
CA_19A-28A ⁴	19			18	18			FDD
NOTE 1: refers to the UL resource blocks shall be located as close as possible to the downlink channel in Band 3 but confined within the transmission bandwidth configuration for the channel bandwidth (Table 5.6-1) in the uplink channel in Band 1.								
NOTE 2: UL allocation when the separation between the lower edge of the uplink channel in Band 1 and the upper edge of the downlink channel in Band 3 is < 60 MHz								
NOTE 3: UL allocation when the separation between the lower edge of the uplink channel in Band 1 and the upper edge of the downlink channel in Band 3 is \geq 60 MHz.								
NOTE 4: refers to the UL resource blocks shall be located as close as possible to the downlink channel in Band 28 but confined within the transmission bandwidth configuration for the channel bandwidth (Table 5.6-1).								

For the UE that supports any of the E-UTRA CA configurations given in Table 7.3.1A-0bC, exceptions are allowed when the uplink is active within a specified frequency range as noted in Table 7.3.1A-0bC. For these exceptions, the UE shall meet the requirements specified in Table 7.3.1A-0bC and Table 7.3.1A-0bD.

Table 7.3.1A-0bC: Reference sensitivity for carrier aggregation QPSK $P_{\text{REFSENS, CA}}$ (exceptions for three bands due to close proximity of UL to DL channel)

EUTRA CA Configuration	Channel bandwidth							Duplex mode
	EUTRA band	1.4 MHz (dBm)	3 MHz (dBm)	5 MHz (dBm)	10 MHz (dBm)	15 MHz (dBm)	20 MHz (dBm)	
CA_1A-3A-5A ⁴	1			-100	-97	-95.2	-94	FDD
	3 ¹²			-94	-91.5	-90	-89	
	5			-98	-95			
CA_1A-3A-5A ⁵	1			-100	-97	-95.2	-94	FDD
	3			-97	-94	-92.2	-91	
	5			-98	-95			
CA_1A-3A-7A ⁹	1			-100	-97	-95.2	-94	FDD
	3 ¹²			-94	-91.5	-90	-89	
	7				-95	-93.2	-92	
CA_1A-3A-7A ¹⁰	1			-100	-97	-95.2	-94	FDD
	3			-97	-94	-92.2	-91	
	7				-95	-93.2	-92	
CA_1A-3A-7C ⁹	1			-100	-97	-95.2	-94	FDD
	3 ¹²				-91.5	-90	-89	
	7				-95	-93.2	-92	
CA_1A-3A-7C ¹⁰	1			-100	-97	-95.2	-94	FDD
	3				-94	-92.2	-91	
	7				-95	-93.2	-92	
CA_1A-3A-8A ⁴	1			-100	-97	-95.2	-94	FDD
	3 ¹²			-94	-91.5	-90	-89	
	8		-99.2	-97	-94			
CA_1A-3A-8A ⁵	1			-100	-97	-95.2	-94	FDD
	3			-97	-94	-92.2	-91	
	8		-99.2	-97	-94			
CA_1A-3A-19A ⁴	1			-100	-97	-95.2	-94	FDD
	3 ¹²			-94	-91.5	-90	-89	
	19			-100	-97	-95.2		
CA_1A-3A-19A ⁵	1			-100	-97	-95.2	-94	FDD
	3			-97	-94	-92.2	-91	
	19			-100	-97	-95.2		
CA_1A-3A-20A ⁴	1			-100	-97	-95.2	-94	FDD
	3 ¹²			-94	-91.5	-90	-89	
	20			-97	-94	-91.2	-90	
CA_1A-3A-20A ⁵	1			-100	-97	-95.2	-94	FDD
	3			-97	-94	-92.2	-91	
	20			-97	-94	-91.2	-90	
CA_1A-3A-26A ⁴	1			-100	-97	-95.2	-94	FDD
	3 ¹²			-94	-91.5	-90	-89	
	26			-97.5 ⁷	-94.5 ⁷			
CA_1A-3A-26A ⁵	1			-100	-97	-95.2	-94	FDD
	3			-97	-94	-92.2	-91	
	26			-97.5 ⁷	-94.5 ⁷			
CA_1A-3A-28A ⁴	1			-100	-97	-95.2	-94	FDD
	3 ¹²			-94	-91.5	-90	-89	
	28			-98.3	-95.3	-93.5	-90.8	
CA_1A-3A-28A ⁵	1			-100	-97	-95.2	-94	FDD
	3			-97	-94	-92.2	-91	
	28			-98.3	-95.3	-93.5	-90.8	

CA_1A-3A-40A ⁴	1			-100	-97	-95.2	-94	FDD
	3 ¹²			-94	-91.5	-90	-89	
	40			[-93.4]	-91.3	-90	-88.9	TDD
CA_1A-3A-40A ⁵	1			-100	-97	-95.2	-94	FDD
	3			-97	-94	-92.2	-91	
	40			[-93.4]	-91.3	-90	-88.9	TDD
CA_1A-3A-42A ⁴	1			-99.8	-96.8	-95	-93.8	FDD
	3 ¹²			-93.8	-91.3	-89.8	-88.8	
	42			-98.5	-95.5	-93.7	-92.5	TDD
CA_1A-3A-42A ⁵	1			-99.8	-96.8	-95	-93.8	FDD
	3			-96.8	-93.8	-92	-90.8	
	42			-98.5	-95.5	-93.7	-92.5	TDD
CA_1A-3A-42C ⁴	1			-99.8	-96.8	-95	-93.8	FDD
	3 ¹²			-93.8	-91.3	-89.8	-88.8	
	42			-98.5	-95.5	-93.7	-92.5	TDD
CA_1A-3A-42C ⁵	1			-99.8	-96.8	-95	-93.8	FDD
	3			-96.8	-93.8	-92	-90.8	
	42			-98.5	-95.5	-93.7	-92.5	TDD
CA_1A-18A-28A ⁶	1			-100	-97	-95.2	-94	FDD
	18			-100	-97	-95.2		
	28			-94	-92.5			
CA_1A-19A-28A ⁸	1			-100	-97	-95.2	-94	FDD
	19			-100	-97	-95.2		
	28			-94	-92			

NOTE 1: The transmitter shall be set to P_{UMAX} as defined in subclause 6.2.5A.

NOTE 2: Reference measurement channel is A.3.2 with one sided dynamic OCNG Pattern OP.1 FDD/TDD as described in Annex A.5.1.1/A.5.2.1

NOTE 3: The signal power is specified per port

NOTE 4: These requirements apply when the uplink is active in Band 1 and the separation between the lower edge of the uplink channel in Band 1 and the upper edge of the downlink channel in Band 3 is < 60 MHz. For each channel bandwidth in Band 3 and Band 5 or Band 8 or Band 19 or Band 20 or Band 26 or Band 28 or Band 42, the requirement applies regardless of channel bandwidth in Band 1.

NOTE 5: These requirements apply when the uplink is active in Band 1 and the separation between the lower edge of the uplink channel in Band 1 and the upper edge of the downlink channel in Band 3 is \geq 60 MHz. For each channel bandwidth in Band 3 and Band 5 or Band 8 or Band 19 or Band 20 or Band 26 or Band 28 or Band 42, the requirement applies regardless of channel bandwidth in Band 1.

NOTE 6: These requirements apply when the uplink is active in Band 18 and the downlink channels in Band 28 are confined within the restricted frequency range specified for this CA configuration (Table 5.5A-2). For each channel bandwidth in Band 28, the requirement applies regardless of channel bandwidth in Band 18.

NOTE 7: ⁷ indicates that the requirement is modified by -0.5 dB when the carrier frequency of the assigned E-UTRA channel bandwidth is within 865-894 MHz.

NOTE 8: These requirements apply when the uplink is active in Band 19 and the downlink channels in Band 28 are allocated at the middle of the restricted frequency range specified for this CA configuration (Table 5.5A-2). For each channel bandwidth in Band 28, the requirement applies regardless of channel bandwidth in Band 19.

NOTE 9: These requirements apply when the uplink is active in Band 1 and the separation between the lower edge of the uplink channel in Band 1 and the upper edge of the downlink channel in Band 3 is < 60 MHz. For each channel bandwidth in Band 3 and Band 7, the requirement applies regardless of channel bandwidth in Band 1.

NOTE 10: These requirements apply when the uplink is active in Band 1 and the separation between the lower edge of the uplink channel in Band 1 and the upper edge of the downlink channel in Band 3 is \geq 60 MHz. For each channel bandwidth in Band 3 and Band 7, the requirement applies regardless of channel bandwidth in Band 1.

NOTE 11: Void

NOTE 12: Applicable for the operations with 2 or 4 antenna ports supported in the band with carrier aggregation configured.

Table 7.3.1A-0bD: Uplink configuration for the uplink band (exceptions for three bands due to close proximity of UL to DL channel)

E-UTRA Band / Channel bandwidth of the affected DL band / N _{RB} / Duplex mode								
EUTRA CA Configuration	UL band	1.4 MHz	3 MHz	5 MHz	10 MHz	15 MHz	20 MHz	Duplex mode
CA_1A-3A-5A ^{1,2}	1			25	25	25	25	FDD
CA_1A-3A-5A ^{1,3}	1			25	45	45	45	FDD
CA_1A-3A-7A ^{1,2}	1			25	25	25	25	FDD
CA_1A-3A-7A ^{1,3}	1			25	45	45	45	FDD
CA_1A-3A-7C ^{1,2}	1			25	25	25	25	FDD
CA_1A-3A-7C ^{1,3}	1			25	45	45	45	FDD
CA_1A-3A-8A ^{1,2}	1			25	25	25	25	FDD
CA_1A-3A-8A ^{1,3}	1			25	45	45	45	FDD
CA_1A-3A-19A ^{1,2}	1			25	25	25	25	FDD
CA_1A-3A-19A ^{1,3}	1			25	45	45	45	FDD
CA_1A-3A-20A ^{1,2}	1			25	25	25	25	FDD
CA_1A-3A-20A ^{1,3}	1			25	45	45	45	FDD
CA_1A-3A-26A ^{1,2}	1			25	25	25	25	FDD
CA_1A-3A-26A ^{1,3}	1			25	45	45	45	FDD
CA_1A-3A-28A ^{1,2}	1			25	25	25	25	FDD
CA_1A-3A-28A ^{1,3}	1			25	45	45	45	FDD
CA_1A-3A-40A ^{1,2}	1			25	25	25	25	FDD
CA_1A-3A-40A ^{1,3}	1			25	45	45	45	FDD
CA_1A-3A-42A ^{1,2}	1			25	25	25	25	FDD
CA_1A-3A-42A ^{1,3}	1			25	45	45	45	FDD
CA_1A-3A-42C ^{1,2}	1			25	25	25	25	FDD
CA_1A-3A-42C ^{1,3}	1			25	45	45	45	FDD
CA_1A-18A-28A ⁴	18			18	18			FDD
CA_1A-19A-28A ⁴	19			18	18			FDD
NOTE 1: refers to the UL resource blocks shall be located as close as possible to the downlink channel in Band 3 but confined within the transmission bandwidth configuration for the channel bandwidth (Table 5.6-1) in the uplink channel in Band 1.								
NOTE 2: UL allocation when the separation between the lower edge of the uplink channel in Band 1 and the upper edge of the downlink channel in Band 3 is < 60 MHz								
NOTE 3: UL allocation when the separation between the lower edge of the uplink channel in Band 1 and the upper edge of the downlink channel in Band 3 is ≥ 60 MHz.								
NOTE 4: refers to the UL resource blocks shall be located as close as possible to the downlink channel in Band 28 but confined within the transmission bandwidth configuration for the channel bandwidth (Table 5.6-1).								

For the UE that supports any of the E-UTRA CA configurations given in Table 7.3.1A-0bD1, exceptions are allowed when the uplink is active within a specified frequency range as noted in Table 7.3.1A-0bD1. For these exceptions, the UE shall meet the requirements specified in Table 7.3.1A-0bD1 and Table 7.3.1A-0bD2.

Table 7.3.1A-0bD1: Reference sensitivity for carrier aggregation QPSK $P_{\text{REFSENS, CA}}$ (exceptions for four bands due to close proximity of UL to DL channel)

Channel bandwidth								
EUTRA CA Configuration	EUTRA band	1.4 MHz (dBm)	3 MHz (dBm)	5 MHz (dBm)	10 MHz (dBm)	15 MHz (dBm)	20 MHz (dBm)	Duplex mode
CA_1A-3A-5A-40A	1			-100	-97	-95.2	-94	FDD
	3 ^{4,7}			-94	-91.5	-90	-89	
	3 ⁵			-97	-94	-92.2	-91	
	5			-98	-95			
	40				-91.9	-90.4	-89.4	TDD
CA_1A-3A-7A-8A	1			-100	-97	-95.2	-94	FDD
	3 ^{4,7}			-94	-91.5	-90	-89	
	3 ⁵			-97	-94	-92.2	-91	
	7				-95	-93.2	-92	
	8			-96.8	-93.8			
CA_1A-3A-7A-28A	1			-100	-97	-95.2	-94	FDD
	3 ^{4,7}				[-91.5]	[-90]	[-89]	
	3 ⁵				-94	-92.2	-91	
	7				-95	-93.2	-92	
	28				-95.3	-93.5	-90.8	
CA_1A-3A-7C-28A	1			-100	-97	-95.2	-94	FDD
	3 ^{4,7}				[-91.5]	[-90]	[-89]	
	3 ⁵				-94	-92.2	-91	
	7				-95	-93.2	-92	
	28				-95.3	-93.5	-90.8	
CA_1A-3A-8A-40A	1			-100	-97	-95.2	-94	FDD
	3 ^{4,7}			-94	-91.5	-90	-89	
	3 ⁵			-97	-94	-92.2	-91	
	8		-99.2	-97	-94			
	40			[-93.4]	-91.9	-90.4	-89.4	TDD
CA_1A-3A-19A-42A	1			-99.8	-96.8	-95	-93.8	FDD
	3 ^{4,7}			-93.8	-91.3	-89.8	-88.8	
	3 ⁵			-96.8	-93.8	-92	-90.8	
	19			-100	-97	-95.2		
	42			-98.5	-95.5	-93.7	-92.5	TDD
CA_1A-3A-19A-42C	1			-99.8	-96.8	-95	-93.8	FDD
	3 ^{4,7}			-93.8	-91.3	-89.8	-88.8	
	3 ⁵			-96.8	-93.8	-92	-90.8	
	19			-100	-97	-95.2		
	42			-98.5	-95.5	-93.7	-92.5	TDD

NOTE 1: The transmitter shall be set to P_{UMAX} as defined in subclause 6.2.5A.

NOTE 2: Reference measurement channel is A.3.2 with one sided dynamic OCNG Pattern OP.1 FDD/TDD as described in Annex A.5.1.1/A.5.2.1

NOTE 3: The signal power is specified per port

NOTE 4: These requirements apply when the uplink is active in Band 1 and the separation between the lower edge of the uplink channel in Band 1 and the upper edge of the downlink channel in Band 3 is < 60 MHz. For each channel bandwidth in the bands other than Band 1, the requirement applies regardless of channel bandwidth in Band 1.

NOTE 5: These requirements apply when the uplink is active in Band 1 and the separation between the lower edge of the uplink channel in Band 1 and the upper edge of the downlink channel in Band 3 is \geq 60 MHz. For each channel bandwidth in the bands other than Band 1, the requirement applies regardless of channel bandwidth in Band 1.

NOTE 6: Void

NOTE 7: Applicable for the operations with 2 or 4 antenna ports supported in the band with carrier aggregation configured.

Table 7.3.1A-0bD2: Uplink configuration for the low band (exceptions for four bands due to close proximity of UL to DL channel)

E-UTRA Band / Channel bandwidth of the affected DL band / N_{RB} / Duplex mode								
EUTRA CA Configuration	UL band	1.4 MHz	3 MHz	5 MHz	10 MHz	15 MHz	20 MHz	Duplex mode
CA_1A-3A-5A-40A	1 ^{1,2}			25	25	25	25	FDD
CA_1A-3A-7A-8A								
CA_1A-3A-7A-28A	1 ^{1,3}			25	45	45	45	
CA_1A-3A-7C-28A								
CA_1A-3A-8A-40A								
CA_1A-3A-19A-42A								
CA_1A-3A-19A-42C	1 ^{1,2}			25	25	25	25	FDD
	1 ^{1,3}			25	45	45	45	
NOTE 1: refers to the UL resource blocks shall be located as close as possible to the downlink channel in Band 3 but confined within the transmission bandwidth configuration for the channel bandwidth (Table 5.6-1) in the uplink channel in Band 1.								
NOTE 2: UL allocation when the separation between the lower edge of the uplink channel in Band 1 and the upper edge of the downlink channel in Band 3 is < 60 MHz								
NOTE 3: UL allocation when the separation between the lower edge of the uplink channel in Band 1 and the upper edge of the downlink channel in Band 3 is \geq 60 MHz.								

For the UE that supports any of the E-UTRA CA configurations given in Table 7.3.1A-0bE, exceptions are allowed when the uplink is active in the applicable active UL bands in Table 7.3.1A-0bE. For these exceptions, the UE shall meet the reference sensitivities specified in Table 7.3.1A-0bE and Table 7.3.1A-0bF.

Table 7.3.1A-0bE: Reference sensitivity for carrier aggregation QPSK $P_{\text{REFSENS, CA}}$ (exceptions due to cross band isolation issues of TDD and FDD bands)

EUTRA CA Configuration	EUTRA band	Channel bandwidth						Duple x mode	Applicable active UL band
		1.4 MHz (dBm)	3 MHz (dBm)	5 MHz (dBm)	10 MHz (dBm)	15 MHz (dBm)	20 MHz (dBm)		
CA_1A-3A-5A-40A	1			-100	-97	-95.2	-94	FDD	3
	3			-97	-94	-92.2	-91		
	5			-98	-95				
	40				-92.9	-91.3	-90.2	TDD	
CA_1A-3A-5A-40A	1 ¹²			-91.7	[-89.5]	[-87.9]	[-86.9]	FDD	40
	3 ¹²			-94.2	-91.2	-89.5	-88.3		
	5			-98	-95				
	40				-97	-95.2	-94	TDD	
CA_1A-3A-8A-40A	1			-100	-97	-95.2	-94	FDD	3
	3			-97	-94	-92.2	-91		
	8		-99.2	-97	-94				
	40			-95.4	-92.9	-91.3	-90.2	TDD	
CA_1A-3A-8A-40A	1 ¹²			-91.7	[-89.5]	[-87.9]	[-86.9]	FDD	40
	3 ¹²			-94.2	-91.2	-89.5	-88.3		
	8		-99.2	-97	-94				
	40			-100	-97	-95.2	-94	TDD	
CA_1A-3A-40A	1			-100	-97	-95.2	-94	FDD	3
	3			-97	-94	-92.2	-91		
	40			-100	-92.9	-91.3	-90.2	TDD	
CA_1A-3A-40A	1 ¹²			-91.7	[-89.5]	[-87.9]	[-86.9]	FDD	40
	3 ¹²			-94.2	-91.2	-89.5	-88.3		
	40			-100	-97	-95.2	-94	TDD	
CA_1A-5A-40A	1			-100	-97	-95.2	-94	FDD	1
	5			-98	-95				
	40				-91.9	-90.4	-89.4	TDD	
CA_1A-5A-40A	1 ¹²			-91.7	[-89.5]	[-87.9]	[-86.9]	FDD	40
	5			-98	-95				
	40				-97	-95.2	-94	TDD	
CA_1A-8A-40A	1			-100	-97	-95.2	-94	FDD	1
	8		-99.2	-97	-94				
	40			[-93.4]	-91.9	-90.4	-89.4	TDD	
CA_1A-8A-40A	1 ¹²			-91.7	[-89.5]	[-87.9]	[-86.9]	FDD	40
	8		-99.2	-97	-94				
	40			-100	-97	-95.2	-94	TDD	
CA_1A-40A	1			-100	-97	-95.2	-94	FDD	1
	40			[-93.4]	-91.9	-90.4	-89.4	TDD	
CA_1A-40A	1 ¹²			-91.7	[-89.5]	[-87.9]	[-86.9]	FDD	40
	40			-100	-97	-95.2	-94	TDD	
CA_3A-5A-40A	3			-97	-94	-92.2	-91	FDD	3
	5			-98	-95				
	40				-92.9	-91.3	-90.2	TDD	
CA_3A-5A-40A	3 ¹²			-94.2	-91.2	-89.5	-88.3	FDD	40
	5			-98	-95				
	40				-97	-95.2	-94	TDD	
CA_3A-7A-38A	3			-97	-94	-92.2	-91	FDD	3
	7			[-93.8]	[-91.2]	[-89.7]	[-88.6]		
	38			[-93.8]	[-91.2]	[-89.7]	[-88.6]	TDD	

CA_3A-8A-40A	3			-97	-94	-92.2	-91	FDD	3
	8		-99.2	-97	-94				
	40			-95.4	-92.9	-91.3	-90.2	TDD	
CA_3A-8A-40A	3 ¹²			-94.2	-91.2	-89.5	-88.3	FDD	40
	8		-99.2	-97	-94				
	40			-100	-97	-95.2	-94	TDD	
CA_3A-28A-40A	3			-97	-94	-92.2	-91	FDD	3
	28			-98.5	-95.5	-93.7	-91		
	40			-95.4	-92.9	-91.3	-90.2	TDD	
CA_3A-28A-40A	3 ¹²			-94.2	-91.2	-89.5	-88.3	FDD	40
	28			-96.8	-94.1	-92.5	-89.8		
	40			-100	-97	-95.2	-94	TDD	
CA_3A-28A-40A	3			-97	-94	-92.2	-91	FDD	28
	28			-98.5	-95.5	-93.7	-91		
	40			-95.1	-92.9	-91.4	-90.5	TDD	
CA_3A-28A-40C	3			-97	-94	-92.2	-91	FDD	3
	28			-98.5	-95.5	-93.7	-91		
	40			-95.4	-92.9	-91.3	-90.2	TDD	
CA_3A-28A-40C	3			-97	-94	-92.2	-91	FDD	28
	28			-98.5	-95.5	-93.7	-91		
	40			-95.1	-92.9	-91.4	-90.5	TDD	
CA_3A-28A-40C	3 ¹²			-94.2	-91.2	-89.5	-88.3	FDD	40
	28			-96.8	-94.1	-92.5	-89.8		
	40			-100	-97	-95.2	-94	TDD	
CA_3A-40A	3			-97	-94	-92.2	-91	FDD	3
	40			-95.4	-92.9	-91.3	-90.2	TDD	
CA_3A-40A	3 ¹²			-94.2	-91.2	-89.5	-88.3	FDD	40
	40			-100	-97	-95.2	-94	TDD	
CA_3A-40C	3			-97	-94	-92.2	-91	FDD	3
	40			-95.4	-92.9	-91.3	-90.2	TDD	
CA_3A-40C	3 ¹²			-94.2	-91.2	-89.5	-88.3	FDD	40
	40			-100	-97	-95.2	-94	TDD	
CA_3A-41A ⁵	3 ¹²			[-94]	[-91]	[-89.2]	[-87.9]	FDD	41
	41			-97.5	-94.5	-92.7	-91.5	TDD	
	3			-97	-94	-92.2	-91	FDD	3
	41 ¹²			[-93.3]	[-90.7]	[-89.2]	[-88.1]	TDD	
CA_3A-41C ⁵	3 ¹²			[-94]	[-91]	[-89.2]	[-87.9]	FDD	41
	41			-97.5	-94.5	-92.7	-91.5	TDD	
	3			-97	-94	-92.2	-91	FDD	3
	41 ¹²			[-93.3]	[-90.7]	[-89.2]	[-88.1]	TDD	
CA_3A-41A-42A ^{5,6,7,8}	3			-96.5	-93.5	-91.7	-90.5	FDD	3
	41 ¹²			[-93.3]	[-90.7]	[-89.2]	[-88.1]	TDD	
	42 ¹²			-71.7	-71.7	-71.7	-71.7		
CA_3A-41A-42A ^{5,6,9}	3			-96.5	-93.5	-91.7	-90.5	FDD	3
	41 ¹²			[-93.3]	[-90.7]	[-89.2]	[-88.1]	TDD	
	42 ¹²			-97.1	-94.7	-93.2	-92.5		
CA_3A-41A-42A ^{5,6,10}	3 ¹²			[-93.5]	[-90.5]	[-88.7]	[-87.4]	FDD	41
	41			-97.5	-94.5	-92.7	-91.5	TDD	
	42			-98.5	-95.5	-93.7	-92.5		
CA_7A-40A	7			-98	-95	-93.2	-92	FDD	7
	40			-96.3	-93.6	-92	-90.9	TDD	
	7 ¹²			-97.1	-94.3	-92.7	-91.5	FDD	40
	40			-99.5	-96.5	-94.7	-93.5	TDD	
CA_7A-40C	7			-98	-95	-93.2	-92	FDD	7

	40			-96.3	-93.6	-92	-90.9	TDD	40
	7 ¹²			-97.1	-94.3	-92.7	-91.5	FDD	
	40			-99.5	-96.5	-94.7	-93.5	TDD	
CA_7A-42A	7			-98	-95	-93.2	-92	FDD	7
	42 ¹²			-95.6	-93	-91.5	-90.4	TDD	
	7 ¹²			-96.2	-93.2	-91.5	-90.3	FDD	42
	42			-98.5	-95.5	-93.7	-92.5	TDD	
CA_7A-42A-42A	7			-98	-95	-93.2	-92	FDD	7
	42 ¹²			-95.6	-93	-91.5	-90.4	TDD	
	7 ¹²			-96.2	-93.2	-91.5	-90.3	FDD	42
	42			-98.5	-95.5	-93.7	-92.5	TDD	
CA_28A-40A	28			-98.5	-95.5	-93.7	-91	FDD	28
	40			-95.1	-92.9	-91.4	-90.5	TDD	
CA_28A-40A	28			-96.8	-94.1	-92.5	-89.8	FDD	40
	40			-100	-97	-95.2	-94	TDD	
CA_28A-40C	28			-98.5	-95.5	-93.7	-91	FDD	28
	40			-95.1	-92.9	-91.4	-90.5	TDD	
CA_28A-40C	28			-96.8	-94.1	-92.5	-89.8	FDD	40
	40			-100	-97	-95.2	-94	TDD	
CA_28A-40D	28			-98.5	-95.5	-93.7	-91	FDD	28
	40			-95.1	-92.9	-91.4	-90.5		
CA_28A-40D	28			-96.8	-94.1	-92.5	-89.8	FDD	40
	40			-100	-97	-95.2	-94		

NOTE 1: The transmitter shall be set to P_{UMAX} as defined in subclause 6.2.5A

NOTE 2: Reference measurement channel is A.3.2 with one sided dynamic OCNG Pattern OP.1 FDD/TDD as described in Annex A.5.1.1/A.5.2.1

NOTE 3: The signal power is specified per port

NOTE 4: These requirements apply regardless of the channel bandwidth and the location of UL band.

NOTE 5: The B41 requirements are modified by -0.5dB when carrier frequency of the assigned E-UTRA channel bandwidth is within 2545-2690 MHz.

NOTE 6: The antenna isolation for MSD calculation is assumed as 10 dB. For conducted mode REFSENS test such antenna isolation is not observed as the antennas are disconnected. Additionally antenna isolation assumption is under discussion depending on the frequency range

NOTE 7: These requirements apply when there is at least one individual RE within the uplink transmission bandwidth of the aggressor (lower) band for which the 2nd transmitter harmonic is within the downlink transmission bandwidth of a victim (higher) band and a range ΔF_{HD} above and below the edge of this downlink transmission bandwidth. The value ΔF_{HD} depends on the E-UTRA configuration: $\Delta F_{HD} = 10$ MHz for CA_3A-42A, CA_3A-42C, CA_1A-3A-42A, CA_1A-3A-42C, CA_3A-19A-42A, CA_3A-19A-42C and CA_1A-3A-19A-42A, CA 3A-41A-42A.

NOTE 8: The requirements should be verified for UL EARFCN of the aggressor (lower) band (superscript LB) such that $f_{UL}^{LB} = \lfloor f_{DL}^{HB} / 0.2 \rfloor \cdot 0.1$ in MHz and $F_{UL_low}^{LB} + BW_{Channel}^{LB} / 2 \leq f_{UL}^{LB} \leq F_{UL_high}^{LB} - BW_{Channel}^{LB} / 2$ with f_{DL}^{HB} carrier frequency in the victim (higher) band in MHz and $BW_{Channel}^{LB}$ the channel bandwidth configured in the lower band.

NOTE 9: The requirements are only applicable to channel bandwidths with a carrier frequency at $\pm (20 + BW_{Channel}^{HB} / 2)$ MHz offset from $2f_{UL}^{LB}$ in the victim (higher band) with

$$F_{UL_low}^{LB} + BW_{Channel}^{LB} / 2 \leq f_{UL}^{LB} \leq F_{UL_high}^{LB} - BW_{Channel}^{LB} / 2, \text{ where } BW_{Channel}^{LB} \text{ and } BW_{Channel}^{HB} \text{ are the channel bandwidths configured in the aggressor (lower) and victim (higher) bands in MHz, respectively.}$$

NOTE 10: Only applicable for UE supporting inter-band carrier aggregation with uplink in one E-UTRA band and without simultaneous Rx/Tx.

NOTE 11: Void

NOTE 12: Applicable for the operations with 2 or 4 antenna ports supported in the band with carrier aggregation configured.

Table 7.3.1A-0bF: Uplink configuration for reference sensitivity (exceptions due to cross band isolation issues of TDD and FDD bands)

E-UTRA Band / Channel bandwidth of the affected DL band / N _{RB} / Duplex mode								
EUTRA CA Configuration	E-UTRA Band	1.4 MHz	3 MHz	5 MHz	10 MHz	15 MHz	20 MHz	Duplex Mode
CA_1A-5A-40A	1			25	50	75	100	FDD
	40			25	50	75	100	TDD
CA_1A-8A-40A	1			25	50	75	100	FDD
	40			25	50	75	100	TDD
CA_1A-40A	1			25	50	75	100	FDD
	40			25	50	75	100	TDD
CA_3A-7A-38A	3			25	50	50 ¹	50 ¹	FDD
CA_3A-8A-40A	3			25	50	50 ¹	50 ¹	FDD
	40			25	50	75	100	TDD
CA_3A-40A CA_3A-40C CA_1A-3A-40A CA_3A-5A-40A CA_3A-28A-40A CA_3A-28A-40C CA_1A-3A-5A-40A CA_1A-3A-8A-40A	3 40			25 25	50 50	50 ¹ 75	50 ¹ 100	FDD TDD
CA_3A-41A	3			25	50	50 ¹	50 ¹	FDD
	41			25	50	75	100	TDD
CA_3A-41C	3			25	50	50 ¹	50 ¹	FDD
	41			25	50	75	100	TDD
CA_3A-41A-42A	3			25	50	50 ¹	50 ¹	FDD
	41			25	50	75	100	TDD
CA_7A-40A, CA_7A-40C	7			25	50	75	75 ¹	FDD
	40			25	50	75	100	TDD
CA_7A-42A, CA_7A-42A-42A	7			25	50	75	75 ¹	FDD
	42			25	50	75	100	TDD
CA_28A-40A, CA_28A-40C	28			25	25 ¹	25 ¹	25 ¹	FDD
	40			25	50	75	100	TDD

NOTE 1: ¹ refers to the UL resource blocks shall be located as close as possible to the downlink operating band but confined within the transmission bandwidth configuration for the channel bandwidth (Table 5.6-1).

NOTE 2: the UL configuration applies regardless of the channel bandwidth of the low band unless the UL resource blocks exceed that specified in Table 7.3.1-2 for the uplink bandwidth in which case the allocation according to Table 7.3.1-2 applies.

For band combinations including operating bands without uplink band (as noted in Table 5.5-1), the requirements are specified in Table 7.3.1A-0d for any uplink band with uplink configuration specified in Table 7.3.1-2.

Table 7.3.1A-0d: Reference sensitivity QPSK P_{REFSENS} (CA with a SDL band)

EUTRA CA Configuration	Channel bandwidth							Duplex mode
	EUTRA band	1.4 MHz (dBm)	3 MHz (dBm)	5 MHz (dBm)	10 MHz (dBm)	15 MHz (dBm)	20 MHz (dBm)	
CA_2A-4A-5A-29A	2			-97.7	-94.7	-92.9	-91.7	FDD
	4			-99.7	-96.7	-94.9	-93.7	
	5			-98	-95			
	29			-97	-94			
CA_2A-4A-29A	2			-97.7	-94.7	-92.9	-91.7	FDD
	4			-99.7	-96.7	-94.9	-93.7	
	29			-97	-94			
CA_2A-4A-29A-30A	2			-97.6	-94.6	-92.8	-91.6	FDD
	4			-99.6	-96.6	-94.8	-93.6	
	29			-97	-94			
	30			-98.5	-95.5			
CA_2A-5A-29A	2			-98	-95	-93.2	-92	FDD
	5			-98	-95			
	29			-97	-94			
CA_2A-29A	2			-98	-95	-93.2	-92	FDD
	29		-98.7	-97	-94			
CA_2C-29A	2			-98	-95	-93.2	-92	FDD
	29			-97	-94			
CA_2A-29A-30A	2			-97.6	-94.6	-92.8	-91.6	FDD
	29			-97	-94			
	30			-98.5	-95.5			
CA_2C-29A-30A	2			-97.6	-94.6	-92.8	-91.6	FDD
	29			-97	-94			
	30			-98.5	-95.5			
CA_4A-4A-29A	4			-100	-97	-95.2	-94	FDD
	29			-97	-94			
CA_4A-4A-29A-30A	4			-99.6	-96.6	-94.8	-93.6	FDD
	29			-97	-94			
	30			-98.5	-95.5			
CA_4A-5A-29A	4			-100	-97	-95.2	-94	FDD
	5			-98	-95			
	29			-97	-94			
CA_4A-29A	4			-100	-97	-95.2	-94	FDD
	29		-98.7	-97	-94			
CA_4A-29A-30A	4			-99.6	-96.6	-94.8	-93.6	FDD
	29			-97	-94			
	30			-98.5	-95.5			
CA_5A-29A	5			-98	-95			FDD
	29			-97	-94			
CA_20A-32A	20			-97	-94			FDD
	32			-100	-97	-95.2	-94	
CA_20A-67A	20			-97	-94	-91.2	-90	FDD
	67			-100	-97	-95.2	-94	
CA_23A-29A	23			-100	-97	-95.2	-94	FDD
	29		-98.7	-97	-94			
CA_29A-30A	29			-97	-94			FDD
	30			-99	-96			

NOTE 1: The transmitter shall be set to P_{UMAX} as defined in subclause 6.2.5A.
NOTE 2: Reference measurement channel is A.3.2 with one sided dynamic OCNG Pattern OP.1 FDD/TDD as described in Annex A.5.1.1/A.5.2.1

NOTE 3: The signal power is specified per port.
NOTE 4: Void

Table 7.3.1A-0e: Void

For band combinations including operating band 46 (Table 5.5-1), the requirements are specified in Table 7.3.1A-0eA, and Table 7.3.1A-0eC for the uplink in any band other than band 46 with the uplink configuration specified in Table 7.3.1-2.

Table 7.3.1A-0eA: Reference sensitivity QPSK P_{REFSENS} (CA with band 46)

EUTRA CA Configuration	EUTRA band	Channel bandwidth						Duplex mode
		1.4 MHz (dBm)	3 MHz (dBm)	5 MHz (dBm)	10 MHz (dBm)	15 MHz (dBm)	20 MHz (dBm)	
CA_1A-46A	1			-100	-97	-95.2	-94	FDD
	46						-90	TDD
CA_2A-46A	2			-98	-95	-93.2	-92	FDD
	46						-90	TDD
CA_3A-46A	3			-97	-94	-92.2	-91	FDD
	46						-90	TDD
CA_4A-46A	4			-100	-97	-95.2	-94	FDD
	46						-90	TDD
CA_7A-46A	7			-98	-95	-93.2	-92	FDD
	46						-90	TDD
CA_41A-46A	41			-98	-95	-93.2	-92	TDD
	46						-90	TDD
CA_42A-46A	42			-99	-96	-94.2	-93	TDD
	46						-83	TDD
NOTE 1: The transmitter shall be set to P_{UMAX} as defined in subclause 6.2.5A.								
NOTE 2: Reference measurement channel is A.3.2 with one sided dynamic OCNG Pattern OP.1 FDD/TDD/FS3 as described in Annex A.5.1.1/A.5.2.1/A.5.4.1.								
NOTE 3: The signal power is specified per port.								
NOTE 4: Void								
NOTE 5: The requirement for B46 does not apply when there is at least one individual RE within the B46 downlink transmission bandwidth which falls into the reference sensitivity exclusion region as specified in Table 7.3.1A-0eC.								
NOTE 6: Void								

Table 7.3.1A-0eB: Void

Table 7.3.1A-0eC specifies the Band 46 reference measurement exclusion region for different licensed component carriers and channel bandwidth. The exclusion region is defined according to the licensed component carrier channel bandwidth. The UL configurations to be adopted for the test are specified in Table 7.3.1-2. The exclusion region in Table 7.3.1A-0eC is specified for the case of 10MHz and 20MHz channel bandwidth in Band 46.

Table 7.3.1A-0eC: Band 46 Reference sensitivity measurement exclusion region in MHz.

Licensed Component Carriers / E-UTRA Band / Harmonic order / Channel BW in UL					
Licensed Component Carriers	Harmonic order	5MHz	10MHz	15MHz	20MHz
1	3	+/- 15	+/- 23	+/- 35	+/- 45
2	3	+/- 15	+/- 23	+/- 35	+/- 45
3	3	+/- 15	+/- 23	+/- 35	+/- 45
4	3	+/- 15	+/- 23	+/- 35	+/- 45
7 ¹	2	+/- 15	+/- 25	+/- 38	+/- 50
41	2	+/- 15	+/- 25	+/- 38	+/- 50
NOTE 1: Even though UL harmonic does not fall directly into Band 46 the exclusion region still applies.					
NOTE 2: The center of the exclusion region is obtained by multiplying the UL channel center frequency by the harmonic order.					

In all cases for single uplink inter-band CA, unless given by Table 7.3.1-3 for the band with the active uplink carrier, the applicable reference sensitivity requirements shall be verified with the network signalling value NS_01 (Table 6.2.4-1) configured.

For inter-band carrier aggregation with one component carrier per operating band and the uplink assigned to two E-UTRA bands the throughput shall be $\geq 95\%$ of the maximum throughput of the reference measurement channels as specified in Annexes A.2.2, A.2.3 and A.3.2 (with one sided dynamic OCNG Pattern OP.1 FDD/TDD for the DL-signal as described in Annex A.5.1.1/A.5.2.1) with parameters specified in Table 7.3.1-1 and Table 7.3.1-2. The reference sensitivity is defined to be met with all downlink component carriers active and both of the uplink carriers active.

For E-UTRA CA configurations with uplink and downlink assigned to two E-UTRA bands given in Table 7.3.1A-0f the reference sensitivity is defined only for the specific uplink and downlink test points which are specified in Table 7.3.1A-0f. For E-UTRA CA configurations with uplink assigned to two E-UTRA bands and downlink assigned to three E-UTRA bands given in Table 7.3.1A-0g the reference sensitivity is defined only for the specific uplink and downlink test points which are specified in Table 7.3.1A-0g. For these test points the reference sensitivity requirement specified in Table 7.3.1-1 is relaxed by the amount of parameter MSD given in Table 7.3.1A-0f.

The allowed exceptions defined in Table 7.3.1A-0a and Table 7.3.1A-0b for inter-band carrier aggregation with a single active uplink are also applicable for dual uplink operation.

Table 7.3.1A-0f: 2 UL and 2 DL interband Reference sensitivity QPSK P_{REFSENS} and uplink/downlink configurations

E-UTRA Band / Channel bandwidth / N_{RB} / Duplex mode							
EUTRA CA Configuration	EUTRA band	UL F_c (MHz)	UL/DL BW (MHz)	UL C_{LRB}	DL F_c (MHz)	MSD (dB)	Duplex mode

CA_1A-3A	1	1950	5	25	2140	23	FDD
	3	1760	5	25	1855	N/A	
CA_1A-8A	1	1965	5	25	2155	6	FDD
	8	887.5	5	25	932.5	N/A	
CA_2A-4A	2	1860	20	50 ²	1940	5	FDD
	4	1752.5	5	25	2152.5	N/A	
CA_2A-4A	2	1868.3	5	25	1948.3	N/A	FDD
	4	1735	5	25	2135	5	
CA_3A-5A	3	1771	10	50	1866	4	FDD
	5	838	5	25	883	N/A	
CA_3A-5A	3	1721	10	50	1816	N/A	FDD
	5	838	5	25	883	24	
CA_3A-7A	3	1730	5	25	1825	N/A	FDD
	7	2535	10	50	2655	13	
CA_3A-8A	3	1755	10	50	1850	N/A	FDD
	8	900	5	25	945	8	
CA_3A-8A	3	1747.5	10	50	1842.5	6.4	FDD
	8	897.5	5	25	942.5	N/A	
CA_3A-19A	3	1771	5	25	1866	4	FDD
	19	838	5	25	883	N/A	
CA_3A-19A	3	1721	5	25	1816	N/A	FDD
	19	838	5	25	883	27	
CA_3A-20A	3	1775	5	25	1870	4	FDD
	20	840	5	25	799	N/A	
CA_3A-20A	3	1735	5	25	1830	N/A	FDD
	20	847	5	25	806	9	
CA_3A-26A	3	1771	5	25	1866	4	FDD
	26	838	5	25	883	N/A	
CA_3A-26A	3	1721	5	25	1816	N/A	FDD
	26	838	5	25	883	26	
CA_4A-5A	4	1721	5	25	2121	N/A	FDD
	5	838	5	25	883	26	
CA_4A-7A	4	1730	5	25	2130	N/A	FDD
	7	2535	5	25	2655	15	
CA_5A-7A	5	834	5	25	879	12	FDD
	7	2547	10	50	2667	N/A	
CA_7A-20A	7	2512	10	50	2632	N/A	FDD
	20	851	5	25	810	12	

NOTE 1: Both of the transmitters shall be set min(+20 dBm, P_{CMAX,L,c}) as defined in subclause 6.2.5A

NOTE 2: RB_{START} = 0

Table 7.3.1A-0g: 2 UL and 3 DL interband Reference sensitivity QPSK P_{REFSENS} and uplink/downlink configurations

E-UTRA Band / Channel bandwidth / NRB / Duplex mode									
EUTRA CA	EUTRA CA	EUTRA band	UL F_c	UL BW	UL	DL F_c	DL BW	MSD	Duplex mode
DL Configuration	UL Configuration		(MHz)	(MHz)	C_{LRB}	(MHz)	(MHz)	(dB)	
CA_1A-5A-7A	CA_1A-7A	1	1968	5	25	2158	5	NA	FDD
		7	2512	10	50	2632	10	NA	
		5	835	5	25	880	5	1.0	
CA_3A-7A-20A	CA_3A-7A	3	1737	5	25	1832	5	NA	FDD
		7	2543	10	50	2663	10	NA	
		20	847	10	20	806	10	10.5	
	CA_3A-20A	3	1775	10	50	1870	10	NA	FDD
		20	855	5	25	896	5	NA	
		7	2510	10	50	2630	10	26.0	
CA_3A-7A-28A	CA_3A-7A	3	1747	5	25	1842	5	NA	FDD
		7	2543	5	25	2663	5	NA	
		28	741	5	25	796.0	5	20	
	CA_7A-28A	7	2543	5	25	2663	5	NA	FDD
		28	710.5	5	25	765.5	5	NA	
		3	1737.5	5	25	1832.5	5	26	

For intra-band contiguous carrier aggregation the throughput of each component carrier shall be $\geq 95\%$ of the maximum throughput of the reference measurement channels as specified in Annexes A.2.2, A.2.3 and A.3.2 (with one sided dynamic OCNG Pattern OP.1 FDD/TDD for the DL-signal as described in Annex A.5.1.1/A.5.2.1) with parameters specified in Table 7.3.1-1, Table 7.3.1-1a, Table 7.3.1-1A, Table 7.3.1-1B, Table 7.3.1-1C, Table 7.3.1A-0h and Table 7.3.1A-1. For operating bands with an unpaired DL part (as noted in Table 5.5-1), the power levels in Table 7.3.1-1 and Table 7.3.1-1a also apply for an SCC assigned in the unpaired part. The requirement is verified using an uplink CA configuration with the largest number of carriers supported by the UE. Table 7.3.1A-1 specifies the maximum number of allocated uplink resource blocks for which the intra-band contiguous carrier aggregation reference sensitivity requirement shall be met. The PCC and SCC allocations as defined in Table 7.3.1A-1 form a contiguous allocation where TX-RX frequency separations of the component carriers are as defined in Table 5.7.4-1. In case downlink CA configuration has additional SCC(s) compared to uplink CA configuration those are configured further away from uplink band. For UE(s) supporting one uplink carrier, the uplink configuration of the PCC shall be in accordance with Table 7.3.1-2 and the downlink PCC carrier center frequency shall be configured closer to uplink operating band than any of the downlink SCC center frequency. Unless given by Table 7.3.1-3, the reference sensitivity requirements shall be verified with the network signalling value NS_01 (Table 6.2.4-1) configured.

Table 7.3.1A-0h: Intra-band contiguous CA uplink configuration for reference sensitivity for Bandwidth Class B

CA configuration / CC combination / N _{RB,agg} / Duplex mode					
Uplink CA configuration	50RB+25RB		50RB+50RB		Duplex Mode
	PCC	SCC	PCC	SCC	
CA_8B	25	0	25	0	FDD
NOTE 1: The carrier centre frequency of SCC in the UL operating band is configured closer to the DL operating band.					
NOTE 2: The transmitted power over both PCC and SCC shall be set to P _{UMAX} as defined in subclause 6.2.5A.					
NOTE 3: The UL resource blocks in both PCC and SCC shall be confined within the transmission bandwidth configuration for the channel bandwidth (Table 5.6-1).					
NOTE 4: The UL resource blocks in PCC shall be located as close as possible to the downlink operating band, while the UL resource blocks in SCC shall be located as far as possible from the downlink operating band.					
NOTE 5: In case a CA configuration consists of CC channel bandwidths which are unequal in bandwidth the PCC channel bandwidth shall be the larger one for reference sensitivity test.					

Table 7.3.1A-1: Intra-band contiguous CA uplink configuration for reference sensitivity for Bandwidth Class C

CA configuration / CC combination / N _{RB,agg} / Duplex mode													
Uplink CA configuration	100RB+25RB		100RB+50RB		75RB+75RB		75RB+50RB		100RB+75RB		100RB+100RB		Duplex Mode
	PCC	SCC	PCC	SCC	PCC	SCC	PCC	SCC	PCC	SCC	PCC	SCC	
CA_1C	N/A	N/A	N/A	N/A	75	54	N/A	N/A	N/A	N/A	100	30	FDD
CA_3C	50	0	50	0	N/A	N/A	N/A	N/A	50	0	50	0	FDD
CA_7C	N/A	N/A	75	0	75	0	75	0	75	0	75	0	FDD
CA_38C	N/A	N/A	N/A	N/A	75	75	N/A	N/A	N/A	N/A	100	100	TDD
CA_39C	100	25	100	50	N/A	N/A	N/A	N/A	100	75	N/A	N/A	TDD
CA_40C	N/A	N/A	100	50	75	75	N/A	N/A	100	75	100	100	TDD
CA_41C	100	25	100	50	75	75	75	50	100	75	100	100	TDD
CA_42C	100	25	100	50	N/A	N/A	N/A	N/A	100	75	100	100	TDD
NOTE 1: The carrier centre frequency of SCC in the UL operating band is configured closer to the DL operating band.													
NOTE 2: The transmitted power over both PCC and SCC shall be set to P _{UMAX} as defined in subclause 6.2.5A.													
NOTE 3: The UL resource blocks in both PCC and SCC shall be confined within the transmission bandwidth configuration for the channel bandwidth (Table 5.6-1).													
NOTE 4: The UL resource blocks in PCC shall be located as close as possible to the downlink operating band, while the UL resource blocks in SCC shall be located as far as possible from the downlink operating band.													
NOTE 5: In case a CA configuration consists of CC channel bandwidths which are unequal in bandwidth the PCC channel bandwidth shall be the larger one for reference sensitivity test.													
NOTE 6: Void.													
NOTE 7: Void													

For intra-band non-contiguous carrier aggregation with one uplink carrier and two downlink sub-blocks, the throughput of each downlink component carrier shall be $\geq 95\%$ of the maximum throughput of the reference measurement channels as specified in Annexes A.2.2, A.2.3 and A.3.2 (with one sided dynamic OCNG Pattern OP.1 FDD/TDD for the DL-signal as described in Annex A.5.1.1/A.5.2.1) and parameters specified in Table 7.3.1-1, Table 7.3.1-1a, Table 7.3.1-1A, Table 7.3.1-1B, Table 7.3.1-1C and Table 7.3.1A-3 with the reference sensitivity power level increased by ΔR_{IBNC} given in Table 7.3.1A-3 for the SCC(s). The requirements apply with all downlink carriers active. Unless given by Table 7.3.1-3, the reference sensitivity requirements shall be verified with the network signalling value NS_01 (Table 6.2.4-1) configured.

Table 7.3.1A-3: Intra-band non-contiguous CA with one uplink configuration for reference sensitivity

CA configuration	Aggregated channel bandwidth (PCC+SCC)	W_{gap} / [MHz]	UL PCC allocation	ΔR_{IBNC} (dB)	Duplex mode
CA_2A-2A	25RB+25RB	$30.0 < W_{\text{gap}} \leq 50.0$	12 ¹	5.3	FDD
		$30.0 < W_{\text{gap}} \leq 50.0$	12 ¹	8.0 ¹⁷	
		$0.0 < W_{\text{gap}} \leq 30.0$	25 ¹	0	
	25RB+50RB	$25.0 < W_{\text{gap}} \leq 45.0$	12 ¹	4.4	
		$25.0 < W_{\text{gap}} \leq 45.0$	12 ¹	7.1 ¹⁷	
		$0.0 < W_{\text{gap}} \leq 25.0$	25 ¹	0	
	25RB+75RB	$20.0 < W_{\text{gap}} \leq 40.0$	12 ¹	4.2	
		$20.0 < W_{\text{gap}} \leq 40.0$	12 ¹	6.9 ¹⁷	
		$0.0 < W_{\text{gap}} \leq 20.0$	25 ¹	0	
	25RB+100RB	$15.0 < W_{\text{gap}} \leq 35.0$	12 ¹	3.8	
		$30.0 < W_{\text{gap}} \leq 50.0$	12 ¹	6.5 ¹⁷	
		$0.0 < W_{\text{gap}} \leq 15.0$	25 ¹	0	
	50RB+25RB	$15.0 < W_{\text{gap}} \leq 45.0$	12 ¹	5.9	
		$15.0 < W_{\text{gap}} \leq 45.0$	12 ¹	8.6 ¹⁷	
		$0.0 < W_{\text{gap}} \leq 15.0$	32 ¹	0	
	50RB+50RB	$10.0 < W_{\text{gap}} \leq 40.0$	12 ¹	4.6	
		$10.0 < W_{\text{gap}} \leq 45.0$	12 ¹	7.3 ¹⁷	
		$0.0 < W_{\text{gap}} \leq 10.0$	32 ¹	0	
	50RB+75RB	$5.0 < W_{\text{gap}} \leq 35.0$	12 ¹	4.1	
		$5.0 < W_{\text{gap}} \leq 35.0$	12 ¹	6.8 ¹⁷	
		$0.0 < W_{\text{gap}} \leq 5.0$	32 ¹	0	
	50RB+100RB	$0.0 < W_{\text{gap}} \leq 30.0$	12 ¹	4.0	
		$0.0 < W_{\text{gap}} \leq 30.0$	12 ¹	6.7 ¹⁷	
	75RB+25RB	$10.0 < W_{\text{gap}} \leq 40.0$	12 ¹²	6.7	
		$10.0 < W_{\text{gap}} \leq 40.0$	12 ¹	9.4 ¹⁷	
		$0.0 < W_{\text{gap}} \leq 10.0$	36 ¹	0	
	75RB+50RB	$5.0 < W_{\text{gap}} \leq 35.0$	12 ¹²	5.4	
		$5.0 < W_{\text{gap}} \leq 35.0$	12 ¹²	8.1 ¹⁷	
		$0.0 < W_{\text{gap}} \leq 5.0$	36 ¹	0	
	75RB+75RB	$0.0 < W_{\text{gap}} \leq 30.0$	12 ¹²	4.6	
		$0.0 < W_{\text{gap}} \leq 30.0$	12 ¹²	7.3 ¹⁷	
	75RB+100RB	$0.0 < W_{\text{gap}} \leq 25.0$	12 ¹²	4.2	
$0.0 < W_{\text{gap}} \leq 25.0$		12 ¹²	6.9 ¹⁷		
100RB+25RB	$0.0 < W_{\text{gap}} \leq 35.0$	16 ¹³	7.2		
	$0.0 < W_{\text{gap}} \leq 35.0$	16 ¹²	9.9 ¹⁷		
100RB+50RB	$0.0 < W_{\text{gap}} \leq 30.0$	16 ¹³	5.8		
	$0.0 < W_{\text{gap}} \leq 30.0$	16 ¹³	8.5 ¹⁷		
100RB+75RB	$0.0 < W_{\text{gap}} \leq 25.0$	16 ¹³	5.0		
	$0.0 < W_{\text{gap}} \leq 25.0$	16 ¹³	7.7 ¹⁷		
100RB+100RB	$0.0 < W_{\text{gap}} \leq 20.0$	16 ¹³	4.6		
	$0.0 < W_{\text{gap}} \leq 20.0$	16 ¹³	7.3 ¹⁷		
CA_3A-3A	25RB+25RB	$45.0 < W_{\text{gap}} \leq 65.0$	12 ¹	4.7	FDD
		$45.0 < W_{\text{gap}} \leq 65.0$	12 ¹	7.4 ¹⁷	
		$0.0 < W_{\text{gap}} \leq 45.0$	25 ¹	0	
	25RB+50RB	$40.0 < W_{\text{gap}} \leq 60.0$	12 ¹	3.8	
$40.0 < W_{\text{gap}} \leq 60.0$		12 ¹	6.5 ¹⁷		

		$0.0 < W_{\text{gap}} \leq 40.0$	25 ¹	0	
	25RB+75RB	$35.0 < W_{\text{gap}} \leq 55.0$	12 ¹	3.6	
		$35.0 < W_{\text{gap}} \leq 55.0$	12 ¹	6.3 ¹⁷	
	25RB+100RB	$0.0 < W_{\text{gap}} \leq 35.0$	25 ¹	0	
		$30.0 < W_{\text{gap}} \leq 50.0$	12 ¹	3.4	
		$30.0 < W_{\text{gap}} \leq 50.0$	12 ¹	6.1 ¹⁷	
	50RB+25RB	$0.0 < W_{\text{gap}} \leq 30.0$	25 ¹	0	
		$30.0 < W_{\text{gap}} \leq 60.0$	12 ⁹	5.1	
		$30.0 < W_{\text{gap}} \leq 60.0$	12 ⁹	7.8 ¹⁷	
	50RB+50RB	$0.0 < W_{\text{gap}} \leq 30.0$	32 ¹	0	
		$25.0 < W_{\text{gap}} \leq 55.0$	12 ⁹	4.3	
		$25.0 < W_{\text{gap}} \leq 55.0$	12 ⁹	7.0 ¹⁷	
	50RB+75RB	$0.0 < W_{\text{gap}} \leq 25.0$	32 ¹	0	
		$20.0 < W_{\text{gap}} \leq 50.0$	12 ⁹	3.8	
		$20.0 < W_{\text{gap}} \leq 50.0$	12 ⁹	6.5 ¹⁷	
	50RB+100RB	$0.0 < W_{\text{gap}} \leq 20.0$	32 ¹	0	
		$15.0 < W_{\text{gap}} \leq 45.0$	12 ⁹	3.4	
		$15.0 < W_{\text{gap}} \leq 45.0$	12 ⁹	6.1 ¹⁷	
	75RB+25RB	$0.0 < W_{\text{gap}} \leq 15.0$	32 ¹	0	
		$25.0 < W_{\text{gap}} \leq 55.0$	12 ¹⁰	6.0	
		$25.0 < W_{\text{gap}} \leq 55.0$	12 ¹⁰	8.7 ¹⁷	
	75RB+50RB	$0.0 < W_{\text{gap}} \leq 25.0$	32 ¹	0	
		$20.0 < W_{\text{gap}} \leq 50.0$	12 ¹⁰	4.7	
		$20.0 < W_{\text{gap}} \leq 50.0$	12 ¹⁰	7.4 ¹⁷	
	75RB+75RB	$0.0 < W_{\text{gap}} \leq 20.0$	32 ¹	0	
		$15.0 < W_{\text{gap}} \leq 45.0$	12 ¹⁰	4.2	
		$15.0 < W_{\text{gap}} \leq 45.0$	12 ¹⁰	6.9 ¹⁷	
	75RB+100RB	$0.0 < W_{\text{gap}} \leq 15.0$	32 ¹	0	
		$10.0 < W_{\text{gap}} \leq 40.0$	12 ¹⁰	3.8	
		$10.0 < W_{\text{gap}} \leq 40.0$	12 ¹⁰	6.5 ¹⁷	
	100RB+25RB	$0.0 < W_{\text{gap}} \leq 10.0$	32 ¹	0	
		$15.0 < W_{\text{gap}} \leq 50.0$	16 ¹¹	6.5	
		$15.0 < W_{\text{gap}} \leq 50.0$	16 ¹¹	9.2 ¹⁷	
	100RB+50RB	$0.0 < W_{\text{gap}} \leq 15.0$	32 ¹	0	
		$10.0 < W_{\text{gap}} \leq 45.0$	16 ¹¹	5.1	
		$10.0 < W_{\text{gap}} \leq 45.0$	16 ¹¹	7.8 ¹⁷	
	100RB+75RB	$0.0 < W_{\text{gap}} \leq 10.0$	32 ¹	0	
		$5.0 < W_{\text{gap}} \leq 40.0$	16 ¹¹	4.5	
		$5.0 < W_{\text{gap}} \leq 40.0$	16 ¹¹	7.2 ¹⁷	
	100RB+100RB	$0.0 < W_{\text{gap}} \leq 5.0$	32 ¹	0	
		$0.0 < W_{\text{gap}} \leq 35.0$	16 ¹¹	4.1	
		$0.0 < W_{\text{gap}} \leq 35.0$	16 ¹¹	6.8 ¹⁷	
CA_4A-4A	NOTE 6	NOTE 7	NOTE 8	0.0	FDD
CA_5A-5A	25RB+25RB	NOTE 7	12 ¹	5.3	FDD
	25RB+50RB	NOTE 7	12 ¹	4.4	
	50RB+25RB	NOTE 7	12 ¹	5.9	
	50RB+50RB	NOTE 7	12 ¹	4.6	
CA_7A-7A	25RB+25RB	$0 < W_{\text{gap}} \leq 60$	25	0.0	FDD
	25RB+50RB	$0 < W_{\text{gap}} \leq 55$	25	0.0	
	25RB+75RB	$0 < W_{\text{gap}} \leq 50$	25	0.0	
	25RB+100RB	$0 < W_{\text{gap}} \leq 45$	25	0.0	

	50RB+25RB	$30 < W_{\text{gap}} \leq 55$	32^1	0.0	
		$0 < W_{\text{gap}} \leq 30$	50	0.0	
	50RB+50RB	$25.0 < W_{\text{gap}} \leq 50.0$	32^1	0.0	
		$0.0 < W_{\text{gap}} \leq 25.0$	50	0.0	
	50RB+75RB	$20 < W_{\text{gap}} \leq 45$	32^1	0.0	
		$0 < W_{\text{gap}} \leq 20$	50	0.0	
	50RB+100RB	$15 < W_{\text{gap}} \leq 40$	32^1	0.0	
		$0 < W_{\text{gap}} \leq 15$	50	0.0	
	75RB+25RB	$20.0 < W_{\text{gap}} \leq 50.0$	32^1	0.0	
		$0.0 < W_{\text{gap}} \leq 20.0$	50^1	0.0	
	75RB+50RB	$20.0 < W_{\text{gap}} \leq 45.0$	32^1	0.0	
		$0.0 < W_{\text{gap}} \leq 20.0$	50^1	0.0	
	75RB+75RB	$15.0 < W_{\text{gap}} \leq 40.0$	32^1	0.0	
		$0.0 < W_{\text{gap}} \leq 15.0$	50^1	0.0	
	75RB+100RB	$10 < W_{\text{gap}} \leq 35$	32^1	0.0	
		$0 < W_{\text{gap}} \leq 10$	50^1	0.0	
	100RB+25RB	$25 < W_{\text{gap}} \leq 45$	32^1	0.0	
		$0 < W_{\text{gap}} \leq 25$	45^1	0.0	
100RB+50RB	$20 < W_{\text{gap}} \leq 40$	32^1	0.0		
	$0 < W_{\text{gap}} \leq 20$	45^1	0.0		
100RB+75RB	$15.0 < W_{\text{gap}} \leq 35.0$	36^1	0.0		
	$0.0 < W_{\text{gap}} \leq 15.0$	50^1	0.0		
100RB+100RB	$15.0 < W_{\text{gap}} \leq 30.0$	32^1	0.0		
	$0.0 < W_{\text{gap}} \leq 15.0$	45^1	0.0		
CA_23A-23A	NOTE 6	NOTE 7	NOTE 8	0.0	FDD
CA_25A-25A	25RB+25RB	$30.0 < W_{\text{gap}} \leq 55.0$	10^1	5.0	FDD
		$0.0 < W_{\text{gap}} \leq 30.0$	25^1	0.0	
	25RB+50RB	$25.0 < W_{\text{gap}} \leq 50.0$	10^1	4.5	
		$0.0 < W_{\text{gap}} \leq 25.0$	25^1	0.0	
	25RB+75RB	$20 < W_{\text{gap}} \leq 45$	10^1	4.3	
		$0 < W_{\text{gap}} \leq 20$	25^1	0	
	25RB+100RB	$15 < W_{\text{gap}} \leq 40$	10^1	4.1	
		$0 < W_{\text{gap}} \leq 15$	25^1	0	
	50RB+25RB	$15.0 < W_{\text{gap}} \leq 50.0$	10^4	5.5	
		$0.0 < W_{\text{gap}} \leq 15.0$	32^1	0.0	
	50RB+50RB	$10.0 < W_{\text{gap}} \leq 45.0$	10^4	5.0	
		$0.0 < W_{\text{gap}} \leq 10.0$	32^1	0.0	
	50RB+75RB	$5 < W_{\text{gap}} \leq 40$	10^4	4.5	
		$0 < W_{\text{gap}} \leq 5$	32^1	0	
	50RB+100RB	$0 < W_{\text{gap}} \leq 35$	10^4	4.2	
	75RB+25RB	$10 < W_{\text{gap}} \leq 45$	10^{14}	7.6	
		$0 < W_{\text{gap}} \leq 10$	32^1	0	
	75RB+50RB	$5 < W_{\text{gap}} \leq 40$	10^{14}	6.7	
$0 < W_{\text{gap}} \leq 5$		32^1	0		
75RB+75RB	$0 < W_{\text{gap}} \leq 35$	10^{14}	5.6		
75RB+100RB	$0 < W_{\text{gap}} \leq 30$	10^{14}	4.8		
100RB+25RB	$0 < W_{\text{gap}} \leq 40$	12^{15}	8		
100RB+50RB	$0 < W_{\text{gap}} \leq 35$	12^{15}	6.7		
100RB+75RB	$0 < W_{\text{gap}} \leq 30$	12^{15}	6.1		
100RB+100RB	$0 < W_{\text{gap}} \leq 25$	12^{15}	5.7		
CA_40A-40A	NOTE 6	NOTE 7	NOTE 8	0.0	TDD
CA_41A-41A	NOTE 6	NOTE 7	NOTE 8	0.0	TDD
CA_41A-41C	NOTE 6	NOTE 7	NOTE 8	0.0	TDD
CA_41A-41D	NOTE 6	NOTE 7	NOTE 8	0.0	TDD
CA_41C-41C	NOTE 6	NOTE 7	NOTE 8	0.0	TDD
CA_42A-42A	NOTE 6	NOTE 7	NOTE 8	0.0	TDD
CA_42A-42C	NOTE 6	NOTE 7	NOTE 8	0.0	TDD
CA_42A-42D	NOTE 6	NOTE 7	NOTE 8	0.0	TDD
CA_42C-42C	NOTE 6	NOTE 7	NOTE 8	0.0	TDD
CA_66A-66A	NOTE 6	NOTE 7	NOTE 8, NOTE 16	0.0	FDD
NOTE 1: ¹ refers to the UL resource blocks shall be located as close as possible to the downlink operating band but confined within the transmission.					
NOTE 2: W_{gap} is the sub-block gap between the two sub-blocks.					

NOTE 3:	The carrier center frequency of PCC in the UL operating band is configured closer to the DL operating band.
NOTE 4:	⁴ refers to the UL resource blocks shall be located at $RB_{start}=33$.
NOTE 5:	For the TDD intra-band non-contiguous CA configurations, the minimum requirements apply only in synchronized operation between all component carriers.
NOTE 6:	All combinations of channel bandwidths defined in Table 5.6A.1-3.
NOTE 7:	All applicable sub-block gap sizes.
NOTE 8:	The PCC allocation is same as Transmission bandwidth configuration N_{RB} as defined in Table 5.6-1. In case of uplink sub-block is TDD intra-band contiguous CA then the uplink PCC and SCC allocations are the same as N_{RB_agg} defined in Table 7.3.1A-1.
NOTE 9:	⁹ refers to the UL resource blocks shall be located at $RB_{start}=25$.
NOTE 10:	¹⁰ refers to the UL resource blocks shall be located at $RB_{start}=35$.
NOTE 11:	¹¹ refers to the UL resource blocks shall be located at $RB_{start}=50$.
NOTE 12:	¹² refers to the UL resource blocks shall be located at $RB_{start}=39$.
NOTE 13:	¹³ refers to the UL resource blocks shall be located at $RB_{start}=57$.
NOTE 14:	¹⁴ refers to the UL resource blocks shall be located at $RB_{start}=44$.
NOTE 15:	¹⁵ refers to the UL resource blocks shall be located at $RB_{start}=62$.
NOTE 16:	The carrier center frequency of PCC in the DL operating band is configured closer to the UL operating band.
NOTE 17:	Applicable only if operation with 4 antenna ports is supported in the band with carrier aggregation configured.

For intra-band non-contiguous carrier aggregation with two uplink and downlink carriers the reference sensitivity is defined to be met with both downlink and uplink carriers activated. The downlink PCC and SCC minimum requirements for reference sensitivity power level as specified in Table 7.3.1-1, Table 7.3.1-1A, Table 7.3.1-1B and Table 7.3.1-1C are increased by amount of ΔR_{2UL_PCC} and ΔR_{2UL_SCC} which are defined in Table 7.3.1A-4 when uplink PCC and SCC allocations are according to the Table 7.3.1A-4.

Table 7.3.1A-4: Intra-band non-contiguous CA with two uplinks configuration for reference sensitivity

CA configuration	Aggregated channel bandwidth (PCC+SCC)	W_{gap} / [MHz]	UL PCC allocation	UL SCC allocation	ΔR_{2UL_PCC} (dB)	ΔR_{2UL_SCC} (dB)	Duplex mode
CA_4A-4A	NOTE 2	NOTE 3	NOTE 4	NOTE 5	0.0	0.0	FDD
NOTE 1: The transmitter shall be set to P_{UMAX} as defined in subclause 6.2.5A.							
NOTE 2: All combinations of channel bandwidths defined in Table 5.6A.1-3.							
NOTE 3: All applicable sub-block gap sizes.							
NOTE 4: The PCC allocation is same as Transmission bandwidth configuration N_{RB} as defined in Table 5.6-1.							
NOTE 5: The SCC allocation is same as Transmission bandwidth configuration N_{RB} as defined in Table 5.6-1.							

For combinations of intra-band and inter-band carrier aggregation with up to five downlink carriers (up to two non-contiguous sub-blocks per band and up to four contiguously aggregated carriers per band) and up to three uplink carriers (up to two contiguously aggregated carriers per band), the requirement is defined with an uplink configuration in accordance with Table 7.3.1A-3 when the uplink is active in a band supporting two non-contiguous component carriers, Table 7.3.1A-1 when the uplink (up to two contiguously aggregated uplink carriers) is active in a band supporting two contiguous component carriers and in accordance with Table 7.3.1-2 when an uplink is active in a band supporting one carrier per band. The downlink PCC shall be configured closer to the uplink operating band than the downlink SCC(s) when the uplink is active in band(s) supporting contiguous aggregation of up to four component carriers. The carrier center frequency of PCC in the UL operating band is configured closer to the DL operating band when the uplink is active in band(s) supporting non-contiguous aggregation of up to two sub-blocks. For these uplink configurations, the UE shall meet the reference sensitivity requirements for intra-band non-contiguous carrier aggregation of two downlink sub-blocks, the requirements for intra-band contiguous carrier aggregation for the contiguously aggregated downlink carriers and for any remaining component carrier(s) the requirements specified in subclause 7.3.1. For the two component carriers within the same band, $\Delta R_{IBNC} = 0$ dB for all sub-block gaps (Table 7.3.1A-3) when the uplink is active in another band. All downlink carriers shall be active throughout the tests and the requirements for the downlinks shall be met with all uplink carriers active in each band capable of UL operation. For contiguously aggregated component carriers configured in Band 46, the said requirements for intra-band contiguous carrier aggregation of downlink carriers are replaced by the requirements in Table 7.3.1A-0eA for the uplink in any band other than band 46 with the uplink configuration specified in Table 7.3.1-2. Unless given by Table 7.3.1-3, the reference sensitivity requirements shall be verified with the network signalling value NS_01 (Table 6.2.4-1) configured.

For the UE that supports any of combinations of intra-band and inter-band carrier aggregation given in Table 7.3.1A-5, exceptions to the aforementioned requirements are allowed when the uplink is active in a lower-frequency band and is within a specified frequency range such that transmitter harmonics fall within the downlink transmission bandwidth assigned in a higher band as noted in Table 7.3.1A-5. For these exceptions, the UE shall meet the requirements specified in Table 7.3.1A-5 and Table 7.3.1A-6.

Table 7.3.1A-5: Reference sensitivity for carrier aggregation QPSK $P_{\text{REFSENS, CA}}$ (exceptions due to harmonic issues in the combinations of intra-band and inter-band CA)

EUTRA CA Configuration	Channel bandwidth							Duplex mode
	EUTRA band	1.4 MHz (dBm)	3 MHz (dBm)	5 MHz (dBm)	10 MHz (dBm)	15 MHz (dBm)	20 MHz (dBm)	
CA_1A-3A-7C-28A ^{5,6}	1 ¹⁸			-89.8	-89.4	-89	-88.7	FDD
	3				-94	-92.2	-91	
	7				-95	-93.2	-92	
	28				-95.3	-93.5	-90.8	
CA_1A-3A-19A-42C ^{8,9}	1			-99.8	-96.8	-95	-93.8	FDD
	3			-96.8	-93.8	-92	-90.8	
	19			-100	-97	-95.2		
	42 ¹⁸			-71.7	-71.7	-71.7	-71.7	TDD
CA_1A-3A-19A-42C ¹⁰	1			-99.8	-96.8	-95	-93.8	FDD
	3			-96.8	-93.8	-92	-90.8	
	19			-100	-97	-95.2		
	42 ¹⁸			-97.1	-94.7	-93.2	-92.5	TDD
CA_1A-3A-42C ^{8,9}	1			-99.8	-96.8	-95	-93.8	FDD
	3			-96.8	-93.8	-92	-90.8	
	42 ¹⁸			-71.7	-71.7	-71.7	-71.7	TDD
CA_1A-7C-28A ^{5,6}	1 ¹⁸			-89.8	-89.4	-89	-88.7	FDD
	7				-95	-93.2	-92	
	28				-95.3	-93.5	-90.8	
CA_1A-3A-42C ¹⁰	1			-99.8	-96.8	-95	-93.8	FDD
	3			-96.8	-93.8	-92	-90.8	
	42 ¹⁸			-97.1	-94.7	-93.2	-92.5	TDD
CA_2A-2A-4A-12A ^{5,6}	2			-97.7	-94.7	-92.9	-91.7	FDD
	4			-90	-89.5	-89	-88.5	
	12			-96.5	-93.5			
CA_2A-4A-4A-12A ^{5,6}	2			-97.7	-94.7	-92.9	-91.7	FDD
	4			-90	-89.5	-89	-88.5	
	12			-96.5	-93.5			
CA_3A-3A-8A ⁴	3			N/A	N/A	N/A	N/A	FDD
	8			N/A	N/A			
CA_3A-19A-42C ^{8,9}	3			-96.8	-93.8	-92	-90.8	FDD
	19			-100	-97	-95.2		
	42 ¹⁸			-71.7	-71.7	-71.7	-71.7	TDD
CA_3A-19A-42C ¹⁰	3			-96.8	-93.8	-92	-90.8	FDD
	19			-100	-97	-95.2		
	42 ¹⁸			-97.1	-94.7	-93.2	-92.5	TDD
CA_3A-42C ^{8,9}	3			-96.8	-93.8	-92	-90.8	FDD
	42 ¹⁸			-71.7	-71.7	-71.7	-71.7	TDD
CA_3A-42C ¹⁰	3			-96.8	-93.8	-92	-90.8	FDD
	42 ¹⁸			-97.1	-94.7	-93.2	-92.5	TDD
CA_4A-4A-5A-12A ^{5,6}	4			-90	-89.5	-89	-88.5	FDD
	5			-97.5	-94.5			
	12			-96.5	-93.5			
CA_4A-4A-12A ^{5,6}	4			-90	-89.5	-89	-88.5	FDD
	12			-96.5	-93.5			
CA_4A-4A-12A-30A ^{5,6}	4			-90	-89.5	-89	-88.5	FDD
	12			-96.5	-93.5			
	30			-98.5	-95.5			
CA_4A-12B ^{5,6}	4			-90	-89.5	-89	-88.5	FDD
	12			-96.5	-93.5			
CA_8A-41C ⁷	8	N/A	N/A	N/A	N/A			FDD
	41				N/A	N/A	N/A	TDD
CA_8A-42C ^{14,15}	8	-102	-99	-96.8	-93.8			FDD
	42 ¹⁸			-84.8	-84.7	-84.6	-84.5	TDD
CA_26A-41C ⁷	26			N/A	N/A	N/A		FDD
	41			N/A	N/A	N/A	N/A	TDD
CA_28A-40C ^{16,17}	28			-60.7	-60.7	-60.7	-60.7	FDD
	40			-100	-97	-95.2	-94	TDD

CA_28A-40D ^{16,17}	28			-60.7	-60.7	-60.7	-60.7	FDD
	40			-100	-97	-95.2	-94	TDD
CA_28A-42C ^{12,13}	28			-98.3	-95.3	-93.5	-92.3	FDD
	42 ¹⁸			-85.7	-85.4	-85.1	-84.9	TDD

- NOTE 1: The transmitter shall be set to P_{UMAX} as defined in subclause 6.2.5A.
- NOTE 2: Reference measurement channel is A.3.2 with one sided dynamic OCNG Pattern OP.1 FDD/TDD as described in Annex A.5.1.1/A.5.2.1
- NOTE 3: The signal power is specified per port
- NOTE 4: No requirements apply when there is at least one individual RE within the uplink transmission bandwidth of the low band for which the 2nd transmitter harmonic is within the downlink transmission bandwidth of the high band. The reference sensitivity is only verified when this is not the case (the requirements specified in clause 7.3.1 apply).
- NOTE 5: These requirements apply when there is at least one individual RE within the uplink transmission bandwidth of a low band for which the 3rd transmitter harmonic is within the downlink transmission bandwidth of a high band.
- NOTE 6: The requirements should be verified for UL EARFCN of a low band (superscript LB) such that $f_{UL}^{LB} = \lfloor f_{DL}^{HB} / 0.3 \rfloor 0.1$ in MHz and $F_{UL_low}^{LB} + BW_{Channel}^{LB} / 2 \leq f_{UL}^{LB} \leq F_{UL_high}^{LB} - BW_{Channel}^{LB} / 2$ with f_{DL}^{HB} the carrier frequency of a high band in MHz and $BW_{Channel}^{LB}$ the channel bandwidth configured in the low band.
- NOTE 7: No requirements apply when there is at least one individual RE within the uplink transmission bandwidth of the low band for which the 3rd transmitter harmonic is within the downlink transmission bandwidth of the high band. The reference sensitivity is only verified when this is not the case (the requirements specified in clause 7.3.1 apply).
- NOTE 8: These requirements apply when there is at least one individual RE within the uplink transmission bandwidth of the aggressor (lower) band for which the 2nd transmitter harmonic is within the downlink transmission bandwidth of a victim (higher) band and a range ΔF_{HD} above and below the edge of this downlink transmission bandwidth. The value ΔF_{HD} depends on the E-UTRA configuration: $\Delta F_{HD} = 10$ MHz for CA_3A-42C, CA_1A-3A-19A-42C, CA_1A-3A-42C and CA_3A-19A-42C.
- NOTE 9: The requirements should be verified for UL EARFCN of the aggressor (lower) band (superscript LB) such that $f_{UL}^{LB} = \lfloor f_{DL}^{HB} / 0.2 \rfloor 0.1$ in MHz and $F_{UL_low}^{LB} + BW_{Channel}^{LB} / 2 \leq f_{UL}^{LB} \leq F_{UL_high}^{LB} - BW_{Channel}^{LB} / 2$ with f_{DL}^{HB} carrier frequency in the victim (higher) band in MHz and $BW_{Channel}^{LB}$ the channel bandwidth configured in the lower band.
- NOTE 10: The requirements are only applicable to channel bandwidths with a carrier frequency at $\pm (20 + BW_{Channel}^{HB} / 2)$ MHz offset from $2f_{UL}^{LB}$ in the victim (higher band) with $F_{UL_low}^{LB} + BW_{Channel}^{LB} / 2 \leq f_{UL}^{LB} \leq F_{UL_high}^{LB} - BW_{Channel}^{LB} / 2$, where $BW_{Channel}^{LB}$ and $BW_{Channel}^{HB}$ are the channel bandwidths configured in the aggressor (lower) and victim (higher) bands in MHz, respectively.
- NOTE 11: Void
- NOTE 12: These requirements apply when there is at least one individual RE within the uplink transmission bandwidth of a low band for which the 5th transmitter harmonic is within the downlink transmission bandwidth of a high band.
- NOTE 13: The requirements should be verified for UL EARFCN of a low band (superscript LB) such that $f_{UL}^{LB} = \lfloor f_{DL}^{HB} / 0.5 \rfloor 0.1$ in MHz and $F_{UL_low}^{LB} + BW_{Channel}^{LB} / 2 \leq f_{UL}^{LB} \leq F_{UL_high}^{LB} - BW_{Channel}^{LB} / 2$ with f_{DL}^{HB} the carrier frequency of a high band in MHz and $BW_{Channel}^{LB}$ the channel bandwidth configured in the low band.
- NOTE 14: These requirements apply when there is at least one individual RE within the uplink transmission bandwidth of a low band for which the 4th transmitter harmonic is within the downlink transmission bandwidth of a high band.
- NOTE 15: The requirements should be verified for UL EARFCN of a low band (superscript LB) such that $f_{UL}^{LB} = \lfloor f_{DL}^{HB} / 0.4 \rfloor 0.1$ in MHz and $F_{UL_low}^{LB} + BW_{Channel}^{LB} / 2 \leq f_{UL}^{LB} \leq F_{UL_high}^{LB} - BW_{Channel}^{LB} / 2$ with f_{DL}^{HB} the carrier frequency of a high band in MHz and $BW_{Channel}^{LB}$ the channel bandwidth configured in the low band.
- NOTE 16: These requirements apply when there is at least one individual RE within the downlink transmission bandwidth of the victim (lower) band for which the 3rd harmonic is within the uplink transmission bandwidth or the uplink adjacent channel's transmission bandwidth of an aggressor (higher) band.
- NOTE 17: The requirements should be verified for UL EARFCN of the aggressor (higher) band (superscript HB) such that $f_{DL}^{LB} = \lfloor f_{UL}^{HB} / 0.3 \rfloor 0.1$ in MHz and $F_{UL_low}^{LB} + BW_{Channel}^{LB} / 2 \leq f_{UL}^{LB} \leq F_{UL_high}^{LB} - BW_{Channel}^{LB} / 2$ with f_{DL}^{LB} the carrier frequency in the victim (lower) band and $BW_{Channel}^{HB}$ the channel bandwidth configured in the higher band.
- NOTE 18: Applicable for the operations with 2 or 4 antenna ports supported in the band with carrier aggregation configured.

Table 7.3.1A-6: Uplink configuration for the low band (exceptions due to harmonic issues in the combinations of intra-band and inter-band CA)

E-UTRA Band / Channel bandwidth of the high band / N _{RB} / Duplex mode								
EUTRA CA Configuration	UL band	1.4 MHz	3 MHz	5 MHz	10 MHz	15 MHz	20 MHz	Duplex mode
CA_1A-3A-7C-28A	28				16	25	25	FDD
CA_1A-3A-19A-42C	3			12	25	36	50	FDD
CA_1A-3A-42C	3			12	25	36	50	FDD
CA_1A-7C-28A	28				16	25	25	FDD
CA_2A-2A-4A-12A	12			8	16	20	20	FDD
CA_2A-4A-4A-12A	12			8	16	20	20	FDD
CA_3A-19A-42C	3			12	25	36	50	FDD
CA_3A-28A-40C	40			25	50	75	100	TDD
CA_3A-42C	3			12	25	36	50	FDD
CA_4A-4A-5A-12A	12			8	16	20	20	FDD
CA_4A-4A-12A	12			8	16	20	20	FDD
CA_4A-4A-12A-30A	12			8	16	20	20	FDD
CA_4A-12B	12			8	16	20	20	FDD
CA_8A-42C	8			8	16	25	25	FDD
CA_28A-40C	40			25	50	75	100	TDD
CA_28A-40D	40			25	50	75	100	TDD
CA_28A-42C	28			5	10	15	20	FDD
NOTE 1: refers to the UL resource blocks, which shall be centred within the transmission bandwidth configuration for the channel bandwidth.								
NOTE 2: the UL configuration applies regardless of the channel bandwidth of the low band unless the UL resource blocks exceed that specified in Table 7.3.1-2 for the uplink bandwidth in which case the allocation according to Table 7.3.1-2 applies.								

7.3.1B Minimum requirements (QPSK) for UL-MIMO

For UE with two transmitter antenna connectors in closed-loop spatial multiplexing scheme, the minimum requirements in Clause 7.3.1 shall be met with the UL-MIMO configurations specified in Table 6.2.2B-2. For UL-MIMO, the parameter P_{UMAX} is the total transmitter power over the two transmits power over the two transmit antenna connectors.

7.3.1D Minimum requirements (QPSK) for ProSe

When UE is configured for E-UTRA ProSe reception non-concurrent with E-UTRA uplink transmissions for E-UTRA ProSe operating bands specified in Table 5.5D-1, the throughput shall be $\geq 95\%$ of the maximum throughput of the reference measurement channels as specified in Annexes A.6.2 with parameters specified in Table 7.3.1D-1 and Table 7.3.1D-2.

Table 7.3.1D-1: Reference sensitivity for ProSe Direct Discovery QPSK P_{REFSENS}

Channel bandwidth							
E-UTRA ProSe Band	1.4 MHz (dBm)	3 MHz (dBm)	5 MHz (dBm)	10 MHz (dBm)	15 MHz (dBm)	20 MHz (dBm)	Duplex Mode
2			-104.1	-104.1	-104.1	-104.1	HD
3			-103.1	-103.1	-103.1	-103.1	HD
4			-106.1	-106.1	-106.1	-106.1	HD
7			-103.8	-103.8	-103.8	-103.8	HD
14			-103.1	-103.1			HD
20			-103.2	-103.2	-102.2	-102.2	HD
26			-103.5 ⁵	-103.5 ⁵	-103.5 ⁵		HD
28			-104.4	-104.4	-104.4	-102.9	HD
31			-99.5				HD
68			-104.4	-104.4	-104.4		HD

NOTE 1: Reference measurement channel is A.6.2
NOTE 2: The signal power is specified per port
NOTE 3: For the UE which supports both Band 3 and Band 9 the reference sensitivity level is FFS.
NOTE 4: For the UE which supports both Band 11 and Band 21 the reference sensitivity level is FFS.
NOTE 5: ⁵ indicates that the requirement is modified by -0.5 dB when the carrier frequency of the assigned E-UTRA channel bandwidth is within 865-894 MHz.
NOTE 6: For a UE that support both Band 18 and Band 26, the reference sensitivity level for Band 26 applies for the applicable channel bandwidths.

Table 7.3.1D-2: Reference sensitivity for ProSe Direct Communication QPSK P_{REFSENS}

Channel bandwidth							
E-UTRA ProSe Band	1.4 MHz (dBm)	3 MHz (dBm)	5 MHz (dBm)	10 MHz (dBm)	15 MHz (dBm)	20 MHz (dBm)	Duplex Mode
3				-97.6			HD
7				-98.3			HD
14				-97.6			HD
20				-97.7			HD
26				-98.0 ⁵			HD
28				-98.9			HD
31			-96.7				HD
68			-101.7	-98.9			HD

NOTE 1: Reference measurement channel is A.6.2
NOTE 2: The signal power is specified per port
NOTE 3: For the UE which supports both Band 3 and Band 9 the reference sensitivity level is FFS.
NOTE 4: For the UE which supports both Band 11 and Band 21 the reference sensitivity level is FFS.
NOTE 5: ⁵ indicates that the requirement is modified by -0.5 dB when the carrier frequency of the assigned E-UTRA channel bandwidth is within 865-894 MHz.
NOTE 6: For a UE that support both Band 18 and Band 26, the reference sensitivity level for Band 26 applies for the applicable channel bandwidths.

NOTE: Table 7.3.1D-1/ Table 7.3.1D-2 is intended for conformance tests and does not necessarily reflect the operational conditions of the network, where the number of allocated resource blocks will be practically constrained by other factors.

For the UE which supports ProSe in an operating band as specified in Section 5.5D, and the UE also supports a E-UTRA downlink inter-band carrier aggregation configuration in Table 7.3.1-1A or Table 7.3.1-1B, the minimum requirement for reference sensitivity in Table 7.3.1D-1 and Table 7.3.1D-2 shall be increased by the amount given in $\Delta R_{\text{IB,c}}$ in Table 7.3.1-1A and Table 7.3.1-1B for the corresponding E-UTRA ProSe band.

When UE is configured for E-UTRA ProSe reception on PCC for the inter-band E-UTRA ProSe / E-UTRA bands specified in Table 5.5D-2, there are no further requirements for reference sensitivity beyond those specified above when only PCC is configured in Table 7.3.1D-1 and Table 7.3.1D-2.

When UE is configured for E-UTRA ProSe reception on SCC or a non-serving carrier concurrent with E-UTRA uplink for inter-band E-UTRA ProSe / E-UTRA bands specified in Table 5.5D-2, E-UTRA ProSe throughput shall be $\geq 95\%$ of the maximum throughput of the reference measurement channels as specified in Annexes A.6.2 with parameters specified in Table 7.3.1D-1 and Table 7.3.1D-2. The reference sensitivity is defined to be met with E-UTRA uplink assigned to one band (that differs from the ProSe operating band) and all E-UTRA downlink carriers active. The E-UTRA uplink resource blocks shall be located as close as possible to E-UTRA ProSe operating band but confined within the transmission bandwidth configuration for the channel bandwidth (Table 5.6-1). The uplink configuration for the E-UTRA operating band is specified in Table 7.3.1D-3.

NOTE: The E-UTRA uplink channel bandwidth and transmission bandwidth specified in this Table 7.3.1D-3 are intended for conformance tests and does not restrict the operating conditions of the network.

Table 7.3.1D-3: Uplink configuration for E-UTRA band / E-UTRA CA band

Inter-band E-UTRA ProSe/E-UTRA configuration		E-UTRA UL band / Channel BW / N _{RB} / Duplex mode			
E-UTRA ProSe band	E-UTRA band / E-UTRA CA band	E-UTRA UL band	Channel Bandwidth (MHz)	N _{RB}	Duplex Mode
2	4	4	5	25	FDD
2	CA_2-4	4	5	25	FDD
28	1	1	5	25	FDD
28	CA_1-28	1	5	25	FDD

NOTE 1: For E-UTRA ProSe reception on SCC, the channel bandwidth of the E-UTRA downlink SCC is set same as the ProSe channel bandwidth for which reference sensitivity is being measured.

7.3.1E Minimum requirements (QPSK) for UE category 0 and M1

The throughput shall be $\geq 95\%$ of the maximum throughput of the reference measurement channels as specified in Annexes A.2.2, A.2.3 and A.3.2 (with one sided dynamic OCNG Pattern OP.1 FDD/TDD for the DL-signal as described in Annex A.5.1.1/A.5.2.1) with parameters specified in Table 7.3.1E-1A/Table 7.3.1E-1B and Table 7.3.1E-2 for category 0 and Table 7.3.1E-3/Table 7.3.1E-4 for category M1.

Table 7.3.1E-1A: Reference sensitivity for FDD and TDD UE category 0 QPSK P_{REFSENS}

E-UTRA Band	Channel bandwidth						Duplex Mode
	1.4 MHz (dBm)	3 MHz (dBm)	5 MHz (dBm)	10 MHz (dBm)	15 MHz (dBm)	20 MHz (dBm)	
2	-100.2	-97.2	-95.5	-92.5	-90.7	-89.5	FDD
3	-99.2	-96.2	-94.5	-91.5	-89.7	-88.5	FDD
4	-102.2	-99.2	-97.5	-94.5	-92.7	-91.5	FDD
5	-100.7	-97.7	-95.5	-92.5			FDD
8	-99.7	-96.7	-94.5	-91.5			FDD
13			-94	-91			FDD
20			-94.5	-91.5	-88.2	-87	FDD
39			-97.5	-94.5	-92.7	-91.5	TDD
41			-95.5	-92.5	-90.7	-89.5	TDD

NOTE 1: The transmitter shall be set to P_{UMAX} as defined in subclause 6.2.5
NOTE 2: Reference measurement channel is A.3.2 with one sided dynamic OCNG Pattern OP.1 FDD/TDD as described in Annex A.5.1.1/A.5.2.1

Table 7.3.1E-1B: Reference sensitivity for HD-FDD UE category 0 QPSK P_{REFSENS}

Channel bandwidth							
E-UTRA Band	1.4 MHz (dBm)	3 MHz (dBm)	5 MHz (dBm)	10 MHz (dBm)	15 MHz (dBm)	20 MHz (dBm)	Duplex Mode
2	-101	-98	-96.3	-93.3	-91.5	-90.3	HD-FDD
3	-100	-97	-95.3	-92.3	-90.5	-89.3	HD-FDD
4	-103	-100	-98.3	-95.3	-93.5	-92.3	HD-FDD
5	-101.5	-98.5	-96.3	-93.3			HD-FDD
8	-100.5	-97.5	-95.3	-92.3			HD-FDD
13			-95.3	-92.3			HD-FDD
20			-95.3	-92.3	-89.5	-88.3	HD-FDD

NOTE 1: The transmitter shall be set to P_{UMAX} as defined in subclause 6.2.5
NOTE 2: Reference measurement channel is A.3.2 with one sided dynamic OCNG Pattern OP.1 FDD/TDD as described in Annex A.5.1.1/A.5.2.1

The reference receive sensitivity (REFSENS) requirement specified in Table 7.3.1E-1A/Table 7.3.1E-1B shall be met for an uplink transmission bandwidth less than or equal to that specified in Table 7.3.1E-2.

Unless given by Table 7.3.1-3, the minimum requirements specified in Table 7.3.1E-1A/Table 7.3.1E-1B shall be verified with the network signalling value NS_01 (Table 6.2.4E-1) configured.

NOTE: Table 7.3.1E-2 is intended for conformance tests and does not necessarily reflect the operational conditions of the network, where the number of uplink and downlink allocated resource blocks will be practically constrained by other factors. Typical receiver sensitivity performance with HARQ retransmission enabled and using a residual BLER metric relevant for e.g. Speech Services is given in the Annex G (informative).

Table 7.3.1E-2: FDD and TDD UE category 0 Uplink configuration for reference sensitivity

E-UTRA Band / Channel bandwidth / N_{RB} / Duplex mode							
E-UTRA Band	1.4 MHz	3 MHz	5 MHz	10 MHz	15 MHz	20 MHz	Duplex Mode
2	6	15	25	36 ¹	36 ¹	36 ¹	FDD and HD-FDD
3	6	15	25	36 ¹	36 ¹	36 ¹	FDD and HD-FDD
4	6	15	25	36 ¹	36 ¹	36 ¹	FDD and HD-FDD
5	6	15	25	25 ¹			FDD and HD-FDD
8	6	15	25	25 ¹			FDD and HD-FDD
13			20 ¹	20 ¹			FDD and HD-FDD
20			25	20 ¹	20 ²	20 ²	FDD and HD-FDD
39			25	36 ¹	36 ¹	36 ¹	TDD
41			25	36 ¹	36 ¹	36 ¹	TDD

NOTE 1: ¹ refers to the UL resource blocks shall be located as close as possible to the downlink operating band but confined within the transmission bandwidth configuration for the channel bandwidth (Table 5.6-1).
NOTE 2: ² refers to Band 20; in the case of 15MHz channel bandwidth, the UL resource blocks shall be located at $\text{RB}_{\text{start}} 11$ and in the case of 20MHz channel bandwidth, the UL resource blocks shall be located at $\text{RB}_{\text{start}} 16$.

Table 7.3.1E-3: Reference sensitivity for FDD and TDD UE category M1 QPSK P_{REFSENS}

E-UTRA Band	REFSENS (dBm)	Duplex Mode
1	-102.2	FDD
2	-100.2	FDD
3	-99.2	FDD
4	-102.2	FDD
5	-100.7	FDD
7	-100.2	FDD
8	-99.7	FDD
11	-102.2 ³	FDD
12	-99.2	FDD
13	-98.7	FDD
18	-102.2 ⁴	FDD
19	-102.2	FDD
20	-99.7	FDD
21	-102.2 ³	FDD
26	-100.2	FDD
27	-100.7	FDD
28	-100.7	FDD
31	-96.5	FDD
...		
39	-103.7	TDD
41	-101.7	TDD

NOTE 1: The transmitter shall be set to P_{UMAX} as defined in subclause 6.2.5

NOTE 2: Reference measurement channel is A.3.2 with one sided dynamic OCNG Pattern OP.1 FDD/TDD as described in Annex A.5.1.1/A.5.2.1

NOTE 3: For the UE which supports both Band 11 and Band 21 the reference sensitivity level is FFS.

NOTE 4: For a UE that support both Band 18 and Band 26, the reference sensitivity level for Band 26 applies for the applicable channel bandwidths.

NOTE 5: For cat M1 the same reference sensitivity requirement applies for all applicable channel bandwidths (Table 5.6.1-1)

NOTE 6: The reference receive sensitivity shall be met for an uplink transmission bandwidth less than or equal to 6 RB except for band 31. For band 31; in the case of 3 MHz channel bandwidth 5 RB applies and the UL resource blocks shall be located at RB_{start} 9. In case of 5 MHz channel bandwidth 5 RB applies and the UL resource blocks shall be located at RB_{start} 10.

NOTE 7: The UL resource blocks shall be located as close as possible to the downlink operating band but confined within the transmission bandwidth configuration for the channel bandwidth.

Table 7.3.1E-4: Reference sensitivity for HD-FDD UE category M1 QPSK P_{REFSENS}

E-UTRA Band	REFSENS (dBm)	Duplex Mode
1	-103	HD-FDD
2	-101	HD-FDD
3	-100	HD-FDD
4	-103	HD-FDD
5	-101.5	HD-FDD
7	-101	HD-FDD
8	-100.5	HD-FDD
11	-103 ³	HD-FDD
12	-100	HD-FDD
13	-100	HD-FDD
18	-103 ⁴	HD-FDD
19	-103	HD-FDD
20	-100.5	HD-FDD
21	-103 ³	HD-FDD
26	-101	HD-FDD
27	-101.5	HD-FDD
28	-101.5	HD-FDD
31	-97.3	HD-FDD
NOTE 1: The transmitter shall be set to P_{UMAX} as defined in subclause 6.2.5		
NOTE 2: Reference measurement channel is A.3.2 with one sided dynamic OCNG Pattern OP.1 FDD/TDD as described in Annex A.5.1.1/A.5.2.1		
NOTE 3: For the UE which supports both Band 11 and Band 21 the reference sensitivity level is FFS.		
NOTE 4: For a UE that support both Band 18 and Band 26, the reference sensitivity level for Band 26 applies for the applicable channel bandwidths.		
NOTE 5: For cat M1 the same reference sensitivity requirement applies for all applicable channel bandwidths (Table 5.6.1-1)		

The reference receive sensitivity (REFSENS) requirement specified in Table 7.3.1E-3/Table 7.3.1E-4 shall be met for an uplink transmission bandwidth less than or equal to that specified in Table 7.3.1E-5.

NOTE: Table 7.3.1E-5 is intended for conformance tests and does not necessarily reflect the operational conditions of the network, where the number of uplink and downlink allocated resource blocks will be practically constrained by other factors. Typical receiver sensitivity performance with HARQ retransmission enabled and using a residual BLER metric relevant for e.g. Speech Services is given in the Annex G (informative).

Table 7.3.1E-5: FDD and TDD UE category M1 Uplink configuration for reference sensitivity

E-UTRA Band	N _{RB}	Duplex Mode
1	6 ¹	FDD and HD-FDD
2	6 ¹	FDD and HD-FDD
3	6 ¹	FDD and HD-FDD
4	6 ¹	FDD and HD-FDD
5	6 ¹	FDD and HD-FDD
7	6 ¹	FDD and HD-FDD
8	6 ¹	FDD and HD-FDD
11	6 ¹	FDD and HD-FDD
12	6 ¹	FDD and HD-FDD
13	6 ¹	FDD and HD-FDD
18	6 ¹	FDD and HD-FDD
19	6 ¹	FDD and HD-FDD
20	6 ¹	FDD and HD-FDD
21	6 ¹	FDD and HD-FDD
26	6 ¹	FDD and HD-FDD
27	6 ¹	FDD and HD-FDD
28	6 ¹	FDD and HD-FDD
31	6 ¹	FDD and HD-FDD
...		
39	6 ¹	TDD
41	6 ¹	TDD

NOTE 1: ¹ refers to the UL resource blocks shall be located as close as possible to the downlink operating band but confined within the transmission bandwidth configuration for the channel bandwidth (Table 5.6-1).

7.3.1F Minimum requirements for UE category NB1

7.3.1F.1 Reference sensitivity for UE category NB1

The category NB1 UE throughput shall be $\geq 95\%$ of the maximum throughput of the reference measurement channel as specified in Annex A.3.2 with received signal level as specified in Table 7.3.1F.1-1. Requirement in Table 7.3.1F.1-1 applies for any uplink configuration.

Table 7.3.1F.1-1: Reference sensitivity for UE category NB1

Operating band	REFSENS [dBm]
1, 2, 3, 5, 8, 12, 13, 17, 18, 19, 20, 26, 28, 66	- 108.2

7.3.1F.2 Void

7.3.2 Void

7.4 Maximum input level

This is defined as the maximum mean power received at the UE antenna port, at which the specified relative throughput shall meet or exceed the minimum requirements for the specified reference measurement channel.

7.4.1 Minimum requirements

The throughput shall be $\geq 95\%$ of the maximum throughput of the reference measurement channels as specified in Annexes A.2.2, A.2.3 and A.3.2 (with one sided dynamic OCNG Pattern OP.1 FDD/TDD as described in Annex A.5.1.1/A.5.2.1) with parameters specified in Table 7.4.1-1. For operating bands with an unpaired DL part (as noted in Table 5.5-1), the requirements only apply for carriers assigned in the paired part.

Table 7.4.1-1: Maximum input level

Rx Parameter	Units	Channel bandwidth					
		1.4 MHz	3 MHz	5 MHz	10 MHz	15 MHz	20 MHz
Power in Transmission	dBm	-25 ²					
Bandwidth Configuration		-27 ³					
NOTE 1: The transmitter shall be set to 4dB below $P_{\text{CMAX_L}}$ at the minimum uplink configuration specified in Table 7.3.1-2 with $P_{\text{CMAX_L}}$ as defined in subclause 6.2.5.							
NOTE 2: Reference measurement channel is Annex A.3.2: 64QAM, R=3/4 variant with one sided dynamic OCNG Pattern OP.1 FDD/TDD as described in Annex A.5.1.1/A.5.2.1.							
NOTE 3: Reference measurement channel is Annex A.3.2: 256QAM, R=4/5 variant with one sided dynamic OCNG Pattern OP.1 FDD/TDD as described in Annex A.5.1.1/A.5.2.1.							

7.4.1A Minimum requirements for CA

For inter-band carrier aggregation with one component carrier per operating band and the uplink assigned to one E-UTRA band the maximum input level is defined with the uplink active on the band(s) other than the band whose downlink is being tested. For E-UTRA CA configurations including an operating band without uplink band or an operating band with an unpaired DL part, the requirements for all downlinks shall be met with the single uplink carrier active in each band capable of UL operation. The UE shall meet the requirements specified in subclause 7.4.1 for each component carrier while all downlink carriers are active.

For intra-band contiguous carrier aggregation maximum input level is defined as the powers received at the UE antenna port over the Transmission bandwidth configuration of each CC, at which the specified relative throughput shall meet or exceed the minimum requirements for the specified reference measurement channel over each component carrier.

The downlink SCC(s) shall be configured at nominal channel spacing to the PCC. For FDD the PCC shall be configured closest to the uplink band. All downlink carriers shall be active throughout the test. The uplink output power shall be set as specified in Table 7.4.1A-1 with the uplink configuration set according to Table 7.3.1A-1 for the applicable carrier aggregation configuration. For UE(s) supporting one uplink carrier, the uplink configuration of the PCC shall be in accordance with Table 7.3.1-2.

The throughput shall be $\geq 95\%$ of the maximum throughput of the reference measurement channels over each component carrier as specified in Annexes A.2.2, A.2.3 and A.3.2 (with one sided dynamic OCNG Pattern OP.1 FDD/TDD as described in Annex A.5.1.1/A.5.2.1) with parameters specified in Table 7.4.1A-1. For operating bands with an unpaired DL part (as noted in Table 5.5-1), the requirements also apply for an SCC assigned in the unpaired part with parameters specified in Table 7.4.1A-1.

For intra-band non-contiguous carrier aggregation with one uplink carrier and two downlink sub-blocks, each larger than or equal to 5 MHz, the maximum input level requirements are defined with the uplink configuration in accordance with Table 7.3.1A-3. For this uplink configuration, the UE shall meet the requirements for each sub-block as specified in Table 7.4.1-1 and Table 7.4.1A-1 for one component carrier and two component carriers per sub-block, respectively. The throughput of each downlink component carrier shall be $\geq 95\%$ of the maximum throughput of the specified reference measurement channel as specified in Annexes A.2.2, A.2.3 and A.3.2 (with one sided dynamic OCNG Pattern OP.1 FDD/TDD as described in Annex A.5.1.1/A.5.2.1). The requirements apply with all downlink carriers active.

Table 7.4.1A-1: Maximum input level for intra-band contiguous CA

Rx Parameter	Units	CA Bandwidth Class					
		A	B	C	D	E	F
Power in largest Transmission Bandwidth Configuration CC	dBm		-28 ²	-25 ²	-25 ²	-26 ²	
			-30 ³	-27 ³	-27 ³	[-28] ³	
Power in each other CC	dBm		-28+ 10log(N _{RB,c} /N _{RB,largest} BW) ²	-25 + 10log(N _{RB,c} /N _{RB,largest} BW) ²	-25 + 10log(N _{RB,c} /N _{RB,largest} BW) ²	-26 + 10log(N _{RB,c} /N _{RB,largest} BW) ²	
			-30+ 10log(N _{RB,c} /N _{RB,largest} BW) ³	-27 + 10log(N _{RB,c} /N _{RB,largest} BW) ³	-27 + 10log(N _{RB,c} /N _{RB,largest} BW) ³	[-28] + 10log(N _{RB,c} /N _{RB,largest} BW) ³	
NOTE 1: The transmitter shall be set to 4dB below P _{CMAX_L,c} or P _{CMAX_L} as defined in subclause 6.2.5A.							
NOTE 2: Reference measurement channel is Annex A.3.2: 64QAM, R=3/4 variant with one sided dynamic OCNG Pattern OP.1 FDD/TDD as described in Annex A.5.1.1/A.5.2.1.							
NOTE 3: Reference measurement channel is Annex A.3.2: 256QAM, R=4/5 variant with one sided dynamic OCNG Pattern OP.1 FDD/TDD as described in Annex A.5.1.1/A.5.2.1.							

For combinations of intra-band and inter-band carrier aggregation with up to five downlink carriers (up to two non-contiguous sub-blocks per band and up to four contiguously aggregated carriers per band) and one uplink assigned to one E-UTRA band, the requirement is defined with the uplink active in a band other than that supporting the downlink(s) under test. The uplink configuration shall be in accordance with Table 7.3.1A-3 when the uplink is active in the band supporting two non-contiguous component carriers, Table 7.3.1A-1 when the uplink is active in a band supporting two contiguous component carriers and in accordance with Table 7.3.1-2 when the uplink is active in a band supporting one carrier per band. The downlink PCC shall be configured closer to the uplink operating band than the downlink SCC(s) when the uplink is active in band(s) supporting contiguous aggregation of up to four component carriers. For these uplink configurations, the UE shall meet the maximum input-level requirements for intra-band non-contiguous carrier aggregation of two downlink sub-blocks, the requirements for intra-band contiguous carrier aggregation for the contiguously aggregated downlink carriers and for any remaining component carrier(s) the requirements specified in subclause 7.4.1. All downlink carriers shall be active throughout the tests and the requirements for the downlinks shall be met with the single uplink carrier active in each band capable of UL operation.

7.4.1B Minimum requirements for UL-MIMO

For UE with two transmitter antenna connectors in closed-loop spatial multiplexing, the minimum requirements in Clause 7.4.1 shall be met with the UL-MIMO configurations specified in Table 6.2.2B-2. For UL-MIMO, the parameter P_{CMAX_L} is defined as the total transmitter power over the two transmit antenna connectors.

7.4.1D Minimum requirements for ProSe

The throughput shall be $\geq 95\%$ of the maximum throughput of the reference measurement channels as specified in Annexes A.6.2.

Table 7.4.1D-1: Maximum input level for ProSe

Rx Parameter	Units	Channel bandwidth					
		1.4 MHz	3 MHz	5 MHz	10 MHz	15 MHz	20 MHz
Power in Transmission Bandwidth Configuration	dBm	-22					
NOTE 1: Reference measurement channel is Annex A.6.2							

7.4.1F Minimum requirements for category NB1

Category NB1 UE maximum input level requirement is -25 dBm. For this input level the throughput shall be $\geq 95\%$ of the maximum throughput of the reference measurement channel as specified in Annex A.3.2.

7.4A Void

7.4A.1 Void

7.5 Adjacent Channel Selectivity (ACS)

Adjacent Channel Selectivity (ACS) is a measure of a receiver's ability to receive a E-UTRA signal at its assigned channel frequency in the presence of an adjacent channel signal at a given frequency offset from the centre frequency of the assigned channel. ACS is the ratio of the receive filter attenuation on the assigned channel frequency to the receive filter attenuation on the adjacent channel(s).

7.5.1 Minimum requirements

The UE shall fulfil the minimum requirement specified in Table 7.5.1-1 for all values of an adjacent channel interferer up to -25 dBm. However it is not possible to directly measure the ACS, instead the lower and upper range of test parameters are chosen in Table 7.5.1-2 and Table 7.5.1-3 where the throughput shall be $\geq 95\%$ of the maximum throughput of the reference measurement channels as specified in Annexes A.2.2, A.2.3 and A.3.2 (with one sided dynamic OCNG Pattern OP.1 FDD/TDD for the DL-signal as described in Annex A.5.1.1/A.5.2.1). For operating bands with an unpaired DL part (as noted in Table 5.5-1), the requirements only apply for carriers assigned in the paired part.

Table 7.5.1-1: Adjacent channel selectivity

Rx Parameter	Units	Channel bandwidth					
		1.4 MHz	3 MHz	5 MHz	10 MHz	15 MHz	20 MHz
ACS	dB	33.0	33.0	33.0	33.0	30	27

Table 7.5.1-2: Test parameters for Adjacent channel selectivity, Case 1

Rx Parameter	Units	Channel bandwidth					
		1.4 MHz	3 MHz	5 MHz	10 MHz	15 MHz	20 MHz
Power in Transmission Bandwidth Configuration	dBm	REFSENS + 14 dB					
$P_{\text{Interferer}}$	dBm	REFSENS +45.5dB	REFSENS +45.5dB	REFSENS +45.5dB	REFSENS +45.5dB	REFSENS +42.5dB	REFSENS +39.5dB
$BW_{\text{Interferer}}$	MHz	1.4	3	5	5	5	5
$F_{\text{Interferer}}$ (offset)	MHz	1.4+0.0025 / -1.4-0.0025	3+0.0075 / -3-0.0075	5+0.0025 / -5-0.0025	7.5+0.0075 / -7.5-0.0075	10+0.0125 / -10-0.0125	12.5+0.0025 / -12.5-0.0025

NOTE 1: The transmitter shall be set to 4dB below $P_{\text{CMAX_L}}$ at the minimum uplink configuration specified in Table 7.3.1-2 with $P_{\text{CMAX_L}}$ as defined in subclause 6.2.5.

NOTE 2: The interferer consists of the Reference measurement channel specified in Annex A.3.2 with one sided dynamic OCNG Pattern OP.1 FDD/TDD as described in Annex A.5.1.1/A.5.2.1 and set-up according to Annex C.3.1.

NOTE 3: The REFSENS power level is specified in Table 7.3.1-1 and Table 7.3.1-1a for two and four antenna ports, respectively.

NOTE 4: For DL category M1 UE, the reference sensitivity for category M1 in table 7.3.1E-3 should be used as REFSENS for the power in Transmission Bandwidth Configuration and $P_{\text{Interferer}}$.

NOTE5: For DL category M1 UE, the parameters for the applicable channel bandwidth apply.

Table 7.5.1-3: Test parameters for Adjacent channel selectivity, Case 2

Rx Parameter	Units	Channel bandwidth					
		1.4 MHz	3 MHz	5 MHz	10 MHz	15 MHz	20 MHz
Power in Transmission Bandwidth Configuration	dBm	-56.5	-56.5	-56.5	-56.5	-53.5	-50.5
$P_{\text{Interferer}}$	dBm	-25					
$BW_{\text{Interferer}}$	MHz	1.4	3	5	5	5	5
$F_{\text{Interferer}}$ (offset)	MHz	1.4+0.0025 / -1.4-0.0025	3+0.0075 / -3-0.0075	5+0.0025 / -5-0.0025	7.5+0.0075 / -7.5-0.0075	10+0.0125 / -10-0.0125	12.5+0.0025 / -12.5-0.0025
NOTE 1: The transmitter shall be set to 24dB below $P_{\text{CMAX_L}}$ at the minimum uplink configuration specified in Table 7.3.1-2 with $P_{\text{CMAX_L}}$ as defined in subclause 6.2.5.							
NOTE 2: The interferer consists of the Reference measurement channel specified in Annex 3.2 with one sided dynamic OCNG Pattern OP.1 FDD/TDD as described in Annex A.5.1.1/A.5.2.1 and set-up according to Annex C.3.1.							

7.5.1A Minimum requirements for CA

For inter-band carrier aggregation with one component carrier per operating band and the uplink assigned to one E-UTRA band, the adjacent channel requirements are defined with the uplink active on the band(s) other than the band whose downlink is being tested. The UE shall meet the requirements specified in subclause 7.5.1 for each component carrier while all downlink carriers are active. For E-UTRA CA configurations including an operating band without uplink operation or an operating band with an unpaired DL part (as noted in Table 5.5-1), the requirements for all downlinks shall be met with the single uplink carrier active in each band capable of UL operation. For a component carrier configured in Band 46, the requirements specified in subclause 7.5.1 are replaced by the requirements in Table 7.5.1A-0a with test parameters in Table 7.5.1A-0b and Table 7.5.1A-0c.

Table 7.5.1A-0a: Adjacent channel selectivity

E-UTRA band	Rx Parameter	Units	Channel bandwidth					
			1.4 MHz	3 MHz	5 MHz	10 MHz	15 MHz	20 MHz
46	ACS	dB						27

Table 7.5.1A-0b: Test parameters for Adjacent channel selectivity, Case 1

E-UTRA Band	Rx Parameter	Units	Channel bandwidth					
			1.4 MHz	3 MHz	5 MHz	10 MHz	15 MHz	20 MHz
46	Power in Transmission Bandwidth Configuration	dBm	REFSENS + 14 dB					
	$P_{\text{Interferer}}$	dBm						REFSENS +39.5dB
	$BW_{\text{Interferer}}$	MHz						20
	$F_{\text{Interferer}}$ (offset)	MHz						20+0.0025 / -20-0.0025
NOTE 1: In a band capable of uplink operation, the transmitter shall be set to 4dB below $P_{\text{CMAX_L}}$ at the minimum uplink configuration specified in Table 7.3.1-2 with $P_{\text{CMAX_L}}$ as defined in subclause 6.2.5.								
NOTE 2: The interferer consists of the Reference measurement channel specified in Annex A.3.2 with one sided dynamic OCNG Pattern OP.1 FDD/TDD/FS3 as described in Annex A.5.1.1/A.5.2.1/A.5.4.1 and set-up according to Annex C.3.1.								

Table 7.5.1A-0c: Test parameters for Adjacent channel selectivity, Case 2

E-UTRA band	Rx Parameter	Units	Channel bandwidth						
			1.4 MHz	3 MHz	5 MHz	10 MHz	15 MHz	20 MHz	
46	Power in Transmission Bandwidth Configuration	dBm							-50.5
	$P_{\text{Interferer}}$	dBm	-25						
	$BW_{\text{Interferer}}$	MHz							20
	$F_{\text{Interferer}}$ (offset)	MHz							20+0.0025 / -20-0.0025
NOTE 1: In a band capable of unlink operation, the transmitter shall be set to 24dB below $P_{\text{CMAX_L}}$ at the minimum uplink configuration specified in Table 7.3.1-2 with $P_{\text{CMAX_L}}$ as defined in subclause 6.2.5.									
NOTE 2: The interferer consists of the Reference measurement channel specified in Annex A.3.2 with one sided dynamic OCNG Pattern OP.1 FDD/TDD/FS3 as described in Annex A.5.1.1/A.5.2.1/A.5.4.1 and set-up according to Annex C.3.1.									

For E-UTRA CA configurations listed in Table 7.3.1A-0a under conditions for which reference sensitivity for the operating band being tested is N/A, the adjacent channel requirements of subclause 7.5.1A do not apply.

For intra-band contiguous carrier aggregation the downlink SCC(s) shall be configured at nominal channel spacing to the PCC. For FDD, the PCC shall be configured closest to the uplink band. All downlink carriers shall be active throughout the test. The uplink output power shall be set as specified in Table 7.5.1A-2 and Table 7.5.1A-3 with the uplink configuration set according to Table 7.3.1A-1 for the applicable carrier aggregation configuration. For UE(s) supporting one uplink carrier, the uplink configuration of the PCC shall be in accordance with Table 7.3.1-2. The UE shall fulfil the minimum requirement specified in Table 7.5.1A-1 for an adjacent channel interferer on either side of the aggregated downlink signal at a specified frequency offset and for an interferer power up to -25 dBm. The throughput of each carrier shall be $\geq 95\%$ of the maximum throughput of the reference measurement channels as specified in Annexes A.2.2, A.2.3 and A.3.2 (with one sided dynamic OCNG Pattern OP.1 FDD/TDD for the DL-signal as described in Annex A.5.1.1/A.5.2.1) with parameters specified in Tables 7.5.1A-2 and 7.5.1A-3. For operating bands with an unpaired DL part (as noted in Table 5.5-1), the requirements also apply for an SCC assigned in the unpaired part with parameters specified in Tables 7.5.1A-2 and 7.5.1A-3.

For intra-band non-contiguous carrier aggregation with one uplink carrier and two downlink sub-blocks, each larger than or equal to 5 MHz, the adjacent channel selectivity requirements are defined with the uplink configuration in accordance with Table 7.3.1A-3. For this uplink configuration, the UE shall meet the requirements for each sub-block as specified in subclauses 7.5.1 and 7.5.1A for one component carrier and two component carriers per sub-block, respectively. The UE shall fulfil the minimum requirements all values of a single adjacent channel interferer in-gap and out-of-gap up to a -25 dBm interferer power while all downlink carriers are active. For the lower range of test parameters (Case 1), the interferer power $P_{\text{interferer}}$ shall be set to the maximum of the levels given by the carriers of the respective sub-blocks as specified in Table 7.5.1-2 and Table 7.5.1A-2 for one component carrier and two component carriers per sub-block, respectively. The wanted signal power levels for the carriers of each sub-block shall then be adjusted relative to $P_{\text{interferer}}$ in accordance with the ACS requirement for each sub-block (Table 7.5.1-1 and Table 7.5.1A-1). For the upper range of test parameters (Case 2) for which the interferer power $P_{\text{interferer}}$ is -25 dBm (Table 7.5.1-3 and Table 7.5.1A-3) the wanted signal power levels for the carriers of each sub-block shall be adjusted relative to $P_{\text{interferer}}$ like for Case 1.

Table 7.5.1A-1: Adjacent channel selectivity

Rx Parameter	Units	CA Bandwidth Class				
		B	C	D	E	F
ACS	dB	27	24	22.2	21	

Table 7.5.1A-2: Test parameters for Adjacent channel selectivity, Case 1

Rx Parameter	Units	CA Bandwidth Class				
		B	C	D	E	F
Pw in Transmission Bandwidth Configuration, per CC		REFSENS + 14 dB	REFSENS + 14 dB	REFSENS + 14 dB	REFSENS + 14 dB	
$P_{\text{Interferer}}$	dBm	Aggregated power + 25.5 dB	Aggregated power + 22.5 dB	Aggregated power + 20.7 dB	Aggregated power + 19.5 dB	
$BW_{\text{Interferer}}$	MHz	5	5	5	5	
$F_{\text{Interferer}}$ (offset)	MHz	$2.5 + F_{\text{offset}}$ / $-2.5 - F_{\text{offset}}$	$2.5 + F_{\text{offset}}$ / $-2.5 - F_{\text{offset}}$	$2.5 + F_{\text{offset}}$ / $-2.5 - F_{\text{offset}}$	$2.5 + F_{\text{offset}}$ / $-2.5 - F_{\text{offset}}$	
NOTE 1: The transmitter shall be set to 4dB below $P_{\text{C}_{\text{MAX_L,c}}}$ or $P_{\text{C}_{\text{MAX_L}}}$ as defined in subclause 6.2.5A.						
NOTE 2: The interferer consists of the Reference measurement channel specified in Annex A.3.2 with one sided dynamic OCNG Pattern OP.1 FDD/TDD as described in Annex A.5.1.1/A.5.2.1 and set-up according to Annex C.3.1						
NOTE 3: The $F_{\text{Interferer}}$ (offset) is the frequency separation of the center frequency of the carrier closest to the interferer and the center frequency of the adjacent channel interferer and shall be further adjusted to $\lfloor F_{\text{Interferer}} / 0.015 + 0.5 \rfloor 0.015 + 0.0075$ MHz to be offset from the sub-carrier raster.						

Table 7.5.1A-3: Test parameters for Adjacent channel selectivity, Case 2

Rx Parameter	Units	CA Bandwidth Class				
		B	C	D	E	F
Pw in Transmission Bandwidth Configuration, per CC	dBm	$-50.5 + 10 \log_{10}(N_{\text{RB,c}} / N_{\text{RB,agg}})$	$-47.5 + 10 \log_{10}(N_{\text{RB,c}} / N_{\text{RB,agg}})$	$45.7 + 10 \log_{10}(N_{\text{RB,c}} / N_{\text{RB,agg}})$	$-44.5 + 10 \log_{10}(N_{\text{RB,c}} / N_{\text{RB,agg}})$	
$P_{\text{Interferer}}$	dBm	-25				
$BW_{\text{Interferer}}$	MHz	5	5	5	5	
$F_{\text{Interferer}}$ (offset)	MHz	$2.5 + F_{\text{offset}}$ / $-2.5 - F_{\text{offset}}$	$2.5 + F_{\text{offset}}$ / $-2.5 - F_{\text{offset}}$	$2.5 + F_{\text{offset}}$ / $-2.5 - F_{\text{offset}}$	$2.5 + F_{\text{offset}}$ / $-2.5 - F_{\text{offset}}$	
NOTE 1: The transmitter shall be set to 24dB below $P_{\text{C}_{\text{MAX_L,c}}}$ or $P_{\text{C}_{\text{MAX_L}}}$ as defined in subclause 6.2.5A.						
NOTE 2: The interferer consists of the Reference measurement channel specified in Annex 3.2 with one sided dynamic OCNG Pattern OP.1 FDD/TDD as described in Annex A.5.1.1/A.5.2.1 and set-up according to Annex C.3.1						
NOTE 3: The $F_{\text{Interferer}}$ (offset) is the frequency separation of the center frequency of the carrier closest to the interferer and the center frequency of the adjacent channel interferer and shall be further adjusted to $\lfloor F_{\text{Interferer}} / 0.015 + 0.5 \rfloor 0.015 + 0.0075$ MHz to be offset from the sub-carrier raster.						

For combinations of intra-band and inter-band carrier aggregation with up to five downlink carriers (up to four non-contiguously aggregated carriers per band and up to four contiguously aggregated carriers per band) and one uplink carrier assigned to one E-UTRA band, the requirement is defined with the uplink active in each band other than that supporting the downlink(s) under test. The uplink configuration shall be in accordance with Table 7.3.1A-3 when the uplink is active in the band supporting two non-contiguous component carriers, Table 7.3.1A-1 when the uplink is active in a band supporting two contiguous component carriers and in accordance with Table 7.3.1-2 when the uplink is active in a band supporting one carrier per band. The downlink PCC shall be configured closer to the uplink operating band than the downlink SCC(s) when the uplink is active in band(s) supporting contiguous aggregation of up to four component carriers. For these uplink configurations, the UE shall meet the adjacent channel selectivity requirements for intra-band non-contiguous carrier aggregation of two downlink sub-blocks with $\Delta R_{\text{IBNC}} = 0$ dB for all sub-block gaps (Table 7.3.1A-3) for the two non-contiguous downlink sub-blocks, the requirements for intra-band contiguous carrier aggregation for the contiguously aggregated downlink carriers and for any remaining component carrier(s) the requirements specified in subclause 7.5.1. For contiguously aggregated component carriers configured in Band 46, the said requirements for intra-band contiguous carrier aggregation of downlink carriers are replaced by requirements in Table 7.5.1A-4 with test parameters in Table 7.5.1A-5 and Table 7.5.1A-6. All downlink carriers shall be active throughout the tests and the requirements for downlinks shall be met with the single uplink carrier active in each band capable of UL operation.

Table 7.5.1A-4: Adjacent channel selectivity

E-UTRA band	Rx Parameter	Units	CA Bandwidth Class				
			B	C	D	E	F
46	ACS	dB		24	22.2	21	

Table 7.5.1A-5: Test parameters for Adjacent channel selectivity, Case 1

E-UTRA Band	Rx Parameter	Units	CA Bandwidth Class				
			B	C	D	E	F
46	Pw in Transmission Bandwidth Configuration, per CC			REFSENS + 14 dB	REFSENS + 14 dB	REFSENS + 14 dB	
	P _{Interferer}	dBm		Aggregate d power + 22.5 dB	Aggregate d power + 20.7 dB	Aggregate d power + 19.5 dB	
	BW _{Interferer}	MHz		20	20	20	
	F _{Interferer (offset)}	MHz		10 + F _{offset} / -10 - F _{offset}	10 + F _{offset} / -10 - F _{offset}	10 + F _{offset} / -10 - F _{offset}	
NOTE 1*: In a band capable of uplink operation, the transmitter shall be set to 4dB below P _{CMAX,L,c} or P _{CMAX,L} as defined in subclause 6.2.5A.							
NOTE 2: The interferer consists of the Reference measurement channel specified in Annex A.3.2 with one sided dynamic OCNG Pattern OP.1 FDD/TDD/FS3 as described in Annex A.5.1.1/A.5.2.1/A.5.4.1 and set-up according to Annex C.3.1.							
NOTE 3: The F _{interferer (offset)} is the frequency separation of the center frequency of the carrier closest to the interferer and the center frequency of the adjacent channel interferer and shall be further adjusted to $\lfloor F_{\text{interferer}} / 0.015 + 0.5 \rfloor 0.015 + 0.0075$ MHz to be offset from the sub-carrier raster.							

Table 7.5.1A-6: Test parameters for Adjacent channel selectivity, Case 2

E-UTRA band	Rx Parameter	Units	CA Bandwidth Class				
			B	C	D	E	F
46	Pw in Transmission Bandwidth Configuration, per CC	dBm		-47.5 + 10log ₁₀ (_{N_{RB},c} /N _{RB agg})	-45.7 + 10log ₁₀ (_{N_{RB,c}} /N _{RB agg})	-44.5 + 10log ₁₀ (_{N_{RB,c}} /N _{RB agg})	
	P _{Interferer}	dBm		-25			
	BW _{Interferer}	MHz		20	20	20	
	F _{Interferer (offset)}	MHz		10 + F _{offset} / -10 - F _{offset}	10 + F _{offset} / -10 - F _{offset}	10 + F _{offset} / -10 - F _{offset}	
NOTE 1: In a band capable of uplink operation, the transmitter shall be set to 24dB below P _{CMAX,L,c} or P _{CMAX,L} as defined in subclause 6.2.5A.							
NOTE 2: The interferer consists of the Reference measurement channel specified in Annex 3.2 with one sided dynamic OCNG Pattern OP.1 FDD/TDD/FS3 as described in Annex A.5.1.1/A.5.2.1/A.5.4.1 and set-up according to Annex C.3.1.							
NOTE 3: The F _{interferer (offset)} is the frequency separation of the center frequency of the carrier closest to the interferer and the center frequency of the adjacent channel interferer and shall be further adjusted to $\lfloor F_{\text{interferer}} / 0.015 + 0.5 \rfloor 0.015 + 0.0075$ MHz to be offset from the sub-carrier raster.							

7.5.1B Minimum requirements for UL-MIMO

For UE(s) with two transmitter antenna connectors in closed-loop spatial multiplexing scheme, the minimum requirements in Clause 7.5.1 shall be met with the UL-MIMO configurations specified in Table 6.2.2B-2. For UL-MIMO, the parameter P_{CMAX,L} is defined as the total transmitter power over the two transmit antenna connectors.

7.5.1D Minimum requirements for ProSe

The UE shall fulfil the minimum requirement specified in Table 7.5.1D-1 for all values of an adjacent channel interferer up to -25 dBm. However it is not possible to directly measure the ACS, instead the lower and upper range of test

parameters are chosen in Table 7.5.1D-2 and Table 7.5.1D-3 where the throughput shall be $\geq 95\%$ of the maximum throughput of the reference measurement channels as specified in Annex A.6.2.

Table 7.5.1D-1: Adjacent channel selectivity for ProSe

Rx Parameter	Units	Channel bandwidth					
		1.4 MHz	3 MHz	5 MHz	10 MHz	15 MHz	20 MHz
ACS	dB			33.0	33.0	30	27

Table 7.5.1D-2: Test parameters for Adjacent channel selectivity for ProSe, Case 1

Rx Parameter	Units	Channel bandwidth					
		1.4 MHz	3 MHz	5 MHz	10 MHz	15 MHz	20 MHz
Power in Transmission Bandwidth Configuration	dBm	P _{REFSENS_ProSe} + 14 dB					
P _{Interferer}	dBm			REFSENS +45.5dB	REFSENS +45.5dB	REFSENS +42.5dB	REFSENS +39.5dB
BW _{Interferer}	MHz			5	5	5	5
F _{Interferer} (offset)	MHz			5+0.0025 / -5-0.0025	7.5+0.0075 / -7.5-0.0075	10+0.0125 / -10-0.0125	12.5+0.0025 / -12.5-0.0025
NOTE 1: The interferer is QPSK modulated PUSCH containing data and reference symbols. Normal cyclic prefix is used. The data content shall be uncorrelated to the wanted signal and modulated according to clause 5 of TS36.211.							

Table 7.5.1D-3: Test parameters for Adjacent channel selectivity for ProSe, Case 2

Rx Parameter	Units	Channel bandwidth					
		1.4 MHz	3 MHz	5 MHz	10 MHz	15 MHz	20 MHz
Power in Transmission Bandwidth Configuration	dBm			-56.5	-56.5	-53.5	-50.5
P _{Interferer}	dBm	-25					
BW _{Interferer}	MHz			5	5	5	5
F _{Interferer} (offset)	MHz			5+0.0025 / -5-0.0025	7.5+0.0075 / -7.5-0.0075	10+0.0125 / -10-0.0125	12.5+0.0025 / -12.5-0.0025
NOTE 1: The interferer is QPSK modulated PUSCH containing data and reference symbols. Normal cyclic prefix is used. The data content shall be uncorrelated to the wanted signal and modulated according to clause 5 of TS36.211.							

7.5.1F Minimum requirements for category NB1

Category NB1 UE shall fulfil the minimum requirement specified in Table 7.5.1F-1 for all values of an adjacent channel interferer up to -25 dBm. However it is not possible to directly measure the ACS, instead the lower and upper range of test parameters are chosen in Table 7.5.1F-1 where the throughput shall be $\geq 95\%$ of the maximum throughput of the reference measurement channel as specified in Annex A.3.2.

Table 7.5.1F: Adjacent channel selectivity parameters for category NB1

ACS1 test Parameters		
Interferer	GSM (GMSK)	E-UTRA
Category NB1 signal power (P_{wanted}) / dBm	REFSENS + 14 dB	
Interferer signal power ($P_{\text{Interferer}}$) / dBm	REFSENS + 42 dB	REFSENS + 47 dB
Interferer bandwidth	200 kHz	5 MHz
Interferer offset from category NB1 channel edge	± 200 kHz	± 2.5 MHz
ACS2 test Parameters		
Interferer	GSM (GMSK)	E-UTRA
Category NB1 signal power (P_{wanted}) / dBm	-53 dBm	-58 dBm
Interferer signal power ($P_{\text{Interferer}}$) / dBm	-25 dBm	
Interferer bandwidth	200 kHz	5 MHz
Interferer offset from category NB1 channel edge	± 200 kHz	± 2.5 MHz

7.6 Blocking characteristics

The blocking characteristic is a measure of the receiver's ability to receive a wanted signal at its assigned channel frequency in the presence of an unwanted interferer on frequencies other than those of the spurious response or the adjacent channels, without this unwanted input signal causing a degradation of the performance of the receiver beyond a specified limit. The blocking performance shall apply at all frequencies except those at which a spurious response occur.

7.6.1 In-band blocking

In-band blocking is defined for an unwanted interfering signal falling into the UE receive band or into the first 15 MHz below or above the UE receive band at which the relative throughput shall meet or exceed the minimum requirement for the specified measurement channels.

For CA configurations including Band 46, in-band blocking in Band 46 is defined for a 20 MHz unwanted interfering signal falling into the UE receive band or into the first 60 MHz below or above the UE receive band (Table 7.6.1.1A-0a and Table 7.6.1.1A-0b).

7.6.1.1 Minimum requirements

The throughput shall be $\geq 95\%$ of the maximum throughput of the reference measurement channels as specified in Annexes A.2.2, A.2.3 and A.3.2 (with one sided dynamic OCNG Pattern OP.1 FDD/TDD for the DL-signal as described in Annex A.5.1.1/A.5.2.1) with parameters specified in Tables 7.6.1.1-1 and 7.6.1.1-2. For operating bands with an unpaired DL part (as noted in Table 5.5-1), the requirements only apply for carriers assigned in the paired part.

Table 7.6.1.1-1: In band blocking parameters

Rx parameter	Units	Channel bandwidth					
		1.4 MHz	3 MHz	5 MHz	10 MHz	15 MHz	20 MHz
Power in Transmission Bandwidth Configuration	dBm	REFSENS + channel bandwidth specific value below					
		6	6	6	6	7	9
BW _{Interferer}	MHz	1.4	3	5	5	5	5
F _{offset, case 1}	MHz	2.1+0.0125	4.5+0.0075	7.5+0.0125	7.5+0.0025	7.5+0.0075	7.5+0.0125
F _{offset, case 2}	MHz	3.5+0.0075	7.5+0.0075	12.5+0.0075	12.5+0.0125	12.5+0.0025	12.5+0.0075

NOTE 1: The transmitter shall be set to 4dB below P_{C_{MAX,L}} at the minimum uplink configuration specified in Table 7.3.1-2 with P_{C_{MAX,L}} as defined in subclause 6.2.5.

NOTE 2: The interferer consists of the Reference measurement channel specified in Annex A.3.2 with one sided dynamic OCNB Pattern OP.1 FDD/TDD as described in Annex A.5.1.1/A.5.2.1 and set-up according to Annex C.3.1.

NOTE 3: The REFSENS power level is specified in Table 7.3.1-1 and Table 7.3.1-1a for two and four antenna ports, respectively.

NOTE 4: For DL category M1 UE, the reference sensitivity for category M1 in table 7.3.1E-3 should be used as REFSENS for the power in Transmission Bandwidth Configuration.

NOTE5: For DL category M1 UE, the parameters for the applicable channel bandwidth apply.

Table 7.6.1.1-2: In-band blocking

E-UTRA band	Parameter	Unit	Case 1	Case 2	Case 3	Case 4	Case 5
		P _{Interferer}	dBm	-56	-44		
	F _{Interferer (offset)}	MHz	$\pm BW/2 - F_{offset, case 1}$ & $\pm BW/2 + F_{offset, case 1}$	$\pm BW/2 - F_{offset, case 2}$ & $\pm BW/2 + F_{offset, case 2}$			-BW/2 - 11
1, 2, 3, 4, 5, 6, 7, 8, 9, 10, 11, 12, 13, 14, 17, 18, 19, 20, 21, 22, 23, 25, 26, 27, 28, 31, 33, 34, 35, 36, 37, 38, 39, 40, 41, 42, 43, 44, 45, 65, 66, 68	F _{Interferer}	MHz	(NOTE 2)	F _{DL_low} - 15 to F _{DL_high} + 15	Void	Void	
30	F _{Interferer}	MHz	(NOTE 2)	F _{DL_low} - 15 to F _{DL_high} + 15			F _{DL_low} - 11

NOTE 1: For certain bands, the unwanted modulated interfering signal may not fall inside the UE receive band, but within the first 15 MHz below or above the UE receive band

NOTE 2: For each carrier frequency the requirement is valid for two frequencies:
a. the carrier frequency -BW/2 - F_{offset, case 1} and
b. the carrier frequency +BW/2 + F_{offset, case 1}

NOTE 3: F_{Interferer} range values for unwanted modulated interfering signal are interferer center frequencies

For the UE which supports inter band CA configuration in Table 7.3.1-1A, P_{Interferer} power defined in Table 7.6.1.1-2 is increased by the amount given by ΔR_{IB,c} in Table 7.3.1-1A.

7.6.1.1A Minimum requirements for CA

For inter-band carrier aggregation with one component carrier per operating band and the uplink assigned to one E-UTRA band the in-band blocking requirements are defined with the uplink active on the band(s) other than the band whose downlink is being tested. The UE shall meet the requirements specified in subclause 7.6.1.1 for each component carrier while all downlink carriers are active. For the UE which supports inter band CA configuration in Table 7.3.1-1A, P_{Interferer} power defined in Table 7.6.1.1-2 is increased by the amount given by ΔR_{IB,c} in Table 7.3.1-1A. For E-UTRA

CA configurations including an operating band without uplink operation or an operating band with an unpaired DL part (as noted in Table 5.5-1), the requirements for all downlinks shall be met with the single uplink carrier active in each band capable of UL operation. The requirements for the component carrier configured in the operating band without uplink operation are specified in Table 7.6.1.1A-0, Table 7.6.1.1A-0a and Table 7.6.1.1A-0b.

Table 7.6.1.1A-0: In-band blocking for additional operating bands for carrier aggregation

E-UTRA band	Parameter	Unit	Case 1	Case 2
		$P_{\text{Interferer}}$	dBm	-56
	$F_{\text{Interferer}}$ (offset)	MHz	$=-BW/2 - F_{\text{offset, case 1}}$ & $=+BW/2 + F_{\text{offset, case 1}}$	$\leq -BW/2 - F_{\text{offset, case 2}}$ & $\geq +BW/2 + F_{\text{offset, case 2}}$
29, 32, 67	$F_{\text{Interferer}}$	MHz	(NOTE 2)	$F_{\text{DL_low}} - 15$ to $F_{\text{DL_high}} + 15$
NOTE 1: For certain bands, the unwanted modulated interfering signal may not fall inside the UE receive band, but within the first 15 MHz below or above the UE receive band				
NOTE 2: For each carrier frequency the requirement is valid for two frequencies: a. the carrier frequency $-BW/2 - F_{\text{offset, case 1}}$ and b. the carrier frequency $+BW/2 + F_{\text{offset, case 1}}$				
NOTE 3: $F_{\text{Interferer}}$ range values for unwanted modulated interfering signal are interferer center frequencies				

Table 7.6.1.1A-0a: In band blocking parameters for additional operating bands for carrier aggregation

E-UTRA band	Rx parameter	Units	Channel bandwidth					
			1.4 MHz	3 MHz	5 MHz	10 MHz	15 MHz	20 MHz
46 (NOTE 3)	Power in Transmission Bandwidth Configuration	dBm	REFSENS + channel bandwidth specific value below					
							9	
	$BW_{\text{Interferer}}$	MHz					20	
	$F_{\text{offset, case 1}}$	MHz					$30+0.0125$	
	$F_{\text{offset, case 2}}$	MHz					$50+0.0075$	
NOTE 1: The transmitter shall be set to 4dB below $P_{\text{CMAX_L}}$ at the minimum uplink configuration specified in Table 7.3.1-2 with $P_{\text{CMAX_L}}$ as defined in subclause 6.2.5.								
NOTE 2: The interferer consists of the Reference measurement channel specified in Annex A.3.2 with one sided dynamic OCNG Pattern OP.1 FDD/TDD/FS3 as described in Annex A.5.1.1/A.5.2.1/A.5.4.1 and set-up according to Annex C.3.1								
NOTE 3: The interferer consists of the Reference measurement channel specified in Annex A.3.2 (TBD)								

Table 7.6.1.1A-0b: In-band blocking for additional operating bands for carrier aggregation

E-UTRA band	Parameter	Unit	Case 1	Case 2
		$P_{\text{Interferer}}$	dBm	-50
	$F_{\text{Interferer}}$ (offset)	MHz	$=-BW/2 - F_{\text{offset, case 1}}$ & $=+BW/2 + F_{\text{offset, case 1}}$	$\leq -BW/2 - F_{\text{offset, case 2}}$ & $\geq +BW/2 + F_{\text{offset, case 2}}$
46	$F_{\text{Interferer}}$	MHz	(Note 2)	$F_{\text{DL_low}} - 60$ to $F_{\text{DL_high}} + 60$
NOTE 1: For certain bands, the unwanted modulated interfering signal may not fall inside the UE receive band, but within the first 15 MHz or 60 MHz below or above the UE receive band				
NOTE 2: For each carrier frequency the requirement is valid for two frequencies: a. the carrier frequency $-BW/2 - F_{\text{offset, case 1}}$ and b. the carrier frequency $+BW/2 + F_{\text{offset, case 1}}$				
NOTE 3: $F_{\text{Interferer}}$ range values for unwanted modulated interfering signal are interferer center frequencies				

For E-UTRA CA configurations listed in Table 7.3.1A-0a under conditions for which reference sensitivity for the operating band being tested is N/A, the in-band blocking requirements of subclause 7.6.1.1A do not apply.

For intra-band contiguous carrier aggregation the downlink SCC(s) shall be configured at nominal channel spacing to the PCC. For FDD, the PCC shall be configured closest to the uplink band. All downlink carriers shall be active throughout the test. The uplink output power shall be set as specified in Table 7.6.1.1A-1 with the uplink configuration set according to Table 7.3.1A-1 for the applicable carrier aggregation configuration. For UE(s) supporting one uplink carrier, the uplink configuration of the PCC shall be in accordance with Table 7.3.1-2. The UE shall fulfil the minimum requirement in presence of an interfering signal specified in Tables 7.6.1.1A-1 and Tables 7.6.1.1A-2 being on either side of the aggregated signal. The throughput of each carrier shall be $\geq 95\%$ of the maximum throughput of the reference measurement channels as specified in Annexes A.2.2, A.2.3 and A.3.2 (with one sided dynamic OCNG Pattern OP.1 FDD/TDD for the DL-signal as described in Annex A.5.1.1/A.5.2.1) with parameters specified in Tables 7.6.1.1A-1 and 7.6.1.1A-2. For operating bands with an unpaired DL part (as noted in Table 5.5-1), the requirements also apply for an SCC assigned in the unpaired part with parameters specified in Tables 7.6.2.1A-1 and 7.6.2.1A-2.

For intra-band non-contiguous carrier aggregation with one uplink carrier and two downlink sub-blocks, each larger than or equal to 5 MHz, the in-band blocking requirements are defined with the uplink configuration in accordance with Table 7.3.1A-3. For this uplink configuration, the UE shall meet the requirements for each sub-block as specified in subclause 7.6.1.1 and in this subclause for one component carrier and two component carriers per sub-block, respectively. The requirements apply for in-gap and out-of-gap interferers while all downlink carriers are active.

Table 7.6.1.1A-1: In band blocking parameters

Rx Parameter	Units	CA Bandwidth Class				
		B	C	D	E	F
Pw in Transmission Bandwidth Configuration, per CC	dBm	REFSENS + CA Bandwidth Class specific value below				
		9	12	13.8	15	
BW _{Interferer}	MHz	5	5	5	5	
F _{offset, case 1}	MHz	7.5	7.5	7.5	7.5	
F _{offset, case 2}	MHz	12.5	12.5	12.5	12.5	
NOTE 1: The transmitter shall be set to 4dB below P _{C_{MAX}L,c} or P _{C_{MAX}L} as defined in subclause 6.2.5A						
NOTE 2: The interferer consists of the Reference measurement channel specified in Annex A.3.2 with one sided dynamic OCNG Pattern OP.1 FDD/TDD as described in Annex A.5.1.1/A.5.2.1 and set-up according to Annex C.3.1						

Table 7.6.1.1A-2: In-band blocking

CA configuration	Parameter	Unit	Case 1	Case 2
		P _{Interferer}	dBm	-56
	F _{Interferer (offset)}	MHz	$= -F_{\text{offset}} - F_{\text{offset, case 1}}$ & $= +F_{\text{offset}} + F_{\text{offset, case 1}}$	$\leq -F_{\text{offset}} - F_{\text{offset, case 2}}$ & $\geq +F_{\text{offset}} + F_{\text{offset, case 2}}$
CA_1C, CA_2C, CA_3C, CA_5B, CA_7B, CA_7C, CA_8B, CA_12B, CA_23B, CA_27B, CA_38C, CA_39C, CA_40C, CA_41C, CA_40D, CA_41D, CA_42C, CA_42D, CA_42E, CA_66B, CA_66C	F _{Interferer (Range)}	MHz	(NOTE 2)	F _{DL,low} - 15 to F _{DL,high} + 15
NOTE 1: For certain bands, the unwanted modulated interfering signal may not fall inside the UE receive band, but within the first 15 MHz below or above the UE receive band				
NOTE 2: For each carrier frequency the requirement is valid for two frequencies: a. the carrier frequency $-F_{\text{offset}} - F_{\text{offset, case 1}}$ and b. the carrier frequency $+F_{\text{offset}} + F_{\text{offset, case 1}}$				
NOTE 3: F _{offset} is the frequency offset from the center frequency of the CC being tested to the edge of aggregated channel bandwidth.				
NOTE 4: The F _{interferer (offset)} is the frequency separation of the center frequency of the carrier closest to the interferer and the center frequency of the interferer and shall be further adjusted to $\lfloor \frac{F_{\text{interferer}}}{0.015 + 0.5} \rfloor 0.015 + 0.0075$ MHz to be offset from the sub-carrier raster.				

For combinations of intra-band and inter-band carrier aggregation with up to five downlink carriers (up to two non-contiguously sub-blocks per band and up to four contiguously aggregated carriers per band) and one uplink carrier assigned to one E-UTRA band, the requirement is defined with the uplink active in the band other than that supporting the downlink(s) under test. The uplink configuration shall be in accordance with Table 7.3.1A-3 when the uplink is

active in the band supporting two non-contiguous component carriers, Table 7.3.1A-1 when the uplink is active in a band supporting two contiguous component carriers and in accordance with Table 7.3.1-2 when the uplink is active in a band supporting one carrier per band. The downlink PCC shall be configured closer to the uplink operating band than the downlink SCC(s) when the uplink is active in band(s) supporting contiguous aggregation of up to four component carriers. For these uplink configurations, the UE shall meet the in-band blocking requirements for intra-band non-contiguous carrier aggregation of two downlink sub-blocks with $\Delta R_{IBNC} = 0$ dB for all sub-block gaps (Table 7.3.1A-3) for the two non-contiguous downlink sub-blocks, the requirements for intra-band contiguous carrier aggregation for the contiguously aggregated downlink carriers and for any remaining component carrier(s) the requirements specified in subclause 7.6.1. For contiguously aggregated component carriers configured in Band 46, the said requirements for intra-band contiguous carrier aggregation of downlink carriers are replaced by requirements in Table 7.6.1.1A-3 and 7.6.1.1A-4. All downlink carriers shall be active throughout the tests and the requirements for the downlinks shall be met with the single uplink carrier active in each band capable of uplink operation.

Table 7.6.1.1A-3: In band blocking parameters

E-UTRA Band	Rx Parameter	Units	CA Bandwidth Class				
			B	C	D	E	F
46	Pw in Transmission Bandwidth Configuration, per CC	dBm	REFSENS + CA Bandwidth Class specific value below				
			12	13.8	15		
	BW _{Interferer}	MHz	20	20	20		
	F _{offset, case 1}	MHz	30	30	30		
	F _{offset, case 2}	MHz	50	50	50		
NOTE 1: In a band capable of uplink operation, the transmitter shall be set to 4dB below P _{CMAX_L,c} or P _{CMAX_L} as defined in subclause 6.2.5A							
NOTE 2: The interferer consists of the Reference measurement channel specified in Annex A.3.2 with one sided dynamic OCNG Pattern OP.1 FDD/TDD/FS3 as described in Annex A.5.1.1/A.5.2.1/A.5.4.1 and set-up according to Annex C.3.1							

Table 7.6.1.1A-4: In-band blocking

E-UTRA Band	Parameter	Unit	Case 1	Case 2
		P _{Interferer}	dBm	-50
	F _{Interferer} (offset)	MHz	$= -F_{\text{offset}} - F_{\text{offset, case 1}}$ & $= +F_{\text{offset}} + F_{\text{offset, case 1}}$	$\leq -F_{\text{offset}} - F_{\text{offset, case 2}}$ & $\geq +F_{\text{offset}} + F_{\text{offset, case 2}}$
46	F _{Interferer} (Range)	MHz	(Note 2)	F _{DL,low} - 60 to F _{DL,high} + 60
NOTE 1: For certain bands, the unwanted modulated interfering signal may not fall inside the UE receive band, but within the first 15 MHz below or above the UE receive band				
NOTE 2: For each carrier frequency the requirement is valid for two frequencies: a. the carrier frequency $-F_{\text{offset}} - F_{\text{offset, case 1}}$ and b. the carrier frequency $+F_{\text{offset}} + F_{\text{offset, case 1}}$				
NOTE 3: F _{offset} is the frequency offset from the center frequency of the CC being tested to the edge of aggregated channel bandwidth.				
NOTE 4: The F _{interferer} (offset) is the frequency separation of the center frequency of the carrier closest to the interferer and the center frequency of the interferer and shall be further adjusted to $\lfloor F_{\text{interferer}} / (0.015 + 0.5) \rfloor 0.015 + 0.0075$ MHz to be offset from the sub-carrier raster.				

7.6.1.1D Minimum requirements for ProSe

The throughput shall be $\geq 95\%$ of the maximum throughput of the reference measurement channels as specified in Annex A.6.2.

Table 7.6.1.1D-1: In band blocking parameters for ProSe Direct Discovery

Rx parameter	Units	Channel bandwidth					
		1.4 MHz	3 MHz	5 MHz	10 MHz	15 MHz	20 MHz
Power in Transmission Bandwidth Configuration	dBm	$P_{\text{REFSENS_ProSe}} + \text{channel bandwidth specific value below} + P_{\text{offset}}$					
				6	6	7	9
$BW_{\text{interferer}}$	MHz			5	5	5	5
$F_{\text{offset, case 1}}$	MHz			$7.5+0.0125$	$7.5+0.0025$	$7.5+0.0075$	$7.5+0.0125$
$F_{\text{offset, case 2}}$	MHz			$12.5+0.0075$	$12.5+0.012$	$12.5+0.002$	$12.5+0.007$
P_{offset}	dB			10.9	13.9	15.7	16.9
NOTE 1: The interferer is QPSK modulated PUSCH containing data and reference symbols. Normal cyclic prefix is used. The data content shall be uncorrelated to the wanted signal and modulated according to clause 5 of TS36.211							

Table 7.6.1.1D-2: In band blocking parameters for ProSe Direct Communication

Rx parameter	Units	Channel bandwidth					
		1.4 MHz	3 MHz	5 MHz	10 MHz	15 MHz	20 MHz
Power in Transmission Bandwidth Configuration	dBm	$P_{\text{REFSENS_ProSe}} + \text{channel bandwidth specific value below}$					
				6	6	7	9
$BW_{\text{interferer}}$	MHz			5	5	5	5
$F_{\text{offset, case 1}}$	MHz			$7.5+0.0125$	$7.5+0.0025$	$7.5+0.0075$	$7.5+0.0125$
$F_{\text{offset, case 2}}$	MHz			$12.5+0.0075$	$12.5+0.012$	$12.5+0.002$	$12.5+0.007$
NOTE 1: The interferer is QPSK modulated PUSCH containing data and reference symbols. Normal cyclic prefix is used. The data content shall be uncorrelated to the wanted signal and modulated according to clause 5 of TS36.211							

Table 7.6.1.1D-3: In-band blocking for ProSe

E-UTRA ProSe band	Parameter	Unit	Case 1	Case 2
		$P_{\text{interferer}}$	dBm	-56
	$F_{\text{interferer (offset)}}$	MHz	$\leq -BW/2 - F_{\text{offset, case 1}}$ & $\geq +BW/2 + F_{\text{offset, case 1}}$	$\leq -BW/2 - F_{\text{offset, case 2}}$ & $\geq +BW/2 + F_{\text{offset, case 2}}$
2,3,4,7,14,20,26,28,31	$F_{\text{interferer}}$	MHz	(NOTE 2)	$F_{\text{DL_low}} - 15$ to $F_{\text{DL_high}} + 15$
NOTE 1: For certain bands, the unwanted modulated interfering signal may not fall inside the UE receive band, but within the first 15 MHz below or above the UE receive band				
NOTE 2: For each carrier frequency the requirement is valid for two frequencies: a. the carrier frequency $-BW/2 - F_{\text{offset, case 1}}$ and b. the carrier frequency $+BW/2 + F_{\text{offset, case 1}}$				
NOTE 3: $F_{\text{interferer}}$ range values for unwanted modulated interfering signal are interferer center frequencies				

For the UE which supports inter band CA configuration in Table 7.3.1-1A, $P_{\text{interferer}}$ power defined in Table 7.6.1.1D-3 is increased by the amount given by $\Delta R_{\text{IB,c}}$ in Table 7.3.1-1A.

7.6.1.1F Minimum requirements for category NB1

Category NB1 UE throughput shall be $\geq 95\%$ of the maximum throughput of the reference measurement channel as specified in Annex A.3.2 with parameters specified in Table 7.6.1.1F-1.

Table 7.6.1.1F-1: In-band blocking parameters for category NB1

IBB1 test Parameters	
Category NB1 signal power (P_{wanted}) / dBm	REFSENS + 6 dB
Interferer	E-UTRA
Interferer signal power ($P_{\text{interferer}}$) / dBm	- 56 dBm
Interferer bandwidth	5 MHz
Interferer offset from category NB1 channel edge	+7.5 MHz + 0.005 MHz and -7.5 MHz - 0.005 MHz
IBB2 test Parameters	
Category NB1 signal power (P_{wanted}) / dBm	REFSENS + 6 dB
Interferer	E-UTRA
Interferer signal power ($P_{\text{interferer}}$) / dBm	- 44 dBm
Interferer bandwidth	5 MHz
Interferer offset range from category NB1 channel edge	From +12.5 MHz to $F_{\text{DL_high}} + 15$ MHz and From -12.5 MHz to $F_{\text{DL_low}} - 15$ MHz

7.6.2 Out-of-band blocking

Out-of-band band blocking is defined for an unwanted CW interfering signal falling more than 15 MHz below or above the UE receive band. For the first 15 MHz below or above the UE receive band the appropriate in-band blocking or adjacent channel selectivity in subclause 7.5.1 and subclause 7.6.1 shall be applied.

For CA configurations including Band 46, out-of-band band blocking is defined for an unwanted CW interfering signal falling more than 60 MHz below or above the UE receive band (see Table 7.6.2.1A-0a). For the first 60 MHz below or above the UE receive band the appropriate in-band blocking or adjacent channel selectivity in subclause 7.5.1A and subclause 7.6.1A shall be applied.

7.6.2.1 Minimum requirements

The throughput shall be $\geq 95\%$ of the maximum throughput of the reference measurement channels as specified in Annexes A.2.2, A.2.3 and A.3.2 (with one sided dynamic OCNCG Pattern OP.1 FDD/TDD for the DL-signal as described in Annex A.5.1.1/A.5.2.1) with parameters specified in Tables 7.6.2.1-1 and 7.6.2.1-2. For operating bands with an unpaired DL part (as noted in Table 5.5-1), the requirements only apply for carriers assigned in the paired part.

For Table 7.6.2.1-2 in frequency range 1, 2 and 3, up to $\max(24, 6 \cdot \lceil N_{RB} / 6 \rceil)$ exceptions are allowed for spurious response frequencies in each assigned frequency channel when measured using a 1MHz step size, where N_{RB} is the number of resource blocks in the downlink transmission bandwidth configuration (see Figure 5.6-1). For these exceptions the requirements of subclause 7.7 Spurious response are applicable.

For Table 7.6.2.1-2 in frequency range 4, up to $\max(8, \lceil (N_{RB} + 2 \cdot L_{CRBs}) / 8 \rceil)$ exceptions are allowed for spurious response frequencies in each assigned frequency channel when measured using a 1MHz step size, where N_{RB} is the number of resource blocks in the downlink transmission bandwidth configurations (see Figure 5.6-1) and L_{CRBs} is the number of resource blocks allocated in the uplink. For these exceptions the requirements of clause 7.7 spurious response are applicable.

Table 7.6.2.1-1: Out-of-band blocking parameters

Rx Parameter	Units	Channel bandwidth					
		1.4 MHz	3 MHz	5 MHz	10 MHz	15 MHz	20 MHz
Power in Transmission Bandwidth Configuration	dBm	REFSENS + channel bandwidth specific value below					
		6	6	6	6	7	9
<p>NOTE 1: The transmitter shall be set to 4dB below $P_{\text{CMAX,L}}$ at the minimum uplink configuration specified in Table 7.3.1-2 with $P_{\text{CMAX,L}}$ as defined in subclause 6.2.5.</p> <p>NOTE 2: Reference measurement channel is specified in Annex A.3.2 with one sided dynamic OCNG Pattern OP.1 FDD/TDD as described in Annex A.5.1.1/A.5.2.</p> <p>NOTE 3: The REFSENS power level is specified in Table 7.3.1-1 and Table 7.3.1-1a for two and four antenna ports, respectively.</p> <p>NOTE 4: For DL category M1 UE, the reference sensitivity for category M1 in table 7.3.1E-3 should be used as REFSENS for the power in Transmission Bandwidth Configuration.</p> <p>NOTE5: For DL category M1 UE, the parameters for the applicable channel bandwidth apply.</p>							

Table 7.6.2.1-2: Out of band blocking

E-UTRA band	Parameter	Units	Frequency			
			Range 1	Range 2	Range 3	Range 4
	$P_{\text{Interferer}}$	dBm	-44	-30	-15	-15
1, 2, 3, 4, 5, 6, 7, 8, 9, 10, 11, 12, 13, 14, 17, 18, 19, 20, 21, 22, 23, 24, 25, 26, 27, 28, 30, 31, 33, 34, 35, 36, 37, 38, 39, 40, 41, 42 (NOTE 2), 43 (NOTE 2), 44, 45, 65, 66, 68	$F_{\text{Interferer}}$ (CW)	MHz	$F_{\text{DL,low}} - 15$ to $F_{\text{DL,low}} - 60$	$F_{\text{DL,low}} - 60$ to $F_{\text{DL,low}} - 85$	$F_{\text{DL,low}} - 85$ to 1 MHz	-
2, 5, 12, 17	$F_{\text{Interferer}}$	MHz	-	-	-	$F_{\text{UL,low}} - F_{\text{UL,high}}$ (NOTE 4)
<p>NOTE 1: For the UE which supports both Band 11 and Band 21 the out of blocking is FFS.</p> <p>NOTE 2: The power level of the interferer ($P_{\text{Interferer}}$) for Range 3 shall be modified to -20 dBm for $F_{\text{Interferer}} > 2800$ MHz and $F_{\text{Interferer}} < 4400$ MHz.</p> <p>NOTE 3: For the UE that supports both Band 4 and Band 66, the out-of-blocking frequency range for Band 4 is defined relative to $F_{\text{DL,low}}$ and $F_{\text{DL,high}}$ of Band 66.</p> <p>NOTE 4: Range 4 requirement does not apply to category M1.</p>						

7.6.2.1A Minimum requirements for CA

For inter-band carrier aggregation with one component carrier per operating band and the uplink assigned to one E-UTRA band, the out-of-band blocking requirements are defined with the uplink active on the band(s) other than the band whose downlink is being tested. The throughput in the downlink measured shall be $\geq 95\%$ of the maximum throughput of the reference measurement channels as specified in Annexes A.2.2, A.2.3 and A.3.2 (with one sided dynamic OCNG Pattern OP.1 FDD/TDD for the DL-signal as described in Annex A.5.1.1/A.5.2.1) with parameters specified in Tables 7.6.2.1-1 and 7.6.2.1A-0. For E-UTRA CA configurations including an operating band without uplink operation (as noted in Table 5.5-1), the requirements for all downlinks shall be met with the uplink active in the band(s) capable of UL operation. For the E-UTRA CA configurations listed in Table 7.6.2.1A-0a, the parameters specified in Table 7.6.2.1A-0 are replaced by those specified in Table 7.6.2.1A-0a. The UE shall meet these requirements for each component carrier while all downlink carriers are active.

For inter-band carrier aggregation with one component carrier per operating band and the uplink active in two E-UTRA bands, the out-of-band blocking requirements specified above shall be met with the transmitter power for the uplink set to 7 dB below $P_{\text{CMAX}_L,c}$ for each serving cell c .

For E-UTRA CA configurations including an operating band without uplink band or an operating band with an unpaired DL part (as noted in Table 5.5-1), the requirements for all downlinks shall be met with the single uplink carrier active in each band capable of UL operation. For E-UTRA CA configurations listed in Table 7.3.1A-0a under conditions for which reference sensitivity for the operating band being tested is N/A, the out-of-band blocking requirements of subclause 7.6.2.1A do not apply.

Table 7.6.2.1A-0: out-of-band blocking for inter-band carrier aggregation

Parameter	Unit	Range 1	Range 2	Range 3
P_w	dBm	Table 7.6.2.1-1 for all component carriers		
$P_{\text{interferer}}$	dBm	$-44 + \Delta R_{\text{IB},c}$	$-30 + \Delta R_{\text{IB},c}$	$-15 + \Delta R_{\text{IB},c}$
$F_{\text{interferer}}$ (CW)	MHz	$-60 < f - F_{\text{DL_Low}(j)} < -15$ or $15 < f - F_{\text{DL_High}(j)} < 60$	$-85 < f - F_{\text{DL_Low}(j)} \leq -60$ or $60 \leq f - F_{\text{DL_High}(j)} < 85$	$1 \leq f \leq F_{\text{DL_Low}(1)} - 85$ or $F_{\text{DL_High}(j)} + 85 \leq f \leq F_{\text{DL_Low}(j+1)} - 85$ with $j < X$ or $F_{\text{DL_High}(X)} + 85 \leq f \leq 12750$
<p>NOTE 1: $F_{\text{DL_Low}(j)}$ and $F_{\text{DL_High}(j)}$ denote the respective lower and upper frequency limits of the operating band containing carrier j, $j = 1, \dots, X$, with carriers numbered in increasing order of carrier frequency and X the number of component carriers in the band combination ($X \leq 5$ for the present version of this specification).</p> <p>NOTE 2: For $F_{\text{DL_Low}(j+1)} - F_{\text{DL_High}(j)} < 145$ MHz and $F_{\text{interferer}}$ in $F_{\text{DL_High}(j)} < f < F_{\text{DL_Low}(j+1)}$ with $j < X$, $F_{\text{interferer}}$ can be in both Range 1 and Range 2. Then the lower of the $P_{\text{interferer}}$ applies.</p> <p>NOTE 3: For $F_{\text{DL_Low}(j)} - 15$ MHz $\leq f \leq F_{\text{DL_High}(j)} + 15$ MHz the appropriate adjacent channel selectivity and in-band blocking requirements in the respective subclauses 7.5.1A and 7.6.1.1A shall be applied for carrier j.</p> <p>NOTE 4: $\Delta R_{\text{IB},c}$ according to Table 7.3.1-1A applies when serving cell c is measured.</p> <p>NOTE 5: For inter-band CA combinations containing Bands 42 or 43, the interferer with respect to Band 42 or Band 43 shall have power level ($P_{\text{interferer}}$) for Range 3 modified to $-20 + \Delta R_{\text{IB},c}$ dBm for $F_{\text{interferer}} > 2800$ MHz and $F_{\text{interferer}} < 4400$ MHz.</p> <p>NOTE 6: For inter-band CA combinations containing Bands 7 and 38 simultaneously, for $F_{\text{interferer}}$ Bands 7 and 38 are considered as one single band as follows: $F_{\text{DL_Low}} = 2570$ MHz and $F_{\text{DL_High}} = 2690$ MHz. For Range 2, the following applies for $F_{\text{DL_Low}}$: $-95 < f - F_{\text{DL_Low}} \leq -60$ or $60 \leq f - F_{\text{DL_High}} < 85$. For Range 3 the following applies $1 \leq f \leq F_{\text{DL_Low}} - 95$ or $F_{\text{DL_High}} + 85 \leq f \leq 12750$.</p>				

Table 7.6.2.1A-0a: out-of-band blocking for inter-band carrier aggregation with one active uplink

E-UTRA CA Configuration	Parameter	Unit	Range 1	Range 2	Range 3
CA_1A-46A, CA_2A-46A, CA_3A-46A, CA_4A-46A, CA_7A-46A, CA_41A-46A, CA_42A-46A	P_{wanted}	dBm	Table 7.6.2.1-1 for all component carriers		
	$P_{interferer}$	dBm	$-44 + \Delta R_{IB,c}$	$-30 + \Delta R_{IB,c}$	$-15 + \Delta R_{IB,c}$ (NOTE 5)
	$F_{interferer}$ (CW)	MHz	$-60 < f - F_{DL_Low(j)} < -15$ with $j \leq K$ or $15 < f - F_{DL_High(j)} < 60$ with $j \leq K$	$-85 < f - F_{DL_Low(j)} \leq -60$ or $60 \leq f - F_{DL_High(j)} < 85$	$1 \leq f \leq F_{DL_Low(j)} - 85$ or $F_{DL_High(j)} + 85 \leq f \leq 12750$
NOTE 1: $F_{DL_Low(j)}$ and $F_{DL_High(j)}$, $j = 1, \dots, K, \dots, N$, denote the respective lower and upper frequency limits of the (non-overlapping) operating bands of the CA configuration numbered in increasing order of frequency, with N the number of bands in the band combination and K the number of bands with $F_{DL_High} \leq 3600$ MHz ($K = 1$ and $N = 2$ in the present version of this specification).					
NOTE 2: For $F_{DL_Low(j)} - 15$ MHz $\leq f \leq F_{DL_High(j)} + 15$ MHz the appropriate adjacent channel selectivity and in-band blocking requirements in the respective subclauses 7.5.1A and 7.6.1.1A shall be applied for carrier $j = 1$.					
NOTE 3: For $F_{DL_Low(N)} - 60$ MHz $\leq f \leq F_{DL_High(N)} + 60$ MHz the appropriate adjacent channel selectivity and in-band blocking requirements in the respective subclauses 7.5.1A and 7.6.1.1A shall be applied for carrier $N = 2$.					
NOTE 4: $\Delta R_{IB,c}$ according to Table 7.3.1-1A applies when serving cell c is measured.					
NOTE 5: The power level ($P_{interferer}$) for Range 3 is modified to -20 dBm for $F_{interferer} > 4400$ MHz except for band combinations with Band 42 for which $P_{interferer}$ for Range 3 is modified to -20 dBm for $F_{interferer} > 2800$ MHz..					

For Table 7.6.2.1A-0 and Table 7.6.2.1A-0b in frequency ranges 1, 2 and 3, up to $\max(24,6 \cdot \lceil N_{RB} \cdot /6 \rceil)$ exceptions per downlink are allowed for spurious response frequencies for one active uplink when measured using a step size of 1 MHz.

For Table 7.6.2.1A-0 in frequency ranges 1, 2 and 3, up to $2 \cdot \max(24,6 \cdot \lceil N_{RB} \cdot /6 \rceil)$ exceptions per downlink are allowed for spurious response frequencies for two active uplinks when measured using a step size of 1 MHz. For these exceptions the requirements in clause 7.7.1A apply.

For intra-band contiguous carrier aggregations the downlink SCC(s) shall be configured at nominal channel spacing to the PCC. For FDD, the PCC shall be configured closest to the uplink band. All downlink carriers shall be active throughout the test. The uplink output power shall be set as specified in Table 7.6.2.1A-1 with the uplink configuration set according to Table 7.3.1A-1 for the applicable carrier aggregation configuration. For UE(s) supporting one uplink carrier, the uplink configuration of the PCC shall be in accordance with Table 7.3.1-2.

The UE shall fulfil the minimum requirement in presence of an interfering signal specified in Tables 7.6.2.1A-1 and Tables 7.6.2.1A-2 being on either side of the aggregated signal. The throughput of each carrier shall be $\geq 95\%$ of the maximum throughput of the reference measurement channels as specified in Annexes A.2.2, A.2.3 and A.3.2 (with one sided dynamic OCNG Pattern OP.1 FDD/TDD for the DL-signal as described in Annex A.5.1.1/A.5.2.1) with parameters specified in Tables 7.6.2.1A-1 and 7.6.2.1A-2. For operating bands with an unpaired DL part (as noted in Table 5.5-1), the requirements also apply for an SCC assigned in the unpaired part with parameters specified in Tables 7.6.2.1A-1 and 7.6.2.1A-2.

For Table 7.6.2.1A-2 in frequency range 1, 2 and 3, up to $\max(24,6 \cdot \lceil N_{RB} \cdot /6 \rceil)$ exceptions are allowed for spurious response frequencies in each assigned frequency channel when measured using a 1MHz step size. For these exceptions the requirements of subclause 7.7 Spurious response are applicable.

Table 7.6.2.1A-1: Out-of-band blocking parameters

Rx Parameter	Units	CA Bandwidth Class				
		B	C	D	E	F
Pw in Transmission Bandwidth Configuration, per CC	dBm	REFSENS + CA Bandwidth Class specific value below				
		9	9	9	9	
NOTE 1: The transmitter shall be set to 4dB below $P_{C_{MAX,L,c}}$ or $P_{C_{MAX,L}}$ as defined in subclause 6.2.5A.						
NOTE 2: Reference measurement channel is specified in Annex A.3.2 with one sided dynamic OCNG Pattern OP.1 FDD/TDD as described in Annex A.5.1.1/A.5.2.						

Table 7.6.2.1A-2: Out of band blocking

CA configuration	Parameter	Units	Frequency		
			Range 1	Range 2	Range 3
			$P_{\text{Interferer}}$	-44	-30
CA_1C, CA_2C, CA_3C, CA_5B, CA_7B, CA_7C, CA_8B, CA_12B, CA_23B, CA_27B, CA_38C, CA_39C, CA_40C, CA_41C, CA_40D, CA_42C ¹ , CA_42D ¹ , CA_42E ¹ , CA_66B, CA_66C	$F_{\text{Interferer}}$ (CW)	MHz	$F_{\text{DL_low}} - 15$ to $F_{\text{DL_low}} - 60$	$F_{\text{DL_low}} - 60$ to $F_{\text{DL_low}} - 85$	$F_{\text{DL_low}} - 85$ to 1 MHz
			$F_{\text{DL_high}} + 15$ to $F_{\text{DL_high}} + 60$	$F_{\text{DL_high}} + 60$ to $F_{\text{DL_high}} + 85$	$F_{\text{DL_high}} + 85$ to +12750 MHz
NOTE 1: The power level of the interferer ($P_{\text{Interferer}}$) for this CA configuration for Range 3 shall be modified to -20 dBm for $F_{\text{Interferer}} > 2800$ MHz and $F_{\text{Interferer}} < 4400$ MHz.					

For intra-band non-contiguous carrier aggregation with one uplink carrier and two downlink sub-blocks, the out-of-band blocking requirements are defined with the uplink configuration in accordance with table 7.3.1A-3. For this uplink configuration, the UE shall meet the requirements for each sub-block as specified in subclauses 7.6.2.1 and 7.6.2.1A for one component carrier and two component carriers per sub-block, respectively. The requirements apply with all downlink carriers active.

For Table 7.6.2.1-2 in frequency range 1, 2 and 3, up to $\max(24,6 \cdot \lceil N_{RB} / 6 \rceil)$ exceptions per assigned E-UTRA channel per sub-block of the E-UTRA CA configuration are allowed for spurious response frequencies for one active uplink when measured using a 1MHz step size. For these exceptions the requirements of subclause 7.7 spurious response are applicable.

For Table 7.6.2.1-2 in frequency range 4, up to $\max(8, \lceil (N_{RB} + 2 \cdot L_{CRBs}) / 8 \rceil)$ exceptions per assigned E-UTRA channel per sub-block of the E-UTRA CA configuration are allowed for spurious response frequencies for one active uplink when measured using a 1MHz step size. For these exceptions the requirements of clause 7.7 spurious response are applicable.

For intra-band non-contiguous carrier aggregation with two uplink carriers and two downlink carriers, the out-of-band blocking requirements are defined with the uplink configuration of the PCC and SCC being in accordance with Table 7.3.1A-4 and powers of both carriers set to $P_{\text{CMAX,L,c}} - 7$ dBm. The UE shall meet the requirements specified in subclause 7.6.2.1 for each component carrier while both downlink carriers are active.

For Table 7.6.2.1-2 in frequency range 1, 2 and 3, up to $2 \cdot \max(24,6 \cdot \lceil N_{RB} / 6 \rceil)$ exceptions per assigned E-UTRA channel per sub-block of the E-UTRA CA configuration are allowed for spurious response frequencies for two active uplinks in the same operating band when measured using a 1MHz step size. For these exceptions the requirements of subclause 7.7 spurious response are applicable.

For Table 7.6.2.1-2 in frequency range 4, up to $2 \cdot \max(8, \lceil (N_{RB} + 2 \cdot L_{CRBs}) / 8 \rceil)$ exceptions per assigned E-UTRA channel per sub-block of the E-UTRA CA configuration are allowed for spurious response frequencies for two active uplinks in the same operating band when measured using a 1MHz step size. For these exceptions the requirements of clause 7.7 spurious response are applicable.

For combinations of intra-band and inter-band carrier aggregation with up to five downlink carriers (up to two non-contiguously sub-blocks per band and up to four contiguously aggregated carriers per band) and the uplink assigned to one E-UTRA band, the requirement is defined with the uplink active a band other than that supporting the downlink(s) under test. The uplink configuration shall be in accordance with Table 7.3.1A-3 when the uplink is active in the band supporting two non-contiguous component carriers, Table 7.3.1A-1 when the uplink is active in a band supporting two contiguous component carriers and in accordance with Table 7.3.1-2 when the uplink is active in a band supporting one carrier per band. The downlink PCC shall be configured closer to the uplink operating band than the downlink SCC(s) when the uplink is active in band(s) supporting contiguous aggregation of up to four component carriers. For the two non-contiguous component carriers within the same band, P_{wanted} in Table 7.6.2.1A-0 is set using $\Delta R_{\text{IBNC}} = 0$ dB for all sub-block gaps (Table 7.3.1A-3) while a band supporting contiguously aggregated carriers the out-of-band blocking parameters in Table 7.6.2.1-1 are replaced by those specified in Table 7.6.2.1A-1. For each downlink the UE shall meet the out-of-band blocking requirements applicable for inter-band carrier aggregation with one component carrier per operating band but with up to four component carriers assigned to the same band with the following exception. For each component carrier of the E-UTRA CA Configurations CA_1A-46A, CA_2A-46A, CA_3A-46A, CA_4A-46A, CA_7A-

46A, CA_41A-46A, CA_42A-46A the requirements specified in Table 7.6.2.1A-0 are replaced by those in 7.6.2.1A-0a. All downlink carriers shall be active throughout the tests and the requirements for the downlinks shall be met with the single uplink carrier active in each band capable of UL operation.

7.6.2.1D Minimum requirements for ProSe

The throughput shall be $\geq 95\%$ of the maximum throughput of the reference measurement channels as specified in Annex A.6.2 with parameters specified in Tables 7.6.2.1D-1, 7.6.2.1D-2 and 7.6.2.1D-3.

For Table 7.6.2.1D-3 in frequency range 1, 2 and 3, up to $\max(24, 6 \cdot \lceil N_{RB} / 6 \rceil)$ exceptions are allowed for spurious response frequencies in each assigned frequency channel when measured using a 1MHz step size, where N_{RB} is the number of resource blocks in the downlink transmission bandwidth configuration (see Figure 5.6-1). For these exceptions the requirements of subclause 7.7 Spurious response are applicable.

Table 7.6.2.1D-1: Out-of-band blocking parameters for ProSe Direct Discovery

Rx Parameter	Units	Channel bandwidth					
		1.4 MHz	3 MHz	5 MHz	10 MHz	15 MHz	20 MHz
Power in Transmission Bandwidth Configuration	dBm	$P_{\text{REFSENS_ProSe}}$ + channel bandwidth specific value below + P_{offset}					
				6	6	7	9
P_{offset}	dB			10.9	13.9	15.7	16.9
NOTE 2: Reference measurement channel is specified in Annex A.6.2.							

Table 7.6.2.1D-2: Out-of-band blocking parameters for ProSe Direct Communication

Rx Parameter	Units	Channel bandwidth					
		1.4 MHz	3 MHz	5 MHz	10 MHz	15 MHz	20 MHz
Power in Transmission Bandwidth Configuration	dBm	$P_{\text{REFSENS_ProSe}}$ + channel bandwidth specific value below					
				6	6	7	9
NOTE 1: Reference measurement channel is specified in Annex A.6.2.							

Table 7.6.2.1D-3: Out of band blocking for ProSe

E-UTRA ProSe band	Parameter	Units	Frequency		
			Range 1	Range 2	Range 3
	$P_{\text{Interferer}}$	dBm	-44	-30	-15
2,3,4,7,14,20,26,28,31	$F_{\text{Interferer}}$ (CW)	MHz	$F_{\text{DL_low}} - 15$ to $F_{\text{DL_low}} - 60$	$F_{\text{DL_low}} - 60$ to $F_{\text{DL_low}} - 85$	$F_{\text{DL_low}} - 85$ to 1 MHz
			$F_{\text{DL_high}} + 15$ to $F_{\text{DL_high}} + 60$	$F_{\text{DL_high}} + 60$ to $F_{\text{DL_high}} + 85$	$F_{\text{DL_high}} + 85$ to +12750 MHz
NOTE 1: For the UE which supports both Band 11 and Band 21 the out of blocking is FFS.					

7.6.2.1F Minimum requirements for category NB1

The category NB1 UE throughput shall be $\geq 95\%$ of the maximum throughput of the reference measurement channels as specified in Annexes A.3.2 with parameters specified in Table 7.6.2.1F-1.

For Table 7.6.2.1F-1 in frequency range 1, 2 and 3, up to 24 exceptions are allowed for spurious response frequencies in each assigned frequency channel when measured using a 1MHz step size. For these exceptions the requirements of subclause 7.7.1F spurious response are applicable.

Table 7.6.2.1F-1: Out-of-band blocking parameters for category NB1 UE

Parameter	Units	Frequency		
		Range 1	Range 2	Range 3
P_{wanted}	dBm	REFSENS + 6 dB		
$P_{\text{interferer (CW)}}$	dBm	-44	-30	-15
$F_{\text{interferer range}}$	MHz	$F_{\text{DL_low}} - 15$ to $F_{\text{DL_low}} - 60$	$F_{\text{DL_low}} - 60$ to $F_{\text{DL_low}} - 85$	$F_{\text{DL_low}} - 85$ to 1 MHz
	MHz	$F_{\text{DL_high}} + 15$ to $F_{\text{DL_high}} + 60$	$F_{\text{DL_high}} + 60$ to $F_{\text{DL_high}} + 85$	$F_{\text{DL_high}} + 85$ to 12750 MHz
NOTE 1: For operating bands which downlink band frequency range is between 729 MHz < 1 GHz the power level of the interferer ($P_{\text{interferer}}$) for Range 3 shall be modified to: -18 dBm for the frequency range which is bounded by $F_{\text{DL_low}} - 150$ MHz of the lowest band that UE supports in frequency range 729 MHz < 1 GHz and $F_{\text{DL_high}} + 150$ MHz of the highest band that UE supports in frequency range 729 MHz < 1 GHz.				
NOTE 2: For operating bands which downlink band frequency range is between 1805 MHz < f < 2200 MHz the power level of the interferer ($P_{\text{interferer}}$) for Range 3 shall be modified to: -20 dBm for the frequency range which is bounded by $F_{\text{DL_low}} - 200$ MHz of the lowest band that UE supports in frequency range 1805 MHz < f < 2200 MHz and $F_{\text{DL_high}} + 200$ MHz of the highest band that UE supports supports in frequency range 1805 MHz < f < 2200 MHz.				

7.6.3 Narrow band blocking

This requirement is measure of a receiver's ability to receive a E-UTRA signal at its assigned channel frequency in the presence of an unwanted narrow band CW interferer at a frequency, which is less than the nominal channel spacing.

7.6.3.1 Minimum requirements

The relative throughput shall be $\geq 95\%$ of the maximum throughput of the reference measurement channels as specified in Annexes A.2.2, A.2.3 and A.3.2 (with one sided dynamic OCNG Pattern OP.1 FDD/TDD for the DL-signal as described in Annex A.5.1.1/A.5.2.1) with parameters specified in Table 7.6.3.1-1. For operating bands with an unpaired DL part (as noted in Table 5.5-1), the requirements only apply for carriers assigned in the paired part.

Table 7.6.3.1-1: Narrow-band blocking

Parameter	Unit	Channel Bandwidth					
		1.4 MHz	3 MHz	5 MHz	10 MHz	15 MHz	20 MHz
P_w	dBm	$P_{\text{REFSENS}} + \text{channel-bandwidth specific value below}$					
		22	18	16	13	14	16
$P_{\text{uw (CW)}}$	dBm	-55	-55	-55	-55	-55	-55
$F_{\text{uw (offset for } \Delta f = 15 \text{ kHz)}}$	MHz	0.9075	1.7025	2.7075	5.2125	7.7025	10.2075
$F_{\text{uw (offset for } \Delta f = 7.5 \text{ kHz)}}$	MHz						
NOTE 1: The transmitter shall be set a 4 dB below $P_{\text{CMAX_L}}$ at the minimum uplink configuration specified in Table 7.3.1-2 with $P_{\text{CMAX_L}}$ as defined in subclause 6.2.5.							
NOTE 2: Reference measurement channel is specified in Annex A.3.2 with one sided dynamic OCNG Pattern OP.1 FDD/TDD as described in Annex A.5.1.1/A.5.2.1.							
NOTE 3: The P_{REFSENS} power level is specified in Table 7.3.1-1 and Table 7.3.1-1a for two and four antenna ports, respectively.							
NOTE 4: For DL category M1 UE, the reference sensitivity for category M1 in table 7.3.1E-3 should be used as P_{REFSENS} for P_w .							
NOTE 5: For DL category M1 UE, the parameters for the applicable channel bandwidth apply.							
NOTE 6: For DL category M1 UE, the parameter, P_w , for all the channel bandwidth will be $P_{\text{REFSENS}} + 22$ dBm.							

For the UE which supports inter-band CA configuration in Table 7.3.1-1A, P_{uw} power defined in Table 7.6.3.1-1 is increased by the amount given by $\Delta R_{\text{IB,c}}$ in Table 7.3.1-1A.

7.6.3.1A Minimum requirements for CA

For inter-band carrier aggregation with one component carrier per operating band and the uplink assigned to one E-UTRA band the narrow-band blocking requirements are defined with the uplink active on the band(s) other than the band whose downlink is being tested. The UE shall meet the requirements specified in subclause 7.6.3.1 for each component carrier while all downlink carriers are active. For E-UTRA CA configurations including an operating band without uplink band or an operating band with an unpaired DL part (as noted in Table 5.5-1), the requirements for all downlinks shall be met with the single uplink carrier active in each band capable of UL operation. For E-UTRA CA configurations listed in Table 7.3.1A-0a under conditions for which reference sensitivity for the operating band being tested is N/A, the narrow-band blocking requirements of subclause 7.6.3.1A do not apply. For E-UTRA CA configurations with a component carrier assigned in Band 46, narrow-band blocking requirements do not apply in the presence of a narrow-band interferer in Band 46.

For intra-band contiguous carrier aggregation the downlink SCC(s) shall be configured at nominal channel spacing to the PCC. For FDD, the PCC shall be configured closest to the uplink band. All downlink carriers shall be active throughout the test. The uplink output power shall be set as specified in Table 7.6.3.1A-1 with the uplink configuration set according to Table 7.3.1A-1 for the applicable carrier aggregation configuration. For UE(s) supporting one uplink, the uplink configuration of the PCC shall be in accordance with Table 7.3.1-2. The UE shall fulfil the minimum requirement in presence of an interfering signal specified in Table 7.6.3.1A-1 being on either side of the aggregated signal. The throughput of each carrier shall be $\geq 95\%$ of the maximum throughput of the reference measurement channels as specified in Annexes A.2.2, A.2.3 and A.3.2 (with one sided dynamic OCNB Pattern OP.1 FDD/TDD for the DL-signal as described in Annex A.5.1.1/A.5.2.1) with parameters specified in Table 7.6.3.1A-1. For operating bands with an unpaired DL part (as noted in Table 5.5-1), the requirements also apply for an SCC assigned in the unpaired part with parameters specified in Table 7.6.3.1A-1.

For intra-band non-contiguous carrier aggregation with one uplink carrier and two downlink sub-blocks, the narrow band blocking requirements are defined with the uplink configuration in accordance with Table 7.3.1A-3. For this uplink configuration, the UE shall meet the requirements for each sub-block as specified in subclauses 7.6.3.1 and 7.6.3.1A for one component carrier and two component carriers per sub-block, respectively. The requirements apply for in-gap and out-of-gap interferers while all downlink carriers are active.

Table 7.6.3.1A-1: Narrow-band blocking

Parameter	Unit	CA Bandwidth Class				
		B	C	D	E	F
P_w in Transmission Bandwidth Configuration, per CC	dBm	REFSENS + CA Bandwidth Class specific value below				
		16	16 ⁴	16	16	
P_{uw} (CW)	dBm	-55	-55	-55	-55	
F_{uw} (offset for $\Delta f = 15$ kHz)	MHz	- $F_{offset} - 0.2$ / + $F_{offset} + 0.2$	- $F_{offset} - 0.2$ / + $F_{offset} + 0.2$	- $F_{offset} - 0.2$ / + $F_{offset} + 0.2$	- $F_{offset} - 0.2$ / + $F_{offset} + 0.2$	
F_{uw} (offset for $\Delta f = 7.5$ kHz)		MHz				
NOTE 1: The transmitter shall be set to 4dB below $P_{CMAX,L,c}$ or $P_{CMAX,L}$ as defined in subclause 6.2.5A.						
NOTE 2: Reference measurement channel is specified in Annex A.3.2 with one sided dynamic OCNB Pattern OP.1 FDD/TDD as described in Annex A.5.1.1/A.5.2.1.						
NOTE 3: The F_{uw} (offset) is the frequency separation of the center frequency of the carrier closest to the interferer and the center frequency of the interferer and shall be further adjusted to $\lfloor F_{interferer} / 0.015 + 0.5 \rfloor 0.015 + 0.0075$ MHz to be offset from the sub-carrier raster.						
NOTE 4: The requirement is applied for the band combinations whose component carriers' $BW \geq 5$ MHz.						

For combinations of intra-band and inter-band carrier aggregation with up to five downlink carriers (up to two non-contiguously sub-blocks per band and up to four contiguously aggregated carriers per band) and one uplink carrier assigned to one E-UTRA band, the requirement is defined with the uplink active in a band other than that supporting the downlink(s) under test. The uplink configuration shall be in accordance with Table 7.3.1A-3 when the uplink is active in the band supporting two non-contiguous component carriers, Table 7.3.1A-1 when the uplink is active in a band supporting two contiguous component carriers and in accordance with Table 7.3.1-2 when the uplink is active in a band supporting one carrier per band. The downlink PCC shall be configured closer to the uplink operating band than the downlink SCC(s) when the uplink is active in band(s) supporting contiguous aggregation of up to four component carriers. For these uplink configurations, the UE shall meet the narrow-band blocking requirements for intra-band non-

contiguous carrier aggregation of two downlink sub-blocks with $\Delta R_{IBNC} = 0$ dB for all sub-block gaps (Table 7.3.1A-3) for the two non-contiguous downlink sub-blocks, the requirements for intra-band contiguous carrier aggregation for the contiguously aggregated downlink carriers and for any remaining component carrier(s) the requirements specified in subclause 7.6.3. For E-UTRA CA configurations with a component carriers assigned in Band 46, narrow-band blocking requirements do not apply in the presence of a narrow-band interferer in Band 46. All downlink carriers shall be active throughout the tests and the requirements for the downlinks shall be met with the single uplink carrier active in each band capable of UL operation.

7.6.3.1D Minimum requirements for ProSe

The relative throughput shall be $\geq 95\%$ of the maximum throughput of the reference measurement channels as specified in Annex A.6.2 with parameters specified in Table 7.6.3.1D-1 and Table 7.6.3.1D-2.

Table 7.6.3.1D-1: Narrow-band blocking for ProSe Direct Discovery

Parameter	Unit	Channel Bandwidth					
		1.4 MHz	3 MHz	5 MHz	10 MHz	15 MHz	20 MHz
P_w	dBm	P _{PREFSENS_ProSe} + channel-bandwidth specific value below + P _{offset}					
				16	13	14	16
P_{UW} (CW)	dBm			-55	-55	-55	-55
P_{offset}	dB			10.9	13.9	15.7	16.9
F_{UW} (offset for $\Delta f = 15$ kHz)	MHz			2.7075	5.2125	7.7025	10.2075
F_{UW} (offset for $\Delta f = 7.5$ kHz)	MHz						

NOTE 1: Reference measurement channel is specified in Annex A.6.2.

Table 7.6.3.1D-2: Narrow-band blocking for ProSe Direct Communication

Parameter	Unit	Channel Bandwidth					
		1.4 MHz	3 MHz	5 MHz	10 MHz	15 MHz	20 MHz
P_w	dBm	P _{PREFSENS_ProSe} + channel-bandwidth specific value below					
				16	13	14	16
P_{UW} (CW)	dBm			-55	-55	-55	-55
F_{UW} (offset for $\Delta f = 15$ kHz)	MHz			2.7075	5.2125	7.7025	10.2075
F_{UW} (offset for $\Delta f = 7.5$ kHz)	MHz						

NOTE 1: Reference measurement channel is specified in Annex A.6.2.

For the UE which supports inter-band CA configuration in Table 7.3.1-1A, P_{UW} power defined in Table 7.6.3.1D-1 and Table 7.6.3.1D-2 is increased by the amount given by $\Delta R_{IB,c}$ in Table 7.3.1-1A.

7.6A Void

<Reserved for future use>

7.6B Blocking characteristics for UL-MIMO

For UE with two transmitter antenna connectors in closed-loop spatial multiplexing scheme, the minimum requirements in subclause 7.6 shall be met with the UL-MIMO configurations specified in Table 6.2.2B-2. For UL-MIMO, the parameter $P_{C_{MAX,L}}$ is defined as the total transmitter power over the two transmit antenna connectors.

7.7 Spurious response

Spurious response is a measure of the receiver's ability to receive a wanted signal on its assigned channel frequency without exceeding a given degradation due to the presence of an unwanted CW interfering signal at any other frequency at which a response is obtained i.e. for which the out of band blocking limit as specified in subclause 7.6.2 is not met.

7.7.1 Minimum requirements

The throughput shall be $\geq 95\%$ of the maximum throughput of the reference measurement channels as specified in Annexes A.2.2, A.2.3 and A.3.2 (with one sided dynamic OCNG Pattern OP.1 FDD/TDD for the DL-signal as described in Annex A.5.1.1/A.5.2.1) with parameters specified in Tables 7.7.1-1 and 7.7.1-2. For operating bands with an unpaired DL part (as noted in Table 5.5-1), the requirements only apply for carriers assigned in the paired part.

Table 7.7.1-1: Spurious response parameters

Rx parameter	Units	Channel bandwidth					
		1.4 MHz	3 MHz	5 MHz	10 MHz	15 MHz	20 MHz
Power in Transmission Bandwidth Configuration	dBm	REFSENS + channel bandwidth specific value below					
		6	6	6	6	7	9
NOTE 1: The transmitter shall be set to 4dB below $P_{\text{CMAX_L}}$ at the minimum uplink configuration specified in Table 7.3.1-2.							
NOTE 2: Reference measurement channel is specified in Annex A.3.2 with one sided dynamic OCNG Pattern OP.1 FDD/TDD as described in Annex A.5.1.1/A.5.2.1.							
NOTE 3: The REFSENS power level is specified in Table 7.3.1-1 and Table 7.3.1-1a for two and four antenna ports, respectively.							

Table 7.7.1-2: Spurious response

Parameter	Unit	Level
$P_{\text{Interferer}}$ (CW)	dBm	-44
$F_{\text{Interferer}}$	MHz	Spurious response frequencies

For the UE which supports inter-band CA configuration in Table 7.3.1-1A, $P_{\text{interferer}}$ power defined in Table 7.7.1-2 is increased by the amount given by $\Delta R_{\text{IB,c}}$ in Table 7.3.1-1A.

7.7.1A Minimum requirements for CA

For inter-band carrier aggregation with one component carrier per operating band and the uplink assigned to one E-UTRA band the spurious response requirements are defined with the uplink active on the band(s) other than the band whose downlink is being tested. The throughput measured in each downlink with $F_{\text{interferer}}$ in Table 7.6.2.1A-0 and Table 7.6.2.1A-0a at spurious response frequencies shall be $\geq 95\%$ of the maximum throughput of the reference measurement channels as specified in Annexes A.2.2, A.2.3 and A.3.2 (with one sided dynamic OCNG Pattern OP.1 FDD/TDD for the DL-signal as described in Annex A.5.1.1/A.5.2.1) with parameters specified in Tables 7.7.1-1 and 7.7.1-2. The UE shall meet these requirements for each component carrier while all downlink carriers are active.

For inter-band carrier aggregation with one component carrier per operating band and the uplink active in two E-UTRA bands, the spurious response requirements applicable specified above shall be met with the transmitter power for the uplink set to 7 dB below $P_{\text{CMAX_L,c}}$ for each serving cell c .

For E-UTRA CA configurations including an operating band without uplink band or an operating band with an unpaired DL part (as noted in Table 5.5-1), the requirements for all downlinks shall be met with the single uplink carrier active in each band capable of UL operation. For E-UTRA CA configurations listed in Table 7.3.1A-0a under conditions for which reference sensitivity for the operating band being tested is N/A, the spurious response requirements of subclause 7.7.1A do not apply.

For intra-band contiguous carrier aggregation the downlink SCC(s) shall be configured at nominal channel spacing to the PCC. For FDD, the PCC shall be configured closest to the uplink band. All downlink carriers shall be active

throughout the test. The uplink output power shall be set as specified in Table 7.7.1A-1 with the uplink configuration set according to Table 7.3.1A-1 for the applicable carrier aggregation configuration. For UE(s) supporting one uplink carrier, the uplink configuration of the PCC shall be in accordance with Table 7.3.1-2. The throughput of each carrier shall be $\geq 95\%$ of the maximum throughput of the reference measurement channels as specified in Annexes A.2.2, A.2.3 and A.3.2 (with one sided dynamic OCNG Pattern OP.1 FDD/TDD for the DL-signal as described in Annex A.5.1.1/A.5.2.1) with parameters specified in Tables 7.7.1A-1 and 7.7.1A-2. For operating bands with an unpaired DL part (as noted in Table 5.5-1), the requirements also apply for an SCC assigned in the unpaired part with parameters specified in Tables 7.7.1A-1 and 7.7.1A-2

For intra-band non-contiguous carrier aggregation with one uplink carrier and two downlink sub-blocks, the spurious response requirements are defined with the uplink configuration in accordance with Table 7.3.1A-3. For this uplink configuration, the UE shall meet the requirements for each sub-block as specified in subclauses 7.7.1 and 7.7.1A for one component carrier and two component carriers per sub-block, respectively. The requirements apply with all downlink carriers active.

For intra-band non-contiguous carrier aggregation with two uplink carriers and two downlink carriers, the spurious response requirements applicable specified above shall be met with the transmitter powers for the uplinks set to $P_{\text{CMAX_L,c}} - 7$ dBm.

Table 7.7.1A-1: Spurious response parameters

Rx Parameter	Units	CA Bandwidth Class				
		B	C	D	E	F
Pw in Transmission Bandwidth Configuration, per CC	dBm	REFSENS + CA Bandwidth Class specific value below				
		9	9	9	9	
NOTE 1: The transmitter shall be set to 4dB below $P_{\text{CMAX_L,c}}$ or $P_{\text{CMAX_L}}$ as defined in subclause 6.2.5A.						
NOTE 2: Reference measurement channel is specified in Annex A.3.2 with one sided dynamic OCNG Pattern OP.1 FDD/TDD as described in Annex A.5.1.1/A.5.2.1.						

Table 7.7.1A-2: Spurious response

Parameter	Unit	Level
$P_{\text{Interferer}}$ (CW)	dBm	-44
$F_{\text{Interferer}}$	MHz	Spurious response frequencies

For combinations of intra-band and inter-band carrier aggregation with up to five downlink carriers (up to two non-contiguously sub-blocks per band and up to four contiguously aggregated carriers per band) and one uplink carrier assigned to one E-UTRA band, the requirement is defined with the uplink active in a band other than that supporting the downlink(s) under test. The uplink configuration shall be in accordance with Table 7.3.1A-3 when the uplink is active in the band supporting two non-contiguous component carriers, Table 7.3.1A-1 when the uplink is active in a band supporting two contiguous component carriers and in accordance with Table 7.3.1-2 when the uplink is active in a band supporting one carrier per band. The downlink PCC shall be configured closer to the uplink operating band than the downlink SCC(s) when the uplink is active in band(s) supporting contiguous aggregation of up to four component carriers. For the two non-contiguous component carriers within the same band, P_{wanted} in Table 7.6.2.1A-0 is set using $\Delta R_{\text{IBNC}} = 0$ dB for all sub-block gaps (Table 7.3.1A-3) while a band supporting contiguously aggregated carriers the out-of-band blocking parameters in Table 7.7.1-1 are replaced by those specified in Table 7.7.1A-1. For each downlink the UE shall meet the spurious-response requirements applicable for inter-band carrier aggregation with one component carrier per operating band but with up to three component carriers assigned to the same band. All downlink carriers shall be active throughout the tests and the requirements for the downlinks shall be met with the single uplink carrier active in each band capable of UL operation.

7.7.1B Minimum requirements for UL-MIMO

For UE with two transmitter antenna connectors in closed-loop spatial multiplexing scheme, the minimum requirements in Clause 7.7.1 shall be met with the UL-MIMO configurations specified in Table 6.2.2B-2. For UL-MIMO, the parameter $P_{\text{CMAX_L}}$ is defined as the total transmitter power over the two transmit antenna connectors.

7.7.1D Minimum requirements for ProSe

The throughput shall be $\geq 95\%$ of the maximum throughput of the reference measurement channels as specified in Annex A.6.2 with parameters specified in Tables 7.7.1D-1, 7.7.1D-2, and 7.7.1D-3.

Table 7.7.1D-1: Spurious response parameters for ProSe Direct Discovery

Rx parameter	Units	Channel bandwidth					
		1.4 MHz	3 MHz	5 MHz	10 MHz	15 MHz	20 MHz
Power in Transmission Bandwidth Configuration	dBm	$P_{\text{REFSENS_ProSe}} + \text{channel bandwidth specific value below} + P_{\text{offset}}$					
				6	6	7	9
P_{offset}	dB			10.9	13.9	15.7	16.9
NOTE 1: Reference measurement channel is specified in Annex A.6.2.							

Table 7.7.1D-2: Spurious response parameters for ProSe Direct Communication

Rx parameter	Units	Channel bandwidth					
		1.4 MHz	3 MHz	5 MHz	10 MHz	15 MHz	20 MHz
Power in Transmission Bandwidth Configuration	dBm	$P_{\text{REFSENS_ProSe}} + \text{channel bandwidth specific value below}$					
				6	6	7	9
NOTE 1: Reference measurement channel is specified in Annex A.6.2.							

Table 7.7.1D-3: Spurious response for ProSe

Parameter	Unit	Level
$P_{\text{Interferer (CW)}}$	dBm	-44
$F_{\text{Interferer}}$	MHz	Spurious response frequencies

For the UE which supports inter-band CA configuration in Table 7.3.1-1A, $P_{\text{interferer}}$ power defined in Table 7.7.1D-3 is increased by the amount given by $\Delta R_{\text{IB,c}}$ in Table 7.3.1-1A.

7.7.1F Minimum requirements for UE category NB1

The category NB1 UE throughput shall be $\geq 95\%$ of the maximum throughput of the reference measurement channel as specified in Annex A.3.2 with parameters specified in Tables 7.7.1F-1.

Table 7.7.1F-1: Spurious response parameters for UE category NB1

Parameter	Unit	Level
P_{signal}	dBm	REFSENS+6
$P_{\text{Interferer (CW)}}$	dBm	-44
$F_{\text{Interferer}}$	MHz	Spurious response frequencies
Number of spurious response frequencies		24 (in OOB range 1, 2, 3)
NOTE 1: Reference measurement channel is specified in Annex A.3.2.		
NOTE 2: The REFSENS power level is specified in 7.3.1F.1-1.		
NOTE 3: OOB range 1, 2, 3 refers to Table 7.6.2.1F-1.		

7.8 Intermodulation characteristics

Intermodulation response rejection is a measure of the capability of the receiver to receive a wanted signal on its assigned channel frequency in the presence of two or more interfering signals which have a specific frequency relationship to the wanted signal.

7.8.1 Wide band intermodulation

The wide band intermodulation requirement is defined following the same principles using modulated E-UTRA carrier and CW signal as interferer.

7.8.1.1 Minimum requirements

The throughput shall be $\geq 95\%$ of the maximum throughput of the reference measurement channels as specified in Annexes A.2.2, A.2.3 and A.3.2 (with one sided dynamic OCNG Pattern OP.1 FDD/TDD for the DL-signal as described in Annex A.5.1.1/A.5.2.1) with parameters specified in Table 7.8.1.1 for the specified wanted signal mean power in the presence of two interfering signals. For operating bands with an unpaired DL part (as noted in Table 5.5-1), the requirements only apply for carriers assigned in the paired part.

Table 7.8.1.1-1: Wide band intermodulation

Rx Parameter	Units	Channel bandwidth					
		1.4 MHz	3 MHz	5 MHz	10 MHz	15 MHz	20 MHz
Power in Transmission Bandwidth Configuration	dBm	REFSENS + channel bandwidth specific value below					
		12	8	6	6	7	9
$P_{\text{Interferer 1}}$ (CW)	dBm	-46					
$P_{\text{Interferer 2}}$ (Modulated)	dBm	-46					
$BW_{\text{Interferer 2}}$		1.4	3	5			
$F_{\text{Interferer 1}}$ (Offset)	MHz	-BW/2 -2.1	-BW/2 -4.5	-BW/2 - 7.5			
		/	/	/			
		+BW/2+ 2.1	+BW/2 + 4.5	+BW/2 + 7.5			
$F_{\text{Interferer 2}}$ (Offset)	MHz	$2 \cdot F_{\text{Interferer 1}}$					
NOTE 1: The transmitter shall be set to 4dB below $P_{\text{CMAX_L}}$ at the minimum uplink configuration specified in Table 7.3.1-2 with $P_{\text{CMAX_L}}$ as defined in subclause 6.2.5.							
NOTE 2: Reference measurement channel is specified in Annex A.3.2 with one sided dynamic OCNG Pattern OP.1 FDD/TDD as described in Annex A.5.1.1/A.5.2.1.							
NOTE 3: The modulated interferer consists of the Reference measurement channel specified in Annex A.3.2 with one sided dynamic OCNG Pattern OP.1 FDD/TDD as described in Annex A.5.1.1/A.5.2.1 with set-up according to Annex C.3.1The interfering modulated signal is 5MHz E-UTRA signal as described in Annex D for channel bandwidth $\geq 5\text{MHz}$.							
NOTE 4: The REFSENS power level is specified in Table 7.3.1-1 and Table 7.3.1-1a for two and four antenna ports, respectively.							
NOTE 5: For DL category M1 UE, the reference sensitivity for category M1 in table 7.3.1E-3 should be used as REFSENS for the power in Transmission Bandwidth Configuration.							
NOTE6: For DL category M1 UE, the parameters for the applicable channel bandwidth apply, and BW refers to the corresponding channel bandwidth.							

For the UE which supports inter band CA configuration in Table 7.3.1-1A, $P_{\text{interferer1}}$ and $P_{\text{interferer2}}$ powers defined in Table 7.8.1.1-1 are increased by the amount given by $\Delta R_{\text{IB,c}}$ in Table 7.3.1-1A.

7.8.1A Minimum requirements for CA

For inter-band carrier aggregation with one component carrier per operating band and the uplink assigned to one E-UTRA band the wide band intermodulation requirements are defined with the uplink active on the band(s) other than the band whose downlink is being tested. The UE shall meet the requirements specified in subclause 7.8.1.1 for each component carrier while all downlink carriers are active. For E-UTRA CA configurations including an operating band without uplink band or an operating band with an unpaired DL part (as noted in Table 5.5-1), the requirements for all

downlinks shall be met with the single uplink carrier active in each band capable of UL operation. For a component carrier configured in Band 46, the requirements specified in subclause 7.8.1.1 are replaced by the requirements in Table 7.8.1-1A-0.

Table 7.8.1.1A-0: Wide band intermodulation

E-UTRA band	Rx Parameter	Units	Channel bandwidth					
			1.4 MHz	3 MHz	5 MHz	10 MHz	15 MHz	20 MHz
46	Power in Transmission Bandwidth Configuration	dBm	REFSENS + channel bandwidth specific value below					
							9	
	$P_{\text{Interferer 1 (CW)}}$	dBm	-46					
	$P_{\text{Interferer 2 (Modulated)}}$	dBm	-46					
	$BW_{\text{Interferer 2}}$						20	
	$F_{\text{Interferer 1 (Offset)}}$	MHz					-BW/2 – 30 / +BW/2 + 30	
$F_{\text{Interferer 2 (Offset)}}$	MHz	$2 \cdot F_{\text{Interferer 1}}$						
NOTE 1: The transmitter shall be set to 4dB below $P_{\text{CMAX_L}}$ at the minimum uplink configuration specified in Table 7.3.1-2 with $P_{\text{CMAX_L}}$ as defined in subclause 6.2.5.								
NOTE 2: Reference measurement channel is specified in Annex A.3.2 with one sided dynamic OCNG Pattern OP.1 FDD/TDD/FS3 as described in Annex A.5.1.1/A.5.2.1/A.5.4.1.								
NOTE 3: The modulated interferer consists of the Reference measurement channel specified in Annex A.3.2 with one sided dynamic OCNG Pattern OP.1 FDD/TDD as described in Annex A.5.1.1/A.5.2.1.								

For E-UTRA CA configurations listed in Table 7.3.1A-0a under conditions for which reference sensitivity for the operating band being tested is N/A, the wideband intermodulation requirements of subclause 7.8.1A do not apply.

For intra-band contiguous carrier aggregation the downlink SCC(s) shall be configured at nominal channel spacing to the PCC, For FDD, the PCC shall be configured closest to the uplink band. All downlink carriers shall be active throughout the test. The uplink output power shall be set as specified in Table 7.8.1A-1 with the uplink configuration set according to Table 7.3.1A-1 for the applicable carrier aggregation configuration. For UE(s) supporting one uplink carrier, the uplink configuration of the PCC shall be in accordance with Table 7.3.1-2. The UE shall fulfil the minimum requirement in presence of an interfering signal specified in Table 7.8.1A-1 being on either side of the aggregated signal. The throughput of each carrier shall be $\geq 95\%$ of the maximum throughput of the reference measurement channels as specified in Annexes A.2.2, A.2.3 and A.3.2 (with one sided dynamic OCNG Pattern OP.1 FDD/TDD for the DL-signal as described in Annex A.5.1.1/A.5.2.1) with parameters specified in Table 7.8.1A-1. For operating bands with an unpaired DL part (as noted in Table 5.5-1), the requirements also apply for an SCC assigned in the unpaired part with parameters specified in Tables 7.8.1A-1.

Table 7.8.1A-1: Wide band intermodulation

Rx parameter	Units	CA Bandwidth Class				
		B	C	D	E	F
$P_{w \text{ in}}$ Transmission Bandwidth Configuration, per CC	dBm	REFSENS + CA Bandwidth Class specific value below				
		9	12	13.8	15	
$P_{\text{Interferer 1}}$ (CW)	dBm	-46				
$P_{\text{Interferer 2}}$ (Modulated)		-46				
$BW_{\text{Interferer 2}}$	MHz	5	5	5	5	
$F_{\text{Interferer 1}}$ (Offset)	MHz	$-F_{\text{offset}}-7.5$ / $+ F_{\text{offset}}+7.5$	$-F_{\text{offset}}-7.5$ / $+ F_{\text{offset}}+7.5$	$-F_{\text{offset}}-7.5$ / $+ F_{\text{offset}}+7.5$	$-F_{\text{offset}}-7.5$ / $+ F_{\text{offset}}+7.5$	
$F_{\text{Interferer 2}}$ (Offset)		MHz	$2 * F_{\text{Interferer 1}}$			
NOTE 1: The transmitter shall be set to 4dB below $P_{\text{CMAX,L,c}}$ or $P_{\text{CMAX,L}}$ as defined in subclause 6.2.5A.						
NOTE 2: Reference measurement channel is specified in Annex A.3.2 with one sided dynamic OCN Pattern OP.1 FDD/TDD as described in Annex A.5.1.1/A.5.2.1.						
NOTE 3: The modulated interferer consists of the Reference measurement channel specified in Annex A.3.2 with one sided dynamic OCN Pattern OP.1 FDD/TDD as described in Annex A.5.1.1/A.5.2.1 with set-up according to Annex C.3.1.						
NOTE 4: The interfering modulated signal is 5MHz E-UTRA signal as described in Annex D for channel bandwidth ≥ 5 MHz;						
NOTE 5: The $F_{\text{interferer 1}}$ (offset) is the frequency separation of the center frequency of the carrier closest to the interferer and the center frequency of the CW interferer and $F_{\text{interferer 2}}$ (offset) is the frequency separation of the center frequency of the carrier closest to the interferer and the center frequency of the modulated interferer.						

For intra-band non-contiguous carrier aggregation with one uplink carrier and two downlink sub-blocks, the wide band intermodulation requirements are defined with the uplink configuration in accordance with Table 7.3.1A-3. For this uplink configuration, the UE shall meet the requirements for each sub-block as specified in subclauses 7.8.1.1 and in this subclause for one component carrier and two component carriers per sub-block, respectively. The requirements apply for out-of-gap interferers while all downlink carriers are active.

For combinations of intra-band and inter-band carrier aggregation with up to five downlink carriers (up to two non-contiguously sub-blocks per band and up to four contiguously aggregated carriers per band) and one uplink carrier assigned to one E-UTRA band, the requirement is defined with the uplink active in a band other than that supporting the downlink(s) under test. The uplink configuration shall be in accordance with Table 7.3.1A-3 when the uplink is active in the band supporting two non-contiguous component carriers, Table 7.3.1A-1 when the uplink is active in a band supporting two contiguous component carriers and in accordance with Table 7.3.1-2 when the uplink is active in a band supporting one carrier per band. For these uplink configurations, the UE shall meet the wide-band intermodulation requirements for intra-band non-contiguous carrier aggregation of two downlink sub-blocks with $\Delta R_{\text{IBNC}} = 0$ dB for all sub-block gaps (Table 7.3.1A-3) for the two non-contiguous downlink sub-blocks, the requirements for intra-band contiguous carrier aggregation for the contiguously aggregated downlink carriers and for any remaining component carrier(s) the requirements specified in subclause 7.8.1. For contiguously aggregated component carriers configured in Band 46, the said requirements for intra-band contiguous carrier aggregation of two downlink carriers are replaced by requirements in Table 7.8.1A-2. All downlink carriers shall be active throughout the tests and the requirements for the downlinks shall be met with the single uplink carrier active in each band capable of UL operation.

Table 7.8.1A-2: Wide band intermodulation

E-UTRA Band	Rx parameter	Units	CA Bandwidth Class				
			B	C	D	E	F
46	Power per CC in Aggregated Transmission Bandwidth Configuration	dBm	REFSENS + CA Bandwidth Class specific value below				
			12	13.8	15		
	$P_{\text{Interferer 1}}$ (CW)	dBm	-46				
	$P_{\text{Interferer 2}}$ (Modulated)		-46				
	$BW_{\text{Interferer 2}}$	MHz		20	20	20	
	$F_{\text{Interferer 1}}$ (Offset)	MHz		$-F_{\text{offset}}-30$ /	$-F_{\text{offset}}-30$ /	$-F_{\text{offset}}-30$ /	
			$+F_{\text{offset}}+30$	$+F_{\text{offset}}+30$	$+F_{\text{offset}}+30$		
$F_{\text{Interferer 2}}$ (Offset)	MHz	$2 * F_{\text{Interferer 1}}$					
NOTE 1: The transmitter shall be set to 4dB below $P_{\text{CMAX,L,c}}$ or $P_{\text{CMAX,L}}$ as defined in subclause 6.2.5A.							
NOTE 2: Reference measurement channel is specified in Annex A.3.2 with one sided dynamic OCNG Pattern OP.1 FDD/TDD as described in Annex A.5.1.1/A.5.2.1.							
NOTE 3: The modulated interferer consists of the Reference measurement channel specified in Annex A.3.2 with one sided dynamic OCNG Pattern OP.1 FDD/TDD/FS3 as described in Annex A.5.1.1/A.5.2.1/A.5.4.1 with set-up according to Annex C.3.1.							
NOTE 4: The interfering modulated signal is 20 MHz E-UTRA signal as described in Annex D interference setting 2;							
NOTE 5: The $F_{\text{Interferer 1}}$ (offset) is the frequency separation of the center frequency of the carrier closest to the interferer and the center frequency of the CW interferer and $F_{\text{Interferer 2}}$ (offset) is the frequency separation of the center frequency of the carrier closest to the interferer and the center frequency of the modulated interferer.							

7.8.1B Minimum requirements for UL-MIMO

For UE(s) with two transmitter antenna connectors in closed-loop spatial multiplexing scheme, the minimum requirements in subclause 7.8.1 shall be met with the UL-MIMO configurations specified in Table 6.2.2B-2. For UL-MIMO, the parameter $P_{\text{CMAX,L}}$ is defined as the total transmitter power over the two transmit antenna connectors.

7.8.1D Minimum requirements for ProSe

The throughput shall be $\geq 95\%$ of the maximum throughput of the reference measurement channels as specified in Annex A.6.2 with parameters specified in Table 7.8.1D-1, Table 7.8.1D-2, and Table 7.8.1D-3 for the specified wanted signal mean power in the presence of two interfering signals

Table 7.8.1D-1: Wide band intermodulation parameters for ProSe Direct Discovery

Rx parameter	Units	Channel bandwidth					
		1.4 MHz	3 MHz	5 MHz	10 MHz	15 MHz	20 MHz
P_{offset}	dB			10.9	13.9	15.7	16.9

Table 7.8.1D-2: Wide band intermodulation for ProSe Direct Communication

Rx parameter	Units	Channel bandwidth					
		1.4 MHz	3 MHz	5 MHz	10 MHz	15 MHz	20 MHz
P_{offset}	dB			0	0	0	0

Table 7.8.1D-3: Wide band intermodulation for ProSe

Rx Parameter	Units	Channel bandwidth					
		1.4 MHz	3 MHz	5 MHz	10 MHz	15 MHz	20 MHz
Power in Transmission Bandwidth Configuration	dBm	P _{REFSENS_ProSe} + channel bandwidth specific value below+ P _{offset}					
		12	8	6	6	7	9
P _{Interferer 1 (CW)}	dBm	-46					
P _{Interferer 2 (Modulated)}	dBm	-46					
BW _{Interferer 2}		1.4	3	5			
F _{Interferer 1 (Offset)}	MHz	-BW/2 -2.1 / +BW/2+ 2.1	-BW/2 -4.5 / +BW/2 + 4.5	-BW/2 - 7.5 / +BW/2 + 7.5			
F _{Interferer 2 (Offset)}	MHz	2*F _{Interferer 1}					
NOTE 1: Reference measurement channel is specified in Annex A.6.2							
NOTE 2: The interferer is QPSK modulated PUSCH containing data and reference symbols. Normal cyclic prefix is used. The data content shall be uncorrelated to the wanted signal and modulated according to clause 5 of TS36.211							

For the UE which supports inter band CA configuration in Table 7.3.1-1A, P_{interferer1} and P_{interferer2} powers defined in Table 7.8.1D-3 are increased by the amount given by $\Delta R_{IB,c}$ in Table 7.3.1-1A.

7.8.1F Minimum requirements for category NB1

The throughput shall be $\geq 95\%$ of the maximum throughput of the reference measurement channel as specified in Annex A.3.2 with parameters specified in Table 7.8.1F-1 for the specified wanted signal mean power in the presence of two interfering signals.

Table 7.8.1F-1: Wide band intermodulation for category NB1

Parameters for wideband intermodulation	
Category NB1 signal power	REFSENS + 12 dB
CW interferer signal power	- 46 dBm
1.4 MHz E-UTRA interferer signal power	- 46 dBm
CW interferer offset	± 2.2 MHz
1.4 MHz E-UTRA interferer offset	± 4.4 MHz

7.8.2 Void

7.9 Spurious emissions

The spurious emissions power is the power of emissions generated or amplified in a receiver that appear at the UE antenna connector.

7.9.1 Minimum requirements

The power of any narrow band CW spurious emission shall not exceed the maximum level specified in Table 7.9.1-1

Table 7.9.1-1: General receiver spurious emission requirements

Frequency band	Measurement bandwidth	Maximum level	NOTE
$30\text{MHz} \leq f < 1\text{GHz}$	100 kHz	-57 dBm	
$1\text{GHz} \leq f \leq 12.75\text{ GHz}$	1 MHz	-47 dBm	
$12.75\text{ GHz} \leq f \leq 5^{\text{th}}$ harmonic of the upper frequency edge of the DL operating band in GHz	1 MHz	-47 dBm	1
NOTE 1: Applies only for Band 22, Band 42 and Band 43			
NOTE 2: Unused PDCCH resources are padded with resource element groups with power level given by PDCCH_RA/RB as defined in Annex C.3.1.			

7.9.1A Minimum requirements

For E-UTRA CA configurations including an operating band without uplink band (as noted in Table 5.5-1), the power of any narrow band CW spurious emission shall not exceed the maximum level specified in Table 7.9.1A-1.

Table 7.9.1A-1: General receiver spurious emission requirements

Frequency band	Measurement bandwidth	Maximum level	NOTE
$30\text{MHz} \leq f < 1\text{GHz}$	100 kHz	-57 dBm	
$1\text{GHz} \leq f \leq 12.75\text{ GHz}$	1 MHz	-47 dBm	
$12.75\text{ GHz} \leq f \leq 26\text{ GHz}$	1 MHz	-47 dBm	3
NOTE 1: Unused PDCCH resources are padded with resource element groups with power level given by PDCCH_RA/RB as defined in Annex C.3.1.			
NOTE 2: The requirements apply when the UE is configured for carrier aggregation but is not transmitting.			
NOTE 3: Applies only for Band 46			

7.10 Receiver image

7.10.1 Void

7.10.1A Minimum requirements for CA

Receiver image rejection is a measure of a receiver's ability to receive the E-UTRA signal on one component carrier while it is also configured to receive an adjacent aggregated carrier. Receiver image rejection ratio is the ratio of the wanted received power on a sub-carrier being measured to the unwanted image power received on the same sub-carrier when both sub-carriers are received with equal power at the UE antenna connector.

For intra-band contiguous carrier aggregation the UE shall fulfil the minimum requirement specified in Table 7.10.1A-1 for all values of aggregated input signal up to -22 dBm .

Table 7.10.1A-1: Receiver image rejection

Rx parameter	Units	CA bandwidth class					
		A	B	C	D	E	F
Receiver image rejection	dB		25	25	25	25	

8 Performance requirement

This clause contains performance requirements for the physical channels specified in TS 36.211 [4]. The performance requirements for the UE in this clause are specified for the measurement channels specified in Annex A.3, the propagation conditions in Annex B and the downlink channels in Annex C.3.2.

NOTE: For the requirements in the following sections, similar Release 8 and 9 requirements apply for time domain measurements restriction under colliding CRS.

8.1 General

8.1.1 Receiver antenna capability

The performance requirements are based on UE(s) that utilize one or more antenna receivers.

For all test cases, the SNR is defined as

$$SNR = \frac{\sum_{j=1}^{N_{RX}} \hat{E}_s^{(j)}}{\sum_{j=1}^{N_{RX}} N_{oc}^{(j)}}$$

where N_{RX} denotes the number of receiver antenna connectors and the superscript receiver antenna connector j . The above SNR definition assumes that the REs are not precoded. The SNR definition does not account for any gain which can be associated to the precoding operation. The relative power of physical channels transmitted is defined in Table C.3.2-1. The SNR requirement applies for the UE categories and CA capabilities given for each test.

For enhanced performance requirements type A, the SINR is defined as

$$SINR = \frac{\sum_{j=1}^{N_{RX}} \hat{E}_s^{(j)}}{\sum_{j=1}^{N_{RX}} N_{oc}^{(j)'}}$$

where N_{RX} denotes the number of receiver antenna connectors and the superscript receiver antenna connector j . The above SINR definition assumes that the REs are not precoded. The SINR definition does not account for any gain which can be associated to the precoding operation. The relative power of physical channels transmitted is defined in Table C.3.2-1. The SINR requirement applies for the UE categories given for each test.

For the performance requirements specified in this clause, it is assumed that $N_{RX}=2$ unless otherwise stated.

Table 8.1.1-1: Void

8.1.1.1 Simultaneous unicast and MBMS operations

8.1.1.2 Dual-antenna receiver capability in idle mode

8.1.2 Applicability of requirements

8.1.2.1 Applicability of requirements for different channel bandwidths

In Clause 8 the test cases may be defined with different channel bandwidth to verify the same target FRC conditions with the same propagation conditions, correlation matrix and antenna configuration.

Test cases defined for 5MHz channel bandwidth that reference this clause are applicable to UEs that support only Band 31.

8.1.2.2 Definition of CA capability

The definition with respect to CA capabilities for 2CCs is given as in Table 8.1.2.2-1. The definition with respect to CA capabilities for 3CCs is given in Table 8.1.2.2-3.

Table 8.1.2.2-1: Definition of CA capability with 2DL CCs

CA Capability	CA Capability Description
CA2_C	Intra-band contiguous CA
CA2_A2	Inter-band CA (two bands)
CA2_N2	Intra-band non-contiguous CA (with two sub-blocks)
NOTE 1: CA2_C corresponds to E-UTRA CA configurations and bandwidth combination sets defined in Table 5.6A.1-1 for 2 DL CCs. CA2_A2 corresponds to E-UTRA CA configurations and bandwidth combination sets defined in Table 5.6A.1-2 for 2 DL CCs. CA2_N2 corresponds to E-UTRA CA configurations and bandwidth combination sets defined in Table 5.6A.1-3 for 2 DL CCs.	

The supported testable aggregated CA bandwidth combinations for 2CCs for each CA capability are listed in Table 8.1.2.2-2.

Table 8.1.2.2-2: Supported testable aggregated CA bandwidth combinations for different CA capability with 2DL CCs

CA Capability	Bandwidth combination for FDD CA	Bandwidth combination for TDD CA	Bandwidth combination for TDD-FDD CA	Bandwidth combination for CA with LAA SCell(s)
CA2_C	5+5MHz, 5+10MHz, 5+15MHz, 10+10MHz, 20+20MHz	20+20MHz, 15+20MHz	NA	NA
CA2_A2	10+10MHz, 20+5MHz, 10+15MHz, 10+20MHz, 15+20MHz, 20+20MHz	20+20MHz	10(FDD)+20(TDD)MHz, 15(FDD)+20(TDD)MHz, 20(FDD)+20(TDD)MHz	20(FDD)+20(LAA)MHz 20(TDD)+20(LAA)MHz
CA2_N2	5+10MHz, 10+10MHz, 10+20MHz, 20+20MHz	20+20MHz	NA	NA
NOTE 1: This table is only for information and applicability and test rules of CA performance requirements are specified in 8.1.2.3 and 9.1.1.2.				

Table 8.1.2.2-3: Definition of CA capability with 3 DL CCs

CA Capability	CA Capability Description
CA3_C	Intra-band contiguous CA
CA3_A2	Inter-band CA (two bands)
CA3_A3	Inter-band CA (three bands)
CA3_N2	Intra-band non-contiguous CA (with two sub-blocks)
NOTE 1:	CA3_C corresponds to E-UTRA CA configurations and bandwidth combination sets defined in Table 5.6A.1-1 for 3 DL CCs. CA3_A2 corresponds to E-UTRA CA configurations and bandwidth combination sets defined in Table 5.6A.1-2 for 3 DL CCs. CA3_A3 corresponds to E-UTRA CA configurations and bandwidth combination sets defined in and Table 5.6A.1-2a for 3 DL CCs. CA3_N2 corresponds to E-UTRA CA configurations and bandwidth combination sets defined in Table 5.6A.1-3 for 3 DL CCs.

The supported testable largest aggregated CA bandwidth combinations for 3CCs for each CA capability are listed in Table 8.1.2.2-4.

Table 8.1.2.2-4: Supported largest aggregated CA bandwidth combinations for different CA capability with 3 CCs

CA capability	Bandwidth combination for FDD CA	Bandwidth combination for TDD CA	Bandwidth combination for TDD-FDD CA
CA3_C	NA	20+20+20MHz	NA
CA3_A2	5+10+10MHz, 5+10+20MHz, 5+15+20MHz, 10+10+20MHz, 10+20+20MHz, 20+20+20MHz	15+20+20MHz, 20+20+20MHz	10(FDD)+20(TDD)+20(TDD)MHz, 15(FDD)+20(TDD)+20(TDD)MHz, 20(FDD)+20(TDD)+20(TDD)MHz
CA3_A3	10+10+20MHz, 10+15+15MHz, 10+15+20MHz, 10+20+20MHz, 15+15+20MHz, 15+20+20MHz, 20+20+20MHz	NA	2x20(FDD)+20(TDD)MHz, 20(FDD)+ 2x20(TDD)MHz, 20(FDD)+15(FDD)+20(TDD)MHz, 20(FDD)+10(FDD)+20(TDD)MHz, 2x15(FDD)+20(TDD)MHz
CA3_N2	NA	20+20+20MHz	NA
NOTE 1:	This table is only for information and applicability and test rules of CA performance requirements are specified in 8.1.2.3 and 9.1.1.2.		

Table 8.1.2.2-5: Definition of CA capability with 4 DL CCs

CA Capability	CA Capability Description
CA4_C	Intra-band contiguous CA
CA4_A2	Inter-band CA (two bands)
CA4_A3	Inter-band CA (three bands)
CA4_A4	Inter-band CA (four bands)
CA4_N2	Intra-band non-contiguous CA (with two sub-blocks)
NOTE 1:	CA4_C corresponds to E-UTRA CA configurations and bandwidth combination sets defined in Table 5.6A.1-1 for 3 DL CCs. CA4_A2 corresponds to E-UTRA CA configurations and bandwidth combination sets defined in Table 5.6A.1-2 for 3 DL CCs. CA4_A3 corresponds to E-UTRA CA configurations and bandwidth combination sets defined in and Table 5.6A.1-2a for 3 DL CCs. CA4_A4 corresponds to E-UTRA CA configurations and bandwidth combination sets defined in and Table 5.6A.1-2b for 4 DL CCs CA4_N2 corresponds to E-UTRA CA configurations and bandwidth combination sets defined in Table 5.6A.1-3 for 3 DL CCs.

The supported testable largest aggregated CA bandwidth combinations for 4CCs for each CA capability are listed in Table 8.1.2.2-6.

Table 8.1.2.2-6: Supported largest aggregated CA bandwidth combinations for different CA capability with 4 CCs

CA capability	Bandwidth combination for FDD CA	Bandwidth combination for TDD CA	Bandwidth combination for TDD-FDD CA
CA4_C	NA	20+20+20+20MHz	NA
CA4_A2	20+20+20+20MHz 20+20+10+5MHz	20+20+20+20MHz 15+20+20+20MHz	20(FDD)+20(TDD)+20(TDD)+20(TDD)MHz
CA4_A3	20+20+20+20MHz 20+20+20+10MHz 20+20+10+10MHz 20+10+10+5MHz	NA	2x20(FDD)+2x20(TDD)MHz, 20(FDD)+15(FDD)+2x20(TDD)MHz, 2x15(FDD)+2x20(TDD)MHz
CA4_A4	20+20+20+20MHz 20+20+20+10MHz 20+20+10+10MHz	NA	2x20(FDD)+15(FDD)+20(TDD)MHz, 2x15(FDD)+20(FDD)+20(TDD)MHz 2x20(FDD)+10(FDD)+20(TDD)MHz
CA4_N2	NA	20+20+20+20MHz	NA

NOTE 1: This table is only for information and applicability and test rules of CA performance requirements are specified in 8.1.2.3 and 9.1.1.2.

Table 8.1.2.2-7: Definition of CA capability with 5 DL CCs

CA Capability	CA Capability Description
CA5_C	Intra-band contiguous CA
CA5_A2	Inter-band CA (two bands)
CA5_A3	Inter-band CA (three bands)
CA5_A4	Inter-band CA (four bands)
CA5_A5	Inter-band CA (five bands)
CA5_N2	Intra-band non-contiguous CA (with two sub-blocks)

NOTE 1: CA5_C corresponds to E-UTRA CA configurations and bandwidth combination sets defined in Table 5.6A.1-1 for 5 DL CCs.
CA5_A2 corresponds to E-UTRA CA configurations and bandwidth combination sets defined in Table 5.6A.1-2 for 5 DL CCs.
CA5_A3 corresponds to E-UTRA CA configurations and bandwidth combination sets defined in and Table 5.6A.1-2a for 5 DL CCs.
CA5_A4 corresponds to E-UTRA CA configurations and bandwidth combination sets defined in and Table 5.6A.1-2b for 5 DL CCs
CA5_A5 corresponds to E-UTRA CA configurations and bandwidth combination sets defined in and Table 5.6A.1-xx for 5 DL CCs
CA5_N2 corresponds to E-UTRA CA configurations and bandwidth combination sets defined in Table 5.6A.1-3 for 5 DL CCs.

The supported testable largest aggregated CA bandwidth combinations for 5CCs for each CA capability are listed in Table 8.1.2.2-8.

Table 8.1.2.2-8: Supported largest aggregated CA bandwidth combinations for different CA capability with 5 CCs

CA capability	Bandwidth combination for FDD CA	Bandwidth combination for TDD CA	Bandwidth combination for TDD-FDD CA
CA5_C	NA	NA	NA
CA5_A2	NA	NA	NA
CA5_A3	5x20MHz	NA	NA
CA5_A4	5x20MHz	NA	15+2x20(FDD)+2x20(TDD)MHz 2x15+20(FDD)+2x20(TDD)MHz
CA5_A5	NA	NA	
CA5_N2	NA	NA	NA

NOTE 1: This table is only for information and applicability and test rules of CA performance requirements are specified in 8.1.2.3 and 9.1.1.2.

For test cases with more than one component carrier, "Fraction of Maximum Throughput" in the performance requirement refers to the ratio of the sum of throughput values of all component carriers to the sum of the nominal maximum throughput values of all component carriers, unless otherwise stated.

8.1.2.2A Definition of dual connectivity capability

The definition with respect to dual connectivity capabilities for configurations with 2CCs is given as in Table 8.1.2.2A-1. The definition with respect to dual connectivity capabilities for configurations with 3CCs is given as in Table 8.1.2.2A-3. The definition with respect to dual connectivity capabilities for configurations with 4CCs is given as in Table 8.1.2.2A-5.

Table 8.1.2.2A-1: Definition of dual connectivity capability with 2DL CCs

Dual connectivity Capability	Dual connectivity capability Description
DC_A_2	Inter-band dual connectivity (two bands)

NOTE 1: DC_A_2 corresponds to E-UTRA dual connectivity configurations and bandwidth combination sets defined for inter-band dual connectivity (two bands) as specified in 5.6C .

The supported testable dual connectivity bandwidth combinations for 2CCs for each dual connectivity capability are listed in Table 8.1.2.2A-2.

Table 8.1.2.2A-2: Supported testable dual connectivity bandwidth combinations for different dual connectivities capability with 2DL CCs

Dual connectivity capability	Bandwidth combination for FDD dual connectivity	Bandwidth combination for TDD dual connectivity	Bandwidth combination for TDD-FDD dual connectivity
DC_A_2	10+10MHz, 10+20MHz, 10+15MHz, 15+15MHz, 15+20MHz, 20+20MHz, 15+5MHz	20+20MHz	20(FDD)+20(TDD)MHz

NOTE 1: This table is only for information and applicability and test rules of dual connectivity performance requirements are specified in 8.1.2.3A

Table 8.1.2.2A-3: Definition of dual connectivity capability with 3DL CCs

Dual connectivity Capability	Dual connectivity capability Description
DC_A_3	Inter-band dual connectivity (three bands)
NOTE 1: DC_A_3 corresponds to E-UTRA dual connectivity configurations and bandwidth combination sets defined for inter-band dual connectivity (three bands) as specified in 5.6C.	

The supported testable dual connectivity bandwidth combinations for 3CCs for each dual connectivity capability are listed in Table 8.1.2.2A-4.

Table 8.1.2.2A-4: Supported testable dual connectivity bandwidth combinations for different dual connectivities capability with 3DL CCs

Dual connectivity capability	Bandwidth combination for FDD dual connectivity	Bandwidth combination for TDD dual connectivity
DC_A_3	20+20+15MHz, 20+15+15MHz, 20+10+10MHz, 15+15+10MHz, 20+10+15MHz, 20+20+20MHz, 20+20+10MHz, 3x20 MHz	3x20MHz
NOTE 1: This table is only for information and applicability and test rules of dual connectivity performance requirements are specified in 8.1.2.3A		

Table 8.1.2.2A-5: Definition of dual connectivity capability with 4DL CCs

Dual connectivity Capability	Dual connectivity capability Description
DC_A_4	Inter-band dual connectivity (four bands)
NOTE 1: DC_A_4 corresponds to E-UTRA dual connectivity configurations and bandwidth combination sets defined for inter-band dual connectivity (four bands) as specified in 5.6C.	

The supported testable dual connectivity bandwidth combinations for 3CCs for each dual connectivity capability are listed in Table 8.1.2.2A-6.

Table 8.1.2.2A-6: Supported testable dual connectivity bandwidth combinations for different dual connectivities capability with 4DL CCs

Dual connectivity capability	Bandwidth combination for FDD dual connectivity	Bandwidth combination for TDD dual connectivity
DC_A_4	N/A	4x20MHz, 3x20+15MHz
NOTE 1: This table is only for information and applicability and test rules of dual connectivity performance requirements are specified in 8.1.2.3A		

8.1.2.3 Applicability and test rules for different CA configurations and bandwidth combination sets

The performance requirement for CA UE demodulation tests in Clause 8 are defined independent of CA configurations and bandwidth combination sets specified in Clause 5.6A. For UEs supporting different CA configurations and bandwidth combination sets, the applicability and test rules are defined for the tests for 2 DL CCs in Table 8.1.2.3-1 and 3 or more DL CCs in Table 8.2.2.3-2. For simplicity, CA configuration below refers to combination of CA configuration and bandwidth combination set.

Table 8.1.2.3-1: Applicability and test rules for CA UE demodulation tests with 2 DL CCs

Tests	CA capability where the tests apply	CA configuration from the selected CA capability where the tests apply	CA Bandwidth combination to be tested in priority order
CA tests with 2CCs in Clause 8.2.1.1.1, 8.2.1.4.3	Any one of the supported CA capabilities	Any one of the supported FDD CA configurations	10+10 MHz, 20+20 MHz, 5+5 MHz, 10MHz+5MHz, 15MHz+5MHz
CA tests with 2CCs in Clause 8.2.1.3.1	Each supported CA capability	Any one of the supported FDD CA configurations in each CA capability	10+10 MHz, 20+20 MHz, 5+5 MHz, 10MHz+5MHz, other combinations
CA tests with 2CCs in Clause 8.2.1.3.1A, 8.7.1	Any one of the supported CA capabilities with largest aggregated CA bandwidth combination	Any one of the supported FDD CA configurations with largest aggregated CA bandwidth combination	Largest aggregated CA bandwidth combination
CA tests with 2CCs in Clause 8.2.1.7.1	CA_C	Supported FDD intra-band contiguous CA configurations covering the lowest and highest operating bands	Largest aggregated CA bandwidth combinations
CA tests with 2CCs in Clause 8.2.2.1.1, 8.2.2.4.3	Any one of the supported CA capabilities with largest aggregated CA bandwidth combination	Any one of the supported TDD CA configurations with largest aggregated CA bandwidth combination	Largest aggregated CA bandwidth combination
CA tests with 2CCs in Clause 8.2.2.3.1	Each supported CA capability	Any one of the supported TDD CA configurations in each CA capability with largest aggregated CA bandwidth combination	Largest aggregated CA bandwidth combination
CA tests with 2CCs in Clause 8.2.2.3.1A, 8.7.2	Any one of the supported CA capabilities with largest aggregated CA bandwidth	Any one of the supported TDD CA configurations with largest aggregated CA bandwidth combination	Largest aggregated CA bandwidth combination
CA tests with 2CCs in 8.2.2.7.1	CA_C	Supported TDD intra-band contiguous CA configurations covering the lowest and highest operating bands	Largest aggregated CA bandwidth combinations
CA tests with 2CCs in Clause 8.2.1.8.1	CA_N	CA_3A-3A defined in Table 5.6A.1-3	10+10 MHz
CA tests with 2CCs in Clause 8.2.2.8.1	CA2_C	CA_41C defined in Table 5.6A.1-1	20+20 MHz
NOTE 1: The applicability and test rules are specified in this table, unless otherwise stated.			
NOTE 2: Number of the supported bandwidth combinations to be tested from each selected CA configuration is 1.			
NOTE 3: A single Uplink CC is configured for all tests			

Table 8.1.2.3-2: Applicability and test rules for CA UE demodulation tests with 3 or more DL CCs

Tests	CA capability where the tests apply	CA configuration from the selected CA capability where the tests apply	CA Bandwidth combination to be tested in priority order
CA tests with 3 or more CCs in Clause 8.2.1.1.1, 8.2.1.4.3, 8.7.1	Any one of the supported CA capabilities with largest aggregated CA bandwidth combination	Any one of the supported FDD CA configurations with largest aggregated CA bandwidth combination	Largest aggregated CA bandwidth combination
CA tests with 3 or more CCs in Clause 8.2.1.3.1	Each supported CA capability	Any one of the supported FDD CA configurations in each CA capability with largest aggregated CA bandwidth combination	Largest aggregated CA bandwidth combination
CA tests with 3 or more CCs in Clause 8.2.2.1.1, 8.2.2.4.3, 8.7.2	Any one of the supported CA capabilities with largest aggregated CA bandwidth combination	Any one of the supported TDD CA configurations with largest aggregated CA bandwidth combination	Largest aggregated CA bandwidth combination
CA tests with 3 or more CCs in Clause 8.2.2.3.1	Each supported CA capability	Any one of the supported TDD CA configurations in each CA capability with largest aggregated CA bandwidth combination	Largest aggregated CA bandwidth combination
CA tests with 3CCs in Clause 8.2.2.8.1	CA3_C	CA_41D defined in Table 5.6A.1-1	20+20+20 MHz
NOTE 1: The applicability and test rules are specified in this table, unless otherwise stated.			
NOTE 2: Number of the supported bandwidth combinations to be tested from each selected CA configuration is 1.			
NOTE 3: A single Uplink CC is configured for all tests			

8.1.2.3A Applicability and test rules for different dual connectivity configuration and bandwidth combination set

The performance requirement for dual connectivity UE demodulation tests in Clause 8 are defined independent of dual connectivity configurations and bandwidth combination sets specified in Clause 5.6C.1. For UEs supporting different dual connectivity configurations and bandwidth combination sets, the applicability and test rules are defined for the tests for the configurations with 2CCs in Table 8.1.2.3A-1 and 3 DL CCs in Table 8.1.2.3A-2. For simplicity, dual connectivity configuration below refers to combination of dual connectivity configuration and bandwidth set.

Both CA performance requirements and dual connectivity performance requirements are applied for dual connectivity capable UE.

Table 8.1.2.3A-1: Applicability and test rules for dual connectivity UE demodulation tests with 2DL CCs

Tests	Dual connectivity capability where the tests apply	Dual connectivity configuration from the selected CA capability where the tests apply	Dual connectivity Bandwidth combination to be tested in priority order
Dual connectivity test with 2CCs in Clause 8.2.1.4.3A, 8.7.6	Any one of the supported dual connectivity capabilities with largest aggregated dual connectivity bandwidth combination	Any one of the supported FDD dual connectivity configurations with the largest aggregated dual connectivity bandwidth combination	Largest dual connectivity aggregated bandwidth combination
Dual connectivity test with 2CCs in Clause 8.2.2.4.3A, 8.7.7	Any one of the supported dual connectivity capabilities with largest aggregated dual connectivity bandwidth combination	Any one of the supported TDD dual connectivity configurations with the largest aggregated dual connectivity bandwidth combination	Largest dual connectivity aggregated bandwidth combination
Dual connectivity test with TDD FDD 2CCs in Clause 8.2.3.4, 8.7.8	Any one of the supported dual connectivity capabilities with largest aggregated dual connectivity bandwidth combination	Any one of the supported TDD FDD dual connectivity configurations with the largest aggregated dual connectivity bandwidth combination	Largest dual connectivity aggregated bandwidth combination

NOTE 1: The applicability and test rules are specified in this table, unless otherwise stated.
NOTE 2: Number of the supported bandwidth combinations to be tested from each selected DC or CA configuration is 1.

Table 8.1.2.3A-2: Applicability and test rules for dual connectivity UE demodulation tests with 3DL CCs

Tests	Dual connectivity capability where the tests apply	Dual connectivity configuration from the selected CA capability where the tests apply	Dual connectivity Bandwidth combination to be tested in priority order
Dual connectivity test with 3CCs in Clause 8.2.1.4.3A, 8.7.6	Any one of the supported dual connectivity capabilities with largest aggregated dual connectivity bandwidth combination	Any one of the supported FDD dual connectivity configurations with the largest aggregated dual connectivity bandwidth combination	Largest dual connectivity aggregated bandwidth combination

NOTE 1: The applicability and test rules are specified in this table, unless otherwise stated.
NOTE 2: Number of the supported bandwidth combinations to be tested from each selected DC or CA configuration is 1.

8.1.2.3B Applicability and test rules for different TDD-FDD CA configurations and bandwidth combination sets

The performance requirement for TDD-FDD CA UE demodulation tests in Clause 8 are defined independent of CA configurations and bandwidth combination sets specified in Clause 5.6A.1. For UEs supporting different CA configurations and bandwidth combination sets, the applicability and test rules are defined for the tests for 2 DL TDD-FDD CA in Table 8.1.2.3B-1 and in Table 8.1.2.3B-2 for 3 or more DL TDD-FDD CA. For simplicity, CA configuration below refers to combination of CA configuration and bandwidth combination set.

Table 8.1.2.3B-1: Applicability and test rules for CA UE demodulation tests for TDD-FDD CA with 2 DL CCs

Tests	CA capability where the tests apply	CA configuration from the selected CA capability where the tests apply	CA Bandwidth combination to be tested in priority order
CA tests with 2CCs in Clause 8.2.3.1.1, 8.2.3.2.1A, 8.2.3.3.1, 8.7.5.1	Any one of the supported CA capabilities with largest aggregated CA bandwidth combination	Any one of the supported TDD-FDD CA configurations with FDD PCell with largest aggregated CA bandwidth combination	Largest aggregated CA bandwidth combination
CA tests with 2CCs in Clause 8.2.3.2.1	Each supported CA capability	Any one of the supported TDD-FDD CA configurations with FDD PCell in each CA capability with largest aggregated CA bandwidth combination	Largest aggregated CA bandwidth combination
CA tests with 2CCs in Clause 8.2.3.1.2, 8.2.3.2.2A, 8.2.3.3.2, 8.7.5.2	Any one of the supported CA capabilities with largest aggregated CA bandwidth combination	Any one of the supported TDD-FDD CA configurations with TDD PCell with largest aggregated CA bandwidth combination	Largest aggregated CA bandwidth combination
CA tests with 2CCs in Clause 8.2.3.2.2	Each supported CA capability	Any one of the supported TDD-FDD CA configurations with TDD PCell in each CA capability with largest aggregated CA bandwidth combination	Largest aggregated CA bandwidth combination
NOTE 1: The applicability and test rules are specified in this table, unless otherwise stated.			
NOTE 2: Number of the supported bandwidth combinations to be tested from each selected CA configuration is 1.			
NOTE 3: A single Uplink CC is configured for all tests.			

Table 8.1.2.3B-2: Applicability and test rules for CA UE demodulation tests for TDD-FDD CA with 3 or more DL CCs

Tests	CA capability where the tests apply	CA configuration from the selected CA capability where the tests apply	CA Bandwidth combination to be tested in priority order
CA tests with 3CCs in Clause 8.2.3.1.1, 8.2.3.2.1A, 8.2.3.3.1, 8.7.5.1	Any one of the supported CA capabilities with largest aggregated CA bandwidth combination	Any one of the supported TDD-FDD CA configurations with FDD PCell with largest aggregated CA bandwidth combination	Largest aggregated CA bandwidth combination
CA tests with 3CCs in Clause 8.2.3.2.1	Each supported CA capability	Any one of the supported TDD-FDD CA configurations with FDD PCell in each CA capability with largest aggregated CA bandwidth combination	Largest aggregated CA bandwidth combination
CA tests with 3CCs in Clause 8.2.3.1.2, 8.2.3.2.2A, 8.2.3.3.2, 8.7.5.2	Any one of the supported CA capabilities with largest aggregated CA bandwidth combination	Any one of the supported TDD-FDD CA configurations with TDD PCell with largest aggregated CA bandwidth combination	Largest aggregated CA bandwidth combination
CA tests with 3CCs in Clause 8.2.3.2.2	Each supported CA capability	Any one of the supported TDD-FDD CA configurations with TDD PCell in each CA capability with largest aggregated CA bandwidth combination	Largest aggregated CA bandwidth combination
NOTE 1: The applicability and test rules are specified in this table, unless otherwise stated.			
NOTE 2: Number of the supported bandwidth combinations to be tested from each selected CA configuration is 1.			
NOTE 3: A single Uplink CC is configured for all tests.			

8.1.2.4 Test coverage for different number of component carriers

For FDD tests specified in 8.2.1.1.1, 8.2.1.3.1, 8.2.1.4.3, and 8.7.1, if corresponding CA tests are tested, the test coverage can be considered fulfilled without executing single carrier tests.

For TDD tests specified in 8.2.2.1.1, 8.2.2.3.1, 8.2.2.4.3, and 8.7.2, if corresponding CA tests are tested, the test coverage can be considered fulfilled without executing single carrier tests.

For TDD FDD tests specified in 8.2.3.1, 8.2.3.2, 8.2.3.3, and 8.7.5, if corresponding TDD FDD CA tests are tested, the test coverage can be considered fulfilled without executing both FDD and TDD single carrier tests.

For FDD CA tests specified in 8.2.1.1.1, 8.2.1.4.3, and 8.7.1, among all supported CA capabilities, if corresponding CA tests with the largest number of CCs supported by the UE are tested, the test coverage can be considered fulfilled without executing the CA tests with less than the largest number of CCs supported by the UE.

For FDD CA tests specified in 8.2.1.3.1, for each supported CA capability, if corresponding CA tests with the largest number of CCs supported by the UE are tested, the test coverage can be considered fulfilled without executing the CA tests with less than the largest number of CCs supported by the UE.

For TDD CA tests specified in 8.2.2.1.1, 8.2.2.4.3, and 8.7.2, among all supported CA capabilities, if corresponding CA tests with the largest number of CCs supported by the UE are tested, the test coverage can be considered fulfilled without executing the CA tests with less than the largest number of CCs supported by the UE.

For TDD CA tests specified in 8.2.2.3.1, for each supported CA capability, if corresponding CA tests with the largest number of CCs supported by the UE are tested, the test coverage can be considered fulfilled without executing the CA tests with less than the largest number of CCs supported by the UE.

For TDD FDD CA tests specified in 8.2.3.1, 8.2.3.3, and 8.7.5, among all supported CA capabilities, if corresponding CA tests with the largest number of CCs supported by the UE are tested, the test coverage can be considered fulfilled without executing the TDD FDD CA tests with less than the largest number of CCs supported by the UE.

For TDD FDD CA tests specified in 8.2.3.2, for each supported CA capability, if corresponding CA tests with the largest number of CCs supported by the UE are tested, the test coverage can be considered fulfilled without executing the TDD FDD CA tests with less than the largest number of CCs supported by the UE.

For FDD CA power imbalance tests specified in 8.2.1.7.1, if they are tested with FDD intra-band contiguous CA configurations with 2 DL CCs, the test coverage can be considered fulfilled with FDD intra-band contiguous CA configurations with 3 or more DL CCs supported by the UE.

For TDD CA power imbalance tests specified in 8.2.2.7.1, if they are tested with TDD intra-band contiguous CA configurations with 2 DL CCs, the test coverage can be considered fulfilled with TDD intra-band contiguous CA configurations with 3 or more DL CCs supported by the UE.

For FDD DC tests specified in 8.2.1.4.3 and 8.7.6, among all supported DC capabilities, if corresponding DC tests with the largest number of CCs supported by the UE are tested, the test coverage can be considered fulfilled without executing the DC tests with less than the largest number of CCs supported by the UE.

For TDD FDD DC tests specified in 8.2.3.4 and 8.7.8, among all supported DC capabilities, if corresponding DC tests with the largest number of CCs supported by the UE are tested, the test coverage can be considered fulfilled without executing the DC tests with less than the largest number of CCs supported by the UE.

For LAA SCell(s) with FDD PCell tests specified in 8.2.4.1.1 and 8.3.3.1.1, for each supported CA capability, if corresponding CA with LAA SCell(s) tests with the largest number of CCs supported by the UE are tested, the test coverage can be considered fulfilled without executing the CA with LAA SCell(s) tests with less than the largest number of CCs supported by the UE.

For LAA SCell(s) with TDD PCell tests specified in 8.2.4.1.2 and 8.3.3.1.2, for each supported CA capability, if corresponding CA with LAA SCell(s) tests with the largest number of CCs supported by the UE are tested, the test coverage can be considered fulfilled without executing the CA with LAA SCell(s) tests with less than the largest number of CCs supported by the UE.

8.1.2.5 Applicability of performance requirements for Type B receiver

For TM10 capable UE, if corresponding tests specified in 8.3.1.1F, 8.3.2.1G, 9.3.8.3 are tested, the test coverage can be considered fulfilled without executing the tests specified in 8.3.1.1C, 8.3.2.1D, 9.3.8.2. For a UE which does not have TM10 capability, the tests specified in sections 8.3.1.1C, 8.3.2.1D, 9.3.8.2 should be used.

8.1.2.6 Applicability of performance requirements for 4Rx capable UEs

For 4Rx capable UEs, the 2Rx supported RF bands and 4Rx supported RF bands are up to UE's declaration.

8.1.2.6.1 Applicability rule and antenna connection for single carrier tests with 2Rx

For 4Rx capable UEs all single carrier tests specified in 8.2 to 8.8 with 2Rx are tested on any of the 2 Rx supported RF bands by connecting 2 out of the 4Rx with data source from system simulator, and the other 2 Rx are connected with zero input, depending on UE's declaration and AP configuration. Same requirements specified with 2Rx should be applied.

For 4Rx capable UEs without any 2Rx RF bands, all single carrier tests specified in 8.2 to 8.8 with 2Rx are tested on any of the 4Rx supported RF bands by duplicating the fading channel from each Tx antenna and add independent noise for each Rx antenna. Figure 8.1.2.6.1-1 shows an example of antenna connection for 4Rx UE in any one 4Rx supported RF band to perform a 2Rx performance test with antenna configuration as 2x2 without interference for information. The SNR requirements should be applied with 1.5 dB less than the number specified with 2Rx for test configuration with CRS-based TM and with 1.5 dB less than the number specified with 2Rx for test configuration with DMRS-based TM.

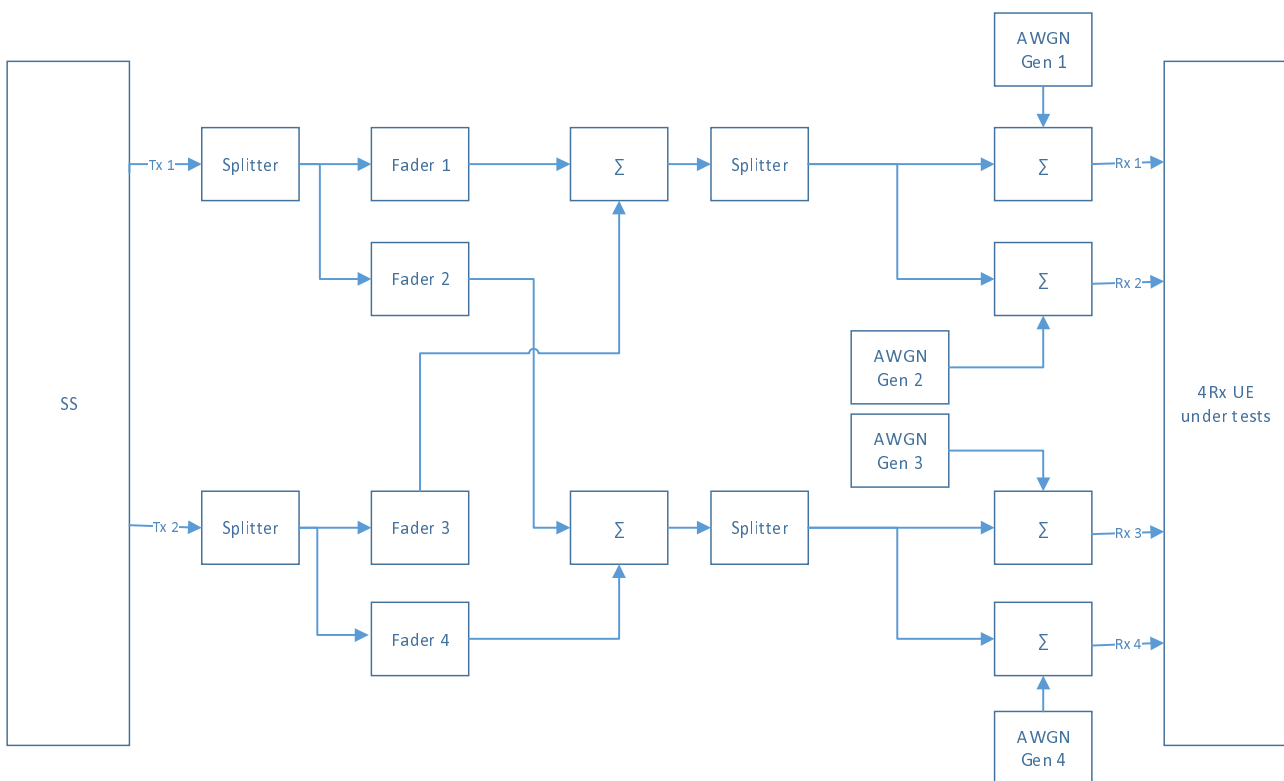

Figure 8.1.2.6.1-1 Antenna connection example for 2Rx tests with antenna configuration as 2x2 without interference (informative)

For 4Rx capable UEs without any 2Rx supported RF bands, for all single carrier tests listed in Table 8.1.2.6.1-0 specified from 8.2 to 8.8 with 2Rx can be skipped.

Table 8.1.2.6.1-0: Requirement lists for 4Rx capable UEs

Requirement lists
Enhanced downlink control channel performance requirements type A
Enhanced downlink control channel performance requirements type B
Enhanced performance requirements type B
Enhanced performance requirements type C
Requirements with demodulation subframe overlaps with aggressor cell ABS
Requirements with demodulation subframe overlaps with aggressor cell ABS and CRS assistance information are configured
Requirements with CRS assistance information configured

For 4Rx capable UEs, if corresponding tests listed from the 4Rx test lists from Table 8.1.2.6.1-1 are tested, the test coverage can be considered fulfilled without executing the corresponding tests listed from the 2Rx test lists from Table 8.1.2.6.1-1.

Table 8.1.2.6.1-1: Applicability rules for single carrier tests with 2Rx

4Rx test lists	2Rx test lists
8.10.1.1.1 Test 1	8.2.1.2.1 Test 1
8.10.1.1.2 Test 1	8.2.1.3.1 Test 1
8.10.1.1.3 Test 1	8.2.1.4.1B Test 1
8.10.1.1.4 Test 1	8.2.1.4.2 Test 1
8.10.1.1.4 Test 2	8.2.1.4.2 Test 3
8.10.1.1.5 Test 1	8.3.1.1A Test 1
8.10.1.1.5A Test 1	8.3.1.1 Test 2
8.10.1.1.5B Test 1	8.3.1.1H Test 1
8.10.1.1.6 Test 1	8.3.1.2 Test 1
8.10.1.2.1 Test 1	8.2.2.2.1 Test 1
8.10.1.2.2 Test 1	8.2.2.3.1 Test 1
8.10.1.2.3 Test 1	8.2.2.4.1B Test 1
8.10.1.2.4 Test 1	8.2.2.4.2 Test 1
8.10.1.2.4 Test 2	8.2.2.4.2 Test 3
8.10.1.2.5 Test 1	8.3.2.1B Test 1
8.10.1.2.5A Test 1	8.3.2.1A Test 2
8.10.1.2.5B Test 1	8.3.1.1I Test 1
8.10.1.2.6 Test 1	8.3.2.2 Test 2
8.10.2.1.1 Test 1	8.4.1.1 Test 1
8.10.2.1.2 Test 1	8.4.1.2.1 Test 1
8.10.2.1.3 Test 1	8.4.1.2.2 Test 1
8.10.2.2.1 Test 1	8.4.2.1 Test 1
8.10.2.2.2 Test 1	8.4.2.2.1 Test 1
8.10.2.2.3 Test 1	8.4.2.2.2 Test 1
8.10.3.1.1 Test 1	8.5.1.1 Test 1
8.10.3.1.2 Test 1	8.5.1.2.1 Test 1
8.10.3.1.3 Test 1	8.5.1.2.2 Test 1
8.10.3.2.1 Test 1	8.5.2.1 Test 1
8.10.3.2.2 Test 1	8.5.2.2.1 Test 1
8.10.3.2.3 Test 1	8.5.2.2.2 Test 1
8.10.4.1.1 Test 1	8.8.1.1 Test 1
8.10.4.1.1 Test 2	8.8.1.1 Test 2
8.10.4.1.2 Test 1	8.8.1.2 Test 1
8.10.4.1.2 Test 2	8.8.1.2 Test 2
8.10.4.2.1 Test 1	8.8.2.1 Test 1
8.10.4.2.1 Test 2	8.8.2.1 Test 2
8.10.4.2.2 Test 1	8.8.2.2 Test 1
8.10.4.2.2 Test 2	8.8.2.2 Test 2

8.1.2.6.2 Applicability rule and antenna connection for CA and DC tests with 2Rx

All tests specified in 8.2 to 8.8 with 2Rx with CA, TDD-FDD CA and DC are tested with 4 Rx capable UEs.

Within the CA/DC configuration if any of the PCell and/or the SCells and/or PSCells is a 2Rx supported RF band, the antenna connection should follow the same method as defined in 8.1.2.6.1 for single carrier tests on any of the 2Rx supported RF bands, with same requirements specified with 2Rx applied. Within the CA configuration if any of the PCell and/or the SCells and/or PSCells is a 4Rx supported RF band, the antenna connection should follow the same as defined in 8.1.2.6.1 for single carrier tests on any of the 4 Rx supported RF bands, with the SNR requirements applied with 1.5 dB less than the number specified with 2Rx.

Same applicability rules defined in 8.1.2.3, 8.1.2.3A, and 8.1.2.3B for CA, TDD-FDD CA and DC applied for different CA and DC configurations and bandwidth combination sets should be applied for 4 Rx capable UEs

8.1.2.6.3 Applicability rule and antenna connection for single carrier tests with 4Rx

For 4Rx capable UEs all single carrier tests specified in 8.10 with 4Rx are tested on any of the 4Rx supported RF bands by connecting all 4Rx with data source from system simulator.

8.1.2.6.4 Applicability rule for 256QAM tests

For 256QAM capable UE, if corresponding tests specified in 8.10.1.1.4 Test 2 and 8.10.1.2.4 Test 2 are tested, the test coverage can be considered fulfilled without executing the tests specified in 8.10.1.1.4 Test 1 and 8.10.1.2.4 Test 1. For a UE which does not have 256QAM capability, the test specified in 8.10.1.1.4 Test 1 and 8.10.1.2.4 Test 1 should be used.

8.1.2.7 Applicability of Enhanced Downlink Control Channel Performance Requirements

For enhanced Downlink Control Channel Type A receiver capable UE the tests from the Type A receiver test lists from Table 8.1.2.7-1 should be applied and for enhanced Downlink Control Channel Type B receiver capable UE the tests from the Type B receiver test lists Table 8.1.2.7-1 should be applied.

For enhanced Downlink Control Channel Type B receiver capable UE if the tests from the Type B receiver test lists are tested, the test coverage can be considered fulfilled without executing the corresponding tests from the Type A receiver test lists.

Table 8.1.2.7-1: Applicability rules for enhanced downlink control channel performance requirements

Test category		Type A receiver test list	Type B receiver test list
FDD Tests	PDCCH/PCFICH	8.4.1.2.5 Test 1	8.4.1.2.5 Test 1 8.4.1.2.7 Test 1
		8.4.1.2.6 Test 1	8.4.1.2.8 Test 1
	PHICH	8.5.1.2.5 Test 1	8.5.1.2.5 Test 1 8.5.1.2.7 Test 1
		8.5.1.2.6 Test 1	8.5.1.2.8 Test 1
	EPDCCH	8.8.4.1 Test 1	8.8.4.1 Test 1
		8.8.6.1 Test 1	8.8.6.1 Test 1
TDD Tests	PDCCH/PCFICH	8.4.2.2.5 Test 1	8.4.2.2.7 Test 1
		8.4.2.2.6 Test 1	8.4.2.2.8 Test 1
	PHICH	8.5.2.2.5 Test 1	8.5.2.2.7 Test 1
		8.5.2.2.6 Test 1	8.5.2.2.8 Test 1
	EPDCCH	8.8.4.2 Test 1	8.8.4.2 Test 1
		8.8.5.1 Test 1	8.8.5.1 Test 1

8.1.2.8 Applicability of performance requirements for CDM-multiplexed DM RS with interfering simultaneous transmission (FRC) with multiple CSI-RS configurations

For a UE which supports DMRS enhancement (dmrs-Enhancements-r13 UE-EUTRA-Capability [7]), if corresponding tests specified in 8.3.1.1H Test 1 and 8.3.2.1I Test 1 are tested, the test coverage can be considered fulfilled without executing the tests specified in 8.3.1.1 Test 2 and 8.3.2.1A Test 2. For a UE which does not have DMRS enhancement capability, the test specified in 8.3.1.1 Test 2 and 8.3.2.1A Test 2 should be used.

8.1.2.8A Applicability of performance requirements for UE supporting coverage enhancement

The applicability and test rules are defined for the tests for UE supporting coverage enhancement with narrowband transmission in Table 8.1.2.8A-1 and 8.1.2.8A-2.

Table 8.1.2.8A-1: Applicability rules for PDSCH requirements (FDD)

	ue-Category or UE-CategoryDL	
	M1, Cat-0, 1bis	>=1 (Note 1)
UE-EUTRA-Capability	M1, Cat-0, 1bis	>=1 (Note 1)
ce-ModeA-r13	8.11.1.1.1.1 Test 1 8.11.1.1.2.1 Test 1 8.11.1.1.3.1 Test 2	8.11.1.1.2.1 Test 2 8.11.1.1.2.1 Test 3
ce-ModeB-r13	8.11.1.1.1.1 Test 1 8.11.1.1.2.1 Test 1 8.11.1.1.3.1 Test 1	8.11.1.1.2.1 Test 2 8.11.1.1.2.1 Test 3 8.11.1.1.3.1 Test 3 8.11.1.1.3.1 Test 4
Note 1: which test case applies to the UE depends on the supported receiver antenna number.		

Table 8.1.2.8A-2: Applicability rules for PDSCH requirements (TDD)

	ue-Category or UE-CategoryDL	
	M1, Cat-0, 1bis	>=1 (Note 1)
UE-EUTRA-Capability	M1, Cat-0, 1bis	>=1 (Note 1)
ce-ModeA-r13	8.11.1.2.1.1 Test 1 8.11.1.2.2.1 Test 1 8.11.1.2.3.1 Test 2	8.11.1.2.2.1 Test 2 8.11.1.2.2.1 Test 3
ce-ModeB-r13	8.11.1.2.1.1 Test 1 8.11.1.2.2.1 Test 1 8.11.1.2.3.1 Test 1	8.11.1.2.2.1 Test 2 8.11.1.2.2.1 Test 3 8.11.1.2.3.1 Test 3 8.11.1.2.3.1 Test 4
Note 1: which test case applies to the UE depends on the supported receiver antenna number.		

8.1.3 UE category and UE DL category

UE category and UE DL category refer to *ue-Category* and *ue-CategoryDL* define in 4.1 and 4.1A from [12]. A UE that belongs to either a UE category or a UE DL category indicated in UE performance requirements in subclause 8, 9, 10 shall fulfil the corresponding requirements.

A UE indicating DL category 13 may indicate category 9 or 10 and shall thereby fulfil all requirements in subclause 8, 9, 10 that are indicated for either cat 9 or DL Cat 13 UEs. For SDR tests in section 8.7 both cat 9 and cat 13 test shall be used for this UE while for the other test only Cat 13 tests needs to be done.

8.2 Demodulation of PDSCH (Cell-Specific Reference Symbols)

8.2.1 FDD (Fixed Reference Channel)

The parameters specified in Table 8.2.1-1 are valid for all FDD tests unless otherwise stated.

Table 8.2.1-1: Common Test Parameters (FDD)

Parameter	Unit	Value
Inter-TTI Distance		1
Number of HARQ processes per component carrier	Processes	8
Maximum number of HARQ transmission		4
Redundancy version coding sequence		{0,1,2,3} for QPSK and 16QAM {0,0,1,2} for 64QAM and 256QAM
Number of OFDM symbols for PDCCH per component carrier	OFDM symbols	4 for 1.4 MHz bandwidth, 3 for 3 MHz and 5 MHz bandwidths, 2 for 10 MHz, 15 MHz and 20 MHz bandwidths unless otherwise stated
Cyclic Prefix		Normal
Cell_ID		0
Cross carrier scheduling		Not configured

8.2.1.1 Single-antenna port performance

The single-antenna performance in a given multi-path fading environments is determined by the SNR for which a certain relative information bit throughput of the reference measurement channels in Annex A.3.3 is achieved. The purpose of these tests is to verify the single-antenna performance with different channel models and MCS. The QPSK and 64QAM cases are also used to verify the performance for all bandwidths specified in Table 5.6.1-1.

8.2.1.1.1 Minimum Requirement

For single carrier, the requirements are specified in Table 8.2.1.1.1-2, with the addition of the parameters in Table 8.2.1.1.1-1 and the downlink physical channel setup according to Annex C.3.2.

For CA with 2 DL CCs, the requirements are specified in Table 8.2.1.1.1-4, with the addition of the parameters in Table 8.2.1.1.1-3 and the downlink physical channel setup according to Annex C.3.2.

For CA with 3 DL CCs, the requirements are specified in Table 8.2.1.1.1-6, based on single carrier requirement specified in Table 8.2.1.1.1-5, with the addition of the parameters in Table 8.2.1.1.1-3 and the downlink physical channel setup according to Annex C.3.2.

For CA with 4 DL CCs, the requirements are specified in Table 8.2.1.1.1-7, based on single carrier requirement specified in Table 8.2.1.1.1-5, with the addition of the parameters in Table 8.2.1.1.1-3 and the downlink physical channel setup according to Annex C.3.2.

For CA with 5 DL CCs, the requirements are specified in Table 8.2.1.1.1-8, based on single carrier requirement specified in Table 8.2.1.1.1-5, with the addition of the parameters in Table 8.2.1.1.1-3 and the downlink physical channel setup according to Annex C.3.2.

The test coverage for different number of component carriers is defined in 8.1.2.4.

Table 8.2.1.1.1-1: Test Parameters

Parameter	Unit	Test 1- 5	Test 6- 8	Test 9- 15	Test 16- 18	Test 19
Downlink power allocation	ρ_A	dB	0	0	0	0
	ρ_B	dB	0 (NOTE 1)	0 (NOTE 1)	0 (NOTE 1)	0 (NOTE 1)
	σ	dB	0	0	0	0
N_{oc} at antenna port	dBm/15kHz	-98	-98	-98	-98	-98
Symbols for unused PRBs		OCNG (NOTE 2)	OCNG (NOTE 2)	OCNG (NOTE 2)	OCNG (NOTE 2)	OCNG (NOTE 2)
Modulation		QPSK	16QAM	64QAM	16QAM	QPSK
PDSCH transmission mode		1	1	1	1	1
NOTE 1: $P_B = 0$.						
NOTE 2: These physical resource blocks are assigned to an arbitrary number of virtual UEs with one PDSCH per virtual UE; the data transmitted over the OCNG PDSCHs shall be uncorrelated pseudo random data, which is QPSK modulated.						
NOTE 3: Void.						
NOTE 4: Void.						

Table 8.2.1.1.1-2: Minimum performance (FRC)

Test num.	Bandwidth	Reference channel	OCNG pattern	Propagation condition	Correlation matrix and antenna config.	Reference value		UE category
						Fraction of maximum throughput (%)	SNR (dB)	
1	10 MHz	R.2 FDD	OP.1 FDD	EVA5	1x2 Low	70	-1.0	≥1
2	10 MHz	R.2 FDD	OP.1 FDD	ETU70	1x2 Low	70	-0.4	≥1
3	10 MHz	R.2 FDD	OP.1 FDD	ETU300	1x2 Low	70	0.0	≥1
4	10 MHz	R.2 FDD	OP.1 FDD	HST	1x2	70	-2.4	≥1
5	1.4 MHz	R.4 FDD	OP.1 FDD	EVA5	1x2 Low	70	0.0	≥1
6	10 MHz	R.3 FDD	OP.1 FDD	EVA5	1x2 Low	70	6.7	≥2
	5 MHz	R.3-1 FDD	OP.1 FDD	EVA5	1x2 Low	70	6.7	1
	5 MHz (NOTE 4)	R.3-1 FDD	OP.1 FDD	EVA5	1x2 Low	70	6.7	≥2
7	10 MHz	R.3 FDD	OP.1 FDD	ETU70	1x2 Low	30	1.4	≥2
	5 MHz	R.3-1 FDD	OP.1 FDD	ETU70	1x2 Low	30	1.4	1
	5 MHz (NOTE 4)	R.3-1 FDD	OP.1 FDD	ETU70	1x2 Low	30	1.4	≥2
8	10 MHz	R.3 FDD	OP.1 FDD	ETU300	1x2 High	70	9.4	≥2
	5 MHz	R.3-1 FDD	OP.1 FDD	ETU300	1x2 High	70	9.4	1
	5 MHz (NOTE 4)	R.3-1 FDD	OP.1 FDD	ETU300	1x2 High	70	9.4	≥2
9	3 MHz	R.5 FDD	OP.1 FDD	EVA5	1x2 Low	70	17.6	≥1
10	5 MHz	R.6 FDD	OP.1 FDD	EVA5	1x2 Low	70	17.4	≥2
	5 MHz	R.6-1 FDD	OP.1 FDD	EVA5	1x2 Low	70	17.5	1
11	10 MHz	R.7 FDD	OP.1 FDD	EVA5	1x2 Low	70	17.7	≥2
	10 MHz	R.7-1 FDD	OP.1 FDD	EVA5	1x2 Low	70	16.7	1
12	10 MHz	R.7 FDD	OP.1 FDD	ETU70	1x2 Low	70	19.0	≥2
	10 MHz	R.7-1 FDD	OP.1 FDD	ETU70	1x2 Low	70	18.1	1
13	10 MHz	R.7 FDD	OP.1 FDD	EVA5	1x2 High	70	19.1	≥2
	10 MHz	R.7-1 FDD	OP.1 FDD	EVA5	1x2 High	70	17.8	1
14	15 MHz	R.8 FDD	OP.1 FDD	EVA5	1x2 Low	70	17.7	≥2
	15 MHz	R.8-1 FDD	OP.1 FDD	EVA5	1x2 Low	70	16.8	1
15	20 MHz	R.9 FDD	OP.1 FDD	EVA5	1x2 Low	70	17.6	≥3
	20 MHz	R.9-2 FDD	OP.1 FDD	EVA5	1x2 Low	70	17.3	2
	20 MHz	R.9-1 FDD	OP.1 FDD	EVA5	1x2 Low	70	16.7	1
16	3 MHz	R.0 FDD	OP.1 FDD	ETU70	1x2 Low	30	1.9	≥1
17	10 MHz	R.1 FDD	OP.1 FDD	ETU70	1x2 Low	30	1.9	≥1
18	20 MHz	R.1 FDD	OP.1 FDD	ETU70	1x2 Low	30	1.9	≥1
19	10 MHz	R.41 FDD	OP.1 FDD	EVA5	1x2 Low	70	-5.4	≥1
NOTE 1: Void.								
NOTE 2: Void.								
NOTE 3: Void.								
NOTE 4: Test case applicability is defined in 8.1.2.1.								

Table 8.2.1.1.1-3: Test Parameters for CA

Parameter	Unit	Value	
Downlink power allocation	ρ_A	dB	0
	ρ_B	dB	0 (NOTE 1)
	σ	dB	0
N_{oc} at antenna port	dBm/15kHz	-98	
Symbols for unused PRBs		OCNG (NOTE 2)	
Modulation		QPSK	
PDSCH transmission mode		1	
NOTE 1: $P_B = 0$.			
NOTE 2: These physical resource blocks are assigned to an arbitrary number of virtual UEs with one PDSCH per virtual UE; the data transmitted over the OCNG PDSCHs shall be uncorrelated pseudo random data, which is QPSK modulated.			
NOTE 3: PUCCH format 1b with channel selection is used to feedback ACK/NACK for Tests in Table 8.2.1.1.1-4, PUCCH format 3 is used to feedback ACK/NACK for Tests in Table 8.2.1.1.1-6.			
NOTE 4: The same PDSCH transmission mode is applied to each component carrier.			

Table 8.2.1.1.1-4: Minimum performance (FRC) for CA with 2DL CCs

Test num.	Bandwidth	Reference channel	OCNG pattern	Propagation condition	Correlation matrix and antenna config.	Reference value		UE category
						Fraction of maximum throughput (%)	SNR (dB)	
1	2x10 MHz	R.2 FDD	OP.1 FDD (NOTE 1)	EVA5	1x2 Low	70	-1.1	≥ 3 (NOTE 2)
2	2x20 MHz	R.42 FDD	OP.1 FDD (NOTE 1)	EVA5	1x2 Low	70	-1.3	≥ 5
3	2x5 MHz	R.42-2 FDD	OP.1 FDD	EVA5	1x2 Low	70	-1.0	≥ 2
			OP.1 FDD			70	-1.0	
4	10MHz +5MHz	R.2 FDD for 10MHz CC	OP.1 FDD	EVA5	1x2 Low	70	-1.7	≥ 3
		R.42-2 FDD for 5MHz CC	OP.1 FDD			70	-1.0	
5	15MHz +5MHz	R.42-3 FDD for 15MHz CC	OP.1 FDD	EVA5	1x2 Low	70	-1.6	≥ 3
		R.42-2 FDD for 5MHz CC	OP.1 FDD			70	-1.0	
NOTE 1: The OCNG pattern applies for each CC.								
NOTE 2: 30usec timing difference between two CCs is applied in inter-band CA case.								
NOTE 3: The applicability of requirements for different CA configurations and bandwidth combination sets is defined in 8.1.2.3.								

Table 8.2.1.1.1-5: Single carrier performance for multiple CA configurations

Band-width	Reference channel	OCNG pattern	Propagation condition	Correlation matrix and antenna config.	Reference value	
					Fraction of maximum throughput (%)	SNR (dB)
1.4MHz	R.4 FDD	OP.1 FDD	EVA5	1x2 Low	70	-1.3
3MHz	R.42-1 FDD	OP.1 FDD	EVA5	1x2 Low	70	-1.1
5MHz	R.42-2 FDD	OP.1 FDD	EVA5	1x2 Low	70	-1.0
10MHz	R.2 FDD	OP.1 FDD	EVA5	1x2 Low	70	-1.7
15MHz	R.42-3 FDD	OP.1 FDD	EVA5	1x2 Low	70	-1.6
20MHz	R.42 FDD	OP.1 FDD	EVA5	1x2 Low	70	-1.7

Table 8.2.1.1.1-6: Minimum performance (FRC) based on single carrier performance for CA with 3DL CCs

Test num.	CA Band-width combination	Requirement	UE category
1	3x20MHz	As specified in Table 8.2.1.1.1-5 per CC	≥5
2	20MHz+20MHz+15MHz	As specified in Table 8.2.1.1.1-5 per CC	≥5
3	20MHz+20MHz+10MHz	As specified in Table 8.2.1.1.1-5 per CC	≥5
4	20MHz+15MHz+15MHz	As specified in Table 8.2.1.1.1-5 per CC	≥5
5	20MHz+15MHz+10MHz	As specified in Table 8.2.1.1.1-5 per CC	≥5
6	20MHz+10MHz+10MHz	As specified in Table 8.2.1.1.1-5 per CC	≥5
7	15MHz+15MHz+10MHz	As specified in Table 8.2.1.1.1-5 per CC	≥5
8	20MHz+10MHz+5MHz	As specified in Table 8.2.1.1.1-5 per CC	≥5
9	20MHz+15MHz+5MHz	As specified in Table 8.2.1.1.1-5 per CC	≥5
10	10MHz+10MHz+5MHz	As specified in Table 8.2.1.1.1-5 per CC	≥5
NOTE 1: The applicability of requirements for different CA configurations and bandwidth combination sets is defined in 8.1.2.3			
NOTE 2: 30usec timing difference between PCell and any SCell, which is not within the same band or sub-block as PCell, is applied in inter-band CA case, where PCell can be assigned on any CC.			

Table 8.2.1.1.1-7: Minimum performance (FRC) based on single carrier performance for CA with 4DL CCs

Test num.	CA Band-width combination	Requirement	UE category
1	4x20MHz	As specified in Table 8.2.1.1.1-5 per CC	≥8
2	10MHz+20MHz+20MHz+20MHz	As specified in Table 8.2.1.1.1-5 per CC	≥8
3	10MHz+10MHz+20MHz+20MHz	As specified in Table 8.2.1.1.1-5 per CC	≥8
4	5MHz+10MHz+20MHz+20MHz	As specified in Table 8.2.1.1.1-5 per CC	≥8
5	5MHz+10MHz+10MHz+20MHz	As specified in Table 8.2.1.1.1-5 per CC	≥8
NOTE 1: The applicability of requirements for different CA configurations and bandwidth combination sets is defined in 8.1.2.3			
NOTE 2: 30usec timing difference between PCell and any SCell, which is not within the same band or sub-block as PCell, is applied in inter-band CA case, where PCell can be assigned on any CC.			

Table 8.2.1.1.1-8: Minimum performance (FRC) based on single carrier performance for CA with 5DL CCs

Test num.	CA Band-width combination	Requirement	UE category
1	5x20MHz	As specified in Table 8.2.1.1.1-5 per CC	8, ≥11
NOTE 1: The applicability of requirements for different CA configurations and bandwidth combination sets is defined in 8.1.2.3			
NOTE 2: 30usec timing difference between PCell and any SCell, which is not within the same band or sub-block as PCell, is applied in inter-band CA case, where PCell can be assigned on any CC.			

8.2.1.1.2 Void

8.2.1.1.3 Void

8.2.1.1.4 Minimum Requirement 1 PRB allocation in presence of MBSFN

The requirements are specified in Table 8.2.1.1.4-2, with the addition of the parameters in Table 8.2.1.1.4-1 and the downlink physical channel setup according to Annex C.3.2. The purpose of these tests is to verify the single-antenna performance with a single PRB allocated at the lower band edge in presence of MBSFN.

Table 8.2.1.1.4-1: Test Parameters for Testing 1 PRB allocation

Parameter	Unit	Test 1	
Downlink power allocation	ρ_A	dB	0
	ρ_B	dB	0 (NOTE 1)
	σ	dB	0
N_{oc} at antenna port	dBm/15kHz	-98	
Symbols for MBSFN portion of MBSFN subframes (NOTE 2)		OCNG (NOTE 3)	
PDSCH transmission mode		1	
NOTE 1: $P_B = 0$			
NOTE 2: The MBSFN portion of an MBSFN subframe comprises the whole MBSFN subframe except the first two symbols in the first slot.			
NOTE 3: The MBSFN portion of the MBSFN subframes shall contain QPSK modulated data. Cell-specific reference signals are not inserted in the MBSFN portion of the MBSFN subframes, QPSK modulated MBSFN data is used instead.			

Table 8.2.1.1.4-2: Minimum performance 1PRB (FRC)

Test number	Bandwidth	Reference Channel	OCNG Pattern	Propagation Condition	Correlation Matrix and Antenna Configuration	Reference value		UE Category
						Fraction of Maximum Throughput (%)	SNR (dB)	
1	10 MHz	R.29 FDD	OP.3 FDD	ETU70	1x2 Low	30	2.0	≥ 1

8.2.1.2 Transmit diversity performance

8.2.1.2.1 Minimum Requirement 2 Tx Antenna Port

The requirements are specified in Table 8.2.1.2.1-2, with the addition of the parameters in Table 8.2.1.2.1-1 and the downlink physical channel setup according to Annex C.3.2. The purpose is to verify the performance of transmit diversity (SFBC) with 2 transmitter antennas.

Table 8.2.1.2.1-1: Test Parameters for Transmit diversity Performance (FRC)

Parameter		Unit	Test 1-2
Downlink power allocation	ρ_A	dB	-3
	ρ_B	dB	-3 (NOTE 1)
	σ	dB	0
N_{oc} at antenna port		dBm/15kHz	-98
PDSCH transmission mode			2
NOTE 1: $P_B = 1$.			

Table 8.2.1.2.1-2: Minimum performance Transmit Diversity (FRC)

Test number	Band-width	Reference Channel	OCNG Pattern	Propagation Condition	Correlation Matrix and Antenna Configuration	Reference value		UE Category
						Fraction of Maximum Throughput (%)	SNR (dB)	
1	10 MHz	R.11 FDD	OP.1 FDD	EVA5	2x2 Medium	70	6.8	≥ 2
	5 MHz	R.11-2 FDD	OP.1 FDD	EVA5	2x2 Medium	70	5.9	1
	5 MHz (NOTE 1)	R.11-2 FDD	OP.1 FDD	EVA5	2x2 Medium	70	5.9	≥ 2
2	10 MHz	R.10 FDD	OP.1 FDD	HST	2x2	70	-2.3	≥ 1
NOTE 1: Test case applicability is defined in 8.1.2.1.								

8.2.1.2.2 Minimum Requirement 4 Tx Antenna Port

The requirements are specified in Table 8.2.1.2.2-2, with the addition of the parameters in Table 8.2.1.2.2-1 and the downlink physical channel setup according Annex C.3.2. The purpose is to verify the performance of transmit diversity (SFBC-FSTD) with 4 transmitter antennas.

Table 8.2.1.2.2-1: Test Parameters for Transmit diversity Performance (FRC)

Parameter		Unit	Test 1-2
Downlink power allocation	ρ_A	dB	-3
	ρ_B	dB	-3 (NOTE 1)
	σ	dB	0
N_{oc} at antenna port		dBm/15kHz	-98
PDSCH transmission mode			2
NOTE 1: $P_B = 1$.			

Table 8.2.1.2.2-2: Minimum performance Transmit Diversity (FRC)

Test number	Band-width	Reference Channel	OCNG Pattern	Propagation Condition	Correlation Matrix and Antenna Configuration	Reference value		UE Category
						Fraction of Maximum Throughput (%)	SNR (dB)	
1	1.4 MHz	R.12 FDD	OP.1 FDD	EPA5	4x2 Medium	70	0.6	≥ 1
2	10 MHz	R.13 FDD	OP.1 FDD	ETU70	4x2 Low	70	-0.9	≥ 1

8.2.1.2.3 Minimum Requirement 2 Tx Antenna Port (demodulation subframe overlaps with aggressor cell ABS)

The requirements are specified in Table 8.2.1.2.3-2, with the addition of parameters in Table 8.2.1.2.3-1 and the downlink physical channel setup according to Annex C.3.2 and Annex C.3.3. The purpose is to verify the performance of transmit diversity (SFBC) with 2 transmit antennas if the PDSCH transmission in the serving cell takes place in subframes that overlap with ABS [9] of the aggressor cell. In Table 8.2.1.2.3-1, Cell 1 is the serving cell, and Cell 2 is the aggressor cell. The downlink physical channel setup for Cell 1 is according to Annex C.3.2 and for Cell 2 is according to Annex C.3.3, respectively.

Table 8.2.1.2.3-1: Test Parameters for Transmit diversity Performance (FRC)

Parameter		Unit	Cell 1	Cell 2
Downlink power allocation	ρ_A	dB	-3	-3
	ρ_B	dB	-3 (NOTE 1)	-3
	σ	dB	0	N/A
N_{oc} at antenna port	N_{oc1}	dBm/15kHz	-102 (NOTE 2)	N/A
	N_{oc2}	dBm/15kHz	-98 (NOTE 3)	N/A
	N_{oc3}	dBm/15kHz	-94.8 (NOTE 4)	N/A
\widehat{E}_s / N_{oc2}		dB	Reference Value in Table 8.2.1.2.3-2	6
BW _{Channel}		MHz	10	10
Subframe Configuration			Non-MBSFN	Non-MBSFN
Time Offset between Cells		μ s	2.5 (synchronous cells)	
Cell Id			0	1
ABS pattern (NOTE 5)			N/A	11000100 11000000 11000000 11000000 11000000
RLM/RRM Measurement Subframe Pattern (NOTE 6)			10000000 10000000 10000000 10000000 10000000	N/A
CSI Subframe Sets (NOTE7)	$C_{CSI,0}$		11000100 11000000 11000000 11000000 11000000	N/A
	$C_{CSI,1}$		00111011 00111111 00111111 00111111 00111111	N/A
Number of control OFDM symbols			2	2
PDSCH transmission mode			2	N/A
Cyclic prefix			Normal	Normal
NOTE 1: $P_B = 1$.				
NOTE 2: This noise is applied in OFDM symbols #1, #2, #3, #5, #6, #8, #9, #10, #12, #13 of a subframe overlapping with the aggressor ABS.				
NOTE 3: This noise is applied in OFDM symbols #0, #4, #7, #11 of a subframe overlapping with the aggressor ABS.				
NOTE 4: This noise is applied in all OFDM symbols of a subframe overlapping with aggressor non-ABS				
NOTE 5: ABS pattern as defined in [9].				
NOTE 6: Time-domain measurement resource restriction pattern for PCell measurements as defined in [7]				
NOTE 7: As configured according to the time-domain measurement resource restriction pattern for CSI measurements defined in [7].				
NOTE 8: Cell 1 is the serving cell. Cell 2 is the aggressor cell. The number of the CRS ports in Cell1 and Cell2 is the same.				
NOTE 9: SIB-1 will not be transmitted in Cell2 in this test.				

Table 8.2.1.2.3-2: Minimum Performance Transmit Diversity (FRC)

Test Number	Reference Channel	OCNG Pattern		Propagation Conditions (NOTE 1)		Correlation Matrix and Antenna Configuration	Reference Value		UE Category
		Cell 1	Cell 2	Cell 1	Cell 2		Fraction of Maximum Throughput (%) NOTE 5	SNR (dB) (Note 2)	
1	R.11-4 FDD (NOTE 4)	OP.1 FDD	OP.1 FDD	EVA5	EVA 5	2x2 Medium	70	3.4	≥2
NOTE 1: The propagation conditions for Cell 1 and Cell2 are statistically independent.									
NOTE 2: SNR corresponds to \hat{E}_s / N_{oc2} of cell 1.									
NOTE 3: The correlation matrix and antenna configuration apply for Cell 1 and Cell 2.									
NOTE 4: Cell 1 Reference channel is modified: PDSCH other than SIB1/paging and its associated PDCCH/PCFICH are transmitted in the serving cell subframe when the subframe is overlapped with the ABS subframe of aggressor cell and the subframe is available in the definition of the reference channel.									
NOTE 5: The maximum Throughput is calculated from the total Payload in 9 subframes, averaged over 40ms.									

8.2.1.2.3A Minimum Requirement 2 Tx Antenna Ports (demodulation subframe overlaps with aggressor cell ABS and CRS assistance information are configured)

The requirements are specified in Table 8.2.1.2.3A-2, with the addition of parameters in Table 8.2.1.2.3A-1. The purpose is to verify the performance of transmit diversity (SFBC) with 2 transmit antennas if the PDSCH transmission in the serving cell takes place in subframes that overlap with ABS [9] of the aggressor cells with CRS assistance information. In Table 8.2.1.2.3A-1, Cell 1 is the serving cell, and Cell 2 and Cell 3 are the aggressor cells. The downlink physical channel setup for Cell 1 is according to Annex C.3.2 and for Cell 2 and Cell 3 is according to Annex C.3.3, respectively. The CRS assistance information [7] includes Cell 2 and Cell 3.

Table 8.2.1.2.3A-1: Test Parameters for Transmit diversity Performance (FRC)

Parameter		Unit	Cell 1	Cell 2	Cell 3
Downlink power allocation	ρ_A	dB	-3	-3	-3
	ρ_B	dB	-3 (NOTE 1)	-3 (NOTE 1)	-3 (NOTE 1)
	σ	dB	0	N/A	N/A
N_{oc} at antenna port	N_{oc1}	dBm/15kHz	-98 (NOTE 2)	N/A	N/A
	N_{oc2}	dBm/15kHz	-98 (NOTE 3)	N/A	N/A
	N_{oc3}	dBm/15kHz	-93 (NOTE 4)	N/A	N/A
\hat{E}_s / N_{oc2}		dB	Reference Value in Table 8.2.1.2.3 A-2	12	10
BW _{Channel}		MHz	10	10	10
Subframe Configuration			Non-MBSFN	Non-MBSFN	Non-MBSFN
Time Offset between Cells		μs	N/A	3	-1
Frequency shift between Cells		Hz	N/A	300	-100
Cell Id			0	126	1
ABS pattern (NOTE 5)			N/A	11000000 11000000 11000000 11000000 11000000	11000000 11000000 11000000 11000000 11000000
RLM/RRM Measurement Subframe Pattern (NOTE 6)			10000000 10000000 10000000 10000000 10000000	N/A	N/A
CSI Subframe Sets (NOTE 7)	$C_{CSI,0}$		11000000 11000000 11000000 11000000 11000000	N/A	N/A
	$C_{CSI,1}$		00111111 00111111 00111111 00111111 00111111	N/A	N/A
Number of control OFDM symbols			2	NOTE 8	NOTE 8
PDSCH transmission mode			2	NOTE 9	NOTE 9
Cyclic prefix			Normal	Normal	Normal
NOTE 1: $P_B = 1$.					
NOTE 2: This noise is applied in OFDM symbols #1, #2, #3, #5, #6, #8, #9, #10, #12, #13 of a subframe overlapping with the aggressor ABS.					
NOTE 3: This noise is applied in OFDM symbols #0, #4, #7, #11 of a subframe overlapping with the aggressor ABS.					
NOTE 4: This noise is applied in all OFDM symbols of a subframe overlapping with aggressor non-ABS					
NOTE 5: ABS pattern as defined in [9].					
NOTE 6: Time-domain measurement resource restriction pattern for PCell measurements as defined in [7]					
NOTE 7: As configured according to the time-domain measurement resource restriction pattern for CSI measurements defined in [7].					
NOTE 8: The number of control OFDM symbols is not available for ABS and is 2 for the subframe indicated by "0" of ABS pattern.					
NOTE 9: Downlink physical channel setup in Cell 2 and Cell 3 in accordance with Annex C.3.3 applying OCN pattern as defined in Annex A.5.					
NOTE 10: The number of the CRS ports in Cell 1, Cell 2 and Cell 3 is the same.					
NOTE 11: SIB-1 will not be transmitted in Cell 2 and Cell 3 in this test.					

Table 8.2.1.2.3A-2: Minimum Performance Transmit Diversity (FRC)

Test Number	Reference Channel	OCNG Pattern			Propagation Conditions (NOTE 1)			Correlation Matrix and Antenna Configuration (NOTE 2)	Reference Value		UE Category
		Cell 1	Cell 2	Cell 3	Cell 1	Cell 2	Cell 3		Fraction of Maximum Throughput (%) NOTE 5	SNR (dB) (NOTE 3)	
1	R.11-4 FDD NOTE 4	OP.1 FDD	OP.1 FDD	OP.1 FDD	EVA5	EVA5	EVA5	2x2 Medium	70	3.4	≥2

NOTE 1: The propagation conditions for Cell 1, Cell 2 and Cell 3 are statistically independent.

NOTE 2: The correlation matrix and antenna configuration apply for Cell 1, Cell 2 and Cell 3.

NOTE 3: SNR corresponds to \hat{E}_s / N_{oc2} of cell 1.

NOTE 4: Cell 1 Reference channel is modified: PDSCH other than SIB1/paging and its associated PDCCH/PCFICH are transmitted in the serving cell subframe when the subframe is overlapped with the ABS subframe of aggressor cell and the subframe is available in the definition of the reference channel.

NOTE 5: The maximum Throughput is calculated from the total Payload in 9 subframes, averaged over 40ms.

8.2.1.2.4 Enhanced Performance Requirement Type A - 2 Tx Antenna Ports with TM3 interference model

The requirements are specified in Table 8.2.1.2.4-2, with the addition of parameters in Table 8.2.1.2.4-1 and the downlink physical channel setup according to Annex C.3.2. The purpose is to verify the performance of transmit diversity (SFBC) with 2 transmit antennas when the PDSCH transmission in the serving cell is interfered by PDSCH of two dominant interfering cells applying transmission mode 3 interference model defined in clause B.5.2. In Table 8.2.1.2.4-1, Cell 1 is the serving cell, and Cell 2, 3 are interfering cells. The downlink physical channel setup is according to Annex C.3.2 for each of Cell 1, Cell 2 and Cell 3, respectively.

Table 8.2.1.2.4-1: Test Parameters for Transmit diversity Performance (FRC) with TM3 interference model

Parameter		Unit	Cell 1	Cell 2	Cell 3
Downlink power allocation	ρ_A	dB	-3	-3	-3
	ρ_B	dB	-3 (NOTE 1)	-3	-3
	σ	dB	0	0	0
Cell-specific reference signals			Antenna ports 0,1	Antenna ports 0,1	Antenna ports 0,1
N_{oc} at antenna port		dBm/15kHz	-98	N/A	N/A
DIP (NOTE 2)		dB	N/A	-2.23	-8.06
$BW_{Channel}$		MHz	10	10	10
Cyclic Prefix			Normal	Normal	Normal
Cell Id			0	1	2
Number of control OFDM symbols			2	2	2
PDSCH transmission mode			2	N/A	N/A
Interference model			N/A	As specified in clause B.5.2	As specified in clause B.5.2
Probability of occurrence of transmission rank in interfering cells	Rank 1	%	N/A	80	80
	Rank 2	%	N/A	20	20
Reporting interval		ms	5	N/A	N/A
Reporting mode			PUCCH 1-0	N/A	N/A
Physical channel for CQI reporting			PUSCH(Note 5)	N/A	N/A
cqi-pmi-ConfigurationIndex			2	N/A	N/A
NOTE 1: $P_B = 1$					
NOTE 2: The respective received power spectral density of each interfering cell relative to N_{oc} is defined by its associated DIP value as specified in clause B.5.1.					
NOTE 3: Cell 1 is the serving cell. Cell 2, 3 are the interfering cells.					
NOTE 4: Cell 2 transmission is delayed with respect to Cell 1 by 0.33 ms and Cell 3 transmission is delayed with respect to Cell 1 by 0.67 ms.					
NOTE 5: To avoid collisions between CQI reports and HARQ-ACK it is necessary to report both on PUSCH instead of PUCCH. PDCCH DCI format 0 shall be transmitted in downlink SF#1 and #6 to allow periodic CQI to multiplex with the HARQ-ACK on PUSCH in uplink subframe SF#5 and #0.					

Table 8.2.1.2.4-2: Enhanced Performance Requirement Type A, Transmit Diversity (FRC) with TM3 interference model

Test Number	Reference Channel	OCNG Pattern			Propagation Conditions			Correlation Matrix and Antenna Configuration (NOTE 3)	Reference Value		UE Category
		Cell 1	Cell 2	Cell 3	Cell 1	Cell 2	Cell 3		Fraction of Maximum Throughput (%)	SINR (dB) (NOTE 2)	
1	R.46 FDD	OP. 1 FD D	N/A	N/A	EV A70	EV A70	EV A70	2x2 Low	70	-1.1	≥ 1
NOTE 1: The propagation conditions for Cell 1, Cell 2 and Cell 3 are statistically independent.											
NOTE 2: SINR corresponds to \hat{E}_s / N_{oc} of Cell 1 as defined in clause 8.1.1.											
NOTE 3: Correlation matrix and antenna configuration parameters apply for each of Cell 1, Cell 2 and Cell 3.											

8.2.1.2.5 Enhanced Performance Requirement Type B - 2 Tx Antenna Ports with TM2 interference model

The requirements are specified in Table 8.2.1.2.5-2, with the addition of parameters in Table 8.2.1.2.5-1 and the downlink physical channel setup according to Annex C.3.2. The purpose is to verify the performance of transmit diversity (SFBC) with 2 transmit antennas when the PDSCH transmission in the serving cell is interfered by PDSCH of two interfering cells applying transmission mode 2 interference model defined in clause B.6.1. In Table 8.2.1.2.5-1, Cell 1 is the serving cell, and Cell 2, 3 are interfering cells. The downlink physical channel setup is according to Annex C.3.2 for each of Cell 1, Cell 2 and Cell 3, respectively.

Table 8.2.1.2.5-1: Test Parameters for Transmit Diversity Performance (FRC) with TM2 interference model

Parameter		Unit	Cell 1	Cell 2	Cell 3
Downlink power allocation	ρ_A	dB	-3	-3	-3
	ρ_B	dB	-3 (Note 1)	-3	-3
	σ	dB	0	0	0
Cell-specific reference signals			Antenna ports 0,1	Antenna ports 0,1	Antenna ports 0,1
N_{oc} at antenna port		dBm/15kHz	-98		
\hat{E}_s/N_{oc}		dB	N/A	13.91	3.34
BW _{Channel}		MHz	10	10	10
Cyclic Prefix			Normal	Normal	Normal
Cell Id			0	6	1
Number of control OFDM symbols			3	3	3
CFI indicated in PCFICH			3	3	3
PDSCH transmission mode			2	2	2
Interference model			N/A	As specified in clause B.6.1	As specified in clause B.6.1
MBSFN			Not configured	Not configured	Not configured
Time offset to cell 1		us	N/A	2	3
Frequency offset to cell 1		Hz	N/A	200	300
NeighCellsInfo-r12 (Note 3)	p-aList-r12		N/A	{dB-6, dB-3, dB0}	{dB-6, dB-3, dB0}
	transmissionModeList-r12		N/A	{2,3,4,8,9}	{2,3,4,8,9}
Note 1: $P_B = 1$					
Note 2: Cell 1 is the serving cell. Cell 2, 3 are the interfering cells.					
Note 3: NeighCellsInfo-r12 is described in subclause 6.3.2 of [7].					

Table 8.2.1.2.5-2: Minimum Performance for Enhanced Performance Requirement Type B, Transmit Diversity (FRC) with TM2 interference model

Test Number	Reference Channel	OCNG Pattern			Propagation Conditions			Correlation Matrix and Antenna Configuration (Note 3)	Reference Value		UE Category
		Cell 1	Cell 2	Cell 3	Cell 1	Cell 2	Cell 3		Fraction of Maximum Throughput (%)	SNR (dB) (Note 2)	
1	R.11-10 FDD	OP. 1 FD D	N/A	N/A	EP A5	EP A5	EP A5	2x2 Low	85	15.5	≥1
Note 1: The propagation conditions for Cell 1, Cell 2 and Cell 3 are statistically independent.											
Note 2: SNR corresponds to \hat{E}_s/N_{oc} of Cell 1 as defined in clause 8.1.1.											
Note 3: Correlation matrix and antenna configuration parameters apply for each of Cell 1, Cell 2 and Cell 3.											

8.2.1.2.6 Enhanced Performance Requirement Type B - 2 Tx Antenna Ports with TM9 interference model

The requirements are specified in Table 8.2.1.2.6-2, with the addition of parameters in Table 8.2.1.2.6-1 and the downlink physical channel setup according to Annex C.3.2. The purpose is to verify the performance of transmit diversity (SFBC) with 2 transmit antennas when the PDSCH transmission in the serving cell is interfered by PDSCH of two interfering cells applying transmission mode 9 interference model defined in clause B.6.4. In Table 8.2.1.2.6-1, Cell 1 is the serving cell, and Cell 2, 3 are interfering cells. The downlink physical channel setup is according to Annex C.3.2 for each of Cell 1, Cell 2 and Cell 3, respectively.

Table 8.2.1.2.6-1: Test Parameters for Transmit Diversity Performance (FRC) with TM9 interference model

Parameter		Unit	Cell 1	Cell 2	Cell 3
Downlink power allocation	ρ_A	dB	-3	0	0
	ρ_B	dB	-3 (Note 1)	0	0
	σ	dB	0	-3	-3
Cell-specific reference signals			Antenna ports 0,1	Antenna ports 0,1	Antenna ports 0,1
N_{oc} at antenna port		dBm/15kHz	-98		
\hat{E}_s/N_{oc}		dB	N/A	3.28	0.74
$BW_{Channel}$		MHz	10	10	10
Cyclic Prefix			Normal	Normal	Normal
Cell Id			0	1	6
Number of control OFDM symbols			3	3	3
CFI indicated in PCFICH			3	Random from set {1,2,3}	Random from set {1,2,3}
PDSCH transmission mode			2	9	9
Interference model			N/A	As specified in clause B.6.4	As specified in clause B.6.4
CSI reference signals			N/A	Antenna ports 15,16	Antenna ports 15,16
CSI-RS periodicity and subframe offset $T_{CSI-RS} / \Delta_{CSI-RS}$		Subframes	N/A	10 / 1	10 / 1
CSI reference signal configuration			N/A	6	7
Zero-power CSI-RS configuration $I_{CSI-RS} / ZeroPowerCSI-RS$ bitmap		Subframes / bitmap	N/A	6 / 0100000000 00000	6 / 0010000000 000000
Time offset to cell 1		us	N/A	5	-5
Frequency offset to cell 1		Hz	N/A	600	-600
MBSFN			Not configured	Not configured	Not configured
NeighCellsInfo- r12 (Note 4)	p-aList-r12		N/A	{dB-6, dB-3, dB0}	{dB-6, dB-3, dB0}
	transmissionModeList- r12		N/A	{2,3,4,8,9}	{2,3,4,8,9}
Note 1: $P_B = 1$					
Note 2: Cell 1 is the serving cell. Cell 2, 3 are the interfering cells.					
Note 3: CSI-RS configurations are according to [4] subclause 6.10.5.2.					
Note 4: NeighCellsInfo-r12 is described in subclause 6.3.2 of [7].					

Table 8.2.1.2.6-2: Minimum Performance for Enhanced Performance Requirement Type B, Transmit Diversity (FRC) with TM9 interference model

Test Number	Reference Channel	OCNG Pattern			Propagation Conditions			Correlation Matrix and Antenna Configuration (Note 3)	Reference Value		UE Category
		Cell 1	Cell 2	Cell 3	Cell 1	Cell 2	Cell 3		Fraction of Maximum Throughput (%)	SNR (dB) (Note 2)	
1	R.11-9 FDD	OP. 1 FDD	N/A	N/A	EP A5	EP A5	EP A5	2x2 Low	85	8.4	≥1

Note 1: The propagation conditions for Cell 1, Cell 2 and Cell 3 are statistically independent.

Note 2: SNR corresponds to \hat{E}_s/N_{oc} of Cell 1 as defined in clause 8.1.1.

Note 3: Correlation matrix and antenna configuration parameters apply for each of Cell 1, Cell 2 and Cell 3.

8.2.1.3 Open-loop spatial multiplexing performance

8.2.1.3.1 Minimum Requirement 2 Tx Antenna Port

For single carrier, the requirements are specified in Table 8.2.1.3.1-2, with the addition of the parameters in Table 8.2.1.3.1-1 and the downlink physical channel setup according to Annex C.3.2.

For CA with 2 DL CC, the requirements are specified in Table 8.2.1.3.1-4, with the addition of the parameters in Table 8.2.1.3.1-3 and the downlink physical channel setup according to Annex C.3.2. The purpose is to verify the performance of large delay CDD with 2 transmitter antennas.

For CA with 3 DL CCs, the requirements are specified in Table 8.2.1.3.1-6, based on single carrier requirement specified in Table 8.2.1.3.1-5, with the addition of the parameters in Table 8.2.1.3.1-3 and the downlink physical channel setup according to Annex C.3.2.

For CA with 4 DL CCs, the requirements are specified in Table 8.2.1.3.1-7, based on single carrier requirement specified in Table 8.2.1.3.1-5, with the addition of the parameters in Table 8.2.1.3.1-3 and the downlink physical channel setup according to Annex C.3.2.

For CA with 5 DL CCs, the requirements are specified in Table 8.2.1.3.1-8, based on single carrier requirement specified in Table 8.2.1.3.1-5, with the addition of the parameters in Table 8.2.1.3.1-3 and the downlink physical channel setup according to Annex C.3.2.

The test coverage for different number of component carriers is defined in 8.1.2.4.

Table 8.2.1.3.1-1: Test Parameters for Large Delay CDD (FRC)

Parameter	Unit	Test 1-4
Downlink power allocation	ρ_A	dB
	ρ_B	dB
	σ	dB
N_{oc} at antenna port	dBm/15kHz	-98
PDSCH transmission mode		3
NOTE 1: $P_B = 1$.		
NOTE 2: Void.		
NOTE 3: Void.		

Table 8.2.1.3.1-2: Minimum performance Large Delay CDD (FRC)

Test num	Bandwidth	Reference channel	OCNG pattern	Propagation condition	Correlation matrix and antenna config.	Reference value		UE category
						Fraction of maximum Throughput (%)	SNR (dB)	
1 (NOTE 4)	10 MHz	R.11 FDD	OP.1 FDD	EVA70	2x2 Low	70	13.0	≥2
2 (NOTE 3)	5 MHz	R.11-2 FDD	OP.1 FDD	EVA70	2x2 Low	70	12.7	≥2
3	10 MHz	R.35 FDD	OP.1 FDD	EVA200	2x2 Low	70	20.2	≥2
4	10 MHz	R.35-4 FDD	OP.1 FDD	ETU600	2x2 Low	70	20.8	≥2

NOTE 1: Void.
NOTE 2: Test 1 may not be executed for UE-s for which Test 1 or 2 in Table 8.2.1.3.1-4 is applicable.
NOTE 3: Test case applicability is defined in 8.1.2.1.
NOTE 4: For UE that supports CRS interference handling, the CRS assistance information defined in [7] is provided. The CRS assistance information includes two aggressor cells with 2 CRS ports and cell ID of aggressor cells are 1 and 128. For UE that does not support CRS interference handling, CRS assistance information is not provided.

Table 8.2.1.3.1-3: Test Parameters for Large Delay CDD (FRC) for CA

Parameter	Unit	Value
Downlink power allocation	ρ_A	dB
	ρ_B	dB
	σ	dB
N_{oc} at antenna port	dBm/15kHz	-98
PDSCH transmission mode		3
NOTE 1: $P_B = 1$.		
NOTE 2: PUCCH format 1b with channel selection is used to feedback ACK/NACK for Tests in Table 8.2.1.3.1-4, PUCCH format 3 is used to feedback ACK/NACK for Tests in Table 8.2.1.3.1-6.		
NOTE 3: The same PDSCH transmission mode is applied to each component carrier.		

Table 8.2.1.3.1-4: Minimum performance Large Delay CDD (FRC) for CA with 2DL CCs

Test num	Bandwidth	Reference channel	OCNG pattern	Propagation condition	Correlation matrix and antenna config.	Reference value		UE category
						Fraction of maximum Throughput (%)	SNR (dB)	
1 (NOTE 2)	2x10 MHz	R.11 FDD	OP.1 FDD (NOTE 1)	EVA70	2x2 Low	70	13.7	≥3
2 (NOTE 2)	2x20 MHz	R.30 FDD	OP.1 FDD (NOTE 1)	EVA70	2x2 Low	70	13.2	≥5
3	2x5 MHz	R.11-2 FDD	OP.1 FDD	EVA70	2x2 Low	70	12.7	≥2
4	10MHz+5 MHz	R.11 FDD for 10MHz CC,	OP.1 FDD (NOTE 1)	EVA70	2x2 Low	70	13.0	≥3
		R.11-2 FDD for 5MHz CC	OP.1 FDD (NOTE 1)			70	12.7	
5	15MHz+5 MHz	R.11-7 FDD for 15MHz CC	OP.1 FDD (NOTE 1)	EVA70	2x2 Low	70	12.8	≥3
		R.11-2 FDD for 5MHz CC	OP.1 FDD (NOTE 1)			70	12.7	

NOTE 1: The OCNG pattern applies for each CC.
NOTE 2: Void
NOTE 3: The applicability of requirements for different CA configurations and bandwidth combination sets is defined in 8.1.2.3.

Table 8.2.1.3.1-5: Single carrier performance for multiple CA configurations

Bandwidth	Reference channel	OCNG pattern	Propagation condition	Correlation matrix and antenna config.	Reference value	
					Fraction of maximum throughput (%)	SNR (dB)
1.4MHz	R.11-5 FDD	OP. 1 FDD	EVA70	2x2 Low	70	13.6
3MHz	R.11-6 FDD	OP. 1 FDD	EVA70	2x2 Low	70	12.3
5MHz	R.11-2 FDD	OP. 1 FDD	EVA70	2x2 Low	70	12.3
10 MHz	R.11 FDD	OP. 1 FDD	EVA70	2x2 Low	70	12.9
15MHz	R.11-7 FDD	OP. 1 FDD	EVA70	2x2 Low	70	12.8
20MHz	R.30 FDD	OP. 1 FDD	EVA70	2x2 Low	70	12.9

Table 8.2.1.3.1-6: Minimum performance (FRC) based on single carrier performance for CA with 3 DL CCs

Test num.	CA Band-width combination	Requirement	UE category
1	3x20MHz	As specified in Table 8.2.1.3.1-5 per CC	≥5
2	20MHz+20MHz+15MHz	As specified in Table 8.2.1.3.1-5 per CC	≥5
3	20MHz+20MHz+10MHz	As specified in Table 8.2.1.3.1-5 per CC	≥5
4	20MHz+15MHz+15MHz	As specified in Table 8.2.1.3.1-5 per CC	≥5
5	20MHz+15MHz+10MHz	As specified in Table 8.2.1.3.1-5 per CC	≥5
6	20MHz+10MHz+10MHz	As specified in Table 8.2.1.3.1-5 per CC	≥5
7	15MHz+15MHz+10MHz	As specified in Table 8.2.1.3.1-5 per CC	≥5
8	20MHz+10MHz+5MHz	As specified in Table 8.2.1.3.1-5 per CC	≥5
9	20MHz+15MHz+5MHz	As specified in Table 8.2.1.3.1-5 per CC	≥5
10	10MHz+10MHz+5MHz	As specified in Table 8.2.1.3.1-5 per CC	≥5

NOTE 1: The applicability of requirements for different CA configurations and bandwidth combination sets is defined in 8.1.2.3

Table 8.2.1.3.1-7: Minimum performance (FRC) based on single carrier performance for CA with 4 DL CCs

Test num.	CA Band-width combination	Requirement	UE category
1	4x20MHz	As specified in Table 8.2.1.3.1-5 per CC	≥8
2	10MHz+20MHz+20MHz+20MHz	As specified in Table 8.2.1.3.1-5 per CC	≥8
3	10MHz+10MHz+20MHz+20MHz	As specified in Table 8.2.1.3.1-5 per CC	≥8
4	5MHz+10MHz+20MHz+20MHz	As specified in Table 8.2.1.3.1-5 per CC	≥8
5	5MHz+10MHz+10MHz+20MHz	As specified in Table 8.2.1.3.1-5 per CC	≥8
NOTE 1: The applicability of requirements for different CA configurations and bandwidth combination sets is defined in 8.1.2.3			

Table 8.2.1.3.1-8: Minimum performance (FRC) based on single carrier performance for CA with 5 DL CCs

Test num.	CA Band-width combination	Requirement	UE category
1	5x20MHz	As specified in Table 8.2.1.3.1-5 per CC	8, ≥11
NOTE 1: The applicability of requirements for different CA configurations and bandwidth combination sets is defined in 8.1.2.3			

8.2.1.3.1A Soft buffer management test

For CA, the requirements are specified in Table 8.2.1.3.1A-2, with the addition of the parameters in Table 8.2.1.3.1A-1 and the downlink physical channel setup according to Annex C.3.2. The purpose is to verify the UE performance with proper instantaneous buffer implementation. The test points are applied to UE category and bandwidth combination with maximum aggregated bandwidth as specified in Table 8.2.1.3.1A-3.

Table 8.2.1.3.1A-1: Test Parameters for soft buffer management test (FRC) for CA

Parameter	Unit	Test 1-7	
Downlink power allocation	ρ_A	dB	-3
	ρ_B	dB	-3 (NOTE 1)
	σ	dB	0
N_{oc} at antenna port	dBm/15kHz	-98	
PDSCH transmission mode		3	
NOTE 1: $P_B = 1$.			
NOTE 2: For CA test cases, PUCCH format 1b with channel selection is used to feedback ACK/NACK.			
NOTE 3: For CA test cases, the same PDSCH transmission mode is applied to each component carrier.			

Table 8.2.1.3.1A-2: Minimum performance soft buffer management test (FRC) for CA

Test num	Bandwidth	Reference channel	OCNG pattern	Propagation condition	Correlation matrix and antenna config.	Reference value	
						Fraction of maximum Throughput (%)	SNR (dB)
1	2x20 MHz	R.30 FDD	OP.1 FDD (NOTE 1)	EVA70	2x2 Low	70	13.2
2	15MHz + 10MHz	R.35-2 FDD for 15MHz CC	OP.1 FDD (NOTE 1)	EVA5	2x2 Low	70	15.1
		R.35-3 FDD for 10MHz CC	OP.1 FDD (NOTE 1)			70	15.1
3	20MHz + 10MHz	R.30 FDD for 20MHz CC	OP.1 FDD (NOTE 1)	EVA70	2x2 Low	70	13.5
		R.11 FDD for 10MHz CC	OP.1 FDD (NOTE 1)			70	13.5
4	20MHz + 15MHz	R.30 FDD for 20MHz CC	OP.1 FDD (NOTE 1)	EVA70	2x2 Low	70	13.5
		R.30-1 FDD for 15MHz CC	OP.1 FDD (NOTE 1)			70	13.5
5	2x20 MHz	R.35-1 FDD	OP.1 FDD (NOTE 1)	EVA5	2x2 Low	70	15.8
6	20MHz + 10MHz	R.35-1 FDD for 20MHz CC	OP.1 FDD (NOTE 1)	EVA5	2x2 Low	70	15.9
		R.35-3 FDD for 10MHz CC	OP.1 FDD (NOTE 1)			70	15.9
7	20MHz + 15MHz	R.35-1 FDD for 20MHz CC	OP.1 FDD (NOTE 1)	EVA5	2x2 Low	70	15.9
		R.35-2 FDD for 15MHz CC	OP.1 FDD (NOTE 1)			70	15.9

NOTE 1: For CA test cases, the OCNG pattern applies for each CC.
NOTE 2: For Test 2, 3, 4, 6, 7 the Fraction of maximum Throughput applies to each CC.
NOTE 3: The applicability of requirements for different CA configurations and bandwidth combination sets is defined in 8.1.2.3.

Table 8.2.1.3.1A-3: Test points for soft buffer management tests for CA

UE category	Bandwidth combination with maximum aggregated bandwidth (NOTE 1)			
	2x20MHz	15MHz+10MHz	20MHz+10MHz	20MHz+15MHz
3	1	2	3	4
4	5	N/A	6	7

NOTE 1: Maximum over all supported CA configurations and bandwidth combination sets according to Table 5.6A.1-1 and Table 5.6A.1-2.

8.2.1.3.1B Enhanced Performance Requirement Type C –2Tx Antenna Ports

The requirements are specified in Table 8.2.1.3.1B-2, with the addition of the parameters in Table 8.2.1.3.1B-1 and the downlink physical channel setup according to Annex C.3.2. The purpose is to verify the performance of large delay CDD with 2 transmitter antennas.

Table 8.2.1.3.1B-1: Test Parameters for Large Delay CDD (FRC)

Parameter	Unit	Test 1	
Downlink power allocation	ρ_A	dB	-3
	ρ_B	dB	-3 (NOTE 1)
	σ	dB	0
N_{oc} at antenna port	dBm/15kHz	-98	
PDSCH transmission mode		3	
NOTE 1: $P_B = 1$.			

Table 8.2.1.3.1B-2: Enhanced Performance Requirement Type C for Large Delay CDD (FRC)

Test num	Bandwidth	Reference channel	OCNG pattern	Propagation condition	Correlation matrix and antenna config.	Reference value		UE category
						Fraction of maximum Throughput (%)	SNR (dB)	
1	10 MHz	R.11 FDD	OP.1 FDD	EVA70	2x2 Medium	70	17.8	≥2

8.2.1.3.1C Enhanced Performance Requirement Type C - 2 Tx Antenna Ports with TM1 interference

The requirements are specified in Table 8.2.1.3.1C-2, with the addition of parameters in Table 8.2.1.3.1C-1 and the downlink physical channel setup according to Annex C.3.2. The purpose is to verify the performance of open-loop spatial multiplexing performance with 2 transmit antennas when the PDSCH transmission in the serving cell is interfered by PDSCH of one dominant interfering cell with transmission mode 1. In Table 8.2.1.3.1C-1, Cell 1 is the serving cell, and Cell 2 is interfering cells. The downlink physical channel setup is according to Annex C.3.2 for each of Cell 1 and Cell 2 respectively.

Table 8.2.1.3.1C-1 Test parameters for Larger Delay CDD (FRC) with TM1 interference

Parameter		Unit	Cell 1	Cell 2
Bandwidth		MHz	10 MHz	
Downlink power allocation	ρ_A	dB	-3	0
	ρ_B		-3 (NOTE 1)	0
	σ		0	0
Cell-specific reference signals			Antenna ports 0,1	Antenna port 0
Cyclic Prefix			Normal	Normal
Cell ID			0	1
Transmission mode			3	NOTE 2
N_{oc} at antenna port		dBm/15kHz	-98	N/A
\hat{E}_s/N_{oc} (NOTE 3)		dB	Reference Value in Table 8.2.1.3.1C-2	12.95
Correlation and antenna configuration			Medium (2x2)	Medium(1x2)
Number of OFDM symbols for PDCCH			2	N/A
Max number of HARQ transmissions			4	N/A
Redundancy version coding sequence			{0,1,2,3}	N/A
NOTE 1: $p_B = 1$				
NOTE 2: Downlink physical channel setup in Cell 2 in accordance with Annex C.3.2 applying OCNG pattern OP.5 FDD as defined in Annex A.5.1.5.				
NOTE 3: Cell 1 is the serving cell. Cell 2 is the interfering cell.				
NOTE 4: All cells are time-synchronous.				
NOTE 5: SIB-1 will not be transmitted in Cell2 in this test.				

Table 8.2.1.3.1C-2 Enhanced Performance Requirement Type C, Larger Delay CDD (FRC) with TM1 interference

Test Number	Reference Channel	OCNG Pattern		Propagation Conditions (NOTE 1)		Reference Value		UE Category
		Cell 1	Cell 2	Cell 1	Cell 2	Fraction of Maximum Throughput (%)	SNR (dB) (NOTE 2)	
1	R.11-8 FDD	OP.1 FDD	OP.5 FDD	EVA70	EVA70	70	19.9	≥2
NOTE 1: The propagation conditions for Cell 1 and Cell 2 are statistically independent. NOTE 2: SNR corresponds to \hat{E}_s/N_{oc} of Cell 1.								

8.2.1.3.2 Minimum Requirement 4 Tx Antenna Port

The requirements are specified in Table 8.2.1.3.2-2, with the addition of the parameters in Table 8.2.1.3.2-1 and the downlink physical channel setup according to Annex C.3.2. The purpose is to verify the performance of large delay CDD with 4 transmitter antennas.

Table 8.2.1.3.2-1: Test Parameters for Large Delay CDD (FRC)

Parameter	Unit	Test 1	
Downlink power allocation	ρ_A	dB	-6
	ρ_B	dB	-6 (NOTE 1)
	σ	dB	3
N_{oc} at antenna port	dBm/15kHz	-98	
PDSCH transmission mode		3	
NOTE 1: $P_B = 1$			

Table 8.2.1.3.2-2: Minimum performance Large Delay CDD (FRC)

Test number	Bandwidth	Reference Channel	OCNG Pattern	Propagation Condition	Correlation Matrix and Antenna Configuration	Reference value		UE Category
						Fraction of Maximum Throughput (%)	SNR (dB)	
1	10 MHz	R.14 FDD	OP.1 FDD	EVA70	4x2 Low	70	14.3	≥2

8.2.1.3.3 Minimum Requirement 2 Tx Antenna Port (demodulation subframe overlaps with aggressor cell ABS)

The requirements for non-MBSFN ABS are specified in Table 8.2.1.3.3-2, with the addition of parameters in Table 8.2.1.3.3-1 and the downlink physical channel setup according to Annex C.3.2 and Annex C.3.3.

The requirements for MBSFN ABS are specified in Table 8.2.1.3.3-4, with the addition of parameters in Table 8.2.1.3.3-3 and the downlink physical channel setup according to Annex C.3.2 and Annex C.3.3.

The purpose is to verify the performance of large delay CDD with 2 transmitter antennas if the PDSCH transmission in the serving cell takes place in subframes that overlap with ABS [9] of the aggressor cell. In Tables 8.2.1.3.3-1 and 8.2.1.3.3-3, Cell 1 is the serving cell, and Cell 2 is the aggressor cell. The downlink physical channel setup for Cell 1 is according to Annex C.3.2 and for Cell 2 is according to Annex C.3.3, respectively.

Table 8.2.1.3.3-1: Test Parameters for Large Delay CDD (FRC) – Non-MBSFN ABS

Parameter		Unit	Cell 1	Cell 2
Downlink power allocation	ρ_A	dB	-3	-3
	ρ_B	dB	-3 (NOTE 1)	-3
	σ	dB	0	N/A
N_{oc} at antenna port	N_{oc1}	dBm/15kHz	-102 (NOTE 2)	N/A
	N_{oc2}	dBm/15kHz	-98 (NOTE 3)	N/A
	N_{oc3}	dBm/15kHz	-94.8 (NOTE 4)	N/A
\widehat{E}_s / N_{oc2}		dB	Reference Value in Table 8.2.1.3.3-2	6
BW _{Channel}		MHz	10	10
Subframe Configuration			Non-MBSFN	Non-MBSFN
Cell Id			0	1
Time Offset between Cells		μ s	2.5 (synchronous cells)	
ABS pattern (NOTE 5)			N/A	11000100, 11000000, 11000000, 11000000, 11000000
RLM/RRM Measurement Subframe Pattern(NOTE 6)			10000000 10000000 10000000 10000000 10000000	N/A
CSI Subframe Sets (NOTE 7)	$C_{CSI,0}$		11000100 11000000 11000000 11000000 11000000	N/A
	$C_{CSI,1}$		00111011 00111111 00111111 00111111 00111111	N/A
Number of control OFDM symbols			2	2
PDSCH transmission mode			3	N/A
Cyclic prefix			Normal	Normal
<p>NOTE 1: $P_B = 1$.</p> <p>NOTE 2: This noise is applied in OFDM symbols #1, #2, #3, #5, #6, #8, #9, #10,#12, #13 of a subframe overlapping with the aggressor ABS.</p> <p>NOTE 3: This noise is applied in OFDM symbols #0, #4, #7, #11 of a subframe overlapping with the aggressor ABS.</p> <p>NOTE 4: This noise is applied in all OFDM symbols of a subframe overlapping with aggressor non-ABS</p> <p>NOTE 5: ABS pattern as defined in [9].</p> <p>NOTE 6: Time-domain measurement resource restriction pattern for PCell measurements as defined in [7].</p> <p>NOTE 7: As configured according to the time-domain measurement resource restriction pattern for CSI measurements defined in [7].</p> <p>NOTE 8: Cell 1 is the serving cell. Cell 2 is the aggressor cell. The number of the CRS ports in Cell1 and Cell2 is the same.</p> <p>NOTE 9: SIB-1 will not be transmitted in Cell2 in this test.</p>				

Table 8.2.1.3.3-2: Minimum Performance Large Delay CDD (FRC) – Non-MBSFN ABS

Test Number	Reference Channel	OCNG Pattern		Propagation Conditions (Note 1)		Correlation Matrix and Antenna Configuration	Reference Value		UE Category
		Cell 1	Cell 2	Cell 1	Cell 2		Fraction of Maximum Throughput (%) Note 5	SNR (dB) (Note 2)	
1	R.11 FDD Note 4	OP.1 FDD	OP.1 FDD	EVA 5	EVA 5	2x2 Low	70	13.3	≥2
<p>Note 1: The propagation conditions for Cell 1 and Cell2 are statistically independent.</p> <p>Note 2: SNR corresponds to \hat{E}_s / N_{oc2} of cell 1.</p> <p>Note 3: The correlation matrix and antenna configuration apply for Cell 1 and Cell 2.</p> <p>Note 4: Cell 1 Reference channel is modified: PDSCH other than SIB1/paging and its associated PDCCH/PCFICH are transmitted in the serving cell subframe when the subframe is overlapped with the ABS subframe of aggressor cell and the subframe is available in the definition of the reference channel.</p> <p>Note 5: The maximum Throughput is calculated from the total Payload in 9 subframes, averaged over 40ms.</p>									

Table 8.2.1.3.3-3: Test Parameters for Large Delay CDD (FRC) – MBSFN ABS

Parameter		Unit	Cell 1	Cell 2
Downlink power allocation	ρ_A	dB	-3	-3
	ρ_B	dB	-3 (Note 1)	-3
	σ	dB	0	N/A
N_{oc} at antenna port	N_{oc1}	dBm/15kHz	-102 (Note 2)	N/A
	N_{oc2}	dBm/15kHz	-98 (Note 3)	N/A
	N_{oc3}	dBm/15kHz	-94.8 (Note 4)	N/A
\widehat{E}_s / N_{oc2}		dB	Reference Value in Table 8.2.1.3.3-4	6
BW _{Channel}		MHz	10	10
Subframe Configuration			Non-MBSFN	MBSFN
Cell Id			0	126
Time Offset between Cells		μ s	2.5 (synchronous cells)	
ABS pattern (Note 5)			N/A	0001000000 0100000010 0000001000 0000000000
RLM/RRM Measurement Subframe Pattern (Note 6)			0001000000 0100000010 0000001000 0000000000	N/A
CSI Subframe Sets (Note 7)	C _{CSI,0}		0001000000 0100000010 0000001000 0000000000	N/A
	C _{CSI,1}		1110111111 1011111101 1111110111 1111111111	N/A
MBSFN Subframe Allocation (Note 10)			N/A	001000 100001 000100 000000
Number of control OFDM symbols			2	2
PDSCH transmission mode			3	N/A
Cyclic prefix			Normal	Normal
<p>Note 1: $P_B = 1$.</p> <p>Note 2: This noise is applied in OFDM symbols #1, #2, #3, #4, #5, #6, #7, #8, #9, #10, #11, #12, #13 of a subframe overlapping with the aggressor ABS.</p> <p>Note 3: This noise is applied in OFDM symbol #0 of a subframe overlapping with the aggressor ABS.</p> <p>Note 4: This noise is applied in all OFDM symbols of a subframe overlapping with aggressor non-ABS.</p> <p>Note 5: ABS pattern as defined in [9]. The 4th, 12th, 19th and 27th subframes indicated by ABS pattern are MBSFN ABS subframes.</p> <p>Note 6: Time-domain measurement resource restriction pattern for PCell measurements as defined in [7].</p> <p>Note 7: As configured according to the time-domain measurement resource restriction pattern for CSI measurements defined in [7].</p> <p>Note 8: Cell 1 is the serving cell. Cell 2 is the aggressor cell. The number of the CRS ports in Cell1 and Cell2 is the same.</p> <p>Note 9: SIB-1 will not be transmitted in Cell2 in this test.</p> <p>Note 10: MBSFN Subframe Allocation as defined in [7], four frames with 24 bits is chosen for MBSFN subframe allocation.</p> <p>Note 11: The maximum number of uplink HARQ transmission is ≤ 2 so that each PHICH channel transmission is in a subframe protected by MBSFN ABS in this test.</p>				

Table 8.2.1.3.3-4: Minimum Performance Large Delay CDD (FRC) – MBSFN ABS

Test Number	Reference Channel	OCNG Pattern		Propagation Conditions (Note 2)		Correlation Matrix and Antenna Configuration	Reference Value		UE Category
		Cell 1	Cell 2	Cell 1	Cell 2		Fraction of Maximum Throughput (%) Note 5	SNR (dB) (Note 2)	
1	R.11 FDD Note 4	OP.1 FDD	OP.1 FDD	EVA 5	EVA 5	2x2 Low	70	12.0	≥2
<p>Note 1: The propagation conditions for Cell 1 and Cell2 are statistically independent.</p> <p>Note 2: SNR corresponds to \hat{E}_s / N_{oc2} of cell 1.</p> <p>Note 3: The correlation matrix and antenna configuration apply for Cell 1 and Cell 2.</p> <p>Note 4: Cell 1 Reference channel is modified: PDSCH other than SIB1/paging and its associated PDCCH/PCFICH are transmitted in the serving cell subframe when the subframe is overlapped with the ABS subframe of aggressor cell and the subframe is available in the definition of the reference channel.</p> <p>Note 5: The maximum Throughput is calculated from the total Payload in 4 subframes, averaged over 40ms.</p>									

8.2.1.3.4 Minimum Requirement 2 Tx Antenna Port (demodulation subframe overlaps with aggressor cell ABS and CRS assistance information are configured)

The requirements for non-MBSFN ABS are specified in Table 8.2.1.3.4-2, with the addition of parameters in Table 8.2.1.3.4-1. The purpose is to verify the performance of large delay CDD with 2 transmit antennas if the PDSCH transmission in the serving cell takes place in subframes that overlap with ABS [9] of the aggressor cells with CRS assistance information. In Table 8.2.1.3.4-1, Cell 1 is the serving cell, and Cell 2 and Cell 3 are the aggressor cells. The downlink physical channel setup for Cell 1 is according to Annex C.3.2 and for Cell 2 and Cell 3 is according to Annex C.3.3, respectively. The CRS assistance information [7] includes Cell 2 and Cell 3.

Table 8.2.1.3.4-1: Test Parameters for Large Delay CDD (FRC) – Non-MBSFN ABS

Parameter		Unit	Cell 1	Cell 2	Cell 3
Downlink power allocation	ρ_A	dB	-3	-3	-3
	ρ_B	dB	-3 (Note 1)	-3 (Note 1)	-3 (Note 1)
	σ	dB	0	N/A	N/A
N_{oc} at antenna port	N_{oc1}	dBm/15kHz	-98 (Note 2)	N/A	N/A
	N_{oc2}	dBm/15kHz	-98 (Note 3)	N/A	N/A
	N_{oc3}	dBm/15kHz	-93 (Note 4)	N/A	N/A
\hat{E}_s / N_{oc2}		dB	Reference Value in Table 8.2.1.3.4-2	Reference Value in Table 8.2.1.3.4-2	Reference Value in Table 8.2.1.3.4-2
$BW_{Channel}$		MHz	10	10	10
Subframe Configuration			Non-MBSFN	Non-MBSFN	Non-MBSFN
Time Offset between Cells		μ s	N/A	3	-1
Frequency shift between Cells		Hz	N/A	300	-100
Cell Id			0	1	126
ABS pattern (Note 5)			N/A	11000000 11000000 11000000 11000000 11000000	11000000 11000000 11000000 11000000 11000000
RLM/RRM Measurement Subframe Pattern (Note 6)			10000000 10000000 10000000 10000000 10000000	N/A	N/A
CSI Subframe Sets (Note7)	$C_{CSI,0}$		11000000 11000000 11000000 11000000 11000000	N/A	N/A
	$C_{CSI,1}$		00111111 00111111 00111111 00111111 00111111	N/A	N/A
Number of control OFDM symbols			2	Note 8	Note 8
PDSCH transmission mode			3	Note 9	Note 9
Cyclic prefix			Normal	Normal	Normal
<p>Note 1: $P_B = 1$.</p> <p>Note 2: This noise is applied in OFDM symbols #1, #2, #3, #5, #6, #8, #9, #10, #12, #13 of a subframe overlapping with the aggressor ABS.</p> <p>Note 3: This noise is applied in OFDM symbols #0, #4, #7, #11 of a subframe overlapping with the aggressor ABS.</p> <p>Note 4: This noise is applied in all OFDM symbols of a subframe overlapping with aggressor non-ABS</p> <p>Note 5: ABS pattern as defined in [9].</p> <p>Note 6: Time-domain measurement resource restriction pattern for PCell measurements as defined in [7]</p> <p>Note 7: As configured according to the time-domain measurement resource restriction pattern for CSI measurements defined in [7].</p> <p>Note 8: The number of control OFDM symbols is not available for ABS and is 2 for the subframe indicated by "0" of ABS pattern.</p> <p>Note 9: Downlink physical channel setup in Cell 2 and Cell 3 in accordance with Annex C.3.3 applying OCNG pattern as defined in Annex A.5.</p> <p>Note 10: The number of the CRS ports in Cell 1, Cell 2 and Cell 3 is the same.</p> <p>Note 11: SIB-1 will not be transmitted in Cell 2 and Cell 3 in this test.</p>					

Table 8.2.1.3.4-2: Minimum Performance Large Delay CDD (FRC) – Non-MBSFN ABS

Test Number	Reference Channel	\hat{E}_s/N_{oc2}		OCNG Pattern			Propagation Conditions (Note1)			Correlation Matrix and Antenna Configuration (Note 2)	Reference Value		UE Category
		Cell 2	Cell 3	Cell 1	Cell 2	Cell 3	Cell 1	Cell 2	Cell 3		Fraction of Maximum Throughput (%) Note 5	SNR (dB) (Note 3)	
1	R.11 FDD Note 4	9	7	OP.1 FDD	OP.1 FDD	OP.1 FDD	EVA5	EVA5	EVA5	2x2 Low	70	13.9	≥ 2
2	R.35 FDD Note 4	9	1	OP.1 FDD	OP.1 FDD	OP.1 FDD	EVA5	EVA5	EVA5	2x2 Low	70	22.6	≥ 2

Note 1: The propagation conditions for Cell 1, Cell 2 and Cell 3 are statistically independent.

Note 2: The correlation matrix and antenna configuration apply for Cell 1, Cell 2 and Cell 3.

Note 3: SNR corresponds to \hat{E}_s/N_{oc2} of cell 1.

Note 4: Cell 1 Reference channel is modified: PDSCH other than SIB1/paging and its associated PDCCH/PCFICH are transmitted in the serving cell subframe when the subframe is overlapped with the ABS subframe of aggressor cell and the subframe is available in the definition of the reference channel.

Note 5: The maximum Throughput is calculated from the total Payload in 9 subframes, averaged over 40ms.

8.2.1.4 Closed-loop spatial multiplexing performance

8.2.1.4.1 Minimum Requirement Single-Layer Spatial Multiplexing 2 Tx Antenna Port

The requirements are specified in Table 8.2.1.4.1-2, with the addition of the parameters in Table 8.2.1.4.1-1 and the downlink physical channel setup according to Annex C.3.2. The purpose of these tests is to verify the closed loop rank-one performance with wideband and frequency selective precoding.

Table 8.2.1.4.1-1: Test Parameters for Single-Layer Spatial Multiplexing (FRC)

Parameter	Unit	Test 1	Test 1A	Test 2
Downlink power allocation	ρ_A	dB	-3	-3
	ρ_B	dB	-3 (Note 1)	-3 (Note 1)
	σ	dB	0	0
N_{oc} at antenna port	dBm/15kHz	-98	-98	-98
Precoding granularity	PRB	6	4	50
PMI delay (Note 2)	ms	8	8	8
Reporting interval	ms	1	1	1
Reporting mode		PUSCH 1-2	PUSCH 1-2	PUSCH 3-1
CodeBookSubsetRestriction bitmap		001111	001111	001111
PDSCH transmission mode		4	4	4
Note 1: $P_B = 1$.				
Note 2: If the UE reports in an available uplink reporting instance at subframe SF#n based on PMI estimation at a downlink SF not later than SF#(n-4), this reported PMI cannot be applied at the eNB downlink before SF#(n+4).				

Table 8.2.1.4.1-2: Minimum performance Single-Layer Spatial Multiplexing (FRC)

Test number	Bandwidth	Reference Channel	OCNG Pattern	Propagation Condition	Correlation Matrix and Antenna Configuration	Reference value		UE Category
						Fraction of Maximum Throughput (%)	SNR (dB)	
1	10 MHz	R.10 FDD	OP.1 FDD	EVA5	2x2 Low	70	-2.5	≥1
1A (Note 1)	5 MHz	R.10-2 FDD	OP.1 FDD	EVA5	2x2 Low	70	-2.9	≥1
2	10 MHz	R.10 FDD	OP.1 FDD	EPA5	2x2 High	70	-2.3	≥1

Note 1: Test case applicability is defined in 8.1.2.1.

8.2.1.4.1A Minimum Requirement Single-Layer Spatial Multiplexing 4 Tx Antenna Port

The requirements are specified in Table 8.2.1.4.1A-2, with the addition of the parameters in Table 8.2.1.4.1A-1 and the downlink physical channel setup according to Annex C.3.2. The purpose of these tests is to verify the closed loop rank-one performance with wideband and frequency selective precoding.

Table 8.2.1.4.1A-1: Test Parameters for Single-Layer Spatial Multiplexing (FRC)

Parameter	Unit	Test 1	
Downlink power allocation	ρ_A	dB	-6
	ρ_B	dB	-6 (Note 1)
	σ	dB	3
N_{oc} at antenna port	dBm/15kHz	-98	
Precoding granularity	PRB	6	
PMI delay (Note 2)	ms	8	
Reporting interval	ms	1	
Reporting mode		PUSCH 1-2	
CodeBookSubsetRestriction on bitmap		0000000000000000 0000000000000000 0000000000000000 1111111111111111	
PDSCH transmission mode		4	
Note 1: $P_B = 1$.			
Note 2: If the UE reports in an available uplink reporting instance at subframe SF#n based on PMI estimation at a downlink SF not later than SF#(n-4), this reported PMI cannot be applied at the eNB downlink before SF#(n+4).			

Table 8.2.1.4.1A-2: Minimum performance Single-Layer Spatial Multiplexing (FRC)

Test number	Bandwidth	Reference Channel	OCNG Pattern	Propagation Condition	Correlation Matrix and Antenna Configuration	Reference value		UE Category
						Fraction of Maximum Throughput (%)	SNR (dB)	
1	10 MHz	R.13 FDD	OP.1 FDD	EVA5	4x2 Low	70	-3.2	≥1

8.2.1.4.1B Enhanced Performance Requirement Type A - Single-Layer Spatial Multiplexing 2 Tx Antenna Port with TM4 interference model

The requirements are specified in Table 8.2.1.4.1B-2, with the addition of the parameters in Table 8.2.1.4.1B-1 and the downlink physical channel setup according to Annex C.3.2. The purpose of these tests is to verify the closed loop rank-one performance with wideband precoding with two transmit antennas when the PDSCH transmission in the serving cell is interfered by PDSCH of two dominant interfering cells applying transmission mode 4 interference model defined

in clause B.5.3. In Table 8.2.1.4.1B-1, Cell 1 is the serving cell, and Cell 2, 3 are interfering cells. The downlink physical channel setup is according to Annex C.3.2 for each of Cell 1, Cell 2 and Cell 3, respectively.

Table 8.2.1.4.1B-1: Test Parameters for Single-Layer Spatial Multiplexing (FRC) with TM4 interference model

Parameter		Unit	Cell 1	Cell 2	Cell 3
Downlink power allocation	ρ_A	dB	-3	-3	-3
	ρ_B	dB	-3 (Note 1)	-3	-3
	σ	dB	0	0	0
Cell-specific reference signals			Antenna ports 0,1	Antenna ports 0,1	Antenna ports 0,1
N_{oc} at antenna port		dBm/15kHz	-98	N/A	N/A
DIP (Note 2)		dB	N/A	-1.73	-8.66
$BW_{Channel}$		MHz	10	10	10
Cyclic Prefix			Normal	Normal	Normal
Cell Id			0	1	2
Number of control OFDM symbols			2	2	2
PDSCH transmission mode			6	N/A	N/A
Interference model			N/A	As specified in clause B.5.3	As specified in clause B.5.3
Probability of occurrence of transmission rank in interfering cells	Rank 1	%	N/A	80	80
	Rank 2	%	N/A	20	20
Precoding granularity		PRB	50	6	6
PMI delay (Note 4)		ms	8	N/A	N/A
Reporting interval		ms	5	N/A	N/A
Reporting mode			PUCCH 1-1	N/A	N/A
CodeBookSubsetRestriction bitmap			1111	N/A	N/A
Physical channel for CQI reporting			PUSCH(Note 6)	N/A	N/A
cqi-pmi-ConfigurationIndex			2	N/A	N/A
<p>Note 1: $P_B = 1$</p> <p>Note 2: The respective received power spectral density of each interfering cell relative to N_{oc} is defined by its associated DIP value as specified in clause B.5.1.</p> <p>Note 3: Cell 1 is the serving cell. Cell 2, 3 are the interfering cells.</p> <p>Note 4: If the UE reports in an available uplink reporting instance at subframe SF#n based on PMI estimation at a downlink SF not later than SF#(n-4), this reported PMI cannot be applied at the eNB downlink before SF#(n+4).</p> <p>Note 5: All cells are time-synchronous.</p> <p>Note 6: To avoid collisions between CQI reports and HARQ-ACK it is necessary to report both on PUSCH instead of PUCCH. PDCCH DCI format 0 shall be transmitted in downlink SF#1 and #6 to allow periodic CQI to multiplex with the HARQ-ACK on PUSCH in uplink subframe SF#5 and #0.</p>					

Table 8.2.1.4.1B-2: Enhanced Performance Requirement Type A, Single-Layer Spatial Multiplexing (FRC) with TM4 interference model

Test Number	Reference Channel	OCNG Pattern			Propagation Conditions			Correlation Matrix and Antenna Configuration (Note 3)	Reference Value		UE Category
		Cell 1	Cell 2	Cell 3	Cell 1	Cell 2	Cell 3		Fraction of Maximum Throughput (%)	SINR (dB) (Note 2)	
1	R.47 FDD	OP. 1 FDD	N/A	N/A	EV A5	EV A5	EV A5	2x2 Low	70	0.8	≥1

Note 1: The propagation conditions for Cell 1, Cell 2 and Cell 3 are statistically independent.

Note 2: SINR corresponds to \hat{E}_s / N_{oc} of Cell 1 as defined in clause 8.1.1.

Note 3: Correlation matrix and antenna configuration parameters apply for each of Cell 1, Cell 2 and Cell 3.

8.2.1.4.1C Minimum Requirement Single-Layer Spatial Multiplexing 2 Tx Antenna Ports (demodulation subframe overlaps with aggressor cell ABS and CRS assistance information are configured)

The requirements are specified in Table 8.2.1.4.1C-2, with the addition of parameters in Table 8.2.1.4.1C-1. The purpose is to verify the closed loop rank-one performance with wideband precoding if the PDSCH transmission in the serving cell takes place in subframes that overlap with ABS [9] of the aggressor cell with CRS assistance information. In Table 8.2.1.4.1C-1, Cell 1 is the serving cell, and Cell 2 and Cell 3 are the aggressor cells. The downlink physical channel setup for Cell 1 is according to Annex C.3.2 and for Cell 2 and Cell 3 is according to Annex C.3.3, respectively. The CRS assistance information [7] includes Cell 2 and Cell 3.

Table 8.2.1.4.1C-1: Test Parameters for Single-Layer Spatial Multiplexing (FRC) – Non-MBSFN ABS

Parameter		Unit	Cell 1	Cell 2	Cell 3
Downlink power allocation	ρ_A	dB	-3	-3	-3
	ρ_B	dB	-3 (Note 1)	-3 (Note 1)	-3 (Note 1)
	σ	dB	0	N/A	N/A
N_{oc} at antenna port	N_{oc1}	dBm/15kHz	-98 (Note 2)	N/A	N/A
	N_{oc2}	dBm/15kHz	-98 (Note 3)	N/A	N/A
	N_{oc3}	dBm/15kHz	-93 (Note 4)	N/A	N/A
\hat{E}_s / N_{oc2}		dB	Reference Value in Table 8.2.1.4.1C-2	12	10
BW _{Channel}		MHz	10	10	10
Subframe Configuration			Non-MBSFN	Non-MBSFN	Non-MBSFN
Time Offset between Cells		μs	N/A	3	-1
Frequency shift between Cells		Hz	N/A	300	-100
Cell Id			0	126	1
ABS pattern (Note 5)			N/A	11000000 11000000 11000000 11000000 11000000	11000000 11000000 11000000 11000000 11000000
RLM/RRM Measurement Subframe Pattern (Note 6)			10000000 10000000 10000000 10000000 10000000	N/A	N/A
CSI Subframe Sets (Note7)	$C_{CSI,0}$		11000000 11000000 11000000 11000000 11000000	N/A	N/A
	$C_{CSI,1}$		00111111 00111111 00111111 00111111 00111111	N/A	N/A
Number of control OFDM symbols			2	Note 8	Note 8
PDSCH transmission mode			6	Note 9	Note 9
Precoding granularity		PRB	50	N/A	N/A
PMI delay (Note 10)		ms	8	N/A	N/A
Reporting interval		ms	1	N/A	N/A
Reporting mode			PUSCH 3-1	N/A	N/A
CodeBookSubsetRestriction bitmap			1111	N/A	N/A
Cyclic prefix			Normal	Normal	Normal

Note 1:	$P_B = 1$.
Note 2:	This noise is applied in OFDM symbols #1, #2, #3, #5, #6, #8, #9, #10, #12, #13 of a subframe overlapping with the aggressor ABS.
Note 3:	This noise is applied in OFDM symbols #0, #4, #7, #11 of a subframe overlapping with the aggressor ABS.
Note 4:	This noise is applied in all OFDM symbols of a subframe overlapping with aggressor non-ABS
Note 5:	ABS pattern as defined in [9].
Note 6:	Time-domain measurement resource restriction pattern for PCell measurements as defined in [7]
Note 7:	As configured according to the time-domain measurement resource restriction pattern for CSI measurements defined in [7].
Note 8:	The number of control OFDM symbols is not available for ABS and is 2 for the subframe indicated by "0" of ABS pattern.
Note 9:	Downlink physical channel setup in Cell 2 and Cell 3 in accordance with Annex C.3.3 applying OCNB pattern as defined in Annex A.5.
Note 10:	If the UE reports in an available uplink reporting instance at subframe SF#n based on PMI estimation at a downlink SF not later than SF#(n-4), this reported PMI cannot be applied at the eNB downlink before SF#(n+4).
Note 11:	The number of the CRS ports in Cell 1, Cell 2 and Cell 3 is the same.
Note 12:	SIB-1 will not be transmitted in Cell 2 and Cell 3 in this test.

Table 8.2.1.4.1C-2: Minimum Performance Single-Layer Spatial Multiplexing (FRC)– Non-MBSFN ABS

Test Number	Reference Channel	OCNB Pattern			Propagation Conditions (Note 1)			Correlation Matrix and Antenna Configuration (Note 2)	Reference Value		UE Category
		Cell 1	Cell 2	Cell 3	Cell 1	Cell 2	Cell 3		Fraction of Maximum Throughput (%) Note 5	SNR (dB) (Note 3)	
1	R.11 FDD Note 4	OP.1 FDD	OP.1 FDD	OP.1 FDD	EPA5	EPA5	EPA5	2x2 High	70	6.1	≥2
Note 1:	The propagation conditions for Cell 1, Cell 2 and Cell 3 are statistically independent.										
Note 2:	The correlation matrix and antenna configuration apply for Cell 1, Cell 2 and Cell 3.										
Note 3:	SNR corresponds to \hat{E}_s / N_{oc2} of cell 1.										
Note 4:	Cell 1 Reference channel is modified: PDSCH other than SIB1/paging and its associated PDCCH/PCFICH are transmitted in the serving cell subframe when the subframe is overlapped with the ABS subframe of aggressor cell and the subframe is available in the definition of the reference channel.										
Note 5:	The maximum Throughput is calculated from the total Payload in 9 subframes, averaged over 40ms.										

8.2.1.4.1D Enhanced Performance Requirement Type B - Single-layer Spatial Multiplexing 2 Tx Antenna Port with TM4 interference model

The requirements are specified in Table 8.2.1.4.1D-2, with the addition of the parameters in Table 8.2.1.4.1D-1 and the downlink physical channel setup according to Annex C.3.2. The purpose of these tests is to verify the closed loop rank-one performance with wideband precoding with two transmit antennas when the PDSCH transmission in the serving cell is interfered by PDSCH of two interfering cells applying transmission mode 4 interference model defined in clause B.6.3. In Table 8.2.1.4.1D-1, Cell 1 is the serving cell, and Cell 2, 3 are interfering cells. The downlink physical channel setup is according to Annex C.3.2 for each of Cell 1, Cell 2 and Cell 3, respectively.

Table 8.2.1.4.1D-1: Test Parameters for Single-layer Spatial Multiplexing (FRC) with TM4 interference model

Parameter		Unit	Cell 1	Cell 2	Cell 3		
Downlink power allocation	ρ_A	dB	-3	-3	-3		
	ρ_B	dB	-3 (Note 1)	-3	-3		
	σ	dB	0	0	0		
Cell-specific reference signals			Antenna ports 0,1	Antenna ports 0,1	Antenna ports 0,1		
N_{oc} at antenna port		dBm/15 kHz	-98				
Test number (Note 4)				Test 1	Test 2	Test 1	Test 2
\hat{E}_s/N_{oc}		dB	N/A	13.91	3.28	3.34	0.74
Cell Id				6	1	1	6
CFI indicated in PCFICH				3	Random from set {1,2,3}	3	Random from set {1,2,3}
$BW_{Channel}$		MHz	10	10	10		
Cyclic Prefix			Normal	Normal	Normal		
Number of control OFDM symbols			3	3	3		
PDSCH transmission mode			4	4	4		
Interference model			N/A	As specified in clause B.6.3	As specified in clause B.6.3		
Precoding			Random wideband precoding per TTI	As specified in clause B.6.3	As specified in clause B.6.3		
Time offset to cell 1		us	N/A	2	3		
Frequency offset to cell 1		Hz	N/A	200	300		
MBSFN			Not configured	Not configured	Not configured		
NeighCellsInfo-r12 (Note 3)	p-aList-r12		N/A	{dB-6, dB-3, dB0}	{dB-6, dB-3, dB0}		
	transmissionModeList-r12		N/A	{2,3,4,8,9}	{2,3,4,8,9}		
Note 1: $P_B = 1$							
Note 2: Cell 1 is the serving cell. Cell 2, 3 are the interfering cells.							
Note 3: NeighCellsInfo-r12 is described in subclause 6.3.2 of [7].							
Note 4: Test 1 and Test 2 are defined in Table 8.2.1.4.1D-2.							

Table 8.2.1.4.1D-2: Minimum Performance for Enhanced Performance Requirement Type B, Single-layer Spatial Multiplexing (FRC) with TM4 interference model

Test Num	Reference Channel	OCNG Pattern			Propagation Conditions			Correlation Matrix and Antenna Configuration (Note 3)	Reference Value		UE Category
		Cell 1	Cell 2	Cell 3	Cell 1	Cell 2	Cell 3		Fraction of Maximum Throughput (%)	SNR (dB) (Note 2)	
1	R.11-10 FDD	OP.1 FDD	N/A	N/A	EVA 5	EVA 5	EVA 5	2x2 Low	85	17.0	≥ 1
2	R.11-9 FDD	OP.1 FDD	N/A	N/A	EPA 5	EPA 5	EPA 5	2x2 Low	85	10.1	≥ 1
Note 1: The propagation conditions for Cell 1, Cell 2 and Cell 3 are statistically independent.											
Note 2: SNR corresponds to \hat{E}_s/N_{oc} of Cell 1 as defined in clause 8.1.1.											
Note 3: Correlation matrix and antenna configuration parameters apply for each of Cell 1, Cell 2 and Cell 3.											

8.2.1.4.1E Minimum Requirement Single-Layer Spatial Multiplexing 2 Tx Antenna Ports with CRS assistance information

The requirements are specified in Table 8.2.1.4.1E-2, with the addition of parameters in Table 8.2.1.4.1E-1. The purpose is to verify the closed loop rank-one performance with wideband precoding when CRS assistance information [7] is configured. In Table 8.2.1.4.1E-1, Cell 1 is the serving cell, and Cell 2 and Cell 3 are the aggressor cells. The downlink physical channel setup is according to Annex C.3.2 for each of Cell 1, Cell 2 and Cell 3, respectively. The CRS assistance information [7] includes Cell 2 and Cell 3.

Table 8.2.1.4.1E-1: Test Parameters for Single-Layer Spatial Multiplexing (FRC)

Parameter		Unit	Cell 1	Cell 2	Cell 3
Downlink power allocation	ρ_A	dB	-3	-3	-3
	ρ_B	dB	-3 (Note 1)	-3 (Note 1)	-3 (Note 1)
	σ	dB	0	0	0
N_{oc} at antenna port		dBm/15kHz	-98	N/A	N/A
\bar{E}_s/N_{oc}		dB	Reference Value in Table 8.2.1.4.1E-2	10.45	4.6
BW _{Channel}		MHz	10	10	10
Subframe Configuration			Non-MBSFN	Non-MBSFN	Non-MBSFN
Time Offset to Cell 1		μs	N/A	3	-1
Frequency shift to Cell 1		Hz	N/A	300	-100
Cell Id			0	1	128
Cell-specific reference signals			Antenna ports 0,1		
Number of control OFDM symbols			2	2	2
PDSCH transmission mode			4	N/A	N/A
Precoding granularity		PRB	50	N/A	N/A
PMI delay (Note 2)		ms	8	N/A	N/A
Reporting interval		ms	1	N/A	N/A
Reporting mode			PUSCH 3-1	N/A	N/A
CodeBookSubsetRestriction bitmap			001111	N/A	N/A
Cyclic prefix			Normal	Normal	Normal
Interference model			N/A	As specified in clause B.5.3	As specified in clause B.5.3
Probability of occurrence of transmission in interference cells		%	N/A	20	20
Probability of occurrence of transmission rank in interfering cells	Rank 1	%	N/A	80	80
	Rank 2	%	N/A	20	20
Note 1: $P_B = 1$.					
Note 2: If the UE reports in an available uplink reporting instance at subframe SF#n based on PMI estimation at a downlink SF not later than SF#(n-4), this reported PMI cannot be applied at the eNB downlink before SF#(n+4).					

Table 8.2.1.4.1E-2: Minimum Performance Single-Layer Spatial Multiplexing (FRC)

Test Number	Reference Channel	OCNG Pattern			Propagation Conditions (Note1)			Correlation Matrix and Antenna Configuration (Note 2)	Reference Value		UE Category
		Cell 1	Cell 2	Cell 3	Cell 1	Cell 2	Cell 3		Fraction of Maximum Throughput (%)	SNR (dB) (Note 3)	

1	R.10-3 FDD	OP.1 FDD	N/A	N/A	EVA5	EVA5	EVA5	2x2 low	70	10.8	≥ 2
Note 1: The propagation conditions for Cell 1, Cell 2 and Cell 3 are statistically independent. Note 2: The correlation matrix and antenna configuration apply for Cell 1, Cell 2 and Cell 3. Note 3: SNR corresponds to \bar{E}_s/N_{oc} of cell 1.											

8.2.1.4.2 Minimum Requirement Multi-Layer Spatial Multiplexing 2 Tx Antenna Port

The requirements are specified in Table 8.2.1.4.2-2, with the addition of the parameters in Table 8.2.1.4.2-1 and the downlink physical channel setup according to Annex C.3.2. The purpose of these tests is to verify the closed loop rank-two performance with wideband and frequency selective precoding.

Table 8.2.1.4.2-1: Test Parameters for Multi-Layer Spatial Multiplexing (FRC)

Parameter	Unit	Test 1-2	Test 2A	Test 3	
Downlink power allocation	ρ_A	dB	-3	-3	-3
	ρ_B	dB	-3 (Note 1)	-3 (Note 1)	-3 (Note 1)
	σ	dB	0	0	0
N_{oc} at antenna port	dBm/15kHz	-98	-98	-98	
Precoding granularity	PRB	50	25	6	
PMI delay (Note 2)	ms	8	8	8	
Reporting interval	ms	1	1	1	
Reporting mode		PUSCH 3-1	PUSCH 3-1	PUSCH 1-2	
CodeBookSubsetRestriction bitmap		110000	110000	110000	
PDSCH transmission mode		4	4	4	
Number of OFDM symbols for PDCCH per component carrier	OFDM symbol	2	3	1	
Note 1: $P_B = 1$. Note 2: If the UE reports in an available uplink reporting instance at subframe SF#n based on PMI estimation at a downlink SF not later than SF#(n-4), this reported PMI cannot be applied at the eNB downlink before SF#(n+4).					

Table 8.2.1.4.2-2: Minimum performance Multi-Layer Spatial Multiplexing (FRC)

Test number	Bandwidth	Reference Channel	OCNG Pattern	Propagation Condition	Correlation Matrix and Antenna Configuration	Reference value		UE Category	UE DL category
						Fraction of Maximum Throughput (%)	SNR (dB)		
1	10 MHz	R.35 FDD	OP.1 FDD	EPA5	2x2 Low	70	18.9	≥ 2	≥ 6
2	10 MHz	R.11 FDD	OP.1 FDD	ETU70	2x2 Low	70	14.3	≥ 2	≥ 6
2A (Note 1)	5 MHz	R.11-2 FDD	OP.1 FDD	ETU70	2x2 Low	70	14.0	≥ 2	≥ 6
3	10MHz 256QAM	R. 65 FDD	OP.1 FDD	EVA5	2x2 Low	70	25.3	11-12	≥ 11
Note 1: Test case applicability is defined in 8.1.2.1.									

8.2.1.4.2A Enhanced Performance Requirement Type C – Multi-layer Spatial Multiplexing 2Tx Antenna Ports

The requirements are specified in Table 8.2.1.4.2A-2, with the addition of the parameters in Table 8.2.1.4.2A-1 and the downlink physical channel setup according to Annex C.3.2. The purpose of these tests is to verify the closed loop rank-two performance with wideband precoding.

Table 8.2.1.4.2A-1: Test Parameters for Multi-Layer Spatial Multiplexing (FRC)

Parameter	Unit	Test 1	
Downlink power allocation	ρ_A	dB	-3
	ρ_B	dB	-3 (Note 1)
	σ	dB	0
N_{oc} at antenna port	dBm/15kHz	-98	
Precoding granularity	PRB	50	
PMI delay (Note 2)	ms	8	
Reporting interval	ms	1	
Reporting mode		PUSCH 3-1	
CodeBookSubsetRestriction bitmap		110000	
PDSCH transmission mode		4	
Note 1: $P_B = 1$.			
Note 2: If the UE reports in an available uplink reporting instance at subframe SF#n based on PMI estimation at a downlink SF not later than SF#(n-4), this reported PMI cannot be applied at the eNB downlink before SF#(n+4).			

Table 8.2.1.4.2A-2: Enhanced Performance Requirement Type C for Multi-Layer Spatial Multiplexing with TM4 (FRC)

Test number	Band-width	Reference Channel	OCNG Pattern	Propagation Condition	Correlation Matrix and Antenna Configuration	Reference value		UE Category
						Fraction of Maximum Throughput (%)	SNR (dB)	
1	10 MHz	R.11 FDD	OP.1 FDD	ETU70	2x2 Medium	70	18.3	≥ 2

8.2.1.4.3 Minimum Requirement Multi-Layer Spatial Multiplexing 4 Tx Antenna Port

For single carrier, the requirements are specified in Table 8.2.1.4.3-2, with the addition of the parameters in Table 8.2.1.4.3-1 and the downlink physical channel setup according to Annex C.3.2.

For CA with 2 DL CCs, the requirements are specified in Table 8.2.1.4.3-4, with the addition of the parameters in Table 8.2.1.4.3-3 and the downlink physical channel setup according to Annex C.3.2. The purpose of these tests is to verify the closed loop rank-two performance with wideband and frequency selective precoding.

For CA with 3 DL CCs, the requirements are specified in Table 8.2.1.4.3-6, based on single carrier requirement specified in Table 8.2.1.4.3-5, with the addition of the parameters in Table 8.2.1.4.3-3 and the downlink physical channel setup according to Annex C.3.2.

For CA with 4 DL CCs, the requirements are specified in Table 8.2.1.4.3-7, based on single carrier requirement specified in Table 8.2.1.4.3-5, with the addition of the parameters in Table 8.2.1.4.3-3 and the downlink physical channel setup according to Annex C.3.2.

For CA with 5 DL CCs, the requirements are specified in Table 8.2.1.4.3-8, based on single carrier requirement specified in Table 8.2.1.4.3-5, with the addition of the parameters in Table 8.2.1.4.3-3 and the downlink physical channel setup according to Annex C.3.2.

The test coverage for different number of component carriers is defined in 8.1.2.4.

Table 8.2.1.4.3-1: Test Parameters for Multi-Layer Spatial Multiplexing (FRC)

Parameter	Unit	Test 1	
Downlink power allocation	ρ_A	dB	-6
	ρ_B	dB	-6 (Note 1)
	σ	dB	3
N_{oc} at antenna port	dBm/15kHz	-98	
Precoding granularity	PRB	6	
PMI delay (Note 2)	ms	8	
Reporting interval	ms	1	
Reporting mode		PUSCH 1-2	
CodeBookSubsetRestriction bitmap		00000000000000000000000000000000 000011111111111111111100000000 00000000	
PDSCH transmission mode		4	
Note 1: $P_B = 1$. Note 2: If the UE reports in an available uplink reporting instance at subframe SF#n based on PMI estimation at a downlink SF not later than SF#(n-4), this reported PMI cannot be applied at the eNB downlink before SF#(n+4). Note 3: Void. Note 4: Void. Note 5: Void.			

Table 8.2.1.4.3-2: Minimum performance Multi-Layer Spatial Multiplexing (FRC)

Test num.	Bandwidth	Reference channel	OCNG pattern	Propagation condition	Correlation matrix and antenna config.	Reference value		UE category
						Fraction of maximum throughput (%)	SNR (dB)	
1	10 MHz	R.36 FDD	OP.1 FDD	EPA5	4x2 Low	70	14.7	≥2
Note 1: Void.								

Table 8.2.1.4.3-3: Test Parameters for Multi-Layer Spatial Multiplexing (FRC) for CA

Parameter	Unit	Value	
Downlink power allocation	ρ_A	dB	-6
	ρ_B	dB	-6 (Note 1)
	σ	dB	3
N_{oc} at antenna port	dBm/15kHz	-98	
Precoding granularity	PRB	4 for 3MHz and 5MHz CCs, 6 for 10MHz CCs, 8 for 15MHz and 20MHz CCs	
PMI delay (Note 2)	ms	8	
Reporting interval	ms	1	
Reporting mode		PUSCH 1-2	
CodeBookSubsetRestriction bitmap		00000000000000000000000000000000 0011111111111111111111000000000000 0000	
CSI request field (Note 3)		'10'	
PDSCH transmission mode		4	
Note 1: $P_B = 1$. Note 2: If the UE reports in an available uplink reporting instance at subframe SF#n based on PMI estimation at a downlink SF not later than SF#(n-4), this reported PMI cannot be applied at the eNB downlink before SF#(n+4). Note 3: Multiple CC-s under test are configured as the 1 st set of serving cells by higher layers. Note 4: ACK/NACK bits are transmitted using PUSCH with PUCCH format 1b with channel selection configured for Tests in Table 8.2.1.4.3-4, and with PUCCH format 3 for Tests in Table 8.2.1.4.3-6. Note 5: The same PDSCH transmission mode is applied to each component carrier.			

Table 8.2.1.4.3-4: Minimum performance Multi-Layer Spatial Multiplexing (FRC) for CA with 2DL CCs

Test num	Bandwidth	Reference channel	OCNG pattern	Propagation condition	Correlation matrix and antenna config.	Reference value		UE category
						Fraction of maximum throughput (%)	SNR (dB)	
1	2x10 MHz	R.14 FDD	OP.1 FDD (Note 1)	EVA5	4x2 Low	70	10.8	≥3
2	2x20 MHz	R.14-3 FDD	OP.1 FDD (Note 1)	EVA5	4x2 Low	70	10.9	≥5
3	2x5 MHz	R.14-6 FDD	OP.1 FDD (Note 1)	EVA5	4x2 Low	70	9.5	≥2
			OP.1 FDD (Note 1)			70	9.5	
4	10MHz+5 MHz	R.14 FDD for 10MHz CC	OP.1 FDD (Note 1)	EVA5	4x2 Low	70	10.1	≥3
		R.14-6 FDD for 5MHz CC	OP.1 FDD (Note 1)			70	9.5	
5	15MHz+5 MHz	R.14-7 FDD for 15MHz CC	OP.1 FDD (Note 1)	EVA5	4x2 Low	70	10.1	≥3
		R.14-6 FDD for 5MHz CC	OP.1 FDD (Note 1)			70	9.5	
NOTE 1: The OCNG pattern applies for each CC.								
NOTE 2: The applicability of requirements for different CA configurations and bandwidth combination sets is defined in 8.1.2.3.								

Table 8.2.1.4.3-5: Single carrier performance for multiple CA configurations

Band-width	Reference channel	OCNG pattern	Propagation condition	Correlation matrix and antenna config.	Reference value	
					Fraction of maximum throughput (%)	SNR (dB)
1.4MHz	R.14-4 FDD	OP.1 FDD	EVA5	4x2 Low	70	10.4
3MHz	R.14-5 FDD	OP.1 FDD	EVA5	4x2 Low	70	9.5
5MHz	R.14-6 FDD	OP.1 FDD	EVA5	4x2 Low	70	9.5
10 MHz	R.14 FDD	OP.1 FDD	EVA5	4x2 Low	70	10.1
15MHz	R.14-7 FDD	OP.1 FDD	EVA5	4x2 Low	70	10.1
20MHz	R.14-3 FDD	OP.1 FDD	EVA5	4x2 Low	70	10.3

Table 8.2.1.4.3-6: Minimum performance (FRC) based on single carrier performance for CA with 3 DL CCs

Test num.	CA Band-width combination	Requirement	UE category
1	3x20MHz	As specified in Table 8.2.1.4.3-5 per CC	≥5
2	20MHz+20MHz+15MHz	As specified in Table 8.2.1.4.3-5 per CC	≥5
3	20MHz+20MHz+10MHz	As specified in Table 8.2.1.4.3-5 per CC	≥5
4	20MHz+15MHz+15MHz	As specified in Table 8.2.1.4.3-5 per CC	≥5
5	20MHz+15MHz+10MHz	As specified in Table 8.2.1.4.3-5 per CC	≥5
6	20MHz+10MHz+10MHz	As specified in Table 8.2.1.4.3-5 per CC	≥5
7	15MHz+15MHz+10MHz	As specified in Table 8.2.1.4.3-5 per CC	≥5
8	20MHz+10MHz+5MHz	As specified in Table 8.2.1.4.3-5 per CC	≥5
9	20MHz+15MHz+5MHz	As specified in Table 8.2.1.4.3-5 per CC	≥5
10	10MHz+10MHz+5MHz	As specified in Table 8.2.1. 4.3-5 per CC	≥5

Note 1: The applicability of requirements for different CA configurations and bandwidth combination sets is defined in 8.1.2.3

Table 8.2.1.4.3-7: Minimum performance (FRC) based on single carrier performance for CA with 4 DL CCs

Test num.	CA Band-width combination	Requirement	UE category
1	4x20MHz	As specified in Table 8.2.1.4.3-5 per CC	≥8
2	10MHz+20MHz+20MHz+20MHz	As specified in Table 8.2.1. 4.3-5 per CC	≥8
3	10MHz+10MHz+20MHz+20MHz	As specified in Table 8.2.1. 4.3-5 per CC	≥8
4	5MHz+10MHz+20MHz+20MHz	As specified in Table 8.2.1. 4.3-5 per CC	≥8
5	5MHz+10MHz+10MHz+20MHz	As specified in Table 8.2.1. 4.3-5 per CC	≥8

NOTE 1: The applicability of requirements for different CA configurations and bandwidth combination sets is defined in 8.1.2.3

Table 8.2.1.4.3-8: Minimum performance (FRC) based on single carrier performance for CA with 5 DL CCs

Test num.	CA Band-width combination	Requirement	UE category
1	5x20MHz	As specified in Table 8.2.1.4.3-5 per CC	8, ≥11

NOTE 1: The applicability of requirements for different CA configurations and bandwidth combination sets is defined in 8.1.2.3

8.2.1.4.3A Minimum Requirement Multi-Layer Spatial Multiplexing 4 Tx Antenna Port for dual connectivity

For dual connectivity the requirements are specified in Table 8.2.1.4.3A-3 for 2DL CCs and Table 8.2.1.4.3A-4 for 3DL CCs, based on single carrier requirement specified in Table 8.2.1.4.3A-2, with the addition of the parameters in Table 8.2.1.4.3A-1 and the downlink physical channel setup according to Annex C.3.2. The purpose of these tests is to verify the closed loop rank-two performance with wideband and frequency selective precoding by using dual connectivity transmission.

Table 8.2.1.4.3A-1: Test Parameters for Multi-Layer Spatial Multiplexing (FRC) for dual connectivity

Parameter	Unit	Values	
Downlink power allocation	ρ_A	dB	-6
	ρ_B	dB	-6 (Note 1)
	σ	dB	3
N_{oc} at antenna port	dBm/15kHz	-98	
Precoding granularity	PRB	6 for 1.4MHz, 4 for 3MHz and 5MHz CCs, 6 for 10MHz CCs, and 8 for 15MHz CCs and 20MHz CCs	
PMI delay (Note 2)	ms	8	
Reporting interval	ms	1	
Reporting mode		PUSCH 1-2	
CodeBookSubsetRestriction bitmap		00000000000000000000000000000000 00001111111111111111111100000000 00000000	
PDSCH transmission mode		4	
ACK/NACK transmission		Separate ACK/NACK feedbacks with PUCCH format 1b on the MCG and SCG	
CSI feedback		Separate PUSCH feedbacks on the MCG and SCG	
Time offset between MCG CC and SCG CC	μ s	0 for UE under test supporting synchronous dual connectivity; 334 for UE under test supporting both asynchronous and synchronous dual connectivity (Note 4)	
Note 1: $P_B = 1$. Note 2: If the UE reports in an available uplink reporting instance at subframe SF#n based on PMI estimation at a downlink SF not later than SF#(n-4), this reported PMI cannot be applied at the eNB downlink before SF#(n+4). Note 3: The same PDSCH transmission mode is applied to each component carrier. Note 4: As defined in TS36.300 [11]. Note 5: If the UE supports both SCG bearer and Split bearer, the SCG bearer is configured.			

Table 8.2.1.4.3A-2: Single carrier performance for multiple dual connectivity configurations

Band-width	Reference channel	OCNG pattern	Propagation condition	Correlation matrix and antenna config.	Reference value	
					Fraction of maximum throughput (%)	SNR (dB)
1.4MHz	R.14-4 FDD	OP. 1 FDD	EVA5	4x2 Low	70	10.36
3MHz	R.14-5 FDD	OP. 1 FDD	EVA5	4x2 Low	70	9.5
5MHz	R.14-6 FDD	OP. 1 FDD	EVA5	4x2 Low	70	9.5
10 MHz	R.14 FDD	OP. 1 FDD	EVA5	4x2 Low	70	10.1
15MHz	R.14-7 FDD	OP. 1 FDD	EVA5	4x2 Low	70	10.1
20MHz	R.14-3 FDD	OP. 1 FDD	EVA5	4x2 Low	70	10.3

Table 8.2.1.4.3A-3: Minimum performance Multi-Layer Spatial Multiplexing (FRC) for dual connectivity with 2 DL CCs

Test num.	Band-width combination	Requirement	UE category
1	2x20 MHz	As specified in Table 8.2.1.4.3A-2 per CC	≥5
2	15+20 MHz	As specified in Table 8.2.1.4.3A-2 per CC	≥5
3	10+20MHz	As specified in Table 8.2.1.4.3A-2 per CC	≥5
4	2x15 MHz	As specified in Table 8.2.1.4.3A-2 per CC	≥5
5	2x10 MHz	As specified in Table 8.2.1.4.3A-2 per CC	≥3
6	15+5 MHz	As specified in Table 8.2.1.4.3A-2 per CC	≥3
7	10+15 MHz	As specified in Table 8.2.1.4.3A-2 per CC	≥5

Note 1: The OCNG pattern applies for each CC.
Note 2: The applicability of requirements for different dual connectivity configurations and bandwidth combination sets is defined in 8.1.2.3A.

Table 8.2.1.4.3A-4: Minimum performance Multi-Layer Spatial Multiplexing (FRC) for dual connectivity with 3DL CCs

Test num.	Band-width combination	Requirement	UE category
1	20+20+15MHz	As specified in Table 8.2.1.4.3A-2 per CC	≥5
2	20+15+15MHz	As specified in Table 8.2.1.4.3A-2 per CC	≥5
3	3x20 MHz	As specified in Table 8.2.1.4.3A-2 per CC	≥5
4	20+20+10 MHz	As specified in Table 8.2.1.4.3A-2 per CC	≥5
5	20+15+10 MHz	As specified in Table 8.2.1.4.3A-2 per CC	≥5
6	20+10+10 MHz	As specified in Table 8.2.1.4.3A-2 per CC	≥5
7	15+15+10 MHz	As specified in Table 8.2.1.4.3A-2 per CC	≥5

Note 1: The OCNG pattern applies for each CC.
Note 2: The applicability of requirements for different dual connectivity configurations and bandwidth combination sets is defined in 8.1.2.3A.

8.2.1.5 MU-MIMO**8.2.1.6 [Control channel performance: D-BCH and PCH]****8.2.1.7 Carrier aggregation with power imbalance**

For CA, the requirements in this section verify the ability of an intraband adjacent carrier aggregation UE to demodulate the signal transmitted by the PCell or SCell in the presence of a stronger SCell or PCell signal on an adjacent frequency. Throughput is measured on the PCell or SCell only.

8.2.1.7.1 Minimum Requirement

The requirements are specified in Table 8.2.1.7.1-2, with the addition of the parameters in Table 8.2.1.7.1-1 and the downlink physical channel setup according to Annex C.3.2.

Table 8.2.1.7.1-1: Test Parameters for CA

Parameter		Unit	Test 1	Test 2-3
Downlink power allocation	ρ_A	dB	0	0
	ρ_B	dB	0 (Note 1)	0 (Note 1)
	σ	dB	0	0
N_{oc} at antenna port		dBm/15kHz	Off (Note 2)	Off (Note 2)
Symbols for unused PRBs			OCNG (Note 3)	OCNG (Note 3)
Modulation			64 QAM	64 QAM
Maximum number of HARQ transmission			1	1
Redundancy version coding sequence			{0}	{0}
PDSCH transmission mode of PCell			1	3
PDSCH transmission mode of SCell			3	1
OCNG Pattern	PCell		OP.1 FDD	OP.5 FDD
	SCell		OP.5 FDD	OP.1 FDD
Propagation Conditions	PCell		Clause B.1	Clause B.1
	SCell		Clause B.1	Clause B.1
Correlation Matrix and Antenna	PCell		1x2	2x2
	SCell		2x2	1x2
Note 1: $P_B = 0$ for 1x2 and $P_B = 1$ for 2x2 antenna configuration.				
Note 2: No external noise sources are applied				
Note 3: These physical resource blocks are assigned to an arbitrary number of virtual UEs with one PDSCH per virtual UE; the data transmitted over the OCNG PDSCHs shall be uncorrelated. pseudo random data.				
Note 4: Void				

Table 8.2.1.7.1-2: Minimum performance (FRC) for CA

Test Number	Bandwidth (MHz)		Reference channel		Power at antenna port (dBm/15KHz)		Reference value Fraction of Maximum Throughput (%)		UE Category
	PCell	SCell	PCell	SCell	\hat{E}_{s_PCell} for PCell	\hat{E}_{s_SCell} for SCell	PCell	SCell	
1	20	20	R.49 FDD	NA	-85	-79	85	NA	≥ 5
2	10	10	NA	R.49-1 FDD	-79	-85.8	NA	85	≥ 5
3	5	5	NA	R.49-2 FDD	-79	-85.9	NA	85	≥ 5
Note 1: The OCNG pattern for PCell is used to fill the control channel. The OCNG pattern for SCell is used to fill the control channel and PDSCH.									
Note 2: The applicability of requirements for different CA configurations and bandwidth combination sets is defined in 8.1.2.3.									

8.2.1.8 Intra-band non-contiguous carrier aggregation with timing offset

The requirements in this section verify the ability of an intraband non-contiguous carrier aggregation UE to demodulate the signal transmitted by the PCell and SCell in the presence of timing offset between the cells. Throughput is measured on both cells.

8.2.1.8.1 Minimum Requirement

For CA the requirements are specified in Table 8.2.1.8.1-2, with the addition of the parameters in Table 8.2.1.8.1-1 and the downlink physical channel setup according to Annex C.3.2.

Table 8.2.1.8.1-1: Test Parameters for CA

Parameter	Unit	Test 1	
Downlink power allocation	ρ_A	dB	-3
	ρ_B	dB	-3 (Note 1)
	σ	dB	0
N_{oc} at antenna port	dBm/15kHz	-98	
Modulation		64 QAM	
Maximum number of HARQ transmission		4	
Redundancy version coding sequence		{0,0,1,2}	
PDSCH transmission mode of PCell		3	
PDSCH transmission mode of SCell		3	
Note 1: $P_B = 1$.			
Note 2: The OCNG pattern is used to fill unused control channel and PDSCH.			

Table 8.2.1.8.1-2: Minimum performance (FRC) for CA

Test Number	Cell	Bandwidth	Reference Channel	OCNG Pattern	Propagation Conditions	Correlation Matrix and Antenna	Reference value		Timing relative to PCell (μ s)	UE Category
							Fraction of Maximum Throughput (%)	SNR (dB)		
1	PCell	10MHz	R.35-4 FDD	OP.1 FDD	EPA200	2x2 Low	70	21.15	N/A	≥ 3
	SCell	10MHz	R.35-3 FDD		EPA200	2x2 Low	60	15.18	-30.26	
Note 1: The EPA200 propagation channels applied to PCell and SCell are statistically independent.										
Note 2: The applicability and test rules of requirements for different CA configurations and bandwidth combination sets are defined in 8.1.2.3.										

8.2.2 TDD (Fixed Reference Channel)

The parameters specified in Table 8.2.2-1 are valid for all TDD tests unless otherwise stated.

Table 8.2.2-1: Common Test Parameters (TDD)

Parameter	Unit	Value
Uplink downlink configuration (Note 1)		1
Special subframe configuration (Note 2)		4
Cyclic prefix		Normal
Cell ID		0
Inter-TTI Distance		1
Number of HARQ processes per component carrier	Processes	7
Maximum number of HARQ transmission		4
Redundancy version coding sequence		{0,1,2,3} for QPSK and 16QAM {0,0,1,2} for 64QAM and 256QAM
Number of OFDM symbols for PDCCH per component carrier	OFDM symbols	4 for 1.4 MHz bandwidth, 3 for 3 MHz and 5 MHz bandwidths, 2 for 10 MHz, 15 MHz and 20 MHz bandwidths unless otherwise stated
Cross carrier scheduling		Not configured
Note 1: as specified in Table 4.2-2 in TS 36.211 [4].		
Note 2: as specified in Table 4.2-1 in TS 36.211 [4].		

8.2.2.1 Single-antenna port performance

The single-antenna performance in a given multi-path fading environments is determined by the SNR for which a certain relative information bit throughput of the reference measurement channels in Annex A.3.4 is achieved. The purpose of these tests is to verify the single-antenna performance with different channel models and MCS. The QPSK and 64QAM cases are also used to verify the performance for all bandwidths specified in Table 5.6.1-1.

8.2.2.1.1 Minimum Requirement

For single carrier, the requirements are specified in Table 8.2.2.1.1-2, with the addition of the parameters in Table 8.2.2.1.1-1 and the downlink physical channel setup according to Annex C.3.2.

For CA with 2 DL CCs, the requirements are specified in Table 8.2.2.1.1-4, with the addition of the parameters in Table 8.2.2.1.1-3 and the downlink physical channel setup according to Annex C.3.2.

For CA with 3 DL CCs, the requirements are specified in Table 8.2.2.1.1-7, based on single carrier requirement specified in Table 8.2.2.1.1-5, with the addition of the parameters in Table 8.2.2.1.1-3 and the downlink physical channel setup according to Annex C.3.2.

For CA with 4 DL CCs, the requirements are specified in Table 8.2.2.1.1-8, based on single carrier requirement specified in Table 8.2.2.1.1-5, with the addition of the parameters in Table 8.2.2.1.1-3 and the downlink physical channel setup according to Annex C.3.2.

The test coverage for different number of component carriers is defined in 8.1.2.4.

Table 8.2.2.1.1-1: Test Parameters

Parameter		Unit	Test 1- 5	Test 6- 8	Test 9- 15	Test 16- 18	Test 19
Downlink power allocation	ρ_A	dB	0	0	0	0	0
	ρ_B	dB	0 (Note 1)	0 (Note 1)	0 (Note 1)	0 (Note 1)	0 (Note 1)
	σ	dB	0	0	0	0	0
N_{oc} at antenna port		dBm/15kHz	-98	-98	-98	-98	-98
Symbols for unused PRBs			OCNG (Note 2)	OCNG (Note 2)	OCNG (Note 2)	OCNG (Note 2)	OCNG (Note 2)
Modulation			QPSK	16QAM	64QAM	16QAM	QPSK
ACK/NACK feedback mode			Multiplexing	Multiplexing	Multiplexing	Multiplexing	Multiplexing
PDSCH transmission mode			1	1	1	1	1
<p>Note 1: $P_B = 0$</p> <p>Note 2: These physical resource blocks are assigned to an arbitrary number of virtual UEs with one PDSCH per virtual UE; the data transmitted over the OCNG PDSCHs shall be uncorrelated pseudo random data, which is QPSK modulated.</p> <p>Note 3: Void</p> <p>Note 4: Void</p>							

Table 8.2.2.1.1-2: Minimum performance (FRC)

Test number	Bandwidth	Reference Channel	OCNG Pattern	Propagation Condition	Correlation Matrix and Antenna Configuration	Reference value		UE Category
						Fraction of Maximum Throughput (%)	SNR (dB)	
1	10 MHz	R.2 TDD	OP.1 TDD	EVA5	1x2 Low	70	-1.2	≥1
2	10 MHz	R.2 TDD	OP.1 TDD	ETU70	1x2 Low	70	-0.6	≥1
3	10 MHz	R.2 TDD	OP.1 TDD	ETU300	1x2 Low	70	-0.2	≥1
4	10 MHz	R.2 TDD	OP.1 TDD	HST	1x2	70	-2.6	≥1
5	1.4 MHz	R.4 TDD	OP.1 TDD	EVA5	1x2 Low	70	0.0	≥1
6	10 MHz	R.3 TDD	OP.1 TDD	EVA5	1x2 Low	70	6.7	≥2
	5 MHz	R.3-1 TDD	OP.1 TDD	EVA5	1x2 Low	70	6.7	1
7	10 MHz	R.3 TDD	OP.1 TDD	ETU70	1x2 Low	30	1.4	≥2
	5 MHz	R.3-1 TDD	OP.1 TDD	ETU70	1x2 Low	30	1.4	1
8	10 MHz	R.3 TDD	OP.1 TDD	ETU300	1x2 High	70	9.3	≥2
	5 MHz	R.3-1 TDD	OP.1 TDD	ETU300	1x2 High	70	9.3	1
9	3 MHz	R.5 TDD	OP.1 TDD	EVA5	1x2 Low	70	17.6	≥1
10	5 MHz	R.6 TDD	OP.1 TDD	EVA5	1x2 Low	70	17.6	≥2
	5 MHz	R.6-1 TDD	OP.1 TDD	EVA5	1x2 Low	70	17.6	1
11	10 MHz	R.7 TDD	OP.1 TDD	EVA5	1x2 Low	70	17.6	≥2
	10 MHz	R.7-1 TDD	OP.1 TDD	EVA5	1x2 Low	70	17.6	1
12	10 MHz	R.7 TDD	OP.1 TDD	ETU70	1x2 Low	70	19.1	≥2
	10 MHz	R.7-1 TDD	OP.1 TDD	ETU70	1x2 Low	70	19.1	1
13	10 MHz	R.7 TDD	OP.1 TDD	EVA5	1x2 High	70	19.1	≥2
	10 MHz	R.7-1 TDD	OP.1 TDD	EVA5	1x2 High	70	19.1	1
14	15 MHz	R.8 TDD	OP.1 TDD	EVA5	1x2 Low	70	17.8	≥2
	15 MHz	R.8-1 TDD	OP.1 TDD	EVA5	1x2 Low	70	17.8	1
15	20 MHz	R.9 TDD	OP.1 TDD	EVA5	1x2 Low	70	17.7	≥3
	20 MHz	R.9-2 TDD	OP.1 TDD	EVA5	1x2 Low	70	17.7	2
	20 MHz	R.9-1 TDD	OP.1 TDD	EVA5	1x2 Low	70	17.7	1
16	3 MHz	R.0 TDD	OP.1 TDD	ETU70	1x2 Low	30	2.1	≥1
17	10 MHz	R.1 TDD	OP.1 TDD	ETU70	1x2 Low	30	2.0	≥1
18	20 MHz	R.1 TDD	OP.1 TDD	ETU70	1x2 Low	30	2.1	≥1
19	10 MHz	R.41 TDD	OP.1 TDD	EVA5	1x2 Low	70	-5.3	≥1

Note 1: Void.

Table 8.2.2.1.1-3: Test Parameters for CA

Parameter		Unit	Value
Downlink power allocation	ρ_A	dB	0
	ρ_B	dB	0 (Note 1)
	σ	dB	0
N_{oc} at antenna port		dBm/15kHz	-98
Symbols for unused PRBs			OCNG (Note 2)
Modulation			QPSK
ACK/NACK feedback mode			PUCCH format 1b with channel selection for Tests in Table 8.2.2.1.1-4; PUCCH format 3 for Tests in Table 8.2.2.1.1-7
PDSCH transmission mode			1
Note 1: $P_B = 0$			
Note 2: These physical resource blocks are assigned to an arbitrary number of virtual UEs with one PDSCH per virtual UE; the data transmitted over the OCNG PDSCHs shall be uncorrelated pseudo random data, which is QPSK modulated.			
Note 3: The same PDSCH transmission mode is applied to each component carrier.			

Table 8.2.2.1.1-4: Minimum performance (FRC) for CA with 2DL CCs

Test number	Bandwidth	Reference Channel	OCNG Pattern	Propagation Condition	Correlation Matrix and Antenna Configuration	Reference value		UE Category
						Fraction of Maximum Throughput (%)	SNR (dB)	
1	2x20MHz	R.42 TDD	OP.1 TDD (Note 1)	EVA5	1x2 Low	70	-1.2	≥ 5
2	20MHz+15MHz	R.42 TDD for 20MHz CC	OP.1 TDD (Note 1)	EVA5	1x2 Low	70	-1.4	≥ 5
		R.42-3 TDD for 15MHz CC	OP.1 TDD (Note 1)			70	-1.4	
Note 1: The OCNG pattern applies for each CC.								
Note 2: The applicability of requirements for different CA configurations and bandwidth combination sets is defined in 8.1.2.3.								
Note 3: 30usec timing difference between PCell and any SCell is applied in inter-band CA case, where PCell can be assigned on any CC.								

Table 8.2.2.1.1-5: Single carrier performance for multiple CA configurations

Band-width	Reference channel	OCNG pattern	Propagation condition	Correlation matrix and antenna config.	Reference value	
					Fraction of maximum throughput (%)	SNR (dB)
1.4MHz	R.4 TDD	OP.1 TDD	EVA5	1x2 Low	70	-0.6
3MHz	R.42-1 TDD	OP.1 TDD	EVA5	1x2 Low	70	-0.8
5MHz	R.42-2 TDD	OP.1 TDD	EVA5	1x2 Low	70	-1.2
10MHz	R.2 TDD	OP.1 TDD	EVA5	1x2 Low	70	-1.6
15MHz	R.42-3 TDD	OP.1 TDD	EVA5	1x2 Low	70	-1.4
20MHz	R.42 TDD	OP.1 TDD	EVA5	1x2 Low	70	-1.4

Table 8.2.2.1.1-6: Void

Table 8.2.2.1.1-7: Minimum performance (FRC) based on single carrier performance for CA with 3 DL CCs

Test num.	CA Band-width combination	Requirement	UE category
1	3x20MHz	As specified in Table 8.2.2.1.1-5 per CC	≥5
2	20MHz+20MHz+15MHz	As specified in Table 8.2.2.1.1-5 per CC	≥5
Note 1: The applicability of requirements for different CA configurations and bandwidth combination sets is defined in 8.1.2.3			
Note 2: 30usec timing difference between PCell and any SCell is applied in inter-band CA case, where PCell can be assigned on any CC.			

Table 8.2.2.1.1-8: Minimum performance (FRC) based on single carrier performance for CA with 4 DL CCs

Test num.	CA Band-width combination	Requirement	UE category
1	4x20MHz	As specified in Table 8.2.2.1.1-5 per CC	≥8
2	20MHz+20MHz+20MHz+15MHz	As specified in Table 8.2.2.1.1-5 per CC	≥8
Note 1: The applicability of requirements for different CA configurations and bandwidth combination sets is defined in 8.1.2.3			

8.2.2.1.2 Void

8.2.2.1.3 Void

8.2.2.1.4 Minimum Requirement 1 PRB allocation in presence of MBSFN

The requirements are specified in Table 8.2.2.1.4-2, with the addition of the parameters in Table 8.2.2.1.4-1 and the downlink physical channel setup according to Annex C.3.2. The purpose of these tests is to verify the single-antenna performance with a single PRB allocated at the lower band edge in presence of MBSFN.

Table 8.2.2.1.4-1: Test Parameters for Testing 1 PRB allocation

Parameter	Unit	Test 1	
Downlink power allocation	ρ_A	dB	0
	ρ_B	dB	0 (Note 1)
	σ	dB	0
N_{oc} at antenna port	dBm/15kHz	-98	
Symbols for MBSFN portion of MBSFN subframes (Note 2)		OCNG (Note 3)	
ACK/NACK feedback mode		Multiplexing	
PDSCH transmission mode		1	
Note 1: $P_B = 0$ Note 2: The MBSFN portion of an MBSFN subframe comprises the whole MBSFN subframe except the first two symbols in the first slot. Note 3: The MBSFN portion of the MBSFN subframes shall contain QPSK modulated data. Cell-specific reference signals are not inserted in the MBSFN portion of the MBSFN subframes, QPSK modulated MBSFN data is used instead.			

Table 8.2.2.1.4-2: Minimum performance 1PRB (FRC)

Test number	Bandwidth	Reference Channel	OCNG Pattern	Propagation Condition	Correlation Matrix and Antenna Configuration	Reference value		UE Category
						Fraction of Maximum Throughput (%)	SNR (dB)	
1	10 MHz	R.29 TDD	OP.3 TDD	ETU70	1x2 Low	30	2.0	≥1

8.2.2.2 Transmit diversity performance

8.2.2.2.1 Minimum Requirement 2 Tx Antenna Port

The requirements are specified in Table 8.2.2.2.1-2, with the addition of the parameters in Table 8.2.2.2.1-1 and the downlink physical channel setup according to Annex C.3.2. The purpose is to verify the performance of transmit diversity (SFBC) with 2 transmitter antennas.

Table 8.2.2.2.1-1: Test Parameters for Transmit diversity Performance (FRC)

Parameter		Unit	Test 1-2
Downlink power allocation	ρ_A	dB	-3
	ρ_B	dB	-3 (Note 1)
	σ	dB	0
N_{oc} at antenna port		dBm/15kHz	-98
ACK/NACK feedback mode			Multiplexing
PDSCH transmission mode			2
Note 1: $P_B = 1$			

Table 8.2.2.2.1-2: Minimum performance Transmit Diversity (FRC)

Test number	Bandwidth	Reference Channel	OCNG Pattern	Propagation Condition	Correlation Matrix and Antenna Configuration	Reference value		UE Category
						Fraction of Maximum Throughput (%)	SNR (dB)	
1	10 MHz	R.11 TDD	OP.1 TDD	EVA5	2x2 Medium	70	6.8	≥2
	5 MHz	R.11-2 TDD	OP.1 TDD	EVA5	2x2 Medium	70	6.8	1
2	10 MHz	R.10 TDD	OP.1 TDD	HST	2x2	70	-2.3	≥1

8.2.2.2.2 Minimum Requirement 4 Tx Antenna Port

The requirements are specified in Table 8.2.2.2.2-2, with the addition of the parameters in Table 8.2.2.2.2-1 and the downlink physical channel setup according to Annex C.3.2. The purpose is to verify the performance of transmit diversity (SFBC-FSTD) with 4 transmitter antennas.

Table 8.2.2.2-1: Test Parameters for Transmit diversity Performance (FRC)

Parameter	Unit	Test 1-2	
Downlink power allocation	ρ_A	dB	-3
	ρ_B	dB	-3 (Note 1)
	σ	dB	0
N_{oc} at antenna port	dBm/15kHz	-98	
ACK/NACK feedback mode		Multiplexing	
PDSCH transmission mode		2	
Note 1: $P_B = 1$			

Table 8.2.2.2-2: Minimum performance Transmit Diversity (FRC)

Test number	Band-width	Reference Channel	OCNG Pattern	Propagation Condition	Correlation Matrix and Antenna Configuration	Reference value		UE Category
						Fraction of Maximum Throughput (%)	SNR (dB)	
1	1.4 MHz	R.12 TDD	OP.1 TDD	EPA5	4x2 Medium	70	0.2	≥ 1
2	10 MHz	R.13 TDD	OP.1 TDD	ETU70	4x2 Low	70	-0.5	≥ 1

8.2.2.2.3 Minimum Requirement 2 Tx Antenna Port (demodulation subframe overlaps with aggressor cell ABS)

The requirements are specified in Table 8.2.2.2.3-2, with the addition of parameters in Table 8.2.2.2.3-1 and the downlink physical channel setup according to Annex C.3.2 and Annex C.3.3. The purpose is to verify the performance of transmit diversity (SFBC) with 2 transmit antennas if the PDSCH transmission in the serving cell takes place in subframes that overlap with ABS [9] of the aggressor cell. In Table 8.2.2.2.3-1, Cell 1 is the serving cell, and Cell 2 is the aggressor cell. The downlink physical channel setup for Cell 1 is according to Annex C.3.2 and for Cell 2 is according to Annex C.3.3, respectively.

Table 8.2.2.3-1: Test Parameters for Transmit diversity Performance (FRC)

Parameter		Unit	Cell 1	Cell 2
Uplink downlink configuration			1	1
Special subframe configuration			4	4
Downlink power allocation	ρ_A	dB	-3	-3
	ρ_B	dB	-3 (Note 1)	-3 (Note 1)
	σ	dB	0	N/A
N_{oc} at antenna port	N_{oc1}	dBm/15kHz	-102 (Note 2)	N/A
	N_{oc2}	dBm/15kHz	-98 (Note 3)	N/A
	N_{oc3}	dBm/15kHz	-94.8 (Note 4)	N/A
\hat{E}_s / N_{oc2}		dB	Reference Value in Table 8.2.2.3-2	6
$BW_{Channel}$		MHz	10	10
Subframe Configuration			Non-MBSFN	Non-MBSFN
Time Offset between Cells		μ s	2.5 (synchronous cells)	
Cell Id			0	1
ABS pattern (Note 5)			N/A	0000010001 0000000001
RLM/RRM Measurement Subframe Pattern (Note 6)			0000000001 0000000001	N/A
CSI Subframe Sets (Note 7)	$C_{CSI,0}$		0000010001 0000000001	N/A
	$C_{CSI,1}$		1100101000 1100111000	N/A
Number of control OFDM symbols			2	2
ACK/NACK feedback mode			Multiplexing	N/A
PDSCH transmission mode			2	N/A
Cyclic prefix			Normal	Normal
<p>Note 1: $P_B = 1$.</p> <p>Note 2: This noise is applied in OFDM symbols #1, #2, #3, #5, #6, #8, #9, #10, #12, #13 of a subframe overlapping with the aggressor ABS.</p> <p>Note 3: This noise is applied in OFDM symbols #0, #4, #7, #11 of a subframe overlapping with the aggressor ABS.</p> <p>Note 4: This noise is applied in all OFDM symbols of a subframe overlapping with aggressor non-ABS.</p> <p>Note 5: ABS pattern as defined in [9].</p> <p>Note 6: Time-domain measurement resource restriction pattern for PCell measurements as defined in [7].</p> <p>Note 7: As configured according to the time-domain measurement resource restriction pattern for CSI measurements defined in [7].</p> <p>Note 8: Cell 1 is the serving cell. Cell 2 is the aggressor cell. The number of the CRS ports in Cell1 and Cell2 is the same.</p> <p>Note 9: SIB-1 will not be transmitted in Cell2 in this test.</p>				

Table 8.2.2.3-2: Minimum Performance Transmit Diversity (FRC)

Test Number	Reference Channel	OCNG Pattern		Propagation Conditions (Note 1)		Correlation Matrix and Antenna Configuration	Reference Value		UE Category
		Cell 1	Cell 2	Cell 1	Cell 2		Fraction of Maximum Throughput (%) Note 5	SNR (dB) (Note 2)	
1	R.11-4 TDD Note 4	OP.1 TDD	OP.1 TDD	EVA5	EVA5	2x2 Medium	70	3.8	≥2
<p>Note 1: The propagation conditions for Cell 1 and Cell2 are statistically independent.</p> <p>Note 2: SNR corresponds to \widehat{E}_s/N_{oc2} of cell 1.</p> <p>Note 3: The correlation matrix and antenna configuration apply for Cell 1 and Cell 2.</p> <p>Note 4: Cell 1 Reference channel is modified: PDSCH other than SIB1/paging and its associated PDCCH/PCFICH are transmitted in the serving cell subframe when the subframe is overlapped with the ABS subframe of aggressor cell and the subframe is available in the definition of the reference channel.</p> <p>Note 5: The maximum Throughput is calculated from the total Payload in 2 subframes, averaged over 20ms.</p>									

8.2.2.3A Minimum Requirement 2 Tx Antenna Ports (demodulation subframe overlaps with aggressor cell ABS and CRS assistance information are configured)

The requirements are specified in Table 8.2.2.3A-2, with the addition of parameters in Table 8.2.2.3A-1. The purpose is to verify the performance of transmit diversity (SFBC) with 2 transmit antennas if the PDSCH transmission in the serving cell takes place in subframes that overlap with ABS [9] of the aggressor cell with CRS assistance information. In Table 8.2.2.3A-1, Cell 1 is the serving cell, and Cell 2 and Cell 3 are the aggressor cells. The downlink physical channel setup for Cell 1 is according to Annex C.3.2 and for Cell 2 and Cell 3 is according to Annex C.3.3, respectively. The CRS assistance information [7] includes Cell 2 and Cell 3.

Table 8.2.2.3A-1: Test Parameters for Transmit diversity Performance (FRC)

Parameter		Unit	Cell 1	Cell 2	Cell 3
Uplink downlink configuration			1	1	1
Special subframe configuration			4	4	4
Downlink power allocation	ρ_A	dB	-3	-3	-3
	ρ_B	dB	-3 (Note 1)	-3 (Note 1)	-3 (Note 1)
	σ	dB	0	N/A	N/A
N_{oc} at antenna port	N_{oc1}	dBm/15kHz	-98 (Note 2)	N/A	N/A
	N_{oc2}	dBm/15kHz	-98 (Note 3)	N/A	N/A
	N_{oc3}	dBm/15kHz	-93 (Note 4)	N/A	N/A
\hat{E}_s / N_{oc2}		dB	Reference Value in Table 8.2.2.3A-2	12	10
BW _{Channel}		MHz	10	10	10
Subframe Configuration			Non-MBSFN	Non-MBSFN	Non-MBSFN
Time Offset between Cells		μs	N/A	3	-1
Frequency shift between Cells		Hz	N/A	300	-100
Cell Id			0	126	1
ABS pattern (Note 5)			N/A	0000000001 0000000001	0000000001 0000000001
RLM/RRM Measurement Subframe Pattern (Note 6)			0000000001 0000000001	N/A	N/A
CSI Subframe Sets (Note7)	C _{CSI,0}		0000000001 0000000001	N/A	N/A
	C _{CSI,1}		1100111000 1100111000	N/A	N/A
Number of control OFDM symbols			2	Note 8	Note 8
ACK/NACK feedback mode			Multiplexing	N/A	N/A
PDSCH transmission mode			2	Note 9	Note 9
Cyclic prefix			Normal	Normal	Normal
<p>Note 1: $P_B = 1$.</p> <p>Note 2: This noise is applied in OFDM symbols #1, #2, #3, #5, #6, #8, #9, #10, #12, #13 of a subframe overlapping with the aggressor ABS.</p> <p>Note 3: This noise is applied in OFDM symbols #0, #4, #7, #11 of a subframe overlapping with the aggressor ABS.</p> <p>Note 4: This noise is applied in all OFDM symbols of a subframe overlapping with aggressor non-ABS</p> <p>Note 5: ABS pattern as defined in [9].</p> <p>Note 6: Time-domain measurement resource restriction pattern for PCell measurements as defined in [7]</p> <p>Note 7: As configured according to the time-domain measurement resource restriction pattern for CSI measurements defined in [7].</p> <p>Note 8: The number of control OFDM symbols is not available for ABS and is 2 for the subframe indicated by "0" of ABS pattern.</p> <p>Note 9: Downlink physical channel setup in Cell 2 and Cell 3 in accordance with Annex C.3.3 applying OCN pattern as defined in Annex A.5.</p> <p>Note 10: The number of the CRS ports in Cell 1, Cell 2 and Cell 3 is the same.</p> <p>Note 11: SIB-1 will not be transmitted in Cell 2 and Cell 3 in this test.</p>					

Table 8.2.2.2.3A-2: Minimum Performance Transmit Diversity (FRC)

Test Number	Reference Channel	OCNG Pattern			Propagation Conditions (Note 1)			Correlation Matrix and Antenna Configuration (Note 2)	Reference Value		UE Category
		Cell 1	Cell 2	Cell 3	Cell 1	Cell 2	Cell 3		Fraction of Maximum Throughput (%) Note 5	SNR (dB) (Note 3)	
1	R.11-4 TDD Note 4	OP.1 TDD	OP.1 TDD	OP.1 TDD	EVA5	EVA5	EVA5	2x2 Medium	70	3.5	≥2

Note 1: The propagation conditions for Cell 1, Cell 2 and Cell 3 are statistically independent.

Note 2: The correlation matrix and antenna configuration apply for Cell 1, Cell 2 and Cell 3..

Note 3: SNR corresponds to \hat{E}_s / N_{oc2} of cell 1.

Note 4: Cell 1 Reference channel is modified: PDSCH other than SIB1/paging and its associated PDCCH/PCFICH are transmitted in the serving cell subframe when the subframe is overlapped with the ABS subframe of aggressor cell and the subframe is available in the definition of the reference channel.

Note 5: The maximum Throughput is calculated from the total Payload in 2 subframes, averaged over 20ms.

8.2.2.2.4 Enhanced Performance Requirement Type A – 2 Tx Antenna Ports with TM3 interference model

The requirements are specified in Table 8.2.2.2.4-2, with the addition of parameters in Table 8.2.2.2.4-1 and the downlink physical channel setup according to Annex C.3.2. The purpose is to verify the performance of transmit diversity (SFBC) with 2 transmit antennas when the PDSCH transmission in the serving cell is interfered by PDSCH of two dominant interfering cells applying transmission mode 3 interference model defined in clause B.5.2. In Table 8.2.2.2.4-1, Cell 1 is the serving cell, and Cell 2, 3 are interfering cells. The downlink physical channel setup is according to Annex C.3.2 for each of Cell 1, Cell 2 and Cell 3, respectively.

Table 8.2.2.4-1: Test Parameters for Transmit diversity Performance (FRC) with TM3 interference model

Parameter		Unit	Cell 1	Cell 2	Cell 3
Downlink power allocation	ρ_A	dB	-3	-3	-3
	ρ_B	dB	-3 (Note 1)	-3	-3
	σ	dB	0	0	0
Cell-specific reference signals			Antenna ports 0,1	Antenna ports 0,1	Antenna ports 0,1
N_{oc} at antenna port		dBm/15kHz	-98	N/A	N/A
DIP (Note 2)		dB	N/A	-1.73	-8.66
$BW_{Channel}$		MHz	10	10	10
Cyclic Prefix			Normal	Normal	Normal
Cell Id			0	1	2
Number of control OFDM symbols			2	2	2
PDSCH transmission mode			2	N/A	N/A
Interference model			N/A	As specified in clause B.5.2	As specified in clause B.5.2
Probability of occurrence of transmission rank in interfering cells	Rank 1	%	N/A	80	80
	Rank 2	%	N/A	20	20
Reporting interval		ms	5	N/A	N/A
Reporting mode			PUCCH 1-0	N/A	N/A
ACK/NACK feedback mode			Multiplexing	N/A	N/A
Physical channel for CQI reporting			PUSCH(Note 5)	N/A	N/A
cqi-pmi-ConfigurationIndex			4	N/A	N/A
Note 1: $P_B = 1$					
Note 2: The respective received power spectral density of each interfering cell relative to N_{oc} is defined by its associated DIP value as specified in clause B.5.1.					
Note 3: Cell 1 is the serving cell. Cell 2, 3 are the interfering cells.					
Note 4: All cells are time-synchronous.					
Note 5: To avoid collisions between CQI reports and HARQ-ACK it is necessary to report both on PUSCH instead of PUCCH. PDCCH DCI format 0 shall be transmitted in downlink SF#4 and #9 to allow periodic CQI to multiplex with the HARQ-ACK on PUSCH in uplink subframe SF#8 and #3.					

Table 8.2.2.4-2: Enhanced Performance Requirement Type A, Transmit Diversity (FRC) with TM3 interference model

Test Number	Reference Channel	OCNG Pattern			Propagation Conditions			Correlation Matrix and Antenna Configuration (Note 3)	Reference Value		UE Category
		Cell 1	Cell 2	Cell 3	Cell 1	Cell 2	Cell 3		Fraction of Maximum Throughput (%)	SINR (dB) (Note 2)	
1	R.46 TDD	OP. 1 TD D	N/A	N/A	EV A70	EV A70	EV A70	2x2 Low	70	-1.4	≥ 1
Note 1: The propagation conditions for Cell 1, Cell 2 and Cell 3 are statistically independent.											
Note 2: SINR corresponds to \hat{E}_s / N_{oc} of Cell 1 as defined in clause 8.1.1.											
Note 3: Correlation matrix and antenna configuration parameters apply for each of Cell 1, Cell 2 and Cell 3.											

8.2.2.2.5 Minimum Requirement 2 Tx Antenna Port (when *EIMTA-MainConfigServCell-r12* is configured)

The requirements are specified in Table 8.2.2.2.5-2 with the addition of the parameters in Table 8.2.2.2.5-1 and the downlink physical channel setup according to Annex C.3.2. The test purpose is to verify the performance of transmit diversity (SFBC) with 2 transmitter antennas in case of using eIMTA TDD UL-DL reconfiguration for TDD serving cell(s) via monitoring PDCCH with eIMTA-RNTI on a PCell.

Table 8.2.2.2.5-1: Test Parameters for Transmit diversity Performance (FRC) when EIMTA-MainConfigServCell-r12 is configured

Parameter		Unit	Value
Downlink power allocation	ρ_A	dB	-3
	ρ_B	dB	-3 (Note 1)
	σ	dB	0
N_{oc} at antenna port		dBm/15kHz	-98
Uplink downlink configuration in SIB1 (Note 2)			0
Downlink HARQ reference configuration (eimta-HarqReferenceConfig-r12) (Note 2)			5
Set of dynamic TDD UL-DL configurations (NOTES 2,3)			{0, 1, 2, 3, 4, 5, 6}
Periodicity of monitoring the L1 reconfiguration DCI (eimta-CommandPeriodicity-r12)		ms	10
Set of subframes to monitor the L1 reconfiguration DCI (eimta-CommandSubframeSet-r12) (Note 4)			{0,1,5,6}
Number of DL HARQ processes		Processes	15
PDSCH transmission mode			2
ACK/NACK feedback mode (Note 5)			Multiplexing
Note 1: $P_B = 1$			
Note 2: As specified in Table 4.2-2 in TS 36.211.			
Note 3: UL/DL configuration in PDCCH with eIMTA-RNTI is randomly selected from the given set on a per-DCI basis with equal probability.			
Note 4: The set of subframes to monitor PDCCH with eIMTA-RNTI for frame n includes subframes {1,5,6} in frame n-1 and subframe 0 in frame n. Subframes for reconfiguration DCI transmission are chosen in a random way on a per-DCI basis with equal probability.			
Note 5: PUCCH Format 3 is used for DL HARQ feedback.			

Table 8.2.2.2.5-2: Minimum performance Transmit diversity when EIMTA-MainConfigServCell-r12 is configured

Test	Reference channel	OCNG Pattern	Propagation Conditions	Correlation Matrix and Antenna Configuration	Reference value		UE Category
					Fraction of Maximum Throughput (%)	SNR (dB)	
1	R.67 TDD	OP.1 TDD	EVA5	2x2 Medium	70	5.0	≥ 1

8.2.2.2.6 Enhanced Performance Requirement Type B - 2 Tx Antenna Ports with TM2 interference model

The requirements are specified in Table 8.2.2.2.6-2, with the addition of parameters in Table 8.2.2.2.6-1 and the downlink physical channel setup according to Annex C.3.2. The purpose is to verify the performance of transmit diversity (SFBC) with 2 transmit antennas when the PDSCH transmission in the serving cell is interfered by PDSCH of two interfering cells applying transmission mode 2 interference model defined in clause B.6.1. In Table 8.2.2.2.6-1, Cell 1 is the serving cell, and Cell 2, 3 are interfering cells. The downlink physical channel setup is according to Annex C.3.2 for each of Cell 1, Cell 2 and Cell 3, respectively.

Table 8.2.2.6-1: Test Parameters for Transmit Diversity Performance (FRC) with TM2 interference model

Parameter		Unit	Cell 1	Cell 2	Cell 3
Uplink downlink Configuration			1	1	1
Special subframe configuration			4	4	4
Downlink power allocation	ρ_A	dB	-3	-3	-3
	ρ_B	dB	-3 (Note 1)	-3	-3
	σ	dB	0	0	0
Cell-specific reference signals			Antenna ports 0,1	Antenna ports 0,1	Antenna ports 0,1
N_{oc} at antenna port		dBm/15kHz	-98		
\widehat{E}_s/N_{oc}		dB	N/A	13.91	3.34
BW _{Channel}		MHz	10	10	10
Cyclic Prefix			Normal	Normal	Normal
Cell Id			0	6	1
Number of control OFDM symbols in normal subframes			3	3	3
CFI indicated in PCFICH in normal subframes			3	3	3
Number of control OFDM symbols in special subframes			2	2	2
CFI indicated in PCFICH in special subframes			2	2	2
PDSCH transmission mode			2	2	2
Interference model			N/A	As specified in clause B.6.1	As specified in clause B.6.1
MBSFN			Not configured	Not configured	Not configured
Time offset to cell 1		us	N/A	2	3
Frequency offset to cell 1		Hz	N/A	200	300
NeighCellsInfo-r12 (Note 3)	p-aList-r12		N/A	{dB-6, dB-3, dB0}	{dB-6, dB-3, dB0}
	transmissionModelList-r12		N/A	{2,3,4,8,9}	{2,3,4,8,9}
Note 1: $P_B = 1$					
Note 2: Cell 1 is the serving cell. Cell 2, 3 are the interfering cells.					
Note 3: NeighCellsInfo-r12 is described in subclause 6.3.2 of [7].					

Table 8.2.2.6-2: Minimum Performance for Enhanced Performance Requirement Type B, Transmit Diversity (FRC) with TM2 interference model

Test Number	Reference Channel	OCNG Pattern			Propagation Conditions			Correlation Matrix and Antenna Configuration (Note 3)	Reference Value		UE Category
		Cell 1	Cell 2	Cell 3	Cell 1	Cell 2	Cell 3		Fraction of Maximum Throughput (%)	SNR (dB) (Note 2)	
1	R.11-12 TDD	OP. 1 TD D	N/A	N/A	EP A5	EP A5	EP A5	2x2 Low	85	15.3	≥1
Note 1: The propagation conditions for Cell 1, Cell 2 and Cell 3 are statistically independent.											
Note 2: SNR corresponds to \widehat{E}_s/N_{oc} of Cell 1 as defined in clause 8.1.1.											
Note 3: Correlation matrix and antenna configuration parameters apply for each of Cell 1, Cell 2 and Cell 3.											

8.2.2.2.7 Enhanced Performance Requirement Type B - 2 Tx Antenna Ports with TM9 interference model

The requirements are specified in Table 8.2.2.2.7-2, with the addition of parameters in Table 8.2.2.2.7-1 and the downlink physical channel setup according to Annex C.3.2. The purpose is to verify the performance of transmit diversity (SFBC) with 2 transmit antennas when the PDSCH transmission in the serving cell is interfered by PDSCH of two interfering cells applying transmission mode 9 interference model defined in clause B.6.4. In Table 8.2.2.2.7-1, Cell 1 is the serving cell, and Cell 2, 3 are interfering cells. The downlink physical channel setup is according to Annex C.3.2 for each of Cell 1, Cell 2 and Cell 3, respectively.

Table 8.2.2.2.7-1: Test Parameters for Transmit Diversity Performance (FRC) with TM9 interference model

Parameter		Unit	Cell 1	Cell 2	Cell 3
Uplink downlink Configuration			1	1	1
Special subframe configuration			4	4	4
Downlink power allocation	ρ_A	dB	-3	0	0
	ρ_B	dB	-3 (Note 1)	0	0
	σ	dB	0	-3	-3
Cell-specific reference signals			Antenna ports 0,1	Antenna ports 0,1	Antenna ports 0,1
N_{oc} at antenna port		dBm/15kHz	-98		
\bar{E}_s/N_{oc}		dB	N/A	3.28	0.74
BW _{Channel}		MHz	10	10	10
Cyclic Prefix			Normal	Normal	Normal
Cell Id			0	1	6
Number of control OFDM symbols in normal subframes			3	3	3
CFI indicated in PCFICH in normal subframes			3	Random from set {1,2,3}	Random from set {1,2,3}
Number of control OFDM symbols in special subframes			2	2	2
CFI indicated in PCFICH in special subframes			2	Random from set {1,2}	Random from set {1,2}
PDSCH transmission mode			2	9	9
Interference model			N/A	As specified in clause B.6.4	As specified in clause B.6.4
CSI reference signals			N/A	Antenna ports 15,16	Antenna ports 15,16
CSI-RS periodicity and subframe offset $T_{CSI-RS} / \Delta_{CSI-RS}$		Subframes	N/A	10 / 4	10 / 4
CSI reference signal configuration			N/A	6	7
Zero-power CSI-RS configuration $I_{CSI-RS} / ZeroPowerCSI-RS$ bitmap		Subframes / bitmap	N/A	9 / 010000000000 0000	9 / 001000000000 0000
Time offset to cell 1		us	N/A	5	-5
Frequency offset to cell 1		Hz	N/A	600	-600
MBSFN			Not configured	Not configured	Not configured
NeighCellsInfo-r12 (Note 4)	p-aList-r12		N/A	{dB-6, dB-3, dB0}	{dB-6, dB-3, dB0}
	transmissionModeList-r12		N/A	{2,3,4,8,9}	{2,3,4,8,9}
Note 1: $P_B = 1$					
Note 2: Cell 1 is the serving cell. Cell 2, 3 are the interfering cells.					
Note 3: CSI-RS configurations are according to [4] subclause 6.10.5.2.					
Note 4: NeighCellsInfo-r12 is described in subclause 6.3.2 of [7].					

Table 8.2.2.2.7-2: Minimum Performance for Enhanced Performance Requirement Type B, Transmit Diversity (FRC) with TM9 interference model

Test Number	Reference Channel	OCNG Pattern			Propagation Conditions			Correlation Matrix and Antenna Configuration (Note 3)	Reference Value		UE Category
		Cell 1	Cell 2	Cell 3	Cell 1	Cell 2	Cell 3		Fraction of Maximum Throughput (%)	SNR (dB) (Note 2)	
1	R.11-11 TDD	OP. 1 TD D	N/A	N/A	EP A5	EP A5	EP A5	2x2 Low	85	8.1	≥1

Note 1: The propagation conditions for Cell 1, Cell 2 and Cell 3 are statistically independent.

Note 2: SNR corresponds to \hat{E}_s/N_{oc} of Cell 1 as defined in clause 8.1.1.

Note 3: Correlation matrix and antenna configuration parameters apply for each of Cell 1, Cell 2 and Cell 3.

8.2.2.3 Open-loop spatial multiplexing performance

8.2.2.3.1 Minimum Requirement 2 Tx Antenna Port

For single carrier, the requirements are specified in Table 8.2.2.3.1-2, with the addition of the parameters in Table 8.2.2.3.1-1 and the downlink physical channel setup according to Annex C.3.2.

For CA with 2 DL CCs, the requirements are specified in Table 8.2.2.3.1-4, with the addition of the parameters in Table 8.2.2.3.1-3 and the downlink physical channel setup according to Annex C.3.2. The purpose is to verify the performance of large delay CDD with 2 transmitter antennas.

For CA with 3 DL CCs, the requirements are specified in Table 8.2.2.3.1-7, based on single carrier requirement specified in Table 8.2.2.3.1-5, with the addition of the parameters in Table 8.2.2.3.1-3 and the downlink physical channel setup according to Annex C.3.2.

For CA with 4 DL CCs, the requirements are specified in Table 8.2.2.3.1-8, based on single carrier requirement specified in Table 8.2.2.3.1-5, with the addition of the parameters in Table 8.2.2.3.1-3 and the downlink physical channel setup according to Annex C.3.2.

The test coverage for different number of component carriers is defined in 8.1.2.4.

Table 8.2.2.3.1-1: Test Parameters for Large Delay CDD (FRC)

Parameter	Unit	Test 1-3
Downlink power allocation	ρ_A	dB
	ρ_B	dB
	σ	dB
N_{oc} at antenna port	dBm/15kHz	-98
ACK/NACK feedback mode		Bundling
PD SCH transmission mode		3
Note 1: $P_B = 1$		
Note 2: Void.		
Note 3: Void.		

Table 8.2.2.3.1-2: Minimum performance Large Delay CDD (FRC)

Test number	Bandwidth	Reference Channel	OCNG Pattern	Propagation Condition	Correlation Matrix and Antenna Configuration	Reference value		UE Category
						Fraction of Maximum Throughput (%)	SNR (dB)	
1 (Note 2)	10 MHz	R.11-1 TDD	OP.1 TDD	EVA70	2x2 Low	70	13.1	≥2
2	10 MHz	R.35 TDD	OP.1 TDD	EVA200	2x2 Low	70	20.3	≥2
3	10 MHz	R.35-2 TDD	OP.1 TDD	ETU600	2x2 Low	70	21.1	≥2
Note 1:	Void.							
Note 2:	For UE that supports CRS interference handling, the CRS assistance information defined in [7] is provided. The CRS assistance information includes two aggressor cells with 2 CRS ports and cell ID of aggressor cells are 1 and 128. For UE that does not support CRS interference handling, CRS assistance information is not provided.							

Table 8.2.2.3.1-3: Test Parameters for Large Delay CDD (FRC) for CA

Parameter	Unit	Value
Downlink power allocation	ρ_A	dB
	ρ_B	dB
	σ	dB
N_{oc} at antenna port	dBm/15kHz	-98
ACK/NACK feedback mode		PUCCH format 1b with channel selection for Tests in Table 8.2.2.3.1-4; PUCCH format 3 for Tests in Table 8.2.2.3.1-7
PDSCH transmission mode		3
Note 1:	$P_B = 1$	
Note 2:	Void	
Note 3:	The same PDSCH transmission mode is applied to each component carrier.	

Table 8.2.2.3.1-4: Minimum performance Large Delay CDD (FRC) for CA with 2DL CCs

Test number	Bandwidth	Reference Channel	OCNG Pattern	Propagation Condition	Correlation Matrix and Antenna Configuration	Reference value		UE Category
						Fraction of Maximum Throughput (%)	SNR (dB)	
1	2x20 MHz	R.30-1 TDD	OP.1 TDD (Note 1)	EVA70	2x2 Low	70	13.7	≥5
2	20MHz+15M Hz	R.30-1 TDD for 20MHz CC	OP.1 TDD (Note 1)	EVA70	2x2 Low	70	13.0	≥5
		R.11-9 TDD for 15MHz CC	OP.1 TDD (Note 1)	EVA70		70	12.9	
Note 1:	The OCNG pattern applies for each CC.							
Note 2:	The applicability of requirements for different CA configurations and bandwidth combination sets is defined in 8.1.2.3.							

Table 8.2.2.3.1-5: Single carrier performance for multiple CA configurations

Bandwidth	Reference channel	OCNG pattern	Propagation condition	Correlation matrix and antenna config.	Reference value	
					Fraction of maximum	SNR (dB)

					throughput (%)	
1.4MHz	R.11-5 TDD	OP.1 TDD	EVA70	2x2 Low	70	13.2
3MHz	R.11-6 TDD	OP.1 TDD	EVA70	2x2 Low	70	12.8
5MHz	R.11-7 TDD	OP.1 TDD	EVA70	2x2 Low	70	12.6
10 MHz	R.11-8 TDD	OP.1 TDD	EVA70	2x2 Low	70	12.8
15MHz	R.11-9 TDD	OP.1 TDD	EVA70	2x2 Low	70	12.9
20MHz	R.30-1 TDD	OP. 1 TDD	EVA70	2x2 Low	70	13.0

Table 8.2.2.3.1-6: Void

Table 8.2.2.3.1-7: Minimum performance (FRC) based on single carrier performance for CA with 3 DL CCs

Test num.	CA Band-width combination	Requirement	UE category
1	3x20MHz	As specified in Table 8.2.2.3.1-5 per CC	≥5
2	20MHz+20MHz+15MHz	As specified in Table 8.2.2.3.1-5 per CC	≥5
Note 1: The applicability of requirements for different CA configurations and bandwidth combination sets is defined in 8.1.2.3			

Table 8.2.2.3.1-8: Minimum performance (FRC) based on single carrier performance for CA with 4 DL CCs

Test num.	CA Band-width combination	Requirement	UE category
1	4x20MHz	As specified in Table 8.2.2.3.1-5 per CC	≥8
2	20MHz+20MHz+20MHz+15MHz	As specified in Table 8.2.2.3.1-5 per CC	≥8
Note 1: The applicability of requirements for different CA configurations and bandwidth combination sets is defined in 8.1.2.3			

8.2.2.3.1A Soft buffer management test

For CA, the requirements are specified in Table 8.2.2.3.1A-2, with the addition of the parameters in Table 8.2.2.3.1A-1 and the downlink physical channel setup according to Annex C.3.2. The purpose is to verify UE performance with proper instantaneous buffer implementation.

Table 8.2.2.3.1A-1: Test Parameters for soft buffer management test (FRC) for CA

Parameter	Unit	Test 1-2
Downlink power allocation	ρ_A	-3
	ρ_B	-3 (Note 1)
	σ	0
N_{oc} at antenna port	dBm/15kHz	-98
ACK/NACK feedback mode		- (Note 2)
PDSCH transmission mode		3
Note 1: $P_B = 1$		
Note 2: PUCCH format 1b with channel selection is used to feedback ACK/NACK.		
Note 3: For CA test cases, the same PDSCH transmission mode is applied to each component carrier.		

Table 8.2.2.3.1A-2: Minimum performance soft buffer management test (FRC) for CA

Test number	Bandwidth	Reference Channel	OCNG Pattern	Propagation Condition	Correlation Matrix and Antenna Configuration	Reference value		UE Category
						Fraction of Maximum Throughput (%)	SNR (dB)	
1	2x20 MHz	R.30-2 TDD	OP.1 TDD (Note 1)	EVA70	2x2 Low	70	13.2	3
2	2x20 MHz	R.35-1 TDD	OP.1 TDD (Note 1)	EVA5	2x2 Low	70	15.7	4

Note 1: For CA test cases, the OCNG pattern applies for each CC.
Note 2: The applicability of requirements for different CA configurations and bandwidth combination sets is defined in 8.1.2.3.

8.2.2.3.1B Enhanced Performance Requirement Type C - 2Tx Antenna Ports

The requirements are specified in Table 8.2.2.3.1B-2, with the addition of the parameters in Table 8.2.2.3.1B-1 and the downlink physical channel setup according to Annex C.3.2. The purpose is to verify the performance of large delay CDD with 2 transmitter antennas.

Table 8.2.2.3.1B-1: Test Parameters for Large Delay CDD (FRC)

Parameter	Unit	Test 1
Downlink power allocation	ρ_A	dB
	ρ_B	dB
	σ	dB
N_{oc} at antenna port	dBm/15kHz	-98
ACK/NACK feedback mode		Bundling
PDSCH transmission mode		3
Note 1: $P_B = 1$		

Table 8.2.2.3.1B-2: Enhanced Performance Requirement Type C for Large Delay CDD (FRC)

Test number	Bandwidth	Reference Channel	OCNG Pattern	Propagation Condition	Correlation Matrix and Antenna Configuration	Reference value		UE Category
						Fraction of Maximum Throughput (%)	SNR (dB)	
1	10 MHz	R.11-1 TDD	OP.1 TDD	EVA70	2x2 Medium	70	17.4	≥ 2

8.2.2.3.1C Enhanced Performance Requirement Type C - 2 Tx Antenna Ports with TM1 interference

The requirements are specified in Table 8.2.2.3.1C-2, with the addition of parameters in Table 8.2.2.3.1C-1 and the downlink physical channel setup according to Annex C.3.2. The purpose is to verify the performance of open-loop spatial multiplexing performance with 2 transmit antennas when the PDSCH transmission in the serving cell is interfered by PDSCH of one dominant interfering cell with transmission mode 1. In Table 8.2.2.3.1C-1, Cell 1 is the serving cell, and Cell 2 is interfering cells. The downlink physical channel setup is according to Annex C.3.2 for each of Cell 1 and Cell 2 respectively.

Table 8.2.2.3.1C-1 Test parameters for Larger Delay CDD (FRC) with TM1 interference

Parameter		Unit	Cell 1	Cell 2
Bandwidth		MHz	10 MHz	
Downlink power allocation	ρ_A	dB	-3	0
	ρ_B		-3 (Note 1)	0
	σ		0	0
Cell-specific reference signals			Antenna ports 0,1	Antenna port 0
Cyclic Prefix			Normal	Normal
Cell ID			0	1
Transmission mode			3	Note 2
N_{oc} at antenna port		dBm/15kHz	-98	N/A
\hat{E}_s/N_{oc} (Note 3)		dB	Reference Value in Table 8.2.2.3.1C-2	12.95
Correlation and antenna configuration			Medium (2x2)	Medium(1x2)
Number of OFDM symbols for PDCCH			2	N/A
Max number of HARQ transmissions			4	N/A
Redundancy version coding sequence			{0,1,2,3}	N/A
Note 1: $P_B = 1$				
Note 2: Downlink physical channel setup in Cell 2 in accordance with Annex C.3.2 applying OCNB pattern OP.5 TDD as defined in Annex A.5.2.5.				
Note 3: Cell 1 is the serving cell. Cell 2 is the interfering cell.				
Note 4: All cells are time-synchronous.				
Note 5: SIB-1 will not be transmitted in Cell2 in this test.				

Table 8.2.2.3.1C-2 Enhanced Performance Requirement Type C, Larger Delay CDD (FRC) with TM1 interference

Test Number	Reference Channel	OCNB Pattern		Propagation Conditions (Note 1)		Reference Value		UE Category
		Cell 1	Cell 2	Cell 1	Cell 2	Fraction of Maximum Throughput (%)	SNR (dB) (Note 2)	
1	R.11-10 TDD	OP.1 TDD	OP.5 TDD	EVA70	EVA70	70	19.6	≥ 2
Note 1: The propagation conditions for Cell 1 and Cell 2 are statistically independent.								
Note 2: SNR corresponds to \hat{E}_s/N_{oc} of Cell 1.								

8.2.2.3.2 Minimum Requirement 4 Tx Antenna Port

The requirements are specified in Table 8.2.2.3.2-2, with the addition of the parameters in Table 8.2.2.3.2-1 and the downlink physical channel setup according to Annex C.3.2. The purpose is to verify the performance of large delay CDD with 4 transmitter antennas.

Table 8.2.2.3.2-1: Test Parameters for Large Delay CDD (FRC)

Parameter	Unit	Test 1
Downlink power allocation	ρ_A	dB
	ρ_B	dB
	σ	dB
N_{oc} at antenna port	dBm/15kHz	-98
ACK/NACK feedback mode		Bundling
PDSCH transmission mode		3
Note 1: $P_B = 1$.		

Table 8.2.2.3.2-2: Minimum performance Large Delay CDD (FRC)

Test number	Bandwidth	Reference Channel	OCNG Pattern	Propagation Condition	Correlation Matrix and Antenna Configuration	Reference value		UE Category
						Fraction of Maximum Throughput (%)	SNR (dB)	
1	10 MHz	R.14 TDD	OP.1 TDD	EVA70	4x2 Low	70	14.2	≥ 2

8.2.2.3.3 Minimum Requirement 2Tx antenna port (demodulation subframe overlaps with aggressor cell ABS)

The requirements for non-MBSFN ABS are specified in Table 8.2.2.3.3-2, with the addition of parameters in Table 8.2.2.3.3-1 and the downlink physical channel setup according to Annex C.3.2 and Annex C.3.3.

The requirements for MBSFN ABS are specified in Table 8.2.2.3.3-4, with the addition of parameters in Table 8.2.2.3.3-3 and the downlink physical channel setup according to Annex C.3.2 and Annex C.3.3.

The purpose is to verify the performance of large delay CDD with 2 transmitter antennas if the PDSCH transmission in the serving cell takes place in subframes that overlap with ABS [9] of the aggressor cell. In Tables 8.2.2.3.3-1 and 8.2.2.3.3-3, Cell 1 is the serving cell, and Cell 2 is the aggressor cell. The downlink physical channel setup for Cell 1 is according to Annex C.3.2 and for Cell 2 is according to Annex C.3.3, respectively.

Table 8.2.2.3.3-1: Test Parameters for Large Delay CDD (FRC) – Non-MBSFN ABS

Parameter	Unit	Cell 1	Cell 2
Uplink downlink configuration		1	1
Special subframe configuration		4	4
Downlink power allocation	ρ_A	dB	-3
	ρ_B	dB	-3 (Note 1)
	σ	dB	0
N_{oc} at antenna port	N_{oc1}	dBm/15kHz	-102 (Note 2)
	N_{oc2}	dBm/15kHz	-98 (Note 3)
	N_{oc3}	dBm/15kHz	-94.8 (Note 4)
\widehat{E}_s / N_{oc2}	dB	Reference Value in Table 8.2.2.3.3-2	6
$BW_{Channel}$	MHz	10	10
Subframe Configuration		Non-MBSFN	Non-MBSFN
Cell Id		0	1
Time Offset between Cells	μs	2.5 (synchronous cells)	
ABS pattern (Note 5)		N/A	0000010001, 0000000001
RLM/RRM Measurement Subframe Pattern (Note 6)		0000000001, 0000000001	N/A
CSI Subframe Sets (Note 7)	$C_{CSI,0}$	0000010001, 0000000001	N/A
	$C_{CSI,1}$	1100101000 1100111000	N/A
Number of control OFDM symbols		2	2
ACK/NACK feedback mode		Multiplexing	N/A
PDSCH transmission mode		3	N/A
Cyclic prefix		Normal	Normal
<p>Note 1: $P_B = 1$.</p> <p>Note 2: This noise is applied in OFDM symbols #1, #2, #3, #5, #6, #8, #9, #10, #12, #13 of a subframe overlapping with the aggressor ABS.</p> <p>Note 3: This noise is applied in OFDM symbols #0, #4, #7, #11 of a subframe overlapping with the aggressor ABS.</p> <p>Note 4: This noise is applied in all OFDM symbols of a subframe overlapping with aggressor non-ABS.</p> <p>Note 5: ABS pattern as defined in [9].</p> <p>Note 6: Time-domain measurement resource restriction pattern for PCell measurements as defined in [7].</p> <p>Note 7: As configured according to the time-domain measurement resource restriction pattern for CSI measurements defined in [7].</p> <p>Note 8: Cell 1 is the serving cell. Cell 2 is the aggressor cell. The number of the CRS ports in Cell1 and Cell2 is the same.</p> <p>Note 9: SIB-1 will not be transmitted in Cell2 in this test.</p>			

Table 8.2.2.3.3-2: Minimum Performance Large Delay CDD (FRC) – Non-MBSFN ABS

Test Number	Reference Channel	OCNG Pattern		Propagation Conditions (Note 1)		Correlation Matrix and Antenna Configuration	Reference Value		UE Category
		Cell 1	Cell 2	Cell 1	Cell 2		Fraction of Maximum Throughput (%) Note 5	SNR (dB) (Note 2)	
1	R.11 TDD Note 4	OP.1 TDD	OP.1 TDD	EVA 5	EVA 5	2x2 Low	70	14.0	≥2
<p>Note 1: The propagation conditions for Cell 1 and Cell2 are statistically independent.</p> <p>Note 2: SNR corresponds to \hat{E}_s / N_{oc2} of cell 1.</p> <p>Note 3: The correlation matrix and antenna configuration apply for Cell 1 and Cell 2.</p> <p>Note 4: Cell 1 Reference channel is modified: PDSCH other than SIB1/paging and its associated PDCCH/PCFICH are transmitted in the serving cell subframe when the subframe is overlapped with the ABS subframe of aggressor cell and the subframe is available in the definition of the reference channel.</p> <p>Note 5: The maximum Throughput is calculated from the total Payload in 2 subframes, averaged over 20ms.</p>									

Table 8.2.2.3.3-3: Test Parameters for Large Delay CDD (FRC) – MBSFN ABS

Parameter	Unit	Cell 1	Cell 2
Uplink downlink configuration		1	1
Special subframe configuration		4	4
Downlink power allocation	ρ_A	dB	-3
	ρ_B	dB	-3 (Note 1)
	σ	dB	0
N_{oc} at antenna port	N_{oc1}	dBm/15kHz	-102 (Note 2)
	N_{oc2}	dBm/15kHz	-98 (Note 3)
	N_{oc3}	dBm/15kHz	-94.8 (Note 4)
\widehat{E}_s / N_{oc2}	dB	Reference Value in Table 8.2.2.3.3-4	6
$BW_{Channel}$	MHz	10	10
Subframe Configuration		Non-MBSFN	MBSFN
Cell Id		0	126
Time Offset between Cells	μs	2.5 (synchronous cells)	
ABS pattern (Note 5)		N/A	0000000001 0000000001
RLM/RRM Measurement Subframe Pattern (Note 6)		0000000001 0000000001	N/A
CSI Subframe Sets (Note 7)	$C_{CSI,0}$	0000000001 0000000001	N/A
	$C_{CSI,1}$	1100111000 1100111000	N/A
MBSFN Subframe Allocation (Note 10)		N/A	000010
Number of control OFDM symbols		2	2
ACK/NACK feedback mode		Multiplexing	N/A
PDSCH transmission mode		3	N/A
Cyclic prefix		Normal	Normal
<p>Note 1: $P_B = 1$.</p> <p>Note 2: This noise is applied in OFDM symbols #1, #2, #3, #4, #5, #6, #7, #8, #9, #10, #11, #12, #13 of a subframe overlapping with the aggressor ABS.</p> <p>Note 3: This noise is applied in OFDM symbol #0 of a subframe overlapping with the aggressor ABS.</p> <p>Note 4: This noise is applied in all OFDM symbols of a subframe overlapping with aggressor non-ABS.</p> <p>Note 5: ABS pattern as defined in [9]. The 10th and 20th subframes indicated by ABS pattern are MBSFN ABS subframes.</p> <p>Note 6: Time-domain measurement resource restriction pattern for PCell measurements as defined in [7]</p> <p>Note 7: As configured according to the time-domain measurement resource restriction pattern for CSI measurements defined in [7].</p> <p>Note 8: Cell 1 is the serving cell. Cell 2 is the aggressor cell. The number of the CRS ports in Cell1 and Cell2 is the same.</p> <p>Note 9: SIB-1 will not be transmitted in Cell2 in this test.</p> <p>Note 10: MBSFN Subframe Allocation as defined in [7], one frame with 6 bits is chosen for MBSFN subframe allocation.</p>			

Table 8.2.2.3.3-4: Minimum Performance Large Delay CDD (FRC) – MBSFN ABS

Test Number	Reference Channel	OCNG Pattern		Propagation Conditions (Note 1)		Correlation Matrix and Antenna Configuration	Reference Value		UE Category
		Cell 1	Cell 2	Cell 1	Cell 2		Fraction of Maximum Throughput (%) Note 5	SNR (dB) (Note 2)	
1	R.11 TDD Note 4	OP.1 TDD	OP.1 TDD	EVA 5	EVA 5	2x2 Low	70	12.2	≥2
<p>Note 1: The propagation conditions for Cell 1 and Cell2 are statistically independent.</p> <p>Note 2: SNR corresponds to \hat{E}_s / N_{oc2} of cell 1.</p> <p>Note 3: The correlation matrix and antenna configuration apply for Cell 1 and Cell 2.</p> <p>Note 4: Cell 1 Reference channel is modified: PDSCH other than SIB1/paging and its associated PDCCH/PCFICH are transmitted in the serving cell subframe when the subframe is overlapped with the ABS subframe of aggressor cell and the subframe is available in the definition of the reference channel.</p> <p>Note 5: The maximum Throughput is calculated from the total Payload in 2 subframes, averaged over 20ms.</p>									

8.2.2.3.4 Minimum Requirement 2 Tx Antenna Port (demodulation subframe overlaps with aggressor cell ABS and CRS assistance information are configured)

The requirements for non-MBSFN ABS are specified in Table 8.2.2.3.4-2, with the addition of parameters in Table 8.2.2.3.4-1. The purpose is to verify the performance of large delay CDD with 2 transmitter antennas if the PDSCH transmission in the serving cell takes place in subframes that overlap with ABS [9] of the aggressor cell with CRS assistance information. In Table 8.2.2.3.4-1, Cell 1 is the serving cell, and Cell 2 and Cell3 are the aggressor cells. The downlink physical channel setup for Cell 1 is according to Annex C.3.2 and for Cell 2 and Cell 3 is according to Annex C.3.3, respectively. The CRS assistance information [7] includes Cell 2 and Cell 3.

Table 8.2.2.3.4-1: Test Parameters for Large Delay CDD (FRC) – Non-MBSFN ABS

Parameter		Unit	Cell 1	Cell 2	Cell 3
Uplink downlink configuration			1	1	1
Special subframe configuration			4	4	4
Downlink power allocation	ρ_A	dB	-3	-3	-3
	ρ_B	dB	-3 (Note 1)	-3 (Note 1)	-3 (Note 1)
	σ	dB	0	N/A	N/A
N_{oc} at antenna port	N_{oc1}	dBm/15kHz	-98 (Note 2)	N/A	N/A
	N_{oc2}	dBm/15kHz	-98 (Note 3)	N/A	N/A
	N_{oc3}	dBm/15kHz	-93 (Note 4)	N/A	N/A
\hat{E}_s / N_{oc2}		dB	Reference Value in Table 8.2.2.3.4-2	Reference Value in Table 8.2.2.3.4-2	Reference Value in Table 8.2.2.3.4-2
BW _{Channel}		MHz	10	10	10
Subframe Configuration			Non-MBSFN	Non-MBSFN	Non-MBSFN
Time Offset between Cells		μs	N/A	3	-1
Frequency shift between Cells		Hz	N/A	300	-100
Cell Id			0	1	126
ABS pattern (Note 5)			N/A	0000000001 0000000001	0000000001 0000000001
RLM/RRM Measurement Subframe Pattern (Note 6)			0000000001 0000000001	N/A	N/A
CSI Subframe Sets (Note7)	C _{CSI,0}		0000000001 0000000001	N/A	N/A
	C _{CSI,1}		1100111000 1100111000	N/A	N/A
Number of control OFDM symbols			2	Note 8	Note 8
ACK/NACK feedback mode			Multiplexing	N/A	N/A
PDSCH transmission mode			3	Note 9	Note 9
Cyclic prefix			Normal	Normal	Normal
<p>Note 1: $P_B = 1$.</p> <p>Note 2: This noise is applied in OFDM symbols #1, #2, #3, #5, #6, #8, #9, #10, #12, #13 of a subframe overlapping with the aggressor ABS.</p> <p>Note 3: This noise is applied in OFDM symbols #0, #4, #7, #11 of a subframe overlapping with the aggressor ABS.</p> <p>Note 4: This noise is applied in all OFDM symbols of a subframe overlapping with aggressor non-ABS</p> <p>Note 5: ABS pattern as defined in [9].</p> <p>Note 6: Time-domain measurement resource restriction pattern for PCell measurements as defined in [7]</p> <p>Note 7: As configured according to the time-domain measurement resource restriction pattern for CSI measurements defined in [7].</p> <p>Note 8: The number of control OFDM symbols is not available for ABS and is 2 for the subframe indicated by "0" of ABS pattern.</p> <p>Note 9: Downlink physical channel setup in Cell 2 and Cell 3 in accordance with Annex C.3.3 applying OCN pattern as defined in Annex A.5.</p> <p>Note 10: The number of the CRS ports in Cell1, Cell2 and Cell 3 is the same.</p> <p>Note 11: SIB-1 will not be transmitted in Cell2 and Cell 3 in this test.</p>					

Table 8.2.2.3.4-2: Minimum Performance Large Delay CDD (FRC) – Non-MBSFN ABS

Test Number	Reference Channel	\hat{E}_s/N_{oc2}		OCNG Pattern			Propagation Conditions (Note1)			Correlation Matrix and Antenna Configuration (Note 2)	Reference Value		UE Category
		Cell 2	Cell 3	Cell 1	Cell 2	Cell 3	Cell 1	Cell 2	Cell 3		Fraction of Maximum Throughput (%) Note 5	SNR (dB) (Note 3)	
1	R.11 TDD Note 4	9	7	OP.1 TDD	OP.1 TDD	OP.1 TDD	EVA5	EVA5	EVA5	2x2 Low	70	14.2	≥ 2
2	R.35 TDD Note 4	9	1	OP.1 TDD	OP.1 TDD	OP.1 TDD	EVA5	EVA5	EVA5	2x2 Low	70	22.7	≥ 2

Note 1: The propagation conditions for Cell 1, Cell 2 and Cell 3 are statistically independent.

Note 2: The correlation matrix and antenna configuration apply for Cell 1, Cell 2 and Cell 3.

Note 3: SNR corresponds to \hat{E}_s/N_{oc2} of cell 1.

Note 4: Cell 1 Reference channel is modified: PDSCH other than SIB1/paging and its associated PDCCH/PCFICH are transmitted in the serving cell subframe when the subframe is overlapped with the ABS subframe of aggressor cell and the subframe is available in the definition of the reference channel.

Note 5: The maximum Throughput is calculated from the total Payload in 2 subframes, averaged over 20ms.

8.2.2.4 Closed-loop spatial multiplexing performance

8.2.2.4.1 Minimum Requirement Single-Layer Spatial Multiplexing 2 Tx Antenna Port

The requirements are specified in Table 8.2.2.4.1-2, with the addition of the parameters in Table 8.2.2.4.1-1 and the downlink physical channel setup according to Annex C.3.2. The purpose of these tests is to verify the closed loop rank-one performance with wideband and frequency selective precoding.

Table 8.2.2.4.1-1: Test Parameters for Single-Layer Spatial Multiplexing (FRC)

Parameter	Unit	Test 1	Test 2
Downlink power allocation	ρ_A	dB	-3
	ρ_B	dB	-3 (Note 1)
	σ	dB	0
N_{oc} at antenna port	dBm/15kHz	-98	-98
Precoding granularity	PRB	6	50
PMI delay (Note 2)	ms	10 or 11	10 or 11
Reporting interval	ms	1 or 4 (Note 3)	1 or 4 (Note 3)
Reporting mode		PUSCH 1-2	PUSCH 3-1
CodeBookSubsetRestriction bitmap		001111	001111
ACK/NACK feedback mode		Multiplexing	Multiplexing
PDSCH transmission mode		4	4
Note 1: $P_B = 1$.			
Note 2: If the UE reports in an available uplink reporting instance at subframe SF#n based on PMI estimation at a downlink SF not later than SF#(n-4), this reported PMI cannot be applied at the eNB downlink before SF#(n+4).			
Note 3: For Uplink - downlink configuration 1 the reporting interval will alternate between 1ms and 4ms.			

Table 8.2.2.4.1-2: Minimum performance Single-Layer Spatial Multiplexing (FRC)

Test number	Bandwidth	Reference Channel	OCNG Pattern	Propagation Condition	Correlation Matrix and Antenna Configuration	Reference value		UE Category
						Fraction of Maximum Throughput (%)	SNR (dB)	
1	10 MHz	R.10 TDD	OP.1 TDD	EVA5	2x2 Low	70	-3.1	≥1
2	10 MHz	R.10 TDD	OP.1 TDD	EPA5	2x2 High	70	-2.8	≥1

8.2.2.4.1A Minimum Requirement Single-Layer Spatial Multiplexing 4 Tx Antenna Port

The requirements are specified in Table 8.2.2.4.1A-2, with the addition of the parameters in Table 8.2.2.4.1A-1 and the downlink physical channel setup according to Annex C.3.2. The purpose of these tests is to verify the closed loop rank-one performance with wideband and frequency selective precoding.

Table 8.2.2.4.1A-1: Test Parameters for Single-Layer Spatial Multiplexing (FRC)

Parameter	Unit	Test 1
Downlink power allocation	ρ_A	dB
	ρ_B	dB
	σ	dB
N_{oc} at antenna port	dBm/15kHz	-98
Precoding granularity	PRB	6
PMI delay (Note 2)	ms	10 or 11
Reporting interval	ms	1 or 4 (Note 3)
Reporting mode		PUSCH 1-2
CodeBookSubsetRestriction bitmap		0000000000000000 0000000000000000 0000000000000011 11111111111111
ACK/NACK feedback mode		Multiplexing
PDSCH transmission mode		4
Note 1: $P_B = 1$. Note 2: If the UE reports in an available uplink reporting instance at subframe SF#n based on PMI estimation at a downlink SF not later than SF#(n-4), this reported PMI cannot be applied at the eNB downlink before SF#(n+4). Note 3: For Uplink - downlink configuration 1 the reporting interval will alternate between 1ms and 4ms.		

Table 8.2.2.4.1A-2: Minimum performance Single-Layer Spatial Multiplexing (FRC)

Test number	Bandwidth	Reference Channel	OCNG Pattern	Propagation Condition	Correlation Matrix and Antenna Configuration	Reference value		UE Category
						Fraction of Maximum Throughput (%)	SNR (dB)	
1	10 MHz	R.13 TDD	OP.1 TDD	EVA5	4x2 Low	70	-3.5	≥1

8.2.2.4.1B Enhanced Performance Requirement Type A – Single-Layer Spatial Multiplexing 2 Tx Antenna Port with TM4 interference model

The requirements are specified in Table 8.2.2.4.1B-2, with the addition of the parameters in Table 8.2.2.4.1B-1 and the downlink physical channel setup according to Annex C.3.2. The purpose of these tests is to verify the closed loop rank-

one performance with wideband precoding with two transmit antennas when the PDSCH transmission in the serving cell is interfered by PDSCH of two dominant interfering cells applying transmission mode 4 interference model defined in clause B.5.3. In Table 8.2.2.4.1B-1, Cell 1 is the serving cell, and Cell 2, 3 are interfering cells. The downlink physical channel setup is according to Annex C.3.2 for each of Cell 1, Cell 2 and Cell 3, respectively.

Table 8.2.2.4.1B-1: Test Parameters for Single-Layer Spatial Multiplexing (FRC) with TM4 interference model

Parameter		Unit	Cell 1	Cell 2	Cell 3
Downlink power allocation	ρ_A	dB	-3	-3	-3
	ρ_B	dB	-3 (Note 1)	-3	-3
	σ	dB	0	0	0
Cell-specific reference signals			Antenna ports 0,1	Antenna ports 0,1	Antenna ports 0,1
N_{oc} at antenna port		dBm/15kHz	-98	N/A	N/A
DIP (Note 2)		dB	N/A	-1.73	-8.66
$BW_{Channel}$		MHz	10	10	10
Cyclic Prefix			Normal	Normal	Normal
Cell Id			0	1	2
Number of control OFDM symbols			2	2	2
PDSCH transmission mode			6	N/A	N/A
Interference model			N/A	As specified in clause B.5.3	As specified in clause B.5.3
Probability of occurrence of transmission rank in interfering cells	Rank 1	%	N/A	80	80
	Rank 2	%	N/A	20	20
Precoding granularity		PRB	50	6	6
PMI delay (Note 4)		ms	10 or 11	N/A	N/A
Reporting interval		ms	5	N/A	N/A
Reporting mode			PUCCH 1-1	N/A	N/A
CodeBookSubsetRestriction bitmap			1111	N/A	N/A
ACK/NACK feedback mode			Multiplexing	N/A	N/A
Physical channel for CQI reporting			PUSCH(Note 6)	N/A	N/A
cqi-pmi-ConfigurationIndex			4	N/A	N/A
<p>Note 1: $P_B = 1$</p> <p>Note 2: The respective received power spectral density of each interfering cell relative to N_{oc} is defined by its associated DIP value as specified in clause B.5.1.</p> <p>Note 3: Cell 1 is the serving cell. Cell 2, 3 are the interfering cells.</p> <p>Note 4: If the UE reports in an available uplink reporting instance at subframe SF#n based on PMI estimation at a downlink SF not later than SF#(n-4), this reported PMI cannot be applied at the eNB downlink before SF#(n+4).</p> <p>Note 5: All cells are time-synchronous.</p> <p>Note 6: To avoid collisions between CQI reports and HARQ-ACK it is necessary to report both on PUSCH instead of PUCCH. PDCCH DCI format 0 shall be transmitted in downlink SF#4 and #9 to allow periodic CQI to multiplex with the HARQ-ACK on PUSCH in uplink subframe SF#8 and #3.</p>					

Table 8.2.2.4.1B-2: Enhanced Performance Requirement Type A, Single-Layer Spatial Multiplexing (FRC) with TM4 interference model

Test Number	Reference Channel	OCNG Pattern			Propagation Conditions			Correlation Matrix and Antenna Configuration (Note 3)	Reference Value		UE Category
		Cell 1	Cell 2	Cell 3	Cell 1	Cell 2	Cell 3		Fraction of Maximum Throughput (%)	SINR (dB) (Note 2)	
1	R.47 TDD	OP. 1 TD D	N/A	N/A	EV A5	EV A5	EV A5	2x2 Low	70	1.1	≥1

Note 1: The propagation conditions for Cell 1, Cell 2 and Cell 3 are statistically independent.

Note 2: SINR corresponds to \hat{E}_s / N_{oc} of Cell 1 as defined in clause 8.1.1.

Note 3: Correlation matrix and antenna configuration parameters apply for each of Cell 1, Cell 2 and Cell 3.

8.2.2.4.1C Minimum Requirement Single-Layer Spatial Multiplexing 2 Tx Antenna Ports (demodulation subframe overlaps with aggressor cell ABS and CRS assistance information are configured)

The requirements are specified in Table 8.2.2.4.1C-2, with the addition of parameters in Table 8.2.2.4.1C-1. The purpose is to verify the closed loop rank-one performance with wideband precoding if the PDSCH transmission in the serving cell takes place in subframes that overlap with ABS [9] of the aggressor cell with CRS assistance information. In Table 8.2.2.4.1C-1, Cell 1 is the serving cell, and Cell 2 and Cell 3 are the aggressor cells. The downlink physical channel setup for Cell 1 is according to Annex C.3.2 and for Cell 2 and Cell 3 is according to Annex C.3.3, respectively. The CRS assistance information [7] includes Cell 2 and Cell 3.

Table 8.2.2.4.1C-1: Test Parameters for Single-Layer Spatial Multiplexing (FRC) – Non-MBSFN ABS

Parameter		Unit	Cell 1	Cell 2	Cell 3
Uplink downlink configuration			1	1	1
Special subframe configuration			4	4	4
Downlink power allocation	ρ_A	dB	-3	-3	-3
	ρ_B	dB	-3 (Note 1)	-3 (Note 1)	-3 (Note 1)
	σ	dB	0	N/A	N/A
N_{oc} at antenna port	N_{oc1}	dBm/15kHz	-98 (Note 2)	N/A	N/A
	N_{oc2}	dBm/15kHz	-98 (Note 3)	N/A	N/A
	N_{oc3}	dBm/15kHz	-93 (Note 4)	N/A	N/A
\hat{E}_s / N_{oc2}		dB	Reference Value in Table 8.2.2.4.1C-2	12	10
$BW_{Channel}$		MHz	10	10	10
Subframe Configuration			Non-MBSFN	Non-MBSFN	Non-MBSFN
Time Offset between Cells		μ s	N/A	3	-1
Frequency shift between Cells		Hz	N/A	300	-100
Cell Id			0	126	1
ABS pattern (Note 5)			N/A	0000000001 0000000001	0000000001 0000000001
RLM/RRM Measurement Subframe Pattern (Note 6)			0000000001 0000000001	N/A	N/A
CSI Subframe Sets (Note7)	$C_{CSI,0}$		0000000001 0000000001	N/A	N/A
	$C_{CSI,1}$		1100111000 1100111000	N/A	N/A
Number of control OFDM symbols			2	Note 8	Note 8
ACK/NACK feedback mode			Multiplexing	N/A	N/A
PDSCH transmission mode			6	Note 9	Note 9
Precoding granularity		PRB	50	N/A	N/A
PMI delay (Note 10)		ms	10 or 11	N/A	N/A
Reporting interval		ms	1 or 4 (Note 11)	N/A	N/A
Reporting mode			PUSCH 3-1	N/A	N/A
CodeBookSubsetRestriction bitmap			1111	N/A	N/A
Cyclic prefix			Normal	Normal	Normal
<p>Note 1: $P_B = 1$.</p> <p>Note 2: This noise is applied in OFDM symbols #1, #2, #3, #5, #6, #8, #9, #10, #12, #13 of a subframe overlapping with the aggressor ABS.</p> <p>Note 3: This noise is applied in OFDM symbols #0, #4, #7, #11 of a subframe overlapping with the aggressor ABS.</p> <p>Note 4: This noise is applied in all OFDM symbols of a subframe overlapping with aggressor non-ABS</p> <p>Note 5: ABS pattern as defined in [9].</p> <p>Note 6: Time-domain measurement resource restriction pattern for PCell measurements as defined in [7]</p> <p>Note 7: As configured according to the time-domain measurement resource restriction pattern for CSI measurements defined in [7].</p> <p>Note 8: The number of control OFDM symbols is not available for ABS and is 2 for the subframe indicated by "0" of ABS pattern.</p> <p>Note 9: Downlink physical channel setup in Cell 2 and Cell 3 in accordance with Annex C.3.3 applying OCNG pattern as defined in Annex A.5.</p> <p>Note 10: If the UE reports in an available uplink reporting instance at subframe SF#n based on PMI estimation at a downlink SF not later than SF#(n-4), this reported PMI cannot be applied at the eNB downlink before SF#(n+4).</p> <p>Note 11: For Uplink - downlink configuration 1 the reporting interval will alternate between 1ms and 4ms.</p> <p>Note 12: The number of the CRS ports in Cell 1, Cell 2 and Cell 3 is the same.</p> <p>Note 13: SIB-1 will not be transmitted in Cell 2 and Cell 3 in this test.</p>					

Table 8.2.2.4.1C-2: Minimum Performance Single-Layer Spatial Multiplexing (FRC)– Non-MBSFN ABS

Test Number	Reference Channel	OCNG Pattern			Propagation Conditions (Note1)			Correlation Matrix and Antenna Configuration (Note 2)	Reference Value		UE Category
		Cell 1	Cell 2	Cell 3	Cell 1	Cell 2	Cell 3		Fraction of Maximum Throughput (%) Note 5	SNR (dB) (Note 3)	
1	R.11 TDD Note 4	OP.1 TDD	OP.1 FDD	OP.1 TDD	EPA5	EPA5	EPA5	2x2 High	70	6.4	≥2
<p>Note 1: The propagation conditions for Cell 1, Cell 2 and Cell 3 are statistically independent.</p> <p>Note 2: The correlation matrix and antenna configuration apply for Cell 1, Cell 2 and Cell 3.</p> <p>Note 3: SNR corresponds to \hat{E}_s / N_{oc2} of cell 1.</p> <p>Note 4: Cell 1 Reference channel is modified: PDSCH other than SIB1/paging and its associated PDCCH/PCFICH are transmitted in the serving cell subframe when the subframe is overlapped with the ABS subframe of aggressor cell and the subframe is available in the definition of the reference channel.</p> <p>Note 5: The maximum Throughput is calculated from the total Payload in 2 subframes, averaged over 20ms.</p>											

8.2.2.4.1D Enhanced Performance Requirement Type B - Single-layer Spatial Multiplexing 2 Tx Antenna Port with TM4 interference model

The requirements are specified in Table 8.2.2.4.1D-2, with the addition of the parameters in Table 8.2.2.4.1D-1 and the downlink physical channel setup according to Annex C.3.2. The purpose of these tests is to verify the closed loop rank-one performance with wideband precoding with two transmit antennas when the PDSCH transmission in the serving cell is interfered by PDSCH of two interfering cells applying transmission mode 4 interference model defined in clause B.6.3. In Table 8.2.2.4.1D-1, Cell 1 is the serving cell, and Cell 2, 3 are interfering cells. The downlink physical channel setup is according to Annex C.3.2 for each of Cell 1, Cell 2 and Cell 3, respectively.

Table 8.2.2.4.1D-1: Test Parameters for Single-layer Spatial Multiplexing (FRC) with TM4 interference model

Parameter		Unit	Cell 1	Cell 2		Cell 3	
Uplink downlink Configuration			1	1		1	
Special subframe configuration			4	4		4	
Downlink power allocation	ρ_A	dB	-3	-3		-3	
	ρ_B	dB	-3 (Note 1)	-3		-3	
	σ	dB	0	0		0	
Cell-specific reference signals			Antenna ports 0,1	Antenna ports 0,1		Antenna ports 0,1	
N_{oc} at antenna port		dBm/15 kHz	-98				
Test number (Note 4)				Test 1	Test 2	Test 1	Test 2
\hat{E}_s/N_{oc}		dB	N/A	13.91	3.28	3.34	0.74
Cell Id				6	1	1	6
CFI indicated in PCFICH in normal subframes				3	Random from set {1,2,3}	3	Random from set {1,2,3}
CFI indicated in PCFICH in special subframes				2	Random from set {1,2}	2	Random from set {1,2}
BW _{Channel}		MHz	10	10		10	
Cyclic Prefix			Normal	Normal		Normal	
Number of control OFDM symbols in normal subframes			3	3		3	
Number of control OFDM symbols in special subframes			2	2		2	
PDSCH transmission mode			4	4		4	
Interference model			N/A	As specified in clause B.6.3		As specified in clause B.6.3	
Precoding			Random wideband precoding per TTI	As specified in clause B.6.3		As specified in clause B.6.3	
Time offset to cell 1		us	N/A	2		3	
Frequency offset to cell 1		Hz	N/A	200		300	
MBSFN			Not configured	Not configured		Not configured	
NeighCellsInfo-r12 (Note 3)	p-aList-r12		N/A	{dB-6, dB-3, dB0}		{dB-6, dB-3, dB0}	
	transmissionModeList-r12		N/A	{2,3,4,8,9}		{2,3,4,8,9}	
Note 1: $P_b = 1$							
Note 2: Cell 1 is the serving cell. Cell 2, 3 are the interfering cells.							
Note 3: NeighCellsInfo-r12 is described in subclause 6.3.2 of [7].							
Note 4: Test 1 and Test 2 are defined in Table 8.2.2.4.1D-2.							

Table 8.2.2.4.1D-2: Minimum Performance for Enhanced Performance Requirement Type B, Single-layer Spatial Multiplexing (FRC) with TM4 interference model

Test Num	Reference Channel	OCNG Pattern			Propagation Conditions			Correlation Matrix and Antenna Configuration (Note 3)	Reference Value		UE Category
		Cell 1	Cell 2	Cell 3	Cell 1	Cell 2	Cell 3		Fraction of Maximum Throughput (%)	SNR (dB) (Note 2)	
1	R.11-12 TDD	OP.1 TDD	N/A	N/A	EVA 5	EVA 5	EVA 5	2x2 Low	85	16.1	≥1
2	R.11-11 TDD	OP.1 TDD	N/A	N/A	EPA 5	EPA 5	EPA 5	2x2 Low	85	9.5	≥1

Note 1: The propagation conditions for Cell 1, Cell 2 and Cell 3 are statistically independent.

Note 2: SNR corresponds to \hat{E}_s/N_{oc} of Cell 1 as defined in clause 8.1.1.

Note 3: Correlation matrix and antenna configuration parameters apply for each of Cell 1, Cell 2 and Cell 3.

8.2.2.4.1E Minimum Requirement Single-Layer Spatial Multiplexing 2 Tx Antenna Ports with CRS assistance information

The requirements are specified in Table 8.2.2.4.1E-2, with the addition of parameters in Table 8.2.2.4.1E-1. The purpose is to verify the closed loop rank-one performance with wideband precoding when CRS assistance information [7] is configured. In Table 8.2.2.4.1E-1, Cell 1 is the serving cell, and Cell 2 and Cell 3 are the aggressor cells. The downlink physical channel setup is according to Annex C.3.2 for each of Cell 1, Cell 2 and Cell 3, respectively. The CRS assistance information [7] includes Cell 2 and Cell 3.

Table 8.2.2.4.1E-1: Test Parameters for Single-Layer Spatial Multiplexing (FRC)

Parameter	Unit	Cell 1	Cell 2	Cell 3
Uplink downlink configuration		1	1	1
Special subframe configuration		4	4	4
Downlink power allocation	ρ_A	dB	-3	-3
	ρ_B	dB	-3 (Note 1)	-3 (Note 1)
	σ	dB	0	0

N_{oc} at antenna port		dBm/15kHz	-98	N/A	N/A
\bar{E}_s/N_{oc}		dB	Reference Value in Table 8.2.2.4.1E-2	10.45	4.6
BW _{Channel}		MHz	10	10	10
Subframe Configuration			Non-MBSFN	Non-MBSFN	Non-MBSFN
Time Offset to Cell 1		μs	N/A	3	-1
Frequency shift to Cell 1		Hz	N/A	300	-100
Cell Id			0	1	128
Cell-specific reference signals			Antenna ports 0,1		
Number of control OFDM symbols			2	2	2
Interference model			N/A	As specified in clause B.5.3	As specified in clause B.5.3
Probability of occurrence of transmission in interference cells		%	N/A	20	20
Probability of occurrence of transmission rank in interfering cells	Rank 1	%	N/A	80	80
	Rank 2	%	N/A	20	20
ACK/NACK feedback mode			Multiplexing	N/A	N/A
PDSCH transmission mode			4	N/A	N/A
Precoding granularity		PRB	50	N/A	N/A
PMI delay (Note 2)		ms	10 or 11	N/A	N/A
Reporting interval		ms	1 or 4 (Note 3)	N/A	N/A
Reporting mode			PUSCH 3-1	N/A	N/A
CodeBookSubsetRestriction bitmap			001111	N/A	N/A
Cyclic prefix			Normal	Normal	Normal
<p>Note 1: $P_B = 1$.</p> <p>Note 2: If the UE reports in an available uplink reporting instance at subframe SF#n based on PMI estimation at a downlink SF not later than SF#(n-4), this reported PMI cannot be applied at the eNB downlink before SF#(n+4).</p> <p>Note 3: For Uplink - downlink configuration 1 the reporting interval will alternate between 1ms and 4ms.</p>					

Table 8.2.2.4.1E-2: Minimum Performance Single-Layer Spatial Multiplexing (FRC)

Test Number	Reference Channel	OCNG Pattern			Propagation Conditions (Note1)			Correlation Matrix and Antenna Configuration (Note 2)	Reference Value		UE Category
		Cell 1	Cell 2	Cell 3	Cell 1	Cell 2	Cell 3		Fraction of Maximum Throughput (%)	SNR (dB) (Note 3)	
1	R.10-3 TDD	OP.1 TDD	N/A	N/A	EVA5	EVA5	EVA5	2x2 Low	70	11.2	≥2
<p>Note 1: The propagation conditions for Cell 1, Cell 2 and Cell 3 are statistically independent.</p> <p>Note 2: The correlation matrix and antenna configuration apply for Cell 1, Cell 2 and Cell 3.</p> <p>Note 3: SNR corresponds to \bar{E}_s/N_{oc} of cell 1.</p>											

8.2.2.4.2 Minimum Requirement Multi-Layer Spatial Multiplexing 2 Tx Antenna Port

The requirements are specified in Table 8.2.2.4.2-2, with the addition of the parameters in Table 8.2.2.4.2-1 and the downlink physical channel setup according to Annex C.3.2. The purpose of these tests is to verify the closed loop rank-two performance with wideband and frequency selective precoding.

Table 8.2.2.4.2-1: Test Parameters for Multi-Layer Spatial Multiplexing (FRC)

Parameter	Unit	Test 1-2	Test 3
Downlink power allocation	ρ_A	dB	-3
	ρ_B	dB	-3 (Note 1)
	σ	dB	0
N_{oc} at antenna port	dBm/15kHz	-98	-98
Precoding granularity	PRB	50	8
PMI delay (Note 2)	ms	10 or 11	10 or 11
Reporting interval	ms	1 or 4 (Note 3)	1 or 4 (Note 3)
Reporting mode		PUSCH 3-1	PUSCH 1-2
ACK/NACK feedback mode		Bundling	Bundling
CodeBookSubsetRestriction bitmap		110000	110000
PDSCH transmission mode		4	4
Number of OFDM symbols for PDCCH per component carrier	OFDM symbol	2	1
Note 1: $P_B = 1$. Note 2: If the UE reports in an available uplink reporting instance at subframe SF#n based on PMI estimation at a downlink SF not later than SF#(n-4), this reported PMI cannot be applied at the eNB downlink before SF#(n+4). Note 3: For Uplink - downlink configuration 1 the reporting interval will alternate between 1ms and 4ms.			

Table 8.2.2.4.2-2: Minimum performance Multi-Layer Spatial Multiplexing (FRC)

Test number	Bandwidth	Reference Channel	OCNG Pattern	Propagation Condition	Correlation Matrix and Antenna Configuration	Reference value		UE Category	UE DL category
						Fraction of Maximum Throughput (%)	SNR (dB)		
1	10 MHz	R.35 TDD	OP.1 TDD	EPA5	2x2 Low	70	19.5	≥ 2	≥ 6
2	10 MHz	R.11-1 TDD	OP.1 TDD	ETU70	2x2 Low	70	13.9	≥ 2	≥ 6
3	20 MHz 256QAM	R. 65 TDD	OP.1 TDD	EVA5	2x2 Low	70	24.9	11-12	≥ 11

8.2.2.4.2A Enhanced Performance Requirement Type C Multi-Layer Spatial Multiplexing 2 Tx Antenna Port

The requirements are specified in Table 8.2.2.4.2A-2, with the addition of the parameters in Table 8.2.2.4.2A-1 and the downlink physical channel setup according to Annex C.3.2. The purpose of these tests is to verify the closed loop rank-two performance with wideband precoding.

Table 8.2.2.4.2A-1: Test Parameters for Multi-Layer Spatial Multiplexing (FRC)

Parameter	Unit	Test 1	
Downlink power allocation	ρ_A	dB	-3
	ρ_B	dB	-3 (Note 1)
	σ	dB	0
N_{oc} at antenna port	dBm/15kHz	-98	
Precoding granularity	PRB	50	
PMI delay (Note 2)	ms	10 or 11	
Reporting interval	ms	1 or 4 (Note 3)	
Reporting mode		PUSCH 3-1	
ACK/NACK feedback mode		Bundling	
CodeBookSubsetRestriction bitmap		110000	
PDSCH transmission mode		4	
Note 1: $P_B = 1$.			
Note 2: If the UE reports in an available uplink reporting instance at subframe SF#n based on PMI estimation at a downlink SF not later than SF#(n-4), this reported PMI cannot be applied at the eNB downlink before SF#(n+4).			
Note 3: For Uplink - downlink configuration 1 the reporting interval will alternate between 1ms and 4ms.			

Table 8.2.2.4.2A-2: Enhanced Performance Requirement Type C for Multi-Layer Spatial Multiplexing (FRC)

Test number	Bandwidth	Reference Channel	OCNG Pattern	Propagation Condition	Correlation Matrix and Antenna Configuration	Reference value		UE Category
						Fraction of Maximum Throughput (%)	SNR (dB)	
1	10 MHz	R.11-1 TDD	OP.1 TDD	ETU70	2x2 Medium	70	17.8	≥ 2

8.2.2.4.3 Minimum Requirement Multi-Layer Spatial Multiplexing 4 Tx Antenna Port

For single carrier, the requirements are specified in Table 8.2.2.4.3-2, with the addition of the parameters in Table 8.2.2.4.3-1 and the downlink physical channel setup according to Annex C.3.2.

For CA with 2 DL CCs, the requirements are specified in Table 8.2.2.4.3-4, with the addition of the parameters in Table 8.2.2.4.3-3 and the downlink physical channel setup according to Annex C.3.2. The purpose of these tests is to verify the closed loop rank-two performance with wideband and frequency selective precoding.

For CA with 3 DL CCs, the requirements are specified in Table 8.2.2.4.3-7, based on single carrier requirement specified in Table 8.2.2.4.3-5, with the addition of the parameters in Table 8.2.2.4.3-3 and the downlink physical channel setup according to Annex C.3.2.

For CA with 4 DL CCs, the requirements are specified in Table 8.2.2.4.3-8, based on single carrier requirement specified in Table 8.2.2.4.3-5, with the addition of the parameters in Table 8.2.2.4.3-3 and the downlink physical channel setup according to Annex C.3.2.

The test coverage for different number of component carriers is defined in 8.1.2.4.

Table 8.2.2.4.3-1: Test Parameters for Multi-Layer Spatial Multiplexing (FRC)

Parameter	Unit	Test 1	
Downlink power allocation	ρ_A	dB	-6
	ρ_B	dB	-6 (Note 1)
	σ	dB	3
N_{oc} at antenna port	dBm/15kHz	-98	
Precoding granularity	PRB	6	
PMI delay (Note 2)	ms	10 or 11	
Reporting interval	ms	1 or 4 (Note 3)	
Reporting mode		PUSCH 1-2	
ACK/NACK feedback mode		Bundling	
CodeBookSubsetRestriction bitmap		00000000000000000000000000000000 00001111111111111111111100000000 00000000	
PDSCH transmission mode		4	
Note 1: $P_B = 1$. Note 2: If the UE reports in an available uplink reporting instance at subframe SF#n based on PMI estimation at a downlink SF not later than SF#(n-4), this reported PMI cannot be applied at the eNB downlink before SF#(n+4) Note 3: For Uplink - downlink configuration 1 the reporting interval will alternate between 1ms and 4ms. Note 4: Void. Note 5: Void. Note 6: Void.			

Table 8.2.2.4.3-2: Minimum performance Multi-Layer Spatial Multiplexing (FRC)

Test number	Bandwidth	Reference Channel	OCNG Pattern	Propagation Condition	Correlation Matrix and Antenna Configuration	Reference value		UE Category
						Fraction of Maximum Throughput (%)	SNR (dB)	
1	10 MHz	R.36 TDD	OP.1 TDD	EPA5	4x2 Low	70	15.7	≥ 2
Note 1: Void								

Table 8.2.2.4.3-3: Test Parameters for Multi-Layer Spatial Multiplexing (FRC) for CA

Parameter	Unit	Value	
Downlink power allocation	ρ_A	dB	-6
	ρ_B	dB	-6 (Note 1)
	σ	dB	3
N_{oc} at antenna port	dBm/15kHz	-98	
Precoding granularity	PRB	8	
PMI delay (Note 2)	ms	10 or 11	
Reporting interval	ms	1 or 4 (Note 3)	
Reporting mode		PUSCH 1-2	
ACK/NACK feedback mode		PUCCH format 1b with channel selection for Tests in Table 8.2.2.4.3-4; PUCCH format 3 for Tests in Table 8.2.2.4.3-7 and Table 8.2.2.4.3-8.	
CodeBookSubsetRestriction bitmap		00000000000000000000000000000000 00001111111111111111111100000000 00000000	
CSI request field (Note 4)		'10'	
PDSCH transmission mode		4	
Note 1: $P_B = 1$. Note 2: If the UE reports in an available uplink reporting instance at subframe SF#n based on PMI estimation at a downlink SF not later than SF#(n-4), this reported PMI cannot be applied at the eNB downlink before SF#(n+4) Note 3: For Uplink - downlink configuration 1 the reporting interval will alternate between 1ms and 4ms. Note 4: Multiple CC-s under test are configured as the 1 st set of serving cells by high layers. Note 5: The same PDSCH transmission mode is applied to each component carrier.			

Table 8.2.2.4.3-4: Minimum performance Multi-Layer Spatial Multiplexing (FRC) for CA with 2DL CCs

Test number	Bandwidth	Reference Channel	OCNG Pattern	Propagation Condition	Correlation Matrix and Antenna Configuration	Reference value		UE Category
						Fraction of Maximum Throughput (%)	SNR (dB)	
1	2x20 MHz	R.43 TDD	OP.1 TDD (Note 1)	EVA5	4x2 Low	70	11.1	≥5
2	20MHz +15MHz z	R.43 TDD for 20MHz CC	OP.1 TDD (Note 1)	EVA5	4x2 Low	70	10.7	≥5
		R.43-5 TDD for 15MHz CC	OP.1 TDD (Note 1)				10.6	
Note 1: The OCNG pattern applies for each CC. Note 2: The applicability of requirements for different CA configurations and bandwidth combination sets is defined in 8.1.2.3.								

Table 8.2.2.4.3-5: Single carrier performance for multiple CA configurations

Band-width	Reference channel	OCNG pattern	Propagation condition	Correlation matrix and antenna config.	Reference value	
					Fraction of maximum throughput (%)	SNR (dB)
1.4MHz	R.43-1 TDD	OP.1 TDD	EVA5	4x2 Low	70	11.0
3MHz	R.43-2 TDD	OP.1 TDD	EVA5	4x2 Low	70	9.8
5MHz	R.43-3 TDD	OP.1 TDD	EVA5	4x2 Low	70	10.0
10 MHz	R.43-4 TDD	OP.1 TDD	EVA5	4x2 Low	70	10.5
15MHz	R.43-5 TDD	OP.1 TDD	EVA5	4x2 Low	70	10.6
20MHz	R.43 TDD	OP. 1 TDD	EVA5	4x2 Low	70	10.7

Table 8.2.2.4.3-6: Void**Table 8.2.2.4.3-7: Minimum performance (FRC) based on single carrier performance for CA with 3 DL CCs**

Test num.	CA Band-width combination	Requirement	UE category
1	3x20MHz	As specified in Table 8.2.2.4.3-5 per CC	≥5
2	20MHz+20MHz+15MHz	As specified in Table 8.2.2.4.3-5 per CC	≥5
Note 1: The applicability of requirements for different CA configurations and bandwidth combination sets is defined in 8.1.2.3			

Table 8.2.2.4.3-8: Minimum performance (FRC) based on single carrier performance for CA with 4 DL CCs

Test num.	CA Band-width combination	Requirement	UE category
1	4x20MHz	As specified in Table 8.2.2.4.3-5 per CC	≥8
2	20MHz+20MHz+20MHz+15MHz	As specified in Table 8.2.2.4.3-5 per CC	≥8
Note 1: The applicability of requirements for different CA configurations and bandwidth combination sets is defined in 8.1.2.3			

8.2.2.4.3A Minimum Requirement Multi-Layer Spatial Multiplexing 4 Tx Antenna Port for dual connectivity

For dual connectivity the requirements are specified in Table 8.2.2.4.3A-3, for 2DL CCs, in Table 8.2.2.4.3A-4 for 3DL CCs, and Table 8.2.2.4.3A-5 for 4DL CCs, based on single carrier requirement specified in Table 8.2.2.4.3A-2, with the addition of the parameters in Table 8.2.2.4.3A-1 and the downlink physical channel setup according to Annex C.3.2. The purpose of these tests is to verify the closed loop rank-two performance with wideband and frequency selective precoding by using dual connectivity.

Table 8.2.2.4.3A-1: Test Parameters for Multi-Layer Spatial Multiplexing (FRC) for dual connectivity

Parameter	Unit	Value	
Downlink power allocation	ρ_A	dB	-6
	ρ_B	dB	-6 (Note 1)
	σ	dB	3
N_{oc} at antenna port	dBm/15kHz	-98	
Precoding granularity	PRB	6 for 1.4MHz, 4 for 3MHz and 5MHz CCs, 6 for 10MHz CCs, and 8 for 15MHz CCs and 20MHz CCs	
PMI delay (Note 2)	ms	10 or 11	
Reporting interval	ms	1 or 4 (Note 3)	
Reporting mode		PUSCH 1-2	
CodeBookSubsetRestriction bitmap		00000000000000000000000000000000 00001111111111111111100000000 00000000	
PDSCH transmission mode		4	
ACK/NACK transmission		Separate ACK/NACK feedbacks with PUCCH format 1b on the MCG and SCG	
CSI feedback		Separate PUSCH feedbacks on the MCG and SCG	
Time offset between MCG CC and SCG CC	μ s	0 for UE under test supporting synchronous dual connectivity; 334 for UE under test supporting both asynchronous and synchronous dual connectivity (Note 5)	
Note 1: $P_B = 1$. Note 2: If the UE reports in an available uplink reporting instance at subframe SF#n based on PMI estimation at a downlink SF not later than SF#(n-4), this reported PMI cannot be applied at the eNB downlink before SF#(n+4) Note 3: For Uplink - downlink configuration 1 the reporting interval will alternate between 1ms and 4ms. Note 4: The same PDSCH transmission mode is applied to each component carrier. Note 5: As defined in TS36.300 [11]. Note 6: If the UE supports both SCG bearer and Split bearer, the SCG bearer is configured.			

Table 8.2.2.4.3A-2: Single carrier performance for multiple dual connectivity configurations

Band-width	Reference channel	OCNG pattern	Propa- gation condi- tion	Correlation matrix and antenna config.	Reference value	
					Fraction of maximum throughput (%)	SNR (dB)
1.4MHz	R.43-1 TDD	OP.1 TDD	EVA5	4x2 Low	70	11.0
3MHz	R.43-2 TDD	OP.1 TDD	EVA5	4x2 Low	70	9.8
5MHz	R.43-3 TDD	OP.1 TDD	EVA5	4x2 Low	70	10.0
10 MHz	R.43-4 TDD	OP.1 TDD	EVA5	4x2 Low	70	10.5
15MHz	R.43-5 TDD	OP.1 TDD	EVA5	4x2 Low	70	10.6
20MHz	R.43 TDD	OP. 1 TDD	EVA5	4x2 Low	70	10.7

Table 8.2.2.4.3A-3: Minimum performance Multi-Layer Spatial Multiplexing (FRC) for dual connectivity

Test num.	Band-width combination	Requirement	UE category
-----------	------------------------	-------------	-------------

1	2x20 MHz	As specified in Table 8.2.2.4.3A-2 per CC	≥5
Note 1: The OCNG pattern applies for each CC. Note 2: The applicability of requirements for different dual connectivity configurations and bandwidth combination sets is defined in 8.1.2.3A.			

Table 8.2.2.4.3A-4: Minimum performance Multi-Layer Spatial Multiplexing (FRC) for dual connectivity

Test num.	Band-width combination	Requirement	UE category
1	3x20 MHz	As specified in Table 8.2.2.4.3A-2 per CC	≥5
Note 1: The OCNG pattern applies for each CC. Note 2: The applicability of requirements for different dual connectivity configurations and bandwidth combination sets is defined in 8.1.2.3A.			

Table 8.2.2.4.3A-5: Minimum performance Multi-Layer Spatial Multiplexing (FRC) for dual connectivity

Test num.	Band-width combination	Requirement	UE category
1	4x20 MHz	As specified in Table 8.2.2.4.3A-2 per CC	≥8
2	15+20+20+20MHz	As specified in Table 8.2.2.4.3A-2 per CC	≥8
Note 1: The OCNG pattern applies for each CC. Note 2: The applicability of requirements for different dual connectivity configurations and bandwidth combination sets is defined in 8.1.2.3A.			

8.2.2.4.4 Void

8.2.2.5 MU-MIMO

8.2.2.6 [Control channel performance: D-BCH and PCH]

8.2.2.7 Carrier aggregation with power imbalance

The requirements in this section verify the ability of an intraband adjacent carrier aggregation UE to demodulate the signal transmitted by the PCell or SCell in the presence of a stronger SCell or PCell signal on an adjacent frequency. Throughput is measured on the PCell or SCell only.

8.2.2.7.1 Minimum Requirement

For CA, the requirements are specified in Table 8.2.2.7.1-2, with the addition of the parameters in Table 8.2.2.7.1-1 and the downlink physical channel setup according to Annex C.3.2.

Table 8.2.2.7.1-1: Test Parameters for CA

Parameter		Unit	Test 1	Test 2
Downlink power allocation	ρ_A	dB	0	0
	ρ_B	dB	0 (Note 1)	0 (Note 1)
	σ	dB	0	0
N_{oc} at antenna port		dBm/15kHz	Off (Note 2)	Off (Note 2)
Symbols for unused PRBs			OCNG (Note 3)	OCNG (Note 3)
Modulation			64 QAM	64 QAM
Maximum number of HARQ transmission			1	1
Redundancy version coding sequence			{0}	{0}
PDSCH transmission mode of PCell			1	3
PDSCH transmission mode of SCell			3	1
OCNG Pattern	PCell		OP.1 TDD	OP.5 TDD
	SCell		OP.5 TDD	OP.1 TDD
Propagation Conditions	PCell		Clause B.1	Clause B.1
	SCell		Clause B.1	Clause B.1
Correlation Matrix and Antenna	PCell		1x2	2x2
	SCell		2x2	1x2
Note 1: $P_B = 0$ for 1x2 and $P_B = 1$ for 2x2 antenna configuration.				
Note 2: No external noise sources are applied.				
Note 3: These physical resource blocks are assigned to an arbitrary number of virtual UEs with one PDSCH per virtual UE; the data transmitted over the OCNG PDSCHs shall be uncorrelated pseudo random data.				
Note 4: Void.				

Table 8.2.2.7.1-2: Minimum performance (FRC) for CA

Test Number	Bandwidth (MHz)		Reference channel		Power at antenna port (dBm/15KHz)		Reference value Fraction of Maximum Throughput (%)		UE Category
	PCell	SCell	PCell	SCell	\hat{E}_{s_PCell} for PCell	\hat{E}_{s_SCell} for SCell	PCell	SCell	
1	20	20	R.49 TDD	NA	-85	-79	85	NA	≥ 5
2	20	15	NA	R.49-1 TDD	-79	-85.8	NA	85	≥ 5
Note 1: The OCNG pattern for PCell is used to fill the control channel. The OCNG pattern for SCell is used to fill the control channel and PDSCH.									
Note 2: The applicability of requirements for different CA configurations and bandwidth combination sets is defined in 8.1.2.3.									

8.2.2.8 Intra-band contiguous carrier aggregation with minimum channel spacing

The requirements in this section verify the ability of an UE supporting intraband contiguous carrier aggregation with minimum channel spacing to demodulate the signal transmitted by the PCell and SCell(s). Throughput is measured on each cell. The minimum channel spacing of intra-band contiguous carrier aggregation refers to the possible minimum channel spacing as any multiple of 300 kHz less than the nominal channel spacing defined in 5.7.1A.

8.2.2.8.1 Minimum Requirement

For CA the requirements are specified in Table 8.2.2.8.1-2, with the addition of the parameters in Table 8.2.2.8.1-1 and the downlink physical channel setup according to Annex C.3.2.

Table 8.2.2.8.1-1: Test Parameters for CA

Parameter		Unit	Test 1-2
Downlink power allocation	ρ_A	dB	0
	ρ_B	dB	0 (Note 1)
	σ	dB	0
N_{oc} at antenna port		dBm/15kHz	-98
Symbols for unused PRBs			OCNG (Note 2)
Modulation			64QAM
ACK/NACK feedback mode			PUCCH format 1b with channel selection for Test 1; PUCCH format 3 for Test 2
PDSCH transmission mode			1
Note 1: $P_B = 0$			
Note 2: These physical resource blocks are assigned to an arbitrary number of virtual UEs with one PDSCH per virtual UE; the data transmitted over the OCNG PDSCHs shall be uncorrelated pseudo random data, which is QPSK modulated.			
Note 3: The same PDSCH transmission mode is applied to each component carrier.			

Table 8.2.2.8.1-2: Minimum performance (FRC) for intra-band CA with minimum channel spacing

Test number	Bandwidth	Reference Channel	OCNG Pattern	Propagation Condition	Correlation Matrix and Antenna Configuration	Reference value		UE Category
						Fraction of Maximum Throughput (%)	SNR (dB)	
1	2x20MHz	R.9 TDD	OP.1 TDD (Note 1)	EVA5	1x2 Low	70	17.16	≥ 5
		R.9 TDD	OP.1 TDD (Note 1)			70	17.16	
2	3x20MHz	R.9 TDD	OP.1 TDD (Note 1)	EVA5	1x2 Low	70	17.16	≥ 5
		R.9 TDD	OP.1 TDD (Note 1)			70	17.16	
		R.9 TDD	OP.1 TDD (Note 1)			70	17.16	
Note 1: The OCNG pattern applies for each CC.								
Note 2: The applicability and test rules of requirements for different CA configurations and bandwidth combination sets are defined in 8.1.2.3.								

8.2.3 TDD FDD CA (Fixed Reference Channel)

The parameters specified in Table 8.2.3-1 are valid for all the TDD FDD CA tests unless otherwise stated.

Table 8.2.3-1: Common Test Parameters

Parameter		Unit	Value
Uplink downlink configuration (Note 1) for TDD CC only			1
Special subframe configuration (Note 2) for TDD CC only			4
Inter-TTI Distance			1
Maximum number of HARQ processes per component carrier	FDD PCell	Processes	8 for FDD and TDD CCs
	TDD PCell	Processes	11 for FDD CC; 7 for TDD CC
Maximum number of HARQ transmission			4
Redundancy version coding sequence			{0,1,2,3} for QPSK and 16QAM {0,0,1,2} for 64QAM
Number of OFDM symbols for PDCCH per component carrier		OFDM symbols	4 for 1.4 MHz bandwidth, 3 for 3 MHz and 5 MHz bandwidths, 2 for 10 MHz, 15 MHz and 20 MHz bandwidths
Cyclic Prefix			Normal
Cell_ID			0
Cross carrier scheduling			Not configured
ACK/NACK feedback mode			PUCCH format 3
Downlink HARQ-ACK timing	FDD PCell		As specified in Clause 7.3.3 in TS36.213 [6]
	TDD PCell		As specified in Clause 7.3.4 in TS36.213 [6]
Note 1: as specified in Table 4.2-2 in TS 36.211 [4].			
Note 2: as specified in Table 4.2-1 in TS 36.211 [4].			

The applicability of the requirements are specified in Clause 8.1.2.3. The single carrier performance with different bandwidths for multiple CA configurations specified in Clause 8.2.3 cannot be applied for UE single carrier test.

8.2.3.1 Single-antenna port performance

The single-antenna performance in a given multi-path fading environments is determined by the SNR for which a certain relative information bit throughput of the reference measurement channels in Annex A.3.3 is achieved. The purpose of these tests is to verify the single-antenna performance with different channel models and MCS.

8.2.3.1.1 Minimum Requirement for FDD PCell

For TDD FDD CA with FDD PCell and 2DL CCs, the requirements are specified in Table 8.2.3.1.1-4 based on single carrier requirement specified in Table 8.2.3.1.1-2 and Table 8.2.3.1.1-3, with the addition of the parameters in Table 8.2.3.1.1-1 and the downlink physical channel setup according to Annex C.3.2.

For TDD FDD CA with FDD PCell and 3DL CCs, the requirements are specified in Table 8.2.3.1.1-5 based on single carrier requirement specified in Table 8.2.3.1.1-2 and Table 8.2.3.1.1-3, with the addition of the parameters in Table 8.2.3.1.1-1 and the downlink physical channel setup according to Annex C.3.2.

For TDD FDD CA with FDD PCell and 4DL CCs, the requirements are specified in Table 8.2.3.1.1-6 based on single carrier requirement specified in Table 8.2.3.1.1-2 and Table 8.2.3.1.1-3, with the addition of the parameters in Table 8.2.3.1.1-1 and the downlink physical channel setup according to Annex C.3.2.

For TDD FDD CA with FDD PCell and 5DL CCs, the requirements are specified in Table 8.2.3.1.1-7 based on single carrier requirement specified in Table 8.2.3.1.1-2 and Table 8.2.3.1.1-3, with the addition of the parameters in Table 8.2.3.1.1-1 and the downlink physical channel setup according to Annex C.3.2.

The test coverage for different number of component carriers is defined in 8.1.2.4.

Table 8.2.3.1.1-1: Test Parameters for CA

Parameter		Unit	Value
Downlink power allocation	ρ_A	dB	0
	ρ_B	dB	0 (Note 1)
	σ	dB	0
N_{oc} at antenna port		dBm/15kHz	-98
Symbols for unused PRBs			OCNG (Note 2)
Modulation			QPSK
PDSCH transmission mode			1
Note 1: $P_B = 0$.			
Note 2: These physical resource blocks are assigned to an arbitrary number of virtual UEs with one PDSCH per virtual UE; the data transmitted over the OCNG PDSCHs shall be uncorrelated pseudo random data, which is QPSK modulated.			
Note 3: The same PDSCH transmission mode is applied to each component carrier.			

Table 8.2.3.1.1-2: Single carrier performance with different bandwidths for multiple CA configurations for FDD PCell and SCell (FRC)

Band-width	Reference Channel	OCNG Pattern	Propagation Condition	Correlation Matrix and Antenna Configuration	Reference value	
					Fraction of Maximum Throughput (%)	SNR (dB)
1.4 MHz	R.4 FDD	OP.1 FDD	EVA5	1x2 Low	70	-1.3
3 MHz	R.42-1 FDD	OP.1 FDD	EVA5	1x2 Low	70	-1.1
5MHz	R.42-2 FDD	OP.1 FDD	EVA5	1x2 Low	70	-1.0
10MHz	R.2 FDD	OP.1 FDD	EVA5	1x2 Low	70	-1.7
15MHz	R.42-3 FDD	OP.1 FDD	EVA5	1x2 Low	70	-1.6
20MHz	R.42 FDD	OP.1 FDD	EVA5	1x2 Low	70	-1.7

Table 8.2.3.1.1-3: Single carrier performance with different bandwidths for multiple CA configurations for TDD SCell (FRC)

Band-width	Reference Channel	OCNG Pattern	Propagation Condition	Correlation Matrix and Antenna Configuration	Reference value	
					Fraction of Maximum Throughput (%)	SNR (dB)
1.4 MHz	R.4 TDD	OP.1 TDD	EVA5	1x2 Low	70	-0.6
3 MHz	R.42-1 TDD	OP.1 TDD	EVA5	1x2 Low	70	-0.8
5MHz	R.42-2 TDD	OP.1 TDD	EVA5	1x2 Low	70	-1.2
10MHz	R.2 TDD	OP.1 TDD	EVA5	1x2 Low	70	-1.6
15MHz	R.42-3 TDD	OP.1 TDD	EVA5	1x2 Low	70	-1.4
20MHz	R.42 TDD	OP.1 TDD	EVA5	1x2 Low	70	-1.4

Table 8.2.3.1.1-4: Minimum performance for multiple CA configurations with 2DL CCs (FRC)

Test number	CA Bandwidth combination (MHz)			Minimum performance requirement	UE Category
	Total	FDD CC	TDD CC		
1	2x20	20	20	As defined in Table 8.2.3.1.1-2 and Table 8.2.3.1.1-3 per CC	≥5
2	20+10	10	20	As defined in Table 8.2.3.1.1-2 and Table 8.2.3.1.1-3 per CC	≥5
3	20+15	15	20	As defined in Table 8.2.3.1.1-2 and Table 8.2.3.1.1-3 per CC	≥5
Note 1:	The applicability of requirements for different CA configurations and bandwidth combination sets is defined in 8.1.2.3B.				
Note 2:	30usec timing difference between PCell and any SCell is applied in inter-band CA case, where PCell can be assigned on any FDD CC.				

Table 8.2.3.1.1-5: Minimum performance for multiple CA configurations with 3DL CCs (FRC)

Test number	CA Bandwidth combination (MHz)			Minimum performance requirement	UE Category
	Total	FDD CC	TDD CC		
1	3x20	20	2x20	As defined in Table 8.2.3.1.1-2 and Table 8.2.3.1.1-3 per CC	≥5
2	20+20+15	15	2x20	As defined in Table 8.2.3.1.1-2 and Table 8.2.3.1.1-3 per CC	≥5
3	20+20+10	10	2x20	As defined in Table 8.2.3.1.1-2 and Table 8.2.3.1.1-3 per CC	≥5
4	3x20	2x20	20	As defined in Table 8.2.3.1.1-2 and Table 8.2.3.1.1-3 per CC	≥5
5	20+20+15	20+15	20	As defined in Table 8.2.3.1.1-2 and Table 8.2.3.1.1-3 per CC	≥5
6	20+20+10	20+10	20	As defined in Table 8.2.3.1.1-2 and Table 8.2.3.1.1-3 per CC	≥5
7	20+10+10	2x10	20	As defined in Table 8.2.3.1.1-2 and Table 8.2.3.1.1-3 per CC	≥5
Note 1:	The applicability of requirements for different CA configurations and bandwidth combination sets is defined in 8.1.2.3B.				
Note 2:	30usec timing difference between PCell and any SCell is applied in inter-band CA case, where PCell can be assigned on any FDD CC.				

Table 8.2.3.1.1-6: Minimum performance for multiple CA configurations with 4DL CCs (FRC)

Test number	CA Bandwidth combination (MHz)			Minimum performance requirement	UE Category
	Total	FDD CC	TDD CC		
1	4x20	20	3x20	As defined in Table 8.2.3.1.1-2 and Table 8.2.3.1.1-3 per CC	≥8
2	4x20	2x20	2x20	As defined in Table 8.2.3.1.1-2 and Table 8.2.3.1.1-3 per CC	≥8
3	3x20+15	20+15	2x20	As defined in Table 8.2.3.1.1-2 and Table 8.2.3.1.1-3 per CC	≥8
4	2x15+2x20	2x15	2x20	As defined in Table 8.2.3.1.1-2 and Table 8.2.3.1.1-3 per CC	≥8
5	3x20+15	2x20+15	20	As defined in Table 8.2.3.1.1-2 and Table 8.2.3.1.1-3 per CC	≥8
6	2x15+2x20	2x15+20	20	As defined in Table 8.2.3.1.1-2 and Table 8.2.3.1.1-3 per CC	≥8
7	3x20+10	2x20+10	20	As defined in Table 8.2.3.1.1-2 and Table 8.2.3.1.1-3 per CC	≥8
Note 1:	The applicability of requirements for different CA configurations and bandwidth combination sets is defined in 8.1.2.3B.				
Note 2:	30usec timing difference between PCell and any SCell is applied in inter-band CA case, where PCell can be assigned on any CC.				

Table 8.2.3.1.1-7: Minimum performance for multiple CA configurations with 5DL CCs (FRC)

Test number	CA Bandwidth combination (MHz)			Minimum performance requirement	UE Category
	Total	FDD CC	TDD CC		
1	15+4x20	15+2x20	2x20	As defined in Table 8.2.3.1.1-2 and Table 8.2.3.1.1-3 per CC	8, ≥11
2	2x15+3x20	2x15+20	2x20	As defined in Table 8.2.3.1.1-2 and Table 8.2.3.1.1-3 per CC	8, ≥11
Note 1:	The applicability of requirements for different CA configurations and bandwidth combination sets is defined in 8.1.2.3B.				
Note 2:	30usec timing difference between PCell and any SCell is applied in inter-band CA case, where PCell can be assigned on any CC.				

8.2.3.1.2 Minimum Requirement for TDD PCell

For TDD FDD CA with TDD PCell and 2DL CCs, the requirements are specified in Table 8.2.3.1.2-4 based on single carrier requirement specified in Table 8.2.3.1.2-2 and Table 8.2.3.1.2-3, with the addition of the parameters in Table 8.2.3.1.2-1 and the downlink physical channel setup according to Annex C.3.2.

For TDD FDD CA with TDD PCell with 3DL CCs, the requirements are specified in Table 8.2.3.1.2-5 based on single carrier requirement specified in Table 8.2.3.1.2-2 and Table 8.2.3.1.2-3, with the addition of the parameters in Table 8.2.3.1.2-1 and the downlink physical channel setup according to Annex C.3.2.

For TDD FDD CA with TDD PCell with 4DL CCs, the requirements are specified in Table 8.2.3.1.2-6 based on single carrier requirement specified in Table 8.2.3.1.2-2 and Table 8.2.3.1.2-3, with the addition of the parameters in Table 8.2.3.1.2-1 and the downlink physical channel setup according to Annex C.3.2.

For TDD FDD CA with TDD PCell with 5DL CCs, the requirements are specified in Table 8.2.3.1.2-7 based on single carrier requirement specified in Table 8.2.3.1.2-2 and Table 8.2.3.1.2-3, with the addition of the parameters in Table 8.2.3.1.2-1 and the downlink physical channel setup according to Annex C.3.2.

The test coverage for different number of component carriers is defined in 8.1.2.4.

Table 8.2.3.1.2-1: Test Parameters for CA

Parameter	Unit	Value
Downlink power allocation	ρ_A	dB
	ρ_B	dB
	σ	dB
N_{oc} at antenna port	dBm/15kHz	-98
Symbols for unused PRBs		OCNG (Note 2)
Modulation		QPSK
PDSCH transmission mode		1
Note 1: $P_B = 0$.		
Note 2: These physical resource blocks are assigned to an arbitrary number of virtual UEs with one PDSCH per virtual UE; the data transmitted over the OCNG PDSCHs shall be uncorrelated pseudo random data, which is QPSK modulated.		
Note 3: The same PDSCH transmission mode is applied to each component carrier.		

Table 8.2.3.1.2-2: Single carrier performance with different bandwidths for multiple CA configurations for FDD SCell (FRC)

Band-width	Reference Channel	OCNG Pattern	Propagation Condition	Correlation Matrix and Antenna Configuration	Reference value	
					Fraction of Maximum Throughput (%)	SNR (dB)
1.4 MHz	R.4 FDD	OP.1 FDD	EVA5	1x2 Low	70	-1.3
3 MHz	R.42-1 FDD	OP.1 FDD	EVA5	1x2 Low	70	-1.1
5MHz	R.42-2 FDD	OP.1 FDD	EVA5	1x2 Low	70	-1.0
10MHz	R.2 FDD	OP.1 FDD	EVA5	1x2 Low	70	-1.7
15MHz	R.42-3 FDD	OP.1 FDD	EVA5	1x2 Low	70	-1.6
20MHz	R.42 FDD	OP.1 FDD	EVA5	1x2 Low	70	-1.7

Table 8.2.3.1.2-3: Single carrier performance with different bandwidths for multiple CA configurations for TDD PCell and SCell (FRC)

Band-width	Reference Channel	OCNG Pattern	Propagation Condition	Correlation Matrix and Antenna Configuration	Reference value	
					Fraction of Maximum Throughput (%)	SNR (dB)
1.4 MHz	R.4 TDD	OP.1 TDD	EVA5	1x2 Low	70	-0.6
3 MHz	R.42-1 TDD	OP.1 TDD	EVA5	1x2 Low	70	-0.8
5MHz	R.42-2 TDD	OP.1 TDD	EVA5	1x2 Low	70	-1.2
10MHz	R.2 TDD	OP.1 TDD	EVA5	1x2 Low	70	-1.6
15MHz	R.42-3 TDD	OP.1 TDD	EVA5	1x2 Low	70	-1.4
20MHz	R.42 TDD	OP.1 TDD	EVA5	1x2 Low	70	-1.4

Table 8.2.3.1.2-4: Minimum performance for multiple CA configurations with 2DL CCs (FRC)

Test number	Aggregated Bandwidth (MHz)			Minimum performance requirement	UE Category
	Total	FDD CC	TDD CC		
1	2x20	20	20	As defined in Table 8.2.3.1.2-2 and Table 8.2.3.1.2-3 per CC	≥5
2	20+10	10	20	As defined in Table 8.2.3.1.2-2 and Table 8.2.3.1.2-3 per CC	≥5
3	20+15	15	20	As defined in Table 8.2.3.1.2-2 and Table 8.2.3.1.2-3 per CC	≥5
Note 1:	The applicability of requirements for different CA configurations and bandwidth combination sets is defined in 8.1.2.3B				
Note 2:	30usec timing difference between PCell and any SCell is applied in inter-band CA case, where PCell can be assigned on any TDD CC.				

Table 8.2.3.1.2-5: Minimum performance for multiple CA configurations with 3DL CCs (FRC)

Test number	Aggregated Bandwidth (MHz)			Minimum performance requirement	UE Category
	Total	FDD CC	TDD CC		
1	3x20	20	2x20	As defined in Table 8.2.3.1.2-2 and Table 8.2.3.1.2-3 per CC	≥5
2	20+20+15	15	2x20	As defined in Table 8.2.3.1.2-2 and Table 8.2.3.1.2-3 per CC	≥5
3	20+20+10	10	2x20	As defined in Table 8.2.3.1.2-2 and Table 8.2.3.1.2-3 per CC	≥5
4	3x20	2x20	20	As defined in Table 8.2.3.1.2-2 and Table 8.2.3.1.2-3 per CC	≥5
5	20+20+15	20+15	20	As defined in Table 8.2.3.1.2-2 and Table 8.2.3.1.2-3 per CC	≥5
6	20+20+10	20+10	20	As defined in Table 8.2.3.1.2-2 and Table 8.2.3.1.2-3 per CC	≥5
7	20+10+10	2x10	20	As defined in Table 8.2.3.1.2-2 and Table 8.2.3.1.2-3 per CC	≥5
Note 1:	The applicability of requirements for different CA configurations and bandwidth combination sets is defined in 8.1.2.3B.				
Note 2:	30usec timing difference between PCell and any SCell is applied in inter-band CA case, where PCell can be assigned on any TDD CC.				

Table 8.2.3.1.2-6: Minimum performance for multiple CA configurations with 4DL CCs (FRC)

Test number	CA Bandwidth combination (MHz)			Minimum performance requirement	UE Category
	Total	FDD CC	TDD CC		
1	4x20	20	3x20	As defined in Table 8.2.3.1.2-2 and Table 8.2.3.1.2-3 per CC	≥8
2	4x20	2x20	2x20	As defined in Table 8.2.3.1.2-2 and Table 8.2.3.1.2-3 per CC	≥8
3	3x20+15	20+15	2x20	As defined in Table 8.2.3.1.2-2 and Table 8.2.3.1.2-3 per CC	≥8
4	2x15+2x20	2x15	2x20	As defined in Table 8.2.3.1.2-2 and Table 8.2.3.1.2-3 per CC	≥8
5	3x20+15	2x20+15	20	As defined in Table 8.2.3.1.2-2 and Table 8.2.3.1.2-3 per CC	≥8
6	2x15+2x20	2x15+20	20	As defined in Table 8.2.3.1.2-2 and Table 8.2.3.1.2-3 per CC	≥8
7	3x20+10	2x20+10	20	As defined in Table 8.2.3.1.2-2 and Table 8.2.3.1.2-3 per CC	≥8
Note 1:	The applicability of requirements for different CA configurations and bandwidth combination sets is defined in 8.1.2.3B.				
Note 2:	30usec timing difference between PCell and any SCell is applied in inter-band CA case, where PCell can be assigned on any CC.				

Table 8.2.3.1.2-7: Minimum performance for multiple CA configurations with 5DL CCs (FRC)

Test number	Aggregated Bandwidth (MHz)			Minimum performance requirement	UE Category
	Total	FDD CC	TDD CC		
1	15+4x20	15+2x20	2x20	As defined in Table 8.2.3.1.1-2 and Table 8.2.3.1.1-3 per CC	8, ≥11
2	2x15+3x20	2x15+20	2x20	As defined in Table 8.2.3.1.1-2 and Table 8.2.3.1.1-3 per CC	8, ≥11
Note 1:	The applicability of requirements for different CA configurations and bandwidth combination sets is defined in 8.1.2.3B.				
Note 2:	30usec timing difference between PCell and any SCell is applied in inter-band CA case, where PCell can be assigned on any CC.				

8.2.3.2 Open-loop spatial multiplexing performance 2Tx Antenna port

8.2.3.2.1 Minimum Requirement for FDD PCell

For TDD FDD CA with FDD PCell and 2DL CCs, the requirements are specified in Table 8.2.3.2.1-4 based on single carrier requirement specified in Table 8.2.3.2.1-2 and Table 8.2.3.2.1-3, with the addition of the parameters in Table 8.2.3.2.1-1 and the downlink physical channel setup according to Annex C.3.2. The purpose is to verify the performance of large delay CDD with 2 transmitter antennas.

For TDD FDD CA with FDD PCell and 3DL CCs, the requirements are specified in Table 8.2.3.2.1-5 based on single carrier requirement specified in Table 8.2.3.2.1-2 and Table 8.2.3.2.1-3, with the addition of the parameters in Table 8.2.3.2.1-1 and the downlink physical channel setup according to Annex C.3.2. The purpose is to verify the performance of large delay CDD with 2 transmitter antennas.

For TDD FDD CA with FDD PCell and 4DL CCs, the requirements are specified in Table 8.2.3.2.1-6 based on single carrier requirement specified in Table 8.2.3.2.1-2 and Table 8.2.3.2.1-3, with the addition of the parameters in Table 8.2.3.2.1-1 and the downlink physical channel setup according to Annex C.3.2. The purpose is to verify the performance of large delay CDD with 2 transmitter antennas.

For TDD FDD CA with FDD PCell and 5DL CCs, the requirements are specified in Table 8.2.3.2.1-7 based on single carrier requirement specified in Table 8.2.3.2.1-2 and Table 8.2.3.2.1-3, with the addition of the parameters in Table 8.2.3.2.1-1 and the downlink physical channel setup according to Annex C.3.2. The purpose is to verify the performance of large delay CDD with 2 transmitter antennas.

The test coverage for different number of component carriers is defined in 8.1.2.4.

Table 8.2.3.2.1-1: Test Parameters for Large Delay CDD (FRC) for CA

Parameter	Unit	Value	
Downlink power allocation	ρ_A	dB	-3
	ρ_B	dB	-3 (Note 1)
	σ	dB	0
N_{oc} at antenna port	dBm/15kHz	-98	
PDSCH transmission mode		3	
Note 1: $P_B = 1$.			
Note 2: The same PDSCH transmission mode is applied to each component carrier.			

Table 8.2.3.2.1-2: Single carrier performance with different bandwidths for multiple CA configurations for FDD PCell and SCell (FRC)

Bandwidth	Reference Channel	OCNG Pattern	Propagation Condition	Correlation Matrix and Antenna Configuration	Reference value	
					Fraction of Maximum Throughput (%)	SNR (dB)
1.4 MHz	R.11-5 FDD	OP.1 FDD	EVA70	2x2 Low	70	13.6
3 MHz	R.11-6 FDD	OP.1 FDD	EVA70	2x2 Low	70	12.3
5MHz	R.11-2 FDD	OP.1 FDD	EVA70	2x2 Low	70	12.3
10MHz	R.11 FDD	OP.1 FDD	EVA70	2x2 Low	70	12.9
15MHz	R.11-7 FDD	OP.1 FDD	EVA70	2x2 Low	70	12.8
20MHz	R.30 FDD	OP.1 FDD	EVA70	2x2 Low	70	12.9

Table 8.2.3.2.1-3: Single carrier performance with different bandwidths for multiple CA configurations for TDD SCell (FRC)

Bandwidth	Reference Channel	OCNG Pattern	Propagation Condition	Correlation Matrix and Antenna Configuration	Reference value	
					Fraction of Maximum Throughput (%)	SNR (dB)
1.4 MHz	R.11-5 TDD	OP.1 TDD	EVA70	2x2 Low	70	13.2
3 MHz	R.11-6 TDD	OP.1 TDD	EVA70	2x2 Low	70	12.8
5MHz	R.11-7 TDD	OP.1 TDD	EVA70	2x2 Low	70	12.6
10MHz	R.11-8 TDD	OP.1 TDD	EVA70	2x2 Low	70	12.8
15MHz	R.11-9 TDD	OP.1 TDD	EVA70	2x2 Low	70	12.9
20MHz	R.30-1 TDD	OP.1 TDD	EVA70	2x2 Low	70	13.0

Table 8.2.3.2.1-4: Minimum performance for multiple CA configurations with 2DL CCs (FRC)

Test number	Aggregated Bandwidth (MHz)			Minimum performance requirement	UE Category
	Total	FDD CC	TDD CC		
1	2x20	20	20	As defined in Table 8.2.3.2.1-2 and Table 8.2.3.2.1-3 per CC	≥5
2	20+10	10	20	As defined in Table 8.2.3.2.1-2 and Table 8.2.3.2.1-3 per CC	≥5
3	20+15	15	20	As defined in Table 8.2.3.2.1-2 and Table 8.2.3.2.1-3 per CC	≥5
Note 1: The applicability of requirements for different CA configurations and bandwidth combination sets is defined in 8.1.2.3B					

Table 8.2.3.2.1-5: Minimum performance for multiple CA configurations with 3DL CCs (FRC)

Test number	Aggregated Bandwidth (MHz)			Minimum performance requirement	UE Category
	Total	FDD CC	TDD CC		
1	3x20	20	2x20	As defined in Table 8.2.3.2.1-2 and Table 8.2.3.2.1-3 per CC	≥5
2	20+20+15	15	2x20	As defined in Table 8.2.3.2.1-2 and Table 8.2.3.2.1-3 per CC	≥5
3	20+20+10	10	2x20	As defined in Table 8.2.3.2.1-2 and Table 8.2.3.2.1-3 per CC	≥5
4	3x20	2x20	20	As defined in Table 8.2.3.2.1-2 and Table 8.2.3.2.1-3 per CC	≥5
5	20+20+15	20+15	20	As defined in Table 8.2.3.2.1-2 and Table 8.2.3.2.1-3 per CC	≥5
6	20+20+10	20+10	20	As defined in Table 8.2.3.2.1-2 and Table 8.2.3.2.1-3 per CC	≥5
7	20+10+10	2x10	20	As defined in Table 8.2.3.1.1-2 and Table 8.2.3.1.1-3 per CC	≥5
Note 1: The applicability of requirements for different CA configurations and bandwidth combination sets is defined in 8.1.2.3B.					

Table 8.2.3.2.1-6: Minimum performance for multiple CA configurations with 4DL CCs (FRC)

Test number	Aggregated Bandwidth (MHz)			Minimum performance requirement	UE Category
	Total	FDD CC	TDD CC		
1	4x20	20	3x20	As defined in Table 8.2.3.2.1-2 and Table 8.2.3.2.1-3 per CC	≥8
2	4x20	2x20	2x20	As defined in Table 8.2.3.2.1-2 and Table 8.2.3.2.1-3 per CC	≥8
3	3x20+15	20+15	2x20	As defined in Table 8.2.3.2.1-2 and Table 8.2.3.2.1-3 per CC	≥8
4	2x15+2x20	2x15	2x20	As defined in Table 8.2.3.2.1-2 and Table 8.2.3.2.1-3 per CC	≥8
5	3x20+15	2x20+15	20	As defined in Table 8.2.3.2.1-2 and Table 8.2.3.2.1-3 per CC	≥8
6	2x15+2x20	2x15+20	20	As defined in Table 8.2.3.2.1-2 and Table 8.2.3.2.1-3 per CC	≥8
7	3x20+10	2x20+10	20	As defined in Table 8.2.3.2.1-2 and Table 8.2.3.2.1-3 per CC	≥8

Note 1: The applicability of requirements for different CA configurations and bandwidth combination sets is defined in 8.1.2.3B.

Table 8.2.3.2.1-7: Minimum performance for multiple CA configurations with 5DL CCs (FRC)

Test number	Aggregated Bandwidth (MHz)			Minimum performance requirement	UE Category
	Total	FDD CC	TDD CC		
1	15+4x20	15+2x20	2x20	As defined in Table 8.2.3.1.1-2 and Table 8.2.3.1.1-3 per CC	8, ≥11
2	2x15+3x20	2x15+20	2x20	As defined in Table 8.2.3.1.1-2 and Table 8.2.3.1.1-3 per CC	8, ≥11

Note 1: The applicability of requirements for different CA configurations and bandwidth combination sets is defined in 8.1.2.3B.

8.2.3.2.1A Soft buffer management test for FDD PCell

For TDD-FDD CA, the requirements are specified in Table 8.2.3.2.1A-2, with the addition of the parameters in Table 8.2.3.2.1A-1 and the downlink physical channel setup according to Annex C.3.2. The purpose is to verify the UE performance with proper instantaneous buffer implementation for FDD as PCell.

Table 8.2.3.2.1A-1: Test Parameters for CA

Parameter		Unit	Value	
			FDD Carrier	TDD Carrier
Downlink power allocation	ρ_A	dB	-3	-3
	ρ_B	dB	-3 (Note 1)	-3 (Note 1)
	σ	dB	0	0
N_{oc} at antenna port		dBm/15kHz	-98	-98
PDSCH transmission mode			3	3

Note 1: $P_B = 1$.

Note 2: The same PDSCH transmission mode is applied to each component carrier.

Table 8.2.3.2.1A-2: Minimum performance (FRC) for CA

Test num.	Band-width		Reference channel	OCNG pattern	Propagation condition	Correlation matrix and antenna config	Reference value		UE category
							Fraction of maximum throughput (%)	SNR (dB)	
1	PCell	20MHz	R.30 FDD	OP.1 FDD (Note 1)	EVA70	2x2 Low	70	13.2	3
	SCell	20MHz	R.30-2 TDD	OP.1 TDD (Note 1)			70	13.2	
2	PCell	20MHz	R.35-1 FDD	OP.1 FDD (Note 1)	EVA70	2x2 Low	70	16.3	4
	SCell	20MHz	R.35-1 TDD	OP.1 TDD (Note 1)			70	16.3	
3	PCell	10MHz	R.35-3 FDD	OP.1 FDD (Note 1)	EVA70	2x2 Low	70	16.0	3
	SCell	20MHz	R.30-2 TDD	OP.1 TDD (Note 1)			70	13.2	
4	PCell	10MHz	R.35-3 FDD	OP.1 FDD (Note 1)	EVA70	2x2 Low	70	16.0	4
	SCell	20MHz	R.35-1 TDD	OP.1 TDD (Note 1)			70	16.3	
5	PCell	15MHz	R.35-2 FDD	OP.1 FDD (Note 1)	EVA70	2x2 Low	70	16.0	3
	SCell	20MHz	R.30-2 TDD	OP.1 TDD (Note 1)			70	13.2	
6	PCell	15MHz	R.35-2 FDD	OP.1 FDD (Note 1)	EVA70	2x2 Low	70	16.0	4
	SCell	20MHz	R.35-1 TDD	OP.1 TDD (Note 1)			70	16.3	
Note 1: The OCNG pattern applies for each CC.									
Note 2: The applicability and test rules of requirements for different CA configurations and bandwidth combination sets are defined in 8.1.2.3B.									

8.2.3.2.2 Minimum Requirement for TDD PCell

For TDD FDD CA with TDD PCell and 2DL CCs, the requirements are specified in Table 8.2.3.2.2-4 based on single carrier requirement specified in Table 8.2.3.2.2-2 and Table 8.2.3.2.2-3, with the addition of the parameters in Table 8.2.3.2.2-1 and the downlink physical channel setup according to Annex C.3.2. The purpose is to verify the performance of large delay CDD with 2 transmitter antennas.

For TDD FDD CA with TDD PCell and 3DL CCs, the requirements are specified in Table 8.2.3.2.2-5 based on single carrier requirement specified in Table 8.2.3.2.2-2 and Table 8.2.3.2.2-3, with the addition of the parameters in Table 8.2.3.2.2-1 and the downlink physical channel setup according to Annex C.3.2. The purpose is to verify the performance of large delay CDD with 2 transmitter antennas.

For TDD FDD CA with TDD PCell and 4DL CCs, the requirements are specified in Table 8.2.3.2.2-6 based on single carrier requirement specified in Table 8.2.3.2.2-2 and Table 8.2.3.2.2-3, with the addition of the parameters in Table 8.2.3.2.2-1 and the downlink physical channel setup according to Annex C.3.2. The purpose is to verify the performance of large delay CDD with 2 transmitter antennas.

For TDD FDD CA with TDD PCell and 5DL CCs, the requirements are specified in Table 8.2.3.2.2-7 based on single carrier requirement specified in Table 8.2.3.2.2-2 and Table 8.2.3.2.2-3, with the addition of the parameters in Table 8.2.3.2.2-1 and the downlink physical channel setup according to Annex C.3.2. The purpose is to verify the performance of large delay CDD with 2 transmitter antennas.

The test coverage for different number of component carriers is defined in 8.1.2.4.

Table 8.2.3.2.2-1: Test Parameters for Large Delay CDD (FRC) for CA

Parameter		Unit	Value
Downlink power allocation	ρ_A	dB	-3
	ρ_B	dB	-3 (Note 1)
	σ	dB	0
N_{oc} at antenna port		dBm/15kHz	-98
PDSCH transmission mode			3
Note 1: $P_B = 1$.			
Note 2: The same PDSCH transmission mode is applied to each component carrier.			

Table 8.2.3.2.2-2: Single carrier performance with different bandwidths for multiple CA configurations for FDD SCell (FRC)

Band-width	Reference Channel	OCNG Pattern	Propagation Condition	Correlation Matrix and Antenna Configuration	Reference value	
					Fraction of Maximum Throughput (%)	SNR (dB)
1.4 MHz	R.11-5 FDD	OP.1 FDD	EVA70	2x2 Low	70	13.6
3 MHz	R.11-6 FDD	OP.1 FDD	EVA70	2x2 Low	70	12.3
5MHz	R.11-2 FDD	OP.1 FDD	EVA70	2x2 Low	70	12.3
10MHz	R.11 FDD	OP.1 FDD	EVA70	2x2 Low	70	12.9
15MHz	R.11-7 FDD	OP.1 FDD	EVA70	2x2 Low	70	12.8
20MHz	R.30 FDD	OP.1 FDD	EVA70	2x2 Low	70	12.9

Table 8.2.3.2.2-3: Single carrier performance with different bandwidths for multiple CA configurations for TDD PCell and SCell (FRC)

Band-width	Reference Channel	OCNG Pattern	Propagation Condition	Correlation Matrix and Antenna Configuration	Reference value	
					Fraction of Maximum Throughput (%)	SNR (dB)
1.4 MHz	R.11-5 TDD	OP.1 TDD	EVA70	2x2 Low	70	13.2
3 MHz	R.11-6 TDD	OP.1 TDD	EVA70	2x2 Low	70	12.8
5MHz	R.11-7 TDD	OP.1 TDD	EVA70	2x2 Low	70	12.6
10MHz	R.11-8 TDD	OP.1 TDD	EVA70	2x2 Low	70	12.8
15MHz	R.11-9 TDD	OP.1 TDD	EVA70	2x2 Low	70	12.9
20MHz	R.30-1 TDD	OP.1 TDD	EVA70	2x2 Low	70	13.0

Table 8.2.3.2.2-4: Minimum performance for multiple CA configurations with 2DL CCs (FRC)

Test number	Aggregated Bandwidth (MHz)			Minimum performance requirement	UE Category
	Total	FDD CC	TDD CC		
1	2x20	20	20	As defined in Table 8.2.3.2.2-2 and Table 8.2.3.2.2-3 per CC	≥5
2	20+10	10	20	As defined in Table 8.2.3.2.2-2 and Table 8.2.3.2.2-3 per CC	≥5
3	20+15	15	20	As defined in Table 8.2.3.2.2-2 and Table 8.2.3.2.2-3 per CC	≥5
Note 1: The applicability of requirements for different CA configurations and bandwidth combination sets is defined in 8.1.2.3B					

Table 8.2.3.2.2-5: Minimum performance for multiple CA configurations with 3DL CCs (FRC)

Test number	Aggregated Bandwidth (MHz)			Minimum performance requirement	UE Category
	Total	FDD CC	TDD CC		
1	3x20	20	2x20	As defined in Table 8.2.3.2.2-2 and Table 8.2.3.2.2-3 per CC	≥5
2	20+20+15	15	2x20	As defined in Table 8.2.3.2.2-2 and Table 8.2.3.2.2-3 per CC	≥5
3	20+20+10	10	2x20	As defined in Table 8.2.3.2.2-2 and Table 8.2.3.2.2-3 per CC	≥5
4	3x20	2x20	20	As defined in Table 8.2.3.2.2-2 and Table 8.2.3.2.2-3 per CC	≥5
5	20+20+15	20+15	20	As defined in Table 8.2.3.2.2-2 and Table 8.2.3.2.2-3 per CC	≥5
6	20+20+10	20+10	20	As defined in Table 8.2.3.2.2-2 and Table 8.2.3.2.2-3 per CC	≥5
7	20+10+10	2x10	20	As defined in Table 8.2.3.2.2-2 and Table 8.2.3.2.2-3 per CC	≥5
Note 1: The applicability of requirements for different CA configurations and bandwidth combination sets is defined in 8.1.2.3B.					

Table 8.2.3.2.2-6: Minimum performance for multiple CA configurations with 4DL CCs (FRC)

Test number	Aggregated Bandwidth (MHz)			Minimum performance requirement	UE Category
	Total	FDD CC	TDD CC		
1	4x20	20	3x20	As defined in Table 8.2.3.2.2-2 and Table 8.2.3.2.2-3 per CC	≥8
2	4x20	2x20	2x20	As defined in Table 8.2.3.2.2-2 and Table 8.2.3.2.2-3 per CC	≥8
3	3x20+15	20+15	2x20	As defined in Table 8.2.3.2.2-2 and Table 8.2.3.2.2-3 per CC	≥8
4	2x15+2x20	2x15	2x20	As defined in Table 8.2.3.2.2-2 and Table 8.2.3.2.2-3 per CC	≥8
5	3x20+15	2x20+15	20	As defined in Table 8.2.3.2.2-2 and Table 8.2.3.2.2-3 per CC	≥8
6	2x15+2x20	2x15+20	20	As defined in Table 8.2.3.2.2-2 and Table 8.2.3.2.2-3 per CC	≥8
7	3x20+10	2x20+10	20	As defined in Table 8.2.3.2.2-2 and Table 8.2.3.2.2-3 per CC	≥8
Note 1: The applicability of requirements for different CA configurations and bandwidth combination sets is defined in 8.1.2.3B.					

Table 8.2.3.2.2-7: Minimum performance for multiple CA configurations with 5DL CCs (FRC)

Test number	Aggregated Bandwidth (MHz)			Minimum performance requirement	UE Category
	Total	FDD CC	TDD CC		
1	15+4x20	15+2x20	2x20	As defined in Table 8.2.3.1.1-2 and Table 8.2.3.1.1-3 per CC	8, ≥11
2	2x15+3x20	2x15+20	2x20	As defined in Table 8.2.3.1.1-2 and Table 8.2.3.1.1-3 per CC	8, ≥11
Note 1: The applicability of requirements for different CA configurations and bandwidth combination sets is defined in 8.1.2.3B.					

8.2.3.2.2A Soft buffer management test for TDD PCell

For TDD-FDD CA, the requirements are specified in Table 8.2.3.2.2A-2, with the addition of the parameters in Table 8.2.3.2.2A-1 and the downlink physical channel setup according to Annex C.3.2. The purpose is to verify the UE performance with proper instantaneous buffer implementation for TDD as PCell.

Table 8.2.3.2.2A-1: Test Parameters for CA

Parameter		Unit	Value	
			FDD Carrier	TDD Carrier
Downlink power allocation	ρ_A	dB	-3	-3
	ρ_B	dB	-3 (Note 1)	-3 (Note 1)
	σ	dB	0	0
N_{oc} at antenna port		dBm/15kHz	-98	-98
PDSCH transmission mode			3	3
Note 1: $P_B = 1$.				
Note 2: The same PDSCH transmission mode is applied to each component carrier.				

Table 8.2.3.2.2A-2: Minimum performance (FRC) for CA

Test num.	Band-width		Reference channel	OCNG pattern	Propagation condition	Correlation matrix and antenna config	Reference value		UE category
							Fraction of maximum throughput (%)	SNR (dB)	
1	PCell	20MHz	R.30-2 TDD	OP.1 TDD (Note 1))	EVA70	2x2 Low	70	13.2	3
	SCell	20MHz	R.30 FDD	OP.1 FDD (Note 1)			70	13.2	
2	PCell	20MHz	R.35-1 TDD	OP.1 TDD (Note 1)	EVA70	2x2 Low	70	16.2	4
	SCell	20MHz	R.35-1 FDD	OP.1 FDD (Note 1)			70	16.2	
3	PCell	20MHz	R.30-2 TDD	OP.1 TDD (Note 1)	EVA70	2x2 Low	70	13.2	3
	SCell	10MHz	R.35-3 FDD	OP.1 FDD (Note 1)			70	16.0	
4	PCell	20MHz	R.35-1 TDD	OP.1 TDD (Note 1)	EVA70	2x2 Low	70	16.2	4
	SCell	10MHz	R.35-3 FDD	OP.1 FDD (Note 1)			70	15.8	
5	PCell	20MHz	R.30-2 TDD	OP.1 TDD (Note 1)	EVA70	2x2 Low	70	13.2	3
	SCell	15MHz	R.35-2 FDD	OP.1 FDD (Note 1)			70	15.8	
6	PCell	20MHz	R.35-1 TDD	OP.1 TDD (Note 1)	EVA70	2x2 Low	70	16.2	4
	SCell	15MHz	R.35-2 FDD	OP.1 FDD (Note 1)			70	15.8	
Note 1: The OCNG pattern applies for each CC.									
Note 2: The applicability and test rules of requirements for different CA configurations and bandwidth combination sets are defined in 8.1.2.3B.									

8.2.3.3 Closed-loop spatial multiplexing performance 4Tx Antenna Port

8.2.3.3.1 Minimum Requirement for FDD PCell

For TDD FDD CA with FDD PCell and 2DL CCs, the requirements are specified in Table 8.2.3.3.1-4 based on single carrier requirement specified in Table 8.2.3.3.1-2 and Table 8.2.3.3.1-3, with the addition of the parameters in Table 8.2.3.3.1-1 and the downlink physical channel setup according to Annex C.3.2. The purpose of these tests is to verify the closed loop rank-two performance with wideband and frequency selective precoding.

For TDD FDD CA with FDD PCell and 3DL CCs, the requirements are specified in Table 8.2.3.3.1-5 based on single carrier requirement specified in Table 8.2.3.3.1-2 and Table 8.2.3.3.1-3, with the addition of the parameters in Table 8.2.3.3.1-1 and the downlink physical channel setup according to Annex C.3.2. The purpose of these tests is to verify the closed loop rank-two performance with wideband and frequency selective precoding.

For TDD FDD CA with FDD PCell and 4DL CCs, the requirements are specified in Table 8.2.3.3.1-6 based on single carrier requirement specified in Table 8.2.3.3.1-2 and Table 8.2.3.3.1-3, with the addition of the parameters in Table 8.2.3.3.1-1 and the downlink physical channel setup according to Annex C.3.2. The purpose of these tests is to verify the closed loop rank-two performance with wideband and frequency selective precoding.

For TDD FDD CA with FDD PCell and 5DL CCs, the requirements are specified in Table 8.2.3.3.1-7 based on single carrier requirement specified in Table 8.2.3.3.1-2 and Table 8.2.3.3.1-3, with the addition of the parameters in Table 8.2.3.3.1-1 and the downlink physical channel setup according to Annex C.3.2. The purpose of these tests is to verify the closed loop rank-two performance with wideband and frequency selective precoding.

The test coverage for different number of component carriers is defined in 8.1.2.4.

Table 8.2.3.3.1-1: Test Parameters for Multi-Layer Spatial Multiplexing (FRC) for CA

Parameter		Unit	Value
Downlink power allocation	ρ_A	dB	-6
	ρ_B	dB	-6 (Note 1)
	σ	dB	3
N_{oc} at antenna port		dBm/15kHz	-98
Precoding granularity		PRB	Wideband precoding for 1.4MHz, 4 for 3MHz and 5MHz CCs, 6 for 10MHz CCs, 8 for 15MHz and 20MHz CCs
PMI delay (Note 2)	FDD CC	ms	8
	TDD CC	ms	10 or 11
Reporting interval	FDD CC	ms	1
	TDD CC	ms	1 or 4 (Note 3)
Reporting mode			PUSCH 1-2
CodeBookSubsetRestriction bitmap			00000000000000000000000000000000 000011111111111111111111111100000000 00000000
CSI request field (Note 3)			'10'
PDSCH transmission mode			4
Note 1: $P_B = 1$.			
Note 2: If the UE reports in an available uplink reporting instance at subframe SF#n based on PMI estimation at a downlink SF not later than SF#(n-4), this reported PMI cannot be applied at the eNB downlink before SF#(n+4).			
Note 3: Multiple CC-s under test are configured as the 1 st set of serving cells by higher layers.			
Note 4: ACK/NACK bits are transmitted using PUSCH with PUCCH format 3.			
Note 5: The same PDSCH transmission mode is applied to each component carrier.			

Table 8.2.3.3.1-2: Single carrier performance with different bandwidths for multiple CA configurations for FDD PCell and SCell (FRC)

Band-width	Reference Channel	OCNG Pattern	Propagation Condition	Correlation Matrix and Antenna Configuration	Reference value	
					Fraction of Maximum Throughput (%)	SNR (dB)
1.4 MHz	R.14-4 FDD	OP.1 FDD	EVA5	4x2 Low	70	10.4
3 MHz	R.14-5 FDD	OP.1 FDD	EVA5	4x2 Low	70	9.5
5MHz	R.14-6 FDD	OP.1 FDD	EVA5	4x2 Low	70	9.5
10MHz	R.14 FDD	OP.1 FDD	EVA5	4x2 Low	70	10.1
15MHz	R.14-7 FDD	OP.1 FDD	EVA5	4x2 Low	70	10.1
20MHz	R.14-3 FDD	OP.1 FDD	EVA5	4x2 Low	70	10.3

Table 8.2.3.3.1-3: Single carrier performance with different bandwidths for multiple CA configurations for TDD SCell (FRC)

Bandwidth	Reference Channel	OCNG Pattern	Propagation Condition	Correlation Matrix and Antenna Configuration	Reference value	
					Fraction of Maximum Throughput (%)	SNR (dB)
1.4 MHz	R.43-1 TDD	OP.1 TDD	EVA5	4x2 Low	70	11.0
3 MHz	R.43-2 TDD	OP.1 TDD	EVA5	4x2 Low	70	9.8
5MHz	R.43-3 TDD	OP.1 TDD	EVA5	4x2 Low	70	10.0
10MHz	R.43-4 TDD	OP.1 TDD	EVA5	4x2 Low	70	10.5
15MHz	R.43-5 TDD	OP.1 TDD	EVA5	4x2 Low	70	10.6
20MHz	R.43 TDD	OP.1 TDD	EVA5	4x2 Low	70	10.7

Table 8.2.3.3.1-4: Minimum performance for multiple CA configurations with 2DL CCs (FRC)

Test number	Aggregated Bandwidth (MHz)			Minimum performance requirement	UE Category
	Total	FDD CC	TDD CC		
1	2x20	20	20	As defined in Table 8.2.3.3.1-2 and Table 8.2.3.3.1-3 per CC	≥5
2	20+10	10	20	As defined in Table 8.2.3.3.1-2 and Table 8.2.3.3.1-3 per CC	≥5
3	20+15	15	20	As defined in Table 8.2.3.3.1-2 and Table 8.2.3.3.1-3 per CC	≥5
Note 1:	The applicability of requirements for different CA configurations and bandwidth combination sets is defined in 8.1.2.3B				

Table 8.2.3.3.1-5: Minimum performance for multiple CA configurations with 3DL CCs (FRC)

Test number	Aggregated Bandwidth (MHz)			Minimum performance requirement	UE Category
	Total	FDD CC	TDD CC		
1	3x20	20	2x20	As defined in Table 8.2.3.3.1-2 and Table 8.2.3.3.1-3 per CC	≥5
2	20+20+15	15	2x20	As defined in Table 8.2.3.3.1-2 and Table 8.2.3.3.1-3 per CC	≥5
3	20+20+10	10	2x20	As defined in Table 8.2.3.3.1-2 and Table 8.2.3.3.1-3 per CC	≥5
4	3x20	2x20	20	As defined in Table 8.2.3.3.1-2 and Table 8.2.3.3.1-3 per CC	≥5
5	20+20+15	20+15	20	As defined in Table 8.2.3.3.1-2 and Table 8.2.3.3.1-3 per CC	≥5
6	20+20+10	20+10	20	As defined in Table 8.2.3.3.1-2 and Table 8.2.3.3.1-3 per CC	≥5
7	20+10+10	2x10	20	As defined in Table 8.2.3.3.1-2 and Table 8.2.3.3.1-3 per CC	≥5
Note 1:	The applicability of requirements for different CA configurations and bandwidth combination sets is defined in 8.1.2.3B.				

Table 8.2.3.3.1-6: Minimum performance for multiple CA configurations with 4DL CCs (FRC)

Test number	Aggregated Bandwidth (MHz)			Minimum performance requirement	UE Category
	Total	FDD CC	TDD CC		
1	4x20	20	3x20	As defined in Table 8.2.3.3.1-2 and Table 8.2.3.3.1-3 per CC	≥8
2	4x20	2x20	2x20	As defined in Table 8.2.3.3.1-2 and Table 8.2.3.3.1-3 per CC	≥8
3	3x20+15	20+15	2x20	As defined in Table 8.2.3.3.1-2 and Table 8.2.3.3.1-3 per CC	≥8
4	2x15+2x20	2x15	2x20	As defined in Table 8.2.3.3.1-2 and Table 8.2.3.3.1-3 per CC	≥8
5	3x20+15	2x20+15	20	As defined in Table 8.2.3.3.1-2 and Table 8.2.3.3.1-3 per CC	≥8
6	2x15+2x20	2x15+20	20	As defined in Table 8.2.3.3.1-2 and Table 8.2.3.3.1-3 per CC	≥8
7	3x20+10	2x20+10	20	As defined in Table 8.2.3.3.1-2 and Table 8.2.3.3.1-3 per CC	≥8
Note 1: The applicability of requirements for different CA configurations and bandwidth combination sets is defined in 8.1.2.3B.					

Table 8.2.3.3.1-7: Minimum performance for multiple CA configurations with 5DL CCs (FRC)

Test number	Aggregated Bandwidth (MHz)			Minimum performance requirement	UE Category
	Total	FDD CC	TDD CC		
1	15+4x20	15+2x20	2x20	As defined in Table 8.2.3.1.1-2 and Table 8.2.3.1.1-3 per CC	8, ≥11
2	2x15+3x20	2x15+20	2x20	As defined in Table 8.2.3.1.1-2 and Table 8.2.3.1.1-3 per CC	8, ≥11
Note 1: The applicability of requirements for different CA configurations and bandwidth combination sets is defined in 8.1.2.3B					

8.2.3.3.2 Minimum Requirement for TDD PCell

For TDD FDD CA with TDD PCell and 2DL CCs, the requirements are specified in Table 8.2.3.3.2-4 based on single carrier requirement specified in Table 8.2.3.3.2-2 and Table 8.2.3.3.2-3, with the addition of the parameters in Table 8.2.3.3.2-1 and the downlink physical channel setup according to Annex C.3.2. The purpose of these tests is to verify the closed loop rank-two performance with wideband and frequency selective precoding.

For TDD FDD CA with TDD PCell and 3DL CCs, the requirements are specified in Table 8.2.3.3.2-5 based on single carrier requirement specified in Table 8.2.3.3.2-2 and Table 8.2.3.3.2-3, with the addition of the parameters in Table 8.2.3.3.2-1 and the downlink physical channel setup according to Annex C.3.2. The purpose of these tests is to verify the closed loop rank-two performance with wideband and frequency selective precoding.

For TDD FDD CA with TDD PCell and 4DL CCs, the requirements are specified in Table 8.2.3.3.2-6 based on single carrier requirement specified in Table 8.2.3.3.2-2 and Table 8.2.3.3.2-3, with the addition of the parameters in Table 8.2.3.3.2-1 and the downlink physical channel setup according to Annex C.3.2. The purpose of these tests is to verify the closed loop rank-two performance with wideband and frequency selective precoding.

For TDD FDD CA with TDD PCell and 5DL CCs, the requirements are specified in Table 8.2.3.3.2-7 based on single carrier requirement specified in Table 8.2.3.3.2-2 and Table 8.2.3.3.2-3, with the addition of the parameters in Table 8.2.3.3.2-1 and the downlink physical channel setup according to Annex C.3.2. The purpose of these tests is to verify the closed loop rank-two performance with wideband and frequency selective precoding.

The test coverage for different number of component carriers is defined in 8.1.2.4.

Table 8.2.3.3.2-1: Test Parameters for Multi-Layer Spatial Multiplexing (FRC) for CA

Parameter		Unit	Value
Downlink power allocation	ρ_A	dB	-6
	ρ_B	dB	-6 (Note 1)
	σ	dB	3
N_{oc} at antenna port		dBm/15kHz	-98
Precoding granularity		PRB	Widelband pre-coding for 1.4MHz, 4 for 3MHz and 5MHz CCs, 6 for 10MHz CCs, 8 for 15MHz and 20MHz CCs
PMI delay (Note 2)	FDD CC	ms	8
	TDD CC	ms	10 or 11
Reporting interval	FDD CC	ms	1
	TDD CC	ms	1 or 4 (Note 3)
Reporting mode			PUSCH 1-2
CodeBookSubsetRestriction bitmap			00000000000000000000000000000000 000011111111111111111111111100000000 00000000
CSI request field (Note 3)			'10'
PDSCH transmission mode			TM4
Note 1: $P_B = 1$. Note 2: If the UE reports in an available uplink reporting instance at subframe SF#n based on PMI estimation at a downlink SF not later than SF#(n-4), this reported PMI cannot be applied at the eNB downlink before SF#(n+4). Note 3: Multiple CC-s under test are configured as the 1 st set of serving cells by higher layers. Note 4: ACK/NACK bits are transmitted using PUSCH with PUCCH format 3. Note 5: The same PDSCH transmission mode is applied to each component carrier.			

Table 8.2.3.3.2-2: Single carrier performance with different bandwidths for multiple CA configurations for FDD SCell (FRC)

Band-width	Reference Channel	OCNG Pattern	Propagation Condition	Correlation Matrix and Antenna Configuration	Reference value	
					Fraction of Maximum Throughput (%)	SNR (dB)
1.4 MHz	R.14-4 FDD	OP.1 FDD	EVA5	4x2 Low	70	10.4
3 MHz	R.14-5 FDD	OP.1 FDD	EVA5	4x2 Low	70	9.5
5MHz	R.14-6 FDD	OP.1 FDD	EVA5	4x2 Low	70	9.5
10MHz	R.14 FDD	OP.1 FDD	EVA5	4x2 Low	70	10.1
15MHz	R.14-7 FDD	OP.1 FDD	EVA5	4x2 Low	70	10.1
20MHz	R.14-3 FDD	OP.1 FDD	EVA5	4x2 Low	70	10.3

Table 8.2.3.3.2-3: Single carrier performance with different bandwidths for multiple CA configurations for TDD PCell and SCell (FRC)

Bandwidth	Reference Channel	OCNG Pattern	Propagation Condition	Correlation Matrix and Antenna Configuration	Reference value	
					Fraction of Maximum Throughput (%)	SNR (dB)
1.4 MHz	R.43-1 TDD	OP.1 TDD	EVA5	4x2 Low	70	11.0
3 MHz	R.43-2 TDD	OP.1 TDD	EVA5	4x2 Low	70	9.8
5MHz	R.43-3 TDD	OP.1 TDD	EVA5	4x2 Low	70	10.0
10MHz	R.43-4 TDD	OP.1 TDD	EVA5	4x2 Low	70	10.5
15MHz	R.43-5 TDD	OP.1 TDD	EVA5	4x2 Low	70	10.6
20MHz	R.43 TDD	OP.1 TDD	EVA5	4x2 Low	70	10.7

Table 8.2.3.3.2-4: Minimum performance for multiple CA configurations with 2DL CCs (FRC)

Test number	Aggregated Bandwidth (MHz)			Minimum performance requirement	UE Category
	Total	FDD CC	TDD CC		
1	2x20	20	20	As defined in Table 8.2.3.3.2-2 and Table 8.2.3.3.2-3 per CC	≥5
2	20+10	10	20	As defined in Table 8.2.3.3.2-2 and Table 8.2.3.3.2-3 per CC	≥5
3	20+15	15	20	As defined in Table 8.2.3.1.1-2 and Table 8.2.3.1.1-3 per CC	≥5
Note 1:	The applicability of requirements for different CA configurations and bandwidth combination sets is defined in 8.1.2.3B				

Table 8.2.3.3.2-5: Minimum performance for multiple CA configurations with 3DL CCs (FRC)

Test number	Aggregated Bandwidth (MHz)			Minimum performance requirement	UE Category
	Total	FDD CC	TDD CC		
1	3x20	20	2x20	As defined in Table 8.2.3.3.2-2 and Table 8.2.3.3.2-3 per CC	≥5
2	20+20+15	15	2x20	As defined in Table 8.2.3.3.2-2 and Table 8.2.3.3.2-3 per CC	≥5
3	20+20+10	10	2x20	As defined in Table 8.2.3.3.2-2 and Table 8.2.3.3.2-3 per CC	≥5
4	3x20	2x20	20	As defined in Table 8.2.3.3.2-2 and Table 8.2.3.3.2-3 per CC	≥5
5	20+20+15	20+15	20	As defined in Table 8.2.3.3.2-2 and Table 8.2.3.3.2-3 per CC	≥5
6	20+20+10	20+10	20	As defined in Table 8.2.3.3.2-2 and Table 8.2.3.3.2-3 per CC	≥5
7	20+10+10	2x10	20	As defined in Table 8.2.3.3.2-2 and Table 8.2.3.3.2-3 per CC	≥5
Note 1:	The applicability of requirements for different CA configurations and bandwidth combination sets is defined in 8.1.2.3B.				

Table 8.2.3.3.2-6: Minimum performance for multiple CA configurations with 4DL CCs (FRC)

Test number	Aggregated Bandwidth (MHz)			Minimum performance requirement	UE Category
	Total	FDD CC	TDD CC		
1	4x20	20	3x20	As defined in Table 8.2.3.3.2-2 and Table 8.2.3.3.2-3 per CC	≥8
2	4x20	2x20	2x20	As defined in Table 8.2.3.3.2-2 and Table 8.2.3.3.2-3 per CC	≥8
3	3x20+15	20+15	2x20	As defined in Table 8.2.3.3.2-2 and Table 8.2.3.3.2-3 per CC	≥8
4	2x15+2x20	2x15	2x20	As defined in Table 8.2.3.3.2-2 and Table 8.2.3.3.2-3 per CC	≥8
5	3x20+15	2x20+15	20	As defined in Table 8.2.3.3.2-2 and Table 8.2.3.3.2-3 per CC	≥8
6	2x15+2x20	2x15+20	20	As defined in Table 8.2.3.3.2-2 and Table 8.2.3.3.2-3 per CC	≥8
7	3x20+10	2x20+10	20	As defined in Table 8.2.3.3.2-2 and Table 8.2.3.3.2-3 per CC	≥8

Note 1: The applicability of requirements for different CA configurations and bandwidth combination sets is defined in 8.1.2.3B.

Table 8.2.3.3.2-7: Minimum performance for multiple CA configurations with 5DL CCs (FRC)

Test number	Aggregated Bandwidth (MHz)			Minimum performance requirement	UE Category
	Total	FDD CC	TDD CC		
1	15+4x20	15+2x20	2x20	As defined in Table 8.2.3.1.1-2 and Table 8.2.3.1.1-3 per CC	8, ≥11
2	2x15+3x20	2x15+20	2x20	As defined in Table 8.2.3.1.1-2 and Table 8.2.3.1.1-3 per CC	8, ≥11

Note 1: The applicability of requirements for different CA configurations and bandwidth combination sets is defined in 8.1.2.3B.

8.2.3.4 Minimum Requirement for Closed-loop spatial multiplexing performance 4Tx Antenna Port for dual connectivity

For dual connectivity the requirements are specified in Table 8.2.3.4-4, based on single carrier requirement specified in Table 8.2.3.4-2 and Table 8.2.3.4-3, with the addition of the parameters in Table 8.2.3.4-1 and the downlink physical channel setup according to Annex C.3.2. The purpose of these tests is to verify the closed loop rank-two performance with wideband and frequency selective precoding by using dual connectivity transmission.

Table 8.2.3.4-1: Test Parameters for Multi-Layer Spatial Multiplexing (FRC) for TDD-FDD dual connectivity

Parameter	Unit	Values	
Downlink power allocation	ρ_A	dB	-6
	ρ_B	dB	-6 (Note 1)
	σ	dB	-3

N_{oc} at antenna port	dBm/15kHz	-98
Precoding granularity	PRB	6 for 1.4MHz, 4 for 3MHz and 5MHz CCs, 6 for 10MHz CCs, and 8 for 15MHz CCs and 20MHz CCs
PMI delay (Note 2)	ms	8 for FDD CC 10 or 11 for TDD CC
Reporting interval	ms	1 for FDD CC 1 or 4 for TDD CC (Note 3)
Reporting mode		PUSCH 1-2
CodeBookSubsetRestriction bitmap		00000000000000000000000000000000 000011111111111111111100000000 00000000
PDSCH transmission mode		4
ACK/NACK transmission		Separate ACK/NACK feedbacks with PUCCH format 1b on the MCG and SCG
CSI feedback		Separate PUSCH feedbacks on the MCG and SCG
Time offset between MCG CC and SCG CC	μ s	0 for UE under test supporting synchronous dual connectivity; 334 for UE under test supporting both asynchronous and synchronous dual connectivity (Note 5)
<p>Note 1: $P_B = 1$.</p> <p>Note 2: If the UE reports in an available uplink reporting instance at subframe SF#n based on PMI estimation at a downlink SF not later than SF#(n-4), this reported PMI cannot be applied at the eNB downlink before SF#(n+4).</p> <p>Note 3: For Uplink - downlink configuration 1 the reporting interval will alternate between 1ms and 4ms.</p> <p>Note 4: The same PDSCH transmission mode is applied to each component carrier.</p> <p>Note 5: As defined in TS36.300 [11].</p> <p>Note 6: If the UE supports both SCG bearer and Split bearer, the SCG bearer is configured.</p>		

Table 8.2.3.4-2: FDD single carrier performance for multiple dual connectivity configurations

Bandwidth	Reference channel	OCNG pattern	Propagation condition	Correlation matrix and antenna config.	Reference value	
					Fraction of maximum throughput (%)	SNR (dB)
1.4MHz	R.14-4 FDD	OP. 1 FDD	EVA5	4x2 Low	70	10.36
3MHz	R.14-5 FDD	OP. 1 FDD	EVA5	4x2 Low	70	9.5
5MHz	R.14-6 FDD	OP. 1 FDD	EVA5	4x2 Low	70	9.5
10 MHz	R.14 FDD	OP. 1 FDD	EVA5	4x2 Low	70	10.1
15MHz	R.14-7 FDD	OP. 1 FDD	EVA5	4x2 Low	70	10.1
20MHz	R.14-3 FDD	OP. 1 FDD	EVA5	4x2 Low	70	10.3

Table 8.2.3.4-3: TDD single carrier performance for multiple dual connectivity configurations

Bandwidth	Reference channel	OCNG pattern	Propagation condition	Correlation matrix and antenna config.	Reference value	
					Fraction of maximum throughput (%)	SNR (dB)

1.4MHz	R.43-1 TDD	OP.1 TDD	EVA5	4x2 Low	70	11.0
3MHz	R.43-2 TDD	OP.1 TDD	EVA5	4x2 Low	70	9.8
5MHz	R.43-3 TDD	OP.1 TDD	EVA5	4x2 Low	70	10.0
10 MHz	R.43-4 TDD	OP.1 TDD	EVA5	4x2 Low	70	10.5
15MHz	R.43-5 TDD	OP.1 TDD	EVA5	4x2 Low	70	10.6
20MHz	R.43 TDD	OP. 1 TDD	EVA5	4x2 Low	70	10.7

Table 8.2.3.4-4: Minimum performance Multi-Layer Spatial Multiplexing (FRC) for dual connectivity

Test num.	Bandwidth combination	Requirement	UE category
1	2x20 MHz	As specified in Table 8.2.3.4-2 and Table 8.2.3.4-3 per CC	≥5
Note 1: The OCNG pattern applies for each CC.			
Note 2: The applicability of requirements for different dual connectivity configurations and bandwidth combination sets is defined in 8.1.2.3A.			

8.2.4 LAA

8.2.4.1 Closed-loop spatial multiplexing performance 4Tx Antenna Port

8.2.4.1.1 FDD PCell (FDD single carrier)

The parameters specified in Table 8.2.4.1.1-1 are valid for FDD CC and LAA SCell(s) unless otherwise stated. And the additional parameters specified in Table 8.2.4.1.1-2 are valid for LAA SCell(s).

Table 8.2.4.1.1-1: Common Test Parameters

Parameter	Unit	Value
Inter-TTI Distance		1
Number of HARQ processes per component carrier	Processes	8
Maximum number of HARQ transmission (Note 1)		4
Redundancy version coding sequence		{0,1,2,3} for QPSK and 16QAM {0,0,1,2} for 64QAM and 256QAM
Cyclic Prefix		Normal
Cell_ID		0
Cross carrier scheduling		Not configured
Note 1: For retransmission in partial subframes, the TB size should be kept the same as the initial transmission regardless of the initial transmission is performed in full subframes or partial subframes.		

Table 8.2.4.1.1-2: Additional Test Parameters for LAA SCell(s)

Parameter	Unit	Value
DMTC Periodicity	ms	80
dmtc-PeriodOffset-r12 ms80-r12		0
Discovery signal occasion duration	subframe	1
Power allocation of discovery signal		Same as power allocation of CRS within a transmission burst in the test

For CA with LAA SCell(s), the requirements are specified in Table 8.2.4.1.1-4, with the addition of the parameters in Table 8.2.4.1.1-1, Table 8.2.4.1.1-2, Table 8.2.4.1.1-3 and the downlink physical channel setup according to Annex C.3.2. The purpose of these tests is to verify the closed loop rank-two performance with frequency selective precoding for CA with LAA SCell(s).

The test coverage for different number of component carriers is defined in 8.1.2.4.

Table 8.2.4.1.1-3: Test Parameters for Dual-Layer Spatial Multiplexing (FRC)

Parameter	Unit	Value	
Downlink power allocation	ρ_A	dB	-6
	ρ_B	dB	-6 (Note 1)
	σ	dB	3
N_{oc} at antenna port	dBm/15kHz	-98	
Precoding granularity	PRB	4 for 3MHz and 5MHz CCs, 6 for 10MHz CCs, 8 for 15MHz and 20MHz CCs	
PMI delay (Note 2)	ms	8	
Reporting interval	ms	1	
Reporting mode		PUSCH 1-2	
CodeBookSubsetRestriction bitmap		00000000000000000000000000000000 0011111111111111111111000000000000 0000	
CSI request field (Note 3)		'10'	
PDSCH transmission mode		TM4	
DL Burst transmission pattern for LAA SCell		As specified in B.8	
The number of subframes set (S_i) in a burst		{1,3,5,8}	
Occupied OFDM symbols set in the last subframe		{6,9,12,14}	
Random variable p defined in B.8		0.5	
timing error relative of LAA SCell to PCell	μ s	0	
Frequency offset of th i -th LAA SCell relative to PCell	Hz	200	
Note 1: $P_B = 1$. Note 2: If the UE reports in an available uplink reporting instance at subframe SF#n based on PMI estimation at a downlink SF not later than SF#(n-4), this reported PMI cannot be applied at the eNB downlink before SF#(n+4). Note 3: Multiple CC-s under test are configured as the 1 st set of serving cells by higher layers. Note 4: ACK/NACK bits are transmitted using PUSCH with PUCCH format 3. Note 5: The same PDSCH transmission mode is applied to each component carrier.			

Table 8.2.4.1.1-4: Single carrier performance for PCell for multiple CA configurations

Band-width	Reference channel	OCNG pattern	Propa-gation condi-tion	Correlation matrix and antenna config.	Reference value	
					Fraction of maximum throughput (%)	SNR (dB)
1.4MHz	R.14-4 FDD	OP.1 FDD	EVA5	4x2 Low	70	10.4
3MHz	R.14-5 FDD	OP.1 FDD	EVA5	4x2 Low	70	9.5
5MHz	R.14-6 FDD	OP.1 FDD	EVA5	4x2 Low	70	9.5
10MHz	R.14 FDD	OP.1 FDD	EVA5	4x2 Low	70	10.1
15MHz	R.14-7 FDD	OP.1 FDD	EVA5	4x2 Low	70	10.1
20MHz	R.14-3 FDD	OP.1 FDD	EVA5	4x2 Low	70	10.3

Table 8.2.4.1.1-5: Single carrier performance for LAA SCell(s) for multiple CA configurations

Band-width	Sub-test (Note 2)	Reference channel	OCNG pattern	Propa-gation condition	Correlation matrix and antenna config.	Reference value	
						Fraction of nominal maximum throughput (%) (Note 1)	SNR (dB)
20MHz	1	R.1 FS3	OP.1 FS3	EVA5	4x2 Low	70	18.7
	2	R.1 FS3	OP.1 FS3	EVA5	4x2 Low	70	18.6
	3	R.1 FS3	OP.1 FS3	EVA5	4x2 Low	70	18.9
	4	R.1 FS3	OP.1 FS3	EVA5	4x2 Low	70	19
Note 1: Fraction of nominal maximum throughput is calculated based on random transmission occasions of PDSCH. Note 2: An UE is required to fulfill only one test of Sub-test 1-4 depending on UE capabilities of endingDwPTS and secondSlotStartingPosition. For an UE not supporting both endingDwPTS and secondSlotStartingPosition, it is required to fulfill Sub-test 1; For an UE not supporting endingDwPTS but supporting secondSlotStartingPosition, it is required to fulfill Sub-test 2; For an UE supporting endingDwPTS but not supporting secondSlotStartingPosition, it is required to fulfill Sub-test 3; and For an UE supporting both endingDwPTS and secondSlotStartingPosition, it is required to fulfill Sub-test 4.							

Table 8.2.4.1.1-6: Minimum performance (FRC) based on single carrier performance for CA with LAA SCell(s)

Test number	Aggregated Bandwidth (MHz)			Minimum performance requirement (Note 2)	UE Category
	Total	PCell	LAA SCell		
1	2x20	20	20	As defined in Table 8.2.4.1.1-4 and Table 8.2.4.1.1-5	≥5
Note 1: The applicability of requirements for different CA configurations and bandwidth combination sets is defined in 8.1.2.3C. Note 2: Apply a per-CC requirement defined in 8.2.4.1.1-4 for PCell and apply a per-CC requirement defined in 8.2.4.1.1-5 for LAA SCell.					

8.2.4.1.2 TDD PCell (TDD single carrier)

The parameters specified in Table 8.2.4.1.2-1 are valid for TDD CC and LAA SCell(s) unless otherwise stated. And the additional parameters specified in Table 8.2.4.1.2-2 are valid for LAA SCell(s).

Table 8.2.4.1.2-1: Common Test Parameters (TDD)

Parameter	Unit	Value
Uplink downlink configuration (Note 1)		1
Special subframe configuration (Note 2)		4
Cyclic prefix		Normal
Cell ID		0
Inter-TTI Distance		1
Number of HARQ processes per component carrier	Processes	7
Maximum number of HARQ transmission (Note 3)		4
Redundancy version coding sequence		{0,1,2,3} for QPSK and 16QAM {0,0,1,2} for 64QAM and 256QAM
Cross carrier scheduling		Not configured
Note 1: as specified in Table 4.2-2 in TS 36.211 [4]. Note 2: as specified in Table 4.2-1 in TS 36.211 [4]. Note 3: For retransmission in partial subframes, the TB size should be kept the same as the initial transmission regardless of the initial transmission is performed in full subframes or partial subframes.		

Table 8.2.4.1.2-2: Additional Test Parameters for LAA SCell(s)

Parameter	Unit	Value
DMTC Periodicity	ms	80
dmtc-PeriodOffset-r12 ms80-r12		0
Discovery signal occasion duration	subframe	1
Power allocation of discovery signal		Same as power allocation of CRS within a transmission burst in the test

For CA with LAA SCell(s), the requirements are specified in Table 8.2.4.1.2-4, with the addition of the parameters in Table 8.2.4.1.2-1, Table 8.2.4.1.2-2, Table 8.2.4.1.2-3 and the downlink physical channel setup according to Annex C.3.2. The purpose of these tests is to verify the closed loop rank-two performance with frequency selective precoding for CA with LAA SCell(s).

The test coverage for different number of component carriers is defined in 8.1.2.4.

Table 8.2.4.1.2-3: Test Parameters for Dual-Layer Spatial Multiplexing (FRC)

Parameter	Unit	Value	
Downlink power allocation	ρ_A	dB	-6
	ρ_B	dB	-6 (Note 1)
	σ	dB	3
N_{oc} at antenna port	dBm/15kHz	-98	
Precoding granularity	PRB	4 for 3MHz and 5MHz CCs, 6 for 10MHz CCs, 8 for 15MHz and 20MHz CCs	
PMI delay (Note 2)	ms	10 or 11	
Reporting interval	ms	1 or 4 (Note 3)	
Reporting mode		PUSCH 1-2	
CodeBookSubsetRestriction bitmap		00000000000000000000000000000000 0011111111111111111110000000000000 0000	
CSI request field (Note 4)		'10'	
PDSCH transmission mode		TM4	
DL Burst transmission pattern for LAA SCell		As specified in B.8	
The number of subframes set (S_i) in a burst		{1,3,5,8}	
Occupied OFDM symbols set in the last subframe		{6,9,12,14}	
Random variable p defined in B.8		0.5	
timing error relative of LAA SCell to PCell	μ s	0	
Frequency offset of the i -th LAA SCell relative to PCell	Hz	200	
Note 1: $P_B = 1$. Note 2: If the UE reports in an available uplink reporting instance at subframe SF#n based on PMI estimation at a downlink SF not later than SF#(n-4), this reported PMI cannot be applied at the eNB downlink before SF#(n+4). Note 3: For Uplink - downlink configuration 1 the reporting interval will alternate between 1ms and 4ms. Note 4: Multiple CC-s under test are configured as the 1 st set of serving cells by higher layers. Note 5: ACK/NACK bits are transmitted using PUSCH with PUCCH format 3. Note 6: The same PDSCH transmission mode is applied to each component carrier.			

Table 8.2.4.1.2-4: Single carrier performance for PCell for multiple CA configurations

Bandwidth	Reference channel	OCNG pattern	Propagation condition	Correlation matrix and antenna config.	Reference value	
					Fraction of maximum throughput (%)	SNR (dB)
1.4MHz	R.43-1 TDD	OP.1 TDD	EVA5	4x2 Low	70	11.0
3MHz	R.43-2 TDD	OP.1 TDD	EVA5	4x2 Low	70	9.8
5MHz	R.43-3 TDD	OP.1 TDD	EVA5	4x2 Low	70	10.0
10MHz	R.43-4 TDD	OP.1 TDD	EVA5	4x2 Low	70	10.5
15MHz	R.43-5 TDD	OP.1 TDD	EVA5	4x2 Low	70	10.6
20MHz	R.43 TDD	OP.1 TDD	EVA5	4x2 Low	70	10.7

Table 8.2.4.1.2-5: Single carrier performance for LAA SCell for multiple CA configurations

Bandwidth	Sub-test (Note 2)	Reference channel	OCNG pattern	Propagation condition	Correlation matrix and antenna config.	Reference value	
						Fraction of maximum throughput (%) (Note 1)	SNR (dB)
20MHz	1	R.1 FS3	OP.1 FS3	EVA5	4x2 Low	70	18.7
	2	R.1 FS3	OP.1 FS3	EVA5	4x2 Low	70	18.6
	3	R.1 FS3	OP.1 FS3	EVA5	4x2 Low	70	18.9
	4	R.1 FS3	OP.1 FS3	EVA5	4x2 Low	70	19
Note 1: Fraction of nominal maximum throughput is calculated based on random transmission occasions of PDSCH. Note 2: An UE is required to fulfill only one test of Sub-test 1-4 depending on UE capabilities of endingDwPTS and secondSlotStartingPosition. For an UE not supporting both endingDwPTS and secondSlotStartingPosition, it is required to fulfill Sub-test 1; For an UE not supporting endingDwPTS but supporting secondSlotStartingPosition, it is required to fulfill Sub-test 2; For an UE supporting endingDwPTS but not supporting secondSlotStartingPosition, it is required to fulfill Sub-test 3; and For an UE supporting both endingDwPTS and secondSlotStartingPosition, it is required to fulfill Sub-test 4.							

Table 8.2.4.1.2-6: Minimum performance (FRC) based on single carrier performance for CA with LAA SCell(s)

Test number	Aggregated Bandwidth (MHz)			Minimum performance requirement (Note 2)	UE Category
	Total	PCell	LAA SCell		
1	2x20	20	20	As defined in Table 8.2.4.1.2-4 and Table 8.2.4.1.2-5	≥5
Note 1: The applicability of requirements for different CA configurations and bandwidth combination sets is defined in 8.1.2.3C. Note 2: Apply a per-CC requirement defined in 8.2.4.1.2-4 for PCell and apply a per-CC requirement defined in 8.2.4.1.2-5 for LAA SCell.					

8.3 Demodulation of PDSCH (User-Specific Reference Symbols)

8.3.1 FDD

The parameters specified in Table 8.3.1-1 are valid for FDD unless otherwise stated.

Table 8.3.1-1: Common Test Parameters for User-specific Reference Symbols

Parameter	Unit	Value
Cyclic prefix		Normal
Cell ID		0
Inter-TTI Distance		1
Number of HARQ processes	Processes	8
Maximum number of HARQ transmission		4
Redundancy version coding sequence		{0,1,2,3} for QPSK and 16QAM {0,0,1,2} for 64QAM and 256QAM
Number of OFDM symbols for PDCCH	OFDM symbols	2
Precoder update granularity		Frequency domain: 1 PRG for Transmission modes 9 and 10 Time domain: 1 ms
Note 1: Void. Note 2: Void.		

8.3.1.1 Single-layer Spatial Multiplexing

For single-layer transmission on antenna ports 7 or 8 upon detection of a PDCCH with DCI format 2C, the requirements are specified in Table 8.3.1.1-1 and 8.3.1.1-2, with the addition of the parameters in Table 8.3.1.1-3 and the downlink physical channel setup according to Annex C.3.2. The purpose of these tests is to verify rank-1 performance on one of the antenna ports 7 or 8 with and without a simultaneous transmission on the other antenna port, and to verify rate matching with multiple CSI reference symbol configurations with non-zero and zero transmission power.

Table 8.3.1.1-1: Test Parameters for Testing CDM-multiplexed DM RS (single layer) with multiple CSI-RS configurations

parameter		Unit	Test 1, Test 1a	Test 2	Test 3
Downlink power allocation	ρ_A	dB	0	0	0
	ρ_B	dB	0 (Note 1)	0 (Note 1)	0 (Note 1)
	σ	dB	-3	-3	-3
Beamforming model			Annex B.4.1	Annex B.4.1	Annex B.4.1
Cell-specific reference signals			Antenna ports 0,1		
CSI reference signals			Antenna ports 15,...,18	Antenna ports 15,...,18	Antenna ports 15, ..., 18
CSI-RS periodicity and subframe offset $T_{\text{CSI-RS}} / \Delta_{\text{CSI-RS}}$		Subframes	5 / 2	5 / 2	5 / 2
CSI reference signal configuration			0	3	0
Zero-power CSI-RS configuration $I_{\text{CSI-RS}} / \text{ZeroPowerCSI-RS}$ bitmap		Subframes / bitmap	3 / 0001000000000000	3 / 0001000000000000	3 / 0001000000000000
N_{oc} at antenna port		dBm/15kHz	-98	-98	-98
Symbols for unused PRBs			OCNG (Note 4)	OCNG (Note 4)	OCNG (Note 4)
Number of allocated resource blocks (Note 2)		PRB	50	50	50
Simultaneous transmission			No	Yes (Note 3, 5)	No
PDSCH transmission mode			9	9	9
Number of MBSFN subframes		Subframes	6 (Note 6)	NA	NA
Note 1: $P_B = 1$.					
Note 2: The modulation symbols of the signal under test are mapped onto antenna port 7 or 8.					
Note 3: Modulation symbols of an interference signal is mapped onto the antenna port (7 or 8) not used for the input signal under test.					
Note 4: These physical resource blocks are assigned to an arbitrary number of virtual UEs with one PDSCH per virtual UE; the data transmitted over the OCNG PDSCHs shall be uncorrelated pseudo random data, which is QPSK modulated.					
Note 5: The two UEs' scrambling identities n_{SCID} are set to 0 for CDM-multiplexed DM RS with interfering simultaneous transmission test cases.					
Note 6: For FDD mode, 6 subframes (#1/2/3/6/7/8) are allocated as MBSFN subframes.					

Table 8.3.1.1-2: Minimum performance for CDM-multiplexed DM RS without simultaneous transmission (FRC) with multiple CSI-RS configurations

Test number	Bandwidth and MCS	Reference Channel	OCNG Pattern	Propagation Condition	Correlation Matrix and Antenna Configuration	Reference value		UE Category	UE DL Category
						Fraction of Maximum Throughput (%)	SNR (dB)		
1	10 MHz QPSK 1/3	R.43-1 FDD	OP.1 FDD	EVA5	2x2 Low	70	-1.2	≥1	≥6
1a	10 MHz QPSK 1/3	R.43-2 FDD	OP.1 FDD	EVA5	2x2 Low	70	[-1.3]	≥1	≥6
3	10MHz 256QAM	R. 66 FDD	OP.1 FDD	EPA5	2x2 Low	70	24.3	11-12	≥11

Note 1: For UE that indicates support of *pdsch-CollisionHandling-r13*, test 1a will be run and test 1 will be skipped. Otherwise, test 1 will be run and test 1a will be skipped.

Table 8.3.1.1-3: Minimum performance for CDM-multiplexed DM RS with interfering simultaneous transmission (FRC) with multiple CSI-RS configurations

Test number	Bandwidth and MCS	Reference Channel	OCNG Pattern	Propagation Condition	Correlation Matrix and Antenna Configuration	Reference value		UE Category
						Fraction of Maximum Throughput (%)	SNR (dB)	
2	10 MHz 64QAM 1/2	R.50 FDD	OP.1 FDD	EPA5	2x2 Low	70	21.9	≥2

Note 1: The reference channel applies to both the input signal under test and the interfering signal.

8.3.1.1A Enhanced Performance Requirement Type A – Single-layer Spatial Multiplexing with TM9 interference model

The requirements are specified in Table 8.3.1.1A-2, with the addition of the parameters in Table 8.3.1.1A-1 and the downlink physical channel setup according to Annex C.3.2. The purpose of these tests is to verify closed loop rank one performance on one of the antenna ports 7 or 8 without a simultaneous transmission on the other antenna port in the serving cell when the PDSCH transmission in the serving cell is interfered by PDSCH of one dominant interfering cell applying transmission mode 9 interference model defined in clause B.5.4. In 8.3.1.1A-1, Cell 1 is the serving cell, and Cell 2 is the interfering cell. The downlink physical channel setup is according to Annex C.3.2 for each of Cell 1 and Cell 2, respectively.

Table 8.3.1.1A-1: Test Parameters for Testing CDM-multiplexed DM RS (single layer) with TM9 interference model

parameter		Unit	Cell 1	Cell 2
Downlink power allocation	ρ_A	dB	0	0
	ρ_B	dB	0 (Note 1)	0
	σ	dB	-3	-3
Cell-specific reference signals			Antenna ports 0,1	Antenna ports 0,1
CSI reference signals			Antenna ports 15,...,18	N/A
CSI-RS periodicity and subframe offset $T_{\text{CSI-RS}} / \Delta_{\text{CSI-RS}}$		Subframes	5 / 2	N/A
CSI reference signal configuration			0	N/A
N_{oc} at antenna port		dBm/15kHz z	-98	N/A
DIP (Note 2)		dB	N/A	-1.73
BW_{Channel}		MHz	10	10
Cyclic Prefix			Normal	Normal
Cell Id			0	126
Number of control OFDM symbols			2	2
PDSCH transmission mode			9	N/A
Beamforming model			As specified in clause B.4.3 (Note 4, 5)	N/A
Interference model			N/A	As specified in clause B.5.4
Probability of occurrence of transmission rank in interfering cells	Rank 1		N/A	70
	Rank 2		N/A	30
Precoder update granularity		PRB	50	6
PMI delay (Note 5)		Ms	8	N/A
Reporting interval		Ms	5	N/A
Reporting mode			PUCCH 1-1	N/A
CodeBookSubsetRestriction bitmap			0000000000000000 0000000000000000 0000000000000000 1111111111111111	N/A
Symbols for unused PRBs			OCNG (Note 6)	N/A
Simultaneous transmission			No simultaneous transmission on the other antenna port in (7 or 8) not used for the input signal under test	N/A
Physical channel for CQI reporting			PUSCH(Note 8)	N/A
cqi-pmi-ConfigurationIndex			5	N/A
Note 1: $P_B = 1$ Note 2: The respective received power spectral density of each interfering cell relative to N_{oc} is defined by its associated DIP value as specified in clause B.5.1. Note 3: The modulation symbols of the signal under test in Cell 1 are mapped onto antenna port 7 or 8.				

Note 4:	The precoder in clause B.4.3 follows UE recommended PMI.
Note 5:	If the UE reports in an available uplink reporting instance at subframe SF#n based on PMI estimation at a downlink SF not later than SF#(n-4), this reported PMI cannot be applied at the eNB downlink before SF#(n+4).
Note 6:	These physical resource blocks are assigned to an arbitrary number of virtual UEs with one PDSCH per virtual UE; the data transmitted over the OCNG PDSCHs shall be uncorrelated pseudo random data, which is QPSK modulated.
Note 7:	All cells are time-synchronous.
Note 8:	To avoid collisions between CQI reports and HARQ-ACK it is necessary to report both on PUSCH instead of PUCCH. PDCCH DCI format 0 shall be transmitted in downlink SF#4 and #9 to allow periodic CQI to multiplex with the HARQ-ACK on PUSCH in uplink subframe SF#8 and #3.

Table 8.3.1.1A-2: Enhanced Performance Requirement Type A, CDM-multiplexed DM RS with TM9 interference model

Test Number	Reference Channel	OCNG Pattern		Propagation Conditions		Correlation Matrix and Antenna Configuration (Note 3)	Reference Value		UE Category
		Cell 1	Cell 2	Cell 1	Cell 2		Fraction of Maximum Throughput (%)	SINR (dB) (Note 2)	
1	R.48 FDD	OP.1 FDD	N/A	EVA5	EVA5	4x2 Low	70	-1.1	≥1
Note 1: The propagation conditions for Cell 1 and Cell 2 are statistically independent. Note 2: SINR corresponds to \hat{E}_s / N_{oc} of Cell 1 as defined in clause 8.1.1. Note 3: Correlation matrix and antenna configuration parameters apply for each of Cell 1 and Cell 2.									

8.3.1.1B Single-layer Spatial Multiplexing (demodulation subframe overlaps with aggressor cell ABS and CRS assistance information are configured)

The requirements are specified in Table 8.3.1.1B-2, with the addition of parameters in Table 8.3.1.1B-1. The purpose is to verify the performance of the antenna ports 7 or 8 without a simultaneous transmission on the other antenna port in the serving cell if the PDSCH transmission in the serving cell takes place in subframes that overlap with ABS [9] of the aggressor cell with CRS assistance information. In Table 8.3.1.1B-1, Cell 1 is the serving cell, and Cell 2 and Cell 3 are the aggressor cells. The downlink physical channel setup for Cell 1 is according to Annex C.3.2 and for Cell 2 and Cell 3 is according to Annex C.3.3, respectively. The CRS assistance information [7] includes Cell 2 and Cell 3.

Table 8.3.1.1B-1: Test parameters of TM9-Single-Layer (2 CSI-RS ports) – Non-MBSFN ABS

Parameter		Unit	Cell 1	Cell 2	Cell 3
Downlink power allocation	ρ_A	dB	0	-3	-3
	ρ_B	dB	0 (Note 1)	-3 (Note 1)	-3 (Note 1)
	σ	dB	-3	N/A	N/A
N_{oc} at antenna port	N_{oc1}	dBm/15kHz	-98 (Note 2)	N/A	N/A
	N_{oc2}	dBm/15kHz	-98 (Note 3)	N/A	N/A
	N_{oc3}	dBm/15kHz	-93 (Note 4)	N/A	N/A
\hat{E}_s / N_{oc2}		dB	Reference Value in Table 8.3.1.1B-2	12	10
BW _{Channel}		MHz	10	10	10
Subframe Configuration			Non-MBSFN	Non-MBSFN	Non-MBSFN
Time Offset between Cells		μs	N/A	3	-1
Frequency shift between Cells		Hz	N/A	300	-100
Cell Id			0	1	126
Cell-specific reference signals			Antenna ports 0,1		
CSI reference signals			Antenna ports 15,16	N/A	N/A
CSI-RS periodicity and subframe offset $T_{CSI-RS} / \Delta_{CSI-RS}$		Subframes	5 / 2	N/A	N/A
CSI reference signal configuration			8	N/A	N/A
Zero-power CSI-RS configuration $I_{CSI-RS} / \text{ZeroPowerCSI-RS bitmap}$		Subframes / bitmap	3 / 00100000000000 00	N/A	N/A
ABS pattern (Note 5)			N/A	11000000 11000000 11000000 11000000 11000000	11000000 11000000 11000000 11000000 11000000
RLM/RRM Measurement Subframe Pattern (Note 6)			10000000 10000000 10000000 10000000 10000000	N/A	N/A
CSI Subframe Sets (Note7)	$C_{CSI,0}$		11000000 11000000 11000000 11000000 11000000	N/A	N/A
	$C_{CSI,1}$		00111111 00111111 00111111 00111111 00111111	N/A	N/A
Number of control OFDM symbols			2	Note 8	Note 8
PDSCH transmission mode			TM9-1layer	Note 9	Note 9
Precoding granularity			Frequency domain: 1 PRG Time domain: 1 ms	N/A	N/A
Beamforming model			Annex B.4.1	N/A	N/A
Cyclic prefix			Normal	Normal	Normal

- Note 1: $P_B = 1$.
- Note 2: This noise is applied in OFDM symbols #1, #2, #3, #5, #6, #8, #9, #10, #12, #13 of a subframe overlapping with the aggressor ABS.
- Note 3: This noise is applied in OFDM symbols #0, #4, #7, #11 of a subframe overlapping with the aggressor ABS.
- Note 4: This noise is applied in all OFDM symbols of a subframe overlapping with aggressor non-ABS
- Note 5: ABS pattern as defined in [9]. PDSCH other than SIB1/paging and its associated PDCCH/PCFICH are transmitted in the serving cell subframe when the subframe is overlapped with the ABS subframe of aggressor cell and the subframe is available in the definition of the reference channel.
- Note 6: Time-domain measurement resource restriction pattern for PCell measurements as defined in [7]
- Note 7: As configured according to the time-domain measurement resource restriction pattern for CSI measurements defined in [7].
- Note 8: The number of control OFDM symbols is not available for ABS and is 2 for the subframe indicated by "0" of ABS pattern.
- Note 9: Downlink physical channel setup in Cell 2 and Cell 3 in accordance with Annex C.3.3 applying OCNNG pattern as defined in Annex A.5.
- Note 10: If the UE reports in an available uplink reporting instance at subframe SF#n based on PMI estimation at a downlink SF not later than SF#(n-4), this reported PMI cannot be applied at the eNB downlink before SF#(n+4).
- Note 11: The number of the CRS ports in Cell 1, Cell 2 and Cell 3 is the same.
- Note 12: SIB-1 will not be transmitted in Cell 2 and Cell 3 in this test.
- Note 13: The modulation symbols of the signal under test are mapped onto antenna port 7 or 8.

Table 8.3.1.1B-2: Minimum Performance of TM9-Single-Layer (2 CSI-RS ports) – Non-MBSFN ABS

Test Number	Reference Channel	OCNG Pattern			Propagation Conditions (Note1)			Correlation Matrix and Antenna Configuration (Note 2)	Reference Value		UE Category
		Cell 1	Cell 2	Cell 3	Cell 1	Cell 2	Cell 3		Fraction of Maximum Throughput (%)	SNR (dB) (Note 3)	
1	R.51 FDD	OP.1 FDD	OP.1 FDD	OP.1 FDD	EVA5			2x2 Low	70	7.8	≥2
Note 1: The propagation conditions for Cell 1, Cell 2 and Cell 3 are statistically independent. Note 2: The correlation matrix and antenna configuration apply for Cell 1, Cell 2 and Cell 3. Note 3: SNR corresponds to \hat{E}_s / N_{oc2} of cell 1.											

8.3.1.1C Enhanced Performance Requirement Type B – Single-layer Spatial Multiplexing with TM9 interference model

The requirements are specified in Table 8.3.1.1C-2, with the addition of the parameters in Table 8.3.1.1C-1 and the downlink physical channel setup according to Annex C.3.2. The purpose of these tests is to verify closed loop rank one performance on one of the antenna ports 7, 8 without a simultaneous transmission on the other antenna port in the serving cell when the PDSCH transmission in the serving cell is interfered by PDSCH of two interfering cells applying transmission mode 9 interference model defined in clause B.6.4. In 8.3.1.1C-1, Cell 1 is the serving cell, and Cell 2, 3 are interfering cells. The downlink physical channel setup is according to Annex C.3.2 for each of Cell 1, Cell 2 and Cell 3, respectively.

Table 8.3.1.1C-1: Test Parameters for Testing CDM-multiplexed DM RS (Single-layer) with TM9 interference model

Parameter		Unit	Cell 1	Cell 2	Cell 3
Downlink power allocation	ρ_A	dB	0	0	0
	ρ_B	dB	0 (Note 1)	0	0
	σ	dB	-3	-3	-3
Cell-specific reference signals			Antenna ports 0,1	Antenna ports 0,1	Antenna ports 0,1
N_{oc} at antenna port		dBm/15kHz	-98		
\bar{E}_s/N_{oc}		dB	N/A	13.91	3.34
$BW_{Channel}$		MHz	10	10	10
Cyclic Prefix			Normal	Normal	Normal
Cell Id			0	1	6
Number of control OFDM symbols			3	3	3
CFI indicated in PCFICH			3	3	3
PDSCH transmission mode			9	9	9
Interference model			N/A	As specified in clause B.6.4	As specified in clause B.6.4
Precoding			Random wideband precoding per TTI	As specified in clause B.6.4	As specified in clause B.6.4
CSI reference signals			Antenna ports 15, 16, 17, 18	Antenna ports 15, 16	Antenna ports 15, 16
CSI-RS periodicity and subframe offset $T_{CSI-RS} / \Delta_{CSI-RS}$		Subframes	10 / 1	10 / 1	10 / 1
CSI reference signal configuration			5	6	7
Zero-power CSI-RS configuration $l_{CSI-RS} / ZeroPowerCSI-RS$ bitmap		Subframes / bitmap	6 / 10000000000000000000	6 / 0100000000000000	6 / 0010000000000000
Time offset to cell 1		us	N/A	2	3
Frequency offset to cell 1		Hz	N/A	200	300
MBSFN			Not configured	Not configured	Not configured
NeighCellsInfo-r12 (Note 4)	p-aList-r12		N/A	{dB-6, dB-3, dB0}	{dB-6, dB-3, dB0}
	transmissionModelList-r12		N/A	{2,3,4,8,9}	{2,3,4,8,9}
Note 1: $P_B = 1$					
Note 2: Cell 1 is the serving cell. Cell 2, 3 are the interfering cells.					
Note 3: CSI-RS configurations are according to [4] subclause 6.10.5.2.					
Note 4: NeighCellsInfo-r12 is described in subclause 6.3.2 of [7].					

Table 8.3.1.1C-2: Minimum Performance for Enhanced Performance Requirement Type B, CDM-multiplexed DM RS with TM9 interference model

Test Number	Reference Channel	OCNG Pattern			Propagation Conditions			Correlation Matrix and Antenna Configuration			Reference Value		UE Category
		Cell 1	Cell 2	Cell 3	Cell 1	Cell 2	Cell 3	Cell 1	Cell 2	Cell 3	Fraction of Maximum Throughput (%)	SNR (dB) (Note 2)	
1	R.69 FDD	OP. 1 FDD	N/A	N/A	EP A5	EP A5	EP A5	4x2 Low	2x2 Low	2x2 Low	85	18.5	≥1

Note 1: The propagation conditions for Cell 1, Cell 2 and Cell 3 are statistically independent.

Note 2: SNR corresponds to \bar{E}_s/N_{oc} of Cell 1 as defined in clause 8.1.1.

8.3.1.1D Enhanced Performance Requirement Type B – Single-layer Spatial Multiplexing with CRS interference model

The requirements are specified in Table 8.3.1.1D-2, with the addition of the parameters in Table 8.3.1.1D-1 and the downlink physical channel setup according to Annex C.3.2. The purpose of these tests is to verify closed loop rank one performance on one of the antenna ports 7 or 8 without a simultaneous transmission on the other antenna port in the serving cell when the PDSCH transmission in the serving cell is interfered by the CRS of the interfering cell, applying the CRS interference model defined in clause B.6.5. In 8.3.1.1D-1, Cell 1 is the serving cell, and Cell 2, 3 are interfering cells. The downlink physical channel setup is according to Annex C.3.2 for each of Cell 1, Cell 2 and Cell 3, respectively.

Table 8.3.1.1D-1: Test Parameters for Testing CDM-multiplexed DM RS (Single-layer) with CRS interference model

Parameter		Unit	Cell 1	Cell 2	Cell 3
Downlink power allocation	ρ_A	dB	0	0	0
	ρ_B	dB	0 (Note 1)	0	0
	σ	dB	-3	-3	-3
Cell-specific reference signals			Antenna ports 0,1	Antenna ports 0,1	Antenna ports 0,1
N_{oc} at antenna port		dBm/15kHz	-98		
\widehat{E}_s/N_{oc}		dB	N/A	13.91	3.34
$BW_{Channel}$		MHz	10	10	10
Cyclic Prefix			Normal	Normal	Normal
Cell Id			0	1	6
Number of control OFDM symbols			3	3	3
CFI indicated in PCFICH			3	3	3
PDSCH transmission mode			8	N/A	N/A
Interference model			N/A	As specified in clause B.6.5	As specified in clause B.6.5
Precoding			Random wideband precoding per TTI	N/A	N/A
Time offset to cell 1		us	N/A	2	3
Frequency offset to cell 1		Hz	N/A	200	300
MBSFN			Not configured	Not configured	Not configured
NeighCellsInfo-r12 (Note 3)	p-aList-r12		N/A	{dB-6, dB-3, dB0}	{dB-6, dB-3, dB0}
	transmissionModelList-r12		N/A	{2,3,4,8,9}	{2,3,4,8,9}
Note 1: $P_B = 1$					
Note 2: Cell 1 is the serving cell. Cell 2, 3 are the interfering cells.					
Note 3: NeighCellsInfo-r12 is described in subclause 6.3.2 of [7].					

Table 8.3.1.1D-2: Minimum Performance for Enhanced Performance Requirement Type B, CDM-multiplexed DM RS with CRS interference model

Test Number	Reference Channel	OCNG Pattern			Propagation Conditions			Correlation Matrix and Antenna Configuration (Note 3)	Reference Value		UE Category
		Cell 1	Cell 2	Cell 3	Cell 1	Cell 2	Cell 3		Fraction of Maximum Throughput (%)	SNR (dB) (Note 2)	
1	R.71 FDD	OP. 1 FDD	N/A	N/A	EP A5	EP A5	EP A5	2x2 Low	85	14.3	≥2

Note 1: The propagation conditions for Cell 1, Cell 2 and Cell 3 are statistically independent.

Note 2: SNR corresponds to \hat{E}_s/N_{oc} of Cell 1 as defined in clause 8.1.1.

Note 3: Correlation matrix and antenna configuration parameters apply for each of Cell 1, Cell 2 and Cell 3.

8.3.1.1E Enhanced Performance Requirement Type B – Single-layer Spatial Multiplexing with TM3 interference model

The requirements are specified in Table 8.3.1.1E-2, with the addition of the parameters in Table 8.3.1.1E-1 and the downlink physical channel setup according to Annex C.3.2. The purpose of these tests is to verify closed loop rank one performance on one of the antenna ports 7 or 8 without a simultaneous transmission on the other antenna port in the serving cell when the PDSCH transmission in the serving cell is interfered by PDSCH of two interfering cells applying transmission mode 3 interference model defined in clause B.6.2. In 8.3.1.1E-1, Cell 1 is the serving cell, and Cell 2, 3 are interfering cells. The downlink physical channel setup is according to Annex C.3.2 for each of Cell 1, Cell 2 and Cell 3, respectively.

Table 8.3.1.1E-1: Test Parameters for Testing CDM-multiplexed DM RS (Single-layer) with TM3 interference model

Parameter		Unit	Cell 1	Cell 2	Cell 3
Downlink power allocation	ρ_A	dB	0	-3	-3
	ρ_B	dB	0 (Note 1)	-3	-3
	σ	dB	-3	0	0
Cell-specific reference signals			Antenna ports 0,1	Antenna ports 0,1	Antenna ports 0,1
N_{oc} at antenna port		dBm/15kHz	-98		
\bar{E}_s/N_{oc}		dB	N/A	3.28	0.74
$BW_{Channel}$		MHz	10	10	10
Cyclic Prefix			Normal	Normal	Normal
Cell Id			0	1	6
Number of control OFDM symbols			3	3	3
CFI indicated in PCFICH			3	Random from {1,2,3}	Random from {1,2,3}
PDSCH transmission mode			8	3	3
Interference model			N/A	As specified in clause B.6.2	As specified in clause B.6.2
Precoding			Random wideband precoding per TTI	As specified in clause B.6.2	As specified in clause B.6.2
Time offset to cell 1		us	N/A	2	3
Frequency offset to cell 1		Hz	N/A	200	300
MBSFN			Not configured	Not configured	Not configured
NeighCellsInfo-r12 (Note 4)	p-aList-r12		N/A	{dB-6, dB-3, dB0}	{dB-6, dB-3, dB0}
	transmissionModeList-r12		N/A	{2,3,4,8,9}	{2,3,4,8,9}
Note 1: $P_B = 1$					
Note 2: Cell 1 is the serving cell. Cell 2, 3 are the interfering cells.					
Note 3: CSI-RS configurations are according to [4] subclause 6.10.5.2.					
Note 4: NeighCellsInfo-r12 is described in subclause 6.3.2 of [7].					

Table 8.3.1.1E-2: Minimum Performance for Enhanced Performance Requirement Type B, CDM-multiplexed DM RS with TM3 interference model

Test Number	Reference Channel	OCNG Pattern			Propagation Conditions			Correlation Matrix and Antenna Configuration (Note 3)	Reference Value		UE Category
		Cell 1	Cell 2	Cell 3	Cell 1	Cell 2	Cell 3		Fraction of Maximum Throughput (%)	SNR (dB) (Note 2)	
1	R.70 FDD	OP. 1 FD D	N/A	N/A	EP A5	EP A5	EP A5	2x2 Low	85	11.5	≥ 1
Note 1: The propagation conditions for Cell 1, Cell 2 and Cell 3 are statistically independent.											
Note 2: SNR corresponds to \bar{E}_s/N_{oc} of Cell 1 as defined in clause 8.1.1.											
Note 3: Correlation matrix and antenna configuration parameters apply for each of Cell 1, Cell 2 and Cell 3.											

8.3.1.1F Enhanced Performance Requirement Type B – Single-layer Spatial Multiplexing with TM10 serving cell configuration and TM9 interference model

The requirements are specified in Table 8.3.1.1F-2, with the addition of the parameters in Table 8.3.1.1F-1 and the downlink physical channel setup according to Annex C.3.2. The purpose of these tests is to verify closed loop rank one performance on one of the antenna ports 7 or 8 without a simultaneous transmission on the other antenna port in the

servicing cell when the PDSCH transmission configured with TM10 in the servicing cell is interfered by PDSCH of one dominant interfering cell applying transmission mode 9 interference model defined in clause B.6.3. The NAICS network assistance is provided when the servicing cell TM10 is configured with QCL-type A and PCID based DM-RS scrambling. The neighbouring cell has transmission mode TM9 and NeighCellsInfo-r12 for interfering cell indicates presence of TM9. In 8.3.1.1F-1, Cell 1 is the servicing cell, and Cell 2, 3 are interfering cells. The downlink physical channel setup is according to Annex C.3.2 for each of Cell 1, Cell 2 and Cell 3, respectively.

Table 8.3.1.1F-1: Test Parameters for Testing CDM-multiplexed DM RS (single layer) with TM10 servicing cell configuration and TM9 interference model

Parameter		Unit	Cell 1	Cell 2	Cell 3
Downlink power allocation	ρ_A	dB	0	0	0
	ρ_B	dB	0 (Note 1)	0	0
	σ	dB	-3	-3	-3
Cell-specific reference signals			Antenna ports 0,1	Antenna ports 0,1	Antenna ports 0,1
N_{oc} at antenna port		dBm/15kHz	-98		
\hat{E}_s/N_{oc}		dB	N/A	13.91	3.34
BW _{Channel}		MHz	10	10	10
Cyclic Prefix			Normal	Normal	Normal
Cell Id			0	1	6
Number of control OFDM symbols			3	3	3
CFI indicated in PCFICH			3	3	3
PDSCH transmission mode			10	9	9
Interference model			N/A	As specified in clause B.6.4	As specified in clause B.6.4
Precoding			Random wideband precoding per TTI	As specified in clause B.6.4	As specified in clause B.6.4
CSI reference signals			Antenna ports 15, 16, 17, 18	Antenna ports 15, 16	Antenna ports 15, 16
CSI-RS periodicity and subframe offset $T_{CSI-RS} / \Delta_{CSI-RS}$		Subframes	10 / 1	10 / 1	10 / 1
CSI reference signal configuration			5	6	7
Zero-power CSI-RS configuration $l_{CSI-RS} / \text{ZeroPowerCSI-RS}$ bitmap		Subframes / bitmap	6 / 1000000000 00000	6 / 01000000000 0000	6 / 00100000000 00000
Time offset to cell 1		us	N/A	2	3
Frequency offset to cell 1		Hz	N/A	200	300
MBSFN			Not configured	Not configured	Not configured
NeighCellsInfo-r12 (Note 4)	p-aList-r12		N/A	{dB-6, dB-3, dB0}	{dB-6, dB-3, dB0}
	transmissionModeList-r12		N/A	{2,3,4,8,9}	{2,3,4,8,9}
Note 1: $P_B = 1$					
Note 2: Cell 1 is the servicing cell. Cell 2, 3 are the interfering cells.					
Note 3: CSI-RS configurations are according to [4] subclause 6.10.5.2.					
Note 4: NeighCellsInfo-r12 is described in subclause 6.3.2 of [7].					

Table 8.3.1.1F-2: Minimum Performance for Enhanced Performance Requirement Type B, CDM-multiplexed DM RS with TM10 serving cell configuration and TM9 interference model

Test Number	Reference Channel	OCNG Pattern			Propagation Conditions			Correlation Matrix and Antenna Configuration			Reference Value		UE Category
		Cell 1	Cell 2	Cell 3	Cell 1	Cell 2	Cell 3	Cell 1	Cell 2	Cell 3	Fraction of Maximum Throughput (%)	SNR (dB) (Note 2)	
1	R.69 FDD	OP. 1 FDD	N/A	N/A	EP A5	EP A5	EP A5	4x2 Low	2x2 Low	2x2 Low	85	18.2	≥1
Note 1: The propagation conditions for Cell 1, Cell 2 and Cell 3 are statistically independent. Note 2: SINR corresponds to \hat{E}_s / N_{oc} of Cell 1 as defined in clause 8.1.1.													

8.3.1.1G Single-layer Spatial Multiplexing (CRS assistance information is configured)

The requirements are specified in Table 8.3.1.1G-2, with the addition of parameters in Table 8.3.1.1G-1. The purpose is to verify the performance of the antenna ports 7 or 8 without a simultaneous transmission on the other antenna port in the serving cell with CRS assistance information. In Table 8.3.1.1G-1, Cell 1 is the serving cell, and Cell 2 and Cell 3 are the aggressor cells. The downlink physical channel setup for Cell 1, Cell2 and Cell 3 is according to Annex C.3.2. The CRS assistance information [7] includes Cell 2 and Cell 3.

Table 8.3.1.1G-1: Test parameters of TM9-Single-Layer (2 CSI-RS ports)

Parameter		Unit	Cell 1	Cell 2	Cell 3
Downlink power allocation	ρ_A	dB	0	0	0
	ρ_B	dB	0 (Note 1)	0 (Note 1)	0 (Note 1)
	σ	dB	-3	-3	-3
N_{oc} at antenna port		dBm/15kHz	-98	N/A	N/A
\bar{E}_s/N_{oc}		dB	Reference Value in Table 8.3.1.1G-2	10.45	4.6
BW _{Channel}		MHz	10	10	10
Subframe Configuration			Non-MBSFN	Non-MBSFN	Non-MBSFN
Time Offset to Cell 1		μs	N/A	3	-1
Frequency shift to Cell 1		Hz	N/A	300	-100
Cell Id			0	1	128
Cell-specific reference signals			Antenna ports 0,1		
CSI reference signals			Antenna ports 15,16	N/A	N/A
CSI-RS periodicity and subframe offset $T_{CSI-RS} / \Delta_{CSI-RS}$		Subframes	5 / 2	N/A	N/A
CSI reference signal configuration			8	N/A	N/A
Zero-power CSI-RS configuration $l_{CSI-RS} / \text{ZeroPowerCSI-RS}$ bitmap		Subframes / bitmap	3 / 001000000000000	N/A	N/A
Number of control OFDM symbols			2	2	2
PDSCH transmission mode			TM9-1layer	N/A	N/A
Precoding granularity			Frequency domain: 1 PRG Time domain: 1 ms	N/A	N/A
Beamforming model			Annex B.4.1	N/A	N/A
Interference model			N/A	As specified in clause B.5.4	As specified in clause B.5.4
Probability of occurrence of transmission in interference cells		%	N/A	20	20
Probability of occurrence of transmission rank in interfering cells	Rank 1	%	N/A	80	80
	Rank 2	%	N/A	20	20
Cyclic prefix			Normal	Normal	Normal
<p>Note 1: $P_B = 1$.</p> <p>Note 2: If the UE reports in an available uplink reporting instance at subframe SF#n based on PMI estimation at a downlink SF not later than SF#(n-4), this reported PMI cannot be applied at the eNB downlink before SF#(n+4).</p> <p>Note 3: The number of the CRS ports in Cell 1, Cell 2 and Cell 3 is the same.</p> <p>Note 4: SIB-1 will not be transmitted in Cell 2 and Cell 3 in this test.</p> <p>Note 5: The modulation symbols of the signal under test are mapped onto antenna port 7 or 8.</p>					

Table 8.3.1.1G-2: Minimum Performance of TM9-Single-Layer (2 CSI-RS ports)

Test Number	Reference Channel	OCNG Pattern			Propagation Conditions (Note1)			Correlation Matrix and Antenna Configuration (Note 2)	Reference Value		UE Category
		Cell 1	Cell 2	Cell 3	Cell 1	Cell 2	Cell 3		Fraction of Maximum Throughput (%)	SNR (dB) (Note 3)	
1	R.51-1 FDD	OP.1 FDD	N/A	N/A	EVA5			2x2 Low	70	11.6	≥2
Note 1:	The propagation conditions for Cell 1, Cell 2 and Cell 3 are statistically independent.										
Note 2:	The correlation matrix and antenna configuration apply for Cell 1, Cell 2 and Cell 3.										
Note 3:	SNR corresponds to \hat{E}_s/N_{0c} of cell 1.										

8.3.1.1H Single-layer Spatial Multiplexing (With Enhanced DMRS table configured)

For single-layer transmission on antenna port 7, 8, 11 or 13 upon detection of a PDCCH with DCI format 2C, the requirement is specified in Table 8.3.1.1H-2, with the addition of the parameters in Table 8.3.1.1H-1 and the downlink physical channel setup according to Annex C.3.2. The purpose of the test is to verify rank-1 performance on antenna port 11 with a simultaneous transmission on the antenna port 7, 8 or 13 with DMRS enhancement table and 4 orthogonal DMRS ports (dmrs-Enhancements-r13 UE-EUTRA-Capability [7]).

Table 8.3.1.1H-1: Test Parameters for Testing CDM-multiplexed DM RS (single layer) with interfering simultaneous transmission (FRC) with multiple CSI-RS configurations with Enhanced DMRS table

parameter		Unit	Test 1
Downlink power allocation	ρ_A	dB	0
	ρ_B	dB	0 (Note 1)
	σ	dB	-3
Beamforming model			Annex B.4.1A
Cell-specific reference signals			Antenna ports 0,1
CSI reference signals			Antenna ports 15,...,18
CSI-RS periodicity and subframe offset $T_{\text{CSI-RS}} / \Delta_{\text{CSI-RS}}$		Subframes	5 / 2
CSI reference signal configuration			3
Zero-power CSI-RS configuration $I_{\text{CSI-RS}} / \text{ZeroPowerCSI-RS}$ bitmap		Subframes / bitmap	3 / 0001000000000000
N_{oc} at antenna port		dBm/15kHz	-98
Symbols for unused PRBs			OCNG (Note 4)
Number of allocated resource blocks (Note 2)		PRB	50
Simultaneous transmission			Yes (Note 3, 5)
dmrs-Enhancements-r13			Enable
PDSCH transmission mode			9
<p>Note 1: $P_B = 1$.</p> <p>Note 2: The modulation symbols of the signal under test are mapped onto antenna port 11.</p> <p>Note 3: Modulation symbols of an interference signal are random mapped onto one antenna port among antenna port 7, 8 and 13. The update granularity for randomized mapping antenna port is 1 PRG in frequency domain and 1ms in time domain.</p> <p>Note 4: These physical resource blocks are assigned to an arbitrary number of virtual UEs with one PDSCH per virtual UE; the data transmitted over the OCNG PDSCHs shall be uncorrelated pseudo random data, which is QPSK modulated.</p> <p>Note 5: The two UEs' scrambling identities n_{SCID} are set to 0 with OCC =4.</p>			

Table 8.3.1.1H-2: Minimum performance for CDM-multiplexed DM RS with interfering simultaneous transmission (FRC) with multiple CSI-RS configurations with Enhanced DMRS table

Test number	Bandwidth and MCS	Reference Channel	OCNG Pattern	Propagation Condition	Correlation Matrix and Antenna Configuration	Reference value		UE Category
						Fraction of Maximum Throughput (%)	SNR (dB)	
1	10 MHz 64QAM 1/2	R.50 FDD	OP.1 FDD	EPA5	2x2 Low	70	21.9	≥2

Note 1: The reference channel applies to both the input signal under test and the interfering signal.

8.3.1.2 Dual-Layer Spatial Multiplexing

For dual-layer transmission on antenna ports 7 and 8 upon detection of a PDCCH with DCI format 2C, the requirements are specified in Table 8.3.1.2-2, with the addition of the parameters in Table 8.3.1.2-1 where Cell 1 is the serving cell and Cell 2 is the interfering cell. The downlink physical channel setup is set according to Annex C.3.2. The purpose of

these tests is to verify the rank-2 performance for full RB allocation, to verify rate matching with multiple CSI reference symbol configurations with non-zero and zero transmission power, and to verify that the UE correctly estimate SNR.

Table 8.3.1.2-1: Test Parameters for Testing CDM-multiplexed DM RS (dual layer) with multiple CSI-RS configurations

Parameter		Unit	Test 1	
			Cell 1	Cell 2
Downlink power allocation	ρ_A	dB	0	0
	ρ_B	dB	0 (Note 1)	0
	σ	dB	-3	-3
	PDSCH_RA	dB	4	NA
	PDSCH_RB	dB	4	NA
Cell-specific reference signals			Antenna ports 0 and 1	Antenna ports 0 and 1
Cell ID			0	126
CSI reference signals			Antenna ports 15,16	NA
Beamforming model			Annex B.4.2	NA
CSI-RS periodicity and subframe offset $T_{\text{CSI-RS}} / \Delta_{\text{CSI-RS}}$		Subframes	5 / 2	NA
CSI reference signal configuration			8	NA
Zero-power CSI-RS configuration $I_{\text{CSI-RS}} / \text{ZeroPowerCSI-RS}$ bitmap		Subframes / bitmap	3 / 0010000000000000	NA
N_{oc} at antenna port		dBm/15kHz	-98	-98
\hat{E}_s / N_{oc}			Reference Value in Table 8.3.1.2-2	7.25dB
Symbols for unused PRBs			OCNG (Note 2)	NA
Number of allocated resource blocks (Note 2)		PRB	50	NA
Simultaneous transmission			No	NA
PDSCH transmission mode			9	Blanked
Note 1: $P_B = 1$ Note 2: These physical resource blocks are assigned to an arbitrary number of virtual UEs with one PDSCH per virtual UE; the data transmitted over the OCNG PDSCHs shall be uncorrelated pseudo random data, which is QPSK modulated.				

Table 8.3.1.2-2: Minimum performance for CDM-multiplexed DM RS (FRC) with multiple CSI-RS configurations

Test number	Bandwidth and MCS	Reference Channel	OCNG Pattern		Propagation Condition		Correlation Matrix and Antenna Configuration	Reference value		UE Category
			Cell1	Cell 2	Cell 1	Cell 2		Fraction of Maximum Throughput (%)	SNR (dB)	
1	10 MHz 16QAM 1/2	R.51 FDD	OP.1 FDD	N/A	ETU5	ETU5	2x2 Low	70	14.2	≥ 2
Note 1: The propagation conditions for Cell 1 and Cell 2 are statistically independent. Note 2: Correlation matrix and antenna configuration parameters apply for each of Cell 1 and Cell 2. Note 3: SNR corresponds to \hat{E}_s / N_{oc} of Cell 1.										

8.3.1.2A Enhanced Performance Requirement Type C - Dual-Layer Spatial Multiplexing

The requirements are specified in Table 8.3.1.2A-2, with the addition of the parameters in Table 8.3.1.2A-1 and the downlink physical channel setup according to Annex C.3.2. The purpose of this test is to verify rank two performance for full RB allocation upon antenna ports 7 and 8.

Table 8.3.1.2A-1: Test Parameters for Testing CDM-multiplexed DM RS (dual layer) with multiple CSI-RS configurations

parameter	Unit	Test 1	
Downlink power allocation	ρ_A	dB	0
	ρ_B	dB	0 (Note 1)
	σ	dB	-3
Cell-specific reference signals		Antenna ports 0 and 1	
CSI reference signals		Antenna ports 15,16	
Beamforming model		Annex B.4.2	
CSI-RS periodicity and subframe offset $T_{\text{CSI-RS}} / \Delta_{\text{CSI-RS}}$	Subframes	5 / 2	
CSI reference signal configuration		8	
Zero-power CSI-RS configuration $l_{\text{CSI-RS}} / \text{ZeroPowerCSI-RS}$ bitmap	Subframes / bitmap	3 / 0010000000000000	
N_{oc} at antenna port	dBm/15kHz	-98	
Symbols for unused PRBs		OCNG (Note 2)	
Number of allocated resource blocks (Note 2)	PRB	50	
Simultaneous transmission		No	
PDSCH transmission mode		9	
Note 1: $P_B = 1$ Note 2: These physical resource blocks are assigned to an arbitrary number of virtual UEs with one PDSCH per virtual UE; the data transmitted over the OCNG PDSCHs shall be uncorrelated pseudo random data, which is QPSK modulated.			

Table 8.3.1.2A-2: Enhanced Performance Requirement Type C for CDM-multiplexed DM RS (FRC) with multiple CSI-RS configurations

Test number	Bandwidth and MCS	Reference Channel	OCNG Pattern	Propagation Condition	Correlation Matrix and Antenna Configuration	Reference value		UE Category
						Fraction of Maximum Throughput (%)	SNR (dB)	
1	10 MHz 16QAM 1/2	R.51 FDD	OP.1 FDD	EPA5	2x2 Medium	70	17.4	≥ 2

8.3.1.3 Performance requirements for DCI format 2D and non Quasi Co-located Antenna Ports

8.3.1.3.1 Minimum requirement with Same Cell ID (with single NZP CSI-RS resource)

The requirements are specified in Table 8.3.1.3.1-3, with the additional parameters in Table 8.3.1.3.1-1 and Table 8.3.1.3.1-2. The purpose of this test is to verify the UE capability of supporting non quasi-co-located antenna ports when the UE receives DCI format 2D in a scenario where the two transmission point share the same Cell ID. In particular the test verifies that the UE, configured with quasi co-location type B, performs correct tracking and compensation of the timing difference between two transmission points, channel parameters estimation and rate matching according to the ‘PDSCH RE Mapping and Quasi-Co-Location Indicator’ (PQI) signalling defined in [6], configured according to Table 8.3.1.3.1-2. In Tables 8.3.1.3.1-1 and 8.3.1.3.1-2, transmission point 1 (TP 1) is the serving cell and transmission point 2 (TP 2) transmits PDSCH. The downlink physical channel setup for TP 1 is according to Table C.3.4-1 and for TP 2 according to Table C.3.4-2.

Table 8.3.1.3.1-1: Test Parameters for quasi co-location type B: same Cell ID

Parameter	Unit	TP 1	TP 2
Downlink power allocation	ρ_A	dB	0
	ρ_B	dB	0 (Note 1)
	σ	dB	-3
Cell-specific reference signals		Antenna ports 0,1	(Note 2)
CSI-RS 0 antenna ports		NA	Port {15,16}
<i>qcl-CSI-RS-ConfigNZPId-r11</i> , CSI-RS 0 periodicity and subframe offset $T_{CSI-RS} / \Delta_{CSI-RS}$	Subframes	NA	5/2
<i>qcl-CSI-RS-ConfigNZPId-r11</i> , CSI-RS 0 configuration		NA	8
<i>csi-RS-ConfigZPId-r11</i> , Zero-power CSI-RS 0 configuration $l_{CSI-RS} / \text{ZeroPower CSI-RS bitmap}$		NA	2/ 0000010000000000
N_{oc} at antenna port	dBm/15kHz	-98	-98
\widehat{E}_s / N_{oc}	dB	Reference point in Table 8.3.1.3.1-3	Reference point in Table 8.3.1.3.1-3
$BW_{Channel}$	MHz	10	10
Cyclic Prefix		Normal	Normal
Cell Id		0	0
Number of control OFDM symbols		2	2
PDSCH transmission mode		Blanked	10
Number of allocated PRB	PRB	NA	50
<i>qcl-Operation</i> , 'PDSCH RE Mapping and Quasi-Co-Location Indicator'		Type B, '00'	
Time offset between TPs	μs	NA	Reference point in Table 8.3.1.3.1-3
Frequency error between TPs	Hz	NA	0
Beamforming model		NA	Port 7 as specified in clause B.4.1
Symbols for unused PRBs		NA	OCNG (Note 3)
Note 1: $P_B = 1$ Note 2: REs for antenna ports 0 and 1 have zero transmission power. Note 3: These physical resource blocks are assigned to an arbitrary number of virtual UEs with one PDSCH per virtual UE; the data transmitted over the OCNG PDSCHs shall be uncorrelated pseudo random data, which is QPSK modulated.			

Table 8.3.1.3.1-2: Configurations of PQI and DL transmission hypothesis for each PQI set

PQI set index	Parameters in each PQI set		DL transmission hypothesis for each PQI Set	
	NZP CSI-RS Index (For quasi co-location)	ZP CSI-RS configuration	TP 1	TP 2
PQI set 0	CSI-RS 0	ZP CSI-RS 0	Blanked	PDSCH

Table 8.3.1.3.1-3: Minimum performance for quasi co-location type B: same Cell ID

Test Number	Reference Channel	OGCN pattern		Time offset between TPs (μ s)	Propagation Conditions (Note1)		Correlation Matrix and Antenna Configuration (Note 2)	Reference Value		UE Category
		TP 1	TP 2		TP 1	TP 2		Fraction of Maximum Throughput (%)	SNR (dB) (Note 3)	
1	R.52 FDD	NA	OP.1 FDD	2	EPA5	EPA5	2x2 Low	70	12.1	≥ 2
2	R.52 FDD	NA	OP.1 FDD	-0.5	EPA5	EPA5	2x2 Low	70	12.6	≥ 2

Note 1: The propagation conditions for TP 1 and TP 2 are statistically independent.
Note 2: The correlation matrix and antenna configuration apply for TP 1 and TP 2.
Note 3: SNR corresponds to \hat{E}_s / N_{oc} of TP 2 as defined in clause 8.1.1.

8.3.1.3.2 Minimum requirements with Same Cell ID (with multiple NZP CSI-RS resources)

The requirements are specified in Table 8.3.1.3.2-3, with the additional parameters in Tables 8.3.1.3.2-1 and 8.3.1.3.2-2. The purpose of this test is to verify the UE capability of supporting non quasi-co-located antenna ports when the UE receives DCI format 2D in a scenario where the two transmission point share the same Cell ID. In particular the test verifies that the UE, configured with quasi co-location type B, performs correct tracking and compensation of the timing difference between two transmission points, channel parameters estimation and rate matching according to the ‘PDSCH RE Mapping and Quasi-Co-Location Indicator’ (PQI) signalling defined in [6]. In Tables 8.3.1.3.2-1 and 8.3.1.3.2-2, transmission point 1 (TP 1) is the serving cell transmitting PDCCH, synchronization signals and PBCH, and transmission point 2 (TP 2) has same Cell ID as TP 1. Multiple NZP CSI-RS resources and ZP CSI-RS resources are configured. In each sub-frame, DL PDSCH transmission is dynamically switched between 2 TPs with multiple PDSCH RE Mapping and Quasi-Co-Location Indicator configuration (PQI). Configurations of PDSCH RE Mapping and Quasi-Co-Location Indicator and downlink transmission hypothesis are defined in Table 8.3.1.3.2-2. The downlink physical channel setup for TP 1 is according to Table C.3.4-1 and for TP 2 according to Table C.3.4-2.

Table 8.3.1.3.2-1: Test Parameters for timing offset compensation with DPS transmission

parameter	Unit	TP 1	TP 2
Downlink power allocation	ρ_A	dB	0
	ρ_B	dB	0 (Note 1)
	σ	dB	-3

Beamforming model		As specified in clause B.4.1	As specified in clause B.4.1
Cell-specific reference signals		Antenna ports 0,1	(Note 2)
CSI reference signals 0		Antenna ports {15,16}	N/A
CSI-RS 0 periodicity and subframe offset $T_{\text{CSI-RS}} / \Delta_{\text{CSI-RS}}$	Subframes	5 / 2	N/A
CSI reference signal 0 configuration		0	N/A
CSI reference signals 1		N/A	Antenna ports {15,16}
CSI-RS 1 periodicity and subframe offset $T_{\text{CSI-RS}} / \Delta_{\text{CSI-RS}}$	Subframes	N/A	5 / 2
CSI reference signal 1 configuration		N/A	8
Zero-power CSI-RS 0 configuration $l_{\text{CSI-RS}} /$ <i>ZeroPower CSI-RS</i> bitmap	Subframes /bitmap	2/ 0010000000000000	N/A
Zero-power CSI-RS1 configuration $l_{\text{CSI-RS}} /$ <i>ZeroPower CSI-RS</i> bitmaps	Subframes /bitmap	N/A	2/ 0000010000000000
\hat{E}_s / N_{oc}	dB	Reference Value in Table 8.3.1.3.2-3	Reference Value in Table 8.3.1.3.2-3
N_{oc} at antenna port	dBm/15kHz	-98	-98
BW_{Channel}	MHz	10	10
Cyclic Prefix		Normal	Normal
Cell Id		0	0
Number of control OFDM symbols		2	2
Timing offset between TPs		N/A	Reference Value in Table 8.3.1.3.2-3
Frequency offset between TPs	Hz	N/A	0
Number of allocated resource blocks	PRB	50	50
PDSCH transmission mode		10	10
Probability of occurrence of PDSCH transmission(Note 3)	%	30	70
Symbols for unused PRBs		OCNG (Note 4)	OCNG (Note 4)
<p>Note 1: $P_B = 1$</p> <p>Note 2: REs for antenna ports 0 and 1 have zero transmission power.</p> <p>Note 3: PDSCH transmission from TPs shall be randomly determined independently for each subframe. Probabilities of occurrence of PDSCH transmission from TPs are specified.</p> <p>Note 4: These physical resource blocks are assigned to an arbitrary number of virtual UEs with one PDSCH per virtual UE; the data transmitted over the OCNG PDSCHs shall be uncorrelated pseudo random data, which is QPSK modulated.</p>			

Table 8.3.1.3.2-2: Configurations of PQI and DL transmission hypothesis for each PQI set

PQI set index	Parameters in each PQI set		DL transmission hypothesis for each PQI Set	
	NZP CSI-RS Index (For quasi co-location)	ZP CSI-RS configuration	TP 1	TP 2
PQI set 0	CSI-RS 0	ZP CSI-RS 0	PDSCH	Blanked
PQI set 3	CSI-RS 1	ZP CSI-RS 1	Blanked	PDSCH

Table 8.3.1.3.2-3: Performance Requirements for timing offset compensation with DPS transmission

Test Number	Timing offset(us)	Reference Channel	OCNG Pattern		Propagation Conditions		Correlation Matrix and Antenna Configuration (Note 2)	Reference Value		UE Category
			TP 1	TP 2	TP 1	TP 2		Fraction of Maximum Throughput (%)	SNR (dB) (Note 3)	
1	2	R.53 FDD	OP.1 FDD	OP.1 FDD	EPA5	EPA5	2x2 Low	70	12.2	≥2
2	-0.5	R.53 FDD	OP.1 FDD	OP.1 FDD	EPA5	EPA5	2x2 Low	70	12.5	≥2

Note 1: The propagation conditions for TP 1 and TP 2 are statistically independent.
Note 2: Correlation matrix and antenna configuration parameters apply for each of TP 1 and TP 2.
Note 3: SNR corresponds to \hat{E}_s / N_{oc} of both TP 1 and TP 2 as defined in clause 8.1.1.

8.3.1.3.3 Minimum requirement with Different Cell ID and Colliding CRS (with single NZP CSI-RS resource)

The requirements are specified in Table 8.3.1.3.3-2, with the additional parameters in Table 8.3.1.3.3-1. The purpose of this test is to verify the UE capability of supporting non quasi-co-located antenna ports when the UE receives DCI format 2D in a scenario where the two transmission points have different Cell ID and colliding CRS. In particular the test verifies that the UE, configured with quasi co-location type B, performs correct tracking and compensation of the frequency difference between two transmission points, channel parameters estimation and rate matching behaviour according to the 'PDSCH RE Mapping and Quasi-Co-Location Indicator' signalling defined in [6]. In Table 8.3.1.3.3-1, transmission point 1 (TP 1) is serving cell transmitting PDCCH, synchronization signals and PBCH, and transmission point 2 (TP 2) transmits PDSCH with different Cell ID. The downlink physical channel setup for TP 1 is according to Table C.3.4-1 and for TP 2 according to Table C.3.4-2.

Table 8.3.1.3.3-1: Test Parameters for quasi co-location type B with different Cell ID and Colliding CRS

parameter	Unit	TP 1	TP 2
Downlink power allocation	ρ_A	dB	0
	ρ_B	dB	0 (Note 1)
	σ	dB	-3

Beamforming model		N/A	As specified in clause B.4.2
Cell-specific reference signals		Antenna ports 0,1	Antenna ports 0,1
CSI reference signals 0		N/A	Antenna ports {15,16}
CSI-RS 0 periodicity and subframe offset $T_{CSI-RS} / \Delta_{CSI-RS}$	Subframes	N/A	5 / 2
CSI reference signal 0 configuration		N/A	0
Zero-power CSI-RS 0 configuration $I_{CSI-RS} / ZeroPower\ CSI-RS\ bitmap$	Subframes /bitmap	N/A	2/ 0010000000000000
\hat{E}_s / N_{oc}	dB	Reference point in Table 8.3.1.3.3-2 + 4dB	Reference Value in Table 8.3.1.3.3-2
N_{oc} at antenna port	dBm/15kHz	-98	-98
$BW_{Channel}$	MHz	10	10
Cyclic Prefix		Normal	Normal
Cell Id		0	126
Number of control OFDM symbols		1	2
Timing offset between TPs	us	N/A	0
Frequency offset between TPs	Hz	N/A	200
<i>qcl-Operation, PDSCH RE Mapping and Quasi-Co-Location Indicator</i>		Type B, '00'	
PDSCH transmission mode		Blank	10
Number of allocated resource block		N/A	50
Symbols for unused PRBs		N/A	OCNG(Note2)
Note 1: $P_b = 1$ Note 2: These physical resource blocks are assigned to an arbitrary number of virtual UEs with one PDSCH per virtual UE; the data transmitted over the OCNG PDSCHs shall be uncorrelated pseudo random data, which is QPSK modulated.			

Table 8.3.1.3.3-2: Performance Requirements for quasi co-location type B with different Cell ID and Colliding CRS

Test Number	Reference Channel	OCNG Pattern		Propagation Conditions (Note1)		Correlation Matrix and Antenna Configuration (Note 2)	Reference Value		UE Category
		TP 1	TP 2	TP 1	TP 2		Fraction of Maximum Throughput (%)	SNR (dB) (Note 3)	
1	R.54 FDD	N/A	OP.1 FDD	EPA5	ETU5	2x2 Low	70	14.4	≥2
Note 1: The propagation conditions for TP.1 and TP.2 are statistically independent. Note 2: Correlation matrix and antenna configuration parameters apply for each of TP.1 and TP.2. Note 3: SNR corresponds to \hat{E}_s / N_{oc} of TP.2 as defined in clause 8.1.1.									

8.3.1.3.4 Minimum requirement with Different Cell ID and non-colliding CRS (with single NZP CSI-RS resource and CRS assistance information is configured)

The requirements are specified in Table 8.3.1.3.4-3, with the additional parameters in Table 8.3.1.3.4-1 and Table 8.3.1.3.4-2. The purpose of this test is to verify the UE capability of supporting non quasi-colocated antenna ports when the UE receives DCI format 2D in a scenario where three transmission points have different Cell ID and non-colliding CRS. In particular the test verifies that the UE, configured with quasi co-location type B, performs correct tracking and compensation of the frequency difference and time difference between two transmission points, channel parameters estimation and rate matching behaviour according to the 'PDSCH RE Mapping and Quasi-Co-Location Indicator' signalling defined in [6]. Further, the test verifies that the UE, configured with the CRS assistance information [7], can mitigate interference from CRS for demodulation. The CRS assistance information [7] includes TP 3. In Table 8.3.1.3.4-1, transmission point 1 (TP 1) is serving cell transmitting PDCCH, synchronization signals and PBCH, transmission point 2 (TP 2) transmits PDSCH with different Cell ID, and Transmission point 3 (TP 3) is the aggressor transmission point. The downlink physical channel setup for TP 1 is according to Table C.3.4-1, for TP 2 is according to Table C.3.4-2, and for TP 3 is according to Annex C.3.2.

Table 8.3.1.3.4-1: Test Parameters for quasi co-location type B with different Cell ID and non-Colliding CRS when CRS assistance information is configured

parameter		Unit	TP 1	TP 2	TP 3
Downlink power allocation	ρ_A	dB	0	0	0
	ρ_B	dB	0 (Note 1)	0	0
	σ	dB	-3	-3	-3
Beamforming model			N/A	Port 7 as specified in clause B.4.1	N/A
Cell-specific reference signals			Antenna ports 0,1	Antenna ports 0,1	Antenna ports 0,1
CSI reference signals 0			N/A	Antenna ports {15,16}	N/A
CSI-RS 0 periodicity and subframe offset $T_{\text{CSI-RS}} / \Delta_{\text{CSI-RS}}$		Subframes	N/A	5 / 2	N/A
CSI reference signal 0 configuration			N/A	0	N/A
Zero-power CSI-RS 0 configuration $I_{\text{CSI-RS}} / \text{ZeroPower CSI-RS bitmap}$		Subframes /bitmap	N/A	2/ 0010000000000000	N/A
\widehat{E}_s / N_{oc}		dB	10.45	Reference Value in Table 8.3.1.3.4-3	8.45
N_{oc} at antenna port		dBm/15kHz	-98	-98	N/A
BW_{Channel}		MHz	10	10	10
Cyclic Prefix			Normal	Normal	Normal
Cell Id			0	1	128
Number of control OFDM symbols			1	2	2
Timing offset to TP 1		us	N/A	-0.5	3
Frequency offset to TP 1		Hz	N/A	200	-100
<i>qcl-Operation</i> , 'PDSCH RE Mapping and Quasi-Co-Location Indicator'			Type B, '00'		N/A
PDSCH transmission mode			Blank	10	9
Number of allocated resource block			N/A	50	N/A
Symbols for unused PRBs			N/A	OCNG(Note2)	N/A
Interference model			N/A	N/A	As specified in clause B.5.4
Probability of occurrence of transmission in interference cells		%	N/A	N/A	20
Probability of occurrence of transmission rank in interfering cells	Rank 1	%	N/A	N/A	80
	Rank 2	%	N/A	N/A	20
Note 1: $P_B = 1$ Note 2: These physical resource blocks are assigned to an arbitrary number of virtual UEs with one PDSCH per virtual UE; the data transmitted over the OCNG PDSCHs shall be uncorrelated pseudo random data, which is QPSK modulated.					

Table 8.3.1.3.4-2: Configurations of PQI and DL transmission hypothesis for each PQI set

PQI set index	Parameters in each PQI set		DL transmission hypothesis for each PQI Set	
	NZP CSI-RS Index (For quasi co-location)	ZP CSI-RS configuration	TP 1	TP 2
PQI set 0	CSI-RS 0	ZP CSI-RS 0	Blanked	PDSCH

Table 8.3.1.3.4-3: Performance Requirements for quasi co-location type B with different Cell ID and non-Colliding CRS when CRS assistance information is configured

Test Number	Reference Channel	OCNG Pattern			Propagation Conditions (Note1)			Correlation Matrix and Antenna Configuration (Note 2)	Reference Value		UE Category
		TP 1	TP 2	TP3	TP 1	TP 2	TP3		Fraction of Maximum Throughput (%)	SNR (dB) (Note 3)	
1	R.52-1 FDD	N/A	OP.1 FDD	N/A	EVA5	EVA5	EVA5	2x2 Low	70	10.8	≥2
Note 1: The propagation conditions for TP.1, TP.2 and TP.3 are statistically independent. Note 2: Correlation matrix and antenna configuration parameters apply for each of TP.1, TP.2 and TP.3. Note 3: SNR corresponds to \hat{E}_s / N_{oc} of TP.2 as defined in clause 8.1.1.											

8.3.1.3.5 Minimum requirements with different Cell ID and non-colliding CRS (with multiple NZP CSI-RS resources and CRS assistance information is configured)

The requirements are specified in Table 8.3.1.3.5-3, with the additional parameters in Tables 8.3.1.3.5-1 and 8.3.1.3.5-2. The purpose of this test is to verify the UE capability of supporting non quasi-colocated antenna ports when the UE receives DCI format 2D in a scenario where three transmission points have different Cell ID and non-colliding CRS. In particular the test verifies that the UE, configured with quasi co-location type B, performs correct tracking and compensation of the frequency difference and timing difference between two transmission points, channel parameters estimation and rate matching according to the 'PDSCH RE Mapping and Quasi-Co-Location Indicator' (PQI) signalling defined in [6]. Further, the test verifies that the UE, configured with the CRS assistance information [7], can mitigate interference from CRS for demodulation. The CRS assistance information [7] includes TP 3. In Tables 8.3.1.3.5-1 and 8.3.1.3.5-2, transmission point 1 (TP 1) is the serving cell transmitting PDCCH, synchronization signals and PBCH, Transmission point 2 (TP 2) has different Cell ID as TP 1, and Transmission point 3 (TP 3) is the aggressor transmission point. Multiple NZP CSI-RS resources and ZP CSI-RS resources are configured. In each sub-frame, DL PDSCH transmission is dynamically switched between TP 1 and TP 2 with multiple PDSCH RE Mapping and Quasi-Co-Location Indicator configuration (PQI). Configurations of PDSCH RE Mapping and Quasi-Co-Location Indicator and downlink transmission hypothesis are defined in Table 8.3.1.3.5-2. The downlink physical channel setup for TP 1 is according to Table C.3.4-1, for TP 2 is according to Table C.3.4-2, and for TP 3 is according to Annex C.3.2.

Table 8.3.1.3.5-1: Test Parameters DPS transmission with CRS assistance information

parameter		Unit	TP 1	TP 2	TP 3
Downlink power allocation	ρ_A	dB	0	0	0
	ρ_B	dB	0 (Note 1)	0	0
	σ	dB	-3	-3	-3
Beamforming model			As specified in clause B.4.1	As specified in clause B.4.1	N/A
Cell-specific reference signals			Antenna ports 0,1	Antenna ports 0,1	Antenna ports 0,1
CSI reference signals 0			Antenna ports {15,16}	N/A	N/A
CSI-RS 0 periodicity and subframe offset $T_{\text{CSI-RS}} / \Delta_{\text{CSI-RS}}$		Subframes	5 / 2	N/A	N/A
CSI reference signal 0 configuration			0	N/A	N/A
CSI reference signals 1			N/A	Antenna ports {15,16}	N/A
CSI-RS 1 periodicity and subframe offset $T_{\text{CSI-RS}} / \Delta_{\text{CSI-RS}}$		Subframes	N/A	5 / 2	N/A
CSI reference signal 1 configuration			N/A	8	N/A
Zero-power CSI-RS 0 configuration $I_{\text{CSI-RS}} / \text{ZeroPower CSI-RS}$ bitmap		Subframes /bitmap	2/ 0010000000000000	N/A	N/A
Zero-power CSI-RS1 configuration $I_{\text{CSI-RS}} / \text{ZeroPower CSI-RS}$ bitmaps		Subframes /bitmap	N/A	2/ 0000010000000000	N/A
\widehat{E}_s / N_{oc} (Note 2)		dB	Reference Value in Table 8.3.1.3.5-3	Reference Value in Table 8.3.1.3.5-3	8.45
N_{oc} at antenna port		dBm/15kHz	-98	-98	N/A
BW_{Channel}		MHz	10	10	10
Cyclic Prefix			Normal	Normal	Normal
Cell Id			0	1	128
Number of control OFDM symbols			2	2	2
Timing offset to TP 1			N/A	-0.5	3
Frequency offset to TP 1		Hz	N/A	200	-100
Number of allocated resource blocks		PRB	50	50	N/A
PDSCH transmission mode			10	10	9
Probability of occurrence of PDSCH transmission(Note 3)		%	30	70	N/A
Symbols for unused PRBs			OCNG (Note 4)	OCNG (Note 4)	N/A
Interference model			N/A	N/A	As specified in clause B.5.4
Probability of occurrence of transmission in interference cells		%	N/A	N/A	20
Probability of occurrence of transmission rank in interfering cells	Rank 1	%	N/A	N/A	80
	Rank 2	%	N/A	N/A	20

Note 1:	$P_B = 1$
Note 2:	\widehat{E}_s / N_{oc} of TP1 is set the same as that of TP2.
Note 3:	PDSCH transmission from TP 1 and TP 2 shall be randomly determined independently for each subframe. Probabilities of occurrence of PDSCH transmission from TPs are specified.
Note 4:	These physical resource blocks are assigned to an arbitrary number of virtual UEs with one PDSCH per virtual UE; the data transmitted over the OCNG PDSCHs shall be uncorrelated pseudo random data, which is QPSK modulated.

Table 8.3.1.3.5-2: Configurations of PQI and DL transmission hypothesis for each PQI set

PQI set index	Parameters in each PQI set		DL transmission hypothesis for each PQI Set	
	NZP CSI-RS Index (For quasi co-location)	ZP CSI-RS configuration	TP 1	TP 2
PQI set 0	CSI-RS 0	ZP CSI-RS 0	PDSCH	Blanked
PQI set 1	CSI-RS 1	ZP CSI-RS 1	Blanked	PDSCH

Table 8.3.1.3.5-3: Performance Requirements DPS transmission with CRS assistance information

Test Number	Reference Channel	OCNG Pattern			Propagation Conditions (Note1)			Correlation Matrix and Antenna Configuration (Note 2)	Reference Value		UE Category
		TP 1	TP 2	TP3	TP 1	TP 2	TP3		Fraction of Maximum Throughput (%)	SNR (dB) (Note 3)	
1	R.52-1 FDD	OP.1 FDD	OP.1 FDD	N/A	EVA5	EVA5	EVA5	2x2 Low	70	10.7	≥2

Note 1: The propagation conditions for TP.1, TP.2 and TP.3 are statistically independent.
 Note 2: Correlation matrix and antenna configuration parameters apply for each of TP.1, TP.2 and TP.3.
 Note 3: SNR corresponds to \widehat{E}_s / N_{oc} of both TP.1 and TP.2 as defined in clause 8.1.1.

8.3.2 TDD

The parameters specified in Table 8.3.2-1 are valid for TDD unless otherwise stated.

Table 8.3.2-1: Common Test Parameters for User-specific Reference Symbols

Parameter	Unit	Value
Uplink downlink configuration (Note 1)		1
Special subframe configuration (Note 2)		4
Cyclic prefix		Normal
Cell ID		0
Inter-TTI Distance		1
Number of HARQ processes	Processes	7
Maximum number of HARQ transmission		4
Redundancy version coding sequence		{0,1,2,3} for QPSK and 16QAM {0,0,1,2} for 64QAM and 256QAM
Number of OFDM symbols for PDCCH	OFDM symbols	2
Precoder update granularity		Frequency domain: 1 PRB for Transmission mode 8, 1 PRG for Transmission modes 9 and 10 Time domain: 1 ms
ACK/NACK feedback mode		Multiplexing
Note 1: as specified in Table 4.2-2 in TS 36.211 [4]		
Note 2: as specified in Table 4.2-1 in TS 36.211 [4]		

8.3.2.1 Single-layer Spatial Multiplexing

For single-layer transmission on antenna port 5, the requirements are specified in Table 8.3.2.1-2, with the addition of the parameters in Table 8.3.2.1-1 and the downlink physical channel setup according to Annex C.3.2. The purpose is to verify the demodulation performance using user-specific reference signals with full RB or single RB allocation.

Table 8.3.2.1-1: Test Parameters for Testing DRS

Parameter	Unit	Test 1	Test 2	Test 3	Test 4	
Downlink power allocation	ρ_A	dB	0	0	0	0
	ρ_B	dB	0 (Note 1)	0 (Note 1)	0 (Note 1)	0 (Note 1)
	σ	dB	0	0	0	0
Cell-specific reference signals		Antenna port 0				
Beamforming model		Annex B.4.1				
N_{oc} at antenna port	dB/15kHz	-98	-98	-98	-98	
Symbols for unused PRBs		OCNG (Note 2)	OCNG (Note 2)	OCNG (Note 2)	OCNG (Note 2)	
PDSCH transmission mode		7	7	7	7	
Note 1: $P_B = 0$.						
Note 2: These physical resource blocks are assigned to an arbitrary number of virtual UEs with one PDSCH per virtual UE; the data transmitted over the OCNG PDSCHs shall be uncorrelated pseudo random data, which is QPSK modulated.						

Table 8.3.2.1-2: Minimum performance DRS (FRC)

Test number	Bandwidth and MCS	Reference Channel	OCNG Pattern	Propagation Condition	Correlation Matrix and Antenna Configuration	Reference value		UE Category
						Fraction of Maximum Throughput (%)	SNR (dB)	
1	10 MHz QPSK 1/3	R.25 TDD	OP.1 TDD	EPA5	2x2 Low	70	-0.8	≥1
2	10 MHz 16QAM 1/2	R.26 TDD	OP.1 TDD	EPA5	2x2 Low	70	7.0	≥2
	5MHz 16QAM 1/2	R.26-1 TDD	OP.1 TDD	EPA5	2x2 Low	70	7.0	1
3	10 MHz 64QAM 3/4	R.27 TDD	OP.1 TDD	EPA5	2x2 Low	70	17.0	≥2
	10 MHz 64QAM 3/4	R.27-1 TDD	OP.1 TDD	EPA5	2x2 Low	70	17.0	1
4	10 MHz 16QAM 1/2	R.28 TDD	OP.1 TDD	EPA5	2x2 Low	30	1.7	≥1

For single-layer transmission on antenna ports 7 or 8 upon detection of a PDCCH with DCI format 2B, the requirements are specified in Table 8.3.2.1-4 and 8.3.2.1-5, with the addition of the parameters in Table 8.3.2.1-3 and the downlink physical channel setup according to Annex C.3.2. The purpose of these tests is to verify rank-1 performance on one of the antenna ports 7 or 8 with and without a simultaneous transmission on the other antenna port.

Table 8.3.2.1-3: Test Parameters for Testing CDM-multiplexed DM RS (single layer)

Parameter	Unit	Test 1	Test 2	Test 3	Test 4	Test 5	
Downlink power allocation	ρ_A	dB	0	0	0	0	0
	ρ_B	dB	0 (Note 1)	0 (Note 1)	0 (Note 1)	0 (Note 1)	0 (Note 1)
	σ	dB	-3	-3	-3	-3	-3
Cell-specific reference signals		Antenna port 0 and antenna port 1					
Beamforming model		Annex B.4.1					
N_{oc} at antenna port	dBm/15kHz	-98	-98	-98	-98	-98	
Symbols for unused PRBs		OCNG (Note 4)	OCNG (Note 4)	OCNG (Note 4)	OCNG (Note 4)	OCNG (Note 4)	
Simultaneous transmission		No	No	No	Yes (Note 3, 5)	Yes (Note 3, 5)	
PDSCH transmission mode		8	8	8	8	8	
Note 1: $P_B = 1$. Note 2: The modulation symbols of the signal under test is mapped onto antenna port 7 or 8. Note 3: Modulation symbols of an interference signal is mapped onto the antenna port (7 or 8) not used for the input signal under test. Note 4: These physical resource blocks are assigned to an arbitrary number of virtual UEs with one PDSCH per virtual UE; the data transmitted over the OCNG PDSCHs shall be uncorrelated pseudo random data, which is QPSK modulated. Note 5: The two UEs' scrambling identities n_{SCID} are set to 0 for CDM-multiplexed DM RS with interfering simultaneous transmission test cases.							

Table 8.3.2.1-4: Minimum performance for CDM-multiplexed DM RS without simultaneous transmission (FRC)

Test number	Bandwidth and MCS	Reference Channel	OCNG Pattern	Propagation Condition	Correlation Matrix and Antenna Configuration	Reference value		UE Category
						Fraction of Maximum Throughput (%)	SNR (dB)	
1	10 MHz QPSK 1/3	R.31 TDD	OP.1 TDD	EVA5	2x2 Low	70	-1.0	≥1
2	10 MHz 16QAM 1/2	R.32 TDD	OP.1 TDD	EPA5	2x2 Medium	70	7.7	≥2
	5MHz 16QAM 1/2	R.32-1 TDD	OP.1 TDD	EPA5	2x2 Medium	70	7.7	1
3	10 MHz 64QAM 3/4	R.33 TDD	OP.1 TDD	EPA5	2x2 Low	70	17.7	≥2
	10 MHz 64QAM 3/4	R.33-1 TDD	OP.1 TDD	EPA5	2x2 Low	70	17.7	1

Table 8.3.2.1-5: Minimum performance for CDM-multiplexed DM RS with interfering simultaneous transmission (FRC)

Test number	Bandwidth and MCS	Reference Channel	OCNG Pattern	Propagation Condition	Correlation Matrix and Antenna Configuration	Reference value		UE Category
						Fraction of Maximum Throughput (%)	SNR (dB)	
4	10 MHz 16QAM 1/2	R.32 TDD (Note 1)	OP.1 TDD	EPA5	2x2 Medium	70	21.9	≥2
5	10 MHz 64QAM 1/2	R.34 TDD (Note 1)	OP.1 TDD	EPA5	2x2 Low	70	22.0	≥2

Note 1: The reference channel applies to both the input signal under test and the interfering signal.

8.3.2.1A Single-layer Spatial Multiplexing (with multiple CSI-RS configurations)

For single-layer transmission on antenna ports 7 or 8 upon detection of a PDCCH with DCI format 2C, the requirements are specified in Table 8.3.2.1A-2 and 8.3.2.1A-3, with the addition of the parameters in Table 8.3.2.1A-1 and the downlink physical channel setup according to Annex C.3.2. The purpose of these tests is to verify rank-1 performance on one of the antenna ports 7 or 8 with and without a simultaneous transmission on the other antenna port, and to verify rate matching with multiple CSI reference symbol configurations with non-zero and zero transmission power.

Table 8.3.2.1A-1: Test Parameters for Testing CDM-multiplexed DM RS (single layer) with multiple CSI-RS configurations

Parameter		Unit	Test 1, Test 1a	Test 2	Test 3
Downlink power allocation	ρ_A	dB	0	0	0
	ρ_B	dB	0 (Note 1)	0 (Note 1)	0 (Note 1)
	σ	dB	-3	-3	-3
Cell-specific reference signals			Antenna ports 0,1		
CSI reference signals			Antenna ports 15,...,22	Antenna ports 15,...,18	Antenna ports 15,...,18
Beamforming model			Annex B.4.1	Annex B.4.1	Annex B.4.1
CSI-RS periodicity and subframe offset $T_{\text{CSI-RS}} / \Delta_{\text{CSI-RS}}$		Subframes	5 / 4	5 / 4	5 / 4
CSI reference signal configuration			1	3	3
Zero-power CSI-RS configuration $I_{\text{CSI-RS}} / \text{ZeroPowerCSI-RS}$ bitmap		Subframes / bitmap	4 / 0010000100000000	4 / 0010000000000000	4 / 0010000000000000
N_{oc} at antenna port		dBm/15kHz	-98	-98	-98
Symbols for unused PRBs			OCNG (Note 4)	OCNG (Note 4)	OCNG (Note 4)
Number of allocated resource blocks (Note 2)		PRB	50	50	100
Simultaneous transmission			No	Yes (Note 3, 5)	No
PDSCH transmission mode			9	9	9
Number of MBSFN subframes		Subframes	2 (Note 6)	NA	NA
<p>Note 1: $P_B = 1$.</p> <p>Note 2: The modulation symbols of the signal under test are mapped onto antenna port 7 or 8.</p> <p>Note 3: Modulation symbols of an interference signal is mapped onto the antenna port (7 or 8) not used for the input signal under test.</p> <p>Note 4: These physical resource blocks are assigned to an arbitrary number of virtual UEs with one PDSCH per virtual UE; the data transmitted over the OCNG PDSCHs shall be uncorrelated pseudo random data, which is QPSK modulated.</p> <p>Note 5: The two UEs' scrambling identities n_{SCID} are set to 0 for CDM-multiplexed DM RS with interfering simultaneous transmission test cases.</p> <p>Note 6: For TDD mode, 2 subframes (#4/9) are allocated as MBSFN subframes.</p>					

Table 8.3.2.1A-2: Minimum performance for CDM-multiplexed DM RS without simultaneous transmission (FRC) with multiple CSI-RS configurations

Test number	Bandwidth and MCS	Reference Channel	OCNG Pattern	Propagation Condition	Correlation Matrix and Antenna Configuration	Reference value		UE Category	UE DL Category
						Fraction of Maximum Throughput (%)	SNR (dB)		
1	10 MHz QPSK 1/3	R.50-1 TDD	OP.1 TDD	EVA5	2x2 Low	70	-0.73	≥ 1	≥ 6
1a	10 MHz QPSK 1/3	R.50-2 TDD	OP.1 TDD	EVA5	2x2 Low	70	[-0.6]	≥ 1	≥ 6
3	20MHz 256QAM	R. 66 TDD	OP.1 TDD	EPA5	2x2 Low	70	24.3	11-12	≥ 11

Note 1: For UE that indicates support of *pdsch-CollisionHandling-r13*, test 1a will be run and test 1 will be skipped. Otherwise, test 1 will be run and test 1a will be skipped.

Table 8.3.2.1A-3: Minimum performance for CDM-multiplexed DM RS with interfering simultaneous transmission (FRC) with multiple CSI-RS configurations

Test number	Bandwidth and MCS	Reference Channel	OCNG Pattern	Propagation Condition	Correlation Matrix and Antenna Configuration	Reference value		UE Category
						Fraction of Maximum Throughput (%)	SNR (dB)	
2	10 MHz 64QAM 1/2	R.44 TDD	OP.1 TDD	EPA5	2x2 Low	70	22.1	≥2

Note 1: The reference channel applies to both the input signal under test and the interfering signal.

8.3.2.1B Enhanced Performance Requirement Type A – Single-layer Spatial Multiplexing with TM9 interference model

The requirements are specified in Table 8.3.2.1B-2, with the addition of the parameters in Table 8.3.2.1B-1 and the downlink physical channel setup according to Annex C.3.2. The purpose of these tests is to verify closed-loop rank one performance on one of the antenna ports 7 or 8 without a simultaneous transmission on the other antenna port in the serving cell when the PDSCH transmission in the serving cell is interfered by PDSCH of one dominant interfering cell applying transmission mode 9 interference model defined in clause B.5.4. In 8.3.2.1B-1, Cell 1 is the serving cell, and Cell 2 is the interfering cell. The downlink physical channel setup is according to Annex C.3.2 for each of Cell 1 and Cell 2, respectively.

Table 8.3.2.1B-1: Test Parameters for Testing CDM-multiplexed DM RS (single layer) with TM9 interference model

parameter		Unit	Cell 1	Cell 2
Downlink power allocation	ρ_A	dB	0	0
	ρ_B	dB	0 (Note 1)	0
	σ	dB	-3	-3
Cell-specific reference signals			Antenna ports 0,1	Antenna ports 0,1
CSI reference signals			Antenna ports 15,...,18	N/A
CSI-RS periodicity and subframe offset $T_{\text{CSI-RS}} / \Delta_{\text{CSI-RS}}$		Subframes	5 / 4	N/A
CSI reference signal configuration			0	N/A
N_{oc} at antenna port		dBm/15kHz z	-98	N/A
DIP (Note 2)		dB	N/A	-1.73
BW_{Channel}		MHz	10	10
Cyclic Prefix			Normal	Normal
Cell Id			0	126
Number of control OFDM symbols			2	2
PDSCH transmission mode			9	N/A
Beamforming model			As specified in clause B.4.3 (Note 4, 5)	N/A
Interference model			N/A	As specified in clause B.5.4
Probability of occurrence of transmission rank in interfering cells	Rank 1		N/A	70
	Rank 2		N/A	30
Precoder update granularity		PRB	50	6
PMI delay (Note 5)		ms	10 or 11	N/A
Reporting interval		ms	5	N/A
Reporting mode			PUCCH 1-1	N/A
CodeBookSubsetRestriction bitmap			0000000000000000 0000000000000000 0000000000000000 1111111111111111	N/A
Symbols for unused PRBs			OCNG (Note 6)	N/A
Simultaneous transmission			No simultaneous transmission on the other antenna port in (7 or 8) not used for the input signal under test	N/A
Physical channel for CQI reporting			PUSCH(Note 8)	N/A
cqi-pmi-ConfigurationIndex			4	N/A
<p>Note 1: $P_B = 1$</p> <p>Note 2: The respective received power spectral density of each interfering cell relative to N_{oc} is defined by its associated DIP value as specified in clause B.5.1.</p> <p>Note 3: The modulation symbols of the signal under test in Cell 1 are mapped onto antenna port 7 or 8.</p>				

Note 4:	The precoder in clause B.4.3 follows UE recommended PMI.
Note 5:	If the UE reports in an available uplink reporting instance at subframe SF#n based on PMI estimation at a downlink SF not later than SF#(n-4), this reported PMI cannot be applied at the eNB downlink before SF#(n+4).
Note 6:	These physical resource blocks are assigned to an arbitrary number of virtual UEs with one PDSCH per virtual UE; the data transmitted over the OCNG PDSCHs shall be uncorrelated pseudo random data, which is QPSK modulated.
Note 7:	All cells are time-synchronous.
Note 8:	To avoid collisions between CQI reports and HARQ-ACK it is necessary to report both on PUSCH instead of PUCCH. PDCCH DCI format 0 shall be transmitted in downlink SF#4 and #9 to allow periodic CQI to multiplex with the HARQ-ACK on PUSCH in uplink subframe SF#8 and #3.

Table 8.3.2.1B-2: Enhanced Performance Requirement Type A, CDM-multiplexed DM RS with TM9 interference model

Test Number	Reference Channel	OCNG Pattern		Propagation Conditions		Correlation Matrix and Antenna Configuration (Note 3)	Reference Value		UE Category
		Cell 1	Cell 2	Cell 1	Cell 2		Fraction of Maximum Throughput (%)	SINR (dB) (Note 2)	
1	R.48 TDD	OP.1 TDD	N/A	EVA5	EVA5	4x2 Low	70	-1.0	≥1
Note 1: The propagation conditions for Cell 1 and Cell 2 are statistically independent. Note 2: SINR corresponds to \hat{E}_s / N_{oc} of Cell 1 as defined in clause 8.1.1. Note 3: Correlation matrix and antenna configuration parameters apply for each of Cell 1 and Cell 2.									

8.3.2.1C Single-layer Spatial Multiplexing (demodulation subframe overlaps with aggressor cell ABS and CRS assistance information are configured)

The requirements are specified in Table 8.3.2.1C-2, with the addition of parameters in Table 8.3.2.1C-1. The purpose is to verify the performance of the antenna ports 7 or 8 without a simultaneous transmission on the other antenna port in the serving cell if the PDSCH transmission in the serving cell takes place in subframes that overlap with ABS [9] of the aggressor cell with CRS assistance information. In Table 8.3.2.1C-1, Cell 1 is the serving cell, and Cell 2 and Cell 3 are the aggressor cells. The downlink physical channel setup for Cell 1 is according to Annex C.3.2 and for Cell 2 and Cell 3 is according to Annex C.3.3, respectively. The CRS assistance information [7] includes Cell 2 and Cell 3.

Table 8.3.2.1C-1: Test parameters of TM9-Single-Layer (2 CSI-RS ports) – Non-MBSFN ABS

Parameter		Unit	Cell 1	Cell 2	Cell 3
Uplink downlink Configuration			1	1	1
Special subframe configuration			4	4	4
Downlink power allocation	ρ_A	dB	0	-3	-3
	ρ_B	dB	0 (Note 1)	-3 (Note 1)	-3 (Note 1)
	σ	dB	-3	N/A	N/A
N_{oc} at antenna port	N_{oc1}	dBm/15kHz	-98 (Note 2)	N/A	N/A
	N_{oc2}	dBm/15kHz	-98 (Note 3)	N/A	N/A
	N_{oc3}	dBm/15kHz	-93 (Note 4)	N/A	N/A
\hat{E}_s / N_{oc2}		dB	Reference Value in Table 8.3.2.1C-2	12	10
BW _{Channel}		MHz	10	10	10
Subframe Configuration			Non-MBSFN	Non-MBSFN	Non-MBSFN
Time Offset between Cells		μs	N/A	3	-1
Frequency shift between Cells		Hz	N/A	300	-100
Cell Id			0	1	126
Cell-specific reference signals			Antenna ports 0,1		
CSI reference signals			Antenna ports 15,16	N/A	N/A
CSI-RS periodicity and subframe offset $T_{CSI-RS} / \Delta_{CSI-RS}$		Subframes	5 / 4	N/A	N/A
CSI reference signal configuration			8	N/A	N/A
Zero-power CSI-RS configuration $I_{CSI-RS} / \text{ZeroPowerCSI-RS bitmap}$		Subframes / bitmap	4 / 00100000000000 00	N/A	N/A
ABS pattern (Note 5)			N/A	000000001 000000001	000000001 000000001
RLM/RRM Measurement Subframe Pattern (Note 6)			000000001 000000001	N/A	N/A
CSI Subframe Sets (Note7)	$C_{CSI,0}$		000000001 000000001	N/A	N/A
	$C_{CSI,1}$		1100111000 1100111000	N/A	N/A
Number of control OFDM symbols			2	Note 8	Note 8
PDSCH transmission mode			TM9-1layer	Note 9	Note 9
Precoding granularity			Frequency domain: 1 PRG Time domain: 1 ms	N/A	N/A
Beamforming model			Annex B.4.1	N/A	N/A
Cyclic prefix			Normal	Normal	Normal

- Note 1: $P_B = 1$.
- Note 2: This noise is applied in OFDM symbols #1, #2, #3, #5, #6, #8, #9, #10, #12, #13 of a subframe overlapping with the aggressor ABS.
- Note 3: This noise is applied in OFDM symbols #0, #4, #7, #11 of a subframe overlapping with the aggressor ABS.
- Note 4: This noise is applied in all OFDM symbols of a subframe overlapping with aggressor non-ABS
- Note 5: ABS pattern as defined in [9]. PDSCH other than SIB1/paging and its associated PDCCH/PCFICH are transmitted in the serving cell subframe when the subframe is overlapped with the ABS subframe of aggressor cell and the subframe is available in the definition of the reference channel.
- Note 6: Time-domain measurement resource restriction pattern for PCell measurements as defined in [7]
- Note 7: As configured according to the time-domain measurement resource restriction pattern for CSI measurements defined in [7].
- Note 8: The number of control OFDM symbols is not available for ABS and is 2 for the subframe indicated by "0" of ABS pattern.
- Note 9: Downlink physical channel setup in Cell 2 and Cell 3 in accordance with Annex C.3.3 applying OCNG pattern as defined in Annex A.5.
- Note 10: If the UE reports in an available uplink reporting instance at subframe SF#n based on PMI estimation at a downlink SF not later than SF#(n-4), this reported PMI cannot be applied at the eNB downlink before SF#(n+4).
- Note 11: For Uplink - downlink configuration 1 the reporting interval will alternate between 1ms and 4ms.
- Note 12: The number of the CRS ports in Cell 1, Cell 2 and Cell 3 is the same.
- Note 13: SIB-1 will not be transmitted in Cell 2 and Cell 3 in this test.
- Note 14: The modulation symbols of the signal under test are mapped onto antenna port 7 or 8.

Table 8.3.2.1C-2: Minimum Performance of TM9-Single-Layer (2 CSI-RS ports) – Non-MBSFN ABS

Test Number	Reference Channel	OCNG Pattern			Propagation Conditions (Note1)			Correlation Matrix and Antenna Configuration (Note 2)	Reference Value		UE Category
		Cell 1	Cell 2	Cell 3	Cell 1	Cell 2	Cell 3		Fraction of Maximum Throughput (%)	SNR (dB) (Note 3)	
1	R.51 TDD	OP.1 TDD	OP.1 TDD	OP.1 TDD	EVA5			2x2 Low	70	8.5	≥2
Note 1: The propagation conditions for Cell 1, Cell 2 and Cell 3 are statistically independent. Note 2: The correlation matrix and antenna configuration apply for Cell 1, Cell 2 and Cell 3. Note 3: SNR corresponds to \hat{E}_s / N_{oc2} of cell 1.											

8.3.2.1D Enhanced Performance Requirement Type B – Single-layer Spatial Multiplexing with TM9 interference

The requirements are specified in Table 8.3.2.1D-2, with the addition of the parameters in Table 8.3.2.1D-1 and the downlink physical channel setup according to Annex C.3.2. The purpose of these tests is to verify closed loop rank one performance on one of the antenna ports 7 or 8 without a simultaneous transmission on the other antenna port in the serving cell when the PDSCH transmission in the serving cell is interfered by PDSCH of two interfering cells applying transmission mode 9 interference model defined in clause B.6.4. In 8.3.2.1D-1, Cell 1 is the serving cell, and Cell 2, 3 are interfering cells. The downlink physical channel setup is according to Annex C.3.2 for each of Cell 1, Cell 2 and Cell 3, respectively.

Table 8.3.2.1D-1: Test Parameters for Testing CDM-multiplexed DM RS (Single-layer) with TM9 interference model

Parameter		Unit	Cell 1	Cell 2	Cell 3
Uplink downlink Configuration			1	1	1
Special subframe configuration			4	4	4
Downlink power allocation	ρ_A	dB	0	0	0
	ρ_B	dB	0 (Note 1)	0	0
	σ	dB	-3	-3	-3
Cell-specific reference signals			Antenna ports 0,1	Antenna ports 0,1	Antenna ports 0,1
N_{oc} at antenna port		dBm/15kHz	-98		
\hat{E}_s / N_{oc}		dB	N/A	13.91	3.34
BW _{Channel}		MHz	10	10	10
Cyclic Prefix			Normal	Normal	Normal
Cell Id			0	1	6
Number of control OFDM symbols in normal subframes			3	3	3
CFI indicated in PCFICH in normal subframes			3	3	3
Number of control OFDM symbols in special subframes			2	2	2
CFI indicated in PCFICH in special subframes			2	2	2
PDSCH transmission mode			9	9	9
Interference model			N/A	As specified in clause B.6.4	As specified in clause B.6.4
Precoding			Random wideband precoding per TTI	As specified in clause B.6.4	As specified in clause B.6.4
CSI reference signals			Antenna ports 15, 16, 17, 18	Antenna ports 15, 16	Antenna ports 15, 16
CSI-RS periodicity and subframe offset $T_{CSI-RS} / \Delta_{CSI-RS}$		Subframes	10 / 4	10 / 4	10 / 4
CSI reference signal configuration			5	6	7
Zero-power CSI-RS configuration $I_{CSI-RS} / \text{ZeroPowerCSI-RS}$ bitmap		Subframes / bitmap	9 / 1000000000 00000	9 / 01000000000 0000	9 / 00100000000 00000
Time offset to cell 1		us	N/A	2	3
Frequency offset to cell 1		Hz	N/A	200	300
MBSFN			Not configured	Not configured	Not configured
NeighCellsInfo-r12 (Note 4)	p-aList-r12		N/A	{dB-6, dB-3, dB0}	{dB-6, dB-3, dB0}
	transmissionModeList-r12		N/A	{2,3,4,8,9}	{2,3,4,8,9}
Note 1: $P_B = 1$					
Note 2: Cell 1 is the serving cell. Cell 2, 3 are the interfering cells.					
Note 3: CSI-RS configurations are according to [4] subclause 6.10.5.2.					
Note 4: NeighCellsInfo-r12 is described in subclause 6.3.2 of [7].					

Table 8.3.2.1D-2: Minimum Performance for Enhanced Performance Requirement Type B, CDM-multiplexed DM RS with TM9 interference model

Test Number	Reference Channel	OCNG Pattern			Propagation Conditions			Correlation Matrix and Antenna Configuration			Reference Value		UE Category
		Cell 1	Cell 2	Cell 3	Cell 1	Cell 2	Cell 3	Cell 1	Cell 2	Cell 3	Fraction of Maximum Throughput (%)	SNR (dB) (Note 2)	
1	R.69 TDD	OP. 1 TDD	N/A	N/A	EP A5	EP A5	EP A5	4x2 Low	2x2 Low	2x2 Low	85	18.0	≥1
Note 1: The propagation conditions for Cell 1, Cell 2 and Cell 3 are statistically independent. Note 2: SNR corresponds to \hat{E}_s/N_{oc} of Cell 1 as defined in clause 8.1.1.													

8.3.2.1E Enhanced Performance Requirement Type B – Single-layer Spatial Multiplexing with CRS interference model

The requirements are specified in Table 8.3.2.1E-2, with the addition of the parameters in Table 8.3.2.1E-1 and the downlink physical channel setup according to Annex C.3.2. The purpose of these tests is to verify closed loop rank one performance on one of the antenna ports 7 or 8 without a simultaneous transmission on the other antenna port in the serving cell when the PDSCH transmission in the serving cell is interfered by the CRS of the interfering cell, applying the CRS interference model defined in clause B.6.5. In 8.3.2.1E-1, Cell 1 is the serving cell, and Cell 2, 3 are interfering cells. The downlink physical channel setup is according to Annex C.3.2 for each of Cell 1, Cell 2 and Cell 3, respectively.

Table 8.3.2.1E-1: Test Parameters for Testing CDM-multiplexed DM RS (Single-layer) with CRS interference model

Parameter		Unit	Cell 1	Cell 2	Cell 3
Uplink downlink Configuration			1	1	1
Special subframe configuration			4	4	4
Downlink power allocation	ρ_A	dB	0	0	0
	ρ_B	dB	0 (Note 1)	0	0
	σ	dB	-3	-3	-3
Cell-specific reference signals			Antenna ports 0,1	Antenna ports 0,1	Antenna ports 0,1
N_{oc} at antenna port		dBm/15kHz	-98		
\widehat{E}_s/N_{oc}		dB	N/A	13.91	3.34
$BW_{Channel}$		MHz	10	10	10
Cyclic Prefix			Normal	Normal	Normal
Cell Id			0	1	6
Number of control OFDM symbols in normal subframes			3	3	3
CFI indicated in PCFICH in normal subframes			3	3	3
Number of control OFDM symbols in special subframes			2	2	2
CFI indicated in PCFICH in special subframes			2	2	2
PDSCH transmission mode			8	N/A	N/A
Interference model			N/A	As specified in clause B.6.5	As specified in clause B.6.5
Precoding			Random wideband precoding per TTI	N/A	N/A
Time offset to cell 1		us	N/A	2	3
Frequency offset to cell 1		Hz	N/A	200	300
MBSFN			Not configured	Not configured	Not configured
NeighCellsInfo-r12 (Note 3)	p-aList-r12		N/A	{dB-6, dB-3, dB0}	{dB-6, dB-3, dB0}
	transmissionModeList-r12		N/A	{2,3,4,8,9}	{2,3,4,8,9}
Note 1: $P_B = 1$					
Note 2: Cell 1 is the serving cell. Cell 2, 3 are the interfering cells.					
Note 3: NeighCellsInfo-r12 is described in subclause 6.3.2 of [7].					

Table 8.3.2.1E-2: Minimum Performance for Enhanced Performance Requirement Type B, CDM-multiplexed DM RS with CRS interference model

Test Number	Reference Channel	OCNG Pattern			Propagation Conditions			Correlation Matrix and Antenna Configuration (Note 3)	Reference Value		UE Category
		Cell 1	Cell 2	Cell 3	Cell 1	Cell 2	Cell 3		Fraction of Maximum Throughput (%)	SNR (dB) (Note 2)	
1	R.71 TDD	OP. 1 TD D	N/A	N/A	EP A5	EP A5	EP A5	2x2 Low	85	14.0	≥ 2
Note 1: The propagation conditions for Cell 1, Cell 2 and Cell 3 are statistically independent.											
Note 2: SNR corresponds to \widehat{E}_s/N_{oc} of Cell 1 as defined in clause 8.1.1.											
Note 3: Correlation matrix and antenna configuration parameters apply for each of Cell 1, Cell 2 and Cell 3.											

8.3.2.1F Enhanced Performance Requirement Type B – Single-layer Spatial Multiplexing with TM3 interference

The requirements are specified in Table 8.3.2.1F-2, with the addition of the parameters in Table 8.3.2.1F-1 and the downlink physical channel setup according to Annex C.3.2. The purpose of these tests is to verify closed loop rank one performance on one of the antenna ports 7 or 8 without a simultaneous transmission on the other antenna port in the serving cell when the PDSCH transmission in the serving cell is interfered by PDSCH of two interfering cells applying transmission mode 3 interference model defined in clause B.6.2. In 8.3.2.1F-1, Cell 1 is the serving cell, and Cell 2, 3 are interfering cells. The downlink physical channel setup is according to Annex C.3.2 for each of Cell 1, Cell 2 and Cell 3, respectively.

Table 8.3.2.1F-1: Test Parameters for Testing CDM-multiplexed DM RS (Single-layer) with TM3 interference model

Parameter		Unit	Cell 1	Cell 2	Cell 3
Uplink downlink Configuration			1	1	1
Special subframe configuration			4	4	4
Downlink power allocation	ρ_A	dB	0	-3	-3
	ρ_B	dB	0 (Note 1)	-3	-3
	σ	dB	-3	0	0
Cell-specific reference signals			Antenna ports 0,1	Antenna ports 0,1	Antenna ports 0,1
N_{oc} at antenna port		dBm/15kHz	-98		
\hat{E}_s/N_{oc}		dB	N/A	3.28	0.74
BW _{Channel}		MHz	10	10	10
Cyclic Prefix			Normal	Normal	Normal
Cell Id			0	1	6
Number of control OFDM symbols in normal subframes			3	3	3
CFI indicated in PCFICH in normal subframes			3	Random from set {1,2,3}	Random from set {1,2,3}
Number of control OFDM symbols in special subframes			2	2	2
CFI indicated in PCFICH in special subframes			2	Random from set {1,2}	Random from set {1,2}
PDSCH transmission mode			8	3	3
Interference model			N/A	As specified in clause B.6.2	As specified in clause B.6.2
Precoding			Random wideband precoding per TTI	As specified in clause B.6.2	As specified in clause B.6.2
Time offset to cell 1		us	N/A	2	3
Frequency offset to cell 1		Hz	N/A	200	300
MBSFN			Not configured	Not configured	Not configured
NeighCellsInfo-r12 (Note 4)	p-aList-r12		N/A	{dB-6, dB-3, dB0}	{dB-6, dB-3, dB0}
	transmissionModelList-r12		N/A	{2,3,4,8,9}	{2,3,4,8,9}
Note 1: $P_B = 1$					
Note 2: Cell 1 is the serving cell. Cell 2, 3 are the interfering cells.					
Note 3: CSI-RS configurations are according to [4] subclause 6.10.5.2.					
Note 4: NeighCellsInfo-r12 is described in subclause 6.3.2 of [7].					

Table 8.3.2.1F-2: Minimum Performance for Enhanced Performance Requirement Type B, CDM-multiplexed DM RS with TM3 interference model

Test Number	Reference Channel	OCNG Pattern			Propagation Conditions			Correlation Matrix and Antenna Configuration (Note 3)	Reference Value		UE Category
		Cell 1	Cell 2	Cell 3	Cell 1	Cell 2	Cell 3		Fraction of Maximum Throughput (%)	SNR (dB) (Note 2)	
1	R.70 TDD	OP. 1 TD D	N/A	N/A	EP A5	EP A5	EP A5	2x2 Low	85	11.3	≥1

Note 1: The propagation conditions for Cell 1, Cell 2 and Cell 3 are statistically independent.

Note 2: SNR corresponds to \hat{E}_s/N_{oc} of Cell 1 as defined in clause 8.1.1.

Note 3: Correlation matrix and antenna configuration parameters apply for each of Cell 1, Cell 2 and Cell 3.

8.3.2.1G Enhanced Performance Requirement Type B – Single-layer Spatial Multiplexing with TM10 serving cell configuration and TM9 interference model

The requirements are specified in Table 8.3.2.1G-2, with the addition of the parameters in Table 8.3.2.1G-1 and the downlink physical channel setup according to Annex C.3.2. The purpose of these tests is to verify closed loop rank one performance on one of the antenna ports 7 or 8 without a simultaneous transmission on the other antenna port in the serving cell when the PDSCH transmission configured with TM10 in the serving cell is interfered by PDSCH of one dominant interfering cell applying transmission mode 9 interference model defined in clause B.6.3. The NAICS network assistance is provided when the serving cell TM10 is configured with QCL-type A and PCID based DM-RS scrambling. The neighbouring cell has transmission mode TM9 and NeighCellsInfo-r12 for interfering cell indicates presence of TM9. In 8.3.2.1G-1, Cell 1 is the serving cell, and Cell 2, 3 are interfering cells. The downlink physical channel setup is according to Annex C.3.2 for each of Cell 1, Cell 2 and Cell 3, respectively.

Table 8.3.2.1G-1: Test Parameters for Testing CDM-multiplexed DM RS (single layer) Multiplexing with TM10 serving cell configuration and TM9 interference model

Parameter		Unit	Cell 1	Cell 2	Cell 3
Uplink downlink Configuration			1	1	1
Special subframe configuration			4	4	4
Downlink power allocation	ρ_A	dB	0	0	0
	ρ_B	dB	0 (Note 1)	0	0
	σ	dB	-3	-3	-3
Cell-specific reference signals			Antenna ports 0,1	Antenna ports 0,1	Antenna ports 0,1
N_{oc} at antenna port		dBm/15kHz	-98		
\hat{E}_s / N_{oc}		dB	N/A	13.91	3.34
BW _{Channel}		MHz	10	10	10
Cyclic Prefix			Normal	Normal	Normal
Cell Id			0	1	6
Number of control OFDM symbols in normal subframes			3	3	3
CFI indicated in PCFICH in normal subframes			3	3	3
Number of control OFDM symbols in special subframes			2	2	2
CFI indicated in PCFICH in special subframes			2	2	2
PDSCH transmission mode			10	9	9
Interference model			N/A	As specified in clause B.6.4	As specified in clause B.6.4
Precoding			Random wideband precoding per TTI	As specified in clause B.6.4	As specified in clause B.6.4
CSI reference signals			Antenna ports 15, 16, 17, 18	Antenna ports 15, 16	Antenna ports 15, 16
CSI-RS periodicity and subframe offset $T_{CSI-RS} / \Delta_{CSI-RS}$		Subframes	10 / 4	10 / 4	10 / 4
CSI reference signal configuration			5	6	7
Zero-power CSI-RS configuration $l_{CSI-RS} / ZeroPowerCSI-RS$ bitmap		Subframes / bitmap	9 / 1000000000 00000	9 / 01000000000 0000	9 / 00100000000 00000
Time offset to cell 1		us	N/A	2	3
Frequency offset to cell 1		Hz	N/A	200	300
MBSFN			Not configured	Not configured	Not configured
NeighCellsInfo-r12 (Note 4)	p-aList-r12		N/A	{dB-6, dB-3, dB0}	{dB-6, dB-3, dB0}
	transmissionModeList-r12		N/A	{2,3,4,8,9}	{2,3,4,8,9}
Note 1: $P_B = 1$					
Note 2: Cell 1 is the serving cell. Cell 2, 3 are the interfering cells.					
Note 3: CSI-RS configurations are according to [4] subclause 6.10.5.2.					
Note 4: NeighCellsInfo-r12 is described in subclause 6.3.2 of [7].					

Table 8.3.2.1G-2: Minimum Performance for Enhanced Performance Requirement Type B, CDM-multiplexed DM RS Multiplexing with TM10 serving cell configuration and TM9 interference model

Test Number	Reference Channel	OCNG Pattern			Propagation Conditions			Correlation Matrix and Antenna Configuration			Reference Value		UE Category
		Cell 1	Cell 2	Cell 3	Cell 1	Cell 2	Cell 3	Cell 1	Cell 2	Cell 3	Fraction of Maximum Throughput (%)	SNR (dB) (Note 2)	
1	R.69 TDD	OP. 1 TD D	N/A	N/A	EP A5	EP A5	EP A5	4x Lo w	2x Lo w	2x Lo w	85	18.0	≥1

Note 1: The propagation conditions for Cell 1, Cell 2 and Cell 3 are statistically independent.

Note 2: SINR corresponds to \hat{E}_s / N_{oc} of Cell 1 as defined in clause 8.1.1.

8.3.2.1H Single-layer Spatial Multiplexing (CRS assistance information is configured)

The requirements are specified in Table 8.3.2.1H-2, with the addition of parameters in Table 8.3.2.1H-1. The purpose is to verify the performance of the antenna ports 7 or 8 without a simultaneous transmission on the other antenna port in the serving cell with CRS assistance information. In Table 8.3.2.1H-1, Cell 1 is the serving cell, and Cell 2 and Cell 3 are the aggressor cells. The downlink physical channel setup for Cell 1, Cell 2 and Cell 3 is according to Annex C.3.2. The CRS assistance information [7] includes Cell 2 and Cell 3.

Table 8.3.2.1H-1: Test parameters of TM9-Single-Layer (2 CSI-RS ports)

Parameter		Unit	Cell 1	Cell 2	Cell 3
Uplink downlink Configuration			1	1	1
Special subframe configuration			4	4	4
Downlink power allocation	ρ_A	dB	0	0	0
	ρ_B	dB	0 (Note 1)	0 (Note 1)	0 (Note 1)
	σ	dB	-3	-3	-3
N_{oc} at antenna port		dBm/15kHz	-98	N/A	N/A
\bar{E}_s/N_{oc}		dB	Reference Value in Table 8.3.2.1H-2	10.45	4.6
$BW_{Channel}$		MHz	10	10	10
Subframe Configuration			Non-MBSFN	Non-MBSFN	Non-MBSFN
Time Offset to Cell 1		μ s	N/A	3	-1
Frequency shift to Cell 1		Hz	N/A	300	-100
Cell Id			0	1	126
Cell-specific reference signals			Antenna ports 0,1		
CSI reference signals			Antenna ports 15,16	N/A	N/A
CSI-RS periodicity and subframe offset $T_{CSI-RS} / \Delta_{CSI-RS}$		Subframes	5 / 4	N/A	N/A
CSI reference signal configuration			8	N/A	N/A
Zero-power CSI-RS configuration $l_{CSI-RS} / ZeroPowerCSI-RS$ bitmap		Subframes / bitmap	4 / 00100000000000	N/A	N/A
Number of control OFDM symbols			2	2	2
PDSCH transmission mode			TM9-1layer	N/A	N/A
Interference model			N/A	As specified in clause B.5.4	As specified in clause B.5.4
Probability of occurrence of transmission in interference cells		%	N/A	20	20
Probability of occurrence of transmission rank in interfering cells	Rank 1	%	N/A	80	80
	Rank 2	%	N/A	20	20
Precoding granularity			Frequency domain: 1 PRG Time domain: 1 ms	N/A	N/A
Beamforming model			Annex B.4.1	N/A	N/A
Cyclic prefix			Normal	Normal	Normal
<p>Note 1: $P_B = 1$.</p> <p>Note 2: If the UE reports in an available uplink reporting instance at subframe SF#n based on PMI estimation at a downlink SF not later than SF#(n-4), this reported PMI cannot be applied at the eNB downlink before SF#(n+4).</p> <p>Note 3: For Uplink - downlink configuration 1 the reporting interval will alternate between 1ms and 4ms.</p> <p>Note 4: The number of the CRS ports in Cell 1, Cell 2 and Cell 3 is the same.</p> <p>Note 5: SIB-1 will not be transmitted in Cell 2 and Cell 3 in this test.</p> <p>Note 6: The modulation symbols of the signal under test are mapped onto antenna port 7 or 8.</p>					

Table 8.3.2.1H-2: Minimum Performance of TM9-Single-Layer (2 CSI-RS ports)

Test Number	Reference Channel	OCNG Pattern			Propagation Conditions (Note1)			Correlation Matrix and Antenna Configuration (Note 2)	Reference Value		UE Category
		Cell 1	Cell 2	Cell 3	Cell 1	Cell 2	Cell 3		Fraction of Maximum Throughput (%)	SNR (dB) (Note 3)	
1	R.51-1 TDD	OP.1 TDD	N/A	N/A	EVA5			2x2 Low	70	11.9	≥2
Note 1: The propagation conditions for Cell 1, Cell 2 and Cell 3 are statistically independent. Note 2: The correlation matrix and antenna configuration apply for Cell 1, Cell 2 and Cell 3. Note 3: SNR corresponds to \hat{E}_s/N_{0c} of cell 1.											

8.3.2.11 Single-layer Spatial Multiplexing (With Enhanced DMRS table configured)

For single-layer transmission on antenna port 7, 8, 11 or 13 upon detection of a PDCCH with DCI format 2C, the requirement is specified in Table 8.3.2.1I-2, with the addition of the parameters in Table 8.3.2.1I-1 and the downlink physical channel setup according to Annex C.3.2. The purpose of the test is to verify rank-1 performance on antenna port 11 with a simultaneous transmission on the antenna port 7, 8 or 13 with DMRS enhancement table and 4 orthogonal DMRS ports (dmrs-Enhancements-r13 UE-EUTRA-Capability [7]).

Table 8.3.2.11-1: Test Parameters for Testing CDM-multiplexed DM RS (single layer) with interfering simultaneous transmission (FRC) with multiple CSI-RS configurations with Enhanced DMRS table

parameter		Unit	Test 1
Downlink power allocation	ρ_A	dB	0
	ρ_B	dB	0 (Note 1)
	σ	dB	-3
Beamforming model			Annex B.4.1A
Cell-specific reference signals			Antenna ports 0,1
CSI reference signals			Antenna ports 15,...,18
CSI-RS periodicity and subframe offset $T_{\text{CSI-RS}} / \Delta_{\text{CSI-RS}}$		Subframes	5 / 4
CSI reference signal configuration			3
Zero-power CSI-RS configuration $I_{\text{CSI-RS}} / \text{ZeroPowerCSI-RS}$ bitmap		Subframes / bitmap	4 / 0010000000000000
N_{oc} at antenna port		dBm/15kHz	-98
Symbols for unused PRBs			OCNG (Note 4)
Number of allocated resource blocks (Note 2)		PRB	50
Simultaneous transmission			Yes (Note 3, 5)
dmrs-Enhancements-r13			Enable
PDSCH transmission mode			9
Note 1: $P_B = 1$. Note 2: The modulation symbols of the signal under test are mapped onto antenna port 11. Note 3: Modulation symbols of an interference signal are random mapped onto one antenna port among antenna port 7, 8 and 13. The update granularity for randomized mapping antenna port is 1 PRG in frequency domain and 1ms in time domain. Note 4: These physical resource blocks are assigned to an arbitrary number of virtual UEs with one PDSCH per virtual UE; the data transmitted over the OCNG PDSCHs shall be uncorrelated pseudo random data, which is QPSK modulated. Note 5: The two UEs' scrambling identities n_{SCID} are set to 0 with OCC =4.			

Table 8.3.2.11-2: Minimum performance for CDM-multiplexed DM RS with interfering simultaneous transmission (FRC) with multiple CSI-RS configurations with Enhanced DMRS table

Test number	Bandwidth and MCS	Reference Channel	OCNG Pattern	Propagation Condition	Correlation Matrix and Antenna Configuration	Reference value		UE Category
						Fraction of Maximum Throughput (%)	SNR (dB)	
1	10 MHz 64QAM 1/2	R.44 TDD	OP.1 TDD	EPA5	2x2 Low	70	22.1	≥ 2

Note 1: The reference channel applies to both the input signal under test and the interfering signal.

8.3.2.2 Dual-Layer Spatial Multiplexing

For dual-layer transmission on antenna ports 7 and 8 upon detection of a PDCCH with DCI format 2B, the requirements are specified in Table 8.3.2.2-2, with the addition of the parameters in Table 8.3.2.2-1 and the downlink physical channel setup according to Annex C.3.2. The purpose of these tests is to verify the rank-2 performance for full RB allocation.

Table 8.3.2.2-1: Test Parameters for Testing CDM-multiplexed DM RS (dual layer)

Parameter	Unit	Test 1	Test 2	
Downlink power allocation	ρ_A	dB	0	0
	ρ_B	dB	0 (Note 1)	0 (Note 1)
	σ	dB	-3	-3
Cell-specific reference symbols		Antenna port 0 and antenna port 1		
Beamforming model		Annex B.4.2		
N_{oc} at antenna port	dBm/15kHz	-98	-98	
Symbols for unused PRBs		OCNG (Note 2)	OCNG (Note 2)	
Number of allocated resource blocks	PRB	50	50	
PDSCH transmission mode		8	8	
Note 1: $P_B = 1$.				
Note 2: These physical resource blocks are assigned to an arbitrary number of virtual UEs with one PDSCH per virtual UE; the data transmitted over the OCNG PDSCHs shall be uncorrelated pseudo random data, which is QPSK modulated.				

Table 8.3.2.2-2: Minimum performance for CDM-multiplexed DM RS (FRC)

Test number	Bandwidth and MCS	Reference Channel	OCNG Pattern	Propagation Condition	Correlation Matrix and Antenna Configuration	Reference value		UE Category
						Fraction of Maximum Throughput (%)	SNR (dB)	
1	10 MHz QPSK 1/3	R.31 TDD	OP.1 TDD	EVA5	2x2 Low	70	4.5	≥ 2
2	10 MHz 16QAM 1/2	R.32 TDD	OP.1 TDD	EPA5	2x2 Medium	70	21.7	≥ 2

8.3.2.2A Enhanced Performance Requirement Type C - Dual-Layer Spatial Multiplexing

The requirements are specified in Table 8.3.2.2A-2, with the addition of the parameters in Table 8.3.2.2A-1 and the downlink physical channel setup according to Annex C.3.2. The purpose of these tests is to verify the rank-2 performance for full RB allocation upon antenna ports 7 and 8.

Table 8.3.2.2A-1: Test Parameters for Testing CDM-multiplexed DM RS (dual layer)

Parameter	Unit	Test 1	
Downlink power allocation	ρ_A	dB	0
	ρ_B	dB	0 (Note 1)
	σ	dB	-3
Cell-specific reference symbols		Antenna port 0 and antenna port 1	
Beamforming model		Annex B.4.2	
N_{oc} at antenna port	dBm/15kHz	-98	
Symbols for unused PRBs		OCNG (Note 2)	
Number of allocated resource blocks	PRB	50	
PDSCH transmission mode		8	
Note 1: $P_B = 1$.			
Note 2: These physical resource blocks are assigned to an arbitrary number of virtual UEs with one PDSCH per virtual UE; the data transmitted over the OCNG PDSCHs shall be uncorrelated pseudo random data, which is QPSK modulated.			

Table 8.3.2.2A-2: Enhanced Performance Requirement Type C for CDM-multiplexed DM RS (FRC)

Test number	Bandwidth and MCS	Reference Channel	OCNG Pattern	Propagation Condition	Correlation Matrix and Antenna Configuration	Reference value		UE Category
						Fraction of Maximum Throughput (%)	SNR (dB)	
1	10 MHz 16QAM 1/2	R.32 TDD	OP.1 TDD	EPA5	2x2 Medium	70	17.0	≥ 2

8.3.2.3 Dual-Layer Spatial Multiplexing (with multiple CSI-RS configurations)

For dual-layer transmission on antenna ports 7 and 8 upon detection of a PDCCH with DCI format 2C, the requirements are specified in Table 8.3.2.3-2, with the addition of the parameters in Table 8.3.2.3-1 where Cell 1 is the serving cell and Cell 2 is the interfering cell. The downlink physical channel setup is set according to Annex C.3.2. The purpose of these tests is to verify the rank-2 performance for full RB allocation, to verify rate matching with multiple CSI reference symbol configurations with non-zero and zero transmission power, and to verify that the UE correctly estimate SNR.

Table 8.3.2.3-1: Test Parameters for Testing CDM-multiplexed DM RS (dual layer) with multiple CSI-RS configurations

Parameter	Unit	Test 1		
		Cell 1	Cell 2	
Downlink power allocation	ρ_A	dB	0	0
	ρ_B	dB	0 (Note 1)	0
	σ	dB	-3	-3
	PDSCH_RA	dB	4	NA
	PDSCH_RB	dB	4	NA

Cell-specific reference signals		Antenna ports 0 and 1	Antenna ports 0 and 1
Cell ID		0	126
CSI reference signals		Antenna ports 15,16	NA
Beamforming model		Annex B.4.2	NA
CSI-RS periodicity and subframe offset $T_{CSI-RS} / \Delta_{CSI-RS}$	Subframes	5 / 4	NA
CSI reference signal configuration		8	NA
Zero-power CSI-RS configuration $I_{CSI-RS} / ZeroPowerCSI-RS$ bitmap	Subframes / bitmap	4 / 0010000000000000	NA
N_{oc} at antenna port	dBm/15kHz	-98	-98
\hat{E}_s / N_{oc}		Reference Value in Table 8.3.2.3-2	Test specific, 7.25dB
Symbols for unused PRBs		OCNG (Note 2)	NA
Number of allocated resource blocks (Note 2)	PRB	50	NA
Simultaneous transmission		No	NA
PDSCH transmission mode		9	Blanked
Note 1: $P_B = 1$ Note 2: These physical resource blocks are assigned to an arbitrary number of virtual UEs with one PDSCH per virtual UE; the data transmitted over the OCNG PDSCHs shall be uncorrelated pseudo random data, which is QPSK modulated.			

Table 8.3.2.3-2: Minimum performance for CDM-multiplexed DM RS (FRC) with multiple CSI-RS configurations

Test number	Bandwidth and MCS	Reference Channel	OCNG Pattern		Propagation Condition		Correlation Matrix and Antenna Configuration	Reference value		UE Category
			Cell 1	Cell 2	Cell 1	Cell 2		Fraction of Maximum Throughput (%)	SNR (dB)	
1	10 MHz 16QAM 1/2	R.51 TDD	OP.1 TDD	N/A	ETU5	ETU5	2x2 Low	70	14.8	≥ 2
Note 1: The propagation conditions for Cell 1 and Cell 2 are statistically independent. Note 2: Correlation matrix and antenna configuration parameters apply for each of Cell 1 and Cell 2. Note 3: SNR corresponds to \hat{E}_s / N_{oc} of Cell 1.										

8.3.2.4 Performance requirements for DCI format 2D and non Quasi Co-located Antenna Ports

8.3.2.4.1 Minimum requirement with Same Cell ID (with single NZP CSI-RS resource)

The requirements are specified in Table 8.3.2.4.1-3, with the additional parameters in Table 8.3.2.4.1-1 and Table 8.3.2.4.1-2. The purpose of this test is to verify the UE capability of supporting non quasi-co-located antenna ports when the UE receives DCI format 2D in a scenario where the two transmission point share the same Cell ID. In particular the test verifies that the UE, configured with quasi co-location type B, performs correct tracking and compensation of the

timing difference between two transmission points, channel parameters estimation and rate matching according to the ‘PDSCH RE Mapping and Quasi-Co-Location Indicator’ (PQI) signalling defined in [6], configured according to Table 8.3.2.4.1-2. In Tables 8.3.2.4.1-1 and 8.3.2.4.1-2, transmission point 1 (TP 1) is the serving cell and transmission point 2 (TP 2) transmits PDSCH. The downlink physical channel setup for TP 1 is according to Table C.3.4-1 and for TP 2 according to Table C.3.4-2.

Table 8.3.2.4.1-1: Test Parameters for quasi co-location type B: same Cell ID

Parameter	Unit	TP 1	TP 2
Downlink power allocation	ρ_A	dB	0
	ρ_B	dB	0 (Note 1)
	σ	dB	-3
Cell-specific reference signals		Antenna ports 0,1	(Note 2)
CSI-RS 0 antenna ports		NA	Port {15,16}
<i>qcl-CSI-RS-ConfigNZPId-r11</i> , CSI-RS 0 periodicity and subframe offset $T_{CSI-RS} / \Delta_{CSI-RS}$	Subframes	NA	5/4
<i>qcl-CSI-RS-ConfigNZPId-r11</i> , CSI-RS 0 configuration		NA	8
<i>csi-RS-ConfigZPId-r11</i> , Zero-power CSI-RS 0 configuration $l_{CSI-RS} /$ ZeroPower CSI-RS bitmap		NA	4/ 0000010000000000
N_{oc} at antenna port	dBm/15kHz	-98	-98
\hat{E}_s / N_{oc}	dB	Reference point in Table 8.3.2.4.1-3	Reference point in Table 8.3.2.4.1-3
BW _{Channel}	MHz	10	10
Cyclic Prefix		Normal	Normal
Cell Id		0	0
Number of control OFDM symbols		2	2
PDSCH transmission mode		Blanked	10
Number of allocated PRB	PRB	NA	50
<i>qcl-Operation</i> , ‘PDSCH RE Mapping and Quasi-Co-Location Indicator’		Type B, ‘00’	
Time offset between TPs	µs	NA	Reference point in Table 8.3.2.4.1-3
Frequency error between TPs	Hz	NA	0
Beamforming model		NA	Port 7 as specified in clause B.4.1
Symbols for unused PRBs		NA	OCNG (Note 3)
Note 1: $P_B = 1$ Note 2: REs for antenna ports 0 and 1 have zero transmission power. Note 3: These physical resource blocks are assigned to an arbitrary number of virtual UEs with one PDSCH per virtual UE; the data transmitted over the OCNG PDSCHs shall be uncorrelated pseudo random data, which is QPSK modulated.			

Table 8.3.2.4.1-2: Configurations of PQI and DL transmission hypothesis for each PQI set

PQI set index	Parameters in each PQI set	DL transmission hypothesis for each PQI Set

	NZP CSI-RS Index (For quasi co-location)	ZP CSI-RS configuration	TP 1	TP 2
PQI set 0	CSI-RS 0	ZP CSI-RS 0	Blanked	PDSCH

Table 8.3.2.4.1-3: Minimum performance for quasi co-location type B: same Cell ID

Test Number	Reference Channel	OGCN pattern		Time offset between TPs (μ s)	Propagation Conditions (Note1)		Correlation Matrix and Antenna Configuration (Note 2)	Reference Value		UE Category
		TP 1	TP 2		TP 1	TP 2		Fraction of Maximum Throughput (%)	SNR (dB) (Note 3)	
1	R.52 TDD	NA	OP.1 TDD	2	EPA5	EPA5	2x2 Low	70	12	≥ 2
2	R.52 TDD	NA	OP.1 TDD	-0.5	EPA5	EPA5	2x2 Low	70	12.4	≥ 2

Note 1: The propagation conditions for TP 1 and TP 2 are statistically independent.
Note 2: The correlation matrix and antenna configuration apply for TP 1 and TP 2.
Note 3: SNR corresponds to \hat{E}_s / N_{oc} of TP 2 as defined in clause 8.1.1.

8.3.2.4.2 Minimum requirements with Same Cell ID (with multiple NZP CSI-RS resources)

The requirements are specified in Table 8.3.2.4.2-3, with the additional parameters in Tables 8.3.2.4.2-1 and 8.3.2.4.2-2. The purpose of this test is to verify the UE capability of supporting non quasi-co-located antenna ports when the UE receives DCI format 2D in a scenario where the two transmission point share the same Cell ID. In particular the test verifies that the UE, configured with quasi co-location type B, performs correct tracking and compensation of the timing difference between two transmission points, channel parameters estimation and rate matching according to the ‘PDSCH RE Mapping and Quasi-Co-Location Indicator’ (PQI) signalling defined in [6]. In Tables 8.3.2.4.2-1 and 8.3.2.4.2-2, transmission point 1 (TP 1) is the serving cell transmitting PDCCH, synchronization signals and PBCH, and transmission point 2 (TP 2) has same Cell ID as TP 1. Multiple NZP CSI-RS resources and ZP CSI-RS resources are configured. In each sub-frame, DL PDSCH transmission is dynamically switched between 2 TPs with multiple PDSCH RE Mapping and Quasi-Co-Location Indicator configuration (PQI). Configurations of PDSCH RE Mapping and Quasi-Co-Location Indicator and downlink transmission hypothesis are defined in Table 8.3.2.4.2-2. The downlink physical channel setup for TP 1 is according to Table C.3.4-1 and for TP 2 according to Table C.3.4-2.

Table 8.3.2.4.2-1: Test Parameters for timing offset compensation with DPS transmission

parameter	Unit	TP 1	TP 2
Downlink power allocation	ρ_A	dB	0
	ρ_B	dB	0 (Note 1)
	σ	dB	-3

Beamforming model		As specified in clause B.4.1	As specified in clause B.4.1
Cell-specific reference signals		Antenna ports 0,1	(Note 2)
CSI reference signals 0		Antenna ports {15,16}	N/A
CSI-RS 0 periodicity and subframe offset $T_{\text{CSI-RS}} / \Delta_{\text{CSI-RS}}$	Subframes	5 / 4	N/A
CSI reference signal 0 configuration		0	N/A
CSI reference signals 1		N/A	Antenna ports {15,16}
CSI-RS 1 periodicity and subframe offset $T_{\text{CSI-RS}} / \Delta_{\text{CSI-RS}}$	Subframes	N/A	5 / 4
CSI reference signal 1 configuration		N/A	8
Zero-power CSI-RS 0 configuration $l_{\text{CSI-RS}} /$ <i>ZeroPower CSI-RS</i> bitmap	Subframes /bitmap	4/ 0010000000000000	N/A
Zero-power CSI-RS1 configuration $l_{\text{CSI-RS}} /$ <i>ZeroPower CSI-RS</i> bitmaps	Subframes /bitmap	N/A	4/ 0000010000000000
\hat{E}_s / N_{oc}	dB	Reference Value in Table 8.3.2.4.2-3	Reference Value in Table 8.3.2.4.2-3
N_{oc} at antenna port	dBm/15kHz	-98	-98
BW_{Channel}	MHz	10	10
Cyclic Prefix		Normal	Normal
Cell Id		0	0
Number of control OFDM symbols		2	2
Timing offset between TPs		N/A	Reference Value in Table 8.3.2.4.2-3
Frequency offset between TPs	Hz	N/A	0
Number of allocated resource blocks	PRB	50	50
PDSCH transmission mode		10	10
Probability of occurrence of PDSCH transmission(Note 3)	%	30	70
Symbols for unused PRBs		OCNG (Note 4)	OCNG (Note 4)
<p>Note 1: $P_B = 1$</p> <p>Note 2: REs for antenna ports 0 and 1 have zero transmission power.</p> <p>Note 3: PDSCH transmission from TPs shall be randomly determined independently for each subframe. Probabilities of occurrence of PDSCH transmission from TPs are specified.</p> <p>Note 4: These physical resource blocks are assigned to an arbitrary number of virtual UEs with one PDSCH per virtual UE; the data transmitted over the OCNG PDSCHs shall be uncorrelated pseudo random data, which is QPSK modulated.</p>			

Table 8.3.2.4.2-2: Configurations of PQI and DL transmission hypothesis for each PQI set

PQI set index	Parameters in each PQI set		DL transmission hypothesis for each PQI Set	
	NZP CSI-RS Index (For quasi co-location)	ZP CSI-RS configuration	TP 1	TP 2
PQI set 0	CSI-RS 0	ZP CSI-RS 0	PDSCH	Blanked
PQI set 1	CSI-RS 1	ZP CSI-RS 1	Blanked	PDSCH

Table 8.3.2.4.2-3: Performance Requirements for timing offset compensation with DPS transmission

Test Number	Timing offset(us)	Reference Channel	OCNG Pattern		Propagation Conditions		Correlation Matrix and Antenna Configuration (Note 2)	Reference Value		UE Category
			TP 1	TP 2	TP 1	TP 2		Fraction of Maximum Throughput (%)	SNR (dB) (Note 3)	
1	2	R.53 TDD	OP.1 TDD	OP.1 TDD	EPA5	EPA5	2x2 Low	70	12.3	≥2
2	-0.5	R.53 TDD	OP.1 TDD	OP.1 TDD	EPA5	EPA5	2x2 Low	70	12.5	≥2

Note 1: The propagation conditions for TP 1 and TP 2 are statistically independent.
Note 2: Correlation matrix and antenna configuration parameters apply for each of TP 1 and TP 2.
Note 3: SNR corresponds to \hat{E}_s/N_{oc} of both TP 1 and TP 2 as defined in clause 8.1.1.

8.3.2.4.3 Minimum requirement with Different Cell ID and Colliding CRS (with single NZP CSI-RS resource)

The requirements are specified in Table 8.3.2.4.3-2, with the additional parameters in Table 8.3.2.4.3-1. The purpose of this test is to verify the UE capability of supporting non quasi-co-located antenna ports when the UE receives DCI format 2D in a scenario where the two transmission points have different Cell ID and colliding CRS. In particular the test verifies that the UE, configured with quasi co-location type B, performs correct tracking and compensation of the frequency difference between two transmission points, channel parameters estimation and rate matching behaviour according to the 'PDSCH RE Mapping and Quasi-Co-Location Indicator' signalling defined in [6]. In Table 8.3.2.4.3-1, transmission point 1 (TP 1) is serving cell transmitting PDCCH, synchronization signals and PBCH, and transmission point 2 (TP 2) transmits PDSCH with different Cell ID. The downlink physical channel setup for TP 1 is according to Table C.3.4-1 and for TP 2 according to Table C.3.4-2.

Table 8.3.2.4.3-1: Test Parameters for quasi co-location type B with different Cell ID and Colliding CRS

parameter	Unit	TP 1	TP 2
Downlink power allocation	ρ_A	dB	0
	ρ_B	dB	0 (Note 1)
	σ	dB	-3

Beamforming model		N/A	As specified in clause B.4.2
Cell-specific reference signals		Antenna ports 0,1	Antenna ports 0,1
CSI reference signals 0		N/A	Antenna ports {15,16}
CSI-RS 0 periodicity and subframe offset $T_{\text{CSI-RS}} / \Delta_{\text{CSI-RS}}$	Subframes	N/A	5 / 4
CSI reference signal 0 configuration		N/A	0
Zero-power CSI-RS 0 configuration $I_{\text{CSI-RS}} / \text{ZeroPower CSI-RS bitmap}$	Subframes /bitmap	N/A	4/ 0010000000000000
\hat{E}_s / N_{oc}	dB	Reference point in Table 8.3.2.4.3-2 + 4dB	Reference Value in Table 8.3.2.4.3-2
N_{oc} at antenna port	dBm/15kHz	-98	-98
BW_{Channel}	MHz	10	10
Cyclic Prefix		Normal	Normal
Cell Id		0	126
Number of control OFDM symbols		1	2
Timing offset between TPs	us	N/A	0
Frequency offset between TPs	Hz	N/A	200
<i>qcl-Operation, PDSCH RE Mapping and Quasi-Co-Location Indicator</i>		Type B, '00'	
PDSCH transmission mode		Blank	10
Number of allocated resource block		N/A	50
Symbols for unused PRBs		N/A	OCNG(Note2)
Note 1: $P_b = 1$			
Note 2: These physical resource blocks are assigned to an arbitrary number of virtual UEs with one PDSCH per virtual UE; the data transmitted over the OCNG PDSCHs shall be uncorrelated pseudo random data, which is QPSK modulated.			

Table 8.3.2.4.3-2: Performance Requirements for quasi co-location type B with different Cell ID and Colliding CRS

Test Number	Reference Channel	OCNG Pattern		Propagation Conditions (Note1)		Correlation Matrix and Antenna Configuration (Note 2)	Reference Value		UE Category
		TP 1	TP 2	TP 1	TP 2		Fraction of Maximum Throughput (%)	SNR (dB) (Note 3)	
1	R.54 TDD	N/A	OP.1 TDD	EPA5	ETU5	2x2 Low	70	14.7	≥2
Note 1: The propagation conditions for TP 1 and TP 2 are statistically independent.									
Note 2: Correlation matrix and antenna configuration parameters apply for each of TP 1 and TP 2.									
Note 3: SNR corresponds to \hat{E}_s / N_{oc} of TP 2 as defined in clause 8.1.1.									

8.3.2.4.4 Minimum requirement with Different Cell ID and non-Colliding CRS (with single NZP CSI-RS resource and CRS assistance information is configured)

The requirements are specified in Table 8.3.2.4.4-3, with the additional parameters in Table 8.3.2.4.4-1 and Table 8.3.2.4.4-2. The purpose of this test is to verify the UE capability of supporting non quasi-co-located antenna ports when the UE receives DCI format 2D in a scenario where three transmission points have different Cell ID and non-colliding CRS. In particular the test verifies that the UE, configured with quasi co-location type B, performs correct tracking and compensation of the frequency difference and time difference between two transmission points, channel parameters estimation and rate matching behaviour according to the 'PDSCH RE Mapping and Quasi-Co-Location Indicator' signalling defined in [6]. Further, the test verifies that the UE, configured with the CRS assistance information [7], can mitigate interference from CRS for demodulation. The CRS assistance information [7] includes TP 3. In Table 8.3.2.4.4-1, transmission point 1 (TP 1) is serving cell transmitting PDCCH, synchronization signals and PBCH, transmission point 2 (TP 2) transmits PDSCH with different Cell ID, and Transmission point 3 (TP 3) is the aggressor transmission point. The downlink physical channel setup for TP 1 is according to Table C.3.4-1, for TP 2 is according to Table C.3.4-2, and for TP 3 is according to Annex C.3.2.

Table 8.3.2.4.4-1: Test Parameters for quasi co-location type B with different Cell ID and non-colliding CRS when CRS assistance information is configured

parameter		Unit	TP 1	TP 2	TP 3
Downlink power allocation	ρ_A	dB	0	0	0
	ρ_B	dB	0 (Note 1)	0	0
	σ	dB	-3	-3	-3
Beamforming model			N/A	Port 7 as specified in clause B.4.1	N/A
Cell-specific reference signals			Antenna ports 0,1	Antenna ports 0,1	Antenna ports 0,1
CSI reference signals 0			N/A	Antenna ports {15,16}	N/A
CSI-RS 0 periodicity and subframe offset $T_{\text{CSI-RS}} / \Delta_{\text{CSI-RS}}$		Subframes	N/A	5 / 4	N/A
CSI reference signal 0 configuration			N/A	0	N/A
Zero-power CSI-RS 0 configuration $I_{\text{CSI-RS}} / \text{ZeroPower CSI-RS bitmap}$		Subframes /bitmap	N/A	4/ 0010000000000000	N/A
\hat{E}_s / N_{oc}		dB	10.45	Reference Value in Table 8.3.2.4.4-3	8.45
N_{oc} at antenna port		dBm/15kHz	-98	-98	N/A
BW_{Channel}		MHz	10	10	10
Cyclic Prefix			Normal	Normal	Normal
Cell Id			0	1	128
Number of control OFDM symbols			1	2	2
Timing offset to TP 1		us	N/A	-0.5	3
Frequency offset to TP 1		Hz	N/A	200	-100
<i>qcl-Operation</i> , 'PDSCH RE Mapping and Quasi-Co-Location Indicator'			Type B, '00'		N/A
PDSCH transmission mode			Blank	10	9
Number of allocated resource block			N/A	50	N/A
Symbols for unused PRBs			N/A	OCNG(Note2)	N/A
Interference model			N/A	N/A	As specified in clause B.5.4
Probability of occurrence of transmission in interference cells		%	N/A	N/A	20
Probability of occurrence of transmission rank in interfering cells	Rank 1	%	N/A	N/A	80
	Rank 2	%	N/A	N/A	20
Note 1: $P_B = 1$ Note 2: These physical resource blocks are assigned to an arbitrary number of virtual UEs with one PDSCH per virtual UE; the data transmitted over the OCNG PDSCHs shall be uncorrelated pseudo random data, which is QPSK modulated.					

Table 8.3.2.4.4-2: Configurations of PQI and DL transmission hypothesis for each PQI set

PQI set index	Parameters in each PQI set		DL transmission hypothesis for each PQI Set	
	NZP CSI-RS Index (For quasi co-location)	ZP CSI-RS configuration	TP 1	TP 2
PQI set 0	CSI-RS 0	ZP CSI-RS 0	Blanked	PDSCH

Table 8.3.2.4.4-3: Performance Requirements for quasi co-location type B with different Cell ID and non-Colliding CRS when CRS assistance information is configured

Test Number	Reference Channel	OCNG Pattern			Propagation Conditions (Note1)			Correlation Matrix and Antenna Configuration (Note 2)	Reference Value		UE Category
		TP 1	TP 2	TP3	TP 1	TP 2	TP3		Fraction of Maximum Throughput (%)	SNR (dB) (Note 3)	
1	R.52-1 TDD	N/A	OP.1 TDD	N/A	EVA5	EVA5	EVA5	2x2 Low	70	11.1	≥2
Note 1: The propagation conditions for TP.1, TP.2 and TP.3 are statistically independent. Note 2: Correlation matrix and antenna configuration parameters apply for each of TP.1, TP.2 and TP.3. Note 3: SNR corresponds to \hat{E}_s / N_{oc} of TP.2 as defined in clause 8.1.1.											

8.3.2.4.5 Minimum requirements with different Cell ID and non-colliding CRS (with multiple NZP CSI-RS resources and CRS assistance information is configured)

The requirements are specified in Table 8.3.2.4.5-3, with the additional parameters in Tables 8.3.2.4.5-1 and 8.3.2.4.5-2. The purpose of this test is to verify the UE capability of supporting non quasi-colocated antenna ports when the UE receives DCI format 2D in a scenario where three transmission point have the different Cell ID and non-colliding CRS. In particular the test verifies that the UE, configured with quasi co-location type B, performs correct tracking and compensation of the frequency difference and timing difference between two transmission points, channel parameters estimation and rate matching according to the ‘PDSCH RE Mapping and Quasi-Co-Location Indicator’ (PQI) signalling defined in [6]. Further, the test verifies that the UE, configured with the CRS assistance information [7], can mitigate interference from CRS for demodulation. The CRS assistance information [7] includes TP 3. In Tables 8.3.2.4.5-1 and 8.3.2.4.5-2, transmission point 1 (TP 1) is the serving cell transmitting PDCCH, synchronization signals and PBCH, Transmission point 2 (TP 2) has different Cell ID as TP 1, and Transmission point 3 (TP3) is the aggressor transmission point. Multiple NZP CSI-RS resources and ZP CSI-RS resources are configured. In each sub-frame, DL PDSCH transmission is dynamically switched between TP 1 and TP 2 with multiple PDSCH RE Mapping and Quasi-Co-Location Indicator configuration (PQI). Configurations of PDSCH RE Mapping and Quasi-Co-Location Indicator and downlink transmission hypothesis are defined in Table 8.3.2.4.5-2. The downlink physical channel setup for TP 1 is according to Table C.3.4-1, for TP 2 is according to Table C.3.4-2, and for TP 3 is according to Annex C.3.2

Table 8.3.2.4.5-1: Test Parameters for DPS transmission with CRS assistance information

parameter		Unit	TP 1	TP 2	TP 3
Downlink power allocation	ρ_A	dB	0	0	0
	ρ_B	dB	0 (Note 1)	0	0
	σ	dB	-3	-3	-3
Beamforming model			As specified in clause B.4.1	As specified in clause B.4.1	N/A
Cell-specific reference signals			Antenna ports 0,1	Antenna ports 0,1	Antenna ports 0,1
CSI reference signals 0			Antenna ports {15,16}	N/A	N/A
CSI-RS 0 periodicity and subframe offset $T_{\text{CSI-RS}} / \Delta_{\text{CSI-RS}}$		Subframes	5 / 4	N/A	N/A
CSI reference signal 0 configuration			0	N/A	N/A
CSI reference signals 1			N/A	Antenna ports {15,16}	N/A
CSI-RS 1 periodicity and subframe offset $T_{\text{CSI-RS}} / \Delta_{\text{CSI-RS}}$		Subframes	N/A	5 / 4	N/A
CSI reference signal 1 configuration			N/A	8	N/A
Zero-power CSI-RS 0 configuration $I_{\text{CSI-RS}} / \text{ZeroPower CSI-RS}$ bitmap		Subframes /bitmap	4/ 0010000000000000	N/A	N/A
Zero-power CSI-RS1 configuration $I_{\text{CSI-RS}} / \text{ZeroPower CSI-RS}$ bitmaps		Subframes /bitmap	N/A	4/ 0000010000000000	N/A
\widehat{E}_s / N_{oc} (Note 2)		dB	Reference Value in Table 8.3.2.4.5-3	Reference Value in Table 8.3.2.4.5-3	8.45
N_{oc} at antenna port		dBm/15kHz	-98	-98	N/A
BW_{Channel}		MHz	10	10	10
Cyclic Prefix			Normal	Normal	Normal
Cell Id			0	1	128
Number of control OFDM symbols			2	2	2
Timing offset to TP 1			N/A	-0.5	3
Frequency offset to TP 1		Hz	N/A	200	-100
Number of allocated resource blocks		PRB	50	50	N/A
PDSCH transmission mode			10	10	9
Probability of occurrence of PDSCH transmission(Note 3)		%	30	70	N/A
Symbols for unused PRBs			OCNG (Note 4)	OCNG (Note 4)	N/A
Interference model			N/A	N/A	As specified in clause B.5.4
Probability of occurrence of transmission in interference cells		%	N/A	N/A	20
Probability of occurrence of transmission rank in interfering cells	Rank 1	%	N/A	N/A	80
	Rank 2	%	N/A	N/A	20
Note 1: $P_B = 1$					

Note 2:	\widehat{E}_s/N_{oc} of TP 1 is set the same as that of TP 2.
Note 3:	PDSCH transmission from TP 1 and TP 2 shall be randomly determined independently for each subframe. Probabilities of occurrence of PDSCH transmission from TPs are specified.
Note 4:	These physical resource blocks are assigned to an arbitrary number of virtual UEs with one PDSCH per virtual UE; the data transmitted over the OCNG PDSCHs shall be uncorrelated pseudo random data, which is QPSK modulated.

Table 8.3.2.4.5-2: Configurations of PQI and DL transmission hypothesis for each PQI set

PQI set index	Parameters in each PQI set		DL transmission hypothesis for each PQI Set	
	NZP CSI-RS Index (For quasi co-location)	ZP CSI-RS configuration	TP 1	TP 2
PQI set 0	CSI-RS 0	ZP CSI-RS 0	PDSCH	Blanked
PQI set 1	CSI-RS 1	ZP CSI-RS 1	Blanked	PDSCH

Table 8.3.2.4.5-3: Performance Requirements for DPS transmission with CRS assistance information

Test Number	Reference Channel	OCNG Pattern			Propagation Conditions (Note1)			Correlation Matrix and Antenna Configuration (Note 2)	Reference Value		UE Category
		TP 1	TP 2	TP3	TP 1	TP 2	TP3		Fraction of Maximum Throughput (%)	SNR (dB) (Note 3)	
1	R.52-1 TDD	OP.1 TDD	OP.1 TDD	N/A	EVA5	EVA5	EVA5	2x2 Low	70	11.2	≥2
Note 1: The propagation conditions for TP.1, TP.2 and TP.3 are statistically independent. Note 2: Correlation matrix and antenna configuration parameters apply for each of TP.1, TP.2 and TP.3. Note 3: SNR corresponds to \widehat{E}_s/N_{oc} of both TP.1 and TP.2 as defined in clause 8.1.1.											

8.3.3 LAA

8.3.3.1 Dual-Layer Spatial Multiplexing with DM-RS

8.3.3.1.1 FDD PCell (FDD single carrier)

The parameters specified in Table 8.3.3.1.1-1 are valid for FDD CC and LAA SCell(s) unless otherwise stated. And the additional parameters specified in Table 8.3.3.1.1-2 are valid for LAA SCell(s).

Table 8.3.3.1.1-1: Common Test Parameters

Parameter	Unit	Value
Cyclic prefix		Normal
Cell ID		0
Inter-TTI Distance		1
Number of HARQ processes	Processes	8
Maximum number of HARQ transmission (Note 1)		4
Redundancy version coding sequence		{0,1,2,3} for QPSK and 16QAM {0,0,1,2} for 64QAM and 256QAM
Precoder update granularity		Frequency domain: 1 PRG Time domain: 1 ms
Note 1: For retransmission in partial subframes, the TB size should be kept the same as the initial transmission regardless of the initial transmission is performed in full subframes or partial subframes.		
Note 2: Void.		

Table 8.3.3.1.1-2: Additional Test Parameters for LAA SCell(s)

Parameter	Unit	Value
DMTC Periodicity	ms	80
dmtc-PeriodOffset-r12 ms80-r12		0
Discovery signal occasion duration	subframe	1
Power allocation of discovery signal		Same as power allocation of CRS within a transmission burst in the test

For CA with LAA SCell(s), the requirements for dual-layer transmission on antenna ports 7 and 8 upon detection of a PDCCH with DCI format 2C are specified in Table 8.3.3.1.1-7, with the addition of the parameters in Table 8.3.3.1.1-3, Table 8.3.3.1.1-4 and Table 8.3.3.1.1-5. The downlink physical channel setup is set according to Annex C.3.2. The purpose of these tests is to verify the rank-2 performance for full RB allocation for CA with LAA SCell(s).

Table 8.3.3.1.1-3: Test Parameters for Large Delay CDD (FRC) for PCell

Parameter	Unit	Value	
Downlink power allocation	ρ_A	dB	-3
	ρ_B	dB	-3 (NOTE 1)
	σ	dB	0
N_{oc} at antenna port	dBm/15kHz	-98	
PDSCH transmission mode		TM3	
Subframe configuration		Non-MBSFN	
NOTE 1: $P_B = 1$.			
NOTE 2: PUCCH format 3 is used to feedback ACK/NACK.			
NOTE 3: Void			

Table 8.3.3.1.1-4: Test Parameters for CDM-multiplexed DM RS (dual layer) for CA with LAA SCell(s)

Parameter		Unit	Test 1
Downlink power allocation	ρ_A	dB	0
	ρ_B	dB	0 (Note 1)
	σ	dB	-3
Cell-specific reference signals			Antenna ports 0 and 1
CSI reference signals			Antenna ports 15,16
DMRS ports (dual layer transmission)			port 7 and port 8
Beamforming model			Annex B.4.2
CSI-RS periodicity and subframe offset $T_{\text{CSI-RS}} / \Delta_{\text{CSI-RS}}$		Subframes	5/2
CSI reference signal configuration			8
Zero-power CSI-RS configuration $I_{\text{CSI-RS}} / \text{ZeroPowerCSI-RS}$ bitmap		Subframes / bitmap	3 / 0010000000000000
N_{oc} at antenna port		dBm/15kHz	-98
Symbols for unused PRBs			OCNG (Note 2)
PDSCH transmission mode			9
DL Burst transmission pattern for LAA SCell			As specified in B.8
The number of subframes set (S_1) in a burst			{1,3,5,8}
Occupied OFDM symbols set in the last subframe			{6,9,12,14}
Random variable p defined in B.8			0.5
timing error relative of LAA SCell to PCell		μs	0
Frequency offset of the i -th LAA SCell relative to PCell		Hz	200
Note 1: $P_B = 1$			
Note 2: These physical resource blocks are assigned only within burst transmissions to a LAA UE; the data transmitted over the OCNG PDSCHs shall be uncorrelated pseudo random data, which is QPSK modulated.			

Table 8.3.3.1.1-5: Single carrier performance Large Delay CDD (FRC) for PCell for multiple CA configurations

Band-width	Reference channel	OCNG pattern	Propa-gation condition	Correlation matrix and antenna config.	Reference value	
					Fraction of Norminal maximum throughput (%)	SNR (dB)
1.4MHz	R.11-5 FDD	OP.1 FDD	EVA70	2x2 Low	70	13.6
3MHz	R.11-6 FDD	OP.1 FDD	EVA70	2x2 Low	70	12.3
5MHz	R.11-2 FDD	OP.1 FDD	EVA70	2x2 Low	70	12.3
10MHz	R.11 FDD	OP.1 FDD	EVA70	2x2 Low	70	12.9
15MHz	R.11-7 FDD	OP.1 FDD	EVA70	2x2 Low	70	12.8
20MHz	R.30 FDD	OP.1 FDD	EVA70	2x2 Low	70	12.9

Table 8.3.3.1.1-6: Single carrier performance for CDM-multiplexed DM RS (dual layer) for LAA SCell for multiple CA configurations

Band-width	Sub-test (Note 2)	Reference channel	OCNG pattern	Propa-gation condition	Correlation matrix and antenna config.	Reference value	
						Fraction of maximum throughput (%) (Note 1)	SNR (dB)
20MHz	1	R.2 FS3	OP.1 FS3	EVA5	2x2 Low	70	14.1
	2	R.2 FS3	OP.1 FS3	EVA5	2x2 Low	70	14
	3	R.2 FS3	OP.1 FS3	EVA5	2x2 Low	70	14.2
	4	R.2 FS3	OP.1 FS3	EVA5	2x2 Low	70	14.2
<p>Note 1: Fraction of nominal maximum throughput is calculated based on random occasions of LAA PDSCH transmission.</p> <p>Note 2: An UE is required to fulfill only one test of Sub-test 1-4 depending on UE capabilities of endingDwPTS and secondSlotStartingPosition. For an UE not supporting both endingDwPTS and secondSlotStartingPosition, it is required to fulfill Sub-test 1; For an UE not supporting endingDwPTS but supporting secondSlotStartingPosition, it is required to fulfill Sub-test 2; For an UE supporting endingDwPTS but not supporting secondSlotStartingPosition, it is required to fulfill Sub-test 3; and For an UE supporting both endingDwPTS and secondSlotStartingPosition, it is required to fulfill Sub-test 4.</p>							

Table 8.3.3.1.1-7: Minimum performance (FRC) based on single carrier performance for CA with LAA SCell(s)

Test number	Aggregated Bandwidth (MHz)			Minimum performance requirement (Note 2)	UE Category
	Total	PCell	LAA SCell		
1	2x20	20	20	As defined in Table 8.3.3.1.1-5 and Table 8.3.3.1.1-6	≥5
<p>Note 1: The applicability of requirements for different CA configurations and bandwidth combination sets is defined in 8.1.2.3C.</p> <p>Note 2: Apply a per-CC requirement defined in Table 8.3.3.1.1-5 for PCell and apply a per-CC requirement defined in Table 8.3.3.1.1-6 for LAA SCell.</p>					

8.3.3.1.2 TDD Pcell (TDD single carrier)

The parameters specified in Table 8.3.3.1.2-1 are valid for TDD CC and LAA SCell(s) unless otherwise stated. And the additional parameters specified in Table 8.3.3.1.2-2 are valid for LAA SCell(s).

Table 8.3.3.1.2-1: Common Test Parameters

Parameter	Unit	Value
Uplink downlink configuration (Note 1)		1
Special subframe configuration (Note 2)		4
Cyclic prefix		Normal
Cell ID		0
Inter-TTI Distance		1
Number of HARQ processes	Processes	7
Maximum number of HARQ transmission (Note 3)		4
Redundancy version coding sequence		{0,1,2,3} for QPSK and 16QAM {0,0,1,2} for 64QAM and 256QAM
Precoder update granularity		Frequency domain: 1 PRG for Transmission modes 9 Time domain: 1 ms
ACK/NACK feedback mode		Multiplexing
Note 1: As specified in Table 4.2-2 in TS 36.211 [4]		
Note 2: As specified in Table 4.2-1 in TS 36.211 [4]		
Note 3: For retransmission in partial subframes, the TB size should be kept the same as the initial transmission regardless of the initial transmission is performed in full subframes or partial subframes.		

Table 8.3.3.1.2-2: Additional Test Parameters for LAA SCell(s)

Parameter	Unit	Value
DMTC Periodicity	ms	80
dmtc-PeriodOffset-r12 ms80-r12		0
Discovery signal occasion duration	subframe	1
Power allocation of discovery signal		Same as power allocation of CRS within a transmission burst in the test

For CA with LAA SCell(s), the requirements for dual-layer transmission on antenna ports 7 and 8 upon detection of a PDCCH with DCI format 2C are specified in Table 8.3.3.1.2-7, with the addition of the parameters in Table 8.3.3.1.2-3, Table 8.3.3.1.2-4 and Table 8.3.3.1.2-5, The downlink physical channel setup is set according to Annex C.3.2. The purpose of these tests is to verify the rank-2 performance for full RB allocation for CA with LAA SCell(s).

Table 8.3.3.1.2-3: Test Parameters for Large Delay CDD (FRC) for PCell

Parameter	Unit	Value	
Downlink power allocation	ρ_A	dB	-3
	ρ_B	dB	-3 (NOTE 1)
	σ	dB	0
N_{oc} at antenna port	dBm/15kHz	-98	
PDSCCH transmission mode		TM3	
Subframe configuration		Non-MBSFN	
NOTE 1: $P_B = 1$.			
NOTE 2: PUCCH format 3 is used to feedback ACK/NACK.			
NOTE 3: Void			

Table 8.3.3.1.2-4: Test Parameters for CDM-multiplexed DM RS (dual layer) for LAA SCell(s)

Parameter		Unit	Test 1
Downlink power allocation	ρ_A	dB	0
	ρ_B	dB	0 (Note 1)
	σ	dB	-3
Cell-specific reference signals			Antenna ports 0 and 1
CSI reference signals			Antenna ports 15,16
DMRS ports (dual layer transmission)			port 7 and port 8
Beamforming model			Annex B.4.2
CSI-RS periodicity and subframe offset $T_{\text{CSI-RS}} / \Delta_{\text{CSI-RS}}$	Subframes		5/4
CSI reference signal configuration			8
Zero-power CSI-RS configuration $I_{\text{CSI-RS}} / \text{ZeroPowerCSI-RS}$ bitmap	Subframes / bitmap		4/ 0010000000000000
N_{oc} at antenna port	dBm/15kHz		-98
Symbols for unused PRBs			OCNG (Note 2)
PDSCH transmission mode			9
DL Burst transmission pattern for LAA SCell			As specified in B.8
The number of subframes set (S_1) in a burst			{1,3,5,8}
Occupied OFDM symbols set in the last subframe			{6,9,12,14}
Random variable p defined in B.8			0.5
Timing error relative of LAA SCell to PCell		μs	0
Frequency offset of th i -th LAA SCell relative to PCell		Hz	200
Note 1: $P_B = 1$			
Note 2: These physical resource blocks are assigned only within burst transmissions to a LAA UE; the data transmitted over the OCNG PDSCHs shall be uncorrelated pseudo random data, which is QPSK modulated.			

Table 8.3.3.1.2-5: Single carrier performance Large Delay CDD (FRC) for PCell for multiple CA configurations

Band-width	Reference channel	OCNG pattern	Propa-gation condition	Correlation matrix and antenna config.	Reference value	
					Fraction of maximum throughput (%)	SNR (dB)
1.4MHz	R.11-5 TDD	OP.1 TDD	EVA70	2x2 Low	70	13.2
3MHz	R.11-6 TDD	OP.1 TDD	EVA70	2x2 Low	70	12.8
5MHz	R.11-7 TDD	OP.1 TDD	EVA70	2x2 Low	70	12.6
10MHz	R.11-8 TDD	OP.1 TDD	EVA70	2x2 Low	70	12.8
15MHz	R.11-9 TDD	OP.1 TDD	EVA70	2x2 Low	70	12.9
20MHz	R.30-1 TDD	OP.1 TDD	EVA70	2x2 Low	70	13.0

Table 8.3.3.1.2-6: Single carrier performance for CDM-multiplexed DM RS (dual layer) for LAA SCell(s) for multiple CA configurations

Band-width	Sub-test (Note2)	Reference channel	OCNG pattern	Propa-gation condition	Correlation matrix and antenna config.	Reference value	
						Fraction of Normal maximum throughput (%) (Note 1)	SNR (dB)
20MHz	1	R.2 FS3	OP.1 FS3	EVA5	2x2 Low	70	14.1
	2	R.2 FS3	OP.1 FS3	EVA5	2x2 Low	70	14
	3	R.2 FS3	OP.1 FS3	EVA5	2x2 Low	70	14.2
	4	R.2 FS3	OP.1 FS3	EVA5	2x2 Low	70	14.2
<p>Note 1: Fraction of nominal maximum throughput is calculated based on random occasions of LAA PDSCH transmission.</p> <p>Note 2: An UE is required to fulfill only one test of Sub-test 1-4 depending on UE capabilities of endingDwPTS and secondSlotStartingPosition. For an UE not supporting both endingDwPTS and secondSlotStartingPosition, it is required to fulfill Sub-test 1; For an UE not supporting endingDwPTS but supporting secondSlotStartingPosition, it is required to fulfill Sub-test 2; For an UE supporting endingDwPTS but not supporting secondSlotStartingPosition, it is required to fulfill Sub-test 3; and For an UE supporting both endingDwPTS and secondSlotStartingPosition, it is required to fulfill Sub-test 4.</p>							

Table 8.3.3.1.2-7: Minimum performance (FRC) based on single carrier performance for CA with LAA SCell(s)

Test number	Aggregated Bandwidth (MHz)			Minimum performance requirement (Note 2)	UE Category
	Total	PCell	LAA SCell		
1	2x20	20	20	As defined in Table 8.3.3.1.2-5 and Table 8.3.3.1.2-6	≥5
<p>Note 1: The applicability of requirements for different CA configurations and bandwidth combination sets is defined in 8.1.2.3C.</p> <p>Note 2: Apply a per-CC requirement defined in Table 8.3.3.1.2-5 for PCell and apply a per-CC requirement defined in Table 8.3.3.1.2-6 for LAA SCell.</p>					

8.4 Demodulation of PDCCH/PCFICH

The receiver characteristics of the PDCCH/PCFICH are determined by the probability of miss-detection of the Downlink Scheduling Grant (Pm-dsg). PDCCH and PCFICH are tested jointly, i.e. a miss detection of PCFICH implies a miss detection of PDCCH.

8.4.1 FDD

The parameters specified in Table 8.4.1-1 are valid for all FDD tests unless otherwise stated.

Table 8.4.1-1: Test Parameters for PDCCH/PCFICH

Parameter		Unit	Single antenna port	Transmit diversity
Number of PDCCH symbols		symbols	2	2
PHICH Ng (Note 1)			1	1
PHICH duration			Normal	Normal
Unused RE-s and PRB-s			OCNG	OCNG
Cell ID			0	0
Downlink power allocation	PDCCH_RA PHICH_RA OCNG_RA	dB	0	-3
	PCFICH_RB PDCCH_RB PHICH_RB OCNG_RB	dB	0	-3
N_{oc} at antenna port		dBm/15kHz	-98	-98
Cyclic prefix			Normal	Normal
Note 1: According to Clause 6.9 in TS 36.211 [4]				

8.4.1.1 Single-antenna port performance

For the parameters specified in Table 8.4.1-1 the average probability of a missed downlink scheduling grant (Pm-dsg) shall be below the specified value in Table 8.4.1.1-1. The downlink physical setup is in accordance with Annex C.3.2.

Table 8.4.1.1-1: Minimum performance PDCCH/PCFICH

Test number	Bandwidth	Aggregation level	Reference Channel	OCNG Pattern	Propagation Condition	Antenna configuration and correlation Matrix	Reference value	
							Pm-dsg (%)	SNR (dB)
1	10 MHz	8 CCE	R.15 FDD	OP.1 FDD	ETU70	1x2 Low	1	-1.7

8.4.1.2 Transmit diversity performance

8.4.1.2.1 Minimum Requirement 2 Tx Antenna Port

For the parameters specified in Table 8.4.1-1 the average probability of a missed downlink scheduling grant (Pm-dsg) shall be below the specified value in Table 8.4.1.2.1-1. The downlink physical setup is in accordance with Annex C.3.2.

Table 8.4.1.2.1-1: Minimum performance PDCCH/PCFICH

Test number	Bandwidth	Aggregation level	Reference Channel	OCNG Pattern	Propagation Condition	Antenna configuration and correlation Matrix	Reference value	
							Pm-dsg (%)	SNR (dB)
1	10 MHz	4 CCE	R.16 FDD	OP.1 FDD	EVA70	2 x 2 Low	1	-0.6

8.4.1.2.2 Minimum Requirement 4 Tx Antenna Port

For the parameters specified in Table 8.4.1-1 the average probability of a missed downlink scheduling grant (Pm-dsg) shall be below the specified value in Table 8.4.1.2.2-1. The downlink physical setup is in accordance with Annex C.3.2.

Table 8.4.1.2.2-1: Minimum performance PDCCH/PCFICH

Test number	Bandwidth	Aggregation level	Reference Channel	OCNG Pattern	Propagation Condition	Antenna configuration and correlation Matrix	Reference value	
							Pm-dsg (%)	SNR (dB)
1	5 MHz	2 CCE	R.17 FDD	OP.1 FDD	EPA5	4 x 2 Medium	1	6.3

8.4.1.2.3 Minimum Requirement 2 Tx Antenna Port (demodulation subframe overlaps with aggressor cell ABS)

For the parameters for non-MBSFN ABS specified in Table 8.4.1-1 and Table 8.4.1.2.3-1, the average probability of a missed downlink scheduling grant (Pm-dsg) shall be below the specified value in Table 8.4.1.2.3-2. The downlink physical setup is in accordance with Annex C.3.2 and Annex C.3.3. In Table 8.4.1.2.3-1, Cell 1 is the serving cell, and Cell 2 is the aggressor cell. The downlink physical channel setup for Cell 1 is according to Annex C.3.2 and for Cell 2 is according to Annex C.3.3, respectively.

For the parameters for MBSFN ABS specified in Table 8.4.1-1 and Table 8.4.1.2.3-3, the average probability of a missed downlink scheduling grant (Pm-dsg) shall be below the specified value in Table 8.4.1.2.3-4. The downlink physical channel setup for Cell 1 is according to Annex C.3.2 and for Cell 2 is according to Annex C.3.3, respectively.

Table 8.4.1.2.3-1: Test Parameters for PDCCH/PCFICH – Non-MBSFN ABS

Parameter		Unit	Cell 1	Cell 2
Downlink power allocation	PDCCH_RA PHICH_RA OCNG_RA	dB	-3	-3
	PCFICH_RB PDCCH_RB PHICH_RB OCNG_RB	dB	-3	-3
N_{oc} at antenna port	N_{oc1}	dBm/15kHz	-100.5 (Note 1)	N/A
	N_{oc2}	dBm/15kHz	-98 (Note 2)	N/A
	N_{oc3}	dBm/15kHz	-95.3 (Note 3)	N/A
\hat{E}_s/N_{oc2}		dB	Reference Value in Table 8.4.1.2.3- 2	1.5
BW _{Channel}		MHz	10	10
Subframe Configuration			Non-MBSFN	Non-MBSFN
Time Offset between Cells		μs	2.5 (synchronous cells)	
Cell Id			0	1
ABS pattern (Note 4)			N/A	00000100 00000100 00000100 01000100 00000100
RLM/RRM Measurement Subframe Pattern (Note 5)			00000100 00000100 00000100 00000100	N/A
CSI Subframe Sets (Note 6)	C _{csi,0}		00000100 00000100 00000100 01000100 00000100	N/A
	C _{csi,1}		11111011 11111011 11111011 10111011 11111011	N/A
Number of control OFDM symbols			3	3
PHICH Ng (Note 9)			1	N/A
PHICH duration			Extended	N/A
Unused RE-s and PRB-s			OCNG	OCNG
Cyclic prefix			Normal	Normal
<p>Note 1: This noise is applied in OFDM symbols #1, #2, #3, #5, #6, #8, #9, #10, #12, #13 of a subframe overlapping with the aggressor ABS.</p> <p>Note 2: This noise is applied in OFDM symbols #0, #4, #7, #11 of a subframe overlapping with the aggressor ABS.</p> <p>Note 3: This noise is applied in all OFDM symbols of a subframe overlapping with aggressor non-ABS</p> <p>Note 4: ABS pattern as defined in [9]. PDCCH/PCFICH other than that associated with SIB1/Paging are transmitted in the serving cell subframe when the subframe is overlapped with the ABS subframe of aggressor cell.</p> <p>Note 5: Time-domain measurement resource restriction pattern for PCell measurements as defined in [7];</p> <p>Note 6: As configured according to the time-domain measurement resource restriction pattern for CSI measurements defined in [7];</p> <p>Note 7: Cell 1 is the serving cell. Cell 2 is the aggressor cell. The number of the CRS ports in Cell1 and Cell2 is the same.</p> <p>Note 8: SIB-1 will not be transmitted in Cell2 in the test.</p> <p>Note 9: According to Clause 6.9 in TS 36.211 [4]</p>				

Table 8.4.1.2.3-2: Minimum performance PDCCH/PCFICH – Non-MBSFN ABS

Test Number	Aggregation Level	Reference Channel	OCNG Pattern		Propagation Conditions (Note 1)		Correlation Matrix and Antenna Configuration	Reference Value	
			Cell 1	Cell 2	Cell 1	Cell 2		Pm-dsg (%)	SNR (dB) (Note 2)
1	8 CCE	R15-1 FDD	OP.1 FDD	OP.1 FDD	EVA5	EVA5	2x2 Low	1	-3.9
Note 1: The propagation conditions for Cell 1 and Cell 2 are statistically independent. Note 2: SNR corresponds to \hat{E}_s / N_{oc2} of cell 1. Note 3: The correlation matrix and antenna configuration apply for Cell 1 and Cell 2.									

Table 8.4.1.2.3-3: Test Parameters for PDCCH/PCFICH – MBSFN ABS

Parameter		Unit	Cell 1	Cell 2
Downlink power allocation	PDCCH_RA PHICH_RA OCNG_RA	dB	-3	-3
	PCFICH_RB PDCCH_RB PHICH_RB OCNG_RB	dB	-3	-3
N_{oc} at antenna port	N_{oc1}	dBm/15kHz	-100.5 (Note 1)	N/A
	N_{oc2}	dBm/15kHz	-98 (Note 2)	N/A
	N_{oc3}	dBm/15kHz	-95.3 (Note 3)	N/A
\hat{E}_s / N_{oc2}		dB	Reference Value in Table 8.4.1.2.3-4	1.5
$BW_{Channel}$		MHz	10	10
Subframe Configuration			Non-MBSFN	MBSFN
Time Offset between Cells		μ s	2.5 (synchronous cells)	
Cell Id			0	126
ABS pattern (Note 4)			N/A	0001000000 0100000010 0000001000 0000000000
RLM/RRM Measurement Subframe Pattern (Note 5)			0001000000 0100000010 0000001000 0000000000	N/A
CSI Subframe Sets (Note 6)	$C_{CSI,0}$		0001000000 0100000010 0000001000 0000000000	N/A
	$C_{CSI,1}$		1110111111 1011111101 1111110111 1111111111	N/A
MBSFN Subframe Allocation (Note 9)			N/A	001000 100001 000100 000000
Number of control OFDM symbols			3	3
PHICH N_g (Note 11)			1	N/A
PHICH duration			extended	N/A
Unused RE-s and PRB-s			OCNG	OCNG
Cyclic prefix			Normal	Normal

Note 1:	This noise is applied in OFDM symbols #1, #2, #3, #4, #5, #6, #7, #8, #9, #10, #11, #12, #13 of a subframe overlapping with the aggressor ABS.
Note 2:	This noise is applied in OFDM symbols #0 of a subframe overlapping with the aggressor ABS.
Note 3:	This noise is applied in all OFDM symbols of a subframe overlapping with aggressor non-ABS
Note 4:	ABS pattern as defined in [9]. The 4 th , 12 th , 19 th and 27 th subframes indicated by ABS pattern are MBSFN ABS subframes. PDSCH other than SIB1/paging and its associated PDCCH/PCFICH are transmitted in the serving cell subframe when the subframe is overlapped with the MBSFN ABS subframe of aggressor cell and the subframe is available in the definition of the reference channel.
Note 5:	Time-domain measurement resource restriction pattern for PCell measurements as defined in [7].
Note 6:	As configured according to the time-domain measurement resource restriction pattern for CSI measurements defined in [7].
Note 7:	Cell 1 is the serving cell. Cell 2 is the aggressor cell. The number of the CRS ports in Cell1 and Cell2 is the same.
Note 8:	SIB-1 will not be transmitted in Cell2 in this test.
Note 9:	MBSFN Subframe Allocation as defined in [7], four frames with 24 bits is chosen for MBSFN subframe allocation.
Note 10:	The maximum number of uplink HARQ transmission is ≤ 2 so that each PHICH channel transmission is in a subframe protected by MBSFN ABS in this test.
Note 11:	According to Clause 6.9 in TS 36.211 [4]

Table 8.4.1.2.3-4: Minimum performance PDCCH/PCHICH – MBSFN ABS

Test Number	Aggregation Level	Reference Channel	OCNG Pattern		Propagation Conditions (Note 1)		Correlation Matrix and Antenna Configuration	Reference Value	
			Cell 1	Cell 2	Cell 1	Cell 2		Pm-dsg (%)	SNR (dB) (Note 2)
1	8 CCE	R15-1 FDD	OP.1 FDD	OP.1 FDD	EVA5	EVA5	2x2 Low	1	-4.2
Note 1: The propagation conditions for Cell 1 and Cell2 are statistically independent. Note 2: SNR corresponds to \hat{E}_s / N_{oc2} of cell 1. Note 3: The correlation matrix and antenna configuration apply for Cell 1 and Cell 2.									

8.4.1.2.4 Minimum Requirement 2 Tx Antenna Port (demodulation subframe overlaps with aggressor cell ABS and CRS assistance information are configured)

For the parameters for non-MBSFN ABS specified in Table 8.4.1-1 and Table 8.4.1.2.4-1, the average probability of a missed downlink scheduling grant (Pm-dsg) shall be below the specified value in Table 8.4.1.2.4-2.

For the parameters for MBSFN ABS specified in Table 8.4.1-1 and Table 8.4.1.2.4-3, the average probability of a missed downlink scheduling grant (Pm-dsg) shall be below the specified value in Table 8.4.1.2.4-4.

In Tables 8.4.1.2.4-1 and 8.4.1.2.4-3, Cell 1 is the serving cell, and Cell 2 and Cell 3 are the aggressor cells. The downlink physical channel setup for Cell 1 is according to Annex C.3.2 and for Cell 2 and Cell 3 is according to Annex C.3.3, respectively. The CRS assistance information [7] including Cell 2 and Cell 3 is provided.

Table 8.4.1.2.4-1: Test Parameters for PDCCH/PCFICH – Non-MBSFN ABS

Parameter		Unit	Cell 1	Cell 2	Cell 3
Downlink power allocation	PDCCH_RA PHICH_RA OCNG_RA	dB	-3	-3	-3
	PCFICH_RB PDCCH_RB PHICH_RB OCNG_RB	dB	-3	-3	-3
N_{oc} at antenna port	N_{oc1}	dBm/15kHz	-98(Note 1)	N/A	N/A
	N_{oc2}	dBm/15kHz	-98 (Note 2)	N/A	N/A
	N_{oc3}	dBm/15kHz	-93 (Note 3)	N/A	N/A
\hat{E}_s / N_{oc2}		dB	Reference Value in Table 8.4.1.2.4-2	5	3
BW _{Channel}		MHz	10	10	10
Subframe Configuration			Non-MBSFN	Non-MBSFN	Non-MBSFN
Time Offset between Cells		μs	N/A	3	-1
Frequency shift between Cells		Hz	N/A	300	-100
Cell Id			0	126	1
ABS pattern (Note 4)			N/A	00000100 00000100 00000100 00000100 00000100	00000100 00000100 00000100 00000100 00000100
RLM/RRM Measurement Subframe Pattern (Note 5)			00000100 00000100 00000100 00000100 00000100	N/A	N/A
CSI Subframe Sets (Note 6)	C _{CSI,0}		00000100 00000100 00000100 00000100 00000100	N/A	N/A
	C _{CSI,1}		11111011 11111011 11111011 11111011 11111011	N/A	N/A
Number of control OFDM symbols			2	Note 7	Note 7
PHICH Ng (Note 10)			1	N/A	N/A
PHICH duration			Normal	N/A	N/A
Unused RE-s and PRB-s			OCNG	OCNG	OCNG
Cyclic prefix			Normal	Normal	Normal

Note 1:	This noise is applied in OFDM symbols #1, #2, #3, #5, #6, #8, #9, #10, #12, #13 of a subframe overlapping with the aggressor ABS.
Note 2:	This noise is applied in OFDM symbols #0, #4, #7, #11 of a subframe overlapping with the aggressor ABS.
Note 3:	This noise is applied in all OFDM symbols of a subframe overlapping with aggressor non-ABS
Note 4:	ABS pattern as defined in [9]. PDCCH/PCFICH other than that associated with SIB1/Paging are transmitted in the serving cell subframe when the subframe is overlapped with the ABS subframe of aggressor cell.
Note 5:	Time-domain measurement resource restriction pattern for PCell measurements as defined in [7];
Note 6:	As configured according to the time-domain measurement resource restriction pattern for CSI measurements defined in [7];
Note 7:	The number of control OFDM symbols is not available for ABS and is 2 for the subframe indicated by "0" of ABS pattern.
Note 8:	The number of the CRS ports in Cell1, Cell2 and Cell 3 is the same.
Note 9:	SIB-1 will not be transmitted in Cell2 and Cell 3 in the test.
Note 10:	According to Clause 6.9 in TS 36.211 [4]

Table 8.4.1.2.4-2: Minimum performance PDCCH/PCFICH – Non-MBSFN ABS

Test Number	Aggregation Level	Reference Channel	OCNG Pattern			Propagation Conditions (Note 1)			Correlation Matrix and Antenna Configuration (Note 2)	Reference Value	
			Cell 1	Cell 2	Cell 3	Cell 1	Cell 2	Cell 3		Pm-dsg (%)	SNR (dB) (Note 3)
1	8 CCE	R.15-2 FDD	OP.1 FDD	OP.1 FDD	OP.1 FDD	EVA5	EVA5	EVA5	2x2 Low	1	-2.2
Note 1: The propagation conditions for Cell 1, Cell 2 and Cell 3 are statistically independent. Note 2: The correlation matrix and antenna configuration apply for Cell 1, Cell 2 and Cell 3. Note 3: SNR corresponds to \hat{E}_s / N_{oc2} of cell 1.											

Table 8.4.1.2.4-3: Test Parameters for PDCCH/PCFICH – MBSFN ABS

Parameter		Unit	Cell 1	Cell 2	Cell 3
Downlink power allocation	PDCCH_RA PHICH_RA OCNG_RA	dB	-3	-3	-3
	PCFICH_RB PDCCH_RB PHICH_RB OCNG_RB	dB	-3	-3	-3
N_{oc} at antenna port	N_{oc1}	dBm/15kHz	-98(Note 1)	N/A	N/A
	N_{oc2}	dBm/15kHz	-98 (Note 2)	N/A	N/A
	N_{oc3}	dBm/15kHz	-93 (Note 3)	N/A	N/A
\hat{E}_s/N_{oc2}		dB	Reference Value in Table 8.4.1.2.4-4	5	3
$BW_{Channel}$		MHz	10	10	10
Subframe Configuration			Non-MBSFN	MBSFN	MBSFN
Time Offset between Cells		μ s	N/A	3	-1
Frequency shift between Cells		Hz	N/A	300	-100
Cell Id			0	126	1
ABS pattern (Note 4)			N/A	0001000000 0100000010 0000001000 0000000000	0001000000 0100000010 0000001000 0000000000
RLM/RRM Measurement Subframe Pattern (Note 5)			0001000000 0100000010 0000001000 0000000000	N/A	N/A
CSI Subframe Sets (Note 6)	$C_{CSI,0}$		0001000000 0100000010 0000001000 0000000000	N/A	N/A
	$C_{CSI,1}$		1110111111 1011111101 1111110111 1111111111	N/A	N/A
MBSFN Subframe Allocation (Note 7)			N/A	001000 100001 000100 000000	001000 100001 000100 000000
Number of control OFDM symbols			2	Note 8	Note 8
PHICH N_g (Note 12)			1	N/A	N/A
PHICH duration			Normal	N/A	N/A
Unused RE-s and PRB-s			OCNG	OCNG	OCNG
Cyclic prefix			Normal	Normal	Normal

Note 1:	This noise is applied in OFDM symbols #1, #2, #3, #4, #5, #6, #7, #8, #9, #10, #11, #12, #13 of a subframe overlapping with the aggressor ABS.
Note 2:	This noise is applied in OFDM symbols #0 of a subframe overlapping with the aggressor ABS.
Note 3:	This noise is applied in all OFDM symbols of a subframe overlapping with aggressor non-ABS ABS pattern as defined in [9]. The 4 th , 12 th , 19 th and 27 th subframes indicated by ABS pattern
Note 4:	are MBSFN ABS subframes. PDSCH other than SIB1/paging and its associated PDCCH/PCFICH are transmitted in the serving cell subframe when the subframe is overlapped with the MBSFN ABS subframe of aggressor cell and the subframe is available in the definition of the reference channel.
Note 5:	Time-domain measurement resource restriction pattern for PCell measurements as defined in [7].
Note 6:	As configured according to the time-domain measurement resource restriction pattern for CSI measurements defined in [7].
Note 7:	MBSFN Subframe Allocation as defined in [7], four frames with 24 bits are chosen for MBSFN subframe allocation.
Note 8:	The number of control OFDM symbols is not available for ABS and is 2 for the subframe indicated by "0" of ABS pattern.
Note 9:	The maximum number of uplink HARQ transmission is ≤ 2 so that each PHICH channel transmission is in a subframe protected by MBSFN ABS in this test.
Note 10:	The number of the CRS ports in Cell 1, Cell 2 and Cell 3 is the same.
Note 11:	SIB-1 will not be transmitted in Cell 2 and Cell 3 in this test.
Note 12:	According to Clause 6.9 in TS 36.211 [4]

Table 8.4.1.2.4-4: Minimum performance PDCCH/PCFICH – MBSFN ABS

Test Number	Aggregation Level	Reference Channel	OCNG Pattern			Propagation Conditions (Note 1)			Correlation Matrix and Antenna Configuration (Note 2)	Reference Value	
			Cell 1	Cell 2	Cell 3	Cell 1	Cell 2	Cell 3		Pm-dsg (%)	SNR (dB) (Note 3)
1	8 CCE	R.15-2 FDD	OP.1 FDD	OP.1 FDD	OP.1 FDD	EVA5	EVA5	EVA5	2x2 Low	1	-2.0
Note 1:	The propagation conditions for Cell 1, Cell 2 and Cell 3 are statistically independent.										
Note 2:	The correlation matrix and antenna configuration apply for Cell 1, Cell 2 and Cell 3.										
Note 3:	SNR corresponds to \hat{E}_s / N_{oc2} of cell 1.										

8.4.1.2.5 Enhanced Downlink Control Channel Performance Requirement Type A - 2 Tx Antenna Port under Asynchronous Network

The test purpose is to verify the Enhanced Downlink Control Channel Performance Requirement Type A for PDCCH/PCFICH with 2 transmit antennas for the case of dominant interferer with interference model defined in clause B.5.2. For the parameters specified in Table 8.4.1-1 and Table 8.4.1.2.5-1, the average probability of a missed downlink scheduling grant (Pm-dsg) shall be below the specified value in Table 8.4.1.2.5-2 for the Enhanced Downlink Control Channel Performance Requirement Type A. In Table 8.4.1.2.5-1, Cell 1 is the serving cell, and Cell 2 and Cell 3 are the aggressor cells. The downlink physical channel setup is according to Annex C.3.2 for each of Cell 1, Cell 2 and Cell 3, respectively. The CRS assistance information [7] is not provided.

Table 8.4.1.2.5-1: Test Parameters for PDCCH/PCFICH

Parameter		Unit	Cell 1	Cell 2	Cell 3
Downlink power allocation	PDCCH_RA PHICH_RA PDSCH_RA OCNG_RA	dB	-3	-3	-3
	PCFICH_RB PDCCH_RB PHICH_RB PDSCH_RB OCNG_RB	dB	-3	-3	-3
Cell-specific reference signals			Antenna ports 0,1	Antenna ports 0,1	Antenna ports 0,1
N_{oc} at antenna port		dBm/15kHz	-98		
\hat{E}_s/N_{oc}		dB	N/A	13.91	3.34
$BW_{Channel}$		MHz	10	10	10
Cyclic Prefix			Normal	Normal	Normal
Cell Id			0	1	6
Subframe Configuration			Non-MBSFN	Non-MBSFN	Non-MBSFN
Number of DL control region OFDM symbols			3	3	3
PHICH Ng (Note 1)			1	N/A	N/A
PHICH duration			Normal	N/A	N/A
PDSCH TM			4	3	3
Interference model			N/A	As specified in clause B.5.2	As specified in clause B.5.2
Probability of occurrence of PDSCH transmission rank in interfering cells	Rank 1	%	N/A	80	80
	Rank 2	%	N/A	20	20
Unused RE-s and PRB-s			OCNG	OCNG	OCNG
Time offset relative to Cell 1		ms	N/A	0.33	0.67
Frequency shift relative to Cell 1		Hz	N/A	0	0
Note 1: According to Clause 6.9 in TS 36.211 [4].					

Table 8.4.1.2.5-2: Minimum Performance for PDCCH/PCFICH for Enhanced Downlink Control Channel Performance Requirement Type A

Test Number	Aggregation level	Reference Channel	OCNG Pattern (Note 1)	Propagation Conditions (Note 2)			Antenna Configuration and Correlation Matrix (Note 3)	Reference Value	
				Cell 1	Cell 2	Cell 3		Pm-dsg (%)	SNR (dB) (Note 4)
1	2 CCE	R.16-1 FDD	OP.1 FDD	EVA70	EVA70	EVA70	2x2 Low	1	16.5

Note 1: The OCNG pattern applies for Cell 1, Cell 2 and Cell 3.

Note 2: The propagation conditions for Cell 1, Cell 2 and Cell 3 are statistically independent.

Note 3: The correlation matrix and antenna configuration apply for Cell 1, Cell 2 and Cell 3.

Note 4: SNR corresponds to \hat{E}_s/N_{oc} of Cell 1 as defined in clause 8.1.1.

8.4.1.2.6 Enhanced Downlink Control Channel Performance Requirement Type A - 2 Tx Antenna Port with Non-Colliding CRS Dominant Interferer

The purpose of this test is to verify the Enhanced Downlink Control Channel Performance Requirement Type A for PDCCH/PCFICH with 2 transmit antennas for the case of dominant interferer with the non-colliding CRS pattern and applying interference model defined in clause B.7.1. For the parameters specified in Table 8.4.1-1 and Table 8.4.1.2.6-1, the average probability of a missed downlink scheduling grant (Pm-dsg) shall be below the specified value in Table 8.4.1.2.6-2. In Table 8.4.1.2.6-1, Cell 1 is the serving cell, and Cell 2 and Cell 3 are the aggressor cells. The downlink

physical channel setup is according to Annex C.3.2 for each of Cell 1, Cell 2 and Cell 3, respectively. The CRS assistance information [7] is provided and includes Cell 2 and Cell 3.

Table 8.4.1.2.6-1: Test Parameters for PDCCH/PCFICH

Parameter		Unit	Cell 1	Cell 2	Cell 3
Downlink power allocation	PDCCH_RA OCNG_RA	dB	-3	-3	-3
	PHICH_RA	dB	-3	N/A	N/A
	PCFICH_RB PDCCH_RB OCNG_RB	dB	-3	-3	-3
	PHICH_RB	dB	-3	N/A	N/A
Cell-specific reference signals			Antenna ports 0,1	Antenna ports 0,1	Antenna ports 0,1
N_{oc} at antenna port		dBm/15kHz	-98		
\hat{E}_s/N_{oc}		dB	N/A	13.91	3.34
$BW_{Channel}$		MHz	10	10	10
Cyclic Prefix			Normal	Normal	Normal
Cell Id			0	1	6
Subframe Configuration			Non-MBSFN	Non-MBSFN	Non-MBSFN
Number of DL control region OFDM symbols			3	3	3
CFI indicated in PCFICH			3	3	3
PHICH Ng (Note 1)			1/6	N/A	N/A
PHICH duration			Normal	N/A	N/A
PDSCH TM			4	N/A	N/A
Interference model			NA	As specified in clause B.7.1	As specified in clause B.7.1
Unused RE-s and PRB-s (Note 2)			OCNG	OCNG	OCNG
Time Offset relative to Cell 1		μ s	N/A	2	3
Frequency shift relative to Cell 1		Hz	N/A	200	300
Note 1: According to Clause 6.9 in TS 36.211 [4].					
Note 2: For Cell 2 and Cell 3 unused RE-s and PRB-s do not include control region REs.					

Table 8.4.1.2.6-2: Minimum Performance for PDCCH/PCFICH for Enhanced Downlink Control Channel Performance Requirement Type A

Test Number	Aggregation level	Reference Channel	OCNG Pattern (Note 1)	Propagation Conditions (Note 2)			Antenna Configuration and Correlation Matrix (Note 3)	Reference Value	
				Cell 1	Cell 2	Cell 3		Pm-dsg (%)	SNR (dB) (Note 4)
1	4 CCE	R.16-2 FDD	OP.1 FDD	EPA5	EPA5	EPA5	2x2 Low	1	12.8
Note 1: The OCNG pattern applies for Cell 1, Cell 2 and Cell 3.									
Note 2: The propagation conditions for Cell 1, Cell 2 and Cell 3 are statistically independent.									
Note 3: The correlation matrix and antenna configuration apply for Cell 1, Cell 2 and Cell 3.									
Note 4: SNR corresponds to \hat{E}_s/N_{oc} of Cell 1 as defined in clause 8.1.1.									

8.4.1.2.7 Enhanced Downlink Control Channel Performance Requirement Type B - 2 Tx Antenna Port with Colliding CRS Dominant Interferer

The purpose of this test is to verify the Enhanced Downlink Control Channel Performance Requirement Type B for PDCCH/PCFICH with 2 transmit antennas for the case of dominant interferer with the colliding CRS pattern and applying interference model defined in clause B.7.1. For the parameters specified in Table 8.4.1-1 and Table 8.4.1.2.7-1, the average probability of a missed downlink scheduling grant (Pm-dsg) shall be below the specified value in Table 8.4.1.2.7-2. In Table 8.4.1.2.7-1, Cell 1 is the serving cell, and Cell 2 and Cell 3 are the aggressor cells. The downlink physical channel setup is according to Annex C.3.2 for each of Cell 1, Cell 2 and Cell 3, respectively. The CRS assistance information [7] is provided and includes Cell 2 and Cell 3.

Table 8.4.1.2.7-1: Test Parameters for PDCCH/PCFICH

Parameter		Unit	Cell 1	Cell 2	Cell 3
Downlink power allocation	PDCCH_RA OCNG_RA	dB	-3	-3	-3
	PHICH_RA	dB	-3	N/A	N/A
	PCFICH_RB PDCCH_RB OCNG_RB	dB	-3	-3	-3
	PHICH_RB	dB	-3	N/A	N/A
Cell-specific reference signals			Antenna ports 0,1	Antenna ports 0,1	Antenna ports 0,1
N_{oc} at antenna port		dBm/15kHz	-98		
\hat{E}_s/N_{oc}		dB	N/A	13.91	3.34
BW _{Channel}		MHz	10	10	10
Cyclic Prefix			Normal	Normal	Normal
Cell Id			0	6	1
Subframe Configuration			Non-MBSFN	Non-MBSFN	Non-MBSFN
Number of DL control region OFDM symbols			1	1	1
CFI indicated in PCFICH			1	1	1
PHICH Ng (Note 1)			1/6	N/A	N/A
PHICH duration			Normal	N/A	N/A
PDSCH TM			4	N/A	N/A
Interference model			NA	As specified in clause B.7.1	As specified in clause B.7.1
Unused RE-s and PRB-s (Note 2)			OCNG	OCNG	OCNG
Time Offset relative to Cell 1		μs	N/A	2	3
Frequency shift relative to Cell 1		Hz	N/A	200	300
Note 1: According to Clause 6.9 in TS 36.211 [4].					
Note 2: For Cell 2 and Cell 3 unused RE-s and PRB-s do not include control region REs.					

Table 8.4.1.2.7-2: Minimum Performance for PDCCH/PCFICH for Enhanced Downlink Control Channel Performance Requirement Type B

Test Number	Aggregation level	Reference Channel	OCNG Pattern (Note 1)	Propagation Conditions (Note 2)			Antenna Configuration and Correlation Matrix (Note 3)	Reference Value	
				Cell 1	Cell 2	Cell 3		Pm-dsg (%)	SNR (dB) (Note 4)
1	2 CCE	R.16-3 FDD	OP.1 FDD	EPA5	EPA5	EPA5	2x2 Low	1	12.7
Note 1: The OCNG pattern applies for Cell 1, Cell 2 and Cell 3.									
Note 2: The propagation conditions for Cell 1, Cell 2 and Cell 3 are statistically independent.									
Note 3: The correlation matrix and antenna configuration apply for Cell 1, Cell 2 and Cell 3.									
Note 4: SNR corresponds to \hat{E}_s/N_{oc} of Cell 1 as defined in clause 8.1.1.									

8.4.1.2.8 Enhanced Downlink Control Channel Performance Requirement Type B - 2 Tx Antenna Port with Non-Colliding CRS Dominant Interferer

The purpose of this test is to verify the Enhanced Downlink Control Channel Performance Requirement Type B for PDCCH/PCFICH with 2 transmit antennas for the case of dominant interferer with the non-colliding CRS pattern and applying interference model defined in clause B.7.1. For the parameters specified in Table 8.4.1-1 and Table 8.4.1.2.8-1, the average probability of a missed downlink scheduling grant (Pm-dsg) shall be below the specified value in Table 8.4.1.2.8-2. In Table 8.4.1.2.8-1, Cell 1 is the serving cell, and Cell 2 and Cell 3 are the aggressor cells. The downlink physical channel setup is according to Annex C.3.2 for each of Cell 1, Cell 2 and Cell 3, respectively. The CRS assistance information [7] is provided and includes Cell 2 and Cell 3.

Table 8.4.1.2.8-1: Test Parameters for PDCCH/PCFICH

Parameter		Unit	Cell 1	Cell 2	Cell 3
Downlink power allocation	PDCCH_RA OCNG_RA	dB	-3	-3	-3
	PHICH_RA	dB	-3	N/A	N/A
	PCFICH_RB PDCCH_RB OCNG_RB	dB	-3	-3	-3
	PHICH_RB	dB	-3	N/A	N/A
Cell-specific reference signals			Antenna ports 0,1	Antenna ports 0,1	Antenna ports 0,1
N_{oc} at antenna port		dBm/15kHz	-98		
\hat{E}_s/N_{oc}		dB	N/A	13.91	3.34
BW _{Channel}		MHz	10	10	10
Cyclic Prefix			Normal	Normal	Normal
Cell Id			0	1	6
Subframe Configuration			Non-MBSFN	Non-MBSFN	Non-MBSFN
Number of DL control region OFDM symbols			1	1	1
CFI indicated in PCFICH			1	1	1
PHICH Ng (Note 1)			1/6	N/A	N/A
PHICH duration			Normal	N/A	N/A
PDSCH TM			4	N/A	N/A
Interference model				As specified in clause B.7.1	As specified in clause B.7.1
Unused RE-s and PRB-s (Note 2)			OCNG	OCNG	OCNG
Time Offset relative to Cell 1		μs	N/A	2	3
Frequency shift relative to Cell 1		Hz	N/A	200	300
Note 1: According to Clause 6.9 in TS 36.211 [4].					
Note 2: For Cell 2 and Cell 3 unused RE-s and PRB-s do not include control region REs.					

Table 8.4.1.2.8-2: Minimum Performance for PDCCH/PCFICH for Enhanced Downlink Control Channel Performance Requirement Type B

Test Number	Aggregation level	Reference Channel	OCNG Pattern (Note 1)	Propagation Conditions (Note 2)			Antenna Configuration and Correlation Matrix (Note 3)	Reference Value	
				Cell 1	Cell 2	Cell 3		Pm-dsg (%)	SNR (dB) (Note 4)
1	4 CCE	R.16-4 FDD	OP.1 FDD	EPA5	EPA5	EPA5	2x2 Low	1	10.3
Note 1: The OCNG pattern applies for Cell 1, Cell 2 and Cell 3.									
Note 2: The propagation conditions for Cell 1, Cell 2 and Cell 3 are statistically independent.									
Note 3: The correlation matrix and antenna configuration apply for Cell 1, Cell 2 and Cell 3.									
Note 4: SNR corresponds to \hat{E}_s/N_{oc} of Cell 1 as defined in clause 8.1.1.									

8.4.2 TDD

The parameters specified in Table 8.4.2-1 are valid for all TDD tests unless otherwise stated.

Table 8.4.2-1: Test Parameters for PDCCH/PCFICH

Parameter		Unit	Single antenna port	Transmit diversity
Uplink downlink configuration (Note 1)			0	0
Special subframe configuration (Note 2)			4	4
Number of PDCCH symbols		symbols	2	2
PHICH Ng (Note 3)			1	1
PHICH duration			Normal	Normal
Unused RE-s and PRB-s			OCNG	OCNG
Cell ID			0	0
Downlink power allocation	PDCCH_RA PHICH_RA OCNG_RA	dB	0	-3
	PCFICH_RB PDCCH_RB PHICH_RB OCNG_RB	dB	0	-3
N_{oc} at antenna port		dBm/15kHz	-98	-98
Cyclic prefix			Normal	Normal
ACK/NACK feedback mode			Multiplexing	Multiplexing
Note 1: as specified in Table 4.2-2 in TS 36.211 [4].				
Note 2: as specified in Table 4.2-1 in TS 36.211 [4].				
Note 3: According to Clause 6.9 in TS 36.211 [4]				

8.4.2.1 Single-antenna port performance

For the parameters specified in Table 8.4.2-1 the average probability of a missed downlink scheduling grant (Pm-dsg) shall be below the specified value in Table 8.4.2.1-1. The downlink physical setup is in accordance with Annex C.3.2.

Table 8.4.2.1-1: Minimum performance PDCCH/PCFICH

Test number	Bandwidth	Aggregation level	Reference Channel	OCNG Pattern	Propagation Condition	Antenna configuration and correlation Matrix	Reference value	
							Pm-dsg (%)	SNR (dB)
1	10 MHz	8 CCE	R.15 TDD	OP.1 TDD	ETU70	1x2 Low	1	-1.6

8.4.2.2 Transmit diversity performance

8.4.2.2.1 Minimum Requirement 2 Tx Antenna Port

For the parameters specified in Table 8.4.2-1 the average probability of a missed downlink scheduling grant (Pm-dsg) shall be below the specified value in Table 8.4.2.2.1-1. The downlink physical setup is in accordance with Annex C.3.2.

Table 8.4.2.2.1-1: Minimum performance PDCCH/PCFICH

Test number	Bandwidth	Aggregation level	Reference Channel	OCNG Pattern	Propagation Condition	Antenna configuration and correlation Matrix	Reference value	
							Pm-dsg (%)	SNR (dB)
1	10 MHz	4 CCE	R.16 TDD	OP.1 TDD	EVA70	2 x 2 Low	1	0.1

8.4.2.2.2 Minimum Requirement 4 Tx Antenna Port

For the parameters specified in Table 8.4.2-1 the average probability of a missed downlink scheduling grant (Pm-dsg) shall be below the specified value in Table 8.4.2.2-1. The downlink physical setup is in accordance with Annex C.3.2.

Table 8.4.2.2-1: Minimum performance PDCCH/PCFICH

Test number	Bandwidth	Aggregation level	Reference Channel	OCNG Pattern	Propagation Condition	Antenna configuration and correlation Matrix	Reference value	
							Pm-dsg (%)	SNR (dB)
1	5 MHz	2 CCE	R.17 TDD	OP.1 TDD	EPA5	4 x 2 Medium	1	6.5

8.4.2.2.3 Minimum Requirement 2 Tx Antenna Port (demodulation subframe overlaps with aggressor cell ABS)

For the parameters for non-MBSFN ABS specified in Table 8.4.2-1 and Table 8.4.2.2.3-1, the average probability of a missed downlink scheduling grant (Pm-dsg) shall be below the specified value in Table 8.4.2.2.3-2. The downlink physical setup is in accordance with Annex C.3.2 and Annex C.3.3. In Table 8.4.2.2.3-1, Cell 1 is the serving cell, and Cell 2 is the aggressor cell. The downlink physical channel setup for Cell 1 is according to Annex C.3.2 and for Cell 2 is according to Annex C.3.3, respectively.

For the parameters for MBSFN ABS specified in Table 8.4.2-1 and Table 8.4.2.2.3-3, the average probability of a missed downlink scheduling grant (Pm-dsg) shall be below the specified value in Table 8.4.2.2.3-4. The downlink physical channel setup for Cell 1 is according to Annex C.3.2 and for Cell 2 is according to Annex C.3.3, respectively.

Table 8.4.2.2.3-1: Test Parameters for PDCCH/PCFICH – Non-MBSFN ABS

Parameter		Unit	Cell 1	Cell 2
Uplink downlink configuration			1	1
Special subframe configuration			4	4
Downlink power allocation	PDCCH_RA PHICH_RA OCNG_RA	dB	-3	-3
	PCFICH_RB PDCCH_RB PHICH_RB OCNG_RB	dB	-3	-3
N_{oc} at antenna port	N_{oc1}	dBm/15kHz	-100.5 (Note 1)	N/A
	N_{oc2}	dBm/15kHz	-98 (Note 2)	N/A
	N_{oc3}	dBm/15kHz	-95.3 (Note 3)	N/A
\hat{E}_s / N_{oc2}		dB	Reference Value in Table 8.4.2.2.3-2	1.5
$BW_{Channel}$		MHz	10	10
Subframe Configuration			Non-MBSFN	Non-MBSFN
Time Offset between Cells		μ s	2.5 (synchronous cells)	
Cell Id			0	1
ABS pattern (Note 4)			N/A	0000010001 0000000001
RLM/RRM Measurement Subframe Pattern(Note 5)			0000000001 0000000001	N/A
CSI Subframe Sets(Note 6)	$C_{CSI,0}$		0000010001 0000000001	N/A
	$C_{CSI,1}$		1100101000 1100111000	N/A
Number of control OFDM symbols			3	3
ACK/NACK feedback mode			Multiplexing	N/A
PHICH Ng (Note 9)			1	N/A
PHICH duration			extended	N/A
Unused RE-s and PRB-s			OCNG	OCNG
Cyclic prefix			Normal	Normal
Note 1:	This noise is applied in OFDM symbols #1, #2, #3, #5, #6, #8, #9, #10, #12, #13 of a subframe overlapping with the aggressor ABS.			
Note 2:	This noise is applied in OFDM symbols #0, #4, #7, #11 of a subframe overlapping with the aggressor ABS.			
Note 3:	This noise is applied in OFDM symbols of a subframe overlapping with aggressor non-ABS			
Note 4:	ABS pattern as defined in [9]. PDCCH/PCFICH other than that associated with SIB1/Paging are transmitted in the serving cell subframe when the subframe is overlapped with the ABS subframe of aggressor cell.			
Note 5:	Time-domain measurement resource restriction pattern for PCell measurements as defined in [7].			
Note 6:	As configured according to the time-domain measurement resource restriction pattern for CSI measurements defined in [7].			
Note 7:	Cell 1 is the serving cell. Cell 2 is the aggressor cell. The number of the CRS ports in Cell1 and Cell2 is the same.			
Note 8:	SIB-1 will not be transmitted in Cell2 in the test.			
Note 9:	According to Clause 6.9 in TS 36.211 [4]			

Table 8.4.2.3-2: Minimum performance PDCCH/PCFICH – Non-MBSFN ABS

Test Number	Aggregation Level	Reference Channel	OCNG Pattern		Propagation Conditions (Note 1)		Correlation Matrix and Antenna Configuration	Reference Value	
			Cell 1	Cell 2	Cell 1	Cell 2		Pm-dsg (%)	SNR (dB) (Note 2)
1	8 CCE	R15-1 TDD	OP.1 TDD	OP.1 TDD	EVA5	EVA5	2x2 Low	1	-3.9
Note 1: The propagation conditions for Cell 1 and Cell 2 are statistically independent. Note 2: SNR corresponds to \hat{E}_s / N_{oc2} of cell 1. Note 3: The correlation matrix and antenna configuration apply for Cell 1 and Cell 2.									

Table 8.4.2.2.3-3: Test Parameters for PDCCH/PCFICH – MBSFN ABS

Parameter		Unit	Cell 1	Cell 2
Uplink downlink configuration			1	1
Special subframe configuration			4	4
Downlink power allocation	PDCCH_RA PHICH_RA OCNG_RA	dB	-3	-3
	PCFICH_RB PDCCH_RB PHICH_RB OCNG_RB	dB	-3	-3
N_{oc} at antenna port	N_{oc1}	dBm/15kHz	-100.5 (Note 1)	N/A
	N_{oc2}	dBm/15kHz	-98 (Note 2)	N/A
	N_{oc3}	dBm/15kHz	-95.3 (Note 3)	N/A
\hat{E}_s / N_{oc2}		dB	Reference Value in Table 8.4.2.2.3-4	1.5
$BW_{Channel}$		MHz	10	10
Subframe Configuration			Non-MBSFN	MBSFN
Time Offset between Cells		μ s	2.5 (synchronous cells)	
Cell Id			0	126
ABS pattern (Note 4)			N/A	000000001 000000001
RLM/RRM Measurement Subframe Pattern(Note 5)			000000001 000000001	N/A
CSI Subframe Sets(Note 6)	$C_{CSI,0}$		000000001 000000001	N/A
	$C_{CSI,1}$		1100111000 1100111000	N/A
MBSFN Subframe Allocation (Note 9)			N/A	000010
Number of control OFDM symbols			3	3
ACK/NACK feedback mode			Multiplexing	N/A
PHICH Ng (Note 10)			1	N/A
PHICH duration			extended	N/A
Unused RE-s and PRB-s			OCNG	OCNG
Cyclic prefix			Normal	Normal
<p>Note 1: This noise is applied in OFDM symbols #1, #2, #3, #4, #5, #6, #7, #8, #9, #10, #11, #12, #13 of a subframe overlapping with the aggressor ABS.</p> <p>Note 2: This noise is applied in OFDM symbols #0 of a subframe overlapping with the aggressor ABS.</p> <p>Note 3: This noise is applied in OFDM symbols of a subframe overlapping with aggressor non-ABS</p> <p>Note 4: ABS pattern as defined in [9]. The 10th and 20th subframes indicated by ABS pattern are MBSFN ABS subframes. PDSCH other than SIB1/paging and its associated PDCCH/PCFICH are transmitted in the serving cell subframe when the subframe is overlapped with the MBSFN ABS subframe of aggressor cell and the subframe is available in the definition of the reference channel.</p> <p>Note 5: Time-domain measurement resource restriction pattern for PCell measurements as defined in [7].</p> <p>Note 6: As configured according to the time-domain measurement resource restriction pattern for CSI measurements defined in [7].</p> <p>Note 7: Cell 1 is the serving cell. Cell 2 is the aggressor cell. The number of the CRS ports in Cell1 and Cell2 is the same.</p> <p>Note 8: SIB-1 will not be transmitted in Cell2 in this test.</p> <p>Note 9: MBSFN Subframe Allocation as defined in [7], one frame with 6 bits is chosen for MBSFN subframe allocation.</p> <p>Note 10: According to Clause 6.9 in TS 36.211 [4]</p>				

Table 8.4.2.2.3-4: Minimum performance PDCCH/PCFICH – MBSFN ABS

Test Number	Aggregation Level	Reference Channel	OCNG Pattern		Propagation Conditions(Note 1)		Correlation Matrix and Antenna Configuration	Reference Value	
			Cell 1	Cell 2	Cell 1	Cell 2		Pm-dsg (%)	SNR (dB) (Note 2)
1	8 CCE	R15-1 TDD	OP.1 TDD	OP.1 TDD	EVA5	EVA5	2x2 Low	1	-4.1
Note 1: The propagation conditions for Cell 1 and Cell2 are statistically independent. Note 2: SNR corresponds to \hat{E}_s / N_{oc2} of cell 1. Note 3: The correlation matrix and antenna configuration apply for Cell 1 and Cell 2.									

8.4.2.2.4 Minimum Requirement 2 Tx Antenna Port (demodulation subframe overlaps with aggressor cell ABS and CRS assistance information are configured)

For the parameters for non-MBSFN ABS specified in Table 8.4.2-1 and Table 8.4.2.2.4-1, the average probability of a missed downlink scheduling grant (Pm-dsg) shall be below the specified value in Table 8.4.2.2.4-2.

For the parameters for MBSFN ABS specified in Table 8.4.2-1 and Table 8.4.2.2.4-3, the average probability of a missed downlink scheduling grant (Pm-dsg) shall be below the specified value in Table 8.4.2.2.4-4.

In Tables 8.4.2.2.4-1 and 8.4.2.2.4-3, Cell 1 is the serving cell, and Cell 2 and Cell 3 are the aggressor cells. The downlink physical channel setup for Cell 1 is according to Annex C.3.2 and for Cell 2 and Cell 3 is according to Annex C.3.3, respectively. The CRS assistance information [7] including Cell 2 and Cell 3 is provided.

Table 8.4.2.2.4-1: Test Parameters for PDCCH/PCFICH – Non-MBSFN ABS

Parameter		Unit	Cell 1	Cell 2	Cell 3
Uplink downlink configuration			1	1	1
Special subframe configuration			4	4	4
Downlink power allocation	PDCCH_RA PHICH_RA OCNG_RA	dB	-3	-3	-3
	PCFICH_RB PDCCH_RB PHICH_RB OCNG_RB	dB	-3	-3	-3
N_{oc} at antenna port	N_{oc1}	dBm/15kHz	-98(Note 1)	N/A	N/A
	N_{oc2}	dBm/15kHz	-98 (Note 2)	N/A	N/A
	N_{oc3}	dBm/15kHz	-93 (Note 3)	N/A	N/A
\hat{E}_s/N_{oc2}		dB	Reference Value in Table 8.4.2.2.4-2	5	3
BW _{Channel}		MHz	10	10	10
Subframe Configuration			Non-MBSFN	Non-MBSFN	Non-MBSFN
Time Offset between Cells		μs	N/A	3	-1
Frequency shift between Cells		Hz	N/A	300	-100
Cell Id			0	126	1
ABS pattern (Note 4)			N/A	0000000001 0000000001	0000000001 0000000001
RLM/RRM Measurement Subframe Pattern (Note 5)			0000000001 0000000001	N/A	N/A
CSI Subframe Sets (Note 6)	$C_{CSI,0}$		0000000001 0000000001	N/A	N/A
	$C_{CSI,1}$		1100111000 1100111000	N/A	N/A
Number of control OFDM symbols			2	Note 7	Note 7
ACK/NACK feedback mode			Multiplexing	N/A	N/A
PHICH Ng (Note 10)			1	N/A	N/A
PHICH duration			Normal	N/A	N/A
Unused RE-s and PRB-s			OCNG	OCNG	OCNG
Cyclic prefix			Normal	Normal	Normal
<p>Note 1: This noise is applied in OFDM symbols #1, #2, #3, #5, #6, #8, #9, #10, #12, #13 of a subframe overlapping with the aggressor ABS.</p> <p>Note 2: This noise is applied in OFDM symbols #0, #4, #7, #11 of a subframe overlapping with the aggressor ABS.</p> <p>Note 3: This noise is applied in all OFDM symbols of a subframe overlapping with aggressor non-ABS</p> <p>Note 4: ABS pattern as defined in [9]. PDCCH/PCFICH other than that associated with SIB1/Paging are transmitted in the serving cell subframe when the subframe is overlapped with the ABS subframe of aggressor cell.</p> <p>Note 5: Time-domain measurement resource restriction pattern for PCell measurements as defined in [7];</p> <p>Note 6: As configured according to the time-domain measurement resource restriction pattern for CSI measurements defined in [7];</p> <p>Note 7: The number of control OFDM symbols is not available for ABS and is 2 for the subframe indicated by "0" of ABS pattern.</p> <p>Note 8: The number of the CRS ports in Cell1, Cell2 and Cell 3 is the same.</p> <p>Note 9: SIB-1 will not be transmitted in Cell2 and Cell 3 in the test.</p> <p>Note 10: According to Clause 6.9 in TS 36.211 [4]</p>					

Table 8.4.2.2.4-2: Minimum performance PDCCH/PCFICH – Non-MBSFN ABS

Test Number	Aggregation Level	Reference Channel	OCNG Pattern			Propagation Conditions (Note 1)			Correlation Matrix and Antenna Configuration (Note 2)	Reference Value	
			Cell 1	Cell 2	Cell 3	Cell 1	Cell 2	Cell 3		Pm-dsg (%)	SNR (dB) (Note 3)
1	8 CCE	R.15-2 TDD	OP.1 TDD	OP.1 TDD	OP.1 TDD	EVA5	EVA5	EVA5	2x2 Low	1	-2.0
Note 1:	The propagation conditions for Cell 1, Cell 2 and Cell 3 are statistically independent.										
Note 2:	The correlation matrix and antenna configuration apply for Cell 1, Cell 2 and Cell 3.										
Note 3:	SNR corresponds to \hat{E}_s / N_{oc2} of cell 1.										

Table 8.4.2.2.4-3: Test Parameters for PDCCH/PCFICH – MBSFN ABS

Parameter		Unit	Cell 1	Cell 2	Cell 3
Uplink downlink configuration			1	1	1
Special subframe configuration			4	4	4
Downlink power allocation	PDCCH_RA PHICH_RA OCNG_RA	dB	-3	-3	-3
	PCFICH_RB PDCCH_RB PHICH_RB OCNG_RB	dB	-3	-3	-3
N_{oc} at antenna port	N_{oc1}	dBm/15kHz	-98 (Note 1)	N/A	N/A
	N_{oc2}	dBm/15kHz	-98 (Note 2)	N/A	N/A
	N_{oc3}	dBm/15kHz	-93 (Note 3)	N/A	N/A
\hat{E}_s / N_{oc2}		dB	Reference Value in Table 8.4.2.2.4-4	5	3
BW _{Channel}		MHz	10	10	10
Subframe Configuration			Non-MBSFN	MBSFN	MBSFN
Time Offset between Cells		μs	N/A	3	-1
Frequency shift between Cells		Hz	N/A	300	-100
Cell Id			0	126	1
ABS pattern (Note 4)			N/A	000000001 000000001	000000001 000000001
RLM/RRM Measurement Subframe Pattern (Note 5)			000000001 000000001	N/A	N/A
CSI Subframe Sets (Note 6)	C _{CSI,0}		000000001 000000001	N/A	N/A
	C _{CSI,1}		1100111000 1100111000	N/A	N/A
MBSFN Subframe Allocation (Note 7)			N/A	000010	000010
Number of control OFDM symbols			2	Note 8	Note 8
ACK/NACK feedback mode			Multiplexing	N/A	N/A
PHICH Ng (Note 11)			1	N/A	N/A
PHICH duration			Normal	N/A	N/A
Unused RE-s and PRB-s			OCNG	OCNG	OCNG
Cyclic prefix			Normal	Normal	Normal
<p>Note 1: This noise is applied in OFDM symbols #1, #2, #3, #4, #5, #6, #7, #8, #9, #10, #11, #12, #13 of a subframe overlapping with the aggressor ABS.</p> <p>Note 2: This noise is applied in OFDM symbols #0 of a subframe overlapping with the aggressor ABS.</p> <p>Note 3: This noise is applied in OFDM symbols of a subframe overlapping with aggressor non-ABS</p> <p>Note 4: ABS pattern as defined in [9]. The 10th and 20th subframes indicated by ABS pattern are MBSFN ABS subframes. PDSCH other than SIB1/paging and its associated PDCCH/PCFICH are transmitted in the serving cell subframe when the subframe is overlapped with the MBSFN ABS subframe of aggressor cell and the subframe is available in the definition of the reference channel.</p> <p>Note 5: Time-domain measurement resource restriction pattern for PCell measurements as defined in [7].</p> <p>Note 6: As configured according to the time-domain measurement resource restriction pattern for CSI measurements defined in [7].</p> <p>Note 7: MBSFN Subframe Allocation as defined in [7], one frame with 6 bits is chosen for MBSFN subframe allocation.</p> <p>Note 8: The number of control OFDM symbols is not available for ABS and is 2 for the subframe indicated by "0" of ABS pattern.</p> <p>Note 9: Cell 1 is the serving cell. Cell 2 is the aggressor cell. The number of the CRS ports in Cell1 and Cell2 is the same.</p> <p>Note 10: SIB-1 will not be transmitted in Cell2 in this test.</p> <p>Note 11: According to Clause 6.9 in TS 36.211 [4]</p>					

Table 8.4.2.2.4-4: Minimum performance PDCCH/PCFICH – MBSFN ABS

Test Number	Aggregation Level	Reference Channel	OCNG Pattern			Propagation Conditions (Note 1)			Correlation Matrix and Antenna Configuration (Note 2)	Reference Value	
			Cell 1	Cell 2	Cell 3	Cell 1	Cell 2	Cell 3		Pm-dsg (%)	SNR (dB) (Note 3)
1	8 CCE	R.15-2 TDD	OP.1 TDD	OP.1 TDD	OP.1 TDD	EVA5	EVA5	EVA5	2x2 Low	1	-1.8
Note 1: The propagation conditions for Cell 1, Cell 2 and Cell 3 are statistically independent. Note 2: The correlation matrix and antenna configuration apply for Cell 1, Cell 2 and Cell 3. Note 3: SNR corresponds to \hat{E}_s/N_{oc2} of cell 1.											

8.4.2.2.5 Enhanced Downlink Control Channel Performance Requirement Type A - 2 Tx Antenna Port with Colliding CRS Dominant Interferer

The purpose of this test is to verify the Enhanced Downlink Control Channel Performance Requirement Type A for PDCCH/PCFICH with 2 transmit antennas for the case of dominant interferer with the colliding CRS pattern and applying interference model defined in clause B.7.1. For the parameters specified in Table 8.4.2-1 and Table 8.4.2.2.5-1, the average probability of a missed downlink scheduling grant (Pm-dsg) shall be below the specified value in Table 8.4.2.2.5-2. In Table 8.4.2.2.5-1, Cell 1 is the serving cell, and Cell 2 and Cell 3 are the aggressor cells. The downlink physical channel setup is according to Annex C.3.2 for each of Cell 1, Cell 2 and Cell 3, respectively. The CRS assistance information [7] is provided and includes Cell 2 and Cell 3.

Table 8.4.2.2.5-1: Test Parameters for PDCCH/PCFICH

Parameter		Unit	Cell 1	Cell 2	Cell 3
Downlink power allocation	PDCCH_RA OCNG_RA	dB	-3	-3	-3
	PHICH_RA	dB	-3	N/A	N/A
	PCFICH_RB PDCCH_RB OCNG_RB	dB	-3	-3	-3
	PHICH_RB	dB	-3	N/A	N/A
Cell-specific reference signals			Antenna ports 0,1	Antenna ports 0,1	Antenna ports 0,1
N_{oc} at antenna port		dBm/15kHz	-98		
\hat{E}_s/N_{oc}		dB	N/A	13.91	3.34
BW _{Channel}		MHz	10	10	10
Cyclic Prefix			Normal	Normal	Normal
Cell Id			0	6	1
UL/DL Configuration			0	0	0
Special Subframe Configuration			4	4	4
Subframe Configuration			Non-MBSFN	Non-MBSFN	Non-MBSFN
Number of DL control region OFDM symbols			3 for subframes 0 and 5 2 for subframes 1 and 6		
CFI indicated in PCFICH			3 for subframes 0 and 5 2 for subframes 1 and 6		
PHICH Ng (Note 1)			1/6	N/A	N/A
PHICH duration			Normal	N/A	N/A
PDSCH TM			4	N/A	N/A
Interference model				As specified in clause B.7.1	As specified in clause B.7.1
Unused RE-s and PRB-s (Note 2)			OCNG	OCNG	OCNG
Time Offset relative to Cell 1		μs	N/A	2	3
Frequency shift relative to Cell 1		Hz	N/A	200	300
Note 1: According to Clause 6.9 in TS 36.211 [4]. Note 2: For Cell 2 and Cell 3 unused RE-s and PRB-s do not include control region REs.					

Table 8.4.2.2.5-2: Minimum Performance for PDCCH/PCFICH for Enhanced Downlink Control Channel Performance Requirement Type A

Test Number	Aggregation level	Reference Channel	OCNG Pattern (Note 1)	Propagation Conditions (Note 2)			Antenna Configuration and Correlation Matrix (Note 3)	Reference Value	
				Cell 1	Cell 2	Cell 3		Pm-dsg (%)	SNR (dB) (Note 4)
1	2 CCE	R.16-1 TDD	OP.1 TDD	EPA5	EPA5	EPA5	2x2 Low	1	16.1
Note 1: The OCNG pattern applies for Cell 1, Cell 2 and Cell 3. Note 2: The propagation conditions for Cell 1, Cell 2 and Cell 3 are statistically independent. Note 3: The correlation matrix and antenna configuration apply for Cell 1, Cell 2 and Cell 3. Note 4: SNR corresponds to \hat{E}_s/N_{oc} of Cell 1 as defined in clause 8.1.1.									

8.4.2.2.6 Enhanced Downlink Control Channel Performance Requirement Type A - 2 Tx Antenna Port with Non-Colliding CRS Dominant Interferer

The purpose of this test is to verify the Enhanced Downlink Control Channel Performance Requirement Type A for PDCCH/PCFICH with 2 transmit antennas for the case of dominant interferer with the non-colliding CRS pattern and applying interference model defined in clause B.7.1. For the parameters specified in Table 8.4.2-1 and Table 8.4.2.2.6-1, the average probability of a missed downlink scheduling grant (Pm-dsg) shall be below the specified value in Table 8.4.2.2.6-2. In Table 8.4.2.2.6-1, Cell 1 is the serving cell, and Cell 2 and Cell 3 are the aggressor cells. The downlink physical channel setup is according to Annex C.3.2 for each of Cell 1, Cell 2 and Cell 3, respectively. The CRS assistance information [7] is provided and includes Cell 2 and Cell 3.

Table 8.4.2.2.6-1: Test Parameters for PDCCH/PCFICH

Parameter		Unit	Cell 1	Cell 2	Cell 3
Downlink power allocation	PDCCH_RA OCNG_RA	dB	-3	-3	-3
	PHICH_RA	dB	-3	N/A	N/A
	PCFICH_RB PDCCH_RB OCNG_RB	dB	-3	-3	-3
	PHICH_RB	dB	-3	N/A	N/A
Cell-specific reference signals			Antenna ports 0,1	Antenna ports 0,1	Antenna ports 0,1
N_{oc} at antenna port		dBm/15kHz	-98		
\hat{E}_s/N_{oc}		dB	N/A	13.91	3.34
BW _{Channel}		MHz	10	10	10
Cyclic Prefix			Normal	Normal	Normal
Cell Id			0	1	6
UL/DL Configuration			0	0	0
Special Subframe Configuration			4	4	4
Subframe Configuration			Non-MBSFN	Non-MBSFN	Non-MBSFN
Number of DL control region OFDM symbols			3 for subframes 0 and 5 2 for subframes 1 and 6		
CFI indicated in PCFICH			3 for subframes 0 and 5 2 for subframes 1 and 6		
PHICH Ng (Note 1)			1/6	N/A	N/A
PHICH duration			Normal	N/A	N/A
PDSCH TM			4	N/A	N/A
Interference model				As specified in clause B.7.1	As specified in clause B.7.1
Unused RE-s and PRB-s (Note 2)			OCNG	OCNG	OCNG
Time Offset relative to Cell 1		μs	N/A	2	3
Frequency shift relative to Cell 1		Hz	N/A	200	300
Note 1: According to Clause 6.9 in TS 36.211 [4]. Note 2: For Cell 2 and Cell 3 unused RE-s and PRB-s do not include control region REs.					

Table 8.4.2.2.6-2: Minimum Performance for PDCCH/PCFICH for Enhanced Downlink Control Channel Performance Requirement Type A

Test Number	Aggregation level	Reference Channel	OCNG Pattern (Note 1)	Propagation Conditions (Note 2)			Antenna Configuration and Correlation Matrix (Note 3)	Reference Value	
				Cell 1	Cell 2	Cell 3		Pm-dsg (%)	SNR (dB) (Note 4)
1	4 CCE	R.16-2 TDD	OP.1 TDD	EPA5	EPA5	EPA5	2x2 Low	1	13.3
Note 1: The OCNG pattern applies for Cell 1, Cell 2 and Cell 3. Note 2: The propagation conditions for Cell 1, Cell 2 and Cell 3 are statistically independent. Note 3: The correlation matrix and antenna configuration apply for Cell 1, Cell 2 and Cell 3. Note 4: SNR corresponds to \widehat{E}_s/N_{oc} of Cell 1 as defined in clause 8.1.1.									

8.4.2.2.7 Enhanced Downlink Control Channel Performance Requirement Type B - 2 Tx Antenna Port with Colliding CRS Dominant Interferer

The purpose of this test is to verify the Enhanced Downlink Control Channel Performance Requirement Type B for PDCCH/PCFICH with 2 transmit antennas for the case of dominant interferer with the colliding CRS pattern and applying interference model defined in clause B.7.1. For the parameters specified in Table 8.4.2-1 and Table 8.4.2.2.7-1, the average probability of a missed downlink scheduling grant (Pm-dsg) shall be below the specified value in Table 8.4.2.2.7-2. In Table 8.4.2.2.7-1, Cell 1 is the serving cell, and Cell 2 and Cell 3 are the aggressor cells. The downlink physical channel setup is according to Annex C.3.2 for each of Cell 1, Cell 2 and Cell 3, respectively. The CRS assistance information [7] is provided and includes Cell 2 and Cell 3.

Table 8.4.2.2.7-1: Test Parameters for PDCCH/PCFICH

Parameter		Unit	Cell 1	Cell 2	Cell 3
Downlink power allocation	PDCCH_RA OCNG_RA	dB	-3	-3	-3
	PHICH_RA	dB	-3	N/A	N/A
	PCFICH_RB PDCCH_RB OCNG_RB	dB	-3	-3	-3
	PHICH_RB	dB	-3	N/A	N/A
Cell-specific reference signals			Antenna ports 0,1	Antenna ports 0,1	Antenna ports 0,1
N_{oc} at antenna port		dBm/15kHz	-98		
\widehat{E}_s/N_{oc}		dB	N/A	13.91	3.34
BW _{Channel}		MHz	10	10	10
Cyclic Prefix			Normal	Normal	Normal
Cell Id			0	6	1
UL/DL Configuration			0	0	0
Special Subframe Configuration			4	4	4
Subframe Configuration			Non-MBSFN	Non-MBSFN	Non-MBSFN
Number of DL control region OFDM symbols			1	1	1
CFI indicated in PCFICH			1	1	1
PHICH Ng (Note 1)			1/6	N/A	N/A
PHICH duration			Normal	N/A	N/A
PDSCH TM			4	N/A	N/A
Interference model				As specified in clause B.7.1	As specified in clause B.7.1
Unused RE-s and PRB-s (Note 2)			OCNG	OCNG	OCNG
Time Offset relative to Cell 1		μs	N/A	2	3
Frequency shift relative to Cell 1		Hz	N/A	200	300
Note 1: According to Clause 6.9 in TS 36.211 [4].					
Note 2: For Cell 2 and Cell 3 unused RE-s and PRB-s do not include control region REs.					

Table 8.4.2.2.7-2: Minimum Performance for PDCCH/PCFICH for Enhanced Downlink Control Channel Performance Requirement Type B

Test Number	Aggregation level	Reference Channel	OCNG Pattern (Note 1)	Propagation Conditions (Note 2)			Antenna Configuration and Correlation Matrix (Note 3)	Reference Value	
				Cell 1	Cell 2	Cell 3		Pm-dsg (%)	SNR (dB) (Note 4)
1	2 CCE	R.16-3 TDD	OP.1 TDD	EPA5	EPA5	EPA5	2x2 Low	1	13.7
Note 1: The OCNG pattern applies for Cell 1, Cell 2 and Cell 3.									
Note 2: The propagation conditions for Cell 1, Cell 2 and Cell 3 are statistically independent.									
Note 3: The correlation matrix and antenna configuration apply for Cell 1, Cell 2 and Cell 3.									
Note 4: SNR corresponds to \hat{E}_s / N_{oc} of Cell 1 as defined in clause 8.1.1.									

8.4.2.2.8 Enhanced Downlink Control Channel Performance Requirement Type B - 2 Tx Antenna Port with Non-Colliding CRS Dominant Interferer

The purpose of this test is to verify the Enhanced Downlink Control Channel Performance Requirement Type A for PDCCH/PCFICH with 2 transmit antennas for the case of dominant interferer with the non-colliding CRS pattern and applying interference model defined in clause B.7.1. For the parameters specified in Table 8.4.2-1 and Table 8.4.2.2.8-1, the average probability of a missed downlink scheduling grant (Pm-dsg) shall be below the specified value in Table 8.4.2.2.8-2. In Table 8.4.2.2.8-1, Cell 1 is the serving cell, and Cell 2 and Cell 3 are the aggressor cells. The downlink physical channel setup is according to Annex C.3.2 for each of Cell 1, Cell 2 and Cell 3, respectively. The CRS assistance information [7] is provided and includes Cell 2 and Cell 3.

Table 8.4.2.2.8-1: Test Parameters for PDCCH/PCFICH

Parameter		Unit	Cell 1	Cell 2	Cell 3
Downlink power allocation	PDCCH_RA OCNG_RA	dB	-3	-3	-3
	PHICH_RA	dB	-3	N/A	N/A
	PCFICH_RB PDCCH_RB OCNG_RB	dB	-3	-3	-3
	PHICH_RB	dB	-3	N/A	N/A
Cell-specific reference signals			Antenna ports 0,1	Antenna ports 0,1	Antenna ports 0,1
N_{oc} at antenna port		dBm/15kHz	-98		
\hat{E}_s / N_{oc}		dB	N/A	13.91	3.34
BW _{Channel}		MHz	10	10	10
Cyclic Prefix			Normal	Normal	Normal
Cell Id			0	1	6
UL/DL Configuration			0	0	0
Special Subframe Configuration			4	4	4
Subframe Configuration			Non-MBSFN	Non-MBSFN	Non-MBSFN
Number of DL control region OFDM symbols			1	1	1
CFI indicated in PCFICH			1	1	1
PHICH Ng (Note 1)			1/6	N/A	N/A
PHICH duration			Normal	N/A	N/A
PDSCH TM			4	N/A	N/A
Interference model				As specified in clause B.7.1	As specified in clause B.7.1
Unused RE-s and PRB-s (Note 2)			OCNG	OCNG	OCNG
Time Offset relative to Cell 1		μs	N/A	2	3
Frequency shift relative to Cell 1		Hz	N/A	200	300
Note 1: According to Clause 6.9 in TS 36.211 [4].					
Note 2: For Cell 2 and Cell 3 unused RE-s and PRB-s do not include control region REs.					

Table 8.4.2.2.8-2: Minimum Performance for PDCCH/PCFICH for Enhanced Downlink Control Channel Performance Requirement Type B

Test Number	Aggregation level	Reference Channel	OCNG Pattern (Note 1)	Propagation Conditions (Note 2)			Antenna Configuration and Correlation Matrix (Note 3)	Reference Value	
				Cell 1	Cell 2	Cell 3		Pm-dsg (%)	SNR (dB) (Note 4)
1	4 CCE	R.16-4 TDD	OP.1 TDD	EPA5	EPA5	EPA5	2x2 Low	1	11.2
Note 1: The OCNG pattern applies for Cell 1, Cell 2 and Cell 3. Note 2: The propagation conditions for Cell 1, Cell 2 and Cell 3 are statistically independent. Note 3: The correlation matrix and antenna configuration apply for Cell 1, Cell 2 and Cell 3. Note 4: SNR corresponds to \hat{E}_s / N_{oc} of Cell 1 as defined in clause 8.1.1.									

8.4.3 LAA

The parameters specified in Table 8.4.3-1 are valid for all LAA PDCCH tests unless otherwise stated.

Table 8.4.3-1: Common test Parameters for PDCCH

Parameter		Unit	Transmit diversity
Downlink power allocation (Note 1)	PDCCH_RA PHICH_RA OCNG_RA	dB	-3
	PCFICH_RB PDCCH_RB PHICH_RB OCNG_RB	dB	-3
N_{oc} at antenna port		dBm/15kHz	-98
PHICH Ng (Note 1)			1
PHICH duration			Normal
Unused RE-s and PRB-s (Note 2)			OCNG
Cell ID			0
Cyclic prefix			Normal
ACK/NACK feedback mode			Multiplexing
Note 1: In LAA Scell(s), PCFICH_RB, PHICH_RA, and PHICH_RB are not available. Note 2: OCNG is applied only within LAA burst.			

8.4.3.1 Transmit diversity performance

8.4.3.1.1 FDD Pcell (FDD single carrier)

8.4.3.1.1.1 Minimum Requirement 2 Tx Antenna Port

The average probability of a missed downlink scheduling grant (Pm-dsg) shall be below the specified value in Table 8.4.3.1.1.1-2 for Pcell and in Table 8.4.3.1.1.1-3 for LAA Scell(s), with the addition of the parameters in Table 8.4.3-1, and Table 8.4.3.1.1.1-1. The downlink physical setup is in accordance with Annex C.3.2.

Table 8.4.3.1.1.1-1: Test Parameters for LAA Scell(s)

Parameter	Unit	Value
DMTC Periodicity	ms	80
dmtc-PeriodOffset-r12 ms80-r12		0
Downlink Burst transmission pattern for LAA SCell		As specified in B.8
The number of subframes set (S_i) in a burst		{1,3, 5, 8}
Uniform random number (p) in the burst model		0.5
Occupied OFDM symbols set in the last subframe		{6, 9, 12,14}
timing error relative of LAA SCell to PCell	μ s	15
Frequency offset of the i -th LAA SCell relative to PCell	Hz	200
Note 1: The same PDSCH transmission mode is applied to each component carrier. Note 2: The OCNB shall be applied for the non-scheduled OFDM symbols within the burst, and which OFDM symbols are scheduled within the burst is according to UE capability.		

Table 8.4.3.1.1.1-2: Single carrier performance for CCs which are not LAA Scells for multiple CA configurations

Test number	Bandwidth	Aggregation level	Reference Channel	OCNB Pattern	Propagation Condition	Antenna configuration and correlation Matrix	Reference value	
							Pm-dsg (%)	SNR (dB)
1	10 MHz	4 CCE	R.16 FDD	OP.1 FDD	EVA5	2 x 2 Low	1	-0.6

Table 8.4.3.1.1.1-3: Single carrier performance for LAA Scell(s) for multiple CA configurations

Test number	Bandwidth	Aggregation level	Reference Channel	OCNB Pattern	Propagation Condition	Antenna configuration and correlation Matrix	Reference value	
							Pm-dsg (%)	SNR (dB)
1	20 MHz	4 CCE	R.3 FS3	OP.1 FS3	EVA5	2 x 2 Low	1	0.2
2	20 MHz	4 CCE	R.3 FS3	OP.1 FS3	EVA5	2 x 2 Low	1	0.2
3	20 MHz	4 CCE	R.3 FS3	OP.1 FS3	EVA5	2 x 2 Low	1	0.3
4	20 MHz	4 CCE	R.3 FS3	OP.1 FS3	EVA5	2 x 2 Low	1	0.1
Note1 : UE is required to fulfill only one test among test 1-4 depending on it's capability for endingDwPTS and secondSlotStartingPosition. For UE don't support endingDwPTS and secondSlotStartingPosition, it is required to fulfill test 1; For UE don't support endingDwPTS and support secondSlotStartingPosition, it is required to fulfill test 2; For UE support endingDwPTS and don't support secondSlotStartingPosition, it is required to fulfill test 3; and for UE support both endingDwPTS and secondSlotStartingPosition, it is required to fulfill test 4.								

8.4.3.1.2 TDD Pcell (TDD single carrier)

8.4.3.1.2.1 Minimum Requirement 2 Tx Antenna Port

The average probability of a missed downlink scheduling grant (Pm-dsg) shall be below the specified value in Table 8.4.3.1.2.1-2 for Pcell and in Table 8.4.3.1.2.1-3 for LAA Scell(s), with the additional of the parameters in Table 8.4.3-1, and Table 8.4.3.1.2.1-1. The downlink physical setup is in accordance with Annex C.3.2.

Table 8.4.3.1.2.1-1: Test Parameters for LAA Scell(s)

Parameter	Unit	Value
DMTC Periodicity	ms	80
dmtc-PeriodOffset-r12 ms80-r12		0
Downlink Burst transmission pattern for LAA SCell		As specified in B.8
The number of subframes set (S_i) in a burst		{1,3, 5, 8}
Uniform random number (p) in the burst model		0.5
subframeStartPosition		's07'
Occupied OFDM symbols set in the last subframe		{6, 9, 12,14}
timing error relative of LAA SCell to PCell	μ s	15
Frequency offset of the i -th LAA SCell relative to PCell	Hz	200
Note 1: The same PDSCH transmission mode is applied to each component carrier. Note 2: The OCNG shall be applied for the non-scheduled OFDM symbols within the burst, and which OFDM symbols are scheduled within the burst is according to UE capability.		

Table 8.4.3.1.2.1-2: Single carrier performance for CCs which are not LAA Scells for multiple CA configurations

Test number	Bandwidth	Aggregation level	Reference Channel	OCNG Pattern	Propagation Condition	Antenna configuration and correlation Matrix	Reference value	
							Pm-dsg (%)	SNR (dB)
1	10 MHz	4 CCE	R.16 TDD	OP.1 TDD	EVA5	2 x 2 Low	1	-0.6

Table 8.4.3.1.2.1-3: Single carrier performance for LAA Scell(s) for multiple CA configurations

Test number	Bandwidth	Aggregation level	Reference Channel	OCNG Pattern	Propagation Condition	Antenna configuration and correlation Matrix	Reference value	
							Pm-dsg (%)	SNR (dB)
1	20 MHz	4 CCE	R.4 FS3	OP.1 FS3	EVA5	2 x 2 Low	1	0.2
2	20 MHz	4 CCE	R.4 FS3	OP.1 FS3	EVA5	2 x 2 Low	1	0.2
3	20 MHz	4 CCE	R.4 FS3	OP.1 FS3	EVA5	2 x 2 Low	1	0.3
4	20 MHz	4 CCE	R.4 FS3	OP.1 FS3	EVA5	2 x 2 Low	1	0.1
Note 1 : UE is required to fulfill only one test among test 1-4 depending on its capability for endingDwPTS and secondSlotStartingPosition. For UE don't support endingDwPTS and secondSlotStartingPosition, it is required to fulfill test 1; For UE don't support endingDwPTS and support secondSlotStartingPosition, it is required to fulfill test 2; For UE support endingDwPTS and don't support secondSlotStartingPosition, it is required to fulfill test 3; and For UE support both endingDwPTS and secondSlotStartingPosition, it is required to fulfill test 4.								

8.5 Demodulation of PHICH

The receiver characteristics of the PHICH are determined by the probability of miss-detecting an ACK for a NACK (Pm-an). It is assumed that there is no bias applied to the detection of ACK and NACK (zero-threshold detection).

8.5.1 FDD

The parameters specified in Table 8.5.1-1 are valid for all FDD tests unless otherwise stated.

Table 8.5.1-1: Test Parameters for PHICH

Parameter		Unit	Single antenna port	Transmit diversity
Downlink power allocation	PDCCH_RA PHICH_RA OCNG_RA	dB	0	-3
	PCFICH_RB PDCCH_RB PHICH_RB OCNG_RB	dB	0	-3
PHICH duration			Normal	Normal
PHICH Ng (Note 1)			Ng = 1	Ng = 1
PDCCH Content			UL Grant should be included with the proper information aligned with A.3.6.	
Unused RE-s and PRB-s			OCNG	OCNG
Cell ID			0	0
N_{oc} at antenna port		dBm/15kHz	-98	-98
Cyclic prefix			Normal	Normal
Note 1: according to Clause 6.9 in TS 36.211 [4]				

8.5.1.1 Single-antenna port performance

For the parameters specified in Table 8.5.1-1 the average probability of a miss-detecting ACK for NACK (P_{m-an}) shall be below the specified value in Table 8.5.1.1-1. The downlink physical setup is in accordance with Annex C.3.2.

Table 8.5.1.1-1: Minimum performance PHICH

Test number	Bandwidth	Reference Channel	OCNG Pattern	Propagation Condition	Antenna configuration and correlation Matrix	Reference value	
						P_{m-an} (%)	SNR (dB)
1	10 MHz	R.18	OP.1 FDD	ETU70	1 x 2 Low	0.1	5.5
2	10 MHz	R.24	OP.1 FDD	ETU70	1 x 2 Low	0.1	0.6

8.5.1.2 Transmit diversity performance

8.5.1.2.1 Minimum Requirement 2 Tx Antenna Port

For the parameters specified in Table 8.5.1-1 the average probability of a miss-detecting ACK for NACK (P_{m-an}) shall be below the specified value in Table 8.5.1.2-1. The downlink physical setup is in accordance with Annex C.3.2.

Table 8.5.1.2.1-1: Minimum performance PHICH

Test number	Bandwidth	Reference Channel	OCNG Pattern	Propagation Condition	Antenna configuration and correlation Matrix	Reference value	
						P_{m-an} (%)	SNR (dB)
1	10 MHz	R.19	OP.1 FDD	EVA70	2 x 2 Low	0.1	4.4
1A	5MHz (Note 1)	R.19-1	OP.1 FDD	EVA 70	2x2 Low	0.1	4
Note 1: Test case applicability is defined in 8.1.2.1.							

8.5.1.2.2 Minimum Requirement 4 Tx Antenna Port

For the parameters specified in Table 8.5.1-1 the average probability of a miss-detecting ACK for NACK (P_{m-an}) shall be below the specified value in Table 8.5.1.2.2-1. The downlink physical setup is in accordance with Annex C.3.2.

Table 8.5.1.2.2-1: Minimum performance PHICH

Test number	Bandwidth	Reference Channel	OCNG Pattern	Propagation Condition	Antenna configuration and correlation Matrix	Reference value	
						P_{m-an} (%)	SNR (dB)
1	5 MHz	R.20	OP.1 FDD	EPA5	4 x 2 Medium	0.1	6.1

8.5.1.2.3 Minimum Requirement 2 Tx Antenna Port (demodulation subframe overlaps with aggressor cell ABS)

For the parameters specified in Table 8.5.1-1 and Table 8.5.1.2.3-1, the average probability of a miss-detecting ACK for NACK (P_{m-an}) shall be below the specified value in Table 8.5.1.2.3-2. The downlink physical setup is in accordance with Annex C.3.2 and Annex C.3.3. In Table 8.5.1.2.3-1, Cell 1 is the serving cell, and Cell 2 is the aggressor cell. The downlink physical channel setup for Cell 1 is according to Annex C.3.2 and for Cell 2 is according to Annex C.3.3, respectively.

Table 8.5.1.2.3-1: Test Parameters for PHICH

Parameter		Unit	Cell 1	Cell 2
Downlink power allocation	PDCCH_RA PHICH_RA OCNG_RA	dB	-3	-3
	PCFICH_RB PDCCH_RB PHICH_RB OCNG_RB			
N_{oc} at antenna port	N_{oc1}	dBm/15kHz	-100.5 (Note 1)	N/A
	N_{oc2}	dBm/15kHz	-98 (Note 2)	N/A
	N_{oc3}	dBm/15kHz	-95.3 (Note 3)	N/A
\hat{E}_s/N_{oc2}		dB	Reference Value in Table 8.5.1.2.3-2	1.5
BW _{Channel}		MHz	10	10
Subframe Configuration			Non-MBSFN	Non-MBSFN
Time Offset between Cells		μs	2.5 (synchronous cells)	
Cell Id			0	1
ABS pattern (Note 4)			N/A	00000100 00000100 00000100 01000100 00000100
RLM/RRM Measurement Subframe Pattern (Note 5)			00000100 00000100 00000100 00000100 00000100	N/A
CSI Subframe Sets (Note 6)	$C_{CSI,0}$		00000100 00000100 00000100 01000100 00000100	N/A
	$C_{CSI,1}$		11111011 11111011 11111011 10111011 11111011	N/A
Number of control OFDM symbols			3	3
PHICH Ng (Note 9)			1	N/A
PHICH duration			extended	N/A
Unused RE-s and PRB-s			OCNG	OCNG
Cyclic prefix			Normal	Normal
<p>Note 1: This noise is applied in OFDM symbols #1, #2, #3, #5, #6, #8, #9, #10,#12, #13 of a subframe overlapping with the aggressor ABS</p> <p>Note 2: This noise is applied in OFDM symbols #0, #4, #7, #11 of a subframe overlapping with the aggressor ABS</p> <p>Note 3: This noise is applied in OFDM symbols of a subframe overlapping with aggressor non-ABS</p> <p>Note 4: ABS pattern as defined in [9]. PHICH is transmitted in the serving cell subframe when the subframe is overlapped with the ABS subframe of aggressor cell but not in the 26th subframe indicated by the ABS pattern.</p> <p>Note 5: Time-domain measurement resource restriction pattern for PCell measurements as defined in [7]</p> <p>Note 6: As configured according to the time-domain measurement resource restriction pattern for CSI measurements defined in [7]</p> <p>Note 7: Cell 1 is the serving cell. Cell 2 is the aggressor cell. The number of the CRS ports in Cell1 and Cell2 is the same.</p> <p>Note 8: SIB-1 will not be transmitted in Cell2 in the test.</p> <p>Note 9: According to Clause 6.9 in TS 36.211 [4]</p>				

Table 8.5.1.2.3-2: Minimum performance PHICH

Test Number	Reference Channel	OCNG Pattern		Propagation Conditions (Note 1)		Antenna Configuration and Correlation Matrix	Reference Value	
		Cell 1	Cell 2	Cell 1	Cell 2		Pm-an (%)	SNR (dB) (Note 2)
1	R.19	OP.1 FDD	OP.1 FDD	EPA5	EPA5	2x2 Low	0.1	4.6
Note 1: The propagation conditions for Cell 1 and Cell 2 are statistically independent. Note 2: SNR corresponds to \hat{E}_s / N_{oc2} of cell 1. Note 3: The correlation matrix and antenna configuration apply for Cell 1 and Cell 2.								

8.5.1.2.4 Minimum Requirement 2 Tx Antenna Port (demodulation subframe overlaps with aggressor cell ABS and CRS assistance information are configured)

For the parameters specified in Table 8.5.1-1 and Table 8.5.1.2.4-1, the average probability of a miss-detecting ACK for NACK (Pm-an) shall be below the specified value in Table 8.5.1.2.4-2. In Table 8.5.1.2.4-1, Cell 1 is the serving cell, and Cell 2 and Cell 3 are the aggressor cells. The downlink physical channel setup for Cell 1 is according to Annex C.3.2 and for Cell 2 and Cell 3 is according to Annex C.3.3, respectively. The CRS assistance information [7] including Cell 2 and Cell 3 is provided.

Table 8.5.1.2.4-1: Test Parameters for PHICH

Parameter		Unit	Cell 1	Cell 2	Cell 3
Downlink power allocation	PDCCH_RA PHICH_RA OCNG_RA	dB	-3	-3	-3
	PCFICH_RB PDCCH_RB PHICH_RB OCNG_RB	dB	-3	-3	-3
N_{oc} at antenna port	N_{oc1}	dBm/15kHz	-98 (Note 1)	N/A	N/A
	N_{oc2}	dBm/15kHz	-98 (Note 2)	N/A	N/A
	N_{oc3}	dBm/15kHz	-93 (Note 3)	N/A	N/A
\hat{E}_s / N_{oc2}		dB	Reference Value in Table 8.5.1.2.4-2	5	3
$BW_{Channel}$		MHz	10	10	10
Subframe Configuration			Non-MBSFN	Non-MBSFN	Non-MBSFN
Time Offset between Cells		μ s	N/A	3	-1
Frequency shift between Cells		Hz	N/A	300	-100
Cell Id			0	126	1
PDCCH Content			UL Grant should be included with the proper information aligned with A.3.6.	N/A	N/A
ABS pattern (Note 4)			N/A	00000100 00000100 00000100 00000100 00000100	00000100 00000100 00000100 00000100 00000100
RLM/RRM Measurement Subframe Pattern (Note 5)			00000100 00000100 00000100 00000100 00000100	N/A	N/A
CSI Subframe Sets (Note 6)	$C_{CSI,0}$		00000100 00000100 00000100 00000100 00000100	N/A	N/A
	$C_{CSI,1}$		11111011 11111011 11111011 11111011 11111011	N/A	N/A
Number of control OFDM symbols			2	Note 7	Note 7
PHICH N_g (Note 10)			1	N/A	N/A
PHICH duration			Normal	N/A	N/A
Unused RE-s and PRB-s			OCNG	OCNG	OCNG
Cyclic prefix			Normal	Normal	Normal

- Note 1: This noise is applied in OFDM symbols #1, #2, #3, #5, #6, #8, #9, #10, #12, #13 of a subframe overlapping with the aggressor ABS
- Note 2: This noise is applied in OFDM symbols #0, #4, #7, #11 of a subframe overlapping with the aggressor ABS
- Note 3: This noise is applied in OFDM symbols of a subframe overlapping with aggressor non-ABS
- Note 4: ABS pattern as defined in [9]. PHICH is transmitted in the serving cell subframe when the subframe is overlapped with the ABS subframe of aggressor cell but not in the 26th subframe indicated by the ABS pattern.
- Note 5: Time-domain measurement resource restriction pattern for PCell measurements as defined in [7]
- Note 6: As configured according to the time-domain measurement resource restriction pattern for CSI measurements defined in [7]
- Note 7: The number of control OFDM symbols is not available for ABS and is 2 for the subframe indicated by "0" of ABS pattern.
- Note 8: The number of the CRS ports in Cell 1, Cell 2 and Cell 3 is the same.
- Note 9: SIB-1 will not be transmitted in Cell 2 and Cell 3 in the test
- Note 10: According to Clause 6.9 in TS 36.211 [4].

Table 8.5.1.2.4-2: Minimum performance PHICH

Test Number	Reference Channel	OCNG Pattern			Propagation Conditions (Note 1)			Antenna Configuration and Correlation Matrix (Note 2)	Reference Value	
		Cell 1	Cell 2	Cell 3	Cell 1	Cell 2	Cell 3		Pm-an (%)	SNR (dB) (Note 3)
1	R.19	OP.1 FDD	OP.1 FDD	OP.1 FDD	EPA5	EVA5	EVA5	2x2 Low	0.1	5.0

Note 1: The propagation conditions for Cell 1, Cell 2 and Cell 3 are statistically independent.
 Note 2: The correlation matrix and antenna configuration apply for Cell 1, Cell 2 and Cell 3.
 Note 3: SNR corresponds to \hat{E}_s / N_{oc2} of Cell 1.

8.5.1.2.5 Enhanced Downlink Control Channel Performance Requirement Type A - 2 Tx Antenna Ports under Asynchronous Network

For the parameters specified in Table 8.5.1-1 and Table 8.5.1.2.5-1, the average probability of a miss-detecting ACK for NACK (Pm-an) shall be below the specified value in Table 8.5.1.2.5-2. The purpose of this test is to verify the PHICH performance with 2 transmit antennas when the serving cell PHICH transmission is interfered by two interfering cells and applying interference model defined in clause B.5.2. In Table 8.5.1.2.5-1, Cell 1 is the serving cell, and Cell 2 and Cell 3 are the aggressor cells. The downlink physical channel setup is according to Annex C.3.2 for each of Cell 1, Cell 2 and Cell 3, respectively. The CRS assistance information [7] is not provided.

Table 8.5.1.2.5-1: Test Parameters for PHICH

Parameter		Unit	Cell 1	Cell 2	Cell 3
Downlink power allocation	PDCCH_RA PHICH_RA PDSCH_RA OCNG_RA	dB	-3	-3	-3
	PCFICH_RB PHICH_RB PDCCH_RB PDSCH_RB OCNG_RB	dB	-3	-3	-3
Cell-specific reference signals			Antenna ports 0,1	Antenna ports 0,1	Antenna ports 0,1
N_{oc} at antenna port		dBm/15kHz	-98		
\hat{E}_s/N_{oc}		dB	N/A	13.91	3.34
$BW_{Channel}$		MHz	10	10	10
Cyclic Prefix			Normal	Normal	Normal
Cell ID			0	1	6
Subframe Configuration			Non-MBSFN	Non-MBSFN	Non-MBSFN
Number of control OFDM symbols			1	1	1
PHICH Ng (Note 1)			1	N/A	N/A
PHICH duration			Normal	N/A	N/A
Interference model			N/A	As specified in clause B.5.2	As specified in clause B.5.2
Probability of occurrence of PDSCH transmission rank in interfering cells	Rank 1	%	N/A	80	80
	Rank 2	%	N/A	20	20
Unused RE-s and PRB-s			OCNG	OCNG	OCNG
Time offset relative to Cell 1		ms	N/A	0.33	0.67
Frequency offset relative to Cell 1		Hz	N/A	0	0
Note 1: According to Clause 6.9 in TS 36.211 [4].					

Table 8.5.1.2.5-2: Minimum performance PHICH for Enhanced Downlink Control Channel Performance Requirement Type A

Test Number	Reference Channel	OCNG Pattern			Propagation Conditions (Note 1)			Antenna Configuration and Correlation Matrix (Note 2)	Reference Value	
		Cell 1	Cell 2	Cell 3	Cell 1	Cell 2	Cell 3		Pm-an (%)	SNR (dB) (Note 3)
1	R.19	OP.1 FDD	OP.1 FDD	OP.1 FDD	EVA7 0	EVA7 0	EVA7 0	2x2 Low	0.1	17.9
Note 1: The propagation conditions for Cell 1, Cell 2 and Cell 3 are statistically independent.										
Note 2: The correlation matrix and antenna configuration apply for Cell 1, Cell 2 and Cell 3.										
Note 3: SNR corresponds to \hat{E}_s/N_{oc2} of Cell 1 as defined in clause 8.1.1.										

8.5.1.2.6 Enhanced Downlink Control Channel Performance Requirement Type A - 2 Tx Antenna Ports with Non-Colliding CRS Dominant Interferer

For the parameters specified in Table 8.5.1-1 and Table 8.5.1.2.6-1, the average probability of a miss-detecting ACK for NACK (Pm-an) shall be below the specified value in Table 8.5.1.2.6-2. The purpose of this test is to verify the PHICH performance with 2 transmit antennas when the serving cell PHICH transmission is interfered by two interfering cells with the dominant interferer having the non-colliding CRS pattern and applying interference model defined in clause B.7.1. In Table 8.5.1.2.6-1, Cell 1 is the serving cell, and Cell 2 and Cell 3 are the aggressor cells. The downlink physical channel setup is according to Annex C.3.2 for each of Cell 1, Cell 2 and Cell 3, respectively. The CRS assistance information [7] is provided and includes Cell 2 and Cell 3.

Table 8.5.1.2.6-1: Test Parameters for PHICH

Parameter		Unit	Cell 1	Cell 2	Cell 3
Downlink power allocation	PDCCH_RA OCNG_RA	dB	-3	-3	-3
	PHICH_RA	dB	-3	N/A	N/A
	PCFICH_RB PDCCH_RB OCNG_RB	dB	-3	-3	-3
	PHICH_RB	dB	-3	N/A	N/A
Cell-specific reference signals			Antenna ports 0,1	Antenna ports 0,1	Antenna ports 0,1
N_{oc} at antenna port		dBm/15kHz	-98		
\widehat{E}_s/N_{oc}		dB	N/A	13.91	3.34
$BW_{Channel}$		MHz	10	10	10
Cyclic Prefix			Normal	Normal	Normal
Cell ID			0	1	6
Subframe Configuration			Non-MBSFN	Non-MBSFN	Non-MBSFN
Number of control OFDM symbols			1	1	1
PHICH Ng (Note 1)			1	N/A	N/A
PHICH duration			Normal	N/A	N/A
Interference model			N/A	As specified in clause B.7.1	As specified in clause B.7.1
Unused RE-s and PRB-s (Note 2)			OCNG	OCNG	OCNG
Time offset to cell 1		us	N/A	2	3
Frequency offset to cell 1		Hz	N/A	200	300
Note 1: According to Clause 6.9 in TS 36.211 [4].					
Note 2: For Cell 2 and Cell 3 unused RE-s and PRB-s do not include control region REs.					

Table 8.5.1.2.6-2: Minimum performance PHICH for Enhanced Downlink Control Channel Performance Requirement Type A

Test Number	Reference Channel	OCNG Pattern			Propagation Conditions (Note 1)			Antenna Configuration and Correlation Matrix (Note 2)	Reference Value	
		Cell 1	Cell 2	Cell 3	Cell 1	Cell 2	Cell 3		Pm-an (%)	SNR (dB) (Note 3)
1	R.19	OP.1 FDD	OP.1 FDD	OP.1 FDD	EPA5	EPA5	EPA5	2x2 Low	0.1	15.8
Note 1: The propagation conditions for Cell 1, Cell 2 and Cell 3 are statistically independent.										
Note 2: The correlation matrix and antenna configuration apply for Cell 1, Cell 2 and Cell 3.										
Note 3: SNR corresponds to \widehat{E}_s/N_{oc2} of Cell 1 as defined in clause 8.1.1.										

8.5.1.2.7 Enhanced Downlink Control Channel Performance Requirement Type B - 2 Tx Antenna Ports with Colliding CRS Dominant Interferer

For the parameters specified in Table 8.5.1-1 and Table 8.5.1.2.7-1, the average probability of a miss-detecting ACK for NACK (Pm-an) shall be below the specified value in Table 8.5.1.2.7-2. The purpose of this test is to verify the PHICH performance with 2 transmit antennas when the serving cell PHICH transmission is interfered by two interfering cells with the dominant interferer having the colliding CRS pattern and applying interference model defined in clause B.7.1. In Table 8.5.1.2.7-1, Cell 1 is the serving cell, and Cell 2 and Cell 3 are the aggressor cells. The downlink physical channel setup is according to Annex C.3.2 for each of Cell 1, Cell 2 and Cell 3, respectively. The CRS assistance information [7] is provided and includes Cell 2 and Cell 3.

Table 8.5.1.2.7-1: Test Parameters for PHICH

Parameter		Unit	Cell 1	Cell 2	Cell 3
Downlink power allocation	PDCCH_RA OCNG_RA	dB	-3	-3	-3
	PHICH_RA	dB	-3	N/A	N/A
	PCFICH_RB PDCCH_RB OCNG_RB	dB	-3	-3	-3
	PHICH_RB	dB	-3	N/A	N/A
Cell-specific reference signals			Antenna ports 0,1	Antenna ports 0,1	Antenna ports 0,1
N_{oc} at antenna port		dBm/15kHz	-98		
\widehat{E}_s/N_{oc}		dB	N/A	13.91	3.34
$BW_{Channel}$		MHz	10	10	10
Cyclic Prefix			Normal	Normal	Normal
Cell ID			0	6	1
Subframe Configuration			Non-MBSFN	Non-MBSFN	Non-MBSFN
Number of control OFDM symbols			1	1	1
PHICH Ng (Note 1)			1	N/A	N/A
PHICH duration			Normal	N/A	N/A
Interference model			N/A	As specified in clause B.7.1	As specified in clause B.7.1
Unused RE-s and PRB-s (Note 2)			OCNG	OCNG	OCNG
Time offset to cell 1		us	N/A	2	3
Frequency offset to cell 1		Hz	N/A	200	300
Note 1: According to Clause 6.9 in TS 36.211 [4].					
Note 2: For Cell 2 and Cell 3 unused RE-s and PRB-s do not include control region REs.					

Table 8.5.1.2.7-2: Minimum performance PHICH for Enhanced Downlink Control Channel Performance Requirement Type B

Test Number	Reference Channel	OCNG Pattern			Propagation Conditions (Note 1)			Antenna Configuration and Correlation Matrix (Note 2)	Reference Value	
		Cell 1	Cell 2	Cell 3	Cell 1	Cell 2	Cell 3		Pm-an (%)	SNR (dB) (Note 3)
1	R.19	OP.1 FDD	OP.1 FDD	OP.1 FDD	EPA5	EPA5	EPA5	2x2 Low	0.1	13.4
Note 1: The propagation conditions for Cell 1, Cell 2 and Cell 3 are statistically independent.										
Note 2: The correlation matrix and antenna configuration apply for Cell 1, Cell 2 and Cell 3.										
Note 3: SNR corresponds to \widehat{E}_s/N_{oc2} of Cell 1 as defined in clause 8.1.1.										

8.5.1.2.8 Enhanced Downlink Control Channel Performance Requirement Type B - 2 Tx Antenna Ports with Non-Colliding CRS Dominant Interferer

For the parameters specified in Table 8.5.1-1 and Table 8.5.1.2.8-1, the average probability of a miss-detecting ACK for NACK (Pm-an) shall be below the specified value in Table 8.5.1.2.8-2. The purpose of this test is to verify the PHICH performance with 2 transmit antennas when the serving cell PHICH transmission is interfered by two interfering cells with the dominant interferer having the non-colliding CRS pattern and applying interference model defined in clause B.7.1. In Table 8.5.1.2.8-1, Cell 1 is the serving cell, and Cell 2 and Cell 3 are the aggressor cells. The downlink physical channel setup is according to Annex C.3.2 for each of Cell 1, Cell 2 and Cell 3, respectively. The CRS assistance information [7] is provided and includes Cell 2 and Cell 3.

Table 8.5.1.2.8-1: Test Parameters for PHICH

Parameter		Unit	Cell 1	Cell 2	Cell 3
Downlink power allocation	PDCCH_RA OCNG_RA	dB	-3	-3	-3
	PHICH_RA	dB	-3	N/A	N/A
	PCFICH_RB PDCCH_RB OCNG_RB	dB	-3	-3	-3
	PHICH_RB	dB	-3	N/A	N/A
Cell-specific reference signals			Antenna ports 0,1	Antenna ports 0,1	Antenna ports 0,1
N_{oc} at antenna port		dBm/15kHz	-98		
\widehat{E}_s/N_{oc}		dB	N/A	13.91	3.34
$BW_{Channel}$		MHz	10	10	10
Cyclic Prefix			Normal	Normal	Normal
Cell ID			0	1	6
Subframe Configuration			Non-MBSFN	Non-MBSFN	Non-MBSFN
Number of control OFDM symbols			1	1	1
PHICH Ng (Note 1)			1	N/A	N/A
PHICH duration			Normal	N/A	N/A
Interference model			N/A	As specified in clause B.7.1	As specified in clause B.7.1
Unused RE-s and PRB-s (Note 2)			OCNG	OCNG	OCNG
Time offset to cell 1		us	N/A	2	3
Frequency offset to cell 1		Hz	N/A	200	300
Note 1: According to Clause 6.9 in TS 36.211 [4].					
Note 2: For Cell 2 and Cell 3 unused RE-s and PRB-s do not include control region REs.					

Table 8.5.1.2.8-2: Minimum performance PHICH for Enhanced Downlink Control Channel Performance Requirement Type B

Test Number	Reference Channel	OCNG Pattern			Propagation Conditions (Note 1)			Antenna Configuration and Correlation Matrix (Note 2)	Reference Value	
		Cell 1	Cell 2	Cell 3	Cell 1	Cell 2	Cell 3		Pm-an (%)	SNR (dB) (Note 3)
1	R.19	OP.1 FDD	OP.1 FDD	OP.1 FDD	EPA5	EPA5	EPA5	2x2 Low	0.1	15.0
Note 1: The propagation conditions for Cell 1, Cell 2 and Cell 3 are statistically independent.										
Note 2: The correlation matrix and antenna configuration apply for Cell 1, Cell 2 and Cell 3.										
Note 3: SNR corresponds to \widehat{E}_s/N_{oc2} of Cell 1 as defined in clause 8.1.1.										

8.5.2 TDD

The parameters specified in Table 8.5.2-1 are valid for all TDD tests unless otherwise stated.

Table 8.5.2-1: Test Parameters for PHICH

Parameter		Unit	Single antenna port	Transmit diversity
Uplink downlink configuration (Note 1)			1	1
Special subframe configuration (Note 2)			4	4
Downlink power allocation	PDCCH_RA PHICH_RA OCNG_RA	dB	0	-3
	PCFICH_RB PDCCH_RB PHICH_RB OCNG_RB	dB	0	-3
PHICH duration			Normal	Normal
PHICH Ng (Note 3)			Ng = 1	Ng = 1
PDCCH Content			UL Grant should be included with the proper information aligned with A.3.6.	
Unused RE-s and PRB-s			OCNG	OCNG
Cell ID			0	0
N_{oc} at antenna port		dBm/15kHz	-98	-98
Cyclic prefix			Normal	Normal
ACK/NACK feedback mode			Multiplexing	Multiplexing
Note 1: as specified in Table 4.2-2 in TS 36.211 [4]				
Note 2: as specified in Table 4.2-1 in TS 36.211 [4]				
Note 3: according to Clause 6.9 in TS 36.211 [4]				

8.5.2.1 Single-antenna port performance

For the parameters specified in Table 8.5.2-1 the average probability of a miss-detecting ACK for NACK (P_{m-an}) shall be below the specified value in Table 8.5.2.1-1. The downlink physical setup is in accordance with Annex C.3.2.

Table 8.5.2.1-1: Minimum performance PHICH

Test number	Bandwidth	Reference Channel	OCNG Pattern	Propagation Condition	Antenna configuration and correlation Matrix	Reference value	
						P_{m-an} (%)	SNR (dB)
1	10 MHz	R.18	OP.1 TDD	ETU70	1 x 2 Low	0.1	5.8
2	10 MHz	R.24	OP.1 TDD	ETU70	1 x 2 Low	0.1	1.3

8.5.2.2 Transmit diversity performance

8.5.2.2.1 Minimum Requirement 2 Tx Antenna Port

For the parameters specified in Table 8.5.2-1 the average probability of a miss-detecting ACK for NACK (P_{m-an}) shall be below the specified value in Table 8.5.2.2.1-1. The downlink physical setup is in accordance with Annex C.3.2.

Table 8.5.2.2.1-1: Minimum performance PHICH

Test number	Bandwidth	Reference Channel	OCNG Pattern	Propagation Condition	Antenna configuration and correlation Matrix	Reference value	
						Pm-an (%)	SNR (dB)
1	10 MHz	R.19	OP.1 TDD	EVA70	2 x 2 Low	0.1	4.2

8.5.2.2.2 Minimum Requirement 4 Tx Antenna Port

For the parameters specified in Table 8.5.2-1 the average probability of a miss-detecting ACK for NACK (Pm-an) shall be below the specified value in Table 8.5.2.2.2-1. The downlink physical setup is in accordance with Annex C.3.2.

Table 8.5.2.2.2-1: Minimum performance PHICH

Test number	Bandwidth	Reference Channel	OCNG Pattern	Propagation Condition	Antenna configuration and correlation Matrix	Reference value	
						Pm-an (%)	SNR (dB)
1	5 MHz	R.20	OP.1 TDD	EPA5	4 x 2 Medium	0.1	6.2

8.5.2.2.3 Minimum Requirement 2 Tx Antenna Port (demodulation subframe overlaps with aggressor cell ABS)

For the parameters specified in Table 8.5.2-1 and Table 8.5.2.2.3-1, the average probability of a miss-detecting ACK for NACK (Pm-an) shall be below the specified value in Table 8.5.2.2.3-2. The downlink physical setup is in accordance with Annex C.3.2 and Annex C.3.3, In Table 8.5.2.2.3-1, Cell 1 is the serving cell, and Cell 2 is the aggressor cell. The downlink physical channel setup for Cell 1 is according to Annex C.3.2 and for Cell 2 is according to Annex C.3.3, respectively.

Table 8.5.2.2.3-1: Test Parameters for PHICH

Parameter		Unit	Cell 1	Cell 2
Uplink downlink configuration			1	1
Special subframe configuration			4	4
Downlink power allocation	PDCCH_RA PHICH_RA OCNG_RA	dB	-3	-3
	PCFICH_RB PDCCH_RB PHICH_RB OCNG_RB	dB	-3	-3
N_{oc} at antenna port	N_{oc1}	dBm/15kHz	-100.5 (Note 1)	N/A
	N_{oc2}	dBm/15kHz	-98 (Note 2)	N/A
	N_{oc3}	dBm/15kHz	-95.3 (Note 3)	N/A
\hat{E}_s / N_{oc2}		dB	Reference Value in Table 8.5.2.2.3-2	1.5
$BW_{Channel}$		MHz	10	10
Subframe Configuration			Non-MBSFN	Non-MBSFN
Time Offset between Cells		μ s	2.5 (synchronous cells)	
Cell Id			0	1
ABS pattern (Note 4)			N/A	0000010001 0000000001
RLM/RRM Measurement Subframe Pattern (Note 5)			0000000001 0000000001	N/A
CSI Subframe Sets (Note 6)	$C_{CSI,0}$		0000010001 0000000001	N/A
	$C_{CSI,1}$		1100101000 1100111000	N/A
Number of control OFDM symbols			3	3
ACK/NACK feedback mode			Multiplexing	N/A
PHICH N_g (Note 9)			1	N/A
PHICH duration			extended	N/A
Unused RE-s and PRB-s			OCNG	OCNG
Cyclic prefix			Normal	Normal
<p>Note 1: This noise is applied in OFDM symbols #1, #2, #3, #5, #6, #8, #9, #10, #12, #13 of a subframe overlapping with the aggressor ABS</p> <p>Note 2: This noise is applied in OFDM symbols #0, #4, #7, #11 of a subframe overlapping with the aggressor ABS</p> <p>Note 3: This noise is applied in OFDM symbols of a subframe overlapping with aggressor non-ABS</p> <p>Note 4: ABS pattern as defined in [9]. PHICH is transmitted in the serving cell subframe when the subframe is overlapped with the ABS subframe of aggressor cell but not in subframe 5</p> <p>Note 5: Time-domain measurement resource restriction pattern for PCell measurements as defined in [7]</p> <p>Note 6: As configured according to the time-domain measurement resource restriction pattern for CSI measurements defined in [7]</p> <p>Note 7: Cell 1 is the serving cell. Cell 2 is the aggressor cell. The number of the CRS ports in Cell1 and Cell2 is the same.</p> <p>Note 8: SIB-1 will not be transmitted in Cell2 in the test.</p> <p>Note 9: According to Clause 6.9 in TS 36.211 [4]</p>				

Table 8.5.2.2.3-2: Minimum performance PHICH

Test Number	Reference Channel	OCNG Pattern		Propagation Conditions (Note 1)		Antenna Configuration and Correlation Matrix	Reference Value	
		Cell 1	Cell 2	Cell 1	Cell 2		Pm-an (%)	SNR (dB) (Note 2)
1	R.19	OP.1 TDD	OP.1 TDD	EPA5	EPA5	2x2 Low	0.1	4.6
Note 1: The propagation conditions for Cell 1 and Cell 2 are statistically independent. Note 2: SNR corresponds to \hat{E}_s / N_{oc2} of cell 1. Note 3: The correlation matrix and antenna configuration apply for Cell 1 and Cell 2.								

8.5.2.2.4 Minimum Requirement 2 Tx Antenna Port (demodulation subframe overlaps with aggressor cell ABS and CRS assistance information are configured)

For the parameters specified in Table 8.5.2-1 and Table 8.5.2.2.4-1, the average probability of a miss-detecting ACK for NACK (Pm-an) shall be below the specified value in Table 8.5.2.2.4-2. In Table 8.5.2.2.4-1, Cell 1 is the serving cell, and Cell 2 and Cell 3 are the aggressor cells. The downlink physical channel setup for Cell 1 is according to Annex C.3.2 and for Cell 2 and Cell 3 is according to Annex C.3.3, respectively. The CRS assistance information [7] including Cell 2 and Cell 3 is provided.

Table 8.5.2.4-1: Test Parameters for PHICH

Parameter		Unit	Cell 1	Cell 2	Cell 3
Uplink downlink configuration			1	1	1
Special subframe configuration			4	4	4
Downlink power allocation	PDCCH_RA PHICH_RA OCNG_RA	dB	-3	-3	-3
	PCFICH_RB PDCCH_RB PHICH_RB OCNG_RB	dB	-3	-3	-3
N_{oc} at antenna port	N_{oc1}	dBm/15kHz	-98 (Note 1)	N/A	N/A
	N_{oc2}	dBm/15kHz	-98 (Note 2)	N/A	N/A
	N_{oc3}	dBm/15kHz	-93 (Note 3)	N/A	N/A
\hat{E}_s/N_{oc2}		dB	Reference Value in Table 8.5.2.4-2	5	3
$BW_{Channel}$		MHz	10	10	10
Subframe Configuration			Non-MBSFN	Non-MBSFN	Non-MBSFN
Time Offset between Cells		μ s	N/A	3	-1
Frequency shift between Cells		Hz	N/A	300	-100
Cell Id			0	126	1
PDCCH Content			UL Grant should be included with the proper information aligned with A.3.6.	N/A	N/A
ABS pattern (Note 4)			N/A	000000001 000000001	000000001 000000001
RLM/RRM Measurement Subframe Pattern (Note 5)			000000001 000000001	N/A	N/A
CSI Subframe Sets (Note 6)	$C_{CSI,0}$		000000001 000000001	N/A	N/A
	$C_{CSI,1}$		1100111000 1100111000	N/A	N/A
Number of control OFDM symbols			2	Note 7	Note 7
ACK/NACK feedback mode			Multiplexing	N/A	N/A
PHICH N_g (Note 10)			1	N/A	N/A
PHICH duration			Normal	N/A	N/A
Unused RE-s and PRB-s			OCNG	OCNG	OCNG
Cyclic prefix			Normal	Normal	Normal
<p>Note 1: This noise is applied in OFDM symbols #1, #2, #3, #5, #6, #8, #9, #10, #12, #13 of a subframe overlapping with the aggressor ABS</p> <p>Note 2: This noise is applied in OFDM symbols #0, #4, #7, #11 of a subframe overlapping with the aggressor ABS</p> <p>Note 3: This noise is applied in OFDM symbols of a subframe overlapping with aggressor non-ABS</p> <p>Note 4: ABS pattern as defined in [9]. PHICH is transmitted in the serving cell subframe when the subframe is overlapped with the ABS subframe of aggressor cell but not in subframe 5</p> <p>Note 5: Time-domain measurement resource restriction pattern for PCell measurements as defined in [7]</p> <p>Note 6: As configured according to the time-domain measurement resource restriction pattern for CSI measurements defined in [7]</p> <p>Note 7: The number of control OFDM symbols is not available for ABS and is 2 for the subframe indicated by "0" of ABS pattern.</p> <p>Note 8: The number of the CRS ports in Cell 1, Cell 2 and Cell 3 is the same.</p> <p>Note 9: SIB-1 will not be transmitted in Cell 2 and Cell 3 in the test.</p> <p>Note 10: According to Clause 6.9 in TS 36.211 [4]</p>					

Table 8.5.2.2.4-2: Minimum performance PHICH

Test Number	Reference Channel	OCNG Pattern			Propagation Conditions (Note 1)			Antenna Configuration and Correlation Matrix (Note 2)	Reference Value	
		Cell 1	Cell 2	Cell 3	Cell 1	Cell 2	Cell 3		Pm-an (%)	SNR (dB) (Note 3)
1	R.19	OP.1 TDD	OP.1 TDD	OP.1 TDD	EPA5	EVA5	EVA5	2x2 Low	0.1	5.7
Note 1: The propagation conditions for Cell 1, Cell 2 and Cell 3 are statistically independent. Note 2: The correlation matrix and antenna configuration apply for Cell 1, Cell 2 and Cell 3. Note 3: SNR corresponds to \hat{E}_s / N_{oc2} of Cell 1.										

8.5.2.2.5 Enhanced Downlink Control Channel Performance Requirement Type A - 2 Tx Antenna Ports with Colliding CRS Dominant Interferer

For the parameters specified in Table 8.5.2-1 and Table 8.5.2.2.5-1, the average probability of a miss-detecting ACK for NACK (Pm-an) shall be below the specified value in Table 8.5.2.2.5-2. The purpose of this test is to verify the PHICH performance with 2 transmit antennas when the serving cell PHICH transmission is interfered by two interfering cells with the dominant interferer having the colliding CRS pattern and applying interference model defined in clause B.7.1. In Table 8.5.2.2.5-1, Cell 1 is the serving cell, and Cell 2 and Cell 3 are the aggressor cells. The downlink physical channel setup is according to Annex C.3.2 for each of Cell 1, Cell 2 and Cell 3, respectively. The CRS assistance information [7] is provided and includes Cell 2 and Cell 3.

Table 8.5.2.2.5-1: Test Parameters for PHICH

Parameter	Unit	Cell 1	Cell 2	Cell 3
Uplink downlink configuration		1	1	1
Special subframe configuration		4	4	4
Downlink power allocation	PDCCH_RA OCNG_RA	dB	-3	-3
	PHICH_RA	dB	-3	N/A
	PCFICH_RB PDCCH_RB OCNG_RB	dB	-3	-3
	PHICH_RB	dB	-3	N/A
Cell-specific reference signals		Antenna ports 0,1	Antenna ports 0,1	Antenna ports 0,1
N_{oc} at antenna port	dBm/15kHz		-98	
\hat{E}_s / N_{oc}	dB	N/A	13.91	3.34
$BW_{Channel}$	MHz	10	10	10
Cyclic Prefix		Normal	Normal	Normal
Cell ID		0	6	1
Subframe Configuration		Non-MBSFN	Non-MBSFN	Non-MBSFN
Number of control OFDM symbols		1	1	1
PHICH Ng (Note 1)		1	N/A	N/A
PHICH duration		Normal	N/A	N/A
Interference model		N/A	As specified in clause B.7.1	As specified in clause B.7.1
Unused RE-s and PRB-s (Note 2)		OCNG	OCNG	OCNG
Time offset to cell 1	us	N/A	2	3
Frequency offset to cell 1	Hz	N/A	200	300
Note 1: According to Clause 6.9 in TS 36.211 [4].				
Note 2: For Cell 2 and Cell 3 unused RE-s and PRB-s do not include control region REs.				

Table 8.5.2.2.5-2: Minimum performance PHICH for Enhanced Downlink Control Channel Performance Requirement Type A

Test Number	Reference Channel	OCNG Pattern			Propagation Conditions (Note 1)			Antenna Configuration and Correlation Matrix (Note 2)	Reference Value	
		Cell 1	Cell 2	Cell 3	Cell 1	Cell 2	Cell 3		Pm-an (%)	SNR (dB) (Note 3)
1	R.19	OP.1 TDD	OP.1 TDD	OP.1 TDD	EPA5	EPA5	EPA5	2x2 Low	0.1	16.2
Note 1: The propagation conditions for Cell 1, Cell 2 and Cell 3 are statistically independent. Note 2: The correlation matrix and antenna configuration apply for Cell 1, Cell 2 and Cell 3. Note 3: SNR corresponds to \hat{E}_s/N_{oc2} of Cell 1 as defined in clause 8.1.1.										

8.5.2.2.6 Enhanced Downlink Control Channel Performance Requirement Type A - 2 Tx Antenna Ports with Non-Colliding CRS Dominant Interferer

For the parameters specified in Table 8.5.2-1 and Table 8.5.2.2.6-1, the average probability of a miss-detecting ACK for NACK (Pm-an) shall be below the specified value in Table 8.5.2.2.6-2. The purpose of this test is to verify the PHICH performance with 2 transmit antennas when the serving cell PHICH transmission is interfered by two interfering cells with the dominant interferer having the non-colliding CRS pattern and applying interference model defined in clause B.7.1. In Table 8.5.2.2.6-1, Cell 1 is the serving cell, and Cell 2 and Cell 3 are the aggressor cells. The downlink physical channel setup is according to Annex C.3.2 for each of Cell 1, Cell 2 and Cell 3, respectively. The CRS assistance information [7] is provided and includes Cell 2 and Cell 3.

Table 8.5.2.2.6-1: Test Parameters for PHICH

Parameter	Unit	Cell 1	Cell 2	Cell 3	
Uplink downlink configuration		1	1	1	
Special subframe configuration		4	4	4	
Downlink power allocation	PDCCH_RA OCNG_RA	dB	-3	-3	-3
	PHICH_RA	dB	-3	N/A	N/A
	PCFICH_RB PDCCH_RB OCNG_RB	dB	-3	-3	-3
	PHICH_RB	dB	-3	N/A	N/A
Cell-specific reference signals		Antenna ports 0,1	Antenna ports 0,1	Antenna ports 0,1	
N_{oc} at antenna port	dBm/15kHz	-98			
\hat{E}_s/N_{oc}	dB	N/A	13.91	3.34	
BW _{Channel}	MHz	10	10	10	
Cyclic Prefix		Normal	Normal	Normal	
Cell ID		0	1	6	
Subframe Configuration		Non-MBSFN	Non-MBSFN	Non-MBSFN	
Number of control OFDM symbols		1	1	1	
PHICH Ng (Note 1)		1	N/A	N/A	
PHICH duration		Normal	N/A	N/A	
Interference model		N/A	As specified in clause B.7.1	As specified in clause B.7.1	
Unused RE-s and PRB-s (Note 2)		OCNG	OCNG	OCNG	
Time offset to cell 1	us	N/A	2	3	
Frequency offset to cell 1	Hz	N/A	200	300	
Note 1: According to Clause 6.9 in TS 36.211 [4].					
Note 2: For Cell 2 and Cell 3 unused RE-s and PRB-s do not include control region REs.					

Table 8.5.2.2.6-2: Minimum performance PHICH for Enhanced Downlink Control Channel Performance Requirement Type A

Test Number	Reference Channel	OCNG Pattern			Propagation Conditions (Note 1)			Antenna Configuration and Correlation Matrix (Note 2)	Reference Value	
		Cell 1	Cell 2	Cell 3	Cell 1	Cell 2	Cell 3		Pm-an (%)	SNR (dB) (Note 3)
1	R.19	OP.1 TDD	OP.1 TDD	OP.1 TDD	EPA5	EPA5	EPA5	2x2 Low	0.1	16.1
Note 1: The propagation conditions for Cell 1, Cell 2 and Cell 3 are statistically independent. Note 2: The correlation matrix and antenna configuration apply for Cell 1, Cell 2 and Cell 3. Note 3: SNR corresponds to \hat{E}_s/N_{oc2} of Cell 1 as defined in clause 8.1.1.										

8.5.2.2.7 Enhanced Downlink Control Channel Performance Requirement Type B - 2 Tx Antenna Ports with Colliding CRS Dominant Interferer

For the parameters specified in Table 8.5.2-1 and Table 8.5.2.2.7-1, the average probability of a miss-detecting ACK for NACK (Pm-an) shall be below the specified value in Table 8.5.2.2.7-2. The purpose of this test is to verify the PHICH performance with 2 transmit antennas when the serving cell PHICH transmission is interfered by two interfering cells with the dominant interferer having the colliding CRS pattern and applying interference model defined in clause B.7.1. In Table 8.5.2.2.7-1, Cell 1 is the serving cell, and Cell 2 and Cell 3 are the aggressor cells. The downlink physical channel setup is according to Annex C.3.2 for each of Cell 1, Cell 2 and Cell 3, respectively. The CRS assistance information [7] is provided and includes Cell 2 and Cell 3.

Table 8.5.2.2.7-1: Test Parameters for PHICH

Parameter	Unit	Cell 1	Cell 2	Cell 3	
Uplink downlink configuration		1	1	1	
Special subframe configuration		4	4	4	
Downlink power allocation	PDCCH_RA OCNG_RA	dB	-3	-3	-3
	PHICH_RA	dB	-3	N/A	N/A
	PCFICH_RB PDCCH_RB OCNG_RB	dB	-3	-3	-3
	PHICH_RB	dB	-3	N/A	N/A
Cell-specific reference signals		Antenna ports 0,1	Antenna ports 0,1	Antenna ports 0,1	
N_{oc} at antenna port	dBm/15kHz	-98			
\hat{E}_s/N_{oc}	dB	N/A	13.91	3.34	
BW _{Channel}	MHz	10	10	10	
Cyclic Prefix		Normal	Normal	Normal	
Cell ID		0	6	1	
Subframe Configuration		Non-MBSFN	Non-MBSFN	Non-MBSFN	
Number of control OFDM symbols		1	1	1	
PHICH Ng (Note 1)		1	N/A	N/A	
PHICH duration		Normal	N/A	N/A	
Interference model		N/A	As specified in clause B.7.1	As specified in clause B.7.1	
Unused RE-s and PRB-s (Note 2)		OCNG	OCNG	OCNG	
Time offset to cell 1	us	N/A	2	3	
Frequency offset to cell 1	Hz	N/A	200	300	
Note 1: According to Clause 6.9 in TS 36.211 [4]. Note 2: For Cell 2 and Cell 3 unused RE-s and PRB-s do not include control region REs.					

Table 8.5.2.2.7-2: Minimum performance PHICH for Enhanced Downlink Control Channel Performance Requirement Type B

Test Number	Reference Channel	OCNG Pattern			Propagation Conditions (Note 1)			Antenna Configuration and Correlation Matrix (Note 2)	Reference Value	
		Cell 1	Cell 2	Cell 3	Cell 1	Cell 2	Cell 3		Pm-an (%)	SNR (dB) (Note 3)
1	R.19	OP.1 TDD	OP.1 TDD	OP.1 TDD	EPA5	EPA5	EPA5	2x2 Low	0.1	14.0
Note 1: The propagation conditions for Cell 1, Cell 2 and Cell 3 are statistically independent.										
Note 2: The correlation matrix and antenna configuration apply for Cell 1, Cell 2 and Cell 3.										
Note 3: SNR corresponds to \hat{E}_s/N_{oc2} of Cell 1 as defined in clause 8.1.1.										

8.5.2.2.8 Enhanced Downlink Control Channel Performance Requirement Type B - 2 Tx Antenna Ports with Non-Colliding CRS Dominant Interferer

For the parameters specified in Table 8.5.2-1 and Table 8.5.2.2.8-1, the average probability of a miss-detecting ACK for NACK (Pm-an) shall be below the specified value in Table 8.5.2.2.8-2. The purpose of this test is to verify the PHICH performance with 2 transmit antennas when the serving cell PHICH transmission is interfered by two interfering cells with the dominant interferer having the non-colliding CRS pattern and applying interference model defined in clause B.7.1. In Table 8.5.2.2.8-1, Cell 1 is the serving cell, and Cell 2 and Cell 3 are the aggressor cells. The downlink physical channel setup is according to Annex C.3.2 for each of Cell 1, Cell 2 and Cell 3, respectively. The CRS assistance information [7] is provided and includes Cell 2 and Cell 3.

Table 8.5.2.2.8-1: Test Parameters for PHICH

Parameter	Unit	Cell 1	Cell 2	Cell 3	
Uplink downlink configuration		1	1	1	
Special subframe configuration		4	4	4	
Downlink power allocation	PDCCH_RA OCNG_RA	dB	-3	-3	-3
	PHICH_RA	dB	-3	N/A	N/A
	PCFICH_RB PDCCH_RB OCNG_RB	dB	-3	-3	-3
	PHICH_RB	dB	-3	N/A	N/A
Cell-specific reference signals		Antenna ports 0,1	Antenna ports 0,1	Antenna ports 0,1	
N_{oc} at antenna port	dBm/15kHz	-98			
\hat{E}_s/N_{oc}	dB	N/A	13.91	3.34	
BW _{Channel}	MHz	10	10	10	
Cyclic Prefix		Normal	Normal	Normal	
Cell ID		0	1	6	
Subframe Configuration		Non-MBSFN	Non-MBSFN	Non-MBSFN	
Number of control OFDM symbols		1	1	1	
PHICH Ng (Note 1)		1	N/A	N/A	
PHICH duration		Normal	N/A	N/A	
Interference model		N/A	As specified in clause B.7.1	As specified in clause B.7.1	
Unused RE-s and PRB-s (Note 2)		OCNG	OCNG	OCNG	
Time offset to cell 1	us	N/A	2	3	
Frequency offset to cell 1	Hz	N/A	200	300	
Note 1: According to Clause 6.9 in TS 36.211 [4].					
Note 2: For Cell 2 and Cell 3 unused RE-s and PRB-s do not include control region REs.					

Table 8.5.2.2.8-2: Minimum performance PHICH for Enhanced Downlink Control Channel Performance Requirement Type B

Test Number	Reference Channel	OCNG Pattern			Propagation Conditions (Note 1)			Antenna Configuration and Correlation Matrix (Note 2)	Reference Value	
		Cell 1	Cell 2	Cell 3	Cell 1	Cell 2	Cell 3		Pm-an (%)	SNR (dB) (Note 3)
1	R.19	OP.1 TDD	OP.1 TDD	OP.1 TDD	EPA5	EPA5	EPA5	2x2 Low	0.1	15.5
Note 1: The propagation conditions for Cell 1, Cell 2 and Cell 3 are statistically independent. Note 2: The correlation matrix and antenna configuration apply for Cell 1, Cell 2 and Cell 3. Note 3: SNR corresponds to \hat{E}_s / N_{oc2} of Cell 1 as defined in clause 8.1.1.										

8.6 Demodulation of PBCH

The receiver characteristics of the PBCH are determined by the probability of miss-detection of the PBCH (Pm-bch), which is defined as

$$P_{m-bch} = 1 - \frac{A}{B}$$

Where A is the number of correctly decoded MIB PDUs and B is the Number of transmitted MIB PDUs (Redundancy versions for the same MIB are not counted separately).

8.6.1 FDD

Table 8.6.1-1: Test Parameters for PBCH

Parameter		Unit	Single antenna port	Transmit diversity
Downlink power allocation	PBCH_RA	dB	0	-3
	PBCH_RB	dB	0	-3
N_{oc} at antenna port		dBm/15kHz	-98	-98
Cyclic prefix			Normal	Normal
Cell ID			0	0
Note 1: as specified in Table 4.2-2 in TS 36.211 [4]				
Note 2: as specified in Table 4.2-1 in TS 36.211 [4]				

8.6.1.1 Single-antenna port performance

For the parameters specified in Table 8.6.1-1 the average probability of a miss-detecting PBCH (Pm-bch) shall be below the specified value in Table 8.6.1.1-1. The downlink physical setup is in accordance with Annex C.3.2.

Table 8.6.1.1-1: Minimum performance PBCH

Test number	Bandwidth	Reference Channel	Propagation Condition	Antenna configuration and correlation Matrix	Reference value	
					Pm-bch (%)	SNR (dB)
1	1.4 MHz	R.21	ETU70	1 x 2 Low	1	-6.1

8.6.1.2 Transmit diversity performance

8.6.1.2.1 Minimum Requirement 2 Tx Antenna Port

For the parameters specified in Table 8.6.1-1 the average probability of a miss-detected PBCH (Pm-bch) shall be below the specified value in Table 8.6.1.2.1-1. The downlink physical setup is in accordance with Annex C.3.2.

Table 8.6.1.2.1-1: Minimum performance PBCH

Test number	Bandwidth	Reference Channel	Propagation Condition	Antenna configuration and correlation Matrix	Reference value	
					Pm-bch (%)	SNR (dB)
1	1.4 MHz	R.22	EPA5	2 x 2 Low	1	-4.8

8.6.1.2.2 Minimum Requirement 4 Tx Antenna Port

For the parameters specified in Table 8.6.1-1 the average probability of a miss-detected PBCH (Pm-bch) shall be below the specified value in Table 8.6.1.2.2-1. The downlink physical setup is in accordance with Annex C.3.2.

Table 8.6.1.2.2-1: Minimum performance PBCH

Test number	Bandwidth	Reference Channel	Propagation Condition	Antenna configuration and correlation Matrix	Reference value	
					Pm-bch (%)	SNR (dB)
1	1.4 MHz	R.23	EVA5	4 x 2 Medium	1	-3.5

8.6.1.2.3 Minimum Requirement 2 Tx Antenna Port under Time Domain Measurement Resource Restriction with CRS Assistance Information

For the parameters specified in Table 8.6.1.2.3-1 and Table 8.6.1.2.3-2, the averaged probability of a miss-detected PBCH (Pm-bch) shall be below the specified value in Table 8.6.1.2.3-2. Cell 1 is the serving cell, and Cell 2 and Cell 3 are the aggressor cells. The downlink physical channel setup for Cell 1 is according to Annex C.3.2 and for Cell 2 and Cell 3 is according to Annex C.3.3, respectively. The CRS assistance information [7] including Cell 2 and Cell 3 is provided.

Table 8.6.1.2.3-1: Test Parameters for PBCH

Parameter		Unit	Cell 1	Cell 2	Cell 3
Downlink power allocation	PBCH_RA OCNG_RA	dB	-3	-3	-3
	PBCH_RB OCNG_RB	dB	-3	-3	-3
N_{oc} at antenna port		dBm/15kHz	-98	N/A	N/A
$\frac{E_s}{N_{oc}}$		dB	Reference Value in Table 8.6.1.2.3-2	4	2
BW _{Channel}		MHz	1.4	1.4	1.4
Time Offset between Cells		μs	N/A	3	-1
Frequency shift between Cells		Hz	N/A	300	-100
Cell Id			0	126	1
ABS Pattern (Note 4)			N/A	01000000 01000000 01000000 01000000 01000000	01000000 01000000 01000000 01000000 01000000
Unused RE-s and PRB-s			OCNG	OCNG	OCNG
Cyclic prefix			Normal	Normal	Normal
<p>Note 1: The number of the CRS ports in Cell1, Cell2 and Cell 3 is the same.</p> <p>Note 2: SIB-1 will not be transmitted in Cell2 and Cell 3 in the test.</p> <p>Note 3: The PBCH transmission from Cell 1, Cell 2 and Cell 3 overlap. The same PBCH transmission redundancy version is used for Cell 1, Cell 2 and Cell 3.</p> <p>Note 4: ABS pattern as defined in [9]. PDSCH other than SIB1/paging and its associated PDCCH/PCFICH are transmitted in the serving cell subframe when the subframe is overlapped with the ABS subframe of aggressor cell and the subframe is available in the definition of the reference channel.</p>					

Table 8.6.1.2.3-2: Minimum performance PBCH

Test Number	Reference Channel	Propagation Conditions (Note 1)			Antenna Configuration and Correlation Matrix (Note 2)	Reference Value	
		Cell 1	Cell 2	Cell 3		Pm-bch (%)	SNR (dB) (Note 3)
1	R.22	ETU30	ETU30	ETU30	2x2 Low	1	-3.0
<p>Note 1: The propagation conditions for Cell 1, Cell 2 and Cell 3 are statistically independent.</p> <p>Note 2: The correlation matrix and antenna configuration apply for Cell 1, Cell 2 and Cell 3.</p> <p>Note 3: SNR corresponds to \hat{E}_s / N_{oc} of cell 1.</p>							

8.6.2 TDD

Table 8.6.2-1: Test Parameters for PBCH

Parameter		Unit	Single antenna port	Transmit diversity
Uplink downlink configuration (Note 1)			1	1
Special subframe configuration (Note 2)			4	4
Downlink power allocation	PBCH_RA	dB	0	-3
	PBCH_RB	dB	0	-3
N_{oc} at antenna port		dBm/15kHz	-98	-98
Cyclic prefix			Normal	Normal
Cell ID			0	0
Note 1: as specified in Table 4.2-2 in TS 36.211 [4].				
Note 2: as specified in Table 4.2-1 in TS 36.211 [4].				

8.6.2.1 Single-antenna port performance

For the parameters specified in Table 8.6.2-1 the average probability of a miss-detected PBCH (Pm-bch) shall be below the specified value in Table 8.6.2.1-1. The downlink physical setup is in accordance with Annex C.3.2.

Table 8.6.2.1-1: Minimum performance PBCH

Test number	Bandwidth	Reference Channel	Propagation Condition	Antenna configuration and correlation Matrix	Reference value	
					Pm-bch (%)	SNR (dB)
1	1.4 MHz	R.21	ETU70	1 x 2 Low	1	-6.4

8.6.2.2 Transmit diversity performance

8.6.2.2.1 Minimum Requirement 2 Tx Antenna Port

For the parameters specified in Table 8.6.2-1 the average probability of a miss-detected PBCH (Pm-bch) shall be below the specified value in Table 8.6.2.2.1-1. The downlink physical setup is in accordance with Annex C.3.2.

Table 8.6.2.2.1-1: Minimum performance PBCH

Test number	Bandwidth	Reference Channel	Propagation Condition	Antenna configuration and correlation Matrix	Reference value	
					Pm-bch (%)	SNR (dB)
1	1.4 MHz	R.22	EPA5	2 x 2 Low	1	-4.8

8.6.2.2.2 Minimum Requirement 4 Tx Antenna Port

For the parameters specified in Table 8.6.2-1 the average probability of a miss-detected PBCH (Pm-bch) shall be below the specified value in Table 8.6.2.2.2-1. The downlink physical setup is in accordance with Annex C.3.2.

Table 8.6.2.2-1: Minimum performance PBCH

Test number	Bandwidth	Reference Channel	Propagation Condition	Antenna configuration and correlation Matrix	Reference value	
					Pm-bch (%)	SNR (dB)
1	1.4 MHz	R.23	EVA5	4 x 2 Medium	1	-4.1

8.6.2.2.3 Minimum Requirement 2 Tx Antenna Port under Time Domain Measurement Resource Restriction with CRS Assistance Information

For the parameters specified in Table 8.6.2.2.3-1 and Table 8.6.2.2.3-2, the averaged probability of a miss-detected PBCH (Pm-bch) shall be below the specified value in Table 8.6.2.2.3-2. Cell 1 is the serving cell, and Cell 2 and Cell 3 are the aggressor cells. The downlink physical channel setup for Cell 1 is according to Annex C.3.2 and for Cell 2 and Cell 3 is according to Annex C3.3, respectively. The CRS assistance information [7] including Cell 2 and Cell 3 is provided.

Table 8.6.2.2.3-1: Test Parameters for PBCH

Parameter		Unit	Cell 1	Cell 2	Cell 3
Downlink power allocation	PBCH_RA OCNG_RA	dB	-3	-3	-3
	PBCH_RB OCNG_RB	dB	-3	-3	-3
N_{oc} at antenna port		dBm/15kHz	-98	N/A	N/A
$\frac{\hat{E}_s}{N_{oc}}$		dB	Reference Value in Table 8.6.2.2.3-2	4	2
BW _{Channel}		MHz	1.4	1.4	1.4
Time Offset between Cells		μs	N/A	3	-1
Frequency shift between Cells		Hz	N/A	300	-100
Cell Id			0	126	1
ABS Pattern (Note 4)			N/A	000000001 000000001	000000001 000000001
Unused RE-s and PRB-s			OCNG	OCNG	OCNG
Cyclic prefix			Normal	Normal	Normal
Note 1: The number of the CRS ports in Cell1, Cell2 and Cell 3is the same. Note 2: SIB-1 will not be transmitted in Cell2 and Cell 3 in the test. Note 3: The PBCH transmission from Cell 1, Cell 2 and Cell 3 overlap. The same PBCH transmission redundancy version is used for Cell 1, Cell 2 and Cell 3. Note 4: ABS pattern as defined in [9]. PDSCH other than SIB1/paging and its associated PDCCH/PCFICH are transmitted in the serving cell subframe when the subframe is overlapped with the ABS subframe of aggressor cell and the subframe is available in the definition of the reference channel.					

Table 8.6.2.2.3-2: Minimum performance PBCH

Test Number	Reference Channel	Propagation Conditions (Note 1)			Antenna Configuration and Correlation Matrix (Note 2)	Reference Value	
		Cell 1	Cell 2	Cell 3		Pm-bch (%)	SNR (dB) (Note 3)
1	R.22	ETU30	ETU30	ETU30	2x2 Low	1	-3.0
Note 1: The propagation conditions for Cell 1, Cell 2 and Cell 3 are statistically independent. Note 2: The correlation matrix and antenna configuration apply for Cell 1, Cell 2 and Cell 3. Note 3: SNR corresponds to \hat{E}_s / N_{oc} of cell 1.							

8.7 Sustained downlink data rate provided by lower layers

The purpose of the test is to verify that the Layer 1 and Layer 2 correctly process in a sustained manner the received packets corresponding to the maximum number of DL-SCH transport block bits received within a TTI for the UE category indicated. The sustained downlink data rate shall be verified in terms of the success rate of delivered PDCP SDU(s) by Layer 2. The test case below specifies the RF conditions and the required success rate of delivered TB by Layer 1 to meet the sustained data rate requirement. The size of the TB per TTI corresponds to the largest possible DL-SCH transport block for each UE category using the maximum number of layers for spatial multiplexing. Transmission modes 1 and 3 are used with radio conditions resembling a scenario where sustained maximum data rates are available.

Test case is selected according to table 8.7-1 depending on UE capability for CA and EPDCCH.

Table 8.7-1: SDR test applicability

	Single carrier UE not supporting EPDCCH	CA UE not supporting EPDCCH	Single carrier UE supporting EPDCCH	CA UE supporting EPDCCH
FDD	8.7.1	8.7.1	8.7.3	8.7.1, 8.7.3
TDD	8.7.2	8.7.2	8.7.4	8.7.2, 8.7.4

8.7.1 FDD (single carrier and CA)

The parameters specified in Table 8.7.1-1 are valid for all FDD tests unless otherwise stated.

Table 8.7.1-1: Common Test Parameters (FDD)

Parameter	Unit	Value
Cyclic prefix		Normal
Cell ID		0
Inter-TTI Distance		1
Number of HARQ processes per component carrier	Processes	8
Maximum number of HARQ transmission		4
Redundancy version coding sequence		{0,0,1,2} for 64QAM and 256QAM
Number of OFDM symbols for PDCCH per component carrier	OFDM symbols	1
Cross carrier scheduling		Not configured
Propagation condition		Static propagation condition No external noise sources are applied

For UE not supporting 256QAM, the requirements are specified in Table 8.7.1-3, with the addition of the parameters in Table 8.7.1-2 and the downlink physical channel setup according to Annex C.3.2. The test points are applied to UE category and bandwidth combination with maximum aggregated bandwidth as specified in Table 8.7.1-4. The TB success rate shall be sustained during at least 300 frames.

For UE supporting 256QAM, the requirements are specified in Table 8.7.1-6, with the addition of the parameters in Table 8.7.1-5 and the downlink physical channel setup according to Annex C.3.2. The test points are applied to UE category and bandwidth combination with maximum aggregated bandwidth as specified in Table 8.7.1-7, the TB success rate shall be sustained during at least 300 frames. For UE supporting 256QAM, the requirement in Table 8.7.1-3 is not applicable.

For UE supporting 256QAM and category 9/10 and category 13, the requirements are specified in both Table 8.7.1-3 and Table 8.7.1-6, with the addition of the parameters in Table 8.7.1-2 and in Table 8.7.1-5 respectively. The downlink physical channel setup according to Annex C.3.2. The test points are applied to UE category and bandwidth combination with maximum aggregated bandwidth as specified in Table 8.7.1-4 and in Table 8.7.1-7 for the category 9/10 and category 13, the TB success rate shall be sustained during at least 300 frames.

The test coverage for different number of component carriers is defined in 8.1.2.4.

Table 8.7.1-2: test parameters for sustained downlink data rate (FDD 64QAM)

Test	Bandwidth (MHz)	Transmission mode	Antenna configuration	Codebook subset restriction	Downlink power allocation (dB)			\hat{E}_s at antenna port (dBm/15kHz)	Symbols for unused PRBs
					ρ_A	ρ_B	σ		
1	10	1	1 x 2	N/A	0	0	0	-85	OP.6 FDD
2	10	3	2 x 2	10	-3	-3	0	-85	OP.1 FDD
3,4,6	20	3	2 x 2	10	-3	-3	0	-85	OP.1 FDD
3A	10	3	2 x 2	10	-3	-3	0	-85	OP.1 FDD
3B, 4A	2x10	3	2 x 2	10	-3	-3	0	-85	OP.1 FDD
3C, 4B	15	3	2 x 2	10	-3	-3	0	-85	OP.1 FDD
6A	2x20	3	2 x 2	10	-3	-3	0	-85	OP.1 FDD
6B	10+15	3	2 x 2	10	-3	-3	0	-85	OP.1 FDD
6C	10+20	3	2 x 2	10	-3	-3	0	-85	OP.1 FDD
6D	15+20	3	2 x 2	10	-3	-3	0	-85	OP.1 FDD
6E	2x15	3	2 x 2	10	-3	-3	0	-85	OP.1 FDD
6F	15+5	3	2 x 2	10	-3	-3	0	-85	OP.1 FDD
6G	20+5	3	2 x 2	10	-3	-3	0	-85	OP.1 FDD
7	3x20	3	2 x 2	10	-3	-3	0	-85	OP.1 FDD
7A	15+20+20	3	2 x 2	10	-3	-3	0	-85	OP.1 FDD
7B	10+20+20	3	2 x 2	10	-3	-3	0	-85	OP.1 FDD
7C	15+15+20	3	2 x 2	10	-3	-3	0	-85	OP.1 FDD
7D	10+15+20	3	2 x 2	10	-3	-3	0	-85	OP.1 FDD
7E	10+10+20	3	2 x 2	10	-3	-3	0	-85	OP.1 FDD
7F	10+15+15	3	2 x 2	10	-3	-3	0	-85	OP.1 FDD
7G	5+10+20	3	2 x 2	10	-3	-3	0	-85	OP.1 FDD
7H	5+15+20	3	2 x 2	10	-3	-3	0	-85	OP.1 FDD
7I	5+10+10	3	2 x 2	10	-3	-3	0	-85	OP.1 FDD
8	4x20	3	2 x 2	10	-3	-3	0	-85	OP.1 FDD
8A	20+20+20+10	3	2 x 2	10	-3	-3	0	-85	OP.1 FDD
8B	20+20+10+10	3	2 x 2	10	-3	-3	0	-85	OP.1 FDD
8C	20+20+10+5	3	2 x 2	10	-3	-3	0	-85	OP.1 FDD
8D	20+10+10+5	3	2 x 2	10	-3	-3	0	-85	OP.1 FDD
9	5x20	3	2 x 2	10	-3	-3	0	-85	OP.1 FDD

NOTE 1: For CA test cases, PUCCH format 1b with channel selection is used to feedback ACK/NACK for Test 1-6E, and PUCCH format 3 is used to feedback ACK/NACK for Test 7-7G.

Table 8.7.1-3: Minimum requirement (FDD 64QAM)

Test	Number of bits of a DL-SCH transport block received within a TTI	Measurement channel	Reference value
			TB success rate [%]
1	10296	R.31-1 FDD	95
2	25456	R.31-2 FDD	95
3	51024	R.31-3 FDD	95
3A	36696 (Note 2)	R.31-3A FDD	85
3B	25456	R.31-2 FDD	95
3C	51024	R.31-3C FDD	85
4	75376 (Note 3)	R.31-4 FDD	85
4A	36696 (Note 2)	R.31-3A FDD	85
4B	55056 (Note 5)	R.31-4B FDD	85
6	75376 (Note 3)	R.31-4 FDD	85
6A	75376 (Note 3)	R.31-4 FDD	85
6B	36696 (Note 2) for 10MHz CC 55056 for 15MHz CC	R.31-3A FDD for 10MHz CC R.31-5 FDD for 15MHz CC	85
6C	36696 (Note 2) for 10MHz CC 75376 (Note 3) for 20MHz CC	R.31-3A FDD for 10MHz CC R.31-4 FDD for 20MHz CC	85
6D	55056 for 15MHz CC 75376 (Note 3) for 20MHz CC	R.31-5 FDD for 15MHz CC R.31-4 FDD for 20MHz CC	85
6E	55056 (Note 5) for two 15MHz CCs	R.31-4B FDD for two 15MHz CCs	85
6F	55056 (Note 5) for 15MHz CC 18336 (Note 6) for 5MHz CC	R.31-5 FDD for 15MHz CC R.31-6 FDD for 5MHz CC	85
6G	75376 (Note 3) for 20MHz CC 18336 (Note 6) for 5MHz CC	R.31-4 FDD for 20MHz CC R.31-6 FDD for 5MHz CC	85
7	75376 (Note 3)	R.31-4 FDD	85
7A	55056 (Note 5) for 15MHz CC 75376 (Note 3) for 20MHz CC	R.31-5 FDD for 15MHz CC R.31-4 FDD for 20MHz CC	85
7B	36696 (Note 2) for 10MHz CC 75376 (Note 3) for 20MHz CC	R.31-3A FDD for 10MHz CC R.31-4 FDD for 20MHz CC	85
7C	55056 (Note 5) for 15MHz CC 75376 (Note 3) for 20MHz CC	R.31-5 FDD for 15MHz CC R.31-4 FDD for 20MHz CC	85
7D	36696 (Note 2) for 10MHz CC 55056 (Note 5) for 15MHz CC 75376 (Note 3) for 20MHz CC	R.31-3A FDD for 10MHz CC R.31-5 FDD for 15MHz CC R.31-4 FDD for 20MHz CC	85
7E	36696 (Note 2) for 10MHz CC 75376 (Note 3) for 20MHz CC	R.31-3A FDD for 10MHz CC R.31-4 FDD for 20MHz CC	85
7F	36696 (Note 2) for 10MHz CC 55056 (Note 5) for 15MHz CC	R.31-3A FDD for 10MHz CC R.31-5 FDD for 15MHz CC	85
7G	18336 (Note 6) for 5MHz CC 36696 (Note 2) for 10MHz CC 75376 (Note 3) for 20MHz CC	R.31-6 FDD for 5MHz CC R.31-3A FDD for 10MHz CC R.31-4 FDD for 20MHz CC	85
7H	18336 (Note 6) for 5MHz CC 55056 (Note 5) for 15MHz CC 75376 (Note 3) for 20MHz CC	R.31-6 FDD for 5MHz CC R.31-5 FDD for 15MHz CC R.31-4 FDD for 20MHz CC	85
7I	18336 (Note 6) for 5MHz CC 36696 (Note 2) for 10MHz CC	R.31-6 FDD for 5MHz CC R.31-3A FDD for 10MHz CC	85
8	75376 (Note 3)	R.31-4 FDD	85
8A	36696 (Note 2) for 10MHz CC 75376 (Note 3) for 20MHz CC	R.31-3A FDD for 10MHz CC R.31-4 FDD for 20MHz CC	85
8B	36696 (Note 2) for 10MHz CC 75376 (Note 3) for 20MHz CC	R.31-3A FDD for 10MHz CC R.31-4 FDD for 20MHz CC	85
8C	18336 (Note 6) for 5MHz CC 36696 (Note 2) for 10MHz CC 75376 (Note 3) for 20MHz CC	R.31-6 FDD for 5MHz CC R.31-3A FDD for 10MHz CC R.31-4 FDD for 20MHz CC	85
8D	18336 (Note 6) for 5MHz CC 36696 (Note 2) for 10MHz CC 75376 (Note 3) for 20MHz CC	R.31-6 FDD for 5MHz CC R.31-3A FDD for 10MHz CC R.31-4 FDD for 20MHz CC	85
9	75376 (Note 3)	R.31-4 FDD	85

Note 1: For 2 layer transmissions, 2 transport blocks are received within a TTI.
Note 2: 35160 bits for sub-frame 5.
Note 3: 71112 bits for sub-frame 5.
Note 4: The TB success rate is defined as $TB\ success\ rate = 100\% * N_{DL_correct_rx} / (N_{DL_newtx} + N_{DL_retx})$, where N_{DL_newtx} is the number of newly transmitted DL transport blocks, N_{DL_retx} is the number of retransmitted DL transport blocks, and $N_{DL_correct_rx}$ is the number of correctly received DL transport blocks.
Note 5: 52752bits for sub-frame 5.

Note 6: 15840bits for sub-frame 0.

Table 8.7.1-4: Test points for sustained data rate (FRC 64QAM)

CA config	Maximum supported Bandwidth/ Bandwidth combination (MHz)	Cat. 1	Cat. 2	Cat. 3	Cat. 4	Cat. 6,7	Cat. 9,10	Cat 11, 12	DL Cat. 15
								DL Cat. 11,12	
Single carrier	10	1	2	3A	3A	-	-	-	-
	15	-	-	3C	4B	-	-	-	-
	20	-	-	3	4	6	-	-	-
CA with 2CCs	10+10	-	-	3B	4A	4A	4A	-	-
	10+15	-	-	3B	4A	6B	6B	-	-
	10+20	-	-	3B	4A	6C	6C	-	-
	15+15	-	-	3B	4A	6E	6E	-	-
	15+5	-	-	3B	4A	6F	6F	-	-
	20+5	-	-	3	4	6G	6G	-	-
	15+20	-	-	3B	4A	6D	6D	-	-
20+20	-	-	3B or 3 (Note 4)	4A or 4 (Note 4)	6A	6A	-	-	
CA with 3CCs	3x20	-	-	-	-	6A	7	7	-
	15+20+20	-	-	-	-	6A	7A	7A	-
	10+20+20	-	-	-	-	6A	7B	7B	-
	15+15+20	-	-	-	-	6D	7C	7C	-
	10+15+20	-	-	-	-	6D	7D	7D	-
	10+10+20	-	-	-	-	7E	7E	7E	-
	10+15+15	-	-	-	-	7F	7F	7F	-
	5+10+20	-	-	-	-	7G	7G	7G	-
	5+15+20	-	-	-	-	7H	7H	7H	-
5+10+10	-	-	-	-	7I	7I	7I	-	
CA with 4CCs	4x20	-	-	-	-	-	7	8	8
	20+20+20+10	-	-	-	-	-	7	8A	8A
	20+20+10+10	-	-	-	-	-	8B	8B	8B
	20+20+10+5	-	-	-	-	-	8C	8C	8C
20+10+10+5	-	-	-	-	-	8D	8D	8D	
CA with 5CCs	5x20	-	-	-	-	-	-	8	9
Note 1:	Void.								
Note 2:	For non-CA UE, test is selected for maximum supported bandwidth.								
Note 3:	Void.								
Note 4:	If the intra-band contiguous CA is the only CA configuration supported by category 3 or 4 UE, the single carrier test is selected, i.e., Test 3 for UE category 3 and Test 4 for UE category 4. Otherwise, Test 3B applies for category 3 UE and Test 4A applies for category 4 UE.								
Note 5:	The applicability of requirements for different CA configurations and bandwidth combination sets is defined in 8.1.2.3.								
Note 6:	If DL category is signalled by the UE under test, then select the test point according to UE DL Category. Otherwise, select the test point according to the UE category signalled.								

Table 8.7.1-5: test parameters for sustained downlink data rate (FDD 256QAM)

Test	Bandwidth (MHz)	Transmission mode	Antenna configuration	Codebook subset restriction	Downlink power allocation (dB)			\hat{E}_s at antenna port (dBm/15kHz)	Symbols for unused PRBs
					ρ_A	ρ_B	σ		
1	20	3	2 x 2	10	-3	-3	0	-85	OP.1 FDD
2	2x15	3	2 x 2	10	-3	-3	0	-85	OP.1 FDD
2A	15+5	3	2 x 2	10	-3	-3	0	-85	OP.1 FDD
3	10+15	3	2 x 2	10	-3	-3	0	-85	OP.1 FDD
3A	20+5	3	2 x 2	10	-3	-3	0	-85	OP.1 FDD
4	10+20	3	2 x 2	10	-3	-3	0	-85	OP.1 FDD
6	15+20	3	2 x 2	10	-3	-3	0	-85	OP.1 FDD
7	2x20	3	2 x 2	10	-3	-3	0	-85	OP.1 FDD
8	3x20	3	2 x 2	10	-3	-3	0	-85	OP.1 FDD
9	15+20+20	3	2 x 2	10	-3	-3	0	-85	OP.1 FDD
10	10+20+20	3	2 x 2	10	-3	-3	0	-85	OP.1 FDD
11	15+15+20	3	2 x 2	10	-3	-3	0	-85	OP.1 FDD
12	10+15+20	3	2 x 2	10	-3	-3	0	-85	OP.1 FDD
13	10+10+20	3	2 x 2	10	-3	-3	0	-85	OP.1 FDD
14	10+15+15	3	2 x 2	10	-3	-3	0	-85	OP.1 FDD
15	5+10+20	3	2 x 2	10	-3	-3	0	-85	OP.1 FDD
15A	5+15+20	3	2 x 2	10	-3	-3	0	-85	OP.1 FDD
15B	5+10+10	3	2 x 2	10	-3	-3	0	-85	OP.1 FDD
16	4x20	3	2 x 2	10	-3	-3	0	-85	OP.1 FDD
17	20+20+20+10	3	2 x 2	10	-3	-3	0	-85	OP.1 FDD
18	20+20+10+10	3	2 x 2	10	-3	-3	0	-85	OP.1 FDD
18A	20+20+10+5	3	2 x 2	10	-3	-3	0	-85	OP.1 FDD
18B	20+10+10+5	3	2 x 2	10	-3	-3	0	-85	OP.1 FDD
19	5x20	3	2 x 2	10	-3	-3	0	-85	OP.1 FDD

Note 1: For CA test cases, PUCCH format 3 is used to feedback ACK/NACK.

Table 8.7.1-6: Minimum requirement (FDD 256QAM)

Test	Measurement channel	Reference value
		TB success rate [%]
1	R.68 FDD	85
2	R.68-1 FDD	85
2A	R.68-1 FDD for 15MHz CC R.68-3 FDD for 5MHz CC	85
3	R.68-2 FDD for 10MHz CC R.68-1 FDD for 15MHz CC	85
3A	R.68 FDD for 20MHz CC R.68-3 FDD for 5MHz CC	85
4	R.68-2 FDD for 10MHz CC R.68 FDD for 20MHz CC	85
6	R.68-1 FDD for 15MHz CC R.68 FDD for 20MHz CC	85
7	R.68 FDD	85
8	R.68 FDD	85
9	R.68-1 FDD for 15MHz CC R.68 FDD for 20MHz CC	85
10	R.68-2 FDD for 10MHz CC R.68 FDD for 20MHz CC	85
11	R.68-1 FDD for 15MHz CC R.68 FDD for 20MHz CC	85
12	R.68-2 FDD for 10MHz CC R.68-1 FDD for 15MHz CC R.68 FDD for 20MHz CC	85
13	R.68-2 FDD for 10MHz CC R.68 FDD for 20MHz CC	85
14	R.68-2 FDD for 10MHz CC R.68-1 FDD for 15MHz CC	85
15	R.68-3 FDD for 5MHz CC R.68-2 FDD for 10MHz CC R.68 FDD for 20MHz CC	85
15A	R.68-3 FDD for 5MHz CC R.68-1 FDD for 15MHz CC R.68 FDD for 20MHz CC	85
15B	R.68-3 FDD for 5MHz CC R.68-2 FDD for 10MHz CC	85
16	R.68 FDD	85
17	R.68-2 FDD for 10MHz CC R.68 FDD for 20MHz CC	85
18	R.68-2 FDD for 10MHz CC R.68 FDD for 20MHz CC	85
18A	R.68-3 FDD for 5MHz CC R.68-2 FDD for 10MHz CC R.68 FDD for 20MHz CC	85
18B	R.68-3 FDD for 5MHz CC R.68-2 FDD for 10MHz CC R.68 FDD for 20MHz CC	85
19	R.68 FDD	85
Note 1:	For 2 layer transmissions, 2 transport blocks are received within a TTI.	
Note 2:	The TB success rate is defined as TB success rate = $100\% \cdot N_{DL_correct_rx} / (N_{DL_newtx} + N_{DL_retx})$, where N_{DL_newtx} is the number of newly transmitted DL transport blocks, N_{DL_retx} is the number of retransmitted DL transport blocks, and $N_{DL_correct_rx}$ is the number of correctly received DL transport blocks.	

Table 8.7.1-7: Test points for sustained data rate (FRC 256QAM)

CA config	Maximum supported Bandwidth/ Bandwidth combination (MHz)	Cat. 11, 12	DL Cat. 13	DL Cat. 15	DL Cat. 16		
		DL Cat. 11, 12					
Single carrier	20	-	1	-	-		
CA with 2CCs	2x15	2	2	-	-		
	15+5	2A	2A	-	-		
	10+15	3	3	-	-		
	20+5	3A	3A	-	-		
	10+20	4	4	-	-		
	15+20	6	6	-	-		
	20+20	7	7	-	-		
CA with 3CCs	3x20	8	7	8	-		
	15+20+20	9	7	9	-		
	10+20+20	10	7	10	-		
	15+15+20	11	6	11	-		
	10+15+20	12	6	12	-		
	10+10+20	13	13	13	-		
	10+15+15	14	14	14	-		
	5+10+20	15	15	15	-		
	5+15+20	15A	15A	15A	-		
5+10+10	15B	15B	15B	-			
CA with 4CCs	4x20	8	-	16	16		
	20+20+20+10	8	-	17	17		
	20+20+10+10	18	-	18	18		
	20+20+10+5	18A	-	18A	18A		
	20+10+10+5	18B	-	18B	18B		
CA with 5CCs	5x20	-	-	16	19		
NOTE 1: If DL category is signalled by the UE under test, then select the test point according to UE DL Category. Otherwise, select the test point according to the UE category signalled.							

8.7.2 TDD (single carrier and CA)

The parameters specified in Table 8.7.2-1 are valid for all TDD tests unless otherwise stated.

Table 8.7.2-1: Common Test Parameters (TDD)

Parameter	Unit	Value
Special subframe configuration (Note 1)		4
Cyclic prefix		Normal
Cell ID		0
Inter-TTI Distance		1
Maximum number of HARQ transmission		4
Redundancy version coding sequence		{0,0,1,2} for 64QAM and 256QAM
Number of OFDM symbols for PDCCH per component carrier	OFDM symbols	1
Cross carrier scheduling		Not configured
Propagation condition		Static propagation condition No external noise sources are applied
Note 1: as specified in Table 4.2-1 in TS 36.211 [4].		

For UE not supporting 256QAM, the requirements are specified in Table 8.7.2-3, with the addition of the parameters in Table 8.7.2-2 and the downlink physical channel setup according to Annex C.3.2. The test points are applied to UE category and bandwidth combination with maximum aggregated bandwidth as specified in Table 8.7.2-4. The TB success rate shall be sustained during at least 300 frames.

For UE supporting 256QAM, the requirements are specified in Table 8.7.2-6, with the addition of the parameters in Table 8.7.2-5 and the downlink physical channel setup according to Annex C.3.2. The test points are applied to UE category and bandwidth combination with maximum aggregated bandwidth as specified in Table 8.7.2-7. The TB success rate shall be sustained during at least 300 frames. For UE supporting 256QAM, the requirement in Table 8.7.2-3 is not applicable.

The test coverage for different number of component carriers is defined in 8.1.2.4.

Table 8.7.2-2: test parameters for sustained downlink data rate (TDD 64QAM)

Test	Bandwidth (MHz)	Transmission mode	Antenna configuration	Codebook subset restriction	Downlink power allocation (dB)			\hat{E}_s at antenna port (dBm/15 kHz)	ACK/NACK feedback mode	Symbols for unused PRBs
					ρ_A	ρ_B	σ			
1	10	1	1 x 2	N/A	0	0	0	-85	Bundling	OP.6 TDD
2	10	3	2 x 2	10	-3	-3	0	-85	Bundling	OP.1 TDD
3	20	3	2 x 2	10	-3	-3	0	-85	Bundling	OP.1 TDD
3A	15	3	2 x 2	10	-3	-3	0	-85	Multiplexing	OP.2 TDD
4,6	20	3	2 x 2	10	-3	-3	0	-85	Multiplexing	OP.1 TDD
6A	2x20	3	2 x 2	10	-3	-3	0	-85	- (Note 1)	OP.1 TDD
6B	20+15	3	2 x 2	10	-3	-3	0	-85	(Note 1)	OP.1 TDD
7	3x20	3	2 x 2	10	-3	-3	0	-85	(Note 2)	OP.1 TDD
7A	15+20+20	3	2 x 2	10	-3	-3	0	-85	(Note 2)	OP.1 TDD
8	4x20	3	2 x 2	10	-3	-3	0	-85	(Note 2)	OP.1 TDD
9	15+3x20	3	2 x 2	10	-3	-3	0	-85	(Note 2)	OP.1 TDD
Note 1: PUCCH format 1b with channel selection is used to feedback ACK/NACK.										
Note 2: PUCCH format 3 is used to feedback ACK/NACK.										

Table 8.7.2-3: Minimum requirement (TDD 64QAM)

Test	Number of bits of a DL-SCH transport block received within a TTI for normal/special sub-frame	Measurement channel	Reference value
			TB success rate [%]
1	10296/0	R.31-1 TDD	95
2	25456/0	R.31-2 TDD	95
3	51024/0	R.31-3 TDD	95
3A	51024/0	R.31-3A TDD	85
4	75376/0 (Note 2)	R.31-4 TDD	85
6	75376/0 (Note 2)	R.31-4 TDD	85
6A	75376/0 (Note 2)	R.31-4 TDD	85
6B	55056/0 for 15MHz CC 75376/0 for 20MHz CC (Note 2)	R.31-5 TDD for 15MHz CC R.31-4 TDD for 20MHz CC	85
7	75376/0 (Note 2)	R.31-4 TDD	85
7A	55056/0 for 15MHz CC 75376/0 for 20MHz CC (Note 2)	R.31-5 TDD for 15MHz CC R.31-4 TDD for 20MHz CC	85
8	75376/0 (Note 2)	R.31-4 TDD	85
9	55056/0 for 15MHz CC 75376/0 for 20MHz CC (Note 2)	R.31-5 TDD for 15MHz CC R.31-4 TDD for 20MHz CC	85

Note 1: For 2 layer transmissions, 2 transport blocks are received within a TTI.
Note 2: 71112 bits for sub-frame 5.
Note 3: The TB success rate is defined as $TB\ success\ rate = 100\% * N_{DL_correct_rx} / (N_{DL_newtx} + N_{DL_retx})$, where N_{DL_newtx} is the number of newly transmitted DL transport blocks, N_{DL_retx} is the number of retransmitted DL transport blocks, and $N_{DL_correct_rx}$ is the number of correctly received DL transport blocks.

Table 8.7.2-4: Test points for sustained data rate (FRC 64QAM)

CA config	Bandwidth/ Bandwidth combination (MHz)	Cat. 1	Cat. 2	Cat. 3	Cat. 4	Cat. 6,7	Cat. 9, 10	Cat. 11, 12	DL Cat. 15
								DL Cat. 11, 12	
Single carrier	10	1	2	-	-	-	-	-	-
	15	-	-	3A	3A	-	-	-	-
	20	-	-	3	4	6	-	-	-
CA with 2CCs	20+20	-	--	3(Note 4)	4 (Note 4)	6A	6A	-	-
	15+20	-	-	3(Note 4)	4 (Note 4)	6B	6B	-	-
CA with 3 CCs	3x20	-	-	-	-	6A	7	7	-
	15+20+20	-	-	-	-	6A	7A	7A	-
CA with 4 CCs	4x20	-	-	-	-	-	7	8	8
	15+3x20	-	-	-	-	-	7	9	9

Note 1: If DL category is signalled by the UE under test, then select the test point according to UE DL Category. Otherwise, select the test point according to the UE category signalled.
Note 2: For non-CA UE, test is selected for maximum supported bandwidth.
Note 3: Void.
Note 4: If the intra-band contiguous CA is the only CA configuration supported by category 3 or 4 UE, single carrier test is selected.
Note 5: The applicability of requirements for different CA configurations and bandwidth combination sets is defined in 8.1.2.3.

Table 8.7.2-5: test parameters for sustained downlink data rate (TDD 256QAM)

Test	Bandwidth (MHz)	Transmission mode	Antenna configuration	Codebook subset restriction	Downlink power allocation (dB)			\hat{E}_s at antenna port (dBm/15 kHz)	ACK/NACK feedback mode	Symbols for unused PRBs
					ρ_A	ρ_B	σ			
1	20	3	2 x 2	10	-3	-3	0	-85	Bundling	OP.1 TDD
2	15+20	3	2 x 2	10	-3	-3	0	-85	(Note 1)	OP.1 TDD
3	2x20	3	2 x 2	10	-3	-3	0	-85	(Note 1)	OP.1 TDD
4	3x20	3	2 x 2	10	-3	-3	0	-85	(Note 1)	OP.1 TDD
5	15+20+20	3	2 x 2	10	-3	-3	0	-85	(Note 1)	OP.1 TDD
6	4x20	3	2 x 2	10	-3	-3	0	-85	(Note 1)	OP.1 TDD
7	15+3x20	3	2 x 2	10	-3	-3	0	-85	(Note 1)	OP.1 TDD

Note 1: For CA test cases, PUCCH format 3 is used to feedback ACK/NACK.

Table 8.7.2-6: Minimum requirement (TDD 256QAM)

Test	Measurement channel	Reference value
		TB success rate [%]
1	R.68 TDD	85
2	R.68-1 TDD for 15MHz CC R.68 TDD for 20MHz CC	85
3	R.68 TDD	85
4	R.68 TDD	85
5	R.68-1 TDD for 15MHz CC R.68 TDD for 20MHz CC	85
6	R.68 TDD	85
7	R.68-1 TDD for 15MHz CC R.68 TDD for 20MHz CC	85

Note 1: For 2 layer transmissions, 2 transport blocks are received within a TTI.

Note 2: The TB success rate is defined as TB success rate = $100\% \cdot N_{DL_correct_rx} / (N_{DL_newtx} + N_{DL_retx})$, where N_{DL_newtx} is the number of newly transmitted DL transport blocks, N_{DL_retx} is the number of retransmitted DL transport blocks, and $N_{DL_correct_rx}$ is the number of correctly received DL transport blocks.

Table 8.7.2-7: Test points for sustained data rate (FRC 256QAM)

CA config	Bandwidth/ Bandwidth combination (MHz)	Cat. 11, 12	DL Cat. 13	DL Cat. 15	DL Cat. 16		
		DL Cat. 11, 12					
Single carrier	20	-	1	-	-		
CA with 2CCs	15+20	2	2	-	-		
	2x20	3	3	-	-		
CA with 3 CCs	3x20	4	3	4	-		
	15+20+20	5	3	5	-		
CA with 4 CCs	4x20	4	-	6	6		
	15+3x20	5	-	7	7		

8.7.3 FDD (EPDCCH scheduling)

The parameters specified in Table 8.7.3-1 are valid for all FDD tests unless otherwise stated.

Table 8.7.3-1: Common test parameters (FDD)

Parameter	Unit	Value
Cyclic prefix		Normal
Cell ID		0
Inter-TTI Distance		1
Number of HARQ processes per component carrier	Processes	8
Maximum number of HARQ transmission		4
Redundancy version coding sequence		{0,0,1,2} for 64QAM
Number of OFDM symbols for PDCCH per component carrier	OFDM symbols	1
Cross carrier scheduling		Not configured
Number of EPDCCH sets		1
EPDCCH transmission type		Localized
Number of PRB per EPDCCH set and EPDCCH PRB pair allocation		2 PRB pairs 10MHz BW: Resource blocks $n_{PRB} = 48, 49$ 15MHz BW: Resource blocks $n_{PRB} = 70, 71$ 20MHz BW: Resource blocks $n_{PRB} = 98, 99$
EPDCCH Starting Symbol		Derived from CFI (i.e. default behaviour)
ECCE Aggregation Level		2 ECCEs
Number of EREGs per ECCE		4
EPDCCH scheduling		EPDCCH candidate is randomly assigned in each subframe
EPDCCH precoder (Note 1)		Fixed PMI 0
EPDCCH monitoring SF pattern		1111111111 0000000000 1111111111 0000000000
Timing advance	μ s	100
Propagation condition		Static propagation condition No external noise sources are applied
Note 1: EPDCCH precoder parameters are defined for tests with 2 x 2 antenna configuration		

The requirements are specified in Table 8.7.3-3, with the addition of the parameters in Table 8.7.3-2 and the downlink physical channel setup according to Annex C.3.2. The test points are applied to UE category, CA capability and bandwidth combination with maximum aggregated bandwidth as specified in Table 8.7.3-4. The TB success rate shall be sustained during at least 300 frames.

Table 8.7.3-2: Test parameters for SDR test for PDSCH scheduled by EPDCCH (FDD)

Test	Bandwidth (MHz)	Transmission mode	Antenna configuration	Codebook subset restriction	Downlink power allocation (dB)				\hat{E}_s at antenna port (dBm/15kHz)	Symbols for unused PRBs
					ρ_A	ρ_B	σ	δ		
1	10	1	1 x 2	N/A	0	0	0	0	-85	OP.6 FDD
2	10	3	2 x 2	10	-3	-3	0	3	-85	OP.1 FDD
3,4,6	20	3	2 x 2	10	-3	-3	0	3	-85	OP.1 FDD
3A	10	3	2 x 2	10	-3	-3	0	3	-85	OP.1 FDD
3C, 4B	15	3	2 x 2	10	-3	-3	0	3	-85	OP.1 FDD

Table 8.7.3-3: Minimum requirement (FDD)

Test	Number of bits of a DL-SCH transport block received within a TTI	Measurement channel	Reference value
			TB success rate [%]
1	10296	R.31E-1 FDD	95
2	25456	R.31E-2 FDD	95
3	51024	R.31E-3 FDD	95
3A	36696 (Note 2)	R.31E-3A FDD	85
3C	51024	R.31E-3C FDD	85
4	75376 (Note 3)	R.31E-4 FDD	85
4B	55056 (Note 5)	R.31E-4B FDD	85
6	75376 (Note 3)	R.31E-4 FDD	85
Note 1:	For 2 layer transmissions, 2 transport blocks are received within a TTI.		
Note 2:	35160 bits for sub-frame 5.		
Note 3:	71112 bits for sub-frame 5.		
Note 4:	The TB success rate is defined as $TB\ success\ rate = 100\% * N_{DL_correct_rx} / (N_{DL_newtx} + N_{DL_retx})$, where N_{DL_newtx} is the number of newly transmitted DL transport blocks, N_{DL_retx} is the number of retransmitted DL transport blocks, and $N_{DL_correct_rx}$ is the number of correctly received DL transport blocks.		
Note 5:	52752 bits for sub-frame 5.		

Table 8.7.3-4: Test points for sustained data rate (FRC)

CA config	Bandwidth (MHz)	Category 1	Category 2	Category 3	Category 4	Category 6	Category 7
Single carrier	10	1	2	3A	3A	-	-
	15	-	-	3C	4B	-	-
	20	-	-	3	4	6	6
Note 1: The test is selected for maximum supported bandwidth.							

8.7.4 TDD (EPDCCH scheduling)

The parameters specified in Table 8.7.4-1 are valid for all TDD tests unless otherwise stated.

Table 8.7.4-1: Common test parameters (TDD)

Parameter	Unit	Value
Special subframe configuration (Note 1)		4
Cyclic prefix		Normal
Cell ID		0
Inter-TTI Distance		1
Maximum number of HARQ transmission		4
Redundancy version coding sequence		{0,0,1,2} for 64QAM
Number of OFDM symbols for PDCCH per component carrier	OFDM symbols	1
Cross carrier scheduling		Not configured
Number of EPDCCH sets		1
EPDCCH transmission type		Localized
Number of PRB per EPDCCH set and EPDCCH PRB pair allocation		2 PRB pairs 10MHz BW: Resource blocks $n_{PRB} = 48, 49$ 15MHz BW: Resource blocks $n_{PRB} = 70, 71$ 20MHz BW: Resource blocks $n_{PRB} = 98, 99$
EPDCCH Starting Symbol		Derived from CFI (i.e. default behaviour)
ECCE Aggregation Level		2 ECCEs
Number of REGs per ECCE		4 for normal subframe and for special subframe
EPDCCH scheduling		EPDCCH candidate is randomly assigned in each subframe
EPDCCH precoder (Note 2)		Fixed PMI 0
EPDCCH monitoring SF pattern		UL-DL configuration 1: 110111111 000000000 UL-DL configuration 5: 1100111001 000000000
Timing advance	μs	100
Propagation condition		Static propagation condition No external noise sources are applied
Note 1:	As specified in Table 4.2-1 in TS 36.211 [4].	
Note 2:	EPDCCH precoder parameters are defined for tests with 2 x 2 antenna configuration	

The requirements are specified in Table 8.7.4-3, with the addition of the parameters in Table 8.7.4-2 and the downlink physical channel setup according to Annex C.3.2. The test points are applied to UE category, CA capability and bandwidth combination with maximum aggregated bandwidth as specified in Table 8.7.4-4. The TB success rate shall be sustained during at least 300 frames.

Table 8.7.4-2: Test parameters for SDR test for PDSCH scheduled by EPDCCH (TDD)

Test	Bandwidth (MHz)	Transmission mode	Antenna configuration	Codebook subset restriction	Downlink power allocation (dB)				\hat{E}_s at antenna port (dBm/15kHz)	Symbols for unused PRBs	ACK/NACK feedback mode
					ρ_A	ρ_B	σ	δ			
1	10	1	1 x 2	N/A	0	0	0	0	-85	OP.6 TDD	Bundling
2	10	3	2 x 2	10	-3	-3	0	3	-85	OP.1 TDD	Bundling
3	20	3	2 x 2	10	-3	-3	0	3	-85	OP.1 TDD	Bundling
3A	15	3	2 x 2	10	-3	-3	0	3	-85	OP.2 TDD	Multiplexing
4,6	20	3	2 x 2	10	-3	-3	0	3	-85	OP.1 TDD	Multiplexing

Table 8.7.4-3: Minimum requirement (TDD)

Test	Number of bits of a DL-SCH transport block received within a TTI for normal/special sub-frame	Measurement channel	Reference value
			TB success rate [%]
1	10296/0	R.31E-1 TDD	95
2	25456/0	R.31E-2 TDD	95
3	51024/0	R.31E-3 TDD	95
3A	51024/0	R.31E-3A TDD	85
4	75376/0 (Note 2)	R.31E-4 TDD	85
6	75376/0 (Note 2)	R.31E-4 TDD	85

Note 1: For 2 layer transmissions, 2 transport blocks are received within a TTI.
Note 2: 71112 bits for sub-frame 5.
Note 3: The TB success rate is defined as TB success rate = 100% * $N_{DL_correct_rx} / (N_{DL_newtx} + N_{DL_retx})$, where N_{DL_newtx} is the number of newly transmitted DL transport blocks, N_{DL_retx} is the number of retransmitted DL transport blocks, and $N_{DL_correct_rx}$ is the number of correctly received DL transport blocks.

Table 8.7.4-4: Test points for sustained data rate (FRC)

CA config	Bandwidth/ Bandwidth combination (MHz)	Category 1	Category 2	Category 3	Category 4	Category 6	Category 7
Single carrier	10	1	2	-	-	-	-
	15	-	-	3A	3A	-	-
	20	-	-	3	4	6	6

Note 1: The test is selected for maximum supported bandwidth.

8.7.5 TDD FDD CA

The parameters specified in Table 8.7.5-1 are valid for all TDD FDD CA tests unless otherwise stated.

Table 8.7.5-1: Common Test Parameters (TDD FDD CA)

Parameter		Unit	Value
Uplink downlink configuration (Note 1) for TDD CC			1
Special subframe configuration (Note 2) for TDD CC			4
Downlink power allocation	ρ_A	dB	-3
	ρ_B	dB	-3
	σ	dB	0
Cyclic prefix			Normal
Cell ID			0
Inter-TTI Distance			1
Maximum number of HARQ processes per component carrier	FDD PCell	Processes	8 for FDD and TDD CCs
	TDD PCell	Processes	11 for FDD CC; 7 for TDD CC
Maximum number of HARQ transmission			4
Redundancy version coding sequence			{0,0,1,2} for 64QAM, 256QAM
Number of OFDM symbols for PDCCH per component carrier		OFDM symbols	1
Cross carrier scheduling			Not configured
Propagation condition			Static propagation condition No external noise sources are applied
Transmission mode			TM3
Codebook subset restriction			10
Antenna configuration			2 x 2
\hat{E}_s at antenna port (dBm/15kHz)			-85
Symbols for unused PRBs			OP.1 FDD for FDD CC, OP.1 TDD for TDD CC
ACK/NACK feedback mode			PUCCH format 3
Downlink HARQ-ACK timing	FDD PCell		As specified in Clause 7.3.3 in TS36.213 [6]
	TDD PCell		As specified in Clause 7.3.4 in TS36.213 [6]
Note 1:		as specified in Table 4.2-2 in TS 36.211 [4].	
Note 2:		as specified in Table 4.2-1 in TS 36.211 [4].	

8.7.5.1 Minimum Requirement FDD PCell

For UE not supporting 256QAM, the requirements for TDD FDD CA with FDD PCell are specified in Table 8.7.5.1-1 with the additional parameters specified in Table 8.7.5-1, and the downlink physical channel setup according to Annex C.3.2. The test points are applied to UE category and bandwidth combination with maximum aggregated bandwidth as specified in Table 8.7.5.1-2. The TB success rate shall be sustained during at least 300 frames.

For UE supporting 256QAM, the requirements for TDD FDD CA with FDD PCell are specified in Table 8.7.5.1-3 with the additional parameters specified in Table 8.7.5-1, and the downlink physical channel setup according to Annex C.3.2. The test points are applied to UE category or UE DL category, and bandwidth combination with the maximum aggregated bandwidth as specified in Table 8.7.5.1-4. The TB success rate shall be sustained during at least 300 frames. For UE supporting 256QAM, the requirement in Table 8.7.5.1-1 is not applicable.

The applicability of the requirements are specified in Clause 8.1.2.3B. The test coverage for different number of component carriers is defined in 8.1.2.4.

Table 8.7.5.1-1: test parameters for sustained downlink data rate (TDD FDD CA 64QAM)

Test number	Bandwidth (MHz)			Number of bits of a DL-SCH transport block received within a TTI (for normal/special subframe for TDD, except for subframe #5)		Measurement channel		Reference value
	Total	FDD CC	TDD CC	FDD CC	TDD CC	FDD CC	TDD CC	TB success rate [%]
1	2x20	20	20	75376	75376/0	R.31-4 FDD	R.31-4 TDD	85
2	10+20	10	20	36696	75376/0	R.31-3A FDD	R.31-4 TDD	85
2A	15+20	15	20	55056	75376/0	R.31-5 FDD	R.31-4 TDD	85
3	10+10	10	10	36696	36696/0	R.31-3A FDD	R.31-6 TDD	85
4	3x20	20	2x20	75376	75376/0	R.31-4 FDD	R.31-4 TDD	85
5	15+20+20	15	2x20	55056	75376/0	R.31-5 FDD	R.31-4 TDD	85
6	10+20+20	10	2x20	36696	75376/0	R.31-3A FDD	R.31-4 TDD	85
7	3x20	2x20	20	75376	75376/0	R.31-4 FDD	R.31-4 TDD	85
8	20+20+15	20+15	20	75376 for 20MHz CC 55056 for 15MHz CC	75376/0	R.31-4 FDD for 20MHz CC, R.31-5 FDD for 15MHz CC	R.31-4 TDD	85
9	20+20+10	20+10	20	75376 for 20MHz CC 36696 for 10MHz CC	75376/0	R.31-4 FDD for 20MHz CC, R.31-3A FDD for 10MHz CC	R.31-4 TDD	85
9A	20+10+10	2x10	20	36696	75376/0	R.31-3A	R.31-4 TDD	85
10	4x20	20	3x20	75376	75376/0	R.31-4 FDD	R.31-4 TDD	85
11	4x20	2x20	2x20	75376	75376/0	R.31-4 FDD	R.31-4 TDD	85
12	3x20+15	20+15	2x20	75376 for 20MHz CC 55056 for 15MHz CC	75376/0	R.31-4 FDD for 20MHz CC, R.31-5 FDD for 15MHz CC	R.31-4 TDD	85
13	2x15+2x20	2x15	2x20	55056	75376/0	R.31-5 FDD	R.31-4 TDD	85
14	3x20+15	2x20+15	20	75376 for 20MHz CC 55056 for 15MHz CC	75376/0	R.31-4 FDD for 20MHz CC, R.31-5 FDD for 15MHz CC	R.31-4 TDD	85
15	2x15+2x20	2x15+20	20	75376 for 20MHz CC 55056 for 15MHz CC	75376/0	R.31-4 FDD for 20MHz CC, R.31-5 FDD for 15MHz CC	R.31-4 TDD	85
15A	3x20+10	2x20+10	20	75376 for 20MHz CC 36696 for 10MHz CC	75376/0	R.31-4 FDD for 20MHz CC, R.31-3A FDD for 10MHz CC	R.31-4 TDD	85
15B	2x15+2x20	2x15+20	20	75376 for 20MHz CC 55056 for 15MHz CC	75376/0	R.31-4 FDD for 20MHz CC, R.31-5 FDD for 15MHz CC	R.31-4 TDD	85
16	4x20+15	2x20+15	2x20	75376 for 20MHz CC 55056 for 15MHz CC	75376/0	R.31-4 FDD for 20MHz CC, R.31-5 FDD for 15MHz CC	R.31-4 TDD	85
17	2x15+3x20	2x15+20	2x20	75376 for 20MHz CC 55056 for 15MHz CC	75376/0	R.31-4 FDD for 20MHz CC, R.31-5 FDD for 15MHz CC	R.31-4 TDD	85

Table 8.7.5.1-2: Test points for sustained data rate (FRC 64QAM)

CA config	Maximum supported Bandwidth/ Bandwidth combination (MHz)			Cat. 1	Cat. 2	Cat. 3	Cat. 4	Cat. 6, 7	Cat. 9,10	Cat 11, 12	DL Cat. 15
	Total	FDD CC	TDD CC					DL Cat. 6, 7	DL Cat. 9, 10	DL Cat. 11, 12	
CA with 2CCs	2x20	20	20	-	-	3	3	1	1	-	-
	10+20	10	20	-	-	3	3	2	2	-	-
	15+20	15	20	-	-	3	3	2A	2A	-	-
	10+10	10	10	-	-	3	3	3	3	-	-
CA with 3CCs	3x20	20	2x20	-	-	-	-	1	4	4	-
	15+20+20	15	2x20	-	-	-	-	2A	5	5	-
	10+20+20	10	2x20	-	-	-	-	2	6	6	-
	3x20	2x20	20	-	-	-	-	1	7	7	-
	20+20+15	20+15	20	-	-	-	-	1	8	8	-
	20+20+10	20+10	20	-	-	-	-	1	9	9	-
20+10+10	2x10	20	-	-	-	-	2	9A	9A	-	
CA with 4CCs	4x20	20	3x20	-	-	-	-	-	4	10	10
	4x20	2x20	2x20	-	-	-	-	-	4 or 7	11	11
	3x20+15	20+15	2x20	-	-	-	-	-	4	12	12
	2x15+2x20	2x15	2x20	-	-	-	-	-	5	13	13
	3x20+15	2x20+15	20	-	-	-	-	-	7	14	14
	2x15+2x20	2x15+20	20	-	-	-	-	-	8	15	15
	3x20+10	2x20+10	20	-	-	-	-	-	7	15A	15A
2x15+2x20	2x15+20	20	-	-	-	-	-	8	15B	15B	
CA with 5 CCs	4x20+15	2x20+15	2x20	-	-	-	-	-	-	11	16
	2x15+3x20	2x15+20	2x20	-	-	-	-	-	-	12	17
Note 1:	Void.										
Note 2:	Void.										
Note 3:	If DL category is signalled by the UE under test, then select the test point according to UE DL Category. Otherwise, select the test point according to the UE category signalled.										

Table 8.7.5.1-3: Minimum requirement (TDD FDD CA 256QAM)

Test number	Bandwidth (MHz)			Measurement channel		Reference value
	Total	FDD CC	TDD CC	FDD CC	TDD CC	TB success rate [%]
1	2x20	20	20	R.68 FDD	R.68 TDD	85
2	10+20	10	20	R.68-2 FDD	R.68 TDD	85
3	15+20	15	20	R.68-1 FDD	R.68 TDD	85
4	3x20	20	2x20	R.68 FDD	R.68 TDD	85
5	15+20+20	15	2x20	R.68-1 FDD	R.68 TDD	85
6	10+20+20	10	2x20	R.68-2 FDD	R.68TDD	85
7	3x20	2x20	20	R.68 FDD	R.68 TDD	85
8	20+20+15	20+15	20	R.68 FDD for 20MHz CC, R.68-1 FDD for 15MHz CC	R.68 TDD	85
9	20+20+10	20+10	20	R.68 FDD for 20MHz CC, R.68-2 FDD for 10MHz CC	R.68 TDD	85
9A	20+10+10	2x10	20	R.68-2 FDD	R.68 TDD	85
10	4x20	20	3x20	R.68-2 FDD	R.68TDD	85
11	4x20	2x20	2x20	R.68 FDD	R.68 TDD	85
12	3x20+15	20+15	2x20	R.68 FDD for 20MHz CC, R.68-1 FDD for 15MHz CC	R.68 TDD	85
13	2x15+2x20	2x15	2x20	R.68-1 FDD	R.68 TDD	85
14	3x20+15	2x20+15	20	R.68 FDD for 20MHz CC, R.68-1 FDD for 15MHz CC	R.68 TDD	85
15	2x15+2x20	2x15+20	20	R.68 FDD for 20MHz CC, R.68-1 FDD for 15MHz CC	R.68 TDD	85
15A	3x20+10	2x20+10	20	R.68 FDD for 20MHz CC, R.68-2 FDD for 10MHz CC	R.68 TDD	85
15B	2x15+2x20	2x15+20	20	R.68 FDD for 20MHz CC, R.68-1 FDD for 15MHz CC	R.68 TDD	85
16	4x20+15	2x20+15	2x20	R.68 FDD for 20MHz CC, R.68-1 FDD for 15MHz CC	R.68 TDD	85
17	2x15+3x20	2x15+20	2x20	R.68 FDD for 20MHz CC, R.68-1 FDD for 15MHz CC	R.68 TDD	85

Table 8.7.5.1-4: Test points for sustained data rate (FRC 256QAM)

CA config	Maximum supported Bandwidth/ Bandwidth combination (MHz)			Cat. 11, 12	DL Cat. 13	DL Cat. 15	DL Cat. 16		
	Total	FDD CC	TDD CC	DL Cat. 11, 12					
CA with 2CCs	2x20	20	20	1	1	-	-		
	10+20	10	20	2	2				
	15+20	15	20	3	3	-	-		
CA with 3CCs	3x20	20	2x20	4	1	4	-		
	15+20+20	15	2x20	5	3	5	-		
	10+20+20	10	2x20	6	2	6	-		
	3x20	2x20	20	7	1	7	-		
	20+20+15	20+15	20	8	1	8	-		
	20+20+10	20+10	20	9	1	9	-		
	20+10+10	2x10	20	9A	2	9A			
CA with 4CCs	4x20	20	3x20	4	-	10	10		
	4x20	2x20	2x20	4 or 7	-	11	11		
	3x20+15	20+15	2x20	8	-	12	12		
	2x15+2x20	2x15	2x20	5	-	13	13		
	3x20+15	2x20+15	20	7	-	14	14		
	2x15+2x20	2x15+20	20	8	-	15	15		
	3x20+10	2x20+10	20	7	-	15A	15A		
2x15+2x20	2x15+20	20	8	-	15B	15B			
CA with 5CCs	4x20+15	2x20+15	2x20	-	-	14 or 12	16		
	2x15+3x20	2x15+20	2x20	-	-	15 or 12	17		

Note 1: If DL category is signalled by the UE under test, then select the test point according to UE DL Category. Otherwise, select the test point according to the UE category signalled.

8.7.5.2 Minimum Requirement TDD PCell

For UE not supporting 256QAM, the requirements for TDD FDD CA with TDD PCell are specified in Table 8.7.5.2-1 with the additional parameters specified in Table 8.7.5-1, and the downlink physical channel setup according to Annex C.3.2. The test points are applied to UE category and bandwidth combination with maximum aggregated bandwidth as specified in Table 8.7.5.2-2. The TB success rate shall be sustained during at least 300 frames.

For UE supporting 256QAM, the requirements for TDD FDD CA with FDD PCell are specified in Table 8.7.5.2-3 with the additional parameters specified in Table 8.7.5-1, and the downlink physical channel setup according to Annex C.3.2. The test points are applied to UE category or UE DL category, and bandwidth combination with maximum aggregated bandwidth as specified in Table 8.7.5.2-4. The TB success rate shall be sustained during at least 300 frames. For UE supporting 256QAM, the requirements in Table 8.7.5.2-1 is not applicable.

The applicability of their requirements are specified in Clause 8.1.2.3B. The test coverage for different number of component carriers is defined in 8.1.2.4.

Table 8.7.5.2-1: test parameters for sustained downlink data rate (TDD FDD CA 64QAM)

Test number	Bandwidth (MHz)			Number of bits of a DL-SCH transport block received within a TTI (for normal/special subframe for TDD, except for subframe #5)		Measurement channel		Reference value
	Total	FDD CC	TDD CC	FDD CC	TDD CC	FDD CC	TDD CC	TB success rate [%]
1	2x20	20	20	75376	75376/0	R.31-4 FDD	R.31-4 TDD	85
2	10+20	10	20	36696	75376/0	R.31-3A FDD	R.31-4 TDD	85
2A	15+20	15	20	55056	75376/0	R.31-5 FDD	R.31-4 TDD	85
3	10+10	10	10	36696	36696/0	R.31-3A FDD	R.31-6 TDD	85
4	3x20	20	2x20	75376	75376/0	R.31-4 FDD	R.31-4 TDD	85
5	15+20+20	15	2x20	55056	75376/0	R.31-5 FDD	R.31-4 TDD	85
6	10+20+20	10	2x20	36696	75376/0	R.31-3A FDD	R.31-4 TDD	85
7	3x20	2x20	20	75376	75376/0	R.31-4 FDD	R.31-4 TDD	85
8	20+20+15	20+15	20	75376 for 20MHz CC 55056 for 15MHz CC	75376/0	R.31-4 FDD for 20MHz CC, R.31-5 FDD for 15MHz CC	R.31-4 TDD	85
9	20+20+10	20+10	20	75376 for 20MHz CC 36696 for 10MHz CC	75376/0	R.31-4 FDD for 20MHz CC, R.31-3A FDD for 10MHz CC	R.31-4 TDD	85
9A	20+10+10	2x10	20	36696	75376/0	R.31-3A	R.31-4 TDD	85
10	4x20	20	3x20	75376	75376/0	R.31-4 FDD	R.31-4 TDD	85
11	4x20	2x20	2x20	75376	75376/0	R.31-4 FDD	R.31-4 TDD	85
12	3x20+15	20+15	2x20	75376 for 20MHz CC 55056 for 15MHz CC	75376/0	R.31-4 FDD for 20MHz CC, R.31-5 FDD for 15MHz CC	R.31-4 TDD	85
13	2x15+2x20	2x15	2x20	55056	75376/0	R.31-5 FDD	R.31-4 TDD	85
14	3x20+15	2x20+15	20	75376 for 20MHz CC 55056 for 15MHz CC	75376/0	R.31-4 FDD for 20MHz CC, R.31-5 FDD for 15MHz CC	R.31-4 TDD	85
15	2x15+2x20	2x15+20	20	75376 for 20MHz CC 55056 for 15MHz CC	75376/0	R.31-4 FDD for 20MHz CC, R.31-5 FDD for 15MHz CC	R.31-4 TDD	85
15A	3x20+10	2x20+10	20	75376 for 20MHz CC 36696 for 10MHz CC	75376/0	R.31-4 FDD for 20MHz CC, R.31-3A FDD for 10MHz CC	R.31-4 TDD	85
15B	2x15+2x20	2x15+20	20	75376 for 20MHz CC 55056 for 15MHz CC	75376/0	R.31-4 FDD for 20MHz CC, R.31-5 FDD for 15MHz CC	R.31-4 TDD	85
16	4x20+15	2x20+15	2x20	75376 for 20MHz CC 55056 for 15MHz CC	75376/0	R.31-4 FDD for 20MHz CC, R.31-5 FDD for 15MHz CC	R.31-4 TDD	85
17	2x15+3x20	2x15+20	2x20	75376 for 20MHz CC 55056 for 15MHz CC	75376/0	R.31-4 FDD for 20MHz CC, R.31-5 FDD for 15MHz CC	R.31-4 TDD	85

Table 8.7.5.2-2: Test points for sustained data rate (FRC 64QAM)

CA config	Maximum supported Bandwidth/ Bandwidth combination (MHz)			Cat. 1	Cat. 2	Cat. 3	Cat. 4	Cat. 6, 7	Cat. 9,10	Cat 11, 12	DL Cat. 15
	Total	FDD CC	TDD CC					DL Cat. 6, 7	DL Cat. 9, 10	DL Cat. 11, 12	
CA with 2CCs	2x20	20	20	-	-	3	3	1	1	-	-
	10+20	10	20	-	-	3	3	2	2	-	-
	15+20	15	20	-	-	3	3	2A	2A	-	-
	10+10	10	10	-	-	3	3	3	3	-	-
CA with 3CCs	3x20	20	2x20	-	-	-	-	1	4	4	-
	15+20+20	15	2x20	-	-	-	-	2A	5	5	-
	10+20+20	10	2x20	-	-	-	-	2	6	6	-
	3x20	2x20	20	-	-	-	-	1	7	7	-
	20+20+15	20+15	20	-	-	-	-	1	8	8	-
	20+20+10	20+10	20	-	-	-	-	1	9	9	-
20+10+10	2x10	20	-	-	-	-	2	9A	9A	-	
CA with 4CCs	4x20	20	3x20	-	-	-	-	-	4	10	10
	4x20	2x20	2x20	-	-	-	-	-	4 or 7	11	11
	3x20+15	20+15	2x20	-	-	-	-	-	4	12	12
	2x15+2x20	2x15	2x20	-	-	-	-	-	5	13	13
	3x20+15	2x20+15	20	-	-	-	-	-	7	14	14
	2x15+2x20	2x15+20	20	-	-	-	-	-	8	15	15
	3x20+10	2x20+10	20	-	-	-	-	-	7	15A	15A
2x15+2x20	2x15+20	20	-	-	-	-	-	8	15B	15B	
CA with 5 CCs	4x20+15	2x20+15	2x20	-	-	-	-	-	-	11	16
	2x15+3x20	2x15+20	2x20	-	-	-	-	-	-	12	17
Note 1:	Void.										
Note 2:	Void.										
Note 3:	If DL category is signalled by the UE under test, then select the test point according to UE DL Category. Otherwise, select the test point according to the UE category signalled.										

Table 8.7.5.2-3: Minimum requirement (TDD FDD CA 256QAM)

Test number	Bandwidth (MHz)			Measurement channel		Reference value
	Total	FDD CC	TDD CC	FDD CC	TDD CC	TB success rate [%]
1	2x20	20	20	R.68 FDD	R.68 TDD	85
2	10+20	10	20	R.68-2 FDD	R.68 TDD	85
3	15+20	15	20	R.68-1 FDD	R.68 TDD	85
4	3x20	20	2x20	R.68 FDD	R.68 TDD	85
5	15+20+20	15	2x20	R.68-1 FDD	R.68 TDD	85
6	10+20+20	10	2x20	R.68-2 FDD	R.68TDD	85
7	3x20	2x20	20	R.68 FDD	R.68 TDD	85
8	20+20+15	20+15	20	R.68 FDD for 20MHz CC, R.68-1 FDD for 15MHz CC	R.68 TDD	85
9	20+20+10	20+10	20	R.68 FDD for 20MHz CC, R.68-2 FDD for 10MHz CC	R.68 TDD	85
9A	20+10+10	2x10	20	R.68-2 FDD	R.68 TDD	85
10	4x20	20	3x20	R.68-2 FDD	R.68TDD	85
11	4x20	2x20	2x20	R.68 FDD	R.68 TDD	85
12	3x20+15	20+15	2x20	R.68 FDD for 20MHz CC, R.68-1 FDD for 15MHz CC	R.68 TDD	85
13	2x15+2x20	2x15	2x20	R.68-1 FDD	R.68 TDD	85
14	3x20+15	2x20+15	20	R.68 FDD for 20MHz CC, R.68-1 FDD for 15MHz CC	R.68 TDD	85
15	2x15+2x20	2x15+20	20	R.68 FDD for 20MHz CC, R.68-1 FDD for 15MHz CC	R.68 TDD	85
15A	3x20+10	2x20+10	20	R.68 FDD for 20MHz CC, R.68-2 FDD for 10MHz CC	R.68 TDD	85
15B	2x15+2x20	2x15+20	20	R.68 FDD for 20MHz CC, R.68-1 FDD for 15MHz CC	R.68 TDD	85
16	4x20+15	2x20+15	2x20	R.68 FDD for 20MHz CC, R.68-1 FDD for 15MHz CC	R.68 TDD	85
17	2x15+3x20	2x15+20	2x20	R.68 FDD for 20MHz CC, R.68-1 FDD for 15MHz CC	R.68 TDD	85

Table 8.7.5.2-4: Test points for sustained data rate (FRC 256QAM)

CA config	Maximum supported Bandwidth/ Bandwidth combination (MHz)			Cat. 11, 12	DL Cat. 13	DL Cat. 15	DL Cat. 16		
	Total	FDD CC	TDD CC	DL Cat. 11, 12					
CA with 2CCs	2x20	20	20	1	1	-	-		
	10+20	10	20	2	2				
	15+20	15	20	3	3	-	-		
CA with 3CCs	3x20	20	2x20	4	1	4	-		
	15+20+20	15	2x20	5	3	5	-		
	10+20+20	10	2x20	6	2	6	-		
	3x20	2x20	20	7	1	7	-		
	20+20+15	20+15	20	8	1	8	-		
	20+20+10	20+10	20	9	1	9	-		
	20+10+10	2x10	20	9A	2	9A			
CA with 4CCs	4x20	20	3x20	4	-	10	10		
	4x20	2x20	2x20	4 or 7	-	11	11		
	3x20+15	20+15	2x20	8	-	12	12		
	2x15+2x20	2x15	2x20	5	-	13	13		
	3x20+15	2x20+15	20	7	-	14	14		
	2x15+2x20	2x15+20	20	8	-	15	15		
	3x20+10	2x20+10	20	7	-	15A	15A		
2x15+2x20	2x15+20	20	8	-	15B	15B			
CA with 5CCs	4x20+15	2x20+15	2x20	-	-	14 or 12	16		
	2x15+3x20	2x15+20	2x20	-	-	15 or 12	17		

Note 1: If DL category is signalled by the UE under test, then select the test point according to UE DL Category. Otherwise, select the test point according to the UE category signalled.

8.7.6 FDD (DC)

The parameters specified in Table 8.7.6-1 are valid for all FDD DC tests unless otherwise stated.

Table 8.7.6-1: Common Test Parameters (FDD)

Parameter	Unit	Value	
Cyclic prefix		Normal	
Cell ID		0	
Inter-TTI Distance		1	
Number of HARQ processes per component carrier	Processes	8	
Maximum number of HARQ transmission		4	
Redundancy version coding sequence		{0,0,1,2} for 64QAM and 256QAM	
Number of OFDM symbols for PDCCH per component carrier	OFDM symbols	1	
Cross carrier scheduling		Not configured	
Propagation condition		Static propagation condition No external noise sources are applied	
Transmission mode		TM3	
Codebook subset restriction		10	
Antenna configuration		2x2	
\hat{E}_s at antenna port (dBm/15kHz)		-85	
Symbols for unused PRBs		OP.1 FDD	
ACK/NACK feedback mode		Separate ACK/NACK feedbacks with PUCCH format 3 on the MCG and SCG	
Time offset between MCG CC and SCG CC	μs	0 for UE under test supporting synchronous dual connectivity; 500 for UE under test supporting both asynchronous and synchronous dual connectivity (Note 1)	
Downlink power allocation	ρ_A	dB	-3
	ρ_B	dB	-3
	σ	dB	0
Note 1: Asynchronous and synchrons dual connectivity are defined in TS36.300 [11].			
Note 2: If the UE supports both SCG bearer and Split bearer, the Split bearer is configured.			

For UE not supporting 256QAM, the requirements are specified in Table 8.7.6-2, with the addition of the parameters in Table 8.7.6-1 and the downlink physical channel setup according to Annex C.3.2. The test points are applied to UE category and bandwidth combination with maximum aggregated bandwidth as specified in Table 8.7.6-3. The TB success rate across CGs shall be sustained during at least 300 frames.

For UE supporting 256QAM, the requirements are specified in Table 8.7.6-4, with the addition of the parameters in Table 8.7.6-1 and the downlink physical channel setup according to Annex C.3.2. The test points are applied to UE category and bandwidth combination with maximum aggregated bandwidth as specified in Table 8.7.6-5. The TB success rate across CGs shall be sustained during at least 300 frames. For UE supporting 256QAM, the requirements in Table 8.7.6-2 are not applicable.

The applicability of their requirements are specified in Clause 8.1.2.3A.

Table 8.7.6-2: Minimum requirement (DC 64QAM)

Test number	Bandwidth combination (MHz)	Number of bits of a DL-SCH transport block received within a TTI	Measurement channel	Reference value TB success rate(%)		
				DRB type of Split bearer (Note 2)	DRB type of SCG bearer (Note 3)	
					MCG	SCG
1	2x10	25456	R.31-2 FDD	95	95	95
2	2x10	36696 (Note 4)	R.31-3A FDD	85	85	85
3	10+20	36696 (Note 4) for 10MHz CC 75376 (Note 5) for 20MHz CC	R.31-3A FDD for 10MHz CC R.31-4 FDD for 20MHz CC	85	85	85
4	2x15	55056 (Note 6)	R.31-4B FDD	85	85	85
5	15+20	55056 for 15MHz CC 75376 (Note 5) for 20MHz CC	R.31-5 FDD for 15MHz CC R.31-4 FDD for 20MHz CC	85	85	85
6	2x20	75376 (Note 5)	R.31-4 FDD	85	85	85
6A	10+15	36696 (Note 4) for 10MHz CC 55056 (Note 6) for 15MHz CC	R.31-2 FDD for 10MHz CC R.31-5 FDD for 15MHz CC	85	85	85
7	15+5	55056 for 15MHz CC 18336 for 5MHz CC	R.31-5 FDD for 15MHz CC R.31-6 FDD for 5MHz CC	85	85	85
8	15+20+20	55056 for 15MHz CC 75376 (Note 5) for 20MHz CC	R.31-5 FDD for 15MHz CC R.31-4 FDD for 20MHz CC	85	85	85
9	15+15+20	55056 for 15MHz CC 75376 (Note 5) for 20MHz CC	R.31-5 FDD for 15MHz CC R.31-4 FDD for 20MHz CC	85	85	85
10	10+10+20	36696 (Note 4) for 10MHz CC 75376 (Note 5) for 20MHz CC	R.31-2 FDD for 10MHz CC R.31-4 FDD for 20MHz CC	85	85	85
11	10+15+15	36696 (Note 4) for 10MHz CC 55056 (Note 6) for 15MHz CC	R.31-2 FDD for 10MHz CC R.31-5 FDD for 15MHz CC	85	85	85
12	10+15+20	36696 (Note 4) for 10MHz CC 55056 (Note 6) for 15MHz CC 75376 (Note 5) for 20MHz CC	R.31-2 FDD for 10MHz CC R.31-5 FDD for 15MHz CC R.31-4 FDD for 20MHz CC	85	85	85
13	10+20+20	36696 (Note 4) for 10MHz CC 75376 (Note 5) for 20MHz CC	R.31-2 FDD for 10MHz CC R.31-4 FDD for 20MHz CC	85	85	85
14	3x20	75376 (Note 5)	R.31-4 FDD	85	85	85
Note 1:	For 2 layer transmissions, 2 transport blocks are received within a TTI.					
Note 2:	For the configuration of DRB type of Split bearer, the TB success rate across CGs is defined as TB success rate = $100\% \times N_{DL_correct_rx} / (N_{DL_newtx} + N_{DL_retx})$, where N_{DL_newtx} is the number of newly transmitted DL transport blocks, N_{DL_retx} is the number of retransmitted DL transport blocks, and $N_{DL_correct_rx}$ is the number of correctly received DL transport blocks. All the above numbers of transmitted, retransmitted or correctly received DL transport blocks are calculated as the sum of the numbers of DL transport blocks across all the CGs used for DC transmission or reception.					
Note 3:	For the configuration of DRB type of SCG bearer, the TB success rate across CGs is defined as TB success rate = $100\% \times N_{DL_correct_rx} / (N_{DL_newtx} + N_{DL_retx})$, where N_{DL_newtx} is the number of newly transmitted DL transport blocks, N_{DL_retx} is the number of retransmitted DL transport blocks, and $N_{DL_correct_rx}$ is the number of correctly received DL transport blocks. All the above numbers of transmitted, retransmitted or correctly received DL transport blocks are calculated as the sum of the numbers of DL transport blocks per CG used for DC					

transmission or reception, separately.
Note 4: 35160 bits for sub-frame 5.
Note 5: 71112 bits for sub-frame 5.
Note 6: 52752 bits for sub-frame 5.

Table 8.7.6-3: Test points for sustained data rate (FRC DC 64QAM)

DC config	Maximum supported Bandwidth combination (MHz)	Cat. 3	Cat. 4	Cat. 6, 7	Cat. 9, 10	Cat. 11, 12	
						DL Cat. 11,12	
DC with 2CCs	2x10	1	2	2	2	-	
	10+20	1	2	3	3	-	
	2x15	1	2	4	4	-	
	15+20	1	2	5	5	-	
	2x20	1	2	6	6	-	
	10+15	1	2	6A	6A	-	
	15+5	7	7	7	7	-	
DC with 3 CCs	15+20+20	-	-	8	8	8	
	15+15+20	-	-	9	9	9	
	10+10+20	-	-	10	10	10	
	10+15+15	-	-	11	11	11	
	10+15+20	-	-	12	12	12	
	10+20+20	-	-	13	13	13	
	20+20+20	-	-	14	14	14	

Table 8.7.6-4: Minimum requirement (DC 256QAM)

Test number	Bandwidth combination (MHz)	Measurement channel	Reference value TB success rate (%)		
			DRB type of Split bearer (Note 2)	DRB type of SCG bearer (Note 3)	
				MCG	SCG
1	2x10	R.68-2 FDD	85	85	85
2	10+20	R.68-2 FDD for 10MHz CC R.68 FDD for 20MHz CC	85	85	85
3	2x15	R.68-1 FDD	85	85	85
4	15+20	R.68-1 FDD for 15MHz CC R.68 FDD for 20MHz CC	85	85	85
5	2x20	R.68 FDD	85	85	85
6	15+5	R.68-1 FDD for 15MHz CC R.68-3 FDD for 5MHz CC	85	85	85
6A	10+15	R.68-2 FDD for 10MHz CC R.68-1 FDD for 15MHz CC	85	85	85
7	15+20+20	R.68-1 FDD for 15MHz CC R.68 FDD for 20MHz CC	85	85	85
8	15+15+20	R.68-1 FDD for 15MHz CC R.68 FDD for 20MHz CC	85	85	85
9	10+10+20	R.68-2 FDD for 10MHz CC R.68 FDD for 20MHz CC	85	85	85
10	10+15+15	R.68-2 FDD for 10MHz CC R.68-1 FDD for 15MHz CC	85	85	85
11	10+15+20	R.68-2 FDD for 10MHz CC R.68-1 FDD for 15MHz CC R.68 FDD for 20MHz CC	85	85	85
12	10+20+20	R.68-2 FDD for 10MHz CC R.68 FDD for 20MHz CC	85	85	85
13	20+20+20	R.68 FDD	85	85	85
Note 1:	For 2 layer transmissions, 2 transport blocks are received within a TTI.				
Note 2:	For the configuration of DRB type of Split bearer, the TB success rate across CGs is defined as TB success rate = $100\% \cdot N_{DL_correct_rx} / (N_{DL_newtx} + N_{DL_retx})$, where N_{DL_newtx} is the number of newly transmitted DL transport blocks, N_{DL_retx} is the number of retransmitted DL transport blocks, and $N_{DL_correct_rx}$ is the number of correctly received DL transport blocks. All the above numbers of transmitted, retransmitted or correctly received DL transport blocks are calculated as the sum of the numbers of DL transport blocks across all the CGs used for DC transmission or reception.				
Note 3:	For the configuration of DRB type of SCG bearer, the TB success rate across CGs is defined as TB success rate = $100\% \cdot N_{DL_correct_rx} / (N_{DL_newtx} + N_{DL_retx})$, where N_{DL_newtx} is the number of newly transmitted DL transport blocks, N_{DL_retx} is the number of retransmitted DL transport blocks, and $N_{DL_correct_rx}$ is the number of correctly received DL transport blocks. All the above numbers of transmitted, retransmitted or correctly received DL transport blocks are calculated as the sum of the numbers of DL				

transport blockes per CG used for DC transmission or reception, separately.

Table 8.7.6-5: Test points for sustained data rate (FRC DC 256QAM)

DC config	Maximum supported Bandwidth combination (MHz)	Cat. 11, 12	DL Cat. 13	DL Cat. 15				
		DL Cat. 11,12						
DC with 2CCs	2x10	1	1	-				
	10+20	2	2	-				
	2x15	3	3	-				
	15+20	4	4	-				
	2x20	5	5	-				
	10+15	6A	6A	-				
	15+5	6	6	-				
DC with 3CCs	15+20+20	7	5	7				
	15+15+20	8	4	8				
	10+10+20	9	2	9				
	10+15+15	10	3	10				
	10+15+20	11	4	11				
	10+20+20	12	5	12				
	20+20+20	13	5	13				

8.7.7 TDD (DC)

The parameters specified in Table 8.7.7-1 are valid for all TDD DC tests unless otherwise stated.

Table 8.7.7-1: Common Test Parameters (TDD)

Parameter	Unit	Value	
Uplink downlink configuration		2 (Note 2)	
Special subframe configuration		4	
Cyclic prefix		Normal	
Cell ID		0	
Inter-TTI Distance		1	
Number of HARQ processes per component carrier	Processes	7	
Maximum number of HARQ transmission		4	
Redundancy version coding sequence		{0,0,1,2} for 64QAM and 256QAM	
Number of OFDM symbols for PDCCH per component carrier	OFDM symbols	1	
Cross carrier scheduling		Not configured	
Propagation condition		Static propagation condition No external noise sources are applied	
Transmission mode		TM3	
Codebook subset restriction		10	
Antenna configuration		2x2	
\hat{E}_s at antenna port (dBm/15kHz)		-85	
Symbols for unused PRBs		OP.1 TDD	
ACK/NACK feedback mode		Separate ACK/NACK feedbacks with PUCCH format 3 on the MCG and SCG	
Time offset between MCG CC and SCG CC	μs	0 for UE under test supporting synchronous dual connectivity; 500 for UE under test supporting both asynchronous and synchronous dual connectivity (Note 1)	
Downlink power allocation	ρ_A	dB	-3
	ρ_B	dB	-3
	σ	dB	0
Note 1: Asynchronous and synchronous dual connectivity are defined in TS36.300 [11].			
Note 2: If the UE supports both SCG bearer and Split bearer, the Split bearer is configured.			

For UE not supporting 256QAM, the requirements are specified in Table 8.7.7-2, with the addition of the parameters in Table 8.7.7-1 and the downlink physical channel setup according to Annex C.3.2. The test points are applied to UE category and bandwidth combination with maximum aggregated bandwidth as specified in Table 8.7.7-3. The TB success rate shall be sustained during at least 300 frames.

For UE supporting 256QAM, the requirements are specified in Table 8.7.7-4, with the addition of the parameters in Table 8.7.7-1 and the downlink physical channel setup according to Annex C.3.2. The test points are applied to UE category and bandwidth combination with maximum aggregated bandwidth as specified in Table 8.7.7-5. The TB success rate shall be sustained during at least 300 frames. For UE supporting 256QAM, the requirements in Table 8.7.7-2 are not applicable.

The applicability of their requirements are specified in Clause 8.1.2.3A.

Table 8.7.7-2: Minimum requirement (DC 64QAM)

Test number	Bandwidth combination (MHz)	Number of bits of a DL-SCH transport block received within a TTI	Measurement channel	Reference value TB success rate across CGs(%)		
				DRB type of Split bearer (Note 2)	DRB type of SCG bearer (Note 3)	
					MCG	SCG
1	2x20	75376/0 (Note 4)	R.31-4A TDD	85	85	85
2	3x20	75376/0 (Note 4)	R.31-4A TDD	85	85	85
3	4x20	75376/0 (Note 4)	R.31-4A TDD	85	85	85
4	15+3x20	55056/0 for 15MHz CC 75376/0 for 20MHz CC (Note 4)	R.31-5 TDD for 15MHz CC R.31-4 TDD for 20MHz CC	85	85	85
Note 1:	For 2 layer transmissions, 2 transport blocks are received within a TTI.					
Note 2:	For the configuration of DRB type of Split bearer, the TB success rate across CGs is defined as TB success rate = $100\% \cdot N_{DL_correct_rx} / (N_{DL_newtx} + N_{DL_retx})$, where N_{DL_newtx} is the number of newly transmitted DL transport blocks, N_{DL_retx} is the number of retransmitted DL transport blocks, and $N_{DL_correct_rx}$ is the number of correctly received DL transport blocks. All the above numbers of transmitted, retransmitted or correctly received DL transport blocks are calculated as the sum of the numbers of DL transport blocks across all the CGs used for DC transmission or reception.					
Note 3:	For the configuration of DRB type of SCG bearer, the TB success rate across CGs is defined as TB success rate = $100\% \cdot N_{DL_correct_rx} / (N_{DL_newtx} + N_{DL_retx})$, where N_{DL_newtx} is the number of newly transmitted DL transport blocks, N_{DL_retx} is the number of retransmitted DL transport blocks, and $N_{DL_correct_rx}$ is the number of correctly received DL transport blocks. All the above numbers of transmitted, retransmitted or correctly received DL transport blocks are calculated as the sum of the numbers of DL transport blocks per CG used for DC transmission or reception, separately.					
Note 4:	71112 bits for sub-frame 5.					

Table 8.7.7-3: Test points for sustained data rate (FRC DC 64QAM)

DC config	Maximum supported Bandwidth combination (MHz)	Cat. 3	Cat. 4	Cat. 6, 7	Cat. 9, 10	Cat. 11, 12	DL Cat.15
						DL Cat. 11, 12	
DC with 2CCs	2x20	-	-	1	1	-	-
DC with 3CCs	3x20	-	-	1	2	2	-
DC with 4CCs	4x20	-	-	-	2	3	3
	15+3x20	-	-	-	2	4	4

Table 8.7.7-4: Minimum requirement (DC 256QAM)

Test number	Bandwidth combination (MHz)	Measurement channel	Reference value TB success rate (%)		
			DRB type of Split bearer (Note 2)	DRB type of SCG bearer (Note 3)	
				MCG	SCG
1	2x20	R.68-3 TDD	85	85	85
Note 1:	For 2 layer transmissions, 2 transport blocks are received within a TTI.				
Note 2:	For the configuration of DRB type of Split bearer, the TB success rate across CGs is defined as TB success rate = $100\% \cdot N_{DL_correct_rx} / (N_{DL_newtx} + N_{DL_retx})$, where N_{DL_newtx} is the number of newly transmitted DL transport blocks, N_{DL_retx} is the number of retransmitted DL transport blocks, and $N_{DL_correct_rx}$ is the number of correctly received DL transport blocks. All the above numbers of transmitted, retransmitted or correctly received DL transport blocks are calculated as the sum of the numbers of DL transport blocks across all the CGs used for DC transmission or reception.				
Note 3:	For the configuration of DRB type of SCG bearer, the TB success rate across CGs is defined as TB success rate = $100\% \cdot N_{DL_correct_rx} / (N_{DL_newtx} + N_{DL_retx})$, where N_{DL_newtx} is the number of newly transmitted DL transport blocks, N_{DL_retx} is the number of				

retransmitted DL transport blocks, and $N_{DL_correct_rx}$ is the number of correctly received DL transport blocks. All the above numbers of transmitted, retransmitted or correctly received DL transport blocks are calculated as the sum of the numbers of DL transport blockes per CG used for DC transmission or reception, separately.

Table 8.7.7-5: Test points for sustained data rate (FRC DC 256QAM)

DC config	Maximum supported Bandwidth combination (MHz)	Cat. 11, 12	DL Cat. 13	DL Cat. 15	DL Cat. 16		
		DL Cat. 11, 12					
DC with 2CCs	2x20	1	1	-	-		
DC with 3CCs	3x20	2	1	2	-		
DC with 4CCs	4x20	2	-	3	3		
	15+3x20	2	-	4	4		

8.7.8 TDD FDD (DC)

The parameters specified in Table 8.7.8-1 are valid for all TDD FDD DC tests unless otherwise stated.

Table 8.7.8-1: Common Test Parameters (TDD FDD DC)

Parameter	Unit	Value	
Uplink downlink configuration for TDD CC		2 (Note 2)	
Special subframe configuration for TDD CC		4	
Cyclic prefix		Normal	
Cell ID		0	
Inter-TTI Distance		1	
Number of HARQ processes per component carrier	Processes	8 for FDD CC; 7 for TDD CC	
Maximum number of HARQ transmission		4	
Redundancy version coding sequence		{0,0,1,2} for 64QAM and 256QAM	
Number of OFDM symbols for PDCCH per component carrier	OFDM symbols	1	
Cross carrier scheduling		Not configured	
Propagation condition		Static propagation condition No external noise sources are applied	
Transmission mode		TM3	
Codebook subset restriction		10	
Antenna configuration		2x2	
\hat{E}_s at antenna port (dBm/15kHz)		-85	
Symbols for unused PRBs		OP.1 TDD for TDD CC; OP.1 FDD for FDD CC	
ACK/NACK feedback mode		Separate ACK/NACK feedbacks with PUCCH format 3 on the MCG and SCG	
Time offset between MCG CC and SCG CC	μ s	0 for UE under test supporting synchronous dual connectivity; 500 for UE under test supporting both asynchronous and synchronous dual connectivity (Note 1)	
Downlink power allocation	ρ_A	dB	-3
	ρ_B	dB	-3
	σ	dB	0
Note 1: Asynchronous and synchrony dual connectivity are defined in TS36.300 [11].			
Note 2: If the UE supports both SCG bearer and Split bearer, the Split bearer is configured.			

For UE not supporting 256QAM, the requirements are specified in Table 8.7.8-2, with the addition of the parameters in Table 8.7.8-1 and the downlink physical channel setup according to Annex C.3.2. The test points are applied to UE category and bandwidth combination with maximum aggregated bandwidth as specified in Table 8.7.8-3. The TB success rate shall be sustained during at least 300 frames.

For UE supporting 256QAM, the requirements are specified in Table 8.7.8-4, with the addition of the parameters in Table 8.7.7-1 and the downlink physical channel setup according to Annex C.3.2. The test points are applied to UE category and bandwidth combination with maximum aggregated bandwidth as specified in Table 8.7.8-5. The TB success rate shall be sustained during at least 300 frames. For UE supporting 256QAM, the requirements in Table 8.7.8-2 are not applicable.

The applicability of their requirements are specified in Clause 8.1.2.3A.

Table 8.7.8-2: Minimum requirement (TDD FDD DC 64QAM)

Test number	Bandwidth (MHz)			Number of bits of a DL-SCH transport block received within a TTI (for normal/special subframe for TDD, except for subframe #5)		Measurement channel		Reference value TB success rate across CGs(%)		
								DRB type of Split bearer (Note 2)	DRB type of SCG bearer (Note 3)	
	Total	FDD CC	TDD CC	FDD CC	TDD CC	FDD CC	TDD CC		MCG	SCG
1	2x20	20	20	75376 (Note 4)	75376/0 (Note 4)	R.31-4 FDD	R.31-4A TDD	85	85	85
Note 1:	For 2 layer transmissions, 2 transport blocks are received within a TTI.									
Note 2:	For the configuration of DRB type of Split bearer, the TB success rate across CGs is defined as TB success rate = $100\% \cdot N_{DL_correct_rx} / (N_{DL_newtx} + N_{DL_retx})$, where N_{DL_newtx} is the number of newly transmitted DL transport blocks, N_{DL_retx} is the number of retransmitted DL transport blocks, and $N_{DL_correct_rx}$ is the number of correctly received DL transport blocks. All the above numbers of transmitted, retransmitted or correctly received DL transport blocks are calculated as the sum of the numbers of DL transport blocks across all the CGs used for DC transmission or reception.									
Note 3:	For the configuration of DRB type of SCG bearer, the TB success rate across CGs is defined as TB success rate = $100\% \cdot N_{DL_correct_rx} / (N_{DL_newtx} + N_{DL_retx})$, where N_{DL_newtx} is the number of newly transmitted DL transport blocks, N_{DL_retx} is the number of retransmitted DL transport blocks, and $N_{DL_correct_rx}$ is the number of correctly received DL transport blocks. All the above numbers of transmitted, retransmitted or correctly received DL transport blocks are calculated as the sum of the numbers of DL transport blocks per CG used for DC transmission or reception, separately.									
Note 4:	71112 bits for sub-frame 5.									

Table 8.7.8-3: Test points for sustained data rate (FRC TDD FDD DC 64QAM)

CA config	Maximum supported Bandwidth/ Bandwidth combination (MHz)			Cat. 6, 7	Cat. 9,10	
	Total	FDD CC	TDD CC			
DC with 2CCs	2x20	20	20	1	1	

Table 8.7.8-4: Minimum requirement (TDD FDD DC 256QAM)

Test number	Bandwidth (MHz)			Measurement channel		Reference value TB success rate across CGs(%)		
						DRB type of Split bearer (Note 2)	DRB type of SCG bearer (Note 3)	
	Total	FDD CC	TDD CC	FDD CC	TDD CC		MCG	SCG

1	2x20	20	20	R.68 FDD	R.68-3 TDD	85	85	85
<p>Note 1: For 2 layer transmissions, 2 transport blocks are received within a TTI.</p> <p>Note 2: For the configuration of DRB type of Split bearer, the TB success rate across CGs is defined as TB success rate = $100\% \cdot N_{DL_correct_rx} / (N_{DL_newtx} + N_{DL_retx})$, where N_{DL_newtx} is the number of newly transmitted DL transport blocks, N_{DL_retx} is the number of retransmitted DL transport blocks, and $N_{DL_correct_rx}$ is the number of correctly received DL transport blocks. All the above numbers of transmitted, retransmitted or correctly received DL transport blocks are calculated as the sum of the numbers of DL transport blocks across all the CGs used for DC transmission or reception.</p> <p>Note 3: For the configuration of DRB type of SCG bearer, the TB success rate across CGs is defined as TB success rate = $100\% \cdot N_{DL_correct_rx} / (N_{DL_newtx} + N_{DL_retx})$, where N_{DL_newtx} is the number of newly transmitted DL transport blocks, N_{DL_retx} is the number of retransmitted DL transport blocks, and $N_{DL_correct_rx}$ is the number of correctly received DL transport blocks. All the above numbers of transmitted, retransmitted or correctly received DL transport blocks are calculated as the sum of the numbers of DL transport blocks per CG used for DC transmission or reception, separately.</p>								

Table 8.7.8-5: Test points for sustained data rate (FRC TDD FDD DC 256QAM)

CA config	Maximum supported Bandwidth/ Bandwidth combination (MHz)			Cat. 11, 12	DL Cat. 13				
	Total	FDD CC	TDD CC	DL Cat. 11, 12					
DC with 2CCs	2x20	20	20	1	1				
<p>Note 1: If DL category is signalled by the UE under test, then select the test point according to UE DL Category. Otherwise, select the test point according to the UE category signalled.</p>									

8.7.9 Void

Table 8.7.9-1: Void

Table 8.7.9-2: Void

Table 8.7.9-3: Void

Table 8.7.9-4: Void

Table 8.7.9-5: Void

8.7.10 Void

Table 8.7.10-1: Void

Table 8.7.10-2: Void

Table 8.7.10-3: Void

Table 8.7.10-4: Void

Table 8.7.10-5: Void

8.7.11 Void

Table 8.7.11-1: Void

8.7.11.1 Void

Table 8.7.11.1-1: Void

Table 8.7.11.1-2: Void

Table 8.7.11.1-3: Void

Table 8.7.11.1-4: Void

8.8 Demodulation of EPDCCH

The receiver characteristics of the EPDCCH are determined by the probability of miss-detection of the Downlink Scheduling Grant (Pm-dsg). For the distributed transmission tests in 8.8.1, EPDCCH and PCFICH are tested jointly, i.e. a miss detection of PCFICH implies a miss detection of EPDCCH. For other tests, EPDCCH and PCFICH are not tested jointly.

8.8.1 Distributed Transmission

8.8.1.1 FDD

The parameters specified in Table 8.8.1.1-1 are valid for all FDD distributed EPDCCH tests unless otherwise stated.

Table 8.8.1.1-1: Test Parameters for Distributed EPDCCH

Parameter		Unit	Value
Number of PDCCH symbols		symbols	2 (Note 1)
PHICH duration			Normal
Unused RE-s and PRB-s			OCNG
Cell ID			0
Downlink power allocation	ρ_A	dB	-3
	ρ_B	dB	-3
	σ	dB	0
	δ	dB	3
N_{oc} at antenna port		dBm/15 kHz	-98
Cyclic prefix			Normal
Subframe Configuration			Non-MBSFN
Precoder Update Granularity	PRB		1
	ms		1
Beamforming Pre-Coder			Annex B. 4.4
Cell Specific Reference Signal			Port 0 and 1
Number of EPDCCH Sets Configured			2 (Note 2)
Number of PRB per EPDCCH Set			4 (1 st Set) 8 (2 nd Set)
EPDCCH Subframe Monitoring			NA
PDSCH TM			TM3
DCI Format			2A
Note 1: The starting symbol for EPDCCH is derived from the PCFICH. RRC signalling <i>epdcch-StartSymbol-r11</i> is not configured.			
Note 2: The two sets are distributed EPDCCH sets and non-overlapping with PRB = {3, 17, 31, 45} for the first set and PRB = {0, 7, 14, 21, 28, 35, 42, 49} for the second set. EPDCCH is scheduled in the first set for Test 1 and second set for Test 2, respectively. Both sets are always configured.			

For the parameters specified in Table 8.8.1.1-1 the average probability of a missed downlink scheduling grant (Pm-dsg) shall be below the specified value in Table 8.8.1.1-2. The downlink physical setup is in accordance with Annex C.3.2.

Table 8.8.1.1-2: Minimum performance Distributed EPDCCH

Test number	Bandwidth	Aggregation level	Reference Channel	OCNG Pattern	Propagation Condition	Antenna configuration and correlation Matrix	Reference value	
							Pm-dsg (%)	SNR (dB)
1	10 MHz	4 ECCE	R.55 FDD	OP.7 FDD	EVA5	2 x 2 Low	1	2.60
2	10 MHz	16 ECCE	R.56 FDD	OP.7 FDD	EVA70	2 x 2 Low	1	-3.20

8.8.1.1.1 Void

Table 8.8.1.1.1-1: Void

8.8.1.2 TDD

The parameters specified in Table 8.8.1.2-1 are valid for all TDD distributed EPDCCH tests unless otherwise stated.

Table 8.8.1.2-1: Test Parameters for Distributed EPDCCH

Parameter		Unit	Value
Number of PDCCH symbols		symbols	2 (Note 1)
PHICH duration			Normal
Unused RE-s and PRB-s			OCNG
Cell ID			0
Downlink power allocation	ρ_A	dB	-3
	ρ_B	dB	-3
	σ	dB	0
	δ	dB	3
N_{oc} at antenna port		dBm/15 kHz	-98
Cyclic prefix			Normal
Subframe Configuration			Non-MBSFN
Precoder Update Granularity	PRB		1
	ms		1
Beamforming Pre-Coder			Annex B. 4.4
Cell Specific Reference Signal			Port 0 and 1
Number of EPDCCH Sets Configured			2 (Note 2)
Number of PRB per EPDCCH Set			4 (1 st Set) 8 (2 nd Set)
EPDCCH Subframe Monitoring			NA
PDSCH TM			TM3
DCI Format			2A
TDD UL/DL Configuration			0
TDD Special Subframe			1 (Note 3)
Note 1: The starting symbol for EPDCCH is derived from the PCFICH. RRC signalling <i>epdcch-StartSymbol-r11</i> is not configured.			
Note 2: The two sets are distributed EPDCCH sets and non-overlapping with PRB = {3, 17, 31, 45} for the first set and PRB = {0, 7, 14, 21, 28, 35, 42, 49} for the second set. EPDCCH is scheduled in the first set for Test 1 and second set for Test 2, respectively. Both sets are always configured.			
Note 3: Demodulation performance is averaged over normal and special subframe.			

For the parameters specified in Table 8.8.1.2-1 the average probability of a missed downlink scheduling grant (Pm-dsg) shall be below the specified value in Table 8.8.1.2-2. The downlink physical setup is in accordance with Annex C.3.2.

Table 8.8.1.2-2: Minimum performance Distributed EPDCCH

Test number	Bandwidth	Aggregation level	Reference Channel	OCNG Pattern	Propagation Condition	Antenna configuration and correlation Matrix	Reference value	
							Pm-dsg (%)	SNR (dB)
1	10 MHz	4 ECCE	R.55 TDD	OP.7 TDD	EVA5	2 x 2 Low	1	2.80
2	10 MHz	16 ECCE	R.56 TDD	OP.7 TDD	EVA70	2 x 2 Low	1	-3.10

8.8.1.2.1 Void

Table 8.8.1.2.1-1: Void

8.8.2 Localized Transmission with TM9

8.8.2.1 FDD

The parameters specified in Table 8.8.2.1-1 are valid for all FDD TM9 localized ePDCCH tests unless otherwise stated.

Table 8.8.2.1-1: Test Parameters for Localized EPDCCH with TM9

Parameter		Unit	Value
Number of PDCCH symbols		symbols	1 (Note 1)
EPDCCH starting symbol		symbols	2 (Note 1)
PHICH duration			Normal
Unused RE-s and PRB-s			OCNG
Cell ID			0
Downlink power allocation	ρ_A	dB	0
	ρ_B	dB	0
	σ	dB	-3
	δ	dB	0
N_{oc} at antenna port		dBm/15 kHz	-98
Cyclic prefix			Normal
Subframe Configuration			Non-MBSFN
Precoder Update Granularity	PRB		1
	ms		1
Beamforming Pre-Coder			Annex B.4.5
Cell Specific Reference Signal			Port 0 and 1
CSI-RS Reference Signal			Port 15 and 16
CSI-RS reference signal resource configuration			0
CSI reference signal subframe configuration l_{CSI-RS}			2
ZP-CSI-RS configuration bitmap			0000010000000000
ZP-CSI-RS subframe configuration $l_{ZP-CSI-RS}$			2
Number of EPDCCH Sets			2 (Note 2)
EPDCCH Subframe Monitoring pattern <i>subframePatternConfig-r11</i>			1111111110 1111111101 1111111011 1111110111 (Note 3)
PDSCH TM			TM9
Note 1: The starting symbol for EPDCCH is signalled with <i>epdcch-StartSymbol-r11</i> . However, CFI is set to 1.			
Note 2: The first set is distributed transmission with PRB = {0, 49} and the second set is localized transmission with PRB = {0, 7, 14, 21, 28, 35, 42, 49}. ePDCCH is scheduled in the second set for all tests.			
Note 3: EPDCCH is scheduled in every SF. UE is required to monitor ePDCCH for UE-specific search space only in SFs configured by <i>subframePatternConfig-r11</i> . Legacy PDCCH is not scheduled.			

For the parameters specified in Table 8.8.2.1-1 the average probability of a missed downlink scheduling grant (Pm-dsg) shall be below the specified value in Table 8.8.2.1-2. EPDCCH subframe monitoring is configured and the subframe monitoring requirement in EPDCCH restricted subframes is statDTX of 99.9%.

The downlink physical setup is in accordance with Annex C.3.2.

Table 8.8.2.1-2: Minimum performance Localized EPDCCH with TM9

Test number	Bandwidth	Aggregation level	Reference Channel	OCNG Pattern	Propagation Condition	Antenna configuration and correlation Matrix	Reference value	
							Pm-dsg (%)	SNR (dB)
1	10 MHz	2 ECCE	R.57 FDD	OP.7 FDD	EVA5	2 x 2 Low	1	12.2
2	10 MHz	8 ECCE	R.58 FDD	OP.7 FDD	EVA5	2 x 2 Low	1	2.5

8.8.2.1.1 Void

Table 8.8.2.1.1-1: Void

8.8.2.1.2 Void

Table 8.8.2.1.2-1: Void**Table 8.8.2.1.2-2: Void****Table 8.8.2.1.2-3: Void**

8.8.2.2 TDD

The parameters specified in Table 8.8.2.2-1 are valid for all TDD TM9 localized ePDCCH tests unless otherwise stated.

Table 8.8.2.2-1: Test Parameters for Localized EPDCCH with TM9

Parameter		Unit	Value
Number of PDCCH symbols		symbols	1 (Note 1)
EPDCCH starting symbol		symbols	2 (Note 1)
PHICH duration			Normal
Unused RE-s and PRB-s			OCNG
Cell ID			0
Downlink power allocation	ρ_A	dB	0
	ρ_B	dB	0
	σ	dB	-3
	δ	dB	0
N_{oc} at antenna port		dBm/15 kHz	-98
Cyclic prefix			Normal
Subframe Configuration			Non-MBSFN
Precoder Update Granularity	PRB		1
	ms		1
Beamforming Pre-Coder			Annex B.4.5
Cell Specific Reference Signal			Port 0 and 1
CSI-RS Reference Signal			Port 15 and 16
CSI-RS reference signal resource configuration			0
CSI reference signal subframe configuration l_{CSI-RS}			0
ZP-CSI-RS configuration bitmap			0000010000000000
ZP-CSI-RS subframe configuration $l_{ZP-CSI-RS}$			0
Number of EPDCCH Sets			2 (Note 2)
EPDCCH Subframe Monitoring pattern <i>subframePatternConfig-r11</i>			1100011000 1100010000 1100011000 1100001000 1100011000 1000011000 1100011000 (Note 3)
PDSCH TM			TM9
TDD UL/DL Configuration			0
TDD Special Subframe			1 (Note 4)
Note 1: The starting symbol for EPDCCH is signalled with <i>epdcch-StartSymbol-r11</i> . However, CFI is set to 1.			
Note 2: The first set is distributed transmission with PRB = {0, 49} and the second set is localized transmission with PRB = {0, 7, 14, 21, 28, 35, 42, 49}. ePDCCH is scheduled in the second set for all tests.			
Note 3: EPDCCH is scheduled in every SF. UE is required to monitor ePDCCH for UE-specific search space only in SFs configured by <i>subframePatternConfig-r11</i> . Legacy PDCCH is not scheduled.			
Note 4: Demodulation performance is averaged over normal and special subframe.			

For the parameters specified in Table 8.8.2.2-1 the average probability of a missed downlink scheduling grant (Pm-dsg) shall be below the specified value in Table 8.2.2.2-2. EPDCCH subframe monitoring is configured and the subframe monitoring requirement in EPDCCH restricted subframes is statDTX of 99.9%.

The downlink physical setup is in accordance with Annex C.3.2.

Table 8.8.2.2-2: Minimum performance Localized EPDCCH with TM9

Test number	Bandwidth	Aggregation level	Reference Channel	OCNG Pattern	Propagation Condition	Antenna configuration and correlation Matrix	Reference value	
							Pm-dsg (%)	SNR (dB)
1	10 MHz	2 ECCE	R.57 TDD	OP.7 TDD	EVA5	2 x 2 Low	1	12.8
2	10 MHz	8 ECCE	R.58 TDD	OP.7 TDD	EVA5	2 x 2 Low	1	2.0

8.8.2.2.1 Void

Table 8.8.2.2.1-1: Void

8.8.2.2.2 Void

Table 8.8.2.2.2-1: Void

Table 8.8.2.2.2-2: Void

Table 8.8.2.2.2-3: Void

8.8.3 Localized transmission with TM10 Type B quasi co-location type

8.8.3.1 FDD

For the parameters specified in Table 8.8.3.1-1 the average probability of a missed downlink scheduling grant (P_{m-dsg}) shall be below the specified values in Table 8.8.3.1-2. In Table 8.8.3.1-1, transmission point 1 (TP 1) is the serving cell. The downlink physical setup is in accordance with Annex C.3.2.

Table 8.8.3.1-1: Test Parameters for Localized Transmission TM10 Type B quasi co-location type

Parameter		Unit	Test 1		Test 2	
			TP 1	TP 2	TP 1	TP 2
PHICH duration			Normal			
Downlink power allocation	ρ_A	dB	0			
	ρ_B	dB	0			
	σ	dB	-3			
	δ	dB	0			
\hat{E}_s / N_{oc}		dB	0dB power imbalance is considered between TP 1 and TP 2,	Reference value in Table 8.8.3.1-2	Reference value in Table 8.8.3.1-2	Reference value in Table 8.8.3.1-2
N_{oc} at antenna port		dBm/15kHz	-98			
Bandwidth		MHz	10	10	10	10
Number of configured EPDCCH Sets			2 (Note 1)		2 (Note1)	
EPDCCH-PRB-Set ID (setConfigId)			0	1	0	1
Transmission type of EPDCCH-PRB-set			Localized	Localized	Localized	Localized
Number of PRB pair per EPDCCH-PRB-set		PRB	8	8	8	8
EPDCCH beamforming model			Annex B.4.5	Annex B.4.5	Annex B.4.5	Annex B.4.5
PDSCH transmission mode			TM10	TM10	TM10	TM10
PDSCH transmission scheduling			Blanked in all the subframes	Transmit in all the subframes	Probability of occurrence of PDSCH transmission is 30% (Note 3)	Probability of occurrence of PDSCH transmission is 70% (Note 3)
Non-zero power CSI reference signal (NZPId=1)	CSI reference signal configuration		N/A	0	N/A	0
	CSI reference signal subframe configuration l_{CSI-RS}		N/A	2	N/A	2
Non-zero power CSI reference signal (NZPId=2)	CSI reference signal configuration		N/A	N/A	10	N/A
	CSI reference signal subframe configuration l_{CSI-RS}		N/A	N/A	2	N/A
Zero power CSI reference signal (ZPId=1)	CSI-RS Configuration list (ZeroPowerCSI-RS bitmap)	Bitmap	N/A	000001000000000	N/A	100001000000000
	CSI-RS subframe configuration l_{CSI-RS}		N/A	2	N/A	2
Zero power CSI reference signal (ZPId=2)	CSI-RS Configuration list (ZeroPowerCSI-RS bitmap)	Bitmap	N/A	N/A	100001000000000	N/A
	CSI-RS subframe configuration l_{CSI-RS}		N/A	N/A	2	N/A
PQI set 0 (Note 4)	Non-Zero power CSI RS Identity (NZPId)		N/A	1	N/A	1

	Zero power CSI RS Identity (ZPId)		N/A	1	N/A	1
PQI set 1 (Note 4)	Non-Zero power CSI RS Identity (NZPId)		N/A	N/A	2	N/A
	Zero power CSI RS Identity (ZPId)		N/A	N/A	2	N/A
Number of PDCCH symbols	Symbols	1 (Note 2)				
EPDCCH starting position		pdsch-Start-r11=2 (Note 2)	pdsch-Start-r11=2 (Note 2)	pdsch-Start-r11=2 (Note 2)	pdsch-Start-r11=2 (Note 2)	
Subframe configuration		Non-MBSFN	Non-MBSFN	Non-MBSFN	Non-MBSFN	
Time offset between TPs	μ s	N/A	2	N/A	2	
Frequency shift between TPs	Hz	N/A	200	N/A	200	
Cell ID		0	126	0	126	
Note 1:	Resource blocks $n_{PRB} = 0, 7, 14, 21, 28, 35, 42, 49$ are allocated for both the first set and the second set.					
Note 2:	The starting OFDM symbol for EPDCCH is determined from the higher layer signalling pdsch-Start-r11. And CFI is set to 1.					
Note 3:	The TP from which PDSCH is transmitted shall be randomly determined independently for each subframe. Probabilities of occurrence of PDSCH transmission from TP 1 and TP 2 are specified.					
Note 4:	For PQI set 0, PDSCH and EPDCCH are transmitted from TP 2. For PQI set 1, PDSCH and EPDCCH are transmitted from TP1. EPDCCH and PDSCH are transmitted from same TP.					

Table 8.8.3.1-2: Minimum Performance

Test number	Aggregation level	Reference Channel	OCNG Pattern	Propagation Condition	Antenna configuration and correlation Matrix	Reference value	
						Pm-dsg (%)	SNR (dB)
1	2 ECCE	R.59 FDD	OP.7 FDD	EVA5	2 x 2 Low	1	13.4
2	2 ECCE	R.59 FDD	OP.7 FDD	EVA5	2 x 2 Low	1	13.4

8.8.3.2 TDD

For the parameters specified in Table 8.8.3.2-1 the average probability of a missed downlink scheduling grant (Pm-dsg) shall be below the specified values in Table 8.8.3.2-2. In Table 8.8.3.2-1, transmission point 1 (TP1) is the serving cell. The downlink physical setup is in accordance with Annex C.3.2.

Table 8.8.3.2-1: Test Parameters for Localized Transmission TM10 Type B quasi co-location type

Parameter		Unit	Test 1		Test 2	
			TP 1	TP 2	TP 1	TP 2
PHICH duration			Normal			
Downlink power allocation	ρ_A	dB	0			
	ρ_B	dB	0			
	σ	dB	-3			
	δ	dB	0			
\hat{E}_s/N_{oc}		dB	0dB power imbalance is considered between TP 1 and TP 2,	Reference value in Table 8.8.3.2-2	Reference value in Table 8.8.3.2-2	Reference value in Table 8.8.3.2-2
N_{oc} at antenna port		dBm/15kHz	-98			
Bandwidth		MHz	10	10	10	10
Number of EPDCCH Sets			2 (Note 1)		2 (Note1)	
EPDCCH-PRB-Set ID (setConfigId)			0	1	0	1
Transmission type of EPDCCH-PRB-set			Localized	Localized	Localized	Localized
Number of PRB pair per EPDCCH-PRB-set		PRB	8	8	8	8
EPDCCH beamforming model			Annex B.4.5	Annex B.4.5	Annex B.4.5	Annex B.4.5
PDSCH transmission mode			TM10	TM10	TM10	TM10
PDSCH transmission scheduling			Blanked in all the subframes	Transmit in all the subframes	Probability of occurrence of PDSCH transmission is 30% (Note 3)	Probability of occurrence of PDSCH transmission is 70% (Note 3)
CSI reference signal configurations			Antenna ports 15,16	Antenna ports 15,16	Antenna ports 15,16	Antenna ports 15,16
Non-zero power CSI reference signal (NZPId=1)	CSI reference signal configuration		N/A	0	N/A	0
	CSI reference signal subframe configuration l_{CSI-RS}		N/A	0	N/A	0
Non-zero power CSI reference signal (NZPId=2)	CSI reference signal configuration		N/A	N/A	10	N/A
	CSI reference signal subframe configuration l_{CSI-RS}		N/A	N/A	0	N/A
Zero power CSI reference signal (ZPId=1)	CSI-RS Configuration list (ZeroPowerCSI-RS bitmap)	Bitmap	N/A	000001000000000	N/A	100001000000000
	CSI-RS subframe configuration l_{CSI-RS}		N/A	0	N/A	0
Zero power CSI reference signal (ZPId=2)	CSI-RS Configuration list (ZeroPowerCSI-RS bitmap)	Bitmap	N/A	N/A	100001000000000	N/A
	CSI-RS subframe configuration l_{CSI-RS}		N/A	N/A	0	N/A

PQI set 0 (Note 4)	Non-Zero power CSI RS Identity (NZPId)		N/A	1	N/A	1
	Zero power CSI RS Identity (ZPId)		N/A	1	N/A	1
PQI set 1 (Note 4)	Non-Zero power CSI RS Identity (NZPId)		N/A	N/A	2	N/A
	Zero power CSI RS Identity (ZPId)		N/A	N/A	2	N/A
Number of PDCCH symbols		Symbols	1 (Note 2)			
EPDCCH starting position			pdsch-Start-r11=2 (Note 2)	pdsch-Start-r11=2 (Note 2)	pdsch-Start-r11=2 (Note 2)	pdsch-Start-r11=2 (Note 2)
Subframe configuration			Non-MBSFN	Non-MBSFN	Non-MBSFN	Non-MBSFN
Time offset between TPs		μ s	N/A	2	N/A	2
Frequency shift between TPs		Hz	N/A	200	N/A	200
Cell ID			0	126	0	126
TDD UL/DL configuration			0			
TDD special subframe			1			
Note 1:	Resource blocks $n_{PRB} = 0, 7, 14, 21, 28, 35, 42, 49$ are allocated for both the first set and the second set.					
Note 2:	The starting OFDM symbol for EPDCCH is determined from the higher layer signalling pdsch-Start-r11. And CFI is set to 1.					
Note 3:	The TP from which PDSCH is transmitted shall be randomly determined independently for each subframe. Probabilities of occurrence of PDSCH transmission from TP 1 and TP 2 are specified.					
Note 4:	For PQI set 0, PDSCH and EPDCCH are transmitted from TP 2. For PQI set 1, PDSCH and EPDCCH are transmitted from TP1. EPDCCH and PDSCH are transmitted from same TP.					

Table 8.8.3.2-2: Minimum Performance

Test number	Aggregation level	Reference Channel	OCNG Pattern	Propagation Condition	Antenna configuration and correlation Matrix	Reference value	
						Pm-dsg (%)	SNR (dB)
1	2 ECCE	R.59 TDD	OP.7 TDD	EVA5	2 x 2 Low	1	13.6
2	2 ECCE	R.59 TDD	OP.7 TDD	EVA5	2 x 2 Low	1	13.6

8.8.4 Enhanced Downlink Control Channel Performance Requirements Type A - Localized Transmission with CRS Interference Model

8.8.4.1 FDD

For the parameters specified in Table 8.8.4.1-1 the average probability of a missed downlink scheduling grant (Pm-dsg) shall be below the specified value in Table 8.8.4.1-2. The purpose of this test is to verify the localized EPDCCH performance, when the EPDCCH transmission in the serving cell is interfered by the CRS of the interfering cells, applying the CRS interference model defined in clause B.6.5. In Table 8.8.4.1-1, Cell 1 is the serving cell, and Cell 2 and Cell 3 are the aggressor cells. The downlink physical setup is in accordance with Annex C.3.2 for each of Cell 1, Cell 2 and Cell 3, respectively. The CRS assistance information [7] is provided and includes Cell 2 and Cell 3.

Table 8.8.4.1-1: Test Parameters for EPDCCH

Parameter		Unit	Cell 1	Cell 2	Cell 3
Number of PDCCH symbols		symbols	1 (Note 1)	2	2
EPDCCH starting symbol		symbols	2 (Note 1)	N/A	N/A
PHICH duration			Normal	Normal	Normal
Unused RE-s and PRB-s			OCNG	N/A	N/A
Cell ID			0	1	6
Downlink power allocation	ρ_A	dB	0	-3	-3
	ρ_B	dB	0	-3	-3
	σ	dB	-3	0	0
	δ	dB	0	0	0
Cell-specific reference signals			Antenna ports 0,1	Antenna ports 0,1	Antenna ports 0,1
N_{oc} at antenna port		dBm/15kHz	-98		
\bar{E}_s/N_{oc}		dB	N/A	13.91	3.34
$BW_{Channel}$		MHz	10	10	10
Cyclic Prefix			Normal	Normal	Normal
Subframe Configuration			Non-MBSFN	Non-MBSFN	Non-MBSFN
EPDCCH Precoder Update Granularity	PRB		1	N/A	N/A
	ms		1	N/A	N/A
EPDCCH Beamforming Pre-Coder			Annex B. 4.5	N/A	N/A
CSI-RS Reference Signal			Port 15 and 16	N/A	N/A
CSI-RS reference signal resource configuration			0	N/A	N/A
CSI reference signal subframe configuration l_{CSI-RS}			2	N/A	N/A
ZP-CSI-RS configuration bitmap			000001000000 0000	N/A	N/A
ZP-CSI-RS subframe configuration $l_{ZP-CSI-RS}$			2	N/A	N/A
Number of EPDCCH Sets			1	N/A	N/A
EPDCCH Set type			Localized	N/A	N/A
Number of PRB per EPDCCH Set			8	N/A	N/A
EPDCCH Set PRBs			0, 7, 14, 21, 28, 35, 42, 49	N/A	N/A
PDSCH TM			TM9	N/A	N/A
Interference model			N/A	As specified in clause B.6.5	As specified in clause B.6.5
Time offset to cell 1		μ s	N/A	2	3
Frequency offset to cell 1		Hz	N/A	200	300
Note 1: The starting symbol for EPDCCH is signalled with <i>epdcch-StartSymbol-r11</i> . CFI is set to 1.					
Note 2: EPDCCH is scheduled in every subframe. EPDCCH Subframe Monitoring pattern is not configured.					

Table 8.8.4.1-2: Minimum performance for EPDCCH for enhanced downlink control channel performance requirements Type A

Test number	Bandwidth	Aggregation level	Reference Channel	OCNG Pattern	Propagation Condition	Antenna configuration and correlation Matrix	Reference value	
							Pm-dsg (%)	SNR (dB)
1	10 MHz	2 ECCE	R.57 FDD	OP.7 FDD	EPA5	2 x 2 Low	1	13.4

8.8.4.2 TDD

For the parameters specified in Table 8.8.4.2-1 the average probability of a missed downlink scheduling grant (Pm-dsg) shall be below the specified value in Table 8.8.4.2-2. The purpose of this test is to verify the localized EPDCCH performance, when the EPDCCH transmission in the serving cell is interfered by the CRS of the interfering cells, applying the CRS interference model defined in clause B.6.5. In Table 8.8.4.2-1, Cell 1 is the serving cell, and Cell 2 and Cell 3 are the aggressor cells. The downlink physical setup is in accordance with Annex C.3.2 for each of Cell 1, Cell 2 and Cell 3, respectively. The CRS assistance information [7] is provided and includes Cell 2 and Cell 3.

Table 8.8.4.2-1: Test Parameters for EPDCCH

Parameter		Unit	Cell 1	Cell 2	Cell 3
Number of PDCCH symbols		symbols	1 (Note 1)	2	2
EPDCCH starting symbol		symbols	2 (Note 1)	N/A	N/A
PHICH duration			Normal	Normal	Normal
Unused RE-s and PRB-s			OCNG	N/A	N/A
Cell ID			0	1	6
Downlink power allocation	ρ_A	dB	0	-3	-3
	ρ_B	dB	0	-3	-3
	σ	dB	-3	0	0
	δ	dB	0	0	0
Cell-specific reference signals			Antenna ports 0,1	Antenna ports 0,1	Antenna ports 0,1
N_{oc} at antenna port		dBm/15kHz	-98		
\bar{E}_s/N_{oc}		dB	N/A	13.91	3.34
$BW_{Channel}$		MHz	10	10	10
Cyclic Prefix			Normal	Normal	Normal
Subframe Configuration			Non-MBSFN	Non-MBSFN	Non-MBSFN
EPDCCH Precoder Update Granularity	PRB		1	N/A	N/A
	ms		1	N/A	N/A
EPDCCH Beamforming Pre-Coder			Annex B. 4.5	N/A	N/A
CSI-RS Reference Signal			Port 15 and 16	N/A	N/A
CSI-RS reference signal resource configuration			0	N/A	N/A
CSI reference signal subframe configuration l_{CSI-RS}			2	N/A	N/A
ZP-CSI-RS configuration bitmap			000001000000 0000	N/A	N/A
ZP-CSI-RS subframe configuration $l_{ZP-CSI-RS}$			2	N/A	N/A
Number of EPDCCH Sets			1	N/A	N/A
EPDCCH Set type			Localized	N/A	N/A
Number of PRB per EPDCCH Set			8	N/A	N/A
EPDCCH Set PRBs			0, 7, 14, 21, 28, 35, 42, 49	N/A	N/A
PDSCH TM			TM9	N/A	N/A
Interference model			N/A	As specified in clause B.6.5	As specified in clause B.6.5
Time offset to cell 1		μ s	N/A	2	3
Frequency offset to cell 1		Hz	N/A	200	300
TDD UL/DL Configuration			0	0	0
TDD Special Subframe			1 (Note 4)	1	1
Note 1: The starting symbol for EPDCCH is signalled with <i>epdcch-StartSymbol-r11</i> . CFI is set to 1.					
Note 2: EPDCCH is scheduled in every subframe. EPDCCH Subframe Monitoring pattern is not configured.					
Note 3: Demodulation performance is averaged over normal and special subframes.					

Table 8.8.4.2-2: Minimum performance for EPDCCH for enhanced downlink control channel performance requirements Type A

Test number	Bandwidth	Aggregation level	Reference Channel	OCNG Pattern	Propagation Condition	Antenna configuration and correlation Matrix	Reference value	
							Pm-dsg (%)	SNR (dB)
1	10 MHz	2 ECCE	R.57 TDD	OP.7 TDD	EPA5	2 x 2 Low	1	14.2

8.8.5 Enhanced Downlink Control Channel Performance Requirements Type A - Distributed Transmission with TM9 Interference Model

8.8.5.1 TDD

For the parameters specified in Table 8.8.5.1-1 the average probability of a missed downlink scheduling grant (P_{m-dsg}) shall be below the specified value in Table 8.8.5.1-2. The purpose of this test is to verify the distributed EPDCCH performance when the EPDCCH transmission in the serving cell is interfered by two interfering cells and applying TM9 interference model. In Table 8.8.5.1-1, Cell 1 is the serving cell, and Cell 2 and Cell 3 are the aggressor cells. The downlink physical setup is in accordance with Annex C.3.2 for each of Cell 1, Cell 2 and Cell 3, respectively. The CRS assistance information [7] is provided and includes Cell 2 and Cell 3.

Table 8.8.5.1-1: Test Parameters for EPDCCH

Parameter		Unit	Cell 1	Cell 2	Cell 3
Number of PDCCH symbols		symbols	2 (Note 1)	2	2
PHICH duration			Normal	Normal	Normal
Cell ID			0	6	1
Downlink power allocation	ρ_A	dB	-3	-3	-3
	ρ_B	dB	-3	-3	-3
	σ	dB	0	0	0
	δ	dB	3	3	3
Cell-specific reference signals			Antenna ports 0,1	Antenna ports 0,1	Antenna ports 0,1
N_{oc} at antenna port		dBm/15kHz	-98		
\hat{E}_s/N_{oc}		dB	N/A	13.91	3.34
BW _{Channel}		MHz	10	10	10
Cyclic Prefix			Normal	Normal	Normal
Subframe Configuration			Non-MBSFN	Non-MBSFN	Non-MBSFN
EPDCCH precoder Update Granularity	PRB		1	N/A	N/A
	ms		1	N/A	N/A
Beamforming Pre-Coder			Annex B. 4.4	N/A	N/A
Number of EPDCCH Sets Configured			1	N/A	N/A
EPDCCH Set type			Distributed	N/A	N/A
Number of PRB per EPDCCH Set			4	N/A	N/A
EPDCCH Set PRBs			3, 17, 31, 45	N/A	N/A
PDSCH TM			TM9	N/A	N/A
Interference model			N/A	As specified in clause B.5.4	As specified in clause B.5.4
Probability of occurrence of PDSCH transmission rank in interfering cells	Rank 1	%	N/A	70	70
	Rank 2	%	N/A	30	30
PDSCH precoder update granularity		PRB	N/A	50	50
Time offset to cell 1		μ s	N/A	2	3
Frequency offset to cell 1		Hz	N/A	200	300
TDD UL/DL Configuration			0	0	0
TDD Special Subframe			1 (Note 3)	1	1
Note 1: The starting symbol for EPDCCH is derived from the PCFICH. RRC signalling <i>epdcch-StartSymbol-r11</i> is not configured.					
Note 2: EPDCCH is scheduled in every subframe. EPDCCH Subframe Monitoring pattern is not configured.					
Note 3: Demodulation performance is averaged over normal and special subframes.					

Table 8.8.5.1-2: Minimum performance for EPDCCH for enhanced downlink control channel performance requirements Type A

Test number	Bandwidth	Aggregation level	Reference Channel	OCNG Pattern	Propagation Condition	Antenna configuration and correlation Matrix	Reference value	
							Pm-dsg (%)	SNR (dB)
1	10 MHz	4 ECCE	R.55-1 TDD	OP.7 TDD	EPA5	2 x 2 Low	1	14.8

8.8.6 Enhanced Downlink Control Channel Performance Requirements Type A - Distributed Transmission with TM3 Interference Model

8.8.6.1 FDD

For the parameters specified in Table 8.8.6.1-1 the average probability of a missed downlink scheduling grant (Pm-dsg) shall be below the specified value in Table 8.8.6.1-2. The purpose of this test is to verify the distributed EPDCCH performance when the serving cell EPDCCH transmission is interfered by two interfering cells applying asynchronous TM3 interference model. In Table 8.8.6.1-1, Cell 1 is the serving cell, and Cell 2 and Cell 3 are the aggressor cells. The downlink physical setup is in accordance with Annex C.3.2 for each of Cell 1, Cell 2 and Cell 3, respectively. The CRS assistance information [7] is not provided.

Table 8.8.6.1-1: Test Parameters for EPDCCH

Parameter		Unit	Cell 1	Cell 2	Cell 3
Number of PDCCH symbols		symbols	2 (Note 1)	2	2
PHICH duration			Normal	Normal	Normal
Cell ID			0	1	6
Downlink power allocation	ρ_A	dB	-3	-3	-3
	ρ_B	dB	-3	-3	-3
	σ	dB	0	0	0
	δ	dB	3	0	0
Cell-specific reference signals			Antenna ports 0,1	Antenna ports 0,1	Antenna ports 0,1
N_{oc} at antenna port		dBm/15kHz	-98		
\bar{E}_s/N_{oc}		dB	N/A	13.91	3.34
$BW_{Channel}$		MHz	10	10	10
Cyclic Prefix			Normal	Normal	Normal
Subframe Configuration			Non-MBSFN	Non-MBSFN	Non-MBSFN
EPDCCH Precoder Update Granularity	PRB		1	N/A	N/A
	ms		1	N/A	N/A
EPDCCH Beamforming Pre-Coder			Annex B.4.4	N/A	N/A
Number of EPDCCH Sets Configured			1	N/A	N/A
EPDCCH Set type			Distributed	N/A	N/A
Number of PRB per EPDCCH Set			4	N/A	N/A
EPDCCH Set PRBs			3, 17, 31, 45	N/A	N/A
PDSCH TM			TM9	N/A	N/A
Interference model			N/A	As specified in clause B.5.2	As specified in clause B.5.2
Probability of occurrence of PDSCH transmission rank in interfering cells	Rank 1	%	N/A	70	70
	Rank 2	%	N/A	30	30
Time offset to cell 1		μ s	N/A	330	667
Frequency offset to cell 1		Hz	N/A	0	0
Note 1: The starting symbol for EPDCCH is derived from the PCFICH. RRC signalling <i>epdcch-StartSymbol-r11</i> is not configured.					
Note 2: EPDCCH is scheduled in every subframe. EPDCCH Subframe Monitoring pattern is not configured.					

Table 8.8.6.1-2: Minimum performance for EPDCCH for enhanced downlink control channel performance requirements Type A

Test number	Bandwidth	Aggregation level	Reference Channel	OCNG Pattern	Propagation Condition	Antenna configuration and correlation Matrix	Reference value	
							Pm-dsg (%)	SNR (dB)
1	10 MHz	4 ECCE	R.55-1 FDD	OP.7 FDD	EVA70	2 x 2 Low	1	15.9

8.9 Demodulation (single receiver antenna)

The SNR definition is given in Clause 8.1.1 where the number of receiver antennas N_{RX} assumed for the minimum performance requirement in this clause is 1.

8.9.1 PDSCH

8.9.1.1 FDD and half-duplex FDD (Fixed Reference Channel)

The parameters specified in Table 8.9.1.1-1 are valid for FDD and half-duplex FDD tests unless otherwise stated.

Table 8.9.1.1-1: Common Test Parameters (FDD and half-duplex FDD)

Parameter	Unit	Value
Inter-TTI Distance		1
Number of HARQ processes per component carrier	Processes	8
Maximum number of HARQ transmission		4
Redundancy version coding sequence		{0,1,2,3} for QPSK and 16QAM {0,0,1,2} for 64QAM
Number of OFDM symbols for PDCCH per component carrier	OFDM symbols	4 for 1.4 MHz bandwidth, 3 for 3 MHz and 5 MHz bandwidths, 2 for 10 MHz, 15 MHz and 20 MHz bandwidths
Cyclic Prefix		Normal
Precoder update granularity		Frequency domain: 1 PRG Time domain: 1 ms for Transmission mode 9

8.9.1.1.1 Transmit diversity performance (Cell-Specific Reference Symbols)

8.9.1.1.1.1 Minimum Requirement 2 Tx Antenna Port

The requirements are specified in Table 8.9.1.1.1-2, with the addition of the parameters in Table 8.9.1.1.1-1 and the downlink physical channel setup according to Annex C.3.2. The purpose is to verify the performance of transmit diversity (SFBC) with 2 transmitter antennas.

Table 8.9.1.1.1-1: Test Parameters for Transmit diversity Performance (FRC)

Parameter	Unit	Test 1	
Downlink power allocation	ρ_A	dB	-3
	ρ_B	dB	-3 (Note 1)
	σ	dB	0
N_{oc} at antenna port	dBm/15kHz	-98	
PDSCH transmission mode		2	
Note 1: $P_B = 1$.			

Table 8.9.1.1.1-2: Minimum performance Transmit Diversity (FRC)

Test number	Bandwidth and MCS	Reference Channel	OCNG Pattern	Propagation Condition	Correlation Matrix and Antenna Configuration	Reference value		UE DL category
						Fraction of Maximum Throughput (%)	SNR (dB)	
1	10 MHz 16QAM 1/2	R. 62 FDD	OP.1 FDD	EPA5	2x1 Low	70	9.0	0

8.9.1.1.2 Closed-loop spatial multiplexing performance (Cell-Specific Reference Symbols)

8.9.1.1.2.1 Minimum Requirement Single-Layer Spatial Multiplexing 2 Tx Antenna Port

The requirements are specified in Table 8.9.1.1.2.1-2, with the addition of the parameters in Table 8.9.1.1.2.1-1 and the downlink physical channel setup according to Annex C.3.2. The purpose of these tests is to verify the closed loop rank-one performance with frequency selective precoding.

Table 8.9.1.1.2.1-1: Test Parameters for Single-Layer Spatial Multiplexing (FRC)

Parameter	Unit	Test 1	
Downlink power allocation	ρ_A	dB	-3
	ρ_B	dB	-3 (Note 1)
	σ	dB	0
N_{oc} at antenna port	dBm/15kHz	-98	
Precoding granularity	PRB	6	
PMI delay (Note 2)	ms	8	
Reporting interval	ms	8	
Reporting mode		PUSCH 1-2	
CodeBookSubsetRestriction bitmap		001111	
PDSCH transmission mode		4	
Note 1: $P_B = 1$.			
Note 2: If the UE reports in an available uplink reporting instance at subframe SF#n based on PMI estimation at a downlink SF not later than SF#(n-4), this reported PMI cannot be applied at the eNB downlink before SF#(n+4).			

Table 8.9.1.1.2.1-2: Minimum performance Single-Layer Spatial Multiplexing (FRC)

Test number	Bandwidth and MCS	Reference Channel	OCNG Pattern	Propagation Condition	Correlation Matrix and Antenna Configuration	Reference value		UE DL category
						Fraction of Maximum Throughput (%)	SNR (dB)	
1	10 MHz 64QAM 1/2	R. 63 FDD	OP.1 FDD	EPA5	2x1Low	70	13.2	0

8.9.1.1.3 Closed-loop spatial multiplexing performance (User-Specific Reference Symbols)

8.9.1.1.3.1 Single-layer Spatial Multiplexing

For single-layer transmission on antenna ports 7 or 8 upon detection of a PDCCH with DCI format 2C, the requirements are specified in Table 8.9.1.1.3.1-2 with the addition of the parameters in Table 8.9.1.1.3.1-1 and the downlink physical channel setup according to Annex C.3.2. The purpose of these tests is to verify rank-1 performance on one of the antenna ports 7 or 8, and to verify rate matching with multiple CSI reference symbol configurations with non-zero and zero transmission power.

Table 8.9.1.1.3.1-1: Test Parameters for Testing CDM-multiplexed DM RS (single layer) with multiple CSI-RS configurations

parameter	Unit	Test 1	
Downlink power allocation	ρ_A	dB	0
	ρ_B	dB	0 (Note 1)
	σ	dB	-3
Beamforming model		Annex B.4.1	
Cell-specific reference signals		Antenna ports 0,1	
CSI reference signals		Antenna ports 15,...,18	
CSI-RS periodicity and subframe offset $T_{\text{CSI-RS}} / \Delta_{\text{CSI-RS}}$	Subframes	5 / 2	
CSI reference signal configuration		0	
Zero-power CSI-RS configuration $I_{\text{CSI-RS}} / \text{ZeroPowerCSI-RS}$ bitmap	Subframes / bitmap	3 / 0001000000000000	
N_{oc} at antenna port	dBm/15kHz	-98	
Symbols for unused PRBs		OCNG (Note 4)	
Number of allocated resource blocks (Note 2)	PRB	6	
PDSCH transmission mode		9	
Note 1: $P_B = 1$. Note 2: The modulation symbols of the signal under test are mapped onto antenna port 7 or 8. Note 3: These physical resource blocks are assigned to an arbitrary number of virtual UEs with one PDSCH per virtual UE; the data transmitted over the OCNG PDSCHs shall be uncorrelated pseudo random data, which is QPSK modulated.			

Table 8.9.1.1.3.1-2: Minimum performance for CDM-multiplexed DM RS (FRC) with multiple CSI-RS configurations

Test number	Bandwidth and MCS	Reference Channel	OCNG Pattern	Propagation Condition	Correlation Matrix and Antenna Configuration	Reference value		UE DL category
						Fraction of Maximum Throughput (%)	SNR (dB)	
1	10 MHz QPSK 1/3	R. 64 FDD	OP.1 FDD	EPA5	2x1 Low	70	4.7	0

8.9.1.2 TDD (Fixed Reference Channel)

The parameters specified in Table 8.9.1.2-1 are valid for all TDD tests unless otherwise stated.

Table 8.9.1.2-1: Common Test Parameters (TDD)

Parameter	Unit	Value
Uplink downlink configuration (Note 1)		1
Special subframe configuration (Note 2)		4
Cyclic prefix		Normal
Cell ID		0
Inter-TTI Distance		1
Number of HARQ processes per component carrier	Processes	7
Maximum number of HARQ transmission		4
Redundancy version coding sequence		{0,1,2,3} for QPSK and 16QAM {0,0,1,2} for 64QAM
Number of OFDM symbols for PDCCH per component carrier	OFDM symbols	4 for 1.4 MHz bandwidth, 3 for 3 MHz and 5 MHz bandwidths, 2 for 10 MHz, 15 MHz and 20 MHz bandwidths
Precoder update granularity		Frequency domain: 1 PRG Time domain: 1 ms for Transmission mode 9
ACK/NACK feedback mode		Multiplexing
Note 1: as specified in Table 4.2-2 in TS 36.211 [4].		
Note 2: as specified in Table 4.2-1 in TS 36.211 [4].		

8.9.1.2.1 Transmit diversity performance (Cell-Specific Reference Symbols)

8.9.1.2.1.1 Minimum Requirement 2 Tx Antenna Port

The requirements are specified in Table 8.9.1.2.1.1-2, with the addition of the parameters in Table 8.9.1.2.1.1-1 and the downlink physical channel setup according to Annex C.3.2. The purpose is to verify the performance of transmit diversity (SFBC) with 2 transmitter antennas.

Table 8.9.1.2.1.1-1: Test Parameters for Transmit diversity Performance (FRC)

Parameter	Unit	Test 1-2	
Downlink power allocation	ρ_A	dB	-3
	ρ_B	dB	-3 (Note 1)
	σ	dB	0
N_{oc} at antenna port	dBm/15kHz	-98	
ACK/NACK feedback mode		Multiplexing	
PDSCH transmission mode		2	
Note 1: $P_B = 1$			

Table 8.9.1.2.1.1-2: Minimum performance Transmit Diversity (FRC)

Test number	Bandwidth	Reference Channel	OCNG Pattern	Propagation Condition	Correlation Matrix and Antenna Configuration	Reference value		UE DL category
						Fraction of Maximum Throughput (%)	SNR (dB)	
1	10 MHz 16QAM 1/2	R. 62 TDD	OP.1 TDD	EPA5	2x1 Low	70	8.8	0

8.9.1.2.2 Closed-loop spatial multiplexing performance (Cell-Specific Reference Symbols)

8.9.1.2.2.1 Minimum Requirement Single-Layer Spatial Multiplexing 2 Tx Antenna Port

The requirements are specified in Table 8.9.1.2.2.1-2, with the addition of the parameters in Table 8.9.1.2.2.1-1 and the downlink physical channel setup according to Annex C.3.2. The purpose of these tests is to verify the closed loop rank-one performance with frequency selective precoding.

Table 8.9.1.2.2.1-1: Test Parameters for Single-Layer Spatial Multiplexing (FRC)

Parameter	Unit	Test 1	
Downlink power allocation	ρ_A	dB	-3
	ρ_B	dB	-3 (Note 1)
	σ	dB	0
N_{oc} at antenna port	dBm/15kHz	-98	
Precoding granularity	PRB	6	
PMI delay (Note 2)	ms	10 or 11	
Reporting interval	ms	1 or 4 (Note 3)	
Reporting mode		PUSCH 1-2	
CodeBookSubsetRestriction bitmap		001111	
ACK/NACK feedback mode		Multiplexing	
PDSCH transmission mode		4	
Note 1: $P_B = 1$.			
Note 2: If the UE reports in an available uplink reporting instance at subframe SF#n based on PMI estimation at a downlink SF not later than SF#(n-4), this reported PMI cannot be applied at the eNB downlink before SF#(n+4).			
Note 3: For Uplink - downlink configuration 1 the reporting interval will alternate between 1ms and 4ms.			

Table 8.9.1.2.2.1-2: Minimum performance Single-Layer Spatial Multiplexing (FRC)

Test number	Bandwidth	Reference Channel	OCNG Pattern	Propagation Condition	Correlation Matrix and Antenna Configuration	Reference value		UE DL category
						Fraction of Maximum Throughput (%)	SNR (dB)	
1	10 MHz 64QAM 1/2	R. 63 TDD	OP.1 TDD	EPA5	2x1 Low	70	13.1	0

8.9.1.2.3 Closed-loop spatial multiplexing performance (User-Specific Reference Symbols)

8.9.1.2.3.1 Single-layer Spatial Multiplexing

For single-layer transmission on antenna ports 7 or 8 upon detection of a PDCCH with DCI format 2C, the requirements are specified in Table 8.9.1.2.3.1-2 with the addition of the parameters in Table 8.9.1.2.3.1-1 and the downlink physical channel setup according to Annex C.3.2. The purpose of these tests is to verify rank-1 performance on one of the antenna ports 7 or 8, and to verify rate matching with multiple CSI reference symbol configurations with non-zero and zero transmission power.

Table 8.9.1.2.3.1-1: Test Parameters for Testing CDM-multiplexed DM RS (single layer) with multiple CSI-RS configurations

Parameter	Unit	Test 1	
Downlink power allocation	ρ_A	dB	0
	ρ_B	dB	0 (Note 1)
	σ	dB	-3
Cell-specific reference signals		Antenna ports 0,1	
CSI reference signals		Antenna ports 15,...,18	
Beamforming model		Annex B.4.1	
CSI-RS periodicity and subframe offset $T_{\text{CSI-RS}} / \Delta_{\text{CSI-RS}}$	Subframes	5 / 4	
CSI reference signal configuration		1	
Zero-power CSI-RS configuration $l_{\text{CSI-RS}} / \text{ZeroPowerCSI-RS}$ bitmap	Subframes / bitmap	4 / 0010000100000000	
N_{oc} at antenna port	dBm/15kHz	-98	
Symbols for unused PRBs		OCNG (Note 4)	
Number of allocated resource blocks (Note 2)	PRB	6	
Simultaneous transmission		No	
PDSCH transmission mode		9	
Note 1: $P_B = 1$. Note 2: The modulation symbols of the signal under test are mapped onto antenna port 7 or 8. Note 3: These physical resource blocks are assigned to an arbitrary number of virtual UEs with one PDSCH per virtual UE; the data transmitted over the OCNG PDSCHs shall be uncorrelated pseudo random data, which is QPSK modulated.			

Table 8.9.1.2.3.1-2: Minimum performance for CDM-multiplexed DM RS without simultaneous transmission (FRC) with multiple CSI-RS configurations

Test number	Bandwidth and MCS	Reference Channel	OCNG Pattern	Propagation Condition	Correlation Matrix and Antenna Configuration	Reference value		UE DL category
						Fraction of Maximum Throughput (%)	SNR (dB)	
1	10 MHz QPSK 1/3	R. 64 TDD	OP.1 TDD	EPA5	2x1 Low	70	4.5	0

8.9.2 PHICH

8.9.2.1 FDD and half-duplex FDD

8.9.2.1.1 Transmit diversity performance

For the parameters specified in Table 8.5.1-1 the average probability of a miss-detecting ACK for NACK (P_{m-an}) shall be below the specified value in Table 8.9.2.1.1-1. The downlink physical setup is in accordance with Annex C.3.2.

Table 8.9.2.1.1-1: Minimum performance PHICH

Test number	Bandwidth	Reference Channel	OCNG Pattern	Propagation Condition	Antenna configuration and correlation Matrix	Reference value	
						P_{m-an} (%)	SNR (dB)
1	10 MHz	R.19	OP.1 FDD	EPA5	2 x 1 Low	0.1	8.6

8.9.2.2 TDD

8.9.2.2.1 Transmit diversity performance

For the parameters specified in Table 8.5.2-1 the average probability of a miss-detecting ACK for NACK (P_{m-an}) shall be below the specified value in Table 8.9.2.2.1-1. The downlink physical setup is in accordance with Annex C.3.2.

Table 8.9.2.2.1-1: Minimum performance PHICH

Test number	Bandwidth	Reference Channel	OCNG Pattern	Propagation Condition	Antenna configuration and correlation Matrix	Reference value	
						P_{m-an} (%)	SNR (dB)
1	10 MHz	R.19	OP.1 TDD	EPA5	2 x 1 Low	0.1	8.6

8.9.3 PBCH

8.9.3.1 FDD and half-duplex FDD

8.9.3.1.1 Transmit diversity performance

For the parameters specified in Table 8.6.1-1 the average probability of a miss-detected PBCH (P_{m-bch}) shall be below the specified value in Table 8.9.3.1.1-1. The downlink physical setup is in accordance with Annex C.3.2.

Table 8.9.3.1.1-1: Minimum performance PBCH

Test number	Bandwidth	Reference Channel	Propagation Condition	Antenna configuration and correlation Matrix	Reference value	
					Pm-bch (%)	SNR (dB)
1	1.4 MHz	R.22	EPA5	2 x 1 Low	1	-1.3

8.9.3.2 TDD

8.9.3.2.1 Transmit diversity performance

For the parameters specified in Table 8.6.2-1 the average probability of a miss-detected PBCH (Pm-bch) shall be below the specified value in Table 8.9.3.2.1-1. The downlink physical setup is in accordance with Annex C.3.2.

Table 8.9.3.2.1-1: Minimum performance PBCH

Test number	Bandwidth	Reference Channel	Propagation Condition	Antenna configuration and correlation Matrix	Reference value	
					Pm-bch (%)	SNR (dB)
1	1.4 MHz	R.22	EPA5	2 x 1 Low	1	-1.7

8.10 Demodulation (4 receiver antenna ports)

The performance requirements specified in this clause are valid for 4Rx capable UEs.

8.10.1 PDSCH

8.10.1.1 FDD (Fixed Reference Channel)

The parameters specified in Table 8.10.1.1-1 are valid for all FDD tests unless otherwise stated.

Table 8.10.1.1-1: Common Test Parameters (FDD)

Parameter	Unit	Value
Inter-TTI Distance		1
Number of HARQ processes per component carrier	Processes	8
Maximum number of HARQ transmission		4
Redundancy version coding sequence		{0,1,2,3} for QPSK and 16QAM {0,0,1,2} for 64QAM and 256QAM
Number of OFDM symbols for PDCCH	OFDM symbols	4 for 1.4 MHz bandwidth, 3 for 3 MHz and 5 MHz bandwidths, 2 for 10 MHz, 15 MHz and 20 MHz bandwidths unless otherwise stated
Precoder update granularity		Frequency domain: 1 PRG for Transmission modes 9 and 10 Time domain: 1 ms
Cyclic Prefix		Normal
Cell_ID		0
Cross carrier scheduling		Not configured

8.10.1.1.1 Transmit diversity performance with 2Tx Antenna Ports (Cell-Specific Reference Symbols)

The requirements are specified in Table 8.10.1.1.1-2, with the addition of the parameters in Table 8.10.1.1.1-1 and the downlink physical channel setup according to Annex C.3.2. The purpose is to verify the performance of transmit diversity (SFBC) with 2 transmitter antennas.

Table 8.10.1.1.1-1: Test Parameters for Transmit diversity Performance (FRC) with 4 RX Antenna Ports

Parameter		Unit	Test 1
Downlink power allocation	ρ_A	dB	-3
	ρ_B	dB	-3 (NOTE 1)
	σ	dB	0
N_{oc} at antenna port		dBm/15kHz	-98
PDSCH transmission mode			2
NOTE 1: $P_B = 1$.			

Table 8.10.1.1.1-2: Minimum performance Transmit Diversity (FRC) with 4 RX Antenna Ports

Test number	Bandwidth and MCS	Reference Channel	OCNG Pattern	Propagation Condition	Correlation Matrix and Antenna Configuration	Reference value		UE Category
						Fraction of Maximum Throughput (%)	SNR (dB)	
1	10 MHz 16QAM 1/2	R.11 FDD	OP.1 FDD	EVA5	2x4 Medium correlation A, ULA	70	3.9	≥ 2

8.10.1.1.1A Transmit diversity performance with Enhanced Performance Requirement Type A - 2 Tx Antenna Ports with TM3 interference model

The requirements are specified in Table 8.10.1.1.1A-2, with the addition of parameters in Table 8.10.1.1.1A-1 and the downlink physical channel setup according to Annex C.3.2. The purpose is to verify the performance of transmit diversity (SFBC) with 2 transmit antennas when the PDSCH transmission in the serving cell is interfered by PDSCH of one dominant interfering cells applying transmission mode 3 interference model defined in clause B.5.2. In Table 8.10.1.1.1A-1, Cell 1 is the serving cell, and Cell 2 is an interfering cell. The downlink physical channel setup is according to Annex C.3.2 for each of Cell 1 and Cell 2, respectively.

Table 8.10.1.1A-1: Test Parameters for Transmit diversity Performance (FRC) with TM3 interference model

Parameter		Unit	Cell 1	Cell 2
Downlink power allocation	ρ_A	dB	-3	-3
	ρ_B	dB	-3 (NOTE 1)	-3
	σ	dB	0	0
Cell-specific reference signals			Antenna ports 0,1	Antenna ports 0,1
N_{oc} at antenna port		dBm/15kHz	-98	N/A
DIP (NOTE 2)		dB	N/A	-2.23
BW _{Channel}		MHz	10	10
Cyclic Prefix			Normal	Normal
Cell Id			0	1
Number of control OFDM symbols			2	2
PDSCH transmission mode			2	N/A
Interference model			N/A	As specified in clause B.5.2
Probability of occurrence of transmission rank in interfering cells	Rank 1	%	N/A	80
	Rank 2	%	N/A	20
Reporting interval		ms	5	N/A
Reporting mode			PUCCH 1-0	N/A
Physical channel for CQI reporting			PUSCH(Note 5)	N/A
cqi-pmi-ConfigurationIndex			2	N/A
NOTE 1: $P_B = 1$				
NOTE 2: The respective received power spectral density of each interfering cell relative to N_{oc} is defined by its associated DIP value as specified in clause B.5.1.				
NOTE 3: Cell 1 is the serving cell. Cell 2 is the interfering cell.				
NOTE 4: Cell 2 transmission is delayed with respect to Cell 1 by 0.33 ms.				
NOTE 5: To avoid collisions between CQI reports and HARQ-ACK it is necessary to report both on PUSCH instead of PUCCH. PDCCH DCI format 0 shall be transmitted in downlink SF#1 and #6 to allow periodic CQI to multiplex with the HARQ-ACK on PUSCH in uplink subframe SF#5 and #0.				

Table 8.10.1.1A-2: Enhanced Performance Requirement Type A, Transmit Diversity (FRC) with TM3 interference model

Test Number	Reference Channel	OCNG Pattern		Propagation Conditions		Correlation Matrix and Antenna Configuration (NOTE 3)	Reference Value		UE Category
		Cell 1	Cell 2	Cell 1	Cell 2		Fraction of Maximum Throughput (%)	SINR (dB) (NOTE 2)	
1	R.46 FDD	OP.1 FDD	N/A	EVA70	EVA70	2x4 Low	70	-4.4	≥1
NOTE 1: The propagation conditions for Cell 1 and Cell 2 are statistically independent.									
NOTE 2: SINR corresponds to \hat{E}_s / N_{oc} of Cell 1 as defined in clause 8.1.1.									
NOTE 3: Correlation matrix and antenna configuration parameters apply for each of Cell 1 and Cell 2.									

8.10.1.1.2 Open-loop spatial multiplexing performance with 2Tx Antenna Ports (Cell-Specific Reference Symbols)

The requirements are specified in Table 8.10.1.1.2-2, with the addition of the parameters in Table 8.10.1.1.2-1 and the downlink physical channel setup according to Annex C.3.2.

Table 8.10.1.1.2-1: Test Parameters for Large Delay CDD (FRC) with 4 RX Antenna Ports

Parameter	Unit	Test 1
Downlink power allocation	ρ_A	dB
	ρ_B	dB
	σ	dB
N_{oc} at antenna port	dBm/15kHz	-98
PDSCH transmission mode		3
NOTE 1: $P_B = 1$.		

Table 8.10.1.1.2-2: Minimum performance Large Delay CDD (FRC) with 4 RX Antenna Ports

Test num	Bandwidth and MCS	Reference channel	OCNG pattern	Propagation condition	Correlation matrix and antenna config.	Reference value		UE category
						Fraction of maximum Throughput (%)	SNR (dB)	
1	10 MHz 16QAM 1/2	R.11 FDD	OP.1 FDD	EVA70	2x4 Low	70	8.0	≥ 2

8.10.1.1.3 Closed-loop spatial multiplexing Enhanced Performance Requirements Type A - Single-Layer Spatial Multiplexing 2 Tx Antenna Port with TM4 interference model (Cell-Specific Reference Symbols)

The requirements are specified in Table 8.10.1.1.3-2, with the addition of the parameters in Table 8.10.1.1.3-1 and the downlink physical channel setup according to Annex C.3.2. The purpose of these tests is to verify the closed loop rank-one performance with wideband precoding with two transmit antennas when the PDSCH transmission in the serving cell is interfered by PDSCH of one dominant interfering cell applying transmission mode 4 interference model defined in clause B.5.3. In Table 8.10.1.1.3-1, Cell 1 is the serving cell, and Cell 2 is the interfering cell. The downlink physical channel setup is according to Annex C.3.2 for each of Cell 1 and Cell 2, respectively.

Table 8.10.1.1.3-1: Test Parameters for Single-Layer Spatial Multiplexing (FRC) with TM4 interference model and 4 RX Antenna Ports

Parameter		Unit	Cell 1	Cell 2
Downlink power allocation	ρ_A	dB	-3	-3
	ρ_B	dB	-3 (Note 1)	-3
	σ	dB	0	0
Cell-specific reference signals			Antenna ports 0,1	Antenna ports 0,1
N_{oc} at antenna port		dBm/15kHz	-98	N/A
DIP (Note 2)		dB	N/A	-1.73
BW_{Channel}		MHz	10	10
Cell Id			0	1
PDSCH transmission mode			6	4
Interference model			N/A	As specified in clause B.5.3
Probability of occurrence of transmission rank in interfering cells	Rank 1	%	N/A	80
	Rank 2	%	N/A	20
Precoding granularity		PRB	50	6
PMI delay (Note 4)		ms	8	N/A
Reporting interval		ms	5	N/A
Reporting mode			PUCCH 1-1	N/A
CodeBookSubsetRestriction bitmap			1111	N/A
Note 1: $P_B = 1$				
Note 2: The respective received power spectral density of each interfering cell relative to N_{oc} is defined by its associated DIP value as specified in clause B.5.1.				
Note 3: Cell 1 is the serving cell. Cell 2 is the interfering cell.				
Note 4: If the UE reports in an available uplink reporting instance at subframe SF#n based on PMI estimation at a downlink SF not later than SF#(n-4), this reported PMI cannot be applied at the eNB downlink before SF#(n+4).				
Note 5: All cells are time-synchronous.				

Table 8.10.1.1.3-2: Enhanced Performance Requirement Type A, Single-Layer Spatial Multiplexing (FRC) with TM4 interference model and 4 RX Antenna Ports

Test Number	Reference Channel and MCS	OCNG Pattern		Propagation Conditions		Correlation Matrix and Antenna Configuration (Note 3)	Reference Value		UE Category
		Cell 1	Cell 2	Cell 1	Cell 2		Fraction of Maximum Throughput (%)	SINR (dB) (Note 2)	
1	R.47 FDD 16QAM	OP.1 FDD	N/A	EVA5	EVA5	2x4 Low	70	-2.3	≥ 1
Note 1: The propagation conditions for Cell 1 and Cell 2 are statistically independent.									
Note 2: SINR corresponds to \hat{E}_s / N_{oc} of Cell 1 as defined in clause 8.1.1.									
Note 3: Correlation matrix and antenna configuration parameters apply for each of Cell 1 and Cell 2.									

8.10.1.1.4 Closed-loop spatial multiplexing performance, Dual-Layer Spatial Multiplexing 4 Tx Antenna Port (Cell-Specific Reference Symbols)

For single carrier, the requirements are specified in Table 8.10.1.1.4-2, with the addition of the parameters in Table 8.10.1.1.4-1 and the downlink physical channel setup according to Annex C.3.2.

Table 8.10.1.1.4-1: Test Parameters for Dual-Layer Spatial Multiplexing (FRC) with 4 RX Antenna Ports

Parameter		Unit	Test 1-2
Downlink power allocation	ρ_A	dB	-6
	ρ_B	dB	-6 (Note 1)
	σ	dB	3
N_{oc} at antenna port		dBm/15kHz	-98
Precoding granularity		PRB	6
PMI delay (Note 2)		ms	8
Reporting interval		ms	1
Reporting mode			PUSCH 1-2
CodeBookSubsetRestriction bitmap			00000000000000000000000000000000 00001111111111111111111100000000 00000000
PDSCH transmission mode			4
Note 1: $P_B = 1$.			
Note 2: If the UE reports in an available uplink reporting instance at subframe SF#n based on PMI estimation at a downlink SF not later than SF#(n-4), this reported PMI cannot be applied at the eNB downlink before SF#(n+4).			

Table 8.10.1.1.4-2: Minimum performance Dual-Layer Spatial Multiplexing (FRC) with 4 RX Antenna Ports

Test num.	Bandwidth and MCS	Reference channel	OCNG pattern	Propagation condition	Correlation matrix and antenna config.	Reference value		UE category	DL UE category
						Fraction of maximum throughput (%)	SNR (dB)		
1	10 MHz	R.36 FDD	OP.1 FDD	EPA5	4x4 Low	70	10.1	≥ 2	≥ 6
2	10 MHz 256 QAM	R.72 FDD	OP.1 FDD	EPA5	4x4 Low	70	18.0	11-12	≥ 11

8.10.1.1.5 Enhanced Performance Requirement Type A – Single-layer Spatial Multiplexing with TM9 interference model (User-Specific Reference Symbols)

The requirements are specified in Table 8.10.1.1.5-2, with the addition of the parameters in Table 8.10.1.1.5-1 and the downlink physical channel setup according to Annex C.3.2. The purpose of these tests is to verify closed loop rank one performance on one of the antenna ports 7 or 8 without a simultaneous transmission on the other antenna port in the serving cell when the PDSCH transmission in the serving cell is interfered by PDSCH of one dominant interfering cell applying transmission mode 9 interference model defined in clause B.5.4. In 8.10.1.1.5-1, Cell 1 is the serving cell, and Cell 2 is the interfering cell. The downlink physical channel setup is according to Annex C.3.2 for each of Cell 1 and Cell 2, respectively.

Table 8.10.1.1.5-1: Test Parameters for Testing CDM-multiplexed DM RS (single layer) with TM9 interference model and 4 RX Antenna Ports

parameter		Unit	Cell 1	Cell 2
Downlink power allocation	ρ_A	dB	0	0
	ρ_B	dB	0 (Note 1)	0
	σ	dB	-3	-3
Cell-specific reference signals			Antenna ports 0,1	Antenna ports 0,1
CSI reference signals			Antenna ports 15,16	N/A
CSI-RS periodicity and subframe offset $T_{\text{CSI-RS}} / \Delta_{\text{CSI-RS}}$		Subframes	5 / 2	N/A
CSI reference signal configuration			0	N/A
N_{oc} at antenna port z		dBm/15kHz	-98	N/A
DIP (Note 2)		dB	N/A	-1.73
BW_{Channel}		MHz	10	10
Cell Id			0	126
PDSCH transmission mode			9	9
Beamforming model			As specified in clause B.4.3 (Note 4, 5)	N/A
Interference model			N/A	As specified in clause B.5.4
Probability of occurrence of transmission rank in interfering cells	Rank 1		N/A	70
	Rank 2		N/A	30
Precoder update granularity		PRB	50	6
PMI delay (Note 5)		Ms	8	N/A
Reporting interval		Ms	5	N/A
Reporting mode			PUCCH 1-1	N/A
CodeBookSubsetRestriction bitmap			001111	N/A
Symbols for unused PRBs			OCNG (Note 6)	N/A
Simultaneous transmission			No simultaneous transmission on the other antenna port in (7 or 8) used for the input signal under test	N/A
Physical channel for CQI reporting			PUSCH(Note 8)	N/A
cqi-pmi-ConfigurationIndex			5	N/A
<p>Note 1: $P_B = 1$</p> <p>Note 2: The respective received power spectral density of each interfering cell relative to N_{oc} is defined by its associated DIP value as specified in clause B.5.1.</p> <p>Note 3: The modulation symbols of the signal under test in Cell 1 are mapped onto antenna port 7 or 8.</p> <p>Note 4: The precoder in clause B.4.3 follows UE recommended PMI.</p> <p>Note 5: If the UE reports in an available uplink reporting instance at subframe SF#n based on PMI estimation at a downlink SF not later than SF#(n-4), this reported PMI cannot be applied at the eNB downlink before SF#(n+4).</p> <p>Note 6: These physical resource blocks are assigned to an arbitrary number of virtual UEs with one PDSCH per virtual UE; the data transmitted over the OCNG PDSCHs</p>				

	shall be uncorrelated pseudo random data, which is QPSK modulated.
Note 7:	All cells are time-synchronous.
Note 8:	To avoid collisions between CQI reports and HARQ-ACK it is necessary to report both on PUSCH instead of PUCCH. PDCCH DCI format 0 shall be transmitted in downlink SF#4 and #9 to allow periodic CQI to multiplex with the HARQ-ACK on PUSCH in uplink subframe SF#8 and #3.

Table 8.10.1.1.5-2: Enhanced Performance Requirement Type A, CDM-multiplexed DM RS with TM9 interference model and 4 RX Antenna Ports

Test Number	Reference Channel and MCS	OCNG Pattern		Propagation Conditions		Correlation Matrix and Antenna Configuration (Note 3)	Reference Value		UE Category
		Cell 1	Cell 2	Cell 1	Cell 2		Fraction of Maximum Throughput (%)	SINR (dB) (Note 2)	
1	R. 76 FDD QPSK	OP.1 FDD	N/A	EVA5	EVA5	2x4 Low	70	-3.0	≥1
Note 1: The propagation conditions for Cell 1 and Cell 2 are statistically independent.									
Note 2: SINR corresponds to \hat{E}_s / N_{oc} of Cell 1 as defined in clause 8.1.1.									
Note 3: Correlation matrix and antenna configuration parameters apply for each of Cell 1 and Cell 2.									

8.10.1.1.5A Single-layer Spatial Multiplexing (User-Specific Reference Symbols)

The requirements are specified in Table 8.10.1.1.5A-2, with the addition of the parameters in Table 8.10.1.1.5A-1 and the downlink physical channel setup according to Annex C.3.2. The purpose of these tests is to verify closed loop rank one performance on one of the antenna ports 7 or 8 with a simultaneous transmission on the other antenna port in the serving cell, and to verify rate matching with multiple CSI reference symbol configurations with non-zero and zero transmission power.

Table 8.10.1.1.5A-1: Test Parameters for Testing CDM-multiplexed DM RS (single layer) with multiple CSI-RS configurations

Parameter	Unit	Test 1
Downlink power allocation	ρ_A	dB
	ρ_B	dB
	σ	dB

Beamforming model		Annex B.4.1
Cell-specific reference signals		Antenna ports 0,1
CSI reference signals		Antenna ports 15,...,18
CSI-RS periodicity and subframe offset $T_{CSI-RS} / \Delta_{CSI-RS}$	Subframes	5 / 2
CSI reference signal configuration		3
Zero-power CSI-RS configuration $I_{CSI-RS} / ZeroPowerCSI-RS$ bitmap	Subframes / bitmap	3 / 0001000000000000
N_{oc} at antenna port	dBm/15kHz	-98
Symbols for unused PRBs		OCNG (Note 4)
Number of allocated resource blocks (Note 2)	PRB	50
Simultaneous transmission		Yes (Note 3, 5)
PDSCH transmission mode		9
Number of MBSFN subframes	Subframes	NA
<p>Note 1: $P_B = 1$.</p> <p>Note 2: The modulation symbols of the signal under test are mapped onto antenna port 7 or 8.</p> <p>Note 3: Modulation symbols of an interference signal is mapped onto the antenna port (7 or 8) not used for the input signal under test.</p> <p>Note 4: These physical resource blocks are assigned to an arbitrary number of virtual UEs with one PDSCH per virtual UE; the data transmitted over the OCNG PDSCHs shall be uncorrelated pseudo random data, which is QPSK modulated.</p> <p>Note 5: The two UEs' scrambling identities n_{SCID} are set to 0 for CDM-multiplexed DM RS with interfering simultaneous transmission test cases.</p>		

Table 8.10.1.1.5A-2: Minimum performance for CDM-multiplexed DM RS with interfering simultaneous transmission (FRC) with multiple CSI-RS configurations

Test number	Bandwidth and MCS	Reference Channel	OCNG Pattern	Propagation Condition	Correlation Matrix and Antenna Configuration	Reference value		UE Category
						Fraction of Maximum Throughput (%)	SNR (dB)	
1	10 MHz 64QAM 1/2	R.50 FDD	OP.1 FDD	EPA5	2x4 Low	70	15.8	≥2
Note 1: The reference channel applies to both the input signal under test and the interfering signal.								

8.10.1.1.5B Single-layer Spatial Multiplexing (With Enhanced DMRS table configured)

For single-layer transmission on antenna port 7, 8, 11 or 13 upon detection of a PDCCH with DCI format 2C, the requirement is specified in Table 8.10.1.1.5B-2, with the addition of the parameters in Table 8.10.1.1.5B-1 and the downlink physical channel setup according to Annex C.3.2. The purpose of the test is to verify rank-1 performance on antenna port 11 with a simultaneous transmission on the antenna port 7, 8 or 13 with DMRS enhancement table and 4 orthogonal DMRS ports (dmrs-Enhancements-r13 UE-EUTRA-Capability [7]).

Table 8.10.1.1.5B -1: Test Parameters for Testing CDM-multiplexed DM RS (single layer) with interfering simultaneous transmission (FRC) with multiple CSI-RS configurations with Enhanced DMRS table

Parameter		Unit	Test 1
Downlink power allocation	ρ_A	dB	0
	ρ_B	dB	0 (Note 1)
	σ	dB	-3
Beamforming model			Annex B.4.1A
Cell-specific reference signals			Antenna ports 0,1
CSI reference signals			Antenna ports 15,...,18
CSI-RS periodicity and subframe offset $T_{\text{CSI-RS}} / \Delta_{\text{CSI-RS}}$		Subframes	5 / 2
CSI reference signal configuration			3
Zero-power CSI-RS configuration $I_{\text{CSI-RS}} /$ ZeroPowerCSI-RS bitmap		Subframes / bitmap	3 / 0001000000000000
N_{oc} at antenna port		dBm/15kHz	-98
Symbols for unused PRBs			OCNG (Note 4)
Number of allocated resource blocks (Note 2)		PRB	50
Simultaneous transmission			Yes (Note 3, 5)
dmrs-Enhancements-r13			Enable
PDSCH transmission mode			9
Note 1: $P_B = 1$. Note 2: The modulation symbols of the signal under test are mapped onto antenna port 11. Note 3: Modulation symbols of an interference signal are random mapped onto one antenna port among antenna port 7, 8 and 13. The update granularity for randomized mapping antenna port is 1 PRG in frequency domain and 1ms in time domain. Note 4: These physical resource blocks are assigned to an arbitrary number of virtual UEs with one PDSCH per virtual UE; the data transmitted over the OCNG PDSCHs shall be uncorrelated pseudo random data, which is QPSK modulated. Note 5: The two UEs' scrambling identities n_{SCID} are set to 0 with OCC =4.			

Table 8.10.1.1.5B-2: Minimum performance for CDM-multiplexed DM RS with interfering simultaneous transmission (FRC) with multiple CSI-RS configurations with Enhanced DMRS table

Test number	Bandwidth and MCS	Reference Channel	OCNG Pattern	Propagation Condition	Correlation Matrix and Antenna Configuration	Reference value		UE Category
						Fraction of Maximum Throughput (%)	SNR (dB)	
1	10 MHz 64QAM 1/2	R.50 FDD	OP.1 FDD	EPA5	2x4 Low	70	15.8	≥2
Note 1: The reference channel applies to both the input signal under test and the interfering signal.								

8.10.1.1.6 Dual-Layer Spatial Multiplexing (User-Specific Reference Symbols)

For dual-layer transmission on antenna ports 7 and 8 upon detection of a PDCCH with DCI format 2C, the requirements are specified in Table 8.10.1.1.6-2, with the addition of the parameters in Table 8.10.1.1.6-1 where Cell 1 is the serving cell and Cell 2 is the interfering cell. The downlink physical channel setup is set according to Annex C.3.2. The purpose of these tests is to verify the rank-2 performance for full RB allocation, to verify rate matching with multiple CSI reference symbol configurations with non-zero and zero transmission power, and to verify that the UE correctly estimate SNR.

Table 8.10.1.1.6-1: Test Parameters for Testing CDM-multiplexed DM RS (dual layer) with multiple CSI-RS configurations with 4 RX Antenna Ports

Parameter		Unit	Test 1	
			Cell 1	Cell 2
Downlink power allocation	ρ_A	dB	0	0
	ρ_B	dB	0 (Note 1)	0
	σ	dB	-3	-3
	PDSCH_RA	dB	4	NA
	PDSCH_RB	dB	4	NA
Cell-specific reference signals			Antenna ports 0 and 1	Antenna ports 0 and 1
Cell ID			0	126
CSI reference signals			Antenna ports 15,16	NA
Beamforming model			Annex B.4.2	NA
CSI-RS periodicity and subframe offset $T_{\text{CSI-RS}} / \Delta_{\text{CSI-RS}}$		Subframes	5 / 2	NA
CSI reference signal configuration			8	NA
Zero-power CSI-RS configuration $I_{\text{CSI-RS}} / \text{ZeroPowerCSI-RS}$ bitmap		Subframes / bitmap	3 / 0010000000000000	NA
N_{oc} at antenna port		dBm/15kHz	-98	NA
\widehat{E}_s / N_{oc}			Reference Value in Table 8.10.1.1.6-2	7.25dB
Symbols for unused PRBs			OCNG (Note 2)	NA
Number of allocated resource blocks (Note 2)		PRB	50	NA
Simultaneous transmission			No	NA
PDSCH transmission mode			9	Blanked
Note 1: $P_B = 1$				
Note 2: These physical resource blocks are assigned to an arbitrary number of virtual UEs with one PDSCH per virtual UE; the data transmitted over the OCNG PDSCHs shall be uncorrelated pseudo random data, which is QPSK modulated.				

Table 8.10.1.1.6-2: Minimum performance for CDM-multiplexed DM RS (FRC) with multiple CSI-RS configurations and 4 RX Antenna Ports

Test number	Bandwidth and MCS	Reference Channel	OCNG Pattern		Propagation Condition		Correlation Matrix and Antenna Configuration	Reference value		UE Category
			Cell1	Cell 2	Cell 1	Cell 2		Fraction of Maximum Throughput (%)	SNR (dB)	
1	10 MHz 16QAM 1/2	R.51 FDD	OP.1 FDD	N/A	ETU5	ETU5	2x4 Low	70	9.2	≥2
Note 1: The propagation conditions for Cell 1 and Cell 2 are statistically independent.										
Note 2: Correlation matrix and antenna configuration parameters apply for each of Cell 1 and Cell 2.										
Note 3: SNR corresponds to \widehat{E}_s / N_{oc} of Cell 1.										

8.10.1.1.7 Open-loop spatial multiplexing, 3 Layer Multiplexing with 4 Tx Antenna Ports (Cell-Specific Reference Symbols)

The requirements are specified in Table 8.10.1.1.7-2, with the addition of the parameters in Table 8.10.1.1.7-1 and the downlink physical channel setup according to Annex C.3.2.

Table 8.10.1.1.7-1: Test parameters for Open Loop spatial multiplexing, 3 Layers with 4 Tx ports and 4 Rx ports

Parameter	Unit	Test 1	
Downlink power allocation	ρ_A	dB	-6
	ρ_B	dB	-6 (Note 1)
	σ	dB	0
Cell-specific reference signals		Antenna ports 0,1,2,3	
N_{oc} at antenna port	dBm/15k Hz	-98	
PDSCH transmission mode		3	
PDSCH rank		3	
CodeBookSubsetRestriction bitmap		0100	
Note 1: $P_B = 1$.			

Table 8.10.1.1.7-2: Minimum performance Open Loop spatial multiplexing, 3 Layers with 4 Tx ports and 4 Rx ports

Test number	Bandwidth and MCS	Reference Channel	OCNG Pattern	Propagation Condition	Correlation Matrix and Antenna Configuration	Reference value		UE Category
						Fraction of Maximum Throughput (%)	SNR (dB)	
1	10 MHz 64QAM	R.73 FDD	OP.1 FDD	EVA70	4x4 Low	70	15.1	≥5

8.10.1.1.8 Closed-loop spatial multiplexing performance, 4 Layers spatial multiplexing 4 Tx antennas (Cell-Specific Reference Symbols)

The requirements are specified in Table 8.10.1.1.8-2, with the addition of the parameters in Table 8.10.1.1.8-1 and the downlink physical channel setup according to Annex C.3.2.

Table 8.10.1.1.8-1: Test parameters for Closed Loop spatial multiplexing, 4 Layers spatial multiplexing with 4 Tx ports and 4 Rx ports

Parameter		Unit	Test 1
Downlink power allocation	ρ_A	dB	-6
	ρ_B	dB	-6 (Note 1)
	σ	dB	0
N_{oc} at antenna port		dBm/15k Hz	-98
Cell-specific reference signals			Antenna Ports 0,1,2,3
PDSCH transmission mode			4
PDSCH rank			4
Precoding granularity		PRB	50
PMI delay		ms	8
Reporting interval		ms	1
Reporting mode			PUSCH 3-1
CodeBookSubsetRestriction bitmap			0xFFFF000000000000
Note 1: $P_B = 1$.			

Table 8.10.1.1.8-2: Minimum performance for Closed Loop spatial multiplexing, 4 Layers spatial multiplexing with 4 Tx ports and 4 Rx ports

Test number	Bandwidth and MCS	Reference Channel	OCNG Pattern	Propagation Condition	Correlation Matrix and Antenna Configuration	Reference value		UE Category
						Fraction of Maximum Throughput (%)	SNR (dB)	
1	10 MHz 16QAM 1/2	R.74 FDD	OP.1 FDD	EPA5	4x4 Low	70	14.9	≥5

8.10.1.1.9 4 Layer Spatial Multiplexing (User-Specific Reference Symbols)

The requirements are specified in Table 8.10.1.1.9-2, with the addition of the parameters in Table 8.10.1.1.9-1 and the downlink physical channel setup according to Annex C.3.2.

Table 8.10.1.1.9-1: Minimum performance for 4 Layer Spatial Multiplexing (User-Specific Reference Symbols)

Parameter		Unit	Test 1
Downlink power allocation	ρ_A	dB	0
	ρ_B	dB	0 (Note 1)
	σ	dB	-3
Beamforming model			4 layer precoding based on WB PMI feedback
Cell-specific reference signals			Antenna ports 0,1
CSI reference signals			Antenna ports 15,...,18
Beamforming model			Annex B.4.3
CSI-RS periodicity and subframe offset $T_{\text{CSI-RS}} / \Delta_{\text{CSI-RS}}$		Subframes	5 / 2
CSI reference signal configuration			3
Zero-power CSI-RS configuration $I_{\text{CSI-RS}} /$ ZeroPowerCSI-RS bitmap		Subframes / bitmap	3 / 0001000000000000
N_{oc} at antenna port		dBm/15kHz	-98
Symbols for unused PRBs			OCNG (Note 3)
Number of allocated resource blocks (Note 2)		PRB	50
Simultaneous transmission			No
PDSCH transmission mode			9
Precoding granularity			50
PMI delay			8
Reporting interval			1
Reporting mode			PUSCH 3-1
alternativeCodeBookEnabledFor4TX-r12			False
CodeBookSubsetRestriction bitmap			0xFFFF000000000000
Note 1: $P_B = 1$. Note 2: 50 resource blocks are allocated in sub-frames 1,2,3,4,6,7,8,9 and 41 resource blocks (RB0–RB20 and RB30–RB49) are allocated in sub-frame 0. Note 3: These physical resource blocks are assigned to an arbitrary number of virtual UEs with one PDSCH per virtual UE; the data transmitted over the OCNG PDSCHs shall be uncorrelated pseudo random data, which is QPSK modulated.			

Table 8.10.1.1.9-2: Minimum performance for for 4 Layer Spatial Multiplexing (User-Specific Reference Symbols)

Test number	Bandwidth and MCS	Reference Channel	OCNG Pattern	Propagation Condition	Correlation Matrix and Antenna Configuration	Reference value		UE Category
						Fraction of Maximum Throughput (%)	SNR (dB)	
1	10 MHz 16QAM	R.75 FDD	OP.1 FDD	EPA5	4x4 Low	70	18.4	≥5

8.10.1.2 TDD (Fixed Reference Channel)

The parameters specified in Table 8.10.1.2-1 are valid for all TDD tests unless otherwise stated.

Table 8.10.1.2-1: Common Test Parameters (TDD)

Parameter	Unit	Value
Uplink downlink configuration (Note 1)		1
Special subframe configuration (Note 2)		4
Cyclic prefix		Normal
Cell ID		0
Inter-TTI Distance		1
Number of HARQ processes per component carrier	Processes	7
Maximum number of HARQ transmission		4
Redundancy version coding sequence		{0,1,2,3} for QPSK and 16QAM {0,0,1,2} for 64QAM and 256QAM
Number of OFDM symbols for PDCCH	OFDM symbols	4 for 1.4 MHz bandwidth, 3 for 3 MHz and 5 MHz bandwidths, 2 for 10 MHz, 15 MHz and 20 MHz bandwidths unless otherwise stated
Cross carrier scheduling		Not configured
Precoder update granularity		Frequency domain: 1 PRG for Transmission modes 9 and 10 Time domain: 1 ms
ACK/NACK feedback mode		Multiplexing
Note 1: as specified in Table 4.2-2 in TS 36.211 [4].		
Note 2: as specified in Table 4.2-1 in TS 36.211 [4].		

8.10.1.2.1 Transmit diversity performance with 2Tx Antenna Ports (Cell-Specific Reference Symbols)

The requirements are specified in Table 8.10.1.2.1-2, with the addition of the parameters in Table 8.10.1.2.1-1 and the downlink physical channel setup according to Annex C.3.2. The purpose is to verify the performance of transmit diversity (SFBC) with 2 transmitter antennas.

Table 8.10.1.2.1-1: Test Parameters for Transmit diversity Performance (FRC) with 4Rx Antenna Ports

Parameter	Unit	Test 1
Downlink power allocation	ρ_A	dB
	ρ_B	dB
	σ	dB
N_{oc} at antenna port	dBm/15kHz	-98
PDSCH transmission mode		2
Note 1: $P_B = 1$		

Table 8.10.1.2.1-2: Minimum performance Transmit Diversity (FRC) with 4Rx Antenna Ports

Test number	Bandwidth and MCS	Reference Channel	OCNG Pattern	Propagation Condition	Correlation Matrix and Antenna Configuration	Reference value		UE Category
						Fraction of Maximum Throughput (%)	SNR (dB)	
1	10 MHz 16QAM 1/2	R.11 TDD	OP.1 TDD	EVA5	2x4 Medium correlation A, ULA	70	3.9	≥2

8.10.1.2.1A Transmit diversity performance with Enhanced Performance Requirement Type A – 2 Tx Antenna Ports with TM3 interference model

The requirements are specified in Table 8.10.1.2.1A-2, with the addition of parameters in Table 8.10.1.2.1A-1 and the downlink physical channel setup according to Annex C.3.2. The purpose is to verify the performance of transmit diversity (SFBC) with 2 transmit antennas when the PDSCH transmission in the serving cell is interfered by PDSCH of one dominant interfering cells applying transmission mode 3 interference model defined in clause B.5.2. In Table 8.10.1.2.1A-1, Cell 1 is the serving cell, and Cell 2, 3 are interfering cells. The downlink physical channel setup is according to Annex C.3.2 for each of Cell 1, Cell 2 and Cell 3, respectively.

Table 8.10.1.2.1A-1: Test Parameters for Transmit diversity Performance (FRC) with TM3 interference model

Parameter		Unit	Cell 1	Cell 2
Downlink power allocation	ρ_A	dB	-3	-3
	ρ_B	dB	-3 (Note 1)	-3
	σ	dB	0	0
Cell-specific reference signals			Antenna ports 0,1	Antenna ports 0,1
N_{oc} at antenna port		dBm/15kHz	-98	N/A
DIP (Note 2)		dB	N/A	-1.73
$BW_{Channel}$		MHz	10	10
Cyclic Prefix			Normal	Normal
Cell Id			0	1
Number of control OFDM symbols			2	2
PDSCH transmission mode			2	N/A
Interference model			N/A	As specified in clause B.5.2
Probability of occurrence of transmission rank in interfering cells	Rank 1	%	N/A	80
	Rank 2	%	N/A	20
Reporting interval		ms	5	N/A
Reporting mode			PUCCH 1-0	N/A
ACK/NACK feedback mode			Multiplexing	N/A
Physical channel for CQI reporting			PUSCH(Note 5)	N/A
cqi-pmi-ConfigurationIndex			4	N/A
Note 1: $P_B = 1$ Note 2: The respective received power spectral density of each interfering cell relative to N_{oc} is defined by its associated DIP value as specified in clause B.5.1. Note 3: Cell 1 is the serving cell. Cell 2 is the interfering cell. Note 4: The cells are time-synchronous. Note 5: To avoid collisions between CQI reports and HARQ-ACK it is necessary to report both on PUSCH instead of PUCCH. PDCCH DCI format 0 shall be transmitted in downlink SF#4 and #9 to allow periodic CQI to multiplex with the HARQ-ACK on PUSCH in uplink subframe SF#8 and #3.				

Table 8.10.1.2.1A-2: Enhanced Performance Requirement Type A, Transmit Diversity (FRC) with TM3 interference model

Test Number	Reference Channel	OCNG Pattern		Propagation Conditions		Correlation Matrix and Antenna Configuration (Note 3)	Reference Value		UE Category
		Cell 1	Cell 2	Cell 1	Cell 2		Fraction of Maximum Throughput (%)	SINR (dB) (Note 2)	
1	R.46 TDD	OP.1 TDD	N/A	EVA70	EVA70	2x4 Low	70	-4.9	≥1

Note 1: The propagation conditions for Cell 1 and Cell 2 are statistically independent.

Note 2: SINR corresponds to \hat{E}_s / N_{oc} of Cell 1 as defined in clause 8.1.1.

Note 3: Correlation matrix and antenna configuration parameters apply for each of Cell 1 and Cell 2.

8.10.1.2.2 Open-loop spatial multiplexing performance with 2Tx Antenna Ports (Cell-Specific Reference Symbols)

The requirements are specified in Table 8.10.1.2.2-2, with the addition of the parameters in Table 8.10.1.2.2-1 and the downlink physical channel setup according to Annex C.3.2.

Table 8.10.1.2.2-1: Test Parameters for Large Delay CDD (FRC) with 4Rx Antenna Ports

Parameter	Unit	Test 1
Downlink power allocation	ρ_A	dB
	ρ_B	dB
	σ	dB
N_{oc} at antenna port	dBm/15kHz	-98
ACK/NACK feedback mode		Bundling
PDSCH transmission mode		3
Note 1: $P_B = 1$		

Table 8.10.1.2.2-2: Minimum performance Large Delay CDD (FRC) with 4Rx Antenna Ports

Test number	Bandwidth and MCS	Reference Channel	OCNG Pattern	Propagation Condition	Correlation Matrix and Antenna Configuration	Reference value		UE Category
						Fraction of Maximum Throughput (%)	SNR (dB)	
1	10 MHz 16QAM 1/2	R.11-1 TDD	OP.1 TDD	EVA70	2x4 Low	70	7.7	≥2

8.10.1.2.3 Closed-loop spatial multiplexing Enhanced Performance Requirements Type A - Single-Layer Spatial Multiplexing 2 Tx Antenna Port with TM4 interference model (Cell-Specific Reference Symbols)

The requirements are specified in Table 8.10.1.2.3-2, with the addition of the parameters in Table 8.10.1.2.3-1 and the downlink physical channel setup according to Annex C.3.2. The purpose of these tests is to verify the closed loop rank-one performance with wideband precoding with two transmit antennas when the PDSCH transmission in the serving cell is interfered by PDSCH of one dominant interfering cell applying transmission mode 4 interference model defined in clause B.5.3. In Table 8.10.1.2.3-1, Cell 1 is the serving cell, and Cell 2 is the interfering cells. The downlink physical channel setup is according to Annex C.3.2 for each of Cell 1 and Cell 2, respectively.

Table 8.10.1.2.3-1: Test Parameters for Single-Layer Spatial Multiplexing (FRC) with TM4 interference model and 4Rx Antenna Ports

Parameter		Unit	Cell 1	Cell 2
Downlink power allocation	ρ_A	dB	-3	-3
	ρ_B	dB	-3 (Note 1)	-3
	σ	dB	0	0
Cell-specific reference signals			Antenna ports 0,1	Antenna ports 0,1
N_{oc} at antenna port		dBm/15kHz	-98	N/A
DIP (Note 2)		dB	N/A	-1.73
BW_{Channel}		MHz	10	10
Cell Id			0	1
PDSCH transmission mode			6	N/A
Interference model			N/A	As specified in clause B.5.3
Probability of occurrence of transmission rank in interfering cells	Rank 1	%	N/A	80
	Rank 2	%	N/A	20
Precoding granularity		PRB	50	6
PMI delay (Note 4)		ms	10 or 11	N/A
Reporting interval		ms	5	N/A
Reporting mode			PUCCH 1-1	N/A
CodeBookSubsetRestriction bitmap			1111	N/A
Note 1: $P_B = 1$				
Note 2: The respective received power spectral density of each interfering cell relative to N_{oc} is defined by its associated DIP value as specified in clause B.5.1.				
Note 3: Cell 1 is the serving cell. Cell 2, 3 are the interfering cells.				
Note 4: If the UE reports in an available uplink reporting instance at subframe SF#n based on PMI estimation at a downlink SF not later than SF#(n-4), this reported PMI cannot be applied at the eNB downlink before SF#(n+4).				
Note 5: All cells are time-synchronous.				

Table 8.10.1.2.3-2: Enhanced Performance Requirement Type A, Single-Layer Spatial Multiplexing (FRC) with TM4 interference model and 4Rx Antenna Ports

Test Number	Reference Channel and MCS	OCNG Pattern		Propagation Conditions		Correlation Matrix and Antenna Configuration (Note 3)	Reference Value		UE Category
		Cell 1	Cell 2	Cell 1	Cell 2		Fraction of Maximum Throughput (%)	SINR (dB) (Note 2)	
1	R.47 TDD 16QAM	OP.1 TDD	N/A	EVA5	EVA5	2x4 Low	70	-1.9	≥ 1
Note 1: The propagation conditions for Cell 1 and Cell 2 are statistically independent.									
Note 2: SINR corresponds to \hat{E}_s / N_{oc} of Cell 1 as defined in clause 8.1.1.									
Note 3: Correlation matrix and antenna configuration parameters apply for each of Cell 1 and Cell 2.									

8.10.1.2.4 Closed-loop spatial multiplexing performance, Dual-Layer Spatial Multiplexing 4 Tx Antenna Ports (Cell-Specific Reference Symbols)

The requirements are specified in Table 8.10.1.2.4-2, with the addition of the parameters in Table 8.10.1.2.4-1 and the downlink physical channel setup according to Annex C.3.2.

Table 8.10.1.2.4-1: Test Parameters for Dual-Layer Spatial Multiplexing (FRC) with 4Rx Antenna Ports

Parameter	Unit	Test 1-2	
Downlink power allocation	ρ_A	dB	-6
	ρ_B	dB	-6 (Note 1)
	σ	dB	3
N_{oc} at antenna port	dBm/15kHz	-98	
Precoding granularity	PRB	6	
PMI delay (Note 2)	ms	10 or 11	
Reporting interval	ms	1 or 4 (Note 3)	
Reporting mode		PUSCH 1-2	
ACK/NACK feedback mode		Bundling	
CodeBookSubsetRestriction bitmap		00000000000000000000000000000000 00001111111111111111111100000000 00000000	
PDSCH transmission mode		4	
Note 1: $P_B = 1$. Note 2: If the UE reports in an available uplink reporting instance at subframe SF#n based on PMI estimation at a downlink SF not later than SF#(n-4), this reported PMI cannot be applied at the eNB downlink before SF#(n+4) Note 3: For Uplink - downlink configuration 1 the reporting interval will alternate between 1ms and 4ms.			

Table 8.10.1.2.4-2: Minimum performance Dual-Layer Spatial Multiplexing (FRC) with 4Rx Antenna Ports

	Bandwidth and MCS	Reference Channel	OCNG Pattern	Propagation Condition	Correlation Matrix and Antenna Configuration	Reference value		UE Category	DL UE category
						Fraction of Maximum Throughput (%)	SNR (dB)		
1	10 MHz 64 QAM	R.36 TDD	OP.1 TDD	EPA5	4x4 Low	70	10.4	≥2	≥6
2	10 MHz 256QAM	R.72 TDD	OP.1 TDD	EPA5	4x4 Low	70	17.5	11-12	≥11

8.10.1.2.5 Enhanced Performance Requirement Type A – Single-layer Spatial Multiplexing with TM9 interference model (User-Specific Reference Symbols)

The requirements are specified in Table 8.10.1.2.5-2, with the addition of the parameters in Table 8.10.1.2.5-1 and the downlink physical channel setup according to Annex C.3.2. The purpose of these tests is to verify closed-loop rank one performance on one of the antenna ports 7 or 8 without a simultaneous transmission on the other antenna port in the serving cell when the PDSCH transmission in the serving cell is interfered by PDSCH of one dominant interfering cell applying transmission mode 9 interference model defined in clause B.5.4. In 8.10.1.2.5-1, Cell 1 is the serving cell, and Cell 2 is the interfering cell. The downlink physical channel setup is according to Annex C.3.2 for each of Cell 1 and Cell 2, respectively.

Table 8.10.1.2.5-1: Test Parameters for Testing CDM-multiplexed DM RS (single layer) with TM9 interference model and 4Rx Antenna Ports

parameter		Unit	Cell 1	Cell 2
Downlink power allocation	ρ_A	dB	0	0
	ρ_B	dB	0 (Note 1)	0
	σ	dB	-3	-3
Cell-specific reference signals			Antenna ports 0,1	Antenna ports 0,1
CSI reference signals			Antenna ports 15,16	N/A
CSI-RS periodicity and subframe offset $T_{\text{CSI-RS}} / \Delta_{\text{CSI-RS}}$		Subframes	5 / 4	N/A
CSI reference signal configuration			0	N/A
N_{oc} at antenna port		dBm/15kHz z	-98	N/A
DIP (Note 2)		dB	N/A	-1.73
BW_{Channel}		MHz	10	10
Cell Id			0	126
PDSCH transmission mode			9	9
Beamforming model			As specified in clause B.4.3 (Note 4, 5)	N/A
Interference model			N/A	As specified in clause B.5.4
Probability of occurrence of transmission rank in interfering cells	Rank 1		N/A	70
	Rank 2		N/A	30
Precoder update granularity		PRB	50	6
PMI delay (Note 5)		ms	10 or 11	N/A
Reporting interval		ms	5	N/A
Reporting mode			PUCCH 1-1	N/A
CodeBookSubsetRestriction bitmap			001111	N/A
Symbols for unused PRBs			OCNG (Note 6)	N/A
Simultaneous transmission			No simultaneous transmission on the other antenna port in (7 or 8) not used for the input signal under test	N/A
Physical channel for CQI reporting			PUSCH(Note 8)	N/A
cqi-pmi-ConfigurationIndex			4	N/A
<p>Note 1: $P_B = 1$</p> <p>Note 2: The respective received power spectral density of each interfering cell relative to N_{oc} is defined by its associated DIP value as specified in clause B.5.1.</p> <p>Note 3: The modulation symbols of the signal under test in Cell 1 are mapped onto antenna port 7 or 8.</p> <p>Note 4: The precoder in clause B.4.3 follows UE recommended PMI.</p> <p>Note 5: If the UE reports in an available uplink reporting instance at subframe SF#n based on PMI estimation at a downlink SF not later than SF#(n-4), this reported PMI cannot be applied at the eNB downlink before SF#(n+4).</p> <p>Note 6: These physical resource blocks are assigned to an arbitrary number of virtual UEs with one PDSCH per virtual UE; the data transmitted over the OCNG PDSCHs</p>				

shall be uncorrelated pseudo random data, which is QPSK modulated.
 Note 7: All cells are time-synchronous.
 Note 8: To avoid collisions between CQI reports and HARQ-ACK it is necessary to report both on PUSCH instead of PUCCH. PDCCH DCI format 0 shall be transmitted in downlink SF#4 and #9 to allow periodic CQI to multiplex with the HARQ-ACK on PUSCH in uplink subframe SF#8 and #3.

Table 8.10.1.2.5-2: Enhanced Performance Requirement Type A, CDM-multiplexed DM RS with TM9 interference model and 4Rx Antenna Ports

Test Number	Reference Channel and MCS	OCNG Pattern		Propagation Conditions		Correlation Matrix and Antenna Configuration (Note 3)	Reference Value		UE Category
		Cell 1	Cell 2	Cell 1	Cell 2		Fraction of Maximum Throughput (%)	SINR (dB) (Note 2)	
1	R.76 TDD QPSK	OP.1 TDD	N/A	EVA5	EVA5	2x4 Low	70	-3.3	≥1

Note 1: The propagation conditions for Cell 1 and Cell 2 are statistically independent.
 Note 2: SINR corresponds to \hat{E}_s / N_{oc} of Cell 1 as defined in clause 8.1.1.
 Note 3: Correlation matrix and antenna configuration parameters apply for each of Cell 1 and Cell 2.

8.10.1.2.5A Single-layer Spatial Multiplexing (with multiple CSI-RS configurations)

The requirements are specified in Table 8.10.1.2.5A-2, with the addition of the parameters in Table 8.10.1.2.5A-1 and the downlink physical channel setup according to Annex C.3.2. The purpose of these tests is to verify closed loop rank one performance on one of the antenna ports 7 or 8 with a simultaneous transmission on the other antenna port in the serving cell, and to verify rate matching with multiple CSI reference symbol configurations with non-zero and zero transmission power.

Table 8.10.1.2.5A-1: Test Parameters for Testing CDM-multiplexed DM RS (single layer) with multiple CSI-RS configurations

Parameter	Unit	Test 1
Downlink power allocation	ρ_A	dB
	ρ_B	dB
	σ	dB

Cell-specific reference signals		Antenna ports 0,1
CSI reference signals		Antenna ports 15,...,18
Beamforming model		Annex B.4.1
CSI-RS periodicity and subframe offset $T_{CSI-RS} / \Delta_{CSI-RS}$	Subframes	5 / 4
CSI reference signal configuration		3
Zero-power CSI-RS configuration $I_{CSI-RS} /$ $ZeroPowerCSI-RS$ bitmap	Subframes / bitmap	4 / 0010000000000000
N_{oc} at antenna port	dBm/15kHz	-98
Symbols for unused PRBs		OCNG (Note 4)
Number of allocated resource blocks (Note 2)	PRB	50
Simultaneous transmission		Yes (Note 3, 5)
PDSCH transmission mode		9
Number of MBSFN subframes	Subframes	NA
<p>Note 1: $P_B = 1$.</p> <p>Note 2: The modulation symbols of the signal under test are mapped onto antenna port 7 or 8.</p> <p>Note 3: Modulation symbols of an interference signal is mapped onto the antenna port (7 or 8) not used for the input signal under test.</p> <p>Note 4: These physical resource blocks are assigned to an arbitrary number of virtual UEs with one PDSCH per virtual UE; the data transmitted over the OCNG PDSCHs shall be uncorrelated pseudo random data, which is QPSK modulated.</p> <p>Note 5: The two UEs' scrambling identities n_{SCID} are set to 0 for CDM-multiplexed DM RS with interfering simultaneous transmission test cases.</p>		

Table 8.10.1.2.5A-2: Minimum performance for CDM-multiplexed DM RS with interfering simultaneous transmission (FRC) with multiple CSI-RS configurations

Test number	Bandwidth and MCS	Reference Channel	OCNG Pattern	Propagation Condition	Correlation Matrix and Antenna Configuration	Reference value		UE Category
						Fraction of Maximum Throughput (%)	SNR (dB)	
1	10 MHz 64QAM 1/2	R.44 TDD	OP.1 TDD	EPA5	2x4 Low	70	15.8	≥2
Note 1: The reference channel applies to both the input signal under test and the interfering signal.								

Table 8.10.1.2.5A-3: Void

8.10.1.2.5B Single-layer Spatial Multiplexing (With Enhanced DMRS table configured)

For single-layer transmission on antenna port 7, 8, 11 or 13 upon detection of a PDCCH with DCI format 2C, the requirement is specified in Table 8.10.1.2.5B -2, with the addition of the parameters in Table 8.10.1.2.5B -1 and the downlink physical channel setup according to Annex C.3.2. The purpose of the test is to verify rank-1 performance on antenna port 11 with a simultaneous transmission on the antenna port 7, 8 or 13 with DMRS enhancement table and 4 orthogonal DMRS ports (dmrs-Enhancements-r13 UE-EUTRA-Capability [7]).

Table 8.10.1.2.5B -1: Test Parameters for Testing CDM-multiplexed DM RS (single layer) with interfering simultaneous transmission (FRC) with multiple CSI-RS configurations with Enhanced DMRS table

Parameter		Unit	Test 1
Downlink power allocation	ρ_A	dB	0
	ρ_B	dB	0 (Note 1)
	σ	dB	-3
Beamforming model			Annex B.4.1A
Cell-specific reference signals			Antenna ports 0,1
CSI reference signals			Antenna ports 15,...,18
CSI-RS periodicity and subframe offset $T_{\text{CSI-RS}} / \Delta_{\text{CSI-RS}}$		Subframes	5 / 4
CSI reference signal configuration			3
Zero-power CSI-RS configuration $I_{\text{CSI-RS}} / \text{ZeroPowerCSI-RS}$ bitmap		Subframes / bitmap	4 / 0010000000000000
N_{oc} at antenna port		dBm/15kHz	-98
Symbols for unused PRBs			OCNG (Note 4)
Number of allocated resource blocks (Note 2)		PRB	50
Simultaneous transmission			Yes (Note 3, 5)
dmrs-Enhancements-r13			Enable
PDSCH transmission mode			9
Note 1: $P_B = 1$. Note 2: The modulation symbols of the signal under test are mapped onto antenna port 11. Note 3: Modulation symbols of an interference signal are random mapped onto one antenna port among antenna port 7, 8 and 13. The update granularity for randomized mapping antenna port is 1 PRG in frequency domain and 1ms in time domain. Note 4: These physical resource blocks are assigned to an arbitrary number of virtual UEs with one PDSCH per virtual UE; the data transmitted over the OCNG PDSCHs shall be uncorrelated pseudo random data, which is QPSK modulated. Note 5: The two UEs' scrambling identities n_{SCID} are set to 0 with OCC =4.			

Table 8.10.1.2.5B-2: Minimum performance for CDM-multiplexed DM RS with interfering simultaneous transmission (FRC) with multiple CSI-RS configurations with Enhanced DMRS table

Test number	Bandwidth and MCS	Reference Channel	OCNG Pattern	Propagation Condition	Correlation Matrix and Antenna Configuration	Reference value		UE Category
						Fraction of Maximum Throughput (%)	SNR (dB)	
1	10 MHz 64QAM 1/2	R.44 TDD	OP.1 TDD	EPA5	2x4 Low	70	15.8	≥ 2

Note 1: The reference channel applies to both the input signal under test and the interfering signal.

8.10.1.2.6 Dual-Layer Spatial Multiplexing (User-Specific Reference Symbols)

For dual-layer transmission on antenna ports 7 and 8 upon detection of a PDCCH with DCI format 2C, the requirements are specified in Table 8.10.1.2.6-2, with the addition of the parameters in Table 8.10.1.2.6-1 where Cell 1 is the serving cell and Cell 2 is the interfering cell. The downlink physical channel setup is set according to Annex C.3.2. The purpose

of these tests is to verify the rank-2 performance for full RB allocation, to verify rate matching with multiple CSI reference symbol configurations with non-zero and zero transmission power, and to verify that the UE correctly estimate SNR.

Table 8.10.1.2.6-1: Test Parameters for Testing CDM-multiplexed DM RS (dual layer) with multiple CSI-RS configurations and 4Rx Antenna Ports

Parameter		Unit	Test 1	
			Cell 1	Cell 2
Downlink power allocation	ρ_A	dB	0	0
	ρ_B	dB	0 (Note 1)	0
	σ	dB	-3	-3
	PDSCH_RA	dB	4	NA
	PDSCH_RB	dB	4	NA
Cell-specific reference signals			Antenna ports 0 and 1	Antenna ports 0 and 1
Cell ID			0	126
CSI reference signals			Antenna ports 15,16	NA
Beamforming model			Annex B.4.2	NA
CSI-RS periodicity and subframe offset $T_{\text{CSI-RS}} / \Delta_{\text{CSI-RS}}$		Subframes	5 / 4	NA
CSI reference signal configuration			8	NA
Zero-power CSI-RS configuration $I_{\text{CSI-RS}} / \text{ZeroPowerCSI-RS}$ bitmap		Subframes / bitmap	4 / 0010000000000000	NA
N_{oc} at antenna port		dBm/15kHz	-98	NA
\hat{E}_s / N_{oc}			Reference Value in Table 8.10.1.2.6-2	7.25dB
Symbols for unused PRBs			OCNG (Note 2)	NA
Number of allocated resource blocks (Note 2)		PRB	50	NA
Simultaneous transmission			No	NA
PDSCH transmission mode			9	Blanked
Note 1: $P_B = 1$				
Note 2: These physical resource blocks are assigned to an arbitrary number of virtual UEs with one PDSCH per virtual UE; the data transmitted over the OCNG PDSCHs shall be uncorrelated pseudo random data, which is QPSK modulated.				

Table 8.10.1.2.6-2: Minimum performance for CDM-multiplexed DM RS (FRC) with multiple CSI-RS configurations

Test number	Bandwidth and MCS	Reference Channel	OCNG Pattern		Propagation Condition		Correlation Matrix and Antenna Configuration	Reference value		UE Category
			Cell 1	Cell 2	Cell 1	Cell 2		Fraction of Maximum Throughput (%)	SNR (dB)	
1	10 MHz 16QAM 1/2	R.51 TDD	OP.1 TDD	N/A	ETU5	ETU5	2x4 Low	70	9.5	≥2

Note 1: The propagation conditions for Cell 1 and Cell 2 are statistically independent.
Note 2: Correlation matrix and antenna configuration parameters apply for each of Cell 1 and Cell 2.
Note 3: SNR corresponds to \hat{E}_s/N_{oc} of Cell 1.

8.10.1.2.7 Open-loop spatial multiplexing, 3 Layer Multiplexing with 4 Tx Antenna Ports (Cell-Specific Reference Symbols)

The requirements are specified in Table 8.10.1.2.7-2, with the addition of the parameters in Table 8.10.1.2.7-1 and the downlink physical channel setup according to Annex C.3.2.

Table 8.10.1.2.7-1: Test parameters for Open Loop spatial multiplexing, 3 Layers with 4 Tx ports and 4 Rx ports

Parameter	Unit		
Downlink power allocation	ρ_A	dB	-6
	ρ_B	dB	-6 (Note 1)
	σ	dB	0
N_{oc} at antenna port		dBm/15kHz	-98
Cell-specific reference signals			Antenna Ports 0,1,2,3
PDSCH transmission mode			3
PDSCH rank			3
CodeBookSubsetRestriction bitmap			0100
Note 1: $P_B = 1$.			

Table 8.10.1.2.7-2: Minimum performance Open Loop spatial multiplexing, 3 Layers with 4 Tx ports and 4 Rx ports

Test number	Bandwidth and MCS	Reference Channel	OCNG Pattern	Propagation Condition	Correlation Matrix and Antenna Configuration	Reference value		UE Category
						Fraction of Maximum Throughput (%)	SNR (dB)	
1	10 MHz 64QAM	R.73 TDD	OP.1 TDD	EVA70	4x4 Low	70	14.9	≥5

8.10.1.2.8 Closed-loop spatial multiplexing performance, 4 Layers spatial multiplexing 4 Tx antennas

The requirements are specified in Table 8.10.1.2.8-2, with the addition of the parameters in Table 8.10.1.2.8-1 and the downlink physical channel setup according to Annex C.3.2.

Table 8.10.1.2.8-1: Test parameters for Closed Loop spatial multiplexing, 4 Layers spatial multiplexing with 4 Tx ports and 4 Rx ports

Parameter		Unit	Test 1
Downlink power allocation	ρ_A	dB	-6
	ρ_B	dB	-6 (Note 1)
	σ	dB	0
N_{oc} at antenna port		dBm/15k Hz	-98
Cell-specific reference signals			Antenna ports 0,1,2,3
PDSCH transmission mode			4
PDSCH rank			4
Precoding granularity		PRB	50
PMI delay		ms	10 or 11
Reporting interval		ms	1 or 4
Reporting mode			PUSCH 3-1
CodeBookSubsetRestriction bitmap			0xFFFF000000000000
Uplink-Downlink Configuration			1
Special subframe configuration			4
Note 1: $P_B = 1$.			

Table 8.10.1.2.8-2: Minimum performance for Closed Loop spatial multiplexing, 4 Layers spatial multiplexing with 4 Tx ports and 4 Rx ports

Test number	Bandwidth and MCS	Reference Channel	OCNG Pattern	Propagation Condition	Correlation Matrix and Antenna Configuration	Reference value		UE Category
						Fraction of Maximum Throughput (%)	SNR (dB)	
1	10 MHz 16QAM 1/2	R.74 TDD	OP.1 TDD	EPA5	4x4 Low	70	14.4	≥ 5

8.10.1.2.9 4 Layer Spatial Multiplexing (User-Specific Reference Symbols)

The requirements are specified in Table 8.10.1.2.9-2, with the addition of the parameters in Table 8.10.1.2.9-1 and the downlink physical channel setup according to Annex C.3.2.

Table 8.10.1.2.9-1: Minimum performance for 4 Layer Spatial Multiplexing (User-Specific Reference Symbols)

Parameter		Unit	Test 1
Downlink power allocation	ρ_A	dB	0
	ρ_B	dB	0 (Note 1)
	σ	dB	-3
Beamforming model			4 layer precoding based on WB PMI feedback
Cell-specific reference signals			Antenna ports 0,1
CSI reference signals			Antenna ports 15,...,18
Beamforming model			Annex B.4.3
CSI-RS periodicity and subframe offset $T_{\text{CSI-RS}} / \Delta_{\text{CSI-RS}}$		Subframes	5 / 4
CSI reference signal configuration			3
Zero-power CSI-RS configuration $l_{\text{CSI-RS}} /$ ZeroPowerCSI-RS bitmap		Subframes / bitmap	4 / 0010000000000000
N_{oc} at antenna port		dBm/15kHz	-98
Symbols for unused PRBs			OCNG (Note 3)
Number of allocated resource blocks (Note 2)		PRB	50
Simultaneous transmission			No
PDSCH transmission mode			9
Precoding granularity			50
PMI delay			10 or 11
Reporting interval			1 or 4
Reporting mode			PUSCH 3-1
alternativeCodeBookEnabledFor4TX-r12			False
CodeBookSubsetRestriction bitmap			0xFFFF000000000000
Note 1: $P_B = 1$. Note 2: 50 resource blocks are allocated in sub-frames 4, 9 and 41 resource blocks (RB0–RB20 and RB30–RB49) are allocated in sub-frame 0,1 and 6. Note 3: These physical resource blocks are assigned to an arbitrary number of virtual UEs with one PDSCH per virtual UE; the data transmitted over the OCNG PDSCHs shall be uncorrelated pseudo random data, which is QPSK modulated.			

Table 8.10.1.2.9-2: Minimum performance for for 4 Layer Spatial Multiplexing (User-Specific Reference Symbols)

Test number	Bandwidth and MCS	Reference Channel	OCNG Pattern	Propagation Condition	Correlation Matrix and Antenna Configuration	Reference value		UE Category
						Fraction of Maximum Throughput (%)	SNR (dB)	
1	10 MHz 16QAM	R.75 TDD	OP.1 TDD	EPA5	4x4 Low	70	19.0	≥5

8.10.2 PDCCH/PCFICH

8.10.2.1 FDD

The parameters specified in Table 8.10.2.1-1 are valid for all FDD tests unless otherwise stated.

Table 8.10.2.1-1: Test Parameters for PDCCH/PCFICH with 4 Rx Antenna Ports

Parameter		Unit	Single antenna port	Transmit diversity
Number of PDCCH symbols		symbols	2	2
PHICH Ng (Note 1)			1	1
PHICH duration			Normal	Normal
Unused RE-s and PRB-s (Note 2)			OCNG	OCNG
Cell ID			0	0
Downlink power allocation	ρ_A	dB	0	-3
	ρ_B	dB	0	-3
	σ	dB	0	0
N_{oc} at antenna port		dBm/15kHz	-98	-98
Cyclic prefix			Normal	Normal
Note 1: according to Clause 6.9 in TS 36.211 [4].				
Note 2: PDSCH is mapped as OCNG.				

8.10.2.1.1 Single-antenna port performance

For the parameters specified in Table 8.10.2.1-1 the average probability of a missed downlink scheduling grant (Pm-dsg) shall be below the specified value in Table 8.10.2.1.1-1. The downlink physical setup is in accordance with Annex C.3.2.

Table 8.10.2.1.1-1: Minimum performance PDCCH/PCFICH with 4Rx Antenna ports

Test number	Bandwidth	Aggregation level	Reference Channel	OCNG Pattern	Propagation Condition	Antenna configuration and correlation Matrix	Reference value	
							Pm-dsg (%)	SNR (dB)
1	10 MHz	8 CCE	R.15 FDD	OP.1 FDD	ETU70	1x4 Low	1	-5.4

8.10.2.1.2 Transmit diversity performance with 2 Tx Antenna Ports

For the parameters specified in Table 8.10.2.1-1 the average probability of a missed downlink scheduling grant (Pm-dsg) shall be below the specified value in Table 8.10.2.1.2-1. The downlink physical setup is in accordance with Annex C.3.2.

Table 8.10.2.1.2-1: Minimum performance PDCCH/PCFICH with 4 Rx Antenna Ports

Test number	Bandwidth	Aggregation level	Reference Channel	OCNG Pattern	Propagation Condition	Antenna configuration and correlation Matrix	Reference value	
							Pm-dsg (%)	SNR (dB)
1	10 MHz	4 CCE	R.16 FDD	OP.1 FDD	EVA70	2 x 4 Low	1	-3.5

8.10.2.1.3 Transmit diversity performance with 4 Tx Antenna Ports

For the parameters specified in Table 8.10.2.1-1 the average probability of a missed downlink scheduling grant (Pm-dsg) shall be below the specified value in Table 8.10.2.1.3-1. The downlink physical setup is in accordance with Annex C.3.2.

Table 8.10.2.1.3-1: Minimum performance PDCCH/PCFICH with 4Rx Antenna ports

Test number	Bandwidth	Aggregation level	Reference Channel	OCNG Pattern	Propagation Condition	Antenna configuration and correlation Matrix	Reference value	
							Pm-dsg (%)	SNR (dB)
1	5 MHz	2 CCE	R.17 FDD	OP.1 FDD	EPA5	4 x 4 Medium A Xpol	1	-0.4

8.10.2.2 TDD

Table 8.10.2.2-1: Test Parameters for PDCCH/PCFICH

Parameter	Unit	Single antenna port	Transmit diversity
Uplink downlink configuration (Note 1)		0	0
Special subframe configuration (Note 2)		4	4
Number of PDCCH symbols	symbols	2	2
PHICH Ng (Note 3)		1	1
PHICH duration		Normal	Normal
Unused RE-s and PRB-s (Note 4)		OCNG	OCNG
Cell ID		0	0
Downlink power allocation	ρ_A	dB	-3
	ρ_B	dB	-3
	σ	dB	0
N_{oc} at antenna port	dBm/15kHz	-98	-98
Cyclic prefix		Normal	Normal
ACK/NACK feedback mode		Multiplexing	Multiplexing
Note 1: as specified in Table 4.2-2 in TS 36.211 [4].			
Note 2: as specified in Table 4.2-1 in TS 36.211 [4].			
Note 3: according to Clause 6.9 in TS 36.211 [4].			
Note 4: PDSCH is mapped as OCNG.			

8.10.2.2.1 Single-antenna port performance

For the parameters specified in Table 8.10.2.2-1 the average probability of a missed downlink scheduling grant (Pm-dsg) shall be below the specified value in Table 8.10.2.2.1-1. The downlink physical setup is in accordance with Annex C.3.2.

Table 8.10.2.2.1-1: Minimum performance PDCCH/PCFICH

Test number	Bandwidth	Aggregation level	Reference Channel	OCNG Pattern	Propagation Condition	Antenna configuration and correlation Matrix	Reference value	
							Pm-dsg (%)	SNR (dB)
1	10 MHz	8 CCE	R.15 TDD	OP.1 TDD	ETU70	1x4 Low	1	-4.7

8.10.2.2.2 Transmit diversity performance with 2 Tx Antenna Ports

For the parameters specified in Table 8.10.2.2-1 the average probability of a missed downlink scheduling grant (Pm-dsg) shall be below the specified value in Table 8.10.2.2.2-1. The downlink physical setup is in accordance with Annex C.3.2.

Table 8.10.2.2-1: Minimum performance PDCCH/PCFICH with 4Rx Antenna ports

Test number	Bandwidth	Aggregation level	Reference Channel	OCNG Pattern	Propagation Condition	Antenna configuration and correlation Matrix	Reference value	
							Pm-dsg (%)	SNR (dB)
1	10 MHz	4 CCE	R.16 TDD	OP.1 TDD	EVA70	2 x 4 Low	1	-3.2

8.10.2.2.3 Transmit diversity performance with 4 Tx Antenna Ports

For the parameters specified in Table 8.10.2.2-1 the average probability of a missed downlink scheduling grant (Pm-dsg) shall be below the specified value in Table 8.10.2.2.3-1. The downlink physical setup is in accordance with Annex C.3.2.

Table 8.10.2.2.3-1: Minimum performance PDCCH/PCFICH with 4Rx Antenna ports

Test number	Bandwidth	Aggregation level	Reference Channel	OCNG Pattern	Propagation Condition	Antenna configuration and correlation Matrix	Reference value	
							Pm-dsg (%)	SNR (dB)
1	5 MHz	2 CCE	R.17 TDD	OP.1 TDD	EPA5	4 x 4 Medium A Xpol	1	0.0

8.10.3 PHICH

The receiver characteristics of the PHICH are determined by the probability of miss-detecting an ACK for a NACK (Pm-an). It is assumed that there is no bias applied to the detection of ACK and NACK (zero-threshold detection).

8.10.3.1 FDD

The parameters specified in Table 8.10.3.1-1 are valid for all FDD tests with 4Rx unless otherwise stated.

Table 8.10.3.1-1: Test Parameters for PHICH with 4 Rx Antenna Ports

Parameter		Unit	Single antenna port	Transmit diversity
Downlink power allocation	ρ_A	dB	0	-3
	ρ_B	dB	0	-3
	σ	dB	0	0
PHICH duration			Normal	Normal
PHICH Ng (Note 1)			Ng = 1	Ng = 1
PDCCH Content			UL Grant should be included with the proper information aligned with A.3.6. DL Grant: Note 2	
Unused RE-s and PRB-s (Note 2)			OCNG	OCNG
Cell ID			0	0
N_{oc} at antenna port		dBm/15kHz	-98	-98
Cyclic prefix			Normal	Normal
Note 1: according to Clause 6.9 in TS 36.211 [4]. Note 2: Reference measurement channel R.15 FDD for Single Tx Antenna 8.10.3.1.1, R15-2 FDD for Transmit Diversity with 2Tx Antenna Port 8.10.3.1.2, R17 FDD for Transmit diversity with 4Tx Antenna Port 8.10.3.1.3, according to Table A.3.5.1-1 with one sided dynamic OCNG Pattern OP.1 FDD as described in Annex A.5.1.1 for the serving cell.				

8.10.3.1.1 Single Tx Antenna Port performance

For the parameters specified in Table 8.10.3.1-1 the average probability of a miss-detecting ACK for NACK (P_{m-an}) shall be below the specified value in Table 8.10.3.1.1-1. The downlink physical setup is in accordance with Annex C.3.2.

Table 8.10.3.1.1-1: Minimum performance PHICH with 4 Rx Antenna Ports

Test number	Bandwidth	Reference Channel	OCNG Pattern	Propagation Condition	Antenna configuration and correlation Matrix	Reference value	
						P _{m-an} (%)	SNR (dB)
1	10 MHz	R.18	OP.1 FDD	ETU70	1 x 4 Low	0.1	1.6

8.10.3.1.2 Transmit diversity performance with 2 Tx Antenna Ports

For the parameters specified in Table 8.10.3.1-1 the average probability of a miss-detecting ACK for NACK (P_{m-an}) shall be below the specified value in Table 8.10.3.1.2-1. The downlink physical setup is in accordance with Annex C.3.2.

Table 8.10.3.1.2-1: Minimum performance PHICH with 4 Rx Antenna Ports

Test number	Bandwidth	Reference Channel	OCNG Pattern	Propagation Condition	Antenna configuration and correlation Matrix	Reference value	
						P _{m-an} (%)	SNR (dB)
1	10 MHz	R.19	OP.1 FDD	EVA70	2 x 4 Low	0.1	0.6

8.10.3.1.3 Transmit diversity performance with 4 Tx Antenna Ports

For the parameters specified in Table 8.10.3.1-1 the average probability of a miss-detecting ACK for NACK (P_{m-an}) shall be below the specified value in Table 8.10.3.1.3-1. The downlink physical setup is in accordance with Annex C.3.2.

Table 8.10.3.1.3-1: Minimum performance PHICH with 4 Rx Antenna Ports

Test number	Bandwidth	Reference Channel	OCNG Pattern	Propagation Condition	Antenna configuration and correlation Matrix	Reference value	
						P _{m-an} (%)	SNR (dB)
1	5 MHz	R.20	OP.1 FDD	EPA5	4 x 4 Medium correlation A, Cross polarized	0.1	0.1

8.10.3.2 TDD

The parameters specified in Table 8.10.3.2-1 are valid for all TDD tests with 4 Rx unless otherwise stated.

Table 8.10.3.2-1: Test Parameters for PHICH with 4 Rx Antenna Ports

Parameter		Unit	Single antenna port	Transmit diversity
Uplink downlink configuration (Note 1)			1	1
Special subframe configuration (Note 2)			4	4
Downlink power allocation	ρ_A	dB	0	-3
	ρ_B	dB	0	-3
	σ	dB	0	0
PHICH duration			Normal	Normal
PHICH Ng (Note 1)			Ng = 1	Ng = 1
PDCCH Content			UL Grant should be included with the proper information aligned with A.3.6. DL Grant: Note 4	
Unused RE-s and PRB-s (Note 4)			OCNG	OCNG
Cell ID			0	0
N_{oc} at antenna port		dBm/15kHz	-98	-98
Cyclic prefix			Normal	Normal
ACK/NACK feedback mode			Multiplexing	Multiplexing
Note 1: as specified in Table 4.2-2 in TS 36.211 [4]. Note 2: as specified in Table 4.2-1 in TS 36.211 [4]. Note 3: according to Clause 6.9 in TS 36.211 [4]. Note 4: Reference measurement channel R.15 TDD for Single Tx Antenna 8.10.3.2.1, R15-2 TDD for Transmit Diversity with 2Tx Antenna Port 8.10.3.2.2, R17 TDD for Transmit diversity with 4Tx Antenna Port 8.10.3.2.3, according to Table A.3.5.2-1 with one sided dynamic OCNG Pattern OP.1 TDD as described in Annex A.5.2.1 for the serving cell.				

8.10.3.2.1 Single Tx Antenna Port performance

For the parameters specified in Table 8.10.3.2-1 the average probability of a miss-detecting ACK for NACK (P_{m-an}) shall be below the specified value in Table 8.10.3.2.1-1. The downlink physical setup is in accordance with Annex C.3.2.

Table 8.10.3.2.1-1: Minimum performance PHICH with 4 Rx Antenna Ports

Test number	Bandwidth	Reference Channel	OCNG Pattern	Propagation Condition	Antenna configuration and correlation Matrix	Reference value	
						P_{m-an} (%)	SNR (dB)
1	10 MHz	R.18	OP.1 TDD	ETU70	1 x 4 Low	0.1	1.7

8.10.3.2.2 Transmit diversity performance with 2 Tx Antenna Ports

For the parameters specified in Table 8.10.3.2-1 the average probability of a miss-detecting ACK for NACK (P_{m-an}) shall be below the specified value in Table 8.10.3.2.2-1. The downlink physical setup is in accordance with Annex C.3.2.

Table 8.10.3.2.2-1: Minimum performance PHICH with 4 Rx Antenna Ports

Test number	Bandwidth	Reference Channel	OCNG Pattern	Propagation Condition	Antenna configuration and correlation Matrix	Reference value	
						P_{m-an} (%)	SNR (dB)
1	10 MHz	R.19	OP.1 TDD	EVA70	2 x 4 Low	0.1	0.9

8.10.3.2.3 Transmit diversity performance with 4 Tx Antenna Ports

For the parameters specified in Table 8.10.3.2-1 the average probability of a miss-detecting ACK for NACK (P_{m-an}) shall be below the specified value in Table 8.10.3.2.3-1. The downlink physical setup is in accordance with Annex C.3.2.

Table 8.10.3.2.3-1: Minimum performance PHICH with 4 Rx Antenna Ports

Test number	Bandwidth	Reference Channel	OCNG Pattern	Propagation Condition	Antenna configuration and correlation Matrix	Reference value	
						P_{m-an} (%)	SNR (dB)
1	5 MHz	R.20	OP.1 TDD	EPA5	4 x 4 Medium cotrrelation A, Cross polarized	0.1	0.3

8.10.4 ePDCCH

The receiver characteristics of the EPDCCH are determined by the probability of miss-detection of the Downlink Scheduling Grant (P_{m-dsg}). For the distributed transmission tests in 8.10.4.1, EPDCCH and PCFICH are tested jointly, i.e. a miss detection of PCFICH implies a miss detection of EPDCCH. For other tests, EPDCCH and PCFICH are not tested jointly.

8.10.4.1 Distributed Transmission with 4Rx

8.10.4.1.1 FDD

The parameters specified in Table 8.10.4.1.1-1 are valid for all FDD distributed EPDCCH test with 4Rx unless otherwise stated.

Table 8.10.4.1.1-1: Test Parameters for Distributed EPDCCH with 4Rx

Parameter		Unit	Value
Number of PDCCH symbols		symbols	2 (Note 1)
PHICH duration			Normal
Unused RE-s and PRB-s			OCNG
Cell ID			0
Downlink power allocation	ρ_A	dB	-3
	ρ_B	dB	-3
	σ	dB	0
	δ	dB	3
N_{oc} at antenna port		dBm/15 kHz	-98
Cyclic prefix			Normal
Subframe Configuration			Non-MBSFN
Precoder Update Granularity	PRB		1
	ms		1
Beamforming Pre-Coder			Annex B.4.4
Cell Specific Reference Signal			Port 0 and 1
Number of EPDCCH Sets Configured			2 (Note 2)
Number of PRB per EPDCCH Set			4 (1 st Set) 8 (2 nd Set)
EPDCCH Subframe Monitoring			NA
PDSCH TM			TM3
DCI Format			2A
Note 1: The starting symbol for EPDCCH is derived from the PCFICH. RRC signalling <i>epdcch-StartSymbol-r11</i> is not configured.			
Note 2: The two sets are distributed EPDCCH sets and non-overlapping with PRB = {3, 17, 31, 45} for the first set and PRB = {0, 7, 14, 21, 28, 35, 42, 49} for the second set. EPDCCH is scheduled in the first set for Test 1 and second set for Test 2, respectively. Both sets are always configured.			

For the parameters specified in Table 8.10.4.1.1-1 the average probability of a missed downlink scheduling grant (Pm-dsg) shall be below the specified value in Table 8.10.4.1.1-2. The downlink physical setup is in accordance with Annex C.3.2.

Table 8.10.4.1.1-2: Minimum performance Distributed EPDCCH with 4Rx Antenna ports

Test number	Bandwidth	Aggregation level	Reference Channel	OCNG Pattern	Propagation Condition	Antenna configuration and correlation Matrix	Reference value	
							Pm-dsg (%)	SNR (dB)
1	10 MHz	4 ECCE	R.55 FDD	OP.7 FDD	EVA5	2 x 4 Low	1	-0.7
2	10 MHz	16 ECCE	R.56 FDD	OP.7 FDD	EVA70	2 x 4 Low	1	-5.8

8.10.4.1.2 TDD

The parameters specified in Table 8.10.4.1.2-1 are valid for all TDD distributed EPDCCH tests with 4Rx unless otherwise stated.

Table 8.10.4.1.2-1: Test Parameters for Distributed EPDCCH with 4Rx

Parameter		Unit	Value
Number of PDCCH symbols		symbols	2 (Note 1)
PHICH duration			Normal
Unused RE-s and PRB-s			OCNG
Cell ID			0
Downlink power allocation	ρ_A	dB	-3
	ρ_B	dB	-3
	σ	dB	0
	δ	dB	3
N_{oc} at antenna port		dBm/15 kHz	-98
Cyclic prefix			Normal
Subframe Configuration			Non-MBSFN
Precoder Update Granularity	PRB		1
	ms		1
Beamforming Pre-Coder			Annex B.4.4
Cell Specific Reference Signal			Port 0 and 1
Number of EPDCCH Sets Configured			2 (Note 2)
Number of PRB per EPDCCH Set			4 (1 st Set) 8 (2 nd Set)
EPDCCH Subframe Monitoring			NA
PDSCH TM			TM3
DCI Format			2A
TDD UL/DL Configuration			0
TDD Special Subframe			1 (Note 3)
Note 1: The starting symbol for EPDCCH is derived from the PCFICH. RRC signalling <i>epdcch-StartSymbol-r11</i> is not configured.			
Note 2: The two sets are distributed EPDCCH sets and non-overlapping with PRB = {3, 17, 31, 45} for the first set and PRB = {0, 7, 14, 21, 28, 35, 42, 49} for the second set. EPDCCH is scheduled in the first set for Test 1 and second set for Test 2, respectively. Both sets are always configured.			
Note 3: Demodulation performance is averaged over normal and special subframe.			

For the parameters specified in Table 8.10.4.1.2-1 the average probability of a missed downlink scheduling grant (Pm-dsg) shall be below the specified value in Table 8.10.4.1.2-2. The downlink physical setup is in accordance with Annex C.3.2.

Table 8.10.4.1.2-2: Minimum performance Distributed EPDCCH with 4Rx Antenna ports

Test number	Bandwidth	Aggregation level	Reference Channel	OCNG Pattern	Propagation Condition	Antenna configuration and correlation Matrix	Reference value	
							Pm-dsg (%)	SNR (dB)
1	10 MHz	4 ECCE	R.55 TDD	OP.7 TDD	EVA5	2 x 4 Low	1	-0.7
2	10 MHz	16 ECCE	R.56 TDD	OP.7 TDD	EVA70	2 x 4 Low	1	-5.8

8.10.4.2 Localized Transmission with TM9 and 4Rx

8.10.4.2.1 FDD

The parameters specified in Table 8.10.4.2.1-1 are valid for all FDD TM9 localized ePDCCH tests with 4Rx unless otherwise stated.

Table 8.10.4.2.1-1: Test Parameters for Localized EPDCCH with TM9 and 4Rx

Parameter		Unit	Value
Number of PDCCH symbols		symbols	1 (Note 1)
EPDCCH starting symbol		symbols	2 (Note 1)
PHICH duration			Normal
Unused RE-s and PRB-s			OCNG
Cell ID			0
Downlink power allocation	ρ_A	dB	0
	ρ_B	dB	0
	σ	dB	-3
	δ	dB	0
N_{oc} at antenna port		dBm/15 kHz	-98
Cyclic prefix			Normal
Subframe Configuration			Non-MBSFN
Precoder Update Granularity	PRB		1
	ms		1
Beamforming Pre-Coder			Annex B.4.5
Cell Specific Reference Signal			Port 0 and 1
CSI-RS Reference Signal			Port 15 and 16
CSI-RS reference signal resource configuration			0
CSI reference signal subframe configuration l_{CSI-RS}			2
ZP-CSI-RS configuration bitmap			0000010000000000
ZP-CSI-RS subframe configuration $l_{ZP-CSI-RS}$			2
Number of EPDCCH Sets			2 (Note 2)
EPDCCH Subframe Monitoring pattern <i>subframePatternConfig-r11</i>			1111111110 1111111101 1111111011 1111110111 (Note 3)
PDSCH TM			TM9
Note 1: The starting symbol for EPDCCH is signalled with <i>epdcch-StartSymbol-r11</i> . However, CFI is set to 1.			
Note 2: The first set is distributed transmission with PRB = {0, 49} and the second set is localized transmission with PRB = {0, 7, 14, 21, 28, 35, 42, 49}. ePDCCH is scheduled in the second set for all tests.			
Note 3: EPDCCH is scheduled in every SF. UE is required to monitor ePDCCH for UE-specific search space only in SFs configured by <i>subframePatternConfig-r11</i> . Legacy PDCCH is not scheduled.			

For the parameters specified in Table 8.10.4.2.1-1 the average probability of a missed downlink scheduling grant (Pm-dsg) shall be below the specified value in Table 8.10.4.2.1-2. EPDCCH subframe monitoring is configured and the subframe monitoring requirement in EPDCCH restricted subframes is statDTX of 99.9%.

The downlink physical setup is in accordance with Annex C.3.2.

Table 8.10.4.2.1-2: Minimum performance Localized EPDCCH with TM9 and 4Rx Antenna ports

Test number	Bandwidth	Aggregation level	Reference Channel	OCNG Pattern	Propagation Condition	Antenna configuration and correlation Matrix	Reference value	
							Pm-dsg (%)	SNR (dB)
1	10 MHz	2 ECCE	R.57 FDD	OP.7 FDD	EVA5	2 x 4 Low	1	6.5
2	10 MHz	8 ECCE	R.58 FDD	OP.7 FDD	EVA5	2 x 4 Low	1	-1.5

8.10.4.2.2 TDD

The parameters specified in Table 8.10.4.2.2-1 are valid for all TDD TM9 localized ePDCCH tests unless otherwise stated.

Table 8.10.4.2.2-1: Test Parameters for Localized EPDCCH with TM9 and 4Rx

Parameter		Unit	Value
Number of PDCCH symbols		symbols	1 (Note 1)
EPDCCH starting symbol		symbols	2 (Note 1)
PHICH duration			Normal
Unused RE-s and PRB-s			OCNG
Cell ID			0
Downlink power allocation	ρ_A	dB	0
	ρ_B	dB	0
	σ	dB	-3
	δ	dB	0
N_{oc} at antenna port		dBm/15 kHz	-98
Cyclic prefix			Normal
Subframe Configuration			Non-MBSFN
Precoder Update Granularity	PRB		1
	ms		1
Beamforming Pre-Coder			Annex B.4.5
Cell Specific Reference Signal			Port 0 and 1
CSI-RS Reference Signal			Port 15 and 16
CSI-RS reference signal resource configuration			0
CSI reference signal subframe configuration l_{CSI-RS}			0
ZP-CSI-RS configuration bitmap			0000010000000000
ZP-CSI-RS subframe configuration $l_{ZP-CSI-RS}$			0
Number of EPDCCH Sets			2 (Note 2)
EPDCCH Subframe Monitoring pattern <i>subframePatternConfig-r11</i>			1100011000 1100010000 1100011000 1100001000 1100011000 1000011000 1100011000 (Note 3)
PDSCH TM			TM9
TDD UL/DL Configuration			0
TDD Special Subframe			1 (Note 4)
Note 1: The starting symbol for EPDCCH is signalled with <i>epdcch-StartSymbol-r11</i> . However, CFI is set to 1.			
Note 2: The first set is distributed transmission with PRB = {0, 49} and the second set is localized transmission with PRB = {0, 7, 14, 21, 28, 35, 42, 49}. ePDCCH is scheduled in the second set for all tests.			
Note 3: EPDCCH is scheduled in every SF. UE is required to monitor ePDCCH for UE-specific search space only in SFs configured by <i>subframePatternConfig-r11</i> . Legacy PDCCH is not scheduled.			
Note 4: Demodulation performance is averaged over normal and special subframe.			

For the parameters specified in Table 8.10.4.2.2-1 the average probability of a missed downlink scheduling grant (Pm-dsg) shall be below the specified value in Table 8.10.4.2.2-2. EPDCCH subframe monitoring is configured and the subframe monitoring requirement in EPDCCH restricted subframes is statDTX of 99.9%.

The downlink physical setup is in accordance with Annex C.3.2.

Table 8.10.4.2.2-2: Minimum performance Localized EPDCCH with TM9 and 4Rx Antenna ports

Test number	Bandwidth	Aggregation level	Reference Channel	OCNG Pattern	Propagation Condition	Antenna configuration and correlation Matrix	Reference value	
							Pm-dsg (%)	SNR (dB)
1	10 MHz	2 ECCE	R.57 TDD	OP.7 TDD	EVA5	2 x 4 Low	1	6.0
2	10 MHz	8 ECCE	R.58 TDD	OP.7 TDD	EVA5	2 x 4 Low	1	-2.1

8.11 Demodulation (UE supporting coverage enhancement)

The requirements in this sub-clause are defined based on the simulation results with UE DL Category M1 unless otherwise stated.

The requirements of UE DL Category M1 in this sub-clause are applicable for UE DL Category 1bis and Category 0.

8.11.1 PDSCH

8.11.1.1 FDD and half-duplex FDD (Fixed Reference Channel)

The parameters specified in Table 8.11.1.1-1 are valid for FDD and half-duplex FDD tests unless otherwise stated.

Table 8.11.1.1-1: Common Test Parameters (FDD and half-duplex FDD)

Parameter	Unit	CE Mode A	CE Mode B
Inter-TTI Distance		1	1
Number of HARQ processes per component carrier	Processes	8	2
Maximum number of HARQ transmission		4	4
Redundancy version coding sequence r_{Vidx} (Note 1)		{0, 2, 3, 1} for QPSK and 16QAM	{0,0,0,0,2,2,2,2,3,3,3,3,1,1,1,1 ...} for QPSK
Number of OFDM symbols for PDCCH per component carrier	OFDM symbols	4 for 1.4 MHz bandwidth, 3 for 3 MHz and 5 MHz bandwidths, 2 for 10 MHz, 15 MHz and 20 MHz bandwidths	4 for 1.4 MHz bandwidth, 3 for 3 MHz and 5 MHz bandwidths, 2 for 10 MHz, 15 MHz and 20 MHz bandwidths
Cyclic Prefix		Normal	Normal
Beamforming Precoder for MPDCCH		Annex B.4.4	Annex B.4.4
Precoder update granularity for MPDCCH		Frequency domain: 1 PRB Time domain: identical during the hopping period (interval-FDD for CE Mode A)	Frequency domain: 1 PRB Time domain: identical during the hopping period (interval-FDD for CE Mode B)
BL/CE DL subframe configuration (fdd-DownlinkOrTddSubframeBitmapBR)		1111111111	1111111111
Note 1: r_{Vidx} is defined in TS 36.213 [6] Table 7.1.7.1-2.			

8.11.1.1.1 Closed-loop spatial multiplexing performance (Cell-Specific Reference Symbols)

8.11.1.1.1.1 Minimum Requirement Single-Layer Spatial Multiplexing 2 Tx Antenna Port

The requirements are specified in Table 8.11.1.1.1-2, with the addition of the parameters in Table 8.11.1.1.1-1 and the downlink physical channel setup according to Annex C.3.2. The purpose of these tests is to verify the closed loop rank-one performance with frequency selective precoding.

Table 8.11.1.1.1.1-1: Test Parameters for Single-Layer Spatial Multiplexing (FRC)

Parameter	Unit	Test 1	
Downlink power allocation	ρ_A	dB	-3
	ρ_B	dB	-3 (Note 1)
	σ	dB	0
	δ	dB	3
N_{oc} at antenna port	dBm/15kHz	-98	
Precoding granularity	PRB	6	
PMI delay (Note 2)	ms	10	
Reporting interval	ms	10	
Reporting mode		PUCCH 1-1	
Physical channel for CQI reporting		PUSCH(Note4)	
cqi-pmi-ConfigIndex		12	
CodeBookSubsetRestriction bitmap		001111	
PDSCH transmission mode		6	
Coverage enhancement mode		CE Mode A	
OFDM starting symbol (startSymbolBR)		2	
Maximum number of repetitions (mpdcch-NumRepetition)		1	
Frequency hopping (mpdcch-pdsch-HoppingConfig)		Disabled	
MPDCCH transmission duration	ms	1	
Starting subframe configuration for MPDCCH (mpdcch_startSF_U ESS)		1	
Narrowband for MPDCCH (mpdcch_Narrowband)		1	
<p>Note 1: $P_B = 1$.</p> <p>Note 2: If the UE reports in an available uplink reporting instance at subframe SF#n based on PMI estimation at a downlink SF not later than SF#(n-4), This reported PMI cannot be applied at the eNB downlink before SF#(n+4).</p> <p>Note 3: For each test, DC subcarrier puncturing shall be considered.</p> <p>Note 4: To avoid collisions between CQI reports and HARQ-ACK it is necessary to report both on PUSCH instead of PUCCH. PDCCH DCI format 6-0A shall be transmitted in downlink SF#1 to allow periodic CQI to multiplex with the HARQ-ACK on PUSCH in uplink subframe SF#5.</p> <p>Note 5: If not otherwise stated, the values in this table refer to parameters in TS 36.211 [4] or/and TS 36.213 [6] as appropriate.</p>			

Table 8.11.1.1.1.1-2: Minimum performance Single-Layer Spatial Multiplexing (FRC)

Test number	Bandwidth and MCS	Reference Channel	OCNG Pattern	Propagation Condition	Correlation Matrix and Antenna Configuration	Reference value	
						Fraction of Maximum Throughput (%)	SNR (dB)
1	10MHz 16QAM 1/2	R.79 FDD	OP.2 FDD	EPA5	2x1 Low	70%	8.6

8.11.1.1.2 Closed-loop spatial multiplexing performance (User-Specific Reference Symbols)

8.11.1.1.2.1 Single-layer Spatial Multiplexing

For single-layer transmission on antenna ports 7 or 8 upon detection of a MPDCCH with DCI format 6-1A, the requirements are specified in Table 8.11.1.1.2.1-2 with the addition of the parameters in Table 8.11.1.1.2.1-1 and the downlink physical channel setup according to Annex C.3.2. The purpose of these tests is to verify rank-1 performance on one of the antenna ports 7 or 8.

Table 8.11.1.1.2.1-1: Test Parameters for Testing CDM-multiplexed DM RS (single layer)

parameter	Unit	Test 1	Test 2	Test 3	
Downlink power allocation	ρ_A	dB	0	0	0
	ρ_B	dB	0 (Note 1)	0 (Note 1)	0 (Note 1)
	σ	dB	-3	-3	-3
	δ	dB	0	0	0
Beamforming model		Annex B.4.1	Annex B.4.1	Annex B.4.1	
Cell-specific reference signals		Antenna ports 0,1	Antenna ports 0,1	Antenna ports 0,1	
N_{oc} at antenna port	dBm/15kHz	-98 (Note 6)	-98 (Note 6)	-98 (Note 6)	
Symbols for unused PRBs		OCNG (Note 3)	OCNG (Note 3)	OCNG (Note 3)	
Number of allocated resource blocks (Note 2)	PRB	6	6	6	
Simultaneous transmission		No	No	No	
PDSCH transmission mode		9	9	9	
Coverage enhancement mode		CE Mode A	CE Mode A	CE Mode A	
OFDM starting symbol (startSymbolBR)		2	2	2	
Maximum number of repetitions for PDSCH (<i>pdsch-maxNumRepetitionCEmodeA</i>)		16	16	Not configured	
PDSCH repetition number		8	4	2	
Frequency hopping (<i>mpdcch-pdsch-HoppingConfig</i>)		Enabled	Enabled	Enabled	
Frequency hopping offset (<i>mpdcch-pdsch-HoppingOffset</i>)		1	1	1	
Frequency hopping interval (<i>interval-FDD</i>)	ms	8	2	1	
MPDCCH transmission duration (<i>mpdcch-NumRepetition</i>)	ms	8	2	1	
MPDCCH repetition number		8	2	1	
Number of narrowbands for frequency hopping (<i>mpdcch-pdsch-HoppingNB</i>)		2	2	2	
Starting subframe configuration for MPDCCH (<i>mpdcch_startSF_U ESS</i>)		4	8	10	
Narrowband for MPDCCH (<i>mpdcch_Narrowband</i>)		7	7	7	
MPDCCH aggregation level		24	24	24	
Note 1: $P_B = 1$.					
Note 2: The modulation symbols of the signal under test are mapped onto antenna port 7 or 8.					
Note 3: These physical resource blocks are assigned to an arbitrary number of virtual UEs with one PDSCH per virtual UE; the data transmitted over the OCNG PDSCHs shall be uncorrelated pseudo random data, which is QPSK modulated.					
Note 4: For each test, DC subcarrier puncturing shall be considered.					
Note 5: If not otherwise stated, the values in this table refer to parameters in TS 36.211 [4] or/and TS 36.213 [6] as appropriate.					

Table 8.11.1.1.2.1-2: Minimum performance for CDM-multiplexed DM RS (FRC)

Test number	Bandwidth and MCS	Reference Channel	OCNG Pattern	Propagation Condition	Correlation Matrix and Antenna Configuration	Reference value		UE Category
						Fraction of Maximum Throughput (%)	SNR (dB)	
1	10MHz QPSK 1/3	R.80 FDD	OP.2 FDD	EPA5	2x1 Low	70	-2.0	M1
2	10MHz QPSK 1/3	R.80-1 FDD	OP.2 FDD	EPA5	2x2 Low	70	-4.0	≥1
3	10MHz QPSK 1/3	R.80-2 FDD	OP.2 FDD	EPA5	2x4 Low	70	-4.0	≥1

8.11.1.1.3 Transmit diversity performance (Cell-Specific Reference Symbols)

8.11.1.1.3.1 Minimum Requirement 2 Tx Antenna Port

The requirements are specified in Table 8.11.1.1.3.1-2, with the addition of the parameters in Table 8.11.1.1.3.1-1 and the downlink physical channel setup according to Annex C.3.2. The purpose is to verify the performance of transmit diversity (SFBC) with 2 transmitter antennas.

Table 8.11.1.1.3.1-1: Test Parameters for Transmit diversity performance (FRC)

Parameter		Unit	Test 1 (Note 3)	Test 2 (Note 3)	Test 3 (Note 3)	Test 4 (Note 3)
Downlink power allocation	ρ_A	dB	-3	-3	-3	-3
	ρ_B	dB	-3 (Note 1)	-3 (Note 1)	-3 (Note 1)	-3 (Note 1)
	σ	dB	0	0	0	0
	δ	dB	3	3	3	3
N_{oc} at antenna port		dBm/15kHz	-98	-98	-98	-98
Coverage enhancement mode			CE Mode B	CE Mode A	CE Mode B	CE Mode B
PDSCH transmission mode			2	2	2	2
OFDM starting symbol (startSymbolBR)			2	2	2	2
Maximum number of repetitions for PDSCH (<i>pdsch-maxNumRepetitionCEmodeA/ pdsch-maxNumRepetitionCEmodeB</i>)			Not configured	Not configured	Not configured	Not configured
PDSCH repetition number			64	1	32	16
Frequency hopping (mpdcch-pdsch-HoppingConfig)			Enabled	Disabled	Enabled	Enabled
Frequency hopping offset (mpdcch-pdsch-HoppingOffset)			1	N/A	1	1
Frequency hopping interval (interval-FDD)		ms	16	N/A	8	4
MPDCCH transmission duration (mPDCCH-NumRepetition)		ms	64	1	32	8
MPDCCH repetition number			64	1	32	8
Number of narrowbands for frequency hopping (mpdcch-pdsch-HoppingNB)			4	N/A	4	4
Starting subframe configuration for MPDCCH (mpdcch_startSF_U ESS)			2.5	1	2.5	4
Narrowband for MPDCCH (mpdcch_Narrowband)			7	0	7	7
MPDCCH aggregation level			24	8	24	24
<p>Note 1: $P_B = 1$.</p> <p>Note 2: For each test, DC subcarrier puncturing shall be considered.</p> <p>Note 3: Test 1, test 3 and test 4 are applicable for UE supporting CE Mode B. Test 2 is applicable for UE not supporting CE Mode B.</p> <p>Note 4: If not otherwise stated, the values in this table refer to parameters in TS 36.211 [4] or/and TS 36.213 [6] as appropriate.</p>						

Table 8.11.1.1.3.1-2: Minimum performance Transmit Diversity (FRC)

Test number	Bandwidth and MCS	Reference Channel	OCNG Pattern	Propagation Condition	Correlation Matrix and Antenna Configuration	Reference value		UE Category
						Fraction of Maximum Throughput (%)	SNR (dB)	
1	10MHz QPSK 1/10	R.81 FDD	OP.2 FDD	ETU1	2x1 Low	70	-13.5	M1
2	10MHz 16QAM 1/2	R.79 FDD	OP.2 FDD	EPA5	2x1 Low	70	9.4	M1
3	10MHz QPSK 1/10	R.81-1 FDD	OP.2 FDD	ETU1	2x2 Low	70	-13.3	≥1
4	10MHz QPSK 1/10	R.81-2 FDD	OP.2 FDD	ETU1	2x4 Low	70	-13.3	≥1

8.11.1.2 TDD (Fixed Reference Channel)

The parameters specified in Table 8.11.1.2-1 are valid for all TDD tests unless otherwise stated.

Table 8.11.1.2-1: Common Test Parameters (TDD)

Parameter	Unit	CE Mode A	CE Mode B
Uplink downlink configuration (Note 1)		1	1
Special subframe configuration (Note 2)		4	4
Cyclic prefix		Normal	Normal
Cell ID		0	0
Inter-TTI Distance		1	1
Number of HARQ processes per component carrier	Processes	7	2
Maximum number of HARQ transmission		4	4
Redundancy version coding sequence r_{Vidx} (Note 3)		{0, 2, 3, 1} for QPSK and 16QAM	{0,0,0,0,0,0,0,0,0,2,2,2,2,2,2,2,2,3,3,3,3,3,3,3,3,3,3,1,1,1,1,1,1,1,1,1,1} for QPSK
Number of OFDM symbols for PDCCH per component carrier	OFDM symbols	4 for 1.4 MHz bandwidth, 3 for 3 MHz and 5 MHz bandwidths, 2 for 10 MHz, 15 MHz and 20 MHz bandwidths	4 for 1.4 MHz bandwidth, 3 for 3 MHz and 5 MHz bandwidths, 2 for 10 MHz, 15 MHz and 20 MHz bandwidths
ACK/NACK feedback mode		Multiplexing	Multiplexing
Beamforming Precoder for MPDCCH		Annex B.4.4	Annex B.4.4
Precoder update granularity for MPDCCH		Frequency domain: 1 PRB Time domain: identical during the hopping period (interval-TDD for CE Mode A)	Frequency domain: 1 PRB Time domain: identical during the hopping period (interval-TDD for CE Mode B)
BL/CE DL subframe configuration (fdd-DownlinkOrTddSubframeBitmapBR)		1011110111	1011110111
Note 1: as specified in Table 4.2-2 in TS 36.211 [4]. Note 2: as specified in Table 4.2-1 in TS 36.211 [4]. Note 3: r_{Vidx} is defined in TS 36.213 [6] Table 7.1.7.1-2			

8.11.1.2.1 Closed-loop spatial multiplexing performance (Cell-Specific Reference Symbols)

8.11.1.2.1.1 Minimum Requirement Single-Layer Spatial Multiplexing 2 Tx Antenna Port

The requirements are specified in Table 8.11.1.2.1.1-2, with the addition of the parameters in Table 8.11.1.2.1.1-1 and the downlink physical channel setup according to Annex C.3.2. The purpose of these tests is to verify the closed loop rank-one performance with frequency selective precoding.

Table 8.11.1.2.1.1-1: Test Parameters for Single-Layer Spatial Multiplexing (FRC)

Parameter	Unit	Test 1	
Downlink power allocation	ρ_A	dB	-3
	ρ_B	dB	-3 (Note 1)
	σ	dB	0
	δ	dB	3
N_{oc} at antenna port	dBm/15kHz	-98	
Precoding granularity	PRB	6	
PMI delay (Note 2)	ms	10 or 11	
Reporting interval	ms	5	
Reporting mode		PUCCH 1-1	
cqi-pmi-ConfigIndex		4	
CodeBookSubsetRestriction on bitmap		001111	
ACK/NACK feedback mode		Multiplexing	
Physical channel for CQI reporting		PUSCH (Note 3)	
PDSCH transmission mode		6	
Coverage enhancement mode		CE Mode A	
OFDM starting symbol (startSymbolBR)		2	
Maximum number of repetitions (mpdcch-NumRepetition)		1	
Frequency hopping (mpdcch-pdsch-HoppingConfig)		Disabled	
MPDCCH transmission duration	ms	1	
Starting subframe configuration for MPDCCH (mpdcch_startSF_U ESS)		1	
Narrowband for MPDCCH (mpdcch_Narrowband)		1	
<p>Note 1: $P_B = 1$.</p> <p>Note 2: If the UE reports in an available uplink reporting instance at subframe SF#n based on PMI estimation at a downlink SF not later than SF#(n-4), this reported PMI cannot be applied at the eNB downlink before SF#(n+4).</p> <p>Note 3: To avoid collisions between CQI reports and HARQ-ACK it is necessary to report both on PUSCH instead of PUCCH. MPDCCH DCI format 6-0A shall be transmitted in downlink SF#4 and #9 to allow periodic CQI to multiplex with the HARQ-ACK on PUSCH in uplink subframe SF#8 and #3.</p> <p>Note 4: For each test, DC subcarrier puncturing shall be considered.</p> <p>Note 5: If not otherwise stated, the values in this table refer to parameters in TS 36.211 [4] or/and TS 36.213 [6] as appropriate.</p>			

Table 8.11.1.2.1-2: Minimum performance Single-Layer Spatial Multiplexing (FRC)

Test number	Bandwidth and MCS	Reference Channel	OCNG Pattern	Propagation Condition	Correlation Matrix and Antenna Configuration	Reference value	
						Fraction of Maximum Throughput (%)	SNR (dB)
1	10MHz 16QAM 1/2	R.79 TDD	OP.2 TDD	EPA5	2x1 Low	70%	11.4

8.11.1.2.2 Closed-loop spatial multiplexing performance (User-Specific Reference Symbols)

8.11.1.2.2.1 Single-layer Spatial Multiplexing

For single-layer transmission on antenna ports 7 or 8 upon detection of a PDCCH with DCI format 6-1A, the requirements are specified in Table 8.11.1.2.2.1-2 with the addition of the parameters in Table 8.11.1.2.2.1-1 and the downlink physical channel setup according to Annex C.3.2. The purpose of these tests is to verify rank-1 performance on one of the antenna ports 7 or 8.

Table 8.11.1.2.2.1-1: Test Parameters for Testing CDM-multiplexed DM RS (single layer)

Parameter	Unit	Test 1	Test 2	Test 3	
Downlink power allocation	ρ_A	dB	0	0	0
	ρ_B	dB	0 (Note 1)	0 (Note 1)	0 (Note 1)
	σ	dB	-3	-3	-3
	δ	dB	0	0	0
Cell-specific reference signals		Antenna ports 0,1	Antenna ports 0,1	Antenna ports 0,1	
Beamforming model		Annex B.4.1	Annex B.4.1	Annex B.4.1	
N_{oc} at antenna port	dBm/15kHz	-98	-98	-98	
Symbols for unused PRBs		OCNG (Note 3)	OCNG (Note 3)	OCNG (Note 3)	
Number of allocated resource blocks (Note 2)	PRB	6	6	6	
Simultaneous transmission		No	No	No	
PDSCH transmission mode		9	9	9	
Coverage enhancement mode		CE Mode A	CE Mode A	CE Mode A	
OFDM starting symbol (startSymbolBR)		2	2	2	
Maximum number of repetitions for PDSCH (<i>pdsch-maxNumRepetitionCEmodeA</i>)		Not configured	Not configured	Not configured	
Frequency hopping (mpdcch-pdsch-HoppingConfig)		Enabled	Enabled	Enabled	
Frequency hopping offset (mpdcch-pdsch-HoppingOffset)		1	1	1	
Frequency hopping interval (interval-TDD)	ms	10	1	1	
MPDCCH transmission duration (mPDCCH-NumRepetition)	ms	8	2	1	
MPDCCH repetition number		8	2	1	
Number of narrowbands for frequency hopping (mpdcch-pdsch-HoppingNB)		2	2	2	
Starting subframe configuration for MPDCCH (mpdcch_startSF_UESS)		10	20	20	
Narrowband for MPDCCH (mpdcch_Narrowband)		7	7	7	
MPDCCH aggregation level		24	24	24	
<p>Note 1: $P_B = 1$.</p> <p>Note 2: The modulation symbols of the signal under test are mapped onto antenna port 7 or 8.</p> <p>Note 3: These physical resource blocks are assigned to an arbitrary number of virtual UEs with one PDSCH per virtual UE; the data transmitted over the OCNG PDSCHs shall be uncorrelated pseudo random data, which is QPSK modulated.</p> <p>Note 4: For each test, DC subcarrier puncturing shall be considered.</p> <p>Note 5: If not otherwise stated, the values in this table refer to parameters in TS 36.211 [4] or/and TS 36.213 [6] as appropriate.</p>					

Table 8.11.1.2.2.1-2: Minimum performance for CDM-multiplexed DM RS without simultaneous transmission (FRC) with multiple CSI-RS configurations

Test number	Bandwidth and MCS	Reference Channel	OCNG Pattern	Propagation Condition	Correlation Matrix and Antenna Configuration	Reference value		UE Category
						Fraction of Maximum Throughput (%)	SNR (dB)	
1	10MHz QPSK 1/3	R.80 TDD	OP.2 TDD	EPA5	2x1 Low	70	-2.5	M1
2	10MHz QPSK 1/3	R.80-1 TDD	OP.2 TDD	EPA5	2x2 Low	70	-3.6	≥1
3	10MHz QPSK 1/3	[R.80 TDD]	OP.2 TDD	EPA5	2x4 Low	70	-3.7	≥1

9

8.11.1.2.3 Transmit diversity performance (Cell-Specific Reference Symbols)

8.11.1.2.3.1 Minimum Requirement 2 Tx Antenna Port

The requirements are specified in Table 8.11.1.2.3.1-2, with the addition of the parameters in Table 8.11.1.2.3.1-1 and the downlink physical channel setup according to Annex C.3.2. The purpose is to verify the performance of transmit diversity (SFBC) with 2 transmitter antennas.

Table 8.11.1.2.3.1-1: Test Parameters for Transmit diversity performance (FRC)

Parameter		Unit	Test 1 (Note 3)	Test 2 (Note 3)	Test 3 (Note 3)	Test 4 (Note 3)
Downlink power allocation	ρ_A	dB	-3	-3	-3	-3
	ρ_B	dB	-3 (Note 1)	-3 (Note 1)	-3 (Note 1)	-3 (Note 1)
	σ	dB	0	0	0	0
	δ	dB	3	3	3	3
N_{oc} at antenna port		dBm/15kHz	-98	-98	-98	-98
ACK/NACK feedback mode			Multiplexing	Multiplexing	Multiplexing	Multiplexing
PDSCH transmission mode			2	2	2	2
Coverage enhancement mode			CE Mode B	CE Mode A	CE Mode B	CE Mode B
PDSCH transmission mode			2	2	2	2
OFDM starting symbol (startSymbolBR)			2	2	2	2
Maximum number of repetitions for PDSCH (<i>pdsch-maxNumRepetitionCEmodeA/ pdsch-maxNumRepetitionCEmodeB</i>)			Not configured	Not configured	Not configured	Not configured
PDSCH repetition number			64	1	32	16
Frequency hopping (<i>mpdcch-pdsch-HoppingConfig</i>)			Enabled	Disabled	Enabled	Enabled
Frequency hopping offset (<i>mpdcch-pdsch-HoppingOffset</i>)			1	N/A	1	1
Frequency hopping interval (interval-TDD)		ms	20	N/A	20	10
MPDCCH transmission duration (<i>mPDCCH-NumRepetition</i>)		ms	64	1	32	8
MPDCCH repetition number			64	1	32	8
Number of narrowbands for frequency hopping (<i>mpdcch-pdsch-HoppingNB</i>)			4	N/A	4	4
Starting subframe configuration for MPDCCH (<i>mpdcch-startSF-U ESS</i>)			8	1	8	10
Narrowband for MPDCCH (<i>mpdcch_Narrowband</i>)			7	0	7	7
MPDCCH aggregation level			24	8	24	24
Note 1: $P_B = 1$.						
Note 2: For each test, DC subcarrier puncturing shall be considered.						
Note 3: Test 1, test 3 and test 4 are applicable for UE supporting CE Mode B. Test 2 is applicable for UE not supporting CE Mode B.						
Note 4: If not otherwise stated, the values in this table refer to parameters in TS 36.211 [4] or/and TS 36.213 [6] as appropriate.						

Table 8.11.1.2.3.1-2: Minimum performance Transmit Diversity (FRC)

Test number	Bandwidth and MCS	Reference Channel	OCNG Pattern	Propagation Condition	Correlation Matrix and Antenna Configuration	Reference value		UE Category
						Fraction of Maximum Throughput (%)	SNR (dB)	
1	10MHz QPSK 1/10	R.81 TDD	OP.2 TDD	ETU1	2x1 Low	70	-14.0	M1
2	10MHz 16QAM 1/2	R.79 TDD	OP.2 TDD	EPA5	2x1 Low	70	9.6	M1
3	10MHz QPSK 1/10	R.81-1 TDD	OP.2 TDD	ETU1	2x2 Low	70	-13.3	≥ 1
4	10MHz QPSK 1/10	R.81-2 TDD	OP.2 TDD	ETU1	2x4 Low	70	-13.3	≥ 1

8.11.2 MPDCCH

The receiver characteristics of the MPDCCH are determined by the probability of miss-detection of the Downlink Scheduling Grant (Pm-dsg).

8.11.2.1 FDD and half-duplex FDD

Table 8.11.2.1-1: Test Parameters for MPDCCH (Category M1)

Parameter		Unit	CE Mode A (Test 1)	CE Mode B (Test 1)
OFDM starting symbol (startSymbolLC)		symbols	2	2
Unused RE-s and PRB-s			OCNG	OCNG
Cell ID			0	0
Downlink power allocation	ρ_A	dB	-3	0
	ρ_B	dB	-3	0
	σ	dB	0	-3
	δ	dB	3	0
N_{oc} at antenna port		dBm/15 kHz	-98	-98
Cyclic prefix			Normal	Normal
Subframe Configuration			Non-MBSFN	Non-MBSFN
Precoder Update Granularity		PRB	1	1
		ms	4(Note 2)	16 (Note 2)
Beamforming Pre-Coder			Annex B.4.4	Annex B.4.4
Cell Specific Reference Signal			Port 0 and 1	Port 0 and 1
Number of PRB per MPDCCH Set			4	2+4
Transmission type			Distributed	Localized
Frequency hopping			Disabled	Enabled
Number of frequency hopping narrowbands			N/A	4
Frequency hopping offset			N/A	1
Frequency hopping interval		ms	N/A	16
Value of G in MPDCCH start subframe (<i>mpdcch-startSF-U ESS</i>) ^{Note 3}			1.5	1.5
Maximum number of repetitions (<i>mpdcch-NumRepetition</i>)			32	64
MPDCCH repetition number			32	64
MPDCCH narrowband (<i>mpdcch-Narrowband</i>)			1	7
PDSCH TM			TM2	TM2
DCI Format			6-1A	6-1B
fdd-DownlinkOrTddSubframeBitmapBR			1111111111	1111111111
Note 1: For each test, DC subcarrier puncturing shall be considered.				
Note 2: Same precoding matrix is used for a PRB across subframes during the frequency hopping interval.				
Note 3: For MPDCCH UE-specific search space the formula for the start subframe k0 is given in TS 36.213 [6] clause 9.1.5.				
Note 4: If not otherwise stated, the values in this table refer to parameters in TS 36.211 [4] or/and TS 36.213 [6] as appropriate.				

Table 8.11.2.1-2: Test Parameters for MPDCCH (Category ≥ 1)

Parameter		Unit	CE Mode A (Test 2)	CE Mode A (Test 3)	CE Mode B (Test 2)	CE Mode B (Test 3)
OFDM starting symbol (startSymbolLC)		symbols	2	2	2	2
Unused RE-s and PRB-s			OCNG	OCNG	OCNG	OCNG
Cell ID			0	0	0	0
Downlink power allocation	ρ_A	dB	-3	0	0	0
	ρ_B	dB	-3	0	0	0
	σ	dB	0	-3	-3	-3
	δ	dB	3	0	0	0
N_{oc} at antenna port		dBm/15kHz	-98	-98	-98	-98
Cyclic prefix			Normal	Normal	Normal	Normal
Subframe Configuration			Non-MBSFN	Non-MBSFN	Non-MBSFN	Non-MBSFN
Precoder Update Granularity	PRB		1	1	1	1
	ms		4(Note 2)	4(Note 2)	16 (Note 2)	16 (Note 2)
Beamforming Pre-Coder			Annex B.4.4	Annex B.4.4	Annex B.4.4	Annex B.4.4
Cell Specific Reference Signal			Port 0 and 1	Port 0 and 1	Port 0 and 1	Port 0 and 1
Number of PRB per MPDCCH Set			4	4	2+4	2+4
Transmission type			Distributed	Distributed	Localized	Localized
Frequency hopping			Disabled	Disabled	Enabled	Enabled
Number of frequency hopping narrowbands			N/A	N/A	4	4
Frequency hopping offset			N/A	N/A	1	1
Frequency hopping interval		ms	N/A	N/A	8	2
Value of G in MPDCCH start subframe (<i>mpdcch-startSF-UESS</i>) ^{Note 3}			1.5	1.5	1.5	1.5
Maximum number of repetitions(<i>mpdcch-NumRepetition</i>)			8	2	32	8
MPDCCH repetition number			8	2	32	8
MPDCCH narrowband (<i>mpdcch-Narrowband</i>)			1	1	7	7
PDSCH TM			TM2	TM2	TM2	TM2
DCI Format			6-1A	6-1A	6-1B	6-1B
fdd-DownlinkOrTddSubframeBitmapBR			1111111111	1111111111	1111111111	1111111111
Note 1: For each test, DC subcarrier puncturing shall be considered.						
Note 2: Same precoding matrix is used for a PRB across subframes during the frequency hopping interval.						
Note 3: For MPDCCH UE-specific search space the formula for the start subframe k_0 is given in TS 36.213 [6] clause 9.1.5.						
Note 4: If not otherwise stated, the values in this table refer to parameters in TS 36.211 [4] or/and TS 36.213 [6] as appropriate.						

8.11.2.1.1 CE Mode A

For the parameters specified in Table 8.11.2.1-1 and 8.11.2.1-2 the average probability of a missed downlink scheduling grant (Pm-dsg) shall be below the specified value in Table 8.11.2.1.1-1. The downlink physical setup is in accordance with Annex C.3.2.

Table 8.11.2.1.1-1: Minimum performance CE Mode A MPDCCH

Test number	Bandwidth	Aggregation level	Reference Channel	OCNG Pattern	Propagation Condition	Antenna configuration and correlation Matrix	Reference value		UE Category
							Pm-dsg (%)	SNR (dB)	
1	10 MHz	16 ECCE	R.82 FDD	OP.2 FDD	EPA5	2 x 1 Low	1	-4.8	M1
2	10 MHz	16 ECCE	[R.82 FDD]	OP.2 FDD	EPA5	2 x 2 Low	1	-6.5	≥1
3	10 MHz	16 ECCE	[R.82 FDD]	OP.2 FDD	EPA5	2 x 4 Low	1	-6.5	≥1

8.11.2.1.2 CE Mode B

For the parameters specified in Table 8.11.2.1-1 and 8.11.2.1-2 the average probability of a missed downlink scheduling grant (Pm-dsg) shall be below the specified value in Table 8.11.2.1.2-1. The downlink physical setup is in accordance with Annex C.3.2.

Table 8.11.2.1.2-1: Minimum performance CE Mode B MPDCCH

Test number	Bandwidth	Aggregation level	Reference Channel	OCNG Pattern	Propagation Condition	Antenna configuration and correlation Matrix	Reference value		UE Category
							Pm-dsg (%)	SNR (dB)	
1	10 MHz	24 ECCE	R.83 FDD	OP.2 FDD	ETU1	2 x 1 Low	1	-12.0	M1
2	10 MHz	24 ECCE	R.83 FDD	OP.2 FDD	ETU1	2 x 2 Low	1	-13.2	≥1
3	10 MHz	24 ECCE	R.83 FDD	OP.2 FDD	ETU1	2 x 4 Low	1	-12.8	≥1

8.11.2.2 TDD

Table 8.11.2.2-1: Test Parameters for MPDCCH (Category M1)

Parameter		Unit	CE Mode A	CE Mode B
OFDM starting symbol (startSymbolLC)		symbols	2	2
Unused RE-s and PRB-s			OCNG	OCNG
Cell ID			0	0
Downlink power allocation	ρ_A	dB	-3	0
	ρ_B	dB	-3	0
	σ	dB	0	-3
	δ	dB	3	0
N_{oc} at antenna port		dBm/15 kHz	-98	-98
Cyclic prefix			Normal	Normal
Subframe Configuration			Non-MBSFN	Non-MBSFN
Precoder Update Granularity	PRB		1	1
	ms		5 (Note 2)	20 (Note 2)
Beamforming Pre-Coder			Annex B.4.4	Annex B.4.4
Cell Specific Reference Signal			Port 0 and 1	Port 0 and 1
Number of PRB per MPDCCH Set			4	2+4
Transmission type			Distributed	Localized
Frequency hopping			Disabled	Enabled
Number of frequency hopping narrowbands			N/A	4
Frequency hopping offset			N/A	1
Frequency hopping interval		ms	N/A	20
Value of G in MPDCCH start subframe (<i>mpdcch-startSF-U ESS</i>) ^{Note 4}			5	5
Maximum number of repetitions (<i>mPDCCH-NumRepetition</i>)			16	32
MPDCCH repetition number			16	32
MPDCCH narrowband (<i>mpdcch-Narrowband</i>)			1	7
PDSCH TM			TM2	TM2
DCI Format			6-1A	6-1B
TDD UL/DL Configuration			0	0
TDD Special Subframe			1	1
fdd-DownlinkOrTddSubframeBitmapBR			1000010000	1000010000
<p>Note 1: For each test, DC subcarrier puncturing shall be considered.</p> <p>Note 2: Same precoding matrix is used for a PRB across subframes during the frequency hopping interval.</p> <p>Note 3: The special subframes are not supported by MPDCCH, and are assumed as non- BL/CE DL subframes.</p> <p>Note 4: For MPDCCH UE-specific search space the formula for the start subframe k_0 is given in TS 36.213 [6] clause 9.1.5.</p> <p>Note 5: If not otherwise stated, the values in this table refer to parameters in TS 36.211 [4] or/and TS 36.213 [6] as appropriate.</p>				

Table 8.11.2.2-2: Test Parameters for MPDCCH (Category ≥ 1)

Parameter		Unit	CE Mode A (Test 2)	CE Mode A (Test 3)	CE Mode B (Test 2)	CE Mode B (Test 3)
OFDM starting symbol (startSymbolLC)		symbols	2	2	2	2
Unused RE-s and PRB-s			OCNG	OCNG	OCNG	OCNG
Cell ID			0	0	0	0
Downlink power allocation	ρ_A	-3	-3	-3	0	0
	ρ_B	-3	-3	-3	0	0
	σ	0	0	0	-3	-3
	δ	3	3	3	0	0
N_{oc} at antenna port		dBm/15kHz	-98	-98	-98	-98
Cyclic prefix			Normal	Normal	Normal	Normal
Subframe Configuration			Non-MBSFN	Non-MBSFN	Non-MBSFN	Non-MBSFN
Precoder Update Granularity	PRB		1	1	1	1
	ms		5 (Note 2)	5 (Note 2)	20 (Note 2)	20 (Note 2)
Beamforming Pre-Coder			Annex B.4.4	Annex B.4.4	Annex B.4.4	Annex B.4.4
Cell Specific Reference Signal			Port 0 and 1	Port 0 and 1	Port 0 and 1	Port 0 and 1
Number of PRB per MPDCCH Set			4	4	2+4	2+4
Transmission type			Distributed	Distributed	Localized	Localized
Frequency hopping			Disabled	Disabled	Enabled	Enabled
Number of frequency hopping narrowbands			N/A	N/A	4	4
Frequency hopping offset			N/A	N/A	1	1
Frequency hopping interval		ms	N/A	N/A	5	5
Value of G in MPDCCH start subframe (<i>mpdcch-startSF-UESS</i>) ^{Note 3}			5	5	5	5
Maximum number of repetitions (<i>mpdcch-NumRepetition</i>)			4	2	16	8
MPDCCH repetition number			4	2	16	8
MPDCCH narrowband (<i>mpdcch-Narrowband</i>)			1	1	7	7
PDSCH TM			TM2	TM2	TM2	TM2
DCI Format			6-1A	6-1A	6-1B	6-1B
fdd-DownlinkOrTddSubframeBitmapBR			1000010000	1000010000	1000010000	1000010000
<p>Note 1: For each test, DC subcarrier puncturing shall be considered.</p> <p>Note 2: Same precoding matrix is used for a PRB across subframes during the frequency hopping interval.</p> <p>Note 3: For MPDCCH UE-specific search space the formula for the start subframe k_0 is given in TS 36.213 [6] clause 9.1.5.</p> <p>Note 4: If not otherwise stated, the values in this table refer to parameters in TS 36.211 [4] or/and TS 36.213 [6] as appropriate.</p>						

8.11.2.2.1 CE Mode A

For the parameters specified in Table 8.11.2.2-1 and 8.11.2.2-2 the average probability of a missed downlink scheduling grant (P_{m-dsg}) shall be below the specified value in Table 8.11.2.2.1-1. The downlink physical setup is in accordance with Annex C.3.2.

Table 8.11.2.2.1-1: Minimum performance CE Mode A MPDCCH

Test number	Bandwidth	Aggregation level	Reference Channel	OCNG Pattern	Propagation Condition	Antenna configuration and correlation Matrix	Reference value		UE Category
							Pm-dsg (%)	SNR (dB)	
1	10 MHz	16 ECCE	R.82 TDD	OP.2 TDD	EPA5	2 x 1 Low	1	-5.3	M1
2	10 MHz	16 ECCE	R.82 TDD	OP.2 TDD	EPA5	2 x 2 Low	1	[-12.3]	≥1
3	10 MHz	16 ECCE	R.82 TDD	OP.2 TDD	EPA5	2 x 4 Low	1	[-12.8]	≥1

8.11.2.2.2 CE Mode B

For the parameters specified in Table 8.11.2.2-1 and 8.11.2.2-2 the average probability of a missed downlink scheduling grant (Pm-dsg) shall be below the specified value in Table 8.11.2.2.2-1. The downlink physical setup is in accordance with Annex C.3.2.

Table 8.11.2.2.2-1: Minimum performance CE Mode B MPDCCH

Test number	Bandwidth	Aggregation level	Reference Channel	OCNG Pattern	Propagation Condition	Antenna configuration and correlation Matrix	Reference value		UE Category
							Pm-dsg (%)	SNR (dB)	
1	10 MHz	24 ECCE	R.83 TDD	OP.2 TDD	ETU1	2 x 1 Low	1	-10.1	M1
2	10 MHz	24 ECCE	[R.83 TDD]	OP.2 TDD	ETU1	2 x 2 Low	1	[TBD]	≥1
3	10 MHz	24 ECCE	[R.83 TDD]	OP.2 TDD	ETU1	2 x 4 Low	1	[TBD]	≥1

8.11.3 PBCH

The receiver characteristics of the PBCH are determined by the probability of miss-detection of the PBCH for single decoding interval (Pm-bch-s) and the probability of miss-detection of the PBCH for multiple decoding intervals (Pm-bch-m), which are defined as

$$P_{m-bch-s} = 1 - \frac{A_s}{B_s}$$

$$P_{m-bch-m} = 1 - \frac{A_m}{B_m}$$

The probability of miss-detection of the PBCH for single decoding interval (Pm-bch-s) is calculated under assumption of single PBCH TTI interval decoding. A_s is the number of correctly decoded MIB PDUs and B_s is the number of transmitted MIB PDUs (redundancy versions for the same MIB are not counted separately).

The probability of miss-detection of the PBCH for multiple decoding intervals (Pm-bch-m) is calculated over multiple PBCH TTI intervals under assumption of independent PBCH decoding over these intervals. A_m is the number of PBCH decoding intervals with at least one correctly decoded MIB PDU and B_m is the total number of PBCH decoding intervals. A multiple PBCH decoding interval has 1120 ms duration consisting of continuous PBCH TTIs during the test.

8.11.3.1 FDD and half-duplex FDD

Table 8.11.3.1-1: Test Parameters for PBCH

Parameter		Unit	Transmit diversity
Downlink power allocation	PBCH_RA	dB	-3
	PBCH_RB	dB	-3
N_{oc} at antenna port		dBm/15kHz	-98
Cyclic prefix			Normal
Cell ID			0
Repetition of the physical broadcast channel (Note 1)			Enabled
Cyclic prefix			Normal
Note 1: as specified in Table 6.6.4-1 in TS 36.211 [4].			

8.11.3.1.1 Transmit diversity performance

For the parameters specified in Table 8.11.3.1-1 and Table 8.11.3.1.1-1, the averaged probability of a miss-detected PBCH (Pm-bch-s and Pm-bch-m) shall be below the specified value in Table 8.11.3.1.1-1. The downlink physical setup is in accordance with Annex C.3.2.

Table 8.11.3.1.1-1: Minimum performance PBCH

Test number	Bandwidth	Reference Channel	Propagation Condition	Antenna configuration and correlation Matrix	Reference value for single PBCH TTI		Reference value for multiple PBCH TTI	
					Pm-bch-s (%)	SNR (dB)	Pm-bch-m (%)	SNR (dB)
1	10 MHz	R.22	EPA1	2 x 1 Low	1	-1.9	1	-12.6

8.11.3.2 TDD

Table 8.11.3.2-1: Test Parameters for PBCH

Parameter		Unit	Transmit diversity
Uplink downlink configuration (Note 1)			1
Special subframe configuration (Note 2)			4
Downlink power allocation	PBCH_RA	dB	-3
	PBCH_RB	dB	-3
N_{oc} at antenna port		dBm/15kHz	-98
Cyclic prefix			Normal
Cell ID			0
Repetition of the physical broadcast channel (Note 3)			Enabled
Cyclic prefix			Normal
Note 1: as specified in Table 4.2-2 in TS 36.211 [4].			
Note 2: as specified in Table 4.2-1 in TS 36.211 [4].			
Note 3: as specified in Table 6.6.4-2 in TS 36.211 [4].			

8.11.3.2.1 Transmit diversity performance

For the parameters specified in Table 8.11.3.2-1 and Table 8.11.3.2.1-1, the averaged probability of a miss-detected PBCH (Pm-bch-s and Pm-bch-m) shall be below the specified value in Table 8.11.3.2.1-1. The downlink physical setup is in accordance with Annex C.3.2.

Table 8.11.3.2.1-1: Minimum performance PBCH

Test number	Bandwidth	Reference Channel	Propagation Condition	Antenna configuration and correlation Matrix	Reference value for single PBCH TTI		Reference value for multiple PBCH TTI	
					Pm-bch-s (%)	SNR (dB)	Pm-bch-m (%)	SNR (dB)
1	10 MHz	R.22	EPA1	2 x 1 Low	1	-2.8	1	-12.9

8.12 Demodulation of Narrowband IoT

8.12.1 NPDSCH

8.12.1.1 Half-duplex FDD

Table 8.12.1.1-1: Common Test Parameters

Parameter	Unit	Value
Number of HARQ processes per component carrier	Processes	1
Maximum number of HARQ transmission		4
Cyclic Prefix		Normal
extraControlRegionSize-r13		3 for In-band and N/A for Standalone/Guard-band unless otherwise stated
downlinkBitmap-r13 and dl-Gap-r13		Not configured
dl-GapNonAnchor-r13 and downlinkBitmapNonAnchor-r13		Not configured
Unused REs or RB (Note 1)		OCNG
OCNG pattern		NB.OP.1
Note 1: For in-band mode, the REs for transmission of LTE signals including PDCCH, CRS should be filled by OCNG.		

Table 8.12.1.1-2: Test Parameters of related NPDCCH and NPUSCH format 2 configurations

Parameter	Unit	Value
DCI format		DCI format N1
scheduling delay field (I_{Delay})		1
$N_{\text{Rep}}^{\text{AN}}$ (<i>ack-NACK-NumRepetitions-r13</i>)		1
ACK/NACK resource field		0
Reference channel for NPDCCH		R.NB.3 for one NRS antenna port; R.NB.4 for two NRS antenna ports
α_{offset} (<i>npdcch-Offset-USS-r13</i>)		0

8.12.1.1.1 Minimum Requirements for In-band

The requirements are specified in Table 8.12.1.1-2, with the addition of the parameters in Table 8.12.1.1-1 and the downlink physical channel setup according to Annex C.3.2 and C.3.6. The purpose of these tests is to verify the performance.

Table 8.12.1.1.1-1: Test Parameters for NPDSCH under In-band

Parameter		Unit	Test 1, 2
Downlink power allocation of LTE signal	ρ_A	dB	-3
	ρ_B	dB	-3(Note 1)
	σ	dB	0
N_{oc} at antenna port	N_{oc1}	dBm/15kHz	-93 (Note 2)
	N_{oc2}	dBm/15kHz	-99 (Note 3)
LTE CRS port number (eutra-NumCRS-Ports-r13)			4
NPDCCH repetition number		subframe	8 for Test 1; 16 for Test 2; 128 for Test 3.
R_{max} (<i>npdcch-NumRepetitions-r13</i>)		subframe	8 for Test 1;16 for Test 2;128 for Test 3.
G (<i>npDCCH-startSF-USS-r13</i>)			4 for Test 1; 2 for Test 2; 1.5 for Test 3
Note 1: $P_B = 1$.			
Note 2: This noise is applied to all subframes from the end of the NPDCCH to the end of the following NPDSCH transmission;			
Note 3: This noise is applied to all subframes from the end of the NPDSCH to the end of the following NPDCCH transmission.			

Table 8.12.1.1.1-2: Minimum performance under In-band with 2 NRS ports

Test number	Bandwidth	Carrier Type	Reference Channel	Repetition number	Propagation Condition	Correlation Matrix and Antenna Configuration	Reference value	
							Fraction of Maximum Throughput (%)	SNR (dB)
1	200kHz	Anchor	R.NB.5 FDD	1	EPA5	2x1 Low	70%	6.9
2	200kHz	Anchor	R.NB.5 FDD	32	EPA5	2x1 Low	70%	-4.8
3	200kHz	Non-anchor	R.NB.5-1 FDD	256	ETU1	2x1 Low	70%	-9.8

8.12.1.1.2 Minimum Requirements for Standalone/Guard-band

The requirements are specified in Table 8.12.1.1.2-2, with the addition of the parameters in Table 8.12.1.1.2 -1 and the downlink physical channel setup according to Annex C.3.6. The purpose of these tests is to verify the performance.

Table 8.12.1.1.2-1: Test Parameters for NPDSCH under Standalone/Guard-band

Parameter		Unit	Test 1, 2
N_{oc} at antenna port	N_{oc1}	dBm/15kHz	-93 (Note 1)
	N_{oc2}	dBm/15kHz	-99 (Note 2)
NPDCCH repetition number		subframe	32 for Test 1; 256 for Test 2.
R_{max} (<i>npdcch-NumRepetitions-r13</i>)		subframe	64 for Test 1; 512 for Test 2.
G (<i>npDCCH-startSF-USS-r13</i>)			1.5
Note 1: This noise is applied to all subframes from the end of the NPDCCH to the end of the following NPDSCH transmission;			
Note 2: This noise is applied to all subframes from the end of the NPDSCH to the end of the following NPDCCH transmission.			

Table 8.12.1.1.2-2: Minimum performance for NPDSCH under Standalone/Guard-band with 1 NRS port

Test number	Bandwidth	Carrier Type	Reference Channel	Repetition number	Propagation condition	Number of NRS ports	Antenna Configuration	Reference value	
								Fraction of Maximum Throughput (%)	SNR (dB)
1	200kHz	Anchor	R.NB.6 FDD	32	EPA5	1	1x1	70%	-3.4
2	200kHz	Non-anchor	R.NB.6-1 FDD	256	ETU1	1	1x1	70%	-10.2

8.12.2 NPDCCH

The receiver characteristics of the NPDCCH are determined by the probability of miss-detection of the Downlink Scheduling Grant (Pm-dsg).

8.12.2.1 Half-duplex FDD

The parameters specified in Table 8.12.2.1-1 and Table 8.12.2.1-2 are valid for all half-duplex FDD tests unless otherwise stated.

Table 8.12.2.1-1: Test Parameters for NPDCCH

Parameter	Unit	Single antenna port	Transmit diversity
Narrowband physical layer Cell ID		0	0
N_{oc} at antenna port	dBm/15kHz	-98	-98
Cyclic prefix		Normal	Normal
Number of CRS ports for in-band deployment mode		4	4
NPDCCH starting position (<i>extraControlRegionSize-r13</i>) (Note 1)		3	3
Maximum number of repetitions R_{max} (<i>npdcch-NumRepetitions-r13</i>)		128 for Test 1; 1024 for Test 2.	64 for Test 1; 512 for Test 2.
NPDCCH start subframe G (<i>npdcch-startSF-USS-r13</i>)		2 for test 1, 1.5 for test 2	2 for test 1, 1.5 for test 2
NPDCCH fractional period offset of starting subframe α_{offset} (<i>npdcch-Offset-USS-r13</i>)		0	0
NB-IoT downlink subframe bitmap for anchor carrier (<i>downlinkBitmap-r13</i>)		Not configured	Not configured
NB-IoT downlink subframe bitmap for non-anchor carrier (<i>downlinkBitmapNonAnchor-r13</i>)		Not configured	Not configured
Downlink gap configuration for anchor carrier (<i>dl-Gap-r13</i>)		Not configured	Not configured
Downlink gap configuration for non-anchor carrier (<i>dl-GapNonAnchor-r13</i>)		Not configured	Not configured
Unused REs or RBs (Note 1)		OCNG	OCNG
OCNG pattern		NB.OP.1	NB.OP.1
Note 1: Applicable only for in-band deployment mode.			

Table 8.12.2.1-2: Test Parameters of related NPDSCH and NPUSCH format 2 configurations

Parameter	Unit	Value
Scheduling delay field (I_{Delay})		0
NPDSCH Repetition number		1
N_{oc} at antenna port for NPDSCH	dBm/15kHz	-98
N_{Rep}^{AN} (ack-NACK- NumRepetitions-r13)		1
ACK/NACK resource field		0
Reference channel for NPDSCH		R.NB.6 and R.NB.6-1 for one NRS antenna port; R.NB.5 and R.NB.5-1 for two NRS antenna ports

8.12.2.1.1 Single-antenna performance

For the parameters specified in Table 8.12.2.1.1-1 the average probability of a missed downlink scheduling grant (Pm-dsg) shall be below the specified value in Table 8.12.2.1.1-1. The downlink physical channel setup is in accordance with Annex C.3.6.

Table 8.12.2.1.1-1: Minimum performance NPDCCH

Test number	Deployment mode	Repetition number (R)	Carrier Type	Reference Channel	Propagation Condition	Number of NRS ports	Antenna Configuration	Reference value	
								Pm-dsg (%)	SNR (dB)
1	Stand-alone/Guard-band	128	Anchor	R.NB.3 FDD	EPA5	1	1x1	1	-4.9
2	Stand-alone/Guard-band	1024	Non-anchor	R.NB.3 FDD	ETU1	1	1x1	1	-11.4

8.12.2.1.2 Transmit diversity performance

For the parameters specified in Table 8.12.2.1.2-1 the average probability of a missed downlink scheduling grant (Pm-dsg) shall be below the specified value in Table 8.12.2.1.2-1. The downlink physical channel setup is in accordance with Annex C.3.6.

Table 8.12.2.1.2-1: Minimum performance NPDCCH

Test number	Deployment mode	Repetition number (R)	Carrier Type	Reference Channel	Propagation Condition	Number of NRS ports	Antenna Configuration and correlation Matrix	Reference value	
								Pm-dsg (%)	SNR (dB)
1	In-band	64	Anchor	R.NB.4 FDD	EPA5	2	2x1 Low	1	-3.9
2	In-band	512	Non-anchor	R.NB.4 FDD	ETU1	2	2x1 Low	1	-10.0

8.12.3 Demodulation of NPBCH

The receiver characteristics of the NPBCH are determined by the probability of miss-detection of the NPBCH (Pm-bch), which is defined as

$$P_{m-bch} = 1 - \frac{A}{B}$$

For the performance with single a NPBCH TTI decoding, A is the number of correctly decoded MIB-NB PDUs and B is the number of transmitted MIB-NB PDUs.

For the performance with multiple NPBCH TTIs decoding, A is the number of 5120ms durations consisting of contiguous NPBCH TTIs where there is at least one correctly decoded MIB-NB PDU, and B is the number of 5120ms durations consisting of contiguous NPBCH TTIs during the test.

8.12.3.1 HD-FDD

Table 8.12.3.1-1: Test Parameters for NPBCH

Parameter		Unit	Single antenna port	Transmit diversity
Downlink power allocation	NPBCH_RA	dB	0	-3
	NPBCH_RB	dB	0	-3
N_{oc} at antenna port		dBm/15kHz	-98	-98
Cyclic prefix			Normal	Normal
Cell ID			0	0

8.12.3.1.1 Single-antenna port performance with single NPBCH TTI

For the parameters specified in Table 8.12.3.1-1 the average probability of a miss-detecting NPBCH (P_{m-bch}) shall be below the specified value in Table 8.12.3.1.1-1. The downlink physical setup is in accordance with Annex C.3.6.

Table 8.12.3.1.1-1: Minimum performance NPBCH

Test number	Bandwidth	Reference Channel	Propagation Condition	Antenna configuration	Reference value	
					P_{m-bch} (%)	SNR (dB)
1	200 KHz	R.NB1.1	EPA1	1 x 1	1	-2.0

8.12.3.1.2 Transmit diversity performance

8.12.3.1.2.1 Minimum Requirement 2 Tx Antenna Port with multiple NPBCH TTIs

For the parameters specified in Table 8.12.3.1-1 the average probability of a miss-detected NPBCH (P_{m-bch}) shall be below the specified value in Table 8.12.3.1.2.1-1. The downlink physical setup is in accordance with Annex C.3.6.

Table 8.12.3.1.2.1-1: Minimum performance NPBCH

Test number	Bandwidth	Reference Channel	Propagation Condition	Antenna configuration and correlation Matrix	Reference value	
					P_{m-bch} (%)	SNR (dB)
1	200 KHz	R.NB1.2	EPA1	2 x 1 Low	1	-11.5

9 Reporting of Channel State Information

9.1 General

This section includes requirements for the reporting of channel state information (CSI). For all test cases in this section, the definition of SNR and SINR are in accordance with the one given in clause 8.1.1.

For the performance requirements specified in this clause, it is assumed that $N_{RX}=2$ unless otherwise stated.

Unless otherwise stated, 4-bit CQI Table in Table 7.2.3-1 in TS 36.213 [6], and Modulation and TBS index table in Table 7.1.7.1-1 for PDSCH in TS 36.213 [6] are applied in all the CSI requirements.

9.1.1 Applicability of requirements

9.1.1.1 Applicability of requirements for different channel bandwidths

In Clause 9 the test cases may be defined with different channel bandwidth to verify the same CSI requirement.

Test cases defined for 5MHz channel bandwidth that reference this clause are applicable to UEs that support only Band 31.

9.1.1.2 Applicability and test rules for different CA configurations and bandwidth combination sets

The performance requirement for CA CQI tests in Clause 9 are defined independent of CA configurations and bandwidth combination sets specified in Clause 5.6A.1. For UEs supporting different CA configurations and bandwidth combination sets, the applicability and test rules are defined for the tests for 2 DL CCs in Table 9.1.1.2-1 and 3 or more DL CCs in Table 9.1.1.2-2. For simplicity, CA configuration below refers to combination of CA configuration and bandwidth combination set.

Table 9.1.1.2-1: Applicability and test rules for CA UE CQI tests with 2 DL CCs

Tests	CA capability where the tests apply	CA configuration from the selected CA capability where the tests apply	CA Bandwidth combination to be tested in priority order
CA tests with 2CCs in Clause 9.6.1.1	Any of one of the supported CA capabilities	Any one of the supported FDD CA configurations	10+10 MHz, 20+20 MHz, 5+5 MHz, 10MHz+5MHz, 15MHz+5MHz
CA tests with 2CCs in Clause 9.6.1.2	Any of one of the supported CA capabilities with largest aggregated CA bandwidth combination	Any one of the supported TDD CA configurations with largest aggregated CA bandwidth combination	Largest aggregated CA bandwidth combination
Note 1:	The applicability and test rules are specified in this table, unless otherwise stated.		
Note 2:	Number of the supported bandwidth combinations to be tested from each selected CA configuration is 1.		
Note 3:	A single Uplink CC is configured for all tests		

Table 9.1.1.2-2: Applicability and test rules for CA UE CQI tests with 3 or more DL CCs

Tests	CA capability where the tests apply	CA configuration from the selected CA capability where the tests apply	CA Bandwidth combination to be tested in priority order
CA tests with 3 or more CCs in Clause 9.6.1.1	Any of one of the supported CA capabilities with largest aggregated CA bandwidth combination	Any one of the supported FDD CA configurations with largest aggregated CA bandwidth combination	Largest aggregated CA bandwidth combination
CA tests with 3 or more CCs in Clause 9.6.1.2	Any of one of the supported CA capabilities with largest aggregated CA bandwidth combination	Any one of the supported TDD CA configurations with largest aggregated CA bandwidth combination	Largest aggregated CA bandwidth combination
Note 1: The applicability and test rules are specified in this table, unless otherwise stated. Note 2: Number of the supported bandwidth combinations to be tested from each selected CA configuration is 1. Note 3: A single Uplink CC is configured for all tests			

9.1.1.2A Applicability and test rules for different TDD-FDD CA configurations and bandwidth combination sets

The performance requirement for TDD-FDD CA CQI tests in Clause 9 are defined independent of CA configurations and bandwidth combination sets specified in Clause 5.6A.1. For UEs supporting different CA configurations and bandwidth combination sets, the applicability and test rules are defined for the tests for 2 DL TDD-FDD CA in Table 9.1.1.2A-1 and for 3 or more DL TDD-FDD CA in Table 9.1.1.2A-2. For simplicity, CA configuration below refers to combination of CA configuration and bandwidth combination set.

Table 9.1.1.2A-1: Applicability and test rules for CA UE CQI tests for TDD-FDD CA with 2 DL CCs

Tests	CA capability where the tests apply	CA configuration from the selected CA capability where the tests apply	CA Bandwidth combination to be tested in priority order
CA tests with 2CCs in Clause 9.6.1.3	Any of one of the supported CA capabilities	Any one of the supported TDD-FDD CA configurations with FDD PCell with largest aggregated CA bandwidth combination	Largest aggregated CA bandwidth combination
CA tests with 2CCs in Clause 9.6.1.4	Any of one of the supported CA capabilities	Any one of the supported TDD-FDD CA configurations with TDD PCell with largest aggregated CA bandwidth combination	Largest aggregated CA bandwidth combination
Note 1: The applicability and test rules are specified in this table, unless otherwise stated. Note 2: Number of the supported bandwidth combinations to be tested from each selected CA configuration is 1. Note 3: A single Uplink CC is configured for all tests			

Table 9.1.1.2A-2: Applicability and test rules for CA UE CQI tests for TDD-FDD CA with 3 or more DL CCs

Tests	CA capability where the tests apply	CA configuration from the selected CA capability where the tests apply	CA Bandwidth combination to be tested in priority order
CA tests with 3CCs in Clause 9.6.1.3	Any of one of the supported CA capabilities	Any one of the supported TDD-FDD CA configurations with FDD PCell with largest aggregated CA bandwidth combination	Largest aggregated CA bandwidth combination
CA tests with 3CCs in Clause 9.6.1.4	Any of one of the supported CA capabilities	Any one of the supported TDD-FDD CA configurations with TDD PCell with largest aggregated CA bandwidth combination	Largest aggregated CA bandwidth combination
Note 1:	The applicability and test rules are specified in this table, unless otherwise stated.		
Note 2:	Number of the supported bandwidth combinations to be tested from each selected CA configuration is 1.		
Note 3:	A single Uplink CC is configured for all tests		

9.1.1.3 Test coverage for different number of component carriers

For FDD CA tests specified in 9.6.1.1, among all supported CA capabilities, if corresponding CA tests with the largest number of CCs supported by the UE are tested, the test coverage can be considered fulfilled without executing the CA tests with less than the largest number of CCs supported by the UE.

For TDD CA tests specified in 9.6.1.2, among all supported CA capabilities, if corresponding CA tests with the largest number of CCs supported by the UE are tested, the test coverage can be considered fulfilled without executing the CA tests with less than the largest number of CCs supported by the UE.

For TDD FDD CA tests specified in 9.6.1.3 and 9.6.1.4, among all supported CA capabilities, if corresponding CA tests with the largest number of CCs supported by the UE are tested, the test coverage can be considered fulfilled without executing the TDD FDD CA tests with less than the largest number of CCs supported by the UE.

9.1.1.4 Applicability of performance requirements for 4Rx capable UEs

9.1.1.4.1 Applicability rule and antenna connection for single carrier tests with 2Rx

For 4Rx capable UEs all single carrier tests specified in 9.2 to 9.5 with 2Rx are tested on any of the 2Rx supported RF bands by connecting 2 out of the 4Rx with data source from system simulator, and the other 2 Rx are connected with zero input, depending on UE's declaration and AP configuration. Same requirements specified with 2Rx should be applied.

For 4Rx capable UEs without any 2Rx supported RF bands, all single carrier tests specified in 9.2 to 9.5 with 2Rx are tested on any of the 4Rx supported RF bands by duplicating the fading channel from each Tx antenna and add independent noise for each Rx antenna where applicable. Figure 9.1.1.4.1-1 shows an example of antenna connection for 4Rx UE in any one 4Rx supported RF band to perform a 2Rx performance test with antenna configuration as 2x2 without interference for information. The SNR requirements should be applied with 3 dB less than the number specified with 2Rx, unless there is no SNR requirements specified.

For 4Rx capable UEs without any 2Rx supported RF bands, all single carrier tests specified in 9.3.3 with 2Rx are tested on any of the 4Rx supported RF bands by duplicating the fading channel from each Tx antenna and add independent interference for each Rx antenna.

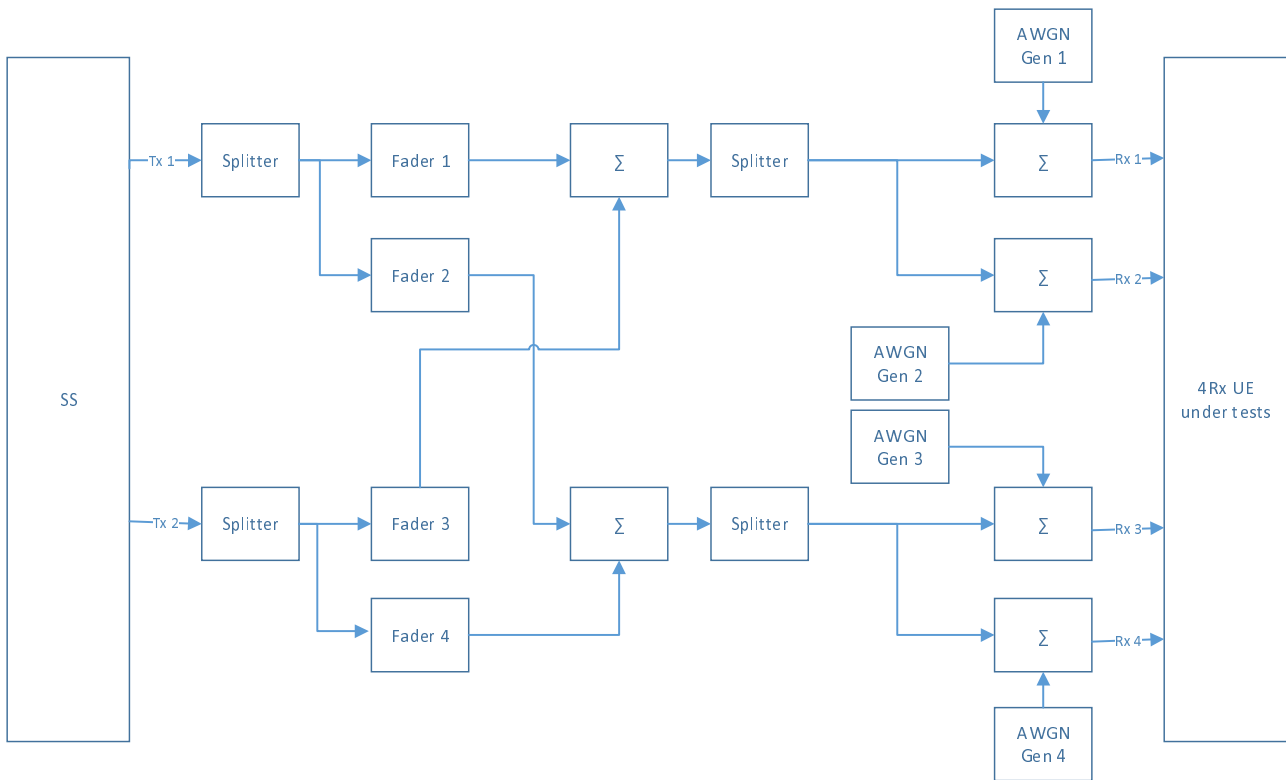

Figure 9.1.1.4.1-1 Antenna connection example for 2Rx tests with antenna configuration as 2x2 without interference (informative)

For 4Rx capable UEs without any 2Rx supported RF bands, for all single carrier tests listed in Table 9.1.1.4.1-1 specified from 9.2 to 9.5 with 2Rx can be skipped.

Table 9.1.1.4.1-1: Requirement lists for 4Rx capable UEs

Requirement lists
Enhanced performance requirements type B
Requirements with demodulation subframe overlaps with aggressor cell ABS
Requirements with demodulation subframe overlaps with aggressor cell ABS and CRS assistance information are configured

For 4Rx capable UEs, if corresponding tests listed from the 4Rx test lists from Table 9.1.1.4.1-2 are tested, the test coverage can be considered fulfilled without executing the corresponding tests listed from the 2Rx test lists from Table 9.1.1.4.1-2.

Table 9.1.1.4.1-2: Applicability rules for single carrier tests with 2Rx

4Rx test lists	2Rx test lists
9.9.1.1.1 Test 1	9.2.1.1 Test 1
9.9.1.1.1 Test 2	9.2.1.1 Test 2
9.9.1.1.2 Test 1	9.2.1.2 Test 1
9.9.1.1.2 Test 2	9.2.1.2 Test 2
9.9.1.2.1 Test 1	9.2.3.1 Test 1
9.9.1.2.1 Test 2	9.2.3.1 Test 2
9.9.1.2.2 Test 1	9.2.3.2 Test 1
9.9.1.2.2 Test 2	9.2.3.2 Test 2
9.9.2.1.1	9.3.5.1.1
9.9.2.1.2	9.3.5.1.2
9.9.2.2.1	9.3.5.2.1
9.9.2.2.2	9.3.5.2.2
9.9.3.1.1 Test 1	9.4.2.3.2 Test 1
9.9.4.1.1 Test 1	9.5.1.1 Test 1
9.9.4.1.1 Test 2	9.5.1.1 Test 2
9.9.4.1.1 Test 3	9.5.1.1 Test 3
9.9.4.1.2 Test 1	9.5.1.2 Test 1
9.9.4.1.2 Test 2	9.5.1.2 Test 2
9.9.4.1.2 Test 3	9.5.1.2 Test 3
9.9.4.2.1 Test 1	9.5.2.1 Test 1
9.9.4.2.1 Test 2	9.5.2.1 Test 2
9.9.4.2.1 Test 3	9.5.2.1 Test 3
9.9.4.2.2 Test 1	9.5.2.2 Test 1
9.9.4.2.2 Test 2	9.5.2.2 Test 2
9.9.4.2.2 Test 3	9.5.2.2 Test 3

9.1.1.4.2 Applicability rule and antenna connection for CA tests with 2Rx

All tests specified in 9.6 with 2Rx with CA and TDD-FDD CA are tested with 4 Rx capable UEs by connecting all 4Rx with data source from system simulator with the following change on the power level in the test configurations listed in Table 9.1.1.4.2-1 and by scheduling the PDSCH for user data based on the Reference measurement channel RC.1 FDD according to Table A.4-1 with one sided dynamic OCNG Pattern OP.1 FDD as described in Annex A.5.1.1 for FDD cells and Reference measurement channel RC.1 TDD according to Table A.4-1 with one sided dynamic OCNG Pattern OP.1 TDD as described in Annex A.5.2.1 for TDD cells.

Table 9.1.1.4.2-1: Power level for 4Rx capable UE to verify CA tests with 2Rx

Number of CCs		$\hat{I}_{or}^{(j)}$ dB[mW/15kHz]
2	PCell	-88
	SCell	-95
3,4	PCell	-85
	SCell1	-92
	SCell2, SCell3	-99
5	PCell	-85
	SCell1	-92
	SCell2, SCell3, SCell4	-99

Within the CA configuration if any of the PCell and/or the SCells is a 2Rx supported RF band, keep the same power level listed in Table 9.1.1.4.2-1. Within the CA configuration if any of the PCell and/or the SCells is a 4Rx supported RF band, configure the power level 3 dB smaller than the number listed in Table 9.1.1.4.2-1. Same requirements specified with 2Rx should be applied.

Same applicability rules defined in 9.1.1.2, 9.1.1.2A for CA and TDD-FDD CA applied for different CA configurations and bandwidth combination sets should be applied for 4 Rx capable UEs.

9.1.1.4.3 Applicability rule and antenna connection for single carrier tests with 4Rx

For 4Rx capable UEs all single carrier tests specified in 9.9 with 4Rx are tested on any of the 4 Rx supported RF bands by connecting all 4Rx with data source from system simulator.

9.1.1.5 Applicability of requirements for UEs supporting coverage enhancement

For 2Rx capable UEs supporting coverage enhancement mode A (ce-ModeA in UE-EUTRA-Capability [7]), all the tests for CE Mode A specified in 9.8 are tested on any of the 2Rx supported RF bands by connecting all 2Rx with data source from system simulator. The SNR requirements should be applied with 3dB less than the number specified with UE DL Category M1.

For 4Rx capable UEs supporting coverage enhancement mode A (ce-ModeA in UE-EUTRA-Capability [7]), all the tests for CE Mode A specified in 9.8 are tested on any of the 4Rx supported RF bands by connecting all 4Rx with data source from system simulator. The SNR requirements should be applied with 6dB less than the number specified with UE DL Category M1.

9.2 CQI reporting definition under AWGN conditions

The reporting accuracy of the channel quality indicator (CQI) under frequency non-selective conditions is determined by the reporting variance and the BLER performance using the transport format indicated by the reported CQI median. The purpose is to verify that the reported CQI values are in accordance with the CQI definition given in TS 36.213 [6]. To account for sensitivity of the input SNR the reporting definition is considered to be verified if the reporting accuracy is met for at least one of two SNR levels separated by an offset of 1 dB.

9.2.1 Minimum requirement PUCCH 1-0 (Cell-Specific Reference Symbols)

9.2.1.1 FDD

The following requirements apply to UE Category ≥ 1 . For the parameters specified in Table 9.2.1.1-1 and Table 9.2.1.1-2, and using the downlink physical channels specified in tables C.3.2-1 and C.3.2-2, the reported CQI value according to RC.1 FDD / RC.14 FDD in Table A.4-1 shall be in the range of ± 1 of the reported median more than 90% of the time. If the PDSCH BLER using the transport format indicated by median CQI is less than or equal to 0.1, the BLER using the transport format indicated by the (median CQI + 1) shall be greater than 0.1. If the PDSCH BLER using the transport format indicated by the median CQI is greater than 0.1, the BLER using transport format indicated by (median CQI - 1) shall be less than or equal to 0.1.

The applicability of the requirement with 5MHz bandwidth as specified in Table 9.2.1.1-2 is defined in 9.1.1.1.

Table 9.2.1.1-1: PUCCH 1-0 static test (FDD)

Parameter		Unit	Test 1		Test 2	
Bandwidth		MHz	10			
PDSCH transmission mode			1			
Downlink power allocation	ρ_A	dB	0			
	ρ_B	dB	0			
	σ	dB	0			
Propagation condition and antenna configuration			AWGN (1 x 2)			
SNR (Note 2)		dB	0	1	6	7
$\hat{I}_{or}^{(j)}$		dB[mW/15kHz]	-98	-97	-92	-91
$N_{oc}^{(j)}$		dB[mW/15kHz]	-98		-98	
Max number of HARQ transmissions			1			
Physical channel for CQI reporting			PUCCH Format 2			
PUCCH Report Type			4			
Reporting periodicity		ms	$N_{pd} = 5$			
<i>cqi-pmi-ConfigurationIndex</i>			6			
Note 1: Reference measurement channel RC.1 FDD according to Table A.4-1 with one sided dynamic OCNG Pattern OP.1 FDD as described in Annex A.5.1.1, except for category 1 UE use RC.4 FDD with two sided dynamic OCNG Pattern OP.2 FDD as described in Annex A.5.1.2.						
Note 2: For each test, the minimum requirements shall be fulfilled for at least one of the two SNR(s) and the respective wanted signal input level.						

Table 9.2.1.1-2: PUCCH 1-0 static test (FDD 5MHz)

Parameter		Unit	Test 1		Test 2	
Bandwidth		MHz	5			
PDSCH transmission mode			1			
Downlink power allocation	ρ_A	dB	0			
	ρ_B	dB	0			
	σ	dB	0			
Propagation condition and antenna configuration			AWGN (1 x 2)			
SNR (Note 2)		dB	[0]	[1]	[6]	[7]
$\hat{I}_{or}^{(j)}$		dB[mW/15kHz]	[-98]	[-97]	[-92]	[-91]
$N_{oc}^{(j)}$		dB[mW/15kHz]	-98		-98	
Max number of HARQ transmissions			1			
Physical channel for CQI reporting			PUCCH Format 2			
PUCCH Report Type			4			
Reporting periodicity		ms	$N_{pd} = 5$			
<i>cqi-pmi-ConfigurationIndex</i>			6			
Note 1: Reference measurement channel RC.14 FDD according to Table A.4-1 with one sided dynamic OCNG Pattern OP.1 FDD as described in Annex A.5.1.1, except for category 1 UE use RC.15 FDD with two sided dynamic OCNG Pattern OP.2 FDD as described in Annex A.5.1.2.						
Note 2: For each test, the minimum requirements shall be fulfilled for at least one of the two SNR(s) and the respective wanted signal input level.						

9.2.1.2 TDD

The following requirements apply to UE Category ≥ 1 . For the parameters specified in Table 9.2.1.2-1, and using the downlink physical channels specified in tables C.3.2-1 and C.3.2-2, the reported CQI value according to RC.1 TDD in Table A.4-1 shall be in the range of ± 1 of the reported median more than 90% of the time. If the PDSCH BLER using

the transport format indicated by median CQI is less than or equal to 0.1, the BLER using the transport format indicated by the (median CQI + 1) shall be greater than 0.1. If the PDSCH BLER using the transport format indicated by the median CQI is greater than 0.1, the BLER using transport format indicated by (median CQI – 1) shall be less than or equal to 0.1.

Table 9.2.1.2-1: PUCCH 1-0 static test (TDD)

Parameter		Unit	Test 1		Test 2	
Bandwidth		MHz	10			
PDSCH transmission mode			1			
Uplink downlink configuration			2			
Special subframe configuration			4			
Downlink power allocation	ρ_A	dB	0			
	ρ_B	dB	0			
	σ	dB	0			
Propagation condition and antenna configuration			AWGN (1 x 2)			
SNR (Note 2)		dB	0	1	6	7
$\hat{I}_{or}^{(j)}$		dB[mW/15kHz]	-98	-97	-92	-91
$N_{oc}^{(j)}$		dB[mW/15kHz]	-98		-98	
Max number of HARQ transmissions			1			
Physical channel for CQI reporting			PUSCH (Note 3)			
PUCCH Report Type			4			
Reporting periodicity		ms	$N_{pd} = 5$			
<i>cqi-pmi-ConfigurationIndex</i>			3			
ACK/NACK feedback mode			Multiplexing			
<p>Note 1: Reference measurement channel RC.1 TDD according to Table A.4-1 with one sided dynamic OCNG Pattern OP.1 TDD as described in Annex A.5.2.1, except for category 1 UE use RC.4 TDD with two sided dynamic OCNG Pattern OP.2 TDD as described in Annex A.5.2.2.</p> <p>Note 2: For each test, the minimum requirements shall be fulfilled for at least one of the two SNR(s) and the respective wanted signal input level.</p> <p>Note 3: To avoid collisions between CQI reports and HARQ-ACK it is necessary to report both on PUSCH instead of PUCCH. PDCCH DCI format 0 shall be transmitted in downlink SF#3 and #8 to allow periodic CQI to multiplex with the HARQ-ACK on PUSCH in uplink subframe SF#7 and #2.</p>						

9.2.1.3 FDD (CSI measurements in case two CSI subframe sets are configured)

The following requirements apply to UE Category ≥ 1 . For the parameters specified in Table 9.2.1.3-1, and using the downlink physical channels specified in tables C.3.2-1 for Cell 1, C.3.3-1 for Cell 2 and C.3.2-2, the reported CQI value according to RC.2 FDD / RC.6 FDD in Table A.4-1 in subframes overlapping with aggressor cell ABS and non-ABS subframes shall be in the range of ± 1 of the reported median more than 90% of the time. If the PDSCH BLER in non-ABS subframes using the transport format indicated by median CQI obtained by reports in CSI subframe sets $C_{CSI,1}$ is less than or equal to 0.1, the BLER in non-ABS subframes using the transport format indicated by the (median CQI + 1) shall be greater than 0.1. If the PDSCH BLER in non-ABS subframes using the transport format indicated by the median CQI is greater than 0.1, the BLER in non-ABS subframes using transport format indicated by (median CQI – 1) shall be less than or equal to 0.1. The value of the median CQI obtained by reports in CSI subframe sets $C_{CSI,0}$ minus the median CQI obtained by reports in CSI subframe sets $C_{CSI,1}$ shall be larger than or equal to 2 and less than or equal to 5 in Test 1 and shall be larger than or equal to 0 and less than or equal to 1 in Test 2.

Table 9.2.1.3-1: PUCCH 1-0 static test (FDD)

Parameter		Unit	Test 1			Test 2		
			Cell 1	Cell 2		Cell 1	Cell 2	
Bandwidth		MHz	10			10		
PDSCH transmission mode			2	Note 10		2	Note 10	
Downlink power allocation	ρ_A	dB	-3			-3		
	ρ_B	dB	-3			-3		
	σ	dB	0			0		
Propagation condition and antenna configuration			Clause B.1 (2x2)			Clause B.1 (2x2)		
\hat{E}_s / N_{oc2} (Note 1)		dB	4	5	6	4	5	-12
$N_{oc}^{(j)}$ at antenna port	$N_{oc1}^{(j)}$	dBm/15kHz	-102 (Note 7)		N/A	-98(Note 7)		N/A
	$N_{oc2}^{(j)}$	dBm/15kHz	-98 (Note 8)		N/A	-98(Note 8)		N/A
	$N_{oc3}^{(j)}$	dBm/15kHz	-94.8 (Note 9)		N/A	-98(Note 9)		N/A
$\hat{I}_{or}^{(j)}$		dB[mW/15kHz]	-94	-93	-92	-94	-93	-110
Subframe Configuration			Non-MBSFN		Non-MBSFN	Non-MBSFN		Non-MBSFN
Cell Id			0		1	0		1
Time Offset between Cells		μ s	2.5 (synchronous cells)			2.5 (synchronous cells)		
ABS pattern (Note 2)			N/A		01010101 01010101 01010101 01010101 01010101	N/A		01010101 01010101 01010101 01010101 01010101
RLM/RRM Measurement Subframe Pattern (Note 4)			00000100 00000100 00000100 00000100 00000100		N/A	00000100 00000100 00000100 00000100 00000100		N/A
CSI Subframe Sets (Note 3)	$C_{CSI,0}$		01010101 01010101 01010101 01010101 01010101		N/A	01010101 01010101 01010101 01010101 01010101		N/A
	$C_{CSI,1}$		10101010 10101010 10101010 10101010 10101010		N/A	10101010 10101010 10101010 10101010 10101010		N/A
Number of control OFDM symbols			3			3		
Max number of HARQ transmissions			1			1		
Physical channel for $C_{CSI,0}$ CQI reporting			PUCCH Format 2			PUCCH Format 2		
Physical channel for $C_{CSI,1}$ CQI reporting			PUSCH (Note 12)			PUSCH (Note 12)		
PUCCH Report Type			4			4		
Reporting periodicity		Ms	$N_{pd} = 5$			$N_{pd} = 5$		
$cqi-pmi-ConfigurationIndex_{C_{CSI,0}}$ (Note 13)			6	N/A		6	N/A	
$cqi-pmi-ConfigurationIndex2_{C_{CSI,1}}$ (Note 14)			5	N/A		5	N/A	

Note 1:	For each test, the minimum requirements shall be fulfilled for at least one of the two SNR(s) and the respective wanted signal input level.
Note 2:	ABS pattern as defined in [9].
Note 3:	Time-domain measurement resource restriction pattern for PCell measurements as defined in [7]
Note 4:	As configured according to the time-domain measurement resource restriction pattern for CSI measurements defined in [7]
Note 5:	Time-domain measurement resource restriction pattern for PCell measurements as defined in [7]
Note 6:	Cell 1 is the serving cell. Cell 2 is the aggressor cell. The number of the CRS ports in Cell1 and Cell2 is the same.
Note 7:	This noise is applied in OFDM symbols #1, #2, #3, #5, #6, #8, #9, #10,#12, #13 of a subframe overlapping with the aggressor ABS.
Note 8:	This noise is applied in OFDM symbols #0, #4, #7, #11 of a subframe overlapping with the aggressor ABS.
Note 9:	This noise is applied in all OFDM symbols of a subframe overlapping with aggressor non-ABS.
Note 10:	Downlink physical channel setup in Cell 2 in accordance with Annex C.3.3 applying OCNG pattern as defined in Annex A.5.1.5
Note 11:	Reference measurement channel in Cell 1 RC.2 FDD according to Table A.4-1 for UE Category 2-8 with one sided dynamic OCNG Pattern OP.1 FDD as described in Annex A.5.1.1, and RC.6 FDD according to Table A.4-1 for Category 1 with one/two sided dynamic OCNG Pattern OP. 1/2 FDD as described in Annex A.5.1.1 and A.5.1.2.
Note 12:	To avoid collisions between HARQ-ACK and wideband CQI it is necessary to report both on PUSCH instead of PUCCH. PDCCH DCI format 0 shall be transmitted in downlink SF#4 and #9 to allow periodic CQI to multiplex with the HARQ-ACK on PUSCH in uplink subframe SF#8 and #3.
Note 13:	<i>cqi-pmi-ConfigurationIndex</i> is applied for $C_{CSI,0}$.
Note 14:	<i>cqi-pmi-ConfigurationIndex2</i> is applied for $C_{CSI,1}$.

9.2.1.4 TDD (CSI measurements in case two CSI subframe sets are configured)

The following requirements apply to UE Category ≥ 1 . For the parameters specified in Table 9.2.1.4-1, and using the downlink physical channels specified in tables C.3.2-1 for Cell 1, C.3.3-1 for Cell 2 and C.3.2-2, the reported CQI value according to RC.2 TDD / RC.6 TDD in Table A.4-1 in subframes overlapping with aggressor cell ABS and non-ABS subframes shall be in the range of ± 1 of the reported median more than 90% of the time. If the PDSCH BLER in non-ABS subframes using the transport format indicated by median CQI obtained by reports in CSI subframe sets $C_{CSI,1}$ is less than or equal to 0.1, the BLER in non-ABS subframes using the transport format indicated by the (median CQI + 1) shall be greater than 0.1. If the PDSCH BLER in non-ABS subframes using the transport format indicated by the median CQI is greater than 0.1, the BLER in non-ABS subframes using transport format indicated by (median CQI – 1) shall be less than or equal to 0.1. The value of the median CQI obtained by reports in CSI subframe sets $C_{CSI,0}$ minus the median CQI obtained by reports in CSI subframe sets $C_{CSI,1}$ shall be larger than or equal to 2 and less than or equal to 5 in Test 1 and shall be larger than or equal to 0 and less than or equal to 1 in Test 2.

Table 9.2.1.4-1: PUCCH 1-0 static test (TDD)

Parameter	Unit	Test 1			Test 2			
		Cell 1		Cell 2	Cell 1		Cell 2	
Bandwidth	MHz	10			10			
PDSCH transmission mode		2		Note 10	2		Note 10	
Uplink downlink configuration		1			1			
Special subframe configuration		4			4			
Downlink power allocation	ρ_A	dB			-3			
	ρ_B	dB			-3			
	σ	dB			0			
Propagation condition and antenna configuration		Clause B.1 (2x2)			Clause B.1 (2x2)			
\hat{E}_s / N_{oc2} (Note 1)	dB	4	5	6	4	5	-12	
$N_{oc}^{(j)}$ at antenna port	$N_{oc1}^{(j)}$	dBm/15kHz		-102 (Note 7)	N/A		-98 (Note 7)	N/A
	$N_{oc2}^{(j)}$	dBm/15kHz		-98 (Note 8)	N/A		-98 (Note 8)	N/A
	$N_{oc3}^{(j)}$	dBm/15kHz		-94.8 (Note 9)	N/A		-98 (Note 9)	N/A
$\hat{I}_{or}^{(j)}$	dB[mW/15kHz]	-94	-93	-92	-94	-93	-110	
Subframe Configuration		Non-MBSFN		Non-MBSFN	Non-MBSFN		Non-MBSFN	
Cell Id		0		1	0		1	
Time Offset between Cells	μ s	2.5 (synchronous cells)			2.5 (synchronous cells)			
ABS pattern (Note 2)		N/A		0100010001 0100010001	N/A		0100010001 0100010001	
RLM/RRM Measurement Subframe Pattern (Note 4)		0000000001 0000000001		N/A	0000000001 0000000001		N/A	
CSI Subframe Sets (Note 3)	$C_{CSI,0}$	0100010001 0100010001		N/A	0100010001 0100010001		N/A	
	$C_{CSI,1}$	1000101000 1000101000		N/A	1000101000 1000101000		N/A	
Number of control OFDM symbols		3			3			
Max number of HARQ transmissions		1			1			
Physical channel for $C_{CSI,0}$ CQI reporting		PUCCH Format 2			PUCCH Format 2			
Physical channel for $C_{CSI,1}$ CQI reporting		PUSCH (Note 12)			PUSCH			
PUCCH Report Type		4			4			
Reporting periodicity	ms	$N_{pd} = 5$			$N_{pd} = 5$			
<i>cqi-pmi-ConfigurationIndex</i> $C_{CSI,0}$ (Note 13)		3		N/A	3		N/A	
<i>cqi-pmi-ConfigurationIndex2</i> $C_{CSI,1}$ (Note 14)		4		N/A	4		N/A	
ACK/NACK feedback mode		Multiplexing			Multiplexing			

Note 1:	For each test, the minimum requirements shall be fulfilled for at least one of the two SNR(s) and the respective wanted signal input level.
Note 2:	ABS pattern as defined in [9].
Note 3:	Time-domain measurement resource restriction pattern for PCell measurements as defined in [7]
Note 4:	As configured according to the time-domain measurement resource restriction pattern for CSI measurements defined in [7].
Note 5:	Time-domain measurement resource restriction pattern for PCell measurements as defined in [7]
Note 6:	Cell 1 is the serving cell. Cell 2 is the aggressor cell. The number of the CRS ports in Cell1 and Cell2 is the same.
Note 7:	This noise is applied in OFDM symbols #1, #2, #3, #5, #6, #8, #9, #10,#12, #13 of a subframe overlapping with the aggressor ABS.
Note 8:	This noise is applied in OFDM symbols #0, #4, #7, #11 of a subframe overlapping with the aggressor ABS
Note 9:	This noise is applied in all OFDM symbols of a subframe overlapping with aggressor non-ABS.
Note 10:	Downlink physical channel setup in Cell 2 in accordance with Annex C.3.3 applying OCNG pattern as defined in Annex A.5.2.5
Note 11:	Reference measurement channel in Cell 1 RC.2 TDD according to Table A.4-1 for UE Category ≥ 2 with one sided dynamic OCNG Pattern OP.1 TDD as described in Annex A.5.2.1, and RC.6 TDD according to Table A.4-1 for Category 1 with one/two sided dynami OCNG Pattern OP.1/2 TDD as described in Annex A.5.2.1 and Annex A.5.2.2.
Note 12:	To avoid collisions between HARQ-ACK and wideband CQI it is necessary to report both on PUSCH instead of PUCCH. PDCCH DCI format 0 shall be transmitted in downlink SF#4 and #9 to allow periodic CQI to multiplex with the HARQ-ACK on PUSCH in uplink subframe SF#8 and #3.
Note 13:	<i>cqi-pmi-ConfigurationIndex</i> is applied for $C_{CSI,0}$.
Note 14:	<i>cqi-pmi-ConfigurationIndex2</i> is applied for $C_{CSI,1}$.

9.2.1.5 FDD (CSI measurements in case two CSI subframe sets are configured and with CRS assistance information)

The following requirements apply to UE Category ≥ 2 . For the parameters specified in Table 9.2.1.5-1, and using the downlink physical channels specified in tables C.3.2-1 for Cell 1, C.3.3-2 for Cell 2 and Cell 3, and C.3.2-2, the reported CQI value according to RC.2 FDD in Table A.4-1 in subframes overlapping with aggressor cell ABS and non-ABS subframes shall be in the range of ± 1 of the reported median more than 90% of the time.

For test 1 and test 2, if the PDSCH BLER in ABS subframes using the transport format indicated by median CQI obtained by reports in CSI subframe sets $C_{CSI,0}$ is less than or equal to 0.1, the BLER in ABS subframes using the transport format indicated by the (median CQI + 1) shall be greater than 0.1. If the PDSCH BLER in ABS subframes using the transport format indicated by the median CQI is greater than 0.1, the BLER in ABS subframes using transport format indicated by (median CQI – 1) shall be less than or equal to 0.1.

For test 2, if the PDSCH BLER in non-ABS subframes using the transport format indicated by median CQI obtained by reports in CSI subframe sets $C_{CSI,1}$ is less than or equal to 0.1, the BLER in non-ABS subframes using the transport format indicated by the (median CQI + 2) shall be greater than 0.1. If the PDSCH BLER in non-ABS subframes using the transport format indicated by the median CQI is greater than 0.1, the BLER in non-ABS subframes using transport format indicated by (median CQI – 1) shall be less than or equal to 0.1.

Table 9.2.1.5-1: PUCCH 1-0 static test (FDD)

Parameter		Unit	Test 1			Test 2		
			Cell 1		Cell 2 and 3	Cell 1		Cell 2 and 3
Bandwidth		MHz	10			10		
PDSCH transmission mode			2		Note 10	2		Note 10
Downlink power allocation	ρ_A	dB	-3			-3		
	ρ_B	dB	-3			-3		
	σ	dB	0			0		
Propagation condition and antenna configuration			Clause B.1 (2x2)			Clause B.1 (2x2)		
\widehat{E}_s/N_{oc2} (Note 1)		dB	4	5	Cell 2: 12 Cell 3: 10	13	14	Cell 2: 12 Cell 3: 10
$N_{oc}^{(j)}$ at antenna port	$N_{oc1}^{(j)}$	dBm/15kHz	-98 (Note 7)		N/A	-98 (Note 7)		N/A
	$N_{oc2}^{(j)}$	dBm/15kHz	-98 (Note 8)		N/A	-98 (Note 8)		N/A
	$N_{oc3}^{(j)}$	dBm/15kHz	-93 (Note 9)		N/A	-93 (Note 9)		N/A
Subframe Configuration			Non-MBSFN		Non-MBSFN	Non-MBSFN		Non-MBSFN
Cell Id			0		Cell 2: 6 Cell 3: 1	0		Cell 2: 6 Cell 3: 1
Time Offset between Cells		μ s	Cell 2: 3 usec Cell 3: -1usec			Cell 2: 3 usec Cell 3: -1usec		
Frequency Shift between Cells		Hz	Cell 2: 300Hz Cell 3: -100Hz			Cell 2: 300Hz Cell 3: -100Hz		
ABS pattern (Note 2)			N/A		01010101 01010101 01010101 01010101 01010101	N/A		01010101 01010101 01010101 01010101 01010101
RLM/RRM Measurement Subframe Pattern (Note 4)			00000100 00000100 00000100 00000100 00000100		N/A	00000100 00000100 00000100 00000100 00000100		N/A
CSI Subframe Sets (Note 3)	$C_{CSI,0}$		01010101 01010101 01010101 01010101 01010101		N/A	01010101 01010101 01010101 01010101 01010101		N/A
	$C_{CSI,1}$		10101010 10101010 10101010 10101010 10101010		N/A	10101010 10101010 10101010 10101010 10101010		N/A
Number of control OFDM symbols			3			3		
Max number of HARQ transmissions			1			1		
Physical channel for $C_{CSI,0}$ CQI reporting			PUCCH Format 2			PUCCH Format 2		
Physical channel for $C_{CSI,1}$ CQI reporting			PUSCH (Note 12)			PUSCH (Note 12)		
PUCCH Report Type			4			4		
Reporting periodicity		Ms	$N_{pd} = 5$			$N_{pd} = 5$		
$cqi-pmi-ConfigurationIndex$ $C_{CSI,0}$ (Note 13)			6		N/A	6		N/A
$cqi-pmi-ConfigurationIndex2$ $C_{CSI,1}$ (Note 14)			5		N/A	5		N/A

Note 1:	For each test, the minimum requirements shall be fulfilled for at least one of the two SNR(s) and the respective wanted signal input level.
Note 2:	ABS pattern as defined in [9].
Note 3:	Time-domain measurement resource restriction pattern for PCell measurements as defined in [7]
Note 4:	As configured according to the time-domain measurement resource restriction pattern for CSI measurements defined in [7]
Note 5:	Time-domain measurement resource restriction pattern for PCell measurements as defined in [7]
Note 6:	Cell 1 is the serving cell. Cell 2 and Cell 3 are the aggressor cells. The number of the CRS ports in Cell1, Cell2, and Cell3 are the same.
Note 7:	This noise is applied in OFDM symbols #1, #2, #3, #5, #6, #8, #9, #10,#12, #13 of a subframe overlapping with the aggressor ABS.
Note 8:	This noise is applied in OFDM symbols #0, #4, #7, #11 of a subframe overlapping with the aggressor ABS.
Note 9:	This noise is applied in all OFDM symbols of a subframe overlapping with aggressor non-ABS.
Note 10:	Downlink physical channel setup in Cell 2 and Cell 3 in accordance with Annex C.3.3 applying OCNG pattern as defined in Annex A.5.1.5
Note 11:	Reference measurement channel in Cell 1 RC.2 FDD according to Table A.4-1 with one sided dynamic OCNG Pattern OP.1 FDD as described in Annex A.5.1.1.
Note 12:	To avoid collisions between HARQ-ACK and wideband CQI it is necessary to report both on PUSCH instead of PUCCH. PDCCH DCI format 0 shall be transmitted in downlink SF#4 and #9 to allow periodic CQI to multiplex with the HARQ-ACK on PUSCH in uplink subframe SF#8 and #3.
Note 13:	<i>cqi-pmi-ConfigurationIndex</i> is applied for $C_{CSI,0}$.
Note 14:	<i>cqi-pmi-ConfigurationIndex2</i> is applied for $C_{CSI,1}$.

9.2.1.6 TDD (CSI measurements in case two CSI subframe sets are configured and with CRS assistance information)

The following requirements apply to UE Category ≥ 2 . For the parameters specified in Table 9.2.1.6-1, and using the downlink physical channels specified in tables C.3.2-1 for Cell 1, C3.3-2 for Cell 2 and Cell 3, and C.3.2-2, the reported CQI value according to RC.2 TDD in Table A.4-1 in subframes overlapping with aggressor cell ABS and non-ABS subframes shall be in the range of ± 1 of the reported median more than 90% of the time.

For test 1 and test 2, if the PDSCH BLER in ABS subframes using the transport format indicated by median CQI obtained by reports in CSI subframe sets $C_{CSI,0}$ is less than or equal to 0.1, the BLER in ABS subframes using the transport format indicated by the (median CQI + 1) shall be greater than 0.1. If the PDSCH BLER in ABS subframes using the transport format indicated by the median CQI is greater than 0.1, the BLER in ABS subframes using transport format indicated by (median CQI – 1) shall be less than or equal to 0.1.

For test 2, if the PDSCH BLER in non-ABS subframes using the transport format indicated by median CQI obtained by reports in CSI subframe sets $C_{CSI,1}$ is less than or equal to 0.1, the BLER in non-ABS subframes using the transport format indicated by the (median CQI + 2) shall be greater than 0.1. If the PDSCH BLER in non-ABS subframes using the transport format indicated by the median CQI is greater than 0.1, the BLER in non-ABS subframes using transport format indicated by (median CQI – 1) shall be less than or equal to 0.1.

Table 9.2.1.6-1: PUCCH 1-0 static test (TDD)

Parameter	Unit	Test 1			Test 2		
		Cell 1	Cell 2 and 3		Cell 1	Cell 2 and 3	
Bandwidth	MHz	10			10		
PDSCH transmission mode		2	Note 10		2	Note 10	
Uplink downlink configuration		1			1		
Special subframe configuration		4			4		
Downlink power allocation	ρ_A	dB			-3		
	ρ_B	dB			-3		
	σ	dB			0		
Propagation condition and antenna configuration		Clause B.1 (2x2)			Clause B.1 (2x2)		
\hat{E}_s / N_{oc2} (Note 1)	dB	4	5	Cell 2: 12 Cell 3: 10	13	14	Cell 2: 12 Cell 3: 10
$N_{oc}^{(j)}$ at antenna port	$N_{oc1}^{(j)}$	dBm/15kHz		-98 (Note 7)	N/A		-98 (Note 7)
	$N_{oc2}^{(j)}$	dBm/15kHz		-98 (Note 8)	N/A		-98 (Note 8)
	$N_{oc3}^{(j)}$	dBm/15kHz		-93 (Note 9)	N/A		-93 (Note 9)
Subframe Configuration		Non-MBSFN		Non-MBSFN	Non-MBSFN		Non-MBSFN
Cell Id		0		Cell 2: 6 Cell 3: 1	0		Cell 2: 6 Cell 3: 1
Time Offset between Cells	μ s	Cell 2: 3 usec Cell 3: -1usec			Cell 2: 3 usec Cell 3: -1usec		
Frequency shift between Cells	Hz	Cell 2: 300Hz Cell 3: -100Hz			Cell 2: 300Hz Cell 3: -100Hz		
ABS pattern (Note 2)		N/A		0100010001 0100010001	N/A		0100010001 0100010001
RLM/RRM Measurement Subframe Pattern (Note 4)		0000000001 0000000001		N/A		0000000001 0000000001	
CSI Subframe Sets (Note 3)	$C_{CSI,0}$	0100010001 0100010001		N/A		0100010001 0100010001	
	$C_{CSI,1}$	1000101000 1000101000		N/A		1000101000 1000101000	
Number of control OFDM symbols		3			3		
Max number of HARQ transmissions		1			1		
Physical channel for $C_{CSI,0}$ CQI reporting		PUCCH Format 2			PUCCH Format 2		
Physical channel for $C_{CSI,1}$ CQI reporting		PUSCH (Note 12)			PUSCH (Note 12)		
PUCCH Report Type		4			4		
Reporting periodicity	ms	$N_{pd} = 5$			$N_{pd} = 5$		
$cqi-pmi-ConfigurationIndex_{C_{CSI,0}}$ (Note 13)		3	N/A		3	N/A	
$cqi-pmi-ConfigurationIndex2_{C_{CSI,1}}$ (Note 14)		4	N/A		4	N/A	
ACK/NACK feedback mode		Multiplexing			Multiplexing		

Note 1:	For each test, the minimum requirements shall be fulfilled for at least one of the two SNR(s) and the respective wanted signal input level.
Note 2:	ABS pattern as defined in [9].
Note 3:	Time-domain measurement resource restriction pattern for PCell measurements as defined in [7]
Note 4:	As configured according to the time-domain measurement resource restriction pattern for CSI measurements defined in [7].
Note 5:	Time-domain measurement resource restriction pattern for PCell measurements as defined in [7]
Note 6:	Cell 1 is the serving cell. Cell 2 and Cell 3 are the aggressor cells. The number of the CRS ports in Cell1, Cell2, and Cell3 is the same.
Note 7:	This noise is applied in OFDM symbols #1, #2, #3, #5, #6, #8, #9, #10,#12, #13 of a subframe overlapping with the aggressor ABS.
Note 8:	This noise is applied in OFDM symbols #0, #4, #7, #11 of a subframe overlapping with the aggressor ABS
Note 9:	This noise is applied in all OFDM symbols of a subframe overlapping with aggressor non-ABS.
Note 10:	Downlink physical channel setup in Cell 2 and Cell 3 in accordance with Annex C.3.3 applying OCNG pattern as defined in Annex A.5.2.5
Note 11:	Reference measurement channel in Cell 1 RC.2 TDD according to Table A.4-1 with one sided dynamic OCNG Pattern OP.1 TDD as described in Annex A.5.2.1.
Note 12:	To avoid collisions between HARQ-ACK and wideband CQI it is necessary to report both on PUSCH instead of PUCCH. PDCCH DCI format 0 shall be transmitted in downlink SF#4 and #9 to allow periodic CQI to multiplex with the HARQ-ACK on PUSCH in uplink subframe SF#8 and #3.
Note 13:	<i>cqi-pmi-ConfigurationIndex</i> is applied for $C_{CSI,0}$.
Note 14:	<i>cqi-pmi-ConfigurationIndex2</i> is applied for $C_{CSI,1}$.

9.2.1.7 FDD (Modulation and TBS index Table 2 and 4-bit CQI Table 2 are used)

The following requirements apply to UE Category 11-12 and DL Category ≥ 11 . For the parameters specified in Table 9.2.1.7-1, and using the downlink physical channels specified in tables C.3.2-1 and C.3.2-2, the reported CQI value according to RC.1A FDD in Table A.4-1 shall be in the range of ± 1 of the reported median more than 90% of the time. If the PDSCH BLER using the transport format indicated by median CQI is less than or equal to 0.1, the BLER using the transport format indicated by the (median CQI + 1) shall be greater than 0.1. If the PDSCH BLER using the transport format indicated by the median CQI is greater than 0.1, the BLER using transport format indicated by (median CQI – 1) shall be less than or equal to 0.1.

In this test, 4-bit CQI Table 2 in Table 7.2.3-2 in TS 36.213 [6], and Modulation and TBS index table 2 in Table 7.1.7.1-1A for PDSCH in TS 36.213 [6] are applied.

Table 9.2.1.7-1: PUCCH 1-0 static test (FDD)

Parameter		Unit	Test 1		Test 2	
Bandwidth		MHz	10			
PDSCH transmission mode			1			
Downlink power allocation	ρ_A	dB	0			
	ρ_B	dB	0			
	σ	dB	0			
Propagation condition and antenna configuration			AWGN (1 x 2)			
SNR (Note 2)		dB	-1	0	20	21
$\hat{I}_{or}^{(j)}$		dB[mW/15kHz]	-99	-98	-78	-77
$N_{oc}^{(j)}$		dB[mW/15kHz]	-98		-98	
Max number of HARQ transmissions			1			
Physical channel for CQI reporting			PUCCH Format 2			
PUCCH Report Type			4			
Reporting periodicity		ms	$N_{pd} = 5$			
<i>cqi-pmi-ConfigurationIndex</i>			6			
Note 1:	Reference measurement channel RC.1A FDD according to Table A.4-1 with one sided dynamic OCNG Pattern OP.1 FDD as described in Annex A.5.1.1.					
Note 2:	For each test, the minimum requirements shall be fulfilled for at least one of the two SNR(s) and the respective wanted signal input level.					

9.2.1.8 TDD (Modulation and TBS index Table 2 and 4-bit CQI Table 2 are used)

The following requirements apply to UE Category 11-12 and UE DL Category ≥ 11 . For the parameters specified in Table 9.2.1.8-1, and using the downlink physical channels specified in tables C.3.2-1 and C.3.2-2, the reported CQI value according to RC.1A TDD in Table A.4-1 shall be in the range of ± 1 of the reported median more than 90% of the time. If the PDSCH BLER using the transport format indicated by median CQI is less than or equal to 0.1, the BLER using the transport format indicated by the (median CQI + 1) shall be greater than 0.1. If the PDSCH BLER using the transport format indicated by the median CQI is greater than 0.1, the BLER using transport format indicated by (median CQI – 1) shall be less than or equal to 0.1.

In this test, 4-bit CQI Table 2 in Table 7.2.3-2 in TS 36.213 [6], and Modulation and TBS index table 2 in Table 7.1.7.1-1A for PDSCH in TS 36.213 [6] are applied.

Table 9.2.1.8-1: PUCCH 1-0 static test (TDD)

Parameter		Unit	Test 1		Test 2	
Bandwidth		MHz	20			
PDSCH transmission mode			1			
Uplink downlink configuration			2			
Special subframe configuration			4			
Downlink power allocation	ρ_A	dB	0			
	ρ_B	dB	0			
	σ	dB	0			
Propagation condition and antenna configuration			AWGN (1 x 2)			
SNR (Note 2)		dB	-1	0	20	21
$\hat{I}_{or}^{(j)}$ or		dB[mW/15kHz]	-99	-98	-78	-77
$N_{oc}^{(j)}$		dB[mW/15kHz]	-98		-98	
Max number of HARQ transmissions			1			
Physical channel for CQI reporting			PUSCH (Note 3)			
PUCCH Report Type			4			
Reporting periodicity		ms	$N_{pd} = 5$			
<i>cqi-pmi-ConfigurationIndex</i>			3			
ACK/NACK feedback mode			Multiplexing			
Note 1: Reference measurement channel RC.1A TDD according to Table A.4-1 with one sided dynamic OCNG Pattern OP.1 TDD as described in Annex A.5.2.1. Note 2: For each test, the minimum requirements shall be fulfilled for at least one of the two SNR(s) and the respective wanted signal input level. Note 3: To avoid collisions between CQI reports and HARQ-ACK it is necessary to report both on PUSCH instead of PUCCH. PDCCH DCI format 0 shall be transmitted in downlink SF#3 and #8 to allow periodic CQI to multiplex with the HARQ-ACK on PUSCH in uplink subframe SF#7 and #2.						

9.2.2 Minimum requirement PUCCH 1-1 (Cell-Specific Reference Symbols)

The minimum requirements for dual codeword transmission are defined in terms of a reporting spread of the wideband CQI value for codeword #1, and their BLER performance using the transport format indicated by the reported CQI median of codeword #0 and codeword #1. The precoding used at the transmitter is a fixed precoding matrix specified by the bitmap parameter *codebookSubsetRestriction*. The propagation condition assumed for the minimum performance requirement is defined in subclause B.1.

9.2.2.1 FDD

The following requirements apply to UE Category ≥ 2 . For the parameters specified in table 9.2.2.1-1, and using the downlink physical channels specified in tables C.3.2-1 and C.3.2-2, the reported offset level of the wideband spatial

differential CQI for codeword #1 (Table 7.2-2 in TS 36.213 [6]) shall be used to determine the wideband CQI index for codeword #1 as

$$\text{wideband CQI}_1 = \text{wideband CQI}_0 - \text{Codeword 1 offset level}$$

The wideband CQI₁ shall be within the set {median CQI₁ -1, median CQI₁, median CQI₁ +1} for more than 90% of the time, where the resulting wideband values CQI₁ shall be used to determine the median CQI values for codeword #1. For both codewords #0 and #1, the PDSCH BLER using the transport format indicated by the respective median CQI₀ - 1 and median CQI₁ - 1 shall be less than or equal to 0.1. Furthermore, for both codewords #0 and #1, the PDSCH BLER using the transport format indicated by the respective median CQI₀ + 1 and median CQI₁ + 1 shall be greater than or equal to 0.1.

Table 9.2.2.1-1: PUCCH 1-1 static test (FDD)

Parameter	Unit	Test 1		Test 2	
Bandwidth	MHz	10			
PDSCH transmission mode		4			
Downlink power allocation	ρ_A	dB		-3	
	ρ_B	dB		-3	
	σ	dB		0	
Propagation condition and antenna configuration		Clause B.1 (2 x 2)			
CodeBookSubsetRestriction bitmap		010000			
SNR (Note 2)	dB	10	11	16	17
$\hat{I}_{or}^{(j)}$	dB[mW/15kHz]	-88	-87	-82	-81
$N_{oc}^{(j)}$	dB[mW/15kHz]	-98		-98	
Max number of HARQ transmissions		1			
Physical channel for CQI/PMI reporting		PUCCH Format 2			
PUCCH Report Type for CQI/PMI		2			
PUCCH Report Type for RI		3			
Reporting periodicity	ms	$N_{pd} = 5$			
<i>cqi-pmi-ConfigurationIndex</i>		6			
<i>ri-ConfigIndex</i>		1 (Note 3)			
Note 1:	Reference measurement channel RC.2 FDD according to Table A.4-1 with one sided dynamic OCNG Pattern OP.1 FDD as described in Annex A.5.1.1.				
Note 2:	For each test, the minimum requirements shall be fulfilled for at least one of the two SNR(s) and the respective wanted signal input level.				
Note 3:	It is intended to have UL collisions between RI reports and HARQ-ACK, since the RI reports shall not be used by the eNB in this test.				

9.2.2.2 TDD

The following requirements apply to UE Category ≥ 2 . For the parameters specified in table 9.2.2.2-1, and using the downlink physical channels specified in tables C.3.2-1 and C.3.2-2, the reported offset level of the wideband spatial differential CQI for codeword #1 (Table 7.2-2 in TS 36.213 [6]) shall be used to determine the wideband CQI index for codeword #1 as

$$\text{wideband CQI}_1 = \text{wideband CQI}_0 - \text{Codeword 1 offset level}$$

The wideband CQI₁ shall be within the set {median CQI₁ -1, median CQI₁, median CQI₁ +1} for more than 90% of the time, where the resulting wideband values CQI₁ shall be used to determine the median CQI values for codeword #1. For both codewords #0 and #1, the PDSCH BLER using the transport format indicated by the respective median CQI₀ - 1 and median CQI₁ - 1 shall be less than or equal to 0.1. Furthermore, for both codewords #0 and #1, the PDSCH BLER using the transport format indicated by the respective median CQI₀ + 1 and median CQI₁ + 1 shall be greater than or equal to 0.1.

Table 9.2.2.2-1: PUCCH 1-1 static test (TDD)

Parameter		Unit	Test 1		Test 2	
Bandwidth		MHz			10	
PDSCH transmission mode					4	
Uplink downlink configuration					2	
Special subframe configuration					4	
Downlink power allocation	ρ_A	dB			-3	
	ρ_B	dB			-3	
	σ	dB			0	
Propagation condition and antenna configuration			Clause B.1 (2 x 2)			
CodeBookSubsetRestriction bitmap			010000			
SNR (Note 2)		dB	10	11	16	17
$\hat{I}_{or}^{(j)}$		dB[mW/15kHz]	-88	-87	-82	-81
$N_{oc}^{(j)}$		dB[mW/15kHz]	-98		-98	
Max number of HARQ transmissions			1			
Physical channel for CQI/PMI reporting			PUSCH (Note 3)			
PUCCH Report Type			2			
Reporting periodicity		ms	$N_{pd} = 5$			
<i>cqi-pmi-ConfigurationIndex</i>			3			
<i>ri-ConfigIndex</i>			805 (Note 4)			
ACK/NACK feedback mode			Multiplexing			
Note 1:		Reference measurement channel RC.2 TDD according to Table A.4-1 with one sided dynamic OCNG Pattern OP.1 TDD as described in Annex A.5.2.1.				
Note 2:		For each test, the minimum requirements shall be fulfilled for at least one of the two SNR(s) and the respective wanted signal input level.				
Note 3:		To avoid collisions between CQI/PMI reports and HARQ-ACK it is necessary to report both on PUSCH instead of PUCCH. PDCCH DCI format 0 shall be transmitted in downlink SF#3 and #8 to allow periodic CQI/PMI to multiplex with the HARQ-ACK on PUSCH in uplink subframe SF#7 and #2.				
Note 4:		RI reporting interval is set to the maximum allowable length of 160ms to minimise collisions between RI, CQI/PMI and HARQ-ACK reports. In the case when all three reports collide, it is expected that CQI/PMI reports will be dropped, while RI and HARQ-ACK will be multiplexed. At eNB, CQI report collection shall be skipped every 160ms during performance verification.				

9.2.3 Minimum requirement PUCCH 1-1 (CSI Reference Symbols)

The minimum requirements for dual codeword transmission are defined in terms of a reporting spread of the wideband CQI value for codeword #1, and their BLER performance using the transport format indicated by the reported CQI median of codeword #0 and codeword #1. The precoding used at the transmitter is a fixed precoding matrix specified by the bitmap parameter *codebookSubsetRestriction*. The propagation condition assumed for the minimum performance requirement is defined in subclause B.1.

9.2.3.1 FDD

The following requirements apply to UE Category ≥ 2 . For the parameters specified in table 9.2.3.1-1, and using the downlink physical channels specified in tables C.3.2-1 and C.3.2-2, the reported offset level of the wideband spatial differential CQI for codeword #1 (Table 7.2-2 in TS 36.213 [6]) shall be used to determine the wideband CQI index for codeword #1 as

$$\text{wideband CQI}_1 = \text{wideband CQI}_0 - \text{Codeword 1 offset level}$$

The wideband CQI₁ shall be within the set {median CQI₁ - 1, median CQI₁, median CQI₁ + 1} for more than 90% of the time, where the resulting wideband values CQI₁ shall be used to determine the median CQI values for codeword #1. For both codewords #0 and #1, the PDSCH BLER using the transport format indicated by the respective median CQI₀ - 1 and median CQI₁ - 1 shall be less than or equal to 0.1. Furthermore, for both codewords #0 and #1, the PDSCH BLER

using the transport format indicated by the respective median $CQI_0 + 1$ and median $CQI_1 + 1$ shall be greater than or equal to 0.1.

Table 9.2.3.1-1: PUCCH 1-1 static test (FDD)

Parameter		Unit	Test 1		Test 2	
Bandwidth		MHz	10			
PDSCH transmission mode			9			
Downlink power allocation	ρ_A	dB	0			
	ρ_B	dB	0			
	P_c	dB	-3			
	σ	dB	-3			
Cell-specific reference signals			Antenna ports 0, 1			
CSI reference signals			Antenna ports 15,...,18			
CSI-RS periodicity and subframe offset $T_{CSI-RS} / \Delta_{CSI-RS}$			5/1			
CSI reference signal configuration			0			
Propagation condition and antenna configuration			Clause B.1 (4 x 2)			
Beamforming Model			As specified in Section B.4.3			
CodeBookSubsetRestriction bitmap			0x0000 0000 0100 0000			
SNR (Note 2)		dB	7	8	13	14
$\hat{I}_{or}^{(j)}$		dB[mW/15kHz]	-91	-90	-85	-84
$N_{oc}^{(j)}$		dB[mW/15kHz]	-98		-98	
Max number of HARQ transmissions			1			
Physical channel for CQI/PMI reporting			PUSCH (Note3)			
PUCCH Report Type for CQI/PMI			2			
Physical channel for RI reporting			PUCCH Format 2			
PUCCH Report Type for RI			3			
Reporting periodicity		ms	$N_{pd} = 5$			
CQI delay		ms	8			
<i>cqi-pmi-ConfigurationIndex</i>			2			
<i>ri-ConfigIndex</i>			1			
Note 1: Reference measurement channel RC.7 FDD according to Table A.4-1 with one sided dynamic OCNG Pattern OP.1 FDD as described in Annex A.5.1.1.						
Note 2: For each test, the minimum requirements shall be fulfilled for at least one of the two SNR(s) and the respective wanted signal input level.						
Note 3: To avoid collisions between CQI/PMI reports and HARQ-ACK it is necessary to report both on PUSCH instead of PUCCH. PDCCH DCI format 0 shall be transmitted in downlink SF#1 and #6 to allow periodic CQI/PMI to multiplex with the HARQ-ACK on PUSCH in uplink SF#0 and #5.						

9.2.3.1A FDD (With *channelMeasRestriction* configured)

The following requirements apply to UE Category ≥ 2 . For the parameters specified in table 9.2.3.1A-1, and using the downlink physical channels specified in tables C.3.2-1 and C.3.2-2, the reported offset level of the wideband spatial differential CQI for codeword #1 (Table 7.2-2 in TS 36.213 [6]) shall be used to determine the wideband CQI index for codeword #1 as

$$\text{wideband } CQI_1 = \text{wideband } CQI_0 - \text{Codeword 1 offset level}$$

The wideband CQI_1 shall be within the set $\{\text{median } CQI_1 - 1, \text{median } CQI_1, \text{median } CQI_1 + 1\}$ for more than 90% of the time, where the resulting wideband values CQI_1 shall be used to determine the median CQI values for codeword #1. For both codewords #0 and #1, the PDSCH BLER using the transport format indicated by the respective median $CQI_0 - 1$ and median $CQI_1 - 1$ shall be less than or equal to 0.1. Furthermore, for both codewords #0 and #1, the PDSCH BLER using the transport format indicated by the respective median $CQI_0 + 1$ and median $CQI_1 + 1$ shall be greater than or equal to 0.1.

Table 9.2.3.1A-1: PUCCH 1-1 static test (FDD)

Parameter		Unit	Test 1		Test 2	
Bandwidth		MHz	10			
PDSCH transmission mode			9			
Downlink power allocation	ρ_A	dB	0			
	ρ_B	dB	0			
	P_c	dB	-3			
	σ	dB	-3			
Cell-specific reference signals			Antenna ports 0, 1			
e-MIMO Type			Class B			
Number of CSI-RS resource (K)			1			
<i>channelMeasRestriction</i>			Enable			
CSI reference signals			Antenna ports 15,...,18			
CSI-RS periodicity and subframe offset $T_{\text{CSI-RS}} / \Delta_{\text{CSI-RS}}$			5/1			
CSI reference signal configuration			0			
Propagation condition and antenna configuration			Clause B.1 (4 x 2)			
Beamforming Model			As specified in Section B.4.3			
CodeBookSubsetRestriction bitmap			0x0000 0000 0100 0000			
SNR (Note 2)		dB	[7]	[8]	[13]	[14]
$\hat{I}_{or}^{(j)}$		dB[mW/15kHz]	-91	-90	-85	-84
$N_{oc}^{(j)}$		dB[mW/15kHz]	-98		-98	
Max number of HARQ transmissions			1			
Physical channel for CQI/PMI reporting			PUSCH (Note3)			
PUCCH Report Type for CQI/PMI			2			
Physical channel for RI reporting			PUCCH Format 2			
PUCCH Report Type for RI			3			
Reporting periodicity		ms	$N_{pd} = 10$			
CQI delay		ms	8			
<i>cqi-pmi-ConfigurationIndex</i>			12			
<i>ri-ConfigIndex</i>			1			
PDSCH scheduled sub-frames			1,2,3,4,7,8,9			
Note 1: Reference measurement channel RC.7 FDD according to Table A.4-1 with one sided dynamic OCNG Pattern OP.1 FDD as described in Annex A.5.1.1.						
Note 2: For each test, the minimum requirements shall be fulfilled for at least one of the two SNR(s) and the respective wanted signal input level.						
Note 3: To avoid collisions between CQI/PMI reports and HARQ-ACK it is necessary to report both on PUSCH instead of PUCCH. PDCCH DCI format 0 shall be transmitted in downlink SF#1 to allow periodic CQI/PMI to multiplex with the HARQ-ACK on PUSCH in uplink #5.						
Note 4: In sub-frame 6, transmission power of CSI-RS REs is 9dB lower than CRS REs, in sub-frame 1, there is no power offset between CSI-RS REs and CRS REs.						

9.2.3.2 TDD

The following requirements apply to UE Category ≥ 2 . For the parameters specified in table 9.2.3.2-1, and using the downlink physical channels specified in tables C.3.2-1 and C.3.2-2, the reported offset level of the wideband spatial differential CQI for codeword #1 (Table 7.2-2 in TS 36.213 [6]) shall be used to determine the wideband CQI index for codeword #1 as

$$\text{wideband CQI}_1 = \text{wideband CQI}_0 - \text{Codeword 1 offset level}$$

The wideband CQI_1 shall be within the set $\{\text{median CQI}_1 - 1, \text{median CQI}_1, \text{median CQI}_1 + 1\}$ for more than 90% of the time, where the resulting wideband values CQI_1 shall be used to determine the median CQI values for codeword #1. For both codewords #0 and #1, the PDSCH BLER using the transport format indicated by the respective median $\text{CQI}_0 - 1$ and median $\text{CQI}_1 - 1$ shall be less than or equal to 0.1. Furthermore, for both codewords #0 and #1, the PDSCH BLER using the transport format indicated by the respective median $\text{CQI}_0 + 1$ and median $\text{CQI}_1 + 1$ shall be greater than or equal to 0.1.

Table 9.2.3.2-1: PUCCH 1-1 submode 1 static test (TDD)

Parameter		Unit	Test 1		Test 2	
Bandwidth		MHz	10			
PDSCH transmission mode			9			
Uplink downlink configuration			2			
Special subframe configuration			4			
Downlink power allocation	ρ_A	dB	0			
	ρ_B	dB	0			
	P_c	dB	-6			
	σ	dB	-3			
CRS reference signals			Antenna ports 0, 1			
CSI reference signals			Antenna ports 15,...,22			
CSI-RS periodicity and subframe offset $T_{\text{CSI-RS}} / \Delta_{\text{CSI-RS}}$			5/3			
CSI reference signal configuration			0			
Propagation condition and antenna configuration			Clause B.1 (8 x 2)			
Beamforming Model			As specified in Section B.4.3			
CodeBookSubsetRestriction bitmap			0x0000 0000 0020 0000 0000 0001 0000			
SNR (Note 2)		dB	4	5	10	11
$\hat{I}_{or}^{(j)}$		dB[mW/15kHz]	-94	-93	-88	-87
$N_{oc}^{(j)}$		dB[mW/15kHz]	-98		-98	
Max number of HARQ transmissions			1			
Physical channel for CQI/PMI reporting			PUSCH (Note 3)			
PUCCH Report Type for CQI/second PMI			2b			
Physical channel for RI reporting			PUSCH			
PUCCH Report Type for RI/ first PMI			5			
Reporting periodicity		ms	$N_{pd} = 5$			
CQI delay		ms	10 or 11			
<i>cqi-pmi-ConfigurationIndex</i>			3			
<i>ri-ConfigIndex</i>			805 (Note 4)			
ACK/NACK feedback mode			Multiplexing			
Note 1: Reference measurement channel RC.7 TDD according to Table A.4-1 with one sided dynamic OCNG Pattern OP.1 TDD as described in Annex A.5.2.1.						
Note 2: For each test, the minimum requirements shall be fulfilled for at least one of the two SNR(s) and the respective wanted signal input level.						
Note 3: To avoid collisions between CQI/PMI reports and HARQ-ACK it is necessary to report both on PUSCH instead of PUCCH. PDCCH DCI format 0 shall be transmitted in downlink SF#3 and #8 to allow periodic CQI/PMI to multiplex with the HARQ-ACK on PUSCH in uplink SF#7 and #2.						
Note 4: RI reporting interval is set to the maximum allowable length of 160ms to minimise collisions between RI, CQI/PMI and HARQ-ACK reports. In the case when all three reports collide, it is expected that CQI/PMI reports will be dropped, while RI and HARQ-ACK will be multiplexed. At eNB, CQI report collection shall be skipped every 160ms during performance verification.						

9.2.3.2A TDD (With *channelMeasRestriction* configured)

The following requirements apply to UE Category ≥ 2 . For the parameters specified in table 9.2.3.2A-1, and using the downlink physical channels specified in tables C.3.2-1 and C.3.2-2, the reported offset level of the wideband spatial differential CQI for codeword #1 (Table 7.2-2 in TS 36.213 [6]) shall be used to determine the wideband CQI index for codeword #1 as

$$\text{wideband CQI}_1 = \text{wideband CQI}_0 - \text{Codeword 1 offset level}$$

The wideband CQI_1 shall be within the set {median $\text{CQI}_1 - 1$, median CQI_1 , median $\text{CQI}_1 + 1$ } for more than 90% of the time, where the resulting wideband values CQI_1 shall be used to determine the median CQI values for codeword #1. For both codewords #0 and #1, the PDSCH BLER using the transport format indicated by the respective median $\text{CQI}_0 - 1$ and median $\text{CQI}_1 - 1$ shall be less than or equal to 0.1. Furthermore, for both codewords #0 and #1, the PDSCH BLER

using the transport format indicated by the respective median $CQI_0 + 1$ and median $CQI_1 + 1$ shall be greater than or equal to 0.1.

Table 9.2.3.2A-1: PUCCH 1-1 submode 1 static test (TDD)

Parameter		Unit	Test 1		Test 2	
Bandwidth		MHz			10	
PDSCH transmission mode					9	
Uplink downlink configuration					2	
Special subframe configuration					4	
Downlink power allocation	ρ_A	dB			0	
	ρ_B	dB			0	
	P_C	dB			-6	
	σ	dB			-3	
CRS reference signals					Antenna ports 0, 1	
e-MIMO Type					Class B	
Number of CSI-RS resource (K)					1	
<i>channelMeasRestriction</i>					Enable	
CSI reference signals					Antenna ports 15,...,22	
CSI-RS periodicity and subframe offset $T_{CSI-RS} / \Delta_{CSI-RS}$					5/3	
CSI reference signal configuration					0	
Propagation condition and antenna configuration					Clause B.1 (8 x 2)	
Beamforming Model					As specified in Section B.4.3	
CodeBookSubsetRestriction bitmap					0x0000 0000 0020 0000 0000 0001 0000	
SNR (Note 2)		dB	[4]	[5]	[10]	[11]
$\hat{I}_{or}^{(j)}$		dB[mW/15kHz]	-94	-93	-88	-87
$N_{oc}^{(j)}$		dB[mW/15kHz]	-98		-98	
Max number of HARQ transmissions					1	
Physical channel for CQI/PMI reporting					PUSCH (Note 3)	
PUCCH Report Type for CQI/second PMI					2b	
Physical channel for RI reporting					PUSCH	
PUCCH Report Type for RI/ first PMI					5	
Reporting periodicity		ms			$N_{pd} = 10$	
CQI delay		ms			10 or 11	
<i>cqi-pmi-ConfigurationIndex</i>					13	
<i>ri-ConfigIndex</i>					805 (Note 4)	
ACK/NACK feedback mode					Multiplexing	
PDSCH scheduled sub-frames					3,4,9	
<p>Note 1: Reference measurement channel RC.7 TDD according to Table A.4-1 with one sided dynamic OCNG Pattern OP.1 TDD as described in Annex A.5.2.1.</p> <p>Note 2: For each test, the minimum requirements shall be fulfilled for at least one of the two SNR(s) and the respective wanted signal input level.</p> <p>Note 3: To avoid collisions between CQI/PMI reports and HARQ-ACK it is necessary to report both on PUSCH instead of PUCCH. PDCCH DCI format 0 shall be transmitted in downlink SF#3 to allow periodic CQI/PMI to multiplex with the HARQ-ACK on PUSCH in uplink SF#7.</p> <p>Note 4: RI reporting interval is set to the maximum allowable length of 160ms to minimise collisions between RI, CQI/PMI and HARQ-ACK reports. In the case when all three reports collide, it is expected that CQI/PMI reports will be dropped, while RI and HARQ-ACK will be multiplexed. At eNB, CQI report collection shall be skipped every 160ms during performance verification.</p> <p>Note 5: In sub-frame 8, transmission power of CSI-RS REs is 9dB lower than CRS REs, in sub-frame 3, there is no power offset between CSI-RS REs and CRS REs.</p>						

9.2.4 Minimum requirement PUCCH 1-1 (With Single CSI Process)

The minimum requirements for dual codeword transmission are defined in terms of a reporting spread of the wideband CQI value for codeword #1, and their BLER performance using the transport format indicated by the reported CQI

median of codeword #0 and codeword #1. The precoding used at the transmitter is a fixed precoding matrix specified by the bitmap parameter *codebookSubsetRestriction*. The propagation condition assumed for the minimum performance requirement is defined in subclause B.1.

If UE supporting *interferenceMeasRestriction*, test cases specified in 9.2.4.1A and 9.2.4.2A are applicable for such UE otherwise test cases specified in 9.2.4.1 and 9.2.4.2 are applied.

9.2.4.1 FDD

The following requirements apply to UE Category ≥ 2 . For the parameters specified in table 9.2.4.1-1, and using the downlink physical channels specified in Tables C.3.4-1 and C.3.4-2, the reported offset level of the wideband spatial differential CQI for codeword #1 (Table 7.2-2 in TS 36.213 [6]) shall be used to determine the wideband CQI index for codeword #1 as

$$\text{wideband CQI}_1 = \text{wideband CQI}_0 - \text{Codeword 1 offset level}$$

The wideband CQI_1 shall be within the set $\{\text{median CQI}_1 - 1, \text{median CQI}_1, \text{median CQI}_1 + 1\}$ for more than 90% of the time, where the resulting wideband values CQI_1 shall be used to determine the median CQI values for codeword #1. For both codewords #0 and #1, the PDSCH BLER using the transport format indicated by the respective median $\text{CQI}_0 - 1$ and median $\text{CQI}_1 - 1$ shall be less than or equal to 0.1. Furthermore, for both codewords #0 and #1, the PDSCH BLER using the transport format indicated by the respective median $\text{CQI}_0 + 1$ and median $\text{CQI}_1 + 1$ shall be greater than or equal to 0.1.

Table 9.2.4.1-1: PUCCH 1-1 static test (FDD)

Parameter	Unit	Test 1			Test 2		
		TP1	TP2		TP1	TP2	
Bandwidth	MHz	10					
PDSCH transmission mode		10					
Downlink power allocation (Note 1)	ρ_A	dB	0	0	0	0	0
	ρ_B	dB	0	0	0	0	0
	P_c	dB	-3	-3	-3	-3	-3
	σ	dB	-3	N/A	-3	N/A	N/A
Cell ID		0			0		
Cell-specific reference signals		Antenna ports 0, 1	(Note 2)		Antenna ports 0, 1	(Note 2)	
CSI reference signals		Antenna ports 15, ..., 18	N/A		Antenna ports 15, ..., 18	N/A	
CSI-RS periodicity and subframe offset $T_{\text{CSI-RS}} / \Delta_{\text{CSI-RS}}$		5/1	N/A		5/1	N/A	
CSI-RS configuration		0	N/A		0	N/A	
Zero-Power CSI-RS configuration $l_{\text{CSI-RS}} / \text{ZeroPowerCSI-RS}$ bitmap		1 / 001000000000 0000	1 / 100000000000 00000		1 / 001000000000 0000	1 / 100000000000 00000	
CSI-IM configuration $l_{\text{CSI-IM}} / \text{ZeroPowerCSI-RS}$ bitmap		1 / 001000000000 0000	N/A		1 / 001000000000 0000	N/A	
CSI process configuration Signal/Interference/Reporting mode		CSI-RS/CSI-IM/PUCCH 1-1			CSI-RS/CSI-IM/PUCCH 1-1		
Propagation condition and antenna configuration		Clause B.1 (4 x 2)	Clause B.1 (2 x 2)		Clause B.1 (4 x 2)	Clause B.1 (2 x 2)	
CodeBookSubsetRestriction bitmap		0x0000 0000 0100 0000	100000		0x0000 0000 0100 0000	100000	
SNR (Note 3)	dB	20	6	7	20	14	15
$\hat{I}_{or}^{(j)}$	dB[mW/15kHz]	-78	-92	-91	-78	-84	-83
$N_{oc}^{(j)}$	dB[mW/15kHz]	-98			-98		
Modulation / Information bit payload		(Note4)	QPSK / 4392		(Note4)	QPSK / 4392	
Max number of HARQ transmissions		1	N/A		1	N/A	
Physical channel for CQI/PMI reporting		PUSCH (Note5)	N/A		PUSCH (Note5)	N/A	
PUCCH Report Type for CQI/PMI		2	N/A		2	N/A	
PUCCH Report Type for RI		3	N/A		3	N/A	
Reporting periodicity	ms	$N_{pd} = 5$	N/A		$N_{pd} = 5$	N/A	
CQI Delay	ms	8	N/A		8	N/A	
$cqi-pmi-ConfigurationIndex$		2	N/A		2	N/A	
$ri-ConfigIndex$		1	N/A		1	N/A	
PDSCH scheduled sub-frames		1,2,3,4,6,7,8,9			1,2,3,4,6,7,8,9		
Timing offset between TPs	us	0			0		
Frequency offset between TPs	Hz	0			0		
Note 1:	Reference measurement channel RC.10 FDD according to Table A.4-1 with one sided dynamic OCNG Pattern OP.1 FDD as described in Annex A.5.1.1.						
Note 2:	REs for antenna ports 0 and 1 CRS have zero transmission power.						
Note 3:	For each test, the minimum requirements shall be fulfilled for at least one of the two SNR(s) and the respective wanted signal input level.						
Note 4:	N/A.						
Note 5:	To avoid collisions between CQI/PMI reports and HARQ-ACK it is necessary to report both on PUSCH instead of PUCCH. PDCCH DCI format 0 shall be transmitted in downlink SF#1 and #6 to allow periodic CQI/PMI to multiplex with the HARQ-ACK on PUSCH in uplink SF#0 and #5.						

9.2.4.1A FDD (With *interferenceMeasRestriction* configured)

The following requirements apply to UE Category ≥ 2 . For the parameters specified in table 9.2.4.1A-1, and using the downlink physical channels specified in Tables C.3.4-1 and C.3.4-2, the reported offset level of the wideband spatial differential CQI for codeword #1 (Table 7.2-2 in TS 36.213 [6]) shall be used to determine the wideband CQI index for codeword #1 as

$$\text{wideband CQI}_1 = \text{wideband CQI}_0 - \text{Codeword 1 offset level}$$

The wideband CQI_1 shall be within the set $\{\text{median CQI}_1 - 1, \text{median CQI}_1, \text{median CQI}_1 + 1\}$ for more than 90% of the time, where the resulting wideband values CQI_1 shall be used to determine the median CQI values for codeword #1. For both codewords #0 and #1, the PDSCH BLER using the transport format indicated by the respective median $\text{CQI}_0 - 1$ and median $\text{CQI}_1 - 1$ shall be less than or equal to 0.1. Furthermore, for both codewords #0 and #1, the PDSCH BLER using the transport format indicated by the respective median $\text{CQI}_0 + 1$ and median $\text{CQI}_1 + 1$ shall be greater than or equal to 0.1.

Table 9.2.4.1A-1: PUCCH 1-1 static test (FDD)

Parameter		Unit	Test 1			Test 2		
			TP1	TP2		TP1	TP2	
Bandwidth		MHz	10					
PDSCH transmission mode			10					
Downlink power allocation (Note 1)	ρ_A	dB	0	0		0	0	
	ρ_B	dB	0	0		0	0	
	P_c	dB	-3	-3		-3	-3	
	σ	dB	-3	N/A		-3	N/A	
Cell ID			0			0		
Cell-specific reference signals			Antenna ports 0, 1	(Note 2)		Antenna ports 0, 1	(Note 2)	
e-MIMO Type			Class B					
Number of CSI-RS resource (K)			1					
<i>interferenceMeasRestriction</i>			Enable					
CSI reference signals			Antenna ports 15,...,18	N/A		Antenna ports 15,...,18	N/A	
CSI-RS periodicity and subframe offset $T_{CSI-RS} / \Delta_{CSI-RS}$			5/1	N/A		5/1	N/A	
CSI-RS configuration			0	N/A		0	N/A	
Zero-Power CSI-RS configuration $l_{CSI-RS} / ZeroPowerCSI-RS$ bitmap			1 / 001000000000 0000	1 / 100000000000 00000		1 / 001000000000 0000	1 / 100000000000 00000	
CSI-IM configuration $l_{CSI-RS} / ZeroPowerCSI-RS$ bitmap			1 / 001000000000 0000	N/A		1 / 001000000000 0000	N/A	
CSI process configuration Signal/Interference/Reporting mode			CSI-RS/CSI-IM/PUCCH 1-1			CSI-RS/CSI-IM/PUCCH 1-1		
Propagation condition and antenna configuration			Clause B.1 (4 x 2)	Clause B.1 (2 x 2)		Clause B.1 (4 x 2)	Clause B.1 (2 x 2)	
CodeBookSubsetRestriction bitmap			0x0000 0000 0100 0000	100000		0x0000 0000 0100 0000	100000	
SNR (Note 3)	Sub-frame 6	dB	20	[15]	[16]	20	[23]	[24]
	Other sub-frames		20	6	7	20	14	15
$\hat{I}_{or}^{(j)}$	Sub-frame 6	dB[mW/15kHz]	-78	[-83]	[-82]	-78	[-75]	[-74]
	Other sub-frames		-78	-92	-91	-78	-84	-83
$N_{oc}^{(j)}$		dB[mW/15kHz]	-98			-98		
Modulation / Information bit payload			(Note4)	QPSK / 4392		(Note4)	QPSK / 4392	
Max number of HARQ transmissions			1	N/A		1	N/A	
Physical channel for CQI/PMI reporting			PUSCH (Note5)	N/A		PUSCH (Note5)	N/A	
PUCCH Report Type for CQI/PMI			2	N/A		2	N/A	
PUCCH Report Type for RI			3	N/A		3	N/A	
Reporting periodicity		ms	$N_{pd} = 10$	N/A		$N_{pd} = 10$	N/A	
CQI Delay		ms	8	N/A		8	N/A	
<i>cqi-pmi-ConfigurationIndex</i>			12	N/A		12	N/A	
<i>ri-ConfigIndex</i>			1	N/A		1	N/A	
PDSCH scheduled sub-frames			1,2,3,4,7,8,9	1,2,3,4,6,7,8,9		1,2,3,4,7,8,9	1,2,3,4,6,7,8,9	
Timing offset between TPs		us	0			0		
Frequency offset between TPs		Hz	0			0		

Note 1:	Reference measurement channel RC.10 FDD according to Table A.4-1 with one sided dynamic OCNG Pattern OP.1 FDD as described in Annex A.5.1.1.
Note 2:	REs for antenna ports 0 and 1 CRS have zero transmission power.
Note 3:	For each test, the minimum requirements shall be fulfilled for at least one of the two SNR(s) and the respective wanted signal input level.
Note 4:	N/A.
Note 5:	To avoid collisions between CQI/PMI reports and HARQ-ACK it is necessary to report both on PUSCH instead of PUCCH. PDCCH DCI format 0 shall be transmitted in downlink SF#1 to allow periodic CQI/PMI to multiplex with the HARQ-ACK on PUSCH in uplink #5.

9.2.4.2 TDD

The following requirements apply to UE Category ≥ 2 . For the parameters specified in table 9.2.4.2-1, and using the downlink physical channels specified in Tables C.3.4-1 and C.3.4-2, the reported offset level of the wideband spatial differential CQI for codeword #1 (Table 7.2-2 in TS 36.213 [6]) shall be used to determine the wideband CQI index for codeword #1 as

$$\text{wideband CQI}_1 = \text{wideband CQI}_0 - \text{Codeword 1 offset level}$$

The wideband CQI_1 shall be within the set $\{\text{median CQI}_1 - 1, \text{median CQI}_1, \text{median CQI}_1 + 1\}$ for more than 90% of the time, where the resulting wideband values CQI_1 shall be used to determine the median CQI values for codeword #1. For both codewords #0 and #1, the PDSCH BLER using the transport format indicated by the respective median $\text{CQI}_0 - 1$ and median $\text{CQI}_1 - 1$ shall be less than or equal to 0.1. Furthermore, for both codewords #0 and #1, the PDSCH BLER using the transport format indicated by the respective median $\text{CQI}_0 + 1$ and median $\text{CQI}_1 + 1$ shall be greater than or equal to 0.1.

Table 9.2.4.2-1: PUCCH 1-1 static test (TDD)

Parameter		Unit	Test 1			Test 2		
			TP1	TP2		TP1	TP2	
Bandwidth		MHz	10					
PDSCH transmission mode			10					
Uplink downlink configuration			2					
Special subframe configuration			4					
Downlink power allocation (Note 1)	ρ_A	dB	0	0	0	0	0	
	ρ_B	dB	0	0	0	0	0	
	P_c	dB	-6	-6	-6	-6	-6	
	σ	dB	-3	N/A	-3	N/A	N/A	
Cell ID			0			0		
Cell-specific reference signals			Antenna ports 0, 1	(Note 2)	Antenna ports 0, 1	(Note 2)		
CSI reference signals			Antenna ports 15, ..., 22	N/A	Antenna ports 15, ..., 22	N/A		
CSI-RS periodicity and subframe offset $T_{CSI-RS} / \Delta_{CSI-RS}$			5/3	N/A	5/3	N/A		
CSI-RS configuration			0	N/A	0	N/A		
Zero-Power CSI-RS configuration $l_{CSI-RS} / ZeroPowerCSI-RS$ bitmap			3 / 001000000000 0000	3 / 10000100000 00000	3 / 001000000000 0000	3 / 10000100000 00000		
CSI-IM configuration $l_{CSI-RS} / ZeroPowerCSI-RS$ bitmap			3 / 001000000000 0000	N/A	3 / 001000000000 0000	N/A		
CSI process configuration Signal/Interference/Reporting mode			CSI-RS/CSI-IM/PUCCH 1-1			CSI-RS/CSI-IM/PUCCH 1-1		
Propagation condition and antenna configuration			Clause B.1 (8 x 2)	Clause B.1 (2 x 2)	Clause B.1 (8 x 2)	Clause B.1 (2 x 2)		
CodeBookSubsetRestriction bitmap			0x0000 0000 0020 0000 0000 0001 0000	100000	0x0000 0000 0020 0000 0000 0001 0000	100000		
SNR (Note 3)		dB	17	6	7	17	14	15
$\hat{I}_{or}^{(j)}$		dB[mW/15kHz]	-81	-92	-91	-81	-84	-83
$N_{oc}^{(j)}$		dB[mW/15kHz]	-98			-98		
Modulation / Information bit payload			(Note4)	QPSK / 4392		(Note4)	QPSK / 4392	
Max number of HARQ transmissions			1	N/A		1	N/A	
Physical channel for CQI/PMI reporting			PUSCH (Note5)	N/A		PUSCH (Note5)	N/A	
PUCCH Report Type for CQI/second PMI			2b	N/A		2b	N/A	
Physical channel for RI reporting			PUSCH	N/A		PUSCH	N/A	
PUCCH Report Type for RI/ first PMI			5	N/A		5	N/A	
Reporting periodicity		ms	$N_{pd} = 5$			$N_{pd} = 5$		
CQI Delay		ms	10 or 11			10 or 11		
$cqi-pmi-ConfigurationIndex$			3			3		
$ri-ConfigIndex$			805 (Note 6)			805 (Note 6)		
ACK/NACK feedback mode			Multiplexing			Multiplexing		
PDSCH scheduled sub-frames			3,4,8,9			3,4,8,9		
Timing offset between TPs		us	0			0		
Frequency offset between TPs		Hz	0			0		

Note 1:	Reference measurement channel RC.10 TDD according to Table A.4-1 with one sided dynamic OCNG Pattern OP.1 TDD as described in Annex A.5.2.1.
Note 2:	REs for antenna ports 0 and 1 CRS have zero transmission power.
Note 3:	For each test, the minimum requirements shall be fulfilled for at least one of the two SNR(s) and the respective wanted signal input level.
Note 4:	N/A.
Note 5:	To avoid collisions between CQI/PMI reports and HARQ-ACK it is necessary to report both on PUSCH instead of PUCCH. PDCCH DCI format 0 shall be transmitted in downlink SF#3 and #8 to allow periodic CQI/PMI to multiplex with the HARQ-ACK on PUSCH in uplink SF#7 and #2.
Note 6:	RI reporting interval is set to the maximum allowable length of 160ms to minimise collisions between RI, CQI/PMI and HARQ-ACK reports. In the case when all three reports collide, it is expected that CQI/PMI reports will be dropped, while RI and HARQ-ACK will be multiplexed. At eNB, CQI report collection shall be skipped every 160ms during performance verification.

9.2.4.2A TDD (With *interferenceMeasRestriction* configured)

The following requirements apply to UE Category ≥ 2 . For the parameters specified in table 9.2.4.2A-1, and using the downlink physical channels specified in Tables C.3.4-1 and C.3.4-2, the reported offset level of the wideband spatial differential CQI for codeword #1 (Table 7.2-2 in TS 36.213 [6]) shall be used to determine the wideband CQI index for codeword #1 as

$$\text{wideband CQI}_1 = \text{wideband CQI}_0 - \text{Codeword 1 offset level}$$

The wideband CQI_1 shall be within the set $\{\text{median CQI}_1 - 1, \text{median CQI}_1, \text{median CQI}_1 + 1\}$ for more than 90% of the time, where the resulting wideband values CQI_1 shall be used to determine the median CQI values for codeword #1. For both codewords #0 and #1, the PDSCH BLER using the transport format indicated by the respective median $\text{CQI}_0 - 1$ and median $\text{CQI}_1 - 1$ shall be less than or equal to 0.1. Furthermore, for both codewords #0 and #1, the PDSCH BLER using the transport format indicated by the respective median $\text{CQI}_0 + 1$ and median $\text{CQI}_1 + 1$ shall be greater than or equal to 0.1.

Table 9.2.4.2A-1: PUCCH 1-1 static test (TDD)

Parameter		Unit	Test 1			Test 2		
			TP1	TP2		TP1	TP2	
Bandwidth		MHz	10					
PDSCH transmission mode			10					
Uplink downlink configuration			2					
Special subframe configuration			4					
Downlink power allocation (Note 1)	ρ_A	dB	0	0		0	0	
	ρ_B	dB	0	0		0	0	
	P_c	dB	-6	-6		-6	-6	
	σ	dB	-3	N/A		-3	N/A	
Cell ID			0			0		
Cell-specific reference signals			Antenna ports 0, 1	(Note 2)		Antenna ports 0, 1	(Note 2)	
e-MIMO Type			Class B					
Number of CSI-RS resource (K)			1					
<i>interferenceMeasRestriction</i>			Enable					
CSI reference signals			Antenna ports 15,...,22	N/A		Antenna ports 15,...,22	N/A	
CSI-RS periodicity and subframe offset $T_{\text{CSI-RS}} / \Delta_{\text{CSI-RS}}$			5/3	N/A		5/3	N/A	
CSI-RS configuration			0	N/A		0	N/A	
Zero-Power CSI-RS configuration <i>l</i> _{CSI-RS} / <i>ZeroPowerCSI-RS</i> bitmap			3 / 001000000000 0000	3 / 10000100000 00000		3 / 001000000000 0000	3 / 10000100000 00000	
CSI-IM configuration <i>l</i> _{CSI-RS} / <i>ZeroPowerCSI-RS</i> bitmap			3 / 001000000000 0000	N/A		3 / 001000000000 0000	N/A	
CSI process configuration Signal/Interference/Reporting mode			CSI-RS/CSI-IM/PUCCH 1-1			CSI-RS/CSI-IM/PUCCH 1-1		
Propagation condition and antenna configuration			Clause B.1 (8 x 2)	Clause B.1 (2 x 2)		Clause B.1 (8 x 2)	Clause B.1 (2 x 2)	
CodeBookSubsetRestriction bitmap			0x0000 0000 0020 0000 0000 0001 0000	100000		0x0000 0000 0020 0000 0000 0001 0000	100000	
SNR (Note 3)	Sub-frame 8	dB	17	[15]	[16]	17	[23]	[24]
	Other sub-frames		17	6	7	17	14	15
$\hat{I}_{or}^{(j)}$	Sub-frame 8	dB[mW/15kHz]	-81	[-83]	[-82]	-81	[-75]	[-74]
	Other sub-frames		-81	-92	-91	-81	-84	-83
$N_{oc}^{(j)}$		dB[mW/15kHz]	-98			-98		
Modulation / Information bit payload			(Note4)	QPSK / 4392		(Note4)	QPSK / 4392	
Max number of HARQ transmissions			1	N/A		1	N/A	
Physical channel for CQI/PMI reporting			PUSCH (Note5)	N/A		PUSCH (Note5)	N/A	
PUCCH Report Type for CQI/second PMI			2b	N/A		2b	N/A	
Physical channel for RI reporting			PUSCH	N/A		PUSCH	N/A	
PUCCH Report Type for RI/ first PMI			5	N/A		5	N/A	
Reporting periodicity		ms	$N_{pd} = 10$	N/A		$N_{pd} = 10$	N/A	
CQI Delay		ms	10 or 11	N/A		10 or 11	N/A	
<i>cqi-pmi-ConfigurationIndex</i>			13	N/A		13	N/A	
<i>ri-ConfigIndex</i>			805 (Note 6)	N/A		805 (Note 6)	N/A	
<i>ACK/NACK feedback mode</i>			Multiplexing	N/A		Multiplexing	N/A	
PDSCH scheduled sub-frames			3,4,9	3,4,8,9		3,4,9	3,4,8,9	
Timing offset between TPs		us	0			0		

Frequency offset between TPs	Hz	0	0
Note 1:	Reference measurement channel RC.10 TDD according to Table A.4-1 with one sided dynamic OCNG Pattern OP.1 TDD as described in Annex A.5.2.1.		
Note 2:	REs for antenna ports 0 and 1 CRS have zero transmission power.		
Note 3:	For each test, the minimum requirements shall be fulfilled for at least one of the two SNR(s) and the respective wanted signal input level.		
Note 4:	N/A.		
Note 5:	To avoid collisions between CQI/PMI reports and HARQ-ACK it is necessary to report both on PUSCH instead of PUCCH. PDCCH DCI format 0 shall be transmitted in downlink SF#3 to allow periodic CQI/PMI to multiplex with the HARQ-ACK on PUSCH in uplink SF#7.		
Note 6:	RI reporting interval is set to the maximum allowable length of 160ms to minimise collisions between RI, CQI/PMI and HARQ-ACK reports. In the case when all three reports collide, it is expected that CQI/PMI reports will be dropped, while RI and HARQ-ACK will be multiplexed. At eNB, CQI report collection shall be skipped every 160ms during performance verification.		

9.2.5 Minimum requirement PUCCH 1-1 (when *csi-SubframeSet-r12* and *EIMTA-MainConfigServCell-r12* are configured)

The following requirements apply to UE Category ≥ 2 which supports eIMTA TDD UL-DL reconfiguration for TDD serving cell(s) via monitoring PDCCH with eIMTA-RNTI and Rel-12 CSI subframe sets. For the parameters specified in table 9.2.5-1, and using the downlink physical channels specified in Tables C.3.2-1 and C.3.2-2, for each CSI subframe set, the reported CQI value shall be in the range of ± 1 of the reported median more than 90% of the time. For each CSI subframe set, if the PDSCH BLER using the transport format indicated by median CQI is less than or equal to 0.1, the BLER using the transport format indicated by the (median CQI + 1) shall be greater than 0.1. If the PDSCH BLER using the transport format indicated by the median CQI is greater than 0.1, the BLER using transport format indicated by (median CQI - 1) shall be less than or equal to 0.1. The difference of the median CQI obtained by reports in CSI subframe sets $C_{CSI,0}$ and the median CQI obtained by reports in CSI subframe sets $C_{CSI,1}$ shall be larger than or equal to 3.

Table 9.2.5 -1: PUCCH 1-1 static test (TDD)

Parameter	Unit	Test	
Bandwidth	MHz	10	
PDSCH transmission mode		9	
Uplink downlink configuration in SIB1		0	
Downlink HARQ reference configuration (eimta-HarqReferenceConfig-r12) (Note 4)		2	
Set of dynamic TDD UL-DL configurations (Notes 4,5)		{0, 2}	
Periodicity of monitoring the L1 reconfiguration DCI (eimta-CommandPeriodicity-r12)	ms	10	
Set of subframes to monitor the L1 reconfiguration DCI (eimta-CommandSubframeSet-r12)		SF#5	
CSI-MeasSubframeSet-r12		0001100011	
Special subframe configuration		4	
Downlink power allocation	ρ_A	dB	0
	ρ_B	dB	0
	P_C	dB	0
	σ	dB	-3
CRS reference signals		Antenna ports 0, 1	
CSI reference signals		Antenna ports 15,16	
CSI-RS periodicity and subframe offset $T_{\text{CSI-RS}} / \Delta_{\text{CSI-RS}}$		5/4	
CSI reference signal configuration		4	
Zero-Power CSI-RS configuration 0 $I_{\text{CSI-RS}} / \text{ZeroPowerCSI-RS}$ bitmap		0 / 0000010000000000	
Zero-Power CSI-RS configuration 1 $I_{\text{CSI-RS}} / \text{ZeroPowerCSI-RS}$ bitmap		4 / 0100000000000000	
Propagation condition and antenna configuration		Clause B.1 (2 x 2)	
Beamforming Model		As specified in Section B.4.3	
CodeBookSubsetRestriction bitmap		'000001'	
SNR in CSI subframe set 0	dB	0	1
SNR in CSI subframe set 1	dB	10	11
$\hat{I}_{or}^{(j)}$	dB[mW/15kHz]	-98	-97
$N_{oc1}^{(j)}$ for CSI subframe set 0	dB[mW/15kHz]	-98	-98
$N_{oc2}^{(j)}$ for CSI subframe set 1	dB[mW/15kHz]	-108	-108
PDSCH scheduled subframes for CSI subframe set 0		0,5	
PDSCH scheduled subframes for CSI subframe set 1		3,4,8,9	
Max number of HARQ transmissions		1	
Physical channel for CQI/PMI reporting		PUSCH (Note 6)	
PUCCH Report Type for CQI/second PMI		2b	
Physical channel for RI reporting		PUSCH	
PUCCH Report Type for RI/ first PMI		5	
Reporting periodicity	ms	$N_{pd} = 10$ for each Rel-12 CSI subframe set	
CQI delay	ms	14 for CSI subframe set 0 12 for CSI subframe set 1	
<i>cqi-pmi-ConfigurationIndex</i>		8 for set 0 13 for set 1	
<i>ri-ConfigIndex</i>		805 for both set 0 and set 1 (Note 7)	
ACK/NACK feedback mode		Multiplexing	

Note 1:	Reference measurement channel RC.19 TDD according to Table A.4-1 with one sided dynamic OCNG Pattern OP.1 TDD and dynamic OCNG Pattern with multiple non-contiguous blocks OP.7 TDD as described in Annex A.5.2.1/7 for CSI subframe set 0.
Note 2:	Reference measurement channel RC.20 TDD according to Table A.4-1 with one sided dynamic OCNG Pattern OP.1 TDD as described in Annex A.5.2.1 for CSI subframe set 1.
Note 3:	In the test, the minimum requirements shall be fulfilled for at least one of the two SNR(s) and the respective wanted signal input level for each CSI subframe set separately.
Note 4:	As specified in Table 4.2-2 in TS 36.211.
Note 5:	UL/DL configuration in PDCCH with eIMTA-RNTI is cyclically selected from the given set on a per-DCI basis.
Note 6:	To avoid collisions between CQI/PMI reports and HARQ-ACK it is necessary to report both on PUSCH instead of PUCCH. PDCCH DCI format 0 shall be transmitted in downlink SF#1 and #6 to allow periodic CQI/PMI to multiplex with the HARQ-ACK on PUSCH in uplink SF#7 and #2. CQI/PMI reports for CSI subframe set 0 is transmitted in SF#2 and CQI/PMI reports for CSI subframe set 1 is transmitted in SF#7.
Note 7:	RI reporting interval is set to the maximum allowable length of 160ms to minimise collisions between RI, CQI/PMI and HARQ-ACK reports. In the case when all three reports collide, it is expected that CQI/PMI reports will be dropped, while RI and HARQ-ACK will be multiplexed. At eNB, CQI report collection shall be skipped every 160ms during performance verification.

9.2.6 Minimum requirement PUSCH 3-0 (Cell-Specific Reference Symbols)

9.2.6.1 Frame structure type 3 with FDD Pcell

The following requirements apply to UE Category ≥ 1 . For the parameters specified in Table 9.2.6.1-1, Table 9.2.6.1-2, and using the downlink physical channels specified in tables C.3.2-1 and C.3.2-2, two sets of CQI reports are obtained for LAA Scell. The first one is obtained by reports whose reference resource is in the downlink subframes with 6 dB transmission power boost, i.e., high power subframes. The second one is obtained by reports whose reference resource is in the downlink subframe with 0 dB transmission power boost, i.e., low power subframe. In the test, PDSCH transport format in high power subframe is determined by first set of CQI reports and PDSCH transport format in low power subframe is determined by second set of CQI reports.

The reported CQI value in the first set of reports shall be in the range of ± 1 of the reported median more than 90% of the first set of reports. The reported CQI value in the second set of reports shall be in the range of ± 1 of the reported median more than 90% of the second set of reports.

If the PDSCH BLER in the high power subframes using the transport format indicated by wideband CQI median is less than or equal to 0.1, the BLER in high power subframes using the transport format indicated by the (wideband CQI median + 1) shall be greater than 0.1. If the PDSCH BLER in the high power subframes using the transport format indicated by the wideband CQI median is greater than 0.1, the BLER in high power subframes using transport format indicated by (wideband CQI median – 1) shall be less than or equal to 0.1.

If the PDSCH BLER in the low power subframes using the transport format indicated by wideband CQI median is less than or equal to 0.1, the BLER in low power subframes using the transport format indicated by the (wideband CQI median + 1) shall be greater than 0.1. If the PDSCH BLER in the low power subframes using the transport format indicated by the wideband CQI median is greater than 0.1, the BLER in low power subframes using transport format indicated by (wideband CQI median – 1) shall be less than or equal to 0.1.

The value of the wideband CQI median for first set of CQI reports minus the wideband CQI median for second set of CQI reports shall be larger than or equal to 2 in Test 1 and Test 2.

Table 9.2.6.1-1: Parameters for PUSCH 3-0 static test on FDD Pcell

Parameter	Unit	Value	
Bandwidth	MHz	20	
PDSCH transmission mode		3	
Downlink power allocation	ρ_A	dB	-3
	ρ_B	dB	-3
	σ	dB	0
Propagation condition and antenna configuration		Clause B.1 (2 x 2)	
SNR	dB	20	
$\hat{I}_{or}^{(j)}$	dB[mW/15kHz]	-78	
$N_{oc}^{(j)}$	dB[mW/15kHz]	-98	
Max number of HARQ transmissions		1	
Reporting mode		PUSCH 3-0	
CSI request field		'10'	
trigger1 (Note 2)		01000000	
trigger2 (Note 2)		00000000	
Note 1:	PCell is used for HARQ ACK/NACK feedback and aperiodic CSI triggering/reporting. One sided dynamic OCNG Pattern OP.1 FDD as described in A.5.1.1 is transmitted on PCell on all RBs, but PDSCH for user data is not transmitted on PCell.		
Note 2:	trigger1 and trigger2 are defined as TS 36.331 for aperiodicCSI-Trigger. They Indicate for which serving cell(s) the aperiodic CSI report is triggered when one or more SCells are configured. PDCCH DCI format 0 with a trigger for aperiodic CQI is transmitted periodically in subframe 1 and subframe 6 with 5ms periodicity.		

Table 9.2.6.1-2: PUSCH 3-0 static test on LAA Scell

Parameter	Unit	Test 1	Test 2
Bandwidth	MHz	20	
PDSCH transmission mode		3	
Downlink power allocation	ρ_A	dB	
	ρ_B	dB	
	σ	dB	
Propagation condition and antenna configuration		Clause B.1 (2x2)	
SNR in subframes with 6 dB power boost (Note 2)	dB	9	10
SNR in subframes with 0 dB power boost (Note 2)	dB	3	4
$\hat{I}_{or}^{(j)}$ in subframes with 6 dB power	dB[mW/15kHz]	-89	-88
$\hat{I}_{or}^{(j)}$ in subframes with 0 dB power	dB[mW/15kHz]	-95	-94
$N_{oc}^{(j)}$	dB[mW/15kHz]	-98	
MBSFN subframe Configuration		Non-MBSFN	
Cell Id		0	
dmtc-Periodicity	ms	80	
dmtc-Offset		0	
Number of control OFDM symbols		3	
Max number of HARQ transmissions		1	
Reporting mode		PUSCH 3-0	
PDSCH transmission model	Basic model	As specified in Section B.8	
	subframeStartPosition	s0	
	Number of occupied symbols per subframe	14	
	The number of subframes set (S_1) per burst	{3,8}	
	Random variable p defined in B.8	0.5	
	Power configuration for each burst	$\hat{I}_{or}^{(j)}$ is randomly selected from 6 dB power boosting or 0 dB power boosting with equal probability	
Note 1:	Reference measurement channel RC.2A FDD according to Table A.4-1 with one sided dynamic OCNB Pattern OP.1 FS3 as described in Annex A.5.4.1, except for category 1 UE use RC.4A FDD with two sided dynamic OCNB Pattern OP.2 FS3 as described in Annex A.5.4.2.		
Note 2:	For each test, the minimum requirements shall be fulfilled for at least one of the two SNR(s) and the respective wanted signal input level.		

9.2.6.2 Frame structure type 3 with TDD Pcell

The following requirements apply to UE Category ≥ 1 . For the parameters specified in Table 9.2.6.2-1, Table 9.2.6.2-2, and using the downlink physical channels specified in tables C.3.2-1 and C.3.2-2, two sets of CQI reports are obtained for LAA Scell. The first one is obtained by reports whose reference resource is in the downlink subframes with 6 dB transmission power boost, i.e., high power subframes. The second one is obtained by reports whose reference resource is in the downlink subframe with 0 dB transmission power boost, i.e., low power subframe. In the test, PDSCH transport format in high power subframe is determined by first set of CQI reports and PDSCH transport format in low power subframe is determined by second set of CQI reports.

The reported CQI value in the first set of reports shall be in the range of ± 1 of the reported median more than 90% of the first set of reports. The reported CQI value in the second set of reports shall be in the range of ± 1 of the reported median more than 90% of the second set of reports.

If the PDSCH BLER in the high power subframes using the transport format indicated by wideband CQI median is less than or equal to 0.1, the BLER in high power subframes using the transport format indicated by the (wideband CQI

median + 1) shall be greater than 0.1. If the PDSCH BLER in the high power subframes using the transport format indicated by the wideband CQI median is greater than 0.1, the BLER in high power subframes using transport format indicated by (wideband CQI median – 1) shall be less than or equal to 0.1.

If the PDSCH BLER in the low power subframes using the transport format indicated by wideband CQI median is less than or equal to 0.1, the BLER in low power subframes using the transport format indicated by the (wideband CQI median + 1) shall be greater than 0.1. If the PDSCH BLER in the low power subframes using the transport format indicated by the wideband CQI median is greater than 0.1, the BLER in low power subframes using transport format indicated by (wideband CQI median – 1) shall be less than or equal to 0.1.

The value of the wideband CQI median for first set of CQI reports minus the wideband CQI median for second set of CQI reports shall be larger than or equal to 2 in Test 1 and Test 2.

Table 9.2.6.2-1: Parameters for PUSCH 3-0 static test on TDD Pcell

Parameter	Unit	Value	
Bandwidth	MHz	20	
Uplink downlink configuration		2	
Special subframe configuration		4	
PDSCH transmission mode		3	
Downlink power allocation	ρ_A	dB	-3
	ρ_B	dB	-3
	σ	dB	0
Propagation condition and antenna configuration		Clause B.1 (2 x 2)	
SNR	dB	20	
$\hat{I}_{or}^{(j)}$	dB[mW/15kHz]	-78	
$N_{oc}^{(j)}$	dB[mW/15kHz]	-98	
Max number of HARQ transmissions		1	
Reporting mode		PUSCH 3-0	
CSI request field		'10'	
trigger1 (Note 2)		01000000	
trigger2 (Note 2)		00000000	
<p>Note 1: PCell is used for HARQ ACK/NACK feedback and aperiodic CSI triggering/reporting. One sided dynamic OCNG Pattern OP.1 TDD as described in A.5.2.1 is transmitted on PCell on all RBs, but PDSCH for user data is not transmitted on PCell.</p> <p>Note 2: trigger1 and trigger2 are defined as TS 36.331 for aperiodicCSI-Trigger. They Indicate for which serving cell(s) the aperiodic CSI report is triggered when one or more SCells are configured. PDCCH DCI format 0 with a trigger for aperiodic CQI is transmitted periodically in subframe 3 and subframe 8 with 5ms periodicity.</p>			

Table 9.2.6.2-2: PUSCH 3-0 static test on LAA Scell

Parameter	Unit	Test 1	Test 2
Bandwidth	MHz	20	
PDSCH transmission mode		3	
Downlink power allocation	ρ_A	dB	
	ρ_B	dB	
	σ	dB	
Propagation condition and antenna configuration		Clause B.1 (2x2)	
SNR in subframes with 6 dB power boost (Note 2)	dB	9	10
SNR in subframes with 0 dB power boost (Note 2)	dB	3	4
$\hat{I}_{or}^{(j)}$ in subframes with 6 dB power	dB[mW/15kHz]	-89	-88
$\hat{I}_{or}^{(j)}$ in subframes with 0 dB power	dB[mW/15kHz]	-95	-94
$N_{oc}^{(j)}$	dB[mW/15kHz]	-98	
MBSFN subframe Configuration		Non-MBSFN	
Cell Id		0	
dmtc-Periodicity	ms	80	
dmtc-Offset		0	
Number of control OFDM symbols		3	
Max number of HARQ transmissions		1	
Reporting mode		PUSCH 3-0	
PDSCH transmission model	Basic model	As specified in Section B.8	
	subframeStartPosition	s0	
	Number of occupied symbols per subframe	14	
	The number of subframes set $\{s_1\}$ per burst	{3,8}	
	Random variable p defined in B.8	0.5	
	Power configuration for each burst	$\hat{I}_{or}^{(j)}$ is randomly selected from 6 dB power boosting or 0 dB power boosting with equal probability	
Note 1:	Reference measurement channel RC.2A FDD according to Table A.4-1 with one sided dynamic OCNB Pattern OP.1 FS3 as described in Annex A.5.4.1, except for category 1 UE use RC.4A FDD with two sided dynamic OCNB Pattern OP.2 FS3 as described in Annex A.5.4.2.		
Note 2:	For each test, the minimum requirements shall be fulfilled for at least one of the two SNR(s) and the respective wanted signal input level.		

9.2.7 Minimum requirement PUSCH 3-1 (CSI Reference Symbol)

9.2.7.1 Frame structure type 3 with FDD Pcell

The following requirements apply to UE Category ≥ 1 . For the parameters specified in Table 9.2.7.1-1, Table 9.2.7.1-2 and using the downlink physical channels specified in tables C.3.2-1 and C.3.2-2, two sets of CQI reports are obtained for LAA Scell, The first one is obtained by reports whose reference resource is in the downlink subframes with 6 dB transmission power boost, i.e., high power subframes. The second one is obtained by reports whose reference resource is in the downlink subframe with 0 dB transmission power boost, i.e., low power subframe. In the test, PDSCH transport format in high power subframe is determined by first set of CQI reports and PDSCH transport format in low power subframe is determined by second set of CQI reports.

The reported CQI value in the first set of reports shall be in the range of ± 1 of the reported median more than 90% of the first set of reports. The reported CQI value in the second set of reports shall be in the range of ± 1 of the reported median more than 90% of the second set of reports.

If the PDSCH BLER in the high power subframes using the transport format indicated by wideband CQI median is less than or equal to 0.1, the BLER in high power subframes using the transport format indicated by the (wideband CQI median + 1) shall be greater than 0.1. If the PDSCH BLER in high power subframes using the transport format indicated by the wideband CQI median is greater than 0.1, the BLER in high power subframes using transport format indicated by (wideband CQI median – 1) shall be less than or equal to 0.1.

If the PDSCH BLER in the low power subframes using the transport format indicated by wideband CQI median is less than or equal to 0.1, the BLER in low power subframes using the transport format indicated by the (wideband CQI median + 1) shall be greater than 0.1. If the PDSCH BLER in the low power subframes using the transport format indicated by the wideband CQI median is greater than 0.1, the BLER in low power subframes using transport format indicated by (wideband CQI median – 1) shall be less than or equal to 0.1.

The value of the wideband CQI for the first set of CQI report minus the wideband CQI median for second set of CQI shall be larger than or equal to 2 in Test 1 and Test 2.

Table 9.2.7.1-1: Parameters for PUSCH 3-1 static test on FDD Pcell

Parameter	Unit	Value	
Bandwidth	MHz	20	
PDSCH transmission mode		9	
Downlink power allocation	ρ_A	dB	0
	ρ_B	dB	0
	P_C	dB	0
	σ	dB	0
Propagation condition and antenna configuration		Clause B.1 (2 x 2)	
SNR	dB	20	
$\hat{I}_{or}^{(j)}$	dB[mW/15kHz]	-78	
$N_{oc}^{(j)}$	dB[mW/15kHz]	-98	
CRS reference signals		Antenna ports 0	
CSI reference signals		Antenna ports 15, 16	
CSI-RS periodicity and subframe offset $T_{CSI-RS} / \Delta_{CSI-RS}$		5/ 1	
CSI-RS reference signal configuration		4	
CodeBookSubsetRestriction bitmap		000001	
Number of control OFDM symbols		3	
Max number of HARQ transmissions		1	
Reporting mode		PUSCH 3-1	
CSI request field		'10'	
trigger1 (Note 2)		01000000	
trigger2 (Note 2)		00000000	
Note 1:	PCell is used for HARQ ACK/NACK feedback and aperiodic CSI triggering/reporting. One sided dynamic OCNG Pattern OP.1 FDD as described in A.5.1.1 is transmitted on PCell on all RBs, but PDSCH for user data is not transmitted on PCell.		
Note 2:	trigger1 and trigger2 are defined as TS 36.331 for aperiodicCSI-Trigger. They Indicate for which serving cell(s) the aperiodic CSI report is triggered when one or more SCells are configured. PDCCH DCI format 0 with a trigger for aperiodic CQI is transmitted periodically in subframe 1 and subframe 6 with 5ms periodicity.		

Table 9.2.7.1-2: PUSCH 3-1 static test on LAA Scell

Parameter		Unit	Test 1	Test 2
Bandwidth		MHz	20 MHz	
Transmission mode			9	
Downlink power allocation	ρ_A	dB	0	
	ρ_B	dB	0	
	P_c	dB	0	
	σ	dB	0	
SNR in subframes with 6 dB power boost (Note 3)		dB	9	10
SNR in subframes with 0 dB power boost (Note 3)			3	4
$\hat{I}_{or}^{(j)}$ in subframes with 6 dB power			-89	-88
$\hat{I}_{or}^{(j)}$ in subframes with 0 dB power		dB[mW/15kHz]	-95	-94
$N_{oc}^{(j)}$		dB[mW/15kHz]	-98	-98
MBSFN subframe Configuration			Non-MBSFN	
Cell Id			0	
dmtd-Periodicity		ms	80	
dmtd-Offset			0	
Propagation condition and antenna configuration			Clause B.1 (2x2)	
Beamforming Model			As specified in Section B.4.3	
CRS reference signals			Antenna ports 0	
CSI reference signals			Antenna ports 15, 16	
CSI-RS periodicity and subframe offset $T_{CSI-RS} / \Delta_{CSI-RS}$			5/ 1	
CSI-RS reference signal configuration			4	
CodeBookSubsetRestriction bitmap			000001	
Number of control OFDM symbols			3	
Max number of HARQ transmissions			1	
Reporting mode			PUSCH 3-1	
PDSCH transmission model	Basic model		As specified in Section B.8	
	subframeStartPosition		s0	
	Number of occupied symbols per subframe		14	
	The number of subframes set (S_1) per burst		{3, 8}	
	Random variable p defined in B.8		0.5	
	Power configuration for each burst		$\hat{I}_{or}^{(j)}$ is randomly selected from 6 dB power boosting or 0 dB power boosting with equal probability	
Note 1: If the UE reports in an available uplink reporting instance at subframe SF#n based on CQI estimation at a downlink subframe not later than SF#(n-4), this reported subband or wideband CQI cannot be applied at the eNB downlink before SF#(n+4)				
Note 2: Reference measurement channel RC.9A FDD according to Table A.4-1 with one/two sided dynamic OCNG Pattern OP.1/2 FS3 as described in Annex A.5.4.1/2.				
Note 3: For each test, the minimum requirements shall be fulfilled for at least one of the two SNR(s) and the respective wanted signal input level.				

9.2.7.2 Frame structure type 3 with TDD Pcell

The following requirements apply to UE Category ≥ 1 . For the parameters specified in Table 9.2.7.2-1, Table 9.2.7.2-2 and using the downlink physical channels specified in tables C.3.2-1 and C.3.2-2, two sets of CQI reports are obtained for LAA Scell, The first one is obtained by reports whose reference resource is in the downlink subframes with 6 dB transmission power boost, i.e., high power subframes. The second one is obtained by reports whose reference resource

is in the downlink subframe with 0 dB transmission power boost, i.e., low power subframe. In the test, PDSCH transport format in high power subframe is determined by first set of CQI reports and PDSCH transport format in low power subframe is determined by second set of CQI reports.

The reported CQI value in the first set of reports shall be in the range of ± 1 of the reported median more than 90% of the first set of reports. The reported CQI value in the second set of reports shall be in the range of ± 1 of the reported median more than 90% of the second set of reports.

If the PDSCH BLER in the high power subframes using the transport format indicated by wideband CQI median is less than or equal to 0.1, the BLER in high power subframes using the transport format indicated by the (wideband CQI median + 1) shall be greater than 0.1. If the PDSCH BLER in high power subframes using the transport format indicated by the wideband CQI median is greater than 0.1, the BLER in high power subframes using transport format indicated by (wideband CQI median – 1) shall be less than or equal to 0.1.

If the PDSCH BLER in the low power subframes using the transport format indicated by wideband CQI median is less than or equal to 0.1, the BLER in low power subframes using the transport format indicated by the (wideband CQI median + 1) shall be greater than 0.1. If the PDSCH BLER in the low power subframes using the transport format indicated by the wideband CQI median is greater than 0.1, the BLER in low power subframes using transport format indicated by (wideband CQI median – 1) shall be less than or equal to 0.1.

The value of the wideband CQI for the first set of CQI report minus the wideband CQI median for second set of CQI shall be larger than or equal to 2 in Test 1 and Test 2.

Table 9.2.7.2-1: Parameters for PUSCH 3-1 static test on TDD Pcell

Parameter	Unit	Value	
Bandwidth	MHz	20	
PDSCH transmission mode		9	
Uplink downlink configuration		2	
Special subframe configuration		4	
Downlink power allocation	ρ_A	dB	0
	ρ_B	dB	0
	P_C	dB	0
	σ	dB	0
Propagation condition and antenna configuration		Clause B.1 (2 x 2)	
SNR	dB	20	
$\hat{I}_{or}^{(j)}$	dB[mW/15kHz]	-78	
$N_{oc}^{(j)}$	dB[mW/15kHz]	-98	
CRS reference signals		Antenna ports 0	
CSI reference signals		Antenna ports 15, 16	
CSI-RS periodicity and subframe offset $T_{CSI-RS} / \Delta_{CSI-RS}$		5/ 1	
CSI-RS reference signal configuration		4	
CodeBookSubsetRestriction bitmap		000001	
Number of control OFDM symbols		3	
Max number of HARQ transmissions		1	
Reporting mode		PUSCH 3-1	
CSI request field		'10'	
trigger1 (Note 2)		01000000	
trigger2 (Note 2)		00000000	
Note 1:	PCell is used for HARQ ACK/NACK feedback and aperiodic CSI triggering/reporting. One sided dynamic OCNG Pattern OP.1 TDD as described in A.5.2.1 is transmitted on PCell on all RBs, but PDSCH for user data is not transmitted on PCell.		
Note 2:	trigger1 and trigger2 are defined as TS 36.331 for aperiodicCSI-Trigger. They Indicate for which serving cell(s) the aperiodic CSI report is triggered when one or more SCells are configured. PDCCH DCI format 0 with a trigger for aperiodic CQI is transmitted periodically in subframe 3 and subframe 8 with 5ms periodicity.		

Table 9.2.7.2-2: PUSCH 3-1 static test on LAA Scell

Parameter		Unit	Test 1	Test 2
Bandwidth		MHz	20 MHz	
Transmission mode			9	
Downlink power allocation	ρ_A	dB	0	
	ρ_B	dB	0	
	P_c	dB	0	
	σ	dB	0	
SNR in subframes with 6 dB power boost (Note 3)		dB	9	10
SNR in subframes with 0 dB power boost (Note 3)			3	4
$\hat{I}_{or}^{(j)}$ in subframes with 6 dB power			-89	-88
$\hat{I}_{or}^{(j)}$ in subframes with 0 dB power		dB[mW/15kHz]	-95	-94
$N_{oc}^{(j)}$		dB[mW/15kHz]	-98	-98
MBSFN subframe Configuration			Non-MBSFN	
Cell Id			0	
dmtd-Periodicity		ms	80	
dmtd-Offset			0	
Propagation condition and antenna configuration			Clause B.1 (2x2)	
Beamforming Model			As specified in Section B.4.3	
CRS reference signals			Antenna ports 0	
CSI reference signals			Antenna ports 15, 16	
CSI-RS periodicity and subframe offset $T_{CSI-RS} / \Delta_{CSI-RS}$			5/ 3	
CSI-RS reference signal configuration			4	
CodeBookSubsetRestriction bitmap			000001	
Number of control OFDM symbols			3	
Max number of HARQ transmissions			1	
Reporting mode			PUSCH 3-1	
PDSCH transmission model	Basic model		As specified in Section B.8	
	subframeStartPosition		s0	
	Number of occupied symbols per subframe		14	
	The number of subframes set (S_1) per burst		{3, 8}	
	Random variable p defined in B.8		0.5	
	Power configuration for each burst		$\hat{I}_{or}^{(j)}$ is randomly selected from 6 dB power boosting or 0 dB power boosting with equal probability	
Note 1: If the UE reports in an available uplink reporting instance at subframe SF#n based on CQI estimation at a downlink subframe not later than SF#(n-4), this reported subband or wideband CQI cannot be applied at the eNB downlink before SF#(n+4)				
Note 2: Reference measurement channel RC.9A FDD according to Table A.4-1 with one/two sided dynamic OCNG Pattern OP.1/2 FS3 as described in Annex A.5.4.1/2.				
Note 3: For each test, the minimum requirements shall be fulfilled for at least one of the two SNR(s) and the respective wanted signal input level.				

9.3 CQI reporting under fading conditions

9.3.1 Frequency-selective scheduling mode

The accuracy of sub-band channel quality indicator (CQI) reporting under frequency selective fading conditions is determined by a double-sided percentile of the reported differential CQI offset level 0 per sub-band, and the relative increase of the throughput obtained when transmitting on a randomly selected sub-band among the sub-bands with the highest reported differential CQI offset level the corresponding transport format compared to the case for which a fixed format is transmitted on any sub-band in set S of TS 36.213 [6]. The purpose is to verify that preferred sub-bands can be used for frequently-selective scheduling. To account for sensitivity of the input SNR the sub-band CQI reporting under frequency selective fading conditions is considered to be verified if the reporting accuracy is met for at least one of two SNR levels separated by an offset of 1 dB.

9.3.1.1 Minimum requirement PUSCH 3-0 (Cell-Specific Reference Symbols)

9.3.1.1.1 FDD

For the parameters specified in Table 9.3.1.1.1-1, and using the downlink physical channels specified in Annex C.3.2, the minimum requirements are specified in Table 9.3.1.1.1-2 and by the following

- a) a sub-band differential CQI offset level of 0 shall be reported at least $\alpha\%$ of the time but less than $\beta\%$ for each sub-band;
- b) the ratio of the throughput obtained when transmitting on a randomly selected sub-band among the sub-bands with the highest differential CQI offset level the corresponding TBS and that obtained when transmitting the TBS indicated by the reported wideband CQI median on a randomly selected sub-band in set S shall be $\geq \gamma$;
- c) when transmitting on a randomly selected sub-band among the sub-bands with the highest differential CQI offset level the corresponding TBS, the average BLER for the indicated transport formats shall be greater or equal to 0.05.

The requirements only apply for sub-bands of full size and the random scheduling across the sub-bands is done by selecting a new sub-band in each TTI for FDD, each available downlink transmission instance for TDD.

Table 9.3.1.1.1-1 Sub-band test for single antenna transmission (FDD)

Parameter		Unit	Test 1		Test 2	
Bandwidth		MHz	10 MHz			
Transmission mode			1 (port 0)			
Downlink power allocation	ρ_A	dB	0			
	ρ_B	dB	0			
	σ	dB	0			
SNR (Note 3)		dB	9	10	14	15
$\hat{I}_{or}^{(j)}$		dB[mW/15kHz]	-89	-88	-84	-83
$N_{oc}^{(j)}$		dB[mW/15kHz]	-98		-98	
Propagation channel			Clause B.2.4 with $\tau_d = 0.45 \mu s$, $a = 1$, $f_D = 5$ Hz			
Antenna configuration			1 x 2			
Reporting interval		ms	5			
CQI delay		ms	8			
Reporting mode			PUSCH 3-0			
Sub-band size		RB	6 (full size)			
Max number of HARQ transmissions			1			
<p>Note 1: If the UE reports in an available uplink reporting instance at subframe SF#n based on CQI estimation at a downlink subframe not later than SF#(n-4), this reported subband or wideband CQI cannot be applied at the eNB downlink before SF#(n+4)</p> <p>Note 2: Reference measurement channel RC.3 FDD according to Table A.4-1 with one/two sided dynamic OCNG Pattern OP.1/2 FDD as described in Annex A.5.1.1/2.</p> <p>Note 3: For each test, the minimum requirements shall be fulfilled for at least one of the two SNR(s) and the respective wanted signal input level.</p>						

Table 9.3.1.1.1-2 Minimum requirement (FDD)

	Test 1	Test 2
α [%]	2	2
β [%]	55	55
γ	1.1	1.1
UE Category	≥ 1	≥ 1

9.3.1.1.2 TDD

For the parameters specified in Table 9.3.1.1.2-1, and using the downlink physical channels specified in Annex C.3.2, the minimum requirements are specified in Table 9.3.1.1.2-2 and by the following

- a sub-band differential CQI offset level of 0 shall be reported at least α % of the time but less than β % for each sub-band;
- the ratio of the throughput obtained when transmitting on a randomly selected sub-band among the sub-bands with the highest differential CQI offset level the corresponding TBS and that obtained when transmitting the TBS indicated by the reported wideband CQI median on a randomly selected sub-band in set S shall be $\geq \gamma$;
- when transmitting on a randomly selected sub-band among the sub-bands with the highest differential CQI offset level the corresponding TBS, the average BLER for the indicated transport formats shall be greater or equal to 0.05.

The requirements only apply for sub-bands of full size and the random scheduling across the sub-bands is done by selecting a new sub-band in each TTI for FDD, each available downlink transmission instance for TDD.

Table 9.3.1.1.2-1 Sub-band test for single antenna transmission (TDD)

Parameter		Unit	Test 1		Test 2	
Bandwidth		MHz	10 MHz			
Transmission mode			1 (port 0)			
Downlink power allocation	ρ_A	dB	0			
	ρ_B	dB	0			
	σ	dB	0			
Uplink downlink configuration			2			
Special subframe configuration			4			
SNR (Note 3)		dB	9	10	14	15
$\hat{I}_{or}^{(j)}$		dB[mW/15kHz]	-89	-88	-84	-83
$N_{oc}^{(j)}$		dB[mW/15kHz]	-98		-98	
Propagation channel			Clause B.2.4 with $\tau_d = 0.45 \mu\text{s}$, $a = 1$, $f_D = 5 \text{ Hz}$			
Antenna configuration			1 x 2			
Reporting interval		ms	5			
CQI delay		ms	10 or 11			
Reporting mode			PUSCH 3-0			
Sub-band size		RB	6 (full size)			
Max number of HARQ transmissions			1			
ACK/NACK feedback mode			Multiplexing			
<p>Note 1: If the UE reports in an available uplink reporting instance at subframe SF#n based on CQI estimation at a downlink subframe not later than SF#(n-4), this reported subband or wideband CQI cannot be applied at the eNB downlink before SF#(n+4)</p> <p>Note 2: Reference measurement channel RC.3 TDD according to Table A.4-1 with one/two sided dynamic OCNG Pattern OP.1/2 TDD as described in Annex A.5.2.1/2.</p> <p>Note 3: For each test, the minimum requirements shall be fulfilled for at least one of the two SNR(s) and the respective wanted signal input level.</p>						

Table 9.3.1.1.2-2 Minimum requirement (TDD)

	Test 1	Test 2
α [%]	2	2
β [%]	55	55
γ	1.1	1.1
UE Category	≥ 1	≥ 1

9.3.1.1.3 FDD (CSI measurements in case two CSI subframe sets are configured and with CRS assistance information)

For the parameters specified in Table 9.3.1.1.3-1, and using the downlink physical channels specified in Annex C.3.2, the minimum requirements are specified in Table 9.3.1.1.3-2 and by the following

- a sub-band differential CQI offset level of 0 shall be reported at least α % of the time but less than β % for each sub-band;
- the ratio of the throughput in ABS subframes obtained when transmitting on a randomly selected sub-band among the sub-bands with the highest differential CQI offset level the corresponding TBS and that obtained when transmitting the TBS indicated by the reported wideband CQI median on a randomly selected sub-band in set S shall be $\geq \gamma$;

- c) when transmitting on a randomly selected sub-band among the sub-bands with the highest differential CQI offset level the corresponding TBS, the average BLER in ABS subframes for the indicated transport formats shall be greater than or equal to ϵ .

The requirements only apply for sub-bands of full size and the random scheduling across the sub-bands is done by selecting a new sub-band in each TTI for FDD, each available downlink transmission instance for TDD.

Table 9.3.1.1.3-1 Sub-band test for single antenna transmission (FDD)

Parameter		Unit	Test 1			Test 2		
			Cell 1		Cell 2 and 3	Cell 1		Cell 2 and 3
Bandwidth		MHz	10			10		
PDSCH transmission mode			1		Note 10	1		Note 10
Downlink power allocation	ρ_A	dB	0			0		
	ρ_B	dB	0			0		
	σ	dB	0			0		
Propagation condition			Clause B.2.4 with Td = 0.45 us, a = 1, fd = 5 Hz		EVA5 Low antenna correlation	Clause B.2.4 with Td = 0.45 us, a = 1, fd = 5 Hz		EVA5 Low antenna correlation
Antenna configuration			1x2			1x2		
\widehat{E}_s / N_{oc2} (Note 1)		dB	4	5	Cell 2: 12 Cell 3: 10	14	15	Cell 2: 12 Cell 3: 10
$N_{oc}^{(j)}$ at antenna port	$N_{oc1}^{(j)}$	dBm/15kHz	-98 (Note 7)		N/A	-98 (Note 7)		N/A
	$N_{oc2}^{(j)}$	dBm/15kHz	-98 (Note 8)		N/A	-98 (Note 8)		N/A
	$N_{oc3}^{(j)}$	dBm/15kHz	-93 (Note 9)		N/A	-93 (Note 9)		N/A
Subframe Configuration			Non-MBSFN		Non-MBSFN	Non-MBSFN		Non-MBSFN
Cell Id			0		Cell 2: 6 Cell 3: 1	0		Cell 2: 6 Cell 3: 1
Time Offset between Cells		μ s	Cell 2: 3 usec Cell 3: -1usec			Cell 2: 3 usec Cell 3: -1usec		
Frequency Shift between Cells		Hz	Cell 2: 300Hz Cell 3: -100Hz			Cell 2: 300Hz Cell 3: -100Hz		
ABS pattern (Note 2)			N/A		01010101 01010101 01010101 01010101 01010101	N/A		01010101 01010101 01010101 01010101 01010101
RLM/RRM Measurement Subframe Pattern (Note 4)			00000100 00000100 00000100 00000100 00000100		N/A	00000100 00000100 00000100 00000100 00000100		N/A
CSI Subframe Sets (Note 3)	$C_{CSI,0}$		01010101 01010101 01010101 01010101 01010101		N/A	01010101 01010101 01010101 01010101 01010101		N/A
	$C_{CSI,1}$		10101010 10101010 10101010 10101010 10101010		N/A	10101010 10101010 10101010 10101010 10101010		N/A
Number of control OFDM symbols			3			3		
Max number of HARQ transmissions			1			1		
CQI delay		ms	8					
Reporting interval (Note 13)		ms	10					
Reporting mode			PUSCH 3-0					
Sub-band size		RB	6 (full size)					

Note 1:	For each test, the minimum requirements shall be fulfilled for at least one of the two SNR(s) and the respective wanted signal input level.
Note 2:	ABS pattern as defined in [9]. PDSCH other than SIB1/paging and its associated PDCCH/PCFICH are transmitted in the serving cell subframe when the subframe is overlapped with the ABS subframe of aggressor cell and the subframe is available in the definition of the reference channel.
Note 3:	Time-domain measurement resource restriction pattern for PCell measurements as defined in [7]
Note 4:	As configured according to the time-domain measurement resource restriction pattern for CSI measurements defined in [7]
Note 5:	Time-domain measurement resource restriction pattern for PCell measurements as defined in [7]
Note 6:	Cell 1 is the serving cell. Cell 2 and Cell 3 are the aggressor cells. The number of the CRS ports in Cell1, Cell2, and Cell3 are the same.
Note 7:	This noise is applied in OFDM symbols #1, #2, #3, #5, #6, #8, #9, #10,#12, #13 of a subframe overlapping with the aggressor ABS.
Note 8:	This noise is applied in OFDM symbols #0, #4, #7, #11 of a subframe overlapping with the aggressor ABS.
Note 9:	This noise is applied in all OFDM symbols of a subframe overlapping with aggressor non-ABS.
Note 10:	Downlink physical channel setup in Cell 2 and Cell 3 in accordance with Annex C.3.3 applying OCNB pattern as defined in Annex A.5.1.5
Note 11:	Reference measurement channel in Cell 1 RC.3 FDD according to Table A.4-1 with one/two sided dynamic OCNB Pattern OP.1/2 FDD as described in Annex A.5.1.1/2.
Note 12:	If the UE reports in an available uplink reporting instance at subframe SF#n based on CQI estimation at a downlink subframe not later than SF#(n-4), this reported subband or wideband CQI cannot be applied at the eNB downlink before SF#(n+4).
Note 13:	The CSI reporting is such that reference subframes belong to $C_{csi,0}$.

Table 9.3.1.1.3-2 Minimum requirement (FDD)

	Test 1	Test 2
α [%]	2	2
β [%]	55	55
γ	1.1	1.1
ϵ	0.01	0.01
UE Category	≥ 1	≥ 1

9.3.1.1.4 TDD (CSI measurements in case two CSI subframe sets are configured and with CRS assistance information)

For the parameters specified in Table 9.3.1.1.4-1, and using the downlink physical channels specified in Annex C.3.2, the minimum requirements are specified in Table 9.3.1.1.4-2 and by the following

- a sub-band differential CQI offset level of 0 shall be reported at least $\alpha\%$ of the time but less than $\beta\%$ for each sub-band;
- the ratio of the throughput in ABS subframes obtained when transmitting on a randomly selected sub-band among the sub-bands with the highest differential CQI offset level the corresponding TBS and that obtained when transmitting the TBS indicated by the reported wideband CQI median on a randomly selected sub-band in set S shall be $\geq \gamma$;
- when transmitting on a randomly selected sub-band among the sub-bands with the highest differential CQI offset level the corresponding TBS, the average BLER in ABS subframes for the indicated transport formats shall be greater than or equal to ϵ .

The requirements only apply for sub-bands of full size and the random scheduling across the sub-bands is done by selecting a new sub-band in each TTI for FDD, each available downlink transmission instance for TDD.

Table 9.3.1.1.4-1: Sub-band test for single antenna transmission (TDD)

Parameter	Unit	Test 1		Test 2			
		Cell 1	Cell 2 and 3	Cell 1	Cell 2 and 3		
Bandwidth	MHz	10		10			
PDSCH transmission mode		1	Note 10	1	Note 10		
Uplink downlink configuration		1		1			
Special subframe configuration		4		4			
Downlink power allocation	ρ_A	dB		0			
	ρ_B	dB		0			
	σ	dB		0			
Propagation condition		Clause B.2.4 with $T_d = 0.45$ μ s, $a = 1$, $f_d = 5$ Hz	EVA5 Low antenna correlation	Clause B.2.4 with $T_d = 0.45$ μ s, $a = 1$, $f_d = 5$ Hz	EVA5 Low antenna correlation		
Antenna configuration		1x2		1x2			
\hat{E}_s / N_{oc2} (Note 1)	dB	4	5	Cell 2: 12 Cell 3: 10	14 15 Cell 2: 12 Cell 3: 10		
$N_{oc}^{(j)}$ at antenna port	$N_{oc1}^{(j)}$	dBm/15kHz		-98 (Note 7)	N/A	-98 (Note 7)	N/A
	$N_{oc2}^{(j)}$	dBm/15kHz		-98 (Note 8)	N/A	-98 (Note 8)	N/A
	$N_{oc3}^{(j)}$	dBm/15kHz		-93 (Note 9)	N/A	-93 (Note 9)	N/A
Subframe Configuration		Non-MBSFN	Non-MBSFN	Non-MBSFN	Non-MBSFN		
Cell Id		0	Cell 2: 6 Cell 3: 1	0	Cell 2: 6 Cell 3: 1		
Time Offset between Cells	μ s	Cell 2: 3 usec Cell 3: -1usec		Cell 2: 3 usec Cell 3: -1usec			
Frequency shift between Cells	Hz	Cell 2: 300Hz Cell 3: -100Hz		Cell 2: 300Hz Cell 3: -100Hz			
ABS pattern (Note 2)		N/A	0100010001 0100010001	N/A	0100010001 0100010001		
RLM/RRM Measurement Subframe Pattern (Note 4)		0000000001 0000000001	N/A	0000000001 0000000001	N/A		
CSI Subframe Sets (Note 3)	$C_{CSI,0}$	0100010001 0100010001	N/A	0100010001 0100010001	N/A		
	$C_{CSI,1}$	1000101000 1000101000	N/A	1000101000 1000101000	N/A		
Number of control OFDM symbols		3		3			
Max number of HARQ transmissions		1		1			
CQI delay	ms	10					
Reporting interval (Note 13)	ms	10					
Reporting mode		PUSCH 3-0					
Sub-band size	RB	6 (full size)					
ACK/NACK feedback mode		Multiplexing		Multiplexing			

Note 1:	For each test, the minimum requirements shall be fulfilled for at least one of the two SNR(s) and the respective wanted signal input level.
Note 2:	ABS pattern as defined in [9]. PDSCH other than SIB1/paging and its associated PDCCH/PCFICH are transmitted in the serving cell subframe when the subframe is overlapped with the ABS subframe of aggressor cell and the subframe is available in the definition of the reference channel.
Note 3:	Time-domain measurement resource restriction pattern for PCell measurements as defined in [7]
Note 4:	As configured according to the time-domain measurement resource restriction pattern for CSI measurements defined in [7].
Note 5:	Time-domain measurement resource restriction pattern for PCell measurements as defined in [7]
Note 6:	Cell 1 is the serving cell. Cell 2 and Cell 3 are the aggressor cells. The number of the CRS ports in Cell1, Cell2, and Cell3 is the same.
Note 7:	This noise is applied in OFDM symbols #1, #2, #3, #5, #6, #8, #9, #10, #12, #13 of a subframe overlapping with the aggressor ABS.
Note 8:	This noise is applied in OFDM symbols #0, #4, #7, #11 of a subframe overlapping with the aggressor ABS
Note 9:	This noise is applied in all OFDM symbols of a subframe overlapping with aggressor non-ABS.
Note 10:	Downlink physical channel setup in Cell 2 and Cell 3 in accordance with Annex C.3.3 applying OCNG pattern as defined in Annex A.5.2.5
Note 11:	Reference measurement channel in Cell 1 RC.3 TDD according to Table A.4-1 with one/two sided dynamic OCNG Pattern OP.1/2 TDD as described in Annex A.5.2.1/2.
Note 12:	If the UE reports in an available uplink reporting instance at subframe SF#n based on CQI estimation at a downlink subframe not later than SF#(n-4), this reported subband or wideband CQI cannot be applied at the eNB downlink before SF#(n+4).
Note 13:	The CSI reporting is such that reference subframes belong to $C_{csi,0}$.

Table 9.3.1.1.4-2 Minimum requirement (TDD)

	Test 1	Test 2
α [%]	2	2
β [%]	55	55
γ	1.1	1.1
ε	0.01	0.01
UE Category	≥ 1	≥ 1

9.3.1.1.5 TDD (when *csi-SubframeSet* $-r12$ is configured)

The following requirements apply to UE Category ≥ 1 which supports Rel-12 CSI subframe sets. For the parameters specified in Table 9.3.1.1.5-1, and using the downlink physical channels specified in Annex C.3.2, the minimum requirements are specified in Table 9.3.1.1.5-2 and by the following

- a sub-band differential CQI offset level of 0 shall be reported at least α % of the time but less than β % for each sub-band for each CSI subframe set;
- the ratio of the throughput obtained when transmitting on a randomly selected sub-band among the sub-bands with the highest differential CQI offset level the corresponding TBS and that obtained when transmitting the TBS indicated by the reported wideband CQI median on a randomly selected sub-band in set S shall be $\geq \gamma$ for each CSI subframe set;
- when transmitting on a randomly selected sub-band among the sub-bands with the highest differential CQI offset level the corresponding TBS, the average BLER for the indicated transport formats shall be greater or equal to 0.05 and less than 0.60 for each CSI subframe set.
- the difference of the wide-band median CQI obtained by reports in CSI subframe sets $C_{csi,0}$ and the wide-band median CQI obtained by reports in CSI subframe sets $C_{csi,1}$ shall be larger than or equal to 3.

The requirements only apply for sub-bands of full size and the random scheduling across the sub-bands is done by selecting a new sub-band in each available downlink transmission instance. Sub-bands of a size smaller than full size are excluded from the test.

Table 9.3.1.1.5-1: Sub-band test for TDD

Parameter		Unit	Test	
Bandwidth		MHz	10	
Transmission mode			2	
Uplink downlink configuration			2	
Special subframe configuration			4	
CSI-MeasSubframeSet-r12			0001100000	
Downlink power allocation	ρ_A	dB	-3	
	ρ_B	dB	-3	
	σ	dB	0	
SNR in CSI subframe set 0		dB	0	1
SNR in CSI subframe set 1		dB	10	11
$\hat{I}_{or}^{(j)}$		dB[mW/15kHz]	-98	-97
$N_{oc1}^{(j)}$ for CSI subframe set 0		dB[mW/15kHz]	-98	-98
$N_{oc2}^{(j)}$ for CSI subframe set 1		dB[mW/15kHz]	-108	-108
Propagation channel			Clause B.2.4 with $\tau_d = 0.45 \mu s$, $a = 1$, $f_D = 5$ Hz	
Antenna configuration			2x2	
CRS reference signals			Antenna port 0 and 1	
Zero-Power CSI-RS configuration 0 $l_{CSI-RS} / ZeroPowerCSI-RS$ bitmap			3 / 0000010000000000	
Zero-Power CSI-RS configuration 1 $l_{CSI-RS} / ZeroPowerCSI-RS$ bitmap			4 / 0100000000000000	
PDSCH scheduled subframes for CSI subframe set 0			8,9	
PDSCH scheduled subframes for CSI subframe set 1			3,4	
Reporting interval (Note 4)		ms	10 per subframe set	
CQI delay		ms	15 for CSI subframe set 0 15 for CSI subframe set 1	
Reporting mode			PUSCH 3-0	
Sub-band size		RB	6 (full size)	
Max number of HARQ transmissions			1	
ACK/NACK feedback mode			Multiplexing	
Number of EPDCCH Sets Configured			2 (Note 5,6)	
Number of PRB per EPDCCH Set			4	
EPDCCH Subframe Monitoring			NA	
EPDCCH Aggregation level			8ECCE	
EPDCCH beamforming model			Annex B.4.4	
<p>Note 1: If the UE reports in an available uplink reporting instance at subframe SF#n based on CQI estimation at a downlink subframe not later than SF#(n-4), this reported subband or wideband CQI cannot be applied at the eNB downlink before SF#(n+4)</p> <p>Note 2: Reference measurement channel RC.17 TDD according to Table A.4-1 with one/two sided dynamic OCNG Pattern OP.1/2 TDD as described in Annex A.5.2.1/2.</p> <p>Note 3: In the test, the minimum requirements shall be fulfilled for at least one of the two SNR(s) and the respective wanted signal input level for each subframe set separately..</p> <p>Note 4: For CSI subframe set 0, PDCCH DCI format 0 with a trigger for aperiodic CQI shall be transmitted in downlink SF#3 to allow aperiodic CQI/PMI/RI to be transmitted on uplink SF #7. For CSI subframe set 1, PDCCH DCI format 0 with a trigger for aperiodic CQI shall be transmitted in downlink SF#8 to allow aperiodic CQI/PMI/RI to be transmitted on uplink SF#2.</p> <p>Note 5: In case UE supports EPDCCH, the PDSCH scheduling grants are transmitted via EPDCCH, otherwise PDCCH is used.</p> <p>Note 6: The two sets are distributed EPDCCH sets and non-overlapping with PRB = {0, 3, 6, 9} for the first set and PRB = {40, 43, 46, 49} for the second set. EPDCCH set is selected after scheduling decision for PDSCH to avoid collision between PDSCH and EPDCCH PRBs, respectively. EPDCCH is only transmitted from one set. The starting symbol for EPDCCH is derived from the PCFICH. RRC signalling epdcch-StartSymbol-r11 is not configured</p>				

Table 9.3.1.1.5-2: Minimum requirement (TDD)

	Test
α [%]	2
β [%]	55
γ	1.1
UE Category	≥ 1

9.3.1.2 Minimum requirement PUSCH 3-1 (CSI Reference Symbol)

9.3.1.2.1 FDD

For the parameters specified in Table 9.3.1.2.1-1, and using the downlink physical channels specified in Annex C.3.2, the minimum requirements are specified in Table 9.3.1.2.1-2 and by the following

- a) a sub-band differential CQI offset level of 0 shall be reported at least α % of the time but less than β % for each sub-band;
- b) the ratio of the throughput obtained when transmitting on a randomly selected sub-band among the sub-bands with the highest differential CQI offset level the corresponding TBS and that obtained when transmitting the TBS indicated by the reported wideband CQI median on a randomly selected sub-band in set S shall be $\geq \gamma$;
- c) when transmitting on a randomly selected sub-band among the sub-bands with the highest differential CQI offset level the corresponding TBS, the average BLER for the indicated transport formats shall be greater or equal to 0.05.

The requirements only apply for sub-bands of full size and the random scheduling across the sub-bands is done by selecting a new sub-band in each TTI for FDD, each available downlink transmission instance for TDD. Sub-bands of a size smaller than full size are excluded from the test.

Table 9.3.1.2.1-1 Sub-band test for FDD

Parameter		Unit	Test 1		Test 2	
Bandwidth		MHz	10 MHz			
Transmission mode			9			
Downlink power allocation	ρ_A	dB	0			
	ρ_B	dB	0			
	P_c	dB	0			
	σ	dB	0			
SNR (Note 3)		dB	4	5	11	12
$\hat{I}_{or}^{(j)}$		dB[mW/15kHz]	-94	-93	-87	-86
$N_{oc}^{(j)}$		dB[mW/15kHz]	-98		-98	
Propagation channel			Clause B.2.4 with $\tau_d = 0.45 \mu s$, $a = 1$, $f_D = 5$ Hz			
Antenna configuration			2x2			
Beamforming Model			As specified in Section B.4.3			
CRS reference signals			Antenna ports 0			
CSI reference signals			Antenna ports 15, 16			
CSI-RS periodicity and subframe offset $T_{CSI-RS} / \Delta_{CSI-RS}$			5/ 1			
CSI-RS reference signal configuration			4			
CodeBookSubsetRestriction bitmap			000001			
Reporting interval (Note 4)		ms	5			
CQI delay		ms	8			
Reporting mode			PUSCH 3-1			
Sub-band size		RB	6 (full size)			
Max number of HARQ transmissions			1			
<p>Note 1: If the UE reports in an available uplink reporting instance at subframe SF#n based on CQI estimation at a downlink subframe not later than SF#(n-4), this reported subband or wideband CQI cannot be applied at the eNB downlink before SF#(n+4)</p> <p>Note 2: Reference measurement channel RC.8 FDD according to Table A.4-1 with one/two sided dynamic OCNG Pattern OP.1/2 FDD as described in Annex A.5.1.1/2.</p> <p>Note 3: For each test, the minimum requirements shall be fulfilled for at least one of the two SNR(s) and the respective wanted signal input level.</p> <p>Note 4: PDCCH DCI format 0 with a trigger for aperiodic CQI shall be transmitted in downlink SF#1 and #6 to allow aperiodic CQI/PMI/RI to be transmitted in uplink SF#0 and #5.</p>						

Table 9.3.1.2.1-2 Minimum requirement (FDD)

	Test 1	Test 2
α [%]	2	2
β [%]	40	40
γ	1.1	1.1
UE Category	≥ 1	≥ 1

9.3.1.2.2 TDD

For the parameters specified in Table 9.3.1.2.2-1, and using the downlink physical channels specified in Annex C.3.2, the minimum requirements are specified in Table 9.3.1.2.2-2 and by the following

- a sub-band differential CQI offset level of 0 shall be reported at least α % of the time but less than β % for each sub-band;
- the ratio of the throughput obtained when transmitting on a randomly selected sub-band among the sub-bands with the highest differential CQI offset level the corresponding TBS and that obtained when transmitting the TBS indicated by the reported wideband CQI median on a randomly selected sub-band in set S shall be $\geq \gamma$;

- c) when transmitting on a randomly selected sub-band among the sub-bands with the highest differential CQI offset level the corresponding TBS, the average BLER for the indicated transport formats shall be greater or equal to 0.05.

The requirements only apply for sub-bands of full size and the random scheduling across the sub-bands is done by selecting a new sub-band in each TTI for FDD, each available downlink transmission instance for TDD. Sub-bands of a size smaller than full size are excluded from the test.

Table 9.3.1.2.2-1 Sub-band test for TDD

Parameter		Unit	Test 1		Test 2	
Bandwidth		MHz	10 MHz			
Transmission mode			9			
Uplink downlink configuration			2			
Special subframe configuration			4			
Downlink power allocation	ρ_A	dB	0			
	ρ_B	dB	0			
	P_c	dB	0			
	σ	dB	0			
SNR (Note 3)		dB	4	5	11	12
$\hat{I}_{or}^{(j)}$		dB[mW/15kHz]	-94	-93	-87	-86
$N_{oc}^{(j)}$		dB[mW/15kHz]	-98		-98	
Propagation channel			Clause B.2.4 with $\tau_d = 0.45 \mu s$, $a = 1$, $f_D = 5$ Hz			
Antenna configuration			2x2			
Beamforming Model			As specified in Section B.4.3			
CRS reference signals			Antenna port 0			
CSI reference signals			Antenna port 15,16			
CSI-RS periodicity and subframe offset $T_{CSI-RS} / \Delta_{CSI-RS}$			5/ 3			
CSI-RS reference signal configuration			4			
CodeBookSubsetRestriction bitmap			000001			
Reporting interval (Note 4)		ms	5			
CQI delay		ms	10			
Reporting mode			PUSCH 3-1			
Sub-band size		RB	6 (full size)			
Max number of HARQ transmissions			1			
ACK/NACK feedback mode			Multiplexing			
<p>Note 1: If the UE reports in an available uplink reporting instance at subframe SF#n based on CQI estimation at a downlink subframe not later than SF#(n-4), this reported subband or wideband CQI cannot be applied at the eNB downlink before SF#(n+4)</p> <p>Note 2: Reference measurement channel RC.8 TDD according to Table A.4-1 with one/two sided dynamic OCNG Pattern OP.1/2 TDD as described in Annex A.5.2.1/2.</p> <p>Note 3: For each test, the minimum requirements shall be fulfilled for at least one of the two SNR(s) and the respective wanted signal input level.</p> <p>Note 4: PDCCH DCI format 0 with a trigger for aperiodic CQI shall be transmitted in downlink SF#3 and #8 to allow aperiodic CQI/PMI/RI to be transmitted on uplink SF#2 and #7.</p>						

Table 9.3.1.2.2-2 Minimum requirement (TDD)

	Test 1	Test 2
α [%]	2	2
β [%]	40	40
γ	1.1	1.1
UE Category	≥ 1	≥ 1

9.3.1.2.3 FDD (Modulation and TBS index Table 2 and 4-bit CQI Table 2 are used)

For the parameters specified in Table 9.3.1.2.3-1, and using the downlink physical channels specified in Annex C.3.2, the minimum requirements are specified in Table 9.3.1.2.3-2 and by the following

- a sub-band differential CQI offset level of 0 shall be reported at least $\alpha\%$ of the time but less than $\beta\%$ for each sub-band;
- the ratio of the throughput obtained when transmitting on a randomly selected sub-band among the sub-bands with the highest differential CQI offset level the corresponding TBS and that obtained when transmitting the TBS indicated by the reported wideband CQI median on a randomly selected sub-band in set S shall be $\geq \gamma$;
- when transmitting on a randomly selected sub-band among the sub-bands with the highest differential CQI offset level the corresponding TBS, the average BLER for the indicated transport formats shall be greater or equal to 0.05.

The requirements only apply for sub-bands of full size and the random scheduling across the sub-bands is done by selecting a new sub-band in each TTI for FDD, each available downlink transmission instance for TDD. Sub-bands of a size smaller than full size are excluded from the test.

In this test, 4-bit CQI Table 2 in Table 7.2.3-2 in TS 36.213 [6], and Modulation and TBS index table 2 in Table 7.1.7.1-1A for PDSCH in TS 36.213 [6] are applied.

Table 9.3.1.2.3-1 Sub-band test for FDD

Parameter	Unit	Test 1	
Bandwidth	MHz	10 MHz	
Transmission mode		9	
Downlink power allocation	ρ_A	dB	0
	ρ_B	dB	0
	P_c	dB	0
	σ	dB	0
SNR (Note 3)	dB	16	17
$\hat{I}_{or}^{(j)}$	dB[mW/15kHz]	-82	-81
$N_{oc}^{(j)}$	dB[mW/15kHz]	-98	-98
Propagation channel		Clause B.2.4 with $\tau_d = 0.45 \mu s$, $a = 1$, $f_D = 5$ Hz	
Antenna configuration		2x2	
Beamforming Model		As specified in Section B.4.3	
CRS reference signals		Antenna ports 0	
CSI reference signals		Antenna ports 15, 16	
CSI-RS periodicity and subframe offset $T_{CSI-RS} / \Delta_{CSI-RS}$		5/ 1	
CSI-RS reference signal configuration		4	
CodeBookSubsetRestriction bitmap		000001	
Reporting interval (Note 4)	ms	5	
CQI delay	ms	8	
Reporting mode		PUSCH 3-1	
Sub-band size	RB	6 (full size)	
Max number of HARQ transmissions		1	
Note 1:	If the UE reports in an available uplink reporting instance at subframe SF#n based on CQI estimation at a downlink subframe not later than SF#(n-4), this reported subband or wideband CQI cannot be applied at the eNB downlink before SF#(n+4)		
Note 2:	Reference measurement channel RC.8A FDD according to Table A.4-1 with one/two sided dynamic OCNG Pattern OP.1/2 FDD as described in Annex A.5.1.1/2.		
Note 3:	For each test, the minimum requirements shall be fulfilled for at least one of the two SNR(s) and the respective wanted signal input level.		
Note 4:	PDCCH DCI format 0 with a trigger for aperiodic CQI shall be transmitted in downlink SF#1 and #6 to allow aperiodic CQI/PMI/RI to be transmitted in uplink SF#0 and #5.		

Table 9.3.1.2.3-2 Minimum requirement (FDD)

	Test 1
α [%]	2
β [%]	40
γ	1.1
UE Category	11-12
UE DL Category	≥ 11

9.3.1.2.4 TDD (Modulation and TBS index Table 2 and 4-bit CQI Table 2 are used)

For the parameters specified in Table 9.3.1.2.4-1, and using the downlink physical channels specified in Annex C.3.2, the minimum requirements are specified in Table 9.3.1.2.4-2 and by the following

- a sub-band differential CQI offset level of 0 shall be reported at least α % of the time but less than β % for each sub-band;
- the ratio of the throughput obtained when transmitting on a randomly selected sub-band among the sub-bands with the highest differential CQI offset level the corresponding TBS and that obtained when transmitting the TBS indicated by the reported wideband CQI median on a randomly selected sub-band in set S shall be $\geq \gamma$;
- when transmitting on a randomly selected sub-band among the sub-bands with the highest differential CQI offset level the corresponding TBS, the average BLER for the indicated transport formats shall be greater or equal to 0.05.

The requirements only apply for sub-bands of full size and the random scheduling across the sub-bands is done by selecting a new sub-band in each TTI for FDD, each available downlink transmission instance for TDD. Sub-bands of a size smaller than full size are excluded from the test.

In this test, 4-bit CQI Table 2 in Table 7.2.3-2 in TS 36.213 [6], and Modulation and TBS index table 2 in Table 7.1.7.1-1A for PDSCH in TS 36.213 [6] are applied.

Table 9.3.1.2.4-1 Sub-band test for TDD

Parameter		Unit	Test 1
Bandwidth		MHz	20 MHz
Transmission mode			9
Uplink downlink configuration			2
Special subframe configuration			4
Downlink power allocation	ρ_A	dB	0
	ρ_B	dB	0
	P_c	dB	0
	σ	dB	0

SNR (Note 3)	dB	16	17
$\hat{I}_{or}^{(j)}$	dB[mW/15kHz]	-82	-81
$N_{oc}^{(j)}$	dB[mW/15kHz]	-98	-98
Propagation channel		Clause B.2.4 with $\tau_d = 0.45 \mu s$, $a = 1$, $f_D = 5$ Hz	
Antenna configuration		2x2	
Beamforming Model		As specified in Section B.4.3	
CRS reference signals		Antenna port 0	
CSI reference signals		Antenna port 15,16	
CSI-RS periodicity and subframe offset $T_{CSI-RS} / \Delta_{CSI-RS}$		5/ 3	
CSI-RS reference signal configuration		4	
CodeBookSubsetRestriction bitmap		000001	
Reporting interval (Note 4)	ms	5	
CQI delay	ms	10	
Reporting mode		PUSCH 3-1	
Sub-band size	RB	8 (full size)	
Max number of HARQ transmissions		1	
ACK/NACK feedback mode		Multiplexing	
<p>Note 1: If the UE reports in an available uplink reporting instance at subframe SF#n based on CQI estimation at a downlink subframe not later than SF#(n-4), this reported subband or wideband CQI cannot be applied at the eNB downlink before SF#(n+4)</p> <p>Note 2: Reference measurement channel RC.8A TDD according to Table A.4-1 with one/two sided dynamic OCNG Pattern OP.1/2 TDD as described in Annex A.5.2.1/2.</p> <p>Note 3: For each test, the minimum requirements shall be fulfilled for at least one of the two SNR(s) and the respective wanted signal input level.</p> <p>Note 4: PDCCH DCI format 0 with a trigger for aperiodic CQI shall be transmitted in downlink SF#3 and #8 to allow aperiodic CQI/PMI/RI to be transmitted on uplink SF#2 and #7.</p>			

Table 9.3.1.2.4-2 Minimum requirement (TDD)

	Test 1
α [%]	2
β [%]	40
γ	1.1
UE Category	11-12
UE DL Category	≥ 11

9.3.1.2.5 Void

Table 9.3.1.2.5-1: Void**Table 9.3.1.2.5-2: Void**9.3.1.2.6 TDD (when *csi-SubframeSet -r12* is configured with one CSI process)

The following requirements apply to UE Category ≥ 1 which supports Rel-12 CSI subframe sets and TM10. For the parameters specified in Table 9.3.1.2.6-1, and using the downlink physical channels specified in Annex C.3.2, the minimum requirements are specified in Table 9.3.1.2.6-2 and by the following

- a sub-band differential CQI offset level of 0 shall be reported at least α % of the time but less than β % for each sub-band for each CSI subframe set;
- the ratio of the throughput obtained when transmitting on a randomly selected sub-band among the sub-bands with the highest differential CQI offset level the corresponding TBS and that obtained when transmitting the

TBS indicated by the reported wideband CQI median on a randomly selected sub-band in set S shall be $\geq \gamma$ for each CSI subframe set;

- c) when transmitting on a randomly selected sub-band among the sub-bands with the highest differential CQI offset level the corresponding TBS, the average BLER for the indicated transport formats shall be greater or equal to 0.01 for each CSI subframe set.
- d) The difference of the wide-band median CQI obtained by reports in CSI subframe sets $C_{CSI,0}$ and the wide-band median CQI obtained by reports in CSI subframe sets $C_{CSI,1}$ shall be larger than or equal to 3.

The requirements only apply for sub-bands of full size and the random scheduling across the sub-bands is done by selecting a new sub-band in each available downlink transmission instance. Sub-bands of a size smaller than full size are excluded from the test.

Table 9.3.1.2.6-1: Sub-band test for TDD

Parameter		Unit	Test	
Bandwidth		MHz	10	
Transmission mode			10	
Uplink downlink configuration			2	
Special subframe configuration			4	
CSI-MeasSubframeSet-r12			0001100000	
Downlink power allocation	ρ_A	dB	0	
	ρ_B	dB	0	
	P_C	dB	-3	
	σ	dB	-3	
SNR in CSI subframe set 0		dB	0	1
SNR in CSI subframe set 1		dB	10	11
$\hat{I}_{or}^{(j)}$		dB[mW/15kHz]	-98	-97
$N_{oc1}^{(j)}$ for CSI subframe set 0		dB[mW/15kHz]	-98	-98
$N_{oc2}^{(j)}$ for CSI subframe set 1		dB[mW/15kHz]	-108	-108
Propagation channel			Clause B.2.4 with $\tau_d = 0.45 \mu\text{s}$, $a = 1$, $f_D = 5 \text{ Hz}$	
Antenna configuration			2x2	
Beamforming Model			As specified in Section B.4.3	
CRS reference signals			Antenna port 0 and 1	
CSI reference signals			Antenna port 15,16	
CSI-RS periodicity and subframe offset $T_{\text{CSI-RS}} / \Delta_{\text{CSI-RS}}$			5/ 0	
CSI-RS reference signal configuration			0	
Zero-Power CSI-RS configuration 0 $l_{\text{CSI-RS}} / \text{ZeroPowerCSI-RS}$ bitmap			3 / 0000010000000000	
Zero-Power CSI-RS configuration 1 $l_{\text{CSI-RS}} / \text{ZeroPowerCSI-RS}$ bitmap			4 / 0100000000000000	
CSI-IM configuration 0 $l_{\text{CSI-RS}} / \text{ZeroPowerCSI-RS}$ bitmap			3 / 0000010000000000	
CSI-IM configuration 1 $l_{\text{CSI-RS}} / \text{ZeroPowerCSI-RS}$ bitmap			4 / 0100000000000000	
CSI process configuration Signal/Interference/Reporting mode for CSI subframe set 0			CSI-RS/CSI-IM 0/PUSCH 3-1	
CSI process configuration Signal/Interference/Reporting mode for CSI subframe set 1			CSI-RS/CSI-IM 1/PUSCH 3-1	
CodeBookSubsetRestriction bitmap			000001	
Reporting interval (Note 4)		ms	10 per subframe set	
CQI delay		ms	15 for CSI subframe set 0 15 for CSI subframe set 1	
Sub-band size		RB	6 (full size)	
PDSCH scheduled subframes for CSI subframe set 0			8,9	
PDSCH scheduled subframes for CSI subframe set 1			3,4	
Max number of HARQ transmissions			1	
ACK/NACK feedback mode			Multiplexing	
Note 1: If the UE reports in an available uplink reporting instance at subframe SF#n based on CQI estimation at a downlink subframe not later than SF#(n-4), this reported subband or wideband CQI cannot be applied at the eNB downlink before SF#(n+4)				
Note 2: Reference measurement channel RC.18 TDD according to Table A.4-1 with one/two sided dynamic OCNB Pattern OP.1/2 TDD as described in Annex A.5.2.1/2.				
Note 3: For each test, the minimum requirements shall be fulfilled for at least one of the two SNR(s) and the respective wanted signal input level for each subframe set separately.				
Note 4: For CSI subframe set 0, PDCCH DCI format 0 with a trigger for aperiodic CQI/PMI/RI shall be transmitted in downlink SF#3 to allow aperiodic CQI/PMI/RI to be transmitted on uplink SF #7. For CSI subframe set 1, PDCCH DCI format 0 with a trigger for aperiodic CQI shall be transmitted in downlink SF#8 to allow aperiodic CQI/PMI/RI to be transmitted				

on uplink SF#2.

Table 9.3.1.2.6-2: Minimum requirement (TDD)

	Test
α [%]	2
β [%]	55
γ	1.02
UE Category	≥ 1

9.3.2 Frequency non-selective scheduling mode

The reporting accuracy of the channel quality indicator (CQI) under frequency non-selective fading conditions is determined by the reporting variance, and the relative increase of the throughput obtained when the transport format transmitted is that indicated by the reported CQI compared to the case for which a fixed transport format configured according to the reported median CQI is transmitted. In addition, the reporting accuracy is determined by a minimum BLER using the transport formats indicated by the reported CQI. The purpose is to verify that the UE is tracking the channel variations and selecting the largest transport format possible according to the prevailing channel state for frequently non-selective scheduling. To account for sensitivity of the input SNR the CQI reporting under frequency non-selective fading conditions is considered to be verified if the reporting accuracy is met for at least one of two SNR levels separated by an offset of 1 dB.

9.3.2.1 Minimum requirement PUCCH 1-0 (Cell-Specific Reference Symbol)

9.3.2.1.1 FDD

For the parameters specified in Table 9.3.2.1.1-1 and Table 9.3.2.1.1-3, and using the downlink physical channels specified in Annex C.3.2, the minimum requirements are specified in Table 9.3.2.1.1-2 and Table 9.3.2.1.1-4 and by the following

- a CQI index not in the set {median CQI -1, median CQI, median CQI +1} shall be reported at least α % of the time;
- the ratio of the throughput obtained when transmitting the transport format indicated by each reported wideband CQI index and that obtained when transmitting a fixed transport format configured according to the wideband CQI median shall be $\geq \gamma$;
- when transmitting the transport format indicated by each reported wideband CQI index, the average BLER for the indicated transport formats shall be greater or equal to 0.02

The applicability of the requirement with 5MHz bandwidth as specified in Table 9.3.2.1.1-3 and Table 9.3.2.1.1-4 is defined in 9.1.1.1.

Table 9.3.2.1.1-1 Fading test for single antenna (FDD)

Parameter		Unit	Test 1		Test 2	
Bandwidth		MHz	10 MHz			
Transmission mode			1 (port 0)			
Downlink power allocation	ρ_A	dB	0			
	ρ_B	dB	0			
	σ	dB	0			
SNR (Note 3)		dB	6	7	12	13
$\hat{I}_{or}^{(j)}$		dB[mW/15kHz]	-92	-91	-86	-85
$N_{oc}^{(j)}$		dB[mW/15kHz]	-98		-98	
Propagation channel			EPA5			
Correlation and antenna configuration			High (1 x 2)			
Reporting mode			PUCCH 1-0			
Reporting periodicity		ms	$N_{pd} = 2$			
CQI delay		ms	8			
Physical channel for CQI reporting			PUSCH (Note 4)			
PUCCH Report Type			4			
<i>cqi-pmi-ConfigurationIndex</i>			1			
Max number of HARQ transmissions			1			
<p>Note 1: If the UE reports in an available uplink reporting instance at subframe SF#n based on CQI estimation at a downlink SF not later than SF#(n-4), this reported wideband CQI cannot be applied at the eNB downlink before SF#(n+4)</p> <p>Note 2: Reference measurement channel RC.1 FDD according to Table A.4-1 for Category 2-8 with one sided dynamic OCNG Pattern OP.1 FDD as described in Annex A.5.1.1 and RC.4 FDD according to Table A.4-1 for Category 1 with one/two sided dynamic OCNG Pattern OP.1/2 FDD as described in Annex A.5.1.1/2.</p> <p>Note 3: For each test, the minimum requirements shall be fulfilled for at least one of the two SNR(s) and the respective wanted signal input level.</p> <p>Note 4: To avoid collisions between CQI reports and HARQ-ACK it is necessary to report both on PUSCH instead of PUCCH. PDCCH DCI format 0 shall be transmitted in downlink SF#1, #3, #7 and #9 to allow periodic CQI to multiplex with the HARQ-ACK on PUSCH in uplink subframe SF#5, #7, #1 and #3.</p>						

Table 9.3.2.1.1-2 Minimum requirement (FDD)

	Test 1	Test 2
α [%]	20	20
γ	1.05	1.05
UE Category	≥ 1	≥ 1

Table 9.3.2.1.1-3 Fading test for single antenna (FDD)

Parameter		Unit	Test 1		Test 2	
Bandwidth		MHz	5 MHz			
Transmission mode			1 (port 0)			
Downlink power allocation	ρ_A	dB	0			
	ρ_B	dB	0			
	σ	dB	0			
SNR (Note 3)		dB	6	7	12	13
$\hat{I}_{or}^{(j)}$		dB[mW/15kHz]	-92	-91	-86	-85
$N_{oc}^{(j)}$		dB[mW/15kHz]	-98		-98	
Propagation channel			EPA5			
Correlation and antenna configuration			High (1 x 2)			
Reporting mode			PUCCH 1-0			
Reporting periodicity		ms	$N_{pd} = 2$			
CQI delay		ms	8			
Physical channel for CQI reporting			PUSCH (Note 4)			
PUCCH Report Type			4			
<i>cqi-pmi-ConfigurationIndex</i>			1			
Max number of HARQ transmissions			1			
<p>Note 1: If the UE reports in an available uplink reporting instance at subframe SF#n based on CQI estimation at a downlink SF not later than SF#(n-4), this reported wideband CQI cannot be applied at the eNB downlink before SF#(n+4)</p> <p>Note 2: Reference measurement channel RC.14 FDD according to Table A.4-1 for Category ≥ 2 with one sided dynamic OCNG Pattern OP.1 FDD as described in Annex A.5.1.1 and RC.15 FDD according to Table A.4-1 for Category 1 with one/two sided dynamic OCNG Pattern OP.1/2 FDD as described in Annex A.5.1.1/2. Note 3: For each test, the minimum requirements shall be fulfilled for at least one of the two SNR(s) and the respective wanted signal input level.</p> <p>Note 4: To avoid collisions between CQI reports and HARQ-ACK it is necessary to report both on PUSCH instead of PUCCH. PDCCH DCI format 0 shall be transmitted in downlink SF#1, #3, #7 and #9 to allow periodic CQI to multiplex with the HARQ-ACK on PUSCH in uplink subframe SF#5, #7, #1 and #3.</p>						

Table 9.3.2.1.1-4 Minimum requirement (FDD)

	Test 1	Test 2
α [%]	20	20
γ	1.05	1.05
UE Category	≥ 1	≥ 1

9.3.2.1.2 TDD

For the parameters specified in Table 9.3.2.1.2-1, and using the downlink physical channels specified in Annex C.3.2, the minimum requirements are specified in Table 9.3.2.1.2-2 and by the following

- a CQI index not in the set {median CQI -1, median CQI, median CQI +1} shall be reported at least α % of the time;
- the ratio of the throughput obtained when transmitting the transport format indicated by each reported wideband CQI index and that obtained when transmitting a fixed transport format configured according to the wideband CQI median shall be $\geq \gamma$;
- when transmitting the transport format indicated by each reported wideband CQI index, the average BLER for the indicated transport formats shall be greater or equal to 0.02.

Table 9.3.2.1.2-1 Fading test for single antenna (TDD)

Parameter		Unit	Test 1		Test 2	
Bandwidth		MHz	10 MHz			
Transmission mode			1 (port 0)			
Downlink power allocation	ρ_A	dB	0			
	ρ_B	dB	0			
	σ	dB	0			
Uplink downlink configuration			2			
Special subframe configuration			4			
SNR (Note 3)		dB	6	7	12	13
$\hat{I}_{or}^{(j)}$		dB[mW/15kHz]	-92	-91	-86	-85
$N_{oc}^{(j)}$		dB[mW/15kHz]	-98		-98	
Propagation channel			EPA5			
Correlation and antenna configuration			High (1 x 2)			
Reporting mode			PUCCH 1-0			
Reporting periodicity		ms	$N_{pd} = 5$			
CQI delay		ms	10 or 11			
Physical channel for CQI reporting			PUSCH (Note 4)			
PUCCH Report Type			4			
<i>cqi-pmi-ConfigurationIndex</i>			3			
Max number of HARQ transmissions			1			
ACK/NACK feedback mode			Multiplexing			
<p>Note 1: If the UE reports in an available uplink reporting instance at subframe SF#n based on CQI estimation at a downlink SF not later than SF#(n-4), this reported wideband CQI cannot be applied at the eNB downlink before SF#(n+4).</p> <p>Note 2: Reference measurement channel RC.1 TDD according to Table A.4-1 for Category 2-8 with one sided dynamic OCNG Pattern OP.1 TDD as described in Annex A.5.2.1 and RC.4 TDD according to Table A.4-1 for Category 1 with one/two sided dynamic OCNG Pattern OP.1/2 TDD as described in Annex A.5.2.1/2.</p> <p>Note 3: For each test, the minimum requirements shall be fulfilled for at least one of the two SNR(s) and the respective wanted signal input level.</p> <p>Note 4: To avoid collisions between CQI reports and HARQ-ACK it is necessary to report both on PUSCH instead of PUCCH. PDCCH DCI format 0 shall be transmitted in downlink SF#3 and #8 to allow periodic CQI to multiplex with the HARQ-ACK on PUSCH in uplink subframe SF#7 and #2.</p>						

Table 9.3.2.1.2-2 Minimum requirement (TDD)

	Test 1	Test 2
α [%]	20	20
γ	1.05	1.05
UE Category	≥ 1	≥ 1

9.3.2.2 Minimum requirement PUCCH 1-1 (CSI Reference Symbol)

9.3.2.2.1 FDD

For the parameters specified in Table 9.3.2.2.1-1, and using the downlink physical channels specified in Annex C.3.2, the minimum requirements are specified in Table 9.3.2.2.1-2 and by the following

- a CQI index not in the set {median CQI -1, median CQI, median CQI +1} shall be reported at least $\alpha\%$ of the time;
- the ratio of the throughput obtained when transmitting the transport format indicated by each reported wideband CQI index and that obtained when transmitting a fixed transport format configured according to the wideband CQI median shall be $\geq \gamma$;
- when transmitting the transport format indicated by each reported wideband CQI index, the average BLER for the indicated transport formats shall be greater or equal to 0.02.

Table 9.3.2.2.1-1 Fading test for FDD

Parameter		Unit	Test 1		Test 2	
Bandwidth		MHz	10 MHz			
Transmission mode			9			
Downlink power allocation	ρ_A	dB	0			
	ρ_B	dB	0			
	P_C	dB	-3			
	σ	dB	-3			
SNR (Note 3)		dB	2	3	7	8
$\hat{I}_{or}^{(j)}$		dB[mW/15kHz]	-96	-95	-91	-90
$N_{oc}^{(j)}$		dB[mW/15kHz]	-98		-98	
Propagation channel			EPA5			
Correlation and antenna configuration			ULA High (4 x 2)			
Beamforming Model			As specified in Section B.4.3			
Cell-specific reference signals			Antenna ports 0,1			
CSI reference signals			Antenna ports 15,...,18			
CSI-RS periodicity and subframe offset $T_{CSI-RS} / \Delta_{CSI-RS}$			5/1			
CSI-RS reference signal configuration			2			
CodeBookSubsetRestriction bitmap			0x0000 0000 0000 0001			
Reporting mode			PUCCH 1-1			
Reporting periodicity		ms	$N_{pd} = 5$			
CQI delay		ms	8			
Physical channel for CQI/ PMI reporting			PUSCH (Note 4)			
PUCCH Report Type for CQI/PMI			2			
PUCCH channel for RI reporting			PUCCH Format 2			
PUCCH report type for RI			3			
<i>cqi-pmi-ConfigurationIndex</i>			2			
<i>ri-ConfigIndex</i>			1			
Max number of HARQ transmissions			1			
<p>Note 1: If the UE reports in an available uplink reporting instance at subframe SF#n based on CQI estimation at a downlink SF not later than SF#(n-4), this reported wideband CQI cannot be applied at the eNB downlink before SF#(n+4)</p> <p>Note 2: Reference measurement channel RC.7 FDD according to Table A.4-1 with one sided dynamic OCNG Pattern OP.1 FDD as described in Annex A.5.1.1.</p> <p>Note 3: For each test, the minimum requirements shall be fulfilled for at least one of the two SNR(s) and the respective wanted signal input level.</p> <p>Note 4: To avoid collisions between CQI/ PMI reports and HARQ-ACK it is necessary to report both on PUSCH instead of PUCCH. PDCCH DCI format 0 shall be transmitted in downlink SF#1 and #6 to allow periodic CQI/ PMI to multiplex with the HARQ-ACK on PUSCH in uplink subframe SF#0 and #5.</p>						

Table 9.3.2.2.1-2 Minimum requirement (FDD)

	Test 1	Test 2
α [%]	20	20
γ	1.05	1.05
UE Category	≥ 2	≥ 2

9.3.2.2.2 TDD

For the parameters specified in Table 9.3.2.2.2-1, and using the downlink physical channels specified in Annex C.3.2, the minimum requirements are specified in Table 9.3.2.2.2-2 and by the following

- a) a CQI index not in the set {median CQI -1, median CQI, median CQI +1} shall be reported at least α % of the time;
- b) the ratio of the throughput obtained when transmitting the transport format indicated by each reported wideband CQI index and that obtained when transmitting a fixed transport format configured according to the wideband CQI median shall be $\geq \gamma$;
- c) when transmitting the transport format indicated by each reported wideband CQI index, the average BLER for the indicated transport formats shall be greater or equal to 0.02.

Table 9.3.2.2-1 Fading test for TDD

Parameter		Unit	Test 1		Test 2	
Bandwidth		MHz	10 MHz			
Transmission mode			9			
Uplink downlink configuration			2			
Special subframe configuration			4			
Downlink power allocation	ρ_A	dB	0			
	ρ_B	dB	0			
	P_C	dB	-6			
	σ	dB	-3			
SNR (Note 3)		dB	1	2	7	8
$\hat{I}_{or}^{(j)}$		dB[mW/15kHz]	-97	-96	-91	-90
$N_{oc}^{(j)}$		dB[mW/15kHz]	-98		-98	
Propagation channel			EPA5			
Correlation and antenna configuration			XP High (8 x 2)			
Beamforming Model			As specified in Section B.4.3			
CRS reference signals			Antenna ports 0, 1			
CSI reference signals			Antenna ports 15, ..., 22			
CSI-RS periodicity and subframe offset $T_{CSI-RS} / \Delta_{CSI-RS}$			5/ 3			
CSI-RS reference signal configuration			2			
CodeBookSubsetRestriction bitmap			0x0000 0000 0000 0020 0000 0000 0001			
Reporting mode			PUCCH 1-1 (Sub-mode: 2)			
Reporting periodicity		ms	$N_{pd} = 5$			
CQI delay		ms	10			
Physical channel for CQI/ PMI reporting			PUSCH (Note 4)			
PUCCH Report Type for CQI/ PMI			2c			
Physical channel for RI reporting			PUCCH Format 2			
PUCCH report type for RI			3			
<i>cqi-pmi-ConfigurationIndex</i>			3			
<i>ri-ConfigIndex</i>			805 (Note 5)			
Max number of HARQ transmissions			1			
ACK/NACK feedback mode			Multiplexing			
<p>Note 1: If the UE reports in an available uplink reporting instance at subframe SF#n based on CQI estimation at a downlink SF not later than SF#(n-4), this reported wideband CQI cannot be applied at the eNB downlink before SF#(n+4)</p> <p>Note 2: Reference measurement channel RC.7 TDD according to Table A.4-1 with one sided dynamic OCNG Pattern OP.1 TDD as described in Annex A.5.2.1.</p> <p>Note 3: For each test, the minimum requirements shall be fulfilled for at least one of the two SNR(s) and the respective wanted signal input level.</p> <p>Note 4: To avoid collisions between CQI/ PMI reports and HARQ-ACK it is necessary to report both on PUSCH instead of PUCCH. PDCCH DCI format 0 shall be transmitted in downlink SF#3 and #8 to allow periodic CQI/ PMI to multiplex with the HARQ-ACK on PUSCH in uplink subframe SF#2 and #7.</p> <p>Note 5: RI reporting interval is set to the maximum allowable length of 160ms to minimise collisions between RI, CQI/PMI and HARQ-ACK reports. In the case when all three reports collide, it is expected that CQI/PMI reports will be dropped, while RI and HARQ-ACK will be multiplexed. At eNB, CQI report collection shall be skipped every 160ms during performance verification and the reported CQI in subframe SF#7 of the previous frame is applied in downlink subframes until a new CQI (after CQI/PMI dropping) is available.</p>						

Table 9.3.2.2-2 Minimum requirement (TDD)

	Test 1	Test 2
α [%]	20	20
γ	1.05	1.05
UE Category	≥ 2	≥ 2

9.3.3 Frequency-selective interference

The accuracy of sub-band channel quality indicator (CQI) reporting under frequency selective interference conditions is determined by a percentile of the reported differential CQI offset level +2 for a preferred sub-band, and the relative increase of the throughput obtained when transmitting on a randomly selected sub-band among the sub-bands with the highest reported differential CQI offset level the corresponding transport format compared to the case for which a fixed format is transmitted on any sub-band in set S of TS 36.213 [6]. The purpose is to verify that preferred sub-bands are used for frequently-selective scheduling under frequency-selective interference conditions.

9.3.3.1 Minimum requirement PUSCH 3-0 (Cell-Specific Reference Symbol)

9.3.3.1.1 FDD

For the parameters specified in Table 9.3.3.1.1-1, and using the downlink physical channels specified in Annex C.3.2, the minimum requirements are specified in Table 9.3.3.1.1-2 and by the following

- a) a sub-band differential CQI offset level of +2 shall be reported at least $\alpha\%$ for at least one of the sub-bands of full size at the channel edges;
- b) the ratio of the throughput obtained when transmitting on a randomly selected sub-band among the sub-bands with the highest differential CQI offset level the corresponding TBS and that obtained when transmitting the TBS indicated by the reported wideband CQI median on a randomly selected sub-band in set S shall be $\geq \gamma$;

The requirements only apply for sub-bands of full size and the random scheduling across the sub-bands is done by selecting a new sub-band in each TTI for FDD, each available downlink transmission instance for TDD. Sub-bands of a size smaller than full size are excluded from the test.

Table 9.3.3.1.1-1 Sub-band test for single antenna transmission (FDD)

Parameter		Unit	Test 1	Test 2
Bandwidth		MHz	10 MHz	10 MHz
Transmission mode			1 (port 0)	1 (port 0)
Downlink power allocation	ρ_A	dB	0	0
	ρ_B	dB	0	0
	σ	dB	0	0
$I_{ot}^{(j)}$ for RB 0...5		dB[mW/15kHz]	-102	-93
$I_{ot}^{(j)}$ for RB 6...41		dB[mW/15kHz]	-93	-93
$I_{ot}^{(j)}$ for RB 42...49		dB[mW/15kHz]	-93	-102
$\hat{I}_{or}^{(j)}$		dB[mW/15kHz]	-94	-94
Max number of HARQ transmissions			1	
Propagation channel			Clause B.2.4 with $\tau_d = 0.45 \mu s$, $a = 1$, $f_D = 5$ Hz	
Reporting interval		ms	5	
Antenna configuration			1 x 2	
CQI delay		ms	8	
Reporting mode			PUSCH 3-0	
Sub-band size		RB	6 (full size)	
Note 1: If the UE reports in an available uplink reporting instance at subframe SF#n based on CQI estimation at a downlink subframe not later than SF#(n-4), this reported subband or wideband CQI cannot be applied at the eNB downlink before SF#(n+4) Note 2: Reference measurement channel RC.3 FDD according to Table A.4-1 with one/two sided dynamic OCNG Pattern OP.1/2 FDD as described in Annex A.5.1.1/2.				

Table 9.3.3.1.1-2 Minimum requirement (FDD)

	Test 1	Test 2
α [%]	60	60
γ	1.6	1.6
UE Category	≥ 1	≥ 1

9.3.3.1.2 TDD

For the parameters specified in Table 9.3.3.1.2-1, and using the downlink physical channels specified in Annex C.3.2, the minimum requirements are specified in Table 9.3.3.1.2-2 and by the following

- a sub-band differential CQI offset level of +2 shall be reported at least α % for at least one of the sub-bands of full size at the channel edges;
- the ratio of the throughput obtained when transmitting on a randomly selected sub-band among the sub-bands with the highest differential CQI offset level the corresponding TBS and that obtained when transmitting the TBS indicated by the reported wideband CQI median on a randomly selected sub-band in set S shall be $\geq \gamma$;

The requirements only apply for sub-bands of full size and the random scheduling across the sub-bands is done by selecting a new sub-band in each TTI for FDD, each available downlink transmission instance for TDD. Sub-bands of a size smaller than full size are excluded from the test.

Table 9.3.3.1.2-1 Sub-band test for single antenna transmission (TDD)

Parameter	Unit	Test 1	Test 2
Bandwidth	MHz	10 MHz	10 MHz
Transmission mode		1 (port 0)	1 (port 0)
Downlink power allocation	ρ_A	dB	0
	ρ_B	dB	0
	σ	dB	0
Uplink downlink configuration		2	
Special subframe configuration		4	
$I_{ot}^{(j)}$ for RB 0...5	dB[mW/15kHz]	-102	-93
$I_{ot}^{(j)}$ for RB 6...41	dB[mW/15kHz]	-93	-93
$I_{ot}^{(j)}$ for RB 42...49	dB[mW/15kHz]	-93	-102
$\hat{I}_{or}^{(j)}$	dB[mW/15kHz]	-94	-94
Max number of HARQ transmissions		1	
Propagation channel		Clause B.2.4 with $\tau_d = 0.45 \mu s$, $a = 1$, $f_D = 5$ Hz	
Antenna configuration		1 x 2	
Reporting interval	ms	5	
CQI delay	ms	10 or 11	
Reporting mode		PUSCH 3-0	
Sub-band size	RB	6 (full size)	
ACK/NACK feedback mode		Multiplexing	
Note 1:	If the UE reports in an available uplink reporting instance at subframe SF#n based on CQI estimation at a downlink subframe not later than SF#(n-4), this reported subband or wideband CQI cannot be applied at the eNB downlink before SF#(n+4).		
Note 2:	Reference measurement channel RC.3 TDD according to table A.4-1 with one/two sided dynamic OCNG Pattern OP.1/2 TDD as described in Annex A.5.2.1/2.		

Table 9.3.3.1.2-2 Minimum requirement (TDD)

	Test 1	Test 2
α [%]	60	60
γ	1.6	1.6
UE Category	≥ 1	≥ 1

9.3.3.2 Void

9.3.3.2.1 Void

9.3.3.2.2 Void

9.3.4 UE-selected subband CQI

The accuracy of UE-selected subband channel quality indicator (CQI) reporting under frequency-selective fading conditions is determined by the relative increase of the throughput obtained when transmitting on the UE-selected subbands with the corresponding transport format compared to the case for which a fixed format is transmitted on any subband in set S of TS 36.213 [6]. The purpose is to verify that correct subbands are accurately reported for frequency-selective scheduling. To account for sensitivity of the input SNR the subband CQI reporting under frequency-selective fading conditions is considered to be verified if the reporting accuracy is met for at least one of two SNR levels separated by an offset of 1 dB.

9.3.4.1 Minimum requirement PUSCH 2-0 (Cell-Specific Reference Symbols)

9.3.4.1.1 FDD

For the parameters specified in Table 9.3.4.1.1-1, and using the downlink physical channels specified in Annex C.3.2, the minimum requirements are specified in Table 9.3.4.1.1-2 and by the following

- a) the ratio of the throughput obtained when transmitting on a randomly selected subband among the best M subbands reported by the UE the corresponding TBS and that obtained when transmitting the TBS indicated by the reported wideband CQI median on a randomly selected subband in set S shall be $\geq \gamma$;

The requirements only apply for subbands of full size and the random scheduling across the subbands is done by selecting a new subband in each TTI for FDD. The transport block size TBS (wideband CQI median) is that resulting from the code rate which is closest to that indicated by the wideband CQI median and the N_{PRB} entry in Table 7.1.7.2.1-1 of TS 36.213 [6] that corresponds to the subband size.

Table 9.3.4.1.1-1 Subband test for single antenna transmission (FDD)

Parameter		Unit	Test 1		Test 2	
Bandwidth		MHz	10 MHz			
Transmission mode			1 (port 0)			
Downlink power allocation	ρ_A	dB	0			
	ρ_B	dB	0			
	σ	dB	0			
SNR (Note 3)		dB	9	10	14	15
$\hat{I}_{or}^{(j)}$		dB[mW/15kHz]	-89	-88	-84	-83
$N_{oc}^{(j)}$		dB[mW/15kHz]	-98		-98	
Propagation channel			Clause B.2.4 with $\tau_d = 0.45 \mu\text{s}$, $a = 1$, $f_D = 5 \text{ Hz}$			
Reporting interval		ms	5			
CQI delay		ms	8			
Reporting mode			PUSCH 2-0			
Max number of HARQ transmissions			1			
Subband size (k)		RBs	3 (full size)			
Number of preferred subbands (M)			5			
<p>Note 1: If the UE reports in an available uplink reporting instance at subframe SF#n based on CQI estimation at a downlink subframe not later than SF#($n-4$), this reported subband or wideband CQI cannot be applied at the eNB downlink before SF#($n+4$)</p> <p>Note 2: Reference measurement channel RC.5 FDD according to Table A.4-1 with one/two sided dynamic OCNG Pattern OP.1/2 FDD as described in Annex A.5.1.1/2.</p> <p>Note 3: For each test, the minimum requirements shall be fulfilled for at least one of the two SNR(s) and the respective wanted signal input level.</p>						

Table 9.3.4.1.1-2 Minimum requirement (FDD)

	Test 1	Test 2
γ	1.2	1.2
UE Category	≥ 1	≥ 1

9.3.4.1.2 TDD

For the parameters specified in Table 9.3.4.1.2-1, and using the downlink physical channels specified in Annex C.3.2, the minimum requirements are specified in Table 9.3.4.1.2-2 and by the following

- a) the ratio of the throughput obtained when transmitting on a randomly selected subband among the best M subbands reported by the UE the corresponding TBS and that obtained when transmitting the TBS indicated by the reported wideband CQI median on a randomly selected subband in set S shall be $\geq \gamma$;

The requirements only apply for subbands of full size and the random scheduling across the subbands is done by selecting a new subband in each available downlink transmission instance for TDD. The transport block size TBS (wideband CQI median) is that resulting from the code rate which is closest to that indicated by the wideband CQI median and the N_{PRB} entry in Table 7.1.7.2.1-1 of TS 36.213 [6] that corresponds to the subband size.

Table 9.3.4.1.2-1 Sub-band test for single antenna transmission (TDD)

Parameter		Unit	Test 1		Test 2	
Bandwidth		MHz	10 MHz			
Transmission mode			1 (port 0)			
Downlink power allocation	ρ_A	dB	0			
	ρ_B	dB	0			
	σ	dB	0			
Uplink downlink configuration			2			
Special subframe configuration			4			
SNR (Note 3)		dB	9	10	14	15
$\hat{I}_{or}^{(j)}$		dB[mW/15kHz]	-89	-88	-84	-83
$N_{oc}^{(j)}$		dB[mW/15kHz]	-98		-98	
Propagation channel			Clause B.2.4 with $\tau_d = 0.45 \mu\text{s}$, $a = 1$, $f_D = 5 \text{ Hz}$			
Reporting interval		ms	5			
CQI delay		ms	10 or 11			
Reporting mode			PUSCH 2-0			
Max number of HARQ transmissions			1			
Subband size (k)		RBs	3 (full size)			
Number of preferred subbands (M)			5			
ACK/NACK feedback mode			Multiplexing			
<p>Note 1: If the UE reports in an available uplink reporting instance at subframe SF#n based on CQI estimation at a downlink subframe not later than SF#($n-4$), this reported subband or wideband CQI cannot be applied at the eNB downlink before SF#($n+4$)</p> <p>Note 2: Reference measurement channel RC.5 TDD according to Table A.4-1 with one/two sided dynamic OCNG Pattern OP.1/2 TDD as described in Annex A.5.2.1/2.</p> <p>Note 3: For each test, the minimum requirements shall be fulfilled for at least one of the two SNR(s) and the respective wanted signal input level.</p>						

Table 9.3.4.1.2-2 Minimum requirement (TDD)

	Test 1	Test 2
γ	1.2	1.2
UE Category	≥ 1	≥ 1

9.3.4.2 Minimum requirement PUCCH 2-0 (Cell-Specific Reference Symbols)

9.3.4.2.1 FDD

For the parameters specified in Table 9.3.4.2.1-1, and using the downlink physical channels specified in Annex C.3.2, the minimum requirements are specified in Table 9.3.4.2.1-2 and by the following

- a) the ratio of the throughput obtained when transmitting on subbands reported by the UE the corresponding TBS and that obtained when transmitting the TBS indicated by the reported wideband CQI median on a randomly selected subband in set S shall be $\geq \gamma$;

The requirements only apply for subbands of full size and the random scheduling across the subbands is done by selecting a new subband in each TTI for FDD. The transport block size TBS (wideband CQI median) is that resulting

from the code rate which is closest to that indicated by the wideband CQI median and the N_{PRB} entry in Table 7.1.7.2.1-1 of TS 36.213 [6] that corresponds to the subband size.

Table 9.3.4.2.1-1 Subband test for single antenna transmission (FDD)

Parameter	Unit	Test 1		Test 2	
Bandwidth	MHz	10 MHz			
Transmission mode		1 (port 0)			
Downlink power allocation	ρ_A	dB			
	ρ_B	dB			
	σ	dB			
SNR (Note 3)	dB	8	9	13	14
$\hat{I}_{or}^{(j)}$	dB[mW/15kHz]	-90	-89	-85	-84
$N_{oc}^{(j)}$	dB[mW/15kHz]	-98		-98	
Propagation channel		Clause B.2.4 with $\tau_d = 0.45 \mu s$, $a = 1$, $f_D = 5$ Hz			
Reporting periodicity	ms	$N_P = 2$			
CQI delay	ms	8			
Physical channel for CQI reporting		PUSCH (Note 4)			
PUCCH Report Type for wideband CQI		4			
PUCCH Report Type for subband CQI		1			
Max number of HARQ transmissions		1			
Subband size (k)	RBs	6 (full size)			
Number of bandwidth parts (J)		3			
K		1			
<i>cqi-pmi-ConfigIndex</i>		1			
Note 1:	If the UE reports in an available uplink reporting instance at subframe SF# n based on CQI estimation at a downlink subframe not later than SF#($n-4$), this reported subband or wideband CQI cannot be applied at the eNB downlink before SF#($n+4$)				
Note 2:	Reference measurement channel RC.3 FDD according to Table A.4-1 with one/two sided dynamic OCNG Pattern OP.1/2 FDD as described in Annex A.5.1.1/2.				
Note 3:	For each test, the minimum requirements shall be fulfilled for at least one of the two SNR(s) and the respective wanted signal input level.				
Note 4:	To avoid collisions between CQI reports and HARQ-ACK it is necessary to report both on PUSCH instead of PUCCH. PDCCH DCI format 0 shall be transmitted in downlink SF#1, #3, #7 and #9 to allow periodic CQI to multiplex with the HARQ-ACK on PUSCH in uplink subframe SF#5, #7, #1 and #3.				
Note 5:	CQI reports for the short subband (having 2RBs in the last bandwidth part) are to be disregarded and data scheduling according to the most recent subband CQI report for bandwidth part with $j=1$.				
Note 6:	In the case where wideband CQI is reported, data is to be scheduled according to the most recently used subband CQI report.				

Table 9.3.4.2.1-2 Minimum requirement (FDD)

	Test 1	Test 2
γ	1.15	1.15
UE Category	≥ 1	≥ 1

9.3.4.2.2 TDD

For the parameters specified in Table 9.3.4.2.2-1, and using the downlink physical channels specified in Annex C.3.2, the minimum requirements are specified in Table 9.3.4.2.2-2 and by the following

- a) the ratio of the throughput obtained when transmitting on subbands reported by the UE the corresponding TBS and that obtained when transmitting the TBS indicated by the reported wideband CQI median on a randomly selected subband in set S shall be $\geq \gamma$;

The requirements only apply for subbands of full size and the random scheduling across the subbands is done by selecting a new subband in each available downlink transmission instance for TDD. The transport block size TBS (wideband CQI median) is that resulting from the code rate which is closest to that indicated by the wideband CQI median and the N_{PRB} entry in Table 7.1.7.2.1-1 of TS 36.213 [6] that corresponds to the subband size.

Table 9.3.4.2.2-1 Sub-band test for single antenna transmission (TDD)

Parameter	Unit	Test 1		Test 2	
Bandwidth	MHz	10 MHz			
Transmission mode		1 (port 0)			
Downlink power allocation	ρ_A	dB	0		
	ρ_B	dB	0		
	σ	dB	0		
Uplink downlink configuration		2			
Special subframe configuration		4			
SNR (Note 3)	dB	8	9	13	14
$\hat{I}_{or}^{(j)}$	dB[mW/15kHz]	-90	-89	-85	-84
$N_{oc}^{(j)}$	dB[mW/15kHz]	-98		-98	
Propagation channel		Clause B.2.4 with $\tau_d = 0.45 \mu\text{s}$, $a = 1$, $f_D = 5 \text{ Hz}$			
Reporting periodicity	ms	$N_p = 5$			
CQI delay	ms	10 or 11			
Physical channel for CQI reporting		PUSCH (Note 4)			
PUCCH Report Type for wideband CQI		4			
PUCCH Report Type for subband CQI		1			
Max number of HARQ transmissions		1			
Subband size (k)	RBs	6 (full size)			
Number of bandwidth parts (J)		3			
K		1			
$cqi-pmi-ConfigIndex$		3			
ACK/NACK feedback mode		Multiplexing			
Note 1:	If the UE reports in an available uplink reporting instance at subframe SF# n based on CQI estimation at a downlink subframe not later than SF# $(n-4)$, this reported subband or wideband CQI cannot be applied at the eNB downlink before SF# $(n+4)$.				
Note 2:	Reference measurement channel RC.3 TDD according to Table A.4-1 with one/two sided dynamic OCNG Pattern OP.1/2 TDD as described in Annex A.5.2.1/2.				
Note 3:	For each test, the minimum requirements shall be fulfilled for at least one of the two SNR(s) and the respective wanted signal input level.				
Note 4:	To avoid collisions between CQI reports and HARQ-ACK it is necessary to report both on PUSCH instead of PUCCH. PDCCH DCI format 0 shall be transmitted in downlink SF#3 and #8 to allow periodic CQI to multiplex with the HARQ-ACK on PUSCH in uplink subframe SF#7 and #2.				
Note 5:	CQI reports for the short subband (having 2RBs in the last bandwidth part) are to be disregarded and data scheduling according to the most recent subband CQI report for bandwidth part with $j=1$.				
Note 6:	In the case where wideband CQI is reported, data is to be scheduled according to the most recently used subband CQI report.				

Table 9.3.4.2.2-2 Minimum requirement (TDD)

	Test 1	Test 2
γ	1.15	1.15
UE Category	≥ 1	≥ 1

9.3.5 Additional requirements for enhanced receiver Type A

The purpose of the test is to verify that the reporting of the channel quality is based on the receiver of the enhanced Type A. Performance requirements are specified in terms of the relative increase of the throughput obtained when the transport format is that indicated by the reported CQI subject to an interference model compared to the case with a white Gaussian noise model, and a requirement on the minimum BLER of the transmitted transport formats indicated by the reported CQI subject to an interference model.

9.3.5.1 Minimum requirement PUCCH 1-0 (Cell-Specific Reference Symbol)

9.3.5.1.1 FDD

For the parameters specified in Table 9.3.5.1.1-1, and using the downlink physical channels specified in Annex C, the minimum requirements are specified in Table 9.3.5.1.1-2 and by the following

- a) the ratio of the throughput obtained when transmitting the transport format indicated by each reported wideband CQI index subject to an interference source with specified DIP and that obtained when transmitting the transport format indicated by each reported wideband CQI index subject to a white Gaussian noise source shall be $\geq \gamma$;
- b) when transmitting the transport format indicated by each reported wideband CQI index subject to an interference source with specified DIP, the average BLER for the indicated transport formats shall be greater than or equal to 2%.

Table 9.3.5.1.1-1 Fading test for single antenna (FDD)

Parameter	Unit	Cell 1	Cell 2
Bandwidth	MHz	10 MHz	
Transmission mode		1 (port 0)	
Cyclic Prefix		Normal	Normal
Cell ID		0	1
SINR (Note 8)	dB	-2	N/A
$N_{oc}^{(j)}$	dB[mW/15kHz]	-98	N/A
Propagation channel		EPA5	Static (Note 7)
Correlation and antenna configuration		Low (1 x 2)	(1 x 2)
DIP (Note 4)	dB	N/A	-0.41
Reference measurement channel		Note 2	R.2 FDD
Reporting mode		PUCCH 1-0	N/A
Reporting periodicity	ms	$N_{pd} = 2$	N/A
CQI delay	ms	8	N/A
Physical channel for CQI reporting		PUSCH (Note 3)	N/A
PUCCH Report Type		4	N/A
<i>cqi-pmi-ConfigurationIndex</i>		1	N/A
Max number of HARQ transmissions		1	N/A
<p>Note 1: If the UE reports in an available uplink reporting instance at subframe SF#n based on CQI estimation at a downlink SF not later than SF#(n-4), this reported wideband CQI cannot be applied at the eNB downlink before SF#(n+4)</p> <p>Note 2: Reference measurement channel RC.1 FDD according to Table A.4-1 for Category 2-8 with one sided dynamic OCNG Pattern OP.1 FDD as described in Annex A.5.1.1 and RC.4 FDD according to Table A.4-1 for Category 1 with one/two sided dynamic OCNG Pattern OP.1/2 FDD as described in Annex A.5.1.1/2.</p> <p>Note 3: To avoid collisions between CQI reports and HARQ-ACK it is necessary to report both on PUSCH instead of PUCCH. PDCCH DCI format 0 shall be transmitted in downlink SF#1, #3, #7 and #9 to allow periodic CQI to multiplex with the HARQ-ACK on PUSCH in uplink subframe SF#5, #7, #1 and #3.</p> <p>Note 4: The respective received power spectral density of each interfering cell relative to N_{oc} is defined by its associated DIP value as specified in clause B.5.1.</p> <p>Note 5: Two cells are considered in which Cell 1 is the serving cell and Cell 2 is the interfering cell. The number of the CRS ports in both cells is the same. Interfering cell is fully loaded.</p> <p>Note 6: Both cells are time-synchronous.</p> <p>Note 7: Static channel is used for the interference model. In case for white Gaussian noise model Cell 2 is not present.</p> <p>Note 8: SINR corresponds to \hat{E}_s / N_{oc} of Cell 1 as defined in clause 8.1.1.</p>			

Table 9.3.5.1.1-2 Minimum requirement (FDD)

γ	1.8
UE Category	≥ 1

9.3.5.1.2 TDD

For the parameters specified in Table 9.3.5.1.2-1, and using the downlink physical channels specified in Annex C, the minimum requirements are specified in 9.3.5.1.2-2 and by the following

- the ratio of the throughput obtained when transmitting the transport format indicated by each reported wideband CQI index subject to an interference source with specified DIP and that obtained when transmitting the transport format indicated by each reported wideband CQI index subject to a white Gaussian noise source shall be $\geq \gamma$;

- b) when transmitting the transport format indicated by each reported wideband CQI index subject to an interference source with specified DIP, the average BLER for the indicated transport formats shall be greater than or equal to 2%.

Table 9.3.5.1.2-1 Fading test for single antenna (TDD)

Parameter	Unit	Cell 1	Cell 2
Bandwidth	MHz	10 MHz	
Transmission mode		1 (port 0)	
Uplink downlink configuration		2	
Special subframe configuration		4	
Cyclic Prefix		Normal	Normal
Cell ID		0	1
SINR (Note 8)	dB	-2	N/A
$N_{oc}^{(j)}$	dB[mW/15kHz]	-98	-98
Propagation channel		EPA5	Static (Note 7)
Correlation and antenna configuration		Low (1 x 2)	(1 x 2)
DIP (Note 4)	dB	N/A	-0.41
Reference measurement channel		Note 2	R.2A TDD
Reporting mode		PUCCH 1-0	N/A
Reporting periodicity	ms	$N_{pd} = 5$	N/A
CQI delay	ms	10 or 11	N/A
Physical channel for CQI reporting		PUSCH (Note 3)	N/A
PUCCH Report Type		4	N/A
<i>cqi-pmi-ConfigurationIndex</i>		3	N/A
Max number of HARQ transmissions		1	N/A
ACK/NACK feedback mode		Multiplexing	N/A
Note 1:	If the UE reports in an available uplink reporting instance at subframe SF#n based on CQI estimation at a downlink SF not later than SF#(n-4), this reported wideband CQI cannot be applied at the eNB downlink before SF#(n+4)		
Note 2:	Reference measurement channel RC.1 TDD according to Table A.4-1 for Category 2-8 with one sided dynamic OCNG Pattern OP.1 TDD as described in Annex A.5.2.1 and RC.4 TDD according to Table A.4-1 for Category 1 with one/two sided dynamic OCNG Pattern OP.1/2 TDD as described in Annex A.5.2.1/2.		
Note 3:	To avoid collisions between CQI reports and HARQ-ACK it is necessary to report both on PUSCH instead of PUCCH. PDCCH DCI format 0 shall be transmitted in downlink SF#3 and #8 to allow periodic CQI to multiplex with the HARQ-ACK on PUSCH in uplink subframe SF#7 and #2.		
Note 4:	The respective received power spectral density of each interfering cell relative to N_{oc} is defined by its associated DIP value as specified in clause B.5.1.		
Note 5:	Two cells are considered in which Cell 1 is the serving cell and Cell 2 is the interfering cell. The number of the CRS ports in both cells is the same. Interfering cell is fully loaded.		
Note 6:	Both cells are time-synchronous.		
Note 7:	Static channel is used for the interference model. In case for white Gaussian noise model Cell 2 is not present.		
Note 8:	SINR corresponds to \hat{E}_s / N_{oc} of Cell 1 as defined in clause 8.1.1.		

Table 9.3.5.1.2-2 Minimum requirement (TDD)

γ	1.8
UE Category	≥ 1

9.3.5.2 Minimum requirement PUCCH 1-1 (CSI Reference Symbol)

9.3.5.2.1 FDD

For the parameters specified in Table 9.3.5.2.1-1, and using the downlink physical channels specified in Annex C, the minimum requirements are specified in Table 9.3.5.2.1-2 and by the following

- a) the ratio of the throughput obtained when transmitting the transport format indicated by each reported wideband CQI index subject to an interference source with specified DIP and that obtained when transmitting the transport format indicated by each reported wideband CQI index subject to a white Gaussian noise source shall be $\geq \gamma$;
- b) when transmitting the transport format indicated by each reported wideband CQI index subject to an interference source with specified DIP, the average BLER for the indicated transport formats shall be greater than or equal to 2%.

Table 9.3.5.2.1-1 Fading test for two antennas (FDD)

Parameter	Unit	Cell 1	Cell 2
Bandwidth	MHz	10 MHz	
Transmission mode		9	
Cyclic Prefix		Normal	Normal
Cell ID		0	1
SINR (Note 8)	dB	-2	N/A
$N_{oc}^{(j)}$	dB[mW/15kHz]	-98	N/A
Propagation channel		EPA5	Static (Note 7)
Correlation and antenna configuration		Low (2 x 2)	(1 x 2)
Beamforming Model		As specified in Section B.4.3 (Note 10, 11)	N/A
DIP (Note 4)	dB	N/A	-0.41
Cell-specific reference signals		Antenna ports 0,1	Antenna port 0
CSI reference signals		Antenna ports 15,16	N/A
CSI-RS periodicity and subframe offset		5/1	N/A
CSI-RS reference signal configuration		2	N/A
Zero-power CSI-RS configuration I_{CSI-RS} / ZeroPowerCSI-RS bitmap	Subframes / bitmap	N/A	1 / 001000000000 000
CodeBookSubsetRestriction bitmap		001111	N/A
Reference measurement channel		Note 2	R.2 FDD
Reporting mode		PUCCH 1-1	N/A
Reporting periodicity	ms	$N_{pd} = 5$	N/A
CQI delay	ms	8	N/A
Physical channel for CQI/PMI reporting		PUSCH (Note 3)	N/A
PUCCH Report Type for CQI/PMI		2	N/A
PUCCH channel for RI reporting		PUCCH Format 2	N/A
PUCCH Report Type for RI		3	N/A
$cqi-pmi-ConfigurationIndex$		2	N/A
$ri-ConfigIndex$		1	N/A
Max number of HARQ transmissions		1	N/A
Note 1:	If the UE reports in an available uplink reporting instance at subframe SF#n based on CQI estimation at a downlink SF not later than SF#(n-4), this reported wideband CQI cannot be applied at the eNB downlink before SF#(n+4)		
Note 2:	Reference measurement channel RC.11 FDD according to Table A.4-1 with one sided dynamic OCN Pattern OP.1 FDD as described in Annex A.5.1.1.		
Note 3:	To avoid collisions between CQI/ PMI reports and HARQ-ACK it is necessary to report both on PUSCH instead of PUCCH. PDCCH DCI format 0 shall be transmitted in downlink SF#1 and #6 to allow periodic CQI/ PMI to multiplex with the HARQ-ACK on PUSCH in uplink subframe SF#0 and #5.		
Note 4:	The respective received power spectral density of each interfering cell relative to N_{oc} is defined by its associated DIP value as specified in clause B.5.1.		
Note 5:	Two cells are considered in which Cell 1 is the serving cell and Cell 2 is the interfering cell. Interfering cell is fully loaded.		

Note 6:	Both cells are time-synchronous.
Note 7:	Static channel is used for the interference model. In case for white Gaussian noise model Cell 2 is not present.
Note 8:	SINR corresponds to \widehat{E}_s / N_{oc} of Cell 1 as defined in clause 8.1.1.
Note 9:	N/A.
Note 10:	The precoder in clause B.4.3 follows UE recommended PMI.
Note 11:	If the UE reports in an available uplink reporting instance at subframe SF#n based on PMI estimation at a downlink SF not later than SF#(n-4), this reported PMI cannot be applied at the eNB downlink before SF#(n+4).

Table 9.3.5.2.1-2 Minimum requirement (FDD)

γ	1.8
UE Category	≥ 2

9.3.5.2.2 TDD

For the parameters specified in Table 9.3.5.2.2-1, and using the downlink physical channels specified in Annex C, the minimum requirements are specified in 9.3.5.2.2-2 and by the following

- a) the ratio of the throughput obtained when transmitting the transport format indicated by each reported wideband CQI index subject to an interference source with specified DIP and that obtained when transmitting the transport format indicated by each reported wideband CQI index subject to a white Gaussian noise source shall be $\geq \gamma$;
- b) when transmitting the transport format indicated by each reported wideband CQI index subject to an interference source with specified DIP, the average BLER for the indicated transport formats shall be greater than or equal to 2%.

Table 9.3.5.2.2-1 Fading test for single antenna (TDD)

Parameter	Unit	Cell 1	Cell 2
Bandwidth	MHz	10 MHz	
Transmission mode		9	
Uplink downlink configuration		2	
Special subframe configuration		4	
Cyclic Prefix		Normal	Normal
Cell ID		0	1
SINR (Note 8)	dB	-2	N/A
$N_{oc}^{(j)}$	dB[mW/15kHz]	-98	-98
Propagation channel		EPA5	Static (Note 7)
Correlation and antenna configuration		Low (2 x 2)	(1 x 2)
Beamforming Model		As specified in Section B.4.3 (Note 11, 12)	N/A
DIP (Note 4)	dB	N/A	-0.41
Cell-specific reference signals		Antenna ports 0,1	Antenna port 0
CSI reference signals		Antenna ports 15,16	N/A
CSI-RS periodicity and subframe offset		5/3	N/A
CSI-RS reference signal configuration		2	N/A
Zero-power CSI-RS configuration I_{CSI-RS} / ZeroPowerCSI-RS bitmap	Subframes / bitmap	N/A	3 / 001000000000 0000
CodeBookSubsetRestriction bitmap		001111	N/A
Reference measurement channel		Note 2	R.2A TDD
Reporting mode		PUCCH 1-1	N/A
Reporting periodicity	ms	$N_{pd} = 5$	N/A
CQI delay	ms	10	N/A
Physical channel for CQI/PMI reporting		PUSCH (Note 3)	N/A
PUCCH Report Type for CQI/PMI		2	N/A
Physical channel for RI reporting		PUCCH Format 2	N/A
PUCCH Report Type for RI		3	N/A
$cqi-pmi-ConfigurationIndex$		3	N/A
$ri-ConfigIndex$		805 (Note 9)	N/A
Max number of HARQ transmissions		1	N/A
ACK/NACK feedback mode		Multiplexing	N/A
<p>Note 1: If the UE reports in an available uplink reporting instance at subframe SF#n based on CQI estimation at a downlink SF not later than SF#(n-4), this reported wideband CQI cannot be applied at the eNB downlink before SF#(n+4)</p> <p>Note 2: Reference measurement channel RC.11 TDD according to Table A.4-1 with one sided dynamic OCNG Pattern OP.1 TDD as described in Annex A.5.2.1.</p> <p>Note 3: To avoid collisions between CQI/ PMI reports and HARQ-ACK it is necessary to report both on PUSCH instead of PUCCH. PDCCH DCI format 0 shall be transmitted in downlink SF#3 and #8 to allow periodic CQI/ PMI to multiplex with the HARQ-ACK on PUSCH in</p>			

Note 4:	uplink subframe SF#2 and #7. The respective received power spectral density of each interfering cell relative to N_{oc} is defined by its associated DIP value as specified in clause B.5.1.
Note 5:	Two cells are considered in which Cell 1 is the serving cell and Cell 2 is the interfering cell. Interfering cell is fully loaded.
Note 6:	Both cells are time-synchronous.
Note 7:	Static channel is used for the interference model. In case for white Gaussian noise model Cell 2 is not present.
Note 8:	SINR corresponds to \hat{E}_s / N_{oc} of Cell 1 as defined in clause 8.1.1.
Note 9:	RI reporting interval is set to the maximum allowable length of 160ms to minimise collisions between RI, CQI/PMI and HARQ-ACK reports. In the case when all three reports collide, it is expected that CQI/PMI reports will be dropped, while RI and HARQ-ACK will be multiplexed. At eNB, CQI report collection shall be skipped every 160ms during performance verification and the reported CQI in subframe SF#7 of the previous frame is applied in downlink subframes until a new CQI (after CQI/PMI dropping) is available.
Note 10:	N/A.
Note 11:	The precoder in clause B.4.3 follows UE recommended PMI.
Note 12:	If the UE reports in an available uplink reporting instance at subframe SF#n based on PMI estimation at a downlink SF not later than SF#(n-4), this reported PMI cannot be applied at the eNB downlink before SF#(n+4).

Table 9.3.5.2-2 Minimum requirement (TDD)

γ	1.8
UE Category	≥ 2

9.3.6 Minimum requirement (With multiple CSI processes)

The purpose of the test is to verify the reporting accuracy of the CQI and the UE processing capability for multiple CSI processes. Each CSI process is associated with a CSI-RS resource and a CSI-IM resource as shown in Table 9.3.6-1. For UE supports one CSI process, CSI process 2 is configured and the corresponding requirements shall be fulfilled. For UE supports three CSI processes, CSI processes 0, 1 and 2 are configured and the corresponding requirements shall be fulfilled. For UE supports four CSI processes, CSI processes 0, 1, 2 and 3 are configured and the corresponding requirements shall be fulfilled.

Table 9.3.6-1: Configuration of CSI processes

	CSI process 0	CSI process 1	CSI process 2	CSI process 3
CSI-RS resource	CSI-RS signal 0	CSI-RS signal 1	CSI-RS signal 0	CSI-RS signal 1
CSI-IM resource	CSI-IM resource 0	CSI-IM resource 0	CSI-IM resource 1	CSI-IM resource 2

9.3.6.1 FDD

For the parameters specified in Table 9.3.6.1-1, and using the downlink physical channels specified in Annex C.3.2, the minimum requirements are specified in Table 9.3.6.1-2 and by the following

- a sub-band differential CQI offset level of 0 shall be reported at least $\alpha\%$ of the time but less than $\beta\%$ for each sub-band for CSI process 1, 2, or 3;
- a CQI index not in the set {median CQI -1, median CQI, median CQI +1} shall be reported at least $\delta\%$ of the time for CSI process 0;
- the difference of the median CQIs of the reported wideband CQI for configured CSI processes shall be greater or equal to the values as in Table 9.3.6.1-3;

- d) the ratio of the throughput obtained when transmitting on a randomly selected sub-band among the sub-bands with the highest differential CQI offset level the corresponding TBS and that obtained when transmitting the TBS indicated by the reported wideband CQI median on a randomly selected sub-band in set S shall be $\geq \gamma$;
- e) when transmitting on a randomly selected sub-band among the sub-bands with the highest differential CQI offset level the corresponding TBS, the average BLER for the indicated transport formats shall be greater or equal to 0.02.

The requirements only apply for sub-bands of full size and the random scheduling across the sub-bands is done by selecting a new sub-band in each TTI for FDD, each available downlink transmission instance for TDD. Sub-bands of a size smaller than full size are excluded from the test.

Table 9.3.6.1-1: Fading test for FDD

Parameter	Unit	Test 1				Test 2				
		TP1		TP2		TP1		TP2		
Bandwidth	MHz	10 MHz				10 MHz				
Transmission mode		10		10		10		10		
Downlink power allocation	ρ_A	0				0				
	ρ_B	0				0				
	P_c	-3		0		-3		0		
	σ	-3				-3				
SNR (Note 7)	dB	10	11	7	8	14	15	9	10	
$\hat{I}_{or}^{(j)}$	dB[mW/15kHz]	-88	-87	-91	-90	-84	-85	-89	-88	
$N_{oc}^{(j)}$	dB[mW/15kHz]	-98				-98				
Propagation channel		EPA 5 Low		Clause B.2.4.1 with $\tau_d = 0.45 \mu\text{s}$, $a = 1$, $f_D = 5 \text{ Hz}$		EPA 5 Low		Clause B.2.4.1 with $\tau_d = 0.45 \mu\text{s}$, $a = 1$, $f_D = 5 \text{ Hz}$		
Antenna configuration		4x2		2x2		4x2		2x2		
Beamforming Model		As specified in Section B.4.3				As specified in Section B.4.3				
Timing offset between TPs	us	0				0				
Frequency offset between TPs	Hz	0				0				
Cell-specific reference signals		Antenna ports 0,1				Antenna ports 0,1				
CSI-RS signal 0		Antenna ports 15,...,18		N/A		Antenna ports 15,...,18		N/A		
CSI-RS 0 periodicity and subframe offset $T_{\text{CSI-RS}} / \Delta_{\text{CSI-RS}}$		5/1		N/A		5/1		N/A		
CSI-RS 0 configuration		0		N/A		0		N/A		
CSI-RS signal 1		N/A		Antenna ports 15,16		N/A		Antenna ports 15,16		
CSI-RS 1 periodicity and subframe offset $T_{\text{CSI-RS}} / \Delta_{\text{CSI-RS}}$		N/A		5/1		N/A		5/1		
CSI-RS 1 configuration		N/A		5		N/A		5		
Zero-power CSI-RS 0 configuration $I_{\text{CSI-RS}} / \text{ZeroPowerCSI-RS}$ bitmap		N/A		1 / 111000000000 0000		N/A		1 / 111000000000 0000		
Zero-power CSI-RS 1 configuration $I_{\text{CSI-RS}} / \text{ZeroPowerCSI-RS}$ bitmap		1 / 00100110000 00000		N/A		1 / 00100110000 00000		N/A		
CSI-IM 0 periodicity and subframe offset $T_{\text{CSI-IM}} / \Delta_{\text{CSI-IM}}$		5/1		5/1		5/1		5/1		
CSI-IM 0 configuration		2		2		2		2		
CSI-IM 1 periodicity and subframe offset $T_{\text{CSI-IM}} / \Delta_{\text{CSI-IM}}$		5/1		N/A		5/1		N/A		
CSI-IM 1 configuration		6		N/A		6		N/A		
CSI-IM 2 periodicity and subframe offset $T_{\text{CSI-IM}} / \Delta_{\text{CSI-IM}}$		N/A		5/1		N/A		5/1		
CSI-IM 2 configuration		N/A		1		N/A		1		
CSI process 0	CSI-RS	CSI-RS 0				CSI-RS 0				
	CSI-IM	CSI-IM 0				CSI-IM 0				
	Reporting mode	PUCCH 1-1				PUCCH 1-1				
	CodeBookSubsetRestriction bitmap	0x0000 0000 0000 0001				0x0000 0000 0000 0001				
	Reporting periodicity	ms	$N_{pd} = 5$				$N_{pd} = 5$			
	CQI delay	ms	11				11			
	Physical channel for CQI/ PMI reporting		PUSCH (Note 6)				PUSCH (Note 6)			
	PUCCH Report Type for CQI/PMI		2				2			
	PUCCH channel		PUCCH Format 2				PUCCH Format 2			

	for RI reporting				
	PUCCH report type for RI		3	3	
	<i>cqi-pmi-ConfigurationIndex</i>		4	4	
	<i>ri-ConfigIndex</i>		2	2	
CSI process 1	CSI-RS		CSI-RS 1	CSI-RS 1	
	CSI-IM		CSI-IM 0	CSI-IM 0	
	Reporting mode		PUSCH 3-1	PUSCH 3-1	
	CodeBookSubsetRestriction bitmap		000001	000001	
	Reporting interval (Note 10)	ms	5	5	
	CQI delay	ms	11	11	
	Sub-band size	RB	6 (full size)	6 (full size)	
CSI process 2 (For UE configured single process)	CSI-RS		CSI-RS 0	CSI-RS 0	
	CSI-IM		CSI-IM 1	CSI-IM 1	
	Reporting mode		PUSCH 3-1	PUSCH 3-1	
	CodeBookSubsetRestriction bitmap		0x0000 0000 0000 0001	0x0000 0000 0000 0001	
	Reporting interval (Note 8)	ms	5	5	
	CQI delay	ms	8	8	
	Sub-band size	RB	6 (full size) (Note 9)	6 (full size) (Note 9)	
CSI process 3	CSI-RS		CSI-RS 1	CSI-RS 1	
	CSI-IM		CSI-IM 2	CSI-IM 2	
	Reporting mode		PUSCH 3-1	PUSCH 3-1	
	CodeBookSubsetRestriction bitmap		000001	000001	
	Reporting interval (Note 10)	ms	5	5	
	CQI delay	ms	11	11	
	Sub-band size	RB	6 (full size)	6 (full size)	
CSI process for PDSCH scheduling			CSI process 2		CSI process 2
Cell ID		0	6	0	6
Quasi-co-located CSI-RS		CSI-RS 0	CSI-RS 1	CSI-RS 0	CSI-RS 1
Quasi-co-located CRS		Same Cell ID as Cell 1	Same Cell ID as Cell 2	Same Cell ID as Cell 1	Same Cell ID as Cell 2
PMI for subframe 2, 3, 4, 7, 8 and 9		0x0000 0000 0000 0001	100000	0x0000 0000 0000 0001	100000
PMI for subframe 1 and 6		0x0000 0000 0001 0000	100000	0x0000 0000 0001 0000	100000
Max number of HARQ transmissions		1	N/A	1	N/A
Note 1: If the UE reports in an available uplink reporting instance at subframe SF#n based on CQI estimation at a downlink SF not later than SF#(n-4), this reported wideband CQI cannot be applied at the eNB downlink before SF#(n+4)					
Note 2: 3 symbols allocated to PDCCH					
Note 3: Reference measurement channel RC.12 FDD according to Table A.4-1. PDSCH transmission is scheduled on subframe 2, 3, 4, 7, 8 and 9 from TP1.					
Note 4: TM10 OCNG OP.8 FDD as specified in A.5.1.8 is transmitted on subframe 1 and 6 from TP1.					
Note 5: TM10 OCNG OP.8 FDD as specified in A.5.1.8 is transmitted on subframe 1, 2, 3, 4, 6, 7, 8 and 9 from TP2					
Note 6: To avoid collisions between CQI/PMI reports and HARQ-ACK it is necessary to report both on PUSCH instead of PUCCH. PDCCH DCI format 0 shall be transmitted in downlink SF#3 and #8 to allow periodic CQI/PMI to multiplex with the HARQ-ACK on PUSCH in uplink SF#2 and #7.					
Note 7: For each test, the minimum requirements shall be fulfilled for at least one of the two SNR(s) and the respective wanted signal input level.					
Note 8: PDCCH DCI format 0 with a trigger for aperiodic CQI shall be transmitted in downlink SF#1 and #6 to allow aperiodic CQI/PMI/RI to be transmitted in uplink SF#0 and #5.					
Note 9: For these sub-bands which are not selected for PDSCH transmission, TM10 OCNG should be transmitted.					
Note 10: PDCCH DCI format 0 with a trigger for aperiodic CQI shall be transmitted in downlink SF#2 and #7 to allow aperiodic CQI/PMI/RI to be transmitted in uplink SF#1 and #6.					

Table 9.3.6.1-2: Minimum requirement (FDD)

	CSI process 0	CSI process 1	CSI process 2	CSI process 3
α [%]	N/A	2	2	2
β [%]	N/A	40	40	40
δ [%]	10	N/A	N/A	N/A
γ	N/A	N/A	1.02	N/A
UE Category	≥ 1			

Table 9.3.6.1-3: Minimum median CQI difference between configured CSI processes (FDD)

	CSI process 1	CSI process 2	CSI process 3
CSI process 0	N/A	1	3
UE Category	≥ 1		

9.3.6.2 TDD

For the parameters specified in Table 9.3.6.2-1, and using the downlink physical channels specified in Annex C.3.2, the minimum requirements are specified in Table 9.3.6.2-2 and by the following

- a sub-band differential CQI offset level of 0 shall be reported at least α % of the time but less than β % for each sub-band for CSI process 1, 2, or 3;
- a CQI index not in the set {median CQI -1, median CQI, median CQI +1} shall be reported at least δ % of the time for CSI process 0;
- the difference of the median CQIs of the reported wideband CQI for configured CSI processes shall be greater or equal to the values as in Table 9.3.6.2-3;
- the ratio of the throughput obtained when transmitting on a randomly selected sub-band among the sub-bands with the highest differential CQI offset level the corresponding TBS and that obtained when transmitting the TBS indicated by the reported wideband CQI median on a randomly selected sub-band in set S shall be $\geq \gamma$;
- when transmitting on a randomly selected sub-band among the sub-bands with the highest differential CQI offset level the corresponding TBS, the average BLER for the indicated transport formats shall be greater or equal to 0.02.

The requirements only apply for sub-bands of full size and the random scheduling across the sub-bands is done by selecting a new sub-band in each TTI for FDD, each available downlink transmission instance for TDD. Sub-bands of a size smaller than full size are excluded from the test.

Table 9.3.6.2-1: Fading test for TDD

Parameter		Unit	Test 1				Test 2			
			TP1		TP2		TP1		TP2	
Bandwidth		MHz	10 MHz				10 MHz			
Transmission mode			10		10		10		10	
Uplink downlink configuration			2		2		2		2	
Special subframe configuration			4		4		4		4	
Downlink power allocation	ρ_A	dB	0				0			
	ρ_B	dB	0				0			
	P_C	dB	-3		0		-3		0	
	σ	dB	-3				-3			
SNR (Note 7)		dB	10	11	7	8	14	15	9	10
$\hat{I}_{or}^{(j)}$		dB[mW/15kHz]	-88	-87	-91	-90	-84	-85	-89	-88
$N_{oc}^{(j)}$		dB[mW/15kHz]	-98				-98			
Propagation channel			EPA 5 Low		Clause B.2.4.1 with $\tau_d = 0.45 \mu\text{s}$, $a = 1$, $f_D = 5 \text{ Hz}$		EPA 5 Low		Clause B.2.4.1 with $\tau_d = 0.45 \mu\text{s}$, $a = 1$, $f_D = 5 \text{ Hz}$	
Antenna configuration			4x2		2x2		4x2		2x2	
Beamforming Model			As specified in Section B.4.3				As specified in Section B.4.3			
Timing offset between TPs		us	0				0			
Frequency offset between TPs		Hz	0				0			
Cell-specific reference signals			Antenna ports 0,1				Antenna ports 0,1			
CSI-RS signal 0			Antenna ports 15,..., 18		N/A		Antenna ports 15,..., 18		N/A	
CSI-RS 0 periodicity and subframe offset $T_{\text{CSI-RS}} / \Delta_{\text{CSI-RS}}$			5/3		N/A		5/3		N/A	
CSI-RS 0 configuration			0		N/A		0		N/A	
CSI-RS signal 1			N/A		Antenna ports 15, 16		N/A		Antenna ports 15, 16	
CSI-RS 1 periodicity and subframe offset $T_{\text{CSI-RS}} / \Delta_{\text{CSI-RS}}$			N/A		5/3		N/A		5/3	
CSI-RS 1 configuration			N/A		5		N/A		5	
Zero-power CSI-RS 0 configuration $l_{\text{CSI-RS}} / \text{ZeroPowerCSI-RS}$ bitmap			N/A		3 / 1110000000 00000		N/A		3 / 1110000000 00000	
Zero-power CSI-RS 1 configuration $l_{\text{CSI-RS}} / \text{ZeroPowerCSI-RS}$ bitmap			3 / 00100110000 00000		N/A		3 / 00100110000 00000		N/A	
CSI-IM 0 periodicity and subframe offset $T_{\text{CSI-IM}} / \Delta_{\text{CSI-IM}}$			5/3		5/3		5/3		5/3	
CSI-IM 0 configuration			2		2		2		2	
CSI-IM 1 periodicity and subframe offset $T_{\text{CSI-IM}} / \Delta_{\text{CSI-IM}}$			5/3		N/A		5/3		N/A	
CSI-IM 1 configuration			6		N/A		6		N/A	
CSI-IM 2 periodicity and subframe offset $T_{\text{CSI-IM}} / \Delta_{\text{CSI-IM}}$			N/A		5/3		N/A		5/3	
CSI-IM 2 configuration			N/A		1		N/A		1	
CSI process 0	CSI-RS		CSI-RS 0				CSI-RS 0			
	CSI-IM		CSI-IM 0				CSI-IM 0			
	Reporting mode		PUCCH 1-1				PUCCH 1-1			
	CodeBookSubsetRestriction bitmap		0x0000 0000 0000 0001				0x0000 0000 0000 0001			
	Reporting periodicity	ms	$N_{pd} = 5$				$N_{pd} = 5$			
	CQI delay	ms	12				12			
	Physical channel for CQI/ PMI reporting		PUSCH (Note 6)				PUSCH (Note 6)			
	PUCCH Report		2				2			

	Type for CQI/PMI				
	PUCCH channel for RI reporting		PUCCH Format 2		PUCCH Format 2
	PUCCH report type for RI		3		3
	<i>cqi-pmi-ConfigurationIndex</i>		3		3
	<i>ri-ConfigIndex</i>		805 (Note 10)		805 (Note 10)
CSI process 1	CSI-RS		CSI-RS 1		CSI-RS 1
	CSI-IM		CSI-IM 0		CSI-IM 0
	Reporting mode		PUSCH 3-1		PUSCH 3-1
	CodeBookSubsetRestriction bitmap		000001		000001
	Reporting interval (Note 9)	ms	5		5
	CQI delay	ms	12		12
	Sub-band size	RB	6 (full size)		6 (full size)
CSI process 2	CSI-RS		CSI-RS 0		CSI-RS 0
	CSI-IM		CSI-IM 1		CSI-IM 1
	Reporting mode		PUSCH 3-1		PUSCH 3-1
	CodeBookSubsetRestriction bitmap		0x0000 0000 0000 0001		0x0000 0000 0000 0001
	Reporting interval (Note 9)	ms	5		5
	CQI delay	ms	12		12
	Sub-band size	RB	6 (full size) (Note 8)		6 (full size) (Note 8)
CSI process 3	CSI-RS		CSI-RS 1		CSI-RS 1
	CSI-IM		CSI-IM 2		CSI-IM 2
	Reporting mode		PUSCH 3-1		PUSCH 3-1
	CodeBookSubsetRestriction bitmap		000001		000001
	Reporting interval (Note 9)	ms	5		5
	CQI delay	ms	12		12
	Sub-band size	RB	6 (full size)		6 (full size)
CSI process for PDSCH scheduling			CSI process 2		CSI process 2
Cell ID		0	6	0	6
Quasi-co-located CSI-RS		CSI-RS 0	CSI-RS 1	CSI-RS 0	CSI-RS 1
Quasi-co-located CRS		Same Cell ID as Cell 1	Same Cell ID as Cell 2	Same Cell ID as Cell 1	Same Cell ID as Cell 2
PMI for subframe 4 and 9		0x0000 0000 0000 0001	100000	0x0000 0000 0000 0001	100000
PMI for subframe 3 and 8		0x0000 0000 0001 0000	100000	0x0000 0000 0001 0000	100000
Max number of HARQ transmissions		1	N/A	1	N/A
ACK/NACK feedback mode		Multiplexing	N/A	Multiplexing	N/A
Note 1:	If the UE reports in an available uplink reporting instance at subframe SF#n based on CQI estimation at a downlink SF not later than SF#(n-4), this reported wideband CQI cannot be applied at the eNB downlink before SF#(n+4)				
Note 2:	3 symbols allocated to PDCCH				
Note 3:	Reference measurement channel RC.12 TDD according to Table A.4-1. PDSCH transmission is scheduled on subframe 4 and 9 from TP1.				
Note 4:	TM10 OCNG OP.8 TDD is transmitted as specified in A.5.2.8 on subframe 3 and 8 from TP1.				
Note 5:	TM10 OCNG OP.8 TDD is transmitted as specified in A.5.2.8 on subframe 3, 4, 8 and 9 from TP2				
Note 6:	To avoid collisions between CQI/PMI reports and HARQ-ACK it is necessary to report both on PUSCH instead of PUCCH. PDCCH DCI format 0 shall be transmitted in downlink SF#3 and #8 to allow periodic CQI/PMI to multiplex with the HARQ-ACK on PUSCH in uplink SF#7 and #2.				
Note 7:	For each test, the minimum requirements shall be fulfilled for at least one of the two SNR(s) and the respective wanted signal input level.				
Note 8:	PDCCH DCI format 0 with a trigger for aperiodic CQI shall be transmitted in downlink SF#3 and #8 to allow aperiodic CQI/PMI/RI to be transmitted in uplink SF#7 and #2.				
Note 9:	For these sub-bands which are not selected for PDSCH transmission, TM10 OCNG should be transmitted.				
Note 10:	RI reporting interval is set to the maximum allowable length of 160ms to minimise collisions between RI, CQI/PMI and HARQ-ACK reports. In the case when all three reports collide, it is expected that CQI/PMI reports will be dropped, while RI and HARQ-ACK will be multiplexed. At eNB, CQI report collection shall be skipped every 160ms during performance verification and the reported CQI in subframe SF#7 of the previous frame is applied in downlink subframes until a new CQI (after CQI/PMI dropping) is available.				

Table 9.3.6.2-2: Minimum requirement (TDD)

	CSI process 0	CSI process 1	CSI process 2	CSI process 3
α [%]	N/A	2	2	2
β [%]	N/A	40	40	40
δ [%]	10	N/A	N/A	N/A
γ	N/A	N/A	1.02	N/A
UE Category	≥ 1			

Table 9.3.6.2-3: Minimum median CQI difference between configured CSI processes (TDD)

	CSI process 1	CSI process 2	CSI process 3
CSI process 0	N/A	1	3
UE Category	≥ 1		

9.3.7 Minimum requirement PUSCH 3-2

9.3.7.1 FDD

For the parameters specified in Table 9.3.7.1-1, and using the downlink physical channels specified in Annex C.3.2, the minimum requirements are specified in Table 9.3.7.1-2 and by the following.

- a) the ratio of the throughput obtained when transmitting based on UE PUSCH 3-2 reported wideband CQI and subband PMI and that obtained when transmitting based on PUSCH 3-1 reported wideband CQI and wideband PMI shall be $\geq \alpha$;
- b) The ratio of the throughput obtained when transmitting on a randomly selected sub-band among the sub-bands with the highest differential CQI offset level the corresponding TBS based on UE PUSCH3-2 reported subband CQI and subband PMI and that obtained when transmitting on a randomly selected sub-band in set S based on PUSCH 1-2 reported wideband CQI and subband PMI shall be $\geq \beta$;

The transport block sizes TBS for wideband CQI and subband CQI are selected according to RC.17 FDD for test 1 and according to RC.18 FDD for test 2.

Table 9.3.7.1-1 Sub-band test for FDD

Parameter		Unit	Test 1		Test 2	
Bandwidth		MHz	10MHz			
PDSCH resource allocation		RB	50PRB		a subband, 6PRB	
Transmission mode			TM6		TM9	
Downlink power allocation	ρ_A	dB	-6		0	
	ρ_B	dB	-6		0	
	P_c	dB	-		-3	
	σ	dB	3		-3	
SNR (Note 3)		dB	0	1	5	6
$\hat{I}_{or}^{(j)}$		dB[mW/15kHz]	-98	-97	-93	-92
$N_{oc}^{(j)}$		dB[mW/15kHz]	-98	-98	-98	-98
Propagation channel			EVA5		EVA5	
Antenna configuration			4x2 ULA low		4x2 XP high (Note 4)	
Beamforming Model			-		B.4.3	
CRS reference signals			Antenna ports 0, 1, 2, 3		Antenna ports 0, 1	
Time offset between TX antenna (Note 5)		ns	65		-	
CSI reference signals					Antenna ports 15, 16, 17, 18	
CSI-RS periodicity and subframe offset $T_{CSI-RS} / \Delta_{CSI-RS}$			-		5/ 1	
CSI-RS reference signal configuration alternativeCodebookEnabledFor4TX			-		4	
			No		Yes	
CodeBookSubsetRestriction bitmap			0x0000 0000 0000 FFFF		0x0000 0000 0000 FFFF 0000 FFFF	
Reporting interval (Note 6)		ms	5		5	
CQI delay		ms	8		8	
Reporting mode			PUSCH 3-2, PUSCH 3-1		PUSCH 3-2, PUSCH 1-2	
Sub-band size		RB	6 (full size)		6 (full size)	
Max number of HARQ transmissions			1		1	
<p>Note 1: If the UE reports in an available uplink reporting instance at subframe SF#n based on CQI estimation at a downlink subframe not later than SF#(n-4), this reported subband or wideband CQI cannot be applied at the eNB downlink before SF#(n+4)</p> <p>Note 2: Reference measurement channel RC.17 FDD / RC.18 FDD for Test 1 / 2 according to Table A.4-1 with one/two sided dynamic OCNB Pattern OP.1/2 FDD as described in Annex A.5.1.1/2.</p> <p>Note 3: For each test, the minimum requirements shall be fulfilled for at least one of the two SNR(s) and the respective wanted signal input level.</p> <p>Note 4: Randomization of the principle beam direction shall be used as specified in B.2.3A.4.</p> <p>Note 5: The values of time offset are [0ns 65ns 0ns 65ns] for antenna port [0, 1, 2, 3] respectively.</p> <p>Note 6: PDCCH DCI format 0 with a trigger for aperiodic CQI shall be transmitted in downlink SF#1 and #6 to allow aperiodic CQI/PMI/RI to be transmitted in uplink SF#0 and #5.</p>						

Table 9.3.7.1-2 Minimum requirement (FDD)

	Test 1	Test 2
α	1.05	-
β	-	1.15
UE Category	≥ 2	≥ 2

9.3.7.2 TDD

For the parameters specified in Table 9.3.7.2-1, and using the downlink physical channels specified in Annex C.3.2, the minimum requirements are specified in Table 9.3.7.2-2 and by the following.

- a) the ratio of the throughput obtained when transmitting based on UE PUSCH 3-2 reported wideband CQI and subband PMI and that obtained when transmitting based on PUSCH 3-1 reported wideband CQI and wideband PMI shall be $\geq \alpha$;

- b) The ratio of the throughput obtained when transmitting on a randomly selected sub-band among the sub-bands with the highest differential CQI offset level the corresponding TBS based on UE PUSCH3-2 reported subband CQI and subband PMI and that obtained when transmitting on a randomly selected sub-band in set S based on PUSCH 1-2 reported wideband CQI and subband PMI shall be $\geq \beta$;

The transport block sizes TBS for wideband CQI and subband CQI are selected according to RC.17 TDD for test 1 and RC.18 TDD for test 2.

Table 9.3.7.2-1 Sub-band test for TDD

Parameter		Unit	Test 1		Test 2	
Bandwidth		MHz	10MHz			
PDSCH resource allocation		RB	50PRB		a subband, 6PRB	
Transmission mode			TM6		TM9	
Uplink downlink configuration			1		1	
Special subframe configuration			4		4	
Downlink power allocation	ρ_A	dB	-6		0	
	ρ_B	dB	-6		0	
	P_c	dB	-		-3	
	σ	dB	3		-3	
SNR (Note 3)		dB	0	1	5	6
$\hat{I}_{or}^{(j)}$		dB[mW/15kHz]	-98	-97	-93	-92
$N_{oc}^{(j)}$		dB[mW/15kHz]	-98	-98	-98	-98
Propagation channel			EVA5		EVA5	
Antenna configuration			4x2 ULA low		4x2 XP high (Note 4)	
Beamforming Model			-		B.4.3	
CRS reference signals			Antenna ports 0, 1, 2, 3		Antenna ports 0, 1	
Time offset between TX antenna (Note 5)		ns	65		-	
CSI reference signals					Antenna ports 15, 16, 17, 18	
CSI-RS periodicity and subframe offset $T_{CSI-RS} / \Delta_{CSI-RS}$			-		5/ 4	
CSI-RS reference signal configuration alternativeCodebookEnabledFor4TX			-		4	
CodeBookSubsetRestriction bitmap			No		Yes	
CodeBookSubsetRestriction bitmap			0x0000 0000 0000 FFFF		0x0000 0000 0000 FFFF 0000 FFFF	
Reporting interval (Note 6)		ms	5		5	
CQI delay		ms	8		8	
Reporting mode			PUSCH 3-2, PUSCH 3-1		PUSCH 3-2, PUSCH 1-2	
Sub-band size		RB	6 (full size)		6 (full size)	
Max number of HARQ transmissions			1		1	
Note 1: If the UE reports in an available uplink reporting instance at subframe SF#n based on CQI estimation at a downlink subframe not later than SF#(n-4), this reported subband or wideband CQI cannot be applied at the eNB downlink before SF#(n+4)						
Note 2: Reference measurement channel RC.17 TDD / RC.18 TDD for Test 1 / 2 according to Table A.4-1 with one/two sided dynamic OCNG Pattern OP.1/2 TDD as described in Annex A.5.2.1/2.						
Note 3: For each test, the minimum requirements shall be fulfilled for at least one of the two SNR(s) and the respective wanted signal input level.						
Note 4: Randomization of the principle beam direction shall be used as specified in B.2.3A.4.						
Note 5: The values of time offset are [0ns 65ns 0ns 65ns] for antenna port [0, 1, 2, 3] respectively.						
Note 6: PDCCH DCI format 0 with a trigger for aperiodic CQI shall be transmitted in downlink SF#4 and #9 to allow aperiodic CQI/PMI/RI to be transmitted in uplink SF#3 and #8.						

Table 9.3.7.2-2 Minimum requirement (TDD)

	Test 1	Test 2
α	1.05	-
β	-	1.15
UE Category	≥ 2	≥ 2

9.3.8 Additional requirements for enhanced receiver Type B

The purpose of the test is to verify that the reporting of the channel quality based on the receiver of the enhanced Type B meets a minimum performance. Performance requirements are specified in terms of the relative throughput obtained when the transport format is that indicated by the reported CQI with NeighCellsInfo-r12 configured compared to the case without NeighCellsInfo-r12 configured. Cell 1 is the serving cell, and Cell 2 and Cell 3 are the interference cells.

9.3.8.1 Minimum requirement PUCCH 1-1 (Cell-Specific Reference Symbols)

9.3.8.1.1 FDD

For the parameters specified in Table 9.3.8.1.1-1, and using the downlink physical channels specified in Annex C, the minimum requirements are specified in Table 9.3.8.1.1-2 and by the following

- a) the ratio of the throughput obtained when transmitting the transport format indicated by each reported wideband CQI index subject to interference sources with NeighCellsInfo-r12 configured and that obtained when transmitting the transport format indicated by each reported wideband CQI index subject to interference sources without NeighCellsInfo-r12 configured shall be $\geq \gamma$;

Table 9.3.8.1.1-1 Fading test for FDD

Parameter		Unit	Cell 1	Cell 2	Cell 3
Bandwidth		MHz		10	
Transmission mode				4	
Downlink power allocation	ρ_A	dB		-3	
	ρ_B	dB		-3	
	σ	dB		0	
Cyclic Prefix			Normal	Normal	Normal
Cell ID			0	1	6
SNR		dB	8.34	N/A	N/A
\hat{E}_s/N_{oc}			N/A	3.28	0.74
$\hat{I}_{or}^{(j)}$		dB [mW/15kHz]	-89.66	-94.72	-97.26
N_{oc}		dB [mW/15kHz]		-98	
Propagation channel			EPA5	EPA5	EPA5
Correlation and antenna configuration			Low 2 x 2	Low 2 x 2	Low 2 x 2
Cell-specific reference signals			Antenna ports 0,1	Antenna ports 0,1	Antenna ports 0,1
Interference model			N/A	As specified in clause B.6.3	As specified in clause B.6.3
Reporting periodicity		ms	$N_{pd} = 5$	N/A	N/A
Physical channel for CQI/PMI reporting			PUCCH Format 2	N/A	N/A
PUCCH Report Type for CQI/PMI			2	N/A	N/A
PUCCH Report Type for RI			3	N/A	N/A
<i>cqi-pmi-ConfigurationIndex</i>			6	N/A	N/A
<i>ri-ConfigurationIndex</i>			1	N/A	N/A
<i>CodeBookSubsetRestriction bitmap</i>			000001	N/A	N/A
Max number of HARQ transmissions			1	N/A	N/A
NeighCellsInfo-r12 (Note 4)	p-aList-r12		N/A	{dB-6, dB-3, dB0}	{dB-6, dB-3, dB0}
	transmissionModeList-r12		N/A	{2,3,4,8,9}	{2,3,4,8,9}
Note 1: If the UE reports in an available uplink reporting instance at subframe SF#n based on CQI estimation at a downlink SF not later than SF#(n-4), this reported wideband CQI cannot be applied at the eNB downlink before SF#(n+4)					
Note 2: Reference measurement channel RC.2 FDD according to Table A.4-1 with one sided dynamic OCNG Pattern OP.1 FDD as described in Annex A.5.1.1.					
Note 3: All cells are time-synchronous.					
Note 4: NeighCellsInfo-r12 is described in subclause 6.3.2 of [7].					

Table 9.3.8.1.1-2 Minimum requirement (FDD)

	Test 1
γ	0.925
UE Category	≥ 2

9.3.8.1.2 TDD

For the parameters specified in Table 9.3.8.1.2-1, and using the downlink physical channels specified in Annex C, the minimum requirements are specified in 9.3.8.1.2-2 and by the following

- the ratio of the throughput obtained when transmitting the transport format indicated by each reported wideband CQI index subject to interference sources with NeighCellsInfo-r12 configured and that obtained when transmitting the transport format indicated by each reported wideband CQI index subject to interference sources without NeighCellsInfo-r12 configured shall be $\geq \gamma$;

Table 9.3.8.1.2-1 Fading test for TDD

Parameter		Unit	Cell 1	Cell 2	Cell 3
Bandwidth		MHz		10	
Transmission mode				4	
Uplink downlink configuration				2	
Special subframe configuration				4	
Downlink power allocation	ρ_A	dB		-3	
	ρ_B	dB		-3	
	σ	dB		0	
Cyclic Prefix			Normal	Normal	Normal
Cell ID			0	1	6
SNR		dB	8.34	N/A	N/A
\hat{E}_s/N_{oc}			N/A	3.28	0.74
$\hat{I}_{or}^{(j)}$		dB [mW/15kHz]	-89.66	-94.72	-97.26
N_{oc}		dB [mW/15kHz]	-98		
Propagation channel			EPA5	EPA5	EPA5
Correlation and antenna configuration			Low 2 x 2	Low 2 x 2	Low 2 x 2
Cell-specific reference signals			Antenna ports 0,1	Antenna ports 0,1	Antenna ports 0,1
Interference model			N/A	As specified in clause B.6.3	As specified in clause B.6.3
Reporting periodicity		ms	$N_{pd} = 5$	N/A	N/A
Physical channel for CQI/PMI reporting			PUSCH (Note 3)	N/A	N/A
PUCCH Report Type			2	N/A	N/A
<i>cqi-pmi-ConfigurationIndex</i>			3	N/A	N/A
<i>ri-ConfigIndex</i>			805 (Note 5)	N/A	N/A
<i>CodeBookSubsetRestriction bitmap</i>			000001	N/A	N/A
Max number of HARQ transmissions			1	N/A	N/A
ACK/NACK feedback mode			Multiplexing	N/A	N/A
NeighCellsInfo-r12 (Note 6)	<i>p-aList-r12</i>		N/A	{dB-6, dB-3, dB0}	{dB-6, dB-3, dB0}
	<i>transmissionModeList-r12</i>		N/A	{2,3,4,8,9}	{2,3,4,8,9}
<p>Note 1: If the UE reports in an available uplink reporting instance at subframe SF#n based on CQI estimation at a downlink SF not later than SF#(n-4), this reported wideband CQI cannot be applied at the eNB downlink before SF#(n+4)</p> <p>Note 2: Reference measurement channel RC.2 TDD according to Table A.4-1 with one sided dynamic OCNG Pattern OP.1 TDD as described in Annex A.5.2.1.</p> <p>Note 3: To avoid collisions between CQI reports and HARQ-ACK it is necessary to report both on PUSCH instead of PUCCH. PDCCH DCI format 0 shall be transmitted in downlink SF#3 and #8 to allow periodic CQI to multiplex with the HARQ-ACK on PUSCH in uplink subframe SF#7 and #2.</p> <p>Note 4: All cells are time-synchronous.</p> <p>Note 5: RI reporting interval is set to the maximum allowable length of 160ms to minimise collisions between RI, CQI/PMI and HARQ-ACK reports. In the case when all three reports collide, it is expected that CQI/PMI reports will be dropped, while RI and HARQ-ACK will be multiplexed. At eNB, CQI report collection shall be skipped every 160ms during performance verification.</p> <p>Note 6: NeighCellsInfo-r12 is described in subclause 6.3.2 of [7].</p>					

Table 9.3.8.1.2-2 Minimum requirement (TDD)

	Test 1
γ	0.925
UE Category	≥ 2

9.3.8.2 Minimum requirement PUCCH 1-1 (CSI Reference Symbols)

9.3.8.2.1 FDD

For the parameters specified in Table 9.3.8.2.1-1, and using the downlink physical channels specified in Annex C, the minimum requirements are specified in Table 9.3.8.2.1-2 and by the following

- a) the ratio of the throughput obtained when transmitting the transport format indicated by each reported wideband CQI index subject to interference sources with NeighCellsInfo-r12 configured and that obtained when transmitting the transport format indicated by each reported wideband CQI index subject to interference sources without NeighCellsInfo-r12 configured shall be $\geq \gamma$;

Table 9.3.8.2.1-1 Fading test for FDD

Parameter		Unit	Cell 1	Cell 2	Cell 3
Bandwidth		MHz		10	
Transmission mode				9	
Downlink power allocation	ρ_A	dB		0	
	ρ_B	dB		0	
	P_c	dB		0	
	σ	dB		0	
Cyclic Prefix			Normal	Normal	Normal
Cell ID			0	1	6
SNR		dB	8.34	N/A	N/A
\hat{E}_s/N_{oc}			N/A	3.28	0.74
$\hat{I}_{or}^{(j)}$		dB [mW/15kHz]	-89.66	-94.72	-97.26
N_{oc}		dB [mW/15kHz]		-98	
Propagation channel			EPA5	EPA5	EPA5
Correlation and antenna configuration			Low 2 x 2	Low 2 x 2	Low 2 x 2
Cell-specific reference signals			Antenna ports 0,1	Antenna ports 0,1	Antenna ports 0,1
Beamforming Model			As specified in Section B.4.3		
CSI reference signals			Antenna ports 15,16	N/A	N/A
CSI-RS periodicity and subframe offset			5/1	N/A	N/A
CSI-RS reference signal configuration			2	N/A	N/A
Zero-power CSI-RS configuration $I_{CSI-RS} / ZeroPowerCSI-RS$ bitmap		Subframes / bitmap	N/A	1 / 00010000000000 00	1 / 00010000000000 00
CodeBookSubsetRestriction bitmap			000001	N/A	N/A
Interference model			N/A	As specified in clause B.6.4	As specified in clause B.6.4
Reporting periodicity		ms	$N_{pd} = 5$	N/A	N/A
Physical channel for CQI/PMI reporting			PUSCH (Note 3)	N/A	N/A
PUCCH Report Type for CQI/PMI			2	N/A	N/A
PUCCH channel for RI reporting			PUCCH Format 2	N/A	N/A
PUCCH Report Type for RI			3	N/A	N/A
$cqi-pmi-ConfigurationIndex$			2	N/A	N/A
$ri-ConfigIndex$			1	N/A	N/A
Max number of HARQ transmissions			1	N/A	N/A
NeighCellsInfo- r12 (Note 5)	p-aList-r12 transmission		N/A	{dB-6, dB-3, dB0}	{dB-6, dB-3, dB0}
	ModeList-r12		N/A	{2,3,4,8,9}	{2,3,4,8,9}
<p>Note 1: If the UE reports in an available uplink reporting instance at subframe SF#n based on CQI estimation at a downlink SF not later than SF#(n-4), this reported wideband CQI cannot be applied at the eNB downlink before SF#(n+4)</p> <p>Note 2: Reference measurement channel RC.11 FDD according to Table A.4-1 with one sided dynamic OCNG Pattern OP.1 FDD as described in Annex A.5.1.1.</p> <p>Note 3: To avoid collisions between CQI/PMI reports and HARQ-ACK it is necessary to report both on PUSCH instead of PUCCH. PDCCH DCI format 0 shall be transmitted in downlink SF#1 and #6 to allow periodic CQI/ PMI to multiplex with the HARQ-ACK on PUSCH in uplink subframe SF#0 and #5.</p> <p>Note 4: All cells are time-synchronous.</p> <p>Note 5: NeighCellsInfo-r12 is described in subclause 6.3.2 of [7].</p>					

Table 9.3.8.2.1-2 Minimum requirement (FDD)

	Test 1
γ	0.925
UE Category	≥ 2

9.3.8.2.2 TDD

For the parameters specified in Table 9.3.8.2.2-1, and using the downlink physical channels specified in Annex C, the minimum requirements are specified in 9.3.8.2.2-2 and by the following

- a) the ratio of the throughput obtained when transmitting the transport format indicated by each reported wideband CQI index subject to interference sources with NeighCellsInfo-r12 configured and that obtained when transmitting the transport format indicated by each reported wideband CQI index subject to interference sources without NeighCellsInfo-r12 configured shall be $\geq \gamma$;

Table 9.3.8.2.2-1 Fading test for TDD

Parameter		Unit	Cell 1	Cell 2	Cell 3
Bandwidth		MHz	10		
Transmission mode			9		
Downlink power allocation	ρ_A	dB	0		
	ρ_B	dB	0		
	ρ_C	dB	0		
	σ	dB	0		
Uplink downlink configuration			2		
Special subframe configuration			4		
Cyclic Prefix			Normal	Normal	Normal
Cell ID			0	1	6
SNR		dB	8.34	N/A	N/A
\hat{E}_s/N_{oc}			N/A	3.28	0.74
$\hat{I}_{or}^{(j)}$		dB [mW/15kHz]	-89.66	-94.72	-97.26
N_{oc}		dB [mW/15kHz]	-98		
Propagation channel			EPA5	EPA5	EPA5
Correlation and antenna configuration			Low 2 x 2	Low 2 x 2	Low 2 x 2
Cell-specific reference signals			Antenna ports 0,1	Antenna ports 0,1	Antenna ports 0,1
Beamforming Model			As specified in Section B.4.3		
CSI reference signals			Antenna ports 15,16	N/A	N/A
CSI-RS periodicity and subframe offset			5/3	N/A	N/A
CSI-RS reference signal configuration			2	N/A	N/A
Zero-power CSI-RS configuration $I_{CSI-RS} / \text{ZeroPowerCSI-RS}$ bitmap		Subframes / bitmap	N/A	3 / 000100000000000	3 / 000100000000000
CodeBookSubsetRestriction bitmap			000001	N/A	N/A
Interference model			N/A	As specified in clause B.6.4	As specified in clause B.6.4
Reporting periodicity		ms	$N_{pd} = 5$	N/A	N/A
Physical channel for CQI/PMI reporting			PUSCH (Note 3)	N/A	N/A
PUCCH Report Type for CQI/PMI			2	N/A	N/A
Physical channel for RI reporting			PUCCH Format 2	N/A	N/A
PUCCH Report Type for RI			3	N/A	N/A
$cqi\text{-}pmi\text{-}ConfigurationIndex$			3	N/A	N/A
$ri\text{-}ConfigIndex$			805 (Note 5)	N/A	N/A
Max number of HARQ transmissions			1	N/A	N/A
ACK/NACK feedback mode			Multiplexing	N/A	N/A
NeighCellsInfo-r12 (Note 6)	p-aList-r12		N/A	{dB-6, dB-3, dB0}	{dB-6, dB-3, dB0}
	transmission ModeList-r12		N/A	{2,3,4,8,9}	{2,3,4,8,9}
<p>Note 1: If the UE reports in an available uplink reporting instance at subframe SF#n based on CQI estimation at a downlink SF not later than SF#(n-4), this reported wideband CQI cannot be applied at the eNB downlink before SF#(n+4)</p> <p>Note 2: Reference measurement channel RC.11 TDD according to Table A.4-1 with one sided dynamic OCNG Pattern OP.1 TDD as described in Annex A.5.2.1.</p> <p>Note 3: To avoid collisions between CQI/PMI reports and HARQ-ACK it is necessary to report both on PUSCH instead of PUCCH. PDCCH DCI format 0 shall be transmitted in downlink SF#3 and #8 to allow periodic CQI/ PMI to multiplex with the HARQ-ACK on PUSCH in uplink subframe SF#2 and #7.</p> <p>Note 4: All cells are time-synchronous.</p>					

Note 5:	RI reporting interval is set to the maximum allowable length of 160ms to minimise collisions between RI, CQI/PMI and HARQ-ACK reports. In the case when all three reports collide, it is expected that CQI/PMI reports will be dropped, while RI and HARQ-ACK will be multiplexed. At eNB, CQI report collection shall be skipped every 160ms during performance verification and the reported CQI in subframe SF#7 of the previous frame is applied in downlink subframes until a new CQI (after CQI/PMI dropping) is available.
Note 6:	NeighCellsInfo-r12 is described in subclause 6.3.2 of [7].

Table 9.3.8.2.2-2 Minimum requirement (TDD)

	Test 1
γ	0.925
UE Category	≥ 2

9.3.8.3 Minimum requirement with CSI process

9.3.8.3.1 FDD

For the parameters specified in Table 9.3.8.3.1-1, and using the downlink physical channels specified in Annex C, the minimum requirements are specified in Table 9.3.8.3.1-2 and by the following

- a) the ratio of the throughput obtained for the Type B receiver with NAICS assistance information when transmitting the transport format indicated by each reported wideband CQI index subject to interference sources with specified \hat{E}_s/N_{oc} and that obtained for the Type B receiver without NAICS assistance information when transmitting the transport format indicated by each reported wideband CQI index subject to interference sources with the same specified \hat{E}_s/N_{oc} shall be $\geq \gamma$;

Table 9.3.8.3.1-1 Fading test for single antenna (FDD)

Parameter		Unit	Cell 1	Cell 2	Cell 3
Bandwidth		MHz	10		
Transmission mode			10	9	9
Downlink power allocation	ρ_A	dB	0		
	ρ_B	dB	0		
	P_C	dB	0		
	σ	dB	0		
Cyclic Prefix			Normal	Normal	Normal
Cell ID			0	1	6
SNR		dB	8.34	N/A	N/A
\hat{E}_s/N_{oc}		dB	N/A	3.28	0.74
$\hat{I}_{or}^{(j)}$		dB [mW/15kHz]	-89.66	-94.72	-97.26
N_{oc}		dB[mW/15kHz]	-98		
Propagation channel			EPA5	EPA5	EPA5
Correlation and antenna configuration			Low 2 x 2	Low 2 x 2	Low 2 x 2
Cell-specific reference signals			Antenna ports 0,1	Antenna port 0, 1	Antenna port 0, 1
Beamforming Model			As specified in Section B.4.3		
CSI reference signals			Antenna ports 15,16	N/A	N/A
CSI-RS periodicity and subframe offset			5/1	N/A	N/A
CSI-RS reference signal configuration			2	N/A	N/A
Zero-power CSI-RS configuration l_{CSI-RS} / $ZeroPowerCSI-RS$ bitmap		Subframes / bitmap	N/A	1 / 000100000000 0000	1 / 000100000000 0000
Interference model			N/A	As specified in clause B.6.4	As specified in clause B.6.4
CSI process	CSI-RS		CSI-RS	N/A	N/A
	CSI-IM		CSI-IM	N/A	N/A
	Reporting mode		PUCCH 1-1	N/A	N/A
	CodeBookSubsetRestriction bitmap		000001	N/A	N/A
	Reporting periodicity	ms	$N_{pd} = 5$	N/A	N/A
	CQI delay	ms	8	N/A	N/A
	Physical channel for CQI/ PMI reporting		PUSCH (Note 3)	N/A	N/A
	PUCCH Report Type for CQI/PMI		2	N/A	N/A
	PUCCH channel for RI reporting		PUCCH Format 2	N/A	N/A
	PUCCH report type for RI		3	N/A	N/A
	$cqi-pmi-ConfigurationIndex$		2	N/A	N/A
	$ri-ConfigIndex$		1	N/A	N/A
CSI-IM periodicity and subframe offset $T_{CSI-RS} / \Delta_{CSI-RS}$			5/1	N/A	N/A
CSI-IM configuration			6	N/A	N/A
CSI process for PDSCH scheduling			CSI process	N/A	N/A
Quasi-co-located CSI-RS			CSI-RS	N/A	N/A
Quasi-co-located CRS			Same Cell ID as Cell 1	N/A	N/A
Reference measurement channel			Note 2	N/A	N/A
Max number of HARQ transmissions			1	N/A	N/A
NeighCellsInfo-r12 (Note 5)	p-aList-r12		N/A	{dB-6, dB-3, dB0}	{dB-6, dB-3, dB0}
	transmissionModeList-r12		N/A	{2,3,4,8,9}	{2,3,4,8,9}
Note 1: If the UE reports in an available uplink reporting instance at subframe SF#n based on CQI estimation at a downlink SF not later than SF#(n-4), this reported wideband CQI cannot be applied at the eNB downlink before SF#(n+4)					
Note 2: Reference measurement channel RC.11 FDD according to Table A.4-1 with one sided dynamic OCNG					

	Pattern OP.1 FDD as described in Annex A.5.1.1.
Note 3:	To avoid collisions between CQI/ PMI reports and HARQ-ACK it is necessary to report both on PUSCH instead of PUCCH. PDCCH DCI format 0 shall be transmitted in downlink SF#1 and #6 to allow periodic CQI/ PMI to multiplex with the HARQ-ACK on PUSCH in uplink subframe SF#0 and #5.
Note 4:	All cells are time-synchronous.
Note 5:	NeighCellsInfo-r12 is described in subclause 6.3.2 of [7].

Table 9.3.8.3.1-2 Minimum requirement (FDD)

	Test 1
γ	0.925
UE Category	≥ 2

9.3.8.3.2 TDD

For the parameters specified in Table 9.3.8.3.2-1, and using the downlink physical channels specified in Annex C, the minimum requirements are specified in Table 9.3.8.3.2-2 and by the following

- a) the ratio of the throughput obtained for the Type B receiver with NAICS assistance information when transmitting the transport format indicated by each reported wideband CQI index subject to interference sources with specified \hat{E}_s/N_{oc} and that obtained for the Type B receiver without NAICS assistance information when transmitting the transport format indicated by each reported wideband CQI index subject to interference sources with the same specified \hat{E}_s/N_{oc} shall be $\geq \gamma$;

Table 9.3.8.3.2-1 Fading test for single antenna (TDD)

Parameter		Unit	Cell 1	Cell 2	Cell 3
Bandwidth		MHz	10		
Transmission mode			10	9	9
Downlink power allocation	ρ_A	dB	0		
	ρ_B	dB	0		
	P_c	dB	0		
	σ	dB	0		
Uplink downlink configuration			2		
Special subframe configuration			4		
Cyclic Prefix			Normal	Normal	Normal
Cell ID			0	1	6
SNR		dB	8.34	N/A	N/A
\hat{E}_s/N_{oc}		dB	N/A	3.28	0.74
$\hat{I}_{or}^{(j)}$		dB [mW/15kHz]	-89.66	-94.72	-97.26
N_{oc}		dB[mW/15k Hz]	-98		
Propagation channel			EPA5	EPA5	EPA5
Correlation and antenna configuration			Low 2 x 2	Low 2 x 2	Low 2 x 2
Cell-specific reference signals			Antenna ports 0,1	Antenna port 0,1	Antenna port 0,1
Beamforming Model			As specified in Section B.4.3		
CSI reference signals			Antenna ports 15,16	N/A	N/A
CSI-RS periodicity and subframe offset			5/3	N/A	N/A
CSI-RS reference signal configuration			2	N/A	N/A
Zero-power CSI-RS configuration l_{CSI-RS} / $ZeroPowerCSI-RS$ bitmap		Subframes / bitmap	N/A	3 / 000100000000 0000	3 / 000100000000 00000
Interference model			N/A	As specified in clause B.6.4	As specified in clause B.6.4
CSI process	CSI-RS		CSI-RS	N/A	N/A
	CSI-IM		CSI-IM	N/A	N/A
	Reporting mode		PUCCH 1-1	N/A	N/A
	CodeBookSubsetRestriction bitmap		000001	N/A	N/A
	Reporting periodicity	ms	$N_{pd} = 5$	N/A	N/A
	CQI delay	ms	8	N/A	N/A
	Physical channel for CQI/ PMI reporting		PUSCH (Note 3)	N/A	N/A
	PUCCH Report Type for CQI/PMI		2	N/A	N/A
	PUCCH channel for RI reporting		PUCCH Format 2	N/A	N/A
	PUCCH report type for RI		3	N/A	N/A
	$cqi-pmi$ - $ConfigurationIndex$		3	N/A	N/A
$ri-ConfigIndex$		805 (Note 5)	N/A	N/A	
CSI-IM periodicity and subframe offset $T_{CSI-RS} / \Delta_{CSI-RS}$			5/1	N/A	N/A
CSI-IM configuration			6	N/A	N/A
CSI process for PDSCH scheduling			CSI process	N/A	N/A
Quasi-co-located CSI-RS			CSI-RS	N/A	N/A
Quasi-co-located CRS			Same Cell ID as Cell 1	N/A	N/A
Reference measurement channel			Note 2	N/A	N/A
Max number of HARQ transmissions			1	N/A	N/A
ACK/NACK feedback mode			Multiplexing	N/A	N/A
NeighCellsInfo-r12 (Note 6)	p-aList-r12		N/A	{dB-6, dB-3, dB0}	{dB-6, dB-3, dB0}
	transmissionModeList-r12		N/A	{2,3,4,8,9}	{2,3,4,8,9}
Note 1: If the UE reports in an available uplink reporting instance at subframe SF#n based on CQI estimation at a downlink SF not later than SF#(n-4), this reported wideband CQI cannot be applied at the eNB downlink					

	before SF#(n+4)
Note 2:	Reference measurement channel RC.11 TDD according to Table A.4-1 with one sided dynamic OCNB Pattern OP.1 TDD as described in Annex A.5.2.1.
Note 3:	To avoid collisions between CQI/ PMI reports and HARQ-ACK it is necessary to report both on PUSCH instead of PUCCH. PDCCH DCI format 0 shall be transmitted in downlink SF#1 and #6 to allow periodic CQI/ PMI to multiplex with the HARQ-ACK on PUSCH in uplink subframe SF#0 and #5.
Note 4:	All cells are time-synchronous.
Note 5:	RI reporting interval is set to the maximum allowable length of 160ms to minimise collisions between RI, CQI/PMI and HARQ-ACK reports. In the case when all three reports collide, it is expected that CQI/PMI reports will be dropped, while RI and HARQ-ACK will be multiplexed. At eNB, CQI report collection shall be skipped every 160ms during performance verification and the reported CQI in subframe SF#7 of the previous frame is applied in downlink subframes until a new CQI (after CQI/PMI dropping) is available.
Note 6:	NeighCellsInfo-r12 is described in subclause 6.3.2 of [7].

Table 9.3.8.3.2-2 Minimum requirement (TDD)

	Test 1
γ	0.925
UE Category	≥ 2

9.4 Reporting of Precoding Matrix Indicator (PMI)

The minimum performance requirements of PMI reporting are defined based on the precoding gain, expressed as the relative increase in throughput when the transmitter is configured according to the UE reports compared to the case when the transmitter is using random precoding, respectively. When the transmitter uses random precoding, for each PDSCH allocation a precoder is randomly generated and applied to the PDSCH. A fixed transport format (FRC) is configured for all requirements.

The requirements for transmission mode 6, transmission mode 9 with 4 TX and transmission mode 9 with 8 TX *alternativeCodebookEnabledCLASSB_K1=TRUE* configured are specified in terms of the ratio

$$\gamma = \frac{t_{ue}}{t_{rnd}}$$

In the definition of γ , for PUSCH 3-1 single PMI and PUSCH 1-2 multiple PMI requirements, t_{rnd} is 60% of the maximum throughput obtained at SNR_{rnd} using random precoding, and t_{ue} the throughput measured at SNR_{rnd} with precoders configured according to the UE reports;

For the PUCCH 2-1 single PMI requirement, t_{rnd} is 60% of the maximum throughput obtained at SNR_{rnd} using random precoding on a randomly selected full-size subband in set S subbands, and t_{ue} the throughput measured at SNR_{rnd} with both the precoder and the preferred full-size subband applied according to the UE reports;

For PUSCH 2-2 multiple PMI requirements, t_{rnd} is 60% of the maximum throughput obtained at SNR_{rnd} using random precoding on a randomly selected full-size subband in set S subbands, and t_{ue} the throughput measured at SNR_{rnd} with both the subband precoder and a randomly selected full-size subband (within the preferred subbands) applied according to the UE reports.

For PUCCH 1-1 single PMI requirement under transmission mode 9 with 4Tx and 8 TX when *alternativeCodebookEnabledCLASSB_K1=TRUE* configured, t_{ue} is 70% of the maximum throughput obtained at SNR_{follow} using the precoders configured according to the UE reports, and t_{rnd} is the throughput measured at SNR_{follow} with random precoding.

The requirements for transmission mode 9 with 8 TX and transmission mode 9 with 4TX enhanced codebook are specified in terms of the ratio

$$\gamma = \frac{t_{ue, follow1, follow2}}{t_{rnd1, rnd2}}$$

In the definition of γ , for PUSCH 3-1 single PMI, PUCCH 1-1 single PMI and PUSCH 1-2 multiple PMI requirements, $t_{follow1,follow2}$ is 70% of the maximum throughput obtained at $SNR_{follow1,follow2}$ using the precoders configured according to the UE reports, and $t_{rnd1,rnd2}$ is the throughput measured at $SNR_{follow1,follow2}$ with random precoding.

The requirements for transmission mode 9 with 12 TX and 16 TX are specified in terms of the ratio

$$\gamma = \frac{t_{ue,follow1,1,follow1,2,follow2}}{t_{rnd1,1,rnd1,2,rnd2}}$$

In the definition of γ , for PUSCH 3-1 single PMI and PUSCH 1-2 multiple PMI requirements, $t_{ue,follow1,1,follow1,2,follow2}$ is 90% of the maximum throughput obtained at $SNR_{follow1,1,follow1,2,follow2}$ using the precoders configured according to the UE reports, and $t_{rnd1,1,rnd1,2,rnd2}$ is the throughput measured at $SNR_{follow1,1,follow1,2,follow2}$ with random precoding.

9.4.1 Single PMI

9.4.1.1 Minimum requirement PUSCH 3-1 (Cell-Specific Reference Symbols)

9.4.1.1.1 FDD

For the parameters specified in Table 9.4.1.1.1-1, and using the downlink physical channels specified in Annex C.3.2, the minimum requirements are specified in Table 9.4.1.1.1-2.

Table 9.4.1.1.1-1: PMI test for single-layer (FDD)

Parameter	Unit	Test 1	
Bandwidth	MHz	10	
Transmission mode		6	
Propagation channel		EVA5	
Precoding granularity	PRB	50	
Correlation and antenna configuration		Low 2 x 2	
Downlink power allocation	ρ_A	dB	-3
	ρ_B	dB	-3
	σ	dB	0
$N_{oc}^{(j)}$	dB[mW/15kHz]	-98	
Reporting mode		PUSCH 3-1	
Reporting interval	ms	1	
PMI delay (Note 2)	ms	8	
Measurement channel		R. 10 FDD	
OCNG Pattern		OP.1 FDD	
Max number of HARQ transmissions		4	
Redundancy version coding sequence		{0,1,2,3}	
Note 1:	For random precoder selection, the precoder shall be updated in each TTI (1 ms granularity).		
Note 2:	If the UE reports in an available uplink reporting instance at subframe SF#n based on PMI estimation at a downlink SF not later than SF#(n-4), this reported PMI cannot be applied at the eNB downlink before SF#(n+4).		

Table 9.4.1.1.1-2 Minimum requirement (FDD)

Parameter	Test 1
γ	1.1
UE Category	≥ 1

9.4.1.1.2 TDD

For the parameters specified in Table 9.4.1.1.2-1, and using the downlink physical channels specified in Annex C.3.2, the minimum requirements are specified in 9.4.1.1.2-2.

Table 9.4.1.1.2-1: PMI test for single-layer (TDD)

Parameter	Unit	Test 1	
Bandwidth	MHz	10	
Transmission mode		6	
Uplink downlink configuration		1	
Special subframe configuration		4	
Propagation channel		EVA5	
Precoding granularity	PRB	50	
Correlation and antenna configuration		Low 2 x 2	
Downlink power allocation	ρ_A	dB	-3
	ρ_B	dB	-3
	σ	dB	0
$N_{oc}^{(j)}$	dB[mW/15kHz]	-98	
Reporting mode		PUSCH 3-1	
Reporting interval	ms	1	
PMI delay (Note 2)	ms	10 or 11	
Measurement channel		R.10 TDD	
OCNG Pattern		OP.1 TDD	
Max number of HARQ transmissions		4	
Redundancy version coding sequence		{0,1,2,3}	
ACK/NACK feedback mode		Multiplexing	
Note 1: For random precoder selection, the precoder shall be updated in each available downlink transmission instance. Note 2: If the UE reports in an available uplink reporting instance at subframe SF#n based on PMI estimation at a downlink SF not later than SF#(n-4), this reported PMI cannot be applied at the eNB downlink before SF#(n+4).			

Table 9.4.1.1.2-2: Minimum requirement (TDD)

Parameter	Test 1
γ	1.1
UE Category	≥ 1

9.4.1.2 Minimum requirement PUCCH 2-1 (Cell-Specific Reference Symbols)

9.4.1.2.1 FDD

For the parameters specified in Table 9.4.1.2.1-1, and using the downlink physical channels specified in Annex C.3.2, the minimum requirements are specified in Table 9.4.1.2.1-2.

Table 9.4.1.2.1-1: PMI test for single-layer (FDD)

Parameter		Unit	Test 1
Bandwidth		MHz	10
Transmission mode			6
Propagation channel			EVA5
Correlation and antenna configuration			Low 4 x 2
Downlink power allocation	ρ_A	dB	-6
	ρ_B	dB	-6
	σ	dB	3
$N_{oc}^{(j)}$		dB[mW/15kHz]	-98
PMI delay		ms	8 or 9
Reporting mode			PUCCH 2-1 (Note 6)
Reporting periodicity		ms	$N_{pd} = 2$
Physical channel for CQI reporting			PUSCH (Note 3)
PUCCH Report Type for wideband CQI/PMI			2
PUCCH Report Type for subband CQI			1
Measurement channel			R.14-1 FDD
OCNG Pattern			OP.1/2 FDD
Precoding granularity		PRB	6 (full size)
Number of bandwidth parts (J)			3
K			1
$cqi-pmi-ConfigIndex$			1
Max number of HARQ transmissions			4
Redundancy version coding sequence			{0,1,2,3}
<p>Note 1: For random precoder selection, the precoder shall be updated every two TTI (2 ms granularity).</p> <p>Note 2: If the UE reports in an available uplink reporting instance at subframe SF#n based on PMI estimation at a downlink SF not later than SF#(n-4), this reported PMI cannot be applied at the eNB downlink before SF#(n+4).</p> <p>Note 3: To avoid collisions between HARQ-ACK and wideband CQI/PMI or subband CQI, it is necessary to report both on PUSCH instead of PUCCH. PDCCH DCI format 0 shall be transmitted in downlink SF#1, #3, #7 and #9 to allow periodic CQI to multiplex with the HARQ-ACK on PUSCH in uplink subframe SF#5, #7, #1 and #3.</p> <p>Note 4: Reports for the short subband (having 2RBs in the last bandwidth part) are to be disregarded and instead data is to be transmitted on the most recently used subband for bandwidth part with $j=1$.</p> <p>Note 5: In the case where wideband PMI is reported, data is to be transmitted on the most recently used subband.</p> <p>Note 6: The bit field for PMI confirmation in DCI format 1B shall be mapped to "0" and TPMI information shall indicate the codebook index used in Table 6.3.4.2.3-2 of TS36.211 [4] according to the latest PMI report on PUCCH.</p>			

Table 9.4.1.2.1-2: Minimum requirement (FDD)

	Test 1
γ	1.2
UE Category	≥ 1

9.4.1.2.2 TDD

For the parameters specified in Table 9.4.1.2.2-1, and using the downlink physical channels specified in Annex C.3.2, the minimum requirements are specified in Table 9.4.1.2.2-2.

Table 9.4.1.2.2-1: PMI test for single-layer (TDD)

Parameter	Unit	Test 1	
Bandwidth	MHz	10	
Transmission mode		6	
Uplink downlink configuration		1	
Special subframe configuration		4	
Propagation channel		EVA5	
Correlation and antenna configuration		Low 4 x 2	
Downlink power allocation	ρ_A	dB	-6
	ρ_B	dB	-6
	σ	dB	3
$N_{oc}^{(j)}$	dB[mW/15kHz]	-98	
PMI delay	ms	10	
Reporting mode		PUCCH 2-1 (Note 6)	
Reporting periodicity	ms	$N_P = 5$	
Physical channel for CQI reporting		PUSCH (Note 3)	
PUCCH Report Type for wideband CQI/PMI		2	
PUCCH Report Type for subband CQI		1	
Measurement channel		R.14-1 TDD	
OCNG Pattern		OP.1/2 TDD	
Precoding granularity	PRB	6 (full size)	
Number of bandwidth parts (J)		3	
K		1	
<i>cqi-pmi-ConfigIndex</i>		4	
Max number of HARQ transmissions		4	
Redundancy version coding sequence		{0,1,2,3}	
ACK/NACK feedback mode		Multiplexing	
<p>Note 1: For random precoder selection, the precoder shall be updated in each available downlink transmission instance.</p> <p>Note 2: If the UE reports in an available uplink reporting instance at subframe SF#n based on PMI estimation at a downlink SF not later than SF#(n-4), this reported PMI cannot be applied at the eNB downlink before SF#(n+4).</p> <p>Note 3: To avoid collisions between HARQ-ACK and wideband CQI/PMI or subband CQI it is necessary to report both on PUSCH instead of PUCCH. PDCCH DCI format 0 shall be transmitted in downlink SF#4 and #9 to allow periodic CQI to multiplex with the HARQ-ACK on PUSCH in uplink subframe SF#8 and #3.</p> <p>Note 4: Reports for the short subband (having 2RBs in the last bandwidth part) are to be disregarded and instead data is to be transmitted on the most recently used subband for bandwidth part with j=1.</p> <p>Note 5: In the case where wideband PMI is reported, data is to be transmitted on the most recently used subband.</p> <p>Note 6: The bit field for PMI confirmation in DCI format 1B shall be mapped to "0" and TPMI information shall indicate the codebook index used in Table 6.3.4.2.3-2 of TS36.211 [4] according to the latest PMI report on PUCCH.</p>			

Table 9.4.1.2.2-2: Minimum requirement (TDD)

	Test 1
γ	1.2
UE Category	≥ 1

9.4.1.3 Minimum requirement PUSCH 3-1 (CSI Reference Symbol)

9.4.1.3.1 FDD

For the parameters specified in Table 9.4.1.3.1-1, and using the downlink physical channels specified in Annex C.3.2, the minimum requirements are specified in Table 9.4.1.3.1-2.

Table 9.4.1.3.1-1: PMI test for single-layer (FDD)

Parameter		Unit	Test 1
Bandwidth		MHz	10
Transmission mode			9
Propagation channel			EPA5
Precoding granularity		PRB	50
Correlation and antenna configuration			Low ULA 4 x 2
Cell-specific reference signals			Antenna ports 0,1
CSI reference signals			Antenna ports 15,...,18
Beamforming model			Annex B.4.3
CSI-RS periodicity and subframe offset $T_{\text{CSI-RS}} / \Delta_{\text{CSI-RS}}$			5/ 1
CSI-RS reference signal configuration			6
CodeBookSubsetRestriction bitmap			0x0000 0000 0000 FFFF
Downlink power allocation	ρ_A	dB	0
	ρ_B	dB	0
	P_c	dB	-3
	σ	dB	-3
$N_{oc}^{(j)}$		dB[mW/15kHz]	-98
Reporting mode			PUSCH 3-1
Reporting interval		ms	5
PMI delay (Note 2)		ms	8
Measurement channel			R.44 FDD
OCNG Pattern			OP.1 FDD
Max number of HARQ transmissions			4
Redundancy version coding sequence			{0,1,2,3}
<p>Note 1: For random precoder selection, the precoder shall be updated in each TTI (1 ms granularity).</p> <p>Note 2: If the UE reports in an available uplink reporting instance at subframe SF#n based on PMI estimation at a downlink SF not later than SF#(n-4), this reported PMI cannot be applied at the eNB downlink before SF#(n+4).</p> <p>Note 3: PDSCH_RA= 0 dB, PDSCH_RB= 0 dB in order to have the same PDSCH and OCNG power per subcarrier at the receiver.</p>			

Table 9.4.1.3.1-2: Minimum requirement (FDD)

Parameter	Test 1
γ	1.2
UE Category	≥ 1

9.4.1.3.2 TDD

For the parameters specified in Table 9.4.1.3.2-1, and using the downlink physical channels specified in Annex C.3.2, the minimum requirements are specified in Table 9.4.1.3.2-2.

Table 9.4.1.3.2-1: PMI test for single-layer (TDD)

Parameter	Unit	Test 1	
Bandwidth	MHz	10	
Transmission mode		9	
Uplink downlink configuration		1	
Special subframe configuration		4	
Propagation channel		EVA5	
Precoding granularity	PRB	50	
Antenna configuration		8 x 2	
Correlation modeling		High, Cross polarized	
Cell-specific reference signals		Antenna ports 0,1	
CSI reference signals		Antenna ports 15,...,22	
Beamforming model		Annex B.4.3	
CSI-RS periodicity and subframe offset $T_{\text{CSI-RS}} / \Delta_{\text{CSI-RS}}$		5/ 4	
CSI-RS reference signal configuration		0	
CodeBookSubsetRestriction bitmap		0x0000 0000 001F FFE0 0000 0000 FFFF	
Downlink power allocation	ρ_A	dB	0
	ρ_B	dB	0
	P_c	dB	-6
	σ	dB	-3
$N_{oc}^{(j)}$	dB[mW/15kHz]	-98	
Reporting mode		PUSCH 3-1	
Reporting interval	ms	5	
PMI delay (Note 2)	ms	10	
Measurement channel		R.45-1 TDD for UE Category 1, R.45 TDD for UE Category ≥ 2	
OCNG Pattern		OP.7 TDD for UE Category 1, and OP.1 TDD for UE Category ≥ 2	
Max number of HARQ transmissions		4	
Redundancy version coding sequence		{0,1,2,3}	
ACK/NACK feedback mode		Multiplexing	
Note 1:	For random precoder selection, the precoder shall be updated in each TTI (1 ms granularity).		
Note 2:	If the UE reports in an available uplink reporting instance at subframe SF#n based on PMI estimation at a downlink SF not later than SF#(n-4), this reported PMI cannot be applied at the eNB downlink before SF#(n+4).		
Note 3:	PDCCH DCI format 0 with a trigger for aperiodic CQI shall be transmitted in downlink SF#4 and #9 to allow aperiodic CQI/PMI/RI to be transmitted on uplink SF#3 and #8.		

Note 4: Randomization of the principle beam direction shall be used as specified in B.2.3A.4
--

Table 9.4.1.3.2-2: Minimum requirement (TDD)

Parameter	Test 1
γ	3
UE Category	≥ 1

9.4.1.3.3 FDD (with Class A 12Tx codebook)

For the parameters specified in Table 9.4.1.3.3-1, and using the downlink physical channels specified in Annex C.3.2, the minimum requirements are specified in Table 9.4.1.3.3-2.

Table 9.4.1.3.3-1: PMI test for single-layer (FDD)

Parameter		Unit	Test 1
Bandwidth		MHz	10
Transmission mode			9
Propagation channel			EPA5
Precoding granularity		PRB	50
Correlation and antenna configuration			High 2D XP 12(2,3,2) x 2
Cell-specific reference signals			Antenna ports 0,1
CSI reference signals			Antenna ports 15,...,26
Beamforming model			Annex B.4.3
CDM Type			CDM2
CSI-RS periodicity and subframe offset $T_{\text{CSI-RS}} / \Delta_{\text{CSI-RS}}$			5/ 1
NZP-CSI-RS-Configuration-List			{0,1,2}
eMIMO-Type			Class A
codebookConfig-N1			2
codebookConfig-N2			3
codebook-Over-Sampling-RateConfig-O1			8
codebook-Over-Sampling-RateConfig-O2			4
Codebook-Config			Note 5
codebookSubsetRestriction-1			0x01 FFFF FFFF FFFF FFFF FFFF FFFF FFFF FFFF FFFF FFFF FFFF FFFF
codebookSubsetRestriction-2			Codebook-Config 1: 0000 0000 1111 Codebook-Config 2,3,4: 0x 00 000000 0000 FFFF
Downlink power allocation	ρ_A	dB	0
	ρ_B	dB	0
	P_C	dB	-8
	σ	dB	-3
$N_{oc}^{(j)}$		dB[mW/15kHz]	-98
Reporting mode			PUSCH 3-1
Reporting interval		ms	5
PMI delay (Note 2)		ms	8
Measurement channel			R.77 FDD
Rank Number of PDSCH			1
OCNG Pattern			OP.1 FDD
Max number of HARQ transmissions			4
Redundancy version coding sequence			{0,1,2,3}
<p>Note 1: For random precoder selection, the precoder shall be updated in each TTI (1 ms granularity).</p> <p>Note 2: If the UE reports in an available uplink reporting instance at subframe SF#n based on PMI estimation at a downlink SF not later than SF#(n-4), this reported PMI cannot be applied at the eNB downlink before SF#(n+4).</p> <p>Note 3: PDSCH_RA= 0 dB, PDSCH_RB= 0 dB in order to have the same PDSCH and OCNG power per subcarrier at the receiver.</p> <p>Note 4: Randomization of the principle beam direction shall be used as specified in B.2.3B.4.</p> <p>Note 5: Value of parameter codebookConfig shall be random selected one value from UE supported codebook configurations.</p>			

Table 9.4.1.3.3-2: Minimum requirement (FDD)

Parameter	Test 1
γ	2.5
UE Category	≥ 2

9.4.1.3.4 TDD (with Class A 12Tx codebook)

For the parameters specified in Table 9.4.1.3.4-1, and using the downlink physical channels specified in Annex C.3.2, the minimum requirements are specified in Table 9.4.1.3.4-2.

Table 9.4.1.3.4-1: PMI test for single-layer (TDD)

Parameter	Unit	Test 1	
Bandwidth	MHz	10	
Transmission mode		9	
Uplink downlink configuration		1	
Special subframe configuration		4	
Propagation channel		EPA5	
Precoding granularity	PRB	50	
Correlation and antenna configuration		High 2D XP 12(2,3,2) x 2	
Cell-specific reference signals		Antenna ports 0,1	
CSI reference signals		Antenna ports 15,...,26	
Beamforming model		Annex B.4.3	
CDM Type		CDM2	
CSI-RS periodicity and subframe offset $T_{\text{CSI-RS}} / \Delta_{\text{CSI-RS}}$		5/4	
NZP-CSI-RS-Configuration-List		{0,1,2}	
eMIMO-Type		Class A	
codebookConfig-N1		2	
codebookConfig-N2		3	
codebook-Over-Sampling-RateConfig-O1		8	
codebook-Over-Sampling-RateConfig-O2		4	
Codebook-Config		Note 5	
codebookSubsetRestriction-1		0x01 FFFF FFFF FFFF FFFF FFFF FFFF FFFF FFFF FFFF FFFF FFFF FFFF	
codebookSubsetRestriction-2		Codebook-Config 1: 0000 0000 1111 Codebook-Config 2,3,4: 0x 00 000000 0000 FFFF	
Downlink power allocation	ρ_A	dB	0
	ρ_B	dB	0
	P_c	dB	-8
	σ	dB	-3
$N_{oc}^{(j)}$	dB[mW/15kHz]	-98	
Reporting mode		PUSCH 3-1	
Reporting interval	ms	5	
PMI delay (Note 2)	ms	10	
Measurement channel		R.77 TDD	
Rank Number of PDSCH		1	
OCNG Pattern		OP.1 TDD	
Max number of HARQ transmissions		4	
Redundancy version coding sequence		{0,1,2,3}	
ACK/NACK feedback mode		Multiplexing	
Note 1:	For random precoder selection, the precoder shall be updated in each TTI (1 ms granularity).		
Note 2:	If the UE reports in an available uplink reporting instance at subframe SF#n based on PMI estimation at a downlink SF not later than SF#(n-4), this reported PMI cannot be applied at the eNB downlink before SF#(n+4).		
Note 3:	PDCCH DCI format 0 with a trigger for aperiodic CQI shall be transmitted in downlink SF#4 and #9 to allow aperiodic CQI/PMI/RI to be transmitted on uplink SF#3 and #8.		
Note 4:	Randomization of the principle beam direction shall be used as specified in B.2.3B.4.		

Note 5: Value of parameter codebookConfig shall be random selected one value from UE supported codebook configurations.

Table 9.4.1.3.4-2: Minimum requirement (TDD)

Parameter	Test 1
γ	2.5
UE Category	≥ 2

9.4.1.4 Minimum requirement PUCCH 1-1 (CSI Reference Symbol)

9.4.1.4.1 FDD (with 4Tx enhanced codebook)

For the parameters specified in Table 9.4.1.4.1-1, and using the downlink physical channels specified in Annex C.3.2, the minimum requirements are specified in Table 9.4.1.4.1-2.

Table 9.4.1.4.1-1 PMI test for single-layer (FDD)

Parameter	Unit	Test 1	
Bandwidth	MHz	10	
Transmission mode		9	
Propagation channel		EPA5	
Precoding granularity	PRB	50	
Correlation and antenna configuration		High XP 4 x 2	
Beamforming model		Annex B.4.3	
Cell-specific reference signals		Antenna ports 0,1	
CSI reference signals		Antenna ports 15,...,18	
CSI-RS periodicity and subframe offset $T_{\text{CSI-RS}} / \Delta_{\text{CSI-RS}}$		5/ 1	
CSI-RS reference signal configuration		6	
CodeBookSubsetRestriction bitmap		0x0000 0000 0000 FFFF 0000 00FF	
Downlink power allocation	ρ_A	dB	0
	ρ_B	dB	0
	P_c	dB	-3
	σ	dB	-3
$N_{oc}^{(j)}$	dB[mW/15kHz]	-98	
Reporting mode		PUCCH 1-1 submode1	
Reporting interval	ms	5	
PMI delay (Note 2)	ms	10	
Physical channel for CQI/PMI reporting		PUSCH (Note 3)	
PUCCH Report Type for CQI/second PMI		2b	
Physical channel for RI reporting		PUSCH	
PUCCH Report Type for RI/first PMI		5	
<i>cqi-pmi-ConfigurationIndex</i>		4	
<i>ri-ConfigIndex</i>		1	
Measurement channel		R.60 FDD	
OCNG Pattern		OP.1 FDD	
Max number of HARQ transmissions		4	
Redundancy version coding sequence		{0,1,2,3}	
alternativeCodeBookEnable dFor4TX-r12		True	
Note 1:	For random precoder selection, the precoder shall be updated in each TTI (1 ms granularity)		
Note 2:	If the UE reports in an available uplink reporting instance at subframe SF#n based on PMI estimation at a downlink SF not later than SF#(n-4), this reported PMI cannot be applied at the eNB downlink before SF#(n+4).		
Note 3:	To avoid collisions between CQI/PMI reports and HARQ-ACK it is necessary to report both on PUSCH instead of PUCCH.		
Note 4:	PDSCH_RA= 0 dB, PDSCH_RB= 0 dB in order to have the same PDSCH and OCNG power per subcarrier at the receiver.		
Note 5:	Randomization of the principle beam direction shall be used as specified in B.2.3A.4		

Table 9.4.1.4.1-2 Minimum requirement (FDD)

Parameter	Test 1
γ	1.8
UE Category	≥ 1

9.4.1.4.2 TDD (with 4Tx enhanced codebook)

For the parameters specified in Table 9.4.1.4.2-1, and using the downlink physical channels specified in Annex C.3.2, the minimum requirements are specified in Table 9.4.1.4.2-2.

Table 9.4.1.4.2-1 PMI test for single-layer (TDD)

Parameter	Unit	Test 1	
Bandwidth	MHz	10	
Transmission mode		9	
Uplink downlink configuration		1	
Special subframe configuration		4	
Propagation channel		EPA5	
Precoding granularity	PRB	50	
Correlation and antenna configuration		High XP 4 x 2	
Beamforming model		Annex B.4.3	
Cell-specific reference signals		Antenna ports 0,1	
CSI reference signals		Antenna ports 15,...,18	
CSI-RS periodicity and subframe offset $T_{CSI-RS} / \Delta_{CSI-RS}$		5/ 4	
CSI-RS reference signal configuration		6	
CodeBookSubsetRestriction bitmap		0x0000 0000 0000 FFFF 0000 00FF	
Downlink power allocation	ρ_A	dB	0
	ρ_B	dB	0
	P_c	dB	-3
	σ	dB	-3
$N_{oc}^{(j)}$	dB[mW/15kHz]	-98	
Reporting mode		PUCCH 1-1 submode1	
Reporting interval	ms	5	
PMI delay (Note 2)	ms	15	
Physical channel for CQI/PMI reporting		PUSCH (Note 3)	
PUCCH Report Type for CQI/second PMI		2b	
Physical channel for RI reporting		PUSCH	
PUCCH Report Type for RI/first PMI		5	
<i>cqi-pmi-ConfigurationIndex</i>		4	
<i>ri-ConfigIndex</i>		1	
Measurement channel		R.60 TDD	
OCNG Pattern		OP.1 TDD	
Max number of HARQ transmissions		4	
Redundancy version coding sequence		{0,1,2,3}	
ACK/NACK feedback mode		Multiplexing	
alternativeCodeBookEnable dFor4TX-r12		True	
Note 1:	For random precoder selection, the precoder shall be updated in each TTI (1 ms granularity)		
Note 2:	If the UE reports in an available uplink reporting instance at subframe SF#n based on PMI estimation at a downlink SF not later than SF#(n-4), this reported PMI cannot be applied at the eNB downlink before SF#(n+4).		
Note 3:	To avoid collisions between CQI/PMI reports and HARQ-ACK it is necessary to report both on PUSCH instead of PUCCH.		
Note 4:	PDCCH DCI format 0 with a trigger for aperiodic CQI shall be transmitted in downlink SF#4 and #9 to allow aperiodic CQI/PMI/RI to be transmitted on uplink SF#3 and #8.		

Note 5: Randomization of the principle beam direction shall be used as specified in B.2.3A.4.

Table 9.4.1.4.2-2 Minimum requirement (TDD)

Parameter	Test 1
γ	1.8
UE Category	≥ 1

9.4.1.4.3 FDD (with Class B alternative codebook for one CSI-RS resource configured)

For the parameters specified in Table 9.4.1.4.3-1, and using the downlink physical channels specified in Annex C.3.2, the minimum requirements are specified in Table 9.4.1.4.3-2.

Table 9.4.1.4.3-1 PMI test for single-layer (FDD)

Parameter	Unit	Test 1	
Bandwidth	MHz	10	
Transmission mode		9	
Propagation channel		EPA5	
Precoding granularity	PRB	50	
Correlation and antenna configuration		ULA Low 4 x 2	
Beamforming model		Annex B.4.3	
Cell-specific reference signals		Antenna ports 0,1	
CSI reference signals		Antenna ports 15,...,18	
CSI-RS periodicity and subframe offset $T_{CSI-RS} / \Delta_{CSI-RS}$		5/ 1	
CSI-RS reference signal configuration		6	
eMIMO-Type		Class B	
alternativeCodebookEnabled CLASSB_K1		TRUE	
codebookSubsetRestriction-3		00 0000 0000 0000 1111 1111	
Downlink power allocation	ρ_A	dB	0
	ρ_B	dB	0
	ρ_C	dB	-6
	σ	dB	-3
$N_{oc}^{(j)}$	dB[mW/15kHz]	-98	
Reporting mode		PUCCH 1-1	
Reporting interval	ms	5	
PMI delay (Note 2)	ms	10	
Physical channel for CQI/PMI reporting		PUSCH (Note 3)	
PUCCH Report Type for CQI/PMI		2	
Physical channel for RI reporting		PUSCH	
PUCCH Report Type for RI		3	
<i>cqi-pmi-ConfigurationIndex</i>		2	
<i>ri-ConfigIndex</i>		1	
Measurement channel		R.45 FDD	
Rank number of PDSCH		1	
OCNG Pattern		OP.1 FDD	
Max number of HARQ transmissions		4	
Redundancy version coding sequence		{0,1,2,3}	
<p>Note 1: For random precoder selection, the precoder shall be updated in each TTI (1 ms granularity).</p> <p>Note 2: If the UE reports in an available uplink reporting instance at subframe SF#n based on PMI estimation at a downlink SF not later than SF#(n-4), this reported PMI cannot be applied at the eNB downlink before SF#(n+4).</p> <p>Note 3: To avoid collisions between CQI/PMI reports and HARQ-ACK it is necessary to report both on PUSCH instead of PUCCH.</p> <p>Note 4: PDSCH_RA= 0 dB, PDSCH_RB= 0 dB in order to have the same PDSCH and OCNG power per subcarrier at the receiver.</p>			

Table 9.4.1.4.3-2 Minimum requirement (FDD)

Parameter	Test 1
γ	1.1
UE Category	≥ 2

9.4.1.4.4 TDD (with Class B alternative codebook for one CSI-RS resource configured)

For the parameters specified in Table 9.4.1.4.4-1, and using the downlink physical channels specified in Annex C.3.2, the minimum requirements are specified in Table 9.4.1.4.4-2.

Table 9.4.1.4.4-1 PMI test for single-layer (TDD)

Parameter	Unit	Test 1	
Bandwidth	MHz	10	
Transmission mode		9	
Uplink downlink configuration		1	
Special subframe configuration		4	
Propagation channel		EPA5	
Precoding granularity	PRB	50	
Correlation and antenna configuration		ULA Low 8 x 2	
Beamforming model		Annex B.4.3	
Cell-specific reference signals		Antenna ports 0,1	
CSI reference signals		Antenna ports 15,...,22	
CSI-RS periodicity and subframe offset $T_{\text{CSI-RS}} / \Delta_{\text{CSI-RS}}$		5/4	
CSI-RS reference signal configuration		0	
eMIMO-Type		Class B	
alternativeCodebookEnabled CLASSB_K1		TRUE	
codebookSubsetRestriction-3		0x 000 0000 0000 FFFF	
Downlink power allocation	ρ_A	dB	0
	ρ_B	dB	0
	ρ_C	dB	-3
	σ	dB	-3
$N_{oc}^{(j)}$	dB[mW/15kHz]	-98	
Reporting mode		PUCCH 1-1	
Reporting interval	ms	5	
PMI delay (Note 2)	ms	10	
Physical channel for CQI/PMI reporting		PUSCH (Note 3)	
PUCCH Report Type for CQI/PMI		2	
Physical channel for RI reporting		PUSCH	
PUCCH Report Type for RI		3	
<i>cqi-pmi-ConfigurationIndex</i>		4	
<i>ri-ConfigIndex</i>		805	
Measurement channel		R.45 TDD	
Rank number of PDSCH		1	
OCNG Pattern		OP.1 TDD	
Max number of HARQ transmissions		4	
Redundancy version coding sequence		{0,1,2,3}	
ACK/NACK feedback mode		Multiplexing	
<p>Note 1: For random precoder selection, the precoder shall be updated in each TTI (1 ms granularity).</p> <p>Note 2: If the UE reports in an available uplink reporting instance at subframe SF#n based on PMI estimation at a downlink SF not later than SF#(n-4), this reported PMI cannot be applied at the eNB downlink before SF#(n+4).</p> <p>Note 3: To avoid collisions between CQI/PMI reports and HARQ-ACK it is necessary to report both on PUSCH instead of PUCCH.</p> <p>Note 4: PDCCH DCI format 0 with a trigger for aperiodic CQI shall be transmitted in downlink SF#4 and #9 to allow aperiodic CQI/PMI/RI to be transmitted on uplink SF#3 and #8.</p>			

Table 9.4.1.4.4-2 Minimum requirement (TDD)

Parameter	Test 1
γ	1.2
UE Category	≥ 2

9.4.1a Void

9.4.1a.1 Void

9.4.1a.1.1 Void

9.4.1a.1.2 Void

9.4.2 Multiple PMI

9.4.2.1 Minimum requirement PUSCH 1-2 (Cell-Specific Reference Symbols)

9.4.2.1.1 FDD

For the parameters specified in Table 9.4.2.1.1-1, and using the downlink physical channels specified in Annex C.3.2, the minimum requirements are specified in 9.4.2.1.1-2.

Table 9.4.2.1.1-1: PMI test for single-layer (FDD)

Parameter	Unit	Test 1	
Bandwidth	MHz	10	
Transmission mode		6	
Propagation channel		EPA5	
Precoding granularity (only for reporting and following PMI)	PRB	6	
Correlation and antenna configuration		Low 2 x 2	
Downlink power allocation	ρ_A	dB	-3
	ρ_B	dB	-3
	σ	dB	0
$N_{oc}^{(j)}$	dB[mW/15kHz]	-98	
Reporting mode		PUSCH 1-2	
Reporting interval	ms	1	
PMI delay	ms	8	
Measurement channel		R.11-3 FDD for UE Category 1, R.11 FDD for UE Category ≥ 2	
OCNG Pattern		OP.1/2 FDD	
Max number of HARQ transmissions		4	
Redundancy version coding sequence		{0,1,2,3}	
Note 1:	For random precoder selection, the precoders shall be updated in each TTI (1 ms granularity).		
Note 2:	If the UE reports in an available uplink reporting instance at subframe SF#n based on PMI estimation at a downlink SF not later than SF#(n-4), this reported PMI cannot be applied at the eNB downlink before SF#(n+4).		
Note 3:	One/two sided dynamic OCNG Pattern OP.1/2 FDD as described in Annex A.5.1.1/2 shall be used.		

Table 9.4.2.1.1-2: Minimum requirement (FDD)

Parameter	Test 1
γ	1.2
UE Category	≥ 1

9.4.2.1.2 TDD

For the parameters specified in Table 9.4.2.1.2-1, and using the downlink physical channels specified in Annex C.3.2, the minimum requirements are specified in 9.4.2.1.2-2.

Table 9.4.2.1.2-1: PMI test for single-layer (TDD)

Parameter		Unit	Test 1
Bandwidth		MHz	10
Transmission mode			6
Uplink downlink configuration			1
Special subframe configuration			4
Propagation channel			EPA5
Precoding granularity (only for reporting and following PMI)		PRB	6
Correlation and antenna configuration			Low 2 x 2
Downlink power allocation	ρ_A	dB	-3
	ρ_B	dB	-3
	σ	dB	0
$N_{oc}^{(j)}$		dB[mW/15kHz]	-98
Reporting mode			PUSCH 1-2
Reporting interval		ms	1
PMI delay		ms	10 or 11
Measurement channel			R.11-3 TDD for UE Category 1 R.11 TDD for UE Category ≥ 2
OCNG Pattern			OP.1/2 TDD
Max number of HARQ transmissions			4
Redundancy version coding sequence			{0,1,2,3}
ACK/NACK feedback mode			Multiplexing
<p>Note 1: For random precoder selection, the precoders shall be updated in each available downlink transmission instance.</p> <p>Note 2: If the UE reports in an available uplink reporting instance at subframe SF#n based on PMI estimation at a downlink SF not later than SF#(n-4), this reported PMI cannot be applied at the eNB downlink before SF#(n+4).</p> <p>Note 3: One/two sided dynamic OCNG Pattern OP.1/2 TDD as described in Annex A.5.2.1/2 shall be used.</p>			

Table 9.4.2.1.2-2: Minimum requirement (TDD)

Parameter	Test 1
γ	1.2
UE Category	≥ 1

9.4.2.2 Minimum requirement PUSCH 2-2 (Cell-Specific Reference Symbols)

9.4.2.2.1 FDD

For the parameters specified in Table 9.4.2.2.1-1, and using the downlink physical channels specified in Annex C.3.2, the minimum requirements are specified in Table 9.4.2.2.1-2.

Table 9.4.2.2.1-1: PMI test for single-layer (FDD)

Parameter		Unit	Test 1
Bandwidth		MHz	10
Transmission mode			6
Propagation channel			EVA5
Correlation and antenna configuration			Low 4 x 2
Downlink power allocation	ρ_A	dB	-6
	ρ_B	dB	-6
	σ	dB	3
$N_{oc}^{(j)}$		dB[mW/15kHz]	-98
PMI delay		ms	8
Reporting mode			PUSCH 2-2
Reporting interval		ms	1
Measurement channel			R.14-2 FDD
OCNG Pattern			OP. 1/2 FDD
Subband size (k)		RBs	3 (full size)
Number of preferred subbands (M)			5
Max number of HARQ transmissions			4
Redundancy version coding sequence			{0,1,2,3}
Note 1: For random precoder selection, the precoder shall be updated in each TTI (1 ms granularity)			
Note 2: If the UE reports in an available uplink reporting instance at subframe SF#n based on PMI estimation at a downlink SF not later than SF#(n-4), this reported PMI cannot be applied at the eNB downlink before SF#(n+4)			

Table 9.4.2.2.1-2: Minimum requirement (FDD)

	Test 1
γ	1.2
UE Category	≥ 1

9.4.2.2.2 TDD

For the parameters specified in Table 9.4.2.2.1, and using the downlink physical channels specified in Annex C.3.2, the minimum requirements are specified in Table 9.4.2.2.2-2.

Table 9.4.2.2-1: PMI test for single-layer (TDD)

Parameter	Unit	Test 1	
Bandwidth	MHz	10	
Transmission mode		6	
Uplink downlink configuration		1	
Special subframe configuration		4	
Propagation channel		EVA5	
Correlation and antenna configuration		Low 4 x 2	
Downlink power allocation	ρ_A	dB	-6
	ρ_B	dB	-6
	σ	dB	3
$N_{oc}^{(j)}$	dB[mW/15kHz]	-98	
PMI delay	ms	10	
Reporting mode		PUSCH 2-2	
Reporting interval	ms	1	
Measurement channel		R.14-2 TDD	
OCNG Pattern		OP.1/2 TDD	
Subband size (k)	RBs	3 (full size)	
Number of preferred subbands (M)		5	
Max number of HARQ transmissions		4	
Redundancy version coding sequence		{0,1,2,3}	
ACK/NACK feedback mode		Multiplexing	
Note 1: For random precoder selection, the precoders shall be updated in each available downlink transmission instance. Note 2: If the UE reports in an available uplink reporting instance at subframe SF# n based on PMI estimation at a downlink SF not later than SF# $(n-4)$, this reported PMI cannot be applied at the eNB downlink before SF# $(n+4)$.			

Table 9.4.2.2-2 Minimum requirement (TDD)

	Test 1
γ	1.15
UE Category	≥ 1

9.4.2.3 Minimum requirement PUSCH 1-2 (CSI Reference Symbol)

9.4.2.3.1 FDD

For the parameters specified in Table 9.4.2.3.1-1, and using the downlink physical channels specified in Annex C.3.2, the minimum requirements are specified in 9.4.2.3.1-2.

Table 9.4.2.3.1-1: PMI test for single-layer (FDD)

Parameter		Unit	Test 1
Bandwidth		MHz	10
Transmission mode			9
Propagation channel			EVA5
Precoding granularity (only for reporting and following PMI)		PRB	6
Correlation and antenna configuration			Low ULA 4 x 2
Cell-specific reference signals			Antenna ports 0,1
CSI reference signals			Antenna ports 15,...,18
Beamforming model			Annex B.4.3
CSI-RS periodicity and subframe offset $T_{\text{CSI-RS}} / \Delta_{\text{CSI-RS}}$			5/ 1
CSI-RS reference signal configuration			8
CodeBookSubsetRestriction bitmap			0x0000 0000 0000 FFFF
Downlink power allocation	ρ_A	dB	0
	ρ_B	dB	0
	P_c	dB	-3
	σ	dB	-3
$N_{oc}^{(j)}$		dB[mW/15kHz]	-98
Reporting mode			PUSCH 1-2
Reporting interval		ms	5
PMI delay		ms	8
Measurement channel			R.45-1 FDD for UE Category 1, R.45 FDD for UE Category ≥ 2
OCNG Pattern			OP.7 FDD for UE Category 1 OP.1 FDD for UE Category ≥ 2
Max number of HARQ transmissions			4
Redundancy version coding sequence			{0,1,2,3}
<p>Note 1: For random precoder selection, the precoders shall be updated in each TTI (1 ms granularity).</p> <p>Note 2: If the UE reports in an available uplink reporting instance at subframe SF#n based on PMI estimation at a downlink SF not later than SF#(n-4), this reported PMI cannot be applied at the eNB downlink before SF#(n+4).</p> <p>Note 3: Void.</p> <p>Note 4: PDSCH_RA= 0 dB, PDSCH_RB= 0 dB in order to have the same PDSCH and OCNG power per subcarrier at the receiver.</p>			

Table 9.4.2.3.1-2: Minimum requirement (FDD)

Parameter	Test 1
γ	1.3
UE Category	≥ 1

9.4.2.3.2 TDD

For the parameters specified in Table 9.4.2.3.2-1, and using the downlink physical channels specified in Annex C.3.2, the minimum requirements are specified in 9.4.2.3.2-2.

Table 9.4.2.3.2-1: PMI test for single-layer (TDD)

Parameter	Unit	Test 1	
Bandwidth	MHz	10	
Transmission mode		9	
Uplink downlink configuration		1	
Special subframe configuration		4	
Propagation channel		EVA5	
Precoding granularity (only for reporting and following PMI)	PRB	6	
Antenna configuration		8 x 2	
Correlation modeling		High, Cross polarized	
Cell-specific reference signals		Antenna ports 0,1	
CSI reference signals		Antenna ports 15,...,22	
Beamforming model		Annex B.4.3	
CSI-RS periodicity and subframe offset $T_{\text{CSI-RS}} / \Delta_{\text{CSI-RS}}$		5/ 4	
CSI-RS reference signal configuration		4	
CodeBookSubsetRestriction bitmap		0x0000 0000 001F FFE0 0000 0000 FFFF	
Downlink power allocation	ρ_A	dB	0
	ρ_B	dB	0
	P_c	db	-6
	σ	dB	-3
$N_{oc}^{(j)}$	dB[mW/15kHz]	-98	
Reporting mode		PUSCH 1-2	
Reporting interval	ms	5 (Note 4)	
PMI delay	ms	10	
Measurement channel		R.45-1 TDD for UE Category 1, R.45 TDD for UE Category ≥ 2	
OCNG Pattern		OP.7 TDD for UE Category 1 OP.1 TDD for UE Category ≥ 2	
Max number of HARQ transmissions		4	
Redundancy version coding sequence		{0,1,2,3}	
ACK/NACK feedback mode		Multiplexing	
<p>Note 1: For random precoder selection, the precoders shall be updated in each TTI (1 ms granularity).</p> <p>Note 2: If the UE reports in an available uplink reporting instance at subframe SF#n based on PMI estimation at a downlink SF not later than SF#(n-4), this reported PMI cannot be applied at the eNB downlink before SF#(n+4).</p> <p>Note 3: Void.</p> <p>Note 4: PDCCH DCI format 0 with a trigger for aperiodic</p>			

CQI shall be transmitted in downlink SF#4 and #9 to allow aperiodic CQI/PMI/RI to be transmitted on uplink SF#3 and #8. Note 5: Randomization of the principle beam direction shall be used as specified in B.2.3A.4.
--

Table 9.4.2.3.2-2: Minimum requirement (TDD)

Parameter	Test 1
γ	3.5
UE Category	≥ 1

9.4.2.3.3 FDD (with 4Tx enhanced codebook)

For the parameters specified in Table 9.4.2.3.3-1, and using the downlink physical channels specified in Annex C.3.2, the minimum requirements are specified in 9.4.2.3.3-2.

Table 9.4.2.3.3-1 PMI test for dual-layer (FDD)

Parameter		Unit	Test 1
Bandwidth		MHz	10
Transmission mode			9
Propagation channel			EVA5
Precoding granularity (only for reporting and following PMI)		PRB	6
Correlation and antenna configuration			High XP 4 x 2
Beamforming model			Annex B.4.3
Cell-specific reference signals			Antenna ports 0,1
CSI reference signals			Antenna ports 15,...,18
CSI-RS periodicity and subframe offset $T_{\text{CSI-RS}}$ $/ I_{\text{CSI-RS}}$			5/ 1
CSI-RS reference signal configuration			8
CodeBookSubsetRestriction bitmap			0x0000 0000 FFFF 0000 FFFF 0000
Downlink power allocation	ρ_A	dB	0
	ρ_B	dB	0
	P_c	dB	-3
	σ	dB	-3
$N_{oc}^{(j)}$		dB[mW/15kHz]	-98
Reporting mode			PUSCH1-2
Reporting interval		ms	5
PMI delay (Note 2)		ms	8
Measurement channel			R.45-1 FDD for UE Category 1, R.45 FDD for UE Category ≥ 2
Rank Number of PDSCH			2
OCNG Pattern			OP.7 FDD for UE Category 1 OP.1 FDD for UE Category ≥ 2
Max number of HARQ transmissions			4
Redundancy version coding sequence			{0,1,2,3}
alternativeCodeBookEnable dFor4TX-r12			True
<p>Note 1: For random precoder selection, the precoder shall be updated in each TTI (1 ms granularity)</p> <p>Note 2: If the UE reports in an available uplink reporting instance at subframe SF#n based on PMI estimation at a downlink SF not later than SF#(n-4), this reported PMI cannot be applied at the eNB downlink before SF#(n+4).</p> <p>Note 3: Void.</p> <p>Note 4: PDSCH_RA= 0 dB, PDSCH_RB= 0 dB in order to have the same PDSCH and OCNG power per subcarrier at the receiver.</p> <p>Note 5: Randomization of the principle beam direction shall be used as specified in B.2.3A.4</p>			

Table 9.4.2.3.3-2 Minimum requirement (FDD)

Parameter	Test 1
γ	1.2
UE Category	≥ 1

9.4.2.3.4 TDD (with 4Tx enhanced codebook)

For the parameters specified in Table 9.4.2.3.4-1, and using the downlink physical channels specified in Annex C.3.2, the minimum requirements are specified in 9.4.2.3.4-2.

Table 9.4.2.3.4-1 PMI test for dual-layer (TDD)

Parameter	Unit	Test 1	
Bandwidth	MHz	10	
Transmission mode		9	
Uplink downlink configuration		1	
Special subframe configuration		4	
Propagation channel		EVA5	
Precoding granularity (only for reporting and following PMI)	PRB	6	
Correlation and antenna configuration		XP High 4 x 2	
Beamforming model		Annex B.4.3	
Cell-specific reference signals		Antenna ports 0,1	
CSI reference signals		Antenna ports 15,...,18	
CSI-RS periodicity and subframe offset $T_{\text{CSI-RS}} / I_{\text{CSI-RS}}$		5/ 4	
CSI-RS reference signal configuration		4	
CodeBookSubsetRestriction bitmap		0x0000 0000 FFFF 0000 FFFF 0000	
Downlink power allocation	ρ_A	dB	0
	ρ_B	dB	0
	P_c	dB	-3
	σ	dB	-3
$N_{oc}^{(j)}$	dB[mW/15kHz]	-98	
Reporting mode		PUSCH1-2	
Reporting interval	ms	5	
PMI delay (Note 2)	ms	10	
Measurement channel		R.61-1 TDD for UE Category 1, R.61 TDD for UE Category ≥ 2	
Rank Number of PDSCH		2	
OCNG Pattern		OP.7 FDD for UE Category 1 OP.1 FDD for UE Category ≥ 2	
Max number of HARQ transmissions		4	
Redundancy version coding sequence		{0,1,2,3}	
ACK/NACK feedback mode		Multiplexing	
alternativeCodeBookEnable dFor4TX-r12		True	
Note 1:	For random precoder selection, the precoder shall be updated in each TTI (1 ms granularity)		
Note 2:	If the UE reports in an available uplink reporting instance at subframe SF#n based on PMI estimation at a downlink SF not later than SF#(n-4), this reported PMI cannot be applied at the eNB downlink before SF#(n+4).		
Note3:	Void.		
Note 4:	PDCCH DCI format 0 with a trigger for aperiodic CQI shall be transmitted in downlink SF#4 and #9 to allow aperiodic CQI/PMI/RI to be transmitted on uplink SF#3 and #8.		
Note 5:	Randomization of the principle beam direction shall be used as specified in B.2.3A.4.		

Table 9.4.2.3.4-2 Minimum requirement (TDD)

Parameter	Test 1
γ	1.2
UE Category	≥ 1

9.4.2.3.5 FDD (with Class A 16Tx codebook)

For the parameters specified in Table 9.4.2.3.5-1, and using the downlink physical channels specified in Annex C.3.2, the minimum requirements are specified in Table 9.4.2.3.5-2.

Table 9.4.2.3.5-1: PMI test for dual-layer (FDD)

Parameter		Unit	Test 1
Bandwidth		MHz	10
Transmission mode			9
Propagation channel			EVA5
Precoding granularity (only for reporting and following PMI)		PRB	6
Correlation and antenna configuration			High 2D XP 16(2,4,2) x 2
Cell-specific reference signals			Antenna ports 0,1
CSI reference signals			Antenna ports 15,...,30
Beamforming model			Annex B.4.3
CDM Type			CDM4
CSI-RS periodicity and subframe offset $T_{\text{CSI-RS}} / \Delta_{\text{CSI-RS}}$			5/ 1
NZP-CSI-RS-Configuration-List			{0,1}
eMIMO-Type			Class A
codebookConfig-N1			2
codebookConfig-N2			4
codebook-Over-Sampling-RateConfig-O1			8
codebook-Over-Sampling-RateConfig-O2			8
Codebook-Config			Note 5
codebookSubsetRestriction-1			0x02 FFFF
codebookSubsetRestriction-2			Codebook-Config 1: 0000 1111 0000 Codebook-Config 2,3,4: 0x 00 000000 FFFF 0000
Downlink power allocation	ρ_A	dB	0
	ρ_B	dB	0
	P_C	dB	-6
	σ	dB	-3
$N_{oc}^{(j)}$		dB[mW/15kHz]	-98
Reporting mode			PUSCH 1-2
Reporting interval		ms	5
PMI delay (Note 2)		ms	8
Measurement channel			R.78 FDD
Rank Number of PDSCH			2
OCNG Pattern			OP.1 FDD
Max number of HARQ transmissions			4
Redundancy version coding sequence			{0,1,2,3}
Note 1: For random precoder selection, the precoder shall be updated in each TTI (1 ms granularity).			
Note 2: If the UE reports in an available uplink reporting instance at subframe SF#n based on PMI estimation at a downlink SF not later than SF#(n-4), this reported PMI cannot be applied at the eNB downlink before SF#(n+4).			
Note 3: PDSCH_RA= 0 dB, PDSCH_RB= 0 dB in order to have the same PDSCH and OCNG power per subcarrier at the receiver.			

Note 4:	Randomization of the principle beam direction shall be used as specified in B.2.3B.4.
Note 5:	Value of parameter codebookConfig shall be random selected one value from UE supported codebook configurations.

Table 9.4.2.3.5-2: Minimum requirement (FDD)

Parameter	Test 1
γ	2.5
UE Category	≥ 2

9.4.2.3.6 TDD (with Class A 16Tx codebook)

For the parameters specified in Table 9.4.2.3.6-1, and using the downlink physical channels specified in Annex C.3.2, the minimum requirements are specified in Table 9.4.2.3.6-2.

Table 9.4.2.3.6-1: PMI test for dual-layer (TDD)

Parameter	Unit	Test 1	
Bandwidth	MHz	10	
Transmission mode		9	
Uplink downlink configuration		1	
Special subframe configuration		4	
Propagation channel		EVA5	
Precoding granularity (only for reporting and following PMI)	PRB	6	
Correlation and antenna configuration		High 2D XP 16(2,4,2) x 2	
Cell-specific reference signals		Antenna ports 0,1	
CSI reference signals		Antenna ports 15,...,26	
Beamforming model		Annex B.4.3	
CDM Type		CDM4	
CSI-RS periodicity and subframe offset $T_{\text{CSI-RS}} / \Delta_{\text{CSI-RS}}$		5/ 4	
NZP-CSI-RS-Configuration-List		{0,1}	
eMIMO-Type		Class A	
codebookConfig-N1		2	
codebookConfig-N2		4	
codebook-Over-Sampling-RateConfig-O1		8	
codebook-Over-Sampling-RateConfig-O2		8	
Codebook-Config		Note 5	
codebookSubsetRestriction-1		0x02 FFFF	
codebookSubsetRestriction-2		Codebook-Config 1: 0000 1111 0000 Codebook-Config 2,3,4: 0x 00 000000 FFFF 0000	
Downlink power allocation	ρ_A	dB	0
	ρ_B	dB	0
	P_c	dB	-6
	σ	dB	-3
$N_{oc}^{(j)}$	dB[mW/15kHz]	-98	
Reporting mode		PUSCH 1-2	
Reporting interval	ms	5	
PMI delay (Note 2)	ms	10	
Measurement channel		R.78 TDD	
Rank Number of PDSCH		2	
OCNG Pattern		OP.1 TDD	
Max number of HARQ transmissions		4	
Redundancy version coding sequence		{0,1,2,3}	
ACK/NACK feedback mode		Multiplexing	
Note 1:	For random precoder selection, the precoder shall be updated in each TTI (1 ms granularity).		
Note 2:	If the UE reports in an available uplink reporting instance at subframe SF#n based on PMI estimation at a downlink SF not later than SF#(n-		

	4), this reported PMI cannot be applied at the eNB downlink before SF#(n+4).
Note 3:	PDCCH DCI format 0 with a trigger for aperiodic CQI shall be transmitted in downlink SF#4 and #9 to allow aperiodic CQI/PMI/RI to be transmitted on uplink SF#3 and #8.
Note 4:	Randomization of the principle beam direction shall be used as specified in B.2.3B.4
Note 5:	Value of parameter codebookConfig shall be random selected one value from UE supported codebook configurations.

Table 9.4.2.3.6-2: Minimum requirement (TDD)

Parameter	Test 1
γ	2.5
UE Category	≥ 2

9.4.3 Void

9.4.3.1 Void

9.4.3.1.1 Void

9.4.3.1.2 Void

9.5 Reporting of Rank Indicator (RI)

The purpose of this test is to verify that the reported rank indicator accurately represents the channel rank. The accuracy of RI (CQI) reporting is determined by the relative increase of the throughput obtained when transmitting based on the reported rank compared to the case for which a fixed rank is used for transmission. Transmission mode 4 is used with the specified CodebookSubSetRestriction in section 9.5.1, transmission mode 9 is used with the specified CodebookSubSetRestriction in section 9.5.2 and transmission mode 3 is used with the specified CodebookSubSetRestriction in section 9.5.3, and transmission mode 10 is used with the specified CodebookSubSetRestriction in section 9.5.5.

For fixed rank 1 transmission in sections 9.5.1, 9.5.2 and 9.5.5, the RI and PMI reporting is restricted to two single-layer precoders, For fixed rank 2 transmission in sections 9.5.1, 9.5.2 and 9.5.5, the RI and PMI reporting is restricted to one two-layer precoder, For follow RI transmission in sections 9.5.1 and 9.5.2, the RI and PMI reporting is restricted to select the union of these precoders. Channels with low and high correlation are used to ensure that RI reporting reflects the channel condition.

For fixed rank 1 transmission in section 9.5.3, the RI reporting is restricted to single-layer, for fixed rank 2 transmission in section 9.5.3, the RI reporting is restricted to two-layers. For follow RI transmission in section 9.5.3, the RI reporting is either one or two layers.

9.5.1 Minimum requirement (Cell-Specific Reference Symbols)

9.5.1.1 FDD

The minimum performance requirement in Table 9.5.1.1-2 is defined as

- The ratio of the throughput obtained when transmitting based on UE reported RI and that obtained when transmitting with fixed rank 1 shall be $\geq \gamma_1$;
- The ratio of the throughput obtained when transmitting based on UE reported RI and that obtained when transmitting with fixed rank 2 shall be $\geq \gamma_2$;

For the parameters specified in Table 9.5.1.1-1, and using the downlink physical channels specified in Annex C.3.2, the minimum requirements are specified in Table 9.5.1.1-2.

Table 9.5.1.1-1: RI Test (FDD)

Parameter	Unit	Test 1	Test 2	Test 3
Bandwidth	MHz		10	
PDSCH transmission mode			4	
Downlink power allocation	ρ_A	dB	-3	
	ρ_B	dB	-3	
	σ	dB	0	
Propagation condition and antenna configuration		2 x 2 EPA5		
CodeBookSubsetRestriction bitmap		000011 for fixed RI = 1 010000 for fixed RI = 2 010011 for UE reported RI		
Antenna correlation		Low	Low	High
RI configuration		Fixed RI=2 and follow RI	Fixed RI=1 and follow RI	Fixed RI=1 and follow RI
SNR	dB	0	20	20
$N_{oc}^{(j)}$	dB[mW/15kHz]	-98	-98	-98
$\hat{I}_{or}^{(j)}$	dB[mW/15kHz]	-98	-78	-78
Maximum number of HARQ transmissions		1		
Reporting mode		PUCCH 1-1 (Note 4)		
Physical channel for CQI/PMI reporting		PUCCH Format 2		
PUCCH Report Type for CQI/PMI		2		
Physical channel for RI reporting		PUSCH (Note 3)		
PUCCH Report Type for RI		3		
Reporting periodicity	ms	$N_{pd}=5$		
PMI and CQI delay	ms	8		
<i>cqi-pmi-ConfigurationIndex</i>		6		
<i>ri-ConfigurationInd</i>		1 (Note 5)		
<p>Note 1: If the UE reports in an available uplink reporting instance at subframe SF#n based on PMI and CQI estimation at a downlink subframe not later than SF#(n-4), this reported PMI and wideband CQI cannot be applied at the eNB downlink before SF#(n+4).</p> <p>Note 2: Reference measurement channel RC.2 FDD according to Table A.4-1 with one sided dynamic OCNG Pattern OP.1 FDD as described in Annex A.5.1.1.</p> <p>Note 3: To avoid collisions between RI reports and HARQ-ACK it is necessary to report both on PUSCH instead of PUCCH. PDCCH DCI format 0 shall be transmitted in downlink SF#4 and #9 to allow periodic RI to multiplex with the HARQ-ACK on PUSCH in uplink subframe SF#8 and #3.</p> <p>Note 4: The bit field for precoding information in DCI format 2 shall be mapped as:</p> <ul style="list-style-type: none"> • For reported RI = 1 and PMI = 0 >> precoding information bit field index = 1 • For reported RI = 1 and PMI = 1 >> precoding information bit field index = 2 • For reported RI = 2 and PMI = 0 >> precoding information bit field index = 0 <p>Note 5: To avoid the ambiguity of TE behaviour when applying CQI and PMI during rank switching, RI reports are to be applied at the TE with one subframe delay in addition to Note 1 to align with CQI and PMI reports.</p>				

Table 9.5.1.1-2: Minimum requirement (FDD)

	Test 1	Test 2	Test 3
γ_1	N/A	1.05	0.9
γ_2	1	N/A	N/A
UE Category	≥ 2	≥ 2	≥ 2

9.5.1.2 TDD

The minimum performance requirement in Table 9.5.1.2-2 is defined as

- a) The ratio of the throughput obtained when transmitting based on UE reported RI and that obtained when transmitting with fixed rank 1 shall be $\geq \gamma_1$;
- b) The ratio of the throughput obtained when transmitting based on UE reported RI and that obtained when transmitting with fixed rank 2 shall be $\geq \gamma_2$;

For the parameters specified in Table 9.5.1.2-1, and using the downlink physical channels specified in Annex C.3.2, the minimum requirements are specified in Table 9.5.1.2-2.

Table 9.5.1.2-1: RI Test (TDD)

Parameter	Unit	Test 1	Test 2	Test 3
Bandwidth	MHz	10		
PDSCH transmission mode		4		
Downlink power allocation	ρ_A	dB	-3	
	ρ_B	dB	-3	
	σ	dB	0	
Uplink downlink configuration		2		
Special subframe configuration		4		
Propagation condition and antenna configuration		2 x 2 EPA5		
CodeBookSubsetRestriction bitmap		000011 for fixed RI = 1 010000 for fixed RI = 2 010011 for UE reported RI		
Antenna correlation		Low	Low	High
RI configuration		Fixed RI=2 and follow RI	Fixed RI=1 and follow RI	Fixed RI=1 and follow RI
SNR	dB	0	20	20
$N_{oc}^{(j)}$	dB[mW/15kHz]	-98	-98	-98
$\hat{I}_{or}^{(j)}$	dB[mW/15kHz]	-98	-78	-78
Maximum number of HARQ transmissions		1		
Reporting mode		PUSCH 3-1 (Note 3)		
Reporting interval	ms	5		
PMI and CQI delay	ms	10 or 11		
ACK/NACK feedback mode		Bundling		
Note 1:	If the UE reports in an available uplink reporting instance at subframe SF#n based on PMI and CQI estimation at a downlink subframe not later than SF#(n-4), this reported PMI and wideband CQI cannot be applied at the eNB downlink before SF#(n+4).			
Note 2:	Reference measurement channel RC.2 TDD according to Table A.4-1 with one sided dynamic OCNG Pattern OP.1 TDD as described in Annex A.5.2.1.			
Note 3:	Reported wideband CQI and PMI are used and sub-band CQI is discarded.			

Table 9.5.1.2-2: Minimum requirement (TDD)

	Test 1	Test 2	Test 3
γ_1	N/A	1.05	0.9
γ_2	1	N/A	N/A
UE Category	≥ 2	≥ 2	≥ 2

9.5.2 Minimum requirement (CSI Reference Symbols)

9.5.2.1 FDD

The minimum performance requirement in Table 9.5.2.1-2 is defined as

- a) The ratio of the throughput obtained when transmitting based on UE reported RI and that obtained when transmitting with fixed rank 1 shall be $\geq \gamma_1$;

b) The ratio of the throughput obtained when transmitting based on UE reported RI and that obtained when transmitting with fixed rank 2 shall be $\geq \gamma_2$;

For the parameters specified in Table 9.5.2.1-1, and using the downlink physical channels specified in Annex C.3.2, the minimum requirements are specified in Table 9.5.2.1-2.

Table 9.5.2.1-1: RI Test (FDD)

Parameter		Unit	Test 1	Test 2	Test 3
Bandwidth		MHz	10		
PDSCH transmission mode			9		
Downlink power allocation	ρ_A	dB	0		
	ρ_B	dB	0		
	ρ_C	dB	0		
	σ	dB	0		
Propagation condition and antenna configuration			2 x 2 EPA5		
Cell-specific reference signals			Antenna ports 0		
Beamforming Model			As specified in Section B.4.3		
CSI reference signals			Antenna ports 15, 16		
CSI-RS periodicity and subframe offset $T_{\text{CSI-RS}} / \Delta_{\text{CSI-RS}}$			5/1		
CSI reference signal configuration			6		
CodeBookSubsetRestriction bitmap			000011 for fixed RI = 1 010000 for fixed RI = 2 010011 for UE reported RI		
Antenna correlation			Low	Low	High
RI configuration			Fixed RI=2 and follow RI	Fixed RI=1 and follow RI	Fixed RI=1 and follow RI
SNR		dB	0	20	20
$N_{oc}^{(j)}$		dB[mW/15kHz]	-98	-98	-98
$\hat{I}_{or}^{(j)}$		dB[mW/15kHz]	-98	-78	-78
Maximum number of HARQ transmissions			1		
Reporting mode			PUCCH 1-1		
Physical channel for CQI/PMI reporting			PUSCH (Note 3)		
PUCCH Report Type for CQI/PMI			2		
Physical channel for RI reporting			PUCCH Format 2		
PUCCH Report Type for RI			3		
Reporting periodicity		ms	$N_{pd} = 5$		
PMI and CQI delay		ms	8		
<i>cqi-pmi-ConfigurationIndex</i>			2		
<i>ri-ConfigurationIndex</i>			1 (Note 4)		
<p>Note 1: If the UE reports in an available uplink reporting instance at subframe SF#n based on PMI and CQI estimation at a downlink subframe not later than SF#(n-4), this reported PMI and wideband CQI cannot be applied at the eNB downlink before SF#(n+4).</p> <p>Note 2: Reference measurement channel RC.9 FDD according to Table A.4-1 with one sided dynamic OCNG Pattern OP.1 FDD as described in Annex A.5.1.1.</p> <p>Note 3: To avoid collisions between CQI/ PMI reports and HARQ-ACK it is necessary to report both on PUSCH instead of PUCCH. PDCCH DCI format 0 shall be transmitted in downlink SF#1 and #6 to allow periodic CQI/ PMI to multiplex with the HARQ-ACK on PUSCH in uplink SF#0 and #5.</p> <p>Note 4: To avoid the ambiguity of TE behaviour when applying CQI and PMI during rank switching, RI reports are to be applied at the TE with one subframe delay in addition to Note 1 to align with CQI and PMI reports.</p>					

Table 9.5.2.1-2: Minimum requirement (FDD)

	Test 1	Test 2	Test 3
γ_1	N/A	1.05	0.9
γ_2	1	N/A	N/A
UE Category	≥ 2	≥ 2	≥ 2

9.5.2.2 TDD

The minimum performance requirement in Table 9.5.2.2-2 is defined as

- a) The ratio of the throughput obtained when transmitting based on UE reported RI and that obtained when transmitting with fixed rank 1 shall be $\geq \gamma_1$;
- b) The ratio of the throughput obtained when transmitting based on UE reported RI and that obtained when transmitting with fixed rank 2 shall be $\geq \gamma_2$;

For the parameters specified in Table 9.5.2.2-1, and using the downlink physical channels specified in Annex C.3.2, the minimum requirements are specified in Table 9.5.2.2-2.

Table 9.5.2.2-1: RI Test (TDD)

Parameter		Unit	Test 1	Test 2	Test 3
Bandwidth		MHz		10	
PDSCH transmission mode				9	
Downlink power allocation	ρ_A	dB		0	
	ρ_B	dB		0	
	P_c	dB		0	
	σ	dB		0	
Uplink downlink configuration				1	
Special subframe configuration				4	
Propagation condition and antenna configuration				2 x 2 EPA5	
Cell-specific reference signals				Antenna ports 0	
CSI reference signals				Antenna ports 15, 16	
Beamforming Model				As specified in Section B.4.3	
CSI reference signal configuration				4	
CSI-RS periodicity and subframe offset $T_{\text{CSI-RS}} / \Delta_{\text{CSI-RS}}$				5/4	
CodeBookSubsetRestriction bitmap				000011 for fixed RI = 1 010000 for fixed RI = 2 010011 for UE reported RI	
Antenna correlation			Low	Low	High
RI configuration			Fixed RI=2 and follow RI	Fixed RI=1 and follow RI	Fixed RI=1 and follow RI
SNR		dB	0	20	20
$N_{oc}^{(j)}$		dB[mW/15kHz]	-98	-98	-98
$\hat{I}_{or}^{(j)}$		dB[mW/15kHz]	-98	-78	-78
Maximum number of HARQ transmissions			1		
Reporting mode			PUCCH 1-1		
Physical channel for CQI/ PMI reporting			PUSCH (Note 3)		
PUCCH report type for CQI/ PMI			2		
Physical channel for RI reporting			PUCCH Format 2		
Reporting periodicity		ms	$N_{pd} = 5$		
PMI and CQI delay		ms	10		
ACK/NACK feedback mode			Bundling		
<i>cqi-pmi-ConfigurationIndex</i>			4		
<i>ri-ConfigurationInd</i>			1		
<p>Note 1: If the UE reports in an available uplink reporting instance at subframe SF#n based on PMI and CQI estimation at a downlink subframe not later than SF#(n-4), this reported PMI and wideband CQI cannot be applied at the eNB downlink before SF#(n+4).</p> <p>Note 2: Reference measurement channel RC.9 TDD according to Table A.4-1 with one sided dynamic OCNG Pattern OP.1 TDD as described in Annex A.5.2.1.</p> <p>Note 3: To avoid collisions between CQI/PMI reports and HARQ-ACK it is necessary to report both on PUSCH instead of PUCCH. PDCCH DCI format 0 shall be transmitted in downlink SF#4 and #9 to allow periodic CQI/PMI to multiplex with the HARQ-ACK on PUSCH in uplink SF#3 and #8.</p>					

Table 9.5.2.2-2: Minimum requirement (TDD)

	Test 1	Test 2	Test 3
γ_1	N/A	1.05	0.9
γ_2	1	N/A	N/A
UE Category	≥ 2	≥ 2	≥ 2

9.5.3 Minimum requirement (CSI measurements in case two CSI subframe sets are configured)

9.5.3.1 FDD

The minimum performance requirement in Table 9.5.3.1-2 is defined as

- a) The ratio of the throughput obtained when transmitting based on UE reported RI and that obtained when transmitting with fixed rank 1 shall be $\geq \gamma_1$

For the parameters specified in Table 9.5.3.1-1, and using the downlink physical channels specified in Annex C.3.2, the minimum requirements are specified in Table 9.5.3.1-2.

Table 9.5.3.1-1: RI Test (FDD)

Parameter	Unit	Test 1		Test 2		
		Cell 1	Cell 2	Cell 1	Cell 2	
Bandwidth	MHz	10		10		
PDSCH transmission mode		3	Note 10	3	Note 10	
Downlink power allocation	ρ_A	-3		-3		
	ρ_B	-3		-3		
	σ	0		0		
Propagation condition and antenna configuration		2 x 2 EPA5		2 x 2 EPA5		
CodeBookSubsetRestriction bitmap		01 for fixed RI = 1 10 for fixed RI = 2 11 for UE reported RI	N/A	01 for fixed RI = 1 10 for fixed RI = 2 11 for UE reported RI	N/A	
Antenna correlation		Low		Low		
RI configuration		Fixed RI=1 and follow RI	N/A	Fixed RI=1 and follow RI	N/A	
\hat{E}_s / N_{oc2}	dB	0	-12	20	6	
$N_{oc}^{(j)}$	$N_{oc1}^{(j)}$	dBmW/15kHz z	-98 (Note 3)	N/A	-102 (Note 3)	N/A
	$N_{oc2}^{(j)}$		-98 (Note 4)	N/A	-98 (Note 4)	N/A
	$N_{oc3}^{(j)}$		-98 (Note 5)	N/A	-94.8 (Note 5)	N/A
$\hat{I}_{or}^{(j)}$	dB[mW/15k Hz]	-98	-110	-78	-92	
Subframe Configuration		Non-MBSFN	Non-MBSFN	Non-MBSFN	Non-MBSFN	
Cell Id		0	1	0	1	
Time Offset between Cells	μs	2.5 (synchronous cells)		2.5 (synchronous cells)		
ABS Pattern (Note 6)		N/A	10000000 10000000 10000000 10000000 10000000	N/A	10000000 10000000 10000000 10000000 10000000	
RLM/RRM Measurement Subframe Pattern (Note 7)		10000000 10000000 10000000 10000000 10000000	N/A	10000000 10000000 10000000 10000000 10000000	N/A	
CSI Subframe Sets (Note 8)	$C_{csi,0}$	10000000 10000000 10000000 10000000 10000000	N/A	10000000 10000000 10000000 10000000 10000000	N/A	
	$C_{csi,1}$	01111111 01111111 01111111 01111111 01111111		01111111 01111111 01111111 01111111 01111111		
Number of control OFDM Symbols		3	3	3	3	
Maximum number of HARQ transmissions		1		1		
Reporting mode		PUCCH 1-0		PUCCH 1-0		
Physical channel for CQI reporting		PUCCH Format 2		PUCCH Format 2		
PUCCH Report Type for CQI		4		4		

Physical channel for RI reporting		PUCCH Format 2		PUCCH Format 2	
PUCCH Report Type for RI		3		3	
Reporting periodicity	ms	$N_{pd}=10$		$N_{pd}=10$	
<i>cqi-pmi-ConfigurationIndex</i>		11		11	
<i>ri-ConfigurationInd</i>		5		5	
<i>cqi-pmi-ConfigurationIndex2</i>		10		10	
<i>ri-ConfigurationInd2</i>		2		2	
Cyclic prefix		Normal	Normal	Normal	Normal
Note 1:	If the UE reports in an available uplink reporting instance at subframe SF#n based on CQI estimation at a downlink subframe not later than SF#(n-4), this reported wideband CQI cannot be applied at the eNB downlink before SF#(n+4).				
Note 2:	Reference measurement channel in Cell 1 RC.2 FDD according to Table A.4-1 with one sided dynamic OCNG Pattern OP.1 FDD as described in Annex A.5.1.1.				
Note 3:	This noise is applied in OFDM symbols #1, #2, #3, #5, #6, #8, #9, #10,#12, #13 of a subframe overlapping with the aggressor ABS.				
Note 4:	This noise is applied in OFDM symbols #0, #4, #7, #11 of a subframe overlapping with the aggressor ABS.				
Note 5:	This noise is applied in all OFDM symbols of a subframe overlapping with aggressor non-ABS				
Note 6:	ABS pattern as defined in [9].				
Note 7:	Time-domain measurement resource restriction pattern for PCell measurements as defined in [7].				
Note 8:	As configured according to the time-domain measurement resource restriction pattern for CSI measurements defined in [7].				
Note 9:	Cell 1 is the serving cell. Cell 2 is the aggressor cell. The number of the CRS ports in Cell 1 and Cell 2 is the same.				
Note 10:	Downlink physical channel setup in Cell 2 in accordance with Annex C.3.3 applying OCNG pattern as defined in Annex A.5.1.5.				

Table 9.5.3.1-2: Minimum requirement (FDD)

	Test 1	Test 2
γ	0.9	1.05
UE Category	≥ 2	≥ 2

9.5.3.2 TDD

The minimum performance requirement in Table 9.5.3.2-2 is defined as

- a) The ratio of the throughput obtained when transmitting based on UE reported RI and that obtained when transmitting with fixed rank 1 shall be $\geq \gamma_1$.

For the parameters specified in Table 9.5.3.2-1, and using the downlink physical channels specified in Annex C.3.2, the minimum requirements are specified in Table 9.5.3.2-2.

Table 9.5.3.2-1: RI Test (TDD)

Parameter		Unit	Test1		Test2	
			Cell 1	Cell 2	Cell 1	Cell 2
Bandwidth		MHz	10		10	
PDSCH transmission mode			3	Note 11	3	Note 11
Uplink downlink configuration			1		1	
Special subframe configuration			4		4	
Downlink power allocation	ρ_A	dB	-3		-3	
	ρ_B	dB	-3		-3	
	σ	dB	0		0	
Propagation condition and antenna configuration			2 x 2 EPA5		2 x 2 EPA5	
CodeBookSubsetRestriction bitmap			01 for fixed RI = 1 10 for fixed RI = 2 11 for UE reported RI	N/A	01 for fixed RI = 1 10 for fixed RI = 2 11 for UE reported RI	N/A
Antenna correlation			Low		Low	
RI configuration			Fixed RI=1 and follow RI	N/A	Fixed RI=1 and follow RI	N/A
\widehat{E}_s/N_{oc2}		dB	0	-12	20	6
$N_{oc}^{(j)}$	$N_{oc1}^{(j)}$	dB[mW/15k Hz]	-98 (Note 4)	N/A	-102 (Note 4)	N/A
	$N_{oc2}^{(j)}$		-98 (Note 5)	N/A	-98 (Note 5)	N/A
	$N_{oc3}^{(j)}$		-98 (Note 6)	N/A	-94.8 (Note 6)	N/A
$\widehat{I}_{or}^{(j)}$		dB[mW/15k Hz]	-98	-110	-78	-92
Subframe Configuration			Non-MBSFN	Non-MBSFN	Non-MBSFN	Non-MBSFN
Cell Id			0	1	0	1
Time Offset between Cells		μ s	2.5 (synchronous cells)		2.5 (synchronous cells)	
ABS Pattern (Note 7)			N/A	0000000 001 0000000 001	N/A	000000001 000000001
RLM/RRM Measurement Subframe Pattern (Note 8)			00000000 01 00000000 01	N/A	000000001 000000001	N/A
CSI Subframe Sets (Note 9)	$C_{CSI,0}$		00000000 01 00000000 01	N/A	000000001 000000001	N/A
	$C_{CSI,1}$		11001110 00 11001110 00		1100111000 1100111000	
Number of control OFDM Symbols			3	3	3	3
Maximum number of HARQ transmissions			1		1	
Reporting mode			PUCCH 1-0		PUCCH 1-0	
Physical channel for $C_{CSI,0}$ CQI and RI reporting			PUCCH Format 2		PUCCH Format 2	
PUCCH Report Type for CQI			4		4	

Physical channel for C _{CSI,1} CQI and RI reporting		PUSCH (Note 3)		PUSCH (Note 3)	
PUCCH Report Type for RI		3		3	
Reporting periodicity	ms	N _{pd} = 10		N _{pd} = 10	
ACK/NACK feedback mode		Multiplexing		Multiplexing	
<i>cqi-pmi-ConfigurationIndex</i>		8		8	
<i>ri-ConfigurationInd</i>		5		5	
<i>cqi-pmi-ConfigurationIndex2</i>		9		9	
<i>ri-ConfigurationInd2</i>		0		0	
Cyclic prefix		Normal	Normal	Normal	Normal
Note 1:	If the UE reports in an available uplink reporting instance at subframe SF#n based on CQI estimation at a downlink subframe not later than SF#(n-4), this reported wideband CQI cannot be applied at the eNB downlink before SF#(n+4).				
Note 2:	Reference measurement channel in Cell 1 RC.2 TDD according to Table A.4-1 with one sided dynamic OCNNG Pattern OP.1 TDD as described in Annex A.5.2.1.				
Note 3:	To avoid collisions between RI/CQI reports and HARQ-ACK it is necessary to report them on PUSCH instead of PUCCH. PDCCH DCI format 0 shall be transmitted in downlink SF#4 and #9 to allow periodic RI/CQI to multiplex with the HARQ-ACK on PUSCH in uplink subframe SF#8 and #3.				
Note 4:	This noise is applied in OFDM symbols #1, #2, #3, #5, #6, #8, #9, #10,#12, #13 of a subframe overlapping with the aggressor ABS				
Note 5:	This noise is applied in OFDM symbols #0, #4, #7, #11 of a subframe overlapping with the aggressor ABS.				
Note 6:	This noise is applied in all OFDM symbols of a subframe overlapping with aggressor non-ABS				
Note 7:	ABS pattern as defined in [9].				
Note 8:	Time-domain measurement resource restriction pattern for PCell measurements as defined in [7].				
Note 9:	As configured according to the time-domain measurement resource restriction pattern for CSI measurements defined in [7].				
Note 10:	Cell 1 is the serving cell. Cell 2 is the aggressor cell. The number of the CRS ports in Cell 1 and Cell 2 is the same.				
Note 11:	Downlink physical channel setup in Cell 2 in accordance with Annex C.3.3 applying OCNNG pattern as defined in Annex A.5.2.5.				

Table 9.5.3.2-2: Minimum requirement (TDD)

	Test 1	Test 2
γ	0.9	1.05
UE Category	≥ 2	≥ 2

9.5.4 Minimum requirement (CSI measurements in case two CSI subframe sets are configured and CRS assistance information are configured)

9.5.4.1 FDD

For the parameters specified in Table 9.5.4.1-1, the minimum performance requirement in Table 9.5.4.1-2 is defined as

- a) The ratio of the throughput obtained when transmitting based on UE reported RI and that obtained when transmitting with fixed rank 1 shall be $\geq \gamma_1$;
- b) The ratio of the throughput obtained when transmitting based on UE reported RI and that obtained when transmitting with fixed rank 2 shall be $\geq \gamma_2$;

In Table 9.5.4.1-1, Cell 1 is the serving cell, and Cell 2 and Cell 3 are the aggressor cells. The downlink physical channel setup for Cell 1 is according to Annex C.3.2 and for Cell 2 and Cell 3 is according to Annex C.3.3, respectively. The CRS assistance information [7] including Cell 2 and Cell 3 is provided.

Table 9.5.4.1-1: RI Test (FDD)

Parameter		Unit	Cell 1	Cell 2	Cell 3
Bandwidth		MHz	10	10	10
PDSCH transmission mode			3	As defined in Note 1	As defined in Note 1
Downlink power allocation	ρ_A	dB	-3	-3	-3
	ρ_B	dB	-3	-3	-3
	σ	dB	0	N/A	N/A
Propagation condition and antenna configuration			2x2 EPA5 (Note 2)	2x2 EPA5 (Note 2)	2x2 EPA5 (Note 2)
CodeBookSubsetRestriction bitmap			01 for fixed RI = 1 10 for fixed RI = 2 11 for UE reported RI	As defined in Note 1	As defined in Note 1
N_{oc} at antenna port	N_{oc1}	dB[mW/15k Hz]	-98 (Note 3)	N/A	N/A
	N_{oc2}	dB[mW/15k Hz]	-98 (Note 4)	N/A	N/A
	N_{oc3}	dB[mW/15k Hz]	-93 (Note 5)	N/A	N/A
\hat{E}_s/N_{oc2}		dB	Reference Value in Table 9.5.4.1-2 for each test	12	10
$\hat{I}_{or}^{(j)}$		dB[mW/15k Hz]	Reference Value in Table 9.5.4.1-2 for each test	-86	-88
Subframe Configuration			Non-MBSFN	Non-MBSFN	Non-MBSFN
Time Offset between Cells		μ s	N/A	3	-1
Frequency shift between Cells		Hz	N/A	300	-100
Cell Id			0	126	1
ABS pattern (Note 6)			N/A	10000000 10000000 10000000 10000000 10000000	10000000 10000000 10000000 10000000 10000000
RLM/RRM Measurement Subframe Pattern (Note 7)			10000000 10000000 10000000 10000000 10000000	N/A	N/A
CSI Subframe Sets (Note 8)	$C_{csi,0}$		10000000 10000000 10000000 10000000 10000000	N/A	N/A
	$C_{csi,1}$		01111111 01111111 01111111 01111111 01111111	N/A	N/A
Number of control OFDM symbols			3	Note 9	Note 9
Maximum number of HARQ transmissions			1	N/A	N/A
Reporting mode			PUCCH 1-0	N/A	N/A
Physical channel for CQI reporting			PUCCH format 2	N/A	N/A
PUCCH Report Type for CQI			4	N/A	N/A
Physical channel for RI reporting			PUCCH Format 2	N/A	N/A
PUCCH Report Type for RI			3	N/A	N/A
Reporting periodicity		ms	$N_{pd} = 10$	N/A	N/A

<i>cqi-pmi-ConfigurationIndex</i>		11	N/A	N/A
<i>ri-ConfigurationInd</i>		5	N/A	N/A
<i>cqi-pmi-ConfigurationIndex2</i>		10	N/A	N/A
<i>ri-ConfigurationInd2</i>		2	N/A	N/A
Cyclic prefix		Normal	Normal	Normal
Note 1:	Downlink physical channel setup in Cell 2 and Cell 3 in accordance with Annex C.3.3 applying OCNG pattern OP.5 FDD as defined in Annex A.5.1.5.			
Note 2:	The propagation conditions for Cell 1, Cell 2 and Cell 3 are statistically independent.			
Note 3:	This noise is applied in OFDM symbols #1, #2, #3, #5, #6, #8, #9, #10, #12, #13 of a subframe overlapping with the aggressor ABS.			
Note 4:	This noise is applied in OFDM symbols #0, #4, #7, #11 of a subframe overlapping with the aggressor ABS.			
Note 5:	This noise is applied in all OFDM symbols of a subframe overlapping with aggressor non-ABS			
Note 6:	ABS pattern as defined in [9]. PDSCH other than SIB1/paging and its associated PDCCH/PCFICH are transmitted in the serving cell subframe when the subframe is overlapped with the ABS subframe of aggressor cell and the subframe is available in the definition of the reference channel.			
Note 7:	Time-domain measurement resource restriction pattern for PCell measurements as defined in [7]			
Note 8:	As configured according to the time-domain measurement resource restriction pattern for CSI measurements defined in [7].			
Note 9:	The number of control OFDM symbols is not available for ABS and is 3 for the subframe indicated by "0" of ABS pattern.			
Note 10:	If the UE reports in an available uplink reporting instance at subframe SF#n based on CQI estimation at a downlink subframe not later than SF#(n-4), this reported wideband CQI cannot be applied at the eNB downlink before SF#(n+4).			
Note 11:	Reference measurement channel in Cell 1 RC.2 FDD according to Table A.4-1 with one sided dynamic OCNG Pattern OP.1 FDD as described in Annex A.5.1.1.			
Note 12:	The number of the CRS ports in Cell1, Cell2 and Cell 3 is the same.			
Note 13:	SIB-1 will not be transmitted in Cell2 and Cell 3 in this test.			

Table 9.5.4.1-2: Minimum requirement (FDD)

	Test 1	Test 2	Test 3
\hat{E}_s / N_{oc2} for Cell 1 (dB)	4	20	20
$\hat{I}_{or}^{(j)}$ for Cell 1 (dB[mW/15kHz])	-94	-78	-78
Antenna correlation	High for Cell 1, low for Cell 2 and Cell 3	Low for Cell 1, Cell 2 and Cell 3	High for Cell 1, low for Cell 2 and Cell 3
γ_1	N/A	1.05	0.9
γ_2	1.05	N/A	N/A
UE Category	≥ 2	≥ 2	≥ 2

9.5.4.2 TDD

For the parameters specified in Table 9.5.4.2-1, the minimum performance requirement in Table 9.5.4.2-2 is defined as

- The ratio of the throughput obtained when transmitting based on UE reported RI and that obtained when transmitting with fixed rank 1 shall be $\geq \gamma_1$;
- The ratio of the throughput obtained when transmitting based on UE reported RI and that obtained when transmitting with fixed rank 2 shall be $\geq \gamma_2$;

In Table 9.5.4.2-1, Cell 1 is the serving cell, and Cell 2 and Cell 3 are the aggressor cells. The downlink physical channel setup for Cell 1 is according to Annex C.3.2 and for Cell 2 and Cell 3 is according to Annex C.3.3, respectively. The CRS assistance information [7] including Cell 2 and Cell 3 is provided.

Table 9.5.4.2-1: RI Test (TDD)

Parameter		Unit	Cell 1	Cell 2	Cell 3
Bandwidth		MHz	10	10	10
PDSCH transmission mode			3	As defined in Note 1	As defined in Note 1
Uplink downlink configuration			1	1	1
Special subframe configuration			4	4	4
Downlink power allocation	ρ_A	dB	-3	-3	-3
	ρ_B	dB	-3	-3	-3
	σ	dB	0	N/A	N/A
Propagation condition and antenna configuration			2x2 EPA5 (Note 2)	2x2 EPA5 (Note 2)	2x2 EPA5 (Note 2)
CodeBookSubsetRestriction bitmap			01 for fixed RI = 1 10 for fixed RI = 2 11 for UE reported RI	As defined in Note 1	As defined in Note 1
N_{oc} at antenna port	N_{oc1}	dB[mW/15k Hz]	-98 (Note 3)	N/A	N/A
	N_{oc2}	dB[mW/15k Hz]	-98 (Note 4)	N/A	N/A
	N_{oc3}	dB[mW/15k Hz]	-93 (Note 5)	N/A	N/A
\hat{E}_s / N_{oc2}		dB	Reference Value in Table 9.5.4.2-2 for each test	12	10
$\hat{I}_{or}^{(j)}$		dB[mW/15k Hz]	Reference Value in Table 9.5.4.2-2 for each test	-86	-88
Subframe Configuration			Non-MBSFN	Non-MBSFN	Non-MBSFN
Time Offset between Cells		μ s	N/A	3	-1
Frequency shift between Cells		Hz	N/A	300	-100
Cell Id			0	126	1
ABS pattern (Note 6)			N/A	000000001 000000001	000000001 000000001
RLM/RRM Measurement Subframe Pattern (Note 7)			000000001 000000001	N/A	N/A
CSI Subframe Sets (Note 8)	$C_{CSI,0}$		000000001 000000001	N/A	N/A
	$C_{CSI,1}$		1100111000 1100111000	N/A	N/A
Number of control OFDM symbols			3	Note 9	Note 9
Maximum number of HARQ transmissions			1	N/A	N/A
Reporting mode			PUCCH 1-0	N/A	N/A
Physical channel for $C_{CSI,0}$ CQI and RI reporting			PUCCH format 2	N/A	N/A
Physical channel for $C_{CSI,1}$ CQI and RI reporting			PUSCH (Note 14)	N/A	N/A
PUCCH Report Type for CQI			4	N/A	N/A
PUCCH Report Type for RI			3	N/A	N/A
Reporting periodicity		ms	$N_{pd}= 10$	N/A	N/A
ACK/NACK feedback mode			Multiplexing	N/A	N/A
$cqi-pmi-ConfigurationIndex$			8	N/A	N/A
$ri-ConfigurationInd$			5	N/A	N/A
$cqi-pmi-ConfigurationIndex2$			9	N/A	N/A
$ri-ConfigurationInd2$			0	N/A	N/A
Cyclic prefix			Normal	Normal	Normal

Note 1:	Downlink physical channel setup in Cell 2 and Cell 3 in accordance with Annex C.3.3 applying OCN pattern OP.5 TDD as defined in Annex A.5.2.5.
Note 2:	The propagation conditions for Cell 1, Cell 2 and Cell 3 are statistically independent.
Note 3:	This noise is applied in OFDM symbols #1, #2, #3, #5, #6, #8, #9, #10, #12, #13 of a subframe overlapping with the aggressor ABS.
Note 4:	This noise is applied in OFDM symbols #0, #4, #7, #11 of a subframe overlapping with the aggressor ABS.
Note 5:	This noise is applied in all OFDM symbols of a subframe overlapping with aggressor non-ABS
Note 6:	ABS pattern as defined in [9]. PDSCH other than SIB1/paging and its associated PDCCH/PCFICH are transmitted in the serving cell subframe when the subframe is overlapped with the ABS subframe of aggressor cell and the subframe is available in the definition of the reference channel.
Note 7:	Time-domain measurement resource restriction pattern for PCell measurements as defined in [7]
Note 8:	As configured according to the time-domain measurement resource restriction pattern for CSI measurements defined in [7].
Note 9:	The number of control OFDM symbols is not available for ABS and is 3 for the subframe indicated by "0" of ABS pattern.
Note 10:	If the UE reports in an available uplink reporting instance at subframe SF#n based on CQI estimation at a downlink subframe not later than SF#(n-4), this reported wideband CQI cannot be applied at the eNB downlink before SF#(n+4).
Note 11:	Reference measurement channel in Cell 1 RC.2 TDD according to Table A.4-1 with one sided dynamic OCN Pattern OP.1 TDD as described in Annex A.5.2.1.
Note 12:	The number of the CRS ports in Cell1, Cell2 and Cell 3 is the same.
Note 13:	SIB-1 will not be transmitted in Cell2 and Cell 3 in this test.
Note 14:	To avoid collisions between RI/CQI reports and HARQ-ACK it is necessary to report them on PUSCH instead of PUCCH. PDCCH DCI format 0 shall be transmitted in downlink SF#4 and #9 to allow periodic RI/CQI to multiplex with the HARQ-ACK on PUSCH in uplink subframe SF#8 and #3.

Table 9.5.4-2: Minimum requirement (TDD)

	Test 1	Test 2	Test 3
\hat{E}_s / N_{oc2} for Cell 1 (dB)	4	20	20
$\hat{I}_{or}^{(j)}$ for Cell 1 (dB[mW/15kHz])	-94	-78	-78
Antenna correlation	High for Cell 1, low for Cell 2 and Cell 3	Low for Cell 1, Cell 2 and Cell 3	High for Cell 1, low for Cell 2 and Cell 3
γ_1	N/A	1.05	0.9
γ_2	1.05	N/A	N/A
UE Category	≥ 2	≥ 2	≥ 2

9.5.5 Minimum requirement (with CSI process)

Each CSI process is associated with a CSI-RS resource and a CSI-IM resource as shown in Table 9.5.5-1.

For UE supports one CSI process, CSI process 0 is configured for Test 1 and Test 2, but CSI process 1 is not configured for Test 2. The corresponding γ requirements for Test 1 and Test 2 shall be fulfilled. The requirement on reported RI for CSI process 1 in Test 2 is not applicable.

For UE supports multiple CSI processes, CSI process 0 is configured for Test 1 and CSI processes 0 and 1 are configured for Test 2. The corresponding γ requirements for Test 1 and Test 2 shall be fulfilled, and also the requirement on reported RI for CSI process 1 in Test 2.

Table 9.5.5-1: Configuration of CSI processes

	CSI process 0	CSI process 1
CSI-RS resource	CSI-RS signal 0	CSI-RS signal 1
CSI-IM resource	CSI-IM resource 0	CSI-IM resource 1

9.5.5.1 FDD

The minimum performance requirement in Table 9.5.5.1-2 is defined as

- a) The ratio of the throughput obtained when transmitting based on UE reported RI and that obtained when transmitting with fixed rank 1 shall be $\geq \gamma_1$;
- b) The ratio of the throughput obtained when transmitting based on UE reported RI and that obtained when transmitting with fixed rank 2 shall be $\geq \gamma_2$;
- c) For Test 2, the RI reported for CSI process 1 shall be the same as the most recent RI reported for CSI process 0 if UE is configured with multiple CSI processes.

For the parameters specified in Table 9.5.5.1-1, and using the downlink physical channels specified in Annex C.3.2, the minimum requirements are specified in Table 9.5.5.1-2.

Table 9.5.5.1-1: RI Test (FDD)

Parameter		Unit	Test 1		Test 2	
			TP1	TP2	TP1	TP2
Bandwidth		MHz	10 MHz		10 MHz	
Transmission mode			10	10	10	10
Downlink power allocation	ρ_A	dB	0		0	
	ρ_B	dB	0		0	
	P_c	dB	0	0	0	0
	σ	dB	0		0	
SNR		dB	0	0	20	20
$\hat{I}_{or}^{(j)}$		dB[mW/15kHz]	-98	-98	-78	-78
$N_{oc}^{(j)}$		dB[mW/15kHz]	-98		-98	
Propagation channel			EPA 5 Low	EPA 5 Low	EPA 5 Low	EPA 5 High
Antenna configuration			2x2	2x2	2x2	2x2
Beamforming Model			As specified in Section B.4.3		As specified in Section B.4.3	
Timing offset between TPs		us	0		0	
Frequency offset between TPs		Hz	0		0	
Cell-specific reference signals			Antenna ports 0		Antenna ports 0	
CSI-RS signal 0			Antenna ports 15,16	N/A	Antenna ports 15,16	N/A
CSI-RS 0 periodicity and subframe offset $T_{CSI-RS} / \Delta_{CSI-RS}$			5/1	N/A	5/1	N/A
CSI-RS 0 configuration			0	N/A	0	N/A
CSI-RS signal 1			N/A	Antenna ports 15,16	N/A	Antenna ports 15,16
CSI-RS 1 periodicity and subframe offset $T_{CSI-RS} / \Delta_{CSI-RS}$			N/A	5/1	N/A	5/1
CSI-RS 1 configuration			N/A	3	N/A	3
Zero-power CSI-RS 0 configuration $l_{CSI-RS} / ZeroPowerCSI-RS$ bitmap			N/A	1 / 10000010000 00000	N/A	1] / 10000010000 00000
Zero-power CSI-RS 1 configuration $l_{CSI-RS} / ZeroPowerCSI-RS$ bitmap			1 / 00110000000 00000	N/A	1 / 00110000000 00000	N/A
CSI-IM 0 periodicity and subframe offset $T_{CSI-RS} / \Delta_{CSI-RS}$			5/1	N/A	5/1	N/A
CSI-IM 0 configuration			2	N/A	2	N/A
CSI-IM 1 periodicity and subframe offset $T_{CSI-RS} / \Delta_{CSI-RS}$			N/A	5/1	N/A	5/1
CSI-IM 1 configuration			N/A	6	N/A	6
RI configuration			Fixed RI=2 and follow RI	N/A	Fixed RI=1 and follow RI	N/A
Physical channel for CQI/PMI reporting			PUSCH (Note 6)	N/A	PUSCH (Note 6)	PUSCH (Note 6)
PUCCH Report Type for CQI/PMI			2	N/A	2	2
Physical channel for RI reporting			PUCCH Format 2	N/A	PUCCH Format 2	PUCCH Format 2
PUCCH Report Type for RI			3	N/A	3	3
CSI process 0 (Note 7)	CSI-RS		CSI-RS 0	N/A	CSI-RS 0	N/A
	CSI-IM		CSI-IM 0	N/A	CSI-IM 0	N/A
	Reporting mode		PUCCH 1-1	N/A	PUCCH 1-1	N/A
	Reporting periodicity	ms	$N_{pd} = 5$	N/A	$N_{pd} = 5$	N/A
	CQI delay	ms	8	N/A	10	N/A
	$cqi-pmi-ConfigurationIndex$		6	N/A	6	N/A
	$ri-ConfigIndex$		1	N/A	1	N/A
CSI process 1 (Note 7, Note 9)	CSI-RS		N/A	N/A	N/A	CSI-RS 1
	CSI-IM		N/A	N/A	N/A	CSI-IM 1
	Reporting mode		N/A	N/A	N/A	PUCCH 1-1
	Reporting periodicity	ms	N/A	N/A	N/A	$N_{pd} = 5$

	CQI delay	ms	N/A	N/A	N/A	10
	<i>cqi-pmi-ConfigurationIndex</i>		N/A	N/A	N/A	4
	<i>ri-ConfigIndex</i>		N/A	N/A	N/A	1
CSI process for PDSCH scheduling			CSI process 0		CSI process 0	
Cell ID			0	6	0	6
Quasi-co-located CSI-RS			CSI-RS 0	CSI-RS 1	CSI-RS 0	CSI-RS 1
Quasi-co-located CRS			Same Cell ID as Cell 1	Same Cell ID as Cell 2	Same Cell ID as Cell 1	Same Cell ID as Cell 2
PMI for subframe 2, 3, 4, 7, 8 and 9			010000 for fixed RI = 2 010011 for UE reported RI	100000	000011 for fixed RI = 1 010011 for UE reported RI	N/A
PMI for subframe 1 and 6			100000	100000	100000	N/A
Max number of HARQ transmissions			1	N/A	1	N/A
Note 1:	If the UE reports in an available uplink reporting instance at subframe SF#n based on CQI estimation at a downlink SF not later than SF#(n-4), this reported wideband CQI cannot be applied at the eNB downlink before SF#(n+4)					
Note 2:	3 symbols allocated to PDCCH					
Note 3:	Reference measurement channel RC.13 FDD according to Table A.4-1. PDSCH transmission is scheduled on subframe 2, 3, 4, 7, 8 and 9 from TP1.					
Note 4:	TM10 OCNG as specified in A.5.1.8 is transmitted on subframe 1 and 6 from TP1.					
Note 5:	TM10 OCNG as specified in A.5.1.8 is transmitted on subframe 1, 2, 3, 4, 6, 7, 8 and 9 from TP2 for Test 1; TP2 is blanked for Test 2.					
Note 6:	To avoid collisions between CQI/PMI reports and HARQ-ACK it is necessary to report both on PUSCH instead of PUCCH. PDCCH DCI format 0 shall be transmitted in downlink SF#1 and #6 to allow periodic CQI/PMI to multiplex with the HARQ-ACK on PUSCH in uplink SF#0 and #5.					
Note 7:	If UE supports multiple CSI processes, CSI process 0 is configured as 'RI-reference CSI process' for CSI process 1.					
Note 8:	PDCCH DCI format 0 with a trigger for aperiodic CQI shall be transmitted in downlink SF#1 and #6 to allow aperiodic CQI/PMI/RI to be transmitted in uplink SF#0 and #5.					
Note 9:	If UE supports one CSI process, CSI process 1 is not configured in Test 2.					

Table 9.5.5.1-2: Minimum requirement (FDD)

	Test 1	Test 2
γ_1	N/A	1.0
γ_2	1.0	N/A
UE Category	≥ 2	≥ 2

9.5.5.2 TDD

The minimum performance requirement in Table 9.5.5.2-2 is defined as

- The ratio of the throughput obtained when transmitting based on UE reported RI and that obtained when transmitting with fixed rank 1 shall be $\geq \gamma_1$;
- The ratio of the throughput obtained when transmitting based on UE reported RI and that obtained when transmitting with fixed rank 2 shall be $\geq \gamma_2$;
- For Test 2, the RI reported for CSI process 1 shall be the same as the most recent RI reported for CSI process 0 if UE is configured with multiple CSI processes.

For the parameters specified in Table 9.5.5.2-1, and using the downlink physical channels specified in Annex C.3.2, the minimum requirements are specified in Table 9.5.5.2-2.

Table 9.5.5.2-1: RI Test (TDD)

Parameter		Unit	Test 1		Test 2	
			TP1	TP2	TP1	TP2
Bandwidth		MHz	10 MHz		10 MHz	
Transmission mode			10	10	10	10
Downlink power allocation	ρ_A	dB	0		0	
	ρ_B	dB	0		0	
	P_c	dB	0	0	0	0
	σ	dB	0		0	
Uplink downlink configuration			2	2	2	2
Special subframe configuration			4	4	4	4
SNR		dB	0	0	20	20
$\hat{I}_{or}^{(j)}$		dB[mW/15kHz]	-98	-98	-78	-78
$N_{oc}^{(j)}$		dB[mW/15kHz]	-98		-98	
Propagation channel			EPA 5 Low	EPA 5 Low	EPA 5 Low	EPA 5 High
Antenna configuration			2x2	2x2	2x2	2x2
Beamforming Model			As specified in Section B.4.3		As specified in Section B.4.3	
Timing offset between TPs		us	0		0	
Frequency offset between TPs		Hz	0		0	
Cell-specific reference signals			Antenna ports 0		Antenna ports 0	
CSI-RS signal 0			Antenna ports 15,16	N/A	Antenna ports 15,16	N/A
CSI-RS 0 periodicity and subframe offset $T_{CSI-RS} / \Delta_{CSI-RS}$			5/3	N/A	5/3	N/A
CSI-RS 0 configuration			0	N/A	0	N/A
CSI-RS signal 1			N/A	Antenna ports 15,16	N/A	Antenna ports 15,16
CSI-RS 1 periodicity and subframe offset $T_{CSI-RS} / \Delta_{CSI-RS}$			N/A	5/3	N/A	5/3
CSI-RS 1 configuration			N/A	3	N/A	3
Zero-power CSI-RS 0 configuration $l_{CSI-RS} / ZeroPowerCSI-RS$ bitmap			N/A	3 / 10000010000 00000	N/A	3 / 10000010000 00000
Zero-power CSI-RS 1 configuration $l_{CSI-RS} / ZeroPowerCSI-RS$ bitmap			3 / 00110000000 00000	N/A	3 / 00110000000 00000	N/A
CSI-IM 0 periodicity and subframe offset $T_{CSI-RS} / \Delta_{CSI-RS}$			5/3	N/A	5/3	N/A
CSI-IM 0 configuration			2	N/A	2	N/A
CSI-IM 1 periodicity and subframe offset $T_{CSI-RS} / \Delta_{CSI-RS}$			N/A	5/3	N/A	5/3
CSI-IM 1 configuration			N/A	6	N/A	6
RI configuration			Fixed RI=2 and follow RI	N/A	Fixed RI=1 and follow RI	N/A
CSI process 0 (Note 6, 7)	CSI-RS		CSI-RS 0	N/A	CSI-RS 0	N/A
	CSI-IM		CSI-IM 0	N/A	CSI-IM 0	N/A
	Reporting mode		PUSCH 3-1	N/A	PUSCH 3-1	N/A
	Reporting Interval	ms	5	N/A	5	N/A
	CQI delay	ms	11	N/A	11	N/A
CSI process 1 (Note 6, 7, 8)	CSI-RS		N/A	N/A	N/A	CSI-RS 1
	CSI-IM		N/A	N/A	N/A	CSI-IM 1
	Reporting mode		N/A	N/A	N/A	PUSCH 3-1
	Reporting Interval	ms	N/A	N/A	N/A	5
	CQI delay	ms	N/A	N/A	N/A	11
CSI process for PDSCH scheduling			CSI process 0		CSI process 0	
Cell ID			0	6	0	6
Quasi-co-located CSI-RS			CSI-RS 0	CSI-RS 1	CSI-RS 0	CSI-RS 1
Quasi-co-located CRS			Same Cell ID as Cell 1	Same Cell ID as Cell 2	Same Cell ID as Cell 1	Same Cell ID as Cell 2
PMI for subframe 4 and 9			010000 for	100000	000011 for	N/A

		fixed RI = 2 010011 for UE reported RI		fixed RI = 1 010011 for UE reported RI	
PMI for subframe 3 and 8		100000	100000	100000	N/A
Max number of HARQ transmissions		1	N/A	1	N/A
ACK/NACK feedback mode		Multiplexing	N/A	Multiplexing	N/A
<p>Note 1: If the UE reports in an available uplink reporting instance at subframe SF#n based on CQI estimation at a downlink SF not later than SF#(n-4), this reported wideband CQI cannot be applied at the eNB downlink before SF#(n+4)</p> <p>Note 2: 3 symbols allocated to PDCCH</p> <p>Note 3: Reference measurement channel RC.13 TDD according to Table A.4-1. PDSCH transmission is scheduled on subframe 4 and 9 from TP1.</p> <p>Note 4: TM10 OCNG as specified in A.5.2.8 is transmitted on subframe 3 and 8 from TP1.</p> <p>Note 5: TM10 OCNG as specified in A.5.2.8 is transmitted on subframe 3, 4, 8 and 9 from TP2 for Test 1; TP2 is blanked for Test 2.</p> <p>Note 6: Reported wideband CQI and PMI are used and sub-band CQI is discarded.</p> <p>Note 7: If UE supports multiple CSI processes, CSI process 0 is configured as 'RI-reference CSI process' for CSI process 1.</p> <p>Note 8: If UE supports one CSI process, CSI process 1 is not configured in Test 2.</p> <p>Note 9: PDCCH DCI format 0 with a trigger for aperiodic CQI shall be transmitted in downlink SF#3 and #8 to allow aperiodic CQI/PMI/RI to be transmitted in uplink SF#7 and #2.</p>					

Table 9.5.5.2-2: Minimum requirement (TDD)

	Test 1	Test 2
γ_1	N/A	1.0
γ_2	1.0	N/A
UE Category	≥ 2	≥ 2

9.6 Additional requirements for carrier aggregation

This clause includes requirements for the reporting of channel state information (CSI) with the UE configured for carrier aggregation. The purpose is to verify that the channel state for each cell is correctly reported with multiple cells configured for periodic reporting.

9.6.1 Periodic reporting on multiple cells (Cell-Specific Reference Symbols)

9.6.1.1 FDD

The following requirements apply to UE Category ≥ 3 . For CA with 2 DL CC, for the parameters specified in Table 9.6.1.1-1 and Table 9.6.1.1-2, and using the downlink physical channels specified in tables C.3.2-1 and C.3.2-2 on each cell, the difference between the wideband CQI indices of Pcell and Scell reported shall be such that

$$\text{wideband CQI}_{\text{Pcell}} - \text{wideband CQI}_{\text{Scell}} \geq 2$$

for more than 90% of the time.

Table 9.6.1.1-1: Parameters for PUCCH 1-0 static test on multiple cells (FDD, 2 DL CA)

Parameter	Unit	Pcell	Scell
PDSCH transmission mode			1
Downlink power allocation	ρ_A	dB	0
	ρ_B	dB	0
Propagation condition and antenna configuration		AWGN (1 x 2)	
SNR	dB	10	4
$\hat{I}_{or}^{(j)}$	dB[mW/15kHz]	-88	-94
$N_{oc}^{(j)}$	dB[mW/15kHz]	-98	-98
Physical channel for CQI reporting		PUCCH Format 2	
PUCCH Report Type		4	
Reporting periodicity	ms	$N_{pd} = 10$	
<i>cqi-pmi-ConfigurationIndex</i>		11	16 (shift of 5 ms relative to Pcell)
Note 1:	3 symbols are allocated to PDCCH. No PDSCH for user data is scheduled for the UE with one sided dynamic OCNG Pattern OP.1 FDD as described in Annex A.5.1.1.		
Note 2:	Void		

Table 9.6.1.1-2: PUCCH 1-0 static test (FDD, 2 DL CA)

Test number	Bandwidth combination
1	10MHz for both cells
2	20MHz for both cells
3	5MHz for both cells
4	5MHz for PCell and 10MHz for SCell
5	5MHz for PCell and 15MHz for SCell
Note 1:	The applicability of requirements for different CA configurations and bandwidth combination sets is defined in 9.1.1.2. The test coverage for different number of component carriers is defined in 9.1.1.3.
Note 2:	Mapping of PCell and SCell to the CCs shall be constant for all the iterations during the test. Each execution of the test shall use the same mapping.

The following requirements for 3DL CA apply to UE Category ≥ 5 . For CA with 3 DL CC, for the parameters specified in Table 9.6.1.1-3 and Table 9.6.1.1-4, and using the downlink physical channels specified in tables C.3.2-1 and C.3.2-2 on each cell, the difference between the wideband CQI indices of PCell and SCell1 reported, and the difference between the wideband CQI indices of SCell 1 and SCell2 reported shall be such that

$$\text{wideband CQI}_{\text{PCell}} - \text{wideband CQI}_{\text{SCell1}} \geq 2$$

$$\text{wideband CQI}_{\text{SCell1}} - \text{wideband CQI}_{\text{SCell2}} \geq 2$$

for more than 90% of the time.

The following requirements for 4DL CA apply to UE Category ≥ 8 . For CA with 4 DL CC, for the parameters specified in Table 9.6.1.1-3 and Table 9.6.1.1-5, and using the downlink physical channels specified in tables C.3.2-1 and C.3.2-2 on each cell, the difference between the wideband CQI indices of PCell and SCell1 reported, and the difference between the wideband CQI indices of SCell 1 and SCell2, and SCell 1 and SCell 3 reported shall be such that

$$\text{wideband CQI}_{\text{PCell}} - \text{wideband CQI}_{\text{SCell1}} \geq 2$$

$$\text{wideband CQI}_{\text{SCell1}} - \text{wideband CQI}_{\text{SCell2}} \geq 2$$

$$\text{wideband CQI}_{\text{SCell1}} - \text{wideband CQI}_{\text{SCell3}} \geq 2$$

for more than 90% of the time.

Table 9.6.1.1-3: Parameters for PUCCH 1-0 static test on multiple cells (FDD, 3 and 4 DL CA)

Parameter		Unit	Pcell	Scell1	Scell2, 3
PDSCH transmission mode					1
Downlink power allocation	ρ_A	dB			0
	ρ_B	dB			0
Propagation condition and antenna configuration			AWGN (1 x 2)		
SNR		dB	12	6	0
$\hat{I}_{or}^{(j)}$		dB[mW/15kHz]	-86	-92	-98
$N_{oc}^{(j)}$		dB[mW/15kHz]	-98	-98	-98
Physical channel for CQI reporting			PUCCH Format 2		
PUCCH Report Type			4		
Reporting periodicity		ms	$N_{pd} = 20$		
<i>cqi-pmi-ConfigurationIndex</i>			21	26 (shift of 5 ms relative to Pcell)	31 for Scell2 (shift of 10 ms relative to Pcell) , 36 for Scell3 (shift of 15ms relative to Pcell)
Note 1: 3 symbols are allocated to PDCCH. No PDSCH for user data is scheduled for the UE with one sided dynamic OCNG Pattern OP.1 FDD as described in Annex A.5.1.1.					
Note 2: Void					

Table 9.6.1.1-4: PUCCH 1-0 static test (FDD, 3 DL CA)

Test number	Bandwidth combination (MHz)
1	3x20
2	20+20+15
3	20+20+10
4	20+15+15
5	20+15+10
6	20+10+10
7	15+15+10
8	20+10+5
9	20+15+5
10	10+10+5
Note 1:	The applicability of requirements for different CA configurations and bandwidth combination sets is defined in 9.1.1.2. The test coverage for different number of component carriers is defined in 9.1.1.3.
Note 2:	If more than one cell can be configured as PCell, choose one of the cells with the smallest bandwidth as PCell. Mapping of PCell and Scells to the CCs shall be constant for all the iterations during the test. Each execution of the test shall use the same mapping.

Table 9.6.1.1-5: PUCCH 1-0 static test (FDD, 4 DL CA)

Test number	Bandwidth combination (MHz)
1	4x20
2	20+20+20+10
3	20+20+10+10
4	20+20+10+5
5	20+10+10+5
Note 1:	The applicability of requirements for different CA configurations and bandwidth combination sets is defined in 9.1.1.2. The test coverage for different number of component carriers is defined in 9.1.1.3.
Note 2:	If more than one cell can be configured as PCell, choose one of the cells with the smallest bandwidth as PCell. Mapping of PCell and SCells to the CCs shall be constant for all the iterations during the test. Each execution of the test shall use the same mapping.

The following requirements for 5DL CA apply to UE Category 8 and ≥ 11 . For CA with 5 DL CC, for the parameters specified in Table 9.6.1.1-6 and Table 9.6.1.1-7, and using the downlink physical channels specified in tables C.3.2-1 and C.3.2-2 on each cell, the difference between the wideband CQI indices of PCell and SCell1 reported, and the difference between the wideband CQI indices of SCell 1 and SCell2, SCell 1 and SCell 3, and SCell 1 and SCell 4 reported shall be such that

$$\text{wideband CQI}_{\text{PCell}} - \text{wideband CQI}_{\text{SCell1}} \geq [2]$$

$$\text{wideband CQI}_{\text{SCell1}} - \text{wideband CQI}_{\text{SCell2}} \geq [2]$$

$$\text{wideband CQI}_{\text{SCell1}} - \text{wideband CQI}_{\text{SCell3}} \geq [2]$$

$$\text{wideband CQI}_{\text{SCell1}} - \text{wideband CQI}_{\text{SCell4}} \geq [2]$$

for more than 90% of the time.

Table 9.6.1.1-6: Parameters for PUCCH 1-0 static test on multiple cells (FDD, 5 DL CA)

Parameter	Unit	Pcell	Scell1	Scell2, 3, 4
PDSCH transmission mode		1		
Downlink power allocation	ρ_A	0		
	ρ_B	0		
Propagation condition and antenna configuration		AWGN (1 x 2)		
SNR	dB	12	6	0
$\hat{I}_{or}^{(j)}$	dB[mW/15kHz]	-86	-92	-98
$N_{oc}^{(j)}$	dB[mW/15kHz]	-98	-98	-98
Physical channel for CQI reporting		PUCCH Format 2		
PUCCH Report Type		4		
Reporting periodicity	ms	$N_{pd} = 40$		
<i>cqi-pmi-ConfigurationIndex</i>		41	46 (shift of 5 ms relative to Pcell)	51 for Scell 2 (shift of 10 ms relative to Pcell), 56 for Scell 3 (shift of 15ms relative to Pcell), 61 for Scell4 (shift of 20ms relative to Pcell)
Note 1:	3 symbols are allocated to PDCCH. No PDSCH for user data is scheduled for the UE with one sided dynamic OCNG Pattern OP.1 FDD as described in Annex A.5.1.1.			
Note 2:	Void			

Table 9.6.1.1-7: PUCCH 1-0 static test (FDD, 5 DL CA)

Test number	Bandwidth combination (MHz)
1	5x20
Note 1:	The applicability of requirements for different CA configurations and bandwidth combination sets is defined in 9.1.1.2. The test coverage for different number of component carriers is defined in 9.1.1.3.
Note 2:	If more than one cell can be configured as PCell, choose one of the cells with the smallest bandwidth as PCell. Mapping of PCell and Scells to the CCs shall be constant for all the iterations during the test. Each execution of the test shall use the same mapping.

9.6.1.2 TDD

The following requirements apply to UE Category ≥ 3 . For CA with 2 DL CC, for the parameters specified in Table 9.6.1.2-1 and Table 9.6.1.2-2, and using the downlink physical channels specified in tables C.3.2-1 and C.3.2-2 on each cell, the difference between the wideband CQI indices of Pcell and Scell reported shall be such that

$$\text{wideband CQI}_{\text{Pcell}} - \text{wideband CQI}_{\text{Scell}} \geq 2$$

for more than 90% of the time.

Table 9.6.1.2-1: PUCCH 1-0 static test on multiple cells (TDD, 2 DL CA)

Parameter	Unit	Pcell	Scell
PDSCH transmission mode			1
Uplink downlink configuration			2
Special subframe configuration			4
Downlink power allocation	ρ_A	dB	0
	ρ_B	dB	0
Propagation condition and antenna configuration		AWGN (1 x 2)	
SNR	dB	10	4
$\hat{I}_{or}^{(j)}$	dB[mW/15kHz]	-88	-94
$N_{oc}^{(j)}$	dB[mW/15kHz]	-98	-98
Physical channel for CQI reporting		PUCCH Format 2	
PUCCH Report Type		4	
Reporting periodicity	ms	$N_{pd} = 10$	
<i>cqi-pmi-ConfigurationIndex</i>		8	13 (shift of 5 ms relative to Pcell)
Note 1:	3 symbols are allocated to PDCCH. No PDSCH for user data is scheduled for the UE with one sided dynamic OCNG Pattern OP.1 TDD as described in Annex A.5.2.1.		
Note 2:	Void		

Table 9.6.1.2-2: PUCCH 1-0 static test (TDD, 2 DL CA)

Test number	Bandwidth combination
1	20MHz for both cells
2	15MHz for PCell and 20MHz for SCell
Note 1:	The applicability of requirements for different CA configurations and bandwidth combination sets is defined in 9.1.1.2. The test coverage for different number of component carriers is defined in 9.1.1.3.
Note 2:	Mapping of PCell and SCell to the CCs shall be constant for all the iterations during the test. Each execution of the test shall use the same mapping.

The following requirements for 3DL CA apply to UE Category ≥ 5 . For CA with 3 DL CC, for the parameters specified in Table 9.6.1.2-3 and Table 9.6.1.2-4, and using the downlink physical channels specified in tables C.3.2-1 and C.3.2-2 on each cell, the difference between the wideband CQI indices of PCell and SCell1 reported, and the difference between the wideband CQI indices of SCell 1 and SCell2 reported shall be such that

$$\text{wideband CQI}_{\text{PCell}} - \text{wideband CQI}_{\text{SCell1}} \geq 2$$

$$\text{wideband CQI}_{\text{SCell1}} - \text{wideband CQI}_{\text{SCell2}} \geq 2$$

for more than 90% of the time.

The following requirements for 4DL CA apply to UE Category ≥ 8 . For CA with 4 DL CC, for the parameters specified in Table 9.6.1.2-3 and Table 9.6.1.2-5, and using the downlink physical channels specified in tables C.3.2-1 and C.3.2-2 on each cell, the difference between the wideband CQI indices of PCell and SCell1 reported, and the difference between the wideband CQI indices of SCell 1 and SCell2, and SCell 1 and SCell 3 reported shall be such that

$$\text{wideband CQI}_{\text{PCell}} - \text{wideband CQI}_{\text{SCell1}} \geq 2$$

$$\text{wideband CQI}_{\text{SCell1}} - \text{wideband CQI}_{\text{SCell2}} \geq 2$$

$$\text{wideband CQI}_{\text{SCell1}} - \text{wideband CQI}_{\text{SCell3}} \geq 2$$

for more than 90% of the time.

Table 9.6.1.2-3: PUCCH 1-0 static test on multiple cells (TDD, 3 and 4 DL CA)

Parameter		Unit	Pcell	Scell1	Scell2, 3
PDSCH transmission mode				1	
Uplink downlink configuration				2	
Special subframe configuration				4	
Downlink power allocation	ρ_A	dB		0	
	ρ_B	dB		0	
Propagation condition and antenna configuration			AWGN (1 x 2)		
SNR		dB	12	6	0
$\hat{I}_{or}^{(j)}$		dB[mW/15kHz]	-86	-92	-98
$N_{oc}^{(j)}$		dB[mW/15kHz]	-98	-98	-98
Physical channel for CQI reporting			PUCCH Format 2		
PUCCH Report Type			4		
Reporting periodicity		ms	$N_{pd} = 20$		
<i>cqi-pmi-ConfigurationIndex</i>			18	23 (shift of 5 ms relative to Pcell)	28 (shift of 10 ms relative to Pcell) , 33 for Scell3 (shift of 15ms relative to Pcell)
Note 1: 3 symbols are allocated to PDCCH. No PDSCH for user data is scheduled for the UE with one sided dynamic OCNG Pattern OP.1 TDD as described in Annex A.5.2.1.					
Note 2: Void					

Table 9.6.1.2-4: PUCCH 1-0 static test (TDD, 3 DL CA)

Test number	Bandwidth combination (MHz)
1	3x20
2	20+20+15
Note 1: The applicability of requirements for different CA configurations and bandwidth combination sets is defined in 9.1.1.2. The test coverage for different number of component carriers is defined in 9.1.1.3. Note 2: If more than one cell can be configured as PCell, choose one of the cells with the smallest bandwidth as PCell. Mapping of PCell and Scells to the CCs shall be constant for all the iterations during the test. Each execution of the test shall use the same mapping.	

Table 9.6.1.2-5: PUCCH 1-0 static test (TDD, 4 DL CA)

Test number	Bandwidth combination (MHz)
1	4x20
2	20+20+20+15
Note 1: The applicability of requirements for different CA configurations and bandwidth combination sets is defined in 9.1.1.2. The test coverage for different number of component carriers is defined in 9.1.1.3. Note 2: If more than one cell can be configured as PCell, choose one of the cells with the smallest bandwidth as PCell. Mapping of PCell and Scells to the CCs shall be constant for all the iterations during the test. Each execution of the test shall use the same mapping.	

9.6.1.3 TDD-FDD CA with FDD PCell

The following requirements apply to UE Category ≥ 5 . For TDD-FDD CA with FDD PCell with 2 DL CC, for the parameters specified in Table 9.6.1.3-1 and Table 9.6.1.3-2, and using the downlink physical channels specified in tables C.3.2-1 and C.3.2-2 on each cell, the difference between the wideband CQI indices of PCell and SCell reported shall be such that

$$\text{wideband CQI}_{\text{PCell}} - \text{wideband CQI}_{\text{SCell}} \geq 2$$

for more than 90% of the time.

Table 9.6.1.3-1: Parameters for PUCCH 1-0 static test on multiple cells (TDD-FDD CA with FDD PCell, 2 DL CA)

Parameter	Unit	PCell	SCell
PDSCH transmission mode			1
Uplink downlink configuration		N/A	2
Special subframe configuration		N/A	4
Downlink power allocation	ρ_A	dB	0
	ρ_B	dB	0
Propagation condition and antenna configuration		AWGN (1 x 2)	
SNR	dB	10	4
$\hat{I}_{or}^{(j)}$	dB[mW/15kHz]	-88	-94
$N_{oc}^{(j)}$	dB[mW/15kHz]	-98	-98
Physical channel for CQI reporting		PUCCH Format 2	
PUCCH Report Type		4	
Reporting periodicity	ms	$N_{pd} = 10$	
<i>cqi-pmi-ConfigurationIndex</i>		9	14 (shift of 5 ms relative to Pcell)
Note 1:	3 symbols are allocated to PDCCH. No PDSCH for user data is scheduled for the UE with one sided dynamic OCNG Pattern OP.1 FDD and OP.1 TDD as described in Annex A.5.1.1 and A.5.2.1.		
Note 2:	Void		
Note 3:	Void		

Table 9.6.1.3-2: PUCCH 1-0 static test (TDD-FDD CA with FDD PCell, 2 DL CA)

Test number	Bandwidth combination
1	20MHz for FDD cell and 20MHz for TDD cell
2	10MHz for FDD cell and 20MHz for TDD cell
3	15MHz for FDD cell and 20MHz for TDD cell
Note 1:	The applicability of requirements for different CA configurations and bandwidth combination sets is defined in 9.1.1.2A. The test coverage for different number of component carriers is defined in 9.1.1.3.

The following requirements for 3DL CA apply to UE Category ≥ 5 . For TDD-FDD CA with FDD PCell with 3 DL CC, for the parameters specified in Table 9.6.1.3-3 and Table 9.6.1.3-4, and using the downlink physical channels specified in tables C.3.2-1 and C.3.2-2 on each cell, the difference between the wideband CQI indices of PCell and SCell1 reported, and the difference between the wideband CQI indices of SCell1 and SCell2 reported shall be such that

$$\text{wideband CQI}_{\text{PCell}} - \text{wideband CQI}_{\text{SCell1}} \geq 2$$

$$\text{wideband CQI}_{\text{SCell1}} - \text{wideband CQI}_{\text{SCell2}} \geq 2$$

for more than 90% of the time.

The following requirements for 4DL CA apply to UE Category ≥ 8 . For TDD-FDD CA with FDD PCell with 4 DL CC, for the parameters specified in Table 9.6.1.3-3 and Table 9.6.1.3-5, and using the downlink physical channels specified

in tables C.3.2-1 and C.3.2-2 on each cell, the difference between the wideband CQI indices of PCell and SCell1 reported, and the difference between the wideband CQI indices of SCell1 and SCell2, and SCell1 and SCell3 reported shall be such that

$$\text{wideband CQI}_{\text{PCell}} - \text{wideband CQI}_{\text{SCell1}} \geq 2$$

$$\text{wideband CQI}_{\text{SCell1}} - \text{wideband CQI}_{\text{SCell2}} \geq 2$$

$$\text{wideband CQI}_{\text{SCell1}} - \text{wideband CQI}_{\text{SCell3}} \geq 2$$

for more than 90% of the time.

Table 9.6.1.3-3: PUCCH 1-0 static test on multiple cells (TDD-FDD CA with FDD PCell, 3 and 4 DL CA)

Parameter	Unit	PCell	SCell1	SCell2, SCell3
PDSCH transmission mode			1	
Uplink downlink configuration		N/A	2 for TDD Cell N/A for FDD Cell	
Special subframe configuration		N/A	4 for TDD Cell N/A for is FDD Cell	
Downlink power allocation	ρ_A	dB	0	
	ρ_B	dB	0	
Propagation condition and antenna configuration		AWGN (1 x 2)		
SNR	dB	12	6	0
$\hat{I}_{or}^{(j)}$	dB[mW/15kHz]	-86	-92	-98
$N_{oc}^{(j)}$	dB[mW/15kHz]	-98	-98	-98
Physical channel for CQI reporting		PUCCH Format 2		
PUCCH Report Type		4		
Reporting periodicity	ms	$N_{pd} = 20$		
<i>cqi-pmi-ConfigurationIndex</i>		19	24 (shift of 5 ms relative to Pcell)	29 for SCell 2 (shift of 10 ms relative to Pcell) , 34 for SCell 3 (shift of 15ms relative to PCell)
Note 1:	3 symbols are allocated to PDCCH. No PDSCH for user data is scheduled for the UE with one sided dynamic OCN Pattern OP.1 FDD and OP.1 TDD as described in Annex A.5.1.1 and A.5.2.1.			
Note 2:	Void			
Note 3:	Void			

Table 9.6.1.3-4: PUCCH 1-0 static test (TDD-FDD CA with FDD PCell, 3 DL CA)

Test number	Bandwidth combination (MHz)
1	20MHz for FDD cell and 2x20MHz for TDD cell
2	15MHz for FDD cell and 2x20MHz for TDD cell
3	10MHz for FDD cell and 2x20MHz for TDD cell
4	2x20MHz for FDD cell and 20MHz for TDD cell
5	20+15MHz for FDD cell and 20MHz for TDD cell
6	20+10MHz for FDD cell and 20MHz for TDD cell
Note 1:	The applicability of requirements for different CA configurations and bandwidth combination sets is defined in 9.1.1.2A. The test coverage for different number of component carriers is defined in 9.1.1.3.
Note 2:	If more than one cell can be configured as PCell, choose one of the cells with the smallest bandwidth as PCell. Mapping of PCell and Scells to the CCs shall be constant for all the iterations during the test. Each execution of the test shall use the same mapping.

Table 9.6.1.3-5: PUCCH 1-0 static test (TDD-FDD CA with FDD PCell, 4 DL CA)

Test number	Bandwidth combination (MHz)
1	20MHz for FDD cell and 3x20MHz for TDD cell
2	2x20MHz for FDD cell and 2x20MHz for TDD cell
3	20+15MHz for FDD cell and 2x20MHz for TDD cell
4	2x15MHz for FDD cell and 2x20MHz for TDD cell
5	2x20+15MHz for FDD cell and 20MHz for TDD cell
6	2x15+20MHz for FDD cell and 20MHz for TDD cell
Note 1:	The applicability of requirements for different CA configurations and bandwidth combination sets is defined in 9.1.1.2A. The test coverage for different number of component carriers is defined in 9.1.1.3.
Note 2:	If more than one cell can be configured as PCell, choose one of the cells with the smallest bandwidth as PCell. Mapping of PCell and SCells to the CCs shall be constant for all the iterations during the test. Each execution of the test shall use the same mapping.

The following requirements for 5DL CA apply to UE Category 8 and ≥ 11 . For TDD-FDD CA with FDD PCell with 5 DL CC, for the parameters specified in Table 9.6.1.3-3 and Table 9.6.1.3-6, and using the downlink physical channels specified in tables C.3.2-1 and C.3.2-2 on each cell, the difference between the wideband CQI indices of PCell and SCell1 reported, and the difference between the wideband CQI indices of SCell1 and SCell2, SCell1 and SCell3, and SCell 1 and SCell 4 reported shall be such that

$$\text{wideband CQI}_{\text{PCell}} - \text{wideband CQI}_{\text{SCell1}} \geq 2$$

$$\text{wideband CQI}_{\text{SCell1}} - \text{wideband CQI}_{\text{SCell2}} \geq 2$$

$$\text{wideband CQI}_{\text{SCell1}} - \text{wideband CQI}_{\text{SCell3}} \geq 2$$

$$\text{wideband CQI}_{\text{SCell1}} - \text{wideband CQI}_{\text{SCell4}} \geq 2$$

for more than 90% of the time.

Table 9.6.1.3-6: PUCCH 1-0 static test on multiple cells (TDD-FDD CA with FDD PCell, 5 DL CA)

Parameter	Unit	PCell	SCell1	SCell2, SCell3, SCell4
PDSCH transmission mode				1
Uplink downlink configuration		N/A		2 for TDD Cell N/A for FDD Cell
Special subframe configuration		N/A		4 for TDD Cell N/A for FDD Cell
Downlink power allocation	ρ_A	dB		0
	ρ_B	dB		0
Propagation condition and antenna configuration				AWGN (1 x 2)
SNR	dB	12	6	0
$\hat{I}_{or}^{(j)}$	dB[mW/15kHz]	-86	-92	-98
$N_{oc}^{(j)}$	dB[mW/15kHz]	-98	-98	-98
Physical channel for CQI reporting				PUCCH Format 2
PUCCH Report Type				4
Reporting periodicity	ms			$N_{pd} = 40$
<i>cqi-pmi-ConfigurationIndex</i>		39	44 (shift of 5 ms relative to Pcell)	49 for SCell 2 (shift of 10 ms relative to Pcell), 54 for SCell 3 (shift of 15 ms relative to Pcell), 59 for SCell 4 (shift of 20 ms relative to Pcell)
Note 1:	3 symbols are allocated to PDCCH. No PDSCH for user data is scheduled for the UE with one sided dynamic OCNB Pattern OP.1 FDD and OP.1 TDD as described in Annex A.5.1.1 and A.5.2.1.			
Note 2:	Void			
Note 3:	Void			

Table 9.6.1.3-7: PUCCH 1-0 static test (TDD-FDD CA with FDD PCell, 5 DL CA)

Test number	Bandwidth combination (MHz)
1	15MHz+2x20MHz for FDD cell and 2x20MHz for TDD cell
2	2x15MHz+20MHz for FDD cell and 2x20MHz for TDD cell
Note 1: The applicability of requirements for different CA configurations and bandwidth combination sets is defined in 9.1.1.2A. The test coverage for different number of component carriers is defined in 9.1.1.3. Note 2: If more than one cell can be configured as PCell, choose one of the cells with the smallest bandwidth as PCell. Mapping of PCell and SCells to the CCs shall be constant for all the iterations during the test. Each execution of the test shall use the same mapping.	

9.6.1.4 TDD-FDD CA with TDD PCell

The following requirements apply to UE Category ≥ 5 . For TDD-FDD CA with TDD PCell with 2 DL CC, for the parameters specified in Table 9.6.1.4-1 and Table 9.6.1.4-2, and using the downlink physical channels specified in tables C.3.2-1 and C.3.2-2 on each cell, the difference between the wideband CQI indices of PCell and SCell reported shall be such that

$$\text{wideband CQI}_{\text{PCell}} - \text{wideband CQI}_{\text{SCell}} \geq 2$$

for more than 90% of the time.

Table 9.6.1.4-1: Parameters for PUCCH 1-0 static test on multiple cells (TDD-FDD CA with TDD PCell, 2 DL CA)

Parameter	Unit	PCell	SCell
PDSCH transmission mode			1
Uplink downlink configuration		2	N/A
Special subframe configuration		4	N/A
Downlink power allocation	ρ_A	dB	0
	ρ_B	dB	0
Propagation condition and antenna configuration		AWGN (1 x 2)	
SNR	dB	10	4
$\hat{I}_{or}^{(j)}$	dB[mW/15kHz]	-88	-94
$N_{oc}^{(j)}$	dB[mW/15kHz]	-98	-98
Physical channel for CQI reporting		PUCCH Format 2	
PUCCH Report Type		4	
Reporting periodicity	ms	$N_{pd} = 10$	
<i>cqi-pmi-ConfigurationIndex</i>		8	13 (shift of 5 ms relative to Pcell)
Note 1: 3 symbols are allocated to PDCCH. No PDSCH for user data is scheduled for the UE with one sided dynamic OCNG Pattern OP.1 FDD and OP.1 TDD as described in Annex A.5.1.1 and A.5.2.1. Note 2: Void Note 3: Void			

Table 9.6.1.4-2: PUCCH 1-0 static test (TDD-FDD CA with TDD PCell, 2 DL CA)

Test number	Bandwidth combination
1	20MHz for TDD cell and 20MHz for FDD cell
2	20MHz for TDD cell and 10MHz for FDD cell
3	20MHz for TDD cell and 15MHz for FDD cell
Note 1: The applicability of requirements for different CA configurations and bandwidth combination sets is defined in 9.1.1.2A. The test coverage for different number of component carriers is defined in 9.1.1.3.	

The following requirements for 3DL CA apply to UE Category ≥ 5 . For TDD-FDD CA with TDD PCell with 3 DL CC, for the parameters specified in Table 9.6.1.4-3 and Table 9.6.1.4-4, and using the downlink physical channels specified in tables C.3.2-1 and C.3.2-2 on each cell, the difference between the wideband CQI indices of PCell and SCell1 reported, and the difference between the wideband CQI indices of SCell1 and SCell2 reported shall be such that

$$\text{wideband CQI}_{\text{PCell}} - \text{wideband CQI}_{\text{SCell1}} \geq 2$$

$$\text{wideband CQI}_{\text{SCell1}} - \text{wideband CQI}_{\text{SCell2}} \geq 2$$

for more than 90% of the time.

The following requirements for 4DL CA apply to UE Category ≥ 8 . For TDD-FDD CA with TDD PCell with 4 DL CC, for the parameters specified in Table 9.6.1.4-3 and Table 9.6.1.4-5, and using the downlink physical channels specified in tables C.3.2-1 and C.3.2-2 on each cell, the difference between the wideband CQI indices of PCell and SCell1 reported, and the difference between the wideband CQI indices of SCell1 and SCell2, and SCell1 and SCell3 reported shall be such that

$$\text{wideband CQI}_{\text{PCell}} - \text{wideband CQI}_{\text{SCell1}} \geq 2$$

$$\text{wideband CQI}_{\text{SCell1}} - \text{wideband CQI}_{\text{SCell2}} \geq 2$$

$$\text{wideband CQI}_{\text{SCell1}} - \text{wideband CQI}_{\text{SCell3}} \geq 2$$

for more than 90% of the time.

Table 9.6.1.4-3: PUCCH 1-0 static test on multiple cells (TDD-FDD CA with TDD PCell, 3 and 4 DL CA)

Parameter		Unit	PCell	SCell1	SCell2, SCell3
PDSCH transmission mode			1		
Uplink downlink configuration			2	2 for TDD Cell N/A for FDD Cell	
Special subframe configuration			4	4 for TDD Cell N/A for FDD Cell	
Downlink power allocation	ρ_A	dB	0		
	ρ_B	dB	0		
Propagation condition and antenna configuration			AWGN (1 x 2)		
SNR		dB	12	6	0
$\hat{I}_{or}^{(j)}$		dB[mW/15kHz]	-86	-92	-98
$N_{oc}^{(j)}$		dB[mW/15kHz]	-98	-98	-98
Physical channel for CQI reporting			PUCCH Format 2		
PUCCH Report Type			4		
Reporting periodicity		ms	$N_{pd} = 20$		
<i>cqi-pmi-ConfigurationIndex</i>			18	23 (shift of 5 ms relative to Pcell)	28 for SCell 2 (shift of 10 ms relative to Pcell) , 33 for SCell 3 (shift of 15ms relative to PCell)
Note 1: 3 symbols are allocated to PDCCH. No PDSCH for user data is scheduled for the UE with one sided dynamic OCNG Pattern OP.1 FDD and OP.1 TDD as described in Annex A.5.1.1 and A.5.2.1.					
Note 2: Void					
Note 3: Void					

Table 9.6.1.4-4: PUCCH 1-0 static test (TDD-FDD CA with TDD PCell, 3 DL CA)

Test number	Bandwidth combination (MHz)
1	2x20MHz for TDD cell and 20MHz for FDD cell
2	2x20MHz for TDD cell and 15MHz for FDD cell
3	2x20MHz for TDD cell and 10MHz for FDD cell
4	2x20MHz for FDD cell and 20MHz for TDD cell
5	20+15MHz for FDD cell and 20MHz for TDD cell
6	20+10MHz for FDD cell and 20MHz for TDD cell
Note 1:	The applicability of requirements for different CA configurations and bandwidth combination sets is defined in 9.1.1.2A. The test coverage for different number of component carriers is defined in 9.1.1.3.
Note 2:	If more than one cell can be configured as PCell, choose one of the cells with the smallest bandwidth as PCell. Mapping of PCell and SCells to the CCs shall be constant for all the iterations during the test. Each execution of the test shall use the same mapping.

Table 9.6.1.4-5: PUCCH 1-0 static test (TDD-FDD CA with TDD PCell, 4 DL CA)

Test number	Bandwidth combination (MHz)
1	3x20MHz for TDD cell and 20MHz for FDD cell
2	2x20MHz for FDD cell and 2x20MHz for TDD cell
3	20+15MHz for FDD cell and 2x20MHz for TDD cell
4	2x15MHz for FDD cell and 2x20MHz for TDD cell
5	2x20+15MHz for FDD cell and 20MHz for TDD cell
6	2x15+20MHz for FDD cell and 20MHz for TDD cell
Note 1:	The applicability of requirements for different CA configurations and bandwidth combination sets is defined in 9.1.1.2A. The test coverage for different number of component carriers is defined in 9.1.1.3.
Note 2:	If more than one cell can be configured as PCell, choose one of the cells with the smallest bandwidth as PCell. Mapping of PCell and SCells to the CCs shall be constant for all the iterations during the test. Each execution of the test shall use the same mapping.

The following requirements for 5DL CA apply to UE Category 8 and ≥ 11 . For TDD-FDD CA with TDD PCell with 5 DL CC, for the parameters specified in Table 9.6.1.4-3 and Table 9.6.1.4-6, and using the downlink physical channels specified in tables C.3.2-1 and C.3.2-2 on each cell, the difference between the wideband CQI indices of PCell and SCell1 reported, and the difference between the wideband CQI indices of SCell1 and SCell2, SCell1 and SCell3 and SCell 1 and SCell 4 reported shall be such that

$$\text{wideband CQI}_{\text{PCell}} - \text{wideband CQI}_{\text{SCell1}} \geq 2$$

$$\text{wideband CQI}_{\text{SCell1}} - \text{wideband CQI}_{\text{SCell2}} \geq 2$$

$$\text{wideband CQI}_{\text{SCell1}} - \text{wideband CQI}_{\text{SCell3}} \geq 2$$

$$\text{wideband CQI}_{\text{SCell1}} - \text{wideband CQI}_{\text{SCell4}} \geq 2$$

for more than 90% of the time.

Table 9.6.1.4-6: PUCCH 1-0 static test on multiple cells (TDD-FDD CA with TDD PCell, 5 DL CA)

Parameter		Unit	PCell	SCell1	SCell2, SCell3, SCell4
PDSCH transmission mode				1	
Uplink downlink configuration			2	2 if SCell1 is TDD Cell N/A if SCell1 is FDD Cell	
Special subframe configuration			4	4 if SCell1 is TDD Cell N/A if SCell1 is FDD Cell	
Downlink power allocation	ρ_A	dB	0		
	ρ_B	dB	0		
Propagation condition and antenna configuration			AWGN (1 x 2)		
SNR		dB	12	6	0
$\hat{I}_{or}^{(j)}$		dB[mW/15kHz]	-86	-92	-98
$N_{oc}^{(j)}$		dB[mW/15kHz]	-98	-98	-98
Physical channel for CQI reporting			PUCCH Format 2		
PUCCH Report Type			4		
Reporting periodicity		ms	$N_{pd} = 40$		
<i>cqi-pmi-ConfigurationIndex</i>			38	43 (shift of 5 ms relative to Pcell)	48 for SCell 2 (shift of 10 ms relative to Pcell), 53 for SCell 3 (shift of 15 ms relative to Pcell), 58 for SCell 4 (shift of 20 ms relative to Pcell)
Note 1: 3 symbols are allocated to PDCCH. No PDSCH for user data is scheduled for the UE with one sided dynamic OCNB Pattern OP.1 FDD and OP.1 TDD as described in Annex A.5.1.1 and A.5.2.1.					
Note 2: Void					
Note 3: Void					

Table 9.6.1.4-7: PUCCH 1-0 static test (TDD-FDD CA with TDD PCell, 5 DL CA)

Test number	Bandwidth combination (MHz)
1	15MHz+2x20MHz for FDD cell and 2x20MHz for TDD cell
2	2x15MHz+20MHz for FDD cell and 2x20MHz for TDD cell
Note 1: The applicability of requirements for different CA configurations and bandwidth combination sets is defined in 9.1.1.2A. The test coverage for different number of component carriers is defined in 9.1.1.3.	
Note 2: If more than one cell can be configured as PCell, choose one of the cells with the smallest bandwidth as PCell. Mapping of PCell and Scells to the CCs shall be constant for all the iterations during the test. Each execution of the test shall use the same mapping.	

9.7 CSI reporting (Single receiver antenna)

The number of receiver antennas N_{RX} assumed for the minimum performance requirement in this clause is 1.

9.7.1 CQI reporting definition under AWGN conditions

9.7.1.1 FDD and half-duplex FDD

The following requirements apply to UE DL Category 0. For the parameters specified in Table 9.7.1.1-1, and using the downlink physical channels specified in tables C.3.2-1 and C.3.2-2, the reported CQI value according to RC.16 FDD in Table A.4-1 shall be in the range of ± 1 of the reported median more than 90% of the time. If the PDSCH BLER using the transport format indicated by median CQI is less than or equal to 0.1, the BLER using the transport format indicated by the (median CQI + 1) shall be greater than 0.1. If the PDSCH BLER using the transport format indicated by the median CQI is greater than 0.1, the BLER using transport format indicated by (median CQI – 1) shall be less than or equal to 0.1.

Table 9.7.1.1-1: PUCCH 1-0 static test (FDD and half-duplex FDD)

Parameter		Unit	Test 1		Test 2	
Bandwidth		MHz	10			
PDSCH transmission mode			1			
Downlink power allocation	ρ_A	dB	0			
	ρ_B	dB	0			
	σ	dB	0			
Propagation condition and antenna configuration			AWGN (1 x 1)			
SNR (Note 2)		dB	0	1	6	7
$\hat{I}_{or}^{(j)}$		dB[mW/15kHz]	-98	-97	-92	-91
$N_{oc}^{(j)}$		dB[mW/15kHz]	-98		-98	
Max number of HARQ transmissions			1			
Physical channel for CQI reporting			PUCCH Format 2			
PUCCH Report Type			4			
Reporting periodicity		ms	$N_{pd} = 40$			
<i>cqi-pmi-ConfigurationIndex</i>			41			
Note 1: Reference measurement channel RC.16 FDD according to Table A.4-1 with one/two sided dynamic OCNG Pattern OP.1/OP.2 FDD as described in Annex A.5.1.1/A.5.1.2.						
Note 2: For each test, the minimum requirements shall be fulfilled for at least one of the two SNR(s) and the respective wanted signal input level.						

9.7.1.2 TDD

The following requirements apply to UE DL Category 0. For the parameters specified in Table 9.7.1.2-1, and using the downlink physical channels specified in tables C.3.2-1 and C.3.2-2, the reported CQI value according to RC.16 TDD in Table A.4-1 shall be in the range of ± 1 of the reported median more than 90% of the time. If the PDSCH BLER using the transport format indicated by median CQI is less than or equal to 0.1, the BLER using the transport format indicated by the (median CQI + 1) shall be greater than 0.1. If the PDSCH BLER using the transport format indicated by the median CQI is greater than 0.1, the BLER using transport format indicated by (median CQI – 1) shall be less than or equal to 0.1.

Table 9.7.1.2-1: PUCCH 1-0 static test (TDD)

Parameter		Unit	Test 1		Test 2	
Bandwidth		MHz			10	
PDSCH transmission mode					1	
Uplink downlink configuration					2	
Special subframe configuration					4	
Downlink power allocation	ρ_A	dB			0	
	ρ_B	dB			0	
	σ	dB			0	
Propagation condition and antenna configuration			AWGN (1 x 1)			
SNR (Note 2)		dB	0	1	6	7
$\hat{I}_{or}^{(j)}$		dB[mW/15kHz]	-98	-97	-92	-91
$N_{oc}^{(j)}$		dB[mW/15kHz]	-98		-98	
Max number of HARQ transmissions			1			
Physical channel for CQI reporting			PUSCH (Note 3)			
PUCCH Report Type			4			
Reporting periodicity		ms	$N_{pd} = 5$			
<i>cqi-pmi-ConfigurationIndex</i>			3			
ACK/NACK feedback mode			Multiplexing			
<p>Note 1: Reference measurement channel RC.16 TDD according to Table A.4-1 with one/two sided dynamic OCNG Pattern OP.1/OP.2 TDD as described in Annex A.5.2.1/A.5.2.2.</p> <p>Note 2: For each test, the minimum requirements shall be fulfilled for at least one of the two SNR(s) and the respective wanted signal input level.</p> <p>Note 3: To avoid collisions between CQI reports and HARQ-ACK it is necessary to report both on PUSCH instead of PUCCH. PDCCH DCI format 0 shall be transmitted in downlink SF#3 and #8 to allow periodic CQI to multiplex with the HARQ-ACK on PUSCH in uplink subframe SF#7 and #2.</p>						

9.7.2 CQI reporting under fading conditions

9.7.2.1 FDD and half-duplex FDD

For the parameters specified in Table 9.7.2.1-1, and using the downlink physical channels specified in Annex C.3.2, the minimum requirements are specified in Table 9.7.2.1-2 and by the following

- a sub-band differential CQI offset level of 0 shall be reported at least $\alpha\%$ of the time but less than $\beta\%$ for each sub-band;
- the ratio of the throughput obtained when transmitting on a randomly selected sub-band among the sub-bands with the highest differential CQI offset level the corresponding TBS and that obtained when transmitting the TBS indicated by the reported wideband CQI median on a randomly selected sub-band in set S shall be $\geq \gamma$;
- when transmitting on a randomly selected sub-band among the sub-bands with the highest differential CQI offset level the corresponding TBS, the average BLER for the indicated transport formats shall be greater or equal to 0.05.

The requirements only apply for sub-bands of full size and the random scheduling across the sub-bands is done by selecting a new sub-band in each TTI for FDD and in each available downlink transmission instance for half-duplex FDD.

Table 9.7.2.1-1 Sub-band test for single antenna transmission (FDD and half-duplex FDD)

Parameter		Unit	Test 1		Test 2	
Bandwidth		MHz	10 MHz			
Transmission mode			1 (port 0)			
Downlink power allocation	ρ_A	dB	0			
	ρ_B	dB	0			
	σ	dB	0			
SNR (Note 3)		dB	8	9	13	14
$\hat{I}_{or}^{(j)}$		dB[mW/15kHz]	-90	-89	-85	-84
$N_{oc}^{(j)}$		dB[mW/15kHz]	-98		-98	
Propagation channel			Clause B.2.4 with $\tau_d = 0.45 \mu s$, $a = 1$, $f_D = 5$ Hz			
Antenna configuration			1 x 1			
Reporting interval		ms	8			
CQI delay		ms	8			
Reporting mode			PUSCH 3-0			
Sub-band size		RB	6 (full size)			
Max number of HARQ transmissions			1			
<p>Note 1: If the UE reports in an available uplink reporting instance at subframe SF#n based on CQI estimation at a downlink subframe not later than SF#(n-4), this reported subband or wideband CQI cannot be applied at the eNB downlink before SF#(n+4)</p> <p>Note 2: Reference measurement channel RC.16 FDD according to Table A.4-1 with one/two sided dynamic OCNG Pattern OP.1/2 FDD as described in Annex A.5.1.1/2.</p> <p>Note 3: For each test, the minimum requirements shall be fulfilled for at least one of the two SNR(s) and the respective wanted signal input level.</p>						

Table 9.7.2.1-2 Minimum requirement (FDD and half-duplex FDD)

	Test 1	Test 2
α [%]	2	2
β [%]	55	55
γ	1.1	1.1
UE DL Category	0	0

9.7.2.2 TDD

For the parameters specified in Table 9.7.2.2-1, and using the downlink physical channels specified in Annex C.3.2, the minimum requirements are specified in Table 9.7.2.2-2 and by the following

- a sub-band differential CQI offset level of 0 shall be reported at least α % of the time but less than β % for each sub-band;
- the ratio of the throughput obtained when transmitting on a randomly selected sub-band among the sub-bands with the highest differential CQI offset level the corresponding TBS and that obtained when transmitting the TBS indicated by the reported wideband CQI median on a randomly selected sub-band in set S shall be $\geq \gamma$;
- when transmitting on a randomly selected sub-band among the sub-bands with the highest differential CQI offset level the corresponding TBS, the average BLER for the indicated transport formats shall be greater or equal to 0.05.

The requirements only apply for sub-bands of full size and the random scheduling across the sub-bands is done by selecting a new sub-band in each available downlink transmission instance for TDD.

Table 9.7.2.2-1 Sub-band test for single antenna transmission (TDD)

Parameter		Unit	Test 1		Test 2	
Bandwidth		MHz	10 MHz			
Transmission mode			1 (port 0)			
Downlink power allocation	ρ_A	dB	0			
	ρ_B	dB	0			
	σ	dB	0			
Uplink downlink configuration			2			
Special subframe configuration			4			
SNR (Note 3)		dB	8	9	13	14
$\hat{I}_{or}^{(j)}$		dB[mW/15kHz]	-90	-89	-85	-84
$N_{oc}^{(j)}$		dB[mW/15kHz]	-98		-98	
Propagation channel			Clause B.2.4 with $\tau_d = 0.45 \mu\text{s}$, $a = 1$, $f_D = 5 \text{ Hz}$			
Antenna configuration			1 x 1			
Reporting interval		ms	5			
CQI delay		ms	10 or 11			
Reporting mode			PUSCH 3-0			
Sub-band size		RB	6 (full size)			
Max number of HARQ transmissions			1			
ACK/NACK feedback mode			Multiplexing			
<p>Note 1: If the UE reports in an available uplink reporting instance at subframe SF#n based on CQI estimation at a downlink subframe not later than SF#(n-4), this reported subband or wideband CQI cannot be applied at the eNB downlink before SF#(n+4)</p> <p>Note 2: Reference measurement channel RC.16 TDD according to Table A.4-1 with one/two sided dynamic OCNG Pattern OP.1/2 TDD as described in Annex A.5.2.1/2.</p> <p>Note 3: For each test, the minimum requirements shall be fulfilled for at least one of the two SNR(s) and the respective wanted signal input level.</p>						

Table 9.7.2.2-2 Minimum requirement (TDD)

	Test 1	Test 2
α [%]	2	2
β [%]	55	55
γ	1.1	1.1
UE DL Category	0	0

9.8 CSI reporting (UE supporting coverage enhancement)

The requirements in this sub-clause are defined based on the simulation results with UE DL Category M1 unless otherwise stated.

The requirements of UE DL Category M1 in this sub-clause are applicable for UE DL Category 0.

9.8.1 CQI reporting definition under AWGN conditions

9.8.1.1 FDD and half-duplex FDD

The following requirements apply to UE supporting coverage enhancement. For the parameters specified in Table 9.8.1.1-1, and using the downlink physical channels specified in tables C.3.2-1 and C.3.2-2, the reported CQI value

according to RC.23 FDD in Table A.4-1 shall be in the range of ± 1 of the reported median more than 90% of the time. If the PDSCH BLER using the transport format indicated by median CQI is less than or equal to 0.1, the BLER using the transport format indicated by the (median CQI + 1) shall be greater than 0.1. If the PDSCH BLER using the transport format indicated by the median CQI is greater than 0.1, the BLER using transport format indicated by (median CQI – 1) shall be less than or equal to 0.1.

Table 9.8.1.1-1: PUCCH 1-0 static test (FDD and half-duplex FDD)

Parameter		Unit	Test 1	
Bandwidth		MHz	10	
PDSCH transmission mode			1	
Downlink power allocation	ρ_A	dB	0	
	ρ_B	dB	0	
	σ	dB	0	
	δ	dB	0	
Propagation condition and antenna configuration			AWGN (1 x 1)	
SNR (Note 2)		dB	5	6
$\hat{I}_{or}^{(j)}$		dB[mW/15kHz]	-93	-92
$N_{oc}^{(j)}$		dB[mW/15kHz]	-98	-98
Max number of HARQ transmissions			1	
Physical channel for CQI reporting			PUSCH (Note 4)	
PUCCH Report Type			4	
Reporting periodicity		ms	10	
CQI delay		ms	10	
<i>cqi-pmi-ConfigurationIndex</i>			12	
Frequency hopping			Disabled	
Frequency hopping interval (interval-FDD)			N/A	
Starting OFDM symbol (startSymbolBR)			3	
PDSCH repetition level			1	
MPDCCH repetition level			1	
Beamforming Precoder for MPDCCH			No precoding	
Precoder update granularity for MPDCCH			N/A	
BL/CE DL subframe configuration (fdd-DownlinkOrTddSubframeBitmapBR)			1111111111	
Note 1:	Reference measurement channel RC.23 FDD according to Table A.4-1 with one sided dynamic OCNG Pattern OP.1 FDD and two sided dynamic OCNG pattern OP.2 FDD as described in Annex A.5.1.1 and A.5.1.2.			
Note 2:	The minimum requirements shall be fulfilled for at least one of the two SNR(s) and the respective wanted signal input level.			
Note 3:	DC subcarrier puncturing shall be considered.			
Note 4:	To avoid collisions between CQI reports and HARQ-ACK it is necessary to report both on PUSCH instead of PUCCH. MPDCCH DCI format 6-0A shall be transmitted in downlink SF#1 to allow periodic CQI to multiplex with the HARQ-ACK on PUSCH in uplink subframe SF#5.			

9.8.1.2 TDD

The following requirements apply to UE supporting coverage enhancement. For the parameters specified in Table 9.7.3.2-1, and using the downlink physical channels specified in tables C.3.2-1 and C.3.2-2, the reported CQI value according to RC.23 TDD in Table A.4-1 shall be in the range of ± 1 of the reported median more than 90% of the time. If the PDSCH BLER using the transport format indicated by median CQI is less than or equal to 0.1, the BLER using the transport format indicated by the (median CQI + 1) shall be greater than 0.1. If the PDSCH BLER using the

transport format indicated by the median CQI is greater than 0.1, the BLER using transport format indicated by (median CQI – 1) shall be less than or equal to 0.1.

Table 9.8.1.2-1: PUCCH 1-0 static test (TDD)

Parameter	Unit	Test 1	
Bandwidth	MHz	10	
PDSCH transmission mode		1	
Downlink power allocation	ρ_A	dB	0
	ρ_B	dB	0
	σ	dB	0
	δ	dB	0
Propagation condition and antenna configuration		AWGN (1 x 1)	
SNR (Note 2)	dB	4	5
$\hat{I}_{or}^{(j)}$	dB[mW/15kHz]	-94	-93
$N_{oc}^{(j)}$	dB[mW/15kHz]	-98	-98
Max number of HARQ transmissions		1	
Physical channel for CQI reporting		PUSCH (Note 3)	
PUCCH Report Type		4	
Reporting periodicity	ms	$N_{pd} = 5$	
<i>cqi-pmi-ConfigurationIndex</i>		3	
Frequency hopping		Disabled	
Frequency hopping interval (interval-TDD)		N/A	
Starting OFDM symbol (startSymbolLC)		3	
PDSCH repetition level		1	
ACK/NACK feedback mode		Multiplexing	
MPDCCH repetition level		1	
Beamforming Precoder for MPDCCH		No precoding	
Precoder update granularity for MPDCCH		N/A	
BL/CE DL subframe configuration (fdd-DownlinkOrTddSubframeBitmapBR)		1011110111	
Note 1:	Reference measurement channel RC.23 TDD according to Table A.4-1 with one sided dynamic OCNG Pattern OP.1 TDD and two sided dynamic OCNG pattern OP. 2 TDD as described in Annex A.5.2.1 and A.5.2.2.		
Note 2:	The minimum requirements shall be fulfilled for at least one of the two SNR(s) and the respective wanted signal input level.		
Note 3:	To avoid collisions between CQI reports and HARQ-ACK it is necessary to report both on PUSCH instead of PUCCH. MPDCCH DCI format 6-0A shall be transmitted in downlink SF#3 and #8 to allow periodic CQI to multiplex with the HARQ-ACK on PUSCH in uplink subframe SF#7 and #2.		
Note 4:	DC subcarrier puncturing shall be considered.		

9.8.2 UE-selected subband CQI

9.8.2.1 FDD and half-duplex FDD

The following requirements apply to UE supporting coverage enhancement. For the parameters specified in Table 9.8.2.1-1, and using the downlink physical channels specified in Annex C.3.2, the minimum requirements are specified in Table 9.8.2.1-2 and by the following

- the ratio of the throughput obtained when transmitting on the best narrowband reported by the UE the corresponding TBS and that obtained when transmitting the TBS indicated by the reported wideband CQI

median on a randomly selected narrowband within the set of narrowbands in which MPDCCH is monitored shall be $\geq \gamma$;

The requirements only apply for narrowbands of full size and the random scheduling across the narrowbands is done by selecting a new narrowband in each TTI for FDD and half-duplex FDD. The transport block size TBS (wideband CQI median) is that resulting from the code rate which is closest to that indicated by the wideband CQI median and the N_{PRB} entry in Table 7.1.7.2.1-1 of TS 36.213 [6] that corresponds to the narrowband size.

Table 9.8.2.1-1 Sub-band test for single antenna transmission (FDD and half-duplex FDD)

Parameter		Unit	Test 1	
Bandwidth		MHz	10 MHz	
Transmission mode			1 (port 0)	
Downlink power allocation	ρ_A	dB	0	
	ρ_B	dB	0	
	σ	dB	0	
	δ	dB	0	
SNR (Note 3)		dB	5	6
$\hat{I}_{or}^{(j)}$		dB[mW/15kHz]	-93	-92
$N_{oc}^{(j)}$		dB[mW/15kHz]	-98	-98
Propagation channel			Clause B.2.4 with $\tau_d = 0.45 \mu\text{s}$, $a = 1$, $f_D = 1 \text{ Hz}$	
Reporting interval		ms	10	
CQI delays for each narrowband		ms	11, 12, 13, 14	
Reporting mode			PUSCH 2-0	
Max number of HARQ transmissions			1	
Number of preferred subbands (M)			1	
Number of narrowbands			4	
Frequency hopping			Enabled	
Frequency hopping offset			1	
Starting OFDM symbol (startSymbolBR)			3	
Maximum number of MPDCCH repetitions (mpdcch-NumRepetition)			4	
MPDCCH repetition level (Note 6)			1	
PDSCCH repetition level			1	
MPDCCH narrowband (mpdcch-Narrowband)			7 (Note 5)	
MPDCCH hopping interval (interval-FDD)			1	
Start subframe configuration for MPDCCH (mpdcch-startSF-UeSS)			2.5	
Beamforming Precoder for MPDCCH			No preconding	
Precoder update granularity for MPDCCH			N/A	
BL/CE DL subframe configuration (fdd-DownlinkOrTddSubframeBitmapBR)			1111111111	
$R_{CSI}^{(j)}$ (csi-NumRepetitionCE)		Subframe	1	
<p>Note 1: If the UE reports in an available uplink reporting instance at subframe SF#n based on CQI estimation at a downlink subframe not later than SF#(n-4), this reported narrowband or wideband CQI cannot be applied at the eNB downlink before SF#(n+4)</p> <p>Note 2: Reference measurement channel RC.25 FDD according to Table A.4-1 with one sided and dynamic OCNG Pattern OP.1/2 FDD as described in Annex A.5.1.1/2.</p> <p>Note 3: The minimum requirements shall be fulfilled for at least one of the two SNR(s) and the respective wanted signal input level</p> <p>Note 4: DC subcarrier puncturing shall be considered</p>				

Note 5: For RRC parameter setting, mpdcch-narrowband is set to 8.
 Note 6: DCI format 6-1A is scheduled in the subframe k2 according to TS36.213 subclause 9.1.5.

Table 9.8.2.1-2 Minimum requirement (FDD and half-duplex FDD)

	Test 1
γ	1.3
UE DL Category	M1, ≥ 0

9.8.2.2 TDD

The following requirements apply to UE supporting coverage enhancement. For the parameters specified in Table 9.8.2.2-1, and using the downlink physical channels specified in Annex C.3.2, the minimum requirements are specified in Table 9.8.2.2-2 and by the following

- a) the ratio of the throughput obtained when transmitting on the best narrowband reported by the UE the corresponding TBS and that obtained when transmitting the TBS indicated by the reported wideband CQI median on a randomly selected narrowband within the set of narrowbands in which MPDCCH is monitored shall be $\geq \gamma$;

The requirements only apply for subbands of full size and the random scheduling across the subbands is done by selecting a new narrowband in each available downlink transmission instance for TDD. The transport block size TBS (wideband CQI median) is that resulting from the code rate which is closest to that indicated by the wideband CQI median and the N_{PRB} entry in Table 7.1.7.2.1-1 of TS 36.213 [6] that corresponds to the narrowband size.

Table 9.8.2.2-1 Sub-band test for single antenna transmission (TDD)

Parameter	Unit	Test 1	
Bandwidth	MHz	10 MHz	
Transmission mode		1 (port 0)	
Downlink power allocation	ρ_A	dB	0
	ρ_B	dB	0
	σ	dB	0
	δ	dB	0
Uplink downlink configuration		2	
Special subframe configuration		4	
SNR (Note 3)	dB	5	6
$\hat{I}_{or}^{(j)}$	dB[mW/15kHz]	-93	-92
$N_{oc}^{(j)}$	dB[mW/15kHz]	-98	-98
Propagation channel		Clause B.2.4 with $\tau_d = 0.45 \mu\text{s}$, $a = 1$, $f_D = 1 \text{ Hz}$	
Reporting interval	ms	20	
CQI delay	ms	23, 24, 25, 28	
Reporting mode		PUSCH 2-0	
Max number of HARQ transmissions		1	
Number of preferred subbands (M)		1	
ACK/NACK feedback mode		Multiplexing	
Number of narrowbands		4	
Frequency hopping		Enabled	
Frequency hopping offset		1	
Starting OFDM symbol (startSymbolBR)		3	
Maximum number of MPDCCH repetitions (mpdcch-NumRepetition)		4	
PDSCH repetition level		1	
MPDCCH narrowband (mpdcch-Narrowband)		7 (Note 5)	
MPDCCH hopping interval (interval-TDD)		1	
Start subframe configuration for MPDCCH (mpdcch-startSF-UeSS)		5	
Beamforming Precoder for MPDCCH		No precoding	
Precoder update granularity for MPDCCH		N/A	
BL/CE DL subframe configuration (fdd-DownlinkOrTddSubframeBitmapBR)		1011110111	
R^{CSI} (csi-NumRepetitionCE)	Subframe	1	
Note 1: If the UE reports in an available uplink reporting instance at subframe SF#n based on CQI estimation at a downlink subframe not later than SF#(n-4), this reported subband or wideband CQI cannot be applied at the eNB downlink before SF#(n+4)			

Note 2:	Reference measurement channel RC.25 TDD according to Table A.4-1 with onesided and dynamic OCNG Pattern OP.1/2 TDD as described in Annex A.5.2.1/2.
Note 3:	The minimum requirements shall be fulfilled for at least one of the two SNR(s) and the respective wanted signal input level.
Note 4:	DC subcarrier puncturing shall be considered
Note 5:	For RRC parameter setting, mpdcch-narroband is set to 8.
Note 6:	DCI format 6-1A is scheduled in the subframe k2 according to TS36.213 subclause 9.1.5.
Note 7:	In the case CQI reports and HARQ-ACK collide, CQI reports and HARQ-ACK will be multiplexed.

Table 9.8.2.2-2 Minimum requirement (TDD)

	Test 1
γ	1.3
UE Category	M1, ≥ 0

9.9 CSI reporting for 4Rx UE

9.9.1 CQI reporting definition under AWGN conditions

The reporting accuracy of the channel quality indicator (CQI) under frequency non-selective conditions is determined by the reporting variance and the BLER performance using the transport format indicated by the reported CQI median. The purpose is to verify that the reported CQI values are in accordance with the CQI definition given in TS 36.213 [6]. To account for sensitivity of the input SNR the reporting definition is considered to be verified if the reporting accuracy is met for at least one of two SNR levels separated by an offset of 1 dB.

9.9.1.1 Minimum requirement PUCCH 1-0 with Rank 1 (Cell-Specific Reference Symbols)

9.9.1.1.1 FDD

The following requirements apply to UE Category ≥ 1 . For the parameters specified in Table 9.9.1.1.1-1, using the downlink physical channels specified in tables C.3.2-1 and C.3.2-2, the reported CQI value according to RC.1 FDD / RC.4 FDD in Table A.4-1 shall be in the range of ± 1 of the reported median more than 90% of the time. If the PDSCH BLER using the transport format indicated by median CQI is less than or equal to 0.1, the BLER using the transport format indicated by the (median CQI + 1) shall be greater than 0.1. If the PDSCH BLER using the transport format indicated by the median CQI is greater than 0.1, the BLER using transport format indicated by (median CQI – 1) shall be less than or equal to 0.1.

Table 9.9.1.1.1-1: PUCCH 1-0 static test (FDD)

Parameter		Unit	Test 1		Test 2	
Bandwidth		MHz			10	
PDSCH transmission mode					1	
Downlink power allocation	ρ_A	dB			0	
	ρ_B	dB			0	
	σ	dB			0	
Propagation condition and antenna configuration			AWGN (1 x 4)			
SNR (Note 2)		dB	-2	-1	4	5
$\hat{I}_{or}^{(j)}$		dB[mW/15kHz]	-100	-99	-94	-93
$N_{oc}^{(j)}$		dB[mW/15kHz]	-98		-98	
Max number of HARQ transmissions			1			
Physical channel for CQI reporting			PUCCH Format 2			
PUCCH Report Type			4			
Reporting periodicity		ms	$N_{pd} = 5$			
<i>cqi-pmi-ConfigurationIndex</i>			6			
<p>Note 1: Reference measurement channel RC.1 FDD according to Table A.4-1 with one sided dynamic OCNG Pattern OP.1 FDD as described in Annex A.5.1.1, except for category 1 UE use RC.4 FDD with two sided dynamic OCNG Pattern OP.2 FDD as described in Annex A.5.1.2.</p> <p>Note 2: For each test, the minimum requirements shall be fulfilled for at least one of the two SNR(s) and the respective wanted signal input level.</p>						

9.9.1.1.2 TDD

The following requirements apply to UE Category ≥ 1 . For the parameters specified in Table 9.9.1.1.2-1, using the downlink physical channels specified in tables C.3.2-1 and C.3.2-2, the reported CQI value according to RC.1/RC.4 TDD in Table A.4-1 shall be in the range of ± 1 of the reported median more than 90% of the time. If the PDSCH BLER using the transport format indicated by median CQI is less than or equal to 0.1, the BLER using the transport format indicated by the (median CQI + 1) shall be greater than 0.1. If the PDSCH BLER using the transport format indicated by the median CQI is greater than 0.1, the BLER using transport format indicated by (median CQI - 1) shall be less than or equal to 0.1.

Table 9.9.1.1.2-1: PUCCH 1-0 static test (TDD)

Parameter		Unit	Test 1		Test 2	
Bandwidth		MHz			10	
PDSCH transmission mode					1	
Uplink downlink configuration					2	
Special subframe configuration					4	
Downlink power allocation	ρ_A	dB			0	
	ρ_B	dB			0	
	σ	dB			0	
Propagation condition and antenna configuration			AWGN (1 x 4)			
SNR (Note 2)		dB	-2	-1	4	5
$\hat{I}_{or}^{(j)}$		dB[mW/15kHz]	-100	-99	-94	-93
$N_{oc}^{(j)}$		dB[mW/15kHz]	-98		-98	
Max number of HARQ transmissions			1			
Physical channel for CQI reporting			PUSCH (Note 3)			
PUCCH Report Type			4			
Reporting periodicity		ms	$N_{pd} = 5$			
<i>cqi-pmi-ConfigurationIndex</i>			3			
ACK/NACK feedback mode			Multiplexing			
Note 1:		Reference measurement channel RC.1 TDD according to Table A.4-1 with one sided dynamic OCNG Pattern OP.1 TDD as described in Annex A.5.2.1, except for category 1 UE use RC.4 TDD with two sided dynamic OCNG Pattern OP.2 TDD as described in Annex A.5.2.2.				
Note 2:		For each test, the minimum requirements shall be fulfilled for at least one of the two SNR(s) and the respective wanted signal input level.				
Note 3:		To avoid collisions between CQI reports and HARQ-ACK it is necessary to report both on PUSCH instead of PUCCH. PDCCH DCI format 0 shall be transmitted in downlink SF#3 and #8 to allow periodic CQI to multiplex with the HARQ-ACK on PUSCH in uplink subframe SF#7 and #2.				

9.9.1.2 Minimum requirement PUCCH 1-1 with Rank 2 (CSI Reference Symbols)

The minimum requirements for dual codeword transmission are defined in terms of a reporting spread of the wideband CQI value for codeword #1, and their BLER performance using the transport format indicated by the reported CQI median of codeword #0 and codeword #1. The precoding used at the transmitter is a fixed precoding matrix specified by the bitmap parameter *codebookSubsetRestriction*. The propagation condition assumed for the minimum performance requirement is defined in subclause B.1.

9.9.1.2.1 FDD

The following requirements apply to UE Category ≥ 2 . For the parameters specified in table 9.9.1.2.1-1, and using the downlink physical channels specified in tables C.3.2-1 and C.3.2-2, the reported offset level of the wideband spatial differential CQI for codeword #1 (Table 7.2-2 in TS 36.213 [6]) shall be used to determine the wideband CQI index for codeword #1 as

$$\text{wideband CQI}_1 = \text{wideband CQI}_0 - \text{Codeword 1 offset level}$$

The wideband CQI_1 shall be within the set $\{\text{median CQI}_1 - 1, \text{median CQI}_1, \text{median CQI}_1 + 1\}$ for more than 90% of the time, where the resulting wideband values CQI_1 shall be used to determine the median CQI values for codeword #1. For both codewords #0 and #1, the PDSCH BLER using the transport format indicated by the respective median $\text{CQI}_0 - 1$ and median $\text{CQI}_1 - 1$ shall be less than or equal to 0.1. Furthermore, for both codewords #0 and #1, the PDSCH BLER using the transport format indicated by the respective median $\text{CQI}_0 + 1$ and median $\text{CQI}_1 + 1$ shall be greater than or equal to 0.1.

Table 9.9.1.2.1-1: PUCCH 1-1 static test (FDD)

Parameter	Unit	Test 1		Test 2	
Bandwidth	MHz			10	
PDSCH transmission mode				9	
Downlink power allocation	ρ_A	dB		0	
	ρ_B	dB		0	
	P_c	dB		-3	
	σ	dB		-3	
Cell-specific reference signals		Antenna ports 0, 1			
CSI reference signals		Antenna ports 15,...,18			
CSI-RS periodicity and subframe offset $T_{\text{CSI-RS}} / \Delta_{\text{CSI-RS}}$		5/1			
CSI reference signal configuration		0			
Propagation condition and antenna configuration		Clause B.1 (4 x 4)			
Beamforming Model		As specified in Section B.4.3			
CodeBookSubsetRestriction bitmap		0x0000 0000 0100 0000			
SNR (Note 2)	dB	5	6	11	12
$\hat{I}_{or}^{(j)}$	dB[mW/15kHz]	-93	-92	-87	-86
$N_{oc}^{(j)}$	dB[mW/15kHz]	-98		-98	
Max number of HARQ transmissions		1			
Physical channel for CQI/PMI reporting		PUSCH (Note3)			
PUCCH Report Type for CQI/PMI		2			
Physical channel for RI reporting		PUCCH Format 2			
PUCCH Report Type for RI		3			
Reporting periodicity	ms	$N_{pd} = 5$			
CQI delay	ms	8			
<i>cqi-pmi-ConfigurationIndex</i>		2			
<i>ri-ConfigIndex</i>		1			
Note 1:	Reference measurement channel RC.7 FDD according to Table A.4-1 with one sided dynamic OCNG Pattern OP.1 FDD as described in Annex A.5.1.1.				
Note 2:	For each test, the minimum requirements shall be fulfilled for at least one of the two SNR(s) and the respective wanted signal input level.				
Note 3:	To avoid collisions between CQI/PMI reports and HARQ-ACK it is necessary to report both on PUSCH instead of PUCCH. PDCCH DCI format 0 shall be transmitted in downlink SF#1 and #6 to allow periodic CQI/PMI to multiplex with the HARQ-ACK on PUSCH in uplink SF#0 and #5.				

9.9.1.2.2 TDD

The following requirements apply to UE Category ≥ 2 . For the parameters specified in table 9.9.1.2.2-1, and using the downlink physical channels specified in tables C.3.2-1 and C.3.2-2, the reported offset level of the wideband spatial differential CQI for codeword #1 (Table 7.2-2 in TS 36.213 [6]) shall be used to determine the wideband CQI index for codeword #1 as

$$\text{wideband CQI}_1 = \text{wideband CQI}_0 - \text{Codeword 1 offset level}$$

The wideband CQI_1 shall be within the set $\{\text{median CQI}_1 - 1, \text{median CQI}_1, \text{median CQI}_1 + 1\}$ for more than 90% of the time, where the resulting wideband values CQI_1 shall be used to determine the median CQI values for codeword #1. For both codewords #0 and #1, the PDSCH BLER using the transport format indicated by the respective median $\text{CQI}_0 - 1$ and median $\text{CQI}_1 - 1$ shall be less than or equal to 0.1. Furthermore, for both codewords #0 and #1, the PDSCH BLER using the transport format indicated by the respective median $\text{CQI}_0 + 1$ and median $\text{CQI}_1 + 1$ shall be greater than or equal to 0.1.

Table 9.9.1.2.2-1: PUCCH 1-1 submode 1 static test (TDD)

Parameter		Unit	Test 1		Test 2	
Bandwidth		MHz	10			
PDSCH transmission mode			9			
Uplink downlink configuration			2			
Special subframe configuration			4			
Downlink power allocation	ρ_A	dB	0			
	ρ_B	dB	0			
	P_c	dB	-6			
	σ	dB	-3			
CRS reference signals			Antenna ports 0, 1			
CSI reference signals			Antenna ports 15,...,22			
CSI-RS periodicity and subframe offset $T_{\text{CSI-RS}} / \Delta_{\text{CSI-RS}}$			5/3			
CSI reference signal configuration			0			
Propagation condition and antenna configuration			Clause B.1 (8 x 4)			
Beamforming Model			As specified in Section B.4.3			
CodeBookSubsetRestriction bitmap			0x0000 0000 0020 0000 0000 0001 0000			
SNR (Note 2)		dB	2	3	8	9
$\hat{I}_{or}^{(j)}$		dB[mW/15kHz]	-96	-95	-90	-89
$N_{oc}^{(j)}$		dB[mW/15kHz]	-98		-98	
Max number of HARQ transmissions			1			
Physical channel for CQI/PMI reporting			PUSCH (Note 3)			
PUCCH Report Type for CQI/second PMI			2b			
Physical channel for RI reporting			PUSCH			
PUCCH Report Type for RI/ first PMI			5			
Reporting periodicity		ms	$N_{pd} = 5$			
CQI delay		ms	10 or 11			
<i>cqi-pmi-ConfigurationIndex</i>			3			
<i>ri-ConfigIndex</i>			805 (Note 4)			
ACK/NACK feedback mode			Multiplexing			
Note 1: Reference measurement channel RC.7 TDD according to Table A.4-1 with one sided dynamic OCNG Pattern OP.1 TDD as described in Annex A.5.2.1.						
Note 2: For each test, the minimum requirements shall be fulfilled for at least one of the two SNR(s) and the respective wanted signal input level.						
Note 3: To avoid collisions between CQI/PMI reports and HARQ-ACK it is necessary to report both on PUSCH instead of PUCCH. PDCCH DCI format 0 shall be transmitted in downlink SF#3 and #8 to allow periodic CQI/PMI to multiplex with the HARQ-ACK on PUSCH in uplink SF#7 and #2.						
Note 4: RI reporting interval is set to the maximum allowable length of 160ms to minimise collisions between RI, CQI/PMI and HARQ-ACK reports. In the case when all three reports collide, it is expected that CQI/PMI reports will be dropped, while RI and HARQ-ACK will be multiplexed. At eNB, CQI report collection shall be skipped every 160ms during performance verification.						

9.9.1.3 Minimum requirement PUCCH 1-1 with Rank 4 (Cell-Specific Reference Symbols)

The minimum requirements for dual codeword transmission are defined in terms of a reporting spread of the wideband CQI value for codeword #1, and their BLER performance using the transport format indicated by the reported CQI median of codeword #0 and codeword #1. The precoding used at the transmitter is a fixed precoding matrix specified by the bitmap parameter *codebookSubsetRestriction*. The propagation condition assumed for the minimum performance requirement is defined in subclause B.1.

9.9.1.3.1 FDD

The following requirements apply to UE Category ≥ 5 . For the parameters specified in table 9.9.1.3.1-1, and using the downlink physical channels specified in tables C.3.2-1 and C.3.2-2, the reported offset level of the wideband spatial differential CQI for codeword #1 (Table 7.2-2 in TS 36.213 [6]) shall be used to determine the wideband CQI index for codeword #1 as

$$\text{wideband CQI}_1 = \text{wideband CQI}_0 - \text{Codeword 1 offset level}$$

The wideband CQI_1 shall be within the set {median $\text{CQI}_1 - 1$, median CQI_1 , median $\text{CQI}_1 + 1$ } for more than 90% of the time, where the resulting wideband values CQI_1 shall be used to determine the median CQI values for codeword #1. For both codewords #0 and #1, the PDSCH BLER using the transport format indicated by the respective median $\text{CQI}_0 - 1$ and median $\text{CQI}_1 - 1$ shall be less than or equal to 0.1. Furthermore, for both codewords #0 and #1, the PDSCH BLER using the transport format indicated by the respective median $\text{CQI}_0 + 1$ and median $\text{CQI}_1 + 1$ shall be greater than or equal to 0.1.

Table 9.9.1.3.1-1: PUCCH 1-1 static test (FDD)

Parameter		Unit	Test 1		Test 2	
Bandwidth		MHz	10			
PDSCH transmission mode			4			
Downlink power allocation	ρ_A	dB	-6			
	ρ_B	dB	-6			
	σ	dB	0			
Propagation condition and antenna configuration			Clause B.1 (4 x 4)			
CodeBookSubsetRestriction bitmap			0x0002 0000 0000 0000			
SNR (Note 2)		dB	5	6	11	12
$\hat{I}_{or}^{(j)}$		dB[mW/15kHz]	-93	-92	-87	-86
$N_{oc}^{(j)}$		dB[mW/15kHz]	-98		-98	
Max number of HARQ transmissions			1			
Physical channel for CQI/PMI reporting			PUCCH Format 2			
PUCCH Report Type for CQI/PMI			2			
PUCCH Report Type for RI			3			
Reporting periodicity		ms	$N_{pd} = 5$			
<i>cqi-pmi-ConfigurationIndex</i>			6			
<i>ri-ConfigIndex</i>			1 (Note 3)			
Note 1: Reference measurement channel RC.21 FDD according to Table A.4-1 with one sided dynamic OCNG Pattern OP.1 FDD as described in Annex A.5.1.1.						
Note 2: For each test, the minimum requirements shall be fulfilled for at least one of the two SNR(s) and the respective wanted signal input level.						
Note 3: It is intended to have UL collisions between RI reports and HARQ-ACK, since the RI reports shall not be used by the eNB in this test.						

9.9.1.3.2 TDD

The following requirements apply to UE Category ≥ 5 . For the parameters specified in table 9.9.1.3.2-1, and using the downlink physical channels specified in tables C.3.2-1 and C.3.2-2, the reported offset level of the wideband spatial differential CQI for codeword #1 (Table 7.2-2 in TS 36.213 [6]) shall be used to determine the wideband CQI index for codeword #1 as

$$\text{wideband CQI}_1 = \text{wideband CQI}_0 - \text{Codeword 1 offset level}$$

The wideband CQI_1 shall be within the set {median $\text{CQI}_1 - 1$, median CQI_1 , median $\text{CQI}_1 + 1$ } for more than 90% of the time, where the resulting wideband values CQI_1 shall be used to determine the median CQI values for codeword #1. For both codewords #0 and #1, the PDSCH BLER using the transport format indicated by the respective median $\text{CQI}_0 - 1$ and median $\text{CQI}_1 - 1$ shall be less than or equal to 0.1. Furthermore, for both codewords #0 and #1, the PDSCH BLER

using the transport format indicated by the respective median $CQI_0 + 1$ and median $CQI_1 + 1$ shall be greater than or equal to 0.1.

Table 9.9.1.3.2-1: PUCCH 1-1 static test (TDD)

Parameter		Unit	Test 1		Test 2	
Bandwidth		MHz	10			
PDSCH transmission mode			4			
Uplink downlink configuration			2			
Special subframe configuration			4			
Downlink power allocation	ρ_A	dB	-6			
	ρ_B	dB	-6			
	σ	dB	0			
Propagation condition and antenna configuration			Clause B.1 (4x4)			
CodeBookSubsetRestriction bitmap			0x0002 0000 0000 0000			
SNR (Note 2)		dB	5	6	11	12
$\hat{I}_{or}^{(j)}$		dB[mW/15kHz]	-93	-92	-87	-86
$N_{oc}^{(j)}$		dB[mW/15kHz]	-98		-98	
Max number of HARQ transmissions			1			
Physical channel for CQI/PMI reporting			PUSCH (Note 3)			
PUCCH Report Type			2			
Reporting periodicity		ms	$N_{pd} = 5$			
<i>cqi-pmi-ConfigurationIndex</i>			3			
<i>ri-ConfigIndex</i>			805 (Note 4)			
ACK/NACK feedback mode			Multiplexing			
<p>Note 1: Reference measurement channel RC.21 TDD according to Table A.4-1 with one sided dynamic OCNG Pattern OP.1 TDD as described in Annex A.5.2.1.</p> <p>Note 2: For each test, the minimum requirements shall be fulfilled for at least one of the two SNR(s) and the respective wanted signal input level.</p> <p>Note 3: To avoid collisions between CQI/PMI reports and HARQ-ACK it is necessary to report both on PUSCH instead of PUCCH. PDCCH DCI format 0 shall be transmitted in downlink SF#3 and #8 to allow periodic CQI/PMI to multiplex with the HARQ-ACK on PUSCH in uplink subframe SF#7 and #2.</p> <p>Note 4: RI reporting interval is set to the maximum allowable length of 160ms to minimise collisions between RI, CQI/PMI and HARQ-ACK reports. In the case when all three reports collide, it is expected that CQI/PMI reports will be dropped, while RI and HARQ-ACK will be multiplexed. At eNB, CQI report collection shall be skipped every 160ms during performance verification.</p>						

9.9.1.4 Minimum requirement PUCCH 1-1 with Rank 3 (CSI Reference Symbols)

The minimum requirements for dual codeword transmission are defined in terms of a reporting spread of the wideband CQI value for codeword #1, and their BLER performance using the transport format indicated by the reported CQI median of codeword #0 and codeword #1. The precoding used at the transmitter is a fixed precoding matrix specified by the bitmap parameter *codebookSubsetRestriction*. The propagation condition assumed for the minimum performance requirement is defined in subclause B.1.

9.9.1.4.1 FDD

The following requirements apply to UE Category ≥ 5 . For the parameters specified in table 9.9.1.4.1-1, and using the downlink physical channels specified in tables C.3.2-1 and C.3.2-2, the reported offset level of the wideband spatial differential CQI for codeword #1 (Table 7.2-2 in TS 36.213 [6]) shall be used to determine the wideband CQI index for codeword #1 as

$$\text{wideband } CQI_1 = \text{wideband } CQI_0 - \text{Codeword 1 offset level}$$

The wideband CQI₁ shall be within the set {median CQI₁ -1, median CQI₁, median CQI₁ +1} for more than 90% of the time, where the resulting wideband values CQI₁ shall be used to determine the median CQI values for codeword #1. For both codewords #0 and #1, the PDSCH BLER using the transport format indicated by the respective median CQI₀ - 1 and median CQI₁ - 1 shall be less than or equal to 0.1. Furthermore, for both codewords #0 and #1, the PDSCH BLER using the transport format indicated by the respective median CQI₀ + 1 and median CQI₁ + 1 shall be greater than or equal to 0.1.

Table 9.9.1.4.1-1: PUCCH 1-1 static test (FDD)

Parameter		Unit	Test 1		Test 2	
Bandwidth		MHz	10			
PDSCH transmission mode			9			
Downlink power allocation	ρ_A	dB	0			
	ρ_B	dB	0			
	P_C	dB	-3			
	σ	dB	-3			
Cell-specific reference signals			Antenna ports 0, 1			
CSI reference signals			Antenna ports 15,...,18			
CSI-RS periodicity and subframe offset $T_{\text{CSI-RS}} / \Delta_{\text{CSI-RS}}$			5/1			
CSI reference signal configuration			0			
Propagation condition and antenna configuration			Clause B.1 (4 x 4)			
Beamforming Model			As specified in Section B.4.3			
CodeBookSubsetRestriction bitmap			0x0000 0020 0000 0000			
SNR (Note 2)		dB	[5]	[6]	[11]	[12]
$\hat{I}_{or}^{(j)}$		dB[mW/15kHz]	[-93]	[-92]	[-87]	[-86]
$N_{oc}^{(j)}$		dB[mW/15kHz]	-98		-98	
Max number of HARQ transmissions			1			
Physical channel for CQI/PMI reporting			PUSCH (Note3)			
PUCCH Report Type for CQI/PMI			2			
Physical channel for RI reporting			PUCCH Format 2			
PUCCH Report Type for RI			3			
Reporting periodicity		ms	$N_{pd} = 5$			
CQI delay		ms	8			
<i>cqi-pmi-ConfigurationIndex</i>			2			
<i>ri-ConfigIndex</i>			1			
<p>Note 1: Reference measurement channel RC.22 FDD according to Table A.4-1 with one sided dynamic OCNG Pattern OP.1 FDD as described in Annex A.5.1.1.</p> <p>Note 2: For each test, the minimum requirements shall be fulfilled for at least one of the two SNR(s) and the respective wanted signal input level.</p> <p>Note 3: To avoid collisions between CQI/PMI reports and HARQ-ACK it is necessary to report both on PUSCH instead of PUCCH. PDCCH DCI format 0 shall be transmitted in downlink SF#1 and #6 to allow periodic CQI/PMI to multiplex with the HARQ-ACK on PUSCH in uplink SF#0 and #5.</p>						

9.9.1.4.2 TDD

The following requirements apply to UE Category ≥ 5 . For the parameters specified in table 9.9.1.4.2-1, and using the downlink physical channels specified in tables C.3.2-1 and C.3.2-2, the reported offset level of the wideband spatial differential CQI for codeword #1 (Table 7.2-2 in TS 36.213 [6]) shall be used to determine the wideband CQI index for codeword #1 as

$$\text{wideband CQI}_1 = \text{wideband CQI}_0 - \text{Codeword 1 offset level}$$

The wideband CQI₁ shall be within the set {median CQI₁ -1, median CQI₁, median CQI₁ +1} for more than 90% of the time, where the resulting wideband values CQI₁ shall be used to determine the median CQI values for codeword #1. For both codewords #0 and #1, the PDSCH BLER using the transport format indicated by the respective median CQI₀ - 1 and median CQI₁ - 1 shall be less than or equal to 0.1. Furthermore, for both codewords #0 and #1, the PDSCH BLER

using the transport format indicated by the respective median $CQI_0 + 1$ and median $CQI_1 + 1$ shall be greater than or equal to 0.1.

Table 9.9.1.4.2-1: PUCCH 1-1 static test (TDD)

Parameter		Unit	Test 1		Test 2	
Bandwidth		MHz	10			
PDSCH transmission mode			9			
Uplink downlink configuration			2			
Special subframe configuration			4			
Downlink power allocation	ρ_A	dB	0			
	ρ_B	dB	0			
	P_C	dB	-3			
	σ	dB	-3			
CRS reference signals			Antenna ports 0, 1			
CSI reference signals			Antenna ports 15,...,18			
CSI-RS periodicity and subframe offset $T_{\text{CSI-RS}} / \Delta_{\text{CSI-RS}}$			5/ 3			
CSI reference signal configuration			0			
Propagation condition and antenna configuration			Clause B.1 (4 x 4)			
Beamforming Model			As specified in Section B.4.3			
CodeBookSubsetRestriction bitmap			0x0000 0020 0000 0000			
SNR (Note 2)		dB	5	6	11	12
$\hat{I}_{or}^{(j)}$		dB[mW/15kHz]	-93	-92	-87	-86
$N_{oc}^{(j)}$		dB[mW/15kHz]	-98		-98	
Max number of HARQ transmissions			1			
Physical channel for CQI/PMI reporting			PUSCH (Note 3)			
PUCCH Report Type for CQI/PMI			2			
Physical channel for RI reporting			PUSCH			
PUCCH Report Type for RI			3			
Reporting periodicity		ms	$N_{pd} = 5$			
CQI delay		ms	10 or 11			
<i>cqi-pmi-ConfigurationIndex</i>			3			
<i>ri-ConfigIndex</i>			805 (Note 4)			
ACK/NACK feedback mode			Multiplexing			
<p>Note 1: Reference measurement channel RC.22 TDD according to Table A.4-1 with one sided dynamic OCNG Pattern OP.1 TDD as described in Annex A.5.2.1.</p> <p>Note 2: For each test, the minimum requirements shall be fulfilled for at least one of the two SNR(s) and the respective wanted signal input level.</p> <p>Note 3: To avoid collisions between CQI/PMI reports and HARQ-ACK it is necessary to report both on PUSCH instead of PUCCH. PDCCH DCI format 0 shall be transmitted in downlink SF#3 and #8 to allow periodic CQI/PMI to multiplex with the HARQ-ACK on PUSCH in uplink SF#7 and #2.</p> <p>Note 4: RI reporting interval is set to the maximum allowable length of 160ms to minimise collisions between RI, CQI/PMI and HARQ-ACK reports. In the case when all three reports collide, it is expected that CQI/PMI reports will be dropped, while RI and HARQ-ACK will be multiplexed. At eNB, CQI report collection shall be skipped every 160ms during performance verification.</p>						

9.9.2 CQI reporting definition under fading conditions

9.9.2.1 Minimum requirement PUCCH 1-0 (Cell-Specific Reference Symbol) for enhanced receiver Type A

The purpose of the test is to verify that the reporting of the channel quality is based on the receiver of the enhanced Type A. Performance requirements are specified in terms of the relative increase of the throughput obtained when the transport format is that indicated by the reported CQI subject to an interference model compared to the case with a white Gaussian noise model, and a requirement on the minimum BLER of the transmitted transport formats indicated by the reported CQI subject to an interference model.

9.9.2.1.1 FDD

For the parameters specified in Table 9.9.2.1.1-1, and using the downlink physical channels specified in Annex C, the minimum requirements are specified in Table 9.9.2.1.1-2 and by the following

- the ratio of the throughput obtained when transmitting the transport format indicated by each reported wideband CQI index subject to an interference source with specified DIP and that obtained when transmitting the transport format indicated by each reported wideband CQI index subject to a white Gaussian noise source shall be $\geq \gamma$;
- when transmitting the transport format indicated by each reported wideband CQI index subject to an interference source with specified DIP, the average BLER for the indicated transport formats shall be greater than or equal to 2%.

Table 9.9.2.1.1-1 Fading test for single antenna (FDD)

Parameter	Unit	Cell 1	Cell 2
Bandwidth	MHz	10 MHz	
Transmission mode		1 (port 0)	
Cyclic Prefix		Normal	Normal
Cell ID		0	1
SINR (Note 8)	dB	-4	N/A
$N_{oc}^{(j)}$	dB[mW/15kHz]	-98	N/A
Propagation channel		EPA5	Static (Note 7)
Correlation and antenna configuration		Low (1 x 4)	(1 x 4)
DIP (Note 4)	dB	N/A	-0.41
Reference measurement channel		Note 2	R.2 FDD
Reporting mode		PUCCH 1-0	N/A
Reporting periodicity	ms	$N_{pd} = 2$	N/A
CQI delay	ms	8	N/A
Physical channel for CQI reporting		PUSCH (Note 3)	N/A
PUCCH Report Type		4	N/A
<i>cqi-pmi-ConfigurationIndex</i>		1	N/A
Max number of HARQ transmissions		1	N/A
<p>Note 1: If the UE reports in an available uplink reporting instance at subframe SF#n based on CQI estimation at a downlink SF not later than SF#(n-4), this reported wideband CQI cannot be applied at the eNB downlink before SF#(n+4)</p> <p>Note 2: Reference measurement channel RC.1 FDD according to Table A.4-1 for Category 2-8 with one sided dynamic OCNG Pattern OP.1 FDD as described in Annex A.5.1.1 and RC.4 FDD according to Table A.4-1 for Category 1 with one/two sided dynamic OCNG Pattern OP.1/2 FDD as described in Annex A.5.1.1/2.</p> <p>Note 3: To avoid collisions between CQI reports and HARQ-ACK it is necessary to report both on PUSCH instead of PUCCH. PDCCH DCI format 0 shall be transmitted in downlink SF#1, #3, #7 and #9 to allow periodic CQI to multiplex with the HARQ-ACK on PUSCH in uplink subframe SF#5, #7, #1 and #3.</p> <p>Note 4: The respective received power spectral density of each interfering cell relative to N_{oc} is defined by its associated DIP value as specified in clause B.5.1.</p> <p>Note 5: Two cells are considered in which Cell 1 is the serving cell and Cell 2 is the interfering cell. The number of the CRS ports in both cells is the same. Interfering cell is fully loaded.</p> <p>Note 6: Both cells are time-synchronous.</p> <p>Note 7: Static channel is used for the interference model. In case for white Gaussian noise model Cell 2 is not present.</p> <p>Note 8: SINR corresponds to \hat{E}_s / N_{oc} of Cell 1 as defined in clause 8.1.1.</p>			

Table 9.9.2.1.1-2 Minimum requirement (FDD)

γ	1.8
UE Category	≥ 1

9.9.2.1.2 TDD

For the parameters specified in Table 9.9.2.1.2-1, and using the downlink physical channels specified in Annex C, the minimum requirements are specified in 9.9.2.1.2-2 and by the following

- a) the ratio of the throughput obtained when transmitting the transport format indicated by each reported wideband CQI index subject to an interference source with specified DIP and that obtained when transmitting the transport format indicated by each reported wideband CQI index subject to a white Gaussian noise source shall be $\geq \gamma$;
- b) when transmitting the transport format indicated by each reported wideband CQI index subject to an interference source with specified DIP, the average BLER for the indicated transport formats shall be greater than or equal to 2%.

Table 9.9.2.1.2-1 Fading test for single antenna (TDD)

Parameter	Unit	Cell 1	Cell 2
Bandwidth	MHz	10 MHz	
Transmission mode		1 (port 0)	
Uplink downlink configuration		2	
Special subframe configuration		4	
Cyclic Prefix		Normal	Normal
Cell ID		0	1
SINR (Note 8)	dB	-4	N/A
$N_{oc}^{(j)}$	dB[mW/15kHz]	-98	-98
Propagation channel		EPA5	Static (Note 7)
Correlation and antenna configuration		Low (1 x 4)	(1 x 4)
DIP (Note 4)	dB	N/A	-0.41
Reference measurement channel		Note 2	R.2A TDD
Reporting mode		PUCCH 1-0	N/A
Reporting periodicity	ms	$N_{pd} = 5$	N/A
CQI delay	ms	10 or 11	N/A
Physical channel for CQI reporting		PUSCH (Note 3)	N/A
PUCCH Report Type		4	N/A
<i>cqi-pmi-ConfigurationIndex</i>		3	N/A
Max number of HARQ transmissions		1	N/A
ACK/NACK feedback mode		Multiplexing	N/A
<p>Note 1: If the UE reports in an available uplink reporting instance at subframe SF#n based on CQI estimation at a downlink SF not later than SF#(n-4), this reported wideband CQI cannot be applied at the eNB downlink before SF#(n+4)</p> <p>Note 2: Reference measurement channel RC.1 TDD according to Table A.4-1 for Category 2-8 with one sided dynamic OCNG Pattern OP.1 TDD as described in Annex A.5.2.1 and RC.4 TDD according to Table A.4-1 for Category 1 with one/two sided dynamic OCNG Pattern OP.1/2 TDD as described in Annex A.5.2.1/2.</p> <p>Note 3: To avoid collisions between CQI reports and HARQ-ACK it is necessary to report both on PUSCH instead of PUCCH. PDCCH DCI format 0 shall be transmitted in downlink SF#3 and #8 to allow periodic CQI to multiplex with the HARQ-ACK on PUSCH in uplink subframe SF#7 and #2.</p> <p>Note 4: The respective received power spectral density of each interfering cell relative to N_{oc} is defined by its associated DIP value as specified in clause B.5.1.</p> <p>Note 5: Two cells are considered in which Cell 1 is the serving cell and Cell 2 is the interfering cell. The number of the CRS ports in both cells is the same. Interfering cell is fully loaded.</p> <p>Note 6: Both cells are time-synchronous.</p> <p>Note 7: Static channel is used for the interference model. In case for white Gaussian noise model Cell 2 is not present.</p> <p>Note 8: SINR corresponds to \hat{E}_s / N_{oc} of Cell 1 as defined in clause 8.1.1.</p>			

Table 9.3.5.1.2-2 Minimum requirement (TDD)

γ	1.8
UE Category	≥ 1

9.9.2.2 Minimum requirement PUCCH 1-1 (CSI Reference Symbol) for enhanced receiver Type A

The purpose of the test is to verify that the reporting of the channel quality is based on the receiver of the enhanced Type A. Performance requirements are specified in terms of the relative increase of the throughput obtained when the transport format is that indicated by the reported CQI subject to an interference model compared to the case with a white Gaussian noise model, and a requirement on the minimum BLER of the transmitted transport formats indicated by the reported CQI subject to an interference model.

9.9.2.2.1 FDD

For the parameters specified in Table 9.9.2.2.1-1, and using the downlink physical channels specified in Annex C, the minimum requirements are specified in Table 9.9.2.2.1-2 and by the following

- a) the ratio of the throughput obtained when transmitting the transport format indicated by each reported wideband CQI index subject to an interference source with specified DIP and that obtained when transmitting the transport format indicated by each reported wideband CQI index subject to a white Gaussian noise source shall be $\geq \gamma$;
- b) when transmitting the transport format indicated by each reported wideband CQI index subject to an interference source with specified DIP, the average BLER for the indicated transport formats shall be greater than or equal to 2%.

Table 9.9.2.2.1-1 Fading test for single antenna (FDD)

Parameter	Unit	Cell 1	Cell 2
Bandwidth	MHz	10 MHz	
Transmission mode		9	
Cyclic Prefix		Normal	Normal
Cell ID		0	1
SINR (Note 8)	dB	-4	N/A
$N_{oc}^{(j)}$	dB[mW/15kHz]	-98	N/A
Propagation channel		EPA5	Static (Note 7)
Correlation and antenna configuration		Low (2 x 4)	(1 x 4)
Beamforming Model		As specified in Section B.4.3 (Note 9, 10)	N/A
DIP (Note 4)	dB	N/A	-0.41
Cell-specific reference signals		Antenna ports 0,1	Antenna port 0
CSI reference signals		Antenna ports 15,16	N/A
CSI-RS periodicity and subframe offset		5/1	N/A
CSI-RS reference signal configuration		2	N/A
Zero-power CSI-RS configuration I_{CSI-RS} / ZeroPowerCSI-RS bitmap	Subframes / bitmap	N/A	1 / 001000000000 000
CodeBookSubsetRestriction bitmap		001111	N/A
Reference measurement channel		Note 2	R.2 FDD
Reporting mode		PUCCH 1-1	N/A
Reporting periodicity	ms	$N_{pd} = 5$	N/A
CQI delay	ms	8	N/A
Physical channel for CQI/PMI reporting		PUSCH (Note 3)	N/A
PUCCH Report Type for CQI/PMI		2	N/A
PUCCH channel for RI reporting		PUCCH Format 2	N/A
PUCCH Report Type for RI		3	N/A
$cqi-pmi-ConfigurationIndex$		2	N/A
$ri-ConfigIndex$		1	N/A
Max number of HARQ transmissions		1	N/A
Note 1:	If the UE reports in an available uplink reporting instance at subframe SF#n based on CQI estimation at a downlink SF not later than SF#(n-4), this reported wideband CQI cannot be applied at the eNB downlink before SF#(n+4)		
Note 2:	Reference measurement channel RC.11 FDD according to Table A.4-1 with one sided dynamic OCNG Pattern OP.1 FDD as described in Annex A.5.1.1.		
Note 3:	To avoid collisions between CQI/ PMI reports and HARQ-ACK it is necessary to report both on PUSCH instead of PUCCH. PDCCH DCI format 0 shall be transmitted in downlink SF#1 and #6 to allow periodic CQI/ PMI to multiplex with the HARQ-ACK on PUSCH in uplink subframe SF#0 and #5.		
Note 4:	The respective received power spectral density of each interfering cell relative to N_{oc} is defined by its associated DIP value as specified in clause B.5.1.		
Note 5:	Two cells are considered in which Cell 1 is the serving cell and Cell 2 is the interfering cell. Interfering cell is fully loaded.		

Note 6:	Both cells are time-synchronous.
Note 7:	Static channel is used for the interference model. In case for white Gaussian noise model Cell 2 is not present.
Note 8:	SINR corresponds to \widehat{E}_s / N_{oc} of Cell 1 as defined in clause 8.1.1.
Note 9:	The precoder in clause B.4.3 follows UE recommended PMI.
Note 10:	If the UE reports in an available uplink reporting instance at subframe SF#n based on PMI estimation at a downlink SF not later than SF#(n-4), this reported PMI cannot be applied at the eNB downlink before SF#(n+4).

Table 9.9.2.2.1-2 Minimum requirement (FDD)

γ	1.8
UE Category	≥ 2

9.9.2.2.2 TDD

For the parameters specified in Table 9.9.2.2.2-1, and using the downlink physical channels specified in Annex C, the minimum requirements are specified in 9.9.2.2.2-2 and by the following

- the ratio of the throughput obtained when transmitting the transport format indicated by each reported wideband CQI index subject to an interference source with specified DIP and that obtained when transmitting the transport format indicated by each reported wideband CQI index subject to a white Gaussian noise source shall be $\geq \gamma$;
- when transmitting the transport format indicated by each reported wideband CQI index subject to an interference source with specified DIP, the average BLER for the indicated transport formats shall be greater than or equal to 2%.

Table 9.9.2.2.2-1

Fading test for single antenna (TDD)Parameter	Unit	Cell 1	Cell 2
Bandwidth	MHz	10 MHz	
Transmission mode		9	
Uplink downlink configuration		2	
Special subframe configuration		4	
Cyclic Prefix		Normal	Normal
Cell ID		0	1
SINR (Note 8)	dB	-4	N/A
$N_{oc}^{(j)}$	dB[mW/15kHz]	-98	-98
Propagation channel		EPA5	Static (Note 7)
Correlation and antenna configuration		Low (2 x 4)	(1 x 4)
Beamforming Model		As specified in Section B.4.3 (Note 10, 11)	N/A
DIP (Note 4)	dB	N/A	-0.41
Cell-specific reference signals		Antenna ports 0,1	Antenna port 0
CSI reference signals		Antenna ports 15,16	N/A
CSI-RS periodicity and subframe offset		5/3	N/A
CSI-RS reference signal configuration		2	N/A
Zero-power CSI-RS configuration I_{CSI-RS} / ZeroPowerCSI-RS bitmap	Subframes / bitmap	N/A	3 / 001000000000 0000
CodeBookSubsetRestriction bitmap		001111	N/A
Reference measurement channel		Note 2	R.2A TDD
Reporting mode		PUCCH 1-1	N/A
Reporting periodicity	ms	$N_{pd} = 5$	N/A
CQI delay	ms	10	N/A
Physical channel for CQI/PMI reporting		PUSCH (Note 3)	N/A
PUCCH Report Type for CQI/PMI		2	N/A
Physical channel for RI reporting		PUCCH Format 2	N/A
PUCCH Report Type for RI		3	N/A
$cqi-pmi-ConfigurationIndex$		3	N/A
$ri-ConfigIndex$		805 (Note 9)	N/A
Max number of HARQ transmissions		1	N/A
ACK/NACK feedback mode		Multiplexing	N/A
Note 1:	If the UE reports in an available uplink reporting instance at subframe SF#n based on CQI estimation at a downlink SF not later than SF#(n-4), this reported wideband CQI cannot be applied at the eNB downlink before SF#(n+4)		
Note 2:	Reference measurement channel RC.11 TDD according to Table A.4-1 with one sided dynamic OCN Pattern OP.1 TDD as described in Annex A.5.2.1.		
Note 3:	To avoid collisions between CQI/ PMI reports and HARQ-ACK it is necessary to report both on PUSCH instead of PUCCH. PDCCH		

	DCI format 0 shall be transmitted in downlink SF#3 and #8 to allow periodic CQI/ PMI to multiplex with the HARQ-ACK on PUSCH in uplink subframe SF#2 and #7.
Note 4:	The respective received power spectral density of each interfering cell relative to N_{oc} is defined by its associated DIP value as specified in clause B.5.1.
Note 5:	Two cells are considered in which Cell 1 is the serving cell and Cell 2 is the interfering cell. Interfering cell is fully loaded.
Note 6:	Both cells are time-synchronous.
Note 7:	Static channel is used for the interference model. In case for white Gaussian noise model Cell 2 is not present.
Note 8:	SINR corresponds to \widehat{E}_s / N_{oc} of Cell 1 as defined in clause 8.1.1.
Note 9:	RI reporting interval is set to the maximum allowable length of 160ms to minimise collisions between RI, CQI/PMI and HARQ-ACK reports. In the case when all three reports collide, it is expected that CQI/PMI reports will be dropped, while RI and HARQ-ACK will be multiplexed. At eNB, CQI report collection shall be skipped every 160ms during performance verification and the reported CQI in subframe SF#7 of the previous frame is applied in downlink subframes until a new CQI (after CQI/PMI dropping) is available.
Note 10:	The precoder in clause B.4.3 follows UE recommended PMI.
Note 11:	If the UE reports in an available uplink reporting instance at subframe SF#n based on PMI estimation at a downlink SF not later than SF#(n-4), this reported PMI cannot be applied at the eNB downlink before SF#(n+4).

Table 9.9.2.2-2 Minimum requirement (TDD)

γ	1.8
UE Category	≥ 2

9.9.3 Reporting of Precoding Matrix Indicator (PMI) for 4Rx UE

The minimum performance requirements of PMI reporting are defined based on the precoding gain, expressed as the relative increase in throughput when the transmitter is configured according to the UE reports compared to the case when the transmitter is using random precoding, respectively. When the transmitter uses random precoding, for each PDSCH allocation a precoder is randomly generated and applied to the PDSCH. A fixed transport format (FRC) is configured for all requirements.

The requirements for transmission mode 9 with 8 TX are specified in terms of the ratio

$$\gamma = \frac{t_{ue, follow1, follow2}}{t_{rnd1, rnd2}}$$

In the definition of γ , for PUSCH 3-1 single PMI $t_{follow1, follow2}$ is 70% of the maximum throughput obtained at

$SNR_{follow1, follow2}$ using the precoders configured according to the UE reports, and $t_{rnd1, rnd2}$ is the throughput measured at $SNR_{follow1, follow2}$ with random precoding.

9.9.3.1 Minimum requirement PUSCH 3-1 (CSI Reference Symbol)

9.9.3.1.1 TDD

For the parameters specified in Table 9.9.3.1.1-1, and using the downlink physical channels specified in Annex C.3.2, the minimum requirements are specified in Table 9.9.3.1.1-2.

Table 9.9.3.1.1-1: PMI test for single-layer (TDD)

Parameter	Unit	Test 1	
Bandwidth	MHz	10	
Transmission mode		9	
Uplink downlink configuration		1	
Special subframe configuration		4	
Propagation channel		EVA5	
Precoding granularity	PRB	50	
Antenna configuration		8 x 4	
Correlation modeling		High, Cross polarized	
Cell-specific reference signals		Antenna ports 0,1	
CSI reference signals		Antenna ports 15,...,22	
Beamforming model		Annex B.4.3	
CSI-RS periodicity and subframe offset $T_{\text{CSI-RS}} / \Delta_{\text{CSI-RS}}$		5/ 4	
CSI-RS reference signal configuration		0	
CodeBookSubsetRestriction bitmap		0x0000 0000 001F FFE0 0000 0000 FFFF	
Downlink power allocation	ρ_A	dB	0
	ρ_B	dB	0
	P_c	dB	-6
	σ	dB	-3
$N_{oc}^{(j)}$	dB[mW/15kHz]	-98	
Reporting mode		PUSCH 3-1	
Reporting interval	ms	5	
PMI delay (Note 2)	ms	10	
Measurement channel		R.45-2 TDD	
OCNG Pattern		OP.1 TDD	
Max number of HARQ transmissions		4	
Redundancy version coding sequence		{0,0,1,2}	
ACK/NACK feedback mode		Multiplexing	
<p>Note 1: For random precoder selection, the precoder shall be updated in each TTI (1 ms granularity).</p> <p>Note 2: If the UE reports in an available uplink reporting instance at subframe SF#n based on PMI estimation at a downlink SF not later than SF#(n-4), this reported PMI cannot be applied at the eNB downlink before SF#(n+4).</p> <p>Note 3: PDCCH DCI format 0 with a trigger for aperiodic CQI shall be transmitted in downlink SF#4 and #9 to allow aperiodic CQI/PMI/RI to be transmitted on uplink SF#3 and #8.</p> <p>Note 4: Randomization of the principle beam direction shall be used as specified in B.2.3A.4</p>			

Table 9.9.3.1.1-2: Minimum requirement (TDD)

Parameter	Test 1
γ	2.5
UE Category	≥ 2

9.9.4 Reporting of Rank Indicator (RI)

The purpose of this test for 4Rx UEs is to verify that the reported rank indicator accurately represents the channel rank. The accuracy of RI (CQI) reporting is determined by the relative increase of the throughput obtained when transmitting based on the reported rank compared to the case for which a fixed rank is used for transmission. Transmission mode 4 is used with the specified CodebookSubSetRestriction in section 9.9.4.1, transmission mode 9 is used with the specified CodebookSubSetRestriction in section 9.9.4.2.

For the fixed rank 1 transmission with 2 Tx ports the RI and PMI reporting is restricted to two single-layer precoders, For fixed rank 2 transmission with 2 Tx ports the RI and PMI reporting is restricted to one two-layer precoder. For the follow RI transmission for rank 1 and 2 and 2 Tx ports the RI and PMI reporting is restricted to select the union of these precoders.

For the fixed rank 2 transmission with 4 Tx ports the RI and PMI reporting is restricted to any 2 Layer precoder, for the follow RI transmission the RI and PMI reporting is not restricted at all.

Channels with low and high correlation are used to ensure that RI reporting reflects the channel condition.

9.9.4.1 Minimum requirement (Cell-Specific Reference Symbols)

9.9.4.1.1 FDD

The minimum performance requirement in Table 9.9.4.1.1-2 is defined as

- a) The ratio of the throughput obtained when transmitting based on UE reported RI and that obtained when transmitting with fixed rank 1 shall be $\geq \gamma_1$;
- b) The ratio of the throughput obtained when transmitting based on UE reported RI and that obtained when transmitting with fixed rank 2 shall be $\geq \gamma_2$;

For the parameters specified in Table 9.9.4.1.1-1, and using the downlink physical channels specified in Annex C.3.2, the minimum requirements are specified in Table 9.9.4.1.1-2.

Table 9.9.4.1.1-1: RI Test (FDD)

Parameter	Unit	Test 1	Test 2	Test 3	Test 4
Bandwidth	MHz	10			
PDSCH transmission mode		4			
Downlink power allocation	ρ_A	dB	-3		-6
	ρ_B	dB	-3		-6
	σ	dB	0		3
Propagation condition and antenna configuration		2 x 4 EPA5			4 x 4 EPA5
Cell-specific reference signals		Antenna ports 0, 1			Antenna ports 0-3
CodeBookSubsetRestriction bitmap		000011 for fixed RI = 1 010000 for fixed RI = 2 010011 for UE reported RI			Note 6
Antenna correlation		Low	Low	High	Low
RI configuration		Fixed RI=2 and follow RI	Fixed RI=1 and follow RI	Fixed RI=1 and follow RI	Fixed RI=2 and follow RI
SNR	dB	-4	16	16	25
$N_{oc}^{(j)}$	dB[mW/15kHz]	-98	-98	-98	-98
$\hat{I}_{or}^{(j)}$	dB[mW/15kHz]	-102	-82	-82	-73
Maximum number of HARQ transmissions		1			
Reporting mode		PUCCH 1-1 (Note 4)			
Physical channel for CQI/PMI reporting		PUCCH Format 2			
PUCCH Report Type for CQI/PMI		2			
Physical channel for RI reporting		PUSCH (Note 3)			
PUCCH Report Type for RI		3			
Reporting periodicity	ms	$N_{pd}=5$			
PMI and CQI delay	ms	8			
<i>cqi-pmi-ConfigurationIndex</i>		6			
<i>ri-ConfigurationInd</i>		1 (Note 5)			
Note 1:	If the UE reports in an available uplink reporting instance at subframe SF#n based on PMI and CQI estimation at a downlink subframe not later than SF#(n-4), this reported PMI and wideband CQI cannot be applied at the eNB downlink before SF#(n+4).				
Note 2:	Reference measurement channel RC.2 FDD / RC.21 FDD respectively for Test 1-3 / 4 according to Table A.4-1 with one sided dynamic OCNG Pattern OP.1 FDD as described in Annex A.5.1.1.				
Note 3:	To avoid collisions between RI reports and HARQ-ACK it is necessary to report both on PUSCH instead of PUCCH. PDCCH DCI format 0 shall be transmitted in downlink SF#4 and #9 to allow periodic RI to multiplex with the HARQ-ACK on PUSCH in uplink subframe SF#8 and #3.				
Note 4:	The bit field for precoding information in DCI format 2 shall be mapped as: <ul style="list-style-type: none"> • For reported RI = 1 and PMI = 0 >> precoding information bit field index = 1 • For reported RI = 1 and PMI = 1 >> precoding information bit field index = 2 • For reported RI = 2 and PMI = 0 >> precoding information bit field index = 0 				
Note 5:	To avoid the ambiguity of TE behaviour when applying CQI and PMI during rank switching, RI reports are to be applied at the TE with one subframe delay in addition to Note 1 to align with CQI and PMI reports.				
Note 6:	The following precoders are allowed in Test 4: "0x0000 0000 FFFF 0000" for RI=2 "0xFFFF FFFF FFFF FFFF" for UE reported RI				

Table 9.9.4.1.1-2: Minimum requirement (FDD)

	Test 1	Test 2	Test 3	Test 4
γ_1	N/A	1.05	0.9	N/A
γ_2	1	N/A	N/A	1.1
UE Category	≥ 2	≥ 2	≥ 2	≥ 5

9.9.4.1.2 TDD

The minimum performance requirement in Table 9.9.4.1.2-2 is defined as

- The ratio of the throughput obtained when transmitting based on UE reported RI and that obtained when transmitting with fixed rank 1 shall be $\geq \gamma_1$;
- The ratio of the throughput obtained when transmitting based on UE reported RI and that obtained when transmitting with fixed rank 2 shall be $\geq \gamma_2$;

For the parameters specified in Table 9.9.4.1.2-1, and using the downlink physical channels specified in Annex C.3.2, the minimum requirements are specified in Table 9.9.4.1.2-2.

Table 9.9.4.1.2-1: RI Test (TDD)

Parameter		Unit	Test 1	Test 2	Test 3	Test 4
Bandwidth		MHz	10			
PDSCH transmission mode			4			
Downlink power allocation	ρ_A	dB	-3			-6
	ρ_B	dB	-3			-6
	σ	dB	0			3
Uplink downlink configuration			2			
Special subframe configuration			4			
Propagation condition and antenna configuration			2 x 4 EPA5			4 x 4 EPA5
Cell-specific reference signals			Antenna ports 0, 1			Antenna ports 0-3
CodeBookSubsetRestriction bitmap			000011 for fixed RI = 1 010000 for fixed RI = 2 010011 for UE reported RI			Note 4
Antenna correlation			Low	Low	High	Low
RI configuration			Fixed RI=2 and follow RI	Fixed RI= 1 and follow RI	Fixed RI=1 and follow RI	Fixed RI=2 and follow RI
SNR		dB	-4	16	16	25
$N_{oc}^{(j)}$		dB[mW/15kHz]	-98	-98	-98	-98
$\hat{I}_{or}^{(j)}$		dB[mW/15kHz]	-102	-82	-82	-73
Maximum number of HARQ transmissions			1			
Reporting mode			PUSCH 3-1 (Note 3)			
Reporting interval		ms	5			
PMI and CQI delay		ms	10 or 11			
ACK/NACK feedback mode			Bundling			
Note 1:	If the UE reports in an available uplink reporting instance at subframe SF#n based on PMI and CQI estimation at a downlink subframe not later than SF#(n-4), this reported PMI and wideband CQI cannot be applied at the eNB downlink before SF#(n+4).					
Note 2:	Reference measurement channel RC.2 TDD / RC.21 TDD respectively for Test 1-3 / 4 according to Table A.4-1 with one sided dynamic OCNB Pattern OP.1 TDD as described in Annex A.5.2.1.					
Note 3:	Reported wideband CQI and PMI are used and sub-band CQI is discarded.					
Note 4:	The following precoders are allowed in Test 4: "0x0000 0000 FFFF 0000" for RI=2 "0xFFFF FFFF FFFF FFFF" for UE reported RI					

Table 9.9.4.1.2-2: Minimum requirement (TDD)

	Test 1	Test 2	Test 3	Test 4
γ_1	N/A	1.05	0.9	N/A
γ_2	1	N/A	N/A	1.1
UE Category	≥ 2	≥ 2	≥ 2	≥ 5

9.9.4.2 Minimum requirement (CSI Reference Symbols)

9.9.4.2.1 FDD

The minimum performance requirement in Table 9.9.4.2.1-2 is defined as

- a) The ratio of the throughput obtained when transmitting based on UE reported RI and that obtained when transmitting with fixed rank 1 shall be $\geq \gamma_1$;
- b) The ratio of the throughput obtained when transmitting based on UE reported RI and that obtained when transmitting with fixed rank 2 shall be $\geq \gamma_2$;

For the parameters specified in Table 9.9.4.2.1-1, and using the downlink physical channels specified in Annex C.3.2, the minimum requirements are specified in Table 9.9.4.2.1-2.

Table 9.9.4.2.1-1: RI Test (FDD)

Parameter	Unit	Test 1	Test 2	Test 3	Test 4
Bandwidth	MHz	10			
PDSCH transmission mode		9			
Downlink power allocation	ρ_A	dB			
	ρ_B	dB			
	P_c	0			-3
	σ	0			-3
Propagation condition and antenna configuration		2 x 4 EPA5			4 x 4 EPA5
Cell-specific reference signals		Antenna ports 0			
Beamforming Model		As specified in Section B.4.3			
CSI reference signals		Antenna ports 15, 16			Antenna ports 15-18
CSI-RS periodicity and subframe offset $T_{\text{CSI-RS}} / \Delta_{\text{CSI-RS}}$		5/1			
CSI reference signal configuration		6			
CodeBookSubsetRestriction bitmap		000011 for fixed RI = 1 010000 for fixed RI = 2 010011 for UE reported RI			Note 5
Antenna correlation		Low	Low	High	Low
RI configuration		Fixed RI=2 and follow RI	Fixed RI=1 and follow RI	Fixed RI=1 and follow RI	Fixed RI=2 and follow RI
SNR	dB	-4	16	16	25
$N_{oc}^{(j)}$	dB[mW/15kHz]	-98	-98	-98	-98
$\hat{I}_{or}^{(j)}$	dB[mW/15kHz]	-102	-82	-82	-73
Maximum number of HARQ transmissions		1			
Reporting mode		PUCCH 1-1			
Physical channel for CQI/PMI reporting		PUSCH (Note 3)			
PUCCH Report Type for CQI/PMI		2			
Physical channel for RI reporting		PUCCH Format 2			
PUCCH Report Type for RI		3			
Reporting periodicity	ms	$N_{pd} = 5$			
PMI and CQI delay	ms	8			
<i>cqi-pmi-ConfigurationIndex</i>		2			
<i>ri-ConfigurationInd</i>		1 (Note 4)			
Note 1:	If the UE reports in an available uplink reporting instance at subframe SF#n based on PMI and CQI estimation at a downlink subframe not later than SF#(n-4), this reported PMI and wideband CQI cannot be applied at the eNB downlink before SF#(n+4).				
Note 2:	Reference measurement channel RC.9 FDD / RC.9B FDD respectively for Test 1-3 / 4 according to Table A.4-1 with one sided dynamic OCN Pattern OP.1 FDD as described in Annex A.5.1.1.				
Note 3:	To avoid collisions between CQI/ PMI reports and HARQ-ACK it is necessary to report both on PUSCH instead of PUCCH. PDCCH DCI format 0 shall be transmitted in downlink SF#1 and #6 to allow periodic CQI/ PMI to multiplex with the HARQ-ACK on PUSCH in uplink SF#0 and #5.				
Note 4:	To avoid the ambiguity of TE behaviour when applying CQI and PMI during rank switching, RI reports are to be applied at the TE with one subframe delay in addition to Note 1 to align with CQI and PMI reports.				
Note 5:	The following precoders are allowed in Test 4: "0x0000 0000 FFFF 0000" for RI=2 "0xFFFF FFFF FFFF FFFF" for UE reported RI				

Table 9.9.4.2.1-2: Minimum requirement (FDD)

	Test 1	Test 2	Test 3	Test 4
γ_1	N/A	1.05	0.9	N/A
γ_2	1	N/A	N/A	1.1
UE Category	≥ 2	≥ 2	≥ 2	≥ 5

9.9.4.2.2 TDD

The minimum performance requirement in Table 9.9.4.2.2-2 is defined as

- a) The ratio of the throughput obtained when transmitting based on UE reported RI and that obtained when transmitting with fixed rank 1 shall be $\geq \gamma_1$;
- b) The ratio of the throughput obtained when transmitting based on UE reported RI and that obtained when transmitting with fixed rank 2 shall be $\geq \gamma_2$;

For the parameters specified in Table 9.9.4.2.2-1, and using the downlink physical channels specified in Annex C.3.2, the minimum requirements are specified in Table 9.9.4.2.2-2.

Table 9.9.4.2.2-1: RI Test (TDD)

Parameter	Unit	Test 1	Test 2	Test 3	Test 4
Bandwidth	MHz	10			
PDSCH transmission mode		9			
Downlink power allocation	ρ_A	dB	0		
	ρ_B	dB	0		
	P_c	dB	0	-3	
	σ	dB	0	-3	
Uplink downlink configuration		1			
Special subframe configuration		4			
Propagation condition and antenna configuration		2 x 4 EPA5			4 x 4 EPA5
Cell-specific reference signals		Antenna ports 0			
CSI reference signals		Antenna ports 15, 16			Antenna ports 15-18
Beamforming Model		As specified in Section B.4.3			
CSI reference signal configuration		4			
CSI-RS periodicity and subframe offset $T_{\text{CSI-RS}} / \Delta_{\text{CSI-RS}}$		5/4			
CodeBookSubsetRestriction bitmap		000011 for fixed RI = 1 010000 for fixed RI = 2 010011 for UE reported RI			Note 4
Antenna correlation		Low	Low	High	Low
RI configuration		Fixed RI=2 and follow RI	Fixed RI=1 and follow RI	Fixed RI=1 and follow RI	Fixed RI=2 and follow RI
SNR	dB	-4	16	16	25
$N_{oc}^{(j)}$	dB[mW/15kHz]	-98	-98	-98	-98
$\hat{I}_{or}^{(j)}$	dB[mW/15kHz]	-102	-82	-82	-73
Maximum number of HARQ transmissions		1			
Reporting mode		PUCCH 1-1			
Physical channel for CQI/ PMI reporting		PUSCH (Note 3)			
PUCCH report type for CQI/ PMI		2			
Physical channel for RI reporting		PUCCH Format 2			
Reporting periodicity	ms	$N_{pd} = 5$			
PMI and CQI delay	ms	10			
ACK/NACK feedback mode		Bundling			
<i>cqi-pmi-ConfigurationIndex</i>		4			
<i>ri-ConfigurationInd</i>		1			
Note 1:	If the UE reports in an available uplink reporting instance at subframe SF#n based on PMI and CQI estimation at a downlink subframe not later than SF#(n-4), this reported PMI and wideband CQI cannot be applied at the eNB downlink before SF#(n+4).				
Note 2:	Reference measurement channel RC.9 TDD / RC.9B TDD respectively for Test 1-3 / 4 according to Table A.4-1 with one sided dynamic OCNG Pattern OP.1 TDD as described in Annex A.5.2.1.				
Note 3:	To avoid collisions between CQI/PMI reports and HARQ-ACK it is necessary to report both on PUSCH instead of PUCCH. PDCCH DCI format 0 shall be transmitted in downlink SF#4 and #9 to allow periodic CQI/PMI to multiplex with the HARQ-ACK on PUSCH in uplink SF#3 and #8.				
Note 4:	The following precoders are allowed in Test 4: "0x0000 0000 FFFF 0000" for RI=2 "0xFFFF FFFF FFFF FFFF" for UE reported RI				

Table 9.9.4.2.2-2: Minimum requirement (TDD)

	Test 1	Test 2	Test 3	Test 4
γ_1	N/A	1.05	0.9	N/A
γ_2	1	N/A	N/A	1.1
UE Category	≥ 2	≥ 2	≥ 2	≥ 5

9.10 Reporting of CSI-RS Resource Indicator (CRI)

The purpose of this test is to verify that the reported CSI-RS Resource Indicator is accurate. The accuracy of CRI reporting is determined by:

- a) The ratio of the throughput obtained when transmitting based on the reported CRI and fixed precoder with multiple CSI-RS resources configured compared to that obtained when transmitting based on the fixed precoder with one CSI-RS resource configured: $\gamma = \frac{t_{ue, follow_CRI, fixed_PMI}}{t_{fixed_CRI, fixed_PMI}}$
- $t_{ue, follow_CRI, fixed_PMI}$ is [70%] of the maximum throughput obtained at $SNR_{ue, follow_CRI, fixed_PMI}$ using fixed precoder and power scaling factor according to UE reported CRI value with multiple CSI-RS resources configured
 - $t_{fixed_CRI, fixed_PMI}$ is throughput obtained at $SNR_{ue, follow_CRI, fixed_PMI}$ using fixed precoder and power scaling factor according to the one configured CSI-RS resource
 - $SNR_{ue, follow_CRI, fixed_PMI}$ is specified based on CRS RE power
- b) Each candidate CRI value among 0, 1, ..., K-1 shall be reported at least $\alpha\%$ of the time at $SNR_{ue, follow_CRI, fixed_PMI}$ with multiple CSI-RS resources configured
- The number of configured CSI-RS resources K is specific to a test.

9.10.1 Minimum requirement (PUSCH 3-1)

9.10.1.1 FDD

For the parameters specified in Table 9.10.1.1-1, and using the downlink physical channels specified in Annex C.3.2, the minimum requirements are specified in Table 9.10.1.1-2.

Table 9.10.1.1-1: CRI Test (FDD)

Parameter		Unit	Test 1-1 (K,N)=(2,8)	Test 1-2 (K,N)=(2,16)	Test 1-3 (K,N)=(4,32)	Test 1-4 (K,N)=(8,64)
Bandwidth		MHz	10			
Transmission mode			9			
Propagation channel			EPA5			
Beamforming model			Annex B.4.6			
Precoding granularity		PRB	50			
Correlation and antenna configuration (Note 1)			4x2 XP High	8x2 XP High	8x2 XP High	8x2 XP High
Cell-specific reference signals			Antenna ports 0,1			
eMIMO-Type			Class B			
Number of NZP-CSI resources (K) (Note 3)			2 for following CRI 1 for fixed CRI	2 for following CRI 1 for fixed CRI	4 for following CRI 1 for fixed CRI	8 for following CRI 1 for fixed CRI
NZP-CSI-RS-ID-List			{0,1}	{0,1}	{0,1,2,3}	{0,1,2,3,4,5,6,7}
legacyCSRList			{0,0}	{0,0}	{0,0,0,0}	{0,0,0,0,0,0,0,0}
CSI reference signal configuration List			{0,1}	{0,1}	{0,1,2,3}	{0,1,2,3,0,1,2,3}
Number of CSI-RS ports (N _k)			{4,4}	{8,8}	{8,8,8,8}	{8,8,8,8,8,8,8,8}
CSI-RS-SubframeConfig List			{1,1}	{1,1}	{1,1,1,1}	{1,1,1,1,2,2,2,2}
CodeBookSubsetRestriction with ID=0			0x 0000 00000000 0001	0x 0000 0000 0000 0020 0000 0000 0001	0x 0000 0000 0000 0020 0000 0000 0001	0x 0000 0000 0000 0020 0000 0000 0001
alternativeCodeBookEnabledFor4TX-r12			FALSE	N/A	N/A	N/A
Downlink power allocation	ρ_A	dB	0	0	0	0
	ρ_B	dB	0	0	0	0
	P_c	dB	-3	-6	-6	-6
	σ	dB	-3	-3	-3	-3
$N_{oc}^{(j)}$		dB[mW/15kHz]	-98			
Reporting mode			PUSCH 3-1			
Reporting interval		ms	5			
CRI Delay		ms	8			
PMI delay		ms	8			
Measurement channel			R.50A-1 FDD	R.50A-2 FDD	R.50A-2 FDD	R.50A-3 FDD
OCNG Pattern			OP.1 FDD			
Rank Number of PDSCH			1			
Scheduled PDSCH SFs			SF 0,2,3,4,7,8,9	SF 0,2,3,4,7,8,9	SF 0,2,3,4,7,8,9	SF 0,3,4,8,9
Max number of HARQ transmissions			4			
Redundancy version coding sequence			{0,1,2,3}			
Note 1: If the UE reports in an available uplink reporting instance at subframe SF#n based on CRI/PMI estimation at a downlink SF not later than SF#(n-4), this reported CRI/PMI cannot be applied at the eNB downlink before SF#(n+4).						
Note 2: PDSCH_RA= 0 dB, PDSCH_RB= 0 dB in order to have the same PDSCH and OCNG power per subcarrier at the receiver.						
Note 3: When one CSI-RS resource configured, the configurations according to NZP-CSI-RS-ID = 0 are configured.						

Table 9.10.1.1-2: Minimum requirement (FDD)

	Test 1-1	Test 1-2	Test 1-3	Test 1-4
□	1.2	1.2	1.3	1.35
□	40	40	20	10
UE Category	≥2	≥2	≥2	≥2
Note1: According to UE capability configuration list for the maximum number of NZP CSI-RS resource Kmax and the maximum number of total NZP CSI-RS ports N in each K =2,..., Kmax: if UE supports the combination of (K,N) =(8,64), then test 1-4 is applicable ; else if UE supports the combination of (K,N) =(4,32), then test 1-3 is applicable; else if UE supports the combination of (K,N) =(2,16), then test 1-2 is applicable; otherwise test 1-1 is applicable.				

9.10.1.2 TDD

For the parameters specified in Table 9.10.1.2-1, and using the downlink physical channels specified in Annex C.3.2, the minimum requirements are specified in Table 9.10.1.2-2.

Table 9.10.1.2-1: CRI Test (TDD)

Parameter		Unit	Test 1-1 (K,N)=(2,8)	Test 1-2 (K,N)=(2,16)	Test 1-3 (K,N)=(4,32)	Test 1-4 (K,N)=(8,64)
Bandwidth		MHz	10			
Transmission mode			9			
Uplink downlink configuration			2			
Special subframe configuration			4			
Propagation channel			EPA5			
Beamforming model			Annex B.4.6			
Precoding granularity		PRB	50			
Correlation and antenna configuration (Note 1)			4x2 XP High	8x2 XP High	8x2 XP High	8x2 XP High
Cell-specific reference signals eMIMO-Type			Antenna ports 0,1 Class B			
Number of NZP-CSI resources (K) (Note 3)			2 for following CRI 1 for fixed CRI	2 for following CRI 1 for fixed CRI	4 for following CRI 1 for fixed CRI	8 for following CRI 1 for fixed CRI
NZP-CSI-RS-ID-List			{0,1}	{0,1}	{0,1,2,3}	{0,1,2,3,4,5,6,7}
legacyCSRList			{0,0}	{0,0}	{0,0,0,0}	{0,0,0,0,0,0,0,0}
CSI reference signal configuration List			{0,1}	{0,1}	{0,1,2,3}	{0,1,2,3,0,1,2,3}
Number of CSI-RS ports (N _k)			{4,4}	{8,8}	{8,8,8,8}	{8,8,8,8,8,8,8,8}
CSI-RS-SubframeConfig List			{9,9}	{9,9}	{9,9,9,9}	{8,8,8,8,9,9,9,9}
CodeBookSubsetRestriction with ID=0			0x 0000 00000000 0001	0x 0000 0000 0000 0020 0000 0000 0001	0x 0000 0000 0000 0020 0000 0000 0001	0x 0000 0000 0000 0020 0000 0000 0001
alternativeCodeBookEnabledFor4TX-r12			FALSE	N/A	N/A	N/A
Downlink power allocation	ρ_A	dB	0	0	0	0
	ρ_B	dB	0	0	0	0
	P _c	dB	-3	-6	-6	-6
	σ	dB	-3	-3	-3	-3
$N_{oc}^{(j)}$		dB[mW/15kHz]	-98			
Reporting mode			PUSCH 3-1			
Reporting interval		ms	10			
CRI Delay		ms	12			
PMI delay		ms	12			
Measurement channel			R.44A-1 TDD	R.44A-2 TDD	R.44A-2 TDD	R.44A-3 TDD
OCNG Pattern			OP.1 TDD			
Rank Number of PDSCH			1			
Scheduled PDSCH SFs			SF 0,1,3,6,8,9	SF 0,1,3,6,8,9	SF 0,1,3,6,8,9	SF 0,1,6,8,9
Max number of HARQ transmissions			4			
Redundancy version coding sequence			{0,1,2,3}			
ACK/NACK feedback mode			Multiplexing			
Note 1: If the UE reports in an available uplink reporting instance at subframe SF#n based on PMI estimation at a downlink SF not later than SF#(n-4), this reported PMI cannot be applied at the eNB downlink before SF#(n+4).						
Note 2: PDSCH_RA= 0 dB, PDSCH_RB= 0 dB in order to have the same PDSCH and OCNG power per subcarrier at the receiver.						
Note 3: When one CSI-RS resource configured, the configurations according to NZP-CSI-RS-ID 0 are configured.						
Note 4: PDCCH DCI format 0 with a trigger for aperiodic CQI shall be transmitted in downlink SF#4 to allow aperiodic CRI/CQI/PMI/RI to be transmitted on uplink SF#2.						

Table 9.10.1.2-2: Minimum requirement (TDD)

	Test 1-1	Test 1-2	Test 1-3	Test 1-4
□	1.2	1.2	1.3	1.35
□	40	40	20	10
UE Category	≥2	≥2	≥2	≥2
Note1:	According to UE capability configuration list for the maximum number of NZP CSI-RS resource Kmax and the maximum number of total NZP CSI-RS ports N in each K =2,..., Kmax: if UE supports the combination of (K,N) =(8,64), then test 1-4 is applicable; else if UE supports the combination of (K,N) =(4,32), then test 1-3 is applicable; else if UE supports the combination of (K,N) =(2,16), then test 1-2 is applicable; otherwise test 1-1 is applicable.			

10 Performance requirement (MBMS)

10.1 FDD (Fixed Reference Channel)

The parameters specified in Table 10.1-1 are valid for all FDD tests unless otherwise stated. For the requirements defined in this section, the difference between CRS EPRE and the MBSFN RS EPRE should be set to 0 dB as the UE demodulation performance might be different when this condition is not met (e.g. in scenarios where power offsets are present, such as scenarios when reserved cells are present).

Table 10.1-1: Common Test Parameters (FDD)

Parameter	Unit	Value
Number of HARQ processes	Processes	None
Subcarrier spacing	kHz	15 kHz
Allocated subframes per Radio Frame (Note 1)		6 subframes
Number of OFDM symbols for PDCCH		2
Cyclic Prefix		Extended
Note1:	For FDD mode, up to 6 subframes (#1/2/3/6/7/8) are available for MBMS, in line with TS 36.331.	

10.1.1 Minimum requirement

The receive characteristic of MBMS is determined by the BLER. The requirement is valid for all RRC states for which the UE has capabilities for MBMS.

For the parameters specified in Table 10.1-1 and Table 10.1.1-1 and Annex A.3.8.1, the average downlink SNR shall be below the specified value for the BLER shown in Table 10.1.1-2.

Table 10.1.1-1: Test Parameters for Testing

Parameter	Unit	Test 1-4	
Downlink power allocation	ρ_A	dB	0
	ρ_B	dB	0 (Note 1)
	σ	dB	0
N_{oc} at antenna port	dBm/15kHz	-98	
Note 1: $P_B = 0$.			

Table 10.1.1-2: Minimum performance

Test number	Bandwidth	Reference Channel	OCNG Pattern	Propagation condition	Correlation Matrix and antenna	Reference value		MBMS UE Category
						BLER (%)	SNR(dB)	
1	10 MHz	R.37 FDD	OP.4 FDD	MBSFN channel model (Table B.2.6-1)	1x2 low	1	4.1	≥ 1
2	10 MHz	R.38 FDD	OP.4 FDD				11.0	≥ 1
3	10 MHz	R.39 FDD	OP.4 FDD				20.1	≥ 2
	5.0MHz	R.39-1 FDD	OP.4 FDD				20.5	1
4	1.4 MHz	R.40 FDD	OP.4 FDD				6.6	≥ 1

10.2 TDD (Fixed Reference Channel)

The parameters specified in Table 10.2-1 are valid for all TDD tests unless otherwise stated. For the requirements defined in this section, the difference between CRS EPRE and the MBSFN RS EPRE should be set to 0 dB as the UE demodulation performance might be different when this condition is not met (e.g. in scenarios where power offsets are present, such as scenarios when reserved cells are present).

Table 10.2-1: Common Test Parameters (TDD)

Parameter	Unit	Value
Number of HARQ processes	Processes	None
Subcarrier spacing	kHz	15 kHz
Allocated subframes per Radio Frame (Note 1)		5 subframes
Number of OFDM symbols for PDCCH		2
Cyclic Prefix		Extended
Note1: For TDD mode, in line with TS 36.331, Uplink-Downlink Configuration 5 is proposed, up to 5 subframes (#3/4/7/8/9) are available for MBMS.		

10.2.1 Minimum requirement

The receive characteristic of MBMS is determined by the BLER. The requirement is valid for all RRC states for which the UE has capabilities for MBMS.

For the parameters specified in Table 10.2-1 and Table 10.2.1-1 and Annex A.3.8.2, the average downlink SNR shall be below the specified value for the BLER shown in Table 10.2.1-2.

Table 10.2.1-1: Test Parameters for Testing

Parameter	Unit	Test 1-4	
Downlink power allocation	ρ_A	dB	0
	ρ_B	dB	0 (Note 1)
	σ	dB	0
N_{oc} at antenna port	dBm/15kHz	-98	
Note 1: $P_B = 0$.			

Table 10.2.1-2: Minimum performance

Test number	Bandwidth	Reference Channel	OCNG Pattern	Propagation condition	Correlation Matrix and antenna	Reference value		MBMS UE Category
						BLER (%)	SNR(dB)	
1	10 MHz	R.37 TDD	OP.4 TDD	MBSFN channel model (Table B.2.6-1)	1x2 low	1	3.4	≥ 1
2	10 MHz	R.38 TDD	OP.4 TDD				11.1	≥ 1
3a	10 MHz	R.39 TDD	OP.4 TDD				20.1	≥ 2
3b	5MHz	R.39-1 TDD	OP.4 TDD				20.5	1
4	1.4 MHz	R.40 TDD	OP.4 TDD				5.8	≥ 1

11 Performance requirement (ProSe Direct Discovery)

This clause contains the performance requirements for the Sidelink physical channels specified for ProSe Direct Discovery.

11.1 General

11.1.1 Applicability of requirements

The requirements in this clause are applicable to UEs that support ProSe Direct Discovery. The test case applicability is in according to table 11.1.1-1 depending on set of supported UE capabilities.

Table 11.1.1-1: ProSe Direct Discovery test applicability

FDD/TDD	Tests / clause	Applicable if UE indicates at least the following capability
FDD	11.2.1	ProSe Direct Discovery without support of <i>disc-SLSS-r12</i>
	11.2.3	ProSe Direct Discovery with support of <i>discPeriodicSLSS-r13</i> and ProSe Direct Communication
	11.3.1	ProSe Direct Discovery
	11.4.1	ProSe Direct Discovery with support of <i>disc-SLSS-r12</i>
	11.5.1	ProSe Direct Discovery
TDD	11.2.2	ProSe Direct Discovery
	11.3.2	ProSe Direct Discovery
	11.5.2	ProSe Direct Discovery

For maximum Sidelink Processes test specified in clause 11.5, the UE is required to only meet the test for the maximum channel bandwidth over the ProSe operating bands supported by the UE. Test case 11.2.3 for 5MHz channel bandwidth is applicable to UEs that support ProSe Direct Communication on Band 31 only.

11.1.2 Reference DRX configuration

Table 11.1.2-1: Reference DRX configuration

Parameter	Value	Comments
onDurationTimer	psf1	
drx-InactivityTimer	psf1	
drx-RetransmissionTimer	psf1	
longDRX-CycleStartOffset	sf2560, 0	
shortDRX	disabled	
NOTE 1: For further information see clause 6.3.2 in TS 36.331.		

11.2 Demodulation of PSDCH (single link performance)

The purpose of the requirements in this subclause is to verify the PSDCH demodulation performance with a single active PSDCH link under different operating scenarios and channel conditions.

The active cell(s), when present, are specified in the test parameters specific to the test.

11.2.1 FDD (in-coverage)

The minimum requirements are specified in Table 11.2.1-2 with the test parameters specified in Table 11.2.1-1. The receiver UE under test is associated with Cell 1.

Table 11.2.1-1: Test Parameters

Parameter		Unit	Test 1	
Discovery resource pool configuration			As specified in Table A.7.1.1-1 (Configuration #1-FDD)	
DRX configuration			As specified in Table 11.1.2-1	
N_{oc} at antenna port (NOTE 3)		dBm/15kHz	-98	
Active cell(s)			Cell 1 (Serving cell)	
Cell 1	Cyclic prefix		Normal	
	Cell ID		0	
	Downlink power allocation	ρ_A	dB	0
		ρ_B	dB	0 (NOTE 1)
		σ	dB	0
	OCNG Pattern (NOTE 2)		OP.1 FDD	
	Propagation channel		AWGN	
Antenna configuration		1x2		
RSRP		dBm/15kHz	-92	
Active Sidelink UE(s)			Sidelink UE 1	
Sidelink UE 1	Sidelink Transmissions		PSDCH	
	PSDCH RB allocation		PRB pairs $\{2i..2i+1\}$, where i is chosen randomly uniformly from $[0,11]$ in each discovery period.	
	Time offset (NOTE 4)	μ s	+1	
	Frequency offset (NOTE 5)	Hz	+200	
	Propagation Channel		EPA5	
	Antenna configuration		1x2 Low	
NOTE 1: $P_B = 0$.				
NOTE 2: OCNG is used to fully allocate the available resource blocks to virtual UEs.				
NOTE 3: Applicable to both DL channel and ProSe Direct Discovery Subframes on UL.				
NOTE 4: Time offset of Sidelink UE receive signal with respect to Cell 1 downlink timing at the tested UE.				
NOTE 5: Frequency offset of Sidelink UE with respect to Cell 1 uplink frequency.				

Table 11.2.1-2: Minimum performance

Test num.	Sidelink UE	Band-width	Reference channel	Reference value	
				BLER of PSDCH (%)	SNR (dB)
1	1	5 MHz	D.1 FDD	30	4.6

11.2.2 TDD (in-coverage)

The minimum requirements are specified in Table 11.2.2-2 with the test parameters specified in Table 11.2.2-1. The receiver UE under test is associated with Cell 1.

Table 11.2.2-1: Test Parameters

Parameter		Unit	Test 1	
Discovery resource pool configuration			As specified in Table A.7.1.2-1 (Configuration #1-TDD)	
DRX configuration			As specified in Table 11.1.2-1	
N_{oc} at antenna port (NOTE 5)		dBm/15kHz	-98	
Active cell(s)			Cell 1 (Serving cell)	
Cell 1	Cyclic prefix		Normal	
	Uplink downlink configuration (NOTE 3)		0	
	Special subframe configuration (NOTE 4)		4	
	Cell ID		0	
	Downlink power allocation	ρ_A	dB	0
		ρ_B	dB	0 (NOTE 1)
		σ	dB	0
	OCNG Pattern ^{NOTE 2}			OP.1 TDD
	Propagation channel			AWGN
Antenna configuration			1x2	
RSRP		dBm/15kHz	-92	
Active Sidelink UE(s)			Sidelink UE 1	
Sidelink UE 1	Sidelink Transmissions		PSDCH	
	RB allocation		PRB pairs $\{2i..2i+1\}$, where i is chosen randomly uniformly from $[0,11]$ in each discovery period.	
	Time offset (NOTE 6)	μ s	+1	
	Frequency offset (NOTE 7)	Hz	+200	
	Propagation Channel			EPA5
	Antenna configuration			1x2 Low
NOTE 1: $P_B = 0$.				
NOTE 2: OCNG is used to fully allocate the available resource blocks to virtual UEs.				
NOTE 3: As specified in Table 4.2-2 in TS 36.211 [4].				
NOTE 4: As specified in Table 4.2-1 in TS 36.211 [4].				
NOTE 5: Applicable to both DL subframes and UL subframes configured for ProSe Direct Discovery.				
NOTE 6: Time offset of Sidelink UE receive signal with respect to Cell 1 downlink timing at the tested UE.				
NOTE 7: Frequency offset of Sidelink UE with respect to Cell 1 uplink frequency.				

Table 11.2.2-2: Minimum performance

Test num.	Sidelink UE	Band-width	Reference channel	Reference value	
				BLER of PSDCH (%)	SNR (dB)
1	1	5 MHz	D.1 TDD	30	4.6

11.2.3 FDD (out-of-coverage)

The minimum requirements are specified in Table 11.2.3-2 with the test parameters specified in Table 11.2.3-1. The receiver UE under test is out of network coverage.

Table 11.2.3-1: Test Parameters

Parameter		Unit	Test 1
Resource pool configuration			As specified in Table A.7.1.1-4 (Configuration #4-FDD)
DRX configuration			As specified in Table 11.1.2-1
N_{oc} at antenna port		dBm/15kHz	-98
Active cell(s)			None
Active Sidelink UE(s)			Sidelink UEs 1, 2
Sidelink UE 1	Sidelink Transmissions		SLSS + PSBCH
	networkControlledSyncTx		ON
	sssid		30
	inCoverage (in MIB-SL)		TRUE
	syncOffsetIndicator		Set same as syncOffsetIndicator1 in Configuration #4-FDD
	Propagation channel		EPA5
	Antenna configuration		1x2 Low
	\widehat{E}_s at antenna port	dBm/15kHz	-82
Sidelink UE 2	Sidelink Transmissions		PSDCH
	PSDCH RB allocation		PRB pairs $\{2i..2i+1\}$, where i is chosen randomly uniformly from $[0,11]$ (for 5MHz) or $[0,24]$ (for 10MHz) in each discovery period.
	Time offset (Note 1)	μ s	+1
	Frequency offset (Note 2)	Hz	+200
	Propagation Channel		EPA5
	Antenna configuration		1x2 Low
NOTE 1: Time offset of Sidelink UE 2 receive signal timing with respect to Sidelink UE 1 receive signal timing at the tested UE.			
NOTE 2: Frequency offset of Sidelink UE 2 with respect to Sidelink UE 1 transmit frequency.			

Table 11.2.3-2: Minimum performance

Test number	Sidelink UE	Band-width	Reference channel	Reference value	
				BLER of PSDCH (%)	SNR (dB)
1	1	5 MHz	D.1 FDD	30	4.6

11.3 Power imbalance performance with two links

The purpose of this test is to check the demodulation performance when receiving PSDCH transmissions from two Sidelink UEs with power imbalance in one subframe.

11.3.1 FDD

The minimum requirements are specified in Table 11.3.1-2 with the test parameters specified in Table 11.3.1-1. The receiver UE under test is associated with Cell 1. The Sidelink UE 1 and 2 are synchronized to Cell 1 and transmit PSDCH on adjacent RBs.

Table 11.3.1-1: Test Parameters

Parameter			Unit	Test 1
Discovery resource pool configuration				As specified in Table A.7.1.1-1 (Configuration #1-FDD)
DRX configuration				As specified in Table 11.1.2-1
N_{oc} at antenna port (NOTE 3)			dBm/15kHz	-98
Active cell(s)				Cell 1 (Serving cell)
Cell 1	Cyclic prefix			Normal
	Cell ID			0
	Downlink power allocation	ρ_A	dB	0
		ρ_B	dB	0 (NOTE 1)
		σ	dB	0
	OCNG Pattern (NOTE 2)			OP.1 FDD
	Propagation channel			AWGN
	Antenna configuration			1x2
RSRP		dBm/15kHz	-92	
Active Sidelink UE(s)				Sidelink UE 1, Sidelink UE 2
Sidelink UE 1	Sidelink Transmissions			PSDCH
	PSDCH RB allocation			PRB pairs {4..5}
	Time offset (NOTE 3)		μ s	0
	Frequency offset (NOTE 4)		Hz	0
	Propagation Channel			AWGN
	Antenna configuration			1x2 Low
Sidelink UE 2	Sidelink Transmissions			PSDCH
	PSDCH RB allocation			PRB pairs {6..7}
	Time offset (w.r.t. Cell 1 DL)		μ s	0
	Frequency offset (w.r.t. Cell 1 UL)		Hz	0
	Propagation Channel			AWGN
	Antenna configuration			1x2 Low
NOTE 1: $P_B = 0$.				
NOTE 2: OCNG is used to fully allocate the available resource blocks to virtual UEs.				
NOTE 3: Applicable to both DL channel and ProSe Direct Discovery Subframes on UL.				
NOTE 4: Time offset of Sidelink UE receive signal with respect to Cell 1 downlink timing at the tested UE.				
NOTE 5: Frequency offset of Sidelink UE with respect to Cell 1 uplink frequency.				

Table 11.3.1-2: Minimum performance

Test num.	Band-width	Sidelink UE	Reference channel	Reference value	
				BLER of PSDCH (%)	SNR (dB)
1	5 MHz	1	D.1 FDD	(NOTE 1)	24.3
		2	D.1 FDD	30	6.9
NOTE 1: There is no BLER requirement for Sidelink UE 1.					

11.3.2 TDD

The minimum requirements are specified in Table 11.3.2-2 with the test parameters specified in Table 11.3.2-1. The receiver UE under test is associated with Cell 1. The Sidelink UE 1 and 2 are synchronized to Cell 1 and transmit PSDCH on adjacent RBs.

Table 11.3.2-1: Test Parameters

Parameter		Unit	Test 1	
Discovery resource pool configuration			As specified in Table A.7.1.2-1 (Configuration #1-TDD)	
DRX configuration			As specified in Table 11.1.2-1	
N_{oc} at antenna port (NOTE 5)		dBm/15kHz	-98	
Active cell(s)			Cell 1 (Serving cell)	
Cell 1	Cyclic prefix		Normal	
	Uplink downlink configuration (NOTE 3)		0	
	Special subframe configuration (NOTE 4)		4	
	Cell ID		0	
	Downlink power allocation	ρ_A	dB	0
		ρ_B	dB	0 (NOTE 1)
		σ	dB	0
	OCNG Pattern ^{NOTE 2}		OP.1 TDD	
	Propagation channel		AWGN	
	Antenna configuration		1x2	
RSRP	dBm/15kHz	-92		
Active Sidelink UE(s)			Sidelink UE 1, Sidelink UE 2	
Sidelink UE 1	Sidelink Transmissions		PSDCH	
	PSDCH RB allocation		PRB pairs {4..5}	
	Time offset (NOTE 6)	μ s	0	
	Frequency offset (NOTE 7)	Hz	0	
	Propagation Channel		AWGN	
	Antenna configuration		1x2 Low	
Sidelink UE 2	Sidelink Transmissions		PSDCH	
	RB allocation		PRB pairs {6..7}	
	Time offset (NOTE 6)	μ s	0	
	Frequency offset (NOTE 7)	Hz	0	
	Propagation Channel		AWGN	
	Antenna configuration		1x2 Low	
NOTE 1: $P_B = 0$.				
NOTE 2: OCNG is used to fully allocate the available resource blocks to virtual UEs.				
NOTE 3: As specified in Table 4.2-2 in TS 36.211 [4].				
NOTE 4: As specified in Table 4.2-1 in TS 36.211 [4].				
NOTE 5: Applicable to both DL subframes and UL subframes configured for ProSe Direct Discovery.				
NOTE 6: Time offset of Sidelink UE receive signal with respect to Cell 1 downlink timing at the tested UE.				
NOTE 7: Frequency offset of Sidelink UE with respect to Cell 1 uplink frequency.				

Table 11.3.2-2: Minimum performance

Test num.	Band-width	Sidelink UE	Reference channel	Reference value	
				BLER of PSDCH (%)	SNR (dB)
1	5 MHz	1	D.1 TDD	(NOTE 1)	24.3
		2	D.1 TDD	30	6.9
NOTE 1: There is no BLER requirement for Sidelink UE 1.					

11.4 Multiple timing reference test

The purpose of this test is to check the demodulation performance when receiving from two Sidelink UEs that follow different timing references and transmitting on different resources (non-overlapping in time).

11.4.1 FDD

The test parameters are specified in Table 11.4.1-1. Sidelink UE 2 and the receiver UE under test are associated with Cell 1. Sidelink UE 1 and 3 are associated with another cell and use a different timing, and UE 1 acts as a synchronization reference. The minimum requirements are specified in Table 11.4.1-2.

Table 11.4.1-1: Test Parameters

Parameter		Unit	Test 1	
Discovery resource pool configuration			As specified in Table A.7.1.1-2 (Configuration #2-FDD)	
DRX configuration			As specified in Table 11.1.2-1	
N_{oc} at antenna port (NOTE 3)		dBm/15kHz	-98	
Active cell(s)			Cell 1 (Serving cell)	
Cell 1	Cyclic prefix		Normal	
	Cell ID		0	
	Downlink power allocation	ρ_A	dB	0
		ρ_B	dB	0 (NOTE 1)
		σ	dB	0
	OCNG Pattern ^{NOTE 2}		OP.1 FDD	
	Propagation channel		AWGN	
	Antenna configuration		1x2	
RSRP	dBm/15kHz	-92		
Active Sidelink UE(s)			Sidelink UEs 1, 2, 3	
Sidelink UE 1	Sidelink Transmissions		SLSS	
	networkControlledSyncTx		ON	
	slssid		30	
	Time offset (NOTE 4)	μ s	3511	
	Frequency offset (NOTE 5)	Hz	-100	
	Propagation channel		EPA5	
	Antenna configuration		1x2 Low	
	\widehat{E}_s of SLSS at antenna port	dBm/15kHz	-82	
Sidelink UE 2	Sidelink Transmissions		PSDCH	
	Resource pool used for transmissions		<i>discRxPool(0)</i>	
	RB allocation		PRB pairs $\{2i..2i+1\}$, where i is chosen randomly uniformly from $[0,11]$ in each discovery period.	
	Time offset (NOTE 4)	μ s	+1	
	Frequency offset (NOTE 5)	Hz	+200	
	Propagation Channel		EPA5	
	Antenna configuration		1x2 Low	
Sidelink UE 3	Sidelink Transmissions		PSDCH	
	Resource pool used for transmissions		<i>discRxPool(1)</i>	
	RB allocation		PRB pairs $\{2i..2i+1\}$, where i is chosen randomly uniformly from $[0,11]$ in each discovery period.	
	Time offset (NOTE 4)	μ s	3511	
	Frequency offset (NOTE 5)	Hz	+300	
	Propagation Channel		EPA5	
Antenna configuration		1x2 Low		
NOTE 1: $P_B = 0$.				
NOTE 2: OCNG is used to fully allocate the available resource blocks to virtual UEs.				
NOTE 3: Applicable to both DL channel and ProSe Direct Discovery Subframes on UL.				
NOTE 4: Time offset of Sidelink UE receive signal with respect to Cell 1 downlink timing at the tested UE.				
NOTE 5: Frequency offset of Sidelink UE with respect to Cell 1 uplink frequency.				

Table 11.4.1-2: Minimum performance

Test num.	Band-width	Sidelink UE	Reference channel	Reference value	
				BLER of PSDCH (%) ^{NOTE 1}	SNR (dB)
1	5 MHz	2	D.1 FDD	30	4.6
		3	D.1 FDD	30	4.6

NOTE 1: The BLER is measured after 5 D2D Discovery periods (1600 frames) of lead time during which the test UE detects and synchronizes to Sidelink UE 1 SLSS.

11.5 Maximum Sidelink processes test

The purpose of this test is to verify the maximum number of Sidelink processes supported by the UE as reported using UE capability signalling (*discSupportedProc*).

The UE is required to meet only the test for the maximum channel bandwidth over the ProSe operating bands supported by the UE.

11.5.1 FDD

The test parameters are specified in Table 11.5.1-1. Multiple discovery resource pools are interleaved. Each Sidelink UE transmits in one of the resource pools with 3 retransmissions. The minimum requirements are specified in Table 11.5.1-2.

Table 11.5.1-1: Test Parameters

Parameter		Unit	Test 1-7	
Discovery resource pool configuration			As specified in Table A.7.1.1-3 (Configuration #3-FDD) with parameters $BW_{Channel}$, N_{Pools} = Number of configured resource pools (as specified in Table 11.5.1-2), and $N = discSupportedProc$	
DRX configuration			As specified in Table 11.1.2-1	
Active cell(s)			Cell 1 (Serving cell)	
Cell 1	Cyclic prefix		Normal	
	Cell ID		0	
	Downlink power allocation	ρ_A	dB	0
		ρ_B	dB	0 (NOTE 1)
		σ	dB	0
	OCNG Pattern ^{NOTE 2}		OP.1 FDD	
	Propagation channel		Static propagation condition No external noise sources are applied	
	Antenna configuration		1x2	
RSRP	dBm/15kHz	-85		
Active Sidelink UE(s)			Sidelink UE i , $i = 0, \dots, discSupportedProc-1$	
Sidelink UE i	Sidelink Transmissions		PSDCH (D.1 FDD)	
	Resource pool index (NOTE 3)		$\lfloor \frac{i}{N_{MAX_SF}} \rfloor$	
	PSDCH RB allocation (NOTE 3)		PRB pairs $\{2*(i \% N_{MAX_SF}), 2*(i \% N_{MAX_SF})+1\}$	
	Time offset (NOTE 4)	μs	0	
	Frequency offset (NOTE 4)	Hz	0	
	Propagation Channel		Static propagation condition No external noise sources are applied	
	Antenna configuration		1x2 Low	
NOTE 1: $P_B = 0$.				
NOTE 2: OCNG is used to fully allocate the available resource blocks to virtual UEs..				
NOTE 3: N_{MAX_SF} represents the maximum number of Sidelink UEs transmitting in one subframe. $N_{MAX_SF} = 12$ (5 MHz), 25 (10MHz), 37 (15MHz), 50 (10MHz).				
NOTE 4: Time offset of Sidelink UE receive signal with respect to Cell 1 downlink timing at the tested UE.				
NOTE 5: Frequency offset of Sidelink UE with respect to Cell 1 uplink frequency.				

Table 11.5.1-2: Minimum performance

Test num.	Bandwidth	discSupportedProc	Number of configured resource pools	\hat{E}_s at antenna port (dBm/15kHz)	Reference value for Sidelink UE $i=0\dots discSupportedProc-1$
					Fraction of maximum throughput (%)
1	5 MHz	50	5	-85	95
2	10 MHz	50	2	-85	95
3	15 MHz	50	2	-85	95
4	20 MHz	50	1	-85	95
5	10 MHz	400	16	-85	95
6	15 MHz	400	11	-85	95
7	20 MHz	400	8	-85	95

11.5.2 TDD

The test parameters are specified in Table 11.5.2-1. Multiple discovery resource pools are interleaved. Each Sidelink UE transmits in one of the resource pools with 3 retransmissions. The minimum requirements are specified in Table 11.5.2-2.

Table 11.5.2-1: Test Parameters

Parameter		Unit	Test 1-7	
Discovery resource pool configuration			As specified in Table A.7.1.2-2 (Configuration #2-TDD) with parameters BW_{Channel} , N_{Pools} = Number of configured resource pools (as specified in Table 11.5.2-2), and $N = \text{discSupportedProc}$	
DRX configuration			As specified in Table 11.1.2-1	
Active cell(s)			Cell 1 (Serving cell)	
Cell 1	Cyclic prefix		Normal	
	Uplink downlink configuration (NOTE 3)		0	
	Special subframe configuration (NOTE 4)		4	
	Cell ID		0	
	Downlink power allocation	ρ_A	dB	0
		ρ_B	dB	0 (NOTE 1)
		σ	dB	0
	OCNG Pattern ^{NOTE 2}		OP.1 TDD	
	Propagation channel		Static propagation condition No external noise sources are applied	
	Antenna configuration		1x2	
RSRP	dBm/15kHz	-85		
Active Sidelink UE(s)			Sidelink UE i , $i = 0, \dots, \text{discSupportedProc}-1$	
Sidelink UE i	Sidelink Transmissions		PSDCH (D.1 TDD)	
	PSDCH Resource pool (NOTE 5)		$\left\lfloor \frac{i}{N_{\text{MAX_SF}}} \right\rfloor$	
	PSDCH RB allocation (NOTE 5)		PRB pairs $\{2*(i \% N_{\text{MAX_SF}}), 2*(i \% N_{\text{MAX_SF}})+1\}$	
	Time offset (NOTE 6)	μs	0	
	Frequency offset (NOTE 7)	Hz	0	
	Propagation Channel		Static propagation condition No external noise sources are applied	
	Antenna configuration		1x2 Low	
NOTE 1: $P_B = 0$.				
NOTE 2: OCNG is used to fully allocate the available resource blocks to virtual UEs.				
NOTE 3: As specified in Table 4.2-2 in TS 36.211 [4].				
NOTE 4: As specified in Table 4.2-1 in TS 36.211 [4].				
NOTE 5: $N_{\text{MAX_SF}}$ represents the maximum number of Sidelink UEs transmitting in one subframe. $N_{\text{MAX_SF}} = 12$ (5 MHz), 25 (10MHz), 37 (15MHz), 50 (10MHz).				
NOTE 6: Time offset of Sidelink UE receive signal with respect to Cell 1 downlink timing at the tested UE.				
NOTE 7: Frequency offset of Sidelink UE with respect to Cell 1 uplink frequency.				

Table 11.5.2-2: Minimum performance

Test num.	Bandwidth	discSupportedProc	Number of configured resource pools	\hat{E}_s at antenna port (dBm/15kHz)	Reference value
					Fraction of maximum throughput (%) for Sidelink UE $i=0\dots\text{discSupportedProc}-1$
1	5 MHz	50	5	-85	95
2	10 MHz	50	2	-85	95
3	15 MHz	50	2	-85	95
4	20 MHz	50	1	-85	95
5	10 MHz	400	16	-85	95
6	15 MHz	400	11	-85	95
7	20 MHz	400	8	-85	95

12 Performance requirement (ProSe Direct Communication)

This clause contains the performance requirements for the Sidelink physical channels specified for ProSe Direct Communication in TS 36.211 [4].

12.1 General

12.1.1 Applicability of requirements

12.1.1.1 Applicability of requirements for different channel bandwidths

The requirements in this clause are applicable to UEs that support ProSe Direct Communication. Test cases defined for 5MHz channel bandwidth are applicable to UEs that support ProSe Direct Communication on only Band 31.

12.1.1.2 Test coverage for different number of component carriers

For FDD tests specified in 12.8, if corresponding CA tests are tested, the test coverage can be considered fulfilled without executing single carrier tests.

12.1.1.3 Applicability and test rules for different CA configurations and bandwidth combination sets

The performance requirement for CA UE demodulation tests with active Sidelink in Clause 12 are defined independent of CA configurations and bandwidth combination sets specified in Clause 5.6A.1. For UEs supporting different CA configurations and bandwidth combination sets, the applicability and test rules are defined in Table 12.1.1.3-1. For simplicity, CA configuration below refers to combination of CA configuration and bandwidth combination set.

Table 12.1.1.3-1: Applicability and test rules for CA UE demodulation tests with active Sidelink

Tests	CA capability where the tests apply	CA configuration from the selected CA capability where the tests apply	CA Bandwidth combination to be tested in priority order
CA tests with 2CCs in Clause 12.8	Any one of the supported CA capabilities with largest aggregated CA bandwidth combination	Any one of the supported FDD CA configurations with largest aggregated CA bandwidth combination	Largest aggregated CA bandwidth combination

12.1.2 Reference DRX configuration

Table 12.1.2-1: Reference DRX configuration

Parameter	Value	Comments
onDurationTimer	psf1	
drx-InactivityTimer	psf1	
drx-RetransmissionTimer	psf1	
longDRX-CycleStartOffset	sf2560, 0	
shortDRX	disabled	
NOTE 1: For further information see clause 6.3.2 in TS 36.331.		

12.2 Demodulation of PSSCH

The purpose of the requirements in this subclause is to verify the PSSCH demodulation performance with a single active PSSCH link.

12.2.1 FDD

The minimum requirements are specified in Table 12.2.1-2 with the test parameters specified in Table 12.2.1-1. This test specifies an out-of-coverage scenario where Sidelink UE 1 is the synchronization reference only and Sidelink UE 2 transmits PSCCH and PSSCH.

Table 12.2.1-1: Test Parameters

Parameter		Unit	Test 1
Communication resource pool configuration			As specified in Table A.7.2.1-1 (Configuration #1-FDD)
N_{oc} at antenna port (NOTE 1)		dBm/15 kHz	-98
Active cell(s)			None
Sidelink UE 1	Sidelink Transmissions		SLSS + PSBCH
	networkControlledSyncTx		ON
	slssid		30
	inCoverage (in MIB-SL)		FALSE
	syncOffsetIndicator		Set same as syncOffsetIndicator1 in Configuration #1-FDD
	Propagation channel		EPA5
	Antenna configuration		1x2 Low
	\widehat{E}_s at antenna port	dBm/15 kHz	-85
Sidelink UE 2	Sidelink Transmissions		PSCCH + PSSCH
	PSCCH RMC		5MHz: CC.3 FDD 10 MHz: CC.4 FDD
	PSCCH subframe allocation		As defined by TS 36.213 with n_{PSCCH} chosen randomly (uniformly) in $[0, \lfloor M_{RB}^{PSCCH_RP} / 2 \rfloor L_{PSCCH} - 1]$ every sc-period
	PSCCH RB allocation		
	\widehat{E}_s of PSCCH at antenna port	dBm/15 kHz	-85
	PSSCH RMC		As specified in Table 12.2.1-2
	PSSCH subframe allocation		As per time repetition pattern specified in PSCCH
	PSSCH RB allocation		First transmission: Chosen randomly (uniformly) among the allowed RBs as per TS36.213 HARQ retransmission: As per frequency hopping indicated in PSCCH and specified in TS36.213
	Time offset (NOTE 2)	μ s	+1
	Frequency offset (NOTE 3)	Hz	+200
	Propagation Channel		EVA70
	Antenna configuration		1x2 Low
NOTE 1: Applicable to both DL channel and ProSe Direct Communication Subframes on UL.			
NOTE 2: Time offset of Sidelink UE 2 receive signal timing with respect to Sidelink UE 1 receive signal timing at the tested UE.			
NOTE 3: Frequency offset of Sidelink UE 2 with respect to Sidelink UE 1 transmit frequency.			

Table 12.2.1-2: Minimum performance

Test num.	Sidelink UE	Band-width	PSSCH Reference channel	Reference value	
				Fraction of maximum throughput (%) (NOTE 1)	SNR (dB) of PSSCH
1	2	10 MHz	CD.1 FDD	70	-3.4
		5 MHz		70	-3.3
NOTE 1: The throughput is measured after 40 radio frames of lead time during which the test UE detects and synchronizes to Sidelink UE 1.					

12.3 Demodulation of PSCCH

The purpose of the requirements in this subclause is to verify the PSCCH demodulation performance with a single active PSSCH link.

12.3.1 FDD

The minimum requirements are specified in Table 12.3.1-2 with the test parameters specified in Table 12.3.1-1. This test specifies an out-of-coverage scenario where Sidelink UE 1 is the synchronization reference only and Sidelink UE 2 transmits PSCCH and PSSCH.

Table 12.3.1-1: Test Parameters

Parameter		Unit	Test 1
Communication resource pool configuration			As specified in Table A.7.2.1-1 (Configuration #1-FDD)
N_{oc} at antenna port (NOTE 1)		dBm/15 kHz	-98
Active cell(s)			None
Sidelink UE 1	Sidelink Transmissions		SLSS + PSBCH
	networkControlledSyncTx		ON
	slssid		30
	inCoverage (in MIB-SL)		FALSE
	syncOffsetIndicator		Set same as syncOffsetIndicator1 in Configuration #1-FDD
	Propagation channel		EPA5
	Antenna configuration		1x2 Low
\hat{E}_s at antenna port	dBm/15 kHz	-85	
Sidelink UE 2	Sidelink Transmissions		PSCCH + PSSCH
	PSCCH RMC		As specified in Table 12.3.1-2
	PSCCH subframe allocation		As defined by TS 36.213 with n_{PSCCH} chosen randomly (uniformly) in $[0, \lfloor M_{RB}^{PSCCH-RP} / 2 \rfloor L_{PSCCH} - 1]$ every sc-period
	PSCCH RB allocation		
	PSSCH RMC		CD.1 FDD
	PSSCH subframe allocation		As per time repetition pattern specified in PSCCH
	PSSCH RB allocation		First transmission: Chosen randomly (uniformly) among the allowed RBs as per TS36.213 HARQ retransmission: As per frequency hopping indicated in PSCCH and specified in TS36.213
	Time offset (NOTE 2)	μ s	+1
	Frequency offset (NOTE 3)	Hz	+200
	Propagation Channel		EVA70
Antenna configuration		1x2 Low	
NOTE 1: Applicable to both DL channel and ProSe Direct Communication Subframes on UL.			
NOTE 2: Time offset of Sidelink UE 2 receive signal timing with respect to Sidelink UE 1 receive signal timing at the tested UE.			
NOTE 3: Frequency offset of Sidelink UE 2 with respect to Sidelink UE 1 transmit frequency.			

Table 12.3.1-2: Minimum performance

Test num.	Sidelink UE	Bandwidth	PSCCH Reference channel	Reference value	
				Probability of missed PSCCH (%) (NOTE 1)	SNR (dB) of PSCCH
1	2	10 MHz	CC.4 FDD	1	4.7
		5 MHz	CC.3 FDD	1	4.8
NOTE 1: The probability is measured after 40 radio frames of lead time during which the test UE detects and synchronizes to Sidelink UE 1.					

12.4 Demodulation of PSBCH

The purpose of the requirements in this subclause is to verify the PSBCH demodulation performance with a single active link.

12.4.1 FDD

The minimum requirements are specified in Table 12.4.1-2 with the test parameters specified in Table 12.4.1-1.

Table 12.4.1-1: Test Parameters

Parameter		Unit	Test 1
Communication resource pool configuration			As specified in Table A.7.2.1-1 (Configuration #1-FDD)
N_{oc} at antenna port		dBm/15kHz	-98
Active cell(s)			None
Sidelink UE 1	Sidelink Transmissions		SLSS + PSBCH (CP.1 FDD)
	networkControlledSyncTx		ON
	slssid		30
	inCoverage (in MIB-SL)		FALSE
	syncOffsetIndicator		Set same as syncOffsetIndicator1 in Configuration #1-FDD
	Propagation channel		EPA5
	Antenna configuration		1x2 Low

Table 12.4.1-2: Minimum performance

Test num.	Sidelink UE	Band-width	Reference channel	Reference value	
				Probability of missed PSBCH (%) (NOTE 1)	SNR (dB)
1	1	10 MHz	PSBCH (CP.1 FDD)	1	4.4
		5 MHz			
NOTE 1: The probability is measured after 40 radio frames of lead time during which the test UE detects and synchronizes to Sidelink UE 1.					

12.5 Power imbalance performance with two links

The purpose of this test is to check the demodulation performance when receiving PSSCH transmissions from two Sidelink UEs with power imbalance in one subframe.

12.5.1 FDD

The test parameters in Table 12.5.1-1 specifies an in-coverage scenario where Sidelink UE 1 and 2 are synchronized to Cell 1 and transmit PSSCH on adjacent RBs. The minimum requirements are specified in Table 12.5.1-2.

Table 12.5.1-1: Test Parameters

Parameter		Unit	Test 1	
Communication resource pool configuration			As specified in Table A.7.2.1-2 (Configuration #2-FDD)	
DRX configuration			As specified in Table 12.1.2-1	
N_{oc} at antenna port (Note 3)		dBm/15kHz	-98	
Active cell(s)			Cell 1 (Serving cell)	
Cell 1	Cyclic prefix		Normal	
	Cell ID		0	
	Downlink power allocation	ρ_A	dB	0
		ρ_B	dB	0 (NOTE 1)
		σ	dB	0
	OCNG Pattern (Note 2)			OP.1 FDD
	Propagation channel			AWGN
	Antenna configuration			1x2
RSRP		dBm/15kHz	-92	
Active Sidelink UE(s)			Sidelink UE 1, Sidelink UE 2	
Sidelink UE 1	Sidelink Transmissions		PSCCH + PSSCH	
	PSCCH RMC		5 MHz: CC.1 FDD 10 MHz: CC.2 FDD	
	PSCCH subframe allocation		$n_{PSCCH} = 0$ (as defined in TS 36.213)	
	PSCCH RB allocation			
	\hat{E}_s of PSCCH at antenna port		dBm/15kHz	-85
	PSSCH RMC		As specified in Table 12.5.1-2	
	PSSCH subframe allocation		As per time repetition pattern specified in PSCCH	
	PSSCH RB allocation		PRB pairs {4, 5}	
	Time offset (NOTE 4)		μ s	0
	Frequency offset (NOTE 5)		Hz	0
	Propagation Channel			AWGN
Antenna configuration			1x2	
Sidelink UE 2	Sidelink Transmissions		PSCCH + PSSCH	
	PSCCH RMC		5 MHz: CC.1 FDD 10 MHz: CC.2 FDD	
	PSCCH subframe allocation		$n_{PSCCH} = 2$ (as defined in TS 36.213)	
	PSCCH RB allocation			
	\hat{E}_s of PSCCH at antenna port		dBm/15kHz	-85
	PSSCH RMC		As specified in Table 12.5.1-2	
	PSSCH subframe allocation		As per time repetition pattern specified in PSCCH	
	PSSCH RB allocation		PRB pairs {6, 7}	
	Time offset (NOTE 4)		μ s	0
	Frequency offset (NOTE 5)		Hz	0
	Propagation Channel			AWGN
Antenna configuration			1x2	
NOTE 1: $P_B = 0$.				
NOTE 2: OCNG is used to fully allocate the available resource blocks to virtual UEs.				
NOTE 3: Applicable to both DL channel and ProSe Direct Communication Subframes on UL.				
NOTE 4: The power of PSCCH is set high to ensure reliable reception of PSCCH.				
NOTE 4: Time offset of Sidelink UE receive signal with respect to Cell 1 downlink timing at the tested UE.				
NOTE 5: Frequency offset of Sidelink UE with respect to Cell 1 uplink frequency.				

Table 12.5.1-2: Minimum performance

Test num.	Bandwidth	Sidelink UE	PSSCH Reference channel	Reference value	
				Fraction of maximum throughput (%)	SNR (dB) of PSSCH
1	5 / 10 MHz	1	CD.5 FDD	(NOTE 1)	24.35
		2	CD.5 FDD	70	2.4
NOTE 1: There is no throughput requirement for Sidelink UE 1.					

12.6 Multiple timing reference test

The purpose of this test is to check the PSSCH demodulation performance when receiving from two Sidelink UEs that follow different timing references and transmitting on different resources (non-overlapping in time).

12.6.1 FDD

The test parameters are specified in Table 12.6.1-1. Sidelink UE 2 and the receiver UE under test are associated with Cell 1. Sidelink UE 1 and Sidelink UE 3 are associated with another cell and use a different timing, and Sidelink UE 1 acts as a synchronization reference only. The minimum requirements are specified in Table 12.6.1-2.

Table 12.6.1-1: Test Parameters

Parameter		Unit	Test 1	
Communication resource pool configuration			As specified in Table A.7.2.1-3 (Configuration #3-FDD)	
DRX configuration			As specified in Table 12.1.2-1	
N_{oc} at antenna port (Note 3)		dBm/15kHz	-98	
Active cell(s)			Cell 1 (Serving cell)	
Cell 1	Cyclic prefix		Normal	
	Cell ID		0	
	Downlink power allocation	ρ_A	dB	0
		ρ_B	dB	0 (NOTE 1)
		σ	dB	0
	OCNG Pattern ^{NOTE 2}		OP.1 FDD	
	Propagation channel		AWGN	
	Antenna configuration		1x2	
RSRP	dBm/15kHz	-92		
Active Sidelink UE(s)			Sidelink UE 1, Sidelink UE 2, Sidelink UE 3	
Sidelink UE 1	Sidelink Transmissions		SLSS + PSBCH	
	networkControlledSyncTx		ON	
	slssid		30	
	inCoverage (in MIB-SL)		TRUE	
	syncOffsetIndicator		Set same as syncOffsetIndicator in Configuration #3-FDD	
	Time offset (NOTE 5)	ms	+12.51 ms	
	Frequency offset (NOTE 6)	Hz	-100 Hz	
	Propagation channel		EPA5	
	Antenna configuration		1x2 Low	
\widehat{E}_s at antenna port	dBm/15kHz	-85		
Sidelink UE 2	Sidelink Transmissions		PSCCH + PSSCH	
	Resource pool		<i>commRxPool(0)</i>	
	PSCCH RMC		5MHz: CC.1 FDD 10 MHz: CC.2 FDD (NOTE 5)	
	PSCCH subframe allocation		As defined by TS 36.213 with n_{PSCCH} chosen randomly (uniformly) in	
	PSCCH RB allocation		$[0, \lfloor M_{RB}^{PSCCH - RP} / 2 \rfloor L_{PSCCH} - 1]$ every sc-period	
	\widehat{E}_s of PSCCH at antenna port	dBm/15kHz	-85	
	PSSCH RMC		As specified in Table 12.6.1-2	
	PSSCH subframe allocation		As per time repetition pattern specified in PSCCH	
	PSSCH RB allocation		First transmission: Chosen randomly (uniformly) among the allowed RBs as per TS36.213 HARQ retransmission: As per frequency hopping indicated in PSCCH and specified in TS36.213	
	Time offset (NOTE 4, 5)		PSCCH: +1 μ s PSSCH: +1 μ s – 288T _s	
	Frequency offset (NOTE 6)	Hz	+200	
	Propagation Channel		EVA70	
Antenna configuration		1x2 Low		
Sidelink UE 3	Sidelink Transmissions		PSCCH + PSSCH	
	Resource pool		<i>commRxPool(1)</i>	
	PSCCH RMC		5MHz: CC.5 FDD 10 MHz: CC.6 FDD	
	PSCCH subframe allocation		As defined by TS 36.213 with n_{PSCCH} chosen randomly (uniformly) in	
	PSCCH RB allocation		$[0, \lfloor M_{RB}^{PSCCH - RP} / 2 \rfloor L_{PSCCH} - 1]$ every sc-period	
	\widehat{E}_s of PSCCH at antenna port	dBm/15kHz	-85	
	PSSCH RMC		As specified in Table 12.6.1-2	

	PSSCH subframe allocation		As per time repetition pattern specified in PSCCH
	PSSCH RB allocation		First transmission: Chosen randomly (uniformly) among the allowed RBs as per TS36.213 HARQ retransmission: As per frequency hopping indicated in PSCCH and specified in TS36.213
	Time offset (NOTE 5)	ms	+12.509
	Frequency offset (NOTE 6)	Hz	+300
	Propagation Channel		EVA70
	Antenna configuration		1x2 Low
NOTE 1: $P_B = 0$.			
NOTE 2: OCNG is used to fully allocate the available resource blocks to virtual UEs.			
NOTE 3: Applicable to both DL channel and ProSe Direct Communication Subframes on UL.			
NOTE 4: Timing advance indication in PSSCH is set as 18 ($=288T_s$) in this test. PSSCH timing is advanced with respect to PSCCH timing by the quantity (i.e., PSSCH timing shall be $+1\mu s - 288T_s$ in this test).			
NOTE 5: Time offset of Sidelink UE receive signal with respect to Cell 1 downlink timing at the tested UE.			
NOTE 6: Frequency offset of Sidelink UE with respect to Cell 1 uplink frequency.			

Table 12.6.1-2: Minimum performance

Test num.	Bandwidth	Sidelink UE	PSSCH Reference channel	Reference value	
				Fraction of maximum throughput (%) (NOTE 1)	SNR (dB)
1	10 MHz	2	CD.4 FDD	70	3.0
		3	CD.2 FDD	70	2.8
	5 MHz	2	CD.3 FDD	70	2.9
		3	CD.2 FDD	70	2.8
NOTE 1: The throughput is measured after 40 radio frames of lead time during which the test UE detects and synchronizes to Sidelink UE 1.					

12.7 Maximum Sidelink processes test

The purpose of this test is to verify the maximum number of Sidelink processes and the maximum number of bits per TTI supported by the UE.

12.7.1 FDD

The test parameters are specified in Table 12.7.1-1. Multiple communication resource pools are interleaved. Each active Sidelink UE transmits in one of the resource pools with 3 retransmissions. The minimum requirements are specified in Table 12.7.1-2.

Table 12.7.1-1: Test Parameters

Parameter		Unit	Test 1	
Communication resource pool configuration			As specified in Table A.7.2.1-4 (Configuration #4-FDD)	
DRX configuration			As specified in Table 12.1.2-1	
Active cell(s)			Cell 1 (Serving cell)	
Cell 1	Cyclic prefix		Normal	
	Cell ID		0	
	Downlink power allocation	ρ_A	dB	0
		ρ_B	dB	0 (NOTE 1)
		σ	dB	0
	OCNG Pattern (Note 2)			OP.1 FDD
	Propagation channel			Static propagation condition No external noise sources are applied
	Antenna configuration			1x2
RSRP		dBm/15kHz	-85	
Active Sidelink UE(s)			Sidelink UE i , $0 \leq i \leq 15$	
Sidelink UE i , $0 \leq i \leq 15$	Sidelink Transmissions		PSCCH + PSSCH	
	Resource pool		$commRxPool(\lfloor \frac{i}{8} \rfloor)$	
	PSCCH RMC		5MHz: CC.1 FDD with $I_{TRP}=i\%8$ (NOTE 3) 10 MHz: CC.2 FDD with $I_{TRP}=i\%8$ (NOTE 3)	
	PSCCH subframe allocation		As defined by TS 36.213 with $n_{PSCCH} = i$	
	PSCCH RB allocation			
	PSSCH RMC		As specified in Table 12.7.1-2	
	PSSCH subframe allocation		As per time repetition pattern specified in PSCCH	
	PSSCH RB allocation		Fully allocated	
	Time offset (NOTE 4)		μs	0
	Frequency offset (NOTE 5)		Hz	0
	Propagation Channel			Static propagation condition No external noise sources are applied
	Antenna configuration			1x2 Low
NOTE 1: $P_B = 0$.				
NOTE 2: OCNG is used to fully allocate the available resource blocks to virtual UEs.				
NOTE 3: For $N_{TRP} = 8$ (FDD) and $trpt-Subset = 001$, $I_{TRP} = 0$ corresponds to a time repetition pattern of (1,0,0,0,0,0,0,0), $I_{TRP} = 1$ corresponds to a time repetition pattern of (0,1,0,0,0,0,0,0), etc.				
NOTE 4: Time offset of Sidelink UE receive signal with respect to Cell 1 downlink timing at the tested UE.				
NOTE 5: Frequency offset of Sidelink UE with respect to Cell 1 uplink frequency.				

Table 12.7.1-2: Minimum performance

Test num.	Bandwidth	PSCCH Reference channel	\hat{E}_s at antenna port (dBm/15kHz)	Reference value for Sidelink UE $i=0...15$
				Fraction of maximum throughput (%)
1	10 MHz	CD.7 FDD	-85	95
	5 MHz	CD.6 FDD	-85	95

12.8 Sustained downlink data rate with active Sidelink

The purpose of this test is to verify the downlink data rate is not impacted when Sidelink resource are also configured. The test parameters are in Table 12.8.1-1. Cell 1 is the serving cell and UE 1 and UE 2 are transmitters of Prose Direct Communication. The test UE is expected to receive all PDSCH transmissions, and prioritize the transmission of ACK/NACK over the reception of UE 2's PSSCH.

The test cases apply to UE categories and bandwidth combinations with maximum aggregated bandwidth as specified in Table 12.8.1-2. The minimum requirements are specified in Table 12.8.1-3. The TB success rate in the cellular link shall be sustained during at least 300 frames.

Table 12.8.1-1: Test parameters for sustained downlink data rate (FDD 64QAM) with active Sidelink

Parameter		Unit	Test 1, 2, 3A, 3B, 4A, 6C
Communication resource pool configuration ^{Note 5}			As specified in Table A.7.2.1-5 (Configuration #5-FDD)
Active cell(s)			Cell 1 (PCell) Cell 2 (SCell) for Test 3B, 4A, 6C
Cell 1	Test parameters		As specified in clause 8.7.1: Table 8.7.1-1 and Test 1, 2, 3A, 3B, 4A, 6C in Table 8.7.1-2
Active Sidelink UE(s)			Sidelink UE 1, Sidelink UE 2
Sidelink UE 1	Sidelink Transmissions		PSCCH + PSSCH
	PSCCH RMC		10 MHz: CC.2 FDD with $I_{TRP}=0$ (NOTE 1)
	PSCCH subframe allocation		As defined by TS 36.213 with $n_{PSCCH} = 0$
	PSCCH RB allocation		
	PSSCH RMC		10 MHz: CD.7 FDD
	PSSCH subframe allocation		As per time repetition pattern specified in PSCCH
	PSSCH RB allocation		Fully allocated
	Time offset (NOTE 3)	μs	0
	Frequency offset (NOTE 4)	Hz	0
	Propagation Channel		Static propagation condition No external noise sources are applied
Antenna configuration		1x2 Low	
\hat{E}_s at antenna port	dBm/15kHz	-85	
Sidelink UE 2	Sidelink Transmissions		PSCCH (NOTE 2)
	PSCCH RMC		10 MHz: CC.2 FDD with $I_{TRP}=1$ (NOTE 1)
	PSCCH subframe allocation		As defined by TS 36.213 with $n_{PSCCH} = 1$
	PSCCH RB allocation		
	Time offset (NOTE 3)	μs	0
	Frequency offset (NOTE 4)	Hz	0
	Propagation Channel		Static propagation condition No external noise sources are applied
	Antenna configuration		1x2 Low
	\hat{E}_s at antenna port	dBm/15kHz	-85

NOTE 1: For $N_{TRP} = 8$ (FDD) and $trpt-Subset = 001$, $I_{TRP} = 0$ corresponds to a time repetition pattern of (1,0,0,0,0,0,0,0), $I_{TRP} = 1$ corresponds to a time repetition pattern of (0,1,0,0,0,0,0,0).

NOTE 2: Sidelink UE 2 transmits PSCCH but not PSSCH.

NOTE 3: Time offset of Sidelink UE receive signal with respect to Cell 1 downlink timing at the tested UE.

NOTE 4: Frequency offset of Sidelink UE with respect to Cell 1 uplink frequency.

NOTE 5: Sidelink Communication resources are configured on the primary serving cell.

Table 12.8.1-2: Test cases for sustained data rate

CA config	Maximum supported Bandwidth/ Bandwidth combination (MHz)	Cat. 1	Cat. 2	Cat. 3	Cat. 4	Cat. 6,7	Cat. 9,10	Cat 11, 12	DL Cat. 15
								DL Cat. 11,12	
Single carrier	10	1	2	3A	3A	3A	3A	3A	3A
CA with 2CCs (Note1)	10+10	-	-	3B	4A	4A	4A	4A	4A
	10+20	-	-	3B	4A	6C	6C	6C	6C

NOTE 1: Sidelink operation is configured on PCC

Table 12.8.1-3: Minimum requirements (FDD 64QAM) with active Sidelink

Test	Bandwidth (MHz)	Number of bits of a DL-SCH transport block received within a TTI	Measurement channel	Reference value
				PDSCH TB success rate (%)
1	10	10296	R.31-1 FDD (NOTE 2)	95
2	10	25456	R.31-2 FDD (NOTE 2)	95
3A	10	36696 (NOTE 1)	R.31-3A FDD (NOTE 2)	85
3B	10+10	25456	R.31-2 FDD (NOTE 2)	95
4A	10+10	75376 (NOTE 3)	R.31-4 FDD (NOTE 2)	85
6C	10+20	36696 (NOTE 1) for 10MHz CC 75376 (NOTE 3) for 20MHz CC	R.31-3A FDD for 10MHz CC R.31-4 FDD for 20MHz CC	85
NOTE 1: 35160 bits for sub-frame 5.				
NOTE 2: PDSCH scheduling pattern is changed as per the following bitmap that repeats every 40ms, and applies to all the serving cells. PDSCH scheduling subframe bitmap = {01110111 11110111 11110111 11110111 11111110}.				
NOTE 3: 71112 bits for sub-frame 5.				
NOTE 1: 35160 bits for sub-frame 5.				
NOTE 2: PDSCH scheduling pattern is changed as per the following bitmap that repeats every 40ms, and applies to all the serving cells. PDSCH scheduling subframe bitmap = {01110111 11110111 11110111 11110111 11111110}.				
NOTE 3: 71112 bits for sub-frame 5.				

Annex A (normative): Measurement channels

A.1 General

The throughput values defined in the measurement channels specified in Annex A, are calculated and are valid per datastream (codeword). For multi-stream (more than one codeword) transmissions, the throughput referenced in the minimum requirements is the sum of throughputs of all datastreams (codewords).

The UE category entry in the definition of the reference measurement channel in Annex A is only informative and reveals the UE categories, which can support the corresponding measurement channel. Whether the measurement channel is used for testing a certain UE category or not is specified in the individual minimum requirements.

A.2 UL reference measurement channels

A.2.1 General

The measurement channels in the following subclauses are defined to derive the requirements in clause 6 (Transmitter Characteristics) and clause 7 (Receiver Characteristics). The measurement channels represent example configurations of physical channels for different data rates.

A.2.1.1 Applicability and common parameters

The UL reference measurement channels comprise assume transmission of PUSCH and Demodulation Reference signals only. The following conditions apply:

- 1 HARQ transmission
- Cyclic Prefix normal
- PUSCH hopping off
- Link adaptation off
- Demodulation Reference signal as per TS 36.211 [4] subclause 5.5.2.1.2.

Where ACK/NACK is transmitted, it is assumed to be multiplexed on PUSCH as per TS 36.212 [5] subclause 5.2.2.6.

- ACK/NACK 1 bit
- ACK/NACK mapping adjacent to Demodulation Reference symbol
- ACK/NACK resources punctured into data
- Max number of resources for ACK/NACK: 4 SC-FDMA symbols per subframe
- No CQI transmitted, no RI transmitted

A.2.1.2 Determination of payload size

The algorithm for determining the payload size A is as follows; given a desired coding rate R and radio block allocation N_{RB}

1. Calculate the number of channel bits N_{ch} that can be transmitted during the first transmission of a given sub-frame.
2. Find A such that the resulting coding rate is as close to R as possible, that is,

$$\min |R - (A + 24 * (N_{CB} + 1)) / N_{ch}|, \text{ where } N_{CB} = \begin{cases} 0, & \text{if } C = 1 \\ C, & \text{if } C > 1 \end{cases}$$

subject to

- A is a valid TB size according to section 7.1.7 of TS 36.213 [6] assuming an allocation of N_{RB} resource blocks.
- C is the number of Code Blocks calculated according to section 5.1.2 of TS 36.212 [5].
- For RMC-s, which at the nominal target coding rate do not cover all the possible UE categories for the given modulation, reduce the target coding rate gradually (within the same modulation), until the maximal possible number of UE categories is covered.

3. If there is more than one A that minimises the equation above, then the larger value is chosen per default and the chosen code rate should not exceed 0.93.

A.2.1.3 Overview of UL reference measurement channels

In Table A.2.1.3-1 to A.2.1.3-1L are listed the UL reference measurement channels specified in annexes A.2.2 and A.2.3 of this release of TS 36.101. This table is informative and serves only to a better overview. The reference for the concrete reference measurement channels and corresponding implementation's parameters as to be used for requirements are annexes A.2.2 and A.2.3 as appropriate.

Table A.2.1.3-1: Overview of UL reference measurement channels (FDD, Full RB allocation, QPSK)

Duplex	Table	Name	BW	Mod	TCR	RB	RB Off set	UE Cat eg	Notes
FDD	Table A.2.2.1.1-1		1.4	QPSK	1/3	6		≥ 1	
FDD	Table A.2.2.1.1-1		3	QPSK	1/3	15		≥ 1	
FDD	Table A.2.2.1.1-1		5	QPSK	1/3	25		≥ 1	
FDD	Table A.2.2.1.1-1		10	QPSK	1/3	50		≥ 1	
FDD	Table A.2.2.1.1-1		15	QPSK	1/5	75		≥ 1	
FDD	Table A.2.2.1.1-1		20	QPSK	1/6	100		≥ 1	
FDD / HD-FDD	Table A.2.2.1.1-1a		1.4	QPSK	1/3	6		-	UE UL category 0
FDD / HD-FDD	Table A.2.2.1.1-1a		3	QPSK	1/5	15		-	UE UL category 0
FDD / HD-FDD	Table A.2.2.1.1-1a		5	QPSK	1/8	25		-	UE UL category 0
FDD / HD-FDD	Table A.2.2.1.1-1a		10	QPSK	1/10	36		-	UE UL category 0
FDD / HD-FDD	Table A.2.2.1.1-1a		15	QPSK	1/10	36		-	UE UL category 0
FDD / HD-FDD	Table A.2.2.1.1-1a		20	QPSK	1/10	36		-	UE UL category 0
FDD / HD-FDD	Table A.2.2.1.1-1b		1.4	QPSK	1/3	6		-	UE UL category M1
FDD / HD-FDD	Table A.2.2.1.1-1b		3	QPSK	1/3	6		-	UE UL category M1
FDD / HD-FDD	Table A.2.2.1.1-1b		5	QPSK	1/3	6		-	UE UL category M1
FDD / HD-FDD	Table A.2.2.1.1-1b		10	QPSK	1/3	6		-	UE UL category M1
FDD / HD-FDD	Table A.2.2.1.1-1b		15	QPSK	1/3	6		-	UE UL category M1
FDD / HD-FDD	Table A.2.2.1.1-1b		20	QPSK	1/3	6		-	UE UL category M1

Table A.2.1.3-1A: Overview of UL reference measurement channels (FDD, Full RB allocation, 16-QAM)

Duplex	Table	Name	BW	Mod	TCR	RB	RB Off set	UE Cat eg	Notes
FDD	Table A.2.2.1.2-1		1.4	16QAM	3/4	6		≥ 1	
FDD	Table A.2.2.1.2-1		3	16QAM	1/2	15		≥ 1	
FDD	Table A.2.2.1.2-1		5	16QAM	1/3	25		≥ 1	
FDD	Table A.2.2.1.2-1		10	16QAM	3/4	50		≥ 2	
FDD	Table A.2.2.1.2-1		15	16QAM	1/2	75		≥ 2	
FDD	Table A.2.2.1.2-1		20	16QAM	1/3	100		≥ 2	
FDD / HD-FDD	Table A.2.2.1.2-1a		1.4	16QAM	1/3	5		-	UE UL category 0
FDD / HD-FDD	Table A.2.2.1.2-1a		3	16QAM	1/3	5		-	UE UL category 0
FDD / HD-FDD	Table A.2.2.1.2-1a		5	16QAM	1/3	5		-	UE UL category 0
FDD / HD-FDD	Table A.2.2.1.2-1a		10	16QAM	1/3	5		-	UE UL category 0
FDD / HD-FDD	Table A.2.2.1.2-1a		15	16QAM	1/3	5		-	UE UL category 0
FDD / HD-FDD	Table A.2.2.1.2-1a		20	16QAM	1/3	5		-	UE UL category 0
FDD / HD-FDD	Table A.2.2.1.2-1b		1.4	16QAM	1/3	5		-	UE UL category M1
FDD / HD-FDD	Table A.2.2.1.2-1b		3	16QAM	1/3	5		-	UE UL category M1
FDD / HD-FDD	Table A.2.2.1.2-1b		5	16QAM	1/3	5		-	UE UL category M1
FDD / HD-FDD	Table A.2.2.1.2-1b		10	16QAM	1/3	5		-	UE UL category M1
FDD / HD-FDD	Table A.2.2.1.2-1b		15	16QAM	1/3	5		-	UE UL category M1
FDD / HD-FDD	Table A.2.2.1.2-1b		20	16QAM	1/3	5		-	UE UL category M1

Table A.2.1.3-1B: Overview of UL reference measurement channels (FDD, Full RB allocation, 64-QAM)

Duplex	Table	Name	BW	Mod	TCR	RB	RB Off set	UE Cat eg	Notes
FDD	Table A.2.2.1.3-1		1.4	64QAM	3/4	6		5,8	UL category 5, 8, 13, 14
FDD	Table A.2.2.1.3-1		3	64QAM	3/4	15		5,8	UL category 5, 8, 13, 14
FDD	Table A.2.2.1.3-1		5	64QAM	3/4	25		5,8	UL category 5, 8, 13, 14
FDD	Table A.2.2.1.3-1		10	64QAM	3/4	50		5,8	UL category 5, 8, 13, 14
FDD	Table A.2.2.1.3-1		15	64QAM	3/4	75		5,8	UL category 5, 8, 13, 14
FDD	Table A.2.2.1.3-1		20	64QAM	3/4	100		5,8	UL category 5, 8, 13, 14

Table A.2.1.3-1C: Overview of UL reference measurement channels (FDD, Partial RB allocation, QPSK)

Duplex	Table	Name	BW	Mod	TCR	RB	RB Off set	UE Cat eg	Notes
FDD	Table A.2.2.2.1-1		1.4 - 20	QPSK	1/3	1		≥ 1	
FDD	Table A.2.2.2.1-1		1.4 - 20	QPSK	1/3	2		≥ 1	
FDD	Table A.2.2.2.1-1		1.4 - 20	QPSK	1/3	3		≥ 1	
FDD	Table A.2.2.2.1-1		1.4 - 20	QPSK	1/3	4		≥ 1	
FDD	Table A.2.2.2.1-1		1.4 - 20	QPSK	1/3	5		≥ 1	
FDD	Table A.2.2.2.1-1		3 - 20	QPSK	1/3	6		≥ 1	
FDD	Table A.2.2.2.1-1		3 - 20	QPSK	1/3	8		≥ 1	
FDD	Table A.2.2.2.1-1		3 - 20	QPSK	1/3	9		≥ 1	
FDD	Table A.2.2.2.1-1		3 - 20	QPSK	1/3	10		≥ 1	
FDD	Table A.2.2.2.1-1		3 - 20	QPSK	1/3	12		≥ 1	
FDD	Table A.2.2.2.1-1		5 - 20	QPSK	1/3	15		≥ 1	
FDD	Table A.2.2.2.1-1		5 - 20	QPSK	1/3	16		≥ 1	
FDD	Table A.2.2.2.1-1		5 - 20	QPSK	1/3	18		≥ 1	
FDD	Table A.2.2.2.1-1		5 - 20	QPSK	1/3	20		≥ 1	
FDD	Table A.2.2.2.1-1		5 - 20	QPSK	1/3	24		≥ 1	
FDD	Table A.2.2.2.1-1		10 - 20	QPSK	1/3	25		≥ 1	
FDD	Table A.2.2.2.1-1		10 - 20	QPSK	1/3	27		≥ 1	
FDD	Table A.2.2.2.1-1		10 - 20	QPSK	1/3	30		≥ 1	
FDD	Table A.2.2.2.1-1		10 - 20	QPSK	1/3	32		≥ 1	
FDD	Table A.2.2.2.1-1		10 - 20	QPSK	1/3	36		≥ 1	
FDD	Table A.2.2.2.1-1		10 - 20	QPSK	1/3	40		≥ 1	
FDD	Table A.2.2.2.1-1		10 - 20	QPSK	1/3	45		≥ 1	
FDD	Table A.2.2.2.1-1		10 - 20	QPSK	1/3	48		≥ 1	
FDD	Table A.2.2.2.1-1		15 - 20	QPSK	1/3	50		≥ 1	
FDD	Table A.2.2.2.1-1		15 - 20	QPSK	1/3	54		≥ 1	
FDD	Table A.2.2.2.1-1		15 - 20	QPSK	1/4	60		≥ 1	
FDD	Table A.2.2.2.1-1		15 - 20	QPSK	1/4	64		≥ 1	
FDD	Table A.2.2.2.1-1		15 - 20	QPSK	1/4	72		≥ 1	
FDD	Table A.2.2.2.1-1		20	QPSK	1/5	75		≥ 1	
FDD	Table A.2.2.2.1-1		20	QPSK	1/5	80		≥ 1	
FDD	Table A.2.2.2.1-1		20	QPSK	1/5	81		≥ 1	
FDD	Table A.2.2.2.1-1		20	QPSK	1/6	90		≥ 1	
FDD	Table A.2.2.2.1-1		20	QPSK	1/6	96		≥ 1	
FDD / HD-FDD	Table A.2.2.2.1-1a		1.4 - 20	QPSK	1/3	1		-	UE UL category 0
FDD / HD-FDD	Table A.2.2.2.1-1a		1.4 - 20	QPSK	1/3	2		-	UE UL category 0
FDD / HD-FDD	Table A.2.2.2.1-1a		1.4 - 20	QPSK	1/3	3		-	UE UL category 0
FDD / HD-FDD	Table A.2.2.2.1-1a		1.4 - 20	QPSK	1/3	4		-	UE UL category 0
FDD / HD-FDD	Table A.2.2.2.1-1a		1.4 - 20	QPSK	1/3	5		-	UE UL category 0
FDD / HD-FDD	Table A.2.2.2.1-1a		3-20	QPSK	1/3	6		-	UE UL category 0
FDD / HD-FDD	Table A.2.2.2.1-1a		3-20	QPSK	1/3	8		-	UE UL category 0
FDD / HD-FDD	Table A.2.2.2.1-1a		3-20	QPSK	1/3	9		-	UE UL category 0
FDD / HD-FDD	Table A.2.2.2.1-1a		3-20	QPSK	1/3	10		-	UE UL category 0
FDD / HD-FDD	Table A.2.2.2.1-1a		3-20	QPSK	1/4	12		-	UE UL category 0
FDD / HD-FDD	Table A.2.2.2.1-1a		5-20	QPSK	1/5	15		-	UE UL category 0

FDD / HD-FDD	Table A.2.2.2.1-1a		5-20	QPSK	1/5	16		-	UE UL category 0
FDD / HD-FDD	Table A.2.2.2.1-1a		5-20	QPSK	1/6	18		-	UE UL category 0
FDD / HD-FDD	Table A.2.2.2.1-1a		5-20	QPSK	1/6	20		-	UE UL category 0
FDD / HD-FDD	Table A.2.2.2.1-1a		5-20	QPSK	1/8	24		-	UE UL category 0
FDD / HD-FDD	Table A.2.2.2.1-1a		10-20	QPSK	1/8	25		-	UE UL category 0
FDD / HD-FDD	Table A.2.2.2.1-1a		10-20	QPSK	1/8	27		-	UE UL category 0
FDD / HD-FDD	Table A.2.2.2.1-1a		10-20	QPSK	1/10	30		-	UE UL category 0
FDD / HD-FDD	Table A.2.2.2.1-1b		1.4-20	QPSK	1/3	1		-	UE UL category M1
FDD / HD-FDD	Table A.2.2.2.1-1b		1.4-20	QPSK	1/3	2		-	UE UL category M1
FDD / HD-FDD	Table A.2.2.2.1-1b		1.4-20	QPSK	1/3	3		-	UE UL category M1
FDD / HD-FDD	Table A.2.2.2.1-1b		1.4-20	QPSK	1/3	4		-	UE UL category M1
FDD / HD-FDD	Table A.2.2.2.1-1b		1.4-20	QPSK	1/3	5		-	UE UL category M1
FDD / HD-FDD	Table A.2.2.2.1-1b		3-20	QPSK	1/3	6		-	UE UL category M1

Table A.2.1.3-1D: Overview of UL reference measurement channels (FDD, Partial RB allocation, 16-QAM)

Duplex	Table	Name	BW	Mod	TCR	RB	RB Off set	UE Cat eg	Notes
FDD	Table A.2.2.2.2-1		1.4 - 20	16QAM	3/4	1		≥ 1	
FDD	Table A.2.2.2.2-1		1.4 - 20	16QAM	3/4	2		≥ 1	
FDD	Table A.2.2.2.2-1		1.4 - 20	16QAM	3/4	3		≥ 1	
FDD	Table A.2.2.2.2-1		1.4 - 20	16QAM	3/4	4		≥ 1	
FDD	Table A.2.2.2.2-1		1.4 - 20	16QAM	3/4	5		≥ 1	
FDD	Table A.2.2.2.2-1		3 - 20	16QAM	3/4	6		≥ 1	
FDD	Table A.2.2.2.2-1		3 - 20	16QAM	3/4	8		≥ 1	
FDD	Table A.2.2.2.2-1		3 - 20	16QAM	3/4	9		≥ 1	
FDD	Table A.2.2.2.2-1		3 - 20	16QAM	3/4	10		≥ 1	
FDD	Table A.2.2.2.2-1		3 - 20	16QAM	3/4	12		≥ 1	
FDD	Table A.2.2.2.2-1		5 - 20	16QAM	1/2	15		≥ 1	
FDD	Table A.2.2.2.2-1		5 - 20	16QAM	1/2	16		≥ 1	
FDD	Table A.2.2.2.2-1		5 - 20	16QAM	1/2	18		≥ 1	
FDD	Table A.2.2.2.2-1		5 - 20	16QAM	1/3	20		≥ 1	
FDD	Table A.2.2.2.2-1		5 - 20	16QAM	1/3	24		≥ 1	
FDD	Table A.2.2.2.2-1		10 - 20	16QAM	1/3	25		≥ 1	
FDD	Table A.2.2.2.2-1		10 - 20	16QAM	1/3	27		≥ 1	
FDD	Table A.2.2.2.2-1		10 - 20	16QAM	3/4	30		≥ 2	
FDD	Table A.2.2.2.2-1		10 - 20	16QAM	3/4	32		≥ 2	
FDD	Table A.2.2.2.2-1		10 - 20	16QAM	3/4	36		≥ 2	
FDD	Table A.2.2.2.2-1		10 - 20	16QAM	3/4	40		≥ 2	
FDD	Table A.2.2.2.2-1		10 - 20	16QAM	3/4	45		≥ 2	
FDD	Table A.2.2.2.2-1		10 - 20	16QAM	3/4	48		≥ 2	
FDD	Table A.2.2.2.2-1		15 - 20	16QAM	3/4	50		≥ 2	
FDD	Table A.2.2.2.2-1		15 - 20	16QAM	3/4	54		≥ 2	
FDD	Table A.2.2.2.2-1		15 - 20	16QAM	2/3	60		≥ 2	
FDD	Table A.2.2.2.2-1		15 - 20	16QAM	2/3	64		≥ 2	
FDD	Table A.2.2.2.2-1		15 - 20	16QAM	1/2	72		≥ 2	
FDD	Table A.2.2.2.2-1		20	16QAM	1/2	75		≥ 2	
FDD	Table A.2.2.2.2-1		20	16QAM	1/2	80		≥ 2	
FDD	Table A.2.2.2.2-1		20	16QAM	1/2	81		≥ 2	
FDD	Table A.2.2.2.2-1		20	16QAM	2/5	90		≥ 2	
FDD	Table A.2.2.2.2-1		20	16QAM	2/5	96		≥ 2	
FDD / HD-FDD	Table A.2.2.2.2-1a		1.4 - 20	16QAM	3/4	1		-	UE UL category 0
FDD / HD-FDD	Table A.2.2.2.2-1a		1.4 - 20	16QAM	3/4	2		-	UE UL category 0
FDD / HD-FDD	Table A.2.2.2.2-1a		1.4 - 20	16QAM	2/5	4		-	UE UL category 0
FDD / HD-FDD	Table A.2.2.2.2-1b		1.4 - 20	16QAM	3/4	1		-	UE UL category M1
FDD / HD-FDD	Table A.2.2.2.2-1b		1.4 - 20	16QAM	3/4	2		-	UE UL category M1
FDD / HD-FDD	Table A.2.2.2.2-1b		1.4 - 20	16QAM	2/5	4		-	UE UL category M1

Table A.2.1.3-1E: Overview of UL reference measurement channels (FDD, Partial RB allocation, 64-QAM)

Duplex	Table	Name	BW	Mod	TCR	RB	RB Off set	UE Cat eg	Notes
FDD	Table A.2.2.2.3-1		1.4 - 20	64QAM	3/4	1		5,8	UL category 5, 8, 13, 14
FDD	Table A.2.2.2.3-1		1.4 - 20	64QAM	3/4	2		5,8	UL category 5, 8, 13, 14
FDD	Table A.2.2.2.3-1		1.4 - 20	64QAM	3/4	3		5,8	UL category 5, 8, 13, 14
FDD	Table A.2.2.2.3-1		1.4 - 20	64QAM	3/4	4		5,8	UL category 5, 8, 13, 14
FDD	Table A.2.2.2.3-1		1.4 - 20	64QAM	3/4	5		5,8	UL category 5, 8, 13, 14
FDD	Table A.2.2.2.3-1		3 - 20	64QAM	3/4	6		5,8	UL category 5, 8, 13, 14
FDD	Table A.2.2.2.3-1		3 - 20	64QAM	3/4	8		5,8	UL category 5, 8, 13, 14
FDD	Table A.2.2.2.3-1		3 - 20	64QAM	3/4	9		5,8	UL category 5, 8, 13, 14
FDD	Table A.2.2.2.3-1		3 - 20	64QAM	3/4	10		5,8	UL category 5, 8, 13, 14
FDD	Table A.2.2.2.3-1		3 - 20	64QAM	3/4	12		5,8	UL category 5, 8, 13, 14
FDD	Table A.2.2.2.3-1		5 - 20	64QAM	3/4	15		5,8	UL category 5, 8, 13, 14
FDD	Table A.2.2.2.3-1		5 - 20	64QAM	3/4	16		5,8	UL category 5, 8, 13, 14
FDD	Table A.2.2.2.3-1		5 - 20	64QAM	3/4	18		5,8	UL category 5, 8, 13, 14
FDD	Table A.2.2.2.3-1		5 - 20	64QAM	3/4	20		5,8	UL category 5, 8, 13, 14
FDD	Table A.2.2.2.3-1		5 - 20	64QAM	3/4	24		5,8	UL category 5, 8, 13, 14
FDD	Table A.2.2.2.3-1		10 - 20	64QAM	3/4	25		5,8	UL category 5, 8, 13, 14
FDD	Table A.2.2.2.3-1		10 - 20	64QAM	3/4	27		5,8	UL category 5, 8, 13, 14
FDD	Table A.2.2.2.3-1		10 - 20	64QAM	3/4	30		5,8	UL category 5, 8, 13, 14
FDD	Table A.2.2.2.3-1		10 - 20	64QAM	3/4	32		5,8	UL category 5, 8, 13, 14
FDD	Table A.2.2.2.3-1		10 - 20	64QAM	3/4	36		5,8	UL category 5, 8, 13, 14
FDD	Table A.2.2.2.3-1		10 - 20	64QAM	3/4	40		5,8	UL category 5, 8, 13, 14
FDD	Table A.2.2.2.3-1		10 - 20	64QAM	3/4	45		5,8	UL category 5, 8, 13, 14
FDD	Table A.2.2.2.3-1		10 - 20	64QAM	3/4	48		5,8	UL category 5, 8, 13, 14
FDD	Table A.2.2.2.3-1		15 - 20	64QAM	3/4	50		5,8	UL category 5, 8, 13, 14
FDD	Table A.2.2.2.3-1		15 - 20	64QAM	3/4	54		5,8	UL category 5, 8, 13, 14
FDD	Table A.2.2.2.3-1		15 - 20	64QAM	3/4	60		5,8	UL category 5, 8, 13, 14
FDD	Table A.2.2.2.3-1		15 - 20	64QAM	3/4	64		5,8	UL category 5, 8, 13, 14
FDD	Table A.2.2.2.3-1		15 - 20	64QAM	3/4	72		5,8	UL category 5, 8, 13, 14
FDD	Table A.2.2.2.3-1		20	64QAM	3/4	75		5,8	UL category 5, 8, 13, 14
FDD	Table A.2.2.2.3-1		20	64QAM	3/4	80		5,8	UL category 5, 8, 13, 14
FDD	Table A.2.2.2.3-1		20	64QAM	3/4	81		5,8	UL category 5, 8, 13, 14
FDD	Table A.2.2.2.3-1		20	64QAM	3/4	90		5,8	UL category 5, 8, 13, 14
FDD	Table A.2.2.2.3-1		20	64QAM	3/4	96		5,8	UL category 5, 8, 13, 14

Table A.2.1.3-1F: Overview of UL reference measurement channels (TDD, Full RB allocation, QPSK)

Duplex	Table	Name	BW	Mod	TCR	RB	RB Off set	UE Cat eg	Notes
TDD	Table A.2.3.1.1-1		1.4	QPSK	1/3	6		≥ 1	
TDD	Table A.2.3.1.1-1		3	QPSK	1/3	15		≥ 1	
TDD	Table A.2.3.1.1-1		5	QPSK	1/3	25		≥ 1	
TDD	Table A.2.3.1.1-1		10	QPSK	1/3	50		≥ 1	
TDD	Table A.2.3.1.1-1		15	QPSK	1/5	75		≥ 1	
TDD	Table A.2.3.1.1-1		20	QPSK	1/6	100		≥ 1	
TDD	Table A.2.3.1.1-1a		1.4	QPSK	1/3	6		-	UE UL category 0
TDD	Table A.2.3.1.1-1a		3	QPSK	1/5	15		-	UE UL category 0
TDD	Table A.2.3.1.1-1a		5	QPSK	1/8	25		-	UE UL category 0
TDD	Table A.2.3.1.1-1a		10	QPSK	1/10	36		-	UE UL category 0
-	Table A.2.3.1.1-1a		15	QPSK	1/10	36		-	UE UL category 0
TDD	Table A.2.3.1.1-1a		20	QPSK	1/10	36		-	UE UL category 0
TDD	Table A.2.3.1.1-1b		1.4	QPSK	1/3	6		-	UE UL category M1
TDD	Table A.2.3.1.1-1b		3	QPSK	1/3	6		-	UE UL category M1
TDD	Table A.2.3.1.1-1b		5	QPSK	1/3	6		-	UE UL category M1
TDD	Table A.2.3.1.1-1b		10	QPSK	1/3	6		-	UE UL category M1
TDD	Table A.2.3.1.1-1b		15	QPSK	1/3	6		-	UE UL category M1
TDD	Table A.2.3.1.1-1b		20	QPSK	1/3	6		-	UE UL category M1

Table A.2.1.3-1G: Overview of UL reference measurement channels (TDD, Full RB allocation, 16-QAM)

Duplex	Table	Name	BW	Mod	TCR	RB	RB Off set	UE Cat eg	Notes
TDD	Table A.2.3.1.2-1		1.4	16QAM	3/4	6		≥ 1	
TDD	Table A.2.3.1.2-1		3	16QAM	1/2	15		≥ 1	
TDD	Table A.2.3.1.2-1		5	16QAM	1/3	25		≥ 1	
TDD	Table A.2.3.1.2-1		10	16QAM	3/4	50		≥ 2	
TDD	Table A.2.3.1.2-1		15	16QAM	1/2	75		≥ 2	
TDD	Table A.2.3.1.2-1		20	16QAM	1/3	100		≥ 2	
TDD	Table A.2.3.1.2-1a		1.4	16QAM	1/3	5		-	UE UL category 0
TDD	Table A.2.3.1.2-1a		3	16QAM	1/3	5		-	UE UL category 0
TDD	Table A.2.3.1.2-1a		5	16QAM	1/3	5		-	UE UL category 0
TDD	Table A.2.3.1.2-1a		10	16QAM	1/3	5		-	UE UL category 0
TDD	Table A.2.3.1.2-1a		15	16QAM	1/3	5		-	UE UL category 0
TDD	Table A.2.3.1.2-1a		20	16QAM	1/3	5		-	UE UL category 0
TDD	Table A.2.3.1.1-1b		1.4	16QAM	1/3	5		-	UE UL category M1
TDD	Table A.2.3.1.1-1b		3	16QAM	1/3	5		-	UE UL category M1
TDD	Table A.2.3.1.1-1b		5	16QAM	1/3	5		-	UE UL category M1
TDD	Table A.2.3.1.1-1b		10	16QAM	1/3	5		-	UE UL category M1
TDD	Table A.2.3.1.1-1b		15	16QAM	1/3	5		-	UE UL category M1
TDD	Table A.2.3.1.1-1b		20	16QAM	1/3	5		-	UE UL category M1

Table A.2.1.3-1H: Overview of UL reference measurement channels (TDD, Full RB allocation, 64-QAM)

Duplex	Table	Name	BW	Mod	TCR	RB	RB Off set	UE Cat eg	Notes
TDD	Table A.2.3.1.3-1		1.4	64QAM	3/4	6		5,8	UL category 5, 8, 13, 14
TDD	Table A.2.3.1.3-1		3	64QAM	3/4	15		5,8	UL category 5, 8, 13, 14
TDD	Table A.2.3.1.3-1		5	64QAM	3/4	25		5,8	UL category 5, 8, 13, 14
TDD	Table A.2.3.1.3-1		10	64QAM	3/4	50		5,8	UL category 5, 8, 13, 14
TDD	Table A.2.3.1.3-1		15	64QAM	3/4	75		5,8	UL category 5, 8, 13, 14
TDD	Table A.2.3.1.3-1		20	64QAM	3/4	100		5,8	UL category 5, 8, 13, 14

Table A.2.1.3-11: Overview of UL reference measurement channels (TDD, Partial RB allocation, QPSK)

Duplex	Table	Name	BW	Mod	TCR	RB	RB Off set	UE Cat eg	Notes
TDD	Table A.2.3.2.1-1		1.4 - 20	QPSK	1/3	1		≥ 1	
TDD	Table A.2.3.2.1-1		1.4 - 20	QPSK	1/3	2		≥ 1	
TDD	Table A.2.3.2.1-1		1.4 - 20	QPSK	1/3	3		≥ 1	
TDD	Table A.2.3.2.1-1		1.4 - 20	QPSK	1/3	4		≥ 1	
TDD	Table A.2.3.2.1-1		1.4 - 20	QPSK	1/3	5		≥ 1	
TDD	Table A.2.3.2.1-1		3 - 20	QPSK	1/3	6		≥ 1	
TDD	Table A.2.3.2.1-1		3 - 20	QPSK	1/3	8		≥ 1	
TDD	Table A.2.3.2.1-1		3 - 20	QPSK	1/3	9		≥ 1	
TDD	Table A.2.3.2.1-1		3 - 20	QPSK	1/3	10		≥ 1	
TDD	Table A.2.3.2.1-1		3 - 20	QPSK	1/3	12		≥ 1	
TDD	Table A.2.3.2.1-1		5 - 20	QPSK	1/3	15		≥ 1	
TDD	Table A.2.3.2.1-1		5 - 20	QPSK	1/3	16		≥ 1	
TDD	Table A.2.3.2.1-1		5 - 20	QPSK	1/3	18		≥ 1	
TDD	Table A.2.3.2.1-1		5 - 20	QPSK	1/3	20		≥ 1	
TDD	Table A.2.3.2.1-1		5 - 20	QPSK	1/3	24		≥ 1	
TDD	Table A.2.3.2.1-1		10 - 20	QPSK	1/3	25		≥ 1	
TDD	Table A.2.3.2.1-1		10 - 20	QPSK	1/3	27		≥ 1	
TDD	Table A.2.3.2.1-1		10 - 20	QPSK	1/3	30		≥ 1	
TDD	Table A.2.3.2.1-1		10 - 20	QPSK	1/3	32		≥ 1	
TDD	Table A.2.3.2.1-1		10 - 20	QPSK	1/3	36		≥ 1	
TDD	Table A.2.3.2.1-1		10 - 20	QPSK	1/3	40		≥ 1	
TDD	Table A.2.3.2.1-1		10 - 20	QPSK	1/3	45		≥ 1	
TDD	Table A.2.3.2.1-1		10 - 20	QPSK	1/3	48		≥ 1	
TDD	Table A.2.3.2.1-1		15 - 20	QPSK	1/3	50		≥ 1	
TDD	Table A.2.3.2.1-1		15 - 20	QPSK	1/3	54		≥ 1	
TDD	Table A.2.3.2.1-1		15 - 20	QPSK	1/4	60		≥ 1	
TDD	Table A.2.3.2.1-1		15 - 20	QPSK	1/4	64		≥ 1	
TDD	Table A.2.3.2.1-1		15 - 20	QPSK	1/4	72		≥ 1	
TDD	Table A.2.3.2.1-1		20	QPSK	1/5	75		≥ 1	
TDD	Table A.2.3.2.1-1		20	QPSK	1/5	80		≥ 1	
TDD	Table A.2.3.2.1-1		20	QPSK	1/5	81		≥ 1	
TDD	Table A.2.3.2.1-1		20	QPSK	1/6	90		≥ 1	
TDD	Table A.2.3.2.1-1		20	QPSK	1/6	96		≥ 1	
TDD	Table A.2.3.2.1-1a		1.4 - 20	QPSK	1/3	1		-	UE UL category 0
TDD	Table A.2.3.2.1-1a		1.4 - 20	QPSK	1/3	2		-	UE UL category 0
TDD	Table A.2.3.2.1-1a		1.4 - 20	QPSK	1/3	3		-	UE UL category 0
TDD	Table A.2.3.2.1-1a		1.4 - 20	QPSK	1/3	4		-	UE UL category 0
TDD	Table A.2.3.2.1-1a		1.4 - 20	QPSK	1/3	5		-	UE UL category 0
TDD	Table A.2.3.2.1-1a		3-20	QPSK	1/3	6		-	UE UL category 0
TDD	Table A.2.3.2.1-1a		3-20	QPSK	1/3	8		-	UE UL category 0
TDD	Table A.2.3.2.1-1a		3-20	QPSK	1/3	9		-	UE UL category 0
TDD	Table A.2.3.2.1-1a		3-20	QPSK	1/3	10		-	UE UL category 0
TDD	Table A.2.3.2.1-1a		3-20	QPSK	1/4	12		-	UE UL category 0
TDD	Table A.2.3.2.1-1a		5-20	QPSK	1/5	15		-	UE UL category 0
TDD	Table A.2.3.2.1-1a		5-20	QPSK	1/5	16		-	UE UL category 0

TDD	Table A.2.3.2.1-1a		5-20	QPSK	1/6	18		-	UE UL category 0
TDD	Table A.2.3.2.1-1a		5-20	QPSK	1/6	20		-	UE UL category 0
TDD	Table A.2.3.2.1-1a		5-20	QPSK	1/8	24		-	UE UL category 0
TDD	Table A.2.3.2.1-1a		10-20	QPSK	1/8	25		-	UE UL category 0
TDD	Table A.2.3.2.1-1a		10-20	QPSK	1/8	27		-	UE UL category 0
TDD	Table A.2.3.2.1-1a		10-20	QPSK	1/10	30		-	UE UL category 0
TDD	Table A.2.3.2.1-1b		1.4-20	QPSK	1/3	1		-	UE UL category M1
TDD	Table A.2.3.2.1-1b		1.4-20	QPSK	1/3	2		-	UE UL category M1
TDD	Table A.2.3.2.1-1b		1.4-20	QPSK	1/3	3		-	UE UL category M1
TDD	Table A.2.3.2.1-1b		1.4-20	QPSK	1/3	4		-	UE UL category M1
TDD	Table A.2.3.2.1-1b		1.4-20	QPSK	1/3	5		-	UE UL category M1
TDD	Table A.2.3.2.1-1b		3-20	QPSK	1/3	6		-	UE UL category M1

Table A.2.1.3-1J: Overview of UL reference measurement channels (TDD, Partial RB allocation, 16-QAM)

Duplex	Table	Name	BW	Mod	TCR	RB	RB Off set	UE Cat eg	Notes
TDD	Table A.2.3.2.2-1		1.4 - 20	16QAM	3/4	1		≥ 1	
TDD	Table A.2.3.2.2-1		1.4 - 20	16QAM	3/4	2		≥ 1	
TDD	Table A.2.3.2.2-1		1.4 - 20	16QAM	3/4	3		≥ 1	
TDD	Table A.2.3.2.2-1		1.4 - 20	16QAM	3/4	4		≥ 1	
TDD	Table A.2.3.2.2-1		1.4 - 20	16QAM	3/4	5		≥ 1	
TDD	Table A.2.3.2.2-1		3 - 20	16QAM	3/4	6		≥ 1	
TDD	Table A.2.3.2.2-1		3 - 20	16QAM	3/4	8		≥ 1	
TDD	Table A.2.3.2.2-1		3 - 20	16QAM	3/4	9		≥ 1	
TDD	Table A.2.3.2.2-1		3 - 20	16QAM	3/4	10		≥ 1	
TDD	Table A.2.3.2.2-1		3 - 20	16QAM	3/4	12		≥ 1	
TDD	Table A.2.3.2.2-1		5 - 20	16QAM	1/2	15		≥ 1	
TDD	Table A.2.3.2.2-1		5 - 20	16QAM	1/2	16		≥ 1	
TDD	Table A.2.3.2.2-1		5 - 20	16QAM	1/2	18		≥ 1	
TDD	Table A.2.3.2.2-1		5 - 20	16QAM	1/3	20		≥ 1	
TDD	Table A.2.3.2.2-1		5 - 20	16QAM	1/3	24		≥ 1	
TDD	Table A.2.3.2.2-1		10 - 20	16QAM	1/3	25		≥ 1	
TDD	Table A.2.3.2.2-1		10 - 20	16QAM	1/3	27		≥ 1	
TDD	Table A.2.3.2.2-1		10 - 20	16QAM	3/4	30		≥ 2	
TDD	Table A.2.3.2.2-1		10 - 20	16QAM	3/4	32		≥ 2	
TDD	Table A.2.3.2.2-1		10 - 20	16QAM	3/4	36		≥ 2	
TDD	Table A.2.3.2.2-1		10 - 20	16QAM	3/4	40		≥ 2	
TDD	Table A.2.3.2.2-1		10 - 20	16QAM	3/4	45		≥ 2	
TDD	Table A.2.3.2.2-1		10 - 20	16QAM	3/4	48		≥ 2	
TDD	Table A.2.3.2.2-1		15 - 20	16QAM	3/4	50		≥ 2	
TDD	Table A.2.3.2.2-1		15 - 20	16QAM	3/4	54		≥ 2	
TDD	Table A.2.3.2.2-1		15 - 20	16QAM	2/3	60		≥ 2	
TDD	Table A.2.3.2.2-1		15 - 20	16QAM	2/3	64		≥ 2	
TDD	Table A.2.3.2.2-1		15 - 20	16QAM	1/2	72		≥ 2	
TDD	Table A.2.3.2.2-1		20	16QAM	1/2	75		≥ 2	
TDD	Table A.2.3.2.2-1		20	16QAM	1/2	80		≥ 2	
TDD	Table A.2.3.2.2-1		20	16QAM	1/2	81		≥ 2	
TDD	Table A.2.3.2.2-1		20	16QAM	2/5	90		≥ 2	
TDD	Table A.2.3.2.2-1		20	16QAM	2/5	96		≥ 2	
TDD	Table A.2.3.2.2-1a		1.4 - 20	16QAM	3/4	1		-	UE UL category 0
TDD	Table A.2.3.2.2-1a		1.4 - 20	16QAM	3/4	2		-	UE UL category 0
TDD	Table A.2.3.2.2-1a		1.4 - 20	16QAM	2/5	4		-	UE UL category 0
TDD	Table A.2.3.2.2-1b		1.4 - 20	16QAM	3/4	1		-	UE UL category M1
TDD	Table A.2.3.2.2-1b		1.4 - 20	16QAM	3/4	2		-	UE UL category M1
TDD	Table A.2.3.2.2-1b		1.4 - 20	16QAM	2/5	4		-	UE UL category M1

Table A.2.1.3-1K: Overview of UL reference measurement channels (TDD, Partial RB allocation, 64-QAM)

Duplex	Table	Name	BW	Mod	TCR	RB	RB Off set	UE Cat eg	Notes
TDD	Table A.2.3.2.3-1		1.4 - 20	64QAM	3/4	1		5,8	UL category 5, 8, 13, 14
TDD	Table A.2.3.2.3-1		1.4 - 20	64QAM	3/4	2		5,8	UL category 5, 8, 13, 14
TDD	Table A.2.3.2.3-1		1.4 - 20	64QAM	3/4	3		5,8	UL category 5, 8, 13, 14
TDD	Table A.2.3.2.3-1		1.4 - 20	64QAM	3/4	4		5,8	UL category 5, 8, 13, 14
TDD	Table A.2.3.2.3-1		1.4 - 20	64QAM	3/4	5		5,8	UL category 5, 8, 13, 14
TDD	Table A.2.3.2.3-1		3 - 20	64QAM	3/4	6		5,8	UL category 5, 8, 13, 14
TDD	Table A.2.3.2.3-1		3 - 20	64QAM	3/4	8		5,8	UL category 5, 8, 13, 14
TDD	Table A.2.3.2.3-1		3 - 20	64QAM	3/4	9		5,8	UL category 5, 8, 13, 14
TDD	Table A.2.3.2.3-1		3 - 20	64QAM	3/4	10		5,8	UL category 5, 8, 13, 14
TDD	Table A.2.3.2.3-1		3 - 20	64QAM	3/4	12		5,8	UL category 5, 8, 13, 14
TDD	Table A.2.3.2.3-1		5 - 20	64QAM	3/4	15		5,8	UL category 5, 8, 13, 14
TDD	Table A.2.3.2.3-1		5 - 20	64QAM	3/4	16		5,8	UL category 5, 8, 13, 14
TDD	Table A.2.3.2.3-1		5 - 20	64QAM	3/4	18		5,8	UL category 5, 8, 13, 14
TDD	Table A.2.3.2.3-1		5 - 20	64QAM	3/4	20		5,8	UL category 5, 8, 13, 14
TDD	Table A.2.3.2.3-1		5 - 20	64QAM	3/4	24		5,8	UL category 5, 8, 13, 14
TDD	Table A.2.3.2.3-1		10 - 20	64QAM	3/4	25		5,8	UL category 5, 8, 13, 14
TDD	Table A.2.3.2.3-1		10 - 20	64QAM	3/4	27		5,8	UL category 5, 8, 13, 14
TDD	Table A.2.3.2.3-1		10 - 20	64QAM	3/4	30		5,8	UL category 5, 8, 13, 14
TDD	Table A.2.3.2.3-1		10 - 20	64QAM	3/4	32		5,8	UL category 5, 8, 13, 14
TDD	Table A.2.3.2.3-1		10 - 20	64QAM	3/4	36		5,8	UL category 5, 8, 13, 14
TDD	Table A.2.3.2.3-1		10 - 20	64QAM	3/4	40		5,8	UL category 5, 8, 13, 14
TDD	Table A.2.3.2.3-1		10 - 20	64QAM	3/4	45		5,8	UL category 5, 8, 13, 14
TDD	Table A.2.3.2.3-1		10 - 20	64QAM	3/4	48		5,8	UL category 5, 8, 13, 14
TDD	Table A.2.3.2.3-1		15 - 20	64QAM	3/4	50		5,8	UL category 5, 8, 13, 14
TDD	Table A.2.3.2.3-1		15 - 20	64QAM	3/4	54		5,8	UL category 5, 8, 13, 14
TDD	Table A.2.3.2.3-1		15 - 20	64QAM	3/4	60		5,8	UL category 5, 8, 13, 14
TDD	Table A.2.3.2.3-1		15 - 20	64QAM	3/4	64		5,8	UL category 5, 8, 13, 14
TDD	Table A.2.3.2.3-1		15 - 20	64QAM	3/4	72		5,8	UL category 5, 8, 13, 14
TDD	Table A.2.3.2.3-1		20	64QAM	3/4	75		5,8	UL category 5, 8, 13, 14
TDD	Table A.2.3.2.3-1		20	64QAM	3/4	80		5,8	UL category 5, 8, 13, 14
TDD	Table A.2.3.2.3-1		20	64QAM	3/4	81		5,8	UL category 5, 8, 13, 14
TDD	Table A.2.3.2.3-1		20	64QAM	3/4	90		5,8	UL category 5, 8, 13, 14
TDD	Table A.2.3.2.3-1		20	64QAM	3/4	96		5,8	UL category 5, 8, 13, 14

Table A.2.1.3-1L: Overview of UL reference measurement channels (HD-FDD, NB-IoT, QPSK)

Duplex	Table	Name	BW	Mod	TCR	RB	RB Off set	UE Cat eg	Notes
HD-FDD	Table A.2.4-1		0.2	$\pi/2$ BPSK	1/3	1		NB1	
HD-FDD	Table A.2.4-1		0.2	$\pi/4$ QPSK	1/3	1		NB1	
HD-FDD	Table A.2.4-1		0.2	$\pi/2$ BPSK	1/3	1		NB1	
HD-FDD	Table A.2.4-1		0.2	$\pi/4$ QPSK	1/3	1		NB1	
HD-FDD	Table A.2.4-1		0.2	QPSK	1/3	1		NB1	
HD-FDD	Table A.2.4-1		0.2	QPSK	1/3	1		NB1	
HD-FDD	Table A.2.4-1		0.2	QPSK	1/3	1		NB1	

A.2.2 Reference measurement channels for FDD

A.2.2.1 Full RB allocation

A.2.2.1.1 QPSK

Table A.2.2.1.1-1 Reference Channels for QPSK with full RB allocation

Parameter	Unit	Value					
Channel bandwidth	MHz	1.4	3	5	10	15	20
Allocated resource blocks		6	15	25	50	75	100
DFT-OFDM Symbols per Sub-Frame		12	12	12	12	12	12
Modulation		QPSK	QPSK	QPSK	QPSK	QPSK	QPSK
Target Coding rate		1/3	1/3	1/3	1/3	1/5	1/6
Payload size	Bits	600	1544	2216	5160	4392	4584
Transport block CRC	Bits	24	24	24	24	24	24
Number of code blocks per Sub-Frame (Note 1)		1	1	1	1	1	1
Total number of bits per Sub-Frame	Bits	1728	4320	7200	14400	21600	28800
Total symbols per Sub-Frame		864	2160	3600	7200	10800	14400
UE Category		≥ 1	≥ 1	≥ 1	≥ 1	≥ 1	≥ 1
Note 1: If more than one Code Block is present, an additional CRC sequence of L = 24 Bits is attached to each Code Block (otherwise L = 0 Bit)							

Table A.2.2.1.1-1a Reference Channels for QPSK with full/maximum RB allocation for UE UL category 0

Parameter	Unit	Value					
		1.4	3	5	10	15	20
Channel bandwidth	MHz	1.4	3	5	10	15	20
Allocated resource blocks		6	15	25	36	36	36
DFT-OFDM Symbols per Sub-Frame		12	12	12	12	12	12
Modulation		QPSK	QPSK	QPSK	QPSK	QPSK	QPSK
Target Coding rate		1/3	1/5	1/8	1/10	1/10	1/10
Payload size	Bits	600	872	904	1000	1000	1000
Transport block CRC	Bits	24	24	24	24	24	24
Number of code blocks per Sub-Frame (NOTE 1)		1	1	1	1	1	1
Total number of bits per Sub-Frame	Bits	1728	4320	7200	10368	10368	10368
Total symbols per Sub-Frame		864	2160	3600	5184	5184	5184
UE UL Category		0	0	0	0	0	0
NOTE 1: If more than one Code Block is present, an additional CRC sequence of L = 24 Bits is attached to each Code Block (otherwise L = 0 Bit)							
NOTE 2: For HD-FDD UE, the uplink subframes are scheduled at the 4th, 5th, 6th, 12th, 13th, 14th, 20th, 21st, 22nd, 28th, 29th, 30th, 36th, 37th, and 38th subframes every 40ms. Information bit payload is available if uplink subframe is scheduled.							

Table A.2.2.1.1-1b Reference Channels for QPSK with full/maximum RB allocation for UE UL category M1

Parameter	Unit	Value					
		1.4	3	5	10	15	20
Channel bandwidth	MHz	1.4	3	5	10	15	20
Allocated resource blocks		6	6	6	6	6	6
DFT-OFDM Symbols per Sub-Frame		12	12	12	12	12	12
Modulation		QPSK	QPSK	QPSK	QPSK	QPSK	QPSK
Target Coding rate		1/3	1/3	1/3	1/3	1/3	1/3
Payload size	Bits	600	600	600	600	600	600
Transport block CRC	Bits	24	24	24	24	24	24
Number of code blocks per Sub-Frame (NOTE 1)		1	1	1	1	1	1
Total number of bits per Sub-Frame	Bits	1728	1728	1728	1728	1728	1728
Total symbols per Sub-Frame		864	864	864	864	864	864
UE UL Category		M1	M1	M1	M1	M1	M1
NOTE 1: If more than one Code Block is present, an additional CRC sequence of L = 24 Bits is attached to each Code Block (otherwise L = 0 Bit)							
NOTE 2: For HD-FDD UE with $N_{abs}^{PUSCH} = 1$, the uplink subframes are scheduled at the 4th, 5th, and 6th subframes every 10ms for the channel bandwidth 5MHz/10MHz/15MHz/20MHz. For HD-FDD UE, the uplink subframes are scheduled at the 5th, 6th and 7th subframes every 10ms for the channel bandwidth 1.4MHz/3MHz. Information bit payload is available if uplink subframe is scheduled. N_{abs}^{PUSCH} is total number of absolute subframes a PUSCH with repetition spans [4].							
NOTE 3: For HD-FDD UE with $N_{abs}^{PUSCH} > 1$, MPDCCH are scheduled at 0th DL subframe every $N_{abs}^{PUSCH} + 5$ subframes (starting from the 0th subframe). The associated PUSCH is scheduled at the 4th to $(N_{abs}^{PUSCH} + 3)$ -th UL subframes every $N_{abs}^{PUSCH} + 5$ subframes. Information bit payload is available if uplink subframe is scheduled.							

A.2.2.1.2 16-QAM

Table A.2.2.1.2-1: Reference Channels for 16-QAM with full RB allocation

Parameter	Unit	Value					
		1.4	3	5	10	15	20
Channel bandwidth	MHz	1.4	3	5	10	15	20
Allocated resource blocks		6	15	25	50	75	100
DFT-OFDM Symbols per Sub-Frame		12	12	12	12	12	12
Modulation		16QAM	16QAM	16QAM	16QAM	16QAM	16QAM
Target Coding rate		3/4	1/2	1/3	3/4	1/2	1/3
Payload size	Bits	2600	4264	4968	21384	21384	19848
Transport block CRC	Bits	24	24	24	24	24	24
Number of code blocks per Sub-Frame (Note 1)		1	1	1	4	4	4
Total number of bits per Sub-Frame	Bits	3456	8640	14400	28800	43200	57600
Total symbols per Sub-Frame		864	2160	3600	7200	10800	14400
UE Category		≥ 1	≥ 1	≥ 1	≥ 2	≥ 2	≥ 2
Note 1: If more than one Code Block is present, an additional CRC sequence of L = 24 Bits is attached to each Code Block (otherwise L = 0 Bit)							

Table A.2.2.1.2-1a: Reference Channels for 16-QAM with maximum RB allocation for UE UL category 0

Parameter	Unit	Value					
		1.4	3	5	10	15	20
Channel bandwidth	MHz	1.4	3	5	10	15	20
Allocated resource blocks		5	5	5	5	5	5
DFT-OFDM Symbols per Sub-Frame		12	12	12	12	12	12
Modulation		16QAM	16QAM	16QAM	16QAM	16QAM	16QAM
Target Coding rate		1/3	1/3	1/3	1/3	1/3	1/3
Payload size	Bits	872	872	872	872	872	872
Transport block CRC	Bits	24	24	24	24	24	24
Number of code blocks per Sub-Frame		1	1	1	1	1	1
Total number of bits per Sub-Frame	Bits	2880	2880	2880	2880	2880	2880
Total symbols per Sub-Frame		720	720	720	720	720	720
UE UL Category		0	0	0	0	0	0
NOTE 1: If more than one Code Block is present, an additional CRC sequence of L = 24 Bits is attached to each Code Block (otherwise L = 0 Bit)							
NOTE 2: For HD-FDD UE, the uplink subframes are scheduled at the 4th, 5th, 6th, 12th, 13th, 14th, 20th, 21st, 22nd, 28th, 29th, 30th, 36th, 37th, and 38th subframes every 40ms. Information bit payload is available if uplink subframe is scheduled.							

Table A.2.2.1.2-1b: Reference Channels for 16-QAM with maximum RB allocation for UE UL category M1

Parameter	Unit	Value					
		1.4	3	5	10	15	20
Channel bandwidth	MHz	1.4	3	5	10	15	20
Allocated resource blocks		5	5	5	5	5	5
DFT-OFDM Symbols per Sub-Frame		12	12	12	12	12	12
Modulation		16QAM	16QAM	16QAM	16QAM	16QAM	16QAM
Target Coding rate		1/3	1/3	1/3	1/3	1/3	1/3
Payload size	Bits	872	872	872	872	872	872
Transport block CRC	Bits	24	24	24	24	24	24
Number of code blocks per Sub-Frame		1	1	1	1	1	1
Total number of bits per Sub-Frame	Bits	2880	2880	2880	2880	2880	2880
Total symbols per Sub-Frame		720	720	720	720	720	720
UE Category		M1	M1	M1	M1	M1	M1
NOTE 1: If more than one Code Block is present, an additional CRC sequence of L = 24 Bits is attached to each Code Block (otherwise L = 0 Bit).							
NOTE 2: For HD-FDD UE, the uplink subframes are scheduled at the 4th, 5th and 6th subframes every 10ms for the channel bandwidth 5MHz/10MHz/15MHz/20MHz. For HD-FDD UE, the uplink subframes are scheduled at the 5th, 6th, and 7th subframes every 10ms for the channel bandwidth 1.4MHz/3MHz. Information bit payload is available if uplink subframe is scheduled.							

A.2.2.1.3 64-QAM

Table A.2.2.1.3-1: Reference Channels for 64-QAM with full RB allocation

Parameter	Unit	Value					
Channel bandwidth	MHz	1.4	3	5	10	15	20
Allocated resource blocks		6	15	25	50	75	100
DFT-OFDM Symbols per Sub-Frame		12	12	12	12	12	12
Modulation		64QAM	64QAM	64QAM	64QAM	64QAM	64QAM
Target Coding rate		3/4	3/4	3/4	3/4	3/4	3/4
Payload size	Bits	3752	9528	15840	31704	46888	63776
Transport block CRC	Bits	24	24	24	24	24	24
Number of code blocks per Sub-Frame (Note 1)		1	2	3	6	8	11
Total number of bits per Sub-Frame	Bits	5184	12960	21600	43200	64800	86400
Total symbols per Sub-Frame		864	2160	3600	7200	10800	14400
UE Category (Note 2)		5,8	5,8	5,8	5,8	5,8	5,8
UE UL Category (Note 2)		5, 8, 13, 14	5, 8, 13, 14	5, 8, 13, 14	5, 8, 13, 14	5, 8, 13, 14	5, 8, 13, 14
Note 1:	If more than one Code Block is present, an additional CRC sequence of L = 24 Bits is attached to each Code Block (otherwise L = 0 Bit)						
Note2 :	If UE does not report UE UL category, then the applicability of reference channel is determined by UE category. If UE reports UE UL category, then the applicability of reference channel is determined by UE UL category.						

A.2.2.2 Partial RB allocation

For each channel bandwidth, various partial RB allocations are specified. The number of allocated RBs is chosen according to values specified in the Tx and Rx requirements. The single allocated RB case is included.

The allocated RBs are contiguous and start from one end of the channel bandwidth. A single allocated RB is at one end of the channel bandwidth.

A.2.2.2.1 QPSK

Table A.2.2.2.1-1: Reference Channels for QPSK with partial RB allocation

Parameter	Ch BW	Allocated RBs	DFT-OFDM Symbols per Sub-Frame	Mod'n	Target Coding rate	Payload size	Transport block CRC	Number of code blocks per Sub-Frame (Note 1)	Total number of bits per Sub-Frame	Total symbols per Sub-Frame	UE Category
Unit	MHz					Bits	Bits		Bits		
	1.4 - 20	1	12	QPSK	1/3	72	24	1	288	144	≥ 1
	1.4 - 20	2	12	QPSK	1/3	176	24	1	576	288	≥ 1
	1.4 - 20	3	12	QPSK	1/3	256	24	1	864	432	≥ 1
	1.4 - 20	4	12	QPSK	1/3	392	24	1	1152	576	≥ 1
	1.4 - 20	5	12	QPSK	1/3	424	24	1	1440	720	≥ 1
	3-20	6	12	QPSK	1/3	600	24	1	1728	864	≥ 1
	3-20	8	12	QPSK	1/3	808	24	1	2304	1152	≥ 1
	3-20	9	12	QPSK	1/3	776	24	1	2592	1296	≥ 1
	3-20	10	12	QPSK	1/3	872	24	1	2880	1440	≥ 1
	3-20	12	12	QPSK	1/3	1224	24	1	3456	1728	≥ 1
	5-20	15	12	QPSK	1/3	1320	24	1	4320	2160	≥ 1
	5-20	16	12	QPSK	1/3	1384	24	1	4608	2304	≥ 1
	5-20	18	12	QPSK	1/3	1864	24	1	5184	2592	≥ 1
	5-20	20	12	QPSK	1/3	1736	24	1	5760	2880	≥ 1
	5-20	24	12	QPSK	1/3	2472	24	1	6912	3456	≥ 1
	10-20	25	12	QPSK	1/3	2216	24	1	7200	3600	≥ 1
	10-20	27	12	QPSK	1/3	2792	24	1	7776	3888	≥ 1
	10-20	30	12	QPSK	1/3	2664	24	1	8640	4320	≥ 1
	10-20	32	12	QPSK	1/3	2792	24	1	9216	4608	≥ 1
	10-20	36	12	QPSK	1/3	3752	24	1	10368	5184	≥ 1
	10-20	40	12	QPSK	1/3	4136	24	1	11520	5760	≥ 1
	10-20	45	12	QPSK	1/3	4008	24	1	12960	6480	≥ 1
	10-20	48	12	QPSK	1/3	4264	24	1	13824	6912	≥ 1
	15 - 20	50	12	QPSK	1/3	5160	24	1	14400	7200	≥ 1
	15 - 20	54	12	QPSK	1/3	4776	24	1	15552	7776	≥ 1
	15 - 20	60	12	QPSK	1/4	4264	24	1	17280	8640	≥ 1
	15 - 20	64	12	QPSK	1/4	4584	24	1	18432	9216	≥ 1
	15 - 20	72	12	QPSK	1/4	5160	24	1	20736	10368	≥ 1
	20	75	12	QPSK	1/5	4392	24	1	21600	10800	≥ 1
	20	80	12	QPSK	1/5	4776	24	1	23040	11520	≥ 1
	20	81	12	QPSK	1/5	4776	24	1	23328	11664	≥ 1
	20	90	12	QPSK	1/6	4008	24	1	25920	12960	≥ 1
	20	96	12	QPSK	1/6	4264	24	1	27648	13824	≥ 1

Note 1: If more than one Code Block is present, an additional CRC sequence of L = 24 Bits is attached to each Code Block (otherwise L = 0 Bit)

Table A.2.2.1-1a: Reference Channels for QPSK with partial RB allocation for UE UL category 0

Parameter	Ch BW	Allocated RBs	DFT-OFDM Symbols per Sub-Frame	Mod'n	Target Coding rate	Payload size	Transport block CRC	Number of code blocks per Sub-Frame (Note 1)	Total number of bits per Sub-Frame	Total symbols per Sub-Frame	UE UL Category
Unit	MHz					Bits	Bits		Bits		
	1.4 - 20	1	12	QPSK	1/3	72	24	1	288	144	0
	1.4 - 20	2	12	QPSK	1/3	176	24	1	576	288	0
	1.4 - 20	3	12	QPSK	1/3	256	24	1	864	432	0
	1.4 - 20	4	12	QPSK	1/3	392	24	1	1152	576	0
	1.4 - 20	5	12	QPSK	1/3	424	24	1	1440	720	0
	3-20	6	12	QPSK	1/3	600	24	1	1728	864	0
	3-20	8	12	QPSK	1/3	808	24	1	2304	1152	0
	3-20	9	12	QPSK	1/3	776	24	1	2592	1296	0
	3-20	10	12	QPSK	1/3	872	24	1	2880	1440	0
	3-20	12	12	QPSK	1/4	840	24	1	3456	1728	0
	5-20	15	12	QPSK	1/5	872	24	1	4320	2160	0
	5-20	16	12	QPSK	1/5	904	24	1	4608	2304	0
	5-20	18	12	QPSK	1/6	776	24	1	5184	2592	0
	5-20	20	12	QPSK	1/6	872	24	1	5760	2880	0
	5-20	24	12	QPSK	1/8	872	24	1	6912	3456	0
	10-20	25	12	QPSK	1/8	904	24	1	7200	3600	0
	10-20	27	12	QPSK	1/8	968	24	1	7776	3888	0
	10-20	30	12	QPSK	1/10	808	24	1	8640	4320	0

Note 1: If more than one Code Block is present, an additional CRC sequence of L = 24 Bits is attached to each Code Block (otherwise L = 0 Bit)

Note 2: For HD-FDD UE, the uplink subframes are scheduled at the 4th, 5th, 6th, 12th, 13th, 14th, 20th, 21st, 22nd, 28th, 29th, 30th, 36th, 37th, and 38th subframes every 40ms. Information bit payload is available if uplink subframe is scheduled.

Table A.2.2.1-1b: Reference Channels for QPSK with partial RB allocation for UE UL category M1

Parameter	Ch BW	Allocated RBs	DFT-OFDM Symbols per Sub-Frame	Mod'n	Target Coding rate	Payload size	Transport block CRC	Number of code blocks per Sub-Frame (Note 1)	Total number of bits per Sub-Frame	Total symbols per Sub-Frame	UE Category
Unit	MHz					Bits	Bits		Bits		
	1.4 - 20	1	12	QPSK	1/3	72	24	1	288	144	M1
	1.4 - 20	2	12	QPSK	1/3	176	24	1	576	288	M1
	1.4 - 20	3	12	QPSK	1/3	256	24	1	864	432	M1
	1.4 - 20	4	12	QPSK	1/3	392	24	1	1152	576	M1
	1.4 - 20	5	12	QPSK	1/3	424	24	1	1440	720	M1
	3-20	6	12	QPSK	1/3	600	24	1	1728	864	M1

Note 1: If more than one Code Block is present, an additional CRC sequence of L = 24 Bits is attached to each Code Block (otherwise L = 0 Bit).

Note 2: For HD-FDD UE, the uplink subframes are scheduled at the 4th, 5th and 6th subframes every 10ms for the channel bandwidth 5MHz/10MHz/15MHz/20MHz. For FD-FDD UE, the uplink subframes are scheduled at the 5th, 6th, and 7th subframes every 10ms for the channel bandwidth 1.4MHz/3MHz. Information bit payload is available if uplink subframe is scheduled.

A.2.2.2.2 16-QAM

Table A.2.2.2-1 Reference Channels for 16-QAM with partial RB allocation

Parameter	Ch BW	Allocated RBs	DFT-OFDM Symbols per Sub-Frame	Mod'n	Target Coding rate	Payload size	Transport block CRC	Number of code blocks per Sub-Frame (Note 1)	Total number of bits per Sub-Frame	Total symbols per Sub-Frame	UE Category
Unit	MHz					Bits	Bits		Bits		
	1.4 - 20	1	12	16QAM	3/4	408	24	1	576	144	≥ 1
	1.4 - 20	2	12	16QAM	3/4	840	24	1	1152	288	≥ 1
	1.4 - 20	3	12	16QAM	3/4	1288	24	1	1728	432	≥ 1
	1.4 - 20	4	12	16QAM	3/4	1736	24	1	2304	576	≥ 1
	1.4 - 20	5	12	16QAM	3/4	2152	24	1	2880	720	≥ 1
	3-20	6	12	16QAM	3/4	2600	24	1	3456	864	≥ 1
	3-20	8	12	16QAM	3/4	3496	24	1	4608	1152	≥ 1
	3-20	9	12	16QAM	3/4	3880	24	1	5184	1296	≥ 1
	3-20	10	12	16QAM	3/4	4264	24	1	5760	1440	≥ 1
	3-20	12	12	16QAM	3/4	5160	24	1	6912	1728	≥ 1
	5-20	15	12	16QAM	1/2	4264	24	1	8640	2160	≥ 1
	5-20	16	12	16QAM	1/2	4584	24	1	9216	2304	≥ 1
	5-20	18	12	16QAM	1/2	5160	24	1	10368	2592	≥ 1
	5-20	20	12	16QAM	1/3	4008	24	1	11520	2880	≥ 1
	5-20	24	12	16QAM	1/3	4776	24	1	13824	3456	≥ 1
	10-20	25	12	16QAM	1/3	4968	24	1	14400	3600	≥ 1
	10-20	27	12	16QAM	1/3	4776	24	1	15552	3888	≥ 1
	10-20	30	12	16QAM	3/4	12960	24	3	17280	4320	≥ 2
	10-20	32	12	16QAM	3/4	13536	24	3	18432	4608	≥ 2
	10-20	36	12	16QAM	3/4	15264	24	3	20736	5184	≥ 2
	10-20	40	12	16QAM	3/4	16992	24	3	23040	5760	≥ 2
	10-20	45	12	16QAM	3/4	19080	24	4	25920	6480	≥ 2
	10-20	48	12	16QAM	3/4	20616	24	4	27648	6912	≥ 2
	15 - 20	50	12	16QAM	3/4	21384	24	4	28800	7200	≥ 2
	15 - 20	54	12	16QAM	3/4	22920	24	4	31104	7776	≥ 2
	15 - 20	60	12	16QAM	2/3	23688	24	4	34560	8640	≥ 2
	15 - 20	64	12	16QAM	2/3	25456	24	4	36864	9216	≥ 2
	15 - 20	72	12	16QAM	1/2	20616	24	4	41472	10368	≥ 2
	20	75	12	16QAM	1/2	21384	24	4	43200	10800	≥ 2
	20	80	12	16QAM	1/2	22920	24	4	46080	11520	≥ 2
	20	81	12	16QAM	1/2	22920	24	4	46656	11664	≥ 2
	20	90	12	16QAM	2/5	20616	24	4	51840	12960	≥ 2
	20	96	12	16QAM	2/5	22152	24	4	55296	13824	≥ 2

Note 1: If more than one Code Block is present, an additional CRC sequence of L = 24 Bits is attached to each Code Block (otherwise L = 0 Bit)

Table A.2.2.2-1a Reference Channels for 16-QAM with partial RB allocation for UE UL category 0

Parameter	Ch BW	Allocated RBs	DFT-OFDM Symbols per Sub-Frame	Mod'n	Target Coding rate	Payload size	Transport block CRC	Number of code blocks per Sub-Frame (Note 1)	Total number of bits per Sub-Frame	Total symbols per Sub-Frame	UE UL Category
Unit	MHz					Bits	Bits		Bits		
	1.4 - 20	1	12	16QAM	3/4	408	24	1	576	144	0
	1.4 - 20	2	12	16QAM	3/4	840	24	1	1152	288	0
	1.4 - 20	4	12	16QAM	2/5	904	24	1	2304	576	0

Note 1: If more than one Code Block is present, an additional CRC sequence of L = 24 Bits is attached to each Code Block (otherwise L = 0 Bit)

Note 2: For HD-FDD UE, the uplink subframes are scheduled at the 4th, 5th, 6th, 12th, 13th, 14th, 20th, 21st, 22nd, 28th, 29th, 30th, 36th, 37th, and 38th subframes every 40ms. Information bit payload is available if uplink subframe is scheduled.

Table A.2.2.2-1b Reference Channels for 16-QAM with partial RB allocation for UE UL category M1

Parameter	Ch BW	Allocated RBs	DFT-OFDM Symbols per Sub-Frame	Mod'n	Target Coding rate	Payload size	Transport block CRC	Number of code blocks per Sub-Frame (Note 1)	Total number of bits per Sub-Frame	Total symbols per Sub-Frame	UE Category
Unit	MHz					Bits	Bits		Bits		
	1.4 - 20	1	12	16QAM	1/2	256	24	1	576	144	M1
	1.4 - 20	2	12	16QAM	1/2	552	24	1	1152	288	M1
	1.4 - 20	3	12	16QAM	1/2	840	24	1	1728	432	M1
	1.4 - 20	4	12	16QAM	2/5	904	24	1	2304	576	M1
Note 1:	If more than one Code Block is present, an additional CRC sequence of L = 24 Bits is attached to each Code Block (otherwise L = 0 Bit)										
Note 2:	For HD-FDD UE, the uplink subframes are scheduled at the 4th, 5th and 6th subframes every 10ms for the channel bandwidth 5MHz/10MHz/15MHz/20MHz. For TD-FDD UE, the uplink subframes are scheduled at the 5th, 6th, and 7th subframes every 10ms for the channel bandwidth 1.4MHz/3MHz. Information bit payload is available if uplink subframe is scheduled.										

A.2.2.2.3 64-QAM

Table A.2.2.2.3-1: Reference Channels for 64-QAM with partial RB allocation

Parameter	Ch BW	Allocated RBs	DFT-OFDM Symbols per Sub-Frame	Mod'n	Target Coding rate	Payload size	Transport block CRC	Number of code blocks per Sub-Frame (Note 1)	Total number of bits per Sub-Frame	Total symbols per Sub-Frame	UE Category (Note 2)	UE UL Category (Note 2)
Unit	MHz					Bits	Bits		Bits			
	1.4 - 20	1	12	64QAM	3/4	616	24	1	864	144	5,8	5, 8, 13, 14
	1.4 - 20	2	12	64QAM	3/4	1256	24	1	1728	288	5,8	5, 8, 13, 14
	1.4 - 20	3	12	64QAM	3/4	1864	24	1	2592	432	5,8	5, 8, 13, 14
	1.4 - 20	4	12	64QAM	3/4	2536	24	1	3456	576	5,8	5, 8, 13, 14
	1.4 - 20	5	12	64QAM	3/4	3112	24	1	4320	720	5,8	5, 8, 13, 14
	3-20	6	12	64QAM	3/4	3752	24	1	5184	864	5,8	5, 8, 13, 14
	3-20	8	12	64QAM	3/4	5160	24	1	6912	1152	5,8	5, 8, 13, 14
	3-20	9	12	64QAM	3/4	5736	24	1	7776	1296	5,8	5, 8, 13, 14
	3-20	10	12	64QAM	3/4	6200	24	2	8640	1440	5,8	5, 8, 13, 14
	3-20	12	12	64QAM	3/4	7480	24	2	10368	1728	5,8	5, 8, 13, 14
	5-20	15	12	64QAM	3/4	9528	24	2	12960	2160	5,8	5, 8, 13, 14
	5-20	16	12	64QAM	3/4	10296	24	2	13824	2304	5,8	5, 8, 13, 14
	5-20	18	12	64QAM	3/4	11448	24	2	15552	2592	5,8	5, 8, 13, 14
	5-20	20	12	64QAM	3/4	12576	24	3	17280	2880	5,8	5, 8, 13, 14
	5-20	24	12	64QAM	3/4	15264	24	3	20736	3456	5,8	5, 8, 13, 14
	10-20	25	12	64QAM	3/4	15840	24	3	21600	3600	5,8	5, 8, 13, 14
	10-20	27	12	64QAM	3/4	16992	24	3	23328	3888	5,8	5, 8, 13, 14
	10-20	30	12	64QAM	3/4	19080	24	4	25920	4320	5,8	5, 8, 13, 14
	10-20	32	12	64QAM	3/4	20616	24	4	27648	4608	5,8	5, 8, 13, 14
	10-20	36	12	64QAM	3/4	22920	24	4	31104	5184	5,8	5, 8, 13, 14
	10-20	40	12	64QAM	3/4	25456	24	5	34560	5760	5,8	5, 8, 13, 14
	10-20	45	12	64QAM	3/4	28336	24	5	38880	6480	5,8	5, 8, 13, 14
	10-20	48	12	64QAM	3/4	30576	24	5	41472	6912	5,8	5, 8, 13, 14
	15 - 20	50	12	64QAM	3/4	31704	24	6	43200	7200	5,8	5, 8, 13, 14
	15 - 20	54	12	64QAM	3/4	34008	24	6	46656	7776	5,8	5, 8, 13, 14
	15 - 20	60	12	64QAM	3/4	37888	24	7	51840	8640	5,8	5, 8, 13, 14
	15 - 20	64	12	64QAM	3/4	40576	24	7	55296	9216	5,8	5, 8, 13, 14
	15 - 20	72	12	64QAM	3/4	45352	24	8	62208	10368	5,8	5, 8, 13, 14
	20	75	12	64QAM	3/4	46888	24	8	64800	10800	5,8	5, 8, 13, 14
	20	80	12	64QAM	3/4	51024	24	9	69120	11520	5,8	5, 8, 13, 14

	20	81	12	64QAM	3/4	51024	24	9	69984	11664	5,8	5, 8, 13, 14
	20	90	12	64QAM	2/3	51024	24	9	77760	12960	5,8	5, 8, 13, 14
	20	96	12	64QAM	3/4	61664	24	11	82944	13824	5,8	5, 8, 13, 14
Note 1:	If more than one Code Block is present, an additional CRC sequence of L = 24 Bits is attached to each Code Block (otherwise L = 0 Bit)											
Note2:	If UE does not report UE UL category, then the applicability of reference channel is determined by UE category. If UE reports UE UL category, then the applicability of reference channel is determined by UE UL category											

A.2.2.3 Void

Table A.2.2.3-1: Void

A.2.3 Reference measurement channels for TDD

For TDD, the measurement channel is based on DL/UL configuration ratio of 2DL:2UL.

A.2.3.1 Full RB allocation

A.2.3.1.1 QPSK

Table A.2.3.1.1-1 Reference Channels for QPSK with full RB allocation

Parameter	Unit	Value					
		1.4	3	5	10	15	20
Channel bandwidth	MHz	1.4	3	5	10	15	20
Allocated resource blocks		6	15	25	50	75	100
Uplink-Downlink Configuration (Note 2)		1	1	1	1	1	1
DFT-OFDM Symbols per Sub-Frame		12	12	12	12	12	12
Modulation		QPSK	QPSK	QPSK	QPSK	QPSK	QPSK
Target Coding rate		1/3	1/3	1/3	1/3	1/5	1/6
Payload size							
For Sub-Frame 2,3,7,8	Bits	600	1544	2216	5160	4392	4584
Transport block CRC	Bits	24	24	24	24	24	24
Number of code blocks per Sub-Frame (Note 1)							
For Sub-Frame 2,3,7,8		1	1	1	1	1	1
Total number of bits per Sub-Frame							
For Sub-Frame 2,3,7,8	Bits	1728	4320	7200	14400	21600	28800
Total symbols per Sub-Frame							
For Sub-Frame 2,3,7,8		864	2160	3600	7200	10800	14400
UE Category		≥ 1	≥ 1	≥ 1	≥ 1	≥ 1	≥ 1
Note 1:	If more than one Code Block is present, an additional CRC sequence of L = 24 Bits is attached to each Code Block (otherwise L = 0 Bit)						
Note 2:	As per Table 4.2-2 in TS 36.211 [4]						

Table A.2.3.1.1-1a Reference Channels for QPSK with full/maximum RB allocation for UE UL category 0

Parameter	Unit	Value					
		1.4	3	5	10	15	20
Channel bandwidth	MHz	1.4	3	5	10	15	20
Allocated resource blocks		6	15	25	36	36	36
Uplink-Downlink Configuration (Note 2)		1	1	1	1	1	1
DFT-OFDM Symbols per Sub-Frame		12	12	12	12	12	12
Modulation		QPSK	QPSK	QPSK	QPSK	QPSK	QPSK
Target Coding rate		1/3	1/5	1/8	1/10	1/10	1/10
Payload size							
For Sub-Frame 2,3,7,8	Bits	600	872	904	1000	1000	1000
Transport block CRC	Bits	24	24	24	24	24	24
Number of code blocks per Sub-Frame (Note 1)							
For Sub-Frame 2,3,7,8		1	1	1	1	1	1
Total number of bits per Sub-Frame							
For Sub-Frame 2,3,7,8	Bits	1728	4320	7200	10368	10368	10368
Total symbols per Sub-Frame							
For Sub-Frame 2,3,7,8		864	2160	3600	5184	5184	5184
UE UL Category		0	0	0	0	0	0
NOTE 1: If more than one Code Block is present, an additional CRC sequence of L = 24 Bits is attached to each Code Block (otherwise L = 0 Bit)							
NOTE 2: As per Table 4.2-2 in TS 36.211							

Table A.2.3.1.1-1b Reference Channels for QPSK with full/maximum RB allocation for UE UL category M1

Parameter	Unit	Value					
		1.4	3	5	10	15	20
Channel bandwidth	MHz	1.4	3	5	10	15	20
Allocated resource blocks		6	6	6	6	6	6
Uplink-Downlink Configuration (Note 2)		1	1	1	1	1	1
DFT-OFDM Symbols per Sub-Frame		12	12	12	12	12	12
Modulation		QPSK	QPSK	QPSK	QPSK	QPSK	QPSK
Target Coding rate		1/3	1/3	1/3	1/3	1/3	1/3
Payload size							
For Sub-Frame 2,3,7,8	Bits	600	600	600	600	600	600
Transport block CRC	Bits	24	24	24	24	24	24
Number of code blocks per Sub-Frame (Note 1)							
For Sub-Frame 2,3,7,8		1	1	1	1	1	1
Total number of bits per Sub-Frame							
For Sub-Frame 2,3,7,8	Bits	1728	1728	1728	1728	1728	1728
Total symbols per Sub-Frame							
For Sub-Frame 2,3,7,8		864	864	864	864	864	864
UE UL Category		M1	M1	M1	M1	M1	M1
NOTE 1: If more than one Code Block is present, an additional CRC sequence of L = 24 Bits is attached to each Code Block (otherwise L = 0 Bit)							
NOTE 2: As per Table 4.2-2 in TS 36.211							

A.2.3.1.2 16-QAM

Table A.2.3.1.2-1: Reference Channels for 16-QAM with full RB allocation

Parameter	Unit	Value					
		1.4	3	5	10	15	20
Channel bandwidth	MHz	1.4	3	5	10	15	20
Allocated resource blocks		6	15	25	50	75	100
Uplink-Downlink Configuration (Note 2)		1	1	1	1	1	1
DFT-OFDM Symbols per Sub-Frame		12	12	12	12	12	12
Modulation		16QAM	16QAM	16QAM	16QAM	16QAM	16QAM
Target Coding rate		3/4	1/2	1/3	3/4	1/2	1/3
Payload size							
For Sub-Frame 2,3,7,8	Bits	2600	4264	4968	21384	21384	19848
Transport block CRC	Bits	24	24	24	24	24	24
Number of code blocks per Sub-Frame (Note 1)							
For Sub-Frame 2,3,7,8		1	1	1	4	4	4
Total number of bits per Sub-Frame							
For Sub-Frame 2,3,7,8	Bits	3456	8640	14400	28800	43200	57600
Total symbols per Sub-Frame							
For Sub-Frame 2,3,7,8		864	2160	3600	7200	10800	14400
UE Category		≥ 1	≥ 1	≥ 1	≥ 2	≥ 2	≥ 2
Note 1: If more than one Code Block is present, an additional CRC sequence of L = 24 Bits is attached to each Code Block (otherwise L = 0 Bit)							
Note 2: As per Table 4.2-2 in TS 36.211 [4]							

Table A.2.3.1.2-1a: Reference Channels for 16-QAM with maximum RB allocation for UE UL category 0

Parameter	Unit	Value					
		1.4	3	5	10	15	20
Channel bandwidth	MHz	1.4	3	5	10	15	20
Allocated resource blocks		5	5	5	5	5	5
Uplink-Downlink Configuration (Note 2)		1	1	1	1	1	1
DFT-OFDM Symbols per Sub-Frame		12	12	12	12	12	12
Modulation		16QAM	16QAM	16QAM	16QAM	16QAM	16QAM
Target Coding rate		1/3	1/3	1/3	1/3	1/3	1/3
Payload size							
For Sub-Frame 2,3,7,8	Bits	872	872	872	872	872	872
Transport block CRC	Bits	24	24	24	24	24	24
Number of code blocks per Sub-Frame (Note 1)							
For Sub-Frame 2,3,7,8		1	1	1	1	1	1
Total number of bits per Sub-Frame							
For Sub-Frame 2,3,7,8	Bits	2880	2880	2880	2880	2880	2880
Total symbols per Sub-Frame							
For Sub-Frame 2,3,7,8		720	720	720	720	720	720
UE UL Category		0	0	0	0	0	0
NOTE 1: If more than one Code Block is present, an additional CRC sequence of L = 24 Bits is attached to each Code Block (otherwise L = 0 Bit)							
NOTE 2: As per Table 4.2-2 in TS 36.211[4]							

Table A.2.3.1.2-1b: Reference Channels for 16-QAM with maximum RB allocation for UE UL category M1

Parameter	Unit	Value					
		1.4	3	5	10	15	20
Channel bandwidth	MHz	1.4	3	5	10	15	20
Allocated resource blocks		5	5	5	5	5	5
Uplink-Downlink Configuration (Note 2)		1	1	1	1	1	1
DFT-OFDM Symbols per Sub-Frame		12	12	12	12	12	12
Modulation		16QAM	16QAM	16QAM	16QAM	16QAM	16QAM
Target Coding rate		1/3	1/3	1/3	1/3	1/3	1/3
Payload size							
For Sub-Frame 2,3,7,8	Bits	872	872	872	872	872	872
Transport block CRC	Bits	24	24	24	24	24	24
Number of code blocks per Sub-Frame (Note 1)							
For Sub-Frame 2,3,7,8		1	1	1	1	1	1
Total number of bits per Sub-Frame							
For Sub-Frame 2,3,7,8	Bits	2880	2880	2880	2880	2880	2880
Total symbols per Sub-Frame							
For Sub-Frame 2,3,7,8		720	720	720	720	720	720
UE Category		M1	M1	M1	M1	M1	M1
NOTE 1: If more than one Code Block is present, an additional CRC sequence of L = 24 Bits is attached to each Code Block (otherwise L = 0 Bit)							
NOTE 2: As per Table 4.2-2 in TS 36.211[4]							

A.2.3.1.3 64-QAM

Table A.2.3.1.3-1: Reference Channels for 64-QAM with full RB allocation

Parameter	Unit	Value					
		1.4	3	5	10	15	20
Channel bandwidth	MHz	1.4	3	5	10	15	20
Allocated resource blocks		6	15	25	50	75	100
Uplink-Downlink Configuration (Note 2)		1	1	1	1	1	1
DFT-OFDM Symbols per Sub-Frame		12	12	12	12	12	12
Modulation		64QAM	64QAM	64QAM	64QAM	64QAM	64QAM
Target Coding rate		3/4	3/4	3/4	3/4	3/4	3/4
Payload size							
For Sub-Frame 2,3,7,8	Bits	3752	9528	15840	31704	46888	63776
Transport block CRC	Bits	24	24	24	24	24	24
Number of code blocks per Sub-Frame (Note 1)							
For Sub-Frame 2,3,7,8		1	2	3	6	8	11
Total number of bits per Sub-Frame							
For Sub-Frame 2,3,7,8	Bits	5184	12960	21600	43200	64800	86400
Total symbols per Sub-Frame							
For Sub-Frame 2,3,7,8		864	2160	3600	7200	10800	14400
UE Category (Note 3)		5, 8	5, 8	5, 8	5, 8	5, 8	5, 8
UE UL Category (Note 3)		5, 8, 13, 14	5, 8, 13, 14	5, 8, 13, 14	5, 8, 13, 14	5, 8, 13, 14	5, 8, 13, 14
Note 1: If more than one Code Block is present, an additional CRC sequence of L = 24 Bits is attached to each Code Block (otherwise L = 0 Bit)							
Note 2: As per Table 4.2-2 in TS 36.211 [4]							
Note 3: If UE does not report UE UL category, then the applicability of reference channel is determined by UE category. If UE reports UE UL category, then the applicability of reference channel is determined by UE UL category.							

A.2.3.2 Partial RB allocation

For each channel bandwidth, various partial RB allocations are specified. The number of allocated RBs is chosen according to values specified in the Tx and Rx requirements. The single allocated RB case is included.

The allocated RBs are contiguous and start from one end of the channel bandwidth. A single allocated RB is at one end of the channel bandwidth.

A.2.3.2.1 QPSK

Table A.2.3.2.1-1: Reference Channels for QPSK with partial RB allocation

Parameter	Ch BW	Allocated RBs	UDL Configuration (Note 2)	DFT-OFDM Symbols per Sub-Frame	Mod'n	Target Coding rate	Payload size for Sub-Frame 2, 3, 7, 8	Transport block CRC	Number of code blocks per Sub-Frame (Note 1)	Total number of bits per Sub-Frame for Sub-Frame 2, 3, 7, 8	Total symbols per Sub-Frame for Sub-Frame 2, 3, 7, 8	UE Category
Unit	MHz						Bits	Bits		Bits		
	1.4 - 20	1	1	12	QPSK	1/3	72	24	1	288	144	≥ 1
	1.4 - 20	2	1	12	QPSK	1/3	176	24	1	576	288	≥ 1
	1.4 - 20	3	1	12	QPSK	1/3	256	24	1	864	432	≥ 1
	1.4 - 20	4	1	12	QPSK	1/3	392	24	1	1152	576	≥ 1
	1.4 - 20	5	1	12	QPSK	1/3	424	24	1	1440	720	≥ 1
	3-20	6	1	12	QPSK	1/3	600	24	1	1728	864	≥ 1
	3-20	8	1	12	QPSK	1/3	808	24	1	2304	1152	≥ 1
	3-20	9	1	12	QPSK	1/3	776	24	1	2592	1296	≥ 1
	3-20	10	1	12	QPSK	1/3	872	24	1	2880	1440	≥ 1
	3-20	12	1	12	QPSK	1/3	1224	24	1	3456	1728	≥ 1
	5-20	15	1	12	QPSK	1/3	1320	24	1	4320	2160	≥ 1
	5-20	16	1	12	QPSK	1/3	1384	24	1	4608	2304	≥ 1
	5-20	18	1	12	QPSK	1/3	1864	24	1	5184	2592	≥ 1
	5-20	20	1	12	QPSK	1/3	1736	24	1	5760	2880	≥ 1
	5-20	24	1	12	QPSK	1/3	2472	24	1	6912	3456	≥ 1
	10-20	25	1	12	QPSK	1/3	2216	24	1	7200	3600	≥ 1
	10-20	27	1	12	QPSK	1/3	2792	24	1	7776	3888	≥ 1
	10-20	30	1	12	QPSK	1/3	2664	24	1	8640	4320	≥ 1
	10-20	32	1	12	QPSK	1/3	2792	24	1	9216	4608	≥ 1
	10-20	36	1	12	QPSK	1/3	3752	24	1	10368	5184	≥ 1
	10-20	40	1	12	QPSK	1/3	4136	24	1	11520	5760	≥ 1
	10-20	45	1	12	QPSK	1/3	4008	24	1	12960	6480	≥ 1
	10-20	48	1	12	QPSK	1/3	4264	24	1	13824	6912	≥ 1
	15 - 20	50	1	12	QPSK	1/3	5160	24	1	14400	7200	≥ 1
	15 - 20	54	1	12	QPSK	1/3	4776	24	1	15552	7776	≥ 1
	15 - 20	60	1	12	QPSK	1/4	4264	24	1	17280	8640	≥ 1
	15 - 20	64	1	12	QPSK	1/4	4584	24	1	18432	9216	≥ 1
	15 - 20	72	1	12	QPSK	1/4	5160	24	1	20736	10368	≥ 1
	20	75	1	12	QPSK	1/5	4392	24	1	21600	10800	≥ 1
	20	80	1	12	QPSK	1/5	4776	24	1	23040	11520	≥ 1
	20	81	1	12	QPSK	1/5	4776	24	1	23328	11664	≥ 1
	20	90	1	12	QPSK	1/6	4008	24	1	25920	12960	≥ 1
	20	96	1	12	QPSK	1/6	4264	24	1	27648	13824	≥ 1

Note 1: If more than one Code Block is present, an additional CRC sequence of L = 24 Bits is attached to each Code Block (otherwise L = 0 Bit)

Note 2: As per Table 4.2-2 in TS 36.211 [4]

Table A.2.3.2.1-1a: Reference Channels for QPSK with partial RB allocation for UE UL category 0

Parameter	Ch BW	Allocated RBs	UDL Configuration (Note 2)	DFT-OFDM Symbols per Sub-Frame	Mod'n	Target Coding rate	Payload size for Sub-Frame 2, 3, 7, 8	Transport block CRC	Number of code blocks per Sub-Frame (Note 1)	Total number of bits per Sub-Frame for Sub-Frame 2, 3, 7, 8	Total symbols per Sub-Frame for Sub-Frame 2, 3, 7, 8	UE UL Category
Unit	MHz						Bits	Bits		Bits		
	1.4 - 20	1	1	12	QPSK	1/3	72	24	1	288	144	0
	1.4 - 20	2	1	12	QPSK	1/3	176	24	1	576	288	0
	1.4 - 20	3	1	12	QPSK	1/3	256	24	1	864	432	0
	1.4 - 20	4	1	12	QPSK	1/3	392	24	1	1152	576	0
	1.4 - 20	5	1	12	QPSK	1/3	424	24	1	1440	720	0
	3-20	6	1	12	QPSK	1/3	600	24	1	1728	864	0
	3-20	8	1	12	QPSK	1/3	808	24	1	2304	1152	0
	3-20	9	1	12	QPSK	1/3	776	24	1	2592	1296	0
	3-20	10	1	12	QPSK	1/3	872	24	1	2880	1440	0
	3-20	12	1	12	QPSK	1/4	840	24	1	3456	1728	0
	5-20	15	1	12	QPSK	1/5	872	24	1	4320	2160	0
	5-20	16	1	12	QPSK	1/5	904	24	1	4608	2304	0
	5-20	18	1	12	QPSK	1/6	776	24	1	5184	2592	0
	5-20	20	1	12	QPSK	1/6	872	24	1	5760	2880	0
	5-20	24	1	12	QPSK	1/8	872	24	1	6912	3456	0
	10-20	25	1	12	QPSK	1/8	904	24	1	7200	3600	0
	10-20	27	1	12	QPSK	1/8	968	24	1	7776	3888	0
	10-20	30	1	12	QPSK	1/10	808	24	1	8640	4320	0
Note 1:	If more than one Code Block is present, an additional CRC sequence of L = 24 Bits is attached to each Code Block (otherwise L = 0 Bit)											
Note 2:	As per Table 4.2-2 in TS 36.211 [4]											

Table A.2.3.2.1-1b: Reference Channels for QPSK with partial RB allocation for UE UL category M1

Parameter	Ch BW	Allocated RBs	UDL Configuration (Note 2)	DFT-OFDM Symbols per Sub-Frame	Mod'n	Target Coding rate	Payload size for Sub-Frame 2, 3, 7, 8	Transport block CRC	Number of code blocks per Sub-Frame (Note 1)	Total number of bits per Sub-Frame for Sub-Frame 2, 3, 7, 8	Total symbols per Sub-Frame for Sub-Frame 2, 3, 7, 8	UE Category
Unit	MHz						Bits	Bits		Bits		
	1.4 - 20	1	1	12	QPSK	1/3	72	24	1	288	144	M1
	1.4 - 20	2	1	12	QPSK	1/3	176	24	1	576	288	M1
	1.4 - 20	3	1	12	QPSK	1/3	256	24	1	864	432	M1
	1.4 - 20	4	1	12	QPSK	1/3	392	24	1	1152	576	M1
	1.4 - 20	5	1	12	QPSK	1/3	424	24	1	1440	720	M1
	3-20	6	1	12	QPSK	1/3	600	24	1	1728	864	M1
Note 1:	If more than one Code Block is present, an additional CRC sequence of L = 24 Bits is attached to each Code Block (otherwise L = 0 Bit).											
Note 2:	As per Table 4.2-2 in TS 36.211 [4].											

A.2.3.2.2 16-QAM

Table A.2.3.2.2-1: Reference Channels for 16QAM with partial RB allocation

Parameter	Ch BW	Allocated RBs	UDL Configuration (Note 2)	DFT-OFDM Symbols per Sub-Frame	Mod'n	Target Coding rate	Payload size for Sub-Frame 2, 3, 7, 8	Transport block CRC	Number of code blocks per Sub-Frame (Note 1)	Total number of bits per Sub-Frame for Sub-Frame 2, 3, 7, 8	Total symbols per Sub-Frame for Sub-Frame 2, 3, 7, 8	UE Category
Unit	MHz						Bits	Bits		Bits		
	1.4 - 20	1	1	12	16QAM	3/4	408	24	1	576	144	≥ 1
	1.4 - 20	2	1	12	16QAM	3/4	840	24	1	1152	288	≥ 1
	1.4 - 20	3	1	12	16QAM	3/4	1288	24	1	1728	432	≥ 1
	1.4 - 20	4	1	12	16QAM	3/4	1736	24	1	2304	576	≥ 1
	1.4 - 20	5	1	12	16QAM	3/4	2152	24	1	2880	720	≥ 1
	3-20	6	1	12	16QAM	3/4	2600	24	1	3456	864	≥ 1
	3-20	8	1	12	16QAM	3/4	3496	24	1	4608	1152	≥ 1
	3-20	9	1	12	16QAM	3/4	3880	24	1	5184	1296	≥ 1
	3-20	10	1	12	16QAM	3/4	4264	24	1	5760	1440	≥ 1
	3-20	12	1	12	16QAM	3/4	5160	24	1	6912	1728	≥ 1
	5-20	15	1	12	16QAM	1/2	4264	24	1	8640	2160	≥ 1
	5-20	16	1	12	16QAM	1/2	4584	24	1	9216	2304	≥ 1
	5-20	18	1	12	16QAM	1/2	5160	24	1	10368	2592	≥ 1
	5-20	20	1	12	16QAM	1/3	4008	24	1	11520	2880	≥ 1
	5-20	24	1	12	16QAM	1/3	4776	24	1	13824	3456	≥ 1
	10-20	25	1	12	16QAM	1/3	4968	24	1	14400	3600	≥ 1
	10-20	27	1	12	16QAM	1/3	4776	24	1	15552	3888	≥ 1
	10-20	30	1	12	16QAM	3/4	12960	24	3	17280	4320	≥ 2
	10-20	32	1	12	16QAM	3/4	13536	24	3	18432	4608	≥ 2
	10-20	36	1	12	16QAM	3/4	15264	24	3	20736	5184	≥ 2
	10-20	40	1	12	16QAM	3/4	16992	24	3	23040	5760	≥ 2
	10-20	45	1	12	16QAM	3/4	19080	24	4	25920	6480	≥ 2
	10-20	48	1	12	16QAM	3/4	20616	24	4	27648	6912	≥ 2
	15 - 20	50	1	12	16QAM	3/4	21384	24	4	28800	7200	≥ 2
	15 - 20	54	1	12	16QAM	3/4	22920	24	4	31104	7776	≥ 2
	15 - 20	60	1	12	16QAM	2/3	23688	24	4	34560	8640	≥ 2
	15 - 20	64	1	12	16QAM	2/3	25456	24	4	36864	9216	≥ 2
	15 - 20	72	1	12	16QAM	1/2	20616	24	4	41472	10368	≥ 2
	20	75	1	12	16QAM	1/2	21384	24	4	43200	10800	≥ 2
	20	80	1	12	16QAM	1/2	22920	24	4	46080	11520	≥ 2
	20	81	1	12	16QAM	1/2	22920	24	4	46656	11664	≥ 2
	20	90	1	12	16QAM	2/5	20616	24	4	51840	12960	≥ 2
	20	96	1	12	16QAM	2/5	22152	24	4	55296	13824	≥ 2

Note 1: If more than one Code Block is present, an additional CRC sequence of L = 24 Bits is attached to each Code Block (otherwise L = 0 Bit)
 Note 2: As per Table 4.2-2 in TS 36.211 [4]

Table A.2.3.2.2-1a: Reference Channels for 16QAM with partial RB allocation UE UL category 0

Parameter	Ch BW	Allocated RBs	UDL Configuration (Note 2)	DFT-OFDM Symbols per Sub-Frame	Mod'n	Target Coding rate	Payload size for Sub-Frame 2, 3, 7, 8	Transport block CRC	Number of code blocks per Sub-Frame (Note 1)	Total number of bits per Sub-Frame for Sub-Frame 2, 3, 7, 8	Total symbols per Sub-Frame for Sub-Frame 2, 3, 7, 8	UE UL Category
Unit	MHz						Bits	Bits		Bits		
	1.4 - 20	1	1	12	16QAM	3/4	408	24	1	576	144	0
	1.4 - 20	2		12	16QAM	3/4	840	24	1	1152	288	0
	1.4 - 20	4		12	16QAM	2/5	904	24	1	2304	576	0

Note 1: If more than one Code Block is present, an additional CRC sequence of L = 24 Bits is attached to each Code Block (otherwise L = 0 Bit)
 Note 2: As per Table 4.2-2 in TS 36.211 [4]

Table A.2.3.2.2-1b: Reference Channels for 16QAM with partial RB allocation UE UL category M1

Parameter	Ch BW	Allocated RBs	UDL Configuration (Note 2)	DFT-OFDM Symbols per Sub-Frame	Mod'n	Target Coding rate	Payload size for Sub-Frame 2, 3, 7, 8	Transport block CRC	Number of code blocks per Sub-Frame (Note 1)	Total number of bits per Sub-Frame for Sub-Frame 2, 3, 7, 8	Total symbols per Sub-Frame for Sub-Frame 2, 3, 7, 8	UE Category
Unit	MHz						Bits	Bits		Bits		
	1.4 - 20	1	1	12	16QAM	1/2	256	24	1	576	144	M1
	1.4 - 20	2		12	16QAM	1/2	552	24	1	1152	288	M1
	1.4 - 20	3	1	12	16QAM	1/2	840	24	1	1728	432	M1
	1.4 - 20	4		12	16QAM	2/5	904	24	1	2304	576	M1
Note 1:	If more than one Code Block is present, an additional CRC sequence of L = 24 Bits is attached to each Code Block (otherwise L = 0 Bit).											
Note 2:	As per Table 4.2-2 in TS 36.211 [4].											

A.2.3.2.3 64-QAM

Table A.2.3.2.3-1: Reference Channels for 64-QAM with partial RB allocation

Parameter	Ch BW	Allocated RBs	DFT-OFDM Symbols per Sub-Frame	Mod'n	Target Coding rate	Payload size	Transport block CRC	Number of code blocks per Sub-Frame (Note 1)	Total number of bits per Sub-Frame	Total symbols per Sub-Frame	UE Category (Note 3)	UE UL Category (Note 3)
Unit	MHz					Bits	Bits		Bits			
	1.4 - 20	1	12	64QAM	3/4	616	24	1	864	144	5,8	5, 8, 13, 14
	1.4 - 20	2	12	64QAM	3/4	1256	24	1	1728	288	5,8	5, 8, 13, 14
	1.4 - 20	3	12	64QAM	3/4	1864	24	1	2592	432	5,8	5, 8, 13, 14
	1.4 - 20	4	12	64QAM	3/4	2536	24	1	3456	576	5,8	5, 8, 13, 14
	1.4 - 20	5	12	64QAM	3/4	3112	24	1	4320	720	5,8	5, 8, 13, 14
	3-20	6	12	64QAM	3/4	3752	24	1	5184	864	5,8	5, 8, 13, 14
	3-20	8	12	64QAM	3/4	5160	24	1	6912	1152	5,8	5, 8, 13, 14
	3-20	9	12	64QAM	3/4	5736	24	1	7776	1296	5,8	5, 8, 13, 14
	3-20	10	12	64QAM	3/4	6200	24	2	8640	1440	5,8	5, 8, 13, 14
	3-20	12	12	64QAM	3/4	7480	24	2	10368	1728	5,8	5, 8, 13, 14
	5-20	15	12	64QAM	3/4	9528	24	2	12960	2160	5,8	5, 8, 13, 14
	5-20	16	12	64QAM	3/4	10296	24	2	13824	2304	5,8	5, 8, 13, 14
	5-20	18	12	64QAM	3/4	11448	24	2	15552	2592	5,8	5, 8, 13, 14
	5-20	20	12	64QAM	3/4	12576	24	3	17280	2880	5,8	5, 8, 13, 14
	5-20	24	12	64QAM	3/4	15264	24	3	20736	3456	5,8	5, 8, 13, 14
	10-20	25	12	64QAM	3/4	15840	24	3	21600	3600	5,8	5, 8, 13, 14
	10-20	27	12	64QAM	3/4	16992	24	3	23328	3888	5,8	5, 8, 13, 14
	10-20	30	12	64QAM	3/4	19080	24	4	25920	4320	5,8	5, 8, 13, 14
	10-20	32	12	64QAM	3/4	20616	24	4	27648	4608	5,8	5, 8, 13, 14
	10-20	36	12	64QAM	3/4	22920	24	4	31104	5184	5,8	5, 8, 13, 14
	10-20	40	12	64QAM	3/4	25456	24	5	34560	5760	5,8	5, 8, 13, 14
	10-20	45	12	64QAM	3/4	28336	24	5	38880	6480	5,8	5, 8, 13, 14
	10-20	48	12	64QAM	3/4	30576	24	5	41472	6912	5,8	5, 8, 13, 14
	15 - 20	50	12	64QAM	3/4	31704	24	6	43200	7200	5,8	5, 8, 13, 14
	15 - 20	54	12	64QAM	3/4	34008	24	6	46656	7776	5,8	5, 8, 13, 14
	15 - 20	60	12	64QAM	3/4	37888	24	7	51840	8640	5,8	5, 8, 13, 14
	15 - 20	64	12	64QAM	3/4	40576	24	7	55296	9216	5,8	5, 8, 13, 14
	15 - 20	72	12	64QAM	3/4	45352	24	8	62208	10368	5,8	5, 8, 13, 14
	20	75	12	64QAM	3/4	46888	24	8	64800	10800	5,8	5, 8, 13, 14
	20	80	12	64QAM	3/4	51024	24	9	69120	11520	5,8	5, 8, 13, 14

	20	81	12	64QAM	3/4	51024	24	9	69984	11664	5,8	5, 8, 13, 14
	20	90	12	64QAM	3/4	51024	24	9	77760	12960	5,8	5, 8, 13, 14
	20	96	12	64QAM	3/4	61664	24	11	82944	13824	5,8	5, 8, 13, 14
Note 1:	If more than one Code Block is present, an additional CRC sequence of L = 24 Bits is attached to each Code Block (otherwise L = 0 Bit)											
Note 2:	As per Table 4.2-2 in TS 36.211 [4].											
Note 3:	If UE does not report UE UL category, then the applicability of reference channel is determined by UE category. If UE reports UE UL category, then the applicability of reference channel is determined by UE UL category											

A.2.3.3 Void

Table A.2.3.3-1: Void

A.2.4 Reference measurement channels for UE category NB1

Table A.2.4-1 Reference Channels for UE category NB1

Parameter	Value						
Sub-carrier spacing (kHz)	3.75	3.75	15	15	15	15	15
Number of tone	1	1	1	1	3	6	12
Modulation	$\pi/2$ BPSK	$\pi/4$ QPSK	$\pi/2$ BPSK	$\pi/4$ QPSK	QPSK	QPSK	QPSK
Number of NPUSCH repetition	1	1	1	1	1	1	1
IMCS / ITBS	0 / 0	3 / 3	0 / 0	3 / 3	5 / 5	5 / 5	5 / 5
Payload size (bits)	32	40	32	40	72	72	72
Allocated resource unit	2	1	2	1	1	1	1
Code rate (target)	1/3	1/3	1/3	1/3	1/3	1/3	1/3
Code rate (effective)	0.29	0.33	0.29	0.33	0.33	0.33	0.33
Transport block CRC (bits)	24	24	24	24	24	24	24
Code block CRC size (bits)	0	0	0	0	0	0	0
Number of code blocks – C	1	1	1	1	1	1	1
Total number of bits per resource unit	96	192	96	192	288	288	288
Total symbols per resource unit	96	96	96	96	144	144	144
Tx time (ms)	64	32	16	8	4	2	1
NOTE 1:	If more than one Code Block is present, an additional CRC sequence of L = 24 Bits is attached to each Code Block (otherwise L = 0 Bit)						
NOTE 2:	Parameters related to NPUSCH format 1 scheduling are defined in Table A.2.4-2.						
NOTE 3:	NPDCCH is not transmitted in the subframes used for transmission of SI messages.						
NOTE 4:	SI messages transmission should be prioritized over NPDCCH transmission in case of collision. NPDCCH transmission is postponed until the next NB-IoT downlink subframe in case NPDCCH transmission occurs in a non NB-IoT downlink subframe, where an NB-IoT downlink subframe is a subframe that does not contain NPSS/NSSS/NPBCH/SIB1-NB transmission.						

Table A.2.4-2: NPDCCH configuration for NPUSCH format 1 scheduling

Parameter	Unit	Value
DCI format		DCI format N0
NPDCCH format		1
Scheduling delay (I_{Delay})		0
DCI subframe repetition number		00
R_{max} (<i>npdcch-NumRepetitions</i>)		1
G (<i>NPDCCH-startSF-USS</i>)		8
α_{offset} (<i>npdcch-Offset-USS</i>)		1/4

A.3 DL reference measurement channels

A.3.1 General

The number of available channel bits varies across the sub-frames due to PBCH and PSS/SSS overhead. The payload size per sub-frame is varied in order to keep the code rate constant throughout a frame.

Unless otherwise stated, no user data is scheduled on subframes #5 in order to facilitate the transmission of system information blocks (SIB).

The algorithm for determining the payload size A is as follows; given a desired coding rate R and radio block allocation N_{RB}

1. Calculate the number of channel bits N_{ch} that can be transmitted during the first transmission of a given sub-frame.
2. Find A such that the resulting coding rate is as close to R as possible, that is,

$$\min |R - (A + 24 * (N_{\text{CB}} + 1)) / N_{\text{ch}}|, \text{ where } N_{\text{CB}} = \begin{cases} 0, & \text{if } C = 1 \\ C, & \text{if } C > 1 \end{cases}$$

subject to

- a) A is a valid TB size according to section 7.1.7 of TS 36.213 [6] assuming an allocation of N_{RB} resource blocks.
 - b) C is the number of Code Blocks calculated according to section 5.1.2 of TS 36.212 [5].
3. If there is more than one A that minimizes the equation above, then the larger value is chosen per default and the chosen code rate should not exceed 0.93.
 4. For TDD, the measurement channel is based on DL/UL configuration ratio of 2DL+DwPTS (12 OFDM symbol):
2UL

A.3.1.1 Overview of DL reference measurement channels

In Table A.3.1.1-1 to A.3.1.1-1V are listed the DL reference measurement channels specified in annexes A.3.2 to A.3.10 of this release of TS 36.101. This table is informative and serves only to a better overview. The reference for the concrete reference measurement channels and corresponding implementation's parameters as to be used for requirements are annexes A.3.2 to A.3.10 as appropriate.

Table A.3.1.1-1: Overview of DL reference measurement channels (FDD, Receiver requirements)

Duplex	Table	Name	BW	Mod	TCR	RB	RB Off set	UE Cat eg	Notes
FDD	Table A.3.2-1		1.4	QPSK	1/3	6		≥ 1	
FDD	Table A.3.2-1		3	QPSK	1/3	15		≥ 1	
FDD	Table A.3.2-1		5	QPSK	1/3	25		≥ 1	
FDD	Table A.3.2-1		10	QPSK	1/3	50		≥ 1	
FDD	Table A.3.2-1		15	QPSK	1/3	75		≥ 1	
FDD	Table A.3.2-1		20	QPSK	1/3	100		≥ 1	
FDD / HD-FDD	Table A.3.2-1a		1.4	QPSK	1/3	6		-	UE DL Category 0
FDD / HD-FDD	Table A.3.2-1a		3	QPSK	1/3	14		-	UE DL Category 0
FDD / HD-FDD	Table A.3.2-1a		5	QPSK	1/3	14		-	UE DL Category 0
FDD / HD-FDD	Table A.3.2-1a		10	QPSK	1/3	14		-	UE DL Category 0
FDD / HD-FDD	Table A.3.2-1a		15	QPSK	1/3	14		-	UE DL Category 0
FDD / HD-FDD	Table A.3.2-1a		20	QPSK	1/3	14		-	UE DL Category 0
FDD / HD-FDD	Table A.3.2-1b		1.4	QPSK	1/3	4		M1	
FDD / HD-FDD	Table A.3.2-1b		3	QPSK	1/3	4		M1	
FDD / HD-FDD	Table A.3.2-1b		5	QPSK	1/3	4		M1	
FDD / HD-FDD	Table A.3.2-1b		10	QPSK	1/3	4		M1	
FDD / HD-FDD	Table A.3.2-1b		15	QPSK	1/3	4		M1	
FDD / HD-FDD	Table A.3.2-1b		20	QPSK	1/3	4		M1	
HD-FDD	Table A.3.2-1c		0.2	QPSK	1/3	1		NB1	
HD-FDD	Table A.3.2-1d		0.2	QPSK	1/3	1		NB1	

Table A.3.1.1-1A: Overview of DL reference measurement channels (TDD, Receiver requirements)

Duplex	Table	Name	BW	Mod	TCR	RB	RB Off set	UE Cat eg	Notes
TDD	Table A.3.2-2		1.4	QPSK	1/3	6		≥ 1	
TDD	Table A.3.2-2		3	QPSK	1/3	15		≥ 1	
TDD	Table A.3.2-2		5	QPSK	1/3	25		≥ 1	
TDD	Table A.3.2-2		10	QPSK	1/3	50		≥ 1	
TDD	Table A.3.2-2		15	QPSK	1/3	75		≥ 1	
TDD	Table A.3.2-2		20	QPSK	1/3	100		≥ 1	
TDD	Table A.3.2-2a		1.4	QPSK	1/3	6		-	UE DL Category 0
TDD	Table A.3.2-2a		3	QPSK	1/3	14		-	UE DL Category 0
TDD	Table A.3.2-2a		5	QPSK	1/3	14		-	UE DL Category 0
TDD	Table A.3.2-2a		10	QPSK	1/3	14		-	UE DL Category 0
TDD	Table A.3.2-2a		15	QPSK	1/3	14		-	UE DL Category 0
-	Table A.3.2-2a		20	QPSK	1/3	14		-	UE DL Category 0
TDD Band 46	Table A.3.2-2c		20	QPSK	1/3	100		≥ 3	
TDD	Table A.3.2-2b		1.4	QPSK	1/3	4		M1	
TDD	Table A.3.2-2b		3	QPSK	1/3	4		M1	
TDD	Table A.3.2-2b		5	QPSK	1/3	4		M1	
TDD	Table A.3.2-2b		10	QPSK	1/3	4		M1	
TDD	Table A.3.2-2b		15	QPSK	1/3	4		M1	
TDD	Table A.3.2-2b		20	QPSK	1/3	4		M1	

Table A.3.1.1-1B: Overview of DL reference measurement channels (FDD, Receiver requirements, Maximum input level)

Duplex	Table	Name	BW	Mod	TCR	RB	RB Off set	UE Cat eg	Notes
UE Categories ≥ 3									
FDD	Table A.3.2-3		1.4	64QAM	3/4	6		-	
FDD	Table A.3.2-3		3	64QAM	3/4	15		-	
FDD	Table A.3.2-3		5	64QAM	3/4	25		-	
FDD	Table A.3.2-3		10	64QAM	3/4	50		-	
FDD	Table A.3.2-3		15	64QAM	3/4	75		-	
FDD	Table A.3.2-3		20	64QAM	3/4	100		-	
UE Category 1									
FDD	Table A.3.2-3a		1.4	64QAM	3/4	6		-	
FDD	Table A.3.2-3a		3	64QAM	3/4	15		-	
FDD	Table A.3.2-3a		5	64QAM	3/4	18		-	
FDD	Table A.3.2-3a		10	64QAM	3/4	17		-	
FDD	Table A.3.2-3a		15	64QAM	3/4	17		-	
FDD	Table A.3.2-3a		20	64QAM	3/4	17		-	
UE Category 2									
FDD	Table A.3.2-3b		1.4	64QAM	3/4	6		-	
FDD	Table A.3.2-3b		3	64QAM	3/4	15		-	
FDD	Table A.3.2-3b		5	64QAM	3/4	25		-	
FDD	Table A.3.2-3b		10	64QAM	3/4	50		-	
FDD	Table A.3.2-3b		15	64QAM	3/4	75		-	
FDD	Table A.3.2-3b		20	64QAM	3/4	83		-	
UE DL Category 0									
FDD	Table A.3.2-3c		1.4	64QAM	3/4	2		-	
FDD	Table A.3.2-3c		3	64QAM	3/4	2		-	
FDD	Table A.3.2-3c		5	64QAM	3/4	2		-	
FDD	Table A.3.2-3c		10	64QAM	3/4	2		-	
FDD	Table A.3.2-3c		15	64QAM	3/4	2		-	
FDD	Table A.3.2-3c		20	64QAM	3/4	2		-	
UE DL Category M1									
FDD/HD-FDD	Table A.3.2-3d		1.4	16QAM	3/5	2		-	
FDD/HD-FDD	Table A.3.2-3d		3	16QAM	3/5	2		-	
FDD/HD-FDD	Table A.3.2-3d		5	16QAM	3/5	2		-	
FDD/HD-FDD	Table A.3.2-3d		10	16QAM	3/5	2		-	
FDD/HD-FDD	Table A.3.2-3d		15	16QAM	3/5	2		-	
FDD/HD-FDD	Table A.3.2-3d		20	16QAM	3/5	2		-	

Table A.3.1.1-1C: Overview of DL reference measurement channels (TDD, Receiver requirements, Maximum input level)

Duplex	Table	Name	BW	Mod	TCR	RB	RB Off set	UE Cat eg	Notes
UE Categories ≥ 3									
TDD	Table A.3.2-4		1.4	64QAM	3/4	6		-	
TDD	Table A.3.2-4		3	64QAM	3/4	15		-	
TDD	Table A.3.2-4		5	64QAM	3/4	25		-	
TDD	Table A.3.2-4		10	64QAM	3/4	50		-	
TDD	Table A.3.2-4		15	64QAM	3/4	75		-	
TDD	Table A.3.2-4		20	64QAM	3/4	100		-	
TDD Band 46	Table A.3.2-4d		20	64QAM	3/4	100		-	
UE Category 1									
TDD	Table A.3.2-4a		1.4	64QAM	3/4	6		-	
TDD	Table A.3.2-4a		3	64QAM	3/4	15		-	
TDD	Table A.3.2-4a		5	64QAM	3/4	18		-	
TDD	Table A.3.2-4a		10	64QAM	3/4	17		-	
TDD	Table A.3.2-4a		15	64QAM	3/4	17		-	
TDD	Table A.3.2-4a		20	64QAM	3/4	17		-	
UE Category 2									
TDD	Table A.3.2-4b		1.4	64QAM	3/4	6		-	
TDD	Table A.3.2-4b		3	64QAM	3/4	15		-	
TDD	Table A.3.2-4b		5	64QAM	3/4	25		-	
TDD	Table A.3.2-4b		10	64QAM	3/4	50		-	
TDD	Table A.3.2-4b		15	64QAM	3/4	75		-	
TDD	Table A.3.2-4b		20	64QAM	3/4	83		-	
UE DL Category 0									
TDD	Table A.3.2-4c		1.4	64QAM	3/4	2		-	
TDD	Table A.3.2-4c		3	64QAM	3/4	2		-	
TDD	Table A.3.2-4c		5	64QAM	3/4	2		-	
TDD	Table A.3.2-4c		10	64QAM	3/4	2		-	
TDD	Table A.3.2-4c		15	64QAM	3/4	2		-	
TDD	Table A.3.2-4c		20	64QAM	3/4	2		-	
UE Categories 11/12 and UE DL categories ≥ 11									
FDD	Table A.3.2-5		1.4	256QAM	4/5	6		-	
FDD	Table A.3.2-5		3	256QAM	4/5	15		-	
FDD	Table A.3.2-5		5	256QAM	4/5	25		-	
FDD	Table A.3.2-5		10	256QAM	4/5	50		-	
FDD	Table A.3.2-5		15	256QAM	4/5	75		-	
FDD	Table A.3.2-5		20	256QAM	4/5	100		-	
UE Categories 11/12 and UE DL categories ≥ 11									
TDD	Table A.3.2-6		1.4	256QAM	4/5	6		-	
TDD	Table A.3.2-6		3	256QAM	4/5	15		-	
TDD	Table A.3.2-6		5	256QAM	4/5	25		-	
TDD	Table A.3.2-6		10	256QAM	4/5	50		-	
TDD	Table A.3.2-6		15	256QAM	4/5	75		-	
TDD	Table A.3.2-6		20	256QAM	4/5	100		-	

TDD Band 46	Table A.3.2-7		20	256QAM	4/5	100		-	
UE DL Category M1									
TDD	Table A.3.2-4e		1.4	16QAM	3/5	2		-	
TDD	Table A.3.2-4e		3	16QAM	3/5	2		-	
TDD	Table A.3.2-4e		5	16QAM	3/5	2		-	
TDD	Table A.3.2-4e		10	16QAM	3/5	2		-	
TDD	Table A.3.2-4e		15	16QAM	3/5	2		-	
TDD	Table A.3.2-4e		20	16QAM	3/5	2		-	

Table A.3.1.1-1D: Overview of DL reference measurement channels (FDD, PDSCH Performance, Single-antenna transmission (CRS))

Duplex	Table	Name	BW	Mod	TCR	RB	RB Off set	UE Cat eg	Notes
FDD	Table A.3.3.1-1	R.4 FDD	1.4	QPSK	1/3	6		≥ 1	
FDD	Table A.3.3.1-1	R.42 FDD	20	QPSK	1/3	100		≥ 1	
FDD	Table A.3.3.1-1	R.42-1 FDD	3	QPSK	1/3	15		≥ 1	
FDD	Table A.3.3.1-1	R.42-2 FDD	5	QPSK	1/3	25		≥ 1	
FDD	Table A.3.3.1-1	R.42-3 FDD	15	QPSK	1/3	75		≥ 1	
FDD	Table A.3.3.1-1	R.2 FDD	10	QPSK	1/3	50		≥ 1	
FDD	Table A.3.3.1-2	R.3-1 FDD	5	16QAM	1/2	25		≥ 1	
FDD	Table A.3.3.1-2	R.3 FDD	10	16QAM	1/2	50		≥ 2	
FDD	Table A.3.3.1-3	R.5 FDD	3	64QAM	3/4	15		≥ 1	
FDD	Table A.3.3.1-3	R.6 FDD	5	64QAM	3/4	25		≥ 2	
FDD	Table A.3.3.1-3	R.7 FDD	10	64QAM	3/4	50		≥ 2	
FDD	Table A.3.3.1-3	R.8 FDD	15	64QAM	3/4	75		≥ 2	
FDD	Table A.3.3.1-3	R.9 FDD	20	64QAM	3/4	100		≥ 3	
FDD	Table A.3.3.1-3a	R.6-1 FDD	5	64QAM	3/4	18		≥ 1	
FDD	Table A.3.3.1-3a	R.7-1 FDD	10	64QAM	3/4	17		≥ 1	
FDD	Table A.3.3.1-3a	R.8-1 FDD	15	64QAM	3/4	17		≥ 1	
FDD	Table A.3.3.1-3a	R.9-1 FDD	20	64QAM	3/4	17		≥ 1	
FDD	Table A.3.3.1-3a	R.9-2 FDD	20	64QAM	3/4	83		≥ 2	
FDD	Table A.3.3.1-6	R.41 FDD	10	QPSK	1/10	50		≥ 1	
Single PRB (Channel edge)									
FDD	Table A.3.3.1-4	R.0 FDD	3	16QAM	1/2	1		≥ 1	
FDD	Table A.3.3.1-4	R.1 FDD	10/ 20	16QAM	1/2	1		≥ 1	
Single PRB (MBSFN Configuration)									
FDD	Table A.3.3.1-5	R.29 FDD	10	16QAM	1/2	1		≥ 1	

Table A.3.1.1-1E: Overview of DL reference measurement channels (PDSCH Performance: Carrier aggregation with power imbalance)

Duplex	Table	Name	BW	Mod	TCR	RB	RB Off set	UE Cat eg	Notes
FDD									
FDD	Table A.3.3.1-7	R.49 FDD	20	64QAM	0.84-0.87	100		≥ 5	
FDD	Table A.3.3.1-7	R.49-1 FDD	10	64QAM	0.84-0.87	50		≥ 2	
FDD	Table A.3.3.1-7	R.49-2 FDD	5	64QAM	0.84-0.86	25		≥ 2	
TDD									
TDD	Table A.3.4.1-7	R.49 TDD	20	64QAM	0.81-0.87	100		≥ 5	
TDD	Table A.3.4.1-7	R.49-1 TDD	15	64QAM	0.80-0.86	75		≥ 3	

Table A.3.1.1-1F: Overview of DL reference measurement channels (FDD, PDSCH Performance, Multi-antenna transmission (CRS))

Duplex	Table	Name	BW	Mod	TCR	RB	RB Off set	UE Cat eg	Notes
Two antenna ports									
FDD	Table A.3.3.2.1-1	R.10 FDD	10	QPSK	1/3	50		≥ 1	
FDD	Table A.3.3.2.1-1	R.11 FDD	10	16QAM	1/2	50		≥ 2	
FDD	Table A.3.3.2.1-1	R.11-1 FDD	10	16QAM	1/2	50		≥ 2	
FDD	Table A.3.3.2.1-1	R.11-2 FDD	5	16QAM	1/2	25		≥ 1	
FDD	Table A.3.3.2.1-1	R.11-3 FDD	10	16QAM	1/2	40		≥ 1	
FDD	Table A.3.3.2.1-1	R.11-4 FDD	10	QPSK	1/2	50		≥ 1	
FDD	Table A.3.3.2.1-1	R.30 FDD	20	16QAM	1/2	100		≥ 2	
FDD	Table A.3.3.2.1-1	R.30-1 FDD	15	16QAM	1/2	75		≥ 2	
FDD	Table A.3.3.2.1-1	R.35 FDD	10	64QAM	1/2	50		≥ 2	
FDD	Table A.3.3.2.1-1	R.35-1 FDD	20	64QAM	0.39	100		4	
FDD	Table A.3.3.2.1-1	R.35-2 FDD	15	64QAM	0.39	75		≥ 2	
FDD	Table A.3.3.2.1-1	R.35-3 FDD	10	64QAM	0.39	50		≥ 2	
FDD	Table A.3.3.2.1-2	R.35-4 FDD	10	64QAM	0.47	50		≥ 2	
FDD	Table A.3.3.2.1-2	R.46 FDD	10	QPSK		50		≥ 1	
FDD	Table A.3.3.2.1-2	R.47 FDD	10	16QAM		50		≥ 1	
FDD	Table A.3.3.2.1-2	R.11-5 FDD	1.4	16QAM	1/2	6		≥ 1	
FDD	Table A.3.3.2.1-2	R.11-6 FDD	3	16QAM	1/2	15		≥ 1	
FDD	Table A.3.3.2.1-2	R.11-7 FDD	15	16QAM	1/2	75		≥ 2	
FDD	Table A.3.3.2.1-2	R.11-8 FDD	10	QPSK	3/5	50		≥ 2	
FDD	Table A.3.3.2.1-2	R.11-9 FDD	10	QPSK	0.58	50		≥ 1	
FDD	Table A.3.3.2.1-2	R.11-10 FDD	10	QPSK	0.67	50		≥ 1	
FDD	Table A.3.3.2.1-2	R.10-2 FDD	5	QPSK	1/3	25		≥ 1	
FDD	Table A.3.3.2.1-2	R.10-3 FDD	10	16QAM	0.58	50		≥ 2	

FDD	Table A.3.3.2.1-2	R.65 FDD	10	256QAM	0.55	50		11-15	
FDD	Table A.3.3.2.1-3	R.62 FDD	10	16QAM	1/2	3		0	
FDD	Table A.3.3.2.1-3	R.63 FDD	10	64QAM	1/2	1		0	
FDD	Table A.3.3.2.1-4	R.79 FDD	10	16QAM	1/2	3		M1, ≥ 0	
FDD	Table A.3.3.2.1-5	R.81 FDD	10	QPSK	1/10	6		M1, ≥ 0	
Four antenna ports									
FDD	Table A.3.3.2.2-1	R.12 FDD	1.4	QPSK	1/3	6		≥ 1	
FDD	Table A.3.3.2.2-1	R.13 FDD	10	QPSK	1/3	50		≥ 1	
FDD	Table A.3.3.2.2-1	R.14 FDD	10	16QAM	1/2	50		≥ 2	
FDD	Table A.3.3.2.2-1	R.14-1 FDD	10	16QAM	1/2	6		≥ 1	
FDD	Table A.3.3.2.2-1	R.14-2 FDD	10	16QAM	1/2	3		≥ 1	
FDD	Table A.3.3.2.2-1	R.14-3 FDD	20	16QAM	1/2	100		≥ 2	
FDD	Table A.3.3.2.2-1	R.36 FDD	10	64QAM	1/2	50		≥ 2	
FDD	Table A.3.3.2.2-1	R.14-4 FDD	1.4	16QAM	1/2	6		≥ 1	
FDD	Table A.3.3.2.2-1	R.14-5 FDD	3	16QAM	1/2	15		≥ 1	
FDD	Table A.3.3.2.2-1	R.14-6 FDD	5	16QAM	1/2	25		≥ 1	
FDD	Table A.3.3.2.2-1	R.14-7 FDD	15	16QAM	1/2	75		≥ 2	
FDD	Table A.3.3.2.2-1	R.72 FDD	10	256QAM	0.62	50		≥ 11	
FDD	Table A.3.3.2.2-1	R.73 FDD	10	64QAM	0.43	50		≥ 5	
FDD	Table A.3.3.2.2-1	R.74 FDD	10	16QAM	1/2	50		≥ 5	

Table A.3.1.1-1G: Overview of DL reference measurement channels (FDD, PDSCH Performance (UE specific RS))

Duplex	Table	Name	BW	Mod	TCR	RB	RB Off set	UE Cat eg	Notes
Without CSI-RS									
FDD	Table A.3.3.3.0-1	R.70 FDD	10	QPSK	0.65	50		≥ 1	
FDD	Table A.3.3.3.0-1	R.71 FDD	10	16QAM	0.6	50		≥ 2	
FDD	Table A.3.3.3.0-2	R.80 FDD	10	QPSK	1/3	6		M1, ≥ 0	
Two antenna ports (CSI-RS)									
FDD	Table A.3.3.3.1-1	R.51 FDD	10	16QAM	1/2	50		≥ 2	
FDD	Table A.3.3.3.1-1	R.51-1 FDD	10	16QAM	0.54	50		≥ 2	

FDD	Table A.3.3.3.1-1	R.76 FDD	10	QPSK		50		≥ 2	
Two antenna ports (CSI-RS, non Quasi Co-located)									
FDD	Table A.3.3.3.1-2	R.52 FDD	10	64QAM	1/2	50		≥ 2	
FDD	Table A.3.3.3.1-2	R.52-1 FDD	10	16QAM	0.54	50		≥ 2	
FDD	Table A.3.3.3.1-2	R.53 FDD	10	64QAM	1/2	50		≥ 2	
FDD	Table A.3.3.3.1-2	R.54 FDD	10	16QAM	1/2	50		≥ 2	
Four antenna ports (CSI-RS)									
FDD	Table A.3.3.3.2-1	R.43 FDD	10	QPSK	1/3	50		≥ 1	
FDD	Table A.3.3.3.2-1	R.50 FDD	10	64QAM	1/2	50		≥ 2	
FDD	Table A.3.3.3.2-2	R.50A-1 FDD	10	64QAM	1/2	50		≥ 2	
FDD	Table A.3.3.3.2-2	R.44 FDD	10	QPSK	1/3	50		≥ 1	
FDD	Table A.3.3.3.2-2	R.45 FDD	10	16QAM	1/2	50		≥ 2	
FDD	Table A.3.3.3.2-2	R.45-1 FDD	10	16QAM	1/2	39		≥ 1	
FDD	Table A.3.3.3.2-1	R.48 FDD	10	QPSK		50		≥ 1	
FDD	Table A.3.3.3.2-2	R.60 FDD	10	QPSK	1/2	50		≥ 1	
FDD	Table A.3.3.3.2-3	R.64 FDD	10	QPSK	1/3	6		0	
FDD	Table A.3.3.3.2-1	R.66 FDD	10	256QAM	0.77	50		11-15	
FDD	Table A.3.3.3.2-4	R.69 FDD	10	QPSK	0.74-0.8	50		≥ 1	
FDD	Table A.3.3.3.2-1	R.75 FDD	10	16QAM	0.57	50		≥ 5	
Eight antenna ports (CSI-RS)									
FDD	Table A.3.3.3.2A-1	R.50A-2 FDD	10	64QAM	1/2	50		≥ 2	
FDD	Table A.3.3.3.2A-1	R.50A-3 FDD	10	64QAM	1/2	50		≥ 2	
Twelve antenna ports (CSI-RS)									
FDD	Table A.3.3.3.3-1	R.77 FDD	10	64QAM	1/2	50		≥ 2	
Sixteen antenna ports (CSI-RS)									
FDD	Table A.3.3.3.4-1	R.78 FDD	10	16QAM	1/2	50		≥ 2	

Table A.3.1.1-1H: Overview of DL reference measurement channels (TDD, PDSCH Performance, Single-antenna transmission (CRS))

Duplex	Table	Name	BW	Mod	TCR	RB	RB Off set	UE Cat eg	Notes
TDD	Table A.3.4.1-1	R.4 TDD	1.4	QPSK	1/3	6		≥ 1	
TDD	Table A.3.4.1-1	R.42 TDD	20	QPSK	1/3	100		≥ 1	
TDD	Table A.3.4.1-1	R.2 TDD	10	QPSK	1/3	50		≥ 1	
TDD	Table A.3.4.1-1	R.2A TDD	10	QPSK	1/3	50		≥ 1	
TDD	Table A.3.4.1-1	R.42-1 TDD	3	QPSK	1/3	15		≥ 1	
TDD	Table A.3.4.1-1	R.42-2 TDD	5	QPSK	1/3	25		≥ 1	
TDD	Table A.3.4.1-1	R.42-3 TDD	15	QPSK	1/3	75		≥ 1	
TDD	Table A.3.4.1-2	R.3-1 TDD	5	16QAM	1/2	25		≥ 1	
TDD	Table A.3.4.1-2	R.3 TDD	10	16QAM	1/2	50		≥ 2	
TDD	Table A.3.4.1-3	R.5 TDD	3	64QAM	3/4	15		≥ 1	
TDD	Table A.3.4.1-3	R.6 TDD	5	64QAM	3/4	25		≥ 2	
TDD	Table A.3.4.1-3	R.7 TDD	10	64QAM	3/4	50		≥ 2	
TDD	Table A.3.4.1-3	R.8 TDD	15	64QAM	3/4	75		≥ 2	
TDD	Table A.3.4.1-3	R.9 TDD	20	64QAM	3/4	100		≥ 3	
TDD	Table A.3.4.1-3a	R.6-1 TDD	5	64QAM	3/4	18		≥ 1	
TDD	Table A.3.4.1-3a	R.7-1 TDD	10	64QAM	3/4	17		≥ 1	
TDD	Table A.3.4.1-3a	R.8-1 TDD	15	64QAM	3/4	17		≥ 1	
TDD	Table A.3.4.1-3a	R.9-1 TDD	20	64QAM	3/4	17		≥ 1	
TDD	Table A.3.4.1-3a	R.9-2 TDD	20	64QAM	3/4	83		≥ 2	
TDD	Table A.3.4.1-6	R.41 TDD	10	QPSK	1/10	50		≥ 1	
Single PRB (Channel edge)									
TDD	Table A.3.4.1-4	R.0 TDD	3	16QAM	1/2	1		≥ 1	
TDD	Table A.3.4.1-4	R.1 TDD	10 / 20	16QAM	1/2	1		≥ 1	
Single PRB (MBSFN Configuration)									
TDD	Table A.3.4.1-5	R.29 TDD	10	16QAM	1/2	1		≥ 1	

Table A.3.1.1-1I: Overview of DL reference measurement channels (TDD, PDSCH Performance, Multi-antenna transmission (CRS))

Duplex	Table	Name	BW	Mod	TCR	RB	RB Off set	UE Cat eg	Notes
Two antenna ports									
TDD	Table A.3.4.2.1-1	R.10 TDD	10	QPSK	1/3	50		≥ 1	
TDD	Table A.3.4.2.1-1	R.11 TDD	10	16QAM	1/2	50		≥ 2	
TDD	Table A.3.4.2.1-1	R.11-1 TDD	10	16QAM	1/2	50		≥ 2	
TDD	Table A.3.4.2.1-1	R.11-2 TDD	5	16QAM	1/2	25		≥ 1	
TDD	Table A.3.4.2.1-1	R.11-3 TDD	10	16QAM	1/2	40		≥ 1	
TDD	Table A.3.4.2.1-1	R.11-4 TDD	10	QPSK	1/2	50		≥ 1	
TDD	Table A.3.4.2.1-1	R.30 TDD	20	16QAM	1/2	100		≥ 2	
TDD	Table A.3.4.2.1-1	R.30-1 TDD	20	16QAM	1/2	100		≥ 2	
TDD	Table A.3.4.2.1-1	R.30-2 TDD	20	16QAM	1/2	100		3	
TDD	Table A.3.4.2.1-1	R.35 TDD	10	64QAM	1/2	50		≥ 2	
TDD	Table A.3.4.2.1-1	R.35-1 TDD	20	64QAM	0.39	100		4	
TDD	Table A.3.4.2.1-2	R.35-2 TDD	10	64QAM	0.47	50		≥ 2	
TDD	Table A.3.4.2.1-2	R.46 TDD	10	QPSK		50		≥ 1	
TDD	Table A.3.4.2.1-2	R.47 TDD	10	16QAM		50		≥ 1	
TDD	Table A.3.4.2.1-2	R.11-5 TDD	1.4	16QAM	1/2	6		≥ 1	
TDD	Table A.3.4.2.1-2	R.11-6 TDD	3	16QAM	1/2	15		≥ 1	
TDD	Table A.3.4.2.1-2	R.11-7 TDD	5	16QAM	1/2	25		≥ 1	
TDD	Table A.3.4.2.1-2	R.11-8 TDD	10	16QAM	1/2	50		≥ 2	
TDD	Table A.3.4.2.1-2	R.11-9 TDD	15	16QAM	1/2	75		≥ 2	
TDD	Table A.3.4.2.1-2	R.11-10 TDD	10	QPSK	3/5	50		≥ 2	
TDD	Table A.3.4.2.1-2	R.11-11 TDD	10	QPSK	0.48-0.58	50		≥ 1	
TDD	Table A.3.4.2.1-2	R.11-12 TDD	10	QPSK	0.54-0.66	50		≥ 1	
TDD	Table A.3.4.2.1-2	R.10-3 TDD	10	16QAM	0.57-0.58	50		≥ 1	

TDD	Table A.3.4.2.1-3	R.62 TDD	10	16QAM	1/2	3		0	
TDD	Table A.3.4.2.1-3	R.63 TDD	10	64QAM	1/2	1		0	
TDD	Table A.3.4.2.1-4	R.65 TDD	20	256QAM	0.6	100		11-15	
TDD	Table A.3.4.2.1-5	R.67 TDD	10	16QAM	0.4	50		≥ 1	
TDD	Table A.3.4.2.1-6	R.79 TDD	10	16QAM	1/2	3		M1, ≥ 0	
TDD	Table A.3.4.2.1-7	R.81 TDD	10	QPSK	1/10	6		M1, ≥ 0	
Four antenna ports									
TDD	Table A.3.4.2.2-1	R.12 TDD	1.4	QPSK	1/3	6		≥ 1	
TDD	Table A.3.4.2.2-1	R.13 TDD	10	QPSK	1/3	50		≥ 1	
TDD	Table A.3.4.2.2-1	R.14 TDD	10	16QAM	1/2	50		≥ 2	
TDD	Table A.3.4.2.2-1	R.14-1 TDD	10	16QAM	1/2	6		≥ 1	
TDD	Table A.3.4.2.2-1	R.14-2 TDD	10	16QAM	1/2	3		≥ 1	
TDD	Table A.3.4.2.2-1	R.43 TDD	20	16QAM	1/2	100		≥ 2	
TDD	Table A.3.4.2.2-1	R.36 TDD	10	64QAM	1/2	50		≥ 2	
TDD	Table A.3.4.2.2-1	R.43-1 TDD	1.4	16QAM	1/2	6		≥ 1	
TDD	Table A.3.4.2.2-1	R.43-2 TDD	3	16QAM	1/2	15		≥ 1	
TDD	Table A.3.4.2.2-1	R.43-3 TDD	5	16QAM	1/2	25		≥ 1	
TDD	Table A.3.4.2.2-1	R.43-4 TDD	10	16QAM	1/2	50		≥ 2	
TDD	Table A.3.4.2.2-1	R.43-5 TDD	15	16QAM	1/2	75		≥ 2	
TDD	Table A.3.4.2.2-1	R.72 TDD	10	256QAM	0.62	50		≥ 11	
TDD	Table A.3.4.2.2-1	R.73 TDD	10	64QAM	0.44	50		≥ 5	
TDD	Table A.3.4.2.2-1	R.74 TDD	10	16QAM	1/2	50		≥ 5	

Table A.3.1.1-1J: Overview of DL reference measurement channels (TDD, PDSCH Performance (DRS))

Duplex	Table	Name	BW	Mod	TCR	RB	RB Off set	UE Cat eg	Notes
Single antenna port									
TDD	Table A.3.4.3.1-1	R.25 TDD	10	QPSK	1/3	50		≥ 1	
TDD	Table A.3.4.3.1-1	R.26 TDD	10	16QAM	1/2	50		≥ 2	
TDD	Table A.3.4.3.1-1	R.26-1 TDD	5	16QAM	1/2	25		≥ 1	
TDD	Table A.3.4.3.1-1	R.27 TDD	10	64QAM	3/4	50		≥ 2	
TDD	Table A.3.4.3.1-1	R.27-1 TDD	10	64QAM	3/4	18		≥ 1	
TDD	Table A.3.4.3.1-1	R.28 TDD	10	16QAM	1/2	1		≥ 1	
TDD	Table A.3.4.3.1-2	R.80 TDD	10	QPSK	1/3	6		M1, ≥ 0	
Two antenna ports									
TDD	Table A.3.4.3.2-1	R.31 TDD	10	QPSK	1/3	50		≥ 1	
TDD	Table A.3.4.3.2-1	R.32 TDD	10	16QAM	1/2	50		≥ 2	
TDD	Table A.3.4.3.2-1	R.32-1 TDD	5	16QAM	1/2	[25]		≥ 1	
TDD	Table A.3.4.3.2-1	R.33 TDD	10	64QAM	3/4	50		≥ 2	
TDD	Table A.3.4.3.2-1	R.33-1 TDD	10	64QAM	3/4	[18]		≥ 1	
TDD	Table A.3.4.3.2-1	R.34 TDD	10	64QAM	1/2	50		≥ 2	
TDD	Table A.3.4.3.2	R.70 TDD	10	QPSK	0.54-0.65	50		≥ 1	
TDD	Table A.3.4.3.2	R.71 TDD	10	16QAM	0.5-0.6	50		≥ 2	

Table A.3.1.1-1K: Overview of DL reference measurement channels (TDD, PDSCH Performance (UE specific RS))

Duplex	Table	Name	BW	Mod	TCR	RB	RB Off set	UE Cat eg	Notes
Two antenna ports (CSI-RS)									
TDD	Table A.3.4.3.3-1	R.51 TDD	10	16QAM	1/2	50		≥ 2	
TDD	Table A.3.4.3.3-1	R.51-1 TDD	10	16QAM	0.57	50		≥ 2	
TDD	Table A.3.4.3.1-1	R.76 FDD	10	QPSK		50		≥ 2	
Two antenna ports (CSI-RS, non Quasi Co-located)									
TDD	Table A.3.4.3.3-2	R.52 TDD	10	64QAM	1/2	50		≥ 2	
TDD	Table A.3.4.3.3-2	R.52-1 TDD	10	16QAM	0.57	50		≥ 2	
TDD	Table A.3.4.3.3-2	R.53 TDD	10	64QAM	1/2	50		≥ 2	
TDD	Table A.3.4.3.3-2	R.54 TDD	10	16QAM	1/2	50		≥ 2	
Four antenna ports (CSI-RS)									
TDD	Table A.3.4.3.4-1	R.44 TDD	10	64QAM	1/2	50		≥ 2	
TDD	Table A.3.4.3.4-5	R.44A-1 TDD	10	64QAM	1/2	50		≥ 2	
TDD	Table A.3.4.3.4-1	R.48 TDD	10	QPSK		50		≥ 1	
TDD	Table A.3.4.3.4-2	R.60 TDD	10	QPSK	1/2	50		≥ 1	
TDD	Table A.3.4.3.4-2	R.61 TDD	10	16QAM	1/2	50		≥ 2	
TDD	Table A.3.4.3.4-2	R.61-1 TDD	10	16QAM	1/2	39		≥ 1	
TDD	Table A.3.4.3.4-3	R.64 TDD	10	QPSK	1/3	6		0	
TDD	Table A.3.4.3.4-1	R.66 TDD	20	256QAM		100		11-15	
TDD	Table A.3.4.3.4-4	R.69 TDD	10	QPSK	0.61-0.8	50		≥ 1	
TDD	Table A.3.4.3.4-1	R.75 TDD	10	16QAM	0.57	50		≥ 5	
Eight antenna ports (CSI-RS)									
TDD	Table A.3.4.3.5-1	R.50 TDD	10	QPSK	1/3	50		≥ 1	
TDD	Table A.3.4.3.5-2	R.45 TDD	10	16QAM	1/2	50		≥ 2	
TDD	Table A.3.4.3.5-2	R.45-1 TDD	10	16QAM	1/2	39		≥ 1	
TDD	Table A.3.4.3.5-2	R.45-2 TDD	10	64QAM		50		≥ 2	
TDD	Table A.3.4.3.5-3	R.44A-2 TDD	10	64QAM	1/2	50		≥ 2	
TDD	Table A.3.4.3.5-3	R.44A-3 TDD	10	64QAM	1/2	50		≥ 2	
Twelve antenna ports (CSI-RS)									
TDD	Table A.3.4.3.6-1	R.77 TDD	10	64QAM	1/2	50		≥ 2	
Sixteen antenna ports (CSI-RS)									
TDD	Table A.3.4.3.7-1	R.78 TDD	10	16QAM	1/2	50		≥ 2	

Table A.3.1.1-1L: Overview of DL reference measurement channels (PDCCH / PCFICH Performance)

Duplex	Table	Name	BW	Mod	TCR	RB	RB Off set	UE Cat eg	Notes
FDD									
FDD	Table A.3.5.1-1	R.15 FDD	10	PDCCH					
FDD	Table A.3.5.1-1	R.15-1 FDD	10	PDCCH					
FDD	Table A.3.5.1-1	R.15-2 FDD	10	PDCCH					
FDD	Table A.3.5.1-1	R.16 FDD	10	PDCCH					
FDD	Table A.3.5.1-1	R.16-1 FDD	10	PDCCH					
FDD	Table A.3.5.1-1	R.16-2 FDD	10	PDCCH					
FDD	Table A.3.5.1-1	R.16-3 FDD	10	PDCCH					
FDD	Table A.3.5.1-1	R.16-4 FDD	10	PDCCH					
FDD	Table A.3.5.1-1	R.17 FDD	5	PDCCH					
TDD									
TDD	Table A.3.5.2-1	R.15 TDD	10	PDCCH					
TDD	Table A.3.5.2-1	R.15-1 TDD	10	PDCCH					
TDD	Table A.3.5.2-1	R.15-2 TDD	10	PDCCH					
TDD	Table A.3.5.2-1	R.16 TDD	10	PDCCH					
TDD	Table A.3.5.2-1	R.16-1 TDD	10	PDCCH					
TDD	Table A.3.5.2-1	R.16-2 TDD	10	PDCCH					
TDD	Table A.3.5.2-1	R.16-3 TDD	10	PDCCH					
TDD	Table A.3.5.2-1	R.16-4 TDD	10	PDCCH					
TDD	Table A.3.5.2-1	R.17 TDD	5	PDCCH					
FS3									
FS3	Table A.3.5.3-1	R.3 FS3	20	PDCCH					
FS3	Table A.3.5.3-2	R.4 FS3	20	PDCCH					

Table A.3.1.1-1M: Overview of DL reference measurement channels (PHICH Performance)

Duplex	Table	Name	BW	Mod	TCR	RB	RB Off set	UE Cat eg	Notes
FDD / TDD	Table A.3.6-1	R.18	10	PHICH					
FDD / TDD	Table A.3.6-1	R.19	10	PHICH					
FDD	Table A.3.6.1	R.19-1	5	PHICH					
FDD / TDD	Table A.3.6-1	R.20	5	PHICH					
FDD / TDD	Table A.3.6-1	R.24	10	PHICH					

Table A.3.1.1-1N: Overview of DL reference measurement channels (PBCH Performance)

Duplex	Table	Name	BW	Mod	TCR	RB	RB Off set	UE Cat eg	Notes
FDD / TDD	Table A.3.7-1	R.21	1.4	QPSK	40/1920				
FDD / TDD	Table A.3.7-1	R.22	1.4	QPSK	40/1920				
FDD / TDD	Table A.3.7-1	R.23	1.4	QPSK	40/1920				

Table A.3.1.1-10: Overview of DL reference measurement channels (PMCH Performance)

Duplex	Table	Name	BW	Mod	TCR	RB	RB Off set	UE Cat eg	Notes
FDD									
FDD	Table A.3.8.1-1	R.40 FDD	1.4	QPSK	1/3	6		≥ 1	
FDD	Table A.3.8.1-1	R.37 FDD	10	QPSK	1/3	50		≥ 1	
FDD	Table A.3.8.1-2	R.38 FDD	10	16QAM	1/2	50		≥ 1	
FDD	Table A.3.8.1-3	R.39-1 FDD	5	64QAM	2/3	25		≥ 1	
FDD	Table A.3.8.1-3	R.39 FDD	10	64QAM	2/3	50		≥ 2	
TDD									
TDD	Table A.3.8.2-1	R.40 TDD	1.4	QPSK	1/3	6		≥ 1	
TDD	Table A.3.8.2-1	R.37 TDD	10	QPSK	1/3	50		≥ 1	
TDD	Table A.3.8.2-2	R.38 TDD	10	16QAM	1/2	50		≥ 1	
TDD	Table A.3.8.2-3	R.39-1 TDD	5	64QAM	2/3	25		≥ 1	
TDD	Table A.3.8.2-3	R.39 TDD	10	64QAM	2/3	50		≥ 2	

Table A.3.1.1-1P: Overview of DL reference measurement channels (Sustained data rate)

Duplex	Table	Name	BW	Mod	TCR	RB	RB Off set	UE Cat eg	Notes
FDD									
FDD	Table A.3.9.1-1	R.31-1 FDD	10	64QAM	0.40			≥ 1	
FDD	Table A.3.9.1-1	R.31-2 FDD	10	64QAM	0.59-0.64			≥ 2	
FDD	Table A.3.9.1-1	R.31-3 FDD	20	64QAM	0.59-0.62			≥ 2	
FDD	Table A.3.9.1-1	R.31-3A FDD	10	64QAM	0.85-0.90			≥ 2	
FDD	Table A.3.9.1-1	R.31-3C FDD	15	64QAM	0.87-0.91			≥ 3	
FDD	Table A.3.9.1-1	R.31-4 FDD	20	64QAM	0.87-0.90			≥ 3	
FDD	Table A.3.9.1-1	R.31-4B FDD	15	64QAM	0.85-0.88			≥ 4	
FDD	Table A.3.9.1-1	R.31-5 FDD	15	64QAM	0.85-0.91			≥ 3	
FDD	Table A.3.9.1-2	R.31-6 FDD	5	64QAM	0.83-0.85			≥ 2	
FDD	Table A.3.9.1-3	R.68 FDD	20	256QAM	0.74-0.85			11-12	
FDD	Table A.3.9.1-3	R.68-1 FDD	15	256QAM	0.74-0.88			11-12	
FDD	Table A.3.9.1-3	R.68-2 FDD	10	256QAM	0.74-0.85			11-12	
FDD	Table A.3.9.1-3	R.68-3 FDD	5	256QAM	0.77-0.85			11-12	
TDD									
TDD	Table A.3.9.2-1	R.31-1 TDD	10	64QAM	0.40			≥ 1	
TDD	Table A.3.9.2-1	R.31-2 TDD	10	64QAM	0.59-0.64			≥ 2	
TDD	Table A.3.9.2-1	R.31-3 TDD	20	64QAM	0.59-0.62			≥ 2	
TDD	Table A.3.9.2-1	R.31-3A TDD	15	64QAM	0.87-0.90			≥ 2	
TDD	Table A.3.9.2-1	R.31-4 TDD	20	64QAM	0.87-0.90			≥ 3	
TDD	Table A.3.9.2-1	R.31-4A TDD	20	64QAM	0.87-0.90			≥ 3	
TDD	Table A.3.9.2-1	R.31-5 TDD	15	64QAM	0.85-0.88			≥ 3	
TDD	Table A.3.9.2-1	R.31-5A TDD	15	64QAM	0.85-0.88			≥ 3	
TDD	Table A.3.9.2-1	R.31-6 TDD	10	64QAM	0.85-0.88			≥ 2	
TDD	Table A.3.9.2-2	R.68 TDD	20	256QAM				11-12	
TDD	Table A.3.9.2-2	R.68-1 TDD	15	256QAM				11-12	
TDD	Table A.3.9.2-2	R.68-2 TDD	10	256QAM				11-12	
TDD	Table A.3.9.2-2	R.68-3 TDD	20	256QAM				11-12	
TDD	Table A.3.9.2-2	R.68-4 TDD	15	256QAM				11-12	
FDD, EPDCCH scheduling									
FDD	Table A.3.9.3-1	R.31E-1 FDD	10	64QAM	0.40-0			≥ 1	
FDD	Table A.3.9.3-1	R.31E-2 FDD	10	64QAM	0.59-0.66			≥ 2	
FDD	Table A.3.9.3-1	R.31E-3 FDD	20	64QAM	0.59-0.63			≥ 2	
FDD	Table A.3.9.1-1	R.31E-3C FDD	15	64QAM	0.87-0.92			≥ 3	
FDD	Table A.3.9.3-1	R.31E-3A FDD	10	64QAM	0.85-0.92			≥ 2	
FDD	Table A.3.9.3-1	R.31E-4 FDD	20	64QAM	0.87-0.91			≥ 3	

FDD	Table A.3.9.1-1	R.31E-4B FDD	15	64QAM	0.87-0.90			≥ 4	
TDD, EPDCCH scheduling									
TDD	Table A.3.9.4-1	R.31E-1 TDD	10	64QAM	0.40-0.41			≥ 1	
TDD	Table A.3.9.4-1	R.31E-2 TDD	10	64QAM	0.59-0.65			≥ 2	
TDD	Table A.3.9.4-1	R.31E-3 TDD	20	64QAM	0.59-0.63			≥ 2	
TDD	Table A.3.9.4-1	R.31E-3A TDD	15	64QAM	0.87-0.92			≥ 2	
TDD	Table A.3.9.4-1	R.31E-4 TDD	20	64QAM	0.87-0.90			≥ 3	

Table A.3.1.1-1Q: Overview of DL reference measurement channels (EPDCCH)

Duplex	Table	Name	BW	Mod	TCR	RB	RB Off set	UE Cat eg	Notes
FDD									
FDD	Table A.3.10.1-1	R.55 FDD	10	EPDCC H					
FDD	Table A.3.10.1-1	R.55-1 FDD	10	EPDCC H					
FDD	Table A.3.10.1-1	R.56 FDD	10	EPDCC H					
FDD	Table A.3.10.1-1	R.57 FDD	10	EPDCC H					
FDD	Table A.3.10.1-1	R.58 FDD	10	EPDCC H					
FDD	Table A.3.10.1-1	R.59 FDD	10	EPDCC H					
TDD									
TDD	Table A.3.10.2-1	R.55 TDD	10	EPDCC H					
TDD	Table A.3.10.2-1	R.55-1 TDD	10	EPDCC H					
TDD	Table A.3.10.2-1	R.56 TDD	10	EPDCC H					
TDD	Table A.3.10.2-1	R.57 TDD	10	EPDCC H					
TDD	Table A.3.10.2-1	R.58 TDD	10	EPDCC H					
TDD	Table A.3.10.2-1	R.59 TDD	10	EPDCC H					

Table A.3.1.1-1R: Overview of DL reference measurement channels (MPDCCH)

Duplex	Table	Name	BW	Mod	TCR	RB	RB Off set	UE Cat eg	Notes
FDD									
FDD	Table A.3.11.1-1	R.82 FDD	10	MPDCC H					
FDD	Table A.3.11.1-1	R.83 FDD	10	MPDCC H					
TDD									
TDD	Table A.3.11.2-1	R.82 TDD	10	MPDCC H					
TDD	Table A.3.11.2-1	R.83 TDD	10	MPDCC H					

Table A.3.1.1-1S: Overview of DL reference measurement channels (NPDSCH)

Duplex	Table	Name	BW(KHz)	Mod	TC R	RB	RB Off set	UE Cat eg	Notes
FDD									
HD-FDD	Table A.3.12.1.2-1	R.NB.5 FDD	200	QPSK	1/3			NB1	
HD-FDD	Table A.3.12.1.2-1	R.NB.5-1 FDD	200	QPSK	1/3			NB1	
HD-FDD	Table A.3.12.2.1-1	R.NB.6 FDD	200	QPSK	1/2			NB1	
HD-FDD	Table A.3.12.2.1-1	R.NB.6-1 FDD	200	QPSK	1/3			NB1	

Table A.3.1.1-1T: Overview of DL reference measurement channels (NPDCCH)

Duplex	Table	Name	BW(KHz)	Mod	TC R	RB	RB Off set	UE Cat eg	Notes
FDD									
HD-FDD	Table A.3.13.1-1	R.NB.3 FDD	200	QPSK				NB1	
HD-FDD	Table A.3.13.1-1	R.NB.4 FDD	200	QPSK				NB1	

Table A.3.1.1-1U: Overview of DL reference measurement channels (NPBCH)

Duplex	Table	Name	BW(KHz)	Mod	TC R	RB	RB Off set	UE Cat eg	Notes
FDD									
HD-FDD	Table A.3.14-1	R.NB.1 FDD	200	QPSK				NB1	
HD-FDD	Table A.3.14-1	R.NB.2 FDD	200	QPSK				NB1	

Table A.3.1.1-1V: Overview of DL reference measurement channels (FS3)

Duplex	Table	Name	BW	Mod	TCR	RB	RB Off set	UE Cat eg	Notes
FS3									
FS3	Table A.3.5.1.1-2	R.1 FS3	20	64QAM	0.6	100		≥ 5	
FS3	Table A.3.15.2.1-1	R.2 FS3	20	16QAM	1/2	100		≥ 5	
FS3	Table A.3.9.5-1	R.5 FS3	20	64QAM	0.88-0.89	100		≥ 5	not supporting both initial and end partial SF
FS3	Table A.3.9.5-1	R.6 FS3	20	64QAM	0.77-0.89	100		≥ 5	supporting end partial SF
FS3	Table A.3.9.5-1	R.7 FS3	20	64QAM	0.88-0.90	100		≥ 5	supporting initial partial SF but not supporting end partial SF
FS3	Table A.3.9.5-1	R.8 FS3	20	64QAM	0.79-0.80	100		≥ 5	not supporting both initial and end partial SF
FS3	Table A.3.9.5-1	R.9 FS3	20	64QAM	0.79-0.82	100		≥ 5	supporting end partial SF
FS3	Table A.3.9.5-1	R.10 FS3	20	64QAM	0.79-0.81	100		≥ 5	supporting initial partial SF but not supporting end partial SF
FS3	Table A.3.9.5-2	R.11 FS3	20	256QAM	0.75-0.85	100		≥ 11	not supporting both initial and end partial SF
FS3	Table A.3.9.5-2	R.12 FS3	20	256QAM	0.74-0.85	100		≥ 11	supporting end partial SF
FS3	Table A.3.9.5-2	R.13 FS3	20	256QAM	0.74-0.85	100		≥ 11	supporting initial partial SF but not supporting end partial SF
FS3	Table A.3.9.5-2	R.14 FS3	20	256QAM	0.78-0.79	100		≥ 11	not supporting both initial and end partial SF
FS3	Table A.3.9.5-2	R.15 FS3	20	256QAM	0.74-0.79	100		≥ 11	supporting end partial SF
FS3	Table A.3.9.5-2	R.16 FS3	20	256QAM	0.77-0.79	100		≥ 11	supporting initial partial SF but not supporting end partial SF

A.3.2 Reference measurement channel for receiver characteristics

Unless otherwise stated, Tables A.3.2-1, A.3.2-1a, A.3.2-1b, A.3.2-2, A.3.2-2a and A.3.2-2b are applicable for measurements on the Receiver Characteristics (clause 7) with the exception of subclause 7.4 (Maximum input level).

Unless otherwise stated, Tables A.3.2-3, A.3.2-3a, A.3.2-3b, A.3.2-4, A.3.2-4a and A.3.2-4b are applicable for subclause 7.4 (Maximum input level).

Unless otherwise stated, Tables A.3.2-1, A.3.2-1a, A.3.2-1b, A.3.2-2, A.3.2-2a and A.3.2-2b also apply for the modulated interferer used in Clauses 7.5, 7.6 and 7.8 with test specific bandwidths.

For transmissions in TDD Band 46, Table A.3.2-2c is applicable for measurements of Receiver Characteristics (clause 7) except for the Maximum Input Level (clause 7.4A) for which Table A.3.2-4d and Table A.3.2-7 apply. For these measurements, the discovery signals measurement timing configuration (DMTC) periodicity shall be set at *dmtc-Periodicity* = 40 ms with an offset *dmtc-Offset* = 0 for the channel and the DRS shall be transmitted in the first subframe of each DMTC occasion. Furthermore, no PBCH is transmitted and the PDSCH is also scheduled in subframe #5.

Table A.3.2-1 Fixed Reference Channel for Receiver Requirements (FDD)

Parameter	Unit	Value					
		1.4	3	5	10	15	20
Channel bandwidth	MHz	1.4	3	5	10	15	20
Allocated resource blocks		6	15	25	50	75	100
Subcarriers per resource block		12	12	12	12	12	12
Allocated subframes per Radio Frame		9	9	9	9	9	9
Modulation		QPSK	QPSK	QPSK	QPSK	QPSK	QPSK
Target Coding Rate		1/3	1/3	1/3	1/3	1/3	1/3
Number of HARQ Processes	Processes	8	8	8	8	8	8
Maximum number of HARQ transmissions		1	1	1	1	1	1
Information Bit Payload per Sub-Frame							
For Sub-Frames 1,2,3,4,6,7,8,9	Bits	408	1320	2216	4392	6712	8760
For Sub-Frame 5	Bits	N/A	N/A	N/A	N/A	N/A	N/A
For Sub-Frame 0	Bits	152	872	1800	4392	6712	8760
Transport block CRC	Bits	24	24	24	24	24	24
Number of Code Blocks per Sub-Frame (Note 3)							
For Sub-Frames 1,2,3,4,6,7,8,9	Bits	1	1	1	1	2	2
For Sub-Frame 5	Bits	N/A	N/A	N/A	N/A	N/A	N/A
For Sub-Frame 0	Bits	1	1	1	1	2	2
Binary Channel Bits Per Sub-Frame							
For Sub-Frames 1,2,3,4,6,7,8,9	Bits	1368	3780	6300	13800	20700	27600
For Sub-Frame 5	Bits	N/A	N/A	N/A	N/A	N/A	N/A
For Sub-Frame 0	Bits	528	2940	5460	12960	19860	26760
Max. Throughput averaged over 1 frame	kbps	341.6	1143. 2	1952. 8	3952. 8	6040. 8	7884
UE Category		≥ 1	≥ 1	≥ 1	≥ 1	≥ 1	≥ 1
Note 1:	2 symbols allocated to PDCCH for 20 MHz, 15 MHz and 10MHz channel BW. 3 symbols allocated to PDCCH for 5 MHz and 3 MHz. 4 symbols allocated to PDCCH for 1.4 MHz						
Note 2:	Reference signal, Synchronization signals and PBCH allocated as per TS 36.211 [4]						
Note 3:	If more than one Code Block is present, an additional CRC sequence of L = 24 Bits is attached to each Code Block (otherwise L = 0 Bit)						

Table A.3.2-1a Fixed Reference Channel for Receiver Requirements (FDD)

Parameter	Unit	Value					
		1.4	3	5	10	15	20
Channel bandwidth	MHz	1.4	3	5	10	15	20
Allocated resource blocks		6	14	14	14	14	14
Subcarriers per resource block		12	12	12	12	12	12
Allocated subframes per Radio Frame		9	9	9	9	9	9
Modulation		QPSK	QPSK	QPSK	QPSK	QPSK	QPSK
Target Coding Rate		1/3	1/3	1/3	1/3	1/3	1/3
Number of HARQ Processes	Processes	8	8	8	8	8	8
Maximum number of HARQ transmissions		1	1	1	1	1	1
Information Bit Payload per Sub-Frame							
For Sub-Frames 1,2,3,4,6,7,8,9	Bits	408	1000	1000	1000	1000	1000
For Sub-Frame 5	Bits	N/A	N/A	N/A	N/A	N/A	N/A
For Sub-Frame 0 (Note 3)	Bits	152	840	840	904	904	904
Transport block CRC	Bits	24	24	24	24	24	24
Number of Code Blocks per Sub-Frame							
For Sub-Frames 1,2,3,4,6,7,8,9	Bits	1	1	1	1	1	1
For Sub-Frame 5	Bits	N/A	N/A	N/A	N/A	N/A	N/A
For Sub-Frame 0	Bits	1	1	1	1	1	1
Binary Channel Bits Per Sub-Frame							
For Sub-Frames 1,2,3,4,6,7,8,9	Bits	1368	3528	3528	3864	3864	3864
For Sub-Frame 5	Bits	N/A	N/A	N/A	N/A	N/A	N/A
For Sub-Frame 0 (Note 3)	Bits	528	2688	2688	3024	3024	3024
Max. Throughput averaged over 1 frame	kbps	341.6	884	884	890.4	890.4	890.4
UE DL Category		0	0	0	0	0	0
Note 1:	2 symbols allocated to PDCCH for 20 MHz, 15 MHz and 10MHz channel BW. 3 symbols allocated to PDCCH for 5 MHz and 3 MHz. 4 symbols allocated to PDCCH for 1.4 MHz						
Note 2:	Reference signal, Synchronization signals and PBCH allocated as per TS 36.211.						
Note 3:	For Sub-Frame 0, it is assumed the 6PRBs are allocated in the centre of the channel where some REs of the same PRBs are occupied by PBCH and synchronization signals.						
Note 4:	For HD-FDD UE, the downlink subframes are scheduled at the 0th, 1st, 2nd, 8th, 9th, 10th, 16th, 17th, 18th, 24th, 25th, 26th, 32nd, 33rd, 34th subframes every 40ms. Information bit payload is available if downlink subframe is scheduled.						

Table A.3.2-1b Fixed Reference Channel for Receiver Requirements (FDD and HD-FDD) – for CAT-M1

Parameter	Unit	Value					
		1.4	3	5	10	15	20
Channel bandwidth	MHz	1.4	3	5	10	15	20
Allocated resource blocks		4	4	4	4	4	4
Subcarriers per resource block		12	12	12	12	12	12
Allocated subframes per Radio Frame (Note 6)		2	2	8	8	8	8
Modulation		QPSK	QPSK	QPSK	QPSK	QPSK	QPSK
Target Coding Rate		1/3	1/3	1/3	1/3	1/3	1/3
Number of HARQ Processes	Processes	8	8	8	8	8	8
Maximum number of HARQ transmissions		1	1	1	1	1	1
Information Bit Payload per Sub-Frame							
For Sub-Frames 3,8	Bits	256	256	256	328	328	328
For Sub-Frames 0,1,2,5,7,9	Bits	N/A	N/A	256	328	328	328
For Sub-Frame 4	Bits	N/A	N/A	N/A	N/A	N/A	N/A
For Sub-Frame 6	Bits	N/A	N/A	N/A	N/A	N/A	N/A
Transport block CRC	Bits	24	24	24	24	24	24
Number of Code Blocks per Sub-Frame							
For Sub-Frames 3,8	Bits	1	1	1	1	1	1
For Sub-Frames 0,1,2,5,7,9	Bits	N/A	N/A	1	1	1	1
For Sub-Frame 4	Bits	N/A	N/A	N/A	N/A	N/A	N/A
For Sub-Frame 6	Bits	N/A	N/A	N/A	N/A	N/A	N/A
Binary Channel Bits Per Sub-Frame							
For Sub-Frames 3,8	Bits	912	1008	1008	1104	1104	1104
For Sub-Frames 0,1,2,5,7,9	Bits	N/A	N/A	1008	1104	1104	1104
For Sub-Frame 4	Bits	N/A	N/A	N/A	N/A	N/A	N/A
For Sub-Frame 6	Bits	N/A	N/A	N/A	N/A	N/A	N/A
Max. Throughput averaged over 1 frame for FDD	kbps	51.2	51.2	204.8	262.4	262.4	262.4
Max. Throughput averaged over 1 frames for HD-FDD	kbps	25.6	25.6	76.8	98.4	98.4	98.4
UE DL Category		M1	M1	M1	M1	M1	M1
Note 1:	2 symbols allocated to PDCCH for 20 MHz, 15 MHz and 10MHz channel BW. 3 symbols allocated to PDCCH for 5 MHz and 3 MHz. 4 symbols allocated to PDCCH for 1.4 MHz						
Note 2:	Reference signal, Synchronization signals and PBCH allocated as per TS 36.211.						
Note 3:	The scheduled narrowband other than 1.4MHz and 3MHz channel bandwidth avoids the centre of the channel where some REs of the same PRBs are occupied by PBCH and synchronization signals.						
Note 4:	For HD-FDD UE, PDSCH are scheduled at the 3rd subframe every 1 radio frame for 1.4MHz and 3MHz channel bandwidth. For other channel bandwidth, PDSCH are scheduled at the 0th, 1st, and 2nd subframes every 1 radio frame. Information bit payload is available if downlink subframe is scheduled. The corresponding MPDCCH is scheduled 2 subframes before the corresponding PDSCH transmission.						
Note 5:	2 resource blocks allocated to MPDCCH.						

Table A.3.2-1c Fixed Reference Channel for Receiver Requirements (HD-FDD) without repetition – for CAT-NB1

Parameter	Unit	Value
Channel bandwidth	MHz	0.2
Number of subcarriers		12
Modulation		QPSK
Target Coding Rate		1/3
Number of HARQ Processes	Processes	1
Maximum number of HARQ transmissions		1
Transport block size	Bits	88
Number of Sub-Frames per transport block		1
Transport block CRC	Bits	24
Binary Channel Bits Per Sub-Frame	Bits	320
LTE CRS port		N/A
Number of NRS ports		1
Number of NPDSCH repetitions		0
UE DL Category		NB1
Note 1:	Category NB1 in stand-alone mode has been considered here.	
Note 2:	Reference signal, Synchronization signals and NPBCH allocated as per TS 36.211.	
Note 3:	If more than one Code Block is present, an additional CRC sequence of L = 24 Bits is attached to each Code Block (otherwise L = 0 Bit)	
Note 4:	Parameters related to NPDSCH scheduling are defined in Table A.3.2-1e to Table A.3.2-1g.	
Note 5:	NPDCCH and information bit payload are not transmitted in the subframes used for transmission of SI messages.	
Note 6:	SI messages transmission should be prioritized over NPDCCH transmission in case of collision. NPDCCH transmission is postponed until the next NB-IoT downlink subframe in case NPDCCH transmission occurs in a non NB-IoT downlink subframe, where an NB-IoT downlink subframe is a subframe that does not contain NPSS/NSSS/NPBCH/SIB1-NB transmission.	

Table A.3.2-1d: Void**Table A.3.2-1e: General configuration for CAT-NB1**

Parameter	Unit	Value
NB-IoT downlink subframe bitmap for anchor carrier (<i>downlinkBitmap</i>)		Not configured
NB-IoT downlink subframe bitmap for non-anchor carrier (<i>downlinkBitmapNonAnchor</i>)		Not configured
Downlink gap configuration for anchor carrier (<i>dl-Gap</i>)		Not configured
Downlink gap configuration for non-anchor carrier (<i>dl-GapNonAnchor</i>)		Not configured

Table A.3.2-1f: NPDCCH configuration for NPDSCH scheduling

Parameter	Unit	Value
DCI format		DCI format N1
NPDCCH format		1
Scheduling delay (I_{Delay})		0
DCI subframe repetition number		00
R_{max} (<i>npdcch-NumRepetitions</i>)		1
G (<i>NPDCCH-startSF-USS</i>)		8
α_{offset} (<i>npdcch-Offset-USS</i>)		1/4

Table A.3.2-1g: NPUSCH format 2 configurations for NPDSCH scheduling

Parameter	Unit	Value
Scheduling delay (I_{Delay})		0
$N_{\text{Rep}}^{\text{AN}}$ (<i>ack-NACK-NumRepetitions</i>)		1
ACK/NACK resource field		0

Table A.3.2-2 Fixed Reference Channel for Receiver Requirements (TDD)

Parameter	Unit	Value					
		1.4	3	5	10	15	20
Channel Bandwidth	MHz	1.4	3	5	10	15	20
Allocated resource blocks		6	15	25	50	75	100
Uplink-Downlink Configuration (Note 5)		1	1	1	1	1	1
Allocated subframes per Radio Frame (D+S)		3	3+2	3+2	3+2	3+2	3+2
Number of HARQ Processes	Processes	7	7	7	7	7	7
Maximum number of HARQ transmission		1	1	1	1	1	1
Modulation		QPSK	QPSK	QPSK	QPSK	QPSK	QPSK
Target coding rate		1/3	1/3	1/3	1/3	1/3	1/3
Information Bit Payload per Sub-Frame	Bits						
For Sub-Frame 4, 9		408	1320	2216	4392	6712	8760
For Sub-Frame 1, 6		N/A	968	1544	3240	4968	6712
For Sub-Frame 5		N/A	N/A	N/A	N/A	N/A	N/A
For Sub-Frame 0		208	1064	1800	4392	6712	8760
Transport block CRC	Bits	24	24	24	24	24	24
Number of Code Blocks per Sub-Frame (Note 4)							
For Sub-Frame 4, 9		1	1	1	1	2	2
For Sub-Frame 1, 6		N/A	1	1	1	1	2
For Sub-Frame 5		N/A	N/A	N/A	N/A	N/A	N/A
For Sub-Frame 0		1	1	1	1	2	2
Binary Channel Bits Per Sub-Frame	Bits						
For Sub-Frame 4, 9		1368	3780	6300	13800	20700	27600
For Sub-Frame 1, 6		N/A	3276	5556	11256	16956	22656
For Sub-Frame 5		N/A	N/A	N/A	N/A	N/A	N/A
For Sub-Frame 0		672	3084	5604	13104	20004	26904
Max. Throughput averaged over 1 frame	kbps	102.4	564	932	1965.6	3007.2	3970.4
UE Category		≥ 1	≥ 1	≥ 1	≥ 1	≥ 1	≥ 1
Note 1:	For normal subframes(0,4,5,9), 2 symbols allocated to PDCCH for 20 MHz, 15 MHz and 10 MHz channel BW; 3 symbols allocated to PDCCH for 5 MHz and 3 MHz; 4 symbols allocated to PDCCH for 1.4 MHz. For special subframe (1&6), only 2 OFDM symbols are allocated to PDCCH for all BWs.						
Note 2:	For 1.4MHz, no data shall be scheduled on special subframes(1&6) to avoid problems with insufficient PDCCH performance						
Note 3:	Reference signal, Synchronization signals and PBCH allocated as per TS 36.211 [4]						
Note 4:	If more than one Code Block is present, an additional CRC sequence of L = 24 Bits is attached to each Code Block (otherwise L = 0 Bit).						
Note 5:	As per Table 4.2-2 in TS 36.211 [4]						

Table A.3.2-2a Fixed Reference Channel for Receiver Requirements (TDD)

Parameter	Unit	Value					
		1.4	3	5	10	15	20
Channel Bandwidth	MHz	1.4	3	5	10	15	20
Allocated resource blocks		6	14	14	14	14	14
Uplink-Downlink Configuration (Note 5)		1	1	1	1	1	1
Allocated subframes per Radio Frame (D+S)		3	3+2	3+2	3+2	3+2	3+2
Number of HARQ Processes	Processes	7	7	7	7	7	7
Maximum number of HARQ transmission		1	1	1	1	1	1
Modulation		QPSK	QPSK	QPSK	QPSK	QPSK	QPSK
Target coding rate		1/3	1/3	1/3	1/3	1/3	1/3
Information Bit Payload per Sub-Frame	Bits						
For Sub-Frame 4, 9		408	1000	1000	1000	1000	1000
For Sub-Frame 1, 6		N/A	872	872	872	872	872
For Sub-Frame 5		N/A	N/A	N/A	N/A	N/A	N/A
For Sub-Frame 0		208	1000	1000	1000	1000	1000
Transport block CRC	Bits	24	24	24	24	24	24
Number of Code Blocks per Sub-Frame (Note 4)							
For Sub-Frame 4, 9		1	1	1	1	1	1
For Sub-Frame 1, 6		N/A	1	1	1	1	1
For Sub-Frame 5		N/A	N/A	N/A	N/A	N/A	N/A
For Sub-Frame 0		1	1	1	1	1	1
Binary Channel Bits Per Sub-Frame	Bits						
For Sub-Frame 4, 9		1368	3528	3528	3864	3864	3864
For Sub-Frame 1, 6		N/A	3048	3048	3048	3048	3048
For Sub-Frame 5		N/A	N/A	N/A	N/A	N/A	N/A
For Sub-Frame 0		672	2832	2832	3168	3168	3168
Max. Throughput averaged over 1 frame	kbps	102.4	474.4	474.4	474.4	474.4	474.4
UE DL Category		0	0	0	0	0	0
Note 1:	For normal subframes(0,4,5,9), 2 symbols allocated to PDCCH for 20 MHz, 15 MHz and 10 MHz channel BW; 3 symbols allocated to PDCCH for 5 MHz and 3 MHz; 4 symbols allocated to PDCCH for 1.4 MHz. For special subframe (1&6), only 2 OFDM symbols are allocated to PDCCH for all BWs.						
Note 2:	For 1.4MHz, no data shall be scheduled on special subframes(1&6) to avoid problems with insufficient PDCCH performance						
Note 3:	Reference signal, Synchronization signals and PBCH allocated as per TS 36.211 [4]						
Note 4:	If more than one Code Block is present, an additional CRC sequence of L = 24 Bits is attached to each Code Block (otherwise L = 0 Bit).						
Note 5:	As per Table 4.2-2 in TS 36.211 [4]						

Table A.3.2-2b Fixed Reference Channel for Receiver Requirements (TDD) – for CAT-M1

Parameter	Unit	Value					
		1.4	3	5	10	15	20
Channel Bandwidth	MHz	1.4	3	5	10	15	20
Allocated resource blocks		4	4	4	4	4	4
Uplink-Downlink Configuration (Note 5)		1	1	1	1	1	1
Allocated subframes per Radio Frame (D)		3	3	3	3	3	3
Number of HARQ Processes	Processes	7	7	7	7	7	7
Maximum number of HARQ transmission		1	1	1	1	1	1
Modulation		QPSK	QPSK	QPSK	QPSK	QPSK	QPSK
Target coding rate		1/3	1/3	1/3	1/3	1/3	1/3
Information Bit Payload per Sub-Frame	Bits						
For Sub-Frame 4, 9		256	256	256	328	328	328
For Sub-Frame 1, 6		N/A	N/A	N/A	N/A	N/A	N/A
For Sub-Frame 5		N/A	N/A	N/A	N/A	N/A	N/A
For Sub-Frame 0		256	256	256	328	328	328
Transport block CRC	Bits	24	24	24	24	24	24
Number of Code Blocks per Sub-Frame (Note 4)							
For Sub-Frame 4, 9		1	1	1	1	1	1
For Sub-Frame 1, 6		N/A	1	1	1	1	1
For Sub-Frame 5		N/A	N/A	N/A	N/A	N/A	N/A
For Sub-Frame 0		1	1	1	1	1	1
Binary Channel Bits Per Sub-Frame	Bits						
For Sub-Frame 4, 9		912	1008	1008	1104	1104	1104
For Sub-Frame 1, 6		N/A	N/A	N/A	N/A	N/A	N/A
For Sub-Frame 5		N/A	N/A	N/A	N/A	N/A	N/A
For Sub-Frame 0		912	1008	1008	1104	1104	1104
Max. Throughput averaged over 1 frame	kbps	76.8	76.8	76.8	98.4	98.4	98.4
UE DL Category		M1	M1	M1	M1	M1	M1
Note 1:	For normal subframes(0,4,5,9), 2 symbols allocated to PDCCH for 20 MHz, 15 MHz and 10 MHz channel BW; 3 symbols allocated to PDCCH for 5 MHz and 3 MHz; 4 symbols allocated to PDCCH for 1.4 MHz. For special subframe (1&6), only 2 OFDM symbols are allocated to PDCCH for all BWs.						
Note 2:	No data shall be scheduled on special subframes(1&6) to avoid problems with insufficient PDCCH performance						
Note 3:	Reference signal, Synchronization signals and PBCH allocated as per TS 36.211 [4]						
Note 4:	If more than one Code Block is present, an additional CRC sequence of L = 24 Bits is attached to each Code Block (otherwise L = 0 Bit).						
Note 5:	As per Table 4.2-2 in TS 36.211 [4]						
Note 6:	For Sub-Frame 0, the scheduled narrowband avoids the centre of the channel where some REs of the same PRBs are occupied by PBCH and synchronization signals.						
Note 7:	2 resource blocks allocated to MPDCCH						

Table A.3.2-2c Fixed Reference Channel for Receiver Requirements (TDD Band 46)

Parameter	Unit	Value
Channel bandwidth	MHz	20
Allocated resource blocks		100
Uplink-Downlink Configuration		N/A
Subcarriers per resource block		12
Allocated subframes per Radio Frame (D)		8
Modulation		QPSK
Target Coding Rate		1/3
Number of HARQ Processes	Processes	N/A
Maximum number of HARQ transmissions		N/A
Information Bit Payload per Sub-Frame		
For Sub-Frames 3,4,6,7,8,9	Bits	8760
For Sub-Frame 1,2	Bits	N/A
For Sub-Frame 0,5	Bits	8760
Transport block CRC	Bits	24
Number of Code Blocks per Sub-Frame (Note 3)		
For Sub-Frames 3,4,6,7,8,9	Bits	2
For Sub-Frame 1,2	Bits	N/A
For Sub-Frame 0,5	Bits	2
Binary Channel Bits Per Sub-Frame		
For Sub-Frames 3,4,6,7,8,9	Bits	27600
For Sub-Frame 1,2	Bits	N/A
For Sub-Frame 0,5	Bits	27312
Max. Throughput averaged over 1 frame	kbps	7008
UE Category		≥ 1
Note 1:	2 symbols allocated to PDCCH.	
Note 2:	Reference signal and Synchronization signals allocated as per TS 36.211 [4].	
Note 3:	If more than one Code Block is present, an additional CRC sequence of L = 24 Bits is attached to each Code Block (otherwise L = 0 Bit).	

Table A.3.2-3 Fixed Reference Channel for Maximum input level for UE Categories ≥ 3 (FDD)

Parameter	Unit	Value					
		1.4	3	5	10	15	20
Channel bandwidth	MHz	1.4	3	5	10	15	20
Allocated resource blocks		6	15	25	50	75	100
Subcarriers per resource block		12	12	12	12	12	12
Allocated subframes per Radio Frame		8	9	9	9	9	9
Modulation		64QAM	64QAM	64QAM	64QAM	64QAM	64QAM
Target Coding Rate		3/4	3/4	3/4	3/4	3/4	3/4
Number of HARQ Processes	Processes	8	8	8	8	8	8
Maximum number of HARQ transmissions		1	1	1	1	1	1
Information Bit Payload per Sub-Frame							
For Sub-Frames 1,2,3,4,6,7,8,9	Bits	2984	8504	14112	30576	46888	61664
For Sub-Frame 5	Bits	N/A	N/A	N/A	N/A	N/A	N/A
For Sub-Frame 0	Bits	N/A	6456	12576	28336	45352	61664
Transport block CRC	Bits	24	24	24	24	24	24
Number of Code Blocks per Sub-Frame (Note 3)							
For Sub-Frames 1,2,3,4,6,7,8,9		1	2	3	5	8	11
For Sub-Frame 5		N/A	N/A	N/A	N/A	N/A	N/A
For Sub-Frame 0		N/A	2	3	5	8	11
Binary Channel Bits Per Sub-Frame							
For Sub-Frames 1,2,3,4,6,7,8,9	Bits	4104	11340	18900	41400	62100	82800
For Sub-Frame 5	Bits	N/A	N/A	N/A	N/A	N/A	N/A
For Sub-Frame 0	Bits	N/A	8820	16380	38880	59580	80280
Max. Throughput averaged over 1 frame	kbps	2387.2	7448.8	12547	27294	42046	55498
Note 1:	2 symbols allocated to PDCCH for 20 MHz, 15 MHz and 10 MHz channel BW. 3 symbols allocated to PDCCH for 5 MHz and 3 MHz. 4 symbols allocated to PDCCH for 1.4 MHz.						
Note 2:	Reference signal, Synchronization signals and PBCH allocated as per TS 36.211 [4].						
Note 3:	If more than one Code Block is present, an additional CRC sequence of L = 24 Bits is attached to each Code Block (otherwise L = 0 Bit).						

Table A.3.2-3a Fixed Reference Channel for Maximum input level for UE Category 1 (FDD)

Parameter	Unit	Value					
		1.4	3	5	10	15	20
Channel bandwidth	MHz	1.4	3	5	10	15	20
Allocated resource blocks		6	15	18	17	17	17
Subcarriers per resource block		12	12	12	12	12	12
Allocated subframes per Radio Frame		8	9	9	9	9	9
Modulation		64QAM	64QAM	64QAM	64QAM	64QAM	64QAM
Target Coding Rate		3/4	3/4	3/4	3/4	3/4	3/4
Number of HARQ Processes	Processes	8	8	8	8	8	8
Maximum number of HARQ transmissions		1	1	1	1	1	1
Information Bit Payload							
For Sub-Frames 1,2,3,4,6,7,8,9	Bits	2984	8504	10296	10296	10296	10296
For Sub-Frame 5	Bits	N/A	N/A	N/A	N/A	N/A	N/A
For Sub-Frame 0	Bits	N/A	6456	8248	10296	10296	10296
Transport block CRC	Bits	24	24	24	24	24	24
Number of Code Blocks per Sub-Frame (Note 3)							
For Sub-Frames 1,2,3,4,6,7,8,9		1	2	2	2	2	2
For Sub-Frame 5		N/A	N/A	N/A	N/A	N/A	N/A
For Sub-Frame 0		N/A	2	2	2	2	2
Binary Channel Bits Per Sub-Frame							
For Sub-Frames 1,2,3,4,6,7,8,9	Bits	4104	11340	13608	14076	14076	14076
For Sub-Frame 5	Bits	N/A	N/A	N/A	N/A	N/A	N/A
For Sub-Frame 0	Bits	N/A	8820	11088	14076	14076	14076
Max. Throughput averaged over 1 frame	kbps	2387.2	7448.8	9079.6	9266.4	9266.4	9266.4
Note 1:	2 symbols allocated to PDCCH for 20 MHz, 15 MHz and 10 MHz channel BW. 3 symbols allocated to PDCCH for 5 MHz and 3 MHz. 4 symbols allocated to PDCCH for 1.4 MHz.						
Note 2:	Reference signal, Synchronization signals and PBCH allocated as per TS 36.211 [4].						
Note 3:	If more than one Code Block is present, an additional CRC sequence of L = 24 Bits is attached to each Code Block (otherwise L = 0 Bit).						

Table A.3.2-3b Fixed Reference Channel for Maximum input level for UE Category 2 (FDD)

Parameter	Unit	Value					
		1.4	3	5	10	15	20
Channel bandwidth	MHz	1.4	3	5	10	15	20
Allocated resource blocks		6	15	25	50	75	83
Subcarriers per resource block		12	12	12	12	12	12
Allocated subframes per Radio Frame		8	9	9	9	9	9
Modulation		64QAM	64QAM	64QAM	64QAM	64QAM	64QAM
Target Coding Rate		3/4	3/4	3/4	3/4	3/4	3/4
Number of HARQ Processes	Processes	8	8	8	8	8	8
Maximum number of HARQ transmissions		1	1	1	1	1	1
Information Bit Payload							
For Sub-Frames 1,2,3,4,6,7,8,9	Bits	2984	8504	14112	30576	46888	51024
For Sub-Frame 5	Bits	N/A	N/A	N/A	N/A	N/A	N/A
For Sub-Frame 0	Bits	N/A	6456	12576	28336	45352	51024
Transport block CRC	Bits	24	24	24	24	24	24
Number of Code Blocks per Sub-Frame (Note 3)							
For Sub-Frames 1,2,3,4,6,7,8,9		1	2	3	5	8	9
For Sub-Frame 5		N/A	N/A	N/A	N/A	N/A	N/A
For Sub-Frame 0		N/A	2	3	5	8	9
Binary Channel Bits Per Sub-Frame							
For Sub-Frames 1,2,3,4,6,7,8,9	Bits	4104	11340	18900	41400	62100	68724
For Sub-Frame 5	Bits	N/A	N/A	N/A	N/A	N/A	N/A
For Sub-Frame 0	Bits	N/A	8820	16380	38880	59580	66204
Max. Throughput averaged over 1 frame	kbps	2387.2	7448.8	12547	27294	42046	45922
Note 1:	2 symbols allocated to PDCCH for 20 MHz, 15 MHz and 10 MHz channel BW. 3 symbols allocated to PDCCH for 5 MHz and 3 MHz. 4 symbols allocated to PDCCH for 1.4 MHz.						
Note 2:	Reference signal, Synchronization signals and PBCH allocated as per TS 36.211 [4].						
Note 3:	If more than one Code Block is present, an additional CRC sequence of L = 24 Bits is attached to each Code Block (otherwise L = 0 Bit).						

Table A.3.2-3c Fixed Reference Channel for Maximum input level for UE DL Category 0 (FDD)

Parameter	Unit	Value					
		1.4	3	5	10	15	20
Channel bandwidth	MHz	1.4	3	5	10	15	20
Allocated resource blocks		2	2	2	2	2	2
Subcarriers per resource block		12	12	12	12	12	12
Allocated subframes per Radio Frame		8	9	9	9	9	9
Modulation		64QAM	64QAM	64QAM	64QAM	64QAM	64QAM
Target Coding Rate		3/4	3/4	3/4	3/4	3/4	3/4
Number of HARQ Processes	Processes	8	8	8	8	8	8
Maximum number of HARQ transmissions		1	1	1	1	1	1
Information Bit Payload							
For Sub-Frames 1,2,3,4,6,7,8,9	Bits	1000	1000	1000	1000	1000	1000
For Sub-Frame 5	Bits	N/A	N/A	N/A	N/A	N/A	N/A
For Sub-Frame 0 (Note 3)	Bits	N/A	1000	1000	1000	1000	1000
Transport block CRC	Bits	24	24	24	24	24	24
Number of Code Blocks per Sub-Frame							
For Sub-Frames 1,2,3,4,6,7,8,9		1	1	1	1	1	1
For Sub-Frame 5		N/A	N/A	N/A	N/A	N/A	N/A
For Sub-Frame 0		N/A	1	1	1	1	1
Binary Channel Bits Per Sub-Frame							
For Sub-Frames 1,2,3,4,6,7,8,9	Bits	1368	1512	1512	1656	1656	1656
For Sub-Frame 5	Bits	N/A	N/A	N/A	N/A	N/A	N/A
For Sub-Frame 0 (Note 3)	Bits	N/A	1512	1512	1656	1656	1656
Max. Throughput averaged over 1 frame	kbps	800	900	900	900	900	900
Note 1:	2 symbols allocated to PDCCH for 20 MHz, 15 MHz and 10 MHz channel BW. 3 symbols allocated to PDCCH for 5 MHz and 3 MHz. 4 symbols allocated to PDCCH for 1.4 MHz.						
Note 2:	Reference signal, Synchronization signals and PBCH allocated as per TS 36.211.						
Note 3:	For Sub-Frame 0, it is assumed that the allocated 2PRBs are scheduled on the RBs other than the center 6PRBs as most of the symbols are occupied by PBCH and synchronization signals.						

Table A.3.2-3d Fixed Reference Channel for Maximum input level for UE DL Category M1 (FDD and HD-FDD)

Parameter	Unit	Value					
		1.4	3	5	10	15	20
Channel bandwidth	MHz	1.4	3	5	10	15	20
Allocated resource blocks		2	2	2	2	2	2
Subcarriers per resource block		12	12	12	12	12	12
Allocated subframes per Radio Frame (Note 6)		2	2	8	8	8	8
Modulation		16QAM	16QAM	16QAM	16QAM	16QAM	16QAM
Target Coding Rate		3/5	3/5	3/5	3/5	3/5	3/5
Number of HARQ Processes	Processes	8	8	8	8	8	8
Maximum number of HARQ transmissions		1	1	1	1	1	1
Information Bit Payload							
For Sub-Frames 3,8	Bits	552	552	552	552	552	552
For Sub-Frames 0,1,2,5,7,9	Bits	N/A	N/A	552	552	552	552
For Sub-Frame 4	Bits	N/A	N/A	N/A	N/A	N/A	N/A
For Sub-Frame 6	Bits	N/A	N/A	N/A	N/A	N/A	N/A
Transport block CRC	Bits	24	24	24	24	24	24
Number of Code Blocks per Sub-Frame							
For Sub-Frames 3,8		1	1	1	1	1	1
For Sub-Frames 0,1,2,5,7,9		N/A	N/A	1	1	1	1
For Sub-Frame 4		N/A	N/A	N/A	N/A	N/A	N/A
For Sub-Frame 6		N/A	N/A	N/A	N/A	N/A	N/A
Binary Channel Bits Per Sub-Frame							
For Sub-Frames 3,8	Bits	912	1008	1008	1008	1008	1008
For Sub-Frames 0,1,2,5,7,9		N/A	N/A	1008	1008	1008	1008
For Sub-Frame 4	Bits	N/A	N/A	N/A	N/A	N/A	N/A
For Sub-Frame 6	Bits	N/A	N/A	N/A	N/A	N/A	N/A
Max. Throughput averaged over 1 frame for FDD	kbps	110.4	110.4	441.6	441.6	441.6	441.6
Max. Throughput averaged over 1 frame for HD-FDD		55.2	55.2	165.6	165.6	165.6	165.6
Note 1:	4 symbols allocated to PDCCH for 1.4MHz channel bandwidth. 3 symbols allocated to PDCCH for all other channel bandwidths.						
Note 2:	Reference signal, Synchronization signals and PBCH allocated as per TS 36.211.						
Note 3:	The scheduled narrowband other than 1.4MHz and 3MHz channel bandwidth avoids the centre of the channel where some REs of the same PRBs are occupied by PBCH and synchronization signals.						
Note 4:	For HD-FDD UE, PDSCH are scheduled at the 3rd subframe every 1 radio frame for 1.4MHz and 3MHz channel bandwidth. For other channel bandwidth, PDSCH are scheduled at the 0th, 1st, and 2nd subframes every 1 radio frame. Information bit payload is available if downlink subframe is scheduled. The corresponding MPDCCH is scheduled 2 subframes before the corresponding PDSCH transmission.						
Note 5:	2 resource blocks allocated to MPDCCH.						

Table A.3.2-4 Fixed Reference Channel for Maximum input level for UE Categories ≥ 3 (TDD)

Parameter	Unit	Value					
		1.4	3	5	10	15	20
Channel bandwidth	MHz	1.4	3	5	10	15	20
Allocated resource blocks		6	15	25	50	75	100
Subcarriers per resource block		12	12	12	12	12	12
Uplink-Downlink Configuration (Note 5)		1	1	1	1	1	1
Allocated subframes per Radio Frame		2	3+2	3+2	3+2	3+2	3+2
Modulation		64QAM	64QAM	64QAM	64QAM	64QAM	64QAM
Target Coding Rate		3/4	3/4	3/4	3/4	3/4	3/4
Number of HARQ Processes	Processes	7	7	7	7	7	7
Maximum number of HARQ transmissions		1	1	1	1	1	1
Information Bit Payload per Sub-Frame							
For Sub-Frames 4,9	Bits	2984	8504	14112	30576	46888	61664
For Sub-Frames 1,6	Bits	N/A	6968	11448	23688	35160	46888
For Sub-Frame 5	Bits	N/A	N/A	N/A	N/A	N/A	N/A
For Sub-Frame 0	Bits	N/A	6968	12576	30576	45352	61664
Transport block CRC	Bits	24	24	24	24	24	24
Number of Code Blocks per Sub-Frame (Note 4)							
For Sub-Frames 4,9		1	2	3	5	8	11
For Sub-Frames 1,6		N/A	2	2	4	6	8
For Sub-Frame 5		N/A	N/A	N/A	N/A	N/A	N/A
For Sub-Frame 0		N/A	2	3	5	8	11
Binary Channel Bits per Sub-Frame							
For Sub-Frames 4,9	Bits	4104	11340	18900	41400	62100	82800
For Sub-Frames 1,6		N/A	9828	16668	33768	50868	67968
For Sub-Frame 5	Bits	N/A	N/A	N/A	N/A	N/A	N/A
For Sub-Frame 0	Bits	N/A	9252	16812	39312	60012	80712
Max. Throughput averaged over 1 frame	kbps	596.8	3791.2	6369.6	13910	20945	27877
Note 1:	For normal subframes(0,4,5,9), 2 symbols allocated to PDCCH for 20 MHz, 15 MHz and 10 MHz channel BW; 3 symbols allocated to PDCCH for 5 MHz and 3 MHz; 4 symbols allocated to PDCCH for 1.4 MHz. For special subframe (1&6), only 2 OFDM symbols are allocated to PDCCH for all BWs.						
Note 2:	For 1.4MHz, no data shall be scheduled on special subframes(1&6) to avoid problems with insufficient PDCCH performance.						
Note 3:	Reference signal, Synchronization signals and PBCH allocated as per TS 36.211 [4].						
Note 4:	If more than one Code Block is present, an additional CRC sequence of L = 24 Bits is attached to each Code Block (otherwise L = 0 Bit).						
Note 5:	As per Table 4.2-2 in TS 36.211 [4].						

Table A.3.2-4a Fixed Reference Channel for Maximum input level for UE Category 1 (TDD)

Parameter	Unit	Value					
		1.4	3	5	10	15	20
Channel bandwidth	MHz	1.4	3	5	10	15	20
Allocated resource blocks		6	15	18	17	17	17
Subcarriers per resource block		12	12	12	12	12	12
Uplink-Downlink Configuration (Note 5)		1	1	1	1	1	1
Allocated subframes per Radio Frame		2	3+2	3+2	3+2	3+2	3+2
Modulation		64QAM	64QAM	64QAM	64QAM	64QAM	64QAM
Target Coding Rate		3/4	3/4	3/4	3/4	3/4	3/4
Number of HARQ Processes	Processes	7	7	7	7	7	7
Maximum number of HARQ transmissions		1	1	1	1	1	1
Information Bit Payload per Sub-Frame							
For Sub-Frames 4,9	Bits	2984	8504	10296	10296	10296	10296
For Sub-Frames 1,6	Bits	N/A	6968	8248	7480	7480	7480
For Sub-Frame 5	Bits	N/A	N/A	N/A	N/A	N/A	N/A
For Sub-Frame 0	Bits	N/A	6968	8248	10296	10296	10296
Transport block CRC	Bits	24	24	24	24	24	24
Number of Code Blocks per Sub-Frame (Note 4)							
For Sub-Frames 4,9		1	2	2	2	2	2
For Sub-Frames 1,6		N/A	2	2	2	2	2
For Sub-Frame 5		N/A	N/A	N/A	N/A	N/A	N/A
For Sub-Frame 0		N/A	2	2	2	2	2
Binary Channel Bits per Sub-Frame							
For Sub-Frames 4,9	Bits	4104	11340	13608	14076	14076	14076
For Sub-Frames 1,6		N/A	9828	11880	11628	11628	11628
For Sub-Frame 5	Bits	N/A	N/A	N/A	N/A	N/A	N/A
For Sub-Frame 0	Bits	N/A	9252	11520	14076	14076	14076
Max. Throughput averaged over 1 frame	kbps	596.8	3791.2	4533.6	4584.8	4584.8	4584.8
Note 1:	For normal subframes(0,4,5,9), 2 symbols allocated to PDCCH for 20 MHz, 15 MHz and 10 MHz channel BW; 3 symbols allocated to PDCCH for 5 MHz and 3 MHz; 4 symbols allocated to PDCCH for 1.4 MHz. For special subframe (1&6), only 2 OFDM symbols are allocated to PDCCH for all BWs.						
Note 2:	For 1.4MHz, no data shall be scheduled on special subframes(1&6) to avoid problems with insufficient PDCCH performance.						
Note 3:	Reference signal, Synchronization signals and PBCH allocated as per TS 36.211 [4].						
Note 4:	If more than one Code Block is present, an additional CRC sequence of L = 24 Bits is attached to each Code Block (otherwise L = 0 Bit).						
Note 5:	As per Table 4.2-2 in TS 36.211 [4].						

Table A.3.2-4b Fixed Reference Channel for Maximum input level for UE Category 2 (TDD)

Parameter	Unit	Value					
		1.4	3	5	10	15	20
Channel bandwidth	MHz	1.4	3	5	10	15	20
Allocated resource blocks		6	15	25	50	75	83
Subcarriers per resource block		12	12	12	12	12	12
Uplink-Downlink Configuration (Note 5)		1	1	1	1	1	1
Allocated subframes per Radio Frame		2	3+2	3+2	3+2	3+2	3+2
Modulation		64QAM	64QAM	64QAM	64QAM	64QAM	64QAM
Target Coding Rate		3/4	3/4	3/4	3/4	3/4	3/4
Number of HARQ Processes	Processes	7	7	7	7	7	7
Maximum number of HARQ transmissions		1	1	1	1	1	1
Information Bit Payload per Sub-Frame							
For Sub-Frames 4,9	Bits	2984	8504	14112	30576	46888	51024
For Sub-Frames 1,6	Bits	N/A	6968	11448	23688	35160	39232
For Sub-Frame 5	Bits	N/A	N/A	N/A	N/A	N/A	N/A
For Sub-Frame 0	Bits	N/A	6968	12576	30576	45352	51024
Transport block CRC	Bits	24	24	24	24	24	24
Number of Code Blocks per Sub-Frame (Note 4)							
For Sub-Frames 4,9		1	2	3	5	8	9
For Sub-Frames 1,6		N/A	2	3	5	7	7
For Sub-Frame 5		N/A	N/A	N/A	N/A	N/A	N/A
For Sub-Frame 0		N/A	2	3	5	8	9
Binary Channel Bits per Sub-Frame							
For Sub-Frames 4,9	Bits	4104	11340	18900	41400	62100	68724
For Sub-Frames 1,6		N/A	9828	16668	33768	50868	56340
For Sub-Frame 5	Bits	N/A	N/A	N/A	N/A	N/A	N/A
For Sub-Frame 0	Bits	N/A	9252	16380	39312	60012	66636
Max. Throughput averaged over 1 frame	kbps	596.8	3791.2	6369.6	13910	20945	23154
Note 1:	For normal subframes(0,4,5,9), 2 symbols allocated to PDCCH for 20 MHz, 15 MHz and 10 MHz channel BW; 3 symbols allocated to PDCCH for 5 MHz and 3 MHz; 4 symbols allocated to PDCCH for 1.4 MHz. For special subframe (1&6), only 2 OFDM symbols are allocated to PDCCH for all BWs.						
Note 2:	For 1.4MHz, no data shall be scheduled on special subframes(1&6) to avoid problems with insufficient PDCCH performance.						
Note 3:	Reference signal, Synchronization signals and PBCH allocated as per TS 36.211 [4].						
Note 4:	If more than one Code Block is present, an additional CRC sequence of L = 24 Bits is attached to each Code Block (otherwise L = 0 Bit).						
Note 5:	As per Table 4.2-2 in TS 36.211 [4].						

Table A.3.2-4c Fixed Reference Channel for Maximum input level for UE DL Category 0 (TDD)

Parameter	Unit	Value					
		1.4	3	5	10	15	20
Channel bandwidth	MHz	1.4	3	5	10	15	20
Allocated resource blocks		2	2	2	2	2	2
Subcarriers per resource block		12	12	12	12	12	12
Uplink-Downlink Configuration (Note 5)		1	1	1	1	1	1
Allocated subframes per Radio Frame		2	3+2	3+2	3+2	3+2	3+2
Modulation		64QAM	64QAM	64QAM	64QAM	64QAM	64QAM
Target Coding Rate		3/4	3/4	3/4	3/4	3/4	3/4
Number of HARQ Processes	Processes	7	7	7	7	7	7
Maximum number of HARQ transmissions		1	1	1	1	1	1
Information Bit Payload per Sub-Frame							
For Sub-Frames 4,9	Bits	1000	1000	1000	1000	1000	1000
For Sub-Frames 1,6	Bits	N/A	712	712	712	712	712
For Sub-Frame 5	Bits	N/A	N/A	N/A	N/A	N/A	N/A
For Sub-Frame 0	Bits	N/A	1000	1000	1000	1000	1000
Transport block CRC	Bits	24	24	24	24	24	24
Number of Code Blocks per Sub-Frame (Note 4)							
For Sub-Frames 4,9		1	1	1	1	1	1
For Sub-Frames 1,6		N/A	1	1	1	1	1
For Sub-Frame 5		N/A	N/A	N/A	N/A	N/A	N/A
For Sub-Frame 0		N/A	1	1	1	1	1
Binary Channel Bits per Sub-Frame							
For Sub-Frames 4,9	Bits	1368	1512	1512	1656	1656	1656
For Sub-Frames 1,6		N/A	1224	1224	1368	1368	1368
For Sub-Frame 5	Bits	N/A	N/A	N/A	N/A	N/A	N/A
For Sub-Frame 0	Bits	N/A	1512	1512	1656	1656	1656
Max. Throughput averaged over 1 frame	kbps	200	442.4	442.4	442.4	442.4	442.4
Note 1:	For normal subframes(0,4,5,9), 2 symbols allocated to PDCCH for 20 MHz, 15 MHz and 10 MHz channel BW; 3 symbols allocated to PDCCH for 5 MHz and 3 MHz; 4 symbols allocated to PDCCH for 1.4 MHz. For special subframe (1&6), only 2 OFDM symbols are allocated to PDCCH for all BWs.						
Note 2:	For 1.4MHz, no data shall be scheduled on special subframes(1&6) to avoid problems with insufficient PDCCH performance.						
Note 3:	Reference signal, Synchronization signals and PBCH allocated as per TS 36.211 [4].						
Note 4:	If more than one Code Block is present, an additional CRC sequence of L = 24 Bits is attached to each Code Block (otherwise L = 0 Bit).						
Note 5:	As per Table 4.2-2 in TS 36.211 [4].						

Table A.3.2-4d Fixed Reference Channel for Maximum input level for UE Categories ≥ 3 (TDD Band 46)

Parameter	Unit	Value
Channel bandwidth	MHz	20
Allocated resource blocks		100
Uplink-Downlink Configuration		N/A
Subcarriers per resource block		12
Allocated subframes per Radio Frame (D)		8
Modulation		64QAM
Target Coding Rate		3/4
Number of HARQ Processes	Processes	N/A
Maximum number of HARQ transmissions		N/A
Information Bit Payload per Sub-Frame		
For Sub-Frames 3,4,6,7,8,9	Bits	61664
For Sub-Frame 1,2	Bits	N/A
For Sub-Frame 0,5	Bits	61664
Transport block CRC	Bits	24
Number of Code Blocks per Sub-Frame (Note 3)		
For Sub-Frames 3,4,6,7,8,9		11
For Sub-Frame 1,2		N/A
For Sub-Frame 0,5		11
Binary Channel Bits Per Sub-Frame		
For Sub-Frames 3,4,6,7,8,9	Bits	82800
For Sub-Frame 1,2	Bits	N/A
For Sub-Frame 0,5	Bits	81936
Max. Throughput averaged over 1 frame	kbps	49331.2
Note 1:	2 symbols allocated to PDCCH for 20 MHz.	
Note 2:	Reference signal, Synchronization signals allocated as per TS 36.211 [4].	
Note 3:	If more than one Code Block is present, an additional CRC sequence of L = 24 Bits is attached to each Code Block (otherwise L = 0 Bit).	

Table A.3.2-4e Fixed Reference Channel for Maximum input level for UE DL Category M1 (TDD)

Parameter	Unit	Value					
		1.4	3	5	10	15	20
Channel bandwidth	MHz	1.4	3	5	10	15	20
Allocated resource blocks		2	2	2	2	2	2
Subcarriers per resource block		12	12	12	12	12	12
Uplink-Downlink Configuration (Note 5)		1	1	1	1	1	1
Allocated subframes per Radio Frame		2	2	2	2	2	2
Modulation		16QAM	16QAM	16QAM	16QAM	16QAM	16QAM
Target Coding Rate		3/5	3/5	3/5	3/5	3/5	3/5
Number of HARQ Processes	Processes	7	7	7	7	7	7
Maximum number of HARQ transmissions		1	1	1	1	1	1
Information Bit Payload per Sub-Frame							
For Sub-Frames 4,9	Bits	552	552	552	552	552	552
For Sub-Frames 1,6	Bits	N/A	N/A	N/A	N/A	N/A	N/A
For Sub-Frame 5	Bits	N/A	N/A	N/A	N/A	N/A	N/A
For Sub-Frame 0	Bits	N/A	N/A	N/A	N/A	N/A	N/A
Transport block CRC	Bits	24	24	24	24	24	24
Number of Code Blocks per Sub-Frame (Note 4)							
For Sub-Frames 4,9		1	1	1	1	1	1
For Sub-Frames 1,6		N/A	N/A	N/A	N/A	N/A	N/A
For Sub-Frame 5		N/A	N/A	N/A	N/A	N/A	N/A
For Sub-Frame 0		N/A	N/A	N/A	N/A	N/A	N/A
Binary Channel Bits per Sub-Frame							
For Sub-Frames 4,9	Bits	912	1008	1008	1008	1008	1008
For Sub-Frames 1,6		N/A	N/A	N/A	N/A	N/A	N/A
For Sub-Frame 5	Bits	N/A	N/A	N/A	N/A	N/A	N/A
For Sub-Frame 0	Bits	N/A	N/A	N/A	N/A	N/A	N/A
Max. Throughput averaged over 1 frame	kbps	110.4	110.4	110.4	110.4	110.4	110.4
Note 1:	For normal subframes(0,4,5,9), 4 symbols allocated to PDCCH for 1.4MHz channel bandwidth and 3 symbols allocated to PDCCH for all other channel bandwidths. For special subframe (1&6), only 2 OFDM symbols are allocated to PDCCH for all BWs.						
Note 2:	For 1.4MHz, no data shall be scheduled on special subframes(1&6) to avoid problems with insufficient PDCCH performance.						
Note 3:	Reference signal, Synchronization signals and PBCH allocated as per TS 36.211 [4].						
Note 4:	If more than one Code Block is present, an additional CRC sequence of L = 24 Bits is attached to each Code Block (otherwise L = 0 Bit).						
Note 5:	As per Table 4.2-2 in TS 36.211 [4].						
Note 6:	2 resource blocks allocated to MPDCCH						

Table A.3.2-5 Fixed Reference Channel for Maximum input level for UE Categories 11/12 and UE DL categories ≥ 11 (FDD)

Parameter	Unit	Value					
		1.4	3	5	10	15	20
Channel bandwidth	MHz	1.4	3	5	10	15	20
Allocated resource blocks		6	15	25	50	75	100
Subcarriers per resource block		12	12	12	12	12	12
Allocated subframes per Radio Frame		8	9	9	9	9	9
Modulation		256QAM	256QAM	256QAM	256QAM	256QAM	256QAM
Target Coding Rate		4/5	4/5	4/5	4/5	4/5	4/5
Number of HARQ Processes	Processes	8	8	8	8	8	8
Maximum number of HARQ transmissions		1	1	1	1	1	1
Information Bit Payload per Sub-Frame							
For Sub-Frames 1,2,3,4,6,7,8,9	Bits	4392	12216	19848	42368	63776	84760
For Sub-Frame 5	Bits	N/A	N/A	N/A	N/A	N/A	N/A
For Sub-Frame 0	Bits	N/A	9912	17568	40576	63776	84760
Transport block CRC	Bits	24	24	24	24	24	24
Number of Code Blocks per Sub-Frame (Note 3)							
For Sub-Frames 1,2,3,4,6,7,8,9		1	2	4	7	11	14
For Sub-Frame 5		N/A	N/A	N/A	N/A	N/A	N/A
For Sub-Frame 0		N/A	2	3	7	11	14
Binary Channel Bits Per Sub-Frame							
For Sub-Frames 1,2,3,4,6,7,8,9	Bits	5472	15120	25200	55200	82800	110400
For Sub-Frame 5	Bits	N/A	N/A	N/A	N/A	N/A	N/A
For Sub-Frame 0	Bits	N/A	12210	22290	51840	79440	107040
Max. Throughput averaged over 1 frame	kbps	3513.6	10764	17635.2	37952	57398.4	76284
Note 1:	2 symbols allocated to PDCCH for 20 MHz, 15 MHz and 10 MHz channel BW. 3 symbols allocated to PDCCH for 5 MHz and 3 MHz. 4 symbols allocated to PDCCH for 1.4 MHz.						
Note 2:	Reference signal, Synchronization signals and PBCH allocated as per TS 36.211 [4].						
Note 3:	If more than one Code Block is present, an additional CRC sequence of L = 24 Bits is attached to each Code Block (otherwise L = 0 Bit).						

Table A.3.2-6 Fixed Reference Channel for Maximum input level for UE Categories 11/12 and UE DL categories ≥ 11 (TDD)

Parameter	Unit	Value					
		1.4	3	5	10	15	20
Channel bandwidth	MHz	1.4	3	5	10	15	20
Allocated resource blocks		6	15	25	50	75	100
Subcarriers per resource block		12	12	12	12	12	12
Uplink-Downlink Configuration (Note 5)		1	1	1	1	1	1
Allocated subframes per Radio Frame		2	3+2	3+2	3+2	3+2	3+2
Modulation		256QAM	256QAM	256QAM	256QAM	256QAM	256QAM
Target Coding Rate		4/5	4/5	4/5	4/5	4/5	4/5
Number of HARQ Processes	Processes	7	7	7	7	7	7
Maximum number of HARQ transmissions		1	1	1	1	1	1
Information Bit Payload per Sub-Frame							
For Sub-Frames 4,9	Bits	4392	12216	19848	42368	63776	84760
For Sub-Frames 1,6	Bits	N/A	10680	17568	36696	55056	75376
For Sub-Frame 5	Bits	N/A	N/A	N/A	N/A	N/A	N/A
For Sub-Frame 0	Bits	N/A	9912	17568	42368	63776	84760
Transport block CRC	Bits	24	24	24	24	24	24
Number of Code Blocks per Sub-Frame (Note 4)							
For Sub-Frames 4,9		1	2	4	7	11	14
For Sub-Frames 1,6		N/A	2	3	6	9	13
For Sub-Frame 5		N/A	N/A	N/A	N/A	N/A	N/A
For Sub-Frame 0		N/A	2	3	7	11	14
Binary Channel Bits per Sub-Frame							
For Sub-Frames 4,9	Bits	5472	15120	25200	55200	82800	110400
For Sub-Frames 1,6		N/A	13104	22224	45024	67824	90624
For Sub-Frame 5	Bits	N/A	N/A	N/A	N/A	N/A	N/A
For Sub-Frame 0	Bits	N/A	12336	22416	52416	80016	107616
Max. Throughput averaged over 1 frame	kbps	878.4	5570.4	9240	20049.6	30144	40503.2
Note 1:	For normal subframes(0,4,5,9), 2 symbols allocated to PDCCH for 20 MHz, 15 MHz and 10 MHz channel BW; 3 symbols allocated to PDCCH for 5 MHz and 3 MHz; 4 symbols allocated to PDCCH for 1.4 MHz. For special subframe (1&6), only 2 OFDM symbols are allocated to PDCCH for all BWs.						
Note 2:	For 1.4MHz, no data shall be scheduled on special subframes(1&6) to avoid problems with insufficient PDCCH performance.						
Note 3:	Reference signal, Synchronization signals and PBCH allocated as per TS 36.211 [4].						
Note 4:	If more than one Code Block is present, an additional CRC sequence of L = 24 Bits is attached to each Code Block (otherwise L = 0 Bit).						
Note 5:	As per Table 4.2-2 in TS 36.211 [4].						

Table A.3.2-7 Fixed Reference Channel for Maximum input level for UE Categories 11/12 and UE DL categories ≥ 11 (TDD Band 46)

Parameter	Unit	Value
Channel bandwidth	MHz	20
Allocated resource blocks		100
Uplink-Downlink Configuration		N/A
Subcarriers per resource block		12
Allocated subframes per Radio Frame (D)		8
Modulation		256QAM
Target Coding Rate		4/5
Number of HARQ Processes	Processes	N/A
Maximum number of HARQ transmissions		N/A
Information Bit Payload per Sub-Frame		
For Sub-Frames 3,4,6,7,8,9	Bits	84760
For Sub-Frame 1,2	Bits	N/A
For Sub-Frame 0,5	Bits	84760
Transport block CRC	Bits	24
Number of Code Blocks per Sub-Frame (Note 3)		
For Sub-Frames 3,4,6,7,8,9		14
For Sub-Frame 1,2		N/A
For Sub-Frame 0,5		14
Binary Channel Bits Per Sub-Frame		
For Sub-Frames 3,4,6,7,8,9	Bits	110400
For Sub-Frame 1,2	Bits	N/A
For Sub-Frame 0,5	Bits	109248
Max. Throughput averaged over 1 frame	kbps	67808
Note 1:	2 symbols allocated to PDCCH for 20 MHz.	
Note 2:	Reference signal, Synchronization signals allocated as per TS 36.211 [4].	
Note 3:	If more than one Code Block is present, an additional CRC sequence of L = 24 Bits is attached to each Code Block (otherwise L = 0 Bit).	

A.3.3 Reference measurement channels for PDSCH performance requirements (FDD)

A.3.3.1 Single-antenna transmission (Common Reference Symbols)

Table A.3.3.1-1: Fixed Reference Channel QPSK R=1/3

Parameter	Unit	Value					
		R.4 FDD	R.42 FDD	R.42-1 FDD	R.42-2 FDD	R.42-3 FDD	R.2 FDD
Reference channel							
Channel bandwidth	MHz	1.4	20	3	5	15	10
Allocated resource blocks (Note 4)		6	100	15	25	75	50
Allocated subframes per Radio Frame		9	9	9	9	9	9
Modulation		QPSK	QPSK	QPSK	QPSK	QPSK	QPSK
Target Coding Rate		1/3	1/3	1/3	1/3	1/3	1/3
Information Bit Payload (Note 4)							
For Sub-Frames 1,2,3,4,6,7,8,9	Bits	408	8760	1320	2216	6712	4392
For Sub-Frame 5	Bits	N/A	N/A	N/A	N/A	N/A	N/A
For Sub-Frame 0	Bits	152	8760	1064	1800	6712	4392
Number of Code Blocks (Notes 3 and 4)							
For Sub-Frames 1,2,3,4,6,7,8,9		1	2	1	1	2	1
For Sub-Frame 5		N/A	N/A	N/A	N/A	N/A	N/A
For Sub-Frame 0		1	2	1	1	2	1
Binary Channel Bits (Note 4)							
For Sub-Frames 1,2,3,4,6,7,8,9	Bits	1368	27600	3780	6300	20700	13800
For Sub-Frame 5	Bits	N/A	N/A	N/A	N/A	N/A	N/A
For Sub-Frame 0	Bits	528	26760	2940	5460	19860	12960
Max. Throughput averaged over 1 frame (Note 4)	Mbps	0.342	7.884	1.162	1.953	6.041	3.953
UE Category		≥ 1	≥ 1	≥ 1	≥ 1	≥ 1	≥ 1
Note 1:	2 symbols allocated to PDCCH for 20 MHz, 15 MHz and 10 MHz channel BW; 3 symbols allocated to PDCCH for 5 MHz and 3 MHz; 4 symbols allocated to PDCCH for 1.4 MHz.						
Note 2:	Reference signal, synchronization signals and PBCH allocated as per TS 36.211 [4].						
Note 3:	If more than one Code Block is present, an additional CRC sequence of L = 24 Bits is attached to each Code Block (otherwise L = 0 Bit).						
Note 4:	Given per component carrier per codeword.						

Table A.3.3.1-2: Fixed Reference Channel 16QAM R=1/2

Parameter	Unit	Value					
				R.3-1 FDD	R.3 FDD		
Reference channel							
Channel bandwidth	MHz	1.4	3	5	10	15	20
Allocated resource blocks				25	50		
Allocated subframes per Radio Frame				9	9		
Modulation				16QAM	16QAM		
Target Coding Rate				1/2	1/2		
Information Bit Payload							
For Sub-Frames 1,2,3,4,6,7,8,9	Bits			6456	14112		
For Sub-Frame 5	Bits			N/A	N/A		
For Sub-Frame 0	Bits			5736	12960		
Number of Code Blocks per Sub-Frame (Note 3)							
For Sub-Frames 1,2,3,4,6,7,8,9				2	3		
For Sub-Frame 5				N/A	N/A		
For Sub-Frame 0				1	3		
Binary Channel Bits Per Sub-Frame							
For Sub-Frames 1,2,3,4,6,7,8,9	Bits			12600	27600		
For Sub-Frame 5	Bits			N/A	N/A		
For Sub-Frame 0	Bits			10920	25920		
Max. Throughput averaged over 1 frame	Mbps			5.738	12.586		
UE Category				≥ 1	≥ 2		
Note 1: 2 symbols allocated to PDCCH for 20 MHz, 15 MHz and 10 MHz channel BW; 3 symbols allocated to PDCCH for 5 MHz and 3 MHz; 4 symbols allocated to PDCCH for 1.4 MHz. Note 2: Reference signal, synchronization signals and PBCH allocated as per TS 36.211 [4]. Note 3: If more than one Code Block is present, an additional CRC sequence of L = 24 Bits is attached to each Code Block (otherwise L = 0 Bit).							

Table A.3.3.1-3: Fixed Reference Channel 64QAM R=3/4

Parameter	Unit	Value					
			R.5 FDD	R.6 FDD	R.7 FDD	R.8 FDD	R.9 FDD
Reference channel							
Channel bandwidth	MHz	1.4	3	5	10	15	20
Allocated resource blocks			15	25	50	75	100
Allocated subframes per Radio Frame			9	9	9	9	9
Modulation		64QAM	64QAM	64QAM	64QAM	64QAM	64QAM
Target Coding Rate		3/4	3/4	3/4	3/4	3/4	3/4
Information Bit Payload							
For Sub-Frames 1,2,3,4,6,7,8,9	Bits		8504	14112	30576	46888	61664
For Sub-Frame 5	Bits		N/A	N/A	N/A	N/A	N/A
For Sub-Frame 0	Bits		6456	12576	28336	45352	61664
Number of Code Blocks per Sub-Frame (Note 3)							
For Sub-Frames 1,2,3,4,6,7,8,9			2	3	5	8	11
For Sub-Frame 5			N/A	N/A	N/A	N/A	N/A
For Sub-Frame 0			2	3	5	8	11
Binary Channel Bits Per Sub-Frame							
For Sub-Frames 1,2,3,4,6,7,8,9	Bits		11340	18900	41400	62100	82800
For Sub-Frame 5	Bits		N/A	N/A	N/A	N/A	N/A
For Sub-Frame 0	Bits		8820	16380	38880	59580	80280
Max. Throughput averaged over 1 frame	Mbps		7.449	12.547	27.294	42.046	55.498
UE Category			≥ 1	≥ 2	≥ 2	≥ 2	≥ 3
Note 1: 2 symbols allocated to PDCCH for 20 MHz, 15 MHz and 10 MHz channel BW; 3 symbols allocated to PDCCH for 5 MHz and 3 MHz; 4 symbols allocated to PDCCH for 1.4 MHz. Note 2: Reference signal, synchronization signals and PBCH allocated as per TS 36.211 [4]. Note 3: If more than one Code Block is present, an additional CRC sequence of L = 24 Bits is attached to each Code Block (otherwise L = 0 Bit).							

Table A.3.3.1-3a: Fixed Reference Channel 64QAM R=3/4

Parameter	Unit	Value				
		R.6-1 FDD	R.7-1 FDD	R.8-1 FDD	R.9-1 FDD	R.9-2 FDD
Reference channel						
Channel bandwidth	MHz	5	10	15	20	20
Allocated resource blocks (Note 3)		18	17	17	17	83
Allocated subframes per Radio Frame		9	9	9	9	9
Modulation		64QAM	64QAM	64QAM	64QAM	64QAM
Target Coding Rate		3/4	3/4	3/4	3/4	3/4
Information Bit Payload						
For Sub-Frames 1,2,3,4,6,7,8,9	Bits	10296	10296	10296	10296	51024
For Sub-Frame 5	Bits	N/A	N/A	N/A	N/A	N/A
For Sub-Frame 0	Bits	8248	10296	10296	10296	51024
Number of Code Blocks per Sub-Frame (Note 4)						
For Sub-Frames 1,2,3,4,6,7,8,9		2	2	2	2	9
For Sub-Frame 5		N/A	N/A	N/A	N/A	N/A
For Sub-Frame 0		2	2	2	2	9
Binary Channel Bits Per Sub-Frame						
For Sub-Frames 1,2,3,4,6,7,8,9	Bits	13608	14076	14076	14076	68724
For Sub-Frame 5	Bits	N/A	N/A	N/A	N/A	N/A
For Sub-Frame 0	Bits	11088	14076	14076	14076	66204
Max. Throughput averaged over 1 frame	Mbps	9.062	9.266	9.266	9.266	45.922
UE Category		≥ 1	≥ 1	≥ 1	≥ 1	≥ 2
Note 1:	2 symbols allocated to PDCCH for 20 MHz, 15 MHz and 10 MHz channel BW; 3 symbols allocated to PDCCH for 5 MHz and 3 MHz; 4 symbols allocated to PDCCH for 1.4 MHz.					
Note 2:	Reference signal, synchronization signals and PBCH allocated as per TS 36.211 [4].					
Note 3:	Localized allocation started from RB #0 is applied.					
Note 4:	If more than one Code Block is present, an additional CRC sequence of L = 24 Bits is attached to each Code Block (otherwise L = 0 Bit).					

Table A.3.3.1-4: Fixed Reference Channel Single PRB (Channel Edge)

Parameter	Unit	Value					
		R.0 FDD		R.1 FDD			
Reference channel							
Channel bandwidth	MHz	1.4	3	5	10/20	15	20
Allocated resource blocks			1		1		
Allocated subframes per Radio Frame			9		9		
Modulation			16QAM		16QAM		
Target Coding Rate			1/2		1/2		
Information Bit Payload							
For Sub-Frames 1,2,3,4,6,7,8,9	Bits		224		256		
For Sub-Frame 5	Bits		N/A		N/A		
For Sub-Frame 0	Bits		224		256		
Number of Code Blocks per Sub-Frame (Note 3)							
For Sub-Frames 1,2,3,4,6,7,8,9			1		1		
For Sub-Frame 5			N/A		N/A		
For Sub-Frame 0			1		1		
Binary Channel Bits Per Sub-Frame							
For Sub-Frames 1,2,3,4,6,7,8,9	Bits		504		552		
For Sub-Frame 5	Bits		N/A		N/A		
For Sub-Frame 0	Bits		504		552		
Max. Throughput averaged over 1 frame	Mbps		0.202		0.230		
UE Category			≥ 1		≥ 1		
Note 1:	2 symbols allocated to PDCCH for 20 MHz, 15 MHz and 10 MHz channel BW; 3 symbols allocated to PDCCH for 5 MHz and 3 MHz; 4 symbols allocated to PDCCH for 1.4 MHz.						
Note 2:	Reference signal, synchronization signals and PBCH allocated as per TS 36.211 [4].						
Note 3:	If more than one Code Block is present, an additional CRC sequence of L = 24 Bits is attached to each Code Block (otherwise L = 0 Bit).						

Table A.3.3.1-5: Fixed Reference Channel Single PRB (MBSFN Configuration)

Parameter	Unit	Value
Reference channel		R.29 FDD (MBSFN)
Channel bandwidth	MHz	10
Allocated resource blocks		1
MBSFN Configuration (Note 4)		111111
Allocated subframes per Radio Frame		3
Modulation		16QAM
Target Coding Rate		1/2
Information Bit Payload		
For Sub-Frames 4,9	Bits	256
For Sub-Frame 5	Bits	N/A
For Sub-Frame 0	Bits	256
For Sub-Frame 1,2,3,6,7,8	Bits	0 (MBSFN)
Number of Code Blocks per Sub-Frame (Note 3)		
For Sub-Frames 4,9		1
For Sub-Frame 5		N/A
For Sub-Frame 0		1
For Sub-Frame 1,2,3,6,7,8		0 (MBSFN)
Binary Channel Bits Per Sub-Frame		
For Sub-Frames 4,9	Bits	552
For Sub-Frame 5	Bits	N/A
For Sub-Frame 0	Bits	552
For Sub-Frame 1,2,3,6,7,8	Bits	0 (MBSFN)
Max. Throughput averaged over 1 frame	kbps	76.8
UE Category		≥ 1
Note 1:	2 symbols allocated to PDCCH.	
Note 2:	Reference signal, synchronization signals and PBCH allocated as per TS 36.211 [4].	
Note 3:	If more than one Code Block is present, an additional CRC sequence of L = 24 Bits is attached to each Code Block (otherwise L = 0 Bit).	
Note 4:	MBSFN Subframe Allocation as defined in [7], one frame with 6 bits is chosen for MBSFN subframe allocation	

Table A.3.3.1-6: Fixed Reference Channel QPSK R=1/10

Parameter	Unit	Value					
					R.41 FDD		
Reference channel							
Channel bandwidth	MHz	1.4	3	5	10	15	20
Allocated resource blocks					50		
Allocated subframes per Radio Frame					9		
Modulation					QPSK		
Target Coding Rate					1/10		
Information Bit Payload							
For Sub-Frames 1,2,3,4,6,7,8,9	Bits				1384		
For Sub-Frame 5	Bits				N/A		
For Sub-Frame 0	Bits				1384		
Number of Code Blocks per Sub-Frame (Note 3)							
For Sub-Frames 1,2,3,4,6,7,8,9					1		
For Sub-Frame 5					N/A		
For Sub-Frame 0					1		
Binary Channel Bits Per Sub-Frame							
For Sub-Frames 1,2,3,4,6,7,8,9	Bits				13800		
For Sub-Frame 5	Bits				N/A		
For Sub-Frame 0	Bits				12960		
Max. Throughput averaged over 1 frame	Mbps				1.246		
UE Category					≥ 1		
<p>Note 1: 2 symbols allocated to PDCCH for 20 MHz, 15 MHz and 10 MHz channel BW; 3 symbols allocated to PDCCH for 5 MHz and 3 MHz; 4 symbols allocated to PDCCH for 1.4 MHz.</p> <p>Note 2: Reference signal, synchronization signals and PBCH allocated as per TS 36.211 [4].</p> <p>Note 3: If more than one Code Block is present, an additional CRC sequence of L = 24 Bits is attached to each Code Block (otherwise L = 0 Bit).</p>							

Table A.3.3.1-7: Fixed Reference Channel for CA demodulation with power imbalance

Parameter	Unit	Value		
		R.49 FDD	R.49-1 FDD	R.49-2 FDD
Reference channel				
Channel bandwidth	MHz	20	10	5
Allocated resource blocks		100	50	25
Allocated subframes per Radio Frame		9	9	9
Modulation		64QAM	64QAM	64QAM
Coding Rate				
For Sub-Frame 1,2,3,4,6,7,8,9,		0.84	0.84	0.84
For Sub-Frame 5		N/A	N/A	N/A
For Sub-Frame 0		0.87	0.87	0.86
Information Bit Payload				
For Sub-Frames 1,2,3,4,6,7,8,9	Bits	63776	31704	15840
For Sub-Frame 5	Bits	N/A	N/A	N/A
For Sub-Frame 0		63776	30576	14112
Number of Code Blocks per Sub-Frame (Note 3)				
For Sub-Frames 0,1,2,3,4,6,7,8,9	Code Blocks	11	6	3
For Sub-Frame 5	Code Blocks	N/A	N/A	N/A
Binary Channel Bits Per Sub-Frame			5	3
For Sub-Frames 1,2,3,4,6,7,8,9	Bits	75600		
For Sub-Frame 5	Bits	N/A	37800	18900
For Sub-Frame 0	Bits	73080	N/A	N/A
Max. Throughput averaged over 1 frame	Mbps	57.398	35280	16380
UE Category		≥5	≥2	≥2
<p>Note 1: 3 symbols allocated to PDCCH.</p> <p>Note 2: Reference signal, synchronization signals and PBCH allocated as per TS 36.211 [4].</p> <p>Note 3: If more than one Code Block is present, an additional CRC sequence of L = 24 Bits is attached to each Code Block (otherwise L = 0 Bit).</p>				

A.3.3.2 Multi-antenna transmission (Common Reference Symbols)

A.3.3.2.1 Two antenna ports

Table A.3.3.2.1-1: Fixed Reference Channel two antenna ports

Parameter	Unit	Value											
		R.10 FDD	R.11 FDD	R.11-1 FDD	R.11-2 FDD	R.11-3 FDD Note 5	R.11-4 FDD	R.30 FDD	R.30-1 FDD	R.35-1 FDD	R.35 FDD	R.35-2 FDD	R.35-3 FDD
Reference channel													
Channel bandwidth	MHz	10	10	10	5	10	10	20	15	20	10	15	10
Allocated resource blocks (Note 4)		50	50	50	25	40	50	100	75	100	50	75	50
Allocated subframes per Radio Frame		9	9	8	9	9	9	9	8	8	9	8	8
Modulation		QPSK	16QA M	16QA M	16QA M	16QA M	QPSK	16QA M	16QA M	64QA M	64QA M	64QA M	64QA M
Target Coding Rate		1/3	1/2	1/2	1/2	1/2	1/2	1/2	1/2	0.39	1/2	0.39	0.39
Information Bit Payload (Note 4)													
For Sub-Frames 1,2,3,4,6,7,8,9	Bits	4392	12960	12960	5736	10296	6968	25456	19080	30576	19848	22920	15264
For Sub-Frame 5	Bits	N/A	N/A	N/A	N/A	N/A	N/A	N/A	N/A	N/A	N/A	N/A	N/A
For Sub-Frame 0	Bits	4392	12960	N/A	4968	10296	6968	25456	N/A	N/A	18336	N/A	N/A
Number of Code Blocks (Notes 3 and 4)													
For Sub-Frames 1,2,3,4,6,7,8,9	Bits	1	3	3	1	2	2	5	4	5	4	4	3
For Sub-Frame 5	Bits	N/A	N/A	N/A	N/A	N/A	N/A	N/A	N/A	N/A	N/A	N/A	N/A
For Sub-Frame 0	Bits	1	3	N/A	1	2	2	5	N/A	N/A	3	N/A	N/A
Binary Channel Bits (Note 4)													
For Sub-Frames 1,2,3,4,6,7,8,9	Bits	13200	26400	26400	12000	21120	13200	52800	39600	79200	39600	59400	39600
For Sub-Frame 5	Bits	N/A	N/A	N/A	N/A	N/A	N/A	N/A	N/A	N/A	N/A	N/A	N/A
For Sub-Frame 0	Bits	12384	24768	N/A	10368	19488	12384	51168	N/A	N/A	37152	N/A	N/A
Max. Throughput averaged over 1 frame (Note 4)	Mbps	3.953	11.664	10.368	5.086	9.266	6.271	22.910	15.264	24.461	17.712	18.336	12.211
UE Category		≥ 1	≥ 2	≥ 2	≥ 1	≥ 1	≥ 1	≥ 2	≥ 2	4	≥ 2	≥ 2	≥ 2
Note 1:	2 symbols allocated to PDCCH for 20 MHz, 15 MHz and 10 MHz channel BW; 3 symbols allocated to PDCCH for 5 MHz and 3 MHz; 4 symbols allocated to PDCCH for 1.4 MHz.												
Note 2:	Reference signal, synchronization signals and PBCH allocated as per TS 36.211 [4].												
Note 3:	If more than one Code Block is present, an additional CRC sequence of L = 24 Bits is attached to each Code Block (otherwise L = 0 Bit).												
Note 4:	Given per component carrier per codeword.												
Note 5:	For R.11-3 resource blocks of RB6–RB45 are allocated.												

Table A.3.3.2.1-2: Fixed Reference Channel two antenna ports

Parameter	Unit	Value											
		R.46 FDD	R.47 FDD	R.35-4 FDD	R.11-5 FDD	R.11-6 FDD	R.11-7 FDD	R.11-8 FDD	R.11-9 FDD	R.11-10 FDD	R.65 FDD	R.10-2 FDD	R.10-3 FDD
Reference channel													
Channel bandwidth	MHz	10	10	10	1.4	3	15	10	10	10	10	5	10
Allocated resource blocks (Note 4)		50	50	50	6	15	75	50	50	50	50	25	50
Allocated number of PDCCH symbols		2	2	2	4	3	2	2	3	3	2	3	2
Allocated subframes per Radio Frame		9	9	9	8	9	9	9	8	8	8	9	9
Modulation		QPSK	16QA M	64QA M	16QA M	16QA M	16QA M	QPSK	QPSK	QPSK	256QA M	QPSK	16QA M
Target Coding Rate				0.47	1/2	1/2	1/2	3/5	0.58	0.67	0.55	1/3	0.58
Information Bit Payload (Note 4)													
For Sub-Frames 1,2,3,4,6,7,8,9	Bits	5160	8760	18336	1352	3368	19080	7992	6968	7992	31704	1800	15264
For Sub-Frame 5	Bits	N/A	N/A	N/A	N/A	N/A	N/A	N/A	N/A	N/A	N/A	n/a	n/a
For Sub-Frame 0	Bits	5160	8760	16416	N/A	2664	19080	6968	N/A	N/A	N/A	1800	14112
Number of Code Blocks (Notes 3 and 4)													
For Sub-Frames 1,2,3,4,6,7,8,9	Bits	1	2	3	1	1	4	2	2	2	6	1	3
For Sub-Frame 5	Bits	N/A	N/A	N/A	N/A	N/A	N/A	N/A	N/A	N/A	N/A	n/a	n/a
For Sub-Frame 0	Bits	1	2	3	1	1	4	2	N/A	N/A	N/A	1	3
Binary Channel Bits (Note 4)													
For Sub-Frames 1,2,3,4,6,7,8,9	Bits	13200	26400	39600	2592	7200	39600	13200	12000	12000	57600	6000	26400
For Sub-Frame 5	Bits	N/A	N/A	N/A	N/A	N/A	N/A	N/A	N/A	N/A	N/A	n/a	n/a
For Sub-Frame 0	Bits	12384	24768	37152	N/A	5568	37968	12384	N/A	N/A	N/A	5184	24768
Max. Throughput averaged over 1 frame (Note 4)	Mbps	4.644	7.884	16.310	1.082	2.961	17.172	7.0904	5.5744	6.3936	25.363	1.620	13.62 24
UE Category		≥ 1	≥ 1	≥ 2	≥ 1	≥ 1	≥ 2	≥ 2	≥ 1	≥ 1	11-12	≥ 1	≥ 2
UE DL Category		≥ 6	≥ 6	≥ 6	≥ 6	≥ 6	≥ 6	≥ 6			≥ 11	≥ 6	
Note 1:	Void												
Note 2:	Reference signal, synchronization signals and PBCH allocated as per TS 36.211 [4]												
Note 3:	If more than one Code Block is present, an additional CRC sequence of L = 24 Bits is attached to each Code Block (otherwise L = 0 Bit)												
Note 4:	Given per component carrier per codeword.												

Table A.3.3.2.1-3: Fixed Reference Channel two antenna ports

Parameter	Unit	Value	
Reference channel		R.62 FDD	R.63 FDD
Channel bandwidth	MHz	10	10
Allocated resource blocks (Note 4)		3	1
Allocated DL subframes per 4 Radio Frames (Note 3)		15	15
Modulation		16QAM	64QAM
Target Coding Rate		1/2	1/2
Information Bit Payload			
For Sub-Frames 0,1,2,3,4,5,6,7,8,9	Bits	744	408
Number of Code Blocks			
For Sub-Frames 0,1,2,3,4,5,6,7,8,9	Code blocks	1	1
Binary Channel Bits			
For Sub-Frames 0,1,2,3,4,5,6,7,8,9	Bits	1584	792
Max. Throughput averaged over 4 frames	Mbps	0.279	0.153
UE DL Category		0	0
Note 1:	2 symbols allocated to PDCCH		
Note 2:	Reference signal, synchronization signals and PBCH allocated as per TS 36.211 [4]		
Note 3:	The downlink subframes are scheduled at the 0th, 1st, 2nd, 8th, 9th, 10th, 16th, 17th, 18th, 24th, 25th, 26th, 32nd, 33rd, 34th subframes every 40ms. Information bit payload is available if downlink subframe is scheduled.		
Note 4:	Allocated PRB positions start from {9, 10, ..., 9+N-1}, where N is the number of allocated resource blocks.		

Table A.3.3.2.1-4: Fixed Reference Channel two antenna ports

Parameter	Unit	Values
Reference channel		R.79 FDD
Channel bandwidth	MHz	10
Allocated resource blocks (Note 4)		3
Allocated DL subframes per Radio Frame (Note 3)		2
Modulation		16QAM
Target Coding Rate		1/2
Information Bit Payload		
For Sub-Frames 0,1,2,3,4,5,6,7,8,9	Bits	744
Number of Code Blocks		
For Sub-Frames 0,1,2,3,4,5,6,7,8,9	Code blocks	1
Binary Channel Bits		
For Sub-Frames 0,1,2,3,4,5,6,7,8,9	Bits	1584
Max. Throughput averaged over 1 frame	Mbps	0.149
UE DL Category		M1, ≥ 0
Note 1:	2 symbols allocated to PDCCH.	
Note 2:	Reference signal, synchronization signals and PBCH allocated as per TS 36.211 [4].	
Note 3:	The downlink subframes are scheduled at the 0th and 1st subframes every 10ms. Information bit payload is available if downlink subframe is scheduled (starting from 0th subframe). The corresponding MPDCCH is scheduled 2 subframes before the corresponding PDSCH transmissions.	
Note 4:	Allocated PRB positions for PDSCH are {3, 4, 5} within the assigned narrowband. Allocated PRB positions for MPDCCH are {0, 1} within the assigned narrowband.	

Table A.3.3.2.1-5: Fixed Reference Channel two antenna ports

Parameter	Unit	Values		
		R.81 FDD	R.81-1 FDD	R.81-2 FDD
Reference channel		R.81 FDD	R.81-1 FDD	R.81-2 FDD
Channel bandwidth	MHz	10	10	10
Allocated resource blocks (Note 4)		6	6	6
Allocated PDSCH subframes (Note 3)		(Note 3)	(Note 6)	(Note 7)
Modulation		QPSK	QPSK	QPSK
Target Coding Rate		1/10	1/10	1/10
Information Bit Payload				
For Sub-Frames 0,1,2,3,4,5,6,7,8,9	Bits	152	152	152
Number of Code Blocks				
For Sub-Frames 0,1,2,3,4,5,6,7,8,9	Code blocks	1	1	1
Binary Channel Bits				
For Sub-Frames 0,1,2,3,4,5,6,7,8,9	Bits	1584	1584	1584
Max. Throughput averaged over one period	kbps	0.950	1.9	4.75
UE DL Category		M1, ≥ 0	≥ 1	≥ 1
Note 1:	2 symbols allocated to PDCCH			
Note 2:	Reference signal, synchronization signals and PBCH allocated as per TS 36.211 [4]			
Note 3:	PDSCH subframes are scheduled at the 65th to 128th subframes every period=160 ms. Information bit payload is available at the 65th to 128th subframes with repetition. (Starting from the 0th subframe)			
Note 4:	Allocated PRB positions are {0, 1, 2, 3, 4, 5} within the assigned narrowband.			
Note 5:	MPDCCH are scheduled at the 0th to 63rd subframes with repetition. The allocated PRB positions are {0, 1, 2, 3, 4, 5} within the assigned narrowband. (Starting from the 0th subframe)			
Note 6:	PDSCH subframes are scheduled at the 33th to 64th subframes every period=80 ms. Information bit payload is available at the 33th to 64th subframes with repetition. (Starting from the 0th subframe)			
Note 7:	PDSCH subframes are scheduled at the 9th to 24th subframes every period=32 ms. Information bit payload is available at the 9th to 24th subframes with repetition. (Starting from the 0th subframe)			

A.3.3.2.2 Four antenna ports

Table A.3.3.2.2-1: Fixed Reference Channel four antenna ports

Parameter	Unit	Value													
		R.12 FDD	R.13 FDD	R.14 FDD	R.14-1 FDD	R.14-2 FDD	R.14-3 FDD	R.36 FDD	R.14-4 FDD	R.14-5 FDD	R.14-6 FDD	R.14-7 FDD	R.72 FDD	R.73 FDD	R.74 FDD
Reference channel															
Channel bandwidth	MHz	1.4	10	10	10	10	20	10	1.4	3	5	15	10	10	10
Allocated resource blocks (Note 4)		6	50	50	6	3	100	50	6	15	25	75	50	50	50
Allocated subframes per Radio Frame		9	9	9	8	8	9	9	8	9	9	9	9	9	9
Modulation		QPS K	QPS K	16Q AM	16QA M	16QA M	16QA M	64Q AM	16QA M	16QA M	16QA M	16QA M	256Q AM	64QAM	16QA M
Target Coding Rate		1/3	1/3	1/2	1/2	1/2	1/2	1/2	1/2	1/2	1/2	1/2	0.62	0.43	1/2
Information Bit Payload (Note 4)															
For Sub-Frames 1,2,3,4,6,7,8,9	Bits	408	4392	12960	1544	744	25456	18336	1192	3368	5736	19080	31704	16416 (CW0) 32856 (CW1)	25456
For Sub-Frame 5	Bits	N/A	N/A	N/A	N/A	N/A	n/a	N/A	N/A	N/A	N/A	N/A	N/A	N/A	N/A
For Sub-Frame 0	Bits	152	3624	11448	N/A	N/A	22920	18336	N/A	2664	4968	19080	31704	15264 (CW0) 30576 (CW1)	22920
Number of Code Blocks (Notes 3 and 4)															
For Sub-Frames 1,2,3,4,6,7,8,9		1	1	3	1	1	5	3	1	1	1	4	3	3 (CW0) 6 (CW1)	5
For Sub-Frame 5		N/A	N/A	N/A	N/A	N/A	n/a	N/A	N/A	N/A	N/A	N/A	N/A	N/A	N/A
For Sub-Frame 0		1	1	2	N/A	N/A	4	3	N/A	1	1	4	3	3 (CW0) 5 (CW1)	5
Binary Channel Bits (Note 4)															
For Sub-Frames 1,2,3,4,6,7,8,9	Bits	1248	12800	25600	3072	1536	51200	38400	2496	6960	11600	38400	51200	38400 (CW0) 76800 (CW1)	51200
For Sub-Frame 5	Bits	N/A	N/A	N/A	N/A	N/A	n/a	N/A	N/A	N/A	N/A	N/A	N/A	N/A	N/A
For Sub-Frame 0	Bits	480	1203	2406	N/A	N/A	49664	3609	N/A	5424	10064	36864	48128	36096	48128

			2	4				6						(CW0) 72192 (CW1)	
Max. Throughput averaged over 1 frame (Note 4)	Mbps	0.34 2	3.87 6	11.5 13	1.235	0.595	22.65 6	16.5 02	0.954	2.961	5.086	17.17 2	28.53 4	14.659 (CW0) 29.342 (CW1)	22.65 7
UE Category		≥ 1	≥ 1	≥ 2	≥ 1	≥ 1	≥ 2	≥ 2	≥ 1	≥ 1	≥ 1	≥ 2	≥ 11	≥ 5	≥ 5
<p>Note 1: 2 symbols allocated to PDCCH for 20 MHz, 15 MHz and 10 MHz channel BW; 3 symbols allocated to PDCCH for 5 MHz and 3 MHz; 4 symbols allocated to PDCCH for 1.4 MHz.</p> <p>Note 2: Reference signal, synchronization signals and PBCH allocated as per TS 36.211 [4].</p> <p>Note 3: If more than one Code Block is present, an additional CRC sequence of L = 24 Bits is attached to each Code Block (otherwise L = 0 Bit).</p> <p>Note 4: Given per component carrier per codeword.</p>															

A.3.3.3 Reference Measurement Channel for UE-Specific Reference Symbols

A.3.3.3.0 Two antenna ports (no CSI-RS)

The reference measurement channels in Table A.3.3.3.0-1 apply with two CRS antenna ports and without CSI-RS.

Table A.3.3.3.0-1: Fixed Reference Channel without CSI-RS

Parameter	Unit	Value	
Reference channel		R.70 FDD	R.71 FDD
Channel bandwidth	MHz	10	10
Allocated resource blocks		50	50
Allocated subframes per Radio Frame		10	10
Modulation		QPSK	16QAM
Target Coding Rate		0.65	0.6
Information Bit Payload			
For Sub-Frames 1,2,3,4,6,7,8,9	Bits	6968	12960
For Sub-Frame 5	Bits	N/A	N/A
For Sub-Frame 0	Bits	N/A	N/A
Number of Code Blocks per Sub-Frame (Note 4)			
For Sub-Frames 1,2,3,4,6,7,8,9		2	3
For Sub-Frame 5		N/A	N/A
For Sub-Frame 0		N/A	N/A
Binary Channel Bits Per Sub-Frame			
For Sub-Frames 1,2,3,4,6,7,8,9	Bits	10800	21600
For Sub-Frame 5	Bits	N/A	N/A
For Sub-Frame 0	Bits	N/A	N/A
Max. Throughput averaged over 1 frame	Mbps	5.5744	10.368
UE Category		≥ 1	≥ 2
Note 1: 3 symbols allocated to PDCCH.			
Note 2: Reference signal, synchronization signals and PBCH allocated as per TS 36.211 [4]			
Note 3: If more than one Code Block is present, an additional CRC sequence of L = 24 Bits is attached to each Code Block (otherwise L = 0 Bit)			

The reference measurement channels in Table A.3.3.3.0-2 apply for verifying demodulation performance for UE-specific reference symbols without CSI-RS.

Table A.3.3.3.0-2: Fixed Reference Channel without CSI-RS

Parameter	Unit	Value		
		R.80 FDD	R.80-1 FDD	R.80-2 FDD
Reference channel		R.80 FDD	R.80-1 FDD	R.80-2 FDD
Channel bandwidth	MHz	10	10	10
Allocated resource blocks (Note 4)		6	6	6
Allocated PDSCH subframes		Note 3	Note 6	Note 7
Modulation		QPSK	QPSK	QPSK
Target Coding Rate		1/3	1/3	1/3
Information Bit Payload				
For Sub-Frames 0,1,2,3,4,5,6,7,8,9	Bits	504	504	504
Number of Code Blocks				
For Sub-Frames 0,1,2,3,4,5,6,7,8,9	Code blocks	1	1	1
Binary Channel Bits				
For Sub-Frames 0,1,2,3,4,5,6,7,8,9	Bits	1440	1440	1440
Max. Throughput averaged over one period	kbps	15.75	31.5	50.4
UE DL Category		M1, ≥ 0	≥ 1	≥ 1
Note 1: 2 symbols allocated to PDCCH Note 2: Reference signal, synchronization signals and PBCH allocated as per TS 36.211 [4] Note 3: PDSCH subframes are scheduled at the 9th to 16th subframes every period=32 ms. Information bit payload is available from the 9th to 16th subframes with repetition. (Starting from the 0th subframe) Note 4: Allocated PRB positions are {0, 1, 2, 3, 4, 5} within the assigned narrowband. Note 5: MPDCCH are scheduled at the 0th to 7th subframes with repetition. The allocated PRB positions are {0, 1, 2, 3, 4, 5} within the assigned narrowband. (Starting from the 0th subframe) Note 6: PDSCH subframes are scheduled at the 3th to 6th subframes every period=16 ms. Information bit payload is available from the 3th to 6th subframes with repetition. (Starting from the 0th subframe) Note 7: PDSCH subframes are scheduled at the 2th to 3th subframes every period=10 ms. Information bit payload is available from the 2th to 3th subframes with repetition. (Starting from the 0th subframe)				

A.3.3.3.1 Two antenna port (CSI-RS)

The reference measurement channels in Table A.3.3.3.1-1 apply for verifying demodulation performance for UE-specific reference symbols with two cell-specific antenna ports and two CSI-RS antenna ports.

Table A.3.3.3.1-1: Fixed Reference Channel for CDM-multiplexed DM RS with two CSI-RS antenna ports

Parameter	Unit	Value		
		R.51 FDD	R.51-1 FDD	R.76 FDD
Reference channel		R.51 FDD	R.51-1 FDD	R.76 FDD
Channel bandwidth	MHz	10	10	10
Allocated resource blocks		50 (Note 3)	50 (Note 3)	50 (Note 3)
Allocated subframes per Radio Frame		9	9	9
Modulation		16QAM	16QAM	QPSK
Target Coding Rate		1/2	0.54	
Information Bit Payload				
For Sub-Frames 1,4,6,9	Bits	11448	12960	6200
For Sub-Frames 2,3,7,8	Bits	11448	12960	6200
For Sub-Frame 5	Bits	N/A	N/A	n/a
For Sub-Frame 0	Bits	9528	10680	4968
Number of Code Blocks (Note 4)				
For Sub-Frames 1,4,6,9	Code blocks	2	3	2
For Sub-Frames 2,3,7,8	Code blocks	2	3	2
For Sub-Frame 5	Bits	N/A	N/A	n/a
For Sub-Frame 0	Bits	2	2	1
Binary Channel Bits				
For Sub-Frames 1,4,6,9	Bits	24000	24000	12000
For Sub-Frames 2,7		23600	23600	11800
For Sub-Frames 3,8		23200	23200	12000
For Sub-Frame 5	Bits	N/A	N/A	n/a
For Sub-Frame 0	Bits	19680	19680	9840
Max. Throughput averaged over 1 frame	Mbps	10.1112	11.436	5.4568
UE Category		≥ 2	≥ 2	≥ 2
Note 1:	2 symbols allocated to PDCCH.			
Note 2:	Reference signal, synchronization signals and PBCH allocated as per TS 36.211 [4].			
Note 3:	50 resource blocks are allocated in sub-frames 1, 2, 3, 4, 6, 7, 8, 9 and 41 resource blocks (RB0–RB20 and RB30–RB49) are allocated in sub-frame 0.			
Note 4:	If more than one Code Block is present, an additional CRC sequence of L = 24 Bits is attached to each Code Block (otherwise L = 0 Bit).			

The reference measurement channels in Table A3.3.3.1-2 apply for verifying demodulation performance for UE-specific reference symbols with two cell specific antenna ports and two CSI-RS antenna ports with ZP CSI-RS and NZP CSI-RS in same subframe.

Table A.3.3.3.1-2: Fixed Reference Channel for CDM-multiplexed DM RS with two CSI-RS antenna ports with ZP CSI-RS and NZP CSI-RS

Parameter	Unit	Value			
		R.52 FDD	R.52-1 FDD	R.53 FDD	R.54 FDD
Reference channel		R.52 FDD	R.52-1 FDD	R.53 FDD	R.54 FDD
Channel bandwidth	MHz	10	10	10	10
Allocated resource blocks		50 (Note 3)	50 (Note 3)	50 (Note 3)	50 (Note 3)
Allocated subframes per Radio Frame		9	9	9	9
Modulation		64QAM	16QAM	64QAM	16QAM
Target Coding Rate		1/2	0.54	1/2	1/2
Information Bit Payload					
For Sub-Frames 1,3,4,6,8,9	Bits	18336	12960	18336	11448
For Sub-Frames 2,7	Bits	16416	12960	16416	11448
For Sub-Frame 5	Bits	n/a	n/a	n/a	n/a
For Sub-Frame 0	Bits	14688	10680	14688	9528
Number of Code Blocks (Note 4)					
For Sub-Frames 1,3,4,6,8,9	Code blocks	3	3	3	2
For Sub-Frames 2, 7	Code blocks	3	3	3	2
For Sub-Frame 5	Bits	n/a	n/a	n/a	n/a
For Sub-Frame 0	Bits	3	2	3	2
Binary Channel Bits					
For Sub-Frames 1,3,4,6,8,9	Bits	36000	24000	36000	24000
For Sub-Frames 2,7		34200	22800	33600	22800
For Sub-Frame 5	Bits	n/a	n/a	n/a	n/a
For Sub-Frame 0	Bits	29520	19680	29520	19680
Max. Throughput averaged over 1 frame	Mbps	15.7536	11.436	15.7536	10.1112
Note 1:	2 symbols allocated to PDCCH.				
Note 2:	Reference signal, synchronization signals and PBCH allocated as per TS 36.211 [4].				
Note 3:	50 resource blocks are allocated in sub-frames 1, 2, 3, 4, 6, 7, 8, 9 and 41 resource blocks (RB0–RB20 and RB30–RB49) are allocated in sub-frame 0.				
Note 4:	If more than one Code Block is present, an additional CRC sequence of L = 24 Bits is attached to each Code Block (otherwise L = 0 Bit).				

A.3.3.3.2 Four antenna ports (CSI-RS)

The reference measurement channels in Table A.3.3.3.2-1 apply for verifying demodulation performance for UE-specific reference symbols with two cell-specific antenna ports and four CSI-RS antenna ports.

Table A.3.3.3.2-1: Fixed Reference Channel for CDM-multiplexed DM RS with four CSI-RS antenna ports

Parameter	Unit	Value						
		R.43 FDD	R.43-1 FDD	R.43-2 FDD	R.50 FDD	R.48 FDD	R.66 FDD	R.75 FDD
Reference channel								
Channel bandwidth	MHz	10	10	10	10	10	10	10
Allocated resource blocks		50 (Note 3)	50 (Note 3)	50 (Note 5)	50 (Note 3)	50 (Note 3)	50 (Note 3)	50 (Note 3)
Allocated subframes per Radio Frame		9	9	9	9	9	9	9
Modulation		QPSK	QPSK	QPSK	64QAM	QPSK	256QAM	16QAM
Target Coding Rate		1/3	1/3	1/3	1/2		0.77	0.57
Information Bit Payload								
For Sub-Frames 1,4,6,9	Bits	3624	3624	3624	18336	6200	36696	25456
For Sub-Frames 2,3,7,8	Bits	3624	3624	3624	16416	6200	35160	25456
For Sub-Frame 5	Bits	N/A	N/A	N/A	N/A	N/A	N/A	N/A
For Sub-Frame 0	Bits	2984	2984	3368	14688	4968	30576	21384
Number of Code Blocks (Note 4)								
For Sub-Frames 1,4,6,9	Code blocks	1	1	1	3	2	6	5
For Sub-Frames 2,3,7,8	Code blocks	1	1	1	3	2	6	5
For Sub-Frame 5	Bits	N/A	N/A	N/A	N/A	N/A	N/A	N/A
For Sub-Frame 0	Bits	1	1	1	3	1	5	4
Binary Channel Bits								
For Sub-Frames 1,6	Bits	12000	13200	13200	36000	12000	48000	43200
For Sub-Frames 4,9	Bits	12000	12000	12000	36000	12000	48000	43200
For Sub-Frames 2,7	Bits	11600	12800	12800	34800	11600	46400	41600
For Sub-Frames 3,8	Bits	11600	12800	12800	34800	12000	46400	41600
For Sub-Frame 5	Bits	N/A	N/A	N/A	N/A	N/A	N/A	N/A
For Sub-Frame 0	Bits	9840	9840	10560	29520	9840	39360	35424
Max. Throughput averaged over 1 frame	Mbps	3.1976	3.1976	3.236	15.3696	5.4568	31.800	22.503
UE Category		≥ 1	≥ 1	≥ 1	≥ 2	≥ 1	11-12	≥ 5
UE DL Category		≥ 6	≥ 6	≥ 6	≥ 6	≥ 6	≥ 11	≥ 6
Note 1:	2 symbols allocated to PDCCH.							
Note 2:	Reference signal, synchronization signals and PBCH allocated as per TS 36.211 [4].							
Note 3:	50 resource blocks are allocated in sub-frames 1, 2, 3, 4, 6, 7, 8, 9 and 41 resource blocks (RB0–RB20 and RB30–RB49) are allocated in sub-frame 0.							
Note 4:	If more than one Code Block is present, an additional CRC sequence of L = 24 Bits is attached to each Code Block (otherwise L = 0 Bit).							
Note 5:	50 resource blocks are allocated in sub-frames 1, 2, 3, 4, 6, 7, 8, 9 and 47 resource blocks (RB0–RB23 and RB27–RB49) are allocated in sub-frame 0. In sub-frame 0, PDSCH is rate matched around RB22, RB23 and RB27.							

The reference measurement channels in Table A.3.3.3.2-2 apply for verifying FDD PMI accuracy measurement and CRI accuracy measurement with two CRS antenna ports and four CSI-RS antenna ports.

Table A.3.3.3.2-2: Fixed Reference Channel for four antenna ports (CSI-RS)

Parameter	Unit	Value				
		R.44 FDD	R.45 FDD	R.45-1 FDD	R.60 FDD	R.50A-1 FDD
Reference channel						
Channel bandwidth	MHz	10	10	10	10	10
Allocated resource blocks		50 ³	50 ³	39	50 ³	50 ³
Allocated subframes per Radio Frame		10	10	10	10	7
Modulation		QPSK	16QAM	16QAM	QPSK	64QAM
Target Coding Rate		1/3	1/2	1/2	1/2	1/2
Information Bit Payload						
For Sub-Frames (Non CSI-RS subframe)	Bits	3624	11448	8760	6200	18336
For Sub-Frames (CSI-RS subframe)	Bits	3624	11448	8760	6200	N/A
For Sub-Frames (ZeroPowerCSI-RS subframe)	Bits	N/A	N/A	N/A	N/A	N/A
For Sub-Frame 5	Bits	N/A	N/A	N/A	N/A	N/A
For Sub-Frame 0	Bits	2984	9528	8760	N/A	14688
Number of Code Blocks per Sub-Frame (Note 4)						
For Sub-Frames (Non CSI-RS subframe)		1	2	2	2	3
For Sub-Frames (CSI-RS subframe)		1	2	2	2	N/A
For Sub-Frames (ZeroPowerCSI-RS subframe)	Bits	N/A	N/A	N/A	N/A	N/A
For Sub-Frame 5		N/A	N/A	N/A	N/A	N/A
For Sub-Frame 0		1	2	2	N/A	3
Binary Channel Bits Per Sub-Frame						
For Sub-Frames (Non CSI-RS subframe)	Bits	12000	24000	18720	12000	36000
For Sub-Frames (CSI-RS subframe)	Bits	11600	23200	18096	11600	N/A
For Sub-Frames (ZeroPowerCSI-RS subframe)	Bits	N/A	N/A	N/A	N/A	N/A
For Sub-Frame 5	Bits	N/A	N/A	N/A	N/A	N/A
For Sub-Frame 0	Bits	9840	19680	18720	N/A	29520
Max. Throughput averaged over 1 frame	Mbps	3.1976	10.1112	7.884	4.96	12.4704
UE Category		≥ 1	≥ 2	≥ 1	≥ 1	≥ 2
Note 1:	2 symbols allocated to PDCCH for 20 MHz, 15 MHz and 10 MHz channel BW; 3 symbols allocated to PDCCH for 5 MHz and 3 MHz; 4 symbols allocated to PDCCH for 1.4 MHz					
Note 2:	Reference signal, synchronization signals and PBCH allocated as per TS 36.211 [4]					
Note 3:	For R.44, R.45 and R.60, 50 resource blocks are allocated in sub-frames 1,2,3,4,6,7,8,9 and 41 resource blocks (RB0–RB20 and RB30–RB49) are allocated in sub-frame 0. For R.45-1, 39 resource blocks are allocated in all subframes (RB0–RB20 and RB30–RB47). For R.50A-1, 50 resource blocks are allocated in sub-frames 2, 3, 4, 7, 8, 9 and 41 resource blocks (RB0–RB20 and RB30–RB49) are allocated in sub-frame 0.					
Note 4:	If more than one Code Block is present, an additional CRC sequence of L = 24 Bits is attached to each Code Block (otherwise L = 0 Bit)					

The reference measurement channels in Table A.3.3.3.2-3 apply for verifying demodulation performance for UE-specific reference symbols with two cell-specific antenna ports and four CSI-RS antenna ports.

Table A.3.3.3.2-3: Fixed Reference Channel for CDM-multiplexed DM RS with four CSI-RS antenna ports

Parameter	Unit	Value
Reference channel		R.64 FDD
Channel bandwidth	MHz	10
Allocated resource blocks (Note 4)		6
Allocated subframes per 4 Radio Frames		15
Modulation		QPSK
Target Coding Rate		1/3
Information Bit Payload		
For Sub-Frames 0,1,4,5,6,9 (Note 3)	Bits	504
For Sub-Frames 2,3,7,8 (Note 3)	Bits	504
Number of Code Blocks		
For Sub-Frames 0,1,4,5,6,9	Code blocks	1
For Sub-Frames 2,3,7,8	Code blocks	1
Binary Channel Bits		
For Sub-Frames 0,1,4,5,6,9	Bits	1440
For Sub-Frames 2,3,7,8	Bits	1392
Max. Throughput averaged over 4 frames	Mbps	0.189
UE DL Category		0
Note 1:	2 symbols allocated to PDCCH.	
Note 2:	Reference signal, synchronization signals and PBCH allocated as per TS 36.211 [4].	
Note 3:	The downlink subframes are scheduled at the 0th, 1st, 2nd, 8th, 9th, 10th, 16th, 17th, 18th, 24th, 25th, 26th, 32nd, 33rd, 34th subframes every 40ms. Information bit payload is available if downlink subframe is scheduled.	
Note 4:	Allocated PRB positions start from {9, 10, ..., 9+N-1}, where N is the number of allocated resource blocks.	

The reference measurement channels in Table A.3.3.3.2-4 apply with two CRS antenna ports and four CSI-RS antenna ports.

Table A.3.3.2-4: Fixed Reference Channel for four antenna ports (CSI-RS)

Parameter	Unit	Value
Reference channel		R.69 FDD
Channel bandwidth	MHz	10
Allocated resource blocks		50
Allocated subframes per Radio Frame		8
Modulation		QPSK
Target Coding Rate		
For Sub-Frames 2,3,4,6,7,8,9		0.74
For Sub-Frame 1		0.8
Information Bit Payload		
For Sub-Frames 2,3,4,6,7,8,9	Bits	7992
For Sub-Frame 1	Bits	7992
For Sub-Frame 5	Bits	N/A
For Sub-Frame 0	Bits	N/A
Number of Code Blocks per Sub-Frame (Note 4)		
For Sub-Frames 2,3,4,6,7,8,9		2
For Sub-Frame 1		2
For Sub-Frame 5		N/A
For Sub-Frame 0		N/A
Binary Channel Bits Per Sub-Frame		
For Sub-Frames 2,3,4,6,7,8,9	Bits	10800
For Sub-Frame 1	Bits	10000
2 For Sub-Frame 5	Bits	N/A
For Sub-Frame 0	Bits	N/A
Max. Throughput averaged over 1 frame	Mbps	6.3936
UE Category		≥ 1
Note 1:	3 symbols allocated to PDCCH.	
Note 2:	Reference signal, synchronization signals and PBCH allocated as per TS 36.211 [4]	
Note 3:	If more than one Code Block is present, an additional CRC sequence of L = 24 Bits is attached to each Code Block (otherwise L = 0 Bit)	

A.3.3.3.2A Eight antenna ports (CSI-RS)

The reference measurement channels in Table A.3.3.3.2A-1 apply for verifying FDD CRI accuracy measurement with two CRS antenna ports and eight CSI-RS antenna ports.

Table A.3.3.3.2A-1: Fixed Reference Channel for eight antenna ports (CSI-RS)

Parameter	Unit	Value	
		R.50A-2 FDD	R.50A-3 FDD
Reference channel		R.50A-2 FDD	R.50A-3 FDD
Channel bandwidth	MHz	10	10
Allocated resource blocks		50 ³	50 ³
Allocated subframes per Radio Frame		7	5
Modulation		64QAM	64QAM
Target Coding Rate		1/2	1/2
Information Bit Payload			
For Sub-Frames (Non CSI-RS subframe)	Bits	18336	18336
For Sub-Frames (CSI-RS subframe)	Bits	N/A	N/A
For Sub-Frames (ZeroPowerCSI-RS subframe)	Bits	N/A	N/A
For Sub-Frame 5	Bits	N/A	N/A
For Sub-Frame 0	Bits	14688	14688
Number of Code Blocks per Sub-Frame (Note 4)			
For Sub-Frames (Non CSI-RS subframe)		3	3
For Sub-Frames (CSI-RS subframe)		N/A	N/A
For Sub-Frames (ZeroPowerCSI-RS subframe)	Bits	N/A	N/A
For Sub-Frame 5		N/A	N/A
For Sub-Frame 0		3	3
Binary Channel Bits Per Sub-Frame			
For Sub-Frames (Non CSI-RS subframe)	Bits	36000	36000
For Sub-Frames (CSI-RS subframe)	Bits	N/A	N/A
For Sub-Frames (ZeroPowerCSI-RS subframe)	Bits	N/A	N/A
For Sub-Frame 5	Bits	N/A	N/A
For Sub-Frame 0	Bits	29520	29520
Max. Throughput averaged over 1 frame	Mbps	12.4704	8.8032
UE Category		≥ 2	≥ 2
Note 1:	2 symbols allocated to PDCCH for 20 MHz, 15 MHz and 10 MHz channel BW; 3 symbols allocated to PDCCH for 5 MHz and 3 MHz; 4 symbols allocated to PDCCH for 1.4 MHz		
Note 2:	Reference signal, synchronization signals and PBCH allocated as per TS 36.211 [4]		
Note 3:	For R.50A-2, 50 resource blocks are allocated in sub-frames 2, 3, 4, 7, 8, 9 and 41 resource blocks (RB0–RB20 and RB30–RB49) are allocated in sub-frame 0. For R.50A-3, 50 resource blocks are allocated in sub-frames 3, 4, 8, 9 and 41 resource blocks (RB0–RB20 and RB30–RB49) are allocated in sub-frame 0.		
Note 4:	If more than one Code Block is present, an additional CRC sequence of L = 24 Bits is attached to each Code Block (otherwise L = 0 Bit)		

A.3.3.3.3 Twelve antenna port (CSI-RS)

The reference measurement channels in Table A.3.3.3.3-1 apply for verifying PMI accuracy performance for UE-specific reference symbols with two cell-specific antenna ports and twelve CSI-RS antenna ports.

Table A.3.3.3.3-1: Fixed Reference Channel for CDM-multiplexed DM RS with twelve CSI-RS antenna ports

Parameter	Unit	Value
Reference channel		R.77 FDD
Channel bandwidth	MHz	10
Allocated resource blocks		50 (Note 3)
Allocated subframes per Radio Frame		9
Modulation		64QAM
Target Coding Rate		1/2
Information Bit Payload		
For Sub-Frames (Non CSI-RS subframe)	Bits	18336
For Sub-Frames (CSI-RS subframe)	Bits	16416
For Sub-Frames (ZeroPowerCSI-RS subframe)	Bits	N/A
For Sub-Frame 5	Bits	N/A
For Sub-Frame 0		14688
Number of Code Blocks per Sub-Frame	Code blocks	
For Sub-Frames (Non CSI-RS subframe)	Code blocks	3
For Sub-Frames (CSI-RS subframe)	Bits	3
For Sub-Frames (ZeroPowerCSI-RS subframe)	Bits	N/A
For Sub-Frame 5		N/A
For Sub-Frame 0	Bits	3
Binary Channel Bits Per Sub-Frame		
For Sub-Frames (Non CSI-RS subframe)		36000
For Sub-Frames (CSI-RS subframe)	Bits	32400
For Sub-Frames (ZeroPowerCSI-RS subframe)	Bits	N/A
For Sub-Frame 5	Bits	N/A
For Sub-Frame 0	Bits	29520
Max. Throughput averaged over 1 frame	Mbps	15.7536
UE Category		≥ 2
Note 1:	2 symbols allocated to PDCCH.	
Note 2:	Reference signal, synchronization signals and PBCH allocated as per TS 36.211 [4].	
Note 3:	50 resource blocks are allocated in sub-frames 1, 2, 3, 4, 6, 7, 8, 9 and 41 resource blocks (RB0–RB20 and RB30–RB49) are allocated in sub-frame 0.	
Note 4:	If more than one Code Block is present, an additional CRC sequence of L = 24 Bits is attached to each Code Block (otherwise L = 0 Bit).	

A.3.3.3.4 Sixteen antenna port (CSI-RS)

The reference measurement channels in Table A.3.3.3.4-1 apply for verifying PMI accuracy performance for UE-specific reference symbols with two cell-specific antenna ports and sixteen CSI-RS antenna ports.

Table A.3.3.3.4-1: Fixed Reference Channel for CDM-multiplexed DM RS with sixteen CSI-RS antenna ports

Parameter	Unit	Value
-----------	------	-------

Reference channel		R.78 FDD
Channel bandwidth	MHz	10
Allocated resource blocks		50 (Note 3)
Allocated subframes per Radio Frame		9
Modulation		16QAM
Target Coding Rate		1/2
Information Bit Payload		
For Sub-Frames (Non CSI-RS subframe)	Bits	11448
For Sub-Frames (CSI-RS subframe)	Bits	9912
For Sub-Frames (ZeroPowerCSI-RS subframe)	Bits	N/A
For Sub-Frame 5	Bits	N/A
For Sub-Frame 0		9528
Number of Code Blocks per Sub-Frame	Code blocks	
For Sub-Frames (Non CSI-RS subframe)	Code blocks	2
For Sub-Frames (CSI-RS subframe)	Bits	2
For Sub-Frames (ZeroPowerCSI-RS subframe)	Bits	N/A
For Sub-Frame 5		N/A
For Sub-Frame 0	Bits	2
Binary Channel Bits Per Sub-Frame		
For Sub-Frames (Non CSI-RS subframe)		24000
For Sub-Frames (CSI-RS subframe)	Bits	20800
For Sub-Frames (ZeroPowerCSI-RS subframe)	Bits	N/A
For Sub-Frame 5	Bits	N/A
For Sub-Frame 0	Bits	19680
Max. Throughput averaged over 1 frame	Mbps	9.804
UE Category		≥ 2
<p>Note 1: 2 symbols allocated to PDCCH.</p> <p>Note 2: Reference signal, synchronization signals and PBCH allocated as per TS 36.211 [4].</p> <p>Note 3: 50 resource blocks are allocated in sub-frames 1, 2, 3, 4, 6, 7, 8, 9 and 41 resource blocks (RB0–RB20 and RB30–RB49) are allocated in sub-frame 0.</p> <p>Note 4: If more than one Code Block is present, an additional CRC sequence of L = 24 Bits is attached to each Code Block (otherwise L = 0 Bit).</p>		

A.3.4 Reference measurement channels for PDSCH performance requirements (TDD)

A.3.4.1 Single-antenna transmission (Common Reference Symbols)

Table A.3.4.1-1: Fixed Reference Channel QPSK R=1/3

Parameter	Unit	Value						
		R.4 TDD	R.42 TDD	R.2A TDD	R.2 TDD	R.42-1 TDD	R.42-2 TDD	R.42-3 TDD
Reference channel								
Channel bandwidth	MHz	1.4	20	10	10	3	5	15
Allocated resource blocks (Note 6)		6	100	50	50	15	25	75
Uplink-Downlink Configuration (Note 4)		1	1	2	1	1	1	1
Allocated subframes per Radio Frame (D+S)		3	3+2	5+2	3+2	3+2	3+2	3+2
Modulation		QPSK	QPSK	QPSK	QPSK	QPSK	QPSK	QPSK
Target Coding Rate		1/3	1/3	1/3	1/3	1/3	1/3	1/3
Information Bit Payload (Note 6)								
For Sub-Frames 4,9	Bits	408	8760	4392	4392	1320	2216	6712
For Sub-Frames 1,6	Bits	N/A	7736	3240	3240	1128	1864	5992
For Sub-Frames 3,8	Bits	N/A	N/A	4392	N/A	N/A	N/A	N/A
For Sub-Frame 5	Bits	N/A	N/A	N/A	N/A	N/A	N/A	N/A
For Sub-Frame 0	Bits	208	8760	4392	4392	1064	1800	6712
Number of Code Blocks (Notes 5 and 6)								
For Sub-Frames 4,9		1	2	1	1	1	1	2
For Sub-Frames 1,6		N/A	2	1	1	1	1	1
For Sub-Frames 3,8		N/A	N/A	1	N/A	N/A	N/A	N/A
For Sub-Frame 5		N/A	N/A	N/A	N/A	N/A	N/A	N/A
For Sub-Frame 0		1	2	1	1	1	1	2
Binary Channel Bits (Note 6)								
For Sub-Frames 4,9	Bits	1368	27600	13800	13800	3780	6300	20700
For Sub-Frames 1,6	Bits	N/A	22656	11256	11256	3276	5556	16956
For Sub-Frames 3,8		N/A	N/A	13800	N/A	N/A	N/A	N/A
For Sub-Frame 5	Bits	N/A	N/A	N/A	N/A	N/A	N/A	N/A
For Sub-Frame 0	Bits	672	26904	13104	13104	3084	5604	20004
Max. Throughput averaged over 1 frame (Note 6)	Mbps	0.102	4.175	2.844	1.966	0.596	0.996	3.212
UE Category		≥ 1	≥ 1	≥ 1	≥ 1	≥ 1	≥ 1	≥ 1
Note 1:	2 symbols allocated to PDCCH for 20 MHz, 15 MHz and 10 MHz channel BW; 3 symbols allocated to PDCCH for 5 MHz and 3 MHz; 4 symbols allocated to PDCCH for 1.4 MHz. For subframe 1&6, only 2 OFDM symbols are allocated to PDCCH.							
Note 2:	For BW=1.4 MHz, the information bit payloads of special subframes are set to zero (no scheduling) to avoid problems with insufficient PDCCH performance at the test point.							
Note 3:	Reference signal, synchronization signals and PBCH allocated as per TS 36.211 [4].							
Note 4:	As per Table 4.2-2 in TS 36.211 [4].							
Note 5:	If more than one Code Block is present, an additional CRC sequence of L = 24 Bits is attached to each Code Block (otherwise L = 0 Bit).							
Note 6:	Given per component carrier per codeword.							

Table A.3.4.1-2: Fixed Reference Channel 16QAM R=1/2

Parameter	Unit	Value					
				R.3-1 TDD	R.3 TDD		
Reference channel							
Channel bandwidth	MHz	1.4	3	5	10	15	20
Allocated resource blocks				25	50		
Uplink-Downlink Configuration (Note 3)				1	1		
Allocated subframes per Radio Frame (D+S)				3+2	3+2		
Modulation				16QAM	16QAM		
Target Coding Rate				1/2	1/2		
Information Bit Payload							
For Sub-Frames 4,9	Bits			6456	14112		
For Sub-Frames 1,6	Bits			5160	11448		
For Sub-Frame 5	Bits			N/A	N/A		
For Sub-Frame 0	Bits			5736	12960		
Number of Code Blocks per Sub-Frame (Note 4)							
For Sub-Frames 4,9				2	3		
For Sub-Frames 1,6				1	2		
For Sub-Frame 5				N/A	N/A		
For Sub-Frame 0				1	3		
Binary Channel Bits Per Sub-Frame							
For Sub-Frames 4,9	Bits			12600	27600		
For Sub-Frames 1,6	Bits			11112	22512		
For Sub-Frame 5	Bits			N/A	N/A		
For Sub-Frame 0	Bits			11208	26208		
Max. Throughput averaged over 1 frame	Mbps			2.897	6.408		
UE Category				≥ 1	≥ 2		
Note 1:	2 symbols allocated to PDCCH for 20 MHz, 15 MHz and 10 MHz channel BW; 3 symbols allocated to PDCCH for 5 MHz and 3 MHz; 4 symbols allocated to PDCCH for 1.4 MHz. For subframe 1&6, only 2 OFDM symbols are allocated to PDCCH.						
Note 2:	Reference signal, synchronization signals and PBCH allocated as per TS 36.211 [4]						
Note 3:	As per Table 4.2-2 in TS 36.211 [4].						
Note 4:	If more than one Code Block is present, an additional CRC sequence of L = 24 Bits is attached to each Code Block (otherwise L = 0 Bit).						

Table A.3.4.1-3: Fixed Reference Channel 64QAM R=3/4

Parameter	Unit	Value					
			R.5 TDD	R.6 TDD	R.7 TDD	R.8 TDD	R.9 TDD
Reference channel							
Channel bandwidth	MHz	1.4	3	5	10	15	20
Allocated resource blocks			15	25	50	75	100
Uplink-Downlink Configuration (Note 3)			1	1	1	1	1
Allocated subframes per Radio Frame (D+S)			3+2	3+2	3+2	3+2	3+2
Modulation		64QAM	64QAM	64QAM	64QAM	64QAM	64QAM
Target Coding Rate			3/4	3/4	3/4	3/4	3/4
Information Bit Payload							
For Sub-Frames 4,9	Bits		8504	14112	30576	46888	61664
For Sub-Frames 1,6	Bits		6968	11448	23688	35160	46888
For Sub-Frame 5	Bits		N/A	N/A	N/A	N/A	N/A
For Sub-Frame 0	Bits		6968	12576	30576	45352	61664
Number of Code Blocks per Sub-Frame (Note 4)							
For Sub-Frames 4,9			2	3	5	8	11
For Sub-Frames 1,6			2	2	4	6	8
For Sub-Frame 5			N/A	N/A	N/A	N/A	N/A
For Sub-Frame 0			2	3	5	8	11
Binary Channel Bits Per Sub-Frame							
For Sub-Frames 4,9	Bits		11340	18900	41400	62100	82800
For Sub-Frames 1,6	Bits		9828	16668	33768	50868	67968
For Sub-Frame 5	Bits		N/A	N/A	N/A	N/A	N/A
For Sub-Frame 0	Bits		9252	16812	39312	60012	80712
Max. Throughput averaged over 1 frame	Mbps		3.791	6.370	13.910	20.945	27.877
UE Category			≥ 1	≥ 2	≥ 2	≥ 2	≥ 3
Note 1:	2 symbols allocated to PDCCH for 20 MHz, 15 MHz and 10 MHz channel BW; 3 symbols allocated to PDCCH for 5 MHz and 3 MHz; 4 symbols allocated to PDCCH for 1.4 MHz. For subframe 1&6, only 2 OFDM symbols are allocated to PDCCH.						
Note 2:	Reference signal, synchronization signals and PBCH allocated as per TS 36.211 [4]						
Note 3:	As per Table 4.2-2 TS 36.211 [4].						
Note 4:	If more than one Code Block is present, an additional CRC sequence of L = 24 Bits is attached to each Code Block (otherwise L = 0 Bit).						

Table A.3.4.1-3a: Fixed Reference Channel 64QAM R=3/4

Parameter	Unit	Value				
		R.6-1 TDD	R.7-1 TDD	R.8-1 TDD	R.9-1 TDD	R.9-2 TDD
Reference channel						
Channel bandwidth	MHz	5	10	15	20	20
Allocated resource blocks (Note 3)		18	17	17	17	83
Uplink-Downlink Configuration (Note 4)		1	1	1	1	1
Allocated subframes per Radio Frame (D+S)		3+2	3+2	3+2	3+2	3+2
Modulation		64QAM	64QAM	64QAM	64QAM	64QAM
Target Coding Rate		3/4	3/4	3/4	3/4	3/4
Information Bit Payload						
For Sub-Frames 4,9	Bits	10296	10296	10296	10296	51024
For Sub-Frames 1,6	Bits	8248	7480	7480	7480	39232
For Sub-Frame 5	Bits	N/A	N/A	N/A	N/A	N/A
For Sub-Frame 0	Bits	8248	10296	10296	10296	51024
Number of Code Blocks per Sub-Frame (Note 5)						
For Sub-Frames 4,9		2	2	2	2	9
For Sub-Frames 1,6		2	2	2	2	7
For Sub-Frame 5		N/A	N/A	N/A	N/A	N/A
For Sub-Frame 0		2	2	2	2	9
Binary Channel Bits Per Sub-Frame						
For Sub-Frames 4,9	Bits	13608	14076	14076	14076	68724
For Sub-Frames 1,6	Bits	11880	11628	11628	11628	56340
For Sub-Frame 5	Bits	N/A	N/A	N/A	N/A	N/A
For Sub-Frame 0	Bits	11520	14076	14076	14076	66636
Max. Throughput averaged over 1 frame	Mbps	4.534	4.585	4.585	4.585	23.154
UE Category		≥ 1	≥ 1	≥ 1	≥ 1	≥ 2
Note 1:	2 symbols allocated to PDCCH for 20 MHz, 15 MHz and 10 MHz channel BW; 3 symbols allocated to PDCCH for 5 MHz and 3 MHz; 4 symbols allocated to PDCCH for 1.4 MHz. For subframe 1&6, only 2 OFDM symbols are allocated to PDCCH.					
Note 2:	Reference signal, synchronization signals and PBCH allocated as per TS 36.211 [4]					
Note 3:	Localized allocation started from RB #0 is applied.					
Note 4:	As per Table 4.2-2 TS 36.211 [4].					
Note 5:	If more than one Code Block is present, an additional CRC sequence of L = 24 Bits is attached to each Code Block (otherwise L = 0 Bit).					

Table A.3.4.1-4: Fixed Reference Channel Single PRB

Parameter	Unit	Value					
			R.0 TDD		R.1 TDD		
Reference channel							
Channel bandwidth	MHz	1.4	3	5	10/20	15	20
Allocated resource blocks			1		1		
Uplink-Downlink Configuration (Note 3)			1		1		
Allocated subframes per Radio Frame (D+S)			3+2		3+2		
Modulation			16QAM		16QAM		
Target Coding Rate			1/2		1/2		
Information Bit Payload							
For Sub-Frames 4,9	Bits		224		256		
For Sub-Frames 1,6	Bits		208		208		
For Sub-Frame 5	Bits		N/A		N/A		
For Sub-Frame 0	Bits		224		256		
Number of Code Blocks per Sub-Frame (Note 4)							
For Sub-Frames 4,9			1		1		
For Sub-Frames 1,6			1		1		
For Sub-Frame 5			N/A		N/A		
For Sub-Frame 0			1		1		
Binary Channel Bits Per Sub-Frame							
For Sub-Frames 4,9	Bits		504		552		
For Sub-Frames 1,6	Bits		456		456		
For Sub-Frame 5	Bits		N/A		N/A		
For Sub-Frame 0	Bits		504		552		
Max. Throughput averaged over 1 frame	Mbps		0.109		0.118		
UE Category			≥ 1		≥ 1		
Note 1:	2 symbols allocated to PDCCH for 20 MHz, 15 MHz and 10 MHz channel BW; 3 symbols allocated to PDCCH for 5 MHz and 3 MHz; 4 symbols allocated to PDCCH for 1.4 MHz. For subframe 1&6, only 2 OFDM symbols are allocated to PDCCH.						
Note 2:	Reference signal, synchronization signals and PBCH allocated as per TS 36.211 [4]						
Note 3:	As per Table 4.2-2 in TS 36.211 [4].						
Note 4:	If more than one Code Block is present, an additional CRC sequence of L = 24 Bits is attached to each Code Block (otherwise L = 0 Bit).						

Table A.3.4.1-5: Fixed Reference Channel Single PRB (MBSFN Configuration)

Parameter	Unit	Value
Reference channel		R.29 TDD (MBSFN)
Channel bandwidth	MHz	10
Allocated resource blocks		1
MBSFN Configuration (Note 5)		010010
Uplink-Downlink Configuration (Note 3)		1
Allocated subframes per Radio Frame (D+S)		1+2
Modulation		16QAM
Target Coding Rate		1/2
Information Bit Payload		
For Sub-Frames 4,9	Bits	0 (MBSFN)
For Sub-Frames 1,6	Bits	208
For Sub-Frame 5	Bits	N/A
For Sub-Frame 0	Bits	256
Number of Code Blocks per Sub-Frame (Note 4)		
For Sub-Frames 4,9	Bits	0 (MBSFN)
For Sub-Frames 1,6	Bits	1
For Sub-Frame 5	Bits	N/A
For Sub-Frame 0	Bits	1
Binary Channel Bits Per Sub-Frame		
For Sub-Frames 4,9	Bits	0 (MBSFN)
For Sub-Frames 1,6	Bits	456
For Sub-Frame 5	Bits	N/A
For Sub-Frame 0	Bits	552
Max. Throughput averaged over 1 frame	kbps	67.2
UE Category		≥ 1
Note 1:	2 symbols allocated to PDCCH.	
Note 2:	Reference signal, synchronization signals and PBCH allocated as per TS 36.211 [4].	
Note 3:	as per Table 4.2-2 in TS 36.211 [4].	
Note 4:	If more than one Code Block is present, an additional CRC sequence of L = 24 Bits is attached to each Code Block (otherwise L = 0 Bit).	
Note 5:	MBSFN Subframe Allocation as defined in [7], one frame with 6 bits is chosen for MBSFN subframe allocation	

Table A.3.4.1-6: Fixed Reference Channel QPSK R=1/10

Parameter	Unit	Value					
					R.41 TDD		
Reference channel							
Channel bandwidth	MHz	1.4	3	5	10	15	20
Allocated resource blocks					50		
Uplink-Downlink Configuration (Note 4)					1		
Allocated subframes per Radio Frame (D+S)					3+2		
Modulation					QPSK		
Target Coding Rate					1/10		
Information Bit Payload							
For Sub-Frames 4,9	Bits				1384		
For Sub-Frames 1,6	Bits				1032		
For Sub-Frame 5	Bits				N/A		
For Sub-Frame 0	Bits				1384		
Number of Code Blocks per Sub-Frame (Note 5)							
For Sub-Frames 4,9					1		
For Sub-Frames 1,6					1		
For Sub-Frame 5					N/A		
For Sub-Frame 0					1		
Binary Channel Bits Per Sub-Frame							
For Sub-Frames 4,9	Bits				13800		
For Sub-Frames 1,6	Bits				11256		
For Sub-Frame 5	Bits				N/A		
For Sub-Frame 0	Bits				13104		
Max. Throughput averaged over 1 frame	Mbps				0.622		
UE Category					≥ 1		
Note 1:	2 symbols allocated to PDCCH for 20 MHz, 15 MHz and 10 MHz channel BW; 3 symbols allocated to PDCCH for 5 MHz and 3 MHz; 4 symbols allocated to PDCCH for 1.4 MHz. For subframe 1&6, only 2 OFDM symbols are allocated to PDCCH.						
Note 2:	For BW=1.4 MHz, the information bit payloads of special subframes are set to zero (no scheduling) to avoid problems with insufficient PDCCH performance at the test point.						
Note 3:	Reference signal, synchronization signals and PBCH allocated as per TS 36.211 [4]						
Note 4:	As per Table 4.2-2 in TS 36.211 [4].						
Note 5:	If more than one Code Block is present, an additional CRC sequence of L = 24 Bits is attached to each Code Block (otherwise L = 0 Bit).						

Table A.3.4.1-7: Fixed Reference Channel for CA demodulation with power imbalance

Parameter	Unit	Value	
		R.49 TDD	R.49-1 TDD
Reference channel		R.49 TDD	R.49-1 TDD
Channel bandwidth	MHz	20	15
Allocated resource blocks		100	75
Uplink-Downlink Configuration (Note 1)		1	1
Allocated subframes per Radio Frame (D+S)		3+2	3+2
Modulation		64QAM	64QAM
Number of OFDM symbols for PDCCH per component carrier			
For Sub-Frames 0,4,5,9	OFDM symbols	3	3
For Sub-Frames 1,6	OFDM symbols	2	2
Target Coding Rate			
For Sub-Frames 4,9		0.84	0.83
For Sub-Frames 1,6		0.81	0.80
For Sub-Frames 5		N/A	N/A
For Sub-Frames 0		0.87	0.86
Information Bit Payload			
For Sub-Frames 0, 4, 9	Bits	63776	46888
For Sub-Frame 1,6	Bits	55056	40576
For Sub-Frame 5	Bits	N/A	N/A
Number of Code Blocks per Sub-Frame (Note 2)			
For Sub-Frames 0, 4, 9	Code Blocks	11	8
For Sub-Frame 1,6	Code Blocks	9	7
For Sub-Frame 5	Code Blocks	N/A	N/A
Binary Channel Bits Per Sub-Frame			
For Sub-Frames 4,9	Bits	75600	56700
For Sub-Frame 1,6	Bits	67968	50868
For Sub-Frame 5	Bits	N/A	N/A
For Sub-Frame 0	Bits	73512	54612
Max. Throughput averaged over 1 frame	Mbps	30.144	22.182
UE Category		≥5	≥3
Note 1: Reference signal, synchronization signals and PBC allocated as per TS 36.211 [4].			
Note 2: If more than one Code Block is present, an additional CRC sequence of L = 24 Bits is attached to each Code Block (otherwise L = 0 Bit).			

A.3.4.2 Multi-antenna transmission (Common Reference Signals)

A.3.4.2.1 Two antenna ports

Table A.3.4.2.1-1: Fixed Reference Channel two antenna ports

Parameter	Unit						Value					
		R.10 TDD	R.11 TDD	R.11-1 TDD	R.11-2 TDD	R.11-3 TDD Note 6	R.11-4 TDD	R.30 TDD	R.30-1 TDD	R.30-2 TDD	R.35 TDD	R.35-1 TDD
Reference channel												
Channel bandwidth	MHz	10	10	10	5	10	10	20	20	20	10	20
Allocated resource blocks (Note 5)		50	50	50	25	40	50	100	100	100	50	100
Uplink-Downlink Configuration (Note 3)		1	1	1	1	1	1	1	1	1	1	1
Allocated subframes per Radio Frame (D+S)		3+2	3+2	2+2	3+2	3+2	2	3+2	2+2	2	2+2	2
Modulation		QPSK	16QAM	16QAM	16QAM	16QAM	QPSK	16QAM	16QAM	16QAM	64QAM	64QAM
Target Coding Rate		1/3	1/2	1/2	1/2	1/2	1/2	1/2	1/2	1/2	1/2	0.39
Information Bit Payload (Note 5)												
For Sub-Frames 4,9	Bits	4392	12960	12960	5736	10296	6968	25456	25456	25456	19848	30576
For Sub-Frames 1,6		3240	9528	9528	5160	9144	N/A	22920	21384	N/A	15840	N/A
For Sub-Frame 5	Bits	N/A	N/A	N/A	N/A	N/A	N/A	N/A	N/A	N/A	N/A	N/A
For Sub-Frame 0	Bits	4392	12960	N/A	4968	10296	N/A	25456	N/A	N/A	N/A	N/A
Number of Code Blocks (Notes 4 and 5)												
For Sub-Frames 4,9		1	3	3	1	2	2	5	5	5	4	5
For Sub-Frames 1,6		1	2	2	1	2	N/A	4	4	N/A	3	N/A
For Sub-Frame 5		N/A	N/A	N/A	N/A	N/A	N/A	N/A	N/A	N/A	N/A	N/A
For Sub-Frame 0		1	3	N/A	1	2	N/A	5	N/A	N/A	N/A	N/A
Binary Channel Bits (Note 5)												
For Sub-Frames 4,9	Bits	13200	26400	26400	12000	21120	13200	52800	52800	52800	39600	79200

For Sub-Frames 1,6		10656	21312	21312	10512	16992	10656	42912	42912	N/A	31968	N/A
For Sub-Frame 5	Bits	N/A	N/A	N/A	N/A	N/A	N/A	N/A	N/A	N/A	N/A	N/A
For Sub-Frame 0	Bits	12528	25056	N/A	10656	19776	12528	51456	N/A	N/A	N/A	N/A
Max. Throughput averaged over 1 frame (Note 5)	Mbps	1.966	5.794	4.498	2.676	4.918	1.39	12.221	9.368	5.091	7.138	6.115
UE Category		≥ 1	≥ 2	≥ 2	≥ 1	≥ 1	≥ 1	≥ 2	≥ 2	3	≥ 2	4
<p>Note 1: 2 symbols allocated to PDCCH for 20 MHz, 15 MHz and 10 MHz channel BW; 3 symbols allocated to PDCCH for 5 MHz and 3 MHz; 4 symbols allocated to PDCCH for 1.4 MHz. For subframe 1&6, only 2 OFDM symbols are allocated to PDCCH.</p> <p>Note 2: Reference signal, synchronization signals and PBCH allocated as per TS 36.211 [4].</p> <p>Note 3: As per Table 4.2-2 in TS 36.211 [4].</p> <p>Note 4: If more than one Code Block is present, an additional CRC sequence of L = 24 Bits is attached to each Code Block (otherwise L = 0 Bit).</p> <p>Note 5: Given per component carrier per codeword.</p> <p>Note 6: For R.11-3 resource blocks of RB6–RB45 are allocated.</p>												

Table A.3.4.2.1-2: Fixed Reference Channel two antenna ports

Parameter	Unit	Value											
		R.46 TDD	R.47 TDD	R.35-2 TDD	R.11-5 TDD	R.11-6 TDD	R.11-7 TDD	R.11-8 TDD	R.11-9 TDD	R.11-10 TDD	R.11-11 TDD	R.11-12 TDD	R.10-3 TDD
Reference channel													
Channel bandwidth	MHz	10	10	10	1.4	3	5	10	15	10	10	10	10
Allocated resource blocks (Note 5)		50	50	50	6	15	25	50	75	50	50	50	50
Uplink-Downlink Configuration (Note 3)		1	1	1	1	1	1	1	1	1	1	1	1
Allocated number of PDCCH symbols in normal subframes		2	2	2	4	3	3	2	2	2	3	3	2
Allocated number of PDCCH symbols in special subframes		2	2	2	2	2	2	2	2	2	2	2	2
Allocated subframes per Radio Frame (D+S)		3+2	3+2	2+2	2+2	2+2	2+2	2+2	2+2	3+2	2+2	2+2	3+2
Modulation		QPSK	16QAM	64QAM	16QAM	16QAM	16QAM	16QAM	16QAM	QPSK	QPSK	QPSK	16QAM
Target Coding Rate				0.47	1/2	1/2	1/2	1/2	1/2	3/5			
For Sub-Frames 4,9											0.58	0.66	0.58
For Sub-Frames 1,6											0.48	0.54	0.57
Information Bit Payload (Note 5)													
For Sub-Frames 4,9	Bits	5160	8760	18336	1352	3368	5736	12960	19080	7992	6968	7992	15264
For Sub-Frames 1,6		3880	7480	14688	1128	3112	5160	10680	15840	5736	5160	5736	12216
For Sub-Frame 5	Bits	N/A	N/A	N/A	N/A	N/A	N/A	N/A	N/A	N/A	N/A	N/A	N/A
For Sub-Frame 0	Bits	5160	8760	N/A	N/A	N/A	N/A	N/A	N/A	7992	N/A	N/A	14112
Number of Code Blocks (Notes 4 and 5)													
For Sub-Frames 4,9		1	2	3	1	1	1	3	4	2	2	2	3
For Sub-Frames 1,6		1	2	3	1	1	1	2	3	1	1	1	2
For Sub-Frame 5		N/A	N/A	N/A	N/A	N/A	N/A	N/A	N/A	N/A	N/A	N/A	N/A
For Sub-Frame 0		1	2	N/A	N/A	N/A	N/A	N/A	N/A	2	N/A	N/A	3
Binary Channel Bits (Note 5)													
For Sub-Frames 4,9	Bits	13200	26400	39600	2592	7200	12000	26400	39600	13200	12000	12000	26400
For Sub-Frames 1,6		10656	21312	31968	2304	6192	10512	21312	32112	10656	10656	10656	21312
For Sub-Frame 5	Bits	N/A	N/A	N/A	N/A	N/A	N/A	N/A	N/A	N/A	N/A	N/A	N/A
For Sub-Frame 0	Bits	12528	25056	N/A	N/A	N/A	N/A	N/A	N/A	12528	N/A	N/A	25056
Max. Throughput averaged over 1 frame (Note 5)	Mbps	2.324	4.124	6.604	0.496	1.296	2.179	4.498	6.984	3.5448	2.4256	2.7456	6.9072
UE Category		≥ 1	≥ 1	≥ 2	≥ 1	≥ 1	≥ 1	≥ 1	≥ 2	≥ 2	≥ 2	≥ 1	≥ 1
Note 1:	Void												
Note 2:	Reference signal, synchronization signals and PBCH allocated as per TS 36.211 [4].												
Note 3:	As per Table 4.2-2 in TS 36.211 [4].												
Note 4:	If more than one Code Block is present, an additional CRC sequence of L = 24 Bits is attached to each Code Block (otherwise L = 0 Bit).												
Note 5:	Given per component carrier per codeword												

Table A.3.4.2.1-3: Fixed Reference Channel two antenna ports

Parameter	Unit	Value	
		R.62 TDD	R.63 TDD
Reference channel		R.62 TDD	R.63 TDD
Channel bandwidth	MHz	10	10
Allocated resource blocks (Note 4)		3	1
Uplink-Downlink Configuration (Note 3)		1	1
Allocated subframes per Radio Frame (D+S)		4+2	4+2
Modulation		16QAM	64QAM
Target Coding Rate		1/2	1/2
Information Bit Payload			
For Sub-Frames 0,4,5,9	Bits	744	408
For Sub-Frames 1,6	Bits	440	280
Number of Code Blocks			
For Sub-Frames 0,4,5,9	Code blocks	1	1
For Sub-Frames 1,6	Code blocks	1	1
Binary Channel Bits			
For Sub-Frames 0,4,5,9	Bits	1584	792
For Sub-Frames 1,6		1296	648
Max. Throughput averaged over 1 frame	Mbps	0.3856	0.2192
UE DL Category		0	0
Note 1: 2 symbols allocated to PDCCH.			
Note 2: Reference signal, synchronization signals and PBCH allocated as per TS 36.211 [4].			
Note 3: As per Table 4.2-2 in TS 36.211 [4].			
Note 4: Allocated PRB positions start from {9, 10, ..., 9+N-1}, where N is the number of allocated resource blocks.			

Table A.3.4.2.1-4: Fixed Reference Channel two antenna ports

Parameter	Unit	Value
Reference channel		R.65 TDD
Channel bandwidth	MHz	20
Allocated resource blocks (Note 5)		100
Uplink-Downlink Configuration (Note 3)		1
Allocated subframes per Radio Frame (D+S)		2+2
Modulation		256QAM
Target Coding Rate		
Information Bit Payload (Note 5)		
For Sub-Frames 4,9	Bits	63776
For Sub-Frames 1,6		46888
For Sub-Frame 5	Bits	N/A
For Sub-Frame 0	Bits	N/A
Number of Code Blocks (Notes 4 and 5)		
For Sub-Frames 4,9		11
For Sub-Frames 1,6		9
For Sub-Frame 5		N/A
For Sub-Frame 0		N/A
Binary Channel Bits (Note 5)		
For Sub-Frames 4,9	Bits	115200
For Sub-Frames 1,6		95424
For Sub-Frame 5	Bits	N/A
For Sub-Frame 0	Bits	N/A
Max. Throughput averaged over 1 frame (Note 5)	Mbps	22.133
UE Category		11-12
UE DL Category		≥ 11
Note 1:	2 symbols allocated to PDCCH for 20 MHz, 15 MHz and 10 MHz channel BW; 3 symbols allocated to PDCCH for 5 MHz and 3 MHz; 4 symbols allocated to PDCCH for 1.4 MHz. For subframe 1&6, only 2 OFDM symbols are allocated to PDCCH. For 256QAM reference channel 1 symbol is allocated.	
Note 2:	Reference signal, synchronization signals and PBCH allocated as per TS 36.211 [4].	
Note 3:	As per Table 4.2-2 in TS 36.211 [4].	
Note 4:	If more than one Code Block is present, an additional CRC sequence of L = 24 Bits is attached to each Code Block (otherwise L = 0 Bit).	
Note 5:	Given per component carrier per codeword	

Table A.3.4.2.1-5: Fixed Reference Channel two antenna ports when *EIMTA-MainConfigServCell-r12* is configured

Parameter	Unit	Value							
Reference channel		R.67 TDD							
Channel bandwidth	MHz	10							
Allocated resource blocks (Note 5)		50							
Modulation		16QAM							
Target Coding Rate		0.4							
Dynamic Uplink-Downlink Configuration (Note 3)		0	1	2	3	4	5	6	
Allocated subframes per Radio Frame (D+S)		1+2	3+2	5+2	5+1	6+1	7+1	2+2	
Information Bit Payload (Note 5)									
For Sub-Frame 0	Bits	9912	9912	9912	9912	9912	9912	9912	
For Sub-Frame 1	Bits	7480	7480	7480	7480	7480	7480	7480	
For Sub-Frame 2	Bits	NA	NA	NA	NA	NA	NA	NA	
For Sub-Frame 3	Bits	NA	NA	9912	NA	NA	9912	NA	
For Sub-Frame 4	Bits	NA	9912	9912	NA	9912	9912	NA	
For Sub-Frame 5	Bits	NA	NA	NA	NA	NA	NA	NA	
For Sub-Frame 6	Bits	7480	7480	7480	9912	9912	9912	7480	
For Sub-Frame 7	Bits	NA	NA	NA	9912	9912	9912	NA	
For Sub-Frame 8	Bits	NA	NA	9912	9912	9912	9912	NA	
For Sub-Frame 9	Bits	NA	9912	9912	9912	9912	9912	9912	

Number of Code Blocks (Notes 4 and 5)								
For Sub-Frame 0		2	2	2	2	2	2	2
For Sub-Frame 1		2	2	2	2	2	2	2
For Sub-Frame 2		NA	NA	NA	NA	NA	NA	NA
For Sub-Frame 3		NA	NA	2	NA	NA	2	NA
For Sub-Frame 4		NA	2	2	NA	2	2	NA
For Sub-Frame 5		NA	NA	NA	NA	NA	NA	NA
For Sub-Frame 6		2	2	2	2	2	2	2
For Sub-Frame 7		NA	NA	NA	2	2	2	NA
For Sub-Frame 8		NA	NA	2	2	2	2	NA
For Sub-Frame 9		NA	2	2	2	2	2	2
Binary Channel Bits (Note 5)								
For Sub-Frame 0	Bits	25056	25056	25056	25056	25056	25056	25056
For Sub-Frame 1	Bits	21312	21312	21312	21312	21312	21312	21312
For Sub-Frame 2	Bits	NA	NA	NA	NA	NA	NA	NA
For Sub-Frame 3	Bits	NA	NA	26400	NA	NA	26400	NA
For Sub-Frame 4	Bits	NA	26400	26400	NA	26400	26400	NA
For Sub-Frame 5	Bits	NA	NA	NA	NA	NA	NA	NA
For Sub-Frame 6	Bits	21312	21312	21312	26112	26112	26112	21312
For Sub-Frame 7	Bits	NA	NA	NA	26400	26400	26400	NA
For Sub-Frame 8	Bits	NA	NA	26400	26400	26400	26400	NA
For Sub-Frame 9	Bits	NA	26400	26400	26400	26400	26400	26400
Max. Throughput averaged over 1 frame (Note 5)	Mbps	2.49	4.47	6.45	5.70	6.70	7.69	3.48
Max. Throughput averaged over 1 frame and over all dynamic UL-DL configurations (Note 5)	Mbps	5.28						
UE Category		≥ 1						
Note 1: 2 OFDM symbols are allocated to PDCCH in all subframes								
Note 2: Reference signal, synchronization signals and PBCH allocated as per TS 36.211 [4].								
Note 3: As per Table 4.2-2 in TS 36.211 [4].								
Note 4: If more than one Code Block is present, an additional CRC sequence of L = 24 Bits is attached to each Code Block (otherwise L = 0 Bit).								
Note 5: Given per component carrier per codeword.								

Table A.3.4.2.1-6: Fixed Reference Channel two antenna ports

Parameter	Unit	Values
Reference channel		R.79 TDD
Channel bandwidth	MHz	10
Allocated resource blocks (Note 4)		3
Allocated subframes per Radio Frame (D+S)		4+2
Modulation		16QAM
Target Coding Rate		1/2
Information Bit Payload		
For Sub-Frames 0,4,5,9	Bits	744
For Sub-Frames 1,6	Bits	440
Number of Code Blocks		
For Sub-Frames 0,4,5,9	Code blocks	1
For Sub-Frames 0,4,5,9	Code blocks	1
Binary Channel Bits		
For Sub-Frames 0,4,5,9	Bits	1584
For Sub-Frames 1,6	Bits	1296
Max. Throughput averaged over 1 frame	Mbps	0.3856
UE DL Category		M1, ≥ 0
Note 1: 2 symbols allocated to PDCCH.		
Note 2: Reference signal, synchronization signals and PBCH allocated as per TS 36.211 [4].		
Note 3: As per Table 4.2-2 in TS 36.211 [4].		
Note 4: Allocated PRB positions for PDSCH are {3, 4, 5} within the assigned narrowband. Allocated PRB positions for MPDCCH are {0, 1} within the assigned narrowband.		

Table A.3.4.2.1-7: Fixed Reference Channel two antenna ports

Parameter	Unit	Value		
		R.81 TDD	R.81-1 TDD	R.81-2 TDD
Reference channel		R.81 TDD	R.81-1 TDD	R.81-2 TDD
Channel bandwidth	MHz	10	10	10
Allocated resource blocks (Note 4)		6	6	6
Uplink-Downlink Configuration (Note 3)		1	1	1
Allocated PDSCH subframes		Note 6	Note 7	Note 8
Modulation		QPSK	QPSK	QPSK
Target Coding Rate		1/10	1/10	1/10
Information Bit Payload				
For Sub-Frames 0,4,5,9	Bits	152	152	152
For Sub-Frames 1,6	Bits	N/A	N/A	N/A
Number of Code Blocks				
For Sub-Frames 0,4,5,9	Code blocks	1	1	1
For Sub-Frames 1,6	Code blocks	N/A	N/A	N/A
Binary Channel Bits				
For Sub-Frames 0,4,5,9	Bits	1584	1584	1584
For Sub-Frames 1,6		N/A	N/A	N/A
Max. Throughput averaged over one period	kbps	0.297	0.594	1.9
UE DL Category		M1, ≥ 0	≥ 1	≥ 1
Note 1:	2 symbols allocated to PDCCH.			
Note 2:	Reference signal, synchronization signals and PBCH allocated as per TS 36.211 [4].			
Note 3:	As per Table 4.2-2 in TS 36.211 [4].			
Note 4:	Allocated PRB positions are {0, 1, 2, 3, 4, 5} within the assigned narrowband.			
Note 5:	The allocated PRB positions are {0, 1, 2, 3, 4, 5} within the assigned narrowband. If it is not the BL/CE DL subframes, MPDCCH/PDSCH transmission is postponed until the next BL/CE DL subframe. Note the DL subframes in the TDD uplink-downlink configuration are considered as the BL/CE DL subframes.			
Note 6:	MPDCCH are scheduled at the 0th to 63rd BL/CE DL subframes with repetition every period=512ms. The associated PDSCH is scheduled at the 65th to 128th BL/CE DL subframes with repetition every 512ms (starting from the 0th subframe).			
Note 7:	MPDCCH are scheduled at the 0th to 31rd BL/CE DL subframes with repetition every period=256ms. The associated PDSCH is scheduled at the 33rd to 64 rd BL/CE DL subframes with repetition every 256ms (starting from the 0th subframe).			
Note 8:	MPDCCH are scheduled at the 0th to 7rd BL/CE DL subframes with repetition every period=80ms. The associated PDSCH is scheduled at the 9rd to 24 rd BL/CE DL subframes with repetition every 80ms (starting from the 0th subframe).			

A.3.4.2.2 Four antenna ports

Table A.3.4.2.2-1: Fixed Reference Channel four antenna ports

Parameter	Unit	Value														
		R.12 TDD	R.13 TDD	R.14 TDD	R.14-1 TDD	R.14-2 TDD	R.43 TDD	R.36 TDD	R.43-1 TDD	R.43-2 TDD	R.43-3 TDD	R.43-4 TDD	R.43-5 TDD	R.72 TDD	R.73 TDD	R.74 TDD
Reference channel																
Channel bandwidth	MHz	1.4	10	10	10	10	20	10	1.4	3	5	10	15	10	10	10
Allocated resource blocks (Note 6)		6	50	50	6	3	100	50	6	15	25	50	75	50	50	50
Uplink-Downlink Configuration (Note 4)		1	1	1	1	1	1	1	1	1	1	1	1	1	1	1
Allocated subframes per Radio Frame (D+S)		3	3+2	2+2	2	2	2+2	2+2	2	2+2	2+2	2+2	2+2	2+2	2+2	2+2
Modulation		QPS K	QPS K	16Q AM	16QA M	16QA M	16Q AM	64Q AM	16QA M	16QA M	16QA M	16QA M	16QA M	256Q AM	64QAM	16QA M
Target Coding Rate		1/3	1/3	1/2	1/2	1/2	1/2	1/2	1/2	1/2	1/2	1/2	1/2	0.62	0.44	1/2
Information Bit Payload (Note 6)																
For Sub-Frames 4,9	Bits	408	4392	12960	1544	744	25456	18336	1192	3368	5736	12960	19080	31704	16416 (CW0) 32856 (CW1)	25456
For Sub-Frames 1,6	Bits	N/A	3240	9528	N/A	N/A	21384	15840	N/A	2856	5160	10680	15840	23688	12216 (CW0) 24496 (CW1)	19080
For Sub-Frame 5	Bits	N/A	N/A	N/A	N/A	N/A	N/A	N/A	N/A	N/A	N/A	N/A	N/A	N/A	N/A	N/A
For Sub-Frame 0	Bits	208	4392	N/A	N/A	N/A	N/A	N/A	N/A	N/A	N/A	N/A	N/A	N/A	N/A	N/A
Number of Code Blocks (Notes 5 and 6)																
For Sub-Frames 4,9		1	1	3	1	1	5	3	1	1	1	3	4	3	3 (CW0) 6 (CW1)	5
For Sub-Frames 1,6		N/A	1	2	N/A	N/A	4	3	N/A	1	1	2	3	3	2 (CW0) 4 (CW1)	4
For Sub-Frame 5		N/A	N/A	N/A	N/A	N/A	N/A	N/A	N/A	N/A	N/A	N/A	N/A	N/A	N/A	N/A
For Sub-Frame 0		1	1	N/A	N/A	N/A	N/A	N/A	N/A	N/A	N/A	N/A	N/A	N/A	N/A	N/A
Binary Channel Bits (Note 6)																
For Sub-Frames	Bits	1248	1280	2560	3072	1536	5120	3840	2496	6960	11600	25600	38400	51200	38400	51200

4,9			0	0			0	0							(CW0) 76800 (CW1)	
For Sub-Frames 1,6		N/A	1025 6	2051 2	N/A	N/A	4131 2	3076 8	N/A	5952	10112	20512	30912	41024	30768 (CW0) 61536 (CW1)	41024
For Sub-Frame 5	Bits	N/A	N/A	N/A	N/A	N/A	N/A	N/A	N/A	N/A	N/A	N/A	N/A	N/A	N/A	N/A
For Sub-Frame 0	Bits	624	1217 6	N/A	N/A	N/A	N/A	N/A	N/A	N/A	N/A	N/A	N/A	N/A	N/A	N/A
Max. Throughput averaged over 1 frame (Note 6)	Mbps	0.10 2	1.96 6	4.49 8	0.309	0.149	9.36 8	6.83 5	0.238	1.245	2.179	4.728	6.984	18.44 5	5.726 (CW0) 11.470 (CW1)	8.907
UE Category		≥ 1	≥ 1	≥ 2	≥ 1	≥ 1	≥ 2	≥ 2	≥ 1	≥ 1	≥ 1	≥ 2	≥ 2	≥ 11	≥ 5	≥ 5
Note 1:	2 symbols allocated to PDCCH for 20 MHz, 15 MHz and 10 MHz channel BW; 3 symbols allocated to PDCCH for 5 MHz and 3 MHz; 4 symbols allocated to PDCCH for 1.4 MHz. For subframe 1&6, only 2 OFDM symbols are allocated to PDCCH.															
Note 2:	For BW=1.4 MHz, the information bit payloads of special subframes are set to zero (no scheduling) to avoid problems with insufficient PDCCH performance at the test point.															
Note 3:	Reference signal, synchronization signals and PBCH allocated as per TS 36.211 [4].															
Note 4:	As per Table 4.2-2 in TS 36.211 [4].															
Note 5:	If more than one Code Block is present, an additional CRC sequence of L = 24 Bits is attached to each Code Block (otherwise L = 0 Bit).															
Note 6:	Given per component carrier per codeword.															

A.3.4.3 Reference Measurement Channels for UE-Specific Reference Symbols

A.3.4.3.1 Single antenna port (Cell Specific)

The reference measurement channels in Table A.3.4.3.1-1 apply for verifying demodulation performance for UE-specific reference symbols with one cell-specific antenna port.

Table A.3.4.3.1-1: Fixed Reference Channel for DRS

Parameter	Unit	Value					
		R.25 TDD	R.26 TDD	R.26-1 TDD	R.27 TDD	R.27-1 TDD	R.28 TDD
Reference channel							
Channel bandwidth	MHz	10	10	5	10	10	10
Allocated resource blocks		50 ⁴	50 ⁴	25 ⁴	50 ⁴	18 ⁶	1
Uplink-Downlink Configuration (Note 3)		1	1	1	1	1	1
Allocated subframes per Radio Frame (D+S)		3+2	3+2	3+2	3+2	3+2	3+2
Modulation		QPSK	16QAM	16QAM	64QAM	64QAM	16QAM
Target Coding Rate		1/3	1/2	1/2	3/4	3/4	1/2
Information Bit Payload							
For Sub-Frames 4,9	Bits	4392	12960	5736	28336	10296	224
For Sub-Frames 1,6	Bits	3240	9528	4584	22920	8248	176
For Sub-Frame 5	Bits	N/A	N/A	N/A	N/A	N/A	N/A
For Sub-Frame 0	Bits	2984	9528	3880	22152	10296	224
Number of Code Blocks per Sub-Frame (Note 5)							
For Sub-Frames 4,9		1	3	1	5	2	1
For Sub-Frames 1,6		1	2	1	4	2	1
For Sub-Frame 5		N/A	N/A	N/A	N/A	N/A	N/A
For Sub-Frame 0		1	2	1	4	2	1
Binary Channel Bits Per Sub-Frame							
For Sub-Frames 4,9	Bits	12600	25200	11400	37800	13608	504
For Sub-Frames 1,6	Bits	10356	20712	10212	31068	11340	420
For Sub-Frame 5	Bits	N/A	N/A	N/A	N/A	N/A	N/A
For Sub-Frame 0	Bits	10332	20664	7752	30996	13608	504
Max. Throughput averaged over 1 frame	Mbps	1.825	5.450	2.452	12.466	4.738	0.102
UE Category		≥ 1	≥ 2	≥ 1	≥ 2	≥ 1	≥ 1
Note 1:	2 symbols allocated to PDCCH for 20 MHz, 15 MHz and 10 MHz channel BW; 3 symbols allocated to PDCCH for 5 MHz and 3 MHz; 4 symbols allocated to PDCCH for 1.4 MHz. For subframe 1&6, only 2 OFDM symbols are allocated to PDCCH.						
Note 2:	Reference signal, synchronization signals and PBCH allocated as per TS 36.211 [4].						
Note 3:	as per Table 4.2-2 in TS 36.211 [4].						
Note 4:	For R.25, R.26 and R.27, 50 resource blocks are allocated in sub-frames 1, 4, 6, 9 and 41 resource blocks (RB0–RB20 and RB30–RB49) are allocated in sub-frame 0. For R.26-1, 25 resource blocks are allocated in sub-frames 1, 4, 6, 9 and 17 resource blocks (RB0–RB7 and RB16–RB24) are allocated in sub-frame 0.						
Note 5:	If more than one Code Block is present, an additional CRC sequence of L = 24 Bits is attached to each Code Block (otherwise L = 0 Bit).						
Note 6:	Localized allocation started from RB #0 is applied.						

The reference measurement channels in Table A.3.4.3.1-2 apply for verifying demodulation performance for UE-specific reference symbols with one cell-specific antenna port.

Table A.3.4.3.1-2: Fixed Reference Channel for DRS

Parameter	Unit	Value		
		R.80 TDD	R.80-1 TDD	R.80-2 TDD
Reference channel		R.80 TDD	R.80-1 TDD	R.80-2 TDD
Channel bandwidth	MHz	10	10	10
Allocated resource blocks (Note 4)		6	6	6
Uplink-Downlink Configuration (Note 3)		1	1	1
Allocated PDSCH subframes		Note 6	Note 7	Note 8
Modulation		QPSK	QPSK	QPSK
Target Coding Rate		1/3	1/3	1/3
Information Bit Payload				
For Sub-Frames 4,9	Bits	504	504	504
For Sub-Frames 1,6		N/A	N/A	N/A
For Sub-Frames 0,5	Bits	504	504	504
Number of Code Blocks per Sub-Frame				
For Sub-Frames 4,9	Code blocks	1	1	1
For Sub-Frames 1,6	Code blocks	N/A	N/A	N/A
For Sub-Frames 0,5	Code blocks	1	1	1
Binary Channel Bits Per Sub-Frame				
For Sub-Frames 4,9	Bits	1440	1440	1440
For Sub-Frames 1,6		N/A	N/A	N/A
For Sub-Frames 0,5	Bits	1440	1440	1440
Max. Throughput averaged over one period	kbps	6.3	12.6	25.2
UE DL Category		M1, ≥ 0	≥ 1	≥ 1
Note 1:	2 symbols allocated to PDCCH.			
Note 2:	Reference signal, synchronization signals and PBCH allocated as per TS 36.211 [4].			
Note 3:	as per Table 4.2-2 in TS 36.211 [4].			
Note 4:	Allocated PRB positions are {0, 1, 2, 3, 4, 5} within the assigned narrowband.			
Note 5:	The allocated PRB positions are {0, 1, 2, 3, 4, 5} within the assigned narrowband. If it is not BL/CE DL subframes, MPDCCH/PDSCH transmission is postponed until the next BL/CE DL subframe. Note the DL subframes in the TDD uplink-downlink configuration are considered as the BL/CE DL subframes.			
Note 6:	MPDCCH are scheduled at the 0th to 7th BL/CE DL subframes with repetition every period=80ms. The associated PDSCH is scheduled at the 9th to 16th BL/CE DL subframes every 80ms (starting from the 0th subframe).			
Note 7:	MPDCCH are scheduled at the 0th to 1th BL/CE DL subframes with repetition every period=40ms. The associated PDSCH is scheduled at the 3th to 6th BL/CE DL subframes every 40ms (starting from the 0th subframe).			
Note 8:	MPDCCH are scheduled at the 0th BL/CE DL subframes with repetition every period=20ms. The associated PDSCH is scheduled at the 1th to 2th BL/CE DL subframes every 20ms (starting from the 0th subframe).			

A.3.4.3.2 Two antenna ports (Cell Specific)

The reference measurement channels in Table A.3.4.3.2-1 apply for verifying demodulation performance for CDM-multiplexed UE specific reference symbols with two cell-specific antenna ports.

Table A.3.4.3.2-1: Fixed Reference Channel for CDM-multiplexed DM RS

Reference channel		R.31 TDD	R.32 TDD	R.32-1 TDD	R.33 TDD	R.33-1 TDD	R.34 TDD
Channel bandwidth	MHz	10	10	5	10	10	10
Allocated resource blocks		50 ⁴	50 ⁴	25 ⁴	50 ⁴	18 ⁶	50 ⁴
Uplink-Downlink Configuration (Note 3)		1	1	1	1	1	1
Allocated subframes per Radio Frame (D+S)		3+2	3+2	3+2	3+2	3+2	3+2
Modulation		QPSK	16QAM	16QAM	64QAM	64QAM	64QAM
Target Coding Rate		1/3	1/2	1/2	3/4	3/4	1/2
Information Bit Payload							
For Sub-Frames 4,9	Bits	3624	11448	5736	27376	9528	18336
For Sub-Frames 1,6		2664	7736	3112	16992	7480	11832
For Sub-Frame 5	Bits	N/A	N/A	N/A	N/A	N/A	N/A
For Sub-Frame 0	Bits	2984	9528	3496	22152	9528	14688
Number of Code Blocks per Sub-Frame (Note 5)							
For Sub-Frames 4,9		1	2	1	5	2	3
For Sub-Frames 1,6		1	2	1	3	2	2
For Sub-Frame 5		N/A	N/A	N/A	N/A	N/A	N/A
For Sub-Frame 0		1	2	1	4	2	3
Binary Channel Bits Per Sub-Frame							
For Sub-Frames 4,9	Bits	12000	24000	10800	36000	12960	36000
For Sub-Frames 1,6		7872	15744	6528	23616	10368	23616
For Sub-Frame 5	Bits	N/A	N/A	N/A	N/A	N/A	N/A
For Sub-Frame 0	Bits	9840	19680	7344	29520	12960	29520
Max. Throughput averaged over 1 frame	Mbps	1.556	4.79	2.119	11.089	4.354	7.502
UE Category		≥ 1	≥ 2	≥ 1	≥ 2	≥ 1	≥ 2
Note 1:	2 symbols allocated to PDCCH for 20 MHz, 15 MHz and 10 MHz channel BW; 3 symbols allocated to PDCCH for 5 MHz and 3 MHz; 4 symbols allocated to PDCCH for 1.4 MHz. For subframe 1&6, only 2 OFDM symbols are allocated to PDCCH.						
Note 2:	Reference signal, synchronization signals and PBCH allocated as per TS 36.211 [4].						
Note 3:	as per Table 4.2-2 in TS 36.211 [4].						
Note 4:	For R.31, R.32, R.33 and R.34, 50 resource blocks are allocated in sub-frames 4,9 and 41 resource blocks (RB0–RB20 and RB30–RB49) are allocated in sub-frame 0 and the DwPTS portion of sub-frames 1,6. For R.32-1, 25 resource blocks (RB0–RB7 and RB16–RB24) are allocated in sub-frame 0 and the DwPTS portion of sub-frames 1, 6.						
Note 5:	If more than one Code Block is present, an additional CRC sequence of L = 24 Bits is attached to each Code Block (otherwise L = 0 Bit).						
Note 6:	Localized allocation started from RB #0 is applied.						

The reference measurement channels in Table A.3.4.3.2-2 apply with two CRS antenna ports.

Table A.3.4.3.2-2: Fixed Reference Channel for CDM-multiplexed DM RS

Parameter	Unit	Value	
		R.70 TDD	R.71 TDD
Reference channel		R.70 TDD	R.71 TDD
Channel bandwidth	MHz	10	10
Allocated resource blocks		50 (Note 4)	50 (Note 4)
Uplink-Downlink Configuration (Note 3)		1	1
Allocated subframes per Radio Frame (D+S)		2+2	2+2
Modulation		QPSK	16QAM
Target Coding Rate			
For Sub-Frames 4,9		0.65	0.6
For Sub-Frames 1,6		0.54	0.5
Information Bit Payload			
For Sub-Frames 4,9	Bits	6968	12960
For Sub-Frames 1,6	Bits	4264	7736
For Sub-Frame 5	Bits	N/A	N/A
For Sub-Frame 0	Bits	N/A	N/A
Number of Code Blocks per Sub-Frame (Note 5)			
For Sub-Frames 4,9		2	3
For Sub-Frames 1,6		1	2
For Sub-Frame 5		N/A	N/A
For Sub-Frame 0		N/A	N/A
Binary Channel Bits Per Sub-Frame			
For Sub-Frames 4,9	Bits	10800	21600
For Sub-Frames 1,6	Bits	7872	15744
For Sub-Frame 5	Bits	N/A	N/A
For Sub-Frame 0	Bits	N/A	N/A
Max. Throughput averaged over 1 frame	Mbps	2.2464	4.1392
UE Category		≥ 1	≥ 2
Note 1:	3 symbols allocated to PDCCH in normal subframes and 2 symbols allocated to PDCCH in special subframes		
Note 2:	Reference signal, synchronization signals and PBCH allocated as per TS 36.211 [4].		
Note 3:	As per Table 4.2-2 in TS 36.211 [4].		
Note 4:	For R.63, and R.64, 50 resource blocks are allocated in sub-frames 4,9 and 41 resource blocks (RB0–RB20 and RB30–RB49) are allocated in the DwPTS portion of sub-frames 1,6.		
Note 5:	If more than one Code Block is present, an additional CRC sequence of L = 24 Bits is attached to each Code Block (otherwise L = 0 Bit).		

A.3.4.3.3 Two antenna ports (CSI-RS)

The reference measurement channels in Table A.3.4.3.3-1 apply for verifying demodulation performance for CDM-multiplexed UE specific reference symbols with two cell-specific antenna ports and two CSI-RS antenna ports.

Table A.3.4.3.3-1: Fixed Reference Channel for CDM-multiplexed DM RS with two CSI-RS antenna ports

Parameter	Unit	Value		
		R.51 TDD	R.51-1 TDD	R.76 TDD
Reference channel		R.51 TDD	R.51-1 TDD	R.76 TDD
Channel bandwidth	MHz	10	10	10
Allocated resource blocks		50 (Note 5)	50 (Note 5)	50 (Note 5)
Uplink-Downlink Configuration (Note 3)		1	1	1
Allocated subframes per Radio Frame (D+S)		3+2	3+2	3+2
Modulation		16QAM	16QAM	QPSK
Target Coding Rate		1/2	0.57	
Information Bit Payload				
For Sub-Frames 4,9 (non CSI-RS subframe)	Bits	11448	N/A	6200
For Sub-Frame 4,9	Bits	11448	12960	6200
For Sub-Frames 1,6	Bits	7736	9144	4264
For Sub-Frame 5	Bits	N/A	N/A	n/a
For Sub-Frame 0	Bits	9528	10680	4968
Number of Code Blocks (Note 4)				
For Sub-Frames 4, 9 (non CSI-RS subframe)	Code blocks	2	N/A	2
For Sub-Frames 4,9	Code blocks	2	3	2
For Sub-Frames 1,6	Code blocks	2	2	1
For Sub-Frame 5		N/A	N/A	N/A
For Sub-Frame 0	Code blocks	2	2	1
Binary Channel Bits				
For Sub-Frames 4, 9 (non CSI-RS subframe)	Bits	24000	N/A	11800
For Sub-Frames 4,9		22800	22800	11800
For Sub-Frames 1,6		15744	15744	7872
For Sub-Frame 5	Bits	N/A	N/A	N/A
For Sub-Frame 0	Bits	19680	19680	9840
Max. Throughput averaged over 1 frame	Mbps	4.7896	5.4888	2.5896
UE Category		≥ 2	≥ 2	≥ 2
Note 1: 2 symbols allocated to PDCCH. Note 2: Reference signal, synchronization signals and PBCH allocated as per TS 36.211 [4]. Note 3: as per Table 4.2-2 in TS 36.211 [4]. Note 4: If more than one Code Block is present, an additional CRC sequence of L = 24 Bits is attached to each Code Block (otherwise L = 0 Bit). Note 5: 50 resource blocks are allocated in sub-frames 4,9 and 41 resource blocks (RB0–RB20 and RB30–RB49) are allocated in sub-frame 0 and the DwPTS portion of sub-frames 1,6.				

The reference measurement channels in Table A3.4.3.3-2 apply for verifying demodulation performance for UE-specific reference symbols with two cell specific antenna ports and two CSI-RS antenna ports with ZP CSI-RS and NZP CSI-RS in same subframe.

Table A.3.4.3-2: Fixed Reference Channel for CDM-multiplexed DM RS with two CSI-RS antenna ports with ZP CSI-RS and NZP CSI-RS

Parameter	Unit	Value			
		R.52 TDD	R.52-1 TDD	R.53 TDD	R.54 TDD
Reference channel		R.52 TDD	R.52-1 TDD	R.53 TDD	R.54 TDD
Channel bandwidth	MHz	10	10	10	10
Allocated resource blocks		50 (Note 5)	50 (Note 5)	50 (Note 5)	50 (Note 5)
Uplink-Downlink Configuration (Note 3)		1	1	1	1
Allocated subframes per Radio Frame (D+S)		3+2	3+2	3+2	3+2
Modulation		64QAM	16QAM	64QAM	16QAM
Target Coding Rate		1/2	0.57	1/2	1/2
Information Bit Payload					
For Sub-Frame 4,9	Bits	16416	12960	16416	11448
For Sub-Frames 1,6	Bits	11832	9144	11832	7736
For Sub-Frame 5	Bits	n/a	n/a	n/a	n/a
For Sub-Frame 0	Bits	14688	10680	14688	9528
Number of Code Blocks (Note 4)					
For Sub-Frames 4,9	Code blocks	3	3	3	2
For Sub-Frames 1,6	Code blocks	2	2	2	2
For Sub-Frame 5		n/a	n/a	n/a	n/a
For Sub-Frame 0	Code blocks	3	2	3	2
Binary Channel Bits					
For Sub-Frames 4,9		34200	22800	33600	22800
For Sub-Frames 1,6		23616	15744	23616	15744
For Sub-Frame 5	Bits	n/a	n/a	n/a	n/a
For Sub-Frame 0	Bits	29520	19680	29520	19680
Max. Throughput averaged over 1 frame	Mbps	7.1184	5.4888	7.1184	4.7896
UE Category		≥ 2	≥2	≥ 2	≥ 2
Note 1: 2 symbols allocated to PDCCH. Note 2: Reference signal, synchronization signals and PBCH allocated as per TS 36.211 [4]. Note 3: as per Table 4.2-2 in TS 36.211 [4]. Note 4: If more than one Code Block is present, an additional CRC sequence of L = 24 Bits is attached to each Code Block (otherwise L = 0 Bit). Note 5: 50 resource blocks are allocated in sub-frames 4, 9 and 41 resource blocks (RB0–RB20 and RB30–RB49) are allocated in sub-frame 0 and the DwPTS portion of sub-frames 1, 6.					

A.3.4.3.4 Four antenna ports (CSI-RS)

The reference measurement channels in Table A.3.4.3.4-1 apply for verifying demodulation performance for CDM-multiplexed UE specific reference symbols with two cell-specific antenna ports and four CSI-RS antenna ports.

Table A.3.4.3.4-1: Fixed Reference Channel for CDM-multiplexed DM RS with four CSI-RS antenna ports

Parameter	Unit	Value			
		R.44 TDD	R.48 TDD	R.66 TDD	R.75 TDD
Reference channel		R.44 TDD	R.48 TDD	R.66 TDD	R.75 TDD
Channel bandwidth	MHz	10	10	20	10
Allocated resource blocks		50 (Note 4)	50 (Note 4)	100	50 (Note 4)
Uplink-Downlink Configuration (Note 3)		1	1	1	
Allocated subframes per Radio Frame (D+S)		3+2	3+2	3+2	3+2
Modulation		64QAM	QPSK	256QAM	16QAM
Target Coding Rate		$\frac{1}{2}$			0.57
Information Bit Payload					
For Sub-Frames 4,9 (non CSI-RS subframe)	Bits	18336	N/A	N/A	N/A
For Sub-Frames 4,9 (CSI-RS subframe)	Bits	16416	6200	71112	25456
For Sub-Frames 1,6		11832	4264	48936	16992
For Sub-Frame 5	Bits	N/A	N/A	N/A	N/A
For Sub-Frame 0	Bits	14688	4968	66592	21384
Number of Code Blocks per Sub-Frame (Note 5)					
For Sub-Frames 4,9 (non CSI-RS subframe)		3	2	N/A	N/A
For Sub-Frames 4,9 (CSI-RS subframe)		3	2	12	5
For Sub-Frames 1,6		2	1	8	3
For Sub-Frame 5		N/A	N/A	N/A	N/A
For Sub-Frame 0		3	1	11	4
Binary Channel Bits Per Sub-Frame					
For Sub-Frames 4,9 (non CSI-RS subframe)	Bits	36000	12000	N/A	N/A
For Sub-Frames 4,9 (CSI-RS subframe)	Bits	33600	11600	89600	40000
For Sub-Frames 1,6		23616	7872	67584	27552
For Sub-Frame 5	Bits	N/A	N/A	N/A	N/A
For Sub-Frame 0	Bits	29520	9840	84480	35424
Max. Throughput averaged over 1 frame	Mbps	7.1184	2.5896	30.669	10.628
UE Category		≥ 2	≥ 1	11-12	≥ 5
UE DL Category		≥ 6	≥ 6	≥ 11	≥ 6
Note 1:	2 symbols allocated to PDCCH.				
Note 2:	Reference signal, synchronization signals and PBCH allocated as per TS 36.211 [4].				
Note 3:	as per Table 4.2-2 in TS 36.211 [4].				
Note 4:	For R.44,R.48 and R.75, 50 resource blocks are allocated in sub-frames 4,9 and 41 resource blocks (RB0–RB20 and RB30–RB49) are allocated in sub-frame 0 and the DwPTS portion of sub-frames 1,6. For R.66, 100 resource blocks are allocated in sub-frames 4, 9 and 88 resources blocks (RB0–RB43 and RB56–RB99) are allocated in sub-frame 0 and the DwPTS portion of sub-frames 1,6.				
Note 5:	If more than one Code Block is present, an additional CRC sequence of L = 24 Bits is attached to each Code Block (otherwise L = 0 Bit).				

The reference measurement channels in Table A.3.4.3.4-2 apply for verifying TDD PMI accuracy measurement with two CRS antenna ports and four CSI-RS antenna ports.

Table A.3.4.3.4-2: Fixed Reference Channel for four antenna ports (CSI-RS)

Parameter	Unit	Value		
		R.60 TDD	R.61 TDD	R.61-1 TDD
Reference channel		R.60 TDD	R.61 TDD	R.61-1 TDD
Channel bandwidth	MHz	10	10	10
Allocated resource blocks		50 ⁴	50 ⁴	39 ⁵
Uplink-Downlink Configuration (Note 3)		1	1	1
Allocated subframes per Radio Frame (D+S)		4+2	4+2	4+2
Allocated subframes per Radio Frame		10	10	10
Modulation		QPSK	16QAM	16QAM
Target Coding Rate		1/2	1/2	1/2
Information Bit Payload				
For Sub-Frames 4 and 9 (Non CSI-RS subframe)	Bits	N/A	N/A	N/A
For Sub-Frames 4 and 9 (CSI-RS subframe)	Bits	6200	11448	8760
For Sub-Frames 1,6	Bits	N/A	7736	7480
For Sub-Frame 5	Bits	N/A	N/A	N/A
For Sub-Frame 0	Bits	N/A	9528	8760
Number of Code Blocks per Sub-Frame (Note 6)				
For Sub-Frames 4 and 9 (Non CSI-RS subframe)		N/A	N/A	N/A
For Sub-Frames 4 and 9 (CSI-RS subframe)		2	2	2
For Sub-Frames 1,6		N/A	2	2
For Sub-Frame 5		N/A	N/A	N/A
For Sub-Frame 0		N/A	2	2
Binary Channel Bits Per Sub-Frame				
For Sub-Frames 4 and 9 (Non CSI-RS subframe)	Bits	N/A	N/A	N/A
For Sub-Frames 4 and 9 (CSI-RS subframe)	Bits	11600	23200	18096
For Sub-Frames 1,6	Bits	N/A	15744	14976
For Sub-Frame 5	Bits	N/A	N/A	N/A
For Sub-Frame 0	Bits	N/A	19680	18720
Max. Throughput averaged over 1 frame	Mbps	1.24	4.7896	4.1240
UE Category		≥ 1	≥ 2	≥ 1
Note 1:	2 symbols allocated to PDCCH for 20 MHz, 15 MHz and 10 MHz channel BW; 3 symbols allocated to PDCCH for 5 MHz and 3 MHz; 4 symbols allocated to PDCCH for 1.4 MHz. For subframe 1&6, only 2 OFDM symbols are allocated to PDCCH.			
Note 2:	Reference signal, synchronization signals and PBCH allocated as per TS 36.211 [4].			
Note 3:	As per Table 4.2-2 in TS 36.211 [4].			
Note 4:	For R. 60 and R.61, 50 resource blocks are allocated in sub-frames 4,9 and 41 resource blocks (RB0–RB20 and RB30–RB49) are allocated in sub-frame 0 and the DwPTS portion of sub-frames 1,6.			
Note 5:	For R. 61-1, 39 resource blocks (RB0–RB20 and RB30–RB47) are allocated in sub-frame 0, 1, 4, 6 and 9.			
Note 6:	If more than one Code Block is present, an additional CRC sequence of L = 24 Bits is attached to each Code Block (otherwise L = 0 Bit).			
Note 7:	Localized allocation started from RB #0 is applied.			

The reference measurement channels in Table A.3.4.3.4-3 apply for verifying demodulation performance for CDM-multiplexed UE specific reference symbols with two cell-specific antenna ports and four CSI-RS antenna ports.

Table A.3.4.3.4-3: Fixed Reference Channel for CDM-multiplexed DM RS with four CSI-RS antenna ports

Parameter	Unit	Value
Reference channel		R.64 TDD
Channel bandwidth	MHz	10
Allocated resource blocks (Note 4)		6
Uplink-Downlink Configuration (Note 3)		1
Allocated subframes per Radio Frame (D+S)		4+2
Modulation		QPSK
Target Coding Rate		1/3
Information Bit Payload		
For Sub-Frames 4,9 (non CSI-RS subframe)	Bits	504
For Sub-Frames 4,9 (CSI-RS subframe)	Bits	504
For Sub-Frames 1,6		256
For Sub-Frames 0,5	Bits	504
Number of Code Blocks per Sub-Frame		
For Sub-Frames 4,9 (non CSI-RS subframe)	Code blocks	1
For Sub-Frames 4,9 (CSI-RS subframe)	Code blocks	1
For Sub-Frames 1,6	Code blocks	1
For Sub-Frames 0,5	Code blocks	1
Binary Channel Bits Per Sub-Frame		
For Sub-Frames 4,9 (non CSI-RS subframe)	Bits	1440
For Sub-Frames 4,9 (CSI-RS subframe)	Bits	1352
For Sub-Frames 1,6		1152
For Sub-Frames 0,5	Bits	1440
Max. Throughput averaged over 1 frame	Mbps	0.2528
UE DL Category		0
Note 1:	2 symbols allocated to PDCCH.	
Note 2:	Reference signal, synchronization signals and PBCH allocated as per TS 36.211 [4].	
Note 3:	as per Table 4.2-2 in TS 36.211 [4].	
Note 4:	Allocated PRB positions start from {9, 10, ..., 9+N-1}, where N is the number of allocated resource blocks.	

The reference measurement channels in Table A.3.4.3.4-4 apply for verifying demodulation performance for CDM-multiplexed UE specific reference symbols with two cell-specific antenna ports and four CSI-RS antenna ports.

Table A.3.4.3.4-4: Fixed Reference Channel for CDM-multiplexed DM RS with four CSI-RS antenna ports

Parameter	Unit	Value
Reference channel		R.69 TDD
Channel bandwidth	MHz	10
Allocated resource blocks		50 (Note 4)
Uplink-Downlink Configuration (Note 3)		1
Allocated subframes per Radio Frame (D+S)		2+2
Modulation		QPSK
Target Coding Rate		
For Sub-Frame 4(CSI-RS subframe)		0.8
For Sub-Frame 9 (non CSI-RS subframe)		0.74
For Sub-Frames 1,6		0.61
Information Bit Payload		
For Sub-Frame 4(CSI-RS subframe)	Bits	7992
For Sub-Frame 9 (non CSI-RS subframe)	Bits	7992
For Sub-Frames 1,6	Bits	4776
For Sub-Frame 5	Bits	N/A
For Sub-Frame 0	Bits	N/A
Number of Code Blocks per Sub-Frame (Note 5)		
For Sub-Frame 4(CSI-RS subframe)		2
For Sub-Frame 9 (non CSI-RS subframe)		2
For Sub-Frames 1,6		1
For Sub-Frame 5		N/A
For Sub-Frame 0		N/A
Binary Channel Bits Per Sub-Frame		
For Sub-Frame 4(CSI-RS subframe)	Bits	10000
For Sub-Frame 9 (non CSI-RS subframe)	Bits	10800
For Sub-Frames 1,6	Bits	7872
For Sub-Frame 5	Bits	N/A
For Sub-Frame 0	Bits	N/A
Max. Throughput averaged over 1 frame	Mbps	2.5536
UE Category		≥ 1
Note 1: 3 symbols allocated to PDCCH. Note 2: Reference signal, synchronization signals and PBCH allocated as per TS 36.211 [4]. Note 3: As per Table 4.2-2 in TS 36.211 [4]. Note 4: 50 resource blocks are allocated in sub-frames 4,9 and 41 resource blocks (RB0–RB20 and RB30–RB49) are allocated in the DwPTS portion of sub-frames 1,6. Note 5: If more than one Code Block is present, an additional CRC sequence of L = 24 Bits is attached to each Code Block (otherwise L = 0 Bit).		

The reference measurement channels in Table A.3.4.3.4-5 apply for verifying CRI reporting accuracy with two cell-specific antenna ports and four CSI-RS antenna ports.

Table A.3.3.3.4-5: Fixed Reference Channel for four antenna ports (CSI-RS)

Parameter	Unit	Value
Reference channel		R.44A-1 TDD
Channel bandwidth	MHz	10
Uplink-Downlink Configuration (Note 3)		2
Allocated resource blocks		50 ⁴
Allocated subframes per Radio Frame		4+2
Modulation		64QAM
Target Coding Rate		1/2
Information Bit Payload		
For Sub-Frames (Non CSI-RS subframe)	Bits	18336
For Sub-Frames (CSI-RS subframe)	Bits	N/A
For Sub-Frame 5	Bits	N/A
For Sub-Frames 1,6		11832
For Sub-Frame 0	Bits	14688
Number of Code Blocks per Sub-Frame (Note 5)		
For Sub-Frames (Non CSI-RS subframe)		3
For Sub-Frames (CSI-RS subframe)		N/A
For Sub-Frame 5		N/A
For Sub-Frames 1,6		2
For Sub-Frame 0		3
Binary Channel Bits Per Sub-Frame		
For Sub-Frames (Non CSI-RS subframe)	Bits	36000
For Sub-Frames (CSI-RS subframe)	Bits	N/A
For Sub-Frame 5	Bits	N/A
For Sub-Frames 1,6	Bits	23616
For Sub-Frame 0	Bits	29520
Max. Throughput averaged over 1 frame	Mbps	9.336
UE Category		≥ 2
Note 1:	2 symbols allocated to PDCCH for 20 MHz, 15 MHz and 10 MHz channel BW; 3 symbols allocated to PDCCH for 5 MHz and 3 MHz; 4 symbols allocated to PDCCH for 1.4 MHz	
Note 2:	Reference signal, synchronization signals and PBCH allocated as per TS 36.211 [4]	
Note 3:	As per Table 4.2-2 in TS 36.211 [4].	
Note 4:	For R.44A-1, 50 resource blocks are allocated in sub-frames 3, 8, 9 and 41 resource blocks (RB0–RB20 and RB30–RB49) are allocated in sub-frame 0 and and the DwPTS portion of sub-frames 1,6.	
Note 5:	If more than one Code Block is present, an additional CRC sequence of L = 24 Bits is attached to each Code Block (otherwise L = 0 Bit)	

A.3.4.3.5 Eight antenna ports (CSI-RS)

The reference measurement channels in Table A.3.4.3.5-1 apply for verifying demodulation performance for CDM-multiplexed UE specific reference symbols with two cell-specific antenna ports and eight CSI-RS antenna ports.

Table A.3.4.3.5-1: Fixed Reference Channel for CDM-multiplexed DM RS with eight CSI-RS antenna ports

Parameter	Unit	Value		
		R.50 TDD	R.50-1 TDD	R.50-2 TDD
Reference channel		R.50 TDD	R.50-1 TDD	R.50-2 TDD
Channel bandwidth	MHz	10	10	10
Allocated resource blocks		50 (Note 4)	50 (Note 4)	50 (Note 6)
Uplink-Downlink Configuration (Note 3)		1	1	1
Allocated subframes per Radio Frame (D+S)		3+2	3+2	3+2
Modulation		QPSK	QPSK	QPSK
Target Coding Rate		1/3	1/3	1/3
Information Bit Payload				
For Sub-Frames 4,9 (non CSI-RS subframe)	Bits	3624	3624	3624
For Sub-Frames 4,9 (CSI-RS subframe)	Bits	3624	3624	3624
For Sub-Frames 1,6		2664	2664	3112
For Sub-Frame 5	Bits	N/A	N/A	N/A
For Sub-Frame 0	Bits	2984	2984	3368
Number of Code Blocks per Sub-Frame (Note 5)				
For Sub-Frames 4,9 (non CSI-RS subframe)		1	1	1
For Sub-Frames 4,9 (CSI-RS subframe)		1	1	1
For Sub-Frames 1,6		1	1	1
For Sub-Frame 5		N/A	N/A	N/A
For Sub-Frame 0		1	1	1
Binary Channel Bits Per Sub-Frame				
For Sub-Frames 4,9 (non CSI-RS subframe)	Bits	12000	13200	13200
For Sub-Frames 4,9 (CSI-RS subframe)	Bits	10400	11600	11600
For Sub-Frames 1,6		7872	7872	8448
For Sub-Frame 5	Bits	N/A	N/A	N/A
For Sub-Frame 0	Bits	9840	9840	10560
Max. Throughput averaged over 1 frame	Mbps	1.556	1.556	1.684
UE Category		≥ 1	≥ 1	≥ 1
Note 1: 2 symbols allocated to PDCCH. Note 2: Reference signal, synchronization signals and PBCH allocated as per TS 36.211 [4]. Note 3: as per Table 4.2-2 in TS 36.211 [4]. Note 4: 50 resource blocks are allocated in sub-frames 4,9 and 41 resource blocks (RB0–RB20 and RB30–RB49) are allocated in sub-frame 0 and the DwPTS portion of sub-frames 1,6. Note 5: If more than one Code Block is present, an additional CRC sequence of L = 24 Bits is attached to each Code Block (otherwise L = 0 Bit). Note 6: 50 resource blocks are allocated in sub-frames 4,9 and 47 resource blocks (RB0–RB23 and RB27–RB49) are allocated in sub-frame 0 and the DwPTS portion of sub-frames 1,6. In sub-frame 0 and the DwPTS portion of sub-frames 1, 6, PDSCH is rate matched around RB22, RB23 and RB27.				

The reference measurement channels in Table A.3.4.3.5-2 apply for verifying TDD PMI accuracy measurement with two CRS antenna ports and eight CSI-RS antenna ports.

Table A.3.4.3.5-2: Fixed Reference Channel for eight antenna ports (CSI-RS)

Parameter	Unit	Value		
		R.45 TDD	R.45-1 TDD	R.45-2 TDD
Reference channel		R.45 TDD	R.45-1 TDD	R.45-2 TDD
Channel bandwidth	MHz	10	10	10
Allocated resource blocks		50 ⁴	39	50 ⁴
Uplink-Downlink Configuration (Note 3)		1	1	1
Allocated subframes per Radio Frame (D+S)		4+2	4+2	4+2
Allocated subframes per Radio Frame		5	5	10
Modulation		16QAM	16QAM	64QAM
Target Coding Rate		1/2	1/2	
Information Bit Payload				
For Sub-Frames 4 and 9 (Non CSI-RS subframe)	Bits	N/A	N/A	N/A
For Sub-Frames 4 and 9 (CSI-RS subframe)	Bits	11448	8760	[18336]
For Sub-Frames 1,6	Bits	7736	7480	[11832]
For Sub-Frame 5	Bits	N/A	N/A	N/A
For Sub-Frame 0	Bits	9528	8760	[14688]
Number of Code Blocks per Sub-Frame (Note 5)				
For Sub-Frames 4 and 9 (Non CSI-RS subframe)		N/A	N/A	N/A
For Sub-Frames 4 and 9 (CSI-RS subframe)		2	2	
For Sub-Frames 1,6		2	2	
For Sub-Frame 5		N/A	N/A	
For Sub-Frame 0		2	2	
Binary Channel Bits Per Sub-Frame				
For Sub-Frames 4 and 9 (Non CSI-RS subframe)	Bits	N/A	N/A	
For Sub-Frames 4 and 9 (CSI-RS subframe)	Bits	22400	17472	[33600]
For Sub-Frames 1,6	Bits	15744	14976	[23616]
For Sub-Frame 5	Bits	N/A	N/A	N/A
For Sub-Frame 0	Bits	19680	18720	[29520]
Max. Throughput averaged over 1 frame	Mbps	4.7896	4.1240	7.3296
UE Category		≥ 2	≥ 1	≥ 2
Note 1:	2 symbols allocated to PDCCH for 20 MHz, 15 MHz and 10 MHz channel BW; 3 symbols allocated to PDCCH for 5 MHz and 3 MHz; 4 symbols allocated to PDCCH for 1.4 MHz. For subframe 1&6, only 2 OFDM symbols are allocated to PDCCH.			
Note 2:	Reference signal, synchronization signals and PBCH allocated as per TS 36.211 [4].			
Note 3:	As per Table 4.2-2 in TS 36.211 [4].			
Note 4:	For R.45 and R.45-2, 50 resource blocks are allocated in sub-frames 4,9 and 41 resource blocks (RB0–RB20 and RB30–RB49) are allocated in sub-frame 0 and the DwPTS portion of sub-frames 1,6. For R.45-1, 39 resource blocks are allocated in sub-frames 0,4,9 and the DwPTS portion of sub-frames 1,6 (RB0–RB20 and RB30–RB47).			
Note 5:	If more than one Code Block is present, an additional CRC sequence of L = 24 Bits is attached to each Code Block (otherwise L = 0 Bit).			
Note 6:	Localized allocation started from RB #0 is applied.			

The reference measurement channels in Table A.3.4.3.5-3 apply for verifying CRI reporting accuracy with two cell-specific antenna ports and four CSI-RS antenna ports.

Table A.3.4.3.5-3: Fixed Reference Channel for eight antenna ports (CSI-RS)

Parameter	Unit	Value	
		R.44A-2 TDD	R.44A-3 TDD
Reference channel		R.44A-2 TDD	R.44A-3 TDD
Channel bandwidth	MHz	10	10
Uplink-Downlink Configuration (Note 3)		2	2
Allocated resource blocks		50 ⁴	50 ⁴
Allocated subframes per Radio Frame		4+2	3+2
Modulation		64QAM	64QAM
Target Coding Rate		1/2	1/2
Information Bit Payload			
For Sub-Frames (Non CSI-RS subframe)	Bits	18336	18336
For Sub-Frames (CSI-RS subframe)	Bits	N/A	N/A
For Sub-Frame 5	Bits	N/A	N/A
For Sub-Frames 1,6		11832	11832
For Sub-Frame 0	Bits	14688	14688
Number of Code Blocks per Sub-Frame (Note 5)			
For Sub-Frames (Non CSI-RS subframe)		3	3
For Sub-Frames (CSI-RS subframe)		N/A	N/A
For Sub-Frame 5		N/A	N/A
For Sub-Frames 1,6		2	2
For Sub-Frame 0		3	3
Binary Channel Bits Per Sub-Frame			
For Sub-Frames (Non CSI-RS subframe)	Bits	36000	36000
For Sub-Frames (CSI-RS subframe)	Bits	N/A	N/A
For Sub-Frame 5	Bits	N/A	N/A
For Sub-Frames 1,6	Bits	23616	23616
For Sub-Frame 0	Bits	29520	29520
Max. Throughput averaged over 1 frame	Mbps	9.336	7.5024
UE Category		≥ 2	≥ 2
Note 1:	2 symbols allocated to PDCCH for 20 MHz, 15 MHz and 10 MHz channel BW; 3 symbols allocated to PDCCH for 5 MHz and 3 MHz; 4 symbols allocated to PDCCH for 1.4 MHz		
Note 2:	Reference signal, synchronization signals and PBCH allocated as per TS 36.211 [4]		
Note 3:	As per Table 4.2-2 in TS 36.211 [4].		
Note 4:	For R.44A-2, 50 resource blocks are allocated in sub-frames 3, 8, 9 and 41 resource blocks (RB0–RB20 and RB30–RB49) are allocated in sub-frame 0 and and the DwPTS portion of sub-frames 1,6. For R.44A-3, 50 resource blocks are allocated in sub-frames 8, 9 and 41 resource blocks (RB0–RB20 and RB30–RB49) are allocated in sub-frame 0 and and the DwPTS portion of sub-frames 1,6.		
Note 5:	If more than one Code Block is present, an additional CRC sequence of L = 24 Bits is attached to each Code Block (otherwise L = 0 Bit)		

A.3.4.3.6 Twelve antenna ports (CSI-RS)

The reference measurement channels in Table A.3.4.3.6-1 apply for verifying TDD PMI accuracy measurement with two CRS antenna ports and twelve CSI-RS antenna ports.

Table A.3.4.3.6-1: Fixed Reference Channel for twelve antenna ports (CSI-RS)

Parameter	Unit	Value
Reference channel		R.77 TDD
Channel bandwidth	MHz	10
Allocated resource blocks		50 ⁴
Uplink-Downlink Configuration (Note 3)		1
Allocated subframes per Radio Frame (D+S)		3+2
Allocated subframes per Radio Frame		10
Modulation		64QAM
Target Coding Rate		1/2
Information Bit Payload		
For Sub-Frames 4 and 9 (Non CSI-RS subframe)	Bits	N/A
For Sub-Frames 4 and 9 (CSI-RS subframe)	Bits	16416
For Sub-Frames 1,6	Bits	11832
For Sub-Frame 5	Bits	N/A
For Sub-Frame 0	Bits	14688
Number of Code Blocks per Sub-Frame (Note 5)		
For Sub-Frames 4 and 9 (Non CSI-RS subframe)		N/A
For Sub-Frames 4 and 9 (CSI-RS subframe)		3
For Sub-Frames 1,6		2
For Sub-Frame 5		N/A
For Sub-Frame 0		3
Binary Channel Bits Per Sub-Frame		
For Sub-Frames 4 and 9 (Non CSI-RS subframe)	Bits	N/A
For Sub-Frames 4 and 9 (CSI-RS subframe)	Bits	32400
For Sub-Frames 1,6	Bits	23616
For Sub-Frame 5	Bits	N/A
For Sub-Frame 0	Bits	29520
Max. Throughput averaged over 1 frame	Mbps	7.1184
UE Category		≥ 2
Note 1:	2 symbols allocated to PDCCH for 20 MHz, 15 MHz and 10 MHz channel BW; 3 symbols allocated to PDCCH for 5 MHz and 3 MHz; 4 symbols allocated to PDCCH for 1.4 MHz. For subframe 1&6, only 2 OFDM symbols are allocated to PDCCH.	
Note 2:	Reference signal, synchronization signals and PBCH allocated as per TS 36.211 [4].	
Note 3:	As per Table 4.2-2 in TS 36.211 [4].	
Note 4:	50 resource blocks (RB0–RB20 and RB30–RB49) are allocated in sub-frame 0 and the DwPTS portion of sub-frames 1,6.	
Note 5:	If more than one Code Block is present, an additional CRC sequence of L = 24 Bits is attached to each Code Block (otherwise L = 0 Bit).	
Note 6:	Localized allocation started from RB #0 is applied.	

A.3.4.3.7 Sixteen antenna ports (CSI-RS)

The reference measurement channels in Table A.3.4.3.7-1 apply for verifying TDD PMI accuracy measurement with two CRS antenna ports and sixteen CSI-RS antenna ports.

Table A.3.4.3.7-1: Fixed Reference Channel for sixteen antenna ports (CSI-RS)

Parameter	Unit	Value
Reference channel		R.78 TDD
Channel bandwidth	MHz	10
Allocated resource blocks		50 ⁴
Uplink-Downlink Configuration (Note 3)		1
Allocated subframes per Radio Frame (D+S)		3+2
Allocated subframes per Radio Frame		10
Modulation		16QAM
Target Coding Rate		1/2
Information Bit Payload		
For Sub-Frames 4 and 9 (Non CSI-RS subframe)	Bits	N/A
For Sub-Frames 4 and 9 (CSI-RS subframe)	Bits	9912
For Sub-Frames 1,6	Bits	7736
For Sub-Frame 5	Bits	N/A
For Sub-Frame 0	Bits	9528
Number of Code Blocks per Sub-Frame (Note 5)		
For Sub-Frames 4 and 9 (Non CSI-RS subframe)		N/A
For Sub-Frames 4 and 9 (CSI-RS subframe)		2
For Sub-Frames 1,6		2
For Sub-Frame 5		N/A
For Sub-Frame 0		2
Binary Channel Bits Per Sub-Frame		
For Sub-Frames 4 and 9 (Non CSI-RS subframe)	Bits	N/A
For Sub-Frames 4 and 9 (CSI-RS subframe)	Bits	20800
For Sub-Frames 1,6	Bits	15744
For Sub-Frame 5	Bits	N/A
For Sub-Frame 0	Bits	19680
Max. Throughput averaged over 1 frame	Mbps	4.4824
UE Category		≥ 2
Note 1:	2 symbols allocated to PDCCH for 20 MHz, 15 MHz and 10 MHz channel BW; 3 symbols allocated to PDCCH for 5 MHz and 3 MHz; 4 symbols allocated to PDCCH for 1.4 MHz. For subframe 1&6, only 2 OFDM symbols are allocated to PDCCH.	
Note 2:	Reference signal, synchronization signals and PBCH allocated as per TS 36.211 [4].	
Note 3:	As per Table 4.2-2 in TS 36.211 [4].	
Note 4:	50 resource blocks are allocated in sub-frames 4,9 and 41 resource blocks (RB0–RB20 and RB30–RB49) are allocated in sub-frame 0 and the DwPTS portion of sub-frames 1,6.	
Note 5:	If more than one Code Block is present, an additional CRC sequence of L = 24 Bits is attached to each Code Block (otherwise L = 0 Bit).	
Note 6:	Localized allocation started from RB #0 is applied.	

A.3.5 Reference measurement channels for PDCCH/PCFICH performance requirements

A.3.5.1 FDD

Table A.3.5.1-1: Reference Channel FDD

Parameter	Unit	Value								
		R.15 FDD	R.15-1 FDD	R.15-2 FDD	R.16 FDD	R.16-1 FDD	R.16-2 FDD	R.16-3 FDD	R.16-4 FDD	R.17 FDD
Reference channel										
Number of transmitter antennas		1	2	2	2	2	2	2	2	4
Channel bandwidth	MHz	10	10	10	10	10	10	10	10	5
Number of OFDM symbols for PDCCH	symbols	2	3	2	2	3	3	1	1	2
Aggregation level	CCE	8	8	8	4	2	4	2	4	2
DCI Format		1	1	1	2	2	2	2	2	2
Cell ID		0	0	0	0	0	0	0	0	0
Payload (without CRC)	Bits	31	31	31	43	43	43	43	43	42

Table A.3.5.1-2: Void

A.3.5.2 TDD

Table A.3.5.2-1: Reference Channel TDD

Parameter	Unit	Value								
		R.15 TDD	R.15-1 TDD	R.15-2 TDD	R.16 TDD	R.16-1 TDD	R.16-2 TDD	R.16-3 TDD	R.16-4 TDD	R.17 TDD
Reference channel										
Number of transmitter antennas		1	2	2	2	2	2	2	2	4
Channel bandwidth	MHz	10	10	10	10	10	10	10	10	5
Number of OFDM symbols for PDCCH	symbols	2	3	2	2	3	3	1	1	2
Aggregation level	CCE	8	8	8	4	2	4	2	4	2
DCI Format		1	1	1	2	2	2	2	2	2
Cell ID		0	0	0	0	0	0	0	0	0
Payload (without CRC)	Bits	34	34	34	46	46	46	46	46	45

Table A.3.5.2-2: Void

A.3.5.3 LAA

Table A.3.5.3-1: Reference Channel for FS3 with FDD primary cell

Parameter	Unit	Value
Reference channel		R.3 FS3
Number of transmitter antennas		2
Channel bandwidth	MHz	20
Number of OFDM symbols for PDCCH	symbols	2
Aggregation level	CCE	4
DCI Format		Format 2A
Cell ID		0
Payload (without CRC)	Bits	48

Table A.3.5.3-2: Reference Channel for FS3 with TDD primary cell

Parameter	Unit	Value
Reference channel		R.4 FS3
Number of transmitter antennas		2
Channel bandwidth	MHz	20
Number of OFDM symbols for PDCCH	symbols	2
Aggregation level	CCE	4
DCI Format		Format 2A
Cell ID		0
Payload (without CRC)	Bits	51

A.3.6 Reference measurement channels for PHICH performance requirements

Table A.3.6-1: Reference Channel FDD/TDD

Parameter	Unit	Value				
		R.18	R.19	R.19-1	R.20	R.24
Reference channel		R.18	R.19	R.19-1	R.20	R.24
Number of transmitter antennas		1	2	2	4	1
Channel bandwidth	MHz	10	10	5	5	10
User roles (Note 1)		W I1 I2	W I1 I2	W I1 I2	W I1 I2	W I1
Resource allocation (Note 2)		(0,0) (0,1) (0,4)	(0,0) (0,1) (0,4)	(0,0) (0,1) (0,4)	(0,0) (0,1) (0,4)	(0,0) (0,1)
Power offsets (Note 3)	dB	-4 0 -3	-4 0 -3	-4 0 -3	-4 0 -3	+3 0
Payload (Note 4)		A R R	A R R	A R R	A R R	A R
Note 1: W=wanted user, I1=interfering user 1, I2=interfering user 2. Note 2: The resource allocation per user is given as (N_group_PHICH, N_seq_PHICH). Note 3: The power offsets (per user) represent the difference of the power of BPSK modulated symbol per PHICH relative to the first interfering user. Note 4: A=fixed ACK, R=random ACK/NACK.						

A.3.7 Reference measurement channels for PBCH performance requirements

Table A.3.7-1: Reference Channel FDD/TDD

Parameter	Unit	Value		
		R.21	R.22	R.23
Reference channel		R.21	R.22	R.23
Number of transmitter antennas		1	2	4
Channel bandwidth	MHz	1.4	1.4	1.4
Modulation		QPSK	QPSK	QPSK
Target coding rate		40/1920	40/1920	40/1920
Payload (without CRC)	Bits	24	24	24

A.3.8 Reference measurement channels for MBMS performance requirements

A.3.8.1 FDD

Table A.3.8.1-1: Fixed Reference Channel QPSK R=1/3

Parameter	PMCH					
	Unit	Value				
Reference channel		R.40 FDD			R.37 FDD	
Channel bandwidth	MHz	1.4	3	5	10	15 20
Allocated resource blocks		6			50	
Allocated subframes per Radio Frame (Note 1)		6			6	
Modulation		QPSK			QPSK	
Target Coding Rate		1/3			1/3	
Information Bit Payload (Note 2)						
For Sub-Frames 1,2,3,6,7,8	Bits	408			3624	
For Sub-Frames 0,4,5,9	Bits	N/A			N/A	
Number of Code Blocks per Subframe (Note 3)		1			1	
Binary Channel Bits Per Subframe						
For Sub-Frames 1,2,3,6,7,8	Bits	1224			10200	
For Sub-Frames 0,4,5,9	Bits	N/A			N/A	
MBMS UE Category		≥ 1			≥ 1	
Note 1:	For FDD mode, up to 6 subframes (#1/2/3/6/7/8) are available for MBMS, in line with TS 36.331.					
Note 2:	2 OFDM symbols are reserved for PDCCH; and reference signal allocated as per TS 36.211.					
Note 3:	If more than one Code Block is present, an additional CRC sequence of L = 24 Bits is attached to each Code Block (otherwise L = 0 Bit).					

Table A.3.8.1-2: Fixed Reference Channel 16QAM R=1/2

Parameter	PMCH						
	Unit	Value					
Reference channel					R.38 FDD		
Channel bandwidth	MHz	1.4	3	5	10	15	20
Allocated resource blocks					50		
Allocated subframes per Radio Frame (Note 1)					6		
Modulation					16QAM		
Target Coding Rate					1/2		
Information Bit Payload (Note 2)							
For Sub-Frames 1,2,3,6,7,8	Bits				9912		
For Sub-Frames 0,4,5,9	Bits				N/A		
Number of Code Blocks per Subframe (Note 3)					2		
Binary Channel Bits Per Subframe							
For Sub-Frames 1,2,3,6,7,8	Bits				20400		
For Sub-Frames 0,4,5,9	Bits				N/A		
MBMS UE Category					≥ 1		
<p>Note 1: For FDD mode, up to 6 subframes (#1/2/3/6/7/8) are available for MBMS, in line with TS 36.331.</p> <p>Note 2: 2 OFDM symbols are reserved for PDCCH; and reference signal allocated as per TS 36.211.</p> <p>Note 3: If more than one Code Block is present, an additional CRC sequence of L = 24 Bits is attached to each Code Block (otherwise L = 0 Bit).</p>							

Table A.3.8.1-3: Fixed Reference Channel 64QAM R=2/3

Parameter	PMCH						
	Unit	Value					
Reference channel				R.39-1 FDD	R.39 FDD		
Channel bandwidth	MHz	1.4	3	5	10	15	20
Allocated resource blocks				25	50		
Allocated subframes per Radio Frame(Note1)				6	6		
Modulation				64QAM	64QAM		
Target Coding Rate				2/3	2/3		
Information Bit Payload (Note 2)							
For Sub-Frames 1,2,3,6,7,8	Bits			9912	19848		
For Sub-Frames 0,4,5,9	Bits			N/A	N/A		
Number of Code Blocks per Sub-Frame (Note 3)				2	4		
Binary Channel Bits Per Subframe							
For Sub-Frames 1,2,3,6,7,8	Bits			15300	30600		
For Sub-Frames 0,4,5,9	Bits			N/A	N/A		
MBMS UE Category				≥ 1	≥ 2		
<p>Note 1: For FDD mode, up to 6 subframes (#1/2/3/6/7/8) are available for MBMS, in line with TS 36.331.</p> <p>Note 2: 2 OFDM symbols are reserved for PDCCH; and reference signal allocated as per TS 36.211.</p> <p>Note 3: If more than one Code Block is present, an additional CRC sequence of L = 24 Bits is attached to each Code Block (otherwise L = 0 Bit).</p>							

A.3.8.2 TDD

Table A.3.8.2-1: Fixed Reference Channel QPSK R=1/3

Parameter	PMCH						
	Unit	Value					
Reference channel		R.40 TDD			R.37 TDD		
Channel bandwidth	MHz	1.4	3	5	10	15	20
Allocated resource blocks		6			50		
Uplink-Downlink Configuration(Note 1)		5			5		
Allocated subframes per Radio Frame		5			5		
Modulation		QPSK			QPSK		
Target Coding Rate		1/3			1/3		
Information Bit Payload (Note 2)							
For Sub-Frames 3,4,7,8,9	Bits	408			3624		
For Sub-Frames 0,1,2,5,6	Bits	N/A			N/A		
Number of Code Blocks per Subframe (Note 3)		1			1		
Binary Channel Bits Per Subframe							
For Sub-Frames 3,4,7,8,9	Bits	1224			10200		
For Sub-Frames 0,1,2,5,6	Bits	N/A			N/A		
MBMS UE Category		≥ 1			≥ 1		
Note 1: For TDD mode, in line with TS 36.331, Uplink-Downlink Configuration 5 is proposed, up to 5 subframes (#3/4/7/8/9) are available for MBMS.							
Note 2: 2 OFDM symbols are reserved for PDCCH; reference signal allocated as per TS 36.211.							
Note 3: If more than one Code Block is present, an additional CRC sequence of L = 24 Bits is attached to each Code Block (otherwise L = 0 Bit).							

Table A.3.8.2-2: Fixed Reference Channel 16QAM R=1/2

Parameter	PMCH						
	Unit	Value					
Reference channel					R.38 TDD		
Channel bandwidth	MHz	1.4	3	5	10	15	20
Allocated resource blocks					50		
Uplink-Downlink Configuration(Note 1)					5		
Allocated subframes per Radio Frame					5		
Modulation					16QAM		
Target Coding Rate					1/2		
Information Bit Payload (Note 2)							
For Sub-Frames 3,4,7,8,9	Bits				9912		
For Sub-Frames 0,1,2,5,6	Bits				N/A		
Number of Code Blocks per Subframe (Note 3)					2		
Binary Channel Bits Per Subframe							
For Sub-Frames 3,4,7,8,9	Bits				20400		
For Sub-Frames 0,1,2,5,6	Bits				N/A		
MBMS UE Category					≥ 1		
Note 1: For TDD mode, in line with TS 36.331, Uplink-Downlink Configuration 5 is proposed, up to 5 subframes (#3/4/7/8/9) are available for MBMS.							
Note 2: 2 OFDM symbols are reserved for PDCCH; reference signal allocated as per TS 36.211.							
Note 3: If more than one Code Block is present, an additional CRC sequence of L = 24 Bits is attached to each Code Block (otherwise L = 0 Bit).							

Table A.3.8.2-3: Fixed Reference Channel 64QAM R=2/3

Parameter	PMCH						
	Unit	Value					
Reference channel				R.39-1TDD	R.39 TDD		
Channel bandwidth	MHz	1.4	3	5	10	15	20
Allocated resource blocks				25	50		
Uplink-Downlink Configuration(Note 1)				5	5		
Allocated subframes per Radio Frame				5	5		
Modulation				64QAM	64QAM		
Target Coding Rate				2/3	2/3		
Information Bit Payload (Note 2)							
For Sub-Frames 3,4,7,8,9	Bits			9912	19848		
For Sub-Frames 0,1,2,5,6	Bits			N/A	N/A		
Number of Code Blocks per Sub-Frame (Note 3)				2	4		
Binary Channel Bits Per Subframe							
For Sub-Frames 3,4,7,8,9	Bits			15300	30600		
For Sub-Frames 0,1,2,5,6	Bits			N/A	N/A		
MBMS UE Category				≥ 1	≥ 2		
Note 1:	For TDD mode, in line with TS 36.331, Uplink-Downlink Configuration 5 is proposed, up to 5 subframes (#3/4/7/8/9) are available for MBMS.						
Note 2:	2 OFDM symbols are reserved for PDCCH; reference signal allocated as per TS 36.211.						
Note 3:	If more than one Code Block is present, an additional CRC sequence of L = 24 Bits is attached to each Code Block (otherwise L = 0 Bit).						

A.3.9 Reference measurement channels for sustained downlink data rate provided by lower layers

A.3.9.1 FDD

Table A.3.9.1-1: Fixed Reference Channel for sustained data-rate test (FDD 64QAM)

Parameter	Unit	Value							
		R.31-1 FDD	R.31-2 FDD	R.31-3 FDD	R.31-3A FDD	R.31-3C FDD	R.31-4 FDD	R.31-4B FDD	R.31-5 FDD
Reference channel									
Channel bandwidth	MHz	10	10	20	10	15	20	15	15
Allocated resource blocks (Note 8)		Note 5	Note 6	Note 7	Note 6	Note 10	Note 7	Note 11	Note 9
Allocated subframes per Radio Frame		10	10	10	10	10	10	10	10
Modulation		64QAM	64QAM	64QAM	64QAM	64QAM	64QAM	64QAM	64QAM
Coding Rate									
For Sub-Frame 1,2,3,4,6,7,8,9,		0.40	0.59	0.59	0.85	0.87	0.88	0.85	0.85
For Sub-Frame 5		0.40	0.64	0.62	0.89	0.88	0.87	0.87	0.91
For Sub-Frame 0		0.40	0.63	0.61	0.90	0.91	0.90	0.88	0.88
Information Bit Payload (Note 8)									
For Sub-Frames 1,2,3,4,6,7,8,9	Bits	10296	25456	51024	36696	51024	75376	55056	55056
For Sub-Frame 5	Bits	10296	25456	51024	35160	51024	71112	52752	52752
For Sub-Frame 0	Bits	10296	25456	51024	36696	51024	75376	55056	55056
Number of Code Blocks (Notes 3 and 8)									
For Sub-Frames 1,2,3,4,6,7,8,9	Bits	2	5	9	6	9	13	9	9
For Sub-Frame 5	Bits	2	5	9	6	9	12	9	9
For Sub-Frame 0	Bits	2	5	9	6	9	13	9	9
Binary Channel Bits (Note 8)									
For Sub-Frames 1,2,3,4,6,7,8,9	Bits	26100	43200	86400	43200	58752	86400	64800	64800
For Sub-Frame 5	Bits	26100	39744	82080	39744	57888	82080	60480	60480
For Sub-Frame 0	Bits	26100	40752	83952	40752	56304	83952	62352	62352
Number of layers		1	2	2	2	2	2	2	2
Max. Throughput averaged over 1 frame (Note 8)	Mbps	10.296	25.456	51.024	36.542	51.024	74.950	54.826	54.826
UE Categories		≥ 1	≥ 2	≥ 2	≥ 2	≥ 3	≥ 3	≥ 4	≥ 3
Note 1:	1 symbol allocated to PDCCH for all tests.								
Note 2:	Reference signal, synchronization signals and PBCH allocated as per TS 36.211 [4].								
Note 3:	If more than one Code Block is present, an additional CRC sequence of L = 24 Bits is attached to each Code Block (otherwise L = 0 Bit).								
Note 4:	Resource blocks $n_{PRB} = 0..2$ are allocated for SIB transmissions in sub-frame 5 for all bandwidths.								
Note 5:	Resource blocks $n_{PRB} = 6..14,30..49$ are allocated for the user data in all sub-frames.								
Note 6:	Resource blocks $n_{PRB} = 3..49$ are allocated for the user data in sub-frame 5, and resource blocks $n_{PRB} = 0..49$ in sub-frames 0,1,2,3,4,6,7,8,9.								
Note 7:	Resource blocks $n_{PRB} = 4..99$ are allocated for the user data in sub-frame 5, and resource blocks $n_{PRB} = 0..99$ in sub-frames 0,1,2,3,4,6,7,8,9.								
Note 8:	Given per component carrier per codeword.								
Note 9:	Resource blocks $n_{PRB} = 4..74$ are allocated for the user data in sub-frame 5, and resource blocks $n_{PRB} = 0..74$ in sub-frames 0,1,2,3,4,6,7,8,9.								
Note 10:	Resource blocks $n_{PRB} = 4..71$ are allocated for the user data in sub-frames 0,1,2,3,4,5,6,7,8,9.								
Note 11:	Resource blocks $n_{PRB} = 4..74$ are allocated for the user data in sub-frame 5, and resource blocks $n_{PRB} = 0..74$ in sub-frames 0,1,2,3,4,6,7,8,9.								

Table A.3.9.1-2: Fixed Reference Channel for sustained data-rate test (FDD 64QAM)

Parameter	Unit	Value						
Reference channel		R.31-6 FDD						
Channel bandwidth	MHz	5						
Allocated resource blocks (Note 5)		Note 4						
Allocated subframes per Radio Frame		9						
Modulation		64QAM						
Coding Rate								
For Sub-Frame 1,2,3,4,6,7,8,9,		0.85						
For Sub-Frame 5		N/A						
For Sub-Frame 0		0.83						
Information Bit Payload (Note 5)								
For Sub-Frames 1,2,3,4,6,7,8,9	Bits	18336						
For Sub-Frame 5	Bits	N/A						
For Sub-Frame 0	Bits	15840						
Number of Code Blocks (Notes 3 and 5)								
For Sub-Frames 1,2,3,4,6,7,8,9	Bits	3						
For Sub-Frame 5	Bits	N/A						
For Sub-Frame 0	Bits	3						
Binary Channel Bits (Note 5)								
For Sub-Frames 1,2,3,4,6,7,8,9	Bits	21600						
For Sub-Frame 5	Bits	N/A						
For Sub-Frame 0	Bits	19152						
Number of layers		2						
Max. Throughput averaged over 1 frame (Note 5)	Mbps	17.837						
UE Categories		≥ 2						
Note 1:	1 symbol allocated to PDCCH for all tests.							
Note 2:	Reference signal, synchronization signals and PBCH allocated as per TS 36.211 [4].							
Note 3:	If more than one Code Block is present, an additional CRC sequence of L = 24 Bits is attached to each Code Block (otherwise L = 0 Bit).							
Note 4:	Resource blocks $n_{PRB} = 0..24$ in sub-frames 0,1,2,3,4,6,7,8,9.							
Note 5:	Given per component carrier per codeword.							
Note 6:	$N_g = 1/6$.							
Note 7:	Resource blocks $n_{PRB} = 3..49$ are allocated for the user data in sub-frame 5, and resource blocks $n_{PRB} = 0..49$ in sub-frames 0,1,2,3,4,6,7,8,9.							
Note 8:	Resource blocks $n_{PRB} = 4..74$ are allocated for the user data in sub-frame 5, and resource blocks $n_{PRB} = 0..74$ in sub-frames 0,1,2,3,4,6,7,8,9.							
Note 9:	Resource blocks $n_{PRB} = 4..99$ are allocated for the user data in sub-frame 5, and resource blocks $n_{PRB} = 0..99$ in sub-frames 0,1,2,3,4,6,7,8,9.							

Table A.3.9.1-3: Fixed Reference Channel for sustained data-rate test (FDD 256QAM)

Parameter	Unit	Value			
		R.68 FDD	R.68-1 FDD	R.68-2 FDD	R.68-3 FDD
Reference channel					
Channel bandwidth	MHz	20	15	10	5
Allocated resource blocks (Note 4)		Note 5	Note 6	Note 7	Note 8
Allocated subframes per Radio Frame		10	10	10	10
Modulation		256QAM	256QAM	256QAM	256QAM
Coding Rate					
For Sub-Frames 3,4,8,9		0.85	0.88	0.85	0.85
For Sub-Frames 1,2,6,7		0.74	0.74	0.74	0.77
For Sub-Frame 5		0.75	0.77	0.77	0.79
For Sub-Frame 0		0.76	0.77	0.78	0.84
Information Bit Payload (Note 4)					
For Sub-Frames 3,4,8,9	Bits	97896	75376	48936	24496
For Sub-Frames 1,2,6,7		84760	63776	42368	21384
For Sub-Frame 5	Bits	81176	61664	40576	19848
For Sub-Frame 0	Bits	84760	63776	42368	21384
Number of Code Blocks (Notes 3 and 4)					
For Sub-Frames 3,4,8,9	Bits	16	13	8	4
For Sub-Frames 1,2,6,7		14	11	7	4
For Sub-Frame 5	Bits	14	11	7	4
For Sub-Frame 0	Bits	14	11	7	4
Binary Channel Bits (Note 4)					
For Sub-Frames 3,4,8,9	Bits	115200	86400	57600	28800
For Sub-Frames 1,2,6,7		115200	86400	57600	28800
For Sub-Frame 5	Bits	109440	80640	52992	25344
For Sub-Frame 0	Bits	111936	83136	54336	25536
Number of layers		2	2	2	2
Max. Throughput averaged over 1 frame (Note 4)	Mbps	89.656	68.205	44.816	22.475
UE Categories		11-12	11-12	11-12	11-12
UE DL Categories		≥ 11	≥ 11	≥ 11	≥ 11
Note 1:	1 symbol allocated to PDCCH for all tests.				
Note 2:	Reference signal, synchronization signals and PBCH allocated as per TS 36.211 [4].				
Note 3:	If more than one Code Block is present, an additional CRC sequence of L = 24 Bits is attached to each Code Block (otherwise L = 0 Bit).				
Note 4:	Given per component carrier per codeword.				
Note 5:	Resource blocks $n_{PRB} = 4..99$ are allocated for the user data in sub-frame 5, and resource blocks $n_{PRB} = 0..99$ in sub-frames 0,1,2,3,4,6,7,8,9.				
Note 6:	Resource blocks $n_{PRB} = 4..74$ are allocated for the user data in sub-frame 5, and resource blocks $n_{PRB} = 0..74$ in sub-frames 0,1,2,3,4,6,7,8,9.				
Note 7:	Resource blocks $n_{PRB} = 3..49$ are allocated for the user data in sub-frame 5, and resource blocks $n_{PRB} = 0..49$ in sub-frames 0,1,2,3,4,6,7,8,9.				
Note 8:	Resource blocks $n_{PRB} = 2..24$ are allocated for the user data in sub-frame 5, and resource blocks $n_{PRB} = 0..24$ in sub-frames 0,1,2,3,4,6,7,8,9.				

A.3.9.2 TDD

Table A.3.9.2-1: Fixed Reference Channel for sustained data-rate test (TDD 64QAM)

Parameter	Unit	Value								
		R.31-1 TDD	R.31-2 TDD	R.31-3 TDD	R.31-3A TDD	R.31-4 TDD	R.31-4A TDD	R.31-5 TDD	R.31-5A TDD	R.31-6 TDD
Reference channel										
Channel bandwidth	MHz	10	10	20	15	20	20	15	15	10
Allocated resource blocks		Note 6	Note 7	Note 8	Note 9	Note 8	Note 8	Note 11	Note 11	Note 7
Uplink-Downlink Configuration (Note 3)		5	5	5	1	1	2	1	2	1
Number of HARQ Processes per component carrier	Processes	15	15	15	7	7	10	7	10	7
Allocated subframes per Radio Frame (D+S)		8+1	8+1	8+1	4	4	6+2	4	6+2	4
Modulation		64QAM	64QAM	64QAM	64QAM	64QAM	64QAM	64QAM	64QAM	64QAM
Target Coding Rate										
For Sub-Frames 4,9		0.40	0.59	0.59	0.87	0.88	0.88	0.85	0.85	0.85
For Sub-Frames 3,8		0.40	0.59	0.59	N/A	N/A	0.88	N/A	0.85	N/A
For Sub-Frame 7		0.40	0.59	0.59	N/A	N/A	N/A	N/A	N/A	N/A
For Sub-Frames 0		0.40	0.62	0.61	0.90	0.90	0.90	0.88	0.88	0.90
For Sub-Frames 1		N/A	N/A	N/A	N/A	N/A	N/A	N/A	N/A	N/A
For Sub-Frames 5		0.40	0.64	0.62	0.88	0.87	0.87	0.87	0.87	0.88
For Sub-Frames 6		0.40	0.60	0.60	N/A	N/A	N/A	N/A	N/A	N/A
Information Bit Payload										
For Sub-Frames 4,9	Bits	10296	25456	51024	51024	75376	75376	55056	55056	36696
For Sub-Frames 3,8	Bits	10296	25456	51024	0	0	75376	0	55056	0
For Sub-Frame 7	Bits	10296	25456	51024	0	0	N/A	0	N/A	0
For Sub-Frame 0	Bits	10296	25456	51024	51024	75376	75376	55056	55056	36696
For Sub-Frame 1	Bits	0	0	0	0	0	0	0	0	0
For Sub-Frame 5	Bits	10296	25456	51024	51024	71112	71112	52752	52752	35160
For Sub-Frame 6	Bits	10296	25456	51024	0	0	0	0	0	0
Number of Code Blocks per Sub-Frame (Note 4)										
For Sub-Frames 4,9		2	5	9	9	13	13	9	9	6
For Sub-Frames 3,8		2	5	9	N/A	N/A	13	N/A	9	N/A
For Sub-Frame 7		2	5	9	N/A	N/A	N/A	N/A	N/A	N/A
For Sub-Frame 0		2	5	9	9	13	13	9	9	6
For Sub-Frame 1		N/A	N/A	N/A	N/A	N/A	N/A	N/A	N/A	N/A
For Sub-Frame 5		2	5	9	9	12	12	9	9	6
For Sub-Frame 6	Bits	2	5	9	n/a	N/A	N/A	N/A	N/A	N/A
Binary Channel Bits Per Sub-Frame										
For Sub-Frames 4,9	Bits	26100	43200	86400	58752	86400	86400	64800	64800	43200
For Sub-Frames 3,8	Bits	26100	43200	86400	0	0	86400	0	64800	0
For Sub-Frame 7	Bits	26100	43200	86400	0	0	86400	0	64800	0
For Sub-Frame 0	Bits	26100	41184	84384	56736	84384	84384	62784	62784	41184
For Sub-Frame 1	Bits	0	0	0	0	0	0	0	0	0
For Sub-Frame 5	Bits	26100	40176	82512	58320	82512	82512	60912	60912	40176
For Sub-Frame 6	Bits	26100	42768	85968	N/A	N/A	0	N/A	0	N/A
Number of layers		1	2	2	2	2	2	2	2	2
Max. Throughput averaged over 1 frame (Note 10)	Mbps	8.237	20.365	40.819	20.409	29.724	52.337	25.330	38.309	14.525
UE Category		≥ 1	≥ 2	≥ 2	≥ 2	≥ 3	≥ 3	≥ 3	≥ 3	≥ 2
Note 1:	1 symbol allocated to PDCCH for all tests.									
Note 2:	Reference signal, synchronization signals and PBCH allocated as per TS 36.211 [4].									
Note 3:	As per Table 4.2-2 in TS 36.211 [4].									
Note 4:	If more than one Code Block is present, an additional CRC sequence of L = 24 Bits is attached to each Code Block (otherwise L = 0 Bit).									
Note 5:	Resource blocks $n_{PRB} = 0..2$ are allocated for SIB transmissions in sub-frame 5 for all bandwidths.									
Note 6:	Resource blocks $n_{PRB} = 6..14,30..49$ are allocated for the user data in all subframes.									
Note 7:	Resource blocks $n_{PRB} = 3..49$ are allocated for the user data in sub-frame 5, and resource blocks $n_{PRB} = 0..49$ in the available downlink sub-frames according to uplink downlink configurations used .									

- Note 8: Resource blocks $n_{PRB} = 4..99$ are allocated for the user data in sub-frame 5, and resource blocks $n_{PRB} = 0..99$ in sub-frames 0,3,4,6,7,8,9.
- Note 9: Resource blocks $n_{PRB} = 4..71$ are allocated for the user data in all sub-frames
- Note10: Given per component carrier per codeword.
- Note11: Resource blocks $n_{PRB} = 4..74$ are allocated for the user data in sub-frame 5, and resource blocks $n_{PRB} = 0..74$ in other downlink sub-frames.

Table A.3.9.2-1A: Fixed Reference Channel for sustained data-rate test (TDD 64QAM)

Parameter	Unit	Value							
Reference channel									
Channel bandwidth	MHz								
Allocated resource blocks									
Uplink-Downlink Configuration (Note 3)									
Number of HARQ Processes per component carrier	Processes								
Allocated subframes per Radio Frame (D+S)									
Modulation									
Target Coding Rate									
For Sub-Frames 4,9									
For Sub-Frames 3,8									
For Sub-Frame 7									
For Sub-Frames 0									
For Sub-Frames 1									
For Sub-Frames 5									
For Sub-Frames 6									
Information Bit Payload									
For Sub-Frames 4,9	Bits								
For Sub-Frames 3,8	Bits								
For Sub-Frame 7	Bits								
For Sub-Frame 0	Bits								
For Sub-Frame 1	Bits								
For Sub-Frame 5	Bits								
For Sub-Frame 6	Bits								
Number of Code Blocks per Sub-Frame (Note 4)									
For Sub-Frames 4,9									
For Sub-Frames 3,8									
For Sub-Frame 7									
For Sub-Frame 0									
For Sub-Frame 1									
For Sub-Frame 5									
For Sub-Frame 6	Bits								
Binary Channel Bits Per Sub-Frame									
For Sub-Frames 4,9	Bits								
For Sub-Frames 3,8	Bits								
For Sub-Frame 7	Bits								
For Sub-Frame 0	Bits								
For Sub-Frame 1	Bits								
For Sub-Frame 5	Bits								
For Sub-Frame 6	Bits								
Number of layers									
Max. Throughput averaged over 1 frame (Note 10)	Mbps								
UE Category									
<p>Note 1: 1 symbol allocated to PDCCH for all tests.</p> <p>Note 2: Reference signal, synchronization signals and PBCH allocated as per TS 36.211 [4].</p> <p>Note 3: As per Table 4.2-2 in TS 36.211 [4].</p> <p>Note 4: If more than one Code Block is present, an additional CRC sequence of $L = 24$ Bits is attached to each Code Block (otherwise $L = 0$ Bit).</p> <p>Note 5: Resource blocks $n_{PRB} = 0..2$ are allocated for SIB transmissions in sub-frame 5 for all bandwidths.</p> <p>Note 6: Resource blocks $n_{PRB} = 6..14,30..49$ are allocated for the user data in all subframes.</p> <p>Note 7: Resource blocks $n_{PRB} = 3..49$ are allocated for the user data in sub-frame 5, and resource blocks $n_{PRB} = 0..49$ in the available downlink sub-frames according to uplink downlink configurations used .</p> <p>Note 8: Resource blocks $n_{PRB} = 4..99$ are allocated for the user data in sub-frame 5, and resource blocks $n_{PRB} = 0..99$ in sub-frames 0,3,4,6,7,8,9.</p> <p>Note 9: Resource blocks $n_{PRB} = 4..71$ are allocated for the user data in all sub-frames</p> <p>Note10: Given per component carrier per codeword.</p> <p>Note11: Resource blocks $n_{PRB} = 4..74$ are allocated for the user data in sub-frame 5, and resource blocks $n_{PRB} = 0..74$</p>									

in other downlink sub-frames.
Note 12: Resource blocks $n_{PRB} = 4..99$ are allocated for the user data in sub-frame 5, and resource blocks $n_{PRB} = 0..99$ in other downlink sub-frames.

Table A.3.9.2-2: Fixed Reference Channel for sustained data-rate test (TDD 256QAM)

Parameter	Unit	Value					
		R.68 TDD	R.68-1 TDD	R.68-2 TDD	R.68-3 TDD	R.68-4 TDD	
Reference channel							
Channel bandwidth	MHz	20	15	10	20	15	
Allocated resource blocks	PRB	Note 6	Note 7	Note 8	Note 6	Note 7	
Uplink-Downlink Configuration (Note 3)		1	1	1	[2]	[2]	
Number of HARQ Processes per component carrier	Processes	7	7	7	[10]	[10]	
Allocated subframes per Radio Frame (D+S)		4+2	4+2	4+2	[6+2]	[6+2]	
Modulation		256QAM	256QAM	256QAM	256QAM	256QAM	
Target Coding Rate							
For Sub-Frame 0		0.76	0.77	0.78	0.76	0.77	
For Sub-Frame 1		N/A	N/A	N/A	N/A	N/A	
For Sub-Frames 3		N/A	N/A	N/A	0.74	0.79	
For Sub-Frames 4		0.74	0.79	0.74	0.74	0.79	
For Sub-Frame 5		0.74	0.76	0.76	0.74	0.76	
For Sub-Frame 6		N/A	N/A	N/A	[N/A]	[N/A]	
For Sub-Frame 7		N/A	N/A	N/A	[N/A]	[N/A]	
For Sub-Frames 8		N/A	N/A	N/A	0.85	0.88	
For Sub-Frames 9		0.85	0.88	0.85	0.85	0.88	
Information Bit Payload							
For Sub-Frame 0	Bits	84760	63776	42368	84760	63776	
For Sub-Frame 1	Bits	0	0	0	0	0	
For Sub-Frames 3	Bits	N/A	N/A	N/A	84760	63776	
For Sub-Frames 4	Bits	84760	63776	42368	84760	63776	
For Sub-Frame 5	Bits	81176	61664	40576	81176	61664	
For Sub-Frame 6	Bits	0	0	0	[0]	[0]	
For Sub-Frame 7		N/A	N/A	N/A	[N/A]	[N/A]	
For Sub-Frames 8	Bits	N/A	N/A	N/A	97896	75376	
For Sub-Frames 9	Bits	97896	75376	48936	97896	75376	
Number of Code Blocks per Sub-Frame (Note 4)							
For Sub-Frame 0		14	11	7	14	11	
For Sub-Frame 1		N/A	N/A	N/A	N/A	N/A	
For Sub-Frames 3		N/A	N/A	N/A	14	11	
For Sub-Frames 4		14	11	7	14	11	
For Sub-Frame 5		14	11	7	14	11	
For Sub-Frame 6		N/A	N/A	N/A	[N/A]	[11]	
For Sub-Frame 7		N/A	N/A	N/A	[N/A]	[11]	
For Sub-Frames 8		N/A	N/A	N/A	16	13	
For Sub-Frames 9		16	13	8	16	13	
Binary Channel Bits Per Sub-Frame							
For Sub-Frame 0	Bits	112512	83712	54912	112512	83712	
For Sub-Frame 1	Bits	0	0	0	0	0	
For Sub-Frames 3	Bits	N/A	N/A	N/A	115200	86400	
For Sub-Frames 4	Bits	115200	86400	57600	115200	86400	
For Sub-Frame 5		110016	81216	53568	110016	81216	
For Sub-Frame 6	Bits	0	0	0	[0]	[0]	
For Sub-Frame 7		N/A	N/A	N/A	[N/A]	[N/A]	
For Sub-Frames 8	Bits	N/A	N/A	N/A	115200	86400	
For Sub-Frames 9	Bits	115200	86400	57600	115200	86400	
Number of layers		2	2	2	2	2	
Max. Throughput averaged over 1 frame (Note 5)	Mbps	34.859	26.459	17.425	[53.125]	[40.374]	
UE Categories		11-12	11-12	11-12	11-12	11-12	
UE DL Categories		≥ 11	≥ 11	≥ 11	≥ 11	≥ 11	

Note 1: 1 symbol allocated to PDCCH for all tests.

Note 2: Reference signal, synchronization signals and PBCH allocated as per TS 36.211 [4].

Note 3: As per Table 4.2-2 in TS 36.211 [4].

Note 4: If more than one Code Block is present, an additional CRC sequence of L = 24 Bits is attached to each Code Block (otherwise L = 0 Bit).

Note 5: Given per component carrier per codeword.

Note 6: Resource blocks $n_{PRB} = 4..99$ are allocated for the user data in sub-frame 5, and resource blocks $n_{PRB} = 0..99$ in other

downlink sub-frames.

Note 7: Resource blocks $n_{PRB} = 4..74$ are allocated for the user data in sub-frame 5, and resource blocks $n_{PRB} = 0..74$ in other downlink sub-frames.

Note 8: Resource blocks $n_{PRB} = 3..49$ are allocated for the user data in sub-frame 5, and resource blocks $n_{PRB} = 0..49$ in the available downlink sub-frames according to uplink downlink configurations used.

Table A.3.9.3-: Fixed Reference Channel for sustained data-rate test (TDD 256QAM)

Parameter	Unit	Value					
Reference channel							
Channel bandwidth	MHz						
Allocated resource blocks	PRB						
Uplink-Downlink Configuration (Note 3)							
Number of HARQ Processes per component carrier	Processes						
Allocated subframes per Radio Frame (D+S)							
Modulation							
Target Coding Rate							
For Sub-Frame 0							
For Sub-Frame 1							
For Sub-Frames 3							
For Sub-Frames 4							
For Sub-Frame 5							
For Sub-Frame 6							
For Sub-Frame 7							
For Sub-Frames 8							
For Sub-Frames 9							
Information Bit Payload							
For Sub-Frame 0	Bits						
For Sub-Frame 1	Bits						
For Sub-Frames 3	Bits						
For Sub-Frames 4	Bits						
For Sub-Frame 5	Bits						
For Sub-Frame 6	Bits						
For Sub-Frame 7							
For Sub-Frames 8	Bits						
For Sub-Frames 9	Bits						
Number of Code Blocks per Sub-Frame (Note 4)							
For Sub-Frame 0							
For Sub-Frame 1							
For Sub-Frames 3							
For Sub-Frames 4							
For Sub-Frame 5							
For Sub-Frame 6							
For Sub-Frame 7							
For Sub-Frames 8							
For Sub-Frames 9							
Binary Channel Bits Per Sub-Frame							
For Sub-Frame 0	Bits						
For Sub-Frame 1	Bits						
For Sub-Frames 3	Bits						
For Sub-Frames 4	Bits						
For Sub-Frame 5							
For Sub-Frame 6	Bits						
For Sub-Frame 7							
For Sub-Frames 8	Bits						
For Sub-Frames 9	Bits						
Number of layers							
Max. Throughput averaged over 1 frame (Note 5)	Mbps						
UE Categories							
UE DL Categories							
Note 1:	1 symbol allocated to PDCCH for all tests.						
Note 2:	Reference signal, synchronization signals and PBCH allocated as per TS 36.211 [4].						
Note 3:	As per Table 4.2-2 in TS 36.211 [4].						
Note 4:	If more than one Code Block is present, an additional CRC sequence of L = 24 Bits is attached to each Code Block (otherwise L = 0 Bit).						
Note 5:	Given per component carrier per codeword.						
Note 6:	Resource blocks $n_{PRB} = 4..99$ are allocated for the user data in sub-frame 5, and resource blocks $n_{PRB} = 0..99$ in other downlink sub-frames.						

- Note 7: Resource blocks $n_{PRB} = 4..74$ are allocated for the user data in sub-frame 5, and resource blocks $n_{PRB} = 0..74$ in other downlink sub-frames.
- Note 8: Resource blocks $n_{PRB} = 3..49$ are allocated for the user data in sub-frame 5, and resource blocks $n_{PRB} = 0..49$ in the available downlink sub-frames according to uplink downlink configurations used.

A.3.9.3 FDD (EPDCCH scheduling)

Table A.3.9.3-1: Fixed Reference Channel for sustained data-rate test with EPDCCH scheduling (FDD)

Parameter	Unit	Value						
		R.31E-1 FDD	R.31E-2 FDD	R.31E-3 FDD	R.31E-3A FDD	R.31E-3C FDD	R.31E-4 FDD	R.31E-4B FDD
Reference channel								
Channel bandwidth	MHz	10	10	20	10	15	20	15
Allocated resource blocks (Note 8)		Note 5	Note 6	Note 7	Note 6	Note 9	Note 7	Note 10
Allocated subframes per Radio Frame		10	10	10	10	10	10	10
Modulation		64QAM	64QAM	64QAM	64QAM	64QAM	64QAM	64QAM
Coding Rate (subframes with PDCCH USS monitoring)								
For Sub-Frame 1,2,3,4,6,7,8,9,		0.3972	0.5926	0.5933	0.8533	0.8725	0.8763	0.8533
For Sub-Frame 5		0.3972	0.6441	0.6246	0.8889	0.8855	0.8702	0.8762
For Sub-Frame 0		0.3972	0.6282	0.6106	0.9046	0.9105	0.9018	0.8868
Coding Rate (subframes with EPDCCH USS monitoring)								
For Sub-Frame 1,2,3,4,6,7,8,9,		0.4114	0.6047	0.5993	0.8707	0.8855	0.8851	0.8649
For Sub-Frame 5		0.4114	0.6584	0.6312	0.9086	0.8990	0.8794	0.8889
For Sub-Frame 0		0.4114	0.6418	0.6170	0.9242	0.9246	0.9112	0.8993
Information Bit Payload (Note 8)								
For Sub-Frames 1,2,3,4,6,7,8,9	Bits	10296	25456	51024	36696	51024	75376	55056
For Sub-Frame 5	Bits	10296	25456	51024	35160	51024	71112	52752
For Sub-Frame 0	Bits	10296	25456	51024	36696	51024	75376	55056
Number of Code Blocks (Notes 3 and 8)								
For Sub-Frames 1,2,3,4,6,7,8,9	Bits	2	5	9	6	9	13	9
For Sub-Frame 5	Bits	2	5	9	6	9	12	9
For Sub-Frame 0	Bits	2	5	9	6	9	13	9
Binary Channel Bits (Note 8) (subframes with PDCCH USS monitoring)								
For Sub-Frames 1,2,3,4,6,7,8,9	Bits	26100	43200	86400	43200	58752	86400	64800
For Sub-Frame 5	Bits	26100	39744	82080	39744	57888	82080	60480
For Sub-Frame 0	Bits	26100	40752	83952	40752	56304	83952	62352
Binary Channel Bits (Note 8) (subframes with EPDCCH USS monitoring)								
For Sub-Frames 1,2,3,4,6,7,8,9	Bits	25200	42336	85536	42336	57888	85536	63936
For Sub-Frame 5	Bits	25200	38880	81216	38880	57024	81216	59616
For Sub-Frame 0	Bits	25200	39888	83088	39888	55440	83088	61488
Number of layers		1	2	2	2	2	2	2
Max. Throughput averaged over 1 frame (Note 8)	Mbps	10.296	25.456	51.024	36.542	51.024	74.950	54.826
UE Categories		≥ 1	≥ 2	≥ 2	≥ 2	≥ 3	≥ 3	≥ 4
Note 1:	1 symbol allocated to PDCCH for all tests.							
Note 2:	Reference signal, synchronization signals and PBCH allocated as per TS 36.211.							
Note 3:	If more than one Code Block is present, an additional CRC sequence of $L = 24$ Bits is attached to each Code Block (otherwise $L = 0$ Bit).							
Note 4:	Resource blocks $n_{PRB} = 0..2$ are allocated for SIB transmissions in sub-frame 5 for all bandwidths.							
Note 5:	Resource blocks $n_{PRB} = 6..14,30..49$ are allocated for the user data in all sub-frames.							
Note 6:	Resource blocks $n_{PRB} = 3..49$ are allocated for the user data in sub-frame 5, and resource blocks $n_{PRB} = 0..49$ in sub-frames 0,1,2,3,4,6,7,8,9.							
Note 7:	Resource blocks $n_{PRB} = 4..99$ are allocated for the user data in sub-frame 5, and resource blocks $n_{PRB} = 0..99$ in sub-frames 0,1,2,3,4,6,7,8,9.							
Note 8:	Given per component carrier per codeword.							

Note 9: Resource blocks $n_{PRB} = 4..71$ are allocated for the user data in sub-frames 0,1,2,3,4,5,6,7,8,9.
 Note 10: Resource blocks $n_{PRB} = 4..74$ are allocated for the user data in sub-frame 5, and resource blocks $n_{PRB} = 0..74$ in sub-frames 0,1,2,3,4,6,7,8,9.

A.3.9.4 TDD (EPDCCH scheduling)

Table A.3.9.4-1: Fixed Reference Channel for sustained data-rate with EPDCCH scheduling (TDD)

Parameter	Unit	Value				
		R.31E-1 TDD	R.31E-2 TDD	R.31E-3 TDD	R.31E-3A TDD	R.31E-4 TDD
Reference channel						
Channel bandwidth	MHz	10	10	20	15	20
Allocated resource blocks		Note 6	Note 7	Note 8	Note 9	Note 8
Uplink-Downlink Configuration (Note 3)		5	5	5	1	1
Number of HARQ Processes per component carrier	Processes	15	15	15	7	7
Allocated subframes per Radio Frame (D+S)		8+1	8+1	8+1	4	4
Coding Rate (subframes with PDCCH USS monitoring)						
For Sub-Frames 4,9		0.3972	0.5926	0.5933	0.8725	0.8763
For Sub-Frames 3,7,8		0.3972	0.5926	0.5933	N/A	N/A
For Sub-Frames 1		N/A	N/A	N/A	N/A	N/A
For Sub-Frames 5		0.3972	0.6372	0.6213	0.8790	0.8656
For Sub-Frames 6		0.3972	0.5986	0.5963	N/A	N/A
For Sub-Frames 0		0.3972	0.6216	0.6075	0.9036	0.8972
Coding Rate (subframes with EPDCCH USS monitoring)						
For Sub-Frames 4,9		0.4114	0.6047	0.5993	0.8856	0.8851
For Sub-Frames 3,7,8		0.4114	0.6047	0.5993	N/A	N/A
For Sub-Frames 1		N/A	N/A	N/A	N/A	N/A
For Sub-Frames 5		0.4114	0.6512	0.6279	0.8922	0.8748
For Sub-Frames 6		0.4114	0.6109	0.6024	N/A	N/A
For Sub-Frames 0		0.4114	0.6349	0.6138	0.9175	0.9065
Information Bit Payload						
For Sub-Frames 4,9	Bits	10296	25456	51024	51024	75376
For Sub-Frames 3,7,8	Bits	10296	25456	51024	N/A	N/A
For Sub-Frame 1	Bits	0	0	0	N/A	N/A
For Sub-Frame 5	Bits	10296	25456	51024	51024	71112
For Sub-Frame 6	Bits	10296	25456	51024	N/A	N/A
For Sub-Frame 0	Bits	10296	25456	51024	51024	75376
Number of Code Blocks per Sub-Frame (Note 4)						
For Sub-Frames 4,9		2	5	9	9	13
For Sub-Frames 3,7,8		2	5	9	N/A	N/A
For Sub-Frame 1		N/A	N/A	N/A	N/A	N/A
For Sub-Frame 5		2	5	9	9	12
For Sub-Frame 6	Bits	2	5	9	N/A	N/A
For Sub-Frame 0		2	5	9	9	13
Binary Channel Bits per Sub-Frame (subframes with PDCCH USS monitoring)						
For Sub-Frames 4,9	Bits	26100	43200	86400	58752	86400
For Sub-Frames 3,7,8	Bits	26100	43200	86400	N/A	N/A
For Sub-Frame 1	Bits	0	0	0	N/A	N/A
For Sub-Frame 5	Bits	26100	40176	82512	58320	82512
For Sub-Frame 6	Bits	26100	42768	85968	N/A	N/A
For Sub-Frame 0	Bits	26100	41184	84384	56736	84384
Binary Channel Bits per Sub-Frame (subframes with EPDCCH USS monitoring)						

For Sub-Frames 4,9	Bits	25200	42336	85536	57888	85536
For Sub-Frames 3,7,8	Bits	25200	42336	85536	N/A	N/A
For Sub-Frame 1	Bits	0	0	0	N/A	N/A
For Sub-Frame 5	Bits	25200	39312	81648	57456	81648
For Sub-Frame 6	Bits	25200	41904	85104	N/A	N/A
For Sub-Frame 0	Bits	25200	40320	83520	55872	83520
Number of layers		1	2	2	2	2
Max. Throughput averaged over 1 frame (Note 10)	Mbps	8.237	20.365	40.819	20.409	29.724
UE Category		≥ 1	≥ 2	≥ 2	≥ 2	≥ 3
<p>Note 1: 1 symbol allocated to PDCCH for all tests.</p> <p>Note 2: Reference signal, synchronization signals and PBCH allocated as per TS 36.211 [4].</p> <p>Note 3: As per Table 4.2-2 in TS 36.211 [4].</p> <p>Note 4: If more than one Code Block is present, an additional CRC sequence of L = 24 Bits is attached to each Code Block (otherwise L = 0 Bit).</p> <p>Note 5: Resource blocks $n_{PRB} = 0..2$ are allocated for SIB transmissions in sub-frame 5 for all bandwidths.</p> <p>Note 6: Resource blocks $n_{PRB} = 6..14,30..49$ are allocated for the user data in all subframes.</p> <p>Note 7: Resource blocks $n_{PRB} = 3..49$ are allocated for the user data in sub-frame 5, and resource blocks $n_{PRB} = 0..49$ in sub-frames 0,3,4,6,7,8,9.</p> <p>Note 8: Resource blocks $n_{PRB} = 4..99$ are allocated for the user data in sub-frame 5, and resource blocks $n_{PRB} = 0..99$ in sub-frames 0,3,4,6,7,8,9.</p> <p>Note 9: Resource blocks $n_{PRB} = 4..71$ are allocated for the user data in all sub-frames</p> <p>Note10: Given per component carrier per codeword.</p>						

A.3.10 Reference Measurement Channels for EPDCCH performance requirements

A.3.10.1 FDD

Table A.3.10.1-1: Reference Channel FDD

Parameter	Unit	Value					
		R.55 FDD	R.56 FDD	R.57 FDD	R.58 FDD	R.59 FDD	R.55-1 FDD
Reference channel							
Number of transmitter antennas		2	2	2	2	2	2
Channel bandwidth	MHz	10	10	10	10	10	10
Number of OFDM symbols for PDCCH	symbols	2	2	1	1	1	2
Aggregation level	ECCE	4	16	2	8	2	4
DCI Format		2A	2A	2C	2C	2D	2C

A.3.10.2 TDD

Table A.3.10.2-1: Reference Channel TDD

Parameter	Unit	Value					
		R.55 TDD	R.56 TDD	R.57 TDD	R.58 TDD	R.59 TDD	R.55 TDD
Reference channel							
Number of transmitter antennas		2	2	2	2	2	2
Channel bandwidth	MHz	10	10	10	10	10	10
Number of OFDM symbols for PDCCH	symbols	2	2	1	1	1	2
Aggregation level	CCE	4	16	2	8	2	4
DCI Format		2A	2A	2C	2C	2D	2C

A.3.11 Reference Measurement Channels for MPDCCH performance requirements

A.3.11.1 FDD and half-duplex FDD

Table A.3.11.1-1: Reference Channel FDD and half-duplex FDD

Parameter	Unit	Value	Value
Reference channel		R.82 FDD	R.83 FDD
Number of transmitter antennas		2	2
Channel bandwidth	MHz	10	10
OFDM starting symbol (startSymbolLC)	symbols	2	2
Aggregation level	ECCE	16	24
DCI Format		6-1A	6-1B
Payload (without CRC)	Bits	29	18
PRB allocation		8-th ~11-th PRB	As specified in Test

A.3.11.2 TDD

Table A.3.11.2-1: Reference Channel TDD

Parameter	Unit	Value	Value
Reference channel		R.82 TDD	R.83 TDD
Number of transmitter antennas		2	2
Channel bandwidth	MHz	10	10
OFDM starting symbol (startSymbolLC)	symbols	2	2
Aggregation level	ECCE	16	24
DCI Format		6-1A	6-1B
Payload (without CRC)	Bits	32	18
PRB allocation		8-th ~11-th PRB	As specified in Test

A.3.12 Reference measurement channels for NPDSCH performance requirements

A.3.12.1 In-band

A.3.12.1.1 Two-antenna transmission

Table A.3.12.1.1-1: NPDSCH Reference Channel with 2 TX Antennas

Parameter	Unit	Value	Value
Reference channel		R.NB.5 FDD	R.NB.5-1 FDD
Carrier Type		Anchor	Non-anchor
Channel bandwidth	KHz	200	200
Allocated subframes per Radio Frame		Note 2	Note 2
Modulation		QPSK	QPSK
$I_{\text{RBS}}/I_{\text{SF}}$		4/0	4/0
Target Coding Rate		1/3	1/3
Coding Rate		0.4	0.4
Information Bit Payload			
For Sub-Frames 1,2,3,6,7,8	Bits	56	56
For Sub-Frame 0,5	Bits	N/A	56
For Sub-Frame 4,9	Bits	Note 3	56
Number of Code Blocks			
For Sub-Frames 1,2,3,6,7,8		1	1
For Sub-Frame 0,5	Bits	N/A	1
For Sub-Frame 4,9	Bits	Note 4	1
Binary Channel Bits			
For Sub-Frames 1,2,3,6,7,8	Bits	200	200
For Sub-Frame 0,5	Bits	N/A	200
For Sub-Frame 4,9	Bits	Note 5	200
Max. Averaged Throughput	Bps	Note 6	Note 6
UE Category		NB1	NB1
<p>Note 1: For in-band, the first 3 symbols are used for LTE PDCCH and the number of LTE CRS ports is 4.</p> <p>Note 2: It shall depend on the specific NPDSCH scheduling.</p> <p>Note 3: N/A when $n_f \bmod 2 = 0$, otherwise 56.</p> <p>Note 4: N/A when $n_f \bmod 2 = 0$, otherwise 1.</p> <p>Note 5: N/A when $n_f \bmod 2 = 0$, otherwise 200.</p> <p>Note 6: Maximum Average Throughput equals to sum of TB(i) divided by sum of T(i), where TB(i) is the TB size of NPDSCH over i^{th} NPDSCH scheduling period, and T(i) is the total time consisting of NPDCCH transmission duration, NPDCCH to NPDSCH scheduling delay, NPDSCH transmission duration, NPDSCH to NPUSCH format 2 scheduling delay, NPUSCH format 2 transmission duration, possible delay between NPUSCH format 2 and NPDCCH for next NPDSCH scheduling and subframes used for NPSS/NSSS/NPBCH/NB-SIB1/NB-SIB2 transmission during the i^{th} NPDSCH scheduling period.</p>			

A.3.12.2 Standalone/Guard-band

A.3.12.3.1 Single-antenna transmission

Table A.3.12.3.1-1: NPDSCH Reference Channel with 1Tx Antenna

Parameter	Unit	Value	Value
Reference channel		R.NB.6 FDD	R.NB.6-1 FDD
Carrier Type		Anchor	Non-anchor
Channel bandwidth	KHz	200	200
Allocated subframes per Radio Frame		Note 1	Note 1
Modulation		QPSK	QPSK
$T_{\text{BS}}/T_{\text{SF}}$		9/3	6/3
Target Coding Rate		1/2	1/3
Coding Rate		0.5	0.33
Information Bit Payload			
For Sub-Frames 1,2,3,6,7,8	Bits	616	392
For Sub-Frame 0,5	Bits	N/A	392
For Sub-Frame 4,9	Bits	Note 2	392
Number of Code Blocks			
For Sub-Frames 1,2,3,6,7,8		1	1
For Sub-Frame 0,5	Bits	N/A	1
For Sub-Frame 4,9	Bits	Note 3	1
Binary Channel Bits			
For Sub-Frames 1,2,3,6,7,8	Bits	320	320
For Sub-Frame 0,5	Bits	N/A	320
For Sub-Frame 4,9	Bits	Note 4	320
Max. Average Throughput	Bps	Note 5	Note 5
UE Category		NB1	NB1
Note 1: It shall depend on the specific NPDSCH scheduling. Note 2: N/A when $n_f \bmod 2 = 0$, otherwise 616. Note 3: N/A when $n_f \bmod 2 = 0$, otherwise 1. Note 4: N/A when $n_f \bmod 2 = 0$, otherwise 320. Note 5: Maximum Average Throughput equals to sum of TB(i) divided by sum of T(i), where TB(i) is the TB size of NPDSCH over i^{th} NPDSCH scheduling period, and T(i) is the total time consisting of NPDCCH transmission duration, NPDCCH to NPDSCH scheduling delay, NPDSCH transmission duration, NPDSCH to NPUSCH format 2 scheduling delay, NPUSCH format 2 transmission duration, possible delay between NPUSCH format 2 and NPDCCH for next NPDSCH scheduling and subframes used for NPSS/NSSS/NPBCH/NB-SIB1/NB-SIB2 transmission during the i^{th} NPDSCH scheduling period.			

A.3.13 Reference measurement channels for NPDCCH performance requirements

A.3.13.1 Half-duplex FDD

Table A.3.13.1-1: NPDCCH Reference Channel for Category NB1 UE

Parameter	Unit	Value	Value
Reference channel		R.NB.3 FDD	R.NB.4 FDD
Number of NRS ports		1	2
Channel bandwidth	MHz	0.2	0.2
Aggregation level	NCCE	2	2
DCI Format		N1	N1
Payload (without CRC)	Bits	23	23

A.3.14 Reference measurement channels for NPBCH performance requirements for Cat NB1 UEs

Table A.3.14-1: NPBCH Reference Channel for Category NB1 UE

Parameter	Unit	Value	
		R.NB.1	R.NB.2
Reference channel		R.NB.1	R.NB.2
Number of transmitter antennas		1	2
Channel bandwidth	KHz	200	200
Modulation		QPSK	QPSK
Target coding rate		50/1600	50/1600
Payload (without CRC)	Bits	34	34

A.3.15 Reference Measurement Channels for LAA SCell with frame structure Type-3

A.3.15.1 Multi-antenna transmission (Common Reference Symbols)

A.3.15.1.1 Four antenna ports

Table A.3.15.1.1-2: Reference Channel with four CRS ports

Parameter	Unit	Value
Reference channel		R.1 FS3
Channel bandwidth	MHz	20
Allocated resource blocks (Note 4)		100
Allocated subframes per Radio Frame		10
Modulation		64QAM
Target Coding Rate		0.6
Information Bit Payload (Note 4)		
For Sub-Frames 1,4,6,9	Bits	{46888,15840,24496,37888,19848}
For Sub-Frames 2, 7		{46888,15840,24496,37888,19848}
For Sub-Frames 3, 8		{46888,15840,24496,37888,19848}
For Sub-Frame 5	Bits	{46888,15840,24496,37888,19848}
For Sub-Frame 0	Bits	{46888,15840,24496,37888,19848}
Number of Code Blocks (Notes 3 and 4)		
For Sub-Frames 1,4,6,,9		{8,3,4,7,4}
For Sub-Frames 2,7		{8,3,4,7,4}
For Sub-Frames 3, 8		{8,3,4,7,4}
For Sub-Frame 5		{8,3,4,7,4}
For Sub-Frame 0		{8,3,4,7,4}
Binary Channel Bits (Note 4)		
For Sub-Frames 1,4,6,9	Bits	{76800,26400,43200,62400,33600}
For Sub-Frames 2, 7		{76800,26400,43200,62400,33600}
For Sub-Frames 3, 8		{76800,26400,43200,62400,33600}
For Sub-Frame 5	Bits	{75936,26400,43200,61536,33600}
For Sub-Frame 0 (Note 5)	Bits	{75936,26400,43200,61536,33600}
UE Category		≥ 5
Note 1:	2 symbols allocated to PDCCH for 20 MHz, 15 MHz and 10 MHz channel BW; 3 symbols allocated to PDCCH for 5 MHz and 3 MHz; 4 symbols allocated to PDCCH for 1.4 MHz.	
Note 2:	Reference signal, synchronization signals and PBCH allocated as per TS 36.211 [4].	
Note 3:	If more than one Code Block is present, an additional CRC sequence of L = 24 Bits is attached to each Code Block (otherwise L = 0 Bit).	
Note 4:	Given per component carrier per codeword.	
Note 5:	For {a1,a2,a3,a4,a5}, a1, a2, a3, a4 and a5 stand for the setup when the number of OFDM symbols is 14, 6, 9, 12, 7, respectively.	

A.3.15.2 Reference Measurement Channel for UE-Specific Reference Symbols

A.3.15.2.1 Two antenna ports (CSI-RS)

The reference measurement channels in Table A.3.15.2.1-1 apply for verifying demodulation performance for UE-specific reference symbols with two cell-specific antenna ports and two CSI-RS antenna ports for LAA SCell.

Table A.3.15.2.1-1: Reference Channel with two CRS ports

Parameter	Unit	Value
Reference channel		R.2 FS3
Channel bandwidth	MHz	20
Allocated resource blocks (Note 4)		100
Allocated subframes per Radio Frame		10
Modulation		16QAM
Target Coding Rate		1/2
Information Bit Payload (Note 4)		
For Sub-Frames 1,4,6,9	Bits	{22920,7480,12960,19080,10296}
For Sub-Frames 2, 7		{22920,7480,12960,19080,10296}
For Sub-Frames 3, 8		{22920,7480,12960,19080,10296}
For Sub-Frame 5	Bits	{19848, 6712, 11448, 16992, 9144}
For Sub-Frame 0	Bits	{19848, 6712, 11448, 16992, 9144}
Number of Code Blocks (Notes 3 and 4)		
For Sub-Frames 1,4,6,9		{4,2,3,4,2}
For Sub-Frames 2,7		{4,2,3,4,2}
For Sub-Frames 3, 8		{4, 2, 3, 4, 2}
For Sub-Frame 5		{4, 2, 2, 3, 2}
For Sub-Frame 0		{4, 2, 2, 3, 2}
Binary Channel Bits (Note 4)		
For Sub-Frames 1,4,6,9	Bits	{48000,15200,25600,38400,20000}
For Sub-Frames 2, 7		{47200,15200,25600,38400,20000}
For Sub-Frames 3, 8		{46400,15200,25600,38400,20000}
For Sub-Frame 5	Bits	{42240,13376,22528,33792,17600}
For Sub-Frame 0 (Note 5) (Note 6)	Bits	{42240,13376,22528,33792,17600}
UE Category		≥ 5
Note 1:	2 symbols allocated to PDCCH for 20 MHz, 15 MHz and 10 MHz channel BW; 3 symbols allocated to PDCCH for 5 MHz and 3 MHz; 4 symbols allocated to PDCCH for 1.4 MHz.	
Note 2:	Reference signal, synchronization signals and PBCH allocated as per TS 36.211 [4].	
Note 3:	If more than one Code Block is present, an additional CRC sequence of L = 24 Bits is attached to each Code Block (otherwise L = 0 Bit).	
Note 4:	Given per component carrier per codeword.	
Note 5:	For TM9, 100 resource blocks are allocated in sub-frames 1, 2, 3, 4, 6, 7, 8, 9 and 88 resource blocks (RB0-RB43, RB56-RB99) are allocated in subframe 0 and subframe 5	
Note 6:	For {a1,a2,a3,a4,a5}, a1, a2, a3, a4 and a5 stand for the setup when the number of OFDM symbols is 14, 6, 9, 12, 7, respectively	

A.4 CSI reference measurement channels

This section defines the DL signal applicable to the reporting of channel status information (Clause 9.2, 9.3 and 9.5).

In Table A.4-1 are specified the reference channels. Table A.4-13 specifies the mapping of CQI index to modulation coding scheme, which complies with the CQI definition specified in Section 7.2.3 of [6].

Table A.4-0: Void

Table A.4-1: CSI reference measurement channels

RMC Name	Duplex	CH-BW	Alloc. RB-s	UL/DL Config	Alloc. SF-s	MCS Scheme	Nr. HARQ Proc.	Max. nr HARQ Trans.	Notes
1 CRS Port									
RC.1 FDD	FDD	10	50	-		MCS.1	8	1	
RC.1A FDD	FDD	10	50			MCS.1A	8	1	
RC.1 TDD	TDD	10	50	Note 3		MCS.1	10	1	
RC.1A TDD	TDD	20	100	Note 3		MCS.1B	10	1	
RC.3 FDD	FDD	10	6	-		MCS.10	8	1	
RC.3 TDD	TDD	10	6	Note 3		MCS.10	10 or 7 (Note 9)	1	
RC.4 FDD	FDD	10	15	-		MCS.15	8	1	Note 6
RC.4 TDD	TDD	10	15	Note 3		MCS.15	10	1	Note 6
RC.5 FDD	FDD	10	3	-		MCS.17	8	1	
RC.5 TDD	TDD	10	3	Note 3		MCS.17	10	1	
RC.14 FDD	FDD	5	25	-		MCS.14	8	1	
RC.15 FDD	FDD	5	15	-		MCS.15	8	1	Note 6
RC.16 FDD	FDD/HD-FDD	10	2			MCS.20	8	1	Note 8,10
RC.16 TDD	TDD	10	2	Note 3		MCS.20	10	1	Note 8
RC.23 FDD	FDD/HD-FDD	10	3			MCS.28	8	1	Note 12, 13
RC.23 TDD	TDD	10	3			MCS.28	10	1	Note 12
RC.25 FDD	FDD/HD-FDD	10	3			MCS.28	8	1	Note 14, 16
RC.25 TDD	TDD	10	3			MCS.28	10	1	Note 12, 15
2 CRS Ports									
RC.2 FDD	FDD	10	50	-		MCS.2	8	1	
RC.2A FDD	FDD	20	100			MCS.2A	8	1	
RC.2 TDD	TDD	10	50	Note 3		MCS.2	10 or 7 (Note 9)	1	
RC.4A FDD	FDD	20	15	-		MCS.16	8	1	Note 6
RC.6 FDD	FDD	10	15	-		MCS.16	8	1	Note 6
RC.6 TDD	TDD	10	15	Note 3		MCS.16	7	1	Note 6
4 CRS Ports									
RC.17 FDD	FDD	10	50	-		MCS.18	8	1	
RC.17 TDD	TDD	10	50	Note 3		MCS.18	7	1	
RC.21 FDD	FDD	10	50	-		MCS.26	8	1	
RC.21 TDD	TDD	10	50	Note 3		MCS.26	7	1	
1 CRS Port + CSI-RS									
RC.8 FDD	FDD	10	6	-	Non CSI-RS	MCS.11	8	1	
					2 CSI-RS	MCS.12			
RC.8A FDD	FDD	10	6	-	Non CSI-RS	MCS.11A	8	1	
					2 CSI-RS	MCS.12A			
RC.8 TDD	TDD	10	6	Note 3	Non CSI-RS	MCS.11	10	1	
					2 CSI-RS	MCS.12			
RC.8A TDD	TDD	20	8	Note 3	Non CSI-RS	MCS.11B	10	1	

					2 CSI-RS	MCS.12B			
RC.9 FDD	FDD	10	50	-	Non CSI-RS	MCS.3	8	1	
					2 CSI-RS	MCS.4			
RC.9A FDD	FDD	20	100	-	Non CSI-RS	MCS.3A	8	1	
					2 CSI-RS	MCS.4A			
RC.9B FDD	FDD	10	50	-	Non CSI-RS, rank 1/2	MCS.3	8	1	
					Non CSI-RS, rank 3/4	MCS.30			
					4 CSI-RS, rank 1/2	MCS.29			
					4 CSI-RS, rank 3/4	MCS.31			
RC.9 TDD	TDD	10	50	Note 3	Non CSI-RS	MCS.3	7	1	
					2 CSI-RS	MCS.4			
RC.9B TDD	TDD	10	50	Note 3	Non CSI-RS, rank 1/2	MCS.3	7	1	
					Non CSI-RS, rank 3/4	MCS.30			
					4 CSI-RS, rank 1/2	MCS.29			
					4 CSI-RS, rank 3/4	MCS.31			
2 CRS Port + CSI-RS									
RC.7 FDD	FDD	10	50	-	Non CSI-RS	MCS.5	8	1	
					4 CSI-RS	MCS.7			
RC.7 TDD	TDD	10	50	Note 3	Non CSI-RS	MCS.5	10	1	
					8 CSI-RS	MCS.8			
RC.11 FDD	FDD	10	50	-	Non CSI-RS	MCS.5	8	1	
					2 CSI-RS	MCS.6			
RC.11 TDD	TDD	10	50	Note 3	Non CSI-RS	MCS.5	10	1	
					2 CSI-RS	MCS.6			
RC.18 FDD	FDD	10	6	-	Non CSI-RS	MCS.13	8	1	
					4 CSI-RS	MCS.19			
RC.18 TDD	TDD	10	6	Note 3	Non CSI-RS	MCS.13	7	1	
					4 CSI-RS	MCS.19			
RC.17 TDD	TDD	10	6	Note 3	4 ZP-CSI-RS	MCS.21	10	1	
RC.18 TDD	TDD	10	6	Note 3	4 ZP-CSI-RS	MCS.22	10	1	
RC.19 TDD	TDD	10	41	Note3	4 ZP-CSI-RS	MCS.23	10	1	Note 11
RC.20 TDD	TDD	10	50	Note3	Non CSI-RS	MCS.24	10	1	
					2 CSI-RS, 4 ZP-CSI-RS	MCS.25			
RC.22 FDD	FDD	10	50	-	Non CSI-RS	MCS.5	8	1	
					4 CSI-RS	MCS.27			
RC.22 TDD	TDD	10	50	Note 3	Non CSI-RS	MCS.5	10	1	
					4 CSI-RS	MCS.27			
1 CRS Port + CSI-RS + CSI-IM									

RC.13 FDD	FDD	10	50	-	Non CSI-RS/IM	MCS.3	8	1	
					CSI-RS/IM	N/A			
RC.13 TDD	TDD	10	50	Note 3	Non CSI-RS/IM	MCS.3	10	1	
					CSI-RS/IM	N/A			
2 CRS Port + CSI-RS + CSI-IM									
RC.10 FDD	FDD	10	50	-	Non CSI-RS	MCS.5	8	1	
					4 CSI-RS, 1 CSI process	MCS.8			
RC.10 TDD	TDD	10	50	Note 3	Non CSI-RS	MCS.5	10	1	
					8 CSI-RS, 1 CSI process	MCS.9			
RC.12 FDD	FDD	10	6	-	Non CSI-RS/IM	MCS.13	8	1	
					CSI-RS/IM	N/A			
RC.12 TDD	TDD	10	6	Note 3	Non CSI-RS/IM	MCS.13	10	1	
					CSI-RS/IM	N/A			

- Note 1: 3 symbols allocated to PDCCH.
- Note 2: For FDD only subframes 1, 2, 3, 4, 6, 7, 8 and 9 are allocated to avoid PBCH and synchronization signal overhead.
- Note 3: TDD UL-DL configuration as specified in the individual tests.
- Note 4: For TDD when UL-DL configuration 1 is used only subframes 4 and 9 are allocated to avoid PBCH and synchronization signal overhead.
- Note 5: For TDD when UL-DL configuration 2 is used only subframes 3, 4, 8, and 9 are allocated to avoid PBCH and synchronization signal overhead.
- Note 6: Centered within the Transmission Bandwidth Configuration (Figure 5.6-1).
- Note 7: Only subframes 2, 3, 4, 7, 8 and 9 are allocated to avoid PBCH and synchronization signal overhead.
- Note 8: Allocate PDSCH on 5th and 6th PRBs within a subband.
- Note 9: The number of HARQ processes is 10 for TDD UL/DL configuration 2 and 7 for TDD UL/DL configuration 1.
- Note 10: The downlink subframes are scheduled at the 1st, 2nd, 8th, 9th, 16th, 17th, 18th, 24th, 26th, 32nd, 33rd, 34th subframes every 40ms. Information bit payload is available if downlink subframe is scheduled.(starting from 0th subframe)
- Note 11: 41 resource blocks (RB0–RB20 and RB30–RB49) are allocated in subframe 0 and 5 in RC.19 TDD.
- Note 12: Allocate PDSCH on 3th, 4th and 5th PRBs within a narrowband. Allocate MPDCCH on the 0th and 1st PRBs within a narrowband.
- Note 13: The PDSCH subframes are scheduled at the 0th and 1st subframes every 10ms. Information bit payload is available if downlink subframe is scheduled (starting from 0th subframe). MPDCCH subframes are scheduled at the 8th and 9th subframes every 10ms.
- Note 14: The downlink subframes are scheduled at the 0th to 4th subframes every 20ms. Information bit payload is scheduled at the 4th subframe (starting from 0th subframe). MPDCCH and Information bit payload are not scheduled in the radio frames where systemInformation1-BR is scheduled, and $N_{PDSCH}^{SIB1-BR} = 4$ with the set of frames and subframes for SIB1-BR defined in TS 36.211 [16] Table 6.4.1-2.
- Note 15: Information bit payload is scheduled at the 8th subframe every 20ms (starting from 0th subframe).
- Note 16: Allocate PDSCH on 3rd, 4th and 5th PRBs within a narrowband. Allocate MPDCCH on the 0th, 1st, 2nd and 3rd PRBs within a narrowband.

- Table A.4-1a: Void
- Table A.4-1b: Void
- Table A.4-1c: Void
- Table A.4-1d: Void
- Table A.4-1e: Void
- Table A.4-2: Void
- Table A.4-2a: Void
- Table A.4-2b: Void
- Table A.4-2c: Void
- Table A.4-2d: Void
- Table A.4-2e: Void
- Table A.4-3: Void
- Table A.4-3a: Void
- Table A.4-3b: Void
- Table A.4-3c: Void
- Table A.4-3d: Void
- Table A.4-3e: Void
- Table A.4-3f: Void
- Table A.4-3g: Void
- Table A.4-3h: Void
- Table A.4-3i: Void
- Table A.4-3j: Void
- Table A.4-3k: Void
- Table A.4-3l: Void
- Table A.4-3m: Void
- Table A.4-4: Void
- Table A.4-4a: Void
- Table A.4-4b: Void
- Table A.4-5: Void
- Table A.4-5a: Void

Table A.4-5b: Void

Table A.4-6: Void

Table A.4-6a: Void

Table A.4-6b: Void

Table A.4-6c: Void

Table A.4-6d: Void

Table A.4-6e: Void

Table A.4-6f: Void

Table A.4-7: Void

Table A.4-8: Void

Table A.4-9: Void

Table A.4-10: Void

Table A.4-11: Void

Table A.4-12: Void

Table A.4-13: Mapping of CQI Index to Modulation coding scheme (MCS)

CQI Index			0	1	2	3	4	5	6	7	8	9	10	11	12	13	14	15	Notes
Target Coding Rate			OOB	0.0762	0.1172	0.1885	0.3008	0.4385	0.5879	0.3691	0.4785	0.6016	0.4551	0.5537	0.6504	0.7539	0.8525	0.9258	
Modulation			OOB	QPSK						16QAM			64QAM						
MCS Scheme	PRB	Available RE-s	Imcs																
MCS.1	50	6300	DTX	0	0	2	4	6	8	11	13	16	18	21	23	25	27	27	
MCS.2	50	6000	DTX	0	0	2	4	6	8	11	13	15	18	20	22	24	26	27	
MCS.2A	100	12000	DTX	0	0	2	4	6	8	11	13	15	18	20	22	24	26	27	
MCS.3	50	5700	DTX	0	0	2	4	6	8	10	13	15	17	19	21	23	25	26	
MCS.3A	100	11400	DTX	0	0	2	4	6	8	11	13	15	17	19	21	23	25	26	
MCS.4	50	5600	DTX	0	0	2	4	6	7	10	12	14	17	19	21	23	25	26	
MCS.4A	100	11200	DTX	0	0	2	4	6	7	10	12	14	17	19	21	23	25	26	
MCS.5	50	5400	DTX	0	0	2	3	5	7	10	12	14	17	19	21	23	24	25	
MCS.6	50	5300	DTX	0	0	1	3	5	7	10	12	14	17	19	21	22	24	25	
MCS.7	50	5200	DTX	0	0	1	3	5	7	10	12	14	17	18	20	22	24	25	
MCS.8	50	5000	DTX	0	0	1	3	5	7	10	12	13	17	18	20	22	23	24	
MCS.9	50	4800	DTX	0	0	1	3	5	7	10	12	13	17	18	20	22	23	24	
MCS.10	6	756	DTX	0	0	2	4	6	8	11	13	16	19	21	23	25	27	27	
MCS.11	6	684	DTX	0	0	2	4	6	8	11	13	14	17	20	21	23	25	27	
MCS.12	6	672	DTX	0	0	1	4	6	8	10	12	14	17	19	21	23	25	26	
MCS.13	6	648	DTX	0	0	1	3	5	7	10	12	14	17	19	21	22	24	25	
MCS.14	25	3150	DTX	0	0	2	4	6	8	11	13	16	18	21	23	25	27	27	
MCS.15	15	1890	DTX	0	0	2	4	6	8	11	13	16	18	21	23	25	27	27	
MCS.16	15	1800	DTX	0	0	2	4	6	8	11	13	15	18	20	22	24	26	27	
MCS.17	3	378	DTX	0	1	2	5	7	9	12	13	16	19	21	23	25	27	27	
MCS.18	50	5800	DTX	0	0	2	4	6	8	11	13	15	17	20	22	23	26	27	

MCS.19	6	624	DTX	0	0	1	3	5	7	10	12	14	17	18	20	22	24	25		
MCS.20	2	252	DTX	0	0	2	4	6	8	11	13	16	19	21	23	23	23	23		
MCS.21	6	696	DTX	0	0	2	4	6	8	11	13	15	18	20	21	24	25	27		
MCS.22	6	624	DTX	0	0	1	3	5	7	10	12	14	15	19	20	22	24	24		
MCS.23	41	4264	DTX	0	0	1	3	5	7	10	12	14	15	18	20	22	24	24		
MCS.24	50	5400	DTX	0	0	2	3	5	7	10	12	14	15	19	21	23	24	25		
MCS.25	50	5100	DTX	0	0	1	3	5	7	8	12	13	15	18	20	22	23	24		
MCS.26	50	5800	DTX	0	0	2	4	6	8	11	13	15	18	20	22	24	26	27		
MCS.27	CW0	50	4600	DTX	0	0	1	3	5	6	10	11	13	17	18	19	21	23	23	
	CW1	50	4600	DTX	0	0	1	3	5	6	10	11	13	17	18	19	21	22	23	
MCS.29	50	5500	DTX	0	0	2	3	5	7	10	12	14	15	19	21	23	24	25		
MCS.30	50	10200	DTX	0	0	1	3	5	7	8	12	14	15	18	20	22	23	24		
MCS.31	50	9800	DTX	0	0	1	3	5	7	8	11	13	14	18	20	21	23	23		

Note 1: Mapping between *lmcs* and TBS according to Tables 7.1.7.1-1 and 7.1.7.2.1-1 in TS 36.213 [6].

Note 2: 3 symbols allocated to PDCCH.

Note 3: Sub-frame#0 and #5 are not used for the corresponding requirement except for [MCS.23]. The next subframe (i.e. sub-frame#1 or #6) shall be used for potential retransmissions.

Table A.4-14: Mapping of CQI Index to Modulation coding scheme (Modulation and TBS index Table 2 and 4-bit CQI Table 2 are used)

CQI Index			0	1	2	3	4	5	6	7	8	9	10	11	12	13	14	15	Notes
Target Spectral Efficiency			OOR	0.1523	0.3770	0.8770	1.4766	1.9141	2.4063	2.7305	3.3223	3.9023	4.5234	5.1152	5.5547	6.2266	6.9141	7.4063	
MCS Scheme	PRB	Available RE-s	Imcs																
MCS.1A	50	6300	DTX	0	1	3	5	7	10	11	14	16	18	20	22	24	26	26	
MCS.1B	100	12600	DTX	0	1	3	5	7	10	11	14	15	18	20	22	24	26	26	
Note 1:			Mapping between Imcs and CQI Index according to Tables 7.1.7.1-1A, 7.1.7.2.1-1 and 7.2.3-2 in TS 36.213 [6].																
Note 2:			3 symbols allocated to PDCCH.																
Note 3:			Sub-frame#0 and #5 are not used for the corresponding requirement. The next subframe (i.e. sub-frame#1 or #6) shall be used for potential retransmissions.																

Table A.4-15: Mapping of CQI Index to Modulation coding scheme (Modulation and TBS index Table 2 and 4-bit CQI Table 2 are used)

CQI Index			0	1	2	3	4	5	6	7	8	9	10	11	12	13	14	15	Notes
Target Spectral Efficiency			OOR	0.1523	0.3770	0.8770	1.4766	1.9141	2.4063	2.7305	3.3223	3.9023	4.5234	5.1152	5.5547	6.2266	6.9141	7.4063	
MCS Scheme	PRB	Available RE-s	Imcs																
MCS.11A	6	684	DTX	0	1	3	5	7	8	10	13	14	16	18	20	22	24	25	
MCS.12A	6	672	DTX	0	1	3	5	6	8	10	12	14	16	18	20	22	24	25	
MCS.11B	8	912	DTX	0	1	3	5	7	9	10	13	14	16	18	19	22	24	26	
MCS.12B	8	896	DTX	0	1	3	5	6	8	10	12	14	16	18	19	22	24	25	
Note 1:			Mapping between Imcs and CQI Index according to Tables 7.1.7.1-1A, 7.1.7.2.1-1 and 7.2.3-2 in TS 36.213 [6].																
Note 2:			3 symbols allocated to PDCCH.																
Note 3:			Sub-frame#0 and #5 are not used for the corresponding requirement. The next subframe (i.e. sub-frame#1 or #6) shall be used for potential retransmissions.																

Table A.4-16: Mapping of CQI Index to Modulation coding scheme (Modulation and TBS indx Table 3)

CQI Index			0	1	2	3	4	5	6	7	8	9	10	11	12	13	14	15	Notes		
Target Coding Rate			OOR	0.0391	0.0762	0.1172	0.1885	0.3008	0.4385	0.5879	0.3691	0.4785	0.6015	Reserved	Reserved	Reserved	Reserved	Reserved			
Modulation			OOR	QPSK							16QAM										
MCS Scheme	PRB	Available RE-s	Imcs																		
MCS.28	3	378	DTX	0	0	0	2	4	6	8	11	13	15	N/A	N/A	N/A	N/A	N/A			
Note 1:	Mapping between Imcs and TBS according to Tables 7.1.7.1-1 and 7.1.7.2.1-1 in TS 36.213 [6].																				
Note 2:	startSymbolBR = 3																				

A.5 OFDMA Channel Noise Generator (OCNG)

A.5.1 OCNG Patterns for FDD

The following OCNG patterns are used for modelling allocations to virtual UEs (which are not under test) and/or allocations used for MBSFN. The OCNG pattern for each sub frame specifies the allocations that shall be filled with OCNG, and furthermore, the relative power level of each such allocation.

In each test case the OCNG is expressed by parameters OCNG_RA and OCNG_RB which together with a relative power level (γ) specifies the PDSCH EPRE-to-RS EPRE ratios in OFDM symbols with and without reference symbols, respectively. The relative power, which is used for modelling boosting per virtual UE allocation, is expressed by:

$$\gamma_i = PDSCH_{i_RA} / OCNG_RA = PDSCH_{i_RB} / OCNG_RB,$$

where γ_i denotes the relative power level of the i :th virtual UE. The parameter settings of OCNG_RA, OCNG_RB, and the set of relative power levels γ are chosen such that when also taking allocations to the UE under test into account, as given by a PDSCH reference channel, a constant transmitted power spectral density that is constant on an OFDM symbol basis is targeted.

Moreover the OCNG pattern is accompanied by a PCFICH/PDCCH/PHICH reference channel which specifies the control region. For any aggregation and PHICH allocation, the PDCCH and any unused PHICH groups are padded with resource element groups with a power level given respectively by PDCCH_RA/RB and PHICH_RA/RB as specified in the test case such that a total power spectral density in the control region that is constant on an OFDM symbol basis is targeted.

For the performance requirements of UE with the CA capability, the OCNG patterns apply for each CC.

A.5.1.1 OCNG FDD pattern 1: One sided dynamic OCNG FDD pattern

This OCNG Pattern fills with OCNG all empty PRB-s (PRB-s with no allocation of data or system information) of the DL sub-frames, when the unallocated area is continuous in frequency domain (one sided).

Table A.5.1.1-1: OP.1 FDD: One sided dynamic OCNG FDD Pattern

Relative power level γ_{PRB} [dB]			PDSCH Data
Subframe			
0	5	1 – 4, 6 – 9	
Allocation			
First unallocated PRB – Last unallocated PRB	First unallocated PRB – Last unallocated PRB	First unallocated PRB – Last unallocated PRB	
0	0	0	Note 1
Note 1: These physical resource blocks are assigned to an arbitrary number of virtual UEs with one PDSCH per virtual UE; the data transmitted over the OCNG PDSCHs shall be uncorrelated pseudo random data, which is QPSK modulated. The parameter γ_{PRB} is used to scale the power of PDSCH.			
Note 2: If two or more transmit antennas with CRS are used in the test, the OCNG shall be transmitted to the virtual users by all the transmit antennas with CRS according to transmission mode 2. The parameter γ_{PRB} applies to each antenna port separately, so the transmit power is equal between all the transmit antennas with CRS used in the test. The antenna transmission modes are specified in section 7.1 in 3GPP TS 36.213.			

A.5.1.2 OCNG FDD pattern 2: Two sided dynamic OCNG FDD pattern

This OCNG Pattern fills with OCNG all empty PRB-s (PRB-s with no allocation of data or system information) of the DL sub-frames, when the unallocated area is discontinuous in frequency domain (divided in two parts by the allocated area – two sided), starts with PRB 0 and ends with PRB $N_{RB} - 1$.

Table A.5.1.2-1: OP.2 FDD: Two sided dynamic OCNG FDD Pattern

Relative power level γ_{PRB} [dB]			PDSCH Data
Subframe			
0	5	1 – 4, 6 – 9	
Allocation			
0 – (First allocated PRB-1) and (Last allocated PRB+1) – ($N_{RB} - 1$)	0 – (First allocated PRB-1) and (Last allocated PRB+1) – ($N_{RB} - 1$)	0 – (First allocated PRB-1) and (Last allocated PRB+1) – ($N_{RB} - 1$)	
0	0	0	Note 1
<p>Note 1: These physical resource blocks are assigned to an arbitrary number of virtual UEs with one PDSCH per virtual UE; the data transmitted over the OCNG PDSCHs shall be uncorrelated pseudo random data, which is QPSK modulated. The parameter γ_{PRB} is used to scale the power of PDSCH.</p> <p>Note 2: If two or more transmit antennas with CRS are used in the test, the OCNG shall be transmitted to the virtual users by all the transmit antennas with CRS according to transmission mode 2. The parameter γ_{PRB} applies to each antenna port separately, so the transmit power is equal between all the transmit antennas with CRS used in the test. The antenna transmission modes are specified in section 7.1 in 3GPP TS 36.213.</p>			

A.5.1.3 OCNG FDD pattern 3: 49 RB OCNG allocation with MBSFN in 10 MHz

Table A.5.1.3-1: OP.3 FDD: OCNG FDD Pattern 3

Allocation n_{PRB}	Relative power level γ_{PRB} [dB]				PDSCH Data	PMCH Data
	Subframe					
	0	5	4, 9	1 – 3, 6 – 8		
1 – 49	0	0 (Allocation: all empty PRB-s)	0	N/A	Note 1	N/A
0 – 49	N/A	N/A	N/A	0	N/A	Note 2
<p>Note 1: These physical resource blocks are assigned to an arbitrary number of virtual UEs with one PDSCH per virtual UE; the data transmitted over the OCNG PDSCHs shall be uncorrelated pseudo random data, which is QPSK modulated. The parameter γ_{PRB} is used to scale the power of PDSCH.</p> <p>Note 2: Each physical resource block (PRB) is assigned to MBSFN transmission. The data in each PRB shall be uncorrelated with data in other PRBs over the period of any measurement. The MBSFN data shall be QPSK modulated. PMCH subframes shall contain cell-specific Reference Signals only in the first symbol of the first time slot. The parameter γ_{PRB} is used to scale the power of PMCH.</p> <p>Note 3: If two or more transmit antennas are used in the test, the OCNG shall be transmitted to the virtual users by all the transmit antennas according to transmission mode 2. The transmit power shall be equally split between all the transmit antennas used in the test. The antenna transmission modes are specified in section 7.1 in 3GPP TS 36.213.</p> <p>N/A: Not Applicable</p>						

A.5.1.4 OCNG FDD pattern 4: One sided dynamic OCNG FDD pattern for MBMS transmission

This OCNG Pattern fills with OCNG all empty PRB-s (PRB-s with no allocation of data or system information) of the DL sub-frames, when the unallocated area is continuous in frequency domain (one sided) and MBMS performance is tested.

Table A.5.1.4-1: OP.4 FDD: One sided dynamic OCNG FDD Pattern for MBMS transmission

Allocation n_{PRB}	Relative power level γ_{PRB} [dB]			PDSCH Data	PMCH Data
	Subframe				
	0, 4, 9	5	1 – 3, 6 – 8		
First unallocated PRB – Last unallocated PRB	0	0 (Allocation: all empty PRB-s)	N/A	Note 1	N/A
First unallocated PRB – Last unallocated PRB	N/A	N/A	N/A	N/A	Note 2
<p>Note 1: These physical resource blocks are assigned to an arbitrary number of virtual UEs with one PDSCH per virtual UE; the data transmitted over the OCNG PDSCHs shall be uncorrelated pseudo random data, which is QPSK modulated. The parameter γ_{PRB} is used to scale the power of PDSCH.</p> <p>Note 2: Each physical resource block (PRB) is assigned to MBSFN transmission. The data in each PRB shall be uncorrelated with data in other PRBs over the period of any measurement. The MBSFN data shall be QPSK modulated. PMCH subframes shall contain cell-specific Reference Signals only in the first symbol of the first time slot. The parameter γ_{PRB} is used to scale the power of PMCH.</p> <p>Note 3: If two or more transmit antennas are used in the test, the OCNG shall be transmitted to the virtual users by all the transmit antennas according to transmission mode 2. The transmit power shall be equally split between all the transmit antennas used in the test. The antenna transmission modes are specified in section 7.1 in 3GPP TS 36.213.</p> <p>N/A: Not Applicable</p>					

A.5.1.5 OCNG FDD pattern 5: One sided dynamic 16QAM modulated OCNG FDD pattern

This OCNG Pattern fills with OCNG all empty PRB-s (PRB-s with no allocation of data or system information) of DL sub-frames, when the unallocated area is continuous in the frequency domain (one sided).

Table A.5.1.5-1: OP.5 FDD: One sided dynamic 16QAM modulated OCNG FDD Pattern

Relative power level γ_{PRB} [dB]			PDSCH Data
Subframe			
0	5	1 – 4, 6 – 9	
Allocation			
First unallocated PRB – Last unallocated PRB	First unallocated PRB – Last unallocated PRB	First unallocated PRB – Last unallocated PRB	
0	0	0	Note 1
<p>Note 1: These physical resource blocks are assigned to an arbitrary number of virtual UEs with one PDSCH per virtual UE; the data transmitted over the OCNG PDSCHs shall be uncorrelated pseudo random data, which is 16QAM modulated. The parameter γ_{PRB} is used to scale the power of PDSCH.</p> <p>Note 2: If two or more transmit antennas with CRS are used in the test, the OCNG shall be transmitted to the virtual users by all the transmit antennas with CRS according to transmission mode 3 (Large Delay CDD). The parameter γ_{PRB} applies to each antenna port separately, so the transmit power is equal between all the transmit antennas with CRS used in the test. The antenna transmission modes are specified in section 7.1 in 3GPP TS 36.213.</p>			

A.5.1.6 OCNG FDD pattern 6: dynamic OCNG FDD pattern when user data is in 2 non-contiguous blocks

This OCNG Pattern fills with OCNG all empty PRB-s (PRB-s with no allocation of data or system information) of the DL sub-frames, when the unallocated area is discontinuous in frequency domain (divided in two parts by the first allocated block). The second allocated block ends with PRB $N_{RB} - 1$.

Table A.5.1.6-1: OP.6 FDD: OCNG FDD Pattern when user data is in 2 non-contiguous blocks

Relative power level γ_{PRB} [dB]			PDSCH Data
Subframe			
0	5	1 – 4, 6 – 9	
Allocation			
0 – (First allocated PRB of first block -1) and (Last allocated PRB of first block +1) – (First allocated PRB of second block -1)	0 – (First allocated PRB of first block -1) and (Last allocated PRB of first block +1) – (First allocated PRB of second block -1)	0 – (First allocated PRB of first block -1) and (Last allocated PRB of first block +1) – (First allocated PRB of second block -1)	
0	0	0	Note 1
<p>Note 1: These physical resource blocks are assigned to an arbitrary number of virtual UEs with one PDSCH per virtual UE; the data transmitted over the OCNG PDSCHs shall be uncorrelated pseudo random data, which is QPSK modulated. The parameter γ_{PRB} is used to scale the power of PDSCH.</p> <p>Note 2: If two or more transmit antennas with CRS are used in the test, the OCNG shall be transmitted to the virtual users by all the transmit antennas with CRS according to transmission mode 2. The parameter γ_{PRB} applies to each antenna port separately, so the transmit power is equal between all the transmit antennas with CRS used in the test. The antenna transmission modes are specified in section 7.1 in 3GPP TS 36.213.</p>			

A.5.1.7 OCNG FDD pattern 7: dynamic OCNG FDD pattern when user data is in multiple non-contiguous blocks

This OCNG Pattern fills with OCNG all empty PRB-s (PRB-s with no allocation of data, EPDCCH or system information) of the DL sub-frames, when the unallocated area is discontinuous in frequency domain (divided in

multiple parts by the M allocated blocks for data transmission). The m -th allocated block starts with PRB $N_{Start,m}$ and ends with PRB $N_{End,m} - 1$, where $m = 1, \dots, M$. The system bandwidth starts with PRB 0 and ends with $N_{RB} - 1$.

Table A.5.1.7-1: OP.7 FDD: OCNG FDD Pattern when user data is in multiple non-contiguous blocks

Relative power level γ_{PRB} [dB]			PDSCH Data
Subframe			
0	5	1 – 4, 6 – 9	
Allocation			
0 – (PRB $N_{Start,1} - 1$) ... (PRB $N_{End,(m-1)} - 1$) – (PRB $N_{Start,m} - 1$) ... (PRB $N_{End,M} - 1$) – (PRB $N_{RB} - 1$)	0 – (PRB $N_{Start,1} - 1$) ... (PRB $N_{End,(m-1)} - 1$) – (PRB $N_{Start,m} - 1$) ... (PRB $N_{End,M} - 1$) – (PRB $N_{RB} - 1$)	0 – (PRB $N_{Start,1} - 1$) ... (PRB $N_{End,(m-1)} - 1$) – (PRB $N_{Start,m} - 1$) ... (PRB $N_{End,M} - 1$) – (PRB $N_{RB} - 1$)	
0	0	0	Note 1
<p>Note 1: These physical resource blocks are assigned to an arbitrary number of virtual UEs with one PDSCH per virtual UE; the data transmitted over the OCNG PDSCHs shall be uncorrelated pseudo random data, which is QPSK modulated. The parameter γ_{PRB} is used to scale the power of PDSCH.</p> <p>Note 2: If two or more transmit antennas with CRS are used in the test, the OCNG shall be transmitted to the virtual users by all the transmit antennas with CRS according to transmission mode 2. The parameter γ_{PRB} applies to each antenna port separately, so the transmit power is equal between all the transmit antennas with CRS used in the test. The antenna transmission modes are specified in section 7.1 in 3GPP TS 36.213.</p>			

A.5.1.8 OCNG FDD pattern 8: Dynamic OCNG FDD pattern for TM10 transmission

This OCNG Pattern fills with OCNG all empty PRB-s (PRB-s with no allocation of data or system information) of the DL sub-frames, when the unallocated area is discontinuous in frequency domain where there are M unallocated PRB blocks labled from 1-st block to M -th block ($M > 1$) and the m -th block starts with PRB $N_{Start,m}$ and end with PRB $N_{End,m}$, or when the unallocated area is continuous in frequency domain where $M = 1$ (one sided). The system bandwidth starts with PRB 0 and ends with $N_{RB} - 1$. $N_{End,M}$ should be equal to or less than $N_{RB} - 1$.

Table A.5.1.8-1: OP.8 FDD: Dynamic OCNG FDD Pattern

Relative power level γ_{PRB} [dB]			PDSCH Data
Subframe			
0	5	1 – 4, 6 – 9	
Allocation			
1-st unallocated PRB (PRB $N_{Start,1}$ ~ PRB $N_{End,1}$) ... m -th unallocated PRB (PRB $N_{Start,m}$ ~ PRB $N_{End,m}$) ... M -th unallocated PRB (PRB $N_{Start,M}$ ~ PRB $N_{End,M}$)	1-st unallocated PRB (PRB $N_{Start,1}$ ~ PRB $N_{End,1}$) ... m -th unallocated PRB (PRB $N_{Start,m}$ ~ PRB $N_{End,m}$) ... M -th unallocated PRB (PRB $N_{Start,M}$ ~ PRB $N_{End,M}$)	1-st unallocated PRB (PRB $N_{Start,1}$ ~ PRB $N_{End,1}$) ... m -th unallocated PRB (PRB $N_{Start,m}$ ~ PRB $N_{End,m}$) ... M -th unallocated PRB (PRB $N_{Start,M}$ ~ PRB $N_{End,M}$)	
0	0	0	Note 1,2,3
<p>Note 1: These physical resource blocks are assigned to an arbitrary number of virtual UEs with one PDSCH per virtual UE; the data transmitted over the OCNG PDSCHs shall be uncorrelated pseudo random data, which is 16QAM modulated. The parameter γ_{PRB} is used to scale the power of PDSCH.</p> <p>Note 2: The OCNG shall be transmitted to the virtual users by all the transmit antennas according to transmission mode10. The the transmit power is equal between all the transmit antennas used in the test. The antenna transmission modes are specified in section 7.1 in 3GPP TS 36.213.</p> <p>Note 3: The detailed test set-up for TM10 transmission i.e PML configuration is specified to each test case.</p>			

A.5.2 OCNG Patterns for TDD

The following OCNG patterns are used for modelling allocations to virtual UEs (which are not under test). The OCNG pattern for each sub frame specifies the allocations that shall be filled with OCNG, and furthermore, the relative power level of each such allocation.

In each test case the OCNG is expressed by parameters OCNG_RA and OCNG_RB which together with a relative power level (γ) specifies the PDSCH EPRE-to-RS EPRE ratios in OFDM symbols with and without reference symbols, respectively. The relative power, which is used for modelling boosting per virtual UE allocation, is expressed by:

$$\gamma_i = PDSCH_i_RA / OCNG_RA = PDSCH_i_RB / OCNG_RB,$$

where γ_i denotes the relative power level of the i :th virtual UE. The parameter settings of OCNG_RA, OCNG_RB, and the set of relative power levels γ are chosen such that when also taking allocations to the UE under test into account, as given by a PDSCH reference channel, a transmitted power spectral density that is constant on an OFDM symbol basis is targeted.

Moreover the OCNG pattern is accompanied by a PCFICH/PDCCH/PHICH reference channel which specifies the control region. For any aggregation and PHICH allocation, the PDCCH and any unused PHICH groups are padded with resource element groups with a power level given respectively by PDCCH_RA/RB and PHICH_RA/RB as specified in the test case such that a total power spectral density in the control region that is constant on an OFDM symbol basis is targeted.

A.5.2.1 OCNG TDD pattern 1: One sided dynamic OCNG TDD pattern

This OCNG Pattern fills with OCNG all empty PRB-s (PRB-s with no allocation of data or system information) of the subframes available for DL transmission (depending on TDD UL/DL configuration), when the unallocated area is continuous in frequency domain (one sided).

Table A.5.2.1-1: OP.1 TDD: One sided dynamic OCNG TDD Pattern

Relative power level γ_{PRB} [dB]				PDSCH Data
Subframe (only if available for DL)				
0	5	3, 4, 7, 8, 9 and 6 (as normal subframe) <small>Note 2</small>	1 and 6 (as special subframe) <small>Note 2</small>	
Allocation				
First unallocated PRB –	First unallocated PRB –	First unallocated PRB –	First unallocated PRB –	
Last unallocated PRB	Last unallocated PRB	Last unallocated PRB	Last unallocated PRB	
0	0	0	0	Note 1
<p>Note 1: These physical resource blocks are assigned to an arbitrary number of virtual UEs with one PDSCH per virtual UE; the data transmitted over the OCNG PDSCHs shall be uncorrelated pseudo random data, which is QPSK modulated. The parameter γ_{PRB} is used to scale the power of PDSCH.</p> <p>Note 2: Subframes available for DL transmission depends on the Uplink-Downlink configuration in Table 4.2-2 in 3GPP TS 36.211</p> <p>Note 3: If two or more transmit antennas with CRS are used in the test, the OCNG shall be transmitted to the virtual users by all the transmit antennas with CRS according to transmission mode 2. The parameter γ_{PRB} applies to each antenna port separately, so the transmit power is equal between all the transmit antennas with CRS used in the test. The antenna transmission modes are specified in section 7.1 in 3GPP TS 36.213.</p>				

A.5.2.2 OCNG TDD pattern 2: Two sided dynamic OCNG TDD pattern

This OCNG Pattern fills with OCNG all empty PRB-s (PRB-s with no allocation of data or system information) of the subframes available for DL transmission (depending on TDD UL/DL configuration), when the unallocated area is discontinuous in frequency domain (divided in two parts by the allocated area – two sided), starts with PRB 0 and ends with PRB $N_{RB} - 1$.

Table A.5.2.2-1: OP.2 TDD: Two sided dynamic OCNG TDD Pattern

Relative power level γ_{PRB} [dB]				PDSCH Data
Subframe (only if available for DL)				
0	5	3, 4, 6, 7, 8, 9 (6 as normal subframe) <small>Note 2</small>	1,6 (6 as special subframe) <small>Note 2</small>	
Allocation				
0 – (First allocated PRB-1) and (Last allocated PRB+1) – $(N_{RB} - 1)$	0 – (First allocated PRB-1) and (Last allocated PRB+1) – $(N_{RB} - 1)$	0 – (First allocated PRB-1) and (Last allocated PRB+1) – $(N_{RB} - 1)$	0 – (First allocated PRB-1) and (Last allocated PRB+1) – $(N_{RB} - 1)$	
0	0	0	0	
<p>Note 1: These physical resource blocks are assigned to an arbitrary number of virtual UEs with one PDSCH per virtual UE; the data transmitted over the OCNG PDSCHs shall be uncorrelated pseudo random data, which is QPSK modulated. The parameter γ_{PRB} is used to scale the power of PDSCH.</p> <p>Note 2: Subframes available for DL transmission depends on the Uplink-Downlink configuration in Table 4.2-2 in 3GPP TS 36.211</p> <p>Note 3: If two or more transmit antennas with CRS are used in the test, the OCNG shall be transmitted to the virtual users by all the transmit antennas with CRS according to transmission mode 2. The parameter γ_{PRB} applies to each antenna port separately, so the transmit power is equal between all the transmit antennas with CRS used in the test. The antenna transmission modes are specified in section 7.1 in 3GPP TS 36.213.</p>				

A.5.2.3 OCNG TDD pattern 3: 49 RB OCNG allocation with MBSFN in 10 MHz

Table A.5.2.3-1: OP.3 TDD: OCNG TDD Pattern 3 for 5ms downlink-to-uplink switch-point periodicity

Allocation n_{PRB}	Relative power level γ_{PRB} [dB]				PDSCH Data	PMCH Data
	Subframe					
	0	5	4, 9 ^{Note 2}	1, 6		
1 – 49	0	0 (Allocation: all empty PRB-s)	N/A	0	Note 1	N/A
0 – 49	N/A	N/A	0	N/A	N/A	Note 3
<p>Note 1: These physical resource blocks are assigned to an arbitrary number of virtual UEs with one PDSCH per virtual UE; the data transmitted over the OCNG PDSCHs shall be uncorrelated pseudo random data, which is QPSK modulated. The parameter γ_{PRB} is used to scale the power of PDSCH.</p> <p>Note 2: Subframes available for DL transmission depends on the Uplink-Downlink configuration in Table 4.2-2 in 3GPP TS 36.211.</p> <p>Note 3: Each physical resource block (PRB) is assigned to MBSFN transmission. The data in each PRB shall be uncorrelated with data in other PRBs over the period of any measurement. The MBSFN data shall be QPSK modulated. PMCH symbols shall not contain cell-specific Reference Signals.</p> <p>Note 4: If two or more transmit antennas are used in the test, the OCNG shall be transmitted to the virtual users by all the transmit antennas according to transmission mode 2. The transmit power shall be equally split between all the transmit antennas used in the test. The antenna transmission modes are specified in section 7.1 in 3GPP TS 36.213.</p>						
N/A Not Applicable						

A.5.2.4 OCNG TDD pattern 4: One sided dynamic OCNG TDD pattern for MBMS transmission

This OCNG Pattern fills with OCNG all empty PRB-s (PRB-s with no allocation of data or system information) of the DL sub-frames, when the unallocated area is continuous in frequency domain (one sided) and MBMS performance is tested.

Table A.5.2.4-1: OP.4 TDD: One sided dynamic OCNG TDD Pattern for MBMS transmission

Allocation n_{PRB}	Relative power level γ_{PRB} [dB]				PDSCH Data	PMCH Data
	Subframe (only for DL)					
	0 and 6 (as normal subframe)	1 (as special subframe)	5	3, 4, 7 – 9		

First unallocated PRB – Last unallocated PRB	0	0 (Allocation: all empty PRB-s of DwPTS)	0 (Allocation: all empty PRB-s)	N/A	Note 1	N/A
First unallocated PRB – Last unallocated PRB	N/A	N/A	N/A	N/A	N/A	Note2
Note 1:	These physical resource blocks are assigned to an arbitrary number of virtual UEs with one PDSCH per virtual UE; the data transmitted over the OCNG PDSCHs shall be uncorrelated pseudo random data, which is QPSK modulated. The parameter γ_{PRB} is used to scale the power of PDSCH.					
Note 2:	Each physical resource block (PRB) is assigned to MBSFN transmission. The data in each PRB shall be uncorrelated with data in other PRBs over the period of any measurement. The MBSFN data shall be QPSK modulated. PMCH symbols shall not contain cell-specific Reference Signals.					
Note 3:	If two or more transmit antennas are used in the test, the OCNG shall be transmitted to the virtual users by all the transmit antennas according to transmission mode 2. The transmit power shall be equally split between all the transmit antennas used in the test. The antenna transmission modes are specified in section 7.1 in 3GPP TS 36.213.					
N/A	Not Applicable					

A.5.2.5 OCNG TDD pattern 5: One sided dynamic 16QAM modulated OCNG TDD pattern

This OCNG Pattern fills with OCNG all empty PRB-s (PRB-s with no allocation of data or system information) of the sub-frames available for DL transmission (depending on TDD UL/DL configuration), when the unallocated area is continuous in frequency domain (one sided).

Table A.5.2.5-1: OP.5 TDD: One sided dynamic 16QAM modulated OCNG TDD Pattern

Relative power level γ_{PRB} [dB]				PDSCH Data
Subframe (only if available for DL)				
0	5	3, 4, 7, 8, 9 and 6 (as normal subframe) <small>Note 2</small>	1 and 6 (as special subframe) <small>Note 2</small>	
Allocation				
First unallocated PRB –	First unallocated PRB –	First unallocated PRB –	First unallocated PRB –	
Last unallocated PRB	Last unallocated PRB	Last unallocated PRB	Last unallocated PRB	
0	0	0	0	Note 1
<p>Note 1: These physical resource blocks are assigned to an arbitrary number of virtual UEs with one PDSCH per virtual UE; the data transmitted over the OCNG PDSCHs shall be uncorrelated pseudo random data, which is 16QAM modulated. The parameter γ_{PRB} is used to scale the power of PDSCH.</p> <p>Note 2: Subframes available for DL transmission depends on the Uplink-Downlink configuration in Table 4.2-2 in 3GPP TS 36.211</p> <p>Note 3: If two or more transmit antennas with CRS are used in the test, the OCNG shall be transmitted to the virtual users by all the transmit antennas with CRS according to transmission mode 3 (Large Delay CDD). The parameter γ_{PRB} applies to each antenna port separately, so the transmit power is equal between all the transmit antennas with CRS used in the test. The antenna transmission modes are specified in section 7.1 in 3GPP TS 36.213.</p>				

A.5.2.6 OCNG TDD pattern 6: dynamic OCNG TDD pattern when user data is in 2 non-contiguous blocks

This OCNG Pattern fills with OCNG all empty PRB-s (PRB-s with no allocation of data or system information) of the subframes available for DL transmission (depending on TDD UL/DL configuration), when the unallocated area is discontinuous in frequency domain (divided in two parts by the first allocated block). The second allocated block ends with PRB $N_{RB} - 1$.

Table A.5.2.6-1: OP.6 TDD: OCNG TDD Pattern when user data is in 2 non-contiguous blocks

Relative power level γ_{PRB} [dB]				PDSCH Data
Subframe (only if available for DL)				
0	5	3, 4, 6, 7, 8, 9 (6 as normal subframe) <small>Note 2</small>	1,6 (6 as special subframe) <small>Note 2</small>	
Allocation				
0 – (First allocated PRB of first block -1) and (Last allocated PRB of first block +1) – (First allocated PRB of second block -1)	0 – (First allocated PRB of first block -1) and (Last allocated PRB of first block +1) – (First allocated PRB of second block -1)	0 – (First allocated PRB of first block -1) and (Last allocated PRB of first block +1) – (First allocated PRB of second block -1)	0 – (First allocated PRB of first block -1) and (Last allocated PRB of first block +1) – (First allocated PRB of second block -1)	
0	0	0	0	
<p>Note 1: These physical resource blocks are assigned to an arbitrary number of virtual UEs with one PDSCH per virtual UE; the data transmitted over the OCNG PDSCHs shall be uncorrelated pseudo random data, which is QPSK modulated. The parameter γ_{PRB} is used to scale the power of PDSCH.</p> <p>Note 2: Subframes available for DL transmission depends on the Uplink-Downlink configuration in Table 4.2-2 in 3GPP TS 36.211</p> <p>Note 3: If two or more transmit antennas with CRS are used in the test, the OCNG shall be transmitted to the virtual users by all the transmit antennas with CRS according to transmission mode 2. The parameter γ_{PRB} applies to each antenna port separately, so the transmit power is equal between all the transmit antennas with CRS used in the test. The antenna transmission modes are specified in section 7.1 in 3GPP TS 36.213.</p>				

A.5.2.7 OCNG TDD pattern 7: dynamic OCNG TDD pattern when user data is in multiple non-contiguous blocks

This OCNG Pattern fills with OCNG all empty PRB-s (PRB-s with no allocation of data, EPDCCH or system information) of the DL sub-frames, when the unallocated area is discontinuous in frequency domain (divided in multiple parts by the M allocated blocks for data transmission). The m -th allocated block starts with RPB $N_{Start,m}$ and ends with PRB $N_{End,m} - 1$, where $m = 1, \dots, M$. The system bandwidth starts with RPB 0 and ends with $N_{RB} - 1$.

Table A.5.2.7-1: OP.7 TDD: OCNG TDD Pattern when user data is in multiple non-contiguous blocks

Relative power level γ_{PRB} [dB]				PDSCH Data
Subframe (only if available for DL)				
0	5	3, 4, 6, 7, 8, 9 (6 as normal subframe) Note 2	1,6 (6 as special subframe) Note 2	
Allocation				
0 – (PRB $N_{Start,1} - 1$) ... (PRB $N_{End,(m-1)} - 1$) – (PRB $N_{Start,m} - 1$) ... (PRB $N_{End,M} - 1$) – (PRB $N_{RB} - 1$)	0 – (PRB $N_{Start,1} - 1$) ... (PRB $N_{End,(m-1)} - 1$) – (PRB $N_{Start,m} - 1$) ... (PRB $N_{End,M} - 1$) – (PRB $N_{RB} - 1$)	0 – (PRB $N_{Start,1} - 1$) ... (PRB $N_{End,(m-1)} - 1$) – (PRB $N_{Start,m} - 1$) ... (PRB $N_{End,M} - 1$) – (PRB $N_{RB} - 1$)	0 – (PRB $N_{Start,1} - 1$) ... (PRB $N_{End,(m-1)} - 1$) – (PRB $N_{Start,m} - 1$) ... (PRB $N_{End,M} - 1$) – (PRB $N_{RB} - 1$)	Note 1
0	0	0	0	Note 1

Note 1: These physical resource blocks are assigned to an arbitrary number of virtual UEs with one PDSCH per virtual UE; the data transmitted over the OCNG PDSCHs shall be uncorrelated pseudo random data, which is QPSK modulated. The parameter γ_{PRB} is used to scale the power of PDSCH.

Note 2: Subframes available for DL transmission depends on the Uplink-Downlink configuration in Table 4.2-2 in 3GPP TS 36.211

Note 3: If two or more transmit antennas with CRS are used in the test, the OCNG shall be transmitted to the virtual users by all the transmit antennas with CRS according to transmission mode 2. The parameter γ_{PRB} applies to each antenna port separately, so the transmit power is equal between all the transmit antennas with CRS used in the test. The antenna transmission modes are specified in section 7.1 in 3GPP TS 36.213.

A.5.2.8 OCNG TDD pattern 8: Dynamic OCNG TDD pattern for TM10 transmission

This OCNG Pattern fills with OCNG all empty PRB-s (PRB-s with no allocation of data or system information) of the DL sub-frames, when the unallocated area is discontinuous in frequency domain where there are M unallocated PRB blocks labeled from 1-st block to M -th block ($M > 1$) and the m -th block starts with PRB $N_{Start,m}$ and end with PRB $N_{End,m}$, or when the unallocated area is continuous in frequency domain where $M = 1$ (one sided). The system bandwidth starts with RPB 0 and ends with $N_{RB} - 1$. $N_{End,M}$ should be equal to or less than $N_{RB} - 1$.

Table A.5.2.8-1: OP.8 TDD: Dynamic OCNG TDD Pattern

Relative power level γ_{PRB} [dB]			PDSCH Data
Subframe			
0	5	1 – 4, 6 – 9	
Allocation			
1-st unallocated PRB (PRB $N_{Start,1}$ ~ PRB $N_{End,1}$)	1-st unallocated PRB (PRB $N_{Start,1}$ ~ PRB $N_{End,1}$)	1-st unallocated PRB (PRB $N_{Start,1}$ ~ PRB $N_{End,1}$)	
...	
m -th unallocated PRB (PRB $N_{Start,m}$ ~ PRB $N_{End,m}$)	m -th unallocated PRB (PRB $N_{Start,m}$ ~ PRB $N_{End,m}$)	m -th unallocated PRB (PRB $N_{Start,m}$ ~ PRB $N_{End,m}$)	
...	
M -th unallocated PRB (PRB $N_{Start,M}$ ~ PRB $N_{End,M}$)	M -th unallocated PRB (PRB $N_{Start,M}$ ~ PRB $N_{End,M}$)	M -th unallocated PRB (PRB $N_{Start,M}$ ~ PRB $N_{End,M}$)	
0	0	0	
			Note 1,2,3
Note 1: These physical resource blocks are assigned to an arbitrary number of virtual UEs with one PDSCH per virtual UE; the data transmitted over the OCNG PDSCHs shall be uncorrelated pseudo random data, which is 16QAM modulated. The parameter γ_{PRB} is used to scale the power of PDSCH.			
Note 2: The OCNG shall be transmitted to the virtual users by all the transmit antennas according to transmission mode 10. The transmit power is equal between all the transmit antennas used in the test. The antenna transmission modes are specified in section 7.1 in 3GPP TS 36.213.			
Note 3: The detailed test set-up for TM10 transmission i.e PMI configuration is specified to each test case.			

A.5.3 OCNG Patterns for Narrowband IoT

The following OCNG patterns are used for modelling allocations to virtual narrowband IoT UEs (which are not under test). The OCNG pattern for each sub frame specifies the allocations that shall be filled with OCNG, and furthermore, the relative power level of each such allocation.

In each test case the OCNG is expressed by parameters OCNG_RA and OCNG_RB which together with a relative power level (γ) specifies the NPDSCH EPRE-to-NRS EPRE ratios in OFDM symbols with and without Narrowband reference symbols, respectively. The relative power, which is used for modelling boosting per virtual UE allocation, is expressed by:

$$\gamma_i = NPDSCH_i_RA / OCNG_RA = NPDSCH_i_RB / OCNG_RB,$$

where γ_i denotes the relative power level of the i :th virtual UE. The parameter settings of OCNG_RA, OCNG_RB, and the set of relative power levels γ are chosen such that when also taking allocations to the UE under test into account, as given by a NPDSCH or NPDCCH reference channel, a transmitted power spectral density that is constant on an OFDM symbol basis is targeted.

A.5.3.1 Narrowband IoT OCNG pattern 1

Table A.5.3.1-1: NB.OP.1 FDD: OCNG FDD Pattern 1

Bandwidth	Relative power level γ [dB]		NPDCCH and corresponding NPDSCH Data
	Subframe		
	Unused subframes		
200KHz	0		Note 2
Note 1:	These subframes are assigned to an arbitrary number of virtual UEs with one NPDSCH per virtual UE with corresponding NPDCCH; the data transmitted over the OCNG NPDSCHs shall be uncorrelated pseudo random data, which is QPSK modulated. The parameter γ is used to scale the power of NPDSCH and NPDCCH.		
Note 2:	Subframes and/or REs available for narrowband IOT DL transmission depend on the in-band, guard band or standalone mode indicated in MIB, and scheduling delay between NPDCCH, NPDSCH, NPUSCH format 2 and NPDCCH specified in test cases.		
Note 3:	If two or more transmit antennas with NRS are used in the test, the OCNG shall be transmitted to the virtual users by all the transmit antennas with NRS according to transmit diversity scheme. The parameter γ applies to each antenna port separately, so the transmit power is equal between all the transmit antennas with NRS used in the test.		

A.5.4 OCNG Patterns for frame structure type 3

The following OCNG patterns are used for modelling allocations to virtual UEs (which are not under test). The OCNG pattern for each sub frame specifies the allocations that shall be filled with OCNG, and furthermore, the relative power level of each such allocation.

In each test case the OCNG is expressed by parameters OCNG_RA and OCNG_RB which together with a relative power level (γ) specifies the PDSCH EPRE-to-RS EPRE ratios in OFDM symbols with and without reference symbols, respectively. The relative power, which is used for modelling boosting per virtual UE allocation, is expressed by:

$$\gamma_i = PDSCH_{i_RA} / OCNG_RA = PDSCH_{i_RB} / OCNG_RB,$$

where γ_i denotes the relative power level of the i :th virtual UE. The parameter settings of OCNG_RA, OCNG_RB, and the set of relative power levels γ are chosen such that when also taking allocations to the UE under test into account, as given by a PDSCH reference channel, a constant transmitted power spectral density that is constant on an OFDM symbol basis is targeted.

Moreover the OCNG pattern is accompanied by a PDCCH reference channel which specifies the control region. For any aggregation the PDCCH are padded with resource element groups with a power level given respectively by PDCCH_RA/RB as specified in the test case such that a total power spectral density in the control region that is constant on an OFDM symbol basis is targeted.

For the performance requirements of UE with the CA capability, the OCNG patterns apply for each LAA Scell.

A.5.4.1 OCNG FS3 pattern 1: One sided dynamic OCNG frame structure type 3 pattern

This OCNG Pattern fills with OCNG all empty PRB-s (PRB-s with no allocation of data or system information) of the DL sub-frames, when the unallocated area is continuous in frequency domain (one sided).

Table A.5.4.1-1: OP.1 FS3: One sided dynamic OCNG frame structure type 3 Pattern

Relative power level γ_{PRB} [dB]			PDSCH Data
Subframe			
0	5	1 – 4, 6 – 9	
Allocation			
First unallocated PRB – Last unallocated PRB	First unallocated PRB – Last unallocated PRB	First unallocated PRB – Last unallocated PRB	
0	0	0	Note 1
<p>Note 1: These physical resource blocks are assigned to an arbitrary number of virtual UEs with one PDSCH per virtual UE; the data transmitted over the OCNG PDSCHs shall be uncorrelated pseudo random data, which is QPSK modulated. The parameter γ_{PRB} is used to scale the power of PDSCH.</p> <p>Note 2: If two or more transmit antennas with CRS are used in the test, the OCNG shall be transmitted to the virtual users by all the transmit antennas with CRS according to transmission mode 2. The parameter γ_{PRB} applies to each antenna port separately, so the transmit power is equal between all the transmit antennas with CRS used in the test. The antenna transmission modes are specified in section 7.1 in 3GPP TS 36.213.</p> <p>Note 3 : Subframes available for DL transmission and Occupied OFDM symbols in each subframe depend on the downlink burst transmission pattern and its corresponding configuration</p>			

A.5.4.2 OCNG FS3 pattern 2: Two sided dynamic OCNG frame structure 3 pattern

This OCNG Pattern fills with OCNG all empty PRB-s (PRB-s with no allocation of data or system information) of the DL sub-frames, when the unallocated area is discontinuous in frequency domain (divided in two parts by the allocated area – two sided), starts with PRB 0 and ends with PRB $N_{RB} - 1$.

Table A.5.4.2-1: OP.2 FS3: Two sided dynamic OCNG frame structure type 3 Pattern

Relative power level γ_{PRB} [dB]			PDSCH Data
Subframe			
0	5	1 – 4, 6 – 9	
Allocation			
0 – (First allocated PRB-1) and (Last allocated PRB+1) – ($N_{RB} - 1$)	0 – (First allocated PRB-1) and (Last allocated PRB+1) – ($N_{RB} - 1$)	0 – (First allocated PRB-1) and (Last allocated PRB+1) – ($N_{RB} - 1$)	
0	0	0	Note 1
<p>Note 1: These physical resource blocks are assigned to an arbitrary number of virtual UEs with one PDSCH per virtual UE; the data transmitted over the OCNG PDSCHs shall be uncorrelated pseudo random data, which is QPSK modulated. The parameter γ_{PRB} is used to scale the power of PDSCH.</p> <p>Note 2: If two or more transmit antennas with CRS are used in the test, the OCNG shall be transmitted to the virtual users by all the transmit antennas with CRS according to transmission mode 2. The parameter γ_{PRB} applies to each antenna port separately, so the transmit power is equal between all the transmit antennas with CRS used in the test. The antenna transmission modes are specified in section 7.1 in 3GPP TS 36.213.</p> <p>Note 3 : Subframes available for DL transmission and Occupied OFDM symbols in each subframe depend on the downlink burst transmission pattern and its corresponding configuration.</p>			

A.6 Sidelink reference measurement channels

A.6.1 General

The algorithm for determining the payload size A is as follows; given a desired coding rate R and radio block allocation N_{RB}

1. Calculate the number of channel bits N_{ch} that can be transmitted during the first transmission of a given sub-frame.
2. Find A such that the resulting coding rate is as close to R as possible, that is,

$$\min |R - (A + 24 * (N_{CB} + 1)) / N_{ch}|, \text{ where } N_{CB} = \begin{cases} 0, & \text{if } C = 1 \\ C, & \text{if } C > 1 \end{cases}$$

subject to

- a) A is a valid TB size according to section 7.1.7 of TS 36.213 [6] assuming an allocation of N_{RB} resource blocks.
 - b) C is the number of Code Blocks calculated according to section 5.1.2 of TS 36.212 [5].
3. If there is more than one A that minimizes the equation above, then the larger value is chosen per default and the chosen code rate should not exceed 0.93.

A.6.1.1 Overview of ProSe reference measurement channels

In Table A.6.1.1-1 are listed the ProSe reference measurement channels specified in annexes A.6.2 to A.6.6 of this release of TS 36.101. This table is informative and serves only to a better overview. The reference for the concrete reference measurement channels and corresponding implementation's parameters as to be used for requirements are annexes A.6.2 to A.6.6 as appropriate.

Table A.6.1.1-1: Overview of ProSe reference measurement channels

Table	Name	BW	Mod	RB	UE Categ	Notes
Table A.6.2-1	-	5	QPSK	2	≥ 1	
Table A.6.2-1	-	10	QPSK	2	≥ 1	
Table A.6.2-1	-	15	QPSK	2	≥ 1	
Table A.6.2-1	-	20	QPSK	2	≥ 1	
Table A.6.2-2	-	5	QPSK	25	≥ 1	
Table A.6.2-2	-	10	QPSK	50	≥ 1	
Table A.6.2-3	-	5	16QAM	25	2-8	
Table A.6.2-3	-	10	16QAM	50	2-8	
Table A.6.2-4	-	5	16QAM	25	1	
Table A.6.2-4	-	10	16QAM	50	1	
Table A.6.3-1	D.1 FDD / D.1 TDD	5	QPSK	2	≥ 1	
Table A.6.3-1	D.1 FDD / D.1 TDD	10	QPSK	2	≥ 1	
Table A.6.3-1	D.1 FDD / D.1 TDD	15	QPSK	2	≥ 1	
Table A.6.3-1	D.1 FDD / D.1 TDD	20	QPSK	2	≥ 1	
Table A.6.4-1	CC.1 FDD	5	QPSK	1	-	
Table A.6.4-1	CC.2 FDD	10	QPSK	1	-	
Table A.6.4-1	CC.3 FDD	5	QPSK	1	-	
Table A.6.4-1	CC.4 FDD	10	QPSK	1	-	
Table A.6.4-1	CC.5 FDD	5	QPSK	1	-	
Table A.6.4-1	CC.6 FDD	10	QPSK	1	-	
Table A.6.5-1	CD.1 FDD	5/10	QPSK	10	-	
Table A.6.5-1	CD.2 FDD	5/10	16QAM	10	-	
Table A.6.5-1	CD.3 FDD	5	16QAM	25	-	
Table A.6.5-1	CD.4 FDD	10	16QAM	50	-	
Table A.6.5-1	CD.5 FDD	5/10	QPSK	2	-	
Table A.6.5-2	CD.6 FDD	5	16QAM	25	-	
Table A.6.5-2	CD.7 FDD	10	16QAM	50	-	
Table A.6.6-1	CP.1 FDD	5/10	QPSK	6	-	

A.6.2 Reference measurement channel for receiver characteristics

For ProSe Direct Discovery, Table A.6.2-1 is applicable for measurements on the Receiver Characteristics (clause 7) including the requirements of subclause 7.4D (Maximum input level).

For ProSe Direct Communication, Table A.6.2-2 is applicable for measurements on the Receiver Characteristics (clause 7) with the exception of subclause 7.4D (Maximum input level). Tables A.6.2-3, A.6.2-4, are applicable for subclause 7.4D (Maximum input level).

Table A.6.2-1: Fixed Reference measurement channel for ProSe Direct Discovery receiver requirements and maximum input level

Parameter	Unit	Value					
		1.4	3	5	10	15	20
Channel bandwidth	MHz						
Allocated resource blocks				2	2	2	2
Subcarriers per resource block				12	12	12	12
Allocated subframes per Discovery period				1	1	1	1
DFT-OFDM Symbols per subframe (see note)				11	11	11	11
Modulation				QPSK	QPSK	QPSK	QPSK
Transport Block Size				232	232	232	232
Transport block CRC	Bits			24	24	24	24
Maximum number of HARQ transmissions				1	1	1	1
Binary Channel Bits (see note)	Bits			528	528	528	528
Max. Throughput averaged over 1 Discovery period of 320ms	kbps			0.725	0.725	0.725	0.725
UE Category				≥ 1	≥ 1	≥ 1	≥ 1

NOTE1: PSDCH transmissions are rate-matched for 12 DFT-OFDM symbols per subframe, and the last symbol shall be punctured as per TS 36.211.

NOTE2: Throughput is 232 bits per Discovery period. The discovery period is configured as 320ms in the test.

Table A.6.2-2: Fixed Reference measurement channel for ProSe Direct Communication receiver requirements

Parameter	Unit	Value					
		1.4	3	5	10	15	20
Channel bandwidth	MHz						
Allocated resource blocks				25	50		
Subcarriers per resource block				12	12		
Packets per SA period				1	1		
Modulation				QPSK	QPSK		
Transport Block Size				2216	4392		
Transport block CRC	Bits			24	24		
Maximum number of HARQ transmissions				4	4		
Binary Channel Bits	Bits			7200	14400		
Max. Throughput averaged over 1 SA period of 40ms	kbps			55.4	109.8		
UE Category				≥ 1	≥ 1		

NOTE 1: For PSSCH transmission, the last symbol shall be punctured as per TS 36.211.

NOTE 2: Throughput (in kbps) will depend on SA period configuration

Table A.6.2-3: Fixed Reference measurement channel for ProSe Direct Communication for maximum input power for UE categories 2-8

Parameter	Unit	Value					
		1.4	3	5	10	15	20
Channel bandwidth	MHz						
Allocated resource blocks				25	50		
Subcarriers per resource block				12	12		
Packets per SA period				1	1		
Modulation				16QAM	16QAM		
Transport Block Size				9912	18336		
Transport block CRC	Bits			24	24		
Maximum number of HARQ transmissions				4	4		
Binary Channel Bits	Bits			14400	28800		
Max. Throughput averaged over 1 SA period of 40ms	kbps			247.8	458.4		

NOTE 1: For PSSCH transmission, the last symbol shall be punctured as per TS 36.211.

NOTE 2: If more than one Code Block is present, an additional CRC sequence of L = 24 Bits is attached to each Code Block (otherwise L = 0 Bit).

NOTE 3: Throughput (in kbps) will depend on SA period configuration

Table A.6.2-4: Fixed Reference measurement channel for ProSe Direct Communication for maximum input power for UE category 1

Parameter	Unit	Value					
		1.4	3	5	10	15	20
Channel bandwidth	MHz	1.4	3	5	10	15	20
Allocated resource blocks				25	24		
Subcarriers per resource block				12	12		
Packets per SA period				1	1		
Modulation				16QAM	16QAM		
Transport Block Size				9912	10296		
Transport block CRC	Bits			24	24		
Maximum number of HARQ transmissions				4	4		
Binary Channel Bits	Bits			14400	13824		
Max. Throughput averaged over 1 SA period of 40ms	kbps			247.8	257.4		
NOTE 1: For PSSCH transmission, the last symbol shall be punctured as per TS 36.211.							
NOTE 2: If more than one Code Block is present, an additional CRC sequence of L = 24 Bits is attached to each Code Block (otherwise L = 0 Bit).							
NOTE 3: Throughput (in kbps) will depend on SA period configuration							

A.6.3 Reference measurement channels for PSDCH performance requirements

Table A.6.3-1: Fixed Reference measurement channel for PSDCH performance requirement

Parameter	Unit	Value					
		D.1 FDD / D.1 TDD					
Reference channel		1.4	3	5	10	15	20
Channel bandwidth	MHz	1.4	3	5	10	15	20
Allocated resource blocks				2	2	2	2
Subcarriers per resource block				12	12	12	12
DFT-OFDM Symbols per subframe (NOTE 1)				11	11	11	11
Modulation				QPSK	QPSK	QPSK	QPSK
Transport Block Size				232	232	232	232
Transport block CRC	Bits			24	24	24	24
Binary Channel Bits (NOTE 1)	Bits			528	528	528	528
Max. Throughput averaged over 1 Discovery period of 320ms	kbps			0.725	0.725	0.725	0.725
UE Category				≥ 1	≥ 1	≥ 1	≥ 1
NOTE1: PSDCH transmissions are rate-matched for 12 DFT-OFDM symbols per subframe, and the last symbol shall be punctured as per TS 36.211.							

A.6.4 Reference measurement channels for PSCCH performance requirements

Table A.6.4-1: Fixed reference measurement channel for PSCCH performance requirement

Parameter		Unit	Value					
			CC.1 FDD	CC.2 FDD	CC.3 FDD	CC.4 FDD	CC.5 FDD	CC.6 FDD
Reference channel								
Channel bandwidth		MHz	5	10	5	10	5	10
Allocated resource blocks			1	1	1	1	1	1
Subcarriers per resource block			12	12	12	12	12	12
DFT-OFDM Symbols per subframe (see Note 1)			11	11	11	11	11	11
Modulation			QPSK	QPSK	QPSK	QPSK	QPSK	QPSK
Transport Block Size		Bits	41	43	41	43	41	43
Information bits	Frequency hopping flag		0	0	1	1	1	1
	RB assignment		Set as per PSSCH RB allocation specific in the test					
	Hopping bits		N/A	N/A	1 Type 2 Hopping	(1,1) Type 2 Hopping	0 Type 1 Hopping	(1,0) Type 1 Hopping
	Time resource pattern (I_{TRP})		8 (unless specified otherwise in the test) (Note 3)					
	Modulation and coding scheme		Set as the PSSCH MCS specified in the test					
	Timing advance indication		0 (unless specified otherwise in the test)					
Group destination ID			As set by higher layers					
Transport block CRC		Bits	16	16	16	16	16	16
Maximum number of HARQ transmissions			2	2	2	2	2	2
Binary Channel Bits (see Note 1,2)		Bits	264	264	264	264	264	264
Max. Throughput averaged over one sc-period (bits/sc-period)			41	43	41	43	41	43
NOTE 1: PSCCH transmissions are rate-matched for 12 DFT-OFDM symbols per subframe, and the last symbol shall be punctured as per TS 36.211.								
NOTE 2: Binary channel bits per HARQ transmission.								
NOTE 3: For $N_{TRP} = 8$ (FDD) and $trpt-Subset = 010$, $I_{TRP} = 8$ corresponds to a time repetition pattern of (1,1,0,0,0,0,0,0) as per TS 36.213.								

A.6.5 Reference measurement channels for PSSCH performance requirements

Table A.6.5-1: Fixed reference measurement channel for PSSCH performance requirement

Parameter		Unit	Value				
			CD.1 FDD	CD.2 FDD	CD.3 FDD	CD.4 FDD	CD.5 FDD
Reference channel							
Channel bandwidth		MHz	5 / 10	5 / 10	5	10	5 / 10
Allocated resource blocks			10	10	25	50	2
Subcarriers per resource block			12	12	12	12	12
DFT-OFDM Symbols per subframe (see Note 1)			11	11	11	11	11
Modulation			QPSK	16QAM	16QAM	16QAM	QPSK
Transport Block Size			872	2536	6456	12960	328
Transport block CRC		Bits	24	24	24	24	24
Maximum number of HARQ transmissions			4	4	4	4	4
Binary Channel Bits (see Note 1,2)		Bits	2640	5280	13200	26400	528
Max. Throughput averaged over one sc-period (bits/sc-period)			872	2536	6456	12960	328
NOTE 1: PSSCH transmissions are rate-matched for 12 DFT-OFDM symbols per subframe, and the last symbol shall be punctured as per TS 36.211.							
NOTE 2: Binary channel bits per HARQ transmission.							
NOTE 3: If more than one Code Block is present, an additional CRC sequence of L = 24 Bits is attached to each Code Block (otherwise L = 0 Bit).							

Table A.6.5-2: Fixed reference measurement channel for PSSCH for maximum Sidelink processes test

Parameter	Unit	Value	
Reference channel		CD.6 FDD	CD.7 FDD
Channel bandwidth	MHz	5	10
Allocated resource blocks		25	50
Subcarriers per resource block		12	12
DFT-OFDM Symbols per subframe (see Note 1)		11	11
Modulation		16QAM	16QAM
Transport Block Size		15840	25456
Transport block CRC	Bits	24	24
Maximum number of HARQ transmissions		4	4
Binary Channel Bits (see Note 1,2)	Bits	13200	26400
Max. Throughput averaged over one sc-period (bits/sc-period)		15840	25456
NOTE 1: PSSCH transmissions are rate-matched for 12 DFT-OFDM symbols per subframe, and the last symbol shall be punctured as per TS 36.211.			
NOTE 2: Binary channel bits per HARQ transmission.			
NOTE 3: If more than one Code Block is present, an additional CRC sequence of L = 24 Bits is attached to each Code Block (otherwise L = 0 Bit).			

A.6.6 Reference measurement channels for PSBCH performance requirements

Table A.6.6-1: Fixed reference measurement channel for PSBCH performance requirement

Parameter	Unit	Value
Reference channel		CP.1 FDD
Channel bandwidth	MHz	5 / 10
Allocated resource blocks		6
Subcarriers per resource block		12
DFT-OFDM Symbols per subframe (see Note 1)		7
Modulation		QPSK
Transport Block Size		40
Transport block CRC	Bits	16
Maximum number of HARQ transmissions		1
Binary Channel Bits (see Note 1,2)	Bits	1008
Max. Throughput averaged over 40ms	kbps	1
NOTE 1: PSBCH transmissions are rate-matched for 8 DFT-OFDM symbols per subframe, and the last symbol shall be punctured as per TS 36.211.		
NOTE 2: Binary channel bits per HARQ transmission.		

A.7 Sidelink reference resource pool configurations

A.7.1 Reference resource pool configurations for ProSe Direct Discovery demodulation tests

A.7.1.1 FDD

Table A.7.1.1-1: ProSe Direct Discovery configuration for E-UTRA FDD (Configuration #1-FDD)

Information Element		Value
discRxPool	cp-Len	Normal
	discPeriod	rf32
	numRetx	0
	numRepetition	1
tf-ResourceConfig	prb-Num	12
	prb-Start	0
	prb-End	23
	offsetIndicator	160
	subframeBitmap	10000000 00000000 00000000 00000000 00000000
	txParameters	not present
	rxParameters	not present
discTxPoolCommon		not present
discTxPowerInfo		not present
SL-SyncConfig		not present
discInterFreqList		not present

Table A.7.1.1-2: ProSe Direct Discovery configuration for E-UTRA FDD (Configuration #2-FDD)

Information Element			Value	
discRxPool(0)	cp-Len		Normal	
	discPeriod		rf32	
	numRetx		0	
	numRepetition		1	
	tf-ResourceConfig	prb-Num		12
		prb-Start		0
		prb-End		23
		offsetIndicator		150
		subframeBitmap		10000000 00000000 00000000 00000000 00000000
	txParameters		not present	
rxParameters		not present		
discRxPool(1)	cp-Len		Normal	
	discPeriod		rf32	
	numRetx		0	
	numRepetition		1	
	tf-ResourceConfig	prb-Num		12
		prb-Start		0
		prb-End		23
		offsetIndicator		170
		subframeBitmap		10000000 00000000 00000000 00000000 00000000
	txParameters		not present	
rxParameters	tdd-Config		not present	
	syncConfigIndex		0	
discTxPoolCommon			not present	
discTxPowerInfo			not present	
SL-SyncConfig(0)	syncCP-Len		Normal	
	syncOffsetIndicator		0 (160 mod 40)	
	slssid		30	
	txParameters		not present	
	rxParamsNCell	physCellId		1
		discSyncWindow		w1
discInterFreqList			not present	

Table A.7.1.1-3: ProSe Direct Discovery configuration for E-UTRA FDD (Configuration #3-FDD)

Information Element			Value
discRxPool(iPool), iPool = 0...NPool-1	cp-Len		Normal
	discPeriod		rf32
	numRetx		3
	numRepetition		=2 if NPool > 10, =1 otherwise
	tf-ResourceConfig	prb-Num	5MHz: $\min\{24, 2N-24*iPool\} / 2$ 10MHz: 25 15MHz: $\min\{74, 2N-74*iPool\} / 2$ 20MHz: 50
		prb-Start	0
		prb-End	5 MHz: $\min\{24, 2N-24*iPool\} - 1$ 10 MHz: 49 15 MHz: $\min\{74, 2N-74*iPool\} - 1$ 20 MHz: 99
		offsetIndicator	160
		subframeBitmap	a(0), a(1), ..., a(39), s.t. a(i * NPool + iPool) = 1, i = 0,...,K; a(k) = 0 otherwise where K = 1 is NPool > 10, K = 3 otherwise
	txParameters		not present
	rxParameters		not present
discTxPoolCommon			not present
discTxPowerInfo			not present
SL-SyncConfig			not present
discInterFreqList			not present
NOTE 1: The resource pool configuration description is parameterized using channel BW, number of configured resource pools (NPool), and maximum number of configured Sidelink UEs to be supported (N).			

Table A.7.1.1-4: ProSe Direct Discovery configuration for E-UTRA FDD for out-of-network coverage operation (Configuration #4-FDD)

Information Element				Value	
				5MHz	10MHz
preconfigSync	syncCP-Len-r12			Normal	
	syncOffsetIndicator1			1	
	syncOffsetIndicator2			2	
	syncTxParameters			23	
	syncTxThreshOoC			0 (-110dBm / 15kHz)	
	filterCoefficient			fc0	
	syncRefMinHyst			dB0	
	syncRefDiffHyst			dB0	
	syncTxPeriodic			TRUE	
	preconfigDisc	discRxPoolList(0)	cp-Len		Normal
discPeriod				rf4	
numRetx				0	
numRepetition				1	
tf-ResourceConfig		prb-Num		12	25
		prb-Start		0	0
		prb-End		23	49
			offsetIndicator	0	
			subframeBitmap	00000000 10000000 00000000 00000000 00000000	
		txParameters		not present	

A.7.1.2 TDD

Table A.7.1.2-1: ProSe Direct Discovery configuration for E-UTRA TDD Config 0 (Configuration #1-TDD)

Information Element				Value
discRxPool	cp-Len			Normal
	discPeriod			rf32
	numRetx			0
	numRepetition			1
	tf-ResourceConfig	prb-Num		12
		prb-Start		0
		prb-End		23
			offsetIndicator	163
			subframeBitmap	10000000 00000000 00000000 00000000 00000000 00
		txParameters		not present
	rxParameters		not present	
discTxPoolCommon			not present	
discTxPowerInfo			not present	
SL-SyncConfig			not present	
discInterFreqList			not present	

Table A.7.1.2-2: ProSe Direct Discovery configuration for E-UTRA TDD (Configuration #2-TDD)

Information Element			Value
discRxPool(iPool), iPool = 0...NPool-1	cp-Len		Normal
	discPeriod		rf32
	numRetx		3
	numRepetition		=2 if NPool > 10, =1 otherwise
	tf-ResourceConfig	prb-Num	5MHz: $\min\{24, 2N-24*iPool\} / 2$ 10MHz: 25 15MHz: $\min\{74, 2N-74*iPool\} / 2$ 20MHz: 50
		prb-Start	0
		prb-End	5 MHz: $\min\{24, 2N-24*iPool\} - 1$ 10 MHz: 49 15 MHz: $\min\{74, 2N-74*iPool\} - 1$ 20 MHz: 99
		offsetIndicator	163
		subframeBitmap	a(0), a(1), ..., a(39), s.t. a(i * NPool + iPool) = 1, i = 0,...,K; a(k) = 0 otherwise where K = 1 is NPool > 10, K = 3 otherwise
	txParameters		not present
	rxParameters		not present
discTxPoolCommon			not present
discTxPowerInfo			not present
SL-SyncConfig			not present
discInterFreqList			not present
NOTE 1: The resource pool configuration description is parameterized using channel BWs, number of configured resource pools (NPool), and maximum number of configured Sidelink UE to be supported (N).			

A.7.2 Reference resource pool configurations for ProSe Direct Communication demodulation tests

A.7.2.1 FDD

Table A.7.2.1-1: ProSe Direct Communication pre-configuration for E-UTRAN FDD for out-of-network coverage operation (Configuration #1-FDD)

Information Element / (BW configuration)			Value (5MHz)	Value (10MHz)	
preconfigSync	syncCP-Len-r12		Normal		
	syncOffsetIndicator1		1		
	syncOffsetIndicator2		2		
	syncTxParameters		23		
	syncTxThreshOoC		0 (-110dBm / 15kHz)		
	filterCoefficient		fc0		
preconfigComm	syncRefMinHyst		dB0		
	syncRefDiffHyst		dB0		
	sc-CP-Len		Normal		
	sc-Period		sf40		
	sc-TF-ResourceConfig	prb-Num		13	25
		prb-Start		0	0
prb-End			24	49	
offsetIndicator			0		
	subframeBitmap		00011000 00000000 00000000 00000000 00000000		
data-CP-Len		Normal			
dataHoppingConfig	hoppingParameter		504		
	numSubbands		ns2		
	rb-Offset		0		
ue-SelectedResourceConfig	data-TF-ResourceConfig	<i>prb-Num</i>	13	25	
		<i>prb-Start</i>	0	0	
		<i>prb-End</i>	24	49	
		<i>offsetIndicator</i>	0		
	<i>subframeBitmap</i>		00000000 11111111 11111111 00000000 00000000		
	trpt-Subset-r12		010		

Table A.7.2.1-2: ProSe Direct Communication configuration for E-UTRA FDD (Configuration #2-FDD)

Information Element / (BW configuration)				Value (5MHz)	Value (10MHz)
commRxPool	sc-CP-Len			Normal	
	sc-Period			sf40	
	sc-TF-ResourceConfig	prb-Num		13	25
		prb-Start		0	0
		prb-End		24	49
		offsetIndicator		0	
		subframeBitmap		00111100	
				00000000	
				00000000	
				00000000	
				00000000	
	data-CP-Len			Normal	
	dataHoppingConfig	hoppingParameter		504	
		numSubbands		ns2	
		rb-Offset		0	
	ue-SelectedResourceConfig	data-TF-ResourceConfig	prb-Num	13	25
			prb-Start	0	0
			prb-End	24	49
			offsetIndicator	0	
		subframeBitmap		00000000	
				11111111	
				11111111	
				00000000	
				00000000	
		trpt-Subset-r12		010	
	rxParametersNCell			not present	
	txParameters			not present	
commTxPoolNormalCommon				not present	
SL-SyncConfig				not present	

Table A.7.2.1-3: ProSe Direct Communication configuration for E-UTRA FDD (Configuration #3-FDD)

Information Element / (BW configuration)				Value (5MHz)	Value (10MHz)
commRxPool(0)	sc-CP-Len			Normal	
	sc-Period			sf40	
	sc-TF-ResourceConfig	prb-Num		13	25
		prb-Start		0	0
		prb-End		24	49
		offsetIndicator		0	
		subframeBitmap		00110000 00000000 00000000 00000000 00000000	
	data-CP-Len			Normal	
	dataHoppingConfig	hoppingParameter		504	
		numSubbands		ns2	
		rb-Offset		0	
	ue-SelectedResourceConfig	data-TF-ResourceConfig	prb-Num	13	25
			prb-Start		0
		prb-End		24	49
		offsetIndicator		0	
		subframeBitmap		00001111 11110000 00000000 11111111 00000000	
		trpt-Subset-r12		010	
	rxParametersNCell			not present	
	txParameters			not present	
commRxPool(1)	sc-CP-Len			Normal	
	sc-Period			sf40	
	sc-TF-ResourceConfig	prb-Num		13	25
		prb-Start		0	0
		prb-End		24	49
		offsetIndicator		0	
		subframeBitmap		00110000 00000000 00000000 00000000 00000000	
	data-CP-Len			Normal	
	dataHoppingConfig	hoppingParameter		504	
		numSubbands		ns2	
		rb-Offset		0	
	ue-SelectedResourceConfig	data-TF-ResourceConfig	prb-Num	13	25
			prb-Start		0
		prb-End		24	49
		offsetIndicator		0	
		subframeBitmap		00001111 11110000 00001111 11110000 00000000	
		trpt-Subset-r12		010	
	rxParametersNCell	tdd-Config		not present	
		syncConfigIndex		0	
	txParameters			not present	
commTxPoolNormalCommon				not present	
SL-SyncConfig(0)	syncCP-Len			Normal	
	syncOffsetIndicator			1	
	sIssid			30	
	txParameters			not present	

	rxParamsNCell	physCellId		1
		discSyncWindow		w1

Table A.7.2.1-4: ProSe Direct Communication configuration for E-UTRA FDD (Configuration #4-FDD)

Information Element / (BW configuration)				Value (5MHz)	Value (10MHz)	
commRxPool(0)	sc-CP-Len			Normal		
	sc-Period			sf80		
	sc-TF-ResourceConfig	prb-Num		13	25	
		prb-Start		0	0	
		prb-End		24	49	
		offsetIndicator		0		
		subframeBitmap		11110000 00000000 00000000 00000000 00000000		
	data-CP-Len			Normal		
	dataHoppingConfig		hoppingParameter		504	
			numSubbands		ns2	
			rb-Offset		0	
	ue-SelectedResourceConfig	data-TF-ResourceConfig	prb-Num	13	25	
			prb-Start		0	0
			prb-End	24	49	
			offsetIndicator	0		
		subframeBitmap		00000000 11111111 00000000 11111111 00000000		
			trpt-Subset-r12		001	
	rxParametersNCell				not present	
	txParameters				not present	
commRxPool(1)	sc-CP-Len				Normal	
	sc-Period			sf80		
	sc-TF-ResourceConfig	prb-Num		13	25	
		prb-Start		0	0	
		prb-End		24	49	
		offsetIndicator		0		
		subframeBitmap		00001111 00000000 00000000 00000000 00000000		
	data-CP-Len			Normal		
	dataHoppingConfig		hoppingParameter		504	
			numSubbands		ns2	
			rb-Offset		0	
	ue-SelectedResourceConfig	data-TF-ResourceConfig	prb-Num	13	25	
			prb-Start		0	0
			prb-End	24	49	
			offsetIndicator	0		
		subframeBitmap		00000000 00000000 11111111 00000000 11111111		
			trpt-Subset-r12		001	
	rxParametersNCell				not present	
	txParameters				not present	
commTxPoolNormalCommon					not present	
SL-SyncConfig				not present		

Table A.7.2.1-5: ProSe Direct Communication configuration for E-UTRA FDD (Configuration #5-FDD)

Information Element / (BW configuration)				Value (5MHz)	Value (10MHz)
commRxPool	sc-CP-Len			Normal	
	sc-Period			sf40	
	sc-TF-ResourceConfig	prb-Num		13	25
		prb-Start		0	0
		prb-End		24	49
		offsetIndicator		0	
		subframeBitmap		00011000 00000000 00000000 00000000 00000000	
	data-CP-Len			Normal	
	dataHoppingConfig	hoppingParameter		504	
		numSubbands		ns2	
		rb-Offset		0	
	ue-SelectedResourceConfig	data-TF-ResourceConfig	prb-Num	13	25
			prb-Start		0
			prb-End	24	49
			offsetIndicator	0	
			subframeBitmap	00000000 11111111 11111111 11111111 11111111	
		trpt-Subset-r12		001	
	rxParametersNCell			not present	
	txParameters			not present	
commTxPoolNormalCommon				not present	
SL-SyncConfig				not present	

Annex B (normative): Propagation conditions

B.1 Static propagation condition

B.1.1 UE Receiver with 2Rx

For 1 port transmission the channel matrix is defined in the frequency domain by

$$\mathbf{H} = \begin{pmatrix} 1 \\ 1 \end{pmatrix}.$$

For 2 port transmission the channel matrix is defined in the frequency domain by

$$\mathbf{H} = \begin{pmatrix} 1 & j \\ 1 & -j \end{pmatrix}.$$

For 4 port transmission the channel matrix is defined in the frequency domain by

$$\mathbf{H} = \begin{bmatrix} 1 & 1 & j & j \\ 1 & 1 & -j & -j \end{bmatrix}$$

For 8 port transmission the channel matrix is defined in the frequency domain by

$$\mathbf{H} = \begin{bmatrix} 1 & 1 & 1 & 1 & j & j & j & j \\ 1 & 1 & 1 & 1 & -j & -j & -j & -j \end{bmatrix}$$

B.1.2 UE Receiver with 4Rx

For 1 port transmission the channel matrix is defined in the frequency domain by

$$\mathbf{H} = \begin{bmatrix} 1 \\ 1 \\ 1 \\ 1 \end{bmatrix}.$$

For 2 port transmission the channel matrix is defined in the frequency domain by

$$\mathbf{H} = \begin{bmatrix} 1 & j \\ 1 & -j \\ 1 & j \\ 1 & -j \end{bmatrix}.$$

For 4 port transmission the channel matrix is defined in the frequency domain by

$$\mathbf{H} = \begin{bmatrix} 1 & 1 & j & j \\ 1 & 1 & -j & -j \\ 1 & -1 & j & -j \\ 1 & -1 & -j & j \end{bmatrix}.$$

For 8 port transmission the channel matrix is defined in the frequency domain by

$$\mathbf{H} = \begin{bmatrix} 1 & 1 & 1 & 1 & j & j & j & j \\ 1 & 1 & 1 & 1 & -j & -j & -j & -j \\ 1 & 1 & -1 & -1 & j & j & -j & -j \\ 1 & 1 & -1 & -1 & -j & -j & j & j \end{bmatrix}$$

B.2 Multi-path fading propagation conditions

The multipath propagation conditions consist of several parts:

- A delay profile in the form of a "tapped delay-line", characterized by a number of taps at fixed positions on a sampling grid. The profile can be further characterized by the r.m.s. delay spread and the maximum delay spanned by the taps.
- A combination of channel model parameters that include the Delay profile and the Doppler spectrum, that is characterized by a classical spectrum shape and a maximum Doppler frequency
- A set of correlation matrices defining the correlation between the UE and eNodeB antennas in case of multi-antenna systems.
- Additional multi-path models used for CQI (Channel Quality Indication) tests

B.2.1 Delay profiles

The delay profiles are selected to be representative of low, medium and high delay spread environments. The resulting model parameters are defined in Table B.2.1-1 and the tapped delay line models are defined in Tables B.2.1-2, B.2.1-3 and B.2.1-4.

Table B.2.1-1 Delay profiles for E-UTRA channel models

Model	Number of channel taps	Delay spread (r.m.s.)	Maximum excess tap delay (span)
Extended Pedestrian A (EPA)	7	43 ns	410 ns
Extended Vehicular A model (EVA)	9	357 ns	2510 ns
Extended Typical Urban model (ETU)	9	991 ns	5000 ns

Table B.2.1-2 Extended Pedestrian A model (EPA)

Excess tap delay [ns]	Relative power [dB]
0	0.0
30	-1.0
70	-2.0
90	-3.0
110	-8.0
190	-17.2
410	-20.8

Table B.2.1-3 Extended Vehicular A model (EVA)

Excess tap delay [ns]	Relative power [dB]
0	0.0
30	-1.5
150	-1.4
310	-3.6
370	-0.6
710	-9.1
1090	-7.0
1730	-12.0
2510	-16.9

Table B.2.1-4 Extended Typical Urban model (ETU)

Excess tap delay [ns]	Relative power [dB]
0	-1.0
50	-1.0
120	-1.0
200	0.0
230	0.0
500	0.0
1600	-3.0
2300	-5.0
5000	-7.0

B.2.2 Combinations of channel model parameters

The propagation conditions used for the performance measurements in multi-path fading environment are indicated as EVA[number], EPA[number] or ETU[number] where ‘number’ indicates the maximum Doppler frequency (Hz).

Table B.2.2-1 Void

B.2.3 MIMO Channel Correlation Matrices

The MIMO channel correlation matrices defined in B.2.3 apply for the antenna configuration using uniform linear arrays at both eNodeB and UE.

B.2.3.1 Definition of MIMO Correlation Matrices

Table B.2.3.1-1 defines the correlation matrix for the eNodeB

Table B.2.3.1-1 eNodeB correlation matrix

	One antenna	Two antennas	Four antennas
eNode B Correlation	$R_{eNB} = 1$	$R_{eNB} = \begin{pmatrix} 1 & \alpha \\ \alpha^* & \mathbf{1} \end{pmatrix}$	$R_{eNB} = \begin{pmatrix} 1 & \alpha^{1/9} & \alpha^{4/9} & \alpha \\ \alpha^{1/9*} & 1 & \alpha^{1/9} & \alpha^{4/9} \\ \alpha^{4/9*} & \alpha^{1/9*} & 1 & \alpha^{1/9} \\ \alpha^* & \alpha^{4/9*} & \alpha^{1/9*} & 1 \end{pmatrix}$

Table B.2.3.1-2 defines the correlation matrix for the UE:

Table B.2.3.1-2 UE correlation matrix

	One antenna	Two antennas	Four antennas
UE Correlation	$R_{UE} = 1$	$R_{UE} = \begin{pmatrix} 1 & \beta \\ \beta^* & \mathbf{1} \end{pmatrix}$	$R_{UE} = \begin{pmatrix} 1 & \beta^{1/9} & \beta^{4/9} & \beta \\ \beta^{1/9*} & 1 & \beta^{1/9} & \beta^{4/9} \\ \beta^{4/9*} & \beta^{1/9*} & 1 & \beta^{1/9} \\ \beta^* & \beta^{4/9*} & \beta^{1/9*} & 1 \end{pmatrix}$

Table B.2.3.1-3 defines the channel spatial correlation matrix R_{spat} . The parameters, α and β in Table B.2.3.1-3 defines the spatial correlation between the antennas at the eNodeB and UE.

Table B.2.3.1-3: R_{spat} correlation matrices

1x2 case	$R_{spat} = R_{UE} = \begin{bmatrix} 1 & \beta \\ \beta^* & 1 \end{bmatrix}$
1x4 case	$R_{spat} = R_{UE} = \begin{pmatrix} 1 & \beta^{1/9} & \beta^{4/9} & \beta \\ \beta^{1/9*} & 1 & \beta^{1/9} & \beta^{4/9} \\ \beta^{4/9*} & \beta^{1/9*} & 1 & \beta^{1/9} \\ \beta^* & \beta^{4/9*} & \beta^{1/9*} & 1 \end{pmatrix}$
2x1 case	$R_{spat} = R_{eNB} = \begin{bmatrix} 1 & \alpha \\ \alpha^* & 1 \end{bmatrix}$
2x2 case	$R_{spat} = R_{eNB} \otimes R_{UE} = \begin{bmatrix} 1 & \alpha \\ \alpha^* & 1 \end{bmatrix} \otimes \begin{bmatrix} 1 & \beta \\ \beta^* & 1 \end{bmatrix} = \begin{bmatrix} 1 & \beta & \alpha & \alpha\beta \\ \beta^* & 1 & \alpha\beta^* & \alpha \\ \alpha^* & \alpha^*\beta & 1 & \beta \\ \alpha^*\beta^* & \alpha^* & \beta^* & 1 \end{bmatrix}$
2x4 case	$R_{spat} = R_{eNB} \otimes R_{UE} = \begin{bmatrix} 1 & \alpha \\ \alpha^* & 1 \end{bmatrix} \otimes \begin{pmatrix} 1 & \beta^{1/9} & \beta^{4/9} & \beta \\ \beta^{1/9*} & 1 & \beta^{1/9} & \beta^{4/9} \\ \beta^{4/9*} & \beta^{1/9*} & 1 & \beta^{1/9} \\ \beta^* & \beta^{4/9*} & \beta^{1/9*} & 1 \end{pmatrix}$
4x2 case	$R_{spat} = R_{eNB} \otimes R_{UE} = \begin{bmatrix} 1 & \alpha^{1/9} & \alpha^{4/9} & \alpha \\ \alpha^{1/9*} & 1 & \alpha^{1/9} & \alpha^{4/9} \\ \alpha^{4/9*} & \alpha^{1/9*} & 1 & \alpha^{1/9} \\ \alpha^* & \alpha^{4/9*} & \alpha^{1/9*} & 1 \end{bmatrix} \otimes \begin{bmatrix} 1 & \beta \\ \beta^* & 1 \end{bmatrix}$
4x4 case	$R_{spat} = R_{eNB} \otimes R_{UE} = \begin{bmatrix} 1 & \alpha^{1/9} & \alpha^{4/9} & \alpha \\ \alpha^{1/9*} & 1 & \alpha^{1/9} & \alpha^{4/9} \\ \alpha^{4/9*} & \alpha^{1/9*} & 1 & \alpha^{1/9} \\ \alpha^* & \alpha^{4/9*} & \alpha^{1/9*} & 1 \end{bmatrix} \otimes \begin{pmatrix} 1 & \beta^{1/9} & \beta^{4/9} & \beta \\ \beta^{1/9*} & 1 & \beta^{1/9} & \beta^{4/9} \\ \beta^{4/9*} & \beta^{1/9*} & 1 & \beta^{1/9} \\ \beta^* & \beta^{4/9*} & \beta^{1/9*} & 1 \end{pmatrix}$

For cases with more antennas at either eNodeB or UE or both, the channel spatial correlation matrix can still be expressed as the Kronecker product of R_{eNB} and R_{UE} according to $R_{spat} = R_{eNB} \otimes R_{UE}$.

B.2.3.2 MIMO Correlation Matrices at High, Medium and Low Level

The α and β for different correlation types are given in Table B.2.3.2-1.

Table B.2.3.2-1: The α and β parameters for ULA MIMO correlation matrices

Correlation Model	α	β
Low correlation	0	0
Medium Correlation	0.3	0.9
Medium Correlation A	0.3	0.3874
High Correlation	0.9	0.9

The correlation matrices for high, medium, low and medium A correlation are defined in Table B.2.3.1-2, B.2.3.2-3, B.2.3.2-4 and B.2.3.2-5 as below.

The values in Table B.2.3.2-2 have been adjusted for the 4x2 and 4x4 high correlation cases to insure the correlation matrix is positive semi-definite after round-off to 4 digit precision. This is done using the equation:

$$\mathbf{R}_{high} = [\mathbf{R}_{spatial} + a\mathbf{I}_n] / (1 + a)$$

Where the value “a” is a scaling factor such that the smallest value is used to obtain a positive semi-definite result. For the 4x2 high correlation case, a=0.00010. For the 4x4 high correlation case, a=0.00012.

The same method is used to adjust the 4x4 medium correlation matrix in Table B.2.3.2-3 to insure the correlation matrix is positive semi-definite after round-off to 4 digit precision with a = 0.00012.

Table B.2.3.2-2: MIMO correlation matrices for high correlation

1x2 case	$R_{high} = \begin{pmatrix} 1 & 0.9 \\ 0.9 & 1 \end{pmatrix}$																																																																																																																																																																																																																																																																	
2x1 case	$R_{high} = \begin{pmatrix} 1 & 0.9 \\ 0.9 & 1 \end{pmatrix}$																																																																																																																																																																																																																																																																	
2x2 case	$R_{high} = \begin{pmatrix} 1 & 0.9 & 0.9 & 0.81 \\ 0.9 & 1 & 0.81 & 0.9 \\ 0.9 & 0.81 & 1 & 0.9 \\ 0.81 & 0.9 & 0.9 & 1 \end{pmatrix}$																																																																																																																																																																																																																																																																	
4x2 case	$R_{high} =$	<table border="1"> <tr><td>1.0000</td><td>0.8999</td><td>0.9883</td><td>0.8894</td><td>0.9542</td><td>0.8587</td><td>0.8999</td><td>0.8099</td></tr> <tr><td>0.8999</td><td>1.0000</td><td>0.8894</td><td>0.9883</td><td>0.8587</td><td>0.9542</td><td>0.8099</td><td>0.8999</td></tr> <tr><td>0.9883</td><td>0.8894</td><td>1.0000</td><td>0.8999</td><td>0.9883</td><td>0.8894</td><td>0.9542</td><td>0.8587</td></tr> <tr><td>0.8894</td><td>0.9883</td><td>0.8999</td><td>1.0000</td><td>0.8894</td><td>0.9883</td><td>0.8587</td><td>0.9542</td></tr> <tr><td>0.9542</td><td>0.8587</td><td>0.9883</td><td>0.8894</td><td>1.0000</td><td>0.8999</td><td>0.9883</td><td>0.8894</td></tr> <tr><td>0.8587</td><td>0.9542</td><td>0.8894</td><td>0.9883</td><td>0.8999</td><td>1.0000</td><td>0.8894</td><td>0.9883</td></tr> <tr><td>0.8999</td><td>0.8099</td><td>0.9542</td><td>0.8587</td><td>0.9883</td><td>0.8894</td><td>1.0000</td><td>0.8999</td></tr> <tr><td>0.8099</td><td>0.8999</td><td>0.8587</td><td>0.9542</td><td>0.8894</td><td>0.9883</td><td>0.8999</td><td>1.0000</td></tr> </table>	1.0000	0.8999	0.9883	0.8894	0.9542	0.8587	0.8999	0.8099	0.8999	1.0000	0.8894	0.9883	0.8587	0.9542	0.8099	0.8999	0.9883	0.8894	1.0000	0.8999	0.9883	0.8894	0.9542	0.8587	0.8894	0.9883	0.8999	1.0000	0.8894	0.9883	0.8587	0.9542	0.9542	0.8587	0.9883	0.8894	1.0000	0.8999	0.9883	0.8894	0.8587	0.9542	0.8894	0.9883	0.8999	1.0000	0.8894	0.9883	0.8999	0.8099	0.9542	0.8587	0.9883	0.8894	1.0000	0.8999	0.8099	0.8999	0.8587	0.9542	0.8894	0.9883	0.8999	1.0000																																																																																																																																																																																																
1.0000	0.8999	0.9883	0.8894	0.9542	0.8587	0.8999	0.8099																																																																																																																																																																																																																																																											
0.8999	1.0000	0.8894	0.9883	0.8587	0.9542	0.8099	0.8999																																																																																																																																																																																																																																																											
0.9883	0.8894	1.0000	0.8999	0.9883	0.8894	0.9542	0.8587																																																																																																																																																																																																																																																											
0.8894	0.9883	0.8999	1.0000	0.8894	0.9883	0.8587	0.9542																																																																																																																																																																																																																																																											
0.9542	0.8587	0.9883	0.8894	1.0000	0.8999	0.9883	0.8894																																																																																																																																																																																																																																																											
0.8587	0.9542	0.8894	0.9883	0.8999	1.0000	0.8894	0.9883																																																																																																																																																																																																																																																											
0.8999	0.8099	0.9542	0.8587	0.9883	0.8894	1.0000	0.8999																																																																																																																																																																																																																																																											
0.8099	0.8999	0.8587	0.9542	0.8894	0.9883	0.8999	1.0000																																																																																																																																																																																																																																																											
4x4 case	$R_{high} =$	<table border="1"> <tr><td>1.0000</td><td>0.9882</td><td>0.9541</td><td>0.8999</td><td>0.9882</td><td>0.9767</td><td>0.9430</td><td>0.8894</td><td>0.9541</td><td>0.9430</td><td>0.9105</td><td>0.8587</td><td>0.8999</td><td>0.8894</td><td>0.8587</td><td>0.8099</td></tr> <tr><td>0.9882</td><td>1.0000</td><td>0.9882</td><td>0.9541</td><td>0.9767</td><td>0.9882</td><td>0.9767</td><td>0.9430</td><td>0.9430</td><td>0.9541</td><td>0.9430</td><td>0.9105</td><td>0.8894</td><td>0.8999</td><td>0.8894</td><td>0.8587</td></tr> <tr><td>0.9541</td><td>0.9882</td><td>1.0000</td><td>0.9882</td><td>0.9430</td><td>0.9767</td><td>0.9882</td><td>0.9767</td><td>0.9105</td><td>0.9430</td><td>0.9541</td><td>0.9430</td><td>0.8587</td><td>0.8894</td><td>0.8999</td><td>0.8894</td></tr> <tr><td>0.8999</td><td>0.9541</td><td>0.9882</td><td>1.0000</td><td>0.8894</td><td>0.9430</td><td>0.9767</td><td>0.9882</td><td>0.8587</td><td>0.9105</td><td>0.9430</td><td>0.9541</td><td>0.8099</td><td>0.8587</td><td>0.8894</td><td>0.8999</td></tr> <tr><td>0.9882</td><td>0.9767</td><td>0.9430</td><td>0.8894</td><td>1.0000</td><td>0.9882</td><td>0.9541</td><td>0.8999</td><td>0.9882</td><td>0.9767</td><td>0.9430</td><td>0.8894</td><td>0.9541</td><td>0.9430</td><td>0.9105</td><td>0.8587</td></tr> <tr><td>0.9767</td><td>0.9882</td><td>0.9767</td><td>0.9430</td><td>0.9882</td><td>1.0000</td><td>0.9882</td><td>0.9541</td><td>0.9767</td><td>0.9882</td><td>0.9767</td><td>0.9430</td><td>0.9430</td><td>0.9541</td><td>0.9430</td><td>0.9105</td></tr> <tr><td>0.9430</td><td>0.9767</td><td>0.9882</td><td>0.9767</td><td>0.9541</td><td>0.9882</td><td>1.0000</td><td>0.9882</td><td>0.9430</td><td>0.9767</td><td>0.9882</td><td>0.9767</td><td>0.9105</td><td>0.9430</td><td>0.9541</td><td>0.9430</td></tr> <tr><td>0.8894</td><td>0.9430</td><td>0.9767</td><td>0.9882</td><td>0.8999</td><td>0.9541</td><td>0.9882</td><td>1.0000</td><td>0.8894</td><td>0.9430</td><td>0.9767</td><td>0.9882</td><td>0.8587</td><td>0.9105</td><td>0.9430</td><td>0.9541</td></tr> <tr><td>0.9541</td><td>0.9430</td><td>0.9105</td><td>0.8587</td><td>0.9882</td><td>0.9767</td><td>0.9430</td><td>0.8894</td><td>1.0000</td><td>0.9882</td><td>0.9541</td><td>0.8999</td><td>0.9882</td><td>0.9767</td><td>0.9430</td><td>0.8894</td></tr> <tr><td>0.9430</td><td>0.9541</td><td>0.9430</td><td>0.9105</td><td>0.9767</td><td>0.9882</td><td>0.9767</td><td>0.9430</td><td>0.9882</td><td>1.0000</td><td>0.9882</td><td>0.9541</td><td>0.9767</td><td>0.9882</td><td>0.9767</td><td>0.9430</td></tr> <tr><td>0.9105</td><td>0.9430</td><td>0.9541</td><td>0.9430</td><td>0.9430</td><td>0.9767</td><td>0.9882</td><td>0.9767</td><td>0.9541</td><td>0.9882</td><td>1.0000</td><td>0.9882</td><td>0.9430</td><td>0.9767</td><td>0.9882</td><td>0.9767</td></tr> <tr><td>0.8587</td><td>0.9105</td><td>0.9430</td><td>0.9541</td><td>0.8894</td><td>0.9430</td><td>0.9767</td><td>0.9882</td><td>0.8999</td><td>0.9541</td><td>0.9882</td><td>1.0000</td><td>0.8894</td><td>0.9430</td><td>0.9767</td><td>0.9882</td></tr> <tr><td>0.8999</td><td>0.8894</td><td>0.8587</td><td>0.8099</td><td>0.9541</td><td>0.9430</td><td>0.9105</td><td>0.8587</td><td>0.9882</td><td>0.9767</td><td>0.9430</td><td>0.8894</td><td>1.0000</td><td>0.9882</td><td>0.9541</td><td>0.8999</td></tr> <tr><td>0.8894</td><td>0.8999</td><td>0.8894</td><td>0.8587</td><td>0.9430</td><td>0.9541</td><td>0.9430</td><td>0.9105</td><td>0.9767</td><td>0.9882</td><td>0.9767</td><td>0.9430</td><td>0.9882</td><td>1.0000</td><td>0.9882</td><td>0.9541</td></tr> <tr><td>0.8587</td><td>0.8894</td><td>0.8999</td><td>0.8894</td><td>0.9105</td><td>0.9430</td><td>0.9541</td><td>0.9430</td><td>0.9430</td><td>0.9767</td><td>0.9882</td><td>0.9767</td><td>0.9541</td><td>0.9882</td><td>1.0000</td><td>0.9882</td></tr> <tr><td>0.8099</td><td>0.8587</td><td>0.8894</td><td>0.8999</td><td>0.8587</td><td>0.9105</td><td>0.9430</td><td>0.9541</td><td>0.8894</td><td>0.9430</td><td>0.9767</td><td>0.9882</td><td>0.8999</td><td>0.9541</td><td>0.9882</td><td>1.0000</td></tr> </table>	1.0000	0.9882	0.9541	0.8999	0.9882	0.9767	0.9430	0.8894	0.9541	0.9430	0.9105	0.8587	0.8999	0.8894	0.8587	0.8099	0.9882	1.0000	0.9882	0.9541	0.9767	0.9882	0.9767	0.9430	0.9430	0.9541	0.9430	0.9105	0.8894	0.8999	0.8894	0.8587	0.9541	0.9882	1.0000	0.9882	0.9430	0.9767	0.9882	0.9767	0.9105	0.9430	0.9541	0.9430	0.8587	0.8894	0.8999	0.8894	0.8999	0.9541	0.9882	1.0000	0.8894	0.9430	0.9767	0.9882	0.8587	0.9105	0.9430	0.9541	0.8099	0.8587	0.8894	0.8999	0.9882	0.9767	0.9430	0.8894	1.0000	0.9882	0.9541	0.8999	0.9882	0.9767	0.9430	0.8894	0.9541	0.9430	0.9105	0.8587	0.9767	0.9882	0.9767	0.9430	0.9882	1.0000	0.9882	0.9541	0.9767	0.9882	0.9767	0.9430	0.9430	0.9541	0.9430	0.9105	0.9430	0.9767	0.9882	0.9767	0.9541	0.9882	1.0000	0.9882	0.9430	0.9767	0.9882	0.9767	0.9105	0.9430	0.9541	0.9430	0.8894	0.9430	0.9767	0.9882	0.8999	0.9541	0.9882	1.0000	0.8894	0.9430	0.9767	0.9882	0.8587	0.9105	0.9430	0.9541	0.9541	0.9430	0.9105	0.8587	0.9882	0.9767	0.9430	0.8894	1.0000	0.9882	0.9541	0.8999	0.9882	0.9767	0.9430	0.8894	0.9430	0.9541	0.9430	0.9105	0.9767	0.9882	0.9767	0.9430	0.9882	1.0000	0.9882	0.9541	0.9767	0.9882	0.9767	0.9430	0.9105	0.9430	0.9541	0.9430	0.9430	0.9767	0.9882	0.9767	0.9541	0.9882	1.0000	0.9882	0.9430	0.9767	0.9882	0.9767	0.8587	0.9105	0.9430	0.9541	0.8894	0.9430	0.9767	0.9882	0.8999	0.9541	0.9882	1.0000	0.8894	0.9430	0.9767	0.9882	0.8999	0.8894	0.8587	0.8099	0.9541	0.9430	0.9105	0.8587	0.9882	0.9767	0.9430	0.8894	1.0000	0.9882	0.9541	0.8999	0.8894	0.8999	0.8894	0.8587	0.9430	0.9541	0.9430	0.9105	0.9767	0.9882	0.9767	0.9430	0.9882	1.0000	0.9882	0.9541	0.8587	0.8894	0.8999	0.8894	0.9105	0.9430	0.9541	0.9430	0.9430	0.9767	0.9882	0.9767	0.9541	0.9882	1.0000	0.9882	0.8099	0.8587	0.8894	0.8999	0.8587	0.9105	0.9430	0.9541	0.8894	0.9430	0.9767	0.9882	0.8999	0.9541	0.9882	1.0000
1.0000	0.9882	0.9541	0.8999	0.9882	0.9767	0.9430	0.8894	0.9541	0.9430	0.9105	0.8587	0.8999	0.8894	0.8587	0.8099																																																																																																																																																																																																																																																			
0.9882	1.0000	0.9882	0.9541	0.9767	0.9882	0.9767	0.9430	0.9430	0.9541	0.9430	0.9105	0.8894	0.8999	0.8894	0.8587																																																																																																																																																																																																																																																			
0.9541	0.9882	1.0000	0.9882	0.9430	0.9767	0.9882	0.9767	0.9105	0.9430	0.9541	0.9430	0.8587	0.8894	0.8999	0.8894																																																																																																																																																																																																																																																			
0.8999	0.9541	0.9882	1.0000	0.8894	0.9430	0.9767	0.9882	0.8587	0.9105	0.9430	0.9541	0.8099	0.8587	0.8894	0.8999																																																																																																																																																																																																																																																			
0.9882	0.9767	0.9430	0.8894	1.0000	0.9882	0.9541	0.8999	0.9882	0.9767	0.9430	0.8894	0.9541	0.9430	0.9105	0.8587																																																																																																																																																																																																																																																			
0.9767	0.9882	0.9767	0.9430	0.9882	1.0000	0.9882	0.9541	0.9767	0.9882	0.9767	0.9430	0.9430	0.9541	0.9430	0.9105																																																																																																																																																																																																																																																			
0.9430	0.9767	0.9882	0.9767	0.9541	0.9882	1.0000	0.9882	0.9430	0.9767	0.9882	0.9767	0.9105	0.9430	0.9541	0.9430																																																																																																																																																																																																																																																			
0.8894	0.9430	0.9767	0.9882	0.8999	0.9541	0.9882	1.0000	0.8894	0.9430	0.9767	0.9882	0.8587	0.9105	0.9430	0.9541																																																																																																																																																																																																																																																			
0.9541	0.9430	0.9105	0.8587	0.9882	0.9767	0.9430	0.8894	1.0000	0.9882	0.9541	0.8999	0.9882	0.9767	0.9430	0.8894																																																																																																																																																																																																																																																			
0.9430	0.9541	0.9430	0.9105	0.9767	0.9882	0.9767	0.9430	0.9882	1.0000	0.9882	0.9541	0.9767	0.9882	0.9767	0.9430																																																																																																																																																																																																																																																			
0.9105	0.9430	0.9541	0.9430	0.9430	0.9767	0.9882	0.9767	0.9541	0.9882	1.0000	0.9882	0.9430	0.9767	0.9882	0.9767																																																																																																																																																																																																																																																			
0.8587	0.9105	0.9430	0.9541	0.8894	0.9430	0.9767	0.9882	0.8999	0.9541	0.9882	1.0000	0.8894	0.9430	0.9767	0.9882																																																																																																																																																																																																																																																			
0.8999	0.8894	0.8587	0.8099	0.9541	0.9430	0.9105	0.8587	0.9882	0.9767	0.9430	0.8894	1.0000	0.9882	0.9541	0.8999																																																																																																																																																																																																																																																			
0.8894	0.8999	0.8894	0.8587	0.9430	0.9541	0.9430	0.9105	0.9767	0.9882	0.9767	0.9430	0.9882	1.0000	0.9882	0.9541																																																																																																																																																																																																																																																			
0.8587	0.8894	0.8999	0.8894	0.9105	0.9430	0.9541	0.9430	0.9430	0.9767	0.9882	0.9767	0.9541	0.9882	1.0000	0.9882																																																																																																																																																																																																																																																			
0.8099	0.8587	0.8894	0.8999	0.8587	0.9105	0.9430	0.9541	0.8894	0.9430	0.9767	0.9882	0.8999	0.9541	0.9882	1.0000																																																																																																																																																																																																																																																			

Table B.2.3.2-3: MIMO correlation matrices for medium correlation

1x2 case	N/A
2x1 case	N/A
2x2 case	$R_{medium} = \begin{pmatrix} 1 & 0.9 & 0.3 & 0.27 \\ 0.9 & 1 & 0.27 & 0.3 \\ 0.3 & 0.27 & 1 & 0.9 \\ 0.27 & 0.3 & 0.9 & 1 \end{pmatrix}$
4x2 case	$R_{medium} = \begin{pmatrix} 1.0000 & 0.9000 & 0.8748 & 0.7873 & 0.5856 & 0.5271 & 0.3000 & 0.2700 \\ 0.9000 & 1.0000 & 0.7873 & 0.8748 & 0.5271 & 0.5856 & 0.2700 & 0.3000 \\ 0.8748 & 0.7873 & 1.0000 & 0.9000 & 0.8748 & 0.7873 & 0.5856 & 0.5271 \\ 0.7873 & 0.8748 & 0.9000 & 1.0000 & 0.7873 & 0.8748 & 0.5271 & 0.5856 \\ 0.5856 & 0.5271 & 0.8748 & 0.7873 & 1.0000 & 0.9000 & 0.8748 & 0.7873 \\ 0.5271 & 0.5856 & 0.7873 & 0.8748 & 0.9000 & 1.0000 & 0.7873 & 0.8748 \\ 0.3000 & 0.2700 & 0.5856 & 0.5271 & 0.8748 & 0.7873 & 1.0000 & 0.9000 \\ 0.2700 & 0.3000 & 0.5271 & 0.5856 & 0.7873 & 0.8748 & 0.9000 & 1.0000 \end{pmatrix}$
4x4 case	$R_{medium} = \begin{pmatrix} 1.0000 & 0.9882 & 0.9541 & 0.8999 & 0.8747 & 0.8645 & 0.8347 & 0.7872 & 0.5855 & 0.5787 & 0.5588 & 0.5270 & 0.3000 & 0.2965 & 0.2862 & 0.2700 \\ 0.9882 & 1.0000 & 0.9882 & 0.9541 & 0.8645 & 0.8747 & 0.8645 & 0.8347 & 0.5787 & 0.5855 & 0.5787 & 0.5588 & 0.2965 & 0.3000 & 0.2965 & 0.2862 \\ 0.9541 & 0.9882 & 1.0000 & 0.9882 & 0.8347 & 0.8645 & 0.8747 & 0.8645 & 0.5588 & 0.5787 & 0.5855 & 0.5787 & 0.2862 & 0.2965 & 0.3000 & 0.2965 \\ 0.8999 & 0.9541 & 0.9882 & 1.0000 & 0.7872 & 0.8347 & 0.8645 & 0.8747 & 0.5270 & 0.5588 & 0.5787 & 0.5855 & 0.2700 & 0.2862 & 0.2965 & 0.3000 \\ 0.8747 & 0.8645 & 0.8347 & 0.7872 & 1.0000 & 0.9882 & 0.9541 & 0.8999 & 0.8747 & 0.8645 & 0.8347 & 0.7872 & 0.5855 & 0.5787 & 0.5588 & 0.5270 \\ 0.8645 & 0.8747 & 0.8645 & 0.8347 & 0.9882 & 1.0000 & 0.9882 & 0.9541 & 0.8645 & 0.8747 & 0.8645 & 0.8347 & 0.5787 & 0.5855 & 0.5787 & 0.5588 \\ 0.8347 & 0.8645 & 0.8747 & 0.8645 & 0.9541 & 0.9882 & 1.0000 & 0.9882 & 0.8347 & 0.8645 & 0.8747 & 0.8645 & 0.5588 & 0.5787 & 0.5855 & 0.5787 \\ 0.7872 & 0.8347 & 0.8645 & 0.8747 & 0.8999 & 0.9541 & 0.9882 & 1.0000 & 0.7872 & 0.8347 & 0.8645 & 0.8747 & 0.5270 & 0.5588 & 0.5787 & 0.5855 \\ 0.5855 & 0.5787 & 0.5588 & 0.5270 & 0.8747 & 0.8645 & 0.8347 & 0.7872 & 1.0000 & 0.9882 & 0.9541 & 0.8999 & 0.8747 & 0.8645 & 0.8347 & 0.7872 \\ 0.5787 & 0.5855 & 0.5787 & 0.5588 & 0.8645 & 0.8747 & 0.8645 & 0.8347 & 0.9882 & 1.0000 & 0.9882 & 0.9541 & 0.8645 & 0.8747 & 0.8645 & 0.8347 \\ 0.5588 & 0.5787 & 0.5855 & 0.5787 & 0.8347 & 0.8645 & 0.8747 & 0.8645 & 0.9541 & 0.9882 & 1.0000 & 0.9882 & 0.8347 & 0.8645 & 0.8747 & 0.8645 \\ 0.5270 & 0.5588 & 0.5787 & 0.5855 & 0.7872 & 0.8347 & 0.8645 & 0.8747 & 0.8999 & 0.9541 & 0.9882 & 1.0000 & 0.7872 & 0.8347 & 0.8645 & 0.8747 \\ 0.3000 & 0.2965 & 0.2862 & 0.2700 & 0.5855 & 0.5787 & 0.5588 & 0.5270 & 0.8747 & 0.8645 & 0.8347 & 0.7872 & 1.0000 & 0.9882 & 0.9541 & 0.8999 \\ 0.2965 & 0.3000 & 0.2965 & 0.2862 & 0.5787 & 0.5855 & 0.5787 & 0.5588 & 0.8645 & 0.8747 & 0.8645 & 0.8347 & 0.9882 & 1.0000 & 0.9882 & 0.9541 \\ 0.2862 & 0.2965 & 0.3000 & 0.2965 & 0.5588 & 0.5787 & 0.5855 & 0.5787 & 0.8347 & 0.8645 & 0.8747 & 0.8645 & 0.9541 & 0.9882 & 1.0000 & 0.9882 \\ 0.2700 & 0.2862 & 0.2965 & 0.3000 & 0.5270 & 0.5588 & 0.5787 & 0.5855 & 0.7872 & 0.8347 & 0.8645 & 0.8747 & 0.8999 & 0.9541 & 0.9882 & 1.0000 \end{pmatrix}$

Table B.2.3.2-4: MIMO correlation matrices for low correlation

1x2 case	$R_{low} = \mathbf{I}_2$
1x4 case	$R_{low} = \mathbf{I}_4$
2x1 case	$R_{low} = \mathbf{I}_2$
2x2 case	$R_{low} = \mathbf{I}_4$
2x4 case	$R_{low} = \mathbf{I}_8$
4x2 case	$R_{low} = \mathbf{I}_8$
4x4 case	$R_{low} = \mathbf{I}_{16}$

In Table B.2.3.2-4, \mathbf{I}_d is the $d \times d$ identity matrix.

Table B.2.3.2-5: MIMO correlation matrices for medium correlation A

2x4 case	$R_{Medium A} =$	1.0000	0.9000	0.6561	0.3874	0.3000	0.2700	0.1968	0.1162
		0.9000	1.0000	0.9000	0.6561	0.2700	0.3000	0.2700	0.1968
		0.6561	0.9000	1.0000	0.9000	0.1968	0.2700	0.3000	0.2700
		0.3874	0.6561	0.9000	1.0000	0.1162	0.1968	0.2700	0.3000
		0.3000	0.2700	0.1968	0.1162	1.0000	0.9000	0.6561	0.3874
		0.2700	0.3000	0.2700	0.1968	0.9000	1.0000	0.9000	0.6561
		0.1968	0.2700	0.3000	0.2700	0.6561	0.9000	1.0000	0.9000
		0.1162	0.1968	0.2700	0.3000	0.3874	0.6561	0.9000	1.0000

B.2.3A MIMO Channel Correlation Matrices using cross polarized antennas

The MIMO channel correlation matrices defined in B.2.3A apply for the antenna configuration using cross polarized (XP/X-pol) antennas at both eNodeB and UE. The cross-polarized antenna elements with +/-45 degrees polarization slant angles are deployed at eNB and cross-polarized antenna elements with +90/0 degrees polarization slant angles are deployed at UE.

For the cross-polarized antennas, the N antennas are labelled such that antennas for one polarization are listed from 1 to N/2 and antennas for the other polarization are listed from N/2+1 to N, where N is the number of transmit or receive antennas.

B.2.3A.1 Definition of MIMO Correlation Matrices using cross polarized antennas

For the channel spatial correlation matrix, the following is used:

$$R_{spat} = P(R_{eNB} \otimes \Gamma \otimes R_{UE})P^T$$

where

- R_{UE} is the spatial correlation matrix at the UE with same polarization,
- R_{eNB} is the spatial correlation matrix at the eNB with same polarization,
- Γ is a polarization correlation matrix, and
- $(\bullet)^T$ denotes transpose.

The matrix Γ is defined as

$$\Gamma = \begin{bmatrix} 1 & 0 & -\gamma & 0 \\ 0 & 1 & 0 & \gamma \\ -\gamma & 0 & 1 & 0 \\ 0 & \gamma & 0 & 1 \end{bmatrix}$$

A permutation matrix P elements are defined as

$$P(a,b) = \begin{cases} 1 & \text{for } a = (j-1)Nr + i \text{ and } b = 2(j-1)Nr + i, & i = 1, \dots, Nr, j = 1, \dots, Nt/2 \\ 1 & \text{for } a = (j-1)Nr + i \text{ and } b = 2(j - Nt/2)Nr - Nr + i, & i = 1, \dots, Nr, j = Nt/2 + 1, \dots, Nt \\ 0 & \text{otherwise} \end{cases}$$

where N_t and N_r is the number of transmitter and receiver respectively. This is used to map the spatial correlation coefficients in accordance with the antenna element labelling system described in B.2.3A.

B.2.3A.2 Spatial Correlation Matrices using cross polarized antennas at eNB and UE sides

B.2.3A.2.1 Spatial Correlation Matrices at eNB side

For 2-antenna transmitter using one pair of cross-polarized antenna elements, $R_{eNB} = 1$.

For 4-antenna transmitter using two pairs of cross-polarized antenna elements, $R_{eNB} = \begin{pmatrix} 1 & \alpha \\ \alpha^* & 1 \end{pmatrix}$.

For 8-antenna transmitter using four pairs of cross-polarized antenna elements, $R_{eNB} = \begin{pmatrix} 1 & \alpha^{1/9} & \alpha^{4/9} & \alpha \\ \alpha^{1/9*} & 1 & \alpha^{1/9} & \alpha^{4/9} \\ \alpha^{4/9*} & \alpha^{1/9*} & 1 & \alpha^{1/9} \\ \alpha^* & \alpha^{4/9*} & \alpha^{1/9*} & 1 \end{pmatrix}$.

B.2.3A.2.2 Spatial Correlation Matrices at UE side

For 2-antenna receiver using one pair of cross-polarized antenna elements, $R_{UE} = 1$.

For 4-antenna receiver using two pairs of cross-polarized antenna elements, $R_{UE} = \begin{pmatrix} 1 & \beta \\ \beta^* & 1 \end{pmatrix}$.

B.2.3A.3 MIMO Correlation Matrices using cross polarized antennas

The values for parameters α , β and γ for the cross polarized antenna models are given in Table B.2.3A.3-1.

Table B.2.3A.3-1: : The α and β parameters for cross-polarized MIMO correlation matrices

Correlation Model	α	β	γ
Medium Correlation A	0.3	0.6	0.2
High Correlation	0.9	0.9	0.3
Note 1:	Value of α applies when more than one pair of cross-polarized antenna elements at eNB side.		
Note 2:	Value of β applies when more than one pair of cross-polarized antenna elements at UE side.		

The correlation matrices for high spatial correlation and medium correlation A are defined in Table B.2.3A.3-2 and Table B.2.3A.3-3 as below.

The values in Table B.2.3A.3-2 have been adjusted to insure the correlation matrix is positive semi-definite after round-off to 4 digit precision. This is done using the equation:

$$\mathbf{R}_{high} = [\mathbf{R}_{spat} + a\mathbf{I}_n]/(1+a)$$

Where the value “a” is a scaling factor such that the smallest value is used to obtain a positive semi-definite result. For the 8x2 high spatial correlation case, a=0.00010.

Table B.2.3A.3-2: MIMO correlation matrices for high spatial correlation

<p>4x2 case</p>	$R_{high} =$	<table border="1"> <tr><td>1.0000</td><td>0.0000</td><td>0.9000</td><td>0.0000</td><td>-0.3000</td><td>0.0000</td><td>-0.2700</td><td>0.0000</td></tr> <tr><td>0.0000</td><td>1.0000</td><td>0.0000</td><td>0.9000</td><td>0.0000</td><td>0.3000</td><td>0.0000</td><td>0.2700</td></tr> <tr><td>0.9000</td><td>0.0000</td><td>1.0000</td><td>0.0000</td><td>-0.2700</td><td>0.0000</td><td>-0.3000</td><td>0.0000</td></tr> <tr><td>0.0000</td><td>0.9000</td><td>0.0000</td><td>1.0000</td><td>0.0000</td><td>0.2700</td><td>0.0000</td><td>0.3000</td></tr> <tr><td>-0.3000</td><td>0.0000</td><td>-0.2700</td><td>0.0000</td><td>1.0000</td><td>0.0000</td><td>0.9000</td><td>0.0000</td></tr> <tr><td>0.0000</td><td>0.3000</td><td>0.0000</td><td>0.2700</td><td>0.0000</td><td>1.0000</td><td>0.0000</td><td>0.9000</td></tr> <tr><td>-0.2700</td><td>0.0000</td><td>-0.3000</td><td>0.0000</td><td>0.9000</td><td>0.0000</td><td>1.0000</td><td>0.0000</td></tr> <tr><td>0.0000</td><td>0.2700</td><td>0.0000</td><td>0.3000</td><td>0.0000</td><td>0.9000</td><td>0.0000</td><td>1.0000</td></tr> </table>	1.0000	0.0000	0.9000	0.0000	-0.3000	0.0000	-0.2700	0.0000	0.0000	1.0000	0.0000	0.9000	0.0000	0.3000	0.0000	0.2700	0.9000	0.0000	1.0000	0.0000	-0.2700	0.0000	-0.3000	0.0000	0.0000	0.9000	0.0000	1.0000	0.0000	0.2700	0.0000	0.3000	-0.3000	0.0000	-0.2700	0.0000	1.0000	0.0000	0.9000	0.0000	0.0000	0.3000	0.0000	0.2700	0.0000	1.0000	0.0000	0.9000	-0.2700	0.0000	-0.3000	0.0000	0.9000	0.0000	1.0000	0.0000	0.0000	0.2700	0.0000	0.3000	0.0000	0.9000	0.0000	1.0000																																																																																																																																																																																																	
		1.0000	0.0000	0.9000	0.0000	-0.3000	0.0000	-0.2700	0.0000																																																																																																																																																																																																																																																										
		0.0000	1.0000	0.0000	0.9000	0.0000	0.3000	0.0000	0.2700																																																																																																																																																																																																																																																										
		0.9000	0.0000	1.0000	0.0000	-0.2700	0.0000	-0.3000	0.0000																																																																																																																																																																																																																																																										
		0.0000	0.9000	0.0000	1.0000	0.0000	0.2700	0.0000	0.3000																																																																																																																																																																																																																																																										
		-0.3000	0.0000	-0.2700	0.0000	1.0000	0.0000	0.9000	0.0000																																																																																																																																																																																																																																																										
		0.0000	0.3000	0.0000	0.2700	0.0000	1.0000	0.0000	0.9000																																																																																																																																																																																																																																																										
		-0.2700	0.0000	-0.3000	0.0000	0.9000	0.0000	1.0000	0.0000																																																																																																																																																																																																																																																										
0.0000	0.2700	0.0000	0.3000	0.0000	0.9000	0.0000	1.0000																																																																																																																																																																																																																																																												
<p>8x2 case</p>	$R_{high} =$	<table border="1"> <tr><td>1.0000</td><td>0.0000</td><td>0.9883</td><td>0.0000</td><td>0.9542</td><td>0.0000</td><td>0.8999</td><td>0.0000</td><td>-0.3000</td><td>0.0000</td><td>-0.2965</td><td>0.0000</td><td>-0.2862</td><td>0.0000</td><td>-0.2700</td><td>0.0000</td></tr> <tr><td>0.0000</td><td>1.0000</td><td>0.0000</td><td>0.9883</td><td>0.0000</td><td>0.9542</td><td>0.0000</td><td>0.8999</td><td>0.0000</td><td>0.3000</td><td>0.0000</td><td>0.2965</td><td>0.0000</td><td>0.2862</td><td>0.0000</td><td>0.2700</td></tr> <tr><td>0.9883</td><td>0.0000</td><td>1.0000</td><td>0.0000</td><td>0.9883</td><td>0.0000</td><td>0.9542</td><td>0.0000</td><td>-0.2965</td><td>0.0000</td><td>-0.3000</td><td>0.0000</td><td>-0.2965</td><td>0.0000</td><td>-0.2862</td><td>0.0000</td></tr> <tr><td>0.0000</td><td>0.9883</td><td>0.0000</td><td>1.0000</td><td>0.0000</td><td>0.9883</td><td>0.0000</td><td>0.9542</td><td>0.0000</td><td>0.2965</td><td>0.0000</td><td>0.3000</td><td>0.0000</td><td>0.2965</td><td>0.0000</td><td>0.2862</td></tr> <tr><td>0.9542</td><td>0.0000</td><td>0.9883</td><td>0.0000</td><td>1.0000</td><td>0.0000</td><td>0.9883</td><td>0.0000</td><td>-0.2862</td><td>0.0000</td><td>-0.2965</td><td>0.0000</td><td>-0.3000</td><td>0.0000</td><td>-0.2965</td><td>0.0000</td></tr> <tr><td>0.0000</td><td>0.9542</td><td>0.0000</td><td>0.9883</td><td>0.0000</td><td>1.0000</td><td>0.0000</td><td>0.9883</td><td>0.0000</td><td>0.2862</td><td>0.0000</td><td>0.2965</td><td>0.0000</td><td>0.3000</td><td>0.0000</td><td>0.2965</td></tr> <tr><td>0.8999</td><td>0.0000</td><td>0.9542</td><td>0.0000</td><td>0.9883</td><td>0.0000</td><td>1.0000</td><td>0.0000</td><td>-0.2700</td><td>0.0000</td><td>-0.2862</td><td>0.0000</td><td>-0.2965</td><td>0.0000</td><td>-0.3000</td><td>0.0000</td></tr> <tr><td>0.0000</td><td>0.8999</td><td>0.0000</td><td>0.9542</td><td>0.0000</td><td>0.9883</td><td>0.0000</td><td>1.0000</td><td>0.0000</td><td>0.2700</td><td>0.0000</td><td>0.2862</td><td>0.0000</td><td>0.2965</td><td>0.0000</td><td>0.3000</td></tr> <tr><td>-0.3000</td><td>0.0000</td><td>-0.2965</td><td>0.0000</td><td>-0.2862</td><td>0.0000</td><td>-0.2700</td><td>0.0000</td><td>1.0000</td><td>0.0000</td><td>0.9883</td><td>0.0000</td><td>0.9542</td><td>0.0000</td><td>0.8999</td><td>0.0000</td></tr> <tr><td>0.0000</td><td>0.3000</td><td>0.0000</td><td>0.2965</td><td>0.0000</td><td>0.2862</td><td>0.0000</td><td>0.2700</td><td>0.0000</td><td>1.0000</td><td>0.0000</td><td>0.9883</td><td>0.0000</td><td>0.9542</td><td>0.0000</td><td>0.8999</td></tr> <tr><td>-0.2965</td><td>0.0000</td><td>-0.3000</td><td>0.0000</td><td>-0.2965</td><td>0.0000</td><td>-0.2862</td><td>0.0000</td><td>0.9883</td><td>0.0000</td><td>1.0000</td><td>0.0000</td><td>0.9883</td><td>0.0000</td><td>0.9542</td><td>0.0000</td></tr> <tr><td>0.0000</td><td>0.2965</td><td>0.0000</td><td>0.3000</td><td>0.0000</td><td>0.2965</td><td>0.0000</td><td>0.2862</td><td>0.0000</td><td>0.9883</td><td>0.0000</td><td>1.0000</td><td>0.0000</td><td>0.9883</td><td>0.0000</td><td>0.9542</td></tr> <tr><td>-0.2862</td><td>0.0000</td><td>-0.2965</td><td>0.0000</td><td>-0.3000</td><td>0.0000</td><td>-0.2965</td><td>0.0000</td><td>0.9542</td><td>0.0000</td><td>0.9883</td><td>0.0000</td><td>1.0000</td><td>0.0000</td><td>0.9883</td><td>0.0000</td></tr> <tr><td>0.0000</td><td>0.2862</td><td>0.0000</td><td>0.2965</td><td>0.0000</td><td>0.3000</td><td>0.0000</td><td>0.2965</td><td>0.0000</td><td>0.9542</td><td>0.0000</td><td>0.9883</td><td>0.0000</td><td>1.0000</td><td>0.0000</td><td>0.9883</td></tr> <tr><td>-0.2700</td><td>0.0000</td><td>-0.2862</td><td>0.0000</td><td>-0.2965</td><td>0.0000</td><td>-0.3000</td><td>0.0000</td><td>0.8999</td><td>0.0000</td><td>0.9542</td><td>0.0000</td><td>0.9883</td><td>0.0000</td><td>1.0000</td><td>0.0000</td></tr> <tr><td>0.0000</td><td>0.2700</td><td>0.0000</td><td>0.2862</td><td>0.0000</td><td>0.2965</td><td>0.0000</td><td>0.3000</td><td>0.0000</td><td>0.8999</td><td>0.0000</td><td>0.9542</td><td>0.0000</td><td>0.9883</td><td>0.0000</td><td>1.0000</td></tr> </table>	1.0000	0.0000	0.9883	0.0000	0.9542	0.0000	0.8999	0.0000	-0.3000	0.0000	-0.2965	0.0000	-0.2862	0.0000	-0.2700	0.0000	0.0000	1.0000	0.0000	0.9883	0.0000	0.9542	0.0000	0.8999	0.0000	0.3000	0.0000	0.2965	0.0000	0.2862	0.0000	0.2700	0.9883	0.0000	1.0000	0.0000	0.9883	0.0000	0.9542	0.0000	-0.2965	0.0000	-0.3000	0.0000	-0.2965	0.0000	-0.2862	0.0000	0.0000	0.9883	0.0000	1.0000	0.0000	0.9883	0.0000	0.9542	0.0000	0.2965	0.0000	0.3000	0.0000	0.2965	0.0000	0.2862	0.9542	0.0000	0.9883	0.0000	1.0000	0.0000	0.9883	0.0000	-0.2862	0.0000	-0.2965	0.0000	-0.3000	0.0000	-0.2965	0.0000	0.0000	0.9542	0.0000	0.9883	0.0000	1.0000	0.0000	0.9883	0.0000	0.2862	0.0000	0.2965	0.0000	0.3000	0.0000	0.2965	0.8999	0.0000	0.9542	0.0000	0.9883	0.0000	1.0000	0.0000	-0.2700	0.0000	-0.2862	0.0000	-0.2965	0.0000	-0.3000	0.0000	0.0000	0.8999	0.0000	0.9542	0.0000	0.9883	0.0000	1.0000	0.0000	0.2700	0.0000	0.2862	0.0000	0.2965	0.0000	0.3000	-0.3000	0.0000	-0.2965	0.0000	-0.2862	0.0000	-0.2700	0.0000	1.0000	0.0000	0.9883	0.0000	0.9542	0.0000	0.8999	0.0000	0.0000	0.3000	0.0000	0.2965	0.0000	0.2862	0.0000	0.2700	0.0000	1.0000	0.0000	0.9883	0.0000	0.9542	0.0000	0.8999	-0.2965	0.0000	-0.3000	0.0000	-0.2965	0.0000	-0.2862	0.0000	0.9883	0.0000	1.0000	0.0000	0.9883	0.0000	0.9542	0.0000	0.0000	0.2965	0.0000	0.3000	0.0000	0.2965	0.0000	0.2862	0.0000	0.9883	0.0000	1.0000	0.0000	0.9883	0.0000	0.9542	-0.2862	0.0000	-0.2965	0.0000	-0.3000	0.0000	-0.2965	0.0000	0.9542	0.0000	0.9883	0.0000	1.0000	0.0000	0.9883	0.0000	0.0000	0.2862	0.0000	0.2965	0.0000	0.3000	0.0000	0.2965	0.0000	0.9542	0.0000	0.9883	0.0000	1.0000	0.0000	0.9883	-0.2700	0.0000	-0.2862	0.0000	-0.2965	0.0000	-0.3000	0.0000	0.8999	0.0000	0.9542	0.0000	0.9883	0.0000	1.0000	0.0000	0.0000	0.2700	0.0000	0.2862	0.0000	0.2965	0.0000	0.3000	0.0000	0.8999	0.0000	0.9542	0.0000	0.9883	0.0000	1.0000	
		1.0000	0.0000	0.9883	0.0000	0.9542	0.0000	0.8999	0.0000	-0.3000	0.0000	-0.2965	0.0000	-0.2862	0.0000	-0.2700	0.0000																																																																																																																																																																																																																																																		
		0.0000	1.0000	0.0000	0.9883	0.0000	0.9542	0.0000	0.8999	0.0000	0.3000	0.0000	0.2965	0.0000	0.2862	0.0000	0.2700																																																																																																																																																																																																																																																		
		0.9883	0.0000	1.0000	0.0000	0.9883	0.0000	0.9542	0.0000	-0.2965	0.0000	-0.3000	0.0000	-0.2965	0.0000	-0.2862	0.0000																																																																																																																																																																																																																																																		
		0.0000	0.9883	0.0000	1.0000	0.0000	0.9883	0.0000	0.9542	0.0000	0.2965	0.0000	0.3000	0.0000	0.2965	0.0000	0.2862																																																																																																																																																																																																																																																		
		0.9542	0.0000	0.9883	0.0000	1.0000	0.0000	0.9883	0.0000	-0.2862	0.0000	-0.2965	0.0000	-0.3000	0.0000	-0.2965	0.0000																																																																																																																																																																																																																																																		
		0.0000	0.9542	0.0000	0.9883	0.0000	1.0000	0.0000	0.9883	0.0000	0.2862	0.0000	0.2965	0.0000	0.3000	0.0000	0.2965																																																																																																																																																																																																																																																		
		0.8999	0.0000	0.9542	0.0000	0.9883	0.0000	1.0000	0.0000	-0.2700	0.0000	-0.2862	0.0000	-0.2965	0.0000	-0.3000	0.0000																																																																																																																																																																																																																																																		
		0.0000	0.8999	0.0000	0.9542	0.0000	0.9883	0.0000	1.0000	0.0000	0.2700	0.0000	0.2862	0.0000	0.2965	0.0000	0.3000																																																																																																																																																																																																																																																		
		-0.3000	0.0000	-0.2965	0.0000	-0.2862	0.0000	-0.2700	0.0000	1.0000	0.0000	0.9883	0.0000	0.9542	0.0000	0.8999	0.0000																																																																																																																																																																																																																																																		
		0.0000	0.3000	0.0000	0.2965	0.0000	0.2862	0.0000	0.2700	0.0000	1.0000	0.0000	0.9883	0.0000	0.9542	0.0000	0.8999																																																																																																																																																																																																																																																		
		-0.2965	0.0000	-0.3000	0.0000	-0.2965	0.0000	-0.2862	0.0000	0.9883	0.0000	1.0000	0.0000	0.9883	0.0000	0.9542	0.0000																																																																																																																																																																																																																																																		
		0.0000	0.2965	0.0000	0.3000	0.0000	0.2965	0.0000	0.2862	0.0000	0.9883	0.0000	1.0000	0.0000	0.9883	0.0000	0.9542																																																																																																																																																																																																																																																		
		-0.2862	0.0000	-0.2965	0.0000	-0.3000	0.0000	-0.2965	0.0000	0.9542	0.0000	0.9883	0.0000	1.0000	0.0000	0.9883	0.0000																																																																																																																																																																																																																																																		
		0.0000	0.2862	0.0000	0.2965	0.0000	0.3000	0.0000	0.2965	0.0000	0.9542	0.0000	0.9883	0.0000	1.0000	0.0000	0.9883																																																																																																																																																																																																																																																		
		-0.2700	0.0000	-0.2862	0.0000	-0.2965	0.0000	-0.3000	0.0000	0.8999	0.0000	0.9542	0.0000	0.9883	0.0000	1.0000	0.0000																																																																																																																																																																																																																																																		
0.0000	0.2700	0.0000	0.2862	0.0000	0.2965	0.0000	0.3000	0.0000	0.8999	0.0000	0.9542	0.0000	0.9883	0.0000	1.0000																																																																																																																																																																																																																																																				

Table B.2.3A.3-3: MIMO correlation matrices for medium correlation A

4x4	$R_{Medium A} =$	$\begin{pmatrix} 1.0000 & 0.6000 & 0.0000 & 0.0000 & 0.3000 & 0.1800 & 0.0000 & 0.0000 & -0.2000 & -0.1200 & 0.0000 & 0.0000 & -0.0600 & -0.0360 & 0.0000 & 0.0000 \\ 0.6000 & 1.0000 & 0.0000 & 0.0000 & 0.1800 & 0.3000 & 0.0000 & 0.0000 & -0.1200 & -0.2000 & 0.0000 & 0.0000 & -0.0360 & -0.0600 & 0.0000 & 0.0000 \\ 0.0000 & 0.0000 & 1.0000 & 0.6000 & 0.0000 & 0.0000 & 0.3000 & 0.1800 & 0.0000 & 0.0000 & 0.2000 & 0.1200 & 0.0000 & 0.0000 & 0.0600 & 0.0360 \\ 0.0000 & 0.0000 & 0.6000 & 1.0000 & 0.0000 & 0.0000 & 0.1800 & 0.3000 & 0.0000 & 0.0000 & 0.1200 & 0.2000 & 0.0000 & 0.0000 & 0.0360 & 0.0600 \\ 0.3000 & 0.1800 & 0.0000 & 0.0000 & 1.0000 & 0.6000 & 0.0000 & 0.0000 & -0.0600 & -0.0360 & 0.0000 & 0.0000 & -0.2000 & -0.1200 & 0.0000 & 0.0000 \\ 0.1800 & 0.3000 & 0.0000 & 0.0000 & 0.6000 & 1.0000 & 0.0000 & 0.0000 & -0.0360 & -0.0600 & 0.0000 & 0.0000 & -0.1200 & -0.2000 & 0.0000 & 0.0000 \\ 0.0000 & 0.0000 & 0.3000 & 0.1800 & 0.0000 & 0.0000 & 1.0000 & 0.6000 & 0.0000 & 0.0000 & 0.0600 & 0.0360 & 0.0000 & 0.0000 & 0.2000 & 0.1200 \\ 0.0000 & 0.0000 & 0.1800 & 0.3000 & 0.0000 & 0.0000 & 0.6000 & 1.0000 & 0.0000 & 0.0000 & 0.0360 & 0.0600 & 0.0000 & 0.0000 & 0.1200 & 0.2000 \\ -0.2000 & -0.1200 & 0.0000 & 0.0000 & -0.0600 & -0.0360 & 0.0000 & 0.0000 & 1.0000 & 0.6000 & 0.0000 & 0.0000 & 0.3000 & 0.1800 & 0.0000 & 0.0000 \\ -0.1200 & -0.2000 & 0.0000 & 0.0000 & -0.0360 & -0.0600 & 0.0000 & 0.0000 & 0.6000 & 1.0000 & 0.0000 & 0.0000 & 0.1800 & 0.3000 & 0.0000 & 0.0000 \\ 0.0000 & 0.0000 & 0.2000 & 0.1200 & 0.0000 & 0.0000 & 0.0600 & 0.0360 & 0.0000 & 0.0000 & 1.0000 & 0.6000 & 0.0000 & 0.0000 & 0.3000 & 0.1800 \\ 0.0000 & 0.0000 & 0.1200 & 0.2000 & 0.0000 & 0.0000 & 0.0360 & 0.0600 & 0.0000 & 0.0000 & 0.6000 & 1.0000 & 0.0000 & 0.0000 & 0.1800 & 0.3000 \\ -0.0600 & -0.0360 & 0.0000 & 0.0000 & -0.2000 & -0.1200 & 0.0000 & 0.0000 & 0.3000 & 0.1800 & 0.0000 & 0.0000 & 1.0000 & 0.6000 & 0.0000 & 0.0000 \\ -0.0360 & -0.0600 & 0.0000 & 0.0000 & -0.1200 & -0.2000 & 0.0000 & 0.0000 & 0.1800 & 0.3000 & 0.0000 & 0.0000 & 0.6000 & 1.0000 & 0.0000 & 0.0000 \\ 0.0000 & 0.0000 & 0.0600 & 0.0360 & 0.0000 & 0.0000 & 0.2000 & 0.1200 & 0.0000 & 0.0000 & 0.3000 & 0.1800 & 0.0000 & 0.0000 & 1.0000 & 0.6000 \\ 0.0000 & 0.0000 & 0.0360 & 0.0600 & 0.0000 & 0.0000 & 0.1200 & 0.2000 & 0.0000 & 0.0000 & 0.1800 & 0.3000 & 0.0000 & 0.0000 & 0.6000 & 1.0000 \end{pmatrix}$
------------	------------------	--

B.2.3A.4 Beam steering approach

Given the channel spatial correlation matrix in B.2.3A.1, the corresponding random channel matrix H can be calculated. The signal model for the k -th subframe is denoted as

$$y = HD_{\theta_k} Wx + n$$

Where

- H is the $N_r \times N_t$ channel matrix per subcarrier.
- D_{θ_k} is the steering matrix,

$$\text{For 8 transmission antennas, } D_{\theta_k} = \begin{bmatrix} 1 & 0 \\ 0 & 1 \end{bmatrix} \otimes \begin{bmatrix} 1 & 0 & 0 & 0 \\ 0 & e^{j\theta_k} & 0 & 0 \\ 0 & 0 & e^{j2\theta_k} & 0 \\ 0 & 0 & 0 & e^{j3\theta_k} \end{bmatrix};$$

$$\text{For 4 transmission antennas, } D_{\theta_k} = \begin{bmatrix} 1 & 0 \\ 0 & 1 \end{bmatrix} \otimes \begin{bmatrix} 1 & 0 \\ 0 & e^{j3\theta_k} \end{bmatrix}.$$

- θ_k controls the phase variation, and the phase for k -th subframe is denoted by $\theta_k = \theta_0 + \Delta\theta \cdot k$, where θ_0 is the random start value with the uniform distribution, i.e., $\theta_0 \in [0, 2\pi]$, $\Delta\theta$ is the step of phase variation, which is defined in Table B.2.3A.4-1, and k is the linear increment of 1 for every subframe throughout the simulation,
- W is the precoding matrix for N_t transmission antennas,
- y is the received signal, x is the transmitted signal, and n is AWGN.

Table B.2.3A.4-1: The step of phase variation

Variation Step	Value (rad/subframe)
$\Delta\theta$	1.2566×10^{-3}

B.2.3B MIMO Channel Correlation Matrices using two-dimension cross polarized antennas at eNB and cross polarized antennas at UE

The MIMO channel correlation matrices defined in B.2.3B apply for the antenna configuration using two-dimension (2D) cross polarized antennas at eNodeB and the antenna configuration using cross polarized antennas at UE. The cross-polarized antenna elements with ± 45 degrees polarization slant angles are deployed at eNB and cross-polarized antenna elements with $+90/0$ degrees polarization slant angles are deployed at UE.

For 2D cross-polarized antenna array at eNodeB, the N antennas are indexed by (N_1, N_2, P) , and total number of antennas is $N = P \cdot N_1 \cdot N_2$, where

- N_1 is the number of antenna elements in first dimension (i.e. vertical direction) with same polarization,
- N_2 is the number of antenna elements in second dimension (i.e. horizontal direction) with same polarization, and
- P is the number of polarization groups.

For the 2D cross-polarized antennas at eNB, the N antennas are labelled such that antennas shall be in increasing order of the second dimension firstly, then the first dimension, and finally the polarization group. For a specific antenna

element at p -th polarization, n_1 -th row, and n_2 -th column within the 2D antenna array, the following index number is used for antenna labelling:

$$\text{Index}(p, n_1, n_2) = p \cdot N_1 \cdot N_2 + n_1 \cdot N_2 + n_2 + 1, \quad p = 0, 1, \quad n_1 = 0, \dots, N_1 - 1, \quad n_2 = 0, \dots, N_2 - 1.$$

where N is the number of transmit antennas, p is the polarization group index, n_1 is the row index, and n_2 is the column index of the antenna element.

For the cross-polarized antennas at UE, the N antennas are labelled such that antennas for one polarization are listed from 1 to $N/2$ and antennas for the other polarization are listed from $N/2+1$ to N , where N is the number of receive antennas.

B.2.3B.1 Definition of MIMO Correlation Matrices using two-dimension cross polarized antennas at eNB and cross polarized antennas at UE

For the channel spatial correlation matrix, the following is used:

$$R_{\text{spat}} = P(R_{\text{eNB}} \otimes \Gamma \otimes R_{\text{UE}})P^T$$

where

- R_{UE} is the spatial correlation matrix at the UE with same polarization,
- R_{eNB} is the spatial correlation matrix at the eNB with same polarization,
- Γ is a polarization correlation matrix, and
- $(\bullet)^T$ denotes transpose.

The spatial correlation matrix at the eNB is further expressed as following:

$$R_{\text{eNB}} = R_{\text{eNB_Dim,1}} \otimes R_{\text{eNB_Dim,2}}$$

where

- $R_{\text{eNB_Dim,1}}$ is the correlation matrix of antenna elements in first dimension with same polarization, and
- $R_{\text{eNB_Dim,2}}$ is the correlation matrix of antenna elements in second dimension with same polarization.

The matrix Γ is defined as

$$\Gamma = \begin{bmatrix} 1 & 0 & -\gamma & 0 \\ 0 & 1 & 0 & \gamma \\ -\gamma & 0 & 1 & 0 \\ 0 & \gamma & 0 & 1 \end{bmatrix}$$

A permutation matrix P elements are defined as

$$P(a,b) = \begin{cases} 1 & \text{for } a = (j-1)Nr + i \text{ and } b = 2(j-1)Nr + i, \quad i = 1, \dots, Nr, j = 1, \dots, Nt/2 \\ 1 & \text{for } a = (j-1)Nr + i \text{ and } b = 2(j - Nt/2)Nr - Nr + i, \quad i = 1, \dots, Nr, j = Nt/2 + 1, \dots, Nt \\ 0 & \text{otherwise} \end{cases}$$

where N_t and N_r is the number of transmitter and receiver respectively. This is used to map the spatial correlation coefficients in accordance with the antenna element labelling system described in B.2.3B.

B.2.3B.2 Spatial Correlation Matrices using two-dimension cross polarized antennas at eNB and cross polarized antennas at UE

B.2.3B.2.1 Spatial Correlation Matrices at eNB side

For one direction of the 2D antenna array at the eNB side, the followings are used to construct the spatial correlation matrix:

For 1 antenna element of the same polarization in one direction, $R_{eNB_Dim,i} = 1$.

For 2 antenna elements of the same polarization in one direction, $R_{eNB_Dim,i} = \begin{pmatrix} 1 & \alpha_i \\ \alpha_i^* & 1 \end{pmatrix}$.

For 3 antenna elements of the same polarization in one direction, $R_{eNB_Dim,i} = \begin{pmatrix} 1 & \alpha_i^{1/4} & \alpha_i \\ \alpha_i^{1/4*} & 1 & \alpha_i^{1/4} \\ \alpha_i^* & \alpha_i^{1/4*} & 1 \end{pmatrix}$.

For 4 antenna elements of the same polarization in one direction, $R_{eNB_Dim,i} = \begin{pmatrix} 1 & \alpha_i^{1/9} & \alpha_i^{4/9} & \alpha_i \\ \alpha_i^{1/9*} & 1 & \alpha_i^{1/9} & \alpha_i^{4/9} \\ \alpha_i^{4/9*} & \alpha_i^{1/9*} & 1 & \alpha_i^{1/9} \\ \alpha_i^* & \alpha_i^{4/9*} & \alpha_i^{1/9*} & 1 \end{pmatrix}$.

where the index $i=1,2$ stands for first dimension and second dimension respectively.

B.2.3B.2.2 Spatial Correlation Matrices at UE side

For 2-antenna receiver using one pair of cross-polarized antenna elements, $R_{UE} = 1$.

For 4-antenna receiver using two pairs of cross-polarized antenna elements, $R_{UE} = \begin{pmatrix} 1 & \beta \\ \beta^* & 1 \end{pmatrix}$.

B.2.3B.3 MIMO Correlation Matrices using two-dimension cross polarized antennas at eNB and cross polarized antennas at UE

The values for parameters α_1 , α_2 , β and γ for high spatial correlation are given in Table B.2.3B.3-1.

Table B.2.3B.3-1

High spatial correlation			
α_1	α_2	β	γ
0.9	0.9	0.9	0.3
Note 1:	Value of α_1 applies when more than one pair of cross-polarized antenna elements in first dimension at eNB side.		
Note 2:	Value of α_2 applies when more than one pair of cross-polarized antenna elements in second dimension at eNB side.		
Note 3:	Value of β applies when more than one pair of cross-polarized antenna elements at UE side.		

The correlation matrices for high spatial correlation are defined in Table B.2.3B.3-2 as below.

The values in Table B.2.3B.3-2 have been adjusted to insure the correlation matrix is positive semi-definite after round-off to 4 digit precision. This is done using the equation:

$$\mathbf{R}_{high} = [\mathbf{R}_{spat} + a\mathbf{I}_n]/(1 + a)$$

where the value “a” is a scaling factor such that the smallest value is used to obtain a positive semi-definite result. For the 16(2,4,2)x2 high spatial correlation case, a=0.00012.

B.2.3B.4 Beam steering approach

Given the channel spatial correlation matrix in B.2.3B.1, the corresponding random channel matrix \mathbf{H} can be calculated. The signal model for the k -th subframe is denoted as

$$y = \mathbf{H}D_{\theta_{k,1},\theta_{k,2}} \mathbf{W}x + n$$

And the steering matrix is further expressed as following:

$$D_{\theta_{k,1},\theta_{k,2}} = \begin{bmatrix} 1 & 0 \\ 0 & 1 \end{bmatrix} \otimes (D_{\theta_{k,1}}(N_1) \otimes D_{\theta_{k,2}}(N_2))$$

where

- \mathbf{H} is the $N_r \times N_t$ channel matrix per subcarrier.
- $D_{\theta_{k,1},\theta_{k,2}}$ is the steering matrix,
- $D_{\theta_{k,1}}(N_1)$ is the steering matrix in first dimension with same polarization,
- $D_{\theta_{k,2}}(N_2)$ is the steering matrix in second dimension with same polarization,
- N_1 is the number of antenna elements in first dimension with same polarization,
- N_2 is the number of antenna elements in second dimension with same polarization,

For 1 antenna element of the same polarization in one direction, $D_{\theta_{k,i}}(1) = 1$.

For 2 antenna elements of the same polarization in one direction, $D_{\theta_{k,i}}(2) = \begin{bmatrix} 1 & 0 \\ 0 & e^{j3\theta_{k,i}} \end{bmatrix}$.

For 3 antenna elements of the same polarization in one direction, $D_{\theta_{k,i}}(3) = \begin{bmatrix} 1 & 0 & 0 \\ 0 & e^{j1.5\theta_{k,i}} & 0 \\ 0 & 0 & e^{j3\theta_{k,i}} \end{bmatrix}$.

For 4 antenna elements of the same polarization in one direction, $D_{\theta_{k,i}}(4) = \begin{bmatrix} 1 & 0 & 0 & 0 \\ 0 & e^{j\theta_{k,i}} & 0 & 0 \\ 0 & 0 & e^{j2\theta_{k,i}} & 0 \\ 0 & 0 & 0 & e^{j3\theta_{k,i}} \end{bmatrix}$.

where the index $i=1,2$ stands for first dimension and second dimension respectively.

- $\theta_{k,i}$ controls the phase variation in first dimension and second dimension respectively, and the phase for k -th subframe is denoted by $\theta_{k,i} = \theta_{0,i} + \Delta\theta \cdot k$, where $\theta_{0,i}$ is the random start value with the uniform distribution, i.e., $\theta_{0,i} \in [0, 2\pi]$, $\Delta\theta$ is the step of phase variation, which is defined in Table B.2.3B.4-1, and k is the linear increment of 1 for every subframe throughout the simulation, the index $i=1,2$ stands for first dimension and second dimension respectively.
- \mathbf{W} is the precoding matrix for N_t transmission antennas,
- y is the received signal, x is the transmitted signal, and n is AWGN.

Table B.2.3B.4-1: The step of phase variation

Variation Step	Value (rad/subframe)
$\Delta\theta$	1.2566×10^{-3}

B.2.4 Propagation conditions for CQI tests

For Channel Quality Indication (CQI) tests, the following additional multi-path profile is used:

$$h(t, \tau) = \delta(\tau) + a \exp(-i2\pi f_D t) \delta(\tau - \tau_d),$$

in continuous time (t, τ) representation, with τ_d the delay, a a constant and f_D the Doppler frequency. The same $h(t, \tau)$ is used to describe the fading channel between every pair of Tx and Rx.

B.2.4.1 Propagation conditions for CQI tests with multiple CSI processes

For CQI tests with multiple CSI processes, the following additional multi-path profile is used for 2 port transmission:

$$H = \begin{bmatrix} 1 & j \\ 1 & -j \end{bmatrix} \circ H_{MP}$$

Where \circ represents Hadamard product, H_{MP} indicates the 2x2 propagation channel generated in the manner defined in Clause B.2.4.

B.2.5 Void

B.2.6 MBSFN Propagation Channel Profile

Table B.2.6-1 shows propagation conditions that are used for the MBSFN performance requirements in multi-path fading environment in an extended delay spread environment.

Table B.2.6-1: Propagation Conditions for Multi-Path Fading Environments for MBSFN Performance Requirements in an extended delay spread environment

Extended Delay Spread	
Maximum Doppler frequency [5Hz]	
Relative Delay [ns]	Relative Mean Power [dB]
0	0
30	-1.5
150	-1.4
310	-3.6
370	-0.6
1090	-7.0
12490	-10
12520	-11.5
12640	-11.4
12800	-13.6
12860	-10.6
13580	-17.0
27490	-20
27520	-21.5
27640	-21.4
27800	-23.6
27860	-20.6
28580	-27.0

B.3 High speed train scenario

The high speed train condition for the test of the baseband performance is a non fading propagation channel with one tap. Doppler shift is given by

$$f_s(t) = f_d \cos \theta(t) \quad (\text{B.3.1})$$

where $f_s(t)$ is the Doppler shift and f_d is the maximum Doppler frequency. The cosine of angle $\theta(t)$ is given by

$$\cos \theta(t) = \frac{D_s/2 - vt}{\sqrt{D_{\min}^2 + (D_s/2 - vt)^2}}, \quad 0 \leq t \leq D_s/v \quad (\text{B.3.2})$$

$$\cos \theta(t) = \frac{-1.5D_s + vt}{\sqrt{D_{\min}^2 + (-1.5D_s + vt)^2}}, \quad D_s/v < t \leq 2D_s/v \quad (\text{B.3.3})$$

$$\cos \theta(t) = \cos \theta(t \bmod (2D_s/v)), \quad t > 2D_s/v \quad (\text{B.3.4})$$

where $D_s/2$ is the initial distance of the train from eNodeB, and D_{\min} is eNodeB Railway track distance, both in meters; v is the velocity of the train in m/s, t is time in seconds.

Doppler shift and cosine angle are given by equation B.3.1 and B.3.2-B.3.4 respectively, where the required input parameters listed in table B.3-1 and the resulting Doppler shift shown in Figure B.3-1 are applied for all frequency bands.

Table B.3-1: High speed train scenario

Parameter	Value
D_s	300 m
D_{\min}	2 m
v	300 km/h
f_d	750 Hz

NOTE 1: Parameters for HST conditions in table B.3-1 including f_d and Doppler shift trajectories presented on figure B.3-1 were derived from Band 7 and are applied for performance verification in all frequency bands.

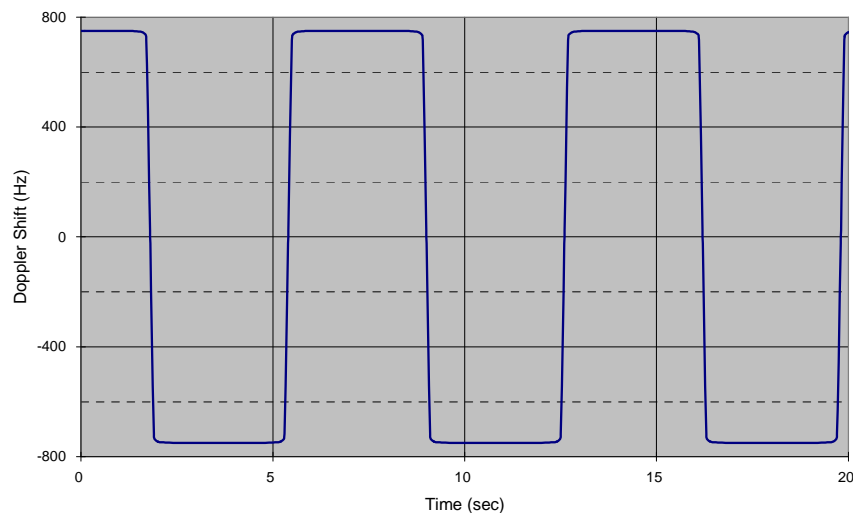

Figure B.3-1: Doppler shift trajectory

For 1x2 antenna configuration, the same $h(t,\tau)$ is used to describe the channel between every pair of Tx and Rx.

For 2x2 antenna configuration, the same $h(t,\tau)$ is used to describe the channel between every pair of Tx and Rx with phase shift according to $\mathbf{H} = \begin{pmatrix} 1 & j \\ 1 & -j \end{pmatrix}$.

B.4 Beamforming Model

B.4.1 Single-layer random beamforming (Antenna port 5, 7, or 8)

Single-layer transmission on antenna port 5 or on antenna port 7 or 8 without a simultaneous transmission on the other antenna port, is defined by using a precoder vector $W(i)$ of size 2×1 randomly selected with the number of layers

$\nu = 1$ from Table 6.3.4.2.3-1 in [4] as beamforming weights. This precoder takes as an input the signal $y^{(p)}(i)$, $i = 0, 1, \dots, M_{\text{symp}}^{\text{ap}} - 1$, for antenna port $p \in \{5, 7, 8\}$, with $M_{\text{symp}}^{\text{ap}}$ the number of modulation symbols including the user-specific reference symbols (DRS), and generates a block of signals $y_{\text{bf}}(i) = [y_{\text{bf}}(i) \ \tilde{y}_{\text{bf}}(i)]^T$ the elements of which are to be mapped onto the same physical RE but transmitted on different antenna elements:

$$\begin{bmatrix} y_{\text{bf}}(i) \\ \tilde{y}_{\text{bf}}(i) \end{bmatrix} = W(i)y^{(p)}(i)$$

Single-layer transmission on antenna port 7 or 8 with a simultaneous transmission on the other antenna port, is defined by using a pair of precoder vectors $W_1(i)$ and $W_2(i)$ each of size 2×1 , which are not identical and randomly selected with the number of layers $\nu = 1$ from Table 6.3.4.2.3-1 in [4], as beamforming weights, and normalizing the transmit power as follows:

$$\begin{bmatrix} y_{\text{bf}}(i) \\ \tilde{y}_{\text{bf}}(i) \end{bmatrix} = \frac{1}{\sqrt{2}} (W_1(i)y^{(7)}(i) + W_2(i)y^{(8)}(i))$$

The precoder update granularity is specific to a test case.

The CSI reference symbols $a_{k,l}^{(p)}$ satisfying $p \bmod 2 = 1$, $p \in \{15, 16, \dots, 22\}$, are transmitted on the same physical antenna element as the modulation symbols $y_{\text{bf}}(i)$. The CSI reference symbols $a_{k,l}^{(p)}$ satisfying $p \bmod 2 = 0$, $p \in \{15, 16, \dots, 22\}$, are transmitted on the same physical antenna element as the modulation symbols $\tilde{y}_{\text{bf}}(i)$.

B.4.1A Single-layer random beamforming (Antenna port 7, 8, 11 or 13 with enhanced DMRS table configured)

Single-layer transmission on antenna port 11 with a simultaneous transmission on one antenna port from antenna port 7, 8 or 13, is defined by using a pair of precoder vectors $W_1(i)$ and $W_2(i)$ each of size 2×1 , which are not identical and randomly selected with the number of layers $\nu = 1$ from Table 6.3.4.2.3-1 in [4], as beamforming weights, and normalizing the transmit power as follows:

$$\begin{bmatrix} y_{\text{bf}}(i) \\ \tilde{y}_{\text{bf}}(i) \end{bmatrix} = \frac{1}{\sqrt{2}} (W_1(i)y^{(11)}(i) + W_2(i)y^{(p_1)}(i))$$

The precoders takes $y^{(11)}(i)$ and $y^{(p_1)}(i)$ as the input the signals, $i = 0, 1, \dots, M_{\text{symp}}^{\text{ap}} - 1$, with $M_{\text{symp}}^{\text{ap}}$ the number of modulation symbols including the user-specific reference symbols (DM-RS), and generates a block of signals $y_{\text{bf}}(i) = [y_{\text{bf}}(i) \ \tilde{y}_{\text{bf}}(i)]^T$ the elements of which are to be mapped onto the same physical RE but transmitted on different antenna elements.

The antenna port $p_1 \in \{7, 8, 13\}$ update granularity is specific to a test case.

The precoder update granularity is specific to a test case.

The CSI reference symbols $a_{k,l}^{(p)}$ satisfying $p \bmod 2 = 1$, $p \in \{15, 16, \dots, 22\}$, are transmitted on the same physical antenna element as the modulation symbols $y_{\text{bf}}(i)$. The CSI reference symbols $a_{k,l}^{(p)}$ satisfying $p \bmod 2 = 0$, $p \in \{15, 16, \dots, 22\}$, are transmitted on the same physical antenna element as the modulation symbols $\tilde{y}_{\text{bf}}(i)$.

B.4.2 Dual-layer random beamforming (antenna ports 7 and 8)

Dual-layer transmission on antenna ports 7 and 8 is defined by using a precoder matrix $W(i)$ of size 2×2 randomly selected with the number of layers $\nu = 2$ from Table 6.3.4.2.3-1 in [4] as beamforming weights. This precoder takes as an input a block of signals for antenna ports 7 and 8, $y(i) = [y^{(7)}(i) \ y^{(8)}(i)]^T$, $i = 0, 1, \dots, M_{\text{symp}}^{\text{ap}} - 1$, with $M_{\text{symp}}^{\text{ap}}$ being the number of modulation symbols per antenna port including the user-specific reference symbols, and generates a block of signals $y_{\text{bf}}(i) = [y_{\text{bf}}(i) \ \tilde{y}_{\text{bf}}(i)]^T$ the elements of which are to be mapped onto the same physical RE but transmitted on different antenna elements:

$$\begin{bmatrix} y_{\text{bf}}(i) \\ \tilde{y}_{\text{bf}}(i) \end{bmatrix} = W(i) \begin{bmatrix} y^{(7)}(i) \\ y^{(8)}(i) \end{bmatrix},$$

The precoder update granularity is specific to a test case.

The CSI reference symbols $a_{k,l}^{(p)}$ satisfying $p \bmod 2 = 1$, $p \in \{15, 16, \dots, 22\}$, are transmitted on the same physical antenna element as the modulation symbols $y_{\text{bf}}(i)$. The CSI reference symbols $a_{k,l}^{(p)}$ satisfying $p \bmod 2 = 0$, $p \in \{15, 16, \dots, 22\}$, are transmitted on the same physical antenna element as the modulation symbols $\tilde{y}_{\text{bf}}(i)$.

B.4.3 Generic beamforming model (antenna ports 7-14)

The transmission on antenna port(s) $p = 7, 8, \dots, \nu + 6$ is defined by using a precoder matrix $W(i)$ of size $N_{\text{CSI}} \times \nu$, where N_{CSI} is the number of CSI reference signals configured per test and ν is the number of spatial layers. This precoder takes as an input a block of signals for antenna port(s) $p = 7, 8, \dots, \nu + 6$, $y^{(p)}(i) = [y^{(7)}(i) \ y^{(8)}(i) \ \dots \ y^{(6+\nu)}(i)]$, $i = 0, 1, \dots, M_{\text{symp}}^{\text{ap}} - 1$, with $M_{\text{symp}}^{\text{ap}}$ being the number of modulation symbols per antenna port including the user-specific reference symbols (DM-RS), and generates a block of signals $y_{\text{bf}}^{(q)}(i) = [y_{\text{bf}}^{(0)}(i) \ y_{\text{bf}}^{(1)}(i) \ \dots \ y_{\text{bf}}^{(N_{\text{CSI}}-1)}(i)]^T$ the elements of which are to be mapped onto the same time-frequency index pair (k, l) but transmitted on different physical antenna elements:

$$\begin{bmatrix} y_{\text{bf}}^{(0)}(i) \\ y_{\text{bf}}^{(1)}(i) \\ \vdots \\ y_{\text{bf}}^{(N_{\text{CSI}}-1)}(i) \end{bmatrix} = W(i) \begin{bmatrix} y^{(7)}(i) \\ y^{(8)}(i) \\ \vdots \\ y^{(6+\nu)}(i) \end{bmatrix}$$

The precoder matrix $W(i)$ is specific to a test case.

The physical antenna elements are identified by indices $j = 0, 1, \dots, N_{\text{ANT}} - 1$, where $N_{\text{ANT}} = N_{\text{CSI}}$ is the number of physical antenna elements configured per test.

Modulation symbols $y_{\text{bf}}^{(q)}(i)$ with $q \in \{0, 1, \dots, N_{\text{CSI}} - 1\}$ (i.e. beamformed PDSCH and DM-RS) are mapped to the physical antenna index $j = q$.

Modulation symbols $y^{(p)}(i)$ with $p \in \{0, 1, \dots, P - 1\}$ (i.e. PBCH, PDCCH, PHICH, PCFICH) are mapped to the physical antenna index $j = p$, where P is the number of cell-specific reference signals configured per test.

Modulation symbols $a_{k,l}^{(p)}$ with $p \in \{0, 1, \dots, P - 1\}$ (i.e. CRS) are mapped to the physical antenna index $j = p$, where P is the number of cell-specific reference signals configured per test.

Modulation symbols $a_{k,l}^{(p)}$ with $p \in \{15, 16, \dots, 14 + N_{CSI}\}$ (i.e. CSI-RS) are mapped to the physical antenna index $j = p - 15$, where N_{CSI} is the number of CSI reference signals configured per test.

B.4.4 Random beamforming for EPDCCH distributed transmission (Antenna port 107 and 109)

EPDCCH distributed transmission on antenna port 107 and antenna port 109 is defined by using a pair of precoder vectors $W_1(i)$ and $W_2(i)$ each of size 2×1 , which are not identical and randomly selected per EPDCCH PRB pair with the number of layers $\nu = 1$ from Table 6.3.4.2.3-1 in [4], as beamforming weights. This precoder takes as an input the signal $y^{(p)}(i)$, $i = 0, 1, \dots, M_{\text{symp}}^{\text{ap}} - 1$, for antenna port $p \in \{107, 109\}$, with $M_{\text{symp}}^{\text{ap}}$ the number of modulation symbols including the user-specific reference symbols (DMRS), and generates a block of signals $y_{bf}(i) = [y_{bf}(i) \ \tilde{y}_{bf}(i)]^T$. When EPDCCH is associated with port 107, the transmitted block of signals is denoted as

$$\begin{bmatrix} y_{bf}(i) \\ \tilde{y}_{bf}(i) \end{bmatrix} = W_1(i) y^{(107)}(i).$$

When EPDCCH is associated with port 109, the transmitted block of signals is denoted as

$$\begin{bmatrix} y_{bf}(i) \\ \tilde{y}_{bf}(i) \end{bmatrix} = W_2(i) y^{(109)}(i).$$

B.4.5 Random beamforming for EPDCCH localized transmission (Antenna port 107, 108, 109 or 110)

EPDCCH localized transmission on antenna port 107, 108, 109 or 110 is defined by using a precoder vector $W(i)$ of size 2×1 randomly selected with the number of layers $\nu = 1$ from Table 6.3.4.2.3-1 in [4] as beamforming weights. This precoder takes as an input the signal $y^{(p)}(i)$, $i = 0, 1, \dots, M_{\text{symp}}^{\text{ap}} - 1$, for antenna port $p \in \{107, 108, 109, 110\}$, with $M_{\text{symp}}^{\text{ap}}$ the number of modulation symbols including the user-specific reference symbols (DMRS), and generates a block of signals $y_{bf}(i) = [y_{bf}(i) \ \tilde{y}_{bf}(i)]^T$ the elements of which are to be mapped onto the same physical RE but transmitted on different antenna elements:

$$\begin{bmatrix} y_{bf}(i) \\ \tilde{y}_{bf}(i) \end{bmatrix} = W(i) y^{(p)}(i).$$

B.4.6 Beamforming model for CRI test

The transmission on antenna port(s) $p = 7, 8, \dots, \nu + 6$ is defined by using a precoder matrix $W(i)$ of size $N_{CSI} \times \nu$, where N_{CSI} is the number of CSI reference signals configured per test and ν is the number of spatial layers. This precoder takes as an input a block of signals for antenna port(s) $p = 7, 8, \dots, \nu + 6$,

$y^{(p)}(i) = [y^{(7)}(i) \ y^{(8)}(i) \ \dots \ y^{(6+\nu)}(i)]$, $i = 0, 1, \dots, M_{\text{symp}}^{\text{ap}} - 1$, with $M_{\text{symp}}^{\text{ap}}$ being the number of modulation symbols per antenna port including the user-specific reference symbols (DM-RS), and generates a block of signals $y_{bf}^{(q)}(i) = [y_{bf}^{(0)}(i) \ y_{bf}^{(1)}(i) \ \dots \ y_{bf}^{(N_{CSI}-1)}(i)]^T$ the elements of which are to be mapped onto the same time-frequency index pair (k, l) but transmitted on different physical antenna elements:

$$\begin{bmatrix} y_{bf}^{(0)}(i) \\ y_{bf}^{(1)}(i) \\ \vdots \\ y_{bf}^{(N_{CSI}-1)}(i) \end{bmatrix} = \alpha(n)W(i) \begin{bmatrix} y^{(7)}(i) \\ y^{(8)}(i) \\ \vdots \\ y^{(6+v)}(i) \end{bmatrix}$$

- $W(i)$ is precoder matrix
- $\alpha(n)$ is amplitude scaling factor for CRI test, $\alpha(n) = 10^{P_{\theta_m}(n)/20}$
- $P_{\theta_m}(n)$ is power scaling factor as following definition:
 - $P_{\theta_m}(n) = A \cos\left(\theta_m + \frac{2\pi n}{K}\right) + B$, $A = 5$ dB, $B = -1.3351$ dB.
 - θ_m controls the phase variation, and the phase for m-th subframe is denoted by $\theta_m = \theta_0 + \Delta\theta \cdot m$, where θ_0 is the random start value with the uniform distribution, i.e., $\theta_0 \in [0, 2\pi]$, $\Delta\theta$ is the step of phase variation which is defined in Table B.4.6-1, and m is the linear increment of 1 for every sub-frame throughout the simulation.
 - K is the number of configured CSI-RS resources
 - $n \in \{0, 1, \dots, K-1\}$
- For following CRI with multiple CSI-RS resources configured, n equals to CRI value reported by UE
- For fixed CRI with single CSI-RS resource configure, n equals to 0.

Table B.4.6-1: The step of phase variation

Variation Step	Value (rad/subframe)
$\Delta\theta$	1.2566×10^{-3}

The physical antenna elements are identified by indices $j = 0, 1, \dots, N_{ANT} - 1$, where $N_{ANT} = N_{CSI}$ is the number of physical antenna elements configured per test.

Modulation symbols $y_{bf}^{(q)}(i)$ with $q \in \{0, 1, \dots, N_{CSI} - 1\}$ (i.e. beamformed PDSCH and DM-RS) are mapped to the physical antenna index $j = q$.

For the k-th configured CSI-RS resource, modulation symbols $a_{k,l}^{(p)}$ with $p \in \{15, 16, \dots, 14 + N_{CSI}\}$ (i.e. CSI-RS) are firstly multiplied by amplitude scaling factor $\alpha(n)$ to generate power scaled symbols $y_{k,l}^{(p)}$:

$$y_{k,l}^{(p)} = \alpha(n)a_{k,l}^{(p)}$$

- n equals to CSI-RS resource index (k-th)

And power scaled symbols $y_{k,l}^{(p)}$ with $p \in \{15, 16, \dots, 14 + N_{CSI}\}$ (i.e. power scaled CSI-RS) are mapped to the physical antenna index $j = p - 15$, where N_{CSI} is the number of CSI reference signals configured per test.

Modulation symbols $y^{(p)}(i)$ with $p \in \{0, 1, \dots, P-1\}$ (i.e. PBCH, PDCCH, PHICH, PCFICH) are mapped to the physical antenna index $j = p$, where P is the number of cell-specific reference signals configured per test.

Modulation symbols $a_{k,l}^{(p)}$ with $p \in \{0,1,\dots,P-1\}$ (i.e. CRS) are mapped to the physical antenna index $j = p$, where P is the number of cell-specific reference signals configured per test.

B.5 Interference models for enhanced performance requirements Type-A

This clause provides a description for the modelling of interfering cell transmissions for enhanced performance requirements Type-A including: definition of dominant interferer proportion, transmission mode 3, 4 and 9 type of interference modelling.

B.5.1 Dominant interferer proportion

Each interfering cell involved in enhanced performance requirements Type-A is characterized by its associated dominant interferer proportion (DIP) value:

$$DIP_i = \frac{\hat{I}_{or(i+1)}}{N_{oc}'}$$

where $\hat{I}_{or(i+1)}$ is the average received power spectral density from the i -th strongest interfering cell involved in the requirement scenario ($\hat{I}_{or(1)}$ is assumed to be the power spectral density associated with the serving cell) and

$N_{oc}' = \sum_{j=2}^N \hat{I}_{or(j)} + N_{oc}$ where N_{oc} is the average power spectral density of a white noise source consistent with the

definition provided in subclause 3.2 and N is the total number of cells involved in a given requirement scenario.

B.5.2 Transmission mode 3 interference model

This subclause provides transmission mode 3 interference modelling for each explicitly modelled interfering cell in the requirement scenario. In each subframe, each interfering cell shall transmit randomly modulated data over the entire PDSCH region and the full transmission bandwidth. Transmitted physical channels shall include PSS, SSS and PBCH.

For each subframe and each CQI subband as defined in subclause 7.2 of [6], a transmission rank shall be randomly determined independently from other CQI subbands as well as other interfering cells. Probabilities of occurrence of each possible transmission rank are as specified in the requirement scenario.

For rank-1 transmission over a subband, precoding for transmit diversity for the number of antenna ports in the requirement scenario shall be applied to 16QAM randomly modulated layer symbols, as specified in subclause 6.3.4.3 of [4].

For rank-2 transmission over a subband, precoding for spatial multiplexing with large delay CDD over two layers for the number of antenna ports in the requirement scenario shall be applied to 16QAM randomly modulated layer symbols, as specified in subclause 6.3.4.2.2 of [4].

For unallocated REs in the control region, precoding for transmit diversity for the number of antenna ports in the requirement scenario shall be applied to QPSK randomly modulated layer symbols, as specified in subclause 6.3.4.3 of [4]. The EPRE ratio for these REs shall be as defined for PDCCH in Annex C.3.2.

B.5.3 Transmission mode 4 interference model

This subclause provides transmission mode 4 interference modelling for each explicitly modelled interfering cell in the requirement scenario. In each subframe, each interfering cell shall transmit randomly modulated data over the entire PDSCH region and the full transmission bandwidth according to the probabilities of occurrence. Transmitted physical channels shall include PSS, SSS and PBCH. Probabilities of occurrence in each subframe are as specified in the

requirement scenario. If the probabilities of occurrence in each subframe are not specified in the requirement scenario, as default, they are equal to 1.

For each subframe and each CQI subband as defined in subclause 7.2 of [6], a transmission rank shall be randomly determined independently from other CQI subbands as well as other interfering cells. Probabilities of occurrence of each possible transmission rank are as specified in the requirement scenario.

For each subframe and CQI subband, a precoding matrix for the number of layers v associated to the selected rank shall be selected randomly from Table 6.3.4.2.3-1 of [4]. Note that codebook index 0 shall be excluded from random precoder selection when the number of layers is $v = 2$.

Precoding for spatial multiplexing with cell-specific reference signals for the number of antenna ports in the requirement scenario shall be applied to 16QAM randomly modulated layer symbols, as specified in subclause 6.3.4.2.1 of [4] with the selected precoding matrices for each subframe and each CQI subband.

For unallocated REs in the control region, precoding for transmit diversity for the number of antenna ports in the requirement scenario shall be applied to QPSK randomly modulated layer symbols, as specified in subclause 6.3.4.3 of [4]. The EPRE ratio for these REs shall be as defined for PDCCH in Annex C.3.2.

B.5.4 Transmission mode 9 interference model

This subclause provides transmission mode 9 interference modelling for each explicitly modelled interfering cell in the requirement scenario. In each subframe, each interfering cell shall transmit randomly modulated data over the entire PDSCH region and the full transmission bandwidth according to the probabilities of occurrence. Transmitted physical channels shall include PSS, SSS and PBCH. Probabilities of occurrence in each subframe are as specified in the requirement scenario. If the probabilities of occurrence in each subframe are not specified in the requirement scenario, as default, they are equal to 1.

For each subframe and each CQI subband as defined in subclause 7.2 of [6], a transmission rank shall be randomly determined independently from other CQI subbands as well as other interfering cells. Probabilities of occurrence of each possible transmission rank are as specified in the requirement scenario.

For each subframe and each CQI subband, a precoding matrix for the number of layers v associated to the selected rank shall be selected randomly from Table 6.3.4.2.3-2 of [4].

The generic beamforming model in subclause B.4.3 shall be applied assuming cell-specific reference signals and CSI reference signals as specified in the requirement scenario. Random precoding with selected rank and precoding matrices for each subframe and each CQI subband shall be applied to 16QAM randomly modulated layer symbols including the user-specific reference symbols over antenna port 7 when the rank is one and antenna ports 7, 8 when the rank is two.

For unallocated REs in the control region, precoding for transmit diversity for the number of antenna ports in the requirement scenario shall be applied to QPSK randomly modulated layer symbols, as specified in subclause 6.3.4.3 of [4]. The EPRE ratio for these REs shall be as defined for PDCCH in Annex C.3.2.

B.6 Interference models for enhanced performance requirements Type-B

This clause provides a description for the modelling of interfering cell transmissions for enhanced performance requirements Type-B including: transmission mode 2, 3, 4 and 9 type of interference modelling and a definition of the random interference model.

B.6.1 Transmission mode 2 interference model

This subclause provides transmission mode 2 interference modelling for each explicitly modelled interfering cell in the requirement scenario. In each subframe, each interfering cell shall transmit randomly modulated data over the PDSCH region as specified in subclause B.6.6. Transmitted physical channels shall include PSS, SSS and PBCH.

The MCS shall be randomly determined with probabilities of occurrence of each possible MCS as specified in subclause B.6.6.

Precoding for transmit diversity for the number of antenna ports in the requirement scenario shall be applied to the randomly modulated layer symbols, as specified in subclause 6.3.4.3 of [4].

For unallocated REs in the control region, precoding for transmit diversity for the number of antenna ports in the requirement scenario shall be applied to QPSK randomly modulated layer symbols, as specified in subclause 6.3.4.3 of [4]. The EPRE ratio for these REs shall be as defined for PDCCH in Annex C.3.2.

B.6.2 Transmission mode 3 interference model

This subclause provides transmission mode 3 interference modelling for each explicitly modelled interfering cell in the requirement scenario. In each subframe, each interfering cell shall transmit randomly modulated data over the PDSCH region as specified in subclause B.6.6. Transmitted physical channels shall include PSS, SSS and PBCH.

The transmission rank shall be randomly determined for each user defined in section B.6.6 with probabilities of occurrence of each possible transmission rank as specified in subclause B.6.6.

The MCS shall be randomly determined with probabilities of occurrence of each possible MCS as specified in subclause B.6.6.

For rank-1 transmission, precoding for transmit diversity for the number of antenna ports in the requirement scenario shall be applied to the randomly modulated layer symbols, as specified in subclause 6.3.4.3 of [4].

For rank-2 transmission, precoding for spatial multiplexing with large delay CDD over two layers for the number of antenna ports in the requirement scenario shall be applied to the randomly modulated layer symbols, as specified in subclause 6.3.4.2.2 of [4].

For unallocated REs in the control region, precoding for transmit diversity for the number of antenna ports in the requirement scenario shall be applied to QPSK randomly modulated layer symbols, as specified in subclause 6.3.4.3 of [4]. The EPRE ratio for these REs shall be as defined for PDCCH in Annex C.3.2.

B.6.3 Transmission mode 4 interference model

This subclause provides transmission mode 4 interference modelling for each explicitly modelled interfering cell in the requirement scenario. In each subframe, each interfering cell shall transmit randomly modulated data over the PDSCH region as specified in subclause B.6.6. Transmitted physical channels shall include PSS, SSS and PBCH.

The transmission rank shall be randomly determined with probabilities of occurrence of each possible transmission rank as specified in subclause B.6.6.

The MCS shall be randomly determined with probabilities of occurrence of each possible MCS as specified in subclause B.6.6.

For each TTI, for each user defined in B.6.6, a single precoding matrix for the number of layers ν associated to the selected rank shall be selected randomly from Table 6.3.4.2.3-1 of [4]. Note that codebook index 0 shall be excluded from random precoder selection when the number of layers is $\nu = 2$.

Precoding for spatial multiplexing with cell-specific reference signals for the number of antenna ports in the requirement scenario shall be applied to randomly modulated layer symbols, as specified in subclause 6.3.4.2.1 of [4] with the selected precoding matrices as specified in subclause B.6.6.

For unallocated REs in the control region, precoding for transmit diversity for the number of antenna ports in the requirement scenario shall be applied to QPSK randomly modulated layer symbols, as specified in subclause 6.3.4.3 of [4]. The EPRE ratio for these REs shall be as defined for PDCCH in Annex C.3.2.

B.6.4 Transmission mode 9 interference model

This subclause provides transmission mode 9 interference modelling for each explicitly modelled interfering cell in the requirement scenario. In each subframe, each interfering cell shall transmit randomly modulated data over the PDSCH region as specified in subclause B.6.6. Transmitted physical channels shall include PSS, SSS and PBCH.

The transmission rank shall be randomly determined with probabilities of occurrence of each possible transmission rank as specified in subclause B.6.6.

The MCS shall be randomly determined with probabilities of occurrence of each possible MCS as specified in subclause B.6.6.

For each TTI, for each user defined in B.6.6, a single precoding matrix for the number of layers v associated to the selected rank shall be selected randomly from Table 6.3.4.2.3-1 of [4]. Note that codebook index 0 shall be excluded from random precoder selection when the number of layers is $v = 2$.

The generic beamforming model in subclause B.4.3 shall be applied assuming cell-specific reference signals and CSI reference signals as specified in the requirement scenario. Random precoding with selected rank and precoding matrices for each subframe shall be applied to randomly modulated layer symbols including the user-specific reference symbols over antenna port 7 when the rank is one and antenna ports 7, 8 when the rank is two.

For each TTI, for each user defined in B.6.6, the scrambling ID value nSCID is randomly assigned from the set of {0,1}.

For unallocated REs in the control region, precoding for transmit diversity for the number of antenna ports in the requirement scenario shall be applied to QPSK randomly modulated layer symbols, as specified in subclause 6.3.4.3 of [4]. The EPRE ratio for these REs shall be as defined for PDCCH in Annex C.3.2.

B.6.5 CRS interference model

This subclause provides for the CRS interference modelling for each explicitly modelled interfering cell in the requirement scenario. In each subframe there is no PDSCH transmitted. Transmitted physical channels shall include PSS, SSS and PBCH.

For unallocated REs in the control region, precoding for transmit diversity for the number of antenna ports in the requirement scenario shall be applied to QPSK randomly modulated layer symbols, as specified in subclause 6.3.4.3 of [4]. The EPRE ratio for these REs shall be as defined for PDCCH in Annex C.3.2.

B.6.6 Random interference model

This subclause presents the interference model which defines the resource allocation, MCS and rank for the two interference cells. The model includes approximately 10% DTX on these interference cells. Table B.6.6-1 shows the resource allocation for four users in two different configurations for each of the two interferers. Table B.6.6-2 shows the resource allocation to be used for special subframes with TM9 interference. Table B.6.6-3 shows the probabilities for the MSC and rank for these users.

Table B.6.6-1: Resource allocation for the random interference model

Resource allocation configurations Indexes	User Index	Resource allocation for random interference model				Probability
		Resource allocation type	Bitmap for resource allocation (Note 1)			
			1st field bitmap	2nd field bitmap	3rd field bitmap	
Configuration 1	User 0	1	00	0	10101000101010	50%
	User 1	1	00	0	01010101010101	
	User 2	0	01001001001001001			
	User 3	0	00100100100100100			
Configuration 2	User 0	1	00	0	10101010101010	50%
	User 1	1	00	1	01010100010101	
	User 2	0	01001001001001001			
	User 3	0	00100100100100100			
Note 1: The 1 st , 2 nd , and 3 rd field bitmaps are only valid for resource allocation type 1 which was defined in [6]. Note 2: The resource allocation model is used for both 1 st and 2 nd interfering cells and the resource allocation is independent for each interfering cell.						

Table B.6.6-2: Resource allocation for the random interference model for TM9 special subframes

Resource allocation configurations Indexes	User Index	Resource allocation for random interference model				Probability
		Resource allocation type	Bitmap for resource allocation (Note 1)			
			1st field bitmap	2nd field bitmap	3rd field bitmap	
Configuration 1	User 0	1	00	0	10101000101010	50%
	User 1	1	00	0	01010101000001	
	User 2	0	01001000001001001			
	User 3	0	00100100000100100			
Configuration 2	User 0	1	00	0	10101000101010	50%
	User 1	1	00	1	01010000010101	
	User 2	0	01001000001001001			
	User 3	0	00100100000100100			

Note 1: The 1st, 2nd, and 3rd field bitmaps are only valid for resource allocation type 1 which was defined in [6].
Note 2: The resource allocation model is used for both 1st and 2nd interfering cells and the resource allocation is independent for each interfering cell.

Table B.6.6-3 MCS and rank configuration for the random interference model

MCS probability			Rank probability	
MCS5	MCS14	MCS25	Rank 1	Rank 2
50%	25%	25%	80%	20%

Note 1: The MCS and rank should follow the probability indicated in the table randomly per UE per TTI.
Note 2: The probabilities for MCS and rank configuration are used for both 1st and 2nd interfering cells. The MCS and rank configurations are independent for each interfering cell.

B.7 Interference models for enhanced downlink control channel performance requirements Type A and B

This clause provides a description for the modelling of interfering cell transmissions for the enhanced downlink control channel performance requirements Type A and B.

B.7.1 PDCCH, PCFICH and PHICH interference model

This subclause provides a description of the interfering cell transmissions model for the enhanced PDCCH/PCFICH and PHICH downlink control channel performance requirements Type A and B under synchronous network scenarios.

The transmitted physical signals and channels shall include CRS, PSS, SSS, PBCH and PCFICH. The PDCCH and PHICH transmit signals are emulated as virtual PDCCH signals described further in the clause.

The PDCCH signals are modelled with a per control channel element (CCE) level granularity and have guaranteed 50% CCE resource loading in each subframe. For each subframe the set of active and inactive CCEs is derived in accordance to the following procedure:

- 1) All available CCEs for the PDCCH and PHICH are marked as $CCE_0, CCE_1, \dots, CCE_{N-1}$.
- 2) For the given partial loading ratio $X = 50\%$ the numbers of active CCEs M_{Active} and inactive CCEs $M_{Inactive}$ are derived

$$M_{Inactive} = \lfloor N * (100 - X\%) \rfloor$$

$$M_{Active} = N - M_{Inactive}$$

- 3) The indexes of $M_{Inactive}$ inactive CCEs are randomly selected out of the full set of CCEs.
- 4) The remaining M_{Active} CCEs are assigned to be active.

No signals are transmitted in the REs corresponding to the inactive CCEs. The PDCCH signals are transmitted in the REs corresponding to the active CCEs. For PDCCH REs, precoding for transmit diversity for the number of antenna ports in the requirement scenario shall be applied to QPSK randomly modulated layer symbols, as specified in subclause 6.3.4.3 of [4]. The EPRE ratio of the PDCCH REs in the active CCEs shall be derived in accordance to the following procedure:

- 1) For each generated active i -th CCE the PDCCH power boosting level $P(i)$ shall be randomly generated using the uniform distribution in the $[P_{min}, P_{max}]$ range. The P_{min} is equal to -6 dB, the P_{max} is equal to 6 dB. The random values should be derived in the dB scale.
- 2) Additional power normalization is applied for each generated i -th PDCCH power boosting level:

$$P_{norm}(i) = P(i) - \alpha$$

where $P(i)$ and $P_{norm}(i)$ are the PDCCH power boosting coefficients before and after normalization in the dB scale; the power normalization factor α is equal to 1.3 dB.

- 3) The normalized PDCCH power boosting coefficients $P_{norm}(i)$ are further applied to the PDCCH_RA and PDCCH_RB values to derive the EPRE ratio of the PDCCH signals transmitted in the REs corresponding the i -th CCE in each subframe.

B.8 Burst transmission models for Frame structure type 3

This clause provides a description for burst transmission models for Frame structure type 3.

B.8.1 Burst transmission model for one LAA SCell

One burst is defined as downlink transmissions which occupy one or more consecutive subframes. The burst transmission format is determined according to the steps below:

- 1) Select the number of subframes N randomly from a given set of the number of subframes \mathcal{S}_1 with equal probability as the total length of burst transmission format. The length includes both occupied OFDM symbols and non-occupied OFDM symbols within the burst format. \mathcal{S}_1 is given per test case.
- 2) If N is equal to 1, the subframe is set as fully occupied, otherwise:
 - For demodulation test, the starting position for the first subframe is randomly selected from OFDM symbol 0 and OFDM symbol 7 with equal probability. For CSI test, the starting position for the first subframe is OFDM symbol 0.
 - The configuration of occupied OFDM symbols in the last subframe is randomly selected from configuration set \mathcal{S}_2 . \mathcal{S}_2 is given per test case.

A uniform random variable from $[0, 1]$ is generated. If the random variable is less than p which is given per test case,

- If both the last subframe of previous burst and first subframe of new burst format are fully occupied, start burst transmission after deferring one subframe from the last subframe of previous burst. Otherwise, start burst transmission at the end of last subframe of previous burst.

Otherwise, the burst transmission is muted and the muting duration is the same as the number of subframes for determined burst format.

Annex C (normative): Downlink Physical Channels

C.1 General

This annex specifies the downlink physical channels that are needed for setting a connection and channels that are needed during a connection.

C.2 Set-up

Table C.2-1 describes the downlink Physical Channels that are required for connection set up.

Table C.2-1: Downlink Physical Channels required for connection set-up

Physical Channel
PBCH
SSS
PSS
PCFICH
PDCCH
EPDCCH
PHICH
PDSCH

C.3 Connection

The following clauses, describes the downlink Physical Channels that are transmitted during a connection i.e., when measurements are done.

C.3.1 Measurement of Receiver Characteristics

Unless otherwise stated, Table C.3.1-1 is applicable for measurements on the Receiver Characteristics (clause 7).

Table C.3.1-1: Downlink Physical Channels transmitted during a connection (FDD and TDD)

Physical Channel	EPRE Ratio
PBCH	PBCH_RA = 0 dB
	PBCH_RB = 0 dB
PSS	PSS_RA = 0 dB
SSS	SSS_RA = 0 dB
PCFICH	PCFICH_RB = 0 dB
PDCCH	PDCCH_RA = 0 dB
	PDCCH_RB = 0 dB
PDSCH	PDSCH_RA = 0 dB
	PDSCH_RB = 0 dB
OCNG	OCNG_RA = 0 dB
	OCNG_RB = 0 dB

NOTE 1: No boosting is applied.

For measurements on cells in TDD Band 46, Table C.3.1-1a is applicable for measurements of Receiver Characteristics (clause 7).

Table C.3.1-1a: Downlink Physical Channels transmitted during a connection (TDD Band 46)

Physical Channel	EPRE Ratio
DRS	NOTE 1
PSS	PSS_RA = 0 dB
SSS	SSS_RA = 0 dB
PCFICH	PCFICH_RB = 0 dB
PDCCH	PDCCH_RA = 0 dB
	PDCCH_RB = 0 dB
PDSCH	PDSCH_RA = 0 dB
	PDSCH_RB = 0 dB
OCNG	OCNG_RA = 0 dB
	OCNG_RB = 0 dB
NOTE 1: No boosting is applied.	

Table C.3.1-2: Power allocation for OFDM symbols and reference signals

Parameter	Unit	Value	Note
Transmitted power spectral density I_{or}	dBm/15 kHz	Test specific	1. I_{or} shall be kept constant throughout all OFDM symbols
Cell-specific reference signal power ratio E_{RS} / I_{or}		0 dB	

C.3.2 Measurement of Performance requirements

Table C.3.2-1 is applicable for measurements in which uniform RS-to-EPRE boosting for all downlink physical channels, unless otherwise stated.

Table C.3.2-1: Downlink Physical Channels transmitted during a connection (FDD and TDD and Frame structure Type 3)

Physical Channel	EPRE Ratio
PBCH	PBCH_RA = $\rho_A + \sigma$
	PBCH_RB = $\rho_B + \sigma$
PSS	PSS_RA = 0 (Note 3)
SSS	SSS_RA = 0 (Note 3)
PCFICH	PCFICH_RB = $\rho_B + \sigma$
PDCCH	PDCCH_RA = $\rho_A + \sigma$
	PDCCH_RB = $\rho_B + \sigma$
EPDCCH	EPDCCH_RA = $\rho_A + \delta$
	EPDCCH_RB = $\rho_B + \delta$
MPDCCH	MPDCCH_RA = $\rho_A + \delta$
	MPDCCH_RB = $\rho_B + \delta$
PDSCH	PDSCH_RA = ρ_A
	PDSCH_RB = ρ_B
PMCH	PMCH_RA = ρ_A
	PMCH_RB = ρ_B
MBSFN RS	MBSFN_RS_RA = ρ_A
	MBSFN_RS_RB = ρ_B
OCNG	OCNG_RA = $\rho_A + \sigma$
	OCNG_RB = $\rho_B + \sigma$

NOTE 1: $\rho_A = \rho_B = 0$ dB means no RS boosting.

NOTE 2: MBSFN RS and OCNG are not defined downlink physical channels in [4].

NOTE 3: Assuming PSS and SSS transmitted on a single antenna port.

NOTE 4: ρ_A , ρ_B , σ , and δ are test specific.

NOTE 5: Void.

NOTE 6: For Frame Structure Type 3, PBCH are not defined.

Table C.3.2-2: Power allocation for OFDM symbols and reference signals

Parameter	Unit	Value	Note
Total transmitted power spectral density I_{or}	dBm/15 kHz	Test specific	1. I_{or} shall be kept constant throughout all OFDM symbols
Cell-specific reference signal power ratio E_{RS} / I_{or}		Test specific	1. Applies for antenna port p
Energy per resource element EPRE		Test specific	1. The complex-valued symbols $y^{(p)}(i)$ and $a_{k,l}^{(p)}$ defined in [4] shall conform to the given EPRE value. 2. For TM8, TM9 and TM10 the reference point for EPRE is before the precoder in Annex B.4.

C.3.3 Aggressor cell power allocation for Measurement of Performance Requirements when ABS is Configured

For the performance requirements and channel state information reporting when ABS is configured, the power allocation for the physical channels of the aggressor cell in non-ABS and ABS is listed in Table C.3.3-1.

Table C.3.3-1: Downlink physical channels transmitted in aggressor cell when ABS is configured in this cell

Physical Channel	Parameters	Unit	EPRE Ratio	
			Non-ABS	ABS
PBCH	PBCH_RA	dB	ρ_A	Note 1
	PBCH_RB	dB	ρ_B	Note 1
PSS	PSS_RA	dB	ρ_A	Note 1
SSS	SSS_RA	dB	ρ_A	Note 1
PCFICH	PCFICH_RB	dB	ρ_B	Note 1
PHICH	PHICH_RA	dB	ρ_A	Note 1
	PHICH_RB	dB	ρ_B	Note 1
PDCCH	PDCCH_RA	dB	ρ_A	Note 1
	PDCCH_RB	dB	ρ_B	Note 1
PDSCH	PDSCH_RA	dB	N/A	Note 1
	PDSCH_RB	dB	N/A	Note 1
OCNG	OCNG_RA	dB	ρ_A	Note 1
	OCNG_RB	dB	ρ_B	Note 1

Note 1: $-\infty$ dB is allocated for this channel in this test.

Table C.3.3-2: Downlink physical channels transmitted in aggressor cell when ABS is configured in this cell when the CRS assistance information is provided

Physical Channel	Parameters	Unit	EPRE Ratio	
			Non-ABS	ABS
PBCH	PBCH_RA	dB	ρ_A	ρ_A
	PBCH_RB	dB	ρ_B	ρ_B
PSS	PSS_RA	dB	ρ_A	ρ_A
SSS	SSS_RA	dB	ρ_A	ρ_A
PCFICH	PCFICH_RB	dB	ρ_B	Note 1
PHICH	PHICH_RA	dB	ρ_A	Note 1
	PHICH_RB	dB	ρ_B	Note 1
PDCCH	PDCCH_RA	dB	ρ_A	Note 1
	PDCCH_RB	dB	ρ_B	Note 1
PDSCH	PDSCH_RA	dB	N/A	Note 1
	PDSCH_RB	dB	N/A	Note 1
OCNG	OCNG_RA	dB	ρ_A	Note 1
	OCNG_RB	dB	ρ_B	Note 1

Note 1: $-\infty$ dB is allocated for this channel in this test.

C.3.4 Power Allocation for Measurement of Performance Requirements when Quasi Co-location Type B: same Cell ID

For the performance requirements related to quasi-colocation type B behaviour when transmission points share the same Cell ID, the power allocation for the physical channels of the serving cell is listed in Table C.3.4-1 and the power allocation for the physical channels of the cell transmitting PDSCH is listed in Table C.3.4-2

Table C.3.4-1: Downlink physical channels transmitted in the serving cell (TP1)

Physical Channel	EPRE Ratio
PBCH	PBCH_RA = $\rho_A + \sigma$
	PBCH_RB = $\rho_B + \sigma$
PSS	PSS_RA = 0 (Note 2)
SSS	SSS_RA = 0 (Note 2)
PDSCH	PDSCH_RA = ρ_A
	PDSCH_RB = ρ_B
PCFICH	PCFICH_RB = $\rho_B + \sigma$
PDCCH	PDCCH_RA = $\rho_A + \sigma$
	PDCCH_RB = $\rho_B + \sigma$

NOTE 1: $\rho_A = \rho_B = 0$ dB means no RS boosting.

NOTE 2: Assuming PSS and SSS transmitted on a single antenna port.

NOTE 3: ρ_A , ρ_B and σ are test specific.

Table C.3.4-2: Downlink physical channels for the transmission point transmitting PDSCH (TP2)

Physical Channel	Value
PDSCH	Test Specific

C.3.5 Simplified CA testing method

For CA tests which require more than 16 independent faders, if a test system cannot support a throughput measurement with fading on all carriers simultaneously, the simplified CA testing method shall be used.

In the simplified CA testing method, the resulting propagation channel(s) shall be generated by considering a number of independent faders needed for one carrier and connecting them to the signal of randomly chosen carrier(s). The maximum number of channel faders on the test will be less than or equal to 16. The remaining carrier(s) shall be connected without a channel fader but with AWGN. The throughput is then collected only for the carrier(s) connected to channel faders.

In the simplified CA testing method, the test shall be repeated by choosing carrier(s) excluding already chosen carrier(s) until all the carrier(s) are tested under fading conditions. All the collected throughputs from each carrier shall be compared against the reference value of the requirements.

All supported carriers shall be configured and activated during the test.

C.3.6 Measurement of Receiver Characteristics for Narrowband IoT

For the performance requirements for Narrowband IoT, the power allocation for the physical channels is listed in Table C.3.6-1

Table C.3.6-1: Downlink Physical Channels transmitted during a connection

Physical Channel	EPRE Ratio for one NRS antenna port	EPRE Ratio for two NRS antenna ports
NPBCH	0 dB	-3 dB
NPDCCH	0 dB	-3 dB
NPDSCH	0 dB	-3 dB
NPSS	0 dB	0 dB
NSSS	0 dB	0 dB

NOTE 1: Assuming NPSS and NSSS transmitted on one NRS antenna port.

Table C.3.6-2: Power allocation for OFDM symbols and reference signals

Parameter	Unit	Value	Note
Transmitted power spectral density I_{or}	dBm/15 kHz	Test specific	I_{or} shall be kept constant throughout all OFDM symbols
Cell-specific reference signal power ratio E_{CRS} / I_{or}		0 dB	Applicable for In-band operation
Narrowband reference signal power ratio E_{NRS} / I_{or}		0 dB	Applicable for Stand-alone and Guard-band operation
Narrowband reference signal power over cell-specific reference signal power E_{NRS} / E_{RS}		0 dB	Applicable for In-band operation

Annex D (normative): Characteristics of the interfering signal

D.1 General

Unless otherwise stated, when the channel bandwidth is wider or equal to 5MHz, a modulated 5MHz full bandwidth E-UTRA downlink signal and CW signal are used as interfering signals when RF performance requirements for E-UTRA UE receiver are defined. For channel bandwidths below 5MHz, the bandwidth of modulated interferer should be equal to bandwidth of the received signal.

For Band 46, the bandwidth of interfering signal is 20MHz when RF performance requirements for E-UTRA UE receiver are defined.

D.2 Interference signals

Table D.2-1 describes the modulated interferer for different channel bandwidth options.

Table D.2-1: Description of modulated E-UTRA interferer

	Channel bandwidth					
	1.4 MHz	3 MHz	5 MHz	10 MHz	15 MHz	20 MHz
BW _{Interferer}	1.4 MHz	3 MHz	5 MHz	5 MHz	5 MHz	5 MHz
RB	6	15	25	25	25	25

Table D.2-2 describes the modulated interferer setting 2 for different channel bandwidth options for Band 46.

Table D.2-2: Description of modulated E-UTRA interferer for Band 46

	Channel bandwidth					
	1.4 MHz	3 MHz	5 MHz	10 MHz	15 MHz	20 MHz
BW _{Interferer}						20 MHz
RB						100

Annex E (normative): Environmental conditions

E.1 General

This normative annex specifies the environmental requirements of the UE. Within these limits the requirements of the present documents shall be fulfilled.

E.2 Environmental

The requirements in this clause apply to all types of UE(s).

E.2.1 Temperature

The UE shall fulfil all the requirements in the full temperature range of:

Table E.2.1-1

+15°C to +35°C	for normal conditions (with relative humidity of 25 % to 75 %)
-10°C to +55°C	for extreme conditions (see IEC publications 68-2-1 and 68-2-2)

Outside this temperature range the UE, if powered on, shall not make ineffective use of the radio frequency spectrum. In no case shall the UE exceed the transmitted levels as defined in clause 6.2 for extreme operation.

E.2.2 Voltage

The UE shall fulfil all the requirements in the full voltage range, i.e. the voltage range between the extreme voltages.

The manufacturer shall declare the lower and higher extreme voltages and the approximate shutdown voltage. For the equipment that can be operated from one or more of the power sources listed below, the lower extreme voltage shall not be higher, and the higher extreme voltage shall not be lower than that specified below.

Table E.2.2-1

Power source	Lower extreme voltage	Higher extreme voltage	Normal conditions voltage
AC mains	0,9 * nominal	1,1 * nominal	nominal
Regulated lead acid battery	0,9 * nominal	1,3 * nominal	1,1 * nominal
Non regulated batteries:			
Leclanché	0,85 * nominal	Nominal	Nominal
Lithium	0,95 * nominal	1,1 * Nominal	1,1 * Nominal
Mercury/nickel & cadmium	0,90 * nominal		Nominal

Outside this voltage range the UE if powered on, shall not make ineffective use of the radio frequency spectrum. In no case shall the UE exceed the transmitted levels as defined in clause 6.2 for extreme operation. In particular, the UE shall inhibit all RF transmissions when the power supply voltage is below the manufacturer declared shutdown voltage.

E.2.3 Vibration

The UE shall fulfil all the requirements when vibrated at the following frequency/amplitudes.

Table E.2.3-1

Frequency	ASD (Acceleration Spectral Density) random vibration
5 Hz to 20 Hz	0,96 m ² /s ³
20 Hz to 500 Hz	0,96 m ² /s ³ at 20 Hz, thereafter -3 dB/Octave

Outside the specified frequency range the UE, if powered on, shall not make ineffective use of the radio frequency spectrum. In no case shall the UE exceed the transmitted levels as defined in TS 36.101 for extreme operation.

Annex F (normative): Transmit modulation

F.1 Measurement Point

Figure F.1-1 shows the measurement point for the unwanted emission falling into non-allocated RB(s) and the EVM for the allocated RB(s).

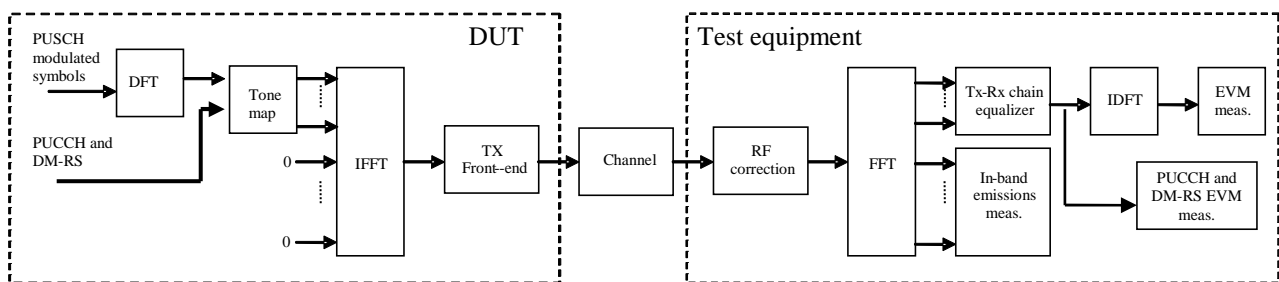

Figure F.1-1: EVM measurement points

F.2 Basic Error Vector Magnitude measurement

The EVM is the difference between the ideal waveform and the measured waveform for the allocated RB(s)

$$EVM = \sqrt{\frac{\sum_{v \in T_m} |z'(v) - i(v)|^2}{|T_m| \cdot P_0}},$$

where

T_m is a set of $|T_m|$ modulation symbols with the considered modulation scheme being active within the measurement period,

$z'(v)$ are the samples of the signal evaluated for the EVM,

$i(v)$ is the ideal signal reconstructed by the measurement equipment, and

P_0 is the average power of the ideal signal. For normalized modulation symbols P_0 is equal to 1.

The basic EVM measurement interval is defined over one slot in the time domain for PUCCH and PUSCH and over one preamble sequence for the PRACH.

F.3 Basic in-band emissions measurement

The in-band emissions are a measure of the interference falling into the non-allocated resources blocks. The in-band emission requirement is evaluated for PUCCH and PUSCH transmissions. The in-band emission requirement is not evaluated for PRACH transmissions.

The in-band emissions are measured as follows

$$Emissions_{absolute}(\Delta_{RB}) = \begin{cases} \frac{1}{|T_s|} \sum_{t \in T_s} \sum_{f_i + (12 \cdot \Delta_{RB} + 1) \Delta f}^{\max(f_{\min}, f_i + 12 \cdot \Delta_{RB} \Delta f)} |Y(t, f)|^2, \Delta_{RB} < 0 \\ \frac{1}{|T_s|} \sum_{t \in T_s} \sum_{f_h + (12 \cdot \Delta_{RB} - 1) \Delta f}^{\min(f_{\max}, f_h + 12 \cdot \Delta_{RB} \Delta f)} |Y(t, f)|^2, \Delta_{RB} > 0 \end{cases},$$

where

T_s is a set of $|T_s|$ SC-FDMA symbols with the considered modulation scheme being active within the measurement period,

Δ_{RB} is the starting frequency offset between the allocated RB and the measured non-allocated RB (e.g. $\Delta_{RB} = 1$ or $\Delta_{RB} = -1$ for the first adjacent RB),

f_{\min} (resp. f_{\max}) is the lower (resp. upper) edge of the UL system BW,

f_l and f_h are the lower and upper edge of the allocated BW, and

$Y(t, f)$ is the frequency domain signal evaluated for in-band emissions as defined in the subsection (ii)

The relative in-band emissions are, given by

$$Emissions_{relative}(\Delta_{RB}) = \frac{Emissions_{absolute}(\Delta_{RB})}{\frac{1}{|T_s|} \cdot N_{RB} \sum_{t \in T_s} \sum_{f_i}^{f_i + (12 \cdot N_{RB} - 1) \Delta f} |Y(t, f)|^2}$$

where

N_{RB} is the number of allocated RBs

The basic in-band emissions measurement interval is defined over one slot in the time domain. When the PUSCH or PUCCH transmission slot is shortened due to multiplexing with SRS, the in-band emissions measurement interval is reduced by one SC-FDMA symbol, accordingly.

In the evaluation of in-band emissions, the timing is set according to $\Delta \tilde{t} = \Delta \tilde{c}$, where sample time offsets $\Delta \tilde{t}$ and $\Delta \tilde{c}$ are defined in subclause F.4.

F.4 Modified signal under test

Implicit in the definition of EVM is an assumption that the receiver is able to compensate a number of transmitter impairments.

The PUSCH data or PRACH or Physical Sidelink Channel signal under test is modified and, in the case of PUSCH or Physical Sidelink Channel data signal, decoded according to:

$$Z'(t, f) = IDFT \left\{ \frac{FFT \left\{ z(v - \Delta\tilde{t}) \cdot e^{-j2\pi\Delta\tilde{f}v} \right\} e^{j2\pi f \Delta\tilde{t}}}{\tilde{a}(t, f) \cdot e^{j\tilde{\varphi}(t, f)}} \right\}$$

where

$z(v)$ is the time domain samples of the signal under test.

The PUCCH or PUSCH or Physical Sidelink Channel demodulation reference signal or PUCCH data signal under test is equalised and, in the case of PUCCH data signal decoded according to:

$$Z'(t, f) = \frac{FFT \left\{ z(v - \Delta\tilde{t}) \cdot e^{-j2\pi\Delta\tilde{f}v} \right\} e^{j2\pi f \Delta\tilde{t}}}{\tilde{a}(t, f) \cdot e^{j\tilde{\varphi}(t, f)}}$$

where

$z(v)$ is the time domain samples of the signal under test.

To minimize the error, the signal under test should be modified with respect to a set of parameters following the procedure explained below.

Notation:

$\Delta\tilde{t}$ is the sample timing difference between the FFT processing window in relation to nominal timing of the ideal signal.

$\Delta\tilde{f}$ is the RF frequency offset.

$\tilde{\varphi}(t, f)$ is the phase response of the TX chain.

$\tilde{a}(t, f)$ is the amplitude response of the TX chain.

In the following $\Delta\tilde{c}$ represents the middle sample of the EVM window of length W (defined in the next subsections) or the last sample of the first window half if W is even.

The EVM analyser shall

- detect the start of each slot and estimate $\Delta\tilde{t}$ and $\Delta\tilde{f}$,
- determine $\Delta\tilde{c}$ so that the EVM window of length W is centred
 - on the time interval determined by the measured cyclic prefix minus 16 samples of the considered OFDM symbol for symbol 0 for normal CP, i.e. the first 16 samples of the CP should not be taken into account for this step. In the determination of the number of excluded samples, a sampling rate of 30.72MHz was assumed. If a different sampling rate is used, the number of excluded samples is scaled linearly.
 - on the measured cyclic prefix of the considered OFDM symbol for symbol 1 to 6 for normal CP and for symbol 0 to 5 for extended CP.
 - on the measured preamble cyclic prefix for the PRACH

To determine the other parameters a sample timing offset equal to $\Delta\tilde{c}$ is corrected from the signal under test. The EVM analyser shall then

- correct the RF frequency offset $\Delta\tilde{f}$ for each time slot, and
- apply an FFT of appropriate size. The chosen FFT size shall ensure that in the case of an ideal signal under test, there is no measured inter-subcarrier interference.

The carrier leakage shall be removed from the evaluated signal before calculating the EVM and the in-band emissions; however, the removed relative carrier leakage power also has to satisfy the applicable requirement.

At this stage the allocated RBs shall be separated from the non-allocated RBs. In the case of PUCCH and PUSCH EVM, the signal on the non-allocated RB(s), $Y(t, f)$, is used to evaluate the in-band emissions.

Moreover, the following procedure applies only to the signal on the allocated RB(s).

- In the case of PUCCH and PUSCH and Physical Sidelink Channel, the UL EVM analyzer shall estimate the TX chain equalizer coefficients $\tilde{a}(t, f)$ and $\tilde{\varphi}(t, f)$ used by the ZF equalizer for all subcarriers by time averaging at each signal subcarrier of the amplitude and phase of the reference and data symbols. The time-averaging length is 1 slot. This process creates an average amplitude and phase for each signal subcarrier used by the ZF equalizer. The knowledge of data modulation symbols may be required in this step because the determination of symbols by demodulation is not reliable before signal equalization.
- In the case of PRACH, the UL EVM analyzer shall estimate the TX chain coefficients $\tilde{a}(t)$ and $\tilde{\varphi}(t)$ used for phase and amplitude correction and are selected so as to minimize the resulting EVM. The TX chain coefficients are not dependent on frequency, i.e. $\tilde{a}(t, f) = \tilde{a}(t)$ and $\tilde{\varphi}(t, f) = \tilde{\varphi}(t)$. The TX chain coefficients are chosen independently for each preamble transmission and for each $\Delta\tilde{t}$.

At this stage estimates of $\Delta\tilde{f}$, $\tilde{a}(t, f)$, $\tilde{\varphi}(t, f)$ and $\Delta\tilde{c}$ are available. $\Delta\tilde{t}$ is one of the extremities of the window W , i.e. $\Delta\tilde{t}$ can be $\Delta\tilde{c} + \alpha - \left\lfloor \frac{W}{2} \right\rfloor$ or $\Delta\tilde{c} + \left\lfloor \frac{W}{2} \right\rfloor$, where $\alpha = 0$ if W is odd and $\alpha = 1$ if W is even. The EVM analyser shall then

- calculate EVM_l with $\Delta\tilde{t}$ set to $\Delta\tilde{c} + \alpha - \left\lfloor \frac{W}{2} \right\rfloor$,
- calculate EVM_h with $\Delta\tilde{t}$ set to $\Delta\tilde{c} + \left\lfloor \frac{W}{2} \right\rfloor$.

F.5 Window length

F.5.1 Timing offset

As a result of using a cyclic prefix, there is a range of $\Delta\tilde{t}$, which, at least in the case of perfect Tx signal quality, would give close to minimum error vector magnitude. As a first order approximation, that range should be equal to the length of the cyclic prefix. Any time domain windowing or FIR pulse shaping applied by the transmitter reduces the $\Delta\tilde{t}$ range within which the error vector is close to its minimum.

F.5.2 Window length

The window length W affects the measured EVM, and is expressed as a function of the configured cyclic prefix length. In the case where equalization is present, as with frequency domain EVM computation, the effect of FIR is reduced. This is because the equalization can correct most of the linear distortion introduced by the FIR. However, the time domain windowing effect can't be removed.

F.5.3 Window length for normal CP

The table below specifies the EVM window length at channel bandwidths 1.4, 3, 5, 10, 15, 20 MHz, for normal CP. The nominal window length for 3 MHz is rounded down one sample to allow the window to be centered on the symbol.

Table F.5.3-1 EVM window length for normal CP

Channel Bandwidth MHz	Cyclic prefix length ¹ N_{cp} for symbol 0	Cyclic prefix length ¹ N_{cp} for symbols 1 to 6	Nominal FFT size	Cyclic prefix for symbols 1 to 6 in FFT samples	EVM window length W in FFT samples	Ratio of W to CP for symbols 1 to 6 ²
1.4	160	144	128	9	5	55.6
3			256	18	12	66.7
5			512	36	32	88.9
10			1024	72	66	91.7
15			1536	108	102	94.4
20			2048	144	136	94.4

Note 1: The unit is number of samples, sampling rate of 30.72MHz is assumed.
Note 2: These percentages are informative and apply to symbols 1 through 6. Symbol 0 has a longer CP and therefore a lower percentage.

F.5.4 Window length for Extended CP

The table below specifies the EVM window length at channel bandwidths 1.4, 3, 5, 10, 15, 20 MHz, for extended CP. The nominal window lengths for 3 MHz and 15 MHz are rounded down one sample to allow the window to be centered on the symbol.

Table F.5.4-1 EVM window length for extended CP

Channel Bandwidth MHz	Cyclic prefix length ¹ N_{cp}	Nominal FFT size	Cyclic prefix in FFT samples	EVM window length W in FFT samples	Ratio of W to CP ²
1.4	512	128	32	28	87.5
3		256	64	58	90.6
5		512	128	124	96.9
10		1024	256	250	97.4
15		1536	384	374	97.4
20		2048	512	504	98.4

Note 1: The unit is number of samples, sampling rate of 30.72MHz is assumed.
Note 2: These percentages are informative

F.5.5 Window length for PRACH

The table below specifies the EVM window length for PRACH preamble formats 0-4.

Table F.5.5-1 EVM window length for PRACH

Preamble format	Cyclic prefix length ¹ N_{cp}	Nominal FFT size ²	EVM window length W in FFT samples	Ratio of W to CP*
0	3168	24576	3072	96.7%
1	21024	24576	20928	99.5%
2	6240	49152	6144	98.5%
3	21024	49152	20928	99.5%
4	448	4096	432	96.4%

Note 1: The unit is number of samples, sampling rate of 30.72MHz is assumed
Note 2: The use of other FFT sizes is possible as long as appropriate scaling of the window length is applied
Note 3: These percentages are informative

F.5.F Window length for category NB1

The EVM window length, W , for NPUSCH is set to 1 (in FFT samples where the nominal FFT size is 128 for 15 kHz sub-carrier spacing and 512 for 3.75 kHz sub-carrier spacing).

The EVM window length, W , for NPRACH is set to 110 for preamble format 0 and to 494 for preamble format 1 (both in FFT samples where the nominal FFT size is 512).

F.6 Averaged EVM

The general EVM is averaged over basic EVM measurements for n slots in the time domain.

$$\overline{EVM} = \sqrt{\frac{1}{n} \sum_{i=1}^n EVM_i^2},$$

where n is

$n = 20$ for PUCCH, PUSCH, PSDCH, PSCCH, and PSSCH,

$n = 48$ for PBSCH.

The EVM requirements shall be tested against the maximum of the RMS average at the window W extremities of the EVM measurements:

Thus \overline{EVM}_l is calculated using $\Delta\tilde{t} = \Delta\tilde{t}_l$ in the expressions above and \overline{EVM}_h is calculated using $\Delta\tilde{t} = \Delta\tilde{t}_h$.

Thus we get:

$$EVM = \max(\overline{EVM}_l, \overline{EVM}_h)$$

The calculation of the EVM for the demodulation reference signal, EVM_{DMRS} , follows the same procedure as calculating the general EVM, with the exception that the modulation symbol set T_m defined in clause F.2 is restricted to symbols containing uplink demodulation reference signals.

The basic EVM_{DMRS} measurements are first averaged over 20 slots in the time domain to obtain an intermediate average \overline{EVM}_{DMRS} .

$$\overline{EVM}_{DMRS} = \sqrt{\frac{1}{20} \sum_{i=1}^{20} EVM_{DMRS,i}^2}$$

In the determination of each $EVM_{DMRS,i}$, the timing is set to $\Delta\tilde{t} = \Delta\tilde{t}_l$ if $\overline{EVM}_l > \overline{EVM}_h$, and it is set to $\Delta\tilde{t} = \Delta\tilde{t}_h$ otherwise, where \overline{EVM}_l and \overline{EVM}_h are the general average EVM values calculated in the same 20 slots over which the intermediate average \overline{EVM}_{DMRS} is calculated. Note that in some cases, the general average EVM may be calculated only for the purpose of timing selection for the demodulation reference signal EVM.

Then the results are further averaged to get the EVM for the demodulation reference signal, EVM_{DMRS} ,

$$EVM_{DMRS} = \sqrt{\frac{1}{6} \sum_{j=1}^6 \overline{EVM}_{DMRS,j}^2}$$

The PRACH EVM, EVM_{PRACH} , is averaged over two preamble sequence measurements for preamble formats 0, 1, 2, 3, and it is averaged over 10 preamble sequence measurements for preamble format 4.

The EVM requirements shall be tested against the maximum of the RMS average at the window W extremities of the EVM measurements:

Thus $\overline{EVM}_{\text{PRACH},1}$ is calculated using $\Delta\tilde{f} = \Delta\tilde{f}_l$ and $\overline{EVM}_{\text{PRACH},h}$ is calculated using $\Delta\tilde{f} = \Delta\tilde{f}_h$.

Thus we get:

$$EVM_{\text{PRACH}} = \max(\overline{EVM}_{\text{PRACH},1}, \overline{EVM}_{\text{PRACH},h})$$

F.6.F Averaged EVM for category NB1

The general EVM for category NB1 is calculated using the procedure defined in Annex F.6 with the exception that the general EVM is averaged over basic EVM measurements for $240/L_{\text{Ctone}}$ slots in the time domain, where $L_{\text{Ctone}} = \{1, 3, 6, 12\}$ is the number of subcarriers for the transmission.

The calculation of the EVM for the demodulation reference symbols for category NB1 follows the procedure defined for DMRS in Annex F.6 with the exception that the basic EVM_{DMRS} measurements are first averaged over $240/L_{\text{Ctone}}$ slots to obtain the intermediate average EVM.

The calculation of the NPRACH EVM for both formats follows the procedure defined for PRACH in Annex F.6 with the exception that EVM_{PRACH} is averaged over 64 preamble measurements.

F.7 Spectrum Flatness

The data shall be taken from FFT coded data symbols and the demodulation reference symbols of the allocated resource block.

Annex G (informative): Reference sensitivity level in lower SNR

This annex contains information on typical receiver sensitivity when HARQ transmission is enabled allowing operation in lower SNR regions (HARQ is disabled in conformance testing), thus representing the configuration normally used in live network operation under noise-limited conditions.

G.1 General

The reference sensitivity power level P_{SENS} with HARQ retransmission enabled (operation in lower SNR) is the minimum mean power applied to both the UE antenna ports at which the residual BLER after HARQ shall meet the requirements for the specified reference measurement channel. The residual BLER after HARQ transmission is defined as follows:

$$BLER_{\text{residual}} = 1 - \frac{A}{B}$$

A : Number of correctly decoded MAC PDUs

B : Number of transmitted MAC PDUs (Retransmitted MAC PDUs are not counted)

G.2 Typical receiver sensitivity performance (QPSK)

The residual BLER after HARQ shall be lower than 1% for the reference measurement channels as specified in Annexes G.3 (with one sided dynamic OCNG Pattern OP.1 FDD/TDD for the DL-signal as described in Annex A.5.1.1/A.5.2.1) with parameters specified in Table G.2-1 and Table G.2-2

Table G.2-1: Reference sensitivity QPSK P_{SENS}

Channel bandwidth							
E-UTRA Band	1.4 MHz (dBm)	3 MHz (dBm)	5 MHz (dBm)	10 MHz (dBm)	15 MHz (dBm)	20 MHz (dBm)	Duplex Mode
1				[-102]			FDD
2				TBD			FDD
3				TBD			FDD
4				TBD			FDD
5				TBD			FDD
6				TBD			FDD
7				TBD			FDD
8				TBD			FDD
9				TBD			FDD
10				TBD			FDD
11				TBD			FDD
12				TBD			FDD
13				TBD			FDD
14				TBD			FDD
...							
17				TBD			FDD
18				TBD			FDD
19				TBD			FDD
20				TBD			FDD
21				TBD			FDD
22				TBD			FDD
23				TBD			FDD
26				TBD			FDD
27				TBD			FDD
28				TBD			FDD
30				TBD			FDD
31			TBD				FDD
...							
33				[-102]			TDD
34				[-102]			TDD
35				[-102]			TDD
36				[-102]			TDD
37				[-102]			TDD
38				[-102]			TDD
39				[-102]			TDD
40				[-102]			TDD
42				[-102]			TDD
43				[-102]			TDD
44				[-102]			TDD
45				[-102]			TDD
...							
65				TBD			FDD
Note 1:	The transmitter shall be set to P _{UMAX} as defined in clause 6.2.5						
Note 2:	Reference measurement channel is G.3 with one sided dynamic OCNG Pattern OP.1 FDD/TDD as described in Annex A.5.1.1/A.5.2.1						
Note 3:	The signal power is specified per port						
Note 4:	For the UE which supports both Band 3 and Band 9 the reference sensitivity level is FFS.						
Note 5:	For the UE which supports both Band 11 and Band 21 the reference sensitivity level is FFS.						

Table G.2-2 specifies the minimum number of allocated uplink resource blocks for which the reference receive sensitivity requirement in lower SNR must be met.

Table G.2-2: Minimum uplink configuration for reference sensitivity

E-UTRA Band / Channel bandwidth / NRB / Duplex mode							
E-UTRA Band	1.4 MHz	3 MHz	5 MHz	10 MHz	15 MHz	20 MHz	Duplex Mode
1				[6] ¹			FDD
2				[6] ¹			FDD
3				[6] ¹			FDD
4				[6] ¹			FDD
5				[6] ¹			FDD
6				[6] ¹			FDD
7				[6] ¹			FDD
8				[6] ¹			FDD
9				[6] ¹			FDD
10				[6] ¹			FDD
11				[6] ¹			FDD
12				[6] ¹			FDD
13				[6] ¹			FDD
14				[6] ¹			FDD
...							
17				[6] ¹			FDD
18				[6] ¹			FDD
19				[6] ¹			FDD
20				[6] ¹			FDD
22				[6] ¹			FDD
21				[6] ¹			FDD
23				[6] ¹			FDD
26				[6] ¹			FDD
27				[6] ¹			FDD
28				[6] ¹			FDD
30				[6] ¹			FDD
31			[5] ⁴				FDD
...							
33				50			TDD
34				50			TDD
35				50			TDD
36				50			TDD
37				50			TDD
38				50			TDD
39				50			TDD
40				50			TDD
42				50			TDD
43				50			TDD
44				50			TDD
45				50			TDD
...							
65				[6] ¹			FDD
Note 1:	The UL resource blocks shall be located as close as possible to the downlink operating band but confined within the transmission bandwidth configuration for the channel bandwidth (Table 5.6-1).						
Note 2:	For the UE which supports both Band 11 and Band 21 the minimum uplink configuration for reference sensitivity is FFS.						
Note 3:	For Band 20; in the case of 15MHz channel bandwidth, the UL resource blocks shall be located at RBstart ₋₁₁ and in the case of 20MHz channel bandwidth, the UL resource blocks shall be located at RBstart ₋₁₆						
Note 4:	For Band 31; in the case of 5MHz channel bandwidth, the UL resource						

blocks shall be located at RBstart _10
--

Unless given by Table G.2-3, the minimum requirements specified in Tables G.2-1 and G.2-2 shall be verified with the network signalling value NS_01 (Table 6.2.4-1) configured.

Table G.2-3: Network Signalling Value for reference sensitivity

E-UTRA Band	Network Signalling value
2	NS_03
4	NS_03
10	NS_03
12	NS_06
13	NS_06
14	NS_06
17	NS_06
19	NS_08
21	NS_09
23	NS_03
30	NS_21
35	NS_03
36	NS_03

G.3 Reference measurement channel for REFSENSE in lower SNR

Tables G.3-1 and G.3-2 are applicable for Annex G.2 (Reference sensitivity level in lower SNR).

Table G.3-1 Fixed Reference Channel for Receiver Requirements (FDD)

Parameter	Unit	Value			
Channel bandwidth	MHz		5	10	
Allocated resource blocks			25	50	
Subcarriers per resource block			12	12	
Allocated subframes per Radio Frame			9	9	
Modulation			QPSK	QPSK	
Target Coding Rate			1/3	1/3	
Number of HARQ Processes	Processes		8	8	
Maximum number of HARQ transmissions			[4]	[4]	
Information Bit Payload per Sub-Frame					
For Sub-Frames 1,2,3,4,6,7,8,9	Bits		2216	4392	
For Sub-Frame 5	Bits		N/A	N/A	
For Sub-Frame 0	Bits		1800	4392	
Transport block CRC	Bits		24	24	
Number of Code Blocks per Sub-Frame (Note 4)					
For Sub-Frames 1,2,3,4,6,7,8,9	Bits		1	1	
For Sub-Frame 5	Bits		N/A	N/A	
For Sub-Frame 0	Bits		1	1	
Binary Channel Bits Per Sub-Frame					
For Sub-Frames 1,2,3,4,6,7,8,9	Bits		6300	13800	
For Sub-Frame 5	Bits		N/A	N/A	
For Sub-Frame 0	Bits		5460	12960	
Max. Throughput averaged over 1 frame	kbps		1952. 8	3952. 8	
UE Category			1-8	1-8	
Note 1:	2 symbols allocated to PDCCH for 20 MHz, 15 MHz and 10MHz channel BW. 3 symbols allocated to PDCCH for 5 MHz and 3 MHz. 4 symbols allocated to PDCCH for 1.4 MHz				
Note 2:	Reference signal, Synchronization signals and PBCH allocated as per TS 36.211 [4]				
Note 3:	If more than one Code Block is present, an additional CRC sequence of L = 24 Bits is attached to each Code Block (otherwise L = 0 Bit)				
Note 4:	Redundancy version coding sequence is {0, 1, 2, 3} for QPSK.				

Table G.3-2 Fixed Reference Channel for Receiver Requirements (TDD)

Parameter	Unit	Value			
Channel Bandwidth	MHz			10	
Allocated resource blocks				50	
Uplink-Downlink Configuration (Note 5)				1	
Allocated subframes per Radio Frame (D+S)				4+2	
Number of HARQ Processes	Processes			7	
Maximum number of HARQ transmission				[4]	
Modulation				QPSK	
Target coding rate				1/3	
Information Bit Payload per Sub-Frame	Bits				
For Sub-Frame 4, 9				4392	
For Sub-Frame 1, 6				3240	
For Sub-Frame 5				N/A	
For Sub-Frame 0				4392	
Transport block CRC	Bits			24	
Number of Code Blocks per Sub-Frame (Note 5)					
For Sub-Frame 4, 9				1	
For Sub-Frame 1, 6				1	
For Sub-Frame 5				N/A	
For Sub-Frame 0				1	
Binary Channel Bits Per Sub-Frame	Bits				
For Sub-Frame 4, 9				13800	
For Sub-Frame 1, 6				11256	
For Sub-Frame 5				N/A	
For Sub-Frame 0				13104	
Max. Throughput averaged over 1 frame	kbps			1965.6	
UE Category				1-5	
Note 1:	For normal subframes(0,4,5,9), 2 symbols allocated to PDCCH for 20 MHz, 15 MHz and 10 MHz channel BW; 3 symbols allocated to PDCCH for 5 MHz and 3 MHz; 4 symbols allocated to PDCCH for 1.4 MHz. For special subframe (1&6), only 2 OFDM symbols are allocated to PDCCH for all BWs.				
Note 2:	For 1.4MHz, no data shall be scheduled on special subframes(1&6) to avoid problems with insufficient PDCCH performance				
Note 3:	Reference signal, Synchronization signals and PBCH allocated as per TS 36.211 [4]				
Note 4:	If more than one Code Block is present, an additional CRC sequence of L = 24 Bits is attached to each Code Block (otherwise L = 0 Bit).				
Note 5:	As per Table 4.2-2 in TS 36.211 [4]				
Note 6:	Redundancy version coding sequence is {0, 1, 2, 3} for QPSK.				

Annex H (normative): Modified MPR behavior

H.1 Indication of modified MPR behavior

This annex contains the definitions of the bits in the field *modifiedMPRbehavior* indicated in the IE UE Radio Access Capability [7] by a UE supporting an MPR or A-MPR modified in a later release of this specification.

Table H.1-1: Definitions of the bits in the field *modifiedMPRbehavior*

Index of field (bit number)	Definition (description of the supported functionality if indicator set to one)	Notes
0 (leftmost bit)	- The MPR for intra-band contiguous carrier aggregation bandwidth class C with non-contiguous resource allocation specified in Clause 6.2.3A in version 12.5.0 of this specification	- This bit shall be set to 1 by a UE supporting intra-band contiguous CA bandwidth class C
1	- The A-MPR associated with NS_05 for Band 1 in Clause 6.2.4 in version 12.10.0 of this specification.	- This bit shall be set to 1 by a UE supporting A-MPR associated to NS_05 for Band 1.
2	The A-MPR associated with NS_04 for Band 41 in Table 6.2.4-4 in version 14.1.0 of this specification.	This bit can be set to 1 by a power class 3 UE supporting A-MPR associated to NS_04 for Band 41.

Annex I (informative): Change history

Table I.1: Change History

Date	Meeting	TDoc	CR	Rev	Cat	Subject/Comment	New version
11-2007	R4#45	R4-72206				TS36.101V0.1.0 approved by RAN4	
12-2007	RP#38	RP-070979				Approved version at TSG RAN #38	8.0.0
03-2008	RP#39	RP-080123	3			TS36.101 - Combined updates of E-UTRA UE requirements	8.1.0
05-2008	RP#40	RP-080325	4			TS36.101 - Combined updates of E-UTRA UE requirements	8.2.0
09-2008	RP#41	RP-080638	5r1			Addition of Ref Sens figures for 1.4MHz and 3MHz Channel bandwidths	8.3.0
09-2008	RP#41	RP-080638	7r1			Transmitter intermodulation requirements	8.3.0
09-2008	RP#41	RP-080638	10			CR for clarification of additional spurious emission requirement	8.3.0
09-2008	RP#41	RP-080638	15			Correction of In-band Blocking Requirement	8.3.0
09-2008	RP#41	RP-080638	18r1			TS36.101: CR for section 6: NS_06	8.3.0
09-2008	RP#41	RP-080638	19r1			TS36.101: CR for section 6: Tx modulation	8.3.0
09-2008	RP#41	RP-080638	20r1			TS36.101: CR for UE minimum power	8.3.0
09-2008	RP#41	RP-080638	21r1			TS36.101: CR for UE OFF power	8.3.0
09-2008	RP#41	RP-080638	24r1			TS36.101: CR for section 7: Band 13 Rx sensitivity	8.3.0
09-2008	RP#41	RP-080638	26			UE EVM Windowing	8.3.0
09-2008	RP#41	RP-080638	29			Absolute ACLR limit	8.3.0
09-2008	RP#41	RP-080731	23r2			TS36.101: CR for section 6: UE to UE co-existence	8.3.0
09-2008	RP#41	RP-080731	30			Removal of [] for UE Ref Sens figures	8.3.0
09-2008	RP#41	RP-080731	31			Correction of PA, PB definition to align with RAN1 specification	8.3.0
09-2008	RP#41	RP-080731	37r2			UE Spurious emission band UE co-existence	8.3.0
09-2008	RP#41	RP-080731	44			Definition of specified bandwidths	8.3.0
09-2008	RP#41	RP-080731	48r3			Addition of Band 17	8.3.0
09-2008	RP#41	RP-080731	50			Alignment of the UE ACS requirement	8.3.0
09-2008	RP#41	RP-080731	52r1			Frequency range for Band 12	8.3.0
09-2008	RP#41	RP-080731	54r1			Absolute power tolerance for LTE UE power control	8.3.0
09-2008	RP#41	RP-080731	55			TS36.101 section 6: Tx modulation	8.3.0
09-2008	RP#41	RP-080732	6r2			DL FRC definition for UE Receiver tests	8.3.0
09-2008	RP#41	RP-080732	46			Additional UE demodulation test cases	8.3.0
09-2008	RP#41	RP-080732	47			Updated descriptions of FRC	8.3.0
09-2008	RP#41	RP-080732	49			Definition of UE transmission gap	8.3.0
09-2008	RP#41	RP-080732	51			Clarification on High Speed train model in 36.101	8.3.0
09-2008	RP#41	RP-080732	53			Update of symbol and definitions	8.3.0
09-2008	RP#41	RP-080743	56			Addition of MIMO (4x2) and (4x4) Correlation Matrices	8.3.0
12-2008	RP#42	RP-080908	94r2			CR TX RX channel frequency separation	8.4.0
12-2008	RP#42	RP-080909	105r1			UE Maximum output power for Band 13	8.4.0
12-2008	RP#42	RP-080909	60			UL EVM equalizer definition	8.4.0
12-2008	RP#42	RP-080909	63			Correction of UE spurious emissions	8.4.0
12-2008	RP#42	RP-080909	66			Clarification for UE additional spurious emissions	8.4.0
12-2008	RP#42	RP-080909	72			Introducing ACLR requirement for coexistence with UTRA 1.6MHz channel from 36.803	8.4.0
12-2008	RP#42	RP-080909	75			Removal of [] from Section 6 transmitter characteristics	8.4.0
12-2008	RP#42	RP-080909	81			Clarification for PHS band protection	8.4.0
12-2008	RP#42	RP-080909	101			Alignment for the measurement interval for transmit signal quality	8.4.0
12-2008	RP#42	RP-080909	98r1			Maximum power	8.4.0
12-2008	RP#42	RP-080909	57r1			CR UE spectrum flatness	8.4.0
12-2008	RP#42	RP-080909	71r1			UE in-band emission	8.4.0
12-2008	RP#42	RP-080909	58r1			CR Number of TX exceptions	8.4.0
12-2008	RP#42	RP-080951	99r2			CR UE output power dynamic	8.4.0
12-2008	RP#42	RP-080951	79r1			LTE UE transmitter intermodulation	8.4.0
12-2008	RP#42	RP-080910	91			Update of Clause 8	8.4.0
12-2008	RP#42	RP-080950	106r1			Structure of Clause 9 including CSI requirements for PUCCH mode 1-0	8.4.0
12-2008	RP#42	RP-080911	59			CR UE ACS test frequency offset	8.4.0
12-2008	RP#42	RP-080911	65			Correction of spurious response parameters	8.4.0

12-2008	RP#42	RP-080911	80		Removal of LTE UE narrowband intermodulation	8.4.0
12-2008	RP#42	RP-080911	90r1		Introduction of Maximum Sensitivity Degradation	8.4.0
12-2008	RP#42	RP-080911	103		Removal of [] from Section 7 Receiver characteristic	8.4.0
12-2008	RP#42	RP-080912	62		Alignment of TB size n Ref Meas channel for RX characteristics	8.4.0
12-2008	RP#42	RP-080912	78		TDD Reference Measurement channel for RX characteristics	8.4.0
12-2008	RP#42	RP-080912	73r1		Addition of 64QAM DL referenbce measurement channel	8.4.0
12-2008	RP#42	RP-080912	74r1		Addition of UL Reference Measurement Channels	8.4.0
12-2008	RP#42	RP-080912	104		Reference measurement channels for PDSCH performance requirements (TDD)	8.4.0
12-2008	RP#42	RP-080913	68		MIMO Correlation Matrix Corrections	8.4.0
12-2008	RP#42	RP-080915	67		Correction to the figure with the Transmission Bandwidth configuration	8.4.0
12-2008	RP#42	RP-080916	77		Modification to EARFCN	8.4.0
12-2008	RP#42	RP-080917	85r1		New Clause 5 outline	8.4.0
12-2008	RP#42	RP-080919	102		Introduction of Bands 12 and 17 in 36.101	8.4.0
12-2008	RP#42	RP-080927	84r1		Clarification of HST propagation conditions	8.4.0
03-2009	RP#43	RP-090170	156r2		A-MPR table for NS_07	8.5.0
03-2009	RP#43	RP-090170	170		Corrections of references (References to tables and figures)	8.5.0
03-2009	RP#43	RP-090170	108		Removal of [] from Transmitter Intermodulation	8.5.0
03-2009	RP#43	RP-090170	155		E-UTRA ACLR for below 5 MHz bandwidths	8.5.0
03-2009	RP#43	RP-090170	116		Clarification of PHS band including the future plan	8.5.0
03-2009	RP#43	RP-090170	119		Spectrum emission mask for 1.4 MHz and 3 MHz bandwidths	8.5.0
03-2009	RP#43	RP-090170	120		Removal of "Out-of-synchronization handling of output power" heading	8.5.0
03-2009	RP#43	RP-090170	126		UE uplink power control	8.5.0
03-2009	RP#43	RP-090170	128		Transmission BW Configuration	8.5.0
03-2009	RP#43	RP-090170	130		Spectrum flatness	8.5.0
03-2009	RP#43	RP-090170	132r2		PUCCH EVM	8.5.0
03-2009	RP#43	RP-090170	134		UL DM-RS EVM	8.5.0
03-2009	RP#43	RP-090170	140		Removal of ACLR2bis requirements	8.5.0
03-2009	RP#43	RP-090171	113		In-band blocking	8.5.0
03-2009	RP#43	RP-090171	127		In-band blocking and sensitivity requirement for band 17	8.5.0
03-2009	RP#43	RP-090171	137r1		Wide band intermodulation	8.5.0
03-2009	RP#43	RP-090171	141		Correction of reference sensitivity power level of Band 9	8.5.0
03-2009	RP#43	RP-090172	109		AWGN level for UE DL demodulation performance tests	8.5.0
03-2009	RP#43	RP-090172	124		Update of Clause 8: additional test cases	8.5.0
03-2009	RP#43	RP-090172	139r1		Performance requirement structure for TDD PDSCH	8.5.0
03-2009	RP#43	RP-090172	142r1		Performance requirements and reference measurement channels for TDD PDSCH demodulation with UE-specific reference symbols	8.5.0
03-2009	RP#43	RP-090172	145		Number of information bits in DwPTS	8.5.0
03-2009	RP#43	RP-090172	160r1		MBSFN-Unicast demodulation test case	8.5.0
03-2009	RP#43	RP-090172	163r1		MBSFN-Unicast demodulation test case for TDD	8.5.0
03-2009	RP#43	RP-090173	162		Clarification of EARFCN for 36.101	8.5.0
03-2009	RP#43	RP-090369	110		Correction to UL Reference Measurement Channel	8.5.0
03-2009	RP#43	RP-090369	114		Addition of MIMO (4x4, medium) Correlation Matrix	8.5.0
03-2009	RP#43	RP-090369	121		Correction of 36.101 DL RMC table notes	8.5.0
03-2009	RP#43	RP-090369	125		Update of Clause 9	8.5.0
03-2009	RP#43	RP-090369	138r1		Clarification on OCNG	8.5.0
03-2009	RP#43	RP-090369	161		CQI reference measurement channels	8.5.0
03-2009	RP#43	RP-090369	164		PUCCH 1-1 Static Test Case	8.5.0
03-2009	RP#43	RP-090369	111		Reference Measurement Channel for TDD	8.5.0
03-2009	RP#44				Editorial correction in Table 6.2.4-1	8.5.1
05-2009	RP#44	RP-090540	167		Boundary between E-UTRA fOOB and spurious emission domain for 1.4 MHz and 3 MHz bandwidths. (Technically Endorsed CR in R4-50bis - R4-091205)	8.6.0
05-2009	RP#44	RP-090540	168		EARFCN correction for TDD DL bands. (Technically Endorsed	8.6.0

					CR in R4-50bis - R4-091206)	
05-2009	RP#44	RP-090540	169		Editorial correction to in-band blocking table. (Technically Endorsed CR in R4-50bis - R4-091238)	8.6.0
05-2009	RP#44	RP-090540	171		CR PRACH EVM. (Technically Endorsed CR in R4-50bis - R4-091308)	8.6.0
05-2009	RP#44	RP-090540	172		CR EVM correction. (Technically Endorsed CR in R4-50bis - R4-091309)	8.6.0
05-2009	RP#44	RP-090540	177		CR power control accuracy. (Technically Endorsed CR in R4-50bis - R4-091418)	8.6.0
05-2009	RP#44	RP-090540	179		Correction of SRS requirements. (Technically Endorsed CR in R4-50bis - R4-091426)	8.6.0
05-2009	RP#44	RP-090540	186		Clarification for EVM. (Technically Endorsed CR in R4-50bis - R4-091512)	8.6.0
05-2009	RP#44	RP-090540	187		Removal of [] from band 17 Refsens values and ACS offset frequencies	8.6.0
05-2009	RP#44	RP-090540	191		Completion of band17 requirements	8.6.0
05-2009	RP#44	RP-090540	192		Removal of 1.4 MHz and 3 MHz bandwidths from bands 13, 14 and 17.	8.6.0
05-2009	RP#44	RP-090540	223		CR: 64 QAM EVM	8.6.0
05-2009	RP#44	RP-090540	201		CR In-band emissions	8.6.0
05-2009	RP#44	RP-090540	203		CR EVM exclusion period	8.6.0
05-2009	RP#44	RP-090540	204		CR In-band emissions timing	8.6.0
05-2009	RP#44	RP-090540	206		CR Minimum Rx exceptions	8.6.0
05-2009	RP#44	RP-090540	207		CR UL DM-RS EVM	8.6.0
05-2009	RP#44	RP-090540	218r1		A-MPR table for NS_07	8.6.0
05-2009	RP#44	RP-090540	205r1		CR In-band emissions in shortened subframes	8.6.0
05-2009	RP#44	RP-090540	200r1		CR PUCCH EVM	8.6.0
05-2009	RP#44	RP-090540	178r2		No additional emission mask indication. (Technically Endorsed CR in R4-50bis - R4-091421)	8.6.0
05-2009	RP#44	RP-090540	220r1		Spectrum emission requirements for band 13	8.6.0
05-2009	RP#44	RP-090540	197r2		CR on aggregate power tolerance	8.6.0
05-2009	RP#44	RP-090540	196r2		CR: Rx IP2 performance	8.6.0
05-2009	RP#44	RP-090541	198r1		Maximum output power relaxation	8.6.0
05-2009	RP#44	RP-090542	166		Update of performance requirement for TDD PDSCH with MBSFN configuration. (Technically Endorsed CR in R4-50bis - R4-091180)	8.6.0
05-2009	RP#44	RP-090542	175		Adding AWGN levels for some TDD DL performance requirements. (Technically Endorsed CR in R4-50bis - R4-091406)	8.6.0
05-2009	RP#44	RP-090542	182		OCNG Patterns for Single Resource Block FRC Requirements. (Technically Endorsed CR in R4-50bis - R4-091504)	8.6.0
05-2009	RP#44	RP-090542	170r1		Update of Clause 8: PHICH and PMI delay. (Technically Endorsed CR in R4-50bis - R4-091275)	8.6.0
05-2009	RP#44	RP-090543	183		Requirements for frequency-selective fading test. (Technically Endorsed CR in R4-50bis - R4-091505)	8.6.0
05-2009	RP#44	RP-090543	199		CQI requirements under AWGN conditions	8.6.0
05-2009	RP#44	RP-090543	188r1		Adaptation of UL-RMC-s for supporting more UE categories	8.6.0
05-2009	RP#44	RP-090543	193r1		Correction of the LTE UE downlink reference measurement channels	8.6.0
05-2009	RP#44	RP-090543	184r1		Requirements for frequency non-selective fading tests. (Technically Endorsed CR in R4-50bis - R4-091506)	8.6.0
05-2009	RP#44	RP-090543	185r1		Requirements for PMI reporting. (Technically Endorsed CR in R4-50bis - R4-091510)	8.6.0
05-2009	RP#44	RP-090543	221r1		Correction to DL RMC-s for Maximum input level for supporting more UE-Categories	8.6.0
05-2009	RP#44	RP-090543	216		Addition of 15 MHz and 20 MHz bandwidths into band 38	8.6.0
05-2009	RP#44	RP-090559	180		Introduction of Extended LTE800 requirements. (Technically Endorsed CR in R4-50bis - R4-091432)	9.0.0
09-2009	RP#45	RP-090826	239		A-MPR for Band 19	9.1.0
09-2009	RP#45	RP-090822	225		LTE UTRA ACLR1 centre frequency definition for 1.4 and 3 MHz BW	9.1.0
09-2009	RP#45	RP-090822	227		Harmonization of text for LTE Carrier leakage	9.1.0
09-2009	RP#45	RP-090822	229		Sensitivity requirements for Band 38 15 MHz and 20 MHz bandwidths	9.1.0
09-2009	RP#45	RP-090822	236		Operating band edge relaxation of maximum output power for Band 18 and 19	9.1.0
09-2009	RP#45	RP-090822	238		Addition of 5MHz channel bandwidth for Band 40	9.1.0
09-2009	RP#45	RP-090822	245		Removal of unnecessary requirements for 1.4 and 3 MHz bandwidths on bands 13 and 17	9.1.0
09-2009	RP#45	RP-090877	261		Correction of LTE UE ACS test parameter	9.1.0
09-2009	RP#45	RP-090877	263R1		Correction of LTE UE ACLR test parameter	9.1.0

09-2009	RP#45	RP-090877	286		Uplink power and RB allocation for receiver tests	9.1.0
09-2009	RP#45	RP-090877	320		CR Sensitivity relaxation for small BW	9.1.0
09-2009	RP#45	RP-090877	324		Correction of Band 3 spurious emission band UE co-existence	9.1.0
09-2009	RP#45	RP-090877	249R1		CR Pcmx definition (working assumption)	9.1.0
09-2009	RP#45	RP-090877	330		Spectrum flatness clarification	9.1.0
09-2009	RP#45	RP-090877	332		Transmit power: removal of TC and modification of REFSENS note	9.1.0
09-2009	RP#45	RP-090877	282R1		Additional SRS relative power requirement and update of measurement definition	9.1.0
09-2009	RP#45	RP-090877	284R1		Power range applicable for relative tolerance	9.1.0
09-2009	RP#45	RP-090878	233		TDD UL/DL configurations for CQI reporting	9.1.0
09-2009	RP#45	RP-090878	235		Further clarification on CQI test configurations	9.1.0
09-2009	RP#45	RP-090878	243		Corrections to UL- and DL-RMC-s	9.1.0
09-2009	RP#45	RP-090878	247		Reference measurement channel for multiple PMI requirements	9.1.0
09-2009	RP#45	RP-090878	290		CQI reporting test for a scenario with frequency-selective interference	9.1.0
09-2009	RP#45	RP-090878	265R2		CQI reference measurement channels	9.1.0
09-2009	RP#45	RP-090878	321R1		CR RI Test	9.1.0
09-2009	RP#45	RP-090875	231		Correction of parameters for demodulation performance requirement	9.1.0
09-2009	RP#45	RP-090875	241R1		UE categories for performance tests and correction to RMC references	9.1.0
09-2009	RP#45	RP-090875	333		Clarification of \hat{E}_s definition in the demodulation requirement	9.1.0
09-2009	RP#45	RP-090875	326		Editorial corrections and updates to PHICH PBCH test cases.	9.1.0
09-2009	RP#45	RP-090875	259R3		Test case numbering in section 8 Performance tests	9.1.0
12-2009	RP-46	RP-091264	335		Test case numbering in TDD PDSCH performance test (Technically endorsed at RAN 4 52bis in R4-093523)	9.2.0
12-2009	RP-46	RP-091261	337		Adding beamforming model for user-specific reference signal (Technically endorsed at RAN 4 52bis in R4-093525)	9.2.0
12-2009	RP-46	RP-091263	339R1		Adding redundancy sequences to PMI test (Technically endorsed at RAN 4 52bis in R4-093581)	9.2.0
12-2009	RP-46	RP-091264	341		Throughput value correction at FRC for Maximum input level (Technically endorsed at RAN 4 52bis in R4-093660)	9.2.0
12-2009	RP-46	RP-091261	343		Correction to the modulated E-UTRA interferer (Technically endorsed at RAN 4 52bis in R4-093662)	9.2.0
12-2009	RP-46	RP-091264	345R1		OCNG: Patterns and present use in tests (Technically endorsed at RAN 4 52bis in R4-093664)	9.2.0
12-2009	RP-46	RP-091264	347		OCNG: Use in receiver and performance tests (Technically endorsed at RAN 4 52bis in R4-093666)	9.2.0
12-2009	RP-46	RP-091263	349		Miscellaneous corrections on CSI requirements (Technically endorsed at RAN 4 52bis in R4-093676)	9.2.0
12-2009	RP-46	RP-091261	351		Removal of RLC modes (Technically endorsed at RAN 4 52bis in R4-093677)	9.2.0
12-2009	RP-46	RP-091261	353		CR Rx diversity requirement (Technically endorsed at RAN 4 52bis in R4-093703)	9.2.0
12-2009	RP-46	RP-091261	355		A-MPR notation in NS_07 (Technically endorsed at RAN 4 52bis in R4-093706)	9.2.0
12-2009	RP-46	RP-091263	359		Single- and multi-PMI requirements (Technically endorsed at RAN 4 52bis in R4-093846)	9.2.0
12-2009	RP-46	RP-091263	363		CQI reference measurement channel (Technically endorsed at RAN 4 52bis in R4-093970)	9.2.0
12-2009	RP-46	RP-091292	364		LTE MBSFN Channel Model (Technically endorsed at RAN 4 52bis in R4-094020)	9.2.0
12-2009	RP-46	RP-091264	367		Numbering of PDSCH (User-Specific Reference Symbols) Demodulation Tests	9.2.0
12-2009	RP-46	RP-091264	369		Numbering of PDCCH/PCFICH, PHICH, PBCH Demod Tests	9.2.0
12-2009	RP-46	RP-091261	371		Remove [] from Reference Measurement Channels in Annex A	9.2.0
12-2009	RP-46	RP-091264	373R1		Corrections to RMC-s for Maximum input level test for low UE categories	9.2.0
12-2009	RP-46	RP-091261	377		Correction of UE-category for R.30	9.2.0
12-2009	RP-46	RP-091286	378		Introduction of Extended LTE1500 requirements for TS36.101	9.2.0
12-2009	RP-46	RP-091262	384		CR: Removal of 1.4 MHz and 3 MHz channel bandwidths from additional spurious emissions requirements for Band 1 PHS protection	9.2.0
12-2009	RP-46	RP-091262	386R3		Clarification of measurement conditions of spurious emission requirements at the edge of spurious domain	9.2.0
12-2009	RP-46	RP-091262	390		Spurious emission table correction for TDD bands 33 and 38.	9.2.0
12-2009	RP-46	RP-091262	392R2		36.101 Symbols and abbreviations for Pcmx	9.2.0
12-2009	RP-46	RP-091262	394		UTRAACL1 requirement definition for 1.4 and 3 MHz BW completed	9.2.0
12-2009	RP-46	RP-091263	396		Introduction of the ACK/NACK feedback modes for TDD	9.2.0

					requirements	
12-2009	RP-46	RP-091262	404R3		CR Power control exception R8	9.2.0
12-2009	RP-46	RP-091262	416R1		Relative power tolerance: special case for receiver tests	9.2.0
12-2009	RP-46	RP-091263	420R1		CSI reporting: test configuration for CQI fading requirements	9.2.0
12-2009	RP-46	RP-091284	421R1		Inclusion of Band 20 UE RF parameters	9.2.0
12-2009	RP-46	RP-091264	425		Editorial corrections and updates to Clause 8.2.1 FDD demodulation test cases	9.2.0
12-2009	RP-46	RP-091262	427		CR: time mask	9.2.0
12-2009	RP-46	RP-091264	430		Correction of the payload size for PDCCH/PCFICH performance requirements	9.2.0
12-2009	RP-46	RP-091263	432		Transport format and test point updates to RI reporting test cases	9.2.0
12-2009	RP-46	RP-091263	434		Transport format and test setup updates to frequency-selective interference CQI tests	9.2.0
12-2009	RP-46	RP-091263	436		CR RI reporting configuration in PUCCH 1-1 test	9.2.0
12-2009	RP-46	RP-091261	438		Addition of R.11-1 TDD references	9.2.0
12-2009	RP-46	RP-091292	439		Performance requirements for LTE MBMS	9.2.0
12-2009	RP-46	RP-091262	442R1		In Band Emissions Requirements Correction CR	9.2.0
12-2009	RP-46	RP-091262	444R1		PCMAX definition	9.2.0
03-2010	RP-47	RP-100246	453r1		Corrections of various errors in the UE RF requirements	9.3.0
03-2010	RP-47	RP-100246	462r1		UTRA ACLR measurement bandwidths for 1.4 and 3 MHz	9.3.0
03-2010	RP-47	RP-100246	493		Band 8 Coexistence Requirement Table Correction	9.3.0
03-2010	RP-47	RP-100246	489r1		Rel 9 CR for Band 14	9.3.0
03-2010	RP-47	RP-100246	485r1		CR Band 1- PHS coexistence	9.3.0
03-2010	RP-47	RP-100247	501		Fading CQI requirements for FDD mode	9.3.0
03-2010	RP-47	RP-100247	499		CR correction to RI test	9.3.0
03-2010	RP-47	RP-100249	451		Reporting mode, Reporting Interval and Editorial corrections for demodulation	9.3.0
03-2010	RP-47	RP-100249	464r1		Corrections to 1PRB PDSCH performance test in presence of MBSFN.	9.3.0
03-2010	RP-47	RP-100249	458r1		OCNG corrections	9.3.0
03-2010	RP-47	RP-100249	467		Addition of ONCG configuration in DRS performance test	9.3.0
03-2010	RP-47	RP-100249	465r1		PDSCH performance tests for low UE categories	9.3.0
03-2010	RP-47	RP-100250	460r1		Use of OCNG in CSI tests	9.3.0
03-2010	RP-47	RP-100250	491r1		Corrections to CQI test configurations	9.3.0
03-2010	RP-47	RP-100250	469r1		Corrections of some CSI test parameters	9.3.0
03-2010	RP-47	RP-100251	456r1		TBS correction for RMC UL TDD 16QAM full allocation BW 1.4 MHz	9.3.0
03-2010	RP-47	RP-100262	449		Editorial corrections on Band 19 REFSSENS	9.3.0
03-2010	RP-47	RP-100263	470r1		Band 20 UE RF requirements	9.3.0
03-2010	RP-47	RP-100264	446r1		A-MPR for Band 21	9.3.0
03-2010	RP-47	RP-100264	448		RF requirements for UE in later releases	9.3.0
03-2010	RP-47	RP-100268	445		36.101 CR: Editorial corrections on LTE MBMS reference measurement channels	9.3.0
03-2010	RP-47	RP-100268	454		The definition of the Doppler shift for LTE MBSFN Channel Model	9.3.0
03-2010	RP-47	RP-100239	478r3		Modification of the spectral flatness requirement and some editorial corrections	9.3.0
06-2010	RP-48	RP-100619	559		Corrections of tables for Additional Spectrum Emission Mask	9.4.0
06-2010	RP-48	RP-100619	538		Correction of transient time definition for EVM requirements	9.4.0
06-2010	RP-48	RP-100619	557r2		CR on UE coexistence requirement	9.4.0
06-2010	RP-48	RP-100619	547r1		Correction of antenna configuration and beam-forming model for DRS	9.4.0
06-2010	RP-48	RP-100619	536r1		CR: Corrections on MIMO demodulation performance requirements	9.4.0
06-2010	RP-48	RP-100619	528r1		Corrections on the definition of PCMAX	9.4.0
06-2010	RP-48	RP-100619	568		Relaxation of the PDSCH demodulation requirements due to control channel errors	9.4.0
06-2010	RP-48	RP-100619	566		Correction of the UE output power definition for RX tests	9.4.0
06-2010	RP-48	RP-100620	505r1		Fading CQI requirements for TDD mode	9.4.0
06-2010	RP-48	RP-100620	521		Correction to FRC for CQI index 0	9.4.0
06-2010	RP-48	RP-100620	516r1		Correction to CQI test configuration	9.4.0
06-2010	RP-48	RP-100620	532		Correction of CQI and PMI delay configuration description for TDD	9.4.0
06-2010	RP-48	RP-100620	574		Correction to FDD and TDD CSI test configurations	9.4.0
06-2010	RP-48	RP-100620	571		Minimum requirements for Rank indicator reporting	9.4.0
06-2010	RP-48	RP-100628	563		LTE MBMS performance requirements (FDD)	9.4.0
06-2010	RP-48	RP-100628	564		LTE MBMS performance requirements (TDD)	9.4.0
06-2010	RP-48	RP-100629	553r2		Performance requirements for dual-layer beamforming	9.4.0
06-2010	RP-48	RP-100630	524r2		CR: low Category CSI requirement	9.4.0
06-2010	RP-48	RP-100630	519		Correction of FRC reference and test case numbering	9.4.0
06-2010	RP-48	RP-100630	526		Correction of carrier frequency and EARFCN of Band 21 for TS36.101	9.4.0
06-2010	RP-48	RP-100630	508r1		Addition of PDSCH TDD DRS demodulation tests for Low UE	9.4.0

					categories	
06-2010	RP-48	RP-100630	539		Specification of minimum performance requirements for low UE category	9.4.0
06-2010	RP-48	RP-100630	569		Addition of minimum performance requirements for low UE category TDD CRS single-antenna port tests	9.4.0
06-2010	RP-48	RP-100631	549r3		Introduction of sustained downlink data-rate performance requirements	9.4.0
06-2010	RP-48	RP-100683	530r1		Band 20 Rx requirements	9.4.0
09-2010	RP-49	RP-100920	614r2		Add OCNG to MBMS requirements	9.5.0
09-2010	RP-49	RP-100916	599		Correction of PDCCH content for PHICH test	9.5.0
09-2010	RP-49	RP-100920	597r1		Beamforming model for transmission on antenna port 7/8	9.5.0
09-2010	RP-49	RP-100920	600r1		Correction of full correlation in frequency-selective CQI test	9.5.0
09-2010	RP-49	RP-100920	601		Correction on single-antenna transmission fixed reference channel	9.5.0
09-2010	RP-49	RP-100914	605		Reference sensitivity requirements for the 1.4 and 3 MHz bandwidths	9.5.0
09-2010	RP-49	RP-100920	608r1		CR for DL sustained data rate test	9.5.0
09-2010	RP-49	RP-100919	611		Correction of references in section 10 (MBMS performance requirements)	9.5.0
09-2010	RP-49	RP-100914	613		Band 13 and Band 14 spurious emission corrections	9.5.0
09-2010	RP-49	RP-100919	617r1		Rx Requirements	9.5.0
09-2010	RP-49	RP-100926	576r1		Clarification on DL-BF simulation assumptions	9.5.0
09-2010	RP-49	RP-100920	582r1		Introduction of additional Rel-9 scenarios	9.5.0
09-2010	RP-49	RP-100925	575r1		Correction to band 20 ue to ue Co-existence table	9.5.0
09-2010	RP-49	RP-100916	581r1		Test configuration corrections to CQI reporting in AWGN	9.5.0
09-2010	RP-49	RP-100916	595		Corrections to RF OCNG Pattern OP.1 and 2	9.5.0
09-2010	RP-49	RP-100919	583		Editorial corrections of 36.101	9.5.0
09-2010	RP-49	RP-100920	586		Addition of minimum performance requirements for low UE category TDD tests	9.5.0
09-2010	RP-49	RP-100914	590r1		Downlink power for receiver tests	9.5.0
09-2010	RP-49	RP-100920	591		OCNG use and power in beamforming tests	9.5.0
09-2010	RP-49	RP-100916	593		Throughput for multi-datastreams transmissions	9.5.0
09-2010	RP-49	RP-100914	588		Missing note in Additional spurious emission test with NS_07	9.5.0
09-2010	RP-49	RP-100927	596r2		CR LTE_TDD_2600_US spectrum band definition additions to TS 36.101	10.0.0
12-2010	RP-50	RP-101309	680		Demodulation performance requirements for dual-layer beamforming	10.1.0
12-2010	RP-50	RP-101325	672		Correction on the statement of TB size and subband selection in CSI tests	10.1.0
12-2010	RP-50	RP-101327	652		Correction to Band 12 frequency range	10.1.0
12-2010	RP-50	RP-101329	630		Removal of [] from TDD Rank Indicator requirements	10.1.0
12-2010	RP-50	RP-101329	635r1		Test configuration corrections to CQI TDD reporting in AWGN (Rel-10)	10.1.0
12-2010	RP-50	RP-101330	645		EVM window length for PRACH	10.1.0
12-2010	RP-50	RP-101330	649		Removal of NS signalling from TDD REFSSENS tests	10.1.0
12-2010	RP-50	RP-101330	642r1		Correction of Note 4 In Table 7.3.1-1: Reference sensitivity QPSK PREFSSENS	10.1.0
12-2010	RP-50	RP-101341	627		Add 20 RB UL Ref Meas channel	10.1.0
12-2010	RP-50	RP-101341	654r1		Additional in-band blocking requirement for Band 12	10.1.0
12-2010	RP-50	RP-101341	678		Further clarifications for the Sustained Downlink Data Rate Test	10.1.0
12-2010	RP-50	RP-101341	673r1		Correction on MBMS performance requirements	10.1.0
12-2010	RP-50	RP-101349	667r3		CR Removing brackets of Band 41 reference sensitivity to TS 36.101	10.1.0
12-2010	RP-50	RP-101356	666r2		Band 42 and 43 parameters for UMTS/LTE 3500 (TDD) for TS 36.101	10.1.0
12-2010	RP-50	RP-101359	646r1		CR for CA, UL-MIMO, eDL-MIMO, CPE	10.1.0
12-2010	RP-50	RP-101361	620r1		Introduction of L-band in TS 36.101	10.1.0
12-2010	RP-50	RP-101379	670r1		Correction on the PMI reporting in Multi-Layer Spatial Multiplexing performance test	10.1.0
12-2010	RP-50	RP-101380	679r1		Adding antenna configuration in CQI fading test case	10.1.0
01-2011					Clause numbering correction	10.1.1
03-2011	RP-51	RP-110359	695		Removal of E-UTRA ACLR for CA	10.2.0
03-2011	RP-51	RP-110338	699		PDCCH and PHICH performance: OCNG and power settings	10.2.0
03-2011	RP-51	RP-110336	706r1		Spurious emissions measurement uncertainty	10.2.0
03-2011	RP-51	RP-110352	707r1		REFSENSE in lower SNR	10.2.0
03-2011	RP-51	RP-110338	710		PMI performance: Power settings and precoding granularity	10.2.0
03-2011	RP-51	RP-110359	715r2		Definition of configured transmitted power for Rel-10	10.2.0
03-2011	RP-51	RP-110359	717		Introduction of requirement for adjacent intraband CA image rejection	10.2.0
03-2011	RP-51	RP-110343	719		Minimum requirements for the additional Rel-9 scenarios	10.2.0
03-2011	RP-51	RP-110343	723		Corrections to power settings for Single layer beamforming with simultaneous transmission	10.2.0
03-2011	RP-51	RP-110343	726r1		Correction to the PUSCH3-0 subband tests for Rel-10	10.2.0

03-2011	RP-51	RP-110338	730		Removing the square bracket for TS36.101	10.2.0
03-2011	RP-51	RP-110349	739		Removal of square brackets for dual-layer beamforming demodulation performance requirements	10.2.0
03-2011	RP-51	RP-110359	751		CR: Maximum input level for intra band CA	10.2.0
03-2011	RP-51	RP-110349	754r2		UE category coverage for dual-layer beamforming	10.2.0
03-2011	RP-51	RP-110343	756r1		Further clarifications for the Sustained Downlink Data Rate Test	10.2.0
03-2011	RP-51	RP-110343	759		Removal of square brackets in sustained data rate tests	10.2.0
03-2011	RP-51	RP-110337	762r1		Clarification to LTE relative power tolerance table	10.2.0
03-2011	RP-51	RP-110343	764		Introducing UE-selected subband CQI tests	10.2.0
03-2011	RP-51	RP-110343	765		Verification framework for PUSCH 2-2 and PUCCH 2-1 reporting	10.2.0
04-2011					Editorial: Spec Title correction, removal of "Draft"	10.2.1
06-2011	RP-52	RP-110804	766		Add Expanded 1900MHz Band (Band 25) in 36.101	10.3.0
06-2011	RP-52	RP-110795	768		Fixing Band 24 inclusion in TS 36.101	10.3.0
06-2011	RP-52	RP-110788	772		CR: Corrections for UE to UE co-existence requirements of Band 3	10.3.0
06-2011	RP-52	RP-110812	774		Add 2GHz S-Band (Band 23) in 36.101	10.3.0
06-2011	RP-52	RP-110789	782		CR: Band 19 A-MPR refinement	10.3.0
06-2011	RP-52	RP-110796	787		REFSENS in lower SNR	10.3.0
06-2011	RP-52	RP-110789	805		Clarification for MBMS reference signal levels	10.3.0
06-2011	RP-52	RP-110792	810		FDD MBMS performance requirements for 64QAM mode	10.3.0
06-2011	RP-52	RP-110787	814		Correction on CQI mapping index of RI test	10.3.0
06-2011	RP-52	RP-110789	824		Corrections to in-band blocking table	10.3.0
06-2011	RP-52	RP-110794	826		Correction of TDD Category 1 DRS and DMRS RMCs	10.3.0
06-2011	RP-52	RP-110794	828		TDD MBMS performance requirements for 64QAM mode	10.3.0
06-2011	RP-52	RP-110796	829		Correction of TDD RMC for Low SNR Demodulation test	10.3.0
06-2011	RP-52	RP-110796	830		Informative reference sensitivity requirements for Low SNR for TDD	10.3.0
06-2011	RP-52	RP-110787	778r1		Minor corrections to DL-RMC-s for Maximum input level	10.3.0
06-2011	RP-52	RP-110789	832		PDCCH and PHICH performance: OCNB and power settings	10.3.0
06-2011	RP-52	RP-110789	818r1		Correction on 2-X PMI test for R10	10.3.0
06-2011	RP-52	RP-110791	816r1		Addition of performance requirements for dual-layer beamforming category 1 UE test	10.3.0
06-2011	RP-52	RP-110789	834		Performance requirements for PUCCH 2-0, PUCCH 2-1 and PUSCH 2-2 tests	10.3.0
06-2011	RP-52	RP-110807	835r1		CR for UL MIMO and CA	10.3.0
09-2011	RP-53	RP-111248	862r1		Removal of unnecessary channel bandwidths from REFSENS tables	10.4.0
09-2011	RP-53	RP-111248	869r1		Clarification on BS precoding information field for RI FDD and PUCCH 2-1 PMI tests	10.4.0
09-2011	RP-53	RP-111248	872r1		CR for B14Rx requirement Rrel 10	10.4.0
09-2011	RP-53	RP-111248	890r1		CR to TS36.101: Correction on the accuracy test of CQI.	10.4.0
09-2011	RP-53	RP-111248	893		CR to TS36.101: Correction on CQI mapping index of TDD RI test	10.4.0
09-2011	RP-53	RP-111248	904		Correction of code block numbers for some RMCs	10.4.0
09-2011	RP-53	RP-111248	907		Correction to UL RMC for FDD and TDD	10.4.0
09-2011	RP-53	RP-111248	914r1		Adding codebook subset restriction for single layer closed-loop spatial multiplexing test	10.4.0
09-2011	RP-53	RP-111251	883		Sustained data rate: Correction of the ACK/NACK feedback mode	10.4.0
09-2011	RP-53	RP-111251	929		36.101 CR on MBSFN FDD requirements(R10)	10.4.0
09-2011	RP-53	RP-111251	938		TDD MBMS performance requirements for 64QAM mode	10.4.0
09-2011	RP-53	RP-111252	895		Further clarification for the dual-layer beamforming demodulation requirements	10.4.0
09-2011	RP-53	RP-111255	908r1		Introduction of Band 22	10.4.0
09-2011	RP-53	RP-111255	939		Modifications of Band 42 and 43	10.4.0
09-2011	RP-53	RP-111260	944		CR for TS 36.101 Annex B: Static channels for CQI tests	10.4.0
09-2011	RP-53	RP-111262	878r1		Correction of CSI reference channel subframe description	10.4.0
09-2011	RP-53	RP-111262	887		Correction to UL MIMO	10.4.0
09-2011	RP-53	RP-111262	926r1		Power control accuracy for intra-band carrier aggregation	10.4.0
09-2011	RP-53	RP-111262	927r1		In-band emissions requirements for intra-band carrier aggregation	10.4.0
09-2011	RP-53	RP-111262	930r1		Adding the operating band for UL-MIMO	10.4.0
09-2011	RP-53	RP-111265	848		Corrections to intra-band contiguous CA RX requirements	10.4.0
09-2011	RP-53	RP-111265	863		Intra-band contiguous CA MPR requirement refinement	10.4.0
09-2011	RP-53	RP-111265	866r1		Intra-band contiguous CA EVM	10.4.0
09-2011	RP-53	RP-111266	935		Introduction of the downlink CA demodulation requirements	10.4.0
09-2011	RP-53	RP-111266	936r1		Introduction of CA UE demodulation requirements for TDD	10.4.0
12-2011	RP-54	RP-111684	947		Corrections of UE categories of Rel-10 reference channels for RF requirements	10.5.0
12-2011	RP-54	RP-111684	948		Alternative way to define channel bandwidths per operating band for	10.5.0
12-2011	RP-54	RP-111686	949		CR for TS36.101: Adding note to the function of MPR	10.5.0

12-2011	RP-54	RP-111680	950		Clarification on applying CSI reports during rank switching in RI FDD test - Rel-10	10.5.0
12-2011	RP-54	RP-111734	953r1		Corrections for Band 42 and 43 introduction	10.5.0
12-2011	RP-54	RP-111680	956		UE spurious emissions	10.5.0
12-2011	RP-54	RP-111682	959		Add scrambling identity n_SCID for MU-MIMO test	10.5.0
12-2011	RP-54	RP-111690	960r1		P-MPR definition	10.5.0
12-2011	RP-54	RP-111693	962		P _{max,c} Computation Assumptions	10.5.0
12-2011	RP-54	RP-111733	963r1		Correction of frequency range for spurious emission requirements	10.5.0
12-2011	RP-54	RP-111680	966		General review of the reference measurement channels	10.5.0
12-2011	RP-54	RP-111691	945		Corrections of Rel-10 demodulation performance requirements This CR is only partially implemented due to confliction with CR 966	10.5.0
12-2011	RP-54	RP-111684	946		Corrections of UE categories for Rel-10 CSI requirements This CR is only partially implemented due to confliction with CR 966	10.5.0
12-2011	RP-54	RP-111691	982r2		Introduction of SDR TDD test scenario for CA UE demodulation This CR is only partially implemented due to confliction with CR 966	10.5.0
12-2011	RP-54	RP-111693	971r1		CR on Colliding CRS for non-MBSFN ABS	10.5.0
12-2011	RP-54	RP-111693	972r1		Introduction of eICIC demodulation performance requirements for FDD and TDD	10.5.0
12-2011	RP-54	RP-111686	985		Adding missing UL configuration specification in some UE receiver requirements for case of 1 CC UL capable UE	10.5.0
12-2011	RP-54	RP-111684	998		Correction and maintenance on CQI and PMI requirements (Rel-10)	10.5.0
12-2011	RP-54	RP-111735	1004		MPR for CA Multi-cluster	10.5.0
12-2011	RP-54	RP-111691	1005		CA demodulation performance requirements for LTE FDD	10.5.0
12-2011	RP-54	RP-111692	1006		CQI reporting accuracy test on frequency non-selective scheduling on eDL MIMO	10.5.0
12-2011	RP-54	RP-111692	1007		CQI reporting accuracy test on frequency-selective scheduling on eDL MIMO	10.5.0
12-2011	RP-54	RP-111692	1008		PMI reporting accuracy test for TDD on eDL MIMO	10.5.0
12-2011	RP-54	RP-111692	1009r1		CR for TS 36.101: RI performance requirements	10.5.0
12-2011	RP-54	RP-111692	1010r1		CR for TS 36.101: Introduction of static CQI tests (Rel-10)	10.5.0
03-2012	RP-55	RP-120291	1014		RF: Updates and corrections to the RMC-s related annexes (Rel-10)	10.6.0
03-2012	RP-55	RP-120300	1015r1		On eICIC ABS pattern	10.6.0
03-2012	RP-55	RP-120300	1016r1		On eICIC interference models	10.6.0
03-2012	RP-55	RP-120299	1017r1		TS36.101 CR: on eDL-MIMO channel model using cross-polarized antennas	10.6.0
03-2012	RP-55	RP-120304	1020r1		TS36.101 CR: Correction to MBMS Performance Test Parameters	10.6.0
03-2012	RP-55	RP-120303	1021		Harmonic exceptions in LTE UE to UE co-ex tests	10.6.0
03-2012	RP-55	RP-120304	1023		Unified titles for Rel-10 CSI tests	10.6.0
03-2012	RP-55	RP-120300	1033r1		Introduction of reference channel for eICIC demodulation	10.6.0
03-2012	RP-55	RP-120304	1040r1		Correction of Actual code rate for CSI RMCs	10.6.0
03-2012	RP-55	RP-120304	1041r1		Definition of synchronized operation	10.6.0
03-2012	RP-55	RP-120296	1048r1		Intra band contiguous CA Ue to Ue Co-ex	10.6.0
03-2012	RP-55	RP-120296	1049r1		REL-10 CA specification editorial consistency	10.6.0
03-2012	RP-55	RP-120299	1053		Beamforming model for TM9	10.6.0
03-2012	RP-55	RP-120296	1054		Requirement for CA demodulation with power imbalance	10.6.0
03-2012	RP-55	RP-120298	1057		Updating Band 23 duplex specifications	10.6.0
03-2012	RP-55	RP-120298	1058r1		Correcting UE Coexistence Requirements for Band 23	10.6.0
03-2012	RP-55	RP-120304	1059r1		CA demodulation performance requirements for LTE TDD	10.6.0
03-2012	RP-55	RP-120304	1061		Requirement for CA SDR FDD test scenario	10.6.0
03-2012	RP-55	RP-120293	1064r1		TS36.101 RF editorial corrections Rel 10	10.6.0
03-2012	RP-55	RP-120299	1067r1		Introduction of TM9 demodulation performance requirements	10.6.0
03-2012	RP-55	RP-120304	1071r1		Introduction of a CA demodulation test for UE soft buffer management testing	10.6.0
03-2012	RP-55	RP-120296	1072		MPR formula correction For intra-band contiguous CA	10.6.0

					Bandwidth Class C	
03-2012	RP-55	RP-120303	1077r 1		CR for 36.101: B41 REFSENS and MOP changes to accommodate single filter architecture	10.6.0
03-2012	RP-55	RP-120300	1082		TM3 tests for eICIC	10.6.0
03-2012	RP-55	RP-120300	1083r 1		Introduction of requirements of CQI reporting definition for eICIC	10.6.0
03-2012	RP-55	RP-120304	1084		eDL MIMO CSI requirements	10.6.0
03-2012	RP-55	RP-120306	1070r 1		Introduction of Band 26/XXVI to TS 36.101	11.0.0
03-2012	RP-55	RP-120310	1074		Band 41 CA CR for TS36.101, section 5	11.0.0
03-2012	RP-55	RP-120310	1075r 1		Band 41 CA CR for TS36.101, section 6	11.0.0
03-2012	RP-55	RP-120310	1076		Band 41 CA CR for TS36.101, section 7	11.0.0
06-2012	RP-56	RP-120795	1085r 2		Modulator specification tightening	11.1.0
06-2012	RP-56	RP-120777	1087r 1		Carrier aggregation Relative power tolerance, removal of TBD.	11.1.0
06-2012	RP-56	RP-120783	1089		UE spurious emissions for Band 7 and Band 38 coexistence	11.1.0
06-2012	RP-56	RP-120780	1092		Deleting square brackets in Reference Measurement Channels	11.1.0
06-2012	RP-56	RP-120779	1097		CR to TS36.101: Correction on parameters for the eDL-MIMO CQI and PMI tests	11.1.0
06-2012	RP-56	RP-120780	1098r 1		CR to TS36.101: Fixed reference channel for PDSCH demodulation performance requirements on eDL-MIMO – NOT implemented as it is based on a wrong version of the spec	11.1.0
06-2012	RP-56	RP-120774	1107		RMC correction on eDL-MIMO RI test	11.1.0
06-2012	RP-56	RP-120774	1108r 1		FRC correction on frequency selective CQI and PMI test (Rel-11)	11.1.0
06-2012	RP-56	RP-120774	1111		Correction on test point for PMI test (Rel-11)	11.1.0
06-2012	RP-56	RP-120784	1114r 1		Corrections and clarifications on eICIC demodulation test	11.1.0
06-2012	RP-56	RP-120784	1117r 1		Corrections and clarifications on eICIC CSI tests	11.1.0
06-2012	RP-56	RP-120783	1119r 1		Corrections on UE performance requirements	11.1.0
06-2012	RP-56	RP-120773	1120		Introduction of CA band combination Band1 + Band19 to TS 36.101	11.1.0
06-2012	RP-56	RP-120769	1127		Addition of ETU30 channel model	11.1.0
06-2012	RP-56	RP-120773	1140		Addition of Maximum Throughput for R.30-1 TDD RMC	11.1.0
06-2012	RP-56	RP-120779	1141		CR for 36.101: The clarification of MPR and A-MPR for CA	11.1.0
06-2012	RP-56	RP-120784	1142		Corrections for eICIC demod test case with MBSN ABS	11.1.0
06-2012	RP-56	RP-120785	1144		Removing brackets of contiguous allocation A-MPR for CA_NS_04	11.1.0
06-2012	RP-56	RP-120784	1149r 1		Introduction of PDCCH test with colliding RS on MBSFN-ABS	11.1.0
06-2012	RP-56	RP-120784	1153r 1		Some clarifications and OCNG pattern for eICIC demodulation requirements	11.1.0
06-2012	RP-56	RP-120773	1155		Introduction of TDD CA Soft Buffer Limitation	11.1.0
06-2012	RP-56	RP-120795	1156		B26 and other editorial corrections	11.1.0
06-2012	RP-56	RP-120779	1161		Corrections on CQI and PMI test	11.1.0
06-2012	RP-56	RP-120780	1163		FRC for TDD PMI test	11.1.0
06-2012	RP-56	RP-120778	1165r 1		Clean-up of UL-MIMO for TS36.101	11.1.0
06-2012	RP-56	RP-120782	1171		Removal of unnecessary references to single carrier requirements from Interband CA subclauses	11.1.0
06-2012	RP-56	RP-120781	1174		PDCCH wrong detection in receiver spurious emissions test	11.1.0
06-2012	RP-56	RP-120776	1184		Corrections to 3500 MHz	11.1.0
06-2012	RP-56	RP-120793	1189r 2		Introduction of Band 44	11.1.0
06-2012	RP-56	RP-120784	1193r 1		Target SNR setting for eICIC demodulation requirement	11.1.0
06-2012	RP-56	RP-120780	1196		Editorial simplification to CA REFSENS UL allocation table	11.1.0
06-2012	RP-56	RP-120778	1199		Correction of wrong table references in CA receiver tests	11.1.0
06-2012	RP-56	RP-120791	1200r 1		Introduction of e850_LB (Band 27) to TS 36.101	11.1.0
06-2012	RP-56	RP-120764	1212		Correction of PHS protection requirements for TS 36.101	11.1.0
06-2012	RP-56	RP-120793	1213r 1		Introduction of Band 28 into TS36.101	11.1.0
06-2012	RP-56	RP-120781	1215r 1		Proposed revision of subclause 4.3A for TS36.101	11.1.0
06-2012	RP-56	RP-120781	1217r 1		Proposed revision on subclause 6.3.4A for TS36.101	11.1.0
06-2012	RP-56	RP-120795	1219r 1		Aligning requirements between Band 18 and Band 26 in TS36.101	11.1.0

06-2012	RP-56	RP-120782	1221			SNR definition	11.1.0
06-2012	RP-56	RP-120778	1223			Correction of CSI configuraiton for CA TM4 tests R11	11.1.0
06-2012	RP-56	RP-120773	1225			CR on CA UE receiver timing window R11	11.1.0
06-2012	RP-56	RP-120784	1226			Extension of static eCIC CQI test	11.1.0
09-2012	RP-57	RP-121294	1230			Correct Transport Block size in 9RB 16QAM Uplink Reference Measurement Channel	11.2.0
09-2012	RP-57	RP-121313	1233r 1			RF: Corrections to power allocation parameters for transmission mode 8 (Rel-11)	11.2.0
09-2012	RP-57	RP-121304	1235			RF-CA: non-CA notation and applicability of test points in scenarios without and with CA operation (Rel-11)	11.2.0
09-2012	RP-57	RP-121305	1237			ACK/NACK feedback modes for FDD and TDD TM4 CA demodulation requirements (Rel-11)	11.2.0
09-2012	RP-57	RP-121305	1239			Correction of feedback mode for CA TDD demodulation requirements (resubmission of R4-63AH-0194 for Rel-11)	11.2.0
09-2012	RP-57	RP-121302	1241			ABS pattern setup for MBSFN ABS test (resubmission of R4-63AH-0204 for Rel-11)	11.2.0
09-2012	RP-57	RP-121302	1243			CR on eCIC CQI definition test (resubmission of R4-63AH-0205 for Rel-11)	11.2.0
09-2012	RP-57	RP-121302	1245			Transmission of CQI feedback and other corrections (Rel-11)	11.2.0
09-2012	RP-57	RP-121302	1247			Target SNR setting for eCIC MBSFN-ABS demodulation requirements (Rel-11)	11.2.0
09-2012	RP-57	RP-121335	1248			Introduction of CA_1_21 RF requirements into TS36.101	11.2.0
09-2012	RP-57	RP-121300	1251			Corrections of spurious emission band UE co-existence applicable in Japan	11.2.0
09-2012	RP-57	RP-121306	1253			Correction on RMC for frequency non-selective CQI test	11.2.0
09-2012	RP-57	RP-121306	1255			Requirements for the eDL-MIMO CQI test	11.2.0
09-2012	RP-57	RP-121302	1257			Clarification on PDSCH test setup under MBSFN ABS	11.2.0
09-2012	RP-57	RP-121316	1258			Update of Band 28 requirements	11.2.0
09-2012	RP-57	RP-121313	1262			Applicability of statement allowing RBW < Meas BW for spurious	11.2.0
09-2012	RP-57	RP-121298	1265			Clarification of RB allocation for DRS demodulation tests	11.2.0
09-2012	RP-57	RP-121304	1267			Removal of brackets for CA Tx	11.2.0
09-2012	RP-57	RP-121337	1268r 1			TS 36.101 CR for CA_38	11.2.0
09-2012	RP-57	RP-121327	1269			Introduction of CA_B7_B20 in 36.101	11.2.0
09-2012	RP-57	RP-121313	1271			Corrections of FRC subframe allocations and other minor problems	11.2.0
09-2012	RP-57	RP-121305	1274			Introduction of requirements for TDD CA Soft Buffer Limitation	11.2.0
09-2012	RP-57	RP-121307	1276			Correction of eDL-MIMO CSI RMC tables and references	11.2.0
09-2012	RP-57	RP-121307	1278			Correction of MIMO channel model for polarized antennas	11.2.0
09-2012	RP-57	RP-121303	1280			Addition of 15 and 20MHz Bandwidths for Band 23 to TS 36.101 (Rel-11)	11.2.0
09-2012	RP-57	RP-121334	1283r 1			Add requirements for inter-band CA of B_1-18 and B_11-18 in TS36.101	11.2.0
09-2012	RP-57	RP-121304	1285r 1			CR for MPR mask for multi-clustered simultaneous transmission in single CC in Rel-11	11.2.0
09-2012	RP-57	RP-121447	1288r 2			Introduction of Japanese Regulatory Requirements to LTE Band 8(R11)	11.2.0
09-2012	RP-57	RP-121315	1289			CR for Band 27 MOP	11.2.0
09-2012	RP-57	RP-121315	1290			CR for Band 27 A-MPR	11.2.0
09-2012	RP-57	RP-121316	1291			CR to replace protected frequency range with new band number 27	11.2.0
09-2012	RP-57	RP-121215	1292r 1			Introduction of CA band combination Band3 + Band5 to TS 36.101	11.2.0
09-2012	RP-57	RP-121306	1300r 1			Requirements for eDL-MIMO RI test	11.2.0
09-2012	RP-57	RP-121306	1304			Corrections to TM9 demodulation tests	11.2.0
09-2012	RP-57	RP-121313	1306			Correction to PCFICH power parameter setting	11.2.0
09-2012	RP-57	RP-121306	1310r 1			Correction on frequency non-selective CQI test	11.2.0
09-2012	RP-57	RP-121306	1313r 1			eDL-MIMO CQI/PMI test	11.2.0
09-2012	RP-57	RP-121313	1316			Correction of the definition of unsynchronized operation	11.2.0
09-2012	RP-57	RP-121304	1320r 1			Correction to Transmit Modulation Quality Tests for Intra-Band CA	11.2.0
09-2012	RP-57	RP-121338	1324r 2			36.101 CR for LTE_CA_B7	11.2.0
09-2012	RP-57	RP-121331	1325			Introduction of CA_3_20 RF requirements into TS36.101	11.2.0
09-2012	RP-57	RP-121316	1326			A-MPR table correction for NS_18	11.2.0
09-2012	RP-57	RP-121304	1332r 1			Bandwidth combination sets for intra-band and inter-band carrier aggregation	11.2.0
09-2012	RP-57	RP-121325	1339			Introduction of LTE Advanced Carrier Aggregation of Band 4 and Band 13	11.2.0
09-2012	RP-57	RP-121326	1340r			Introduction of CA configurations CA-12A-4A and CA-17A-4A	11.2.0

			1			
09-2012	RP-57	RP-121324	1341		Introduction of CA_B3_B7 in 36.101	11.2.0
09-2012	RP-57	RP-121328	1343		Introduction of Band 2 + Band 17 inter-band CA configuration into 36.101	11.2.0
09-2012	RP-57	RP-121306	1351		FRC for TM9 FDD	11.2.0
09-2012	RP-57	RP-121295	1352		Random precoding granularity in PMI tests	11.2.0
09-2012	RP-57	RP-121302	1358		Introduction of RI test for eCIC	11.2.0
09-2012	RP-57	RP-121304	1360		Notes for deltaTib and deltaRib tables	11.2.0
09-2012	RP-57	RP-121304	1361		CR for A-MPR masks for NS_CA_1C	11.2.0
12-2012	RP-58	RP-121884	1362		Introduction of CA_3_8 RF requirements to TS 36.101	11.3.0
12-2012	RP-58	RP-121870	1363		Removal of square brackets for Band 27 in Table 5.6.1-1	11.3.0
12-2012	RP-58	RP-121861	1366		Some changes related to CA tests and overview table of DL measurement channels	11.3.0
12-2012	RP-58	RP-121860	1368		Correction of eCIC CQI tests	11.3.0
12-2012	RP-58	RP-121860	1370		Correction of eCIC demodulation tests	11.3.0
12-2012	RP-58	RP-121862	1374		Correction on CSI-RS subframe offset parameter	11.3.0
12-2012	RP-58	RP-121862	1376		Correction on FRC table in CSI test	11.3.0
12-2012	RP-58	RP-121862	1382		Correction of reference channel table for TDD eDL-MIMO RI test	11.3.0
12-2012	RP-58	RP-121850	1386		OCNG patterns for Sustained Data rate testing	11.3.0
12-2012	RP-58	RP-121867	1388r1		Introduction of one periodic CQI test for CA deployments	11.3.0
12-2012	RP-58	RP-121894	1396		Introduction of CA_B5_B12 in 36.101	11.3.0
12-2012	RP-58	RP-121850	1401		Introducing the additional frequency bands of 5 MHz x 2 in 1.7 GHz in Japan to Band 3	11.3.0
12-2012	RP-58	RP-121887	1406r1		Reference sensitivity for the small bandwidth of CA_4-12	11.3.0
12-2012	RP-58	RP-121860	1407		CR on eCIC RI test	11.3.0
12-2012	RP-58	RP-121862	1409		Cleaning of 36.101 Performance sections Rel-11	11.3.0
12-2012	RP-58	RP-121861	1416		Out-of-band blocking requirements for inter-band carrier aggregation	11.3.0
12-2012	RP-58	RP-121861	1418		Adding missed SNR reference values for CA soft buffer tests	11.3.0
12-2012	RP-58	RP-121890	1422		Introduction of CA_4A-5A into 36.101	11.3.0
12-2012	RP-58	RP-121867	1431		Clean up of specification R11	11.3.0
12-2012	RP-58	RP-121867	1436		Band 1 to Band 33 and Band 39 UE coexistence requirements	11.3.0
12-2012	RP-58	RP-121871	1437r1		Editorial corrections for Band 26	11.3.0
12-2012	RP-58	RP-121896	1438		Introduction of Band 5 + Band 17 inter-band CA configuration into 36.101	11.3.0
12-2012	RP-58	RP-121862	1442		Correction of eDL-MIMO RI test and RMC table for the CSI test	11.3.0
12-2012	RP-58	RP-121861	1444		Minor correction to ceiling function example - rel11	11.3.0
12-2012	RP-58	RP-121862	1449		Correction of SNR definition	11.3.0
12-2012	RP-58	RP-121860	1450		Brackets clean up for eCIC CSI/demodulation	11.3.0
12-2012	RP-58	RP-121860	1455		CR on eCIC RI testing (Rel-11)	11.3.0
12-2012	RP-58	RP-121862	1459		Correction on FRC table	11.3.0
12-2012	RP-58	RP-121879	1461r1		CR for LTE_B14 HPUE (Power Class 1)	11.3.0
12-2012	RP-58	RP-121862	1464		Adding references to the appropriate beamforming model (Rel-11)	11.3.0
12-2012	RP-58	RP-121898	1465r1		Introduction of CA_8_20 RF requirements into TS36.101	11.3.0
12-2012	RP-58	RP-121882	1468r1		Introduction of inter-band CA_11-18 into TS36.101	11.3.0
12-2012	RP-58	RP-121903	1472r1		Introduction of advanced receivers demodulation performance (FDD)	11.3.0
12-2012	RP-58	RP-121903	1473r1		Introduction of performance requirements for verifying the receiver type for advanced receivers (FDD/TDD)	11.3.0
12-2012	RP-58	RP-121886	1474		CR to remove the square bracket of A-MPR in TS36.101	11.3.0
12-2012	RP-58	RP-121861	1476		Correction of some errors in reference sensitivity for CA in TS 36.101 (R11)	11.3.0
12-2012	RP-58	RP-121903	1480r1		Introduction of Advanced Receivers Test Cases for TDD	11.3.0
12-2012	RP-58	RP-121901	1490r1		Introduction of Band 29	11.3.0
12-2012	RP-58	RP-121849	1494		Low-channel Band 1 coexistence with PHS	11.3.0
12-2012	RP-58	RP-121861	1498r1		Completion of the tables of bandwidth combinations specified for CA	11.3.0
12-2012	RP-58	RP-121861	1499r1		Exceptions to REFSENS requirements for class A2 CA combinations	11.3.0
12-2012	RP-58	RP-121892	1500		Introduction of carrier aggregation configuration CA_4-7	11.3.0
12-2012	RP-58	RP-121870	1504		Editorial corrections to Band 27 specifications	11.3.0
12-2012	RP-58	RP-121878	1505		Band 28 AMPR for DTV protection	11.3.0
12-2012	RP-58	RP-121852	1509r1		UE-UE coexistence between bands with small frequency	11.3.0

			1		separation	
12-2012	RP-58	RP-121911	1510		Adding UE-UE Coexistence Requirement for Band 3 and Band 26	11.3.0
12-2012	RP-58	RP-121866	1513		Maintenance of Band 23 UE Coexistence	11.3.0
12-2012	RP-58	RP-121851	1515		Corrections to TM4 rank indicator Test 3	11.3.0
12-2012	RP-58	RP-121861	1517		Correction of test configuraitons and FRC for CA demodulation with power imbalance	11.3.0
12-2012	RP-58	RP-121860	1518		Applicable OFDM symbols of Noc_2 for PDCCH/PCFICH ABS-MBSFN test cases	11.3.0
03-2013	RP-59	RP-130279	1519		OCNG patterns for Enhanced Performance Requirements Type A	11.4.0
03-2013	RP-59	RP-130277	1520		Corrections on in-band blocking for Band 29 for carrier aggregation	11.4.0
03-2013	RP-59	RP-130268	1523		Brackets removal in Rel-11 TM4 rank indicator Test 3	11.4.0
03-2013	RP-59	RP-130279	1524r 1		Cleanup of Advanced Receivers requirement scenarios for demodulation and CSI (FDD/TDD)	11.4.0
03-2013	RP-59	RP-130258	1528		Corrections to CQI reporting	11.4.0
03-2013	RP-59	RP-130262	1536		Corrections for eICIC performance requirements (rel-11)	11.4.0
03-2013	RP-59	RP-130264	1539		Correction of CA power imbalance performance requirements	11.4.0
03-2013	RP-59	RP-130287	1543		Correction of a symbol for MPR in single carrier for TS 36.101(R11)	11.4.0
03-2013	RP-59	RP-130287	1544r 1		Correction of some inter-band CA requiements for TS 36.101 (R11)	11.4.0
03-2013	RP-59	RP-130276	1546		Correction of contiguous allocation A-MPR for CA_NS_05	11.4.0
03-2013	RP-59	RP-130263	1547r 1		Clarification of spurious emission domain for CA in TS 36.101 (R11)	11.4.0
03-2013	RP-59	RP-130264	1548		CR for CA performance requirements	11.4.0
03-2013	RP-59	RP-130284	1553r 1		Introduction of downlink non-contiguous CA into REL -11 TS 36.101	11.4.0
03-2013	RP-59	RP-130263	1557		CA_1C: CA_NS_02 and CA_NS_03 A-MPR REL-11	11.4.0
03-2013	RP-59	RP-130287	1560		Editorial corrections to subclause 5	11.4.0
03-2013	RP-59	RP-130267	1562		Addition of UE Regional Requirements to Band 23 Based on New Regulatory Order in the US	11.4.0
03-2013	RP-59	RP-130272	1567		Band 26: modification of A-MPR for 'NS_15'	11.4.0
03-2013	RP-59	RP-130287	1571r 1		Band 41 requirements for operation in China and Japan	11.4.0
03-2013	RP-59	RP-130260	1574		Remove [] from CSI test case parameters	11.4.0
03-2013	RP-59	RP-130287	1575		Corrections to UE co-existence	11.4.0
03-2013	RP-59	RP-130287	1579		UE-UE co-existence between Band 1 and Band 33/39	11.4.0
03-2013	RP-59	RP-130287	1580		Correction on reference to note for Band 7 and 38 co-existence	11.4.0
03-2013	RP-59	RP-130263	1584r 1		Cleanup for CA UE RF requirements	11.4.0
03-2013	RP-59	RP-130263	1586		Corrections on UL configuration for CA UE receiver requirements	11.4.0
03-2013	RP-59	RP-130263	1588		Correction of Transmit modulation quality requirements for CA	11.4.0
03-2013	RP-59	RP-130268	1590		Revision of Common Test Parameters for User-specific Demodulation Tests	11.4.0
03-2013	RP-59	RP-130278	1595		Correction for a Band 27 A-MPR table	11.4.0
03-2013	RP-59	RP-130264	1597		Correction of CA CQI test setup	11.4.0
03-2013	RP-59	RP-130287	1600r 1		Correction of B12 DL Specification in Table 5.5A-2	11.4.0
03-2013	RP-59	RP-130263	1602		Correction of table reference	11.4.0
06-2013	RP-60	RP-130765	1604r 1		Complementary description for definition of MIMO Correlation Matrices using cross polarized antennas	11.5.0
06-2013	RP-60	RP-130763	1607		Correction of transport format parameters for CQI index 10 (15 RBs) - Rel 11	11.5.0
06-2013	RP-60	RP-130765	1610		Maintenance of Band 23 A-MPR (NS_11) in TS 36.101 (Rel-11)	11.5.0
06-2013	RP-60	RP-130770	1613		CR for 36.101 : Adding the definition of CA_NS_05 and CA_NS_06 for additional spurious emissions for CA	11.5.0
06-2013	RP-60	RP-130770	1619		CR for introducing UE TM3 demodulation performance requirements under high speed	11.5.0
06-2013	RP-60	RP-130765	1623		Correction of test parameters for eICIC performance requirements	11.5.0
06-2013	RP-60	RP-130765	1625		Correction of test parameters for eICIC CSI requirements	11.5.0
06-2013	RP-60	RP-130765	1627		Correction of resource allocation for the multiple PMI Cat 1 UE test	11.5.0
06-2013	RP-60	RP-130766	1629		Removal of note 2 from band 28	11.5.0
06-2013	RP-60	RP-130770	1641		Correction of the CSI-RS parameter configuration	11.5.0
06-2013	RP-60	RP-130770	1650r 1		Addition of Band 41 for intra-band non-contiguous CA for 36.101	11.5.0
06-2013	RP-60	RP-130770	1654r 1		MPR for intra-band non-contiguous CA	11.5.0

06-2013	RP-60	RP-130765	1656		Modification of configured output power to account for larger tolerance	11.5.0
06-2013	RP-60	RP-130769	1658r1		Missing symbols in the NS_15 table	11.5.0
06-2013	RP-60	RP-130766	1673		Corrections to Rx requirements for inter-band CA configurations with REFSSENS exceptions	11.5.0
06-2013	RP-60	RP-130770	1681r1		Correction for TS 36.101	11.5.0
06-2013	RP-60	RP-130763	1684		RF: Corrections to RMC-s for sustained data rate test	11.5.0
06-2013	RP-60	RP-130770	1685		Non-contiguous intraband CA channel spacing	11.5.0
06-2013	RP-60	RP-130766	1689		Carrier aggregation in multi RAT and multiple band combination terminals	11.5.0
06-2013	RP-60	RP-130766	1691		Completion of out-of-band blocking requirements for inter-band CA with one UL	11.5.0
06-2013	RP-60	RP-130767	1695r1		CR on the bandwidth coverage issue of CA demodulation performance (Rel-11)	11.5.0
06-2013	RP-60	RP-130765	1697		Correction on UE maximum output power for intra-band CA (R11)	11.5.0
06-2013	RP-60	RP-130770	1698r1		CR for introduction of FelCIC demodulation performance requirements	11.5.0
06-2013	RP-60	RP-130770	1701		Removing bracket from CA_11A-18A requirements	11.5.0
06-2013	RP-60	RP-130767	1703		CR on the bandwidth coverage issue of CA CQI performance (Rel-11)	11.5.0
06-2013	RP-60	RP-130766	1705		Corrections to ACLR for Rel-11 CA	11.5.0
06-2013	RP-60	RP-130765	1716		Corrections to NS_11 A-MPR Table	11.5.0
06-2013	RP-60	RP-130769	1717		Corrections to NS_12 A-MPR Table	11.5.0
06-2013	RP-60	RP-130771	1532r1		Introduction of CA 1+8 into TS36.101(Rel-12)	12.0.0
06-2013	RP-60	RP-130781	1545r1		Introduction of LTE Advanced inter-band Carrier Aggregation of Band 3 and Band 28 to TS 36.101	12.0.0
06-2013	RP-60	RP-130785	1608r1		Introduction of LTE Advanced inter-band Carrier Aggregation of Band 23 and Band 29 to TS 36.101	12.0.0
06-2013	RP-60	RP-130777	1642r1		Introduction of CA B3+19 into TS36.101(Rel-12)	12.0.0
06-2013	RP-60	RP-130787	1687		Introduction of CA_4A-4A into 36.101	12.0.0
06-2013	RP-60	RP-130795	1712		Adding 5MHz CBW for B3 of Inter band CA of B3+26	12.0.0
06-2013	RP-60	RP-130775	1713r1		Introduction of LTE Advanced Inter-Band Carrier Aggregation of Band 2 and Band 13	12.0.0
06-2013	RP-60	RP-130790	1723r1		Introduction of the LTE 450 band to TS 36.101	12.0.0
06-2013	RP-60	RP-130791	1724r1		Introduction of the WCS band to TS 36.101	12.0.0
06-2013	RP-60	RP-130784	1707r1		Introduction of CA 19+21 into TS36.101(Rel-12)	12.0.0
09-2013	RP-61	RP-131300	1730r1		36.101 CR for LTE_CA_C_B3	12.1.0
09-2013	RP-61	RP-131285	1732		CR on performance requirements of CA soft buffer management (Rel-12)	12.1.0
09-2013	RP-61	RP-131303	1733r1		CR to introduce TM3 and TM4 test for 5MHz channel bandwidth	12.1.0
09-2013	RP-61	RP-131281	1736		CR on applicability of CA sustained data rate tests (Rel-12)	12.1.0
09-2013	RP-61	RP-131293	1739		Performance requirement for UE under EVA200	12.1.0
09-2013	RP-61	RP-131290	1743		CR for introduction of FelCIC PBCH performance requirement	12.1.0
09-2013	RP-61	RP-131290	1745		CR for introduction of FelCIC RI reporting requirements	12.1.0
09-2013	RP-61	RP-131292	1747		Beamforming model for EPDCCH test	12.1.0
09-2013	RP-61	RP-131303	1748		CR to introduce CSI tests for LTE450	12.1.0
09-2013	RP-61	RP-131303	1749		CR to extend UE category of the existing 5MHz performance requirements	12.1.0
09-2013	RP-61	RP-131281	1767		UE REFSSENS when supporting intra-band CA and inter-band CA	12.1.0
09-2013	RP-61	RP-131279	1772		Correlation matrix for high speed train demodulation scenarios (Rel-12)	12.1.0
09-2013	RP-61	RP-131280	1776		Corrections to sustained data rate test (Rel-12)	12.1.0
09-2013	RP-61	RP-131303	1781		CR to introduce a new PHICH test based on 5MHz	12.1.0
09-2013	RP-61	RP-131303	1782		CR placeholder for applicability of new 5MHz tests	12.1.0
09-2013	RP-61	RP-131303	1783r1		CR : Proposal of applicability of new 5MHz tests	12.1.0
09-2013	RP-61	RP-131303	1784		CR: PHICH tests for 5MHz	12.1.0
09-2013	RP-61	RP-131290	1786		CR for introduction of FelCIC CQI requirements	12.1.0
09-2013	RP-61	RP-131281	1794		Clarification of multi-cluster transmission	12.1.0
09-2013	RP-61	RP-131294	1800r1		CA UE Coexistence Table update (Release 12)	12.1.0
09-2013	RP-61	RP-131302	1802		Coexistence between Band 27 and Band 38 (Release 12)	12.1.0
09-2013	RP-61	RP-131285	1803		Additional requirement for CA_1A-18A into TS36.101	12.1.0

09-2013	RP-61	RP-131296	1804		Add requirements for CA_1A-26A into TS36.101	12.1.0
09-2013	RP-61	RP-131281	1807		Incorrect REFSSENS UL allocation for CA_1C	12.1.0
09-2013	RP-61	RP-131297	1808r 1		Introduction of CA_2A-4A into 36.101	12.1.0
09-2013	RP-61	RP-131281	1811		Contiguous intraband CA REFSSENS with one UL	12.1.0
09-2013	RP-61	RP-131281	1822		The P _{max} clauses restructured: This CR was NOT implemented as it was based on the wrong version of the spec	12.1.0
09-2013	RP-61	RP-131298	1824		Introduction of inter-band CA Band 2+5	12.1.0
09-2013	RP-61	RP-131285	1831		MPR for intra-band non-contiguous CA	12.1.0
09-2013	RP-61	RP-131281	1832		Correction to Rel-10 A-MPR for CA_NS_04	12.1.0
09-2013	RP-61	RP-131285	1834		CR for 36.101 : Add the definition of 5+20MHz for spectrum emission mask for CA	12.1.0
09-2013	RP-61	RP-131303	1839		CR to introduce CSI tests for LTE450	12.1.0
09-2013	RP-61	RP-131293	1840		Remained Transmitter requirements for intra-band non-contiguous CA	12.1.0
09-2013	RP-61	RP-131303	1841		CR to introduce TM3 and TM4 test for 5MHz channel bandwidth	12.1.0
12-2013	RP-62	RP-131928	1847r 1		Corrections to the notes in the band UE co-existence requirements table (Rel-12)	12.2.0
12-2013	RP-62	RP-131924	1852		Clean-up of uplink reference measurement channels (Rel-12)	12.2.0
12-2013	RP-62	RP-131946	1857		Introduction of CA band combination Band2 + Band12 to TS 36.101	12.2.0
12-2013	RP-62	RP-131954	1858		Introduction of CA band combination Band12 + Band25 to TS 36.101	12.2.0
12-2013	RP-62	RP-131931	1867		CA_NS_05 Emissions	12.2.0
12-2013	RP-62	RP-131939	1869		NS signaling for CA refsens	12.2.0
12-2013	RP-62	RP-131965	1870		Introduction of CA_23A-23A RF requirements into 36.101	12.2.0
12-2013	RP-62	RP-131928	1877r 2		Intraband CA channel bandwidth combination table restructuring	12.2.0
12-2013	RP-62	RP-131940	1878		Addition of CA_3C missing UE to UE co-existence requirement and correction to SEM	12.2.0
12-2013	RP-62	RP-131959	1885		Introduction of LTE_CA_C_B27 to 36.101	12.2.0
12-2013	RP-62	RP-131939	1887		CR on correction of definition on Fraction of Maximum Throughput for CA	12.2.0
12-2013	RP-62	RP-131939	1889		CR on correction of test configurations of CA soft buffer tests	12.2.0
12-2013	RP-62	RP-131936	1893		CR for FelCIC demodulation performance requirements	12.2.0
12-2013	RP-62	RP-131936	1895r 1		CR on FelCIC PBCH performance requirement	12.2.0
12-2013	RP-62	RP-131936	1897r 1		CR on RI reporting requirement	12.2.0
12-2013	RP-62	RP-131938	1899		Beamforming model for EPDCCH localized test	12.2.0
12-2013	RP-62	RP-131938	1901		Downlink physical setup for EPDCCH test	12.2.0
12-2013	RP-62	RP-131926	1904		Correction on the UE category for eICIC CQI test	12.2.0
12-2013	RP-62	RP-131931	1906		CR for receiver type verification test of CSI-RS based advanced receivers (Rel-12)	12.2.0
12-2013	RP-62	RP-131956	1910r 1		Spurious emission band UE co-existence requirements for cross-region issue	12.2.0
12-2013	RP-62	RP-131928	1916r 2		Allowed power reductions for multiple transmissions in a subframe	12.2.0
12-2013	RP-62	RP-131967	1917r 1		The coexistence requirements between Band 39 and Band 3	12.2.0
12-2013	RP-62	RP-131967	1918r 1		The P _{max} clauses restructured and removal of addition of ΔT _c to P-MPR	12.2.0
12-2013	RP-62	RP-131956	1919		Configured maximum output power for multiple TAG transmission	12.2.0
12-2013	RP-62	RP-131936	1927r 1		Configured maximum output power for multiple TAG transmission	12.2.0
12-2013	RP-62	RP-131927	1934		CR on correction of FRC of power imbalance test	12.2.0
12-2013	RP-62	RP-131927	1937		UE-UE coexistence for Band 40	12.2.0
12-2013	RP-62	RP-131957	1955r 1		Introduction of LTE Advanced intra-band contiguous Carrier Aggregation in Band 23 to TS 36.101	12.2.0
12-2013	RP-62	RP-131961	1956r 1		Introduction of CA_3A-3A into TS 36.101	12.2.0
12-2013	RP-62	RP-131937	1957		CR Minimum requirement with Different Cell ID and Colliding CRS (with single NZP CSI-RS resource)	12.2.0
12-2013	RP-62	RP-131937	1958		CR Minimum requirement with Same Cell ID (with multiple NZP CSI-RS resources)	12.2.0
12-2013	RP-62	RP-131936	1962		Introduction of reference SNR-s for FelCIC demodulation performance requirements	12.2.0
12-2013	RP-62	RP-131938	1964		OCNG pattern for EPDCCH test	12.2.0
12-2013	RP-62	RP-131931	1965		CA performance requirements for TDD intra-band NC CA	12.2.0
12-2013	RP-62	RP-131958	1966r 1		CA performance requirements for TDD intra-band NC CA	12.2.0
12-2013	RP-62	RP-131939	1968		Introduction of UE TM3 demodulation performance requirements under ETU300	12.2.0

12-2013	RP-62	RP-131937	1970		Introduction of test 1-A for CoMP	12.2.0
12-2013	RP-62	RP-131939	1972		Modification of TM9 test to verify correct SNR estimation	12.2.0
12-2013	RP-62	RP-131928	1984		Correction to blocking requirements and use of Delta_RIB	12.2.0
12-2013	RP-62	RP-131950	1985		Introduction of CA band combination Band5 + Band25 to TS 36.101	12.2.0
12-2013	RP-62	RP-131939	1988r1		CR on test point clarification for CA demodulation test	12.2.0
12-2013	RP-62	RP-131937	1994		CR to Introduce fading CQI test for CoMP (TDD)	12.2.0
12-2013	RP-62	RP-131937	1996		CR to Introduce channel model for CoMP fading CQI tests	12.2.0
12-2013	RP-62	RP-131937	1998		CR to Introduce RI test for CoMP (FDD)	12.2.0
12-2013	RP-62	RP-131938	2001r1		Distributed EPDCCH Demodulation Test	12.2.0
12-2013	RP-62	RP-131938	2003r1		Localized EPDCCH Demodulation Test	12.2.0
12-2013	RP-62	RP-131938	2005r1		Localized EPDCCH Demodulation Test	12.2.0
12-2013	RP-62	RP-131937	2007		Introduction of DL CoMP FDD static CQI test	12.2.0
12-2013	RP-62	RP-131937	2009		Introduction of DL CoMP TDD static CQI test	12.2.0
12-2013	RP-62	RP-131924	2014		P-max for Band 38 to Band 7 coexistence	12.2.0
12-2013	RP-62	RP-131948	2015		Introduction of CA band combination B5 + B7 to TS 36.101	12.2.0
12-2013	RP-62	RP-131952	2017		Introduction of CA band combination B7 + B28 to TS 36.101	12.2.0
12-2013	RP-62	RP-131937	2024		Minimum requirement with Same Cell ID (with multiple NZP CSI-RS resources) TDD	12.2.0
12-2013	RP-62	RP-131937	2026		CR Minimum requirement with Different Cell ID and Colliding CRS (with single NZP CSI-RS resource) TDD	12.2.0
12-2013	RP-62	RP-131936	2028		Editorial change on FeICIC PBCH Noc setup	12.2.0
12-2013	RP-62	RP-131937	2032		Introduction of test 1-A for CoMP	12.2.0
12-2013	RP-62	RP-131931	2035r1		Correction of nominal guard bands for bandwidth classes A, B and C	12.2.0
12-2013	RP-62	RP-131937	2042		CR to Introduce RI test for CoMP (TDD)	12.2.0
12-2013	RP-62	RP-131937	2043		CR to Introduce fading CQI test for CoMP (FDD)	12.2.0
12-2013	RP-62	RP-131931	2045		Correction of TDD PCFICH/PDCCH test parameter table	12.2.0
12-2013	RP-62	RP-131939	2047		Add EVA200 to table of channel model parameters	12.2.0
12-2013	RP-62	RP-131963	2050r1		Introduction of CA_7A-7A into TS 36.101	12.2.0
12-2013	RP-62	RP-131967	2057		Band 41 deployment in Japan	12.2.0
12-2013	RP-62	RP-131926	2059		CA_1C: Correction on CA_NS_02 A-MPR table	12.2.0
12-2013	RP-62	RP-131924	2060		Simplification of Band 12/17 in-band blocking test cases	12.2.0
12-2013	RP-62	RP-131967	2064		Correction of duplicated notes on table 7.3.1A-3	12.2.0
12-2013	RP-62	RP-131938	2066		Introduction of EPDCCH TM10 localized test R-12	12.2.0
12-2013	RP-62	RP-131938	2068		Introduction of SDR test for PDSCH with EPDCCH scheduling	12.2.0
03-2014	RP-63	RP-140377	2115		Editorial Correction for TS36.101 Rel-12	12.3.0
03-2014	RP-63	RP-140371	2108		UL-DL configuration and other parameters for FeICIC TDD CQI fading test (Rel-12)	12.3.0
03-2014	RP-63	RP-140374	2097		CR on TM9 localized ePDCCH test	12.3.0
03-2014	RP-63	RP-140374	2101		CR on reference measurement channel for ePDCCH test	12.3.0
03-2014	RP-63	RP-140371	2110		CR for TS36.101 COMP demodulation requirements	12.3.0
03-2014	RP-63	RP-140371	2113		CR for Combinations of channel model parameters	12.3.0
03-2014	RP-63	RP-140374	2114		CR for EPDCCH power allocation (Rel-12)	12.3.0
03-2014	RP-63	RP-140371	2106		Cleanup of the specification for FeICIC (Rel-12)	12.3.0
03-2014	RP-63	RP-140375	2089		CR for introduction of 15MHz based single carrier and CA SDR tests in Rel-12	12.3.0
03-2014	RP-63	RP-140375	2080r1		CR on TM3 demodulation and soft buffer management test	12.3.0
03-2014	RP-63	RP-140371	2086		CR on reference measurement channel for TM10 PDSCH demodulation test	12.3.0
03-2014	RP-63	RP-140241	2174		Introduction of 3MHz in Band 8 for CA_8_20 RF requirements into TS36.101	12.3.0
03-2014	RP-63	RP-140417	2173r1		Addition of bandwidth combination set for CA_2A-29A and CA_4A-29A	12.3.0
03-2014	RP-63	RP-140387	2071r1		Introduction of TDD inter-band CA_B39_B41 into 36.101	12.3.0
03-2014	RP-63	RP-140378	2069		CA_3C is adding 100RB+75RB uplink configuration for reference sensitivity	12.3.0
03-2014	RP-63	RP-140388	2070		CR for TS36.101 on CA_C_B39	12.3.0
03-2014	RP-63	RP-140386	2072		Introduction of CA band B3+B27 to TS36.101	12.3.0
03-2014	RP-63	RP-140374	2074		CR of EPDCCH localized test with TM10 QCL Type-B configuration (Rel-12)	12.3.0
03-2014	RP-63	RP-140371	2142		Clarification of contiguous and non-contiguous intra-band UE capabilities in the same band	12.3.0
03-2014	RP-63	RP-140385	2161		Introduction of additional bandwidth combination set for CA_2A-4A	12.3.0
03-2014	RP-63	RP-140371	2131r1		CR to finalize RI test for CoMP	12.3.0

03-2014	RP-63	RP-140368	2147		Correction of coding rate for 18RBs in UL RMC table	12.3.0
03-2014	RP-63	RP-140371	2144		Channel spacing for non-contiguous intra-band carrier aggregation	12.3.0
03-2014	RP-63	RP-140374	2163		Distributed EPDCCH Demodulation Test	12.3.0
03-2014	RP-63	RP-140368	2137		Configured transmitted power for CA	12.3.0
03-2014	RP-63	RP-140368	2122		CR for 36.101. Editorial correction on OCNG pattern	12.3.0
03-2014	RP-63	RP-140370	2160		Correction of table notes for NS_12-NS_15 spurious emissions requirements	12.3.0
03-2014	RP-63	RP-140371	2129r 1		CR to finalize fading CQI test for CoMP	12.3.0
03-2014	RP-63	RP-140375	2119		Introduction of requirements for SNR test for TM9	12.3.0
03-2014	RP-63	RP-140374	2125		CR on correction of downlink SDR tests with EPDCCH scheduling	12.3.0
03-2014	RP-63	RP-140371	2127		Correction on DL CoMP static CQI tests (Rel 12)	12.3.0
06-2014	RP-64	RP-140909	2177r 3		RF: Corrections to spurious emission requirements with NS different than NS_01 (Rel-12)	12.4.0
06-2014	RP-64	RP-140932	2187r 1		Additional bandwidth combination set for LTE Advanced inter-band Carrier Aggregation of Band 3 and Band 20	12.4.0
06-2014	RP-64	RP-140934	2188		Additional bandwidth combination set for LTE Advanced inter-band Carrier Aggregation of Band 7 and Band 20	12.4.0
06-2014	RP-64	RP-140943	2195r 1		CR for TS 36.101 on introduction CA_41D	12.4.0
06-2014	RP-64	RP-140943	2196r 3		CR to TS 36.101 on introduction of CA BW class D requirements	12.4.0
06-2014	RP-64	RP-140918	2198		CR on correction on TDD IRC CQI test	12.4.0
06-2014	RP-64	RP-140917	2207		CR of EPDCCH localized test with TM10 QCL Type-B configuration (Rel-12): correction of CSI-RS configurations	12.4.0
06-2014	RP-64	RP-140918	2209		Clean up of TM9 SNR tests	12.4.0
06-2014	RP-64	RP-140933	2210r 1		Introduction of band B4+B27 CA to TS36.101	12.4.0
06-2014	RP-64	RP-140942	2213		Introduction of CA band combination B1+B20 to TS 36.101	12.4.0
06-2014	RP-64	RP-140917	2216		CR for EPDCCH test (Rel-12)	12.4.0
06-2014	RP-64	RP-140914	2218		CR of modification on FelCIC rank testing (Rel-12)	12.4.0
06-2014	RP-64	RP-140914	2220		CR on FelCIC PBCH performance requirement (Rel-12)	12.4.0
06-2014	RP-64	RP-140918	2222		Correction on out-of-band blocking for CA	12.4.0
06-2014	RP-64	RP-140918	2226		Update demodulation performance requirements with new UE categories	12.4.0
06-2014	RP-64	RP-140911	2228		Correction for CA sustained data rate test (Rel-12)	12.4.0
06-2014	RP-64	RP-140945	2229		Correction on wrong annotation for close-loop spatial multiplexing performance	12.4.0
06-2014	RP-64	RP-140911	2233		Clarification of Intra-band contiguous CA class C Narrow band blocking requirements	12.4.0
06-2014	RP-64	RP-140911	2239		Correction for CA soft buffer test (Rel-12)	12.4.0
06-2014	RP-64	RP-140918	2241		CR on OCNG and propagation conditions for dual layer TM9 test (Rel-12)	12.4.0
06-2014	RP-64	RP-140911	2247		Remove [] from eLIC TDD RI requirement	12.4.0
06-2014	RP-64	RP-140914	2256		Verification of exceptions of REFSENS requirements for carrier aggregation	12.4.0
06-2014	RP-64	RP-140914	2258		Applicability of exceptions to reference sensitivity requirements for CA	12.4.0
06-2014	RP-64	RP-140909	2269		In-band blocking case numbering re-establishment	12.4.0
06-2014	RP-64	RP-140918	2273		CR for TS36.101 FRC tables for COMP demodulation requirements	12.4.0
06-2014	RP-64	RP-140945	2277		Editorial correction of note in clause 4.4	12.4.0
06-2014	RP-64	RP-140926	2282r 1		Editorial correction of note in clause 4.4	12.4.0
06-2014	RP-64	RP-140911	2283		Introduction of new bandwidth combination set for CA_1A-5A UE	12.4.0
06-2014	RP-64	RP-140914	2286		CR for finalizing DL COMP CSI reporting requirements	12.4.0
06-2014	RP-64	RP-140914	2288		CR for adding DL CoMP CSI RMC tables (Rel-12)	12.4.0
06-2014	RP-64	RP-140921	2291		Simplification of 36.101 Table 5.6A.1-1 for LTE_CA_C_B27	12.4.0
06-2014	RP-64	RP-140914	2293		Finalization of CoMP demodulation test cases	12.4.0
06-2014	RP-64	RP-140918	2294		Editorial corrections for UE performance requirements for R12	12.4.0
06-2014	RP-64	RP-140937	2295		Introduction of CA performance requirements for Band 27 CA	12.4.0
06-2014	RP-64	RP-140931	2296		Introduction of CA 1+11 to 36.101 (Rel-12)	12.4.0
06-2014	RP-64	RP-140994	2309		Inclusion of the out of band emission limit concluded in CEPT into band 28	12.4.0
06-2014	RP-64	RP-140911	2314		UE to UE co-existence between B42/B43	12.4.0
06-2014	RP-64	RP-140911	2318		Perf: Corrections to CA (Class C) performance with power imbalance (Rel-12)	12.4.0
06-2014	RP-64	RP-140920	2319		Introduction of CA performance requirements for Band 23 CA	12.4.0
06-2014	RP-64	RP-140914	2321		CR of modification on FelCIC rank testing (Rel-12)	12.4.0
06-2014	RP-64	RP-140914	2323		CR of introducing FelCIC TM9 testing (Rel-12)	12.4.0
06-2014	RP-64	RP-140917	2325		CR for EPDCCH SDR test (Rel-12)	12.4.0

06-2014	RP-64	RP-140911	2328		Clean-up CR for demodulation requirements (Rel-12)	12.4.0
06-2014	RP-64	RP-140945	2330r 1		Additional updates of UE categories for demodulation performance requirements (Rel-12)	12.4.0
06-2014	RP-64	RP-140911	2333		Throughput calculation for eICIC demodulation requirements	12.4.0
06-2014	RP-64	RP-140914	2335r 1		Introduction of Band 28 requirements for flexible operation in Japan	12.4.0
06-2014	RP-64	RP-140911	2337r 1		Add missing Uplink downlink configuration to eICIC TDD RI requirement	12.4.0
06-2014	RP-64	RP-140945	2338		Add static propagation condition matrix for 1 x 2	12.4.0
06-2014	RP-64	RP-140911	2341		Cleanup of terminology for Rx requirements	12.4.0
06-2014	RP-64	RP-140945	2344		CR on separating CA UE demodulation tests from single carrier tests in Rel-12	12.4.0
06-2014	RP-64	RP-140911	2351		Test configuration for intra-band contiguous carrier aggregation power control	12.4.0
06-2014	RP-64	RP-140935	2358		Addition of bandwidth combination sets for CA_2A-29A, CA_3A-5A, CA_4A-5A, CA_4A-12A, and CA_4A-29A into 36.101	12.4.0
06-2014	RP-64	RP-140914	2362		Correction of test configurations for intra-band non-contiguous aggregation	12.4.0
06-2014	RP-64	RP-140911	2365		Clarification on CA bandwidth classes	12.4.0
06-2014	RP-64	RP-140917	2374		CR on correction of downlink SDR tests with EPDCCH scheduling	12.4.0
06-2014	RP-64	RP-140922	2377		Correction on LTE_CA_C_B39	12.4.0
06-2014	RP-64	RP-140911	2378		Corrections on CA CQI tests	12.4.0
06-2014	RP-64	RP-140930	2381r 1		Introduction of LTE-Advanced CA of Band 8 and Band 40 to TS36.101	12.4.0
06-2014	RP-64	RP-140927	2382r 1		FRC for DL MIMO enhancement PMI requirements	12.4.0
06-2014	RP-64	RP-140603	2384r 2		CR for TS 36.101 on introduction CA_40D	12.4.0
06-2014	RP-64	RP-140944	2385r 1		CR to TS 36.101 on introduction of 3DL intra-band non-contiguous CA requirements	12.4.0
06-2014	RP-64	RP-140938	2387		Introduction of CA_2A-2A into TS 36.101	12.4.0
06-2014	RP-64	RP-140927	2392		Introduction of 4Tx beam steering model	12.4.0
06-2014	RP-64	RP-140914	2394		CA_7C A-MPR Corrections	12.4.0
06-2014	RP-64	RP-140936	2395r 2		Introduction of a new CA_7C bandwidth combination set into 36.101	12.4.0
06-2014	RP-64	RP-140918	2398		CR for TS36.101 CSI RMC table	12.4.0
06-2014	RP-64	RP-140940	2413		Introduction of LTE_CA_NC_B42 into 36.101	12.4.0
06-2014	RP-64	RP-140942	2420		Introduction of CA band combination B1+B20 to TS 36.101	12.4.0
06-2014	RP-64	RP-140919	2422		CA_3C is deleting 75RB+75RB uplink configuration for reference sensitivity	12.4.0
06-2014	RP-64	RP-140914	2425		CR on correction for TM10 CSI reporting requirements	12.4.0
09-2014	RP-65	RP-141197	2458r 1		Introduction of CA_B1_B3_B19 into TS 36.101	12.5.0
09-2014	RP-65	RP-141428	2568		Updated REFSENS requirements for band combinations with Band 4 and Band 12	12.5.0
09-2014	RP-65	RP-141468	2508r 1		Introduction of 3 DL CA for Band 1+3+20	12.5.0
09-2014	RP-65	RP-141469	2571		Correction to CA in Band 1+20	12.5.0
09-2014	RP-65	RP-141525	2504r 1		Perf: Cleanup and better description of DL-RMC-s with dynamic coding rate for CSI requirements (Rel-12)	12.5.0
09-2014	RP-65	RP-141525	2565		Corrections to UE coex table	12.5.0
09-2014	RP-65	RP-141527	2434		Correction on support of a bandwidth combination set	12.5.0
09-2014	RP-65	RP-141527	2452r 1		Remove the redundant table for FDD 4Tx multi-layer tests and correct the test case number (Rel-12)	12.5.0
09-2014	RP-65	RP-141527	2466		Unequal DL CC RB allocations in Maximum input level	12.5.0
09-2014	RP-65	RP-141527	2469		Intra-band contiguous CA ACS case 2 test clarification	12.5.0
09-2014	RP-65	RP-141527	2484		Corrections on delta Tc for UE MOP for intra-band contiguous CA	12.5.0
09-2014	RP-65	RP-141527	2487		Removal of Class B in UE TX requirement	12.5.0
09-2014	RP-65	RP-141527	2516r 1		CR for CA applicability rule in 36.101 in Rel-12	12.5.0
09-2014	RP-65	RP-141527	2519r 1		Editorial CR for CA performance tests in 36.101 in Rel-12	12.5.0
09-2014	RP-65	RP-141527	2548		Correction to NS_20 A-MPR for Band 23	12.5.0
09-2014	RP-65	RP-141530	2447		CR of introducing FeICIC TM9 testing (Rel-12)	12.5.0
09-2014	RP-65	RP-141530	2454		Maintenance of CoMP demodulation performance requirements (Rel-12)	12.5.0
09-2014	RP-65	RP-141530	2456		Clean-up CR for EPDCCH and FeICIC PBCH (Rel-12)	12.5.0
09-2014	RP-65	RP-141530	2471		Throughput calculation for feICIC demodulation requirements	12.5.0
09-2014	RP-65	RP-141532	2439		CR on correction on CQI reporting TDD CSI meas in case two CSI subframe sets with CRS test (Rel-12)	12.5.0
09-2014	RP-65	RP-141532	2441		CR on correction on RI reporting CSI meas in case two CSI	12.5.0

					subframe sets with CRS tests (Rel-12)	
09-2014	RP-65	RP-141532	2444		Clarification of high speed train scenario in 36.101 (Rel-12)	12.5.0
09-2014	RP-65	RP-141532	2478		CQI reporting under fading: CQI indices in set	12.5.0
09-2014	RP-65	RP-141532	2490		Correction on A-MPR table	12.5.0
09-2014	RP-65	RP-141532	2499		RF: Corrections to spurious emission band co-existence requirement for Band 44	12.5.0
09-2014	RP-65	RP-141535	2559		Addition of E-UTRA CA configurations and bandwidth combination sets defined for inter-band CA for Band 4 and 27	12.5.0
09-2014	RP-65	RP-141537	2541		Band 42 contiguous CA channel bandwidth correction	12.5.0
09-2014	RP-65	RP-141546	2463r 1		Introduction of PMI reporting requirements for DL MIMO enhancement	12.5.0
09-2014	RP-65	RP-141548	2457r 2		Introduction of CA_B1_B3 into TS 36.101	12.5.0
09-2014	RP-65	RP-141549	2556		Addition of bandwidth combination set for CA_2A-4A	12.5.0
09-2014	RP-65	RP-141550	2566		Addition of 3MHz bandwidth for Band 12 , in the B2+B12 CA combination	12.5.0
09-2014	RP-65	RP-141551	2445		Introduction of CA 8+11 to 36.101 (Rel-12)	12.5.0
09-2014	RP-65	RP-141553	2491r 1		Introduction of a new bandwidth combination set for CA_25A-25A into 36.101	12.5.0
09-2014	RP-65	RP-141554	2533r 1		Introduction of requirements for 3DL inter-band carrier aggregation (FDD)	12.5.0
09-2014	RP-65	RP-141554	2534		Introduction of requirements for 3DL combinations with Band 30 (FDD)	12.5.0
09-2014	RP-65	RP-141557	2461r 1		Introduction of CA_B19_B42_B42 into TS 36.101	12.5.0
09-2014	RP-65	RP-141559	2460r 1		Introduction of CA_B1_B42_B42 into TS 36.101	12.5.0
09-2014	RP-65	RP-141560	2427		Adding 15MHz channel BW to B40 3DL and new bandwidth combination set for the 2DL	12.5.0
09-2014	RP-65	RP-141561	2488r 1		Corrections on Maximum input level for intra-band non-contiguous 3DL	12.5.0
09-2014	RP-65	RP-141562	2436		Corrections on Maximum input level and ACS for intra-band CA	12.5.0
09-2014	RP-65	RP-141562	2481r 1		Introduction of CA band combination B41+ B42 to TS 36.101	12.5.0
09-2014	RP-65	RP-141562	2522		CR on CA power imbalance tests in Rel-12	12.5.0
09-2014	RP-65	RP-141562	2560		CR Reducing MPR for Contiguous CA with Non-Contiguous Resource Allocations	12.5.0
09-2014	RP-65	RP-141563	2555r 1		UL configuration for CA_4A-12A reference sensitivity	12.5.0
09-2014	RP-65	RP-141563	2557		Addition of bandwidth combination set for CA_4A-12A	12.5.0
09-2014	RP-65	RP-141612	2494r 2		Introduction of inter-band CA_18-28 into TS36.101	12.5.0
09-2014	RP-65	RP-141635	2552r 2		Introduction of CA_1A-7A into 36.101(Rel-12)	12.5.0
09-2014	RP-65	RP-141636	2480r 2		Introduction of 3DLs CA band combination of Band1 +5 + 7 to TS 36.101 Rel-12	12.5.0
09-2014	RP-65	RP-141653	2435r 3		Introduction of 3 Band Carrier Aggregation (3DL/1UL) of Band 1, Band 3 and Band 8 to TS 36.101	12.5.0
09-2014	RP-65	RP-141682	2570r 1		Introduction of CA band combination B1+B7+B20 to TS 36.101	12.5.0
09-2014	RP-65	RP-141708	2492r 3		Introduction of 3 Band Carrier Aggregation of Band 1,Band 3 and Band 5 to TS 36.101	12.5.0
12-2014	RP-66	RP-142147	2671		Correction of CoMP TDD CSI tests (Rel-12)	12.6.0
12-2014	RP-66	RP-142144	2574		CR for REFSENSE in lower SNR and change history	12.6.0
12-2014	RP-66	RP-142173	2581		CR on 4Tx codebook PMI testing	12.6.0
12-2014	RP-66	RP-142142	2587		CR for 1 PRB allocation performance in presence of MBSFN (rel-12)	12.6.0
12-2014	RP-66	RP-142144	2590		Maintenance of CA demodulation performance requirements (Rel-12)	12.6.0
12-2014	RP-66	RP-142147	2592		Clean up for FeICIC demodulation performance requirements (Rel-12)	12.6.0
12-2014	RP-66	RP-142166	2600		Correction of placement of CA_40D in Table	12.6.0
12-2014	RP-66	RP-142162	2601		CQI test for TDD CL_C 20MHz+15MHz in Rel-12	12.6.0
12-2014	RP-66	RP-142162	2602		Sustained downlink data rate test for TDD CL_C 20MHz+15MHz in Rel-12	12.6.0
12-2014	RP-66	RP-142165	2611		Removal of square brackets for CA_B1_B3 and CA_B1_B3_B19	12.6.0
12-2014	RP-66	RP-142147	2620		CQI reporting in AWGN: CQI indices in set	12.6.0
12-2014	RP-66	RP-142147	2629		CR to fix error of CA capability for CA performance tests in 36.101 in Rel-12	12.6.0
12-2014	RP-66	RP-142144	2637		Definition of the bits in the bitmap for indication of modified MPR behavior	12.6.0
12-2014	RP-66	RP-142147	2641		Applicability of in-gap and out-of-gap measurements for intra-band NC CA	12.6.0

12-2014	RP-66	RP-142183	2642			Introduction of additional bandwidth combination set for CA_2A-5A	12.6.0
12-2014	RP-66	RP-142164	2643			Corrections for 3DL inter-band CA band combinations	12.6.0
12-2014	RP-66	RP-142147	2661			Maintenance of TM10 demodulation test configurations on PQI set and ZP-CSIRS (Rel-12 test 8.3.1.3.2, 8.3.2.4.2)	12.6.0
12-2014	RP-66	RP-142173	2582r 1			Introduction of PUSCH 3-2 requirements into TS36.101	12.6.0
12-2014	RP-66	RP-142162	2603r 1			Normal demodulation test for TDD CL_C 20MHz+15MHz in Rel-12	12.6.0
12-2014	RP-66	RP-142164	2576r 1			Corrections on Out-of-band blocking requirements for CA Class B and D	12.6.0
12-2014	RP-66	RP-142149	2678			CR to specify applicability of CoMP RI test (Rel-12)	12.6.0
12-2014	RP-66	RP-142144	2688			Removal of bracket for UL MIMO	12.6.0
12-2014	RP-66	RP-142164	2689			Corection of B29 REFSENS for CA_2A-29A-30A and CA_4A-29A-30A	12.6.0
12-2014	RP-66	RP-142144	2700			Delete the incorrect notes for FDD DMRS demodulation tests (Rel-12)	12.6.0
12-2014	RP-66	RP-142160	2594r 3			Correcting requirements for inter-band CA_18-28 in TS36.101	12.6.0
12-2014	RP-66	RP-142173	2705			CR of modification on PMI reporting requirements for DL MIMO enhancement	12.6.0
12-2014	RP-66	RP-142144	2720			Band 22 correction in UE to UE co-existence table.	12.6.0
12-2014	RP-66	RP-142147	2722			Correction to non-contiguous downlink intraband CA receiver requirements	12.6.0
12-2014	RP-66	RP-142159	2752			Removal of dRib from CA_1A-7A	12.6.0
12-2014	RP-66	RP-142147	2723			Correction to table format of allowed channel bandwidths of non-contiguous intraband CA	12.6.0
12-2014	RP-66	RP-142164	2643r 1			Corrections for 3DL inter-band CA band combinations	12.6.0
12-2014	RP-66	RP-142146	2731			Modifications for NS_12 and NS_13	12.6.0
12-2014	RP-66	RP-142189	2739			Introduction of CA_5-13 into 36.101	12.6.0
12-2014	RP-66	RP-142173	2706r 1			CR of reference measurement channel for PUSCH3-2 test	12.6.0
12-2014	RP-66	RP-142144	2727r 1			CR for CA applicability rule in 36.101 in Rel-12	12.6.0
12-2014	RP-66	RP-142188	2676r 1			CR to remove CA capability column in CA performance test tables (Rel-12)	12.6.0
12-2014	RP-66	RP-142173	r3			Introduction of PUSCH 3-2 requirements into TS36.101	12.6.0
12-2014	RP-66	RP-142187	2690r 1			CR on sustained data rate test for 3DL CA	12.6.0
12-2014	RP-66	RP-142187	2681r 2			CR on normal demodulation test for 3DL CA	12.6.0
12-2014	RP-66	RP-142147	2747r 1			TS36.101 removal of brackets (RF)	12.6.0
12-2014	RP-66	RP-142144	2755			Correction to Transmit Modulation Quality for CA	12.6.0
12-2014	RP-66	RP-142144	2710r 1			Clarification on UL and DL CA	12.6.0
12-2014	RP-66	RP-142144	2717r 1			Clarification of notes relating to interferer offsets in intraband CA receiver requirement tables.	12.6.0
12-2014	RP-66	RP-142147	2735r 1			Band 28 and NS_24	12.6.0
12-2014	RP-66	RP-142179	2684r 1			CR for UE requirements for 256QAM	12.6.0
12-2014	RP-66	RP-142180	2729r 1			Introduction of Dual Connectivity to TS 36.101 Rel-12, RF part	12.6.0
12-2014	RP-66	RP-142184	2680r 1			Introduction of dual uplink inter-band CA in TS 36.101 rel-12	12.6.0
12-2014	RP-66	RP-142182	2701r 1			Introduction of inter-band CA_1-28 into TS36.101	12.6.0
12-2014	RP-66	RP-142144	2758			Correction to Note 2 of Harmonic Signal Exceptions in Spurious Emissions	12.6.0
12-2014	RP-66	RP-142144	2751r 2			Removal of brackets and TBD from CA feature	12.6.0
12-2014	RP-66	RP-142144	2697r 1			Maintenance of CA performance requirements (Rel-12)	12.6.0
12-2014	RP-66	RP-142187	2679r 2			CR to introduce CQI test for 3 DL CA	12.6.0
12-2014	RP-66	RP-142185	2721r 1			Addition of 2UL non-contiguous intraband CA feature	12.6.0
12-2014	RP-66	RP-142144	2704r 2			UE to UE co-existence between B42/B43	12.6.0
12-2014	RP-66	RP-142176	2685r 2			Introduction of LC MTC into TS 36.101	12.6.0
12-2014	RP-66	RP-142190	2759r 1			Introduction of additional band combinations for 3DL inter-band CA	12.6.0

03-2015	RP-67	RP-150387	2760r 2		Introduce additional bands of LC MTC	12.7.0
03-2015	RP-67	RP-150387	2761		CR on corrections to Dual-Layer Spatial Multiplexing with multiple CSI-RS config Rel-12	12.7.0
03-2015	RP-67	RP-150392	2765r 1		CR for applicability and test rules for TDD-FDD CA performance requirements	12.7.0
03-2015	RP-67	RP-150392	2766		Introduction of CQI tests for TDD-FDD CA	12.7.0
03-2015	RP-67	RP-150395	2767r 1		CR to introduce the SU-MIMO whitening verification test	12.7.0
03-2015	RP-67	RP-150392	2768r 1		CR on power imbalance test for 3DL CA	12.7.0
03-2015	RP-67	RP-150392	2769		CR on sustained data rate test for TDD FDD CA	12.7.0
03-2015	RP-67	RP-150394	2770r 1		CR for introduction of 256QAM demodulation performance requirements	12.7.0
03-2015	RP-67	RP-150393	2772r 1		CR: DC UE performance requirements	12.7.0
03-2015	RP-67	RP-150390	2773r 1		CR: MTC demodulation performance requirements	12.7.0
03-2015	RP-67	RP-150390	2774r 1		CR: MTC CSI requirements	12.7.0
03-2015	RP-67	RP-150396	2775r 1		Introduction of the eIMTA functional PDSCH demodulation test	12.7.0
03-2015	RP-67	RP-150387	2776r 3		CR on RF core requirements for D2D	12.7.0
03-2015	RP-67	RP-150387	2777		Modification of CSI reference measurement channel Rel-12	12.7.0
03-2015	RP-67	RP-150388	2779		Editorial correction for CA_18A-28A	12.7.0
03-2015	RP-67	RP-150388	2781		Removing brackets for CA_1A-28A MSD requirements	12.7.0
03-2015	RP-67	RP-150384	2783		Editorial correction on symbols for enhanced performance requirements type A	12.7.0
03-2015	RP-67	RP-150387	2784		Corrections on reference measurement channel	12.7.0
03-2015	RP-67	RP-150388	2792		Correction of TS 36.101 for the Pcell support of 25+41	12.7.0
03-2015	RP-67	RP-150395	2793r 1		CR for single cell demodulation test for SU-MIMO	12.7.0
03-2015	RP-67	RP-150391	2794		Introduction of CA_3A-42A and CA_3A-42C into 36.101	12.7.0
03-2015	RP-67	RP-150384	2797		UL HARQ in PDSCH and PDCCH/PCFICH demod test cases for eCIC/felCIC with MBSFN ABS	12.7.0
03-2015	RP-67	RP-150382	2800		Correction to eCIC aggressor cell configurations	12.7.0
03-2015	RP-67	RP-150387	2801		R4-73AH-0040: Correction for uplink CA configuration in TS 36.101 Rel-12	12.7.0
03-2015	RP-67	RP-150387	2802r 1		Correction of MSD levels for CA_1A-8A in TS 36.101 rel-12	12.7.0
03-2015	RP-67	RP-150387	2805		Removal of eDL-MIMO term from specification	12.7.0
03-2015	RP-67	RP-150388	2809		Clarification of 2UL/3DL contiguous intraband CA REFSSENS test	12.7.0
03-2015	RP-67	RP-150392	2811r 1		CR on TM4 normal demodulation test for 3DL CA	12.7.0
03-2015	RP-67	RP-150392	2812		CR on introducing new DL reference measurement channels	12.7.0
03-2015	RP-67	RP-150392	2813r 1		CR on normal demodulation test for TDD-FDD CA	12.7.0
03-2015	RP-67	RP-150388	2815		Additions of bandwidth combination set reference	12.7.0
03-2015	RP-67	RP-150388	2816		Correction of band number in Table 5.6A.1-2a for LTE_CA_B4_B12_B30	12.7.0
03-2015	RP-67	RP-150382	2819		UE to UE co-existence between B42/B43	12.7.0
03-2015	RP-67	RP-150382	2822		Corrections to CA in-band emissions requirement	12.7.0
03-2015	RP-67	RP-150381	2830		Uplink RMCs for sustained data rate test	12.7.0
03-2015	RP-67	RP-150382	2833		Corrections to the CA power imbalance test	12.7.0
03-2015	RP-67	RP-150392	2839r 1		CR for soft buffer tests for TDD-FDD CA in 36.101 in Rel-12	12.7.0
03-2015	RP-67	RP-150392	2842		Editorial CR for CA UE performance tests in 36.101 in Rel-12	12.7.0
03-2015	RP-67	RP-150387	2847		UE spurious emissions structure correction for CA	12.7.0
03-2015	RP-67	RP-150387	2850		Correction of PCMAX for uplink inter-band and intra-band carrier aggregation	12.7.0
03-2015	RP-67	RP-150387	2851		Exceptions for spurious response for UL CA	12.7.0
03-2015	RP-67	RP-150388	2852r 1		Correction of REFSSENS, OOB and uplink configuration for 3DL/1UL CA	12.7.0
03-2015	RP-67	RP-150390	2853		SNR definition for category 0 UE	12.7.0
03-2015	RP-67	RP-150390	2854r 1		FRC for category 0 UE PDSCH performance requirements	12.7.0
03-2015	RP-67	RP-150390	2855r 1		Introduction of new PHICH and PBCH performance requirements for category 0 UE	12.7.0
03-2015	RP-67	RP-150387	2861		Correction to FOOB reference in definition of MPR for contiguous CA with non-contiguous resource allocation	12.7.0
03-2015	RP-67	RP-150387	2862		Band 31 update	12.7.0
03-2015	RP-67	RP-150384	2867		Implementation of CA configurations specified in later releases	12.7.0

06-2015	RP-68	RP-150958	2870r2		Intra-band contiguous CA reference sensitivity definition for Class D	12.8.0
06-2015	RP-68	RP-150961	2881r2		CR on MTC CQI tests	12.8.0
06-2015	RP-68	RP-150962	2882r2		CR on 256QAM demodulation performance requirements	12.8.0
06-2015	RP-68	RP-150962	2883r3		CR on 256QAM sustained data rate tests for single carrier and TDD or FDD CA	12.8.0
06-2015	RP-68	RP-150962	2885r4		CR on 256QAM CQI test	12.8.0
06-2015	RP-68	RP-150963	2886r3		CR on DC SDR tests	12.8.0
06-2015	RP-68	RP-150963	2887r2		Maintenance CR for DC demodulation performance requirements	12.8.0
06-2015	RP-68	RP-150958	2888		CR to restore R.10-2 FDD	12.8.0
06-2015	RP-68	RP-150961	2889r3		Introduction of UE category 0 PDSCH/PHICH/PBCH performance requirements	12.8.0
06-2015	RP-68	RP-150954	2901		UE to UE co-existence between B42/B43	12.8.0
06-2015	RP-68	RP-150958	2902		Correction of maximum aggregated bandwidth for CA_26A-41A	12.8.0
06-2015	RP-68	RP-150957	2903r2		Introduction of TDD SU-MIMO whitening verification test	12.8.0
06-2015	RP-68	RP-150958	2904		Correction of FRC table for CA demodulation with power imbalance	12.8.0
06-2015	RP-68	RP-150958	2905r1		Add SCell power levels for 2DL CA power imbalance test	12.8.0
06-2015	RP-68	RP-150955	2907		Corrections on UL transmit power for CA receiver requirements	12.8.0
06-2015	RP-68	RP-150958	2909		Corrections to the CA power imbalance test	12.8.0
06-2015	RP-68	RP-150957	2910r1		Clarification on RMC for D2D UE	12.8.0
06-2015	RP-68	RP-150960	2911		Correction on TDD eIMTA PDSCH functionality test	12.8.0
06-2015	RP-68	RP-150954	2931		3.5 GHz out-of-band blocking	12.8.0
06-2015	RP-68	RP-150965	2933		Correction of FRC names	12.8.0
06-2015	RP-68	RP-150954	2936		Correction of the 3DL CA REFSENS	12.8.0
06-2015	RP-68	RP-150962	2939r1		CR on 256QAM sustained data rate tests for TDD FDD CA	12.8.0
06-2015	RP-68	RP-150958	2940r1		Maintenance CR for 3DL CA performance requirements	12.8.0
06-2015	RP-68	RP-150958	2941r1		Maintenance CR for TDD FDD CA demodulation performance requirements	12.8.0
06-2015	RP-68	RP-150965	2944		Corrections on 2UL intra-band non-contiguous CA requirements	12.8.0
06-2015	RP-68	RP-150958	2947		Updates to the definitions of CA capability (Rel-12)	12.8.0
06-2015	RP-68	RP-150955	2950		Clarification of PDSCH allocation in CSI PUSCH 3-0 feICIC tests (Rel-12)	12.8.0
06-2015	RP-68	RP-150954	2956		NS value for intra-band contiguous CA configurations not allowed A-MPR	12.8.0
06-2015	RP-68	RP-150957	2958		Receiver spurious emissions requirements for downlink-only bands	12.8.0
06-2015	RP-68	RP-150958	2959		Amendments to MPR for uplink inter-band and intra-band non-contiguous CA	12.8.0
06-2015	RP-68	RP-150958	2960r1		NS values for secondary cells of non-contiguous CA configurations	12.8.0
06-2015	RP-68	RP-150955	2961r1		Corrections to test configurations for intra-band non-contiguous CA	12.8.0
06-2015	RP-68	RP-150954	2962		Corrections to test configurations for 3DL inter-band CA	12.8.0
06-2015	RP-68	RP-150958	2967		Adding REFSENS exception requirements for 1+3+26	12.8.0
06-2015	RP-68	RP-150954	2971		Corrections to NS_22 and NS_23	12.8.0
06-2015	RP-68	RP-150958	2972		Corrections to 41D fallback	12.8.0
06-2015	RP-68	RP-150957	2972		Corrections to EVM requirements for ProSe and Annex F of 36.101	12.8.0
06-2015	RP-68	RP-150958	2976		Removal of B27 from 2UL CA_7A_20A co-existence protected band list	12.8.0
06-2015	RP-68	RP-150957	2977r1		CR on corrections to D2D RF core requirements	12.8.0
06-2015	RP-68	RP-150963	2978r1		CR on corrections to D2D RF core requirements	12.8.0
06-2015	RP-68	RP-150957	2979		CR clarification of RMC for DL category 0 UE HD-FDD	12.8.0
06-2015	RP-68	RP-150960	2980r1		Introduction of TDD eIMTA CQI requirement	12.8.0
06-2015	RP-68	RP-150958	2985		Change of 1.4MHz single carrier SNR values for multiple CA configurations	12.8.0
06-2015	RP-68	RP-150954	2992		Clarification to spurious emission requirement for the edge of spurious domain	12.8.0

06-2015	RP-68	RP-150955	2996		Correction to CA_7C A-MPR in CA-NS_06	12.8.0
06-2015	RP-68	RP-150965	2998r 1		CR to update UE performance tests for UE DL category in 36.101 in Rel-12	12.8.0
06-2015	RP-68	RP-150965	2999		CR to update Annex for new DL category in 36.101 in Rel-12	12.8.0
06-2015	RP-68	RP-150958	3002		CR for updating CA applicability rule in 36.101 in Rel-12	12.8.0
06-2015	RP-68	RP-150957	3005r 1		CR for Rel-12 NAICS - Definitions	12.8.0
06-2015	RP-68	RP-150965	3012r 1		Clarification on uplink configuration for reference sensitivity of inter-band CA	12.8.0
06-2015	RP-68	RP-150954	3018		EVM for Intra-band contiguous UL CA for non-equal Channel BWs	12.8.0
06-2015	RP-68	RP-150958	3019		A-MPR correction for CA_39C CA_NS_07	12.8.0
06-2015	RP-68	RP-150958	2780r 3		Introduction of dual uplink CA into 36.101	13.0.0
06-2015	RP-68	RP-150646	2785r 2		Introduction of intra-band CA_42D to TS 36.101	13.0.0
06-2015	RP-68	RP-150968	2951r 2		Introduction of additional 2DL inter-band CA	13.0.0
06-2015	RP-68	RP-150972	2952r 1		Introduction of additional 3DL inter-band CA	13.0.0
06-2015	RP-68	RP-150974	2953r 2		Introduction of 4DL inter-band CA	13.0.0
06-2015	RP-68	RP-150975	2994r 1		Introduction of non-contiguous Carrier Aggregation (CA) in Band 42 for 3DL	13.0.0
06-2015	RP-68	RP-150967	3011r 1		CR to 36.101: New CA bandwidth classes for FeCA	13.0.0
06-2015	RP-68	RP-150668	3021		Introduction of CA_3A-40A to TS 36.101	13.0.0
06-2015	RP-68	RP-150673	3022		Introduction of CA_3A-40C to TS 36.101	13.0.0
09-2015	RP-69	RP-151479	3028		Table 7.3.1A-Of (2UL CA MSD) notes numbering correction	13.1.0
09-2015	RP-69	RP-151505	3029		Additional bandwidth combination set for LTE Advanced intra-band non-contiguous Carrier Aggregation in Band 4	13.1.0
09-2015	RP-69	RP-151479	3031		Correction to TDD FDD CA	13.1.0
09-2015	RP-69	RP-151483	3033		Alignment of CA Receiver requirements parameters	13.1.0
09-2015	RP-69	RP-151476	3036		Correction to CoMP demodulation requirements	13.1.0
09-2015	RP-69	RP-151475	3040		Correction to RI test parameters in TS 36.101 (Rel-13)	13.1.0
09-2015	RP-69	RP-151475	3050		UE co-existence requirements between Band 42 and Japanese bands	13.1.0
09-2015	RP-69	RP-151483	3052		Introduction of relaxation rule for multiple 3DL inter-band CA configurations	13.1.0
09-2015	RP-69	RP-151491	3056r 1		Adding CA_42D to the out of band blocking requirement exception	13.1.0
09-2015	RP-69	RP-151501	3057r 1		Introduction of finished 4DL inter-band CAs to TS 36.101	13.1.0
09-2015	RP-69	RP-151487	3060r 1		Corrections on CA reference sensitivity requirements	13.1.0
09-2015	RP-69	RP-151476	3064		Correction to RC.2 TDD Nr. HARQ Proc. into TS36.101	13.1.0
09-2015	RP-69	RP-151483	3065		Corrections to CSI PUCCH 1-0 static test 4 and PUSCH 3-2 tests	13.1.0
09-2015	RP-69	RP-151488	3066		Corrections in Table 5.6A.1-2, 7.3.1-1A and 7.3.1-1B.	13.1.0
09-2015	RP-69	RP-151479	3068		Corrections of Spurious emission band UE co-existence for interband 2UL CA in Table 6.6.3.2A-0	13.1.0
09-2015	RP-69	RP-151483	3070		Revisions of Spurious emission band UE co-existence in Table 6.6.3.2-1	13.1.0
09-2015	RP-69	RP-151475	3076		Correction to PDCCH/PCFICH test parameters in TS 36.101 (Rel-13)	13.1.0
09-2015	RP-69	RP-151475	3080		Correction to PMI delay in PMI test for TDD	13.1.0
09-2015	RP-69	RP-151503	3081r 1		Introduction of dual uplink CA into 36.101	13.1.0
09-2015	RP-69	RP-151479	3083		Maintenance CR for MTC CSI performance requirements	13.1.0
09-2015	RP-69	RP-151479	3085		Maintenance CR for SCE demodulation and CSI requirements	13.1.0
09-2015	RP-69	RP-151479	3087		Maintenance CR for DC demodulation performance requirements and SDR tests	13.1.0
09-2015	RP-69	RP-151479	3089		Cleanup of TDD-FDD CA demodulation performance requirements	13.1.0
09-2015	RP-69	RP-151479	3091		Cleanup of R12 SU-MIMO Enhanced Performance Type C requirements	13.1.0
09-2015	RP-69	RP-151475	3102		Correction on UE maximum output power class of Band 22 for UL MIMO	13.1.0
09-2015	RP-69	RP-151479	3104		Removal of square brackets for Cat-0 UE demodulation requirements	13.1.0
09-2015	RP-69	RP-151479	3106		Removal of square brackets for LTE-CA_B41_B42	13.1.0
09-2015	RP-69	RP-151490	3107		Removal of square brackets for LTE-CA_B41_B42_B42	13.1.0
09-2015	RP-69	RP-151479	3112		Corrections on 3DL CA performance requirements	13.1.0
09-2015	RP-69	RP-151489	3113		CR 36.101 BW combination for CA_8A_41A	13.1.0
09-2015	RP-69	RP-151479	3114		UL DL pairing for CA of B39+B41+B41 and B39+B39+B41	13.1.0

09-2015	RP-69	RP-151498	3116		Introduction of additional band combinations for 2DL inter-band CA	13.1.0
09-2015	RP-69	RP-151499	3117		Introduction of additional band combinations for 3DL inter-band CA	13.1.0
09-2015	RP-69	RP-151475	3118		Minor corrections in 36.101	13.1.0
09-2015	RP-69	RP-151479	3121		CR adding clarification for Band 28 restrictions in 36.101	13.1.0
09-2015	RP-69	RP-151494	3123r 1		Introduction of propagation conditions to handle 4 receivers in the UE	13.1.0
09-2015	RP-69	RP-151504	3125r 1		Addition on interband CA 2UL/3DL pairs without MSD	13.1.0
09-2015	RP-69	RP-151483	3127		CR for UE performance tests for intra-band contiguous CA with minimum channel spacing on Band 41	13.1.0
09-2015	RP-69	RP-151496	3130r 2		TM9 performance with CRS assistance information	13.1.0
09-2015	RP-69	RP-151495	3133r 1		Introduction of UL 64QAM to TS 36.101	13.1.0
09-2015	RP-69	RP-151483	3135r 1		Modification of test parameters for TM9 demodulation with 256QAM (Rel-13)	13.1.0
09-2015	RP-69	RP-151485	3137		CR to add demodulation tests for new release 13 2CC combinations in 36.101	13.1.0
09-2015	RP-69	RP-151501	3139r 1		Introduction of 4CC demodulation requirements for FDD and FDD-TDD CA	13.1.0
09-2015	RP-69	RP-151479	3141		Correction to FDD-TDD closed loop spatial multiplexing 3CC requirement table	13.1.0
09-2015	RP-69	RP-151473	3143r 1		Correction to DC supported testable bandwidth list	13.1.0
09-2015	RP-69	RP-151479	3145		Clarification of UL configuration for CA demodulation requirements	13.1.0
09-2015	RP-69	RP-151479	3146r 1		Spreading of harmonic for 2UL interband and 2 ULnon-contiguous intraband CA	13.1.0
09-2015	RP-69	RP-151502	3147		Correction to dRib and REFSSENS	13.1.0
09-2015	RP-69	RP-151479	3153		Corrections to CSI RMCs used for PUSCH 3-2 testing (Rel-13)	13.1.0
09-2015	RP-69	RP-151483	3155		Corrections to applicability of CSI requirements for low UE categories (Rel-13)	13.1.0
09-2015	RP-69	RP-151482	3164		CR for Rel-12 NAICS - Demodulation Test	13.1.0
09-2015	RP-69	RP-151482	3165		CR for Rel-12 NAICS - Fixed Reference Channels	13.1.0
09-2015	RP-69	RP-151482	3166		CR for Rel-12 NAICS - Interference Models	13.1.0
09-2015	RP-69	RP-151482	3167		CR for Rel-12 NAICS - CQI Tests	13.1.0
09-2015	RP-69	RP-151205	3168		Introduction of CA_7A-40A and CA_7A-40C to TS 36.101	13.1.0
09-2015	RP-69	RP-151593	3170		CR for Rel-13 NAICS – TM10 Demodulation and CSI Test	13.1.0
12-2015	RP-70	RP-152158	3172r 1		Introduction of UE RF requirements for CA_42E	13.2.0
12-2015	RP-70	RP-152137	3173		Correction on UL 64QAM measurement channels	13.2.0
12-2015	RP-70	RP-152131	3175		Release 13 CAT A CR to align NS_04 values to meet FCC OOB requirements	13.2.0
12-2015	RP-70	RP-152136	3178		Maintenance of eIMTA PDSCH demodulation test	13.2.0
12-2015	RP-70	RP-152136	3180r 1		Correction for eIMTA CQI tests	13.2.0
12-2015	RP-70	RP-152133	3186		Simplified CA fading Test method becomes optional	13.2.0
12-2015	RP-70	RP-152133	3191		Correction of the applicable UE categories for 256QAM UE demodulation performance requirements (Rel-13)	13.2.0
12-2015	RP-70	RP-152133	3193r 1		Correction of TDD-FDD CA performance requirements (Rel-13)	13.2.0
12-2015	RP-70	RP-152133	3195r 1		Correction on FDD CA and TDD CA performance requirements (Rel-13)	13.2.0
12-2015	RP-70	RP-152163	3196		CR on introduction of 5CC FDD/TDD CA demodulation performance requirements	13.2.0
12-2015	RP-70	RP-152163	3197		CR on introduction of 5CC TDD FDD CA demodulation performance requirements	13.2.0
12-2015	RP-70	RP-152132	3205		Correction of the AMPR table for NS_14 in TS 36.101 R13	13.2.0
12-2015	RP-70	RP-152134	3206		Correction of the 2UL CA co-existence table for CA_18A-28A	13.2.0
12-2015	RP-70	RP-152152	3209		Introduction of 3DL/2UL DC	13.2.0
12-2015	RP-70	RP-152139	3210r 1		Correction of uplink configuration for CA_42D	13.2.0
12-2015	RP-70	RP-152133	3212		Introduction of dual uplink CA into 36.101	13.2.0
12-2015	RP-70	RP-152133	3214		Corrections to the CSI minimum requirement for PUSCH 3-2 (Rel-13)	13.2.0
12-2015	RP-70	RP-152133	3216		Corrections to MIMO Correlation Matrices using cross polarized antennas (Rel-12)	13.2.0
12-2015	RP-70	RP-152157	3221r 1		Introducing B20 + B67 CA into TS 36.101	13.2.0
12-2015	RP-70	RP-152136	3225		CR for UE performance tests for intra-band contiguous CA with minimum channel spacing on Band 41	13.2.0
12-2015	RP-70	RP-152136	3227r 1		Correction in SNR definition for CSI test	13.2.0

12-2015	RP-70	RP-152130	3232		Correction to reference channel for CQI requirements	13.2.0
12-2015	RP-70	RP-152168	3233r 1		CR 36.101 BW combination for CA_8B	13.2.0
12-2015	RP-70	RP-152164	3241		Correction to mandatory 2UL support for 3DL interband CA	13.2.0
12-2015	RP-70	RP-152164	3242		Introduction of 2 UL and 3 DL interband cases with MSD	13.2.0
12-2015	RP-70	RP-152132	3246		CR on FRC for CDM-multiplexed DM RS	13.2.0
12-2015	RP-70	RP-152132	3249		Correction to physical channel for CQI reporting in type A test case	13.2.0
12-2015	RP-70	RP-152133	3255		CR for Rel-12 NAICS - Demodulation Test	13.2.0
12-2015	RP-70	RP-152133	3263		Correction on CA_4A-4A-5A table reference	13.2.0
12-2015	RP-70	RP-152134	3269r 1		Clarification of Pcell support in 36.101 in CA scenarios	13.2.0
12-2015	RP-70	RP-152132	3273		A-MPR correction for CA_NS_06 CA-7C non-contiguous RB allocation	13.2.0
12-2015	RP-70	RP-152136	3276		Clarification on relative power tolerance for CA	13.2.0
12-2015	RP-70	RP-152133	3278		Correction of uplink configuration for CA_18-28	13.2.0
12-2015	RP-70	RP-152135	3280		CR on corrections for ProSe Direct Discovery demodulation requirements	13.2.0
12-2015	RP-70	RP-152135	3281		CR to finalize demodulation performance requirements for D2D Communication	13.2.0
12-2015	RP-70	RP-152131	3285		Missing RB allocation and OCNG Pattern for Cat 1 UEs in Multiple PMI CSI Reference Symbol tests	13.2.0
12-2015	RP-70	RP-152167	3286r 1		Introduction of CA_5B to TS 36.101	13.2.0
12-2015	RP-70	RP-152169	3287		Introduction of CA_5A-5A to TS 36.101	13.2.0
12-2015	RP-70	RP-152133	3288		Introduction of dual uplink CA into 36.101	13.2.0
12-2015	RP-70	RP-152150	3291r 1		CR on eD2D RF core requirements	13.2.0
			3292r 3		Introduction of B65 in Region 1	13.2.0
12-2015	RP-70	RP-152131	3294		Correction of supported sub-block frequency arrangement for CA_41-41	13.2.0
12-2015	RP-70	RP-152131	3296		Correction of test configuration for combinations of inter-band and intra-band CA	13.2.0
12-2015	RP-70	RP-152147	3299r 2		RF receiver requirements for UE(s) supporting four antenna ports	13.2.0
12-2015	RP-70	RP-152148	3300r 2		Introduction of RF requirements for LAA operation	13.2.0
			3309r 2		Introduction of Band 66	13.2.0
12-2015	RP-70	RP-152172	3311		Correction on CQI test 1A for TDD eIMTA	13.2.0
12-2015	RP-70	RP-152166	3312r 1		Introduction of 3DL/3UL Inter-band CA of CA_39A-41C and CA_39C-41A	13.2.0
12-2015	RP-70	RP-152133	3314		Correction of the resource allocation in FRC for CAT0 UE demodulation tests	13.2.0
12-2015	RP-70	RP-152151	3318		Introduce TM4 performance requirements when CRS assistance information is provided	13.2.0
12-2015	RP-70	RP-152151	3319r 1		Introduce TM10 performance requirements when CRS assistance information is provided for multiple-CSI-process capable UE	13.2.0
12-2015	RP-70	RP-152151	3320r 1		Introduce TM10 performance requirements when CRS assistance information is provided for one-CSI-process capable UE	13.2.0
12-2015	RP-70	RP-152163	3325		Introduction of 5DL/1UL CA combinations into TS 36.101	13.2.0
12-2015	RP-70	RP-152175	3326r 1		Introduction of Region 3 requirement in Band 65	13.2.0
12-2015	RP-70	RP-152138	3327		Correction of CA_8A-41C bandwidth combination set	13.2.0
12-2015	RP-70	RP-152133	3329		Removal of DC channel bandwidth combination set table	13.2.0
12-2015	RP-70	RP-152136	3331		CR on demodulation requirements of Dual Connectivity	13.2.0
12-2015	RP-70	RP-152131	3332r 1		Modification and correction of CA_3A-3A BCS1 in Rel.13 36.101	13.2.0
12-2015	RP-70	RP-152133	3334		Correction of MSD levels for 2UL inter-band CA in TS 36.101 Rel-13	13.2.0
12-2015	RP-70	RP-152162	3338		Introduction of finished 4DL inter-band CAs to TS 36.101	13.2.0
12-2015	RP-70	RP-152170	3339		Introduction of CA_7A-7A BCS1 to TS 36.101	13.2.0
12-2015	RP-70	RP-152164	3340r 1		Introduction of additional 2 UL and 3 DL interband cases with MSD	13.2.0
12-2015	RP-70	RP-152158	3341r 1		Addition of Class E into CA BW Class table.	13.2.0
12-2015	RP-70	RP-152131	3343		Table 6.2.4A-1 note 1 correction	13.2.0
12-2015	RP-70	RP-152164	3345		Removal of (NOTE 4) from Table 5.6A.1-2a	13.2.0
12-2015	RP-70	RP-152160	3347		Introduction of 4DL NC CA in band42 in 36.101	13.2.0
12-2015	RP-70	RP-152173	3348		Introduction of 1447-1467MHz Band into 36.101	13.2.0
12-2015	RP-70	RP-152136	3352		CR: PDSCH ETU600 performance requirements	13.2.0
12-2015	RP-70	RP-152156	3357		Introduction of additional band combinations for 2DL inter-	13.2.0

						band CA	
12-2015	RP-70	RP-151972	3358r 2			Revision of the RAN4 approved R4-158446 (big CR 3DL 36.101)	13.2.0
12-2015	RP-70	RP-152147	3359r 1			Introduction of the Medium Correlation A model	13.2.0
12-2015	RP-70	RP-152147	3360r 1			Requirements for ePDCCH with 4Rx	13.2.0
12-2015	RP-70	RP-152147	3361r 1			Requirements for PDCCH with 4Rx	13.2.0
12-2015	RP-70	RP-152147	3362r 1			Requirements for PDSCH with 4Rx	13.2.0
12-2015	RP-70	RP-152147	3363r 1			Requirements for PHICH with 4Rx	13.2.0
12-2015	RP-70	RP-152159	3367r 1			Introduction of intra-band non-contiguous CA in Band 41 for 4DL	13.2.0
12-2015	RP-70	RP-152165	3368			Addition of 2 UL and 3 DL mixed intra/inter band carrier aggregation combinations without MSD.	13.2.0
12-2015	RP-70	RP-152133	3372r 1			Revision to CR 3256	13.2.0
12-2015	RP-70	RP-152133	3375			Correction to Pcmx for CA to include delta_T_ProSe	13.2.0
12-2015	RP-70	RP-152162	3376			Delta TIB,c and Delta RIB,c for 1UL/4DL	13.2.0
12-2015	RP-70	RP-152136	3378			NS_05 modification for PHS protection in Japan	13.2.0
01-2016	RP-70					Editorial correction: Correction of reference to section 6.6.3.3.19 for NS_04 in Table 6.2.4-1	13.2.1
03/2016	RP-71	RP-160472	3467	1	B	UE receiver requirements for Rel-13 MTC	13.3.0
03/2016	RP-71	RP-160472	3443	1	B	CR on TX requirements for Rel-13 eMTC	13.3.0
03/2016	RP-71	RP-160474	3419		B	Introduce Robustness test for CRS-IM capable UE	13.3.0
03/2016	RP-71	RP-160474	3422	1	B	FRC for non-TM10 with CRS assistance information	13.3.0
03/2016	RP-71	RP-160474	3420	1	B	Introduce non-TM10 performance with CRS assistance information	13.3.0
03/2016	RP-71	RP-160474	3421	1	B	Introduce TM10 performance with CRS assistance information	13.3.0
03/2016	RP-71	RP-160474	3423	1	B	FRC for TM10 with CRS assistance information	13.3.0
03/2016	RP-71	RP-160475	3460	1	B	CR: Correction of FRC for SDR test (Rel-13)	13.3.0
03/2016	RP-71	RP-160479	3459		F	Correction of 4Rx demodulation performance requirements	13.3.0
03/2016	RP-71	RP-160479	3462		B	Correction of Correlation Model for Medium Correlation A	13.3.0
03/2016	RP-71	RP-160479	3466		B	UE Demodulation Requirements for DL Control channels for 4Rx	13.3.0
03/2016	RP-71	RP-160479	3463	1	B	UE Demodulation Requirements for DL PDSCH rank 1 and 2 performance	13.3.0
03/2016	RP-71	RP-160479	3464	1	B	UE Demodulation Requirements for DL PDSCH rank 3 and 4 requirements	13.3.0
03/2016	RP-71	RP-160479	3412	2	F	Corrections to UE RF receiver requirements for 4RX AP and support of CA	13.3.0
03/2016	RP-71	RP-160480	3431		B	Introduction of additional band combinations for 3DL inter-band CA	13.3.0
03/2016	RP-71	RP-160481	3396		B	Introduction of completed R13 4DL inter-band CA's to TS 36.101	13.3.0
03/2016	RP-71	RP-160482	3424		B	Introduction of 5DL/1UL CA combinations	13.3.0
03/2016	RP-71	RP-160483	3415	2	B	Introduction of Band 68 for Arab region into 36.101	13.3.0
03/2016	RP-71	RP-160487	3429		A	[Rel-13] Correction on Intra-band non-contiguous CA	13.3.0
03/2016	RP-71	RP-160488	3381		A	Correction to Type A CQI test parameters in TS 36.101	13.3.0
03/2016	RP-71	RP-160488	3405		A	CQI reports in CoMP fading test	13.3.0
03/2016	RP-71	RP-160488	3453		F	Maintenance CR for CA (Rel-13)	13.3.0
03/2016	RP-71	RP-160488	3461		A	Correction to TDD CQI Reporting for feICIC	13.3.0
03/2016	RP-71	RP-160488	3481		A	Beamforming model correction on TM10 DPS UE tests	13.3.0
03/2016	RP-71	RP-160489	3384		A	Correction in beam steering rate for 4 Tx antenna in Rel-13	13.3.0
03/2016	RP-71	RP-160489	3386		A	CR for correction to syncOffsetIndicator parameter in D2D resource pool configuration	13.3.0
03/2016	RP-71	RP-160489	3390		A	Correction of eIMTA CSI test	13.3.0
03/2016	RP-71	RP-160489	3402		A	[Rel-13] NS_05 modification for PHS protection in Japan	13.3.0
03/2016	RP-71	RP-160489	3411		A	Correction of Pcmx for Dual Connectivity	13.3.0
03/2016	RP-71	RP-160489	3436		A	Correction on UE category in Annex of TS 36.101	13.3.0
03/2016	RP-71	RP-160489	3438		A	Removal of brackets for Maximum input level for 256QAM in TS 36.101	13.3.0
03/2016	RP-71	RP-160489	3440		A	Removal of brackets for Measurement channels for MTC in TS 36.101	13.3.0
03/2016	RP-71	RP-160489	3456		A	Maintenance CR for D2D (Rel-13)	13.3.0
03/2016	RP-71	RP-160489	3458		A	CR: Correction of FRC for SDR test (Rel-13)	13.3.0
03/2016	RP-71	RP-160489	3482		A	Maintenance CR for DC (Rel-13)	13.3.0
03/2016	RP-71	RP-160490	3382		F	Correction in UL CA support table	13.3.0
03/2016	RP-71	RP-160490	3397		F	Removing the brackets for 3+40 REFSSENS	13.3.0
03/2016	RP-71	RP-160490	3416		F	Corrections on BCS and EARFCN tables	13.3.0
03/2016	RP-71	RP-160490	3425		F	Removal of channel bandwidth sets for three bands DC	13.3.0
03/2016	RP-71	RP-160490	3427		F	Corrections to Notes in 2UL spurious emission table	13.3.0

03/2016	RP-71	RP-160490	3442		F	Revision of channel bandwidths for CA_B3_B41_B42 in 36.101	13.3.0
03/2016	RP-71	RP-160490	3447		F	Removing DC_5-17 from 36.101 Rel 13	13.3.0
03/2016	RP-71	RP-160490	3473		D	CR of editorial change on PHICH group and Ng in Rel-13	13.3.0
03/2016	RP-71	RP-160490	3477		F	Supported bandwidths for Band 66	13.3.0
03/2016	RP-71	RP-160490	3478		F	Corrections to CA_66C	13.3.0
03/2016	RP-71	RP-160490	3441	1	F	Correction on Annex D for LAA in TS 36.101	13.3.0
03/2016	RP-71	RP-160490	3406	3	F	Correction to UL 64 QAM measurement channels in TS 36.101	13.3.0
03/2016	RP-71	RP-160490	3430	3	F	Corrections and bracket removals to B46 specifications	13.3.0
06/2016	RP-72	RP-161141	3489		A	Correction on B39 coexistence spurious emission requirements	13.4.0
06/2016	RP-72	RP-161141	3491		A	Square brackets on B39 single carrier spurious emission requirements for protecting B3	13.4.0
06/2016	RP-72	RP-161135	3492		F	Introduction of EB/FD-MIMO channel model using 2D XP antennas at eNB	13.4.0
06/2016	RP-72	RP-161142	3493		F	CR to Correct Notes for CA REFSENS Tables	13.4.0
06/2016	RP-72	RP-161142	3494		D	Editorial modification on uplink inter-band CA	13.4.0
06/2016	RP-72	RP-161141	3496		A	CSI requirements for 2DL FDD-TDD for UE Cat 3 (Rel 13)	13.4.0
06/2016	RP-72	RP-161141	3498		A	Wrong RMC description in overview table (Rel-13)	13.4.0
06/2016	RP-72	RP-161142	3499	1	F	Correction of Pcmx for Prose	13.4.0
06/2016	RP-72	RP-161128	3504	3	B	Introduction of PDSCH demodulation requirement for Cat-M1 UE	13.4.0
06/2016	RP-72	RP-161128	3505	3	B	Introduction of CQI test for Cat-M1 UE	13.4.0
06/2016	RP-72	RP-161142	3507	1	C	Correcting fallback inconsistencies in CA of B41 and B42 in REL-13	13.4.0
06/2016	RP-72	RP-161141	3510	1	F	CR: Addition of performance requirement for TDD-FDD DC(Rel-13)	13.4.0
06/2016	RP-72	RP-161133	3514		F	Correction on 4Rx demodulation tests	13.4.0
06/2016	RP-72	RP-161142	3517		F	Introduction of 4Rx requirement for Band 1	13.4.0
06/2016	RP-72	RP-161142	3522		F	CR on reference measurement channel for Rel-13 eMTC	13.4.0
06/2016	RP-72	RP-161142	3526		F	Introduction of 4Rx REFSENS for Band 41	13.4.0
06/2016	RP-72	RP-161142	3528		F	Rx requirement for the non-contiguous CA with more than two component carriers	13.4.0
06/2016	RP-72	RP-161141	3530		F	Correction on UE category for MTC and eMTC in TS 36.101	13.4.0
06/2016	RP-72	RP-161142	3531	1	F	Correction on eMTC in TS 36.101	13.4.0
06/2016	RP-72	RP-161140	3535		A	ACS for CA Bandwidth Class D: Case 2 wanted signal power	13.4.0
06/2016	RP-72	RP-161140	3538		A	Maintenance CR for demodulation performance requirements (Rel-13)	13.4.0
06/2016	RP-72	RP-161142	3545	1	F	Maintenance CR for CRS-IM	13.4.0
06/2016	RP-72	RP-161142	3548		F	Correction to UE Categories for 64 QAM Reference channels	13.4.0
06/2016	RP-72	RP-161142	3549		F	Clean up for CRS-IM related requirements	13.4.0
06/2016	RP-72	RP-161142	3551	2	F	Correction on eMTC In-band emissions in TS 36.101	13.4.0
06/2016	RP-72	RP-161136	3554	1	B	CR on the introduction of the LTE DL Control Channels Interference Mitigation: PDCCH/PCFICH demodulation performance requirements	13.4.0
06/2016	RP-72	RP-161136	3555	1	B	CR on the introduction of the LTE DL Control Channels Interference Mitigation: Interference models	13.4.0
06/2016	RP-72	RP-161141	3559		F	Corrections to 9.6.1.3 and 9.6.1.4 TDD FDD CQI Reporting test	13.4.0
06/2016	RP-72	RP-161142	3560		F	Corrections for CA_28A-42A and CA_28A-42C requirements	13.4.0
06/2016	RP-72	RP-161128	3568	1	B	CR for eMTC PBCH demodulation requirement for enhanced coverage	13.4.0
06/2016	RP-72	RP-161128	3569	1	B	CR for eMTC M-PDCCH demodulation requirement for CE Mode A and CE Mode B	13.4.0
06/2016	RP-72	RP-161135	3573		B	Introduction of EB/FD-MIMO Class A PMI test	13.4.0
06/2016	RP-72	RP-161135	3574		B	Introduction of EB/FD-MIMO Class B K=1 PMI test	13.4.0
06/2016	RP-72	RP-161142	3576		F	RMC for verification of RF receiver requirements for LAA	13.4.0
06/2016	RP-72	RP-161142	3578		F	Corrections of CA 8A-42A/C in REL-13	13.4.0
06/2016	RP-72	RP-161142	3579	1	F	CR on control channel requirements of 4 Rx UE	13.4.0
06/2016	RP-72	RP-161142	3585		F	CR on Frequency bands for UE category 0 and UE category M1	13.4.0
06/2016	RP-72	RP-161142	3587		F	CR for dTib,c and dRib,c for CA combinations including Band 21 and 42	13.4.0
06/2016	RP-72	RP-161126	3589		B	Category NB1 CR for 36.101	13.4.0
06/2016	RP-72	RP-161142	3590		F	CR for delta F_HD for B46 combinations	13.4.0
06/2016	RP-72	RP-161136	3592	2	B	CR on Definitions for DL control channel IM	13.4.0
06/2016	RP-72	RP-161136	3593	1	B	CR on PHICH performance requirements for DL control channel IM	13.4.0
06/2016	RP-72	RP-161136	3594r1		B	CR on ePDCCH performance requirements for DL control channel IM	13.4.0
06/2016	RP-72	RP-161136	3595		B	CR on FRC for enhanced EPDCCH performance requirements	13.4.0
06/2016	RP-72	RP-161133	3597	1	B	Finalization of 4Rx UE Demodulation Requirements	13.4.0

06/2016	RP-72	RP-161142	3602	1	F	Clarification on eMTC RX requirements in TS 36.101	13.4.0
06/2016	RP-72	RP-161142	3610		F	Uplink configuration for reference sensitivity for B45	13.4.0
06/2016	RP-72	RP-161142	3614		F	CR: Maintenance CR for demodulation performance requirements (Rel-13)	13.4.0
06/2016	RP-72	RP-161142	3619		F	CR 36.101 on 7+38 blocking requirement	13.4.0
06/2016	RP-72	RP-161141	3623		A	Editorial correction for TM4 MMSE-IRC PDSCH demodulation test	13.4.0
06/2016	RP-72	RP-161142	3632	1	F	CR for TM9 tests with MBSFN subframes configured for PDSCH in Rel-13	13.4.0
06/2016	RP-72	RP-161133	3633	2	B	CR for applicability rule, antenna connection and test method for 4Rx UEs in Rel-13	13.4.0
06/2016	RP-72	RP-161136	3634	1	B	CR of introducing enhanced control channels requirements under asynchronous network in Rel-13	13.4.0
06/2016	RP-72	RP-161139	3635	1	F	Reference sensitivity for combinations of inter-band and NC intra-band CA	13.4.0
06/2016	RP-72	RP-161142	3636	1	F	Correction to A-MPR for NS_26	13.4.0
06/2016	RP-72	RP-161136	3640	1	B	CR for applicability rule for control channel enhancement requirements in Rel-13	13.4.0
09/2016	RP-73	RP-161785	3644		A	Correct UE DL category for 256QAM demodulation	13.5.0

09/2016	RP-73	RP-161632	3655		A	Improving the single antenna port description in UL-MIMO clauses	13.5.0
09/2016	RP-73	RP-161635	3658		F	Correction of CA_42-42 sub-block CA configuration	13.5.0
09/2016	RP-73	RP-161784	3662		A	Correction of CA REFSENS harmonic formula	13.5.0
09/2016	RP-73	RP-161635	3664		F	Adding UL configuration for CA_28A-42A and CA_28A-42C	13.5.0
09/2016	RP-73	RP-161640	3671		A	CR: Update the power level setting for tests 8.3.1.2 and 8.3.2.3 (Rel-13)	13.5.0
09/2016	RP-73	RP-161636	3689		F	Removal of brackets from category NB1 specification	13.5.0
09/2016	RP-73	RP-161636	3695		F	Change of NB-IoT term into Category NB1	13.5.0
09/2016	RP-73	RP-161786	3702		F	Completion of the RF RX requirements for 4 RX AP	13.5.0
09/2016	RP-73	RP-161639	3731		F	Correction on in-band emission requirements for cat M1 UE	13.5.0
09/2016	RP-73	RP-161639	3733		F	Overview of UL reference measurement channels	13.5.0
09/2016	RP-73	RP-161634	3746		A	Removal of square brackets for Cat-0 REFSENS configuration	13.5.0
09/2016	RP-73	RP-161615	3750		F	Introduction of performance requirements for FD-MIMO Class A and Class B K=1 PMI test cases	13.5.0
09/2016	RP-73	RP-161615	3751		B	Introduction of FRC for CRI test	13.5.0
09/2016	RP-73	RP-161615	3752		B	Introduction of EB/FD-MIMO MR functionality test	13.5.0
09/2016	RP-73	RP-161638	3753		F	Corrections on TS36.101 for LAA	13.5.0
09/2016	RP-73	RP-161633	3764		A	CR for fixing power level for TM9 dual layer test in Rel-13	13.5.0
09/2016	RP-73	RP-161634	3775		A	2UL CA 5+17 correction	13.5.0
09/2016	RP-73	RP-161636	3787		F	Clarification on EARFCN	13.5.0
09/2016	RP-73	RP-161637	3791		F	Corrections in 36.101 for NB-IoT UE	13.5.0
09/2016	RP-73	RP-161784	3793		A	Modification on E-UTRA Prose out of band blocking requirement	13.5.0
09/2016	RP-73	RP-161640	3798		A	Correction of OCNG	13.5.0
09/2016	RP-73	RP-161640	3803		F	CR: Correction of power parameter for demodulation tests	13.5.0
09/2016	RP-73	RP-161640	3807		B	CR: Introduction of test requirements for new UE behaviour (Rel-13)	13.5.0
09/2016	RP-73	RP-161635	3811		F	Reference sensitivity exception for CA_20A-38A and CA_7A-20A-38A	13.5.0
09/2016	RP-73	RP-161640	3816		F	Missing CA reference sensitivity exceptions	13.5.0
09/2016	RP-73	RP-161634	3821		A	Correction on subframe pair definition for PCMAX of DC	13.5.0
09/2016	RP-73	RP-161784	3826		A	Correction of CR Implementation error to 36.101	13.5.0
09/2016	RP-73	RP-161636	3693	1	D	Editorial correction to category NB1 specifications	13.5.0
09/2016	RP-73	RP-161637	3755	1	F	Editorial modification on TS36.101 for NB-IoT	13.5.0
09/2016	RP-73	RP-161636	3789	1	F	Corrections in 36.101 for NB-IoT UE	13.5.0
09/2016	RP-73	RP-161609	3714	1	B	Downlink physical channel setup for NB-IoT UE demodulation requirements	13.5.0
09/2016	RP-73	RP-161609	3712	1	B	Introduction of NPDCCH demodulation requirements	13.5.0
09/2016	RP-73	RP-161636	3716	2	F	Corrections to channel bandwidth for category NB1 in TS36.101 (Rel-13)	13.5.0
09/2016	RP-73	RP-161613	3782	1	B	Finalizing UE CQI requirements for 4Rx	13.5.0
09/2016	RP-73	RP-161613	3780	1	F	Corrections of UE requirements for 4Rx	13.5.0
09/2016	RP-73	RP-161611	3784	1	B	CR on eD2D demodulation performance requirements	13.5.0
09/2016	RP-73	RP-161782	3677	1	B	CR for eMTC M-PDCCH demodulation requirement for CE Mode B (Rel-13)	13.5.0
09/2016	RP-73	RP-161614	3722	1	B	Introduce PDCCH test for LAA demodulation	13.5.0
09/2016	RP-73	RP-161614	3718	1	B	Introduce aperiodic CSI test for LAA	13.5.0
09/2016	RP-73	RP-161615	3749	1	B	Introduction of EB/FD-MIMO PDSCH demodulation test	13.5.0
09/2016	RP-73	RP-161615	3748	1	B	Introduction of EB/FD-MIMO CRI Test	13.5.0
09/2016	RP-73	RP-161615	3842		F	CR: Correction of test parameters with Class B alternative codebook for one CSI-RS resource configured	13.5.0
09/2016	RP-73	RP-161786	3646	1	F	CR on finalization of enhanced PDCCH/PCFICH performance requirements for DL control channel IM	13.5.0
09/2016	RP-73	RP-161783	3683	1	B	CR for introducing LAA PDSCH demodulation performance requirements (Rel-13)	13.5.0
09/2016	RP-73	RP-161610	3704	1	B	Introduction of TM2/TM9 PDSCH demodulation requirements for eMTC	13.5.0
09/2016	RP-73	RP-161781	3706	1	F	Correction of eMTC PDSCH TM6 demodulation requirements	13.5.0
09/2016	RP-73	RP-161781	3708	1	F	Correction of eMTC CQI definition test	13.5.0
09/2016	RP-73	RP-161610	3710	1	B	Introduction of UE-selected subband CQI test for eMTC	13.5.0
09/2016	RP-73	RP-161630	3829		A	Bracket removal for B3 and B39 UE co-existence	13.5.0
09/2016	RP-73	RP-161635	3838		F	Corrections of 3+41+42	13.5.0
09/2016	RP-73	RP-161638	3697	1	F	Guard band requirements for Band 46 MSD	13.5.0
09/2016	RP-73	RP-161786	3724	1	F	CR on finalization of enhanced PHICH performance requirements for DL control channel IM	13.5.0
09/2016	RP-73	RP-161786	3725	1	F	CR on finalization of enhanced ePDCCH performance requirements for DL control channel IM	13.5.0
09/2016	RP-73	RP-161613	3766	1	B	CR for applicability rule, antenna connection and test method for 4Rx UEs in Rel-13	13.5.0
09/2016	RP-73	RP-161634	3805	1	F	Updated CA demodulation performance requirements (Rel-13)	13.5.0
09/2016	RP-73	RP-161635	3809	1	F	CR: On eDC demodulation performance requirements	13.5.0
09/2016	RP-73	RP-161783	3685	1	B	CR for reference channel for LAA demodulation performance requirements (Rel-13)	13.5.0

09/2016	RP-73	RP-161611	3648	1	B	CR on introduction of OOC D2D Discovery demodulation requirements	13.5.0
09/2016	RP-73	RP-161786	3700	1	F	Miscellaneous corrections of RF RX requirements for 4 RX AP	13.5.0
09/2016	RP-73	RP-161639	3642	1	F	Corrections on eMTC RX in TS 36.101	13.5.0
09/2016	RP-73	RP-161639	3844		F	Corrections for Rel-13 cat M1 UE	13.5.0
09/2016	RP-73	RP-161635	3777	1	F	Rel-13 CA corrections	13.5.0
09/2016	RP-73	RP-161640	3757	1	F	Correction on operating bands for ProSe	13.5.0
09/2016	RP-73	RP-161780	3815	2	B	CR on NPBCH Reference Measurement Channel for NB-IoT	13.5.0
09/2016	RP-73	RP-161780	3687	1	B	CR: NPDSCH Demodulation requirements and FRC definition for NB-IoT (Rel-13)	13.5.0
09/2016	RP-73	RP-161614	3720	2	B	Introduce signal model for LAA demodulation	13.5.0
09/2016	RP-73	RP-161613	3768	2	B	CR for SDR - tests with 4Rx in Rel-13	13.5.0
09/2016	RP-73	RP-161782	3675	3	F	CR for eMTC M-PDCCH demodulation requirement for CE Mode A (Rel-13)	13.5.0
12/2016	RP-74	RP-162428	3866	2	F	Improvement of REFSENS requirement specification for band 46 CA combos	13.6.0
12/2016	RP-74	RP-162435	3875	3	F	Clarification on UE maximum output power	13.6.0
12/2016	RP-74	RP-162386	3878	4	F	CR: Updates to LAA PDSCH demodulation performance requirements (Rel-13)	13.6.0
12/2016	RP-74	RP-162386	3880	1	F	CR: Updates to the reference channel for LAA demodulation performance requirements (Rel-13)	13.6.0
12/2016	RP-74	RP-162383	3884	3	F	CR for Rel-13 eMTC MPDCCH demodulation requirements	13.6.0
12/2016	RP-74	RP-162435	3886	1	F	CR for correction on OCNG pattern (Rel-13)	13.6.0
12/2016	RP-74	RP-162431	3890		F	RMC for maximum input level in category M1 UE	13.6.0
12/2016	RP-74	RP-162434	3896	1	F	A-MPR for NB-IoT	13.6.0
12/2016	RP-74	RP-162459	3900		A	CR for updating applicability rule for UE cat 9 Ues and DL Cat. 13 UEs in Rel-13	13.6.0
12/2016	RP-74	RP-162423	3902	2	F	CR for IRC TM2/3 tests with 4Rx in Rel-13	13.6.0
12/2016	RP-74	RP-162423	3904	2	F	CR for removing square brackets for 4Rx tests in Rel-13	13.6.0
12/2016	RP-74	RP-162412	3926		A	UE to UE co-existence for B42 with 2ULs	13.6.0
12/2016	RP-74	RP-162383	3928	3	F	Correction of PDCSH demodulation requirements for eMTC	13.6.0
12/2016	RP-74	RP-162404	3945	1	F	Clarification of note6 for 3DL/2UL CA	13.6.0
12/2016	RP-74	RP-162423	3947		F	CR for SDR CA tests with 4Rx for DL category 18 and 19	13.6.0
12/2016	RP-74	RP-162434	3951	1	F	Clarification on TX-RX frequency separation for Cat.NB1 (Rel-13)	13.6.0
12/2016	RP-74	RP-162423	3956	2	F	CR for fixing errors for 4Rx tests in Rel-13	13.6.0
12/2016	RP-74	RP-161988	3868	1	B	Addition of 1.4 and 3 MHz channel bandwidths for BAND 65 in TS36.101 (Rel-13)	13.6.0
12/2016	RP-74	RP-162423	3970	2	F	CR on 4-RX TM9 MU test	13.6.0
12/2016	RP-74	RP-162430	3977	1	F	Correction of power control for category M1	13.6.0
12/2016	RP-74	RP-162386	3980	3	F	Clean up and clarification for LAA CSI requirements	13.6.0
12/2016	RP-74	RP-162386	3982	1	F	Add PDCCH performance requirements for LAA demodulation	13.6.0
12/2016	RP-74	RP-162415	3995		A	Correction to cell mapping for periodic CQI reporting on multiple cells	13.6.0
12/2016	RP-74	RP-162430	3997		F	UE cat M1 out of band blocking, Removal of Range 4	13.6.0
12/2016	RP-74	RP-162425	3998		F	Remove square brackets for Rel-13 FD-MIMO performance requirements	13.6.0
12/2016	RP-74	RP-162430	4001	1	F	CR for 36.101: frequency error for eMTC	13.6.0
12/2016	RP-74	RP-162456	4004	2	F	CR: Updates to NPDSCH demodulation requirements for NB-IoT (Rel-13)	13.6.0
12/2016	RP-74	RP-162384	4008	2	F	CR for Rel-13 eMTC PBCH demodulation requirement for enhanced coverage	13.6.0
12/2016	RP-74	RP-162435	4011		F	CR: Corrections for bandwidth combination sets defined for inter-band DC (Rel-13)	13.6.0
12/2016	RP-74	RP-162411	4021		A	RMCs and applicability of core RF requirements	13.6.0
12/2016	RP-74	RP-162411	4030		A	Correction of spurious emissions requirements for Band 9 range and intra-band CA	13.6.0
12/2016	RP-74	RP-162435	4039		F	Optional PCell indication	13.6.0
12/2016	RP-74	RP-162380	4041	1	F	Correction of NPDCCH demodulation requirements	13.6.0
12/2016	RP-74	RP-162383	4043	1	F	Finalizing CQI definition test for eMTC	13.6.0
12/2016	RP-74	RP-162383	4045	1	F	Finalizing UE-selected subband CQI test for eMTC	13.6.0
12/2016	RP-74	RP-162430	4047	1	F	Correction of REFSENS RMC table for Cat-M1 UE	13.6.0
12/2016	RP-74	RP-162433	4058	1	F	NB-IoT aggregate power control Rel-13	13.6.0
12/2016	RP-74	RP-162433	4060	2	F	Correction to NB-IoT ON/OFF power measurement period Rel-13	13.6.0
12/2016	RP-74	RP-162435	4064	2	F	Corrections to CA table reference and header and CA REFSENS table	13.6.0
12/2016	RP-74	RP-162435	4076	1	F	Corrections of CA Refsens exceptions in 7.3.1A (Rel-13)	13.6.0
12/2016	RP-74	RP-162435	4080	2	F	DeltaRIB for SDL and LAA CA	13.6.0
12/2016	RP-74	RP-162420	4084		A	CR for fixing soft buffer management test for TDD-FDD CA in Rel-13	13.6.0
12/2016	RP-74	RP-162435	4086	1	F	CR for fixing editorial errors in Rel-13	13.6.0
12/2016	RP-74	RP-162404	4090		A	Introduction of MSD requirement for IMD5 on band3 of CA_3A-8A 2UL CA	13.6.0

12/2016	RP-74	RP-162386	4092	1	F	CR: Updates to burst transmission model for LAA performance requirements (Rel-13)	13.6.0
12/2016	RP-74	RP-162406	4101		A	Versioning indicator bit for NS_04 A-MPR table	13.6.0
12/2016	RP-74	RP-162427	4103	1	F	Band 68 NS_26 A-MPR correction	13.6.0
12/2016	RP-74	RP-162420	4110		A	RF: Pb setting in power imbalance TCs (Rel-13)	13.6.0
12/2016	RP-74	RP-162420	4113		A	RF: Correction to RMC for UE Category 1 in CSI tests (Rel-13)	13.6.0
12/2016	RP-74	RP-162413	4117		A	RF: Beamforming model missing in chapter 9 TM9 receiver Type A tests (Rel-13)	13.6.0
12/2016	RP-74	RP-162459	4123		A	RF: Incorrect Number of EREGs per ECCE for special subframe mentioned for TC 8.7.4 (Rel-13)	13.6.0
12/2016	RP-74	RP-162428	4126	1	F	MSD and exclusion region specification for 10MHz LAA channels	13.6.0
12/2016	RP-74	RP-162431	4132	1	F	Missing requirements for eMTC/NB IoT UE	13.6.0
12/2016	RP-74	RP-162380	4136	1	B	CR on NPBCH Fixed Reference Channel for NB-IoT	13.6.0
01/2017	RP-74					Page header information update	13.6.1
03/2017	RP-75	RP-170594	4138	1	F	Correction to carrier leakage and in-band emission for Cat. M1 UE	13.7.0
03/2017	RP-75	RP-170594	4140	1	F	Correction to Transmission Gap of Aggregate Power Control for Cat. M1 HD-FDD UE	13.7.0
03/2017	RP-75	RP-170592	4145		F	Correction for LAA TM9 CQI test (R13)	13.7.0
03/2017	RP-75	RP-170603	4152		F	Correction for FD-MIMO CRI test (R13)	13.7.0
03/2017	RP-75	RP-170603	4155		D	Split RMC overview table (R13)	13.7.0
03/2017	RP-75	RP-170587	4157	1	F	4Rx lot connections for 2Rx CQI requirement with frequency-selective interference	13.7.0
03/2017	RP-75	RP-170588	4162		F	Correction to UL/DL configuration & Special subframe configuration for CA CQI tests	13.7.0
03/2017	RP-75	RP-170597	4164		F	Remove [] from UE Cat M1 MPDCCH demodulation SNR values	13.7.0
03/2017	RP-75	RP-170589	4171		F	Missing harmonic reference sensitivity exception for CA_20A-42A and CA_20A-42A-42A	13.7.0
03/2017	RP-75	RP-170589	4174		F	Correction to MPR table for intra-band 2UL CA	13.7.0
03/2017	RP-75	RP-170603	4184	1	F	Correction of Rel-13 CA REFSSENS exceptions	13.7.0
03/2017	RP-75	RP-170597	4191	1	F	Finalize eMTC PDSCH demodulation requirements	13.7.0
03/2017	RP-75	RP-170597	4193		F	Finalize eMTC CQI test requirements	13.7.0
03/2017	RP-75	RP-170594	4197	1	F	Correction of FRC table for eMTC RF test	13.7.0
03/2017	RP-75	RP-170592	4203	1	F	Clean up and correction for LAA PDCCH demodulation requirements	13.7.0
03/2017	RP-75	RP-170599	4207	2	F	PCMAX tolerance for UE Cat NB1 power class 5	13.7.0
03/2017	RP-75	RP-170580	4212		A	Addition of missing note for bands 7 and 39 UE to UE co-ex	13.7.0
03/2017	RP-75	RP-170580	4216		A	Correction of CA_NS_06 non-contiguous resource allocation MPR formula	13.7.0
03/2017	RP-75	RP-170592	4222	1	F	CR: Updates to LAA PDSCH demodulation performance requirements and LBT(R13)	13.7.0
03/2017	RP-75	RP-170598	4224	2	F	CR: Scheduling pattern for NPUSCH format 1 and NPDSCH in NB-IoT RF test(R13)	13.7.0
03/2017	RP-75	RP-170601	4226	2	F	CR: Updates to the overview of RMC for NB-IoT(R13)	13.7.0
03/2017	RP-75	RP-170601	4228	1	F	CR: Cleanup for NB-IoT UE demod performance requirements(R13)	13.7.0
03/2017	RP-75	RP-170585	4231		A	Corrections for D2D resource configuration (Rel-13)	13.7.0
03/2017	RP-75	RP-170595	4234	1	F	clean up the CR for eMTC PBCH requirements(Rel-13)	13.7.0
03/2017	RP-75	RP-170585	4242		A	CR for fixing requirement for soft buffer test for TDD-FDD CA in Rel-13	13.7.0
03/2017	RP-75	RP-170587	4244		F	CR for fixing power ratio errors in 4Rx tests in Rel-13	13.7.0
03/2017	RP-75	RP-170587	4253	1	F	CR for correcting applicability rules for 4Rx tests in Rel-13	13.7.0
03/2017	RP-75	RP-170598	4276	1	F	CR for clarification on SEM of category NB1 [Rel-13]	13.7.0
03/2017	RP-75	RP-170594	4277		F	CR of TX-RX frequency separation for category M1 [Rel-13]	13.7.0
03/2017	RP-75	RP-170587	4281	1	F	CR for fixing antenna configuration for TDD CQI rank 3 test for 4Rx in Rel-13	13.7.0
03/2017	RP-75	RP-170594	4284		F	Reference Channels for partial RB allocation for UE UL category M1	13.7.0
03/2017	RP-75	RP-170598	4292		F	Corrections in TS 36.101 for NB-IoT UE	13.7.0
03/2017	RP-75	RP-170587	4295		F	CR for removing SDR 4Rx tests in Rel-13	13.7.0
06/2017	RP-76	RP-171304	4298		F	Correction to 4Tx/4Rx Cell-specific reference signals in Table 8.10.1.1.7-1	13.8.0
06/2017	RP-76	RP-171308	4305		F	Correction to UL and DL Reference Channels for Cat M1 UE	13.8.0
06/2017	RP-76	RP-171296	4308		A	Corrections for D2D FRCs	13.8.0
06/2017	RP-76	RP-171395	4317		A	Correction to SEM table for intra-band 2UL CA	13.8.0
06/2017	RP-76	RP-171310	4319	1	F	Cleanup of eMTC UE demodulation requirements (Rel-13)	13.8.0
06/2017	RP-76	RP-171311	4321		F	Correction for FD-MIMO demodulation test (R13)	13.8.0
06/2017	RP-76	RP-171301	4357		F	Correction of NPDSCH and NPDCCH	13.8.0
06/2017	RP-76	RP-171304	4359		F	Maintenance CR for 4Rx WI (Rel-13)	13.8.0
06/2017	RP-76	RP-171304	4372	1	F	CR on 4-RX TM9 MU-MIMO performance requirements (Rel-13)	13.8.0
06/2017	RP-76	RP-171298	4374		F	CR on PDCCH/PCFICH DL Control Channel IM Type A TDD	13.8.0

						test case correction (Rel-13)	
06/2017	RP-76	RP-171296	4381	1	F	Corrections of Table 8.7.5.1-2 and Table 8.7.5.2-27	13.8.0
06/2017	RP-76	RP-171309	4382		F	Correction to Table A.4-1 and A.4-16 for Cat M1.	13.8.0
06/2017	RP-76	RP-171310	4384	2	F	Correction to minimum requirement for CatM1 Single-Layer Spatial Multiplexing	13.8.0
06/2017	RP-76	RP-171300	4388		F	CR for demodulation of NB-IoT correction (Rel.13)	13.8.0
06/2017	RP-76	RP-171307	4390		F	CR for LAA TDD test case correction (Rel.13)	13.8.0
06/2017	RP-76	RP-171395	4395		F	Correction to the table of intra-band non-contiguous CA with one uplink configuration for reference sensitivity	13.8.0
06/2017	RP-76	RP-171297	4404		F	Correction of N_RB_agg for CA_41C and CA_7C in Table 7.3.1A-1	13.8.0
06/2017	RP-76	RP-171296	4411		A	Correction to Mapping of CQI Index to Modulation coding scheme for 256QAM	13.8.0
06/2017	RP-76	RP-171304	4413	1	F	CR for correction of 4RX demodulation requirements (Rel-13)	13.8.0
06/2017	RP-76	RP-171311	4423	1	F	Correction of test points for Single-antenna port performance TDD FDD CA	13.8.0
06/2017	RP-76	RP-171304	4436		D	CR for FRC overview table for 4 layer SDR tests (R13)	13.8.0
06/2017	RP-76	RP-171307	4439	2	D	Maintenance CR for LAA demodulation tests	13.8.0
06/2017	RP-76	RP-171304	4445	1	F	4Rx REFSENS requirements spec improvement for 36.101	13.8.0
06/2017	RP-76	RP-171311	4447		F	CR for adding TDD 4 DL CA bandwidth combination for CQI CA tests in Rel-13	13.8.0
06/2017	RP-76	RP-171304	4449	1	F	CR for adding applicability rule for MU TM9 4Rx tests in Rel-13	13.8.0
06/2017	RP-76	RP-171311	4466		F	Correction on TDD-FDD CSI test cases (R13)	13.8.0
06/2017	RP-76	RP-171297	4472		A	Corrections for inCoverage configuration in ProSe direct communication (Rel-13)	13.8.0
06/2017	RP-76	RP-171299	4474	1	F	CR for NB-IoT Absolute power tolerance	13.8.0
06/2017	RP-76	RP-171307	4476	2	F	Update of LAA REFSENS exclusion region	13.8.0
09/2017	RP-77	RP-171973	4486	1	F	Corrections on Rel-13 CA requirements	13.9.0
09/2017	RP-77	RP-171973	4504		F	Addition of OCN Pattern for LAA Rx tests	13.9.0
09/2017	RP-77	RP-171971	4509		F	PDSCH Demodulation downlink power allocation parameters for UEs supporting coverage enhancement	13.9.0
09/2017	RP-77	RP-171970	4513		F	Correction to Test Parameters for MPDCCH in Table 8.11.2.1-1	13.9.0
09/2017	RP-77	RP-171965	4516	2	A	Correction of band 43 spurious emissions limit (Rel-13)	13.9.0
09/2017	RP-77	RP-171947	4540	1	B	Band 68 modification to enable operation in Europe Rel-13	13.9.0
09/2017	RP-77	RP-171967	4543	1	A	Band 31 modification to add DTV protection Rel-13	13.9.0
09/2017	RP-77	RP-171970	4548	1	F	Correction to demodulation requirements for coverage enhancement UEs	13.9.0
09/2017	RP-77	RP-171972	4550	2	F	Correction to ON/OFF time mask for NB-IoT	13.9.0
09/2017	RP-77	RP-171970	4552		F	Correction of UE-selected subband CQI test for eMTC	13.9.0
09/2017	RP-77	RP-171970	4554		F	Correction of RMC for Cat-M1 TDD PDSCH demodulation requirements	13.9.0
09/2017	RP-77	RP-171969	4556	1	F	Addition of scheduling pattern with repetition for Cat-M1 UL FRC	13.9.0
09/2017	RP-77	RP-171969	4558		F	Correction of missing reference to Cat-M1 DL FRC tables	13.9.0
09/2017	RP-77	RP-171964	4596		A	Correction for EPA delay profiles of r.m.s delay spread (Rel-13)	13.9.0
09/2017	RP-77	RP-171970	4601	1	F	CR for requirements of Cat-1bis and Cat-0(R13)	13.9.0
09/2017	RP-77	RP-171970	4603	1	F	CR for requirements of MPDCCH with 2Rx and 4Rx(R13)	13.9.0
09/2017	RP-77	RP-171970	4605	1	F	CR for requirements of TM2 with 2Rx and 4Rx(R13)	13.9.0
09/2017	RP-77	RP-171970	4609	1	F	CR for requirements of TM9 with 2Rx and 4Rx(R13)	13.9.0
09/2017	RP-77	RP-171970	4611		F	Correction to FRC Table A.3.4.2.1-7 for eMTC (R13)	13.9.0
09/2017	RP-77	RP-171972	4614	1	F	CR for R13 NB-IoT performance requirements maintenances (R13)	13.9.0
09/2017	RP-77	RP-171965	4633	2	F	Apply CA demodulation performance requirements with 30us timing difference between two CCs to intra-band non-contiguous CA case	13.9.0
09/2017	RP-77	RP-171966	4638		A	Update to CA_NS_04 SEM and additional spurious emissions	13.9.0
09/2017	RP-77	RP-171969	4647		F	CR for Remove bracket for NS_07 in A-MPR requirement for CAT-M1	13.9.0
2017-12	RAN#78	RP-172574	4652	1	F	Correction to Test Parameters for Cat M1 PUCCH 1-0 static test	13.10.0
2017-12	RAN#78	RP-172607	4655	1	F	Correction of the reference channel for the LAA CSI test	13.10.0
2017-12	RAN#78	RP-172610	4659		F	CR for NB-IoT Transmit Intermodulation	13.10.0
2017-12	RAN#78	RP-172613	4674	2	F	Updates to performance requirements in 8.3.1.1 and 8.3.2.1A	13.10.0
2017-12	RAN#78	RP-172608	4683	3	F	CR for MPDCCH with 2Rx/4Rx (R13)	13.10.0
2017-12	RAN#78	RP-172608	4686	3	F	CR for TM2/TM9 with 2Rx/4Rx (R13)	13.10.0
2017-12	RAN#78	RP-172608	4689	1	F	CR on redundancy version for BL/CE UEs (R13)	13.10.0
2017-12	RAN#78	RP-172608	4702	1	F	Applicability of CQI test for coverage enhancement for non-BL CE UE (Rel-13)	13.10.0
2017-12	RAN#78	RP-172612	4715		F	CR for updating TDD CQI CA tests in Rel-13	13.10.0
2017-12	RAN#78	RP-172582	4718		D	CR for updating overview table for 4Rx RMC in Rel-13	13.10.0
2017-12	RAN#78	RP-172610	4742		F	Corrections to NPDCCH configuration in NPDSCH test case	13.10.0

2017-12	RAN#78	RP-172612	4758	1	F	Correction CR for Rel13 FD-MIMO performance requirements	13.10.0
2017-12	RAN#78	RP-172610	4761	1	F	Correction to NPDCCH configuration in demodulation test case	13.10.0
2017-12	RAN#78	RP-172611	4775	1	F	NB-IoT removal of repetition sensitivity requirement Rel-13	13.10.0
2017-12	RAN#78	RP-172612	4791	1	F	CSI 4RX: Correction to RI tests and used reference channels and MCS schemes (Rel-13)	13.10.0
2017-12	RAN#78	RP-172607	4794	1	F	Correction of FRC for Cat-M1 UE maximum input level test (Rel-13)	13.10.0
2017-12	RAN#78	RP-172606	4806	2	A	Corrections on operating band table for CA (Rel-13)	13.10.0
2017-12	RAN#78	RP-172612	4812		F	Corrections on the description of requirements for inter-band CA (Rel-13)	13.10.0
2017-12	RAN#78	RP-172612	4817	1	F	Corrections on CA operating band information (Rel-13)	13.10.0
2017-12	RAN#78	RP-172606	4825		A	CR for updating overview table for Sidelink (Rel-13)	13.10.0
2017-12	RAN#78	RP-172612	4830		F	Addition of beamforming model to chapter 9 4Rx TM9 requirements	13.10.0
2017-12	RAN#78	RP-172605	4855		A	Update to A-MPR for CA_NS_04	13.10.0
2018-03	RAN#79	RP-180292	4873	1	F	Correction to UE-selected subband CQI test for eMTC	13.11.0
2018-03	RAN#79	RP-180292	4881	1	F	Maintennace CR for R13 Non-BL/UE requirements (R13) This CR is only partially implemented as the changes are not based on the latest version.	13.11.0
2018-03	RAN#79	RP-180295	4886		F	Correction to DL power allocation of CSI reporting for 4Rx UE in 9.9.4.1	13.11.0
2018-03	RAN#79	RP-180291	4889		F	Corrections to LAA CQI reporting requirements	13.11.0
2018-03	RAN#79	RP-180291	4892		F	Addition of two sided OCNG pattern for FS3	13.11.0
2018-03	RAN#79	RP-180292	4895	1	F	Correction of MPDCCH performance requirements	13.11.0
2018-03	RAN#79	RP-180294	4899	1	F	CR to 36.101 on default power class	13.11.0
2018-03	RAN#79	RP-180294	4906		F	Correction on Test Parameters for FRC for CA more than 3DL CA	13.11.0
2018-03	RAN#79	RP-180290	4919		F	Correction for CA CQI tests (R13)	13.11.0
2018-03	RAN#79	RP-180294	4924		F	Corrections to Spurious emission band UE co-existence for CA	13.11.0
2018-03	RAN#79	RP-180285	4930		A	PC2 for CA_41C REL-13	13.11.0
2018-03	RAN#79	RP-180283	4934		F	Correction to UL-MIMO MOP Table Rel-13	13.11.0
2018-03	RAN#79	RP-180290	4946		A	Adding note about timing difference for TDD CA (2Rx)	13.11.0
2018-03	RAN#79	RP-180292	4951	1	B	CR to 36.101: Introduction of A-MPR table for NS4 and NS12 for CAT-M1	13.11.0
2018-03	RAN#79	RP-180294	4954		F	CSI 4RX: Correction to reference channels and MCS schemes used in RI tests (Rel-13)	13.11.0
2018-03	RAN#79	RP-180292	4968		F	PDSCH Demodulation downlink power allocation parameters for UEs supporting coverage enhancement	13.11.0
2018-06	RAN#80	RP-181108	4990		A	CA_NS_08 correction for TS 36.101 R13	13.12.0
2018-06	RAN#80	RP-181108	5007	2	A	Clarification of Transmission Mode for REFSENS test	13.12.0
2018-06	RAN#80	RP-181108	5011		F	Correction for CA CQI tests (R13)	13.12.0
2018-06	RAN#80	RP-181105	5019	1	F	Cat.F CR for UE-to-UE co-existence for Band 3 in Japan (Rel-13)	13.12.0
2018-06	RAN#80	RP-181111	5029		F	Update to eMTC demod requirements	13.12.0
2018-06	RAN#80	RP-181111	5037		F	Correction of UE co-existence from band 28 into band 66	13.12.0
2018-06	RAN#80	RP-181106	5049		A	CR: Corrections for CSI tests (Rel-13)	13.12.0
2018-06	RAN#80	RP-181108	5052		F	Correction to uplink configuration for CA_25A-41C	13.12.0
2018-06	RAN#80	RP-181113	5062		F	Correction to DL power allocation of CSI reporting for 4Rx UE in 9.9.4.2	13.12.0
2018-06	RAN#80	RP-181110	5065	1	F	Correction to CQI reporting definition on PUSCH static test	13.12.0
2018-06	RAN#80	RP-181108	5068	1	F	CR to add notes for CA_26A-41A harmonic table	13.12.0
2018-06	RAN#80	RP-181110	5079		F	Correction to LAA RMC (Rel-13)	13.12.0
2018-06	RAN#80	RP-181110	5082		F	Update to chapter 8 LAA requirements	13.12.0
2018-06	RAN#80	RP-181111	5093		F	Correction to eMTC subband CQI test R13	13.12.0
2018-06	RAN#80	RP-181107	5112		A	Update to CA_NS_04 requirements	13.12.0
2018-06	RAN#80	RP-181108	5116		A	Update to NS_04 requirements	13.12.0
2018-09	RAN#81	RP-181912	5133		F	Correction of cqi-pmi-ConfigurationIndex for PUCCH 1-0 static test on multiple cells	13.13.0
2018-09	RAN#81	RP-181909	5148	1	F	Correction on Table 6.6.3.2A-0 Requirements for uplink inter-band carrier aggregation (two bands)	13.13.0
2018-09	RAN#81	RP-181909	5157		A	Removal of square brackets for CA_4A-7A-12A	13.13.0
2018-09	RAN#81	RP-181912	5180	1	D	Editorial corrections of CA notations	13.13.0
2018-09	RAN#81	RP-181908	5188	1	A	Correction on Table 7.3.1-3 Network signalling value for reference sensitivity	13.13.0
2018-12	RAN#82	RP-182379	5277		A	MCG/SCG Abbreviations in TS36.101 in rel-13	13.14.0
2018-12	RAN#82	RP-182379	5259	1	A	Correction to frequency of CA_4A-7A for MSD with inter-band 2UL	13.14.0
2018-12	RAN#82	RP-182381	5198	1	F	UE category M1 MPR section corrections Rel-13	13.14.0
2018-12	RAN#82	RP-182381	5223	3	F	Correction of spurious emission band UE co-existence for NB-IoT	13.14.0
2018-12	RAN#82	RP-182381	5271		F	PDSCH traffic pattern in 4Rx PHICH Demodulation test	13.14.0
2018-12	RAN#82	RP-182382	5253		F	Correction of LTE UE requirements for inter-band CA	13.14.0

2018-12	RAN#82	RP-182382	5283	1	F	Corrections to CA REFSSENS exception	13.14.0
2019-03	RAN#83	RP-190411	5338		A	CR on protection Band 32 for Band 28 and corresponding band combinations	13.15.0
2019-03	RAN#83	RP-190414	5369	1	F	CR: Correction to 4Rx TDD CQI TC 9.9.1.4.2 (Rel-13)	13.15.0
2019-06	RAN#84	RP-191259	5450		F	Correction to demodulation of PDCCH for LAA	13.16.0
2019-06	RAN#84	RP-191259	5456		F	CR on antenna configurations for NB-IoT demodulation performance requirements (Rel-13)	13.16.0
2019-06	RAN#84	RP-191259	5471		F	Correction to demodulation of PDSCH LAA	13.16.0
2019-09	RAN#85	RP-192051	5491		F	Correction to RMC for Cat M1 CSI tests	13.17.0
2019-09	RAN#85	RP-192051	5500		F	CR for Narrowband blocking for LTE CatM1	13.17.0
2019-12	RAN#86	RP-193043	5575		F	Correction to intraband contiguous CA in-band and out-of-band blocking tables REL-13	13.18.0

History

Document history		
V13.2.1	May 2016	Publication
V13.3.0	May 2016	Publication
V13.4.0	September 2016	Publication
V13.5.0	December 2016	Publication
V13.6.1	March 2017	Publication
V13.7.0	April 2017	Publication
V13.8.0	August 2017	Publication
V13.9.0	November 2017	Publication
V13.10.0	January 2018	Publication
V13.11.0	April 2018	Publication
V13.12.0	October 2018	Publication
V13.13.0	January 2019	Publication
V13.14.0	May 2019	Publication
V13.15.0	May 2019	Publication
V13.16.0	July 2019	Publication
V13.17.0	October 2019	Publication
V13.18.0	February 2020	Publication