

ETSI TS 136 141 V8.8.0 (2010-10)

Technical Specification

**LTE;
Evolved Universal Terrestrial Radio Access (E-UTRA);
Base Station (BS) conformance testing
(3GPP TS 36.141 version 8.8.0 Release 8)**



ReferenceRTS/TSGR-0436141v880

KeywordsLTE

ETSI

650 Route des Lucioles
F-06921 Sophia Antipolis Cedex - FRANCE

Tel.: +33 4 92 94 42 00 Fax: +33 4 93 65 47 16

Siret N° 348 623 562 00017 - NAF 742 C
Association à but non lucratif enregistrée à la
Sous-Préfecture de Grasse (06) N° 7803/88

Important notice

Individual copies of the present document can be downloaded from:

<http://www.etsi.org>

The present document may be made available in more than one electronic version or in print. In any case of existing or perceived difference in contents between such versions, the reference version is the Portable Document Format (PDF). In case of dispute, the reference shall be the printing on ETSI printers of the PDF version kept on a specific network drive within ETSI Secretariat.

Users of the present document should be aware that the document may be subject to revision or change of status. Information on the current status of this and other ETSI documents is available at

<http://portal.etsi.org/tb/status/status.asp>

If you find errors in the present document, please send your comment to one of the following services:

http://portal.etsi.org/chaicor/ETSI_support.asp

Copyright Notification

No part may be reproduced except as authorized by written permission.
The copyright and the foregoing restriction extend to reproduction in all media.

© European Telecommunications Standards Institute 2010.
All rights reserved.

DECT[™], **PLUGTESTS**[™], **UMTS**[™], **TIPHON**[™], the TIPHON logo and the ETSI logo are Trade Marks of ETSI registered for the benefit of its Members.

3GPP[™] is a Trade Mark of ETSI registered for the benefit of its Members and of the 3GPP Organizational Partners.

LTE[™] is a Trade Mark of ETSI currently being registered

for the benefit of its Members and of the 3GPP Organizational Partners.

GSM[®] and the GSM logo are Trade Marks registered and owned by the GSM Association.

Intellectual Property Rights

IPRs essential or potentially essential to the present document may have been declared to ETSI. The information pertaining to these essential IPRs, if any, is publicly available for **ETSI members and non-members**, and can be found in ETSI SR 000 314: "*Intellectual Property Rights (IPRs); Essential, or potentially Essential, IPRs notified to ETSI in respect of ETSI standards*", which is available from the ETSI Secretariat. Latest updates are available on the ETSI Web server (<http://webapp.etsi.org/IPR/home.asp>).

Pursuant to the ETSI IPR Policy, no investigation, including IPR searches, has been carried out by ETSI. No guarantee can be given as to the existence of other IPRs not referenced in ETSI SR 000 314 (or the updates on the ETSI Web server) which are, or may be, or may become, essential to the present document.

Foreword

This Technical Specification (TS) has been produced by ETSI 3rd Generation Partnership Project (3GPP).

The present document may refer to technical specifications or reports using their 3GPP identities, UMTS identities or GSM identities. These should be interpreted as being references to the corresponding ETSI deliverables.

The cross reference between GSM, UMTS, 3GPP and ETSI identities can be found under <http://webapp.etsi.org/key/queryform.asp>.

Contents

Intellectual Property Rights	2
Foreword.....	2
Foreword.....	10
1 Scope	11
2 References	11
3 Definitions, symbols and abbreviations	12
3.1 Definitions	12
3.2 Symbols.....	13
3.3 Abbreviations	14
4 General test conditions and declarations	15
4.1 Measurement uncertainties and Test Requirements	15
4.1.1 General.....	15
4.1.2 Acceptable uncertainty of Test System.....	15
4.1.2.1 Measurement of transmitter	16
4.1.2.2 Measurement of receiver.....	16
4.1.2.3 Measurement of performance requirement	20
4.1.3 Interpretation of measurement results.....	22
4.2 Base station classes	22
4.3 Regional requirements.....	22
4.4 Selection of configurations for testing.....	24
4.5 BS Configurations	24
4.5.1 Transmit configurations	24
4.5.1.1 Transmit diversity and MIMO transmission	24
4.5.2 Receive configurations	24
4.5.2.1 Receiver diversity	25
4.5.3 Duplexers	25
4.5.4 Power supply options.....	25
4.5.5 Ancillary RF amplifiers	26
4.5.6 BS with integrated Iuant BS modem	26
4.5.7 BS using antenna arrays.....	26
4.5.7.1 Receiver tests	27
4.5.7.2 Transmitter tests	27
4.6 Manufacturer"s declarations of regional and optional requirements	28
4.6.1 Operating band and frequency range	28
4.6.2 Channel bandwidth	28
4.6.3 Base station output power.....	28
4.6.4 Spurious emissions Category	28
4.6.5 Additional operating band unwanted emissions	29
4.6.6 Co-existence with other systems.....	29
4.6.7 Co-location with other base stations	29
4.7 Specified frequency range and supported channel bandwidth.....	29
4.8 Format and interpretation of tests	30
5 Operating bands and channel arrangement.....	30
5.1 General	30
5.2 Void.....	31
5.3 Void.....	31
5.4 Void.....	31
5.5 Operating bands.....	31
5.6 Channel bandwidth.....	31
5.7 Channel arrangement.....	32
5.7.1 Channel spacing.....	32
5.7.2 Channel raster	32
5.7.3 Carrier frequency and EARFCN.....	32

6	Transmitter characteristics	34
6.1	General	34
6.1.1	E-UTRA Test Models	34
6.1.1.1	E-UTRA Test Model 1.1 (E-TM1.1).....	34
6.1.1.2	E-UTRA Test Model 1.2 (E-TM1.2).....	35
6.1.1.3	E-UTRA Test Model 2 (E-TM2)	38
6.1.1.4	E-UTRA Test Model 3.1 (E-TM3.1).....	39
6.1.1.5	E-UTRA Test Model 3.2 (E-TM3.2).....	40
6.1.1.6	E-UTRA Test Model 3.3 (E-TM3.3).....	43
6.1.2	Data content of Physical channels and Signals	45
6.1.2.1	Reference signals	46
6.1.2.2	Primary Synchronization signal	46
6.1.2.3	Secondary Synchronization signal	46
6.1.2.4	PBCH	46
6.1.2.5	PCFICH.....	46
6.1.2.6	PHICH.....	46
6.1.2.7	PDCCH	47
6.1.2.8	PDSCH.....	47
6.2	Base station output power	47
6.2.1	Definition and applicability	47
6.2.2	Minimum Requirement	47
6.2.3	Test purpose.....	48
6.2.4	Method of test	48
6.2.4.1	Initial conditions	48
6.2.4.2	Procedure	48
6.2.5	Test Requirements	48
6.3	Output power dynamics.....	48
6.3.1	RE Power control dynamic range	48
6.3.1.1	Definition and applicability.....	48
6.3.1.2	Minimum Requirement	48
6.3.1.3	Method of test	49
6.3.2	Total power dynamic range	49
6.3.2.1	Definition and applicability.....	49
6.3.2.2	Minimum Requirement	49
6.3.2.3	Test purpose	49
6.3.2.4	Method of test	49
6.3.2.4.1	Initial conditions.....	49
6.3.2.4.2	Procedure.....	49
6.3.2.5	Test Requirement	49
6.4	Transmit ON/OFF power	50
6.4.1	Transmitter OFF power	50
6.4.1.1	Definition and applicability.....	50
6.4.1.2	Minimum Requirement	50
6.4.1.3	Test purpose	50
6.4.1.4	Method of test	50
6.4.1.4.1	Void.....	50
6.4.1.4.2	Void.....	50
6.4.1.5	Test requirement	50
6.4.2	Transmitter transient period.....	50
6.4.2.1	Definition and applicability.....	50
6.4.2.2	Minimum Requirement	51
6.4.2.3	Test purpose	51
6.4.2.4	Method of test	51
6.4.2.4.1	Initial conditions.....	51
6.4.2.4.2	Procedure.....	51
6.4.2.5	Test requirement	51
6.5	Transmitted signal quality	52
6.5.1	Frequency error.....	52
6.5.1.1	Definition and applicability.....	52
6.5.1.2	Minimum Requirement	52
6.5.1.3	Test purpose	52
6.5.1.4	Method of test	52

6.5.1.5	Test requirement	52
6.5.2	Error Vector Magnitude	52
6.5.2.1	Definition and applicability	52
6.5.2.2	Minimum Requirement	52
6.5.2.3	Test purpose	52
6.5.2.4	Method of test	53
6.5.2.4.1	Initial conditions	53
6.5.2.4.2	Procedure	53
6.5.2.5	Test requirement	53
6.5.3	Time alignment between transmitter branches	54
6.5.3.1	Definition and applicability	54
6.5.3.2	Minimum Requirement	54
6.5.3.3	Test Purpose	54
6.5.3.4	Method of Test	54
6.5.3.4.1	Initial Conditions	54
6.5.3.4.2	Procedure	54
6.5.3.5	Test Requirement	54
6.5.4	DL RS power	54
6.5.4.1	Definition and applicability	54
6.5.4.2	Minimum Requirement	55
6.5.4.3	Test purpose	55
6.5.4.4	Method of test	55
6.5.4.4.1	Initial conditions	55
6.5.4.4.2	Procedure	55
6.5.4.5	Test requirement	55
6.6	Unwanted emissions	55
6.6.1	Occupied bandwidth	55
6.6.1.1	Definition and applicability	55
6.6.1.2	Minimum Requirements	56
6.6.1.3	Test purpose	56
6.6.1.4	Method of test	56
6.6.1.4.1	Initial conditions	56
6.6.1.4.2	Procedure	56
6.6.1.5	Test requirements	56
6.6.2	Adjacent Channel Leakage power Ratio (ACLR)	57
6.6.2.1	Definition and applicability	57
6.6.2.2	Minimum Requirement	57
6.6.2.3	Test purpose	57
6.6.2.4	Method of test	57
6.6.2.4.1	Initial conditions	57
6.6.2.4.2	Procedure	57
6.6.2.5	Test Requirement	57
6.6.3	Operating band unwanted emissions	58
6.6.3.1	Definition and applicability	58
6.6.3.2	Minimum Requirement	59
6.6.3.3	Test purpose	59
6.6.3.4	Method of test	59
6.6.3.4.1	Initial conditions	59
6.6.3.4.2	Procedure	59
6.6.3.5	Test requirement	60
6.6.3.5.1	Test requirements (Category A)	60
6.6.3.5.2	Test requirements (Category B)	62
6.6.3.5.2.1	Category B test requirements (Option 1)	62
6.6.3.5.2.2	Category B (Option 2)	64
6.6.3.5.3	Additional requirements	65
6.6.4	Transmitter spurious emissions	66
6.6.4.1	Definition and applicability	66
6.6.4.2	Minimum Requirements	67
6.6.4.3	Test Purpose	67
6.6.4.4	Method of Test	67
6.6.4.4.1	Initial conditions	67
6.6.4.4.2	Procedure	67

6.6.4.5	Test requirements	67
6.6.4.5.1	Spurious emissions (Category A)	68
6.6.4.5.2	Spurious emissions (Category B)	68
6.6.4.5.3	Protection of the BS receiver of own or different BS	68
6.6.4.5.4	Co-existence with other systems in the same geographical area	68
6.6.4.5.5	Co-location with other base stations	72
6.7	Transmitter intermodulation	74
6.7.1	Definition and applicability	74
6.7.2	Minimum Requirement	74
6.7.3	Test purpose	74
6.7.4	Method of test	75
6.7.4.1	Initial conditions	75
6.7.4.2	Procedures	75
6.7.5	Test Requirements	75
7	Receiver characteristics	77
7.1	General	77
7.2	Reference sensitivity level	77
7.2.1	Definition and applicability	77
7.2.2	Minimum Requirement	77
7.2.3	Test purpose	77
7.2.4	Method of testing	77
7.2.4.1	Initial conditions	77
7.2.4.2	Procedure	77
7.2.5	Test requirement	78
7.3	Dynamic range	78
7.3.1	Definition and applicability	78
7.3.2	Minimum Requirement	78
7.3.3	Test purpose	78
7.3.4	Method of testing	78
7.3.4.1	Initial conditions	78
7.3.4.2	Procedure	79
7.3.5	Test Requirements	79
7.4	In-channel selectivity	79
7.4.1	Definition and applicability	79
7.4.2	Minimum Requirement	80
7.4.3	Test purpose	80
7.4.4	Method of testing	80
7.4.4.1	Initial conditions	80
7.4.4.2	Procedure	80
7.4.5	Test Requirements	81
7.5	Adjacent Channel Selectivity (ACS) and narrow-band blocking	81
7.5.1	Definition and applicability	81
7.5.2	Minimum Requirement	81
7.5.3	Test purpose	81
7.5.4	Method of test	82
7.5.4.1	Initial conditions	82
7.5.4.2	Procedure for Adjacent Channel Selectivity	82
7.5.4.3	Procedure for narrow-band blocking	82
7.5.5	Test Requirements	82
7.6	Blocking	84
7.6.1	Definition and applicability	84
7.6.2	Minimum Requirements	84
7.6.3	Test purpose	84
7.6.4	Method of test	84
7.6.4.1	Initial conditions	84
7.6.4.2	Procedure	84
7.6.5	Test Requirements	85
7.6.5.1	General requirement	85
7.6.5.2	Co-location with other base stations	86
7.7	Receiver spurious emissions	88
7.7.1	Definition and applicability	88

7.7.2	Minimum Requirements	88
7.7.3	Test purpose.....	88
7.7.4	Method of test	88
7.7.4.1	Initial conditions	88
7.7.4.2	Procedure	88
7.7.5	Test requirements.....	88
7.8	Receiver intermodulation	89
7.8.1	Definition and applicability	89
7.8.2	Minimum Requirement	89
7.8.3	Test purpose.....	89
7.8.4	Method of test	89
7.8.4.1	Initial conditions	89
7.8.4.2	Procedures.....	89
7.8.5	Test requirements.....	90
8	Performance requirement	92
8.1	General	92
8.2	Performance requirements for PUSCH	92
8.2.1	Performance requirements of PUSCH in multipath fading propagation conditions	92
8.2.1.1	Definition and applicability.....	92
8.2.1.2	Minimum Requirement	92
8.2.1.3	Test Purpose	92
8.2.1.4	Method of test	92
8.2.1.4.1	Initial Conditions	92
8.2.1.4.2	Procedure.....	93
8.2.1.5	Test Requirement	93
8.2.2	Performance requirements for UL timing adjustment.....	99
8.2.2.1	Definition and applicability.....	99
8.2.2.2	Minimum Requirement	100
8.2.2.3	Test Purpose	100
8.2.2.4	Method of test	100
8.2.2.4.1	Initial Conditions	100
8.2.2.4.2	Procedure.....	100
8.2.2.5	Test Requirement	101
8.2.3	Performance requirements for HARQ-ACK multiplexed on PUSCH.....	102
8.2.3.1	Definition and applicability.....	102
8.2.3.2	Minimum Requirement	102
8.2.3.3	Test Purpose	102
8.2.3.4	Method of test	102
8.2.3.4.1	Initial Conditions	102
8.2.3.4.2	Procedure.....	102
8.2.3.5	Test Requirement	103
8.2.4	Performance requirements for High Speed Train conditions	104
8.2.4.1	Definition and applicability.....	104
8.2.4.2	Minimum Requirement	104
8.2.4.3	Test Purpose	104
8.2.4.4	Method of test	104
8.2.4.4.1	Initial Conditions	104
8.2.4.4.2	Procedure.....	104
8.2.4.5	Test Requirement	105
8.3	Performance requirements for PUCCH	106
8.3.1	ACK missed detection for single user PUCCH format 1a	106
8.3.1.1	Definition and applicability.....	106
8.3.1.2	Minimum Requirement	107
8.3.1.3	Test purpose	107
8.3.1.4	Method of test	107
8.3.1.4.1	Initial Conditions	107
8.3.1.4.2	Procedure.....	107
8.3.1.5	Test Requirement	107
8.3.2	CQI missed detection for PUCCH format 2	108
8.3.2.1	Definition and applicability.....	108
8.3.2.2	Minimum Requirement	108

8.3.2.3	Test purpose	108
8.3.2.4	Method of test	108
8.3.2.4.1	Initial Conditions	108
8.3.2.4.2	Procedure.....	108
8.3.2.5	Test Requirement	109
8.3.3	ACK missed detection for multi user PUCCH format 1a	109
8.3.3.1	Definition and applicability.....	109
8.3.3.2	Minimum Requirement	110
8.3.3.3	Test purpose	110
8.3.3.4	Method of test	110
8.3.3.4.1	Initial Conditions	110
8.3.3.4.2	Procedure.....	110
8.3.3.5	Test Requirement	111
8.4	Performance requirements for PRACH.....	111
8.4.1	PRACH false alarm probability and missed detection.....	111
8.4.1.1	Definition and applicability.....	111
8.4.1.2	Minimum Requirement	112
8.4.1.3	Test purpose	112
8.4.1.4	Method of test	112
8.4.1.4.1	Initial Conditions	112
8.4.1.4.2	Procedure.....	112
8.4.1.5	Test Requirement	113
Annex A (normative): Reference Measurement channels.....		114
A.0	General	114
A.1	Fixed Reference Channels for reference sensitivity and in-channel selectivity (QPSK, R=1/3).....	114
A.2	Fixed Reference Channels for dynamic range (16QAM, R=2/3).....	115
A.3	Fixed Reference Channels for performance requirements (QPSK 1/3)	115
A.4	Fixed Reference Channels for performance requirements (16QAM 3/4)	116
A.5	Fixed Reference Channels for performance requirements (64QAM 5/6)	116
A.6	PRACH Test preambles	116
A.7	Fixed Reference Channels for UL timing adjustment (Scenario 1)	117
A.8	Fixed Reference Channels for UL timing adjustment (Scenario 2)	117
A.9	Multi user PUCCH test.....	118
Annex B (normative): Propagation conditions.....		119
B.1	Static propagation condition.....	119
B.2	Multi-path fading propagation conditions	119
B.3	High speed train condition.....	120
B.4	Moving propagation conditions.....	121
Annex C (normative): Characteristics of the interfering signals.....		123
Annex D (normative): Environmental requirements for the BS equipment		124
D.1	General	124
D.2	Normal test environment	124
D.3	Extreme test environment.....	124
D.3.1	Extreme temperature	124
D.4	Vibration.....	125
D.5	Power supply	125

D.6	Measurement of test environments.....	125
Annex E (normative):	General rules for statistical testing.....	126
Annex F (normative):	Global In-Channel TX-Test	127
F.1	General	127
F.2.1	Basic principle.....	127
F.2.2	Output signal of the TX under test	127
F.2.3	Reference signal	127
F.2.4	Measurement results.....	127
F.2.5	Measurement points	128
F.3.1	Pre FFT minimization process.....	128
F.3.2	Timing of the FFT window	129
F.3.3	Resource Element TX power.....	129
F.3.4	Post FFT equalisation.....	130
F.4.1	EVM.....	131
F.4.2	Averaged EVM	131
F.4.2.1	Averaged EVM (TDD).....	133
Annex G (informative):	Test Tolerances and Derivation of Test Requirements	134
G.1	Measurement of transmitter.....	135
G.2	Measurement of receiver	138
G.3	Measurement of Performance Requirements	141
Annex H (Informative):	E-UTRAN Measurement Test Cases.....	142
Annex I (Informative):	Measurement system set-up	143
I.1	Transmitter	143
I.1.1	Base station output power, output power dynamics, transmitted signal quality, Frequency error, EVM, DL RS power, Unwanted emissions.....	143
I.1.2	Transmitter intermodulation.....	143
I.1.3	Time alignment between transmitter branches	144
I.2	Receiver.....	144
I.2.1	Reference sensitivity level.....	144
I.2.2	Dynamic range	145
I.2.3	In-channel selectivity	145
I.2.4	Adjacent Channel Selectivity (ACS) and narrowband blocking	146
I.2.5	Blocking characteristics	146
I.2.6	Receiver spurious emission	147
I.2.7	Intermodulation characteristics	147
I.3	Performance requirement	148
I.3.1	Performance requirements for PRACH in static conditions	148
I.3.2	Performance requirements for PUSCH, PRACH, single user PUCCH in multipath fading conditions and for High Speed Train conditions	148
I.3.3	Performance requirements for multi user PUCCH in multipath fading conditions	149
I.3.4	Performance requirement for UL timing adjustment.....	150
Annex J (Informative):	Unwanted emission requirements for multi-carrier BS	151
J.1	General	151
J.2	Multi-carrier BS of different E-UTRA channel bandwidths.....	151
J.3	Multi-carrier BS of E-UTRA and UTRA.....	151
Annex K (informative):	Change history	152
History	155

Foreword

This Technical Specification has been produced by the 3rd Generation Partnership Project (3GPP).

The contents of the present document are subject to continuing work within the TSG and may change following formal TSG approval. Should the TSG modify the contents of the present document, it will be re-released by the TSG with an identifying change of release date and an increase in version number as follows:

Version x.y.z

where:

- x the first digit:
 - 1 presented to TSG for information;
 - 2 presented to TSG for approval;
 - 3 or greater indicates TSG approved document under change control.
- y the second digit is incremented for all changes of substance, i.e. technical enhancements, corrections, updates, etc.
- z the third digit is incremented when editorial only changes have been incorporated in the document.

1 Scope

The present document specifies the Radio Frequency (RF) test methods and conformance requirements for E-UTRA Base Stations (BS) operating either in the FDD mode (used in paired bands) or the TDD mode (used in unpaired bands). These have been derived from, and are consistent with the E-UTRA Base Station (BS) specifications defined in [2].

2 References

The following documents contain provisions which, through reference in this text, constitute provisions of the present document.

- References are either specific (identified by date of publication, edition number, version number, etc.) or non-specific.
- For a specific reference, subsequent revisions do not apply.
- For a non-specific reference, the latest version applies. In the case of a reference to a 3GPP document (including a GSM document), a non-specific reference implicitly refers to the latest version of that document *in the same Release as the present document*.

- [1] 3GPP TR 21.905: "Vocabulary for 3GPP Specifications."
- [2] 3GPP TS 36 104: "E-UTRA Base Station (BS) radio transmission and reception".
- [3] ITU-R Recommendation M.1545, 'Measurement uncertainty as it applies to test limits for the terrestrial component of International Mobile Telecommunications-2000'.
- [4] ITU-R recommendation SM.328: "Spectra and bandwidth of emissions".
- [5] ITU-R recommendation SM.329: "Unwanted emissions in the spurious domain".
- [6] IEC 60721-3-3 (2002): "Classification of environmental conditions - Part 3: Classification of groups of environmental parameters and their severities - Section 3: Stationary use at weather protected locations".
- [7] IEC 60721-3-4 (1995): "Classification of environmental conditions - Part 3: Classification of groups of environmental parameters and their severities - Section 4: Stationary use at non-weather protected locations".
- [8] IEC 60068-2-1 (2007): "Environmental testing - Part 2: Tests. Tests A: Cold".
- [9] IEC 60068-2-2 (2007): "Environmental testing - Part 2: Tests. Tests B: Dry heat".
- [10] IEC 60068-2-6 (2007): "Environmental testing - Part 2: Tests - Test Fc: Vibration (sinusoidal)".
- [11] 3GPP TR 25.942: "RF system scenarios".
- [12] 3GPP TS 36.211: "Evolved Universal Terrestrial Radio Access (E-UTRA); Physical Channels and Modulation".
- [13] 3GPP TS 36.212: "Evolved Universal Terrestrial Radio Access (E-UTRA); Multiplexing and channel coding".
- [14] 3GPP TR 36.942: "E-UTRA RF system scenarios".
- [15] 3GPP TS 25.104: "UTRA (BS) FDD; Radio transmission and Reception".
- [16] 3GPP TS 36.213: "Evolved Universal Terrestrial Radio Access (E-UTRA); Physical layer procedures".

3 Definitions, symbols and abbreviations

3.1 Definitions

For the purposes of the present document, the terms and definitions given in TR 21.905 [1] and the following apply. A term defined in the present document takes precedence over the definition of the same term, if any, in TR 21.905 [1].

Base station receive period: The time during which the base station is receiving data subframes or UpPTS.

Carrier: The modulated waveform conveying the E-UTRA or UTRA (WCDMA) physical channels

Channel bandwidth: The RF bandwidth supporting a single E-UTRA RF carrier with the transmission bandwidth configured in the uplink or downlink of a cell. The channel bandwidth is measured in MHz and is used as a reference for transmitter and receiver RF requirements.

Channel edge: The lowest and highest frequency of the E-UTRA carrier, separated by the channel bandwidth.

DL RS power: The resource element power of Downlink Reference Symbol.

Downlink operating band: The part of the operating band designated for downlink.

Maximum output power: The mean power level per carrier of the base station measured at the antenna connector in a specified reference condition.

Maximum output power: The mean power level per carrier of the base station measured at the antenna connector in a specified reference condition.

Maximum throughput: The maximum achievable throughput for a reference measurement channel.

Mean power: When applied to E-UTRA transmission this is the power measured in the channel bandwidth of the carrier. The period of measurement shall be at least one subframe (1ms), unless otherwise stated.

Multi-carrier transmission configuration: A set of one or more contiguous carriers that a BS is able to transmit simultaneously according to the manufacturer's specification.

Occupied bandwidth: The width of a frequency band such that, below the lower and above the upper frequency limits, the mean powers emitted are each equal to a specified percentage $\beta/2$ of the total mean power of a given emission.

Operating band: A frequency range (paired or unpaired) that is defined with a specific set of technical requirements, in which E-UTRA operates.

NOTE: The operating band(s) for an E-UTRA BS is declared by the manufacturer according to the designations in Table 5.5-1.

Output power: The mean power of one carrier of the base station, delivered to a load with resistance equal to the nominal load impedance of the transmitter.

Rated output power: Rated output power of the base station is the mean power level per carrier that the manufacturer has declared to be available at the antenna connector.

RE power control dynamic range: The difference between the power of a RE and the average RE power for a BS at maximum output power for a specified reference condition.

Reference bandwidth: The bandwidth in which an emission level is specified.

RRC filtered mean power: The mean power as measured through a root raised cosine filter with roll-off factor α and a bandwidth equal to the chip rate of the radio access mode.

NOTE 1: The RRC filtered mean power of a perfectly modulated W-CDMA signal is 0.246 dB lower than the mean power of the same signal.

Throughput: The number of payload bits successfully received per second for a reference measurement channel in a specified reference condition.

Total power dynamic range: The difference between the maximum and the minimum transmit power of an OFDM symbol for a specified reference condition.

Transmission bandwidth: Bandwidth of an instantaneous transmission from a UE or BS, measured in Resource Block units.

Transmission bandwidth configuration: The highest transmission bandwidth allowed for uplink or downlink in a given channel bandwidth, measured in Resource Block units.

Transmitter OFF period: The time period during which the BS transmitter is not allowed to transmit.

Transmitter ON period: The time period during which the BS transmitter is transmitting data and/or reference symbols, i.e. data subframes or DwPTS.

Transmitter transient period: The time period during which the transmitter is changing from the OFF period to the ON period or vice versa.

Uplink operating band: The part of the operating band designated for uplink.

3.2 Symbols

For the purposes of the present document, the following symbols apply:

α	Roll-off factor
β	Percentage of the mean transmitted power emitted outside the occupied bandwidth on the assigned channel
BW_{Channel}	Channel bandwidth
BW_{Config}	Transmission bandwidth configuration, expressed in MHz, where $BW_{\text{Config}} = N_{\text{RB}} \times 180 \text{ kHz}$ in the uplink and $BW_{\text{Config}} = 15 \text{ kHz} + N_{\text{RB}} \times 180 \text{ kHz}$ in the downlink.
f	Frequency
Δf	Separation between the channel edge frequency and the nominal -3dB point of the measuring filter closest to the carrier frequency
Δf_{max}	The largest value of Δf used for defining the requirement
F_{C}	Carrier centre frequency
f_{offset}	Separation between the channel edge frequency and the centre of the measuring filter
$f_{\text{offset}_{\text{max}}}$	The maximum value of f_{offset} used for defining the requirement
E_{A} :	EPRE (energy per resource element) of PDSCH REs (resource elements) type A, i.e. REs in OFDM symbols that do not include reference symbols
E_{B} :	EPRE of PDSCH REs type B, i.e. REs in OFDM symbols that include reference symbols
E_{RS} :	EPRE of reference symbols REs
$F_{\text{DL}_{\text{low}}}$	The lowest frequency of the downlink operating band
$F_{\text{DL}_{\text{high}}}$	The highest frequency of the downlink operating band
$F_{\text{UL}_{\text{low}}}$	The lowest frequency of the uplink operating band
$F_{\text{UL}_{\text{high}}}$	The highest frequency of the uplink operating band
N_{DL}	Downlink EARFCN
$N_{\text{Offis-DL}}$	Offset used for calculating downlink EARFCN
$N_{\text{Offis-UL}}$	Offset used for calculating uplink EARFCN
$N_{\text{ID}}^{\text{cell}}$	Physical layer cell identity
N_{CS}	Number of Cyclic shifts for preamble generation in PRACH
N_{RB}	Transmission bandwidth configuration, expressed in units of Resource Blocks
$N_{\text{RB}}^{\text{DL}}$	Downlink bandwidth configuration, expressed in multiples of $N_{\text{sc}}^{\text{RB}}$
N_{UL}	Uplink EARFCN
$N_{\text{sc}}^{\text{RB}}$	Resource block size in the frequency domain, expressed as a number of subcarriers
n_{f}	System frame number
n_{PRB}	Physical resource block number

n_{RNTI}	Radio network temporary identifier
n_s	Slot number within a radio frame
p	Antenna port number
P_d	Probability of PRACH preamble detection
P_{fa}	Total probability of false detection of the PRACH preamble
P_{out}	Output power
P_{max}	Maximum output power
P_{REFSENS}	Reference sensitivity power level
q	Code word number
T_A	Timing advance command, as defined in [16]
T_s	Basic time unit, as defined in [12]

3.3 Abbreviations

For the purposes of the present document, the abbreviations given in TR 21.905 [1] and the following apply. An abbreviation defined in the present document takes precedence over the definition of the same abbreviation, if any, in TR 21.905 [1].

AC	Alternating Current
ACLR	Adjacent Channel Leakage Ratio
ACK	Acknowledgement (in HARQ protocols)
ACS	Adjacent Channel Selectivity
ATT	Attenuator
AWGN	Additive White Gaussian Noise
B	Bottom RF channel (for testing purposes)
BS	Base Station
BW	Bandwidth
CCE	Control Channel Element
CP	Cyclic prefix
CW	Continuous Wave
DC	Direct Current
DFT	Discrete Fourier Transformation
DUT	Device Under Test
EPRE	Energy per resource element
E-TM	E-UTRA Test Model
E-UTRA	Evolved UTRA
EARFCN	E-UTRA Absolute Radio Frequency Channel Number
EPA	Extended Pedestrian A model
ETU	Extended Typical Urban model
EVA	Extended Vehicular A model
EVM	Error Vector Magnitude
FDD	Frequency Division Duplex
FFT	Fast Fourier Transformation
FRC	Fixed Reference Channel
HARQ	Hybrid Automatic Repeat Request
ICS	In-Channel Selectivity
IQ	In-phase - <i>Quadrature</i> phase
ITU-R	Radiocommunication Sector of the ITU
Iuant	E-Node B internal logical interface between the implementation specific O&M function and the RET antennas and TMAs control unit function of the E-Node B
M	Middle RF channel (for testing purposes)
MIMO	Multiple Input Multiple Output
MCS	Modulation and Coding Scheme
OBW	Occupied Band Width
OFDM	Orthogonal Frequency Division Multiplex
OOB	Out-Of-Band
PBCH	Physical Broadcast Channel
PCFICH	Physical control format indicator channel
PDCCH	Physical downlink control channel

PDSCH	Physical downlink shared channel
PHICH	Physical hybrid-ARQ indicator channel
PUCCH	Physical Uplink Control CHannel
PRACH	Physical Random Access Channel
PRB	Physical Resource Block
QAM	Quadrature Amplitude Modulation
QPSK	Quadrature Phase-Shift Keying
RB	Resource Block
RE	Resource Element
REG	Resource Element Group
RF	Radio Frequency
RS	Reference Symbol
RX	Receive
RRC	Root Raised Cosine
SNR	Signal-to-Noise Ratio
SQRT	SQuare RooT
SRS	Sounding Reference Signal
T	Top RF channel (for testing purposes)
TA	Timing Advance
TDD	Time Division Duplex
TT	Test Tolerance
TX	Transmit
UE	User Equipment
UMTS	Universal Mobile Telecommunications System
UTRA	UMTS Terrestrial Radio Access

4 General test conditions and declarations

Many of the tests in this specification measure a parameter relative to a value that is not fully specified in the E-UTRA specifications. For these tests, the Minimum Requirement is determined relative to a nominal value specified by the manufacturer.

Certain functions of a BS are optional in the E-UTRA specifications. Some requirements for the BS may be regional as listed in subclause 4.3.

When specified in a test, the manufacturer shall declare the nominal value of a parameter, or whether an option is supported.

4.1 Measurement uncertainties and Test Requirements

4.1.1 General

The requirements of this clause apply to all applicable tests in this specification.

The Minimum Requirements are given in 36.104 [2] and test requirements are given in this specification. Test Tolerances are defined in Annex G of this specification. Test Tolerances are individually calculated for each test. The Test Tolerances are used to relax the Minimum Requirements in 36.104 [2] to create Test Requirements.

4.1.2 Acceptable uncertainty of Test System

The maximum acceptable uncertainty of the Test System is specified below for each test, where appropriate. The Test System shall enable the stimulus signals in the test case to be adjusted to within the specified tolerance and the equipment under test to be measured with an uncertainty not exceeding the specified values. All tolerances and uncertainties are absolute values, and are valid for a confidence level of 95 %, unless otherwise stated.

A confidence level of 95% is the measurement uncertainty tolerance interval for a specific measurement that contains 95% of the performance of a population of test equipment.

For RF tests, it should be noted that the uncertainties in subclause 4.1.2 apply to the Test System operating into a nominal 50 ohm load and do not include system effects due to mismatch between the DUT and the Test System.

4.1.2.1 Measurement of transmitter

Table 4.1.2-1: Maximum Test System Uncertainty for transmitter tests

Subclause	Maximum Test System Uncertainty	Derivation of Test System Uncertainty
6.2. Base station output power	± 0.7 dB	
6.3.2 Total power dynamic range	± 0.4 dB	Relative error of two OFDM Symbol TX power (OSTP) measurements
6.4.1 Transmitter OFF power	[TBD]	[TBD]
6.4.2 Transmitter transient period	N/A	
6.5.1 Frequency error	± 12 Hz	
6.5.2 EVM	± 1 %	
6.5.3 Time alignment between transmitter branches	± 25 ns	
6.5.4 DL RS power	± 0.8 dB	
6.6.1 Occupied bandwidth	1.4MHz, 3MHz Channel BW: 30kHz 5MHz, 10MHz Channel BW: 100kHz 15MHz, 20MHz: Channel BW: 300kHz	
6.6.2 Adjacent Channel Leakage power Ratio (ACLR)	ACLR ± 0.8 dB Absolute power ± 2.0 dB	
6.6.3 Operating band unwanted emissions	± 1.5 dB	
6.6.4.5.1 Transmitter spurious emissions, Mandatory Requirements	9 kHz < f \leq 4 GHz: ± 2.0 dB 4 GHz < f \leq 12.75 GHz: ± 4.0 dB	
6.6.4.5.2 Transmitter spurious emissions, Mandatory Requirements	9 kHz < f \leq 4 GHz: ± 2.0 dB 4 GHz < f \leq 12.75 GHz: ± 4.0 dB	
6.6.4.5.3 Transmitter spurious emissions, Protection of BS receiver	± 3.0 dB	
6.6.4.5.4 Transmitter spurious emissions, Additional spurious emissions requirements	± 2.0 dB for > -60dBm ± 3.0 dB for \leq -60dBm	
6.6.4.5.5 Transmitter spurious emissions, Co-location	± 3.0 dB	
6.7 Transmitter intermodulation (interferer requirements)	The value below applies only to the interference signal and is unrelated to the measurement uncertainty of the tests (6.6.2, 6.6.3 and 6.6.4) which have to be carried out in the presence of the interferer. $\pm 1,0$ dB	The uncertainty of interferer has double the effect on the result due to the frequency offset.

4.1.2.2 Measurement of receiver

Table 4.1.2-2: Maximum Test System Uncertainty for receiver tests

Subclause	Maximum Test System Uncertainty ¹	Derivation of Test System Uncertainty
7.2 Reference sensitivity level	± 0.7 dB	

<p>7.3 Dynamic range</p>	<p>±0.3 dB</p>	<p>Overall system uncertainty for static conditions is equal to signal-to-noise ratio uncertainty.</p> <p>Signal-to-noise ratio uncertainty ±0.3 dB</p> <p>Definitions of signal-to-noise ratio, AWGN and related constraints are given in Table 4.1.2-3.</p>
<p>7.4 In-channel selectivity</p>	<p>±1.4 dB</p>	<p>Overall system uncertainty comprises three quantities:</p> <ol style="list-style-type: none"> 1. Wanted signal level error 2. Interferer signal level error 3. Additional impact of interferer leakage <p>Items 1 and 2 are assumed to be uncorrelated so can be root sum squared to provide the ratio error of the two signals. The interferer leakage effect is systematic, and is added arithmetically.</p> <p>Test System uncertainty = [SQRT (wanted_level_error² + interferer_level_error²)] + leakage effect.</p> <p>Wanted signal level ± 0.7dB Interferer signal level ± 0.7dB Impact of interferer leakage 0.4dB.</p>
<p>7.5 Adjacent Channel Selectivity (ACS) and narrow-band blocking</p>	<p>±1.4 dB</p>	<p>Overall system uncertainty comprises three quantities:</p> <ol style="list-style-type: none"> 1. Wanted signal level error 2. Interferer signal level error 3. Additional impact of interferer ACLR <p>Items 1 and 2 are assumed to be uncorrelated so can be root sum squared to provide the ratio error of the two signals. The interferer ACLR effect is systematic, and is added arithmetically.</p> <p>Test System uncertainty = [SQRT (wanted_level_error² + interferer_level_error²)] + ACLR effect.</p> <p>Wanted signal level ± 0.7dB Interferer signal level ± 0.7dB Impact of interferer ACLR 0.4dB. See Note 2.</p>

<p>7.6.5.1 Blocking (General requirements)</p>	<p><u>In-band blocking, using modulated interferer:</u> ±1.6 dB</p> <p><u>Out of band blocking, using CW interferer:</u> 1MHz < f_{interferer} ≤ 3 GHz: ±1.3 dB 3 GHz < f_{interferer} ≤ 12.75 GHz: ±3.2 dB</p>	<p>Overall system uncertainty can have these contributions:</p> <ol style="list-style-type: none"> 1. Wanted signal level error 2. Interferer signal level error 3. Interferer ACLR 4. Interferer broadband noise <p>Items 1 and 2 are assumed to be uncorrelated so can be root sum squared to provide the ratio error of the two signals. The Interferer ACLR or Broadband noise effect is systematic, and is added arithmetically.</p> <p>Test System uncertainty = [SQRT (wanted_level_error² + interferer_level_error²)] + ACLR effect + Broadband noise effect.</p> <p><u>In-band blocking, using modulated interferer:</u> Wanted signal level ± 0.7dB Interferer signal level: ± 1.0dB Interferer ACLR 0.4dB Broadband noise not applicable</p> <p><u>Out of band blocking, using CW interferer:</u> Wanted signal level ± 0.7dB Interferer signal level: ± 1.0dB up to 3GHz ± 3.0dB up to 12.75GHz Interferer ACLR not applicable Impact of interferer Broadband noise 0.1dB</p>
<p>7.6.5.2 Blocking (Co-location with other base stations)</p>	<p><u>Co-location blocking, using CW interferer:</u> ±2.5 dB</p>	<p><u>Co-location blocking, using CW interferer:</u> Wanted signal level ± 0.7dB Interferer signal level: ± 2.0dB Interferer ACLR not applicable Impact of interferer Broadband noise 0.4dB</p>
<p>7.7 Receiver spurious emissions</p>	<p>30 MHz ≤ f ≤ 4 GHz: ±2.0 dB 4 GHz < f ≤ 12.75 GHz: ±4.0 dB</p>	

<p>7.8 Receiver intermodulation</p>	<p>±1.8 dB</p>	<p>Overall system uncertainty comprises four quantities:</p> <ol style="list-style-type: none"> 1. Wanted signal level error 2. CW Interferer level error 3. Modulated Interferer level error 4. Impact of interferer ACLR <p>The effect of the closer CW signal has twice the effect.</p> <p>Items 1, 2 and 3 are assumed to be uncorrelated so can be root sum squared to provide the combined effect of the three signals. The interferer ACLR effect is systematic, and is added arithmetically.</p> <p>Test System uncertainty = $\text{SQRT} [(2 \times \text{CW_level_error})^2 + (\text{mod interferer_level_error})^2 + (\text{wanted signal_level_error})^2] + \text{ACLR effect.}$</p> <p>Wanted signal level ± 0.7dB CW Interferer level ± 0.5dB Mod Interferer level ± 0.7dB Impact of interferer ACLR 0.4dB</p>
<p>Note 1: Unless otherwise noted, only the Test System stimulus error is considered here. The effect of errors in the throughput measurements due to finite test duration is not considered.</p> <p>Note 2: The Test equipment ACLR requirement for a specified uncertainty contribution is calculated as below:</p> <ol style="list-style-type: none"> a) The wanted signal to noise ratio for Reference sensitivity is calculated based on a 5dB noise figure b) The same wanted signal to (noise + interference) ratio is then assumed at the desensitisation level according to the ACS test conditions c) The noise is subtracted from the total (noise + interference) to compute the allowable BS adjacent channel interference. From this an equivalent BS ACS figure can be obtained d) The contribution from the Test equipment ACLR is calculated to give a 0.4dB additional rise in interference. This corresponds to a Test equipment ACLR which is 10.2 dB better than the BS ACS e) This leads to the following Test equipment ACLR requirements for the interfering signal: <p><u>Adjacent channel Selectivity</u> E-UTRA 1.4MHz channel bandwidth: 56dB E-UTRA 3MHz channel bandwidth: 56dB E-UTRA 5MHz channel bandwidth and above: 56dB</p> <p><u>Narrow band blocking</u> E-UTRA 1.4MHz channel bandwidth: 65dB E-UTRA 3MHz channel bandwidth: 61dB E-UTRA 5MHz channel bandwidth and above: 59dB</p>		

4.1.2.3 Measurement of performance requirement

Table 4.1.2-3: Maximum Test System Uncertainty for Performance Requirements

Subclause	Maximum Test System Uncertainty ¹	Derivation of Test System Uncertainty
8.2.1 Performance requirements of PUSCH in multipath fading propagation conditions	± 0.6 dB	Overall system uncertainty for fading conditions comprises two quantities: 1. Signal-to-noise ratio uncertainty 2. Fading profile power uncertainty Items 1 and 2 are assumed to be uncorrelated so can be root sum squared: Test System uncertainty = [SQRT (Signal-to-noise ratio uncertainty ² + Fading profile power uncertainty ²)] Signal-to-noise ratio uncertainty ±0.3 dB Fading profile power uncertainty ±0.5 dB
8.2.2 Performance requirements for UL timing adjustment	± 0.6 dB	Overall system uncertainty for fading conditions comprises two quantities: 1. Signal-to-noise ratio uncertainty 2. Fading profile power uncertainty Items 1 and 2 are assumed to be uncorrelated so can be root sum squared: Test System uncertainty = [SQRT (Signal-to-noise ratio uncertainty ² + Fading profile power uncertainty ²)] Signal-to-noise ratio uncertainty ±0.3 dB Fading profile power uncertainty ±0.5 dB
	± 0.3 dB	Overall system uncertainty for static conditions is equal to signal-to-noise ratio uncertainty. Signal-to-noise ratio uncertainty ±0.3 dB
8.2.3 Performance requirements for HARQ-ACK multiplexed on PUSCH	± 0.6 dB	Overall system uncertainty for fading conditions comprises two quantities: 1. Signal-to-noise ratio uncertainty 2. Fading profile power uncertainty Items 1 and 2 are assumed to be uncorrelated so can be root sum squared: Test System uncertainty = [SQRT (Signal-to-noise ratio uncertainty ² + Fading profile power uncertainty ²)] Signal-to-noise ratio uncertainty ±0.3 dB Fading profile power uncertainty ±0.5 dB
8.2.4 Performance requirements for High Speed Train conditions	± 0.3 dB	Overall system uncertainty for static conditions is equal to signal-to-noise ratio uncertainty. Signal-to-noise ratio uncertainty ±0.3 dB

<p>8.3.1 ACK missed detection for single user PUCCH format 1a</p>	<p>± 0.6 dB</p>	<p>Overall system uncertainty for fading conditions comprises two quantities:</p> <ol style="list-style-type: none"> 1. Signal-to-noise ratio uncertainty 2. Fading profile power uncertainty <p>Items 1 and 2 are assumed to be uncorrelated so can be root sum squared:</p> <p>Test System uncertainty = [SQRT (Signal-to-noise ratio uncertainty² + Fading profile power uncertainty²)]</p> <p>Signal-to-noise ratio uncertainty ±0.3 dB Fading profile power uncertainty ±0.5 dB</p>
<p>8.3.2 CQI missed detection for PUCCH format 2</p>	<p>± 0.6 dB</p>	<p>Overall system uncertainty for fading conditions comprises two quantities:</p> <ol style="list-style-type: none"> 1. Signal-to-noise ratio uncertainty 2. Fading profile power uncertainty <p>Items 1 and 2 are assumed to be uncorrelated so can be root sum squared:</p> <p>Test System uncertainty = [SQRT (Signal-to-noise ratio uncertainty² + Fading profile power uncertainty²)]</p> <p>Signal-to-noise ratio uncertainty ±0.3 dB Fading profile power uncertainty ±0.5 dB</p>
<p>8.3.3 ACK missed detection for multi user PUCCH format 1a</p>	<p>± 0.6 dB</p>	<p>Overall system uncertainty for fading conditions comprises two quantities:</p> <ol style="list-style-type: none"> 1. Signal-to-noise ratio uncertainty 2. Fading profile power uncertainty <p>Items 1 and 2 are assumed to be uncorrelated so can be root sum squared:</p> <p>Test System uncertainty = [SQRT (Signal-to-noise ratio uncertainty² + Fading profile power uncertainty²)]</p> <p>Signal-to-noise ratio uncertainty ±0.3 dB Fading profile power uncertainty ±0.5 dB</p>
<p>8.4.1 PRACH false alarm probability and missed detection</p>	<p>± 0.6 dB</p>	<p>Overall system uncertainty for fading conditions comprises two quantities:</p> <ol style="list-style-type: none"> 1. Signal-to-noise ratio uncertainty 2. Fading profile power uncertainty <p>Items 1 and 2 are assumed to be uncorrelated so can be root sum squared:</p> <p>Test System uncertainty = [SQRT (Signal-to-noise ratio uncertainty² + Fading profile power uncertainty²)]</p> <p>Signal-to-noise ratio uncertainty ±0.3 dB Fading profile power uncertainty ±0.5 dB</p>
	<p>± 0.3 dB</p>	<p>Overall system uncertainty for static conditions is equal to signal-to-noise ratio uncertainty.</p> <p>Signal-to-noise ratio uncertainty ±0.3 dB</p>

In addition, the following Test System uncertainties and related constraints apply:	
AWGN Bandwidth	$\geq 1.08\text{MHz}, 2.7\text{MHz}, 4.5\text{MHz}, 9\text{MHz}, 13.5\text{MHz}, 18\text{MHz};$ $N_{\text{RB}} \times 180\text{kHz}$ according to BW_{Config}
AWGN absolute power uncertainty, averaged over BW_{Config}	± 1.5 dB
AWGN flatness and signal flatness, max deviation for any Resource Block, relative to average over BW_{Config}	± 2 dB
AWGN flatness over BW_{Channel} , max deviation for any Resource Block, relative to average over BW_{Config}	+2 dB
AWGN flatness and signal flatness, max difference between adjacent Resource Blocks	± 0.5 dB
AWGN peak to average ratio	≥ 10 dB @0.001%
Signal-to noise ratio uncertainty, averaged over uplink transmission Bandwidth	± 0.3 dB
Fading profile power uncertainty	± 0.5 dB
Fading profile delay uncertainty, relative to frame timing	± 5 ns (excludes absolute errors related to baseband timing)
Note 1: Only the overall stimulus error is considered here. The effect of errors in the throughput measurements due to finite test duration is not considered.	

4.1.3 Interpretation of measurement results

The measurement results returned by the Test System are compared - without any modification - against the Test Requirements as defined by the Shared Risk principle.

The Shared Risk principle is defined in ITU-R M.1545 [3].

The actual measurement uncertainty of the Test System for the measurement of each parameter shall be included in the test report.

The recorded value for the Test System uncertainty shall be, for each measurement, equal to or lower than the appropriate figure in subclause 4.1.2 of this specification.

If the Test System for a test is known to have a measurement uncertainty greater than that specified in subclause 4.1.2, it is still permitted to use this apparatus provided that an adjustment is made as follows.

Any additional uncertainty in the Test System over and above that specified in subclause 4.1.2 shall be used to tighten the Test Requirement, making the test harder to pass. (For some tests e.g. receiver tests, this may require modification of stimulus signals). This procedure (defined in Annex G) will ensure that a Test System not compliant with subclause 4.1.2 does not increase the chance of passing a device under test where that device would otherwise have failed the test if a Test System compliant with subclause 4.1.2 had been used.

4.2 Base station classes

The requirements in this specification apply to Base Station intended for general-purpose applications.

Other base station classes are for further study. The requirements for these may be different than for general-purpose applications.

4.3 Regional requirements

Some requirements in the present document may only apply in certain regions either as optional requirements or set by local and regional regulation as mandatory requirements. It is normally not stated in the 3GPP specifications under what exact circumstances that the requirements apply, since this is defined by local or regional regulation.

Table 4.3-1 lists all requirements that may be applied differently in different regions.

Table 4.3-1: List of regional requirements

Clause number	Requirement	Comments
5.5	Operating bands	Some bands may be applied regionally.
5.6	Channel bandwidth	Some channel bandwidths may be applied regionally.
5.7	Channel arrangement	The requirement is applied according to what operating bands in Clause 5.5 that are supported by the BS.
6.2.	Base station maximum output power	In certain regions, the minimum requirement for normal conditions may apply also for some conditions outside the range of conditions defined as normal.
		In certain regions, additional regional requirement specified in subclause 6.2.2 in [1] is applied for rated output power declared by the manufacturer.
6.6.3.5.1	Operating band unwanted emissions (Category A)	This requirement is mandatory for regions where Category A limits for spurious emissions, as defined in ITU-R Recommendation SM.329 [5] apply.
6.6.3.5.2	Operating band unwanted emissions (Category B)	This requirement is mandatory for regions where Category B limits for spurious emissions, as defined in ITU-R Recommendation SM.329 [5], apply.
6.6.3.5.3	Additional requirements	These requirements may apply in certain regions as additional Operating band unwanted emission limits.
6.6.4.5.1	Spurious emissions (Category A)	This requirement is mandatory for regions where Category A limits for spurious emissions, as defined in ITU-R Recommendation SM.329 [5] apply.
6.6.4.5.2	Spurious emissions (Category B)	This requirement is mandatory for regions where Category B limits for spurious emissions, as defined in ITU-R Recommendation SM.329 [5], apply.
6.6.4.5.4	Additional spurious emission requirements	These requirements may be applied for the protection of system operating in frequency ranges other than the E-UTRA BS operating band.
6.6.4.5.5	Co-location with other base stations	These requirements may be applied for the protection of other BS receivers when a BS operating in another frequency band is co-located with an E-UTRA BS.
7.6.5.2	Co-location with other base stations	These requirements may be applied for the protection of the BS receivers when a BS operating in another frequency band is co-located with an E-UTRA BS.

4.4 Selection of configurations for testing

Most tests in the present document are only performed for a subset of the possible combinations of test conditions. For instance:

- Not all transceivers in the configuration may be specified to be tested;
- Only one RF channel may be specified to be tested;
- Not all channel bandwidths may be specified to be tested.

4.5 BS Configurations

4.5.1 Transmit configurations

Unless otherwise stated, the transmitter characteristics in clause 6 are specified at the BS antenna connector (test port A) with a full complement of transceivers for the configuration in normal operating conditions. If any external apparatus such as a TX amplifier, a filter or the combination of such devices is used, requirements apply at the far end antenna connector (test port B).

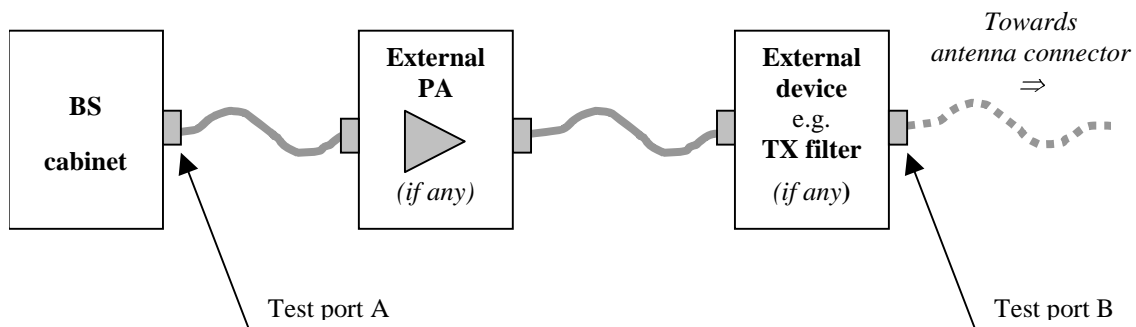

Figure 4.5-1: Transmitter test ports

4.5.1.1 Transmit diversity and MIMO transmission

Unless otherwise stated, for the tests in clause 6 of the present document, the requirement applies for each transmitter antenna connector in the case of transmit diversity or MIMO transmission.

Transmitter requirements are tested at the antenna connector, with the remaining antenna connector(s) being terminated. If the manufacturer has declared the transmitter paths to be equivalent, it is sufficient to measure the signal at any one of the transmitter antenna connectors.

4.5.2 Receive configurations

Unless otherwise stated, the receiver characteristics in clause 7 are specified at the BS antenna connector (test port A) with a full complement of transceivers for the configuration in normal operating conditions. If any external apparatus such as a RX amplifier, a filter or the combination of such devices is used, requirements apply at the far end antenna connector (test port B).

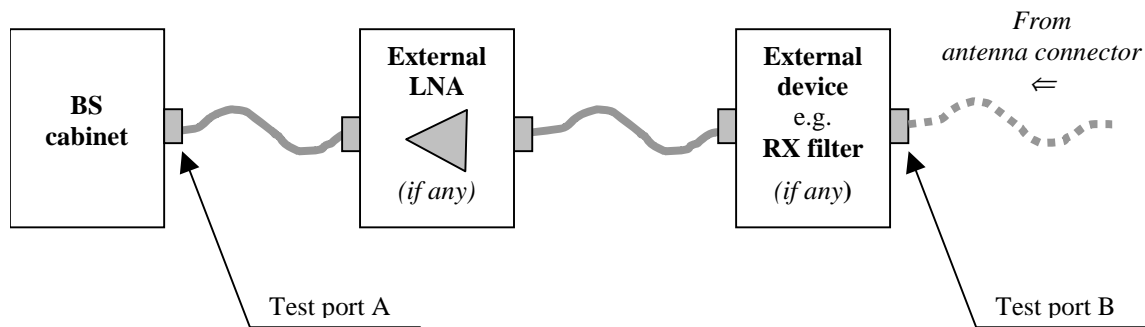

Figure 4.5-2: Receiver test ports

4.5.2.1 Receiver diversity

For the tests in clause 7 of the present document, the requirement applies at each receiver antenna connector for receivers with antenna diversity.

Receiver requirements are tested at the antenna connector, with the remaining receiver(s) disabled or their antenna connector(s) being terminated. If the manufacturer has declared the receiver paths to be equivalent, it is sufficient to apply the specified test signal at any one of the receiver antenna connectors.

4.5.3 Duplexers

The requirements of the present document shall be met with a duplexer fitted, if a duplexer is supplied as part of the BS. If the duplexer is supplied as an option by the manufacturer, sufficient tests should be repeated with and without the duplexer fitted to verify that the BS meets the requirements of the present document in both cases.

The following tests shall be performed with the duplexer fitted, and without it fitted if this is an option:

- 1) subclause 6.2, base station output power, for the highest static power step only, if this is measured at the antenna connector;
- 2) subclause 6.6, unwanted emissions; outside the BS transmit band;
- 3) subclause 6.6.4.5.3, protection of the BS receiver;
- 4) subclause 6.7, transmit intermodulation; for the testing of conformance, the carrier frequencies should be selected to minimize intermodulation products from the transmitters falling in receive channels.

The remaining tests may be performed with or without the duplexer fitted.

NOTE 1: When performing receiver tests with a duplexer fitted, it is important to ensure that the output from the transmitters does not affect the test apparatus. This can be achieved using a combination of attenuators, isolators and filters.

NOTE 2: When duplexers are used, intermodulation products will be generated, not only in the duplexer but also in the antenna system. The intermodulation products generated in the antenna system are not controlled by 3GPP specifications, and may degrade during operation (e.g. due to moisture ingress). Therefore, to ensure continued satisfactory operation of a BS, an operator will normally select EARFCNs to minimize intermodulation products falling on receive channels. For testing of complete conformance, an operator may specify the EARFCNs to be used.

4.5.4 Power supply options

If the BS is supplied with a number of different power supply configurations, it may not be necessary to test RF parameters for each of the power supply options, provided that it can be demonstrated that the range of conditions over which the equipment is tested is at least as great as the range of conditions due to any of the power supply configurations.

This applies particularly if a BS contains a DC rail which can be supplied either externally or from an internal mains power supply. In this case, the conditions of extreme power supply for the mains power supply options can be tested by

testing only the external DC supply option. The range of DC input voltages for the test should be sufficient to verify the performance with any of the power supplies, over its range of operating conditions within the BS, including variation of mains input voltage, temperature and output current.

4.5.5 Ancillary RF amplifiers

The requirements of the present document shall be met with the ancillary RF amplifier fitted. At tests according to clauses 6 and 7 for TX and RX respectively, the ancillary amplifier is connected to the BS by a connecting network (including any cable(s), attenuator(s), etc.) with applicable loss to make sure the appropriate operating conditions of the ancillary amplifier and the BS. The applicable connecting network loss range is declared by the manufacturer. Other characteristics and the temperature dependence of the attenuation of the connecting network are neglected. The actual attenuation value of the connecting network is chosen for each test as one of the applicable extreme values. The lowest value is used unless otherwise stated.

Sufficient tests should be repeated with the ancillary amplifier fitted and, if it is optional, without the ancillary RF amplifier to verify that the BS meets the requirements of the present document in both cases.

When testing, the following tests shall be repeated with the optional ancillary amplifier fitted according to the table below, where x denotes that the test is applicable:

Table 4.5-1: Tests applicable to Ancillary RF Amplifiers

Receiver Tests	Subclause	TX amplifier only	RX amplifier only	TX/RX amplifiers combined (Note)
	7.2		X	X
	7.5 (Narrowband blocking)		X	X
	7.6		X	X
	7.7		X	X
	7.8		X	
Transmitter Tests	6.2	X		X
	6.6.1	X		X
	6.6.2	X		X
	6.6.3	X		X
	6.6.4	X		X
	6.7	X		X

NOTE: Combining can be by duplex filters or any other network. The amplifiers can either be in RX or TX branch or in both. Either one of these amplifiers could be a passive network.

In test according to subclauses 6.2 and 7.2 highest applicable attenuation value is applied.

4.5.6 BS with integrated Iuant BS modem

Unless otherwise stated, for the tests in the present document, the integrated Iuant BS modem shall be switched off. Spurious emissions according to clauses 6.6.4 and 7.7 shall be measured only for frequencies above 20MHz with the integrated Iuant BS modem switched on.

4.5.7 BS using antenna arrays

A BS may be configured with a multiple antenna port connection for some or all of its transceivers or with an antenna array related to one cell (not one array per transceiver). This subclause applies to a BS which meets at least one of the following conditions:

- the transmitter output signals from one or more transceiver appear at more than one antenna port; or
- there is more than one receiver antenna port for a transceiver or per cell and an input signal is required at more than one port for the correct operation of the receiver thus the outputs from the transmitters as well as the inputs to the receivers are directly connected to several antennas (known as "aircombining"); or
- transmitters and receivers are connected via duplexers to more than one antenna.

In case of diversity or spatial multiplexing, multiple antennas are not considered as an antenna array.

If a BS is used, in normal operation, in conjunction with an antenna system which contains filters or active elements which are necessary to meet the E-UTRA requirements, the conformance tests may be performed on a system comprising the BS together with these elements, supplied separately for the purposes of testing. In this case, it must be demonstrated that the performance of the configuration under test is representative of the system in normal operation, and the conformance assessment is only applicable when the BS is used with the antenna system.

For conformance testing of such a BS, the following procedure may be used.

4.5.7.1 Receiver tests

For each test, the test signals applied to the receiver antenna connectors shall be such that the sum of the powers of the signals applied equals the power of the test signal(s) specified in the test.

An example of a suitable test configuration is shown in figure 4.5.7.1-1.

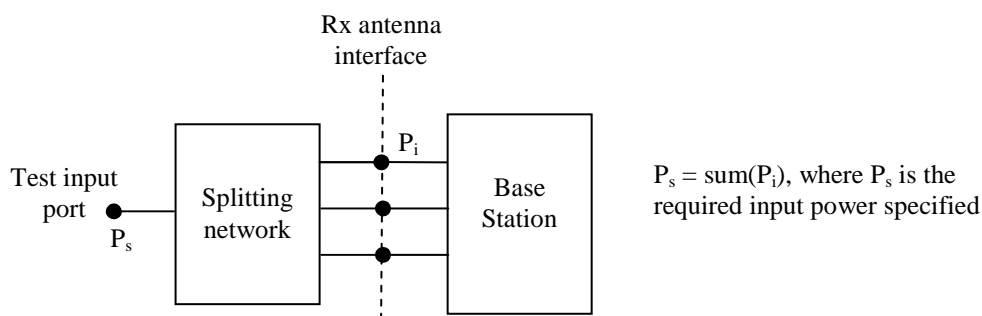

Figure 4.5.7.1-1: Receiver test set-up

For spurious emissions from the receiver antenna connector, the test may be performed separately for each receiver antenna connector.

4.5.7.2 Transmitter tests

For each test, the test signals applied to the transmitter antenna connectors (P_i) shall be such that the sum of the powers of the signals applied equals the power of the test signal(s) (P_s) specified in the test. This may be assessed by separately measuring the signals emitted by each antenna connector and summing the results, or by combining the signals and performing a single measurement. The characteristics (e.g. amplitude and phase) of the combining network should be such that the power of the combined signal is maximised.

An example of a suitable test configuration is shown in figure 4.5.7.2-1.

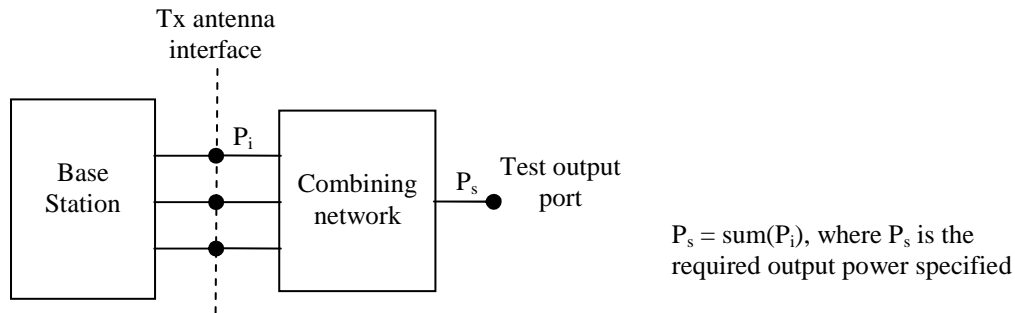

Figure 4.5.7.2-1: Transmitter test set-up

For Intermodulation attenuation, the test may be performed separately for each transmitter antenna connector.

4.6 Manufacturer's declarations of regional and optional requirements

4.6.1 Operating band and frequency range

The manufacturer shall declare which operating band(s) specified in clause 5.5 that is supported by the BS under test and if applicable, which frequency ranges within the operating band(s) that the base station can operate in. Requirements for other operating bands and frequency ranges need not be tested.

4.6.2 Channel bandwidth

The manufacturer shall declare which of the channel bandwidths specified in TS36.104 clause 5.6 that are supported by the BS under test. Requirements for other channel bandwidths need not be tested.

4.6.3 Base station output power

The manufacturer shall declare for the BS under test the rated output power for each supported transmit channel bandwidth.

4.6.4 Spurious emissions Category

The manufacturer shall declare one of the following:

- a) The BS is tested against Category A limits for spurious emissions, as defined in ITU-R Recommendation SM.329 [5]. In this case
 - conformance with the operating band unwanted emissions requirements in clause 6.6.3.5.1 is mandatory, and the requirements specified in clause 6.6.3.5.2 need not be tested..
 - conformance with the spurious emissions requirements in clause 6.6.4.5.1 is mandatory, and the requirements specified in clause 6.6.4.5.2 need not be tested.
- b) The BS is tested against Category B limits for spurious emissions, as defined in ITU-R Recommendation SM.329 [5]. In this case,
 - conformance with the operating band unwanted emissions requirements in clause 6.6.3.5.2 is mandatory, and the requirements specified in clause 6.6.3.5.1 need not be tested.

- conformance with the spurious emissions requirements in clause 6.6.4.5.2 is mandatory, and the requirements specified in clause 6.6.4.5.1 need not be tested.

4.6.5 Additional operating band unwanted emissions

The manufacturer shall declare whether the BS under test is intended to operate in geographic areas where the additional operating band unwanted emission limits defined in clause 6.6.3.5.3 apply. If this is the case, compliance with the test requirement specified in Tables 6.6.3.5.3-1, 6.6.3.5.3-2 or 6.6.3.5.3-3 are mandatory; otherwise these requirements need not be tested.

4.6.6 Co-existence with other systems

The manufacturer shall declare whether the BS under test is intended to operate in geographic areas where one or more of the systems GSM850, GSM900, DCS1800, PCS1900, UTRA FDD, UTRA TDD, E-UTRA and/or PHS operating in another band are deployed. If this is the case, compliance with the applicable test requirement for spurious emissions specified in clause 6.6.4.5.4 shall be tested.

4.6.7 Co-location with other base stations

The manufacturer shall declare whether the BS under test is intended to operate co-located with base stations of one or more of the systems GSM850, GSM900, DCS1800, PCS1900, UTRA FDD, UTRA TDD and/or E-UTRA operating in another band. If this is the case,

- compliance with the applicable test requirement for spurious emissions specified in clause 6.6.4.5.5 shall be tested.
- compliance with the applicable test requirement for receiver blocking specified in clause 7.6 shall be tested.

4.7 Specified frequency range and supported channel bandwidth

Unless otherwise stated, the test shall be performed with a lowest and the highest bandwidth supported by the BS. The manufacturer shall declare that the requirements are fulfilled for all other bandwidths supported by the BS which are not tested.

The manufacturer shall declare:

- which of the operating bands defined in subclause 5.5 are supported by the BS.
- the frequency range within the above frequency band(s) supported by the BS.
- the channel bandwidths supported by the BS

Many tests in this TS are performed with appropriate frequencies in the bottom, middle and top channels of the supported frequency range of the BS. These are denoted as RF channels B (bottom), M (middle) and T (top).

Unless otherwise stated, the test shall be performed with a single carrier at each of the RF channels B, M and T.

When the requirements are specific to multiple carriers, and the BS is declared to support $N > 1$ carriers, numbered from 1 to N, the interpretation of B, M and T for test purposes shall be as follows:

For testing at B,

- the carrier of lowest frequency shall be centred on B

For testing at M,

- if the number N of carriers supported is odd, the carrier $(N+1)/2$ shall be centred on M,
- if the number N of carriers supported is even, the carrier $N/2$ shall be centred on M.

For testing at T

- the carrier of highest frequency shall be centred on T

When a test is performed by a test laboratory, the EARFCNs to be used for RF channels B, M and T shall be specified by the laboratory. The laboratory may consult with operators, the manufacturer or other bodies.

When a test is performed by a manufacturer, the EARFCNs to be used for RF channels B, M and T may be specified by an operator.

4.8 Format and interpretation of tests

Each test in the following clauses has a standard format:

X Title

All tests are applicable to all equipment within the scope of the present document, unless otherwise stated.

X.1 Definition and applicability

This subclause gives the general definition of the parameter under consideration and specifies whether the test is applicable to all equipment or only to a certain subset. Required manufacturer declarations may be included here.

X.2 Minimum Requirement

This subclause contains the reference to the subclause to the 3GPP reference (or core) specification which defines the Minimum Requirement.

X.3 Test Purpose

This subclause defines the purpose of the test.

X.4 Method of test

X.4.1 Initial conditions

This subclause defines the initial conditions for each test, including the test environment, the RF channels to be tested and the basic measurement set-up.

X.4.2 Procedure

This subclause describes the steps necessary to perform the test and provides further details of the test definition like point of access (e.g. test port), domain (e.g. frequency-span), range, weighting (e.g. bandwidth), and algorithms (e.g. averaging).

X.5 Test Requirement

This subclause defines the pass/fail criteria for the equipment under test. See subclause 4.1.2.5 Interpretation of measurement results.

5 Operating bands and channel arrangement

5.1 General

The channel arrangements presented in this clause are based on the operating bands and channel bandwidths defined in the present release of specifications.

NOTE: Other operating bands and channel bandwidths may be considered in future releases.

5.2 Void

5.3 Void

5.4 Void

5.5 Operating bands

E-UTRA is designed to operate in the operating bands defined in Table 5.5-1.

Table 5.5-1 E-UTRA operating bands

E-UTRA Operating Band	Uplink (UL) operating band BS receive UE transmit		Downlink (DL) operating band BS transmit UE receive		Duplex Mode
	F _{UL_low}	F _{UL_high}	F _{DL_low}	F _{DL_high}	
1	1920 MHz	1980 MHz	2110 MHz	2170 MHz	FDD
2	1850 MHz	1910 MHz	1930 MHz	1990 MHz	FDD
3	1710 MHz	1785 MHz	1805 MHz	1880 MHz	FDD
4	1710 MHz	1755 MHz	2110 MHz	2155 MHz	FDD
5	824 MHz	849 MHz	869 MHz	894 MHz	FDD
6	830 MHz	840 MHz	875 MHz	885 MHz	FDD
7	2500 MHz	2570 MHz	2620 MHz	2690 MHz	FDD
8	880 MHz	915 MHz	925 MHz	960 MHz	FDD
9	1749.9 MHz	1784.9 MHz	1844.9 MHz	1879.9 MHz	FDD
10	1710 MHz	1770 MHz	2110 MHz	2170 MHz	FDD
11	1427.9 MHz	1447.9 MHz	1475.9 MHz	1495.9 MHz	FDD
12	698 MHz	716 MHz	728 MHz	746 MHz	FDD
13	777 MHz	787 MHz	746 MHz	756 MHz	FDD
14	788 MHz	798 MHz	758 MHz	768 MHz	FDD
...					
17	704 MHz	716 MHz	734 MHz	746 MHz	FDD
...					
33	1900 MHz	1920 MHz	1900 MHz	1920 MHz	TDD
34	2010 MHz	2025 MHz	2010 MHz	2025 MHz	TDD
35	1850 MHz	1910 MHz	1850 MHz	1910 MHz	TDD
36	1930 MHz	1990 MHz	1930 MHz	1990 MHz	TDD
37	1910 MHz	1930 MHz	1910 MHz	1930 MHz	TDD
38	2570 MHz	2620 MHz	2570 MHz	2620 MHz	TDD
39	1880 MHz	1920 MHz	1880 MHz	1920 MHz	TDD
40	2300 MHz	2400 MHz	2300 MHz	2400 MHz	TDD

5.6 Channel bandwidth

Requirements in present document are specified for the channel bandwidths listed in Table 5.6-1.

Table 5.6-1 Transmission bandwidth configuration N_{RB} in E-UTRA channel bandwidths

Channel bandwidth BW _{Channel} [MHz]	1.4	3	5	10	15	20
Transmission bandwidth configuration N_{RB}	6	15	25	50	75	100

Figure 5.6-1 shows the relation between the Channel bandwidth (BW_{Channel}) and the Transmission bandwidth configuration (N_{RB}). The channel edges are defined as the lowest and highest frequencies of the carrier separated by the channel bandwidth, i.e. at $F_C \pm BW_{Channel}/2$.

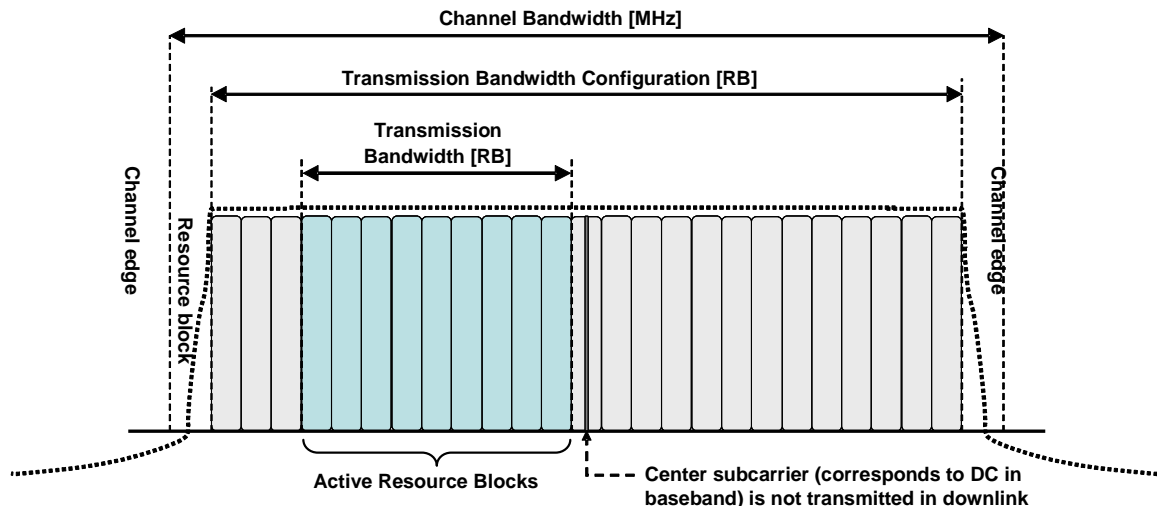

Figure 5.6-1 Definition of Channel Bandwidth and Transmission Bandwidth Configuration for one E-UTRA carrier.

5.7 Channel arrangement

5.7.1 Channel spacing

The spacing between carriers will depend on the deployment scenario, the size of the frequency block available and the channel bandwidths. The nominal channel spacing between two adjacent E-UTRA carriers is defined as following:

$$\text{Nominal Channel spacing} = (BW_{\text{Channel}(1)} + BW_{\text{Channel}(2)})/2$$

where $BW_{\text{Channel}(1)}$ and $BW_{\text{Channel}(2)}$ are the channel bandwidths of the two respective E-UTRA carriers. The channel spacing can be adjusted to optimize performance in a particular deployment scenario.

5.7.2 Channel raster

The channel raster is 100 kHz for all bands, which means that the carrier centre frequency must be an integer multiple of 100 kHz.

5.7.3 Carrier frequency and EARFCN

The carrier frequency in the uplink and downlink is designated by the E-UTRA Absolute Radio Frequency Channel Number (EARFCN) in the range 0 - 65535. The relation between EARFCN and the carrier frequency in MHz for the downlink is given by the following equation, where $F_{\text{DL_low}}$ and $N_{\text{Offs-DL}}$ are given in table 5.7.3-1 and N_{DL} is the downlink EARFCN.

$$F_{\text{DL}} = F_{\text{DL_low}} + 0.1(N_{\text{DL}} - N_{\text{Offs-DL}})$$

The relation between EARFCN and the carrier frequency in MHz for the uplink is given by the following equation where $F_{\text{UL_low}}$ and $N_{\text{Offs-UL}}$ are given in table 5.7.3-1 and N_{UL} is the uplink EARFCN.

$$F_{\text{UL}} = F_{\text{UL_low}} + 0.1(N_{\text{UL}} - N_{\text{Offs-UL}})$$

Table 5.7.3-1 E-UTRA channel numbers

E-UTRA Operating Band	Downlink			Uplink		
	F _{DL_low} [MHz]	N _{Offs-DL}	Range of N _{DL}	F _{UL_low} [MHz]	N _{Offs-UL}	Range of N _{UL}
1	2110	0	0 – 599	1920	18000	18000 – 18599
2	1930	600	600 – 1199	1850	18600	18600 – 19199
3	1805	1200	1200 – 1949	1710	19200	19200 – 19949
4	2110	1950	1950 – 2399	1710	19950	19950 – 20399
5	869	2400	2400 – 2649	824	20400	20400 – 20649
6	875	2650	2650 – 2749	830	20650	20650 – 20749
7	2620	2750	2750 – 3449	2500	20750	20750 – 21449
8	925	3450	3450 – 3799	880	21450	21450 – 21799
9	1844.9	3800	3800 – 4149	1749.9	21800	21800 – 22149
10	2110	4150	4150 – 4749	1710	22150	22150 – 22749
11	1475.9	4750	4750 – 4949	1427.9	22750	22750 – 22949
12	728	5000	5000 – 5179	698	23000	23000 – 23179
13	746	5180	5180 – 5279	777	23180	23180 – 23279
14	758	5280	5280 – 5379	788	23280	23280 – 23379
...						
17	734	5730	5730 – 5849	704	23730	23730 – 23849
...						
33	1900	36000	36000 – 36199	1900	36000	36000 – 36199
34	2010	36200	36200 – 36349	2010	36200	36200 – 36349
35	1850	36350	36350 – 36949	1850	36350	36350 – 36949
36	1930	36950	36950 – 37549	1930	36950	36950 – 37549
37	1910	37550	37550 – 37749	1910	37550	37550 – 37749
38	2570	37750	37750 – 38249	2570	37750	37750 – 38249
39	1880	38250	38250 – 38649	1880	38250	38250 – 38649
40	2300	38650	38650 – 39649	2300	38650	38650 – 39649

NOTE: The channel numbers that designate carrier frequencies so close to the operating band edges that the carrier extends beyond the operating band edge shall not be used. This implies that the first 7, 15, 25, 50, 75 and 100 channel numbers at the lower operating band edge and the last 6, 14, 24, 49, 74 and 99 channel numbers at the upper operating band edge shall not be used for channel bandwidths of 1.4, 3, 5, 10, 15 and 20 MHz respectively.

6 Transmitter characteristics

6.1 General

General test conditions for transmitter tests are given in Clause 4, including interpretation of measurement results and configurations for testing. BS configurations for the tests are defined in Clause 4.5, while Annex H provides an informative description of E-UTRAN test cases.

6.1.1 E-UTRA Test Models

The set-up of physical channels for transmitter tests shall be according to one of the E-UTRA test models (E-TM) below. A reference to the applicable test model is made within each test.

The following general parameters are used by all E-UTRA test models:

- The test models are defined for a single antenna port (using $p = 0$); 1 code word ($q = 0$), 1 layer, precoding is not used
- Duration is 10 subframes (10 ms)
- Normal CP
- Virtual resource blocks of localized type, no intra-subframe hopping for PDSCH
- UE-specific reference signals are not used

Power settings of physical channels are defined by physical channel EPRE relative to the EPRE of the RS. The relative accuracy of the physical channel EPRE as referred to the EPRE of the RS shall have a tolerance of ± 0.5 dB.

For E-UTRA TDD, test models are derived based on the uplink/downlink configuration 3 and special subframe configuration 8 defined in TS36.211, i.e. as showing in the table 6.1.1-1. Number of frames for the test models is 2.

Table 6.1.1-1: Configurations of TDD eNB test models

Downlink-to-Uplink Switch-point periodicity	Number of UL/DL sub-frames per half frame (10 ms)		DwPTS	GP	UpPTS
	DL	UL			
10ms	6	3	$24144 \cdot T_s$	$2192 \cdot T_s$	$4384 \cdot T_s$

6.1.1.1 E-UTRA Test Model 1.1 (E-TM1.1)

This model shall be used for tests on:

- BS output power
- Unwanted emissions
 - Occupied bandwidth
 - ACLR
 - Operating band unwanted emissions
 - Transmitter spurious emissions
- Transmitter intermodulation
- RS absolute accuracy

Table 6.1.1.1-1: Physical channel parameters of E-TM1.1

Parameter	1.4 MHz	3 MHz	5 MHz	10 MHz	15 MHz	20 MHz
Reference, Synchronisation Signals						
RS boosting, $P_B = E_B/E_A$	1	1	1	1	1	1
Synchronisation signal EPRE / E_{RS} [dB]	0.000	0.000	0.000	0.000	0.000	0.000
Reserved EPRE / E_{RS} [dB]	-inf	-inf	-inf	-inf	-inf	-inf
PBCH						
PBCH EPRE / E_{RS} [dB]	0.000	0.000	0.000	0.000	0.000	0.000
Reserved EPRE / E_{RS} [dB]	-inf	-inf	-inf	-inf	-inf	-inf
PCFICH						
# of symbols used for control channels	2	1	1	1	1	1
PCFICH EPRE / E_{RS} [dB]	3.222	0	0	0	0	0
PHICH						
# of PHICH groups	1	1	1	2	2	3
# of PHICH per group	2	2	2	2	2	2
PHICH BPSK symbol power / E_{RS} [dB]	-3.010	-3.010	-3.010	-3.010	-3.010	-3.010
PHICH group EPRE / E_{RS} [dB]	0	0	0	0	0	0
PDCCH						
# of available REGs	23	23	43	90	140	187
# of PDCCH	2	2	2	5	7	10
# of CCEs per PDCCH	1	1	2	2	2	2
# of REGs per CCE	9	9	9	9	9	9
# of REGs allocated to PDCCH	18	18	36	90	126	180
# of <NIL> REGs added for padding	5	5	7	0	14	7
PDCCH REG EPRE / E_{RS} [dB]	0.792	2.290	1.880	1.065	1.488	1.195
<NIL> REG EPRE / E_{RS} [dB]	-inf	-inf	-inf	-inf	-inf	-inf
PDSCH						
# of QPSK PDSCH PRBs which are boosted	6	15	25	50	75	100
PRB $P_A = E_A/E_{RS}$ [dB]	0	0	0	0	0	0
# of QPSK PDSCH PRBs which are de-boosted	0	0	0	0	0	0
PRB $P_A = E_A/E_{RS}$ [dB]	n.a.	n.a.	n.a.	n.a.	n.a.	n.a.

6.1.1.2 E-UTRA Test Model 1.2 (E-TM1.2)

This model shall be used for tests on:

- Unwanted emissions
 - ACLR
 - Operating band unwanted emissions

Table 6.1.1.2-1: Physical channel parameters of E-TM1.2

Parameter	1.4 MHz	3 MHz	5 MHz	10 MHz	15 MHz	20 MHz
Reference, Synchronisation Signals						
RS boosting, $P_B = E_B/E_A$	1	1	1	1	1	1
Synchronisation signal EPRE / E_{RS} [dB]	0.000	-4.730	-4.730	-4.730	-4.730	-4.730
Reserved EPRE / E_{RS} [dB]	-inf	-inf	-inf	-inf	-inf	-inf
PBCH						
PBCH EPRE / E_{RS} [dB]	0.000	-4.730	-4.730	-4.730	-4.730	-4.730
Reserved EPRE / E_{RS} [dB]	-inf	-inf	-inf	-inf	-inf	-inf
PCFICH						
# of symbols used for control channels	2	1	1	1	1	1

PCFICH EPRE / E _{RS} [dB]	3.222	0	0	0	0	0
PHICH						
# of PHICH groups	1	1	1	2	2	3
# of PHICH per group	2	2	2	2	2	2
PHICH BPSK symbol power / E _{RS} [dB]	-3.010	-3.010	-3.010	-3.010	-3.010	-3.010
PHICH group EPRE / E _{RS} [dB]	0	0	0	0	0	0
PDCCH						
# of available REGs	23	23	43	90	140	187
# of PDCCH	2	2	2	5	7	10
# of CCEs per PDCCH	1	1	2	2	2	2
# of REGs per CCE	9	9	9	9	9	9
# of REGs allocated to PDCCH	18	18	36	90	126	180
# of dummy REGs added for padding	5	5	7	0	14	7
PDCCH REG EPRE / E _{RS} [dB]	0.792	2.290	1.880	1.065	1.488	1.195
<NIL> REG EPRE / E _{RS} [dB]	-inf	-inf	-inf	-inf	-inf	-inf
PDSCH						
# of QPSK PDSCH PRBs which are boosted	2	6	10	20	30	40
PRB P _A = E _A /E _{RS} [dB]	3 (*)	3	3	3	3	3
# of QPSK PDSCH PRBs which are de-boosted	4	9	15	30	45	60
PRB P _A = E _A /E _{RS} [dB]	-2.990 (*)	-4.730	-4.730	-4.730	-4.730	-4.730

Note (*): in subframes containing PBCH or synchronisation signal REs, no PRB boosting/deboosting shall be applied, i.e. PRB P_A = E_A/E_{RS} = 0 [dB]

Table 6.1.1.2-2: Numbers (n_{PRB}) of the boosted PRBs (FDD)

	Subframe 0	Subframe 1	Subframe 2	Subframe 3	Subframe 4	Subframe 5	Subframe 6	Subframe 7	Subframe 8	Subframe 9
1.4 MHz	N.A.	1 3	1 3	2 3	2 5	N.A.	0 2	0 5	2 5	1 5
3 MHz	0 1 2 11 12 13	0 4 10 11 12 13	0 3 5 6 11 13	0 1 4 5 7 12	0 2 3 4 9 10	1 2 3 11 12 14	4 6 8 11 13 14	2 5 6 12 13 14	0 3 4 7 8 11	1 3 4 5 11 12
5 MHz	0 1 3 6 7 8 16 18 20 21	0 1 4 5 9 10 12 17 18 24	0 1 2 12 13 14 19 20 23 24	0 5 8 12 13 15 17 20 21 24	0 4 6 7 12 13 15 16 22 23	0 1 2 3 8 16 18 21 22 24	1 3 5 7 9 10 12 15 21 22	0 1 2 3 7 10 14 18 20 21	1 4 8 9 10 12 15 16 18 20	1 2 3 5 6 9 10 13 16 17
10 MHz	1 2 7 8 9 10 11 16 20 31 32 33 35 36 39 40 42 46 47 48	5 6 7 9 11 15 20 21 22 24 25 27 34 35 36 37 40 44 46 49	3 5 11 12 14 17 18 19 20 22 26 27 28 29 31 34 38 41 42 49	1 2 3 5 8 14 16 22 23 26 28 30 32 34 38 41 42 45 46 47	0 3 6 7 8 9 10 12 13 16 18 21 23 31 33 41 42 45 46 47	0 2 3 4 5 7 9 10 11 12 15 19 20 28 29 30 31 34 36 48	0 1 4 6 8 9 10 16 17 19 20 21 24 29 30 31 35 37 38 47	2 3 4 5 6 9 10 12 16 17 19 22 24 25 26 30 34 37 42 48	7 9 14 15 16 21 22 28 30 31 32 34 35 41 42 43 44 46 48 49	11 13 16 17 18 21 24 27 28 29 30 32 37 38 40 42 45 47 48 49
15 MHz	0 1 2 3 5 7 8 9 12 18 19 20 21 23 24 25 29 30 31 32 33 42 47 48 49 63 65 68 71 73	0 1 3 4 5 6 7 11 18 20 21 24 26 30 31 38 46 47 49 50 51 53 54 57 60 67 68 70 73 74	2 11 12 15 18 21 22 24 25 26 29 32 33 34 42 45 46 47 50 51 52 54 58 59 60 64 68 70 72 74	2 3 4 7 9 11 12 15 17 20 24 27 33 34 35 39 42 43 45 46 48 56 59 60 62 67 70 71 73 74	4 5 6 8 13 17 22 25 27 29 31 32 33 34 35 41 44 46 48 50 52 56 59 60 64 67 69 70 71 74	0 2 3 4 7 8 18 20 23 24 25 27 29 42 43 45 47 49 50 54 56 60 62 65 66 67 70 71 72 73	2 11 14 15 18 25 26 28 30 31 32 33 36 37 38 39 41 43 45 50 53 54 58 59 62 65 67 68 70 71	3 4 7 12 19 23 24 26 27 28 30 33 34 35 41 42 49 53 54 58 59 60 61 62 65 67 69 70 71 73	0 3 8 9 10 13 14 15 17 18 19 22 23 24 25 26 27 32 37 39 47 50 53 56 61 63 69 71 73 74	0 3 7 8 11 13 14 16 18 23 25 30 32 35 44 46 47 48 53 55 57 59 61 62 64 67 68 69 70 71
20 MHz	0 6 10 13 15 16 20 23 25 28 29 30 31 32 33 39 41 42 44 45 54 56 57 63 66 67 68 76 77 79 82 84 85 88	1 3 7 9 10 13 19 20 21 22 23 25 26 27 30 33 34 35 36 47 49 50 51 53 55 57 60 61 64 68 76 77 80 83	1 2 3 6 8 10 11 15 16 17 19 21 25 26 28 29 32 35 39 41 42 43 44 51 52 54 60 64 69 76 79 81 84 86 88	5 7 9 10 12 15 16 21 23 24 27 28 29 30 33 34 35 36 39 47 49 54 55 56 57 64 66 70 72 76 77 80 81 86	2 3 4 5 6 7 14 17 19 21 22 24 26 37 42 44 47 49 51 56 57 62 63 65 67 70 71 73 76 77 81 83 85 86 87	1 2 5 6 8 9 12 13 21 22 25 26 28 32 35 39 40 43 45 46 57 59 61 62 64 66 68 71 73 77 78 84 85 86 93	0 1 2 3 5 8 9 10 12 22 25 26 27 29 31 32 33 36 38 39 43 45 49 53 55 59 62 63 64 71 72 73 75 77 78 81	0 1 3 4 5 7 11 18 19 20 21 26 27 29 30 31 33 35 39 40 41 43 44 46 47 50 53 55 56 62 64 66 67 69 70	2 3 4 7 11 13 15 16 24 25 27 29 35 36 40 43 44 45 46 51 52 55 56 57 63 64 65 68 71 77 78 81 82 83	0 4 7 8 10 11 16 18 22 26 29 32 35 37 43 44 46 47 48 49 53 54 57 59 60 61 64 66 67 69 70 76 78 81

	92 94 95 97 98 99	84 86 87 89 95 99	89 90 93 94 99	87 90 91 92 98 99	89 94 95 97 99	94 95 96 97 99	84 89 97 98	72 74 92 93 98	84 85 86 90 94 98	84 87 89 91 95 96
--	----------------------	----------------------	-------------------	----------------------	-------------------	-------------------	----------------	-------------------	----------------------	----------------------

Table 6.1.1.2-3: Numbers (n_{PRB}) of the boosted PRBs (TDD)

Frame1	Subframe 0	Subframe 1	Subframe 5	Subframe 6	Subframe 7	Subframe 8	Subframe 9
1.4 MHz	N.A.	N.A.	N.A.	N.A.	4 5	2 5	0 3
3 MHz	0 1 3 11 12 14	1 2 3 11 12 14	0 1 2 3 11 13	1 3 11 12 13 14	1 4 8 10 11 12	1 6 8 9 11 12	0 2 3 4 5 6
5 MHz	1 2 5 8 17 18 19 21 23 24	1 3 5 6 7 17 19 20 23 24	0 3 4 5 8 17 18 19 21 22	2 3 6 7 8 17 18 19 20 24	1 2 11 13 15 17 18 19 20 21	1 2 4 5 6 7 8 9 10 12	1 3 4 8 10 12 16 19 20 22
10 MHz	2 4 6 7 10 11 13 17 18 19 34 35 37 38 41 42 46 47 48 49	1 3 6 7 9 11 14 15 17 18 19 28 29 30 35 37 38 39 43 44	3 4 5 6 10 11 12 14 16 18 30 34 35 36 37 39 40 41 43 48	2 4 6 7 8 9 10 13 14 16 19 20 21 29 32 34 39 41 44 45	2 4 7 12 14 16 20 21 24 26 28 29 34 41 43 44 45 46 47 48	2 5 8 9 11 12 13 16 18 21 22 23 27 29 30 31 32 33 46 47	1 4 7 11 12 13 14 15 20 21 27 31 34 37 38 41 42 46 48 49
15 MHz	3 5 6 9 10 13 15 17 20 23 25 26 27 28 29 33 44 45 51 53 56 57 58 61 63 66 70 71 73 74	1 5 7 8 9 10 11 13 15 19 21 24 26 42 45 46 51 52 53 55 56 57 58 59 60 61 62 64 65 72	3 4 6 7 9 10 11 13 14 15 16 20 22 24 25 28 31 32 33 43 49 52 55 58 61 62 66 67 70 73	3 4 7 8 12 13 14 16 18 19 20 22 24 27 28 30 32 41 42 43 44 46 49 50 51 65 67 68 69 71	2 6 8 9 10 11 13 16 18 19 21 22 26 30 31 41 45 46 47 48 51 55 57 58 62 63 64 69 73 74	0 2 7 11 13 17 19 20 23 27 28 31 39 40 41 43 45 46 47 48 51 55 57 58 63 65 66 70 71 73	1 2 3 7 8 9 10 12 13 17 19 21 22 23 24 28 30 32 37 40 41 46 48 53 56 58 61 65 69 73
20 MHz	2 4 7 8 12 13 14 18 20 21 23 27 28 31 34 35 37 38 39 44 46 53 56 58 60 68 70 71 74 75 76 78 82 85 87 88 93 95 97 99	4 5 6 7 8 9 10 11 12 14 17 19 20 22 25 27 28 29 32 33 37 38 41 43 53 58 61 65 69 70 73 74 78 79 80 82 83 86 90 97	4 5 9 11 13 14 16 19 22 24 25 27 29 32 33 37 40 42 43 45 46 53 54 57 58 62 66 67 68 69 83 86 88 89 90 91 92 93 95 97	2 3 8 9 10 11 12 14 15 17 18 22 24 26 28 30 35 36 40 41 42 53 55 60 61 62 63 64 65 68 74 77 82 84 85 87 93 97 98 99	0 3 10 13 14 17 23 25 27 28 30 31 36 37 38 40 41 43 49 50 54 55 57 58 60 61 63 64 70 74 76 77 81 84 85 87 88 94 95 98	2 3 4 10 11 12 15 18 21 22 23 26 30 31 32 36 37 39 40 41 42 43 48 50 53 54 56 58 61 64 66 71 72 77 81 82 89 92 98 99	4 9 12 13 17 19 20 21 22 29 31 36 37 39 40 41 42 46 48 49 54 56 57 60 64 66 73 74 75 80 83 86 87 89 90 92 94 96 98 99

Frame2	Subframe 0	Subframe 1	Subframe 5	Subframe 6	Subframe 7	Subframe 8	Subframe 9
1.4 MHz	N.A.	N.A.	N.A.	N.A.	4 5	1 2	1 3
3 MHz	0 1 2 11 12 13	0 1 2 3 13 14	0 1 2 3 12 14	0 1 2 3 11 13	0 3 4 6 10 12	2 6 9 11 13 14	1 5 7 9 13 14
5 MHz	1 2 3 8 17 20 21 22 23 24	1 2 4 5 6 7 16 17 22 23	1 2 4 6 8 16 18 21 23 24	0 3 5 6 7 17 19 20 21 24	2 3 8 10 13 15 16 21 23 24	0 4 6 7 13 14 15 16 19 24	0 2 5 9 14 18 19 21 22 23
10 MHz	1 4 5 6 8 11 12 13 15 17 20 28 30 31 32 42 43 46 48 49	0 1 7 15 18 19 20 21 29 30 32 34 35 37 38 40 42 43 44 47	1 2 5 6 8 9 11 13 14 15 16 18 20 30 32 33 40 41 46 49	6 7 10 11 15 18 19 20 21 28 29 33 35 36 38 40 41 43 44 49	2 4 10 11 18 20 23 24 28 30 32 37 40 41 43 44 45 46 47 48	6 8 9 10 11 14 15 16 18 19 20 21 23 24 27 28 36 37 47 49	2 5 7 8 9 14 16 18 23 30 32 33 34 37 41 42 44 45 46 49
15 MHz	3 7 10 11 15 16 17 23 27 29 30 31 32 42 43 48 49 50 53 54 57 60 62 64 65 66 67 69 72 74	8 9 11 12 14 15 17 22 23 24 27 28 29 31 41 42 45 48 51 54 55 56 62 63 67 68 70 71 73 74	1 3 9 11 13 17 21 22 23 24 25 28 29 46 48 49 51 52 53 54 55 57 61 64 65 67 68 72 73 74	0 2 4 6 10 11 13 14 15 16 17 20 22 23 28 29 43 44 46 47 51 53 54 56 59 61 63 69 71 72	0 1 3 5 9 11 14 15 16 19 24 25 26 27 28 31 33 34 38 40 42 43 46 48 50 52 59 61 67 74	0 4 5 8 9 10 12 13 15 20 22 30 32 33 35 37 38 42 44 45 46 47 48 51 52 55 59 60 66 69	1 5 8 9 10 13 14 15 20 21 23 26 27 28 29 32 33 34 39 43 44 57 60 62 64 65 69 71 72 73
20 MHz	1 4 10 14 15 17 18 19 23 29 30 31 32 33 37 38 39 42 46 55 61 64 65 66 68 69 70 72 73 76 82 83 84 86 89 90 93 95 97 99	0 1 3 5 8 12 14 15 17 19 20 22 23 25 26 28 29 30 37 38 39 45 58 59 62 63 68 71 72 75 78 82 84 85 91 92 93 94 96 98	0 2 4 5 6 7 11 12 13 14 16 19 20 21 27 30 32 33 35 37 41 44 46 53 56 58 60 61 62 64 65 67 68 70 73 79 82 90 92 98	0 2 4 6 7 11 12 13 17 18 19 20 27 28 31 35 37 38 40 43 45 56 57 59 63 68 70 71 77 79 80 82 85 87 89 92 95 96 97 98	3 5 6 7 9 16 20 21 23 24 25 26 31 32 35 37 41 42 43 44 46 48 51 54 59 60 61 62 64 67 76 77 78 79 82 84 86 87 88 95	1 4 7 10 13 18 19 25 26 27 28 30 32 35 37 38 41 46 47 50 51 52 53 54 57 60 62 70 71 73 78 79 81 83 84 87 91 95 98 99	0 1 2 3 5 7 8 10 11 15 19 20 21 24 26 28 31 32 33 34 44 45 54 58 59 61 63 65 67 69 70 77 85 88 89 90 92 94 98 99

6.1.1.3 E-UTRA Test Model 2 (E-TM2)

This model shall be used for tests on:

- Total power dynamic range (lower OFDM symbol power limit at min power),
 - EVM of single 64QAM PRB allocation (at min power)
 - Frequency error (at min power)

Table 6.1.1.3-1: Physical channel parameters of E-TM2

Parameter	1.4 MHz	3 MHz	5 MHz	10 MHz	15 MHz	20 MHz
Reference, Synchronisation Signals						
RS boosting, $P_B = E_B/E_A$	1	1	1	1	1	1
Synchronisation signal EPRE / E_{RS} [dB]	0.000	0.000	0.000	0.000	0.000	0.000
Reserved EPRE / E_{RS} [dB]	-inf	-inf	-inf	-inf	-inf	-inf
PBCH						
PBCH EPRE / E_{RS} [dB]	0.000	0.000	0.000	0.000	0.000	0.000
Reserved EPRE / E_{RS} [dB]	-inf	-inf	-inf	-inf	-inf	-inf
PCFICH						
# of symbols used for control channels	2	1	1	1	1	1
PCFICH EPRE / E_{RS} [dB]	0	0	0	0	0	0
PHICH						
# of PHICH groups	1	1	1	2	2	3
# of PHICH per group	2	2	2	2	2	2
PHICH BPSK symbol power / E_{RS} [dB]	-3.010	-3.010	-3.010	-3.010	-3.010	-3.010
PHICH group EPRE / E_{RS} [dB]	0	0	0	0	0	0
PDCCH						
# of available REGs	23	23	43	90	140	187
# of PDCCH	1	1	1	1	1	1
# of CCEs per PDCCH	1	1	2	2	2	2
# of REGs per CCE	9	9	9	9	9	9
# of REGs allocated to PDCCH	9	9	18	18	18	18
# of <NIL> REGs added for padding	14	14	25	72	122	169
PDCCH REG EPRE / E_{RS} [dB]	0	0	0	0	0	0
<NIL> REG EPRE / E_{RS} [dB]	-inf	-inf	-inf	-inf	-inf	-inf
PDSCH						
# of 64QAM PDSCH PRBs within a slot for which EVM is measured	1	1	1	1	1	1
PRB $P_A = E_A/E_{RS}$ [dB]	0	0	0	0	0	0
# of PDSCH PRBs which are not allocated	5	14	24	49	74	99
PRB $P_A = E_A/E_{RS}$ [dB]	-inf	-inf	-inf	-inf	-inf	-inf

Table 6.1.1.3-2: Numbers (n_{PRB}) of the allocated PRB (64QAM) (FDD)

	Subframe 0	Subframe 1	Subframe 2	Subframe 3	Subframe 4	Subframe 5	Subframe 6	Subframe 7	Subframe 8	Subframe 9
1.4 MHz	4	1	1	2	5	3	0	0	5	4
3 MHz	13	11	13	5	9	14	6	13	0	1
5 MHz	8	17	21	8	22	2	9	14	0	13
10 MHz	16	36	19	26	42	30	17	48	9	0

15 MHz	32	46	18	72	22	4	31	58	27	3
20 MHz	63	34	44	7	94	2	97	19	56	32

Table 6.1.1.3-3: Numbers (n_{PRB}) of the allocated PRB (64QAM) (TDD)

Frame1	Subframe 0	Subframe 1	Subframe 5	Subframe 6	Subframe 7	Subframe 8	Subframe 9
1.4 MHz	4	5	5	2	0	0	3
3 MHz	10	14	12	5	0	1	7
5 MHz	17	24	21	8	1	2	12
10 MHz	35	49	42	17	2	4	25
15 MHz	53	74	63	26	3	6	38
20 MHz	71	99	85	35	4	8	51

Frame2	Subframe 0	Subframe 1	Subframe 5	Subframe 6	Subframe 7	Subframe 8	Subframe 9
1.4 MHz	4	5	2	1	3	1	4
3 MHz	11	14	5	3	8	3	11
5 MHz	18	23	8	5	13	5	19
10 MHz	37	46	17	10	26	11	38
15 MHz	56	70	25	15	40	17	57
20 MHz	75	93	34	20	53	23	76

6.1.1.4 E-UTRA Test Model 3.1 (E-TM3.1)

This model shall be used for tests on:

- Output power dynamics
 - Total power dynamic range (upper OFDM symbol power limit at max power with all 64QAM PRBs allocated)
- Transmitted signal quality
 - Frequency error
 - EVM for 64QAM modulation (at max power)

Table 6.1.1.4-1: Physical channel parameters of E-TM3.1

Parameter	1.4 MHz	3 MHz	5 MHz	10 MHz	15 MHz	20 MHz
Reference, Synchronisation Signals						
RS boosting, $P_B = E_B/E_A$	1	1	1	1	1	1
Synchronisation signal EPRE / E_{RS} [dB]	0.000	0.000	0.000	0.000	0.000	0.000
Reserved EPRE / E_{RS} [dB]	-inf	-inf	-inf	-inf	-inf	-inf
PBCH						
PBCH EPRE / E_{RS} [dB]	0.000	0.000	0.000	0.000	0.000	0.000
Reserved EPRE / E_{RS} [dB]	-inf	-inf	-inf	-inf	-inf	-inf
PCFICH						
# of symbols used for control channels	2	1	1	1	1	1
PCFICH EPRE / E_{RS} [dB]	3.222	0	0	0	0	0
PHICH						
# of PHICH groups	1	1	1	2	2	3
# of PHICH per group	2	2	2	2	2	2
PHICH BPSK symbol power / E_{RS} [dB]	-3.010	-3.010	-3.010	-3.010	-3.010	-3.010

PHICH group EPRE / E_{RS} [dB]	0	0	0	0	0	0
PDCCH						
# of available REGs	23	23	43	90	140	187
# of PDCCH	2	2	2	5	7	10
# of CCEs per PDCCH	1	1	2	2	2	2
# of REGs per CCE	9	9	9	9	9	9
# of REGs allocated to PDCCH	18	18	36	90	126	180
# of <NIL> REGs added for padding	5	5	7	0	14	7
PDCCH REG EPRE / E_{RS} [dB]	0.792	2.290	1.880	1.065	1.488	1.195
<NIL> REG EPRE / E_{RS} [dB]	-inf	-inf	-inf	-inf	-inf	-inf
PDSCH						
# of 64QAM PDSCH PRBs within a slot for which EVM is measured	6	15	25	50	75	100
PRB $P_A = E_A/E_{RS}$ [dB]	0	0	0	0	0	0
# of PDSCH PRBs within a slot for which EVM is not measured (used for power balancing only)	0	0	0	0	0	0
PRB $P_A = E_A/E_{RS}$ [dB]	n.a.	n.a.	n.a.	n.a.	n.a.	n.a.

6.1.1.5 E-UTRA Test Model 3.2 (E-TM3.2)

This model shall be used for tests on:

- Transmitted signal quality
 - Frequency error
 - EVM for 16QAM modulation

Table 6.1.1.5-1: Physical channel parameters of E-TM3.2

Parameter	1.4 MHz	3 MHz	5 MHz	10 MHz	15 MHz	20 MHz
Reference, Synchronisation Signals						
RS boosting, $P_B = E_B/E_A$	1	1	1	1	1	1
Synchronisation signal EPRE / E_{RS} [dB]	0.000	1.573	2.426	2.426	3.005	2.426
Reserved EPRE / E_{RS} [dB]	-inf	-inf	-inf	-inf	-inf	-inf
PBCH						
PBCH EPRE / E_{RS} [dB]	0.000	1.573	2.426	2.426	3.005	2.426
Reserved EPRE / E_{RS} [dB]	-inf	-inf	-inf	-inf	-inf	-inf
PCFICH						
# of symbols used for control channels	2	1	1	1	1	1
PCFICH EPRE / E_{RS} [dB]	3.222	0	0	0	0	0
PHICH						
# of PHICH groups	1	1	1	2	2	3
# of PHICH per group	2	2	2	2	2	2
PHICH BPSK symbol power / E_{RS} [dB]	-3.010	-3.010	-3.010	-3.010	-3.010	-3.010
PHICH group EPRE / E_{RS} [dB]	0	0	0	0	0	0
PDCCH						
# of available REGs	23	23	43	90	140	187
# of PDCCH	2	2	2	5	7	10
# of CCEs per PDCCH	1	1	2	2	2	2
# of REGs per CCE	9	9	9	9	9	9
# of REGs allocated to PDCCH	18	18	36	90	126	180
# of <NIL> REGs added for padding	5	5	7	0	14	7
PDCCH REG EPRE / E_{RS} [dB]	0.792	2.290	1.880	1.065	1.488	1.195
<NIL> REG EPRE / E_{RS} [dB]	-inf	-inf	-inf	-inf	-inf	-inf
PDSCH						

# of 16QAM PDSCH PRBs within a slot for which EVM is measured	4	7	15	30	50	60
PRB $P_A = E_A/E_{RS}$ [dB]	-3 (*)	-3	-3	-3	-3	-3
# of QPSK PDSCH PRBs within a slot for which EVM is not measured (used for power balancing only)	2	8	10	20	25	40
PRB $P_A = E_A/E_{RS}$ [dB]	3.005 (*)	1.573	2.426	2.426	3.005	2.426

Note (*): in subframes containing PBCH or synchronisation signal REs, no PRB boosting/deboosting shall be applied, i.e. PRB $P_A = E_A/E_{RS} = 0$ [dB]

Table 6.1.1.5-2: Numbers (n_{PRB}) of the 16QAM PRBs (FDD)

	Subframe 0	Subframe 1	Subframe 2	Subframe 3	Subframe 4	Subframe 5	Subframe 6	Subframe 7	Subframe 8	Subframe 9
1.4 MHz	1 3 4 5	1 2 3 5	0 1 3 4	1 2 3 5	0 2 3 5	0 1 2 4	0 1 2 5	0 2 4 5	1 2 3 5	0 1 3 5
3 MHz	0 1 2 3 11 12 13	0 3 4 10 11 12 13	0 2 3 5 6 11 13	0 1 4 5 7 10 12	0 2 3 4 9 10 13	0 1 2 3 11 12 14	4 5 6 8 11 13 14	2 5 6 9 12 13 14	0 3 4 7 8 9 11	1 2 3 4 5 11 12
5 MHz	0 1 3 4 6 7 8 16 17 18 19 20 21 23 24	0 1 2 3 4 5 6 9 10 12 13 17 18 20 24	0 1 2 3 7 8 9 10 12 13 14 19 20 23 24	0 5 6 8 10 11 12 13 15 17 18 20 21 22 24	0 1 2 4 6 7 12 13 14 15 16 17 22 23 24	0 1 2 3 4 6 7 8 16 17 18 21 22 23 24	1 3 4 5 7 9 10 11 12 13 14 15 21 22 24	0 1 2 3 4 7 8 10 13 14 18 19 20 21 24	1 4 8 9 10 11 12 13 15 16 18 20 22 23 24	1 2 3 4 5 6 9 10 11 12 13 16 17 21 23
10 MHz	1 2 3 4 5 6 7 8 9 10 11 15 16 17 20 21 28 30 31 32 33 35 36 39 40 42 44 46 47 48	0 1 2 4 5 6 7 9 10 11 13 15 18 20 21 22 24 25 27 28 29 34 35 36 37 40 43 44 46 49	0 1 3 4 5 6 7 11 12 14 17 18 19 20 21 22 24 25 26 27 28 29 31 32 34 38 41 42 45 49	0 1 2 3 5 6 8 12 14 15 16 17 18 22 23 26 28 29 30 32 34 35 38 39 40 41 42 45 46 47	0 3 6 7 8 9 10 12 13 15 16 17 18 21 23 25 28 31 33 37 38 39 41 42 44 45 46 47 48 49	0 2 3 4 5 7 9 10 11 12 13 14 15 19 20 28 29 30 31 34 36 37 38 39 40 42 44 45 48 49	0 1 3 4 5 6 8 9 10 13 14 16 17 18 19 20 21 23 22 24 25 24 29 30 31 32 35 37 38 39 40 47 48	0 1 2 3 4 5 6 7 9 10 12 14 16 17 18 19 22 24 25 26 27 28 30 31 32 34 37 42 45 48	2 5 7 8 9 10 11 14 15 16 17 21 22 27 28 29 30 31 32 34 35 37 38 41 42 43 44 46 48 49	1 3 6 9 11 13 15 16 17 18 21 24 25 26 27 28 29 30 32 34 37 38 39 40 41 42 45 47 48 49
15 MHz	0 1 2 3 5 6 7 8 9 12 14 16 17 18 19 20 21 23 24 25 26 28 29 30 31 32 33 41 42 45 47 48 49 50 52 53 56 57 60 62 63 64 65 67 68 69 70 71 72 73	0 1 2 3 4 5 6 7 8 11 18 20 21 24 25 26 27 29 30 31 33 36 37 38 39 40 43 45 46 47 48 49 50 51 53 54 55 57 58 59 60 61 65 67 68 69 70 71 73 74	1 2 3 4 9 11 12 13 14 15 17 18 20 21 22 24 25 26 28 29 31 32 33 34 40 42 43 44 45 46 47 48 50 51 52 54 56 58 59 60 61 62 63 64 68 70 71 72 73 74	2 3 4 6 7 9 11 12 14 15 17 18 20 22 24 25 27 28 29 30 31 33 34 35 38 39 40 42 43 45 46 47 48 49 55 56 59 60 61 62 63 65 66 67 68 69 70 71 73 74	2 4 5 6 8 10 13 15 16 17 18 20 22 24 25 26 27 28 29 30 31 32 33 34 35 38 40 41 44 45 46 47 50 51 53 54 56 58 60 61 62 63 64 65 66 67 68 69 70 71 72 73 74	0 2 3 4 5 7 8 11 12 14 16 18 20 22 23 24 25 27 28 29 30 31 33 42 33 36 37 38 39 41 42 43 45 46 50 52 54 56 58 60 61 62 63 64 65 66 67 68 69 70 71 72 73	0 1 2 3 9 11 12 14 15 17 18 20 23 25 26 28 29 30 31 32 33 36 37 38 39 41 42 43 45 46 50 52 53 54 57 58 59 60 61 62 63 64 65 67 68 70 71 72 73 74	0 1 3 4 5 6 7 8 11 12 14 19 20 21 23 24 26 27 28 30 31 33 34 35 38 40 41 42 44 45 46 49 51 52 53 54 55 58 59 60 61 62 63 65 67 69 70 71 72 73	0 1 2 3 7 8 9 10 12 13 14 15 17 18 19 21 22 23 24 25 26 27 28 29 32 33 34 36 37 39 40 43 46 47 48 49 50 53 54 56 61 62 63 66 68 69 71 72 73 74	0 1 3 7 8 11 13 14 16 18 19 20 21 22 23 25 27 28 29 30 32 34 35 36 40 41 42 43 44 45 46 47 48 50 51 53 54 55 62 63 64 66 67 68 69 70 71
20 MHz	0 1 4 6 7 8 9 10 11 13 14 15 16 20 21 22 23 25 26 28 29 30 31 32 33 34 36 39 41 42 44 45 54 56 57 58 60 61 63 66 67 68 72 75 76 77 79 81 82 84 85 87 88 91 92 94 95 97 98 99	1 3 5 6 7 9 10 13 17 19 20 21 22 23 24 25 26 27 28 30 32 33 34 35 36 39 41 47 48 49 50 51 53 54 55 57 58 59 60 61 64 65 67 68 75 76 77 79 80 81 83 84 86 87 89 90 91 93 95 99	0 1 2 3 6 8 10 11 15 16 17 19 21 22 23 25 26 28 29 30 32 33 35 38 39 40 41 42 43 44 46 49 51 52 53 54 57 59 60 62 63 64 65 67 69 71 72 73 76 79 81 84 86 85 86 87 88 89 90 92 93 94 99	5 6 7 9 10 12 14 15 16 17 21 22 23 24 27 28 29 30 31 33 34 35 36 37 39 41 44 45 47 49 50 53 54 55 56 57 59 64 65 66 68 70 72 77 78 79 80 81 84 85 86 87 90 91 92 94 95 97 98 99	0 2 3 4 5 6 7 11 12 14 15 17 19 21 22 24 26 32 36 37 40 42 43 44 47 48 49 50 51 54 56 57 60 62 63 65 66 67 70 71 73 76 77 78 79 84 85 86 87 89 91 94 95 96 97 98 99 99	1 2 5 6 8 9 11 12 13 15 21 22 25 26 27 28 29 30 31 32 34 35 38 39 40 41 43 44 45 46 53 57 58 59 61 62 63 64 65 66 68 69 71 72 73 75 77 78 80 82 83 84 85 86 93 94 95 96 97 99	0 1 2 3 5 8 9 10 12 13 14 16 22 25 26 27 28 29 31 32 33 34 36 37 38 39 43 40 41 43 44 45 46 48 49 52 53 55 59 61 62 63 64 70 71 72 73 74 75 77 78 80 81 82 84 86 89 90 91 93 97 98 99	0 1 3 4 5 7 8 10 11 15 18 19 20 21 26 27 29 30 31 33 35 37 38 39 40 41 43 44 45 46 48 49 52 50 52 53 55 56 58 60 62 64 65 66 67 69 70 71 72 73 74 81 82 83 84 85 86 86 92 93 94 96 98 99	2 3 4 5 7 9 11 13 15 16 17 21 23 24 25 27 28 29 31 33 35 36 40 42 43 44 45 46 48 49 51 52 53 54 55 56 57 59 61 63 64 65 68 71 76 77 78 81 82 83 84 85 86 87 90 91 93 94 98 99	0 3 4 6 7 8 10 11 13 16 18 21 22 23 25 26 28 29 32 35 36 37 38 43 44 46 47 48 49 53 54 57 61 64 66 67 68 69 70 72 76 77 78 80 81 82 83 84 86 87 88 89 91 92 94 95 96

Table 6.1.1.5-3: Numbers (n_{PRB}) of the 16QAM PRBs (TDD)

Frame1	Subframe 0	Subframe 1	Subframe 5	Subframe 6	Subframe 7	Subframe 8	Subframe 9
1.4 MHz	0 3 4 5	1 2 3 4	0 1 2 4	0 1 3 4	0 2 4 5	2 3 4 5	1 2 4 5
3 MHz	0 1 2 3 11 12 14	0 1 2 3 11 12 13	0 1 2 3 11 12 14	0 1 2 3 11 12 13	1 2 7 8 10 13 14	2 3 4 6 8 13 14	0 3 6 8 9 10 14
5 MHz	1 2 3 4 5 6 7 8 17 18 19 20 21 23 24	0 2 3 4 5 6 7 8 17 18 19 20 21 22 24	1 2 3 4 5 6 7 8 16 17 18 19 20 21 22	1 2 3 4 5 6 7 8 16 17 20 21 22 23 24	1 2 4 6 7 8 9 11 14 15 16 18 21 23 24	0 2 3 5 6 7 10 13 15 16 17 19 20 21 24	0 2 3 4 6 7 8 13 14 15 16 19 21 23 24
10 MHz	1 2 3 4 6 7 9 10 11 13 14 15 17 18 19 28 29 30 34 35 37 38 39 41 42 44 46 47 48 49	2 3 4 5 6 7 8 9 10 11 12 13 14 16 17 18 19 21 30 32 34 35 36 37 39 40 41 43 45 48	2 4 5 6 7 8 9 11 12 13 14 16 18 20 21 28 29 30 31 32 33 34 41 43 44 45 46 47 48 49	1 4 5 6 7 8 11 12 13 14 15 17 19 20 21 28 29 30 31 32 34 37 38 41 42 44 46 47 48 49	0 1 2 5 6 7 8 11 13 14 15 16 18 20 21 24 25 27 30 32 34 35 37 38 40 41 43 46 47 49	2 4 5 6 7 9 10 11 15 18 19 20 21 24 25 26 28 29 30 32 33 35 36 38 40 41 43 44 48 49	2 5 6 7 8 9 10 11 14 15 16 18 19 20 21 23 27 28 30 32 33 34 37 41 42 44 45 46 47 49
15 MHz	1 3 4 5 6 7 8 9 10 11 13 15 16 17 19 20 21 22 23 24 25 26 27 28 29 33 42 44 45 46 51 52 53 55 56 57 58 59 60 61 62 63 64 65 66 70 71 72 73 74	2 3 4 6 7 8 9 10 11 12 13 14 15 16 18 19 20 22 24 25 27 28 30 31 32 41 42 43 44 45 46 48 49 50 51 52 55 58 61 62 63 65 66 67 68 69 70 71 73 74	0 1 2 3 6 7 8 9 10 11 12 13 16 17 18 19 20 21 22 23 24 26 27 28 30 31 32 41 42 43 45 46 43 45 46 47 48 51 53 55 56 57 58 61 62 63 64 65 66 69 70 71 73 74	3 7 8 9 10 11 12 13 14 15 16 17 22 23 24 27 28 29 30 31 32 41 42 43 45 46 48 49 50 53 54 55 56 57 58 60 61 62 63 64 65 66 67 68 69 70 71 72 73 74	0 1 2 3 4 6 9 10 11 13 14 15 16 17 20 21 22 23 24 25 28 29 34 37 43 44 46 47 48 49 51 52 53 54 55 57 59 61 62 63 64 65 67 68 69 70 71 72 73 74	0 1 3 4 5 8 9 10 11 12 13 14 15 16 19 20 22 24 25 26 27 28 31 32 33 34 35 36 37 38 40 42 43 44 45 46 47 48 50 51 52 55 56 59 60 61 66 67 69 74	1 3 4 5 7 8 9 10 12 13 14 15 16 17 19 20 21 23 26 27 28 29 30 31 32 33 34 36 37 38 39 42 43 44 45 46 52 53 57 58 59 60 62 63 64 65 69 71 72 73
20 MHz	2 4 5 6 7 8 9 10 11 12 13 14 17 18 19 20 21 22 23 25 27 28 29 31 32 33 34 35 37 38 39 43 44 46 53 56 58 60 61 68 69 70 71 73 74 75 76 78 79 80 82 83 85 86 87 88 93 95 97 99	2 4 5 8 9 10 11 12 13 14 16 17 18 19 22 24 25 26 27 29 30 32 33 36 37 38 40 41 42 43 45 46 53 54 55 57 58 60 62 64 65 66 67 68 69 74 78 82 83 84 86 88 89 90 91 92 93 95 97 99	0 2 3 4 9 10 11 12 13 14 15 17 18 21 22 23 24 25 26 27 28 30 31 32 35 36 37 38 40 41 42 43 53 54 55 57 60 61 63 64 65 66 68 70 74 76 77 81 82 84 85 87 88 89 93 94 95 97 98 99	1 4 9 10 12 13 14 15 17 18 19 20 21 22 23 29 30 31 32 33 36 37 39 40 41 42 43 46 53 54 55 56 57 58 60 61 64 66 68 69 71 72 73 74 75 80 82 83 84 86 87 89 90 92 93 94 95 96 98 99	0 1 3 4 5 7 8 12 13 14 15 17 19 20 22 23 25 26 28 30 31 33 35 37 38 39 41 45 48 49 50 51 58 59 62 63 65 67 68 69 70 71 72 73 75 76 78 82 84 85 86 89 90 91 92 93 94 96 97 98	0 2 4 5 6 7 11 12 13 14 16 17 18 19 20 21 23 27 28 30 31 32 35 37 38 40 43 44 45 46 47 50 51 53 56 57 58 59 60 61 62 63 64 65 68 70 71 73 77 79 80 82 85 87 89 92 95 96 97 98	1 3 4 5 6 7 9 10 13 16 18 20 21 24 25 26 27 28 30 31 32 35 37 38 41 42 43 44 46 47 48 50 51 52 53 54 57 59 60 61 62 64 67 70 71 73 76 77 78 79 81 82 84 86 87 88 91 95 98 99

Frame2	Subframe 0	Subframe 1	Subframe 5	Subframe 6	Subframe 7	Subframe 8	Subframe 9
1.4 MHz	0 2 4 5	1 2 4 5	0 1 3 4	0 2 3 5	0 1 2 4	1 2 3 4	1 2 3 5
3 MHz	0 1 2 3 12 13 14	0 1 2 3 11 12 13	1 2 3 11 12 13 14	0 1 2 11 12 13 14	2 4 7 8 9 10 11	0 1 3 4 5 13 14	0 4 6 8 9 11 12
5 MHz	0 2 3 4 5 6 7 16 17 18 19 20 21 22 23	0 1 2 3 4 5 7 8 16 17 18 19 20 23 24	1 2 3 4 5 7 8 16 17 18 20 21 22 23 24	0 1 3 4 5 7 8 16 17 18 19 20 21 22 24	0 1 3 6 7 9 12 14 17 18 20 21 22 23 24	2 3 4 5 6 7 9 11 12 14 15 17 18 21 24	0 1 3 4 5 8 10 11 12 14 16 17 20 22 24
10 MHz	0 1 2 6 7 8 9 11 13 14 15 16 19 29 30 32 34 35 36 37 38 39 41 42 43 44 45 47 48 49	0 2 3 4 6 7 8 9 10 11 12 15 16 17 18 19 20 29 31 33 34 35 36 37 42 45 46 47 48 49	0 1 2 3 5 6 7 8 9 10 13 14 15 16 18 20 21 28 29 30 31 32 34 35 39 40 41 42 44 46	1 2 3 4 5 6 8 9 10 11 12 13 15 16 17 18 19 21 30 35 38 39 40 41 42 43 46 47 48 49	1 2 3 5 6 13 14 15 16 17 19 20 23 25 26 27 29 30 31 32 33 35 38 39 40 41 43 44 47 49	0 1 2 5 9 12 13 14 16 17 18 22 25 26 27 28 29 30 31 33 35 36 38 39 41 42 44 45 47 49	0 1 2 3 4 5 7 8 9 10 12 13 14 15 16 18 22 27 28 29 30 31 32 33 34 42 43 45 46 49
15 MHz	0 1 2 3 4 5 6 7 8 10 11 14 15 16 18 19 20 21 23 24 25 26 27 28 31 32 33 41 43 44 45 46 47 48 50 52 53 55 57 58 59 61 63 65 66 67 68 69 71 74	1 2 3 4 5 6 7 8 9 10 11 13 14 15 16 18 20 21 22 23 27 28 29 30 33 42 43 45 46 47 49 50 51 54 55 56 58 59 60 61 64 65 66 68 69 70 71 72 73 74	0 1 2 4 5 6 7 8 9 10 11 12 13 14 15 16 18 20 22 24 25 26 29 32 33 44 45 46 49 50 51 52 55 56 57 58 59 60 61 63 64 65 66 68 69 70 71 72 73 74	0 1 2 3 4 5 6 7 8 9 10 11 13 14 15 16 17 18 19 21 23 24 26 29 30 33 41 42 45 46 47 49 50 51 53 54 55 56 57 58 60 62 63 66 67 69 71 72 73 74	1 3 4 5 6 7 9 10 11 12 14 15 16 17 18 19 20 21 22 24 26 29 30 32 33 34 35 36 38 39 41 42 44 45 47 48 49 50 52 55 56 57 61 62 63 69 70 71 73 74	1 3 4 6 7 8 10 11 13 14 15 21 22 23 24 26 27 28 29 30 31 32 35 39 40 43 44 45 46 47 48 49 50 51 52 53 54 55 56 57 58 59 60 63 64 65 66 68 71 74	0 1 2 5 6 7 10 11 12 16 17 18 19 22 23 25 27 28 29 30 31 33 34 35 36 37 39 40 43 45 46 47 48 49 50 52 54 55 56 58 61 62 63 64 66 67 68 69 71 73

20 MHz	0 1 2 3 4 5 7 8	0 2 3 4 7 8 10	0 1 2 4 5 6 7	0 1 2 3 4 6 7 8	0 1 2 4 6 8 9	0 1 2 3 7 8 9	3 4 6 7 9 10
	9 10 11 15 17	11 12 13 14	10 11 12 13	9 12 13 15 16	10 11 14 15	13 15 16 21	11 12 13 14
	19 20 21 24	15 16 17 18	14 15 16 18	18 19 20 22	18 19 20 21	23 24 25 29	15 17 19 22
	26 27 28 29	19 20 22 24	19 20 21 23	24 25 27 28	25 29 31 32	30 31 33 34	23 25 26 27
	31 32 33 34	25 27 30 35	24 25 29 32	29 30 32 35	34 36 37 38	36 37 38 39	33 34 37 39
	36 37 44 45	37 39 41 42	33 34 40 42	39 40 42 43	40 41 42 47	40 41 42 44	40 41 43 45
	54 56 57 58	44 53 56 57	43 44 45 46	44 57 59 60	52 53 54 57	45 46 47 48	46 47 48 49
	59 60 61 63	59 61 62 63	53 54 55 57	61 63 64 65	58 59 60 62	49 52 53 57	50 53 55 56
	65 67 68 69	66 67 69 70	59 60 61 62	66 67 68 69	63 64 65 67	60 62 63 64	58 60 61 62
	70 73 77 79	73 74 75 76	63 67 68 71	70 72 73 74	68 69 70 71	65 66 69 72	63 65 69 71
	83 85 86 87	77 78 79 80	72 73 75 77	75 76 81 82	73 74 75 76	73 74 75 77	72 73 74 76
	88 89 90 91	81 82 84 85	81 82 84 85	83 84 88 89	77 78 79 80	81 82 83 84	77 78 79 80
	92 93 94 95	86 88 89 90	87 91 92 93	90 92 94 95	84 85 86 87	86 88 89 90	82 83 85 87
	96 98 99	91 92 94 96	95 96 97 98	97 98 99	88 90 92 95	91 92 93 95	91 92 94 95
	98	99		99	97	96 99	

6.1.1.6 E-UTRA Test Model 3.3 (E-TM3.3)

This model shall be used for tests on:

- Transmitted signal quality
 - Frequency error
 - EVM for QPSK modulation

Table 6.1.1.6-1: Physical channel parameters of E-TM3.3

Parameter	1.4 MHz	3 MHz	5 MHz	10 MHz	15 MHz	20 MHz
Reference, Synchronisation Signals						
RS boosting, $P_B = E_B/E_A$	1	1	1	1	1	1
Synchronisation signal EPRE / E_{RS} [dB]	0.000	2.189	2.580	2.427	2.477	2.427
Reserved EPRE / E_{RS} [dB]	-inf	-inf	-inf	-inf	-inf	-inf
PBCH						
PBCH EPRE / E_{RS} [dB]	0.000	2.189	2.580	2.427	2.477	2.427
Reserved EPRE / E_{RS} [dB]	-inf	-inf	-inf	-inf	-inf	-inf
PCFICH						
# of symbols used for control channels	2	1	1	1	1	1
PCFICH EPRE / E_{RS} [dB]	3.222	0	0	0	0	0
PHICH						
# of PHICH groups	1	1	1	2	2	3
# of PHICH per group	2	2	2	2	2	2
PHICH BPSK symbol power / E_{RS} [dB]	-3.010	-3.010	-3.010	-3.010	-3.010	-3.010
PHICH group EPRE / E_{RS} [dB]	0	0	0	0	0	0
PDCCH						
# of available REGs	23	23	43	90	140	187
# of PDCCH	2	2	2	5	7	10
# of CCEs per PDCCH	1	1	2	2	2	2
# of REGs per CCE	9	9	9	9	9	9
# of REGs allocated to PDCCH	18	18	36	90	126	180
# of <NIL> REGs added for padding	5	5	7	0	14	7
PDCCH REG EPRE / E_{RS} [dB]	0.792	2.290	1.880	1.065	1.488	1.195
<NIL> REG EPRE / E_{RS} [dB]	-inf	-inf	-inf	-inf	-inf	-inf
PDSCH						
# of QPSK PDSCH PRBs within a slot for which EVM is measured	3	7	13	25	38	50
PRB $P_A = E_A/E_{RS}$ [dB]	-6 (*)	-6	-6	-6	-6	-6
# of 16QAM PDSCH PRBs within a slot for which EVM is not measured (used for power balancing only)	3	8	12	25	37	50

PRB $P_A = E_A/E_{RS}$ [dB]	2.427 (*)	2.189	2.580	2.427	2.477	2.427
-----------------------------	-----------	-------	-------	-------	-------	-------

Note (*): in subframes containing PBCH or synchronisation signal REs, no PRB boosting/deboosting shall be applied, i.e. PRB $P_A = E_A/E_{RS} = 0$ [dB]

Table 6.1.1.6-2: Numbers (n_{PRB}) of the QPSK PRBs (FDD)

	Subframe 0	Subframe 1	Subframe 2	Subframe 3	Subframe 4	Subframe 5	Subframe 6	Subframe 7	Subframe 8	Subframe 9
1.4 MHz	2 3 5	1 2 3	0 1 3	1 2 3	2 3 5	1 2 5	0 2 5	0 2 5	1 2 5	1 3 5
3 MHz	0 1 2 3 11 12 13	0 3 4 10 11 12 13	0 2 3 5 6 11 13	0 1 4 5 7 10 12	0 2 3 4 9 10 13	0 1 2 3 11 12 14	4 5 6 8 11 13 14	2 5 6 9 12 13 14	0 3 4 7 8 9 11	1 2 3 4 5 11 12
5 MHz	0 1 3 6 7 8 16 17 18 20 21 23 24	0 1 2 4 5 6 9 10 12 17 18 20 24	0 1 2 3 9 10 12 13 14 19 20 23 24	0 5 6 8 10 12 13 15 17 18 20 21 24	0 2 4 6 7 12 13 15 16 17 22 23 24	0 1 2 3 4 6 7 8 16 18 21 22 24	1 3 4 5 7 9 10 11 12 15 21 22 24	0 1 2 3 4 7 10 14 18 19 20 21 24	1 4 8 9 10 11 12 13 15 16 18 20 23	1 2 3 4 5 6 9 10 11 13 16 17 23
10 MHz	1 2 3 5 6 7 8 9 10 11 15 16 20 28 31 32 33 35 36 39 40 42 46 47 48	1 2 4 5 6 7 9 11 15 18 20 21 22 24 25 27 29 34 35 36 37 40 44 46 49	0 3 5 6 11 12 14 17 18 19 20 21 22 24 25 26 27 28 29 31 34 38 41 42 49	0 1 2 3 5 6 8 14 16 18 22 23 26 28 30 32 34 38 39 40 41 42 45 46 47	0 3 6 7 8 9 10 12 13 16 17 18 21 23 25 31 33 37 41 42 45 46 47 48 49	0 2 3 4 5 7 9 10 11 12 13 15 16 17 18 19 20 28 29 30 31 34 36 37 42 44 48 49	0 1 4 5 6 8 9 10 13 16 17 18 19 20 21 24 29 30 31 32 35 37 38 39 47	0 2 3 4 5 6 7 9 10 12 16 17 18 19 22 24 25 26 30 31 34 37 42 45 48	5 7 8 9 14 15 16 21 22 27 28 30 31 32 34 35 37 38 41 42 43 44 46 48 49	3 9 11 13 16 17 18 21 24 27 28 29 30 32 34 37 38 39 40 41 42 45 47 48 49
15 MHz	0 1 2 3 5 6 7 8 9 12 16 17 18 19 20 21 23 24 25 28 29 30 31 32 33 42 47 48 49 53 60 63 65 67 68 70 71 73	0 1 3 4 5 6 7 8 11 18 20 21 24 25 26 27 29 30 31 38 46 47 49 50 51 53 54 55 57 59 60 61 67 68 69 70 73 74	2 11 12 13 15 17 18 21 22 24 25 26 29 31 32 33 34 40 42 45 46 47 50 51 52 54 58 59 60 61 62 63 64 68 70 71 72 74	2 3 4 6 7 9 11 12 15 17 20 24 27 30 33 34 35 38 39 42 43 45 46 48 49 55 56 59 60 61 62 65 67 69 70 71 73 74	4 5 6 8 10 13 17 22 25 26 27 28 29 30 31 32 33 34 35 38 41 44 46 48 50 52 53 54 56 59 60 64 67 69 70 71 73 74	0 2 3 4 7 8 11 14 18 20 23 24 25 27 29 42 43 30 31 32 45 46 47 48 49 50 51 54 56 60 62 63 65 66 67 68 69 70 71 72 73	1 2 9 11 14 15 18 25 26 28 29 30 31 32 33 36 37 38 39 41 43 45 46 50 53 54 58 59 60 62 63 65 67 68 70 71 72 73	3 4 6 7 8 11 12 19 20 23 24 26 27 28 30 33 34 35 40 41 42 46 49 51 53 54 58 59 60 61 62 65 67 69 70 71 72 73	0 1 2 3 7 8 9 10 13 14 15 17 18 19 22 23 24 25 26 27 28 32 36 37 39 46 47 50 53 56 61 62 63 68 69 71 73 74	0 3 7 8 11 13 14 16 18 19 23 25 27 28 29 30 32 35 41 42 44 46 47 48 50 53 55 57 59 61 62 64 66 67 68 69 70 71
20 MHz	0 1 4 6 10 13 14 15 16 20 22 23 25 26 28 29 30 31 32 33 36 39 41 42 44 45 54 56 57 60 63 66 67 68 72 76 77 79 82 84 85 87 88 91 92 94 95 97 98 99	1 3 7 9 10 13 19 20 21 22 23 24 25 26 27 30 33 34 35 36 47 48 49 50 51 53 54 55 57 59 60 61 64 65 67 68 75 76 77 80 81 83 84 86 87 89 90 93 95 99	1 2 3 6 8 10 11 15 16 17 19 21 25 26 28 29 30 32 33 35 38 39 40 41 42 43 44 46 49 51 52 54 60 62 63 64 65 69 70 72 76 72 76 79 81 84 86 88 89 90 93 94 99	5 7 9 10 12 14 15 16 21 22 23 24 27 28 29 30 33 34 35 36 37 39 41 44 45 47 49 54 55 56 57 64 66 68 70 72 76 77 80 81 85 86 87 90 91 92 94 95 98 99	2 3 4 5 6 7 14 15 17 19 21 22 24 26 37 40 42 43 44 47 49 51 54 56 57 60 62 63 65 66 67 70 71 73 76 77 78 81 82 83 84 85 86 87 89 94 95 96 97 99	1 2 5 6 8 9 12 13 21 22 25 26 27 28 29 31 32 34 35 39 40 43 45 46 53 57 59 61 62 63 64 66 68 69 71 73 75 77 78 82 83 84 85 86 93 94 95 96 97 99	0 1 2 3 5 8 9 10 12 13 22 25 26 27 29 31 32 33 36 37 38 39 43 45 48 49 52 53 55 59 62 63 64 71 72 73 74 75 77 78 81 82 84 86 89 91 93 97 98 99	0 1 3 4 5 7 10 11 15 18 19 20 21 26 27 29 30 31 33 35 39 40 41 43 44 46 47 49 50 54 55 56 57 59 63 62 64 65 66 67 69 70 71 72 74 83 84 86 92 93 94 96 98	2 3 4 7 9 11 13 15 16 24 25 27 29 31 33 35 36 40 43 44 45 46 49 51 52 53 54 55 56 57 59 63 64 65 68 71 77 78 81 82 83 84 85 86 90 91 93 94 98 99	0 4 6 7 8 10 11 13 16 18 21 22 23 26 29 32 35 36 37 43 44 46 47 48 49 53 54 57 59 60 61 64 66 67 68 69 70 72 76 78 80 81 82 84 87 89 91 92 95 96

Table 6.1.1.6-3: Numbers (n_{PRB}) of the QPSK PRBs (TDD)

Frame1	Subframe 0	Subframe 1	Subframe 5	Subframe 6	Subframe 7	Subframe 8	Subframe 9
1.4 MHz	1 3 4	1 4 5	0 1 2	0 2 4	2 4 5	0 3 4	1 2 5
3 MHz	0 1 2 3 11 12 14	0 1 2 3 11 12 13	0 1 2 3 11 12 14	0 1 2 3 11 12 13	1 2 7 8 10 13 14	2 3 4 6 8 13 14	0 3 6 8 9 10 14
5 MHz	1 2 3 5 6 8 17 18 19 20 21 23 24	0 1 2 3 4 5 7 8 17 18 19 20 22	1 2 3 5 6 7 8 17 18 19 20 21 24	1 2 3 4 5 6 8 16 17 19 20 22 23	1 2 3 8 12 13 14 17 20 21 22 23 24	1 4 5 6 7 10 11 13 14 15 16 22 23	1 2 4 6 7 8 9 14 16 18 21 23 24
10 MHz	2 3 4 6 7 10 11 13 15 17	1 3 4 5 6 7 9 10 12 14 16	2 3 4 6 7 8 9 10 11 13 14	2 5 8 9 11 12 13 14 16 18	1 4 5 6 7 11 12 13 14 15	0 1 5 6 7 8 11 12 13 15 19	1 2 5 6 8 11 13 14 15 16

	18 19 29 30 34 35 37 38 39 41 42 46 47 48 49	17 28 30 34 35 36 37 38 39 40 41 43 44 48	16 18 19 20 21 29 32 34 39 41 43 44 45 46	20 21 28 29 30 31 32 33 34 42 44 45 46 47 49	17 20 21 26 27 31 32 34 37 38 41 42 46 48 49	20 26 28 29 30 31 32 37 38 42 43 44 47 49	18 20 21 24 25 27 30 32 34 35 37 40 43 46 47
15 MHz	1 3 5 6 9 10 11 13 15 17 20 21 23 24 25 26 27 28 29 33 42 44 45 51 52 53 56 57 58 61 62 63 65 66 70 71 73 74	3 4 5 6 7 8 9 10 13 14 15 16 19 20 21 22 24 25 28 31 32 33 43 45 46 49 51 52 55 58 59 60 61 62 64 66 67 72	3 4 7 8 10 11 12 13 14 16 18 19 20 22 24 25 27 28 30 32 41 42 43 44 45 46 48 50 51 62 65 67 68 69 70 71 73 74	2 6 7 8 9 10 11 13 16 17 18 19 20 21 22 23 26 30 31 41 43 45 46 47 48 51 55 57 58 62 63 64 65 69 70 71 73 74	0 1 2 3 7 8 9 10 11 12 17 19 21 22 23 24 27 28 30 31 32 37 40 41 45 48 51 53 55 56 57 58 61 63 65 66 70 73	3 7 10 11 13 15 16 17 23 27 29 30 31 32 35 36 37 40 42 43 45 46 48 49 50 53 54 57 60 62 64 65 66 67 68 69 72 74	1 3 8 9 11 12 13 14 15 17 22 23 24 25 28 29 30 31 34 37 40 41 42 46 48 49 51 54 55 56 61 62 63 67 70 71 73 74
20 MHz	2 4 7 8 9 10 11 12 13 14 18 20 21 23 25 27 28 31 32 34 35 37 38 39 44 46 53 56 58 60 61 68 69 70 71 74 75 76 78 79 80 82 83 85 87 88 93 95 97 99	4 5 6 7 8 9 11 12 13 14 16 17 19 20 22 25 27 29 33 37 38 40 41 42 43 44 45 53 54 57 58 61 62 65 67 68 70 73 78 80 82 83 86 88 89 90 91 93 95 97	2 3 4 5 8 9 10 11 12 14 15 17 18 19 22 24 26 27 28 30 32 35 36 37 40 41 42 46 53 55 58 60 61 62 63 64 65 66 68 74 77 82 84 85 87 92 93 97 98 99	0 2 3 4 10 11 12 13 14 17 18 22 23 25 26 27 28 30 31 32 36 37 38 40 41 43 54 55 57 58 60 61 63 64 66 68 70 74 76 77 81 82 84 85 87 88 92 94 95 98	4 9 12 13 15 17 19 20 21 22 29 30 31 36 37 39 40 41 42 43 46 48 49 50 53 54 56 57 58 60 64 66 71 72 73 74 75 80 82 83 86 87 89 90 92 94 95 96 98 99	0 1 4 10 12 14 15 17 18 19 23 28 29 30 31 32 33 37 38 39 42 46 55 61 64 65 66 68 69 70 71 72 73 74 76 78 82 83 84 85 86 89 90 91 93 94 96 97 98 99	0 1 3 4 5 7 8 12 13 14 15 17 19 20 22 23 25 26 30 32 33 35 37 38 39 41 44 45 48 49 50 51 58 59 62 63 67 68 70 72 75 82 84 85 90 92 93 94 96 98

Frame2	Subframe 0	Subframe 1	Subframe 5	Subframe 6	Subframe 7	Subframe 8	Subframe 9
1.4 MHz	1 2 3	1 3 5	0 1 4	0 3 4	1 3 4	2 4 5	0 1 2
3 MHz	0 1 2 3 12 13 14	0 1 2 3 11 12 13	1 2 3 11 12 13 14	0 1 2 11 12 13 14	2 4 7 8 9 10 11	0 1 3 4 5 13 14	0 4 6 8 9 11 12
5 MHz	0 2 3 5 6 7 8 16 17 19 20 21 24	0 2 3 4 5 6 7 16 18 19 22 23 24	0 1 2 3 4 5 6 7 17 18 20 21 23	1 2 3 4 5 7 8 16 17 19 20 22 24	1 2 3 5 7 10 12 14 16 18 20 21 24	1 4 5 9 11 13 15 18 20 21 22 23 24	3 4 5 7 8 9 10 11 12 13 14 18 24
10 MHz	2 5 6 7 9 10 11 15 19 20 21 28 29 30 32 33 35 36 38 40 41 43 44 48 49	2 4 6 8 9 10 11 14 15 16 18 19 20 21 28 30 32 37 40 43 44 45 46 47 49	0 2 5 7 8 9 11 14 15 16 18 19 32 33 34 36 38 41 42 43 44 45 46 48 49	0 1 2 4 6 7 8 9 11 13 14 18 19 29 34 35 36 39 41 42 44 45 47 48 49	0 2 3 6 7 8 10 11 12 15 16 19 20 22 24 25 29 31 33 35 37 42 46 47 49	0 1 2 5 6 7 8 9 10 15 16 17 18 22 23 25 26 28 29 30 31 32 39 41 46	0 1 3 6 9 10 13 14 20 21 22 23 25 28 29 30 31 34 35 36 39 40 42 44 47
15 MHz	0 2 3 4 6 9 10 11 13 14 15 16 17 20 21 22 23 28 29 43 44 48 51 52 53 54 55 57 59 61 63 64 65 67 68 70 72 73	0 1 3 4 5 8 9 10 12 14 15 16 19 20 22 24 25 26 27 28 29 31 33 42 43 46 47 48 50 51 52 56 59 61 67 69 71 74	0 1 5 8 9 10 13 14 15 20 21 23 26 27 28 29 30 32 33 42 43 44 45 47 51 52 55 57 59 60 62 64 65 66 69 71 72 73	2 3 4 5 7 8 10 12 15 16 17 18 19 23 24 26 28 30 31 32 33 41 44 45 46 47 48 50 52 53 57 58 59 61 63 65 66 71	1 2 3 4 5 7 8 14 18 19 20 21 24 25 27 28 33 35 38 40 43 45 46 47 50 52 53 55 58 61 62 63 65 66 67 68 71 74	0 1 2 3 4 5 6 7 8 11 13 14 15 16 20 21 23 24 27 33 35 41 43 44 45 47 48 50 51 52 64 65 68 69 70 71 73 74	1 3 5 6 8 9 10 11 13 14 16 18 20 22 28 29 30 35 36 37 38 42 43 46 47 49 50 51 55 56 59 60 61 68 69 72 73 74
20 MHz	0 2 5 6 7 11 12 13 14 16 17 18 19 20 21 27 28 30 31 35 37 38 40 43 44 45 46 53 56 57 59 60 61 62 63 64 65 68 70 73 77 79 80 82 85 87 89 92 95 97	3 4 5 6 7 9 10 13 16 20 21 23 24 25 26 28 30 31 32 35 37 38 41 42 43 44 46 53 54 59 60 61 62 64 67 70 71 76 77 78 79 81 82 84 86 87 88 95 98 99	0 1 2 3 4 5 10 11 15 18 19 20 21 24 25 26 27 28 32 33 34 37 44 54 57 58 59 60 61 62 63 65 67 70 71 73 77 78 83 84 85 88 89 90 91 92 94 95 98 99	1 2 3 4 5 7 8 9 11 15 17 19 20 21 22 24 27 28 29 30 31 32 33 36 41 44 45 56 57 61 62 63 66 67 68 69 73 79 80 82 85 86 87 91 92 93 95 96 98 99	0 2 3 7 11 12 13 14 15 16 17 18 19 20 22 25 27 30 35 37 39 42 44 48 49 52 53 59 62 63 67 69 73 74 75 76 77 78 79 80 81 84 85 86 88 91 92 94 96 98	0 1 2 5 6 8 10 11 12 13 14 15 16 20 21 24 27 29 33 34 39 40 42 43 46 48 50 54 59 60 61 66 70 71 75 76 78 79 82 84 85 87 89 90 91 95 96 97 98 99	1 2 3 4 6 7 8 9 15 18 19 20 21 23 24 25 28 29 30 32 35 39 44 45 47 48 51 53 55 57 60 61 62 63 67 68 72 73 74 75 76 77 81 90 92 93 95 96 97 99

6.1.2 Data content of Physical channels and Signals

Randomisation of the data content is obtained by utilizing the length-31 Gold sequence scrambling of TS36.211, Clause 7.2 [12] which is invoked by all physical channels prior to modulation and mapping to the RE grid. An appropriate number of "0" bits shall be generated prior to the scrambling.

Initialization of the scrambler and RE-mappers as defined in TS36.211 [12] use the following additional parameters:

- $n_f = 0$ (used for PBCH)
- The E-TM shall start when $n_s = 0$
- $N_{ID}^{cell} = 1$
- $p = 0$ (data generated according to definitions in TS36.211 for antenna port 0). $p = 0$ shall be used for the generation of the E-TM data, even if the signal is transmitted on a physical port other than port 0.
- $q = 0$ (single code word)

6.1.2.1 Reference signals

Sequence generation, modulation and mapping to REs according to TS36.211, clause 6.10.1

6.1.2.2 Primary Synchronization signal

Sequence generation, modulation and mapping to REs according to TS36.211, clause 6.11.1

6.1.2.3 Secondary Synchronization signal

Sequence generation, modulation and mapping to REs according to TS36.211, clause 6.11.2

6.1.2.4 PBCH

- 240 REs (480 bits) are available for PBCH for the duration of the E-UTRA test models (1 frame, 10 ms)
- Generate 480 bits of "all 0" data
- Initialize scrambling generator for each invocation of the E-TM, i.e. set always $n_f = 0$
- Perform scrambling according to TS36.211, clause 6.6.1 of the 480 bits
- Perform modulation according to TS36.211, clause 6.6.2
- Perform mapping to REs according to TS36.211, clause 6.6.4

6.1.2.5 PCFICH

- Generate 32 bit CFI codeword according to TS36.212, clause 5.3.4.
- Perform scrambling according to TS36.211, clause 6.7.1
- Perform modulation according to TS36.211, clause 6.7.2
- Perform mapping to REs according to TS36.211, clause 6.7.4

6.1.2.6 PHICH

- PHICH duration is assumed as "Normal" according to TS36.211, clause 6.9.3
- Set $N_g = 1/6$ to obtain N_{PHICH}^{group} , see TS36.211, clause 6.9
- Use 2 PHICH per group, $n_{PHICH}^{seq} = 0, 4$
- For frame structure type 2 the factor m_i shall not be set as per TS36.211, Table 6.9-1, but instead shall be set to $m_i = 1$ for all transmitted subframes (Note).
- For each subframe the required amount of HARQ Indicators (HI) is as follows: $N_{PHICH}^{group} * (2 \text{ PHICH per group})$.
- Generate this amount of HIs using "0" data for each HI.
- Generate 3 bit HI codeword according to TS36.212, clause 5.3.5
- Perform scrambling and modulation according to TS36.211, clause 6.9.1
- Perform mapping to REs according to TS36.211, clause 6.9.3

Note: this is in order to preserve commonality between FDD and TDD E-TM.

6.1.2.7 PDCCH

- For each subframe the required amount of bits for all PDCCHs is as follows: (# of PDCCH)*(# of CCE per PDCCH)*(9 REG per CCE)*(4 RE per REG)*(2 bits per RE) with these parameters according to the E-TM definitions in subclause 6.1.1
- Generate this amount of bits according to "all 0" data
- Numbering of CCEs shall be according to TS36.211, clause 6.8.1. Mapping of PDCCHs to the available CCEs is performed as follows: First PDCCH is mapped to CCE(0), second PDCCH to CCE(0+ "# of CCEs per PDCCH"), ... etc. The remaining resources not used for PDCCH are treated as <NIL> REGs according to TS36.211, clause 6.8.2
- Perform PDCCH multiplexing and scrambling according to TS36.211, clause 6.8.2
- Perform modulation according to TS36.211, clause 6.8.3
- Perform mapping to REs according to TS36.211, clause 6.8.5

6.1.2.8 PDSCH

- For each subframe generate the required amount of bits for all PRBs according to "all 0" data
- PRB numbering is according to TS36.211, clause 6.2.3
- E-TMs utilize 1 user or 2 user PDSCH transmissions distinguished by n_{RNTI} . For each E-TM, PRBs are mapped to users (n_{RNTI}) according to their respective PRB attribute as follows:

Table 6.1.2.8-1: Mapping of PRBs to n_{RNTI} for each E-TM

	n_{RNTI}
E-TM1.1	0 for all PRBs
E-TM1.2	0 for boosted PRBs or those with $P_A = 0\text{dB}$ 1 for de-boosted PRBs
E-TM2	0 for all PRBs
E-TM3.1	0 for all PRBs
E-TM3.2	0 for QPSK PRBs 1 for 16QAM PRBs
E-TM3.3	0 for 16QAM PRBs 1 for QPSK PRBs

- The required amount of PDSCH "0" bits within a subframes and allocated PRBs shall be generated for each user
- Perform user specific scrambling according to TS36.211, clause 6.3.1. This makes use of n_{RNTI} .
- Perform modulation of the scrambled bits with the modulation scheme defined for each user according to TS36.211, clause 6.3.2
- Perform mapping of the complex-valued symbols to PRBs according to TS36.211, clause 6.3.5

6.2 Base station output power

6.2.1 Definition and applicability

Output power, P_{out} , of the base station is the mean power of one carrier delivered to a load with resistance equal to the nominal load impedance of the transmitter.

Base station maximum output power, P_{max} , of the base station is the mean power level per carrier measured at the antenna connector during the transmitter ON period in a specified reference condition.

In certain regions, the minimum requirement for normal conditions may apply also for some conditions outside the ranges defined for the Normal test environment in Annex D.

6.2.2 Minimum Requirement

The minimum requirement is in TS 36.104 [2] subclause 6.2.

6.2.3 Test purpose

The test purpose is to verify the accuracy of the maximum output power across the frequency range and under normal and extreme conditions for all transmitters in the BS.

6.2.4 Method of test

6.2.4.1 Initial conditions

Test environment: normal; see Annex D2.

RF channels to be tested: B, M and T; see subclause 4.7

In addition, on one EARFCN only, the test shall be performed under extreme power supply as defined in Annex D.5.

NOTE: Tests under extreme power supply also test extreme temperature.

- 1) Connect the power measuring equipment to the base station RF output port as shown in Annex I.1.1.

6.2.4.2 Procedure

- 1) Set the base station to transmit a signal according to E-TM1.1.
- 2) Measure the mean power at the RF output port.

6.2.5 Test Requirements

In normal conditions, the measurement result in step 2 of 6.2.4.2 shall remain within +2.7 dB and -2.7 dB of the manufacturer's rated output power.

In extreme conditions, measurement result in step 2 of 6.2.4.2 shall remain within +3.2 dB and -3.2 dB of the manufacturer's rated output power.

NOTE: If the above Test Requirement differs from the Minimum Requirement then the Test Tolerance applied for this test is non-zero. The Test Tolerance for this test and the explanation of how the Minimum Requirement has been relaxed by the Test Tolerance are given in Annex G.

6.3 Output power dynamics

The requirements in subclause 6.3 apply during the transmitter ON period.

6.3.1 RE Power control dynamic range

6.3.1.1 Definition and applicability

The RE power control dynamic range is the difference between the power of an RE and the average RE power for a BS at maximum output power for a specified reference condition. Unwanted emissions (as specified in subclause 6.6) and Transmit modulation quality (as specified in subclause 6.5) shall be maintained within the whole power control dynamic range.

6.3.1.2 Minimum Requirement

The minimum requirement is in TS 36.104 [2] subclause 6.3.1.1.

6.3.1.3 Method of test

No specific test or test requirements are defined for RE Power control dynamic range. The Error Vector Magnitude test, as described in subclause 6.5.2 provides a sufficient test coverage for this requirement.

6.3.2 Total power dynamic range

6.3.2.1 Definition and applicability

The total power dynamic range is the difference between the maximum and the minimum transmit power of an OFDM symbol for a specified reference condition.

NOTE: The upper limit of the dynamic range is the OFDM symbol power for a BS at maximum output power. The lower limit of the dynamic range is the OFDM symbol power for a BS when one resource block is transmitted. The OFDM symbol shall carry PDSCH and not contain RS, PBCH or synchronisation signals.

6.3.2.2 Minimum Requirement

The minimum requirement is in TS 36.104 [2] subclause 6.3.2.1.

6.3.2.3 Test purpose

The test purpose is to verify that the total power dynamic range is met as specified by the minimum requirement.

6.3.2.4 Method of test

6.3.2.4.1 Initial conditions

Test environment: normal; see Annex D.2.

RF channels to be tested: B, M and T; see subclause 4.7.

Connect the signal analyzer to the base station RF output port as shown in Annex I.1.1.

6.3.2.4.2 Procedure

- 1) Set-up BS transmission at maximum total power as specified by the supplier. Channel set-up shall be according to E-TM 3.1.
- 2) Measure the average OFDM symbol power as defined in Annex F.
- 3) Set the BS to transmit a signal according to E-TM 2.
- 4) Measure the average OFDM symbol power as defined in Annex F. The measured OFDM symbols shall not contain RS, PBCH or synchronisation signals.

6.3.2.5 Test Requirement

The downlink (DL) total power dynamic range shall be larger than or equal to the level in Table 6.3.2-1.

Table 6.3.2-1 E-UTRA BS total power dynamic range, paired spectrum

E-UTRA channel bandwidth (MHz)	Total power dynamic range (dB)
1.4	7.3
3	11.3
5	13.5
10	16.5
15	18.3
20	19.6

NOTE 1: If the above Test Requirement differs from the Minimum Requirement then the Test Tolerance applied for this test is non-zero. The Test Tolerance for this test is defined in Annex G. The explanation of how the Minimum Requirement has been relaxed by the Test Tolerance is given in Annex G.

NOTE2: Additional test requirements for the Error Vector Magnitude (EVM) at the lower limit of the dynamic range are defined in subclause 6.5.2

6.4 Transmit ON/OFF power

The requirements in section 6.4 are only applied for E-UTRA TDD BS.

6.4.1 Transmitter OFF power

6.4.1.1 Definition and applicability

Transmitter OFF power is defined as the mean power measured over [70 us] filtered with a square filter of bandwidth equal to the transmission bandwidth configuration of the BS (BW_{config}) centred on the assigned channel frequency during the transmitter OFF period.

6.4.1.2 Minimum Requirement

The minimum requirement is in TS 36.104 [2] subclause 6.4.1.1.

6.4.1.3 Test purpose

The purpose of this test is to verify the E-UTRA BS transmitter OFF power is within the limit of the minimum requirement.

6.4.1.4 Method of test

Requirement is tested together with transmitter transient period, as described in subclause 6.4.2.4.

6.4.1.4.1 Void

6.4.1.4.2 Void

6.4.1.5 Test requirement

The conformance testing of transmit OFF power is included in the conformance testing of transmitter transient period; therefore, see subclause 6.4.2.5 for test requirements.

6.4.2 Transmitter transient period

6.4.2.1 Definition and applicability

The transmitter transient period is the time period during which the transmitter is changing from the OFF period to the ON period or vice versa. The transmitter transient period is illustrated in Figure 6.4.2.1-1.

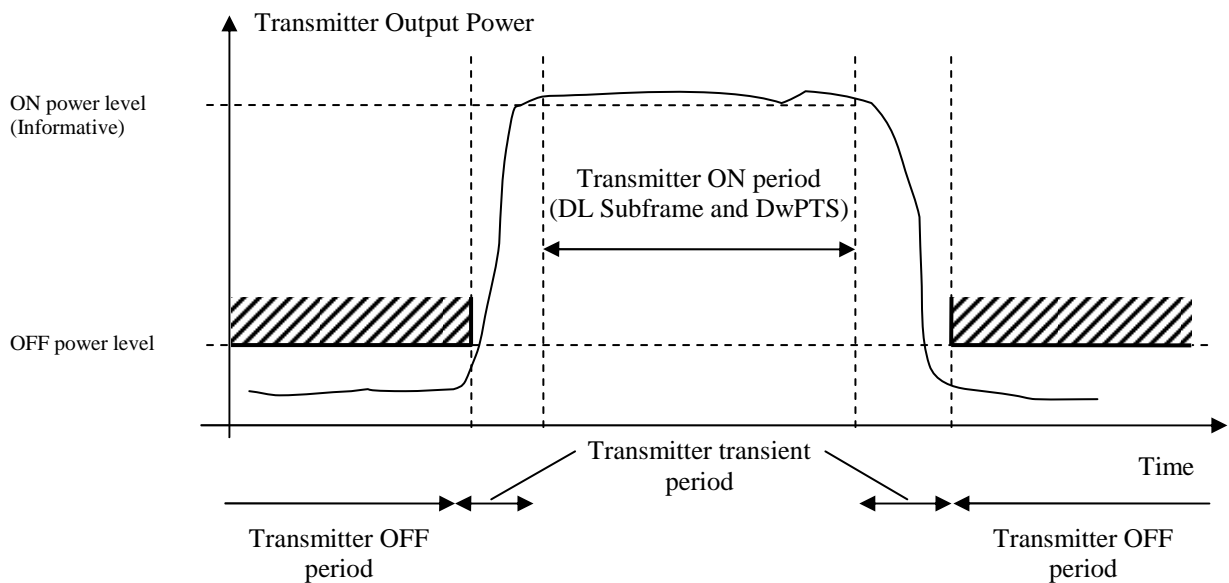

Figure 6.4.2.1-1 Illustration of the relations of transmitter ON period, transmitter OFF period and transmitter transient period.

6.4.2.2 Minimum Requirement

The minimum requirement is in TS 36.104 [2] subclause 6.4.2.1.

6.4.2.3 Test purpose

The purpose of this test is to verify the E-UTRA BS transmitter transient periods are within the limit of the minimum requirement.

6.4.2.4 Method of test

6.4.2.4.1 Initial conditions

Test environment: normal; see Annex D.2.

RF channels to be tested: M; see subclause 4.7.

Connect the signal analyzer to the BS antenna connector as shown in Annex I.1.1.

6.4.2.4.2 Procedure

- 1) Set the BS to transmit a signal according to E-TM1.1 at the manufacturer's specified maximum output power.
- 2) Measure the mean power spectral density over $70\mu\text{s}$ filtered with a square filter of bandwidth equal to the RF bandwidth of the BS centred on the central frequency of the RF bandwidth. $70\mu\text{s}$ average window centre is set from $35\mu\text{s}$ after end of one transmitter ON period + $17\mu\text{s}$ to $35\mu\text{s}$ before start of next transmitter ON period – $17\mu\text{s}$.

6.4.2.5 Test requirement

The measured mean power spectral density shall be less than $-85\text{dBm/MHz} + [\text{TT}]$.

NOTE: If the above Test Requirement differs from the Minimum Requirement then the Test Tolerance applied for this test is non-zero. The Test Tolerance for this test and the explanation of how the Minimum Requirement has been relaxed by the Test Tolerance are given in Annex G..

6.5 Transmitted signal quality

The requirements in subclause 6.5 apply to the transmitter ON period.

6.5.1 Frequency error

6.5.1.1 Definition and applicability

Frequency error is the measure of the difference between the actual BS transmit frequency and the assigned frequency. The same source shall be used for RF frequency and data clock generation.

It is not possible to verify by testing that the data clock is derived from the same frequency source as used for RF generation. This may be confirmed by the manufacturer's declaration.

6.5.1.2 Minimum Requirement

The minimum requirement is in TS 36.104 [2] subclause 6.5.1.

6.5.1.3 Test purpose

To verify that the Frequency Error is within the limit of the minimum requirement.

6.5.1.4 Method of test

Requirement is tested together with Error Vector Magnitude test, as described in subclause 6.5.2.

6.5.1.5 Test requirement

The modulated carrier frequency of the BS shall be accurate to within $\pm(0.05 \text{ ppm} + 12\text{Hz})$ observed over a period of one subframe (1ms).

Table 6.5.1-1: Void

NOTE: If the above Test Requirement differs from the Minimum Requirement then the Test Tolerance applied for this test is non-zero. The Test Tolerance for this test and the explanation of how the Minimum Requirement has been relaxed by the Test Tolerance are given in Annex G.

6.5.2 Error Vector Magnitude

6.5.2.1 Definition and applicability

The Error Vector Magnitude is a measure of the difference between the ideal symbols and the measured symbols after the equalization. This difference is called the error vector. The equaliser parameters are estimated as defined in Annex F. The EVM result is defined as the square root of the ratio of the mean error vector power to the mean reference power expressed in percent.

6.5.2.2 Minimum Requirement

The minimum requirement is in TS 36.104 [2] subclause 6.5.2.

6.5.2.3 Test purpose

The test purpose is to verify that the Error Vector Magnitude is within the limit specified by the minimum requirement.

6.5.2.4 Method of test

6.5.2.4.1 Initial conditions

Test environment: normal; see Annex D.2.

RF channels to be tested: B, M and T; see subclause 4.7.

Connect the signal analyzer to the base station RF output port as shown in Annex I.1.1.

6.5.2.4.2 Procedure

- 1) Start BS transmission at Pmax
- 2) Set the BS to transmit a signal according to E-TM 3.1
- 3) Measure the EVM and frequency error as defined in Annex F.
- 4) Repeat steps 2 and 3 for E-TM 3.2, E-TM 3.3 and E-TM 2. For E-TM2 the OFDM symbol power shall be at the lower limit of the dynamic range according to the test procedure in subclause 6.3.2.4.2 and test requirements in subclause 6.3.2.5.

6.5.2.5 Test requirement

The EVM for different modulation schemes on PDSCH shall be less than the limits in table 6.5.2.5-1:

Table 6.5.2.5-1 EVM requirements

Modulation scheme for PDSCH	Required EVM [%]
QPSK	18.5 %
16QAM	13.5 %
64QAM	9 %

The EVM requirement shall be applicable within a time period around the centre of the CP therefore the EVM requirement is tested against the maximum of the RMS average of 10 subframes at the two window W extremities.

Table 6.5.2.5-2 specifies EVM window length (W) for normal CP, the cyclic prefix length N_{cp} is 160 for symbols 0 and 144 for symbols 1-6.

Table 6.5.2.5-2 EVM window length for normal CP

Channel Bandwidth MHz	FFT size	Cyclic prefix length for symbols 0 in FFT samples	Cyclic prefix length for symbols 1-6 in FFT samples	EVM window length W	Ratio of W to total CP for symbols 1-6* [%]
1.4	128	10	9	5	55.6
3	256	20	18	12	66.7
5	512	40	36	32	88.9
10	1024	80	72	66	91.7
15	1536	120	108	102	94.4
20	2048	160	144	136	94.4

* Note: These percentages are informative and apply to symbols 1 through 6. Symbol 0 has a longer CP and therefore a lower percentage.

NOTE: If the above Test Requirement differs from the Minimum Requirement then the Test Tolerance applied for this test is non-zero. The Test Tolerance for this test is defined in Annex G. The explanation of how the Minimum Requirement has been relaxed by the Test Tolerance is given in Annex G.

6.5.3 Time alignment between transmitter branches

6.5.3.1 Definition and applicability

In Tx Diversity or spatial multiplexing, signals are transmitted from two or more antennas. These signals shall be aligned. The time alignment error in Tx Diversity and spatial multiplexing is specified as the delay between the signals from two antennas at the antenna ports.

This test is only applicable for eNode B supporting TX diversity or spatial multiplexing transmission.

6.5.3.2 Minimum Requirement

The minimum requirement is in TS 36.104 [2] subclause 6.5.3.

6.5.3.3 Test Purpose

To verify that the timing alignment error in TX diversity or spatial multiplexing is within the limit specified by the minimum requirement.

6.5.3.4 Method of Test

6.5.3.4.1 Initial Conditions

Test environment: normal; see Annex D.2.

RF channels to be tested: M; see subclause 4.7.

- 1) Connect two base station RF antenna ports to the measurement equipment according to Annex I.1.3. If available terminate the other unused antenna ports.
- 2) Set the base station to transmit according to E-TM1.1 on both ports or any DL signal using TX diversity or spatial multiplexing.
- 3) Set BS frequency.

6.5.3.4.2 Procedure

- 1) Start BS transmission at the manufacturer's specified maximum output power.
- 2) Measure the time alignment error between the reference symbols on the antenna port 1 and the reference symbols on the antenna port 2.
- 3) Repeat the measurement for any other possible configuration of 2 transmit antennas.

6.5.3.5 Test Requirement

The time alignment error shall be less than 90 ns.

NOTE: If the above Test Requirement differs from the Minimum Requirement then the Test Tolerance applied for this test is non-zero. The Test Tolerance for this test and the explanation of how the Minimum Requirement has been relaxed by the Test Tolerance are given in Annex G.

6.5.4 DL RS power

6.5.4.1 Definition and applicability

DL RS power is the resource element power of Downlink Reference Symbol.

The absolute DL RS power is indicated on the DL-SCH. The absolute accuracy is defined as the maximum deviation between the DL RS power indicated on the DL-SCH and the DL RS power at the BS antenna connector.

6.5.4.2 Minimum Requirement

The minimum requirement is in TS 36.104 [2] subclause 6.5.4.

6.5.4.3 Test purpose

The test purpose is to verify that the DL RS power is within the limit specified by the minimum requirement.

6.5.4.4 Method of test

6.5.4.4.1 Initial conditions

Test environment: normal; see Annex D.2.

RF channels to be tested: B, M and T; see subclause 4.7.

Connect the signal analyzer to the base station RF output port as shown in Annex I.1.1.

6.5.4.4.2 Procedure

Set-up BS transmission at maximum total power (P_{max}) as specified by the supplier. Channel set-up shall be according to E-TM 1.1.

Measure the RS transmitted power according to annex F.

6.5.4.5 Test requirement

DL RS power shall be within ± 2.9 dB of the DL RS power indicated on the DL-SCH.

NOTE: If the above Test Requirement differs from the Minimum Requirement then the Test Tolerance applied for this test is non-zero. The Test Tolerance for this test is defined in Annex G. The explanation of how the Minimum Requirement has been relaxed by the Test Tolerance is given in Annex G.

6.6 Unwanted emissions

Unwanted emissions consist of out-of-band emissions and spurious emissions [5]. Out of band emissions are unwanted emissions immediately outside the channel bandwidth resulting from the modulation process and non-linearity in the transmitter but excluding spurious emissions. Spurious emissions are emissions which are caused by unwanted transmitter effects such as harmonics emission, parasitic emission, intermodulation products and frequency conversion products, but exclude out of band emissions.

The out-of-band emissions requirement for the BS transmitter is specified both in terms of Adjacent Channel Leakage power Ratio (ACLR) and Operating band unwanted emissions. The Operating band unwanted emissions define all unwanted emissions in the downlink operating band plus the frequency ranges 10 MHz above and 10 MHz below the band. Unwanted emissions outside of this frequency range are limited by a spurious emissions requirement.

There is in addition a requirement for occupied bandwidth.

6.6.1 Occupied bandwidth

6.6.1.1 Definition and applicability

The occupied bandwidth is the width of a frequency band such that, below the lower and above the upper frequency limits, the mean powers emitted are each equal to a specified percentage $\beta/2$ of the total mean transmitted power.

The value of $\beta/2$ shall be taken as 0.5%.

6.6.1.2 Minimum Requirements

The minimum requirement is in TS 36.104 [2] subclause 6.6.1.

6.6.1.3 Test purpose

The occupied bandwidth, defined in the Radio Regulations of the International Telecommunication Union ITU, is a useful concept for specifying the spectral properties of a given emission in the simplest possible manner; see also ITU-R Recommendation SM.328 [4]. The test purpose is to verify that the emission of the BS does not occupy an excessive bandwidth for the service to be provided and is, therefore, not likely to create interference to other users of the spectrum beyond undue limits.

6.6.1.4 Method of test

6.6.1.4.1 Initial conditions

Test environment: normal; see Annex D.2.

RF channels to be tested: B, M and T; see subclause 4.7.

Connect the Measurement device to the BS antenna connector as shown in Annex I.1.1.

2) Start transmission according to E-TM1.1 at the manufacturer's specified maximum output power.

6.6.1.4.2 Procedure

1) Measure the spectrum of the transmitted signal across a span of [20] MHz, based on an occupied bandwidth requirement. The selected resolution bandwidth (RBW) filter of the analyser shall be [30 kHz] or less. The spectrum shall be measured at [400] or more points across the measurement span.

NOTE: The detection mode of the spectrum analyzer will not have any effect on the result if the statistical properties of the out-of-OBW power are the same as those of the inside-OBW power. Both are expected to have the Rayleigh distribution of the amplitude of Gaussian noise. In any case where the statistics are not the same, though, the detection mode must be power responding. The analyser may be set to respond to the average of the power (root-mean-square of the voltage) across the measurement cell.

2) Compute the total of the power, P0, (in power units, not decibel units) of all the measurement cells in the measurement span. Compute P1, the power outside the occupied bandwidth on each side. P1 is half of the total power outside the bandwidth. P1 is half of (100 % - (occupied percentage)) of P0. For the occupied percentage of 99 %, P1 is 0.005 times P0.

3) Determine the lowest frequency, f1, for which the sum of all power in the measurement cells from the beginning of the span to f1 exceeds P1.

4) Determine the highest frequency, f2, for which the sum of all power in the measurement cells from the end of the span to f2 exceeds P1.

5) Compute the occupied bandwidth as f2 - f1.

6.6.1.5 Test requirements

The occupied bandwidth shall be less than the channel bandwidth as defined in Table 5.2-1.

NOTE: If the above Test Requirement differs from the Minimum Requirement then the Test Tolerance applied for this test is non-zero. The Test Tolerance for this test and the explanation of how the Minimum Requirement has been relaxed by the Test Tolerance are given in Annex G.

6.6.2 Adjacent Channel Leakage power Ratio (ACLR)

6.6.2.1 Definition and applicability

Adjacent Channel Leakage power Ratio (ACLR) is the ratio of the filtered mean power centered on the assigned channel frequency to the filtered mean power centered on an adjacent channel frequency.

The requirements shall apply whatever the type of transmitter considered (single carrier or multi-carrier). It applies for all transmission modes foreseen by the manufacturer's specification. For a multi-carrier BS, the requirement applies for the adjacent channel frequencies below the lowest carrier frequency transmitted by the BS and above the highest carrier frequency transmitted by the BS for each supported multi-carrier transmission configuration.

6.6.2.2 Minimum Requirement

The minimum requirement is in TS 36.104 [2] subclause 6.6.2.1

6.6.2.3 Test purpose

To verify that the adjacent channel leakage power ratio requirement shall be met as specified by the minimum requirement.

6.6.2.4 Method of test

6.6.2.4.1 Initial conditions

Test environment: normal; see Annex D.2.

RF channels to be tested: B, M and T with multiple carriers if supported; see subclause 4.7.

- 1) Connect measurement device to the base station RF output port as shown in Annex I.1.1.
- 2) The measurement device characteristics shall be:
 - measurement filter bandwidth: defined in subclause 6.6.2.5;
 - detection mode: true RMS voltage or true average power.
- 3) Set the base station to transmit a signal according to E-TM1.1. The mean power at the RF output port shall be the maximum output power as specified by the manufacturer.
- 4) Set carrier frequency within the frequency band supported by BS.

6.6.2.4.2 Procedure

- 1) Measure Adjacent channel leakage power ratio for the frequency offsets both side of channel frequency as specified in Table 6.6.2-1 (Paired spectrum case) or Table 6.6.2-2 (Unpaired spectrum case) respectively. In multiple carrier case only offset frequencies below the lowest and above the highest carrier frequency used shall be measured.
- 2) Repeat the test with the channel set-up according to E-TM1.2.

6.6.2.5 Test Requirement

The ACLR is defined with a square filter of bandwidth equal to the transmission bandwidth configuration of the transmitted signal (BW_{Config}) centered on the assigned channel frequency and a filter centered on the adjacent channel frequency according to the tables below.

For Category A, either the ACLR limits in the tables below or the absolute limit of -13 dBm/MHz apply, whichever is less stringent.

For Category B, either the ACLR limits in the tables below or the absolute limit of -15 dBm/MHz apply, whichever is less stringent.

For operation in paired spectrum, the ACLR shall be higher than the value specified in Table 6.6.2-1.

Table 6.6.2-1: Base Station ACLR in paired spectrum

E-UTRA transmitted signal channel bandwidth BW_{Channel} [MHz]	BS adjacent channel centre frequency offset below the first or above the last carrier centre frequency transmitted	Assumed adjacent channel carrier (informative)	Filter on the adjacent channel frequency and corresponding filter bandwidth	ACLR limit
1.4, 3.0, 5, 10, 15, 20	BW_{Channel}	E-UTRA of same BW	Square (BW_{Config})	44.2 dB
	$2 \times BW_{\text{Channel}}$	E-UTRA of same BW	Square (BW_{Config})	44.2 dB
	$BW_{\text{Channel}}/2 + 2.5$ MHz	3.84 Mcps UTRA	RRC (3.84 Mcps)	44.2 dB
	$BW_{\text{Channel}}/2 + 7.5$ MHz	3.84 Mcps UTRA	RRC (3.84 Mcps)	44.2 dB
NOTE 1: BW_{Channel} and BW_{Config} are the channel bandwidth and transmission bandwidth configuration of the E-UTRA transmitted signal on the assigned channel frequency.				
NOTE 2: The RRC filter shall be equivalent to the transmit pulse shape filter defined in [15], with a chip rate as defined in this table.				

For operation in unpaired spectrum, the ACLR shall be higher than the value specified in Table 6.6.2-2.

Table 6.6.2-2: Base Station ACLR in unpaired spectrum with synchronized operation

E-UTRA transmitted signal channel bandwidth BW_{Channel} [MHz]	BS adjacent channel centre frequency offset below the first or above the last carrier centre frequency transmitted	Assumed adjacent channel carrier (informative)	Filter on the adjacent channel frequency and corresponding filter bandwidth	ACLR limit
1.4, 3.0	BW_{Channel}	E-UTRA of same BW	Square (BW_{Config})	44.2 dB
	$2 \times BW_{\text{Channel}}$	E-UTRA of same BW	Square (BW_{Config})	44.2 dB
	$BW_{\text{Channel}}/2 + 0.8$ MHz	1.28 Mcps UTRA	RRC (1.28 Mcps)	44.2 dB
	$BW_{\text{Channel}}/2 + 2.4$ MHz	1.28 Mcps UTRA	RRC (1.28 Mcps)	44.2 dB
5, 10, 15, 20	BW_{Channel}	E-UTRA of same BW	Square (BW_{Config})	44.2 dB
	$2 \times BW_{\text{Channel}}$	E-UTRA of same BW	Square (BW_{Config})	44.2 dB
	$BW_{\text{Channel}}/2 + 0.8$ MHz	1.28 Mcps UTRA	RRC (1.28 Mcps)	44.2 dB
	$BW_{\text{Channel}}/2 + 2.4$ MHz	1.28 Mcps UTRA	RRC (1.28 Mcps)	44.2 dB
	$BW_{\text{Channel}}/2 + 2.5$ MHz	3.84 Mcps UTRA	RRC (3.84 Mcps)	44.2 dB
	$BW_{\text{Channel}}/2 + 7.5$ MHz	3.84 Mcps UTRA	RRC (3.84 Mcps)	44.2 dB
	$BW_{\text{Channel}}/2 + 5$ MHz	7.68 Mcps UTRA	RRC (7.68 Mcps)	44.2 dB
	$BW_{\text{Channel}}/2 + 15$ MHz	7.68 Mcps UTRA	RRC (7.68 Mcps)	44.2 dB
NOTE 1: BW_{Channel} and BW_{Config} are the channel bandwidth and transmission bandwidth configuration of the E-UTRA transmitted signal on the assigned channel frequency.				
NOTE 2: The RRC filter shall be equivalent to the transmit pulse shape filter defined in [15], with a chip rate as defined in this table.				

NOTE: If the above Test Requirements differ from the Minimum Requirement then the Test Tolerance applied for this test is non-zero. The Test Tolerance for this test and the explanation of how the Minimum Requirement has been relaxed by the Test Tolerance are given in Annex G.

6.6.3 Operating band unwanted emissions

6.6.3.1 Definition and applicability

The Operating band unwanted emission limits are defined from 10 MHz below the lowest frequency of the downlink operating band up to 10 MHz above the highest frequency of the downlink operating band (see Table 5.5-1).

The requirements shall apply whatever the type of transmitter considered (single carrier or multi-carrier) and for all transmission modes foreseen by the manufacturer's specification.

The unwanted emission limits in the part of the downlink operating band that falls in the spurious domain are consistent with ITU-R Recommendation SM.329 [5].

For a multicarrier E-UTRA BS the definitions above apply to the lower edge of the carrier transmitted at the lowest carrier frequency and the higher edge of the carrier transmitted at the highest carrier frequency.

The requirements of either subclause 6.6.3.5.1 (Category A limits) or subclause 6.6.3.5.2 (Category B limits) shall apply. The application of either Category A or Category B limits shall be the same as for Transmitter spurious emissions (Mandatory Requirements) in subclause 6.6.4.5.

For Category B Operating band unwanted emissions, there are two options for the limits that may be applied regionally. Either the limits in subclause 6.6.3.5.2.1 or subclause 6.6.3.5.2.2 shall be applied.

6.6.3.2 Minimum Requirement

The minimum requirement is in TS 36.104 [2] subclause 6.6.3.

6.6.3.3 Test purpose

This test measures the emissions of the BS, close to the assigned channel bandwidth of the wanted signal, while the transmitter is in operation.

6.6.3.4 Method of test

6.6.3.4.1 Initial conditions

Test environment: normal; see Annex D.2.

RF channels to be tested: B, M and T; see subclause 4.7.

- 1) Connect the signal analyzer to the base station RF output port as shown in Annex I.1.1.

As a general rule, the resolution bandwidth of the measuring equipment should be equal to the measurement bandwidth. However, to improve measurement accuracy, sensitivity, efficiency and avoiding e.g. carrier leakage, the resolution bandwidth may be smaller than the measurement bandwidth. When the resolution bandwidth is smaller than the measurement bandwidth, the result should be integrated over the measurement bandwidth in order to obtain the equivalent noise bandwidth of the measurement bandwidth.

- 2) Detection mode: True RMS.

6.6.3.4.2 Procedure

- 1) Set the BS transmission at maximum total power (P_{max}) as specified by the supplier. Channel set-up shall be according to E-TM 1.1.
- 2) Step the centre frequency of the measurement filter in contiguous steps and measure the emission within the specified frequency ranges with the specified measurement bandwidth.
- 3) Repeat the test with the channel set-up according to E-TM 1.2

6.6.3.5 Test requirement

The measurement results in step 2 of 6.6.3.4.2 shall not exceed the maximum levels specified in the tables below, where:

- Δf is the separation between the channel edge frequency and the nominal -3dB point of the measuring filter closest to the carrier frequency.
- f_{offset} is the separation between the channel edge frequency and the centre of the measuring filter.
- $f_{\text{offset}_{\text{max}}}$ is the offset to the frequency 10 MHz outside the downlink operating band.
- Δf_{max} is equal to $f_{\text{offset}_{\text{max}}}$ minus half of the bandwidth of the measuring filter.

6.6.3.5.1 Test requirements (Category A)

For E-UTRA BS operating in Bands 5, 6, 8, 12, 13, 14, 17, emissions shall not exceed the maximum levels specified in Tables 6.6.3.5.1-1 to 6.6.3.5.1-3.

Table 6.6.3.5.1-1: General operating band unwanted emission limits for 1.4 MHz channel bandwidth (E-UTRA bands <1GHz) for Category A

Frequency offset of measurement filter -3dB point, Δf	Frequency offset of measurement filter centre frequency, f_{offset}	Test requirement	Measurement bandwidth (Note 1)
$0 \text{ MHz} \leq \Delta f < 1.4 \text{ MHz}$	$0.05 \text{ MHz} \leq f_{\text{offset}} < 1.45 \text{ MHz}$	$+0.5 \text{ dBm} - \frac{10}{1.4} \cdot \left(\frac{f_{\text{offset}}}{\text{MHz}} - 0.05 \right) \text{ dB}$	100 kHz
$1.4 \text{ MHz} \leq \Delta f < 2.8 \text{ MHz}$	$1.45 \text{ MHz} \leq f_{\text{offset}} < 2.85 \text{ MHz}$	-9.5 dBm	100 kHz
$2.8 \text{ MHz} \leq \Delta f \leq \Delta f_{\text{max}}$	$2.85 \text{ MHz} \leq f_{\text{offset}} < f_{\text{offset}_{\text{max}}}$	-13 dBm	100 kHz

Table 6.6.3.5.1-2: General operating band unwanted emission limits for 3 MHz channel bandwidth (E-UTRA bands <1GHz) for Category A

Frequency offset of measurement filter -3dB point, Δf	Frequency offset of measurement filter centre frequency, f_{offset}	Test requirement	Measurement bandwidth (Note 1)
$0 \text{ MHz} \leq \Delta f < 3 \text{ MHz}$	$0.05 \text{ MHz} \leq f_{\text{offset}} < 3.05 \text{ MHz}$	$-3.5 \text{ dBm} - \frac{10}{3} \cdot \left(\frac{f_{\text{offset}}}{\text{MHz}} - 0.05 \right) \text{ dB}$	100 kHz
$3 \text{ MHz} \leq \Delta f < 6 \text{ MHz}$	$3.05 \text{ MHz} \leq f_{\text{offset}} < 6.05 \text{ MHz}$	-13.5 dBm	100 kHz
$6 \text{ MHz} \leq \Delta f \leq \Delta f_{\text{max}}$	$6.05 \text{ MHz} \leq f_{\text{offset}} < f_{\text{offset}_{\text{max}}}$	-13 dBm	100 kHz

Table 6.6.3.5.1-3: General operating band unwanted emission limits for 5, 10, 15 and 20 MHz channel bandwidth (E-UTRA bands <1GHz) for Category A

Frequency offset of measurement filter -3dB point, Δf	Frequency offset of measurement filter centre frequency, f_{offset}	Test requirement	Measurement bandwidth (Note 1)
$0 \text{ MHz} \leq \Delta f < 5 \text{ MHz}$	$0.05 \text{ MHz} \leq f_{\text{offset}} < 5.05 \text{ MHz}$	$-5.5 \text{ dBm} - \frac{7}{5} \cdot \left(\frac{f_{\text{offset}}}{\text{MHz}} - 0.05 \right) \text{ dB}$	100 kHz
$5 \text{ MHz} \leq \Delta f < \min(10 \text{ MHz}, \Delta f_{\text{max}})$	$5.05 \text{ MHz} \leq f_{\text{offset}} < \min(10.05 \text{ MHz}, f_{\text{offset}_{\text{max}}})$	-12.5 dBm	100 kHz
$10 \text{ MHz} \leq \Delta f \leq \Delta f_{\text{max}}$	$10.05 \text{ MHz} \leq f_{\text{offset}} < f_{\text{offset}_{\text{max}}}$	-13 dBm (Note 4)	100 kHz

For E-UTRA BS operating in Bands 1, 2, 3, 4, 7, 9, 10, 11, 33, 34, 35, 36, 37, 38, 39, 40, emissions shall not exceed the maximum levels specified in Tables 6.6.3.5.1-4 to 6.6.3.5.1-6:

Table 6.6.3.5.1-4: General operating band unwanted emission limits for 1.4 MHz channel bandwidth (E-UTRA bands >1GHz) for Category A

Frequency offset of measurement filter -3dB point, Δf	Frequency offset of measurement filter centre frequency, f_{offset}	Test requirement	Measurement bandwidth (Note 1)
$0 \text{ MHz} \leq \Delta f < 1.4 \text{ MHz}$	$0.05 \text{ MHz} \leq f_{\text{offset}} < 1.45 \text{ MHz}$	$+0.5 \text{ dBm} - \frac{10}{1.4} \cdot \left(\frac{f_{\text{offset}}}{\text{MHz}} - 0.05 \right) \text{ dB}$	100 kHz
$1.4 \text{ MHz} \leq \Delta f < 2.8 \text{ MHz}$	$1.45 \text{ MHz} \leq f_{\text{offset}} < 2.85 \text{ MHz}$	-9.5 dBm	100 kHz
$2.8 \text{ MHz} \leq \Delta f \leq \Delta f_{\text{max}}$	$3.3 \text{ MHz} \leq f_{\text{offset}} < f_{\text{offset}_{\text{max}}}$	-13 dBm	1MHz

Table 6.6.3.5.1-5: General operating band unwanted emission limits for 3 MHz channel bandwidth (E-UTRA bands >1GHz) for Category A

Frequency offset of measurement filter -3dB point, Δf	Frequency offset of measurement filter centre frequency, f_{offset}	Test requirement	Measurement bandwidth (Note 1)
$0 \text{ MHz} \leq \Delta f < 3 \text{ MHz}$	$0.05 \text{ MHz} \leq f_{\text{offset}} < 3.05 \text{ MHz}$	$-3.5 \text{ dBm} - \frac{10}{3} \cdot \left(\frac{f_{\text{offset}}}{\text{MHz}} - 0.05 \right) \text{ dB}$	100 kHz
$3 \text{ MHz} \leq \Delta f < 6 \text{ MHz}$	$3.05 \text{ MHz} \leq f_{\text{offset}} < 6.05 \text{ MHz}$	-13.5 dBm	100 kHz
$6 \text{ MHz} \leq \Delta f \leq \Delta f_{\text{max}}$	$6.5 \text{ MHz} \leq f_{\text{offset}} < f_{\text{offset}_{\text{max}}}$	-13 dBm	1MHz

Table 6.6.3.5.1-6: General operating band unwanted emission limits for 5, 10, 15 and 20 MHz channel bandwidth (E-UTRA bands >1GHz) for Category A

Frequency offset of measurement filter -3dB point, Δf	Frequency offset of measurement filter centre frequency, f_{offset}	Test requirement	Measurement bandwidth (Note 1)
$0 \text{ MHz} \leq \Delta f < 5 \text{ MHz}$	$0.05 \text{ MHz} \leq f_{\text{offset}} < 5.05 \text{ MHz}$	$-5.5 \text{ dBm} - \frac{7}{5} \cdot \left(\frac{f_{\text{offset}}}{\text{MHz}} - 0.05 \right) \text{ dB}$	100 kHz
$5 \text{ MHz} \leq \Delta f < \min(10 \text{ MHz}, \Delta f_{\text{max}})$	$5.05 \text{ MHz} \leq f_{\text{offset}} < \min(10.05 \text{ MHz}, f_{\text{offset}_{\text{max}}})$	-12.5 dBm	100 kHz
$10 \text{ MHz} \leq \Delta f \leq \Delta f_{\text{max}}$	$10.5 \text{ MHz} \leq f_{\text{offset}} < f_{\text{offset}_{\text{max}}}$	-13 dBm (Note 4)	1MHz

6.6.3.5.2 Test requirements (Category B)

For Category B Operating band unwanted emissions, there are two options for the limits that may be applied regionally. Either the limits in subclause 6.6.3.5.2.1 or subclause 6.6.3.5.2.2 shall be applied.

6.6.3.5.2.1 Category B test requirements (Option 1)

For E-UTRA BS operating in Bands 5, 6, 8, 12, 13, 14, 17, emissions shall not exceed the maximum levels specified in Tables 6.6.3.5.2.1-1 to 6.6.3.5.2.1-3:

Table 6.6.3.5.2.1-1: General operating band unwanted emission limits for 1.4 MHz channel bandwidth (E-UTRA bands <1GHz) for Category B

Frequency offset of measurement filter -3dB point, Δf	Frequency offset of measurement filter centre frequency, f_{offset}	Test requirement	Measurement bandwidth (Note 1)
$0 \text{ MHz} \leq \Delta f < 1.4 \text{ MHz}$	$0.05 \text{ MHz} \leq f_{\text{offset}} < 1.45 \text{ MHz}$	$+0.5 \text{ dBm} - \frac{10}{1.4} \cdot \left(\frac{f_{\text{offset}}}{\text{MHz}} - 0.05 \right) \text{ dB}$	100 kHz
$1.4 \text{ MHz} \leq \Delta f < 2.8 \text{ MHz}$	$1.45 \text{ MHz} \leq f_{\text{offset}} < 2.85 \text{ MHz}$	-9.5 dBm	100 kHz
$2.8 \text{ MHz} \leq \Delta f \leq \Delta f_{\text{max}}$	$2.85 \text{ MHz} \leq f_{\text{offset}} < f_{\text{offset}_{\text{max}}}$	-16 dBm	100 kHz

Table 6.6.3.5.2.1-2: General operating band unwanted emission limits for 3 MHz channel bandwidth (E-UTRA bands <1GHz) for Category B

Frequency offset of measurement filter -3dB point, Δf	Frequency offset of measurement filter centre frequency, f_{offset}	Test requirement	Measurement bandwidth (Note 1)
$0 \text{ MHz} \leq \Delta f < 3 \text{ MHz}$	$0.05 \text{ MHz} \leq f_{\text{offset}} < 3.05 \text{ MHz}$	$-3.5 \text{ dBm} - \frac{10}{3} \cdot \left(\frac{f_{\text{offset}}}{\text{MHz}} - 0.05 \right) \text{ dB}$	100 kHz
$3 \text{ MHz} \leq \Delta f < 6 \text{ MHz}$	$3.05 \text{ MHz} \leq f_{\text{offset}} < 6.05 \text{ MHz}$	-13.5 dBm	100 kHz
$6 \text{ MHz} \leq \Delta f \leq \Delta f_{\text{max}}$	$6.05 \text{ MHz} \leq f_{\text{offset}} < f_{\text{offset}_{\text{max}}}$	-16 dBm	100 kHz

Table 6.6.3.5.2.1-3: General operating band unwanted emission limits for 5, 10, 15 and 20 MHz channel bandwidth (E-UTRA bands <1GHz) for Category B

Frequency offset of measurement filter -3dB point, Δf	Frequency offset of measurement filter centre frequency, f_{offset}	Test requirement	Measurement bandwidth (Note 1)
$0 \text{ MHz} \leq \Delta f < 5 \text{ MHz}$	$0.05 \text{ MHz} \leq f_{\text{offset}} < 5.05 \text{ MHz}$	$-5.5 \text{ dBm} - \frac{7}{5} \cdot \left(\frac{f_{\text{offset}}}{\text{MHz}} - 0.05 \right) \text{ dB}$	100 kHz
$5 \text{ MHz} \leq \Delta f < \min(10 \text{ MHz}, \Delta f_{\text{max}})$	$5.05 \text{ MHz} \leq f_{\text{offset}} < \min(10.05 \text{ MHz}, f_{\text{offset}_{\text{max}}})$	-12.5 dBm	100 kHz
$10 \text{ MHz} \leq \Delta f \leq \Delta f_{\text{max}}$	$10.05 \text{ MHz} \leq f_{\text{offset}} < f_{\text{offset}_{\text{max}}}$	-16 dBm (Note 4)	100 kHz

For E-UTRA BS operating in Bands 1, 2, 3, 4, 7, 9, 10, 11, 33, 34, 35, 36, 37, 38, 39, 40, emissions shall not exceed the maximum levels specified in Tables 6.6.3.5.2.1-4 to 6.6.3.5.2.1-6:

Table 6.6.3.5.2.1-4: General operating band unwanted emission limits for 1.4 MHz channel bandwidth (E-UTRA bands >1GHz) for Category B

Frequency offset of measurement filter -3dB point, Δf	Frequency offset of measurement filter centre frequency, f_{offset}	Test requirement	Measurement bandwidth (Note 1)
$0 \text{ MHz} \leq \Delta f < 1.4 \text{ MHz}$	$0.05 \text{ MHz} \leq f_{\text{offset}} < 1.45 \text{ MHz}$	$+0.5 \text{ dBm} - \frac{10}{1.4} \cdot \left(\frac{f_{\text{offset}}}{\text{MHz}} - 0.05 \right) \text{ dB}$	100 kHz
$1.4 \text{ MHz} \leq \Delta f < 2.8 \text{ MHz}$	$1.45 \text{ MHz} \leq f_{\text{offset}} < 2.85 \text{ MHz}$	-9.5 dBm	100 kHz
$2.8 \text{ MHz} \leq \Delta f \leq \Delta f_{\text{max}}$	$3.3 \text{ MHz} \leq f_{\text{offset}} < f_{\text{offset}_{\text{max}}}$	-15 dBm	1MHz

Table 6.6.3.5.2.1-5: General operating band unwanted emission limits for 3 MHz channel bandwidth (E-UTRA bands >1GHz) for Category B

Frequency offset of measurement filter -3dB point, Δf	Frequency offset of measurement filter centre frequency, f_{offset}	Test requirement	Measurement bandwidth (Note 1)
$0 \text{ MHz} \leq \Delta f < 3 \text{ MHz}$	$0.05 \text{ MHz} \leq f_{\text{offset}} < 3.05 \text{ MHz}$	$-3.5 \text{ dBm} - \frac{10}{3} \cdot \left(\frac{f_{\text{offset}}}{\text{MHz}} - 0.05 \right) \text{ dB}$	100 kHz
$3 \text{ MHz} \leq \Delta f < 6 \text{ MHz}$	$3.05 \text{ MHz} \leq f_{\text{offset}} < 6.05 \text{ MHz}$	-13.5 dBm	100 kHz
$6 \text{ MHz} \leq \Delta f \leq \Delta f_{\text{max}}$	$6.5 \text{ MHz} \leq f_{\text{offset}} < f_{\text{offset}_{\text{max}}}$	-15 dBm	1MHz

Table 6.6.3.5.2.1-6: General operating band unwanted emission limits for 5, 10, 15 and 20 MHz channel bandwidth (E-UTRA bands >1GHz) for Category B

Frequency offset of measurement filter -3dB point, Δf	Frequency offset of measurement filter centre frequency, f_{offset}	Test requirement	Measurement bandwidth (Note 1)
$0 \text{ MHz} \leq \Delta f < 5 \text{ MHz}$	$0.05 \text{ MHz} \leq f_{\text{offset}} < 5.05 \text{ MHz}$	$-5.5 \text{ dBm} - \frac{7}{5} \cdot \left(\frac{f_{\text{offset}}}{\text{MHz}} - 0.05 \right) \text{ dB}$	100 kHz
$5 \text{ MHz} \leq \Delta f < \min(10 \text{ MHz}, \Delta f_{\text{max}})$	$5.05 \text{ MHz} \leq f_{\text{offset}} < \min(10.05 \text{ MHz}, f_{\text{offset}_{\text{max}}})$	-12.5 dBm	100 kHz
$10 \text{ MHz} \leq \Delta f \leq \Delta f_{\text{max}}$	$10.5 \text{ MHz} \leq f_{\text{offset}} < f_{\text{offset}_{\text{max}}}$	-15 dBm (Note 4)	1MHz

6.6.3.5.2.2 Category B (Option 2)

The limits in this subclause are intended for Europe and may be applied regionally for BS operating in band 3 and 8.

For a BS operating in band 3 or 8, emissions shall not exceed the maximum levels specified in Table 6.6.3.5.2.2-1 below for 5, 10, 15 and 20 MHz channel bandwidth:

Table 6.6.3.5.2.2-1: Regional operating band unwanted emission limits in 3 and 8 for 5, 10, 15 and 20 MHz channel bandwidth for Category B

Frequency offset of measurement filter -3dB point, Δf	Frequency offset of measurement filter centre frequency, f_{offset}	Minimum requirement	Measurement bandwidth (Note 1)
$0 \text{ MHz} \leq \Delta f < 0.2 \text{ MHz}$	$0.015 \text{ MHz} \leq f_{\text{offset}} < 0.215 \text{ MHz}$	-12.5 dBm	30 kHz
$0.2 \text{ MHz} \leq \Delta f < 1 \text{ MHz}$	$0.215 \text{ MHz} \leq f_{\text{offset}} < 1.015 \text{ MHz}$	$-12.5 \text{ dBm} - 15 \cdot \left(\frac{f_{\text{offset}}}{\text{MHz}} - 0.215 \right) \text{ dB}$	30 kHz
(Note 3)	$1.015 \text{ MHz} \leq f_{\text{offset}} < 1.5 \text{ MHz}$	-24.5 dBm	30 kHz
$1 \text{ MHz} \leq \Delta f \leq \min(10 \text{ MHz}, \Delta f_{\text{max}})$	$1.5 \text{ MHz} \leq f_{\text{offset}} < \min(10.5 \text{ MHz}, f_{\text{offset}_{\text{max}}})$	-11.5 dBm	1 MHz
$10 \text{ MHz} \leq \Delta f \leq \Delta f_{\text{max}}$	$10.5 \text{ MHz} \leq f_{\text{offset}} < f_{\text{offset}_{\text{max}}}$	-15 dBm (Note 4)	1 MHz

For a BS operating in band 3 or 8, emissions shall not exceed the maximum levels specified in Table 6.6.3.5.2.2-2 below for 3 MHz channel bandwidth:

Table 6.6.3.5.2.2-2: Regional operating band unwanted emission limits in band 3 and 8 for 3 MHz channel bandwidth for Category B

Frequency offset of measurement filter -3dB point, Δf	Frequency offset of measurement filter centre frequency, f_{offset}	Minimum requirement	Measurement bandwidth (Note 1)
$0 \text{ MHz} \leq \Delta f < 0.05 \text{ MHz}$	$0.015 \text{ MHz} \leq f_{\text{offset}} < 0.065 \text{ MHz}$	$6.5 \text{ dBm} - 60 \cdot \left(\frac{f_{\text{offset}}}{\text{MHz}} - 0.015 \right) \text{ dB}$	30 kHz
$0.05 \text{ MHz} \leq \Delta f < 0.15 \text{ MHz}$	$0.065 \text{ MHz} \leq f_{\text{offset}} < 0.165 \text{ MHz}$	$3.5 \text{ dBm} - 160 \cdot \left(\frac{f_{\text{offset}}}{\text{MHz}} - 0.065 \right) \text{ dB}$	30 kHz
$0.15 \text{ MHz} \leq \Delta f < 0.2 \text{ MHz}$	$0.165 \text{ MHz} \leq f_{\text{offset}} < 0.215 \text{ MHz}$	-12.5 dBm	30 kHz
$0.2 \text{ MHz} \leq \Delta f < 1 \text{ MHz}$	$0.215 \text{ MHz} \leq f_{\text{offset}} < 1.015 \text{ MHz}$	$-12.5 \text{ dBm} - 15 \cdot \left(\frac{f_{\text{offset}}}{\text{MHz}} - 0.215 \right) \text{ dB}$	30 kHz
(Note 3)	$1.015 \text{ MHz} \leq f_{\text{offset}} < 1.5 \text{ MHz}$	-24.5 dBm	30 kHz
$1 \text{ MHz} \leq \Delta f \leq 6 \text{ MHz}$	$1.5 \text{ MHz} \leq f_{\text{offset}} < 6.5 \text{ MHz}$	-11.5 dBm	1 MHz
$6 \text{ MHz} \leq \Delta f \leq \Delta f_{\text{max}}$	$6.5 \text{ MHz} \leq f_{\text{offset}} < f_{\text{offset}_{\text{max}}}$	-15 dBm	1 MHz

For a BS operating in band 3 or 8, emissions shall not exceed the maximum levels specified in Table 6.6.3.5.2.2-3 below for 1.4 MHz channel bandwidth:

Table 6.6.3.5.2.2-3: Regional operating band unwanted emission limits in band 3 and 8 for 1.4 MHz channel bandwidth for Category B

Frequency offset of measurement filter -3dB point, Δf	Frequency offset of measurement filter centre frequency, f_{offset}	Minimum requirement	Measurement bandwidth (Note 1)
$0 \text{ MHz} \leq \Delta f < 0.05 \text{ MHz}$	$0.015 \text{ MHz} \leq f_{\text{offset}} < 0.065 \text{ MHz}$	$6.5 \text{ dBm} - 60 \cdot \left(\frac{f_{\text{offset}}}{\text{MHz}} - 0.015 \right) \text{ dB}$	30 kHz
$0.05 \text{ MHz} \leq \Delta f < 0.15 \text{ MHz}$	$0.065 \text{ MHz} \leq f_{\text{offset}} < 0.165 \text{ MHz}$	$3.5 \text{ dBm} - 160 \cdot \left(\frac{f_{\text{offset}}}{\text{MHz}} - 0.065 \right) \text{ dB}$	30 kHz
$0.15 \text{ MHz} \leq \Delta f < 0.2 \text{ MHz}$	$0.165 \text{ MHz} \leq f_{\text{offset}} < 0.215 \text{ MHz}$	-12.5 dBm	30 kHz
$0.2 \text{ MHz} \leq \Delta f < 1 \text{ MHz}$	$0.215 \text{ MHz} \leq f_{\text{offset}} < 1.015 \text{ MHz}$	$-12.5 \text{ dBm} - 15 \cdot \left(\frac{f_{\text{offset}}}{\text{MHz}} - 0.215 \right) \text{ dB}$	30 kHz
(Note 3)	$1.015 \text{ MHz} \leq f_{\text{offset}} < 1.5 \text{ MHz}$	-24.5 dBm	30 kHz
$1 \text{ MHz} \leq \Delta f \leq 2.8 \text{ MHz}$	$1.5 \text{ MHz} \leq f_{\text{offset}} < 3.3 \text{ MHz}$	-11.5 dBm	1 MHz
$2.8 \text{ MHz} \leq \Delta f \leq \Delta f_{\text{max}}$	$3.3 \text{ MHz} \leq f_{\text{offset}} < f_{\text{offset}_{\text{max}}}$	-15 dBm	1 MHz

6.6.3.5.3 Additional requirements

In certain regions the following requirement may apply. For E-UTRA BS operating in Bands 5, emissions shall not exceed the maximum levels specified in Tables 6.6.3.5.3-1.

Table 6.6.3.5.3-1: Additional operating band unwanted emission limits for E-UTRA bands <1GHz

Channel bandwidth	Frequency offset of measurement filter -3dB point, Δf	Frequency offset of measurement filter centre frequency, f_{offset}	Test requirement	Measurement bandwidth (Note 1)
1.4 MHz	$0 \text{ MHz} \leq \Delta f < 1 \text{ MHz}$	$0.005 \text{ MHz} \leq f_{\text{offset}} < 0.995 \text{ MHz}$	-14 dBm	10 kHz
3 MHz	$0 \text{ MHz} \leq \Delta f < 1 \text{ MHz}$	$0.015 \text{ MHz} \leq f_{\text{offset}} < 0.985 \text{ MHz}$	-13 dBm	30 kHz
5 MHz	$0 \text{ MHz} \leq \Delta f < 1 \text{ MHz}$	$0.015 \text{ MHz} \leq f_{\text{offset}} < 0.985 \text{ MHz}$	-15 dBm	30 kHz
10 MHz	$0 \text{ MHz} \leq \Delta f < 1 \text{ MHz}$	$0.05 \text{ MHz} \leq f_{\text{offset}} < 0.95 \text{ MHz}$	-13 dBm	100 kHz
15 MHz	$0 \text{ MHz} \leq \Delta f < 1 \text{ MHz}$	$0.05 \text{ MHz} \leq f_{\text{offset}} < 0.95 \text{ MHz}$	-13 dBm	100 kHz
20 MHz	$0 \text{ MHz} \leq \Delta f < 1 \text{ MHz}$	$0.05 \text{ MHz} \leq f_{\text{offset}} < 0.95 \text{ MHz}$	-13 dBm	100 kHz
All	$1 \text{ MHz} \leq \Delta f < \Delta f_{\text{max}}$	$1.05 \text{ MHz} \leq f_{\text{offset}} < f_{\text{offset}_{\text{max}}}$	-13 dBm	100 kHz

In certain regions the following requirement may apply. For E-UTRA BS operating in Bands 2, 4, 10, 35, 36, emissions shall not exceed the maximum levels specified in Table 6.6.3.5.3-2.

Table 6.6.3.5.3-2: Additional operating band unwanted emission limits for E-UTRA bands >1GHz

Channel bandwidth	Frequency offset of measurement filter -3dB point, Δf	Frequency offset of measurement filter centre frequency, f_{offset}	Test requirement	Measurement bandwidth (Note 1)
1.4 MHz	$0 \text{ MHz} \leq \Delta f < 1 \text{ MHz}$	$0.005 \text{ MHz} \leq f_{\text{offset}} < 0.995 \text{ MHz}$	-14 dBm	10 kHz
3 MHz	$0 \text{ MHz} \leq \Delta f < 1 \text{ MHz}$	$0.015 \text{ MHz} \leq f_{\text{offset}} < 0.985 \text{ MHz}$	-13 dBm	30 kHz
5 MHz	$0 \text{ MHz} \leq \Delta f < 1 \text{ MHz}$	$0.015 \text{ MHz} \leq f_{\text{offset}} < 0.985 \text{ MHz}$	-15 dBm	30 kHz
10 MHz	$0 \text{ MHz} \leq \Delta f < 1 \text{ MHz}$	$0.05 \text{ MHz} \leq f_{\text{offset}} < 0.95 \text{ MHz}$	-13 dBm	100 kHz
15 MHz	$0 \text{ MHz} \leq \Delta f < 1 \text{ MHz}$	$0.05 \text{ MHz} \leq f_{\text{offset}} < 0.95 \text{ MHz}$	-15 dBm	100 kHz
20 MHz	$0 \text{ MHz} \leq \Delta f < 1 \text{ MHz}$	$0.05 \text{ MHz} \leq f_{\text{offset}} < 0.95 \text{ MHz}$	-16 dBm	100 kHz
All	$1 \text{ MHz} \leq \Delta f < \Delta f_{\text{max}}$	$1.5 \text{ MHz} \leq f_{\text{offset}} < f_{\text{offset}_{\text{max}}}$	-13 dBm	1 MHz

In certain regions the following requirement may apply. For E-UTRA BS operating in Bands 12, 13, 14, 17, emissions shall not exceed the maximum levels specified in Table 6.6.3.5.3-3.

Table 6.6.3.5.3-3: Additional operating band unwanted emission limits for E-UTRA (bands 12, 13 and 14)

Channel bandwidth	Frequency offset of measurement filter -3dB point, Δf	Frequency offset of measurement filter centre frequency, f_{offset}	Test requirement	Measurement bandwidth (Note 1)
All	$0 \text{ MHz} \leq \Delta f < 100 \text{ kHz}$	$0.015 \text{ MHz} \leq f_{\text{offset}} < 0.085 \text{ MHz}$	-13 dBm	30 kHz
All	$100 \text{ kHz} \leq \Delta f < \Delta f_{\text{max}}$	$150 \text{ kHz} \leq f_{\text{offset}} < f_{\text{offset}_{\text{max}}}$	-13 dBm	100 kHz

In certain regions, the following requirements may apply to an E-UTRA TDD BS operating in the same geographic area and in the same operating band as another E-UTRA TDD system without synchronisation. For this case the emissions shall not exceed -52 dBm/MHz in the downlink operating band except in:

- The frequency range from 10 MHz below the lower channel edge to the frequency 10 MHz above the upper channel edge.

The following notes are common to all subclauses in 6.6.3.5:

NOTE 1: As a general rule, the resolution bandwidth of the measuring equipment should be equal to the measurement bandwidth. However, to improve measurement accuracy, sensitivity and efficiency, the resolution bandwidth can be smaller than the measurement bandwidth. When the resolution bandwidth is smaller than the measurement bandwidth, the result should be integrated over the measurement bandwidth in order to obtain the equivalent noise bandwidth of the measurement bandwidth.

NOTE 2: If the above Test Requirement differs from the Minimum Requirement then the Test Tolerance applied for this test is non-zero. The Test Tolerance for this test is defined in Annex G. The explanation of how the Minimum Requirement has been relaxed by the Test Tolerance is given in Annex G.

NOTE 3: This frequency range ensures that the range of values of f_{offset} is continuous.

NOTE 4: The requirement is not applicable when $\Delta f_{\text{max}} < 10 \text{ MHz}$.

6.6.4 Transmitter spurious emissions

6.6.4.1 Definition and applicability

Spurious emissions are emissions which are caused by unwanted transmitter effects such as harmonics emission, parasitic emission, intermodulation products and frequency conversion products, but exclude out of band emissions. This is measured at the base station RF output port.

The transmitter spurious emission limits apply from 9 kHz to 12.75 GHz, excluding the frequency range from 10 MHz below the lowest frequency of the downlink operating band up to 10 MHz above the highest frequency of the downlink operating band (see Table 5.5-1). Exceptions are the requirement in Table 6.6.4.5.4-2 and 6.6.4.5.4-3 that apply also closer than 10 MHz from the downlink operating band.

The requirements shall apply whatever the type of transmitter considered (single carrier or multi-carrier). It applies for all transmission modes foreseen by the manufacturer's specification.

Unless otherwise stated, all requirements are measured as mean power (RMS).

6.6.4.2 Minimum Requirements

The minimum requirement is in TS 36.104 [2] subclause 6.6.4.

6.6.4.3 Test Purpose

This test measures conducted spurious emission from the E-UTRA BS transmitter antenna connector, while the transmitter is in operation.

6.6.4.4 Method of Test

6.6.4.4.1 Initial conditions

Test environment: normal; see Annex D.2.

RF channels to be tested: B, M and T; see subclause 4.7.

- 1) Connect the BS antenna connector to a measurement receiver according to Annex I.1.1 using an attenuator or a directional coupler if necessary
- 2) Measurements shall use a measurement bandwidth in accordance to the conditions in TS 36.104 [2] subclause 6.6.4.
- 3) Detection mode: True RMS.
- 4) Configure the BS with transmitters active at their maximum output power.

6.6.4.4.2 Procedure

- 1) Set the BS to transmit a signal according to E-TM1.1 at the manufacturer's specified maximum output power.
- 2) Measure the emission at the specified frequencies with specified measurement bandwidth and note that the measured value does not exceed the specified value.

6.6.4.5 Test requirements

The measurement result in step 2 of 6.6.4.4.2 shall not exceed the maximum level specified in Table 6.6.4.5.1-1 to Table 6.6.4.5.6-1 if applicable for the BS under test.

NOTE: If a Test Requirement in this clause differs from the corresponding Minimum Requirement then the Test Tolerance applied for this test is non-zero. The Test Tolerance for this test and the explanation of how the Minimum Requirement has been relaxed by the Test Tolerance are given in Annex G.

As mandatory requirement, either subclause 6.6.4.5.1 (Category A limits) or subclause 6.6.4.5.2 (Category B limits) shall apply. The application of either Category A or Category B limits shall be the same as for Operating band unwanted emissions in subclause 6.6.3.

6.6.4.5.1 Spurious emissions (Category A)

The power of any spurious emission shall not exceed the limits in Table 6.6.4.5.1-1.

Table 6.6.4.5.1-1: BS Spurious emission limits, Category A

Frequency range	Maximum level	Measurement Bandwidth	Note
9kHz - 150kHz	-13 dBm	1 kHz	Note 1
150kHz - 30MHz		10 kHz	Note 1
30MHz - 1GHz		100 kHz	Note 1
1GHz – 12.75 GHz		1 MHz	Note 2
NOTE 1: Bandwidth as in ITU-R SM.329 [5] , s4.1			
NOTE 2: Bandwidth as in ITU-R SM.329 [5] , s4.1. Upper frequency as in ITU-R SM.329 [5] , s2.5 table 1			

6.6.4.5.2 Spurious emissions (Category B)

The power of any spurious emission shall not exceed the limits in Table 6.6.4.5.2-1.

Table 6.6.4.5.2-1: BS Spurious emissions limits, Category B

Frequency range	Maximum Level	Measurement Bandwidth	Note
9 kHz ↔ 150 kHz	-36 dBm	1 kHz	Note 1
150 kHz ↔ 30 MHz	-36 dBm	10 kHz	Note 1
30 MHz ↔ 1 GHz	-36 dBm	100 kHz	Note 1
1 GHz ↔ 12.75 GHz	-30 dBm	1 MHz	Note 2
NOTE 1: Bandwidth as in ITU-R SM.329 [5] , s4.1			
NOTE 2: Bandwidth as in ITU-R SM.329 [5] , s4.1. Upper frequency as in ITU-R SM.329 [5] , s2.5 table 1			

6.6.4.5.3 Protection of the BS receiver of own or different BS

This requirement shall be applied for E-UTRA FDD operation in paired operating bands in order to prevent the receivers of the BSs being desensitised by emissions from a BS transmitter. It is measured at the transmit antenna port for any type of BS which has common or separate Tx/Rx antenna ports.

The power of any spurious emission shall not exceed the limits in Table 6.6.4.5.3-1.

Table 6.6.4.5.3-1: BS Spurious emissions limits for protection of the BS receiver

	Frequency range	Maximum Level	Measurement Bandwidth	Note
	F_{UL_low} – F_{UL_high}	-96 dBm	100 kHz	

6.6.4.5.4 Co-existence with other systems in the same geographical area

6.6.4.5.4.1 Additional spurious emissions requirements

These requirements may be applied for the protection of system operating in frequency ranges other than the E-UTRA BS operating band. The limits may apply as an optional protection of such systems that are deployed in the same geographical area as the E-UTRA BS, or they may be set by local or regional regulation as a mandatory requirement for an E-UTRA operating band. It is in some cases not stated in the present document whether a requirement is mandatory or under what exact circumstances that a limit applies, since this is set by local or regional regulation. An overview of regional requirements in the present document is given in Clause 4.3.

Some requirements may apply for the protection of specific equipment (UE, MS and/or BS) or equipment operating in specific systems (GSM, CDMA, UTRA, E-UTRA, etc.) as listed below. The power of any spurious emission shall not

exceed the limits of Table 6.6.4.5.4-1 for a BS where requirements for co-existence with the system listed in the first column apply.

Table 6.6.4.5.4-1: BS Spurious emissions limits for E-UTRA BS for co-existence with systems operating in other frequency bands

System type for E-UTRA to co-exist with	Frequency range for co-existence requirement	Maximum Level	Measurement Bandwidth	Note
GSM900	921 - 960 MHz	-57 dBm	100 kHz	This requirement does not apply to E-UTRA BS operating in band 8
	876 - 915 MHz	-61 dBm	100 kHz	For the frequency range 880-915 MHz, this requirement does not apply to E-UTRA BS operating in band 8, since it is already covered by the requirement in subclause 6.6.4.5.3.
DCS1800	1805 - 1880 MHz	-47 dBm	100 kHz	This requirement does not apply to E-UTRA BS operating in band 3.
	1710 - 1785 MHz	-61 dBm	100 kHz	This requirement does not apply to E-UTRA BS operating in band 3, since it is already covered by the requirement in subclause 6.6.4.5.3.
PCS1900	1930 - 1990 MHz	-47 dBm	100 kHz	This requirement does not apply to E-UTRA BS operating in frequency band 2 or band 36.
	1850 - 1910 MHz	-61 dBm	100 kHz	This requirement does not apply to E-UTRA BS operating in frequency band 2, since it is already covered by the requirement in subclause 6.6.4.5.3. This requirement does not apply to E-UTRA BS operating in frequency band 35.
GSM850 or CDMA850	869 - 894 MHz	-57 dBm	100 kHz	This requirement does not apply to E-UTRA BS operating in frequency band 5
	824 - 849 MHz	-61 dBm	100 kHz	This requirement does not apply to E-UTRA BS operating in frequency band 5, since it is already covered by the requirement in subclause 6.6.4.5.3.
UTRA FDD Band I or E-UTRA Band 1	2110 - 2170 MHz	-52 dBm	1 MHz	This requirement does not apply to E-UTRA BS operating in band 1,
	1920 - 1980 MHz	-49 dBm	1 MHz	This requirement does not apply to E-UTRA BS operating in band 1, since it is already covered by the requirement in subclause 6.6.4.5.3.
UTRA FDD Band II or E-UTRA Band 2	1930 - 1990 MHz	-52 dBm	1 MHz	This requirement does not apply to E-UTRA BS operating in band 2.
	1850 - 1910 MHz	-49 dBm	1 MHz	This requirement does not apply to E-UTRA BS operating in band 2, since it is already covered by the requirement in subclause 6.6.4.5.3
UTRA FDD Band III or E-UTRA Band 3	1805 - 1880 MHz	-52 dBm	1 MHz	This requirement does not apply to E-UTRA BS operating in band 3.
	1710 - 1785 MHz	-49 dBm	1 MHz	This requirement does not apply to E-UTRA BS operating in band 3, since it is already covered by the requirement in subclause 6.6.4.5.3.
UTRA FDD Band IV or E-UTRA Band 4	2110 - 2155 MHz	-52 dBm	1 MHz	This requirement does not apply to E-UTRA BS operating in band 4 or 10
	1710 - 1755 MHz	-49 dBm	1 MHz	This requirement does not apply to E-UTRA BS operating in band 4 or 10, since it is already covered by the requirement in subclause 6.6.4.5.3.
UTRA FDD Band V or E-UTRA Band 5	869 - 894 MHz	-52 dBm	1 MHz	This requirement does not apply to E-UTRA BS operating in band 5
	824 - 849 MHz	-49 dBm	1 MHz	This requirement does not apply to E-UTRA BS operating in band 5, since it is already covered by the requirement in subclause 6.6.4.5.3.
UTRA FDD Band VI or E-UTRA Band 6	860 - 895 MHz	-52 dBm	1 MHz	This requirement does not apply to E-UTRA BS operating in band 6
	815 - 850 MHz	-49 dBm	1 MHz	This requirement does not apply to E-UTRA BS operating in band 6, since it is already covered by the requirement in subclause 6.6.4.5.3.
UTRA FDD Band VII or E-UTRA Band 7	2620 - 2690 MHz	-52 dBm	1 MHz	This requirement does not apply to E-UTRA BS operating in band 7.
	2500 - 2570 MHz	-49 dBm	1 MHz	This requirement does not apply to E-UTRA BS operating in band 7, since it is already covered by the requirement in subclause 6.6.4.5.3.
UTRA FDD Band VIII or	925 - 960 MHz	-52 dBm	1 MHz	This requirement does not apply to E-UTRA BS operating in band 8.

E-UTRA Band 8	880 - 915 MHz	-49 dBm	1 MHz	This requirement does not apply to E-UTRA BS operating in band 8, since it is already covered by the requirement in subclause 6.6.4.5.3.
UTRA FDD Band IX or E-UTRA Band 9	1844.9 - 1879.9 MHz	-52 dBm	1 MHz	This requirement does not apply to E-UTRA BS operating in band 9.
	1749.9 - 1784.9 MHz	-49 dBm	1 MHz	This requirement does not apply to E-UTRA BS operating in band 9, since it is already covered by the requirement in subclause 6.6.4.5.3.
UTRA FDD Band X or E-UTRA Band 10	2110 - 2170 MHz	-52 dBm	1 MHz	This requirement does not apply to E-UTRA BS operating in band 4 or 10
	1710 - 1770 MHz	-49 dBm	1 MHz	This requirement does not apply to E-UTRA BS operating in band 10, since it is already covered by the requirement in subclause 6.6.4.5.3. For E-UTRA BS operating in Band 4, it applies for 1755 MHz to 1770 MHz, while the rest is covered in sub-clause 6.6.4.5.3.
UTRA FDD Band XI or E-UTRA Band 11	1475.9 –1510.9 MHz	-52 dBm	1 MHz	This requirement does not apply to E-UTRA BS operating in band 11
	1427.9 –1447.9 MHz	-49 dBm	1 MHz	This requirement does not apply to E-UTRA BS operating in band 11, since it is already covered by the requirement in subclause 6.6.4.5.3.
UTRA FDD Band XII or E-UTRA Band 12	728 - 746 MHz	-52 dBm	1 MHz	This requirement does not apply to E-UTRA BS operating in band 12.
	698 - 716 MHz	-49 dBm	1 MHz	This requirement does not apply to E-UTRA BS operating in band 12, since it is already covered by the requirement in subclause 6.6.4.5.3.
UTRA FDD Band XIII or E-UTRA Band 13	746 - 756 MHz	-52 dBm	1 MHz	This requirement does not apply to E-UTRA BS operating in band 13.
	777 - 787 MHz	-49 dBm	1 MHz	This requirement does not apply to E-UTRA BS operating in band 13, since it is already covered by the requirement in subclause 6.6.4.5.3.
UTRA FDD Band XIV or E-UTRA Band 14	758 - 768 MHz	-52 dBm	1 MHz	This requirement does not apply to E-UTRA BS operating in band 14.
	788 - 798 MHz	-49 dBm	1 MHz	This requirement does not apply to E-UTRA BS operating in band 14, since it is already covered by the requirement in subclause 6.6.4.5.3.
E-UTRA Band 17	734 - 746 MHz	-52 dBm	1 MHz	This requirement does not apply to E-UTRA BS operating in band 17.
	704 - 716 MHz	-49 dBm	1 MHz	This requirement does not apply to E-UTRA BS operating in band 17, since it is already covered by the requirement in subclause 6.6.4.5.3.
UTRA TDD in Band a) or E-UTRA Band 33	1900 - 1920 MHz	-52 dBm	1 MHz	This requirement does not apply to E-UTRA BS operating in Band 33.
UTRA TDD in Band a) or E-UTRA Band 34	2010 - 2025 MHz	-52 dBm	1 MHz	This requirement does not apply to E-UTRA BS operating in Band 34.
UTRA TDD in Band b) or E-UTRA Band 35	1850 – 1910 MHz	-52 dBm	1 MHz	This requirement does not apply to E-UTRA BS operating in Band 35.
UTRA TDD in Band b) or E-UTRA Band 36	1930 - 1990 MHz	-52 dBm	1 MHz	This requirement does not apply to E-UTRA BS operating in Band 2 and 36.
UTRA TDD in Band c) or E-UTRA Band 37	1910 - 1930 MHz	-52 dBm	1 MHz	This is not applicable to E-UTRA BS operating in Band 37. This unpaired band is defined in ITU-R M.1036, but is pending any future deployment.
UTRA TDD in Band d) or E-UTRA Band 38	2570 – 2620 MHz	-52 dBm	1 MHz	This requirement does not apply to E-UTRA BS operating in Band 38.
E-UTRA Band 39	1880 – 1920MHz	-52 dBm	1 MHz	This is not applicable to E-UTRA BS operating in Band 39.
E-UTRA Band 40	2300 – 2400MHz	-52 dBm	1 MHz	This is not applicable to E-UTRA BS operating in Band 40.

NOTE 1: As defined in the scope for spurious emissions in this clause, the co-existence requirements in Table 6.6.4.5.4-1 do not apply for the 10 MHz frequency range immediately outside the downlink operating band (see Table 5.5-1). Emission limits for this excluded frequency range may be covered by local or regional requirements.

NOTE 2: The table above assumes that two operating bands, where the frequency ranges in Table 5.5-1 would be overlapping, are not deployed in the same geographical area. For such a case of operation with overlapping frequency arrangements in the same geographical area, special co-existence requirements may apply that are not covered by the 3GPP specifications.

The following requirement may be applied for the protection of PHS. This requirement is also applicable at specified frequencies falling between 10 MHz below the lowest BS transmitter frequency of the downlink operating band and 10 MHz above the highest BS transmitter frequency of the downlink operating band (see Table 5.5-1).

The power of any spurious emission shall not exceed:

Table 6.6.4.5.4-2: E-UTRA BS Spurious emissions limits for BS for co-existence with PHS

Frequency range	Maximum Level	Measurement Bandwidth	Note
1884.5 - 1919.6 MHz	-41 dBm	300 kHz	Applicable when co-existence with PHS system operating in 1884.5 -1919.6MHz.
1884.5 - 1915.7 MHz	-41 dBm	300 kHz	Applicable when co-existence with PHS system operating in 1884.5 -1915.7MHz

The following requirement shall be applied to BS operating in Bands 13 and 14 to ensure that appropriate interference protection is provided to 700 MHz public safety operations. This requirement is also applicable at the frequency range from 10 MHz below the lowest frequency of the BS transmitter operating band up to 10 MHz above the highest frequency of the BS transmitter operating band. The power of any spurious emission shall not exceed:

Table 6.6.4.5.4-3: BS Spurious emissions limits for protection of public safety operations

Operating Band	Band	Maximum Level	Measurement Bandwidth	Note
13	763 - 775 MHz	-46 dBm	6.25 kHz	
13	793 - 805 MHz	-46 dBm	6.25 kHz	
14	769 - 775 MHz	-46 dBm	6.25 kHz	
14	799 - 805 MHz	-46 dBm	6.25 kHz	

6.6.4.5.5 Co-location with other base stations

These requirements may be applied for the protection of other BS receivers when GSM900, DCS1800, PCS1900, GSM850, CDMA850, UTRA FDD, UTRA TDD and/or E-UTRA BS are co-located with an E-UTRA BS.

The requirements assume a 30 dB coupling loss between transmitter and receiver.

NOTE: For co-location with UTRA, the requirements are based on co-location with Wide Area UTRA FDD or TDD base stations.

The power of any spurious emission shall not exceed the limits of Table 6.6.4.5.5-1 for a BS where requirements for co-location with a BS type listed in the first column apply.

Table 6.6.4.5.5-1: BS Spurious emissions limits for BS co-located with another BS

Type of co-located BS	Frequency range for co-location requirement	Maximum Level	Measurement Bandwidth	Note
Macro GSM900	876-915 MHz	-98 dBm	100 kHz	
Macro DCS1800	1710 - 1785 MHz	-98 dBm	100 kHz	
Macro PCS1900	1850 - 1910 MHz	-98 dBm	100 kHz	
Macro GSM850 or CDMA850	824 - 849 MHz	-98 dBm	100 kHz	
UTRA FDD Band I or E-UTRA Band 1	1920 - 1980 MHz	-96 dBm	100 kHz	
UTRA FDD Band II or E-UTRA Band 2	1850 - 1910 MHz	-96 dBm	100 kHz	
UTRA FDD Band III or E-UTRA Band 3	1710 - 1785 MHz	-96 dBm	100 kHz	
UTRA FDD Band IV or E-UTRA Band 4	1710 - 1755 MHz	-96 dBm	100 kHz	
UTRA FDD Band V or E-UTRA Band 5	824 - 849 MHz	-96 dBm	100 kHz	
UTRA FDD Band VI or E-UTRA Band 6	815 - 850 MHz	-96 dBm	100 kHz	
UTRA FDD Band VII or E-UTRA Band 7	2500 - 2570 MHz	-96 dBm	100 KHz	
UTRA FDD Band VIII or E-UTRA Band 8	880 - 915 MHz	-96 dBm	100 KHz	
UTRA FDD Band IX or E-UTRA Band 9	1749.9 - 1784.9 MHz	-96 dBm	100 KHz	
UTRA FDD Band X or E-UTRA Band 10	1710 - 1770 MHz	-96 dBm	100 kHz	
UTRA FDD Band XI or E-UTRA Band 11	1427.9 - 1447.9 MHz	-96 dBm	100 kHz	
UTRA FDD Band XII or E-UTRA Band 12	698 - 716 MHz	-96 dBm	100 kHz	
UTRA FDD Band XIII or E-UTRA Band 13	777 - 787 MHz	-96 dBm	100 kHz	
UTRA FDD Band XIV or E-UTRA Band 14	788 - 798 MHz	-96 dBm	100 kHz	
E-UTRA Band 17	704 - 716 MHz	-96 dBm	100 kHz	
UTRA TDD in Band a) or E-UTRA Band 33	1900 - 1920 MHz	-96 dBm	100 kHz	This is not applicable to E-UTRA BS operating in Band 33
UTRA TDD in Band a) or E-UTRA Band 34	2010 - 2025 MHz	-96 dBm	100 kHz	This is not applicable to E-UTRA BS operating in Band 34
UTRA TDD in Band b) or E-UTRA Band 35	1850 – 1910 MHz	-96 dBm	100 kHz	This is not applicable to E-UTRA BS operating in Band 35
UTRA TDD in Band b) or E-UTRA Band 36	1930 - 1990 MHz	-96 dBm	100 kHz	This is not applicable to E-UTRA BS operating in Band 2 and 36
UTRA TDD in Band c) or E-UTRA Band 37	1910 - 1930 MHz	-96 dBm	100 kHz	This is not applicable to E-UTRA BS operating in Band 37. This unpaired band is defined in ITU-R M.1036, but is pending any future deployment.

UTRA TDD in Band d) or E-UTRA Band 38	2570 – 2620 MHz	-96 dBm	100 kHz	This is not applicable to E-UTRA BS operating in Band 38.
E-UTRA Band 39	1880 – 1920MHz	-96 dBm	100 kHz	This is not applicable to E-UTRA BS operating in Band 33 and 39
E-UTRA Band 40	2300 – 2400MHz	-96 dBm	100 kHz	This is not applicable to E-UTRA BS operating in Band 40

NOTE 1: As defined in the scope for spurious emissions in this clause, the co-location requirements in Table 6.6.4.5.5-1 do not apply for the 10 MHz frequency range immediately outside the BS transmit frequency range of a downlink operating band (see Table 5.5-1). The current state-of-the-art technology does not allow a single generic solution for co-location with other system on adjacent frequencies for 30dB BS-BS minimum coupling loss. However, there are certain site-engineering solutions that can be used. These techniques are addressed in TR 25.942 [11].

NOTE 2: The table above assumes that two operating bands, where the corresponding eNode B transmit and receive frequency ranges in Table 5.3-1 would be overlapping, are not deployed in the same geographical area. For such a case of operation with overlapping frequency arrangements in the same geographical area, special co-location requirements may apply that are not covered by the 3GPP specifications.

NOTE 3: Co-located TDD base stations that are synchronized and using the same operating band can transmit without special co-locations requirements. For unsynchronized base stations, special co-location requirements may apply that are not covered by the 3GPP specifications.

6.7 Transmitter intermodulation

6.7.1 Definition and applicability

The transmit intermodulation requirement is a measure of the capability of the transmitter to inhibit the generation of signals in its non linear elements caused by presence of the own transmit signal and an interfering signal reaching the transmitter via the antenna. The requirement applies during the transmitter ON period and the transmitter transient period.

The transmit intermodulation level is the power of the intermodulation products when an E-UTRA signal of channel bandwidth 5 MHz as an interfering signal is injected into an antenna connector at a mean power level of 30 dB lower than that of the mean power of the wanted signal. The wanted signal channel bandwidth BW_{Channel} shall be the maximum bandwidth supported by the base station. The bandwidth of the wanted signal shall be according to TS 36.104 [1] subclause 6.7.1.

The requirements shall apply whatever the type of transmitter considered (single carrier or multi-carrier). It applies for all transmission modes foreseen by the manufacturer's specification.

6.7.2 Minimum Requirement

The minimum requirement is in TS 36.104 [2] subclause 6.7.1.

6.7.3 Test purpose

The test purpose is to verify the ability of the BS transmitter to restrict the generation of intermodulation products in its non linear elements caused by presence of the wanted signal and an interfering signal reaching the transmitter via the antenna to below specified levels.

6.7.4 Method of test

6.7.4.1 Initial conditions

Test environment: normal; see Annex D.2.

RF channels to be tested: B, M and T; see subclause 4.7.

Connect the signal analyzer to the base station RF output port as shown in Annex I.1.2.

6.7.4.2 Procedures

- 1) Generate the wanted signal according to E-TM1.1 at specified maximum BS output power.
- 2) Generate the interfering signal according to E-TM1.1, with 5 MHz channel bandwidth and centre frequency offset of $BW_{\text{Channel}}/2 + 2.5$ MHz relative to the wanted signal, but exclude interference frequencies that are outside of the allocated frequency band for E-UTRA downlink specified in subclause 5.5.
- 3) Adjust ATT1 so that level of the E-UTRA modulated interfering signal is as defined in subclause 6.7.5.
- 4) Perform the Out-of-band emission tests as specified in subclauses 6.6.2 and 6.6.3, for all third and fifth order intermodulation products which appear in the frequency ranges defined in subclauses 6.6.2 and 6.6.3. The width of the intermodulation products shall be taken into account.
- 5) Perform the Transmitter spurious emissions test as specified in subclause 6.6.4, for all third and fifth order intermodulation products which appear in the frequency ranges defined in subclause 6.6.4. The width of the intermodulation products shall be taken into account.
- 6) Verify that the emission level does not exceed the required level with the exception of interfering signal frequencies.
- 7) Repeat the test for interfering signal centre frequency offset of $-BW_{\text{Channel}}/2 - 2.5$ MHz but exclude interfering signal frequencies that are outside of the allocated frequency band for E-UTRA downlink specified in subclause 5.5.
- 8) Repeat the test for interfering signal centre frequency offsets of $\pm (BW_{\text{Channel}}/2 + 7.5$ MHz) and $\pm (BW_{\text{Channel}}/2 + 12.5$ MHz) but exclude interfering signal frequencies that are outside of the allocated frequency band for E-UTRA downlink specified in subclause 5.5.

NOTE: The third order intermodulation products are centred at $2F1 \pm F2$ and $2F2 \pm F1$. The fifth order intermodulation products are centred at $3F1 \pm 2F2$, $3F2 \pm 2F1$, $4F1 \pm F2$, and $4F2 \pm F1$ where F1 represents the wanted signal centre frequency and F2 represents the interfering signal centre frequency. The width of intermodulation products are

- $(n \cdot BW_{\text{Channel}} + m \cdot 5\text{MHz})$ for the $nF1 \pm mF2$ products
- $(n \cdot 5\text{MHz} + m \cdot BW_{\text{Channel}})$ for the $nF2 \pm mF1$ products

6.7.5 Test Requirements

In the frequency range relevant for this test, the transmit intermodulation level shall not exceed the out-of-band emission requirements of subclauses 6.6.2 and 6.6.3 and transmitter spurious emissions requirements of subclause 6.6.4 in the presence of a E-UTRA modulated interfering signal with a mean power 30 dB below the mean power of the wanted signal.

The measurements for out-of-band emissions and spurious emission requirements due to intermodulation can be limited to the frequency ranges of all third and fifth order intermodulation products, excluding the channel bandwidths of the wanted and interfering signals.

NOTE: If the above Test Requirement differs from the Minimum Requirement then the Test Tolerance applied for this test is non-zero. The Test Tolerance for this test is defined in Annex G. The explanation of how the Minimum Requirement has been relaxed by the Test Tolerance is given in Annex G.

7 Receiver characteristics

7.1 General

General test conditions for receiver tests are given in Clause 4, including interpretation of measurement results and configurations for testing. BS configurations for the tests are defined in Clause 4.5, while Annex H provides an informative description of E-UTRAN test cases.

Unless otherwise stated the requirements in clause 7 apply during the base station receive period.

The throughput requirements defined for the receiver characteristics in this clause do not assume HARQ transmissions.

7.2 Reference sensitivity level

7.2.1 Definition and applicability

The reference sensitivity power level P_{REFSENS} is the minimum mean power received at the antenna connector at which a throughput requirement shall be met for a specified reference measurement channel.

The test is set up according to Annex I.2.1 and performed without interfering signal power applied to the BS antenna connector. For duplex operation, the measurement configuration principle is indicated for one duplex branch in Annex I.2.1. The reference point for signal power is at the input of the receiver (antenna connector).

7.2.2 Minimum Requirement

The minimum requirement is in TS 36.104 [2] subclause 7.2.1.

7.2.3 Test purpose

To verify that at the BS Reference sensitivity level the throughput requirement shall be met for a specified reference measurement channel.

7.2.4 Method of testing

7.2.4.1 Initial conditions

Test environment: normal; see subclause D.2

RF channels to be tested: B, M and T; see subclause 4.7.

The following additional tests shall be performed:

- a) On each of B, M and T, the test shall be performed under extreme power supply as defined in subclause D.5

NOTE: Tests under extreme power supply also test extreme temperature.

- 1) Connect the test equipment as shown in Annex I.2.1.

7.2.4.2 Procedure

- 1) Set the test signal mean power as specified in table 7.2-1.
- 2) Measure the throughput according to Annex E.
- 3) Repeat the measurement for the other RX port.

7.2.5 Test requirement

The throughput shall be $\geq 95\%$ of the maximum throughput of the reference measurement channel as specified in Annex A.1 with parameters specified in Table 7.2-1.

Table 7.2-1: BS reference sensitivity levels

E-UTRA channel bandwidth [MHz]	Reference measurement channel	Reference sensitivity power level, P_{REFSENS} [dBm]
1.4	FRC A1-1 in Annex A.1	-106.1
3	FRC A1-2 in Annex A.1	-102.3
5	FRC A1-3 in Annex A.1	-100.8
10	FRC A1-3 in Annex A.1*	-100.8
15	FRC A1-3 in Annex A.1*	-100.8
20	FRC A1-3 in Annex A.1*	-100.8
Note*: P_{REFSENS} is the power level of a single instance of the reference measurement channel. This requirement shall be met for each consecutive application of a single instance of FRC A1-3 mapped to disjoint frequency ranges with a width of 25 Resource Blocks each.		

NOTE: If the above Test Requirement differs from the Minimum Requirement then the Test Tolerance applied for this test is non-zero. The relationship between Minimum Requirements and Test Requirements is defined in subclause 4.1 and the explanation of how the Minimum Requirement has been relaxed by the Test Tolerance is given in Annex G.

7.3 Dynamic range

7.3.1 Definition and applicability

The dynamic range is specified as a measure of the capability of the receiver to receive a wanted signal in the presence of an interfering signal inside the received channel bandwidth. In this condition a throughput requirement shall be met for a specified reference measurement channel. The interfering signal for the dynamic range requirement is an AWGN signal.

7.3.2 Minimum Requirement

The minimum requirement is in TS 36.104 [2] subclause 7.3.1.

7.3.3 Test purpose

To verify that at the BS receiver dynamic range, the relative throughput shall fulfil the specified limit.

7.3.4 Method of testing

7.3.4.1 Initial conditions

Test environment: normal; see subclause D.2

RF channels to be tested: B, M and T; see subclause 4.7

- 1) Connect the test equipment as shown in Annex I.2.2.

7.3.4.2 Procedure

For each supported E-UTRA channel BW:

- 1) Adjust the signal generator for the wanted signal as specified in Table 7.3-1.
- 2) Adjust the AWGN generator level as specified in Table 7.3-1 and set the frequency to the same frequency as the tested channel.
- 3) Measure the throughput according to Annex E and verify that it is within the specified level.

Repeat the measurement for the other RX port.

7.3.5 Test Requirements

The throughput shall be $\geq 95\%$ of the maximum throughput of the reference measurement channel as specified in Annex A with parameters specified in Table 7.3-1.

Table 7.3-1: Dynamic range

E-UTRA channel bandwidth [MHz]	Reference measurement channel	Wanted signal mean power [dBm]	Interfering signal mean power [dBm] / BW_{Config}	Type of interfering signal
1.4	FRC A2-1 in Annex A.2	-76.0	-88.7	AWGN
3	FRC A2-2 in Annex A.2	-72.1	-84.7	AWGN
5	FRC A2-3 in Annex A.2	-69.9	-82.5	AWGN
10	FRC A2-3 in Annex A.2*	-69.9	-79.5	AWGN
15	FRC A2-3 in Annex A.2*	-69.9	-77.7	AWGN
20	FRC A2-3 in Annex A.2*	-69.9	-76.4	AWGN
Note*:	The wanted signal mean power is the power level of a single instance of the reference measurement channel. This requirement shall be met for each consecutive application of a single instance of FRC A2-3 mapped to disjoint frequency ranges with a width of 25 resource blocks each			

NOTE: If the above Test Requirement differs from the Minimum Requirement then the Test Tolerance applied for this test is non-zero. The relationship between Minimum Requirements and Test Requirements is defined in subclause 4.1 and the explanation of how the Minimum Requirement has been relaxed by the Test Tolerance is given in Annex G.

7.4 In-channel selectivity

7.4.1 Definition and applicability

In-channel selectivity (ICS) is a measure of the receiver ability to receive a wanted signal at its assigned Resource Block locations in the presence of an interfering signal received at a larger power spectral density. In this condition a throughput requirement shall be met for a specified reference measurement channel. The interfering signal shall be an E-UTRA signal as specified in Annex C and shall be time aligned with the wanted signal.

7.4.2 Minimum Requirement

The minimum requirement is in TS 36.104 [2] subclause 7.4.1.

7.4.3 Test purpose

The purpose of this test is to verify the BS receiver ability to suppress the IQ leakage.

7.4.4 Method of testing

7.4.4.1 Initial conditions

Test environment: normal; see subclause D.2.

RF channels to be tested: B, M and T; see subclause 4.7

- 1) Connect the test equipment as shown in Annex I.2.3.

7.4.4.2 Procedure

For each supported E-UTRA channel BW:

- 1) Adjust the signal generator for the wanted signal as specified in Table 7.4-1 on one side of the F_C .
- 2) Adjust the signal generator for the interfering signal as specified in Table 7.4-1 at opposite side of the F_C and adjacent to the wanted signal.
- 3) Measure the throughput according to Annex E.
- 4) Repeat the measurement with the wanted signal on the other side of the F_C .
- 5) Repeat the measurement for the other RX port.

7.4.5 Test Requirements

The throughput shall be $\geq 95\%$ of the maximum throughput of the reference measurement channel as specified in Annex A with parameters specified in Table 7.4-1.

Table 7.4-1 E-UTRA BS in-channel selectivity

E-UTRA channel bandwidth (MHz)	Reference measurement channel	Wanted signal mean power [dBm]	Interfering signal mean power [dBm]	Type of interfering signal
1.4	A1-4 in Annex A.1	-105.5	-87	1.4 MHz E-UTRA signal, 3 RBs
3	A1-5 in Annex A.1	-100.7	-84	3 MHz E-UTRA signal, 6 RBs
5	A1-2 in Annex A.1	-98.6	-81	5 MHz E-UTRA signal, 10 RBs
10	A1-3 in Annex A.1	-97.1	-77	10 MHz E-UTRA signal, 25 RBs
15	A1-3 in Annex A.1*	-97.1	-77	15 MHz E-UTRA signal, 25 RBs*
20	A1-3 in Annex A.1*	-97.1	-77	20 MHz E-UTRA signal, 25 RBs*
Note*: Wanted and interfering signal are placed adjacently around F_c				

NOTE: If the above Test Requirement differs from the Minimum Requirement then the Test Tolerance applied for this test is non-zero. The relationship between Minimum Requirements and Test Requirements is defined in subclause 4.1 and the explanation of how the Minimum Requirement has been relaxed by the Test Tolerance is given in Annex G.

7.5 Adjacent Channel Selectivity (ACS) and narrow-band blocking

7.5.1 Definition and applicability

Adjacent channel selectivity (ACS) is a measure of the receiver's ability to receive a wanted signal at its assigned channel frequency in the presence of an adjacent channel signal with a specified centre frequency offset of the interfering signal to the band edge of a victim system.

The interfering signal shall be an E-UTRA signal as specified in Annex C.

7.5.2 Minimum Requirement

The minimum requirement is in TS 36.104 [2] subclause 7.5.

7.5.3 Test purpose

The test purpose is to verify the ability of the BS receiver filter to suppress interfering signals in the channels adjacent to the wanted channel.

7.5.4 Method of test

7.5.4.1 Initial conditions

Test environment: normal; see subclause D.2.

RF channels to be tested: B, M and T; see subclause 4.7.

- 1) Set-up the measurement system as shown in Annex I.2.4.

7.5.4.2 Procedure for Adjacent Channel Selectivity

- 1) Generate the wanted signal and adjust the input level to the base station under test to the level specified in Table 7.5-3.
- 2) Set-up the interfering signal at the adjacent channel frequency and adjust the interfering signal level at the base station input to the level defined in Table 7.5-3.
- 3) Measure the throughput according to Annex E.
- 4) Repeat the test for the port, which was terminated.

7.5.4.3 Procedure for narrow-band blocking

- 1) Generate the wanted signal and adjust the input level to the base station under test to the level specified in Table 7.5-1.
- 2) Adjust the interfering signal level at the base station input to the level defined in Table 7.5-1. Set-up and sweep the interfering RB centre frequency offset to the channel edge of the wanted signal according to Table 7.5-2.
- 3) Measure the throughput according to Annex E.
- 4) Repeat the test for the port, which was terminated.

7.5.5 Test Requirements

The throughput shall be $\geq 95\%$ of the maximum throughput of the reference measurement channel, with a wanted and an interfering signal coupled to the BS antenna input as specified in Table 7.5-2 for narrowband blocking and 7.5-3 for ACS. The reference measurement channel for the wanted signal is identified in Table 7.2-1 for each channel bandwidth and further specified in Annex A.

Table 7.5-1: Narrowband blocking requirement

Wanted signal mean power [dBm]	Interfering signal mean power [dBm]	Type of interfering signal
$P_{\text{REFSENS}} + 6\text{dB}^*$	-49	See Table 7.5-2
Note*: P_{REFSENS} depends on the channel bandwidth as specified in TS 36.104 [2] subclause 7.2.1.		

Table 7.5-2: Interfering signal for Narrowband blocking requirement

E-UTRA Assigned BW [MHz]	Interfering RB centre frequency offset to the channel edge of the wanted signal [kHz]	Type of interfering signal
1.4	252.5+m*180, m=0, 1, 2, 3, 4, 5	1.4 MHz E-UTRA signal, 1 RB*
3	247.5+m*180, m=0, 1, 2, 3, 4, 7, 10, 13	3 MHz E-UTRA signal, 1 RB*
5	342.5+m*180, m=0, 1, 2, 3, 4, 9, 14, 19, 24	5 MHz E-UTRA signal, 1 RB*
10	347.5+m*180, m=0, 1, 2, 3, 4, 9, 14, 19, 24	5 MHz E-UTRA signal, 1 RB*
15	352.5+m*180, m=0, 1, 2, 3, 4, 9, 14, 19, 24	5 MHz E-UTRA signal, 1 RB*
20	342.5+m*180, m=0, 1, 2, 3, 4, 9, 14, 19, 24	5 MHz E-UTRA signal, 1 RB*
Note*: Interfering signal consisting of one resource block adjacent to the wanted signal, the channel bandwidth of the interfering signal is located adjacently to the channel edge of the wanted signal.		

Table 7.5-3: Adjacent channel selectivity

E-UTRA channel bandwidth [MHz]	Wanted signal mean power [dBm]	Interfering signal mean power [dBm]	Interfering signal centre frequency offset from the channel edge of the wanted signal [MHz]	Type of interfering signal
1.4	$P_{\text{REFSENS}} + 11\text{dB}^*$	-52	0.7025	1.4MHz E-UTRA signal
3	$P_{\text{REFSENS}} + 8\text{dB}^*$	-52	1.5075	3MHz E-UTRA signal
5	$P_{\text{REFSENS}} + 6\text{dB}^*$	-52	2.5025	5MHz E-UTRA signal
10	$P_{\text{REFSENS}} + 6\text{dB}^*$	-52	2.5075	5MHz E-UTRA signal
15	$P_{\text{REFSENS}} + 6\text{dB}^*$	-52	2.5125	5MHz E-UTRA signal
20	$P_{\text{REFSENS}} + 6\text{dB}^*$	-52	2.5025	5MHz E-UTRA signal
Note*: P_{REFSENS} depends on the channel bandwidth as specified in TS 36.104 [2] subclause 7.2.1.				

NOTE: If the above Test Requirement differs from the Minimum Requirement then the Test Tolerance applied for this test is non-zero. The relationship between Minimum Requirements and Test Requirements is defined in subclause 4.1 and the explanation of how the Minimum Requirement has been relaxed by the Test Tolerance is given in Annex G.

7.6 Blocking

7.6.1 Definition and applicability

The blocking characteristics is a measure of the receiver ability to receive a wanted signal at its assigned channel in the presence of an unwanted interferer, which are either a 1.4MHz, 3MHz or 5MHz E-UTRA signal for in-band blocking or a CW signal for out-of-band blocking. The interfering E-UTRA signal shall be as specified in Annex C.

The blocking performance requirement applies as specified in the Tables 7.6-1 and 7.6-2 in clause 7.6.5.

7.6.2 Minimum Requirements

The minimum requirement is in TS 36.104 [2] subclause 7.6.1.

7.6.3 Test purpose

The test stresses the ability of the BS receiver to withstand high-level interference from unwanted signals at specified frequency offsets without undue degradation of its sensitivity.

7.6.4 Method of test

7.6.4.1 Initial conditions

Test environment: normal; see subclause D.2.

RF channels to be tested: M see subclause 4.7. The BS shall be configured to operate as close to the centre of the operating band (see Table 5.5-1) as possible.

Channel bandwidths to be tested:

- a) In the interferer frequency range ($F_{UL_low} - 20$) MHz to ($F_{UL_high} + 20$) MHz the requirement shall be tested with the lowest and the highest bandwidth supported by the BS.
 - b) In the interferer frequency ranges 1 MHz to ($F_{UL_low} - 20$) MHz and ($F_{UL_high} + 20$) MHz to 12750 MHz the requirement shall be tested only with the lowest bandwidth supported by the BS.
- 1) Connect the signal generator for the wanted signal and the signal generator for the interfering signal to the antenna connector of one Rx port as shown in Annex I.2.5.
 - 2) Terminate any other Rx port not under test.
 - 3) Start to transmit according to reference measurement channel in annex A.1 to the BS under test. The level of the wanted signal measured at the BS antenna connector shall be set to the level specified in subclause 7.6.5.

7.6.4.2 Procedure

- 1) Adjust the signal generators to the type of interfering signals, levels and the frequency offsets as specified in Tables 7.6-1, 7.6-2 and 7.6-3. The E-UTRA interfering signal shall be swept with a step size of 1 MHz starting from the minimum offset to the channel edges of the wanted signal as specified in Table 7.6-2. The CW interfering signal shall be swept with a step size of 1 MHz within the range specified in Table 7.6-1 and 7.6-3.
- 2) Measure the throughput of the wanted signal at the BS receiver according to Annex E.
- 3) Interchange the connections of the BS Rx ports and repeat the measurements according to steps (1) to (2).

7.6.5 Test Requirements

7.6.5.1 General requirement

The throughput shall be $\geq 95\%$ of the maximum throughput of the reference measurement channel, with a wanted and an interfering signal coupled to BS antenna input using the parameters in Table 7.6-1 and 7.6-2. The reference measurement channel for the wanted signal is identified in Table 7.2-1 for each channel bandwidth and further specified in Annex A.

Table 7.6-1: Blocking performance requirement

Operating Band	Centre Frequency of Interfering Signal [MHz]	Interfering Signal mean power [dBm]	Wanted Signal mean power [dBm]	Interfering signal centre frequency minimum frequency offset from the channel edge of the wanted signal [MHz]	Type of Interfering Signal
1-7, 9-11, 13-14, 33-40	$(F_{UL_low} - 20)$ to $(F_{UL_high} + 20)$	-43	$P_{REFSENS} + 6dB^*$	See table 7.6-2	See table 7.6-2
	1 to $(F_{UL_low} - 20)$ $(F_{UL_high} + 20)$ to 12750	-15	$P_{REFSENS} + 6dB^*$	—	CW carrier
8	$(F_{UL_low} - 20)$ to $(F_{UL_high} + 10)$	-43	$P_{REFSENS} + 6dB^*$	See table 7.6-2	See table 7.6-2
	1 to $(F_{UL_low} - 20)$ $(F_{UL_high} + 10)$ to 12750	-15	$P_{REFSENS} + 6dB^*$	—	CW carrier
12	$(F_{UL_low} - 20)$ to $(F_{UL_high} + 12)$	-43	$P_{REFSENS} + 6dB^*$	See table 7.6-2	See table 7.6-2
	1 to $(F_{UL_low} - 20)$ $(F_{UL_high} + 12)$ to 12750	-15	$P_{REFSENS} + 6dB^*$	—	CW carrier
17	$(F_{UL_low} - 20)$ to $(F_{UL_high} + 18)$	-43	$P_{REFSENS} + 6dB^*$	See table 7.6-2	See table 7.6-2
	1 to $(F_{UL_low} - 20)$ $(F_{UL_high} + 18)$ to 12750	-15	$P_{REFSENS} + 6dB^*$	—	CW carrier
Note*: $P_{REFSENS}$ depends on the channel bandwidth as specified in TS 36.104 [2] subclause 7.2.1.					

Table 7.6-2: Interfering signals for Blocking performance requirement

E-UTRA channel BW [MHz]	Interfering signal centre frequency minimum offset to the channel edge of the wanted signal [MHz]	Type of interfering signal
1.4	2.1	1.4MHz E-UTRA signal
3	4.5	3MHz E-UTRA signal
5	7.5	5MHz E-UTRA signal
10	7.5	5MHz E-UTRA signal
15	7.5	5MHz E-UTRA signal
20	7.5	5MHz E-UTRA signal

NOTE: If the above Test Requirement differs from the Minimum Requirement then the Test Tolerance applied for this test is non-zero. The relationship between Minimum Requirements and Test Requirements is defined in subclause 4.1 and the explanation of how the Minimum Requirement has been relaxed by the Test Tolerance is given in Annex G.

7.6.5.2 Co-location with other base stations

This additional blocking requirement may be applied for the protection of E-UTRA BS receivers when GSM, CDMA, UTRA or E-UTRA BS operating in a different frequency band are co-located with an E-UTRA BS. The requirement is applicable to all channel bandwidths supported by the E-UTRA BS.

The requirements in this clause assume a 30 dB coupling loss between interfering transmitter and E-UTRA BS receiver.

NOTE: For co-location with UTRA, the requirements are based on co-location with Wide Area UTRA FDD or TDD base stations.

The throughput shall be $\geq 95\%$ of the maximum throughput of the reference measurement channel, with a wanted and an interfering signal coupled to BS antenna input using the parameters in Table 7.6-3. The reference measurement channel for the wanted signal is identified in Table 7.2-1 for each channel bandwidth and further specified in Annex A.

Table 7.6-3: Blocking performance requirement for E-UTRA BS when co-located with BS in other frequency bands.

Co-located BS type	Centre Frequency of Interfering Signal (MHz)	Interfering Signal mean power (dBm)	Wanted Signal mean power (dBm)	Type of Interfering Signal
Macro GSM850 or CDMA850	869 – 894	+16	$P_{\text{REFSENS}} + 6\text{dB}^*$	CW carrier
Macro GSM900	921 – 960	+16	$P_{\text{REFSENS}} + 6\text{dB}^*$	CW carrier
Macro DCS1800	1805 – 1880	+16	$P_{\text{REFSENS}} + 6\text{dB}^*$	CW carrier
Macro PCS1900	1930 – 1990	+16	$P_{\text{REFSENS}} + 6\text{dB}^*$	CW carrier
UTRA FDD Band I or E-UTRA Band 1	2110 – 2170	+16	$P_{\text{REFSENS}} + 6\text{dB}^*$	CW carrier
UTRA FDD Band II or E-UTRA Band 2	1930 – 1990	+16	$P_{\text{REFSENS}} + 6\text{dB}^*$	CW carrier
UTRA FDD Band III or E-UTRA Band 3	1805 – 1880	+16	$P_{\text{REFSENS}} + 6\text{dB}^*$	CW carrier
UTRA FDD Band IV or E-UTRA Band 4	2110 – 2155	+16	$P_{\text{REFSENS}} + 6\text{dB}^*$	CW carrier
UTRA FDD Band V or E-UTRA Band 5	869 – 894	+16	$P_{\text{REFSENS}} + 6\text{dB}^*$	CW carrier
UTRA FDD Band VI or E-UTRA Band 6	875 – 885	+16	$P_{\text{REFSENS}} + 6\text{dB}^*$	CW carrier
UTRA FDD Band VII or E-UTRA Band 7	2620 – 2690	+16	$P_{\text{REFSENS}} + 6\text{dB}^*$	CW carrier
UTRA FDD Band VIII or E-UTRA Band 8	925 – 960	+16	$P_{\text{REFSENS}} + 6\text{dB}^*$	CW carrier
UTRA FDD Band IX or E-UTRA Band 9	1844.9 – 1879.9	+16	$P_{\text{REFSENS}} + 6\text{dB}^*$	CW carrier
UTRA FDD Band X or E-UTRA Band 10	2110 – 2170	+16	$P_{\text{REFSENS}} + 6\text{dB}^*$	CW carrier
UTRA FDD Band XI or E-UTRA Band 11	1475.9 – 1495.9	+16	$P_{\text{REFSENS}} + 6\text{dB}^*$	CW carrier
UTRA FDD Band XII or E-UTRA Band 12	728 - 746	+16	$P_{\text{REFSENS}} + 6\text{dB}^*$	CW carrier
UTRA FDD Band XIII or E-UTRA Band 13	746 - 756	+16	$P_{\text{REFSENS}} + 6\text{dB}^*$	CW carrier
UTRA FDD Band XIV or E-UTRA Band 14	758 - 768	+16	$P_{\text{REFSENS}} + 6\text{dB}^*$	CW carrier
E-UTRA Band 17	734 - 746	+16	$P_{\text{REFSENS}} + 6\text{dB}^*$	CW carrier
UTRA TDD in Band a)	1900-1920 2010-2025	+16	$P_{\text{REFSENS}} + 6\text{dB}^*$	CW carrier
E-UTRA TDD in Band 33	1900-1920	+16	$P_{\text{REFSENS}} + 6\text{dB}^*$	CW carrier
E-UTRA TDD in Band 34	2010-2025	+16	$P_{\text{REFSENS}} + 6\text{dB}^*$	CW carrier
UTRA TDD in Band b)	1850-1910 1930-1990	+16	$P_{\text{REFSENS}} + 6\text{dB}^*$	CW carrier
E-UTRA TDD in Band 35	1850-1910	+16	$P_{\text{REFSENS}} + 6\text{dB}^*$	CW carrier
E-UTRA TDD in Band 36	1930-1990	+16	$P_{\text{REFSENS}} + 6\text{dB}^*$	CW carrier
UTRA TDD in Band c) or E-UTRA TDD in Band 37	1910-1930	+16	$P_{\text{REFSENS}} + 6\text{dB}^*$	CW carrier
UTRA TDD in Band d) or E-UTRA in Band 38	2570-2620	+16	$P_{\text{REFSENS}} + 6\text{dB}^*$	CW carrier
E-UTRA in Band 39	1880-1920	+16	$P_{\text{REFSENS}} + 6\text{dB}^*$	CW carrier
E-UTRA in Band 40	2300-2400	+16	$P_{\text{REFSENS}} + 6\text{dB}^*$	CW carrier
Note*:	P_{REFSENS} is related to the channel bandwidth and specified in TS 36.104 [2] subclause 7.2.1.			
NOTE 1:	Except for a BS operating in Band 13, these requirements do not apply when the interfering signal falls within the uplink operating band or in the 10 MHz immediately outside the uplink operating band. For a BS operating in band 13 the requirements do not apply when the interfering signal falls within the frequency range 768-797 MHz.			
NOTE 2:	Some combinations of bands may not be possible to co-site based on the requirements above. The current state-of-the-art technology does not allow a single generic solution for co-location of UTRA TDD or E-UTRA TDD with E-UTRA FDD on adjacent frequencies			

for 30dB BS-BS minimum coupling loss. However, there are certain site-engineering solutions that can be used. These techniques are addressed in TR 25.942 [11].

7.7 Receiver spurious emissions

7.7.1 Definition and applicability

The spurious emissions power is the power of emissions generated or amplified in a receiver that appear at the BS receiver antenna connector. The requirements apply to all BS with separate RX and TX antenna ports. The test shall be performed when both TX and RX are on, with the TX port terminated.

For TDD BS with common RX and TX antenna port the requirement applies during the Transmitter OFF period. For FDD BS with common RX and TX antenna port the transmitter spurious emission as specified in clause 6.6.4 is valid.

7.7.2 Minimum Requirements

The minimum requirement is in TS 36.104 [2] subclause 7.7.1.

7.7.3 Test purpose

The test purpose is to verify the ability of the BS to limit the interference caused by receiver spurious emissions to other systems.

7.7.4 Method of test

7.7.4.1 Initial conditions

Test environment: normal; see subclause D.2.

RF channels to be tested: M, see subclause 4.7.

- 1) Connect a measurement receiver to the BS antenna connector as shown in Annex I.2.6.
- 2) Enable the BS receiver.
- 3) Terminate the BS Tx antenna connector as shown in Annex I.2.6.

7.7.4.2 Procedure

- 1) Start BS transmission according to E-TM 1.1 at Pmax.
- 2) Set measurement equipment parameters as specified in table 7.7-1.
- 3) Measure the spurious emissions over each frequency range described in subclause 7.7.5.
- 4) Repeat the test using diversity antenna connector if available.

7.7.5 Test requirements

The power of any spurious emission shall not exceed the levels in Table 7.7-1.

In addition to the requirements in Table 7.7-1, the power of any spurious emission shall not exceed the levels specified for Protection of the E-UTRA FDD BS receiver of own or different BS in Clause 6.6.4.2 and for Co-existence with other systems in the same geographical area in Clause 6.6.4.3. In addition, the co-existence requirements for co-located base stations specified in subclause 6.6.4.4 may also be applied.

Table 7.7-1: General spurious emission test requirement

Frequency range	Maximum level	Measurement Bandwidth	Note
30MHz - 1 GHz	-57 dBm	100 kHz	
1 GHz - 12.75 GHz	-47 dBm	1 MHz	
NOTE: The frequency range between $2.5 * BW_{\text{Channel}}$ below the first carrier frequency and $2.5 * BW_{\text{Channel}}$ above the last carrier frequency transmitted by the BS, where BW_{Channel} is the channel bandwidth according to Table 5.6-1, may be excluded from the requirement. However, frequencies that are more than 10 MHz below the lowest frequency of the BS downlink operating band or more than 10 MHz above the highest frequency of the BS downlink operating band (see Table 5.5-1) shall not be excluded from the requirement.			

NOTE: If the above Test Requirement differs from the Minimum Requirement then the Test Tolerance applied for this test is non-zero. The relationship between Minimum Requirements and Test Requirements is defined in subclause 4.1 and the explanation of how the Minimum Requirement has been relaxed by the Test Tolerance is given in Annex G.

7.8 Receiver intermodulation

7.8.1 Definition and applicability

Third and higher order mixing of the two interfering RF signals can produce an interfering signal in the band of the desired channel. Intermodulation response rejection is a measure of the capability of the receiver to receive a wanted signal on its assigned channel frequency in the presence of two interfering signals which have a specific frequency relationship to the wanted signal. Interfering signals shall be a CW signal and an E-UTRA signal as specified in Annex C.

7.8.2 Minimum Requirement

The minimum requirement is in TS 36.104 [2] subclause 7.8.1.

7.8.3 Test purpose

The test purpose is to verify the ability of the BS receiver to inhibit the generation of intermodulation products in its non-linear elements caused by the presence of two high-level interfering signals at frequencies with a specific relationship to the frequency of the wanted signal.

7.8.4 Method of test

7.8.4.1 Initial conditions

Test environment: normal; see subclause D.2.

RF channels to be tested: B, M and T; see subclause 4.7.

- 1) Set-up the measurement system as shown in Annex I.2.7.

7.8.4.2 Procedures

- 1) Generate the wanted signal and adjust the signal level to the BS under test to the level specified in Table 7.8-1.
- 2) Adjust the signal generators to the type of interfering signals, levels and the frequency offsets as specified in Table 7.8-2 for intermodulation requirement and Table 7.8-3 for narrowband intermodulation requirement.
- 3) Adjust the signal generators to obtain the specified level of interfering signal at the BS input.
- 4) Measure the throughput according to Annex E.

5) Repeat the whole test for the port which was terminated.

7.8.5 Test requirements

The throughput shall be $\geq 95\%$ of the maximum throughput of the reference measurement channel, with a wanted signal at the assigned channel frequency and two interfering signals with the conditions specified in Table 7.8-2 for intermodulation performance and in Table 7.8-3 for narrowband intermodulation performance.. The reference measurement channel for the wanted signal is identified in Table 7.2-1 for each channel bandwidth and further specified in Annex A.

Table 7.8-1: Intermodulation performance requirement

Wanted signal mean power [dBm]	Interfering signal mean power [dBm]	Type of interfering signal
$P_{\text{REFSENS}} + 6\text{dB}^*$	-52	See Table 7.8-2
Note*: P_{REFSENS} depends on the channel bandwidth as specified in TS 36.104 [2] subclause 7.2.1. For E-UTRA channel bandwidths 10, 15 and 20 MHz this requirement shall apply only for a FRC A1-3 mapped to the frequency range at the channel edge adjacent to the interfering signals.		

Table 7.8-2: Interfering signal for Intermodulation performance requirement

E-UTRA channel bandwidth [MHz]	Interfering signal centre frequency offset from the channel edge of the wanted signal [MHz]	Type of interfering signal
1.4	2.1	CW
	4.9	1.4MHz E-UTRA signal
3	4.5	CW
	10.5	3MHz E-UTRA signal
5	7.5	CW
	17.5	5MHz E-UTRA signal
10	7.5	CW
	17.7	5MHz E-UTRA signal
15	7.5	CW
	18	5MHz E-UTRA signal
20	7.5	CW
	18.2	5MHz E-UTRA signal

Table 7.8-3: Narrowband intermodulation performance requirement

E-UTRA channel bandwidth [MHz]	Wanted signal mean power [dBm]	Interfering signal mean power [dBm]	Interfering RB centre frequency offset from the channel edge of the wanted signal [kHz]	Type of interfering signal
1.4	$P_{\text{REFSENS}} + 6\text{dB}^*$	-52	270	CW
		-52	790	1.4 MHz E-UTRA signal, 1 RB**
3	$P_{\text{REFSENS}} + 6\text{dB}^*$	-52	275	CW
		-52	790	3.0 MHz E-UTRA signal, 1 RB**
5	$P_{\text{REFSENS}} + 6\text{dB}^*$	-52	360	CW
		-52	1060	5 MHz E-UTRA signal, 1 RB**
10	$P_{\text{REFSENS}} + 6\text{dB}^*$ (***)	-52	415	CW
		-52	1420	5 MHz E-UTRA signal, 1 RB**
15	$P_{\text{REFSENS}} + 6\text{dB}^*$ (***)	-52	380	CW
		-52	1600	5MHz E-UTRA signal, 1 RB**
20	$P_{\text{REFSENS}} + 6\text{dB}^*$ (***)	-52	345	CW
		-52	1780	5MHz E-UTRA signal, 1 RB**
<p>Note*: P_{REFSENS} is related to the channel bandwidth as specified in TS 36.104 [2] subclause 7.2.1.</p> <p>Note**: Interfering signal consisting of one resource block positioned at the stated offset.</p> <p>Note***: This requirement shall apply only for a FRC A1-3 mapped to the frequency range at the channel edge adjacent to the interfering signals</p>				

NOTE: If the above Test Requirement differs from the Minimum Requirement then the Test Tolerance applied for this test is non-zero. The relationship between Minimum Requirements and Test Requirements is defined in subclause 4.1 and the explanation of how the Minimum Requirement has been relaxed by the Test Tolerance is given in Annex G.

8 Performance requirement

8.1 General

Performance requirements are specified for a number of test environments and multipath channel classes.

The requirements only apply to those measurement channels that are supported by the base station.

The performance requirements for High Speed Train conditions defined in Annex B.3 are optional.

The performance requirements for UL timing adjustment scenario 2 defined in Annex B.4 are optional.

For BS with receiver antenna diversity the required SNR shall be applied separately at each antenna port.

In tests performed with signal generators a synchronization signal may be provided, from the base station to the signal generator, to enable correct timing of the wanted signal.

8.2 Performance requirements for PUSCH

8.2.1 Performance requirements of PUSCH in multipath fading propagation conditions

8.2.1.1 Definition and applicability

The performance requirement of PUSCH is determined by a minimum required throughput for a given SNR. The required throughput is expressed as a fraction of maximum throughput for the FRCs listed in Annex A. The performance requirements assume HARQ re-transmissions.

A test for a specific channel bandwidth is only applicable if the BS supports it.

For a BS supporting multiple channel bandwidths only the tests for the lowest and the highest channel bandwidths supported by the BS are applicable.

8.2.1.2 Minimum Requirement

The minimum requirement is in TS 36.104 [2] subclause 8.2.1.1.

8.2.1.3 Test Purpose

The test shall verify the receiver's ability to achieve throughput under multipath fading propagation conditions for a given SNR.

8.2.1.4 Method of test

8.2.1.4.1 Initial Conditions

Test environment: Normal, see subclause D.2.

RF channels to be tested: M; see subclause 4.7.

- 1) Connect the BS tester generating the wanted signal, multipath fading simulators and AWGN generators to all BS antenna connectors for diversity reception via a combining network as shown in Annex I.3.2.

8.2.1.4.2 Procedure

- 1) Adjust the AWGN generator, according to the channel bandwidth, defined in Table 8.2.1.4.2-1.

Table 8.2.1.4.2-1: AWGN power level at the BS input

Channel bandwidth [MHz]	AWGN power level
1.4	-92.7dBm / 1.08MHz
3	-88.7dBm / 2.7MHz
5	-86.5dBm / 4.5MHz
10	-83.5dBm / 9MHz
15	-81.7dBm / 13.5MHz
20	-80.4dBm / 18MHz

- 2) The characteristics of the wanted signal shall be configured according to the corresponding UL reference measurement channel defined in annex A and the test parameters in Table 8.2.1.4.2-2. For reference channels using 1 resource block the resource block in the middle of the channel bandwidth shall be used. In case the number of resource blocks in the channel bandwidth are even the one in the middle with lower number is to be used for testing.

Table 8.2.1.4.2-2 Test parameters for testing PUSCH

Parameter	Value
Maximum number of HARQ transmissions	4
RV sequence	0, 2, 3, 1, 0, 2, 3, 1
Uplink-downlink allocation for TDD	Configuration 1 (2:2)

- 3) The multipath fading emulators shall be configured according to the corresponding channel model defined in annex B.
- 4) Adjust the equipment so that required SNR specified in Table 8.2.1.5-1 to 8.2.1.5-6 is achieved at the BS input.
- 5) For each of the reference channels in Table 8.2.1.5-1 to 8.2.1.5-6 applicable for the base station, measure the throughput, according to annex E.

8.2.1.5 Test Requirement

The throughput measured according to subclause 8.2.1.4.2 shall not be below the limits for the SNR levels specified in Table 8.2.1.5-1 to 8.2.1.5-6..

Table 8.2.1.5-1 Test requirements for PUSCH, 1.4 MHz Channel Bandwidth

Number of RX antennas	Cyclic prefix	Propagation conditions (Annex B)	FRC (Annex A)	Fraction of maximum throughput	SNR [dB]
2	Normal	EPA 5Hz	A3-2	30%	-3.5
				70%	0.7
			A4-3	70%	11.2
		A5-2	70%	18.3	
		EVA 5Hz	A3-1	30%	-2.1
				70%	2.4
			A4-1	30%	5.0
				70%	11.9
			A5-1	70%	19.2
			EVA 70Hz	A3-2	30%
		70%			1.3
		A4-3		30%	4.6
				70%	12.5
				ETU 70Hz	A3-1
		70%	3.0		
		ETU 300Hz	A3-1	30%	-1.6
				70%	3.5
		Extended	ETU 70Hz	A4-2	30%
	70%				14.1
	4	Normal	EPA 5Hz	A3-2	30%
70%					-2.5
A4-3				70%	7.7
A5-2			70%	15.0	
EVA 5Hz			A3-1	30%	-4.4
				70%	-0.7
			A4-1	30%	1.9
				70%	8.4
A5-1			70%	16.0	
EVA 70Hz			A3-2	30%	-5.7
				70%	-2.1
			A4-3	30%	1.4
				70%	8.9
				ETU 70Hz	A3-1
70%			-0.4		
ETU 300Hz			A3-1	30%	-4.0
				70%	0.0
Extended			ETU 70Hz	A4-2	30%
		70%			10.5

Table 8.2.1.5-2 Test requirements for PUSCH, 3 MHz Channel Bandwidth

Number of RX antennas	Cyclic prefix	Propagation conditions (Annex B)	FRC (Annex A)	Fraction of maximum throughput	SNR [dB]	
2	Normal	EPA 5Hz	A3-3	30%	-3.5	
				70%	0.7	
			A4-4	70%	11.5	
		A5-3	70%	18.7		
		EVA 5Hz	A3-1	30%	-2.2	
				70%	2.4	
			A4-1	30%	4.9	
		EVA 70Hz	A3-3	30%	-3.4	
				70%	1.2	
			A4-4	30%	5.3	
		ETU 70Hz	A3-1	30%	-1.9	
				70%	3.0	
			ETU 300Hz	A3-1	30%	-1.6
		70%			3.5	
		Extended	ETU 70Hz	A4-2	30%	5.3
	70%			14.1		
	4	Normal	EPA 5Hz	A3-3	30%	-6.2
					70%	-2.8
A4-4				70%	8.3	
A5-3			70%	15.0		
EVA 5Hz			A3-1	30%	-4.4	
				70%	-0.7	
			A4-1	30%	1.8	
EVA 70Hz			A3-3	30%	-5.9	
				70%	-2.3	
			A4-4	30%	2.2	
ETU 70Hz			A3-1	30%	-4.2	
				70%	-0.3	
			ETU 300Hz	A3-1	30%	-4.0
70%					0.0	
Extended			ETU 70Hz	A4-2	30%	2.1
		70%		10.5		

Table 8.2.1.5-3 Test requirements for PUSCH, 5 MHz Channel Bandwidth

Number of RX antennas	Cyclic prefix	Propagation conditions (Annex B)	FRC (Annex A)	Fraction of maximum throughput	SNR [dB]
2	Normal	EPA 5Hz	A3-4	30%	-4.1
				70%	-0.1
			A4-5	70%	11.0
		A5-4	70%	18.6	
		EVA 5Hz	A3-1	30%	-2.1
				70%	2.4
			A4-1	30%	4.9
		EVA 70Hz	A3-4	30%	-3.9
				70%	0.5
			A4-5	30%	4.9
		ETU 70Hz	A3-1	30%	-1.9
				70%	3.0

		ETU 300Hz	A3-1	30%	-1.6	
				70%	3.5	
	Extended	ETU 70Hz	A4-2	30%	5.4	
				70%	14.1	
4	Normal	EPA 5Hz	A3-4	30%	-6.5	
				70%	-3.2	
			A4-5	70%	8.2	
			A5-4	70%	15.0	
		EVA 5Hz	A3-1	30%	-4.5	
				70%	-0.8	
			A4-1	30%	1.8	
				70%	8.5	
		A5-1	70%	16.1		
		EVA 70Hz	A3-4	30%	-6.3	
				70%	-2.7	
			A4-5	30%	1.8	
				70%	8.9	
		ETU 70Hz	A3-1	30%	-4.2	
				70%	-0.3	
		ETU 300Hz	A3-1	30%	-4.0	
				70%	0.0	
		Extended	ETU 70Hz	A4-2	30%	2.2
					70%	10.5

Table 8.2.1.5-4 Test requirements for PUSCH, 10 MHz Channel Bandwidth

Number of RX antennas	Cyclic prefix	Propagation conditions (Annex B)	FRC (Annex A)	Fraction of maximum throughput	SNR [dB]
2	Normal	EPA 5Hz	A3-5	30%	-3.6
				70%	0.2
			A4-6	70%	11.4
		A5-5	70%	18.9	
		EVA 5Hz	A3-1	30%	-2.1
				70%	2.5
			A4-1	30%	4.9
		EVA 70Hz	A3-5	30%	-3.5
				70%	0.7
			A4-6	30%	5.1
		ETU 70Hz	A3-1	30%	-1.9
				70%	3.0
			ETU 300Hz	A3-1	30%
		70%			3.5
		Extended	ETU 70Hz	A4-2	30%
	70%				14.2
	4	Normal	EPA 5Hz	A3-5	30%
70%					-2.9
A4-6				70%	8.1
A5-5			70%	15.3	
EVA 5Hz			A3-1	30%	-4.4
				70%	-0.6
			A4-1	30%	1.8
EVA 70Hz			A3-5	30%	-6.1
				70%	-2.3
			A4-6	30%	1.3
ETU 70Hz			A3-1	30%	-4.2
				70%	-0.3
			ETU 300Hz	A3-1	30%
70%					0.0
Extended			ETU 70Hz	A4-2	30%
		70%			10.9

Table 8.2.1.5-5 Test requirements for PUSCH, 15 MHz Channel Bandwidth

Number of RX antennas	Cyclic prefix	Propagation conditions (Annex B)	FRC (Annex A)	Fraction of maximum throughput	SNR [dB]
2	Normal	EPA 5Hz	A3-6	30%	-3.9
				70%	-0.2
			A4-7	70%	11.9
		A5-6	70%	19.4	
		EVA 5Hz	A3-1	30%	-2.2
				70%	2.4
			A4-1	30%	4.8
				70%	12.0
			A5-1	70%	19.3
			EVA 70Hz	A3-6	30%
		70%			0.3
		A4-7		30%	4.8
				70%	13.5
		ETU 70Hz	A3-1	30%	-1.9
				70%	3.0
		ETU 300Hz	A3-1	30%	-1.6
				70%	3.5
		Extended	ETU 70Hz	A4-2	30%
	70%				14.2
	4	Normal	EPA 5Hz	A3-6	30%
70%					-3.2
A4-7				70%	8.2
A5-6			70%	15.6	
EVA 5Hz			A3-1	30%	-4.4
				70%	-0.6
			A4-1	30%	1.8
				70%	8.5
A5-1			70%	16.3	
EVA 70Hz			A3-6	30%	-6.4
				70%	-2.7
			A4-7	30%	1.3
				70%	9.1
ETU 70Hz			A3-1	30%	-4.2
				70%	-0.4
ETU 300Hz			A3-1	30%	-4.0
				70%	0.0
Extended			ETU 70Hz	A4-2	30%
		70%			10.7

Table 8.2.1.5-6 Test requirements for PUSCH, 20 MHz Channel Bandwidth

Number of RX antennas	Cyclic prefix	Propagation conditions (Annex B)	FRC (Annex A)	Fraction of maximum throughput	SNR [dB]	
2	Normal	EPA 5Hz	A3-7	30%	-3.6	
				70%	0.2	
			A4-8	70%	12.1	
		A5-7	70%	20.3		
		EVA 5Hz	A3-1	30%	-2.1	
				70%	2.4	
			A4-1	30%	4.9	
		EVA 70Hz	A3-7	30%	-3.5	
				70%	0.8	
			A4-8	30%	4.8	
		ETU 70Hz	A3-1	30%	-1.8	
				70%	3.0	
			ETU 300Hz	A3-1	30%	-1.5
		70%			3.5	
		Extended	ETU 70Hz	A4-2	30%	5.3
	70%				14.2	
	4	Normal	EPA 5Hz	A3-7	30%	-6.2
					70%	-2.9
A4-8				70%	8.1	
A5-7			70%	16.5		
EVA 5Hz			A3-1	30%	-4.5	
				70%	-0.7	
			A4-1	30%	1.8	
EVA 70Hz			A3-7	30%	-6.1	
				70%	-2.3	
			A4-8	30%	1.3	
ETU 70Hz			A3-1	30%	-3.8	
				70%	-0.3	
			ETU 300Hz	A3-1	30%	-4.0
70%					-0.1	
Extended			ETU 70Hz	A4-2	30%	2.2
		70%			10.6	

NOTE: If the above Test Requirement differs from the Minimum Requirement then the Test Tolerance applied for this test is non-zero. The Test Tolerance for this test and the explanation of how the Minimum Requirement has been relaxed by the Test Tolerance is given in Annex G.

8.2.2 Performance requirements for UL timing adjustment

8.2.2.1 Definition and applicability

The performance requirement of PUSCH is determined by a minimum required throughput measured for the moving UE at given SNR. The required throughput is expressed as 70% of maximum throughput for the FRCs listed in Annex A. The performance requirements assume HARQ re-transmissions.

In the tests for UL timing adjustment, two signals are configured, one being transmitted by moving UE and the other being transmitted by stationary UE. The transmission of SRS from UE is optional. FRC parameters in Table A.7-1 and Table A.8-1 are applied for both UEs. The received power for both UEs is the same. The resource blocks allocated for both UEs are consecutive. In Scenario 2, Doppler shift is not taken into account.

A test for a specific channel bandwidth is only applicable if the BS supports it.

For a BS supporting multiple channel bandwidths only the tests for the lowest and the highest channel bandwidths supported by the BS are applicable.

8.2.2.2 Minimum Requirement

The minimum requirement is in TS 36.104 [2] subclause 8.2.2.1.

8.2.2.3 Test Purpose

The test shall verify the receiver's ability to achieve throughput measured for the moving UE at given SNR under moving propagation conditions.

8.2.2.4 Method of test

8.2.2.4.1 Initial Conditions

Test environment: Normal, see subclause D.2.

RF channels to be tested: M; see subclause 4.7.

- 1) Connect the BS tester generating the wanted signal, multipath fading simulators and AWGN generators to all BS antenna connectors for diversity reception via a combining network as shown in Annex I.3.4.

8.2.2.4.2 Procedure

- 1) Adjust the AWGN generator, according to the channel bandwidth, defined in Table 8.2.2.4.2-1.

Table 8.2.2.4.2-1: AWGN power level at the BS input

Channel bandwidth [MHz]	AWGN power level
1.4	-92.7 dBm / 1.08MHz
3	-88.7 dBm / 2.7MHz
5	-86.5 dBm / 4.5MHz
10	-83.5 dBm / 9MHz
15	-81.7 dBm / 13.5MHz
20	-80.4 dBm / 18MHz

- 2) The characteristics of the wanted signals (transmitted by moving UE) shall be configured according to the corresponding UL reference measurement channel defined in Annex A and the test parameters in Table 8.2.2.4.2-2.

Table 8.2.2.4.2-2 Test parameters for testing UL timing adjustment

Parameter	Value
Maximum number of HARQ transmissions	4
RV sequence	0, 2, 3, 1, 0, 2, 3, 1
Uplink-downlink allocation for TDD	Configuration 1 (2:2)
Subframes in which PUSCH is transmitted	For FDD: subframe #0, #2, #4, #6, and #8 in radio frames For TDD: Subframe #2, #3, #7, #8 in each radio frame
Subframes in which sounding RS is transmitted (Note 1)	For FDD: subframe #1 in radio frames For TDD: UpPTS in each radio frame
Note 1. The transmission of SRS is optional.	

- 3) The multipath fading emulators shall be configured according to the corresponding channel model defined in Annex B.
- 4) Adjust the equipment so that required SNR specified in Table 8.2.2.5-1 is achieved at the BS input.
- 5) For each of the reference channels in Table 8.2.2.5-1 applicable for the base station, measure the throughput, according to Annex E.

8.2.2.5 Test Requirement

The throughput measured for the moving UE according to subclause 8.2.2.4.2 shall not be below the limits for the SNR levels specified in Table 8.2.2.5-1.

Table 8.2.2.5-1 Test requirements for UL timing adjustment

Number of RX antennas	Cyclic prefix	Channel Bandwidth [MHz]	Moving propagation conditions (Annex B)	FRC (Annex A)	SNR [dB]
2	Normal	1.4	Scenario 1	A7-1	13.7
			Scenario 2	A8-1	-1.6
		3	Scenario 1	A7-2	14.0
			Scenario 2	A8-2	-1.2
		5	Scenario 1	A7-3	13.8
			Scenario 2	A8-3	-1.3
		10	Scenario 1	A7-4	14.4
			Scenario 2	A8-4	-1.5
		15	Scenario 1	A7-5	14.6
			Scenario 2	A8-5	-1.5
		20	Scenario 1	A7-6	14.5
			Scenario 2	A8-6	-1.5

NOTE: If the above Test Requirement differs from the Minimum Requirement then the Test Tolerance applied for this test is non-zero. The Test Tolerance for this test is defined in subclause 4.1 and the explanation of how the Minimum Requirement has been relaxed by the Test Tolerance is given in Annex G.

8.2.3 Performance requirements for HARQ-ACK multiplexed on PUSCH

8.2.3.1 Definition and applicability

The performance requirement of HARQ-ACK multiplexed on PUSCH is determined by the two parameters: probability of false detection of the ACK and the probability of detection of ACK. The performance is measured by the required SNR at probability of detection equal to 0.99. The probability of false detection of the ACK shall be 0.01 or less at PUSCH power settings presented in table 8.2.3.5-1.

The probability of detection of ACK on PUSCH is defined as conditional probability of detection of the ACK when the ACK is transmitted on PUSCH allocated RE.

The probability of false detection of the ACK on PUSCH is defined as a conditional probability of erroneous detection of the ACK when data only is sent on PUSCH allocated RE, where HARQ-ACK can be allocated (i.e. by puncturing data). Pseudo-random data shall be used as an input for PUSCH coding and modulation purposes.

These tests shall be performed on one of RE"s, where HARQ-ACK information was multiplexed on PUSCH.

In the test for HARQ-ACK multiplexed on PUSCH data is punctured by HARQ-ACK information in both slots within a subframe on symbols as specified in 36.212 [13] subclause 5.2.2.8. Amount of resources for HARQ-ACK information is calculated according to 36.212 [13] subclause 5.2.2.6. None of CQI, RI nor SRS is to be transmitted in these tests. Tests are performed for one bit HARQ-ACK information ($O = 1$).

This test is applied for QPSK 1/3 and 16QAM 3/4 modulation and coding schemes, with appropriate fixed reference channels for performance requirement applied as presented in table 8.2.3.5-1. Normal CP, 2 Rx antennas and ETU70 propagation conditions shall be used for this test.

A test for a specific channel bandwidth is only applicable if the BS supports it.

For a BS supporting multiple channel bandwidths only the tests for the lowest and the highest channel bandwidths supported by the BS are applicable.

8.2.3.2 Minimum Requirement

The minimum requirement is in TS 36.104 [2] subclause 8.2.4.1.

8.2.3.3 Test Purpose

The test shall verify the receiver"s ability to detect HARQ-ACK information multiplexed on PUSCH under multipath fading propagation conditions for a given SNR.

8.2.3.4 Method of test

8.2.3.4.1 Initial Conditions

Test environment: Normal, see subclause D.2.

RF channels to be tested: M; see subclause 4.7.

- 1) Connect the BS tester generating the wanted signal, multipath fading simulators and AWGN generators to all BS antenna connectors for diversity reception via a combining network as shown in Annex I.3.2.

8.2.3.4.2 Procedure

- 1) Adjust the AWGN generator, according to the channel bandwidth, defined in Table 8.2.3.4.2-1.

Table 8.2.3.4.2-1: AWGN power level at the BS input

Channel bandwidth [MHz]	AWGN power level
1.4	-92.7 dBm / 1.08MHz
3	-88.7 dBm / 2.7MHz
5	-86.5 dBm / 4.5MHz
10	-83.5 dBm / 9MHz
15	-81.7 dBm / 13.5MHz
20	-80.4 dBm / 18MHz

- 2) The characteristics of the wanted signal shall be configured according to the corresponding UL reference measurement channel defined in Annex A and details presented in chapter 8.2.3.1. For reference channels using 1 resource block the RB in the middle of the channel bandwidth should be used. In case the number of resource blocks in the channel bandwidth are even the one in the middle with lower number is to be used for testing.
- 3) The multipath fading emulators shall be configured according to ETU70 channel model defined in Annex B.2.
- 4) Adjust the equipment so that required SNR specified in Table 8.2.3.5-1 is achieved at the BS input during the ACK transmissions.
- 5) The signal generator sends a test pattern on one of RE's where HARQ-ACK information can be multiplexed on PUSCH with the pattern outlined in figure 8.2.3.4.2-1. The following statistics are kept: the number of ACKs detected during data only transmissions and the number of missed ACKs during PUSCH with ACK transmission.

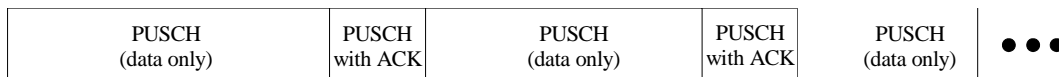

Figure 8.2.3.4.2-1 Test signal pattern for HARQ-ACK multiplexed on PUSCH demodulation tests

8.2.3.5 Test Requirement

The fraction of falsely detected ACKs measured according to subclause 8.2.3.4.2 shall be less than 1% and the fraction of correctly detected ACKs shall be larger than 99% for the SNR listed in table 8.2.3.5-1.

Table 8.2.3.5-1 Test requirements for HARQ-ACK multiplexed on PUSCH

Number of RX antennas	Cyclic Prefix	Propagation conditions (Annex B)	Channel Bandwidth [MHz]	FRC (Annex A)	Error! Objects cannot be created from editing field codes.	SNR [dB]
2	Normal	ETU70	1.4	A.3-1	8	7.2
				A.4-3	5	14.4
			3	A.3-1	8	7.2
				A.4-4	5	13.5
			5	A.3-1	8	7.1
				A.4-5	5	13.1
			10	A.3-1	8	7.2
				A.4-6	5	12.9
			15	A.3-1	8	7.3
				A.4-7	5	12.7
20	A.3-1	8	7.1			
	A.4-8	5	12.6			

NOTE: If the above Test Requirement differs from the Minimum Requirement then the Test Tolerance applied for this test is non-zero. The Test Tolerance for this test and the explanation of how the Minimum Requirement has been relaxed by the Test Tolerance is given in Annex G.

8.2.4 Performance requirements for High Speed Train conditions

8.2.4.1 Definition and applicability

The performance requirement of PUSCH for High Speed Train conditions is determined by a minimum throughput for a given SNR. The required throughput is expressed as 30% and 70% of maximum throughput for the FRCs listed in Annex A. The performance requirements assume HARQ retransmissions and are applied for normal CP.

A test for a specific channel bandwidth is only applicable if the BS supports it.

For a BS supporting multiple channel bandwidths only the tests for the lowest and the highest channel bandwidths supported by the BS are applicable.

The performance requirements for High Speed Train conditions are optional.

8.2.4.2 Minimum Requirement

The minimum requirement is in TS 36.104 [2] subclause 8.2.3.1

8.2.4.3 Test Purpose

The test shall verify the receiver's ability to achieve throughput under High Speed Train conditions for a given SNR.

8.2.4.4 Method of test

8.2.4.4.1 Initial Conditions

Test environment: Normal, see subclause D.2.

RF channels to be tested: M; see subclause 4.7.

- 1) Connect the BS tester generating the wanted signal, channel simulators and AWGN generators to all BS antenna connectors (depending on HST scenario) via a combining network as shown in Annex I.3.2.

8.2.4.4.2 Procedure

- 1) Adjust the AWGN generator, according to the channel bandwidth, defined in Table 8.2.4.4.2-1.

Table 8.2.4.4.2-1: AWGN power level at the BS input

Channel bandwidth [MHz]	AWGN power level
1.4	-92.7 dBm / 1.08MHz
3	-88.7 dBm / 2.7MHz
5	-86.5 dBm / 4.5MHz
10	-83.5 dBm / 9MHz
15	-81.7 dBm / 13.5MHz
20	-80.4 dBm / 18MHz

- 2) The characteristics of the wanted signal shall be configured according to the corresponding UL reference measurement channel defined in Annex A and the test parameters in Table 8.2.4.4.2-2.

Table 8.2.4.4.2-2 Test parameters for High Speed Train conditions

Parameter	Value
<i>Maximum number of HARQ transmissions</i>	4
<i>RV sequence</i>	0, 2, 3, 1, 0, 2, 3, 1
<i>Uplink-downlink allocation for TDD</i>	Configuration 1 (2:2)
<i>Subframes in which PUSCH is transmitted</i>	<p>For FDD: subframe #0 and #8 in radio frames for which SFN mod 4 = 0 subframe #6 in radio frames for which SFN mod 4 = 1 subframe #4 in radio frames for which SFN mod 4 = 2 subframe #2 in radio frames for which SFN mod 4 = 3</p> <p>For TDD: Subframe #2 in each radio frames</p>
<i>Subframes in which PUCCH is transmitted (Note1, Note 2)</i>	<p>For FDD: subframe #5 in radio frames</p> <p>For TDD: Subframe #3 in each radio frame</p>
<p>Note 1. The configuration of PUCCH (format 2) is optional. Note 2. The SNR values per antenna shall be set to [-4.5 dB and -1.5 dB] for Scenario 1 and 3, respectively.</p>	

- 3) The channel simulators shall be configured according to the corresponding channel model defined in Annex B.3.
- 4) Adjust the equipment so that required SNR specified in Table 8.2.4.5-1 is achieved at the BS input.
- 5) For each of the reference channels in Table 8.2.4.5-1 applicable for the base station, measure the throughput, according to Annex E.

8.2.4.5 Test Requirement

The throughput measured according to subclause 8.2.4.4.2 shall not be below the limits for the SNR levels specified in Table 8.2.4.5-1.

Table 8.2.4.5-1 Test requirements for High Speed Train conditions

Channel Bandwidth [MHz]	FRC (Annex A)	Number of RX antennas	Propagation conditions (Annex B)	Fraction of maximum throughput	SNR [dB]
1.4	A3-2	1	HST Scenario 3	30%	-1.2
				70%	2.2
		2	HST Scenario 1	30%	-3.6
				70%	-0.3
3	A3-3	1	HST Scenario 3	30%	-1.8
				70%	1.9
		2	HST Scenario 1	30%	-4.2
				70%	-0.7
5	A3-4	1	HST Scenario 3	30%	-2.3
				70%	1.6
		2	HST Scenario 1	30%	-4.8
				70%	-1.1
10	A3-5	1	HST Scenario 3	30%	-2.4
				70%	1.5
		2	HST Scenario 1	30%	-5.1
				70%	-1.2
15	A3-6	1	HST Scenario 3	30%	-2.4
				70%	1.5
		2	HST Scenario 1	30%	-4.9
				70%	-1.1
20	A3-7	1	HST Scenario 3	30%	-2.4
				70%	1.5
		2	HST Scenario 1	30%	-5.0
				70%	-1.1

NOTE: If the above Test Requirement differs from the Minimum Requirement then the Test Tolerance applied for this test is non-zero. The Test Tolerance for this test and the explanation of how the Minimum Requirement has been relaxed by the Test Tolerance is given in Annex G.

8.3 Performance requirements for PUCCH

8.3.1 ACK missed detection for single user PUCCH format 1a

8.3.1.1 Definition and applicability

The performance requirement of single user PUCCH for ACK missed detection is determined by the two parameters: probability of false detection of the ACK and the probability of detection of ACK. The performance is measured by the required SNR at probability of detection equal to 0.99. The probability of false detection of the ACK shall be 0.01 or less.

The probability of false detection of the ACK is defined as a conditional probability of erroneous detection of the ACK when input is only noise.

The probability of detection of ACK is defined as conditional probability of detection of the ACK when the signal is present.

The test is applicable to all BS. A test for a specific channel bandwidth is only applicable if the BS supports it.

For a BS supporting multiple channel bandwidths only the tests for the lowest and the highest channel bandwidth supported by the BS are applicable.

ACK/NAK repetitions are disabled for PUCCH transmission.

8.3.1.2 Minimum Requirement

The minimum requirement is in TS 36.104 [2] subclause 8.3.1.1 and 8.3.2.1.

8.3.1.3 Test purpose

The test shall verify the receiver's ability to detect ACK under multipath fading propagation conditions for a given SNR.

8.3.1.4 Method of test

8.3.1.4.1 Initial Conditions

Test environment: Normal, see subclause D.2.

RF channels to be tested: M; see subclause 4.7

- 1) Connect the BS tester generating the wanted signal, multipath fading simulators and AWGN generators to all BS antenna connectors for diversity reception via a combining network as shown in Annex I.3.2.

8.3.1.4.2 Procedure

- 1) Adjust the AWGN generator, according to the channel bandwidth defined in Table 8.3.1.4.2-1.

Table 8.3.1.4.2-1: AWGN power level at the BS input

Channel bandwidth [MHz]	AWGN power level
1.4	-89.7 dBm / 1.08MHz
3	-85.7 dBm / 2.7MHz
5	-83.5 dBm / 4.5MHz
10	-80.5 dBm / 9MHz
15	-78.7 dBm / 13.5MHz
20	-77.4 dBm / 18MHz

- 2) The characteristics of the wanted signal shall be configured according to TS 36.211 [12].
- 3) The multipath fading emulators shall be configured according to the corresponding channel model defined in Annex B.
- 4) Adjust the equipment so that the SNR specified in Table 8.3.1.5-1 is achieved at the BS input during the ACK transmissions.
- 5) The signal generator sends a test pattern with the pattern outlined in figure 8.3.1.4.2-1. The following statistics are kept: the number of ACKs detected in the idle periods and the number of missed ACKs.



Figure 8.3.1.4.2-1 Test signal pattern for single user PUCCH format 1a demodulation tests

8.3.1.5 Test Requirement

The fraction of falsely detected ACKs shall be less than 1% and the fraction of correctly detected ACKs shall be larger than 99% for the SNR listed in Table 8.3.1.5-1.

Table 8.3.1.5-1 Required SNR for single user PUCCH format 1a demodulation tests

Number of RX antennas	Cyclic Prefix	Propagation Conditions (Annex B)	Channel Bandwidth / SNR [dB]					
			1.4 MHz	3 MHz	5 MHz	10 MHz	15 MHz	20 MHz
2	Normal	EPA 5	-1.9	-3.3	-4.2	-4.8	-4.7	-4.5
		EVA 5	-3.9	-4.5	-4.5	-4.4	-4.5	-4.5
		EVA 70	-4.3	-4.6	-4.6	-4.5	-4.6	-4.5
		ETU 300	-4.4	-4.5	-4.3	-4.4	-4.6	-4.6
	Extended	ETU 70	-3.6	-3.7	-3.5	-3.7	-3.6	-3.7
4	Normal	EPA 5	-7.3	-7.8	-8.1	-8.3	-8.3	-8.4
		EVA 5	-8.2	-8.5	-8.5	-8.2	-8.3	-8.3
		EVA 70	-8.3	-8.4	-8.4	-8.2	-8.4	-8.2
		ETU 300	-8.1	-8.3	-8.1	-8.1	-8.3	-8.2
	Extended	ETU 70	-7.3	-7.5	-7.3	-7.5	-7.4	-7.4

NOTE: If the above Test Requirement differs from the Minimum Requirement then the Test Tolerance applied for this test is non-zero. The Test Tolerance for this test and the explanation of how the Minimum Requirement has been relaxed by the Test Tolerance is given in Annex G.

8.3.2 CQI missed detection for PUCCH format 2

8.3.2.1 Definition and applicability

The performance requirement of PUCCH for CQI missed detection is determined by the BLER probability of detection of CQI. The performance is measured by the required SNR at BLER probability of detection equal to 0.99.

The probability of detection of CQI is defined as conditional probability of detection of the CQI when the signal is present.

The test is applicable to all BS. A test for a specific channel bandwidth is only applicable if the BS supports it.

For a BS supporting multiple channel bandwidths only the tests for the lowest and the highest channel bandwidths supported by the BS are applicable.

8.3.2.2 Minimum Requirement

The minimum requirement is in TS 36.104 [2] subclause 8.3.3.1.

8.3.2.3 Test purpose

The test shall verify the receiver's ability to detect CQI under multipath fading propagation conditions for a given SNR.

8.3.2.4 Method of test

8.3.2.4.1 Initial Conditions

Test environment: Normal, see subclause D.2.

RF channels to be tested: M; see subclause 4.7

- 1) Connect the BS tester generating the wanted signal, multipath fading simulators and AWGN generators to all BS antenna connectors for diversity reception via a combining network as shown in Annex I.3.2.

8.3.2.4.2 Procedure

- 1) Adjust the AWGN generator, according to the channel bandwidth defined in Table 8.3.2.4.2-1.

Table 8.3.2.4.2-1: AWGN power level at the BS input

Channel bandwidth [MHz]	AWGN power level
1.4	-89.7 dBm / 1.08MHz
3	-85.7 dBm / 2.7MHz
5	-83.5 dBm / 4.5MHz
10	-80.5 dBm / 9MHz
15	-78.7 dBm / 13.5MHz
20	-77.4 dBm / 18MHz

- 2) The characteristics of the wanted signal shall be configured according to TS 36.211. The CQI information bit payload per sub-frame is equal to 4 bits.
- 3) The multipath fading emulators shall be configured according to the corresponding channel model defined in Annex B.
- 4) Adjust the equipment so that the SNR specified in Table 8.3.2.5-1 is achieved at the BS input during the CQI transmissions.
- 5) The signal generator sends a test pattern with the pattern outlined in figure 8.3.2.4.2-1. The following statistics are kept: the number of missed CQIs.



Figure 8.3.2.4.2-1 Test signal pattern for PUCCH format 2 demodulation tests

8.3.2.5 Test Requirement

The fraction of falsely detected CQIs shall be less than 1% and the fraction of correctly detected CQIs shall be larger than 99% for the SNR listed in Table 8.3.2.5-1.

Table 8.3.2.5-1 Required SNR for PUCCH format 2 demodulation tests

Number of RX antennas	Cyclic Prefix	Propagation Conditions (Annex B)	Channel Bandwidth / SNR [dB]					
			1.4 MHz	3 MHz	5 MHz	10 MHz	15 MHz	20 MHz
2	Normal	ETU 70	-3.3	-3.8	-3.6	-3.8	-3.8	-3.8

NOTE: If the above Test Requirement differs from the Minimum Requirement then the Test Tolerance applied for this test is non-zero. The Test Tolerance for this test and the explanation of how the Minimum Requirement has been relaxed by the Test Tolerance is given in Annex G.

8.3.3 ACK missed detection for multi user PUCCH format 1a

8.3.3.1 Definition and applicability

The performance requirement of multi user PUCCH for ACK missed detection is determined by the two parameters: probability of false detection of the ACK and the probability of detection of ACK on the wanted signal. The performance is measured by the required SNR at probability of detection equal to 0.99. The probability of false detection of the ACK shall be 0.01 or less. These probabilities are measured on the wanted signal at presence of three interfering signals as specified in section 8.3.3.4.2.

The probability of false detection of the ACK is defined as a conditional probability of erroneous detection of the ACK when input is only noise and the interfering signals are present.

The probability of detection of ACK is defined as conditional probability of detection of the ACK when the signal is present.

The test is applicable to all BS. A test for a specific channel bandwidth is only applicable if the BS supports it.

For a BS supporting multiple channel bandwidths only the tests for the lowest and the highest channel bandwidths supported by the BS are applicable.

Multi user PUCCH test is performed only for 2 Rx antennas, Normal CP and for ETU70 propagation conditions.

ACK/NAK repetitions are disabled for PUCCH transmission.

8.3.3.2 Minimum Requirement

The minimum requirements are in TS 36.104 [2] subclause 8.3.1.1 and 8.3.4.1.

8.3.3.3 Test purpose

The test shall verify the receiver's ability to detect ACK on the wanted signal at presence of three interfering signals as specified in section 8.3.3.4.2, under multipath fading propagation conditions for a given SNR.

8.3.3.4 Method of test

8.3.3.4.1 Initial Conditions

Test environment: Normal, see subclause D.2.

RF channels to be tested: M; see subclause 4.7.

- 1) Connect the BS tester generating the wanted and all interfering signals, multipath fading simulators and AWGN generators to both BS antenna connectors for 2Rx diversity reception via a combining network as shown in Annex I.3.3.
- 2) Interconnect attenuators for relative power setting purposes for all transmitting branches (wanted signal and all interferers, separately).

8.3.3.4.2 Procedure

- 1) Adjust the AWGN generator, according to the channel bandwidth defined in Table 8.3.3.4.2-1.

Table 8.3.3.4.2-1: AWGN power level at the BS input

Channel bandwidth [MHz]	AWGN power level
1.4	-89.7 dBm / 1.08MHz
3	-85.7 dBm / 2.7MHz
5	-83.5 dBm / 4.5MHz
10	-80.5 dBm / 9MHz
15	-78.7 dBm / 13.5MHz
20	-77.4 dBm / 18MHz

- 2) In multi user PUCCH test, four signals are configured: one wanted signal and three interferers, which are transmitted via separate fading paths using relative power settings presented in Annex A.9.

All signals are transmitted on the same PUCCH resources, with different PUCCH channel indices, as presented in Annex A.9.

The characteristics of the all signals (i.e. wanted and all interferers) shall be configured according to 36.211 [12].

- 3) The multipath fading emulators shall be configured according to ETU70 propagation conditions defined in Annex B.
- 4) Adjust the equipment so that the SNR specified in Table 8.3.3.5-1 is achieved at the BS input during the ACK transmissions on the wanted signal.
- 5) The signal generator sends a test pattern with the pattern outlined in figure 8.3.3.4.2-1. This statement is valid for all signals, i.e. wanted and all interferers. The following statistics are kept: the number of ACKs detected in the idle periods and the number of missed ACKs on the wanted PUCCH signal.

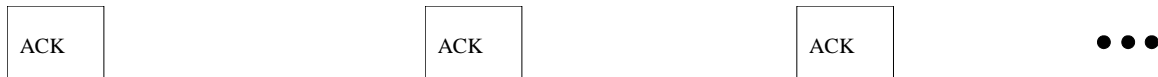

Figure 8.3.3.4.2-1 Test signal pattern for multi user PUCCH demodulation tests

8.3.3.5 Test Requirement

The fraction of falsely detected ACKs on the wanted signal shall be less than 1% and the fraction of correctly detected ACKs shall be larger than 99% for the SNR listed in Table 8.3.3.5-1.

Table 8.3.3.5-1 Required SNR for multi user PUCCH demodulation tests

Number of RX antennas	Cyclic Prefix	Propagation Conditions (Annex B)	Channel Bandwidth / SNR [dB]					
			1.4 MHz	3 MHz	5 MHz	10 MHz	15 MHz	20 MHz
2	Normal	ETU 70	-3.5	-3.8	-3.8	-4.0	-4.0	-3.8

NOTE: If the above Test Requirement differs from the Minimum Requirement then the Test Tolerance applied for this test is non-zero. The Test Tolerance for this test and the explanation of how the Minimum Requirement has been relaxed by the Test Tolerance is given in Annex G.

8.4 Performance requirements for PRACH

8.4.1 PRACH false alarm probability and missed detection

8.4.1.1 Definition and applicability

The performance requirement of PRACH for preamble detection is determined by the two parameters: total probability of false detection of the preamble (P_{fa}) and the probability of detection of preamble (P_d). The performance is measured by the required SNR at probability of detection, P_d of 99%. P_{fa} shall be 0.1% or less.

P_{fa} is defined as a conditional total probability of erroneous detection of the preamble (i.e. erroneous detection from any detector) when input is only noise.

P_d is defined as conditional probability of detection of the preamble when the signal is present. The erroneous detection consists of several error cases – detecting different preamble than the one that was sent, not detecting a preamble at all or correct preamble detection but with the wrong timing estimation. For AWGN, a timing estimation error occurs if the estimation error of the timing of the strongest path is larger than 1.04 μ s. For ETU70, a timing estimation error occurs if the estimation error of the timing of the strongest path is larger than 2.08 μ s. The strongest path for the timing estimation error refers to the strongest path (i.e. average of the delay of all paths having the same highest gain = 310ns for ETU) in the power delay profile.

The normal mode test is applicable to all BS. The high speed mode test is applicable to high speed BS.

8.4.1.2 Minimum Requirement

The minimum requirement is in TS 36.104 [2] subclause 8.4.1.1 and 8.4.2.1.

8.4.1.3 Test purpose

The test shall verify the receiver's ability to detect PRACH preamble under multipath fading propagation conditions for a given SNR.

8.4.1.4 Method of test

8.4.1.4.1 Initial Conditions

Test environment: Normal, see subclause D.2.

RF channels to be tested: M; see subclause 4.7

- 1) Connect the BS tester generating the wanted signal, multipath fading simulators and AWGN generators to all BS antenna connectors for diversity reception via a combining network as shown in Annex I.3.1 or Annex I.3.2 as applicable.

8.4.1.4.2 Procedure

- 1) Adjust the AWGN generator, according to the channel bandwidth.

Table 8.4.1.4.2-1: AWGN power level at the BS input

Channel bandwidth [MHz]	AWGN power level
1.4	-89.7 dBm / 1.08MHz
3	-85.7 dBm / 2.7MHz
5	-83.5 dBm / 4.5MHz
10	-80.5 dBm / 9MHz
15	-78.7 dBm / 13.5MHz
20	-77.4 dBm / 18MHz

- 2) The characteristics of the wanted signal shall be configured according to the corresponding UL reference measurement channel defined in Annex A.
- 3) The multipath fading emulators shall be configured according to the corresponding channel model defined in Annex B.
- 4) Adjust the frequency offset of the test signal according to Table 8.4.1.5-1 or 8.4.1.5-2.
- 5) Adjust the equipment so that the SNR specified in Table 8.4.1.5-1 or 8.4.1.5-2 is achieved at the BS input during the PRACH preambles.
- 6) The test signal generator sends a preamble and the receiver tries to detect the preamble. This pattern is repeated as illustrated in figure 8.4.1.4.2-1. The preambles are sent with certain timing offsets as described below. The following statistics are kept: the number of preambles detected in the idle period and the number of missed preambles.



Figure 8.4.1.4.2-1 PRACH preamble test pattern

The timing offset base value is set to 50% of N_{cs} . This offset is increased within the loop, by adding in each step a value of 0.1 μ s, until the end of the tested range, which is 0.9 μ s. Then the loop is being reset and the timing offset is set again to 50% of N_{cs} . The timing offset scheme is presented in Figure 8.4.1.4.2-2.

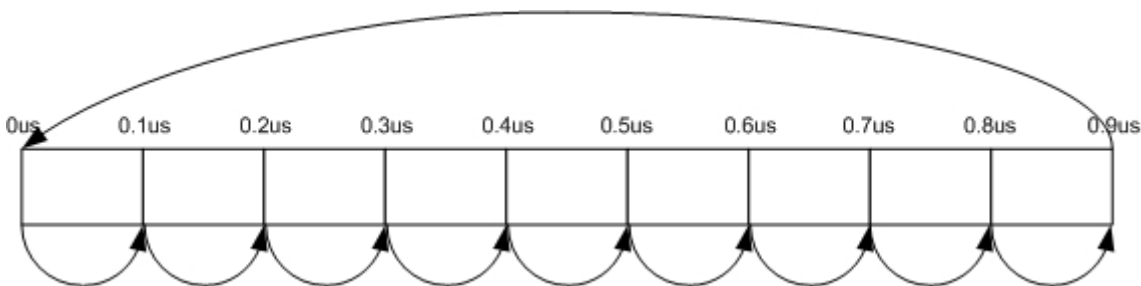

Figure 8.4.1.4.2-2 Timing offset scheme

8.4.1.5 Test Requirement

Pfa shall not exceed 0.1%. Pd shall not be below 99% for the SNRs in Table 8.4.1.5-1 and 8.4.1.5-2.

Table 8.4.1.5-1 PRACH missed detection test requirements for Normal Mode

Number of RX antennas	Propagation conditions (Annex B)	Frequency offset	SNR [dB]				
			Burst format 0	Burst format 1	Burst format 2	Burst format 3	Burst format 4
2	AWGN	0	-13.9	-13.9	-16.1	-16.2	-6.9
	ETU 70	270 Hz	-7.4	-7.2	-9.4	-9.5	0.5
4	AWGN	0	-16.6	-16.4	-18.7	-18.5	-9.5
	ETU 70	270 Hz	-11.5	-11.1	-13.5	-13.3	-4.5

Table 8.4.1.5-2 PRACH missed detection test requirements for High speed Mode

Number of RX antennas	Propagation conditions (Annex B)	Frequency offset	SNR [dB]			
			Burst format 0	Burst format 1	Burst format 2	Burst format 3
2	AWGN	0	-13.8	-13.9	-16.0	-16.3
	ETU 70	270 Hz	-6.8	-6.7	-8.7	-8.9
	AWGN	625 Hz	-12.1	-12.0	-14.1	-14.1
	AWGN	1340 Hz	-13.1	-13.2	-15.2	-15.4
4	AWGN	0	-16.6	-16.3	-18.6	-18.5
	ETU 70	270 Hz	-11.2	-10.8	-13.1	-13.1
	AWGN	625 Hz	-14.6	-14.3	-16.5	-16.5
	AWGN	1340 Hz	-15.6	-15.2	-17.5	-17.5

NOTE: If the above Test Requirement differs from the Minimum Requirement then the Test Tolerance applied for this test is non-zero. The Test Tolerance for this test and the explanation of how the Minimum Requirement has been relaxed by the Test Tolerance is given in Annex G.

Annex A (normative): Reference Measurement channels

A.0 General

The parameters for the reference measurement channels are specified in clause A.1 for reference sensitivity and in-channel selectivity and in clause A.2 for dynamic range.

A schematic overview of the encoding process for the reference measurement channels is provided in Figure A0-1.

Receiver requirements in the present document are defined with a throughput stated relative to the Maximum throughput of the FRC. The Maximum throughput for an FRC equals the Payload size * the Number of uplink subframes per second. For FDD, 1000 uplink sub-frames per second are used.

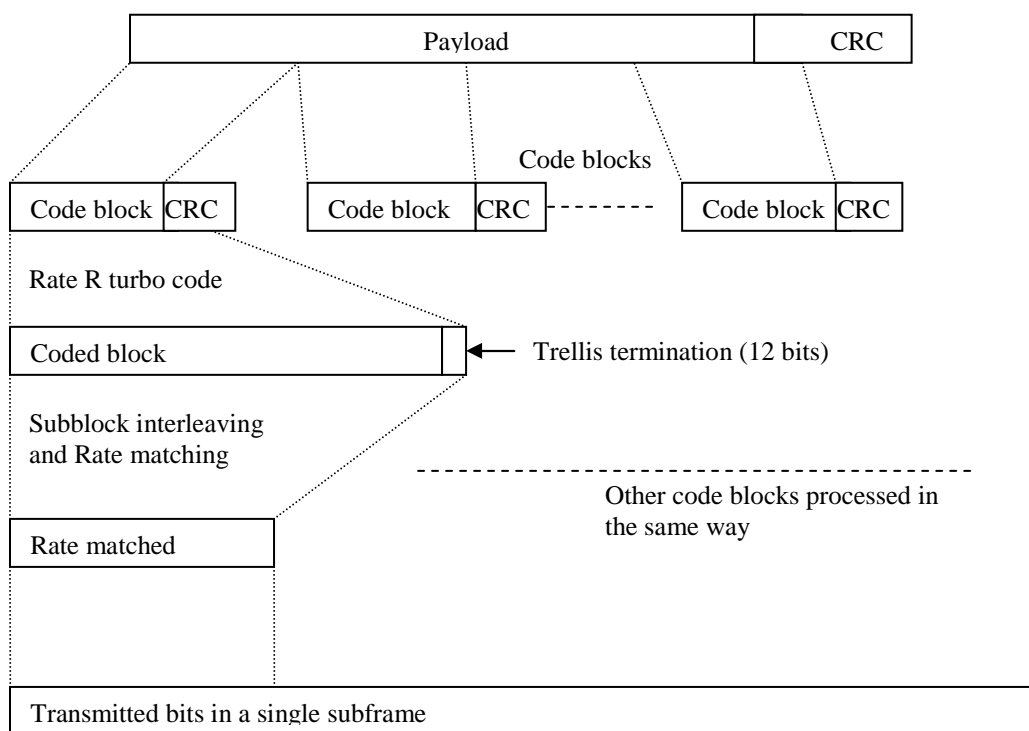

Figure A0-1. Schematic overview of the encoding process

A.1 Fixed Reference Channels for reference sensitivity and in-channel selectivity (QPSK, R=1/3)

The parameters for the reference measurement channels are specified in Table A.1-1 for reference sensitivity and in-channel selectivity

Table A.1-1 FRC parameters for reference sensitivity and in-channel selectivity

Reference channel	A1-1	A1-2	A1-3	A1-4	A1-5
Allocated resource blocks	6	15	25	3	9
DFT-OFDM Symbols per subframe	12	12	12	12	12
Modulation	QPSK	QPSK	QPSK	QPSK	QPSK
Code rate	1/3	1/3	1/3	1/3	1/3
Payload size (bits)	600	1544	2216	256	936
Transport block CRC (bits)	24	24	24	24	24
Code block CRC size (bits)	0	0	0	0	0
Number of code blocks - C	1	1	1	1	1
Coded block size including 12bits trellis termination (bits)	1884	4716	6732	852	2892
Total number of bits per sub-frame	1728	4320	7200	864	2592
Total symbols per sub-frame	864	2160	3600	432	1296

A.2 Fixed Reference Channels for dynamic range (16QAM, R=2/3)

The parameters for the reference measurement channels are specified in Table A.2-1 for dynamic range.

Table A.2-1 FRC parameters for dynamic range

Reference channel	A2-1	A2-2	A2-3
Allocated resource blocks	6	15	25
DFT-OFDM Symbols per subframe	12	12	12
Modulation	16QAM	16QAM	16QAM
Code rate	2/3	2/3	2/3
Payload size (bits)	2344	5992	9912
Transport block CRC (bits)	24	24	24
Code block CRC size (bits)	0	0	24
Number of code blocks - C	1	1	2
Coded block size including 12bits trellis termination (bits)	7116	18060	14988
Total number of bits per sub-frame	3456	8640	14400
Total symbols per sub-frame	864	2160	3600

A.3 Fixed Reference Channels for performance requirements (QPSK 1/3)

Table A.3-1 FRC parameters for performance requirements (QPSK 1/3)

Reference channel	A3-1	A3-2	A3-3	A3-4	A3-5	A3-6	A3-7
Allocated resource blocks	1	6	15	25	50	75	100
DFT-OFDM Symbols per subframe	12	12	12	12	12	12	12
Modulation	QPSK	QPSK	QPSK	QPSK	QPSK	QPSK	QPSK
Code rate	1/3	1/3	1/3	1/3	1/3	1/3	1/3
Payload size (bits)	104	600	1544	2216	5160	6712	10296
Transport block CRC (bits)	24	24	24	24	24	24	24
Code block CRC size (bits)	0	0	0	0	0	24	24
Number of code blocks - C	1	1	1	1	1	2	2
Coded block size including 12bits trellis termination (bits)	396	1884	4716	6732	15564	10188	15564
Total number of bits per sub-frame	288	1728	4320	7200	14400	21600	28800
Total symbols per sub-frame	144	864	2160	3600	7200	10800	14400

A.4 Fixed Reference Channels for performance requirements (16QAM 3/4)

Table A.4-1 FRC parameters for performance requirements (16QAM 3/4)

Reference channel	A4-1	A4-2	A4-3	A4-4	A4-5	A4-6	A4-7	A4-8
Allocated resource blocks	1	1	6	15	25	50	75	100
DFT-OFDM Symbols per subframe	12	10	12	12	12	12	12	12
Modulation	16QAM	16QAM	16QAM	16QAM	16QAM	16QAM	16QAM	16QAM
Code rate	3/4	3/4	3/4	3/4	3/4	3/4	3/4	3/4
Payload size (bits)	408	376	2600	6456	10680	21384	32856	43816
Transport block CRC (bits)	24	24	24	24	24	24	24	24
Code block CRC size (bits)	0	0	0	24	24	24	24	24
Number of code blocks - C	1	1	1	2	2	4	6	8
Coded block size including 12bits trellis termination (bits)	1308	1212	7884	9804	16140	16140	16524	16524
Total number of bits per sub-frame	576	480	3456	8640	14400	28800	43200	57600
Total symbols per sub-frame	144	120	864	2160	3600	7200	10800	14400

A.5 Fixed Reference Channels for performance requirements (64QAM 5/6)

Table A.5-1 FRC parameters for performance requirements (64QAM 5/6)

Reference channel	A5-1	A5-2	A5-3	A5-4	A5-5	A5-6	A5-7
Allocated resource blocks	1	6	15	25	50	75	100
DFT-OFDM Symbols per subframe	12	12	12	12	12	12	12
Modulation	64QAM	64QAM	64QAM	64QAM	64QAM	64QAM	64QAM
Code rate	5/6	5/6	5/6	5/6	5/6	5/6	5/6
Payload size (bits)	712	4392	11064	18336	36696	55056	75376
Transport block CRC (bits)	24	24	24	24	24	24	24
Code block CRC size (bits)	0	0	24	24	24	24	24
Number of code blocks - C	1	1	2	3	6	9	13
Coded block size including 12bits trellis termination (bits)	2220	13260	16716	18444	18444	18444	17484
Total number of bits per sub-frame	864	5184	12960	21600	43200	64800	86400
Total symbols per sub-frame	144	864	2160	3600	7200	10800	14400

A.6 PRACH Test preambles

Table A.6-1 Test preambles for Normal Mode

Burst format	Ncs	Logical sequence index	v
0	13	22	32
1	167	22	2
2	167	22	0
3	0	22	0
4	10	0	0

Table A.6-2 Test preambles for High speed Mode

Burst format	Ncs	Logical sequence index	v
0	15	384	0
1	202	384	0
2	202	384	0
3	237	384	0

A.7 Fixed Reference Channels for UL timing adjustment (Scenario 1)

Table A.7-1 FRC parameters for UL timing adjustment (Scenario 1)

Reference channel	A7-1	A7-2	A7-3	A7-4	A7-5	A7-6
Allocated resource blocks	3	6	12	25	25	25
DFT-OFDM Symbols per subframe	12	12	12	12	12	12
Modulation	16QAM	16QAM	16QAM	16QAM	16QAM	16QAM
Code rate	3/4	3/4	3/4	3/4	3/4	3/4
Payload size (bits)	1288	2600	5160	10680	10680	10680
Transport block CRC (bits)	24	24	24	24	24	24
Code block CRC size (bits)	0	0	0	24	24	24
Number of code blocks - C	1	1	1	2	2	2
Coded block size including 12bits trellis termination (bits)	3948	7884	15564	16140	16140	16140
Total number of bits per sub-frame	1728	3456	6912	14400	14400	14400
Total symbols per sub-frame	432	864	1728	3600	3600	3600
SRS bandwidth configuration (See TS 36.211, 5.5.3) (Note 1)	7	5	3	2	5	2
SRS-Bandwidth b (See TS 36.211, 5.5.3) (Note 1, 2)	0	0	0	0	0	1
Note 1. The transmission of SRS is optional						
Note 2. PUSCH resource blocks shall be included in SRS resource blocks						

A.8 Fixed Reference Channels for UL timing adjustment (Scenario 2)

Table A.8-1 FRC parameters for UL timing adjustment (Scenario 2)

Reference channel	A8-1	A8-2	A8-3	A8-4	A8-5	A8-6
Allocated resource blocks	3	6	12	25	25	25
DFT-OFDM Symbols per subframe	12	12	12	12	12	12
Modulation	QPSK	QPSK	QPSK	QPSK	QPSK	QPSK
Code rate	1/3	1/3	1/3	1/3	1/3	1/3
Payload size (bits)	256	600	1224	2216	2216	2216
Transport block CRC (bits)	24	24	24	24	24	24
Code block CRC size (bits)	0	0	0	0	0	0
Number of code blocks - C	1	1	1	1	1	1
Coded block size including 12bits trellis termination (bits)	852	1884	3756	6732	6732	6732
Total number of bits per sub-frame	864	1728	3456	7200	7200	7200
Total symbols per sub-frame	432	864	1728	3600	3600	3600
SRS bandwidth configuration (See TS 36.211, 5.5.3) (Note 1)	7	5	3	2	5	2
SRS-Bandwidth b (See TS 36.211, 5.5.3) (Note 1, 2)	0	0	0	0	0	1
Note 1. The transmission of SRS is optional						
Note 2. PUSCH resource blocks shall be included in SRS resource blocks						

A.9 Multi user PUCCH test

Table A.9-1 Test parameters for multi user PUCCH case

	Cyclic shift index ($\delta = 0$)	Orthogonal cover index	RS orthogonal cover / ACK/NACK orthogonal cover	Relative power [dB]	Relative timing [ns]
Tested signal	4	0	2	-	-
Interferer 1	2	0	1	0	0
Interferer 2	3	1	7	-3	
Interferer 3	4	2	14	3	

NOTE1: Presented resource index mapping for orthogonal cover and cyclic shift indices are for the first slot of the subframe.

NOTE2: All above listed signals are transmitted on the same PUCCH resources, with different PUCCH channel indices as presented above.

Annex B (normative): Propagation conditions

B.1 Static propagation condition

The propagation for the static performance measurement is an Additive White Gaussian Noise (AWGN) environment. No fading or multi-paths exist for this propagation model.

B.2 Multi-path fading propagation conditions

Tables B.2-1 - B.2-3 show multi-path delay profiles that are used for the performance measurements in multi-path fading environment. All taps have classical Doppler spectrum, defined as:

$$(CLASS) \quad S(f) \propto 1/(1 - (f/f_D)^2)^{0.5} \quad \text{for } f \in [-f_D, f_D]$$

Table B.2-1 Extended Pedestrian A model (EPA)

Excess tap delay [ns]	Relative power [dB]
0	0.0
30	-1.0
70	-2.0
90	-3.0
110	-8.0
190	-17.2
410	-20.8

Table B.2-2 Extended Vehicular A model (EVA)

Excess tap delay [ns]	Relative power [dB]
0	0.0
30	-1.5
150	-1.4
310	-3.6
370	-0.6
710	-9.1
1090	-7.0
1730	-12.0
2510	-16.9

Table B.2-3 Extended Typical Urban model (ETU)

Excess tap delay [ns]	Relative power [dB]
0	-1.0
50	-1.0
120	-1.0
200	0.0
230	0.0
500	0.0
1600	-3.0
2300	-5.0
5000	-7.0

A multipath fading propagation condition is defined by a combination of a multi-path delay profile and a maximum Doppler frequency f_d which is either 5, 70 or 300 Hz. In addition, 200 Hz Doppler frequency is specified for UL timing adjustment performance requirement.

B.3 High speed train condition

High speed train conditions are as follows:

Scenario 1: Open space

Scenario 3: Tunnel for multi-antennas

The high speed train conditions for the test of the baseband performance are two non-fading propagation channels in both scenarios. For BS with Rx diversity defined in scenario 1, the Doppler shift variation is the same between antennas.

Doppler shift for both scenarios is given by:

$$f_s(t) = f_d \cos \theta(t) \quad (\text{B.3.1})$$

where $f_s(t)$ is the Doppler shift and f_d is the maximum Doppler frequency. The cosine of angle $\theta(t)$ is given by:

$$\cos \theta(t) = \frac{D_s/2 - vt}{\sqrt{D_{\min}^2 + (D_s/2 - vt)^2}}, \quad 0 \leq t \leq D_s/v \quad (\text{B.3.2})$$

$$\cos \theta(t) = \frac{-1.5D_s + vt}{\sqrt{D_{\min}^2 + (-1.5D_s + vt)^2}}, \quad D_s/v < t \leq 2D_s/v$$

(B.3.3)

$$\cos \theta(t) = \cos \theta(t \bmod (2D_s/v)), \quad t > 2D_s/v \quad (\text{B.3.4})$$

where $D_s/2$ is the initial distance of the train from BS, and D_{\min} is BS-Railway track distance, both in meters; v is the velocity of the train in m/s, t is time in seconds.

Doppler shift and cosine angle is given by equations B.3.1 and B.3.2-B.3.4 respectively, where the required input parameters listed in Table B.3-1 and the resulting Doppler shift is shown in Figure B.3-1 and B.3-2 are applied for all frequency bands.

Table B.3-1: Parameters for high speed train conditions

Parameter	Value	
	Scenario 1	Scenario 3
D_s	1000 m	300 m
D_{\min}	50 m	2 m
v	350 km/h	300 km/h
f_d	1340 Hz	1150 Hz

NOTE1: Parameters for HST conditions in table B.3-1 including f_d and Doppler shift trajectories presented on figures B.3-1 and B.3-2 were derived for Band 1.

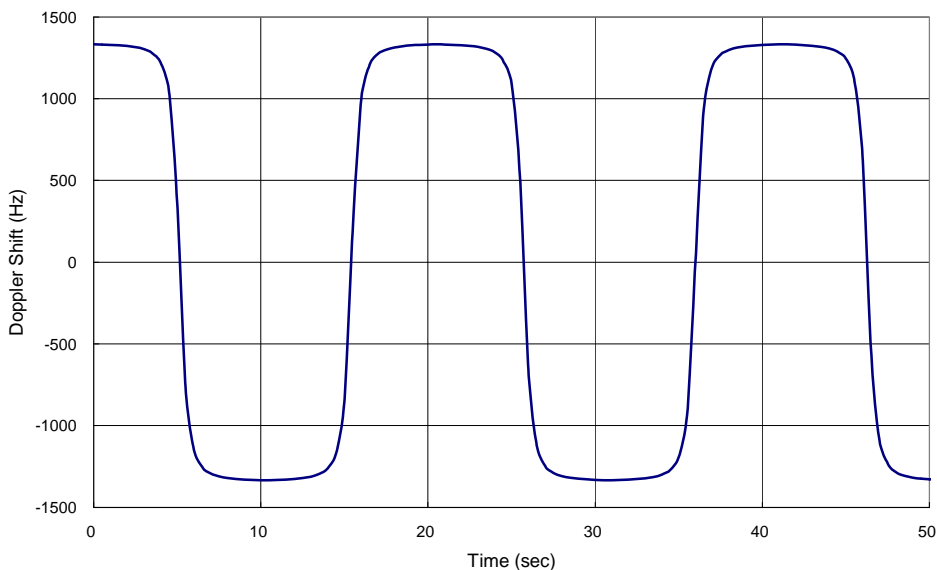

Figure B.3-1: Doppler shift trajectory for scenario 1

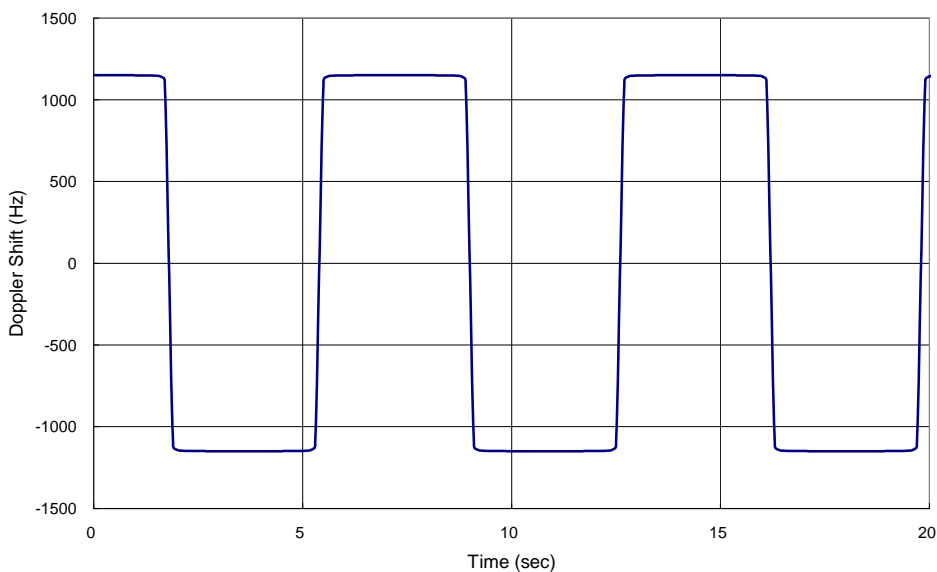

Figure B.3-2: Doppler shift trajectory for scenario 3

B.4 Moving propagation conditions

Figure B.4-1 illustrates the moving propagation conditions for the test of the UL timing adjustment performance. The time difference between the reference timing and the first tap is according Equation (B.4-1). The timing difference between moving UE and stationary UE is equal to $\Delta\tau - (T_A - 31) \times 16T_s$. The relative timing among all taps is fixed. The parameters for the moving propagation conditions are shown in Table B.4-1.

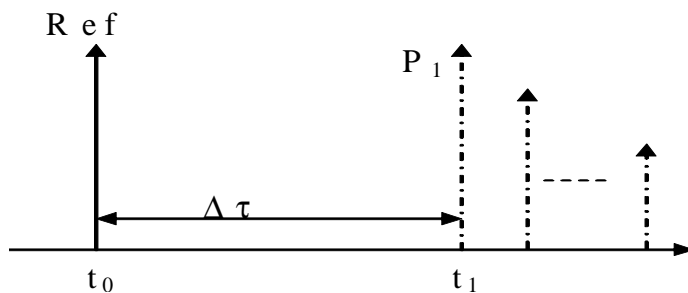

Figure B.4-1: Moving propagation conditions

$$\Delta\tau = \frac{A}{2} \cdot \sin(\Delta\omega \cdot t) \tag{B.4-1}$$

Table B.4-1: Parameters for UL timing adjustment

Parameter	Scenario 1	Scenario 2
Channel model	ETU200	AWGN
UE speed	120 km/h	350 km/h
CP length	Normal	Normal
A	10 μs	10 μs
Δω	0.04 s ⁻¹	0.13 s ⁻¹

NOTE 1: Multipath fading propagation conditions for Scenario 1 were derived for Band 1 with additional rounding applied to the Doppler frequency calculated for the specified UE speed.

NOTE 2: In Scenario 2, Doppler shift is not taken into account.

Annex C (normative): Characteristics of the interfering signals

<Text will be added.>

The interfering signal shall be a PUSCH containing data and reference symbols. Normal cyclic prefix is used. The data content shall be uncorrelated to the wanted signal and modulated according to clause 5 of TS36.211. Mapping of PUSCH modulation to receiver requirement are specified in Table C.1.

Table C.1.: Modulation of the interfering signal

Receiver requirement	Modulation
In-channel selectivity	16QAM
Adjacent channel selectivity and narrow-band blocking	QPSK
Blocking	QPSK
Receiver intermodulation	QPSK

Annex D (normative): Environmental requirements for the BS equipment

D.1 General

For each test in the present document, the environmental conditions under which the BS is to be tested are defined.

D.2 Normal test environment

When a normal test environment is specified for a test, the test should be performed within the minimum and maximum limits of the conditions stated in Table D.1.

Table D.1: Limits of conditions for Normal Test Environment

Condition	Minimum	Maximum
Barometric pressure	86 kPa	106 kPa
Temperature	15°C	30°C
Relative Humidity	20 %	85 %
Power supply	Nominal, as declared by the manufacturer	
Vibration	Negligible	

The ranges of barometric pressure, temperature and humidity represent the maximum variation expected in the uncontrolled environment of a test laboratory. If it is not possible to maintain these parameters within the specified limits, the actual values shall be recorded in the test report.

NOTE: This may, for instance, be the case for measurements of radiated emissions performed on an open field test site.

D.3 Extreme test environment

The manufacturer shall declare one of the following:

- 1) the equipment class for the equipment under test, as defined in the IEC 60 721-3-3 [6];
- 2) the equipment class for the equipment under test, as defined in the IEC 60 721-3-4 [7];
- 3) the equipment that does not comply to the mentioned classes, the relevant classes from IEC 60 721 documentation for Temperature, Humidity and Vibration shall be declared.

NOTE: Reduced functionality for conditions that fall out side of the standard operational conditions are not tested in the present document. These may be stated and tested separately.

D.3.1 Extreme temperature

When an extreme temperature test environment is specified for a test, the test shall be performed at the standard minimum and maximum operating temperatures defined by the manufacturer's declaration for the equipment under test.

Minimum temperature:

The test shall be performed with the environment test equipment and methods including the required environmental phenomena into the equipment, conforming to the test procedure of IEC 60 068-2-1 [8].

Maximum temperature:

The test shall be performed with the environmental test equipment and methods including the required environmental phenomena into the equipment, conforming to the test procedure of IEC 60 068-2-2 [9].

NOTE: It is recommended that the equipment is made fully operational prior to the equipment being taken to its lower operating temperature.

D.4 Vibration

When vibration conditions are specified for a test, the test shall be performed while the equipment is subjected to a vibration sequence as defined by the manufacturer's declaration for the equipment under test. This shall use the environmental test equipment and methods of inducing the required environmental phenomena in to the equipment, conforming to the test procedure of IEC 60 068-2-6 [10]. Other environmental conditions shall be within the ranges specified in clause D.2.

NOTE: The higher levels of vibration may induce undue physical stress in to equipment after a prolonged series of tests. The testing body should only vibrate the equipment during the RF measurement process.

D.5 Power supply

When extreme power supply conditions are specified for a test, the test shall be performed at the standard upper and lower limits of operating voltage defined by manufacturer's declaration for the equipment under test.

Upper voltage limit:

The equipment shall be supplied with a voltage equal to the upper limit declared by the manufacturer (as measured at the input terminals to the equipment). The tests shall be carried out at the steady state minimum and maximum temperature limits declared by the manufacturer for the equipment, to the methods described in IEC 60 068-2-1 [8] Test Ab/Ad and IEC 60 068-2-2 [9] Test Bb/Bd: Dry Heat.

Lower voltage limit:

The equipment shall be supplied with a voltage equal to the lower limit declared by the manufacturer (as measured at the input terminals to the equipment). The tests shall be carried out at the steady state minimum and maximum temperature limits declared by the manufacturer for the equipment, to the methods described in IEC 60 068-2-1 [8] Test Ab/Ad and IEC 60 068-2-2 [9] Test Bb/Bd: Dry Heat.

D.6 Measurement of test environments

The measurement accuracy of the BS test environments defined in Annex D, Test environments shall be.

Pressure:	±5 kPa.
Temperature:	±2 degrees.
Relative Humidity:	±5 %.
DC Voltage:	±1,0 %.
AC Voltage:	±1,5 %.
Vibration:	10 %.
Vibration frequency:	0,1 Hz.

The above values shall apply unless the test environment is otherwise controlled and the specification for the control of the test environment specifies the uncertainty for the parameter.

Annex E (normative): General rules for statistical testing

<Text will be added.>

Annex F (normative): Global In-Channel TX-Test

F.1 General

The global in-channel Tx test enables the measurement of all relevant parameters that describe the in-channel quality of the output signal of the TX under test in a single measurement process.

The parameters describing the in-channel quality of a transmitter, however, are not necessarily independent. The algorithm chosen for description inside this annex places particular emphasis on the exclusion of all interdependencies among the parameters.

F.2.1 Basic principle

The process is based on the comparison of the actual **output signal of the TX under test**, received by an ideal receiver, with a **reference signal**, that is generated by the measuring equipment and represents an ideal error free received signal. All signals are represented as equivalent (generally complex) baseband signals.

The description below uses numbers and illustrations as examples. These numbers are taken from frame structure 1 with normal CP length and a transmission bandwidth configuration of $N_{RB} = 100$. The application of the text below, however, is not restricted to this parameterset.

F.2.2 Output signal of the TX under test

The output signal of the TX under test is acquired by the measuring equipment and stored for further processing. It is sampled at a sampling rate of 30.72 Msps and it is named $z(v)$. In the time domain it comprises at least 1 frame:: $z(v)$. It is modelled as a signal with the following parameters: demodulated data content, carrier frequency, amplitude and phase for each subcarrier.

F.2.3 Reference signal

Two types of reference signal are defined:

The reference signal $i_1(v)$ is constructed by the measuring equipment according to the relevant TX specifications, using the following parameters: demodulated data content, nominal carrier frequency, nominal amplitude and phase for each subcarrier. It is represented as a sequence of samples at a sampling rate of 30.72 Msps in the time domain. The structure of the signal is described in the testmodells.

The reference signal $i_2(v)$ is constructed by the measuring equipment according to the relevant TX specifications, using the following parameters: restricted data content: nominal Reference Symbols and the Primary Synchronisation Channel, (all other modulation symbols are set to 0 V), nominal carrier frequency, nominal amplitude and phase for each applicable subcarrier, nominal timing. It is represented as a sequence of samples at a sampling rate of 30.72 Msps in the time domain.

F.2.4 Measurement results

The measurement results, achieved by the global in channel TX test are the following:

- Carrier Frequency error
- EVM (Error Vector Magnitude)
- Resource Element TX power

- RS TX power (RSTP)
- OFDM Symbol TX power (OSTP)

Other side results are: residual amplitude- and phase response of the TX chain after equalisation.

F.2.5 Measurement points

Resource element TX power is measured after the FFT as described below. EVM is calculated after the Equalizer (Ampl./ Phase correction). The result of the frequency synchronisation is the frequency offset. It is performed in the pre- and/or post-FFT domain. The FFT window of 2048 samples out of 2194 samples (data +CP) in the time domain is selected in the box CP removal.

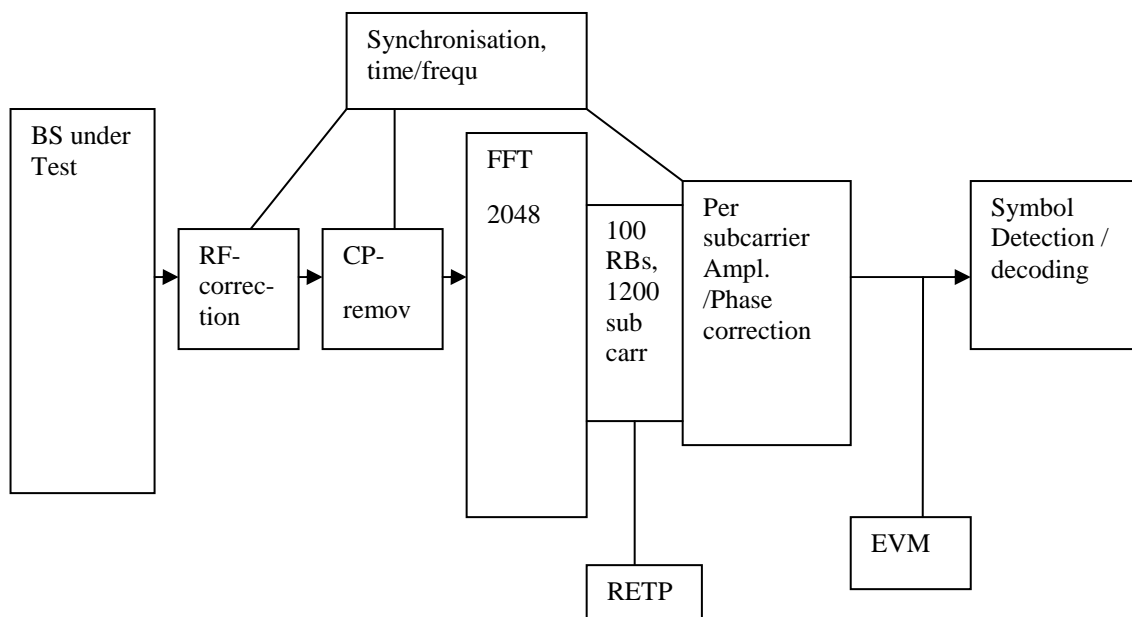

Figure E.2.5-1: Measurement points

F.3.1 Pre FFT minimization process

Sample Timing, Carrier Frequency in $z(v)$ are varied in order to minimise the difference between $z(v)$ and $i_1(v)$. Best fit (minimum difference) is achieved when the RMS difference value between $z(v)$ and $i(v)$ is an absolute minimum.

The carrier frequency variation is the measurement result: Carrier Frequency Error.

From the acquired samples one carrier frequency error can be derived.

Note 1. The minimisation process, to derive the RF error can be supported by Post FFT operations. However the minimisation process defined in the pre FFT domain comprises all acquired samples (i.e. it does not exclude the samples inbetween the FFT widths and it does not exclude the bandwidth outside the transmission bandwidth configuration).

Note 2. The algorithm would allow to derive Carrier Frequency error and Sample Frequency error of the TX under test separately. However there are no requirements for Sample Frequency error. Hence the algorithm models the RF and the sample frequency commonly (not independently). It returns one error and does not distinguish between both.

After this process the samples $z(v)$ are called $z^0(v)$.

F.3.2 Timing of the FFT window

The FFT window length is 2048 samples per OFDM symbol. 140 FFTs (286720 samples) cover less than the acquired number of samples (30720 samples in 10 subframes) The position in time for FFT must be determined.

In an ideal signal, the FFT may start at any instant within the cyclic prefix without causing an error. The TX filter, however, reduces the window. The EVM requirements shall be met within a window $W < CP$. There are three different instants for FFT:

Centre of the reduced window, called $\Delta\tilde{c}$, $\Delta C - W/2$ and $\Delta C + W/2$,

The BS shall transmit a signal according to the Test models, intended for EVM. The primary synchronisation signal and the reference signal shall be used to find the centre of the FFT window.

The timing of the measured signal is determined in the pre FFT domain as follows, using $z^0(v)$ and $i_2(v)$:

1. The measured signal is delay spread by the TX filter. Hence the distinct borders between the OFDM symbols and between Data and CP are also spread and the timing is not obvious.
2. In the Reference Signal $i_2(v)$ the timing is known.
3. Correlation between (1.) and (2.) will result in a correlation peak. The meaning of the correlation peak is approx. the 'impulse response' of the TX filter.
The meaning of 'impulse response' assumes that the autocorrelation of the reference signal $i_2(v)$ is a Dirac peak and that the correlation between the reference signal $i_2(v)$ and the data in the measured signal is 0. The correlation peak, (the highest, or in case of more than one highest, the earliest) indicates the timing in the measured signal.

The number of samples, used for FFT is reduced compared to $z^0(v)$. This subset of samples is called $z''(v)$.

From the acquired samples one timing can be derived.

The timing of the centre $\Delta\tilde{c}$ with respect to the different CP length in a slot is as follows: (Frame structure 1, normal CP length)

$\Delta\tilde{c}$ is on $T_f=72$ within the CP of length 144 (in OFDM symbol 1 to 6)

$\Delta\tilde{c}$ is on $T_f=88 (=160-72)$ within the CP of length 160 (in OFDM symbol 0)

F.3.3 Resource Element TX power

Perform FFT ($z''(v)$) with the FFT window timing $\Delta\tilde{c}$

The result is called $Z''(t,f)$. The RE TX power is then defined as:

$$RETP = |Z''(t, f)|^2 \cdot 15 \text{ KHz}$$

From this the Reference Signal Transmit power (RSTP) is derived as follows:

$$RSTP = \frac{1}{n_{RS \text{ RE locations within subframe}}} \sum RETP,$$

It is an average power and accumulates the powers of the reference symbols within a sub frame divided by n, the number of reference symbols within a sub frame.

From RETP the OFDM Symbol TX power (OSTP) is derived as follows:

$$OSTP = \sum_{\text{all } N_{RB}^{DL} N_{sc}^{RB} \text{ RE locations of 4th symbol within subframe}} RETP$$

It accumulates all sub carrier powers of the 4th OFDM symbol. The 4th (out of 14 OFDM symbols within a subframe (in case of frame type 1 , normal CP length)) contains exclusively PDSCH.

From the acquired samples 10 values for each RSTP and OSTP can be derived.

F.3.4 Post FFT equalisation

Perform 140 FFTs on $z''(v)$, one for each OFDM symbol comprising the full frame with the FFT window timing $\Delta\tilde{C}$. (in case of frame type 1 , normal CP length) The result is an array of samples, 140 in the time axis t times 2048 in the frequency axis f .

The equalizer coefficients $\tilde{a}(t, f)$ and $\tilde{\varphi}(t, f)$ are determined as follows:

1. time averaging at each reference signal subcarrier of the amplitude and phase of the reference symbols, the time-averaging length is 10 subframes This process creates an average amplitude and phase for each reference signal subcarrier (i.e. every third subcarrier with the exception of the reference subcarrier spacing across the DC subcarrier).
2. The equalizer coefficients for amplitude and phase $\hat{a}(t, f)$ and $\hat{\varphi}(t, f)$ at the reference signal subcarriers are obtained by computing the moving average in the frequency domain of the time-averaged reference signal subcarriers, i.e. every third subcarrier. The moving average window size is 19. For reference subcarriers at or near the edge of the channel the window size is reduced accordingly as per figure F. 3.4.
3. performing linear interpolation from the equalizer coefficients $\hat{a}(t, f)$ and $\hat{\varphi}(t, f)$ to compute coefficients $\tilde{a}(t, f)$, $\tilde{\varphi}(t, f)$ for each subcarrier.

The equalized samples are called $Z''_{eq}(f,t)$.

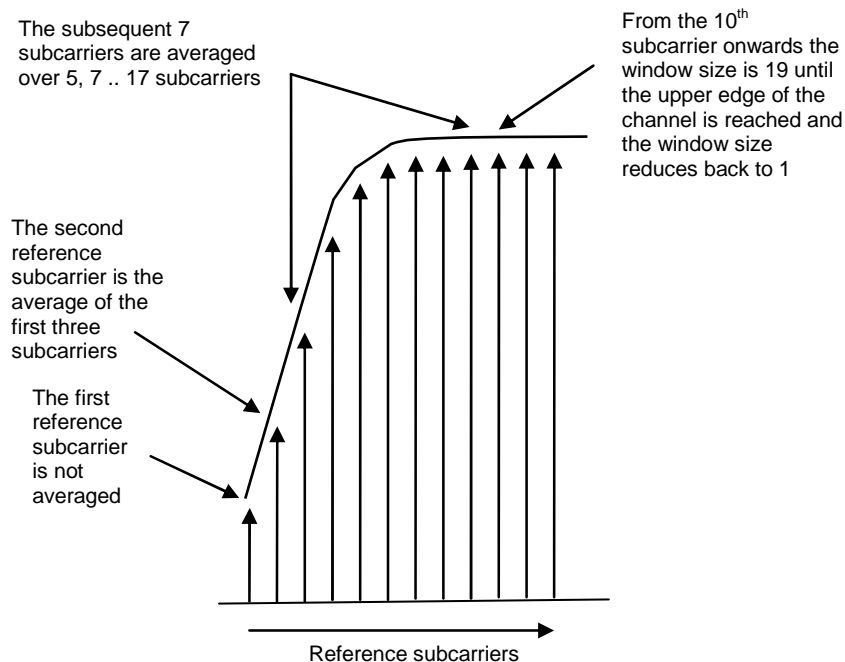

Figure F.3.4-1: Reference subcarrier smoothing in the frequency domain

F.4.1 EVM

For EVM create two sets of $Z'_{eq}(f,t)$, according to the timing ' $\Delta C - W/2$ and $\Delta C + W/2$ ', using the equalizer coefficients from F.3.4.

The equivalent ideal samples are calculated from $i_1(v)$ (clause F.2.3) and are called $I(f,t)$.

The EVM is the difference between the ideal waveform and the measured and equalized waveform.

$$EVM = \sqrt{\frac{\sum_{t \in T} \sum_{f \in F(t)} |Z'_{eq}(f,t) - I(f,t)|^2}{\sum_{t \in T} \sum_{f \in F(t)} |I(f,t)|^2}}$$

where

T is the set of symbols with the considered modulation scheme being active within the subframe,

$F(t)$ is the set of subcarriers within the N_{SC}^{RB} resource blocks with the considered modulation scheme being active in symbol t ,

$I(f,t)$ is the ideal signal reconstructed by the measurement equipment in accordance with relevant Test models,

$Z'_{eq}(f,t)$ is the equalized signal under test.

Note 1: Although the basic unit of measurement is one subframe, the equalizer is calculated over the entire 10 subframes measurement period to reduce the impact of noise in the reference symbols.

Note 2: Applicability of EVM calculation:

One EVM value is associated to 12 subcarriers times 1 subframe = pair of 2 RBs = 168 resource elements.

But only a reduced number of REs in this pair of 2 RBs contribute to EVM. Those are the PDSCH REs, containing the considered modulation scheme. Only those pairs of 2 RBs are evaluated with respect to EVM, which contain the maximum number of PDSCH REs. (EVM-relevant location in the time/frequency grid) The others are not evaluated.

In specific:

For bandwidth 1.4 MHz:

Only the pairs of 2 RBs containing 138 PDSCH REs are used for EVM. Only those 138 REs contribute to EVM
All pairs of 2 RBs, which contain less than 138 PDSCH REs, are not evaluated with respect to EVM.

For all other Bandwidths:

Only the pairs of 2 RBs containing 150 PDSCH REs are used for EVM. Only those 150 REs contribute to EVM

All pairs of 2 RBs, which contain less than 150 PDSCH REs, are not evaluated with respect to EVM.

This restriction serves to avoid weighted averaging in F.4.2.

F.4.2 Averaged EVM

EVM is averaged over all allocated EVM relevant locations in the frequency domain, and 10 consecutive downlink subframes (10 ms):

(The locations in the time-frequency grid are occupied irregularly, see Fig F.4.2-1)

\overline{EVM} is derived by: square the EVM results in F.4.1, sum the squares over all EVM relevant locations in the time/frequency grid, divide the sum by the number of EVM relevant locations, square-root the quotient.

The EVM requirements should be tested against the maximum of the average EVM at the window W extremities of the EVM measurements:

Thus \overline{EVM}_l is calculated using $\Delta\tilde{t} = \Delta\tilde{t}_l$ in the expressions above and \overline{EVM}_h is calculated using $\Delta\tilde{t} = \Delta\tilde{t}_h$. (l and h, low and high. Where l is the timing $\Delta C - W/2$ and high is the timing $\Delta C + W/2$)

Thus we get:

$$EVM_{final} = \max(\overline{EVM}_l, \overline{EVM}_h)$$

For TDD special fields (DwPTS and GP) are not included in the averaging.

15 RBs

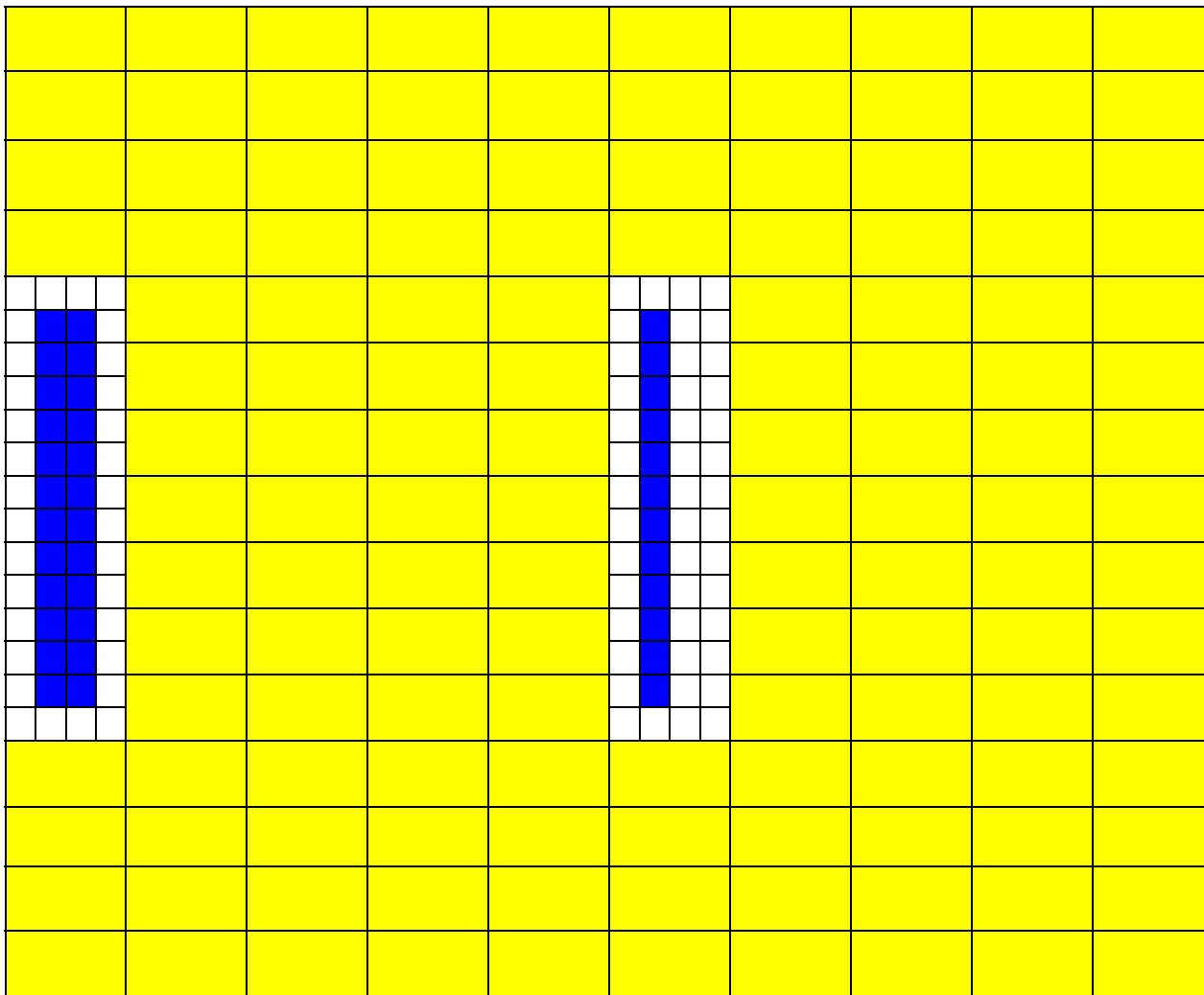

10 subframes →

Yellow: 136 EVM-relevant locations in the time/frequency grid

Blue: non PDSCH REs

White: RBs with non-maximum number of PDSCH REs

Figure F.4.2-1: Applicability of EVM calculation Example: E-TM1.x, E-TM3.x, 3MHz

F.4.2.1 Averaged EVM (TDD)

For TDD the averaging in the time domain can be calculated from subframes of different frames and should have a minimum of 10 subframes averaging length. TDD special fields (DwPTS and GP) are not included in the averaging.

\overline{EVM}_{frame} is derived by: Square the EVM results in a frame. Relevant for EVM are subframes in a frame, which are active in the DL, N_{dl} . Within these subframes, those RBs are relevant, that carry the maximum number of PDSCH REs (same as FDD). Sum the squares, divide the sum by the number of EVM relevant locations, square-root the quotient. (RMS)

The \overline{EVM}_{frame} is calculated, using the maximum of \overline{EVM}_{frame} at the window W extremities. Thus $\overline{EVM}_{frame,l}$ is calculated using $\Delta\tilde{t} = \Delta\tilde{t}_l$ and $\overline{EVM}_{frame,h}$ is calculated using $\Delta\tilde{t} = \Delta\tilde{t}_h$. (l and h, low and high. Where l is the timing $\Delta C - W/2$ and high is the timing $\Delta C + W/2$)

$$\overline{EVM}_{frame} = \max(\overline{EVM}_{frame,l}, \overline{EVM}_{frame,h})$$

In order to unite at least 10 subframes, consider the minimum integer number of radio frames, containing at least 10 EVM relevant subframes. Unite by RMS.

$$\overline{EVM} = \sqrt{\frac{1}{N_{frame}} \sum_{k=1}^{N_{frame}} \overline{EVM}_{frame,k}^2}, \quad N_{frame} = \left\lceil \frac{10}{N_{dl}} \right\rceil$$

The result, \overline{EVM} , is compared against the limit.

Annex G (informative): Test Tolerances and Derivation of Test Requirements

The Test Requirements in this specification have been calculated by relaxing the Minimum Requirements of the core specification using the Test Tolerances defined here. When the Test Tolerance is zero, the Test Requirement will be the same as the Minimum Requirement. When the Test Tolerance is non-zero, the Test Requirements will differ from the Minimum Requirements, and the formula used for this relaxation is given in the following tables.

The Test Tolerances are derived from Test System uncertainties, regulatory requirements and criticality to system performance. As a result, the Test Tolerances may sometimes be set to zero.

The test tolerances should not be modified for any reason e.g. to take account of commonly known test system errors (such as mismatch, cable loss, etc.).

Note that a formula for applying Test Tolerances is provided for all tests, even those with a test tolerance of zero. This is necessary in the case where the Test System uncertainty is greater than that allowed in clause 4.1.2. In this event, the excess error shall be subtracted from the defined test tolerance in order to generate the correct tightened Test Requirements as defined in this Annex.

[FFS: For example, a Test System having 0.9 dB uncertainty for test 6.2 Base Station maximum output power (which is 0.2 dB above the limit specified in clause 4.1.2) would subtract 0.2 dB from the Test Tolerance of 0.7 dB defined in this Annex. This new test tolerance of 0.5 dB would then be applied to the Minimum Requirement using the formula defined in Table G.2-1 to give a new range of ± 2.5 dB of the manufacturer's rated output power.

Using this same approach for the case where a test had a test tolerance of 0 dB, an excess error of 0.2 dB would result in a modified test tolerance of -0.2 dB.]

G.1 Measurement of transmitter

Table G.1-1: Derivation of Test Requirements (Transmitter tests)

Test	Minimum Requirement in TS 36.104	Test Tolerance (TT)	Test Requirement in TS 36.141
6.2 Base station maximum output power	<p>In normal conditions: within ± 2 dB of manufacturer's rated output power</p> <p>In extreme conditions: within ± 2.5 dB of manufacturer's rated output power</p>	<p>0.7 dB</p> <p>0.7 dB</p>	<p>Formula: Upper limit + TT, Lower limit - TT</p> <p>In normal conditions: within +2.7 dB and -2.7 dB of the manufacturer's rated output power</p> <p>In extreme conditions: within +3.2 dB and -3.2 dB of the manufacturer's rated output power</p>
6.3.2 Total power dynamic range	<p>Total power dynamic range (dB):</p> <p>1.4 MHz E-UTRA: 7.7</p> <p>3 MHz E-UTRA: 11.7</p> <p>5 MHz E-UTRA: 13.9</p> <p>10 MHz E-UTRA: 16.9</p> <p>15 MHz E-UTRA: 18.7</p> <p>20 MHz E-UTRA: 20</p>	0.4 dB	<p>Formula: Total power dynamic range – TT (dB)</p> <p>1.4 MHz E-UTRA: 7.3</p> <p>3 MHz E-UTRA: 11.3</p> <p>5 MHz E-UTRA: 13.5</p> <p>10 MHz E-UTRA: 16.5</p> <p>15 MHz E-UTRA: 18.3</p> <p>20 MHz E-UTRA: 19.6</p>
6.4.1 Transmitter OFF power	[TBD]	[TBD]	[TBD]
6.4.2 Transmitter transient period	<p>Transmitter transient period :</p> <p>off to on: 17 us</p> <p>on to off: 17 us</p>	N/A	Minimum Requirement
6.5.1 Frequency error	Frequency error limit ± 0.05 ppm	12 Hz	<p>Formula: Frequency Error limit + TT</p> <p>0.05 ppm + 12 Hz</p>
6.5.2 EVM	<p>EVM limit:</p> <p>QPSK: 17.5 %</p> <p>16QAM: 12.5 %</p> <p>64QAM: 8 %</p>	1 %	<p>Formula:</p> <p>EVM limit + TT</p> <p>QPSK: 18.5 %</p> <p>16QAM: 13.5 %</p> <p>64QAM: 9 %</p>
6.5.3 Time alignment between transmitter branches	Time alignment error within 65 ns	25 ns	<p>Formula:</p> <p>Time alignment error limit + TT</p> <p>90 ns</p>
6.5.4 DL RS power	DL RS power shall be within ± 2.1 dB	0.8 dB	<p>Formula:</p> <p>Upper limit + TT</p> <p>Lower limit - TT</p> <p>DL RS power shall be within ± 2.9 dB</p>
6.6.1 Occupied bandwidth	<p>1.4 MHz</p> <p>3 MHz</p> <p>5 MHz</p> <p>10 MHz</p> <p>15 MHz</p> <p>20 MHz</p>	0 kHz	<p>Formula:</p> <p>Minimum Requirement + TT</p>
6.6.2 Adjacent Channel Leakage power Ratio (ACLR)	Paired spectrum		<p>Formula:</p> <p>ACLR Minimum Requirement - TT</p> <p>Absolute limit +TT</p> <p>Paired spectrum ACLR:</p>

	<p>ACLR: 45 dB for E-UTRA 45 dB for UTRA</p> <p>Unpaired spectrum ACLR: 45 dB for E-UTRA 45 dB for 1.28 Mcps UTRA 45 dB for 3.84 Mcps UTRA 45 dB for 7.82 Mcps UTRA</p> <p>Absolute limit -13dBm / MHz</p>	<p>0.8 dB 0.8 dB</p> <p>0.8 dB 0.8 dB 0.8 dB 0.8 dB</p> <p>0 dB</p>	<p>44.2 dB 44.2 dB</p> <p>Unpaired spectrum ACLR: 44.2 dB 44.2 dB 44.2 dB</p> <p>Absolute limit -13dBm / MHz</p>
<p>6.6.3 Operating band unwanted emissions</p>	<p><u>Category A, bands < 1GHz</u> For 1.4MHz BW: Offsets < 2.8MHz -1dBm to -11dBm / 100kHz Offsets ≥ 2.8MHz -13dBm / 100kHz</p> <p>For 3MHz BW: Offsets < 3MHz -4.5dBm to -14.5dBm / 100kHz Offsets ≥ 3MHz -13dBm / 100kHz</p> <p>For 5, 10, 15, 20MHz BW: Offsets < 10MHz -7dBm to -14dBm / 100kHz Offsets ≥ 10MHz -13dBm / 100kHz</p> <p><u>Category A, bands > 1GHz</u> For 1.4MHz BW: Offsets < 2.8MHz -1dBm to -11dBm / 100kHz Offsets ≥ 2.8MHz -13dBm / 1MHz</p> <p>For 3MHz BW: Offsets < 6MHz -5dBm to -15dBm / 100kHz Offsets ≥ 6MHz -13dBm / 1MHz</p> <p>For 5, 10, 15, 20MHz BW: Offsets < 10MHz -7dBm to -14dBm / 100kHz Offsets ≥ 10MHz -13dBm / 1MHz</p> <p><u>Category B, bands < 1GHz</u> For 1.4MHz BW: Offsets < 2.8MHz</p>	<p>1.5dB 0dB</p> <p>1.5dB 0dB</p> <p>1.5dB 0dB</p> <p>1.5dB 0dB</p> <p>0dB</p> <p>1.5dB 0dB</p> <p>1.5dB 0dB</p> <p>1.5dB 0dB</p> <p>0dB</p>	<p>Formula:</p> <p>Minimum Requirement + TT</p>

	<p>-1dBm to -11dBm / 100kHz Offsets \geq 2.8MHz -16dBm / 100kHz</p> <p>For 3MHz BW: Offsets < 6MHz -5dBm to -15dBm / 100kHz Offsets \geq 6MHz -16dBm / 100kHz</p> <p>For 5, 10, 15, 20MHz BW: Offsets < 10MHz -7dBm to -14dBm / 100kHz Offsets \geq 10MHz -16dBm / 100kHz</p> <p><u>Category B, bands > 1GHz</u> For 1.4MHz BW: Offsets < 2.8MHz -1dBm to -11dBm / 100kHz Offsets \geq 2.8MHz -15dBm / 1MHz</p> <p>For 3MHz BW: Offsets < 6MHz -5dBm to -15dBm / 100kHz Offsets \geq 6MHz -15dBm / 1MHz</p> <p>For 5, 10, 15, 20MHz BW: Offsets < 10MHz -7dBm to -14dBm / 100kHz Offsets \geq 10MHz -15dBm / 1MHz</p> <p><u>Additional Reqts. bands < 1GHz</u> All BWs:</p> <p><u>Additional Reqts. bands > 1GHz</u> All BWs:</p> <p><u>Additional Reqts. bands 12,13,14</u> All BWs:</p>	<p>1.5dB</p> <p>0dB</p> <p>1.5dB</p> <p>0dB</p> <p>1.5dB</p> <p>0dB</p> <p>1.5dB</p> <p>0dB</p> <p>0dB</p> <p>0dB</p> <p>0dB</p>	
<p>6.6.4.5.1 Transmitter spurious emissions, Mandatory Requirements</p>	<p><u>Category A</u> $9 \text{ kHz} \leq f < 150 \text{ kHz}$: -13dBm / 1kHz</p> <p>$150 \text{ kHz} \leq f < 30 \text{ MHz}$: -13dBm / 10 kHz</p> <p>$30 \text{ MHz} \leq f < 1 \text{ GHz}$: -13dBm / 100 kHz</p> <p>$1 \text{ GHz} \leq f < 12.75 \text{ GHz}$: -13dBm / 1 MHz</p>	<p>0dB</p>	<p>Formula: Minimum Requirement + TT</p>

6.6.4.5.2 Transmitter spurious emissions, Mandatory Requirements	<u>Category B</u> $9 \text{ kHz} \leq f < 150 \text{ kHz}$: -36dBm / 1 kHz $150 \text{ kHz} \leq f < 30 \text{ MHz}$: -36dBm / 10 kHz $30 \text{ MHz} \leq f < 1 \text{ GHz}$: -36dBm / 100 kHz $1 \text{ GHz} \leq f < 12.75 \text{ GHz}$: -36dBm / 1 MHz	0dB	Formula: Minimum Requirement + TT
6.6.4.5.3 Transmitter spurious emissions, Protection of BS receiver	-96dBm / 100 kHz	0dB	Formula: Minimum Requirement + TT
6.6.4.5.4 Transmitter spurious emissions, Additional spurious emissions requirements	Levels from -61dBm to -41dBm Bandwidths from 6.25 kHz to 1MHz See TS 36.104 [2] for details	0dB	Formula: Minimum Requirement + TT
6.6.4.5.5 Transmitter spurious emissions, Co-location	Levels from -98dBm to -96dBm Bandwidth 100 kHz See TS 36.104 [2] for details	0dB	Formula: Minimum Requirement + TT
6.7 Transmitter intermodulation (interferer requirements) This tolerance applies to the stimulus and not the measurements defined in 6.6.2, 6.6.3 and 6.6.4.	Wanted signal level - interferer level = 30dB	0dB	Formula: Ratio + TT Wanted signal level - interferer level = 30 + 0dB

G.2 Measurement of receiver

Table G.2-1: Derivation of Test Requirements (Receiver tests)

Test	Minimum Requirement in TS 36.104	Test Tolerance (TT)	Test Requirement in TS 36.141
7.2 Reference sensitivity level	Reference sensitivity power level: -106.8 dBm for 1.4 MHz BW -103.0 dBm for 3 MHz BW -101.5 dBm for 5 MHz BW -101.5 dBm for 10 MHz BW -101.5 dBm for 15 MHz BW -101.5 dBm for 20 MHz BW T-put limit = 95% of maximum for the Ref Meas channel	0.7 dB 0.7 dB 0.7 dB 0.7 dB 0.7 dB 0.7 dB	Formula: Reference sensitivity power level + TT -106.1 dBm for 1.4 MHz BW -102.3 dBm for 3 MHz BW -100.8 dBm for 5 MHz BW -100.8 dBm for 10 MHz BW -100.8 dBm for 15 MHz BW -100.8 dBm for 20 MHz BW T-put limit unchanged

<p>7.3 Dynamic range</p>	<p>Wanted signal power: -76.3 dBm for 1.4 MHz BW -72.4 dBm for 3 MHz BW -70.2 dBm for 5 MHz BW -70.2 dBm for 10 MHz BW -70.2 dBm for 15 MHz BW -70.2 dBm for 20 MHz BW</p> <p>T-put limit = 95% of maximum for the Ref Meas channel</p>	<p>0.3 dB 0.3 dB 0.3 dB 0.3 dB 0.3 dB 0.3 dB</p>	<p>Formula: Wanted signal power + TT</p> <p>-76.0 dBm for 1.4 MHz BW -72.1 dBm for 3 MHz BW -69.9 dBm for 5 MHz BW -69.9 dBm for 10 MHz BW -69.9 dBm for 15 MHz BW -69.9 dBm for 20 MHz BW</p> <p>Interferer signal power unchanged T-put limit unchanged</p>
<p>7.4 In-channel selectivity</p>	<p>Wanted signal power: -106.9 dBm for 1.4 MHz BW -102.1 dBm for 3 MHz BW -100.0 dBm for 5 MHz BW -98.5 dBm for 10 MHz BW -98.5 dBm for 15 MHz BW -98.5 dBm for 20 MHz BW</p> <p>T-put limit = 95% of maximum for the Ref Meas channel</p>	<p>1.4 dB 1.4 dB 1.4 dB 1.4 dB 1.4 dB 1.4 dB</p>	<p>Formula: Wanted signal power + TT</p> <p>-105.5 dBm for 1.4 MHz BW -100.7 dBm for 3 MHz BW -98.6 dBm for 5 MHz BW -97.1 dBm for 10 MHz BW -97.1 dBm for 15 MHz BW -97.1 dBm for 20 MHz BW</p> <p>Interferer signal power unchanged T-put limit unchanged</p>
<p>7.5 Adjacent Channel Selectivity (ACS) and narrow-band blocking</p>	<p><u>Narrowband blocking:</u> Wanted signal power, all BWs: (P_{REFSENS} + 6 dB)</p> <p>Interferer signal power, all BWs: -49dBm</p> <p><u>Adjacent channel selectivity:</u> Wanted signal power For 1.4 MHz BW: (P_{REFSENS} + 11dB) For 3 MHz BW: (P_{REFSENS} + 8dB) For 5 MHz, 10MHz, 15MHz and 20MHz BW: (P_{REFSENS} + 6dB)</p> <p>Interferer signal power, all BWs: -52 dBm</p> <p>T-put limit = 95% of maximum for the Ref Meas channel</p>	<p>0 dB</p>	<p>Formula: Wanted signal power + TT</p> <p><u>Narrowband blocking:</u> all BWs: (P_{REFSENS} + 6 dB)</p> <p>Interferer signal power unchanged</p> <p><u>Adjacent channel selectivity:</u> Wanted signal power For 1.4 MHz BW: (P_{REFSENS} + 11dB) For 3 MHz BW: (P_{REFSENS} + 8dB) For 5 MHz, 10MHz, 15MHz and 20MHz BW: (P_{REFSENS} + 6dB)</p> <p>Interferer signal power unchanged</p> <p>T-put limit unchanged</p>
<p>7.6.5.1 Blocking (General requirements)</p>	<p><u>In-band blocking</u> Wanted signal power, all BWs: (P_{REFSENS} + 6 dB)</p> <p>Interferer signal power, all BWs: -43dBm</p> <p><u>Out of band blocking</u> Wanted signal power, all BWs: (P_{REFSENS} + 6 dB)</p> <p>Interferer signal power, all BWs: -15dBm CW</p> <p>T-put limit = 95% of maximum for the Ref Meas channel</p>	<p>0 dB</p>	<p>Formula: Wanted signal power + TT, all BWs: (P_{REFSENS} + 6 dB)</p> <p>Interferer signal power unchanged</p> <p>T-put limit unchanged</p>

7.6.5.2 Blocking (Co-location with other base stations)	<u>Co-located blocking</u> Wanted signal power, all BWs: ($P_{\text{REFSENS}} + 6 \text{ dB}$) Interferer signal power, all BWs: +16dBm T-put limit = 95% of maximum for the Ref Meas channel	0 dB	Formula: Wanted signal power + TT, all BWs: ($P_{\text{REFSENS}} + 6 \text{ dB}$) Interferer signal power unchanged T-put limit unchanged
7.7 Receiver spurious emissions	-57dBm / 100 kHz -47dBm / 1 MHz	0dB	Formula: Minimum Requirement + TT Emission requirements unchanged
7.8 Receiver intermodulation	Wanted signal power, all BWs: ($P_{\text{REFSENS}} + 6 \text{ dB}$) CW Interferer power, all BWs: -52 dBm Modulated Interferer power:, all BWs: -52 dBm T-put limit = 95% of maximum for the Ref Meas channel	0 dB	Formula: Wanted signal power + TT, all BWs: ($P_{\text{REFSENS}} + 6 \text{ dB}$) CW Interferer signal power unchanged Modulated Interferer signal power unchanged T-put limit unchanged

G.3 Measurement of Performance Requirements

Table G.4-1: Derivation of Test Requirements (Performance tests)

Test	Minimum Requirement in TS 36.104	Test Tolerance (TT)	Test Requirement in TS 36.141
8.2.1 Performance requirements of PUSCH in multipath fading propagation conditions	SNRs as specified	0.6dB	Formula: SNR + TT T-put limit unchanged
8.2.2 Performance requirements for UL timing adjustment	SNRs as specified	0.6dB for fading cases 0.3dB for AWGN cases	Formula: SNR + TT T-put limit unchanged
8.2.3 Performance requirements for HARQ-ACK multiplexed on PUSCH	SNRs as specified	0.6dB	Formula: SNR + TT False ACK limit unchanged Correct ACK limit unchanged
8.2.4 Performance requirements for High Speed Train conditions	SNRs as specified	0.3dB	Formula: SNR + TT T-put limit unchanged
8.3.1 ACK missed detection for single user PUCCH format 1a	SNRs as specified	0.6dB	Formula: SNR + TT False ACK limit unchanged Correct ACK limit unchanged
8.3.2 CQI missed detection for PUCCH format 2	SNRs as specified	0.6dB	Formula: SNR + TT False CQI limit unchanged Correct CQI limit unchanged
8.3.3 ACK missed detection for multi user PUCCH format 1a	SNRs as specified	0.6dB	Formula: SNR + TT False ACK limit unchanged Correct ACK limit unchanged
8.4.1 PRACH false alarm probability and missed detection	SNRs as specified	0.6dB for fading cases 0.3dB for AWGN cases	Formula: SNR + TT PRACH False detection limit unchanged PRACH detection limit unchanged

Annex H (Informative): E-UTRAN Measurement Test Cases

<Text will be added.>

Annex I (Informative): Measurement system set-up

Example of measurement system set-ups are attached below as an informative annex.

I.1 Transmitter

I.1.1 Base station output power, output power dynamics, transmitted signal quality, Frequency error, EVM, DL RS power, Unwanted emissions

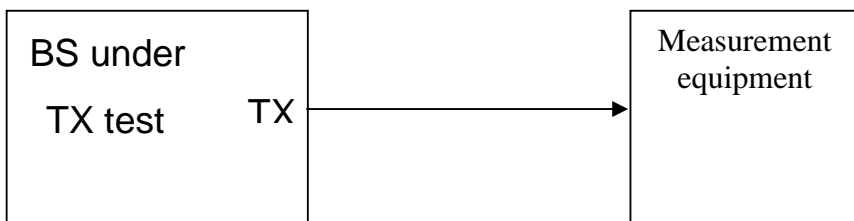

Figure I.1-1: Measuring system Set-up for base station output power, output power dynamics, transmitted signal quality, Frequency error, EVM, DL RS power, Unwanted emissions

I.1.2 Transmitter intermodulation

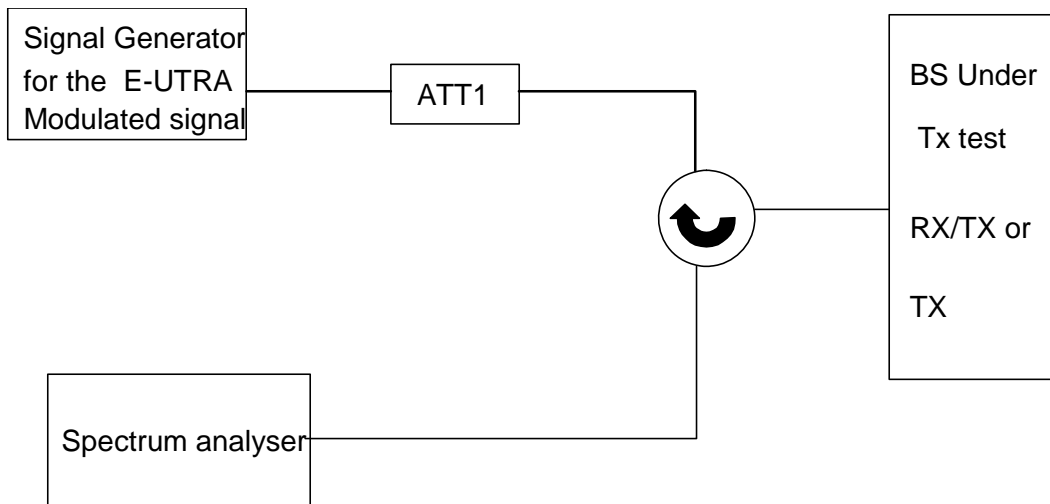

Figure I.1-2: Measuring system Set-up for Transmitter intermodulation

I.1.3 Time alignment between transmitter branches

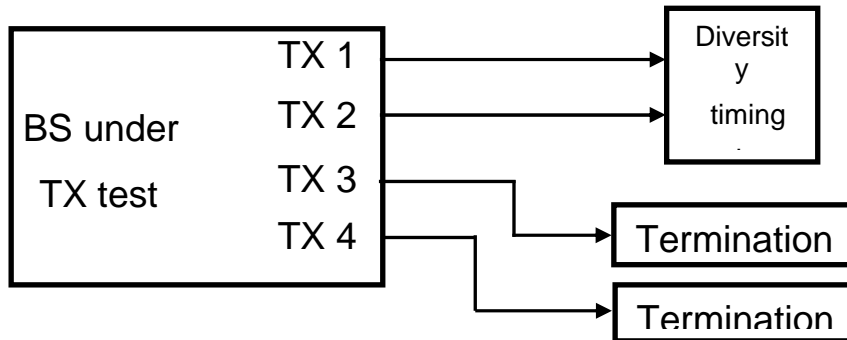

Figure I.1-3: Measuring system Set-up for Test of Time alignment between transmitter branches

I.2 Receiver

NOTE: No HARQ feedback is done for any receiver test in Annex I.2.

I.2.1 Reference sensitivity level

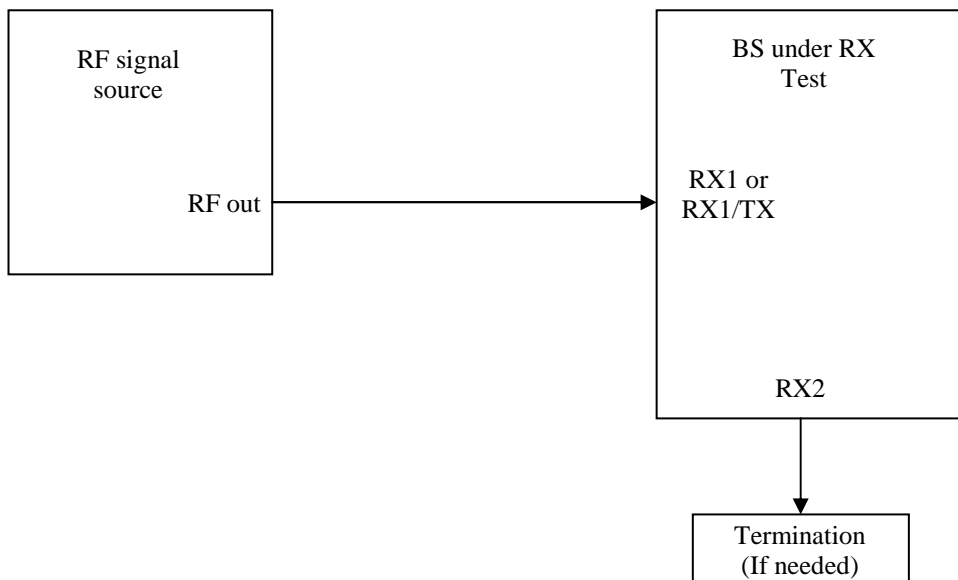

Figure I.2-1: Measuring system Set-up for Base Station Reference sensitivity level Test

I.2.2 Dynamic range

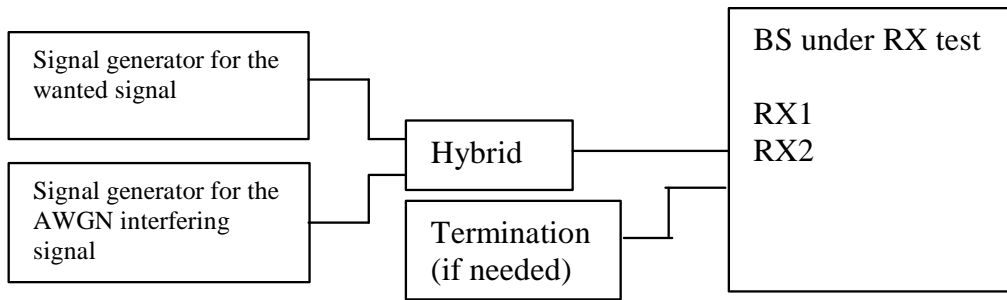

Figure I.2-2: Measuring system Set-up for Dynamic range

I.2.3 In-channel selectivity

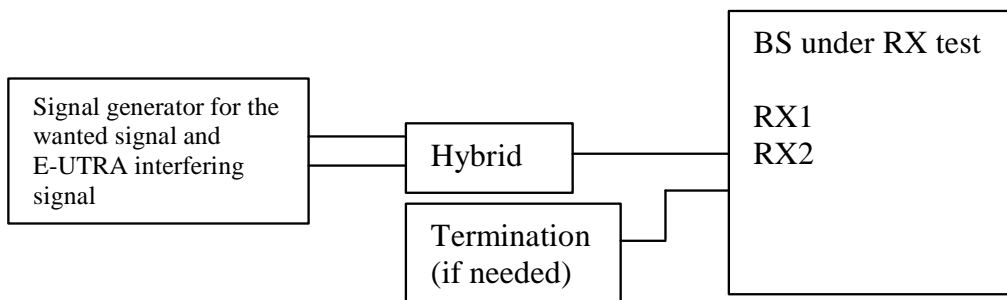

Figure I.2-3: Measuring system Set-up for In-channel selectivity

1.2.4 Adjacent Channel Selectivity (ACS) and narrowband blocking

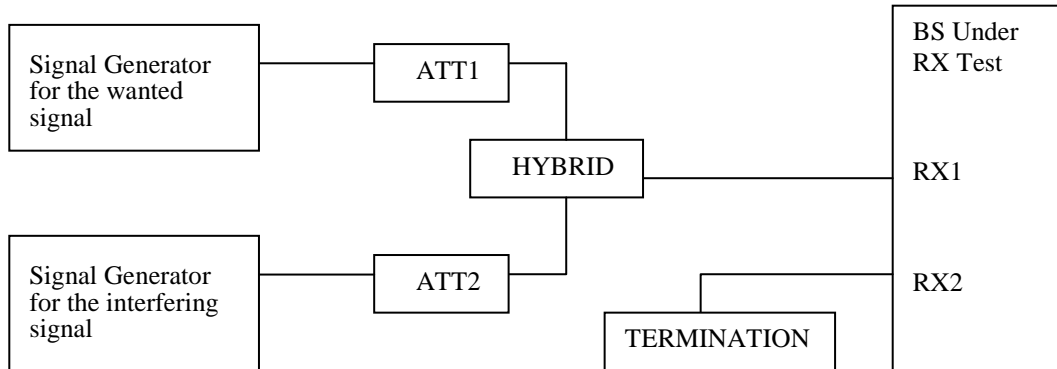

Figure I.2-4: Measuring system Set-up for Adjacent channel selectivity and narrowband blocking

1.2.5 Blocking characteristics

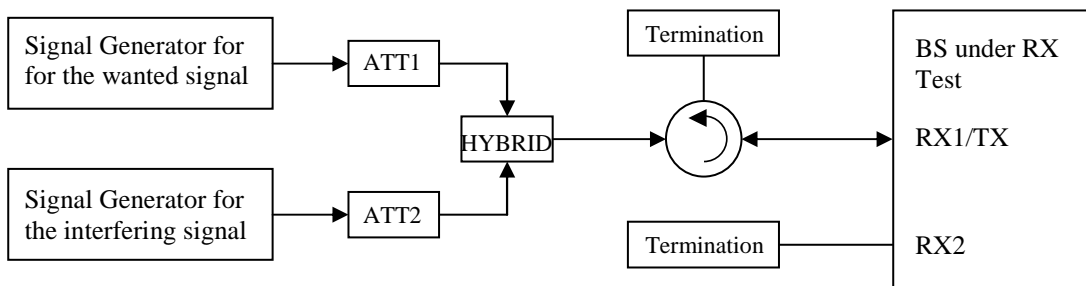

Figure I.2-5: Measuring system Set-up for Blocking characteristics

1.2.6 Receiver spurious emission

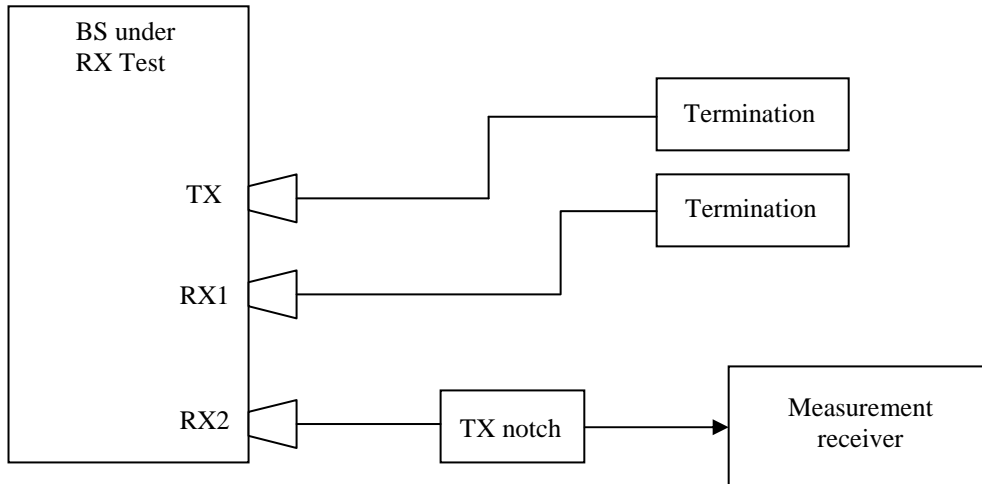

Figure I.2-6: Measuring system Set-up for Receiver spurious emission

1.2.7 Intermodulation characteristics

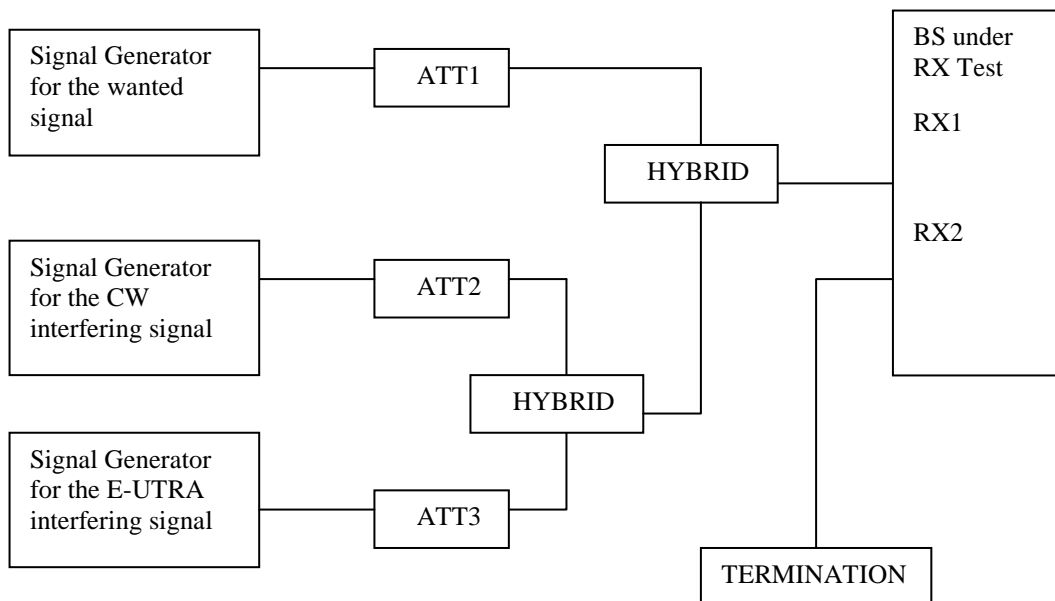

Figure I.2-7: Measuring system Set-up for intermodulation characteristics

I.3 Performance requirement

I.3.1 Performance requirements for PRACH in static conditions

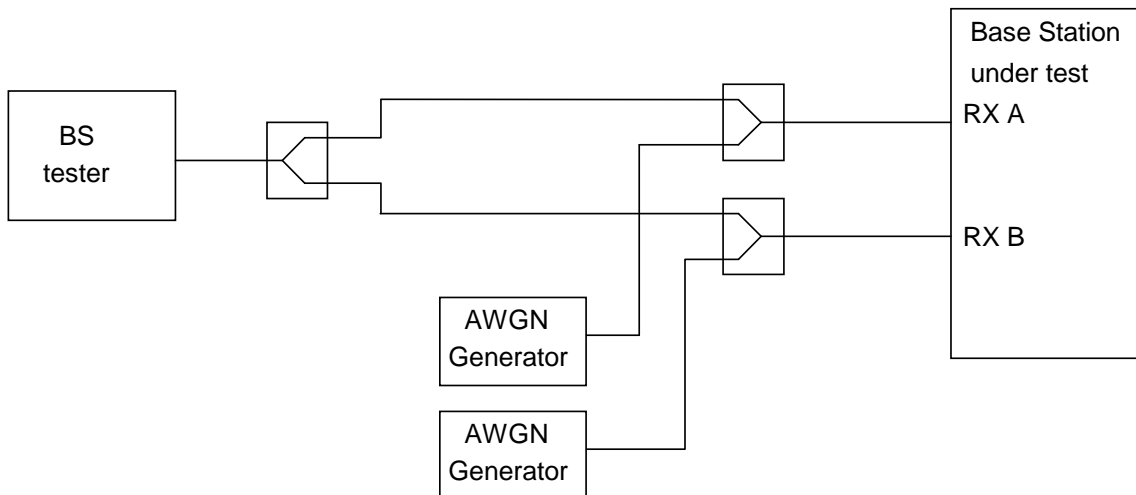

Figure I.3-1: Functional set-up for performance requirements for PRACH in static conditions for BS with Rx diversity (2 Rx case shown)

I.3.2 Performance requirements for PUSCH, PRACH, single user PUCCH in multipath fading conditions and for High Speed Train conditions

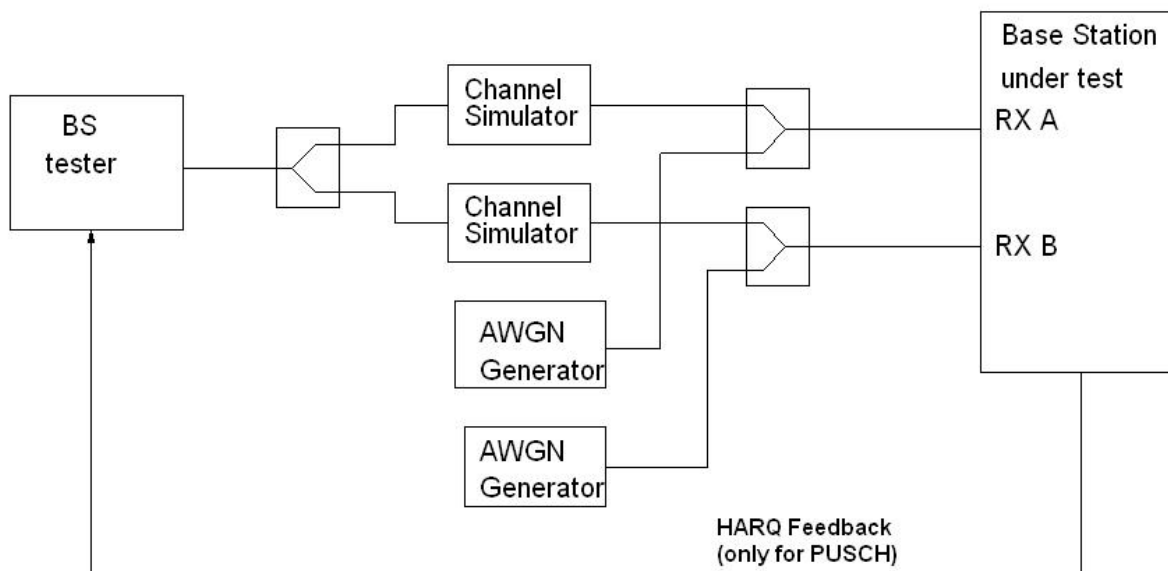

Figure I.3-2: Functional set-up for performance requirements for PUSCH, PRACH, single user PUCCH in multipath fading conditions and for High Speed Train conditions for BS with Rx diversity (2 Rx case shown)

- NOTE 1: For HST tests which are specified in static conditions, the Channel Simulators are assumed to simulate the Doppler shift.
- NOTE 2: The HARQ Feedback could be done as an RF feedback or as a digital feedback. The HARQ Feedback should be error free.

I.3.3 Performance requirements for multi user PUCCH in multipath fading conditions

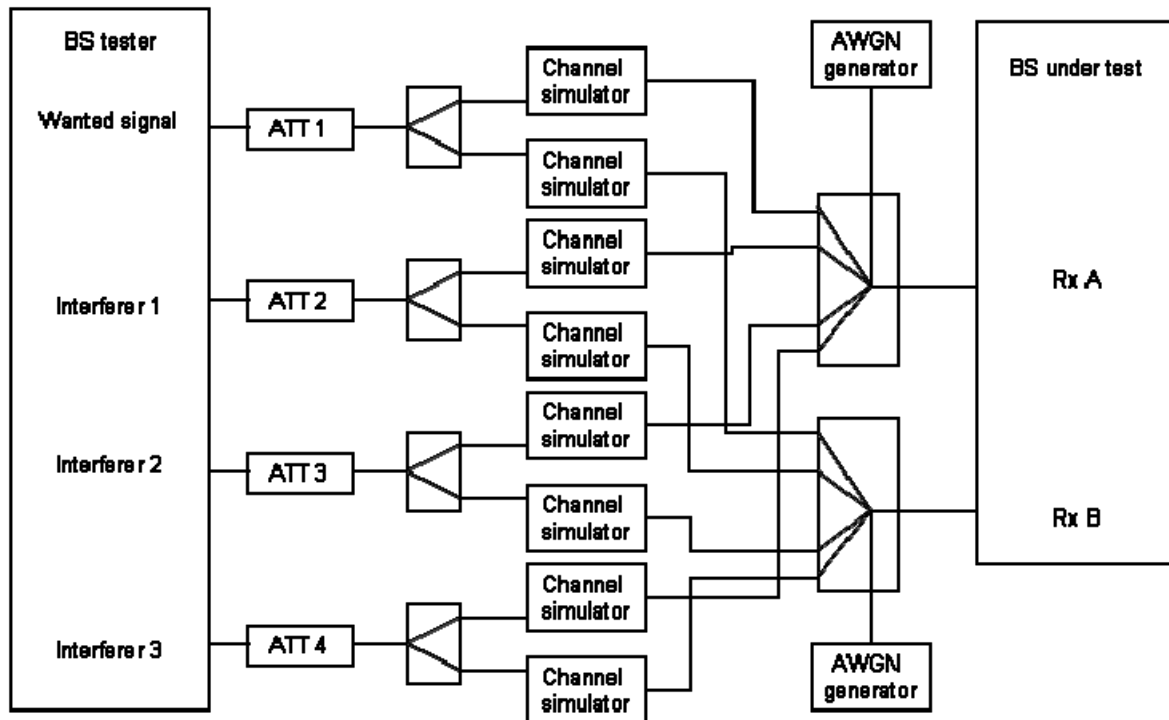

Figure I.3-3: Functional set-up for performance requirements for multi user PUCCH in multipath fading conditions

I.3.4 Performance requirement for UL timing adjustment

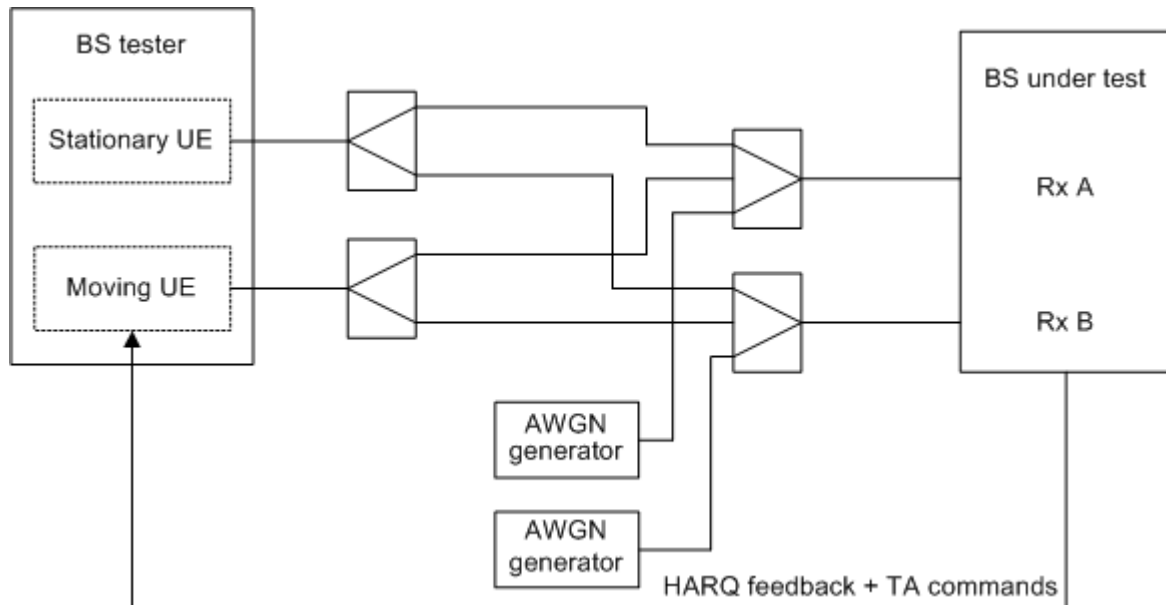

Figure I.3-4: Functional set-up for performance requirement for UL timing adjustment (Scenario 2 case shown)

NOTE 1: In case of UL timing adjustment Scenario 1, channel simulators need to be used for fading and Doppler shift emulation.

NOTE 2: The HARQ feedback and TA commands could be done as an RF feedback or as a digital feedback. The HARQ feedback and TA commands should be error free.

Annex J (Informative): Unwanted emission requirements for multi-carrier BS

J.1 General

In section 6.6, unwanted emission requirements for single carrier or multi-carrier BS are specified. This multi-carrier BS corresponds to a multi-carrier BS of the same channel bandwidth for E-UTRA. The following two pragmatic scenarios are considered in this annex:

- multi-carrier BS of different E-UTRA channel bandwidths, covering only 5 MHz and higher channel bandwidths
- multi-carrier BS of E-UTRA and UTRA, covering only 5 MHz and higher E-UTRA channel bandwidths.

All scenarios for channel bandwidths less than 5 MHz are for further study. Only multi-carrier BS with contiguous carriers are considered. The guidelines below assumes that the power spectral density of the multiple carriers is the same. All other combinations of multiple carriers are ffs.

Note 1: Further information and analysis for these scenarios can be found in TR 36.942 [14].

J.2 Multi-carrier BS of different E-UTRA channel bandwidths

For a multi-carrier E-UTRA BS transmitting a group of carriers of different channel bandwidths (≥ 5 MHz), the channel bandwidth of the outermost carriers should be considered for ACLR and Operating band unwanted emission requirements. That is, the corresponding requirements for the channel bandwidth of each of the outermost carriers should be applied at the respective side of the group of transmitted carriers.

J.3 Multi-carrier BS of E-UTRA and UTRA

For a multi-carrier BS transmitting a group of carriers of E-UTRA (channel bandwidth(s) ≥ 5 MHz) and UTRA, the RAT being used on the outermost carriers should be considered for ACLR and Operating band unwanted emission requirements. That is, the corresponding requirements for the RAT being used on each of the outermost carriers should be applied at the respective side of the group of transmitted carriers.

Annex K (informative): Change history

Change history							
Date	TSG #	TSG Doc.	CR	Rev	Subject/Comment	Old	New
2007-08	RAN4#44	R4-071503			TS skeleton created from 3GPP TS template.	-	0.0.1
2008-02	RAN4#46	R4-080004			Text proposals for section 2 to 4 (R4-072237) and Annex A (R4-072048), which were agreed at RAN4#45, are incorporated.	0.0.1	0.1.0
2008-02	RAN4#46	R4-080446			Section for In-channel selectivity (new 7.4) is inserted and following sections are re-numbered. Editorial corrections are made in section 1, 3.2, 4.3, Table 4.3-1, 4.5.2.1, 4.6, 4.6.3, 4.6.4, 4.6.5 and A.2.	0.1.0	0.1.1
2008-02	RAN4#46	R4-080508			Text proposals in R4-080447, R4-080058, R4-080453, R4-080047, R4-080048, R4-080049, R4-080050, R4-080051, R4-080444, R4-080501, R4-080044, R4-080045 and R4-080046 are incorporated with modifications agreed in the first round discussion in RAN4#46 meeting. Overlapped parts in R4-080058 and R4-080044 for Annx A, R4-080444 and R4-080501 for section 8 are merged by the editor.	0.1.1	0.2.0
2008-03	RAN4#46 bis	R4-080659			Editorial correction on section 8 is made: Text proposals for section 8 in R4-080444 are removed and the text proposal in R4-080501 is applied. Some editorial corrections are applied.	0.2.0	0.2.1
2008-04	RAN4#46 bis	R4-080828			Text proposals agreed in R4-080583, R4-080617, R4-080663, R4-080664, R4-080606, R4-080584, R4-080660, R4-080792, R4-080586, R4-080587, R4-080564, R4-080566 and R4-0806007 are incorporated with some editorial modifications.	0.2.1	0.3.0
2008-05	RAN4#47	R4-080844			Text proposals agreed in R4-080803, R4-0799, R4-0800, R4-080801 and R4-080826 are incorporated with editorial modifications.	0.3.0	0.4.0
2008-05	RAN4#47	R4-081198			Text proposals agreed in R4-081055, R4-081007, R4-081070, R4-081170, R4-080924, R4-080888, R4-081176, R4-080853, R4-080854, R4-080855, R4-081056, R4-080889 and R4-081178 are incorporated.	0.4.0	0.5.0
2008-05	RAN#40	RP-080381			Presented for information as V1.0.0.	0.5.0	1.0.0
2008-05	RAN#40	RP-080456			Editorial corrections on the formats in order to comply with the drafting rule of 3GPP.	1.0.0	1.0.1
2008-06	RAN4#47 bis	R4-081255			Correction in section 6.5.1.5, which was incorrectly proposed in R4-081226, is made. Editorial corrections on 6.5.3.4.1 and 8.4.1.4.2 are made.	1.0.1	1.0.2
2008-06	RAN4#47 bis	R4-081256			Text proposals agreed in R4-081184 and R4-081187 are incorporated.	1.0.2	1.1.0
2008-06	RAN4#47 bis	R4-081329			Editorial corrections in Table 8.4.1.5-2.	1.1.0	1.1.1
2008-08	RAN4#48	R4-081832			Text proposals agreed in the following documents are incorporated: R4-081377, R4-081547, R4-081282, R4-081284, R4-081652, R4-081502, R4-081283, R4-081650, R4-081268, R4-081269, R4-081270, R4-081653, R4-081272, R4-081645, R4-081481, R4-081281, R4-081322.	1.1.1	1.2.0
2008-08	RAN4#48	R4-082185			Text proposals agreed in the following documents are incorporated: R4-081832, R4-082087, R4-082093, R4-081847, R4-081965, R4-081967, R4-081944, R4-081709, R4-082109, R4-081711, R4-081712, R4-082090, R4-081714, R4-081715, R4-081834, R4-082135, R4-082173, R4-082160, R4-082171	1.2.0	1.3.0
2008-09	RAN#41	RP-080715			Typo in Table 8.4.1.5-1 (section 8.4.1.5), which was brought in at V1.1.0 when implementing R4-081187 is corrected.	1.3.0	2.0.0
2008-09	RAN#41	RP-080715			Presented for approval as V2.0.0	2.0.0	8.0.0
2008-12	RAN #42	RP-080915	10		Correction to the figure with the Transmission Bandwidth configuration	8.0.0	8.1.0
2008-12	RAN #42	RP-080916	14		Modification to EARFCN	8.0.0	8.1.0
2008-12	RAN #42	RP-080919	3		Introduction of Band 17	8.0.0	8.1.0
2008-12	RAN #42	RP-080920	27		Update of total dynamic range limits	8.0.0	8.1.0
2008-12	RAN #42	RP-080921	28		Update of TDD-FDD coexistence requirements	8.0.0	8.1.0
2008-12	RAN #42	RP-080922	30		PRACH demodulation requirements update	8.0.0	8.1.0
2008-12	RAN #42	RP-090923	4		General corrections in section 7-Annexes	8.0.0	8.1.0
2008-12	RAN #42	RP-080923	12		General corrections in sections 4-6	8.0.0	8.1.0
2008-12	RAN #42	RP-080923	19	1	Corrections to references, definitions symbols and abbreviations	8.0.0	8.1.0
2008-12	RAN #42	RP-080923	20	1	Corrections to clause 4 and 5	8.0.0	8.1.0
2008-12	RAN #42	RP-080923	21	2	Correction to clause 6	8.0.0	8.1.0
2008-12	RAN #42	RP-080923	22	1	Correction to clause 7	8.0.0	8.1.0
2008-12	RAN #42	RP-080923	23		Correction to clause 8	8.0.0	8.1.0
2008-12	RAN #42	RP-080923	24		Correction to Annex G	8.0.0	8.1.0
2008-12	RAN #42	RP-080924	5		Correction of EVM test condition related to total power dynamic	8.0.0	8.1.0

				range		
2008-12	RAN #42	RP-080924	8		Addition of BS transmit ON/OFF power tests	8.0.0 8.1.0
2008-12	RAN #42	RP-080924	11		Clarification on emission requirements	8.0.0 8.1.0
2008-12	RAN #42	RP-080924	32		E-UTRA TDD test models	8.0.0 8.1.0
2008-12	RAN #42	RP-080924	17		Correction to transmitter intermodulation test	8.0.0 8.1.0
2008-12	RAN #42	RP-080924	26		Correction to E-UTRA test models	8.0.0 8.1.0
2008-12	RAN #42	RP-080925	25		EVM averaging for TDD in the global in channel TX test	8.0.0 8.1.0
2008-12	RAN #42	RP-080926	1	1	eNB performance test requirement for UL timing adjustment	8.0.0 8.1.0
2008-12	RAN #42	RP-080926	2	1	eNB performance test requirement for PUCCH format 2	8.0.0 8.1.0
2008-12	RAN #42	RP-080926	13	1	eNB performance test requirements for Multi User PUCCH	8.0.0 8.1.0
2008-12	RAN #42	RP-080926	31		eNB performance requirements for HARQ ACK multiplexed on PUSCH	8.0.0 8.1.0
2008-12	RAN #42	RP-080927	9		eNB performance test requirements for High Speed Train conditions	8.0.0 8.1.0
2008-12	RAN #42	RP-080927	15	1	Clarification of eNB HST propagation conditions (36.141, rel-8)	8.0.0 8.1.0
2008-12	RAN #42	RP-080927	7	1	Correction of Doppler shift trajectories equations for HST conditions	8.0.0 8.1.0
2009-03	RAN #43	RP-090173	54		Clarification of EARFCN for 36.141	8.1.0 8.2.0
2009-03	RAN #43	RP-090175	55	1	Regional requirement on maximum rated power for Band 34	8.1.0 8.2.0
2009-03	RAN #43	RP-090177	43		Clarification of the BS performance test w.r.t PUCCH ACK/NACK Repetition configuration	8.1.0 8.2.0
2009-03	RAN #43	RP-090177	48		PUSCH ACK/NAK simulation assumptions finalization for simulations with implementation margins	8.1.0 8.2.0
2009-03	RAN #43	RP-090177	53		HARQ-ACK multiplexed on PUSCH performance requirement results	8.1.0 8.2.0
2009-03	RAN #43	RP-090178	36		Correction of clause 4.	8.1.0 8.2.0
2009-03	RAN #43	RP-090178	39		Correction and update of Annex G.	8.1.0 8.2.0
2009-03	RAN #43	RP-090179	34		Corrections related to E-UTRA test models	8.1.0 8.2.0
2009-03	RAN #43	RP-090179	35		Correction of E-UTRAN TDD eNodeB test models	8.1.0 8.2.0
2009-03	RAN #43	RP-090179	37		Correction and update of clause 6.	8.1.0 8.2.0
2009-03	RAN #43	RP-090179	40		Clarification of PHS band including the future plan	8.1.0 8.2.0
2009-03	RAN #43	RP-090179	45		Correction to transmitter intermodulation test	8.1.0 8.2.0
2009-03	RAN #43	RP-090179	49		Unsynchronized TDD coexistence requirements	8.1.0 8.2.0
2009-03	RAN #43	RP-090179	51		Correction to unwanted emission limit for 3MHz(E-UTRA bands < 1GHz) for Category A	8.1.0 8.2.0
2009-03	RAN #43	RP-090180	42	1	Correction to BS receiver test requirements	8.1.0 8.2.0
2009-03	RAN #43	RP-090180	56		eNB ACS frequency offset	8.1.0 8.2.0
2009-03	RAN #43	RP-090181	38		Correction of clause 8.	8.1.0 8.2.0
2009-03	RAN #43	RP-090181	41		Modifications on parameter settings for some demodulation test cases.	8.1.0 8.2.0
2009-03	RAN #43	RP-090181	44		AWGN level for UL demodulation performance tests	8.1.0 8.2.0
2009-05	RAN #44	RP-090544	61		Clarification of requirements for multicarrier BS. (Technically Endorsed CR in R4-50bis - R4-091445)	8.2.0 8.3.0
2009-05	RAN #44	RP-090545	62		Correction of test models for E-UTRAN. (Technically Endorsed CR in R4-50bis - R4-091461)	8.2.0 8.3.0
2009-05	RAN #44	RP-090545	66		Test system uncertainty for Transmitter intermodulation	8.2.0 8.3.0
2009-05	RAN #44	RP-090545	67		Adding test model for transmit ON/OFF test	8.2.0 8.3.0
2009-05	RAN #44	RP-090545	68		Correction to DL RS power	8.2.0 8.3.0
2009-05	RAN #44	RP-090545	64r1		Addition of missing Test Tolerances for transmitter tests	8.2.0 8.3.0
2009-05	RAN #44	RP-090545	70		Test system uncertainty for Receiver dynamic range	8.2.0 8.3.0
2009-05	RAN #44	RP-090545	58		CR 36.141 ACS frequency offset. (Technically Endorsed CR in R4-50bis - R4-091330)	8.2.0 8.3.0
2009-05	RAN #44	RP-090545	63r2		Test Tolerances for Performance test cases	8.2.0 8.3.0
2009-05	RAN #44	RP-090545	59		UL timing adjustment measurement system set-up. (Technically Endorsed CR in R4-50bis - R4-091414)	8.2.0 8.3.0
2009-05	RAN #44	RP-090545	60		UL timing adjustment performance requirement clarifications. (Technically Endorsed CR in R4-50bis - R4-091438)	8.2.0 8.3.0
2009-09	RAN #45	RP-090833	071		Clarification of the multi user PUCCH performance determination (R43-51 Endorsed CR in: R4-092227)	8.3.0 8.4.0
2009-09	RAN #45	RP-090833	073		Clarification of the UL timing adjustment performance determination (R43-51 Endorsed CR in: R4-092229)	8.3.0 8.4.0
2009-09	RAN #45	RP-090833	075		Receiver intermodulation clarification	8.3.0 8.4.0
2009-09	RAN #45	RP-090833	077		Corrections to E-UTRA Rx requirements	8.3.0 8.4.0
2009-09	RAN #45	RP-090833	080		Clarifications on testing UL timing adjustment requirements	8.3.0 8.4.0
2009-09	RAN #45	RP-090833	082		Correction on reference of extreme power supply	8.3.0 8.4.0
2009-09	RAN #45	RP-090833	091		LTE operating band unwanted emissions revision	8.3.0 8.4.0
2009-12	RP-46	RP-091265	096		Corrections to ICS requirement (Technically endorsed at RAN 4 52bis in R4-093640)	8.4.0 8.5.0
2009-12	RP-46	RP-091267	097		Clarification of the test method for blocking (Technically endorsed at RAN 4 52bis in R4-093769)	8.4.0 8.5.0
2009-12	RP-46	RP-091267	099		Adding missing EARFCN for band 33 and 34 (Technically endorsed at RAN 4 52bis in R4-093770)	8.4.0 8.5.0
2009-12	RP-46	RP-091267	101		Incorrect FRC A3-2 Coded block size (Technically endorsed at RAN 4 52bis in R4-093771)	8.4.0 8.5.0

2009-12	RP-46	RP-091266	103		LTE operating band unwanted emissions correction (Technically endorsed at RAN 4 52bis in R4-093802)	8.4.0	8.5.0
2009-12	RP-46	RP-091267	105		HARQ feedback clarification addition (Annex B) (Technically endorsed at RAN 4 52bis in R4-093997)	8.4.0	8.5.0
2009-12	RP-46	RP-091266	107		Clarification on Spurious emissions limits for BS co-existed with another BS (Technically endorsed at RAN 4 52bis in R4-094012)	8.4.0	8.5.0
2009-12	RP-46	RP-091270	110	1	Clarification on PRACH False alarm probability	8.4.0	8.5.0
2009-12	RP-46	RP-091269	116	1	UL Timing Adjustment test clarifications	8.4.0	8.5.0
2009-12	RP-46	RP-091266	118		Multi-path fading propagation conditions reference correction	8.4.0	8.5.0
2009-12	RP-46	RP-091265	120		Corrections on frequency range of unwanted emissions requirements	8.4.0	8.5.0
2009-12	RP-46	RP-091276	123		Testing in case of Rx diversity, Tx diversity and MIMO	8.4.0	8.5.0
2009-12	RP-46	RP-091267	143	1	Applicability of uncertainty for transmitter transient period	8.4.0	8.5.0
2009-12	RP-46	RP-091287	145		Correction of Band 11 requirements for TS36.141 Rel-8	8.4.0	8.5.0
2010-03	RP-47	RP-100252	173		Correction of the frequency range for unwanted emissions limits (cat-B/option 2/BW 3MHz)	8.5.0	8.6.0
2010-03	RP-47	RP-100252	170		Correction of Band 4 and 10 co-existence requirement	8.5.0	8.6.0
2010-06	RP-48	RP-100621	177		Spurious emissions limits and blocking requirements for coexistence with CDMA850	8.6.0	8.7.0
2010-06	RP-48	RP-100621	179		Clarification on narrowband blocking requirements	8.6.0	8.7.0
2010-06	RP-48	RP-100621	182		Correction to the FRC for PUSCH 1.4M requirements	8.6.0	8.7.0
2010-09	RP-49	RP-100916	192		Clarifications on Base Station transmit and receive configurations	8.7.0	8.8.0
2010-09	RP-49	RP-100917	197	1	Modification on testing of time mask of E-UTRA TDD base station in R8	8.7.0	8.8.0
2010-09	RP-49	RP-100916	206		Adding operating unwanted emissions test to tests applicable to Ancillary RF Amplifiers	8.7.0	8.8.0

History

Document history		
V8.1.0	January 2009	Publication
V8.2.0	April 2009	Publication
V8.3.0	July 2009	Publication
V8.4.0	October 2009	Publication
V8.5.0	February 2010	Publication
V8.6.0	April 2010	Publication
V8.7.0	July 2010	Publication
V8.8.0	October 2010	Publication