

# ETSI TS 136 143 V12.0.0 (2014-10)



**LTE;  
Evolved Universal Terrestrial Radio Access (E-UTRA);  
FDD repeater conformance testing  
(3GPP TS 36.143 version 12.0.0 Release 12)**



---

**Reference**RTS/TSGR-0436143vc00

---

**Keywords**

---

LTE

**ETSI**

---

650 Route des Lucioles  
F-06921 Sophia Antipolis Cedex - FRANCE

---

Tel.: +33 4 92 94 42 00 Fax: +33 4 93 65 47 16

Siret N° 348 623 562 00017 - NAF 742 C  
Association à but non lucratif enregistrée à la  
Sous-Préfecture de Grasse (06) N° 7803/88

---

**Important notice**

---

The present document can be downloaded from:

<http://www.etsi.org>

The present document may be made available in electronic versions and/or in print. The content of any electronic and/or print versions of the present document shall not be modified without the prior written authorization of ETSI. In case of any existing or perceived difference in contents between such versions and/or in print, the only prevailing document is the print of the Portable Document Format (PDF) version kept on a specific network drive within ETSI Secretariat.

Users of the present document should be aware that the document may be subject to revision or change of status. Information on the current status of this and other ETSI documents is available at

<http://portal.etsi.org/tb/status/status.asp>

If you find errors in the present document, please send your comment to one of the following services:

[http://portal.etsi.org/chaicor/ETSI\\_support.asp](http://portal.etsi.org/chaicor/ETSI_support.asp)

---

**Copyright Notification**

---

No part may be reproduced or utilized in any form or by any means, electronic or mechanical, including photocopying and microfilm except as authorized by written permission of ETSI.

The content of the PDF version shall not be modified without the written authorization of ETSI.

The copyright and the foregoing restriction extend to reproduction in all media.

© European Telecommunications Standards Institute 2014.

All rights reserved.

**DECT™**, **PLUGTESTS™**, **UMTS™** and the ETSI logo are Trade Marks of ETSI registered for the benefit of its Members. **3GPP™** and **LTE™** are Trade Marks of ETSI registered for the benefit of its Members and of the 3GPP Organizational Partners.

**GSM®** and the GSM logo are Trade Marks registered and owned by the GSM Association.

---

## Intellectual Property Rights

IPRs essential or potentially essential to the present document may have been declared to ETSI. The information pertaining to these essential IPRs, if any, is publicly available for **ETSI members and non-members**, and can be found in ETSI SR 000 314: *"Intellectual Property Rights (IPRs); Essential, or potentially Essential, IPRs notified to ETSI in respect of ETSI standards"*, which is available from the ETSI Secretariat. Latest updates are available on the ETSI Web server (<http://ipr.etsi.org>).

Pursuant to the ETSI IPR Policy, no investigation, including IPR searches, has been carried out by ETSI. No guarantee can be given as to the existence of other IPRs not referenced in ETSI SR 000 314 (or the updates on the ETSI Web server) which are, or may be, or may become, essential to the present document.

---

## Foreword

This Technical Specification (TS) has been produced by ETSI 3rd Generation Partnership Project (3GPP).

The present document may refer to technical specifications or reports using their 3GPP identities, UMTS identities or GSM identities. These should be interpreted as being references to the corresponding ETSI deliverables.

The cross reference between GSM, UMTS, 3GPP and ETSI identities can be found under <http://webapp.etsi.org/key/queryform.asp>.

---

## Modal verbs terminology

In the present document "**shall**", "**shall not**", "**should**", "**should not**", "**may**", "**may not**", "**need**", "**need not**", "**will**", "**will not**", "**can**" and "**cannot**" are to be interpreted as described in clause 3.2 of the [ETSI Drafting Rules](#) (Verbal forms for the expression of provisions).

"**must**" and "**must not**" are **NOT** allowed in ETSI deliverables except when used in direct citation.

# Contents

Intellectual Property Rights .....	2
Foreword.....	2
Modal verbs terminology.....	2
Foreword.....	7
1 Scope .....	8
2 References .....	8
3 Definitions, symbols and abbreviations .....	9
3.1 Definitions .....	9
3.2 Symbols.....	9
3.3 Abbreviations .....	10
4 General test conditions and declarations .....	10
4.1 Measurement uncertainties and test requirements .....	10
4.1.1 General.....	10
4.1.2 Acceptable uncertainty of test system.....	11
4.1.2.1 Measurement of Repeater .....	12
4.1.2.2 Interpretation of measurement results .....	13
4.2 Regional requirements.....	14
4.3 Selection of configurations for testing.....	14
4.4 Repeater configurations.....	15
4.4.1 Power supply options.....	15
4.4.2 Combining of repeaters.....	15
4.5 Manufacturer's declarations of regional and optional requirements .....	15
4.5.1 Operating band and frequency range .....	15
4.5.2 Channel bandwidth .....	15
4.5.3 Repeater output power .....	15
4.5.4 Spurious emissions Category .....	15
4.5.5 Additional operating band unwanted emissions .....	16
4.5.6 Co-existence with other systems.....	16
4.5.7 Co-location with base stations .....	16
4.6 Specified frequency range .....	16
4.7 Format and interpretation of tests.....	16
5 Operating bands and channel arrangement.....	17
5.1 General .....	17
5.2 Void.....	17
5.3 Void.....	17
5.4 Void.....	17
5.5 Operating bands.....	17
5.6 Channel bandwidth.....	18
5.7 Channel arrangement.....	19
5.7.1 Channel spacing.....	19
5.7.2 Channel raster .....	19
5.7.3 Carrier frequency and EARFCN.....	19
6 Output power.....	20
6.1 Definition and applicability .....	20
6.2 Minimum requirement.....	20
6.3 Test purpose .....	20
6.4 Method of test.....	21
6.4.1 Initial conditions .....	21
6.4.2 Procedure .....	21
6.5 Test requirements .....	21
7 Frequency stability .....	22

7.1	Definition and applicability .....	22
7.2	Minimum requirements .....	22
7.3	Test purpose .....	22
7.4	Method of test.....	22
7.5	Test requirement.....	22
8	Out of band gain.....	22
8.1	Definition and applicability .....	22
8.2	Minimum requirements .....	23
8.3	Test purpose .....	23
8.4	Method of test.....	23
8.4.1	Initial conditions .....	23
8.4.2	Procedure .....	23
8.5	Test requirements .....	23
9	Unwanted emissions.....	24
9.1	Operating band unwanted emissions .....	24
9.1.1	Definition and applicability .....	24
9.1.2	Minimum requirements.....	24
9.1.3	Test purpose.....	24
9.1.4	Method of test.....	24
9.1.4.1	Initial conditions .....	24
9.1.4.2	Procedures.....	25
9.1.5	Test requirements.....	26
9.1.5.1	Operating band unwanted emission (Category A) .....	26
9.1.5.2	Operating band unwanted emissions (Category B).....	28
9.1.5.2.1	Category B test requirements (Option 1).....	28
9.1.5.2.2	Category B test requirements (Option 2).....	31
9.1.5.3	Additional requirements.....	32
9.1.5.4	Protection of the BS receiver in the operating band.....	34
9.2	Spurious emissions .....	35
9.2.1	Definition and applicability .....	35
9.2.2	Minimum requirements.....	35
9.2.3	Test purpose.....	35
9.2.4	Method of test.....	35
9.2.4.1	Initial conditions .....	35
9.2.4.2	Procedures.....	35
9.2.5	Test requirements.....	36
9.2.5.1	Spurious emission (Category A) .....	36
9.2.5.2	Spurious emission (Category B) .....	37
9.2.5.3	Co-existence with other systems in the same geographical area.....	37
9.2.5.4	Co-location with base stations.....	42
10	Error Vector Magnitude (EVM).....	46
10.1	Downlink Error Vector Magnitude.....	46
10.1.1	Definition and applicability .....	46
10.1.2	Minimum requirements.....	46
10.1.3	Test purpose.....	47
10.1.4	Method of test.....	47
10.1.4.1	Initial conditions .....	47
10.1.4.2	Procedure .....	47
10.1.5	Test requirement .....	47
10.2	Uplink Error Vector Magnitude .....	47
10.2.1	Definition and applicability .....	47
10.2.2	Minimum requirements.....	47
10.2.3	Test purpose.....	47
10.2.4	Method of test.....	48
10.2.4.1	Initial conditions .....	48
10.2.4.2	Procedure .....	48
10.2.5	Test requirement .....	48
11	Input intermodulation.....	48
11.1	Definition and applicability.....	48

11.2	Minimum requirements .....	48
11.3	Test purpose .....	48
11.4	Method of test.....	49
11.4.1	Initial conditions .....	49
11.4.2	Procedure .....	49
11.5	Test requirements .....	49
11.5.1	General requirement .....	49
11.5.2	Co-location with BS in other systems.....	49
11.5.3	Co-existence with other systems.....	53
12	Output intermodulation .....	56
12.1	Definition and applicability .....	56
12.2	Minimum requirement.....	57
12.3	Test purpose .....	57
12.4	Method of test.....	57
12.4.1	Initial conditions .....	57
12.4.2	Procedure .....	57
12.5	Test Requirements .....	58
13	Adjacent Channel Rejection Ratio (ACRR).....	58
13.1	Definitions and applicability .....	58
13.1.1	Minimum requirements.....	58
13.2	Co-existence with UTRA .....	58
13.2.1	Minimum requirements.....	58
13.2.2	Test purpose.....	58
13.2.3	Method of test .....	59
13.2.3.1	Initial conditions .....	59
13.2.3.2	Procedure .....	59
13.2.3.3	Test Requirements.....	59
<b>Annex A (normative): Environmental requirements for the Repeater .....</b>		<b>60</b>
A.1	General .....	60
A.2	Normal test environment .....	60
A.3	Extreme test environment.....	60
A.3.1	Extreme temperature .....	60
A.4	Vibration.....	61
A.5	Power supply .....	61
A.6	Measurement of test environments.....	61
<b>Annex B (informative): Test tolerances and derivation of test requirements.....</b>		<b>62</b>
<b>Annex C (informative): Measurement system set-up .....</b>		<b>65</b>
C.1	Maximum output power .....	65
C.2	Frequency stability .....	65
C.3	Out of band gain.....	66
C.4	Unwanted emission: Operating band unwanted emission.....	66
C.5	Unwanted emission: Spurious emission.....	67
C.6	Modulation Accuracy: Error Vector Magnitude .....	67
C.7	Input intermodulation.....	68
C.8	Output Intermodulation .....	68
C.9	Adjacent Channel Rejection Ratio .....	69
<b>Annex D (normative): Repeater stimulus signals.....</b>		<b>70</b>

D.1	Repeater stimulus signal 1.....	70
D.2	Repeater stimulus signal 2.....	70
D.3	Repeater stimulus signal 3.....	70
D.4	Repeater stimulus signal 4.....	71
D.5	Repeater stimulus signal spectral purity requirements.....	71
<b>Annex E (informative):</b>	<b>Change history .....</b>	<b>72</b>
History .....		74

---

## Foreword

This Technical Specification has been produced by the 3<sup>rd</sup> Generation Partnership Project (3GPP).

The contents of the present document are subject to continuing work within the TSG and may change following formal TSG approval. Should the TSG modify the contents of the present document, it will be re-released by the TSG with an identifying change of release date and an increase in version number as follows:

Version x.y.z

where:

x the first digit:

1 presented to TSG for information;

2 presented to TSG for approval;

3 or greater indicates TSG approved document under change control.

Y the second digit is incremented for all changes of substance, i.e. technical enhancements, corrections, updates, etc.

z the third digit is incremented when editorial only changes have been incorporated in the document.



---

# 1 Scope

The present document specifies the Radio Frequency (RF) test methods and conformance requirements for E-UTRA FDD Repeater. These have been derived from, and are consistent with the E-UTRA FDD repeater specifications defined in [2].

---

# 2 References

The following documents contain provisions which, through reference in this text, constitute provisions of the present document.

- References are either specific (identified by date of publication, edition number, version number, etc.) or non-specific.
- For a specific reference, subsequent revisions do not apply.
- For a non-specific reference, the latest version applies. In the case of a reference to a 3GPP document (including a GSM document), a non-specific reference implicitly refers to the latest version of that document *in the same Release as the present document*.

- [1] 3GPP TR 21.905: 'Vocabulary for 3GPP Specifications'.
- [2] 3GPP TS 36.106: 'Evolved Universal Terrestrial Radio Access (E-UTRA); FDD repeater radio transmission and reception'.
- [3] ITU-R Recommendation M.1545: 'Measurement uncertainty as it applies to test limits for the terrestrial component of International Mobile Telecommunications-2000'.
- [4] ITU-R recommendation SM.329: 'Unwanted emissions in the spurious domain'.
- [5] 3GPP TR 25.942: 'Radio Frequency (RF) system scenarios'.
- [6] IEC 60721-3-3 (2002): 'Classification of environmental conditions – Part 3: Classification of groups of environmental parameters and their severities – Section 3: Stationary use at weather protected locations'.
- [7] IEC 60721-3-4 (1995): 'Classification of environmental conditions – Part 3: Classification of groups of environmental parameters and their severities – Section 4: Stationary use at non-weather protected locations'.
- [8] IEC 60068-2-1 (2007): 'Environmental testing – Part 2: Tests. Tests A: Cold'.
- [9] IEC 60068-2-2 (2007): 'Environmental testing – Part 2: Tests. Tests B: Dry heat'.
- [10] IEC 60068-2-6 (2007): 'Environmental testing – Part 2: Tests – Test Fc: Vibration (sinusoidal)'.
- [11] 3GPP TS 36.141: 'Evolved Universal Terrestrial Radio Access (E-UTRA); Base Station (BS) conformance testing'.
- [12] 3GPP TS 36.521-1: 'Evolved Universal Terrestrial Radio Access (E-UTRA); User Equipment (UE) conformance specification; Radio transmission and reception; Part 1: Conformance testing'.
- [13] 3GPP TS.36.104: "E-UTRA Base Station (BS) radio transmission and reception".

## 3 Definitions, symbols and abbreviations

### 3.1 Definitions

For the purposes of the present document, the terms and definitions given in TR 21.905 [1] and the following apply. A term defined in the present document takes precedence over the definition of the same term, if any, in TR 21.905 [1].

**Carrier:** The modulated waveform conveying the E-UTRA or UTRA physical channels

**Channel bandwidth:** The RF bandwidth supporting a single E-UTRA RF carrier with the transmission bandwidth configured in the uplink or downlink of a cell. The channel bandwidth is measured in MHz and is used as a reference for transmitter and receiver RF requirements.

**Channel edge:** The lowest and highest frequency of the E-UTRA carrier, separated by the channel bandwidth.

**Donor coupling loss:** is the coupling loss between the repeater and the donor base station.

**Downlink:** Signal path where base station transmits and mobile receives.

**Downlink operating band:** The part of the operating band designated for downlink.

**Maximum output power, P<sub>max</sub>:** This is the mean power level per carrier measured at the antenna connector of the Repeater in specified reference condition.

**Operating band:** A frequency range in which E-UTRA operates (paired or unpaired), that is defined with a specific set of technical requirements.

NOTE1: The operating band(s) for an E-UTRA Repeater is declared by the manufacturer according to the designations in clause 5.5 table 5.5-1.

NOTE2: Unless specified, operating band refers to the uplink operating band and downlink operating band.

**Output power, P<sub>out</sub>:** This is the mean power of one carrier at maximum repeater gain delivered to a load with resistance equal to the nominal load impedance of the transmitter.

**Pass band:** The frequency range in which the repeater operates in with operational configuration. This frequency range can correspond to one or several consecutive nominal channels. If they are not consecutive each subset of channels shall be considered as an individual pass band. A repeater can have one or several pass bands

**Rated output power:** Rated output power of the repeater is the mean power level per carrier that the manufacturer has declared to be available at the antenna connector.

**Repeater:** A device that receives, amplifies and transmits the radiated or conducted RF carrier both in the downlink direction (from the base station to the mobile area) and in the uplink direction (from the mobile to the base station)

**Transmission bandwidth:** Bandwidth of an instantaneous transmission from a UE or BS, measured in Resource Block units.

**Transmission bandwidth configuration:** The highest transmission bandwidth allowed for uplink or downlink in a given channel bandwidth, measured in Resource Block units.

**Uplink:** Signal path where mobile transmits and base station receives.

**Uplink operating band:** The part of the operating band designated for uplink.

### 3.2 Symbols

For the purposes of the present document, the following symbols apply:

$BW_{\text{Channel}}$	Channel bandwidth
$BW_{\text{Config}}$	Transmission bandwidth configuration, expressed in MHz, where $BW_{\text{Config}} = N_{\text{RB}} \times 180 \text{ kHz}$ in the uplink and $BW_{\text{Config}} = 15 \text{ kHz} + N_{\text{RB}} \times 180 \text{ kHz}$ in the downlink.
$BW_{\text{Meas}}$	Measurement bandwidth

$BW_{\text{Signal}}$	Bandwidth of the repeater input signal filling the repeater pass band
$F_{\text{DL\_low}}$	The lowest frequency of the downlink operating band
$F_{\text{DL\_high}}$	The highest frequency of the downlink operating band
$F_{\text{filter}}$	Filter centre frequency
$F_{\text{UL\_low}}$	The lowest frequency of the uplink operating band
$F_{\text{UL\_high}}$	The highest frequency of the uplink operating band
$f_{\text{offset\_PB}}$	Distance from the channel edge frequency of the first or last channel in the pass band
$N_{\text{DL}}$	Downlink EARFCN
$N_{\text{Offs-DL}}$	Offset used for calculating downlink EARFCN
$N_{\text{Offs-UL}}$	Offset used for calculating uplink EARFCN
$N_{\text{RB}}$	Transmission bandwidth configuration, expressed in units of resource blocks
$N_{\text{UL}}$	Uplink EARFCN
$P_{\text{EM,N}}$	Declared emission level for channel N
$P_{\text{max}}$	Maximum output power
$P_{\text{out}}$	Output power

### 3.3 Abbreviations

For the purposes of the present document, the abbreviations given in TR 21.905 [1] and the following apply. An abbreviation defined in the present document takes precedence over the definition of the same abbreviation, if any, in TR 21.905 [1].

ACRR	Adjacent Channel Rejection Ratio
BS	Base Station
BW	Bandwidth
DTT	Digital Terrestrial Television
DUT	Device Under Test
E-TM	E-UTRA Test Model
EARFCN	E-UTRA Absolute Radio Frequency Channel Number
EVM	Error Vector Magnitude
FFS	For Further Study
IDFT	Inverse Discrete Fourier Transform
PB	Pass Band
GSM-R	GSM for Railways
RRC	Root Raised Cosine
RRS	Root Sum of the Squares
TBD	To be defined
TT	Test Tolerance

---

## 4 General test conditions and declarations

Many of the tests in this specification measure a parameter relative to a value that is not fully specified in the E-UTRA specifications. For these tests, the Minimum Requirement is determined relative to a nominal value specified by the manufacturer.

Some requirements for the Repeater may be regional as listed in subclause 4.2.

When specified in a test, the manufacturer shall declare the nominal value of a parameter, or whether an option is supported.

### 4.1 Measurement uncertainties and test requirements

#### 4.1.1 General

The requirements of this clause apply to all applicable tests in this specification.

The Minimum requirements are given in 36.106 [2] and test requirements are given in this specification. Test Tolerances are defined in Annex B of this specification. Test Tolerances are individually calculated for each test. The Test Tolerances are used to relax the Minimum requirements in 36.106 [2] to create Test Requirements.

#### 4.1.2 Acceptable uncertainty of test system

The maximum acceptable uncertainty of the Test System is specified below for each test, where appropriate. The Test System shall enable the stimulus signals in the test case to be adjusted to within the specified tolerance and the equipment under test to be measured with an uncertainty not exceeding the specified values. All tolerances and uncertainties are absolute values, and are valid for a confidence level of 95 %, unless otherwise stated.

A confidence level of 95% is the measurement uncertainty tolerance interval for a specific measurement that contains 95% of the performance of a population of test equipment.

For RF tests, it should be noted that the uncertainties in subclause 4.1.2 apply to the Test System operating into a nominal 50 ohm load and do not include system effects due to mismatch between the DUT and the Test System.

## 4.1.2.1 Measurement of Repeater

Table 4.1.2-1: Maximum test system uncertainty

Subclause	Maximum Test System Uncertainty and Range over which Test System Uncertainty applies	Derivation of Test System Uncertainty
6 Output power	$\pm 0,7$ dB, $f \leq 3.0$ GHz $\pm 1,0$ dB, $3.0$ GHz $< f \leq 4.2$ GHz	
7 Frequency stability	$\pm 12$ Hz Measurement results of $\pm 500$ Hz	
8 Out of band gain	$\pm 0,5$ dB, $f \leq 3.0$ GHz $\pm 0,8$ dB, $3.0$ GHz $< f \leq 4.2$ GHz Calibration of test set-up shall be made without DUT in order to achieve the accuracy	
9.1 Operating band unwanted emission (except 9.1.5.4)	$\pm 1,5$ dB, $f \leq 3.0$ GHz $\pm 1,8$ dB, $3.0$ GHz $< f \leq 4.2$ GHz The interference from the signal generator ACLR shall be minimum 10 dB below that of a Base Station according to TS36.141 [11]	
9.1.5.4 Protection of the BS receiver in the operating band	for results $> -60$ dBm $\pm 2,0$ dB for results $< -60$ dBm $\pm 3,0$ dB	
9.2 Spurious emissions	In E-UTRA and coexistence receive bands: for results $> -60$ dBm $\pm 2,0$ dB for results $< -60$ dBm $\pm 3,0$ dB Outside above range: emission power  $9\text{kHz} < f \leq 4$ GHz $\pm 2,0$ dB; $4\text{GHz} < f \leq 19$ GHz $\pm 4,0$ dB.  The interference from the signal generator ACLR shall be minimum 10 dB below that of a Base Station according to TS36.141 [11]	
10 Error vector magnitude	1% signal analyser, 2% stimulus signal	Requirement limit shifted by RSS requirement and stimulus signal EVM. Analyser error added to requirement limit.
11 Input intermodulation	$\pm 1,2$ dB	Formula: RSS CW1 level error, 2 x CW2 level error, and measurement error (using all errors = $\pm 0,5$ dB)
12 Output intermodulation	$\pm 2,1$ dB operating band unwanted emission  The interference from the signal generator ACLR shall be minimum 10 dB below that of a Base Station  For spurious emission:  In UTRA and coexistence receive bands: for results $> -60$ dBm $\pm 2,0$ dB for results $< -60$ dBm $\pm 3,0$ dB Outside above range: emission power; $9$ kHz $< f \leq 4$ GHz $\pm 2,0$ dB; $4\text{GHz} < f \leq 19$ GHz $\pm 4,0$ dB.  The interference signal must have a spurious emission level at least 10 dB below the spurious levels required in 9.2.	Formula: RSS 2x Interference signal level error and operating band unwanted emission measurement level error. (1 dB interference signal level error is assumed.)
13 Adjacent channel rejection ratio	$\pm 0,7$ dB	

#### 4.1.2.2 Interpretation of measurement results

The measurement results returned by the Test System are compared – without any modification – against the Test Requirements as defined by the Shared Risk principle.

The Shared Risk principle is defined in ITU-R M.1545 [3].

The actual measurement uncertainty of the Test System for the measurement of each parameter shall be included in the test report.

The recorded value for the Test System uncertainty shall be, for each measurement, equal to or lower than the appropriate figure in subclause 4.1.2 of this specification.

If the Test System for a test is known to have a measurement uncertainty greater than that specified in subclause 4.1.2, it is still permitted to use this apparatus provided that an adjustment is made as follows.

Any additional uncertainty in the Test System over and above that specified in subclause 4.1.2 shall be used to tighten the Test Requirement, making the test harder to pass. (For some tests e.g. receiver tests, this may require modification of stimulus signals). This procedure (defined in Annex B) will ensure that a Test System not compliant with subclause 4.1.2 does not increase the chance of passing a device under test where that device would otherwise have failed the test if a Test System compliant with subclause 4.1.2 had been used.

## 4.2 Regional requirements

Some requirements in the present document may only apply in certain regions either as optional requirements or set by local and regional regulation as mandatory requirements. It is normally not stated in the 3GPP specifications under what exact circumstances that the requirements apply, since this is defined by local or regional regulation.

Table 4.2-1 lists all requirements that may be applied differently in different regions.

**Table 4.2-1: List of regional requirements**

Clause number	Requirement	Comments
5.5	Operating bands	Some bands may be applied regionally.
5.6	Channel bandwidth	Some channel bandwidths may be applied regionally.
5.7	Channel arrangement	The requirement is applied according to what operating bands in clause 5.5 that are supported by the Repeater.
6	Output power	In certain regions, the minimum requirement for normal conditions may apply also for some conditions outside the range of conditions defined as normal.
9.1.5.1	Operating band unwanted emissions (Category A)	This requirement is mandatory for regions where Category A limits for spurious emissions, as defined in ITU-R Recommendation SM.329 [5] apply.
9.1.5.2	Operating band unwanted emissions (Category B)	This requirement is mandatory for regions where Category B limits for spurious emissions, as defined in ITU-R Recommendation SM.329 [5], apply.
9.1.5.3	Operating band unwanted emissions : Additional requirements	These requirements may be applied regionally for some operating bands.
9.2.5.1	Spurious emissions (Category A)	This requirement is mandatory for regions where Category A limits for spurious emissions, as defined in ITU-R Recommendation SM.329 [5] apply.
9.2.5.2	Spurious emissions (Category B)	This requirement is mandatory for regions where Category B limits for spurious emissions, as defined in ITU-R Recommendation SM.329 [5], apply.
9.2.5.3	Co-existence with other systems in the same geographical area	These requirements may apply in geographic areas in which both E-UTRA –FDD repeater and a system operating in another frequency band are deployed.
9.2.5.4	Co-location with base stations	These requirements may be applied for the protection of other BS receivers when a BS operating in another frequency band is co-located with an E-UTRA-FDD repeater.
11.5.2	Input Intermodulation: Co-location with other systems	These requirements may be applied for the protection of FDD Repeater input when GSM900, DCS1800, PCS1900, GSM850, UTRA FDD, UTRA TDD and/or E-UTRA BS are co-located with an E-UTRA FDD Repeater.
11.5.3	Input Intermodulation: Co-existence with other systems	These requirements may be applied when GSM900, DCS1800, PCS1900, GSM850, UTRA FDD, UTRA TDD and/or E-UTRA BS operating in another frequency band co-exist with an E-UTRA FDD Repeater

## 4.3 Selection of configurations for testing

Most tests in the present document are only performed for a subset of the possible combinations of test conditions. For instance:

- Only one RF channel may be specified to be tested;
- Not all channel bandwidths may be specified to be tested.

## 4.4 Repeater configurations

### 4.4.1 Power supply options

If the repeater is supplied with a number of different power supply configurations, it may not be necessary to test RF parameters for each of the power supply options, provided that it can be demonstrated that the range of conditions over which the equipment is tested is at least as great as the range of conditions due to any of the power supply configurations.

### 4.4.2 Combining of repeaters

If the repeater is intended for combination with additional apparatus connected to a repeater port and this combination is supplied as a system, the combination of repeater together with the additional apparatus shall also fulfil the repeater requirements. E.g. if the repeater is intended for combination such that multiple repeaters amplify the same signals into the same ports the combination shall also fulfil the repeater requirements.

An example of such a configuration is shown in figure 4.4-1.

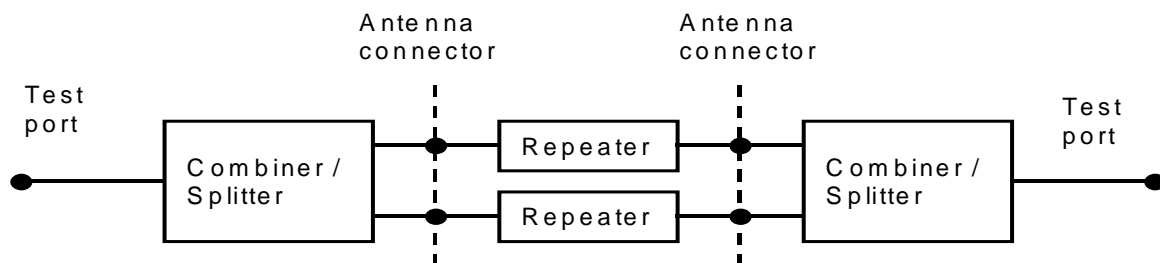

Figure 4.4-1: Example of repeater configuration

## 4.5 Manufacturer's declarations of regional and optional requirements

### 4.5.1 Operating band and frequency range

The manufacturer shall declare which operating band(s) specified in clause 5.3 that is supported by the Repeater under test and if applicable, which frequency ranges (pass band) within the operating band(s) that the Repeater can operate in. Requirements for other operating bands and frequency ranges (pass band) need not be tested.

### 4.5.2 Channel bandwidth

The manufacturer shall declare which of the channel bandwidths specified in TS36.106 [2] clause 5.2 that are supported by the Repeater under test. Requirements for other channel bandwidths need not be tested.

### 4.5.3 Repeater output power

The manufacturer shall declare for the Repeater under test the rated output power.

### 4.5.4 Spurious emissions Category

The manufacturer shall declare one of the following:



- a) The Repeater is tested against Category A limits for spurious emissions, as defined in ITU-R Recommendation SM.329 [2]. In this case
- conformance with the operating band unwanted emissions requirements in clause 9.1.5.1 is mandatory, and the requirements specified in clause 9.1.5.2 need not be tested.
  - conformance with the spurious emissions requirements in clause 9.2.5.1 is mandatory, and the requirements specified in clause 9.2.5.2 need not be tested.
- b) The Repeater is tested against Category B limits for spurious emissions, as defined in ITU-R Recommendation SM.329 [2]. In this case,
- conformance with the operating band unwanted emissions requirements in clause 9.1.5.2 is mandatory, and the requirements specified in clause 9.1.5.1 need not be tested.
  - conformance with the spurious emissions requirements in clause 9.2.5.2 is mandatory, and the requirements specified in clause 9.2.5.1 need not be tested.

#### 4.5.5 Additional operating band unwanted emissions

The manufacturer shall declare whether the Repeater under test is intended to operate in geographic areas where additional operating band unwanted emission limits as defined in clause 9.1.5.3 apply. If this is the case, compliance with the test requirements specified in Tables 9.1.5.3-1, 9.1.5.3-2 or 9.1.5.3-3 are mandatory; otherwise these requirements need not be tested.

#### 4.5.6 Co-existence with other systems

The manufacturer shall declare whether the repeater under test is intended to operate in geographic areas where one or more of the systems GSM850, GSM900, DCS1800, PCS1900, UTRA FDD, UTRA TDD, E-UTRA and/or PHS operating in another frequency bands are deployed. If this is the case,

- compliance with the applicable test requirement for spurious emissions specified in clause 9.2.5.3 shall be tested.
- compliance with the applicable test requirement for input intermodulation specified in clause 11.5.3 shall be tested.

#### 4.5.7 Co-location with base stations

The manufacturer shall declare whether the repeater under test is intended to operate co-located with base stations of one or more of the systems GSM850, GSM900, DCS1800, PCS1900, UTRA FDD, UTRA TDD and/or E-UTRA operating in another frequency band. If this is the case,

- compliance with the applicable test requirement for spurious emissions specified in clause 9.2.5.4 shall be tested.
- compliance with the applicable test requirement for input intermodulation specified in clause 11.5.2 shall be tested.

### 4.6 Specified frequency range

*<Text will be added.>*

### 4.7 Format and interpretation of tests

Each test in the following clauses has a standard format:

#### **X Title**

All tests are applicable to all equipment within the scope of the present document, unless otherwise stated.

### **X.1 Definition and applicability**

This subclause gives the general definition of the parameter under consideration and specifies whether the test is applicable to all equipment or only to a certain subset. Required manufacturer declarations may be included here.

### **X.2 Minimum Requirement**

This subclause contains the reference to the subclause to the 3GPP reference (or core) specification which defines the Minimum Requirement.

### **X.3 Test Purpose**

This subclause defines the purpose of the test.

### **X.4 Method of test**

#### **X.4.1 Initial conditions**

This subclause defines the initial conditions for each test, including the test environment, the RF channels to be tested and the basic measurement set-up.

#### **X.4.2 Procedure**

This subclause describes the steps necessary to perform the test and provides further details of the test definition like point of access (e.g. test port), domain (e.g. frequency-span), range, weighting (e.g. bandwidth), and algorithms (e.g. averaging).

### **X.5 Test Requirement**

This subclause defines the pass/fail criteria for the equipment under test. See subclause 4.1.2.2 Interpretation of measurement results.

---

## **5 Operating bands and channel arrangement**

### **5.1 General**

The channel arrangements presented in this clause are based on the operating bands and channel bandwidths defined in the present release of specifications.

NOTE: Other operating bands and channel bandwidths may be considered in future releases.

### **5.2 Void**

### **5.3 Void**

### **5.4 Void**

### **5.5 Operating bands**

E-UTRA FDD is designed to operate in the operating bands defined in Table 5.5-1.

Table 5.5-1 E-UTRA operating bands

E-UTRA operating band	Uplink (UL) operating band		Downlink (DL) operating band		Duplex Mode
	F <sub>UL_low</sub>	F <sub>UL_high</sub>	F <sub>DL_low</sub>	F <sub>DL_high</sub>	
1	1920 MHz	1980 MHz	2110 MHz	2170 MHz	FDD
2	1850 MHz	1910 MHz	1930 MHz	1990 MHz	FDD
3	1710 MHz	1785 MHz	1805 MHz	1880 MHz	FDD
4	1710 MHz	1755 MHz	2110 MHz	2155 MHz	FDD
5	824 MHz	849 MHz	869 MHz	894 MHz	FDD
6 <sup>†</sup>	830 MHz	840 MHz	875 MHz	885 MHz	FDD
7	2500 MHz	2570 MHz	2620 MHz	2690 MHz	FDD
8	880 MHz	915 MHz	925 MHz	960 MHz	FDD
9	1749.9 MHz	1784.9 MHz	1844.9 MHz	1879.9 MHz	FDD
10	1710 MHz	1770 MHz	2110 MHz	2170 MHz	FDD
11	1427.9 MHz	1447.9 MHz	1475.9 MHz	1495.9 MHz	FDD
12	698 MHz	716 MHz	728 MHz	746 MHz	FDD
13	777 MHz	787 MHz	746 MHz	756 MHz	FDD
14	788 MHz	798 MHz	758 MHz	768 MHz	FDD
15	Reserved		Reserved		
16	Reserved		Reserved		
17	704 MHz	716 MHz	734 MHz	746 MHz	FDD
18	815 MHz	830 MHz	860 MHz	875 MHz	FDD
19	830 MHz	845 MHz	875 MHz	890 MHz	FDD
20	832 MHz	862 MHz	791 MHz	821 MHz	FDD
21	1447.9 MHz	1462.9 MHz	1495.9 MHz	1510.9 MHz	FDD
22	3410 MHz	3490 MHz	3510 MHz	3590 MHz	FDD
23	2000 MHz	2020 MHz	2180 MHz	2200 MHz	FDD
24	1626.5 MHz	1660.5 MHz	1525 MHz	1559 MHz	FDD
25	1850 MHz	1915 MHz	1930 MHz	1995 MHz	FDD

Note 1: Band 6 is not applicable.

## 5.6 Channel bandwidth

Requirements in present document are specified for the channel bandwidths listed in Table 5.6-1.

Table 5.6-1 Transmission bandwidth configuration  $N_{RB}$  in E-UTRA channel bandwidths

Channel bandwidth BW <sub>Channel</sub> [MHz]	1.4	3	5	10	15	20
Transmission bandwidth configuration $N_{RB}$	6	15	25	50	75	100

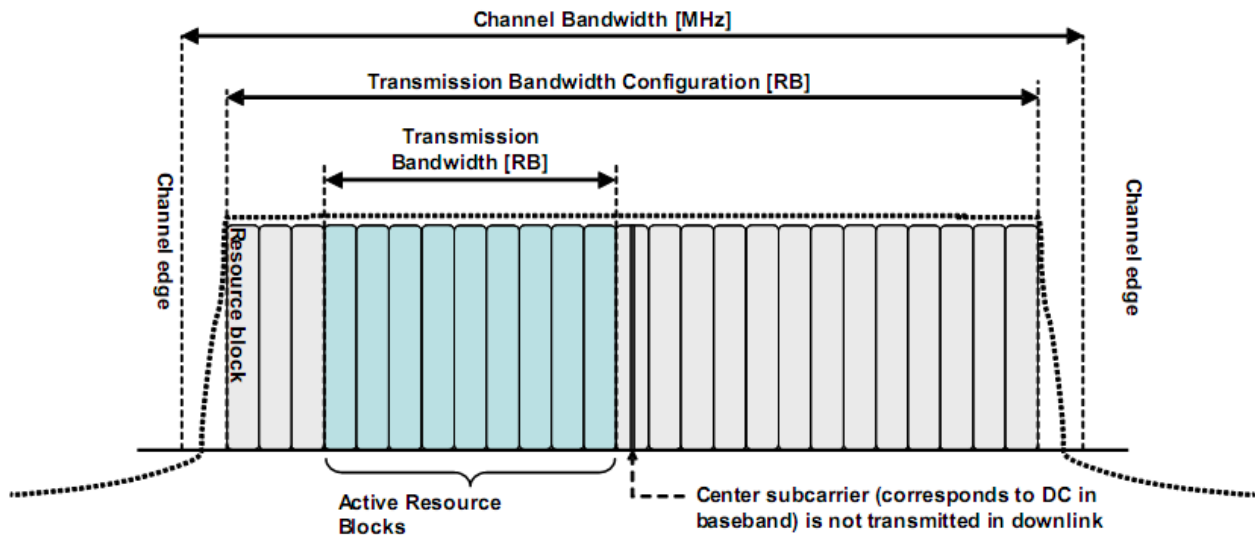

**Figure 5.6-1 Definition of channel bandwidth and transmission bandwidth configuration for one E-UTRA carrier.**

Figure 5.6-1 shows the relation between the Channel bandwidth ( $BW_{\text{Channel}}$ ) and the Transmission bandwidth configuration ( $N_{\text{RB}}$ ). The channel edges are defined as the lowest and highest frequencies of the carrier separated by the channel bandwidth, i.e. at  $F_C \pm BW_{\text{Channel}}/2$ .

## 5.7 Channel arrangement

### 5.7.1 Channel spacing

The spacing between carriers will depend on the deployment scenario, the size of the frequency block available and the channel bandwidths. The nominal channel spacing between two adjacent E-UTRA carriers is defined as following:

$$\text{Nominal Channel spacing} = (BW_{\text{Channel}(1)} + BW_{\text{Channel}(2)})/2$$

where  $BW_{\text{Channel}(1)}$  and  $BW_{\text{Channel}(2)}$  are the channel bandwidths of the two respective E-UTRA carriers. The channel spacing can be adjusted to optimize performance in a particular deployment scenario.

### 5.7.2 Channel raster

The channel raster is 100 kHz for all bands, which means that the carrier centre frequency must be an integer multiple of 100 kHz.

### 5.7.3 Carrier frequency and EARFCN

The carrier frequency in the uplink and downlink is designated by the E-UTRA Absolute Radio Frequency Channel Number (EARFCN) in the range 0 – 65535. The relation between EARFCN and the carrier frequency in MHz for the downlink is given by the following equation, where  $F_{\text{DL\_low}}$  and  $N_{\text{Offs-DL}}$  are given in table 5.7.3-1 and  $N_{\text{DL}}$  is the downlink EARFCN.

$$F_{\text{DL}} = F_{\text{DL\_low}} + 0.1(N_{\text{DL}} - N_{\text{Offs-DL}})$$

The relation between EARFCN and the carrier frequency in MHz for the uplink is given by the following equation where  $F_{\text{UL\_low}}$  and  $N_{\text{Offs-UL}}$  are given in table 5.7.3-1 and  $N_{\text{UL}}$  is the uplink EARFCN.

$$F_{\text{UL}} = F_{\text{UL\_low}} + 0.1(N_{\text{UL}} - N_{\text{Offs-UL}})$$

Table 5.7.3-1 E-UTRA channel numbers

E-UTRA operating band	Downlink			Uplink		
	F <sub>DL_low</sub> [MHz]	N <sub>Offs-DL</sub>	Range of N <sub>DL</sub>	F <sub>UL_low</sub> [MHz]	N <sub>Offs-UL</sub>	Range of N <sub>UL</sub>
1	2110	0	0 – 599	1920	18000	18000 – 18599
2	1930	600	600 – 1199	1850	18600	18600 – 19199
3	1805	1200	1200 – 1949	1710	19200	19200 – 19949
4	2110	1950	1950 – 2399	1710	19950	19950 – 20399
5	869	2400	2400 – 2649	824	20400	20400 – 20649
6	875	2650	2650 – 2749	830	20650	20650 – 20749
7	2620	2750	2750 – 3449	2500	20750	20750 – 21449
8	925	3450	3450 – 3799	880	21450	21450 – 21799
9	1844.9	3800	3800 – 4149	1749.9	21800	21800 – 22149
10	2110	4150	4150 – 4749	1710	22150	22150 – 22749
11	1475.9	4750	4750 – 4999	1427.9	22750	22750 – 22999
12	728	5000	5000 – 5179	698	23000	23000 – 23179
13	746	5180	5180 – 5279	777	23180	23180 – 23279
14	758	5280	5280 – 5379	788	23280	23280 – 23379
15	Reserved			Reserved		
16	Reserved			Reserved		
17	734	5730	5730 – 5849	704	23730	23730 – 23849
18	860	5850	5850 – 5999	815	23850	23850 – 23999
19	875	6000	6000 – 6149	830	24000	24000 – 24149
20	791	6150	6150 – 6449	832	24150	24150 – 24449
21	1495.9	6450	6450 – 6599	1447.9	24450	24450 – 24599
22	3510	6600	6600 – 7399	3410	24600	24600 – 25399
23	2180	7500	7500 – 7699	2000	25500	25500 – 25699
24	1525	7700	7700 – 8039	1626.5	25700	25700 – 26039
25	1930	8040	8040 – 8689	1850	26040	26040 – 26689

NOTE: The channel numbers that designate carrier frequencies so close to the operating band edges that the carrier extends beyond the operating band edge shall not be used. This implies that the first 7, 15, 25, 50, 75 and 100 channel numbers at the lower operating band edge and the last 6, 14, 24, 49, 74 and 99 channel numbers at the upper operating band edge shall not be used for channel bandwidths of 1.4, 3, 5, 10, 15 and 20 MHz respectively.

## 6 Output power

### 6.1 Definition and applicability

Output power,  $P_{out}$ , of the repeater is the mean power of one carrier at maximum repeater gain delivered to a load with resistance equal to the nominal load impedance of the transmitter.

Maximum output power,  $P_{max}$ , of the repeater is the mean power level per carrier measured at the antenna connector in a specified reference condition.

In certain regions, the minimum requirement for normal conditions may apply also for some conditions outside the ranges defined for the Normal test environment in Annex A2.

### 6.2 Minimum requirement

The minimum requirement is in TS 36.106 [2] subclause 6.1.

### 6.3 Test purpose

To verify that the Repeater maximum output power is within the limit specified by the minimum requirement in 6.2.

## 6.4 Method of test

### 6.4.1 Initial conditions

Test environment: normal; see Annex A2.

A measurement system set-up is shown in annex C.

In addition, on one UARFCN only, the test shall be performed under extreme power supply as defined in Annex A5

NOTE: Tests under extreme power supply also test extreme temperature.

- 1) Connect the signal generator equipment to the Repeater input port.
- 2) Connect the power measuring equipment to the Repeater output port.

### 6.4.2 Procedure

- 1) Set the signal generator to transmit signal(s) in accordance to table 6.4.2-1.

**Table 6.4.2-1: Stimulus signal for output power testing**

Repeater under test link and pass band bandwidth	Stimulus reference	Note
Downlink	One E-TM1.1 of the widest possible bandwidth to fit into the Repeater pass band.	The signal is defined in TS36.141 [11]
Uplink pass band BW < 2.8 MHz	Repeater stimulus signal 3	The signal is defined in Annex D.3
Uplink pass band BW ≥ 2.8 MHz	Repeater stimulus signal 1	The signal is defined in Annex D.1

at centre frequencies such that the whole signal can be fitted inside the repeater pass band and at level(s) which produce the manufacturer specified maximum output power at maximum gain.

- 2) Adjust the input power to the Repeater to create the maximum nominal Repeater output power at maximum gain.
- 3) Measure the mean power at the RF output port over a certain slot.
- 4) Increase the power with 10 dB compare to the level obtained in step 2.
- 5) Measure the mean power at the RF output port over a certain slot.

## 6.5 Test requirements

In normal conditions, the Repeater maximum output power shall remain within limits specified in Table 6.3 relative to the manufacturer's rated output power.

**Table 6.3: Repeater output power; normal conditions**

Rated output power	Carrier frequency	Limit
P ≥ 31 dBm	f ≤ 3.0 GHz	+2,7 dB and -2,7 dB
	3.0 GHz < f ≤ 4.2 GHz	+3,0 dB and -3,0 dB
P < 31 dBm	f ≤ 3.0 GHz	+3,7 dB and -3,7 dB
	3.0 GHz < f ≤ 4.2 GHz	+4,0 dB and -4,0 dB

In extreme conditions, the Repeater maximum output power shall remain within limits specified in Table 6.4 relative to the manufacturer's rated output power.

**Table 6.4: Repeater output power; extreme conditions**

Rated output power	Carrier frequency	Limit
P ≥ 31 dBm	f ≤ 3.0 GHz	+3,2 dB and -3,2 dB
	3.0 GHz < f ≤ 4.2 GHz	+3,5 dB and -3,5 dB
P < 31 dBm	f ≤ 3.0 GHz	+4,7 dB and -4,7 dB
	3.0 GHz < f ≤ 4.2 GHz	+5,0 dB and -5,0 dB

NOTE: If the above Test Requirement differs from the Minimum Requirement then the Test Tolerance applied for this test is non zero. The Test Tolerance for this test is defined in subclause 5.2 and the explanation of how the Minimum Requirement has been relaxed by the Test Tolerance is given in Annex B.

---

## 7 Frequency stability

Frequency error is the measure of the difference between the frequency of the received signal and the frequency of the re-transmitted signal.

### 7.1 Definition and applicability

Frequency stability is the ability to maintain the same frequency on the output signal with respect to the input signal.

The test shall address the uplink and the downlink path of the Repeater.

### 7.2 Minimum requirements

The minimum requirement is in TS 36.106 [2] subclause 7.1.

### 7.3 Test purpose

To verify that the frequency error is within the limit specified in the minimum requirements.

### 7.4 Method of test

The frequency error is derived in the measurement procedure of EVM. For method of test refer to clause 10.1.4 for the downlink and 10.2.4 for the uplink.

### 7.5 Test requirement

The measurement result of 7.4 shall not exceed:

$$|f_{IN} - f_{out}| \leq (f_{out} * 0,01) + 12 \text{ Hz}$$

---

## 8 Out of band gain

### 8.1 Definition and applicability

Out of band gain refers to the gain of the Repeater immediately outside the pass band. The measurements shall apply to both paths uplink and downlink of the Repeater.

## 8.2 Minimum requirements

The minimum requirement is in TS 36.106 [2] subclause 8.1.

## 8.3 Test purpose

The purpose of this test is to verify that the Repeater meets the out of band gain requirements as specified by the minimum requirements.

## 8.4 Method of test

### 8.4.1 Initial conditions

Test environment: normal; see Annex A2

A measurement system set-up is shown in annex C.

- 1)  $f_{\text{offset\_CW}}$  is the offset between the outer channel edge frequency of the outer channel in the pass band and a CW-signal.
- 2) The test shall be performed with an  $f_{\text{offset\_CW}}$  of 0.2 MHz, 0.5 MHz, 1 MHz, 5 MHz, 7,5 MHz, 10 MHz, 12,5 MHz, 15 MHz and 20 MHz, excluding other pass bands. In addition the test shall also be performed for all harmonic frequencies of the repeaters pass band up to 12,75 GHz, for carrier frequency  $f \leq 3.0\text{GHz}$ , or up to the 5<sup>th</sup> harmonic of the upper frequency edge of the DL or UL operating band, for carrier frequency  $3.0\text{GHz} < f \leq 4.2\text{GHz}$ .

### 8.4.2 Procedure

- 1) Set the Repeater to maximum gain.
- 2) Set the signal generator to generate a CW-signal, applied to the input port of the Repeater. The power level of the RF input signal shall be at least 5 dB below the power level which, when applied within the pass band, would produce the maximum rated output power, as declared by the manufacturer. This is to ensure that the equipment is operating in the linear output range.
- 3) The average output power in each case shall be measured using a spectrum analyser connected to the output port of the Repeater and the net gain shall be recorded and compared to table 8.5-1 or table 8.5-2 whichever is lower.
- 4) With the same input power as in step 1) set the repeater gain to the minimum specified by the manufacturer.
- 5) The average output power in each case shall be measured using a spectrum analyser connected to the output port of the repeater and the net gain shall be recorded and compared to table 8.5-1 or table 8.5-2 whichever is lower.

## 8.5 Test requirements

**Table 8.5-1: Out of band gain limits 1**

Frequency offset, $f_{\text{offset\_CW}}$	Maximum gain
$0,2 \leq f_{\text{offset\_CW}} < 1 \text{ MHz}$	60,5 dB
$1 \leq f_{\text{offset\_CW}} < 5 \text{ MHz}$	45,5 dB
$5 \leq f_{\text{offset\_CW}} < 10 \text{ MHz}$	45,5 dB
$10 \text{ MHz} \leq f_{\text{offset\_CW}}$	35,5 dB



Table 8.5-2: Out of band gain limits 2

Frequency offset, $f_{\text{offset\_CW}}$	Carrier frequency	Maximum gain
$10 \text{ MHz} \leq f_{\text{offset\_CW}}$	$f \leq 3.0 \text{ GHz}$	Out of band gain $\leq$ minimum donor coupling loss + 0,5 dB
	$3.0 \text{ GHz} < f \leq 4.2 \text{ GHz}$	Out of band gain $\leq$ minimum donor coupling loss + 0,8 dB

## 9 Unwanted emissions

Unwanted emissions consist of out-of-band emissions and spurious emissions [4]. Out of band emissions are unwanted emissions immediately outside the pass band bandwidth resulting from the modulation process and non-linearity in the transmitter, but excluding spurious emissions. Spurious emissions are emissions which are caused by unwanted transmitter effects such as harmonics emission, parasitic emission, intermodulation products and frequency conversion products, but exclude out of band emissions.

The out-of-band emissions requirement for repeater is specified both in terms operating band unwanted emissions and protection of the BS receiver in the uplink operating band. The Operating band unwanted emissions define all unwanted emissions in the repeater operating band plus the frequency ranges 10 MHz above and 10 MHz below that band. Unwanted emissions outside of this frequency range are limited by a spurious emissions requirement.

### 9.1 Operating band unwanted emissions

#### 9.1.1 Definition and applicability

The Operating band unwanted emission limits are defined from 10 MHz below the lowest frequency of the repeater operating band up to 10 MHz above the highest frequency of the repeater operating band.

The unwanted emission limits in the part of the operating band that falls in the spurious domain are consistent with ITU-R Recommendation SM.329 [5].

The requirements shall apply whatever the type of repeater considered (one or several pass bands). It applies for all configurations foreseen by the manufacturer's specification.

The requirements of either subclause 9.1.5.1 (Category A limits) or subclause 9.1.5.2 (Category B limits) shall apply. The application of either Category A or Category B limits shall be the same as for spurious emissions (Mandatory Requirements) in subclause 9.2.5.

#### 9.1.2 Minimum requirements

The minimum requirements are in TS 36.106 [2] sub-clause 9.1.

#### 9.1.3 Test purpose

This test measures the operating band unwanted emission from the Repeater transmitter antenna connector, while the Repeater is in operation with, and without signal.

#### 9.1.4 Method of test

##### 9.1.4.1 Initial conditions

Test environment: normal; see Annex A2.

A measurement system set-up is shown in annex C.

- 1) Connect a signal generator to the input port of the Repeater.
- 2) Detection mode: True RMS.

#### 9.1.4.2 Procedures

- 1) Set the Repeater to maximum gain.
- 2) Set the signal generator to generate signal(s) in accordance to table 9.1.4.2-1

**Table 9.1.4.2-1: Stimulus signal for operating band unwanted emissions testing**

Repeater under test link and passband bandwidth	Stimulus reference	Note
Downlink pass band BW < 2.8 MHz	Repeater stimulus signal 4	The signal is defined in Annex D.4
Uplink pass band BW < 2.8 MHz	Repeater stimulus signal 3	The signal is defined in Annex D.3
Downlink pass band BW ≥ 2.8 MHz	Repeater stimulus signal 2	The signal is defined in Annex D.2
Uplink pass band BW ≥ 2.8 MHz	Repeater stimulus signal 1	The signal is defined in Annex D.1

at centre frequencies such that the whole signal can be fitted inside the repeater pass band and at level(s) which produce the manufacturer specified maximum output power at maximum gain.

- 3) The detecting device shall be configured with a measurement bandwidth as stated in the test requirement tables.
- 4) Measure the emission at the specified frequencies with specified measurement bandwidth and note that the measured value does not exceed the specified value. To select the table and the maximum level, use the repeater pass band and stimulus signal if necessary.
- 5) Increase the input power with 10 dB compared to the level obtained in step 2.
- 6) Measure the emission at the specified frequencies with specified measurement bandwidth and note that the measured value does not exceed the specified value. To select the table and the maximum level, use the repeater pass band and stimulus signal if necessary.
- 7) If the pass band is wider than 2,8 MHz, repeat step 1) to 6) with a new stimulus signal of the same kind, but using different centre frequencies such that the whole signal fitted in the repeater pass band.
- 8) Switch off the input signal to the repeater.
- 9) Measure the emission at the specified frequencies with specified measurement bandwidth and note that the measured value does not exceed the specified value. To select the table and the maximum level, use the repeater pass band.

**NOTE:** As a general rule the resolution bandwidth of the measuring equipment should be equal to the measurement bandwidth. However, to improve measurement accuracy, sensitivity and efficiency, the resolution bandwidth may be smaller than the measurement bandwidth. When the resolution bandwidth is smaller than the measurement bandwidth, the result should be integrated over the measurement bandwidth in order to obtain the equivalent noise bandwidth of the measurement bandwidth.

## 9.1.5 Test requirements

Emissions shall not exceed the maximum levels specified in the tables below, where:

- $\Delta f$  is the separation between the nominal pass band edge frequency and the nominal -3dB point of the measuring filter closest to the carrier frequency.
- Nominal passband edge is the lowest and highest frequency of the pass band of the repeater.
- $BW_{Meas}$  is the measurement bandwidth.
- $BW_{Pass\ band}$  is the bandwidth of the repeaters pass band.
- $f_{offset}$  is the separation between the nominal pass band edge frequency and the centre of the measuring filter.
- $f_{offset,max}$  is the offset to the frequency 10 MHz outside the repeater operating band.
- $\Delta f_{max}$  is equal to  $f_{offset,max}$  minus half of the bandwidth of the measuring filter.

The requirements of either subclause 9.1.5.1 or subclause 9.1.5.2 shall apply.

The Additional operating band unwanted emission limits defined in subclause 9.1.5.3 below may be mandatory in certain regions. In other regions it may not apply.

The requirements of subclause 9.1.5.4 shall apply.

Unless otherwise stated, all requirements are measured as mean power (RMS).

### 9.1.5.1 Operating band unwanted emission (Category A)

For E-UTRA FDD repeater operating in Bands 5, 6, 8, 12, 13, 14, 17, 18 and 19 emissions shall not exceed the maximum levels specified in Tables 9.1.5.1-1 and 9.1.5.1-2. The measurements shall apply to both paths uplink and downlink of the Repeater.

**Table 9.1.5.1-1: General operating band unwanted emission limits for repeater pass band bandwidth lower than 5 MHz (E-UTRA bands <1GHz) for Category A**

Frequency offset of measurement filter -3dB point, $\Delta f$	Frequency offset of measurement filter centre frequency, $f_{offset}$	Test requirement	Measurement bandwidth
$0 \text{ MHz} \leq \Delta f < BW_{Pass\ band}$	$BW_{Meas}/2 \leq f_{offset} < BW_{Pass\ band} + BW_{Meas}/2$	$Max[-2.1875 * BW_{Passband} + 2.0625; -1.25 * BW_{Passband} - 0.75]dB$ $+ \frac{Max[-10; BW_{Passband} - 12]}{BW_{Passband}} * \left( f_{offset} - \frac{BW_{meas}}{2} \right) dB$ $+ 1,5 \text{ dB}$	100 kHz
$BW_{Pass\ band} \leq \Delta f < 2 * BW_{Pass\ band}$	$BW_{Pass\ band} + BW_{Meas}/2 \leq f_{offset} < 2 * BW_{Pass\ band} + BW_{Meas}/2$	$Max[-1.43 * BW_{Passband} - 9.0; -0.45 * BW_{Passband} - 11.73]dBm$ $+ 1,5 \text{ dB}$	100 kHz
$2 * BW_{Pass\ band} \leq \Delta f \leq \Delta f_{max}$	$2 * BW_{Pass\ band} + BW_{Meas}/2 \leq f_{offset} < f_{offset,max}$	-13 dBm	100 kHz

Note: Frequencies and bandwidth are given in MHz

**Table 9.1.5.1-2: General operating band unwanted emission limits for repeater pass band bandwidth 5 MHz and above (E-UTRA bands <1GHz) for Category A**

Frequency offset of measurement filter -3dB point, $\Delta f$	Frequency offset of measurement filter centre frequency, $f_{\text{offset}}$	Test requirement	Measurement bandwidth
$0 \text{ MHz} \leq \Delta f < 5 \text{ MHz}$	$0.05 \text{ MHz} \leq f_{\text{offset}} < 5.05 \text{ MHz}$	$-5.5 \text{ dBm} - \frac{7}{5} \cdot \left( \frac{f_{\text{offset}}}{\text{MHz}} - 0.05 \right) \text{ dB}$	100 kHz
$5 \text{ MHz} \leq \Delta f < 10 \text{ MHz}$	$5.05 \text{ MHz} \leq f_{\text{offset}} < 10.05 \text{ MHz}$	-12.5 dBm	100 kHz
$10 \text{ MHz} \leq \Delta f \leq \Delta f_{\text{max}}$	$10.05 \text{ MHz} \leq f_{\text{offset}} < f_{\text{offset,max}}$	-13 dBm	100 kHz

Note: Frequencies and bandwidth are given in MHz

For E-UTRA FDD repeaters operating in Bands 1, 2, 3, 4, 7, 9, 10, 11, 21, 22, 23, 24 and 25 emissions shall not exceed the maximum levels specified in Tables 9.1.5.1-3 and 9.1.5.1-4: The measurements shall apply to both paths uplink and downlink of the repeater.

**Table 9.1.5.1-3: General operating band unwanted emission limits for repeater pass band bandwidth lower than 5 MHz (E-UTRA bands >1GHz) for Category A**

Frequency offset of measurement filter -3dB point, $\Delta f$	Frequency offset of measurement filter centre frequency, $f_{\text{offset}}$	Test requirement (Note 1)	Measurement bandwidth
$0 \text{ MHz} \leq \Delta f < \text{BW}_{\text{Pass band}}$	$\text{BW}_{\text{Meas}}/2 \leq f_{\text{offset}} < \text{BW}_{\text{Pass band}} + \text{BW}_{\text{Meas}}/2$	$\text{Max}[-2.5 * \text{BW}_{\text{Passband}} + 2.5; -1 * \text{BW}_{\text{Passband}} - 2] \text{ dBm} + \frac{\text{Max}[-10; 1.5 * \text{BW}_{\text{Passband}} - 14.5]}{\text{BW}_{\text{Passband}}} * \left( f_{\text{offset}} - \frac{\text{BW}_{\text{meas}}}{2} \right) \text{ dB} + 1,5 \text{ dB} + \Delta P$	100 kHz
$\text{BW}_{\text{Pass band}} \leq \Delta f < 2 * \text{BW}_{\text{Pass band}}$	$\text{BW}_{\text{Pass band}} + \text{BW}_{\text{Meas}}/2 \leq f_{\text{offset}} < 2 * \text{BW}_{\text{Pass band}} + \text{BW}_{\text{Meas}}/2$	$[ \text{Max}[-2.5 * \text{BW}_{\text{Passband}} - 7.5; 0.5 * \text{BW}_{\text{Passband}} - 16.5] \text{ dBm} + 1,5 \text{ dB} + \Delta P$	100 kHz
$2 * \text{BW}_{\text{Pass band}} \leq \Delta f \leq \Delta f_{\text{max}}$	$2 * \text{BW}_{\text{Pass band}} + \text{BW}_{\text{Meas}}/2 \leq f_{\text{offset}} < f_{\text{offset,max}}$	-13 dBm	1MHz

Note1: Frequencies and bandwidth are given in MHz  
Note2: - for carrier frequency  $1.0 \text{ GHz} < f \leq 3.0 \text{ GHz}$ :  $\Delta P = 0 \text{ dB}$ ;  
- for carrier frequency  $3.0 \text{ GHz} < f \leq 4.2 \text{ GHz}$ :  $\Delta P = 0.3 \text{ dB}$

**Table 9.1.5.1-4: General operating band unwanted emission limits for repeater pass band bandwidth 5 MHz and above (E-UTRA bands >1GHz) for Category A**

Frequency offset of measurement filter -3dB point, $\Delta f$	Frequency offset of measurement filter centre frequency, $f_{\text{offset}}$	Test requirement (Note 1)	Measurement bandwidth
$0 \text{ MHz} \leq \Delta f < 5 \text{ MHz}$	$0.05 \text{ MHz} \leq f_{\text{offset}} < 5.05 \text{ MHz}$	$-5.5 \text{ dBm} - \frac{7}{5} \cdot \left( \frac{f_{\text{offset}}}{\text{MHz}} - 0.05 \right) \text{ dB} + \Delta P$	100 kHz
$5 \text{ MHz} \leq \Delta f < 10 \text{ MHz}$	$5.05 \text{ MHz} \leq f_{\text{offset}} < 10.05 \text{ MHz}$	-12.5 dBm + $\Delta P$	100 kHz
$10 \text{ MHz} \leq \Delta f \leq \Delta f_{\text{max}}$	$10.5 \text{ MHz} \leq f_{\text{offset}} < f_{\text{offset,max}}$	-13 dBm	1MHz

Note1: Frequencies and bandwidth are given in MHz  
NOTE 1: - for carrier frequency  $1.0 \text{ GHz} < f \leq 3.0 \text{ GHz}$ :  $\Delta P = 0 \text{ dB}$ ;  
- for carrier frequency  $3.0 \text{ GHz} < f \leq 4.2 \text{ GHz}$ :  $\Delta P = 0.3 \text{ dB}$

### 9.1.5.2 Operating band unwanted emissions (Category B)

For Category B operating band unwanted emissions, there are two options for the limits that may be applied regionally. Either the limits in subclause 9.1.5.2.1 or subclause 9.1.5.2.2 shall be applied.

The measurements shall apply to both paths uplink and downlink of the Repeater.

#### 9.1.5.2.1 Category B test requirements (Option 1)

For E-UTRA FDD repeater operating in Bands 5, 6, 8, 12, 13, 14, 17 and 20 emissions shall not exceed the maximum levels specified in Tables 9.1.5.2.1-1 and 9.1.5.2.1-2:

**Table 9.1.5.2.1-1: General operating band unwanted emission limits for repeater pass band bandwidth lower than 5 MHz (E-UTRA bands <1GHz) for Category B**

Frequency offset of measurement filter -3dB point, $\Delta f$	Frequency offset of measurement filter centre frequency, $f_{\text{offset}}$	Test requirement	Measurement bandwidth
$0 \text{ MHz} \leq \Delta f < \text{BW}_{\text{Pass band}}$	$\text{BW}_{\text{Meas}}/2 \leq f_{\text{offset}} < \text{BW}_{\text{Pass band}} + \text{BW}_{\text{Meas}}/2$	$\left[ \text{Max}[-2.5 * \text{BW}_{\text{Passband}} + 2.5; -1 * \text{BW}_{\text{Passband}} - 2] \text{dBm} + \frac{\text{Max}[-10; 1.5 * \text{BW}_{\text{Passband}} - 14.5]}{\text{BW}_{\text{Passband}}} * \left( f_{\text{offset}} - \frac{\text{BW}_{\text{meas}}}{2} \right) \text{dB} \right] + 1,5 \text{ dB}$	100 kHz
$\text{BW}_{\text{Pass band}} \leq \Delta f < 2 * \text{BW}_{\text{Pass band}}$	$\text{BW}_{\text{Pass band}} + \text{BW}_{\text{Meas}}/2 \leq f_{\text{offset}} < 2 * \text{BW}_{\text{Pass band}} + \text{BW}_{\text{Meas}}/2$	$\text{Max}[-2.5 * \text{BW}_{\text{Passband}} - 7.5; 0.5 * \text{BW}_{\text{Passband}} - 16.5] \text{dBm} + 1,5 \text{ dB}$	100 kHz
$2 * \text{BW}_{\text{Pass band}} \leq \Delta f \leq \Delta f_{\text{max}}$	$2 * \text{BW}_{\text{Pass band}} + \text{BW}_{\text{Meas}}/2 \leq f_{\text{offset}} < f_{\text{offset}_{\text{max}}}$	-16 dBm	100 kHz

NOTE 1: Frequencies and bandwidth are given in MHz.  
 NOTE 2: If the repeater input signal consists of E-UTRA signals with a channel bandwidth of 1.4 MHz placed so that the channel edge is less than 200 kHz from the pass band edge, the requirements in Table 9.1.5.2.1-3 supersedes Table 9.1.5.2.1-1 and Table 9.1.5.2.1-2 for applicable frequency offsets.  
 NOTE 3: If the repeater input signal consists of E-UTRA signals with a channel bandwidth of 3 MHz placed so that the channel edge is less than 200 kHz from the pass band edge, the requirements in Table 9.1.5.2.1-4 supersedes Table 9.1.5.2.1-1 and Table 9.1.5.2.1-2 for applicable frequency offsets.

**Table 9.1.5.2.1-2: General operating band unwanted emission limits for repeater pass band bandwidth 5 MHz and above (E-UTRA bands <1GHz) for Category B**

Frequency offset of measurement filter -3dB point, $\Delta f$	Frequency offset of measurement filter centre frequency, $f_{\text{offset}}$	Test requirement	Measurement bandwidth (Note 1)
$0 \text{ MHz} \leq \Delta f < 5 \text{ MHz}$	$0.05 \text{ MHz} \leq f_{\text{offset}} < 5.05 \text{ MHz}$	$-5.5 \text{ dBm} - \frac{7}{5} \cdot \left( \frac{f_{\text{offset}}}{\text{MHz}} - 0.05 \right) \text{ dB}$	100 kHz
$5 \text{ MHz} \leq \Delta f < 10 \text{ MHz}$	$5.05 \text{ MHz} \leq f_{\text{offset}} < 10.05 \text{ MHz}$	-12.5 dBm	100 kHz
$10 \text{ MHz} \leq \Delta f \leq \Delta f_{\text{max}}$	$10.05 \text{ MHz} \leq f_{\text{offset}} < f_{\text{offset,max}}$	-16 dBm	100 kHz

NOTE 1: Frequencies and bandwidth are given in MHz.  
 NOTE 2: If the repeater input signal consists of E-UTRA signals with a channel bandwidth of 1.4 MHz placed so that the channel edge is less than 200 kHz from the pass band edge, the requirements in Table 9.1.5.2.1-3 supersedes Table 9.1.5.2.1-1 and Table 9.1.5.2.1-2 for applicable frequency offsets.  
 NOTE 3: If the repeater input signal consists of E-UTRA signals with a channel bandwidth of 3 MHz placed so that the channel edge is less than 200 kHz from the pass band edge, the requirements in Table 9.1.5.2.1-4 supersedes Table 9.1.5.2.1-1 and Table 9.1.5.2.1-2 for applicable frequency offsets.

**Table 9.1.5.2.1-3: Conditional operating band unwanted emission limits for repeater input signal bandwidth of 1.4 MHz**

Frequency offset of measurement filter -3dB point, $\Delta f$	Frequency offset of measurement filter centre frequency, $f_{\text{offset}}$	Test requirement	Measurement bandwidth
$0 \text{ MHz} \leq \Delta f < 1.05 \text{ MHz}$	$0.05 \text{ MHz} \leq f_{\text{offset}} < 1.1 \text{ MHz}$	$+0.5 \text{ dBm} - \frac{10}{1.4} \cdot \left( \frac{f_{\text{offset}}}{\text{MHz}} - 0.05 \right) \text{ dB}$	100 kHz

Note: Frequencies and bandwidth are given in MHz

**Table 9.1.5.2.1-4: Conditional operating band unwanted emission limits for repeater input signal bandwidth of 3 MHz**

Frequency offset of measurement filter -3dB point, $\Delta f$	Frequency offset of measurement filter centre frequency, $f_{\text{offset}}$	Test requirement	Measurement bandwidth
$0 \text{ MHz} \leq \Delta f < 1.05 \text{ MHz}$	$0.05 \text{ MHz} \leq f_{\text{offset}} < 1.1 \text{ MHz}$	$-3.5 \text{ dBm} - \frac{10}{3} \cdot \left( \frac{f_{\text{offset}}}{\text{MHz}} - 0.05 \right) \text{ dB}$	100 kHz

Note: Frequencies and bandwidth are given in MHz

For E-UTRA FDD repeater operating in Bands 1, 2, 3, 4, 7, 9, 10, 22 and 25 emissions shall not exceed the maximum levels specified in Tables 9.1.5.2.1-5 and 9.1.5.2.1-6: The measurements shall apply to both paths uplink and downlink of the Repeater.

**Table 9.1.5.2.1-5: General operating band unwanted emission limits for repeater pass band bandwidth lower than 5 MHz (E-UTRA bands >1GHz) for Category B**

Frequency offset of measurement filter -3dB point, $\Delta f$	Frequency offset of measurement filter centre frequency, $f_{\text{offset}}$	Test requirement (Note 4)	Measurement bandwidth
$0 \text{ MHz} \leq \Delta f < BW_{\text{Pass band}}$	$BW_{\text{Meas}}/2 \leq f_{\text{offset}} < BW_{\text{Pass band}} + BW_{\text{Meas}}/2$	$Max[-2.5 * BW_{\text{Passband}} + 2.5; -1 * BW_{\text{Passband}} - 2] \text{ dBm} + \frac{Max[-10; 1.5 * BW_{\text{Passband}} - 14.5]}{BW_{\text{Passband}}} * \left( f_{\text{offset}} - \frac{BW_{\text{meas}}}{2} \right) \text{ dB} + 1,5 \text{ dB} + \Delta P$	100 kHz
$BW_{\text{Pass band}} \leq \Delta f < 2 * BW_{\text{Pass band}}$	$BW_{\text{Pass band}} + BW_{\text{Meas}}/2 \leq f_{\text{offset}} < 2 * BW_{\text{Pass band}} + BW_{\text{Meas}}/2$	$Max[-2.5 * BW_{\text{Passband}} - 7.5; 0.5 * BW_{\text{Passband}} - 16.5] \text{ dBm} + 1,5 \text{ dB} + \Delta P$	100 kHz
$2 * BW_{\text{Pass band}} \leq \Delta f \leq \Delta f_{\text{max}}$	$2 * BW_{\text{Pass band}} + BW_{\text{Meas}}/2 \leq f_{\text{offset}} < f_{\text{offset}_{\text{max}}}$	-15 dBm	1MHz

NOTE 1: Frequencies and bandwidth are given in MHz.  
 NOTE 2: If the repeater input signal consists of E-UTRA signals with a channel bandwidth of 1.4 MHz placed so that the channel edge is less than 200 kHz from the pass band edge, the requirements in Table 9.1.5.2.1-7 supersedes Table 9.1.5.2.1-5 and Table 9.1.5.2.1-6 for applicable frequency offsets.  
 NOTE 3: If the repeater input signal consists of E-UTRA signals with a channel bandwidth of 3 MHz placed so that the channel edge is less than 200 kHz from the pass band edge, the requirements in Table 9.1.5.2.1-8 supersedes Table 9.1.5.2.1-5 and Table 9.1.5.2.1-6 for applicable frequency offsets.  
 NOTE 4: - for carrier frequency  $1.0 \text{ GHz} < f \leq 3.0 \text{ GHz}$ :  $\Delta P = 0 \text{ dB}$ ;  
 - for carrier frequency  $3.0 \text{ GHz} < f \leq 4.2 \text{ GHz}$ :  $\Delta P = 0.3 \text{ dB}$

**Table 9.1.5.2.1-6: General operating band unwanted emission limits for repeater pass band bandwidth 5 MHz and above (E-UTRA bands >1GHz) for Category B**

Frequency offset of measurement filter -3dB point, $\Delta f$	Frequency offset of measurement filter centre frequency, $f_{\text{offset}}$	Test requirement (Note 4)	Measurement bandwidth
$0 \text{ MHz} \leq \Delta f < 5 \text{ MHz}$	$0.05 \text{ MHz} \leq f_{\text{offset}} < 5.05 \text{ MHz}$	$-5.5 \text{ dBm} - \frac{7}{5} * \left( \frac{f_{\text{offset}}}{\text{MHz}} - 0.05 \right) \text{ dB} + \Delta P$	100 kHz
$5 \text{ MHz} \leq \Delta f < 10 \text{ MHz}$	$5.05 \text{ MHz} \leq f_{\text{offset}} < 10.05 \text{ MHz}$	$-12.5 \text{ dBm} + \Delta P$	100 kHz
$10 \text{ MHz} \leq \Delta f \leq \Delta f_{\text{max}}$	$10.5 \text{ MHz} \leq f_{\text{offset}} < f_{\text{offset}_{\text{max}}}$	-15 dBm	1MHz

NOTE 1: Frequencies and bandwidth are given in MHz.  
 NOTE 2: If the repeater input signal consists of E-UTRA signals with a channel bandwidth of 1.4 MHz placed so that the channel edge is less than 200 kHz from the pass band edge, the requirements in Table 9.1.5.2.1-7 supersedes Table 9.1.5.2.1-5 and Table 9.1.5.2.1-6 for applicable frequency offsets.  
 NOTE 3: If the repeater input signal consists of E-UTRA signals with a channel bandwidth of 3 MHz placed so that the channel edge is less than 200 kHz from the pass band edge, the requirements in Table 9.1.5.2.1-8 supersedes Table 9.1.5.2.1-5 and Table 9.1.5.2.1-6 for applicable frequency offsets.  
 NOTE 4: - for carrier frequency  $1.0 \text{ GHz} < f \leq 3.0 \text{ GHz}$ :  $\Delta P = 0 \text{ dB}$ ;  
 - for carrier frequency  $3.0 \text{ GHz} < f \leq 4.2 \text{ GHz}$ :  $\Delta P = 0.3 \text{ dB}$

**Table 9.1.5.2.1-7: Conditional operating band unwanted emission limits for repeater input signal bandwidth of 1.4 MHz**

Frequency offset of measurement filter -3dB point, $\Delta f$	Frequency offset of measurement filter centre frequency, $f_{\text{offset}}$	Test requirement	Measurement bandwidth
$0 \text{ MHz} \leq \Delta f < 1.05 \text{ MHz}$	$0.05 \text{ MHz} \leq f_{\text{offset}} < 1.1 \text{ MHz}$	$+0.5 \text{ dBm} - \frac{10}{1.4} * \left( \frac{f_{\text{offset}}}{\text{MHz}} - 0.05 \right) \text{ dB}$	100 kHz

Note: Frequencies and bandwidth are given in MHz

**Table 9.1.5.2.1-8: Conditional operating band unwanted emission limits for repeater input signal bandwidth of 3 MHz**

Frequency offset of measurement filter -3dB point, $\Delta f$	Frequency offset of measurement filter centre frequency, $f_{\text{offset}}$	Test requirement	Measurement bandwidth
$0 \text{ MHz} \leq \Delta f < 1.05 \text{ MHz}$	$0.05 \text{ MHz} \leq f_{\text{offset}} < 1.1 \text{ MHz}$	$-3.5\text{dBm} - \frac{10}{3} \cdot \left( \frac{f_{\text{offset}}}{\text{MHz}} - 0.05 \right) \text{dB}$	100 kHz
Note: Frequencies and bandwidth are given in MHz			

### 9.1.5.2.2 Category B test requirements (Option 2)

The limits in this subclause may be applied regionally for E-UTRA FDD Repeater operating in band 3 and 8.

For E-UTRA FDD repeater operating in Bands 3 and 8 emissions shall not exceed the maximum levels specified in Tables 9.1.5.2.2-1 and 9.1.5.2.2-2:

**Table 9.1.5.2.2-1: General operating band unwanted emission limits for repeater pass band lower than 5 MHz**

Frequency offset of measurement filter -3dB point, $\Delta f$	Frequency offset of measurement filter centre frequency, $f_{\text{offset}}$	Test requirement	Measurement bandwidth
$0 \text{ MHz} \leq \Delta f < 0.2 \text{ MHz}$	$0.015 \text{ MHz} \leq f_{\text{offset}} < 0.215 \text{ MHz}$	-12.5 dBm	30 kHz
$0.2 \text{ MHz} \leq \Delta f < 1 \text{ MHz}$	$0.215 \text{ MHz} \leq f_{\text{offset}} < 1.015 \text{ MHz}$	$-12.5\text{dBm} - 15 * \left( \frac{f_{\text{offset}}}{\text{MHz}} - 0.215 \right) \text{dB}$	30 kHz
(Note 3)	$1.015 \text{ MHz} \leq f_{\text{offset}} < 1.5 \text{ MHz}$	-24.5 dBm	30 kHz
$1 \text{ MHz} \leq \Delta f < 2 * \text{BW}_{\text{Pass band}}$	$1.5 \text{ MHz} \leq f_{\text{offset}} < 2 * \text{BW}_{\text{Pass band}} + 0.5 \text{ MHz}$	-11.5 dBm	1 MHz
$2 * \text{BW}_{\text{Pass band}} \leq \Delta f \leq \Delta f_{\text{max}}$	$2 * \text{BW}_{\text{Pass band}} + 0.5 \text{ MHz} \leq f_{\text{offset}} < f_{\text{offset}_{\text{max}}}$	-15 dBm	1 MHz
NOTE 1: Frequencies and bandwidth are given in MHz.			
NOTE 2: If the repeater input signal consists of E-UTRA signals with a channel bandwidth of 1.4 MHz or 3 MHz placed so that the channel edge is less than 200 kHz from the pass band edge, the requirements in Table 9.1.5.2.2-3 supersedes Table 9.1.5.2.2-1 for applicable frequency offsets.			
NOTE 3: This frequency range ensures that the range of values of $f_{\text{offset}}$ is continuous			



**Table 9.1.5.2.2-2: General operating band unwanted emission limits for repeater pass band 5 MHz and above**

Frequency offset of measurement filter -3dB point, $\Delta f$	Frequency offset of measurement filter centre frequency, $f_{\text{offset}}$	Test requirement	Measurement bandwidth
$0 \text{ MHz} \leq \Delta f < 0.2 \text{ MHz}$	$0.015 \text{ MHz} \leq f_{\text{offset}} < 0.215 \text{ MHz}$	-12.5 dBm	30 kHz
$0.2 \text{ MHz} \leq \Delta f < 1 \text{ MHz}$	$0.215 \text{ MHz} \leq f_{\text{offset}} < 1.015 \text{ MHz}$	$-12.5 \text{ dBm} - 15 * \left( \frac{f_{\text{offset}}}{\text{MHz}} - 0.215 \right) \text{ dB}$	30 kHz
(Note 3)	$1.015 \text{ MHz} \leq f_{\text{offset}} < 1.5 \text{ MHz}$	-24.5 dBm	30 kHz
$1 \text{ MHz} \leq \Delta f < 10 \text{ MHz}$	$1.5 \text{ MHz} \leq f_{\text{offset}} < 10.5 \text{ MHz}$	-11.5 dBm	1 MHz
$10 \text{ MHz} \leq \Delta f \leq \Delta f_{\text{max}}$	$10.5 \text{ MHz} \leq f_{\text{offset}} < f_{\text{offset}_{\text{max}}}$	-15 dBm	1 MHz

NOTE 1: Frequencies and bandwidth are given in MHz.  
NOTE 2: If the repeater input signal consists of E-UTRA signals with a channel bandwidth of 1.4 MHz or 3 MHz placed so that the channel edge is less than 200 kHz from the pass band edge, the requirements in Table 9.1.5.2.2-3 supersedes Table 9.1.5.2.2-2 for applicable frequency offsets.  
NOTE 3: This frequency range ensures that the range of values of  $f_{\text{offset}}$  is continuous

**Table 9.1.5.2.2-3: Conditional operating band unwanted emission limits**

Frequency offset of measurement filter -3 dB point, $\Delta f$	Frequency offset of measurement filter centre frequency, $f_{\text{offset}}$	Test requirement	Measurement bandwidth
$0 \text{ MHz} \leq \Delta f < 0.05 \text{ MHz}$	$0.015 \text{ MHz} \leq f_{\text{offset}} < 0.065 \text{ MHz}$	$6.5 \text{ dBm} - 60 \cdot \left( \frac{f_{\text{offset}}}{\text{MHz}} - 0.015 \right) \text{ dB}$	30 kHz
$0.05 \text{ MHz} \leq \Delta f < 0.15 \text{ MHz}$	$0.065 \text{ MHz} \leq f_{\text{offset}} < 0.165 \text{ MHz}$	$3.5 \text{ dBm} - 160 \cdot \left( \frac{f_{\text{offset}}}{\text{MHz}} - 0.065 \right) \text{ dB}$	30 kHz
$0.15 \text{ MHz} \leq \Delta f < 0.2 \text{ MHz}$	$0.165 \text{ MHz} \leq f_{\text{offset}} < 0.215 \text{ MHz}$	-12.5 dBm	30 kHz

NOTE: Frequencies and bandwidth are given in MHz.

### 9.1.5.3 Additional requirements

These requirements may be applied for the protection of other systems operating inside or near the E-UTRA Repeater downlink operating band. The limits may apply as an optional protection of such systems that are deployed in the same geographical area as the E-UTRA Repeater, or they may be set by local or regional regulation as a mandatory requirement for an E-UTRA operating band. It is in some cases not stated in the present document whether a requirement is mandatory or under what exact circumstances that a limit applies, since this is set by local or regional regulation. An overview of regional requirements in the present document is given in subclause 4.2.

In certain regions the following requirement may apply. For E-UTRA FDD repeaters operating in Band 5, emissions shall not exceed the maximum levels specified in Table 9.1.5.3-1. The measurements shall apply to both paths uplink and downlink of the Repeater.

**Table 9.1.5.3-1: Additional operating band unwanted emission limits for E-UTRA bands <1GHz**

Input signal bandwidth	Frequency offset of measurement filter -3dB point, $\Delta f$	Frequency offset of measurement filter centre frequency, $f_{\text{offset}}$	Test requirement	Measurement bandwidth (Note 1)
1.4 MHz	$0 \text{ MHz} \leq \Delta f < 1 \text{ MHz}$	$0.005 \text{ MHz} \leq f_{\text{offset}} < 0.995 \text{ MHz}$	-14 dBm	10 kHz
3 MHz	$0 \text{ MHz} \leq \Delta f < 1 \text{ MHz}$	$0.015 \text{ MHz} \leq f_{\text{offset}} < 0.985 \text{ MHz}$	-13 dBm	30 kHz
5 MHz	$0 \text{ MHz} \leq \Delta f < 1 \text{ MHz}$	$0.015 \text{ MHz} \leq f_{\text{offset}} < 0.985 \text{ MHz}$	-15 dBm	30 kHz
10 MHz	$0 \text{ MHz} \leq \Delta f < 1 \text{ MHz}$	$0.05 \text{ MHz} \leq f_{\text{offset}} < 0.95 \text{ MHz}$	-13 dBm	100 kHz
15 MHz	$0 \text{ MHz} \leq \Delta f < 1 \text{ MHz}$	$0.05 \text{ MHz} \leq f_{\text{offset}} < 0.95 \text{ MHz}$	-13 dBm	100 kHz
20 MHz	$0 \text{ MHz} \leq \Delta f < 1 \text{ MHz}$	$0.05 \text{ MHz} \leq f_{\text{offset}} < 0.95 \text{ MHz}$	-13 dBm	100 kHz
All	$1 \text{ MHz} \leq \Delta f < \Delta f_{\text{max}}$	$1.05 \text{ MHz} \leq f_{\text{offset}} < f_{\text{offset}_{\text{max}}}$	-13 dBm	100 kHz

In certain regions the following requirement may apply. For E-UTRA FDD repeaters operating in Bands 2, 4, 10, 23, and 25 emissions shall not exceed the maximum levels specified in Table 9.1.5.3-2. The measurements shall apply to both paths uplink and downlink of the Repeater.

**Table 9.1.5.3-2: Additional operating band unwanted emission limits for E-UTRA bands >1GHz**

Input signal bandwidth	Frequency offset of measurement filter -3dB point, $\Delta f$	Frequency offset of measurement filter centre frequency, $f_{\text{offset}}$	Test requirement	Measurement bandwidth (Note 1)
1.4 MHz	$0 \text{ MHz} \leq \Delta f < 1 \text{ MHz}$	$0.005 \text{ MHz} \leq f_{\text{offset}} < 0.995 \text{ MHz}$	-14 dBm	10 kHz
3 MHz	$0 \text{ MHz} \leq \Delta f < 1 \text{ MHz}$	$0.015 \text{ MHz} \leq f_{\text{offset}} < 0.985 \text{ MHz}$	-13 dBm	30 kHz
5 MHz	$0 \text{ MHz} \leq \Delta f < 1 \text{ MHz}$	$0.015 \text{ MHz} \leq f_{\text{offset}} < 0.985 \text{ MHz}$	-15 dBm	30 kHz
10 MHz	$0 \text{ MHz} \leq \Delta f < 1 \text{ MHz}$	$0.05 \text{ MHz} \leq f_{\text{offset}} < 0.95 \text{ MHz}$	-13 dBm	100 kHz
15 MHz	$0 \text{ MHz} \leq \Delta f < 1 \text{ MHz}$	$0.05 \text{ MHz} \leq f_{\text{offset}} < 0.95 \text{ MHz}$	-15 dBm	100 kHz
20 MHz	$0 \text{ MHz} \leq \Delta f < 1 \text{ MHz}$	$0.05 \text{ MHz} \leq f_{\text{offset}} < 0.95 \text{ MHz}$	-16 dBm	100 kHz
All	$1 \text{ MHz} \leq \Delta f < \Delta f_{\text{max}}$	$1.5 \text{ MHz} \leq f_{\text{offset}} < f_{\text{offset}_{\text{max}}}$	-13 dBm	1 MHz

In certain regions the following requirement may apply. For E-UTRA FDD repeaters operating in Bands 12, 13, 14 and 17 emissions shall not exceed the maximum levels specified in Table 9.1.5.3-3. The measurements shall apply to both paths Uplink and Downlink of the Repeater.

**Table 9.1.5.3-3: Additional operating band unwanted emission limits for E-UTRA (bands 12, 13, 14 and 17)**

Input signal bandwidth	Frequency offset of measurement filter -3dB point, $\Delta f$	Frequency offset of measurement filter centre frequency, $f_{\text{offset}}$	Test requirement	Measurement bandwidth (Note 1)
All	$0 \text{ MHz} \leq \Delta f < 100 \text{ kHz}$	$0.015 \text{ MHz} \leq f_{\text{offset}} < 0.085 \text{ MHz}$	-13 dBm	30 kHz
All	$100 \text{ kHz} \leq \Delta f < \Delta f_{\text{max}}$	$150 \text{ kHz} \leq f_{\text{offset}} < f_{\text{offset}_{\text{max}}}$	-13 dBm	100 kHz

NOTE : For signal bandwidths between the values given in Table's 9.1.5.3-1 and 9.1.5.3-2, the requirements can be calculated by linearly interpolating between the requirements closest to the wanted signal bandwidth.

In certain regions the following requirement may apply for protection of DTT. For E-UTRA Repeater operating in Band 20, the level of emissions in the band 470-790 MHz, measured in an 8MHz filter bandwidth on centre frequencies  $F_{\text{filter}}$  according to Table 9.1.5.3-3, shall not exceed the maximum emission level  $P_{\text{EM},N}$  declared by the manufacturer. This requirement applies in the frequency range 470-790 MHz even though part of the range falls in the spurious domain.

**Table 9.1.5.3-4: Declared emissions levels for protection of DTT**

Filter centre frequency, $F_{\text{filter}}$	Measurement bandwidth	Declared emission level [dBm]
$F_{\text{filter}} = 8*N + 306 \text{ (MHz)}$ ; $21 \leq N \leq 60$	8 MHz	$P_{\text{EM},N}$

Note: The regional requirement is defined in terms of EIRP (effective isotropic radiated power), which is dependent on both the repeater emissions at the antenna connector and the deployment (including antenna gain and feeder loss). The requirement defined above provides the characteristics of the repeater needed to verify compliance with the regional requirement. Compliance with the regional requirement can be determined using the method outlined in Annex G of TS 36.104 [13].

This requirement may be applied for the protection in bands adjacent to bands 1, as defined in clause 5.5 in geographic areas in which both an adjacent band service and E-UTRA are deployed.

The requirement applies only to the down-link direction of the repeater.

The power of any spurious emission shall not exceed:

**Table 9.1.5.3-5: E-UTRA Repeater down-link spurious emissions limits for protection of adjacent band services**

Operating Band	Band	Maximum Level	Measurement Bandwidth	Note
1	2100-2105 MHz	-30 + 3.4 (f - 2100 MHz) dBm	1 MHz	
	2175-2180 MHz	-30 + 3.4 (2180 MHz - f) dBm	1 MHz	

In regions where FCC regulation applies, requirements for protection of GPS according to FCC Order DA 10-534 applies for operation in Band 24. The following normative requirement covers the repeater to be used together with other information about the site installation to verify compliance with the requirement in FCC Order DA 10-534. The requirement applies to repeater operating in Band 24 to ensure that appropriate interference protection is provided to the 1559 – 1610 MHz band. This requirement applies to the frequency range 1559-1610 MHz even though part of this range falls within the operating band unwanted emissions domain.

The level of emissions in the 1559 – 1610 MHz band, measured in measurement bandwidth according to Table 6.6.4.3.1-4 shall not exceed the maximum emission levels  $P_{E\_1MHz}$  and  $P_{E\_1kHz}$  declared by the manufacturer.

**Table 9.1.5.3-6: Declared emissions levels for protection of the 1559-1610 MHz band**

Operating Band	Frequency range	Declared emission level [dBW] (Measurement bandwidth = 1 MHz)	Declared emission level [dBW] of discrete emissions of less than 700 Hz bandwidth (Measurement bandwidth = 1 kHz)
24	1559 - 1610 MHz	$P_{E\_1MHz}$	$P_{E\_1kHz}$

Note: The regional requirement in FCC Order DA 10-534 is defined in terms of EIRP (effective isotropic radiated power), which is dependent on both the repeater emissions at the antenna connector and the deployment (including antenna gain and feeder loss). The EIRP level is calculated using:  $P_{EIRP} = P_E + G_{ant}$  where  $P_E$  denotes the BS unwanted emission level at the antenna connector,  $G_{ant}$  equals the BS antenna gain minus feeder loss. The requirement defined above provides the characteristics of the repeater needed to verify compliance with the regional requirement.

#### 9.1.5.4 Protection of the BS receiver in the operating band

This requirement shall be applied for the protection of E-UTRA FDD BS receiver in geographic areas in which E-UTRA-FDD Repeater and E-UTRA-FDD BS are deployed.

The requirement applies to the uplink of the repeater, at maximum gain, at frequencies that are more than 10 MHz below or more than 10 MHz above the repeater pass band.

The power of any operating band unwanted emission shall not exceed the limits in Table 9.1.5.4-1.

**Table 9.1.5.4-1: Uplink operating band unwanted emissions limits for protection of the BS receiver**

Maximum Level	Measurement Bandwidth	Note
-53 dBm	100 kHz	

NOTE 1: These requirements in Table 9.1.5.4-1: for the uplink direction of the Repeater reflect what can be achieved with present state of the art technology and are based on a coupling loss of 73 dB between a Repeater and an E-UTRA FDD BS receiver.

NOTE 2: The requirements shall be reconsidered when the state of the art technology progresses.

NOTE 3: The protection of GSM-R is for further study.

## 9.2 Spurious emissions

### 9.2.1 Definition and applicability

The spurious emission limits apply from 9 kHz to 12.75 GHz, for operating bands  $f \leq 3,0\text{GHz}$ , (or above, as indicated in Table 9.2.1.1.1-1 and 9.2.1.2.1-1), excluding the frequency range from 10 MHz below the lowest frequency of the repeaters operating band up to 10 MHz above the highest frequency of the repeaters operating band. Exceptions are the requirement in Table 9.2.5.3-2 and 9.2.5.3-3 that apply also closer than 10 MHz from repeaters operating band.

The requirements shall apply whatever the type of repeater considered (one or several pass bands). It applies for all configurations foreseen by the manufacturer's specification. The measurements shall apply to both paths uplink and downlink of the Repeater.

Unless otherwise stated, all requirements are measured as mean power (RMS).

### 9.2.2 Minimum requirements

The minimum requirements are in TS 36.106 [2] sub-clause 9.2.

### 9.2.3 Test purpose

This test measures the conducted spurious emission from the Repeater transmitter antenna connector, while the Repeater is in operation with, and without signal.

### 9.2.4 Method of test

#### 9.2.4.1 Initial conditions

Test environment: normal; see Annex A2.

A measurement system set-up is shown in annex C.

- 1) Connect a signal generator to the input port of the Repeater
- 2) Detection mode: True RMS.

#### 9.2.4.2 Procedures

- 1) Set the Repeater to maximum gain.
- 2) Set the signal generator to generate signal(s) in accordance to table 9.2.4.2-1

**Table 9.2.4.2-1: Stimulus signal for spurious emissions testing**

Repeater under test link and passband bandwidth	Stimulus reference	Note
Downlink pass band BW < 2.8 MHz	Repeater stimulus signal 4	The signal is defined in Annex D.4
Uplink pass band BW < 2.8 MHz	Repeater stimulus signal 3	The signal is defined in Annex D.3
Downlink pass band BW ≥ 2.8 MHz	Repeater stimulus signal 2	The signal is defined in Annex D.2
Uplink pass band BW ≥ 2.8 MHz	Repeater stimulus signal 1	The signal is defined in Annex D.1

at centre frequencies such that the whole signal can be fitted inside the repeater pass band and at level(s) which produce the manufacturer specified maximum output power at maximum gain.

- 3) The detecting device shall be configured with a measurement bandwidth as stated in the test requirement tables.
- 4) Measure the emission at the specified frequencies with specified measurement bandwidth and note that the measured value does not exceed the specified value.
- 5) Increase the input power with 10 dB compared to the level obtained in step 2.
- 6) Measure the emission at the specified frequencies with specified measurement bandwidth and note that the measured value does not exceed the specified value.
- 7) If the pass band is wider than 2,8 MHz repeat step 1) to 6) with a new stimulus signal of the same kind, but using different centre frequencies such that the whole signal fitted in the repeater pass band.
- 8) Switch off the input signal to the repeater.
- 9) Measure the emission at the specified frequencies with specified measurement bandwidth and note that the measured value does not exceed the specified value.

## 9.2.5 Test requirements

The requirements of either subclause 9.2.5.1 (Category A limits) or subclause 9.2.5.2 (Category B limits) shall apply. The application of either Category A or Category B limits shall be the same as for Operating band unwanted emissions in subclause 9.1.

### 9.2.5.1 Spurious emission (Category A)

The power of any spurious emission shall not exceed the limits in table 9.2.5.1-1 in cases where Category A limits for spurious emissions, as defined in ITU-R Recommendation SM.329 [4], are applied.

**Table 9.2.5.1-1: Uplink and downlink: General spurious emissions limits, Category A**

Frequency range	Maximum level	Measurement Bandwidth	Notes
9kHz – 150kHz	-13 dBm	1 kHz	Note 1
150kHz – 30MHz		10 kHz	Note 1
30MHz – 1GHz		100 kHz	Note 1
1GHz – 12,75 GHz		1 MHz	Note 1, Note 2
12.75 GHz – 5 <sup>th</sup> harmonic of the upper frequency edge of the DL or UL operating band for DL or UL spurious emissions, respectively		1 MHz	Note 2, Note 3
NOTE 1: Bandwidth as in ITU-R SM.329 [4], s4.1			
NOTE 2: Upper frequency as in ITU-R SM.329 [4], s2.5 table 1			
NOTE 3: Applies only for Bands 22.			

### 9.2.5.2 Spurious emission (Category B)

The power of any spurious emission shall not exceed the limits in table 9.2.5.2-1 in cases where Category B limits for spurious emissions, as defined in ITU-R Recommendation SM.329 [4], are applied.

**Table 9.2.5.2-1: Uplink and downlink: General spurious emissions limits, Category B**

Frequency range	Maximum Level	Measurement Bandwidth	Note
9 kHz ↔ 150 kHz	-36 dBm	1 kHz	Note 1
150 kHz ↔ 30 MHz	-36 dBm	10 kHz	Note 1
30 MHz ↔ 1 GHz	-36 dBm	100 kHz	Note 1
1 GHz ↔ 12.75 GHz	-30 dBm	1 MHz	Note1, Note 2
12.75 GHz ↔ 5 <sup>th</sup> harmonic of the upper frequency edge of the DL or UL operating band for DL or UL spurious emissions, respectively	-30 dBm	1 MHz	Note 2, Note 3
NOTE 1: Bandwidth as in ITU-R SM.329 [4] , s4.1			
NOTE 2: Upper frequency as in ITU-R SM.329 [4] , s2.5 table 1			
NOTE 3: Applies only for Bands 22.			

### 9.2.5.3 Co-existence with other systems in the same geographical area

These requirements may be applied for the protection of system operating in frequency ranges other than the E-UTRA Repeater operating band. The limits may apply as an optional protection of such systems that are deployed in the same geographical area as the E-UTRA Repeater, or they may be set by local or regional regulation as a mandatory requirement for an E-UTRA operating band. It is in some cases not stated in the present document whether a requirement is mandatory or under what exact circumstances that a limit applies, since this is set by local or regional regulation. An overview of regional requirements in the present document is given in Clause 4.2.

Some requirements may apply for the protection of specific equipment (UE, MS and/or BS) or equipment operating in specific systems (GSM, UTRA, E-UTRA, etc.) as listed below.

Unless otherwise stated this requirement applies to the uplink and downlink of the repeater, at maximum gain.

The power of any spurious emission shall not exceed the limits of Table 9.2.5.3-1 for an E-UTRA Repeater where requirements for co-existence with the system listed in the first column apply.

**Table 9.2.5.3-1: Spurious emissions limits for E-UTRA-FDD repeater in geographic coverage area of systems operating in other frequency bands**

System type operating in the same geographical area	Frequency range for co-existence requirement	Maximum Level	Measurement Bandwidth	Note
GSM900	921 – 960 MHz	-57 dBm	100 kHz	This requirement does not apply to E-UTRA FDD Repeater operating in band 8.
	876 – 915 MHz	-61 dBm	100 kHz	This requirement does not apply to the uplink of E-UTRA FDD Repeater operating in band 8, since it is already covered by the requirement in sub-clause 9.1.5.4
DCS1800	1805 – 1880 MHz	-47 dBm	100 kHz	This requirement does not apply to E-UTRA FDD Repeater operating in band 3.
	1710 – 1785 MHz	-61 dBm	100 kHz	This requirement does not apply to the uplink of E-UTRA FDD Repeater operating in band 3, since it is already covered by the requirement in sub-clause 9.1.5.4.
PCS1900	1930 – 1990 MHz	-47 dBm	100 kHz	This requirement does not apply to E-UTRA FDD Repeater operating in band 2 or band 25.
	1850 – 1910 MHz	-61 dBm	100 kHz	This requirement does not apply to the uplink of E-UTRA FDD Repeater operating in band 2 or band 25, since it is already covered by the requirement in sub-clause 9.1.5.4.
GSM850 or CDMA850	869 – 894 MHz	-57 dBm	100 kHz	This requirement does not apply to E-UTRA FDD Repeater operating in band 5
	824 – 849 MHz	-61 dBm	100 kHz	This requirement does not apply to the uplink of E-UTRA FDD Repeater operating in band 5, since it is already covered by the requirement in sub-clause 9.1.5.4.
UTRA FDD Band I or E-UTRA Band 1	2110 – 2170 MHz	-52 dBm	1 MHz	This requirement does not apply to E-UTRA FDD Repeater operating in band 1,
	1920 – 1980 MHz	-49 dBm	1 MHz	This requirement does not apply to the uplink of E-UTRA FDD Repeater operating in band 1, since it is already covered by the requirement in sub-clause 9.1.5.4.
UTRA FDD Band II or E-UTRA Band 2	1930 – 1990 MHz	-52 dBm	1 MHz	This requirement does not apply to E-UTRA FDD Repeater operating in band 2 or band 25.
	1850 – 1910 MHz	-49 dBm	1 MHz	This requirement does not apply to the uplink of E-UTRA FDD Repeater operating in band 2 or band 25, since it is already covered by the requirement in sub-clause 9.1.5.4
UTRA FDD Band III or E-UTRA Band 3	1805 – 1880 MHz	-52 dBm	1 MHz	This requirement does not apply to E-UTRA FDD Repeater operating in band 3 or band 9.
	1710 – 1785 MHz	-49 dBm	1 MHz	This requirement does not apply to the uplink of E-UTRA FDD Repeater operating in band 3, since it is already covered by the requirement in sub-clause 9.1.5.4. This requirement does not apply to the uplink of E-UTRA FDD Repeater operating in band 9 in the frequency Range from 1749,9 MHz to 1784,9 MHz, since it is already covered by the requirement in sub-clause 9.1.5.4.
UTRA FDD Band IV or E-UTRA Band 4	2110 – 2155 MHz	-52 dBm	1 MHz	This requirement does not apply to E-UTRA FDD Repeater operating in band 4 or band 10.
	1710 – 1755 MHz	-49 dBm	1 MHz	This requirement does not apply to the uplink of E-UTRA FDD Repeater operating in band 4 or band 10, since it is already covered by the requirement in sub-clause 9.1.5.4.
UTRA FDD Band V or E-UTRA Band 5	869 – 894 MHz	-52 dBm	1 MHz	This requirement does not apply to E-UTRA FDD Repeater operating in band 5
	824 – 849 MHz	-49 dBm	1 MHz	This requirement does not apply to the uplink of E-UTRA FDD Repeater operating in band 5, since it is already covered by the requirement in sub-clause 9.1.5.4.

UTRA FDD Band VI, XIX or E-UTRA Band 6, 18, 19	860 – 890 MHz	-52 dBm	1 MHz	This requirement does not apply to E-UTRA FDD Repeater operating in band 5, 6, 18, 19 or 20.
	815 – 830 MHz	-49 dBm	1 MHz	This requirement does not apply to the uplink of E-UTRA FDD Repeater operating in band 18, since it is already covered by the requirement in sub-clause 9.1.5.4. This requirement does not apply to the uplink of E-UTRA FDD Repeater operating in band 5, 6, 19 or 20.
	830 – 845 MHz	-49 dBm	1 MHz	This requirement does not apply to the uplink of E-UTRA FDD Repeater operating in band 6 or 19, since it is already covered by the requirement in sub-clause 9.1.5.4. This requirement does not apply to the uplink of E-UTRA FDD Repeater operating in band 5, 18 or 20.
UTRA FDD Band VII or E-UTRA Band 7	2620 – 2690 MHz	-52 dBm	1 MHz	This requirement does not apply to E-UTRA FDD Repeater operating in band 7.
	2500 – 2570 MHz	-49 dBm	1 MHz	This requirement does not apply to the uplink of E-UTRA FDD Repeater operating in band 7, since it is already covered by the requirement in sub-clause 9.1.5.4.
UTRA FDD Band VIII or E-UTRA Band 8	925 – 960 MHz	-52 dBm	1 MHz	This requirement does not apply to E-UTRA FDD Repeater operating in band 8.
	880 – 915 MHz	-49 dBm	1 MHz	This requirement does not apply to the uplink of E-UTRA FDD Repeater operating in band 8, since it is already covered by the requirement in sub-clause 9.1.5.4.
UTRA FDD Band IX or E-UTRA Band 9	1844.9 – 1879.9 MHz	-52 dBm	1 MHz	This requirement does not apply to E-UTRA FDD Repeater operating in band 3 or band 9.
	1749.9 – 1784.9 MHz	-49 dBm	1 MHz	This requirement does not apply to the uplink of E-UTRA FDD Repeater operating in band 3 or band 9, since it is already covered by the requirement in sub-clause 9.1.5.4.
UTRA FDD Band X or E-UTRA Band 10	2110 – 2170 MHz	-52 dBm	1 MHz	This requirement does not apply to E-UTRA FDD Repeater operating in band 4 or band 10.
	1710 – 1770 MHz	-49 dBm	1 MHz	This requirement does not apply to the uplink of E-UTRA FDD Repeater operating in band 10, since it is already covered by the requirement in sub-clause 9.1.5.4. This requirement does not apply to the uplink of E-UTRA FDD Repeater operating in band 4 in the frequency Range from 1710 MHz to 1755 MHz, since it is already covered by the requirement in sub-clause 9.1.5.4.
UTRA FDD Band XI or XXI or E-UTRA Band 11 or 21	1475.9 – 1510.9 MHz	-52 dBm	1 MHz	This requirement does not apply to E-UTRA FDD Repeater operating in band 11 or 21
	1427.9 – 1447.9 MHz	-49 dBm	1 MHz	This requirement does not apply to the uplink of E-UTRA FDD Repeater operating in band 11, since it is already covered by the requirement in sub-clause 9.1.5.4.
	1447.9 – 1462.9 MHz	-49 dBm	1 MHz	This requirement does not apply to the uplink of E-UTRA FDD Repeater operating in band 21, since it is already covered by the requirement in sub-clause 9.1.5.4.
UTRA FDD Band XII or E-UTRA Band 12	728 – 746 MHz	-52 dBm	1 MHz	This requirement does not apply to E-UTRA FDD Repeater operating in band 12.
	698 – 716 MHz	-49 dBm	1 MHz	This requirement does not apply to the uplink of E-UTRA FDD Repeater operating in band 12, since it is already covered by the requirement in sub-clause 9.1.5.4.
UTRA FDD Band XIII or E-UTRA Band 13	746 – 756 MHz	-52 dBm	1 MHz	This requirement does not apply to E-UTRA FDD Repeater operating in band 13.
	777 – 787 MHz	-49 dBm	1 MHz	This requirement does not apply to the uplink of E-UTRA FDD Repeater operating in band 13, since it is already covered by the requirement in sub-clause 9.1.5.4.
UTRA FDD Band XIV or	758 – 768 MHz	-52 dBm	1 MHz	This requirement does not apply to E-UTRA FDD Repeater operating in band 14.



E-UTRA Band 14	788 – 798 MHz	-49 dBm	1 MHz	This requirement does not apply to the uplink of E-UTRA FDD Repeater operating in band 14, since it is already covered by the requirement in sub-clause 9.1.5.4.
E-UTRA Band 17	734 – 746 MHz	-52 dBm	1 MHz	This requirement does not apply to E-UTRA FDD Repeater operating in band 17.
	704 - 716 MHz	-49 dBm	1 MHz	This requirement does not apply to the uplink of E-UTRA FDD Repeater operating in band 17, since it is already covered by the requirement in sub-clause 9.1.5.4.
UTRA FDD Band XX or E-UTRA Band 20	791 – 821 MHz	-52 dBm	1 MHz	This requirement does not apply to E-UTRA FDD Repeater operating in band 20.
	832 - 862 MHz	-49 dBm	1 MHz	This requirement does not apply to the uplink of E-UTRA FDD Repeater operating in band 20, since it is already covered by the requirement in sub-clause 9.1.5.4.
UTRA FDD BandXXII or E-UTRA Band 22	3510 – 3590 MHz	-52 dBm	1 MHz	This requirement does not apply to E-UTRA Repeaters operating in band 22.
	3410 – 3490 MHz	-49 dBm	1 MHz	This requirement does not apply to E-UTRA Repeater operating in band 22, since it is already covered by the requirement in subclause 9.1.5.4.
E-UTRA Band 23	2180 – 2200 MHz	-52 dBm	1 MHz	This requirement does not apply to E-UTRA Repeaters operating in band 23.
	2000 – 2020 MHz	-49 dBm	1 MHz	This requirement does not apply to the uplink E-UTRA FDD Repeater operating in band 23 since it is already covered by the requirement in subclause 9.1.5.4. This requirement does not apply to E-UTRA FDD Repeater operating in bands 2 or band 25, where the limits are defined separately.
	2000 – 2010 MHz	-30 dBm	1 MHz	This requirement only applies to the uplink E-UTRA FDD Repeater operating in band 2 or band 25. This requirement applies starting 5 MHz above the band 25 downlink operating band.
	2010 – 2020 MHz	-49dBm	1 MHz	This requirement applies starting 5 MHz above the band 25 downlink operating band.
E-UTRA Band 24	1525 – 1559 MHz	-52 dBm	1 MHz	This requirement does not apply to E-UTRA Repeaters operating in band 24.
	1626.5 – 1660.5 MHz	-49 dBm	1 MHz	This requirement does not apply to E-UTRA Repeater operating in band 24, since it is already covered by the requirement in subclause 9.1.5.4.
UTRA FDD Band XXV or E-UTRA Band 25	1930 – 1995 MHz	-52 dBm	1 MHz	This requirement does not apply to E-UTRA FDD Repeaters operating in band 2 or band 25.
	1850 – 1915 MHz	-49 dBm	1 MHz	This requirement does not apply to the uplink E-UTRA FDD Repeater operating in band 25, since it is already covered by the requirement in subclause 9.1.5.4. For E-UTRA FDD Repeater operating in band 2, it applies for 1910 MHz to 1915 MHz, while the rest is covered in sub-clause 9.1.5.4.
UTRA TDD in Band a) or E-UTRA Band 33	1900 – 1920 MHz	-52 dBm	1 MHz	This requirement does not apply to the uplink of E-UTRA FDD Repeater operating in band 1, band 2 or band 25.
		-53 dBm	100 kHz	This requirement is applied only to the uplink of E-UTRA FDD Repeater operating in band 1, band 2 or band 25.
UTRA TDD in Band a) or E-UTRA Band 34	2010 – 2025 MHz	-52 dBm	1 MHz	
UTRA TDD in Band b) or E-UTRA Band 35	1850 – 1910 MHz	-52 dBm	1 MHz	This requirement does not apply to the downlink of E-UTRA FDD Repeater operating in band 3 or band 9. This requirement does not apply to the uplink of E-UTRA FDD Repeater operating in band 2 or band 25.
		-53 dBm	100 kHz	This requirement is applied only to the uplink of E-UTRA FDD Repeater operating in band 2 or band 25.
UTRA TDD in Band b) or E-UTRA Band 36	1930 – 1990 MHz	-52 dBm	1 MHz	This requirement does not apply to the downlink of E-UTRA FDD Repeater operating in band 2 or band 25. This requirement does not apply to the uplink of E-UTRA FDD Repeater operating in band 1.

		-53 dBm	100 kHz	This requirement is applied only to the uplink of E-UTRA FDD Repeater operating in band 1.
UTRA TDD in Band c) or E-UTRA Band 37	1910 – 1930 MHz	-52 dBm	1 MHz	This requirement does not apply to E-UTRA FDD Repeater operating in band 2 or band 25. This requirement does not apply to the uplink of E-UTRA FDD Repeater operating in band 1. This unpaired band is defined in ITU-R M.1036, but is pending any future deployment.
		-53 dBm	100 kHz	This requirement is applied only to the uplink of E-UTRA FDD Repeater operating in band 1 or band 2 or band 25.
UTRA TDD in Band d) or E-UTRA Band 38	2570 – 2620 MHz	-52 dBm	1 MHz	This requirement does not apply to the uplink of E-UTRA FDD Repeater operating in band 7.
		-53 dBm	100 kHz	This requirement is applied only to the uplink of E-UTRA FDD Repeater operating in band 7.
UTRA TDD Band f) or E-UTRA Band 39	1880 – 1920 MHz	-52 dBm	1 MHz	This requirement does not apply to the uplink of E-UTRA FDD Repeater operating in band 1, band 2 or band 25.
		-53 dBm	100 kHz	This requirement is applied only to the uplink of E-UTRA FDD Repeater operating in band 1, band 2 or band 25.
UTRA TDD Band e) or E-UTRA Band 40	2300 – 2400 MHz	-52 dBm	1 MHz	
E-UTRA Band 41	2496 – 2690 MHz	-52 dBm	1 MHz	
E-UTRA Band 42	3400 – 3600 MHz	-52 dBm	1 MHz	This requirement does not apply to E-UTRA FDD Repeater operating in band 22.
E-UTRA Band 43	3600 – 3800 MHz	-52 dBm	1 MHz	
		-53 dBm	100 kHz	

NOTE 1: As defined in the scope for spurious emissions in this clause, the co-existence requirements in Table 9.2.5.3-1 do not apply for the 10 MHz frequency range immediately outside the repeaters operating band frequency range of an operating band (see Table 5.5-1). This is also the case when the repeaters operating band frequency range is adjacent to the band for the co-existence requirement in the Table 9.2.5.3-1. Emission limits for this excluded frequency range may also be covered by local or regional requirements.

NOTE 2: The Table 9.2.5.3-1 assumes that two operating bands, where the frequency ranges in Table 5.5-1 would be overlapping, are not deployed in the same geographical area. For such a case of operation with overlapping frequency arrangements in the same geographical area, special co-existence requirements may apply that are not covered by the 3GPP specifications.

NOTE 3: The requirements of -53dBm/100kHz in Table 9.2.5.3-1 for the up link direction of the Repeater reflect what can be achieved with present state of the art technology and are based on a coupling loss of 73 dB between a Repeater and a UTRA TDD BS receiver.

NOTE 4: The requirements of -53dBm/100kHz in Table 9.2.5.3-1 shall be reconsidered when the state of the art technology progresses.

The following requirement may be applied for the protection of PHS in geographic areas in which both PHS and E-UTRA-FDD repeaters are deployed. This requirement is also applicable at specified frequencies falling between 10 MHz below the lowest frequency of the repeaters operating band and 10 MHz above the highest frequency of the repeaters operating band.

The power of any spurious emission shall not exceed:

**Table 9.2.5.3-2: Spurious emissions limits for E-UTRA-FDD repeater in geographic coverage area of PHS**

Frequency range	Maximum Level	Measurement Bandwidth	Note
1884.5 – 1915.7 MHz	-41 dBm	300 kHz	Applicable when co-existence with PHS system operating in 1884.5 – 1915.7 MHz

The following requirements shall be applied to E-UTRA-FDD repeaters operating in Bands 13 and 14 to ensure that appropriate interference protection is provided to 700 MHz public safety operations. This requirement is also applicable at specified frequencies falling between 10 MHz below the lowest frequency of the repeaters operating band and 10 MHz above the highest frequency of the repeaters operating band

The power of any spurious emission shall not exceed the limits of Table 9.2.5.3-3 for an E-UTRA Repeater where requirements for co-existence with the system listed in the first column apply.

**Table 9.2.5.3-3: Spurious emissions limits for E-UTRA-FDD repeater for protection of public safety operations**

Operating Band	Frequency range	Maximum Level	Measurement Bandwidth	Note
13	763 – 775 MHz	-46 dBm	6.25 kHz	
13	793 – 805 MHz	-46 dBm	6.25 kHz	
14	769 – 775 MHz	-46 dBm	6.25 kHz	
14	799 – 805 MHz	-46 dBm	6.25 kHz	

#### 9.2.5.4 Co-location with base stations

These requirements may be applied for the protection of other BS receivers when GSM900, DCS1800, PCS1900, GSM850 UTRA FDD, UTRA TDD and/or E-UTRA BS are co-located with an E-UTRA FDD Repeater.

Unless otherwise stated the requirements assume a 30 dB coupling loss between transmitter and receiver.

NOTE: For co-location with UTRA, the requirements are based on co-location with Wide Area UTRA FDD or TDD base stations

Unless otherwise stated this requirement applies to the uplink and downlink of the repeater, at maximum gain.

The power of any spurious emission shall not exceed the limits of Table 9.2.5.4-1 for an E-UTRA FDD Repeater where requirements for co-location with a Base Station listed in the first column apply.

Table 9.2.5.4-1: Spurious emissions limits for E-UTRA-FDD Repeater co-located with Base Stations

Type of co-located Base Station	Frequency range for co-location requirement	Maximum Level	Measurement Bandwidth	Note
GSM900	876 – 915 MHz	-98 dBm	100 kHz	This requirement does not apply to the uplink of E-UTRA FDD Repeater operating in band 8, since it is already covered by the requirement in sub-clause 9.1.5.4, but requires a 75dB coupling loss between base station and the repeater UL transmit port.
DCS1800	1710 – 1785 MHz	-98 dBm	100 kHz	This requirement does not apply to the uplink of E-UTRA FDD Repeater operating in band 3, since it is already covered by the requirement in sub-clause 9.1.5.4, but requires a 75dB coupling loss between base station and the repeater UL transmit port.
PCS1900	1850 – 1910 MHz	-98 dBm	100 kHz	This requirement does not apply to the uplink of E-UTRA FDD Repeater operating in band 2 or band 25, since it is already covered by the requirement in sub-clause 9.1.5.4, but requires a 75dB coupling loss between base station and the repeater UL transmit port.
GSM850 or CDMA850	824 – 849 MHz	-98 dBm	100 kHz	This requirement does not apply to the uplink of E-UTRA FDD Repeater operating in band 5, since it is already covered by the requirement in sub-clause 9.1.5.4, but requires a 75dB coupling loss between base station and the repeater UL transmit port.
UTRA FDD Band I or E-UTRA Band 1	1920 – 1980 MHz	-96 dBm	100 kHz	This requirement does not apply to the uplink of E-UTRA FDD Repeater operating in band 1, since it is already covered by the requirement in sub-clause 9.1.5.4, but requires a 73dB coupling loss between base station and the repeater UL transmit port.
UTRA FDD Band II or E-UTRA Band 2	1850 – 1910 MHz	-96 dBm	100 kHz	This requirement does not apply to the uplink of E-UTRA FDD Repeater operating in band 2 or band 25, since it is already covered by the requirement in sub-clause 9.1.5.4, but requires a 73dB coupling loss between base station and the repeater UL transmit port.
UTRA FDD Band III or E-UTRA Band 3	1710 – 1785 MHz	-96 dBm	100 kHz	This requirement does not apply to the uplink of E-UTRA FDD Repeater operating in band 3, since it is already covered by the requirement in sub-clause 9.1.5.4, but requires a 73dB coupling loss between base station and the repeater UL transmit port. This requirement does not apply to the uplink of E-UTRA FDD Repeater operating in band 9 in the frequency Range from 1749,9 MHz to 1784,9 MHz, since it is already covered by the requirement in sub-clause 9.1.5.4, but requires a 73dB coupling loss between base station and the repeater UL transmit port.
UTRA FDD Band IV or E-UTRA Band 4	1710 – 1755 MHz	-96 dBm	100 kHz	This requirement does not apply to the uplink of E-UTRA FDD Repeater operating in band 4 or band 10, since it is already covered by the requirement in sub-clause 9.1.5.4, but requires a 73dB coupling loss between base station and the repeater UL transmit port.
UTRA FDD Band V or E-UTRA Band 5	824 – 849 MHz	-96 dBm	100 kHz	This requirement does not apply to the uplink of E-UTRA FDD Repeater operating in band 5, since it is already covered by the requirement in sub-clause 9.1.5.4, but requires a 73dB coupling loss between base station and the repeater UL transmit port.
UTRA FDD Band VI XIX or E-UTRA Band 6, 18 or 19	815 – 830 MHz	-96 dBm	100 kHz	This requirement does not apply to the uplink of E-UTRA FDD Repeater operating in band 18, since it is already covered by the requirement in sub-clause 9.1.5.4, but requires a 73dB coupling loss between base station and the repeater UL transmit port. This requirement does not apply to the uplink of E-UTRA FDD Repeater operating in band 5, 6, 19 or 20.

	830 – 845 MHz	-96 dBm	100 kHz	This requirement does not apply to the uplink of E-UTRA FDD Repeater operating in band 6 or 19, since it is already covered by the requirement in sub-clause 9.1.5.4, but requires a 73dB coupling loss between base station and the repeater UL transmit port. This requirement does not apply to the uplink of E-UTRA FDD Repeater operating in band 5, 18 or 20.
UTRA FDD Band VII or E-UTRA Band 7	2500 – 2570 MHz	-96 dBm	100 kHz	This requirement does not apply to the uplink of E-UTRA FDD Repeater operating in band 7, since it is already covered by the requirement in sub-clause 9.1.5.4, but requires a 73dB coupling loss between base station and the repeater UL transmit port.
UTRA FDD Band VIII or E-UTRA Band 8	880 – 915 MHz	-96 dBm	100 kHz	This requirement does not apply to the uplink of E-UTRA FDD Repeater operating in band 8, since it is already covered by the requirement in sub-clause 9.1.5.4, but requires a 73dB coupling loss between base station and the repeater UL transmit port.
UTRA FDD Band IX or E-UTRA Band 9	1749.9 – 1784.9 MHz	-96 dBm	100 kHz	This requirement does not apply to the uplink of E-UTRA FDD Repeater operating in band 3 or band 9, since it is already covered by the requirement in sub-clause 9.1.5.4, but requires a 73dB coupling loss between base station and the repeater UL transmit port.
UTRA FDD Band X or E-UTRA Band 10	1710 – 1770 MHz	-96 dBm	100 kHz	This requirement does not apply to the uplink of E-UTRA FDD Repeater operating in band 10, since it is already covered by the requirement in sub-clause 9.1.5.4, but requires a 73dB coupling loss between base station and the repeater UL transmit port. This requirement does not apply to the uplink of E-UTRA FDD Repeater operating in band 4 in the frequency Range from 1710 MHz to 1755 MHz, since it is already covered by the requirement in sub-clause 9.1.5.4, but requires a 73dB coupling loss between base station and the repeater UL transmit port.
UTRA FDD Band XI or XXI or E-UTRA Band 11 or 21	1427.9 – 1447.9 MHz	-96 dBm	100 kHz	This requirement does not apply to the uplink of E-UTRA FDD Repeater operating in band 11, since it is already covered by the requirement in sub-clause 9.1.5.4, but requires a 73dB coupling loss between base station and the repeater UL transmit port.
	1447.9 – 1462.9 MHz	-96 dBm	100 kHz	This requirement does not apply to the uplink of E-UTRA FDD Repeater operating in band 21, since it is already covered by the requirement in sub-clause 9.1.5.4, but requires a 73dB coupling loss between base station and the repeater UL transmit port.
UTRA FDD Band XII or E-UTRA Band 12	698 – 716 MHz	-96 dBm	100 kHz	This requirement does not apply to the uplink of E-UTRA FDD Repeater operating in band 12, since it is already covered by the requirement in sub-clause 9.1.5.4, but requires a 73dB coupling loss between base station and the repeater UL transmit port.
UTRA FDD Band XIII or E-UTRA Band 13	777 – 787 MHz	-96 dBm	100 kHz	This requirement does not apply to the uplink of E-UTRA FDD Repeater operating in band 13, since it is already covered by the requirement in sub-clause 9.1.5.4, but requires a 73dB coupling loss between base station and the repeater UL transmit port.
UTRA FDD Band XIV or E-UTRA Band 14	788 – 798 MHz	-96 dBm	100 kHz	This requirement does not apply to the uplink of E-UTRA FDD Repeater operating in band 14, since it is already covered by the requirement in sub-clause 9.1.5.4, but requires a 73dB coupling loss between base station and the repeater UL transmit port.
E-UTRA Band 17	704 - 716 MHz	-96 dBm	100 kHz	This requirement does not apply to the uplink of E-UTRA FDD Repeater operating in band 17, since it is already covered by the requirement in sub-clause 9.1.5.4, but requires a 73dB coupling loss between base station and the repeater UL transmit port.

UTRA FDD Band XX or E-UTRA Band 20	832 - 862 MHz	-96 dBm	100 kHz	This requirement does not apply to the uplink of E-UTRA FDD Repeater operating in band 20, since it is already covered by the requirement in sub-clause 9.1.5.4, but requires a 73dB coupling loss between base station and the repeater UL transmit port.
UTRA FDD Band XXII or E-UTRA Band 22	3410 – 3490 MHz	-96 dBm	100 kHz	This requirement does not apply to the uplink of E-UTRA FDD Repeater operating in band 22, since it is already covered by the requirement in sub-clause 9.1.5.4, but requires a 73dB coupling loss between base station and the repeater UL transmit port.
E-UTRA Band 23	2000 – 2020 MHz	-96 dBm	100 kHz	This requirement does not apply to the uplink of E-UTRA FDD Repeater operating in band 23, since it is already covered by the requirement in sub-clause 9.1.5.4, but requires a 73dB coupling loss between base station and the repeater UL transmit port.
E-UTRA Band 24	1626.5 – 1660.5 MHz	-96 dBm	100 kHz	This requirement does not apply to the uplink of E-UTRA FDD Repeater operating in band 24, since it is already covered by the requirement in sub-clause 9.1.5.4, but requires a 73dB coupling loss between base station and the repeater UL transmit port.
UTRA FDD Band XXV or E-UTRA Band 25	1850 – 1915 MHz	-96 dBm	100 kHz	This requirement does not apply to the uplink of E-UTRA FDD Repeater operating in band 25, since it is already covered by the requirement in sub-clause 9.1.5.4, but requires a 73dB coupling loss between base station and the repeater UL transmit port. For E-UTRA FDD Repeater operating in band 2, it applies for 1910 MHz to 1915 MHz, while the rest is covered in sub-clause 9.1.5.4, but requires a 73dB coupling loss between base station and the repeater UL transmit port.
UTRA TDD in Band a) or E-UTRA Band 33	1900 – 1920 MHz	-96 dBm	100 kHz	This requirement does not apply to the uplink of E-UTRA FDD Repeater operating in band 1, band 2 or band 25.
		-53 dBm	100 kHz	This requirement is applied only to the uplink of E-UTRA FDD Repeater operating in band 1, band 2 or band 25.
UTRA TDD in Band a) or E-UTRA Band 34	2010 – 2025 MHz	-96 dBm	100 kHz	This requirement does not apply to the uplink of E-UTRA FDD Repeater operating in band 1.
		-83 dBm	100 kHz	This requirement is applied only to the uplink of E-UTRA FDD Repeater operating in band 1.
UTRA TDD in Band b) or E-UTRA Band 35	1850 – 1910 MHz	-96 dBm	100 kHz	This requirement does not apply to the downlink of E-UTRA FDD Repeater operating in band 3 or band 9. This requirement does not apply to the uplink of E-UTRA FDD Repeater operating in band 2 or band 25.
		-53 dBm	100 kHz	This requirement is applied only to the uplink of E-UTRA FDD Repeater operating in band 2 or band 25.
UTRA TDD in Band b) or E-UTRA Band 36	1930 – 1990 MHz	-96 dBm	100 kHz	This is not applicable to the downlink of E-UTRA-FDD Repeater operating in band 2 or band 25. This requirement does not apply to the uplink of E-UTRA FDD Repeater operating in band 1.
		-53 dBm	100 kHz	This requirement is applied only to the uplink of E-UTRA FDD Repeater operating in band 1.
UTRA TDD in Band c) or E-UTRA Band 37	1910 – 1930 MHz	-96 dBm	100 kHz	This requirement does not apply to E-UTRA FDD Repeater operating in band 2 or band 25. This requirement does not apply to the uplink of E-UTRA FDD Repeater operating in band 1. This unpaired band is defined in ITU-R M.1036, but is pending any future deployment.
		-53 dBm	100 kHz	This requirement is applied only to the uplink of E-UTRA FDD Repeater operating in band 1, band 2 or band 25.
UTRA TDD in Band d) or E-UTRA Band 38	2570 – 2620 MHz	-96 dBm	100 kHz	This requirement does not apply to the uplink of E-UTRA FDD Repeater operating in band 7.
		-53 dBm	100 kHz	This requirement is applied only to the uplink of E-UTRA FDD Repeater operating in band 7.

UTRA TDD Band f) or E-UTRA Band 39	1880 – 1920 MHz	-96 dBm	100 kHz	This requirement does not apply to the uplink of E-UTRA FDD Repeater operating in band 1, band 2 or band 25.
		-53 dBm	100 kHz	This requirement is applied only to the uplink of E-UTRA FDD Repeater operating in band 1, band 2 or band 25.
UTRA TDD Band e) or E-UTRA Band 40	2300 – 2400 MHz	-96 dBm	100 kHz	
E-UTRA Band 41	2496 – 2690 MHz	-96 dBm	100 kHz	
E-UTRA Band 42	3400 – 3600 MHz	-96 dBm	100 kHz	This requirement does not apply to E-UTRA FDD Repeater operating in band 22.
E-UTRA Band 43	3600 – 3800 MHz	-96 dBm	100 kHz	
		-53 dBm	100 kHz	

NOTE 1: As defined in the scope for spurious emissions in this clause, the co-location requirements in Table 9.2.5.4-1 do not apply for the 10 MHz frequency range immediately outside the repeaters operating band frequency range of an operating band (see Table 5.5-1). This is also the case when the repeaters operating band frequency range is adjacent to the frequency range of the co-location requirement in the Table 9.2.5.4-1. The current state-of-the-art technology does not allow a single generic solution for co-location with other system on adjacent frequencies for 30dB Repeater-BS minimum coupling loss. However, there are certain site-engineering solutions that can be used. These techniques are addressed in TR 25.942 [5].

NOTE 2: The Table 9.2.5.4-1 assumes that two operating bands, where the corresponding eNode B transmit and receive frequency ranges in Table 5.5-1 would be overlapping, are not deployed in the same geographical area. For such a case of operation with overlapping frequency arrangements in the same geographical area, special co-location requirements may apply that are not covered by the 3GPP specifications.

NOTE 3: The requirements of -53dBm/100kHz in Table 9.2.5.4-1 for the up link direction of the Repeater reflect what can be achieved with present state of the art technology and are based on a coupling loss of 73 dB between a Repeater and a UTRA TDD BS receiver.

NOTE 4: The requirements of -83dBm/100kHz in Table 9.2.5.4-1 for the up link direction of the Repeater reflect what can be achieved with present state of the art technology and are based on a coupling loss of 43 dB between a Repeater and a UTRA TDD BS receiver.

NOTE 5: The requirements of -53dBm/100kHz and -83dBm/100kHz in Table 9.2.5.4-1 shall be reconsidered when the state of the art technology progresses.

## 10 Error Vector Magnitude (EVM)

### 10.1 Downlink Error Vector Magnitude

#### 10.1.1 Definition and applicability

The Error Vector Magnitude is a measure of the difference between the ideal symbols and the measured symbols after the equalization. This difference is called the error vector. The equaliser parameters are estimated as defined in TS36.104 [4] Annex E. The EVM result is defined as the square root of the ratio of the mean error vector power to the mean reference power expressed in percent.

#### 10.1.2 Minimum requirements

The minimum requirement is in TS 36.106 [2] subclause 10.1.1.

### 10.1.3 Test purpose

To verify that the downlink EVM deterioration is within the limit specified by the minimum requirements after the signal passed through the Repeater.

### 10.1.4 Method of test

#### 10.1.4.1 Initial conditions

Test environment: normal; see Annex A2

A measurement system set-up is shown in annex C.

- 1) Connect the signal generator equipment to the Repeater input port.
- 2) Connect the signal analyser to the Repeater output port.

#### 10.1.4.2 Procedure

- 1) Set the signal generator to transmit one signal according to E-TM3.1 in TS 36.141 [11] of the widest possible bandwidth to fit into the Repeater pass band.
- 2) Adjust the input power to the Repeater to create the maximum nominal Repeater output power at maximum gain.
- 3) Measure the EVM and frequency error as defined in TS 36.141 [11] Annex F.
- 4) Repeat the procedure with all the narrower bandwidths of E-TM3.1

### 10.1.5 Test requirement

For the downlink of the Repeater the Error Vector Magnitude shall not exceed 9,25%.

## 10.2 Uplink Error Vector Magnitude

### 10.2.1 Definition and applicability

The Error Vector Magnitude is a measure of the difference between the reference waveform and the measured waveform. This difference is called the error vector. Before calculating the EVM the measured waveform is corrected by the sample timing offset and RF frequency offset. Then the IQ origin offset shall be removed from the measured waveform before calculating the EVM.

The measured waveform is further modified by selecting the absolute phase and absolute amplitude of the Tx chain. The EVM result is defined after the front-end IDFT as the square root of the ratio of the mean error vector power to the mean reference power expressed as a %. The basic EVM measurement interval is one slot in the time domain.

### 10.2.2 Minimum requirements

The minimum requirement is in TS 36.106 [2] subclause 10.2.1.

### 10.2.3 Test purpose

To verify that the uplink EVM deterioration is within the limit specified by the minimum requirements after the signal passed through the Repeater.



## 10.2.4 Method of test

### 10.2.4.1 Initial conditions

Test environment: normal; see Annex A2

A measurement system set-up is shown in annex C.

- 1) Connect the signal generator equipment to the Repeater input port.
- 2) Connect the signal analyser to the Repeater output port.

### 10.2.4.2 Procedure

- 1) Set the signal generator to transmit the widest bandwidth UL reference signal according to Table A.2.2.1.2-1 in TS36.521-1 [12], that can be fitted inside the repeater passband.
- 2) Adjust the input power to the Repeater to create the maximum nominal Repeater output power at maximum gain.
- 3) Measure the EVM and frequency error as defined in TS 36.521-1 [12] Annex E.
- 4) Repeat the procedure for all narrower BW UL reference signals according to Table A.2.2.1.2-1 in TS36.521-1 [12].

## 10.2.5 Test requirement

For the uplink of the Repeater the Error Vector Magnitude shall not exceed 9,25%.

---

# 11 Input intermodulation

The input intermodulation is a measure of the capability of the Repeater to inhibit the generation of interference in the pass band, in the presence of interfering signals on frequencies other than the pass band.

## 11.1 Definition and applicability

Third and higher order mixing of the two interfering RF signals can produce an interfering signal in the band of the desired channel. Intermodulation response rejection is a measure of the capability of the Repeater to maintain the wanted frequency free of internally created interference.

The additional input intermodulation test requirements in Tables 11.5.2-1 may be applied for the protection of an E-UTRA FDD Repeater input when GSM900, DCS1800, PCS1900, GSM850, UTRA FDD, UTRA TDD and/or E-UTRA BS are co-located with an E-UTRA FDD Repeater.

The additional input intermodulation test requirements in Tables 11.5.3-1 may be applied when GSM900, DCS1800, PCS1900, GSM850, UTRA FDD, UTRA TDD and/or E-UTRA BS operating in another frequency band co-exist with an E-UTRA FDD Repeater.

The measurements shall apply to both paths uplink and downlink of the Repeater, at maximum gain.

## 11.2 Minimum requirements

The minimum requirements are in TS 36.106 [2] sub-clause 11.1.1, 11.2.1 and 11.3.1.

## 11.3 Test purpose

The purpose of this test is to verify that the Repeater meets the intermodulation characteristics requirements as specified by the minimum requirements.

## 11.4 Method of test

### 11.4.1 Initial conditions

Test environment: normal; see Annex A2.

A measurement system set-up is shown in annex C.

- 1) Set the Repeater to maximum gain.
- 2) Connect two signal generators with a combining circuit or one signal generator with the ability to generate several CW carriers to the input.
- 3) Connect a spectrum analyser to the output of the Repeater. Set the resolution bandwidth to 1 MHz in the centre of the pass band. Set averaging to 1 second or more.

### 11.4.2 Procedure

- 1) Adjust the frequency of the input signals, either below or above the pass band, so that one carrier,  $f_1$ , is 1 MHz outside the channel edge frequency of the first or last channel in the pass band, and the lowest order intermodulation product from the two carriers is positioned in the centre of the pass band, according to subclause 11.2.
- 2) Take the measurement of the rise of the output signal.
- 3) Repeat the measurement for the opposite path of the Repeater.

## 11.5 Test requirements

### 11.5.1 General requirement

The intermodulation performance should be met when the following signals are applied to the Repeater:

**Table 11.5.1-1: Input intermodulation requirement**

$f_1$ offset	Interfering Signal Levels	Type of signals	Measurement bandwidth
1,0 MHz	-40 dBm	2 CW carriers	1 MHz

$f_1$  offset is the offset from the channel edge frequency of the first or last channel in the pass band of the closer carrier.

For the parameters specified in table 11.5.1-1, the power in the pass band shall not increase by more than 11,2 dB at the output of the Repeater as measured in the centre of the pass band, compared to the level obtained without interfering signals applied.

### 11.5.2 Co-location with BS in other systems

The intermodulation performance should be met when the following signals are applied to the Repeater:

Table 11.5.2-1: Input intermodulation requirements for interfering signals in co-located other systems

Co-located other systems	Frequency of interfering signals	Interfering Signal Levels	Type of signals	Measurement bandwidth	Note
GSM900	921 – 960 MHz	+16 dBm	2 CW carriers	1 MHz	This requirement does not apply to E-UTRA FDD Repeater operating in band 8, since it is already covered by the requirement in sub-clause 11.5.1, but requires a 86dB coupling loss between base station and the repeater DL receive port.
DCS1800	1805 – 1880 MHz	+16 dBm	2 CW carriers	1 MHz	This requirement does not apply to E-UTRA FDD Repeater operating in band 3, since it is already covered by the requirement in sub-clause 11.5.1, but requires a 86dB coupling loss between base station and the repeater DL receive port.
PCS1900	1930 – 1990 MHz	+16 dBm	2 CW carriers	1 MHz	This requirement does not apply to E-UTRA FDD Repeater operating in band 2 or band 25, since it is already covered by the requirement in sub-clause 11.5.1, but requires a 86dB coupling loss between base station and the repeater DL receive port.
GSM850 or CDMA850	869 – 894 MHz	+16 dBm	2 CW carriers	1 MHz	This requirement does not apply to E-UTRA FDD Repeater operating in band 5, since it is already covered by the requirement in sub-clause 11.5.1, but requires a 86dB coupling loss between base station and the repeater DL receive port.
UTRA-FDD Band I or E-UTRA Band 1	2110 – 2170 MHz	+16 dBm	2 CW carriers	1 MHz	This requirement does not apply to E-UTRA FDD Repeater operating in band 1, since it is already covered by the requirement in sub-clause 11.5.1, but requires a 86dB coupling loss between base station and the repeater DL receive port.
UTRA-FDD Band II or E-UTRA Band 2	1930 – 1990 MHz	+16 dBm	2 CW carriers	1 MHz	This requirement does not apply to E-UTRA FDD Repeater operating in band 2 or band 25, since it is already covered by the requirement in sub-clause 11.5.1, but requires a 86dB coupling loss between base station and the repeater DL receive port.
UTRA-FDD Band III or E-UTRA Band 3	1805 – 1880 MHz	+16 dBm	2 CW carriers	1 MHz	This requirement does not apply to E-UTRA FDD Repeater operating in band 3 or band 9, since it is already covered by the requirement in sub-clause 11.5.1, but requires a 86dB coupling loss between base station and the repeater DL receive port.
UTRA-FDD Band IV or E-UTRA Band 4	2110 – 2155 MHz	+16 dBm	2 CW carriers	1 MHz	This requirement does not apply to E-UTRA FDD Repeater operating in band 4 or band 10, since it is already covered by the requirement in sub-clause 11.5.1, but requires a 86dB coupling loss between base station and the repeater DL receive port.
UTRA-FDD Band V or E-UTRA Band 5	869 – 894 MHz	+16 dBm	2 CW carriers	1 MHz	This requirement does not apply to E-UTRA FDD Repeater operating in band 5, since it is already covered by the requirement in sub-clause 11.5.1, but requires a 86dB coupling loss between base station and the repeater DL receive port.
UTRA-FDD Band VI, XIX or E-UTRA Band 6, 18, 19	860 – 890 MHz	+16 dBm	2 CW carriers	1 MHz	This requirement does not apply to E-UTRA FDD Repeater operating in band 6, 18 or 19, since it is already covered by the requirement in sub-clause 11.5.1, but requires a 86dB coupling loss between base station and the repeater DL receive port.
UTRA-FDD Band VII or E-UTRA	2620 – 2690 MHz	+16 dBm	2 CW carriers	1 MHz	This requirement does not apply to E-UTRA FDD Repeater operating in band 7, since it is already covered by the requirement in

Band 7					sub-clause 11.5.1, but requires a 86dB coupling loss between base station and the repeater DL receive port.
UTRA-FDD Band VIII or E-UTRA Band 8	925 – 960 MHz	+16 dBm	2 CW carriers	1 MHz	This requirement does not apply to E-UTRA FDD Repeater operating in band 8, since it is already covered by the requirement in sub-clause 11.5.1, but requires a 86dB coupling loss between base station and the repeater DL receive port.
UTRA-FDD Band IX or E-UTRA Band 9	1844.9 – 1879.9 MHz	+16 dBm	2 CW carriers	1 MHz	This requirement does not apply to E-UTRA FDD Repeater operating in band 3 or band 9, since it is already covered by the requirement in sub-clause 11.5.1, but requires a 86dB coupling loss between base station and the repeater DL receive port.
UTRA-FDD Band X or E-UTRA Band 10	2110 – 2170 MHz	+16 dBm	2 CW carriers	1 MHz	This requirement does not apply to E-UTRA FDD Repeater operating in band 4 or band 10, since it is already covered by the requirement in sub-clause 11.5.1, but requires a 86dB coupling loss between base station and the repeater DL receive port.
UTRA-FDD Band XI or XXI or E-UTRA Band 11 or 21	1475.9 – 1510.9 MHz	+16 dBm	2 CW carriers	1 MHz	This requirement does not apply to E-UTRA FDD Repeater operating in band 11 or band 21, since it is already covered by the requirement in sub-clause 11.5.1, but requires a 86dB coupling loss between base station and the repeater DL receive port.
UTRA FDD Band XII or E-UTRA Band 12	728 – 746 MHz	+16 dBm	2 CW carriers	1 MHz	This requirement does not apply to E-UTRA FDD Repeater operating in band 12, since it is already covered by the requirement in sub-clause 11.5.1, but requires a 86dB coupling loss between base station and the repeater DL receive port.
UTRA FDD Band XIII or E-UTRA Band 13	746 – 756 MHz	+16 dBm	2 CW carriers	1 MHz	This requirement does not apply to E-UTRA FDD Repeater operating in band 13, since it is already covered by the requirement in sub-clause 11.5.1, but requires a 86dB coupling loss between base station and the repeater DL receive port.
UTRA FDD Band XIV or E-UTRA Band 14	758 – 768 MHz	+16 dBm	2 CW carriers	1 MHz	This requirement does not apply to E-UTRA FDD Repeater operating in band 14, since it is already covered by the requirement in sub-clause 11.5.1, but requires a 86dB coupling loss between base station and the repeater DL receive port.
E-UTRA Band 17	734 - 746 MHz	+16 dBm	2 CW carriers	1 MHz	This requirement does not apply to E-UTRA FDD Repeater operating in band 17, since it is already covered by the requirement in sub-clause 11.5.1, but requires a 86dB coupling loss between base station and the repeater DL receive port.
UTRA FDD Band XX or E-UTRA Band 20	791 - 821 MHz	+16 dBm	2 CW carriers	1 MHz	This requirement does not apply to E-UTRA FDD Repeater operating in band 20, since it is already covered by the requirement in sub-clause 11.5.1, but requires a 86dB coupling loss between base station and the repeater DL receive port.
UTRA FDD Band XXII or E-UTRA Band 22	3510 - 3590 MHz	+16 dBm	2 CW carriers	1 MHz	This requirement does not apply to E-UTRA FDD Repeater operating in band 22, since it is already covered by the requirement in sub-clause 11.5.1, but requires a 86dB coupling loss between base station and the repeater DL receive port.
E-UTRA Band 23	2180 - 2200 MHz	+16 dBm	2 CW carriers	1 MHz	This requirement does not apply to E-UTRA FDD Repeater operating in band 23, since it is already covered by the requirement in sub-clause 11.5.1, but requires a 86dB coupling loss between base station and the

					repeater DL receive port.
E-UTRA Band 24	1525 - 1559 MHz	+16 dBm	2 CW carriers	1 MHz	This requirement does not apply to E-UTRA FDD Repeater operating in band 24, since it is already covered by the requirement in sub-clause 11.5.1, but requires a 86dB coupling loss between base station and the repeater DL receive port.
UTRA FDD Band XXV or E-UTRA Band 25	1930 – 1995 MHz	+16 dBm	2 CW carriers	1 MHz	This requirement does not apply to E-UTRA FDD Repeater operating in band 2 or band 25, since it is already covered by the requirement in sub-clause 11.5.1, but requires a 86dB coupling loss between base station and the repeater DL receive port.
UTRA TDD in Band a) or E-UTRA Band 33	1900 – 1920 MHz	+16 dBm	2 CW carriers	1 MHz	This requirement does not apply to the uplink of E-UTRA FDD Repeater operating in band 1, band 2 or band 25.
UTRA TDD in Band a) or E-UTRA Band 34	2010 – 2025 MHz	+16 dBm	2 CW carriers	1 MHz	
UTRA TDD in Band b) or E-UTRA Band 35	1850 – 1910 MHz	+16 dBm	2 CW carriers	1 MHz	This requirement does not apply to the downlink of E-UTRA FDD Repeater operating in band 3 or band 9. This requirement does not apply to the uplink of E-UTRA FDD Repeater operating in band 2 or band 25.
UTRA TDD in Band b) or E-UTRA Band 36	1930 – 1990 MHz	+16 dBm	2 CW carriers	1 MHz	This requirement does not apply to the downlink of E-UTRA FDD Repeater operating in band 2 or band 25. This requirement does not apply to the uplink of E-UTRA FDD Repeater operating in band 1.
UTRA TDD in Band c) or E-UTRA Band 37	1910 – 1930 MHz	+16 dBm	2 CW carriers	1 MHz	This requirement does not apply to E-UTRA FDD Repeater operating in band 2 or band 25. This requirement does not apply to the uplink of E-UTRA FDD Repeater operating in band 1. This unpaired band is defined in ITU-R M.1036, but is pending any future deployment.
UTRA TDD in Band d) or E-UTRA Band 38	2570 – 2620 MHz	+16 dBm	2 CW carriers	1 MHz	This requirement does not apply to the uplink of E-UTRA FDD Repeater operating in band 7.
UTRA TDD Band f) or E-UTRA Band 39	1880 – 1920 MHz	+16 dBm	2 CW carriers	1 MHz	This requirement does not apply to E-UTRA FDD Repeater operating in band 1, band 2 or band 25.
UTRA TDD Band e) or E-UTRA Band 40	2300 – 2400 MHz	+16 dBm	2 CW carriers	1 MHz	
E-UTRA Band 41	2496 – 2690 MHz	+16 dBm	2 CW carriers	1 MHz	This requirement does not apply E-UTRA FDD Repeater operating in band 7.
E-UTRA Band 42	3400 – 3600 MHz	+16 dBm	2 CW carriers	1 MHz	This requirement does not apply to E-UTRA FDD Repeater operating in band 22.
E-UTRA Band 43	3600 – 3800 MHz	+16 dBm	2 CW carriers	1 MHz	

NOTE 1: The co-location requirements in Table 11.5.2-1 do not apply when the repeaters pass band frequency range is adjacent to the frequency range of the co-location requirement in the Table 11.5.2-1. The current state-of-the-art technology does not allow a single generic solution for co-location with other system on adjacent frequencies for 30dB Repeater-BS minimum coupling loss. However, there are certain site-engineering solutions that can be used. These techniques are addressed in TR 25.942 [5].

NOTE 2: The Table 11.5.2-1 assumes that two operating bands, where the corresponding eNode B transmit and receive frequency ranges in Table 5.5-1 would be overlapping, are not deployed in the same geographical area. For such a case of operation with overlapping frequency arrangements in the same geographical area, special co-location requirements may apply that are not covered by the 3GPP specifications.

For the parameters specified in table 11.5.2-1, the power in the pass band shall not increase with more than 11,2 dB at the output of the repeater as measured in the centre of the pass band, compared to the level obtained without interfering signals applied.

### 11.5.3 Co-existence with other systems

The intermodulation performance should be met when the following signals are applied to the Repeater:

**Table 11.5.3-1: Input intermodulation requirements for interfering signals in co-existing other systems**

Co-existence with other systems	Frequency of interfering signals	Interfering Signal Levels	Type of signals	Measurement bandwidth	Note
GSM900	876 – 915 MHz	-15 dBm	2 CW carriers	1 MHz	This requirement does not apply to E-UTRA FDD Repeater operating in band 8, since it is already covered by the requirement in sub-clause 11.5.1.
DCS1800	1710 – 1785 MHz	-15 dBm	2 CW carriers	1 MHz	This requirement does not apply to E-UTRA FDD Repeater operating in band 3, since it is already covered by the requirement in sub-clause 11.5.1.
PCS1900	1850 – 1910 MHz	-15 dBm	2 CW carriers	1 MHz	This requirement does not apply to E-UTRA FDD Repeater operating in band 2 or band 25, since it is already covered by the requirement in sub-clause 11.5.1.
GSM850 or CDMA850	824 – 849 MHz	-15 dBm	2 CW carriers	1 MHz	This requirement does not apply to E-UTRA FDD Repeater operating in band 5, since it is already covered by the requirement in sub-clause 11.5.1.
UTRA FDD Band I or E-UTRA Band 1	1920 – 1980 MHz	-15 dBm	2 CW carriers	1 MHz	This requirement does not apply to E-UTRA FDD Repeater operating in band 1, since it is already covered by the requirement in sub-clause 11.5.1.
UTRA FDD Band II or E-UTRA Band 2	1850 – 1910 MHz	-15 dBm	2 CW carriers	1 MHz	This requirement does not apply to E-UTRA FDD Repeater operating in band 2 or band 25, since it is already covered by the requirement in sub-clause 11.5.1.
UTRA FDD Band III or E-UTRA Band 3	1710 – 1785 MHz	-15 dBm	2 CW carriers	1 MHz	This requirement does not apply to E-UTRA FDD Repeater operating in band 3 or band 9, since it is already covered by the requirement in sub-clause 11.5.1.
UTRA FDD Band IV or E-UTRA Band 4	1710 – 1755 MHz	-15 dBm	2 CW carriers	1 MHz	This requirement does not apply to E-UTRA FDD Repeater operating in band 4 or band 10, since it is already covered by the requirement in sub-clause 11.5.1.
UTRA FDD Band V or E-UTRA Band 5	824 – 849 MHz	-15 dBm	2 CW carriers	1 MHz	This requirement does not apply to E-UTRA FDD Repeater operating in band 5, since it is already covered by the requirement in sub-clause 11.5.1.
UTRA FDD Band VI or XIX or E-UTRA Band 6, 18 or 19	815 – 830 MHz	-15 dBm	2 CW carriers	1 MHz	This requirement does not apply to E-UTRA FDD Repeater operating in band 18, since it is already covered by the requirement in sub-clause 11.5.1. This requirement does not apply to E-UTRA FDD Repeater operating in band 5, 6, 19 or 20.
	830 - 845 MHz	-15 dBm	2 CW carriers	1 MHz	This requirement does not apply to E-UTRA FDD Repeater operating in band 6 or band 19, since it is already covered by the requirement in sub-clause 11.5.1. This requirement does not apply to E-UTRA FDD Repeater operating in band 5, 18 or 20.
UTRA FDD Band VII or E-UTRA Band 7	2500 – 2570 MHz	-15 dBm	2 CW carriers	1 MHz	This requirement does not apply to E-UTRA FDD Repeater operating in band 7, since it is already covered by the requirement in sub-clause 11.5.1.
UTRA FDD Band VIII or E-UTRA Band 8	880 – 915 MHz	-15 dBm	2 CW carriers	1 MHz	This requirement does not apply to E-UTRA FDD Repeater operating in band 8, since it is already covered by the requirement in sub-clause 11.5.1.

UTRA FDD Band IX or E-UTRA Band 9	1749.9 – 1784.9 MHz	-15 dBm	2 CW carriers	1 MHz	This requirement does not apply to E-UTRA FDD Repeater operating in band 3 or band 9, since it is already covered by the requirement in sub-clause 11.5.1.
UTRA FDD Band X or E-UTRA Band 10	1710 – 1770 MHz	-15 dBm	2 CW carriers	1 MHz	This requirement does not apply to E-UTRA FDD Repeater operating in band 4 or band 10, since it is already covered by the requirement in sub-clause 11.5.1.
UTRA FDD Band XI or XXI or E-UTRA Band 11 or 21	1427.9 – 1447.9 MHz	-15 dBm	2 CW carriers	1 MHz	This requirement does not apply to E-UTRA FDD Repeater operating in band 11, since it is already covered by the requirement in sub-clause 11.5.1.
	1447.9 - 1462.9 MHz	-15 dBm	2 CW carriers	1 MHz	This requirement does not apply to E-UTRA FDD Repeater operating in band 21, since it is already covered by the requirement in sub-clause 11.5.1.
UTRA FDD Band XII or E-UTRA Band 12	698 – 716 MHz	-15 dBm	2 CW carriers	1 MHz	This requirement does not apply to E-UTRA FDD Repeater operating in band 12, since it is already covered by the requirement in sub-clause 11.5.1.
UTRA FDD Band XIII or E-UTRA Band 13	777 – 787 MHz	-15 dBm	2 CW carriers	1 MHz	This requirement does not apply to E-UTRA FDD Repeater operating in band 13, since it is already covered by the requirement in sub-clause 11.5.1.
UTRA FDD Band XIV or E-UTRA Band 14	788 – 798 MHz	-15 dBm	2 CW carriers	1 MHz	This requirement does not apply to E-UTRA FDD Repeater operating in band 14, since it is already covered by the requirement in sub-clause 11.5.1.
E-UTRA Band 17	704 - 716 MHz	-15 dBm	2 CW carriers	1 MHz	This requirement does not apply to E-UTRA FDD Repeater operating in band 17, since it is already covered by the requirement in sub-clause 11.5.1.
UTRA FDD Band XX or E-UTRA Band 20	832 - 862 MHz	-15 dBm	2 CW carriers	1 MHz	This requirement does not apply to E-UTRA FDD Repeater operating in band 20, since it is already covered by the requirement in sub-clause 11.5.1.
UTRA FDD Band XXII or E-UTRA Band 22	3410 – 3490 MHz	-15 dBm	2 CW carriers	1 MHz	This requirement does not apply to E-UTRA FDD Repeater operating in band 22, since it is already covered by the requirement in sub-clause 11.5.1.
E-UTRA Band 23	2000 – 2020 MHz	-15 dBm	2 CW carriers	1 MHz	This requirement does not apply to E-UTRA FDD Repeater operating in band 23, since it is already covered by the requirement in sub-clause 11.5.1.
E-UTRA Band 24	1626.5 – 1660.5 MHz	-15 dBm	2 CW carriers	1 MHz	This requirement does not apply to E-UTRA FDD Repeater operating in band 24, since it is already covered by the requirement in sub-clause 11.5.1.
UTRA FDD Band XXV or E-UTRA Band 25	1850 – 1915 MHz	-15 dBm	2 CW carriers	1 MHz	This requirement does not apply to E-UTRA FDD Repeater operating in band 25, since it is already covered by the requirement in sub-clause 11.5.1. For E-UTRA FDD Repeater operating in band 2, it applies for 1910 MHz to 1915 MHz, while the rest is covered in sub-clause 11.5.1.
UTRA TDD in Band a) or E-UTRA Band 33	1900 – 1920 MHz	-15 dBm	2 CW carriers	1 MHz	This requirement does not apply to the uplink of E-UTRA FDD Repeater operating in band 1, band 2 or band 25.
UTRA TDD in Band a) or E-UTRA Band 34	2010 – 2025 MHz	-15 dBm	2 CW carriers	1 MHz	
UTRA TDD in Band b) or	1850 – 1910 MHz	-15 dBm	2 CW carriers	1 MHz	This requirement does not apply to the downlink of E-UTRA FDD Repeater



E-UTRA Band 35					operating in band 3 or band 9. This requirement does not apply to the uplink of E-UTRA FDD Repeater operating in band 2 or band 25.
UTRA TDD in Band b) or E-UTRA Band 36	1930 – 1990 MHz	-15 dBm	2 CW carriers	1 MHz	This requirement does not apply to the downlink of E-UTRA FDD Repeater operating in band 2 or band 25. This requirement does not apply to the uplink of E-UTRA FDD Repeater operating in band 1.
UTRA TDD in Band c) or E-UTRA Band 37	1910 – 1930 MHz	-15 dBm	2 CW carriers	1 MHz	This requirement does not apply to E-UTRA FDD Repeater operating in band 2 or band 25. This requirement does not apply to the uplink of E-UTRA FDD Repeater operating in band 1. This unpaired band is defined in ITU-R M.1036, but is pending any future deployment.
UTRA TDD in Band d) or E-UTRA Band 38	2570 – 2620 MHz	-15 dBm	2 CW carriers	1 MHz	This requirement does not apply to the uplink of E-UTRA FDD Repeater operating in band 7.
UTRA TDD Band f) or E-UTRA Band 39	1880 – 1920 MHz	-15 dBm	2 CW carriers	1 MHz	This requirement does not apply to E-UTRA FDD Repeater operating in band 1, band 2 or band 25.
UTRA TDD Band e) or E-UTRA Band 40	2300 – 2400 MHz	-15 dBm	2 CW carriers	1 MHz	
E-UTRA Band 41	2496 – 2690 MHz	-15 dBm	2 CW carriers	1 MHz	This requirement does not apply to E-UTRA FDD Repeater operating in band 7.
E-UTRA Band 42	3400 – 3600 MHz	-15 dBm	2 CW carriers	1 MHz	This requirement does not apply to E-UTRA FDD Repeater operating in band 22.
E-UTRA Band 43	3600 – 3800 MHz	-15 dBm	2 CW carriers	1 MHz	

NOTE 1: The co-existence requirements in Table 11.5.3-1 do not apply when the repeaters pass band frequency range is adjacent to the frequency range of the co-existence requirement in the Table 11.3.1-1. The current state-of-the-art technology does not allow a single generic solution for co-existence.

NOTE 2: The Table 11.5.3-1 assumes that two operating bands, where the frequency ranges in Table 5.5-1 would be overlapping, are not deployed in the same geographical area. For such a case of operation with overlapping frequency arrangements in the same geographical area, special co-existence requirements may apply that are not covered by the 3GPP specifications.

For the parameters specified in table 11.5.3-1, the power in the pass band shall not increase with more than 11,2 dB at the output of the repeater as measured in the centre of the pass band, compared to the level obtained without interfering signals applied.

## 12 Output intermodulation

### 12.1 Definition and applicability

The output intermodulation requirement is a measure of the ability of the repeater to inhibit the generation of intermodulation products signals created by the presence of an interfering signal reaching the repeater via the output port.

The output intermodulation level is the power of the intermodulation products when a E-UTRA signal of channel bandwidth 5 MHz as an interference signal is injected into the output port at a level of 30 dB lower than that of the wanted signal. The wanted signal channel bandwidth  $BW_{\text{Channel}}$  shall be the maximum bandwidth supported by the repeater. The Interfering signal centre frequency offset from wanted signal carrier centre frequency shall be according to the table 12.1-1..

The requirement shall apply to the downlink of the Repeater, at maximum gain.

**Table 12.1-1 Interfering and wanted signals for the output intermodulation requirement**

Parameter	Value
Wanted signal	E-UTRA signal of maximum channel bandwidth $BW_{\text{Channel}}$
Interfering signal type	E-UTRA signal of channel bandwidth 5 MHz
Interfering signal level	Mean power level 30 dB below the mean power of the wanted signal
Interfering signal centre frequency offset from wanted signal carrier centre frequency	- $BW_{\text{Channel}}/2 - 12,5$ MHz - $BW_{\text{Channel}}/2 - 7,5$ MHz - $BW_{\text{Channel}}/2 - 2,5$ MHz $BW_{\text{Channel}}/2 + 2,5$ MHz $BW_{\text{Channel}}/2 + 7,5$ MHz $BW_{\text{Channel}}/2 + 12,5$ MHz
NOTE:	Interfering signal positions that are partially or completely outside of the downlink operating band of the repeater are excluded from the requirement.

## 12.2 Minimum requirement

The minimum requirement is in TS 36.106 [2] subclause 12.1.

## 12.3 Test purpose

The test purpose is to verify the ability of the repeater to restrict the generation of intermodulation products in the presence of a subject signal on the repeater input and output ports, and an interfering signal applied at the repeater output port.

## 12.4 Method of test

### 12.4.1 Initial conditions

Test environment: normal; see Annex A2.

A measurement system set-up is shown in annex C.

- 1) Connect a signal generator to the input port of the Repeater (wanted signal). Connect a signal generator to the circulator on the output port (interfering signal) and make sure the signal generator power is directed to the repeater output port.
- 2) Detection mode: True RMS.

### 12.4.2 Procedure

- 1) Set the Repeater to maximum gain.
- 2) Set the signal generator at the repeater input port (wanted signal) to generate a signal in accordance to test model E-TM 1.1, TS 36.141 [11] subclause 6.1.1.1, with a bandwidth as defined in table 12.1-1, at the level which produce the manufacturer specified maximum output power at maximum gain.

- 3) Set the signal generator at the repeater output port (interference signal) to generate a signal in accordance to test model E-TM 1.1, TS 36.141 [11] subclause 6.1.1.1, with a bandwidth, level and frequency offset as defined in table 12.1-1.
- 4) Measure the emission at the specified frequencies with specified measurement bandwidth as described in the test requirements and note that the measured value does not exceed the specified value. Measurements in the band of the interfering signal shall be excluded. The measurements can be limited to the power of all third and fifth order intermodulation products.
- 5) Repeat the test from step 3 on until all interfering signal centre frequency offsets in table 12.1-1 has been tested, but exclude interfering signal frequencies that are outside of the allocated frequency band for E-UTRA downlink specified in subclause 5.3.

NOTE: As a general rule the resolution bandwidth of the measuring equipment should be equal to the measurement bandwidth. However, to improve measurement accuracy, sensitivity and efficiency, the resolution bandwidth can be smaller than the measurement bandwidth. When the resolution bandwidth is smaller than the measurement bandwidth, the result should be integrated over the measurement bandwidth in order to obtain the equivalent noise bandwidth of the measurement bandwidth.

## 12.5 Test Requirements

In all measurements, the requirements according to either subclause 9.1.5.1 Operating band unwanted emission (Category A) and the downlink requirements of 9.2.5.1 Spurious emission (Category A) or 9.1.5.2 Operating band unwanted emissions (Category B) and the downlink requirements of 9.2.5.2 Spurious emission (Category B) shall be fulfilled.

---

# 13 Adjacent Channel Rejection Ratio (ACRR)

## 13.1 Definitions and applicability

Adjacent Channel Rejection Ratio (ACRR) is the ratio of the RRC weighted gain per carrier of the repeater in the pass band to the RRC weighted gain of the repeater on an adjacent channel outside the repeater pass band. The carrier in the pass band and in the adjacent channel shall be of the same type (reference carrier).

The requirement shall apply to the uplink and downlink of the Repeater, at maximum gain, where the donor link is maintained via antennas (over the air Repeater).

### 13.1.1 Minimum requirements

There is no minimum requirement for E-UTRA signals

## 13.2 Co-existence with UTRA

This requirement shall be applied for the protection of UTRA signals in geographic areas in which E-UTRA-FDD Repeater and UTRA BS are deployed so that they serve adjacent channels. The reference carrier is a UTRA-FDD carrier.

### 13.2.1 Minimum requirements

The minimum requirement is in TS 36.106 [2] sub-clause 13.2.1.

### 13.2.2 Test purpose

To verify that the Repeater ACRR requirement is met as specified in sub-clause 13.2.1.

## 13.2.3 Method of test

### 13.2.3.1 Initial conditions

Test environment: normal; see Annex A2.

A measurement system set-up is shown in annex C.

- 1) Connect the signal generator equipment to the Repeater input port.
- 2) Connect the power measuring equipment to the Repeater output port.
- 3) The measurement device characteristics shall be:
  - measurement filter bandwidth: defined in sub-clause 13.1;
  - detection mode: true RMS voltage or true average power.

### 13.2.3.2 Procedure

- 1) Set the signal generator to transmit a signal modulated with a combination of PCCPCH, SCCPCH and Dedicated Physical Channels specified as test model 1 in TS 25.141 at the first or last 5 MHz channel within the pass band.
- 2) Adjust the input power to the Repeater to create the maximum nominal Repeater output power at maximum gain
- 3) Measure the RRC filtered mean power at the RF output port over a certain slot.
- 4) Set the signal generator to transmit the same signal and the same input power at one of the channel offsets outside the repeater pass band according to Table 13.2-1.
- 5) Measure the RRC filtered mean power at the RF output port over a certain slot.
- 6) Calculate the ratio of the measured power in the pass band to the measured power at the channel offset.
- 7) Repeat step 4) to 6) until all channel offsets in Table 13.2-1 are measured.

### 13.2.3.3 Test Requirements

In normal conditions as specified in annex A.2, the ACRR shall be higher than the value specified in the Table 13.2-1.

**Table 13.2-1: Repeater ACRR**

Repeater maximum output power	Channel offset from the centre frequency of the first or last 5 MHz channel within the pass band.	ACRR limit
$P \geq 31$ dBm	5 MHz	32,3dB
$P \geq 31$ dBm	10 MHz	32,3dB
$P < 31$ dBm	5 MHz	19,3dB
$P < 31$ dBm	10 MHz	19,3dB

Note: Repeater maximum output power as defined in TS25.143 clause 9.1.1.

---

## Annex A (normative): Environmental requirements for the Repeater

### A.1 General

For each test in the present document, the environmental conditions under which the Repeater is to be tested are defined.

---

### A.2 Normal test environment

When a normal test environment is specified for a test, the test should be performed within the minimum and maximum limits of the conditions stated in Table A.1-1.

**Table A.1-1: Limits of conditions for Normal Test Environment**

Condition	Minimum	Maximum
Barometric pressure	86 kPa	106 kPa
Temperature	15°C	30°C
Relative Humidity	20 %	85 %
Power supply	Nominal, as declared by the manufacturer	
Vibration	Negligible	

The ranges of barometric pressure, temperature and humidity represent the maximum variation expected in the uncontrolled environment of a test laboratory. If it is not possible to maintain these parameters within the specified limits, the actual values shall be recorded in the test report.

NOTE: This may, for instance, be the case for measurements of radiated emissions performed on an open field test site.

---

### A.3 Extreme test environment

The manufacturer shall declare one of the following:

- 1) the equipment class for the equipment under test, as defined in the IEC 60 721-3-3 [6];
- 2) the equipment class for the equipment under test, as defined in the IEC 60 721-3-4 [7];
- 3) the equipment that does not comply to the mentioned classes, the relevant classes from IEC 60 721 documentation for Temperature, Humidity and Vibration shall be declared.

NOTE: Reduced functionality for conditions that fall out side of the standard operational conditions are not tested in the present document. These may be stated and tested separately.

#### A.3.1 Extreme temperature

When an extreme temperature test environment is specified for a test, the test shall be performed at the standard minimum and maximum operating temperatures defined by the manufacturer's declaration for the equipment under test.

##### Minimum temperature:

The test shall be performed with the environment test equipment and methods including the required environmental phenomena into the equipment, conforming to the test procedure of IEC 60 068-2-1 [8].

##### Maximum temperature:

The test shall be performed with the environmental test equipment and methods including the required environmental phenomena into the equipment, conforming to the test procedure of IEC 60 068-2-2 [9].

NOTE: It is recommended that the equipment is made fully operational prior to the equipment being taken to its lower operating temperature.

---

## A.4 Vibration

When vibration conditions are specified for a test, the test shall be performed while the equipment is subjected to a vibration sequence as defined by the manufacturer's declaration for the equipment under test. This shall use the environmental test equipment and methods of inducing the required environmental phenomena in to the equipment, conforming to the test procedure of IEC 60 068-2-6 [10]. Other environmental conditions shall be within the ranges specified in clause A.2.

NOTE: The higher levels of vibration may induce undue physical stress in to equipment after a prolonged series of tests. The testing body should only vibrate the equipment during the RF measurement process.

---

## A.5 Power supply

When extreme power supply conditions are specified for a test, the test shall be performed at the standard upper and lower limits of operating voltage defined by manufacturer's declaration for the equipment under test.

### Upper voltage limit:

The equipment shall be supplied with a voltage equal to the upper limit declared by the manufacturer (as measured at the input terminals to the equipment). The tests shall be carried out at the steady state minimum and maximum temperature limits declared by the manufacturer for the equipment, to the methods described in IEC 60 068-2-1 [8] Test Ab/Ad and IEC 60 068-2-2 [9] Test Bb/Bd: Dry Heat.

### Lower voltage limit:

The equipment shall be supplied with a voltage equal to the lower limit declared by the manufacturer (as measured at the input terminals to the equipment). The tests shall be carried out at the steady state minimum and maximum temperature limits declared by the manufacturer for the equipment, to the methods described in IEC 60 068-2-1 [8] Test Ab/Ad and IEC 60 068-2-2 [9] Test Bb/Bd: Dry Heat.

---

## A.6 Measurement of test environments

The measurement accuracy of the Repeater test environments defined in Annex A, Test environments shall be.

Pressure:	±5 kPa.
Temperature:	±2 degrees.
Relative Humidity:	±5 %.
DC Voltage:	±1,0 %.
AC Voltage:	±1,5 %.
Vibration:	10 %.
Vibration frequency:	0,1 Hz.

The above values shall apply unless the test environment is otherwise controlled and the specification for the control of the test environment specifies the uncertainty for the parameter.

---

## Annex B (informative): Test tolerances and derivation of test requirements

The test requirements in this specification have been calculated by relaxing the minimum requirements of the core specification using the Test Tolerances defined here. When the test tolerance is zero, the test requirement will be the same as the minimum requirement. When the test tolerance is non-zero, the test requirements will differ from the minimum requirements, and the formula used for this relaxation is given in the following tables.

The test tolerances are derived from test system uncertainties, regulatory requirements and criticality to system performance. As a result, the test tolerances may sometimes be set to zero.

The test tolerances should not be modified for any reason e.g. to take account of commonly known test system errors (such as mismatch, cable loss, etc.).

Note that a formula for applying test tolerances is provided for all tests, even those with a test tolerance of zero. This is necessary in the case where the test system uncertainty is greater than that allowed in clause 4.1.2. In this event, the excess error shall be subtracted from the defined test tolerance in order to generate the correct tightened test requirements as defined in this annex.

[FFS: For example, a test system having 0.9 dB uncertainty for test 6 maximum output power (which is 0.2 dB above the limit specified in clause 4.1.2) would subtract 0.2 dB from the test tolerance of 0.7 dB defined in this annex. This new test tolerance of 0.5 dB would then be applied to the minimum requirement using the formula defined in Table B.2-1 to give a new range of  $\pm 2.5$  dB of the manufacturer's rated output power.

Using this same approach for the case where a test had a test tolerance of 0 dB, an excess error of 0.2 dB would result in a modified test tolerance of -0.2 dB.]

Table B.1-1: Derivation of test requirements

Clause number	Title	Minimum Requirement in TS 36.106 [2]	Test Tolerance (TT)	Test Requirement in TS 36.143
6	Output power			Formula: Upper limit + TT Lower limit – TT
		In normal conditions within $\pm 2$ dB of manufacturer"s rated output power	0,7 dB	In normal conditions: within +2.7 dB and -2.7 dB of the manufacturer"s rated output power for $f \leq 3.0$ GHz
		In normal conditions within $\pm 2$ dB of manufacturer"s rated output power	1.0 dB	In normal conditions: within +3.0 dB and -3.0 dB of the manufacturer"s rated output power for $3.0 \text{ GHz} \leq f \leq 4.2 \text{ GHz}$
		In extreme conditions within $\pm 2,5$ dB of manufacturer"s rated output power	0,7 dB	In extreme conditions: within +3.2 dB and -3.2 dB of the manufacturer"s rated output power for $f \leq 3.0$ GHz
		In extreme conditions within $\pm 2,5$ dB of manufacturer"s rated output power	1.0 dB	In extreme conditions: within +3.5 dB and -3.5 dB of the manufacturer"s rated output power for $3.0 \text{ GHz} \leq f \leq 4.2 \text{ GHz}$
7	Frequency error	0,01 ppm	12 Hz	Formula: Upper limit + TT Lower limit – TT $\pm(0,01 \text{ ppm} + 12 \text{ Hz})$
8	Out of band gain	Table 8.5-1 Out of band gain limits 1 Table 8.5-2 Out of band gain limits 2	0,5 dB for for $f \leq 3.0$ GHz;  0.8 dB for $3.0 \text{ GHz} < f \leq 4.2 \text{ GHz}$	Formula: Maximum limit + TT Table 8.5-1 and Table 8.5-2
9.1	Operating band unwanted emissions	Tables 9.1.1.1-1 to 9.1.1.1-4 (Category A) and tables 9.1.2.1-1 to 9.1.2.1-4 (Category B)  Additional requirements in tables 9.1.3.1-1 to 9.1.3-3 and 9.1.4.1-1.		Formula: Maximum level + TT Tables 9.1.5.1-1 to table 9.1.5.1-4 and tables 9.1.5.2-1 to 9.1.5.2-4.  Tables 9.1.5.3-1 to 9.1.5.3-3 and 9.1.5.4-1
			General requirements: 1,5 dB inside 2 x pass band BW < 10 MHz from pass band edge. 0 dB elsewhere in the operating band 0 dB on additional requirements	For $f \leq 3.0$ GHz
			General requirements: 1,8 dB inside 2 x pass band BW < 10 MHz from pass band edge. 0,3 dB elsewhere in the operating band 0,3 dB on	For $3.0 \text{ GHz} \leq f \leq 4.2 \text{ GHz}$



			additional requirements	
9.2	Spurious emissions	<p><u>Category A</u></p> <p>9 kHz ≤ f &lt; 150 kHz: -13dBm / 1kHz</p> <p>150 kHz ≤ f &lt; 30 MHz: -13dBm / 10 kHz</p> <p>30 MHz ≤ f &lt; 1 GHz: -13dBm / 100 kHz</p> <p>1 GHz ≤ f &lt; 12.75 GHz: -13dBm / 1 MHz</p> <p>12.75 GHz ≤ f &lt; 19 GHz: -13dBm / 1 MHz</p> <p><u>Category B</u></p> <p>9 kHz ≤ f &lt; 150 kHz: -36dBm / 1 kHz</p> <p>150 kHz ≤ f &lt; 30 MHz: -36dBm / 10 kHz</p> <p>30 MHz ≤ f &lt; 1 GHz: -36dBm / 100 kHz</p> <p>1 GHz ≤ f &lt; 12.75 GHz: -30dBm / 1 MHz</p> <p>12.75 GHz ≤ f &lt; 19 GHz: -30dBm / 1 MHz</p> <p>Co-existence requirements in tables 9.2.2.1-1 to 9.2.2.1-3.</p> <p>Co-location requirements in table 9.2.3.1-1</p>	0 dB	<p>Formula: Maximum level + TT</p> <p>Co-existence requirements in tables 9.2.5.3-1 to 9.2.5.3-3.</p> <p>Co-location requirements in table 9.2.5.4-1</p>
10	Error vector magnitude	8%	1.25%	Requirement limit shifted by RSS requirement and stimulus signal EVM. Analyser error added to requirement limit.
11	Input intermodulation	Maximum in-band power increase < 10 dB Tables 11.1.1-1, 11.2.1-1, and 11.3.1-1.	1,2 dB	Maximum in-band power increase + TT
12	Output intermodulation	As in 9.1 and 9.2	As in 9.1 and 9.2	Maximum level + TT
13	Adjacent channel rejection ratio	Table 13.2.1-1	0,7 dB	Formula: Limit – TT

---

## Annex C (informative): Measurement system set-up

Example of measurement system set-ups are attached below as an informative annex.

---

### C.1 Maximum output power

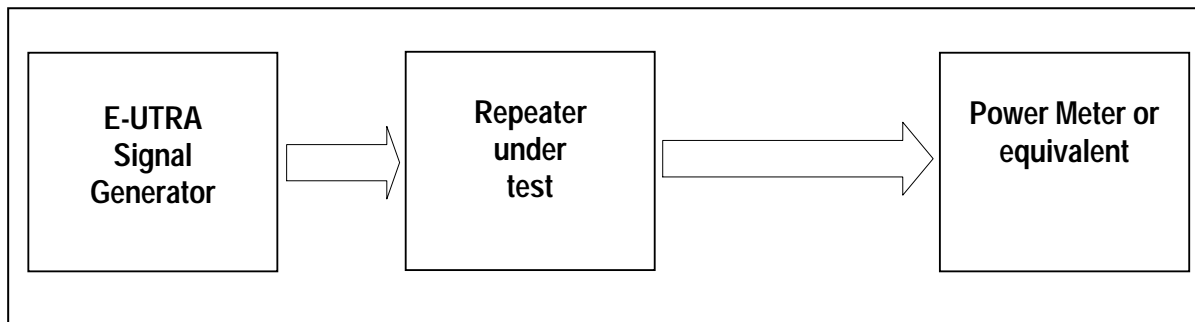
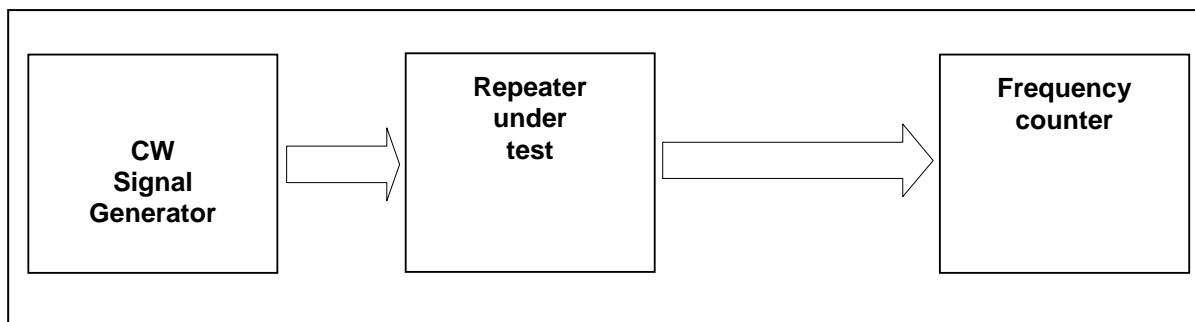

**Figure C.1-1: Measuring system set-up for maximum output power**

Note that a repeater is a bi-directional device. The signal generator may need protection.

---

### C.2 Frequency stability



**Figure C.2-1: Measurement system set-up for frequency stability**

Note that a repeater is a bi-directional device. The signal generator may need protection.

### C.3 Out of band gain

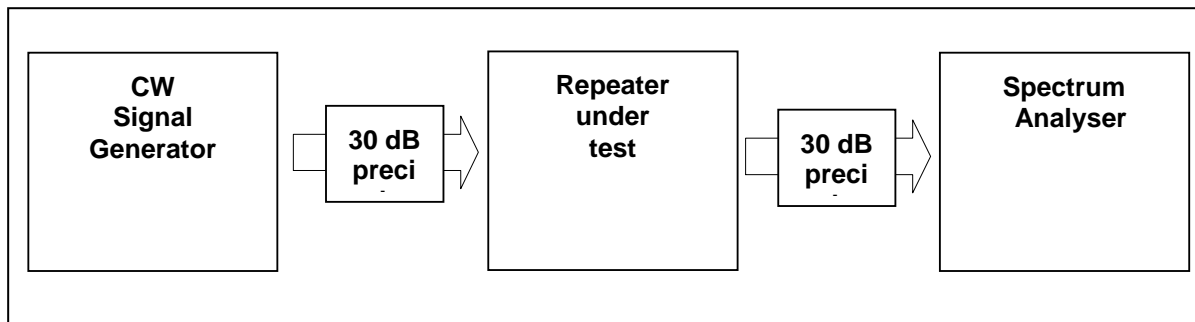

Figure C.3-1: Measuring system set-up for out of band gain

Note that a repeater is a bi-directional device. The signal generator may need protection.

### C.4 Unwanted emission: Operating band unwanted emission

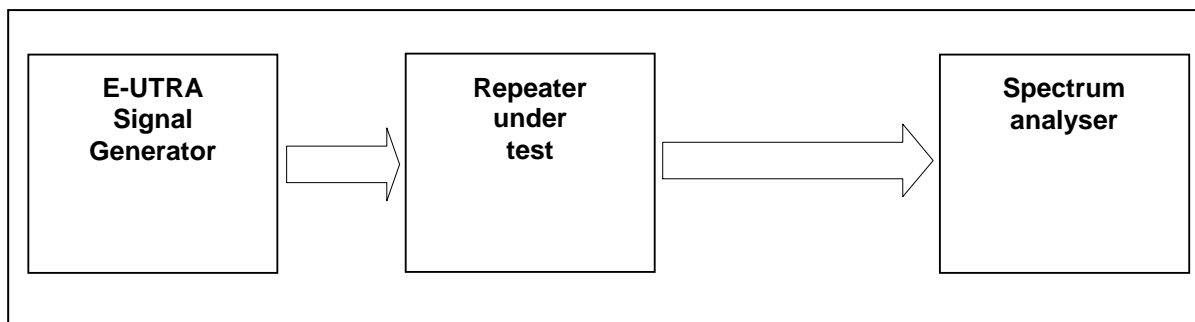
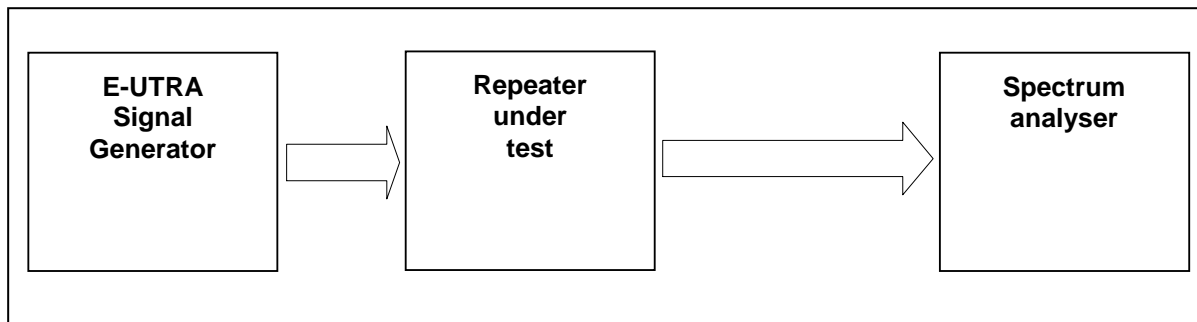

Figure C.4-1: Measuring system set-up for unwanted emission: Operating band unwanted emission

Note that a repeater is a bi-directional device. The signal generator may need protection.

---

## C.5 Unwanted emission: Spurious emission

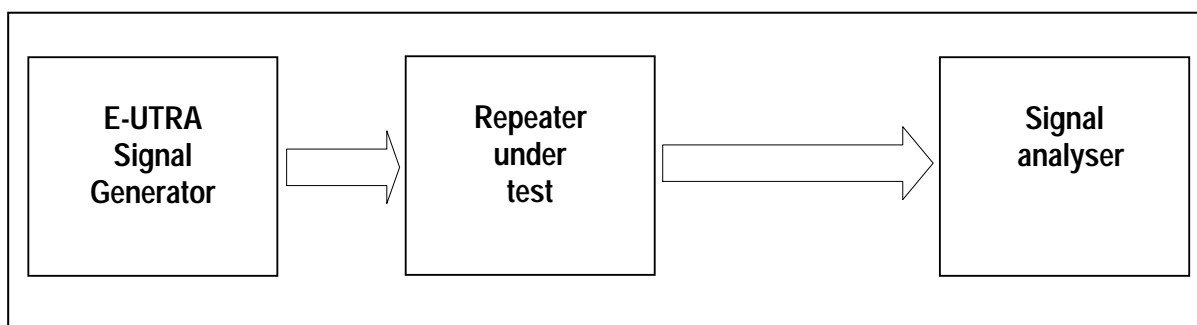

**Figure C.5-1: Measuring system set-up for unwanted emission: Spurious emission.**

Note that a repeater is a bi-directional device. The signal generator may need protection.

---

## C.6 Modulation Accuracy: Error Vector Magnitude



**Figure C.6-1: Measuring system set-up for error vector magnitude.**

Note that a repeater is a bi-directional device. The signal generator may need protection.

## C.7 Input intermodulation

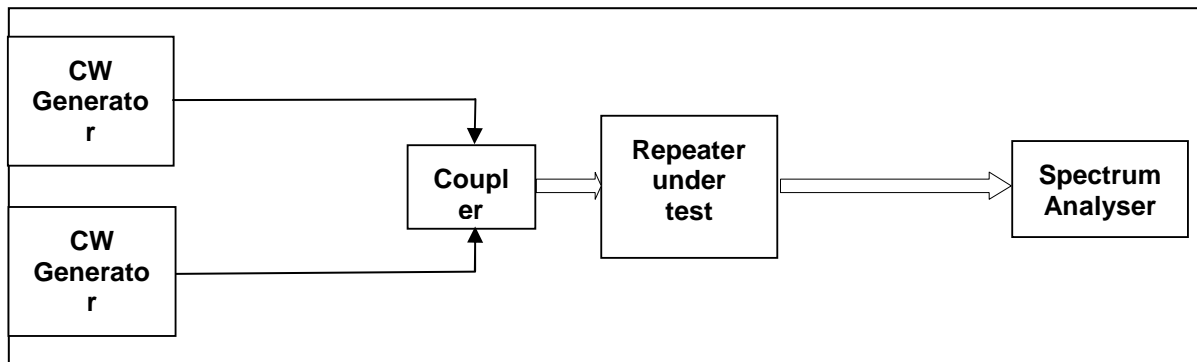

Figure C.7-1: Measuring system set-up for input intermodulation.

Note that a repeater is a bi-directional device. The signal generator may need protection.

## C.8 Output Intermodulation

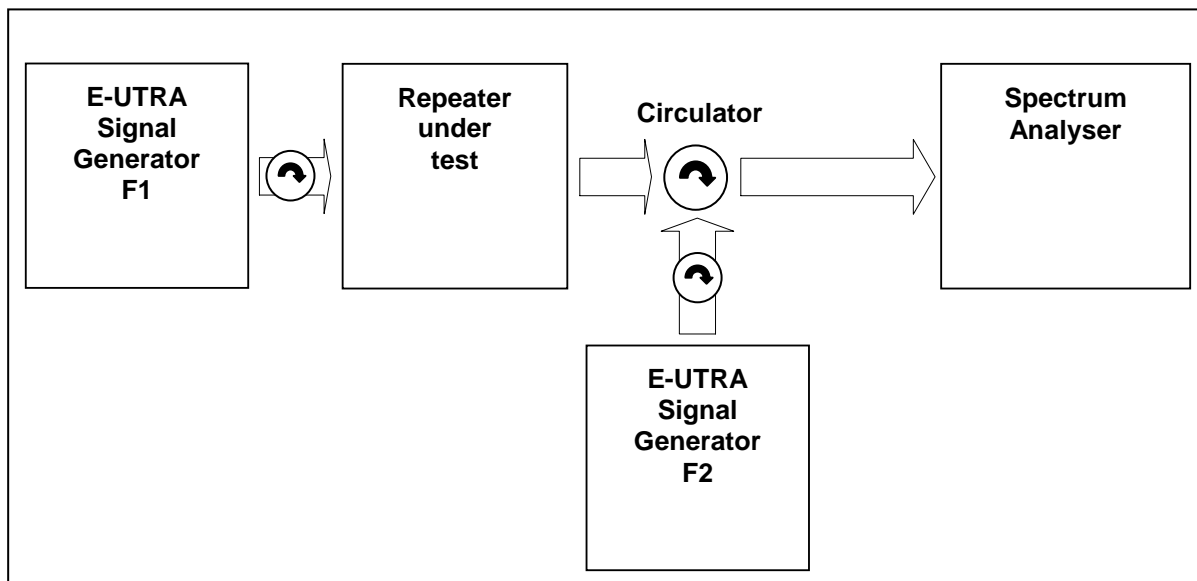
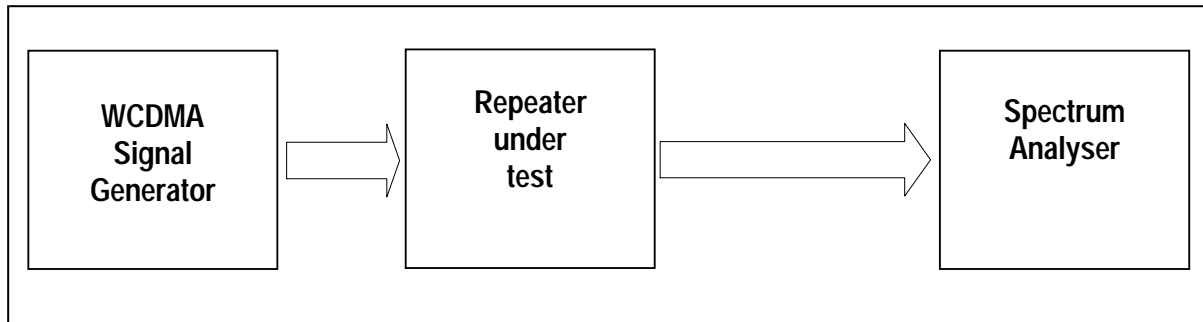

Figure C.8-1: Measuring system set-up for output intermodulation.

Note that a repeater is a bi-directional device. The signal generator may need protection.

## C.9 Adjacent Channel Rejection Ratio



**Figure C.9-1: Measuring system set-up for Adjacent Channel Rejection Ratio**

Note that a repeater is a bi-directional device. The signal generator may need protection.

---

## Annex D (normative): Repeater stimulus signals

### D.1 Repeater stimulus signal 1

This Repeater stimulus signal shall be used for tests on:

- Uplink maximum output power
- Uplink operating band unwanted emissions
- Uplink spurious emissions

Except in the case where the repeater under test has a pass band narrower than 2.8 MHz.

Two uplink fixed reference channels for performance requirements (16QAM  $\frac{3}{4}$ ) for FDD according to the TS36.141 [11], A.4 table A.4-1, channel reference A4-3 of 1.4 MHz bandwidth generated on separate centre frequencies with equal power and combined with a time difference of 266,7  $\mu$ s (4 OFDM symbols)

The PUSCH data payload shall contain only zeroes (0000 0000)

Each reference channel shall be subjected to time windowing and filtering so that it fulfils the spectral purity requirements defined in D.5

---

### D.2 Repeater stimulus signal 2

This Repeater stimulus signal shall be used for tests on:

- Downlink operating band unwanted emissions
- Downlink spurious emissions

Except in the case where the repeater under test has a pass band narrower than 2.8 MHz.

Two E-TM1.1 channels according to the TS36.141 [11] of 1.4 MHz bandwidth generated on separate centre frequencies with equal power and combined with a time difference of 1400  $\mu$ s (21 OFDM symbols).

Each E-TM1.1 channel shall be subjected to time windowing and filtering so that it fulfils the spectral purity requirements defined in D.5

---

### D.3 Repeater stimulus signal 3

This Repeater stimulus signal shall be used for tests on:

- Uplink maximum output power
- Uplink operating band unwanted emissions
- Uplink spurious emissions

One uplink fixed reference channel for performance requirements (16QAM  $\frac{3}{4}$ ) for FDD according to the TS36.141 [11], A.4 table A.4-1, channel reference A4-3 of 1.4 MHz bandwidth .

The PUSCH data payload shall contain only zeroes (0000 0000).

The reference channel shall be subjected to time windowing and filtering so that it fulfils the spectral purity requirements defined in D.5.

## D.4 Repeater stimulus signal 4

This Repeater stimulus signal shall be used for tests on:

- Downlink operating band unwanted emissions
- Downlink spurious emissions

In the case where the repeater under test has a pass band narrower than 2.8 MHz

One E-TM1.1 channels according to the TS36.141 [11] of 1.4 MHz.

The E-TM1.1 channel shall be subjected to time windowing and filtering so that it fulfils the spectral purity requirements defined in D.5.

## D.5 Repeater stimulus signal spectral purity requirements

The reference channels or test models constituting the repeater stimulus signal shall fulfil the spectral purity requirements defined by table D. 5-1, where;

- the reference spectral density shall be taken 200 kHz off the carrier centre frequency with an integration bandwidth of 30 kHz.
- $\Delta f$  is the separation between the channel edge frequency and the nominal -3dB point of the measuring filter closest to the carrier frequency.
- $f_{\text{offset}}$  is the separation between the channel edge frequency and the centre of the measuring filter.
- $f_{\text{offset}_{\text{max}}}$  is the offset to the frequency 10 MHz outside the downlink operating band.
- $\Delta f_{\text{max}}$  is equal to  $f_{\text{offset}_{\text{max}}}$  minus half of the bandwidth of the measuring filter.
- the minimum spectral density suppression is related to the reference spectral density.

**Table D.5-1: Repeater stimulus signal spectral purity requirements**

Frequency offset of measurement filter -3dB point, $\Delta f$	Frequency offset of measurement filter centre frequency, $f_{\text{offset}}$	Minimum requirement	Measurement bandwidth
$0 \text{ MHz} \leq \Delta f < 0.15 \text{ MHz}$	$0.015 \text{ MHz} \leq f_{\text{offset}} < 0.165 \text{ MHz}$	$-40 + 20*(f_{\text{offset}} - 0.015) \text{ dBc}$	30 kHz
$0.15 \text{ MHz} \leq \Delta f < 0.2 \text{ MHz}$	$0.165 \text{ MHz} \leq f_{\text{offset}} < 0.215 \text{ MHz}$	-37 dBc	30 kHz
$0.2 \text{ MHz} \leq \Delta f < 1 \text{ MHz}$	$0.215 \text{ MHz} \leq f_{\text{offset}} < 1.015 \text{ MHz}$	$-94 \text{ dBm} - 15*(f_{\text{offset}} - 0.215) \text{ dB}$	30 kHz
	$1.015 \text{ MHz} \leq f_{\text{offset}} < 1.5 \text{ MHz}$	-106 dBm	30 kHz
$1 \text{ MHz} \leq \Delta f < 2.8 \text{ MHz}$	$1.5 \text{ MHz} \leq f_{\text{offset}} < 2.85 \text{ MHz}$	-78 dBm	1 MHz
$2.8 \text{ MHz} \leq \Delta f \leq \Delta f_{\text{max}}$	$2.85 \text{ MHz} \leq f_{\text{offset}} < f_{\text{offset}_{\text{max}}}$	-80 dBm	1 MHz

NOTE: Frequencies and bandwidth are given in MHz



## Annex E (informative): Change history

Change history							
Date	TSG #	TSG Doc.	CR	Rev	Subject/Comment	Old	New
2008-08	RAN4#48	R4-081757			36.143 TS skeleton created from 3GPP TS template.		0.0.1
2008-10	RAN4#48 bis	R4-082275			Text proposals R4-081758_36.143_TP_Scope-Reference-Definition-General R4-081759_36.143_TP_Frequency bands R4-081760_36.143_TP_Annex A Environmental requirements R4-081761_36.143_TP_Annex B Test Tolerances and Derivation of Test Requirements R4-081762_36.143_TP_Annex C Measurement system set-up which were agreed at RAN4#48, are incorporated	0.0.1	0.1.0
2008-11	RAN4#49	R4-082901			Text proposals which were agreed at RAN4#48bis, are incorporated R4-082276_36.143_TP_Output power R4-082277_TS36.143_TP_Out of band gain R4-082278_TS36.143 Operating band unwanted emissions R4-082279_36.143_TP_Spuriosemission R4-082282_36.143_TP_ACRR R4-082397Correction to the figure with the Transmission Bandwidth Configuration	0.1.0	0.2.0
2008-11	RAN4#49	R4-082913			TS with the Text proposals agreed at RAN4#49 R4-083145 TS36.143 Operating band unwanted emission: Correction of formula R4-083146 TS36.143 TP Input intermodulation R4-083147 TS36.143 TP Output intermodulation R4-083175 TS36.143 TP Measurement uncertainties and test tolerances R4-082909 TS36.143 TP Measurement set ups Presentation to TSG RAN for information as RP-080865.zip	0.2.0	1.0.0
2009-01	RAN4#49 bis	R4-090019			TS with the Text proposals agreed at RAN4#49bis R4-090014 TS36143 Clean-up R4-090018 TS36.143 Adding test tolerances to the requirements R4-090368 Clarification of PHS band including the future plan	1.0.0	1.1.0
2009-02	RAN4#50	R4-090931			TS with the Text proposals agreed at RAN4#50 R4-090573 TS36.143 Introducing E-TM into output power measurements R4-090574 TS36.143 Introducing E-TM into operating band unwanted emission measurements R4-090575 TS36.143 Introducing E-TM into spurious emission measurements R4-090576 TS36.143 Clause 4: TP Manufacturer declaration R4-090579 TS36.143 TP EVM Presentation to TSG RAN	1.1.0	1.2.0
2009-02	RAN4#50	R4-090967			TS with the small text correction agreed at RAN4#50 Presentation to TSG RAN	1.2.0	1.3.0
2009-03	RAN #43	RP-090024			Presented for approval	1.3.0	2.0.0
2009-03	RAN #43	RP-090024			TS approved	2.0.0	8.0.0
2009-03	RAN #43	RP-090552	1		Clarification of EARFCN for 36.143. (Technically Endorsed CR in R4-50bis - R4-091268)	8.0.0	8.1.0
2009-03	RAN #43	RP-090552	2		Alignment with core spec and clean-up	8.0.0	8.1.0
2009-03	RAN #43	RP-090552	3		Output intermodulation: Introduction of test models	8.0.0	8.1.0
2009-03	RAN #43	RP-090552	5		Repeater stimulus signal: time difference	8.0.0	8.1.0
2009-03	RAN #43	RP-090552	6		Frequency stability	8.0.0	8.1.0
2009-09	RAN #45	RP-090819	7		EVM for LTE Repeater : uncertainty and test tolerance	8.1.0	8.2.0
2009-09	RAN #45	RP-090819	8		Introduction of band 17	8.1.0	8.2.0
2009-09	RAN #45	RP-090819	9		EVM for LTE Repeater	8.1.0	8.2.0
2009-09	RAN #45	RP-090819	12		Clarificaton of testresult interpretation of repeater operating band unwanted emissions.	8.1.0	8.2.0
2009-09	RAN #45	RP-090819	11		Repeater stimulus signals	8.1.0	8.2.0
2009-12	RAN #46	RP-091282	13	1	Update of operating band unwanted emissions for LTE Repeater	8.2.0	8.3.0
2009-12	RAN #46	RP-091282	14		Update of Repeater stimulus signals	8.2.0	8.3.0
					Automatic upgrade from previous Release	8.3.0	9.0.0
2010-09	RP-49	RP-100925	15		Introduction of operating band 18, 19, 20 and 21 and correction of band 11.	9.0.0	9.1.0

2010-12	RP-50	RP-101333	021		Clarification on emission requirements	9.1.0	9.2.0
2010-12	RP-50	RP-101333	023		Correction fo derivation of test requirement for frequency error and removal of brackets	9.1.0	9.2.0
2010-12	RP-50	RP-101336	019		Protection of CDMA	9.1.0	9.2.0
2010-12	RP-50	RP-101344	024		CR implementation correction for TS36.143	9.1.0	9.2.0
2010-12	RP-50	RP-101347	016		Corrections to the symbols and abbreviations clause related to DTT requirement	9.1.0	9.2.0
2010-12	RP-50	RP-101347	017		Co-existence with services in adjacent frequency bands	9.1.0	9.2.0
2010-12	RP-50				Automatic upgrade from previous Release	9.2.0	10.0.0
2011-04	RP-51	RP-110360	025	2	Adding Band 24 specification to TS36.143	10.0.0	10.1.0
2011-12	RP-54	RP-111734	026	1	Introduction of operating frequency band 22	10.1.0	10.2.0
2011-12	RP-54	RP-111734	028		Introduction of protection limits towards frequency band 41, 42 and 43	10.1.0	10.2.0
2012-03	RP-55	RP-120303	030	1	Introduction of operating frequency bands 23 and 25	10.2.0	10.3.0
2012-03	RP-55	RP-120303	032		Update of the abbreviations clause	10.2.0	10.3.0
2012-06	RP-56	RP-120780	034		Definition clause updates with improved repeater pass band definition and introduction of minor editorial changes for for better alignment with BS core specification	10.3.0	10.4.0
2012-06	RP-56	RP-120783	035		Update of the upper frequency limit for Spurious Emissions	10.3.0	10.4.0
2012-06	RP-56	RP-120783	036	1	Update of the protection limits tables for spurious emission and input intermodulation	10.3.0	10.4.0
2012-06	RP-56	RP-120781	037		Introduction of editorial changes for better alignment with BS test specification in the maximum limits tables for operating band unwanted emissions test requirements	10.3.0	10.4.0
2012-06	RP-56	RP-120762	041		Correction of PHS protection requirements for TS 36.143	10.3.0	10.4.0
2012-09	RP-57	RP-121312	042		Update on the upper frequency limit for Spurious Emissions for Repeater (The CR was not implemented as it was based on the wrong version of the spec)	10.4.0	10.5.0
2012-09	RP-57	RP-121313	043	1	Introduction of missing uplink Spurious Emission limits for E-UTRA Band 36, 41 and 42	10.4.0	10.5.0
2012-09	SP-57	-	-	-	Update to Rel-11 version (MCC)	10.5.0	11.0.0
2012-12	RP-58	RP-121858	048	-	Modifications of frequency ranges for E-UTRA Band 6, 18, 19 in the Tables for Spurious Emission limits and Input Intermodulation requirements	11.0.0	11.1.0
2012-12	RP-58	RP-121867	049	-	The special cases for protection of E-UTRA Band 3 and Band 10 in co-existence and co-location with E-UTRA Repeaters	11.0.0	11.1.0
2012-12	RP-58	RP-121867	050	-	Correction of the inconsistency sub-clause reference in the tables of Spurious Emission limits for co-existence and co-location of E-UTRA-FDD Repeater with other systems	11.0.0	11.1.0
2012-12	RP-58	RP-121865	051	-	Update on the upper frequency limit for Spurious Emissions for Repeater	11.0.0	11.1.0
2012-12	RP-58	RP-121867	053	-	The special case for protection of E-UTRA Band 42 in co-existence and co-location with E-UTRA FDD Repeaters	11.0.0	11.1.0
2013-03	RP-59	RP-130268	055		Co-existence between adjacent FDD and TDD bands	11.1.0	11.2.0
2014-09	SP-65	-	-	-	Update to Rel-12 version (MCC)	11.2.0	12.0.0

---

## History

<b>Document history</b>		
V12.0.0	October 2014	Publication