

# ETSI TS 136 201 V13.1.0 (2016-04)



**LTE;  
Evolved Universal Terrestrial Radio Access (E-UTRA);  
LTE physical layer;  
General description  
(3GPP TS 36.201 version 13.1.0 Release 13)**



---

Reference

RTS/TSGR-0136201vd10

---

Keywords

LTE

**ETSI**

650 Route des Lucioles  
F-06921 Sophia Antipolis Cedex - FRANCE

Tel.: +33 4 92 94 42 00 Fax: +33 4 93 65 47 16

Siret N° 348 623 562 00017 - NAF 742 C  
Association à but non lucratif enregistrée à la  
Sous-Préfecture de Grasse (06) N° 7803/88

---

**Important notice**

The present document can be downloaded from:  
<http://www.etsi.org/standards-search>

The present document may be made available in electronic versions and/or in print. The content of any electronic and/or print versions of the present document shall not be modified without the prior written authorization of ETSI. In case of any existing or perceived difference in contents between such versions and/or in print, the only prevailing document is the print of the Portable Document Format (PDF) version kept on a specific network drive within ETSI Secretariat.

Users of the present document should be aware that the document may be subject to revision or change of status. Information on the current status of this and other ETSI documents is available at  
<http://portal.etsi.org/tb/status/status.asp>

If you find errors in the present document, please send your comment to one of the following services:  
<https://portal.etsi.org/People/CommitteeSupportStaff.aspx>

---

**Copyright Notification**

No part may be reproduced or utilized in any form or by any means, electronic or mechanical, including photocopying and microfilm except as authorized by written permission of ETSI.

The content of the PDF version shall not be modified without the written authorization of ETSI.  
The copyright and the foregoing restriction extend to reproduction in all media.

© European Telecommunications Standards Institute 2016.  
All rights reserved.

**DECT™**, **PLUGTESTS™**, **UMTS™** and the ETSI logo are Trade Marks of ETSI registered for the benefit of its Members.  
**3GPP™** and **LTE™** are Trade Marks of ETSI registered for the benefit of its Members and of the 3GPP Organizational Partners.  
**GSM®** and the GSM logo are Trade Marks registered and owned by the GSM Association.

---

## Intellectual Property Rights

IPRs essential or potentially essential to the present document may have been declared to ETSI. The information pertaining to these essential IPRs, if any, is publicly available for **ETSI members and non-members**, and can be found in ETSI SR 000 314: *"Intellectual Property Rights (IPRs); Essential, or potentially Essential, IPRs notified to ETSI in respect of ETSI standards"*, which is available from the ETSI Secretariat. Latest updates are available on the ETSI Web server (<https://ipr.etsi.org>).

Pursuant to the ETSI IPR Policy, no investigation, including IPR searches, has been carried out by ETSI. No guarantee can be given as to the existence of other IPRs not referenced in ETSI SR 000 314 (or the updates on the ETSI Web server) which are, or may be, or may become, essential to the present document.

---

## Foreword

This Technical Specification (TS) has been produced by ETSI 3rd Generation Partnership Project (3GPP).

The present document may refer to technical specifications or reports using their 3GPP identities, UMTS identities or GSM identities. These should be interpreted as being references to the corresponding ETSI deliverables.

The cross reference between GSM, UMTS, 3GPP and ETSI identities can be found under <http://webapp.etsi.org/key/queryform.asp>.

---

## Modal verbs terminology

In the present document "**shall**", "**shall not**", "**should**", "**should not**", "**may**", "**need not**", "**will**", "**will not**", "**can**" and "**cannot**" are to be interpreted as described in clause 3.2 of the [ETSI Drafting Rules](#) (Verbal forms for the expression of provisions).

"**must**" and "**must not**" are **NOT** allowed in ETSI deliverables except when used in direct citation.

---

# Contents

Intellectual Property Rights .....	2
Foreword.....	2
Modal verbs terminology.....	2
Foreword.....	4
1 Scope .....	5
2 References .....	5
3 Definitions, symbols and abbreviations .....	5
3.1 Definitions .....	5
3.2 Symbols.....	5
3.3 Abbreviations .....	6
4 General description of LTE Layer 1.....	7
4.1 Relation to other layers.....	7
4.1.1 General Protocol Architecture .....	7
4.1.2 Service provided to higher layers .....	7
4.2 General description of Layer 1 .....	8
4.2.1 Multiple Access .....	8
4.2.2 Physical channels and modulation .....	9
4.2.3 Channel coding and interleaving .....	9
4.2.4 Physical layer procedures .....	10
4.2.5 Physical layer measurements .....	10
5 Document structure of LTE physical layer specification .....	10
5.1 Overview .....	10
5.2 TS 36.201: Physical layer – General description.....	11
5.3 TS 36.211: Physical channels and modulation.....	11
5.4 TS 36.212: Multiplexing and channel coding.....	12
5.5 TS 36.213: Physical layer procedures .....	12
5.6 TS 36.214: Physical layer – Measurements.....	12
5.7 TS 36.216: Physical layer for relaying operation .....	12
<b>Annex A (informative): Preferred mathematical notations.....</b>	<b>13</b>
<b>Annex B (informative): Change history .....</b>	<b>14</b>
History .....	15

---

## Foreword

This Technical Specification has been produced by the 3<sup>rd</sup> Generation Partnership Project (3GPP).

The contents of the present document are subject to continuing work within the TSG and may change following formal TSG approval. Should the TSG modify the contents of the present document, it will be re-released by the TSG with an identifying change of release date and an increase in version number as follows:

Version x.y.z

where:

- x the first digit:
  - 1 presented to TSG for information;
  - 2 presented to TSG for approval;
  - 3 or greater indicates TSG approved document under change control.
- y the second digit is incremented for all changes of substance, i.e. technical enhancements, corrections, updates, etc.
- z the third digit is incremented when editorial only changes have been incorporated in the document.

---

# 1 Scope

The present document describes a general description of the physical layer of the E-UTRA radio interface. The present document also describes the document structure of the 3GPP physical layer specifications, i.e. TS 36.200 series. The TS 36.200 series specifies the Uu and Un points for the 3G LTE mobile system, and defines the minimum level of specifications required for basic connections in terms of mutual connectivity and compatibility.

---

# 2 References

The following documents contain provisions which, through reference in this text, constitute provisions of the present document.

- References are either specific (identified by date of publication, edition number, version number, etc.) or non-specific.
- For a specific reference, subsequent revisions do not apply.
- For a non-specific reference, the latest version applies. In the case of a reference to a 3GPP document (including a GSM document), a non-specific reference implicitly refers to the latest version of that document *in the same Release as the present document*.

- [1] 3GPP TR 21.905: "Vocabulary for 3GPP Specifications".
- [2] 3GPP TS 36.211: "Evolved Universal Terrestrial Radio Access (E-UTRA); Physical channels and modulation".
- [3] 3GPP TS 36.212: "Evolved Universal Terrestrial Radio Access (E-UTRA); Multiplexing and channel coding".
- [4] 3GPP TS 36.213: "Evolved Universal Terrestrial Radio Access (E-UTRA); Physical layer procedures".
- [5] 3GPP TS 36.214: "Evolved Universal Terrestrial Radio Access (E-UTRA); Physical layer – Measurements".
- [6] 3GPP TS 36.216: "Evolved Universal Terrestrial Radio Access (E-UTRA); Physical layer for relaying operation".

---

# 3 Definitions, symbols and abbreviations

## 3.1 Definitions

For the purposes of the present document, the terms and definitions given in TR 21.905 [1] and the following apply. A term defined in the present document takes precedence over the definition of the same term, if any, in TR 21.905 [1].

Definition format

**<defined term>**: <definition>.

**example:** text used to clarify abstract rules by applying them literally.

## 3.2 Symbols

For the purposes of the present document, the following symbols apply:

Symbol format

<symbol>      <Explanation>

### 3.3 Abbreviations

For the purposes of the present document, the abbreviations given in TR 21.905 [1] and the following apply. An abbreviation defined in the present document takes precedence over the definition of the same abbreviation, if any, in TR 21.905 [1].

BPSK	Binary Phase Shift Keying
CoMP	Coordinated Multi-Point
CP	Cyclic Prefix
CQI	Channel Quality Indicator
CRC	Cyclic Redundancy Check
CSI	Channel State Information
eNode-B	Evolved Node B
EPDCCH	Enhanced Physical Downlink Control Channel
E-UTRA	Evolved Universal Terrestrial Radio Access
FDD	Frequency Division Duplex
HARQ	Hybrid Automatic Repeat Request
LAA	Licensed-Assisted Access
LTE	Long Term Evolution
MAC	Medium Access Control
MBMS	Multimedia Broadcast and Multicast Service
MBSFN	Multicast/Broadcast over Single Frequency Network
MIMO	Multiple Input Multiple Output
MPDCCH	MTC Physical Downlink Control Channel
MTC	Machine Type Communications
OFDM	Orthogonal Frequency Division Multiplexing
PBCH	Physical Broadcast Channel
PCFICH	Physical Control Format Indicator Channel
PDSCH	Physical Downlink Shared Channel
PDCCH	Physical Downlink Control Channel
PHICH	Physical Hybrid ARQ Indicator Channel
PMCH	Physical Multicast Channel
PRACH	Physical Random Access Channel
ProSe	Proximity Services
PSBCH	Physical Sidelink Broadcast Channel
PSCCH	Physical Sidelink Control Channel
PSDCH	Physical Sidelink Discovery Channel
PSSCH	Physical Sidelink Shared Channel
PUCCH	Physical Uplink Control Channel
PUSCH	Physical Uplink Shared Channel
QAM	Quadrature Amplitude Modulation
QPP	Quadratic Permutation Polynomial
QPSK	Quadrature Phase Shift Keying
RLC	Radio Link Control
RN	Relay Node
R-PDCCH	Relay Physical Downlink Control Channel
RRC	Radio Resource Control
RSSI	Received Signal Strength Indicator
RSRP	Reference Signal Received Power
RSRQ	Reference Signal Received Quality
SAP	Service Access Point
SC-FDMA	Single-Carrier Frequency Division Multiple Access
TDD	Time Division Duplex
TX Diversity	Transmit Diversity
UE	User Equipment

## 4 General description of LTE Layer 1

### 4.1 Relation to other layers

#### 4.1.1 General Protocol Architecture

The radio interface described in this specification covers the interface between the User Equipment (UE) and the network, and sidelink transmissions between UEs. The radio interface is composed of the Layer 1, 2 and 3. The TS 36.200 series describes the Layer 1 (Physical Layer) specifications. Layers 2 and 3 are described in the 36.300 series.

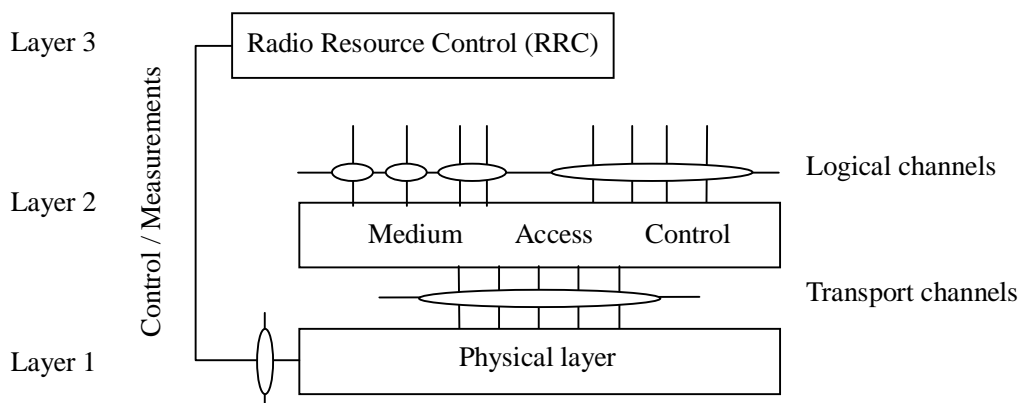

**Figure 1: Radio interface protocol architecture around the physical layer**

Figure 1 shows the E-UTRA radio interface protocol architecture around the physical layer (Layer 1). The physical layer interfaces the Medium Access Control (MAC) sub-layer of Layer 2 and the Radio Resource Control (RRC) Layer of Layer 3. The circles between different layer/sub-layers indicate Service Access Points (SAPs). The physical layer offers a transport channel to MAC. The transport channel is characterized by how the information is transferred over the radio interface. MAC offers different logical channels to the Radio Link Control (RLC) sub-layer of Layer 2. A logical channel is characterized by the type of information transferred.

#### 4.1.2 Service provided to higher layers

The physical layer offers data transport services to higher layers. The access to these services is through the use of a transport channel via the MAC sub-layer. The physical layer is expected to perform the following functions in order to provide the data transport service:

- Error detection on the transport channel and indication to higher layers
- FEC encoding/decoding of the transport channel
- Hybrid ARQ soft-combining
- Rate matching of the coded transport channel to physical channels
- Mapping of the coded transport channel onto physical channels
- Power weighting of physical channels
- Modulation and demodulation of physical channels
- Frequency and time synchronisation
- Radio characteristics measurements and indication to higher layers
- Multiple Input Multiple Output (MIMO) antenna processing
- Transmit Diversity (TX diversity)



- Beamforming
- RF processing. (Note: RF processing aspects are specified in the TS 36.100 series)

## 4.2 General description of Layer 1

### 4.2.1 Multiple Access

The multiple access scheme for the LTE physical layer is based on Orthogonal Frequency Division Multiplexing (OFDM) with a cyclic prefix (CP) in the downlink, and on Single-Carrier Frequency Division Multiple Access (SC-FDMA) with a cyclic prefix in the uplink and sidelink. To support transmission in paired and unpaired spectrum, two duplex modes are supported: Frequency Division Duplex (FDD), supporting full duplex and half duplex operation, and Time Division Duplex (TDD).

The Layer 1 is defined in a bandwidth agnostic way based on resource blocks, allowing the LTE Layer 1 to adapt to various spectrum allocations. A resource block spans either 12 sub-carriers with a sub-carrier bandwidth of 15kHz or 24 sub-carriers with a sub-carrier bandwidth of 7.5kHz each over a slot duration of 0.5ms. Narrowband operation is also defined, whereby certain UEs may operate using a maximum transmission and reception bandwidth of 6 contiguous resource blocks within the total system bandwidth.

The radio frame structure type 1 is only applicable to FDD (for both full duplex and half duplex operation) and has a duration of 10ms and consists of 20 slots with a slot duration of 0.5ms. Two adjacent slots form one sub-frame of length 1ms.

The radio frame structure type 2 is only applicable to TDD and consists of two half-frames with a duration of 5ms each and containing each either 10 slots of length 0.5ms, or 8 slots of length 0.5ms and three special fields (DwPTS, GP and UpPTS) which have configurable individual lengths and a total length of 1ms. A subframe consists of two adjacent slots, except for subframes which consist of DwPTS, GP and UpPTS, namely subframe 1 and, in some configurations, subframe 6. Both 5ms and 10ms downlink-to-uplink switch-point periodicity are supported. Further details on the LTE frame structure are specified in [2]. Adaptation of the uplink-downlink subframe configuration via Layer 1 signalling is supported.

The radio frame structure type 3 is only applicable to LAA secondary cell operation. It has a duration of 10ms and consists of 20 slots with a slot duration of 0.5ms. Two adjacent slots form one subframe of length 1ms. Any subframe may be available for downlink transmission, and the eNB shall perform the channel access procedures as specified in [4] prior to transmitting. A downlink transmission may or may not start at the subframe boundary, and may or may not end at the subframe boundary.

To support a Multimedia Broadcast and Multicast Service (MBMS), LTE offers the possibility to transmit Multicast/Broadcast over a Single Frequency Network (MBSFN), where a time-synchronized common waveform is transmitted from multiple cells for a given duration. MBSFN transmission enables highly efficient MBMS, allowing for over-the-air combining of multi-cell transmissions in the UE, where the cyclic prefix is utilized to cover the difference in the propagation delays, which makes the MBSFN transmission appear to the UE as a transmission from a single large cell. Transmission on a dedicated carrier for MBSFN with the possibility to use a longer CP with a sub-carrier bandwidth of 7.5kHz is supported as well as transmission of MBSFN on a carrier with both MBMS transmissions and point-to-point transmissions using time division multiplexing. Transmission of PDSCH also in MBSFN subframes that are not used for MCH is supported.

Transmission with multiple input and multiple output antennas (MIMO) are supported with configurations in the downlink with up to 16 transmit antennas and eight receive antennas, which allow for multi-layer downlink transmissions with up to eight streams and beamforming in both horizontal and vertical dimensions. Multi-layer uplink transmissions with up to four streams are supported with configurations in the uplink with up to four transmit antennas and four receive antennas. Multi-user MIMO, i.e. allocation of different streams to different users is supported in both UL and DL.

Coordinated Multi-Point (CoMP) transmission and reception are supported, including the possibility to configure a UE with multiple Channel State Information (CSI) feedback processes.

Aggregation of multiple cells is supported in the uplink and downlink with up to 32 serving cells, where each serving cell can use a transmission bandwidth of up to 110 resource blocks and can operate with either frame structure type 1 or frame structure type 2. Dual connectivity to groups of serving cells that belong to two different eNode-Bs is also supported.

Sidelink transmissions are defined for ProSe Direct Discovery and ProSe Direct Communication between UEs. The sidelink transmissions use the same frame structure as uplink and downlink when the UEs are in network coverage; however, the sidelink transmissions are restricted to a sub-set of the uplink resources.

## 4.2.2 Physical channels and modulation

The physical channels defined in the downlink are:

- the Physical Downlink Shared Channel (PDSCH),
- the Physical Multicast Channel (PMCH),
- the Physical Downlink Control Channel (PDCCH),
- the Enhanced Physical Downlink Control Channel (EPDCCH),
- the MTC Physical Downlink Control Channel (MPDCCH),
- the Relay Physical Downlink Control Channel (R-PDCCH),
- the Physical Broadcast Channel (PBCH),
- the Physical Control Format Indicator Channel (PCFICH),
- and the Physical Hybrid ARQ Indicator Channel (PHICH).

The physical channels defined in the uplink are:

- the Physical Random Access Channel (PRACH),
- the Physical Uplink Shared Channel (PUSCH),
- and the Physical Uplink Control Channel (PUCCH).

The physical channels defined in the sidelink are:

- the Physical Sidelink Broadcast Channel (PSBCH),
- the Physical Sidelink Control Channel (PSCCH),
- the Physical Sidelink Discovery Channel (PSDCH),
- and the Physical Sidelink Shared Channel (PSSCH).

In addition, signals are defined as reference signals, primary and secondary synchronization signals, and discovery signals.

The modulation schemes supported are:

- QPSK, 16QAM and 64QAM in the uplink,
- QPSK, 16QAM, 64QAM and 256QAM in the downlink,
- QPSK and 16QAM in the sidelink.

## 4.2.3 Channel coding and interleaving

The channel coding scheme for transport blocks in LTE is Turbo Coding with a coding rate of  $R=1/3$ , two 8-state constituent encoders and a contention-free quadratic permutation polynomial (QPP) turbo code internal interleaver. Trellis termination is used for the turbo coding. Before the turbo coding, transport blocks are segmented into byte aligned segments with a maximum information block size of 6144 bits. Error detection is supported by the use of 24 bit CRC. Further channel coding schemes for BCH and control information are specified in [3].

## 4.2.4 Physical layer procedures

There are several Physical layer procedures involved with LTE operation. Such procedures covered by the physical layer are;

- Cell search,
- Power control,
- Uplink synchronisation and Uplink timing control,
- Random access related procedures,
- HARQ related procedures,
- Relay related procedures,
- ProSe related procedures,
- Channel Access procedures.

Through the control of physical layer resources in the frequency domain as well as in the time and power domains, implicit support of interference coordination is provided in LTE.

## 4.2.5 Physical layer measurements

Radio characteristics are measured by the UE and the eNode-B and reported to higher layers in the network. These include, e.g. measurements for intra- and inter-frequency handover, inter RAT handover, timing measurements and measurements for RRM and in support for positioning.

Measurements for inter-RAT handover are defined in support of handover to GSM, UTRA FDD, UTRA TDD, CDMA2000 1x RTT, CDMA2000 HRPD and IEEE 802.11.

---

# 5 Document structure of LTE physical layer specification

## 5.1 Overview

The physical layer specification consists of a general document (TS 36.201), and five documents (TSs 36.211, 36.212, 36.213, 36.214 and 36.216). The relation between the physical layer specifications in the context of the higher layers is shown in Figure 2; TS 36.216 is the physical layer specification for transmissions between an eNode-B and an RN.

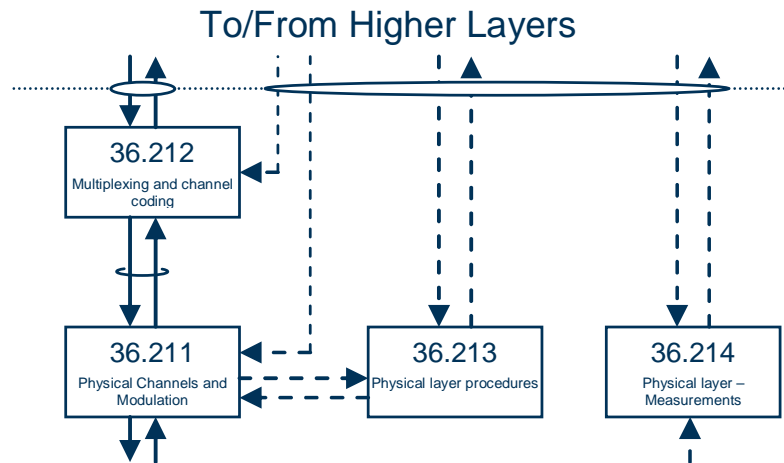

**Figure 2: Relation between Physical Layer specifications**

## 5.2 TS 36.201: Physical layer – General description

The scope is to describe:

- The contents of the Layer 1 documents (TS 36.200 series);
- Where to find information;
- A general description of LTE Layer 1.

## 5.3 TS 36.211: Physical channels and modulation

The scope of this specification is to establish the characteristics of the Layer-1 physical channels, generation of physical layer signals and modulation, and to specify:

- Definition of the uplink, downlink and sidelink physical channels;
- The structure of the physical channels, frame format, physical resource elements, etc.;
- Modulation mapping (BPSK, QPSK, etc);
- Physical shared channel in uplink, downlink and sidelink;
- Reference signals in uplink, downlink and sidelink;
- Random access channel;
- Primary and secondary synchronization signals;
- Primary and secondary sidelink synchronization signals;
- OFDM signal generation in downlink;
- SC-FDMA signal generation in uplink and sidelink;
- Scrambling, modulation and up conversion;
- Uplink-downlink and sidelink timing relations;
- Layer mapping and precoding in downlink, uplink and sidelink.

## 5.4 TS 36.212: Multiplexing and channel coding

The scope of this specification is to describe the transport channel and control channel data processing, including multiplexing, channel coding and interleaving, and to specify:

- Channel coding schemes;
- Coding of Layer 1 / Layer 2 control information;
- Interleaving;
- Rate matching.

## 5.5 TS 36.213: Physical layer procedures

The scope of this specification is to establish the characteristics of the physical layer procedures, and to specify:

- Synchronisation procedures, including cell search procedure and timing synchronisation;
- Power control procedure;
- Random access procedure;
- Physical downlink shared channel related procedures, including CSI feedback reporting;
- Physical uplink shared channel related procedures, including UE sounding and HARQ ACK/NACK detection;
- Physical shared control channel procedures, including assignment of shared control channels;
- Physical multicast channel related procedures;
- ProSe related procedures;
- Channel access procedures.

## 5.6 TS 36.214: Physical layer – Measurements

The scope of this specification is to establish the characteristics of the physical layer measurements, and to specify:

- Measurements to be performed by Layer 1 in UE and E-UTRAN;
- Reporting of measurement results to higher layers and the network;
- Handover measurements, idle-mode measurements, etc.

## 5.7 TS 36.216: Physical layer for relaying operation

The scope of this specification is to establish the characteristics of eNB - RN transmissions, and to specify relay-specific advancements in relation to:

- Physical Channels and Modulation;
- Multiplexing and channel coding;
- Relay Node procedures.

## Annex A (informative): Preferred mathematical notations

The following table contains the preferred mathematical notations used in L1 documentation.

item	notation
multiply product	cross sign, e.g. $a \times b$
matrix product	dot sign, e.g. $a \cdot b$
scalar product (product of a matrix by a scalar)	dot sign, scalar should precede matrix e.g. $(1 + j) \cdot \begin{bmatrix} u \\ v \end{bmatrix}$
matrix dimensioning	number of rows $\times$ number of column, e.g.: $R \times C$
Kronecker product	$a \otimes b$
bracketing of sets (all elements of same type, not ordered elements)	curly brackets {}, e.g. $\{a_1, a_2, \dots, a_p\}$ , or $\{a_i\}_{i \in \{1, 2, \dots, p\}}$
bracketing of lists (all elements not necessary of same type, ordered elements)	round brackets (), e.g. (A, u, x)
bracketing of sequences (all elements of same type, ordered elements)	angle brackets, e.g. $\langle a_1, a_2, \dots, a_p \rangle$ or $\langle a_i \rangle_{i \in \{1, 2, \dots, p\}}$
bracketing of function argument	round brackets, e.g. $f(x)$
bracketing of array index	square brackets, e.g. $a[x]$
bracketing of matrix or vector	square brackets [], e.g. $\begin{bmatrix} x \\ y \end{bmatrix}$ , $\begin{bmatrix} x & y \end{bmatrix}$ , or $\begin{bmatrix} 1 & 1 \\ 1 & -1 \end{bmatrix}$
Separation of indexes	use a comma : e.g. $N_{i,j}$
use of italic for symbols	a symbol should be either in italic or in normal font, but mixing up should be avoided.
bracketing of arithmetic expression to force precedence of operations	round brackets : e.g. $(a + b) \times c$
necessity of bracketing arithmetic expressions	When only + and $\times$ bracketing is not necessary. When the <b>mod</b> operator is used explicit bracketing of mod operands and possibly result should be done.
number type	in a context of non negative integer numbers, some notes should stress when a number is signed, or possibly fractional.
binary <b>xor</b> and <b>and</b>	respectively use + or $\cdot$ . If no "mod 2" is explicitly in the expression some text should stress that the operation is modulo 2.
matrix or vector transpose	$v^T$
1 $\times$ 1 matrices	implicitly cast to its unique element.
vector dot product	$u^T \cdot v$ for column vectors, and $u \cdot v^T$ for line vectors
complex conjugate	$\bar{v}$
matrix or vector Hermitian transpose	$v^H$
real part and imaginary part of complex numbers.	$\text{Re}(x)$ and $\text{Im}(x)$
Modulo operation (including negative value) $r \equiv a \pmod{N}$	Let $q$ be the integer quotient of $a$ and $N$ , $Z$ is integer, $r$ is remainder then $\begin{cases} q \in Z \\ a = N \times q + r, \text{ where } q = \lfloor a/N \rfloor \text{ for all } a \text{ and } N \\ 0 \leq r <  N  \end{cases}$ (Note that $\lfloor \bullet \rfloor$ is floor operation to round the elements of $\bullet$ to the nearest integers towards minus infinity)

## Annex B (informative): Change history

Change history							
Date	Meeting	TDoc	CR	Rev	Cat	Subject/Comment	New version
2006-10	-	-	-			Draft version created	0.0.1
2006-10	-	-	-			Endorsed by RAN1	0.1.0
2006-11	-	-	-			Editors version at RAN1#47	0.1.1
2006-11	-	-	-			Revised editors version at RAN1#47	0.1.2
2007-02	-	-	-			Editors version at RAN1#48	0.2.1
2007-02	-	-	-			Endorsed by RAN1#48	0.3.0
2007-02	-	-	-			Editors version after RAN1#48	0.3.1
2007-02	-	-	-			Editors version after RAN1#48	0.3.2
2007-03	RAN#35	RP-070168	-			For information at RAN#35	1.0.0
2007-05	-	-	-			Editors version at RAN1#49	1.0.1
2007-05	-	-	-			Editors version at RAN1#49	1.0.2
2007-05	-	-	-			Endorsed by RAN1#49	1.1.0
2007-05	-	-	-			Editors version after RAN1#49	1.1.1
2007-06	-	-	-			Endorsed by RAN1#49bis	1.2.0
2007-09	-	-	-			Editors version after RAN1#50	1.2.1
2007-09	-	-	-			Editors version after RAN1#50	1.2.2
2007-09	RAN#37	RP-070728	-			For approval at RAN#37	2.0.0
2007-09	RAN#37	RP-070728				Approved version	8.0.0
2007-11	RAN#38	RP-070949	0001	1		Alignment of 36.201 with other LTE L1 specifications	8.1.0
2008-12	RAN#42	RP-080981	0002	-		Clarification of modular operation	8.2.0
2009-03	RAN#43	RP-090233	0003	-		Removing inverse modulo operation	8.3.0
2009-12	RAN#46	RP-091177	0004	1		Editorial corrections to 36.201	9.0.0
2010-03	RAN#47	RP-100210	0005	1		Introduction of LTE MBMS	9.1.0
2010-12	RAN#50	RP-101320	0006	-		Introduction of Rel-10 LTE-Advanced features in 36.201	10.0.0
2012-09	SP#57	-	-	-		Update to Rel-11 version (MCC)	11.0.0
2012-12	RAN#58	RP-121846	0007	-		Introduction of Rel-11 features	11.1.0
2014-09	SP#65	-	-	-		Update to Rel-12 version (MCC)	12.0.0
2014-12	RAN#66	RP-142104	0008	3		Introduction of TDD-FDD CA, Small-Cell Enhancements, Dual Connectivity, eIMTA, WLAN/3GPP interworking	12.1.0
2015-03	RAN#67	RP-150366	0009	2		Introduction of ProSe	12.2.0
2015-12	RAN#70	RP-152027	0012	-		Introduction of Rel-13 eCA	13.0.0
2015-12	RAN#70	RP-152025	0013	-		Introduction of EB/FD-MIMO	13.0.0
2015-12	RAN#70	RP-152026	0010	3		Introduction of LAA	13.0.0
2016-03	RAN#71	RP-160361	0011	1	B	Introduction of LC/EC MTC	13.1.0

---

# History

<b>Document history</b>		
V13.0.0	January 2016	Publication
V13.1.0	April 2016	Publication