

ETSI TS 136 302 V11.3.0 (2013-07)



Technical Specification

LTE;
Evolved Universal Terrestrial Radio Access (E-UTRA);
Services provided by the physical layer
(3GPP TS 36.302 version 11.3.0 Release 11)



Reference

RTS/TSGR-0236302vb30

Keywords

LTE

ETSI

650 Route des Lucioles
F-06921 Sophia Antipolis Cedex - FRANCE

Tel.: +33 4 92 94 42 00 Fax: +33 4 93 65 47 16

Siret N° 348 623 562 00017 - NAF 742 C
Association à but non lucratif enregistrée à la
Sous-Préfecture de Grasse (06) N° 7803/88

Important notice

Individual copies of the present document can be downloaded from:

<http://www.etsi.org>

The present document may be made available in more than one electronic version or in print. In any case of existing or perceived difference in contents between such versions, the reference version is the Portable Document Format (PDF). In case of dispute, the reference shall be the printing on ETSI printers of the PDF version kept on a specific network drive within ETSI Secretariat.

Users of the present document should be aware that the document may be subject to revision or change of status. Information on the current status of this and other ETSI documents is available at

<http://portal.etsi.org/tb/status/status.asp>

If you find errors in the present document, please send your comment to one of the following services:

http://portal.etsi.org/chaicor/ETSI_support.asp

Copyright Notification

No part may be reproduced except as authorized by written permission.
The copyright and the foregoing restriction extend to reproduction in all media.

© European Telecommunications Standards Institute 2013.
All rights reserved.

DECT™, **PLUGTESTS™**, **UMTS™** and the ETSI logo are Trade Marks of ETSI registered for the benefit of its Members.
3GPP™ and **LTE™** are Trade Marks of ETSI registered for the benefit of its Members and
of the 3GPP Organizational Partners.
GSM® and the GSM logo are Trade Marks registered and owned by the GSM Association.

Intellectual Property Rights

IPRs essential or potentially essential to the present document may have been declared to ETSI. The information pertaining to these essential IPRs, if any, is publicly available for **ETSI members and non-members**, and can be found in ETSI SR 000 314: "*Intellectual Property Rights (IPRs); Essential, or potentially Essential, IPRs notified to ETSI in respect of ETSI standards*", which is available from the ETSI Secretariat. Latest updates are available on the ETSI Web server (<http://ipr.etsi.org>).

Pursuant to the ETSI IPR Policy, no investigation, including IPR searches, has been carried out by ETSI. No guarantee can be given as to the existence of other IPRs not referenced in ETSI SR 000 314 (or the updates on the ETSI Web server) which are, or may be, or may become, essential to the present document.

Foreword

This Technical Specification (TS) has been produced by ETSI 3rd Generation Partnership Project (3GPP).

The present document may refer to technical specifications or reports using their 3GPP identities, UMTS identities or GSM identities. These should be interpreted as being references to the corresponding ETSI deliverables.

The cross reference between GSM, UMTS, 3GPP and ETSI identities can be found under <http://webapp.etsi.org/key/queryform.asp>.

Contents

Intellectual Property Rights	2
Foreword.....	2
Foreword.....	4
1 Scope	5
2 References	5
3 Definitions, symbols and abbreviations	6
3.1 Definitions	6
3.2 Abbreviations	6
4 Interfaces to the physical layer.....	8
4.1 Interface to MAC.....	8
4.2 Interface to RRC.....	8
5 Services and functions of the physical layer	8
5.1 General	8
5.2 Overview of L1 functions.....	8
5.3 L1 interactions with MAC retransmission functionality	9
6 Model of physical layer of the UE	9
6.1 Uplink model.....	9
6.1.1 Uplink Shared Channel	9
6.1.2 Random-access Channel	10
6.2 Downlink model.....	10
6.2.1 Downlink-Shared Channel.....	10
6.2.2 Broadcast Channel	12
6.2.3 Paging Channel	13
6.2.4 Multicast Channel	14
7 Void.....	15
8 Parallel transmission of simultaneous Physical Channels and SRS	15
8.1 Uplink.....	16
8.2 Downlink.....	18
9 Measurements provided by the physical layer	19
9.1 Model of physical layer measurements	19
9.2 UE Measurements	19
9.3 E-UTRAN Measurements	20
Annex A (informative): Change history	21
History	22

Foreword

This Technical Specification has been produced by the 3rd Generation Partnership Project (3GPP).

The contents of the present document are subject to continuing work within the TSG and may change following formal TSG approval. Should the TSG modify the contents of the present document, it will be re-released by the TSG with an identifying change of release date and an increase in version number as follows:

Version x.y.z

where:

- x the first digit:
 - 1 presented to TSG for information;
 - 2 presented to TSG for approval;
 - 3 or greater indicates TSG approved document under change control.
- y the second digit is incremented for all changes of substance, i.e. technical enhancements, corrections, updates, etc.
- z the third digit is incremented when editorial only changes have been incorporated in the document.

1 Scope

The present document is a technical specification of the services provided by the physical layer of E-UTRA to upper layers.

2 References

The following documents contain provisions which, through reference in this text, constitute provisions of the present document.

- References are either specific (identified by date of publication, edition number, version number, etc.) or non-specific.
- For a specific reference, subsequent revisions do not apply.
- For a non-specific reference, the latest version applies. In the case of a reference to a 3GPP document (including a GSM document), a non-specific reference implicitly refers to the latest version of that document *in the same Release as the present document*.

[1] 3GPP TS 41.101: "Technical Specifications and Technical Reports for a GERAN-based 3GPP system".

Support Team note: The reference above is not used in the present document.

[2] 3GPP TR 21 912 (V3.1.0): "Example 2, using fixed text".

Support Team note: The reference above is invalid (there is no such spec) and not used in the present document.

[3] 3GPP TR 21.905: "Vocabulary for 3GPP Specifications".

[4] 3GPP TR 25.913: "Requirements for Evolved UTRA (E-UTRA) and Evolved UTRAN (E-UTRAN)".

Support Team note: The reference above is not used in the present document.

[5] 3GPP TR 25.814, Physical aspects for Evolved UTRA

Support Team note: The reference above is not used in the present document, and is anyway illegal since 25.814 is not published by the OPs.

[6] 3GPP TS 36.300: "Evolved Universal Terrestrial Radio Access (E-UTRA) and Evolved Universal Terrestrial Radio Access (E-UTRAN); Overall description; Stage 2".

Support Team note: The reference above is not used in the present document.

[7] 3GPP TS 36.201: 'Evolved Universal Terrestrial Radio Access (E-UTRA); Physical layer; General description'.

Support Team note: The reference above is not used in the present document.

[8] 3GPP TS 36.211: "Evolved Universal Terrestrial Radio Access (E-UTRA); Physical channels and modulation".

[9] 3GPP TS 36.212: "Evolved Universal Terrestrial Radio Access (E-UTRA); Multiplexing and channel coding".

[10] 3GPP TS 36.213: "Evolved Universal Terrestrial Radio Access (E-UTRA); Physical layer procedures".

Support Team note: The reference above is not used in the present document.

- [11] 3GPP TS 36.214: "Evolved Universal Terrestrial Radio Access (E-UTRA); Physical layer; Measurements".

Support Team note: The reference above is not used in the present document.

- [12] 3GPP TS 36.321: "Evolved Universal Terrestrial Radio Access (E-UTRA); Medium Access Control (MAC) protocol specification".

3 Definitions, symbols and abbreviations

3.1 Definitions

For the purposes of the present document, the terms and definitions given in TR 21.905 [3] and the following apply. A term defined in the present document takes precedence over the definition of the same term, if any, in TR 21.905 [3].

Carrier frequency center frequency of the cell.

Frequency layer: set of cells with the same carrier frequency.

Timing Advance Group: See the definition in [12].

3.2 Abbreviations

For the purposes of the present document, the abbreviations given in TR 21.905 [3] and the following apply. An abbreviation defined in the present document takes precedence over the definition of the same abbreviation, if any, in TR 21.905 [3].

For the purposes of the present document, the following abbreviations apply:

ACK	Acknowledgement
ACLR	Adjacent Channel Leakage Ratio
aGW	Access Gateway
AM	Acknowledge Mode
ARQ	Automatic Repeat Request
AS	Access Stratum
BCCH	Broadcast Control Channel
BCH	Broadcast Channel
C/I	Carrier-to-Interference Power Ratio
CAZAC	Constant Amplitude Zero Auto-Correlation
CMAS	Commercial Mobile Alert System
CMC	Connection Mobility Control
CP	Cyclic Prefix
C-plane	Control Plane
CQI	Channel Quality Indicator
CRC	Cyclic Redundancy Check
DCCH	Dedicated Control Channel
DL	Downlink
DRX	Discontinuous Reception
DTCH	Dedicated Traffic Channel
DTX	Discontinuous Transmission
eNB	E-UTRAN NodeB
EPC	Evolved Packet Core
EPDCCH	Enhanced physical downlink control channel
E-UTRA	Evolved UTRA
E-UTRAN	Evolved UTRAN
FDD	Frequency Division Duplex
FDM	Frequency Division Multiplexing
GERAN	GSM EDGE Radio Access Network
GNSS	Global Navigation Satellite System

GSM	Global System for Mobile communication
HARQ	Hybrid ARQ
HO	Handover
HSDPA	High Speed Downlink Packet Access
ICIC	Inter-Cell Interference Coordination
IP	Internet Protocol
LB	Load Balancing
LCR	Low Chip Rate
LTE	Long Term Evolution
MAC	Medium Access Control
MBMS	Multimedia Broadcast Multicast Service
MBSFN	Multimedia Broadcast multicast service Single Frequency Network
MCCH	Multicast Control Channel
MCS	Modulation and Coding Scheme
MIMO	Multiple Input Multiple Output
MME	Mobility Management Entity
MTCH	Multicast Traffic Channel
NACK	Negative Acknowledgement
NAS	Non-Access Stratum
OFDM	Orthogonal Frequency Division Multiplexing
OFDMA	Orthogonal Frequency Division Multiple Access
PA	Power Amplifier
PAPR	Peak-to-Average Power Ratio
PBCH	Physical broadcast channel
PCCH	Paging Control Channel
PDCCH	Physical downlink control channel
PDCP	Packet Data Convergence Protocol
PDSCH	Physical downlink shared channel
PDU	Packet Data Unit
PHY	Physical layer
PLMN	Public Land Mobile Network
PMCH	Physical multicast channel
PRACH	Physical random access channel
PRB	Physical Resource Block
PSC	Packet Scheduling
PUCCH	Physical uplink control channel
PUSCH	Physical uplink shared channel
QAM	Quadrature Amplitude Modulation
QoS	Quality of Service
RAC	Radio Admission Control
RACH	Random Access Channel
RAT	Radio Access Technology
RB	Radio Bearer
RBC	Radio Bearer Control
RF	Radio Frequency
RLC	Radio Link Control
RNL	Radio Network Layer
ROHC	Robust Header Compression
RRC	Radio Resource Control
RRM	Radio Resource Management
RU	Resource Unit
S1-C	S1-Control plane
S1-U	S1-User plane
SAE	System Architecture Evolution
SAP	Service Access Point
SC-FDMA	Single Carrier – Frequency Division Multiple Access
SCell	Secondary Cell
SCH	Synchronization Channel
SDMA	Spatial Division Multiple Access
SDU	Service Data Unit
SRS	Sounding Reference Symbol
TA	Tracking Area

TAG	Timing Advance Group
TB	Transport Block
TCP	Transmission Control Protocol
TDD	Time Division Duplex
TM	Transparent Mode
TNL	Transport Network Layer
TTI	Transmission Time Interval
UE	User Equipment
UL	Uplink
UM	Un-acknowledge Mode
UMTS	Universal Mobile Telecommunication System
UPE	User Plane Entity
U-plane	User plane
UTRA	Universal Terrestrial Radio Access
UTRAN	Universal Terrestrial Radio Access Network
VRB	Virtual Resource Block
X2-C	X2-Control plane
X2-U	X2-User plane

4 Interfaces to the physical layer

4.1 Interface to MAC

4.2 Interface to RRC

5 Services and functions of the physical layer

5.1 General

The physical layer offers data transport services to higher layers.

The access to these services is through the use of transport channels via the MAC sub-layer.

A transport block is defined as the data delivered by MAC layer to the physical layer and vice versa. Transport blocks are delivered once every TTI.

5.2 Overview of L1 functions

The physical layer offers data transport services to higher layers. The access to these services is through the use of a transport channel via the MAC sub-layer. The physical layer is expected to perform the following functions in order to provide the data transport service:

- Error detection on the transport channel and indication to higher layers
- FEC encoding/decoding of the transport channel
- Hybrid ARQ soft-combining
- Rate matching of the coded transport channel to physical channels
- Mapping of the coded transport channel onto physical channels
- Power weighting of physical channels
- Modulation and demodulation of physical channels

- Frequency and time synchronisation
- Radio characteristics measurements and indication to higher layers
- Multiple Input Multiple Output (MIMO) antenna processing
- Transmit Diversity (TX diversity)
- Beamforming
- RF processing. (Note: RF processing aspects are specified in the TS 36.100)

L1 functions are modelled for each transport channel in subclauses 6.1 and 6.2.

5.3 L1 interactions with MAC retransmission functionality

6 Model of physical layer of the UE

The E-UTRA physical-layer model captures those characteristics of the E-UTRA physical-layer that are relevant from the point-of-view of higher layers. More specifically, the physical-layer model captures:

- The structure of higher-layer data being passed down to or up from the physical layer;
- The means by which higher layers can configure the physical layer;
- The different indications (error indications, channel-quality indications, etc.) that are provided by the physical layer to higher layers;
- Other (non-transport-channel-based) higher-layer peer-to-peer signalling supported by the physical layer.

6.1 Uplink model

6.1.1 Uplink Shared Channel

The physical-layer model for Uplink Shared Channel transmission is described based on the corresponding physical-layer-processing chain, see Figure 6.1.1-1. Processing steps that are relevant for the physical-layer model, e.g. in the sense that they are configurable by higher layers, are highlighted in blue. It should be noted that, in case PUSCH, the scheduling decision is partly made at the network side, if there is no blind decoding it is fully done at the network side. The uplink transmission control in the UE then configures the uplink physical-layer processing, based on uplink transport-format and resource-assignment information received on the downlink.

- **Higher-layer data passed to/from the physical layer**
 - One transport block of dynamic size delivered to the physical layer once every TTI.
- **CRC and transport-block-error indication**
 - Transport-block-error indication delivered to higher layers.
- **FEC and rate matching**
 - Channel coding rate is implicitly given by the combination of transport block size, modulation scheme and resource assignment;
 - Physical layer model support of HARQ: in case of Incremental Redundancy, the corresponding Layer 2 Hybrid-ARQ process controls what redundancy version is to be used for the physical layer transmission for each TTI.
- **Interleaving**
 - No control of interleaving by higher layers.

- **Data modulation**
- Modulation scheme is decided by MAC Scheduler (QPSK, 16QAM and 64QAM).
- **Mapping to physical resource**
- L2-controlled resource assignment.
- **Multi-antenna processing**
- MAC Scheduler partly configures mapping from assigned resource blocks to the available number of antenna ports.
- **Support of L1 control signalling**
- Transmission of ACK/NAK and CQI feedback related to DL data transmission

The model of Figure 6.1.1-1 also captures

- Transport via physical layer of Hybrid-ARQ related information associated with the PUSCH, to the peer HARQ process at the transmitter side;
- Transport via physical layer of corresponding HARQ acknowledgements to PUSCH transmitter side.

If a UE is configured with one or more SCells, the physical-layer-processing chain in Figure 6.1.1-1 is repeated for every UL Serving Cell.

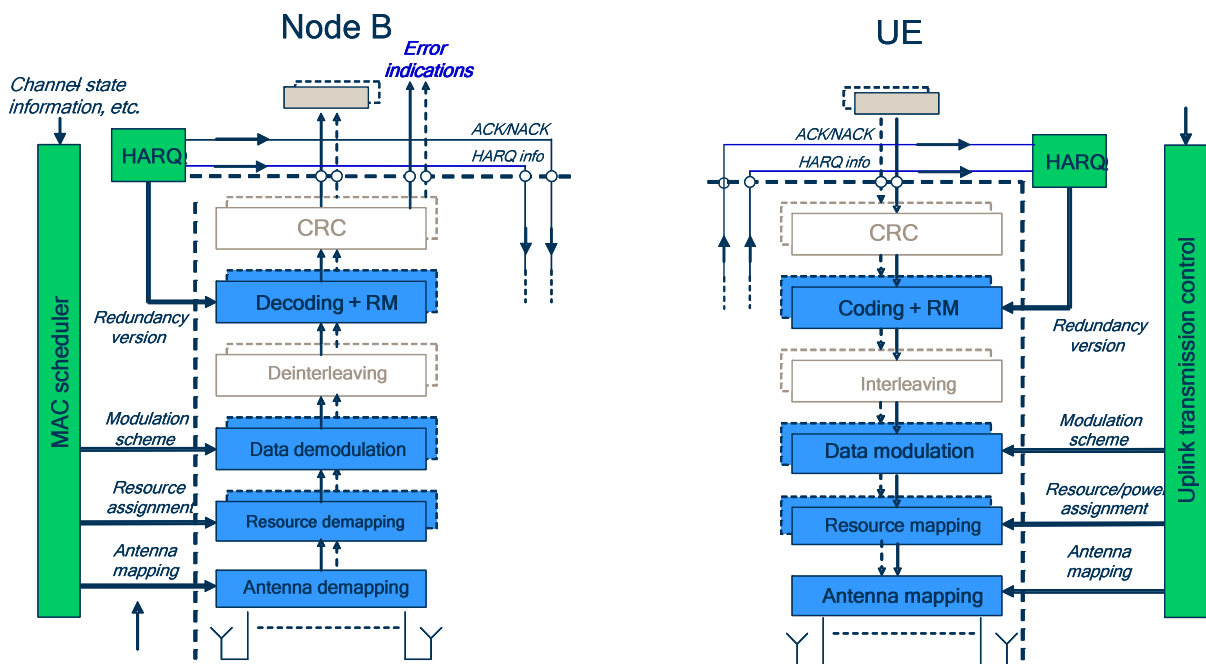

Figure 6.1.1-1: Physical-layer model for UL-SCH transmission

6.1.2 Random-access Channel

6.2 Downlink model

6.2.1 Downlink-Shared Channel

The physical-layer model for Downlink Shared Channel transmission model is described based on the corresponding PDSCH physical-layer-processing chain, see Figure 6.2.1-1. Processing steps that are relevant for the physical-layer model, e.g. in the sense that they are configurable by higher layers, are highlighted in blue on the figure.

- **Higher-layer data passed to/from the physical layer**
- N (up to two) transport blocks of dynamic size delivered to the physical layer once every TTI.
- **CRC and transport-block-error indication**
- Transport-block-error indication delivered to higher layers.
- **FEC and rate matching**
- Channel coding rate is implicitly given by the combination of transport block size, modulation scheme and resource assignment;
- Physical layer model support of HARQ: in case of Incremental Redundancy, the corresponding Layer 2 Hybrid-ARQ process controls what redundancy version is to be used for the physical layer transmission for each TTI.
- **Data modulation**
- Modulation scheme is decided by MAC Scheduler (QPSK, 16QAM and 64 QAM).

Multi-antenna processing

- MAC Scheduler partly configures mapping from modulated code words (for each stream) to the available number of antenna ports.
- **Mapping to physical resource**
- L2-controlled resource assignment.
- **Support of L1 control signalling**
- Transmission of scheduler related control signals.
- **Support for Hybrid-ARQ-related signalling**

The model of Figure 6.2.1-1 also captures:

- Transport via physical layer of Hybrid-ARQ related information associated with the PDSCH, to the peer HARQ process at the receiver side;
- Transport via physical layer of corresponding HARQ acknowledgements to PDSCH transmitter side.

If a UE is configured with one or more SCells, the physical-layer-processing chain in Figure 6.2.1-1 is repeated for every DL Serving Cell.

NOTE: The signalling of transport-format and resource-allocation is not captured in the physical-layer model. At the transmitter side, this information can be directly derived from the configuration of the physical layer. The physical layer then transports this information over the radio interface to its peer physical layer, presumably multiplexed in one way or another with the HARQ-related information. On the receiver side, this information is, in contrast to the HARQ-related information, used directly within the physical layer for PDSCH demodulation, decoding etc., without passing through higher layers.

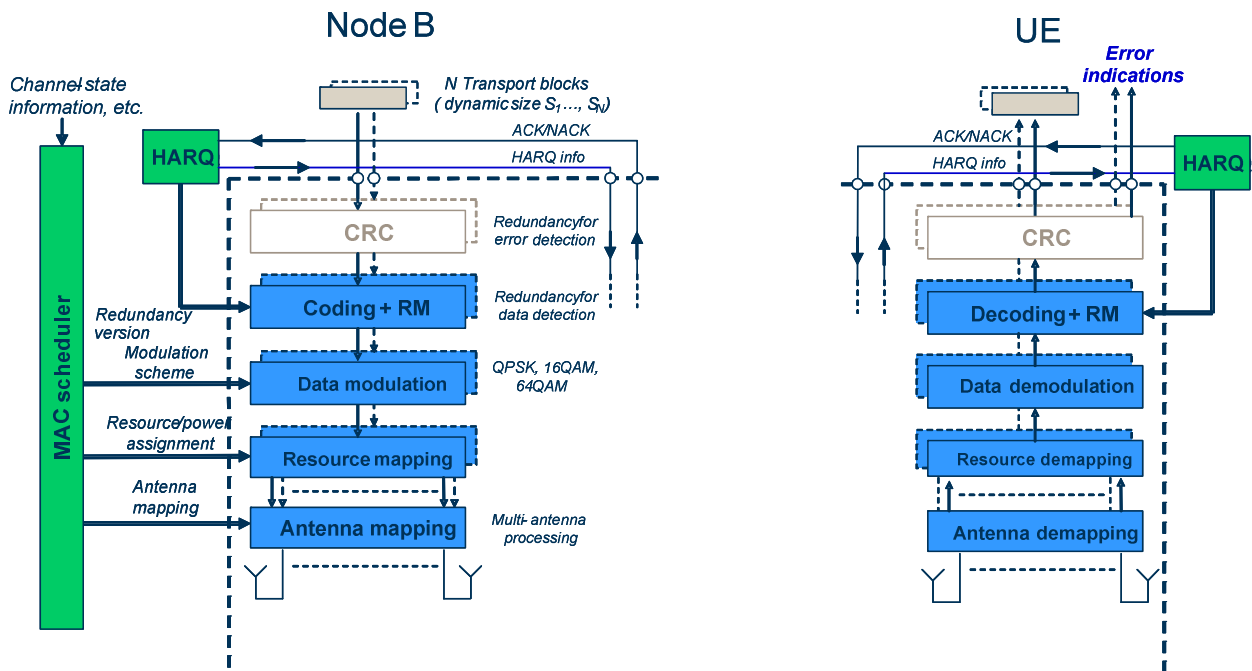

Figure 6.2.1-1: Physical-layer model for DL-SCH transmission

6.2.2 Broadcast Channel

The physical-layer model for BCH transmission is characterized by a fixed pre-defined transport format. The TTI (repetition rate) of the BCH is 40 ms. The BCH physical-layer model is described based on the corresponding BCH physical-layer-processing chain, see Figure 6.2.2-1:

- **Higher-layer data passed to/from the physical layer**
 - A single (fixed-size) transport block per TTI.
- **CRC and transport-block-error indication**
 - Transport-block-error indication delivered to higher layers.
- **FEC and rate matching**
 - Channel coding rate is implicitly given by the combination of transport block size, modulation scheme and resource assignment;
 - No BCH Hybrid ARQ, i.e. no higher-layer control of redundancy version.
- **Data modulation**
 - Fixed modulation scheme (QPSK), i.e. not higher-layer control.
- **Mapping to physical resource**
 - Fixed pre-determined transport format and resource allocation, i.e. no higher-layer control.
- **Multi-antenna processing**
 - Fixed pre-determined processing, i.e. no higher-layer control.
- **Support for Hybrid-ARQ-related signalling**
 - No Hybrid ARQ.

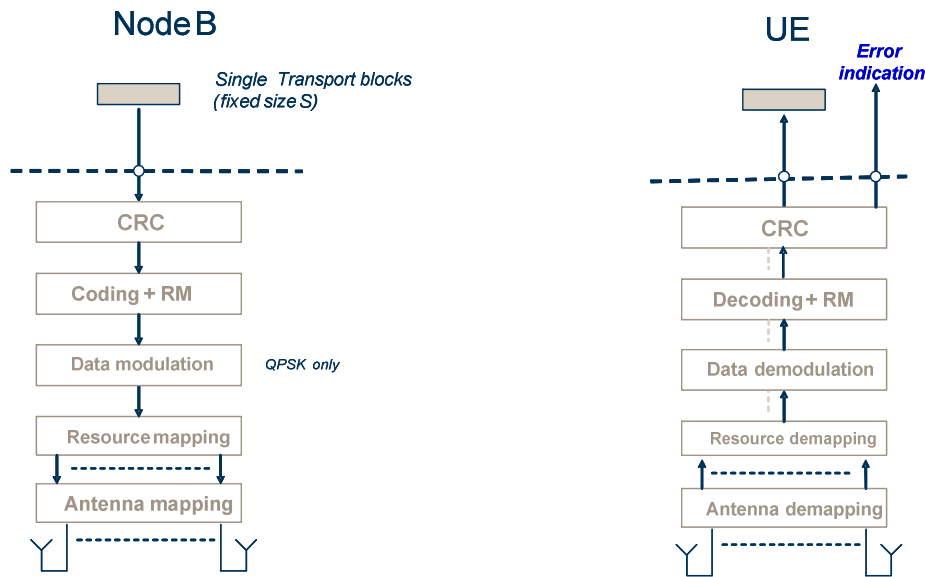

Figure 6.2.2-1: Physical-layer model for BCH transmission

6.2.3 Paging Channel

The physical-layer model for PCH transmission is described based on the corresponding PCH physical-layer-processing chain, see Figure 6.2.3-1. Processing steps that are relevant for the physical-layer model, e.g. in the sense that they are configurable by higher layers, are highlighted in blue on the figure.

- **Higher-layer data passed to/from the physical layer**
- A single transport block per TTI.
- **CRC and transport-block-error indication**
- Transport-block-error indication delivered to higher layers.
- **FEC and rate matching**
- Channel coding rate is implicitly given by the combination of transport block size, modulation scheme and resource assignment;
- No PCH Hybrid ARQ, i.e. no higher-layer control of redundancy version.
- **Data modulation**
- Modulation scheme is decided by MAC Scheduler.
- **Mapping to physical resource**
- L2 controlled resource assignment;
- Possible support of dynamic transport format and resource allocation.
- **Multi-antenna processing**
- MAC Scheduler partly configures mapping from assigned resource blocks to the available number of antenna ports.
- **Support for Hybrid-ARQ-related signalling**
- No Hybrid ARQ.

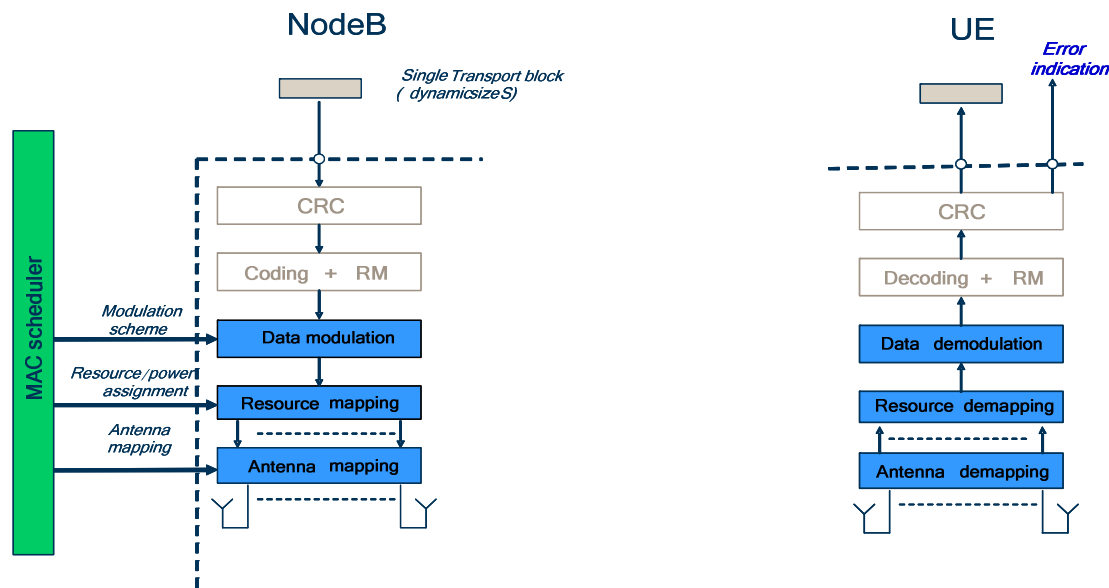

Figure 6.2.3-1: Physical-layer model for PCH transmission

6.2.4 Multicast Channel

The physical-layer model for MCH transmission is characterized by the support for multi-cell reception at the UE (a.k.a. "MBSFN" transmission). This implies that only semi-static configuration of the MCH transport format and resource assignment is possible. The MCH physical-layer model is described based on the corresponding MCH physical-layer-processing chain, see Figure 6.2.4-1. Processing steps that are relevant for the physical-layer model, e.g. in the sense that they are configurable by higher layers, are highlighted in blue.

- **Higher-layer data passed to/from the physical layer**
- One transport block delivered to physical layer once every TTI.
- **CRC and transport-block-error indication**
- Transport-block-error indication delivered to higher layers.
- **FEC and rate matching**
- Channel coding rate is implicitly given by the combination of transport block size, modulation scheme and resource assignment;
- No MCH Hybrid ARQ, i.e. no higher-layer control of redundancy version.
- **Data modulation**
- Modulation scheme is configured by RRC layer.
- **Mapping to physical resource**
- L2 controlled semi-static resource assignment.
- **Multi-antenna processing**
- MAC Scheduler partly configures mapping from assigned resource blocks (for each stream) to the available number of antenna ports.
- **Support for Hybrid-ARQ-related signalling**
- No Hybrid ARQ.

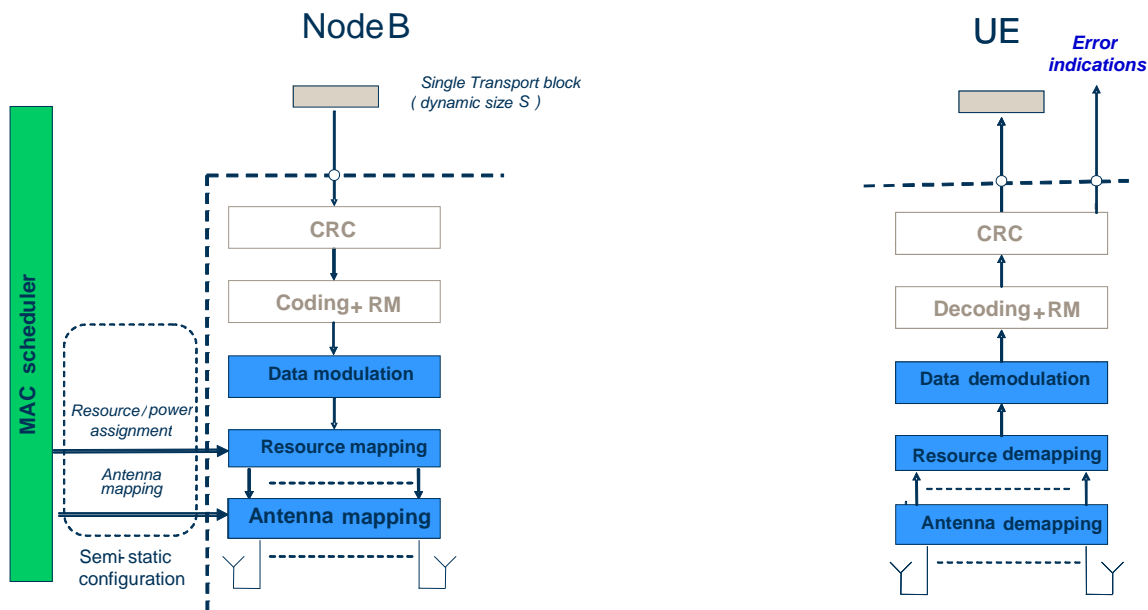

Figure 6.2.4-1: Physical-layer model for MCH transmission

7 Void

8 Parallel transmission of simultaneous Physical Channels and SRS

This clause describes the requirements from the UE to send and receive on multiple Physical and Transport Channels and SRS simultaneously depending on the service capabilities and requirements.

8.1 Uplink

The table 8.1-1 describes the possible combinations of physical channels that can be sent in parallel in the uplink within the same subframe.

Table 8.1-1: Uplink

	Physical Channel Combination	Transport Channel Combination	Mandatory dependent on UE radio access capabilities	Comment
1	$q \times$ PUSCH	UL-SCH	Mandatory	Note 1, Note 2
2	PRACH	RACH	Mandatory	
3	PUCCH	N/A	Mandatory	CQI and Scheduling Requests are provided to Layer 2.
4	$q \times$ PUSCH + PUCCH	UL-SCH	Mandatory for UEs supporting simultaneous transmission of PUSCH and PUCCH	Note1, Note 2
5	PRACH + $(q-1) \times$ PUSCH	RACH UL-SCH	Mandatory for UEs supporting multiple TAGs	Note 1, Note 2, Note 3
6	PRACH + PUCCH	RACH	Mandatory for UEs supporting multiple TAGs	Note 3
7	PRACH + $(q-1) \times$ PUSCH + PUCCH	RACH UL-SCH	Mandatory for UEs supporting simultaneous transmission of PUSCH and PUCCH and multiple TAGs	Note 1, Note 2, Note 3
Note 1: One PUSCH per UL CC. Note 2: q is the number of UL CCs supported by the UE. $q = 1$ implies non-CA capable UE. Note 3: PRACH and PUSCH/PUCCH are from cells in different Timing Advance Groups [12].				

The table 8.1-2 describes the possible combinations of SRS and physical channels that can be sent in parallel in uplink in the last symbol within the same subframe by one UE.

Table 8.1-2: Uplink in combinations with SRS

	Physical Channel and SRS Combination	Transport Channel Combination	Mandatory dependent on UE radio access capabilities	Comment
1	$q \times$ SRS	N/A	Mandatory	Note 2, Note 4
2	PRACH + $(q-1) \times$ SRS	RACH	Mandatory for UEs supporting multiple TAGs	Note 2, Note 3, Note 4
3	$n \times$ PUSCH + $(q-n) \times$ SRS	UL-SCH	Mandatory for UEs supporting multiple TAGs	Note 1, Note 2, Note 4, Note 5, Note 6
4	PUCCH + $(q-1) \times$ SRS	N/A	Mandatory for UEs supporting multiple TAGs	Note 2, Note 4, Note 6
5	$n \times$ PUSCH + PUCCH + $(q-n) \times$ SRS	UL-SCH	Mandatory for UEs supporting simultaneous transmission of PUSCH and PUCCH and multiple TAGs	Note 1, Note 2, Note 4, Note 5, Note 6
6	PRACH + $n \times$ PUSCH + $(q-n-1) \times$ SRS	RACH UL-SCH	Mandatory for UEs supporting multiple TAGs	Note 1, Note 2, Note 3, Note 4, Note 5, Note 6
7	PRACH + PUCCH + $(q-2) \times$ SRS	RACH	Mandatory for UEs supporting multiple TAGs	Note 2, Note 3, Note 4, Note 6
8	PRACH + $n \times$ PUSCH + PUCCH + $(q-n-1) \times$ SRS	RACH UL-SCH	Mandatory for UEs supporting simultaneous transmission of PUSCH and PUCCH and multiple TAGs	Note 1, Note 2, Note 3, Note 4, Note 5, Note 6
Note 1: One PUSCH per UL CC. Note 2: q is the number of UL CCs supported by the UE. $q = 1$ implies non-CA capable UE. Note 3: PRACH and PUSCH/PUCCH/SRS are from cells in different TAGs [12]. Note 4: One SRS per UL CC. Note 5: $n = 1, 2, \dots, q-1$. Note 6: If UE is not configured with multiple TAGs, then SRS and PUSCH/PUCCH are not transmitted in parallel; otherwise, if UE is configured with multiple TAGs, then SRS and PUSCH/PUCCH are transmitted in parallel from different serving cells of the same TAG or different TAGs.				

8.2 Downlink

The table describes the possible combinations of physical channels that can be received in parallel in the downlink in the same subframe by one UE. In one subframe, the UE shall be able to receive all TBs according to the indication on PDCCH.

Table 8.2-1: Downlink "Reception Types"

"Reception Type"	Physical Channel(s)	Monitored RNTI	Associated Transport Channel
A	PBCH	N/A	BCH
B	PDCCH+PDSCH	SI-RNTI	DL-SCH
C	PDCCH+PDSCH	P-RNTI	PCH
D	PDCCH+PDSCH	RA-RNTI (Note 3)	DL-SCH
		Temporary C-RNTI (Note 3) (Note 4)	DL-SCH
	(PDCCH/EPDCCH)+PDSCH	C-RNTI and Semi-Persistent Scheduling C-RNTI	DL-SCH
D1	(PDCCH/EPDCCH)+PDSCH (Note 9)	C-RNTI	DL-SCH
E	PDCCH/EPDCCH (Note 1)	C-RNTI	N/A
F	PDCCH	Temporary C-RNTI (Note 5)	UL-SCH
	PDCCH/EPDCCH	C-RNTI and Semi-Persistent Scheduling C-RNTI	UL-SCH
F1	PDCCH/EPDCCH (Note 9)	C-RNTI	UL-SCH
G	PDCCH	TPC-PUCCH-RNTI	N/A
H	PDCCH	TPC-PUSCH-RNTI	N/A
I	PDCCH/EPDCCH	Semi-Persistent Scheduling C-RNTI (Note 6)	N/A
J	PDCCH/EPDCCH	Semi-Persistent Scheduling C-RNTI (Note 7)	N/A
K	PDCCH	M-RNTI (Note 8)	N/A
L	PMCH	N/A (Note 8)	MCH
Note 1: PDCCH or EPDCCH is used to convey PDCCH order for Random Access. Note 2: Void. Note 3: RA-RNTI and Temporary C-RNTI are mutually exclusive and only applicable during Random Access procedure. Note 4: Temporary C-RNTI is only applicable when no valid C-RNTI is available. Note 5: Temporary C-RNTI is only applicable during contention-based Random Access procedure. Note 6: Semi-Persistent Scheduling C-RNTI is used for DL Semi-Persistent Scheduling release. Note 7: Semi-Persistent Scheduling C-RNTI is used for UL Semi-Persistent Scheduling release. Note 8: In MBSFN subframes only Note 9: DL-SCH reception corresponding to D1, and UL-SCH transmission corresponding to F1, are only applicable to SCells.			

Table 8.2-2: Downlink "Reception Type" Combinations

Combination	Mandatory/Optional	Comment
$1x_A + 1x_B + 1x_C$	Mandatory	RRC_IDLE
$1x_K + 1x_L$	Mandatory for MBMS UEs	RRC_IDLE
$1x_A + 1x_B + 1x(D \text{ or } (1-m)x_E \text{ or } G \text{ or } I) + (p-1-m)x_{D1} + mx_E + 1x(F \text{ or } H \text{ or } J) + (q-1)x_{F1}$	Mandatory. (NOTE 3)	RRC_CONNECTED
$1x_A + 1x_B + 1x(D \text{ or } (1-m)x_E \text{ or } G \text{ or } I) + 1x(F \text{ or } H \text{ or } J) + 1x_{F1} + (p-1-m)x_{D1} + mx_E + 2x(q-1)x_{F1}$	Mandatory for UEs supporting FS2. (NOTE 3) (NOTE 4)	RRC_CONNECTED (NOTE 1)
$((1x((1-m)x_E \text{ or } G \text{ or } I) + 1x_L) \text{ or } 1x_D) + 1x(F \text{ or } H \text{ or } J) + rx_K + (p-1-m)x_{D1} + mx_E + (q-1)x_{F1} + (r-1)x_L$	Mandatory for MBMS UEs. (NOTE 3) (NOTE 4)	RRC_CONNECTED (NOTE 2)
$((1x((1-m)x_E \text{ or } G \text{ or } I) + 1x_L) \text{ or } 1x_D) + 1x(F \text{ or } H \text{ or } J) + 1x_{F1} + rx_K + (p-1-m)x_{D1} + mx_E + 2x(q-1)x_{F1} + (r-1)x_L$	Mandatory for MBMS UEs supporting FS2. (NOTE 3)	RRC_CONNECTED (NOTE 1) (NOTE 2)
$1x_A + 1x_B + 1x_C + 1x(D \text{ or } (1-m)x_E \text{ or } G \text{ or } I) + (p-1-m)x_{D1} + mx_E + 1x(F \text{ or } H \text{ or } J) + (q-1)x_{F1}$	Mandatory for ETWS and CMAS UEs Optional for all other UEs. (NOTE 3)	RRC_CONNECTED
$1x_A + 1x_B + 1x_C + 1x(D \text{ or } (1-m)x_E \text{ or } G \text{ or } I) + 1x(F \text{ or } H \text{ or } J) + 1x_{F1} + (p-1-m)x_{D1} + mx_E + 2x(q-1)x_{F1}$	Mandatory for ETWS and CMAS UEs supporting FS2 Optional for all other UEs. (NOTE 3)	RRC_CONNECTED (NOTE 1)
NOTE 1: For TDD UL/DL configuration 0, two PDCCHs or EPDCCHs can be received in the same subframe for UL-SCH in two different uplink subframes.		
NOTE 2: The combination is the requirement when MBMS reception is on PCell and/or any other cell. r is the number of DL CCs on which the UE supports MBMS reception according to the MBMSInterestIndication.		
NOTE: p is the number of DL CCs supported by the UE. q is the number of UL CCs supported by the UE. $q = p = 1$ implies non-CA capable UE. $m = 0$ or 1 for UE supporting multiple TAGs, otherwise $m=0$.		
NOTE: The UE is only required to receive one PDSCH, pertaining to D or D1, per DL CC.		
NOTE 3: Combination involving EPDCCH is optional and required only for UE supporting EPDCCH.		
NOTE 4: It is not required to simultaneously receive EPDCCH and PMCH on the same cell.		

NOTE: Any subset of the combinations specified in table 8.2-2 is also supported.

9 Measurements provided by the physical layer

9.1 Model of physical layer measurements

9.2 UE Measurements

UE measurement: **Reference signal received power (RSRP)**: Reference signal received power (RSRP) is determined for a considered cell as the linear average over the power contributions (in [W]) of the resource elements that carry cell-specific reference signals within the considered measurement frequency bandwidth. For RSRP determination the cell-specific reference signals R_0 and if available R_1 according to [8] can be used.

If receiver diversity is in use by the UE, the reported value shall be in accordance with [11].

UE measurement: **Reference Signal Received Quality (RSRQ)**: Reference Signal Received Quality (RSRQ) is defined as the ratio $N \times \text{RSRP} / (\text{E-UTRA carrier RSSI})$, where N is the number of RB's of the E-UTRA carrier RSSI measurement bandwidth. The measurements in the numerator and denominator shall be made over the same set of resource blocks.

E-UTRA Carrier Received Signal Strength Indicator (RSSI), comprises the linear average of the total received power (in [W]) observed only in OFDM symbols containing reference symbols for antenna port 0, in the measurement bandwidth, over N number of resource blocks by the UE from all sources, including co-channel serving and non-serving cells, adjacent channel interference, thermal noise etc.

If receiver diversity is in use by the UE, the reported value shall be in accordance with [11].

UE measurement: **UTRA CPICH RSCP**: Received Signal Code Power, the received power on one code measured on the Primary CPICH.

UE measurement: **UTRA FDD carrier RSSI**: received wide band power, including thermal noise and noise generated in the receiver, within the bandwidth defined by the receiver pulse shaping filter.

UE measurement: **UTRA FDD CPICH Ec/No**: received energy per chip divided by the power density in the band. The CPICH Ec/No is identical to CPICH RSCP/UTRA Carrier RSSI. Measurement is performed on the Primary CPICH.

UE measurement: **GSM carrier RSSI**: Received Signal Strength Indicator, the wide-band received power within the relevant channel bandwidth. Measurement is performed on a GSM BCCH carrier.

UE measurement: **UTRA TDD carrier RSSI**: The received wide band power, including thermal noise and noise generated in the receiver, within the bandwidth defined by the receiver pulse shaping filter, for TDD within a specified timeslot.

UE measurement: **UTRA TDD P-CCPCH RSCP**: Received Signal Code Power, the received power on P-CCPCH of a neighbour UTRA TDD cell.

9.3 E-UTRAN Measurements

The detailed E-UTRAN measurements definition is provided in [9]:

eNode B measurement: **DL RS TX power**: Downlink reference signal transmit power is determined for a considered cell as the linear average over the power contributions (in [W]) of the resource elements that carry cell-specific reference signals which are transmitted by the eNode B within its operating system bandwidth.

For DL RS TX power determination the cell-specific reference signals R_0 and if available R_1 according to [8] can be used.

The reference point for the DL RS TX power measurement shall be the TX antenna connector.

Annex A (informative): Change history

Change history							
Date	TSG #	TSG Doc.	CR	Rev	Subject/Comment	Old	New
11/2006	RP-34	RP-060795	-		First version : presented at TSG-RAN #34 and TSG-RAN WG2 #56 (11/2006)	-	0.0.0
05/2007	RP-36	RP-xyztu			Update including physical layer modelling: submitted at TSG-RAN WG2 #58 (05/2006)	0.0.0	0.0.1
06/2007	RP-37	R2-072502			Update including physical Services and functions of the Physical Layer: presented and TSG-RAN WG2 #58bis (06/2006)	0.0.1	0.0.2
06/2007	RP-37	R2-072931			Update after presentation at TSG-RAN WG2 #58bis : physical channel channel terminology used	0.0.2	0.1.0
09/2007	RP-37	RP-070686			Removal of editor"s notes. Presented at TSG-RAN #37 for information	0.1.0	1.0.0
10/2007	R2-59bis	R2-074579			Agreements in RAN1 LS received at RAN2#59 have to be implemented in the specification (by RAN2#59bis): Parallel reception of Physical Broadcast Channel (PBCH) and DL-SCH in the same TTI is feasible; 2 new measurements were introduced for LTE, UE measurement "Reference Signal Received Quality (RSRQ)" and eNode B measurement "DL RS TX power".	1.0.1	1.0.2
10/2007	R2-59bis	R2-074584			Removal of incorrect Parallel reception of physical channels	1.0.2	1.0.3
11/2007	RP-38	RP-070914			Submission to RAN for RAN#38 approval	1.0.3	2.0.0
12/2007	RP-38	-			Apprpved at TSG RAN-38 and placed under change control	2.0.0	8.0.0
03/2009	RP-43	RP-090124	0002	-	Proposed CR on Parallel reception in LTE	8.0.0	8.1.0
	RP-43	RP-090124	0004	-	Correction of out-of-date information	8.0.0	8.1.0
06/2009	RP-44	RP-090509	0005	1	Correction of MBMS	8.1.0	8.2.0
	RP-44	RP-090509	0006	-	Downlink reception types	8.1.0	8.2.0
	RP-44	RP-090509	0009	-	Simultaneous reception of transport channels in the LTE	8.1.0	8.2.0
	RP-44	RP-090509	0010	-	Clarification on the parallel receptions for PDSCBs	8.1.0	8.2.0
12/2009	RP-46	RP-091341	0011	-	Addition of MBMS reception types	8.2.0	9.0.0
	RP-46	RP-091346	0012	-	Remove FFSs from RAN2 specifications	8.2.0	9.0.0
	RP-46	RP-091345	0014	-	Proposed CR to 36.302 on Introduction of CMAS	8.2.0	9.0.0
03/2010	RP-47	RP-100308	0019	1	Correction to RSRP and RSRQ definition with Receiver Diversity to align with TS 36.214	9.0.0	9.1.0
06/2010	RP-48	RP-100556	0020	-	Correction to RSRQ definition to align with TS 36.214	9.1.0	9.2.0
12/2010	RP-50	RP-101226	0021	3	Introduction of CA to TS36.302	9.2.0	10.0.0
03/2011	RP-51	RP-110289	0022	1	Correction to parallel reception and transmission for CA	10.0.0	10.1.0
	RP-51	RP-110270	0025	-	Corrections to TS36.302 on MBMS	10.0.0	10.1.0
	RP-51	RP-110289	0026	-	Update and correction to TS36.302 for CA	10.0.0	10.1.0
06/2011	RP-52	RP-110839	0028	-	DL Assignment in MBSFN Subframe	10.1.0	10.2.0
12/2011	RP-54	RP-111716	0029	-	Corrections to channel model	10.2.0	10.3.0
03/2012	RP-55	RP-120326	0030	1	Correction to the combination of physical uplink channels	10.3.0	10.4.0
09/2012	RP-57	RP-121350	0031	-	Introduction of parallel PRACH and PUSCH/PUCCH/SRS transmission	10.4.0	11.0.0
12/2012	RP-58	RP-121951	0036	-	Correction to parallel PRACH, SRS and PUSCH/PUCCH transmission	11.0.0	11.1.0
	RP-58	RP-121956	0037	-	Introduction of EPDCCH in TS 36.302	11.0.0	11.1.0
03/2013	RP-59	RP-130245	0041	-	Correction to parallel SRS and PUSCH/PUCCH transmission	11.1.0	11.2.0
06/2013	RP-60	RP-130808	0043	-	Clarification on EPDCCH reception in MBSFN subframes	11.2.0	11.3.0
	RP-60	RP-130808	0044	-	Correction on downlink reception type combinations for UEs supporting multiple TAGs	11.2.0	11.3.0
	RP-60	RP-130808	0045	-	Downlink Reception Type Combinations for MBMS capable UE	11.2.0	11.3.0

History

Document history		
V11.0.0	October 2012	Publication
V11.1.0	February 2013	Publication
V11.2.0	April 2013	Publication
V11.3.0	July 2013	Publication