

ETSI TS 136 360 V16.0.0 (2020-07)



**LTE;
Evolved Universal Terrestrial Radio Access (E-UTRA);
LTE-WLAN Aggregation Adaptation Protocol (LWAAP)
specification
(3GPP TS 36.360 version 16.0.0 Release 16)**



Reference

RTS/TSGR-0236360vg00

Keywords

LTE

ETSI

650 Route des Lucioles
F-06921 Sophia Antipolis Cedex - FRANCE

Tel.: +33 4 92 94 42 00 Fax: +33 4 93 65 47 16

Siret N° 348 623 562 00017 - NAF 742 C
Association à but non lucratif enregistrée à la
Sous-Préfecture de Grasse (06) N° 7803/88

Important notice

The present document can be downloaded from:

<http://www.etsi.org/standards-search>

The present document may be made available in electronic versions and/or in print. The content of any electronic and/or print versions of the present document shall not be modified without the prior written authorization of ETSI. In case of any existing or perceived difference in contents between such versions and/or in print, the prevailing version of an ETSI deliverable is the one made publicly available in PDF format at www.etsi.org/deliver.

Users of the present document should be aware that the document may be subject to revision or change of status.

Information on the current status of this and other ETSI documents is available at

<https://portal.etsi.org/TB/ETSIDeliverableStatus.aspx>

If you find errors in the present document, please send your comment to one of the following services:

<https://portal.etsi.org/People/CommitteeSupportStaff.aspx>

Copyright Notification

No part may be reproduced or utilized in any form or by any means, electronic or mechanical, including photocopying and microfilm except as authorized by written permission of ETSI.

The content of the PDF version shall not be modified without the written authorization of ETSI.

The copyright and the foregoing restriction extend to reproduction in all media.

© ETSI 2020.

All rights reserved.

DECT™, **PLUGTESTS™**, **UMTS™** and the ETSI logo are trademarks of ETSI registered for the benefit of its Members.

3GPP™ and **LTE™** are trademarks of ETSI registered for the benefit of its Members and of the 3GPP Organizational Partners.

oneM2M™ logo is a trademark of ETSI registered for the benefit of its Members and of the oneM2M Partners.

GSM® and the GSM logo are trademarks registered and owned by the GSM Association.

Intellectual Property Rights

Essential patents

IPRs essential or potentially essential to normative deliverables may have been declared to ETSI. The information pertaining to these essential IPRs, if any, is publicly available for **ETSI members and non-members**, and can be found in ETSI SR 000 314: "*Intellectual Property Rights (IPRs); Essential, or potentially Essential, IPRs notified to ETSI in respect of ETSI standards*", which is available from the ETSI Secretariat. Latest updates are available on the ETSI Web server (<https://ipr.etsi.org/>).

Pursuant to the ETSI IPR Policy, no investigation, including IPR searches, has been carried out by ETSI. No guarantee can be given as to the existence of other IPRs not referenced in ETSI SR 000 314 (or the updates on the ETSI Web server) which are, or may be, or may become, essential to the present document.

Trademarks

The present document may include trademarks and/or tradenames which are asserted and/or registered by their owners. ETSI claims no ownership of these except for any which are indicated as being the property of ETSI, and conveys no right to use or reproduce any trademark and/or tradename. Mention of those trademarks in the present document does not constitute an endorsement by ETSI of products, services or organizations associated with those trademarks.

Legal Notice

This Technical Specification (TS) has been produced by ETSI 3rd Generation Partnership Project (3GPP).

The present document may refer to technical specifications or reports using their 3GPP identities. These shall be interpreted as being references to the corresponding ETSI deliverables.

The cross reference between 3GPP and ETSI identities can be found under <http://webapp.etsi.org/key/queryform.asp>.

Modal verbs terminology

In the present document "**shall**", "**shall not**", "**should**", "**should not**", "**may**", "**need not**", "**will**", "**will not**", "**can**" and "**cannot**" are to be interpreted as described in clause 3.2 of the [ETSI Drafting Rules](#) (Verbal forms for the expression of provisions).

"**must**" and "**must not**" are **NOT** allowed in ETSI deliverables except when used in direct citation.

Contents

Intellectual Property Rights	2
Legal Notice	2
Modal verbs terminology.....	2
Foreword.....	4
1 Scope	5
2 References	5
3 Definitions, symbols and abbreviations	5
3.1 Definitions	5
3.2 Abbreviations	5
4 General	6
4.1 Introduction	6
4.2 LWAAP architecture.....	6
4.2.1 LWAAP entities.....	6
4.3 Services	7
4.3.1 Services provided to upper layers	7
4.3.2 Services expected from lower layers	7
4.4 Functions	7
5 Procedures	7
5.1 Data transfer procedures.....	7
5.1.1 DL data transfer procedures.....	7
5.1.2 UL data transfer procedures.....	7
5.2 Handling of unknown, unforeseen and erroneous protocol data	8
6 Protocol data units, formats and parameters.....	8
6.1 Protocol data units	8
6.1.1 General.....	8
6.1.2 LWAAP data PDU.....	8
6.2 Formats and parameters.....	8
6.2.1 LWAAP header	8
Annex A (informative): Change history	10
History	11

Foreword

This Technical Specification has been produced by the 3rd Generation Partnership Project (3GPP).

The contents of the present document are subject to continuing work within the TSG and may change following formal TSG approval. Should the TSG modify the contents of the present document, it will be re-released by the TSG with an identifying change of release date and an increase in version number as follows:

Version x.y.z

where:

- x the first digit:
 - 1 presented to TSG for information;
 - 2 presented to TSG for approval;
 - 3 or greater indicates TSG approved document under change control.
- y the second digit is incremented for all changes of substance, i.e. technical enhancements, corrections, updates, etc.
- z the third digit is incremented when editorial only changes have been incorporated in the document.

1 Scope

The present document specifies the E-UTRA LTE-WLAN Aggregation Adaptation Protocol (LWAAP).

2 References

The following documents contain provisions which, through reference in this text, constitute provisions of the present document.

- References are either specific (identified by date of publication, edition number, version number, etc.) or non-specific.
- For a specific reference, subsequent revisions do not apply.
- For a non-specific reference, the latest version applies. In the case of a reference to a 3GPP document (including a GSM document), a non-specific reference implicitly refers to the latest version of that document *in the same Release as the present document*.

- [1] 3GPP TR 21.905: "Vocabulary for 3GPP Specifications".
 - [2] 3GPP TS 36.300: "E-UTRA and E-UTRAN Overall Description; Stage 2".
 - [3] 3GPP TS 36.323: "E-UTRA PDCP specification".
 - [4] 3GPP TS 36.331: "E-UTRA RRC Protocol specification".
-

3 Definitions, symbols and abbreviations

3.1 Definitions

For the purposes of the present document, the terms and definitions given in TR 21.905 [1] and the following apply. A term defined in the present document takes precedence over the definition of the same term, if any, in TR 21.905 [1].

LWA bearer: a bearer used in LTE-WLAN Aggregation, as defined in TS 36.300 [2].

3.2 Abbreviations

For the purposes of the present document, the following abbreviations apply:

DL	DownLink
DRB	Data Radio Bearer
eNB	E-UTRAN Node B
E-UTRA	Evolved UMTS Terrestrial Radio Access
E-UTRAN	Evolved UMTS Terrestrial Radio Access Network
LWAAP	LTE-WLAN Aggregation Adaptation Protocol
PDCP	Packet Data Convergence Protocol
PDU	Protocol Data Unit
RRC	Radio Resource Control
SAP	Service Access Point
SDU	Service Data Unit
UE	User Equipment
UL	UpLink

4 General

4.1 Introduction

The objective is to describe the LWAAP architecture and the LWAAP entities from a functional point of view.

4.2 LWAAP architecture

4.2.1 LWAAP entities

The description in this sub clause is a model and does not specify or restrict implementations.

RRC is generally in control of the LWAAP configuration.

Functions of the LWAAP sublayer are performed by LWAAP entities. For an LWAAP entity configured at the eNB, there is a peer LWAAP entity configured at the UE and vice versa. For all LWA bearers, there is one LWAAP entity in the eNB and one LWAAP entity in the UE.

An LWAAP entity receives/delivers LWAAP SDUs from/to upper layers (i.e. PDCP) and sends/receives LWAAP PDUs to/from its peer LWAAP entity via WLAN:

- At the transmitting side, when an LWAAP entity receives an LWAAP SDU from upper layers, it constructs the corresponding LWAAP PDU and delivers it to lower layers;
- At the receiving side, when an LWAAP entity receives an LWAAP PDU from lower layers, it reassembles the corresponding LWAAP SDU and delivers it to upper layers.

Figure 4.2.1-1 illustrates the overview model of the LWAAP sublayer.

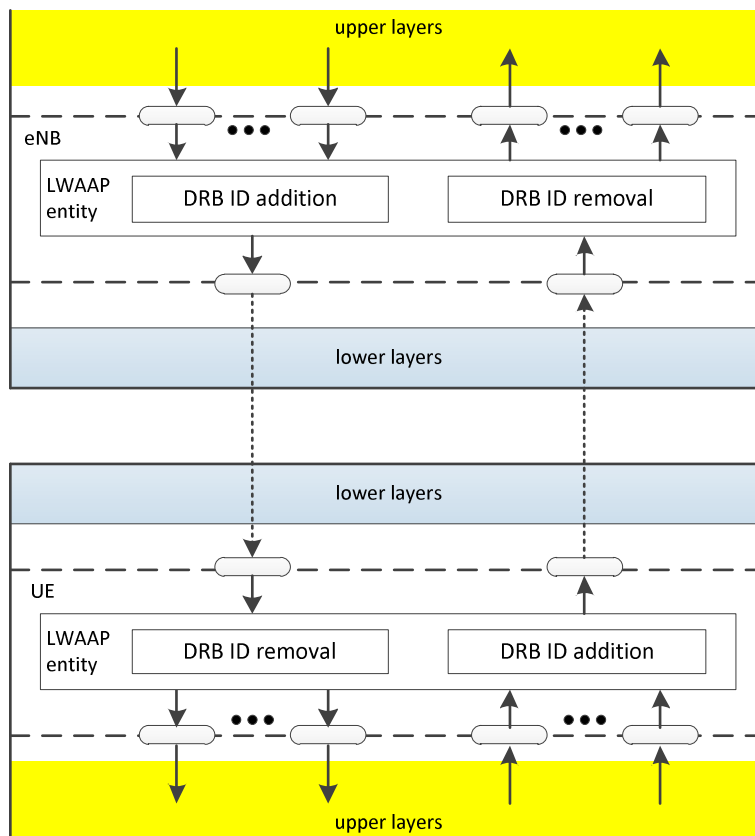

Figure 4.2.1-1: Overview model of the LWAAP sublayer

An LWAAP entity delivers/receives the following LWAAP PDU to/from a lower layer entity:

- LWAAP data PDU.

4.3 Services

4.3.1 Services provided to upper layers

The following services are provided by LWAAP to upper layers (i.e. PDCP):

- transfer of user plane data;

4.3.2 Services expected from lower layers

The following services are expected by LWAAP from lower layers:

- transfer of user plane data;

4.4 Functions

The following functions are supported by the LWAAP sublayer:

- transfer of user plane data;
- identification of the LWA bearer to which the LWAAP SDU belongs;
- enabling or disabling data handling for LWA bearer.

5 Procedures

5.1 Data transfer procedures

5.1.1 DL data transfer procedures

When receiving an LWAAP data PDU from lower layers, the LWAAP entity in the UE shall:

- identify the upper layer entity to which the LWAAP SDU is destined based on the DRB ID included in the LWAAP header;
- if the DRB ID belongs to LWA bearer for which DL data transfer procedures are enabled:
 - reassemble the LWAAP SDU from the LWAAP data PDU by removing the LWAAP header from the LWAAP data PDU;
 - deliver the reassembled LWAAP SDU to the upper layer entity identified by the DRB ID.
- else:
 - discard the LWAAP data PDU.

5.1.2 UL data transfer procedures

When receiving an LWAAP data SDU from upper layers, the LWAAP entity in the UE shall:

- identify the DRB ID of the upper layer entity from which the LWAAP SDU is received;
- assemble the LWAAP data PDU from the LWAAP SDU by adding the LWAAP header to the LWAAP SDU;

- deliver the assembled LWAAP data PDU to the lower layers.

5.2 Handling of unknown, unforeseen and erroneous protocol data

When an LWAAP entity receives an LWAAP PDU that contains reserved or invalid values, the LWAAP entity shall:

- discard the received PDU.

6 Protocol data units, formats and parameters

6.1 Protocol data units

6.1.1 General

An LWAAP PDU is a bit string that is byte aligned (i.e. multiple of 8 bits) in length. In the figures in subclause 6.1, bit strings are represented by tables in which the most significant bit is the leftmost bit of the first line of the table, the least significant bit is the rightmost bit on the last line of the table, and more generally the bit string is to be read from left to right and then in the reading order of the lines. The bit order of each parameter field within an LWAAP PDU is represented with the first and most significant bit in the leftmost bit and the last and least significant bit in the rightmost bit.

An LWAAP SDU is a bit string that is byte aligned (i.e. multiple of 8 bits) in length. An LWAAP SDU is included into an LWAAP PDU from the first bit onward.

The LWAAP entity shall ignore the value of Reserved bits in downlink LWAAP PDUs.

Only one type of LWAAP PDU is defined, i.e. LWAAP data PDU.

6.1.2 LWAAP data PDU

An LWAAP PDU consists of an LWAAP header and a Data field, as described in Figure 6.1.2-1.

An LWAAP header is one byte, and consists of the four header fields R/R/R/DRBID.

A Data field is of variable size, and consists of an LWAAP SDU.

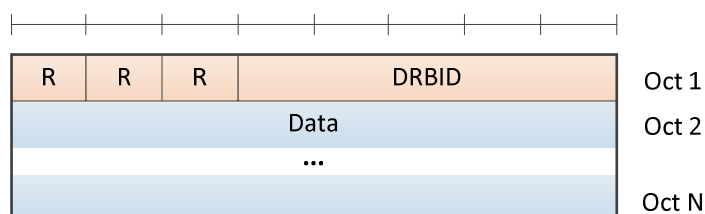

Figure 6.1.2-1: LWAAP data PDU

6.2 Formats and parameters

6.2.1 LWAAP header

The LWAAP header consists of the following fields:

- R: Reserved bit, set to "0". The R field size is 1 bit;

- DRBID: The Data Radio Bearer ID field indicates the RRC configured DRB identity to which the corresponding LWAAP SDU belongs. The DRBID field size is 5 bits.

Annex A (informative): Change history

Change history							
Date	TSG #	TSG Doc.	CR	Rev	Cat	Subject/Comment	New version
2016-02	RAN2#9 3	R2-161087	-	-		draft TS 36.360 v0.0.0 on LTE-WLAN Aggregation Adaptation Protocol (LWAAP) specification after e-mail discussion "[92#42][LTE/WLAN] New specification (LG)"	0.0.0
2016-02	RAN2#9 3	R2-161787	-	-		draft TS 36.360 v0.0.1 on LTE-WLAN Aggregation Adaptation Protocol (LWAAP) specification	0.0.1
2016-02	RAN2#9 3	R2-161986	-	-		draft TS 36.360 v0.0.2 on LTE-WLAN Aggregation Adaptation Protocol (LWAAP) specification	0.0.2
2016-02	RAN2#9 3	R2-162023	-	-		draft TS 36.360 v0.1.0 on LTE-WLAN Aggregation Adaptation Protocol (LWAAP) specification	0.1.0
2016-02	RAN2#9 3	R2-162024	-	-		draft TS 36.360 v1.0.0 on LTE-WLAN Aggregation Adaptation Protocol (LWAAP) specification	1.0.0
2016-03	RP-71	RP-160496	-	-		Approved at TSG RAN#71 and put under Change Control	13.0.0
2017-03	RP-75	RP-170651	0005	2	F	Clarification on data handling for LWA bearer	13.1.0
	RP-75	RP-170628	0006	2	B	Introduction of Enhanced LTE-WLAN Aggregation (eLWA)	14.0.0
2018-07	RP-80					Upgraded to Rel-15. No technical change.	15.0.0
2020-07	RP-88					Upgraded to Rel-16. No technical change.	16.0.0

History

Document history		
V16.0.0	July 2020	Publication