

ETSI TS 136 456 V13.0.0 (2016-01)



**Universal Mobile Telecommunications System (UMTS);
LTE;
Evolved Universal Terrestrial Radio Access Network (E-UTRAN);
S-LM interface general aspects and principles
(3GPP TS 36.456 version 13.0.0 Release 13)**



Reference

RTS/TSGR-0336456vd00

Keywords

LTE,UMTS

ETSI

650 Route des Lucioles
F-06921 Sophia Antipolis Cedex - FRANCE

Tel.: +33 4 92 94 42 00 Fax: +33 4 93 65 47 16

Siret N° 348 623 562 00017 - NAF 742 C
Association à but non lucratif enregistrée à la
Sous-Préfecture de Grasse (06) N° 7803/88

Important notice

The present document can be downloaded from:

<http://www.etsi.org/standards-search>

The present document may be made available in electronic versions and/or in print. The content of any electronic and/or print versions of the present document shall not be modified without the prior written authorization of ETSI. In case of any existing or perceived difference in contents between such versions and/or in print, the only prevailing document is the print of the Portable Document Format (PDF) version kept on a specific network drive within ETSI Secretariat.

Users of the present document should be aware that the document may be subject to revision or change of status. Information on the current status of this and other ETSI documents is available at

<http://portal.etsi.org/tb/status/status.asp>

If you find errors in the present document, please send your comment to one of the following services:

<https://portal.etsi.org/People/CommitteeSupportStaff.aspx>

Copyright Notification

No part may be reproduced or utilized in any form or by any means, electronic or mechanical, including photocopying and microfilm except as authorized by written permission of ETSI.

The content of the PDF version shall not be modified without the written authorization of ETSI.

The copyright and the foregoing restriction extend to reproduction in all media.

© European Telecommunications Standards Institute 2016.

All rights reserved.

DECT™, **PLUGTESTS™**, **UMTS™** and the ETSI logo are Trade Marks of ETSI registered for the benefit of its Members. **3GPP™** and **LTE™** are Trade Marks of ETSI registered for the benefit of its Members and of the 3GPP Organizational Partners.

GSM® and the GSM logo are Trade Marks registered and owned by the GSM Association.

Intellectual Property Rights

IPRs essential or potentially essential to the present document may have been declared to ETSI. The information pertaining to these essential IPRs, if any, is publicly available for **ETSI members and non-members**, and can be found in ETSI SR 000 314: *"Intellectual Property Rights (IPRs); Essential, or potentially Essential, IPRs notified to ETSI in respect of ETSI standards"*, which is available from the ETSI Secretariat. Latest updates are available on the ETSI Web server (<https://ipr.etsi.org/>).

Pursuant to the ETSI IPR Policy, no investigation, including IPR searches, has been carried out by ETSI. No guarantee can be given as to the existence of other IPRs not referenced in ETSI SR 000 314 (or the updates on the ETSI Web server) which are, or may be, or may become, essential to the present document.

Foreword

This Technical Specification (TS) has been produced by ETSI 3rd Generation Partnership Project (3GPP).

The present document may refer to technical specifications or reports using their 3GPP identities, UMTS identities or GSM identities. These should be interpreted as being references to the corresponding ETSI deliverables.

The cross reference between GSM, UMTS, 3GPP and ETSI identities can be found under <http://webapp.etsi.org/key/queryform.asp>.

Modal verbs terminology

In the present document "**shall**", "**shall not**", "**should**", "**should not**", "**may**", "**need not**", "**will**", "**will not**", "**can**" and "**cannot**" are to be interpreted as described in clause 3.2 of the [ETSI Drafting Rules](#) (Verbal forms for the expression of provisions).

"**must**" and "**must not**" are **NOT** allowed in ETSI deliverables except when used in direct citation.

Contents

Intellectual Property Rights	2
Foreword.....	2
Modal verbs terminology.....	2
Foreword.....	4
1 Scope	5
2 References	5
3 Definitions, symbols and abbreviations	5
3.1 Definitions	5
3.2 Symbols.....	5
3.3 Abbreviations	5
3.4 Specification notations	6
4 General aspects.....	6
4.1 E-UTRAN UTDOA architecture.....	6
4.2 SLm interface general principles.....	7
4.3 SLm interface specification objectives.....	7
4.4 SLm interface capabilities	7
4.5 SLm interface characteristics	8
4.5.1 Use of SCTP	8
5 Functions of the SLm interface protocol.....	8
5.1 General	8
5.2 SLm link management function	8
5.3 SLm interface management function.....	8
5.4 SLm location function	8
6 SLm interface protocol structure	8
6.1 General	8
6.2 SLmAP.....	9
7 Other SLm interface specifications	9
7.1 E-UTRAN SLm interface: layer 1 (3GPP TS 36.457)	9
7.2 E-UTRAN SLm interface: signalling transport (3GPP TS 36.458)	9
7.3 E-UTRAN SLm Interface: SLmAP Specification (3GPP TS 36.459)	9
Annex A (informative): Change history	10
History	11

Foreword

This Technical Specification has been produced by the 3rd Generation Partnership Project (3GPP).

The contents of the present document are subject to continuing work within the TSG and may change following formal TSG approval. Should the TSG modify the contents of the present document, it will be re-released by the TSG with an identifying change of release date and an increase in version number as follows:

Version x.y.z

where:

- x the first digit:
 - 1 presented to TSG for information;
 - 2 presented to TSG for approval;
 - 3 or greater indicates TSG approved document under change control.
- y the second digit is incremented for all changes of substance, i.e. technical enhancements, corrections, updates, etc.
- z the third digit is incremented when editorial only changes have been incorporated in the document.

1 Scope

The present document is an introduction to the 3GPP TS 36.45x series of technical specifications that define the SLM interface for the interconnection of the Evolved Serving Mobile Location Centre (E-SMLC) to the Location Measurement Unit (LMU) components of the Evolved Universal Terrestrial Radio Access Network (E-UTRAN).

2 References

The following documents contain provisions which, through reference in this text, constitute provisions of the present document.

- References are either specific (identified by date of publication, edition number, version number, etc.) or non-specific.
- For a specific reference, subsequent revisions do not apply.
- For a non-specific reference, the latest version applies. In the case of a reference to a 3GPP document (including a GSM document), a non-specific reference implicitly refers to the latest version of that document *in the same Release as the present document*.

- [1] 3GPP TR 21.905: "Vocabulary for 3GPP Specifications".
- [2] 3GPP TS 36.305: "Evolved Universal Terrestrial Radio Access Network (E-UTRAN); Architecture description".
- [3] 3GPP TS 36.457: "Evolved Universal Terrestrial Radio Access Network (E-UTRAN); SLM interface layer 1".
- [4] 3GPP TS 36.458: "Evolved Universal Terrestrial Radio Access Network (E-UTRAN); SLM interface signalling transport".
- [5] 3GPP TS 36.459: "Evolved Universal Terrestrial Access (E-UTRA); SLM interface Application Protocol (SLMAP)".
- [6] IETF RFC 4960 (2007-09): "Stream Control Transmission Protocol".

3 Definitions, symbols and abbreviations

3.1 Definitions

For the purposes of the present document, the terms and definitions given in TR 21.905 [1] and the following apply. A term defined in the present document takes precedence over the definition of the same term, if any, in TR 21.905 [1].

3.2 Symbols

For the purposes of the present document, the following symbols apply:

3.3 Abbreviations

For the purposes of the present document, the abbreviations given in TR 21.905 [1] and the following apply. An abbreviation defined in the present document takes precedence over the definition of the same abbreviation, if any, in TR 21.905 [1].

E-SMLC	E-UTRAN Serving Mobile Location Centre
eNB	E-UTRAN Node B

EPC	Evolved Packet Core
EPS	Evolved Packet System
E-UTRAN	Evolved UTRAN
IP	Internet Protocol
LMU	Location Measurement Unit
LTE	Long Term Evolution
MME	Mobility Management Entity
O&M	Operation and Maintenance
QoS	Quality of Service
RNL	Radio Network Layer
SLm	SLm Control Plane Interface
SLmAP	SLm Application Protocol
SAP	Service Access Point
SCTP	Stream Control Transmission Protocol
TNL	Transport Network Layer
UTDOA	Uplink Time Difference of Arrival

3.4 Specification notations

For the purposes of the present document, the following notations apply:

Procedure	When referring to a procedure in the specification the Procedure Name is written with the first letters in each word in upper case characters followed by the word "procedure", e.g. Radio Network Layer procedures.
Message	When referring to a message in the specification the MESSAGE NAME is written with all letters in upper case characters followed by the word "message", e.g. RADIO LINK SETUP REQUEST message.

4 General aspects

4.1 E-UTRAN UTDOA architecture

The E-UTRAN is layered into a Radio Network Layer (RNL) and a Transport Network Layer (TNL). The E-UTRAN architecture, i.e. the E-UTRAN logical nodes and interfaces between them, are defined as part of the Radio Network Layer.

The overall architecture for UE positioning is described in TS 36.305 [2]. The E-UTRAN network based positioning architecture consists of a set of LMUs (either standalone or eNB-integrated LMUs as described in TS 36.305 [2]) contained in the E-UTRAN connected to the E-SMLC in the EPC through the SLm.

This subclause specifies only the architecture of the SLm interface, and shall not constrain the network architecture of either core or radio access networks.

The SLm interface is specified at the boundary between the LMUs and the E-SMLC. Figure 1 depicts the logical division of the SLm interface. From the SLm perspective, the E-UTRAN access point is an LMU, and the EPC access point is the E-SMLC.

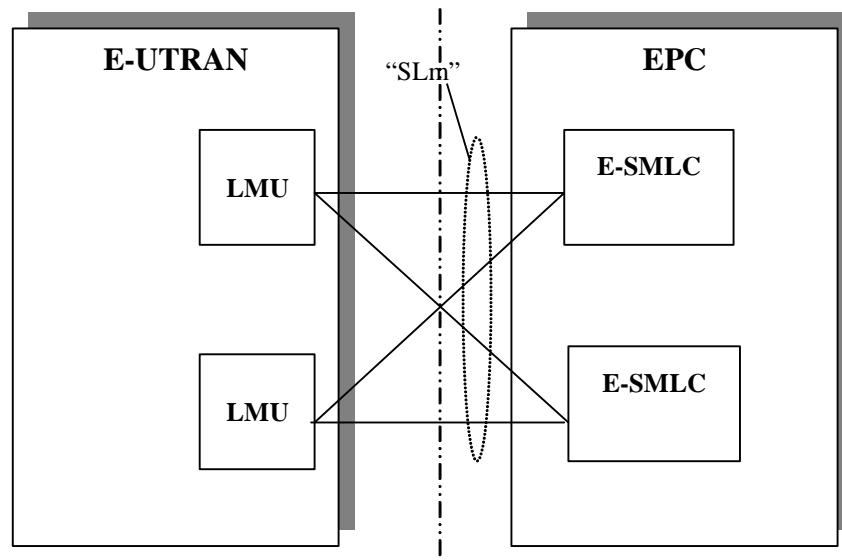

Figure1 SLm Interface architecture

The E-UTRAN may thus have several SLm access points towards the EPC. As a minimum, each SLm access point (in E-UTRAN or EPC) shall independently fulfil the requirements of the relevant SLm specifications (36.x1x series - see clause 7).

SLm is a logical interface.

There is only one SLm logical interface between an LMU and a given E-SMLC. However, an LMU can be connected to multiple E-SMLCs using different logical SLm interfaces.

4.2 SLm interface general principles

The general principles for the specification of the SLm interface are as follows:

- the SLm interface should be open;
- the SLm interface shall support the exchange of signalling information between the LMU and E-SMLC;
- from a logical standpoint, the SLm is a point-to-point interface between an LMU within the E-UTRAN and an E-SMLC in the EPC. A point-to-point logical interface should be feasible even in the absence of a physical direct connection between the LMU and E-SMLC.

4.3 SLm interface specification objectives

The SLm interface specification shall facilitate the following:

- inter-connection of E-SMLCs with LMUs supplied by different manufacturers;
- separation of SLm interface Radio Network functionality and Transport Network functionality to facilitate introduction of future technology.

4.4 SLm interface capabilities

The SLm interface supports:

- procedures to establish, maintain and release connections between the E-SMLC and LMUs;
- the separation of each LMU on the protocol level for specific signalling management;
- location services by transferring location requests from the E-SMLC to LMUs, and UL RTOA measurements from LMUs to E-SMLC;

4.5 SLm interface characteristics

4.5.1 Use of SCTP

The SCTP (IETF RFC 4960 [7]) is used to support the exchange of SLm Application Protocol (SLmAP) signalling messages between an LMU and an E-SMLC.

5 Functions of the SLm interface protocol

5.1 General

The following sections describe the functions to fulfil the SLm interface capabilities.

5.2 SLm link management function

The SLm signalling link management function provides a reliable transfer of the signalling between LMU and E-SMLC.

5.3 SLm interface management function

The error indication function is used by the LMU (respectively the E-SMLC) to indicate to the E-SMLC (respectively the LMU) that a logical error has occurred.

The reset procedure is used to initialize the peer entity after node setup and after a failure event has occurred. This procedure can be initiated by the E-SMLC or the LMU. The information about the LMU capabilities after a reset is preserved in the E-SMLC.

The SLm Setup procedure allows the exchange of application level data, e.g. capability, needed for the LMU and E-SMLC to interoperate correctly on the SLm interface. This procedure is originated by the LMU only and initiates the setup of the SLmAP contexts to the E-SMLC.

5.4 SLm location function

The location function is used by the E-SMLC to request the LMU to perform UL RTOA measurements. The LMU reports UL RTOA measurements back to the requesting E-SMLC.

6 SLm interface protocol structure

Editor's Note: Protocol Structure following the structure defined in TS 36.305 [2].

6.1 General

The network signalling over SLm consists of the SLm Application Protocol (SLmAP). The SLmAP consists of mechanisms to handle all procedures between the E-SMLC in the EPC and LMUs in the E-UTRAN.

Over the SLm interface the SLmAP protocol is, e.g., used to:

- Request LMUs to perform UL RTOA measurements of target UE SRS transmissions.
- Transfer of completed UL RTOA measurements from the LMU to the E-SMLC.

6.2 SLmAP

Figure 6.1 shows the protocol structure for SLmAP, following the structure described in TS 36.305 [2].

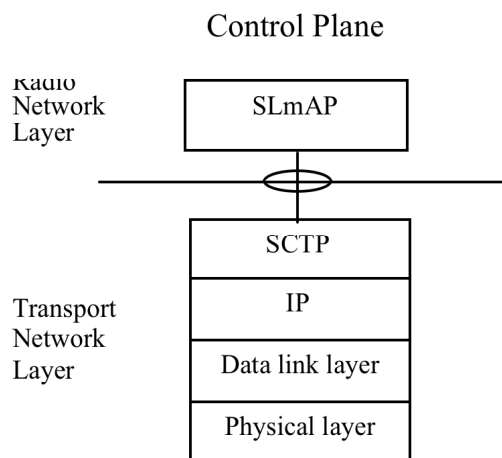

Figure 6.1: Interface protocol structure for SLmAP

The Transport Network Layer is based on IP transport, comprising SCTP on top of IP.

7 Other SLm interface specifications

Editor's Note: Description of the other related specifications.

7.1 E-UTRAN SLm interface: layer 1 (3GPP TS 36.457)

3GPP TS 36.457 [3] specifies the physical layer technologies that may be used to support the SLm interface.

7.2 E-UTRAN SLm interface: signalling transport (3GPP TS 36.458)

3GPP TS 36.458 [4] specifies the signalling bearers for the SLmAP for the SLm interface.

7.3 E-UTRAN SLm Interface: SLmAP Specification (3GPP TS 36.459)

3GPP TS 36.459 [5] specifies the SLmAP for radio network control plane signalling over the SLm interface.

Annex A (informative): Change history

Change history						
Date	TSG #	TSG Doc.	CR	Rev	Subject/Comment	New
2012-12	58	RP-121766			Approved in RAN#58 and put under change control	11.0.0
2014-09					Update to Rel-12 version (MCC)	12.0.0
2015-12					Update to Rel-13 version (MCC)	13.0.0

History

Document history		
V13.0.0	January 2016	Publication