

# ETSI TS 136 462 V14.0.0 (2017-04)



TECHNICAL SPECIFICATION

**LTE;**  
**Evolved Universal Terrestrial Radio Access**  
**Network (E-UTRAN) and Wireless LAN (WLAN);**  
**Xw signalling transport**  
**(3GPP TS 36.462 version 14.0.0 Release 14)**



---

Reference

RTS/TSGR-0336462ve00

---

Keywords

LTE

**ETSI**

650 Route des Lucioles  
F-06921 Sophia Antipolis Cedex - FRANCE

Tel.: +33 4 92 94 42 00 Fax: +33 4 93 65 47 16

Siret N° 348 623 562 00017 - NAF 742 C  
Association à but non lucratif enregistrée à la  
Sous-Préfecture de Grasse (06) N° 7803/88

---

**Important notice**

The present document can be downloaded from:

<http://www.etsi.org/standards-search>

The present document may be made available in electronic versions and/or in print. The content of any electronic and/or print versions of the present document shall not be modified without the prior written authorization of ETSI. In case of any existing or perceived difference in contents between such versions and/or in print, the only prevailing document is the print of the Portable Document Format (PDF) version kept on a specific network drive within ETSI Secretariat.

Users of the present document should be aware that the document may be subject to revision or change of status.

Information on the current status of this and other ETSI documents is available at

<https://portal.etsi.org/TB/ETSIDeliverableStatus.aspx>

If you find errors in the present document, please send your comment to one of the following services:

<https://portal.etsi.org/People/CommitteeSupportStaff.aspx>

---

**Copyright Notification**

No part may be reproduced or utilized in any form or by any means, electronic or mechanical, including photocopying and microfilm except as authorized by written permission of ETSI.

The content of the PDF version shall not be modified without the written authorization of ETSI.

The copyright and the foregoing restriction extend to reproduction in all media.

© European Telecommunications Standards Institute 2017.

All rights reserved.

DECT™, PLUGTESTS™, UMTS™ and the ETSI logo are Trade Marks of ETSI registered for the benefit of its Members.

3GPP™ and LTE™ are Trade Marks of ETSI registered for the benefit of its Members and of the 3GPP Organizational Partners.

oneM2M logo is protected for the benefit of its Members

GSM® and the GSM logo are Trade Marks registered and owned by the GSM Association.

---

## Intellectual Property Rights

IPRs essential or potentially essential to the present document may have been declared to ETSI. The information pertaining to these essential IPRs, if any, is publicly available for **ETSI members and non-members**, and can be found in ETSI SR 000 314: "*Intellectual Property Rights (IPRs); Essential, or potentially Essential, IPRs notified to ETSI in respect of ETSI standards*", which is available from the ETSI Secretariat. Latest updates are available on the ETSI Web server (<https://ipr.etsi.org>).

Pursuant to the ETSI IPR Policy, no investigation, including IPR searches, has been carried out by ETSI. No guarantee can be given as to the existence of other IPRs not referenced in ETSI SR 000 314 (or the updates on the ETSI Web server) which are, or may be, or may become, essential to the present document.

---

## Foreword

This Technical Specification (TS) has been produced by ETSI 3rd Generation Partnership Project (3GPP).

The present document may refer to technical specifications or reports using their 3GPP identities, UMTS identities or GSM identities. These should be interpreted as being references to the corresponding ETSI deliverables.

The cross reference between GSM, UMTS, 3GPP and ETSI identities can be found under <http://webapp.etsi.org/key/queryform.asp>.

---

## Modal verbs terminology

In the present document "**shall**", "**shall not**", "**should**", "**should not**", "**may**", "**need not**", "**will**", "**will not**", "**can**" and "**cannot**" are to be interpreted as described in clause 3.2 of the [ETSI Drafting Rules](#) (Verbal forms for the expression of provisions).

"**must**" and "**must not**" are **NOT** allowed in ETSI deliverables except when used in direct citation.

---

# Contents

Intellectual Property Rights .....	2
Foreword.....	2
Modal verbs terminology.....	2
Foreword.....	4
1 Scope .....	5
2 References .....	5
3 Definitions, symbols and abbreviations .....	5
3.1 Definitions .....	5
3.2 Abbreviations .....	5
4 Xw signalling bearer .....	6
4.1 Function and protocol stack.....	6
5 Data link layer .....	6
6 IP layer .....	6
7 Transport layer .....	6
<b>Annex A (informative): Change history .....</b>	<b>8</b>
History .....	9

---

# Foreword

This Technical Specification has been produced by the 3<sup>rd</sup> Generation Partnership Project (3GPP).

The contents of the present document are subject to continuing work within the TSG and may change following formal TSG approval. Should the TSG modify the contents of the present document, it will be re-released by the TSG with an identifying change of release date and an increase in version number as follows:

Version x.y.z

where:

- x the first digit:
  - 1 presented to TSG for information;
  - 2 presented to TSG for approval;
  - 3 or greater indicates TSG approved document under change control.
- y the second digit is incremented for all changes of substance, i.e. technical enhancements, corrections, updates, etc.
- z the third digit is incremented when editorial only changes have been incorporated in the document.

---

# 1 Scope

The present document specifies the standards for Signalling Transport to be used across the Xw interface. The Xw interface is a logical interface between the eNB and the WT. The present document describes how the Xw-AP signalling messages are transported over Xw.

---

# 2 References

The following documents contain provisions which, through reference in this text, constitute provisions of the present document.

- References are either specific (identified by date of publication, edition number, version number, etc.) or non-specific.
- For a specific reference, subsequent revisions do not apply.
- For a non-specific reference, the latest version applies. In the case of a reference to a 3GPP document (including a GSM document), a non-specific reference implicitly refers to the latest version of that document *in the same Release as the present document*.

- [1] 3GPP TR 21.905: "Vocabulary for 3GPP Specifications".
- [2] IETF RFC 2460 (1998-12): "Internet Protocol, Version 6 (Ipv6) Specification".
- [3] IETF RFC 791(1981-09): "Internet Protocol".
- [4] IETF RFC 2474 (1998-12): "Definition of the Differentiated Services Field (DS Field) in the Ipv4 and Ipv6 Headers".
- [5] IETF RFC 4960 (2007-09): "Stream Control Transmission Protocol".

---

# 3 Definitions, symbols and abbreviations

## 3.1 Definitions

For the purposes of the present document, the terms and definitions given in TR 21.905 [1] and the following apply. A term defined in the present document takes precedence over the definition of the same term, if any, in TR 21.905 [1].

**Xw**: logical interface between eNB and WT.

## 3.2 Abbreviations

For the purposes of the present document, the abbreviations given in 3GPP TR 21.905 [1] and the following apply. An abbreviation defined in the present document takes precedence over the definition of the same abbreviation, if any, in 3GPP TR 21.905 [1].

IANA	<a href="#">Internet Assigned Numbers Authority</a>
IETF	Internet Engineering Task Force
PPP	Point-to-Point Protocol
RFC	Request for Comments
SCTP	Stream Control Transmission Protocol
WT	WLAN Termination

---

## 4 Xw signalling bearer

### 4.1 Function and protocol stack

Xw signalling bearer provides the following functions:

- Provision of reliable transfer of Xw-AP message over Xw interface.
- Provision of networking and routing function;
- Provision of redundancy in the signalling network;
- Support for flow control and congestion control.

The protocol stack for Xw Signalling Bearer is shown in figure 4.1-1 and details on each protocol are described in the following sections.

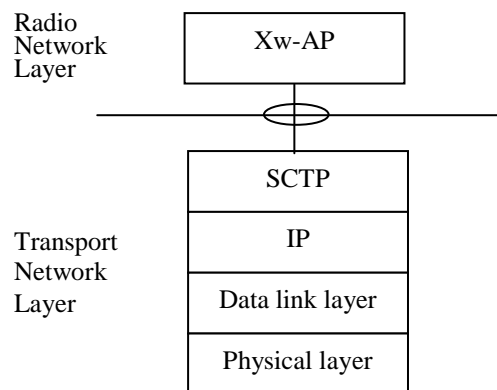

**Figure 4.1-1: Xw signalling bearer protocol stack**

The Transport Network Layer is based on IP transport, comprising SCTP on top of IP.

---

## 5 Data link layer

The support of any suitable Data Link Layer protocol, e.g. PPP, Ethernet, etc., shall not be prevented.

---

## 6 IP layer

The eNB shall support Ipv6 (IETF RFC 2460 [2]) and/or Ipv4 (IETF RFC 791 [3]).

The IP layer of Xw only supports point-to-point transmission for delivering Xw-AP message.

The eNB shall support the Diffserv Code Point marking as described in IETF RFC 2474 [4].

---

## 7 Transport layer

SCTP (IETF RFC 4960 [5]) shall be supported as the transport layer of Xw signalling bearer. The Payload Protocol Identifier assigned by IANA to be used by SCTP for the application layer protocol XwAP is 59.

SCTP refers to the Stream Control Transmission Protocol developed by the Sigtran working group of the IETF for the purpose of transporting various signalling protocols over IP network.

There shall be only one SCTP association established between one eNB and WT pair.

The eNB shall establish the SCTP association. The SCTP Destination Port Number value assigned by IANA to be used for XwAP is 36462.

Within the SCTP association established between an eNB and WT pair;

- A single pair of stream identifiers shall be reserved for the sole use of XwAP elementary procedures that utilize non UE-associated signalling.
- At least one pair of stream identifiers shall be reserved for the sole use of XwAP elementary procedures that utilize UE-associated signalling. However a few pairs (i.e. more than one) should be reserved.
- A single UE-associated signalling shall use one SCTP stream and the stream should not be changed during the communication of the UE-associated signalling.

Transport network redundancy may be achieved by SCTP multi-homing between two endpoints, of which one or both is assigned with multiple IP addresses. SCTP endpoints shall support a multi-homed remote SCTP endpoint. For SCTP endpoint redundancy an INIT may be sent from WT or eNB, at any time for an already established SCTP association, which shall be handled as defined in IETF RFC 4960 [5] in sub-clause 5.2.

The SCTP congestion control may, using an implementation specific mechanism, initiate higher layer protocols to reduce the signalling traffic at the source and prioritise certain messages.



## Annex A (informative): Change history

Change history							
Date	Meeting	TDoc	CR	Rev	Cat	Subject/Comment	New version
2015-10	RAN3#89bis	R3-152078				Xw signaling support	0.1.0
2015-10	RAN3#89bis	R3-152246				Xw_signaling support	0.1.0
2015-10	RAN3#89bis	R3-152247				Draft_TS36462_Update	0.1.0
2015-11	RAN3#90	R3-152417				Draft_TS36462_Update	0.2.0
2015-11	RAN3#90	R3-152774				Draft_TS36462_Update	0.3.0
2015-11	RAN#70	RP-151865				Presentation Specification to TSG RAN#70	1.0.0
2016-01	RAN3# Adhoc NB-IOT	R3-160004				Editorial update: change "Xw signaling support" to "Xw signaling transport"	1.1.0
2016-01	RAN3# Adhoc NB-IOT	R3-160123				Cover page update	1.2.0
2016-02	RAN3#91	R3-160155				Version update	1.3.0
2016-03	RAN#71	RP-160518				MCC clean up and version update	2.0.0
2016-03	RAN#71					Upgraded to Rel-13 and placed under change control	13.0.0
2017-03	SA#75					Promotion to Release 14 without technical change	14.0.0

---

# History

<b>Document history</b>		
V14.0.0	April 2017	Publication