

ETSI TS 136 508 V15.3.0 (2018-10)



**LTE;
Evolved Universal Terrestrial Radio Access (E-UTRA) and
Evolved Packet Core (EPC);
Common test environments for User Equipment (UE)
conformance testing
(3GPP TS 36.508 version 15.3.0 Release 15)**



Reference

RTS/TSGR-0536508vf30

Keywords

LTE

ETSI

650 Route des Lucioles
F-06921 Sophia Antipolis Cedex - FRANCE

Tel.: +33 4 92 94 42 00 Fax: +33 4 93 65 47 16

Siret N° 348 623 562 00017 - NAF 742 C
Association à but non lucratif enregistrée à la
Sous-Préfecture de Grasse (06) N° 7803/88

Important notice

The present document can be downloaded from:

<http://www.etsi.org/standards-search>

The present document may be made available in electronic versions and/or in print. The content of any electronic and/or print versions of the present document shall not be modified without the prior written authorization of ETSI. In case of any existing or perceived difference in contents between such versions and/or in print, the only prevailing document is the print of the Portable Document Format (PDF) version kept on a specific network drive within ETSI Secretariat.

Users of the present document should be aware that the document may be subject to revision or change of status.

Information on the current status of this and other ETSI documents is available at

<https://portal.etsi.org/TB/ETSIDeliverableStatus.aspx>

If you find errors in the present document, please send your comment to one of the following services:

<https://portal.etsi.org/People/CommiteeSupportStaff.aspx>

Copyright Notification

No part may be reproduced or utilized in any form or by any means, electronic or mechanical, including photocopying and microfilm except as authorized by written permission of ETSI.

The content of the PDF version shall not be modified without the written authorization of ETSI.

The copyright and the foregoing restriction extend to reproduction in all media.

© ETSI 2018.

All rights reserved.

DECT™, **PLUGTESTS™**, **UMTS™** and the ETSI logo are trademarks of ETSI registered for the benefit of its Members.

3GPP™ and **LTE™** are trademarks of ETSI registered for the benefit of its Members and of the 3GPP Organizational Partners.

oneM2M logo is protected for the benefit of its Members.

GSM® and the GSM logo are trademarks registered and owned by the GSM Association.

Intellectual Property Rights

Essential patents

IPRs essential or potentially essential to normative deliverables may have been declared to ETSI. The information pertaining to these essential IPRs, if any, is publicly available for **ETSI members and non-members**, and can be found in ETSI SR 000 314: "*Intellectual Property Rights (IPRs); Essential, or potentially Essential, IPRs notified to ETSI in respect of ETSI standards*", which is available from the ETSI Secretariat. Latest updates are available on the ETSI Web server (<https://ipr.etsi.org/>).

Pursuant to the ETSI IPR Policy, no investigation, including IPR searches, has been carried out by ETSI. No guarantee can be given as to the existence of other IPRs not referenced in ETSI SR 000 314 (or the updates on the ETSI Web server) which are, or may be, or may become, essential to the present document.

Trademarks

The present document may include trademarks and/or tradenames which are asserted and/or registered by their owners. ETSI claims no ownership of these except for any which are indicated as being the property of ETSI, and conveys no right to use or reproduce any trademark and/or tradename. Mention of those trademarks in the present document does not constitute an endorsement by ETSI of products, services or organizations associated with those trademarks.

Foreword

This Technical Specification (TS) has been produced by ETSI 3rd Generation Partnership Project (3GPP).

The present document may refer to technical specifications or reports using their 3GPP identities, UMTS identities or GSM identities. These should be interpreted as being references to the corresponding ETSI deliverables.

The cross reference between GSM, UMTS, 3GPP and ETSI identities can be found under <http://webapp.etsi.org/key/queryform.asp>.

Modal verbs terminology

In the present document "**shall**", "**shall not**", "**should**", "**should not**", "**may**", "**need not**", "**will**", "**will not**", "**can**" and "**cannot**" are to be interpreted as described in clause 3.2 of the [ETSI Drafting Rules](#) (Verbal forms for the expression of provisions).

"**must**" and "**must not**" are **NOT** allowed in ETSI deliverables except when used in direct citation.

Contents

Intellectual Property Rights	2
Foreword.....	2
Modal verbs terminology.....	2
Foreword.....	27
Introduction	27
1 Scope	28
2 References	28
3 Definitions, symbols and abbreviations	31
3.1 Definitions.....	31
3.2 Symbols.....	31
3.3 Abbreviations	31
4 Common test environment	32
4.1 Environmental conditions.....	32
4.1.1 Temperature.....	32
4.1.2 Voltage.....	32
4.2 Common requirements of test equipment.....	33
4.2.1 General functional requirements.....	33
4.2.2 Minimum functional requirements	34
4.2.2.1 Supported Cell Configuration	34
4.2.2.1.1 Supported Channels.....	34
4.2.2.2 Support of T _{cell} timing offset	35
4.2.2.3 Supported Sidelink Configuration.....	35
4.2.2.3.1 Supported Sidelink Channels.....	35
4.3 Reference test conditions.....	36
4.3.1 Test frequencies	36
4.3.1.1 FDD Mode Test frequencies	40
4.3.1.1.1 FDD reference test frequencies for operating band 1	40
4.3.1.1.1A FDD reference test frequencies for CA in operating band 1.....	41
4.3.1.1.2 FDD reference test frequencies for operating band 2	41
4.3.1.1.2A FDD reference test frequencies for CA in operating band 2.....	42
4.3.1.1.3 FDD reference test frequencies for operating band 3	44
4.3.1.1.3A FDD reference test frequencies for CA in operating band 3.....	44
4.3.1.1.4 FDD reference test frequencies for operating band 4	45
4.3.1.1.4A FDD reference test frequencies for CA in operating band 4.....	46
4.3.1.1.5 FDD reference test frequencies for operating band 5	47
4.3.1.1.5A FDD reference test frequencies for CA in operating band 5.....	47
4.3.1.1.6 FDD reference test frequencies for operating band 6	48
4.3.1.1.7 FDD reference test frequencies for operating band 7	48
4.3.1.1.7A FDD reference test frequencies for CA in operating band 7.....	49
4.3.1.1.8 FDD reference test frequencies for operating band 8	50
4.3.1.1.8A FDD reference test frequencies for CA in operating band 8.....	51
4.3.1.1.9 FDD reference test frequencies for operating band 9	51
4.3.1.1.10 FDD reference test frequencies for operating band 10	51
4.3.1.1.11 FDD reference test frequencies for operating band 11	52
4.3.1.1.12 FDD reference test frequencies for operating band 12	52
4.3.1.1.12A FDD reference test frequencies for CA in operating band 12.....	52
4.3.1.1.13 FDD reference test frequencies for operating band 13	53
4.3.1.1.14 FDD reference test frequencies for operating band 14	53
4.3.1.1.15 FDD reference test frequencies for operating band 15	53
4.3.1.1.16 FDD reference test frequencies for operating band 16	53
4.3.1.1.17 FDD reference test frequencies for operating band 17	53
4.3.1.1.18 FDD reference test frequencies for operating band 18	54
4.3.1.1.19 FDD reference test frequencies for operating band 19	54

4.3.1.1.20	FDD reference test frequencies for operating band 20	54
4.3.1.1.21	FDD reference test frequencies for operating band 21	55
4.3.1.1.22	FDD reference test frequencies for operating band 22	55
4.3.1.1.23	FDD reference test frequencies for operating band 23	55
4.3.1.1.23A	FDD reference test frequencies for CA in operating band 23.....	56
4.3.1.1.24	FDD reference test frequencies for operating band 24	56
4.3.1.1.25	FDD reference test frequencies for operating band 25	56
4.3.1.1.25A	FDD reference test frequencies for CA in operating band 25.....	57
4.3.1.1.26	FDD reference test frequencies for operating band 26	57
4.3.1.1.27	FDD reference test frequencies for operating band 27	58
4.3.1.1.27A	FDD reference test frequencies for CA in operating band 27.....	58
4.3.1.1.28	FDD reference test frequencies for operating band 28	59
4.3.1.1.29	FDD reference test frequencies for CA in operating band 29.....	60
4.3.1.1.31	FDD reference test frequencies for operating band 31	60
4.3.1.1.32	FDD reference test frequencies for CA in operating band 32.....	60
4.3.1.1.33 to 4.3.1.1.64	Void.....	61
4.3.1.1.65	FDD reference test frequencies for operating band 65	61
4.3.1.1.66	FDD reference test frequencies for operating band 66	62
4.3.1.1.66A	FDD reference test frequencies for CA in operating band 66.....	63
4.3.1.1.67	FDD reference test frequencies for CA in operating band 67.....	81
4.3.1.1.68	FDD reference test frequencies for operating band 68	83
4.3.1.1.69	FDD reference test frequencies for operating band 69	83
4.3.1.1.70	FDD reference test frequencies for operating band 70	83
4.3.1.1.70A	FDD reference test frequencies for CA in operating band 70.....	84
4.3.1.1.71	FDD reference test frequencies for operating band 71	84
4.3.1.1.72	FDD reference test frequencies for operating band 72	84
4.3.1.1.73	Void.....	85
4.3.1.1.74	FDD reference test frequencies for operating band 74	85
4.3.1.2	TDD Mode Test frequencies	85
4.3.1.2.1	TDD reference test frequencies for Operating Band 33	85
4.3.1.2.2	TDD reference test frequencies for Operating Band 34	85
4.3.1.2.3	TDD reference test frequencies for Operating Band 35	86
4.3.1.2.4	TDD reference test frequencies for Operating Band 36	86
4.3.1.2.5	TDD reference test frequencies for Operating Band 37	86
4.3.1.2.6	TDD reference test frequencies for Operating Band 38	87
4.3.1.2.6A	TDD reference test frequencies for CA in operating band 38	87
4.3.1.2.7	TDD reference test frequencies for Operating Band 39	87
4.3.1.2.7A	TDD reference test frequencies for CA in Operating Band 39.....	88
4.3.1.2.8	TDD reference test frequencies for Operating Band 40	88
4.3.1.2.8A	TDD reference test frequencies for CA in operating band 40	89
4.3.1.2.9	TDD reference test frequencies for Operating Band 41	91
4.3.1.2.9A	TDD reference test frequencies for CA in operating band 41	91
4.3.1.2.10	TDD reference test frequencies for Operating Band 42	105
4.3.1.2.10A	TDD reference test frequencies for CA in operating band 42	105
4.3.1.2.11	TDD reference test frequencies for Operating Band 43	113
4.3.1.2.12	TDD reference test frequencies for Operating Band 44	113
4.3.1.2.13	TDD reference test frequencies for Operating Band 45	113
4.3.1.2.14	TDD reference test frequencies for Operating Band 46	114
4.3.1.2.14A	TDD reference test frequencies for CA in operating Band 46.....	114
4.3.1.2.15	TDD reference test frequencies for Operating Band 47	115
4.3.1.2.16	TDD reference test frequencies for Operating Band 48	116
4.3.1.3	HRPD Test frequencies.....	116
4.3.1.3.1	HRPD test frequencies for Band Class 0.....	116
4.3.1.3.2	HRPD test frequencies for Band Class 1	116
4.3.1.3.3	HRPD test frequencies for Band Class 3	116
4.3.1.3.4	HRPD test frequencies for Band Class 4.....	116
4.3.1.3.5	HRPD test frequencies for Band Class 6.....	117
4.3.1.3.6	HRPD test frequencies for Band Class 10.....	117
4.3.1.3.7	HRPD test frequencies for Band Class 15.....	117
4.3.1.4	1xRTT Test frequencies	117
4.3.1.4.1	1xRTT test frequencies for Band Class 0.....	117
4.3.1.4.2	1xRTT test frequencies for Band Class 1	117

4.3.1.4.3	1xRTT test frequencies for Band Class 3	118
4.3.1.4.4	1xRTT test frequencies for Band Class 4	118
4.3.1.4.5	1xRTT test frequencies for Band Class 6	118
4.3.1.4.6	1xRTT test frequencies for Band Class 10	118
4.3.1.4.7	1xRTT test frequencies for Band Class 15	118
4.3.1.5	MFBI Test frequencies	118
4.3.1.5.1	MFBI Test frequencies for operation band 2 overlapping with band 25	119
4.3.1.5.2	MFBI Test frequencies for operation band 3 overlapping with band 9	119
4.3.1.5.3	MFBI Test frequencies for operation band 4 overlapping with band 10	119
4.3.1.5.4	MFBI Test frequencies for operation band 5 overlapping with band 18	119
4.3.1.5.5	MFBI Test frequencies for operation band 5 overlapping with band 19	120
4.3.1.5.6	MFBI Test frequencies for operation band 5 overlapping with band 26	120
4.3.1.5.7	MFBI Test frequencies for operation band 9 overlapping with band 3	120
4.3.1.5.8	MFBI Test frequencies for operation band 10 overlapping with band 4	120
4.3.1.5.9	MFBI Test frequencies for operation band 12 overlapping with band 17	120
4.3.1.5.10	MFBI Test frequencies for operation band 17 overlapping with band 12	121
4.3.1.5.11	MFBI Test frequencies for operation band 18 overlapping with band 5	121
4.3.1.5.12	MFBI Test frequencies for operation band 18 overlapping with band 26	121
4.3.1.5.13	MFBI Test frequencies for operation band 18 overlapping with band 27	121
4.3.1.5.14	MFBI Test frequencies for operation band 19 overlapping with band 5	121
4.3.1.5.15	MFBI Test frequencies for operation band 19 overlapping with band 26	121
4.3.1.5.16	MFBI Test frequencies for operation band 25 overlapping with band 2	122
4.3.1.5.17	MFBI Test frequencies for operation band 26 overlapping with band 5	122
4.3.1.5.18	MFBI Test frequencies for operation band 26 overlapping with band 18	122
4.3.1.5.19	MFBI Test frequencies for operation band 26 overlapping with band 19	123
4.3.1.5.20	MFBI Test frequencies for operation band 26 overlapping with band 27	123
4.3.1.5.21	MFBI Test frequencies for operation band 27 overlapping with band 18	124
4.3.1.5.22	MFBI Test frequencies for operation band 27 overlapping with band 26	124
4.3.1.5.23	MFBI Test frequencies for operation band 33 overlapping with band 39	124
4.3.1.5.24	MFBI Test frequencies for operation band 38 overlapping with band 41	124
4.3.1.5.25	MFBI Test frequencies for operation band 39 overlapping with band 33	124
4.3.1.5.26	MFBI Test frequencies for operation band 41 overlapping with band 38	125
4.3.1.5.27	MFBI Test frequencies for operation band 66 overlapping with band 4	125
4.3.1.5.28	MFBI Test frequencies for operation band 66 overlapping with band 10	125
4.3.1.6	WLAN Test frequencies	126
4.3.1.6.1	WLAN Test frequencies for 2.4 GHz ISM Band	126
4.3.1.6.2	WLAN Test frequencies for 5 GHz ISM Band	126
4.3.2	Radio conditions	126
4.3.2.1	Normal propagation condition	126
4.3.3	Physical channel allocations	126
4.3.3.1	Antennas	126
4.3.3.2	Downlink physical channels and physical signals	126
4.3.3.3	Mapping of downlink physical channels and signals to physical resources	127
4.3.3.4	Uplink physical channels and physical signals	133
4.3.3.5	Mapping of uplink physical channels and signals to physical resources	133
4.3.4	Signal levels	133
4.3.4.1	Downlink signal levels	133
4.3.4.2	Uplink signal levels	134
4.3.5	Standard test signals	134
4.3.5.1	Downlink test signals	134
4.3.5.2	Uplink test signals	134
4.3.6	Physical layer parameters	134
4.3.6.1	Downlink physical layer parameters	134
4.3.6.1.1	Physical layer parameters for DCI format 0	134
4.3.6.1.1A	Physical layer parameters for DCI format 0C	135
4.3.6.1.1B	Physical layer parameters for DCI format 0A	136
4.3.6.1.1C	Physical layer parameters for DCI format 0B	136
4.3.6.1.2	Physical layer parameters for DCI format 1	137
4.3.6.1.3	Physical layer parameters for DCI format 1A	137
4.3.6.1.3A	Physical layer parameters for DCI format 1B	138
4.3.6.1.4	Physical layer parameters for DCI format 1C	138
4.3.6.1.5	Physical layer parameters for DCI format 2	139

4.3.6.1.6	Physical layer parameters for DCI format 2A	140
4.3.6.1.6A	Physical layer parameters for DCI format 3B	140
4.3.6.1.6B	Physical layer parameters for DCI format 4A	141
4.3.6.1.6C	Physical layer parameters for DCI format 4B	141
4.3.6.1.7	Physical layer parameters for DCI format 5	142
4.3.6.1.7A	Physical layer parameters for DCI format 5A	142
4.3.6.1.8	Physical layer parameters for DCI format 6-0A	142
4.3.6.1.9	Physical layer parameters for DCI format 6-0B	144
4.3.6.1.10	Physical layer parameters for DCI format 6-1A	145
4.3.6.1.11	Physical layer parameters for DCI format 6-1B	147
4.3.6.1.12	Physical layer parameters for DCI format 6-2	148
4.4	Reference system configurations	148
4.4.1	Simulated network scenarios	148
4.4.1.1	Single cell network scenarios	148
4.4.1.2	E-UTRA single mode multi cell network scenarios	148
4.4.1.3	E-UTRA dual mode multi cell network scenarios	149
4.4.1.4	3GPP Inter-RAT network scenarios	149
4.4.1.5	3GPP2 Inter-RAT network scenarios	149
4.4.1.6	WLAN Inter-RAT network scenarios	149
4.4.2	Simulated cells	149
4.4.3	Common parameters for simulated E-UTRA cells	156
4.4.3.1	Common configurations of system information blocks	156
4.4.3.1.1	Combinations of system information blocks	156
4.4.3.1.2	Scheduling of system information blocks	161
4.4.3.2	Common contents of system information messages	166
-	<i>MasterInformationBlock</i>	166
-	<i>SystemInformation</i>	167
-	<i>SystemInformation-BR-r13</i>	167
-	<i>SystemInformationBlockType1</i>	169
-	<i>SystemInformationBlockType1-BR-r13</i>	172
4.4.3.3	Common contents of system information blocks	176
-	<i>SystemInformationBlockType2</i>	176
-	<i>SystemInformationBlockType3</i>	179
-	<i>SystemInformationBlockType4</i>	180
-	<i>SystemInformationBlockType5</i>	180
-	<i>SystemInformationBlockType6</i>	184
-	<i>SystemInformationBlockType7</i>	186
-	<i>SystemInformationBlockType8</i>	187
-	<i>SystemInformationBlockType9</i>	190
-	<i>SystemInformationBlockType10</i>	190
-	<i>SystemInformationBlockType11</i>	192
-	<i>SystemInformationBlockType12</i>	194
-	<i>SystemInformationBlockType13</i>	195
-	<i>SystemInformationBlockType14</i>	195
-	<i>SystemInformationBlockType15</i>	196
-	<i>SystemInformationBlockType17</i>	197
-	<i>SystemInformationBlockType18</i>	197
-	<i>SystemInformationBlockType19</i>	204
-	<i>SystemInformationBlockType20</i>	209
-	<i>SystemInformationBlockType21</i>	209
4.4.3.4	Channel-bandwidth-dependent parameters in system information blocks	210
4.4.4	Common parameters for simulated UTRA cells	211
4.4.4.1	Common contents of system information blocks for UTRA cells	212
-	System Information Block type 19	212
4.4.4.2	UTRA SIB scheduling for inter EUTRA - UTRA test	216
4.4.4.3	UTRA SIB scheduling for inter EUTRA - UTRA - GERAN test	216
4.4.5	Common parameters for simulated GERAN cells	217
4.4.6	Common parameters for simulated CDMA2000 cells	220
4.4.7	Default parameters specific for simulated cells	221
4.4.7.1	Common contents of HRPD Overhead messages	221
4.4.7.2	Common contents of 1XRTT Overhead messages	226
4.4.7.2.1	Configuration sequence number	226

4.4.7.2.2	Over Head messages.....	227
4.4.8	Common parameters for simulated WLAN AP's	236
4.5	Generic procedures.....	237
4.5.1	UE test states.....	237
4.5.2	UE Registration (State 2).....	243
4.5.2.1	Initial conditions	244
4.5.2.2	Definition of system information messages	244
4.5.2.3	Procedure	245
4.5.2.4	Specific message contents.....	248
4.5.2A	UE Registration, UE Test Mode Activated (State 2A)	251
4.5.2A.1	Initial conditions	251
4.5.2A.2	Definition of system information messages	251
4.5.2A.3	Procedure	252
4.5.2A.4	Specific message contents.....	254
4.5.2AA	UE Registration in cell supporting BL/CE UE (State 2-CE)	255
4.5.2AA.1	Initial conditions	255
4.5.2AA.2	Definition of system information messages	255
4.5.2AA.3	Procedure	256
4.5.2AA.4	Specific message contents.....	256
4.5.2AB	UE Registration, UE Test Mode Activated in cell supporting BL/CE UE (State 2A-CE).....	256
4.5.2AB.1	Initial conditions	256
4.5.2AB.2	Definition of system information messages	256
4.5.2AB.3	Procedure	257
4.5.2AB.4	Specific message contents.....	257
4.5.2B	UE Registration, pre-registration on HRPD (State 2B)	257
4.5.2B.1	Initial conditions	257
4.5.2B.2	Definition of system information messages	257
4.5.2B.3	Procedure	258
4.5.2B.4	Specific message contents.....	263
4.5.2C	UE Registration, pre-registration on 1xRTT (State 2C)	264
4.5.2C.1	Initial conditions	264
4.5.2C.2	Definition of system information messages	264
4.5.2C.3	Procedure	266
4.5.2C.4	Specific message contents.....	266
4.5.2D	UE Registration, 2 PDN for RAN Assisted WLAN Interworking (State 2).....	272
4.5.2D.1	Initial conditions	272
4.5.2D.2	Definition of system information messages	272
4.5.2D.3	Procedure	273
4.5.2D.4	Specific message contents.....	273
4.5.3	Generic Radio Bearer Establishment (State 3).....	275
4.5.3.1	Initial conditions	275
4.5.3.2	Definition of system information messages	275
4.5.3.3	Procedure	276
4.5.3.4	Specific message contents.....	278
4.5.3A	Generic Radio Bearer Establishment, UE Test Mode Activated (State 3A).....	278
4.5.3A.1	Initial conditions	278
4.5.3A.2	Definition of system information messages	278
4.5.3A.3	Procedure	279
4.5.3A.4	Specific message contents.....	279
4.5.3AA	Generic Radio Bearer Establishment (State 3-CE)	279
4.5.3AA.1	Initial conditions	279
4.5.3AA.2	Definition of system information messages	279
4.5.3AA.3	Procedure	279
4.5.3AA.4	Specific message contents.....	279
4.5.3AB	Generic Radio Bearer Establishment, UE Test Mode Activated (State 3A-CE)	279
4.5.3AB.1	Initial conditions	279
4.5.3AB.2	Definition of system information messages	280
4.5.3AB.3	Procedure	280
4.5.3AB.4	Specific message contents.....	280
4.5.3B	Generic Radio Bearer Establishment, pre-registered on HRPD (State 3B)	280
4.5.3B.1	Initial conditions	280
4.5.3B.2	Definition of system information messages	280

4.5.3B.3	Procedure	280
4.5.3B.4	Specific message contents	280
4.5.3C	Generic Radio Bearer Establishment, pre-registered on 1xRTT (State 3C)	280
4.5.3C.1	Initial conditions	280
4.5.3C.2	Definition of system information messages	281
4.5.3C.3	Procedure	281
4.5.3C.4	Specific message contents	281
4.5.3D	Generic Radio Bearer Establishment for RAN Assisted WLAN Interworking (State 3)	281
4.5.3D.1	Initial conditions	281
4.5.3D.2	Definition of system information messages	281
4.5.3D.3	Procedure	282
4.5.3D.4	Specific message contents	282
4.5.3E	Control plane CIoT connection request (State 3-CP)	282
4.5.3E.1	Initial conditions	282
4.5.3E.2	Definition of system information messages	282
4.5.3E.3	Procedure	283
4.5.3E.4	Specific message contents	283
4.5.3EA	Control plane CIoT connection request, UE Test Mode Activated (State 3A-CP)	283
4.5.3EA.1	Initial conditions	283
4.5.3EA.2	Definition of system information messages	283
4.5.3EA.3	Procedure	283
4.5.3EA.4	Specific message contents	283
4.5.3F	User plane CIoT connection request (State 3-UP)	284
4.5.3F.1	Initial conditions	284
4.5.3F.2	Definition of system information messages	284
4.5.3F.3	Procedure	284
4.5.3F.4	Specific message contents	284
4.5.3FA	User plane CIoT connection request, UE Test Mode Activated (State 3A-UP)	284
4.5.3FA.1	Initial conditions	284
4.5.3FA.2	Definition of system information messages	285
4.5.3FA.3	Procedure	285
4.5.3FA.4	Specific message contents	285
4.5.4	Loopback Activation (State 4)	285
4.5.4.1	Initial conditions	285
4.5.4.2	Definition of system information messages	285
4.5.4.3	Procedure	285
4.5.4.4	Specific message contents	285
4.5.4A	Loopback Activation in cell supporting BL/CE UE (State 4-CE)	285
4.5.4A.1	Initial conditions	285
4.5.4A.2	Definition of system information messages	286
4.5.4A.3	Procedure	286
4.5.4A.4	Specific message contents	286
4.5.4B	Loopback Activation user plane (State 4A-UP)	286
4.5.4B.1	Initial conditions	286
4.5.4B.2	Definition of system information messages	286
4.5.4B.3	Procedure	286
4.5.4B.4	Specific message contents	286
4.5.5	HRPD registration (State H2)	287
4.5.5.1	Initial conditions	287
4.5.5.2	Definition of system information messages	287
4.5.5.3	Procedure	287
4.5.5.4	Specific message contents	287
4.5.5A	HRPD registration, pre-registration on E-UTRAN (State H2A)	287
4.5.5A.1	Initial conditions	287
4.5.5A.2	Definition of system information messages	287
4.5.5A.3	Procedure	287
4.5.5A.4	Specific message contents	287
4.5.6	HRPD session establishment (State H3)	288
4.5.6.1	Initial conditions	288
4.5.6.2	Definition of system information messages	288
4.5.6.3	Procedure	288
4.5.6.4	Specific message contents	288

4.5.6A	HRPD session establishment, pre-registered on E-UTRAN (State H3A).....	288
4.5.6A.1	Initial conditions	288
4.5.6A.2	Definition of system information messages	288
4.5.6A.3	Procedure	288
4.5.6A.4	Specific message contents.....	288
4.5.7	Out of Coverage (State 5)	289
4.5.7.1	Initial conditions	289
4.5.7.2	Definition of system information messages	289
4.5.7.3	Procedure	289
4.5.8	Out of Coverage, V2X setup (State 5-V2X)	289
4.5.8.1	Initial conditions	289
4.5.8.2	Definition of system information messages	289
4.5.8.3	Procedure	289
4.5.9	Out of Coverage, Test Loopback Activation, V2X setup (State 5A-V2X).....	289
4.5.9.1	Initial conditions	289
4.5.9.2	Definition of system information messages	290
4.5.9.3	Procedure	290
4.5.9.4	Specific message contents.....	290
4.5A	Other generic procedures.....	291
4.5A.1	Procedure for IP address allocation in the U-plane.....	291
4.5A.2	Tracking area updating procedure.....	291
4.5A.3	Procedure for IMS signalling.....	292
4.5A.3A	Procedure for IMS Signalling over UTRA	293
4.5A.3A.1	Initial conditions	293
4.5A.3A.2	Procedure	294
4.5A.3A.3	Specific message contents.....	295
4.5A.3B	Procedure for preventing IMS Signalling over GERAN	297
4.5A.3B.1	Initial conditions	297
4.5A.3B.2	Procedure	298
4.5A.3B.3	Specific message contents.....	298
4.5A.4	Generic Test Procedure for IMS Emergency call establishment in EUTRA: Normal Service.....	299
4.5A.4.1	Initial conditions	299
4.5A.4.2	Definition of system information messages	299
4.5A.4.3	Procedure	299
4.5A.4.4	Specific message contents.....	302
4.5A.5	Generic Test Procedure for IMS Emergency call establishment in EUTRA: Limited Service.....	303
4.5A.5.1	Initial conditions	303
4.5A.5.2	Definition of system information messages	303
4.5A.5.3	Procedure	304
4.5A.5.4	Specific message contents.....	307
4.5A.6	Generic Test Procedure for IMS MO speech call establishment in E-UTRA.....	309
4.5A.6.1	Initial conditions	309
4.5A.6.2	Definition of system information messages	309
4.5A.6.3	Procedure	310
4.5A.6.4	Specific message contents.....	311
4.5A.7	Generic Test Procedure for IMS MT Speech call establishment in E-UTRA	311
4.5A.7.1	Initial conditions	311
4.5A.7.2	Definition of system information messages	311
4.5A.7.3	Procedure	312
4.5A.7.4	Specific message contents.....	314
4.5A.8	Generic Test Procedure for IMS MO video call establishment in E-UTRA.....	314
4.5A.8.1	Initial conditions	314
4.5A.8.2	Definition of system information messages	314
4.5A.8.3	Procedure	315
4.5A.8.4	Specific message contents.....	316
4.5A.9	Generic Test Procedure for IMS MT video call establishment in E-UTRA	316
4.5A.9.1	Initial conditions	316
4.5A.9.2	Definition of system information messages	316
4.5A.9.3	Procedure	317
4.5A.9.4	Specific message contents.....	317
4.5A.10	Generic Test Procedure for IMS MO speech and aSRVCC in E-UTRA.....	318
4.5A.10.1	Initial conditions	318

4.5A.10.2	Definition of system information messages	318
4.5A.10.3	Procedure	319
4.5A.10.4	Specific message contents	320
4.5A.11	Generic Test Procedure for IMS MO add video establishment in E-UTRA	320
4.5A.11.1	Initial conditions	320
4.5A.11.2	Definition of system information messages	320
4.5A.11.3	Procedure	320
4.5A.11.4	Specific message contents	321
4.5A.12	Generic Test Procedure for IMS MT add video establishment in E-UTRA	321
4.5A.12.1	Initial conditions	321
4.5A.12.2	Definition of system information messages	321
4.5A.12.3	Procedure	321
4.5A.12.4	Specific message contents	322
4.5A.14	Generic Test Procedure for IMS XCAP establishment in EUTRA	322
4.5A.14.1	Initial conditions	322
4.5A.14.2	Definition of system information messages	322
4.5A.14.3	Procedure	323
4.5A.14.4	Specific message contents	323
4.5A.15	Generic Test Procedure for EPS Bearer Deactivation	323
4.5A.15.1	Initial conditions	323
4.5A.15.2	Definition of system information messages	323
4.5A.15.3	Procedure	324
4.5A.15.4	Specific message contents	324
4.5A.15A	Generic Test Procedure for User or Network Initiated EPS Bearer Deactivation	325
4.5A.15A.1	Initial conditions	325
4.5A.15A.2	Definition of system information messages	325
4.5A.15A.3	Procedure	325
4.5A.15A.4	Specific message contents	326
4.5A.16	Generic Test Procedure to establish additional PDN connectivity	326
4.5A.16.1	Initial conditions	326
4.5A.16.2	Definition of system information messages	326
4.5A.16.3	Procedure	327
4.5A.16.4	Specific message contents	327
4.5A.17	Generic Test Procedure for user initiated release of additional PDN connectivity	328
4.5A.17.1	Initial conditions	328
4.5A.17.2	Definition of system information messages	328
4.5A.17.3	Procedure	329
4.5A.17.4	Specific message contents	329
4.5A.18	Generic Test Procedure for network initiated release of additional PDN connectivity	330
4.5A.18.1	Initial conditions	330
4.5A.18.2	Definition of system information messages	331
4.5A.18.3	Procedure	331
4.5A.18.4	Specific message contents	331
4.5A.19	Generic Test Procedure for IMS MO speech call establishment in E-UTRA / EVS	332
4.5A.19.1	Initial conditions	332
4.5A.19.2	Definition of system information messages	332
4.5A.19.3	Procedure	332
4.5A.19.4	Specific message contents	333
4.5A.20	Generic Test Procedure for IMS MT speech call establishment in E-UTRA / EVS	333
4.5A.20.1	Initial conditions	333
4.5A.20.2	Definition of system information messages	333
4.5A.20.3	Procedure	333
4.5A.20.4	Specific message contents	333
4.5A.21	Generic Test Procedure for IMS MO Customized Alerting Tones and speech establishment in E-UTRA	334
4.5A.21.1	Initial conditions	334
4.5A.21.2	Definition of system information messages	334
4.5A.21.3	Procedure	334
4.5A.21.4	Specific message contents	334
4.5A.22	Communication with the ProSe Function: Initial Access	334
4.5A.22.1	Initial conditions	334
4.5A.22.2	Definition of system information messages	334

4.5A.22.3	Procedure	335
4.5A.22.4	Specific message contents.....	337
4.5A.22A	Communication with the ProSe Function: Subsequent Access	337
4.5A.22A.1	Initial conditions	337
4.5A.22A.2	Definition of system information messages	337
4.5A.22A.3	Procedure	337
4.5A.22A.4	Specific message contents.....	338
4.5A.23	Generic Test Procedure for IMS registration in EPC / WLAN.....	338
4.5A.23.1	Initial conditions	338
4.5A.23.2	Definition of system information messages	338
4.5A.23.3	Procedure	339
4.5A.23.4	Specific message contents.....	339
4.5A.23A	Generic Test Procedure for IPsec Tunnel Disconnection in EPC / WLAN.....	339
4.5A.23A.1	Initial conditions	339
4.5A.23A.2	Definition of system information messages	339
4.5A.23A.3	Procedure	339
4.5A.23A.4	Specific message contents.....	339
4.5A.24	Generic Test Procedure for IMS emergency call establishment in EPC / WLAN.....	340
4.5A.24.1	Initial conditions	340
4.5A.24.2	Definition of system information messages	340
4.5A.24.3	Procedure	340
4.5A.24.4	Specific message contents.....	340
4.5A.25	Generic Test Procedure for XCAP establishment in EPC / WLAN	340
4.5A.25.1	Initial conditions	340
4.5A.25.2	Definition of system information messages	340
4.5A.25.3	Procedure	341
4.5A.25.4	Specific message contents.....	341
4.5A.26	Generic Test Procedure for eCall over IMS establishment in EUTRA: Normal Service	341
4.5A.26.1	Initial conditions	341
4.5A.26.2	Definition of system information messages	341
4.5A.26.3	Procedure	341
4.5A.26.4	Specific message contents.....	343
4.5A.27	Generic Test Procedure for eCall over IMS establishment in EUTRA: eCall Only Support.....	344
4.5A.27.1	Initial conditions	344
4.5A.27.2	Definition of system information messages	344
4.5A.27.3	Procedure	344
4.5A.27.4	Specific message contents.....	346
4.5A.28	Generic Test Procedure for Converged IP Communications establishment in EUTRA.....	347
4.5A.29	Generic Test Procedure for Converged IP Communications establishment in EPC / WLAN.....	348
4.6	Default RRC message and information elements contents.....	349
4.6.1	Contents of RRC messages.....	349
-	<i>CounterCheck</i>	349
-	<i>CounterCheckResponse</i>	350
-	<i>CSFBParametersRequestCDMA2000</i>	350
-	<i>CSFBParametersResponseCDMA2000</i>	350
-	<i>DLInformationTransfer</i>	351
-	<i>HandoverFromEUTRAPreparationRequest</i>	351
-	<i>LoggedMeasurementConfiguration</i>	352
-	<i>MasterInformationBlock-SL</i>	353
-	<i>MasterInformationBlock-SL-V2X</i>	354
-	<i>MBMSCountingRequest</i>	354
-	<i>MBMSCountingResponse</i>	355
-	<i>MBMSInterestIndication</i>	355
-	<i>MBSFNAreaConfiguration</i>	356
-	<i>MeasurementReport</i>	356
-	<i>MobilityFromEUTRACommand</i>	357
-	<i>Paging</i>	357
-	<i>RRCConnectionReconfiguration</i>	358
-	<i>RRCConnectionReconfiguration (SideLink)</i>	363
-	<i>RRCConnectionReconfiguration (V2X)</i>	370
-	<i>RRCConnectionReconfigurationComplete</i>	371
-	<i>RRCConnectionReestablishment</i>	372

-	<i>RRConnectionReestablishmentComplete</i>	372
-	<i>RRConnectionReestablishmentReject</i>	372
-	<i>RRConnectionReestablishmentRequest</i>	373
-	<i>RRConnectionReject</i>	373
-	<i>RRConnectionRelease</i>	374
-	<i>RRConnectionRequest</i>	374
-	<i>RRConnectionResume</i>	375
-	<i>RRConnectionResumeComplete</i>	375
-	<i>RRConnectionResumeRequest</i>	376
-	<i>RRConnectionSetup</i>	376
-	<i>RRConnectionSetupComplete</i>	377
-	<i>SCGFailureInformationNR</i>	378
-	<i>SCPTMConfiguration</i>	380
-	<i>SecurityModeCommand</i>	381
-	<i>SecurityModeComplete</i>	381
-	<i>SecurityModeFailure</i>	381
-	<i>SidelinkUEInformation</i>	382
-	<i>SidelinkUEInformation (V2X)</i>	383
-	<i>UECapabilityEnquiry</i>	384
-	<i>UECapabilityInformation</i>	385
-	<i>UEInformationRequest</i>	392
-	<i>UEInformationResponse</i>	393
-	<i>ULHandoverPreparationTransfer</i>	393
-	<i>ULInformationTransfer</i>	394
-	<i>UEAssistanceInformation</i>	394
-	<i>ULInformationTransferMRDC</i>	395
4.6.2	System information blocks	395
4.6.3	Radio resource control information elements	395
-	<i>BCCH-Config-DEFAULT</i>	395
-	<i>CellSelectionInfoCE-r13-DEFAULT</i>	396
-	<i>CQI-ReportAperiodic-r10-DEFAULT</i>	396
-	<i>CQI-ReportConfig-DEFAULT</i>	397
-	<i>CQI-ReportConfig-r10-DEFAULT</i>	397
-	<i>CQI-ReportConfig-v1130-eIMTA</i>	402
-	<i>CQI-ReportConfig-v1250-DEFAULT</i>	404
-	<i>CQI-ReportConfigSCell-r10-DEFAULT</i>	405
-	<i>CQI-ReportPeriodic-r10-DEFAULT</i>	405
-	<i>CSI-RS-ConfigNZP-r11-DEFAULT</i>	406
-	<i>CSI-RS-ConfigZP-r11-DEFAULT</i>	406
-	<i>DMRS-Config-r11-DEFAULT</i>	407
-	<i>DRB-ToAddModList-RECONFIG</i>	407
-	<i>EPDCCH-Config-r11-DEFAULT</i>	407
-	<i>EPDCCH-Config-r11-eIMTA</i>	410
-	<i>FreqHoppingParameters-r13-DEFAULT</i>	412
-	<i>PCCH-Config-DEFAULT</i>	413
-	<i>PCCH-Config-v1310-DEFAULT</i>	413
-	<i>PHICH-Config-DEFAULT</i>	413
-	<i>PDSCH-ConfigCommon-DEFAULT</i>	414
-	<i>PDSCH-ConfigCommon-v1310-DEFAULT</i>	414
-	<i>PDSCH-ConfigDedicated-DEFAULT</i>	414
-	<i>PDSCH-ConfigDedicated-v1130-DEFAULT</i>	415
-	<i>PhysicalConfigDedicatedSCell-r10-DEFAULT</i>	416
-	<i>PhysicalConfigDedicatedSCell-r10-eIMTA</i>	419
-	<i>PRACH-Config-DEFAULT</i>	420
-	<i>PRACH-Config-v1310-DEFAULT</i>	421
-	<i>PRACH-ConfigSIB-DEFAULT</i>	423
-	<i>PRACH-ConfigSIB-v1310-DEFAULT</i>	424
-	<i>PUCCH-ConfigCommon-DEFAULT</i>	429
-	<i>PUCCH-ConfigCommon-v1310-DEFAULT</i>	429
-	<i>PUCCH-ConfigDedicated-DEFAULT</i>	430
-	<i>PUCCH-ConfigDedicated-v1020-DEFAULT</i>	431
-	<i>PUCCH-ConfigDedicated-v1130-DEFAULT</i>	432

-	PUCCH-ConfigDedicated-v1250-DEFAULT	432
-	PUCCH-ConfigDedicated-r13-DEFAULT	433
-	PUSCH-ConfigCommon-DEFAULT	434
-	PUSCH-ConfigCommon-v1310DEFAULT	434
-	PUSCH-ConfigDedicated-r13DEFAULT	435
-	PUSCH-ConfigDedicated-v1130-DEFAULT	435
-	PUSCH-ConfigDedicated-v1250-DEFAULT	435
-	PUSCH-ConfigDedicated--DEFAULT	436
-	PUSCH-EnhancementsConfig-r14-DEFAULT	436
-	RACH-ConfigCommon-DEFAULT	437
-	Rach-ConfigDedicated-DEFAULT	439
-	RadioResourceConfigCommon-DEFAULT	440
-	RadioResourceConfigCommonSCell-r10-DEFAULT	443
-	RadioResourceConfigCommonSIB-DEFAULT	446
-	RadioResourceConfigDedicated-SRB1	447
-	RadioResourceConfigDedicated-SRB2-DRB(n,m)	448
-	RadioResourceConfigDedicated-DRB(n,m)	449
-	RadioResourceConfigDedicated-HO-TO-EUTRA(n,m)	450
-	RadioResourceConfigDedicated-AM-DRB-ADD(bid)	451
-	RadioResourceConfigDedicated-UM-DRB-ADD(bid)	451
-	RadioResourceConfigDedicated- DRB-REL(bid)	452
-	RadioResourceConfigDedicated-HO	452
-	RadioResourceConfigDedicatedSCell-r10-DEFAULT	452
-	RadioResourceConfigDedicated-SCell_AddMod	453
-	RadioResourceConfigDedicated-V2X	453
-	RadioResourceConfigDedicated-EN-DC-Split	454
-	RadioResourceConfigDedicated-EN-DC_Split_DRB_Rel(bid)	455
-	RadioResourceConfigDedicated-EN-DC-SRB2-DRB	455
-	RLC-Config-DRB-AM-RECONFIG	456
-	RLC-Config-DRB-UM-RECONFIG	456
-	RLC-Config-SRB-AM-RECONFIG	456
-	SCellToAddMod-r10-DEFAULT	457
-	SCellToRelease-r10-DEFAULT	457
-	SCG-Configuration-r12-DEFAULT	458
-	SchedulingRequest-Config-DEFAULT	462
-	SchedulingRequestConfigSCell-r13-DEFAULT	462
-	SL-CommResourcePoolV2X-r14-DEFAULT	463
-	SL-CommTxPoolSensingConfig-r14-DEFAULT	464
-	SL-InterFreqInfoV2X-r14-DEFAULT	465
-	SL-PSSCH-TxConfig-r14-DEFAULT	466
-	SL-TxPoolToAddMod-r14-DEFAULT	466
-	SL-TxPoolToReleaseListV2X-r14-DEFAULT	467
-	SL-V2X-ConfigDedicated-r14-DEFAULT	468
-	SL-V2X-InterFreqUE-Config-r14-DEFAULT	470
-	SL-V2X-PreconfigCommPool-r14-DEFAULT	471
-	SL-V2X-PreconfigFreqInfo-r14-DEFAULT	472
-	SoundingRS-UL-ConfigCommon-DEFAULT	473
-	SoundingRS-UL-ConfigDedicated-DEFAULT	473
-	SoundingRS-UL-ConfigDedicatedAperiodic-r10-DEFAULT	474
-	SRB-ToAddModList-RECONFIG	474
-	SRS-TPC-PDCCH-Config-r14-DEFAULT	475
-	TDD-Config-DEFAULT	475
-	TPC-PDCCH-Config-DEFAULT	475
-	TPC-PDCCH-ConfigSCell-r13-DEFAULT	476
-	UplinkPowerControlCommon-DEFAULT	476
-	UplinkPowerControlCommonSCell-r10-DEFAULT	477
-	UplinkPowerControlCommon-v1020-DEFAULT	477
-	UplinkPowerControlCommonSCell-v1310-DEFAULT	478
-	UplinkPowerControlDedicated-DEFAULT	478
-	UplinkPowerControlDedicated-v1020-DEFAULT	479
-	UplinkPowerControlDedicated-v1130-DEFAULT	479
-	UplinkPowerControlDedicated-v1250-DEFAULT	479

-	UplinkPowerControlDedicatedSCell-r10-DEFAULT	480
-	UplinkPowerControlDedicatedSCell-v1310-DEFAULT	480
-	RadioResourceConfigDedicated-DRB-Mod	480
-	RadioResourceConfigDedicated-PCell-PATTERN	481
-	OtherConfig-r9	481
-	WLAN-OffloadConfig-r12	482
-	EIMTA-MainConfig-r12-DEFAULT	483
-	EIMTA-MainConfigServCell-r12-DEFAULT	483
4.6.4	Security control information elements	484
-	SecurityConfigHO-DEFAULT	484
-	SecurityConfigSMC-DEFAULT	484
4.6.5	Mobility control information elements	485
-	MobilityControlInfo-HO	485
4.6.6	Measurement information elements	488
-	MeasConfig-DEFAULT	488
-	MeasGapConfig-GP1	489
-	MeasGapConfig-CE	489
-	MeasGapConfig-GP2	489
-	MeasDS-Config-DEFAULT	490
-	MeasCSI-RS-Config-DEFAULT	490
-	MeasObjectCDMA2000-GENERIC	491
-	ReportConfigToAddModList_DEFAULT	491
-	MeasIdToAddModList_DEFAULT	491
-	MeasObjectEUTRA-GENERIC	492
-	MeasObjectGERAN-GENERIC	493
-	MeasObjectNR-GENERIC	493
-	MeasObjectUTRA-GENERIC	494
-	QuantityConfig-DEFAULT	494
-	ReportConfigEUTRA-A1	495
-	ReportConfigEUTRA-A2	495
-	ReportConfigEUTRA-A3	496
-	ReportConfigEUTRA-A4	497
-	ReportConfigEUTRA-A5	498
-	ReportConfigEUTRA-A6	499
-	ReportConfigEUTRA-PERIODICAL	499
-	ReportConfigInterRAT-B1-GERAN	500
-	ReportConfig-B1-NR-r15	500
-	ReportConfigInterRAT-B1-UTRA	501
-	ReportConfigInterRAT-B2-CDMA2000	502
-	ReportConfigInterRAT-B2-GERAN	503
-	ReportConfigInterRAT-B2-UTRA	504
-	ReportConfigInterRAT-PERIODICAL	505
-	ReportConfigEUTRA-C1	505
-	ReportConfigEUTRA-C2	506
-	ReportConfigEUTRA-PERIODICAL-CSI-RS	507
-	ReportConfigEUTRA-V1	507
-	ReportConfigEUTRA-V2	508
4.6.7	Other information elements	508
-	RRC-TransactionIdentifier-DL	508
-	RRC-TransactionIdentifier-UL	508
4.6.8	Channel-bandwidth-dependent parameters	508
4.7	Default NAS message and information element contents	509
4.7.1	Security protected NAS messages	509
4.7.2	Contents of EMM messages	511
-	ATTACH ACCEPT	511
-	ATTACH COMPLETE	514
-	ATTACH REJECT	515
-	ATTACH REQUEST	516
-	AUTHENTICATION FAILURE	518
-	AUTHENTICATION REJECT	518
-	AUTHENTICATION REQUEST	519
-	AUTHENTICATION RESPONSE	519

-	CS SERVICE NOTIFICATION	520
-	CONTROL PLANE SERVICE REQUEST.....	520
-	DETACH ACCEPT (UE originating detach).....	521
-	DETACH ACCEPT (UE terminated detach).....	521
-	DETACH REQUEST (UE originating detach).....	522
-	DETACH REQUEST (UE terminated detach)	522
-	DOWNLINK NAS TRANSPORT.....	523
-	EMM INFORMATION	523
-	EMM STATUS	523
-	EXTENDED SERVICE REQUEST	524
-	GUTI REALLOCATION COMMAND	524
-	GUTI REALLOCATION COMPLETE	525
-	IDENTITY REQUEST	525
-	IDENTITY RESPONSE	525
-	SECURITY MODE COMMAND	526
-	SECURITY MODE COMPLETE	527
-	SECURITY MODE REJECT	527
-	SERVICE ACCEPT	527
-	SERVICE REJECT	528
-	SERVICE REQUEST	528
-	TRACKING AREA UPDATE ACCEPT	529
-	TRACKING AREA UPDATE COMPLETE.....	532
-	TRACKING AREA UPDATE REJECT	532
-	TRACKING AREA UPDATE REQUEST.....	533
-	UPLINK NAS TRANSPORT	535
4.7.3	Contents of ESM messages.....	536
-	ACTIVATE DEDICATED EPS BEARER CONTEXT ACCEPT	536
-	ACTIVATE DEDICATED EPS BEARER CONTEXT REJECT	537
-	ACTIVATE DEDICATED EPS BEARER CONTEXT REQUEST	538
-	ACTIVATE DEFAULT EPS BEARER CONTEXT ACCEPT	540
-	ACTIVATE DEFAULT EPS BEARER CONTEXT REJECT	540
-	ACTIVATE DEFAULT EPS BEARER CONTEXT REQUEST.....	542
-	BEARER RESOURCE ALLOCATION REJECT	547
-	BEARER RESOURCE ALLOCATION REQUEST.....	547
-	BEARER RESOURCE MODIFICATION REJECT	548
-	BEARER RESOURCE MODIFICATION REQUEST	549
-	DEACTIVATE EPS BEARER CONTEXT ACCEPT	550
-	DEACTIVATE EPS BEARER CONTEXT REQUEST.....	550
-	ESM DATA TRANSPORT	551
-	ESM DUMMY MESSAGE	551
-	ESM INFORMATION REQUEST.....	552
-	ESM INFORMATION RESPONSE.....	552
-	ESM STATUS	553
-	MODIFY EPS BEARER CONTEXT ACCEPT.....	553
-	MODIFY EPS BEARER CONTEXT REJECT.....	554
-	MODIFY EPS BEARER CONTEXT REQUEST	555
-	NOTIFICATION	556
-	PDN CONNECTIVITY REJECT	556
-	PDN CONNECTIVITY REQUEST	557
-	PDN DISCONNECT REJECT	558
-	PDN DISCONNECT REQUEST.....	558
4.7A	Default TC message and information element contents	559
-	ACTIVATE TEST MODE	559
-	ACTIVATE TEST MODE COMPLETE.....	559
-	CLOSE UE TEST LOOP.....	560
-	CLOSE UE TEST LOOP COMPLETE.....	563
-	DEACTIVATE TEST MODE	563
-	DEACTIVATE TEST MODE COMPLETE	563
-	OPEN UE TEST LOOP	564
-	OPEN UE TEST LOOP COMPLETE	564
-	UE TEST LOOP MODE C MBMS PACKET COUNTER REQUEST	564
-	UE TEST LOOP MODE C MBMS PACKET COUNTER RESPONSE	564

-	UE TEST LOOP PROSE PACKET COUNTER REQUEST	565
-	UE TEST LOOP PROSE PACKET COUNTER RESPONSE	565
-	UE TEST LOOP MODE F SCPTM PACKET COUNTER REQUEST	565
-	UE TEST LOOP MODE F SCPTM PACKET COUNTER RESPONSE	566
4.7B	Default UTRA message and information element contents	567
4.7B.1	UTRA RRC messages	567
-	HANDOVER TO UTRAN COMMAND	567
-	HANDOVER FROM UTRAN COMMAND	579
-	MEASUREMENT CONTROL	579
-	MEASUREMENT REPORT	581
-	PHYSICAL CHANNEL RECONFIGURATION	582
-	PHYSICAL CHANNEL RECONFIGURATION COMPLETE	584
-	RRC CONNECTION REQUEST	584
-	SECURITY MODE COMMAND	585
-	SECURITY MODE COMPLETE	585
-	UTRAN MOBILITY INFORMATION	585
-	UTRAN MOBILITY INFORMATION CONFIRM	585
4.7B.2	UTRA NAS messages	585
4.7C	Default DS-MIPv6 message and information element contents	595
4.7C.1	IKEv2 messages	595
-	IKEv2 IKE_SA_INIT Request	595
-	IKE_SA_INIT Response	598
-	IKE_AUTH Request	599
-	IKE_AUTH Response	602
4.7C.2	Messages used to perform DS-MIPv6 registration and deregistration	606
-	Router Advertisement	606
-	Binding Update	607
-	Binding Acknowledgement	608
-	Binding Revocation Indication	609
-	Binding Revocation Acknowledgement	610
4.7D	Default GERAN message and information element contents	611
4.7D.1	GPRS message	611
-	PS HANDOVER COMMAND	611
4.7E	Default HTTP messages for communication with the ProSe Function	612
-	HTTP Request	612
-	HTTP Response	612
4.7F	Default ProSe messages	613
4.7F.1	ProSe discovery messages	613
-	DISCOVERY_REQUEST	613
-	DISCOVERY_RESPONSE	614
-	MATCH_REPORT	618
-	MATCH_REPORT_ACK	619
-	PC5_DISCOVERY	620
4.7F.2	Messages transmitted over the PC3ch interface	624
-	USAGE_INFORMATION_REPORT_LIST	624
-	USAGE_INFORMATION_REPORT_LIST_RESPONSE	626
4.7F.3	ProSe Direct Communication Messages	627
-	DIRECT_COMMUNICATION_ACCEPT	627
-	DIRECT_COMMUNICATION_KEEPALIVE	627
-	DIRECT_COMMUNICATION_KEEPALIVE_ACK	628
-	DIRECT_COMMUNICATION_RELEASE	628
-	DIRECT_COMMUNICATION_RELEASE_ACCEPT	628
-	DIRECT_COMMUNICATION_REQUEST	629
-	DIRECT_SECURITY_MODE_COMMAND	630
-	DIRECT_SECURITY_MODE_COMPLETE	631
-	KEY_REQUEST	631
-	KEY_RESPONSE	632
-	MIKEY Key Delivery Message	633
-	MIKEY Verification Message	636
4.7G	Default IKEv2 message and information element contents	637
-	IKE_SA_INIT request	637
-	IKE_SA_INIT response	639

-	IKE_AUTH_request	639
-	IKE_AUTH response	640
4.7H	Default TLS message and information element contents	640
-	ClientHello	641
-	ServerHello	641
-	ServerKeyExchange	641
-	ServerHelloDone	641
-	ClientKeyExchange	641
-	ChangeCipherSpec	642
-	Finished	642
4.7I	Default AT Command message and information element	642
-	AT Command +CATM	642
-	AT Command +CCUTLE	643
-	AT Command +CUTCR	643
-	AT Command +CUSPCREQ	643
4.8	Reference radio bearer configurations	644
4.8.1	General	644
4.8.2	SRB and DRB parameters and combinations	644
4.8.2.1	SRB and DRB parameters	644
4.8.2.1.1	SRB configurations	644
4.8.2.1.2	DRB PDCP configurations	644
4.8.2.1.3	DRB RLC configurations	645
4.8.2.1.4	DRB Logical Channel configurations	646
4.8.2.1.5	MAC configurations	647
4.8.2.1.6	Physical Layer configurations	650
4.8.2.1.7	DRB configurations	660
4.8.2.2	SRB and DRB combinations	660
4.8.2.2.1	Combinations on DL-SCH and UL-SCH	660
4.8.3	UTRA reference radio parameters and combinations	660
4.8.4	GERAN reference PDP context parameters	661
4.9	Common test USIM, CSIM and ISIM parameters	661
4.9.1	General	661
4.9.1.1	Definitions	661
4.9.1.2	Definition of the test algorithm for authentication	661
4.9.1.2.1	Authentication and key derivation in the test USIM, CSIM and ISIM and SS	661
4.9.1.2.2	Generation of re-synchronization parameters in the USIM, CSIM and ISIM	662
4.9.1.2.3	Using the authentication test algorithm for UE conformance testing	662
4.9.2	Default parameters for the test USIM, CSIM and ISIM	662
4.9.3	Default settings for the Elementary Files (EFs)	662
4.9.3.1	Modified contents of the USIM Elementary Files and additional USIM Elements files at the DF ProSe level	662
4.9.3.2	Modified contents of the CSIM Elementary Files	669
4.9.3.3	Modified contents of the USIM Elementary Files and additional USIM Elements files at the MCPTT level	680
4.9.3.4	Modified contents of the USIM Elementary Files and additional USIM Elements files at the DF _{V2X} level	681
4.9.3.5	Modified contents of the Elementary Files for eCall over IMS	682
4.10	V2X reference configuration	682
4.10.1	Reference configuration for V2X Sidelink Communication	682
4.10.1.1	V2X Sidelink Communication <i>Preconfiguration</i> for out-of-network coverage operation	682
4.10.2	V2X management data object configuration	683
4.11	GNSS Requirements for V2X and MCS testing	686
4.11.1	General	686
4.11.2	GNSS Scenarios	686
5	Test environment for RF test	691
5.1	Requirements of test equipment	691
5.2	RF Reference system configurations	691
5.2.1	Common parameters for simulated E-UTRA cells	691
5.2.1.1	Combinations of system information blocks	691
5.2.1.2	Scheduling of system information blocks	692
5.2.1.3	Common contents of system information messages	692

5.2A	Generic RF procedures	693
5.2A.1	UE RF test states	694
5.2A.1A	Registered, Idle Mode, UE Test Mode Activated (State 2A-RF)	695
5.2A.1A.1	Initial conditions	695
5.2A.1A.2	Definition of system information messages	695
5.2A.1A.3	Procedure	696
5.2A.1A.4	Specific message contents	697
5.2A.1AA	Registered, Idle Mode, UE Test Mode Activated in cell supporting BL/CE UE (State 2A-RF-CE)	699
5.2A.1AA.1	Initial conditions	699
5.2A.1AA.2	Definition of system information messages	699
5.2A.1AA.3	Procedure	699
5.2A.1AA.4	Specific message contents	700
5.2A.2	Generic Default Radio Bearer Establishment, UE Test Mode Activated (State 3A-RF)	700
5.2A.2.1	Initial conditions	700
5.2A.2.2	Definition of system information messages	700
5.2A.2.3	Procedure	700
5.2A.2.4	Specific message contents	701
5.2A.2A	DC MCG/SCG Dedicated RB established, UE Test Mode Activate (State 3A-RF-DC1)	701
5.2A.2A.1	Initial conditions	701
5.2A.2A.2	Definition of system information messages	701
5.2A.2A.3	Procedure	701
5.2A.2A.4	Specific message contents	701
5.2A.2AA	Generic Default Radio Bearer Establishment, UE Test Mode Activated in cell supporting BL/CE UE (State 3A-RF-CE)	702
5.2A.2AA.1	Initial conditions	702
5.2A.2AA.2	Definition of system information messages	702
5.2A.2AA.3	Procedure	703
5.2A.2AA.4	Specific message contents	703
5.2A.2B	DC Split Default RB established, UE Test Mode Activate (State 3A-RF-DC2)	704
5.2A.2B.1	Initial conditions	704
5.2A.2B.2	Definition of system information messages	704
5.2A.2B.3	Procedure	704
5.2A.2B.4	Specific message contents	705
5.2A.2C	Generic Default Radio Bearer Establishment, UE Test Mode Activated, V2X Setup (State 3A-RF-V2X)	705
5.2A.2C.1	Initial conditions	705
5.2A.2C.2	Definition of system information messages	705
5.2A.2C.3	Procedure	705
5.2A.2C.4	Specific message contents	705
5.2A.3	Loopback Activation without looped data (State 4A-RF)	705
5.2A.3.1	Initial conditions	705
5.2A.3.2	Definition of system information messages	706
5.2A.3.3	Procedure	706
5.2A.3.4	Specific message contents	706
5.2A.3A	DC MCG/SCG DRBs Loopback Activation without looped data (State 4A-RF-DC1)	706
5.2A.3A.1	Initial conditions	706
5.2A.3A.2	Definition of system information messages	707
5.2A.3A.3	Procedure	707
5.2A.3A.4	Specific message contents	707
5.2A.3AA	Loopback Activation without looped data in cell supporting BL/CE UE (State 4A-RF-CE)	707
5.2A.3AA.1	Initial conditions	707
5.2A.3AA.2	Definition of system information messages	707
5.2A.3AA.3	Procedure	708
5.2A.3AA.4	Specific message contents	708
5.2A.3B	DC Split DRB Loopback Activation without looped data (State 4A-RF-DC2)	708
5.2A.3B.1	Initial conditions	708
5.2A.3B.2	Definition of system information messages	708
5.2A.3B.3	Procedure	708
5.2A.3B.4	Specific message contents	708
5.2A.3C	Loopback Activation without looped data, V2X Setup (State 4A-RF-V2X)	708
5.2A.3C.1	Initial conditions	708
5.2A.3C.2	Definition of system information messages	709

5.2A.3C.3	Procedure	709
5.2A.3C.4	Specific message contents	709
5.2A.4	Procedure to configure SCC	709
5.2A.4.1	Specific message contents	709
5.2A.4.1.1	Exceptions for all CA tests	709
5.2A.4.1.2	Exceptions for UL CA tests	710
5.2A.5	Exceptions for feICIC tests	711
5.2A.5.1	Specific message contents	711
5.2A.5.1.1	Neighbour cell info for all feICIC test cases	711
5.2A.6	Exceptions for NAICS tests	712
5.2A.6.1	NAICS specific RRC Connection reconfiguration procedure	712
5.2A.6.1.1	Procedure	712
5.2A.6.1.1	Specific message contents	712
5.2A.6.2	Specific message contents	712
5.2A.6.2.1	RRConnectionReconfiguration for setting up and releasing NAICS configuration in NAICS test cases	713
5.2A.7	Procedure to retrieve additional UE Capabilities for Rel-11 and higher UEs that support frequencyBandRetrieval_r11	714
5.2A.7.1	Initial conditions	714
5.2A.7.2	Definition of system information messages	715
5.2A.7.3	Procedure	715
5.2A.7.4	Specific message contents	715
5.2A.8	Exceptions for DL Control channel interference mitigation (Type A and Type B) tests	716
5.2A.8.1	Specific message contents	716
5.2A.8.1.1	Neighbour cell info for all CCIM test cases	716
5.3	Default RRC message and information elements contents	716
5.3.1	Radio resource control information elements	716
5.3.2	Measurement information elements	718
5.4	Default NAS message and information elements contents	718
5.5	Reference radio bearer configurations	718
5.5.1	SRB and DRB parameters	718
5.5.1.1	MAC configurations	718
5.5.1.2	Physical Layer configurations	720
5.5.1.3	SRB and DRB combinations	721
5.5.1.3.1	Combinations on DL-SCH and UL-SCH	721
6	Test environment for Signalling test	722
6.1	Requirements of test equipment	722
6.2	Reference test conditions	722
6.2.1	Physical channel allocations	722
6.2.1.1	Antennas	722
6.2.1.2	Downlink physical channels and physical signals	722
6.2.1.3	Mapping of downlink physical channels and signals to physical resources	723
6.2.1.4	Uplink physical channels and physical signals	723
6.2.1.5	Mapping of uplink physical channels and signals to physical resources	723
6.2.2	Signal levels	723
6.2.2.1	Downlink signal levels	723
6.2.2.2	Measurement accuracy and side conditions	724
6.2.2.3	Uplink signal levels	725
6.2.3	Default test frequencies	726
6.2.3.1	Test frequencies for signalling test	726
6.2.3.2	Test frequencies for CA signalling test	729
6.2.3.3	Test frequencies for ProSe signalling test	740
6.2.3.4	Test frequencies for MFBI frequency band priority adjustment signalling test	741
6.2.3.5	Test frequencies for V2X Communication	741
6.3	Reference system configurations	741
6.3.1	Default parameter specific for simulated cells	742
6.3.1.1	Intra-frequency neighbouring cell list in SIB4 for E-UTRA cells	742
6.3.1.2	Inter-frequency carrier frequency list in SIB5 for E-UTRA cells	742
6.3.1.3	UTRA carrier frequency list in SIB6 for E-UTRA cells	743
6.3.1.4	GERAN carrier frequency group list in SIB7 for E-UTRA cells	743
6.3.1.5	CDMA2000 HRPD carrier frequency list in SIB8 for E-UTRA cells	744

6.3.1.6	CDMA2000 1xRTT carrier frequency list in SIB8 for E-UTRA cells	744
6.3.1.7	E-UTRA carrier frequency list in SIB19 for UTRA cells	744
6.3.2	Default configurations for NAS test cases	745
6.3.2.1	Simulated network scenarios for NAS test cases	745
6.3.2.2	Simulated NAS cells	745
6.3.2.3	Broadcast system information	746
6.3.2.3.1	Intra-frequency neighbouring cell list in SIB4 for E-UTRA NAS cells	746
6.3.2.3.2	Inter-frequency carrier frequency list in SIB5 for E-UTRA NAS cells	747
6.3.3	Cell configurations	747
6.3.3.1	Full cell configuration	748
6.3.3.2	Minimum uplink cell configuration	748
6.3.3.3	Broadcast only cell configuration	748
6.3.3.3A	Virtual cell configuration	748
6.3.3.4	Application of different cell configurations	748
6.3.4	SCell configurations	749
6.4	Generic procedures	749
6.4.1	Initial UE states and setup procedures	749
6.4.1.1	Initial UE states and setup procedures	749
6.4.1.2	Dedicated Bearer Establishment (to state 5)	750
6.4.1.2.1	Initial conditions	750
6.4.1.2.2	Definition of system information messages	751
6.4.1.2.3	Procedure	751
6.4.1.2.4	Specific message contents	751
6.4.1.2A	DC MCG/SCG Dedicated Bearer Establishment (to state 5A)	751
6.4.1.2A.1	Initial conditions	751
6.4.1.2A.2	Definition of system information messages	751
6.4.1.2A.3	Procedure	751
6.4.1.2A.4	Specific message contents	752
6.4.1.2B	DC Split Dedicated Bearer Establishment (to state 5B)	752
6.4.1.2B.1	Initial conditions	752
6.4.1.2B.2	Definition of system information messages	752
6.4.1.2B.3	Procedure	752
6.4.1.2B.4	Specific message contents	753
6.4.1.3	Loopback Activation (to state 6)	753
6.4.1.3.1	Initial conditions	753
6.4.1.3.2	Definition of system information messages	753
6.4.1.3.3	Procedure	754
6.4.1.3.4	Specific message contents	754
6.4.1.3A	DC MCG/SCG DRB Loopback Activation (to state 6A)	754
6.4.1.3A.1	Initial conditions	754
6.4.1.3A.2	Definition of system information messages	754
6.4.1.3A.3	Procedure	754
6.4.1.3A.4	Specific message contents	754
6.4.1.3B	DC Split DRB Loopback Activation (to state 6B)	754
6.4.1.3B.1	Initial conditions	754
6.4.1.3B.2	Definition of system information messages	755
6.4.1.3B.3	Procedure	755
6.4.1.3B.4	Specific message contents	755
6.4.2	Test procedures	755
6.4.2.1	Introduction	755
6.4.2.2	Test procedure to check RRC_IDLE state	755
6.4.2.3	Test procedure to check RRC_CONNECTED state	756
6.4.2.4	Test procedure Paging (for NAS testing)	756
6.4.2.5	Test procedure for no response to paging (for NAS testing)	756
6.4.2.6	Test procedure to check that a dedicated EPS bearer context is active (for NAS testing)	757
6.4.2.7	Test procedure to check that UE is camped on a new E-UTRAN cell	757
6.4.2.7A	Test procedure to check that UE is camped on E-UTRAN cell upon mobility from another RAT	758
6.4.2.7B	Test procedure to check that UE is camped on a new E-UTRAN cell / UP CIoT	762
6.4.2.8	Test procedure to check that UE is camped on a new UTRAN cell	762
6.4.2.9	Test procedure to check that UE is camped on a new GERAN cell	763
6.4.2.10	Test procedure to check that UE performs tracking area updating procedure without ISR and security reconfiguration after successful completion of handover from UTRA	764

6.4.3	Reference test procedures for TTCN development.....	766
6.4.3.1	UE triggered establishment of a dedicated EPS bearer context	767
6.4.3.2	UE triggered establishment of a default EPS bearer context associated with an additional PDN.....	768
6.4.3.3	UE triggered modification of an EPS bearer context	770
6.4.3.4	UE triggered deletion of an EPS bearer context.....	771
6.4.3.5	UE triggered CS call	772
6.4.3.6	UE triggered MO SMS over SGs.....	773
6.4.3.7	CS fallback to UTRAN procedures (LAI of UTRAN cell same as the LAI received in combined Attach procedure in EUTRA cell).....	773
6.4.3.7.1	CS fallback to UTRAN with redirection / MT call (PS bearers not established)	774
6.4.3.7.2	CS fallback to UTRAN with redirection / MO call (PS bearers not established).....	775
6.4.3.7.3	CS fallback to UTRAN with redirection / MT call (PS bearer established)	776
6.4.3.7.4	CS fallback to UTRAN with redirection / MO call (PS bearer established)	776
6.4.3.7.5	CS fallback to UTRAN with Handover / MT call.....	777
6.4.3.7.5.1	Specific message contents.....	778
6.4.3.7.6	CS fallback to UTRAN with Handover / MO call.....	779
6.4.3.7.6.1	Specific message contents.....	780
6.4.3.7.7	CS fallback to UTRAN with Handover / emergency call.....	781
6.4.3.7.7.1	Specific message contents.....	782
6.4.3.8	CS fallback to GERAN procedures (LAI of GERAN cell same as the LAI received in combined Attach procedure in EUTRA cell).....	782
6.4.3.8.1	CS fallback to GERAN with redirection or CCO / MT call (DTM not supported).....	783
6.4.3.8.2	CS fallback to GERAN with redirection or CCO / MO call (DTM not supported)	784
6.4.3.8.3	CS fallback to GERAN with PS Handover / MT call (EDTM not supported).....	784
6.4.3.8.4	CS fallback to GERAN with PS Handover / MO call (EDTM not supported).....	784
6.4.3.8.5	CS fallback to GERAN with PS Handover / MT call (EDTM supported)	784
6.4.3.9	SRVCC Handover to UTRA.....	784
6.4.3.9.1	Specific message contents	785
6.4.3.10	Offload to WLAN	785
6.4.3.10.1	Specific message contents	786
6.4.3.11	Offload from WLAN.....	786
6.4.3.11.1	Specific message contents	787
6.4.3.12	Check UE does not offload to WLAN	787
6.4.3.12.1	Specific message contents	787
6.4.3.13	Check UE does not Offload to E-UTRAN.....	787
6.4.3.14	Procedure for UE initiated detach at non-switch-off	788
6.4.3.13.1	Specific message contents	788
6.4.3A	Test case postambles.....	788
6.4.3A.1	Introduction.....	788
6.4.3A.2	Reference end states.....	788
6.5	Default RRC message and information element contents	791
6.5.1	Measurement information elements.....	792
-	MeasConfig-DEFAULT	792
-	MeasGapConfig-GP1	792
-	MeasGapConfig-GP2.....	793
-	MeasGapConfig-CE.....	793
6.6	Default NAS message and information element contents	793
6.6.1	Reference default EPS bearer contexts	793
6.6.2	Reference dedicated EPS bearer contexts	794
6.6A	Default SMS over SGs message and information element contents.....	804
6.6A.1	CM-sublayer messages	804
-	CP-ACK.....	804
-	CP-DATA	804
6.6A.2	Short Message Relay Layer (SM-RL) messages	805
-	RP-ACK RPDU	805
-	RP-DATA RPDU.....	805
6.6A.3	Short Message Transfer Layer (SM-TL) messages	806
-	SMS-DELIVER	806
-	SMS-SUBMIT	806
6.6B	Reference radio bearer configurations.....	807
6.6B.1	SRB and DRB parameters and combinations	807
6.6B.1.1	SRB and DRB parameters.....	807

6.6B.1.1.1	Physical Layer configurations	807
6.7	Timer Tolerances.....	807
6.8	SideLink reference configuration	808
6.8.1	Reference configuration for Direct Communication.....	808
6.8.1.1	ProSe Direct Communication <i>Preconfiguration</i> for out-of-network coverage operation	808
6.8.2	Reference configuration for V2X Sidelink Communication.....	811
6.8.2.1	V2X Sidelink Communication <i>Preconfiguration</i> for out-of-network coverage operation.....	811
7	Test environment for RRM tests	811
7.1	Requirements of <i>test</i> equipment	811
7.2	RRM Reference system configurations	811
7.2.1	Common parameters for simulated E-UTRA cells	811
7.2.1.1	Combinations of system information blocks.....	811
7.2.1.2	Scheduling of system information blocks	811
7.2.1.3	Common contents of system information messages	811
7.2.2	Common parameters for simulated GERAN cells	813
7.2.2.1	Mapping of GERAN cells	813
7.2A	Generic RRM procedures	814
7.2A.1	UE RRM test states.....	814
7.2A.2	UE Registration, UE Test Mode Activated (State 2A-RF)	814
7.2A.2A	UE Registration, UE Test Mode Activated in cell supporting BL/CE UE (State 2A-RF-CE)	814
7.2A.3	Generic Default Radio Bearer Establishment, UE Test Mode Activated (State 3A-RF).....	815
7.2A.3A	DC MCG/SCG Dedicated RB established, UE Test Mode Activated (State 3A-RF-DC1).....	815
7.2A.3AA	Generic Default Radio Bearer Establishment, UE Test Mode Activated in cell supporting BL/CE UE (State 3A-RF-CE)	815
7.2A.3B	DC Split Default RB established, UE Test Mode Activated (State 3A-RF-DC2)	815
7.2A.3C	Generic Default Radio Bearer Establishment, UE Test Mode Activated, V2X Setup (State 3A-RF-V2X)	815
7.2A.4	Generic Default Radio Bearer Establishment, UE Test Mode Activated, pre-registration on HRPD (State 3B-RF).....	815
7.2A.4.1	Initial conditions	815
7.2A.4.2	Definition of system information messages	815
7.2A.4.3	Procedure	816
7.2A.4.4	Specific message contents.....	816
7.2A.5	Procedure to configure SCC	816
7.2A.6	Exceptions for feICIC tests.....	816
7.2B	Other generic RRM procedures.....	816
7.2B.1	Tracking area updating procedure.....	816
7.3	Default RRC message and information elements contents.....	818
7.3.1	Contents of RRC messages.....	818
7.3.2	Radio resource control information elements	818
7.3.3	Measurement information elements.....	819
7.3A	Default UTRA message and information element contents	820
7.3A.1	UTRA RRC messages	820
7.4	Default NAS message and information elements contents.....	820
7.5	Reference radio bearer configurations.....	820
7.5.1	SRB and DRB parameters	820
7.5.1.1	MAC configurations.....	820
8	NB-IoT test environment.....	822
8.1	NB-IoT Common test environment.....	822
8.1.1	NB-IoT Environmental conditions	822
8.1.2	NB-IoT Common requirements of test equipment.....	822
8.1.3	NB-IoT Reference test conditions	822
8.1.3.1	NB-IoT Test frequencies	822
8.1.3.1.1	NB-IoT FDD Mode Test frequencies	823
8.1.3.2	NB-IoT Radio conditions.....	840
8.1.3.2.1	NB-IoT Normal propagation condition	840
8.1.3.3	NB-IoT Physical channel allocations	840
8.1.3.3.1	NB-IoT Antennas	840
8.1.3.3.2	NB-IoT Downlink physical channels and physical signals	840
8.1.3.3.3	NB-IoT Mapping of downlink physical channels and signals to physical resources.....	841

8.1.3.3.4	NB-IoT Uplink physical channels and physical signals	843
8.1.3.3.5	NB-IoT Mapping of uplink physical channels and signals to physical resources	843
8.1.3.4	NB-IoT Signal levels.....	843
8.1.3.4.1	NB-IoT Downlink signal levels.....	843
8.1.3.4.2	NB-IoT Uplink signal levels.....	843
8.1.3.5	NB-IoT Standard test signals	844
8.1.3.5.1	NB-IoT Downlink test signals	844
8.1.3.5.2	NB-IoT Uplink test signals.....	844
8.1.3.6	NB-IoT Physical layer parameters	844
8.1.3.6.1	NB-IoT Downlink physical layer parameters	844
8.1.4	NB-IoT Reference system configurations.....	846
8.1.4.1	NB-IoT Simulated network scenarios	846
8.1.4.1.1	NB-IoT Single cell network scenarios.....	846
8.1.4.1.2	NB-IoT single mode multi cell network scenarios	846
8.1.4.2	NB-IoT Simulated cells.....	847
8.1.4.3	NB-IoT Common parameters for simulated cells	850
8.1.4.3.1	NB-IoT Common configurations of system information blocks	851
8.1.4.3.1.1	NB-IoT Combinations of system information blocks	851
8.1.4.3.1.2	NB-IoT Scheduling of system information blocks	851
8.1.4.3.2	NB-IoT Common contents of system information messages	852
-	MasterInformationBlock-NB	852
-	SystemInformation-NB.....	854
-	SystemInformationBlockType1-NB	855
8.1.4.3.3	NB-IoT Common contents of system information blocks.....	856
-	SystemInformationBlockType2-NB	856
-	SystemInformationBlockType3-NB	857
-	SystemInformationBlockType4-NB	857
-	SystemInformationBlockType5-NB	858
-	SystemInformationBlockType14-NB	859
-	SystemInformationBlockType15-NB	860
-	SystemInformationBlockType16-NB	860
-	SystemInformationBlockType20-NB	860
-	SystemInformationBlockType22-NB	860
8.1.5	NB-IoT Generic procedures.....	861
8.1.5.0	General	861
8.1.5.1	NB-IoT UE test states	861
8.1.5.2	NB-IoT UE Attach, Connected mode (State 2-NB).....	863
8.1.5.2.0	General	863
8.1.5.2.1	Initial conditions.....	864
8.1.5.2.2	Definition of system information messages.....	864
8.1.5.2.3	Procedure.....	865
8.1.5.2.4	Specific message contents	867
8.1.5.2A	NB-IoT UE Attach, Connected mode, UE Test Mode Activated (State 2A-NB)	867
8.1.5.2A.0	General	867
8.1.5.2A.1	Initial conditions	867
8.1.5.2A.2	Definition of system information messages.....	868
8.1.5.2A.3	Procedure.....	868
8.1.5.2A.4	Specific message contents	868
8.1.5.2B	NB-IoT UE Attach, Connected Mode, UE Test Loopback Activated (State 2B-NB)	869
8.1.5.2B.1	Initial conditions.....	869
8.1.5.2B.2	Definition of system information messages.....	869
8.1.5.2B.3	Procedure.....	869
8.1.5.2B.4	Specific message contents	869
8.1.5.3	NB-IoT UE Registered, Idle Mode (State 3-NB).....	870
8.1.5.3.1	Initial conditions	870
8.1.5.3.2	Definition of system information messages.....	871
8.1.5.3.3	Procedure.....	871
8.1.5.3.4	Specific message contents	871
8.1.5.3A	NB-IoT UE Registered, Idle Mode, UE Test Mode Activated (State 3A-NB)	871
8.1.5.3A.1	Initial conditions	871
8.1.5.3A.2	Definition of system information messages.....	871
8.1.5.3A.3	Procedure.....	871

8.1.5.3A.4	Specific message contents	871
8.1.5.4	Void.....	872
8.1.5A	Other generic procedures	872
8.1.5A.1	Procedure for IP address allocation in the CP CIoT.....	872
8.1.5A.2	Test procedure to check UE response to Paging for Control Plane CIoT MT access	872
8.1.5A.2.1	Initial conditions.....	872
8.1.5A.2.2	Definition of system information messages.....	872
8.1.5A.2.3	Procedure.....	873
8.1.5A.2.4	Specific message contents	874
8.1.5A.3	Test procedure to check UE initiation of Control Plane CIoT MO user data transfer non-SMS transport	877
8.1.5A.3.1	Initial conditions.....	877
8.1.5A.3.2	Definition of system information messages.....	877
8.1.5A.3.3	Procedure.....	878
8.1.5A.3.4	Specific message contents	878
8.1.5A.3A	Test procedure to check UE initiation of Control Plane CIoT MO user data transfer SMS transport	882
8.1.5A.3A.1	Initial conditions.....	882
8.1.5A.3A.2	Definition of system information messages.....	882
8.1.5A.3A.3	Procedure.....	883
8.1.5A.3A.4	Specific message contents	883
8.1.5A.4	Test procedure to check release of PDN connectivity before leaving RRC-CONNECTED for attach without PDN	887
8.1.5A.4.1	Initial conditions.....	887
8.1.5A.4.2	Definition of system information messages.....	887
8.1.5A.4.3	Procedure.....	888
8.1.5A.4.4	Specific message contents	888
8.1.5A.5	Test procedure to check that NB-IoT UE is camped on a new NB-IOT cell	888
8.1.5A.6	Test procedure to check that NB-IoT UE resume RRC connection on a new NB-IOT cell	889
8.1.5A.7	890
8.1.5A.8	Test procedure to check RRC_CONNECTED state for NB-IoT	890
8.1.5A.9	Test Procedure to establish radio bearers in User Plane.....	890
8.1.5A.9.1	Initial conditions.....	890
8.1.5A.9.2	Definition of system information messages.....	890
8.1.5A.9.3	Procedure.....	891
8.1.5A.9.4	Specific message contents	891
8.1.6	NB-IoT Default RRC message and information elements contents.....	891
8.1.6.1	NB-IoT Contents of RRC messages.....	892
-	<i>DLInformationTransfer-NB</i>	892
-	<i>Paging-NB</i>	892
-	<i>RRCCConnectionReconfiguration-NB</i>	893
-	<i>RRCCConnectionReconfigurationComplete-NB</i>	893
-	<i>RRCCConnectionReestablishment-NB</i>	894
-	<i>RRCCConnectionReestablishmentComplete-NB</i>	894
-	<i>RRCCConnectionReestablishmentRequest-NB</i>	895
-	<i>RRCCConnectionReject-NB</i>	895
-	<i>RRCCConnectionRelease-NB</i>	896
-	<i>RRCCConnectionRequest-NB</i>	896
-	<i>RRCCConnectionResume-NB</i>	897
-	<i>RRCCConnectionResumeComplete-NB</i>	897
-	<i>RRCCConnectionResumeRequest-NB</i>	898
-	<i>RRCCConnectionSetup-NB</i>	898
-	<i>RRCCConnectionSetupComplete-NB</i>	899
-	<i>UECapabilityEnquiry-NB</i>	900
-	<i>UECapabilityInformation-NB</i>	901
-	<i>ULInformationTransfer-NB</i>	901
8.1.6.2	NB-IoT System information blocks	901
8.1.6.3	NB-IoT Radio resource control information elements	902
-	BCCH-Config-NB-DEFAULT	902
-	DL-CarrierConfigCommon-NB-DEFAULT.....	902
-	PCCH-Config-NB-DEFAULT.....	902
-	NPDCCH-ConfigDedicated-NB-DEFAULT.....	903

-	NPDSCH-ConfigCommon-NB-DEFAULT	903
-	NPRACH-ConfigSIB-NB-DEFAULT	903
-	NPUSCH-ConfigCommon-NB-DEFAULT	904
-	NPUSCH-ConfigDedicated-NB-DEFAULT	904
-	RACH-ConfigCommon-NB-DEFAULT	904
-	RadioResourceConfigCommonSIB-NB-DEFAULT	905
-	RadioResourceConfigDedicated-NB-SRB	905
-	RadioResourceConfigDedicated-NB-DRB(n)	906
-	RadioResourceConfigDedicated-NB-DRB-ADD(bid)	906
-	RadioResourceConfigDedicated-NB-DRB-REL(bid)	906
-	RLC-Config-NB-SRB-RECONFIG.....	907
-	SRB-ToAddModList-NB-RECONFIG.....	907
-	UplinkPowerControlCommon-NB-DEFAULT	907
-	UplinkPowerControlDedicated-NB-DEFAULT	907
-	RadioResourceConfigDedicated-NB-DRB-Mod	908
8.1.6.4	NB-IoT Security control information elements.....	908
8.1.6.5	NB-IoT Other information elements	908
-	RRC-TransactionIdentifier-DL	908
-	RRC-TransactionIdentifier-UL	908
8.1.7	NB-IoT Default NAS message and information element contents	908
8.1.7A	NB-IoT Default TC message and information element contents	908
8.1.8	NB-IoT Reference radio bearer configurations.....	909
8.1.8.1	General	909
8.1.8.2	NB-IoT SRB and DRB parameters and combinations	909
8.1.8.2.1	NB-IoT SRB and DRB parameters.....	909
8.1.9	NB-IoT Common test USIM parameters	911
8.1.9.1	General	911
8.2	NB-IoT Test environment for RF test	911
8.2.1	NB-IoT Requirements of test equipment	911
8.2.2	NB-IoT RF Reference system configurations.....	912
8.2.2.1	NB-IoT Common parameters for simulated E-UTRA cells	912
8.2.2.1.1	NB-IoT Combinations of system information blocks.....	912
8.2.2.1.2	NB-IoT Scheduling of system information blocks	912
8.2.2.1.3	NB-IoT Common contents of system information messages	912
8.2.2A	NB-IoT Generic RF procedures.....	912
8.2.3	NB-IoT Default RRC message and information elements contents.....	912
8.2.3.1	NB-IoT Radio resource control information elements	912
8.2.4	NB-IoT Default NAS message and information elements contents.....	913
8.2.5	NB-IoT Reference radio bearer configurations.....	913
8.2.5.1	NB-IoT SRB and DRB parameters	913
8.3	NB-IoT Test environment for Signalling test.....	913
8.3.1	NB-IoT Requirements of test equipment	913
8.3.2	NB-IoT Reference test conditions	913
8.3.2.1	NB-IoT Physical channel allocations	913
8.3.2.2	NB-IoT Signal levels.....	914
8.3.2.2.1	NB-IoT Downlink signal levels.....	914
8.3.2.3	NB-IoT Default test frequencies	914
8.3.2.3.1	NB-IoT Test frequencies for signalling test	914
8.3.3	NB-IoT Reference system configurations.....	915
8.3.3.1	NB-IoT Default parameters specific for simulated cells	916
8.3.3.1.1	Intra-frequency neighbouring cell list in SIB4-NB for NB-IoT cells	916
8.3.3.1.2	Inter-frequency carrier frequency list in SIB5-NB for NB-IoT cells.....	916
8.3.3.2	NB-IoT Default configurations for NAS test cases.....	917
8.3.3.3	NB-IoT Cell configurations	918
8.3.4	NB-IoT Generic signalling procedures	918
8.3.4.1	NB-IoT Initial UE states and setup procedures.....	918
8.3.4.2	NB-IoT Reference procedures and test procedures for TTCN development	918
8.3.4.3	NB-IoT Test case postambles for TTCN development	918
8.3.5	NB-IoT Default RRC message and information element contents	918
8.3.6	NB-IoT Default NAS message and information element contents	918
8.3.7	NB-IoT Timer tolerances.....	918
8.4	NB-IOT Test environment for RRM tests	918

8.4.1	NB-IoT Requirements of test equipment	918
8.4.2	NB-IoT RRM Reference system configurations	919
8.4.2.1	NB-IoT Common parameters for simulated NB-IoT cells	919
8.4.2.1.1	NB-IoT Combinations of system information blocks	919
8.4.2.1.2	NB-IoT Scheduling of system information blocks	919
8.4.2.1.3	NB-IoT Common contents of system information messages	919
8.4.2A	NB-IoT Generic RRM procedures	919
8.4.3	NB-IoT Default RRC message and information elements contents	919
8.4.3.1	NB-IoT Radio resource control information elements	919
8.4.4	NB-IoT Default NAS message and information elements contents	919
8.4.5	NB-IoT Reference radio bearer configurations	920
8.4.5.1	NB-IoT SRB and DRB parameters	920
Annex A (informative):	Connection Diagrams	921
Annex B (informative):	Change history	1054
History		1093

Foreword

This Technical Specification has been produced by the 3rd Generation Partnership Project (3GPP).

The contents of the present document are subject to continuing work within the TSG and may change following formal TSG approval. Should the TSG modify the contents of the present document, it will be re-released by the TSG with an identifying change of release date and an increase in version number as follows:

Version x.y.z

where:

x the first digit:

- 1 presented to TSG for information;
- 2 presented to TSG for approval;
- 3 or greater indicates TSG approved document under change control.

y the second digit is incremented for all changes of substance, i.e. technical enhancements, corrections, updates, etc.

z the third digit is incremented when editorial only changes have been incorporated in the document.

Introduction

The definition of the Conformance Tests for UE in E-UTRAN will be a complex task as the complete test suite covers RF, EMC and Protocol aspects of the UE.

Each test requires a Test Environment to be defined in which the UE has to operate to defined standards, constraints and performance. The overall task can be simplified if there are a number of well defined and agreed Common Test Environments where every one can be used for a number of tests. Hence the present document defines testing conditions that are common to several tests avoiding the need to duplicate the same information for every single test.

The present document defines default values for a variety of common areas. Where values are not specified in test cases, the defaults in the present document will apply. If specified, the test case values will take precedence.

1 Scope

The present document contains definitions of reference conditions and test signals, default parameters, reference radio bearer configurations used in radio bearer interoperability testing, common radio bearer configurations for other test purposes, common requirements for test equipment and generic set-up procedures for use in conformance tests for the 3rd Generation E-UTRAN User Equipment (UE).

2 References

The following documents contain provisions which, through reference in this text, constitute provisions of the present document.

- References are either specific (identified by date of publication, edition number, version number, etc.) or non-specific.
- For a specific reference, subsequent revisions do not apply.
- For a non-specific reference, the latest version applies. In the case of a reference to a 3GPP document (including a GSM document), a non-specific reference implicitly refers to the latest version of that document in the same Release as the present document unless the context in which the reference is made suggests a different Release is relevant (information on the applicable release in a particular context can be found in e.g. test case title, description or applicability, message description or content).

- [1] 3GPP TR 21.905: "Vocabulary for 3GPP Specifications".
- [2] 3GPP TS 23.003: "Numbering, addressing and identification".
- [3] 3GPP TS 23.122: "Non-Access-Stratum functions related to Mobile Station (MS) in idle mode".
- [4] 3GPP TS 24.008: "Mobile radio interface Layer 3 specification; Core network protocols; Stage 3".
- [5] 3GPP TS 34.108: "Common Test Environments for User Equipment (UE); Conformance testing".
- [6] 3GPP TS 34.109: "Terminal logical test interface; Special conformance testing functions".
- [7] 3GPP TS 34.123-1: "User Equipment (UE) conformance specification; Part 1: Protocol conformance specification".
- [8] 3GPP TS 34.123-2: "User Equipment (UE) conformance specification; Part 2: Implementation conformance statement (ICS) specification".
- [9] 3GPP TS 34.123-3: "User Equipment (UE) conformance specification; Part 3: Abstract test suites (ATSs)".
- [10] 3GPP TS 36.300: "Evolved Universal Terrestrial Radio Access (E-UTRA) and Evolved Universal Terrestrial Radio Access Network (E-UTRAN); Overall description; Stage 2".
- [11] 3GPP TS 36.302: "Evolved Universal Terrestrial Radio Access (E-UTRA); Services provided by the physical layer".
- [12] 3GPP TS 36.304: "Evolved Universal Terrestrial Radio Access (E-UTRA); User Equipment (UE) procedures in idle mode".
- [13] 3GPP TS 36.306: "Evolved Universal Terrestrial Radio Access (E-UTRA); User Equipment (UE) radio access capabilities".
- [14] 3GPP TS 36.321: "Evolved Universal Terrestrial Radio Access (E-UTRA); Medium Access Control (MAC) protocol specification".
- [15] 3GPP TS 36.322: "Evolved Universal Terrestrial Radio Access (E-UTRA); Radio Link Control (RLC) protocol specification".

- [16] 3GPP TS 36.323: "Evolved Universal Terrestrial Radio Access (E-UTRA); Packet Data Convergence Protocol (PDCP) specification".
- [17] 3GPP TS 36.331: "Evolved Universal Terrestrial Radio Access (E-UTRA); Radio Resource Control (RRC); Protocol Specification".
- [18] 3GPP TS 36.523-1: "Evolved Universal Terrestrial Radio Access (E-UTRA) and Evolved Packet Core (EPC); User Equipment (UE) conformance specification; Part 1: Protocol conformance specification".
- [19] 3GPP TS 36.523-2: "Evolved Universal Terrestrial Radio Access (E-UTRA) and Evolved Packet Core (EPC); User Equipment (UE) conformance specification; Part 2: Implementation Conformance Statement (ICS) proforma specification".
- [20] 3GPP TS 36.523-3: "Evolved Universal Terrestrial Radio Access (E-UTRA) and Evolved Packet Core (EPC); User Equipment (UE) conformance specification; Part 3: Abstract Test Suites (ATS)".
- [21] 3GPP TS 36.521-1: "Evolved Universal Terrestrial Radio Access (E-UTRA); User Equipment (UE) conformance specification; Radio transmission and reception; Part 1: conformance testing".
- [22] 3GPP TS 36.521-2: "Evolved Universal Terrestrial Radio Access (E-UTRA); User Equipment (UE) conformance specification; Radio transmission and reception; Part 2: Implementation Conformance Statement (ICS)".
- [23] 3GPP TR 24.801: "3GPP System Architecture Evolution; CT WG1 aspects".
- [24] 3GPP TS 23.401: "General Packet Radio Service (GPRS) enhancements for Evolved Universal Terrestrial Access Network (E-UTRAN) access".
- [25] 3GPP TS 51.010-1: "Mobile Station (MS) conformance specification; Part 1: Conformance specification".
- [26] ISO/IEC 9646 (all parts): "Information technology - Open Systems Interconnection - Conformance testing methodology and framework".
- [27] 3GPP TS 36.101: "Evolved Universal Terrestrial Radio Access (E-UTRA); User Equipment (UE) radio transmission and reception".
- [28] 3GPP TS 24.301: "Non-Access-Stratum (NAS) protocol for Evolved Packet System (EPS); Stage 3".
- [29] 3GPP TS 36.213: "Evolved Universal Terrestrial Radio Access (E-UTRA); Physical layer procedures".
- [30] 3GPP TS 36.104: "Evolved Universal Terrestrial Radio Access (E-UTRA); Base Station (BS) radio transmission and reception".
- [31] 3GPP TS 33.401: "3GPP System Architecture Evolution (SAE); Security architecture".
- [32] 3GPP TS 31.101: "UICC-terminal interface; Physical and logical characteristics".
- [33] 3GPP TS 31.102: "Characteristics of the Universal Subscriber Identity Module (USIM) application".
- [34] 3GPP TS 36.521-3: "Evolved Universal Terrestrial Radio Access (E-UTRA); User Equipment (UE) conformance specification; Radio transmission and reception; Part 3: Radio Resource Management conformance testing".
- [35] 3GPP TS 36.211: "Evolved Universal Terrestrial Radio Access (E-UTRA); Physical channels and modulation".
- [36] 3GPP2 TSG-C C.S0038-B v1.0: "Signalling Conformance Specification for High Rate Packet Data Air Interface".

- [37] 3GPP2 TSG-C C.S0043-A v1.0: "Signalling Conformance Test Specification for cdma2000 Spread Spectrum Systems".
- [38] 3GPP TS 36.509: "Evolved Universal Terrestrial Radio Access (E-UTRA); Special conformance testing functions for User Equipment (UE)"
- [39] 3GPP TS 36.133: "Evolved Universal Terrestrial Radio Access (E-UTRA); Requirements for support of radio resource management"
- [40] 3GPP TS 24.229: "IP multimedia call control protocol based on Session Initiation Protocol (SIP) and Session Description Protocol (SDP); Stage 3"
- [41] 3GPP TS 23.402: "Architecture enhancements for non-3GPP accesses"
- [42] 3GPP2 X.S0057-0-B v1.0 "E-UTRAN - eHRPD Connectivity and Interworking: Core Network Aspects"
- [43] 3GPP TS 34.229-1: "Internet Protocol (IP) multimedia call control protocol based on Session Initiation Protocol (SIP) and Session Description Protocol (SDP); User Equipment (UE) conformance specification; Part 1: Protocol conformance specification "
- [44] 3GPP2 C.S0024-B v3.0: "cdma2000 High Rate Packet Data Air Interface Specification".
- [45] 3GPP TS 31.103: "Characteristics of the IP Multimedia Services Identity Module (ISIM) application".
- [46] 3GPP TS 34.229-1: "Internet Protocol (IP) multimedia call control protocol based on Session Initiation Protocol (SIP) and Session Description Protocol (SDP); User Equipment (UE) conformance specification; Part 1: Protocol conformance specification".
- [47] 3GPP TS 34.229-3: "Internet Protocol (IP) multimedia call control protocol based on Session Initiation Protocol (SIP) and Session Description Protocol (SDP); User Equipment (UE) conformance specification; Part 3: Abstract Test Suite (ATS)".
- [48] 3GPP2 C.S0065-B v2.0: "cdma2000 Application on UICC for Spread Spectrum Systems".
- [49] 3GPP2 C.S0005-F v1.0: "Upper Layer (Layer 3) Signalling Standard for cdma2000 Spread Spectrum Systems – Release A, Addendum 2".
- [50] 3GPP TS 34.121-1: "User Equipment (UE) conformance specification; Radio transmission and reception (FDD); Part 1: Conformance specification "
- [51] 3GPP TS 34.122: "Terminal conformance specification; Radio transmission and reception (TDD)".
- [52] GSMA PRD IR.92: "IMS Profile for Voice and SMS".
- [53] 3GPP TS 24.302: "Access to the 3GPP Evolved Packet Core (EPC) via non-3GPP access networks; Stage 3".
- [54] Void
- [55] 3GPP TS 33.402: "3GPP System Architecture Evolution (SAE); Security aspects of non-3GPP accesses".
- [56] GSMA PRD IR.88: "LTE and EPC Roaming Guidelines".
- [57] IETF RFC 5996: "Internet Key Exchange Protocol Version 2 (IKEv2)".
- [58] 3GPP TS 24.334: "Proximity-services (ProSe) User Equipment (UE) to ProSe function protocol aspects; Stage 3".
- [59] 3GPP TS 23.303: "Proximity-based services (ProSe); Stage 2"
- [60] 3GPP TS 33.303: "Proximity-based Services (ProSe); Security aspects"

- [61] 3GPP TS 33.220: "Generic Authentication Architecture (GAA); Generic Bootstrapping Architecture (GBA)"
- [62] 3GPP TS 36.212: "Multiplexing and channel coding"
- [63] IETF RFC 4346: "The Transport Layer Security (TLS) Protocol Version 1.1".
- [64] 3GPP TS 33.310: "Network Domain Security (NDS); Authentication Framework (AF)".
- [65] 3GPP TS 26.114: "IP Multimedia Subsystem (IMS);Multimedia Telephony;Media handling and interaction".
- [66] 3GPP TS 24.483: "Mission Critical Push To Talk (MCPTT) Management Object (MO)".
- [67] 3GPP TS 38.508-1: "5GS; Common test environments for User Equipment (UE) conformance testing"
- [68] 3GPP TS 37.571-1: "User Equipment (UE) conformance specification for UE positioning; Part 1: Terminal conformance"
- [69] 3GPP TS 37.571-5: "User Equipment (UE) conformance specification for UE positioning; Part 5: Test scenarios and assistance data"
- [70] STANAG 4294: "NATO STANAG 4294. Navstar Global Positioning System (GPS) System Characteristics"
- [71] 3GPP TS 38.523-1: "5GS; User Equipment (UE) conformance specification; Part 1: Protocol Conformance Specification"

3 Definitions, symbols and abbreviations

3.1 Definitions

For the purposes of the present document, the terms and definitions given in TR 21.905 [1] apply, unless specified below:

B: a value followed by "B" is a binary value.

H: a value followed by "H" is a hexadecimal value.

3.2 Symbols

For the purposes of the present document, the following symbols apply:

N_{DL}	Downlink EARFCN
N_{RB}	Transmission bandwidth configuration, expressed in units of resource blocks
N_{RB_agg}	Aggregated Transmission Bandwidth Configuration. The number of the aggregated RBs within the fully allocated Aggregated Channel bandwidth.
N_{UL}	Uplink EARFCN

3.3 Abbreviations

For the purposes of the present document, the abbreviations specified in TR 21.905 [1] apply, with any additional abbreviations specified below:

1xRTT	1x Radio Transmission Technology
BR	Bandwidth Reduced
BR-BCCH	Bandwidth Reduced Broadcast Control Channel
BL	Bandwidth reduced Low complexity
CA	Carrier Aggregation
CC	Component Carrier

CE	Coverage Enhancement
DRB	(user) Data Radio Bearer
EARFCN	E-UTRA Absolute Radio Frequency Channel Number
ECM	EPS Connection Management
eIMTA	Enhanced Interference Management and Traffic Adaptation
EMM	EPS Mobility Management
ENB	Evolved Node B
EPRE	Energy Per Resource Element
ESM	EPS Session Management
HRPD	High Rate Packet Data
MAC	Media Access Control
MBS	Metropolitan Beacon System
MCS	Mission Critical Services
MTC	Machine Type Communication
OFDM	Orthogonal Frequency Division Multiplexing
RBs	Resource Blocks
ROHC	Robust Header Compression
SS	System Simulator
TH	Temperature High
TL	Temperature Low
TP	Transmission Point
V2X	Vehicle-to-Everything
VH	Higher extreme Voltage
VL	Lower extreme Voltage
xCH_RA	xCH-to-RS EPRE ratio for the channel xCH in all transmitted OFDM symbols not containing RS
xCH_RB	xCH-to-RS EPRE ratio for the channel xCH in all transmitted OFDM symbols containing RS

4 Common test environment

4.1 Environmental conditions

The requirements in this clause apply to all types of UE(s).

4.1.1 Temperature

The UE shall fulfil all the requirements in the full temperature range of:

Table 4.1.1-1: Temperature Test Environment

+15°C to +35°C	for normal conditions (with relative humidity up to 75 %)
-10°C to +55°C	for extreme conditions (see IEC publications 68-2-1 and 68-2-2)

Outside this temperature range the UE, if powered on, shall not make ineffective use of the radio frequency spectrum. In no case shall the UE exceed the transmitted levels as defined in TS 36.101 [27] for extreme operation.

The normative reference for this requirement is TS 36.101 [27] Annex E.1.

Some tests are performed also in extreme temperature conditions. These test conditions are denoted as TL (temperature low, -10°C) and TH (temperature high, +55°C).

4.1.2 Voltage

The UE shall fulfil all the requirements in the full voltage range, i.e. the voltage range between the extreme voltages.

The manufacturer shall declare the lower and higher extreme voltages and the approximate shutdown voltage. For the equipment that can be operated from one or more of the power sources listed below, the lower extreme voltage shall not be higher, and the higher extreme voltage shall not be lower than that specified below.

Table 4.1.2-1: Voltage Test Environment

Power source	Lower extreme voltage	Higher extreme voltage	Normal conditions voltage
AC mains	0,9 * nominal	1,1 * nominal	nominal
Regulated lead acid battery	0,9 * nominal	1,3 * nominal	1,1 * nominal
Non regulated batteries:			
Leclanché	0,85 * nominal	Nominal	Nominal
Lithium	0,95 * nominal	1,1 * Nominal	1,1 * Nominal
Mercury/nickel & cadmium	0,90 * nominal		Nominal

Outside this voltage range the UE if powered on, shall not make ineffective use of the radio frequency spectrum. In no case shall the UE exceed the transmitted levels as defined in TS 36.101 [27] for extreme operation. In particular, the UE shall inhibit all RF transmissions when the power supply voltage is below the manufacturer declared shutdown voltage.

The normative reference for this requirement is TS 36.101 [27] Annex E.2.

Some tests are performed also in extreme voltage conditions. These test conditions are denoted as VL (lower extreme voltage) and VH (higher extreme voltage).

4.2 Common requirements of test equipment

Mobile conformance testing can be categorized into 3 distinct areas:

- RF Conformance Testing.
- EMC Conformance Testing.
- Signalling Conformance Testing.

The test equipment required for each category of testing may or not be different, depending on the supplier of the test equipment. However, there will be some generic requirements of the test equipment that are essential for all three categories of test, and these are specified in this clause.

In addition, there will be requirements to test operation in multi-system configurations (e.g. EUTRAN plus UTRAN). However, these would not form a common test equipment requirement for the three test areas and are not considered in the present document.

The test equipment shall use the same number of Tx antennas for all parts of the tests, Initial condition and Test procedure, as specified in the minimum requirement.

4.2.1 General functional requirements

NOTE: This clause has been written such that it does not constrain the implementation of different architectures and designs of test equipment.

All test equipment used to perform conformance testing on a UE shall provide a platform suitable for testing UE's that are either:

- a) FDD Mode; or
- b) TDD Mode; or
- c) both FDD/TDD Modes.

All test equipment shall provide (for the mode(s) supported) the following minimum functionality.

- The capability of emulating a single E-UTRA cell with the appropriate channels to allow the UE to register on the cell.
- The capability to allow the UE to set up an RRC connection with the system simulator, and to maintain the connection for the duration of the test.
- The capability (for the specific test):

- to select and support an appropriate radio bearer for the downlink;
- to set the appropriate downlink power levels;
- to set up and support the appropriate radio bearer for the uplink;
- to set and control the uplink power levels.

4.2.2 Minimum functional requirements

4.2.2.1 Supported Cell Configuration

The System Simulator shall provide the capability to simulate a minimum number of cells (of the appropriate E-UTRA Mode) whose number and capabilities are governed by the test cases that need to be performed (test cases are defined in 3GPP TS 36.523-1 [18](Signalling), 3GPP TS 36.521-1 [21] (RF) and 3GPP TS 36.521-3 [34] (RRM)). For this purpose test cases can be split into two different categories: Tests that require only one cell and Tests that require several cells.

To perform test cases requiring one cell, the system simulator must provide a cell offering the capabilities to perform all the test cases in this category.

To perform test cases requiring several cells, additional cells must be provided by the system simulator. The additional cells, however, need only provide a minimum set of capabilities so as to support the first cell in carrying out the multicell test cases.

The type and number of channels (especially physical channels) constitute an important set of capabilities for a cell. The following clauses list possible channels that may be supported by the SS. Each channel type, however, and the minimum number of channels needed are only mandatory if specific test cases require them.

The mapping between Logical and Transport channels is as described in 3GPP TS 36.321 [14]. Similarly the mapping between Transport channels and Physical channels is as described in 3GPP TS 36.211, TS 36.302 and TS 36.212. The reference measurement channels (mapping between Transport channels and Physical channels for PDSCH/PDCCH) are defined in 3GPP TS 36.521-1[21] annex A

4.2.2.1.1 Supported Channels

4.2.2.1.1.1 Logical channels

Logical channel	Minimum number	Comments
BCCH	1	
BR-BCCH	1	For testing of BL/CE UE.
CCCH	1	
DCCH	2	
PCCH	1	
DTCH	n <FFS>	Depending on SS's support for RB service testing (See clause 12 of 3GPP TS 36.523-1 [18])

4.2.2.1.1.2 Transport channels

Transport channel	Minimum number	Comments
BCH	1	
PCH	1	
RACH	1	
DL-SCH	n <FFS>	
UL-SCH	n <FFS>	

4.2.2.1.1.3 Physical channels

Physical channel	Minimum number	Comments
PBCH	1	Physical Broadcast Channel

Physical channel	Minimum number	Comments
PCFICH	1	The physical control format indicator channel carries information about the number of OFDM symbols used for transmission of PDCCHs in a subframe
PDCCH	1	The physical downlink control channel carries scheduling assignments and other control information.
MPDCCH	1	The MTC physical downlink control channel carries scheduling assignments and other control information for BL/CE UE.
PDSCH	1	Physical Downlink Shared Channel
PHICH	[1]	The PHICH carries the hybrid-ARQ ACK/NAK
PUCCH	1	The physical uplink control channel carries uplink control information
PUSCH	1	Physical Uplink Shared Channel
PRACH	1	Physical Random Access Channel

4.2.2.1.1.4 Physical signals

Physical signal	Minimum number	Comments
Demodulation reference signal	NA	UL
Sounding Reference signal	NA	UL TBD, if applicable
Cell-specific Reference Signal	NA	DL
UE-specific reference signal	NA	DL
Primary synchronisation signal	NA	DL
Secondary synchronisation signal	NA	DL

4.2.2.2 Support of T_{cell} timing offset

The timing offset in terms of frame start timing between any pair of TDD cells shall be < [3us]. For FDD cells there is no such restriction.

4.2.2.3 Supported Sidelink Configuration

The System Simulator shall provide the capability to simulate a minimum number of UEs whose number and capabilities are governed by the test cases that need to be performed (test cases are defined in 3GPP TS 36.523-1 [18] (Signalling), 3GPP TS 36.521-1 [21] (RF) and 3GPP TS 36.521-3 [34] (RRM)). For this purpose test cases can be split into two different categories: Tests that require only one simulated UE and Tests that require several simulated UEs.

To perform test cases requiring one simulated UE, the system simulator shall provide a UE offering the capabilities to perform all the test cases in this category.

The type and number of sidelink channels (especially physical channels) constitute an important set of capabilities for a simulated UE. The following clauses list possible sidelink channels that may be supported by the SS. Each channel type, however, and the minimum number of channels needed are only mandatory if specific test cases require them.

The mapping between Logical and Transport channels is as described in 3GPP TS 36.321 [14]. Similarly the mapping between Transport channels and Physical channels is as described in 3GPP TS 36.211, TS 36.302 and TS 36.212.

4.2.2.3.1 Supported Sidelink Channels

4.2.2.3.1.1 Logical channels

Logical channel	Minimum number	Comments
STCH	1	
SBCCH	1	

4.2.2.3.1.2 Transport channels

Transport channel	Minimum number	Comments
SL-BCH	1	
SL-DCH	1	
SL-SCH	1	

4.2.2.3.1.3 Physical channels

Physical channel	Minimum number	Comments
PSBCH	1	Physical Sidelink Broadcast CHannel
PSCCH	1	Physical Sidelink Control CHannel
PSDCH	1	Physical Sidelink Discovery CHannel
PSSCH	1	Physical Sidelink Shared CHannel

4.2.2.3.1.4 Physical signals

Physical signal	Minimum number	Comments
Sidelink Synchronization Signals	NA	Sidelink Synchronization

4.3 Reference test conditions

This clause contains the reference test conditions, which apply to all test cases unless otherwise specified.

4.3.1 Test frequencies

The test frequencies are based on the E-UTRA frequency bands defined in the core specifications.

The raster spacing is 100 KHz.

E-UTRA/FDD is designed to operate in paired bands of 3GPP TS 36.101 [27]. The reference test frequencies for the RF and Signalling test environment for each of the operating bands are defined in sub clause 4.3.1.1.

E-UTRA/TDD is designed to operate in unpaired bands of 3GPP TS 36.101 [27]. The reference test frequencies for the RF and Signalling test environment for each of the operating bands are defined in sub clause 4.3.1.2.

For non-CA Signalling testing, E-UTRA frequency to be tested is mid range and E-UTRA channel bandwidth to be tested is 5MHz for all operating bands for all test cases as the default configuration unless specific channel bandwidth is specified for the operating band below:

For Band 11, 13, 18 and 20, channel bandwidth to be tested is 10 MHz as the default configuration.

For Band 38, 39, 40, 41 and 42, channel bandwidth to be tested is 20 MHz as the default configuration.

For operating band 46, the test frequencies defined in Clause 4.3.1.2.14 and 4.3.1.2.14A are derived based on the rules defined in TS 36.104 [30], table 5.7.3-1 Note 3.

For CA Signalling testing with two component carriers, E-UTRA frequencies to be tested are according to sub clause 6.2.3.2 and the E-UTRA channel bandwidth combination is according to Table 4.3.1-1.

Table 4.3.1-1: Default E-UTRA channel bandwidth combinations for CA Signalling testing with two component carriers

CA configuration (Band(s),BW Class,BW Combination Set)	CA Channel Bandwidth combination carrier 1 + carrier 2 [MHz + MHz]	Comment
Intra-band contiguous and Bandwidth Class C	20+20	This channel bandwidth combination is used for all Intra-band contiguous CA configurations using Bandwidth Class C unless specific channel bandwidth combination is specified for a CA configuration or CA Bandwidth Combination Set by specific entries in this table below.
Intra-band contiguous and Bandwidth Class B	5+5	This channel bandwidth combination is used for all Intra-band contiguous CA configurations using Bandwidth Class B unless specific channel bandwidth combination is specified for a CA configuration or CA Bandwidth Combination Set by specific entries in this table below.
Inter-band CA and CA Bandwidth Class Combination A-A	10 + 10	This channel bandwidth combination is used for all Inter-band CA configurations using Bandwidth Class Combination A-A unless specific channel bandwidth combination is specified for a CA configuration or CA Bandwidth Combination Set by specific entries in this table below.
CA_1A-19A	15 + 10	This channel bandwidth combination is used for Inter-band CA configuration CA_1A-19A.
CA_1A-21A	15 + 15	This channel bandwidth combination is used for Inter-band CA configuration CA_1A-21A.
CA_1A-41A	10 + 20	This channel bandwidth combination is used for Inter-band CA configuration CA_1A-41A.
CA_1A-42A	15 + 20	This channel bandwidth combination is used for Inter-band CA configuration CA_1A-42A.
CA_3A-19A	20 + 10	This channel bandwidth combination is used for Inter-band CA configuration CA_3A-19A.
CA_3A-41A	20 + 20	This channel bandwidth combination is used for Inter-band CA configuration CA_3A-41A.
CA_3A-42A	20 + 20	This channel bandwidth combination is used for Inter-band CA configuration CA_3A-42A.
CA_19A-21A	10 + 15	This channel bandwidth combination is used for Inter-band CA configuration CA_19A-21A.
CA_19A-42A	10 + 20	This channel bandwidth combination is used for Inter-band CA configuration CA_19A-42A.
CA_25A-26A	20 + 20	This channel bandwidth combination is used for Inter-band CA configuration CA_25A-26A.
CA_26A-41A	10 + 20	This channel bandwidth combination is used for Inter-band CA configuration CA_26A-41A.
CA_28A-41A	10 + 20	This channel bandwidth combination is used for Inter-band CA configuration CA_28A-41A.
CA_28A-42A	10 + 20	This channel bandwidth combination is used for Inter-band CA configuration CA_28A-42A.

CA_39A-41A	20+20	This channel bandwidth combination is used for Inter-band CA configuration CA_39A-41A.
CA_41C-41C	20 + 20	This channel bandwidth combination is used for Intra-band CA configuration CA_41C-41C.
CA_41A-42A	20 + 20	This channel bandwidth combination is used for Inter-band CA configuration CA_41A-42A.
CA_39C	20 + 10	This channel bandwidth combination is used for Intra-band contiguous CA configuration CA_39C.

For CA Signalling testing with three component carriers, E-UTRA frequencies to be tested are according to sub clause 6.2.3.2 and the E-UTRA channel bandwidth combination is according to Table 4.3.1-2.

Table 4.3.1-2: Default E-UTRA channel bandwidth combinations for CA Signalling testing with three component carriers

CA configuration (Band(s),BW Class,BW Combination Set)	CA Channel Bandwidth combination carrier 1 + carrier 2 + carrier 3 [MHz + MHz + MHz]	Comment
Intra-band contiguous and Bandwidth Class D	20+20+20	This channel bandwidth combination is used for all Intra-band contiguous CA configurations using Bandwidth Class D unless specific channel bandwidth combination is specified for a CA configuration or CA Bandwidth Combination Set by specific entries in this table below.
Inter-band CA and CA Bandwidth Class Combination A-A-A	10+10+10	This channel bandwidth combination is used for all Inter-band contiguous CA configurations using Bandwidth Class Combination A-A-A unless specific channel bandwidth combination is specified for a CA configuration or CA Bandwidth Combination Set by specific entries in this table below.
Mixed Inter-band and Intra- band contiguous CA and CA Bandwidth Class Combination A-C or C-A	10+20+20 (A-C) or 20+20+10 (C-A)	This channel bandwidth combination is used for all mixed Inter-band and Intra-band contiguous CA configurations using Bandwidth Class combination A-C or C-A unless specific channel bandwidth combination is specified for a CA configuration or CA Bandwidth Combination Set by specific entries in this table below.
Mixed Inter-band and Intra- band contiguous CA and CA Bandwidth Class Combination A-B or B-A	10+5+5 (A-B) or 5+5+10 (B-A)	This channel bandwidth combination is used for all mixed Inter-band and Intra-band contiguous CA configurations using Bandwidth Class combination A-B or B-A unless specific channel bandwidth combination is specified for a CA configuration or CA Bandwidth Combination Set by specific entries in this table below.

For RF testing, E-UTRA frequencies to be tested are low range, mid range and high range for all supported operating bands by default. E-UTRA channel bandwidths to be tested are lowest bandwidth, 5MHz bandwidth and highest bandwidth for all supported operating bands by default. Actual test configurations are specified case by case and stated in test case itself as the initial conditions.

The lowest bandwidth, 5MHz bandwidth and highest bandwidth are selected from the combined table which includes nominal and additional channel bandwidth.

In the case 5MHz bandwidth is not supported by the UE, E-UTRA channel bandwidth to be tested is only lowest bandwidth and highest bandwidth.

If channel bandwidth to be tested is equal to the lowest or highest channel bandwidth, then the same channel bandwidth is not required to be tested twice.

In addition to the default channel bandwidths to be tested specified above, for Bands 2, 4, 18, 19, 20 and 25, an industry requirement of testing in 10MHz channel bandwidth is allowed for test cases in chapters 6 and 7 in TS 36.521-1 [21].

Editor's note: For RF testing, an industry requirement of testing in 10MHz channel bandwidth is requested for Bands 2, 4, 18, 19, 20 and 25 for test cases in chapters 6 and 7 in TS 36.521-1 [21], changing the existing test points to address this is being discussed in RAN5 and will be considered pending technical justification.

For A-GNSS, MBS, WLAN and BLE testing in TS 37.571-1 [68], the E-UTRA frequency and channel bandwidth to be tested follow the same rules as for Signalling testing above.

For intra-band non-contiguous CA (CA_XA-XA) test frequencies have been defined following the basic assumption that CC1 uses the Low Range frequency of the band, while CC2 the High Range frequency. Additional test frequencies not following this rule, are (should be) identified by notes.

For sidelink direct communication and sidelink direct discovery, operating band and bandwidth are specified in section 5.5D and 5.6D in TS 36.101 [27]. Sidelink direct communication and sidelink direct discovery operates in half duplex mode using the uplink frequency of corresponding band.

For V2X sidelink communication, operating band and bandwidth are specified in section 5.5G and 5.6G in TS 36.101 [27]. V2X sidelink communication operates in half duplex mode using the uplink frequency of corresponding band.

4.3.1.1 FDD Mode Test frequencies

4.3.1.1.1 FDD reference test frequencies for operating band 1

Table 4.3.1.1.1-1: Test frequencies for E-UTRA channel bandwidth for operating band 1

Test Frequency ID	Bandwidth [MHz]	N _{UL}	Frequency of Uplink [MHz]	N _{DL}	Frequency of Downlink [MHz]
Low Range	5	18025	1922.5	25	2112.5
	10	18050	1925	50	2115
	15	18075	1927.5	75	2117.5
	20	18100	1930	100	2120
Mid Range	5/10/15/20	18300	1950	300	2140
High Range	5	18575	1977.5	575	2167.5
	10	18550	1975	550	2165
	15	18525	1972.5	525	2162.5
	20	18500	1970	500	2160

4.3.1.1.1A FDD reference test frequencies for CA in operating band 1

Table 4.3.1.1.1A-1: Test frequencies for CA_1C

Range	CC-Combo / N _{RB,agg} [RB]	CC1 Note1					CC2 Note1				
		BW [RB]	N _{UL}	f _{UL} [MHz]	N _{DL}	f _{DL} [MHz]	BW [RB]	N _{UL}	f _{UL} [MHz]	N _{DL}	f _{DL} [MHz]
Low	75+75	75	18075	1927.5	75	2117.5	75	18225	1942.5	225	2132.5
	100+100	100	18100	1930	100	2120	100	18298	1949.8	298	2139.8
Mid	75+75	75	18225	1942.5	225	2132.5	75	18375	1957.5	375	2147.5
	100+100	100	18201	1940.1	201	2130.1	100	18399	1959.9	399	2149.9
High	75+75	75	18375	1957.5	375	2147.5	75	18525	1972.5	525	2162.5
	100+100	100	18302	1950.2	302	2140.2	100	18500	1970	500	2160

Note 1: Carriers in increasing frequency order.

4.3.1.1.2 FDD reference test frequencies for operating band 2

Table 4.3.1.1.2-1: Test frequencies for E-UTRA channel bandwidth for operating band 2

Test Frequency ID	Bandwidth [MHz]	N _{UL}	Frequency of Uplink [MHz]	N _{DL}	Frequency of Downlink [MHz]
Low Range	1.4	18607	1850.7	607	1930.7
	3	18615	1851.5	615	1931.5
	5	18625	1852.5	625	1932.5
	10	18650	1855	650	1935
	15 ^[1]	18675	1857.5	675	1937.5
	20 ^[1]	18700	1860	700	1940
Mid Range	1.4/3/5/10 15 ^[1] /20 ^[1]	18900	1880	900	1960
High Range	1.4	19193	1909.3	1193	1989.3
	3	19185	1908.5	1185	1988.5
	5	19175	1907.5	1175	1987.5
	10	19150	1905	1150	1985
	15 ^[1]	19125	1902.5	1125	1982.5
	20 ^[1]	19100	1900	1100	1980

NOTE 1: Bandwidth for which a relaxation of the specified UE receiver sensitivity requirement (TS 36.101 [27] Clause 7.3) is allowed.

4.3.1.1.2A FDD reference test frequencies for CA in operating band 2

Table 4.3.1.1.2A-1: Test frequencies for CA_2A-2A

Test Frequency ID	CC-Combo / N _{RB,agg} [RB]	CC1 Note1					Wgap [MHz]	CC2 Note1				
		BW [RB]	N _{UL}	f _{UL} [MHz]	N _{DL}	f _{DL} [MHz]		BW [RB]	N _{UL}	f _{UL} [MHz]	N _{DL}	f _{DL} [MHz]
Max WGap	25+25	25	18625	1852.5	625	1932.5	50	25	19175	1907.5	1175	1987.5
	25+50	25	18625	1852.5	625	1932.5	45	50	19150	1905	1150	1985
		50	18650	1855	650	1935	45	25	19175	1907.5	1175	1987.5
	25+75	25	18625	1852.5	625	1932.5	40	75	19125	1902.5	1125	1982.5
		75	18675	1857.5	675	1937.5	40	25	19175	1907.5	1175	1987.5
	50+50	50	18650	1855	650	1935	40	50	19150	1905	1150	1985
	25+100	25	18625	1852.5	625	1932.5	35	100	19100	1900	1100	1980
		100	18700	1860	700	1940	35	25	19175	1907.5	1175	1987.5
	50+75	50	18650	1855	650	1935	35	75	19125	1902.5	1125	1982.5
		75	18675	1857.5	675	1937.5	35	50	19150	1905	1150	1985
	50+100	50	18650	1855	650	1935	30	100	19100	1900	1100	1980
		100	18700	1860	700	1940	30	50	19150	1905	1150	1985
	75+75	75	18675	1857.5	675	1937.5	30	75	19125	1902.5	1125	1982.5
	75+100	75	18675	1857.5	675	1937.5	25	100	19100	1900	1100	1980
100		18700	1860	700	1940	25	75	19125	1902.5	1125	1982.5	
100+100	100	18700	1860	700	1940	20	100	19100	1900	1100	1980	

Note 1: Carriers in increasing frequency order.

Table 4.3.1.1.2A-2: Test frequencies for CA_2C

Range	CC-Combo / N _{RB_agg} [RB]	CC1 Note1					CC2 Note1				
		BW [RB]	N _{UL}	f _{UL} [MHz]	N _{DL}	f _{DL} [MHz]	BW [RB]	N _{UL}	f _{UL} [MHz]	N _{DL}	f _{DL} [MHz]
Low	25+100	25	18633	1853.3	633	1933.3	100	18750	1865	750	1945
		100	18700	1860	700	1940	25	18817	1871.7	817	1951.7
	50+75	50	18653	1855.3	653	1935.3	75	18773	1867.3	773	1947.3
		75	18675	1857.5	675	1937.5	50	18795	1869.5	795	1949.5
	50+100	50	18655	1855.5	655	1935.5	100	18799	1869.9	799	1949.9
		100	18700	1860	700	1940	50	18844	1874.4	844	1954.4
	75+75	75	18675	1857.5	675	1937.5	75	18825	1872.5	825	1952.5
	75+100	75	18678	1857.8	678	1937.8	100	18849	1874.9	849	1954.9
		100	18700	1860	700	1940	75	18871	1877.1	871	1957.1
	100+100	100	18700	1860	700	1940	100	18898	1879.8	898	1959.8
Mid	25+100	25	18808	1870.8	808	1950.8	100	18925	1882.5	925	1962.5
		100	18875	1877.5	875	1957.5	25	18992	1889.2	992	1969.2
	50+75	50	18829	1872.9	829	1952.9	75	18949	1884.9	949	1964.9
		75	18851	1875.1	851	1955.1	50	18971	1887.1	971	1967.1
	50+100	50	18806	1870.6	806	1950.6	100	18950	1885	950	1965
		100	18851	1875.1	851	1955.1	50	18995	1889.5	995	1969.5
	75+75	75	18825	1872.5	825	1952.5	75	18975	1887.5	975	1967.5
	75+100	75	18803	1870.3	803	1950.3	100	18974	1887.4	974	1967.4
		100	18826	1872.6	826	1952.6	75	18997	1889.7	997	1969.7
	100+100	100	18801	1870.1	801	1950.1	100	18999	1889.9	999	1969.9
High	25+100	25	18983	1888.3	983	1968.3	100	19100	1900	1100	1980
		100	19050	1895	1050	1975	25	19167	1906.7	1167	1986.7
	50+75	50	19005	1890.5	1005	1970.5	75	19125	1902.5	1125	1982.5
		75	19027	1892.7	1027	1972.7	50	19147	1904.7	1147	1984.7
	50+100	50	18956	1885.6	956	1965.6	100	19100	1900	1100	1980
		100	19001	1890.1	1001	1970.1	50	19145	1904.5	1145	1984.5
	75+75	75	18975	1887.5	975	1967.5	75	19125	1902.5	1125	1982.5
	75+100	75	18929	1882.9	929	1962.9	100	19100	1900	1100	1980
		100	18951	1885.1	951	1965.1	75	19122	1902.2	1122	1982.2
	100+100	100	18902	1880.2	902	1960.2	100	19100	1900	1100	1980

Note 1: Carriers in increasing frequency order.

4.3.1.1.3 FDD reference test frequencies for operating band 3

Table 4.3.1.1.3-1: Test frequencies for E-UTRA channel bandwidth for operating band 3

Test Frequency ID	Bandwidth [MHz]	N _{UL}	Frequency of Uplink [MHz]	N _{DL}	Frequency of Downlink [MHz]
Low Range	1.4	19207	1710.7	1207	1805.7
	3	19215	1711.5	1215	1806.5
	5	19225	1712.5	1225	1807.5
	10	19250	1715	1250	1810
	15 ^[1]	19275	1717.5	1275	1812.5
	20 ^[1]	19300	1720	1300	1815
Mid Range	1.4/3/5/10 15 ^[1] /20 ^[1]	19575	1747.5	1575	1842.5
High Range	1.4	19943	1784.3	1943	1879.3
	3	19935	1783.5	1935	1878.5
	5	19925	1782.5	1925	1877.5
	10	19900	1780	1900	1875
	15 ^[1]	19875	1777.5	1875	1872.5
	20 ^[1]	19850	1775	1850	1870

NOTE 1: Bandwidth for which a relaxation of the specified UE receiver sensitivity requirement (TS 36.101 [27] Clause 7.3) is allowed.

4.3.1.1.3A FDD reference test frequencies for CA in operating band 3

Table 4.3.1.1.3A-1: Test frequencies for CA_3C

Range	CC-Combo / N _{RB,agg} [RB]	CC1 Note1					CC2 Note1				
		BW [RB]	N _{UL}	f _{UL} [MHz]	N _{DL}	f _{DL} [MHz]	BW [RB]	N _{UL}	f _{UL} [MHz]	N _{DL}	f _{DL} [MHz]
Low	25+100	25	19233	1713.3	1233	1808.3	100	19350	1725	1350	1820
		100	19300	1720	1300	1815	25	19417	1731.7	1417	1826.7
	50+100	50	19255	1715.5	1255	1810.5	100	19399	1729.9	1399	1824.9
		100	19300	1720	1300	1815	50	19444	1734.4	1444	1829.4
	75+100	75	19278	1717.8	1278	1812.8	100	19449	1734.9	1449	1829.9
		100	19300	1720	1300	1815	75	19471	1737.1	1471	1832.1
100+100	100	19300	1720	1300	1815	100	19498	1739.8	1498	1834.8	
Mid	25+100	25	19483	1738.3	1483	1833.3	100	19600	1750.0	1600	1845.0
		100	19550	1745	1550	1840	25	19667	1756.7	1667	1851.7
	50+100	50	19481	1738.1	1481	1833.1	100	19625	1752.5	1625	1847.5
		100	19526	1742.6	1526	1837.6	50	19670	1757.0	1670	1852.0
	75+100	75	19478	1737.8	1478	1832.8	100	19649	1754.9	1649	1849.9
		100	19501	1740.1	1501	1835.1	75	19672	1757.2	1672	1852.2
100+100	100	19476	1737.6	1476	1832.6	100	19674	1757.4	1674	1852.4	
High	25+100	25	19733	1763.3	1733	1858.3	100	19850	1775	1850	1870
		100	19800	1770	1800	1865	25	19917	1781.7	1917	1876.7
	50+100	50	19706	1760.6	1706	1855.6	100	19850	1775	1850	1870
		100	19751	1765.1	1751	1860.1	50	19895	1779.5	1895	1874.5
	75+100	75	19679	1757.9	1679	1852.9	100	19850	1775	1850	1870
		100	19701	1760.1	1701	1855.1	75	19872	1777.2	1872	1872.2
100+100	100	19652	1755.2	1652	1850.2	100	19850	1775	1850	1870	

Note 1: Carriers in increasing frequency order.

Table 4.3.1.1.3A-2: Test frequencies for CA_3A-3A

Test Frequency ID	CC-Combo / N _{RB_agg} [RB]	CC1 Note1					Wgap [MHz]	CC2 Note1				
		BW [RB]	N _{UL}	f _{UL} [MHz]	N _{DL}	f _{DL} [MHz]		BW [RB]	N _{UL}	f _{UL} [MHz]	N _{DL}	f _{DL} [MHz]
Max WGap	15+25	15	19215	1711.5	1215	1806.5	67	25	19925	1782.5	1925	1877.5
		25	19225	1712.5	1225	1807.5	67	15	19935	1783.5	1935	1878.5
	25+25	25	19225	1712.5	1225	1807.5	65	25	19925	1782.5	1925	1877.5
		25+50	25	19225	1712.5	1225	1807.5	60	50	19900	1780	1900
	25+75	50	19250	1715	1250	1810	60	25	19925	1782.5	1925	1877.5
		25	19225	1712.5	1225	1807.5	55	75	19875	1777.5	1875	1872.5
	50+50	75	19275	1717.5	1275	1812.5	55	25	19925	1782.5	1925	1877.5
		50	19250	1715	1250	1810	55	50	19900	1780	1900	1875
	25+100	25	19225	1712.5	1225	1807.5	50	100	19850	1775	1850	1870
		100	19300	1720	1300	1815	50	25	19925	1782.5	1925	1877.5
	50+75	50	19250	1715	1250	1810	50	75	19875	1777.5	1875	1872.5
		75	19275	1717.5	1275	1812.5	50	50	19900	1780	1900	1875
	50+100	50	19250	1715	1250	1810	45	100	19850	1775	1850	1870
		100	19300	1720	1300	1815	45	50	19900	1780	1900	1875
	75+75	75	19275	1717.5	1275	1812.5	45	75	19875	1777.5	1875	1872.5
		75+100	75	19275	1717.5	1275	1812.5	40	100	19850	1775	1850
100+100	100	19300	1720	1300	1815	40	75	19875	1777.5	1875	1872.5	
	100	19300	1720	1300	1815	35	100	19850	1775	1850	1870	
Refsens ²	25+100	25	19575	1747.5	1575	1842.5	15	100	19850	1775	1850	1870
	50 + 100	50	19600	1750	1600	1845	10	100	19850	1775	1850	1870

Note 1: Carriers in increasing frequency order.
 Note 2: Test point derived with regard to REFSENS requirements.

Table 4.3.1.1.3A-3: Test frequencies for CA_3B

Range	CC-Combo / N _{RB_agg} [RB]	CC1 Note1					CC2 Note1				
		BW [RB]	N _{UL}	f _{UL} [MHz]	N _{DL}	f _{DL} [MHz]	BW [RB]	N _{UL}	f _{UL} [MHz]	N _{DL}	f _{DL} [MHz]
Low	15+25	15	19216	1711.6	1216	1806.6	25	19255	1715.5	1255	1810.5
		25	19225	1712.5	1225	1807.5	15	19264	1716.4	1264	1811.4
	25+25	25	19225	1712.5	1225	1807.5	25	19273	1717.3	1273	1812.3
Mid	15+25	15	19551	1745.1	1551	1840.1	25	19590	1749.0	1590	1844.0
		25	19560	1746.0	1560	1841.0	15	19599	1749.9	1599	1844.9
	25+25	25	19551	1745.1	1551	1840.1	25	19599	1749.9	1599	1844.9
High	15+25	15	19886	1778.6	1886	1873.6	25	19925	1782.5	1925	1877.5
		25	19895	1779.5	1895	1874.5	15	19934	1783.4	1934	1878.4
	25+25	25	19877	1777.7	1877	1872.7	25	19925	1782.5	1925	1877.5

Note 1: Carriers in increasing frequency order.

4.3.1.1.4 FDD reference test frequencies for operating band 4

Table 4.3.1.1.4-1: Test frequencies for E-UTRA channel bandwidth for operating band 4

Test Frequency ID	Bandwidth [MHz]	N _{UL}	Frequency of Uplink [MHz]	N _{DL}	Frequency of Downlink [MHz]
Low Range	1.4	19957	1710.7	1957	2110.7
	3	19965	1711.5	1965	2111.5
	5	19975	1712.5	1975	2112.5

	10	20000	1715	2000	2115
	15	20025	1717.5	2025	2117.5
	20	20050	1720	2050	2120
Mid Range	1.4/3/5/10/15/20	20175	1732.5	2175	2132.5
High Range	1.4	20393	1754.3	2393	2154.3
	3	20385	1753.5	2385	2153.5
	5	20375	1752.5	2375	2152.5
	10	20350	1750	2350	2150
	15	20325	1747.5	2325	2147.5
	20	20300	1745	2300	2145

4.3.1.1.4A FDD reference test frequencies for CA in operating band 4

Table 4.3.1.1.4A-1: Test frequencies for CA_4A-4A

Test Frequency ID	CC-Combo / N _{RB_agg} [RB]	CC1 Note1					Wgap [MHz]	CC2 Note1				
		BW [RB]	N _{UL}	f _{UL} [MHz]	N _{DL}	f _{DL} [MHz]		BW [RB]	N _{UL}	f _{UL} [MHz]	N _{DL}	f _{DL} [MHz]
Low WGap	25+25	25	20125	1727.5	2125	2127.5	5	25	20225	1737.5	2225	21
	50+50	50	20100	1725	2100	2125	5	50	20250	1740	2250	2
	50+100	50	20095	1724.5	2095	2124.5	5	100	20255	1740.5	2255	21
	100+100	100	20050	1720	2050	2120	5	100	20300	1745	2300	2
Max WGap	25+25	25	19975	1712.5	1975	2112.5	35	25	20375	1752.5	2375	21
	25+50	25	19975	1712.5	1975	2112.5	30	50	20350	1750	2350	2
		50	20000	1715	2000	2115	30	25	20375	1752.5	2375	21
	25+75	25	19975	1712.5	1975	2112.5	25	75	20325	1747.5	2325	21
		75	20025	1717.5	2025	2117.5	25	25	20375	1752.5	2375	21
	50+50	50	20000	1715	2000	2115	25	50	20350	1750	2350	2
		25+100	25	19975	1712.5	1975	2112.5	20	100	20300	1745	2300
	100		20050	1720	2050	2120	20	25	20375	1752.5	2375	21
		50+75	50	20000	1715	2000	2115	20	75	20325	1747.5	2325
	75		20025	1717.5	2025	2117.5	20	50	20350	1750	2350	2
		50+100	50	20000	1715	2000	2115	15	100	20300	1745	2300
	100		20050	1720	2050	2120	15	50	20350	1750	2350	2
		75+75	75	20025	1717.5	2025	2117.5	15	75	20325	1747.5	2325
	75+100		75	20025	1717.5	2025	2117.5	10	100	20300	1745	2300
100		20050	1720	2050	2120	10	75	20325	1747.5	2325	21	
	100+100	100	20050	1720	2050	2120	5	100	20300	1745	2300	2

Note 1: Carriers in increasing frequency order.

4.3.1.1.5 FDD reference test frequencies for operating band 5

Table 4.3.1.1.5-1: Test frequencies for E-UTRA channel bandwidth for operating band 5

Test Frequency ID	Bandwidth [MHz]	N _{UL}	Frequency of Uplink [MHz]	N _{DL}	Frequency of Downlink [MHz]
Low Range	1.4	20407	824.7	2407	869.7
	3	20415	825.5	2415	870.5
	5	20425	826.5	2425	871.5
	10 ^[1]	20450	829	2450	874
Mid Range	1.4/3/5 10 ^[1]	20525	836.5	2525	881.5
High Range	1.4	20643	848.3	2643	893.3
	3	20635	847.5	2635	892.5
	5	20625	846.5	2625	891.5
	10 ^[1]	20600	844	2600	889

NOTE 1: Bandwidth for which a relaxation of the specified UE receiver sensitivity requirement (TS 36.101 [27] Clause 7.3) is allowed.

4.3.1.1.5A FDD reference test frequencies for CA in operating band 5

Table 4.3.1.1.5A-1: Test frequencies for CA_5B

Range	CC-Combo / N _{RB_agg} [RB]	CC1 Note1					CC2 Note1				
		BW [RB]	N _{UL}	f _{UL} [MHz]	N _{DL}	f _{DL} [MHz]	BW [RB]	N _{UL}	f _{UL} [MHz]	N _{DL}	f _{DL} [MHz]
Low	15+25	15	20416	825.6	2416	870.6	25	20455	829.5	2455	874.5
		25	20425	826.5	2425	871.5	15	20464	830.4	2464	875.4
	25+50	25	20428	826.8	2428	871.8	50	20500	834	2500	879
	50+25	50	20450	829	2450	874	25	20522	836.2	2522	881.2
	50+50	50	20450	829	2450	874	50	20549	838.9	2549	883.9
Mid	15+25	15	20501	834.1	2501	879.1	25	20540	838.0	2540	883.0
		25	20510	835.0	2510	880.0	15	20549	838.9	2549	883.9
	25+50	25	20478	831.8	2478	876.8	50	20550	839	2550	884
	50+25	50	20500	834	2500	879	25	20572	841.2	2572	886.2
	50+50	50	20476	831.6	2476	876.6	50	20575	841.5	2575	886.5
High	15+25	15	20586	842.6	2586	887.6	25	20625	846.5	2625	891.5
		25	20595	843.5	2595	888.5	15	20634	847.4	2634	892.4
	25+50	25	20528	836.8	2528	881.8	50	20600	844	2600	889
	50+25	50	20550	839	2550	884	25	20622	846.2	2622	891.2
	50+50	50	20501	834.1	2501	879.1	50	20600	844	2600	889

Note 1: Carriers in increasing frequency order.

Table 4.3.1.1.5A-2: Test frequencies for CA_5A-5A

Test Frequency ID	CC-Combo / N _{RB_agg} [RB]	CC1 Note1					Wgap [MHz]	CC2 Note1				
		BW [RB]	N _{UL}	f _{UL} [MHz]	N _{DL}	f _{DL} [MHz]		BW [RB]	N _{UL}	f _{UL} [MHz]	N _{DL}	f _{DL} [MHz]
Max WGap	25+25	25	20425	826.5	2425	871.5	15	25	20625	846.5	2625	891.5
	25+50	25	20425	826.5	2425	871.5	10	50	20600	844	2600	889
		50	20450	829	2450	874	10	25	20625	846.5	2625	891.5
	50+50	50	20450	829	2450	874	5	50	20600	844	2600	889

Note 1: Carriers in increasing frequency order.

4.3.1.1.6 FDD reference test frequencies for operating band 6

Table 4.3.1.1.6-1: Test frequencies for E-UTRA channel bandwidth for operating band 6

Test Frequency ID	Bandwidth [MHz]	N _{UL}	Frequency of Uplink [MHz]	N _{DL}	Frequency of Downlink [MHz]
Low Range	5	20675	832.5	2675	877.5
	10 ^[1]	20700	835	2700	880
Mid Range	5	20700	835	2700	880
	10 ^[1]	20700	835	2700	880
High Range	5	20725	837.5	2725	882.5
	10 ^[1]	20700	835	2700	880

NOTE 1: Bandwidth for which a relaxation of the specified UE receiver sensitivity requirement (TS 36.101 [27] Clause 7.3) is allowed.

NOTE: For Band VI testing, the Mobile Country Code shall be set to (MCC = '442/443').

4.3.1.1.7 FDD reference test frequencies for operating band 7

Table 4.3.1.1.7-1: Test frequencies for E-UTRA channel bandwidth for operating band 7

Test Frequency ID	Bandwidth [MHz]	N _{UL}	Frequency of Uplink [MHz]	N _{DL}	Frequency of Downlink [MHz]
Low Range	5	20775	2502.5	2775	2622.5
	10	20800	2505	2800	2625
	15	20825	2507.5	2825	2627.5
	20 ^[1]	20850	2510	2850	2630
Mid Range	5/10/15 20 ^[1]	21100	2535	3100	2655
High Range	5	21425	2567.5	3425	2687.5
	10	21400	2565	3400	2685
	15	21375	2562.5	3375	2682.5
	20 ^[1]	21350	2560	3350	2680

NOTE 1: Bandwidth for which a relaxation of the specified UE receiver sensitivity requirement (TS 36.101 [27] Clause 7.3) is allowed.

4.3.1.1.7A FDD reference test frequencies for CA in operating band 7

Table 4.3.1.1.7A-1: Test frequencies for CA_7C

Range	CC-Combo / N _{RB_agg} [RB]	CC1 Note1					CC2 Note1				
		BW [RB]	N _{UL}	f _{UL} [MHz]	N _{DL}	f _{DL} [MHz]	BW [RB]	N _{UL}	f _{UL} [MHz]	N _{DL}	f _{DL} [MHz]
Low	50+100	50	20805	2505.5	2805	2625.5	100	20949	2519.9	2949	2639.9
		100	20850	2510	2850	2630	50	20994	2524.4	2994	2644.4
	75+50	75	20825	2507.5	2825	2627.5	50	20945	2519.5	2945	2639.5
	75+75	75	20825	2507.5	2825	2627.5	75	20975	2522.5	2975	2642.5
	75+100	75	20828	2507.8	2828	2627.8	100	20999	2524.9	2999	2644.9
		100	20850	2510	2850	2630	75	21021	2527.1	3021	2647.1
100+100	100	20850	2510	2850	2630	100	21048	2529.8	3048	2649.8	
Mid	50+100	50	21006	2525.6	3006	2645.6	100	21150	2540	3150	2660
		100	21051	2530.1	3051	2650.1	50	21195	2544.5	3195	2664.5
	75+50	75	21051	2530.1	3051	2650.1	50	21171	2542.1	3171	2662.1
	75+75	75	21025	2527.5	3025	2647.5	75	21175	2542.5	3175	2662.5
	75+100	75	21003	2525.3	3003	2645.3	100	21174	2542.4	3174	2662.4
		100	21026	2527.6	3026	2647.6	75	21197	2544.7	3197	2664.7
100+100	100	21001	2525.1	3001	2645.1	100	21199	2544.9	3199	2664.9	
High	50+100	50	21206	2545.6	3206	2665.6	100	21350	2560	3350	2680
		100	21251	2550.1	3251	2670.1	50	21395	2564.5	3395	2684.5
	75+50	75	21277	2552.7	3277	2672.7	50	21397	2564.7	3397	2684.7
	75+75	75	21225	2547.5	3225	2667.5	75	21375	2562.5	3375	2682.5
	75+100	75	21179	2542.9	3179	2662.9	100	21350	2560	3350	2680
		100	21201	2545.1	3201	2665.1	75	21372	2562.2	3372	2682.2
100+100	100	21152	2540.2	3152	2660.2	100	21350	2560	3350	2680	

Note 1: Carriers in increasing frequency order.

Table 4.3.1.1.7A-2 : Test frequencies for CA_7B

Range	CC-Combo / N _{RB_agg} [RB]	CC1 Note1					CC2 Note1				
		BW [RB]	N _{UL}	f _{UL} [MHz]	N _{DL}	f _{DL} [MHz]	BW [RB]	N _{UL}	f _{UL} [MHz]	N _{DL}	f _{DL} [MHz]
Low	75+25	75	20825	2507.5	2825	2627.5	25	20918	2516.8	2918	2636.8
Mid	75+25	75	21076	2532.6	3076	2652.6	25	21169	2541.9	3169	2661.9
High	75+25	75	21327	2557.7	3327	2677.7	25	21420	2567.0	3420	2687.0

Note 1: Carriers in increasing frequency order

Table 4.3.1.1.7A-2: Test frequencies for CA_7A-7A

Test Frequency ID	CC-Combo / N _{RB_agg} [RB]	CC1 Note1					Wgap [MHz]	CC2 Note1				
		BW [RB]	N _{UL}	f _{UL} [MHz]	N _{DL}	f _{DL} [MHz]		BW [RB]	N _{UL}	f _{UL} [MHz]	N _{DL}	f _{DL} [MHz]
Max WGap	25+25	25	20775	2502.5	2775	2622.5	60	25	21425	2567.5	3425	2687.5
	25+50	25	20775	2502.5	2775	2622.5	55	50	21400	2565	3400	2685
		50	20800	2505	2800	2625	55	25	21425	2567.5	3425	2687.5
	25+75	25	20775	2502.5	2775	2622.5	50	75	21375	2562.5	3375	2682.5
		75	20825	2507.5	2825	2627.5	50	25	21425	2567.5	3425	2687.5
	50+50	50	20800	2505	2800	2625	50	50	21400	2565	3400	2685
	25+100	25	20775	2502.5	2775	2622.5	45	100	21350	2560	3350	2680
		100	20850	2510	2850	2630	45	25	21425	2567.5	3425	2687.5
	50+75	50	20800	2505	2800	2625	45	75	21375	2562.5	3375	2682.5
		75	20825	2507.5	2825	2627.5	45	50	21400	2565	3400	2685
	50+100	50	20800	2505	2800	2625	40	100	21350	2560	3350	2680
		100	20850	2510	2850	2630	40	50	21400	2565	3400	2685
	75+75	75	20825	2507.5	2825	2627.5	40	75	21375	2562.5	3375	2682.5
	75+100	75	20825	2507.5	2825	2627.5	35	100	21350	2560	3350	2680
100		20850	2510	2850	2630	35	75	21375	2562.5	3375	2682.5	
100+100	100	20850	2510	2850	2630	30	100	21350	2560	3350	2680	
Refsens ²	75+100	75	21025	2527.5	3025	2647.5	15	100	21350	2560	3350	2680
	100+100	100	21000	2525	3000	2645	15	100	21350	2560	3350	2680
	25+100	25	20975	2522.5	2975	2642.5	25	100	21350	2560	3350	2680
	25+50	25	21025	2527.5	3025	2647.5	30	50	21400	2565	3400	2685
	50+100	50	21000	2525	3000	2645	20	100	21350	2560	3350	2680
		100	21100	2535	3100	2655	15	50	21400	2565	3400	2685

Note 1: Carriers in increasing frequency order.
 Note 2: Test point derived with regard to REFSSENS requirements.

4.3.1.1.8 FDD reference test frequencies for operating band 8

Table 4.3.1.1.8-1: Test frequencies for E-UTRA channel bandwidth for operating band 8

Test Frequency ID	Bandwidth [MHz]	N _{UL}	Frequency of Uplink [MHz]	N _{DL}	Frequency of Downlink [MHz]
Low Range	1.4	21457	880.7	3457	925.7
	3	21465	881.5	3465	926.5
	5	21475	882.5	3475	927.5
	10 ^[1]	21500	885	3500	930
Mid Range	1.4/3/5 10 ^[1]	21625	897.5	3625	942.5
High Range	1.4	21793	914.3	3793	959.3
	3	21785	913.5	3785	958.5
	5	21775	912.5	3775	957.5
	10 ^[1]	21750	910	3750	955

NOTE 1: Bandwidth for which a relaxation of the specified UE receiver sensitivity requirement (TS 36.101 [27] Clause 7.3) is allowed.

4.3.1.1.8A FDD reference test frequencies for CA in operating band 8

Table 4.3.1.1. 8 A-1: Test frequencies for CA_8B

Range	CC-Combo / N _{RB_agg} [RB]	CC1 Note1					CC2 Note1				
		BW [RB]	N _{UL}	f _{UL} [MHz]	N _{DL}	f _{DL} [MHz]	BW [RB]	N _{UL}	f _{UL} [MHz]	N _{DL}	f _{DL} [MHz]
Low	25+50	25	21478	882.8	3478	927.8	50	21550	890	3550	935
	50+25	50	21500	885	3500	930	25	21572	892.2	3572	937.2
	50+50	50	21500	885	3500	930	50	21599	894.9	3599	939.9
Mid	25+50	25	21578	892.8	3578	937.8	50	21650	900.0	3650	945.0
	50+25	50	21600	895.0	3600	940.0	25	21672	902.2	3672	947.2
	50+50	50	21576	892.6	3576	937.6	50	21675	902.5	3675	947.5
High	25+50	25	21678	902.8	3678	947.8	50	21750	910	3750	955
	50+25	50	21700	905	3700	950	25	21772	912.2	3772	957.2
	50+50	50	21651	900.1	3651	945.1	50	21750	910	3750	955

Note 1: Carriers in increasing frequency order.

4.3.1.1.9 FDD reference test frequencies for operating band 9

Table 4.3.1.1.9-1: Test frequencies for E-UTRA channel bandwidth for operating band 9

Test Frequency ID	Bandwidth [MHz]	N _{UL}	Frequency of Uplink [MHz]	N _{DL}	Frequency of Downlink [MHz]
Low Range	5	21825	1752.4	3825	1847.4
	10	21850	1754.9	3850	1849.9
	15 ^[1]	21875	1757.4	3875	1852.4
	20 ^[1]	21900	1759.9	3900	1854.9
Mid Range	5/10 15 ^[1] /20 ^[1]	21975	1767.4	3975	1862.4
High Range	5	22125	1782.4	4125	1877.4
	10	22100	1779.9	4100	1874.9
	15 ^[1]	22075	1777.4	4075	1872.4
	20 ^[1]	22050	1774.9	4050	1869.9

NOTE 1: Bandwidth for which a relaxation of the specified UE receiver sensitivity requirement (TS 36.101 [27] Clause 7.3) is allowed.

4.3.1.1.10 FDD reference test frequencies for operating band 10

Table 4.3.1.1.10-1: Test frequencies for E-UTRA channel bandwidth for operating band 10

Test Frequency ID	Bandwidth [MHz]	N _{UL}	Frequency of Uplink [MHz]	N _{DL}	Frequency of Downlink [MHz]
Low Range	5	22175	1712.5	4175	2112.5
	10	22200	1715	4200	2115
	15	22225	1717.5	4225	2117.5
	20	22250	1720	4250	2120
Mid Range	5/10/15/20	22450	1740	4450	2140
High Range	5	22725	1767.5	4725	2167.5
	10	22700	1765	4700	2165
	15	22675	1762.5	4675	2162.5
	20	22650	1760	4650	2160

4.3.1.1.11 FDD reference test frequencies for operating band 11

Table 4.3.1.1.11-1: Test frequencies for E-UTRA channel bandwidth for operating band 11

Test Frequency ID	Bandwidth [MHz]	N _{UL}	Frequency of Uplink [MHz]	N _{DL}	Frequency of Downlink [MHz]
Low Range	5	22775	1430.4	4775	1478.4
	10 ^[1]	22800	1432.9	4800	1480.9
Mid Range	5 / 10 ^[1]	22850	1437.9	4850	1485.9
High Range	5	22925	1445.4	4925	1493.4
	10 ^[1]	22900	1442.9	4900	1490.9

NOTE 1: Bandwidth for which a relaxation of the specified UE receiver sensitivity requirement (TS 36.101 [27] Clause 7.3) is allowed.

4.3.1.1.12 FDD reference test frequencies for operating band 12

Table 4.3.1.1.12-1: Test frequencies for E-UTRA channel bandwidth for operating band 12

Test Frequency ID	Bandwidth [MHz]	N _{UL}	Frequency of Uplink [MHz]	N _{DL}	Frequency of Downlink [MHz]
Low Range	1.4	23017	699.7	5017	729.7
	3	23025	700.5	5025	730.5
	5 ^[1]	23035	701.5	5035	731.5
	10 ^[1]	23060	704	5060	734
Mid Range	1.4/3 5 ^[1] /10 ^[1]	23095	707.5	5095	737.5
High Range	1.4	23173	715.3	5173	745.3
	3	23165	714.5	5165	744.5
	5 ^[1]	23155	713.5	5155	743.5
	10 ^[1]	23130	711	5130	741

NOTE 1: Bandwidth for which a relaxation of the specified UE receiver sensitivity requirement (TS 36.101 [27] Clause 7.3) is allowed.

4.3.1.1.12A FDD reference test frequencies for CA in operating band 12

Table 4.3.1.1.12A-1: Test frequencies for CA_12B

Range	CC-Combo / N _{RB,agg} [RB]	CC1 Note1					CC2 Note1				
		BW [RB]	N _{UL}	f _{UL} [MHz]	N _{DL}	f _{DL} [MHz]	BW [RB]	N _{UL}	f _{UL} [MHz]	N _{DL}	f _{DL} [MHz]
Low	25+25	25	23035	701.5	5035	731.5	25	23083	706.3	5083	736.3
	25+50	25	23038	701.8	5038	731.8	50	23110	709	5110	739
Mid	25+25	25	23071	705.1	5071	735.1	25	23119	709.9	5119	739.9
	25+50	25	23048	702.8	5048	732.8	50	23120	710	5120	740
High	25+25	25	23107	708.7	5107	738.7	25	23155	713.5	5155	743.5
	25+50	25	23058	703.8	5058	733.8	50	23130	711	5130	741

Note 1: Carriers in increasing frequency order.

Table 4.3.1.1.12A-2: Test frequencies for CA_12A-12A

Test Frequency ID	CC-Combo / N _{RB_agg} [RB]	CC1 Note1					Wgap [MHz]	CC2 Note1				
		BW [RB]	N _{UL}	f _{UL} [MHz]	N _{DL}	f _{DL} [MHz]		BW [RB]	N _{UL}	f _{UL} [MHz]	N _{DL}	f _{DL} [MHz]
Max WGap	25+25	25	23035	701.5	5035	731.5	7	25	23155	713.5	5155	743.5

Note 1: Carriers in increasing frequency order.

4.3.1.1.13 FDD reference test frequencies for operating band 13

Table 4.3.1.1.13-1: Test frequencies for E-UTRA channel bandwidth for operating band 13

Test Frequency ID	Bandwidth [MHz]	N _{UL}	Frequency of Uplink [MHz]	N _{DL}	Frequency of Downlink [MHz]
Low Range	5 ^[1]	23205	779.5	5205	748.5
	10 ^[1]	23230	782	5230	751
Mid Range	5 ^[1] /10 ^[1]	23230	782	5230	751
High Range	5 ^[1]	23255	784.5	5255	753.5
	10 ^[1]	23230	782	5230	751

NOTE 1: Bandwidth for which a relaxation of the specified UE receiver sensitivity requirement (TS 36.101 [27] Clause 7.3) is allowed.

4.3.1.1.14 FDD reference test frequencies for operating band 14

Table 4.3.1.1.14-1: Test frequencies for E-UTRA channel bandwidth for operating band 14

Test Frequency ID	Bandwidth [MHz]	N _{UL}	Frequency of Uplink [MHz]	N _{DL}	Frequency of Downlink [MHz]
Low Range	5 ^[1]	23305	790.5	5305	760.5
	10 ^[1]	23330	793	5330	763
Mid Range	5 ^[1] /10 ^[1]	23330	793	5330	763
High Range	5 ^[1]	23355	795.5	5355	765.5
	10 ^[1]	23330	793	5330	763

NOTE 1: Bandwidth for which a relaxation of the specified UE receiver sensitivity requirement (TS 36.101 [27] Clause 7.3) is allowed.

4.3.1.1.15 FDD reference test frequencies for operating band 15

[FFS; not yet specified in TS 36.101]

4.3.1.1.16 FDD reference test frequencies for operating band 16

[FFS; not yet specified in TS 36.101]

4.3.1.1.17 FDD reference test frequencies for operating band 17

Table 4.3.1.1.17-1: Test frequencies for E-UTRA channel bandwidth for operating band 17

Test Frequency ID	Bandwidth [MHz]	N _{UL}	Frequency of Uplink [MHz]	N _{DL}	Frequency of Downlink [MHz]
Low Range	5 ^[1]	23755	706.5	5755	736.5
	10 ^[1]	23780	709	5780	739
Mid Range	5 ^[1] /10 ^[1]	23790	710	5790	740
High Range	5 ^[1]	23825	713.5	5825	743.5
	10 ^[1]	23800	711	5800	741

NOTE 1: Bandwidth for which a relaxation of the specified UE receiver sensitivity requirement (TS 36.101 [27] Clause 7.3) is allowed.

4.3.1.1.18 FDD reference test frequencies for operating band 18

Table 4.3.1.1.18-1: Test frequencies for E-UTRA channel bandwidth for operating band 18

Test Frequency ID	Bandwidth [MHz]	N _{UL}	Frequency of Uplink [MHz]	N _{DL}	Frequency of Downlink [MHz]
Low Range	5	23875	817.5	5875	862.5
	10 ^[1]	23900	820	5900	865
	15 ^[1]	23925	822.5	5925	867.5
Mid Range	5/10 ^[1] /15 ^[1]	23925	822.5	5925	867.5
High range	5	23975	827.5	5975	872.5
	10 ^[1]	23950	825	5950	870
	15 ^[1]	23925	822.5	5925	867.5

NOTE 1: Bandwidth for which a relaxation of the specified UE receiver sensitivity requirement (TS 36.101 [27] Clause 7.3) is allowed.

4.3.1.1.19 FDD reference test frequencies for operating band 19

Table 4.3.1.1.19-1: Test frequencies for E-UTRA channel bandwidth for operating band 19

Test Frequency ID	Bandwidth [MHz]	N _{UL}	Frequency of Uplink [MHz]	N _{DL}	Frequency of Downlink [MHz]
Low Range	5	24025	832.5	6025	877.5
	10 ^[1]	24050	835	6050	880
	15 ^[1]	24075	837.5	6075	882.5
Mid Range	5/10 ^[1] /15 ^[1]	24075	837.5	6075	882.5
High range	5	24125	842.5	6125	887.5
	10 ^[1]	24100	840	6100	885
	15 ^[1]	24075	837.5	6075	882.5

NOTE 1: Bandwidth for which a relaxation of the specified UE receiver sensitivity requirement (TS 36.101 [27] Clause 7.3) is allowed.

4.3.1.1.20 FDD reference test frequencies for operating band 20

Table 4.3.1.1.20-1: Test frequencies for E-UTRA channel bandwidth for operating band 20

Test Frequency ID	Bandwidth [MHz]	N _{UL}	Frequency of Uplink [MHz]	N _{DL}	Frequency of Downlink [MHz]
Low Range	5	24175	834.5	6175	793.5
	10 ^[1]	24200	837	6200	796
	15 ^[1]	24225	839.5	6225	798.5
	20 ^[1]	24250	842	6250	801
Mid Range	5/10 ^[1] /15 ^[1] /20 ^[1]	24300	847	6300	806
High range	5	24425	859.5	6425	818.5
	10 ^[1]	24400	857	6400	816
	15 ^[1]	24375	854.5	6375	813.5
	20 ^[1]	24350	852	6350	811

NOTE 1: Bandwidth for which a relaxation of the specified UE receiver sensitivity requirement (TS 36.101 [27] Clause 7.3) is allowed.

4.3.1.1.21 FDD reference test frequencies for operating band 21

Table 4.3.1.1.21-1: Test frequencies for E-UTRA channel bandwidth for operating band 21

Test Frequency ID	Bandwidth [MHz]	N _{UL}	Frequency of Uplink [MHz]	N _{DL}	Frequency of Downlink [MHz]
Low Range	5	24475	1450.4	6475	1498.4
	10 ^[1]	24500	1452.9	6500	1500.9
	15 ^[1]	24525	1455.4	6525	1503.4
Mid Range	5/10 ^[1] /15 ^[1]	24525	1455.4	6525	1503.4
High range	5	24575	1460.4	6575	1508.4
	10 ^[1]	24550	1457.9	6550	1505.9
	15 ^[1]	24525	1455.4	6525	1503.4

NOTE 1: Bandwidth for which a relaxation of the specified UE receiver sensitivity requirement (TS 36.101 [27] Clause 7.3) is allowed.

4.3.1.1.22 FDD reference test frequencies for operating band 22

Table 4.3.1.1.22-1: Test frequencies for E-UTRA channel bandwidth for operating band 22

Test Frequency ID	Bandwidth [MHz]	N _{UL}	Frequency of Uplink [MHz]	N _{DL}	Frequency of Downlink [MHz]
Low Range	5	24625	3412.5	6625	3512.5
	10	24650	3415	6650	3515
	15	24675	3417.5	6675	3517.5
	20	24700	3420	6700	3520
Mid Range	5/10/15/20	25000	3450	7000	3550
High Range	5	25375	3487.5	7375	3587.5
	10	25350	3485	7350	3585
	15	25325	3482.5	7325	3582.5
	20	25300	3480	7300	3580

4.3.1.1.23 FDD reference test frequencies for operating band 23

Table 4.3.1.1.23-1: Test frequencies for E-UTRA channel bandwidth for operating band 23

Test Frequency ID	Bandwidth [MHz]	N _{UL}	Frequency of Uplink [MHz]	N _{DL}	Frequency of Downlink [MHz]
Low Range	1.4	25507	2000.7	7507	2180.7
	3	25515	2001.5	7515	2181.5
	5	25525	2002.5	7525	2182.5
	10	25550	2005	7550	2185
	15	25575	2007.5	7575	2187.5
	20	25600	2010	7600	2190
Mid Range	1.4/3 5 / 10 / 15 / 20	25600	2010	7600	2190
High Range	1.4	25693	2019.3	7693	2199.3
	3	25685	2018.5	7685	2198.5
	5	25675	2017.5	7675	2197.5
	10	25650	2015	7650	2195
	15	25625	2012.5	7625	2192.5
	20	25600	2010	7600	2190

4.3.1.1.23A FDD reference test frequencies for CA in operating band 23

Table 4.3.1.1.23A-1: Test frequencies for CA_23A-23A

Test Frequency ID	CC-Combo / N _{RB,agg} [RB]	CC1 Note1					Wgap [MHz]	CC2 Note 1				
		BW [RB]	N _{UL}	f _{UL} [MHz]	N _{DL}	f _{DL} [MHz]		BW [RB]	N _{UL}	f _{UL} [MHz]	N _{DL}	f _{DL} [MHz]
Max WGap	25+50	25	25525	2002.5	7525	2182.5	5	50	25650	2015	7650	2195

Note 1: Carriers in increasing frequency order.

Table 4.3.1.1.23A-2: Test frequencies for CA_23B

Range	CC-Combo / N _{RB,agg} [RB]	CC1 Note1					CC2 Note1				
		BW [RB]	N _{UL}	f _{UL} [MHz]	N _{DL}	f _{DL} [MHz]	BW [RB]	N _{UL}	f _{UL} [MHz]	N _{DL}	f _{DL} [MHz]
Low/Mid/High	25+75	25	25531	2003.1	7531	2183.1	75	25624	2012.4	7624	2192.4
	50+50	50	25551	2005.1	7551	2185.1	50	25650	2015	7650	2195

Note 1: Carriers in increasing frequency order.

4.3.1.1.24 FDD reference test frequencies for operating band 24

Table 4.3.1.1.24-1: Test frequencies for E-UTRA channel bandwidth for operating band 24

Test Frequency ID	Bandwidth [MHz]	N _{UL}	Frequency of Uplink [MHz]	N _{DL}	Frequency of Downlink [MHz]
Low Range	5	25725	1629	7725	1527.5
	10	25750	1631.5	7750	1530
Mid Range	5/10	25870	1643.5	7870	1542
High Range	5	26015	1658	8015	1556.5
	10	25990	1655.5	7990	1554

4.3.1.1.25 FDD reference test frequencies for operating band 25

Table 4.3.1.1.25-1: Test frequencies for E-UTRA channel bandwidth for operating band 25

Test Frequency ID	Bandwidth [MHz]	N _{UL}	Frequency of Uplink [MHz]	N _{DL}	Frequency of Downlink [MHz]
Low Range	1.4	26047	1850.7	8047	1930.7
	3	26055	1851.5	8055	1931.5
	5	26065	1852.5	8065	1932.5
	10	26090	1855	8090	1935
	15 ^[1]	26115	1857.5	8115	1937.5
	20 ^[1]	26140	1860	8140	1940
Mid Range	1.4/3/5/10 15 ^[1] /20 ^[1]	26365	1882.5	8365	1962.5
High Range	1.4	26683	1914.3	8683	1994.3
	3	26675	1913.5	8675	1993.5
	5	26665	1912.5	8665	1992.5
	10	26640	1910	8640	1990
	15 ^[1]	26615	1907.5	8615	1987.5
	20 ^[1]	26590	1905	8590	1985

NOTE 1: Bandwidth for which a relaxation of the specified UE receiver sensitivity requirement (TS 36.101 [27] Clause 7.3) is allowed.

4.3.1.1.25A FDD reference test frequencies for CA in operating band 25

Table 4.3.1.1.25A-1: Test frequencies for CA_25A-25A

Test Frequency ID	CC-Combo / N _{RB,agg} [RB]	CC1 Note1					Wgap [MHz]	CC2 Note 1				
		BW [RB]	N _{UL}	f _{UL} [MHz]	N _{DL}	f _{DL} [MHz]		BW [RB]	N _{UL}	f _{UL} [MHz]	N _{DL}	f _{DL} [MHz]
Max WGap	25+25	25	26065	1852.5	8065	1932.5	55	25	26665	1912.5	8665	1992.5
	25+50	25	26065	1852.5	8065	1932.5	50	50	26640	1910	8640	1990
		50	26090	1855	8090	1935	50	25	26665	1912.5	8665	1992.5
	50+50	50	26090	1855	8090	1935	45	50	26640	1910	8640	1990
	25+100	25	26065	1852.5	8065	1932.5	40	100	26590	1905	8590	1985
		100	26140	1860	8140	1940	40	25	26665	1912.5	8665	1992.5
	50+75	50	26090	1855	8090	1935	40	75	26615	1907.5	8615	1987.5
		75	26115	1857.5	8115	1937.5	40	50	26640	1910	8640	1990
	50+100	50	26090	1855	8090	1935	35	100	26590	1905	8590	1985
		100	26140	1860	8140	1940	35	50	26640	1910	8640	1990
	75+75	75	26115	1857.5	8115	1937.5	35	75	26615	1907.5	8615	1987.5
	75+100	75	26115	1857.5	8115	1937.5	30	100	26590	1905	8590	1985
		100	26140	1860	8140	1940	30	75	26615	1907.5	8615	1987.5
	100+100	100	26140	1860	8140	1940	25	100	26590	1905	8590	1985
Refsens ²	25+50	25	26415	1887.5	8415	1967.5	15	50	26640	1910	8640	1990
	50+50	50	26440	1890	8440	1970	10	50	26640	1910	8640	1990

Note 1: Carriers in increasing frequency order.
 Note 2: Test point derived with regard to REFSENS requirements.

4.3.1.1.26 FDD reference test frequencies for operating band 26

Table 4.3.1.1.26-1: Test frequencies for E-UTRA channel bandwidth for operating band 26

Test Frequency ID	Bandwidth [MHz]	N _{UL}	Frequency of Uplink [MHz]	N _{DL}	Frequency of Downlink [MHz]
Low Range	1.4	26697	814.7	8697	859.7
	3	26705	815.5	8705	860.5
	5	26715	816.5	8715	861.5
	10 ^[1]	26740	819	8740	864
	15 ^[1]	26765	821.5	8765	866.5

Mid Range	1.4/3/5/10 ^[1] 15 ^[1]	26865	831.5	8865	876.5
High Range	1.4	27033	848.3	9033	893.3
	3	27025	847.5	9025	892.5
	5	27015	846.5	9015	891.5
	10 ^[1]	26990	844	8990	889
	15 ^[1]	26965	841.5	8965	886.5
NOTE 1: Bandwidth for which a relaxation of the specified UE receiver sensitivity requirement (TS 36.101 [27] Clause 7.3) is allowed.					

4.3.1.1.27 FDD reference test frequencies for operating band 27

Table 4.3.1.1.27-1: Test frequencies for E-UTRA channel bandwidth for operating band 27

Test Frequency ID	Bandwidth [MHz]	N _{UL}	Frequency of Uplink [MHz]	N _{DL}	Frequency of Downlink [MHz]
Low Range	1.4	27047	807.7	9047	852.7
	3	27055	808.5	9055	853.5
	5	27065	809.5	9065	854.5
	10 ^[1]	27090	812	9090	857
Mid Range	1.4/3/5/10 ^[1]	27125	815.5	9125	860.5
High Range	1.4	27203	823.3	9203	868.3
	3	27195	822.5	9195	867.5
	5	27185	821.5	9185	866.5
	10 ^[1]	27160	819	9160	864
NOTE 1: Bandwidth for which a relaxation of the specified UE receiver sensitivity requirement (TS 36.101 [27] Clause 7.3) is allowed.					

4.3.1.1.27A FDD reference test frequencies for CA in operating band 27

Table 4.3.1.1.27A-1: Test frequencies for CA_27B

Range	CC-Combo / N _{RB,agg} [RB]	CC1 Note 1					CC2 Note 1				
		BW [RB]	N _{UL}	f _{UL} [MHz]	N _{DL}	f _{DL} [MHz]	BW [RB]	N _{UL}	f _{UL} [MHz]	N _{DL}	f _{DL} [MHz]
Low	6+25	6	27048	807.8	9048	852.8	25	27078	810.8	9078	855.8
	15+25	15	27056	808.6	9056	853.6	25	27095	812.5	9095	857.5
	25+25	25	27065	809.5	9065	854.5	25	27113	814.3	9113	859.3
	6+50	6	27051	808.1	9051	853.1	50	27102	813.2	9102	858.2
	15+50	15	27059	808.9	9059	853.9	50	27119	814.9	9119	859.9
Mid	6+25	6	27101	813.1	9101	858.1	25	27131	816.1	9131	861.1
	15+25	15	27101	813.1	9101	858.1	25	27140	817.0	9140	862.0
	25+25	25	27101	813.1	9101	858.1	25	27149	817.9	9149	862.9
	6+50	6	27080	811.0	9080	856.0	50	27131	816.1	9131	861.1
	15+50	15	27079	810.9	9079	855.9	50	27139	816.9	9139	861.9
High	6+25	6	27155	818.5	9155	863.5	25	27185	821.5	9185	866.5
	15+25	15	27146	817.6	9146	862.6	25	27185	821.5	9185	866.5
	25+25	25	27137	816.7	9137	861.7	25	27185	821.5	9185	866.5
	6+50	6	27109	813.9	9109	858.9	50	27160	819.0	9160	864.0
	15+50	15	27100	813.0	9100	858.0	50	27160	819.0	9160	864.0
Note 1: Carriers in increasing frequency order.											

4.3.1.1.28 FDD reference test frequencies for operating band 28

Table 4.3.1.1.28-1: Test frequencies for E-UTRA channel bandwidth for operating band 28

Test Frequency ID	Bandwidth [MHz]	N _{UL}	Frequency of Uplink [MHz]	N _{DL}	Frequency of Downlink [MHz]
Low Range	3	27225	704.5	9225	759.5
	5	27235	705.5	9235	760.5
	10 ^[1]	27260	708	9260	763
	15 ^[1]	27285	710.5	9285	765.5
	20 ^[1]	27310	713	9310	768
Mid Range	3	27375	719.5	9375	774.5
	5	27385	720.5	9385	775.5
	10 ^[1]	27410	723	9410	778
	15 ^[1]	27435	725.5	9435	780.5
	20 ^[1,2]	27460	728	9460	783
High Range	3	27645	746.5	9645	801.5
	5	27635	745.5	9635	800.5
	10 ^[1]	27610	743	9610	798
	15 ^[1]	27585	740.5	9585	795.5
	20 ^[1]	27560	738	9560	793
NOTE 1: Bandwidth for which a relaxation of the specified UE receiver sensitivity requirement (TS 36.101 [27] Clause 7.3) is allowed.					
NOTE 2: Mid Range for 20 MHz moved due to note 2 in Table 5.6.1-1 of TS 36.101 [27].					
NOTE 3: For CA_18A-28A and CA_1A-18A-28A use test frequencies in Table 4.3.1.1.28-2.					
NOTE 4: For CA_19A-28A and CA_1A-19A-28A use test frequencies in Table 4.3.1.1.28-3.					

Table 4.3.1.1.28-2: Test frequencies for E-UTRA channel bandwidth for operating band 28 in CA_18A-28A and CA_1A-18A-28A

Test Frequency ID	Bandwidth [MHz]	N _{UL}	Frequency of Uplink [MHz]	N _{DL}	Frequency of Downlink [MHz]
Low Range	5	27235	705.5	9235	760.5
	10 ^[1]	27260	708	9260	763
Mid Range	5/10 ^[1]	27360	718	9360	773
High Range	5	27485	730.5	9485	785.5
	10 ^[1]	27460	728	9460	783
NOTE 1: Bandwidth for which a relaxation of the specified UE receiver sensitivity requirement (TS 36.101 [27] Clause 7.3) is allowed.					

Table 4.3.1.1.28-3: Test frequencies for E-UTRA channel bandwidth for operating band 28 in CA_19A-28A and CA_1A-19A-28A

Test Frequency ID	Bandwidth [MHz]	N _{UL}	Frequency of Uplink [MHz]	N _{DL}	Frequency of Downlink [MHz]
Low Range	5	27385	720.5	9385	775.5
	10 ¹	27410	723	9410	778
Mid Range	5/10 ¹	27510	733	9510	788
High Range	5	27635	745.5	9635	800.5
	10 ¹	27610	743	9610	798
NOTE 1: Bandwidth for which a relaxation of the specified UE receiver sensitivity requirement (TS 36.101 [27] Clause 7.3) is allowed.					

4.3.1.1.29 FDD reference test frequencies for CA in operating band 29

Table 4.3.1.1.29-1: Test frequencies for E-UTRA channel bandwidth for operating band 29

Test Frequency ID	Bandwidth [MHz]	N _{UL}	Frequency of Uplink [MHz]	N _{DL}	Frequency of Downlink [MHz]
Low Range	3	NA ^[1]	NA	9675	718.5
	5	NA ^[1]	NA	9685	719.5
	10	NA ^[1]	NA	9710	722
Mid Range	3 5/10	NA ^[1]	NA	9715	722.5
High Range	3	NA ^[1]	NA	9755	726.5
	5	NA ^[1]	NA	9745	725.5
	10	NA ^[1]	NA	9720	723

NOTE 1: Restricted to E-UTRA operation when carrier aggregation is configured. The downlink operating band is paired with the uplink operating band (external) of the carrier aggregation configuration that is supporting the configured Pcell.

4.3.1.1.30 FDD reference test frequencies for operating band 30

Table 4.3.1.1.30-1: Test frequencies for E-UTRA channel bandwidth for operating band 30

Test Frequency ID	Bandwidth [MHz]	N _{UL}	Frequency of Uplink [MHz]	N _{DL}	Frequency of Downlink [MHz]
Low Range	5	27685	2307.5	9795	2352.5
	10	27710	2310	9820	2355
Mid Range	5/10	27710	2310	9820	2355
High Range	5	27735	2312.5	9845	2357.5
	10	27710	2310	9820	2355

Note 1: The uplink transmission is not allowed at this band for the UE with the externally vehicle-mounted antennas.

4.3.1.1.31 FDD reference test frequencies for operating band 31

Table 4.3.1.1.31-1: Test frequencies for E-UTRA channel bandwidth for operating band 31

Test Frequency ID	Bandwidth [MHz]	N _{UL}	Frequency of Uplink [MHz]	N _{DL}	Frequency of Downlink [MHz]
Low Range	1.4	27767	453.2	9877	463.2
	3 ^[1]	27775	454	9885	464
	5 ^[1]	27785	455	9895	465
Mid Range	1.4/3 ^[1] / 5 ^[1]	27785	455	9895	465
High Range	1.4	27803	456.8	9913	466.8
	3 ^[1]	27795	456	9905	466
	5 ^[1]	27785	455	9895	465

NOTE 1: Bandwidth for which a relaxation of the specified UE receiver sensitivity requirement (TS 36.101 [27] Clause 7.3) is allowed.

4.3.1.1.32 FDD reference test frequencies for CA in operating band 32

Table 4.3.1.1.32-1: Test frequencies for E-UTRA channel bandwidth for operating band 32

Test Frequency ID	Bandwidth [MHz]	N _{UL}	Frequency of Uplink [MHz]	N _{DL}	Frequency of Downlink [MHz]
Low Range	5	NA ^[1]	NA	9945	1454.5
	10	NA ^[1]	NA	9970	1457
	15	NA ^[1]	NA	9995	1459.5
	20	NA ^[1]	NA	10020	1462

Mid Range	5/10/15/20	NA ^[1]	NA	10140	1474
High Range	5	NA ^[1]	NA	10335	1493.5
	10	NA ^[1]	NA	10310	1491
	15	NA ^[1]	NA	10285	1488.5
	20	NA ^[1]	NA	10260	1486
NOTE 1: Restricted to E-UTRA operation when carrier aggregation is configured. The downlink operating band is paired with the uplink operating band (external) of the carrier aggregation configuration that is supporting the configured Pcell.					

4.3.1.1.33 to 4.3.1.1.64 Void

Note: Sub-clauses 4.3.1.1.33 to 4.3.1.1.64 are marked as void as bands 33 to 64 are TDD bands. TDD bands are specified in sub-clause 4.3.1.2.

4.3.1.1.65 FDD reference test frequencies for operating band 65

Table 4.3.1.1.65-1: Test frequencies for E-UTRA channel bandwidth for operating band 65

Test Frequency ID	Bandwidth [MHz]	N _{UL}	Frequency of Uplink [MHz]	N _{DL}	Frequency of Downlink [MHz]
Low Range	1.4	131079	1920.7	65543	2110.7
	3	131087	1921.5	65551	2111.5
	5	131097	1922.5	65561	2112.5
	10	131122	1925	65586	2115
	15	131147	1927.5	65611	2117.5
	20	131172	1930	65636	2120
Mid Range	1.4/3/5/10/15/20	131522	1965	65986	2155
High Range	1.4	131965	2009.3	66429	2199.3
	3	131957	2008.5	66421	2198.5
	5	131947	2007.5	66411	2197.5
	10	131922	2005	66386	2195
	15	131897	2002.5	66361	2192.5
	20	131872	2000	66336	2190

4.3.1.1.66 FDD reference test frequencies for operating band 66

Table 4.3.1.1.66-1: Test frequencies for E-UTRA channel bandwidth for operating band 66

Test Frequency ID	Bandwidth [MHz]	N _{UL}	Frequency of Uplink [MHz]	N _{DL}	Frequency of Downlink [MHz]
Low Range	1.4	131979	1710.7	66443	2110.7
	3	131987	1711.5	66451	2111.5
	5	131997	1712.5	66461	2112.5
	10	132022	1715	66486	2115
	15	132047	1717.5	66511	2117.5
	20	132072	1720	66536	2120
Mid Range Tx ¹	1.4/3/5/10/15/20	132322	1745	66786	2145
Mid Range	1.4/3/5/10/15/20	132422	1755	66886	2155
Paired High Range ²	1.4	132665	1779.3	67129	2179.3
	3	132657	1778.5	67121	2178.5
	5	132647	1777.5	67111	2177.5
	10	132622	1775	67086	2175
	15	132597	1772.5	67061	2172.5
	20	132572	1770	67036	2170
High Range ³	1.4	NA	NA	67329	2199.3
	3	NA	NA	67321	2198.5
	5	NA	NA	67311	2197.5
	10	NA	NA	67286	2195
	15	NA	NA	67261	2192.5
	20	NA	NA	67236	2190
Note 1: Applicable for transmitter testing.					
Note 2: Applicable if UL is configured on the CC.					
Note 3: Applicable if no UL is configured on the CC.					

4.3.1.1.66A FDD reference test frequencies for CA in operating band 66

Table 4.3.1.1.66A-1: Test frequencies for CA_66B

Range	CC-Combo / N _{RB,agg} [RB]	CC1 Note1					CC2 Note1				
		BW [RB]	N _{UL}	f _{UL} [MHz]	N _{DL}	f _{DL} [MHz]	BW [RB]	N _{UL}	f _{UL} [MHz]	N _{DL}	f _{DL} [MHz]
Low	25+25	25	131997	1712.5	66461	2112.5	25	132045	1717.3	66509	2117.3
	25+50	25	132000	1712.8	66464	2112.8	50	132072	1720	66536	2120
		50	132022	1715	66486	2115	25	132094	1722.2	66558	2122.2
	25+75	25	132002	1713	66466	2113	75	132095	1722.3	66559	2122.3
		75	132047	1717.5	66511	2117.5	25	132140	1726.8	66604	2126.8
50+50	50	132022	1715	66486	2115	50	132121	1724.9	66585	2124.9	
Mid	25+25	25	132398	1752.6	66862	2152.6	25	132446	1757.4	66910	2157.4
	25+50	25	132375	1750.3	66839	2150.3	50	132447	1757.5	66911	2157.5
		50	132397	1752.5	66861	2152.5	25	132469	1759.7	66933	2159.7
	25+75	25	132353	1748.1	66817	2148.1	75	132446	1757.4	66910	2157.4
		75	132398	1752.6	66862	2152.6	25	132491	1761.9	66955	2161.9
	50+50	50	132373	1750.1	66837	2150.1	50	132472	1760	66936	2160
High ²	25+25	25	132647	1777.5	67111	2177.5	25	NA	NA	67159	2182.3
	25+50	25	132647	1777.5	67111	2177.5	50	NA	NA	67183	2184.7
		50	132622	1775	67086	2175	25	NA	NA	67158	2182.2
	25+75	25	132647	1777.5	67111	2177.5	75	NA	NA	67204	2186.8
		75	132597	1772.5	67061	2172.5	25	NA	NA	67154	2181.8
	50+50	50	132622	1775	67086	2175	50	NA	NA	67185	2184.9
High ³	25+25	25	132599	1772.7	67063	2172.7	25	132647	1777.5	67111	2177.5
	25+50	25	132550	1767.8	67014	2167.8	50	132622	1775.	67086	2175
		50	132572	1770	67036	2170	25	132644	1777.2	67108	2177.2
	25+75	25	132504	1763.2	66968	2163.2	75	132597	1772.5	67061	2172.5
		75	132549	1767.7	67013	2167.7	25	132642	1777	67106	2177
	50+50	50	132523	1765.1	66987	2165.1	50	132622	1775	67086	2175

Note 1: Carriers in increasing frequency order.
Note 2: Applicable for intra-band contiguous CA without UL CA.
Note 3: Applicable for intra-band contiguous CA with UL CA.

Table 4.3.1.1.66A-2: Test frequencies for CA_66C

Range	CC-Combo / N _{RB,agg} [RB]	CC1 Note1					CC2 Note1				
		BW [RB]	N _{UL}	f _{UL} [MHz]	N _{DL}	f _{DL} [MHz]	BW [RB]	N _{UL}	f _{UL} [MHz]	N _{DL}	f _{DL} [MHz]
Low	50+75	50	132025	1715.3	66489	2115.3	75	132145	1727.3	66609	2127.3
		75	132047	1717.5	66511	2117.5	50	132167	1729.5	66631	2129.5
	50+100	50	132027	1715.5	66491	2115.5	100	132171	1729.9	66635	2129.9
		100	132072	1720	66536	2120	50	132216	1734.4	66680	2134.4
	75+75	75	132047	1717.5	66511	2117.5	75	132197	1732.5	66661	2132.5
	75+100	75	132050	1717.8	66514	2117.8	100	132221	1734.9	66685	2134.9
		100	132072	1720	66536	2120	75	132243	1737.1	66707	2137.1
	100+25	100	132072	1720	66536	2120	25	132189	1731.7	66653	2131.7
		25	132005	1713.3	66469	2113.3	100	132122	1725.0	66586	2125.0
	100+100	100	132072	1720	66536	2120	100	132270	1739.8	66734	2139.8
Mid	50+75	50	132351	1747.9	66815	2147.9	75	132471	1759.9	66935	2159.9
		75	132373	1750.1	66837	2150.1	50	132493	1762.1	66957	2162.1
	50+100	50	132328	1745.6	66792	2145.6	100	132472	1760	66936	2160
		100	132373	1750.1	66837	2150.1	50	132517	1764.5	66981	2164.5
	75+75	75	132347	1747.5	66811	2147.5	75	132497	1762.5	66961	2162.5
	75+100	75	132325	1745.3	66789	2145.3	100	132496	1762.4	66960	2162.4
		100	132348	1747.6	66812	2147.6	75	132519	1764.7	66983	2164.7
	100+25	100	132397	1752.5	66861	2152.5	25	132514	1764.2	66978	2164.2
		25	132330	1745.8	66794	2145.8	100	132447	1757.5	66911	2157.5
	100+100	100	132323	1745.1	66787	2145.1	100	132521	1764.9	66985	2164.9
High ²	50+75	50	132622	1775	67086	2175	75	NA	NA	67206	2187
		75	132597	1772.5	67061	2172.5	50	NA	NA	67181	2184.5
	50+100	50	132622	1775	67086	2175	100	NA	NA	67230	2189.4
		100	132572	1770	67036	2170	50	NA	NA	67180	2184.4
	75+75	75	132597	1772.5	67061	2172.5	75	NA	NA	67211	2187.5
	75+100	75	132597	1772.5	67061	2172.5	100	NA	NA	67232	2189.6
		100	132572	1770	67036	2170	75	NA	NA	67207	2187.1
	100+25	100	132572	1770	67036	2170	25	NA	NA	67153	2181.7
		25	132647	1777.5	67111	2177.5	100	NA	NA	67228	2189.2
	100+100	100	132572	1770	67036	2170	100	NA	NA	67234	2189.8
High ³	50+75	50	132477	1760.5	66941	2160.5	75	132597	1772.5	67061	2172.5
		75	132499	1762.7	66963	2162.7	50	132619	1774.7	67083	2174.7
	50+100	50	132428	1755.6	66892	2155.6	100	132572	1770	67036	2170
		100	132473	1760.1	66937	2160.1	50	132617	1774.5	67081	2174.5
	75+75	75	132447	1757.5	66911	2157.5	75	132597	1772.5	67061	2172.5
	75+100	75	132401	1752.9	66885	2152.9	100	132572	1770	67036	2170
		100	132423	1755.1	66887	2155.1	75	132594	1772.2	67058	2172.2
	100+25	100	132522	1765	66986	2165	25	132639	1776.7	67103	2176.7

		25	132455	1758.3	66919	2158.3	100	132572	1770.0	67036	2170.0
	100+100	100	132374	1750.2	66838	2150.2	100	132572	1770	67036	2170
Note 1:	Carriers in increasing frequency order.										
Note 2:	Applicable for intra-band contiguous CA without UL CA.										
Note 3:	Applicable for intra-band contiguous CA with UL CA.										

Table 4.3.1.1.66A-3: Test frequencies for CA_66A-66A

Test Frequency ID	CC-Combo / N _{RB,agg} [RB]	CC1 Note1					Wgap [MHz]	CC2 Note1				
		BW [RB]	N _{UL}	f _{UL} [MHz]	N _{DL}	f _{DL} [MHz]		BW [RB]	N _{UL}	f _{UL} [MHz]	N _{DL}	f _{DL} [MHz]
Low WGap ²	25+25	25	20125	1727.5	2125	2127.5	5	25	NA	NA	2225	2137.5
	50+50	50	20100	1725	2100	2125	5	50	NA	NA	2250	2140
	50+100	50	20095	1724.5	2095	2124.5	5	100	NA	NA	2255	2140.5
	100+100	100	20050	1720	2050	2120	5	100	NA	NA	2300	2145
Max WGap ²	25+25	25	131997	1712.5	66461	2112.5	80	25	NA	NA	67311	2197.5
	25+50	25	131997	1712.5	66461	2112.5	75	50	NA	NA	67286	2195
		50	132022	1715	66486	2115	75	25	NA	NA	67311	2197.5
	25+75	25	131997	1712.5	66461	2112.5	70	75	NA	NA	67261	2192.5
		75	132047	1717.5	66511	2117.5	70	25	NA	NA	67311	2197.5
	50+50	50	132022	1715	66486	2115	70	50	NA	NA	67286	2195
	25+100	25	131997	1712.5	66461	2112.5	65	100	NA	NA	67236	2190
		100	132072	1720	66536	2120	65	25	NA	NA	67311	2197.5
	50+75	50	132022	1715	66486	2115	65	75	NA	NA	67261	2192.5
		75	132047	1717.5	66511	2117.5	65	50	NA	NA	67286	2195
	50+100	50	132022	1715	66486	2115	60	100	NA	NA	67236	2190
		100	132072	1720	66536	2120	60	50	NA	NA	67286	2195
	75+75	75	132047	1717.5	66511	2117.5	60	75	NA	NA	67261	2192.5
	75+100	75	132047	1717.5	66511	2117.5	55	100	NA	NA	67236	2190
100		132072	1720	66536	2120	55	75	NA	NA	67261	2192.5	
100+100	100	132072	1720	66536	2120	50	100	NA	NA	67236	2190	
Max WGap ³	25+25	25	131997	1712.5	66461	2112.5	60	25	132647	1777.5	67111	2177.5
	25+50	25	131997	1712.5	66461	2112.5	55	50	132622	1775	67086	2175
		50	132022	1715	66486	2115	55	25	132647	1777.5	67111	2177.5
	25+75	25	131997	1712.5	66461	2112.5	50	75	132597	1772.5	67061	2172.5
		75	132047	1717.5	66511	2117.5	50	25	132647	1777.5	67111	2177.5
	50+50	50	132022	1715	66486	2115	50	50	132622	1775	67086	2175
	25+100	25	131997	1712.5	66461	2112.5	45	100	132572	1770	67036	2170
		100	132072	1720	66536	2120	45	25	132647	1777.5	67111	2177.5
	50+75	50	132022	1715	66486	2115	45	75	132597	1772.5	67061	2172.5
		75	132047	1717.5	66511	2117.5	45	50	132622	1775	67086	2175
	50+100	50	132022	1715	66486	2115	40	100	132572	1770	67036	2170
		100	132072	1720	66536	2120	40	50	132622	1775	67086	2175
	75+75	75	132047	1717.5	66511	2117.5	40	75	132597	1772.5	67061	2172.5
	75+100	75	132047	1717.5	66511	2117.5	35	100	132572	1770	67036	2170
100		132072	1720	66536	2120	35	75	132597	1772.5	67061	2172.5	

	100+100	100	132072	1720	66536	2120	30	100	132572	1770	67036	2170
Note 1:	Carriers in increasing frequency order.											
Note 2:	Applicable for intra-band non-contiguous CA without UL CA.											
Note 3:	Applicable for intra-band non-contiguous CA with UL CA.											

Table 4.3.1.1.66A-4: Test frequencies for CA_66D

Range	CC-Combo / N _{RB,agg} [RB]	CC1 Note1					CC2 Note1					CC3 Note1				
		BW [RB]	N _{UL}	f _{UL} [MHz]	N _{DL}	f _{DL} [MHz]	BW [RB]	N _{UL}	f _{UL} [MHz]	N _{DL}	f _{DL} [MHz]	BW [RB]	N _{UL}	f _{UL} [MHz]	N _{DL}	f _{DL} [MHz]
Low	25+100+100	25	132005	1713.3	66469	2113.3	100	132122	1725.0	66586	2125.0	100	132320	1744.8	66784	2144.8
		100	132072	1720.0	66536	2120.0	25	132189	1731.7	66653	2131.7	100	132306	1743.4	66770	2143.4
		100	132072	1720.0	66536	2120.0	100	132270	1739.8	66734	2139.8	25	132387	1751.5	66851	2151.5
	50+75+100	50	132027	1715.5	66491	2115.5	75	132147	1727.5	66611	2127.5	100	132318	1744.6	66782	2144.6
		50	132027	1715.5	66491	2115.5	100	132171	1729.9	66635	2129.9	75	132342	1747.0	66806	2147.0
		75	132050	1717.8	66514	2117.8	50	132170	1729.8	66634	2129.8	100	132314	1744.2	66778	2144.2
		75	132050	1717.8	66514	2117.8	100	132221	1734.9	66685	2134.9	50	132365	1749.3	66829	2149.3
		100	132072	1720.0	66536	2120.0	50	132216	1734.4	66680	2134.4	75	132336	1746.4	66800	2146.4
		100	132072	1720.0	66536	2120.0	75	132243	1737.1	66707	2137.1	50	132363	1749.1	66827	2149.1
	75+75+75	75	132047	1717.5	66511	2117.5	75	132197	1732.5	66661	2132.5	75	132347	1747.5	66811	2147.5
	75+75+100	75	132050	1717.8	66514	2117.8	75	132200	1732.8	66664	2132.8	100	132371	1749.9	66835	2149.9
		75	132050	1717.8	66514	2117.8	100	132221	1734.9	66685	2134.9	75	132392	1752.0	66856	2152.0
		100	132072	1720.0	66536	2120.0	75	132243	1737.1	66707	2137.1	75	132393	1752.1	66857	2152.1
	50+100+100	50	132027	1715.5	66491	2115.5	100	132171	1729.9	66635	2129.9	100	132369	1749.7	66833	2149.7
		100	132072	1720.0	66536	2120.0	50	132216	1734.4	66680	2134.4	100	132360	1748.8	66824	2148.8
		100	132072	1720.0	66536	2120.0	100	132270	1739.8	66734	2139.8	50	132414	1754.2	66878	2154.2
	75+100+100	75	132050	1717.8	66514	2117.8	100	132221	1734.9	66685	2134.9	100	132419	1754.7	66883	2154.7
		100	132072	1720.0	66536	2120.0	75	132243	1737.1	66707	2137.1	100	132414	1754.2	66878	2154.2
		100	132072	1720.0	66536	2120.0	100	132270	1739.8	66734	2139.8	75	132441	1756.9	66905	2156.9
	100+100+100	100	132072	1720.0	66536	2120.0	100	132270	1739.8	66734	2139.8	100	132468	1759.6	66932	2159.6
Mid	25+100+100	25	132231	1735.9	66695	2135.9	100	132348	1747.6	66812	2147.6	100	132546	1767.4	67010	2167.4
		100	132305	1743.3	66769	2143.3	25	132422	1755.0	66886	2155.0	100	132539	1766.7	67003	2166.7
		100	132298	1742.6	66762	2142.6	100	132496	1762.4	66960	2162.4	25	132613	1774.1	67077	2174.1
	50+75+100	50	132254	1738.2	66718	2138.2	75	132374	1750.2	66838	2150.2	100	132545	1767.3	67009	2167.3
		50	132253	1738.1	66717	2138.1	100	132397	1752.5	66861	2152.5	75	132568	1769.6	67032	2169.6
		75	132279	1740.7	66743	2140.7	50	132399	1752.7	66863	2152.7	100	132543	1767.1	67007	2167.1
		75	132276	1740.4	66740	2140.4	100	132447	1757.5	66911	2157.5	50	132591	1771.9	67055	2171.9
		100	132301	1742.9	66765	2142.9	50	132445	1757.3	66909	2157.3	75	132565	1769.3	67029	2169.3
		100	132299	1742.7	66763	2142.7	75	132470	1759.8	66934	2159.8	50	132590	1771.8	67054	2171.8
	75+75+75	75	132272	1740.0	66736	2140.0	75	132422	1755.0	66886	2155.0	75	132572	1770.0	67036	2170.0
	75+75+100	75	132250	1737.8	66714	2137.8	75	132400	1752.8	66864	2152.8	100	132571	1769.9	67035	2169.9
		75	132251	1737.9	66715	2137.9	100	132422	1755.0	66886	2155.0	75	132593	1772.1	67057	2172.1
		100	132273	1740.1	66737	2140.1	75	132444	1757.2	66908	2157.2	75	132594	1772.2	67058	2172.2
	50+100+100	50	132229	1735.7	66693	2135.7	100	132373	1750.1	66837	2150.1	100	132571	1769.9	67035	2169.9
		100	132278	1740.6	66742	2140.6	50	132422	1755.0	66886	2155.0	100	132566	1769.4	67030	2169.4
		100	132274	1740.2	66738	2140.2	100	132472	1760.0	66936	2160.0	50	132616	1774.4	67080	2174.4
75+100+100	75	132226	1735.4	66690	2135.4	100	132397	1752.5	66861	2152.5	100	NA	NA	67059	2172.3	

		100	132251	1737.9	66715	2137.9	75	132422	1755.0	66886	2155.0	100	NA	NA	67057	2172.1
		100	132249	1737.7	66713	2137.7	100	132447	1757.5	66911	2157.5	75	NA	NA	67082	2174.6
	100+100+100	100	132224	1735.2	66688	2135.2	100	132422	1755.0	66886	2155.0	100	NA	NA	67084	2174.8
High	25+100+100	25	132457	1758.5	66921	2158.5	100	NA	NA	67038	2170.2	100	NA	NA	67236	2190.0
		100	132538	1766.6	67002	2166.6	25	NA	NA	67119	2178.3	100	NA	NA	67236	2190.0
		100	132524	1765.2	66988	2165.2	100	NA	NA	67186	2185.0	25	NA	NA	67303	2196.7
	50+75+100	50	132481	1760.9	66945	2160.9	75	NA	NA	67065	2172.9	100	NA	NA	67236	2190.0
		50	132479	1760.7	66943	2160.7	100	NA	NA	67087	2175.1	75	NA	NA	67258	2192.2
		75	132508	1763.6	66972	2163.6	50	NA	NA	67092	2175.6	100	NA	NA	67236	2190.0
		75	132502	1763.0	66966	2163.0	100	NA	NA	67137	2180.1	50	NA	NA	67281	2194.5
		100	132530	1765.8	66994	2165.8	50	NA	NA	67138	2180.2	75	NA	NA	67258	2192.2
		100	132526	1765.4	66990	2165.4	75	NA	NA	67161	2182.5	50	NA	NA	67281	2194.5
	75+75+75	75	132497	1762.5	66961	2162.5	75	NA	NA	67111	2177.5	75	NA	NA	67261	2192.5
	75+75+100	75	132451	1757.9	66915	2157.9	75	NA	NA	67065	2172.9	100	NA	NA	67236	2190.0
		75	132452	1758.0	66916	2158.0	100	NA	NA	67087	2175.1	75	NA	NA	67258	2192.2
		100	132473	1760.1	66937	2160.1	75	NA	NA	67108	2177.2	75	NA	NA	67258	2192.2
	50+100+100	50	132430	1755.8	66894	2155.8	100	NA	NA	67038	2170.2	100	NA	NA	67236	2190.0
		100	132484	1761.2	66948	2161.2	50	NA	NA	67092	2175.6	100	NA	NA	67236	2190.0
		100	132475	1760.3	66939	2160.3	100	NA	NA	67137	2180.1	50	NA	NA	67281	2194.5
	75+100+100	75	132403	1753.1	66867	2153.1	100	NA	NA	67038	2170.2	100	NA	NA	67236	2190.0
		100	132430	1755.8	66894	2155.8	75	NA	NA	67065	2172.9	100	NA	NA	67236	2190.0
		100	132425	1755.3	66889	2155.3	100	NA	NA	67087	2175.1	75	NA	NA	67258	2192.2
	100+100+100	100	132376	1750.4	66840	2150.4	100	NA	NA	67038	2170.2	100	NA	NA	67236	2190.0

Note 1: Carriers in increasing frequency order.

Table 4.3.1.1.66A-5: Test frequencies for CA_66A-66C

Range	CC-Combo / N _{RB,agg} [RB]	CC1 Note1					Wgap [MHz]	CC2 Note1					CC3 Note1				
		BW [RB]	N _{UL}	f _{UL} [MHz]	N _{DL}	f _{DL} [MHz]		BW [RB]	N _{UL}	f _{UL} [MHz]	N _{DL}	f _{DL} [MHz]	BW [RB]	N _{UL}	f _{UL} [MHz]	N _{DL}	f _{DL} [MHz]
Max Wgap	25+25+100	25	131997	1712.5	66461	2112.5	60	100	NA	NA	67186	2185	25	NA	NA	67303	2196.7
		25	131997	1712.5	66461	2112.5	60.8	25	NA	NA	67119	2178.3	100	NA	NA	67236	2190
	25+50+75	25	131997	1712.5	66461	2112.5	60.5	50	NA	NA	67141	2180.5	75	NA	NA	67261	2192.5
		25	131997	1712.5	66461	2112.5	60.2	75	NA	NA	67163	2182.7	50	NA	NA	67283	2194.7
	25+50+100	25	131997	1712.5	66461	2112.5	55.6	50	NA	NA	67092	2175.6	100	NA	NA	67236	2190
		25	131997	1712.5	66461	2112.5	55.1	100	NA	NA	67137	2180.1	50	NA	NA	67281	2194.5
		50	132022	1715	66486	2115	55	100	NA	NA	67186	2185	25	NA	NA	67303	2196.7
		50	132022	1715	66486	2115	55.8	25	NA	NA	67119	2178.3	100	NA	NA	67236	2190
	25+75+75	25	131997	1712.5	66461	2112.5	55	75	NA	NA	67111	2177.5	75	NA	NA	67261	2192.5
	25+75+100	25	131997	1712.5	66461	2112.5	50.4	75	NA	NA	67065	2172.9	100	NA	NA	67236	2190
		25	131997	1712.5	66461	2112.5	50.1	100	NA	NA	67087	2175.1	75	NA	NA	67258	2192.2
		75	132047	1717.5	66511	2117.5	50	100	NA	NA	67186	2185	25	NA	NA	67303	2196.7
		75	132047	1717.5	66511	2117.5	50.8	25	NA	NA	67119	2178.3	100	NA	NA	67236	2190
	25+100+100	25	131997	1712.5	66461	2112.5	45.2	100	NA	NA	67038	2170.2	100	NA	NA	67236	2190
	25+100+100	100	132072	1720	66536	2120	45	100	NA	NA	67186	2185	25	NA	NA	67303	2196.7
		100	132072	1720	66536	2120	45.8	25	NA	NA	67119	2178.3	100	NA	NA	67236	2190
	50+50+75	50	132022	1715	66486	2115	55.5	50	NA	NA	67141	2180.5	75	NA	NA	67261	2192.5
		50	132022	1715	66486	2115	55.2	75	NA	NA	67163	2182.7	50	NA	NA	67283	2194.7
	50+50+100	50	132022	1715	66486	2115	50.6	50	NA	NA	67092	2175.6	100	NA	NA	67236	2190
		50	132022	1715	66486	2115	50.1	100	NA	NA	67137	2180.1	50	NA	NA	67281	2194.5
	50+75+75	50	132022	1715	66486	2115	50	75	NA	NA	67111	2177.5	75	NA	NA	67261	2192.5
		75	132047	1717.5	66511	2117.5	50.5	50	NA	NA	67141	2180.5	75	NA	NA	67261	2192.5
		75	132047	1717.5	66511	2117.5	50.2	75	NA	NA	67163	2182.7	50	NA	NA	67283	2194.7
	50+75+100	50	132022	1715	66486	2115	45.4	75	NA	NA	67065	2172.9	100	NA	NA	67236	2190
		50	132022	1715	66486	2115	45.1	100	NA	NA	67087	2175.1	75	NA	NA	67258	2192.2
		75	132047	1717.5	66511	2117.5	45.6	50	NA	NA	67092	2175.6	100	NA	NA	67236	2190
		100	132072	1720	66536	2120	45.5	50	NA	NA	67141	2180.5	75	NA	NA	67261	2192.5
		100	132072	1720	66536	2120	45.2	75	NA	NA	67163	2182.7	50	NA	NA	67283	2194.7
		75	132047	1717.5	66511	2117.5	45.1	100	NA	NA	67137	2180.1	50	NA	NA	67281	2194.5
		100	132072	1720	66536	2120	45.5	50	NA	NA	67141	2180.5	75	NA	NA	67261	2192.5
		100	132072	1720	66536	2120	45.2	75	NA	NA	67163	2182.7	50	NA	NA	67283	2194.7
	50+100+100	50	132022	1715	66486	2115	40.2	100	NA	NA	67038	2170.2	100	NA	NA	67236	2190
100		132072	1720	66536	2120	40.6	50	NA	NA	67092	2175.6	100	NA	NA	67236	2190	

	100	132072	1720	66536	2120	40.1	100	NA	NA	67137	2180.1	50	NA	NA	67281	2194.5
75+75+75	75	132047	1717.5	66511	2117.5	45	75	NA	NA	67111	2177.5	75	NA	NA	67261	2192.5
75+75+100	75	132047	1717.5	66511	2117.5	40.4	75	NA	NA	67065	2172.9	100	NA	NA	67236	2190
	75	132047	1717.5	66511	2117.5	40.1	100	NA	NA	67087	2175.1	75	NA	NA	67258	2192.2
	100	132072	1720	66536	2120	40	75	NA	NA	67111	2177.5	75	NA	NA	67261	2192.5
75+100+100	75	132047	1717.5	66511	2117.5	35.2	100	NA	NA	67038	2170.2	100	NA	NA	67236	2190
	100	132072	1720	66536	2120	35.4	75	NA	NA	67065	2172.9	100	NA	NA	67236	2190
	100	132072	1720	66536	2120	35.1	100	NA	NA	67087	2175.1	75	NA	NA	67258	2192.2
100+100+100	100	132072	1720	66536	2120	30.2	100	NA	NA	67038	2170.2	100	NA	NA	67236	2190

Note 1: Carriers in increasing frequency order.

Table 4.3.1.1.66A-6: Test frequencies for CA_66C-66A

Range	CC-Combo / N _{RB,agg} [RB]	CC1 Note1					CC2 Note1					Wgap [MHz]	CC3 Note1				
		BW [RB]	N _{UL}	f _{UL} [MHz]	N _{DL}	f _{DL} [MHz]	BW [RB]	N _{UL}	f _{UL} [MHz]	N _{DL}	f _{DL} [MHz]		BW [RB]	N _{UL}	f _{UL} [MHz]	N _{DL}	f _{DL} [MHz]
Max Wgap	25+25+100	100	132072	1720	66536	2120	25	132189	1731.7	66653	2131.7	60.8	25	NA	NA	67311	2197.5
		25	132005	1713.3	66469	2113.3	100	132122	1725	66586	2125	60	25	NA	NA	67311	2197.5
	25+50+75	50	132025	1715.3	66489	2115.3	75	132145	1727.3	66609	2127.3	60.2	25	NA	NA	67311	2197.5
		75	132047	1717.5	66511	2117.5	50	132167	1729.5	66631	2129.5	60.5	25	NA	NA	67311	2197.5
	25+50+100	50	132027	1715.5	66491	2115.5	100	132171	1729.9	66635	2129.9	55.1	25	NA	NA	67311	2197.5
		100	132072	1720	66536	2120	50	132216	1734.4	66680	2134.4	55.6	25	NA	NA	67311	2197.5
		100	132072	1720	66536	2120	25	132189	1731.7	66653	2131.7	55.8	50	NA	NA	67286	2195
		25	132005	1713.3	66469	2113.3	100	132122	1725	66586	2125	55	50	NA	NA	67286	2195
	25+75+75	75	132047	1717.5	66511	2117.5	75	132197	1732.5	66661	2132.5	55	25	NA	NA	67311	2197.5
		75	132050	1717.8	66514	2117.8	100	132221	1734.9	66685	2134.9	50.1	25	NA	NA	67311	2197.5
	25+75+100	100	132072	1720	66536	2120	75	132243	1737.1	66707	2137.1	50.4	25	NA	NA	67311	2197.5
		100	132072	1720	66536	2120	25	132189	1731.7	66653	2131.7	50.8	75	NA	NA	67261	2192.5
		25	132005	1713.3	66469	2113.3	100	132122	1725	66586	2125	50	75	NA	NA	67261	2192.5
		100	132072	1720	66536	2120	100	132270	1739.8	66734	2139.8	45.2	25	NA	NA	67311	2197.5
	25+100+100	100	132072	1720	66536	2120	25	132189	1731.7	66653	2131.7	45.8	100	NA	NA	67236	2190
		25	132005	1713.3	66469	2113.3	100	132122	1725	66586	2125	45	100	NA	NA	67236	2190
	50+50+75	50	132025	1715.3	66489	2115.3	75	132145	1727.3	66609	2127.3	55.2	50	NA	NA	67286	2195
		75	132047	1717.5	66511	2117.5	50	132167	1729.5	66631	2129.5	55.5	50	NA	NA	67286	2195
	50+50+100	50	132027	1715.5	66491	2115.5	100	132171	1729.9	66635	2129.9	50.1	50	NA	NA	67286	2195
		100	132072	1720	66536	2120	50	132216	1734.4	66680	2134.4	50.6	50	NA	NA	67286	2195
	50+75+75	75	132047	1717.5	66511	2117.5	75	132197	1732.5	66661	2132.5	50	50	NA	NA	67286	2195
		50	132025	1715.3	66489	2115.3	75	132145	1727.3	66609	2127.3	50.2	75	NA	NA	67261	2192.5
		75	132047	1717.5	66511	2117.5	50	132167	1729.5	66631	2129.5	50.5	75	NA	NA	67261	2192.5
	50+75+100	75	132050	1717.8	66514	2117.8	100	132221	1734.9	66685	2134.9	45.1	50	NA	NA	67286	2195
		100	132072	1720	66536	2120	75	132243	1737.1	66707	2137.1	45.4	50	NA	NA	67286	2195
		50	132027	1715.5	66491	2115.5	100	132171	1729.9	66635	2129.9	45.1	75	NA	NA	67261	2192.5
		50	132025	1715.3	66489	2115.3	75	132145	1727.3	66609	2127.3	45.2	100	NA	NA	67236	2190
		75	132047	1717.5	66511	2117.5	50	132167	1729.5	66631	2129.5	45.5	100	NA	NA	67236	2190
		100	132072	1720	66536	2120	50	132216	1734.4	66680	2134.4	45.6	75	NA	NA	67261	2192.5
	50+100+100	100	132072	1720	66536	2120	100	132270	1739.8	66734	2139.8	40.2	50	NA	NA	67286	2195
50		132027	1715.5	66491	2115.5	100	132171	1729.9	66635	2129.9	40.1	100	NA	NA	67236	2190	
100		132072	1720	66536	2120	50	132216	1734.4	66680	2134.4	40.6	100	NA	NA	67236	2190	
75+75+75	75	132047	1717.5	66511	2117.5	75	132197	1732.5	66661	2132.5	45	75	NA	NA	67261	2192.5	

75+75+100	75	132050	1717.8	66514	2117.8	100	132221	1734.9	66685	2134.9	40.1	75	NA	NA	67261	2192.5
	100	132072	1720	66536	2120	75	132243	1737.1	66707	2137.1	40.4	75	NA	NA	67261	2192.5
	75	132047	1717.5	66511	2117.5	75	132197	1732.5	66661	2132.5	40	100	NA	NA	67236	2190
75+100+100	100	132072	1720	66536	2120	100	132270	1739.8	66734	2139.8	35.2	75	NA	NA	67261	2192.5
	75	132050	1717.8	66514	2117.8	100	132221	1734.9	66685	2134.9	35.1	100	NA	NA	67236	2190
	100	132072	1720	66536	2120	75	132243	1737.1	66707	2137.1	35.4	100	NA	NA	67236	2190
100+100+100	100	132072	1720	66536	2120	100	132270	1739.8	66734	2139.8	30.2	100	NA	NA	67236	2190

Note 1: Carriers in increasing frequency order.

Table 4.3.1.1.66A-7: Test frequencies for CA_66A-66B

Range	CC-Combo / N _{RB_agg} [RB]	CC1 Note1					Wgap [MHz]	CC2 Note1					CC3 Note1				
		BW [RB]	N _{UL}	f _{UL} [MHz]	N _{DL}	f _{DL} [MHz]		BW [RB]	N _{UL}	f _{UL} [MHz]	N _{DL}	f _{DL} [MHz]	BW [RB]	N _{UL}	f _{UL} [MHz]	N _{DL}	f _{DL} [MHz]
Max Wgap	25+25+25	25	131997	1712.5	66461	2112.5	75.2	25	NA	NA	67263	2192.7	25	NA	NA	67311	2197.5
	25+25+50	25	131997	1712.5	66461	2112.5	70.3	25	NA	NA	67214	2187.8	50	NA	NA	67286	2195
		25	131997	1712.5	66461	2112.5	70	50	NA	NA	67236	2190	25	NA	NA	67308	2197.2
	25+25+50	50	132022	1715	66486	2115	70.2	25	NA	NA	67263	2192.7	25	NA	NA	67311	2197.5
	25+25+75	25	131997	1712.5	66461	2112.5	65.7	25	NA	NA	67168	2183.2	75	NA	NA	67261	2192.5
		25	131997	1712.5	66461	2112.5	65.2	75	NA	NA	67213	2187.7	25	NA	NA	67306	2197
	25+25+75	75	132047	1717.5	66511	2117.5	65.2	25	NA	NA	67263	2192.7	25	NA	NA	67311	2197.5
	25+25+100	100	132072	1720	66536	2120	60.2	25	NA	NA	67263	2192.7	25	NA	NA	67311	2197.5
	25+50+50	25	131997	1712.5	66461	2112.5	65.1	50	NA	NA	67187	2185.1	50	NA	NA	67286	2195
		50	132022	1715	66486	2115	65.3	25	NA	NA	67214	2187.8	50	NA	NA	67286	2195
		50	132022	1715	66486	2115	65	50	NA	NA	67236	2190	25	NA	NA	67308	2197.2
	25+50+75	50	132022	1715	66486	2115	60.7	25	NA	NA	67168	2183.2	75	NA	NA	67261	2192.5
		50	132022	1715	66486	2115	60.2	75	NA	NA	67213	2187.7	25	NA	NA	67306	2197
	25+50+75	75	132047	1717.5	66511	2117.5	60.3	25	NA	NA	67214	2187.8	50	NA	NA	67286	2195
		75	132047	1717.5	66511	2117.5	60	50	NA	NA	67236	2190	25	NA	NA	67308	2197.2
	25+50+100	100	132072	1720	66536	2120	55.3	25	NA	NA	67214	2187.8	50	NA	NA	67286	2195
		100	132072	1720	66536	2120	55	50	NA	NA	67236	2190	25	NA	NA	67308	2197.2
	25+75+75	75	132047	1717.5	66511	2117.5	55.7	25	NA	NA	67168	2183.2	75	NA	NA	67261	2192.5
		75	132047	1717.5	66511	2117.5	55.2	75	NA	NA	67213	2187.7	25	NA	NA	67306	2197
	25+75+100	100	132072	1720	66536	2120	50.7	25	NA	NA	67168	2183.2	75	NA	NA	67261	2192.5
100		132072	1720	66536	2120	50.2	75	NA	NA	67213	2187.7	25	NA	NA	67306	2197	
50+50+50	50	132022	1715	66486	2115	60.1	50	NA	NA	67187	2185.1	50	NA	NA	67286	2195	
50+50+75	75	132047	1717.5	66511	2117.5	55.1	50	NA	NA	67187	2185.1	50	NA	NA	67286	2195	
50+50+100	100	132072	1720	66536	2120	50.1	50	NA	NA	67187	2185.1	50	NA	NA	67286	2195	

Note 1: Carriers in increasing frequency order.

Table 4.3.1.1.66A-8: Test frequencies for CA_66B-66A

Range	CC-Combo / N _{RB,agg} [RB]	CC1 Note1					CC2 Note1					Wgap [MHz]	CC3 Note1				
		BW [RB]	N _{UL}	f _{UL} [MHz]	N _{DL}	f _{DL} [MHz]	BW [RB]	N _{UL}	f _{UL} [MHz]	N _{DL}	f _{DL} [MHz]		BW [RB]	N _{UL}	f _{UL} [MHz]	N _{DL}	f _{DL} [MHz]
Max Wgap	25+25+25	25	131997	1712.5	66461	2112.5	25	132045	1717.3	66509	2117.3	75.2	25	NA	NA	67311	2197.5
	25+25+50	25	132000	1712.8	66464	2112.8	50	132072	1720	66536	2120	70	25	NA	NA	67311	2197.5
		50	132022	1715	66486	2115	25	132094	1722.2	66558	2122.2	70.3	25	NA	NA	67311	2197.5
	25+25+50	25	131997	1712.5	66461	2112.5	25	132045	1717.3	66509	2117.3	70.2	50	NA	NA	67286	2195
	25+25+75	25	132002	1713	66466	2113	75	132095	1722.3	66559	2122.3	65.2	25	NA	NA	67311	2197.5
		75	132047	1717.5	66511	2117.5	25	132140	1726.8	66604	2126.8	65.7	25	NA	NA	67311	2197.5
	25+25+75	25	131997	1712.5	66461	2112.5	25	132045	1717.3	66509	2117.3	65.2	75	NA	NA	67261	2192.5
	25+25+100	25	131997	1712.5	66461	2112.5	25	132045	1717.3	66509	2117.3	60.2	100	NA	NA	67236	2190
	25+50+50	50	132022	1715	66486	2115	50	132121	1724.9	66585	2124.9	65.1	25	NA	NA	67311	2197.5
		25	132000	1712.8	66464	2112.8	50	132072	1720	66536	2120	65	50	NA	NA	67286	2195
		50	132022	1715	66486	2115	25	132094	1722.2	66558	2122.2	65.3	50	NA	NA	67286	2195
	25+50+75	25	132002	1713	66466	2113	75	132095	1722.3	66559	2122.3	60.2	50	NA	NA	67286	2195
		75	132047	1717.5	66511	2117.5	25	132140	1726.8	66604	2126.8	60.7	50	NA	NA	67286	2195
	25+50+75	25	132000	1712.8	66464	2112.8	50	132072	1720	66536	2120	60	75	NA	NA	67261	2192.5
		50	132022	1715	66486	2115	25	132094	1722.2	66558	2122.2	60.3	75	NA	NA	67261	2192.5
	25+50+100	25	132000	1712.8	66464	2112.8	50	132072	1720	66536	2120	55	100	NA	NA	67236	2190
		50	132022	1715	66486	2115	25	132094	1722.2	66558	2122.2	55.3	100	NA	NA	67236	2190
	25+75+75	25	132002	1713	66466	2113	75	132095	1722.3	66559	2122.3	55.2	75	NA	NA	67261	2192.5
		75	132047	1717.5	66511	2117.5	25	132140	1726.8	66604	2126.8	55.7	75	NA	NA	67261	2192.5
	25+75+100	25	132002	1713	66466	2113	75	132095	1722.3	66559	2122.3	50.2	100	NA	NA	67236	2190
75		132047	1717.5	66511	2117.5	25	132140	1726.8	66604	2126.8	50.7	100	NA	NA	67236	2190	
50+50+50	50	132022	1715	66486	2115	50	132121	1724.9	66585	2124.9	60.1	50	NA	NA	67286	2195	
50+50+75	50	132022	1715	66486	2115	50	132121	1724.9	66585	2124.9	55.1	75	NA	NA	67261	2192.5	
50+50+100	50	132022	1715	66486	2115	50	132121	1724.9	66585	2124.9	50.1	100	NA	NA	67236	2190	

Note 1: Carriers in increasing frequency order.

Table 4.3.1.2.9A-10: Test frequencies for CA_41F

Range	CC-Combo / N _{RB,agg} [RB]	CC1 Note1			CC2 Note1			CC3 Note1			CC4 Note1			CC5 Note1		
		BW [RB]	N _{UL/DL}	f _{UL/DL} [MHz]	BW [RB]	N _{UL/DL}	f _{UL/DL} [MHz]	BW [RB]	N _{UL/DL}	f _{UL/DL} [MHz]	BW [RB]	N _{UL/DL}	f _{UL/DL} [MHz]	BW [RB]	N _{UL/DL}	f _{UL/DL} [MHz]
Low	50+75+100+100+100	50	39705	2501.5	75	39825	2513.5	100	39996	2530.6	100	40194	2550.4	100	40392	2570.2
	50+100+100+100+100	50	39705	2501.5	100	39849	2515.9	100	40047	2535.7	100	40245	2555.5	100	40443	2575.3
	75+75+100+100+100	75	39728	2503.8	75	39878	2518.8	100	40049	2535.9	100	40247	2555.7	100	40445	2575.5
	75+100+100+100+1100	75	39728	2503.8	100	39899	2520.9	100	40097	2540.7	100	40295	2560.5	100	40493	2580.3
		100	39750	2506	75	39921	2523.1	100	40092	2540.2	100	40290	2560	100	40488	2579.8
100+100+100+100+100	100	39750	2506	100	39948	2525.8	100	40146	2545.6	100	40344	2565.4	100	40542	2585.2	
Mid	50+75+100+100+100	50	40254	2556.4	75	40374	2568.4	100	40545	2585.5	100	40743	2605.3	100	40941	2625.1
	50+100+100+100+100	50	40229	2553.9	100	40373	2568.3	100	40571	2588.1	100	40769	2607.9	100	40967	2627.7
	75+75+100+100+100	75	40250	2556	75	40400	2571	100	40571	2588.1	100	40769	2607.9	100	40967	2627.7
	75+100+100+100+1100	75	40226	2553.6	100	40397	2570.7	100	40595	2590.5	100	40793	2610.3	100	40991	2630.1
		100	40251	2556.1	75	40422	2573.2	100	40593	2590.3	100	40791	2610.1	100	40989	2629.9
100+100+100+100+100	100	40224	2553.4	100	40422	2573.2	100	40620	2593	100	40818	2612.8	100	41016	2632.6	
High	50+75+100+100+100	50	40803	2611.3	75	40923	2623.3	100	41094	2640.4	100	41292	2660.2	100	41490	2680
	50+100+100+100+100	50	40752	2606.2	100	40896	2620.6	100	41094	2640.4	100	41292	2660.2	100	41490	2680
	75+75+100+100+100	75	40773	2608.3	75	40923	2623.3	100	41094	2640.4	100	41292	2660.2	100	41490	2680
	75+100+100+100+1100	75	40725	2603.5	100	40896	2620.6	100	41094	2640.4	100	41292	2660.2	100	41490	2680
		100	40752	2606.2	75	40923	2623.3	100	41094	2640.4	100	41292	2660.2	100	41490	2680
100+100+100+100+100	100	40698	2600.8	100	40896	2620.6	100	41094	2640.4	100	41292	2660.2	100	41490	2680	

Note 1: Carriers in increasing frequency order.

4.3.1.1.67 FDD reference test frequencies for CA in operating band 67

Table 4.3.1.1.67-1: Test frequencies for E-UTRA channel bandwidth for operating band 67

Test Frequency ID	Bandwidth [MHz]	N _{UL}	Frequency of Uplink [MHz]	N _{DL}	Frequency of Downlink [MHz]
Low Range	5	NA ^[1]	NA	67361	740.5
	10	NA ^[1]	NA	67386	743
	15	NA ^[1]	NA	67411	745.5
Mid Range	5/10/15/20	NA ^[1]	NA	67436	748
High Range	5	NA ^[1]	NA	67511	755.5
	10	NA ^[1]	NA	67486	753
	15	NA ^[1]	NA	67461	750.5

NOTE 1: Restricted to E-UTRA operation when carrier aggregation is configured. The downlink operating band is paired with the uplink operating band (external) of the carrier aggregation configuration that is supporting the configured Pcell.

4.3.1.1.68 FDD reference test frequencies for operating band 68

Table 4.3.1.1.68-1: Test frequencies for E-UTRA channel bandwidth for operating band 68

Test Frequency ID	Bandwidth [MHz]	N _{UL}	Frequency of Uplink [MHz]	N _{DL}	Frequency of Downlink [MHz]
Low Range	5	132697	700.5	67561	755.5
	10	132722	703	67586	758
	15	132747	705.5	67611	760.5
Mid Range	5/10/15	132822	713	67686	768
High Range	5	132947	725.5	67811	780.5
	10	132922	723	67786	778
	15	132897	720.5	67761	775.5

4.3.1.1.69 FDD reference test frequencies for operating band 69

Test Frequency ID	Bandwidth [MHz]	N _{UL}	Frequency of Uplink [MHz]	N _{DL}	Frequency of Downlink [MHz]
Low Range	5	NA ^[1]	NA	67861	2572.5
	10	NA ^[1]	NA	67886	2575
	15	NA ^[1]	NA	67911	2577.5
	20	NA ^[1]	NA	67936	2580
Mid Range	5/10/15/20	NA ^[1]	NA	68086	2595
High Range	5	NA ^[1]	NA	68311	2617.5
	10	NA ^[1]	NA	68286	2615
	15	NA ^[1]	NA	68261	2612.5
	20	NA ^[1]	NA	68236	2610

NOTE 1: Restricted to E-UTRA operation when carrier aggregation is configured. The downlink operating band is paired with the uplink operating band (external) of the carrier aggregation configuration that is supporting the configured Pcell.

4.3.1.1.70 FDD reference test frequencies for operating band 70

Table 4.3.1.1.70-1: Test frequencies for E-UTRA channel bandwidth for operating band 70

Test Frequency ID	Bandwidth [MHz]	N _{UL}	Frequency of Uplink [MHz]	N _{DL}	Frequency of Downlink [MHz]
Low Range	5	132997	1697.5	68361	1997.5
	10	133022	1700	68386	2000
	15	133047	1702.5	68411	2002.5
Paired Mid Range ¹	5/10/15	133047	1702.5	68411	2002.5
Mid Range ²	5/10/15	NA	NA	68461	2007.5
Paired High Range ¹	5	133097	1707.5	68461	2007.5
	10	133072	1705	68436	2005
	15	133047	1702.5	68411	2002.5
High Range ²	5	NA	NA	68561	2017.5
	10	NA	NA	68536	2015
	15	NA	NA	68511	2012.5

Note 1: Applicable if UL is configured on the CC.
Note 2: Applicable if no UL is configured on the CC.

4.3.1.1.70A FDD reference test frequencies for CA in operating band 70

Table 4.3.1.1.70A-1: Test frequencies for CA_70C

Test Frequency ID ²	CC-Combo / N _{RB_agg} [RB]	CC1 Note1					CC2 Note1				
		BW [RB]	N _{UL}	f _{UL} [MHz]	N _{DL}	f _{DL} [MHz]	BW [RB]	N _{UL}	f _{UL} [MHz]	N _{DL}	f _{DL} [MHz]
1	25+100	25	132997	1697.5	68361	1997.5	100	NA	NA	68478	2009.2
2 ³	50+75	50	133072	1705	68386	2000	75	NA	NA	68506	2012
3	75+50	75	133047	1702.5	68411	2002.5	50	NA	NA	68531	2014.5

Note 1: Carriers in increasing frequency order.
Note 2: These reflect the CA operation scenarios defined for CA_70C.
Note 3: This combination is for 295MHz Tx-Rx separation in CA operation.

4.3.1.1.71 FDD reference test frequencies for operating band 71

Table 4.3.1.1.71-1: Test frequencies for E-UTRA channel bandwidth for operating band 71

Test Frequency ID	Bandwidth [MHz]	N _{UL}	Frequency of Uplink [MHz]	N _{DL}	Frequency of Downlink [MHz]
Low Range	5	133147	665.5	68611	619.5
	10	133172	668	68636	622
	15	133197	670.5	68661	624.5
	20	133222	673	68686	627
Mid Range	5/10/15	133297	680.5	68761	634.5
	20	133322	683	68786	637
High Range	5	133447	695.5	68911	649.5
	10	133422	693	68886	647
	15	133397	690.5	68861	644.5
	20	133372	688	68836	642

4.3.1.1.72 FDD reference test frequencies for operating band 72

Table 4.3.1.1.72-1: Test frequencies for E-UTRA channel bandwidth for operating band 72

Test Frequency ID	Bandwidth [MHz]	N _{UL}	Frequency of Uplink [MHz]	N _{DL}	Frequency of Downlink [MHz]
Low Range	1.4	133479	451.7	68943	461.7
	3 ^[1]	133487	452.5	68951	462.5
	5 ^[1]	133497	453.5	68961	463.5
Mid Range	1.4/3 ^[1] / 5 ^[1]	133497	453.5	68961	463.5
High Range	1.4	133515	455.3	68979	465.3
	3 ^[1]	133507	454.5	68971	464.5
	5 ^[1]	133497	453.5	68961	463.5

NOTE 1: Bandwidth for which a relaxation of the specified UE receiver sensitivity requirement (TS 36.101 [27] Clause 7.3) is allowed.

4.3.1.1.73 Void

4.3.1.1.74 FDD reference test frequencies for operating band 74

Table 4.3.1.1.74-1: Test frequencies for E-UTRA channel bandwidth for operating band 74

Test Frequency ID	Bandwidth [MHz]	N _{UL}	Frequency of Uplink [MHz]	N _{DL}	Frequency of Downlink [MHz]
Low Range	1.4	133579	1427.7	69043	1475.7
	3	133587	1428.5	69051	1476.5
	5	133597	1429.5	69061	1477.5
	10	133622	1432	69086	1480
	15	133647	1434.5	69111	1482.5
	20	133672	1437	69136	1485
Mid Range	1.4/3/5/10/15/20	133787	1448.5	69251	1496.5
High Range	1.4	133995	1469.3	69459	1517.3
	3	133987	1468.5	69451	1516.5
	5	133977	1467.5	69441	1515.5
	10	133952	1465	69416	1513
	15	133927	1434.5	69391	1510.5
	20	133902	1460	69366	1508

4.3.1.2 TDD Mode Test frequencies

4.3.1.2.1 TDD reference test frequencies for Operating Band 33

Table 4.3.1.2.1-1: Test frequencies for E-UTRA channel bandwidth for operating band 33

Test Frequency ID	Bandwidth [MHz]	EARFCN	Frequency (UL and DL) [MHz]
Low Range	5	36025	1902.5
	10	36050	1905
	15	36075	1907.5
	20	36100	1910
Mid Range	5/10/15/20	36100	1910
High Range	5	36175	1917.5
	10	36150	1915
	15	36125	1912.5
	20	36100	1910

4.3.1.2.2 TDD reference test frequencies for Operating Band 34

Table 4.3.1.2.2-1: Test frequencies for E-UTRA channel bandwidth for operating band 34

Test Frequency ID	Bandwidth [MHz]	EARFCN	Frequency (UL and DL) [MHz]
Low Range	5	36225	2012.5
	10	36250	2015
	15	36275	2017.5
Mid Range	5/10/15	36275	2017.5
High Range	5	36325	2022.5
	10	36300	2020
	15	36275	2017.5

4.3.1.2.3 TDD reference test frequencies for Operating Band 35

Table 4.3.1.2.3-1: Test frequencies for E-UTRA channel bandwidth for operating band 35

Test Frequency ID	Bandwidth [MHz]	EARFCN [MHz]	Frequency (UL and DL) [MHz]
Low Range	1.4	36357	1850.7
	3	36365	1851.5
	5	36375	1852.5
	10	36400	1855
	15	36425	1857.5
	20	36450	1860
Mid Range	1.4/3/5/10/15/20	36650	1880
High Range	1.4	36943	1909.3
	3	36935	1908.5
	5	36925	1907.5
	10	36900	1905
	15	36875	1902.5
	20	36850	1900

4.3.1.2.4 TDD reference test frequencies for Operating Band 36

Table 4.3.1.2.4-1: Test frequencies for E-UTRA channel bandwidth for operating band 36

Test Frequency ID	Bandwidth [MHz]	EARFCN [MHz]	Frequency (UL and DL) [MHz]
Low Range	1.4	36957	1930.7
	3	36965	1931.5
	5	36975	1932.5
	10	37000	1935
	15	37025	1937.5
	20	37050	1940
Mid Range	1.4/3/5/10/15/20	37250	1960
High Range	1.4	37543	1989.3
	3	37535	1988.5
	5	37525	1987.5
	10	37500	1985
	15	37475	1982.5
	20	37450	1980

4.3.1.2.5 TDD reference test frequencies for Operating Band 37

Table 4.3.1.2.5-1: Test frequencies for E-UTRA channel bandwidth for operating band 37

Test Frequency ID	Bandwidth [MHz]	EARFCN [MHz]	Frequency (UL and DL) [MHz]
Low Range	5	37575	1912.5
	10	37600	1915
	15	37625	1917.5
	20	37650	1920
Mid Range	5/10/15/20	37650	1920
High Range	5	37725	1927.5
	10	37700	1925
	15	37675	1922.5
	20	37650	1920

4.3.1.2.6 TDD reference test frequencies for Operating Band 38

Table 4.3.1.2.6-1: Test frequencies for E-UTRA channel bandwidth for operating band 38

Test Frequency ID	Bandwidth [MHz]	EARFCN	Frequency (UL and DL) [MHz]
Low Range	5	37775	2572.5
	10	37800	2575
	15	37825	2577.5
	20	37850	2580
Mid Range	5/10/15/20	38000	2595
High Range	5	38225	2617.5
	10	38200	2615
	15	38175	2612.5
	20	38150	2610

4.3.1.2.6A TDD reference test frequencies for CA in operating band 38

Table 4.3.1.2.6A-1: Test frequencies for CA_38C

Range	CC-Combo / N _{RB_agg} [RB]	CC1 Note1			CC2 Note1		
		BW [RB]	N _{UL/DL}	f _{UL/DL} [MHz]	BW [RB]	N _{UL/DL}	f _{UL/DL} [MHz]
Low	75+75	75	37825	2577.5	75	37975	2592.5
	100+100	100	37850	2580	100	38048	2599.8
Mid	75+75	75	37925	2587.5	75	38075	2602.5
	100+100	100	37901	2585.1	100	38099	2604.9
High	75+75	75	38025	2597.5	75	38175	2612.5
	100+100	100	37952	2590.2	100	38150	2610

Note 1: Carriers in increasing frequency order.

4.3.1.2.7 TDD reference test frequencies for Operating Band 39

Table 4.3.1.2.7-1: Test frequencies for E-UTRA channel bandwidth for operating band 39

Test Frequency ID	Bandwidth [MHz]	EARFCN	Frequency (UL and DL) [MHz]
Low Range	5	38275	1882.5
	10	38300	1885
	15	38325	1887.5
	20	38350	1890
Mid Range	5/10/15/20	38450	1900
High Range	5	38625	1917.5
	10	38600	1915
	15	38575	1912.5
	20	38550	1910

4.3.1.2.7A TDD reference test frequencies for CA in Operating Band 39

Table 4.3.1.2.7A-1: Test frequencies for CA_39C

Range	CC-Combo / N _{RB_agg} [RB]	CC1 Note1			CC2 Note1		
		BW [RB]	N _{UL/DL}	f _{UL/DL} [MHz]	BW [RB]	N _{UL/DL}	f _{UL/DL} [MHz]
Low	25+100	25	38283	1883.3	100	38400	1895.0
		100	38350	1890	25	38467	1901.7
	50+100	50	38305	1885.5	100	38449	1899.9
		100	38350	1890	50	38494	1904.4
	75+100	75	38328	1887.8	100	38499	1904.9
		100	38350	1890	75	38521	1907.1
Mid	25+100	25	38358	1890.8	100	38475	1902.5
		100	38425	1897.5	25	38542	1909.2
	50+100	50	38356	1890.6	100	38500	1905.0
		100	38401	1895.1	50	38545	1909.5
	75+100	75	38353	1890.3	100	38524	1907.4
		100	38376	1892.6	75	38547	1909.7
High	25+100	25	38433	1898.3	100	38550	1910
		100	38500	1905.0	25	38617	1916.7
	50+100	50	38406	1895.6	100	38550	1910
		100	38451	1900.1	50	38595	1914.5
	75+100	75	38379	1892.9	100	38550	1910
		100	38401	1895.1	75	38572	1912.2

Note 1: Carriers in increasing frequency order.

4.3.1.2.8 TDD reference test frequencies for Operating Band 40

Table 4.3.1.2.8-1: Test frequencies for E-UTRA channel bandwidth for operating band 40

Test Frequency ID	Bandwidth [MHz]	EARFCN	Frequency (UL and DL) [MHz]
Low Range	5	38675	2302.5
	10	38700	2305
	15	38725	2307.5
	20	38750	2310
Mid Range	5/10/15/20	39150	2350
High Range	5	39625	2397.5
	10	39600	2395
	15	39575	2392.5
	20	39550	2390

4.3.1.2.8A TDD reference test frequencies for CA in operating band 40

Table 4.3.1.2.8A-1: Test frequencies for CA_40C

Range	CC-Combo / N _{RB_agg} [RB]	CC1 Note1			CC2 Note1		
		BW [RB]	N _{UL/DL}	f _{UL/DL} [MHz]	BW [RB]	N _{UL/DL}	f _{UL/DL} [MHz]
Low	50+100	50	38705	2305.5	100	38849	2319.9
		100	38750	2310	50	38894	2324.4
	75+75	75	38725	2307.5	75	38875	2322.5
	75+100	75	38728	2307.8	100	38899	2324.9
		100	38750	2310	75	38921	2327.1
100+100	100	38750	2310	100	38948	2329.8	
Mid	50+100	50	39056	2340.6	100	39200	2355.0
		100	39101	2345.1	50	39245	2359.5
	75+75	75	39075	2342.5	75	39225	2357.5
	75+100	75	39053	2340.3	100	39224	2357.4
		100	39076	2342.6	75	39247	2359.7
100+100	100	39051	2340.1	100	39249	2359.9	
High	50+100	50	39406	2375.6	100	39550	2390
		100	39451	2380.1	50	39595	2394.5
	75+75	75	39425	2377.5	75	39575	2392.5
	75+100	75	39379	2372.9	100	39550	2390
		100	39401	2375.1	75	39572	2392.2
100+100	100	39352	2370.2	100	39550	2390	

Note 1: Carriers in increasing frequency order.

Table 4.3.1.2.8A-2: Test frequencies for CA_40D

Range	CC-Combo / N _{RB_agg} [RB]	CC1 Note1			CC2 Note1			CC3 Note1		
		BW [RB]	N _{UL/DL}	f _{UL/DL} [MHz]	BW [RB]	N _{UL/DL}	f _{UL/DL} [MHz]	BW [RB]	N _{UL/DL}	f _{UL/DL} [MHz]
Low	50+100+100	50	38705	2305.5	100	38849	2319.9	100	39047	2339.7
		100	38750	2310	50	38894	2324.4	100	39038	2338.8
		100	38750	2310	100	38948	2329.8	50	39092	2344.2
	75+100+100	75	38728	2307.8	100	38899	2324.9	100	39097	2344.7
		100	38750	2310	75	38921	2327.1	100	39092	2344.2
		100	38750	2310	100	38948	2329.8	75	39119	2346.9
100+100+100	100	38750	2310	100	38948	2329.8	100	39146	2349.6	
Mid	50+100+100	50	38957	2330.7	100	39101	2345.1	100	39299	2364.9
		100	39006	2335.6	50	39150	2350	100	39294	2364.4
		100	39002	2335.2	100	39200	2355	50	39344	2369.4
	75+100+100	75	38954	2330.4	100	39125	2347.5	100	39323	2367.3
		100	38979	2332.9	75	39150	2350	100	39321	2367.1
		100	38977	2332.7	100	39175	2352.5	75	39346	2369.6
100+100+100	100	38952	2330.2	100	39150	2350	100	39348	2369.8	
High	50+100+100	50	39208	2355.8	100	39352	2370.2	100	39550	2390
		100	39262	2361.2	50	39406	2375.6	100	39550	2390
		100	39253	2360.3	100	39451	2380.1	50	39595	2394.5
	75+100+100	75	39181	2353.1	100	39352	2370.2	100	39550	2390
		100	39208	2355.8	75	39379	2372.9	100	39550	2390
		100	39203	2355.3	100	39401	2375.1	75	39572	2392.2
100+100+100	100	39154	2350.4	100	39352	2370.2	100	39550	2390	

Note 1: Carriers in increasing frequency order.

Table 4.3.1.2.8A-3: Test frequencies for CA_40E

Range	CC-Combo / N _{RB,agg} [RB]	CC1 Note1			CC2 Note1			CC3 Note1			CC4 Note1		
		BW [RB]	N _{UL/DL}	f _{UL/DL} [MHz]	BW [RB]	N _{UL/DL}	f _{UL/DL} [MHz]	BW [RB]	N _{UL/DL}	f _{UL/DL} [MHz]	BW [RB]	N _{UL/DL}	f _{UL/DL} [MHz]
Low	75+75+75+100	75	38728	2307.8	75	38878	2322.8	75	39028	2337.8	100	39199	2354.9
	75+75+100+100	75	38728	2307.8	75	38878	2322.8	100	39049	2339.9	100	39247	2359.7
		75	38728	2307.8	100	38899	2324.9	75	39070	2342	100	39241	2359.1
		100	38750	2310	75	38921	2327.1	75	39071	2342.1	100	39242	2359.2
	75+100+100+100	75	38728	2307.8	100	38899	2324.9	100	39097	2344.7	100	39295	2364.5
		100	38750	2310	75	38921	2327.1	100	39092	2344.2	100	39290	2364
		100	38750	2310	100	38948	2329.8	75	39119	2346.9	100	39290	2364
	100+100+100+100	100	38750	2310	100	38948	2329.8	100	39146	2349.6	100	39344	2369.4
	Mid	75+75+75+100	75	38903	2325.3	75	39053	2340.3	75	39203	2355.3	100	39374
75+75+100+100		75	38879	2322.9	75	39029	2337.9	100	39200	2355	100	39398	2374.8
		75	38882	2323.2	100	39053	2340.3	75	39224	2357.4	100	39395	2374.5
		100	38904	2325.4	75	39075	2342.5	75	39225	2357.5	100	39396	2374.6
75+100+100+100		75	38855	2320.5	100	39026	2337.6	100	39224	2357.4	100	39422	2377.2
		100	38880	2323	75	39051	2340.1	100	39222	2357.2	100	39420	2377
		100	38880	2323	100	39078	2342.8	75	39249	2359.9	100	39420	2377
100+100+100+100		100	38853	2320.3	100	39051	2340.1	100	39249	2359.9	100	39447	2379.7
High	75+75+75+100	75	39079	2342.9	75	39229	2357.9	75	39379	2372.9	100	39550	2390
	75+75+100+100	75	39031	2338.1	75	39181	2353.1	100	39352	2370.2	100	39550	2390
		75	39037	2338.7	100	39208	2355.8	75	39379	2372.9	100	39550	2390
		100	39058	2340.8	75	39229	2357.9	75	39379	2372.9	100	39550	2390
	75+100+100+100	75	38983	2333.3	100	39154	2350.4	100	39352	2370.2	100	39550	2390
		100	39010	2336	75	39181	2353.1	100	39352	2370.2	100	39550	2390
		100	39010	2336	100	39208	2355.8	75	39379	2372.9	100	39550	2390
	100+100+100+100	100	38956	2330.6	100	39154	2350.4	100	39352	2370.2	100	39550	2390

Note 1: Carriers in increasing frequency order.

4.3.1.2.9 TDD reference test frequencies for Operating Band 41

Table 4.3.1.2.9-1: Test frequencies for E-UTRA channel bandwidth for operating band 41

Test Frequency ID	Bandwidth [MHz]	EARFCN	Frequency (UL and DL) [MHz]
Low Range	5	39675	2498.5
	10	39700	2501
	15	39725	2503.5
	20	39750	2506
Mid Range	5/10/15/20	40620	2593
High Range	5	41565	2687.5
	10	41540	2685
	15	41515	2682.5
	20	41490	2680

4.3.1.2.9A TDD reference test frequencies for CA in operating band 41

Table 4.3.1.2.9A-1: Test frequencies for CA_41C

Range	CC-Combo / N _{RB_agg} [RB]	CC1 Note1			CC2 Note1		
		BW [RB]	N _{UL/DL}	f _{UL/DL} [MHz]	BW [RB]	N _{UL/DL}	f _{UL/DL} [MHz]
Low	25+100	25	39683	2499.3	100	39800	2511
		100	39750	2506	25	39867	2517.7
	50+75	50	39703	2501.3	75	39823	2513.3
		75	39725	2503.5	50	39845	2515.5
	50+100	50	39705	2501.5	100	39849	2515.9
		100	39750	2506	50	39894	2520.4
	75+75	75	39725	2503.5	75	39875	2518.5
		75	39728	2503.8	100	39899	2520.9
	75+100	100	39750	2506	75	39921	2523.1
		100	39750	2506	100	39948	2525.8
Mid	25+100	25	40528	2583.8	100	40645	2595.5
		100	40595	2590.5	25	40712	2602.2
	50+75	50	40549	2585.9	75	40669	2597.9
		75	40571	2588.1	50	40691	2600.1
	50+100	50	40526	2583.6	100	40670	2598.0
		100	40571	2588.1	50	40715	2602.5
	75+75	75	40545	2585.5	75	40695	2600.5
		75	40523	2583.3	100	40694	2600.4
	75+100	100	40546	2585.6	75	40717	2602.7
		100	40521	2583.1	100	40719	2602.9
High	25+100	25	41373	2668.3	100	41490	2680
		100	41440	2675	25	41557	2686.7
	50+75	50	41395	2670.5	75	41515	2682.5
		75	41417	2672.7	50	41537	2684.7
	50+100	50	41346	2665.6	100	41490	2680
		100	41391	2670.1	50	41535	2684.5
	75+75	75	41365	2667.5	75	41515	2682.5
		75	41319	2662.9	100	41490	2680
	75+100	100	41341	2665.1	75	41512	2682.2
		100	41292	2660.2	100	41490	2680

Note 1: Carriers in increasing frequency order.

Table 4.3.1.2.9A-2: Test frequencies for CA_41A-41A

Test Frequency ID	CC-Combo / N _{RB_agg} [RB]	CC1 Note1			Wgap [MHz]	CC2 Note1		
		BW [RB]	N _{UL/DL}	f _{UL/DL} [MHz]		BW [RB]	N _{UL/DL}	f _{UL/DL} [MHz]
Max WGap	25+25	25	39675	2498.5	184	25	41565	2687.5
	25+50	25	39675	2498.5	179	50	41540	2685
		50	39700	2501	179	25	41565	2687.5
	25+75	25	39675	2498.5	174	75	41515	2682.5
		75	39725	2503.5	174	25	41565	2687.5
	50+50	50	39700	2501	174	50	41540	2685
	25+100	25	39675	2498.5	169	100	41490	2680
		100	39750	2506	169	25	41565	2687.5
	50+75	50	39700	2501	169	75	41515	2682.5
		75	39725	2503.5	169	50	41540	2685
	50+100	50	39700	2501	164	100	41490	2680
		100	39750	2506	164	50	41540	2685
	75+75	75	39725	2503.5	164	75	41515	2682.5
	75+100	75	39725	2503.5	159	100	41490	2680
100		39750	2506	159	75	41515	2682.5	
100+100	100	39750	2506	154	100	41490	2680	

Note 1: Carriers in increasing frequency order.

Table 4.3.1.2.9A-3: Test frequencies for CA_41D

Range	CC-Combo / N _{RB_agg} [RB]	CC1 Note1			CC2 Note1			CC3 Note1			
		BW [RB]	N _{UL/DL}	f _{UL/DL} [MHz]	BW [RB]	N _{UL/DL}	f _{UL/DL} [MHz]	BW [RB]	N _{UL/DL}	f _{UL/DL} [MHz]	
Low	50+75+100	50	39705	2501.5	75	39825	2513.5	100	39996	2530.6	
		50	39705	2501.5	100	39849	2515.9	75	40020	2533	
		75	39728	2503.8	50	39848	2515.8	100	39992	2530.2	
		75	39728	2503.8	100	39899	2520.9	50	40043	2535.3	
		100	39750	2506	50	39894	2520.4	75	40014	2532.4	
		100	39750	2506	75	39921	2523.1	50	40041	2535.1	
	50+100+100	50	39705	2501.5	100	39849	2515.9	100	40047	2535.7	
		100	39750	2506	50	39894	2520.4	100	40038	2534.8	
		100	39750	2506	100	39948	2525.8	50	40092	2540.2	
	75+75+100	75	39728	2503.8	75	39878	2518.8	100	40049	2535.9	
		75	39728	2503.8	100	39899	2520.9	75	40070	2538	
		100	39750	2506	75	39921	2523.1	75	40071	2538.1	
	75+100+100	75	39728	2503.8	100	39899	2520.9	100	40097	2540.7	
		100	39750	2506	75	39921	2523.1	100	40092	2540.2	
		100	39750	2506	100	39948	2525.8	75	40119	2542.9	
	100+100+100	100	39750	2506	100	39948	2525.8	100	40146	2545.6	
	Mid	50+75+100	50	40452	2576.2	75	40572	2588.2	100	40743	2605.3
			50	40451	2576.1	100	40595	2590.5	75	40766	2607.6
75			40477	2578.7	50	40597	2590.7	100	40741	2605.1	
75			40474	2578.4	100	40645	2595.5	50	40789	2609.9	
100			40499	2580.9	50	40643	2595.3	75	40763	2607.3	
100			40497	2580.7	75	40668	2597.8	50	40788	2609.8	
50+100+100		50	40427	2573.7	100	40571	2588.1	100	40769	2607.9	
		100	40476	2578.6	50	40620	2593	100	40764	2607.4	
		100	40472	2578.2	100	40670	2598	50	40814	2612.4	
75+75+100		75	40448	2575.8	75	40598	2590.8	100	40769	2607.9	
		75	40449	2575.9	100	40620	2593	75	40791	2610.1	
		100	40471	2578.1	75	40642	2595.2	75	40792	2610.2	
75+100+100		75	40424	2573.4	100	40595	2590.5	100	40793	2610.3	
		100	40449	2575.9	75	40620	2593	100	40791	2610.1	
		100	40447	2575.7	100	40645	2595.5	75	40816	2612.6	
100+100+100		100	40422	2573.2	100	40620	2593	100	40818	2612.8	
High		50+75+100	50	41199	2650.9	75	41319	2662.9	100	41490	2680
			50	41197	2650.7	100	41341	2665.1	75	41512	2682.2
			75	41226	2653.6	50	41346	2665.6	100	41490	2680
			75	41220	2653	100	41391	2670.1	50	41535	2684.5
			100	41248	2655.8	50	41392	2670.2	75	41512	2682.2
	100		41244	2655.4	75	41415	2672.5	50	41535	2684.5	
	50+100+100	50	41148	2645.8	100	41292	2660.2	100	41490	2680	
		100	41202	2651.2	50	41346	2665.6	100	41490	2680	
		100	41193	2650.3	100	41391	2670.1	50	41535	2684.5	
	75+75+100	75	41169	2647.9	75	41319	2662.9	100	41490	2680	
		75	41170	2648	100	41341	2665.1	75	41512	2682.2	
		100	41191	2650.1	75	41362	2667.2	75	41512	2682.2	
	75+100+100	75	41121	2643.1	100	41292	2660.2	100	41490	2680	
		100	41148	2645.8	75	41319	2662.9	100	41490	2680	
		100	41143	2645.3	100	41341	2665.1	75	41512	2682.2	
	100+100+100	100	41094	2640.4	100	41292	2660.2	100	41490	2680	

Note 1: Carriers in increasing frequency order.

Table 4.3.1.2.9A-4: Test frequencies for CA_41C-41A

Test Frequency ID	CC-Combo / N _{RB,agg} [RB]	CC1 Note1			CC2 Note 1			Wgap [MHz]	CC3 Note 1		
		BW [RB]	N _{UL/DL}	f _{UL/DL} [MHz]	BW [RB]	N _{UL/DL}	f _{UL/DL} [MHz]		BW [RB]	N _{UL/DL}	f _{UL/DL} [MHz]
Max WGap	25+25+100	25	39683	2499.3	10	3980	2511	164	25	41565	2687.5
		100	39750	2506	25	39867	2517.7	164.05	25	41565	2687.5
	25+50+100	25	39683	2499.3	10	3980	2511	159	50	41540	2685
		50	39705	2501.5	10	39849	2515.9	159.1	25	41565	2687.5
		100	39750	2506	25	39867	2517.7	159.05	50	41540	2685
		100	39750	2506	50	39894	2520.4	159.1	25	41565	2687.5
	25+75+75	75	39725	2503.5	75	39875	2518.5	159	25	41565	2687.5
	25+75+100	25	39683	2499.3	10	3980	2511	154	75	41515	2682.5
		75	39728	2503.8	10	39899	2520.9	154.1	25	41565	2687.5
		100	39750	2506	25	39867	2517.7	154.05	75	41515	2682.5
		100	39750	2506	75	39921	2523.1	154.15	25	41565	2687.5
	50+50+100	50	39705	2501.5	10	39849	2515.9	154.1	50	41540	2685
		100	39750	2506	50	39894	2520.4	154.1	50	41540	2685
	50+75+75	75	39725	2503.5	75	39875	2518.5	154	50	41540	2685
	25+100+100	25	39683	2499.3	10	3980	2511	149	100	41490	2680
		100	39750	2506	25	39867	2517.7	149.05	100	41490	2680
		100	39750	2506	10	39948	2525.8	149.2	25	41565	2687.5
	50+75+100	50	39705	2501.5	10	39849	2515.9	149.1	75	41515	2682.5
		75	39728	2503.8	10	39899	2520.9	149.1	50	41540	2685
		100	39750	2506	50	39894	2520.4	149.1	75	41515	2682.5
		100	39750	2506	75	39921	2523.1	149.15	50	41540	2685
	75+75+75	75	39725	2503.5	75	39875	2518.5	149	75	41515	2682.5
	50+100+100	50	39705	2501.5	10	39849	2515.9	144.1	100	41490	2680
		100	39750	2506	50	39894	2520.4	144.1	100	41490	2680
		100	39750	2506	10	39948	2525.8	144.2	50	41540	2685
	75+75+100	75	39725	2503.5	75	39875	2518.5	144	100	41490	2680
		75	39728	2503.8	10	39899	2520.9	144.1	75	41515	2682.5
		100	39750	2506	75	39921	2523.1	144.15	75	41515	2682.5
	75+100+100	75	39728	2503.8	10	39899	2520.9	139.1	100	41490	2680

		100	39750	2506	75	3992 1	2523. 1	139.1 5	100	4149 0	2680
		100	39750	2506	10 0	3994 8	2525. 8	139.2	75	4151 5	2682. 5
	100+100+100	100	39750	2506	10 0	3994 8	2525. 8	134.2	100	4149 0	2680

Note 1: Carriers in increasing frequency order.

Table 4.3.1.2.9A-5: Test frequencies for CA_41A-41C

Test Frequency ID	CC-Combo / N _{RB_agg} [RB]	CC1 Note1			Wgap [MHz]	CC2 Note1			CC3 Note1		
		BW [RB]	N _{UL/DL}	f _{UL/DL} [MHz]		BW [RB]	N _{UL/DL}	f _{UL/DL} [MHz]	BW [RB]	N _{UL/DL}	f _{UL/DL} [MHz]
Max WGap	25+25+100	25	39675	2498.5	164.05	25	41373	2668.3	100	41490	2680
		25	39675	2498.5	164	100	41440	2675	25	41557	2686.7
	25+50+100	25	39675	2498.5	159.1	50	41346	2665.6	100	41490	2680
		25	39675	2498.5	159.1	100	41391	2670.1	50	41535	2684.5
		50	39700	2501	159.05	25	41373	2668.3	100	41490	2680
	25+75+75	25	39675	2498.5	159	75	41365	2667.5	75	41515	2682.5
		25+75+100	25	39675	2498.5	154.15	75	41319	2662.9	100	41490
	25+75+100	25	39675	2498.5	154.1	100	41341	2665.1	75	41512	2682.2
		75	39725	2503.5	154.05	25	41373	2668.3	100	41490	2680
		75	39725	2503.5	154	100	41440	2675	25	41557	2686.7
		50+50+100	50	39700	2501	154.1	50	41346	2665.6	100	41490
	50+50+100	50	39700	2501	154.1	100	41391	2670.1	50	41535	2684.5
		25+100+100	25	39675	2498.5	149.2	100	41292	2660.2	100	41490
	100		39750	2506	149.05	25	41373	2668.3	100	41490	2680
	100		39750	2506	149	100	41440	2675	25	41557	2686.7
	50+75+75	50	39700	2501	154	75	41365	2667.5	75	41515	2682.5
		50+75+100	50	39700	2501	149.15	75	41319	2662.9	100	41490
	50		39700	2501	149.1	100	41341	2665.1	75	41512	2682.2
	75		39725	2503.5	149.1	50	41346	2665.6	100	41490	2680
	75		39725	2503.5	149.1	100	41391	2670.1	50	41535	2684.5
	75+75+75	75	39725	2503.5	149	75	41365	2667.5	75	41515	2682.5
	50+100+100	50	39700	2501	144.2	100	41292	2660.2	100	41490	2680
		100	39750	2506	144.1	50	41346	2665.6	100	41490	2680
		100	39750	2506	144.1	100	41391	2670.1	50	41535	2684.5
	75+75+100	75	39725	2503.5	144.15	75	41319	2662.9	100	41490	2680
		75	39725	2503.5	144.1	100	41341	2665.1	75	41512	2682.2
		100	39750	2506	144	75	41365	2667.5	75	41515	2682.5
	75+100+100	75	39725	2503.5	139.2	100	41292	2660.2	100	41490	2680
		100	39750	2506	139.15	75	41319	2662.9	100	41490	2680
		100	39750	2506	139.1	100	41341	2665.1	75	41512	2682.2
100+100+100	100	39750	2506	134.2	100	41292	2660.2	100	41490	2680	

Note 1: Carriers in increasing frequency order.

Table 4.3.1.2.9A-6: Test frequencies for CA_41C-41C

Test frequency ID	CC-Combo / N _{RB_agg} [RB]	CC1 Note1			CC2 Note1			Wgap [MHz]	CC3 Note1			CC4 Note1		
		BW [RB]	N _{UL/DL}	f _{UL/DL} [MHz]	BW [RB]	N _{UL/DL}	f _{UL/DL} [MHz]		BW [RB]	N _{UL/DL}	f _{UL/DL} [MHz]	BW [RB]	N _{UL/DL}	f _{UL/DL} [MHz]
Max Wgap	50+50+100+100	50	39705	2501.5	100	39849	2515.9	134.7	50	41346	2665.6	100	41490	2680
		100	39750	2506	50	39894	2520.4	134.7	100	41391	2670.1	50	41535	2684.5
		50	39705	2501.5	100	39849	2515.9	134.2	100	41391	2670.1	50	41535	2684.5
		100	39750	2506	50	39894	2520.4	135.2	50	41346	2665.6	100	41490	2680
	50+75+75+100	50	39705	2501.5	100	39849	2515.9	134.1	75	41365	2667.5	75	41515	2682.5
		100	39750	2506	50	39894	2520.4	134.6	75	41365	2667.5	75	41515	2682.5
		75	39725	2503.5	75	39875	2518.5	134.6	50	41346	2665.6	100	41490	2680
		75	39725	2503.5	75	39875	2518.5	134.1	100	41391	2670.1	50	41535	2684.5
	50+75+100+100	50	39705	2501.5	100	39849	2515.9	129.5	75	41319	2662.9	100	41490	2680
		100	39750	2506	50	39894	2520.4	129.7	100	41341	2665.1	75	41512	2682.2
		50	39705	2501.5	100	39849	2515.9	129.2	100	41341	2665.1	75	41512	2682.2
		100	39750	2506	50	39894	2520.4	130	75	41319	2662.9	100	41490	2680
		75	40523	2583.3	100	40694	2600.4	50.2	50	41346	2665.6	100	41490	2680
		100	39750	2506	75	39921	2523.1	129.5	100	41391	2670.1	50	41535	2684.5
		100	39750	2506	75	39921	2523.1	130	50	41346	2665.6	100	41490	2680
		75	40523	2583.3	100	40694	2600.4	49.7	100	41391	2670.1	50	41535	2684.5
	50+100+100+100	50	39705	2501.5	100	39849	2515.9	124.3	100	41292	2660.2	100	41490	2680
		100	39750	2506	50	39894	2520.4	124.8	100	41292	2660.2	100	41490	2680
		100	39750	2506	100	39948	2525.8	124.8	50	41346	2665.6	100	41490	2680
		100	39750	2506	100	39948	2525.8	124.3	100	41391	2670.1	50	41535	2684.5
	75+75+75+100	75	40523	2583.3	100	40694	2600.4	49.6	75	41365	2667.5	75	41515	2682.5
		100	39750	2506	75	39921	2523.1	129.4	75	41365	2667.5	75	41515	2682.5
		75	39725	2503.5	75	39875	2518.5	129.4	75	41319	2662.9	100	41490	2680
		75	39725	2503.5	75	39875	2518.5	129.1	100	41341	2665.1	75	41512	2682.2
	75+75+100+100	75	39725	2503.5	75	39875	2518.5	124.2	100	41292	2660.2	100	41490	2680
		100	39750	2506	100	39948	2525.8	124.2	75	41365	2667.5	75	41515	2682.5
	75+100+100+100	75	40523	2583.3	100	40694	2600.4	39.8	100	41292	2660.2	100	41490	2680

		100	39750	2506	75	39921	2523.1	119.6	100	41292	2660.2	100	41490	2680
		100	39750	2506	100	39948	2525.8	119.6	75	41319	2662.9	100	41490	2680
		100	39750	2506	100	39948	2525.8	119.3	100	41341	2665.1	75	41512	2682.2
	100+100+ 100+100	100	39750	2506	100	39948	2525.8	114.4	100	41292	2660.2	100	41490	2680

Note 1: Carriers in increasing frequency order.

Table 4.3.1.2.9A-7: Test frequencies for CA_41A-41D

Test frequency ID	CC-Combo / N _{RB_agg} [RB]	CC1 Note1			Wgap [MHz]	CC2 Note1			CC3 Note1			CC4 Note1		
		BW [RB]	N _{UL/DL}	f _{UL/DL} [MHz]		BW [RB]	N _{UL/DL}	f _{UL/DL} [MHz]	BW [RB]	N _{UL/DL}	f _{UL/DL} [MHz]	BW [RB]	N _{UL/DL}	f _{UL/DL} [MHz]
Max Wgap	25+50+ 75+100	25	39675	2498.5	144.9	50	41199	2650.9	75	41319	2662.9	100	41490	2680
		25	39675	2498.5	144.7	50	41197	2650.7	100	41341	2665.1	75	41512	2682.2
		25	39675	2498.5	145.1	75	41226	2653.6	50	41346	2665.6	100	41490	2680
		25	39675	2498.5	144.5	75	41220	2653	100	41391	2670.1	50	41535	2684.5
		25	39675	2498.5	144.8	100	41248	2655.8	50	41392	2670.2	75	41512	2682.2
		25	39675	2498.5	144.4	100	41244	2655.4	75	41415	2672.5	50	41535	2684.5
	25+50+ 100+100	25	39675	2498.5	139.8	50	41148	2645.8	100	41292	2660.2	100	41490	2680
		25	39675	2498.5	140.2	100	41202	2651.2	50	41346	2665.6	100	41490	2680
		25	39675	2498.5	139.3	100	41193	2650.3	100	41391	2670.1	50	41535	2684.5
	25+75+ 75+100	25	39675	2498.5	139.4	75	41169	2647.9	75	41319	2662.9	100	41490	2680
		25	39675	2498.5	139.5	75	41170	2648	100	41341	2665.1	75	41512	2682.2
		25	39675	2498.5	139.1	100	41191	2650.1	75	41362	2667.2	75	41512	2682.2
	25+75+ 100+100	25	39675	2498.5	134.6	75	41121	2643.1	100	41292	2660.2	100	41490	2680
		25	39675	2498.5	134.8	100	41148	2645.8	75	41319	2662.9	100	41490	2680
		25	39675	2498.5	134.3	100	41143	2645.3	100	41341	2665.1	75	41512	2682.2
	25+100+ 100+100	25	39675	2498.5	129.4	100	41094	2640.4	100	41292	2660.2	100	41490	2680
	50+50+ 75+100	50	39700	2501	139.9	50	41199	2650.9	75	41319	2662.9	100	41490	2680
		50	39700	2501	139.7	50	41197	2650.7	100	41341	2665.1	75	41512	2682.2
		50	39700	2501	140.1	75	41226	2653.6	50	41346	2665.6	100	41490	2680
		50	39700	2501	139.5	75	41220	2653	100	41391	2670.1	50	41535	2684.5

	50	39700	2501	139.8	100	41248	2655.8	50	41392	2670.2	75	41512	2682.2
	50	39700	2501	139.4	100	41244	2655.4	75	41415	2672.5	50	41535	2684.5
50+50+ 100+100	50	39700	2501	134.8	50	41148	2645.8	100	41292	2660.2	100	41490	2680
	50	39700	2501	135.2	100	41202	2651.2	50	41346	2665.6	100	41490	2680
	50	39700	2501	134.3	100	41193	2650.3	100	41391	2670.1	50	41535	2684.5
50+75+ 75+100	50	39700	2501	134.4	75	41169	2647.9	75	41319	2662.9	100	41490	2680
	50	39700	2501	134.5	75	41170	2648	100	41341	2665.1	75	41512	2682.2
	50	39700	2501	134.1	100	41191	2650.1	75	41362	2667.2	75	41512	2682.2
	75	39725	2503.5	134.9	50	41199	2650.9	75	41319	2662.9	100	41490	2680
	75	39725	2503.5	134.7	50	41197	2650.7	100	41341	2665.1	75	41512	2682.2
	75	39725	2503.5	135.1	75	41226	2653.6	50	41346	2665.6	100	41490	2680
	75	39725	2503.5	134.5	75	41220	2653	100	41391	2670.1	50	41535	2684.5
	75	39725	2503.5	134.8	100	41248	2655.8	50	41392	2670.2	75	41512	2682.2
	75	39725	2503.5	134.4	100	41244	2655.4	75	41415	2672.5	50	41535	2684.5
50+75+ 100+100	50	39700	2501	129.6	75	41121	2643.1	100	41292	2660.2	100	41490	2680
	50	39700	2501	129.8	100	41148	2645.8	75	41319	2662.9	100	41490	2680
	50	39700	2501	129.3	100	41143	2645.3	100	41341	2665.1	75	41512	2682.2
	75	39725	2503.5	129.8	50	41148	2645.8	100	41292	2660.2	100	41490	2680
	75	39725	2503.5	130.2	100	41202	2651.2	50	41346	2665.6	100	41490	2680
	75	39725	2503.5	129.3	100	41193	2650.3	100	41391	2670.1	50	41535	2684.5
	100	39750	2506	129.9	50	41199	2650.9	75	41319	2662.9	100	41490	2680
	100	39750	2506	129.7	50	41197	2650.7	100	41341	2665.1	75	41512	2682.2
	100	39750	2506	130.1	75	41226	2653.6	50	41346	2665.6	100	41490	2680
	100	39750	2506	129.5	75	41220	2653	100	41391	2670.1	50	41535	2684.5
	100	39750	2506	129.8	100	41248	2655.8	50	41392	2670.2	75	41512	2682.2
100	39750	2506	129.4	100	41244	2655.4	75	41415	2672.5	50	41535	2684.5	
50+100+ 100+100	50	39700	2501	124.4	100	41094	2640.4	100	41292	2660.2	100	41490	2680
	100	39750	2506	124.8	50	41148	2645.8	100	41292	2660.2	100	41490	2680
	100	39750	2506	125.2	100	41202	2651.2	50	41346	2665.6	100	41490	2680
	100	39750	2506	124.3	100	41193	2650.3	100	41391	2670.1	50	41535	2684.5
75+75+ 75+100	75	39725	2503.5	129.4	75	41169	2647.9	75	41319	2662.9	100	41490	2680
	75	39725	2503.5	129.5	75	41170	2648	100	41341	2665.1	75	41512	2682.2
	75	39725	2503.5	129.1	100	41191	2650.1	75	41362	2667.2	75	41512	2682.2
75+75+ 100+100	75	39725	2503.5	124.6	75	41121	2643.1	100	41292	2660.2	100	41490	2680
	75	39725	2503.5	124.8	100	41148	2645.8	75	41319	2662.9	100	41490	2680

		75	39725	2503.5	124.3	100	41143	2645.3	100	41341	2665.1	75	41512	2682.2
		100	39750	2506	124.4	75	41169	2647.9	75	41319	2662.9	100	41490	2680
		100	39750	2506	124.5	75	41170	2648	100	41341	2665.1	75	41512	2682.2
		100	39750	2506	124.1	100	41191	2650.1	75	41362	2667.2	75	41512	2682.2
	75+100+ 100+100	75	39725	2503.5	119.4	100	41094	2640.4	100	41292	2660.2	100	41490	2680
		100	39750	2506	119.6	75	41121	2643.1	100	41292	2660.2	100	41490	2680
		100	39750	2506	119.8	100	41148	2645.8	75	41319	2662.9	100	41490	2680
		100	39750	2506	119.3	100	41143	2645.3	100	41341	2665.1	75	41512	2682.2
	100+100+ 100+100	100	39750	2506	114.4	100	41094	2640.4	100	41292	2660.2	100	41490	2680

Note 1: Carriers in increasing frequency order.

Table 4.3.1.2.9A-8: Test frequencies for CA_41D-41A

Test frequency ID	CC-Combo / N _{RB_agg} [RB]	CC1 Note1			CC2 Note1			CC3 Note1			Wgap [MHz]	CC4 Note1		
		BW [RB]	N _{UL/DL}	f _{UL/DL} [MHz]	BW [RB]	N _{UL/DL}	f _{UL/DL} [MHz]	BW [RB]	N _{UL/DL}	f _{UL/DL} [MHz]		BW [RB]	N _{UL/DL}	f _{UL/DL} [MHz]
Max Wgap	25+50+ 75+100	50	39705	2501.5	75	39825	2513.5	100	39996	2530.6	144.4	25	41565	2687.5
		50	39705	2501.5	100	39849	2515.9	75	40020	2533	144.5	25	41565	2687.5
		75	39728	2503.8	50	39848	2515.8	100	39992	2530.2	144.8	25	41565	2687.5
		75	39728	2503.8	100	39899	2520.9	50	40043	2535.3	144.7	25	41565	2687.5
		100	39750	2506	50	39894	2520.4	75	40014	2532.4	145.1	25	41565	2687.5
		100	39750	2506	75	39921	2523.1	50	40041	2535.1	144.9	25	41565	2687.5
	25+50+ 100+100	50	39705	2501.5	100	39849	2515.9	100	40047	2535.7	139.3	25	41565	2687.5
		100	39750	2506	50	39894	2520.4	100	40038	2534.8	140.2	25	41565	2687.5
		100	39750	2506	100	39948	2525.8	50	40092	2540.2	139.8	25	41565	2687.5
	25+75+ 75+100	75	39728	2503.8	75	39878	2518.8	100	40049	2535.9	139.1	25	41565	2687.5
		75	39728	2503.8	100	39899	2520.9	75	40070	2538	139.5	25	41565	2687.5
		100	39750	2506	75	39921	2523.1	75	40071	2538.1	139.4	25	41565	2687.5
	25+75+ 100+100	75	39728	2503.8	100	39899	2520.9	100	40097	2540.7	134.3	25	41565	2687.5
		100	39750	2506	75	39921	2523.1	100	40092	2540.2	134.8	25	41565	2687.5
		100	39750	2506	100	39948	2525.8	75	40119	2542.9	134.6	25	41565	2687.5

25+100+ 100+100	100	39750	2506	100	39948	2525.8	100	40146	2545.6	129.4	25	41565	2687.5
50+50+ 75+100	50	39705	2501.5	75	39825	2513.5	100	39996	2530.6	139.4	50	41540	2685
	50	39705	2501.5	100	39849	2515.9	75	40020	2533	139.5	50	41540	2685
	75	39728	2503.8	50	39848	2515.8	100	39992	2530.2	139.8	50	41540	2685
	75	39728	2503.8	100	39899	2520.9	50	40043	2535.3	139.7	50	41540	2685
	100	39750	2506	50	39894	2520.4	75	40014	2532.4	140.1	50	41540	2685
	100	39750	2506	75	39921	2523.1	50	40041	2535.1	139.9	50	41540	2685
50+50+ 100+100	50	39705	2501.5	100	39849	2515.9	100	40047	2535.7	134.3	50	41540	2685
	100	39750	2506	50	39894	2520.4	100	40038	2534.8	135.2	50	41540	2685
	100	39750	2506	100	39948	2525.8	50	40092	2540.2	134.8	50	41540	2685
50+75+ 75+100	75	39728	2503.8	75	39878	2518.8	100	40049	2535.9	134.1	50	41540	2685
	75	39728	2503.8	100	39899	2520.9	75	40070	2538	134.5	50	41540	2685
	100	39750	2506	75	39921	2523.1	75	40071	2538.1	134.4	50	41540	2685
	50	39705	2501.5	75	39825	2513.5	100	39996	2530.6	134.4	75	41515	2682.5
	50	39705	2501.5	100	39849	2515.9	75	40020	2533	134.5	75	41515	2682.5
	75	39728	2503.8	50	39848	2515.8	100	39992	2530.2	134.8	75	41515	2682.5
	75	39728	2503.8	100	39899	2520.9	50	40043	2535.3	134.7	75	41515	2682.5
	100	39750	2506	50	39894	2520.4	75	40014	2532.4	135.1	75	41515	2682.5
	100	39750	2506	75	39921	2523.1	50	40041	2535.1	134.9	75	41515	2682.5
50+75+ 100+100	75	39728	2503.8	100	39899	2520.9	100	40097	2540.7	129.3	50	41540	2685
	100	39750	2506	75	39921	2523.1	100	40092	2540.2	129.8	50	41540	2685
	100	39750	2506	100	39948	2525.8	75	40119	2542.9	129.6	50	41540	2685
	50	39705	2501.5	100	39849	2515.9	100	40047	2535.7	129.3	75	41515	2682.5
	100	39750	2506	50	39894	2520.4	100	40038	2534.8	130.2	75	41515	2682.5
	100	39750	2506	100	39948	2525.8	50	40092	2540.2	129.8	75	41515	2682.5
	50	39705	2501.5	75	39825	2513.5	100	39996	2530.6	134.4	100	41490	2680
	50	39705	2501.5	100	39849	2515.9	75	40020	2533	129.5	100	41490	2680
	75	39728	2503.8	50	39848	2515.8	100	39992	2530.2	129.8	100	41490	2680
	75	39728	2503.8	100	39899	2520.9	50	40043	2535.3	129.7	100	41490	2680
	100	39750	2506	50	39894	2520.4	75	40014	2532.4	130.1	100	41490	2680
	100	39750	2506	75	39921	2523.1	50	40041	2535.1	129.9	100	41490	2680
	50+100+ 100+100	100	39750	2506	100	39948	2525.8	100	40146	2545.6	124.4	50	41540
50		39705	2501.5	100	39849	2515.9	100	40047	2535.7	124.3	100	41490	2680
100		39750	2506	50	39894	2520.4	100	40038	2534.8	125.2	100	41490	2680
100		39750	2506	100	39948	2525.8	50	40092	2540.2	124.8	100	41490	2680

75+75+ 75+100	75	39728	2503.8	75	39878	2518.8	100	40049	2535.9	129.1	75	41515	2682.5
	75	39728	2503.8	100	39899	2520.9	75	40070	2538	129.5	75	41515	2682.5
	100	39750	2506	75	39921	2523.1	75	40071	2538.1	129.4	75	41515	2682.5
75+75+ 100+100	75	39728	2503.8	100	39899	2520.9	100	40097	2540.7	124.3	75	41515	2682.5
	100	39750	2506	75	39921	2523.1	100	40092	2540.2	124.8	75	41515	2682.5
	100	39750	2506	100	39948	2525.8	75	40119	2542.9	124.6	75	41515	2682.5
	75	39728	2503.8	75	39878	2518.8	100	40049	2535.9	124.1	100	41490	2680
	75	39728	2503.8	100	39899	2520.9	75	40070	2538	124.5	100	41490	2680
	100	39750	2506	75	39921	2523.1	75	40071	2538.1	124.4	100	41490	2680
75+100+ 100+100	100	39750	2506	100	39948	2525.8	100	40146	2545.6	119.4	75	41515	2682.5
	75	39728	2503.8	100	39899	2520.9	100	40097	2540.7	119.3	100	41490	2680
	100	39750	2506	75	39921	2523.1	100	40092	2540.2	119.8	100	41490	2680
	100	39750	2506	100	39948	2525.8	75	40119	2542.9	119.6	100	41490	2680
100+100+ 100+100	100	39750	2506	100	39948	2525.8	100	40146	2545.6	114.4	100	41490	2680

Note 1: Carriers in increasing frequency order.

Table 4.3.1.2.9A-9: Test frequencies for CA_41E

Range	CC-Combo / N _{RB,agg} [RB]	CC1 Note1			CC2 Note1			CC3 Note1			CC4 Note1		
		BW [RB]	N _{UL/DL}	f _{UL/DL} [MHz]	BW [RB]	N _{UL/DL}	f _{UL/DL} [MHz]	BW [RB]	N _{UL/DL}	f _{UL/DL} [MHz]	BW [RB]	N _{UL/DL}	f _{UL/DL} [MHz]
Low	75+75+75+100	75	39725	2503.5	75	39875	2518.5	75	40025	2533.5	100	40200	2551.0
	75+75+100+100	75	39725	2503.5	75	39725	2518.5	100	40050	2536.0	100	40250	2556.0
		75	39725	2503.5	100	39900	2521.0	75	40075	2538.5	100	40250	2556.0
		100	39750	2506.0	75	39925	2523.5	75	40075	2538.5	100	40250	2556.0
	75+100+100+100	75	39725	2503.5	100	39900	2521.0	100	40100	2541.0	100	40300	2561.0
		100	39750	2506.0	75	39925	2523.5	100	40100	2541.0	100	40300	2561.0
		100	39750	2506.0	100	39950	2526.0	75	40125	2543.5	100	40300	2561.0
100+100+100+100	100	39750	2506.0	100	39950	2526.0	100	40150	2546.0	100	40350	2566.0	
Mid	75+75+75+100	75	40370	2568.0	75	40520	2583.0	75	40670	2598.0	100	40845	2615.5
	75+75+100+100	75	40345	2565.5	75	40495	2580.5	100	40670	2598.0	100	40870	2618.0
		75	40345	2565.5	100	40520	2583.0	75	40695	2600.5	100	40870	2618.0
		100	40370	2568.0	75	40545	2585.5	75	40695	2600.5	100	40870	2618.0
	75+100+100+100	75	40320	2563.0	100	40495	2580.5	100	40695	2600.5	100	40895	2620.5
		100	40345	2565.5	75	40520	2583.0	100	40695	2600.5	100	40895	2620.5
		100	40345	2565.5	100	40545	2585.5	75	40720	2603.0	100	40895	2620.5
100+100+100+100	100	40320	2563.0	100	40520	2583.0	100	40720	2603.0	100	40920	2623.0	
High	75+75+75+100	75	41015	2632.5	75	41165	2647.5	75	41315	2662.5	100	41490	2680.0
	75+75+100+100	75	40965	2627.5	75	41115	2642.5	100	41290	2660.0	100	41490	2680.0
		75	40965	2627.5	100	41140	2645.0	75	41315	2662.5	100	41490	2680.0
		100	40990	2630.0	75	41165	2647.5	75	41315	2662.5	100	41490	2680.0
	75+100+100+100	75	40915	2622.5	100	41090	2640.0	100	41290	2660.0	100	41490	2680.0
		100	40940	2625.0	75	41115	2642.5	100	41290	2660.0	100	41490	2680.0
		100	40940	2625.0	100	41140	2645.0	75	41315	2662.5	100	41490	2680.0
100+100+100+100	100	40890	2620.0	100	41090	2640.0	100	41290	2660.0	100	41490	2680.0	
Note 1: Carriers in increasing frequency order.													

Table 4.3.1.2.9A-10: Test frequencies for CA_41F

Range	CC-Combo / N _{RB,agg} [RB]	CC1 Note1			CC2 Note1			CC3 Note1			CC4 Note1			CC5 Note1		
		BW [RB]	N _{UL/DL}	f _{UL/DL} [MHz]	BW [RB]	N _{UL/DL}	f _{UL/DL} [MHz]	BW [RB]	N _{UL/DL}	f _{UL/DL} [MHz]	BW [RB]	N _{UL/DL}	f _{UL/DL} [MHz]	BW [RB]	N _{UL/DL}	f _{UL/DL} [MHz]
Low	50+75+100+100+100	50	39705	2501.5	75	39825	2513.5	100	39996	2530.6	100	40194	2550.4	100	40392	2570.2
	50+100+100+100+100	50	39705	2501.5	100	39849	2515.9	100	40047	2535.7	100	40245	2555.5	100	40443	2575.3
	75+75+100+100+100	75	39728	2503.8	75	39878	2518.8	100	40049	2535.9	100	40247	2555.7	100	40445	2575.5
	75+100+100+100+1100	75	39728	2503.8	100	39899	2520.9	100	40097	2540.7	100	40295	2560.5	100	40493	2580.3
		100	39750	2506	75	39921	2523.1	100	40092	2540.2	100	40290	2560	100	40488	2579.8
100+100+100+100+100	100	39750	2506	100	39948	2525.8	100	40146	2545.6	100	40344	2565.4	100	40542	2585.2	
Mid	50+75+100+100+100	50	40254	2556.4	75	40374	2568.4	100	40545	2585.5	100	40743	2605.3	100	40941	2625.1
	50+100+100+100+100	50	40229	2553.9	100	40373	2568.3	100	40571	2588.1	100	40769	2607.9	100	40967	2627.7
	75+75+100+100+100	75	40250	2556	75	40400	2571	100	40571	2588.1	100	40769	2607.9	100	40967	2627.7
	75+100+100+100+1100	75	40226	2553.6	100	40397	2570.7	100	40595	2590.5	100	40793	2610.3	100	40991	2630.1
		100	40251	2556.1	75	40422	2573.2	100	40593	2590.3	100	40791	2610.1	100	40989	2629.9
100+100+100+100+100	100	40224	2553.4	100	40422	2573.2	100	40620	2593	100	40818	2612.8	100	41016	2632.6	
High	50+75+100+100+100	50	40803	2611.3	75	40923	2623.3	100	41094	2640.4	100	41292	2660.2	100	41490	2680
	50+100+100+100+100	50	40752	2606.2	100	40896	2620.6	100	41094	2640.4	100	41292	2660.2	100	41490	2680
	75+75+100+100+100	75	40773	2608.3	75	40923	2623.3	100	41094	2640.4	100	41292	2660.2	100	41490	2680
	75+100+100+100+1100	75	40725	2603.5	100	40896	2620.6	100	41094	2640.4	100	41292	2660.2	100	41490	2680
		100	40752	2606.2	75	40923	2623.3	100	41094	2640.4	100	41292	2660.2	100	41490	2680
100+100+100+100+100	100	40698	2600.8	100	40896	2620.6	100	41094	2640.4	100	41292	2660.2	100	41490	2680	
Note 1: Carriers in increasing frequency order.																

4.3.1.2.10 TDD reference test frequencies for Operating Band 42

Table 4.3.1.2.10-1: Test frequencies for E-UTRA channel bandwidth for operating band 42

Test Frequency ID	Bandwidth [MHz]	EARFCN	Frequency (UL and DL) [MHz]
Low Range	5	41615	3402.5
	10	41640	3405
	15	41665	3407.5
	20	41690	3410
Mid Range	5/10/15/20	42590	3500
High Range	5	43565	3597.5
	10	43540	3595
	15	43515	3592.5
	20	43490	3590

4.3.1.2.10ATDD reference test frequencies for CA in operating band 42

Table 4.3.1.2.10A-1: Test frequencies for CA_42C

Range	CC-Combo / N _{RB_agg} [RB]	CC1 Note1			CC2 Note1		
		BW [RB]	N _{UL/DL}	f _{UL/DL} [MHz]	BW [RB]	N _{UL/DL}	f _{UL/DL} [MHz]
Low	25+100	25	41623	3403.3	100	41740	3415
		100	41690	3410	25	41807	3421.7
	50+100	50	41645	3405.5	100	41789	3419.9
		100	41690	3410	50	41834	3424.4
	75+100	75	41668	3407.8	100	41839	3424.9
100+100	100	41690	3410	75	41861	3427.1	
Mid	25+100	25	42498	3490.8	100	42615	3502.5
		100	42565	3497.5	25	42682	3509.2
	50+100	50	42496	3490.6	100	42640	3505
		100	42541	3495.1	50	42685	3509.5
	75+100	75	42493	3490.3	100	42664	3507.4
100+100	100	42516	3492.6	75	42687	3509.7	
High	25+100	25	43373	3578.3	100	43490	3590
		100	43440	3585	25	43557	3596.7
	50+100	50	43346	3575.6	100	43490	3590
		100	43391	3580.1	50	43535	3594.5
	75+100	75	43319	3572.9	100	43490	3590
		100	43341	3575.1	75	43512	3592.2
	100+100	100	43292	3570.2	100	43490	3590
Note 1: Carriers in increasing frequency order.							

Table 4.3.1.2.10A-2: Test frequencies for CA_42A-42A

Test Frequency ID	CC-Combo / N _{RB_agg} [RB]	CC1 Note1			Wgap [MHz]	CC2 Note1		
		BW [RB]	N _{UL/DL}	f _{UL/DL} [MHz]		BW [RB]	N _{UL/DL}	f _{UL/DL} [MHz]
Max WGap	25+25	25	41615	3402.5	190	25	43565	3597.5
	25+50	25	41615	3402.5	185	50	43540	3595
		50	41640	3405	185	25	43565	3597.5
	25+75	25	41615	3402.5	180	75	43515	3592.5
		75	41665	3407.5	180	25	43565	3597.5
	50+50	50	41640	3405	180	50	43540	3595
	25+100	25	41615	3402.5	175	100	43490	3590
		100	41690	3410	175	25	43565	3597.5
	50+75	50	41640	3405	175	75	43515	3592.5
		75	41665	3407.5	175	50	43540	3595
	50+100	50	41640	3405	170	100	43490	3590
		100	41690	3410	170	50	43540	3595
	75+100	75	41665	3407.5	165	100	43490	3590
		100	41690	3410	165	75	43515	3592.5
100+100	100	41690	3410	160	100	43490	3590	
Refsens ²	100+100	100	42590	3500	70	100	43490	3590

Note 1: Carriers in increasing frequency order.
 Note 2: Test point derived with regard to REFSSENS requirements.

Table 4.3.1.2.10A-3: Test frequencies for CA_42D

Range	CC-Combo / N _{RB_agg} [RB]	CC1 Note1			CC2 Note1			CC3 Note1		
		BW [RB]	N _{UL/DL}	f _{UL/DL} [MHz]	BW [RB]	N _{UL/DL}	f _{UL/DL} [MHz]	BW [RB]	N _{UL/DL}	f _{UL/DL} [MHz]
Low	25+100+100	25	41623	3403.3	100	41740	3415	100	41938	3434.8
		100	41690	3410	100	41888	3429.8	25	42005	3441.5
	50+100+100	50	41645	3405.5	100	41789	3419.9	100	41987	3439.7
		100	41690	3410	100	41888	3429.8	50	42032	3444.2
	75+100+100	75	41668	3407.8	100	41839	3424.9	100	42037	3444.7
		100	41690	3410	100	41888	3429.8	75	42059	3446.9
100+100+100	100	41690	3410	100	41888	3429.8	100	42086	3449.6	
Mid	25+100+100	25	42399	3480.9	100	42516	3492.6	100	42714	3512.4
		100	42466	3487.6	100	42664	3507.4	25	42781	3519.1
	50+100+100	50	42397	3480.7	100	42541	3495.1	100	42739	3514.9
		100	42442	3485.2	100	42640	3505	50	42784	3519.4
	75+100+100	75	42394	3480.4	100	42565	3497.5	100	42763	3517.3
		100	42417	3482.7	100	42615	3502.5	75	42786	3519.6
100+100+100	100	42392	3480.2	100	42590	3500	100	42788	3519.8	
High	25+100+100	25	43175	3558.5	100	43292	3570.2	100	43490	3590
		100	43242	3565.2	100	43440	3585	25	43557	3596.7
	50+100+100	50	43148	3555.8	100	43292	3570.2	100	43490	3590
		100	43193	3560.3	100	43391	3580.1	50	43535	3594.5
	75+100+100	75	43121	3553.1	100	43292	3570.2	100	43490	3590
		100	43143	3555.3	100	43341	3575.1	75	43512	3592.2
100+100+100	100	43094	3550.4	100	43292	3570.2	100	43490	3590	

Note 1: Carriers in increasing frequency order.

Table 4.3.1.2.10A-4: Test frequencies for CA_42C-42A

Test Frequency ID	CC-Combo / N _{RB,agg} [RB]	CC1 Note1			CC2 Note1			Wgap [MHz]	CC3 Note1		
		BW [RB]	N _{UL/DL}	f _{UL/DL} [MHz]	BW [RB]	N _{UL/DL}	f _{UL/DL} [MHz]		BW [RB]	N _{UL/DL}	f _{UL/DL} [MHz]
Max WGap	25+25+100	25	41623	3403.3	100	41740	3415	170	25	43565	3597.5
		100	41690	3410	25	41807	3421.7	170.8	25	43565	3597.5
	25+50+100	25	41623	3403.3	100	41740	3415	165	50	43540	3595
		50	41645	3405.5	100	41789	3419.9	165.1	25	43565	3597.5
		100	41690	3410	25	41807	3421.7	165.8	50	43540	3595
	25+75+100	100	41690	3410	50	41834	3424.4	165.6	25	43565	3597.5
		25	41623	3403.3	100	41740	3415	160	75	43515	3592.5
		75	41668	3407.8	100	41839	3424.9	160.1	25	43565	3597.5
		100	41690	3410	25	41807	3421.7	160.8	75	43515	3592.5
	50+50+100	100	41690	3410	75	41861	3427.1	160.4	25	43565	3597.5
		50	41645	3405.5	100	41789	3419.9	160.1	50	43540	3595
		100	41690	3410	50	41834	3424.4	160.6	50	43540	3595
	25+100+100	25	41623	3403.3	100	41740	3415	155	100	43490	3590
		100	41690	3410	25	41807	3421.7	155.8	100	43490	3590
		100	41690	3410	100	41888	3429.8	155.2	25	43565	3597.5
	50+75+100	100	41690	3410	50	41834	3424.4	155.6	75	43515	3592.5
		50	41645	3405.5	100	41789	3419.9	155.1	75	43515	3592.5
		75	41668	3407.8	100	41839	3424.9	155.1	50	43540	3595
		100	41690	3410	50	41834	3424.4	155.6	75	43515	3592.5
	50+100+100	100	41690	3410	75	41861	3427.1	155.4	50	43540	3595
		50	41645	3405.5	100	41789	3419.9	150.1	100	43490	3590
		100	41690	3410	50	41834	3424.4	150.6	100	43490	3590
	75+75+100	100	41690	3410	100	41888	3429.8	150.2	50	43540	3595
		75	41668	3407.8	100	41839	3424.9	150.1	75	43515	3592.5
		100	41690	3410	75	41861	3427.1	150.4	75	43515	3592.5
	75+100+100	75	41668	3407.8	100	41839	3424.9	145.1	100	43490	3590
		100	41690	3410	75	41861	3427.1	145.4	100	43490	3590
		100	41690	3410	100	41888	3429.8	145.2	75	43515	3592.5
	100+100+100	100	41690	3410	100	41888	3429.8	140.2	100	43490	3590

Note 1: Carriers in increasing frequency order.

Table 4.3.1.2.10A-5: Test frequencies for CA_42A-42C

Test Frequency ID	CC-Combo / N _{RB_agg} [RB]	CC1 Note1			Wgap [MHz]	CC2 Note1			CC3 Note1		
		BW [RB]	N _{UL/DL}	f _{UL/DL} [MHz]		BW [RB]	N _{UL/DL}	f _{UL/DL} [MHz]	BW [RB]	N _{UL/DL}	f _{UL/DL} [MHz]
Max WGap	25+25+100	25	41615	3402.5	170.8	25	43373	3578.3	100	43490	3590
		25	41615	3402.5	170	100	43440	3585	25	43557	3596.7
	25+50+100	25	41615	3402.5	165.6	50	43346	3575.6	100	43490	3590
		25	41615	3402.5	165.1	100	43391	3580.1	50	43535	3594.5
		50	41640	3405	165.8	25	43373	3578.3	100	43490	3590
	25+75+100	50	41640	3405	165	100	43440	3585	25	43557	3596.7
		25	41615	3402.5	160.4	75	43319	3572.9	100	43490	3590
		25	41615	3402.5	160.1	100	43341	3575.1	75	43512	3592.2
		75	41665	3407.5	160.8	25	43373	3578.3	100	43490	3590
	50+50+100	75	41665	3407.5	160	100	43440	3585	25	43557	3596.7
		50	41640	3405	160.6	50	43346	3575.6	100	43490	3590
		50	41640	3405	160.1	100	43391	3580.1	50	43535	3594.5
	25+100+100	25	41615	3402.5	155.2	100	43292	3570.2	100	43490	3590
		100	41690	3410	155.8	25	43373	3578.3	100	43490	3590
		100	41690	3410	155	100	43440	3585	25	43557	3596.7
	50+75+100	100	41690	3410	155.4	75	43319	3572.9	100	43490	3590
		50	41640	3405	155.1	100	43341	3575.1	75	43512	3592.2
		75	41665	3407.5	155.6	50	43346	3575.6	100	43490	3590
		75	41665	3407.5	155.1	100	43391	3580.1	50	43535	3594.5
	50+100+100	50	41640	3405	150.2	100	43292	3570.2	100	43490	3590
		100	41690	3410	150.6	50	43346	3575.6	100	43490	3590
		100	41690	3410	150.1	100	43391	3580.1	50	43535	3594.5
	75+75+100	75	41665	3407.5	150.4	75	43319	3572.9	100	43490	3590
		75	41665	3407.5	150.1	100	43341	3575.1	75	43512	3592.2
	75+100+100	75	41665	3407.5	145.2	100	43292	3570.2	100	43490	3590
		100	41690	3410	145.4	75	43319	3572.9	100	43490	3590
		100	41690	3410	145.1	100	43341	3575.1	75	43512	3592.2
	100+100+100	100	41690	3410	140.2	100	43292	3570.2	100	43490	3590

Note 1: Carriers in increasing frequency order.

Table 4.3.1.2.10A-6: Test frequencies for CA_42C-42C

Test frequency ID	CC-Combo / N _{RB,agg} [RB]	CC1 Note1			CC2 Note1			Wgap [MHz]	CC3 Note1			CC4 Note1		
		BW [RB]	N _{UL/DL}	f _{UL/DL} [MHz]	BW [RB]	N _{UL/DL}	f _{UL/DL} [MHz]		BW [RB]	N _{UL/DL}	f _{UL/DL} [MHz]	BW [RB]	N _{UL/DL}	f _{UL/DL} [MHz]
Max Wgap	25+25+100+100	25	41623	3403.3	100	41740	3415	150.8	25	43373	3578.3	100	43490	3590
		100	41690	3410	25	41807	3421.7	150.8	100	43440	3585	25	43557	3596.7
		25	41623	3403.3	100	41740	3415	150	100	43440	3585	25	43557	3596.7
		100	41690	3410	25	41807	3421.7	151.6	25	43373	3578.3	100	43490	3590
	25+50+100+100	25	41623	3403.3	100	41740	3415	145.6	50	43346	3575.6	100	43490	3590
		100	41690	3410	25	41807	3421.7	145.9	100	43391	3580.1	50	43535	3594.5
		25	41623	3403.3	100	41740	3415	145.1	100	43391	3580.1	50	43535	3594.5
		100	41690	3410	25	41807	3421.7	146.4	50	43346	3575.6	100	43490	3590
		50	41645	3405.5	100	41789	3419.9	145.9	25	43373	3578.3	100	43490	3590
		100	41690	3410	50	41834	3424.4	145.6	100	43440	3585	25	43557	3596.7
		50	41645	3405.5	100	41789	3419.9	145.1	100	43440	3585	25	43557	3596.7
		100	41690	3410	50	41834	3424.4	146.4	25	43373	3578.3	100	43490	3590
	25+75+100+100	25	41623	3403.3	100	41740	3415	140.4	75	43319	3572.9	100	43490	3590
		100	41690	3410	25	41807	3421.7	140.9	100	43341	3575.1	75	43512	3592.2
		25	41623	3403.3	100	41740	3415	140.1	100	43341	3575.1	75	43512	3592.2
		100	41690	3410	25	41807	3421.7	141.2	75	43319	3572.9	100	43490	3590
		75	41668	3407.8	100	41839	3424.9	140.9	25	43373	3578.3	100	43490	3590
		100	41690	3410	75	41861	3427.1	140.4	100	43440	3585	25	43557	3596.7
		75	41668	3407.8	100	41839	3424.9	140.1	100	43440	3585	25	43557	3596.7
		100	41690	3410	75	41861	3427.1	141.2	25	43373	3578.3	100	43490	3590
	25+100+100+100	25	41623	3403.3	100	41740	3415	135.2	100	43292	3570.2	100	43490	3590
		100	41690	3410	25	41807	3421.7	136	100	43292	3570.2	100	43490	3590
		100	41690	3410	100	41888	3429.8	136	25	43373	3578.3	100	43490	3590
		100	41690	3410	100	41888	3429.8	135.2	100	43440	3585	25	43557	3596.7
	50+50+100+100	50	41645	3405.5	100	41789	3419.9	140.7	50	43346	3575.6	100	43490	3590
		100	41690	3410	50	41834	3424.4	140.7	100	43391	3580.1	50	43535	3594.5
		50	41645	3405.5	100	41789	3419.9	140.2	100	43391	3580.1	50	43535	3594.5
		100	41690	3410	50	41834	3424.4	141.2	50	43346	3575.6	100	43490	3590

50+75+ 100+100	50	41645	3405.5	100	41789	3419.9	135.5	75	43319	3572.9	100	43490	3590
	100	41690	3410	50	41834	3424.4	135.7	100	43341	3575.1	75	43512	3592.2
	50	41645	3405.5	100	41789	3419.9	135.2	100	43341	3575.1	75	43512	3592.2
	100	41690	3410	50	41834	3424.4	136	75	43319	3572.9	100	43490	3590
	75	41668	3407.8	100	41839	3424.9	135.7	50	43346	3575.6	100	43490	3590
	100	41690	3410	75	41861	3427.1	135.5	100	43391	3580.1	50	43535	3594.5
	75	41668	3407.8	100	41839	3424.9	135.2	100	43391	3580.1	50	43535	3594.5
50+100+ 100+100	100	41690	3410	75	41861	3427.1	136	50	43346	3575.6	100	43490	3590
	50	41645	3405.5	100	41789	3419.9	130.3	100	43292	3570.2	100	43490	3590
	100	41690	3410	50	41834	3424.4	130.8	100	43292	3570.2	100	43490	3590
	100	41690	3410	100	41888	3429.8	130.8	50	43346	3575.6	100	43490	3590
75+75+ 100+100	100	41690	3410	100	41888	3429.8	130.3	100	43391	3580.1	50	43535	3594.5
	75	41668	3407.8	100	41839	3424.9	130.5	75	43319	3572.9	100	43490	3590
	100	41690	3410	75	41861	3427.1	130.5	100	43341	3575.1	75	43512	3592.2
	75	41668	3407.8	100	41839	3424.9	130.2	100	43341	3575.1	75	43512	3592.2
75+100+ 100+100	100	41690	3410	75	41861	3427.1	130.8	75	43319	3572.9	100	43490	3590
	75	41668	3407.8	100	41839	3424.9	125.3	100	43292	3570.2	100	43490	3590
	100	41690	3410	75	41861	3427.1	125.6	100	43292	3570.2	100	43490	3590
	100	41690	3410	100	41888	3429.8	125.6	75	43319	3572.9	100	43490	3590
100+100+ 100+100	100	41690	3410	100	41888	3429.8	125.3	100	43341	3575.1	75	43512	3592.2
	100	41690	3410	100	41888	3429.8	120.4	100	43292	3570.2	100	43490	3590
	100	41690	3410	100	41888	3429.8	120.4	100	43292	3570.2	100	43490	3590
	100	41690	3410	100	41888	3429.8	120.4	100	43292	3570.2	100	43490	3590

Note 1: Carriers in increasing frequency order.

Table 4.3.1.2.10A-7: Test frequencies for CA_42A-42D

Test frequency ID	CC-Combo / N _{RB_agg} [RB]	CC1 Note1			Wgap [MHz]	CC2 Note1			CC3 Note1			CC4 Note1		
		BW [RB]	N _{UL/DL}	f _{UL/DL} [MHz]		BW [RB]	N _{UL/DL}	f _{UL/DL} [MHz]	BW [RB]	N _{UL/DL}	f _{UL/DL} [MHz]	BW [RB]	N _{UL/DL}	f _{UL/DL} [MHz]
Max Wgap	25+25+ 100+100	25	41615	3402.5	151	25	43175	3558.5	100	43292	3570.2	100	43490	3590
		25	41615	3402.5	150.2	100	43242	3565.2	100	43440	3585	25	43557	3596.7
	25+50+ 100+100	25	41615	3402.5	145.8	50	43148	3555.8	100	43292	3570.2	100	43490	3590
		25	41615	3402.5	145.3	100	43193	3560.3	100	43391	3580.1	50	43535	3594.5

	50	41640	3405	146	25	43175	3558.5	100	43292	3570.2	100	43490	3590
	50	41640	3405	145.2	100	43242	3565.2	100	43440	3585	25	43557	3596.7
25+75+ 100+100	25	41615	3402.5	140.6	75	43121	3553.1	100	43292	3570.2	100	43490	3590
	25	41615	3402.5	140.3	100	43143	3555.3	100	43341	3575.1	75	43512	3592.2
	75	41665	3407.5	141	25	43175	3558.5	100	43292	3570.2	100	43490	3590
	75	41665	3407.5	140.2	100	43242	3565.2	100	43440	3585	25	43557	3596.7
25+100+ 100+100	25	41615	3402.5	135.4	100	43094	3550.4	100	43292	3570.2	100	43490	3590
	100	41690	3410	136	25	43175	3558.5	100	43292	3570.2	100	43490	3590
	100	41690	3410	135.2	100	43242	3565.2	100	43440	3585	25	43557	3596.7
50+50+ 100+100	50	41640	3405	140.8	50	43148	3555.8	100	43292	3570.2	100	43490	3590
	50	41640	3405	140.3	100	43193	3560.3	100	43391	3580.1	50	43535	3594.5
50+75+ 100+100	50	41640	3405	135.6	75	43121	3553.1	100	43292	3570.2	100	43490	3590
	50	41640	3405	135.3	100	43143	3555.3	100	43341	3575.1	75	43512	3592.2
	75	41665	3407.5	135.8	50	43148	3555.8	100	43292	3570.2	100	43490	3590
	75	41665	3407.5	135.3	100	43193	3560.3	100	43391	3580.1	50	43535	3594.5
50+100+ 100+100	50	41640	3405	130.4	100	43094	3550.4	100	43292	3570.2	100	43490	3590
	100	41690	3410	130.8	50	43148	3555.8	100	43292	3570.2	100	43490	3590
	100	41690	3410	130.3	100	43193	3560.3	100	43391	3580.1	50	43535	3594.5
75+75+ 100+100	75	41665	3407.5	130.6	75	43121	3553.1	100	43292	3570.2	100	43490	3590
	75	41665	3407.5	130.3	100	43143	3555.3	100	43341	3575.1	75	43512	3592.2
75+100+ 100+100	75	41665	3407.5	125.4	100	43094	3550.4	100	43292	3570.2	100	43490	3590
	100	41690	3410	125.6	75	43121	3553.1	100	43292	3570.2	100	43490	3590
	100	41690	3410	125.3	100	43143	3555.3	100	43341	3575.1	75	43512	3592.2
100+100+ 100+100	100	41690	3410	120.4	100	43094	3550.4	100	43292	3570.2	100	43490	3590

Note 1: Carriers in increasing frequency order.

Table 4.3.1.2.10A-8: Test frequencies for CA_42D-42A

Test frequency ID	CC-Combo / N _{RB_agg} [RB]	CC1 Note1			CC2 Note1			CC3 Note1			Wgap [MHz]	CC4 Note1		
		BW [RB]	N _{UL/DL}	f _{UL/DL} [MHz]	BW [RB]	N _{UL/DL}	f _{UL/DL} [MHz]	BW [RB]	N _{UL/DL}	f _{UL/DL} [MHz]		BW [RB]	N _{UL/DL}	f _{UL/DL} [MHz]

Max Wgap	25+25+ 100+100	25	41623	3403.3	100	41740	3415	100	41938	3434.8	150.2	25	43565	3597.5
		100	41690	3410	100	41888	3429.8	25	42005	3441.5	151	25	43565	3597.5
	25+50+ 100+100	50	41645	3405.5	100	41789	3419.9	100	41987	3439.7	145.3	25	43565	3597.5
		100	41690	3410	100	41888	3429.8	50	42032	3444.2	145.8	25	43565	3597.5
		25	41623	3403.3	100	41740	3415	100	41938	3434.8	145.2	50	43540	3595
		100	41690	3410	100	41888	3429.8	25	42005	3441.5	146	50	43540	3595
	25+75+ 100+100	75	41668	3407.8	100	41839	3424.9	100	42037	3444.7	140.3	25	43565	3597.5
		100	41690	3410	100	41888	3429.8	75	42059	3446.9	140.6	25	43565	3597.5
		25	41623	3403.3	100	41740	3415	100	41938	3434.8	140.2	75	43515	3592.5
		100	41690	3410	100	41888	3429.8	25	42005	3441.5	141	75	43515	3592.5
	25+100+ 100+100	100	41690	3410	100	41888	3429.8	100	42086	3449.6	135.4	25	43565	3597.5
		25	41623	3403.3	100	41740	3415	100	41938	3434.8	135.2	100	43490	3590
		100	41690	3410	100	41888	3429.8	25	42005	3441.5	136	100	43490	3590
	50+50+ 100+100	50	41645	3405.5	100	41789	3419.9	100	41987	3439.7	140.3	50	43540	3595
		100	41690	3410	100	41888	3429.8	50	42032	3444.2	140.8	50	43540	3595
50+75+ 100+100	75	41668	3407.8	100	41839	3424.9	100	42037	3444.7	135.3	50	43540	3595	
	100	41690	3410	100	41888	3429.8	75	42059	3446.9	135.6	50	43540	3595	
	50	41645	3405.5	100	41789	3419.9	100	41987	3439.7	135.3	75	43515	3592.5	
	100	41690	3410	100	41888	3429.8	50	42032	3444.2	135.8	75	43515	3592.5	
50+100+ 100+100	100	41690	3410	100	41888	3429.8	100	42086	3449.6	130.4	50	43540	3595	
	50	41645	3405.5	100	41789	3419.9	100	41987	3439.7	130.3	100	43490	3590	
	100	41690	3410	100	41888	3429.8	50	42032	3444.2	130.8	100	43490	3590	
75+75+ 100+100	75	41668	3407.8	100	41839	3424.9	100	42037	3444.7	130.3	75	43515	3592.5	
	100	41690	3410	100	41888	3429.8	75	42059	3446.9	130.6	75	43515	3592.5	
75+100+ 100+100	100	41690	3410	100	41888	3429.8	100	42086	3449.6	125.4	75	43515	3592.5	
	75	41668	3407.8	100	41839	3424.9	100	42037	3444.7	125.3	100	43490	3590	
	100	41690	3410	100	41888	3429.8	75	42059	3446.9	125.6	100	43490	3590	
100+100+ 100+100	100	41690	3410	100	41888	3429.8	100	42086	3449.6	120.4	100	43490	3590	

Note 1: Carriers in increasing frequency order.

4.3.1.2.11 TDD reference test frequencies for Operating Band 43

Table 4.3.1.2.11-1: Test frequencies for E-UTRA channel bandwidth for operating band 43

Test Frequency ID	Bandwidth [MHz]	EARFCN	Frequency (UL and DL) [MHz]
Low Range	5	43615	3602.5
	10	43640	3605
	15	43665	3607.5
	20	43690	3610
Mid Range	5/10/15/20	44590	3700
High Range	5	45565	3797.5
	10	45540	3795
	15	45515	3792.5
	20	45490	3790

4.3.1.2.12 TDD reference test frequencies for Operating Band 44

Table 4.3.1.2.12-1: Test frequencies for E-UTRA channel bandwidth for operating band 44

Test Frequency ID	Bandwidth [MHz]	EARFCN	Frequency (UL and DL) [MHz]
Low Range	3	45605	704.5
	5	45615	705.5
	10	45640	708
	15	45665	710.5
	20	45690	713
Mid Range	3/5/10/15/20	46090	753
High Range	3	46575	801.5
	5	46565	800.5
	10	46540	798
	15	46515	795.5
	20	46490	793

4.3.1.2.13 TDD reference test frequencies for Operating Band 45

Table 4.3.1.2.13-1: Test frequencies for E-UTRA channel bandwidth for operating band 45

Test Frequency ID	Bandwidth [MHz]	EARFCN	Frequency (UL and DL) [MHz]
Low Range	5	46615	1449.5
	10	46640	1452
	15	46665	1454.5
	20	46690	1457
Mid Range	5/10/15/20	46690	1457
High Range	5	46765	1464.5
	10	46740	1462
	15	46715	1459.5
	20	46690	1457

4.3.1.2.14 TDD reference test frequencies for Operating Band 46

Table 4.3.1.2.14-1: Test frequencies for E-UTRA channel bandwidth for operating band 46

Test Frequency ID	Bandwidth [MHz]	EARFCN	Frequency (UL and DL) [MHz]
Low Range	20	46890	5160
Mid Range	20	50690	5540
High Range	20	54340	5905

NOTE 1: In Rel-13, restricted to E-UTRA operation when carrier aggregation is configured. The downlink operating band is paired with the uplink operating band (external) of the carrier aggregation configuration that is supporting the configured Pcell.

4.3.1.2.14A TDD reference test frequencies for CA in operating Band 46

Table 4.3.1.2.14A-1: Test frequencies for CA_46C

Range	CC-Combo / N _{RB_agg} [RB]	CC1 Note1			CC2 Note1		
		BW [RB]	N _{UL/DL}	f _{UL/DL} [MHz]	BW [RB]	N _{UL/DL}	f _{UL/DL} [MHz]
Low	100+100	100	46890	5160.0	100	47088	5179.8
Mid	100+100	100	50692	5540.2	100	50890	5560
High	100+100	100	54142	5885.2	100	54340	5905

NOTE 1: Carriers in increasing frequency order.
NOTE 2: In Rel-13, restricted to E-UTRA operation when carrier aggregation is configured. The downlink operating band is paired with the uplink operating band (external) of the carrier aggregation configuration that is supporting the configured Pcell.

Table 4.3.1.2.14A-2: Test frequencies for CA_46D

Range	CC-Combo / N _{RB_agg} [RB]	CC1 Note1			CC2 Note1			CC3 Note1		
		BW [RB]	N _{UL/DL}	f _{UL/DL} [MHz]	BW [RB]	N _{UL/DL}	f _{UL/DL} [MHz]	BW [RB]	N _{UL/DL}	f _{UL/DL} [MHz]
Low	100+100+100	100	46892	5160.2	100	47090	5180	100	47288	5199.8
Mid	100+100+100	100	50492	5520.2	100	50690	5540	100	50888	5559.8
High	100+100+100	100	53942	5865.2	100	54140	5885	100	54338	5904.8

NOTE 1: Carriers in increasing frequency order.
NOTE 2: In Rel-13, restricted to E-UTRA operation when carrier aggregation is configured. The downlink operating band is paired with the uplink operating band (external) of the carrier aggregation configuration that is supporting the configured Pcell.

Table 4.3.1.2.14A-3: Test frequencies for CA_46E

Range	CC-Combo / N _{RB,agg} [RB]	CC1 Note1			CC2 Note1			CC3 Note1			CC4 Note1		
		BW [RB]	N _{UL/DL}	f _{UL/DL} [MHz]	BW [RB]	N _{UL/DL}	f _{UL/DL} [MHz]	BW [RB]	N _{UL/DL}	f _{UL/DL} [MHz]	BW [RB]	N _{UL/DL}	f _{UL/DL} [MHz]
Low	100+100+100+100	100	46890	5160	100	47088	5179.8	100	47289	5199.9	100	47490	5220
Mid	100+100+100+100	100	50490	5520	100	50688	5539.8	100	50889	5559.9	100	51090	5580
High	100+100+100+100	100	53740	5845	100	53941	5865.1	100	54142	5885.2	100	54340	5905

NOTE 1: Carriers in increasing frequency order.

NOTE 2: In Rel-13, restricted to E-UTRA operation when carrier aggregation is configured. The downlink operating band is paired with the uplink operating band (external) of the carrier aggregation configuration that is supporting the configured Pcell.

Table 4.3.1.2.14A-4: Test frequencies for CA_46A-46A

Test Frequency ID	CC- Combo / N _{RB,agg} [RB]	CC1 Note1			Wgap [MHz]	CC2 Note1		
		BW [RB]	N _{UL/DL}	f _{UL/DL} [MHz]		BW [RB]	N _{UL/DL}	f _{UL/DL} [MHz]
Max WGap	100+100	100	46890	5160	745	100	54340	5905

NOTE 1: Carriers in increasing frequency order.
NOTE 2: In Rel-13, restricted to E-UTRA operation when carrier aggregation is configured. The downlink operating band is paired with the uplink operating band (external) of the carrier aggregation configuration that is supporting the configured Pcell.

4.3.1.2.15 TDD reference test frequencies for Operating Band 47

Table 4.3.1.2.15-1: Test frequencies for E-UTRA channel bandwidth for operating band 47

Test Frequency ID	Bandwidth [MHz]	EARFCN	Frequency (UL and DL) [MHz]
Low Range	10	54590	5860
	20	54640	5865
Mid Range	10/20	54890	5890
High Range	10	55190	5920
	20	55140	5915

Table 4.3.1.2.15-2: Test frequencies for V2X_47B

Range	CC-Combo / N _{RB,agg} [RB]	CC1 Note1			CC2 Note1		
		BW [RB]	N _{UL/DL}	f _{UL/DL} [MHz]	BW [RB]	N _{UL/DL}	f _{UL/DL} [MHz]
Low	50+50	50	54590	5860	50	54689	5869.9
Mid	50+50	50	54841	5885.1	50	54940	5895
High	50+50	50	55091	5910.1	50	55190	5920

Note 1: Carriers in increasing frequency order.

4.3.1.2.16 TDD reference test frequencies for Operating Band 48

Table 4.3.1.2.16-1: Test frequencies for E-UTRA channel bandwidth for operating band 48

Test Frequency ID	Bandwidth [MHz]	EARFCN	Frequency (UL and DL) [MHz]
Low Range	5	55265	3552.5
	10	55290	3555.0
	15	55315	3557.5
	20	55340	3560.0
Mid Range	5/10/15/20	55990	3625.0
High Range	5	56715	3697.5
	10	56690	3695.0
	15	56665	3692.5
	20	56640	3690.0

4.3.1.3 HRPD Test frequencies

4.3.1.3.1 HRPD test frequencies for Band Class 0

Table 4.3.1.3.1-1: Test frequencies for HRPD in Band Class 0

Test Frequency ID	Bandwidth [MHz]	Channel Number	Frequency of Uplink [MHz]	Frequency of Downlink [MHz]
Low Range	1.23	1013	824.70	869.70
Mid Range	1.23	356	835.68	880.68
High Range	1.23	779	848.37	893.37

4.3.1.3.2 HRPD test frequencies for Band Class 1

Table 4.3.1.3.2-1: Test frequencies for HRPD in Band Class 1

Test Frequency ID	Bandwidth [MHz]	Channel Number	Frequency of Uplink [MHz]	Frequency of Downlink [MHz]
Low Range	1.25	25	1851.25	1931.25
Mid Range	1.25	600	1880.00	1960.00
High Range	1.25	1175	1908.75	1988.75

4.3.1.3.3 HRPD test frequencies for Band Class 3

Table 4.3.1.3.3-1: Test frequencies for HRPD in Band Class 3

Test Frequency ID	Bandwidth [MHz]	Channel Number	Frequency of Uplink [MHz]	Frequency of Downlink [MHz]
Low Range	1.25	1120	888.00	833.00
Mid Range	1.25	872	898.90	843.90
High Range	1.25	76	915.95	860.95

4.3.1.3.4 HRPD test frequencies for Band Class 4

Table 4.3.1.3.4-1: Test frequencies for HRPD in Band Class 4

Test Frequency ID	Bandwidth [MHz]	Channel Number	Frequency of Uplink [MHz]	Frequency of Downlink [MHz]
Low Range	1.25	100	1755.00	1845.00
Mid Range	1.25	300	1765.00	1855.00
High Range	1.25	525	1776.25	1866.25

4.3.1.3.5 HRPD test frequencies for Band Class 6

Table 4.3.1.3.5-1: Test frequencies for HRPD in Band Class 6

Test Frequency ID	Bandwidth [MHz]	Channel Number	Frequency of Uplink [MHz]	Frequency of Downlink [MHz]
Low Range	1.25	125	1926.25	2116.25
Mid Range	1.25	200	1930.00	2120.00
High Range	1.25	350	1937.50	2127.50

4.3.1.3.6 HRPD test frequencies for Band Class 10

Table 4.3.1.3.6-1: Test frequencies for HRPD in Band Class 10

Test Frequency ID	Bandwidth [MHz]	Channel Number	Frequency of Uplink [MHz]	Frequency of Downlink [MHz]
Low Range	1.25	100	808.50	853.50
Mid Range	1.25	500	821.00	866.00
High Range	1.25	820	898.50	937.50

4.3.1.3.7 HRPD test frequencies for Band Class 15

Table 4.3.1.3.7-1: Test frequencies for HRPD in Band Class 15

Test Frequency ID	Bandwidth [MHz]	Channel Number	Frequency of Uplink [MHz]	Frequency of Downlink [MHz]
Low Range	1.25	75	1713.75	2113.75
Mid Range	1.25	450	1732.50	2132.50
High Range	1.25	800	1750.00	2150.00

4.3.1.4 1xRTT Test frequencies

4.3.1.4.1 1xRTT test frequencies for Band Class 0

Table 4.3.1.4.1-1: Test frequencies for 1xRTT in Band Class 0

Test Frequency ID	Bandwidth [MHz]	Channel Number	Frequency of Uplink [MHz]	Frequency of Downlink [MHz]
Low Range	1.23	1013	824.70	869.70
Mid Range	1.23	356	835.68	880.68
High Range	1.23	779	848.37	893.37

4.3.1.4.2 1xRTT test frequencies for Band Class 1

Table 4.3.1.4.2-1: Test frequencies for 1xRTT in Band Class 1

Test Frequency ID	Bandwidth [MHz]	Channel Number	Frequency of Uplink [MHz]	Frequency of Downlink [MHz]
Low Range	1.25	25	1851.25	1931.25
Mid Range	1.25	600	1880.00	1960.00
High Range	1.25	1175	1908.75	1988.75

4.3.1.4.3 1xRTT test frequencies for Band Class 3

Table 4.3.1.4.3-1: Test frequencies for 1xRTT in Band Class 3

Test Frequency ID	Bandwidth [MHz]	Channel Number	Frequency of Uplink [MHz]	Frequency of Downlink [MHz]
Low Range	1.25	1120	888.00	833.00
Mid Range	1.25	872	898.90	843.90
High Range	1.25	76	915.95	860.95

4.3.1.4.4 1xRTT test frequencies for Band Class 4

Table 4.3.1.4.4-1: Test frequencies for 1xRTT in Band Class 4

Test Frequency ID	Bandwidth [MHz]	Channel Number	Frequency of Uplink [MHz]	Frequency of Downlink [MHz]
Low Range	1.25	100	1755.00	1845.00
Mid Range	1.25	300	1765.00	1855.00
High Range	1.25	525	1776.25	1866.25

4.3.1.4.5 1xRTT test frequencies for Band Class 6

Table 4.3.1.4.5-1: Test frequencies for 1xRTT in Band Class 6

Test Frequency ID	Bandwidth [MHz]	Channel Number	Frequency of Uplink [MHz]	Frequency of Downlink [MHz]
Low Range	1.25	225	1931.25	2121.25
Mid Range	1.25	275	1933.75	2123.75
High Range	1.25	375	1938.75	2128.75

4.3.1.4.6 1xRTT test frequencies for Band Class 10

Table 4.3.1.4.6-1: Test frequencies for 1xRTT in Band Class 10

Test Frequency ID	Bandwidth [MHz]	Channel Number	Frequency of Uplink [MHz]	Frequency of Downlink [MHz]
Low Range	1.25	100	808.50	853.50
Mid Range	1.25	500	821.00	866.00
High Range	1.25	820	898.50	937.50

4.3.1.4.7 1xRTT test frequencies for Band Class 15

Table 4.3.1.4.7-1: Test frequencies for 1xRTT in Band Class 15

Test Frequency ID	Bandwidth [MHz]	Channel Number	Frequency of Uplink [MHz]	Frequency of Downlink [MHz]
Low Range	1.25	75	1713.75	2113.75
Mid Range	1.25	450	1732.50	2132.50
High Range	1.25	800	1750.00	2150.00

4.3.1.5 MFBI Test frequencies

NOTE: MFBI test frequencies are not used for TS 36.521-1, TS 36.521-3 and TS 37.571-1.

4.3.1.5.1 MFBI Test frequencies for operation band 2 overlapping with band 25

- same as per Table 4.3.1.1.2-1

4.3.1.5.2 MFBI Test frequencies for operation band 3 overlapping with band 9

Table 4.3.1.5.2-1: Test frequencies for E-UTRA channel bandwidth for operating band 3 overlapping with band 9

Test Frequency ID	Bandwidth [MHz]	N _{UL}	Frequency of Uplink [MHz]	N _{DL}	Frequency of Downlink [MHz]
Low Range	1.4	19606	1750.6	1606	1845.6
	3	19614	1751.4	1614	1846.4
	5	19624	1752.4	1624	1847.4
	10	19649	1754.9	1649	1849.9
	15 ^[1]	19674	1757.4	1674	1852.4
	20 ^[1]	19699	1759.9	1699	1854.9
Mid Range	1.4/3/5/10 15 ^[1] /20 ^[1]	19774	1767.4	1774	1862.4
High Range	1.4	19942	1784.2	1942	1879.2
	3	19934	1783.4	1934	1878.4
	5	19924	1782.4	1924	1877.4
	10	19899	1779.9	1899	1874.9
	15 ^[1]	19874	1777.4	1874	1872.4
	20 ^[1]	19849	1774.9	1849	1869.9

NOTE 1: Bandwidth for which a relaxation of the specified UE receiver sensitivity requirement (TS 36.101 [27] Clause 7.3) is allowed.

4.3.1.5.3 MFBI Test frequencies for operation band 4 overlapping with band 10

- same as per Table 4.3.1.1.4-1.

4.3.1.5.4 MFBI Test frequencies for operation band 5 overlapping with band 18

Table 4.3.1.5.4-1: Test frequencies for E-UTRA channel bandwidth for operating band 5 overlapping with band 18

Test Frequency ID	Bandwidth [MHz]	N _{UL}	Frequency of Uplink [MHz]	N _{DL}	Frequency of Downlink [MHz]
Low Range	1.4	20407	824.7	2407	869.7
	3	20415	825.5	2415	870.5
	5	20425	826.5	2425	871.5
Mid Range	1.4/3/5	20430	827	2430	872
High Range	1.4	20453	829.3	2453	874.3
	3	20445	828.5	2445	873.5
	5	20435	827.5	2435	872.5

4.3.1.5.5 MFBI Test frequencies for operation band 5 overlapping with band 19

Table 4.3.1.5.5-1: Test frequencies for E-UTRA channel bandwidth for operating band 5 overlapping with band 19

Test Frequency ID	Bandwidth [MHz]	N _{UL}	Frequency of Uplink [MHz]	N _{DL}	Frequency of Downlink [MHz]
Low Range	1.4	20467	830.7	2467	875.7
	3	20475	831.5	2475	876.5
	5	20485	832.5	2485	877.5
	10 ^[1]	20510	835	2510	880
Mid Range	1.4/3/5 10 ^[1]	20535	837.5	2535	882.5
High Range	1.4	20603	844.3	2603	889.3
	3	20595	843.5	2595	888.5
	5	20585	842.5	2585	887.5
	10 ^[1]	20560	840	2560	885

NOTE 1: Bandwidth for which a relaxation of the specified UE receiver sensitivity requirement (TS 36.101 [27] Clause 7.3) is allowed.

4.3.1.5.6 MFBI Test frequencies for operation band 5 overlapping with band 26

- same as per Table 4.3.1.1.5-1

4.3.1.5.7 MFBI Test frequencies for operation band 9 overlapping with band 3

- same as per Table 4.3.1.1.9-1

4.3.1.5.8 MFBI Test frequencies for operation band 10 overlapping with band 4

Table 4.3.1.5.8-1: Test frequencies for E-UTRA channel bandwidth for operating band 10 overlapping with band 4

Test Frequency ID	Bandwidth [MHz]	N _{UL}	Frequency of Uplink [MHz]	N _{DL}	Frequency of Downlink [MHz]
Low Range	5	22175	1712.5	4175	2112.5
	10	22200	1715	4200	2115
	15	22225	1717.5	4225	2117.5
	20	22250	1720	4250	2120
Mid Range	5/10/15/20	22375	1732.5	4375	2132.5
High Range	5	22575	1752.5	4575	2152.5
	10	22550	1750	4550	2150
	15	22525	1747.5	4525	2147.5
	20	22500	1745	4500	2145

4.3.1.5.9 MFBI Test frequencies for operation band 12 overlapping with band 17

Table 4.3.1.5.9-1: Test frequencies for E-UTRA channel bandwidth for operating band 12 overlapping with band 17

Test Frequency ID	Bandwidth [MHz]	N _{UL}	Frequency of Uplink [MHz]	N _{DL}	Frequency of Downlink [MHz]
Low Range	1.4	23067	704.7	5067	734.7
	3	23075	705.5	5075	735.5
	5 ^[1]	23085	706.5	5085	736.5
	10 ^[1]	23110	709	5110	739
Mid Range	1.4/3 5 ^[1] /10 ^[1]	23120	710	5120	740
High Range	1.4	23173	715.3	5173	745.3

	3	23165	714.5	5165	744.5
	5 [1]	23155	713.5	5155	743.5
	10 [1]	23130	711	5130	741
NOTE 1: Bandwidth for which a relaxation of the specified UE receiver sensitivity requirement (TS 36.101 [27] Clause 7.3) is allowed.					

4.3.1.5.10 MFBI Test frequencies for operation band 17 overlapping with band 12

- same as per Table 4.3.1.1.17-1

4.3.1.5.11 MFBI Test frequencies for operation band 18 overlapping with band 5

Table 4.3.1.5.11-1: Test frequencies for E-UTRA channel bandwidth for operating band 18 overlapping with band 5

Test Frequency ID	Bandwidth [MHz]	N _{UL}	Frequency of Uplink [MHz]	N _{DL}	Frequency of Downlink [MHz]
Low Range	1.4	23947	824.7	5947	869.7
	3	23955	825.5	5955	870.5
	5	23965	826.5	5965	871.5
Mid Range	1.4/3/5	23970	827	5970	872
High Range	1.4	23993	829.3	5993	874.3
	3	23985	828.5	5985	873.5
	5	23975	827.5	5975	872.5

4.3.1.5.12 MFBI Test frequencies for operation band 18 overlapping with band 26

- same as per Table 4.3.1.1.18-1

4.3.1.5.13 MFBI Test frequencies for operation band 18 overlapping with band 27

Table 4.3.1.5.13-1: Test frequencies for E-UTRA channel bandwidth for operating band 18 overlapping with band 27

Test Frequency ID	Bandwidth [MHz]	N _{UL}	Frequency of Uplink [MHz]	N _{DL}	Frequency of Downlink [MHz]
Low Range	1.4	23857	815.7	5857	860.7
	3	23865	816.5	5865	861.5
	5	23875	817.5	5875	862.5
Mid Range	1.4/3/5	23895	819.5	5895	864.5
High Range	1.4	23933	823.3	5933	868.3
	3	23925	822.5	5925	867.5
	5	23915	821.5	5915	866.5

4.3.1.5.14 MFBI Test frequencies for operation band 19 overlapping with band 5

- same as per Table 4.3.1.1.19-1

4.3.1.5.15 MFBI Test frequencies for operation band 19 overlapping with band 26

- same as per Table 4.3.1.1.19-1

4.3.1.5.16 MFBI Test frequencies for operation band 25 overlapping with band 2

Table 4.3.1.5.16-1: Test frequencies for E-UTRA channel bandwidth for operating band 25 overlapping with band 2

Test Frequency ID	Bandwidth [MHz]	N _{UL}	Frequency of Uplink [MHz]	N _{DL}	Frequency of Downlink [MHz]
Low Range	1.4	26047	1850.7	8047	1930.7
	3	26055	1851.5	8055	1931.5
	5	26065	1852.5	8065	1932.5
	10	26090	1855	8090	1935
	15 ^[1]	26115	1857.5	8115	1937.5
	20 ^[1]	26140	1860	8140	1940
Mid Range	1.4/3/5/10 15 ^[1] /20 ^[1]	26340	1880	8340	1960
High Range	1.4	26633	1909.3	8633	1989.3
	3	26625	1908.5	8625	1988.5
	5	26615	1907.5	8615	1987.5
	10	26590	1905	8590	1985
	15 ^[1]	26565	1902.5	8565	1982.5
	20 ^[1]	26540	1900	8540	1980

NOTE 1: Bandwidth for which a relaxation of the specified UE receiver sensitivity requirement (TS 36.101 [27] Clause 7.3) is allowed.

4.3.1.5.17 MFBI Test frequencies for operation band 26 overlapping with band 5

Table 4.3.1.5.17-1: Test frequencies for E-UTRA channel bandwidth for operating band 26 overlapping with band 5

Test Frequency ID	Bandwidth [MHz]	N _{UL}	Frequency of Uplink [MHz]	N _{DL}	Frequency of Downlink [MHz]
Low Range	1.4	26797	824.7	8797	869.7
	3	26805	825.5	8805	870.5
	5	26815	826.5	8815	871.5
	10 ^[1]	26840	829	8840	874
	15 ^[1]	26865	831.5	8865	876.5
Mid Range	1.4/3/5/10 ^[1] 15 ^[1]	26915	836.5	8915	881.5
High Range	1.4	27033	848.3	9033	893.3
	3	27025	847.5	9025	892.5
	5	27015	846.5	9015	891.5
	10 ^[1]	26990	844	8990	889
	15 ^[1]	26965	841.5	8965	886.5

NOTE 1: Bandwidth for which a relaxation of the specified UE receiver sensitivity requirement (TS 36.101 [27] Clause 7.3) is allowed.

4.3.1.5.18 MFBI Test frequencies for operation band 26 overlapping with band 18

Table 4.3.1.5.18-1: Test frequencies for E-UTRA channel bandwidth for operating band 26 overlapping with band 18

Test Frequency ID	Bandwidth [MHz]	N _{UL}	Frequency of Uplink [MHz]	N _{DL}	Frequency of Downlink [MHz]
Low Range	1.4	26707	815.7	8707	860.7
	3	26715	816.5	8715	861.5
	5	26725	817.5	8725	862.5
	10 ^[1]	26750	820	8750	865
Mid Range	1.4/3/5/10 ^[1]	26775	822.5	8775	867.5

High Range	1.4	26843	829.3	8843	874.3
	3	26835	828.5	8835	873.5
	5	26825	827.5	8825	872.5
	10 ^[1]	26800	825	8800	870
NOTE 1: Bandwidth for which a relaxation of the specified UE receiver sensitivity requirement (TS 36.101 [27] Clause 7.3) is allowed.					

4.3.1.5.19 MFBI Test frequencies for operation band 26 overlapping with band 19

Table 4.3.1.5.19-1: Test frequencies for E-UTRA channel bandwidth for operating band 26 overlapping with band 19

Test Frequency ID	Bandwidth [MHz]	N _{UL}	Frequency of Uplink [MHz]	N _{DL}	Frequency of Downlink [MHz]
Low Range	1.4	26857	830.7	8857	875.7
	3	26865	831.5	8865	876.5
	5	26875	832.5	8875	877.5
	10 ^[1]	26900	835	8900	880
Mid Range	1.4/3/5/10 ^[1] 15 ^[1]	26925	837.5	8925	882.5
High Range	1.4	26993	844.3	8993	889.3
	3	26985	843.5	8985	888.5
	5	26975	842.5	8975	887.5
	10 ^[1]	26950	840	8950	885
NOTE 1: Bandwidth for which a relaxation of the specified UE receiver sensitivity requirement (TS 36.101 [27] Clause 7.3) is allowed.					

4.3.1.5.20 MFBI Test frequencies for operation band 26 overlapping with band 27

Table 4.3.1.5.20-1: Test frequencies for E-UTRA channel bandwidth for operating band 26 overlapping with band 27

Test Frequency ID	Bandwidth [MHz]	N _{UL}	Frequency of Uplink [MHz]	N _{DL}	Frequency of Downlink [MHz]
Low Range	1.4	26697	814.7	8697	859.7
	3	26705	815.5	8705	860.5
	5	26715	816.5	8715	861.5
Mid Range	1.4/3/5	26740	819	8740	864
High Range	1.4	26783	823.3	8783	868.3
	3	26775	822.5	8775	867.5
	5	26765	821.5	8765	866.5
NOTE 1: Bandwidth for which a relaxation of the specified UE receiver sensitivity requirement (TS 36.101 [27] Clause 7.3) is allowed.					

4.3.1.5.21 MFBI Test frequencies for operation band 27 overlapping with band 18

Table 4.3.1.5.21-1: Test frequencies for E-UTRA channel bandwidth for operating band 27 overlapping with band 18

Test Frequency ID	Bandwidth [MHz]	N _{UL}	Frequency of Uplink [MHz]	N _{DL}	Frequency of Downlink [MHz]
Low Range	1.4	27127	815.7	9127	860.7
	3	27135	816.5	9135	861.5
	5	27145	817.5	9145	862.5
Mid Range	1.4/3/5	27165	819.5	9165	864.5
High Range	1.4	27203	823.3	9203	868.3
	3	27195	822.5	9195	867.5
	5	27185	821.5	9185	866.5

4.3.1.5.22 MFBI Test frequencies for operation band 27 overlapping with band 26

Table 4.3.1.5.22-1: Test frequencies for E-UTRA channel bandwidth for operating band 27 overlapping with band 26

Test Frequency ID	Bandwidth [MHz]	N _{UL}	Frequency of Uplink [MHz]	N _{DL}	Frequency of Downlink [MHz]
Low Range	1.4	27117	814.7	9117	859.7
	3	27125	815.5	9125	860.5
	5	27135	816.5	9135	861.5
Mid Range	1.4/3/5	27160	819	9160	864
High Range	1.4	27203	823.3	9203	868.3
	3	27195	822.5	9195	867.5
	5	27185	821.5	9185	866.5

NOTE 1: Bandwidth for which a relaxation of the specified UE receiver sensitivity requirement (TS 36.101 [27] Clause 7.3) is allowed.

4.3.1.5.23 MFBI Test frequencies for operation band 33 overlapping with band 39

- same as per Table 4.3.1.2.1-1

4.3.1.5.24 MFBI Test frequencies for operation band 38 overlapping with band 41

- same as per Table 4.3.1.2.6-1

4.3.1.5.25 MFBI Test frequencies for operation band 39 overlapping with band 33

Table 4.3.1.5.25-1: Test frequencies for E-UTRA channel bandwidth for operating band 39 overlapping with band 33

Test Frequency ID	Bandwidth [MHz]	EARFCN	Frequency (UL and DL) [MHz]
Low Range	5	38475	1902.5
	10	38500	1905
	15	38525	1907.5
	20	38550	1910
Mid Range	5/10/15/20	38550	1910
High Range	5	38625	1917.5
	10	38600	1915
	15	38575	1912.5
	20	38550	1910

4.3.1.5.26 MFBI Test frequencies for operation band 41 overlapping with band 38

Table 4.3.1.5.26-1: Test frequencies for E-UTRA channel bandwidth for operating band 41 overlapping with band 38

Test Frequency ID	Bandwidth [MHz]	EARFCN	Frequency (UL and DL) [MHz]
Low Range	5	40415	2572.5
	10	40440	2575
	15	40465	2577.5
	20	40490	2580
Mid Range	5/10/15/20	40640	2595
High Range	5	40865	2617.5
	10	40840	2615
	15	40815	2612.5
	20	40790	2610

4.3.1.5.27 MFBI Test frequencies for operation band 66 overlapping with band 4

Table 4.3.1.5.27-1: Test frequencies for E-UTRA channel bandwidth for operating band 66 overlapping with band 4

Test Frequency ID	Bandwidth [MHz]	N _{UL}	Frequency of Uplink [MHz]	N _{DL}	Frequency of Downlink [MHz]
Low Range	1.4	131979	1710.7	66443	2110.7
	3	131987	1711.5	66451	2111.5
	5	131997	1712.5	66461	2112.5
	10	132022	1715	66486	2115
	15	132047	1717.5	66511	2117.5
	20	132072	1720	66536	2120
Mid Range	1.4/3/5/10/15/20	132197	1732.5	66661	2132.5
High Range	1.4	132415	1754.3	66879	2154.3
	3	132407	1753.5	66871	2153.5
	5	132397	1752.5	66861	2152.5
	10	132372	1750	66836	2150
	15	132347	1747.5	66811	2147.5
	20	132322	1745	66786	2145

4.3.1.5.28 MFBI Test frequencies for operation band 66 overlapping with band 10

Table 4.3.1.5.28-1: Test frequencies for E-UTRA channel bandwidth for operating band 66 overlapping with band 10

Test Frequency ID	Bandwidth [MHz]	N _{UL}	Frequency of Uplink [MHz]	N _{DL}	Frequency of Downlink [MHz]
Low Range	5	131997	1712.5	66461	2112.5
	10	132022	1715	66486	2115
	15	132047	1717.5	66511	2117.5
	20	132072	1720	66536	2120
Mid Range	5/10/15/20	132197	1732.5	66736	2140
High Range	5	132547	1767.5	67011	2167.5
	10	132522	1765	66986	2165
	15	132447	1757.5	66961	2162.5
	20	132472	1760	66936	2160

4.3.1.5.29 MFBI Test frequencies for operation band 4 overlapping with band 66

- same as per Table 4.3.1.1.4-1.

4.3.1.5.30 MFBI Test frequencies for operation band 10 overlapping with band 66

- same as per Table 4.3.1.1.10-1.

4.3.1.6 WLAN Test frequencies

4.3.1.6.1 WLAN Test frequencies for 2.4 GHz ISM Band

Table 4.3.1.6.1-1: Test frequencies for WLAN for 2.4 GHz Band

Test Frequency ID	Bandwidth [MHz]	WLAN Channel Number	Centre Frequency (UL and DL)[MHz]
Low Range (1)	20	1	2412
Mid Range (2)	20	6	2437
High Range (3)	20	11	2462

4.3.1.6.2 WLAN Test frequencies for 5 GHz ISM Band

Table 4.3.1.6.1-1: Test frequencies for WLAN for 5 GHz Band

Test Frequency ID	Bandwidth [MHz]	WLAN Channel Number	Centre Frequency (UL and DL)[MHz]
Low Range (1)	20	48	5240
Mid Range (2)	20	56	5280
High Range (3)	20	64	5320

4.3.2 Radio conditions

4.3.2.1 Normal propagation condition

The downlink connection between the System Simulator and the UE is without Additive White Gaussian Noise, and has no fading or multipath effects.

The uplink connection between the UE and System Simulator is without Additive White Gaussian Noise, and has no fading or multipath effects.

4.3.3 Physical channel allocations

4.3.3.1 Antennas

If the UE has two Rx antennas, the same downlink signal is applied to each one. Both UE Rx antennas shall be connected unless otherwise stated in the test case.

If the UE has one Rx antenna, the downlink signal is applied to it.

4.3.3.2 Downlink physical channels and physical signals

The Downlink Physical channels and Physical signals used and their relative powers are specified for single SS Tx antenna in table 4.3.3.2-1 and for two SS Tx antennas in table 4.3.3.2-2. The details of downlink power allocation for PDSCH channel are described in TS 36.213 [29] clause 5.2. For BL-UE testing, PHICH is not required and MPDCCH is required.

Table 4.3.3.2-1: Power allocation for OFDM symbols and reference signals, single SS Tx antenna

Physical Channel	EPRE Ratio
PBCH	PBCH_RA = 0 dB
	PBCH_RB = 0 dB
PSS	PSS_RA = 0 dB
SSS	SSS_RA = 0 dB
PCFICH	PCFICH_RB = 0 dB
PDCCH	PDCCH_RA = 0 dB
	PDCCH_RB = 0 dB
MPDCCH	MPDCCH_RA = 0 dB
	MPDCCH_RB = 0 dB
PDSCH	PDSCH_RA = 0 dB
	PDSCH_RB = 0 dB
PHICH	PHICH_RB = 0 dB
PMCH	PMCH_RA = 0 dB
MBSFN RS	MBSFN_RS_RA = 0dB

Table 4.3.3.2-2: Power allocation for OFDM symbols and reference signals, two SS Tx antennas

Physical Channel	EPRE Ratio
PBCH	PBCH_RA = 0 dB
	PBCH_RB = 0 dB
PSS	PSS_RA = 0 dB
SSS	SSS_RA = 0 dB
PCFICH	PCFICH_RB = 0 dB
PDCCH	PDCCH_RA = 0 dB
	PDCCH_RB = 0 dB
MPDCCH	MPDCCH_RA = 0 dB
	MPDCCH_RB = 0 dB
PDSCH	PDSCH_RA = -3 dB
	PDSCH_RB = -3 dB
PHICH	PHICH_RB = 0 dB
PMCH	PMCH_RA = 0 dB
MBSFN RS	MBSFN_RS_RA = 0dB

NOTE: MBSFN RS is not defined downlink physical channels in TS 36.211 [35].

4.3.3.3 Mapping of downlink physical channels and signals to physical resources

Parameters for mapping of downlink physical channels and signals are specified as follows.

Normal Cyclic Prefix

N_{ID}^{cell} , Physical layer cell identity = 0 is used as the default physical layer cell identity

CFI = 3 for 1.4, 3 and 5 MHz system bandwidths

= 2 for 10, 15 and 20 MHz system bandwidths

= 2 if PMCH is configured ('mbsfn-SubframeConfiguration' is present in SIB2)

N_g = 1

PHICH duration = Normal

For Signalling testing, the default system bandwidth is 5/10/20 MHz and single SS Tx antenna is used unless specified otherwise in the test case. The mapping of downlink physical channels to physical resources for Single Tx Antenna is described in table 4.3.3.3-1 for 5/10MHz system bandwidth FDD and table 4.3.3.3-2 for 5/20MHz system bandwidth TDD.

For RF testing, the mapping of DL physical channels to resource element is defined TS 36.521-1 [21] Annex C.1.

Table 4.3.3.3-1: Mapping of DL Physical Channels to Resource Elements for Single SS Tx Antenna and 5/10 MHz System Bandwidth (FDD)

Physical channel	Time Domain Location	Frequency Domain Location	Note
PBCH	Symbols 0 to 3 of slot 1 of subframe 0 of each radio frame	Occupies 72 subcarriers centred on the DC subcarrier	Mapping rule is specified in TS36.211 [35] sub clause 6.6.4
PSS	Symbol 6 of slot 0 and 10 of each radio frame	Occupies 62 subcarriers centred on the DC subcarrier. Additional 10 subcarriers (5 on each side) adjacent to the centred 62 subcarriers are reserved.	Mapping rule is specified in TS36.211 [35] sub clause 6.11.1.2
SSS	Symbol 5 of slots 0 and 10 of each radio frame	Occupies 62 subcarriers centred on the DC subcarrier. Additional 10 subcarriers (5 on each side) adjacent to the centred 62 subcarriers are reserved.	Mapping rule is specified in TS36.211 [35] sub clause 6.11.2.2
PCFICH	Symbol 0 of each subframe	Maps into 4 REGs uniformly spread in the frequency domain over the whole system bandwidth.	Mapping rule is specified in TS36.211 [35] sub clause 6.7.4 - CELL_ID = 0
PHICH	Symbol 0 of each subframe	Each PHICH group maps into 3 REGs in the frequency domain on the REGs not assigned to PCFICH over the whole system bandwidth,	Mapping rule is specified in TS36.211 [35] sub clause 6.9.3 - CELL_ID = 0 - Number of PHICH groups = $4(BW=5\text{ MHz})/7(BW=10\text{MHz})$
PDCCH	Symbols 0, 1, 2 of each subframe (BW=5MHz)	The remaining REGs not allocated to both PCFICH and PHICH are used for PDCCH	Mapping rule is specified in TS36.211 [35] sub clause 6.8.5 - CFI = 3 (BW=5MHz)
	Symbols 0, 1 of each subframe (BW=10MHz)		Mapping rule is specified in TS36.211 [35] sub clause 6.8.5 - CFI = 2(BW=10MHz)
	Symbols 0, 1 of each MBSFN subframe		Mapping rule is specified in TS36.211 [35] sub clause 6.8.5 - CFI = 2
MPDCCH	Same as PDSCH	<p>For Subframe 0, subcarriers corresponding to resource elements not allocated to RS, PSS, SSS and PBCH (core set and repetitions) and reserved for PBCH antenna ports 3 and 4 on the 72 central subcarriers.</p> <p>For Subframe 5, subcarriers corresponding to resource elements not allocated to RS, PSS and SSS.</p> <p>For Subframe 9, subcarriers corresponding to resource elements not allocated to RS, PSS, SSS and PBCH (repetitions).</p> <p>For other subframes, subcarriers corresponding to resource elements not allocated to RS.</p>	Mapping rule is specified in TS36.211 [35] sub clause 6.8B.5

PDSCH	All remaining OFDM symbols of each subframe not allocated to PDCCH	For Subframe 0, REs not allocated to RS, PSS, SSS and PBCH is allocated to PDSCH For Subframe 5, REs not allocated to RS, PSS and SSS is allocated to PDSCH For other subframes, REs not allocated to RS is allocated to PDSCH	
PMCH	MBSFN region of MBSFN subframes	REs not allocated to MBSFN RS is allocated to PMCH	

NOTE: In case a single cell-specific RS is configured, cell-specific RS shall be assume to be present on antenna ports 0 and 1 for the purpose of mapping a symbol-quadruplet to a REG (resource element group). (See TS 36.211 [35] sub clause 6.2.4).

Table 4.3.3.3-2: Mapping of DL Physical Channels to Resource Elements for Single SS Tx Antenna and 5/20 MHz System Bandwidth (TDD)

Physical channel	Time Domain Location	Frequency Domain Location	Note
PBCH	Symbols 0 to 3 of slot 1 of subframe 0 of each radio frame	Occupies 72 subcarriers centred on the DC subcarrier	Mapping rule is specified in TS36.211 [35] subclause 6.6.4
PSS	Symbol 2 of slot 2 and 12 of each radio frame	Occupies 62 subcarriers centred on the DC subcarrier. Additional 10 subcarriers (5 on each side) adjacent to the centred 62 subcarriers are reserved.	Mapping rule is specified in TS36.211 [35] subclause 6.11.1.2
SSS	Symbol 6 of slots 1 and 11 of each radio frame	Occupies 62 subcarriers centred on the DC subcarrier. Additional 10 subcarriers (5 on each side) adjacent to the centred 62 subcarriers are reserved.	Mapping rule is specified in TS36.211 [35] subclause 6.11.2.2
PCFICH	Symbol 0 of each downlink subframe and Special subframe	Maps into 4 REGs uniformly spread in the frequency domain over the whole system bandwidth.	Mapping rule is specified in TS36.211 [35] subclause 6.7.4 - CELL_ID = 0
PHICH	Symbol 0 of each downlink subframe and Special subframe	Each PHICH group maps into 3 REGs in the frequency domain on the REGs not assigned to PCFICH over the whole system bandwidth.	Mapping rule is specified in TS36.211 [35] subclause 6.9.3 - CELL_ID = 0 - Number of PHICH groups = $4(BW=5MHz)/13(BW=20MHz)$
PDCCH	Symbols 0, 1 of subframe 1, 6 and Symbols 0, 1, 2 of other downlink subframes (BW=5MHz)	The remaining REGs not allocated to both PCFICH and PHICH are used for PDCCH	Mapping rule is specified in TS36.211 [35] subclause 6.8.5 - CFI = 3 (BW=5MHz)
	Symbols 0, 1 of subframe 1, 6 and Symbols 0, 1 of other downlink subframes (BW=20MHz)		Mapping rule is specified in TS36.211 [35] subclause 6.8.5 - CFI = 2 (BW=20MHz)
	Symbols 0, 1 of each MBSFN subframe		Mapping rule is specified in TS36.211 [35] sub clause 6.8.5 - CFI = 2
MPDCCH	Same as PDSCH	For Subframe 0, subcarriers corresponding to resource elements not allocated to RS, SSS and PBCH (core set and repetitions) and reserved for PBCH antenna ports 3 and 4 on the 72 central subcarriers. For Subframe 5, subcarriers corresponding to resource elements not allocated to RS, SSS and PBCH (repetitions). For Subframe 1 and 6, resource elements not allocated to RS, PSS, GP and UpPTS. For other subframes, subcarriers corresponding to resource elements not allocated to RS.	Mapping rule is specified in TS36.211 [35] sub clause 6.8B.5

PDSCH	All remaining OFDM symbols of each downlink subframe and DwPTS not allocated to PDCCH	For Subframe 0, REs not allocated to RS, SSS and PBCH is allocated to PDSCH For Subframe 5, REs not allocated to RS and SSS is allocated to PDSCH For Subframe 1 and 6, REs not allocated to RS, PSS, GP and UpPTS is allocated to PDSCH For other downlink subframes, REs not allocated to RS is allocated to PDSCH	
PMCH	MBSFN region of MBSFN subframes	REs not allocated to MBSFN RS is allocated to PMCH	

NOTE 1: In case a single cell-specific RS is configured, cell-specific RS shall be assume to be present on antenna ports 0 and 1 for the purpose of mapping a symbol-quadruplet to a REG (resource element group). (See TS 36.211 [35] subclause 6.2.4)

NOTE 2: In case the default TDD configuration for subframe assignment and special subframe patterns (see subclause 4.6.3)

4.3.3.4 Uplink physical channels and physical signals

[FFS].

4.3.3.5 Mapping of uplink physical channels and signals to physical resources

[FFS].

4.3.4 Signal levels

4.3.4.1 Downlink signal levels

The downlink power settings in table 4.3.4.1-1 are used unless otherwise specified in a test case.

Table 4.3.4.1-1: Default Downlink power levels

	Unit	Channel bandwidth					
		1.4 MHz	3 MHz	5 MHz	10 MHz	15 MHz	20 MHz
Number of RBs		6	15	25	50	75	100
Channel BW Power	dBm	-66	-62	-60	-57	-55	-54
RS EPRE	dBm/15kHz	-85	-85	-85	-85	-85	-85
Note 1:	The channel bandwidth powers are informative, based on -85dBm/15kHz RS_EPRES, then scaled according to the number of RBs and rounded to the nearest integer dBm value. Full RE allocation with no boost or deboost is assumed.						
Note 2:	The power level is specified at each UE Rx antenna.						

It is [FFS] whether there is a requirement to specify constant power throughout all OFDM symbols, and if so how unallocated Resource elements should be treated.

The default signal level uncertainty is +/-3dB at each test port, for any level specified. If the uncertainty value is critical for the test purpose a tighter uncertainty is specified for the related test case in TS 36.521-1 [21] Annex F or in TS 36.521-3 [34] Annex F

4.3.4.2 Uplink signal levels

[FFS]

4.3.5 Standard test signals

4.3.5.1 Downlink test signals

[FFS]

4.3.5.2 Uplink test signals

[FFS]

4.3.6 Physical layer parameters

4.3.6.1 Downlink physical layer parameters

4.3.6.1.1 Physical layer parameters for DCI format 0

Default physical layer parameters for DCI format 0 are specified in table 4.3.6.1.1-1.

Table 4.3.6.1.1-1: Physical layer parameters for DCI format 0

Parameter	Value	Value in binary
Flag for format 0/format 1A differentiation	format 0	"0"
Hopping flag	w/o Hopping	"0"
Resource block assignment and hopping resource allocation	Depending on test parameters	-
Modulation and coding scheme and redundancy version	Depending on test parameters	-
New data indicator	Set for every data transmission/retransmission according to the rules specified in TS 36.321	-
TPC command for scheduled PUSCH	0 dB (accumulated TPC)	"01"
Cyclic shift for DM RS	0	"000"
UL index (TDD only)	2 bits as defined in sections 5.1.1.1 and 8 of TS 36.213. This field is present only for TDD configuration 0	-
Downlink Assignment Index (TDD only)	2 bits as defined in Table 7.3-X in TS 36.213. It represents the total number of PDSCH subframes with and without PDCCH and PDCCH indicating downlink SPS release in the window. This field is present only for TDD configuration 1-6	-
CQI request	w/o aperiodic CQI	"0"

4.3.6.1.1A Physical layer parameters for DCI format 0C

Default physical layer parameters for DCI format 0C are specified in table 4.3.6.1.1A-1.

Table 4.3.6.1.1A-1: Physical layer parameters for DCI format 0C

Parameter	Value	Value in binary
Flag for format 0C/format 1A differentiation	format 0	"0"
Resource allocation type	This field is only present if $N_{RB}^{UL} \leq N_{RB}^{DL}$. The interpretation of this field is provided in section 8.1 of TS 36.213.	-
Frequency Hopping flag	w/o Hopping	"0"
Resource block assignment	Depending on test parameters	-
Modulation and coding scheme	5 bits as defined in 8.6 of TS 36.213.	-
Repetition number	No repetitions 3 bits as defined in section 8.0 of 36.213	"000"
HARQ process number	Depending on test parameters, 3bits for FDD, 4 bits for TDD.	-
New data indicator	1 bit.	-
Redundancy version	2 bits.	"00"
TPC command for scheduled PUSCH	0 dB (accumulated TPC)	"01"
Cyclic shift for DM RS and OCC index	3 bits as defined in 5.5.2.1.1 of TS 36.211.	-
UL index	2 bits as defined in 5.1.1.1, 7.2.1, 8 and 8.4 of TS 36.213. (this field is present only for TDD operation with uplink-downlink configuration 0)	-
Downlink Assignment Index (DAI)	2 bits as defined in section 7.3 of TS 36.213 (This field is present only for cases with TDD primary cell and either TDD operation with uplink-downlink configurations 1-6 or FDD operation.)	-
CSI request	1, 2 or 3 bits as defined in section 7.2.1 of TS 36.213.	-
Modulation order override	1 bit as defined in section x.x of TS 36.213.	-
Precoding information	Number of bits as specified in Table 5.3.3.1.8-1 of TS 36.212	-

4.3.6.1.1B Physical layer parameters for DCI format 0A

Default physical layer parameters for DCI format 0A are specified in table 4.3.6.1.1B-1.

Table 4.3.6.1.1B-1: Physical layer parameters for DCI format 0A

Parameter	Value	Value in binary
Carrier indicator	0 or 3 bits. This field is present according to the definitions in TS 36.213.	not present
Flag for format 0A/format 1A differentiation	format 0A	"0"
PUSCH trigger A	non-triggered scheduling	"0"
Timing offset	0	"0000"
Resource block assignment	Depending on test parameters	-
Modulation and coding scheme	Depending on test parameters	-
HARQ process number	Depending on test parameters	-
New data indicator	Set for every data transmission/retransmission according to the rules specified in TS 36.321	
Redundancy version	2 bits.	"00"
TPC command for scheduled PUSCH	0 dB (accumulated TPC)	"01"
Cyclic shift for DM RS and OCC index	3 bits as defined in 5.5.2.1.1 of TS 36.211	
CSI request	w/o aperiodic CQI	"0"
SRS request	w/o SRS	"0"
PUSCH starting position	25us in symbol 0	"01"
PUSCH ending symbol	the last symbol of the subframe	"0"
Channel Access type	channel access Type 2	"1"
Channel Access Priority Class	1	"01"

4.3.6.1.1C Physical layer parameters for DCI format 0B

Default physical layer parameters for DCI format 0B are specified in table 4.3.6.1.1C-1.

Table 4.3.6.1.1C-1: Physical layer parameters for DCI format 0B

Parameter	Value	Value in binary
Carrier indicator	0 or 3 bits. This field is present according to the definitions in TS 36.213.	not present
PUSCH trigger A	non-triggered scheduling	"0"
Timing offset	0	"0000"
Number of scheduled subframes	4	"11"
Resource block assignment	Depending on test parameters	-
Modulation and coding scheme	Depending on test parameters	-
HARQ process number	Depending on test parameters	-
New data indicator	Set for every data transmission/retransmission according to the rules specified in TS 36.321	-
Redundancy version	2 bits.	"00"
TPC command for scheduled PUSCH	0 dB (accumulated TPC)	"01"
Cyclic shift for DM RS and OCC index	3 bits as defined in 5.5.2.1.1 of TS 36.211	
CSI request	w/o aperiodic CQI	"0"
SRS request	w/o SRS	"0"
PUSCH starting position	25us in symbol 0	"01"
PUSCH ending symbol	the last symbol of the subframe	"0"
Channel Access type	channel access Type 2	"1"
Channel Access Priority Class	1	"01"

4.3.6.1.2 Physical layer parameters for DCI format 1

Default physical layer parameters for DCI format 1 are specified in table 4.3.6.1.2-1.

Table 4.3.6.1.2-1: Physical layer parameters for DCI format 1

Parameter	Value	Value in binary
Resource allocation header	Resource allocation type 0	"0"
Resource block assignment	Depending on test parameters	-
Modulation and coding scheme	Depending on test parameters	-
HARQ process number	Depending on test parameters, 3bits for FDD, 4 bits for TDD.	-
New data indicator	Set for every data transmission/retransmission according to the rules specified in TS 36.321	-
Redundancy version	Depending on test parameters	"00"
TPC command for PUCCH	0 dB (accumulated TPC)	"01"
Downlink Assignment Index (TDD only)	2 bits as defined in Table 7.3-X in TS 36.213. It represents the number of PDSCH with PDCCH and PDCCH indicating downlink SPS release in the window up to the present subframe. This is present for all the uplink-downlink configurations and only applies to uplink -downlink configuration 1-6	-

4.3.6.1.3 Physical layer parameters for DCI format 1A

Default physical layer parameters for DCI format 1A are specified in table 4.3.6.1.3-1.

Table 4.3.6.1.3-1: Physical layer parameters for DCI format 1A

Parameter	Value	Value in binary
Flag for format 0/format 1A differentiation	format 1A	"1"
Localized/Distributed VRB assignment flag	Localized VRB assignment	"0"
Resource block assignment	Depending on test parameters	-
Modulation and coding scheme	Depending on test parameters	-
HARQ process number	Depending on test parameters, 3bits for FDD, 4 bits for TDD.	-
New data indicator	Set for every data transmission/retransmission according to the rules specified in TS 36.321	-
Redundancy version	Depending on test parameters	"00"
TPC command for PUCCH	0 dB (accumulated TPC)	"01"
Downlink Assignment Index (TDD only)	2 bits as defined in Table 7.3-X in TS 36.213. It represents the number of PDSCH with PDCCH and PDCCH indicating downlink SPS release in the window up to the present subframe. This is present for all the uplink-downlink configurations and only applies to uplink -downlink configuration 1-6	-

4.3.6.1.3A Physical layer parameters for DCI format 1B

Default physical layer parameters for DCI format 1B are specified in table 4.3.6.1.3A-1.

Table 4.3.6.1.3A-1: Physical layer parameters for DCI format 1B

Parameter	Value	Value in binary
Localized/Distributed VRB assignment flag	Localized VRB assignment	"0"
Resource block assignment	Depending on test parameters	-
Modulation and coding scheme	Depending on test parameters	-
HARQ process number	Depending on test parameters, 3bits for FDD, 4 bits for TDD.	-
New data indicator	Set for every data transmission/retransmission according to the rules specified in TS 36.321	-
Redundancy version	Depending on test parameters	"00"
TPC command for PUCCH	0 dB (accumulated TPC)	"01"
Downlink Assignment Index (TDD only)	2 bits as defined in Table 7.3-X in TS 36.213. It represents the number of PDSCH with PDCCH and PDCCH indicating downlink SPS release in the window up to the present subframe. This is present for all the uplink-downlink configurations and only applies to uplink -downlink configuration 1-6	-
TPMI information for precoding	Set for codebook index according to TS 36.211 Table 6.3.4.2.3-1 for 2 Tx antenna ports and Table 6.3.4.2.3-2 for 4 Tx antenna ports corresponding to the single layer transmission	-
PMI confirmation for precoding	Set for every transmission, 1 for precoding according to the latest reported PMI on PUSCH, 0 for precoding according to the indicated TPMI in the TPMI information field	-

4.3.6.1.4 Physical layer parameters for DCI format 1C

Default physical layer parameters for DCI format 1C are specified in table 4.3.6.1.4-1.

Table 4.3.6.1.4-1: Physical layer parameters for DCI format 1C

Parameter	Value	Value in binary
gap value (N_RB >= 50)	gap1	"0"
Resource block assignment	depending on test parameters	-
Transport block size index	depending on test parameters	-

4.3.6.1.5 Physical layer parameters for DCI format 2

Default physical layer parameters for DCI format 2 are specified in table 4.3.6.1.5-1.

Table 4.3.6.1.5-1: Physical layer parameters for DCI format 2

Parameter	Value	Value in binary
Resource allocation header	Resource allocation type 0	"0"
Resource block assignment	Depending on test parameters	-
TPC command for PUCCH	0 dB (accumulated TPC)	"01"
Downlink Assignment Index (TDD only)	2 bits as defined in Table 7.3-X in TS 36.213. It represents the number of PDSCH with PDCCH and PDCCH indicating downlink SPS release in the window up to the present subframe. This is present for all the uplink-downlink configurations and only applies to uplink-downlink configuration 1-6	-
HARQ process number	Depending on test parameters, 3bits for FDD, 4 bits for TDD.	-
Transport block to codeword swap flag	No swap	"0"
Modulation and coding scheme (transport block 1)	Depending on test parameters	-
New data indicator (transport block 1)	Set for every data transmission/retransmission according to the rules specified in TS 36.321	-
Redundancy version (transport block 1)	Depending on test parameters	-
Modulation and coding scheme (transport block 2)	Depending on test parameters	-
New data indicator (transport block 2)	Set for every data transmission/retransmission according to the rules specified in TS 36.321	-
Redundancy version (transport block 2)	Depending on test parameters	-
Precoding information	Set for every transmission according to 36.212 Table 5.3.3.1.5-4 for 2 Tx antenna ports and Table 5.3.3.1.5-5 for 4 Tx antenna ports	-

4.3.6.1.6 Physical layer parameters for DCI format 2A

Default physical layer parameters for DCI format 2A are specified in table 4.3.6.1.6-1.

Table 4.3.6.1.6-1: Physical layer parameters for DCI format 2A

Parameter	Value	Value in binary
Resource allocation header	Resource allocation type 0	"0"
Resource block assignment	depending on test parameters	-
TPC command for PUCCH	0 dB (accumulated TPC)	"01"
Downlink Assignment Index (TDD only)	2 bits as defined in Table 7.3-X in TS 36.213. It represents the number of PDSCH with PDCCH and PDCCH indicating downlink SPS release in the window up to the present subframe. This is present for all the uplink-downlink configurations and only applies to uplink -downlink configuration 1-6	-
HARQ process number	depending on test parameters, 3bits for FDD, and 4 bits for TDD.	-
Transport block to codeword swap flag	No swap	"0"
Modulation and coding scheme (transport block 1)	depending on test parameters	-
New data indicator (transport block 1)	Set for every data transmission/retransmission according to the rules specified in TS 36.321	-
Redundancy version (transport block 1)	depending on test parameters	-
Modulation and coding scheme (transport block 2)	depending on test parameters	-
New data indicator (transport block 2)	Set for every data transmission/retransmission according to the rules specified in TS 36.321	-
Redundancy version (transport block 2)	depending on test parameters	-
Precoding information	N/A for 2 Tx antenna ports. For 4 Tx antenna ports, set for every transmission according to 36.212 Table 5.3.3.1.5A-2	-

4.3.6.1.6A Physical layer parameters for DCI format 3B

Default physical layer parameters for DCI format 3B are specified in table 4.3.6.1.6A-1 for up to 5 TDD SCells configured without PUCCH/PUSCH.

Table 4.3.6.1.6A-1: Physical layer parameters for DCI format 3B for up to 5 TDD SCells configured without PUCCH/PUSCH

Parameter	Value	Value in binary
SRS request (block number 1)	1 bit. The interpretation of this field is provided in section 8.2 of TS 36.213.	"1"
TPC command (block number 1)	0 dB (accumulated TPC)	"01"

4.3.6.1.6B Physical layer parameters for DCI format 4A

Default physical layer parameters for DCI format 4A are specified in table 4.3.6.1.6B-1.

Table 4.3.6.1.6B-1: Physical layer parameters for DCI format 4A for eLAA

Parameter	Value	Value in binary
Carrier indicator	0 or 3 bits. This field is present according to the definitions in TS 36.213.	not present
PUSCH trigger A	non-triggered scheduling	"0"
Timing offset	0	"0000"
Resource block assignment	Depending on test parameters	-
HARQ process number	2 bits.	"00"
Redundancy version	Depending on test parameters	-
TPC command for scheduled PUSCH	0 dB (accumulated TPC)	"01"
Cyclic shift for DM RS and OCC index	3 bits as defined in 5.5.2.1.1 of TS 36.211	
CSI request	w/o aperiodic CQI	"0"
SRS request	w/o SRS	"0"
PUSCH starting position	25us in symbol 0	"01"
PUSCH ending symbol	the last symbol of the subframe	"0"
Channel Access type	channel access Type 2	"1"
Channel Access Priority Class	1	"01"
Modulation and coding scheme and redundancy version for transport block 1	Depending on test parameters	-
New data indicator for transport block 1	Depending on test parameters	-
Modulation and coding scheme and redundancy version for transport block 2	Depending on test parameters	-
New data indicator for transport block 2	Depending on test parameters	-
Precoding information and number of layers	Depending on test parameters	-

4.3.6.1.6C Physical layer parameters for DCI format 4B

Default physical layer parameters for DCI format 4B are specified in table 4.3.6.1.6C-1.

Table 4.3.6.1.6C-1: Physical layer parameters for DCI format 4B for eLAA

Parameter	Value	Value in binary
Carrier indicator	0 or 3 bits. This field is present according to the definitions in TS 36.213.	not present
PUSCH trigger A	non-triggered scheduling	"0"
Timing offset	0	"0000"
Number of scheduled subframes	4	"11"
Resource block assignment	Depending on test parameters	-
HARQ process number	Depending on test parameters	-
Redundancy version	2 bits.	"00"
TPC command for scheduled PUSCH	0 dB (accumulated TPC)	"01"
Cyclic shift for DM RS and OCC index	3 bits as defined in 5.5.2.1.1 of TS 36.211	
CSI request	w/o aperiodic CQI	"0"
SRS request	w/o SRS	"0"
PUSCH starting position	25us in symbol 0	"01"
PUSCH ending symbol	the last symbol of the subframe	"0"
Channel Access type	channel access Type 2	"1"
Channel Access Priority Class	1	"01"
Modulation and coding scheme and redundancy version for transport block 1	Depending on test parameters	-
New data indicator for transport block 1	Depending on test parameters	-
Modulation and coding scheme and redundancy version for transport block 2	Depending on test parameters	-
New data indicator for transport block 2	Depending on test parameters	-
Precoding information and number of layers	Depending on test parameters	-

4.3.6.1.7 Physical layer parameters for DCI format 5

Default physical layer parameters for DCI format 5 are specified in table 4.3.6.1.7-1.

Table 4.3.6.1.7-1: Physical layer parameters for DCI format 5

Parameter	Value	Value in binary
Resource for PSCCH	Depending on test parameters	-
TPC command for PSCCH and PSSCH		"0"
Frequency hopping flag	w/o hopping	"0"
Resource block assignment and hopping resource allocation		
Time resource pattern	Depending on test parameters	

4.3.6.1.7A Physical layer parameters for DCI format 5A

Default physical layer parameters for DCI format 5A are specified in table 4.3.6.1.7A-1.

Table 4.3.6.1.7A-1: Physical layer parameters for DCI format 5A

Parameter	Value	Value in binary
Carrier indicator	Pcell's frequency	"0"
Lowest index of the subchannel allocation	Depending on test parameters	
Frequency resource location	Depending on test parameters	
Time gap between initial transmission and retransmission	Depending on test parameters	

4.3.6.1.8 Physical layer parameters for DCI format 6-0A

Default physical layer parameters for DCI format 6-0A for scheduling of PUSCH are specified in table 4.3.6.1.8-1.

Table 4.3.6.1.8-1: Physical layer parameters for DCI format 6-0A

Parameter	Value	Value in binary	Condition
Flag format 6-0A/format 6-1A differentiation	format 0A	"0"	Condition
Frequency hopping flag	w/o Hopping	"0"	
Resource block assignment - narrowband index	$n_{NB} = 0$ according to section 5.2.4 in TS 36.211	"0"	RF
	See TS 36.523-3 clause 7.3.3.9		SIG
Resource block assignment – UL resource allocation	Depending on test parameters 5 bits provide the resource allocation using UL resource allocation type 0 within the indicated narrowband	-	
Modulation and coding scheme	Depending on test parameters	-	
Repetition number	No repetitions 2 bits as defined in section 8.0 of 36.213	"00"	
HARQ process number	Depending on test parameters, 3 bits	-	
New data indicator	Set for every data transmission/retransmission according to the rules specified in TS 36.321	-	
Redundancy version	Depending on test parameters	-	
TPC command for scheduled PUSCH	0 dB (accumulated TPC)	"01"	
UL index (TDD only)	2 bits as defined in sections 5.1.1.1 and 8 of TS 36.213. This field is present only for TDD configuration 0	-	
Downlink Assignment Index (TDD only)	2 bits as defined in Table 7.3 in TS 36.213. It represents the total number of PDSCH subframes with and without PDCCH and PDCCH indicating downlink SPS release in the window. This field is present only for TDD configuration 1-6	-	
CSI request	w/o aperiodic CQI	"0"	
SRS request	1 bit. The interpretation of this field is provided in section 8.2 of TS 36.213.	"0"	
DCI subframe repetition number	0	"00"	

Condition	Explanation
RF	For RF, performance and RRM testing
SIG	For protocol testing

4.3.6.1.9 Physical layer parameters for DCI format 6-0B

Default physical layer parameters for DCI format 6-0B are specified in table 4.3.6.1.9-1.

Table 4.3.6.1.9-1: Physical layer parameters for DCI format 6-0B

Parameter	Value	Value in binary	Condition
Flag for format 6-0B/format 6-1B differentiation	format 0B	"0"	
Resource block assignment - narrowband index	$n_{NB} = 0$ according to section 5.2.4 in TS 36.211= 0 according to section 5.2.4 in TS 36.211	"0"	RF
	See TS 36.523-3 clause 7.3.3.9		SIG
Resource block assignment – UL resource allocation	Depending on test parameters. 3 bits provide the resource allocation within the indicated narrowband as specified in section 8.1.3 of 36.213.	-	
Modulation and coding scheme	Depending on test parameters	-	
Repetition number	No repetitions 3 bits as defined in section 8.0 of 36.213	"000"	
HARQ process number	Depending on test parameters, 1 bit	-	
New data indicator	Set for every data transmission/retransmission according to the rules specified in TS 36.321	-	
DCI subframe repetition number	0	"00"	

Condition	Explanation
RF	For RF, performance and RRM testing
SIG	For protocol testing

4.3.6.1.10 Physical layer parameters for DCI format 6-1A

Default physical layer parameters for DCI format 6-1A for scheduling of PDSCH are specified in table 4.3.6.1.10-1.
Default physical layer parameters for DCI format 6-1A for scheduling of random access procedure are specified in table 4.3.6.1.10-2

Table 4.3.6.1.10-1: Physical layer parameters for DCI format 6-1A (PDSCH)

Parameter	Value	Value in binary	Condition
Flag format 6-0A/format 6-1A differentiation	format 6-1A	"1"	
Frequency hopping flag	w/o Hopping	"0"	
Resource block assignment - narrowband index	$n_{NB} = 0$ according to clause 6.2.7 in TS 36.211	"0"	RF
	See TS 36.523-3 clause 7.3.3.9		SIG
Resource block assignment – DL resource allocation	Depending on test parameters 5 bits provide the resource allocation using DL resource allocation type 2 within the indicated narrowband	-	
Modulation and coding scheme	Depending on test parameters	-	
Repetition number	No repetitions		
	2 bits as defined in section 7.1.11 of 36.213	"00"	
HARQ process number	Depending on test parameters, 3bits for FDD, 4 bits for TDD.	-	
New data indicator	Set for every data transmission/retransmission according to the rules specified in TS 36.321	-	
Redundancy version	Depending on test parameters	-	
TPC command for PUCCH	0 dB (accumulated TPC)	"01"	
Downlink Assignment Index	Number of bits as specified in TS 36.212, Table 5.3.3.1.2-2. This field is reserved when the configured maximum repetition number is larger than 1 for either PDSCH or MPDCCH.	-	
Antenna port(s) and scrambling identity	2 bits indicating the values 0 to 3, as specified in TS 36.212, Table 5.3.3.1.5C-1. This field is present only if PDSCH transmission is configured with TM9.	-	
SRS request	1 bit. The interpretation of this field is provided in section 8.2 of TS 36.213.	"0"	
TPMI information for precoding	Number of bits as specified in TS 36.212, Table 5.3.3.1.3A-1. Set for codebook index according to TS 36.211 Table 6.3.4.2.3-1 or Table 6.3.4.2.3-2 corresponding to the single-layer transmission. This field is present only if PDSCH transmission is configured with TM6.	-	
PMI confirmation for precoding	Set for every transmission, 1 for precoding according to the latest reported PMI on PUSCH, 0 for precoding according to the indicated TPMI in the TPMI information field	-	
HARQ-ACK resource offset	No offset 2 bits as defined in TS 36.213, Table 10.1.2.1-1	"0"	
DCI subframe repetition number	0 2 bits as defined in sub-clause 9.1.5 of TS 36.213	"00"	

Condition	Explanation
-----------	-------------

RF	For RF, performance and RRM testing
SIG	For protocol testing

Table 4.3.6.1.10-2: Physical layer parameters for DCI format 6-1A (random access)

Parameter	Value	Value in binary	Condition
Flag format 6-0A/format 6-1A differentiation	format 6-1A	"1"	
Frequency hopping flag	w/o Hopping	"0"	
Resource block assignment - narrowband index	$n_{NB} = 0$ according to clause 6.2.7 in TS 36.211	"0"	RF
	See TS 36.523-3 clause 7.3.3.9		SIG
Resource block assignment – DL resource allocation	All 5 bits set to 1	"11111"	
Preamble Index	0	"000000"	
PRACH Mask Index	All	"0000"	
Starting CE level	Level 0	"00"	
NOTE: All the remaining bits in format 6-1A for compact scheduling assignment of one PDSCH codeword are set to zero			

Condition	Explanation
RF	For RF, performance and RRM testing
SIG	For protocol testing

4.3.6.1.11 Physical layer parameters for DCI format 6-1B

Default physical layer parameters for DCI format 6-1B are specified in table 4.3.6.1.11-1.

Table 4.3.6.1.11-1: Physical layer parameters for DCI format 6-1B

Parameter	Value	Value in binary	Condition
Flag for format 6-0B/format 6-1B differentiation	format 6-1B	"1"	
Resource block assignment - narrowband index	$n_{NB} = 0$ according to clause 6.2.7 in TS 36.211	"0"	RF
	See TS 36.523-3 clause 7.3.3.9		SIG
Resource block assignment - DL resource allocation	6 PRBs	"1"	
Modulation and coding scheme	Depending on test parameters	-	
Repetition number	No repetitions 3 bits as defined in section 8.0 of 36.213	"000"	
HARQ process number	Depending on test parameters, 1 bit	-	
New data indicator	Set for every data transmission/retransmission according to the rules specified in TS 36.321	-	
HARQ-ACK resource offset	No offset 2 bits as defined in TS 36.213, Table 10.1.2.1-1	"0"	
DCI subframe repetition number	0– 2 bits as defined in sub-clause 9.1.5 of TS 36.213	"00"	

Condition	Explanation
RF	For RF, performance and RRM testing
SIG	For protocol testing

4.3.6.1.12 Physical layer parameters for DCI format 6-2

Default physical layer parameters for DCI format 6-2 are specified in table 4.3.6.1.12-1 for direct indication and in Table 4.3.6.1.12-2 for paging.

Table 4.3.6.1.12-1: Physical layer parameters for DCI format 6-2 for direct Indication (Flag=0)

Parameter	Value	Value in binary
Flag for paging/direct indication differentiation	Direct indication	"0"
Direct Indication information	8 bits provide direct indication of system information update and other fields, as defined in TS 36.331.	-
Reserved	Reserved information bits are added until the size is equal to that of format 6-2 with Flag=1	-

Table 4.3.6.1.12-2: Physical layer parameters for DCI format 6-2 for paging (Flag=1)

Parameter	Value	Value in binary
Flag for paging/direct indication differentiation	Paging	"1"
Resource block assignment	Depending on test parameters	-
Modulation and coding scheme	Depending on test parameters	-
Repetition number	{1,2,4,8}	Not configured
DCI subframe repetition number	0 2 bits as defined in sub-clause 9.1.5 of TS 36.213	"00"

4.4 Reference system configurations

The reference system configurations specified in this sub clause apply to all test cases unless otherwise specified.

4.4.1 Simulated network scenarios

The UE will eventually have to operate in either single mode networks (FDD or TDD), dual mode networks (FDD+TDD), or inter-RAT networks ((FDD or TDD) + (UTRA FDD, UTRA TDD, GSM, HRPD or 1xRTT)).

For

Simulated network scenarios to be tested are listed in this sub clause.

NOTE 1: The number of cells specified does not necessarily correspond to the maximum number of resources to be configured simultaneously in test equipment. Please refer to Table 6.1-1 for such information.

NOTE 2: For NAS test cases see sub clause 6.3.2.

4.4.1.1 Single cell network scenarios

For FDD and TDD basic single cell environment, Cell 1 is used.

4.4.1.2 E-UTRA single mode multi cell network scenarios

For FDD or TDD basic intra-frequency multi cell environment, Cell 1, Cell 2 and Cell 4 are used.

For FDD or TDD basic inter-frequency multi cell environment, Cell 1, Cell 3 and Cell 6 are used.

For FDD or TDD basic inter-band cell environment, Cell 1 and Cell 10 are used.

For FDD or TDD multi tracking area intra-frequency multi cell environment, Cell 1 and Cell 11 are used.

For FDD or TDD multi tracking area inter-frequency multi cell environment, Cell 1 and Cell 23 are used.

For FDD or TDD multi PLMN inter-frequency multi cell environment, Cell 1, Cell 12, Cell 13 and Cell 14 are used.

4.4.1.3 E-UTRA dual mode multi cell network scenarios

For FDD and TDD basic multi cell environment, Cell 1, Cell 10 and Cell 31 are used.

For FDD and TDD multi PLMN multi cell environment, Cell 1, Cell 28, Cell 29 and Cell 30 are used.

In addition, E-UTRA single mode multi cell network scenarios defined in clause 4.4.1.2 are combined with the dual mode scenarios defined in this clause when additional intra or inter-frequency cells are used.

4.4.1.4 3GPP Inter-RAT network scenarios

For FDD and TDD basic inter-RAT cell environment with UTRA FDD or UTRA TDD, Cell 1 and Cell 5 are used.

For FDD and TDD inter-RAT cell environment with multi UTRA FDD or UTRA TDD cells, Cell 1 and Cell 7, Cell 8 and Cell 9 is used.

For FDD and TDD inter-RAT cell environment with GERAN, Cell 1 and Cell 24 are used.

For FDD and TDD inter-RAT cell environment with multi GERAN cells, Cell 1 and Cell 25, Cell 26 are used.

For FDD and TDD inter-RAT cell environment with (UTRA FDD or UTRA TDD) and GERAN, Cell 1, Cell 5 and Cell 24 are used.

4.4.1.5 3GPP2 Inter-RAT network scenarios

For FDD and TDD inter-RAT cell environment with HRPD, Cell 1 and Cell 15 are used.

For FDD and TDD inter-RAT cell environment with multi HRPD cells, Cell 1 and Cell 15, Cell 16 and Cell 17 are used.

For FDD and TDD inter-RAT cell environment with 1xRTT, Cell 1 and Cell 19 are used.

For FDD and TDD inter-RAT cell environment with multi 1xRTT cells, Cell 1 and Cell 19, Cell 20 and Cell 21 are used.

4.4.1.6 WLAN Inter-RAT network scenarios

For FDD and TDD inter-RAT cell environment with WLAN, Cell 1 and Cell 27 are used.

4.4.2 Simulated cells

NOTE: For NAS test cases see subclause 6.3.2.

NOTE: Test frequency and range defined in table 4.4.2-1 do not apply to 36.521-1 test cases.

Test frequencies and simulated cells are defined in table 4.4.2-1. For E-UTRA cells, f1 is the default test frequency. For UTRA cells, f8 is the default test frequency. For GERAN cells, f11 is the default test frequency. For CDMA2000 HRPD cells, f14 is the default test frequency. For CDMA 2000 1xRTT cells, f17 is the default test frequency. For WLAN cells, f20 is the default test frequency.

Default parameters for simulated cells are specified in table 4.4.2-1A and table 4.4.2-2.

Common parameters for simulated cells are specified in subclauses 4.4.3 to 4.4.6A.

Other cell specific parameters are specified in subclause 4.4.7.

Table 4.4.2-1: Definition of test frequencies and simulated cells

Test frequency	RAT	Operating band	Range	Simulated cells
f1	E-UTRA	Operating band under test	Mid (Note 1, Note 5, Note 8)	Cell 1, Cell 1a, Cell 2, Cell 4, Cell 11 (Note 4)
f2	E-UTRA	Operating band under test	High (Note 1, Note 6, Note 8)	Cell 3, Cell 12, Cell 23
f3	E-UTRA	Operating band under test	Low (Note 1, Note 7, Note 8)	Cell 6, Cell 13
f4	E-UTRA	Operating band under test	(Note 1)	Cell 14
f5	E-UTRA	Operating band for inter-band cells	Mid (Note 1)	Cell 10, Cell 30, Cell 31
f6	E-UTRA	Operating band for inter-band cells	High (Note 1)	Cell 28, Cell 29, Cell 36 (Note 10)
f7	E-UTRA	Operating band for inter-band cells	Low (Note 1)	Cell 35 (Note 10)
f8	UTRA	Operating band for UTRA cells	Mid (Note 2)	Cell 5, Cell 7
f9	UTRA	Operating band for UTRA cells	High (Note 2)	Cell 8
f10	UTRA	Operating band for UTRA cells	Low (Note 2)	Cell 9
f11	GERAN	Operating band for GERAN cells	Mid (Note 3)	Cell 24
f12	GERAN	Operating band for GERAN cells	High (Note 3)	Cell 25
f13	GERAN	Operating band for GERAN cells	Low (Note 3)	Cell 26
f14	CDMA2000 HRPD	Operating band for CDMA2000 HRPD cells	Mid (Note 9)	Cell 15, Cell 16
f15	CDMA2000 HRPD	Operating band for CDMA2000 HRPD cells	High	Cell 17
f16	CDMA2000 HRPD	Operating band for CDMA2000 HRPD cells	Low (Note 9)	Cell 18
f17	CDMA2000 1xRTT	Operating band for CDMA2000 1xRTT cells	Mid	Cell 19, Cell 20
f18	CDMA2000 1xRTT	Operating band for CDMA2000 1xRTT cells	High	Cell 21
f19	CDMA2000 1xRTT	Operating band for CDMA2000 1xRTT cells	Low	Cell 22
f20	WLAN	Operating band for WLAN AP's	Mid	Cell 27
f21	E-UTRA	Operating band for Inter-band cells (third band)	Low (Note 10)	Cell 32
f22	E-UTRA	Operating band for Inter-band cells (third band)	Mid (Note 10)	Cell 33
f23	E-UTRA	Operating band for Inter-band cells (third band)	High (Note 10)	Cell 34

- | | |
|----------|---|
| Note 1: | For signalling test, see clause 6.2.3. |
| Note 2: | See TS 34.108 [5] clause 5.1. |
| Note 3: | For signalling test, see clause 6.3.1.4. For RRM test, see clause 7.2.2.1. |
| Note 4: | For signalling test, simultaneous co-existence of Cell 2 with Cell 11 is not allowed. |
| Note 5: | For RRM test with intra-band contiguous CA, the set of contiguous component carriers are "Mid", with the test frequencies specified in clauses 4.3.1.1.xA for FDD and 4.3.1.2.xA for TDD |
| Note 6: | For RRM test with intra-band contiguous CA, the set of contiguous component carriers are "High", with the test frequencies specified in clauses 4.3.1.1.xA for FDD and 4.3.1.2.xA for TDD |
| Note 7: | For RRM test with intra-band contiguous CA, the set of contiguous component carriers are "Low", with the test frequencies specified in clauses 4.3.1.1.xA for FDD and 4.3.1.2.xA for TDD. |
| Note 8: | For RRM test with intra-band non-contiguous CA, the test frequencies for the set of non-contiguous component carriers are specified in clauses 4.3.1.1.xA for FDD and 4.3.1.2.xA for TDD without any regard to range. Thus "Low", "Mid" and "High" information in this table does not apply. Unless otherwise stated, test point with maximum Wgap is chosen. |
| Note 9: | For signalling test with band combination E-UTRA band 25 or EUTRA band 2 and HRPD/1xRTT band Class 1, F14 is 'low' and F16 is 'Mid'. |
| Note 10: | For RRM IncMon Test Cases. |

Table 4.4.2-1A: Default E-UTRA parameters for simulated cells

cell ID	E-UTRAN Cell Identifier		Physical layer cell identity	rootSequenceIndex or rootSequenceIndexHighSpeed FDD	rootSequenceIndex or rootSequenceIndexHighSpeed TDD
	eNB Identifier	Cell Identity			
Cell 1	'0000 0000 0000 0000 0001'B	'0000 0000'B	0	22	0
Cell 1a	'0000 0000 0000 0000 0001'B	'0000 0001'B	1	22	0
Cell 2	'0000 0000 0000 0000 0001'B	'0000 0010'B	2	86	8
Cell 3	'0000 0000 0000 0000 0010'B	'0000 0011'B	3	22	0
Cell 4	'0000 0000 0000 0000 0011'B	'0000 0100'B	4	150	16
Cell 6	'0000 0000 0000 0000 0100'B	'0000 0110'B	6	22	0
Cell 10	'0000 0000 0000 0000 0101'B	'0000 1010'B	10	22	0
Cell 11	'0000 0000 0000 0000 0110'B	'0000 1011'B	11	214	24
Cell 12	'0000 0000 0000 0000 0010'B	'0000 1100'B	12	86	8
Cell 13	'0000 0000 0000 0000 0100'B	'0000 1101'B	13	86	8
Cell 14	'0000 0000 0000 0000 0111'B	'0000 1110'B	14	22	0
Cell 23	'0000 0000 0000 0000 0110'B	'0001 0111'B	23	150	16
Cell 28	'0000 0000 0000 0000 0010'B	'0001 1100'B	28	86	8
Cell 29	'0000 0000 0000 0000 0100'B	'0001 1101'B	29	86	8
Cell 30	'0000 0000 0000 0000 0111'B	'0001 1110'B	30	86	8
Cell 31	'0000 0000 0000 0000 0110'B	'0001 1111'B	31	214	24
Cell 32	'0000 0000 0000 0000 0001'B	'0010 0000'B	32	22	0
Cell 33	'0000 0000 0000 0000 0001'B	'0010 0001'B	33	22	0
Cell 34	'0000 0000 0000 0000 0001'B	'0010 0010'B	34	22	0
Cell 35	'0000 0000 0000 0000 0001'B	'0010 0011'B	35	22	0

Cell 36	'0000 0000 0000 0000 0001'B	'0010 0100'B	36	22	0
---------	-----------------------------------	-----------------	----	----	---

Table 4.4.2-2: Default NAS parameters for simulated cells

cell ID	Tracking Area			TA# list (Note 1)	GUTI (Note 2)		M-TMSI	
	TA#	PLMN			TAC	MME Identifier		
		MCC	MNC			MME Group ID		MME Code
Cell 1	TAI-1	(Note 3)		1	TAI-1	32769	1	Arbitrarily selected according to TS 23.003 subclause 2.8 [2].
Cell 1a	TAI-1	(Note 3)		1	TAI-1	32769	1	
Cell 2	TAI-1	(Note 3)		1	TAI-1	32769	1	
Cell 3	TAI-1	(Note 3)		1	TAI-1	32769	1	
Cell 4	TAI-1	(Note 3)		1	TAI-1	32769	1	
Cell 6	TAI-1	(Note 3)		1	TAI-1	32769	1	
Cell 10	TAI-1	(Note 3)		1	TAI-1	32769	1	
Cell 11	TAI-2	(Note 3)		2	TAI-2	32769	1	
Cell 23	TAI-2	(Note 3)		2	TAI-2	32769	1	
Cell 12, Cell 28	TAI-3	002	11	1	TAI-3	32769	1	
Cell 13, Cell 29	TAI-4	003	21	1	TAI-4	32769	1	
Cell 14, Cell 30	TAI-5	004	31	1	TAI-5	32769	1	
Cell 31	TAI-2	(Note 3)		2	TAI-2	32769	1	
Cell 32	TAI-1	(Note 3)		1	TAI-1	32769	1	
Cell 33	TAI-1	(Note 3)		1	TAI-1	32769	1	
Cell 34	TAI-1	(Note 3)		1	TAI-1	32769	1	
Cell 35	TAI-1	(Note 3)		1	TAI-1	32769	1	
Cell 36	TAI-1	(Note 3)		1	TAI-1	32769	1	

Note 1: The value(s) in the column TA# list indicates TAI(s) included in the response messages of the registration procedure (ATTACH ACCEPT or TRACKING AREA UPDATE ACCEPT) when the UE performs the registration procedure on a corresponding cell.

Note 2: The value in the column GUTI indicates GUTI included in the response messages of the registration procedure (ATTACH ACCEPT or TRACKING AREA UPDATE ACCEPT) when the UE performs the registration procedure on a corresponding cell.

Note 3: Set to the same Mobile Country Code and Mobile Network Code stored in EF_{IMSI} on the test USIM card (subclause 4.9.3).

Table 4.4.2-3: Default HRPD parameters for simulated cells

Cell ID	SectorID	ColorCode	Pilot PN Offset	CountryCode
Cell 15	Set according to PIXIT parameter	Set according to PIXIT parameter	50	(Note 1)
Cell 16	Set according to PIXIT parameter	Set according to PIXIT parameter	100	(Note 1)
Cell 17	Set according to PIXIT parameter	Set according to PIXIT parameter	150	(Note 1)
Cell 18	Set according to PIXIT parameter	Set according to PIXIT parameter	200	(Note 1)

Note 1: Set to the same Mobile Country Code stored in EF_{IMSI} on the test USIM card (subclause 4.9.3).

Table 4.4.2-4: Default 1XRTT parameters for simulated cells

Cell ID	SID	NID	BASE_ID	Pilot PN Offset	REG_ZONE	MCC	IMSI_11_12
Cell 19	200	Set according to PIXIT parameter	Set according to PIXIT parameter	50	1	Note 1	Note 2
Cell 20	200	Set according to PIXIT parameter	Set according to PIXIT parameter	100	1	Note 1	Note 2
Cell 21	200	Set according to PIXIT parameter	Set according to PIXIT parameter	150	2	Note 1	Note 2
Cell 22	200	Set according to PIXIT parameter	Set according to PIXIT parameter	200	3	Note 1	Note 2

Note 1: Set to the same Mobile Country Code stored in EFIMSI on the test USIM card (subclause 4.9.3).
Note 2: Set to the same Mobile Network Code stored in EFIMSI on the test USIM card (subclause 4.9.3).

Table 4.4.2-5: Neighbouring cell list for 1XRTT cells

Cell ID	Intra Frequency	Inter Frequency Cells		
Cell 19	cell 20	Cell 21	cell 22	X
Cell 20	cell 19	Cell 21	cell 22	X
Cell 21	X	cell 19	cell 20	cell 22
Cell 22	X	cell 19	cell 20	cell 21

4.4.3 Common parameters for simulated E-UTRA cells

The parameters specified in this sub clause apply to all simulated E-UTRA cells unless otherwise specified.

4.4.3.1 Common configurations of system information blocks

For BL/CE testing the same content of system information blocks SIB2 to SIB20 are used for broadcasting on BCCH and/or BCCH-BR.

4.4.3.1.1 Combinations of system information blocks

The combination of system information blocks required by a test case depends on the test case scenario. In this clause, the following combinations of system information blocks are defined.

Combination 1 is the default combination which applies to the following test case scenarios:

- E-UTRA FDD single cell scenario
- E-UTRA TDD single cell scenario
- E-UTRA FDD intra-frequency multi cell scenario
- E-UTRA TDD intra-frequency multi cell scenario
- E-UTRA FDD and E-UTRA TDD dual mode multi cell roaming scenario

Combination 2 applies to the following test case scenarios:

- E-UTRA FDD intra-frequency multi cell scenario with neighbouring cell related information
- E-UTRA TDD intra-frequency multi cell scenario with neighbouring cell related information

Combination 3 applies to the following test case scenarios:

- E-UTRA FDD inter-frequency multi cell scenario
- E-UTRA TDD inter-frequency multi cell scenario
- E-UTRA FDD inter-band multi cell scenario
- E-UTRA TDD inter-band multi cell scenario
- E-UTRA FDD and E-UTRA TDD dual mode multi cell non-roaming scenario
- E-UTRA FDD intra-band carrier aggregation component carriers cell scenario
- E-UTRA FDD inter-band carrier aggregation component carriers cell scenario
- E-UTRA TDD intra-band carrier aggregation component carriers cell scenario
- E-UTRA FDD and E-UTRA TDD inter-band carrier aggregation component carriers cell scenario
- E-UTRA FDD dual connectivity cell scenario
- E-UTRA TDD dual connectivity cell scenario

Combination 4 applies to the following test case scenarios:

- 3GPP inter-RAT E-UTRA FDD + UTRA FDD multi cell scenario
- 3GPP inter-RAT E-UTRA TDD + UTRA LCR TDD multi cell scenario
- 3GPP inter-RAT E-UTRA TDD + UTRA FDD multi cell scenario

Combination 5 applies to the following test case scenarios:

- 3GPP inter-RAT E-UTRA FDD + GERAN multi cell scenario
- 3GPP inter-RAT E-UTRA TDD + GERAN multi cell scenario

Combination 6 applies to the following test case scenarios:

- 3GPP2 inter-RAT E-UTRA FDD + HRPD multi cell scenario
- 3GPP2 inter-RAT E-UTRA TDD + HRPD multi cell scenario
- 3GPP2 inter-RAT E-UTRA FDD + 1xRTT multi cell scenario
- 3GPP2 inter-RAT E-UTRA TDD + 1xRTT multi cell scenario

Combination 7 applies to the following test case scenarios:

- E-UTRA FDD + home eNB multi cell scenario
- E-UTRA TDD + home eNB multi cell scenario

Combination 8 applies to the following test case scenarios:

- E-UTRA FDD ETWS single cell scenario
- E-UTRA TDD ETWS single cell scenario

Combination 9 applies to the following test case scenarios:

- E-UTRA FDD inter-frequency + 3GPP inter-RAT UTRA multi-cell scenario
- E-UTRA TDD inter-frequency + 3GPP inter-RAT UTRA multi-cell scenario

Combination 10 applies to the following test case scenarios:

- 3GPP inter-RAT E-UTRA FDD + UTRA FDD + GERAN multi cell scenario
- 3GPP inter-RAT E-UTRA TDD + UTRA LCR TDD + GERAN multi cell scenario.

Combination 10a applies to the following test case scenarios:

- E-UTRA FDD inter-frequency + 3GPP inter-RAT E-UTRA FDD + UTRA FDD + GERAN multi cell scenario
- E-UTRA TDD inter-frequency + 3GPP inter-RAT E-UTRA TDD + UTRA LCR TDD + GERAN multi cell scenario

Combination 11 applies to the following test case scenarios:

- 3GPP inter-RAT E-UTRA FDD + UTRA FDD + home eNB multi cell scenario
- 3GPP inter-RAT E-UTRA TDD + UTRA LCR TDD + home eNB multi cell scenario

Combination 12 applies to the following test case scenarios:

- E-UTRA FDD inter-frequency + GERAN cell scenario
- E-UTRA TDD inter-frequency + GERAN cell scenario

Combination 13 applies to the following test case scenarios:

- E-UTRA FDD inter-frequency + home eNB
- E-UTRA TDD inter-frequency + home eNB

Combination 14 applies to the following test case scenarios:

- 3GPP inter-RAT E-UTRA FDD + GERAN + home eNB multi cell scenario
- 3GPP inter-RAT E-UTRA TDD + GERAN + home eNB multi cell scenario

Combination 15 applies to the following test case scenarios:

- 3GPP E-UTRA FDD single cell scenario + MBMS
- 3GPP E-UTRA TDD single cell scenario + MBMS
- 3GPP E-UTRA FDD intra-frequency multi cell scenario + MBMS
- 3GPP E-UTRA TDD intra-frequency multi cell scenario + MBMS

Combination 16 applies to the following test case scenarios:

- 3GPP E-UTRA FDD inter-frequency multi cell scenario + MBMS
- 3GPP E-UTRA TDD inter-frequency multi cell scenario + MBMS

Combination 17 applies to the following test case scenarios:

- 3GPP E-UTRA FDD + CMAS single cell scenario
- 3GPP E-UTRA TDD + CMAS single cell scenario

Combination 18 applies to the following test case scenarios:

- 3GPP E-UTRA FDD + MBMS inter-frequency multi cell scenario (non-MBMS cell broadcasting SIB15)
- 3GPP E-UTRA TDD + MBMS inter-frequency multi cell scenario (non-MBMS cell broadcasting SIB15)
- 3GPP E-UTRA FDD + SC-PTM inter-frequency multi cell scenario (non- SC-PTM cell broadcasting SIB15)
- 3GPP E-UTRA TDD + SC-PTM inter-frequency multi cell scenario (non- SC-PTM cell broadcasting SIB15)

Combination 19 applies to the following test case scenarios:

- 3GPP E-UTRA FDD + MBMS intra-frequency multi cell scenario (MBMS cell broadcasting SIB15)
- 3GPP E-UTRA TDD + MBMS intra-frequency multi cell scenario (MBMS cell broadcasting SIB15)

Combination 20 applies to the following test case scenarios:

- 3GPP E-UTRA FDD + MBMS inter-frequency multi cell scenario (MBMS cell broadcasting SIB15)
- 3GPP E-UTRA TDD + MBMS inter-frequency multi cell scenario (MBMS cell broadcasting SIB15)
- 3GPP E-UTRA FDD + MBMS inter-band multi cell scenario (MBMS cell broadcasting SIB15)
- 3GPP E-UTRA TDD + MBMS inter-band multi cell scenario (MBMS cell broadcasting SIB15)

Combination 21 applies to the following test case scenarios:

- E-UTRA FDD SIMTC single cell scenario
- E-UTRA TDD SIMTC single cell scenario

Combination 22 applies to the following test case scenarios:

- RAN assisted WLAN offload: E-UTRA FDD + WLAN AP scenarios
- RAN assisted WLAN offload: E-UTRA TDD + WLAN AP scenarios

Combination 23 is the default combination which applies to the following test case scenarios:

- E-UTRA FDD single cell scenario + sidelink direct communication
- E-UTRA TDD single cell scenario + sidelink direct communication
- E-UTRA FDD intra-frequency multi cell scenario + sidelink direct communication
- E-UTRA TDD intra-frequency multi cell scenario + sidelink direct communication

Combination 24 is the default combination which applies to the following test case scenarios:

- E-UTRA FDD single cell scenario + sidelink direct discovery
- E-UTRA TDD single cell scenario + sidelink direct discovery
- E-UTRA FDD intra-frequency multi cell scenario + sidelink direct discovery
- E-UTRA TDD intra-frequency multi cell scenario + sidelink direct discovery

Combination 25 applies to the following test case scenarios:

- 3GPP E-UTRA FDD single cell scenario + SC-PTM
- 3GPP E-UTRA TDD single cell scenario + SC-PTM
- 3GPP E-UTRA FDD intra-frequency multi cell scenario + SC-PTM
- 3GPP E-UTRA TDD intra-frequency multi cell scenario + SC-PTM

Combination 26 applies to the following test case scenarios:

- 3GPP E-UTRA FDD inter-frequency multi cell scenario + SC-PTM
- 3GPP E-UTRA TDD inter-frequency multi cell scenario + SC-PTM

Combination 27 applies to the following test case scenarios:

- 3GPP E-UTRA FDD + SC-PTM intra-frequency multi cell scenario (SC-PTM cell broadcasting SIB15)
- 3GPP E-UTRA TDD + SC-PTM intra-frequency multi cell scenario (SC-PTM cell broadcasting SIB15)

Combination 28 applies to the following test case scenarios:

- 3GPP E-UTRA FDD + SC-PTM inter-frequency multi cell scenario (SC-PTM cell broadcasting SIB15)
- 3GPP E-UTRA TDD + SC-PTM inter-frequency multi cell scenario (SC-PTM cell broadcasting SIB15)

- 3GPP E-UTRA FDD + SC-PTM inter-band multi cell scenario (SC-PTM cell broadcasting SIB15)
- 3GPP E-UTRA TDD + SC-PTM inter-band multi cell scenario (SC-PTM cell broadcasting SIB15)

Combination 29 is the default combination which applies to the following test case scenarios:

- E-UTRA FDD single cell scenario + V2X sidelink communication.
- E-UTRA TDD single cell scenario + V2X sidelink communication.
- E-UTRA FDD intra-frequency multi cell scenario + V2X sidelink communication.
- E-UTRA TDD intra-frequency multi cell scenario + V2X sidelink communication.
- E-UTRA FDD inter-frequency + V2X sidelink communication with inter-frequency scheduling
- E-UTRA TDD inter-frequency + V2X sidelink communication with inter-frequency scheduling
- E-UTRA FDD inter-band + V2X sidelink communication with inter-frequency scheduling
- E-UTRA TDD inter-band + V2X sidelink communication with inter-frequency scheduling

Combination 30 applies to the following test case scenarios:

- E-UTRA FDD intra-band carrier aggregation component carriers cell scenario + E-UTRA FDD intra-frequency neighbour.
- E-UTRA FDD inter-band carrier aggregation component carriers cell scenario+ E-UTRA FDD intra-frequency neighbour.
- E-UTRA TDD intra-band carrier aggregation component carriers cell scenario+ E-UTRA FDD intra-frequency neighbour.
- E-UTRA FDD and E-UTRA TDD inter-band carrier aggregation component carriers cell scenario+ E-UTRA FDD intra-frequency neighbour.

Table 4.4.3.1.1-1: Combinations of system information blocks

Combination No.	System information block type																			
	SI B2	SI B3	SI B4	SI B5	SI B6	SI B7	SI B8	SI B9	SI B10	SI B11	SI B12	SI B13	SI B14	SI B15	SI B17	SI B18	SI B19	SI B20	SI B21	
1	X	X																		
2	X	X	X																	
3	X	X		X																
4	X	X			X															
5	X	X				X														
6	X	X					X													
7	X	X	X					X												
8	X	X							X	X										
9	X	X		X	X															
10	X	X			X	X														
10a	X	X		X	X	X														
11	X	X	X		X			X												
12	X	X		X		X														
13	X	X	X	X				X												
14	X	X	X			X		X												
15	X	X										X								
16	X	X		X								X								
17	X	X								X										
18	X	X		X										X						
19	X	X										X		X						
20	X	X		X								X		X						
21	X	X											X							
22	X	X													X					
23	X	X														X				
24	X	X															X			
25	X	X																	X	
26	X	X		X															X	
27	X	X												X					X	
28	X	X		X										X					X	
29	X	X																		X
30	X	X	X	X																

4.4.3.1.2 Scheduling of system information blocks

The scheduling configurations for combinations of system information blocks are defined in the following tables.

Table 4.4.3.1.2-1: Scheduling for combination 1

Scheduling Information No.	Periodicity [radio frames]	Mapping of system information blocks
1	16	SIB2
2	See sub clause 4.4.3.4	SIB3

Table 4.4.3.1.2-2: Scheduling for combination 2

Scheduling Information No.	Periodicity [radio frames]	Mapping of system information blocks
1	16	SIB2
2	See sub clause 4.4.3.4	SIB3
3	See sub clause 4.4.3.4	SIB4

Table 4.4.3.1.2-3: Scheduling for combination 3

Scheduling Information No.	Periodicity [radio frames]	Mapping of system information blocks
1	16	SIB2
2	See sub clause 4.4.3.4	SIB3
3	See sub clause 4.4.3.4	SIB5

Table 4.4.3.1.2-4: Scheduling for combination 4

Scheduling Information No.	Periodicity [radio frames]	Mapping of system information blocks
1	16	SIB2
2	See sub clause 4.4.3.4	SIB3
3	See sub clause 4.4.3.4	SIB6

Table 4.4.3.1.2-5: Scheduling for combination 5

Scheduling Information No.	Periodicity [radio frames]	Mapping of system information blocks
1	16	SIB2
2	See sub clause 4.4.3.4	SIB3
3	See sub clause 4.4.3.4	SIB7

Table 4.4.3.1.2-6: Scheduling for combination 6

Scheduling Information No.	Periodicity [radio frames]	Mapping of system information blocks
1	16	SIB2
2	See sub clause 4.4.3.4	SIB3
3	See sub clause 4.4.3.4	SIB8

Table 4.4.3.1.2-7: Scheduling for combination 7

Scheduling Information No.	Periodicity [radio frames]	Mapping of system information blocks
1	16	SIB2
2	See sub clause 4.4.3.4	SIB3
3	See sub clause 4.4.3.4	SIB4
4	See sub clause 4.4.3.4	SIB9

Table 4.4.3.1.2-8: Scheduling for combination 8

Scheduling Information No.	Periodicity [radio frames]	Mapping of system information blocks
1	16	SIB2
2	See sub clause 4.4.3.4	SIB3
3	See sub clause 4.4.3.4	SIB11
4	See sub clause 4.4.3.4	SIB10

Table 4.4.3.1.2-9: Scheduling for combination 9

Scheduling Information No.	Periodicity [radio frames]	Mapping of system information blocks
1	16	SIB2
2	See sub clause 4.4.3.4	SIB3
3	See sub clause 4.4.3.4	SIB5, SIB6

Table 4.4.3.1.2-10: Scheduling for combination 10

Scheduling Information No.	Periodicity [radio frames]	Mapping of system information blocks
1	16	SIB2
2	See sub clause 4.4.3.4	SIB3
3	See sub clause 4.4.3.4	SIB6
4	See sub clause 4.4.3.4	SIB7

Table 4.4.3.1.2-10a: Scheduling for combination 10a

Scheduling Information No.	Periodicity [radio frames]	Mapping of system information blocks
1	16	SIB2
2	See sub clause 4.4.3.4	SIB3
3	See sub clause 4.4.3.4	SIB5, SIB6
4	See sub clause 4.4.3.4	SIB7

Table 4.4.3.1.2-11: Scheduling for combination 11

Scheduling Information No.	Periodicity [radio frames]	Mapping of system information blocks
1	16	SIB2
2	See sub clause 4.4.3.4	SIB3
3	See sub clause 4.4.3.4	SIB4
4	See sub clause 4.4.3.4	SIB6
5	See sub clause 4.4.3.4	SIB9

Table 4.4.3.1.2-12: Scheduling for combination 12

Scheduling Information No.	Periodicity [radio frames]	Mapping of system information blocks
1	16	SIB2
2	See sub clause 4.4.3.4	SIB3
3	See sub clause 4.4.3.4	SIB5
4	See sub clause 4.4.3.4	SIB7

Table 4.4.3.1.2-13: Scheduling for combination 13

Scheduling Information No.	Periodicity [radio frames]	Mapping of system information blocks
1	16	SIB2
2	See sub clause 4.4.3.4	SIB3
3	See sub clause 4.4.3.4	SIB4
4	See sub clause 4.4.3.4	SIB5

Table 4.4.3.1.2-14: Scheduling for combination 14

Scheduling Information No.	Periodicity [radio frames]	Mapping of system information blocks
1	16	SIB2
2	See sub clause 4.4.3.4	SIB3
3	See sub clause 4.4.3.4	SIB4
4	See sub clause 4.4.3.4	SIB7
5	See sub clause 4.4.3.4	SIB9

Table 4.4.3.1.2-15: Scheduling for combination 15

Scheduling Information No.	Periodicity [radio frames]	Mapping of system information blocks
1	16	SIB2
2	See sub clause 4.4.3.4	SIB3
3	See sub clause 4.4.3.4	SIB13

Table 4.4.3.1.2-16: Scheduling for combination 16

Scheduling Information No.	Periodicity [radio frames]	Mapping of system information blocks
1	16	SIB2
2	See sub clause 4.4.3.4	SIB3
3	See sub clause 4.4.3.4	SIB5
4	See sub clause 4.4.3.4	SIB13

Table 4.4.3.1.2-17: Scheduling for combination 17

Scheduling Information No.	Periodicity [radio frames]	Mapping of system information blocks
1	16	SIB2
2	See sub clause 4.4.3.4	SIB3
3	See sub clause 4.4.3.4	SIB12

Table 4.4.3.1.2-18: Scheduling for combination 18

Scheduling Information No.	Periodicity [radio frames]	Mapping of system information blocks
1	16	SIB2
2	See sub clause 4.4.3.4	SIB3
3	See sub clause 4.4.3.4	SIB5
4	See sub clause 4.4.3.4	SIB15

Table 4.4.3.1.2-19: Scheduling for combination 19

Scheduling Information No.	Periodicity [radio frames]	Mapping of system information blocks
1	16	SIB2
2	See sub clause 4.4.3.4	SIB3
3	See sub clause 4.4.3.4	SIB13
4	See sub clause 4.4.3.4	SIB15

Table 4.4.3.1.2-20: Scheduling for combination 20

Scheduling Information No.	Periodicity [radio frames]	Mapping of system information blocks
1	16	SIB2
2	See sub clause 4.4.3.4	SIB3
3	See sub clause 4.4.3.4	SIB5
4	See sub clause 4.4.3.4	SIB13
5	See sub clause 4.4.3.4	SIB15

Table 4.4.3.1.2-21: Scheduling for combination 21

Scheduling Information No.	Periodicity [radio frames]	Mapping of system information blocks
1	16	SIB2
2	See sub clause 4.4.3.4	SIB3
3	See sub clause 4.4.3.4	SIB14

Table 4.4.3.1.2-22: Scheduling for combination 22

Scheduling Information No.	Periodicity [radio frames]	Mapping of system information blocks
1	16	SIB2
2	See sub clause 4.4.3.4	SIB3
3	See sub clause 4.4.3.4	SIB17

Table 4.4.3.1.2-23: Scheduling for combination 23

Scheduling Information No.	Periodicity [radio frames]	Mapping of system information blocks
1	16	SIB2
2	See sub clause 4.4.3.4	SIB3
3	See sub clause 4.4.3.4	SIB18

Table 4.4.3.1.2-24: Scheduling for combination 24

Scheduling Information No.	Periodicity [radio frames]	Mapping of system information blocks
1	16	SIB2
2	See sub clause 4.4.3.4	SIB3
3	See sub clause 4.4.3.4	SIB19

Table 4.4.3.1.2-25: Scheduling for combination 25

Scheduling Information No.	Periodicity [radio frames]	Mapping of system information blocks
1	16	SIB2
2	See sub clause 4.4.3.4	SIB3
3	See sub clause 4.4.3.4	SIB20

Table 4.4.3.1.2-26: Scheduling for combination 26

Scheduling Information No.	Periodicity [radio frames]	Mapping of system information blocks
1	16	SIB2
2	See sub clause 4.4.3.4	SIB3
3	See sub clause 4.4.3.4	SIB5
4	See sub clause 4.4.3.4	SIB20

Table 4.4.3.1.2-27: Scheduling for combination 27

Scheduling Information No.	Periodicity [radio frames]	Mapping of system information blocks
1	16	SIB2
2	See sub clause 4.4.3.4	SIB3
3	See sub clause 4.4.3.4	SIB15
4	See sub clause 4.4.3.4	SIB20

Table 4.4.3.1.2-28: Scheduling for combination 28

Scheduling Information No.	Periodicity [radio frames]	Mapping of system information blocks
1	16	SIB2
2	See sub clause 4.4.3.4	SIB3
3	See sub clause 4.4.3.4	SIB5
4	See sub clause 4.4.3.4	SIB15
5	See sub clause 4.4.3.4	SIB20

Table 4.4.3.1.2-29: Scheduling for combination 29

Scheduling Information No.	Periodicity [radio frames]	Mapping of system information blocks
1	16	SIB2
2	See sub clause 4.4.3.4	SIB3
3	See sub clause 4.4.3.4	SIB21

Table 4.4.3.1.2-30: Scheduling for combination 30

Scheduling Information No.	Periodicity [radio frames]	Mapping of system information blocks
1	16	SIB2
2	See sub clause 4.4.3.4	SIB3
3	See sub clause 4.4.3.4	SIB4
4	See sub clause 4.4.3.4	SIB5

4.4.3.2 Common contents of system information messages

- *MasterInformationBlock*

The *MasterInformationBlock* includes the system information transmitted on BCH.

Table 4.4.3.2-1: MasterInformationBlock

Derivation Path: 36.331 clause 6.2.2			
Information Element	Value/remark	Comment	Condition
MasterInformationBlock ::= SEQUENCE {			
dl-Bandwidth	Downlink system bandwidth under test.		
phich-Config SEQUENCE {}	PHICH-Config-DEFAULT	See subclause 4.6.3	
systemFrameNumber	A valid value as defined in TS 36.331 [17]		
schedulingInfoSIB1-BR-r13	0	Value 0 means that SystemInformationBlockType1-BR is not scheduled.	
schedulingInfoSIB1-BR-r13	10	4 PDSCH repetitions and 504 bits TBS carrying for PDSCH carrying SystemInformationBlockType1-BR (TS 36.213 [23] Table 7.1.6.1 and Table 7.1.7.2.7-1)	CEmodeA, CEmodeB
spare	'0000 0000 00'B		
spare	'0000 0'B		CEmodeA, CEmodeB
}			

Condition	Explanation
CEmodeA	CE mode A test environment
CEmodeB	CE mode B test environment

- **SystemInformation**

The *SystemInformation* message is used to convey one or more System Information Blocks. All the SIBs included are transmitted with the same periodicity.

Table 4.4.3.2-2: SystemInformation

Derivation Path: 36.331 clause 6.2.2			
Information Element	Value/remark	Comment	Condition
SystemInformation ::= SEQUENCE {			
criticalExtensions CHOICE {			
systemInformation-r8 SEQUENCE {			
sib-TypeAndInfo SEQUENCE (SIZE (1..maxSIB)) OF CHOICE {}	See subclause 4.4.3.1		
criticalExtensionsFuture SEQUENCE {}	Not present		
}			
}			
}			

- **SystemInformation-BR-r13**

The *SystemInformation-BR-r13* message is used to convey one or more System Information Blocks for Bandwidth Redused cell environment . All the SIBs included are transmitted with the same periodicity.

Table 4.4.3.2-2A: SystemInformation-BR-r13

Derivation Path: 36.331 clause 6.2.2			
Information Element	Value/remark	Comment	Condition
SystemInformation-BR-r13 ::= SEQUENCE {			
criticalExtensions CHOICE {			
systemInformation-r8 SEQUENCE {			
sib-TypeAndInfo SEQUENCE (SIZE (1..maxSIB)) OF CHOICE {}	See subclause 4.4.3.1		
criticalExtensionsFuture SEQUENCE {}	Not present		
}			
}			
}			

- *SystemInformationBlockType1*

SystemInformationBlockType1 contains information relevant when evaluating if a UE is allowed to access a cell and defines the scheduling of other system information.

Table 4.4.3.2-3: *SystemInformationBlockType1*

Derivation Path: 36.331 clause 6.2.2			
Information Element	Value/remark	Comment	Condition
SystemInformationBlockType1 ::= SEQUENCE {			
cellAccessRelatedInfo SEQUENCE {			
plmn-IdentityList SEQUENCE (SIZE (1..6)) OF SEQUENCE {	1 entry		
plmn-Identity[1] SEQUENCE {			
mcc SEQUENCE (SIZE (3)) OF MCC-NMC-Digit	See table 4.4.2-2	For NAS test cases, see table 6.3.2.2-1.	
mnc SEQUENCE (SIZE (2..3)) OF MCC-NMC-Digit	See table 4.4.2-2	For NAS test cases, see table 6.3.2.2-1.	
}			
cellReservedForOperatorUse[1]	notReserved		
}			
trackingAreaCode	See table 4.4.2-2	For NAS test cases, see table 6.3.2.2-1.	
cellIdentity	Cell ID for the simulated cell		
cellBarred	notBarred		
intraFreqReselection	notAllowed		
csg-Indication	FALSE		
csg-Identity	Not present		
}			
cellSelectionInfo SEQUENCE {			
q-RxLevMin	-70 (-140 dBm)	For RF/RRM test cases	RF
	-53 (-106 dBm)	For signalling test cases in normal coverage	
	-27 (-54dBm)	For signalling test cases in enhanced coverage The value has been selected such that the UE at signal levels for "Serving cell" and "Suitable neighbour intra-frequency cell" are applied then the cell selection criterion for normal coverage is not fulfilled.	SIG AND (CEmodeA OR CEmodeB)
q-RxLevMinOffset	Not present		
}			
p-Max	Not present		
freqBandIndicator	Operating band under test.		
freqBandIndicator	64	maxFBI	Band > 64
schedulingInfoList SEQUENCE (SIZE (1..maxSI-Message)) OF SEQUENCE {}	See subclause 4.4.3.1		
tdd-Config SEQUENCE {}	Not present		FDD
tdd-Config SEQUENCE {}	TDD-Config-DEFAULT	See subclause 4.6.3	TDD
si-WindowLength	ms20	To allow sufficient number of retransmissions.	
systemInfoValueTag	0		
nonCriticalExtension SEQUENCE {			
lateNonCriticalExtension SEQUENCE {	Not present		
nonCriticalExtension SEQUENCE {			Band > 64
freqBandIndicator-v9e0	Operating band under test.		
}			
}			
nonCriticalExtension SEQUENCE {			
ims-EmergencySupport-r9	True	Support IMS emergency call in limited service mode.	
cellSelectionInfo-v920 SEQUENCE {}	Not present		
cellSelectionInfo-v920 SEQUENCE {}			QBASED
q-QualMin-r9	-20 (-20dB)		
q-QualMinOffset-r9	Not present		

}			
nonCriticalExtension SEQUENCE {	Not present		
tdd-Config-v1130	Not present		
cellSelectionInfo-v1130	Not present		
nonCriticalExtension	Not present		
nonCriticalExtension SEQUENCE {			UECAT0
cellAccessRelatedInfo-v1250			
SEQUENCE {			
category0Allowed-r12	True	Cat 0 Allowed	
}			
cellSelectionInfo-v1250	Not present		
freqBandIndicatorPriority-r12	Not present		
nonCriticalExtension SEQUENCE{			
hyperSFN-r13	Not present		
eDRXAllowed-r13	Not present		
cellSelectionInfoCE-r13	Not present		
bandwidthReducedAccessRelatedInfo-	Not present		
r13			
nonCriticalExtension SEQUENCE {			eCalloverIMS
eCallOverIMS-Support-r14	True	Support eCall over IMS services.	
tdd-Config-v1430	Not present		
cellAccessRelatedInfoList-r14	Not present		
SEQUENCE {}			
nonCriticalExtension	Not present		
}			
}			
}			
}			
}			
}			
}			
}			

Condition	Explanation
FDD	FDD cell environment
TDD	TDD cell environment
QBASED	This condition applies to Quality based cell (re)selection signalling test cases.
UECAT0	This condition applies when UE under test is a UE of Category 0.
RF	For RF, performance and RRM testing
SIG	For protocol testing
CEmodeA	CE mode A test environment
CEmodeB	CE mode B test environment
Band > 64	If band > 64 is selected
eCalloverIMS	eCall over IMS test environment

- *SystemInformationBlockType1-BR-r13*

SystemInformationBlockType1-BR-r13 contains information relevant when evaluating if a UE in a Bandwith Reduced cell environment is allowed to access a cell and defines the scheduling of other system information.

Table 4.4.3.2-3A: *SystemInformationBlockType1-BR-r13*

Derivation Path: 36.331 clause 6.2.2			
Information Element	Value/remark	Comment	Condition
SystemInformationBlockType1-BR-r13 ::= SEQUENCE {			
cellAccessRelatedInfo SEQUENCE {			
plmn-IdentityList SEQUENCE (SIZE (1..6)) OF SEQUENCE {	1 entry		
plmn-Identity[1] SEQUENCE {			
mcc SEQUENCE (SIZE (3)) OF MCC-NMC-Digit	See table 4.4.2-2	For NAS test cases, see table 6.3.2.2-1.	
mnc SEQUENCE (SIZE (2..3)) OF MCC-NMC-Digit	See table 4.4.2-2	For NAS test cases, see table 6.3.2.2-1.	
}			
cellReservedForOperatorUse[1]	notReserved		
}			
trackingAreaCode	See table 4.4.2-2	For NAS test cases, see table 6.3.2.2-1.	
cellIdentity	Cell ID for the simulated cell		
cellBarred	notBarred		
intraFreqReselection	notAllowed		
csg-Indication	FALSE		
csg-Identity	Not present		
}			
cellSelectionInfo SEQUENCE {			
q-RxLevMin	-70 (-140 dBm)	For RF/RRM test cases	RF
	-27 (-54 dBm)	For signalling test cases	SIG and ENHANCED COVERAGE
	-53 (-106 dBm)	For signalling test cases	SIG and NORMAL COVERAGE
q-RxLevMinOffset	Not present		
}			
p-Max	Not present		
freqBandIndicator	Operating band under test.		
freqBandIndicator	64	maxFBI	Band > 64
schedulingInfoList SEQUENCE (SIZE (1..maxSI-Message)) OF SEQUENCE {}	See subclause 4.4.3.1		
tdd-Config SEQUENCE {}	Not present		FDD
tdd-Config SEQUENCE {}	TDD-Config-DEFAULT	See subclause 4.6.3	TDD
si-WindowLength	ms20	To allow sufficient number of retransmissions.	
systemInfoValueTag	0		
nonCriticalExtension SEQUENCE {			
lateNonCriticalExtension	Not present		
nonCriticalExtension SEQUENCE {			Band > 64
freqBandIndicator-v9e0	Operating band under test.		
}			
}			
nonCriticalExtension SEQUENCE {			
ims-EmergencySupport-r9	True	Support IMS emergency call in limited service mode.	
cellSelectionInfo-v920 SEQUENCE {}	Not present		
cellSelectionInfo-v920 SEQUENCE {			QBASED
q-QualMin-r9	-20 (-20dB)		
q-QualMinOffset-r9	Not present		
}			
nonCriticalExtension SEQUENCE {			
tdd-Config-v1130	Not present		

cellSelectionInfo-v1130	Not present		
nonCriticalExtension SEQUENCE {			
cellAccessRelatedInfo-v1250 SEQUENCE {			
category0Allowed-r12	Not Present		
category0Allowed-r12	True	Cat 0 Allowed	UECAT0
}			
cellSelectionInfo-v1250	Not present		
freqBandIndicatorPriority-r12	Not present		
nonCriticalExtension SEQUENCE {			
hyperSFN-r13	Not present		
eDRX-Allowed-r13	Not present		
eDRX-Allowed-r13	True		eDRX
cellSelectionInfoCE-r13	CellSelectionInfoCE-r13-DEFAULT		
bandwidthReducedAccessRelatedInfo-r13 SEQUENCE {			
si-WindowLength-BR-r13	ms20	To allow sufficient number of retransmissions.	
si-RepetitionPattern-r13	every2ndRF	ENUMERATED {everyRF, every2ndRF, every4thRF, every8thRF}	
schedulingInfoList-BR-r13 SEQUENCE (SIZE (1..maxSI-Message)) OF SEQUENCE {	n entries	n is the same number of entries, and listed in the same order, as in SchedulingInfoList (without suffix)	
si-Narrowband-r13[1]	1		
si-Narrowband-r13[1]	2		20MHz BW
si-TBS-r13[1]	b712		
....			
si-Narrowband-r13[n]	1		
si-Narrowband-r13[n]	2		20MHz BW
si-TBS-r13[n]	b712		
}			
fdd-DownlinkOrTddSubframeBitmapBR-r13	Not present	All non-MBSFN subframes are considered as valid subframes for FDD downlink or TDD transmissions	
fdd-UplinkSubframeBitmapBR-r13	Not present	All FDD uplink subframes are considered as valid subframes	
startSymbolBR-r13	3		FDD
	2		TDD
si-HoppingConfigCommon-r13	off		
si-ValidityTime-r13	True		
systemInfoValueTagList-r13 SEQUENCE (SIZE (1..maxSI-Message)) OF	n entries	n is the same number of entries, and listed in the same order, as in SchedulingInfoList (without suffix)	
SystemInfoValueTagSI-r13[1]	0		
....			
SystemInfoValueTagSI-r13[n]	0		
}			
nonCriticalExtension	Not present		
nonCriticalExtension SEQUENCE {			FREQ HOPPING
freqHoppingParametersDL-r13 SEQUENCE {			
mpdcch-pdsch-HoppingNB-r13	nb4	4 narrowbands	
interval-DLHoppingConfigCommonModeA-r13 CHOICE {			
interval-FDD-r13	int4		FDD
interval-TDD-r13	int5		TDD

}			
interval- DLHoppingConfigCommonModeB-r13 CHOICE {			
interval-FDD-r13	int16		FDD
interval-TDD-r13	int20		TDD
}			
mpdcch-pdsch-HoppingOffset-r13	2	INTEGER (1..16 (maxAvailNarrowBands-r13))	
}			
nonCriticalExtension	Not present		
}			
}			
}			
}			
}			
}			
}			

Condition	Explanation
FDD	FDD cell environment
TDD	TDD cell environment
QBASED	This condition applies to Quality based cell (re)selection signalling test cases.
UECAT0	This condition applies when UE under test is a UE of Category 0.
eDRX	This condition applies when UE under test is in enhanced coverage and eDRX is allowed.
RF	For RF, performance and RRM testing
SIG	For Signalling tests
FREQ HOPPING	This condition applies when MPDCCH/PDSCH frequency hopping is used
NORMAL COVERAGE	Normal coverage testing
ENHANCED COVERAGE	This condition applies for enhanced coverage testing
20MHz BW	Used for cells with 20MHz bandwidth
Band > 64	If band > 64 is selected

4.4.3.3 Common contents of system information blocks

- *SystemInformationBlockType2*

The IE *SystemInformationBlockType2* contains radio resource configuration information that is common for all UEs.

Table 4.4.3.3-1: *SystemInformationBlockType2*

Derivation Path: 36.331 clause 6.3.1			
Information Element	Value/remark	Comment	Condition
SystemInformationBlockType2 ::= SEQUENCE {			
ac-BarringInfo SEQUENCE {}	Not present		
radioResourceConfigCommon SEQUENCE {}	RadioResourceConfigCommonSIB-DEFAULT	See subclause 4.6.3	
ue-TimersAndConstants SEQUENCE {			
t300	ms1000	Typical value in real network	
t301	ms1000	Typical value in real network	
t310	ms1000	Typical value in real network	
n310	n1		
t311	ms10000	Typical value in real network	
n311	n1		
}			
freqInfo SEQUENCE {			
ul-CarrierFreq	Not present	Default UL EARFCN applies	
ul-Bandwidth	Not Present		
additionalSpectrumEmission	1 (NS_01)	A-MPR doesn't apply by default. See TS 36.101 table 6.2.4-1.	
additionalSpectrumEmission	32	When IE AdditionalSpectrumEmission - v10I0 is used, 32 should be set to IE AdditionalSpectrumEmission.	NS value > 32
}			
mbsfn-SubframeConfigList	Not present		
mbsfn-SubframeConfigList SEQUENCE (SIZE (1..maxMBSFN-Allocations)) OF SEQUENCE {			MBMS
radioframeAllocationPeriod	n4		
radioframeAllocationOffset	1		FDD
	0		TDD
subframeAllocation CHOICE{			
oneFrame	'100000' B		FDD
	'000010' B		TDD
}			
}			
timeAlignmentTimerCommon	sf750	'sf750' is applicable to the widest range of mobility (up to about 360km/h).	
lateNonCriticalExtension SEQUENCE {	Not present		
lateNonCriticalExtension SEQUENCE {			NS value > 32
SystemInformationBlockType2-v8h0-IEs SEQUENCE {			
nonCriticalExtension SEQUENCE {			
nonCriticalExtension SEQUENCE {			
nonCriticalExtension SEQUENCE {			
freqInfo-v10I0 SEQUENCE {			
additionalSpectrumEmission-v10I0	Specify the network signaling value corresponding to the E-UTRA Band defined in TS 36.101 table 6.2.4-1		
}			
}			
}			
}			
}			
}			

unicastFreqHoppingInd-r13	true	Enabled only for CE Mode test cases requiring frequency hopping.	CEfreqHopp
cloT-EPS-OptimisationInfo-r13 SEQUENCE (SIZE (1.. maxPLMN-r11)) OF SEQUENCE {			CloT-test
up-CIoT-EPS-Optimisation-r13	true		
cp-CIoT-EPS-Optimisation-r13	true		
attachWithoutPDN-Connectivity-r13	false		
}			
useFullResumeID-r13	Not present		
plmn-InfoList-r15 SEQUENCE (SIZE (1..maxPLMN-r11)) OF SEQUENCE {	1 entry		
upperLayerIndication-r15[1]	true		
}			
}			

Condition	Explanation
MBMS	MBMS cell environment
FDD	FDD cell environment
TDD	TDD cell environment
CEfreqHopp	Used when frequency hopping is used in CE test cases
CloT-test	CloT test environment
NS value > 32	When A-MPR applies with Network Signaling value > 32

- SystemInformationBlockType3

The IE *SystemInformationBlockType3* contains cell re-selection information common for intra-frequency, inter-frequency and/or inter-RAT cell re-selection (i.e. applicable for more than one type of cell re-selection but not necessarily all) as well as intra-frequency cell re-selection information other than neighbouring cell related.

Table 4.4.3.3-2: SystemInformationBlockType3

Derivation Path: 36.331 clause 6.3.1			
Information Element	Value/remark	Comment	Condition
SystemInformationBlockType3 ::= SEQUENCE {			
cellReselectionInfoCommon SEQUENCE {			
q-Hyst	dB0	To reduce interference between intra-frequency multiple cells	
speedStateReselectionPars SEQUENCE {}	Not present		
}			
cellReselectionServingFreqInfo SEQUENCE {			
s-NonIntraSearch	Not present		
threshServingLow	0 (0 dB)	Typical value in real network	
cellReselectionPriority	4	A middle value in the range has been selected.	
}			
intraFreqCellReselectionInfo SEQUENCE {			
q-RxLevMin	-70 (-140 dBm)	For RF/RRM test cases	
	-106 dBm	For signalling test cases	
p-Max	Not present		
s-IntraSearch	Not present		
allowedMeasBandwidth	Not present	The downlink bandwidth of the serving cell applies.	
presenceAntennaPort1	FALSE		
	TRUE	At least two cell-specific antenna ports are used in all neighbouring cells.	All neighCells with port1
neighCellConfig	'01'B (No MBSFN subframes are present in all neighbour cells)	MBSFN doesn't apply by default.	
t-ReselectionEUTRA	0	Typical value in real network	
t-ReselectionEUTRA-SF	Not present		
}			
lateNonCriticalExtension {			
s-IntraSearch-v920 SEQUENCE {}	Not present		
s-NonIntraSearch-v920 SEQUENCE {}	Not present		
q-QualMin-r9	Not present		
	-20 (-20dB)		QBASED
threshServingLowQ-r9	Not present		
	3 (3dB)		QBASED
cellSelectionInfoCE-r13	CellSelectionInfoCE-r13-DEFAULT		CEmodeA, CEmodeB
	Not present		
t-ReselectionEUTRA-CE-r13	0		CEmodeA, CEmodeB
	Not present		
}			
}			

Condition	Explanation
QBASED	See the definition below table 4.4.3.2-3.
All neighCells with port1	Used for all neighbouring cells with at least two cell-specific antenna ports
CEmodeA	CE mode A test environment
CEmodeB	CE mode B test environment

- SystemInformationBlockType4

The IE *SystemInformationBlockType4* contains neighbouring cell related information relevant only for intra-frequency cell re-selection. The IE includes cells with specific re-selection parameters as well as blacklisted cells.

Table 4.4.3.3-3: SystemInformationBlockType4

Derivation Path: 36.331 clause 6.3.1			
Information Element	Value/remark	Comment	Condition
SystemInformationBlockType4 ::= SEQUENCE { intraFreqNeighCellList SEQUENCE (SIZE (1..maxCellIntra)) OF SEQUENCE {}	Not present	Not required unless Qoffset configuration is tested. When Qoffset configuration is tested, see table 6.3.1.1-1.	
intraFreqBlackCellList SEQUENCE (SIZE (1..maxCellBlack)) OF SEQUENCE {}	Not present	Not required unless Blacklisted cell list configuration is tested. When Blacklisted cell list configuration is tested, see table 6.3.1.1-1.	
csg-PhysCellIdRange SEQUENCE {}	Not present		NonCSG
csg-PhysCellIdRange SEQUENCE { start	Physical Cell ID of the cell on which this SIB is transmitted		CSG
range	Not present	The UE shall apply value 1 in case the field is absent, in which case only the physical cell identity value indicated by <i>start</i> applies.	
}			
}			

Condition	Explanation
NonCSG	SIB4 transmitted on a non-CSG cell
CSG	SIB4 transmitted on a CSG cell

- SystemInformationBlockType5

The IE *SystemInformationBlockType5* contains information relevant only for inter-frequency cell re-selection i.e. information about other E-UTRA frequencies and inter-frequency neighbouring cells relevant for cell re-selection. The IE includes cell re-selection parameters common for a frequency as well as cell specific re-selection parameters.

Table 4.4.3.3-4: *SystemInformationBlockType5*

Derivation Path: 36.331 clause 6.3.1			
Information Element	Value/remark	Comment	Condition
SystemInformationBlockType5 ::= SEQUENCE { interFreqCarrierFreqList SEQUENCE (SIZE (1..maxFreq)) OF SEQUENCE {			
dl-CarrierFreq[n]	The same number of entries as the configured inter-freq carriers. For Signalling test cases except NAS, see table 6.3.1.2-1. For NAS test cases when cells are on same PLMN, see table 6.3.2.3.2-1.	n denotes the index of the entry	
dl-CarrierFreq[n]	Downlink EARFCN under test For Signalling test cases except NAS, see table 6.3.1.2-1. For NAS test cases when cells are on same PLMN, see table 6.3.2.3.2-1.		
dl-CarrierFreq[n]	65535	maxEARFCN	Band > 64
q-RxLevMin[n]	-65 (-130 dBm)	For RF/RRM test cases	
	-106 dBm	For signalling test cases	
p-Max[n]	Not present		
t-ReselectionEUTRA[n]	0	Typical value in real network	
t-ReselectionEUTRA-SF[n]	Not present	Not required unless speed-dependent cell re-selection is tested.	
threshX-High[n]	2 (4 dB)	This value should be higher than threshServingLow of the serving cell to avoid ping-pong with lower priority cells.	
threshX-Low[n]	1 (2 dB)		
allowedMeasBandwidth[n]	See subclause 4.4.3.4	Channel-bandwidth-dependent parameter	
presenceAntennaPort1[n]	FALSE		
	TRUE	At least two cell-specific antenna ports are used in all neighbouring cells.	All neighCells with port1
cellReselectionPriority[n]	4	The same priority as the one used for serving cell in SIB 3.	
neighCellConfig[n]	'01'B (No MBSFN subframes are present in all neighbour cells)	MBSFN doesn't apply by default.	
q-OffsetFreq[n]	dB0	Q_{offset} doesn't apply by default.	
interFreqNeighCellList[n] SEQUENCE (SIZE (1..maxCellInter)) OF SEQUENCE {	Not present	Not required unless Q_{offset} configuration is tested.	

interFreqBlackCellList[n] SEQUENCE (SIZE (1..maxCellBlack)) OF SEQUENCE {}	Not present	Not required unless Blacklisted cell list configuration is tested.	
q-QualMin-r9[n]	Not present		
	-20 (-20dB)		QBASED
threshX-Q-r9[n] SEQUENCE {}	Not present		
threshX-Q-r9[n] SEQUENCE {			QBASED
threshX-HighQ-r9	5 (5dB)		
threshX-LowQ-r9	5 (5dB)		
}			
}			
SystemInformationBlockType5-v8h0-IEs SEQUENCE {			
nonCriticalExtension SEQUENCE {			Band > 64
interFreqCarrierFreqList-v9e0 SEQUENCE { (SIZE (1..maxFreq)) OF SEQUENCE {			
dl-CarrierFreq-v9e0[n]	Downlink EARFCN under test For Signalling test cases except NAS, see table 6.3.1.2-1. For NAS test cases when cells are on same PLMN, see table 6.3.2.3.2-1		
}			
}			
}			
interFreqCarrierFreqList-v1250[n] SEQUENCE {}	Not present		
interFreqCarrierFreqListExt-r12[n] SEQUENCE {}	Not present		
interFreqCarrierFreqListExt-v1280[n] SEQUENCE {}	Not present		
interFreqCarrierFreqList-v1310[n] SEQUENCE {}	Not present		
interFreqCarrierFreqListExt-v1310[n] SEQUENCE {}	Not present		
}			

Condition	Explanation
QBASED	See the definition below table 4.4.3.2-3.
All neighCells with port1	Used for all neighbouring cells with at least two cell-specific antenna ports
Band > 64	If band > 64 is selected

- *SystemInformationBlockType6*

The IE *SystemInformationBlockType6* contains information relevant only for inter-RAT cell re-selection i.e. information about UTRA frequencies and UTRA neighbouring cells relevant for cell re-selection. The IE includes cell re-selection parameters common for a frequency.

Table 4.4.3.3-5: *SystemInformationBlockType6*

Derivation Path: 36.331 clause 6.3.1			
Information Element	Value/remark	Comment	Condition
SystemInformationBlockType6 ::= SEQUENCE {			
carrierFreqListUTRA-FDD SEQUENCE (SIZE (1..maxUTRA-FDD-Carrier)) OF SEQUENCE {	Not present		UTRA-TDD
carrierFreqListUTRA-FDD SEQUENCE (SIZE (1..maxUTRA-FDD-Carrier)) OF SEQUENCE {	The same number of entries as the configured UTRA FDD carriers For Signalling test cases, see table 6.3.1.3-1	n denotes the index of the entry	UTRA-FDD
carrierFreq[n]	Downlink UARFCN under test For Signalling test cases, see table 6.3.1.3-1		
cellReselectionPriority[n]	3		
threshX-High[n]	2 (4 dB)		
threshX-Low[n]	1 (2 dB)		
q-RxLevMin[n]	-40 (-79 dBm)	The same value as defined in TS 34.108 [5], table 6.1.1.	
p-MaxUTRA[n]	21 (21 dBm)	The same value as defined in TS 34.108 [5], table 6.1.1.	
q-QualMin[n]	-24 (-24 dB)	The same value as defined in TS 34.108 [5], table 6.1.1.	
threshX-Q-r9[n] SEQUENCE {	Not present		
threshX-Q-r9[n] SEQUENCE {			QBASED
threshX-HighQ-r9	9 (9dB)		
threshX-LowQ-r9	9 (9dB)		
}			
}			
carrierFreqListUTRA-TDD SEQUENCE (SIZE (1..maxUTRA-TDD-Carrier)) OF SEQUENCE {	Not present		UTRA-FDD
carrierFreqListUTRA-TDD SEQUENCE (SIZE (1..maxUTRA-TDD-Carrier)) OF SEQUENCE {	The same number of entries as the configured UTRA TDD carriers For Signalling test cases, see table 6.3.1.3-1	n denotes the index of the entry	UTRA-TDD
carrierFreq[n]	Downlink UARFCN under test For Signalling test cases, see table 6.3.1.3-1		
cellReselectionPriority[n]	3		
threshX-High[n]	2 (4 dB)		
threshX-Low[n]	1 (2 dB)		
q-RxLevMin[n]	-41 (-81 dBm)	The same value as defined in TS 34.108 [5], table 6.1.6a	
p-MaxUTRA[n]	21 (21 dBm)	The same value as defined in TS 34.108 [5], table 6.1.6a	
}			
t-ReselectionUTRA	0	Typical value in real network	
t-ReselectionUTRA-SF	Not present		
}			

Condition	Explanation
-----------	-------------

UTRA-FDD	UTRA FDD cell environment
UTRA-TDD	UTRA TDD cell environment
QBASSED	See the definition below table 4.4.3.2-3.

- *SystemInformationBlockType7*

The IE *SystemInformationBlockType7* contains information relevant only for inter-RAT cell re-selection i.e. information about GERAN frequencies relevant for cell re-selection. The IE includes cell re-selection parameters for each frequency.

Table 4.4.3.3-6: *SystemInformationBlockType7*

Derivation Path: 36.331 clause 6.3.1			
Information Element	Value/remark	Comment	Condition
<i>SystemInformationBlockType7</i> ::= SEQUENCE {			
t-ReselectionGERAN	0		
t-ReselectionGERAN-SF	Not present		
carrierFreqsInfoListSEQUENCE (SIZE (1..maxGNFG)) OF SEQUENCE {	The same number of entries as the configured GERAN carriers For RRM test cases, see table 7.2.2.1-1 For Signalling test cases, see table 6.3.1.4-1	<i>n</i> denotes the index of the entry	
carrierFreqs [<i>n</i>] SEQUENCE {			
startingARFCN[<i>n</i>]	Set the corresponding starting ARFCN of the GERAN cells under test. For RRM test cases, see table 7.2.2.1-1 For Signalling test cases, see table 6.3.1.4-1		
bandIndicator[<i>n</i>]	Set according to the band used for GERAN cells under test		
followingARFCNs[<i>n</i>] CHOICE {			
explicitListOfARFCNs[<i>n</i>]	Set the corresponding ARFCN of GERAN cells under test For RRM test cases, see table 7.2.2.1-1 For Signalling test cases, see table 6.3.1.4-1		
}			
}			
commonInfo[<i>n</i>] SEQUENCE {			
cellReselectionPriority[<i>n</i>]	2		
ncc-Permitted[<i>n</i>]	'01000000'B	NCC=1 permitted	
q-RxLevMin[<i>n</i>]	2		
p-MaxGERAN[<i>n</i>]	0		
threshX-High[<i>n</i>]	2		
threshX-Low[<i>n</i>]	2		
}			
}			
}			

- *SystemInformationBlockType8*

The IE *SystemInformationBlockType8* contains information relevant only for inter-RAT cell re-selection i.e. information about CDMA2000 frequencies and CDMA2000 neighbouring cells relevant for cell re-selection. The IE includes cell re-selection parameters common for a frequency as well as cell specific re-selection parameters.

Table 4.4.3.3-7: *SystemInformationBlockType8*

Derivation Path: 36.331 clause 6.3.1			
Information Element	Value/remark	Comment	Condition
SystemInformationBlockType8 ::= SEQUENCE {			
systemTimeInfo SEQUENCE {			
cdma-EUTRA-Synchronisation	TRUE		
cdma-SystemTime CHOICE {			
synchronousSystemTime	A valid value as per TS 36.331 and calculated by the SS		
}			
}			
searchWindowSize	5		
parametersHRPD SEQUENCE {}	Not present		1XRTT
parametersHRPD SEQUENCE {			HRPD
preRegistrationInfoHRPD SEQUENCE {			
preRegistrationAllowed	FALSE		
preRegistrationZoneld	Not present		
secondaryPreRegistrationZoneldList	Not present		
}			
cellReselectionParametersHRPD SEQUENCE {			
bandClassList SEQUENCE (SIZE (1..maxCDMA-BandClass)) OF SEQUENCE {	1 entry		
bandClass	Operating band class under test.	ENUMERATED {bc0, bc1, bc2, bc3, bc4, bc5, bc6, bc7, bc8, bc9, bc10, bc11, bc12, bc13, bc14, bc15, bc16, bc17, spare14, spare13, spare12, spare11, spare10, spare9, spare8, spare7, spare6, spare5, spare4, spare3, spare2, spare1, ...}	
cellReselectionPriority	1		
threshX-High	30(-30)	INTEGER (0..63)	
threshX-Low	32(-32)	INTEGER (0..63)	
}			
neighCellList SEQUENCE (SIZE (1..16)) OF SEQUENCE {	1 entry		
bandClass	Operating band class under test	ENUMERATED {bc0, bc1, bc2, bc3, bc4, bc5, bc6, bc7, bc8, bc9, bc10, bc11, bc12, bc13, bc14, bc15, bc16, bc17, spare14, spare13, spare12, spare11, spare10, spare9, spare8, spare7, spare6, spare5, spare4, spare3, spare2, spare1, ...}	
neighCellsPerFreqList SEQUENCE (SIZE (1..16)) OF SEQUENCE {	The same number of entries as the configured CDMA2000 HRPD frequencies For Signalling test cases, see table 6.3.1.5-1	<i>n</i> denotes the index of the entry	

arfcn[n]	ARFCN of the CDMA2000 HRPD frequency For Signalling test cases, see table 6.3.1.5-1	INTEGER (0..2047)	
physCellIdList[n] SEQUENCE (SIZE (1..16)) OF {INTEGER (0..maxPNOffset) }	Physical Cell ID List of the CDMA2000 HRPD frequency For Signalling test cases, see table 6.3.1.5-1	INTEGER (0..maxPNOffset)	
}			
}			
t-ReselectionCDMA2000	0	INTEGER (0..7)	
t-ReselectionCDMA2000-SF	Not Present		
}			
}			
parameters1XRTT SEQUENCE {	Not present		HRPD
parameters1XRTT SEQUENCE {			1XRTT
csfb-RegistrationParam1XRTT SEQUENCE {			
longCodeState1XRTT	A valid value, calculated and updated by the SS	BIT STRING (SIZE (42)) OPTIONAL	
cellReselectionParameters1XRTT SEQUENCE {			
bandClassList SEQUENCE (SIZE (1..maxCDMA-BandClass)) OF SEQUENCE {	1 entry		
bandClass	Operating band class under test	ENUMERATED {bc0, bc1, bc2, bc3, bc4, bc5, bc6, bc7, bc8, bc9, bc10, bc11, bc12, bc13, bc14, bc15, bc16, bc17, spare14, spare13, spare12, spare11, spare10, spare9, spare8, spare7, spare6, spare5, spare4, spare3, spare2, spare1, ...}	
cellReselectionPriority	0		
threshX-High	30(-30)	INTEGER (0..63)	
threshX-Low	32(-32)	INTEGER (0..63)	
}			
neighCellList SEQUENCE (SIZE (1..16)) OF SEQUENCE {	1 entry		
bandClass	Operating band class under test	ENUMERATED {bc0, bc1, bc2, bc3, bc4, bc5, bc6, bc7, bc8, bc9, bc10, bc11, bc12, bc13, bc14, bc15, bc16, bc17, spare14, spare13, spare12, spare11, spare10, spare9, spare8, spare7, spare6, spare5, spare4, spare3, spare2, spare1, ...}	
neighCellsPerFreqList SEQUENCE (SIZE (1..16)) OF SEQUENCE {	The same number of entries as the configured CDMA2000 1xRTT frequencies For Signalling test cases, see table 6.3.1.6-1	n denotes the index of the entry	

arfcn[n]	ARFCN of the CDMA2000 1xRTT frequency For Signalling test cases, see table 6.3.1.6-1	INTEGER (0..2047)	
physCellIdList[n] SEQUENCE (SIZE (1..16)) OF {INTEGER (0..maxPNOffset) }	Physical Cell ID List of the CDMA2000 1xRTT frequency For Signalling test cases, see table 6.3.1.6-1	INTEGER (0..maxPNOffset)	
}			
}			
t-ReselectionCDMA2000	0	INTEGER (0..7)	
t-ReselectionCDMA2000-SF	Not Present		
}			
}			
}			

Condition	Explanation
HRPD	CDMA2000 HRPD cell environment
1XRTT	CDMA2000 1XRTT cell environment

- **SystemInformationBlockType9**

The IE *SystemInformationBlockType9* contains a home eNB name (HNB Name).

Table 4.4.3.3-8: SystemInformationBlockType9

Derivation Path: 36.331 clause 6.3.1			
Information Element	Value/remark	Comment	Condition
SystemInformationBlockType9 ::= SEQUENCE {			
hnb-Name	"3gppTest"		
}			

- **SystemInformationBlockType10**

The IE *SystemInformationBlockType10* contains an ETWS primary notification.

Table 4.4.3.3-9: SystemInformationBlockType10

Derivation Path: 36.331 clause 6.3.1			
Information Element	Value/remark	Comment	Condition
SystemInformationBlockType10 ::= SEQUENCE {			
messageIdentifier	'0001 0001 0000 0010'B	ETWS message identifier for earthquake and tsunami message [see TS 23.041]	
serialNumber	'0011 0000 0000 0000'B		
- Geographical Scope (2 bit)	Octet 1 bit 7 ~ 6	Cell wide;	
- Message Code (10 bit)	Octet 1 bit 5 ~ Octet 2 bit 4	'11 0000 0000'B	
- Emergency User Alert (1 bit)	Octet 1 bit 5	Activate emergency user alert;	
- Popup (1 bit)	Octet 1 bit 4	Activate popup;	
- Update Number (4 bit)	Octet 2 bit 3 ~ 0	For each update, incremented by one. [see TS 23.041]	
warningType	'0000 0101 1000 0000'B		
- Warning Type Value (7 bit)	Octet 1 bit 7 ~ 1	Earthquake and Tsunami;	
- Emergency User Alert (1 bit)	Octet 1 bit 0	Activate emergency user alert;	
- Popup (1 bit)	Octet 2 bit 7	Activate Popup. [see TS 23.041]	
- Padding (7 bit)	Octet 2 bit 6 ~ bit 0	'000 0000'B	
warningSecurityInfo	Not present		
}			

- *SystemInformationBlockType11*

The IE *SystemInformationBlockType11* contains an ETWS secondary notification.

Table 4.4.3.3-10: *SystemInformationBlockType11* (1st Segment)

Derivation Path: 36.331 clause 6.3.1			
Information Element	Value/remark	Comment	Condition
<i>SystemInformationBlockType11</i> ::= SEQUENCE {			
messageIdentifier	'0001 0001 0000 0010'B	ETWS message identifier for earthquake and tsunami message [see TS 23.041]	
serialNumber - Geographical Scope (2 bit) - Message Code (10 bit) - Emergency User Alert (1 bit) - Popup (1 bit) - Update Number (4 bit)	'0011 0000 0000 0000'B Octet 1 bit 7 ~ 6 Octet 1 bit 5 ~ Octet 2 bit 4 Octet 1 bit 5 Octet 1 bit 4 Octet 2 bit 3 ~ 0	Cell wide; '11 0000 0000'B Activate emergency user alert; Activate popup; For each update, incremented by one. [see TS 23.041]	
warningMessageSegmentType	notLastSegment		
warningMessageSegmentNumber	0		
warningMessageSegment	Octetstring of N	where $N \geq 1$ and less than 1246. [see TS 23.041]	
dataCodingScheme	Bitstring (8) ID of the alphabet/coding and the applied language [see TS 23.041]		
}			

Table 4.4.3.3-11: SystemInformationBlockType11 (2nd Segment)

Derivation Path: 36.331 clause 6.3.1			
Information Element	Value/remark	Comment	Condition
SystemInformationBlockType11 ::= SEQUENCE {			
messageIdentifier	'0001 0001 0000 0010'B	ETWS message identifier for earthquake and tsunami message [see TS 23.041]	
serialNumber - Geographical Scope (2 bit)	'0011 0000 0000 0000'B Octet 1 bit 7 ~ 6	Cell wide;	
- Message Code (10 bit)	Octet 1 bit 5 ~ Octet 2 bit 4	'11 0000 0000'B	
- Emergency User Alert (1 bit)	Octet 1 bit 5	Activate emergency user alert;	
- Popup (1 bit)	Octet 1 bit 4	Activate popup;	
- Update Number (4 bit)	Octet 2 bit 3 ~ 0	For each update, incremented by one. [see TS 23.041]	
warningMessageSegmentType	notLastSegment		
warningMessageSegmentNumber	1		
warningMessageSegment	Octetstring of N	where N ≥ 1 and less than 1246. [see TS 23.041]	
dataCodingScheme	Not present		
}			

Table 4.4.3.3-12: SystemInformationBlockType11 (3rd Segment)

Derivation Path: 36.331 clause 6.3.1			
Information Element	Value/remark	Comment	Condition
SystemInformationBlockType11 ::= SEQUENCE {			
messageIdentifier	'0001 0001 0000 0010'B	ETWS message identifier for earthquake and tsunami message [see TS 23.041]	
serialNumber - Geographical Scope (2 bit)	'0011 0000 0000 0000'B Octet 1 bit 7 ~ 6	Cell wide;	
- Message Code (10 bit)	Octet 1 bit 5 ~ Octet 2 bit 4	'11 0000 0000'B	
- Emergency User Alert (1 bit)	Octet 1 bit 5	Activate emergency user alert;	
- Popup (1 bit)	Octet 1 bit 4	Activate popup;	
- Update Number (4 bit)	Octet 2 bit 3 ~ 0	For each update, incremented by one. [see TS 23.041]	
warningMessageSegmentType	lastSegment		
warningMessageSegmentNumber	2		
warningMessageSegment	Octetstring of N	where N ≥ 1 and less than 1246. [see TS 23.041]	
dataCodingScheme	Not present		
}			

- *SystemInformationBlockType12*

The IE *SystemInformationBlockType12* contains an CMAS notification.

Table 4.4.3.3-12a: *SystemInformationBlockType12* (1st Segment)

Derivation Path: 36.331 clause 6.3.1			
Information Element	Value/remark	Comment	Condition
SystemInformationBlockType11 ::= SEQUENCE {			
messageIdentifier-r9	'0001 0001 0001 0010'B	CMAS CBS Message Identifier for CMAS Presidential Level Alerts (see TS 23.041))	
serialNumber-r9	'0011 0000 0000 0000'B		
warningMessageSegmentType	notLastSegment		
warningMessageSegmentNumber	0		
warningMessageSegment	Octetstring of N	where N ≥ 1 and less than 1246. (see TS 23.041)	
dataCodingScheme	-Bitstring (8) ID of the alphabet/coding and the applied language [see TS 23.041]	Provided as PIXITs [see TS 36.523-3 [20] cl. 9]	
lateNonCriticalExtension	Not present		
}			

Table 4.4.3.3-12b: *SystemInformationBlockType12* (2nd Segment)

Derivation Path: 36.331 clause 6.3.1			
Information Element	Value/remark	Comment	Condition
SystemInformationBlockType11 ::= SEQUENCE {			
messageIdentifier-r9	'0001 0001 0001 0010'B	CMAS CBS Message Identifier for CMAS Presidential Level Alerts (see TS 23.041)	
serialNumber-r9	'0011 0000 0000 0000'B		
warningMessageSegmentType	notLastSegment		
warningMessageSegmentNumber	1		
warningMessageSegment	Octetstring of N	where N ≥ 1 and less than 1246. (see TS 23.041)	
dataCodingScheme	Not present		
lateNonCriticalExtension	Not present		
}			

Table 4.4.3.3-12c: SystemInformationBlockType12 (3rd Segment)

Derivation Path: 36.331 clause 6.3.1			
Information Element	Value/remark	Comment	Condition
SystemInformationBlockType11 ::= SEQUENCE {			
messageIdentifier-r9	'0001 0001 0001 0010'B	CMAS CBS Message Identifier for CMAS Presidential Level Alerts (see TS 23.041)	
serialNumber-r9	'0011 0000 0000 0000'B		
warningMessageSegmentType	lastSegment		
warningMessageSegmentNumber	2		
warningMessageSegment	Octetstring of N	where N ≥ 1 and less than 1246. (see TS 23.041)	
dataCodingScheme	Not present		
lateNonCriticalExtension	Not present		
}			

- **SystemInformationBlockType13**

The IE *SystemInformationBlockType13* contains the information required to acquire the MBMS control information associated with one or more MBSFN areas.

Table 4.4.3.3-13: SystemInformationBlockType13

Derivation Path: 36.331 clause 6.3.1			
Information Element	Value/remark	Comment	Condition
SystemInformationBlockType13 ::= SEQUENCE {			
mbsfn-AreaInfoList-r9 SEQUENCE (SIZE(1..maxMBSFN-Area)) OF SEQUENCE {			
mbsfn-Areald-r9	0		
non-MBSFNregionLength	2		
notificationIndicator-r9	0		
mcch-Config-r9 SEQUENCE {			
mcch-RepetitionPeriod-r9	rf32		
mcch-Offset-r9	1		FDD
	0		TDD
mcch-ModificationPeriod-r9	rf512		
sf-AllocInfo-r9	'100000'B		FDD
	'000010'B		TDD
signallingMCS-r9	n2		
}			
}			
notificationConfig-r9 SEQUENCE {			
notificationRepetitionCoeff-r9	n4		
notificationOffset-r9	1		FDD
	0		TDD
notificationSF-Index-r9	1	Subframe #1	FDD
	5	Subframe #9	TDD
}			
}			

Condition	Explanation
FDD	FDD cell environment
TDD	TDD cell environment

- **SystemInformationBlockType14**

The IE *SystemInformationBlockType14* contains the EAB parameters.

Table 4.4.3.3-13A: SystemInformationBlockType14

Derivation Path: 36.331 clause 6.3.1			
Information Element	Value/remark	Comment	Condition
SystemInformationBlockType14-r11 ::= SEQUENCE {			
eab-Param-r11 CHOICE {			
EAB-Config-r11 ::= SEQUENCE {			
eab-Category-r11	a	EAB applies to all UEs in the PLMN ENUMERATED {a, b, c}	
eab-BarringBitmap-r11	'1111111111'B	All UE classes 0-9 BIT STRING (SIZE (10))	
}			
}			
lateNonCriticalExtension	Not Present		
}			

- **SystemInformationBlockType15**

The IE *SystemInformationBlockType15* contains the MBMS Service Area Identities (SAI) of the current and/ or neighbouring carrier frequencies.

Table 4.4.3.3-14: SystemInformationBlockType15

Derivation Path: 36.331 clause 6.3.1			
Information Element	Value/remark	Comment	Condition
SystemInformationBlockType15 ::= SEQUENCE {			
mbms-SAI-IntraFreq-r11[1] SEQUENCE (SIZE (1..maxSAI-MBMS-r11)) OF { INTEGER (0..65535) }	1	1 entry INTEGER (0..65535)	
mbms-SAI-InterFreqList-r11	Not present		MBMS_intra Freq, SCPTM_intraFreq
mbms-SAI-InterFreqList-r11[n] SEQUENCE (SIZE (1..maxFreq)) OF SEQUENCE {	The same number of entries as the configured inter-freq carriers providing the MBMS service in the test case (including additional bands, if any)	n denotes the index of the entry	MBMS_inter Freq, SCPTM_interFreq
dl-CarrierFreq-r11	Downlink EARFCN under test, see table 6.3.1.2-1.		
mbms-SAI-List-r11[n] SEQUENCE (SIZE (1..maxSAI-MBMS-r11)) OF { INTEGER (0..65535) }	The same number of entries as the configured MBMS SAIs providing the MBMS service in the test case for the specific frequency	n denotes the index of the entry INTEGER (0..65535)	
lateNonCriticalExtension	Not present		MBMS_intra Freq, MBMS_inter Freq, SCPTM_intraFreq, SCPTM_interFreq
}			

Condition	Explanation
-----------	-------------

MBMS_intraFreq	SIB15 transmitted for a MBMS intra-band cell environment (MBMS service only provided for intra-frequency cells).
MBMS_interFreq	SIB15 transmitted for a MBMS inter-frequency cell environment (MBMS service provided on multiple frequencies within a band).
SCPTM_intraFreq	SIB15 transmitted for a SC-PTM intra-band cell environment (SC-PTM service only provided for intra-frequency cells).
SCPTM_interFreq	SIB15 transmitted for a SC-PTM inter-frequency cell environment (SC-PTM service provided on multiple frequencies within a band).

- **SystemInformationBlockType17**

The IE *SystemInformationBlockType17* contains information relevant for RAN Assisted WLAN interworking

Table 4.4.3.3-15: SystemInformationBlockType17

Derivation Path: 36.331 clause 6.3.1			
Information Element	Value/remark	Comment	Condition
SystemInformationBlockType17-r12 ::= SEQUENCE			
{			
wlan-OffloadInfoPerPLMN-List-r12 [1] SEQUENCE (SIZE (1..maxPLMN-r11)) OF {		1 Entry	
wlan-OffloadConfigCommon-r12	WLAN-OffloadConfig-DEFAULT		
wlan-Id-List-r12 [1] SEQUENCE (SIZE (1..maxWLAN-Id-r12)) OF {		1 Entry	
wlan-Identifiers SEQUENCE{			
ssid-r12	Set as per Table 4.4.8-1	OCTET STRING (SIZE (1..32)) Service Set Identifier (SSID) defined in IEEE 802.11-2012	
bssid-r12	Not present		
hessid-r12	Not present		
}			
}			
}			
lateNonCriticalExtension	Not present		
}			

- **SystemInformationBlockType18**

The IE *SystemInformationBlockType18* contains the resource pool information for sidelink direct communication.

Table 4.4.3.3-16: SystemInformationBlockType18

Derivation Path: 36.331 clause 6.3.1			
Information Element	Value/remark	Comment	Condition
SystemInformationBlockType18-r12 ::= SEQUENCE { commConfig-r12 SEQUENCE {			
commRxPool-r12 SEQUENCE (SIZE (1..maxSL-RxPool-r12)) OF SL-CommResourcePool-r12 {		3 Rx pools	
SL-CommResourcePool-r12[1] SEQUENCE {		RxPool 1 A monitoring UE can receive on the resources of this pool when a transmitting UE uses the TxPoolNormal 1	
sc-CP-Len-r12	normal		
sc-Period-r12	sf40		
sc-TF-ResourceConfig-r12 SEQUENCE {			
prb-Num-r12	13 25		BW5 BW10
prb-Start-r12	0		
prb-End-r12	24 49		BW5 BW10
offsetIndicator-r12	0	small-r12	
subframeBitmap-r12	11000000 00000000 00000000 00000000 00000000	bs40-r12	FDD
}			
data-CP-Len-r12	normal		
dataHoppingConfig-r12 SEQUENCE {			
hoppingParameter-r12	0		
numSubbands-r12	ns1		
rb-Offset-r12	0		
}			
ue-SelectedResourceConfig-r12 SEQUENCE {			
data-TF-ResourceConfig-r12 SEQUENCE {			
prb-Num-r12	13 25		BW5 BW10
prb-Start-r12	0		
prb-End-r12	24 49		BW5 BW10
offsetIndicator-r12	0	small-r12	
subframeBitmap-r12	00000000 00000000 11110000 00000000 00000000	bs40-r12	FDD
}			
trpt-Subset-r12	001		
}			
rxParametersNCell-r12	Not present		
txParameters-r12	Not present		
}			
SL-CommResourcePool-r12[2] SEQUENCE {		RxPool 2 A monitoring UE can receive on the resources of this pool when a transmitting UE uses the TxPoolNormal 2	
sc-CP-Len-r12	normal		
sc-Period-r12	sf40		

sc-TF-ResourceConfig-r12 SEQUENCE {			
prb-Num-r12	13		BW5
	25		BW10
prb-Start-r12	0		
prb-End-r12	24		BW5
	49		BW10
offsetIndicator-r12	0	small-r12	
subframeBitmap-r12	00110000 00000000 00000000 00000000 00000000	bs40-r12	FDD
}			
data-CP-Len-r12	normal		
dataHoppingConfig-r12 SEQUENCE {			
hoppingParameter-r12	0		
numSubbands-r12	ns1		
rb-Offset-r12	0		
}			
ue-SelectedResourceConfig-r12 SEQUENCE {			
data-TF-ResourceConfig-r12 SEQUENCE {			
prb-Num-r12	13		BW5
	25		BW10
prb-Start-r12	0		
prb-End-r12	24		BW5
	49		BW10
offsetIndicator-r12	0	small-r12	
subframeBitmap-r12	00000000 00000000 00111100 00000000 00000000	bs40-r12	FDD
}			
trpt-Subset-r12	001		
}			
rxParametersNCell-r12 SEQUENCE {			
tdd-Config-r12 SEQUENCE {}	Not present		
syncConfigIndex-r12	1	Entry 2 in discSyncConfig- r12 (SL- SyncConfig- r12[2])	
}			
txParameters-r12	Not present		
}			
SL-CommResourcePool-r12[3] SEQUENCE {		RxPool 3	
		A monitoring UE can receive on the resources of this pool when a transmitting UE uses the TxPoolExceptiona l 1	
sc-CP-Len-r12	normal		
sc-Period-r12	sf40		
sc-TF-ResourceConfig-r12 SEQUENCE {			
prb-Num-r12	13		BW5
	25		BW10
prb-Start-r12	0		
prb-End-r12	24		BW5
	49		BW10
offsetIndicator-r12	0	small-r12	

subframeBitmap-r12	00001100 00000000 00000000 00000000 00000000	bs40-r12	FDD
}			
data-CP-Len-r12	normal		
dataHoppingConfig-r12 SEQUENCE {			
hoppingParameter-r12	0		
numSubbands-r12	ns1		
rb-Offset-r12	0		
}			
ue-SelectedResourceConfig-r12 SEQUENCE {			
data-TF-ResourceConfig-r12 SEQUENCE {			
prb-Num-r12	13		BW5
	25		BW10
prb-Start-r12	0		
prb-End-r12	24		BW5
	49		BW10
offsetIndicator-r12	0	small-r12	
subframeBitmap-r12	00000000 00000000 00001111 00000000 00000000	bs40-r12	FDD
}			
trpt-Subset-r12	001		
}			
rxParametersNCell-r12	Not present		
txParameters-r12	Not present		
}			
commTxPoolNormalCommon-r12 SEQUENCE (SIZE (1..maxSL-TxPool-r12)) OF SL- CommResourcePool-r12 {		2 Tx pools Normal	
SL-CommResourcePool-r12[1] SEQUENCE {		TxPool 1	
sc-CP-Len-r12	normal		
sc-Period-r12	sf40		
sc-TF-ResourceConfig-r12 SEQUENCE {			
prb-Num-r12	13		BW5
	25		BW10
prb-Start-r12	0		
prb-End-r12	24		BW5
	49		BW10
offsetIndicator-r12	0	small-r12	
subframeBitmap-r12	11000000 00000000 00000000 00000000 00000000	bs40-r12	FDD
}			
data-CP-Len-r12	normal		
dataHoppingConfig-r12 SEQUENCE {			
hoppingParameter-r12	0		
numSubbands-r12	ns1		
rb-Offset-r12	0		
}			
ue-SelectedResourceConfig-r12 SEQUENCE {			
data-TF-ResourceConfig-r12 SEQUENCE {			
prb-Num-r12	13		BW5
	25		BW10
prb-Start-r12	0		
prb-End-r12	24		BW5
	49		BW10
offsetIndicator-r12	0	small-r12	

subframeBitmap-r12	00000000 00000000 11110000 00000000 00000000	bs40-r12	FDD
}			
trpt-Subset-r12	001		
}			
rxParametersNCell-r12	Not present		
txParameters-r12 SEQUENCE {			
sc-TxParameters-r12 SEQUENCE {			
alpha-r12	al0		
p0-r12	31		
}			
dataTxParameters-r12 SEQUENCE {			
alpha-r12	al0		
p0-r12	0		
}			
}			
}			
SL-CommResourcePool-r12[2] SEQUENCE {		TxPool 2	
sc-CP-Len-r12	normal		
sc-Period-r12	sf40		
sc-TF-ResourceConfig-r12 SEQUENCE {			
prb-Num-r12	13		BW5
	25		BW10
prb-Start-r12	0		
prb-End-r12	24		BW5
	49		BW10
offsetIndicator-r12	0	small-r12	
subframeBitmap-r12	00110000 00000000 00000000 00000000 00000000	bs40-r12	FDD
}			
data-CP-Len-r12	normal		
dataHoppingConfig-r12 SEQUENCE {			
hoppingParameter-r12	0		
numSubbands-r12	ns1		
rb-Offset-r12	0		
}			
ue-SelectedResourceConfig-r12 SEQUENCE {			
data-TF-ResourceConfig-r12 SEQUENCE {			
prb-Num-r12	13		BW5
	25		BW10
prb-Start-r12	0		
prb-End-r12	24		BW5
	49		BW10
offsetIndicator-r12	0	small-r12	
subframeBitmap-r12	00000000 00000000 00111100 00000000 00000000	bs40-r12	FDD
}			
trpt-Subset-r12	001		
}			
rxParametersNCell-r12	Not present		
txParameters-r12 SEQUENCE {			
sc-TxParameters-r12 SEQUENCE {			
alpha-r12	al0		
p0-r12	31		
}			
dataTxParameters-r12 SEQUENCE {			
alpha-r12	al0		

p0-r12	0		
}			
}			
}			
commTxPoolExceptional-r12 SEQUENCE (SIZE (1..maxSL-TxPool-r12)) OF SL-CommResourcePool-r12 {		1 Tx pool Exceptional	
SL-CommResourcePool-r12[1] SEQUENCE {		TxExceptionalPool 1	
sc-CP-Len-r12	normal		
sc-Period-r12	sf40		
sc-TF-ResourceConfig-r12 SEQUENCE {			
prb-Num-r12	13		BW5
	25		BW10
prb-Start-r12	0		
prb-End-r12	24		BW5
	49		BW10
offsetIndicator-r12	0	small-r12	
subframeBitmap-r12	00001100 00000000 00000000 00000000 00000000	bs40-r12	FDD
}			
data-CP-Len-r12	normal		
dataHoppingConfig-r12 SEQUENCE {			
hoppingParameter-r12	0		
numSubbands-r12	ns1		
rb-Offset-r12	0		
}			
ue-SelectedResourceConfig-r12 SEQUENCE {			
data-TF-ResourceConfig-r12 SEQUENCE {			
prb-Num-r12	13		BW5
	25		BW10
prb-Start-r12	0		
prb-End-r12	24		BW5
	49		BW10
offsetIndicator-r12	0	small-r12	
subframeBitmap-r12	00000000 00000000 00001111 00000000 00000000	bs40-r12	FDD
}			
trpt-Subset-r12	001		
}			
rxParametersNCell-r12	Not present		
txParameters-r12 SEQUENCE {			
sc-TxParameters-r12 SEQUENCE {			
alpha-r12	al0		
p0-r12	31		
}			
dataTxParameters-r12 SEQUENCE {			
alpha-r12	al0		
p0-r12	0		
}			
}			
}			
}			
commSyncConfig-r12 SEQUENCE (SIZE (1..maxSL-SyncConfig-r12)) OF SL-SyncConfig-r12 {		2 configuration reception/transmission of synchronisation signals	

SL-SyncConfig-r12[1] SEQUENCE {		SyncConfig 1	
		To be used for transmission	
syncCP-Len-r12	normal		
syncOffsetIndicator-r12	2		
slssid-r12	30		
txParameters-r12 SEQUENCE {			
syncTxParameters-r12 SEQUENCE {			
alpha-r12	al0		
p0-r12	31		
}			
syncTxThreshIC-r12	7	-85dBm The threshold for starting transmission of SLSS	
}			
rxParamsNCell-r12	Not present		
}			
SL-SyncConfig-r12[2] SEQUENCE {		SyncConfig 2	
		To be used for reception. RxPool Pool 2 is referring to this SyncConfig 2	
syncCP-Len-r12	normal		
syncOffsetIndicator-r12	25		
slssid-r12	40		
txParameters-r12	Not Present		
rxParamsNCell-r12 SEQUENCE {			
physCellId-r12	Set to the physical cell identity of the PCell		
discSyncWindow-r12	w1		
}			
}			
}			
lateNonCriticalExtension	Not present		
}			
<p>Note 1: For convenience the difference between the different pools is only in the relevant setting of the <i>subframeBitmap</i>.</p> <p>Note 2: Note that the resources defined by the first entry in <i>preconfigComm</i> defined in clause 6.8.1.1 (used for transmission by an out of coverage UE) should not overlap (see TS 36.331 [17], clause 9.3.2) with those of the pool(s) covering scheduled transmissions by in coverage UEs which are defined here for SIB18.</p>			

Condition	Explanation
BW5	5 MHz channel bandwidth cell environment
BW10	10 MHz channel bandwidth cell environment
FDD	FDD cell environment

- *SystemInformationBlockType19*

The IE *SystemInformationBlockType19* contains the resource pool information for sidelink direct discovery.

Table 4.4.3.3-17: SystemInformationBlockType19

Derivation Path: 36.331 clause 6.3.1			
Information Element	Value/remark	Comment	Condition
SystemInformationBlockType19-r12 ::= SEQUENCE {			
discConfig-r12 SEQUENCE {			
discRxPool-r12 SEQUENCE SIZE (1..maxSL-TxPool-r12) OF SL-DiscResourcePool-r12 {		2 RxPools For convenience the difference between the pools is only in <i>subframeBitmap</i> .	
SL-DiscResourcePool-r12[1] SEQUENCE {		RxPool 1 A monitoring UE can receive on the resources of this pool when a transmitting UE uses the TxPoolCommon 1	
cp-Len-r12	normal		
discPeriod-r12	rf128		
numRetx-r12	0		
numRepetition-r12	1		
tf-ResourceConfig-r12 SEQUENCE {		SL-TF-ResourceConfig-r12	
prb-Num-r12	12		BW5
	24		BW10
prb-Start-r12	0		
prb-End-r12	23		BW5
	48		BW10
offsetIndicator-r12	160	small-r12	FDD
	163		TDD
subframeBitmap-r12	11000000 00000000 00000000 00000000 00000000	bs40-r12	FDD
	11000000 00000000	bs16-r12	TDD
}			
txParameters-r12	Not present		
rxParameters-r12	Not present		
}			
SL-DiscResourcePool-r12[2] SEQUENCE {		RxPool 2 A monitoring UE can receive on the resources of this pool when a transmitting UE uses the TxPoolCommon 2	
cp-Len-r12	normal		
discPeriod-r12	rf128		
numRetx-r12	0		
numRepetition-r12	1		
tf-ResourceConfig-r12 SEQUENCE {		SL-TF-ResourceConfig-r12	
prb-Num-r12	12		BW5
	24		BW10
prb-Start-r12	0		
prb-End-r12	23		BW5
	48		BW10
offsetIndicator-r12	160	small-r12	FDD

	163		TDD
subframeBitmap-r12	00110000 00000000 00000000 00000000 00000000	bs40-r12	FDD
	00110000 00000000	bs16-r12	TDD
}			
txParameters-r12	Not present		
rxParameters-r12	Not present		
}			
discTxPoolCommon-r12 SEQUENCE SIZE (1..maxSL-TxPool-r12) OF SL-DiscResourcePool-r12 {		2 TxPools For convenience the difference between the pools is only in <i>subframeBitmap</i> .	
SL-DiscResourcePool-r12[1] SEQUENCE {		TxPool 1	
cp-Len-r12	normal		
discPeriod-r12	rf128		
numRetx-r12	0		
numRepetition-r12	1		
tf-ResourceConfig-r12 SEQUENCE {		SL-TF-ResourceConfig-r12	
prb-Num-r12	12		BW5
	24		BW10
prb-Start-r12	0		
prb-End-r12	23		BW5
	48		BW10
offsetIndicator-r12	160	small-r12	FDD
	163		TDD
subframeBitmap-r12	11000000 00000000 00000000 00000000 00000000	bs40-r12	FDD
bs42-r12	11000000 00000000	bs16-r12	TDD
}			
txParameters-r12 SEQUENCE {			
txParametersGeneral-r12 SEQUENCE {		SL-TxParameters-r12	
alpha-r12	al0		
p0-r12	31	P0-SL-r12	
}			
ue-SelectedResourceConfig-r12 SEQUENCE {			
poolSelection-r12	NULL	random-r12	
txProbability-r12	p100		
}			
}			
rxParameters-r12	Not present		
}			
SL-DiscResourcePool-r12[2] SEQUENCE {		TxPool 2	
cp-Len-r12	normal		
discPeriod-r12	rf128		
numRetx-r12	0		
numRepetition-r12	1		
tf-ResourceConfig-r12 SEQUENCE {		SL-TF-ResourceConfig-r12	
prb-Num-r12	12		BW5
	24		BW10

prb-Start-r12	0		
prb-End-r12	23		BW5
	48		BW10
offsetIndicator-r12	160	small-r12	FDD
	163		TDD
subframeBitmap-r12	00110000 00000000 00000000 00000000 00000000	bs40-r12	FDD
	00110000 00000000	bs16-r12	TDD
}			
txParameters-r12 SEQUENCE {			
txParametersGeneral-r12 SEQUENCE {		SL-TxParameters-r12	
alpha-r12	al0		
p0-r12	31	P0-SL-r12	
}			
ue-SelectedResourceConfig-r12 SEQUENCE {			
poolSelection-r12	NULL	random-r12	
txProbability-r12	p100		
}			
rxParameters-r12	Not Present		
}			
discTxPowerInfo-r12 SEQUENCE (SIZE (maxSL-DiscPowerClass-r12)) OF SL-DiscTxPowerInfo-r12 {			
SL-DiscTxPowerInfo-r12[1] SEQUENCE {		UE range class 'short'	
discMaxTxPower-r12	23		
}			
SL-DiscTxPowerInfo-r12[2] SEQUENCE {		UE range class 'medium'	
discMaxTxPower-r12	16		
}			
SL-DiscTxPowerInfo-r12[3] SEQUENCE {		UE range class 'long'	
discMaxTxPower-r12	10		
}			
discSyncConfig-r12 SEQUENCE (SIZE (1..maxSL-SyncConfig-r12)) OF SL-SyncConfig-r12 {	2 configurations reception/transmission of synchronisation signals		
SL-SyncConfig-r12[1] SEQUENCE {	SyncConfig 1	To be used for transmission	
syncCP-Len-r12	normal		
syncOffsetIndicator-r12	35		
slssid-r12	30		
txParameters-r12 SEQUENCE {			
syncTxParameters-r12 SEQUENCE {		SL-TxParameters-r12	
alpha-r12	al0		
p0-r12	31		
}			
syncTxThreshIC-r12	0	(-infinity) SLSS will not be transmitted	
syncInfoReserved-r12	Not Present		
}			
rxParamsNCell-r12 SEQUENCE {}	Not present		
}			
SL-SyncConfig-r12[2] SEQUENCE {	SyncConfig 2		
syncCP-Len-r12	normal		
syncOffsetIndicator-r12	25		

slssid-r12	40		
txParameters-r12 SEQUENCE {			
syncTxParameters-r12 SEQUENCE {		SL-TxParameters-r12	
alpha-r12	al0		
p0-r12	4		
}			
syncTxThreshIC-r12	7	-85dBm The threshold for starting transmission of SLSS	
syncInfoReserved-r12	Not Present		
}			
rxParamsNCell-r12 SEQUENCE {			
physCellId-r12	Set to the physical cell identity of the PCell		
discSyncWindow-r12	w1		
}			
}			
}			
}			
discInterFreqList-r12	Not present		
lateNonCriticalExtension			
...			
}			

Condition	Explanation
FDD	FDD cell environment
TDD	TDD cell environment (TDD config 1)
BW5	5 MHz channel bandwidth cell environment
BW10	10 MHz channel bandwidth cell environment

- *SystemInformationBlockType20*

The IE *SystemInformationBlockType20* contains the information required to acquire the SC-PTM control information.

Table 4.4.3.3-18: SystemInformationBlockType20

Derivation Path: 36.331 clause 6.3.1			
Information Element	Value/remark	Comment	Condition
SystemInformationBlockType20-r13 ::= SEQUENCE {			
sc-mcch-RepeticionPeriod-r13	Rf32		
sc-mcch-Offset-r13	1		
sc-mcch-FirstSubframe-r13	0		
sc-mcch-duration-r13	Not present		
sc-mcch-ModificationPeriod-r13	Rf512		
lateNonCriticalExtension			
}			

- *SystemInformationBlockType21*

The IE *SystemInformationBlockType21* contains the resource pool information for V2X sidelink communication.

Table 4.4.3.3-19: SystemInformationBlockType21

Derivation Path: 36.331 clause 6.3.1			
Information Element	Value/remark	Comment	Condition
SystemInformationBlockType21-r14 ::= SEQUENCE {			
sl-V2X-ConfigCommon-r14 SEQUENCE {			

v2x-CommRxPool-r14	Not present		
v2x-CommTxPoolNormalCommon-r14	Not present		
p2x-CommTxPoolNormalCommon-r14	Not present		
v2x-CommTxPoolExceptional-r14	Not present		
v2x-SyncConfig-r14	Not present		
v2x-InterFreqInfoList-r14 SEQUENCE (SIZE (0..maxFreqV2X-1-r14)) OF SL-InterFreqInfoV2X-r14		1 entry	
{			
SL-InterFreqInfoV2X-r14[1]	SL-InterFreqInfoV2X-r14-DEFAULT using condition SIB		
}			
v2x-ResourceSelectionConfig-r14	Not present		
zoneConfig-r14 SEQUENCE {}	Not present		
typeTxSync-r14	enb	ENUMERATED {gnss, enb, ue, spare1}	
thresSL-TxPrioritization-r14	Not present		
anchorCarrierFreqList-r14	Not present		
offsetDFN-r14	Not present		
cbr-CommonTxConfigList-r14	Not present		
}			
lateNonCriticalExtension	Not present		
}			

4.4.3.4 Channel-bandwidth-dependent parameters in system information blocks

The default values of parameters in system information blocks which depend on the channel bandwidth are defined in table 4.4.3.4-1.

Table 4.4.3.4-1: Channel-bandwidth-dependent parameters

Information Element	Channel bandwidth						Comment
	1.4 MHz	3 MHz	5 MHz	10 MHz	15 MHz	20MHz	
SIB3 periodicity	64	64	32	32	32	32	
SIB4 periodicity	128	128	64	64	64	64	
SIB5 periodicity	128	128	64	64	64	64	
SIB6 periodicity	128	128	64	64	64	64	
SIB7 periodicity	128	128	64	64	64	64	
SIB8 periodicity	128	128	64	64	64	64	
measurement Bandwidth in SIB5	mbw6	mbw15	mbw25	mbw50	mbw75	mbw100	
SIB9 periodicity	128	128	64	64	64	64	
SIB10 periodicity	64	64	32	32	32	32	
SIB11 periodicity	64	64	32	32	32	32	
SIB12 periodicity	64	64	32	32	32	32	
SIB13 periodicity	64	64	32	32	32	32	
SIB15 periodicity	64	64	32	32	32	32	
SIB17 periodicity	128	128	64	64	64	64	
SIB18 periodicity			32	32	-	32	
SIB19 periodicity			64	64	64	64	
SIB20 periodicity	64	64	32	32	32	32	
SIB21 periodicity				32		32	

4.4.4 Common parameters for simulated UTRA cells

The parameters specified in this subclause apply to all simulated UTRA cells unless otherwise specified.

Default UTRA parameters for simulated cells are specified in table 4.4.4-1 and table 4.4.4-2.

Other parameters are specified in TS 34.108 [5].

Table 4.4.4-1: Default parameters for simulated UTRA cells

cell ID	Primary scrambling code for FDD	Cell parameters ID for TDD
Cell 5	100	0
Cell 7	150	4
Cell 8	200	8
Cell 9	250	12

Table 4.4.4-2: Default NAS parameters for simulated UTRA cells

	PLMN		Location Area Identification		Routing Area Identification		TMSI	P-TMSI signature
	MCC	MNC	LA#	LAC	RA#	RAC		
Cell 5	(Note 1)		LAI-1	1	RAI-1	1	Arbitrarily selected according to TS 23.003 subclause 2.4 [2].	Arbitrarily selected according to TS 23.003 subclause 2.7 [2].
Cell 7	(Note 1)		LAI-1	1	RAI-1	1		
Cell 8	(Note 1)		LAI-1	1	RAI-1	1		
Cell 9	(Note 1)		LAI-1	1	RAI-1	1		
Note 1:	Set to the same Mobile Country Code and Mobile Network Code stored in EF _{TMSI} on the test USIM card (subclause 4.9.3).							

4.4.4.1 Common contents of system information blocks for UTRA cells

- System Information Block type 19

The system information block type 19 contains Inter-RAT frequency and priority information to be used in the cell.

Table 4.4.4.1-1: System Information Block type 19

Derivation Path: 25.331 clause 11.3			
Information Element	Value/remark	Comment	Condition
SysInfoType19 ::= SEQUENCE {			
utra-PriorityInfoList SEQUENCE {			
utra-ServingCell SEQUENCE {			
priority	3		
s-PrioritySearch1	0 (0dB)		
s-PrioritySearch2	Not present	default value is 0	
threshServingLow	0 (0dB)		
}			
utran-FDD-FrequencyList SEQUENCE (SIZE(1..maxNumFDDFreqs)) OF SEQUENCE {}	Not present		
utran-TDD-FrequencyList SEQUENCE (SIZE(1..maxNumTDDFreqs)) OF SEQUENCE {}	Not present		
gsm-PriorityInfoList SEQUENCE (SIZE (1..maxNumGSMCellGroup)) OF SEQUENCE {}	Not present		
eutra-FrequencyAndPriorityInfoList SEQUENCE (SIZE (1..maxNumEUTRAFreqs)) OF SEQUENCE {	The same number of entries as the configured eutra carriers For Signalling test cases, see table 6.3.1.7-1	<i>n</i> denotes the index of the entry	
earfcn[<i>n</i>]	Downlink EARFCN under test For Signalling test cases, see table 6.3.1.7-1		
measurementBandwidth[<i>n</i>]	Set according to EUTRA band ChBw in Table 5.6- 1 of TS36.104.		
priority[<i>n</i>]	4		
qRxLevMinEUTRA[<i>n</i>]	-53 (-106 dBm)	For signalling test cases	
	-70 (-140 dBm)	For RF/RRM test cases	
threshXhigh[<i>n</i>]	2 (4 dB)		
threshXlow[<i>n</i>]	1 (2 dB)		
eutra-blackListedCellList[<i>n</i>]	Not present		
eutraDetection[<i>n</i>]	TRUE		
}			
eutra-FrequencyAndPriorityInfoList	Not present		Band > 64
v920NonCriticalExtensions SEQUENCE {			QBASED
va80NonCriticalExtensions SEQUENCE {			Band > 64
vb30NonCriticalExtensions SEQUENCE {			
vb50NonCriticalExtensions SEQUENCE {			
sysInfoType19-vb50ext SEQUENCE {			
numberOfApplicableEARFCN	0		
eutra- FrequencyAndPriorityInfoExtensionList SEQUENCE (SIZE (1..maxNumEUTRAFreqs)) OF SEQUENCE {			
earfcn	Downlink EARFCN under test For Signalling test cases, see table 6.3.1.7-1		
measurementBandwidth	Set according to EUTRA band ChBw in Table 5.6- 1 of TS 36.104.		
priority	4		
qRxLevMinEUTRA	-53 (-106 dBm)	For signalling test cases	
	-70 (-140 dBm)	For RF/RRM test cases	
threshXhigh	2 (4 dB)		
threshXlow	1 (2 dB)		
qqualMinEUTRA	Not present		
threshXhigh2	Not present		
threshXlow2	Not present		
eutra-blackListedCellList	Not present		

eutraDetection	TRUE		
}			
}			
vb80NonCriticalExtensions SEQUENCE {}			
}			
}			
}			
sysInfoType19-v920ext SEQUENCE {			
utra-PriorityInfoList-v920ext SEQUENCE {			
threshServingLow2	7 (7dB)	default value is 0	
}			
eutra-FrequencyAndPriorityInfoList-v920ext (SIZE (1..maxNumEUTRAFreqs)) OF SEQUENCE {			
qQualMinEUTRA[n]	-20 (-20dB)		
threshXhigh2[n]	5 (5dB)		
threshXlow2[n]	5 (5dB)		
}			
v920NonCriticalExtensions SEQUENCE {			Band > 64
va80NonCriticalExtensions SEQUENCE {			
vb30NonCriticalExtensions SEQUENCE {			
vb50NonCriticalExtensions SEQUENCE {			
sysInfoType19-vb50ext SEQUENCE {			
numberOfApplicableEARFCN	0		
eutra-FrequencyAndPriorityInfoExtensionList SEQUENCE (SIZE (1..maxNumEUTRAFreqs)) OF SEQUENCE {			
earfcn	Downlink EARFCN under test For Signalling test cases, see table 6.3.1.7-1		
measurementBandwidth	Set according to EUTRA band ChBw in Table 5.6-1 of TS 36.104.		
priority	4		
qRxLevMinEUTRA	-53 (-106 dBm)	For signalling test cases	
	-70 (-140 dBm)	For RF/RRM test cases	
threshXhigh	2 (4 dB)		
threshXlow	1 (2 dB)		
qqualMinEUTRA	Not present		
threshXhigh2	Not present		
threshXlow2	Not present		
eutra-blackListedCellList	Not present		
eutraDetection	TRUE		
}			
}			
vb80NonCriticalExtensions SEQUENCE {}			
}			
}			
}			
}			
}			
nonCriticalExtensions SEQUENCE {}	Not present		
}			
}			

Condition	Explanation
QBASED	See the definition below table 4.4.3.2-3.
Band > 64	If band > 64 is selected

4.4.4.2 UTRA SIB scheduling for inter EUTRA - UTRA test

Table 4.4.4.2-1: UTRA SIB schedule

Block Type	MIB	SB1	SIB1	SIB2	SIB3	SIB4	SIB5/SIB5bis	SIB6	SIB7	SIB11	SIB12	SIB18	SIB19
SIB_REP	8	16	64	64	64	64	64	64	16	64	64	64	64
SEG_COUNT	1	1	1	1	1	1	4	4	1	3	1	1	2

Table 4.4.4.2-2: UTRA SIB-repeat period

Frame No / SIB_POS	0	2	4	6	8	10	12	14
Block Type	MIB	SB1	SIB7	SIB6	MIB	SIB6	SIB6	SIB6
Frame No / SIB_POS	16	18	20	22	24	26	28	30
Block Type	MIB	SB1	SIB7/SIB3	SIB1/SIB2	MIB	SIB12	SIB19	SIB19
Frame No / SIB_POS	32	34	36	38	40	42	44	46
Block Type	MIB	SB1	SIB7/SIB18	SIB5/SIB5bis	MIB	SIB5/SIB5bis	SIB5/SIB5bis	SIB5/SIB5bis
Frame No / SIB_POS	48	50	52	54	56	58	60	62
Block Type	MIB	SB1	SIB7/SIB4	-	MIB	SIB11	SIB11	SIB11

4.4.4.3 UTRA SIB scheduling for inter EUTRA – UTRA - GERAN test

Table 4.4.4.3-1: UTRA SIB schedule

Block Type	MIB	SB1	SIB1	SIB2	SIB3	SIB4	SIB5/SIB5bis	SIB7	SIB11	SIB16	SIB18	SIB19
SIB Rep	8	16	128	128	64	64	128	32	128	128	128	128
Max. No of seg.	1	2	1	1	1	1	4	1	3	8	1	3

Table 4.4.4.3-2: UTRA SIB-repeat period

Frame No / SIB_POS	0	2	4	6	8	10	12	14
Block Type	MIB	SB1	SB1	-	MIB	SIB1	SIB18	SIB2
Frame No / SIB_POS	16	18	20	22	24	26	28	30
Block Type	MIB	SB1	SB1	SIB7	MIB	SIB3	-	SIB4
Frame No / SIB_POS	32	34	36	38	40	42	44	46
Block Type	MIB	SB1	SB1	SIB5/ SIB5bis	MIB	SIB5/ SIB5bis	SIB5/ SIB5bis	SIB5/ SIB5bis
Frame No / SIB_POS	48	50	52	54	56	58	60	62
Block Type	MIB	SB1	SB1	SIB7	MIB	SIB11	SIB11	SIB11
Frame No / SIB_POS	64	66	68	70	72	74	76	78
Block Type	MIB	SB1	SB1	SIB16	MIB	SIB16	SIB16	SIB16
Frame No / SIB_POS	80	82	84	86	88	90	92	94
Block Type	MIB	SB1	SB1	SIB7	MIB	SIB3	SIB19	SIB4
Frame No / SIB_POS	96	98	100	102	104	106	108	110
Block Type	MIB	SB1	SB1	SIB16	MIB	SIB16	SIB16	SIB16
Frame No / SIB_POS	112	114	116	118	120	122	124	126
Block Type	MIB	SB1	SB1	SIB7	MIB	SIB19	SIB19	-

4.4.5 Common parameters for simulated GERAN cells

The parameters specified in this subclause apply to all simulated GERAN cells unless otherwise specified.

See TS 51.010 [25].

The contents of SYSTEM INFORMATION TYPE 2 Quarter message specified below are identical for all GERAN cells.

Table 4.4.5-1: System Information 2 Quater

Derivation Path: 44.018 Table 10.5.2.33b.1			
Information Element	Value/remark	Comment	Condition
System information 2Quater			
L2 pseudo length	1		
PROTOCOL DISCRIMINATOR	'0110'B	RR management Protocol	
SKIP INDICATOR	'0000'B		
MESSAGE TYPE	'00000111'B		
SI 2QUATER REST OCTETS			
BA Indicator	0		
3G BA Indicator	0		
MP Change Mark	0		
SI2Q Index	0		
SI2Q Count	0		
Measurement_Parameters Description	0	Not Present	
GPRS_Real Time Difference Description	0	Not Present	
GPRS_BSIC Description	0	Not Present	
GPRS_REPORT PRIORITY Description	0	Not Present	
GPRS_MEASUREMENT_Parameters Description	0	Not Present	
NC Measurement Parameters	0	Not Present	
extension length	0	Not Present	
3G Neighbour Cell Description	0	Not Present	
3G Measurement Parameters Description	0	Not Present	
GPRS_3G_MEASUREMENT Parameters Description	0	Not Present	
Additions in release 5	H		
3G Additional Measurement Parameters Description	0	Not Present	
3G ADDITIONAL MEASUREMENT Parameters Description 2	0	Not Present	
Additions in release 6	H		
3G_CCN_ACTIVE	0		
Additions in release 7	H		
700_REPORTING_OFFSET	0	Not Present	
810_REPORTING_OFFSET	0	Not Present	
Additions in release 8	H		
Priority and E-UTRAN Parameters Description	1	Present	
Serving Cell Priority Parameters Description	1	Present Note: Values as defined from TS 45.008, section 10.4 Table 3	
GERAN_PRIORITY	2		
THRESH_Priority_Search	15 (always)		
THRESH_GSM_low	0		
H_Prio	0		
T_Reselection	0		
3G Priority Parameters Description	0	Not Present	
E-UTRAN Parameters Description	1	Present	
E-UTRAN_CCN_ACTIVE	0	CCN not supported	
E-UTRAN_Start	1		
E-UTRAN_Stop	1		
E-UTRAN Measurement Parameters Description	0	Not Present	
GPRS E-UTRAN Measurement Parameters Description	0	Not Present	
Repeated E-UTRAN Neighbour Cells {	1	Present	
EARFCN	Same as cell 1	This field specifies the E-UTRA Absolute Radio Frequency Channel Number as defined in 3GPP TS 36.104.	
EARFCN	65535		Band > 64

Measurement Bandwidth	Set according to EUTRA band under test		
E-UTRAN_PRIORITY	'100'B	Same as cell 1 as defined in 3GPP TS 36.104.	
THRESH_E-UTRAN_high	'00010'B	Actual value =4 dB	
THRESH_E-UTRAN_low	'00010'B	Actual value =4 dB	
E-UTRAN_QRXLEVMIN	17 (-106 dBm)	For signalling test cases	
	0 (-140 dBm)	For RF/RRM test cases	
}** 0		End of Repeated E-UTRAN Neighbour cells structure. Note: When this message is used in Tics where more than one E-UTRA cells are active, this structure needs to be specified for each cell. EARFCN and EUTRAN_PRIORITY will then need to be configured to the corresponding EUTRAN cell	
Repeated E-UTRAN Not Allowed Cells	0	Not Present	
Repeated E-UTRAN PCID to TA mapping	0	Not Present	
3G CSG Description	0		
E-UTRAN CSG Description	0		
Additions in release 9	L		
Additions in release 9	H		Band > 64
Enhanced Cell Reselection Parameters	0		
CSG Cells Reporting Description	0		
Additions in release 10	H		
INIT_PWR_RED	0		
NC2_CSG_PCCN_permitted	0		
Additions in release 11	H		
Extended EARFCNs Description	1		
Repeated EARFCN_extended {	1	Present	
EARFCN_extended	Same as cell 1	This field specifies the E-UTRA Absolute Radio Frequency Channel Number as defined in 3GPP TS 36.104.	
}** 0		End of Repeated EARFCN_extended	
Extended EARFCNs Description for CSG Cells	0		
spare padding	spare padding		

Condition	Explanation
Band > 64	If band > 64 is selected

4.4.6 Common parameters for simulated CDMA2000 cells

The parameters specified in this subclause apply to all simulated HRPD or 1xRTT cells unless otherwise specified.

See C.S0038-B [36] for HRPD cells and C.S0043-A [37] for 1xRTT cells.

4.4.7 Default parameters specific for simulated cells

Default parameters specific for simulated cells are specified in this subclause.

4.4.7.1 Common contents of HRPD Overhead messages

- QuickConfig

The QuickConfig message is used to indicate a change in the overhead messages' contents and to provide frequently changing information.

Table 4.4.7.1-1: QuickConfig

Derivation Path: C.S0024-B clause 7.11.6.2.1			
Information Element	Value/remark	Comment	Condition
MessageID	0x0	0-255;	
ColorCode	See table 4.4.2-3	0 – 255	
SectorID24	Least significant 24 bits of Sector ID given in table 4.4.2-3	24 bits	
SectorSignature	A valid value and same as used for SectorParameters	16 bits	
AccessSignature	A valid value and same as used for AccessParameters	16 bits	
Redirect	0X0	0-1	
RPCCount63To0	A valid value corresponding to the value of px_MACIndex	0-63	
ForwardTrafficValid63To0	A valid value corresponding to the value of px_MACIndex	0-1; RPCCount63To0 occurrences	
RPCCount127To64Included	A valid value corresponding to the value of px_MACIndex	0 or 1 bits	
RPCCount127To64	A valid value corresponding to the value of px_MACIndex	0 or 6 bits	
ForwardTrafficValid127To64	A valid value corresponding to the value of px_MACIndex	0 or 1 bits;RPCCount127To64 occurrences	
RPCCount130To383Included	Not Present or a valid value corresponding to the value of px_MACIndex	0 or 1 bits	
RPCCount130To383	Not Present or a valid value corresponding to the value of px_MACIndex	0 or 8 bits	
ForwardTrafficValid130To383	Not Present or a valid value corresponding to the value of px_MACIndex	0 or 1 bits	
Reserved	0X0	0 – 7 bits as needed all set to zero	

- SectorParameters

The SectorParameters message is used to convey sector specific information to the access terminals.

Table 4.4.7.1-2: SectorParameters

Derivation Path: C.S0024-B clause 7.11.6.2.2			
Information Element	Value/remark	Comment	Condition
MessageID	0x01	0-255	
CountryCode	See table 4.4.2-3	0 – 999; Depends on test case	
SectorID	See table 4.4.2-3	128 bit value	
SubnetMask	0x40	8 bits	
SectorSignature	Any valid value	16 bits	
Latitude	Any valid value	22 bits	
Longitude	Any valid value	23 bits	
RouteUpdateRadiusOverhead	0x0	11 bits	
LeapSeconds	'A valid value, calculated and updated by the SS'	8 bits	
LocalTimeOffset	Any valid value	11 bits	
ReverseLinkSilenceDuration	0x1 or 0x0	2 bits	
ReverseLinkSilencePeriod	0x1 or 0x0	2 bits	
ChannelCount	0x1 or 0x0	5 bits	
Channel		24 bits; ChannelCount occurrences; Sub-clause 13.1 in 3GPP2 C.S0024-B v3.0	
SystemType	0x00	8 bits	
BandClass	Set according to PIXIT parameter	5 bits; Depends on test case	
ChannelNumber	Set according to PIXIT parameter	11 bits; Depends on BandClass	
NeighborCount	0x0	5 bits	No_NeighPN Inc
	16		NeighPNInc
NeighborPilotPN	Not Present		No_NeighPN Inc
	Pilots PN's of configured cells [FFS]		NeighPNInc
NeighborChannelIncluded	0x0	1 bit; NeighbourCount occurrences	NeighPNInc
	Not Present		No_NeighPN Inc
NeighborChannel	Not Present	0 or 24 bits; NeighbourCount occurrences	
NeighborSearchWindowSizeIncluded	0x0	1 bit	
NeighborSearchWindowSize	Not Present	0 or 4 bits; NeighbourCount occurrences	
NeighborSearchWindowOffsetIncluded	0x0	1 bit	
NeighborSearchWindowOffset	Not Present	0 or 3 bits; NeighbourCount occurrences	
ExtendedChannelIncluded	0x0 or Not Present	0 or 1 bits; The number of cdma2000 high rate packet data extended channels available to the access terminal on this sector; Note 1;	
ExtendedChannelCount	Not Present	0 or 5 bits	
ExtendedChannel	Not Present	24 bits; 0 or ExtendedChannelCount occurrences	
AccessHashingChannelMaskIncluded	0x0 or Not Present	0 or 1 bits; AccessHashingChannelMaskL length occurrences of this field and AccessHashingChannelMask if set as AccessHashingChannelMask; Note 1;	

AccessHashingMaskLength	Not Present	0 or 4 bits; 0<=AccessHashingChannelMaskLength<=(ChannelCount + ExtendedChannelCount),	
AccessHashingChannelMaskSameAsPrevious	Not Present	1 bit; AccessHashingChannelMaskLength occurrences of this field and AccessHashingChannelMask if set as AccessHashingChannelMask	
AccessHashingChannelMask	Not Present	0 or AccessHashingMaskLength+1	
RouteUpdateTriggerCodeIncluded	0x0 or Not Present	0 or 1 bits; Note 1;	
RouteUpdateTriggerCode	Not Present	0 or 12 bits	
RouteUpdateTriggerMaxAge	Not Present	0 or 4 bits	
PriorSessionGAUP	0x0 or Not Present	0 or 1 bits; Note 1;	
FPDCHSupportedInclude	0x0 or Not Present	0 or 1 bits; Note 1;	
FPDCHSupported	Not Present	0 or 1 bits	
SecondaryColorCodeIncluded	0x0 or Not Present	0 or 1 bits; Note 1;	
SecondaryColorCodeCount	Not Present	0 or 3 bits	
SecondaryColorCode	Not Present	8 bits	
PilotGroupIDLoopIncluded	0x0 or Not Present	0 or 1 bits; Note 1;	
PilotGroupIDIncluded	Not Present	0 or 1 bits	
PilotGroupID	Not Present	0 or 3 bits	
IsSectorMultiCarrierCapable	0x0 or Not Present	0 or 1 bits; Note 1;	
ReverseBandClass	Not Present	0 or 5 bits	
ReverseChannelNumber	Not Present	0 or 11 bits	
Reserved	0X0	0 – 7 bits as needed all set to zero	
Note 1: As no Non reserved fields following this are included, it can be Not Present; If not present, AT assumes as 0x0.			

Condition	Explanation
No_NeighPNInc	No neighbour Pilot PN included
NeighPNInc	Neighbor Pilot PN's included

- AccessParameters

The AccessParameters message is used to convey Access Channel information to the access terminals.

Table 4.4.7.1-3: AccessParameters

Derivation Path: C.S0024-B clause 9.4.6.2.6			
Information Element	Value/remark	Comment	Condition
MessageID	0x1	0-255	
Access Cycle Duration	16 slots or 64 slots	16,12,64,128 slots	
Access Signature	Any valid value	16 bits Note1.	
OpenLoopAdjust	Set according to PIXIT parameter for default open loop adjust	8bits(-84 – 115 dB); Actual value is -1 times	
ProbelInitialAdjust	0x0(0 dB)	5 bits(-16 – 15 db)	
ProbeNumStep	0x5	4bits(1 – 15)	
PowerStep	0x8(4 dB)	4 bits(0 – 7.5 dB)	
PreambleLength	0x2	3bits(1 – 7)	
CapsuleLengthMax	0x2 or 0x4	4 bits	
APersistence	0x0 or 0x1	6 bits; 'NACMPAPersist = 4' occurrences	
APersistence	0x0 or 0x1	6 bits	
APersistence	0x0 or 0x1	6 bits	
APersistence	0x0 or 0x1	6 bits	
Reserved	0X0	0 – 7 bits as needed all set to zero	
Note 1: The value specified is the value to be used when the AccessParameters is being sent first time. At every change of content of AccessParameters message it is incremented by 1.			

- Sync

The access network broadcasts the Sync message to convey basic network and timing information

Table 4.4.7.1-4: Sync

Derivation Path: C.S0024-B clause 7.3.6.2.1			
Information Element	Value/remark	Comment	Condition
MessageID	0x0	0-255	
MaximumRevision	0x1	8 bits ; Clause 1.15 of 3GPP2 C.S0024-B v3.0	
MinimumRevision	0x1	8 bits; Clause 1.15 of 3GPP2 C.S0024-B v3.0	
Pilot PN Offset	See table 4.4.2-3	0 – 511	
CDMA System Time	A valid value, calculated and updated by the SS	37 bits	

4.4.7.2 Common contents of 1XRTT Overhead messages

4.4.7.2.1 Configuration sequence number

In general, a base station maintains a configuration sequence number CONFIG_SEQ for configuration messages transmitted on the Paging channel and increments by 1 modulo 64 whenever any of the following messages being transmitted are modified:

System Parameters Message

Neighbor List Message (Band Class 0 only)

CDMA Channel List Message

Extended System Parameters Message

Extended Neighbor List Message (band classes other than Band Class 0).

For simplicity reasons the System Simulator may use any value for this configuration sequence number CONFIG_SEQ.

4.4.7.2.2 Over Head messages

- CDMA Channel List Message

Table 4.4.7.2.2-1: CDMA Channel List Message

Derivation Path: C.S0005 clause 3.7.2.3.2.4			
Information Element	Value/remark	Comment	Condition
PILOT_PN	See table 4.4.2-4	9 bits;	
CONFIG_MSG_SEQ	Set to 'CONFIG_SEQ' of base station as per clause 4.4.7.2.1	6 bits;	
CDMA_FREQ	Set according to PIXIT parameter or as per clause 4.3.1.4	11 bits	

- System Parameters Message

Table 4.4.7.2.2-2: System Parameters Message

Derivation Path: C.S0005 clause 3.7.2.3.2.1			
Information Element	Value/remark	Comment	Condition
PILOT_PN	See table 4.4.2-4	9 bits	
CONFIG_MSG_SEQ	Set to 'CONFIG_SEQ' of base station as per clause 4.4.7.2.1	6 bits	
SID	See table 4.4.2-4	15 bits	
NID	See table 4.4.2-4	16 bits	
REG_ZONE	See table 4.4.2-4	12 bits	
TOTAL_ZONES	1	3 bits	
ZONE_TIMER	0 or 1	3 bits; 1 or 2 minutes	
MULT_SIDS	0 or 1	1 bits; Mobile shall not or shall store SID_NID_List containing different SID's	
MULT_NIDS	0 or 1	1 bits; Mobile shall not or shall store SID_NID_List containing different NID's	
BASE_ID	See table 4.4.2-4	16 bits	
BASE_CLASS	1	4 bits	BandClass1_4
	0		Not BandClass1_4
PAGE_CHAN	1	3 bits; Number of Paging Channels	
MAX_SLOT_CYCLE_INDEX	1 or 0	3 bits; Maximum Slot Cycle index	
HOME_REG	1	1 bits; Home registration enabled	
FOR_SID_REG	1	1 bits; SID roamer registration enabled	
FOR_NID_REG	1	1 bits; NID roamer registration enabled	
POWER_UP_REG	1	1 bits; power-up registration enabled	
POWER_DOWN_REG	Set according to PIXIT parameter	1 bits; power-down registration enabled as per PIXIT	
PARAMETER_REG	0 or 1	1 bits; parameter change registration disabled or enabled	
REG_PRD	0	7 bits; registration period; No timer Based Registration	
BASE_LAT	Any valid value	22 bits; Base Station Latitude	
BASE_LONG	Any valid value	23 bits; Base Station Longitude	
REG_DIST	0	11 bits; Distance based registration disabled	
SRCH_WIN_A	8	4 bits; Search Window size for Active Set; 60 PN Chips	
SRCH_WIN_N	8	4 bits; Search Window Size for the neighbor set; 60 PN Chips	
SRCH_WIN_R	8	4 bits; Search window size for the remaining set; 60 PN Chips	
NGHBR_MAX_AGE	0	4 bits; Minimum Neighbour set age	
PWR_REP_THRESH	0, 1 or 5	5 bits; Power control reporting threshold	
PWR_REP_FRAMES	0, 4 or 7	4 bits; power control reporting frame count; 5 or 28 frames	
PWR_THRESH_ENABLE	0	1 bits; threshold report mode disabled	
PWR_PERIOD_ENABLE	0	1 bits; periodic report mode disabled	

PWR_REP_DELAY	0 or 14	5 bits; 0 or 56 frames	
RESCAN	0	1 bit; re-initialize and re-acquire the system	
T_ADD	28 (-14 dB Ec/Io)	6bits; Pilot detection threshold (-14 dB Ec/Io)	
T_DROP	32	6 bits; Pilot drop threshold (-16 dB Ec/Io)	
T_COMP	5	4; Active set versus candidate set comparison threshold (2.5 dB)	
T_TDROPT	3	4 bits; Drop timer value (4 sec)	
EXT_SYS_PARAMETER	1	1 bit; Extended System Parameters message present	
EXT_NGHR_LST	1	1 bit; Extended neighbor list not present	BandClass1_3_4
	0		Not BandClass1_3_4
GEN_NGHR_LST	0	1 bit; General neighbor list not sent	
GLOBAL_REDIRECT	0	1 bit; Global service redirection message not transmitted	
PRI_NGHR_LST	0	1 bit; Private neighbor list message not transmitted	
USER_ZONE_ID	0	1 bit; User zone Identification not transmitted	
EXT_GLOBAL_REDIRECT	0	1 bit; Extended global redirection not transmitted	
EXT_CHAN_LST	0	1 bit; Extended channel list not sent	

Condition	Explanation
BandClass1_4	If Band Class is 1 or 4
BandClass1_3_4	If Band Class is 1 or 3 or 4

- Access Parameters Message

Table 4.4.7.2.2-3: Access Parameters message

Derivation Path: C.S0005 clause 3.7.2.3.2.2			
Information Element	Value/remark	Comment	Condition
PILOT_PN	See table 4.4.2-4	9 bits;	
ACC_MSG_SEQ	0,1,2..63	6 bits; Access Message Sequence; 0 is used in initial transmission and incremented by 1 modulo 64 every time Access Parameters message is modified; for simplicity reasons any value may be used	
ACC_CHAN	0	5 bits; Number of access channels -1	
NOM_PWR	0	4 bits; Nominal transmit power offset in dB	
INIT_PWR	0	5 bits; Initial power offset in dB	
PWR_STEP	1 or 3	3 bits; Power increment	
NUM_STEP	Any valid value	4 bits; 5 access probes/sequence	
MAX_CAP_SZ	2 or 7	3 bits; Maximum Access channel message capsule size =2 or 7 +3 frames	
PAM_SZ	Any valid value	4 bits; Access Channel preamble length = 2+1 frames	
PSIST(0-9)	0	6 bits; Persistence value for access overload classes 0-9	
PSIST(10)	0	3 bits; Persistence value for access overload classes 10	
PSIST(11)	0	3 bits; Persistence value for access overload classes 11 (emergency)	
PSIST(12)	0	3 bits; Persistence value for access overload classes 12	
PSIST(13)	0	3 bits; Persistence value for access overload classes 13	
PSIST(14)	0	3 bits; Persistence value for access overload classes 14	
PSIST(15)	0	3 bits; Persistence value for access overload classes 15	
MSG_PSIST	0	3 bits; Persistence modifier for access channel attempts for message transmissions	
REG_PSIST	0	3 bits; Persistence modifier for Access Channel attempts for registrations	
PROBE_PN_RAN	4 or 0	4 bits; Time Randomization for Access Channel probes= 0 to 15 PN chips	
ACC_TMO	3, 4 or 5	4 bits; Acknowledgement timeout = (value +2) * 80 ms	
PROBE_BKOFF	1 or 0	4 bits; Access Channel probe back off = no back off	
BKOFF	1 or 0	4 bits; Access channel probe sequence backoff range =no back off	
MAX_REQ_SEQ	Any valid value	4 bits; Max number of access probe sequences for an access channel request	
MAX_RSP_SEQ	Any valid value	4 bits; Max number of access probe sequences for an access channel response	
AUTH	0	2 bits; No authentication data in access channel messages	
RAND	Not present	0 or 32 bits	
NOM_PWR_EXT	0	1 bits; Extended nominal transmit power	

- Extended System Parameters Message

Table 4.4.7.2.2-4: Extended System Parameters Message

Derivation Path: C.S0005 clause 3.7.2.3.2.13			
Information Element	Value/remark	Comment	Condition
PILOT_PN	See table 4.4.2-4	9 bits	
CONFIG_MSG_SEQ	Set to 'CONFIG_SEQ' of base station as per clause 4.4.7.2.1	6 bits	
DELETE_FOR_TMSI	0	1 bits; Delete foreign TMSI	
USE_TMSI	0 or 1	1 bits; Use TMSI indicator	
PREF_MSID_TYPE	3	2 bits; Preferred Access Channel MSID Type	
MCC	See table 4.4.2-4	10 bits	
IMSI_11_12	See table 4.4.2-4	7 bits; 11th and 12th digits of the IMSI	
TMSI_ZONE_LEN	1 or 0	4 bits	
TMSI_ZONE	1 or Not present	8 bits if present	
BCAST_INDEX	0	3 bits	
IMSI_T_SUPPORTED	0	1 bits	
P_REV	6	8 bits	
MIN_P_REV	6	8 bits	
SOFT_SLOPE	0	6 bits	
ADD_INTERCEPT	0	6 bits; 0 dB	
DROP_INTERCEPT	0	6 bits; 0 dB	
PACKET_ZONE_ID	0	8 bits; Packet data service zone not supported	
MAX_NUM_ALT_SO	0	3 bits	
RESELECT_INCLUDED	0	1 bits; System reselection parameters not included	
EC_THRESH	Not present	0 or 5 bits	
EC_I0_THRESH	Not present	0 or 5 bits	
PILOT_REPORT	1 or 0	1 bits; Pilot Report indicator; the MS reports or does not report additional pilots which have strengths exceeding T_ADD	
NGHBR_SET_ENTRY_INFO	0	1 bits	
ACC_ENT_HO_ORDER	Not present	0 or 1 bits	
NGHBR_SET_ACCESS_INFO	0	1 bits	
ACCESS_HO	Not present	0 or 1 bits	
ACCESS_HO_MSG_RSP	Not present	0 or 1 bits	
ACCESS_PROBE_HO	Not present	0 or 1 bits	
ACC_HO_LIST_UPD	Not present	0 or 1 bits	
ACC_PROBE_HO_OTHER_MSG	Not present	0 or 1 bits	
MAX_NUM_PROBE_HO	Not present	0 or 3 bits	
NGHBR_SET_SIZE	Not present	0 or 6 bits	
ACCESS_ENTRY_HO	Not present	1 bits; Access Entry Handoff not permitted	
ACCESS_HO_ALLOWED	Not present	1 bits	
BROADCAST_GPS_ASST	0	1 bits; Broad cast GPS not supported	
QPCH_SUPPORTED	0	1 bits; Quick PCH not supported	
NUM_QPCH	Not present	0 or 2 bits	
QPCH_RATE	Not present	0 or 1 bits	
QPCH_POWER_LEVEL_PAGE	Not present	0 or 3 bits	
QPCH_CCI_SUPPORTED	Not present	0 or 1 bits	
QPCH_POWER_LEVEL_CONFIG	Not present	0 or 3 bits	
SDB_SUPPORTED	0	1 bits; Short Data burst not supported	
RLGAIN_TRAFFIC_PILOT	0	6 bits; 0 dB Gain adjustment of Reverse traffic channel	
REV_PWR_CNTL_DELAY_INCL	0	1 bits	
REV_PWR_CNTL_DELAY	Not present	0 or 2 bits	

- Neighbor List Message

This message is sent when EXT_NGHRBR_LST in Systems parameter message is set as '0'B i.e. the band class is 0;

Table 4.4.7.2.2-6: Neighbor List Message

Derivation Path: C.S0005 clause 3.7.2.3.2.3			
Information Element	Value/remark	Comment	Condition
PILOT_PN	See table 4.4.2-4	9 bits	
CONFIG_MSG_SEQ	Set to 'CONFIG_SEQ' of base station as per clause 4.4.7.2.1	6 bits	
PILOT_INC	10 or 1	4 bits; Pilot PN Sequence offset index increment = $n * 50$	
NGHBR_CONFIG(n)	0 or Not present		
NGHBR_PN(n)	See table 4.4.2-4 or Not Present	9 bits if present	
Note 1: the elements with index n are repeated as per table 4.4.2-5			

- Extended Neighbor List Message

This message is sent when EXT_NGHRBR_LST in Systems parameter message is set as '1'B i.e. the band class is not 0;

Table 4.4.7.2.2-7: Extended Neighbor List Message

Derivation Path: C.S0005 clause 3.7.2.3.2.14			
Information Element	Value/remark	Comment	Condition
PILOT_PN	See table 4.4.2-4	9 bits	
CONFIG_MSG_SEQ	Set to 'CONFIG_SEQ' of base station as per clause 4.4.7.2.1	6 bits	
PILOT_INC	10 or 1	4 bits; Pilot PN Sequence offset index increment = $n * 50$	
NGHBR_CONFIG(n)	0 or Not present	3 bits if present; Neighbor configuration where neighbor base station has same number of frequencies having paging channels as the current base station;	
NGHBR_PN(n)	See table 4.4.2-4 or Not present	9 bits if present	
SEARCH_PRIORITY(n)	1, 2 or Not present	2 bits if present; Medium search priority	
FREQ_INCL(n)	1	1 bit	InterFreqCell
	0 or Not present		
NGHBR_BAND(n)	Set according to PIXIT parameter	0 or 5 bits	InterFreqCell
	Not present		
NGHBR_FREQ(n)	Set according to PIXIT parameter	0 or 11 bits	InterFreqCell
	Not Present		
Note 1: The elements with index n are repeated as per table 4.4.2-5. The SS can transmit up to 7 neighbour intra frequency cell information. The parameters for the first cell should be set as per table 4.4.2-4.			

Condition	Explanation
InterFreqCell	If the configured neighbour cell is on a different frequency compared to the cell in which Extended Neighbour list message is being transmitted

Sync channel Messages

Table 4.4.7.2.2-8: Sync Channel Message

Derivation Path: C.S0005 clause 3.7.2.3.2.26			
Information Element	Value/remark	Comment	Condition
P_REV	6	8 bits; Protocol revision level	
MIN_P_REV	6	8 bits; Minimum protocol revision level	
SID	See table 4.4.2-4	15 bits	
NID	See table 4.4.2-4	16 bits	
PILOT_PN	See table 4.4.2-4	9 bits	
LC_STATE	A valid value, calculated and updated by the SS	42 bits; Long code State	
SYS_TIME	A valid value, calculated and updated by the SS	36 bits; System time	
LP_SEC	A valid value, calculated and updated by the SS	8 bits; The number of leap seconds	
LTM_OFF	A valid value, calculated and updated by the SS	6 bits; Offset of local time from System time	
DAYLT	A valid value, calculated and updated by the SS	1 bits; Daylight savings indicator	
PRAT	0	2 bits; Paging Channel Data rate=9600 bps	
CDMA_FREQ	Set according to PIXIT parameter or as per clause 4.3.1.4	11 bits; Frequency assignment	
EXT_CDMA_FREQ	Set according to PIXIT parameter or as per clause 4.3.1.4	11 bits; Extended frequency assignment	

4.4.8 Common parameters for simulated WLAN AP's

The parameters specified in this subclause apply to all simulated WLAN APs unless otherwise specified.

Default WLAN parameters for simulated APs are specified in table 4.4.8-1.

Table 4.4.8-1: Default parameters for simulated WLAN APs

Parameter	Value	Condition
SSID	3GPP WLAN InterWorking	
Security	[WPA2]	
Hot Spot 2.0 Support	Yes	
Trusted/Un-Trusted non 3GPP Access	Un-Trusted	
EAP-AKA Procedure	CHAP	
Beacon RSSI	42 (-86 dBm), NOTE 1	OFFLOAD
Beacon RSSI	Configured at the SS according to PIXIT parameter	IMSoWLAN
NOTE 1: The power level is specified at each UE Rx antenna.		

Condition	Explanation
OFFLOAD	WLAN offload scenarios
IMSoWLAN	IMS over WLAN scenarios

4.5 Generic procedures

This clause describes UE test states which can be used in the initial condition of many test cases defined in TS 36.521-1 [21], TS 36.523-1 [18] and TS 36.523-3 [34] or other procedures defined in this specification. This section also defines a set of procedures to bring the UE into these states.

4.5.1 UE test states

NOTE: The need to have a procedure for the transition from State 4/State 3 to State 2 is for further study and it can added if the technical motivation for this procedure can be justified.

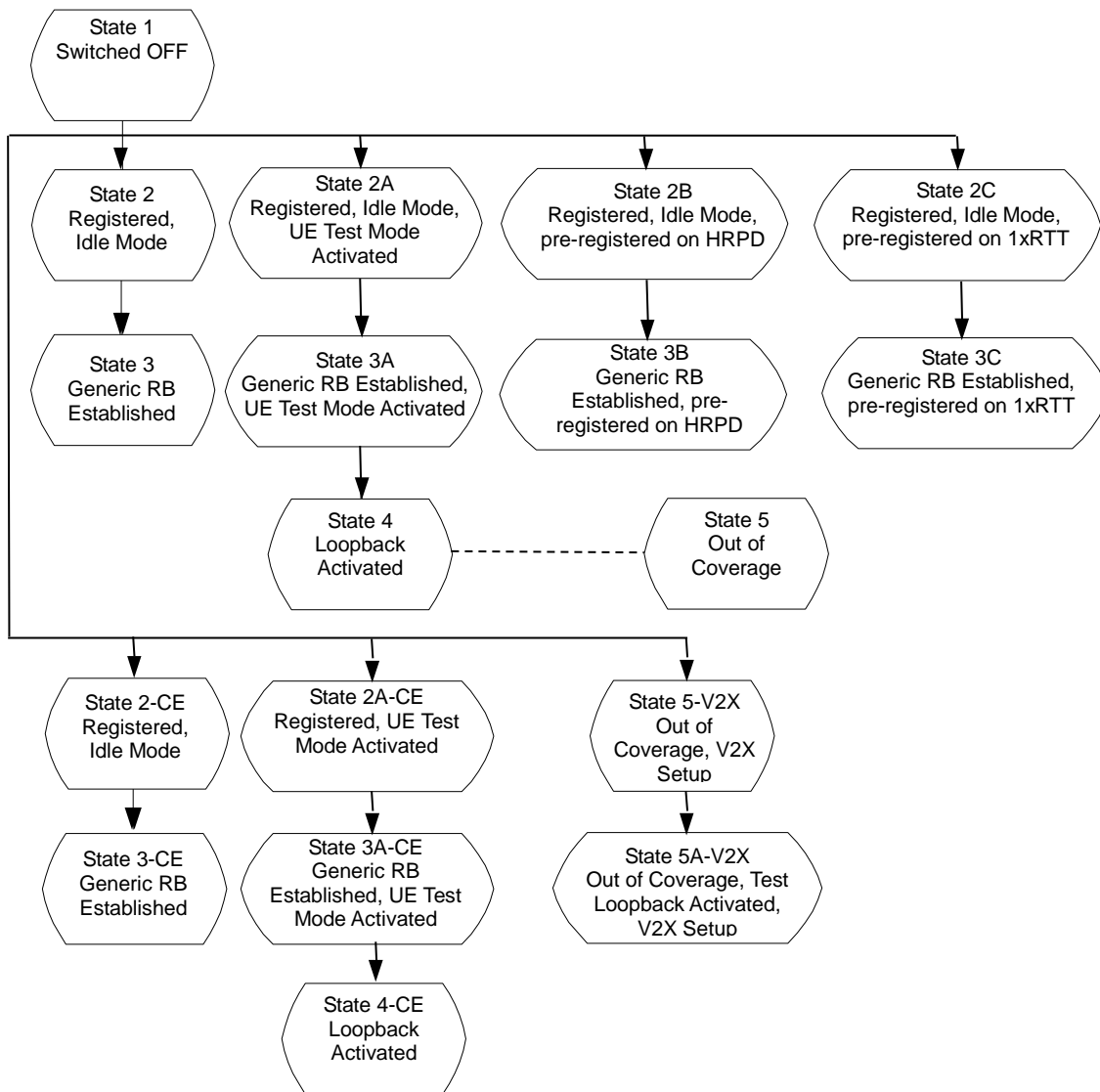

Figure 4.5.1-1: E-UTRAN UE Test States for Basic Generic Procedures

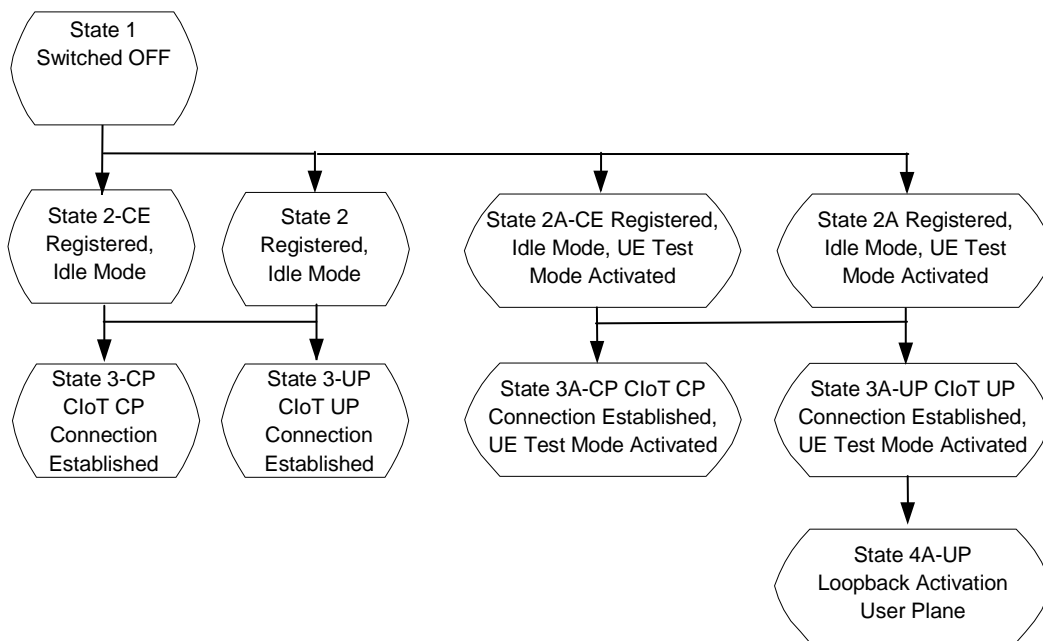

Figure 4.5.1-2: E-UTRAN UE Test States for Clot

NOTE: Transition to state 5 is performed only when Test Loop Mode E is required to be performed when UE is out of coverage.

In order that the UE can set up a call or session in E-UTRAN, there are a number of procedures to be undertaken in a hierarchical sequence to move between known states. The sequences are shown in figure 4.5.1-1 and the status of the relevant protocols in the UE in the different states are given in table 4.5.1-1.

Table 4.5.1-1: The E-UTRAN UE states

		RRC	ECM	EMM	ESM	UE Test Mode
State 1	Switched OFF	----	----	----	----	----
State 2	Registered, Idle Mode	RRC_IDLE	ECM-IDLE	EMM-REGISTERED	1 default EPS bearer context active. 2 default EPS bearer contexts active (only for RAN Assisted WLAN interworking)	Not active
State 2-CE	Registered, Idle Mode, Cell supporting BL/CE UE	RRC_IDLE	ECM-IDLE	EMM-REGISTERED	1 default EPS bearer context active.	Not active
State 2A	Registered, Idle Mode, UE Test Mode Activated	RRC_IDLE	ECM-IDLE	EMM-REGISTERED	1 default EPS bearer context active.	Active
State 2A-CE	Registered, Idle Mode, Cell supporting BL/CE UE, UE Test Mode Activated	RRC_IDLE	ECM-IDLE	EMM-REGISTERED	1 default EPS bearer context active.	Active
State 2B	Registered, Idle Mode, pre-registered on HRPD	RRC_IDLE	ECM-IDLE	EMM-REGISTERED	1 default EPS bearer context active.	Active
State 2C	Registered, Idle Mode, pre-registered on 1xRTT	RRC_IDLE	ECM-IDLE	EMM-REGISTERED	1 default EPS bearer context active.	Active
State 3	Generic RB Established	RRC_CONNECTED 1 + N ($0 \leq N \leq 7$) data radio bearers configured as specified in the test cases. 2 + N ($0 \leq N \leq 7$) data radio bearers configured as specified in the test cases (only for RAN Assisted WLAN interworking)	ECM-CONNECTED	EMM-REGISTERED	1 default EPS bearer context active and N ($0 \leq N \leq 7$) dedicated EPS bearers active as specified in the test cases. 2 default EPS bearer contexts active and N ($0 \leq N \leq 7$) dedicated EPS bearers active as specified in the test cases (only for RAN Assisted WLAN interworking)	Not active
State 3-CP	CIoT CP Connection Established	RRC_CONNECTED	ECM-CONNECTED	EMM-REGISTERED	-	Not active
State 3A-CP	CIoT CP Connection Established, UE Test Mode Activated	RRC_CONNECTED	ECM-CONNECTED	EMM-REGISTERED	-	Active
State 3-UP	CIoT UP Connection Established	RRC_CONNECTED	ECM-CONNECTED	EMM-REGISTERED	1 default EPS bearer context active.	Not active

State 3A-UP	CloT UP Connection Established, UE Test Mode Activated	RRC_CONNECT ED	ECM-CONNECTED	EMM-REGISTERED	1 default EPS bearer context active.	Active
State 4A-UP	Loopback Activation User Plane	RRC_CONNECT ED	ECM-CONNECTED	EMM-REGISTERED	1 default EPS bearer context active.	Active
State 3-CE	Generic RB Established, Cell supporting BL/CE UE	RRC_CONNECT ED 1 + N ($0 \leq N \leq 7$) data radio bearers configured as specified in the test cases.	ECM-CONNECTED	EMM-REGISTERED	1 default EPS bearer context active and N ($0 \leq N \leq 7$) dedicated EPS bearers active as specified in the test cases.	Not active
State 3A	Generic RB Established, UE Test Mode Activated	RRC_CONNECT ED 1 + N ($0 \leq N \leq 7$) data radio bearers configured as specified in the test cases	ECM-CONNECTED	EMM-REGISTERED	1 default EPS bearer context active and N ($0 \leq N \leq 7$) dedicated EPS bearers active as specified in the test cases	Active
State 3A-CE	Generic RB Established, UE Test Mode Activated, Cell supporting BL/CE UE, UE Test Mode Activated	RRC_CONNECT ED 1 + N ($0 \leq N \leq 7$) data radio bearers configured as specified in the test cases	ECM-CONNECTED	EMM-REGISTERED	1 default EPS bearer context active and N ($0 \leq N \leq 7$) dedicated EPS bearers active as specified in the test cases	Active
State 3B	Generic RB Established, pre-registered on HRPD	RRC_CONNECT ED 1 + N ($0 \leq N \leq 7$) data radio bearers configured as specified in the test cases	ECM-CONNECTED	EMM-REGISTERED	1 default EPS bearer context active and N ($0 \leq N \leq 7$) dedicated EPS bearers active as specified in the test cases	Active
State 3C	Generic RB Established, pre-registered on 1xRTT	RRC_CONNECT ED 1 + N ($0 \leq N \leq 7$) data radio bearers configured as specified in the test cases	ECM-CONNECTED	EMM-REGISTERED	1 default EPS bearer context active and N ($0 \leq N \leq 7$) dedicated EPS bearers active as specified in the test cases	Active
State 4	Loopback Activated	RRC_CONNECT ED 1 + N ($0 \leq N \leq 7$) data radio bearers configured as specified in the test cases	ECM-CONNECTED	EMM-REGISTERED	1 default EPS bearer context active and N ($0 \leq N \leq 7$) dedicated EPS bearers active as specified in the test cases	Active
State 4-CE	Loopback Activated, Cell supporting BL/CE UE	RRC_CONNECT ED 1 data radio bearer configured	ECM-CONNECTED	EMM-REGISTERED	1 default EPS bearer context active	Active
State 5	Out of Coverage	Any Cell Selection state	-----	-----	-----	Active
State 5-V2X	Out of Coverage, V2X setup	Any Cell Selection state	-----	-----	-----	Not active

State 5A-V2X	Out of Coverage, Loopback Activated, V2X setup	Any Cell Selection state	-----	-----	-----	Active
--------------	--	--------------------------	-------	-------	-------	--------

NOTE: Refer to TS 24.301 [28] subclause 5.5.1.1 for more details on the ESM state.

NOTE: Refer to TS 36.509 [38] for details regarding UE test mode and UE Loopback.

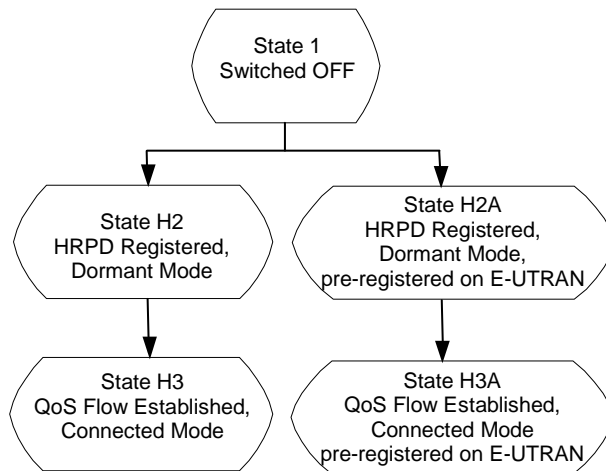

Figure 4.5.1-2: HRPD UE Test States for Basic Generic Procedures

In order for the UE to set up a session in an HRPD RAN, there are a number of procedures that need to be performed in a certain sequence to move between known UE states. These states and sequences are shown in figure 4.5.1-2. HRPD UE states are described in table 4.5.1-2.

Table 4.5.1-2: Description of HRPD UE states

State	Description
H2	The UE is registered on the HRPD network, but has no active connection to the network. The Inter-RAT Idle State Protocol (IR-ISP) is in Monitor State. The UE should be ready to perform a non-optimised cell reselection to E-UTRAN (as per [41] cl. 8 and [42] cl. 14.1).
H3	The UE is registered on the HRPD network, and has an active network connection. The UE should be ready to perform a non-optimised handover to E-UTRAN (as per [41] cl. 8).
H2A	Same state as State H2, but the UE is also pre-registered in E-UTRAN. The UE should be ready to perform an optimised cell reselection to E-UTRAN (as per [41] cl. 9.6).
H3A	Same state as State H3, but the UE is also pre-registered in E-UTRAN. The UE should be ready to perform an optimised handover to E-UTRAN (as per [41] cl. 9.5).

4.5.2 UE Registration (State 2)

IF pc_ue_CategoryDL_M1 THEN use the procedure for State 2-CE according to clause 4.5.2AA ELSE use the procedure defined in the present clause.

NOTE: The statement to use alternate procedure for CAT M1 UE (pc_ue_CategoryDL_M1 is set) is to enable LTE legacy protocol test cases to be used for CAT M1 UE testing. Any CAT M1 or CE specific test cases should not rely on this statement, but refer directly to the relevant CE specific state.

UE Registration depends on the specific configuration of a UE, which is expressed by PICS according to TS 36.523-2 [19]. In order to reduce complexity and to achieve testability several assumptions and definitions are made:

- An IMS capable UE is compliant to GSMA PRD IR.92 [52];
- During initial UE registration the UE requests for one or two PDN connectivities;
- When the UE requests for two PDN connectivities:
 - it re-uses the existing RRC connection for signalling regarding the 2nd PDN connectivity;
 - one of the PDN connectivities is for IMS;
- If the UE is configured with an APN for XCAP only usage (pc_XCAP_only_APN==true), connectivity to this PDN is not established during the initial UE registration;
- As for any 2nd PDN connectivity request security protection is already established the UE provides a valid APN in the PDN CONNECTIVITY REQUEST.

In detail the following UE configurations are supported:

Configuration	Condition	Explanation
IMS_Only	pc_IMS AND NOT pc_Provide_Internet_as_second_APN AND NOT pc_Provide_IMS_as_second_APN	UE is configured to request for IMS PDN connectivity only
Internet_Only	NOT pc_IMS	UE does not support IMS
IMS_Internet	pc_IMS AND pc_Provide_Internet_as_second_APN	UE is configured to request for IMS PDN connectivity first and then to request for an internet PDN connectivity
Internet_IMS	pc_IMS AND pc_Provide_IMS_as_second_APN	UE is configured to request for an internet PDN connectivity first and then to request for the IMS PDN connectivity
NOTE 1: pc_Provide_Internet_as_second_APN and pc_Provide_IMS_as_second_APN are mutually exclusive i.e. shall not be true at the same time.		
NOTE 2: IMS_Only configuration is not considered for EN-DC test cases defined in TS 38.523-1 [71]		

Further auxiliary definitions:

Configuration	Condition
PDN1_IMS	IMS_Only OR IMS_Internet
PDN2_IMS	Internet_IMS
PDN1_INTERNET_ONLY	Internet_Only
MULTI_PDN	IMS_Internet OR Internet_IMS
XCAP_SIGNALLING	test case requires XCAP signalling
EN-DC	Applicable to EN-DC test cases defined in TS 38.523-1 [71]

4.5.2.1 Initial conditions

System Simulator:

- 1 cell, default parameters.
- The procedure shall be performed under ideal radio conditions as defined in clause 5

User Equipment:

- The Test UICC shall be inserted. This shall contain either ISIM and USIM applications or only a USIM application on UICC.
- If RAN Assisted WLAN interworking test cases are being performed for ANDSF rules using RAN provided thresholds, ANDSF rules to match the RAN rules defined in TS 36.304 shall be available in the UE.

4.5.2.2 Definition of system information messages

The default system information messages are used.

4.5.2.3 Procedure

Table 4.5.2.3-1: UE registration procedure (state 1 to state 2)

Step	Procedure	U - S	Message Sequence Message
1		<--	RRC: SYSTEM INFORMATION (BCCH)
2	UE transmits an <i>RRCCONNECTIONREQUEST</i> message.	-->	RRC: <i>RRCCONNECTIONREQUEST</i>
3	SS transmits an <i>RRCCONNECTIONSETUP</i> message.	<--	RRC: <i>RRCCONNECTIONSETUP</i>
4	The UE transmits an <i>RRCCONNECTIONSETUPCOMPLETE</i> message to confirm the successful completion of the connection establishment and to initiate the Attach procedure by including the ATTACH REQUEST message. The PDN CONNECTIVITY REQUEST message is piggybacked in ATTACH REQUEST	-->	RRC: <i>RRCCONNECTIONSETUPCOMPLETE</i> NAS: ATTACH REQUEST NAS: PDN CONNECTIVITY REQUEST
5	The SS transmits an AUTHENTICATION REQUEST message to initiate the EPS authentication and AKA procedure.	<--	RRC: <i>DLInformationTransfer</i> NAS: AUTHENTICATION REQUEST
6	The UE transmits an AUTHENTICATION RESPONSE message and establishes mutual authentication.	-->	RRC: <i>ULInformationTransfer</i> NAS: AUTHENTICATION RESPONSE
7	The SS transmits a NAS SECURITY MODE COMMAND message to activate NAS security.	<--	RRC: <i>DLInformationTransfer</i> NAS: SECURITY MODE COMMAND
8	The UE transmits a NAS SECURITY MODE COMPLETE message and establishes the initial security configuration.	-->	RRC: <i>ULInformationTransfer</i> NAS: SECURITY MODE COMPLETE
-	EXCEPTION: Steps 9a1 to 9a2 describe behaviour that depends on UE configuration; the "lower case letter" identifies a step sequence that take place if the UE has ESM information which needs to be transferred.	-	-
9a1	IF the UE sets the ESM information transfer flag in the last PDN CONNECTIVITY REQUEST message THEN the SS transmits an ESM INFORMATION REQUEST message to initiate exchange of protocol configuration options and/or APN.	<--	RRC: <i>DLInformationTransfer</i> NAS: ESM INFORMATION REQUEST
9a2	The UE transmits an ESM INFORMATION RESPONSE message to transfer protocol configuration options and/or APN.	-->	RRC: <i>ULInformationTransfer</i> NAS: ESM INFORMATION RESPONSE
10	The SS transmits a <i>SecurityModeCommand</i> message to activate AS security.	<--	RRC: <i>SecurityModeCommand</i>
11	The UE transmits a <i>SecurityModeComplete</i> message and establishes the initial security configuration.	-->	RRC: <i>SecurityModeComplete</i>
12	The SS transmits a <i>UECapabilityEnquiry</i> message to initiate the UE radio access capability transfer procedure.	<--	RRC: <i>UECapabilityEnquiry</i>
13	The UE transmits a <i>UECapabilityInformation</i> message to transfer UE radio access capability.	-->	RRC: <i>UECapabilityInformation</i>
14	The SS transmits an <i>RRCCONNECTIONRECONFIGURATION</i> message to establish the default bearer with condition SRB2-DRB(1, 0) according to 4.8.2.2.1.1. This message includes the ATTACH ACCEPT message. The ACTIVATE DEFAULT EPS BEARER CONTEXT REQUEST message is piggybacked in ATTACH ACCEPT.	<--	RRC: <i>RRCCONNECTIONRECONFIGURATION</i> NAS: ATTACH ACCEPT NAS: ACTIVATE DEFAULT EPS BEARER CONTEXT REQUEST
15	The UE transmits an <i>RRCCONNECTIONRECONFIGURATIONCOMPLETE</i> message to confirm the establishment of default bearer.	-->	RRC: <i>RRCCONNECTIONRECONFIGURATIONCOMPLETE</i>

-	EXCEPTION: In parallel to the event described in step 16 below, if initiated by the UE the generic procedure for IP address allocation in the U-plane specified in TS 36.508 subclause 4.5A.1 takes place performing IP address allocation in the U-plane.	-	-
-	EXCEPTION: IF PDN1_IMS THEN in parallel to the event described in step 16 below the generic procedure for IMS signalling in the U-plane specified in TS 36.508 subclause 4.5A.3 takes place if requested by the UE	-	-
16	This message includes the ATTACH COMPLETE message. The ACTIVATE DEFAULT EPS BEARER CONTEXT ACCEPT message is piggybacked in ATTACH COMPLETE.	-->	RRC: <i>ULInformationTransfer</i> NAS: ATTACH COMPLETE NAS: ACTIVATE DEFAULT EPS BEARER CONTEXT ACCEPT
-	EXCEPTION: Steps 16a1 to 16c1 describe behaviour that depends on test case requirements and UE behaviour; the "lower case letter" identifies the different branches.	-	-
16a1	IF IMS VoPS is set to '0' in ATTACH ACCEPT at step 14 THEN the procedure according to Table 4.5.2.3-2 takes place	-	-
16a2 - 16b6	Void.	-	-
16c1	ELSE IF MULTI_PDN = TRUE THEN The generic procedure for UE establishing additional PDN connectivity as specified in TS 36.508 subclause 4.5A.16 takes place	-	-
17	The SS transmits an <i>RRConnectionRelease</i> message to release RRC connection and move to RRC_IDLE (State 2).	<--	RRC: <i>RRConnectionRelease</i>
-	EXCEPTION: Steps 18a1 to 18b1 describe behaviour that depends on UE capabilities/configuration and test requirements; the "lower case letter" identifies a step sequence that takes place if one of those is supported/configured.	-	-
18a1	IF additional PDN has been established AND (pc_XCAP_only_APN OR NOT XCAP_SIGNALLING) AND pc_UE_supports_user_initiated_PDN_disconnect THEN the non-IMS PDN shall be released as specified in TS 36.508 subclause 4.5A.17	-	-
18b1	IF additional PDN has been established AND (pc_XCAP_only_APN OR NOT XCAP_SIGNALLING) AND NOT pc_UE_supports_user_initiated_PDN_disconnect THEN the non-IMS PDN shall be released as specified in TS 36.508 subclause 4.5A.18	-	-
NOTE 1: Void NOTE 2: Void			

Table 4.5.2.3-2: Specific behaviour when IMS voice is not supported by the network

Step	Procedure	Message Sequence	
		U - S	Message
-	EXCEPTION: Steps 1a1 to 1b6 describe behaviour that depends on UE configuration; the "lower case letter" identifies the different branches	-	-
1a1	IF pc_voice_PS_1_CS_2, pc_attach and pc_TAU_connected_in_IMS are set to TRUE (Note 1) THEN The UE transmits a TRACKING AREA UPDATE REQUEST message.	-->	RRC: <i>ULInformationTransfer</i> NAS: TRACKING AREA UPDATE REQUEST
1a2	The SS transmits a TRACKING AREA UPDATE ACCEPT message.	<--	RRC: <i>DLInformationTransfer</i> NAS: TRACKING AREA UPDATE ACCEPT
1a3	The UE transmits a TRACKING AREA UPDATE COMPLETE message.	-->	RRC: <i>ULInformationTransfer</i> NAS: TRACKING AREA UPDATE COMPLETE
1b1	ELSE IF pc_voice_PS_1_CS_2, pc_attach and pc_TAU_idle_in_IMS are set to TRUE (Note 2) THEN The SS transmits an <i>RRCCConnectionRelease</i> message to release the RRC connection.	<--	RRC: <i>RRCCConnectionRelease</i>
1b2	The UE transmits an <i>RRCCConnectionRequest</i> message.	-->	RRC: <i>RRCCConnectionRequest</i>
1b3	The SS transmit an <i>RRCCConnectionSetup</i> message.	<--	RRC: <i>RRCCConnectionSetup</i>
1b4	The UE transmits an <i>RRCCConnectionSetupComplete</i> message including a TRACKING AREA UPDATE REQUEST message.	-->	RRC: <i>RRCCConnectionSetupComplete</i> NAS: TRACKING AREA UPDATE REQUEST
1b5	The SS transmits a TRACKING AREA UPDATE ACCEPT message.	<--	RRC: <i>DLInformationTransfer</i> NAS: TRACKING AREA UPDATE ACCEPT
1b6	The UE transmits a TRACKING AREA UPDATE COMPLETE message.	-->	RRC: <i>ULInformationTransfer</i> NAS: TRACKING AREA UPDATE COMPLETE
2	start timer Timer_1 = 5 s	-	-
-	EXCEPTION: Steps 3a1 to 3b1 describe behaviour that depends on UE behaviour; the "lower case letter" identifies the different branches	-	-
3a1	The generic procedure for UE establishing additional PDN connectivity as specified in TS 36.508 subclause 4.5A.16 takes place	-	-
3a2	Stop Timer_1	-	-
3b1	Timer_1 expires	-	-
NOTE 1: The procedure is used with specific message with no IMS voice network support. The UE is configured for voice domain preference IMS PS voice preferred, CS Voice as secondary and to initiate EPS attach. The UE implementation supports TAU in connected mode,			
NOTE 2: The procedure is used with specific message with no IMS voice network support. The UE is configured for voice domain preference IMS PS voice preferred, CS Voice as secondary and to initiate EPS attach. The UE implementation supports TAU in idle mode,			

4.5.2.4 Specific message contents

All specific message contents shall be referred to clause 4.6 and 4.7 with the exceptions below.

Table 4.5.2.4-1: RRCConnectionRequest (Step 2)

Derivation Path: Table 4.6.1-16			
Information Element	Value/remark	Comment	Condition
RRCConnectionRequest ::= SEQUENCE {			
criticalExtensions CHOICE {			
rrcConnectionRequest-r8 SEQUENCE {			
ue-Identity	Any allowed value		
}			
}			
}			

Table 4.5.2.4-2: UECapabilityInformation (Step 13)

Derivation Path: Table 4.6.1-23			
Information Element	Value/remark	Comment	Condition
UECapabilityInformation ::= SEQUENCE {			
criticalExtensions CHOICE {			
c1 CHOICE{			
ueCapabilityInformation-r8	Any allowed value		
}			
}			
}			

Table 4.5.2.4-3: ACTIVATE DEFAULT EPS BEARER CONTEXT REQUEST (Step 14)

Derivation Path: Table 4.7.3-6 with condition IMS_PDN_ConnEstab for PDN1_IMS and NOT IMS_PDN_ConnEstab			
Information Element	Value/remark	Comment	Condition
EPS bearer identity	'0101'B	arbitrary value used for PDN connectivity being maintained during the test case	PDN1_IMS OR (PDN2_IMS AND ImsVoPS0_NoImsPDN) OR NOT MULTI_PDN
EPS bearer identity	'1100'B	arbitrary value used for additional PDN connectivity which may be released before entering the test procedure of the test case	MULTI_PDN AND NOT PDN1_IMS AND NOT (PDN2_IMS AND ImsVoPS0_NoImsPDN)
EPS bearer identity	'0101'B	arbitrary value used for IMS PDN connectivity being maintained during EN-DC test case	EN-DC AND PDN1_IMS
EPS bearer identity	'1100'B	arbitrary value used for non-IMS PDN connectivity being maintained during EN-DC test case	EN-DC AND (PDN1_INT ERNET_ON LY OR PDN2_IMS)
PDN address			IPv4_addresses_only
Length of PDN address contents	5 octets		
PDN type value	'001'B	IPv4	
PDN address information	IPv4 address	The SS provides a valid IPv4 address	NOT IPv4-DHCP
	0.0.0.0	DHCPv4 is to be used to allocate the IPv4 address	IPv4-DHCP
ESM cause	IF "PDN type" IE in step 4 is 'IPv4v6' THEN '00110010'B ELSE Not present	"PDN type IPv4 only allowed"	

NOTE: The default message contents specified in table 4.7.3-6 apply unless the condition IPv4_address_only in table 4.5.2.4-3 is true.

Condition	Explanation
IPv4_address_only	This condition applies if the test case preamble description indicates that the UE is allocated an IPv4 address only.
IPv4-DHCP	If in the last PDN CONNECTIVITY REQUEST or ESM INFORMATION RESPONSE sent prior to this message, the IE Protocol configuration options contains a configuration protocol option = '000B00H' ("IPv4 address allocation via DHCPv4", length of contents = 0). Note 1: This condition is used in conjunction with IPv4 or IPv4v6 as indicated in the "PDN address row" just above. Note 2: If both messages, PDN CONNECTIVITY REQUEST and ESM INFORMATION RESPONSE, are received and contain a Protocol configuration options IE then the IE from the message which is received later shall be used.
ImsVoPS0_NoImsPDN	If the test case sets IMS VoPS to 0 AND (pc_UE_NoReqIMS_IMSVoPS_0 == TRUE)

Table 4.5.2.4-4: TRACKING AREA UPDATE REQUEST (Steps 16a1 and 16b4)

Derivation Path: 36.508 Table 4.7.2-27 with condition combined_TA_LA
--

Table 4.5.2.4-5: TRACKING AREA UPDATE ACCEPT (Steps 16a2 and 16b5)

Derivation Path: 36.508 Table 4.7.2-24 with condition combined_TA_LA
--

4.5.2A UE Registration, UE Test Mode Activated (State 2A)

IF `pc_ue_CategoryDL_M1` THEN use the procedure for State 2A-CE according to clause 4.5.2AB ELSE use the procedure defined in the present clause.

NOTE: The statement to use alternate procedure for CAT M1 UE (`pc_ue_CategoryDL_M1` is set) is to enable LTE legacy protocol test cases to be used for CAT M1 UE testing. Any CAT M1 or CE specific test cases should not rely on this statement, but refer directly to the relevant CE specific state.

The same assumptions and definitions apply as in clause 4.5.2.

4.5.2A.1 Initial conditions

System Simulator:

- 1 cell, default parameters.
- The procedure shall be performed under ideal radio conditions as defined in clause 5

User Equipment:

- The Test USIM shall be inserted.

4.5.2A.2 Definition of system information messages

The default system information messages are used.

4.5.2A.3 Procedure

Table 4.5.2A.3-1: UE registration with test mode activation procedure (state 1 to state 2A)

Step	Procedure	Message Sequence	
		U - S	Message
1 to 9a2	Same procedure for steps 1 to 9a2 as specified in the procedure in clause 4.5.2.3	-	-
10	The SS transmits an ACTIVATE TEST MODE message to activate UE radio bearer test mode procedure.	<--	RRC: <i>DLInformationTransfer</i> TC: ACTIVATE TEST MODE
11	The UE transmits an ACTIVATE TEST MODE COMPLETE message.	-->	RRC: <i>ULInformationTransfer</i> TC: ACTIVATE TEST MODE COMPLETE
12	The SS transmits a <i>SecurityModeCommand</i> message to activate AS security.	<--	RRC: <i>SecurityModeCommand</i>
13	The UE transmits a <i>SecurityModeComplete</i> message and establishes the initial security configuration.	-->	RRC: <i>SecurityModeComplete</i>
14	The SS transmits a <i>UECapabilityEnquiry</i> message to initiate the UE radio access capability transfer procedure.	<--	RRC: <i>UECapabilityEnquiry</i>
15	The UE transmits a <i>UECapabilityInformation</i> message to transfer UE radio access capability.	-->	RRC: <i>UECapabilityInformation</i>
16	The SS transmits an <i>RRCConnectionReconfiguration</i> message to establish the default bearer with condition SRB2-DRB(1, 0) according to 4.8.2.2.1.1. This message includes the ATTACH ACCEPT message. The ACTIVATE DEFAULT EPS BEARER CONTEXT REQUEST message is piggybacked in ATTACH ACCEPT.	<--	RRC: <i>RRCConnectionReconfiguration</i> NAS: ATTACH ACCEPT NAS: ACTIVATE DEFAULT EPS BEARER CONTEXT REQUEST
17	The UE transmits an <i>RRCConnectionReconfigurationComplete</i> message to confirm the establishment of default bearer.	-->	RRC: <i>RRCConnectionReconfigurationComplete</i>
-	EXCEPTION: In parallel to the event described in step 18 below the generic procedure for IP address allocation in the U-plane specified in TS 36.508 subclause 4.5A.1 takes place performing IP address allocation in the U-plane if requested by the UE.	-	-
18	This message includes the ATTACH COMPLETE message. The ACTIVATE DEFAULT EPS BEARER CONTEXT ACCEPT message is piggybacked in ATTACH COMPLETE.	-->	RRC: <i>ULInformationTransfer</i> NAS: ATTACH COMPLETE NAS: ACTIVATE DEFAULT EPS BEARER CONTEXT ACCEPT
-	EXCEPTION: Steps 18a1 to 18c1 describe behaviour that depends on UE configuration; the "lower case letter" identifies a step sequence that takes place when the UE is configured in a certain way.	-	-
18a1	IF IMS voice not supported and pc_voice_PS_1_CS_2, pc_attach and pc_TAU_connected_in_IMS are set to TRUE (Note 1) THEN The UE transmits a TRACKING AREA UPDATE REQUEST message.	-->	RRC: <i>ULInformationTransfer</i> NAS: TRACKING AREA UPDATE REQUEST
18a2	The SS transmits a TRACKING AREA UPDATE ACCEPT message.	<--	RRC: <i>DLInformationTransfer</i> NAS: TRACKING AREA UPDATE ACCEPT
18a3	The UE transmits a TRACKING AREA UPDATE COMPLETE message.	-->	RRC: <i>ULInformationTransfer</i> NAS: TRACKING AREA UPDATE COMPLETE
18b1	ELSE IF IMS voice not supported and pc_voice_PS_1_CS_2, pc_attach and pc_TAU_idle_in_IMS are set to TRUE (Note 2) THEN The SS transmits an <i>RRCConnectionRelease</i> message to release the RRC connection.	<--	RRC: <i>RRCConnectionRelease</i>

18b2	The UE transmits an <i>RRCCONNECTIONREQUEST</i> message.	-->	RRC: <i>RRCCONNECTIONREQUEST</i>
18b3	The SS transmit an <i>RRCCONNECTIONSETUP</i> message.	<--	RRC: <i>RRCCONNECTIONSETUP</i>
18b4	The UE transmits an <i>RRCCONNECTIONSETUPCOMPLETE</i> message including a TRACKING AREA UPDATE REQUEST message.	-->	RRC: <i>RRCCONNECTIONSETUPCOMPLETE</i> NAS: TRACKING AREA UPDATE REQUEST
18b5	The SS transmits a TRACKING AREA UPDATE ACCEPT message.	<--	RRC: <i>DLINFORMATIONTRANSFER</i> NAS: TRACKING AREA UPDATE ACCEPT
18b6	The UE transmits a TRACKING AREA UPDATE COMPLETE message.	-->	RRC: <i>ULINFORMATIONTRANSFER</i> NAS: TRACKING AREA UPDATE COMPLETE
18c1-18c3	ELSE IF MULTI_PDN = TRUE THEN Steps from 1 to 3 from the generic procedure for UE establishing additional PDN connectivity as specified in TS 36.508 subclause 4.5A.16 takes place	-	-
-	EXCEPTION: In parallel to the event described in step 18c4 below the generic procedure for IP address allocation in the U-plane specified in TS 36.508 subclause 4.5A.1 takes place performing IP address allocation in the U-plane if requested by the UE.	-	-
18c4	The UE transmits an ACTIVATE DEFAULT EPS BEARER CONTEXT ACCEPT message	-->	RRC: <i>ULINFORMATIONTRANSFER</i> NAS:ACTIVATE DEFAULT EPS BEARER CONTEXT ACCEPT
19	The SS transmits an <i>RRCCONNECTIONRELEASE</i> message to release RRC connection and move to RRC_IDLE (State 2A).	<--	RRC: <i>RRCCONNECTIONRELEASE</i>
-	EXCEPTION: Steps 20a1 to 20b1 describe behaviour that depends on UE capabilities/configuration; the "lower case letter" identifies a step sequence that takes place if one of those is supported/configured.	-	-
20a1	IF MULTI_PDN AND pc_UE_supports_user_initiated_PDN_disconnect THEN the non-IMS PDN shall be released as specified in TS 36.508 subclause 4.5A.17	-	-
20b1	IF MULTI_PDN AND NOT pc_UE_supports_user_initiated_PDN_disconnect THEN the non-IMS PDN shall be released as specified in TS 36.508 subclause 4.5A.18	-	-
NOTE 1: The procedure is used with specific message with no IMS voice network support. The UE is configured for voice domain preference IMS PS voice preferred, CS Voice as secondary and to initiate EPS attach. The UE implementation supports TAU in connected mode. NOTE 2: The procedure is used with specific message with no IMS voice network support. The UE is configured for voice domain preference IMS PS voice preferred, CS Voice as secondary and to initiate EPS attach. The UE implementation supports TAU in idle mode.			

4.5.2A.4 Specific message contents

All specific message contents shall be referred to clause 4.6, 4.7 and 4.7A with the exceptions below.

Table 4.5.2A.4-1: RRCConnectionRequest (Step 2)

Derivation Path: Table 4.6.1-16			
Information Element	Value/remark	Comment	Condition
RRCConnectionRequest ::= SEQUENCE {			
criticalExtensions CHOICE {			
rrcConnectionRequest-r8 SEQUENCE {			
ue-Identity	Any allowed value		
}			
}			
}			

Table 4.5.2A.4-2: UECapabilityInformation (Step 15)

Derivation Path: Table 4.6.1-23			
Information Element	Value/remark	Comment	Condition
UECapabilityInformation ::= SEQUENCE {			
criticalExtensions CHOICE {			
c1 CHOICE {			
ueCapabilityInformation-r8	Any allowed value		
}			
}			
}			

Table 4.5.2A.4-3: TRACKING AREA UPDATE REQUEST (Steps 18a1 and 18b4)

Derivation Path: 36.508 Table 4.7.2-27 with condition combined_TA_LA
--

Table 4.5.2A.4-4: TRACKING AREA UPDATE ACCEPT (Steps 18a2 and 18b5)

Derivation Path: 36.508 Table 4.7.2-24 with condition combined_TA_LA
--

4.5.2AA UE Registration in cell supporting BL/CE UE (State 2-CE)

The same assumptions and definitions apply as in clause 4.5.2.

4.5.2AA.1 Initial conditions

System Simulator:

- 1 cell, default parameters.
- The procedure shall be performed under ideal radio conditions as defined in clause 5

User Equipment:

- The Test USIM shall be inserted.

4.5.2AA.2 Definition of system information messages

The default system information messages are used with the exceptions below.

Table 4.5.2AA.2-1: MasterInformationBlock

Derivation Path: 36.508 Table 4.4.3.2-1 using condition CEmodeB if the test case specifically tests CE mode B else use condition CEmodeA.

Table 4.5.2AA.2-2: SystemInformation-BR-r13

Derivation Path: 36.508 Table 4.4.3.2-2A.

Table 4.5.2AA.2-3: SystemInformationBlockType1-BR-r13

Derivation Path: 36.508 Table 4.4.3.2-3A using condition ENHANCED COVERAGE if the BL/CE UE initial condition is intended to be in enhanced coverage; else use condition NORMAL COVERAGE.
--

4.5.2AA.3 Procedure

Table 4.5.2AA.3-1: UE registration procedure (state 1 to state 2-CE)

Step	Procedure	Message Sequence	
		U - S	Message
1	In addition to the system information broadcasted on BCCH the SS broadcasts <i>SystemInformation-BR-r13</i> , <i>SystemInformationBlockType1-BR-r13</i> and other relevant system information blocks as required by the specified combinations of system information blocks specified for the test case on BCCH-BR.	<--	RRC: SYSTEM INFORMATION (BCCH and BCCH-BR)
2 to 18b1	Same procedure for steps 2 to 18b1 as specified in the procedure in clause 4.5.2.3	-	-

4.5.2AA.4 Specific message contents

Same specific message content as in clause 4.5.2.4 with the exception below:

- In addition to any other conditions use the condition CEmodeB if the test case specifically tests CE mode B else use condition CEmodeA.

4.5.2AB UE Registration, UE Test Mode Activated in cell supporting BL/CE UE (State 2A-CE)

The same assumptions and definitions apply as in clause 4.5.2.

4.5.2AB.1 Initial conditions

System Simulator:

- 1 cell, default parameters.
- The procedure shall be performed under ideal radio conditions as defined in clause 5

User Equipment:

- The Test USIM shall be inserted.

4.5.2AB.2 Definition of system information messages

Same system information message content as in clause 4.5.2AA.2.

4.5.2AB.3 Procedure

Table 4.5.2AB.3-1: UE registration procedure (state 1 to state 2A-CE)

Step	Procedure	Message Sequence	
		U - S	Message
1	In addition to the system information broadcasted on BCCH the SS broadcasts <i>SystemInformation-BR-r13</i> , <i>SystemInformationBlockType1-BR-r13</i> and other relevant system information blocks as required by the specified combinations of system information blocks specified for the test case on BCCH-BR.	<--	RRC: SYSTEM INFORMATION (BCCH and BCCH-BR)
2 to 9a2	Same procedure for steps 2 to 9a2 as specified in the procedure in clause 4.5.2.3	-	-
10 to 20b1	Same procedure for steps 10 to 20b1 as specified in the procedure in clause 4.5.2A.3	-	-

4.5.2AB.4 Specific message contents

Same specific message content as in clause 4.5.2A.4 with the exception below:

- In addition to any other conditions use the condition CEmodeB if the test case specifically tests CE mode B else use condition CEmodeA.

4.5.2B UE Registration, pre-registration on HRPD (State 2B)

The same assumptions and definitions apply as in clause 4.5.2.

4.5.2B.1 Initial conditions

System Simulator:

- Cell 1
- Cell 1 is transmitting *SystemInformationBlockType8*

User Equipment:

- The Test USIM shall be inserted.

4.5.2B.2 Definition of system information messages

Table 4.5.2B.2-1: *SystemInformationBlockType1* for cell 1 (Steps 1-41, Table 4.5.2B.3-2)

Derivation Path: 36.508 Table 4.4.3.2-3			
Information Element	Value/remark	Comment	Condition
<i>SystemInformationBlockType1</i> ::= SEQUENCE {			
<i>schedulingInformation</i> ::= SEQUENCE (SIZE (1..maxSI-Message)) OF SEQUENCE {}	Combination 6 in TS 36.508 section 4.4.3.1	SIB2, SIB3 and SIB 8 are transmitted	
}			

Table 4.5.2B.2-2: SystemInformationBlockType8 for cell 1 (Steps 1-41, Table 4.5.2B.3-2)

Derivation Path: 36.508 Table 4.4.3.3-7, condition HRPD			
Information Element	Value/remark	Comment	Condition
SystemInformationBlockType8 ::= SEQUENCE {			
parametersHRPD SEQUENCE {			
preRegistrationInfoHRPD SEQUENCE {			
preRegistrationAllowed	TRUE		
preRegistrationZoneld	ColorCode		
secondaryPreRegistrationZoneldList	Not present		
SEQUENCE (SIZE (1..2)) OF SEQUENCE {			
PreRegistrationZoneldHRPD	Not present		
}			
}			
cellReselectionParametersHRPD SEQUENCE {			
bandClassList SEQUENCE (SIZE (1..maxCDMA-BandClass)) OF SEQUENCE {	1 entry		
bandClass	Band Class of frequency under test	ENUMERATED {bc0, bc1, bc2, bc3, bc4, bc5, bc6, bc7, bc8, bc9, bc10, bc11, bc12, bc13, bc14, bc15, bc16, bc17, spare14, spare13, spare12, spare11, spare10, spare9, spare8, spare7, spare6, spare5, spare4, spare3, spare2, spare1, ...}	
}			
cellReselectionPriority	3		
threshX-High	30(-30)	INTEGER (0..63)	
threshX-Low	32(-32)	INTEGER (0..63)	
}			
neighCellList SEQUENCE (SIZE (1..16)) OF SEQUENCE {	1 entry		
bandClass	Band Class of frequency under test	ENUMERATED {bc0, bc1, bc2, bc3, bc4, bc5, bc6, bc7, bc8, bc9, bc10, bc11, bc12, bc13, bc14, bc15, bc16, bc17, spare14, spare13, spare12, spare11, spare10, spare9, spare8, spare7, spare6, spare5, spare4, spare3, spare2, spare1, ...}	
}			
}			
t-ReselectionCDMA2000	3	INTEGER (0..7)	
}			
}			
}			

4.5.2B.3 Procedure

Table 4.5.2B.3-1 shows the cell power levels during the procedure.

Table 4.5.2B.3-1: Time instances of cell power level and parameter changes

	Parameter	Unit	Cell 1		Remark
T0	Cell-specific RS EPRE	dBm/15kHz	-75		-

Table 4.5.2B.3-2: UE registration with HRPD pre-registration procedure (state 1 to state 2B)

Step	Procedure	Message Sequence	
		U - S	Message
1 to 16	Same procedure for steps 1 to 16 as specified in the procedure in clause 4.5.2.3	-	-
-	EXCEPTION: IF MULTI_PDN = TRUE THEN in parallel to the events described in steps 17 to 40 below, the generic procedure for UE establishing additional PDN connectivity as specified in TS 36.508 subclause 4.5A.16 takes place		
17	The UE transmits an <i>ULInformationTransfer</i> containing a tunneled <i>UATIRequest</i> message on Cell 1.	-->	<i>ULInformationTransfer</i>
18	The SS transmits a <i>DLInformationTransfer</i> containing a tunneled <i>UATIAssignment</i> message on Cell 1.	<--	<i>DLInformationTransfer</i>
19	The UE transmits an <i>ULInformationTransfer</i> containing a tunneled <i>UATISuccess</i> message on Cell 1.	-->	<i>ULInformationTransfer</i>
20	The UE transmits an <i>ULInformationTransfer</i> containing a tunneled <i>AlternateLinkOpenReq</i> message on Cell 1.	-->	<i>ULInformationTransfer</i>
21	The SS transmits a <i>DLInformationTransfer</i> containing a tunneled <i>AlternateLinkOpenConf</i> message on Cell 1.	<--	<i>DLInformationTransfer</i>
22	The UE transmits an <i>ULInformationTransfer</i> containing a tunneled <i>AlternateLinkOpenComplete</i> on Cell 1.	-->	<i>ULInformationTransfer</i>
23	The UE transmits an <i>ULInformationTransfer</i> containing a tunneled <i>ConfigurationRequest</i> message for SCP configuration on Cell 1.	-->	<i>ULInformationTransfer</i>
24	The SS transmits a <i>DLInformationTransfer</i> containing a tunneled <i>ConfigurationResponse</i> message for SCP configuration on Cell 1.	<--	<i>DLInformationTransfer</i>
25	The UE transmits an <i>ULInformationTransfer</i> containing a tunneled <i>ConfigurationRequest</i> message for Stream protocol on Cell 1.	-->	<i>ULInformationTransfer</i>
26	The SS transmits a <i>DLInformationTransfer</i> containing a tunneled <i>ConfigurationResponse</i> message for Stream protocol accepting EMPA bound to service network on Cell 1.	<--	<i>DLInformationTransfer</i>
27	The UE transmits an <i>ULInformationTransfer</i> containing a tunneled <i>EMPA ConfigurationRequest</i> message or <i>MMPA ConfigurationRequest</i> message on Cell 1.	-->	<i>ULInformationTransfer</i>
28	The SS transmits a <i>DLInformationTransfer</i> containing a tunneled <i>EMPA ConfigurationResponse</i> message or <i>MMPA ConfigurationResponse</i> message on Cell 1.	<--	<i>DLInformationTransfer</i>
29	The UE transmits an <i>ULInformationTransfer</i> containing a tunneled <i>ConfigurationComplete</i> message on Cell 1.	-->	<i>ULInformationTransfer</i>
30	The SS transmits a <i>DLInformationTransfer</i> containing a tunneled <i>EMPA ConfigurationRequest</i> message or <i>MMPA ConfigurationRequest</i> message on Cell 1.	<--	<i>DLInformationTransfer</i>
30A	The UE transmits an <i>ULInformationTransfer</i> containing a tunneled <i>EMPA ConfigurationResponse</i> message or <i>MMPA ConfigurationResponse</i> message on Cell 1.	-->	<i>ULInformationTransfer</i>
30B	The SS transmits an <i>DLInformationTransfer</i> containing a tunneled <i>SoftConfigurationComplete</i> message on Cell 1.	<--	<i>DLInformationTransfer</i>
30C	The UE transmits an <i>ULInformationTransfer</i> containing a tunneled <i>AlternateLinkCloseReq</i> message on Cell 1.	-->	<i>ULInformationTransfer</i>

30D	The SS transmits a <i>DLInformationTransfer</i> containing a tunneled <i>AlternateLinkCloseConf</i> message on Cell 1.	<--	<i>DLInformationTransfer</i>
31	Optionally tunneled device level authentication may take place on Cell 1.	<-->	-
32	Optionally tunneled Location Update procedure may take place if the SS is configured to support it.	<-->	-
32A	The UE transmits an <i>ULInformationTransfer</i> containing a tunneled <i>AlternateLinkOpenReq</i> message on Cell 1.	-->	<i>ULInformationTransfer</i>
32B	The SS transmits a <i>DLInformationTransfer</i> containing a tunneled <i>AlternateLinkOpenConf</i> message on Cell 1.	<--	<i>DLInformationTransfer</i>
32C	The UE transmits an <i>ULInformationTransfer</i> containing a tunneled <i>AlternateLinkOpenComplete</i> message on Cell 1.	-->	<i>ULInformationTransfer</i>
33	Tunneled PPP LCP negotiation is performed between the UE and the SS. EAP-AKA' is selected as the authentication protocol.	<-->	-
33A	After entering PPP LCP Open State, optionally tunneled PPP Version Capability Indicaiton and/or Max PPP Inactivity Timer negotiation may take place.	<-->	-
34	Tunneled EAP-AKA' is performed between the UE and the SS.	<-->	-
35	The UE transmits an <i>ULInformationTransfer</i> containing a tunneled <i>VSNCP Configure-Request</i> message, including a PDN-ID, PDN Type, APN, PDN Address, Protocol Configuration Options, and Attach Type = "handover". The Address Allocation Preference option contained in the Protocol Configuration Options indicates whether the UE wants to perform the IP address allocation during the attach procedure or deferred IP address allocation. PDN Type indicates the UE's IP capability (IPv4, IPv6 or IPv4/v6)	-->	<i>ULInformationTransfer</i>
36	The SS transmits a <i>DLInformationTransfer</i> containing a tunneled <i>VSNCP Configure-Ack</i> message.	<--	<i>DLInformationTransfer</i>
37	The SS transmits a <i>DLInformationTransfer</i> containing a tunneled <i>VSNCP Configure-Request</i> message including the PDN-ID configuration option.	<--	<i>DLInformationTransfer</i>
38	The UE transmits an <i>ULInformationTransfer</i> containing a tunneled <i>VSNCP Configure-Ack</i> message.	-->	<i>ULInformationTransfer</i>
39	Optionally deferred IP address allocation using tunnelled IETF messages can take place depending on the Address Allocation Preference indicated by the UE at Step 35.	<-->	
39A	The UE transmits an <i>ULInformationTransfer</i> containing a tunneled <i>AlternateLinkCloseReq</i> message on Cell 1.	-->	<i>ULInformationTransfer</i>
39B	The SS transmits a <i>DLInformationTransfer</i> containing a tunneled <i>AlternateLinkCloseConf</i> message on Cell 1.	<--	<i>DLInformationTransfer</i>
40	Void		
41	The SS transmits an <i>RRCCConnectionRelease</i> message on Cell 1.	<--	<i>RRCCConnectionRelease</i>
-	EXCEPTION: Steps 42a1 to 42b1 describe behaviour that depends on UE capabilities/configuration; the "lower case letter" identifies a step sequence that takes place if one of those is supported/configured.	-	-

42a1	IF MULTI_PDND AND pc_UE_supports_user_initiated_PDN_disconnect THEN the non-IMS PDN shall be released as specified in TS 36.508 subclause 4.5A.17	-	-
42b1	IF MULTI_PDND AND NOT pc_UE_supports_user_initiated_PDN_disconnect THEN the non-IMS PDN shall be released as specified in TS 36.508 subclause 4.5A.18	-	-
<p>Note 1: The sequence in steps 17-40 lists important eHRPD procedures. More protocol negotiations can happen based on UE capability and SS emulation.</p> <p>Note 2: Message contents of tunnelled CDMA2000 messages (steps 17-40) are not checked in terms of conformance testing.</p>			

NOTE: If step 31 is performed, an alternative link establishment procedure is also performed.

4.5.2B.4 Specific message contents

All specific message contents shall be referred to clause 4.6, 4.7 and 4.7A with the exceptions below.

Table 4.5.2B.4-1: RRCConnectionRequest (Step 2, Table 4.5.2B.3-2)

Derivation Path: Table 4.6.1-16			
Information Element	Value/remark	Comment	Condition
RRCConnectionRequest ::= SEQUENCE {			
criticalExtensions CHOICE {			
rrcConnectionRequest-r8 SEQUENCE {			
ue-Identity	Any allowed value		
}			
}			
}			

Table 4.5.2B.4-2: UECapabilityInformation (Step13, Table 4.5.2B.3-2)

Derivation Path: Table 4.6.1-23			
Information Element	Value/remark	Comment	Condition
UECapabilityInformation ::= SEQUENCE {			
criticalExtensions CHOICE {			
c1 CHOICE{			
ueCapabilityInformation-r8	Any allowed value		
}			
}			
}			

Table 4.5.2B.4-3: UATI Request message (Step 17, Table 4.5.2B.3-2)

Field	Value/remark	Comment	Condition
SAPState	'0'B	SAP Header	
SessionConfigurationToken	16 bits, Set by UE		
ConnectionLayerFormat	1 bit, Set by UE		
ATI Record	34 bits, RATI set by UE		
Reserved	'0000'B		
MessageID	'00000000'B	UATI Request	
TransactionID	8 bits, Set by UE		

Table 4.5.2B.4-4: UATI Assignment message (Step 18, Table 4.5.2B.3-2)

Field	Value/remark	Comment	Condition
SAPState	'1'B	SAP Header	
SessionConfigurationToken	'0'		
ConnectionLayerFormat	1 bit, Set by SS		
ATI Record	34 bits, RATI set in UATI Request		
Reserved	'0000'B		
MessageID	'00000001'B	UATI Assignment	
MessageSequence	8 bits, Set by SS		
Reserved1	'0000000'B		
SubnetIncluded	'1'B		
UATISubnetMask	'1101000'B		
UATI104	104 bits, Set by SS		
UATIColorCode	8 bits, Set to ColorCode		
UATI024	24 bits, Set by SS		
UpperOldUATILength	'0000'B		
Reserved2	'0000'B		

4.5.2C UE Registration, pre-registration on 1xRTT (State 2C)

The same assumptions and definitions apply as in clause 4.5.2.

4.5.2C.1 Initial conditions

System Simulator:

- Cell 1
- Cell 1 is transmitting SystemInformationBlockType8

User Equipment:

- The Test USIM shall be inserted.
- The UE is switched OFF.

4.5.2C.2 Definition of system information messages

Table 4.5.2C.2-1: SystemInformationBlockType1 for cell 1 (Steps 1-19, Table 4.5.2C.3-2)

Derivation Path: 36.508 Table 4.4.3.2-3			
Information Element	Value/remark	Comment	Condition
SystemInformationBlockType1 ::= SEQUENCE {			
schedulingInformation ::= SEQUENCE (SIZE (1..maxSI-Message)) OF SEQUENCE {}	Combination 6 in TS 36.508 section 4.4.3.1	SIB2, SIB3 and SIB 8 are transmitted	
}			

Table 4.5.2C.2-2: *SystemInformationBlockType8* for cell 1 (Steps 1-19, Table 4.5.2C.3-2)

Derivation Path: 36.508 Table 4.4.3.3-7, condition 1XRTT			
Information Element	Value/remark	Comment	Condition
SystemInformationBlockType8 ::= SEQUENCE {			
parameters1XRTT SEQUENCE {			
csfb-RegistrationParam1XRTT SEQUENCE {			
Sid	SID under test For Signalling test cases, see table 4.4.2-4	BIT STRING (SIZE (15))	
Nid	NID under test For Signalling test cases, see table 4.4.2-4	BIT STRING (SIZE (16))	
multipleSID	TRUE	BOOLEAN	
multipleNID	TRUE	BOOLEAN	
homeReg	TRUE	BOOLEAN	
foreignSIDReg	TRUE	BOOLEAN	
foreignNIDReg	TRUE	BOOLEAN	
parameterReg	TRUE	BOOLEAN	
powerUpReg	TRUE	BOOLEAN	
registrationPeriod	'0000000'	BIT STRING (SIZE (7))	
registrationZone	Registration zone under test For Signalling test cases, see table 4.4.2-4	BIT STRING (SIZE (12))	
totalZone	'001'B	BIT STRING (SIZE (3))	
zoneTimer	'000'B or '001'B	BIT STRING (SIZE (3))	
}			
longCodeState1XRTT	A valid value, calculated and updated by the SS	BIT STRING (SIZE (42)) OPTIONAL	
cellReselectionParameters1XRTT SEQUENCE {			
bandClassList SEQUENCE (SIZE (1..maxCDMA -BandClass)) OF SEQUENCE {	1 entry		
bandClass	Band Class of frequency under test	ENUMERATED {bc0, bc1, bc2, bc3, bc4, bc5, bc6, bc7, bc8, bc9, bc10, bc11, bc12, bc13, bc14, bc15, bc16, bc17, spare14, spare13, spare12, spare11, spare10, spare9, spare8, spare7, spare6, spare5, spare4, spare3, spare2, spare1, ...}	
cellReselectionPriority	3		
threshX-High	30(-30)	INTEGER (0..63)	
threshX-Low	32(-32)	INTEGER (0..63)	
}			
}			
csfb-RegistrationParam1XRTT-v920{			
powerDownReg-r9	TRUE		
}			
}			
}			

4.5.2C.3 Procedure

Table 4.5.2C.3-1 shows the cell power levels after the preamble.

Table 4.5.2C.3-1: Time instances of cell power level and parameter changes

	Parameter	Unit	Cell 1		Remark
T0	Cell-specific RS EPRE	dBm/15kHz	-60		-

Table 4.5.2C.3-2: UE registration with 1xRTT pre-registration procedure (state 1 to state 2C)

Step	Procedure	Message Sequence	
		U - S	Message
1 to 16	Same procedure for steps 1 to 16 as specified in the procedure in clause 4.5.2.3	-	-
-	EXCEPTION: IF MULTI_PDN = TRUE THEN in parallel to the events described in steps 16A to 18 below, the generic procedure for UE establishing additional PDN connectivity as specified in TS 36.508 subclause 4.5A.16 takes place		
16A	The UE transmits a <i>CSFBParametersRequestCDMA2000</i> on Cell 1?	-->	<i>CSFBParametersRequestCDMA2000</i>
16B	The SS transmits a <i>CSFBParametersResponseCDMA2000</i> on Cell 1.	<<--	<i>CSFBParametersResponseCDMA2000</i>
17	The UE transmits an <i>ULInformationTransfer</i> containing a 1xRTT GCSNA Encapsulated Registration message on Cell 1.	-->	<i>ULInformationTransfer</i>
17A	The SS transmits a <i>DLInformationTransfer</i> containing a GCSNA Ack message on Cell 1.	<<--	<i>DLInformationTransfer</i>
18	The SS transmits a <i>DLInformationTransfer</i> containing a 1x RTT GCSNA Encapsulated Registration Accept Order on Cell 1.	<<--	<i>DLInformationTransfer</i>
19	The SS transmits an <i>RRCCConnectionRelease</i> message on Cell 1.	<<--	<i>RRCCConnectionRelease</i>
-	EXCEPTION: Steps 20a1 to 20b1 describe behaviour that depends on UE capabilities/configuration; the "lower case letter" identifies a step sequence that takes place if one of those is supported/configured.	-	-
20a1	IF MULTI_PDN AND pc_UE_supports_user_initiated_PDN_disconnect THEN the non-IMS PDN shall be released as specified in TS 36.508 subclause 4.5A.17	-	-
20b1	IF MULTI_PDN AND NOT pc_UE_supports_user_initiated_PDN_disconnect THEN the non-IMS PDN shall be released as specified in TS 36.508 subclause 4.5A.18	-	-
Note: Message contents of tunnelled CDMA2000 messages (steps 17-18) are not checked in terms of conformance testing.			

Table 4.5.2C.3-3: Void

4.5.2C.4 Specific message contents

All specific message contents shall be referred to clause 4.6, 4.7 and 4.7A with the exceptions below.

Table 4.5.2C.4-1: RRCConnectionRequest (Step 2, Table 4.5.2C.3-2)

Derivation Path: Table 4.6.1-16			
Information Element	Value/remark	Comment	Condition
RRCConnectionRequest ::= SEQUENCE {			
criticalExtensions CHOICE {			
rrcConnectionRequest-r8 SEQUENCE {			
ue-Identity	Any allowed value		
}			
}			
}			

Table 4.5.2C.4-2: UECapabilityInformation (Step 13, Table 4.5.2C.3-2)

Derivation Path: Table 4.6.1-23			
Information Element	Value/remark	Comment	Condition
UECapabilityInformation ::= SEQUENCE {			
criticalExtensions CHOICE {			
c1 CHOICE{			
ueCapabilityInformation-r8	Any allowed value		
}			
}			
}			

Table 4.5.2C.4-3: Void

Table 4.5.2C.4-4: Void

Table 4.5.2C.4-5: CSFBParametersResponseCDMA2000 (Step 16B, Table 4.5.2C.3-2)

Derivation Path: 36.508 Table 4.6.1-2			
Information Element	Value/remark	Comment	Condition
CSFBParametersResponseCDMA2000 ::= SEQUENCE {			
criticalExtensions CHOICE {			
csfbParametersResponseCDMA2000-r8 SEQUENCE {			
Rand	Random Challenge Data set by SS		
mobilityParameters	Set according to Table 4.5.2C.4-6		
}			
}			
}			

Table 4.5.2C.4-6: *mobilityParameters* (CDMA2000Parameters) (Step 16B, Table 4.5.2C.3-2)

Information Element	Value/remark	Comment	Condition
RecordType	'0000000'B		
SIDIncluded	'1'B		
SID	The same as SIB8		
NIDIncluded	'1'B		
NID	The same as SIB8		
REG_ZONEIncluded	'1'B		
REG_ZONE	The same as SIB8		
TOTAL_ZONESIncluded	'1'B		
TOTAL_ZONES	The same as SIB8		
ZONE_TIMERIncluded	'1'B		
ZONE_TIMER	The same as SIB8		
PACKET_ZONE_IDIncluded	'0'B		
PACKET_ZONE_ID	Not present		
PZIDHystParametersIncluded	'0'B		
PZ_HYST_ENABLED	Not present		
PZ_HYST_INFO_INCL	Not present		
PZ_HYST_LIST_LEN	Not present		
PZ_HYST_ACT_TIMER	Not present		
PZ_HYST_TIMER_MUL	Not present		
PZ_HYST_TIMER_EXP	Not present		
P_REVIncluded	'1'B		
P_REV	'0000110'B		
MIN_P_REVIncluded	'1'B		
MIN_P_REV	'0000110'B		
'0'B NEG_SLOT_CYCLE_INDEX_SUPIncluded			
NEG_SLOT_CYCLE_INDEX_SUP	Not present		
ENCRYPT_MODEIncluded	'0'B		
ENCRYPT_MODE	Not present		
ENC_SUPPORTEDIncluded	'0'B		
ENC_SUPPORTED	Not present		
SIG_ENCRYPT_SUPIncluded	'0'B		
SIG_ENCRYPT_SUP	Not present		
MSG_INTEGRITY_SUPIncluded	'0'B		
MSG_INTEGRITY_SUP	Not present		
SIG_INTEGRITY_SUP_INCLIncluded	'0'B		
SIG_INTEGRITY_SUP_INCL	Not present		
SIG_INTEGRITY_SUPIncluded	'0'B		
SIG_INTEGRITY_SUP	Not present		
AUTHIncluded	'1'B		
AUTH	'00'B		
MAX_NUM_ALT_SOIncluded	'1'B		
MAX_NUM_ALT_SO	'000'B		
USE_SYNC_IDIncluded	'0'B		
USE_SYNC_ID	Not present		
MS_INIT_POS_LOC_SUP_INDIncluded	'0'B		
MS_INIT_POS_LOC_SUP_IND	Not present		
MOB_QOSIncluded	'0'B		
MOB_QOS	Not present		
BAND_CLASS_INFO_REQIncluded	'0'B		
BAND_CLASS_INFO_REQ	Not present		
BAND_CLASSIncluded	'1'B		
BAND_CLASS	'00000'B		
BYPASS_REG_INDIncluded	'0'B		
BYPASS_REG_IND	Not present		
'0'B ALT_BAND_CLASSIncluded			
ALT_BAND_CLASS	Not present		
MAX_ADD_SERV_INSTANCEIncluded	'0'B		
MAX_ADD_SERV_INSTANCE	Not present		
HOME_REGIncluded	'1'B		
HOME_REG	The same as SIB8		
FOR_SID_REGIncluded	'1'B		
FOR_SID_REG	The same as SIB8		
FOR_NID_REGIncluded	'1'B		
FOR_NID_REG	The same as SIB8		

POWER_UP_REGIncluded	'1'B		
POWER_UP_REG	The same as SIB8		
POWER_DOWN_REGIncluded	'1'B		
POWER_DOWN_REG	The same as SIB8		
PARAMETER_REGIncluded	'1'B		
PARAMETER_REG	The same as SIB8		
REG_PRDIncluded	'1'B		
REG_PRD	The same as SIB8		
REG_DISTIncluded	'0'B		
REG_DIST	Not present		
PREF_MSID_TYPEIncluded	'1'B		
PREF_MSID_TYPE	'11'B		
EXT_PREF_MSID_TYPEIncluded	'0'B		
EXT_PREF_MSID_TYPE	Not present		
MEID_REQDIncluded	'0'B		
MEID_REQD	Not present		
MCCIncluded	'1'B		
MCC	See the Table 4.4.2-4 Note 1, Note 2		
IMSI_11_12Included	'1'B		
IMSI_11_12	See the Table 4.4.2-4 Note 1, Note 2		
IMSI_T_SUPPORTEDIncluded	'1'B		
IMSI_T_SUPPORTED	'0'B		
RECONNECT_MSG_INDIncluded	'0'B		
RECONNECT_MSG_IND	Not present		
RER_MODE_SUPPORTEDIncluded	'0'B		
RER_MODE_SUPPORTED	Not present		
TKZ_MODE_SUPPORTEDIncluded	'0'B		
TKZ_MODE_SUPPORTED	Not present		
TKZ_IDIncluded	'0'B		
TKZ_ID	Not present		
PILOT_REPORTIncluded PILOT_REPORT	'0'B		
PILOT_REPORT	Not present		
SDB_SUPPORTEDIncluded	'0'B		
SDB_SUPPORTED	Not present		
AUTO_FCSO_ALLOWEDIncluded	'0'B		
AUTO_FCSO_ALLOWED	Not present		
SDB_IN_RCNM_INDIncluded	'0'B		
SDB_IN_RCNM_IND	Not present		
FPC_FCH_Included	'1'B		
FPC_FCH_INIT_SETPT_RC3	'00011000'B		
FPC_FCH_INIT_SETPT_RC4	'00011000'B		
FPC_FCH_INIT_SETPT_RC5	'00011000'B		
FPC_FCH_INIT_SETPT_RC11	'00000000'B		
FPC_FCH_INIT_SETPT_RC12	'00000000'B		
T_ADD_Included	'0'B		
T_ADD	Not present		
PILOT_INC_Included	'1'B		
PILOT_INC	'0010'B		
RAND_Included	'0'B		
RAND	Not present		
LP_SEC_Included	'1'B		
LP_SEC	'00000000'B		
LTM_OFF_Included	'1'B		
LTM_OFF	'000000'B		
DAYLT_Included	'1'B		
DAYLT	'0'B		
GCSNAL2AckTimer_Included	'1'B		
GCSNAL2AckTimer	'00000001'B		
GCSNASequenceContextTimer_Included	'1'B		
GCSNASequenceContextTimer	'00000101'B		

Table 4.5.2C.4-7: *ULInformationTransfer* (Step 17, Table 4.5.2C.3-2)

Derivation Path: 36.508 Table 4.6.1-25			
Information Element	Value/remark	Comment	Condition
ULInformationTransfer ::= SEQUENCE {			
criticalExtensions CHOICE {			
c1 CHOICE {			
ullInformationTransfer-r8 SEQUENCE {			
dedicatedInformationType CHOICE {			
dedicatedInfoCDMA2000-1XRTT	Set according to Table 4.5.2C.4-8		
}			
}			
}			
}			
}			

Table 4.5.2C.4-8: 1xRTT GCSNA Encapsulated Registration message (Step 17, Table 4.5.2C.3-2)

Information Element	Value/remark	Comment	Condition
MessageID	'00000001'B	GCSNA1xCircuitS ervice message	
GCSNAOption	'00000001'B		
AlternativeGCSNAOption_INCL	'0'B		
IWSIDIncl	'0'B		
AckRequired	'1'B		
StopDupDetect	'0'B		
MessageSequence	Set by UE		
NumTLACEncapsulated1xL3PDU	'00'B		
Reserved	'0000'B		
1xLogicalChannel	'0'B		
1xProtocolRevision	'00000110'B		
MsgType	'00000001'B	Registration message	
NumTLACHeaderRecords	'0001'B		
TLACHeaderRecordType	'0000'B		
TLACHeaderRecordLength	8 bits, Set by UE		
MSID_TYPE	'011'B		
MSID_LEN	4 bits, Set by UE		
MSID	Variable, Set by UE		
Reserved	'0000000'B		
1xL3PDULength	16 bits, Set by UE		
REG_TYPE	'0001'B	Power up registration	
SLOT_CYCLE_INDEX	'010'B		
MOB_P_REV	8 bits, Set by UE		
SCM	8 bits, Set by UE		
MOB_TERM	'1'B		
RETURN_CAUSE	'1'B		
QPCH_SUPPORTED	'1'B		
ENHANCED_RC	'1'B		
UZID_INCL	'0'B		

Table 4.5.2C.4-9: 1xRTT CS Registration Accept Order (Step 18, Table 4.5.2C.3-2)

Information Element	Value/remark	Comment	Condition
MessageID	'00000001'B		
GCSNAOption	'00000001'B		
AlternativeGCSNAOption_INCL	'0'B		
IWSIDIncl	'0'B		
AckRequired	'0'B		
StopDupDetect	'0'B		
MessageSequence	6 bits, Set by SS		
NumTLACEncapsulated1xL3PDU	'00'B		
Reserved	'0000'B		
1xLogicalChannel	'0'B		
1xProtocolRevision	'0000110'B		
MsgType	'00000111'B	Order message	
NumTLACHeaderRecords	'0000'B		
Reserved	'000'B		
1xL3PDULength	16 bits, Set by SS		
ORDER	'011011'B	Registration Accept Order	
ADD_RECORD_LEN	'001'B		
ORDQ	'00000000'B		

Table 4.5.2C.4-10: ATTACH ACCEPT (Step 14, Table 4.5.2C.3-2)

Derivation Path: 36.508 clause 4.7.2			
Information Element	Value/remark	Comment	Condition
EPS attach result	'0001'B	EPS only	
EMM cause	'0001 0010'B	#18 "CS domain not available"	combined_E PS_IMSI

4.5.2D UE Registration, 2 PDN for RAN Assisted WLAN Interworking (State 2)

The same assumptions and definitions apply as in clause 4.5.2.

4.5.2D.1 Initial conditions

System Simulator:

- 1 cell, default parameters.
- The procedure shall be performed under ideal radio conditions as defined in clause 5

User Equipment:

- The Test UICC shall be inserted. This shall contain either ISIM and USIM applications or only a USIM application on UICC.

4.5.2D.2 Definition of system information messages

The default system information messages are used.

4.5.2D.3 Procedure

Table 4.5.2D.3-1: UE registration procedure (state 1 to state 2)

Step	Procedure	Message Sequence	
		U - S	Message
1-16	Steps 1 to 16 of the generic test procedure for UE registration sub clause 4.5.2.3.	-	-
	EXCEPTION: Step17 depends on UE configuration, executed if UE does not automatically trigger additional PDN Connection.		
17	Cause the UE to request connectivity to an additional PDN (see Note 1)		
18-21	The generic procedure for UE establishing additional PDN connectivity as specified in TS 36.508 subclause 4.5A.16 takes place		
22	The SS transmits an <i>RRCCConnectionRelease</i> message to release RRC connection and move to RRC_IDLE (State 2).	<--	RRC: <i>RRCCConnectionRelease</i>

NOTE 1: The request of connectivity to an additional PDN may be performed by MMI or AT command.

4.5.2D.4 Specific message contents

All specific message contents shall be referred to clause 4.6 and 4.7 with the exceptions below.

Table 4.5.2D.4-1: *RRCCConnectionRequest* (Step 2)

Derivation Path: Table 4.6.1-16			
Information Element	Value/remark	Comment	Condition
<i>RRCCConnectionRequest</i> ::= SEQUENCE {			
criticalExtensions CHOICE {			
<i>rrcConnectionRequest-r8</i> SEQUENCE {			
ue-Identity	Any allowed value		
}			
}			
}			

Table 4.5.2D.4-2: *UECapabilityInformation* (Step 13)

Derivation Path: Table 4.6.1-23			
Information Element	Value/remark	Comment	Condition
<i>UECapabilityInformation</i> ::= SEQUENCE {			
criticalExtensions CHOICE {			
c1 CHOICE{			
ueCapabilityInformation-r8	Any allowed value		
}			
}			
}			

Table 4.5.2D.4-3: ACTIVATE DEFAULT EPS BEARER CONTEXT REQUEST (Step 14 a)

Derivation Path: Table 4.7.3-6 with condition IMS_PDN_ConnEstab for PDN1_IMS and NOT IMS_PDN_ConnEstab else			
Information Element	Value/remark	Comment	Condition
EPS bearer identity	'0101'B	arbitrary value used for PDN connectivity being maintained during the test case	PDN1_IMS OR NOT MULTI_PDN
EPS bearer identity	'1100'B	arbitrary value used for additional PDN connectivity which may be released before entering the test procedure of the test case	MULTI_PDN AND NOT PDN1_IMS
PDN address			IPv4_addresses_only
Length of PDN address contents	5 octets		
PDN type value	'001'B	IPv4	
PDN address information	IPv4 address	The SS provides a valid IPv4 address	NOT IPv4-DHCP
	0.0.0.0	DHCPv4 is to be used to allocate the IPv4 address	IPv4-DHCP
ESM cause	IF "PDN type" IE in step 4 is 'IPv4v6' THEN '00110010'B ELSE Not present	"PDN type IPv4 only allowed"	
WLAN offload indication	Not present		NOT PDN1_Offload
WLAN offload indication			PDN1_Offload
WLAN offload acceptability	'0001'B	Offloading the traffic of the PDN connection via a WLAN when in S1 mode is acceptable	

NOTE: The default message contents specified in table 4.7.3-6 apply unless the condition IPv4_address_only in table 4.5.2D.4-3 is true.

Condition	Explanation
IPv4_address_only	This condition applies if the test case preamble description indicates that the UE is allocated an IPv4 address.
IPv4-DHCP	If in the last PDN CONNECTIVITY REQUEST or ESM INFORMATION RESPONSE sent prior to this message, the IE Protocol configuration options contains a configuration protocol option = '000B00H' ("IPv4 address allocation via DHCPv4", length of contents = 0). Note 1: This condition is used in conjunction with IPv4 or IPv4v6 as indicated in the "PDN address row" just above. Note 2: If both messages, PDN CONNECTIVITY REQUEST and ESM INFORMATION RESPONSE, are received and contain a Protocol configuration options IE then the IE from the message which is received later shall be used.
PDN1_Offload	This condition applies if the test execution requests the first PDN connection PDN1 to be offloaded to WLAN

Table 4.5.2D.4-4: Message ACTIVATE DEFAULT EPS BEARER CONTEXT REQUEST (step 19)

Derivation path: Table 4.7.3-6 with condition IMS_PDN_ConnEstab for ADD_IMS and NOT IMS_PDN_ConnEstab else and table 4.6.1-8 with condition AM-DRB-ADD(1) for ADD_IMS or with condition AM-DRB-ADD(8) else			
Information Element	Value/Remark	Comment	Condition
EPS bearer identity	'0101'B	arbitrary value used for PDN connectivity being maintained during the test case	PDN2_IMS
EPS bearer identity	'1100'B	arbitrary value used for additional non-IMS PDN connectivity	NOT PDN2_IMS
Procedure transaction identity	PTI-1	SS re-uses the particular PTI defined by UE for this present additional PDN connectivity request procedure	
WLAN offload indication	Not present		PDN1_Offload
WLAN offload indication			NOT PDN1_Offload
WLAN offload acceptability	'0001'B	Offloading the traffic of the PDN connection via a WLAN when in S1 mode is acceptable	

Condition	Explanation
PDN1_Offload	This condition applies if the test execution requests the first PDN connection PDN1 to be offloaded to WLAN

4.5.3 Generic Radio Bearer Establishment (State 3)

IF pc_ue_CategoryDL_M1 THEN use the procedure for State 3-CE according to clause 4.5.3AA ELSE use the procedure defined in the present clause.

NOTE: The statement to use alternate procedure for CAT M1 UE (pc_ue_CategoryDL_M1 is set) is to enable LTE legacy protocol test cases to be used for CAT M1 UE testing. Any CAT M1 or CE specific test cases should not rely on this statement, but refer directly to the relevant CE specific state.

4.5.3.1 Initial conditions

System Simulator:

- Parameters are set to the default parameters for the basic single cell environment, as defined in subclause 4.4, unless otherwise specified in the test case.

User Equipment:

- The UE shall be in Registered, Idle Mode state (State 2).

4.5.3.2 Definition of system information messages

The default system information messages are used.

4.5.3.3 Procedure

The establishment of generic radio bearer connection is assumed to always be mobile terminated.

Table 4.5.3.3-1: Generic Radio Bearer establishment procedure (state 2 to state 3)

Step	Procedure	U - S	Message Sequence Message
1	Void		
2	SS sends a <i>Paging</i> message to the UE on the appropriate paging block, and including the UE identity in one entry of the IE <i>pagingRecordLists</i> .	<--	RRC: <i>Paging</i> (PCCH)
3	UE transmits an <i>RRCConnectionRequest</i> message.	-->	RRC: <i>RRCConnectionRequest</i>
4	SS transmit an <i>RRCConnectionSetup</i> message.	<--	RRC: <i>RRCConnectionSetup</i>
5	The UE transmits an <i>RRCConnectionSetupComplete</i> message to confirm the successful completion of the connection establishment and to initiate the session management procedure by including the SERVICE REQUEST message. (State3)	-->	RRC: <i>RRCConnectionSetupComplete</i> NAS: SERVICE REQUEST
6	The SS transmits a <i>SecurityModeCommand</i> message to activate AS security.	<--	RRC: <i>SecurityModeCommand</i>
7	The UE transmits a <i>SecurityModeComplete</i> message and establishes the initial security configuration.	-->	RRC: <i>SecurityModeComplete</i>
8	The SS configures a new data radio bearer, associated with the default EPS bearer context. IF the test case using state 3 as an initial state is using N additional data radio bearers ($0 \leq N \leq 7$), the <i>RRCConnectionReconfiguration</i> message contains the configuration of these additional data radio bearers in the drb-ToAddModify IE and one ACTIVATE DEDICATED EPS BEARER CONTEXT REQUEST message per additional data radio bearer. The <i>RRCConnectionReconfiguration</i> message is using condition SRB2-DRB(1+n, m) where n and m are the number of DRBs associated with dedicated EPS bearer contexts and configured respectively with RLC-AM and RLC-UM ($n+m = N$).	<--	RRC: <i>RRCConnectionReconfiguration</i> NAS: ACTIVATE DEDICATED EPS BEARER CONTEXT REQUEST ... ACTIVATE DEDICATED EPS BEARER CONTEXT REQUEST
-	EXCEPTION: the steps 9 and 10a1 to 10a3 (if present) happen in any order.	-	-
9	The UE transmits an <i>RRCConnectionReconfigurationComplete</i> message to confirm the establishment of the new data radio bearer, associated with the default EPS bearer context.	-->	RRC: <i>RRCConnectionReconfigurationComplete</i>
10a1	IF $N \geq 1$ (see step 8), the UE transmits an ACTIVATE DEDICATED EPS BEARER CONTEXT ACCEPT message matching with the 1st ACTIVATE DEDICATED EPS BEARER CONTEXT REQUEST message included in step 8.	-->	RRC: <i>ULInformationTransfer</i> NAS: ACTIVATE DEDICATED EPS BEARER CONTEXT ACCEPT
10a2	IF $N \geq 2$ (see step 8), the UE transmits an ACTIVATE DEDICATED EPS BEARER CONTEXT ACCEPT message matching with the 2nd ACTIVATE DEDICATED EPS BEARER CONTEXT REQUEST message included in step 8.	-->	RRC: <i>ULInformationTransfer</i> NAS: ACTIVATE DEDICATED EPS BEARER CONTEXT ACCEPT
10a3	IF $N \geq 3$ (see step 8), the UE transmits an ACTIVATE DEDICATED EPS BEARER CONTEXT ACCEPT message matching with the 3rd ACTIVATE DEDICATED EPS BEARER CONTEXT REQUEST message included in step 8.	-->	RRC: <i>ULInformationTransfer</i> NAS: ACTIVATE DEDICATED EPS BEARER CONTEXT ACCEPT

10a4	IF $N \geq 4$ (see step 8), the UE transmits an ACTIVATE DEDICATED EPS BEARER CONTEXT ACCEPT message matching with the 4th ACTIVATE DEDICATED EPS BEARER CONTEXT REQUEST message included in step 8.	-->	RRC: ULInformationTransfer NAS: ACTIVATE DEDICATED EPS BEARER CONTEXT ACCEPT
10a5	IF $N \geq 5$ (see step 8), the UE transmits an ACTIVATE DEDICATED EPS BEARER CONTEXT ACCEPT message matching with the 5th ACTIVATE DEDICATED EPS BEARER CONTEXT REQUEST message included in step 8.	-->	RRC: ULInformationTransfer NAS: ACTIVATE DEDICATED EPS BEARER CONTEXT ACCEPT
10a6	IF $N \geq 6$ (see step 8), the UE transmits an ACTIVATE DEDICATED EPS BEARER CONTEXT ACCEPT message matching with the 6th ACTIVATE DEDICATED EPS BEARER CONTEXT REQUEST message included in step 8.	-->	RRC: ULInformationTransfer NAS: ACTIVATE DEDICATED EPS BEARER CONTEXT ACCEPT
10a7	IF $N = 7$ (see step 8), the UE transmits an ACTIVATE DEDICATED EPS BEARER CONTEXT ACCEPT message matching with the 7th ACTIVATE DEDICATED EPS BEARER CONTEXT REQUEST message included in step 8.	-->	RRC: ULInformationTransfer NAS: ACTIVATE DEDICATED EPS BEARER CONTEXT ACCEPT

4.5.3.4 Specific message contents

All specific message contents shall be referred to clause 4.6 and 4.7.

4.5.3A Generic Radio Bearer Establishment, UE Test Mode Activated (State 3A)

IF `pc_ue_CategoryDL_M1` THEN use the procedure for State 3A-CE according to clause 4.5.3AB ELSE use the procedure defined in the present clause.

NOTE: The statement to use alternate procedure for CAT M1 UE (`pc_ue_CategoryDL_M1` is set) is to enable LTE legacy protocol test cases to be used for CAT M1 UE testing. Any CAT M1 or CE specific test cases should not rely on this statement, but refer directly to the relevant CE specific state.

4.5.3A.1 Initial conditions

System Simulator:

- Parameters are set to the default parameters for the basic single cell environment, as defined in subclause 4.4, unless otherwise specified in the test case.

User Equipment:

- The UE shall be in Registered, Idle Mode state, UE Test Mode Activated (State 2A for Signalling testing).
- The UE shall be in Registered, Idle Mode state, UE Test Mode Activated (State 2A-RF for RF and RRM testing).
- The UE shall be in Registered, Idle Mode state, UE Test Mode Activated (State 2A or State 2A-RF for UE positioning testing).

4.5.3A.2 Definition of system information messages

The default system information messages are used.

4.5.3A.3 Procedure

Same procedure as specified in the procedure in clause 4.5.3.3.

4.5.3A.4 Specific message contents

All specific message contents shall be referred to clause 4.6, 4.7 and 4.7A.

4.5.3AA Generic Radio Bearer Establishment (State 3-CE)

4.5.3AA.1 Initial conditions

System Simulator:

- Parameters are set to the default parameters for the basic single cell environment, as defined in subclause 4.4, unless otherwise specified in the test case.

User Equipment:

- The UE shall be in Registered, Idle Mode state (State 2-CE).

4.5.3AA.2 Definition of system information messages

The default system information messages as specified in clause 4.5.2AA.2.

4.5.3AA.3 Procedure

Table 4.5.3AA.3-1: UE registration procedure (state 2-CE to state 3-CE)

Step	Procedure	U - S	Message Sequence Message
1	Void		
2 to 10a7	Same procedure for steps 2 to 10a7 as specified in the procedure in clause 4.5.3.3.	-	-

4.5.3AA.4 Specific message contents

All specific message contents shall be referred to clause 4.6 and 4.7 with the exception below:

- In addition to any other conditions use the condition CEmodeB if the test case specifically tests CE mode B else use condition CEmodeA.

4.5.3AB Generic Radio Bearer Establishment, UE Test Mode Activated (State 3A-CE)

4.5.3AB.1 Initial conditions

System Simulator:

- Parameters are set to the default parameters for the basic single cell environment, as defined in subclause 4.4, unless otherwise specified in the test case.

User Equipment:

- The UE shall be in Registered, Idle Mode state, UE Test Mode Activated (State 2A-CE for Signalling testing).
- The UE shall be in Registered, Idle Mode state, UE Test Mode Activated (State 2A-RF-CE for RF and RRM testing).

4.5.3AB.2 Definition of system information messages

The default system information messages are used as specified in clause 4.5.2AA.2.

4.5.3AB.3 Procedure

Table 4.5.3AB.3-1: UE registration procedure (State 2A-CE/2A-RF-CE to state 3A-CE)

Step	Procedure	U - S	Message Sequence Message
1	Void		
2 to 10a7	Same procedure for steps 2 to 10a7 as specified in the procedure in clause 4.5.3.3	-	-

4.5.3AB.4 Specific message contents

All specific message contents shall be referred to clause 4.6, 4.7 and 4.7A with the exception below:

- In addition to any other conditions use the condition CEmodeB if the test case specifically tests CE mode B else use condition CEmodeA.

4.5.3B Generic Radio Bearer Establishment, pre-registered on HRPD (State 3B)

4.5.3B.1 Initial conditions

System Simulator:

- Parameters are set to the default parameters for the basic single cell environment, as defined in subclause 4.4, unless otherwise specified in the test case.

User Equipment:

- The UE shall be in Registered, Idle Mode state, pre-registered on HRPD (State 2B).

4.5.3B.2 Definition of system information messages

The default system information messages are used.

4.5.3B.3 Procedure

Same procedure as specified in the procedure in clause 4.5.3.3.

4.5.3B.4 Specific message contents

All specific message contents shall be referred to clause 4.6, 4.7 and 4.7A.

4.5.3C Generic Radio Bearer Establishment, pre-registered on 1xRTT (State 3C)

4.5.3C.1 Initial conditions

System Simulator:

- Parameters are set to the default parameters for the basic single cell environment, as defined in subclause 4.4, unless otherwise specified in the test case.

User Equipment:

- The UE shall be in Registered, Idle Mode state, pre-registered on 1xRTT (State 2C).

4.5.3C.2 Definition of system information messages

The default system information messages are used.

4.5.3C.3 Procedure

Same procedure as specified in the procedure in clause 4.5.3.3.

4.5.3C.4 Specific message contents

All specific message contents shall be referred to clause 4.6, 4.7 and 4.7A.

4.5.3D Generic Radio Bearer Establishment for RAN Assisted WLAN Interworking (State 3)

4.5.3D.1 Initial conditions

System Simulator:

- Parameters are set to the default parameters for the basic single cell environment, as defined in subclause 4.4, unless otherwise specified in the test case.

User Equipment:

- The UE shall be in Registered, Idle Mode state (State 2) as per 4.5.2D establishing 2 PDN connections.

4.5.3D.2 Definition of system information messages

The default system information messages are used.

4.5.3D.3 Procedure

The establishment of generic radio bearer connection is assumed to always be mobile terminated.

Table 4.5.3D.3-1: Generic Radio Bearer establishment procedure (state 2 to state 3)

Step	Procedure	U - S	Message Sequence Message
1-7	Steps 1 to 16 of the generic test procedure for Radio Bearer Establishment sub clause 4.5.3.3	-	-
8	The SS configures a 2 new data radio bearer, associated with the 2 default EPS bearer contexts. IF the test case using state 3 as an initial state is using N additional data radio bearers ($0 \leq N \leq 7$), the <i>RRCCONNECTIONRECONFIGURATION</i> message contains the configuration of these additional data radio bearers in the drb-ToAddModify IE and one ACTIVATE DEDICATED EPS BEARER CONTEXT REQUEST message per additional data radio bearer. The <i>RRCCONNECTIONRECONFIGURATION</i> message is using condition SRB2-DRB(1+n, m) where n and m are the number of DRBs associated with dedicated EPS bearer contexts and configured respectively with RLC-AM and RLC-UM ($n+m = N$).	<--	RRC: <i>RRCCONNECTIONRECONFIGURATION</i> NAS: ACTIVATE DEDICATED EPS BEARER CONTEXT REQUEST ... ACTIVATE DEDICATED EPS BEARER CONTEXT REQUEST
9-10a7	Steps 9 to 10a7 of the generic test procedure for Radio Bearer Establishment sub clause 4.5.3.3	-	-

4.5.3D.4 Specific message contents

All specific message contents shall be referred to clause 4.6 and 4.7.

4.5.3E Control plane CIoT connection request (State 3-CP)

4.5.3E.1 Initial conditions

System Simulator:

- Parameters are set to the default parameters for the basic single cell environment, as defined in subclause 4.4, unless otherwise specified in the test case.
- TS 36.508 condition CIoT-test apply.

User Equipment:

- The UE shall be in Registered, Idle Mode state (State 2 or 2-CE).

4.5.3E.2 Definition of system information messages

The default system information messages are used.

4.5.3E.3 Procedure

The establishment of generic radio bearer connection is assumed to always be mobile terminated.

Table 4.5.3E.3-1: Generic control plane CIoT connection request procedure (state 3-CP)

Step	Procedure	U - S	Message Sequence Message
1	Void		
2	SS sends a <i>Paging</i> message to the UE on the appropriate paging block, and including the UE identity in one entry of the IE <i>pagingRecordLists</i> .	<--	RRC: <i>Paging</i> (PCCH)
3	UE transmits an <i>RRCCoalitionRequest</i> message.	-->	RRC: <i>RRCCoalitionRequest</i>
4	SS transmit an <i>RRCCoalitionSetup</i> message.	<--	RRC: <i>RRCCoalitionSetup</i>
5	The UE transmits an <i>RRCCoalitionSetupComplete</i> message to confirm the successful completion of the connection establishment and to initiate the session management procedure by including the CONTROL PLANE SERVICE REQUEST message.	-->	RRC: <i>RRCCoalitionSetupComplete</i> NAS: CONTROL PLANE SERVICE REQUEST
6	The SS transmits a SERVICE ACCEPT message.	<--	RRC: DLInformationTransfer NAS: SERVICE ACCEPT

4.5.3E.4 Specific message contents

All specific message contents shall be referred to clauses 4.6 and 4.7.

4.5.3EA Control plane CIoT connection request, UE Test Mode Activated (State 3A-CP)

4.5.3EA.1 Initial conditions

System Simulator:

- Parameters are set to the default parameters for the basic single cell environment, as defined in subclause 4.4, unless otherwise specified in the test case.
- TS 36.508 condition CIoT-test apply.

User Equipment:

- The UE shall be in Registered, Idle Mode state (State 2A or 2A-CE).

4.5.3EA.2 Definition of system information messages

The default system information messages are used.

4.5.3EA.3 Procedure

Same procedure as specified in the procedure in clause 4.5.3E.3.

4.5.3EA.4 Specific message contents

All specific message contents shall be referred to clauses 4.6 and 4.7.

4.5.3F User plane CIoT connection request (State 3-UP)

4.5.3F.1 Initial conditions

System Simulator:

- Parameters are set to the default parameters for the basic single cell environment, as defined in subclause 4.4, unless otherwise specified in the test case.
- TS 36.508 conditions CIoT-test and UP-CIoT applies.

User Equipment:

- The UE shall be in Registered, Idle Mode state (State 2 or 2-CE).

4.5.3F.2 Definition of system information messages

The default system information messages are used.

4.5.3F.3 Procedure

The establishment of generic radio bearer connection is assumed to always be mobile terminated.

Table 4.5.3F.3-1: Generic user plane CIoT connection request procedure (state 3-UP)

Step	Procedure	Message Sequence	
		U - S	Message
1	Void		
2	SS sends a <i>Paging</i> message to the UE on the appropriate paging block, and including the UE identity in one entry of the IE <i>pagingRecordLists</i> .	<--	RRC: <i>Paging</i> (PCCH)
3	UE transmits an <i>RRCCONNECTIONRESUMEREQUEST</i> message.	-->	RRC: <i>RRCCONNECTIONRESUMEREQUEST</i>
4	SS transmit an <i>RRCCONNECTIONRESUME</i> message.	<--	RRC: <i>RRCCONNECTIONRESUME</i>
5	The UE transmits an <i>RRCCONNECTIONRESUMECOMplete</i> message.	-->	RRC: <i>RRCCONNECTIONRESUMECOMplete</i>

4.5.3F.4 Specific message contents

All specific message contents shall be referred to clauses 4.6 and 4.7.

4.5.3FA User plane CIoT connection request, UE Test Mode Activated (State 3A-UP)

4.5.3FA.1 Initial conditions

System Simulator:

- Parameters are set to the default parameters for the basic single cell environment, as defined in subclause 4.4, unless otherwise specified in the test case.
- TS 36.508 conditions CIoT-test and UP-CIoT applies.

User Equipment:

- The UE shall be in Registered, Idle Mode state (State 2 or 2-CE).

4.5.3FA.2 Definition of system information messages

The default system information messages are used.

4.5.3FA.3 Procedure

Same procedure as specified in the procedure in clause 4.5.3F.3.

4.5.3FA.4 Specific message contents

All specific message contents shall be referred to clauses 4.6 and 4.7.

4.5.4 Loopback Activation (State 4)

IF `pc_ue_CategoryDL_M1` THEN use the procedure for State 4-CE according to clause 4.5.4A ELSE use the procedure defined in the present clause.

NOTE: The statement to use alternate procedure for CAT M1 UE (`pc_ue_CategoryDL_M1` is set) is to enable LTE legacy protocol test cases to be used for CAT M1 UE testing. Any CAT M1 or CE specific test cases should not rely on this statement, but refer directly to the relevant CE specific state.

4.5.4.1 Initial conditions

System Simulator:

- Parameters are set to the default parameters for the basic single cell environment, as defined in subclause 4.4, unless otherwise specified in the test case.

User Equipment:

- The UE shall be in Generic RB Establishment state, UE Test Mode Activated (State 3A).

4.5.4.2 Definition of system information messages

The default system information messages are used.

4.5.4.3 Procedure

Table 4.5: 4.3-1: Loopback activation procedure (state 3A to state 4)

Step	Procedure	Direction	Message Sequence
		UE - SS	Message
1	The SS transmits a CLOSE UE TEST LOOP message to enter the UE test loop mode.	<--	RRC: <i>DLInformationTransfer</i> TC: CLOSE UE TEST LOOP
2	The UE transmits a CLOSE UE TEST LOOP COMPLETE message to confirm that loopback entities for the radio bearer(s) have been created and loop back is activated (State 4).	-->	RRC: <i>ULInformationTransfer</i> TC: CLOSE UE TEST LOOP COMPLETE

4.5.4.4 Specific message contents

All specific message contents shall be referred to clause 4.6 and 4.7A.

4.5.4A Loopback Activation in cell supporting BL/CE UE (State 4-CE)

4.5.4A.1 Initial conditions

System Simulator:

- Parameters are set to the default parameters for the basic single cell environment, as defined in subclause 4.4, unless otherwise specified in the test case.

User Equipment:

- The UE shall be in Generic RB Established, UE Test Mode Activated, Cell supporting BL/CE UE, UE Test Mode Activated (State 3A-CE).

4.5.4A.2 Definition of system information messages

Same system information message content as in clause 4.5.2AA.2.

4.5.4A.3 Procedure

Table 4.5.4A.3-1: Loopback activation procedure (state 2A-CE to state 4-CE)

Step	Procedure	Direction	Message Sequence
		UE - SS	Message
1	The SS transmits a CLOSE UE TEST LOOP message to enter the UE test loop mode.	<--	RRC: <i>DLInformationTransfer</i> TC: CLOSE UE TEST LOOP
2	The UE transmits a CLOSE UE TEST LOOP COMPLETE message to confirm that loopback entities for the radio bearer(s) have been created and loop back is activated (State 4).	-->	RRC: <i>ULInformationTransfer</i> TC: CLOSE UE TEST LOOP COMPLETE

4.5.4A.4 Specific message contents

All specific message contents shall be referred to clause 4.6 and 4.7A.

4.5.4B Loopback Activation user plane (State 4A-UP)

4.5.4B.1 Initial conditions

System Simulator:

- Parameters are set to the default parameters for the basic single cell environment, as defined in subclause 4.4, unless otherwise specified in the test case.
- TS 36.508 conditions CIoT-test and UP-CIoT applies.

User Equipment:

- User plane CIoT connection request, UE Test Mode Activated (State 3A-UP).

4.5.4B.2 Definition of system information messages

The default system information messages are used.

4.5.4B.3 Procedure

Same procedure as specified in the procedure in clause 4.5.4A.3.

4.5.4B.4 Specific message contents

All specific message contents shall be referred to clauses 4.6 and 4.7.

4.5.5 HRPD registration (State H2)

Editor's note: The default parameter and system information will depend on progress in Clause 4.4, once it is finalised RAN5 can refer to them accordingly.

4.5.5.1 Initial conditions

System Simulator:

- Cell 1 and Cell 15.
- Cell 1 has a lower reselection priority than Cell 15.
- Cell 15 is transmitting default overhead messages.

User Equipment:

- The Test USIM shall be inserted (State 1).

4.5.5.2 Definition of system information messages

The default overhead messages as specified in clause 4.4 are used.

4.5.5.3 Procedure

Editor note: procedure needs to be specified.

4.5.5.4 Specific message contents

Editor's note: message contents need to be specified where necessary.

4.5.5A HRPD registration, pre-registration on E-UTRAN (State H2A)

Editor's note: The default parameter and system information will depend on progress in Clause 4.4, once it is finalised RAN5 can refer to them accordingly.

4.5.5A.1 Initial conditions

System Simulator:

- Cell 1 and Cell 15.
- Cell 1 has a lower reselection priority than Cell 15.
- Cell 15 is transmitting default overhead messages.

User Equipment:

- The Test USIM shall be inserted (State 1).

4.5.5A.2 Definition of system information messages

The default overhead messages as specified in clause 4.4 are used.

4.5.5A.3 Procedure

Editor's note: procedure needs to be specified.

4.5.5A.4 Specific message contents

Editor's note: message contents need to be specified where necessary.

4.5.6 HRPD session establishment (State H3)

Editor's note: The default parameter and system information will depend on progress in Clause 4.4, once it is finalised RAN5 can refer to them accordingly.

4.5.6.1 Initial conditions

System Simulator:

- Parameters are set to the default parameters for the basic single cell environment, as defined in subclause 4.4, unless otherwise specified in the test case.

User Equipment:

- The UE shall be in HRPD Registered, Dormant Mode state (State H2).

4.5.6.2 Definition of system information messages

The default overhead messages as specified in clause 4.4 are used.

4.5.6.3 Procedure

Editor's note: procedure needs to be specified.

4.5.6.4 Specific message contents

Editor's note: message contents need to be specified where necessary.

4.5.6A HRPD session establishment, pre-registered on E-UTRAN (State H3A)

Editor's note: The default parameter and system information will depend on progress in Clause 4.4, once it is finalised RAN5 can refer to them accordingly.

4.5.6A.1 Initial conditions

System Simulator:

- Parameters are set to the default parameters for the basic single cell environment, as defined in subclause 4.4, unless otherwise specified in the test case.

User Equipment:

- The UE shall be in HRPD Registered, Dormant Mode, pre-registered on E-UTRAN state (State H2A).

4.5.6A.2 Definition of system information messages

The default overhead messages as specified in clause 4.4 are used.

4.5.6A.3 Procedure

Same procedure as specified in the procedure in clause 4.5.6.3

4.5.6A.4 Specific message contents

Editor's note: message contents need to be specified where necessary.

4.5.7 Out of Coverage (State 5)

Out of coverage UE operation is applicable only for sidelink direct communication. In this case UE uses preconfigured radio parameters for transmission and reception of side link direct communication. UE remains in any cell selection state.

4.5.7.1 Initial conditions

System Simulator:

- 1 cell, default parameters.
- The procedure shall be performed under the condition that there is no reference signal and SIB transmission by the cell.

User Equipment:

- The Test UICC shall be inserted. This shall contain either ISIM and USIM applications or only a USIM application on UICC.

4.5.7.2 Definition of system information messages

MIB and SIBs are not transmitted.

4.5.7.3 Procedure

UE remains in any cell selection state and search for any available cell.

4.5.8 Out of Coverage, V2X setup (State 5-V2X)

4.5.8.1 Initial conditions

System Simulator:

- No E-UTRA cell configured
- 1 GNSS simulator
- 1 simulated V2V UE (transmitter or receiver according to specific test case configuration)

User Equipment:

- If supported by the UE, the Test UICC shall be inserted. This shall contain either ISIM and USIM applications or only a USIM application on UICC.

4.5.8.2 Definition of system information messages

None.

4.5.8.3 Procedure

UE remains in any cell selection state and search for any available cell.

4.5.9 Out of Coverage, Test Loopback Activation, V2X setup (State 5A-V2X)

The same assumptions and definitions apply as in clause 4.5.8. State 5A-V2X shall be invoked either in Receive Mode or in Transmit Mode, depending on the test purpose.

4.5.9.1 Initial conditions

System Simulator:

- No E-UTRA cell configured
- 1 GNSS simulator
- 1 simulated V2X UE (transmitter or receiver according to specific test case configuration)

User Equipment:

- The UE shall be in Out of Coverage, V2X setup state (State 5-V2X)

4.5.9.2 Definition of system information messages

None.

4.5.9.3 Procedure

Table 4.5.9.3-1: Out of Coverage, Test Loopback Activation, V2X setup procedure (state 5-V2X to state 5A-V2X)

Step	Procedure	Message Sequence	
		U	S
1	Trigger UE to activate UE test loop mode. NOTE: The activation of UE test loop mode may be performed by MMI or AT command (+CATM).	-	-
2A	Trigger UE to close UE test loop back mode E (Receive Mode). NOTE: Closing of UE test loop mode E may be performed by MMI or AT command (+CCUTLE)	-	-
2B	Trigger UE to close UE test loop back mode E (Transmit Mode). NOTE: Closing of UE test loop mode E may be performed by MMI or AT command (+CCUTLE)	-	-
3	Trigger UE to reset or clear the current UTC time that has been calculated from GNSS. NOTE: The UTC time can be reset or clear on the UE using AT command (+CUTCRC).	-	-
Note 1: If State 5A-V2X was invoked in Receive Mode use Step 2A; if State 5A-V2X was invoked in Transmit Mode use Step 2B.			

4.5.9.4 Specific message contents

All specific message contents shall be referred to clause 4.7I with the exceptions below.

Table 4.5.9.4-1: AT COMMAND: +CATM (Step 1)

Derivation Path: Table 4.7I-1: +CATM with condition Activation

Table 4.5.9.4-2A: AT COMMAND: +CCUTLE (Step 2A)

Derivation Path: Table 4.7I-2: +CCUTLE with condition Close and Receive.

Table 4.5.9.4-2B: AT COMMAND: +CCUTLE (Step 2B)

Derivation Path: Table 4.7I-2: +CCUTLE with condition Close and Transmit.

Table 4.5.9.4-3: AT COMMAND: +CUTCR (Step 3)

Derivation Path: Table 4.7I-3: +CUTCR

4.5A Other generic procedures

4.5A.1 Procedure for IP address allocation in the U-plane

The purpose of this procedure is to allow the successful completion of IP address allocation if it is initiated by the UE therefore the result from the execution of the Procedure for IP address allocation in the U-plane shall not lead to assignment of a verdict.

Depending on the UE configuration there may be unpredictable delay in the start of the procedure. A guarding time of 1.2 sec is suggested within which the procedure is expected to start. If the timer expires then the test procedure, from which the Procedure for IP address allocation in the U-plane is called, shall advance to the next specified step.

Table 4.5A.1-1: Procedure for IP address allocation in the U-plane

Step	Procedure	Message Sequence	
		U - S	Message
-	EXCEPTION: Step 1 below and Step 1 in Table 4.5A.1-2 describe behaviour that depends on the contents of the latest PDN CONNECTIVITY REQUEST message sent by the UE prior to this procedure.	-	-
-	EXCEPTION: In parallel to the event described in step 1 below the step specified in Table 4.5A.1-2 may take place.	-	-
1	If the "PDN type" in the latest PDN CONNECTIVITY REQUEST message prior to this procedure was 'IPv4' or 'IPv4v6' then, IPv4 address allocation by DHCPv4 may occur on the user plane bearer established for the default EPS bearer context activated with the latest ACTIVATE DEFAULT EPS BEARER CONTEXT message prior to this procedure.	-	-

Table 4.5A.1-2: Procedure for IP address allocation in the U-plane, parallel behaviour

Step	Procedure	Message Sequence	
		U - S	Message
1	If the "PDN type" in the latest PDN CONNECTIVITY REQUEST message prior to this procedure was 'IPv6' or 'IPv4v6' then stateless address auto configuration occurs on the user plane bearer established for the default EPS bearer context activated with the latest ACTIVATE DEFAULT EPS BEARER CONTEXT message prior to this procedure.	-	-

4.5A.2 Tracking area updating procedure

The procedure is defined in table 4.5A.2.1-1.

Table 4.5A.2.1-1: Tracking area updating procedure

Step	Procedure	Message Sequence	
		U - S	Message
1	The SS transmits system information on the cell specified in the test case.	<--	RRC: SYSTEM INFORMATION (BCCH)
2	The UE transmits an <i>RRCCConnectionRequest</i> message on the cell specified in the test case.	-->	RRC: <i>RRCCConnectionRequest</i>
3	SS transmits an <i>RRCCConnectionSetup</i> message.	<--	RRC: <i>RRCCConnectionSetup</i>
4	The UE transmits an <i>RRCCConnectionSetupComplete</i> message to confirm the successful completion of the connection establishment and a TRACKING AREA UPDATE REQUEST message is sent to update the registration of the actual tracking area.	-->	RRC: <i>RRCCConnectionSetupComplete</i> NAS: TRACKING AREA UPDATE REQUEST
5	SS responds with TRACKING AREA UPDATE ACCEPT message.	<--	RRC: <i>DLInformationTransfer</i> NAS: TRACKING AREA UPDATE ACCEPT
6	The UE transmits a TRACKING AREA UPDATE COMPLETE	-->	RRC: <i>ULInformationTransfer</i> NAS: TRACKING AREA UPDATE COMPLETE
7	The SS transmits an <i>RRCCConnectionRelease</i> message to release RRC connection and move to RRC_IDLE.	<--	RRC: <i>RRCCConnectionRelease</i>

NOTE 1: The periodic tracking area updating timer T3412 is deactivated by default during the attach procedure (TS 36.508 clause 4.7.2).

NOTE 2: The SS does not initiate authentication and NAS SECURITY MODE COMMAND are not performed (reuse of keys allocated during the attach procedure).

4.5A.3 Procedure for IMS signalling

The purpose of this procedure is to allow the successful completion of IMS signalling if it is initiated by the UE.

The UE may initiate IMS registration according TS 24.229 [40] clause 5.1. The procedure is applicable for UEs with IMS support (TS 36.523-2 A.4.4-1/25).

Table 4.5A.3-1: Procedure for IMS signalling in the U-plane

Step	Procedure	Message Sequence	
		U - S	Message
1-9	Void	-	-
-	EXCEPTION: Steps 10a1 to 10a2b1 describe a transaction that depends on the UE capability		
10a1	IF pc_IMS then the SS starts timer Timer_1 = 10 s (Note 1)	-	-
-	EXCEPTION: Steps 10a2a1 to 10a2b1 describe a transaction that depends on the UE implementation	-	-
10a2 a1- 10a2 a9	Registration procedure according TS 34.229-1 [43] subclause C.2 (steps 3-11) Note: SS cancels timer Timer_1 at step 10a2a1.	-	-
10a2 b1	The SS waits for Timer_1 expiry	-	-

Note 1: Depending on the UE configuration there may be unpredictable delay in the start of the procedure. A guarding time of [10] sec is suggested within which the procedure is expected to start. If the timer expires then the test procedure, from which the Procedure for IMS signalling U-plane is called, shall advance to the next specified step

4.5A.3A Procedure for IMS Signalling over UTRA

The purpose of this procedure is to allow the successful completion of IMS signalling if it is initiated by the UE.

The UE may initiate IMS registration according TS 24.229 [40] clause 5.1. The procedure is applicable for UEs with IMS support (TS 36.523-2 A.4.4-1/25).

4.5A.3A.1 Initial conditions

System Simulator:

- 1 UTRA cell, default parameters.
- The procedure shall be performed under ideal radio conditions as defined in clause 5

User Equipment:

- The Test UICC shall be inserted. This shall contain either ISIM and USIM applications or only a USIM application on UICC.
- The UE is in state Registered, Idle Mode (state 3 or 7) according to TS 34.108 [5]

4.5A.3A.2 Procedure

Table 4.5A.3A.2-1: Procedure for IMS Signalling over UTRA

Step	Procedure	Message Sequence	
		U - S	Message
-	EXCEPTION: Steps 1a1 to 1a2b1 describe a transaction that depends on UE capability.	-	-
1a1	IF pc_IMS then the SS starts timer Timer_1 = 10 s	-	-
	EXCEPTION: Steps 1a2a1 to 1a2a15 describe a transaction that depends on the UE supporting IMS over UTRA.	-	-
1a2a1	UE transmits a RRC CONNECTION REQUEST message.	-->	RRC CONNECTION REQUEST
1a2a2	SS transmits a RRC CONNECTION SETUP message.	<--	RRC CONNECTION SETUP
1a2a3	The UE transmits a RRC CONNECTION SETUP COMPLETE message	-->	RRC CONNECTION SETUP COMPLETE
1a2a4	The UE transmits a SERVICE REQUEST message	-->	INITIAL DIRECT TRANSFER
1a2a5	SS transmits a GMM AUTHENTICATION AND CIPHERING REQUEST message	<--	GMM AUTHENTICATION AND CIPHERING REQUEST
1a2a6	The UE transmits a GMM AUTHENTICATION AND CIPHERING RESPONSE	-->	GMM AUTHENTICATION AND CIPHERING RESPONSE
1a2a7	SS transmits a SECURITY MODE COMMAND message	<--	SECURITY MODE COMMAND
1a2a8	UE transmits a SECURITY MODE COMPLETE message	-->	SECURITY MODE COMPLETE
1a2a9	The UE transmits a ACTIVATE PDP CONTEXT REQUEST message	-->	ACTIVATE PDP CONTEXT REQUEST
1a2a10	The SS transmits a RADIO BEARER SETUP message	<--	RADIO BEARER SETUP
1a2a11	The UE transmits a RADIO BEARER SETUP COMPLETE message	-->	RADIO BEARER SETUP COMPLETE
1a2a13	The SS transmits a ACTIVATE PDP CONTEXT ACCEPT message	<--	ACTIVATE PDP CONTEXT ACCEPT
-	IF initiated by the UE for IP address allocation	-	-
1a2a13 A1a	IP address allocation in the U-plane specified in TS 34.108 [5] subclause 7.2.6 takes place performing IP address allocation in the U-plane.	-	-
1a2a13 A2- 1a2a13 A10	Registration procedure according TS 34.229-1 [43] subclause C.2 (steps 3-11) whereby the UE is allowed to retransmit the requests in steps 4, 6, and 8 when using UDP. Note: SS cancels timer Timer_1 at step 1a2a13a1.	-	-
1a2a14	Upon completion of the U-plane signalling, the SS transmits a RRC CONNECTION RELEASE message	<--	RRC CONNECTION RELEASE
1a2a15	The UE transmits a RRC CONNECTION RELEASE COMPLETE message	-->	RRC CONNECTION RELEASE COMPLETE
1a2b1	The SS waits for Timer_1 expiry		

4.5A.3A.3 Specific message contents

Table 4.5A.3A.3-1: ACTIVATE PDP CONTEXT REQUEST (Step 1a2a9)

Derivation Path: 24.008 Table 9.5.1			
Information Element	Value/remark	Comment	Condition
Requested NSAPI			
NSAPI value	'0101'B	NSAPI 5	
Requested LLC SAPI			
LLC SAPI value	'0011'B	LLC SAPI 3	
Requested PDP address			
PDP type organisation	'0001'	IETF allocated address	
PDP type number	Any value between '00100001'B, '01010111'B, '10001101'B	The allowed values are respectively IPv4, IPv6, IPv4v6 and "unused but interpreted as lpv4 by the network"	
Address information	Not present		
Access point name	Not present or any allowed value		
Protocol configuration options	Any allowed Value	The SS shall remember this IE and its contents because this affects subsequent SS behaviour, e.g. coding of ACTIVATE PDP CONTEXT ACCEPT	

Table 4.5A.3A.3-2: ACTIVATE PDP CONTEXT ACCEPT (Step 1a2a13)

Derivation Path: 24.008 Table 9.5.2			
Information Element	Value/remark	Comment	Condition
Negotiated LLC SAPI			
LLC SAPI value	Same as requested in ACTIVATE PDP CONTEXT REQUEST		
PDP address			
PDP type number	'00100001'B	IPv4	IPv4
PDN address information	IPv4 address	The SS provides a valid IPv4 address	NOT IPv4-DHCP
	0.0.0.0	DHCPv4 is to be used to allocate the IPv4 address	IPv4-DHCP
PDP type number	'01010111'B	IPv6	IPv6
PDN address information	IPv6 address	The SS provides a valid IPv6 address	
PDP type number	'10001101'B	IPv4v6	IPv4v6
PDN address information (Octets 5 to 8)	IPv4 address	The SS provides a valid IPv4 address	NOT IPv4-DHCP
	0.0.0.0	DHCPv4 is to be used to allocate the IPv4 address	IPv4-DHCP
PDN address information (Octets 9 to 24)	IPv6 address	The SS provides a valid IPv6 address	IPv6
Protocol configuration options			
Configuration protocol	'000'B		
Container ID 1	'0001'H		P-CSCF IPv6
Length of container ID 1 contents		Length value determined by the TTCN implementation	
Container ID 1 contents	IPv6 address	P-CSCF IPv6 Address	
Container ID 2	'000C'H		P-CSCF IPv4
Length of container ID 2 contents		Length value determined by the TTCN implementation	
Container ID 2 contents	IPv4 address	P-CSCF IPv4 Address	
Container ID n	'0003'H	n assigned to next available number	DNS IPv6
Length of container ID n contents		Length value determined by the TTCN implementation	
Container ID n contents	IPv6 address	DNS IPv6 Address	
Container ID n+1	'000D'H	n assigned to next available number	DNS IPv4
Length of container ID n+1 contents		Length value determined by the TTCN implementation	
Container ID n+1 contents	IPv4 address	DNS IPv4 Address	

Condition	Explanation
IPv4	If the ACTIVATE PDP CONTEXT REQUEST message, contains the PDN type as Ipv4
IPv6	If the ACTIVATE PDP CONTEXT REQUEST message, contains the PDN type as Ipv6
IPv4v6	If the ACTIVATE PDP CONTEXT REQUEST message, contains the PDN type as Ipv4v6
IPv4-DHCP	If the ACTIVATE PDP CONTEXT REQUEST message sent prior to this message, the IE Protocol configuration options contains a configuration protocol option "IPv4 address allocation via DHCPv4", length of contents = 0). Note 1: This condition is used in conjunction with IPv4 or IPv4v6 as indicated in the "PDN address row" just above.
P-CSCF IPv6	If the ACTIVATE PDP CONTEXT REQUEST sent prior to this message, the Protocol configuration options and the additional parameter list was included with a "P-CSCF IPv6 Address Request". Note 1: This condition is only applicable for UEs with IMS support (TS 36.523-2 A.4.4-1/25).
P-CSCF IPv4	If in the ACTIVATE PDP CONTEXT REQUEST message sent prior to this message, the Protocol configuration options and the additional parameter list was included with a "P-CSCF IPv4 Address Request" Note 1: This condition is only applicable for UEs with IMS support (TS 36.523-2 A.4.4-1/25).
DNS IPv6	If the ACTIVATE PDP CONTEXT REQUEST message sent prior to this message, the Protocol configuration options and the additional parameter list was included with a "DNS IPv6 Address Request".
DNS IPv4	If the ACTIVATE PDP CONTEXT REQUEST message sent prior to this message, the Protocol configuration options and the additional parameter list was included with a "DNS IPv4 Address Request".

4.5A.3B Procedure for preventing IMS Signalling over GERAN

The purpose of this procedure is to prevent IMS signalling if it is initiated by the UE.

The UE may initiate IMS registration according TS 24.229 [40] clause 5.1. The procedure is applicable for UEs with IMS support (TS 36.523-2 A.4.4-1/25).

4.5A.3B.1 Initial conditions

System Simulator:

- 1 GERAN cell, default parameters.
- The procedure shall be performed under ideal radio conditions as defined in clause 5

User Equipment:

- The Test UICC shall be inserted. This shall contain either ISIM and USIM applications or only a USIM application on UICC.
- The UE is GPRS attached according to TS 51.010 [25]

4.5A.3B.2 Procedure

Table 4.5A.3B.2-1: Procedure for IMS Signalling over GERAN

Step	Procedure	Message Sequence	
		U - S	Message
-	EXCEPTION: Steps 1a1 to 1a2b1 describe a transaction that depends on UE capability.	-	-
1a1	IF pc_IMS then the SS starts timer Timer_1 = 10 s	-	-
	EXCEPTION: Steps 1a2a1 to 1a2a4 describe a transaction that depends on the UE supporting IMS over GERAN	-	-
1a2a1	UE transmits CHANNEL REQUEST	-->	CHANNEL REQUEST
1a2a2	SS sends IMMEDIATE ASSIGNMENT	<--	IMMEDIATE ASSIGNMENT
1a2a3	The UE transmits a ACTIVATE PDP CONTEXT REQUEST message	-->	ACTIVATE PDP CONTEXT REQUEST
1a2a4	The SS transmits a ACTIVATE PDP CONTEXT REJECT message	<--	ACTIVATE PDP CONTEXT REJECT
1a2a5	The SS waits for 5 seconds	-	-
1a2b1	The SS waits for Timer_1 expiry		

4.5A.3B.3 Specific message contents

Table 4.5A.3B.3-1: ACTIVATE PDP CONTEXT REQUEST (Step 1a2a3)

Derivation Path: 24.008 Table 9.5.1			
Information Element	Value/remark	Comment	Condition
Requested NSAPI			
NSAPI value	'0101'B	NSAPI 5	
Requested LLC SAPI			
LLC SAPI value	'0011'B	LLC SAPI 3	
Requested PDP address			
PDP type organisation	'0001'	IETF allocated address	
PDP type number	Any allowed value	The allowed values are respectively IPv4, IPv6, IPv4v6 and "unused but interpreted as Ipv4 by the network"	
Address information	Not present		
Access point name	Not present or any allowed value		
Protocol configuration options	Any allowed Value	The SS shall remember this IE and its contents because this affects subsequent SS behaviour, e.g. coding of ACTIVATE PDP CONTEXT ACCEPT	

Table 4.5A.3B.3-2: ACTIVATE PDP CONTEXT REJECT (Step 1a2a4)

Derivation Path: 24.008 Table 9.5.3			
Information Element	Value/remark	Comment	Condition
Protocol discriminator	'1010'B		
Transaction identifier	Same as requested in ACTIVATE PDP CONTEXT REQUEST		
Activate PDP context reject message identity	'01000011'B		
SM cause	'42'O	#66 Requested APN not supported in current RAT and PLMN combination	
Protocol configuration options	omit		
Back-off timer value	omit		
Re-attempt indicator	omit		

4.5A.4 Generic Test Procedure for IMS Emergency call establishment in EUTRA: Normal Service

4.5A.4.1 Initial conditions

System Simulator:

- Parameters are set to the default parameters for the basic single cell environment, as defined in subclause 4.4, unless otherwise specified in the test case.

User Equipment:

- The UE shall be in Registered, Idle Mode state (State 2).

4.5A.4.2 Definition of system information messages

The default system information messages are used.

4.5A.4.3 Procedure

The establishment of IMS emergency call is assumed to always be mobile originated.

Table 4.5A.4.3-1: EUTRA/EPS signalling for IMS Emergency Call

St	Procedure	Message Sequence	
		U - S	Message
1	Make the UE attempt an IMS emergency call	-	-
2	The UE transmits an <i>RRCConnectionRequest</i> message with 'establishmentCause' set to 'emergency'.	-->	<i>RRCConnectionRequest</i>
3	SS transmit an <i>RRCConnectionSetup</i> message.	<--	RRC: <i>RRCConnectionSetup</i>
4	The UE transmits an <i>RRCConnectionSetupComplete</i> message to confirm the successful completion of the connection establishment and to initiate the session management procedure by including the SERVICE REQUEST message.	-->	RRC: <i>RRCConnectionSetupComplete</i> NAS: SERVICE REQUEST
5	The SS transmits a <i>SecurityModeCommand</i> message to activate AS security.	<--	RRC: <i>SecurityModeCommand</i>
6	The UE transmits a <i>SecurityModeComplete</i> message and establishes the initial security configuration.	-->	RRC: <i>SecurityModeComplete</i>
7	The SS configures a new data radio bearer, associated with the default EPS bearer context. The <i>RRCConnectionReconfiguration</i> message is using condition SRB2-DRB(1, 0). The DRB associated with default EPS bearer context obtained during the attach procedure is established	<--	RRC: <i>RRCConnectionReconfiguration</i>
8	The UE transmits an <i>RRCConnectionReconfigurationComplete</i> message to confirm the establishment of the new data radio bearer, associated with the default EPS bearer context.	-->	RRC: <i>RRCConnectionReconfigurationComplete</i>
9	The UE transmits a PDN CONNECTIVITY REQUEST message to request an additional PDN, with 'Request type' set to 'emergency ('0100'B) '.	-->	PDN CONNECTIVITY REQUEST
10	The SS configures a new data radio bearer, associated with the default EPS bearer context. <i>RRCConnectionReconfiguration</i> message contains the ACTIVATE DEFAULT EPS BEARER CONTEXT REQUEST message. EPS bearer context #2 (QCI 5) according to table 6.6.1-1: Reference default EPS bearer context is used. Note: The APN is set to the test APN defined for emergency bearer services.	<--	RRC: <i>RRCConnectionReconfiguration</i> NAS: ACTIVATE DEFAULT EPS BEARER CONTEXT REQUEST
-	EXCEPTION: In parallel to the events described in steps 11 to 15 below, the behaviour in table 4.5A.4.3-2 occurs. (Optional IP address allocation followed by IMS emergency registration and IMS emergency speech call establishment)	-	-
11	The UE transmits an <i>RRCConnectionReconfigurationComplete</i> message to confirm the establishment of the new data radio bearer, associated with the default EPS bearer for emergency call.	-->	RRC: <i>RRCConnectionReconfigurationComplete</i>
12	The UE transmits an ACTIVATE DEFAULT EPS BEARER CONTEXT ACCEPT message.	-->	RRC: <i>ULInformationTransfer</i> NAS:ACTIVATE DEFAULT EPS BEARER CONTEXT ACCEPT
13	The SS configures a new RLC-UM data radio bearer, associated with the dedicated EPS bearer context. <i>RRCConnectionReconfiguration</i> message contains the ACTIVATE DEDICATED EPS BEARER CONTEXT REQUEST message. EPS bearer context #4 (QCI 1) according to table 6.6.2-1: Reference dedicated EPS bearer contexts is used. Note: the same PDN address is applicable because the linked EPS bearer ID refers to the default EBC allocated in step 10	<--	RRC: <i>RRCConnectionReconfiguration</i> NAS: ACTIVATE DEDICATED EPS BEARER CONTEXT REQUEST
14	The UE transmits an <i>RRCConnectionReconfigurationComplete</i> message to confirm the establishment of the new data radio bearer, associated with the default EPS bearer for emergency IMS signalling.	-->	RRC: <i>RRCConnectionReconfigurationComplete</i>

15	The UE transmits an ACTIVATE DEDICATED EPS BEARER CONTEXT ACCEPT message.	-->	RRC: ULInformationTransfer NAS:ACTIVATE DEDICATED EPS BEARER CONTEXT ACCEPT
----	---	-----	--

Table 4.5A.4.3-2: Parallel behaviour

St	Procedure	Message Sequence	
		U - S	Message
-	EXCEPTION: Step 1 describes behaviour that depends on the UE behaviour.	-	-
1	If initiated by the UE the generic procedure for IP address allocation in the U-plane specified in TS 36.508 subclause 4.5A.1 takes place performing IP address allocation in the U-plane.	-	-
2-5	Steps 1-4 expected sequence defined in annex C.20 of TS 34.229-1 [35]. Emergency registration procedure is performed.	-	-
6-10	Steps 1-5 defined in annex C.22 of TS 34.229-1 [35]. IMS Emergency call for EPS is established.	-	-

4.5A.4.4 Specific message contents

All specific message contents shall be referred to clause 4.6 and 4.7 with the exceptions below.

Table 4.5A.4.4-1: Message ACTIVATE DEFAULT EPS BEARER CONTEXT REQUEST (step 10, Table 4.5A.4.3-1)

Derivation path: Table 4.7.3-6 and table 4.6.1-8 with condition AM-DRB-ADD(2)			
Information Element	Value/Remark	Comment	Condition
Access point name	sos	APN value as recommended by IR.88 clause 6.4 [56]	
EPS QoS	According to reference default EPS bearer context #2 – in table 6.6.1-1	SS defines an additional dedicated EPS QoS	

Table 4.5A.4.4-3: Message ACTIVATE DEDICATED EPS BEARER CONTEXT REQUEST (step 13, Table 4.5A.4.3-1)

Derivation path: Table 4.7.3-3 and table 4.6.1-8 with condition UM-DRB-ADD(3)			
Information Element	Value/Remark	Comment	Condition
Linked EPS bearer identity	Default EBIId-2 (same value like in table 4.5A.4.4-1)		
EPS QoS	According to reference dedicated EPS bearer context #1 - in table 6.6.2-1	SS defines an additional dedicated EPS QoS	
TFT	According to reference dedicated EPS bearer context #1 - in table 6.6.2-1		

Table 4.5A.4.4-4: PDN CONNECTIVITY REQUEST (step 9)

Derivation Path: Table 4.7.3-20			
Information Element	Value/remark	Comment	Condition
Access point name	Not present or any value		

4.5A.5 Generic Test Procedure for IMS Emergency call establishment in EUTRA: Limited Service

4.5A.5.1 Initial conditions

System Simulator:

- Parameters are set to the default parameters for the basic single cell environment, as defined in subclause 4.4, unless otherwise specified in the test case.

User Equipment:

- The UE is switched on and camped on the cell in EMM-DEREGISTERED.LIMITED-SERVICE state.

4.5A.5.2 Definition of system information messages

The default system information messages are used.

4.5A.5.3 Procedure

The establishment of IMS emergency call is assumed to always be mobile originated.

Table 4.5A.5.3-1: EUTRA/EPS signalling for IMS Emergency Call in limited service

St	Procedure	Message Sequence	
		U - S	Message
1	Make the UE attempt an IMS emergency call	-	-
2	The UE transmits an <i>RRCConnectionRequest</i> message with 'establishmentCause' set to 'emergency'.	-->	<i>RRCConnectionRequest</i>
3	SS transmits an <i>RRCConnectionSetup</i> message.	<--	RRC: <i>RRCConnectionSetup</i>
4	The UE transmits an <i>RRCConnectionSetupComplete</i> message to confirm the successful completion of the connection establishment and to initiate the Attach procedure by including the ATTACH REQUEST message, EPS attach type set to "EPS emergency attach" ('0110'B). The PDN CONNECTIVITY REQUEST message is piggybacked in ATTACH REQUEST, with 'Request type' set to 'emergency ('0100'B)'. - EXCEPTION: Steps 5a1 to 5a2b1 describe behaviour that depends on the UE ID sent in the ATTACH REQUEST message in step 4 and take place only if the UE does not send IMEI.	-->	RRC: <i>RRCConnectionSetupComplete</i> NAS: ATTACH REQUEST NAS: PDN CONNECTIVITY REQUEST
5a1	The SS transmits an AUTHENTICATION REQUEST message to initiate the EPS authentication and AKA procedure. - EXCEPTION: Steps 5a2a1 to 5a2b1 describe behaviour that depends on the UE state; the "lower case letter" identifies a step sequence that takes place if the UE is in a particular state.	<--	RRC: <i>DLInformationTransfer</i> NAS: AUTHENTICATION REQUEST
5a2 a1	UE transmits an AUTHENTICATION RESPONSE message and establishes mutual authentication.	-->	RRC: <i>ULInformationTransfer</i> NAS: AUTHENTICATION RESPONSE
5a2 b1	UE transmits an AUTHENTICATION FAILURE message with EMM cause #20 "MAC failure" or EMM cause #21 "synch failure". (Note 2)	-->	RRC: <i>ULInformationTransfer</i> NAS: AUTHENTICATION FAILURE
6a1	Void	-	-
6b1	Void	-	-
7	The SS transmits a NAS SECURITY MODE COMMAND message to activate NAS security selecting. Note: If UE has sent Authentication Failure in step 5a2b16b1 or the behaviour described in steps 5a1 to 5a2b1 does not take place, KSI value is set to "000" and EIA0 (NULL integrity), and EEA0 (NULL ciphering) algorithms are used.	<--	RRC: <i>DLInformationTransfer</i> NAS: SECURITY MODE COMMAND
8	The UE transmits a NAS SECURITY MODE COMPLETE message and establishes the initial security configuration. - EXCEPTION: Steps 9a1 to 9a2 describe behaviour that depends on UE configuration; the "lower case letter" identifies a step sequence that take place if the UE has ESM information which needs to be transferred.	-->	RRC: <i>ULInformationTransfer</i> NAS: SECURITY MODE COMPLETE
9a1	IF the UE sets the ESM information transfer flag in the last PDN CONNECTIVITY REQUEST message THEN the SS transmits an ESM INFORMATION REQUEST message to initiate exchange of protocol configuration options and/or APN.	<--	RRC: <i>DLInformationTransfer</i> NAS: ESM INFORMATION REQUEST
9a2	The UE transmits an ESM INFORMATION RESPONSE message to transfer protocol configuration options and/or APN.	-->	RRC: <i>ULInformationTransfer</i> NAS: ESM INFORMATION RESPONSE

10	The SS transmits a <i>SecurityModeCommand</i> message to activate AS security. Note: If UE has sent Authentication Failure in step 5a2b1, or the behaviour described in steps 5a1 to 5a2b1 does not take place, then, eia0 (NULL integrity), and eea0 (NULL ciphering) algorithms are used.	<--	RRC: <i>SecurityModeCommand</i>
11	The UE transmits a <i>SecurityModeComplete</i> message and establishes the initial security configuration.	-->	RRC: <i>SecurityModeComplete</i>
12	The SS transmits a <i>UECapabilityEnquiry</i> message to initiate the UE radio access capability transfer procedure.	<--	RRC: <i>UECapabilityEnquiry</i>
13	The UE transmits a <i>UECapabilityInformation</i> message to transfer UE radio access capability.	-->	RRC: <i>UECapabilityInformation</i>
14	The SS transmits an <i>RRCCONNECTIONRECONFIGURATION</i> message to establish the default bearer with condition SRB2-DRB(1, 0). The DRB associated with default EPS bearer context #2 (QCI 5) according to table 6.6.1-1: Reference default EPS bearer contexts, obtained during the attach procedure, is established. This message includes the ATTACH ACCEPT message with EPS attach result set to "EPS only" ('001'B). The ACTIVATE DEFAULT EPS BEARER CONTEXT REQUEST message is piggybacked in ATTACH ACCEPT. Note: The APN is set to the test APN defined for emergency bearer services	<--	RRC: <i>RRCCONNECTIONRECONFIGURATION</i> NAS: ATTACH ACCEPT NAS: ACTIVATE DEFAULT EPS BEARER CONTEXT REQUEST
-	EXCEPTION: In parallel to the events described in steps 15 to 19 below, the behaviour in table 4.5A.5.3-2 occurs. (Optional IP address allocation followed by IMS emergency speech call establishment)	-	-
15	The UE transmits an <i>RRCCONNECTIONRECONFIGURATIONCOMPLETE</i> message to confirm the establishment of default bearer.	-->	RRC: <i>RRCCONNECTIONRECONFIGURATIONCOMPLETE</i>
16	This message includes the ATTACH COMPLETE message. The ACTIVATE DEFAULT EPS BEARER CONTEXT ACCEPT message is piggybacked in ATTACH COMPLETE.	-->	RRC: <i>ULINFORMATIONTRANSFER</i> NAS: ATTACH COMPLETE NAS: ACTIVATE DEFAULT EPS BEARER CONTEXT ACCEPT
17	The SS configures a new RLC-UM data radio bearer, associated with the dedicated EPS bearer context. <i>RRCCONNECTIONRECONFIGURATION</i> message contains the ACTIVATE DEDICATED EPS BEARER CONTEXT REQUEST message. EPS bearer context #4 (QCI 1) according to table 6.6.2-1: Reference dedicated EPS bearer contexts is used. Note: the same PDN address is applicable because the linked EPS bearer ID refers to the default EBC allocated in step 10	<--	RRC: <i>RRCCONNECTIONRECONFIGURATION</i> NAS: ACTIVATE DEDICATED EPS BEARER CONTEXT REQUEST
18	The UE transmits an <i>RRCCONNECTIONRECONFIGURATIONCOMPLETE</i> message to confirm the establishment of the new data radio bearer, associated with the default EPS bearer for emergency IMS signalling.	-->	RRC: <i>RRCCONNECTIONRECONFIGURATIONCOMPLETE</i>
19	The UE transmits an ACTIVATE DEDICATED EPS BEARER CONTEXT ACCEPT message.	-->	RRC: <i>ULINFORMATIONTRANSFER</i> NAS:ACTIVATE DEDICATED EPS BEARER CONTEXT ACCEPT

Note 1:	Void
Note 2:	EMM cause #26 "non-EPS authentication unacceptable" is not expected to happen as SS will not set the "separation bit" in the AMF field of AUTN as 0

Table 4.5A.5.3-2: Parallel behaviour

St	Procedure	Message Sequence	
		U - S	Message
-	EXCEPTION: Step 1 describes behaviour that depends on the UE behaviour.	-	-
1	If initiated by the UE the generic procedure for IP address allocation in the U-plane specified in TS 36.508 subclause 4.5A.1 takes place performing IP address allocation in the U-plane.	-	-
2-6	Steps 1-5 defined in annex C.22 of TS 34.229-1 [35]. IMS Emergency call for EPS is established.	-	-

4.5A.5.4 Specific message contents

All specific message contents shall be referred to clause 4.6 and 4.7 with the exceptions below.

Table 4.5A.5.4-1: SECURITY MODE COMMAND (step 7, Table 4.5A.5.3-1)

Derivation Path: Table 4.7.2-19			
Information Element	Value/remark	Comment	Condition
Type of integrity protection algorithm	Set according to PIXIT parameter for default integrity protection algorithm		NOT NullAlgorithmUsed
	EIA0		NullAlgorithmUsed
Type of ciphering algorithm	Set according to PIXIT parameter for default ciphering algorithm		NOT NullAlgorithmUsed
	EEA0		NullAlgorithmUsed
NAS key set identifier			
NAS key set identifier	The valid NAS key set identifier.		NOT NullAlgorithmUsed
	'000'B		NullAlgorithmUsed
TSC	'0'B	native security context (for KSI _{ASME})	
Spare half octet	'0000'B		

Condition	Explanation
NullAlgorithmUsed	UE has sent Authentication Failure in step 5ab1 (Table 4.5A.5.3-1), or the behaviour described in steps 5a1 to 5a2b1 does not take place (Table 4.5A.5.3-1).

Table 4.5A.5.4-2: SecurityModeCommand (step 10, Table 4.5A.5.3-1)

Derivation Path: Table 4.6.1-19			
Information Element	Value/remark	Comment	Condition
SecurityModeCommand ::= SEQUENCE {			
rrc-TransactionIdentifier	RRC-TransactionIdentifier-DL		
criticalExtensions CHOICE {			
c1 CHOICE{			
securityModeCommand-r8 SEQUENCE {			
securityConfigSMC	SecurityConfigSMC-LimitedService	Table 4.5A.5.4-3	
nonCriticalExtension SEQUENCE {}	Not present		
}			
}			
}			
}			

Table 4.5A.5.4-3: SecurityConfigSMC-LimitedService (Table 4.5A.5.4-2)

Derivation Path: Table 4.6.4-2			
Information Element	Value/remark	Comment	Condition
SecurityConfigSMC- LimitedService ::= SEQUENCE {			
securityAlgorithmConfig SEQUENCE {			
cipheringAlgorithm	Set according to PIXIT parameter for default ciphering algorithm		NOT NullAlgorithmUsed
	eea0		NullAlgorithmUsed
integrityProtAlgorithm	Set according to PIXIT parameter for default integrity protection algorithm		NOT NullAlgorithmUsed
	eia0		NullAlgorithmUsed
}			

Condition	Explanation
NullAlgorithmUsed	UE has sent Authentication Failure in step 5a2b1 (Table 4.5A.5.3-1), or the behaviour described in steps 5a1 to 5a2b1 (Table 4.5A.5.3-1) does not take place.

Table 4.5A.5.4-4: Message ACTIVATE DEDICATED EPS BEARER CONTEXT REQUEST (step 17, Table 4.5A.5.3-1)

Derivation path: Table 4.7.3-3 and table 4.6.1-8 with condition UM-DRB-ADD(3)			
Information Element	Value/Remark	Comment	Condition
Linked EPS bearer identity	Default EBId-2 (same value as in table 4.5A.5.4-4)		
EPS QoS	See Reference dedicated EPS bearer context #4 in table 6.6.2-1		
TFT	See Reference dedicated EPS bearer context #4 in table 6.6.2-1		

Table 4.5A.5.4-5: Message ACTIVATE DEFAULT EPS BEARER CONTEXT REQUEST (step 14, Table 4.5A.5.3-1)

Derivation path: Table 4.7.3-6 and table 4.6.1-8 with condition AM-DRB-ADD(2)			
Information Element	Value/Remark	Comment	Condition
Access point name	sos	APN value as recommended by IR.88 clause 6.4 [56]	
EPS QoS	According to reference default EPS bearer context #2 – in table 6.6.1-1	SS defines an additional dedicated EPS bearer	

Table 4.5A.5.4-6: Message ESM INFORMATION RESPONSE (step 9a2, Table 4.5A.5.3-1)

Derivation Path: Table 4.7.3-14			
Information Element	Value/remark	Comment	Condition
Access point name	Not present or any value		

4.5A.6 Generic Test Procedure for IMS MO speech call establishment in E-UTRA

4.5A.6.1 Initial conditions

System Simulator:

- Parameters are set to the default parameters for the basic single cell environment, as defined in subclause 4.4, unless otherwise specified in the test case.

User Equipment:

- The UE shall be in Registered, Idle Mode state (State 2).

4.5A.6.2 Definition of system information messages

The default system information messages are used.

4.5A.6.3 Procedure

Table 4.5A.6.3-1: EUTRA/EPS signalling for IMS MO speech call

St	Procedure	Message Sequence	
		U - S	Message
1	Make the UE attempt an IMS speech call	-	-
2	The UE transmits an <i>RRCConnectionRequest</i> message with 'establishmentCause' set to 'mo-Data'.	-->	<i>RRCConnectionRequest</i>
3	SS transmit an <i>RRCConnectionSetup</i> message.	<--	RRC: <i>RRCConnectionSetup</i>
4	The UE transmits an <i>RRCConnectionSetupComplete</i> message to confirm the successful completion of the connection establishment and to initiate the session management procedure by including the SERVICE REQUEST message.	-->	RRC: <i>RRCConnectionSetupComplete</i> NAS: SERVICE REQUEST
5	The SS transmits a <i>SecurityModeCommand</i> message to activate AS security.	<--	RRC: <i>SecurityModeCommand</i>
6	The UE transmits a <i>SecurityModeComplete</i> message and establishes the initial security configuration.	-->	RRC: <i>SecurityModeComplete</i>
7	The SS configures a new data radio bearer, associated with the default EPS bearer context. The <i>RRCConnectionReconfiguration</i> message is using condition SRB2-DRB(1, 0). The DRB associated with default EPS bearer context obtained during the attach procedure is established	<--	RRC: <i>RRCConnectionReconfiguration</i>
-	EXCEPTION: In parallel to the events described in steps 8 below, the behaviour in table 4.5A.6.3-2 occurs. (IMS MTSI MO speech call establishment)	-	-
8	The UE transmits an <i>RRCConnectionReconfigurationComplete</i> message to confirm the establishment of the new data radio bearer, associated with the default EPS bearer context.	-->	RRC: <i>RRCConnectionReconfigurationComplete</i>
-	EXCEPTION: Steps 9a1 to 11b1 describe behaviour that depends on the UE category.	-	-
9a1-11a1	IF not pc_ue_CategoryDL_M1 THEN steps 3-4 from the expected sequence defined in annex C.21 of TS 34.229-1 [35]. MTSI MO speech call for EPS take place.	-	-
9b1-11b1	IF pc_ue_CategoryDL_M1 THEN steps 3-4 from the expected sequence defined in annex C.21d of TS 34.229-1 [35]. MTSI MO speech call for EPS / UE category M1 take place.	-	-
12	The SS configures a new RLC-UM data radio bearer with condition DRB (0,1), associated with the dedicated EPS bearer context. <i>RRCConnectionReconfiguration</i> message contains the ACTIVATE DEDICATED EPS BEARER CONTEXT REQUEST message. EPS bearer context #4 (QCI 1) according to table 6.6.2-1: Reference dedicated EPS bearer contexts.	<--	RRC: <i>RRCConnectionReconfiguration</i> NAS: ACTIVATE DEDICATED EPS BEARER CONTEXT REQUEST
-	EXCEPTION: In parallel to the events described in steps 13-14 below, the behaviour in table 4.5A.6.3-3 occurs. (IMS MTSI MO speech call establishment)	-	-
13	The UE transmits an <i>RRCConnectionReconfigurationComplete</i> message to confirm the establishment of the new data radio bearer, associated with the dedicated EPS bearer.	-->	RRC: <i>RRCConnectionReconfigurationComplete</i>
14	The UE transmits an ACTIVATE DEDICATED EPS BEARER CONTEXT ACCEPT message.	-->	RRC: ULInformationTransfer NAS:ACTIVATE DEDICATED EPS BEARER CONTEXT ACCEPT

Table 4.5A.6.3-2: Parallel behaviour

St	Procedure	Message Sequence	
		U - S	Message
-	. EXCEPTION: Steps 1a1 to 1b1 describe behaviour that depends on the UE category.		
1a1	IF not pc_ue_CategoryDL_M1 THEN THEN the step 2 expected sequence defined in annex C.21 of TS 34.229-1 [35]. UE sends INVITE take place.	-	-
1b1	IF pc_ue_CategoryDL_M1 THEN THEN Step 2 from the expected sequence defined in annex C.21d of TS 34.229-1 [35]. UE sends INVITE take place.	-	-

Table 4.5A.6.3-3: Parallel behaviour

St	Procedure	Message Sequence	
		U - S	Message
-	. EXCEPTION: Steps 1a1 to 8b1 describe behaviour that depends on the UE category.		
1a1 - 8a1	IF not pc_ue_CategoryDL_M1 THEN HEN the steps from the 5-13 expected sequence defined in annex C.21 of TS 34.229-1 [35]. MTSI MO speech call for EPS take place.	-	-
1b1 - 8b1	IF pc_ue_CategoryDL_M1 THEN the steps 5-13 from the expected sequence defined in annex C.21d of TS 34.229-1 [35]. MTSI MO speech call for EPS / UE category M1 take place.	-	-

4.5A.6.4 Specific message contents

All specific message contents shall be referred to clause 4.6 and 4.7.

4.5A.7 Generic Test Procedure for IMS MT Speech call establishment in E-UTRA

4.5A.7.1 Initial conditions

System Simulator:

- Parameters are set to the default parameters for the basic single cell environment, as defined in subclause 4.4, unless otherwise specified in the test case.

User Equipment:

- The UE shall be in Registered, Idle Mode state (State 2).

4.5A.7.2 Definition of system information messages

The default system information messages are used.

4.5A.7.3 Procedure

Table 4.5A.7.3-1: EUTRA/EPS signalling for IMS MT speech call

St	Procedure	Message Sequence	
		U - S	Message
1	SS sends a <i>Paging</i> message to the UE on the appropriate paging block, and including the UE identity in one entry of the IE <i>pagingRecordLists</i> .	<--	RRC: <i>Paging</i> (PCCH)
2	The UE transmits an <i>RRCConnectionRequest</i> message with 'establishmentCause' set to 'mt-Access'.	-->	<i>RRCConnectionRequest</i>
3	SS transmit an <i>RRCConnectionSetup</i> message.	<--	RRC: <i>RRCConnectionSetup</i>
4	The UE transmits an <i>RRCConnectionSetupComplete</i> message to confirm the successful completion of the connection establishment and to initiate the session management procedure by including the SERVICE REQUEST message.	-->	RRC: <i>RRCConnectionSetupComplete</i> NAS: SERVICE REQUEST
5	The SS transmits a <i>SecurityModeCommand</i> message to activate AS security.	<--	RRC: <i>SecurityModeCommand</i>
6	The UE transmits a <i>SecurityModeComplete</i> message and establishes the initial security configuration.	-->	RRC: <i>SecurityModeComplete</i>
7	The SS configures a new data radio bearer, associated with the default EPS bearer context. The <i>RRCConnectionReconfiguration</i> message is using condition SRB2-DRB(1, 0). The DRB associated with default EPS bearer context obtained during the attach procedure is established	<--	RRC: <i>RRCConnectionReconfiguration</i>
8	The UE transmits an <i>RRCConnectionReconfigurationComplete</i> message to confirm the establishment of the new data radio bearer, associated with the default EPS bearer context.	-->	RRC: <i>RRCConnectionReconfigurationComplete</i>
-	EXCEPTION: Steps 9a1 to 12b3 describe behaviour that depends on the UE category.		
9a1-12a3	IF not pc_ue_CategoryDL_M1 THEN THEN the steps 1-6 from the expected sequence defined in annex C.11 of TS 34.229-1 [35]. MTSI MT speech call take place.	-	-
9b1-12b3	IF pc_ue_CategoryDL_M1 THEN steps 1-6 from the expected sequence defined in annex C.11d of TS 34.229-1 [35]. MTSI MT speech call / UE category M1 take place.	-	-
13	The SS configures a new RLC-UM data radio bearer with condition DRB (0,1), associated with the dedicated EPS bearer context. <i>RRCConnectionReconfiguration</i> message contains the ACTIVATE DEDICATED EPS BEARER CONTEXT REQUEST message.	<--	RRC: <i>RRCConnectionReconfiguration</i> NAS: ACTIVATE DEDICATED EPS BEARER CONTEXT REQUEST
14	The UE transmits an <i>RRCConnectionReconfigurationComplete</i> message to confirm the establishment of the new data radio bearer, associated with the dedicated EPS bearer.	-->	RRC: <i>RRCConnectionReconfigurationComplete</i>
15	The UE transmits an ACTIVATE DEDICATED EPS BEARER CONTEXT ACCEPT message.	-->	RRC: ULInformationTransfer NAS:ACTIVATE DEDICATED EPS BEARER CONTEXT ACCEPT
-	EXCEPTION: Steps 18a1 to 22b1 describe behaviour that depends on the UE category.		
16a1-17	Void	-	-
18a1-22a1	IF not pc_ue_CategoryDL_M1 THEN steps 7-11 from the expected sequence defined in annex C.11 of TS 34.229-1 [35] MTSI MT speech call take place.	-	-
18b1-22b1	IF pc_ue_CategoryDL_M1 THEN the steps 7-11 from the expected sequence defined in annex C.11d of TS 34.229-1 [35] MTSI MT speech call / UE category M1 take place.	-	-
-	EXCEPTION: Steps 23Aa1 to 23Ab1 describe behaviour that depends on the UE category.		

23A a1	IF not pc_ue_CategoryDL_M1 THEN step 11A from the expected sequence defined in annex C.11 of TS 34.229-1 [35] MTSI MT speech call take place.	-	-
23A b1	IF pc_ue_CategoryDL_M1 THEN step 11A from the expected sequence defined in annex C.11d of TS 34.229-1 [35] MTSI MT speech call / UE category M1 take place.	-	-
-	EXCEPTION: Steps 23a1 to 24b1 describe behaviour that depends on the UE category.		
23a1 - 24a1	IF not pc_ue_CategoryDL_M1 THEN steps 12-13 expected sequence defined in annex C.11 of TS 34.229-1 [35] MTSI MT speech call take place.	-	-
23b1 - 24b1	IF pc_ue_CategoryDL_M1 THEN steps 12-13 from the expected sequence defined in annex C.11d of TS 34.229-1 [35] MTSI MT speech call / UE category M1 take place.	-	-
-	EXCEPTION: Steps 25a1 to 26b1 describe behaviour that depends on the UE category.		
25a1 - 26a2	IF not pc_ue_CategoryDL_M1 THEN steps 14-15 from the expected sequence defined in annex C.11 of TS 34.229-1 [35] MTSI MT speech call take place.	-	-
25b1 - 26b1	IF pc_ue_CategoryDL_M1 THEN steps 14-15 from the expected sequence defined in annex C.11d of TS 34.229-1 [35] MTSI MT speech call / UE category M1 take place.	-	-

4.5A.7.4 Specific message contents

All specific message contents shall be referred to clause 4.6 and 4.7.

4.5A.8 Generic Test Procedure for IMS MO video call establishment in E-UTRA

4.5A.8.1 Initial conditions

System Simulator:

- Parameters are set to the default parameters for the basic single cell environment, as defined in subclause 4.4, unless otherwise specified in the test case.

User Equipment:

- The UE shall be in Registered, Idle Mode state (State 2).

4.5A.8.2 Definition of system information messages

The default system information messages are used.

4.5A.8.3 Procedure

Table 4.5A.8.3-1: EUTRA/EPS signalling for IMS MO video call

St	Procedure	Message Sequence	
		U - S	Message
1	Make the UE attempt an IMS video call	-	-
2	The UE transmits an <i>RRCConnectionRequest</i> message with 'establishmentCause' set to 'mo-Data'.	-->	<i>RRCConnectionRequest</i>
3	SS transmit an <i>RRCConnectionSetup</i> message.	<--	RRC: <i>RRCConnectionSetup</i>
4	The UE transmits an <i>RRCConnectionSetupComplete</i> message to confirm the successful completion of the connection establishment and to initiate the session management procedure by including the SERVICE REQUEST message.	-->	RRC: <i>RRCConnectionSetupComplete</i> NAS: SERVICE REQUEST
5	The SS transmits a <i>SecurityModeCommand</i> message to activate AS security.	<--	RRC: <i>SecurityModeCommand</i>
6	The UE transmits a <i>SecurityModeComplete</i> message and establishes the initial security configuration.	-->	RRC: <i>SecurityModeComplete</i>
7	The SS configures a new data radio bearer, associated with the default EPS bearer context. The <i>RRCConnectionReconfiguration</i> message is using condition SRB2-DRB(1, 0). The DRB associated with default EPS bearer context obtained during the attach procedure is established	<--	RRC: <i>RRCConnectionReconfiguration</i>
-	EXCEPTION: In parallel to the events described in steps 8 below, the behaviour in table 4.5A.8.3-2 occurs. (IMS MTSI MO video call establishment)	-	-
8	The UE transmits an <i>RRCConnectionReconfigurationComplete</i> message to confirm the establishment of the new data radio bearer, associated with the default EPS bearer context.	-->	RRC: <i>RRCConnectionReconfigurationComplete</i>
9-11	Steps 3-4 expected sequence defined in annex C.25 of TS 34.229-1 [35]. MTSI MO video call for EPS.	-	-
12	The SS configures two new RLC-UM data radio bearers with condition DRB (0,2), associated with the dedicated EPS bearer context. <i>RRCConnectionReconfiguration</i> message contains one ACTIVATE DEDICATED EPS BEARER CONTEXT REQUEST message per additional data radio bearer. One EPS bearer context #4 (QCI 1) and one EPS bearer context #3 (QCI 2) according table 6.6.2-1: Reference dedicated EPS bearer contexts.	<--	RRC: <i>RRCConnectionReconfiguration</i> NAS: ACTIVATE DEDICATED EPS BEARER CONTEXT REQUEST ACTIVATE DEDICATED EPS BEARER CONTEXT REQUEST
-	EXCEPTION: In parallel to the events described in steps 13-14 below, the behaviour in table 4.5A.8.3-3 occurs. (IMS MTSI MO video call establishment).	-	-
13	The UE transmits an <i>RRCConnectionReconfigurationComplete</i> message to confirm the establishment of the new data radio bearer, associated with the dedicated EPS bearer. EPS bearer context #4 (QCI 1) according table to 6.6.2-1: Reference dedicated EPS bearer contexts.	-->	RRC: <i>RRCConnectionReconfigurationComplete</i>
14	The UE transmits an ACTIVATE DEDICATED EPS BEARER CONTEXT ACCEPT message for the first bearer.	-->	RRC: ULInformationTransfer NAS:ACTIVATE DEDICATED EPS BEARER CONTEXT ACCEPT
15	The UE transmits an ACTIVATE DEDICATED EPS BEARER CONTEXT ACCEPT message for the second bearer.	-->	RRC: ULInformationTransfer NAS:ACTIVATE DEDICATED EPS BEARER CONTEXT ACCEPT

Table 4.5A.8.3-2: Parallel behaviour

St	Procedure	Message Sequence	
		U - S	Message
1	Step 2 expected sequence defined in annex C.25 of TS 34.229-1 [35]. UE sends INVITE.	-	-

Table 4.5A.8.3-3: Parallel behaviour

St	Procedure	Message Sequence	
		U - S	Message
1-8	Steps 5-13 expected sequence defined in annex C.25 of TS 34.229-1 [35]. MTSI MO video call for EPS.	-	-

4.5A.8.4 Specific message contents

All specific message contents shall be referred to clause 4.6 and 4.7.

4.5A.9 Generic Test Procedure for IMS MT video call establishment in E-UTRA

4.5A.9.1 Initial conditions

System Simulator:

- Parameters are set to the default parameters for the basic single cell environment, as defined in subclause 4.4, unless otherwise specified in the test case.

User Equipment:

- The UE shall be in Registered, Idle Mode state (State 2).

4.5A.9.2 Definition of system information messages

The default system information messages are used.

4.5A.9.3 Procedure

Table 4.5A.9.3-1: EUTRA/EPS signalling for IMS MT video call

St	Procedure	Message Sequence	
		U - S	Message
1	SS sends a <i>Paging</i> message to the UE on the appropriate paging block, and including the UE identity in one entry of the IE <i>pagingRecordLists</i> .	<--	RRC: <i>Paging</i> (PCCH)
2	The UE transmits an <i>RRCConnectionRequest</i> message with 'establishmentCause' set to 'mt-Access'.	-->	<i>RRCConnectionRequest</i>
3	SS transmit an <i>RRCConnectionSetup</i> message.	<--	RRC: <i>RRCConnectionSetup</i>
4	The UE transmits an <i>RRCConnectionSetupComplete</i> message to confirm the successful completion of the connection establishment and to initiate the session management procedure by including the SERVICE REQUEST message.	-->	RRC: <i>RRCConnectionSetupComplete</i> NAS: SERVICE REQUEST
5	The SS transmits a <i>SecurityModeCommand</i> message to activate AS security.	<--	RRC: <i>SecurityModeCommand</i>
6	The UE transmits a <i>SecurityModeComplete</i> message and establishes the initial security configuration.	-->	RRC: <i>SecurityModeComplete</i>
7	The SS configures a new data radio bearer, associated with the default EPS bearer context. The <i>RRCConnectionReconfiguration</i> message is using condition SRB2-DRB(1, 0). The DRB associated with default EPS bearer context obtained during the attach procedure is established	<--	RRC: <i>RRCConnectionReconfiguration</i>
8	The UE transmits an <i>RRCConnectionReconfigurationComplete</i> message to confirm the establishment of the new data radio bearer, associated with the default EPS bearer context.	-->	RRC: <i>RRCConnectionReconfigurationComplete</i>
9-12b	Steps 1-6 expected sequence defined in annex C.26 of TS 34.229-1 [35]. MTSI MT video call.	-	-
13	The SS configures a new RLC-UM data radio bearer with condition DRB (0,2), associated with the dedicated EPS bearer context. <i>RRCConnectionReconfiguration</i> message contains one ACTIVATE DEDICATED EPS BEARER CONTEXT REQUEST message per additional data radio bearer. One EPS bearer context #4 (QCI 1) and one EPS bearer context #3 (QCI 2) according table 6.6.2-1: Reference dedicated EPS bearer contexts.	<--	RRC: <i>RRCConnectionReconfiguration</i> NAS: ACTIVATE DEDICATED EPS BEARER CONTEXT REQUEST ACTIVATE DEDICATED EPS BEARER CONTEXT REQUEST
14	The UE transmits an <i>RRCConnectionReconfigurationComplete</i> message to confirm the establishment of the new data radio bearer, associated with the dedicated EPS bearer.	-->	RRC: <i>RRCConnectionReconfigurationComplete</i>
15	The UE transmits an ACTIVATE DEDICATED EPS BEARER CONTEXT ACCEPT message for the first bearer.	-->	RRC: ULInformationTransfer NAS:ACTIVATE DEDICATED EPS BEARER CONTEXT ACCEPT
16	The UE transmits an ACTIVATE DEDICATED EPS BEARER CONTEXT ACCEPT message for the second bearer.	-->	RRC: ULInformationTransfer NAS:ACTIVATE DEDICATED EPS BEARER CONTEXT ACCEPT
17-18	Void	-	-
19-27	Steps 7-15 expected sequence defined in annex C.26 of TS 34.229-1 [35]. MTSI MT video call for EPS.	-	-

4.5A.9.4 Specific message contents

All specific message contents shall be referred to clause 4.6 and 4.7.

4.5A.10 Generic Test Procedure for IMS MO speech and aSRVCC in E-UTRA

4.5A.10.1 Initial conditions

System Simulator:

- Parameters are set to the default parameters for the basic single cell environment, as defined in subclause 4.4, unless otherwise specified in the test case.

User Equipment:

- The UE shall be in Registered, Idle Mode state (State 2).

4.5A.10.2 Definition of system information messages

The default system information messages are used.

4.5A.10.3 Procedure

Table 4.5A.10.3-1: EUTRA/EPS signalling for IMS MO speech to alerting state

St	Procedure	Message Sequence	
		U - S	Message
1	Make the UE attempt an IMS speech call	-	-
2	The UE transmits an <i>RRCConnectionRequest</i> message with 'establishmentCause' set to 'mo-Data'.	-->	<i>RRCConnectionRequest</i>
3	SS transmit an <i>RRCConnectionSetup</i> message.	<--	RRC: <i>RRCConnectionSetup</i>
4	The UE transmits an <i>RRCConnectionSetupComplete</i> message to confirm the successful completion of the connection establishment and to initiate the session management procedure by including the SERVICE REQUEST message.	-->	RRC: <i>RRCConnectionSetupComplete</i> NAS: SERVICE REQUEST
5	The SS transmits a <i>SecurityModeCommand</i> message to activate AS security.	<--	RRC: <i>SecurityModeCommand</i>
6	The UE transmits a <i>SecurityModeComplete</i> message and establishes the initial security configuration.	-->	RRC: <i>SecurityModeComplete</i>
7	The SS configures a new data radio bearer, associated with the default EPS bearer context. The <i>RRCConnectionReconfiguration</i> message is using condition SRB2-DRB(1, 0). The DRB associated with default EPS bearer context obtained during the attach procedure is established	<--	RRC: <i>RRCConnectionReconfiguration</i>
-	EXCEPTION: In parallel to the events described in steps 8 below, the behaviour in table 4.5A.10.3-2 occurs. Initiate MTSI MO speech.	-	-
8	The UE transmits an <i>RRCConnectionReconfigurationComplete</i> message to confirm the establishment of the new data radio bearer, associated with the default EPS bearer context.	-->	RRC: <i>RRCConnectionReconfigurationComplete</i>
9-11	Steps 3-4 expected sequence defined in annex C.21 of TS 34.229-1 [35]. MTSI MO speech call for EPS.	-	-
12	The SS configures a new RLC-UM data radio bearer with condition DRB (0,1), associated with the dedicated EPS bearer context. <i>RRCConnectionReconfiguration</i> message contains the ACTIVATE DEDICATED EPS BEARER CONTEXT REQUEST message. EPS bearer context #4 (QCI 1) according to table 6.6.2-1: Reference dedicated EPS bearer contexts.	<--	RRC: <i>RRCConnectionReconfiguration</i> NAS: ACTIVATE DEDICATED EPS BEARER CONTEXT REQUEST
	EXCEPTION: In parallel to the events described in steps 13-14 below, the behaviour in table 4.5A.10.3-3 occurs. MTSI MO speech call to alerting state.	-	-
13	The UE transmits an <i>RRCConnectionReconfigurationComplete</i> message to confirm the establishment of the new data radio bearer, associated with the dedicated EPS bearer.	-->	RRC: <i>RRCConnectionReconfigurationComplete</i>
14	The UE transmits an ACTIVATE DEDICATED EPS BEARER CONTEXT ACCEPT message.	-->	RRC: <i>ULInformationTransfer</i> NAS:ACTIVATE DEDICATED EPS BEARER CONTEXT ACCEPT

Table 4.5A.10.3-2: Parallel behaviour

St	Procedure	Message Sequence	
		U - S	Message
1	Step 2 expected sequence defined in annex C.21 of TS 34.229-1 [35]. UE sends INVITE.	-	-

Table 4.5A.10.3-3: Parallel behaviour

St	Procedure	Message Sequence	
		U - S	Message
1-7	Steps 5-11 expected sequence defined in annex C.21 of TS 34.229-1 [35]. MTSI MO speech call to alerting state for EPS.	-	-

4.5A.10.4 Specific message contents

All specific message contents shall be referred to clause 4.6 and 4.7.

4.5A.11 Generic Test Procedure for IMS MO add video establishment in E-UTRA

4.5A.11.1 Initial conditions

System Simulator:

- Parameters are set to the default parameters for the basic single cell environment, as defined in subclause 4.4, unless otherwise specified in the test case.

User Equipment:

- The UE shall execute 4.5A.6.

4.5A.11.2 Definition of system information messages

The default system information messages are used.

4.5A.11.3 Procedure

Table 4.5A.11.3-1: EUTRA/EPS signalling for IMS MO add video

St	Procedure	Message Sequence	
		U - S	Message
1	Make the UE attempt add IMS video to the voice call.	-	-
2-4	Steps 2-4 expected sequence defined in expected sequence test case 17.1.4 of TS 34.229-1 [35]. MO Speech, add video remove video.	-	-
5	The SS configures a new RLC-UM data radio bearer with condition DRB (0,1), associated with the dedicated EPS bearer context. <i>RRCConnectionReconfiguration</i> message contains the ACTIVATE DEDICATED EPS BEARER CONTEXT REQUEST message. EPS bearer context #3 (QCI 2) according to table 6.6.2-1: Reference dedicated EPS bearer contexts.	<--	RRC: <i>RRCConnectionReconfiguration</i> NAS: ACTIVATE DEDICATED EPS BEARER CONTEXT REQUEST
-	EXCEPTION: In parallel to the events described in steps 6-7 below, the behaviour in table 4.5A.11.3-2 occurs. (IMS MTSI MO video call establishment).	-	-
6	The UE transmits an <i>RRCConnectionReconfigurationComplete</i> message to confirm the establishment of the new data radio bearer, associated with the dedicated EPS bearer. EPS bearer context #3 (QCI 2) according table to 6.6.2-1: Reference dedicated EPS bearer contexts.	-->	RRC: <i>RRCConnectionReconfigurationComplete</i>
7	The UE transmits an ACTIVATE DEDICATED EPS BEARER CONTEXT ACCEPT message for the first bearer.	-->	RRC: <i>ULInformationTransfer</i> NAS:ACTIVATE DEDICATED EPS BEARER CONTEXT ACCEPT

Table 4.5A.11.3-2: Parallel behaviour

St	Procedure	Message Sequence	
		U - S	Message
1-6	Steps 5-10 expected sequence defined in test case 17.1.4 of TS 34.229-1 [35]. MO Speech, add video remove video.	-	-

4.5A.11.4 Specific message contents

All specific message contents shall be referred to clause 4.6 and 4.7.

4.5A.12 Generic Test Procedure for IMS MT add video establishment in E-UTRA

4.5A.12.1 Initial conditions

System Simulator:

- Parameters are set to the default parameters for the basic single cell environment, as defined in subclause 4.4, unless otherwise specified in the test case.

User Equipment:

- The UE shall execute 4.5A.7.

4.5A.12.2 Definition of system information messages

The default system information messages are used.

4.5A.12.3 Procedure

Table 4.5A.12.3-1: EUTRA/EPS signalling for IMS MT add video

St	Procedure	Message Sequence	
		U - S	Message
1-3b	Steps 1-5 expected sequence defined in expected sequence test case 17.2.4 of TS 34.229-1 [35]. MT Speech, add video remove video.	-	-
4	The SS configures a new RLC-UM data radio bearer with condition DRB (0,1), associated with the dedicated EPS bearer context. <i>RRConnectionReconfiguration</i> message contains the ACTIVATE DEDICATED EPS BEARER CONTEXT REQUEST message. EPS bearer context #3 (QCI 2) according to table 6.6.2-1: Reference dedicated EPS bearer contexts.	<--	RRC: <i>RRConnectionReconfiguration</i> NAS: ACTIVATE DEDICATED EPS BEARER CONTEXT REQUEST
5	The UE transmits an <i>RRConnectionReconfigurationComplete</i> message to confirm the establishment of the new data radio bearer, associated with the dedicated EPS bearer. EPS bearer context #3 (QCI 2) according to table 6.6.2-1: Reference dedicated EPS bearer contexts.	-->	RRC: <i>RRConnectionReconfigurationComplete</i>
6	The UE transmits an ACTIVATE DEDICATED EPS BEARER CONTEXT ACCEPT message for the first bearer.	-->	RRC: <i>ULInformationTransfer</i> NAS:ACTIVATE DEDICATED EPS BEARER CONTEXT ACCEPT
7-8	Void	-	-
9-12	Steps 6-9 expected sequence defined in test case 17.2.4 of TS 34.229-1 [35], MT Speech, add video remove video.	-	-

4.5A.12.4 Specific message contents

All specific message contents shall be referred to clause 4.6 and 4.7.

4.5A.13 Void

4.5A.14 Generic Test Procedure for IMS XCAP establishment in EUTRA

4.5A.14.1 Initial conditions

System Simulator:

- Parameters are set to the default parameters for the basic single cell environment, as defined in subclause 4.4, unless otherwise specified in the test case.

User Equipment:

- The UE shall be in Registered, Idle Mode state (State 2).
- If `pc_XCAP_only_APN==true` then the UE is connected to the IMS PDN only
- else the UE is connected to the IMS PDN and the Internet PDN which is used for XCAP signalling.

4.5A.14.2 Definition of system information messages

The default system information messages are used.

4.5A.14.3 Procedure

Table 4.5A.14.3-1: EUTRA/EPS signalling for XCAP

St	Procedure	Message Sequence	
		U - S	Message
1	Make the UE attempt XCAP signalling.	-	-
2	The UE transmits an <i>RRCConnectionRequest</i> message with 'establishmentCause' set to 'mo-Data'.	-->	<i>RRCConnectionRequest</i>
3	SS transmit an <i>RRCConnectionSetup</i> message.	<--	RRC: <i>RRCConnectionSetup</i>
4	The UE transmits an <i>RRCConnectionSetupComplete</i> message to confirm the successful completion of the connection establishment and to initiate the session management procedure by including the SERVICE REQUEST message.	-->	RRC: <i>RRCConnectionSetupComplete</i> NAS: SERVICE REQUEST
5	The SS transmits a <i>SecurityModeCommand</i> message to activate AS security.	<--	RRC: <i>SecurityModeCommand</i>
6	The UE transmits a <i>SecurityModeComplete</i> message and establishes the initial security configuration.	-->	RRC: <i>SecurityModeComplete</i>
7	The SS configures a new data radio bearer, associated with the default EPS bearer context. The <i>RRCConnectionReconfiguration</i> message is using condition SRB2-DRB(1, 0) in case of pc_XCAP_only_APN==true or using condition SRB2-DRB(2, 0) in case of pc_XCAP_over_Internet_APN==true. The DRBs associated with the respective default EPS bearer context obtained during the attach procedure are established	<--	RRC: <i>RRCConnectionReconfiguration</i>
8	The UE transmits an <i>RRCConnectionReconfigurationComplete</i> message to confirm the establishment of the new data radio bearer, associated with the default EPS bearer context.	-->	RRC: <i>RRCConnectionReconfigurationComplete</i>
	EXCEPTION: IF pc_XCAP_only_APN THEN additional PDN connectivity shall be established as specified in TS 36.508 subclause 4.5A.16 (condition: NOT_ADD_IMS)		

4.5A.14.4 Specific message contents

All specific message contents shall be referred to clause 4.6 and 4.7.

4.5A.15 Generic Test Procedure for EPS Bearer Deactivation

4.5A.15.1 Initial conditions

The EPS bearer to be deactivated has been established before. The EPS bearer has to be specified.

4.5A.15.2 Definition of system information messages

The system information messages applicable in the test case are used.

4.5A.15.3 Procedure

Table 4.5A.15.3-1: Procedure for EPS Bearer Deactivation

Step	Procedure	Message Sequence	
		U - S	Message
1	The SS transmits an <i>RRCConnectionReconfiguration</i> message to deactivate an EPS bearer.	<--	RRC: <i>RRCConnectionReconfiguration</i> NAS: DEACTIVATE EPS BEARER CONTEXT REQUEST
-	EXCEPTION: In parallel to the event described in step2 the step specified in Table 4.5A.15.3-2 should take place.	-	-
2	The UE transmits an <i>RRCConnectionReconfigurationComplete</i> message to confirm the deactivation of EPS bearer.	-->	RRC: <i>RRCConnectionReconfigurationComplete</i>
3	Void	-	-

Table 4.5A.15.3-2: Procedure for EPS Bearer Deactivation (parallel behaviour)

Step	Procedure	Message Sequence	
		U - S	Message
1	The UE transmits an <i>ULInformationTransfer</i> message to accept deactivation of the EPS bearer.	-->	RRC: <i>ULInformationTransfer</i> NAS: DEACTIVATE EPS BEARER CONTEXT ACCEPT

4.5A.15.4 Specific message contents

Table 4.5A.15.4-1: Message DEACTIVATE EPS BEARER CONTEXT REQUEST (step 1, Table 4.5A.15.3-1)

Derivation path: Table 4.7.3-12 and table 4.6.1-8 with condition and condition NETWORK-INITIATED			
Information Element	Value/Remark	Comment	Condition
EPS bearer identity	EPS bearer identity	Same value as in the activation message.	
ESM cause	00100100	regular deactivation	

Table 4.5A.15.4-2: Message DEACTIVATE EPS BEARER CONTEXT ACCEPT (step 2, Table 4.5A.15.3-1)

Derivation Path: Table 4.7.3-11			
Information Element	Value/remark	Comment	Condition
EPS bearer identity	EPS bearer identity	The same value as the value set in DEACTIVATE EPS BEARER CONTEXT REQUEST message.	
Procedure transaction identity	0	No procedure transaction identity assigned	

4.5A.15A Generic Test Procedure for User or Network Initiated EPS Bearer Deactivation

4.5A.15A.1 Initial conditions

The EPS bearer to be deactivated has been established before. The EPS bearer has to be specified.

4.5A.15A.2 Definition of system information messages

The system information messages applicable in the test case are used.

4.5A.15A.3 Procedure

Table 4.5A.15A.3-1: Procedure for EPS Bearer Deactivation

Step	Procedure	Message Sequence	
		U - S	Message
-	EXCEPTION: Step 1Aa describes behaviour that depends on UE capabilities/configuration; the "lower case letter" identifies a step sequence that takes place if one of those is supported/configured. The SS shall wait up to 5s for the UE to trigger the PDN Disconnect procedure. NOTE: The specified wait period of 5s is a working assumption to facilitate test case implementation.	-	-
1Aa	The UE transmits a PDN DISCONNECT REQUEST	-->	RRC: <i>ULInformationTransfer</i> PDN DISCONNECT REQUEST
1	The SS transmits an <i>RRCCConnectionReconfiguration</i> message to deactivate an EPS bearer.	<--	RRC: <i>RRCCConnectionReconfiguration</i> NAS: DEACTIVATE EPS BEARER CONTEXT REQUEST
-	EXCEPTION: In parallel to the event described in step2 the step specified in Table 4.5A.15A.3-2 should take place.	-	-
2	The UE transmits an <i>RRCCConnectionReconfigurationComplete</i> message to confirm the deactivation of EPS bearer.	-->	RRC: <i>RRCCConnectionReconfigurationComplete</i>

Table 4.5A.15A.3-2: Procedure for EPS Bearer Deactivation (parallel behaviour)

Step	Procedure	Message Sequence	
		U - S	Message
1	The UE transmits an <i>ULInformationTransfer</i> message to accept deactivation of the EPS bearer.	-->	RRC: <i>ULInformationTransfer</i> NAS: DEACTIVATE EPS BEARER CONTEXT ACCEPT

4.5A.15A.4 Specific message contents

Table 4.5A.15A.4-1: Message DEACTIVATE EPS BEARER CONTEXT REQUEST (step 1, Table 4.5A.15.3-1)

Derivation path: Table 4.7.3-12 and table 4.6.1-8 with condition and condition NETWORK-INITIATED			
Information Element	Value/Remark	Comment	Condition
EPS bearer identity	EPS bearer identity	Same value as in the activation message.	
ESM cause	00100100	regular deactivation	

Table 4.5A.15A.4-2: Message DEACTIVATE EPS BEARER CONTEXT ACCEPT (step 2, Table 4.5A.15.3-1)

Derivation Path: Table 4.7.3-11			
Information Element	Value/remark	Comment	Condition
EPS bearer identity	EPS bearer identity	The same value as the value set in DEACTIVATE EPS BEARER CONTEXT REQUEST message.	
Procedure transaction identity	0	No procedure transaction identity assigned	

4.5A.16 Generic Test Procedure to establish additional PDN connectivity

The same assumptions and definitions apply as in clause 4.5.2 and in addition:

Condition	Explanation
ADD_IMS	true if this procedure is part of the initial registration (PDN2_IMS==true according to definitions in clause 4.5.2); false for all other cases

4.5A.16.1 Initial conditions

System Simulator:

- 1 cell, default parameters.
- The procedure shall be performed under ideal radio conditions as defined in clause 5

User Equipment:

- The UE is in Registered, RRC_CONNECTED state (State 2).

4.5A.16.2 Definition of system information messages

The default system information messages are used.

4.5A.16.3 Procedure

Table 4.5A.16.3-1: Establishment of additional PDN connectivity

St	Procedure	Message Sequence	
		U - S	Message
1	The UE transmits a PDN CONNECTIVITY REQUEST message to request an additional PDN.	-->	RRC: <i>ULInformationTransfer</i> NAS: PDN CONNECTIVITY REQUEST
2	The SS configures a new data radio bearer, associated with the additional default EPS bearer context. <i>RRCConnectionReconfiguration</i> message contains the ACTIVATE DEFAULT EPS BEARER CONTEXT REQUEST message.	<--	RRC: <i>RRCConnectionReconfiguration</i> NAS: ACTIVATE DEFAULT EPS BEARER CONTEXT REQUEST
3	The UE transmits an <i>RRCConnectionReconfigurationComplete</i> message to confirm the establishment of additional default bearer.	-->	RRC: <i>RRCConnectionReconfigurationComplete</i>
-	EXCEPTION: In parallel to the event described in step 4 below, if initiated by the UE the generic procedure for IP address allocation in the U-plane specified in TS 36.508 subclause 4.5A.1 takes place performing IP address allocation in the U-plane.		
-	EXCEPTION: IF ADD_IMS THEN in parallel to the event described in step 4 below the generic procedure for IMS signalling in the U-plane specified in TS 36.508 subclause 4.5A.3 takes place if requested by the UE		
4	The UE transmits an ACTIVATE DEFAULT EPS BEARER CONTEXT ACCEPT message.	-->	RRC: <i>ULInformationTransfer</i> NAS:ACTIVATE DEFAULT EPS BEARER CONTEXT ACCEPT

4.5A.16.4 Specific message contents

All specific message contents shall be referred to clause 4.6 and 4.7 with the exceptions below.

Table 4.5A.16.4-1: PDN CONNECTIVITY REQUEST (step 1)

Derivation Path: Table 4.7.3-20			
Information Element	Value/remark	Comment	Condition
Access point name	Any allowed value	The UE includes a new APN.	

Table 4.5A.16.4-2: Message ACTIVATE DEFAULT EPS BEARER CONTEXT REQUEST (step 2)

Derivation path: Table 4.7.3-6 with condition IMS_PDN_ConnEstab for ADD_IMS and NOT IMS_PDN_ConnEstab else and table 4.6.1-8 with condition AM-DRB-ADD(1) for ADD_IMS or with condition AM-DRB-ADD(8) else			
Information Element	Value/Remark	Comment	Condition
EPS bearer identity	'0101'B	arbitrary value used for PDN connectivity being maintained during the test case	ADD_IMS
EPS bearer identity	'1100'B	arbitrary value used for additional non-IMS PDN connectivity	NOT ADD_IMS
Procedure transaction identity	PTI-1	SS re-uses the particular PTI defined by UE for this present additional PDN connectivity request procedure	

Table 4.5A.16.4-3: Message ACTIVATE DEFAULT EPS BEARER CONTEXT ACCEPT (step 4)

Derivation path: Table 4.7.3-4			
Information Element	Value/Remark	Comment	Condition
EPS bearer identity	(same value as used in step 2)		
Procedure transaction identity	0	No procedure transaction identity assigned	

4.5A.17 Generic Test Procedure for user initiated release of additional PDN connectivity

4.5A.17.1 Initial conditions

System Simulator:

- 1 cell, default parameters.
- The procedure shall be performed under ideal radio conditions as defined in clause 5

User Equipment:

- The UE shall be in Registered, Idle Mode state (State 2) with connectivity at least to two PDNs

4.5A.17.2 Definition of system information messages

The default system information messages are used.

4.5A.17.3 Procedure

Table 4.5A.17.3-1: Release of additional PDN connectivity

St	Procedure	Message Sequence	
		U - S	Message
1	Cause the UE to request disconnection from the additional PDN (see Note 1)	-	-
2	The UE transmits an <i>RRCCONNECTIONREQUEST</i>	-->	<i>RRCCONNECTIONREQUEST</i>
3	SS transmit an <i>RRCCONNECTIONSETUP</i> message.	<--	RRC: <i>RRCCONNECTIONSETUP</i>
-	EXCEPTION: Steps 4a1 to 4b1 describe behaviour which depends on earlier network indication of supported features.	-	-
4a1	IF the network indicated support of EXTENDED SERVICE REQUEST for packet services in the preceding ATTACH ACCEPT message, THEN the UE transmits an <i>RRCCONNECTIONSETUPCOMPLETE</i> message to confirm the successful completion of the connection establishment and to initiate the session management procedure by including the EXTENDED SERVICE REQUEST message	-->	RRC: <i>RRCCONNECTIONSETUPCOMPLETE</i> NAS: EXTENDED SERVICE REQUEST
4b1	ELSE, the UE transmits an <i>RRCCONNECTIONSETUPCOMPLETE</i> message to confirm the successful completion of the connection establishment and to initiate the session management procedure by including the SERVICE REQUEST message.	-->	RRC: <i>RRCCONNECTIONSETUPCOMPLETE</i> NAS: SERVICE REQUEST
5	The SS transmits a <i>SECURITYMODECOMMAND</i> message to activate AS security.	<--	RRC: <i>SECURITYMODECOMMAND</i>
6	The UE transmits a <i>SECURITYMODECOMPLETE</i> message and establishes the initial security configuration.	-->	RRC: <i>SECURITYMODECOMPLETE</i>
7	The SS transmits a <i>RRCCONNECTIONRECONFIGURATION</i> message to establish SRB2 and DRBs associated with all default EPS bearer contexts	<--	RRC: <i>RRCCONNECTIONRECONFIGURATION</i>
8	The UE transmits an <i>RRCCONNECTIONRECONFIGURATIONCOMPLETE</i> message to confirm the establishment of SRB2 and DRBs associated with all default EPS bearer contexts.	-->	RRC: <i>RRCCONNECTIONRECONFIGURATIONCOMPLETE</i>
9	The UE transmits a PDN DISCONNECT REQUEST	-->	RRC: <i>ULINFORMATIONTRANSFER</i> PDN DISCONNECT REQUEST
10	The SS transmits a DEACTIVATE EPS BEARER CONTEXT REQUEST message included in an <i>RRCCONNECTIONRECONFIGURATION</i> message.	<--	RRC: <i>RRCCONNECTIONRECONFIGURATION</i> NAS: DEACTIVATE EPS BEARER CONTEXT REQUEST
11	The UE transmits an <i>RRCCONNECTIONRECONFIGURATIONCOMPLETE</i> message to confirm the release of the bearer.	-->	RRC: <i>RRCCONNECTIONRECONFIGURATIONCOMPLETE</i>
12	The UE transmits a DEACTIVATE EPS BEARER CONTEXT ACCEPT message.	-->	RRC: <i>ULINFORMATIONTRANSFER</i> DEACTIVATE EPS BEARER CONTEXT ACCEPT
13	The SS transmits an <i>RRCCONNECTIONRELEASE</i> message to release RRC connection	<--	RRC: <i>RRCCONNECTIONRELEASE</i>
NOTE 1: The request to disconnect from a PDN may be performed by MMI or AT command; in any case the EPS bearer identity of the Default EPS Bearer of the PDN to be released needs to be handed over to the UE			

4.5A.17.4 Specific message contents

All specific message contents shall be referred to clause 4.6 and 4.7 with the exceptions below.

Table 4.5A.17.4-1: *RRCCONNECTIONRECONFIGURATION* (step 7)

Derivation path: 36.508 table 4.6.1-8 using condition SRB2-DRB(2, 0)
NOTE: The bid for the AM DRBs shall be 1 and 8 instead of 1 and 2.

Table 4.5A.17.4-2: PDN DISCONNECT REQUEST (step 9)

Derivation Path: TS 36.508 Table 4.7.3-22			
Information Element	Value/remark	Comment	Condition
EPS bearer identity	'0000'	"no EPS bearer identity assigned"	
Procedure transaction identity	PTI-1	UE assigns a particular PTI not yet used between 1 and 254	
Linked EPS bearer identity	(bearer identity as handed over at step 1)		

Table 4.5A.17.4-3: RRCConnectionReconfiguration (step 10)

Derivation path: 36.508 table 4.6.1-8 using condition DRB-REL(8)
--

Table 4.5A.17.4-4: DEACTIVATE EPS BEARER CONTEXT REQUEST (step 10)

Derivation Path: TS 36.508 Table 4.7.3-12			
Information Element	Value/remark	Comment	Condition
EPS bearer identity	(same as in Linked EPS bearer identity of step 9)		
Procedure transaction identity	PTI-1	SS re-uses the particular PTI defined by UE for this present PDN disconnection procedure.	UE-INITIATED
ESM cause	00100100	regular deactivation	

Table 4.5A.17.4-5: DEACTIVATE EPS BEARER CONTEXT ACCEPT (step 12)

Derivation Path: TS 36.508 Table 4.7.3-11			
Information Element	Value/remark	Comment	Condition
EPS bearer identity	(same as in DEACTIVATE EPS BEARER CONTEXT REQUEST of step 10)	The same value as the value set in DEACTIVATE EPS BEARER CONTEXT REQUEST message.	
Procedure transaction identity	0	No procedure transaction identity assigned	

4.5A.18 Generic Test Procedure for network initiated release of additional PDN connectivity

4.5A.18.1 Initial conditions

System Simulator:

- 1 cell, default parameters.
- The procedure shall be performed under ideal radio conditions as defined in clause 5

User Equipment:

- The UE shall be in Registered, Idle Mode state (State 2) with connectivity at least to two PDNs

4.5A.18.2 Definition of system information messages

The default system information messages are used.

4.5A.18.3 Procedure

Table 4.5A.18.3-1: Release of additional PDN connectivity

St	Procedure	Message Sequence	
		U - S	Message
1-7	Steps 1 to 7 of the generic radio bearer establishment procedure (TS 36.508 4.5.3.3-1)		
8	The SS transmits a <i>RRConnectionReconfiguration</i> message to establish SRB2 and DRBs associated with all default EPS bearer contexts	<--	RRC: <i>RRConnectionReconfiguration</i>
9	The UE transmits an <i>RRConnectionReconfigurationComplete</i> message to confirm the establishment of SRB2 and DRBs associated with all default EPS bearer contexts.	-->	RRC: <i>RRConnectionReconfigurationComplete</i>
10	SS releases the PDN connectivity by transmitting a <i>RRConnectionReconfiguration</i> containing a DEACTIVATE EPS BEARER CONTEXT REQUEST	<--	RRC: <i>RRConnectionReconfiguration</i> NAS: DEACTIVATE EPS BEARER CONTEXT REQUEST
11	The UE transmits an <i>RRConnectionReconfigurationComplete</i> message to confirm the release of the bearer.	-->	RRC: <i>RRConnectionReconfigurationComplete</i>
12	The UE transmits a DEACTIVATE EPS BEARER CONTEXT ACCEPT message.	-->	DEACTIVATE EPS BEARER CONTEXT ACCEPT
13	The SS transmits an <i>RRConnectionRelease</i> message to release RRC connection	<--	RRC: <i>RRConnectionRelease</i>

4.5A.18.4 Specific message contents

All specific message contents shall be referred to clause 4.6 and 4.7 with the exceptions below.

Table 4.5A.18.4-1: RRConnectionReconfiguration (step 8)

Derivation path: 36.508 table 4.6.1-8 using condition SRB2-DRB(2, 0)
NOTE: The bid for the AM DRBs shall be 1 and 8 instead of 1 and 2.

Table 4.5A.18.4-2: RRConnectionReconfiguration (step 10)

Derivation path: 36.508 table 4.6.1-8 using condition DRB-REL(8)
--

Table 4.5A.18.4-3: DEACTIVATE EPS BEARER CONTEXT REQUEST (step 10)

Derivation Path: TS 36.508 Table 4.7.3-12			
Information Element	Value/remark	Comment	Condition
EPS bearer identity	(identity of default EPS bearer associated with the PDN to be released)		
ESM cause	00011010	Insufficient resources	

Table 4.5A.18.4-4: DEACTIVATE EPS BEARER CONTEXT ACCEPT (step 12)

Derivation Path: TS 36.508 Table 4.7.3-11			
Information Element	Value/remark	Comment	Condition
EPS bearer identity	(same as in DEACTIVATE EPS BEARER CONTEXT REQUEST of step 10)	The same value as the value set in DEACTIVATE EPS BEARER CONTEXT REQUEST message.	
Procedure transaction identity	0	No procedure transaction identity assigned	

4.5A.19 Generic Test Procedure for IMS MO speech call establishment in E-UTRA / EVS

4.5A.19.1 Initial conditions

See clause 4.5A.6.1.

4.5A.19.2 Definition of system information messages

The default system information messages are used.

4.5A.19.3 Procedure

Table 4.5A.19.3-1: EUTRA/EPS signalling for IMS MO speech call / EVS

St	Procedure	Message Sequence	
		U – S	Message
1-7	Same as table 4.5A.6.3-1, steps 1-7.		
-	EXCEPTION: In parallel to the events described in steps 8 below, the behaviour in table 4.5A.19.3-2 occurs. (IMS MTSI MO speech call establishment)	-	-
8	The UE transmits an <i>RRCCONNECTIONRECONFIGURATIONCOMPLETE</i> message to confirm the establishment of the new data radio bearer, associated with the default EPS bearer context.	-->	RRC: <i>RRCCONNECTIONRECONFIGURATIONCOMPLETE</i>
9-11	Steps 3-4 expected sequence defined in annex C.44 of TS 34.229-1 [35]. MTSI MO speech call for EPS / EVS.	-	-
12	The SS configures a new RLC-UM data radio bearer with condition DRB (0,1), associated with the dedicated EPS bearer context. <i>RRCCONNECTIONRECONFIGURATION</i> message contains the ACTIVATE DEDICATED EPS BEARER CONTEXT REQUEST message. EPS bearer context #4 (QCI 1) according to table 6.6.2-1: Reference dedicated EPS bearer contexts.	<--	RRC: <i>RRCCONNECTIONRECONFIGURATION</i> NAS: ACTIVATE DEDICATED EPS BEARER CONTEXT REQUEST
-	EXCEPTION: In parallel to the events described in steps 13-14 below, the behaviour in table 4.5A.19.3-3 occurs. (IMS MTSI MO speech call establishment)	-	-
13	The UE transmits an <i>RRCCONNECTIONRECONFIGURATIONCOMPLETE</i> message to confirm the establishment of the new data radio bearer, associated with the dedicated EPS bearer.	-->	RRC: <i>RRCCONNECTIONRECONFIGURATIONCOMPLETE</i>
14	The UE transmits an ACTIVATE DEDICATED EPS BEARER CONTEXT ACCEPT message.	-->	RRC: <i>ULINFORMATIONTRANSFER</i> NAS:ACTIVATE DEDICATED EPS BEARER CONTEXT ACCEPT

Table 4.5A.19.3-2: Parallel behaviour

St	Procedure	Message Sequence	
		U - S	Message
1	Step 2 expected sequence defined in annex C.44 of TS 34.229-1 [35]. UE sends INVITE.	-	-

Table 4.5A.19.3-3: Parallel behaviour

St	Procedure	Message Sequence	
		U - S	Message
1-9	Steps 5-13 expected sequence defined in annex C.44 of TS 34.229-1 [35]. MTSI MO speech call for EPS / EVS.	-	-

4.5A.19.4 Specific message contents

All specific message contents shall be referred to clause 4.6 and 4.7.

4.5A.20 Generic Test Procedure for IMS MT speech call establishment in E-UTRA / EVS

4.5A.20.1 Initial conditions

See clause 4.5A.6.1.

4.5A.20.2 Definition of system information messages

The default system information messages are used.

4.5A.20.3 Procedure

Table 4.5A.20.3-1: EUTRA/EPS signalling for IMS MT speech call / EVS

St	Procedure	Message Sequence	
		U - S	Message
1-8	Same as table 4.5A.7.3-1, steps 1-8.		
9-11b	Steps 1-6 expected sequence defined in annex C.45 of TS 34.229-1 [35], MTSI MT speech call for EPS / EVS.	-	-
12-14	Same as table 4.5A.7.3-1, steps 13-15.		
15-16	Void	-	-
17-25	Steps 7-15 expected sequence defined in annex C.45 of TS 34.229-1 [35], MTSI MT speech call for EPS / EVS.	-	-
26	Void	-	-

4.5A.20.4 Specific message contents

All specific message contents shall be referred to clause 4.6 and 4.7.

4.5A.21 Generic Test Procedure for IMS MO Customized Alerting Tones and speech establishment in E-UTRA

4.5A.21.1 Initial conditions

See clause 4.5A.6.1

4.5A.21.2 Definition of system information messages

The default system information messages are used.

4.5A.21.3 Procedure

Table 4.5A.21.3-1: EUTRA/EPS signalling for IMS MO CAT and speech call

St	Procedure	Message Sequence	
		U - S	Message
1-12	See table 4.5A.6.3-1, steps 1-12	-	-
-	EXCEPTION: In parallel to the events described in steps 13-14 below, the behaviour in table 4.5A.21.3-2 occurs. (IMS MTSI MO CAT and speech call establishment)	-	-
13-14	See table 4.5A.6.3-1, steps 13-14	-	-

Table 4.5A.21.3-2: Parallel behaviour

St	Procedure	Message Sequence	
		U - S	Message
1-14	Steps 5-18 expected sequence defined in 20.1.4 of TS 34.229-1 [35]. MTSI MO CAT and speech call for EPS.	-	-

4.5A.21.4 Specific message contents

All specific message contents shall be referred to clause 4.6 and 4.7.

4.5A.22 Communication with the ProSe Function: Initial Access

4.5A.22.1 Initial conditions

System Simulator:

- Parameters are set to the default parameters for the basic single cell environment, as defined in subclause 4.4, unless otherwise specified in the test case.

User Equipment:

- The UE shall be in Registered, Idle Mode state (State 2).

4.5A.22.2 Definition of system information messages

The default system information messages are used.

4.5A.22.3 Procedure

The procedure is only applicable for `pc_Provide_ProSe == true`.

The HTTP signalling between the UE and the ProSe function is done over TLS i.e. the UE connects to TCP port 443 (HTTPS) and starts TLS handshake.

Table 4.5A.22.3-1: Communication with the ProSe Function

St	Procedure	Message Sequence	
		U - S	Message
1	The UE transmits an <code>RRConnectionRequest</code> message with 'establishmentCause' set to 'mo-Data'.	-->	<i>RRConnectionRequest</i>
2	SS transmit an <code>RRConnectionSetup</code> message.	<--	RRC: <i>RRConnectionSetup</i>
3	The UE transmits an <code>RRConnectionSetupComplete</code> message to confirm the successful completion of the connection establishment and to initiate the session management procedure by including the SERVICE REQUEST message.	-->	RRC: <i>RRConnectionSetupComplete</i> NAS: SERVICE REQUEST
4	The SS transmits a <code>SecurityModeCommand</code> message to activate AS security.	<--	RRC: <i>SecurityModeCommand</i>
5	The UE transmits a <code>SecurityModeComplete</code> message and establishes the initial security configuration.	-->	RRC: <i>SecurityModeComplete</i>
6	The SS configures a new data radio bearer, associated with the default EPS bearer context. The <code>RRConnectionReconfiguration</code> message is using condition SRB2-DRB(1, 0). The DRB associated with default EPS bearer context obtained during the attach procedure is established	<--	RRC: <i>RRConnectionReconfiguration</i>
7	The UE transmits an <code>RRConnectionReconfigurationComplete</code> message to confirm the establishment of the new data radio bearer, associated with the default EPS bearer context.	-->	RRC: <i>RRConnectionReconfigurationComplete</i>
8-10	Steps 1-3 of procedure 4.5A.16.3.	-	-
-	EXCEPTION: In parallel to the event described in step 11 below, the behaviour described in Table 4.5A.22.3-2 takes place.	-	-
11	The UE transmits an <code>ACTIVATE DEFAULT EPS BEARER CONTEXT ACCEPT</code> message.	-->	RRC: <i>ULInformationTransfer</i> NAS: <code>ACTIVATE DEFAULT EPS BEARER CONTEXT ACCEPT</code>

Table 4.5A.22.3-2: Parallel behaviour

St	Procedure	Message Sequence	
		U - S	Message
-	EXCEPTION: Step 1a1 describes behaviour that depends on UE configuration; the "lower case letter" identifies a step sequence that take place if the UE does not have a preconfigured IP address.	-	-
1a1	If initiated by the UE the generic procedure for IP address allocation in the U-plane specified in TS 36.508 subclause 4.5A.1 takes place performing IP address allocation in the U-plane.	-	-
2	The UE transmits a ClientHello message including PSK-based ciphersuites.	-->	TLS: ClientHello
3	The SS transmits the ServerHello, ServerKeyExchange and ServerHelloDone messages indicating GBA as required.	<--	TLS: ServerHello TLS: ServerKeyExchange TLS: ServerHelloDone
4-7	The generic procedure for GBA authentication according TS 34.229-1 [43] subclause C.29.2 (steps 1-4) takes place.	-	-
8	The UE transmits the ClientKeyExchange including a PSK identity, ChangeCipherSpec and Finished messages.	-->	TLS: ClientKeyExchange TLS: ChangeCipherSpec TLS: Finished
9	The SS transmits the ChangeCipherSpec and Finished messages.	<--	TLS: ChangeCipherSpec TLS: Finished
-	EXCEPTION: Steps 10a1 to 10d2 describe behaviour which depends on the ProSe Procedure being applied	-	-
10a 1	IF ANNOUNCE/MONITOR REQUEST THEN The UE transmits a DISCOVERY_REQUEST message over the PC3 (UE to ProSe Function) interface.	-->	HTTP Request containing DISCOVERY_REQUEST
10a 2	The SS transmits a DISCOVERY_RESPONSE message over the PC3 (UE to ProSe Function) interface.	<--	HTTP Response containing DISCOVERY_RESPONSE
10a 3	The UE transmits a <i>SidelinkUEInformation</i> message.	-->	<i>SidelinkUEInformation</i>
10b 1	IF MATCH REPORT THEN The UE transmits a MATCH_REPORT message over the PC3 (UE to ProSe Function) interface.	-->	HTTP Request containing MATCH_REPORT
10b 2	The SS transmits a MATCH_REPORT_ACK message over the PC3 (UE to ProSe Function) interface.	<--	HTTP Response containing MATCH_REPORT_ACK
10c 1	IF UREGISTRATION THEN The UE transmits an UE_REGISTRATION_REQUEST message over the PC3 (UE to ProSe Function) interface.	-->	HTTP Request containing UE_REGISTRATION_REQUEST
10c 2	The SS transmits an APPLICATION_REGISTRATION_RESPONSE message with a response-register.	<--	HTTP Response containing UE_REGISTRATION_RESPONSE
10d 1	IF USAGEINFOREPORT THEN The UE transmits an USAGE_INFORMATION_REPORT_LIST message over the PC3ch (UE to ProSe Function) interface.	-->	HTTP Request containing USAGE_INFORMATION_REPORT_LIST
10d 2	SS sends USAGE_INFORMATION_REPORT_LIST_RESPONSE message.	<--	HTTP Response containing USAGE_INFORMATION_REPORT_LIST_RESPONSE

Condition	Explanation
ANNOUNCE/MONITOR REQUEST	Steps applicable to Announce request procedure OR Monitor request procedure
MATCH REPORT	Steps applicable to Match report procedure
UEREISTRATION	Steps applicable to EPC-level ProSe discovery / UE registration procedure
USAGEINFOREPORT	Steps applicable to usage information report list sending procedure.

4.5A.22.4 Specific message contents

HTTP specific message contents shall be referred to clause 4.7E.

ProSe specific message contents shall be referred to clause 4.7F.

TLS specific message contents shall be referred to clause 4.7H.

Further specific message contents shall be referred to clause 4.6 and 4.7.

4.5A.22A Communication with the ProSe Function: Subsequent Access

4.5A.22A.1 Initial conditions

System Simulator:

- Parameters are set to the default parameters for the basic single cell environment, as defined in subclause 4.4, unless otherwise specified in the test case.

User Equipment:

- The UE shall be in Registered Idle Mode state (State 2), or in state Generic RB Established (State 3).
- The Communication with the ProSe Function: Initial Access in subclause 4.5A22 has taken place since the UE was switched on.

4.5A.22A.2 Definition of system information messages

The default system information messages are used.

4.5A.22A.3 Procedure

The procedure is only applicable for `pc_Provide_ProSe == true`.

The HTTP signalling between the UE and the ProSe function is done over an already established TLS connection.

Table 4.5A.22A.3-1: Communication with the ProSe Function

St	Procedure	Message Sequence	
		U - S	Message
-	EXCEPTION: Steps 1a1 to 1a7 describe behaviour that depends on UE configuration; the "lower case letter" identifies a step sequence that takes place if the UE is in RRC_IDLE state.	-	-
1a1	The UE transmits an RRCConnectionRequest message with 'establishmentCause' set to 'mo-Data'.	-->	RRC: RRCConnectionRequest
1a2	SS transmit an RRCConnectionSetup message.	<--	RRC: RRCConnectionSetup
1a3	The UE transmits an RRCConnectionSetupComplete message to confirm the successful completion of the connection establishment and to initiate the session management procedure by including the SERVICE REQUEST message.	-->	RRC: RRCConnectionSetupComplete NAS: SERVICE REQUEST
1a4	The SS transmits a SecurityModeCommand message to activate AS security.	<--	RRC: SecurityModeCommand
1a5	The UE transmits a SecurityModeComplete message and establishes the initial security configuration.	-->	RRC: SecurityModeComplete
1a6	The SS configures two new data radio bearers, associated with the two default EPS bearer contexts. The RRCConnectionReconfiguration message is using condition SRB2-DRB(2, 0).	<--	RRC: RRCConnectionReconfiguration
1a7	The UE transmits an RRCConnectionReconfigurationComplete message to confirm the establishment of the new data radio bearers, associated with the default EPS bearer contexts.	-->	RRC: RRCConnectionReconfigurationComplete
2-10	Void		
-	EXCEPTION: Steps 10a1 to 10d2 describe behaviour which depends on the ProSe Procedure being applied	-	-
10a1-10d2	Steps 10a1-10d2 of Table 4.5A.22.3-2.	-	-

4.5A.22A.4 Specific message contents

HTTP specific message contents shall be referred to clause 4.7E.

ProSe specific message contents shall be referred to clause 4.7F.

Further specific message contents shall be referred to clause 4.6 and 4.7.

4.5A.23 Generic Test Procedure for IMS registration in EPC / WLAN

4.5A.23.1 Initial conditions

System Simulator:

- WLAN Cell 27 according to Table 4.4.8-1 with condition IMSoWLAN.

User Equipment:

- The UE is in state Switched OFF (state 1).

4.5A.23.2 Definition of system information messages

N/A

4.5A.23.3 Procedure

Table 4.5A.23.3-1: IMS registration in EPC / WLAN

St	Procedure	Message Sequence	
		U - S	Message
1	The UE is switched on	-	-
2	The UE associates with the WLAN AP and obtains the local IP address	-	-
3	The UE performs a dynamic selection of ePDG using DNS query	-	-
4	The UE establishes an IPsec tunnel using the IKEv2 protocol as defined in 3GPP TS 33.402 [55] clause 8.2.2, Figure 8.2.2-1.	-	-
5-13	The UE performs the IMS registration procedure according TS 34.229-1 [43] subclause C.2c (steps 2-9).	-	-

4.5A.23.4 Specific message contents

None

4.5A.23A Generic Test Procedure for IPsec Tunnel Disconnection in EPC / WLAN

4.5A.23A.1 Initial conditions

System Simulator:

- WLAN Cell 27 according to Table 4.4.8-1 with condition IMSoWLAN.

User Equipment:

- The UE has established an ePDG Tunnel.

4.5A.23A.2 Definition of system information messages

N/A

4.5A.23A.3 Procedure

Table 4.5A.23A.3-1: Generic Test Procedure for IPsec Tunnel Disconnection in EPC / WLAN

St	Procedure	Message Sequence	
		U - S	Message
1	The UE initiates a disconnection from the existing IPsec tunnel as defined in 3GPP TS 24.302 [53] clause 7.2.4.1, which is acknowledged by the SS.		
NOTE: It is assumed that the WLAN AP association remains throughout the procedure.			

4.5A.23A.4 Specific message contents

None

4.5A.24 Generic Test Procedure for IMS emergency call establishment in EPC / WLAN

4.5A.24.1 Initial conditions

System Simulator:

- WLAN Cell 27 according to Table 4.4.8-1 with condition IMSoWLAN.

User Equipment:

- The UE has selected an ePDG and is registered onto the IMS network according to clause 4.5A.23.

4.5A.24.2 Definition of system information messages

N/A

4.5A.24.3 Procedure

Table 4.5A.24.3-1: IMS emergency call establishment in EPC / WLAN

St	Procedure	Message Sequence	
		U - S	Message
1	The UE is triggered to initiate an emergency call	-	-
2	Void	-	-
3	The UE performs a dynamic selection of an ePDG that supports emergency services using DNS query	-	-
4	The UE establishes an additional IPsec tunnel using the IKEv2 protocol as defined in 3GPP TS 33.402 [55] clause 8.2.2, Figure 8.2.2-1.	-	-
NOTE 1: It is assumed that the WLAN AP association remains throughout the procedure.			
NOTE 2: This procedure is based on 3GPP Release 14.			

4.5A.24.4 Specific message contents

None

4.5A.25 Generic Test Procedure for XCAP establishment in EPC / WLAN

This procedure is applicable only for the case when pc_WLAN_XCAP_without_PDN is set to false.

4.5A.25.1 Initial conditions

System Simulator:

- WLAN Cell 27 according to Table 4.4.8-1 with condition IMSoWLAN.

User Equipment:

- The UE has selected an ePDG and is registered onto the IMS network according to clause 4.5A.23.

4.5A.25.2 Definition of system information messages

N/A

4.5A.25.3 Procedure

Table 4.5A.25.3-1: IMS XCAP establishment in EPC / WLAN

St	Procedure	Message Sequence	
		U - S	Message
1	Make the UE attempt XCAP signalling.	-->	-
2	The UE establishes an additional PDN and IPsec tunnel using the IKEv2 protocol as defined in 3GPP TS 33.402 [55] clause 8.2.2, Figure 8.2.2-1.	-	-

4.5A.25.4 Specific message contents

N/A

4.5A.26 Generic Test Procedure for eCall over IMS establishment in EUTRA:
Normal Service

4.5A.26.1 Initial conditions

System Simulator:

- Parameters are set to the default parameters for the basic single cell environment, as defined in subclause 4.4, unless otherwise specified in the test case.

User Equipment:

- The UE is in state Registered, Idle Mode (State 2)

4.5A.26.2 Definition of system information messages

The default system information messages are used.

4.5A.26.3 Procedure

The establishment of eCall over IMS is assumed to always be mobile originated.

Note: The trigger to initiate MO call will be part of test case from where the generic procedure is called.

Table 4.5A.26.3-1: EUTRA/EPS signalling for eCall over IMS

St	Procedure	Message Sequence	
		U - S	Message
1-8a7	Steps 3 to 10a7 of the generic radio bearer establishment procedure from TS 36.508 subclause 4.5.3.3-3 are executed	-	-
9	The UE transmits a PDN CONNECTIVITY REQUEST message to request an additional PDN, with 'Request type' set to 'emergency ('0100'B)'.	-->	NAS: PDN CONNECTIVITY REQUEST
10	The SS configures a new data radio bearer, associated with the default EPS bearer context. <i>RRCConnectionReconfiguration</i> message contains the ACTIVATE DEFAULT EPS BEARER CONTEXT REQUEST message. EPS bearer context #2 (QCI 5) according to table 6.6.1-1: Reference default EPS bearer context is used. Note: The APN is set to the test APN defined for emergency bearer services.	<--	RRC: <i>RRCConnectionReconfiguration</i> NAS: ACTIVATE DEFAULT EPS BEARER CONTEXT REQUEST
-	EXCEPTION: In parallel to the events described in steps 11 to 15 below, the behaviour in table 4.5A.26.3-2 occurs. (Optional IP address allocation followed by IMS emergency registration and eCall over IMS establishment)	-	-
11	The UE transmits an <i>RRCConnectionReconfigurationComplete</i> message to confirm the establishment of the new data radio bearer, associated with the default EPS bearer for emergency call.	-->	RRC: <i>RRCConnectionReconfigurationComplete</i>
12	The UE transmits an ACTIVATE DEFAULT EPS BEARER CONTEXT ACCEPT message.	-->	RRC: ULInformationTransfer NAS: ACTIVATE DEFAULT EPS BEARER CONTEXT ACCEPT
13	The SS configures a new RLC-UM data radio bearer, associated with the dedicated EPS bearer context. <i>RRCConnectionReconfiguration</i> message contains the ACTIVATE DEDICATED EPS BEARER CONTEXT REQUEST message. EPS bearer context #4 (QCI 1) according to table 6.6.2-1: Reference dedicated EPS bearer contexts is used. Note: the same PDN address is applicable because the linked EPS bearer ID refers to the default EBC allocated in step 2	<--	RRC: <i>RRCConnectionReconfiguration</i> NAS: ACTIVATE DEDICATED EPS BEARER CONTEXT REQUEST
14	The UE transmits an <i>RRCConnectionReconfigurationComplete</i> message to confirm the establishment of the new data radio bearer, associated with the default EPS bearer for emergency IMS signalling.	-->	RRC: <i>RRCConnectionReconfigurationComplete</i>
15	The UE transmits an ACTIVATE DEDICATED EPS BEARER CONTEXT ACCEPT message.	-->	RRC: ULInformationTransfer NAS: ACTIVATE DEDICATED EPS BEARER CONTEXT ACCEPT

Table 4.5A.26.3-2: Parallel behaviour

St	Procedure	Message Sequence	
		U - S	Message
-	EXCEPTION: Step 1 describes behaviour that depends on the UE behaviour.	-	-
1	If initiated by the UE the generic procedure for IP address allocation in the U-plane specified in TS 36.508 subclause 4.5A.1 takes place performing IP address allocation in the U-plane.	-	-
2-5	Steps 1-4 expected sequence defined in annex C.20 of TS 34.229-1 [35]. Emergency registration procedure is performed.	-	-
6-8	Steps 1-3 defined in annex C.47 of TS 34.229-1 [35] Generic Test Procedure for NG eCall setup.	-	-

4.5A.26.4 Specific message contents

All specific message contents shall be referred to clause 4.6 and 4.7 with the exceptions below.

Table 4.5A.26.4-1: PDN CONNECTIVITY REQUEST (step 9, Table 4.5A.26.3-1)

Derivation Path: Table 4.7.3-20			
Information Element	Value/remark	Comment	Condition
Request type	'0100'B	Emergency	
Access point name	Not present or any value		

Table 4.5A.26.4-2: Message ACTIVATE DEFAULT EPS BEARER CONTEXT REQUEST (step 10, Table 4.5A.26.3-1)

Derivation path: Table 4.7.3-6 and table 4.6.1-8 with condition AM-DRB-ADD(2)			
Information Element	Value/Remark	Comment	Condition
Access point name	sos	APN value as recommended by IR.88 clause 6.4 [56]	
EPS QoS	According to reference default EPS bearer context #2 – in table 6.6.1-1	SS defines an additional dedicated EPS QoS	

Table 4.5A.26.4-3: Message ACTIVATE DEDICATED EPS BEARER CONTEXT REQUEST (step 13, Table 4.5A.26.3-1)

Derivation path: Table 4.7.3-3 and table 4.6.1-8 with condition UM-DRB-ADD(3)			
Information Element	Value/Remark	Comment	Condition
Linked EPS bearer identity	Default EBIId-2 (same value like in table 4.5A.4.4-1)		
EPS QoS	According to reference dedicated EPS bearer context #1 - in table 6.6.2-1	SS defines an additional dedicated EPS QoS	
TFT	According to reference dedicated EPS bearer context #1 - in table 6.6.2-1		

4.5A.27 Generic Test Procedure for eCall over IMS establishment in EUTRA: eCall Only Support

4.5A.27.1 Initial conditions

System Simulator:

- Parameters are set to the default parameters for the basic single cell environment, as defined in subclause 4.4, unless otherwise specified in the test case.

User Equipment:

- The UE is in state Switched OFF (State 1).

4.5A.27.2 Definition of system information messages

The default system information messages are used.

4.5A.27.3 Procedure

The establishment of eCall over IMS is assumed to always be mobile originated.

Note: The generic procedure is defined as per TS 23.401 [24] clause 4.3.12.1.

Table 4.5A.27.3-1: EUTRA/EPS signalling for eCall over IMS (eCall only Support)

St	Procedure	Message Sequence	
		U - S	Message
1	The UE is switched on and SS waits 15 sec to allow the UE to camp on the serving cell and enter and remain in substate EMM-DEREGISTERED.eCALL-INACTIVE.	-	-
2	Make the UE attempt an eCall (See Note 1)	-	-
3-18	Steps 1 to 16 of the generic test procedure for UE registration sub clause 4.5.2.3.	-	-
19	The UE transmits a PDN CONNECTIVITY REQUEST message to request an additional PDN, with 'Request type' set to 'emergency ('0100'B)'. Note: The APN is set to the test APN defined for emergency bearer services.	-->	NAS: PDN CONNECTIVITY REQUEST
20	The SS configures a new data radio bearer, associated with the default EPS bearer context. <i>RRCConnectionReconfiguration</i> message contains the ACTIVATE DEFAULT EPS BEARER CONTEXT REQUEST message. EPS bearer context #2 (QCI 5) according to table 6.6.1-1: Reference default EPS bearer context is used. Note: The APN is set to the test APN defined for emergency bearer services.	<--	RRC: <i>RRCConnectionReconfiguration</i> NAS: ACTIVATE DEFAULT EPS BEARER CONTEXT REQUEST
-	EXCEPTION: In parallel to the events described in steps 21 to 25 below, the behaviour in table 4.5A.27.3-2 occurs. (Optional IP address allocation followed by IMS emergency registration and eCall over IMS establishment)	-	-
21	The UE transmits an <i>RRCConnectionReconfigurationComplete</i> message to confirm the establishment of the new data radio bearer, associated with the default EPS bearer for emergency call.	-->	RRC: <i>RRCConnectionReconfigurationComplete</i>
22	The UE transmits an ACTIVATE DEFAULT EPS BEARER CONTEXT ACCEPT message.	-->	RRC: ULInformationTransfer NAS: ACTIVATE DEFAULT EPS BEARER CONTEXT ACCEPT
23	The SS configures a new RLC-UM data radio bearer, associated with the dedicated EPS bearer context. <i>RRCConnectionReconfiguration</i> message contains the ACTIVATE DEDICATED EPS BEARER CONTEXT REQUEST message. EPS bearer context #4 (QCI 1) according to table 6.6.2-1: Reference dedicated EPS bearer contexts is used. Note: the same PDN address is applicable because the linked EPS bearer ID refers to the default EBC allocated in step 2	<--	RRC: <i>RRCConnectionReconfiguration</i> NAS: ACTIVATE DEDICATED EPS BEARER CONTEXT REQUEST
24	The UE transmits an <i>RRCConnectionReconfigurationComplete</i> message to confirm the establishment of the new data radio bearer, associated with the default EPS bearer for emergency IMS signalling.	-->	RRC: <i>RRCConnectionReconfigurationComplete</i>
25	The UE transmits an ACTIVATE DEDICATED EPS BEARER CONTEXT ACCEPT message.	-->	RRC: ULInformationTransfer NAS: ACTIVATE DEDICATED EPS BEARER CONTEXT ACCEPT
Note 1: The request to originate a manual or Automatic eCall may be performed by MMI or AT command.			

Table 4.5A.27.3-2: Parallel behaviour

St	Procedure	Message Sequence	
		U - S	Message
-	EXCEPTION: Step 1 describes behaviour that depends on the UE behaviour.	-	-
1	If initiated by the UE the generic procedure for IP address allocation in the U-plane specified in TS 36.508 subclause 4.5A.1 takes place performing IP address allocation in the U-plane.	-	-
2-5	Steps 1-4 expected sequence defined in annex C.20 of TS 34.229-1 [35]. Emergency registration procedure is performed.	-	-
6-8	Steps 1-3 defined in annex C47 of TS 34.229-1 [35] Generic procedure for NG eCall Setup.	-	-

4.5A.27.4 Specific message contents

All specific message contents shall be referred to clause 4.6 and 4.7 with the exceptions below.

Table 4.5A.27.4-1: PDN CONNECTIVITY REQUEST (step 19)

Derivation Path: Table 4.7.3-20			
Information Element	Value/remark	Comment	Condition
Request type	'0100'B	Emergency	
Access point name	Not present or any value		

Table 4.5A.27.4-2: Message ACTIVATE DEFAULT EPS BEARER CONTEXT REQUEST (step 20, Table 4.5A.27.3-1)

Derivation path: Table 4.7.3-6 and table 4.6.1-8 with condition AM-DRB-ADD(2)			
Information Element	Value/Remark	Comment	Condition
Access point name	sos	APN value as recommended by IR.88 clause 6.4 [56]	
EPS QoS	According to reference default EPS bearer context #2 – in table 6.6.1-1	SS defines an additional dedicated EPS QoS	

Table 4.5A.27.4-3: Message ACTIVATE DEDICATED EPS BEARER CONTEXT REQUEST (step 23, Table 4.5A.27.3-1)

Derivation path: Table 4.7.3-3 and table 4.6.1-8 with condition UM-DRB-ADD(3)			
Information Element	Value/Remark	Comment	Condition
Linked EPS bearer identity	Default EBId-2 (same value like in table 4.5A.4.4-1)		
EPS QoS	According to reference dedicated EPS bearer context #1 - in table 6.6.2-1	SS defines an additional dedicated EPS QoS	
TFT	According to reference dedicated EPS bearer context #1 - in table 6.6.2-1		

4.5A.28 Generic Test Procedure for Converged IP Communications establishment in EUTRA

4.5A.28.1 Initial conditions

System Simulator:

- Parameters are set to the default parameters for the basic single cell environment, as defined in subclause 4.4.

User Equipment:

- The UE is in state Switched OFF (state 1) according to [18].

4.5A.28.2 Definition of system information messages

N/A

4.5A.28.3 Procedure

Table 4.5A.28.3-1: Converged IP Communications service establishment in E-UTRA

St	Procedure	Message Sequence	
		U - S	Message
1	The UE is switched on		
2-16	Steps 2-16 of the generic procedure for UE registration specified in TS 36.508 subclause 4.5.2.3 are performed.	-	-
17-20	Steps 1-4 of the generic procedure to establish an additional PDN Connection specified in TS 36.508 subclause 4.5A.16.		

4.5A.28.4 Specific message contents

All specific message contents shall be referred to clause 4.6 and 4.7 with the exceptions below.

Table 4.5A.26.4-1: PDN CONNECTIVITY REQUEST (step 17)

Derivation Path: Table 4.7.3-20			
Information Element	Value/remark	Comment	Condition
Access point name	Any allowed value	The UE includes a new APN.	

Table 4.5A.28.4-2: Message ACTIVATE DEFAULT EPS BEARER CONTEXT REQUEST (step 18)

Derivation path: Table 4.6.1-8 with condition AM-DRB-ADD(1) for ADD_IMS or with condition AM-DRB-ADD(8) else			
Information Element	Value/Remark	Comment	Condition
EPS bearer identity	'0101'B	arbitrary value used for PDN connectivity being maintained during the test case	ADD_IMS_MultiMedia and SMS
EPS bearer identity	'1100'B	arbitrary value used for additional non-IMS PDN connectivity	ADD_IMS_Advanced_Messaging
Procedure transaction identity	PTI-1	SS re-uses the particular PTI defined by UE for this present additional PDN connectivity request procedure	
EPS QoS	See Reference default EPS bearer context #2 in table 6.6.1-1		
Access point name	APN as provided in ESM INFORMATION RESPONSE or PDN CONNECTIVITY REQUEST		

Condition	Expression	Explanation
ADD_IMS_MultiMedia and SMS	pc_IMS AND pc_Provide_IMS_as_second_APN	UE performs IMS registration for multi-media telephony and SMSoIP first, and IMS registration for advanced messaging services second.
ADD_IMS_Advanced_Messaging	pc_IMS AND NOT pc_Provide_IMS_as_second_APN	UE performs IMS registration for advanced messaging services first, and IMS registration for multi-media telephony and SMSoIP second.

Table 4.5A.28.4-3: Message ACTIVATE DEFAULT EPS BEARER CONTEXT ACCEPT (step 20)

Derivation path: Table 4.7.3-4			
Information Element	Value/Remark	Comment	Condition
EPS bearer identity	(same value as used in step 2)		
Procedure transaction identity	0	No procedure transaction identity assigned	

4.5A.29 Generic Test Procedure for Converged IP Communications establishment in EPC / WLAN

4.5A.29.1 Initial conditions

System Simulator:

- WLAN Cell 27 according to Table 4.4.8-1 in [18].

User Equipment:

- The UE has selected an ePDG and is registered onto the IMS network according to 4.5A.23.

4.5A.29.2 Definition of system information messages

N/A

4.5A.29.3 Procedure

Table 4.5A.29.3-1: Converged IP Communications service establishment in EPC / WLAN

St	Procedure	Message Sequence	
		U - S	Message
1	The UE establishes an IPsec tunnel using the IKEv2 protocol as defined in 3GPP TS 33.402 [55] clause 8.2.2, Figure 8.2.2-1.	-	-
2-9	The UE performs the IMS registration procedure according TS 34.229-1 [43] subclause C.2c (steps 2-9).		
NOTE: It is assumed that the WLAN AP association remains throughout the procedure.			

4.5A.29.4 Specific message contents

FFS

4.6 Default RRC message and information elements contents

This clause contains the default values of common RRC messages and information elements, which unless indicated otherwise in specific clauses of TS 36.521-1 [21], TS 36.521-3 [34], TS 36.523-1 [18] and other clauses in this specification. All the messages and information elements are listed in alphabetical order.

4.6.1 Contents of RRC messages

- *CounterCheck*

Table 4.6.1-0a: CounterCheck

Derivation Path: 36.331 clause 6.2.2			
Information Element	Value/remark	Comment	Condition
CounterCheck ::= SEQUENCE {			
rrc-TransactionIdentifier	RRC-TransactionIdentifier-DL		
criticalExtensions CHOICE {			
c1 CHOICE {			
counterCheck-r8 SEQUENCE {			
drb-CountMSB-InfoList	Set according to specific message content		
nonCriticalExtension SEQUENCE {}	Not present		
}			
}			
}			
}			

– CounterCheckResponse

Table 4.6.1-0b: CounterCheckResponse

Derivation Path: 36.331 clause 6.2.2			
Information Element	Value/remark	Comment	Condition
CounterCheckResponse ::= SEQUENCE {			
rrc-TransactionIdentifier	RRC-TransactionIdentifier-UL		
criticalExtensions CHOICE {			
counterCheckResponse-r8 SEQUENCE {			
drb-CountInfoList	Set according to specific message content		
nonCriticalExtension SEQUENCE {}	Not checked		
}			
}			
}			

– CSFBParametersRequestCDMA2000

Table 4.6.1-1: CSFBParametersRequestCDMA2000

Derivation Path: 36.331 clause 6.2.2			
Information Element	Value/remark	Comment	Condition
CSFBParametersRequestCDMA2000 ::= SEQUENCE {			
criticalExtensions CHOICE {			
csfbParametersRequestCDMA2000-r8 SEQUENCE {			
nonCriticalExtension SEQUENCE {}	Not checked		
}			
}			
}			

– CSFBParametersResponseCDMA2000

Table 4.6.1-2: CSFBParametersResponseCDMA2000

Derivation Path: 36.331 clause 6.2.2			
Information Element	Value/remark	Comment	Condition
CSFBParametersResponseCDMA2000 ::= SEQUENCE {			
rrc-TransactionIdentifier	RRC-TransactionIdentifier-DL		
criticalExtensions CHOICE {			
csfbParametersResponseCDMA2000-r8 SEQUENCE {			
rand	Set according to specific message content		
mobilityParameters	Set according to specific message content		
nonCriticalExtension SEQUENCE {}	Not present		
}			
}			
}			

– *DLInformationTransfer***Table 4.6.1-3: DLInformationTransfer**

Derivation Path: 36.331 clause 6.2.2			
Information Element	Value/remark	Comment	Condition
DLInformationTransfer ::= SEQUENCE {			
rrc-TransactionIdentifier	RRC-TransactionIdentifier-DL		
criticalExtensions CHOICE {			
c1 CHOICE {			
dlInformationTransfer-r8 SEQUENCE {			
dedicatedInfoType CHOICE {			
dedicatedInfoNAS	Set according to specific message content		
}			
nonCriticalExtension SEQUENCE {}	Not present		
}			
}			
}			

– *HandoverFromEUTRAPreparationRequest***Table 4.6.1-4: HandoverFromEUTRAPreparationRequest**

Derivation Path: 36.331 clause 6.2.2			
Information Element	Value/remark	Comment	Condition
HandoverFromEUTRAPreparationRequest ::= SEQUENCE {			
rrc-TransactionIdentifier	RRC-TransactionIdentifier-DL		
criticalExtensions CHOICE {			
c1 CHOICE {			
handoverFromEUTRAPreparationRequest-r8 SEQUENCE {			
cdma2000-Type	type1XRTT		
rand	A random value, generated by the SS		
mobilityParameters	Set according to specific message content		
nonCriticalExtension SEQUENCE {}	Not present		
}			
}			
}			

- LoggedMeasurementConfiguration

Table 4.6.1-4.0A: LoggedMeasurementConfiguration

Derivation Path: 36.331 clause 6.2.2			
Information Element	Value/remark	Comment	Condition
LoggedMeasurementConfiguration-r10 ::= SEQUENCE {			
criticalExtensions CHOICE {			
c1 CHOICE {			
loggedMeasurementConfiguration-r10 SEQUENCE {			
traceReference-r10 SEQUENCE {			
plmn-Identity-r10 SEQUENCE {			
mcc SEQUENCE (SIZE (3)) OF MCC-NMC-Digit	See table 4.4.2-2		
mnc SEQUENCE (SIZE (2..3)) OF MCC-NMC-Digit	See table 4.4.2-2		
}			
traceId-r10	'0EF'H	OCTET STRING (SIZE (3))	
}			
traceRecordingSessionRef-r10	'1A'H	OCTET STRING (SIZE (2))	
tce-Id-r10	'5'H	OCTET STRING (SIZE (1))	
absoluteTimeInfo-r10	Set to value corresponding to the absolute time when the message is sent	BIT STRING (SIZE (48)), see TS 36.331 clause 6.3.6 for format.	
areaConfiguration-r10	Not present		
loggingDuration-r10	min120	ENUMERATED { min10, min20, min40, min60, min90, min120, spare2, spare1}	
loggingInterval-r10	ms10240	ENUMERATED { ms1280, ms2560, ms5120, ms10240, ms20480, ms30720, ms40960, ms61440}	
nonCriticalExtension SEQUENCE {}	Not present		
}			
}			
}			
}			

- *MasterInformationBlock-SL***Table 4.6.1-4A0: *MasterInformationBlock-SL***

Derivation Path: 36.331 clause 6.5.2			
Information Element	Value/remark	Comment	Condition
MasterInformationBlock-SL ::= SEQUENCE {			
sl-Bandwidth-r12	=the value of the corresponding field included in the preconfigured sidelink parameters (i.e. <i>preconfigGeneral</i> in <i>SL-Preconfiguration</i>), Table 6.8.1.1-1		
tdd-ConfigSL-r12 SEQUENCE {			
subframeAssignmentSL-r12	=the value of the corresponding field included in the preconfigured sidelink parameters (i.e. <i>preconfigGeneral</i> in <i>SL-Preconfiguration</i> , Table 6.8.1.1-1)		
}			
directFrameNumber-r12	according to the subframe used to transmit the SLSS		
directSubframeNumber-r12	according to the subframe used to transmit the SLSS		
inCoverage-r12	TRUE	UE is in E-UTRAN coverage	
reserved-r12	000000000000000000		
}			

- *MasterInformationBlock-SL-V2X*

Table 4.6.1-4A1: *MasterInformationBlock-SL-V2X*

Derivation Path: 36.331 clause 6.5.2			
Information Element	Value/remark	Comment	Condition
MasterInformationBlock-SL-V2X-r14 ::= SEQUENCE {			
sl-Bandwidth-r14	=the value of the corresponding field included in the preconfigured sidelink parameters (i.e. <i>SL-V2X-PreconfigFreqInfo-r14</i> in <i>SL-V2X-Preconfiguration</i> , Table 4.10.1.1-1)		
tdd-ConfigSL-r14 SEQUENCE {			
subframeAssignmentSL-r12	=the value of the corresponding field included in the preconfigured sidelink parameters (i.e. <i>SL-V2X-PreconfigFreqInfo-r14</i> in <i>SL-V2X-Preconfiguration</i> , Table 4.10.1.1-1)		
}			
directFrameNumber-r14	according to the subframe used to transmit the SLSS		
directSubframeNumber-r14	according to the subframe used to transmit the SLSS		
inCoverage-r14	TRUE	UE is in E-UTRAN coverage	
reserved-r14	000000000000000000000000		
}			

- *MBMScountingRequest*

Table 4.6.1-4AA: *MBMScountingRequest*

Derivation Path: 36.331 clause 6.2.2			
Information Element	Value/remark	Comment	Condition
MBMScountingRequest-r10 ::= SEQUENCE {			
countingRequestList-r10 SEQUENCE (SIZE (1.. maxServiceCount)) OF SEQUENCE {			
tmgi-r10 SEQUENCE {			
plmn-Id-r9 CHOICE{			
plmn-Index-r9	1		
}			
serviceId-r9	'000000'0	MBMS service ID (TS 24.008 clause 10.5.6.13), OCTET STRING (SIZE (3))	
}			
}			
lateNonCriticalExtension	Not present		
nonCriticalExtension SEQUENCE {	Not present		
}			

– *MBMScountingResponse*

Table 4.6.1-4AB: MBMScountingResponse

Derivation Path: 36.331 clause 6.2.2			
Information Element	Value/remark	Comment	Condition
MBMScountingResponse-r10 ::= SEQUENCE {			
criticalExtensions CHOICE {			
c1 CHOICE{			
countingResponse-r10 OF SEQUENCE {			
mbsfn-AreaIndex-r10	Not present		
countingResponseList-r10 SEQUENCE (SIZE (1... maxServiceCount)) OF SEQUENCE {			
countingResponseService-r10	0		
}			
lateNonCriticalExtension	Not present		
nonCriticalExtension SEQUENCE {}	Not present		
}			
}			
}			
}			

– *MBMSInterestIndication*

Table 4.6.1-4AC: MBMSInterestIndication

Derivation Path: 36.331 clause 6.2.2			
Information Element	Value/remark	Comment	Condition
criticalExtensions CHOICE {			
c1 CHOICE{			
interestIndication-r11 OF SEQUENCE {			
mbms-FreqList-r11[n] SEQUENCE (SIZE (1..maxFreqMBMS-r11)) OF { INTEGER (0..maxEARFCN2) }	The number of entries is set according to specific message content.	INTEGER (0..maxEARFCN2)	
mbms-Priority-r11	Not checked	ENUMERATED {true}	
lateNonCriticalExtension	Not present		
nonCriticalExtension SEQUENCE {}	Not present		MBMS
nonCriticalExtension SEQUENCE {			SC-PTM
mbms-Services-r13 SEQUENCE (SIZE (0..maxMBMS-ServiceListPerUE-r13)) OF SEQUENCE {			
tmgi-r13 SEQUENCE {			
plmn-Id-r9 CHOICE {			
plmn-Index-r9	1		
}			
serviceId-r9	'000001'H	OCTET STRING (SIZE (3))	
}			
}			
nonCriticalExtension SEQUENCE {}	Not present		
}			
}			
}			
}			

Condition	Explanation
MBMS	MBMS cell environment
SC-PTM	SC-PTM cell environment

– *MBSFNAreaConfiguration*

Table 4.6.1-4A: MBSFNAreaConfiguration

Derivation Path: 36.331 clause 6.2.2			
Information Element	Value/remark	Comment	Condition
MBSFNAreaConfiguration-r9 ::= SEQUENCE {			
commonSF-Alloc-r9 SEQUENCE (SIZE			
(1..maxMBSFN-Allocations)) OF SEQUENCE {			
radioframeAllocationPeriod	n4		
radioframeAllocationOffset	1		FDD
	0		TDD
subframeAllocation CHOICE {			
oneFrame	'100000'B		FDD
	'000010'B		TDD
}			
commonSF-AllocPeriod-r9	rf8		
pmch-InfoList-r9 SEQUENCE (SIZE (0..maxPMCH-			
PerMBSFN)) OF SEQUENCE {			
pmch-Config-r9 SEQUENCE {			
sf-AllocEnd-r9	1		
dataMCS-r9	0		
mch-SchedulingPeriod-r9	rf8		
}			
mbms-SessionInfoList-r9 SEQUENCE (SIZE			
(0..maxSessionPerPMCH)) OF SEQUENCE {			
MBMS-SessionInfo-r9 SEQUENCE {			
tmgi-r9 SEQUENCE {			
plmn-Id-r9 CHOICE{			
plmn-Index-r9	1		
}			
serviceld-r9	'000000'O	OCTET STRING	(SIZE (3))
}			
sessionId-r9	Not present		
logicalChannelIdentity-r9	1		
}			
}			
}			

– *MeasurementReport*

Table 4.6.1-5: MeasurementReport

Derivation Path: 36.331 clause 6.2.2			
Information Element	Value/remark	Comment	Condition
MeasurementReport ::= SEQUENCE {			
criticalExtensions CHOICE {			
c1 CHOICE {			
measurementReport-r8 SEQUENCE {			
measResults	Set according to specific		
	message content		
nonCriticalExtension SEQUENCE {}	Not checked		
}			
}			
}			
}			

– *MobilityFromEUTRACommand***Table 4.6.1-6: *MobilityFromEUTRACommand***

Derivation Path: 36.331 clause 6.2.2			
Information Element	Value/remark	Comment	Condition
MobilityFromEUTRACommand ::= SEQUENCE {			
rrc-TransactionIdentifier	RRC-TransactionIdentifier-DL		
criticalExtensions CHOICE {			
c1 CHOICE {			
mobilityFromEUTRACommand-r8 SEQUENCE {			
csFallbackIndicator	Set according to specific message content		
purpose CHOICE {	Set according to specific message content		
handover			
cellChangeOrder			
}			
nonCriticalExtension SEQUENCE {}	Not present		
}			
}			
}			
}			
}			

– *Paging***Table 4.6.1-7: *Paging***

Derivation Path: 36.331 clause 6.2.2			
Information Element	Value/remark	Comment	Condition
Paging ::= SEQUENCE {			
pagingRecordList SEQUENCE (SIZE (1..maxPageRec)) OF SEQUENCE {	1 entry		
ue-Identity[1] CHOICE {			
s-TMSI	Set to the value of the S-TMSI of the UE		
}			
cn-Domain[1]	ps		
}			
systemInfoModification	Not present		
etws-Indication	Not present		
nonCriticalExtension SEQUENCE {}	Not present		
}			

– *RRCConnectionReconfiguration*

Table 4.6.1-8: *RRCConnectionReconfiguration*

Derivation Path: 36.331 clause 6.2.2			
Information Element	Value/remark	Comment	Condition
RRCConnectionReconfiguration ::= SEQUENCE {			
rrc-TransactionIdentifier	RRC-TransactionIdentifier-DL		
criticalExtensions CHOICE {			
c1 CHOICE{			
rrcConnectionReconfiguration-r8 ::= SEQUENCE {			
measConfig	Not present		
	MeasConfig-DEFAULT		MEAS
mobilityControlInfo	Not present		
	MobilityControlInfo-HO		HO, HO-TO-EUTRA
dedicatedInfoNASList	Not present		
	Set according to specific message content		SRB2-DRB(n, m) DRB(n, m) SRB1-SRB2-DRB(n,m) AM-DRB-ADD(bid) UM-DRB-ADD(bid) DRB-REL(bid) DRB-Mod MCG_and_split EN-DC_SRB2-DRB
radioResourceConfigDedicated	Not present		
	RadioResourceConfigDedicated-SRB2-DRB(n, m)		SRB2-DRB(n, m)
	RadioResourceConfigDedicated-DRB(n, m)		DRB(n, m)
	RadioResourceConfigDedicated-AM-DRB-ADD(bid)		AM-DRB-ADD(bid)
	RadioResourceConfigDedicated-UM-DRB-ADD(bid)		UM-DRB-ADD(bid)
	RadioResourceConfigDedicated-DRB-REL(bid)		DRB-REL(bid)
	RadioResourceConfigDedicated-HO		HO
	RadioResourceConfigDedicated-HO-TO-EUTRA(n, m)		HO-TO-EUTRA(n, m)
	RadioResourceConfigDedicated-DRB-Mod		DRB-Mod
	RadioResourceConfigDedicated-SCell_AddMod		SCell_AddMod
	RadioResourceConfigDedicated-PCell-PATTERN		PCell-PATTERN
	RadioResourceConfigDedicated-EN-DC-Split		MCG_and_split
	RadioResourceConfigDedicated-EN-DC_Split_DRB_Rel(bid)		EN-DC_Split_Rel(bid)
	RadioResourceConfigDedicated-EN-DC-SRB2-DRB		EN-DC_SRB2-DRB
securityConfigHO	Not present		

	SecurityConfigHO-DEFAULT		HO, HO-TO-EUTRA
nonCriticalExtension ::= SEQUENCE {			
lateNonCriticalExtension ::= SEQUENCE {			4Rx_PCC
lateNonCriticalExtension	Not present		
nonCriticalExtension ::= SEQUENCE {			
antennaInfoDedicatedPCell-v10i0 ::= SEQUENCE {			
maxLayersMIMO-r10	fourLayers		
}			
nonCriticalExtension SEQUENCE {}	Not present		
}			
}			
nonCriticalExtension ::= SEQUENCE {			
otherConfig-r9	OtherConfig-r9		OtherConfig
fullConfig-r9	Not present		
nonCriticalExtension ::= SEQUENCE {			
sCellToReleaseList-r10	Not present		
sCellToAddModList-r10 ::= SEQUENCE (SIZE (1..maxSCell-r10)) OF	The same number of entries as the configured SCell(s)	<i>n</i> denotes the index of the entry	SCell_AddMod
sCellToAddMod-r10[n]	SCellToAddMod-r10-DEFAULT		
}			
nonCriticalExtension ::= SEQUENCE {			
systemInformationBlockType1Dedicated-r11	Not present		
nonCriticalExtension ::= SEQUENCE {			
wlan-OffloadInfo-r12 CHOICE {}	Not present		
wlan-OffloadInfo-r12 CHOICE {			
release	NULL		WLAN-OffloadRelease
setup ::= SEQUENCE {			WLAN-OffloadSetup
wlan-OffloadConfigDedicated-r12	WLAN-OffloadConfig-DEFAULT		
t350-r12	min10		
}			
}			
scg-Configuration-r12	Not present		
scg-Configuration-r12	SCG-Configuration-r12-DEFAULT		PSCell_Release, PSCell_Mod, PSCell_Add_Split_DRB, PSCell_Add_SCG_DRB
sl-SyncTxControl-r12	Not present		
sl-DiscConfig-r12	Not present		
sl-CommConfig-r12	Not present		
nonCriticalExtension ::= SEQUENCE {}	Not present		
nonCriticalExtension ::= SEQUENCE {			MCG_and_SCG, MCG_and_split, SCG-DRB(n,m), MCG_NR_PDCP, EN-DC_PSCell_Rel, SRB_NR_PDCP
nonCriticalExtension ::= SEQUENCE {			
nonCriticalExtension ::= SEQUENCE {			
nr-Config-r15 CHOICE {			

release			EN-DC_PSCell_Rel
setup SEQUENCE {			MCG_and_SCG, MCG_and_split, SCG-DRB(n,m), MCG_NR_PDCP
endc-ReleaseAndAdd-r15	false		
nr-SecondaryCellGroupConfig-r15	OCTET STRING including the RRCReconfiguration message and the IE secondaryCellGroup according TS 38.508-1 [67], table 4.6.1-3 with condition EN-DC.		MCG_and_SCG,
	OCTET STRING including the RRCReconfiguration message, the IE secondaryCellGroup according TS 38.508-1 [67], table 4.6.1-3 with condition EN-DC and the IE PDCP-Config according TS 38.508-1 [67], table 4.6.3-74 with condition Split.		MCG_and_split
	OCTET STRING including the RRCReconfiguration message and the IE secondaryCellGroup according TS 38.508-1 [67], table [4.8.1-n].		SCG-DRB(n,m)
p-MaxEUTRA-r15	Not present		
}			
}			
sk-Counter-r15	0		
nr-RadioBearerConfig1-r15	OCTET STRING including RadioBearerConfig according TS 38.508-1 [67], [table 4.6.3-n] with condition EN-DC.		MCG_and_SCG, MCG_and_split
	OCTET STRING including RadioBearerConfig according TS 38.508-1 [67], table [4.8.1-n].		SCG-DRB(n,m)
	OCTET STRING including RadioBearerConfig according TS 38.508-1 [67], table [4.8.1-n] with condition MCG_NR_PDCP		MCG_NR_PDCP
	OCTET STRING including RadioBearerConfig according TS 38.508-1 [67], table 4.6.3-100 with condition SRB_NR_PDCP		SRB_NR_PDCP
nr-RadioBearerConfig2-r15	Not present		

tdm-PatternConfig-r15	Not present		
}			
}			
}			
}			
}			
}			
}			
}			
}			
}			
}			
}			
}			
}			

Condition	Explanation
SRB2-DRB(n,m)	Establishment of a SRB and DRB combination with n x AM DRB and m x UM DRB (including establishment of SRB2)
DRB(n,m)	Establishment of additional n x AM DRB:s and m x UM DRB:s (SRB2 should already be established)
AM-DRB-ADD(bid)	Establishment of a single additional AM DRB with bearer identity bid (SRB2 should already be established)
UM-DRB-ADD(bid)	Establishment of a single additional UM DRB with bearer identity bid (SRB2 should already be established)
DRB-REL(bid)	Release of the DRB with bearer identity bid
HO	Intra LTE handover
MEAS	A measurement is configured
HO-TO-EUTRA(n,m)	Inter-RAT handover to E-UTRA including the establishment of a SRB1, SRB2 and n x AM DRB plus m x UM DRB
<i>nonFullConfig</i>	The field is not present in case of handover within E-UTRA when the <i>fullConfig</i> is included or in case of handover of handover to E-UTRA; otherwise it is optional present, need ON.
DRB-Mod	Modification of already established DRB ID 2 and is used for sending Modify EPS Bearer Context Request message (SRB2 should already be established)
SCell_AddMod	Addition or modification of SCell(s)
PCell-PATTERN	eICIC Serving Cell Pattern
OtherConfig	Other Configuration is configured
WLAN-OffloadSetup	When Dedicated WLAN Offload parameters need to be configured in UE
WLAN-OffloadRelease	When Dedicated WLAN Offload parameters need to be released in UE
PSCell_Mod	Modification of PSCell(s)
PSCell_Release	Release of PSCell
PSCell_Add_Split_DRB	Add PSCell(s) and setup of Split DRB
PSCell_Add_SCG_DRB	Add PSCell(s) and setup of SCG DRB
4Rx_PCC	For 4Rx testcases with more than 2 Layers on PCC
MCG_and_SCG	EN-DC with MCG and SCG.
MCG_and_split	EN-DC with MCG and split.
SCG-DRB(n,m)	EN-DC establishment of additional n x AM DRB:s and m x UM DRB:s in SCG.
EN-DC_PSCell_Rel	Release of EN-DC PSCell
EN-DC_Split_Rel(bid)	Release of E-UTRA leg of EN-DC Split DRB with bearer identity bid
MCG_NR_PDCP	EN-DC configuration of MCG DRB with NR PDCP.
SRB_NR_PDCP	EN-DC configuration of SRB1 and SRB2 with NR PDCP.
EN-DC_SRB2-DRB	Establishment of SRB2 and DRB combination for EN-DC

– *RRCConnectionReconfiguration (SideLink)*

Table 4.6.1-8A: *RRCConnectionReconfiguration (SideLink)*

Derivation Path: 36.508 table 4.6.1-8			
Information Element	Value/remark	Comment	Condition
RRCConnectionReconfiguration ::= SEQUENCE {			
criticalExtensions CHOICE {			
c1 CHOICE {			
rrcConnectionReconfiguration-r8 SEQUENCE {			
nonCriticalExtension SEQUENCE {			
nonCriticalExtension SEQUENCE {			
nonCriticalExtension SEQUENCE {			
nonCriticalExtension SEQUENCE {			
sl-SyncTxControl-r12 SEQUENCE {			
networkControlledSyncTx-r12	off	This field indicates whether the UE shall transmit synchronisation information (i.e. become synchronisation source). Value On indicates the UE to transmit synchronisation information while value Off indicates the UE to not transmit such information.	
}			
}			
}			
}			
sl-DiscConfig-r12 SEQUENCE {			DISC
discTxResources-r12 CHOICE {			
release	NULL		RELEASE
setup CHOICE {			SETUP
scheduled-r12 SEQUENCE {			SCHEDULE D
discTxConfig-r12 SEQUENCE {			
cp-Len-r12	normal		
discPeriod-r12	rf32		
numRetx-r12	0		
numRepetition-r12	1		
tf-ResourceConfig-r12 SEQUENCE {			
prb-Num-r12	12		BW5
	24		BW10
prb-Start-r12	0		
prb-End-r12	23		BW5
	48		BW10
offsetIndicator-r12	160	small-r12	FDD
	163		TDD
subframeBitmap-r12	00000000 11000000 00000000 00000000 00000000	bs40-r12	FDD
	00000000 11000000	bs16-r12	TDD
}			
}			
}			
txParameters-r12 SEQUENCE {			
txParametersGeneral-r12			
SEQUENCE {			
alpha-r12	al0		
p0-r12	31		
}			
ue-SelectedResourceConfig-r12	Not present		
}			
rxParameters-r12	Not present		

} discTF-IndexList-r12 SEQUENCE (SIZE (1..maxSL-TF-IndexPair-r12)) OF SL-TF-IndexPair-r12 {			
SL-TF-IndexPair-r12[1] SEQUENCE			
{			
discSF-Index-r12	1	INTEGER (1..200)	
discPRB-Index-r12	1	INTEGER (1.. 50)	
}			
}			
discHoppingConfig-r12 SEQUENCE {			
a-r12	1	INTEGER (1..200) Per cell parameter: $N_{PSDCH}^{(1)}$ see TS 36.213 [29, 14.3.1].	
b-r12	1	INTEGER (1..10) Per UE parameter: $N_{PSDCH}^{(2)}$ see TS 36.213 [29, 14.3.1].	
c-r12	n1	ENUMERATED {n1, n5} Per cell parameter: $N_{PSDCH}^{(3)}$ see TS36.213 [29, 14.3.1]	
}			
}			
ue-Selected-r12 SEQUENCE {			UE-SELECTED
discTxPoolDedicated-r12 SEQUENCE {			
poolToReleaseList-r12 SEQUENCE (SIZE (1..maxSL-TxPool-r12)) OF SL-TxPoolIdentity-r12 {			RELEASE
SL-TxPoolIdentity-r12[1]	1		
}			
poolToAddModList-r12 SEQUENCE (SIZE (1..maxSL-TxPool-r12)) OF SL-DiscTxPoolToAddMod-r12		2 TxPools	SETUP
SL-DiscTxPoolToAddMod-r12[1] ::= SEQUENCE {		TxPool 1	
poolIdentity-r12	1		
pool-r12 SEQUENCE {			
cp-Len-r12	normal		
discPeriod-r12	rf32		
numRetx-r12	0		
numRepetition-r12	1		
tf-ResourceConfig-r12			
SEQUENCE {			
prb-Num-r12	12		BW5
	24		BW10
prb-Start-r12	0		
prb-End-r12	23		BW5
	48		BW10
offsetIndicator-r12	160	small-r12	FDD
	163		TDD

subframeBitmap-r12	00000000 00110000 00000000 00000000 00000000	bs40-r12	FDD
	00000000 00110000	bs16-r12	TDD
}			
txParameters-r12 SEQUENCE {			
txParametersGeneral-r12			
SEQUENCE {			
alpha-r12	al0		
p0-r12	31		
}			
ue-SelectedResourceConfig-r12 SEQUENCE {			
poolSelection-r12		<i>rsrpBased-r12</i>	
SEQUENCE {			
threshLow-r12	3	-90dBm	
threshHigh-r12	4	-80dBm	
}			
txProbability-r12	p100	100% the probability of transmitting announcement in a discovery period when configured with a pool of resources	
}			
}			
rxParameters-r12	Not present		
}			
}			
SL-DiscTxPoolToAddMod-r12[2]		TxPool 2	
::= SEQUENCE {			
poolIdentity-r12	2		
pool-r12 SEQUENCE {			
cp-Len-r12	normal		
discPeriod-r12	rf32		
numRetx-r12	0		
numRepetition-r12	1		
tf-ResourceConfig-r12			
SEQUENCE {			
prb-Num-r12	12		BW5
	24		BW10
prb-Start-r12	0		
prb-End-r12	23		BW5
	48		BW10
offsetIndicator-r12	160	small-r12	FDD
	163		TDD
subframeBitmap-r12	00000000 00000011 00000000 00000000 00000000	bs40-r12	FDD
	00000000 00000011	bs16-r12	TDD
}			
txParameters-r12 SEQUENCE {			
txParametersGeneral-r12			
SEQUENCE {			
alpha-r12	al0		
p0-r12	31		
}			

ue-SelectedResourceConfig- r12 SEQUENCE {			
poolSelection-r12		<i>rsrpBased-r12</i>	
SEQUENCE {			
threshLow-r12	4	-80dBm	
threshHigh-r12	5	-70dBm	
}			
txProbability-r12	p100	100% the probability of transmitting announcement in a discovery period when configured with a pool of resources	
}			
}			
rxParameters-r12	Not present		
}			
}			
}			
}			
}			
}			
}			
discTF-IndexList-v1260 CHOICE {			
release	NULL		
setup SEQUENCE {			
discTF-IndexList-r12b SEQUENCE (SIZE (1..maxSL-TF-IndexPair-r12)) OF SL-TF- IndexPair-r12b			
SL-TF-IndexPair-r12b[1] SEQUENCE			
{			
discSF-Index-r12b	1	INTEGER (1..209)	
discPRB-Index-r12b	1	INTEGER (1.. 49)	
}			
}			
}			
}			
}			
sl-DiscConfig-r12	Not Present		COMM
sl-CommConfig-r12	Not Present		DISC
sl-CommConfig-r12 SEQUENCE {			COMM
commTxResources-r12 CHOICE {			
release	NULL		RELEASE
setup CHOICE {			SETUP
scheduled-r12 SEQUENCE {			SCHEDULE D
}			
}			
}			
sl-RNTI-r12	'1FF1'H		
mac-MainConfig-r12 SEQUENCE {			
periodic-BSR-TimerSL	sf20		
retx-BSR-TimerSL	sf320		
}			

sc-CommTxConfig-r12 SEQUENCE {		SL-CommResourcePool-r12 Indicates a pool of resources for SC when E-UTRAN schedules Tx resources (i.e. when indices included in DCI format 5 indicate the actual data resources to be used as specified in TS 36.212 [61, 5.3.3.1.9]).	
sc-CP-Len-r12	normal		
sc-Period-r12	sf40		
sc-TF-ResourceConfig-r12 SEQUENCE {			
prb-Num-r12	13 25		BW5 BW10
prb-Start-r12	0		
prb-End-r12	24 49		BW5 BW10
offsetIndicator-r12	0	small-r12	
subframeBitmap-r12	00000000 11000000 00000000 00000000 00000000	bs40-r12	FDD
}			
data-CP-Len-r12	normal		
dataHoppingConfig-r12 SEQUENCE {			
hoppingParameter-r12	0		
numSubbands-r12	ns1		
rb-Offset-r12	0		
}			
ue-SelectedResourceConfig-r12	Not present		
rxParametersNCell-r12	Not present		
txParameters-r12	Not present		
}			
mcs-r12	0		
}			
ue-Selected-r12 SEQUENCE {			UE-SELECTED
commTxPoolNormalDedicated-r12 SEQUENCE {			
poolToReleaseList-r12 SEQUENCE (SIZE (1..maxSL-TxPool-r12)) OF SL-TxPoolIdentity-r12 {			RELEASE
SL-TxPoolIdentity-r12[1]	1	INTEGER (1..maxSL-TxPool-r12)	
}			
poolToAddModList-r12 SEQUENCE (SIZE (1..maxSL-TxPool-r12)) OF SL-CommTxPoolToAddMod-r12		1 TxPool	SETUP
SL-CommTxPoolToAddMod-r12[1]		TxPool 1	
::= SEQUENCE {			
poolIdentity-r12	1	INTEGER (1..maxSL-TxPool-r12)	
pool-r12 SEQUENCE {			
sc-CP-Len-r12	normal		

	sc-Period-r12	sf40		
	sc-TF-ResourceConfig-r12			
SEQUENCE {				
	prb-Num-r12	13		BW5
		25		BW10
	prb-Start-r12	0		
	prb-End-r12	24		BW5
		49		BW10
	offsetIndicator-r12	0	small-r12	
	subframeBitmap-r12	00000011 00000000 00000000 00000000 00000000	bs40-r12	FDD
	}			
	data-CP-Len-r12	normal		
SEQUENCE {	dataHoppingConfig-r12			
	hoppingParameter-r12	0		
	numSubbands-r12	ns1		
	rb-Offset-r12	0		
	}			
SEQUENCE {	ue-SelectedResourceConfig-r12			
SEQUENCE {	data-TF-ResourceConfig-r12			
	prb-Num-r12	13		BW5
		25		BW10
	prb-Start-r12	0		
	prb-End-r12	24		BW5
		49		BW10
	offsetIndicator-r12	0	small-r12	
	subframeBitmap-r12	00000000 00000000 00000011 11000000 00000000	bs40-r12	FDD
	}			
	trpt-Subset-r12	001		
	}			
	rxParametersNCell-r12	Not present		
	txParameters-r12	Not present		
	}			
	}			
	}			
	}			
	}			
	}			
	}			
	nonCriticalExtension SEQUENCE {}			
	}			
	}			
	}			
	}			
	}			
	}			
	}			
	}			

Condition	Explanation
-----------	-------------

DISC	Only SideLink Discovery configuration provided
COMM	Only SideLink Communication configuration provided
RELEASE	Release Discovery/Communication Resources
SETUP	Setup Discovery/Communication Resources
SCHEDULED	The resources the UE can use are scheduled by the NW.
UE-SELECTED	The resources the UE can use are to be selected by the UE from set of resources provided by the NW.
FDD	FDD cell environment
TDD	TDD cell environment (TDD config 1)

– *RRCCONNECTIONRECONFIGURATION (V2X)*

Table 4.6.1-8B: RRCCONNECTIONRECONFIGURATION (V2X)

Derivation Path: 36.508 table 4.6.1-8			
Information Element	Value/remark	Comment	Condition
RRCCONNECTIONRECONFIGURATION ::= SEQUENCE {			
criticalExtensions CHOICE {			
c1 CHOICE {			
rrcConnectionReconfiguration-r8 SEQUENCE {			
nonCriticalExtension SEQUENCE {			
nonCriticalExtension SEQUENCE {			
nonCriticalExtension SEQUENCE {			
nonCriticalExtension SEQUENCE {			
nonCriticalExtension SEQUENCE {			
nonCriticalExtension SEQUENCE {			
sl-V2X-ConfigDedicated-r14	SL-V2X-ConfigDedicated-r14-DEFAULT condition SCHEDULED and SETUP		
sCellToAddModListExt-v14xy	Not present		
perCC-GapIndicationRequest-r14	Not present		
systemInformationBlockType2Dedicated-r14	Not present		
nonCriticalExtension SEQUENCE {}	Not present		
}			
}			
}			
}			
}			
}			
}			
}			
}			

RRCConnectionReconfigurationComplete

Table 4.6.1-9: RRCConnectionReconfigurationComplete

Derivation Path: 36.331 clause 6.2.2			
Information Element	Value/remark	Comment	Condition
RRCConnectionReconfigurationComplete ::= SEQUENCE {			
rrc-TransactionIdentifier	RRC-TransactionIdentifier-UL		
criticalExtensions CHOICE {			
rrcConnectionReconfigurationComplete-r8			
SEQUENCE {			
nonCriticalExtension SEQUENCE {}	Not checked		
nonCriticalExtension SEQUENCE {			MCG_and_SCG, MCG_and_spli, SCG-DRB(n,m)
nonCriticalExtension SEQUENCE {			
nonCriticalExtension SEQUENCE {			
nonCriticalExtension SEQUENCE {			
nonCriticalExtension SEQUENCE {			
nonCriticalExtension SEQUENCE {			
scg-ConfigResponseNR-r15	OCTET STRING including the RRCReconfiguration message according TS 38.508-1 [67], table 4.6.1-4.		
}			
}			
}			

Condition	Explanation
-----------	-------------

MCG_and_SCG	EN-DC with MCG and SCG.
MCG_and_split	EN-DC with MCG and split.
SCG-DRB(n,m)	EN-DC establishment of additional n x AM DRB:s and m x UM DRB:s in SCG.

– *RRCCONNECTIONREESTABLISHMENT*

Table 4.6.1-10: RRCCONNECTIONREESTABLISHMENT

Derivation Path: 36.331 clause 6.2.2			
Information Element	Value/remark	Comment	Condition
RRCCONNECTIONREESTABLISHMENT ::= SEQUENCE {			
rrc-TransactionIdentifier	RRC-TransactionIdentifier-DL		
criticalExtensions CHOICE {			
c1 CHOICE {			
rrcConnectionReestablishment-r8 SEQUENCE {			
radioResourceConfigDedicated	RadioResourceConfigDedicated-SRB1		
nextHopChainingCount	0		
nonCriticalExtension SEQUENCE {}	Not present		
}			
}			
}			

– *RRCCONNECTIONREESTABLISHMENTCOMPLETE*

Table 4.6.1-11: RRCCONNECTIONREESTABLISHMENTCOMPLETE

Derivation Path: 36.331 clause 6.2.2			
Information Element	Value/remark	Comment	Condition
RRCCONNECTIONREESTABLISHMENTCOMPLETE ::= SEQUENCE {			
rrc-TransactionIdentifier	RRC-TransactionIdentifier-UL		
criticalExtensions CHOICE {			
rrcConnectionReestablishmentComplete-r8 SEQUENCE {			
nonCriticalExtension SEQUENCE {}	Not checked		
}			
}			
}			

– *RRCCONNECTIONREESTABLISHMENTREJECT*

Table 4.6.1-12: RRCCONNECTIONREESTABLISHMENTREJECT

Derivation Path: 36.331 clause 6.2.2			
Information Element	Value/remark	Comment	Condition
RRCCONNECTIONREESTABLISHMENTREJECT ::= SEQUENCE {			
criticalExtensions CHOICE {			
rrcConnectionReestablishmentReject-r8 SEQUENCE {			
nonCriticalExtension SEQUENCE {}	Not present		
}			
}			
}			

– *RRCCConnectionReestablishmentRequest*

Table 4.6.1-13: RRCCConnectionReestablishmentRequest

Derivation Path: 36.331 clause 6.2.2			
Information Element	Value/remark	Comment	Condition
RRCCConnectionReestablishmentRequest ::= SEQUENCE {			
criticalExtensions CHOICE {			
rrcConnectionReestablishmentRequest-r8			
SEQUENCE {			
ue-Identity	Set according to specific message content		
reestablishmentCause	Set according to specific message content		
spare	Present but contents not checked		
}			
}			
}			

– *RRCCConnectionReject*

Table 4.6.1-14: RRCCConnectionReject

Derivation Path: 36.331 clause 6.2.2			
Information Element	Value/remark	Comment	Condition
RRCCConnectionReject ::= SEQUENCE {			
criticalExtensions CHOICE {			
c1 CHOICE {			
rrcConnectionReject-r8 SEQUENCE {			
waitTime	3(seconds)		
nonCriticalExtension SEQUENCE {}	Not present		
}			
}			
}			
}			

– *RRCCoNNECTIONRelease*

Table 4.6.1-15: RRCCoNNECTIONRelease

Derivation Path: 36.331 clause 6.2.2			
Information Element	Value/remark	Comment	Condition
RRCCoNNECTIONRelease ::= SEQUENCE {			
rrc-TransactionIdentifier	RRC-TransactionIdentifier-DL		
criticalExtensions CHOICE {			
c1 CHOICE {			
rrcCoNNECTIONRelease-r8 SEQUENCE {			
releaseCause	other		
	rrc-Suspend		UP-CIoT
redirectedCarrierInfo	Not present		
idleModeMobilityControllInfo	Not present		
nonCriticalExtension SEQUENCE {}	Not present		
nonCriticalExtension SEQUENCE {}			UP-CIoT
nonCriticalExtension SEQUENCE {}			
nonCriticalExtension SEQUENCE {}			
nonCriticalExtension SEQUENCE {}			
resumeIdentity-r13	A valid value, calculated by the SS	BIT STRING (SIZE(40))	
}			
}			
}			
}			

Condition	Explanation
UP-CIoT	User plane Clot

– *RRCCoNNECTIONRequest*

Table 4.6.1-16: RRCCoNNECTIONRequest

Derivation Path: 36.331 clause 6.2.2			
Information Element	Value/remark	Comment	Condition
RRCCoNNECTIONRequest ::= SEQUENCE {			
criticalExtensions CHOICE {			
rrcCoNNECTIONRequest-r8 SEQUENCE {			
ue-Identity CHOICE {			
s-TMSI	Any allowed value		
}			
establishmentCause	Present but contents not checked		
spare	Present but contents not checked		
}			
}			
}			

RRCConnectionResume

Table 4.6.1-16A: RRCConnectionResume

Derivation Path: 36.331 clause 6.2.2			
Information Element	Value/remark	Comment	Condition
RRCConnectionResume-r13 ::= SEQUENCE {			
rrc-TransactionIdentifier	RRC-TransactionIdentifier-DL		
criticalExtensions CHOICE {			
c1 CHOICE {			
rrcConnectionResume-r13 SEQUENCE {			
radioResourceConfigDedicated-r13	RadioResourceConfigDedicated-SRB2-DRB(1, 0)		
nextHopChainingCount-r13	0		
measConfig-r13	Not present		
antennaInfoDedicatedPCell-r13	Not present		
drb-ContinueROHC-r13	Not present		
lateNonCriticalExtension	Not present		
nonCriticalExtension SEQUENCE {}	Not present		
}			
}			
}			
}			

RRCConnectionResumeComplete

Table 4.6.1-16B: RRCConnectionResumeComplete

Derivation Path: 36.331 clause 6.2.2			
Information Element	Value/remark	Comment	Condition
RRCConnectionResumeComplete-r13 ::= SEQUENCE {			
rrc-TransactionIdentifier	RRC-TransactionIdentifier-UL		
criticalExtensions CHOICE {			
rrcConnectionResumeComplete-r13 SEQUENCE {			
selectedPLMN-Identity-r13	Not checked		
dedicatedInfoNAS-r13	Not checked		
r1f-InfoAvailable-r13	Not checked		
logMeasAvailable-r13	Not checked		
connEstFailInfoAvailable-r13	Not checked		
mobilityState-r13	Normal		
mobilityHistoryAvail-r13	Not checked		
logMeasAvailableMBSFN-r13	Not checked		
lateNonCriticalExtension	Not checked		
nonCriticalExtension SEQUENCE {}	Not checked		
}			
}			
}			

– *RRCCONNECTIONRESUMEREQUEST*

Table 4.6.1-16C: RRCCONNECTIONRESUMEREQUEST

Derivation Path: 36.331 clause 6.2.2			
Information Element	Value/remark	Comment	Condition
RRCCONNECTIONRESUMEREQUEST-r13 ::= SEQUENCE {			
criticalExtensions CHOICE {			
rrcConnectionResumeRequest-r13 SEQUENCE {			
resumeIdentity-r13 CHOICE {			
truncatedResumeID-r13	Present but contents not checked		
}			
shortResumeMAC-I-r13	Present but contents not checked		
resumeCause-r13	mt-Access		
spare	Present but contents not checked		
}			
}			
}			

– *RRCCONNECTIONSETUP*

Table 4.6.1-17: RRCCONNECTIONSETUP

Derivation Path: 36.331 clause 6.2.2			
Information Element	Value/remark	Comment	Condition
RRCCONNECTIONSETUP ::= SEQUENCE {			
rrc-TransactionIdentifier	RRC-TransactionIdentifier-DL		
criticalExtensions CHOICE {			
c1 CHOICE {			
rrcConnectionSetup-r8 SEQUENCE {			
radioResourceConfigDedicated	RadioResourceConfigDedicated-SRB1		
nonCriticalExtension SEQUENCE {}	Not present		
}			
}			
}			
}			

RRCConnectionSetupComplete

Table 4.6.1-18: RRCConnectionSetupComplete

Derivation Path: 36.331 clause 6.2.2			
Information Element	Value/remark	Comment	Condition
RRCConnectionSetupComplete ::= SEQUENCE {			
rrc-TransactionIdentifier	RRC-TransactionIdentifier-UL		
criticalExtensions CHOICE {			
c1 CHOICE {			
rrcConnectionSetupComplete-r8 SEQUENCE {			
selectedPLMN-Identity	1		
registeredMME	Not checked		
dedicatedInfoNAS	Present but contents not checked		
nonCriticalExtension SEQUENCE {}	Not checked		
nonCriticalExtension SEQUENCE {			UP-CIoT or CP-CIoT
nonCriticalExtension SEQUENCE {			
nonCriticalExtension SEQUENCE {			
up-CIoT-EPS-Optimisation-r13	true		UP-CIoT
cp-CIoT-EPS-Optimisation-r13	true		CP-CIoT
}			
}			
}			
}			
}			
}			
}			

Condition	Explanation
UP-CIoT	If user plane CloT supported (TS 36.523-2, A.4.4-1/132). Note 1: This condition is only applicable if also condition CloT-test apply.
CP-CIoT	If control plane CloT supported (TS 36.523-2, A.4.4-1/nnn). Note 1: This condition is only applicable if also condition CloT-test apply.

– *SCGFailureInformationNR*

Table 4.6.1-18AA: *SCGFailureInformationNR*

Derivation Path: 36.331 clause 6.2.2			
Information Element	Value/remark	Comment	Condition
SCGFailureInformationNR-r15 ::= SEQUENCE {			
criticalExtensions CHOICE {			
c1 CHOICE {			
sgsFailureInformationNR-r15-IEs SEQUENCE {			
failureReportSCG-NR-r15 SEQUENCE {			
failureType-r15	Any allowed value	t310-Expiry, OR randomAccessPro blem, OR rlc-MaxNumRetx, OR scg- ChangeFailure, OR scg- reconfigFailure, OR srb3- IntegrityFailure	
measResultFreqListFailNR-r15 SEQUENCE (SIZE (1..maxFreqNR-r15)) OF SEQUENCE {	<i>n</i> entries of MeasResultFreqFailNR- r15	<i>n</i> denotes the number of NR frequencies the UE is configured to measure by measConfig	
MeasResultFreqFailNR-r15 SEQUENCE {	entry [1]		
carrierFreq-r15	Downlink ARFCN of ssbFrequency	ARFCN-ValueNR- r15	
measResultCellListNR-r15 SEQUENCE (SIZE (1..maxCellReport)) OF SEQUENCE {	<i>n</i> entries of MeasResultCellNR-r15	<i>n</i> denotes the number of reported cells/CSI-RS resources	
MeasResultCellNR-r15 SEQUENCE {	entry [1]		
PhysCellIdNR-r15	INTEGER (0.. 1007)	the physical layer identity (PCI) of an NR cell	
MeasResultNR-r15 SEQUENCE {			
RSRP-RangeNR-r15	as specified in TS 38.508-1 [67], Table 4.6.3-114	Integer value for RSRP measurements	
RSRQ-RangeNR-r15	as specified in TS 38.508-1 [67], Table 4.6.3-115	Integer value for RSRQ measurements	
RS-SINR-RangeNR-r15	as specified in TS 38.508-1 [67], Table 4.6.3-130	Integer value for SINR measurements	
}			
MeasResultSSB-IndexList-r15 SEQUENCE (SIZE (1..maxRS-IndexReport-r15)) OF SEQUENCE {	<i>n</i> entries of MeasResultSSB-Index- r15	<i>n</i> denotes the number of RS indices for RRM	
MeasResultSSB-Index-r15 SEQUENCE {	entry [1]		
RS-IndexNR-r15	INTEGER (0.. maxRS- Index-1-r15)		
MeasResultNR-r15 SEQUENCE {			
RSRP-RangeNR-r15	as specified in TS 38.508-1 [67], Table 4.6.3-114	Integer value for RSRP measurements	
RSRQ-RangeNR-r15	as specified in TS 38.508-1 [67], Table 4.6.3-115	Integer value for RSRQ measurements	
RS-SINR-RangeNR-r15	as specified in TS 38.508-1 [67], Table 4.6.3-130	Integer value for SINR measurements	
}			
}			

...		<i>MeasResultSSB-Index-r15</i> entry [x] if any	
}			
}			
...		<i>MeasResultCellNR-r15</i> entry [x] if any	
}			
}			
...			
}			
measResultSCG-r15	containing the NR <i>MeasResultSCG-Failure</i> IE as specified in TS 38.508-1 [67], Table 4.6.3-59		
}			
nonCriticalExtension SEQUENCE {}			
}			
}			
criticalExtensionsFuture SEQUENCE {}			
}			
}			

– SCPTMConfiguration

Table 4.6.1-18a: SCPTMConfiguration

Derivation Path: 36.331 clause 6.2.2			
Information Element	Value/remark	Comment	Condition
SCPTMConfiguration-r13 ::= SEQUENCE {			
sc-mtch-InfoList-r13 SEQUENCE (SIZE (0..maxSC-MTCH-r13)) OF SEQUENCE {			
mbmsSessionInfo-r13 SEQUENCE {			
tmgi-r13 SEQUENCE {			
plmn-Id-r9 CHOICE {			
plmn-Index-r9	1		
}			
}			
serviceld-r9	'000001'H	OCTET STRING (SIZE (3))	
}			
sessionId-r13	Not present		
}			
g-RNTI-r13	'0100'H		
sc-mtch-schedulingInfo-r13 SEQUENCE {			
on-DurationTimerSCPTM-r13	Not present		
drx-InactivityTimerSCPTM-r13	Not present		
schedulingPeriodStartOffsetSCPTM-r13 CHOICE {			
sf20	Not present		
}			
}			
sc-mtch-neighbourCell-r13	Not present		
}			
scptm-NeighbourCellList-r13 SEQUENCE (SIZE (1..maxNeighCell-SCPTM-r13)) OF SEQUENCE {			
physCellId-r13	Not present		
carrierFreq-r13	Not present		
}			
lateNonCriticalExtension	Not present		
nonCriticalExtension SEQUENCE {}	Not present		
}			

– *SecurityModeCommand***Table 4.6.1-19: SecurityModeCommand**

Derivation Path: 36.331 clause 6.2.2			
Information Element	Value/remark	Comment	Condition
SecurityModeCommand ::= SEQUENCE {			
rrc-TransactionIdentifier	RRC-TransactionIdentifier-DL		
criticalExtensions CHOICE {			
c1 CHOICE{			
securityModeCommand-r8 SEQUENCE {			
securityConfigSMC	SecurityConfigSMC-DEFAULT		
nonCriticalExtension SEQUENCE {}	Not present		
}			
}			
}			
}			

– *SecurityModeComplete***Table 4.6.1-20: SecurityModeComplete**

Derivation Path: 36.331 clause 6.2.2			
Information Element	Value/remark	Comment	Condition
SecurityModeComplete ::= SEQUENCE {			
rrc-TransactionIdentifier	RRC-TransactionIdentifier-UL		
criticalExtensions CHOICE {			
securityModeComplete-r8 SEQUENCE {			
nonCriticalExtension SEQUENCE {}	Not checked		
}			
}			
}			

– *SecurityModeFailure***Table 4.6.1-21: SecurityModeFailure**

Derivation Path: 36.331 clause 6.2.2			
Information Element	Value/remark	Comment	Condition
SecurityModeFailure ::= SEQUENCE {			
rrc-TransactionIdentifier	RRC-TransactionIdentifier-UL		
criticalExtensions CHOICE {			
securityModeFailure-r8 SEQUENCE {			
nonCriticalExtension SEQUENCE {}	Not checked		
}			
}			
}			

SidelinkUEInformation

Table 4.6.1-21A: SidelinkUEInformation

Derivation Path: 36.331 clause 6.2.2			
Information Element	Value/remark	Comment	Condition
SidelinkUEInformation-r12 ::= SEQUENCE {			
criticalExtensions CHOICE {			
c1 CHOICE {			
sidelinkUEInformation-r12 SEQUENCE {			
commRxInterestedFreq-r12	set according to specific message content.	INTEGER (0..maxEARFCN2)	
commTxResourceReq-r12 SEQUENCE {			
carrierFreq-r12	set according to specific message content.	INTEGER (0..maxEARFCN2)	
destinationInfoList-r12 SEQUENCE (SIZE (1..maxSL-Dest-r12)) OF SEQUENCE {	The number of entries is set according to specific message content.		
SL-DestinationIdentity-r12	set according to specific message content	BIT STRING (SIZE (24))	
}			
}			
discRxInterest-r12	set according to specific message content.	ENUMERATED {true}	
discTxResourceReq-r12	set according to specific message content.	INTEGER (1..63)	
lateNonCriticalExtension	Not Present		
nonCriticalExtension SEQUENCE {}	Not Present		
}			
}			
}			
}			

SidelinkUEInformation (V2X)

Table 4.6.1-21B: SidelinkUEInformation (V2X)

Derivation Path: 36.331 clause 6.2.2			
Information Element	Value/remark	Comment	Condition
SidelinkUEInformation-r12 ::= SEQUENCE {			
criticalExtensions CHOICE {			
c1 CHOICE {			
sidelinkUEInformation-r12 SEQUENCE {			
commRxInterestedFreq-r12	Not Present		
commTxResourceReq-r12	Not Present		
discRxInterest-r12	Not Present		
discTxResourceReq-r12	Not Present		
lateNonCriticalExtension	Not Present		
nonCriticalExtension SEQUENCE {			
nonCriticalExtension SEQUENCE {			
v2x-CommRxInterestedFreqList-r14	Not Present		
v2x-CommRxInterestedFreqList-r14 SEQUENCE (SIZE (1..maxFreqV2X-r14)) OF INTEGER (0..maxFreqV2X-1-r14)	set according to specific message content	INTEGER (0..maxFreq)	COND_RX
p2x-CommTxType-r14	Not Present		
v2x-CommTxResourceReq-r14	Not Present		
v2x-CommTxResourceReq-r14 SEQUENCE (SIZE (1..maxFreqV2X-r14)) OF SEQUENCE {			COND_TX
carrierFreqCommTx-r14	set according to specific message content		
v2x-TypeTxSync-r14	set according to specific message content		
v2x-DestinationInfoList-r14 SEQUENCE (SIZE (1..maxSL-Dest-r12)) OF SEQUENCE {	The number of entries is set according to specific message content.		
SL-DestinationIdentity-r12	set according to specific message content	BIT STRING (SIZE (24))	
}			
}			
nonCriticalExtension	Not Present		
}			
}			
}			
}			
}			
}			
}			

Condition	Explanation
COND_RX	UE intends to receive V2X sidelink communication
COND_TX	UE intends to transmit V2X sidelink communication

– *UECapabilityEnquiry*

Table 4.6.1-22: UECapabilityEnquiry

Derivation Path: 36.331 clause 6.2.2			
Information Element	Value/remark	Comment	Condition
UECapabilityEnquiry ::= SEQUENCE {			
rrc-TransactionIdentifier	RRC-TransactionIdentifier-DL		
criticalExtensions CHOICE {			
c1 CHOICE {			
ueCapabilityEnquiry-r8 SEQUENCE {			
ue-CapabilityRequest SEQUENCE (SIZE (1..maxRAT-Capabilities)) OF RAT-Type {	1,2 or 3 entries		
RAT-Type[1]	eutra		
RAT-Type[2]	eutra-nr		EN-DC
RAT-Type[3]	nr		NR, EN_DC
}			
nonCriticalExtension SEQUENCE {}	Not present		
nonCriticalExtension SEQUENCE {}			EN-DC, NR
nonCriticalExtension SEQUENCE {}			
nonCriticalExtension SEQUENCE {}			
nonCriticalExtension SEQUENCE {}			
nonCriticalExtension SEQUENCE {			
requestedFreqBandsNR-MRDC-r15	OCTET STRING including the FreqBandList IE according TS 38.508-1 [67], table 4.6.4-9.		
nonCriticalExtension SEQUENCE {}	Not present		
}			
}			
}			

Condition	Explanation
EN-DC	Used in E-UTRA-NR dual connectivity test cases
NR	Used in NR test cases

– *UECapabilityInformation*

Table 4.6.1-23: *UECapabilityInformation*

Derivation Path: 36.331 clause 6.2.2			
Information Element	Value/remark	Comment	Condition
UECapabilityInformation ::= SEQUENCE {			
rrc-TransactionIdentifier	RRC-TransactionIdentifier-UL		
criticalExtensions CHOICE {			
c1 CHOICE {			
ueCapabilityInformation-r8 SEQUENCE {			
ue-CapabilityRAT-ContainerList SEQUENCE (SIZE (1..maxRAT-Capabilities)) OF SEQUENCE {	1 entry		
rat-Type	Set according to specific message content		
ueCapabilityRAT-Container			
ue-EUTRA-Capability SEQUENCE {			
accessStratumRelease	Same as indicated in TC applicability in TS 36.523-2 [19]		
ue-Category	Not checked		
pdcp-Parameters SEQUENCE {			
supportedROHC-Profiles SEQUENCE {			
profile0x0001	Not checked		
profile0x0001	true		ROHC
profile0x0002	Not checked		
profile0x0002	true		ROHC
profile0x0003	Not checked		
profile0x0004	Not checked		
profile0x0006	Not checked		
profile0x0101	Not checked		
profile0x0102	Not checked		
profile0x0103	Not checked		
profile0x0104	Not checked		
}			
maxNumberROHC-ContextSessions	Not checked		
}			
phyLayerParameters	Not checked		
rf-Parameters	Not checked		
measParameters	Not checked		
featureGroupIndicators			
-- FGI 1	Not checked		
-- FGI 2	Not checked		
-- FGI 3	Not checked		
-- FGI 4	Not checked		
-- FGI 5	Not checked		
-- FGI 6	Not checked		
-- FGI 7	Not checked		
-- FGI 8	Not checked		
-- FGI 9	Not checked		
-- FGI 10	Not checked		
-- FGI 11	Not checked		
-- FGI 12	Not checked		
-- FGI 13	Not checked		
-- FGI 14	Not checked		
-- FGI 15	Not checked		
-- FGI 16	Not checked		
-- FGI 17	Not checked		
-- FGI 18	Not checked		
-- FGI 19	Not checked		
-- FGI 20	Not checked		
-- FGI 21	Not checked		
-- FGI 22	Not checked		
-- FGI 23	Not checked		
-- FGI 24	Not checked		
-- FGI 25	Not checked		
-- FGI 26	Not checked		
-- FGI 27	Not checked		
-- FGI 28	Not checked		

-- FGI 29	Not checked		
-- FGI 30	Not checked		
-- FGI 31	Not checked		
-- FGI 32	'0'B (Undefined)		
interRAT-Parameters SEQUENCE {			
utraFDD	Not checked		
utraTDD128	Not checked		
utraTDD384	Not checked		
utraTDD768	Not checked		
geran	Not checked		
cdma2000-HRPD	Not checked		
cdma2000-1xRTT	Not checked		
cdma2000-1xRTT	Not checked		
}			
nonCriticalExtension SEQUENCE {			
phyLayerParameters-v920	Not checked		
interRAT-ParametersGERAN-v920	Not checked		
interRAT-ParametersUTRA-v920	Not checked		
interRAT-ParametersCDMA2000-v920	Not checked		
deviceType-r9	Not checked		
csg-ProximityIndicationParameters-r9	Not checked		
neighCellSI-AcquisitionParameters-r9	Not checked		
son-Parameters-r9	Not checked		
nonCriticalExtension SEQUENCE {			
lateNonCriticalExtension SEQUENCE {			
featureGroupIndRel9Add-r9			
-- FGI 33	Not checked		
-- FGI 34	Not checked		
-- FGI 35	Not checked		
-- FGI 36	Not checked		
-- FGI 37	Not checked		
-- FGI 38	Not checked		
-- FGI 39	Not checked		
-- FGI 40	Not checked		
-- FGI 41	Not checked		
-- FGI 42-64	'0'B (Undefined)		
fdd-Add-UE-EUTRA-Capabilities-r9			
SEQUENCE {			
phyLayerParameters-r9	Not checked		
featureGroupIndicators-r9		BITSTRING 32	
-- FGI 1F	Not checked		
-- FGI 2F	Not checked		
-- FGI 3F	Not checked		FDD = TDD
-- FGI 4F	Not checked		
-- FGI 5F	Not checked		FDD = TDD
-- FGI 6F	Not checked		FDD = TDD
-- FGI 7F	Not checked		FDD = TDD
-- FGI 8F	Not checked		
-- FGI 9F	Not checked		
-- FGI 10F	Not checked		
-- FGI 11F	Not checked		
-- FGI 12F	Not checked		
-- FGI 13F	Not checked		FDD = TDD
-- FGI 14F	Not checked		FDD = TDD
-- FGI 15F	Not checked		
-- FGI 16F	Not checked		FDD = TDD
-- FGI 17F	Not checked		FDD = TDD
-- FGI 18F	Not checked		FDD = TDD
-- FGI 19F	Not checked		
-- FGI 20F	Not checked		FDD = TDD
-- FGI 21F	Not checked		FDD = TDD
-- FGI 22F	Not checked		
-- FGI 23F	Not checked		
-- FGI 24F	Not checked		
-- FGI 25F	Not checked		FDD = TDD

-- FGI 26F	Not checked		
-- FGI 27F	Not checked		
-- FGI 28F	Not checked		
-- FGI 29F	Not checked		
-- FGI 30F	Not checked		FDD = TDD
-- FGI 31F	Not checked		FDD = TDD
-- FGI 32F	'0'B (Undefined) if present		
featureGroupIndRel9Add-r9		BITSTRING 32	
-- FGI 33F	Not checked		
-- FGI 34F	Not checked		
-- FGI 35F	Not checked		
-- FGI 36F	Not checked		
-- FGI 37F	Not checked		
-- FGI 38F	Not checked		
-- FGI 39F	Not checked		
-- FGI 40F	Not checked		
-- FGI 41F	Not checked		
-- FGI 42F-64F	'0'B (Undefined) if present		
interRAT-ParametersGERAN-r9	Not checked		
interRAT-ParametersUTRA-r9	Not checked		
interRAT-ParametersGERAN-r9	Not checked		
interRAT-ParametersCDMA2000-r9	Not checked		
neighCellSI-AcquisitionParameters-r9	Not checked		
}			
tdd-Add-UE-EUTRA-Capabilities-r9			
SEQUENCE {			
phyLayerParameters-r9	Not checked		
featureGroupIndicators-r9		BITSTRING 32	
-- FGI 1T	Not checked		
-- FGI 2T	Not checked		
-- FGI 3T	Not checked		FDD = TDD
-- FGI 4T	Not checked		
-- FGI 5T	Not checked		FDD = TDD
-- FGI 6T	Not checked		FDD = TDD
-- FGI 7T	Not checked		FDD = TDD
-- FGI 8T	Not checked		
-- FGI 9T	Not checked		
-- FGI 10T	Not checked		
-- FGI 11T	Not checked		
-- FGI 12T	Not checked		
-- FGI 13T	Not checked		FDD = TDD
-- FGI 14T	Not checked		FDD = TDD
-- FGI 15T	Not checked		
-- FGI 16T	Not checked		FDD = TDD
-- FGI 17T	Not checked		FDD = TDD
-- FGI 18T	Not checked		FDD = TDD
-- FGI 19T	Not checked		
-- FGI 20T	Not checked		FDD = TDD
-- FGI 21T	Not checked		FDD = TDD
-- FGI 22T	Not checked		
-- FGI 23T	Not checked		
-- FGI 24T	Not checked		
-- FGI 25T	Not checked		FDD = TDD
-- FGI 26T	Not checked		
-- FGI 27T	Not checked		
-- FGI 28T	Not checked		
-- FGI 29T	Not checked		
-- FGI 30T	Not checked		FDD = TDD
-- FGI 31T	Not checked		FDD = TDD
-- FGI 32T	'0'B (Undefined) if present		
featureGroupIndRel9Add-r9		BITSTRING 32	
-- FGI 33T	Not checked		

-- FGI 34T	Not checked		
-- FGI 35T	Not checked		
-- FGI 36T	Not checked		
-- FGI 37T	Not checked		
-- FGI 38T	Not checked		
-- FGI 39T	Not checked		
-- FGI 40T	Not checked		
-- FGI 41T	Not checked		
-- FGI 42T-64T	'0'B (Undefined) if present		
interRAT-ParametersGERAN-r9	Not checked		
interRAT-ParametersUTRA-r9	Not checked		
interRAT-ParametersGERAN-r9	Not checked		
interRAT-ParametersCDMA2000-r9	Not checked		
neighCellSI-AcquisitionParameters-r9	Not checked		
}			
nonCriticalExtension SEQUENCE {	Not checked		
interRAT-ParametersUTRA-v9c0	Not checked		
nonCriticalExtension SEQUENCE {			
phyLayerParameters-v9d0	Not checked		
nonCriticalExtension SEQUENCE {			
rf-Parameters-v9e0	Not checked		
nonCriticalExtension SEQUENCE {}	Not checked		
}			
}			
}			
nonCriticalExtension SEQUENCE {			
ue-Category-v1020	Not checked		
phyLayerParameters-v1020	Not checked		
rf-Parameters-v1020	Not checked		
measParameters-v1020	Not checked		
featureGroupIndRel10-r10		BITSTRING 32	
-- FGI 101	Not checked		
-- FGI 102	Not checked		
-- FGI 103	Not checked		
-- FGI 104	Not checked		
-- FGI 105	Not checked		
-- FGI 106	Not checked		
-- FGI 107	Not checked		
-- FGI 108	Not checked		
-- FGI 109	Not checked		
-- FGI 110	Not checked		
-- FGI 111	Not checked		
-- FGI 112	Not checked		
-- FGI 113	Not checked		
-- FGI 114	Not checked		
-- FGI 115	Not checked		
-- FGI 116	Not checked		
-- FGI 117-132	'0'B (Undefined) if present		
interRAT-ParametersCDMA2000-v1020	Not checked		
ue-BasedNetwPerfMeasParameters-r10	Not checked		
interRAT-ParametersUTRA-TDD-v1020	Not checked		
nonCriticalExtension SEQUENCE {	Not checked		
fdd-Add-UE-EUTRA-Capabilities-v1060	Not checked		
tdd-Add-UE-EUTRA-Capabilities-v1060	Not checked		
rf-Parameters-v1060	Not checked		
nonCriticalExtension SEQUENCE {			
rf-Parameters-v1090	Not checked		
nonCriticalExtension SEQUENCE {			

	pdcp-Parameters-v1130	Not checked		
	phyLayerParameters-v1130	Not checked		
	rf-Parameters-v1130	Not checked		
	measParameters-v1130	Not checked		
v1130	interRAT-ParametersCDMA2000-	Not checked		
	otherParameters-r11	Not checked		
v1130	fdd-Add-UE-EUTRA-Capabilities-	Not checked		
v1130	tdd-Add-UE-EUTRA-Capabilities-	Not checked		
	nonCriticalExtension SEQUENCE {	Not checked		
	phyLayerParameters-v1170	Not checked		
	ue-Category-v1170	Not checked		
	nonCriticalExtension SEQUENCE {			
	rf-Parameters-v1180	Not checked		
	mbms-Parameters-r11	Not checked		
v1180	fdd-Add-UE-EUTRA-Capabilities-	Not checked		
v1180	tdd-Add-UE-EUTRA-Capabilities-	Not checked		
	nonCriticalExtension SEQUENCE {			
	ue-Category-v11a0	Not checked		
	measParameters-v11a0	Not checked		
	nonCriticalExtension SEQUENCE {			
	phyLayerParameters-v1250	Not checked		
	rf-Parameters-v1250	Not checked		
	rlc-Parameters-r12	Not checked		
v1250	ue-BasedNetwPerfMeasParameters-	Not checked		
	ue-Category-v1250	Not checked		
	wlan-IW-Parameters-r12	Not checked		
	measParameters-v1250	Not checked		
	dc-Parameters-r12	Not checked		
	mbms-Parameters-v1250	Not checked		
	mac-Parameters-r12	Not checked		
	fdd-Add-UE-EUTRA-Capabilities-v1250	Not checked		
	tdd-Add-UE-EUTRA-Capabilities-v1250	Not checked		
	sl-Parameters-r12	Not checked		
	nonCriticalExtension SEQUENCE {}			
	ue-CategoryDL-v1260	Not checked		
	nonCriticalExtension {			
	rf-Parameters-v1270	Not checked		
	nonCriticalExtension {			
	phyLayerParameters-v1280	Not checked		
	nonCriticalExtension {			
v1280	phyLayerParameters-	Not checked		
	nonCriticalExtension {			
	ue-CategoryDL-v1310	Not checked		
	ue-CategoryUL-v1310	Not checked		
	pdcp-Parameters-v1310	Not checked		
	rlc-Parameters-v1310	Not checked		
	mac-Parameters-v1310	Not checked		
v1310	phyLayerParameters-	Not checked		
	rf-Parameters-v1310	Not checked		
	measParameters-v1310	Not checked		
	dc-Parameters-v1310	Not checked		
	sl-Parameters-v1310	Not checked		
	scptm-Parameters-r13	Not checked		
	ce-Parameters-r13	Not checked		
ParametersWLAN-r13	interRAT-	Not checked		
	laa-Parameters-r13	Not checked		
	lwa-Parameters-r13	Not checked		

UEInformationRequest

Table 4.6.1-23A: UEInformationRequest

Derivation Path: 36.331 clause 6.2.2			
Information Element	Value/remark	Comment	Condition
UEInformationRequest-r9 ::= SEQUENCE {			
rrc-TransactionIdentifier	RRC-TransactionIdentifier-DL		
criticalExtensions CHOICE {			
c1 CHOICE{			
ueInformationRequest-r9 SEQUENCE {			
rach-ReportReq-r9	FALSE		
rlf-ReportReq-r9	FALSE		
	TRUE		RLF report
nonCriticalExtension SEQUENCE {			
lateNonCriticalExtension	Not present		
nonCriticalExtension SEQUENCE {}	Not present		
nonCriticalExtension SEQUENCE {			Logged MDT, ConEstFail
logMeasReportReq-r10	true		Logged MDT
	Not present		
nonCriticalExtension SEQUENCE {}	Not present		
nonCriticalExtension SEQUENCE {			
connEstFailReportReq-r11	true		ConEstFail
	Not present		
nonCriticalExtension SEQUENCE {}	Not present		
}			
}			
}			
}			

Condition	Explanation
Logged MDT	Used for Logged MDT test cases
ConEstFail	Used for RRC connection establishment failure report related test cases
RLF report	Used for Radio Link Failure Logging test cases

UEInformationResponse

Table 4.6.1-23B: UEInformationResponse

Derivation Path: 36.331 clause 6.2.2			
Information Element	Value/remark	Comment	Condition
UEInformationResponse-r9 ::= SEQUENCE {			
rrc-TransactionIdentifier	RRC-TransactionIdentifier-UL		
criticalExtensions CHOICE {			
c1 CHOICE {			
ueInformationResponse-r9 SEQUENCE {			
rach-Report-r9 SEQUENCE {}	Not checked		
rlf-Report-r9 SEQUENCE {}	Not checked		
nonCriticalExtension SEQUENCE {			
lateNonCriticalExtension	Not checked		
nonCriticalExtension SEQUENCE {			
logMeasReport-r10 SEQUENCE {}	Not checked		
nonCriticalExtension SEQUENCE {	Not checked		
}			
}			
}			
}			
}			

ULHandoverPreparationTransfer

Table 4.6.1-24: ULHandoverPreparationTransfer

Derivation Path: 36.331 clause 6.2.2			
Information Element	Value/remark	Comment	Condition
ULHandoverPreparationTransfer ::= SEQUENCE {			
criticalExtensions CHOICE {			
c1 CHOICE {			
ulHandoverPreparationTransfer-r8 SEQUENCE {			
cdma2000-Type	type1XRTT		
meid	Set to the 56 bit CDMA2000 mobile identification number of the UE		
dedicatedInfo	Set according to specific message content		
nonCriticalExtension SEQUENCE {}	Not checked		
}			
}			
}			
}			

ULInformationTransfer

Table 4.6.1-25: *ULInformationTransfer*

Derivation Path: 36.331 clause 6.2.2			
Information Element	Value/remark	Comment	Condition
ULInformationTransfer ::= SEQUENCE {			
criticalExtensions CHOICE {			
c1 CHOICE {			
ulInformationTransfer-r8 SEQUENCE {			
dedicatedInfoType CHOICE {			
dedicatedInfoNAS	Present but contents not checked		
}			
nonCriticalExtension SEQUENCE {}	Not checked		
}			
}			
}			
}			

UEAssistanceInformation

Table 4.6.1-26: *UEAssistanceInformation*

Derivation Path: 36.331, Clause 6.2.2			
Information Element	Value/remark	Comment	Condition
UEAssistanceInformation-r11 ::= SEQUENCE {			
criticalExtensions CHOICE {			
c1 CHOICE{			
UEAssistanceInformation-r11-IEs SEQUENCE {			
powerPreferenceIndication-r11	lowPowerConsumption		Low_Power
powerPreferenceIndication-r11	normal		Normal
laterNonCriticalExtension	Not Present		
nonCriticalExtension SEQUENCE {			V2X
sps-AssistanceInformation-r14 SEQUENCE {			SL_SPS
trafficPatternInfoListSL-r14 SEQUENCE (SIZE (1..maxTrafficPattern-r14)) OF SEQUENCE{			
trafficPeriodicity-r14	sf20		
timingOffset-r14	0		
priorityInfoSL-r14	2		
logicalChannelIdentityUL-r14	3		
messageSize-r14	010000		
}			
trafficPatternInfoListUL-r14	Not Present		
}			
DelayBudgetReport-r14::= CHOICE {			eVoLTE
type1	ms0		DRX_Cycle
type2	ms0		Coverage
}			
nonCriticalExtension			
}			
}			
}			
}			
}			

Condition	Explanation
-----------	-------------

Low_Power	The UE indicates that it prefers a configuration primarily optimised for power saving
Normal	The UE indicates that it does not prefer a configuration primarily optimised for power saving
V2X	V2X Sidelink Communication
SL_SPS	Sidelink SPS configuration
eVoLTE	The UE Indicates it prefers adjustment to connected mode DRX or coverage enhancement configuration
DRX_Cycle	The UE indicates that it prefers an adjustment in the connected mode DRX cycle length
Coverage	The UE indicates that it prefers coverage enhancement configuration change

– *ULInformationTransferMRDC*

Table 4.6.1-27: ULInformationTransferMRDC

Derivation Path: 36.331 clause 6.2.2			
Information Element	Value/remark	Comment	Condition
ULInformationTransferMRDC-r15 ::= SEQUENCE {			
criticalExtensions CHOICE {			
c1 CHOICE {			
ulInformationTransferMRDC-r15 SEQUENCE {			
ul-DCCH-MessageNR-r15	OCTET STRING including the MeasurementReport message according TS 38.508-1 [67], table 4.6.1-2.		
lateNonCriticalExtension	Not checked		
nonCriticalExtension SEQUENCE {}	Not checked		
}			
}			
}			
}			

4.6.2 System information blocks

See subclause 4.4.3.3 in this document.

4.6.3 Radio resource control information elements

Table 4.6.3-0A: Void

Table 4.6.3-0B: Void

– *BCCH-Config-DEFAULT*

Table 4.6.3-1: BCCH-Config-DEFAULT

Derivation Path: 36.331 clause 6.3.2			
Information Element	Value/remark	Comment	Condition
BCCH-Config-DEFAULT ::= SEQUENCE {			
modificationPeriodCoeff	n4	To provide reliable delivery of SI change notifications.	
}			

– CellSelectionInfoCE-r13-DEFAULT

Table 4.6.3-1AB: CellSelectionInfoCE-r13-DEFAULT

Derivation Path: 36.331 clause 6.3.4			
Information Element	Value/remark	Comment	Condition
CellSelectionInfoCE-r13 ::= SEQUENCE {			
q-RxLevMinCE-r13	-70 (-140 dBm)	For RF/RRM test cases	
	-53 (-106 dBm)	For signalling test cases	
q-QualMinRSRQ-CE-r13	Not present		
}			

– CQI-ReportAperiodic-r10-DEFAULT

Table 4.6.3-1A: CQI-ReportAperiodic-r10-DEFAULT

Derivation Path: 36.331 clause 6.3.2			
Information Element	Value/remark	Comment	Condition
CQI-ReportAperiodic-r10 ::= CHOICE {			
setup SEQUENCE {			
cqi-ReportModeAperiodic-r10	rm30		
	rm20		CEmodeA
	FFS		CEmodeB
aperiodicCSI-Trigger-r10	Not present		
}			
}			

Condition	Explanation
CEmodeA	CE mode A test environment
CEmodeB	CE mode B test environment

– CQI-ReportConfig-DEFAULT

Table 4.6.3-2: CQI-ReportConfig-DEFAULT

Derivation Path: 36.331 clause 6.3.2			
Information Element	Value/remark	Comment	Condition
CQI-ReportConfig-DEFAULT ::= SEQUENCE {			
cqi-ReportModeAperiodic	rm30		
	rm20		CEmodeA
	FFS		CEmodeB
nomPDSCH-RS-EPRE-Offset	0		
cqi-ReportPeriodic	Not present		
cqi-ReportPeriodic CHOICE {			CQI_PERIODIC
setup SEQUENCE {			
cqi-PUCCH-ResourceIndex	0		
cqi-pmi-ConfigIndex	25	(see Table 7.2.2-1A in TS 36.213)	FDD
	24	(see Table 7.2.2-1C in TS 36.213)	TDD
cqi-FormatIndicatorPeriodic CHOICE {			
widebandCQI	NULL		
}			
ri-ConfigIndex	483	(see Table 7.2.2-1B in TS 36.213)	FDD
	484	(see Table 7.2.2-1B in TS 36.213) This value for TDD is selected together with cqi-pmi-ConfigIndex based on TDD configuration 1.	TDD
simultaneousAckNackAndCQI	FALSE		
}			
}			
}			
}			

Condition	Explanation
CQI_PERIODIC	When periodic CQI reporting should be enabled
FDD	FDD cell environment
TDD	TDD cell environment
CEmodeA	CE mode A test environment
CEmodeB	CE mode B test environment

– CQI-ReportConfig-r10-DEFAULT

Table 4.6.3-2AA: CQI-ReportConfig-r10-DEFAULT

Derivation Path: 36.331 clause 6.3.2			
Information Element	Value/remark	Comment	Condition
CQI-ReportConfig-r10 ::= SEQUENCE {			
cqi-ReportAperiodic-r10	CQI-ReportAperiodic-r10-DEFAULT		
nomPDSCH-RS-EPRE-Offset	0		
cqi-ReportPeriodic-r10	Not present		
	CQI-ReportPeriodic-r10-DEFAULT		CQI_PERIODIC
pmi-RI-Report-r9	Not present		
csi-SubframePatternConfig-r10	Not present		
}			

Condition	Explanation
CQI_PERIODIC	When periodic CQI reporting should be enabled

– CQI-ReportConfig-v1130-DEFAULT

Table 4.6.3-2ABA: CQI-ReportConfig-v1130-DEFAULT

Derivation Path: 36.331 clause 6.3.2			
Information Element	Value/remark	Comment	Condition
CQI-ReportConfig-v1130 ::= SEQUENCE {			
cqi-ReportPeriodic-v1130 SEQUENCE {			
simultaneousAckNackAndCQI-Format3-r11	Not present		
cqi-ReportPeriodicProcExtToReleaseList-r11	Not present		
cqi-ReportPeriodicProcExtToAddModList-r11	1 entry		
SEQUENCE (SIZE (1..maxCQI-ProcExt-r11)) OF SEQUENCE {			
cqi-ReportPeriodicProcExtId-r11[1] SEQUENCE {			
cqi-ReportPeriodicProcExtId-r11	1		
cqi-pmi-ConfigIndex-r11	Not present		
cqi-FormatIndicatorPeriodic-r11 CHOICE {			
widebandCQI-r11 SEQUENCE {			
csi-ReportMode-r11	Not present		
}			
subbandCQI-r11 SEQUENCE {			
k	Not present		
periodicityFactor-r11	Not present		
}			
}			
ri-ConfigIndex-r11	Not present		
csi-ConfigIndex-r11 CHOICE {			
release	NULL		
setup SEQUENCE {			
cqi-pmi-ConfigIndex2-r11	Not present		
ri-ConfigIndex2-r11	Not present		
}			
}			
}			
}			
}			
cqi-ReportBoth-r11 SEQUENCE {			
csi-IM-ConfigToReleaseList-r11	Not present		
csi-IM-ConfigToAddModList-r11 SEQUENCE (SIZE (1..maxCSI-IM-r11)) OF SEQUENCE {	1 entry		
csi-IM-ConfigId-r11[1]	1		
resourceConfig-r11[1]	2		FDD
	2		TDD
subframeConfig-r11[1]	1		FDD
	3		TDD
}			
csi-ProcessToReleaseList-r11	Not present		
csi-ProcessToAddModList-r11 SEQUENCE (SIZE (1..maxCSI-Proc-r11)) OF SEQUENCE {	1 entry		
csi-ProcessId-r11[1]	1		
csi-RS-ConfigNZPId-r11[1]	1		
csi-IM-ConfigId-r11[1]	1		
p-C-AndCBSRList-r11[1] SEQUENCE (SIZE (1..2)) OF SEQUENCE {	1 entry		
p-C-r11[1]	-6		
codebookSubsetRestriction-r11[1]	1111111		
}			
cqi-ReportBothProc-r11[1] SEQUENCE {			
ri-Ref-CSI-ProcessId-r11	1		
pmi-RI-Report-r11	Not present		
}			
cqi-ReportPeriodicProcId-r11[1]	1		
cqi-ReportAperiodicProc-r11[1] SEQUENCE {			
cqi-ReportModeAperiodic-r11	Not present		
trigger01-r11	Not present		
trigger10-r11	Not present		
trigger11-r11	Not present		
}			
}			
}			

}			
---	--	--	--

Condition	Explanation
FDD	FDD cell environment
TDD	TDD cell environment

– CQI-ReportConfig-v1130-eIMTA

Table 4.6.3-2ABB: CQI-ReportConfig-v1130-eIMTA

Derivation Path: 36.331 clause 6.3.2			
Information Element	Value/remark	Comment	Condition
CQI-ReportConfig-v1130-eIMTA ::= SEQUENCE {			
cqi-ReportPeriodic-v1130 SEQUENCE {			
simultaneousAckNackAndCQI-Format3-r11	Not present		
cqi-ReportPeriodicProcExtToReleaseList-r11	Not present		
cqi-ReportPeriodicProcExtToAddModList-r11 SEQUENCE (SIZE (1..maxCQI-ProcExt-r11)) OF SEQUENCE {	1 entry		
cqi-ReportPeriodicProcExtId-r11[1] SEQUENCE {			
cqi-ReportPeriodicProcExtId-r11	1		
cqi-pmi-ConfigIndex-r11	Not present		
cqi-FormatIndicatorPeriodic-r11 CHOICE {			
widebandCQI-r11 SEQUENCE {			
csi-ReportMode-r11	Not present		
}			
subbandCQI-r11 SEQUENCE {			
k	Not present		
periodicityFactor-r11	Not present		
}			
}			
}			
ri-ConfigIndex-r11	Not present		
csi-ConfigIndex-r11 CHOICE {			
release	NULL		
setup SEQUENCE {			
cqi-pmi-ConfigIndex2-r11	Not present		
ri-ConfigIndex2-r11	Not present		
}			
}			
}			
}			
cqi-ReportBoth-r11 SEQUENCE {			
csi-IM-ConfigToReleaseList-r11	Not present		
csi-IM-ConfigToAddModList-r11 SEQUENCE (SIZE (1..maxCSI-IM-r11)) OF SEQUENCE {	1 entry		
csi-IM-ConfigId-r11[1]	1		
resourceConfig-r11[1]	2		FDD
	2		TDD
subframeConfig-r11[1]	1		FDD
	3		TDD
}			
csi-ProcessToReleaseList-r11	Not present		
csi-ProcessToAddModList-r11 SEQUENCE (SIZE (1..maxCSI-Proc-r11)) OF SEQUENCE {	1 entry		
csi-ProcessId-r11[1]	1		
csi-RS-ConfigNZPId-r11[1]	1		
csi-IM-ConfigId-r11[1]	1		
p-C-AndCBRLList-r11[1] SEQUENCE (SIZE (1..2)) OF SEQUENCE {	1 entry		
p-C-r11[1]	-6		
codebookSubsetRestriction-r11[1]	1111111		
}			
}			
cqi-ReportBothProc-r11[1] SEQUENCE {			
ri-Ref-CSI-ProcessId-r11	1		
pmi-RI-Report-r11	Not present		
}			
cqi-ReportPeriodicProcId-r11[1]	1		
cqi-ReportAperiodicProc-r11[1] SEQUENCE {			
cqi-ReportModeAperiodic-r11	Not present		
trigger01-r11	Not present		
trigger10-r11	Not present		
trigger11-r11	Not present		
}			
alternativeCodebookEnabledFor4TXProc-r12	Not present		
csi-IM-ConfigIdList-r12[1] CHOICE {			

Setup SEQUENCE (SIZE (1..2)) OF{	1 entry		
CSI-IM-ConfigId-r12[1]	Not present		
}			
}			
cqi-ReportAperiodicProc2-r12[1] CHOICE {			
setup SEQUENCE {			
cqi-ReportModeAperiodic-r11	Not present		
trigger01-r11	Not present		
trigger10-r11	Not present		
trigger11-r11	Not present		
}			
}			
}			
}			
}			

Condition	Explanation
FDD	FDD cell environment
TDD	TDD cell environment

– CQI-ReportConfig-v1250-DEFAULT

Table 4.6.3-2ACA: CQI-ReportConfig-v1250-DEFAULT

Derivation Path: 36.331 clause 6.3.2			
Information Element	Value/remark	Comment	Condition
CQI-ReportConfig-v1250	Not present		DL 256QAM
CQI-ReportConfig-v1250 ::= SEQUENCE {			
csi-SubframePatternConfig-r12 CHOICE {			
setup SEQUENCE {			
csi-MeasSubframeSets-r12	0001100111		
}			
}			
cqiCQI-ReportBoth-v1250	Not present		DL 256QAM
cqiCQI-ReportBoth-v1250 SEQUENCE {			
csi-IM-ConfigToReleaseListExt-r12	Not present		
csi-IM-ConfigToAddModListExt-r12 SEQUENCE {	1 entry		
csi-IM-ConfigId-v1250[1]	1		
resourceConfig-r12[1]	2		FDD
	2		TDD
subframeConfig-r12[1]	1		FDD
	3		TDD
}			
}			
cqi-ReportAperiodic-v1250	Not present		
altCQI-Table-r12	Not present		
	allSubframes		DL 256QAM
}			

Condition	Explanation
FDD	FDD cell environment
TDD	TDD cell environment
TM10	Transmission mode 10
DL 256QAM	When DL 256QAM is used

– CQI-ReportConfigSCell-r10-DEFAULT

Table 4.6.3-2AB: CQI-ReportConfigSCell-r10-DEFAULT

Derivation Path: 36.331 clause 6.3.2			
Information Element	Value/remark	Comment	Condition
CQI-ReportConfigSCell-r10 ::= SEQUENCE {			
cqi-ReportModeAperiodic-r10	rm30		
nomPDSCH-RS-EPRE-Offset-r10	0		
cqi-ReportPeriodicSCell-r10	Not present		
	CQI-ReportPeriodic-r10-DEFAULT		CQI_PERIODIC
pmi-RI-Report-r10	Not present		
}			

Condition	Explanation
CQI_PERIODIC	When periodic CQI reporting should be enabled

– CQI-ReportPeriodic-r10-DEFAULT

Table 4.6.3-2AC: CQI-ReportPeriodic-r10-DEFAULT

Derivation Path: 36.331 clause 6.3.2			
Information Element	Value/remark	Comment	Condition
CQI-ReportPeriodic-r10 ::= CHOICE {			
setup SEQUENCE {			
cqi-PUCCH-ResourceIndex-r10	0		
cqi-PUCCH-ResourceIndexP1-r10	Not present		
cqi-pmi-ConfigIndex	25		FDD
	24		TDD
cqi-FormatIndicatorPeriodic-r10 CHOICE {			
widebandCQI-r10 SEQUENCE {			
csi-ReportMode-r10	Not present		
}			
}			
ri-ConfigIndex	Not present		SCell_Config
	483		FDD and NOT SCell_Config
	484		TDD and NOT SCell_Config
simultaneousAckNackAndCQI	FALSE		
cqi-Mask-r9	Not present		
csi-ConfigIndex-r10	Not present		
}			
}			

Condition	Explanation
FDD	FDD cell environment
TDD	TDD cell environment
SCell_Config	CQI-ReportPeriodic configuration for SCell.

Table 4.6.3-2AD: Void

Table 4.6.3-2AE: Void

– CSI-RS-ConfigNWP-r11-DEFAULT

Table 4.6.3-2AF: CSI-RS-ConfigNWP-r11-DEFAULT

Derivation Path: 36.331 clause 6.3.2			
Information Element	Value/remark	Comment	Condition
CSI-RS-ConfigNWP-r11 ::= SEQUENCE {			
csi-RS-ConfigNWPId-r11	1		
antennaPortsCount-r11	an2		
resourceConfig-r11	0		FDD
	0		TDD
subframeConfig-r11	1		FDD
	3		TDD
scramblingIdentity-r11	0		
qcl-CRS-Info-r11 SEQUENCE {			
qcl-ScramblingIdentity-r11	0		
crs-PortsCount-r11	n2		
mbsfn-SubframeConfigList-r11 CHOICE {			
release	NULL		
setup SEQUENCE {			
subframeConfigList	Not present		
}			
}			
}			

Condition	Explanation
FDD	FDD cell environment
TDD	TDD cell environment

– CSI-RS-ConfigZP-r11-DEFAULT

Table 4.6.3-2AG: CSI-RS-ConfigZP-r11-DEFAULT

Derivation Path: 36.331 clause 6.3.2			
Information Element	Value/remark	Comment	Condition
CSI-RS-ConfigZP-r11 ::= SEQUENCE {			
csi-RS-ConfigZPId-r11	1		
resourceConfigList-r11	0010000000000000		
subframeConfig-r11	1		FDD
	3		TDD
}			

Condition	Explanation
FDD	FDD cell environment
TDD	TDD cell environment

– DMRS-Config-r11-DEFAULT

Table 4.6.3-2AH: DMRS-Config-r11-DEFAULT

Derivation Path: 36.331 clause 6.3.2			
Information Element	Value/remark	Comment	Condition
DMRS-Config-r11 ::= CHOICE {			
release	NULL		
setup SEQUENCE {			
scramblingIdentity-r11	0		
scramblingIdentity2-r11	1		
}			
}			

– DRB-ToAddModList-RECONFIG

Table 4.6.3-2A: DRB-ToAddModList-RECONFIG

Derivation Path: 36.331 clause 6.3.2			
Information Element	Value/remark	Comment	Condition
DRB-ToAddModList ::= SEQUENCE (SIZE (1..maxDRB)) OF SEQUENCE {	2 Entries		
eps-BearerIdentity[1]	Not present		
drb-Identity[1]	1		
pdcp-Config[1]	Not present		
rlc-Config[1]	RLC-Config-DRB-AM-RECONFIG		
logicalChannelIdentity[1]	Not present		
logicalChannelConfig[1]	Not present		
eps-BearerIdentity[2]	Not present		
drb-Identity[2]	2		
pdcp-Config[2]	Not present		
rlc-Config[2]	RLC-Config-DRB-AM-RECONFIG		
logicalChannelIdentity[2]	Not present		
logicalChannelConfig[2]	Not present		
}			

– EPDCCH-Config-r11-DEFAULT

Table 4.6.3-2B: EPDCCH-Config-r11-DEFAULT

Derivation Path: 36.331 clause 6.3.2			
Information Element	Value/remark	Comment	Condition
EPDCCH-Config-r11 ::= SEQUENCE{			
config-r11{			
setup SEQUENCE {			
subframePatternConfig-r11{ }	Not present		CEmodeA, CEmodeB
subframePatternConfig-r11{			
setup SEQUENCE {			
subframePattern-r11 CHOICE {			
subframePatternFDD-r10	00000000000000000000 00000000000000000000 1111111110 1111111101 1111111011 1111110111		FDD FDD AND TM9
subframePatternTDD-r10{			TDD
subframeConfig1-5-r10	0000000000 0000000000 1100111001 1100111001		TM9

}			
}			
}			
}			
startSymbol-r11	Not present		
	2		TM9
setConfigToReleaseList-r11	Not present		
setConfigToAddModList-r11 SEQUENCE {	2 entry		
setConfigId-r11[1]	0		
transmissionType-r11[1]	distributed		
	localized		TM10
resourceBlockAssignment-r11[1] SEQUENCE{			
numberPRB-Pairs-r11	n4		
	n2		TM9
	n8		TM10
resourceBlockAssignment-r11	101001000101101110		
	10010011000		TM9
	11100100101110110011		TM10
	001101100		
}			
dmrs-ScramblingSequenceInt-r11[1]	0		
pucch-ResourceStartOffset-r11[1]	0		
re-MappingQCL-ConfigListId-r11[1]	Not present		
	0		TM10
setConfigId-r11[2]	1		
transmissionType-r11[2]	distributed		
	localized		TM9, TM10
resourceBlockAssignment-r11[2] SEQUENCE{			
numberPRB-Pairs-r11	n8		
resourceBlockAssignment-r11	11100100101110110011		
	001101100		
}			
dmrs-ScramblingSequenceInt-r11[2]	0		
pucch-ResourceStartOffset-r11[2]	0		
re-MappingQCL-ConfigListId-r11[2]	Not present		
	0		TM10
}			
setConfigToAddModList-r11 SEQUENCE {	1 entry		CEmodeA, CEmodeB
setConfigId-r11[1]	0		
transmissionType-r11[1]	distributed		
resourceBlockAssignment-r11[1] SEQUENCE{			
numberPRB-Pairs-r11	n2		
resourceBlockAssignment-r11	1110		SIG
	0000		RF

}			
dmrs-ScramblingSequenceInt-r11[1]	0		
pucch-ResourceStartOffset-r11[1]	0		
re-MappingQCL-ConfigListId-r11[1]	Not present		
numberPRB-Pairs-v1310 CHOICE[1] {			
Setup	n6		
}			
mpdcch-config-r13 CHOICE[1] {			
setup SEQUENCE {			
csi-NumRepetitionCE-r13	sf1		
mpdcch-pdsch-HoppingConfig-r13	off		
mpdcch-StartSF-UeSS-r13 CHOICE {			
fdd-r13	v1		FDD
tdd-r13	v1		TDD
}			
mpdcch-NumRepetition-r13	r1	No repetitions to reduce impact on legacy E-UTRA test cases for category M1 UEs.	
mpdcch-Narrowband-r13	5	Narrowband index 4	RF and 20 MHz BW
	4	Narrowband index 3	RF and (15 MHz BW or 5 MHz BW)
	7	Narrowband index 6	RF and 10 MHz BW
	2	Narrowband index 1	RF and 3 MHz BW
	1	Narrowband index 0	RF and 1.4 MHz BW
		Value as specified in TS 36.523-3 clause 7.3.3.9	
}			
}			
}			
}			
}			
}			
}			

Condition	Explanation
FDD	FDD cell environment
TDD	TDD cell environment
TM9	Transmission mode 9
TM10	Transmission mode 10
CEmodeA	CE mode A test environment
CEmodeB	CE mode B test environment
RF	Used for RF, performance and RRM testing
SIG	Used for protocol testing
20 MHz BW	Used for cells with 20 MHz bandwidth
15 MHz BW	Used for cells with 15 MHz bandwidth
10 MHz BW	Used for cells with 10 MHz bandwidth
5 MHz BW	Used for cells with 5 MHz bandwidth
3 MHz BW	Used for cells with 3 MHz bandwidth
1.4 MHz BW	Used for cells with 1.4 MHz bandwidth

– EPDCCH-Config-r11-eIMTA

Table 4.6.3-2C: EPDCCH-Config-r11-eIMTA

Derivation Path: 36.331 clause 6.3.2			
Information Element	Value/remark	Comment	Condition
EPDCCH-Config-r11-eIMTA ::= SEQUENCE{			
config-r11{			
setup SEQUENCE {			
subframePatternConfig-r11{			
setup SEQUENCE {			
subframePattern-r11 CHOICE {			
subframePatternFDD-r10	00000000000000000000000000000000		FDD
	1111111110 1111111101		FDD, TM9
	1111111011 1111110111		
subframePatternTDD-r10{			TDD
subframeConfig1-5-r10	0000000000 0000000000		
	1100111001 1100111001		TM9
}			
}			
}			
startSymbol-r11	Not present		
	2		TM9
setConfigToReleaseList-r11	Not present		
setConfigToAddModList-r11 SEQUENCE {	2 entry		
setConfigId-r11[1]	0		
transmissionType-r11[1]	distributed		
	localized		TM10
resourceBlockAssignment-r11[1] SEQUENCE{			
numberPRB-Pairs-r11	n4		
	n2		TM9
	n8		TM10
resourceBlockAssignment-r11	101001000101101110		
	10010011000		TM9
	11100100101110110011		TM10
	001101100		
}			
dmrs-ScramblingSequenceInt-r11[1]	0		
pucch-ResourceStartOffset-r11[1]	0		
re-MappingQCL-ConfigListId-r11[1]	Not present		
	0		TM10
csi-RS-ConfigZPId2-r12[1]	Not present		
csi-RS-ConfigZPId2-r12[1] CHOICE {			
Setup {			
CSI-RS-ConfigZPId-r11[1]	1		TM10
}			
}			
setConfigId-r11[2]	1		
transmissionType-r11[2]	distributed		
	localized		TM9, TM10
resourceBlockAssignment-r11[2] SEQUENCE{			
numberPRB-Pairs-r11	n8		
resourceBlockAssignment-r11	11100100101110110011		
	001101100		
}			
dmrs-ScramblingSequenceInt-r11[2]	0		
pucch-ResourceStartOffset-r11[2]	0		
re-MappingQCL-ConfigListId-r11[2]	Not present		
	0		TM10
csi-RS-ConfigZPId2-r12[2]	Not present		
csi-RS-ConfigZPId2-r12[2] CHOICE {			
Setup {			
CSI-RS-ConfigZPId-r11[2]	1		TM10
}			
}			
}			
}			
}			

}		
---	--	--

Condition	Explanation
FDD	FDD cell environment
TDD	TDD cell environment
TM9	Transmission mode 9
TM10	Transmission mode 10

– FreqHoppingParameters-r13-DEFAULT

Table 4.6.3-2D: FreqHoppingParameters-r13-DEFAULT

Derivation Path: 36.331 clause 6.3.2			
Information Element	Value/remark	Comment	Condition
FreqHoppingParameters-r13-DEFAULT ::= SEQUENCE {			
mpdcch-pdsch-HoppingNB-r13	Not present		
interval-DLHoppingConfigCommonModeA-r13 CHOICE {	Not present		
interval-DLHoppingConfigCommonModeB-r13 CHOICE {	Not present		
interval-ULHoppingConfigCommonModeA-r13 CHOICE {			
interval-FDD-r13	int4		FDD
interval-TDD-r13	int5		TDD
}			
interval-ULHoppingConfigCommonModeB-r13 CHOICE {			
interval-FDD-r13	int16		FDD
interval-TDD-r13	int20		TDD
}			
mpdcch-pdsch-HoppingOffset-r13	Not present		
}			

Condition	Explanation
FDD	FDD cell environment
TDD	TDD cell environment

– HighSpeedConfig-r14-DEFAULT

Table 4.6.3-2E: HighSpeedConfig-r14-DEFAULT

Derivation Path: 36.331 clause 6.3.2			
Information Element	Value/remark	Comment	Condition
HighSpeedConfig-r14-DEFAULT ::= SEQUENCE {			
highSpeedEnhancedMeasFlag-r14	true		
highSpeedEnhancedDemodulationFlag-r14	true		
}			

– HighSpeedConfigSCell-r14-DEFAULT

Table 4.6.3-2F: HighSpeedConfigSCell-r14-DEFAULT

Derivation Path: 36.331 clause 6.3.2			
Information Element	Value/remark	Comment	Condition
HighSpeedConfig-r14-DEFAULT ::= SEQUENCE {			
highSpeedEnhancedDemodulationFlag-r14	true		
}			

– PCCH-Config-DEFAULT

Table 4.6.3-3: PCCH-Config-DEFAULT

Derivation Path: 36.331 clause 6.3.2			
Information Element	Value/remark	Comment	Condition
PCCH-Config-DEFAULT ::= SEQUENCE {			
defaultPagingCycle	rf128	Typical value in real network.	
nB	oneT		
}			

– PCCH-Config-v1310-DEFAULT

Table 4.6.3-3A: PCCH-Config-v1310-DEFAULT

Derivation Path: 36.331 clause 6.3.2			
Information Element	Value/remark	Comment	Condition
PCCH-Config-v1310DEFAULT ::= SEQUENCE {			
paging-narrowBands-r13	1		
mpdcch-NumRepetition-Paging-r13	r16		
nB-v1310	Not present	Not present means that nB value in PDCCH-Config applies.	
}			

Condition	Explanation
RF	Used for RF, performance and RRM testing
SIG	Used for protocol testing

– PHICH-Config-DEFAULT

Table 4.6.3-4: PHICH-Config-DEFAULT

Derivation Path: 36.331 clause 6.3.2			
Information Element	Value/remark	Comment	Condition
PHICH-Config-DEFAULT ::= SEQUENCE {			
phich-Duration	normal		
phich-Resource	one	Ng=1 has been selected to ensure enough PHICH resources from the real network point of view.	
}			

PDSCH-ConfigCommon-DEFAULT

Table 4.6.3-5: PDSCH-ConfigCommon-DEFAULT

Derivation Path: 36.331 clause 6.3.2			
Information Element	Value/remark	Comment	Condition
PDSCH-ConfigCommon-DEFAULT ::= SEQUENCE {			
referenceSignalPower	18 (dBm)		
p-b	0 ($\rho_B / \rho_A = 1$)		1TX
	1 ($\rho_B / \rho_A = 1$)		2TX, 4TX
}			

Condition	Explanation
1TX	1 SS Tx antenna environment
2TX	2 SS Tx antenna environment
4TX	4 SS Tx antenna environment

PDSCH-ConfigCommon-v1310-DEFAULT

Table 4.6.3-5A: PDSCH-ConfigCommon-v1310-DEFAULT

Derivation Path: 36.331 clause 6.3.2			
Information Element	Value/remark	Comment	Condition
PDSCH-ConfigCommon-v1310-DEFAULT ::= SEQUENCE {			
pdsch-maxNumRepetitionCEmodeA-r13	r16	Minimum value	CEmodeA AND SIG
	[r32]	Maximum value	CEmodeA AND RF
pdsch-maxNumRepetitionCEmodeB-r13	r192	Minimum value	CEmodeB AND SIG
	[2048]	Maximum value	CEmodeB AND RF
}			

Condition	Explanation
CEmodeA	CE mode A test environment
CEmodeB	CE mode B test environment
RF	Value used for RF, performance and RRM testing
SIG	Value used for protocol testing

PDSCH-ConfigDedicated-DEFAULT

Table 4.6.3-6: PDSCH-ConfigDedicated-DEFAULT

Derivation Path: 36.331 clause 6.3.2			
Information Element	Value/remark	Comment	Condition
PDSCH-ConfigDedicated-DEFAULT ::= SEQUENCE {			
p-a	dB-3 for signalling test cases; dB0 for others	dB-3 for signalling test cases to reduce interference from PDSCH of intra-frequency neighbour cells	1TX
	dB-3		2TX, 4TX
}			

– PDSCH-ConfigDedicated-v1130-DEFAULT

Table 4.6.3-6AA: PDSCH-ConfigDedicated-v1130-DEFAULT

Derivation Path: 36.331 clause 6.3.2			
Information Element	Value/remark	Comment	Condition
PDSCH-ConfigDedicated-v1130 ::= SEQUENCE {			
dmrs-ConfigPDSCH-r11	DMRS-Config-r11-DEFAULT		
qcl-Operation	typeB		
re-MappingQCLConfigToReleaseList-r11	Not present		
re-MappingQCLConfigToAddModList-r11 SEQUENCE (SIZE (1..maxRE-MapQCL-r11)) OF SEQUENCE {	1 entry		
pdsch-RE-MappingQCL-ConfigId-r11[1]	1		
optionalSetOfFields-r11[1] SEQUENCE {	0		TM10
crs-PortsCount-r11	Not present		
crs-FreqShift-r11	Not present		
mbsfn-SubframeConfigList-r11{ setup SEQUENCE { subframeConfigList	Not present		
}			
}			
pdsch-Start-r11	Not present		
}	2		TM10
csi-RS-ConfigZPId-r11[1]	1		
qcl-CSI-RS-ConfigNZPId-r11[1]	1		
}			
}			

Condition	Explanation
TM10	Transmission mode 10

– PhysicalConfigDedicatedSCell-r10-DEFAULT

Table 4.6.3-6A: PhysicalConfigDedicatedSCell-r10-DEFAULT

Derivation Path: 36.331 clause 6.3.2			
Information Element	Value/remark	Comment	Condition
PhysicalConfigDedicatedSCell-r10-DEFAULT ::= SEQUENCE {			
nonUL-Configuration-r10 SEQUENCE {			
antennaInfo-r10 SEQUENCE {			
transmissionMode-r10	tm1		1TX
	tm2		2TX
codebookSubsetRestriction-r10	Not present		
ue-TransmitAntennaSelection	release		
}			
crossCarrierSchedulingConfig-r10	Not present		
csi-RS-Config-r10	Not present		
pdsch-ConfigDedicated-r10	PDSCH-ConfigDedicated-DEFAULT		
}			
ul-Configuration-r10	Not present		
ul-Configuration-r10 SEQUENCE {			UL CA
antennaInfoUL-r10	Not present		
pusch-ConfigDedicatedSCell-r10	Not present		
uplinkPowerControlDedicatedSCell-r10	UplinkPowerControlDedicatedSCell-r10-DEFAULT		
cqi-ReportConfigSCell-r10	CQI-ReportConfigSCell-r10-DEFAULT		
soundingRS-UL-ConfigDedicated-r10	Not present		
soundingRS-UL-ConfigDedicated-v1020	Not present		
soundingRS-UL-ConfigDedicatedAperiodic-r10	Not present		
}			
cqi-ReportConfigSCell-v1250	Not present		
	CQI-ReportConfig-v1250-DEFAULT		DL 256QAM
pucch-Cell-r13	Not present		
	true		PUCCH-SCell1
pucch-SCell	Not present		
pucch-SCell CHOICE {			PUCCH-SCell
setup SEQUENCE {			
pucch-ConfigDedicated-r13	PUCCH-ConfigDedicated-r13-DEFAULT		
schedulingRequestConfig-r13	SchedulingRequestConfigSCell-r13-DEFAULT		
tpc-PDCCH-ConfigPUCCH-SCell-r13	TPC-PDCCH-ConfigSCell-r13-DEFAULT		
pusch-ConfigDedicated-r13	Not present		
uplinkPowerControlDedicated-r13	UplinkPowerControlDedicatedSCell-v1310-DEFAULT		
}			
}			
crossCarrierSchedulingConfig-r13	Not present		
pdcch-ConfigSCell-r13	Not present		
cqi-ReportConfig-v1310	Not present		
pdsch-ConfigDedicated-v1310	Not present		
soundingRS-UL-ConfigDedicated-v1310	Not present		
soundingRS-UL-ConfigDedicatedUpPTsExt-r13	Not present		
soundingRS-UL-ConfigDedicatedAperiodic-v1310	Not present		
soundingRS-UL-ConfigDedicatedAperiodicUpPTsExt-r13	Not present		
csi-RS-Config-v1310	Not present		
Laa-ScellConfiguration-r13	Not present		
Laa-ScellConfiguration-r13 SEQUENCE {			LAA
subframeStartPosition	's0'		

Laa-SCellSubframeConfig	'00000000'		
}			
csi-RS-ConfigNZPTToAddModListExt-r13	Not present		
csi-RS-ConfigNZPTToReleaseListExt-r13	Not present		
laa-SCellConfiguration-v1430 SEQUENCE {			eLAA
pdcch-ConfigLAA-r14 SEQUENCE {			
maxNumberOfSchedSubframes-Format0B-r14	sf4		
maxNumberOfSchedSubframes-Format4B-r14	sf4		
}			
}			
typeB-SRS-TPC-PDCCH-Config-r14	SRS-TPC-PDCCH-Config-r14-DEFAULT condition SETUP		SRS-Switching
uplinkPUSCH-LessPowerControlDedicated-v14xy SEQUENCE {			SRS-Switching
p0-UE-PeriodicSRS	0		
p0-UE-AperiodicSRS	0		
accumulationEnabled	true		
}			
soundingRS-UL-PeriodicConfigDedicatedList-r14 SEQUENCE (SIZE (1..2)) OF SEQUENCE {			SRS-Switching
soundingRS-UL-ConfigDedicated	SoundingRS-UL-ConfigDedicated-DEFAULT		
}			
soundingRS-UL-PeriodicConfigDedicatedUpPTsExtList-r14	Not Present		
soundingRS-UL-AperiodicConfigDedicatedList-r14	Not Present		
soundingRS-UL-ConfigDedicatedApUpPTsExtList-r14	Not Present		
}			

Condition	Explanation
UL CA	When UL Carrier Aggregation is used
1TX	1 SS Tx antenna environment
2TX	2 SS Tx antenna environment
DL 256QAM	When DL 256QAM is used
LAA	For LAA test cases
SRS-Switching	SRS transmission is switched to a PUSCH-less TDD SCell
PUCCH-SCell1	When PUCCH feedback of this SCell is sent on the PUCCH SCell
PUCCH-SCell	When this SCell is configured as PUCCH SCell
eLAA	When this SCell is configured as uplink LAA SCell

PhysicalConfigDedicatedSCell-r10-eIMTA

Table 4.6.3-6B: PhysicalConfigDedicatedSCell-r10-eIMTA

Derivation Path: 36.331 clause 6.3.2			
Information Element	Value/remark	Comment	Condition
PhysicalConfigDedicatedSCell-r10-eIMTA ::= SEQUENCE {			
nonUL-Configuration-r10 SEQUENCE {			
antennaInfo-r10 SEQUENCE {			
transmissionMode-r10	tm1		1TX
	tm2		2TX
codebookSubsetRestriction-r10	Not present		
ue-TransmitAntennaSelection	release		
}			
crossCarrierSchedulingConfig-r10	Not present		
csi-RS-Config-r10	Not present		
pdsch-ConfigDedicated-r10	PDSCH-ConfigDedicated-DEFAULT		
}			
ul-Configuration-r10	Not present		
ul-Configuration-r10 SEQUENCE {			UL CA
antennaInfoUL-r10	Not present		
pusch-ConfigDedicatedSCell-r10	Not present		
uplinkPowerControlDedicatedSCell-r10	UplinkPowerControlDedicatedSCell-r10-DEFAULT		
cqi-ReportConfigSCell-r10	CQI-ReportConfigSCell-r10-DEFAULT		
soundingRS-UL-ConfigDedicated-r10	Not present		
soundingRS-UL-ConfigDedicated-v1020	Not present		
soundingRS-UL-ConfigDedicatedAperiodic-r10	Not present		
}			
antennaInfo-v1250	Not present		eIMTA
eimta-MainConfigSCell-r12	EIMTA-MainConfigServCell-r12-DEFAULT		eIMTA
	Not present		
cqi-ReportConfigSCell-v1250	CQI-ReportConfig-v1250-DEFAULT		eIMTA
	Not present		
uplinkPowerControlDedicatedSCell-v1250	UplinkPowerControlDedicated-v1250-DEFAULT		eIMTA
	Not present		
csi-RS-Config-v1250	Not present		eIMTA
}			

Condition	Explanation
UL CA	When UL Carrier Aggregation is used.
1TX	1 SS Tx antenna environment
2TX	2 SS Tx antenna environment
eIMTA	eIMTA cell environment

PRACH-Config-DEFAULT

Table 4.6.3-7: PRACH-Config-DEFAULT

Derivation Path: 36.331 clause 6.3.2			
Information Element	Value/remark	Comment	Condition
PRACH-Config-DEFAULT ::= SEQUENCE {			
rootSequenceIndex	See clause 4.4.2, Table 4.4.2-1A and clause 6.3.2.2 Table 6.3.2.2-2	See table 5.7.2-4 in TS 36.211 for PRACH format 0-3	FDD
	See clause 4.4.2, Table 4.4.2-1A and clause 6.3.2.2 Table 6.3.2.2-2	See table 5.7.2-5 in TS 36.211 for PRACH format 4	TDD
prach-ConfigInfo SEQUENCE {			
prach-ConfigIndex	3	Typical value in real network for FDD (see table 5.7.1-1 and 5.7.1-2 in TS 36.211)	FDD
	51	Typical value in real network for TDD (see table 5.7.1-3 and 5.7.1-4 in TS 36.211)	TDD
highSpeedFlag	FALSE (Unrestricted set)	High speed train configuration doesn't apply by default.	
zeroCorrelationZoneConfig	5 (N _{cs} configuration = 5)	Assuming cell radius is up to approximately 3 km.	FDD
	4 (N _{cs} configuration = 4)	Assuming cell radius is up to approximately 1 km.	TDD
prach-FreqOffset	See subclause 4.6.8	Channel-bandwidth-dependent parameter	
}			
}			
Note: Although PRACH format 0-3 is applicable for both FDD and TDD, the PRACH format 4 is used as default for testing for TDD.			

Condition	Explanation
FDD	FDD cell environment
TDD	TDD cell environment

- PRACH-Config-v1310-DEFAULT

Table 4.6.3-7A: PRACH-Config-v1310-DEFAULT

Derivation Path: 36.331 clause 6.3.2			
Information Element	Value/remark	Comment	Condition
PRACH-Config-v1310-DEFAULT ::= SEQUENCE {			
rsrp-ThresholdsPrachInfoList-r13 SEQUENCE (SIZE(1..3)) OF {	Not present		
rsrp-ThresholdsPrachInfoList-r13 SEQUENCE (SIZE(1..3)) OF {	1 entry	Threshold values to determine the CE level for PRACH	CEmodeA
RSRP-Range[1]	42	-99dBm	
}			
mpdcch-startSF-CSS-RA-r13 CHOICE {			
fdd-r13	v1		FDD
tdd-r13	v1	ENUMERATED { v1, v2, v4, v5, v8, v10, v20, spare }	TDD
}			
prach-HoppingOffset-r13	Not present		
prach-ParametersListCE-r13 SEQUENCE (SIZE(1..maxCE-Level-r13)) OF SEQUENCE {	2 entries	1: CE level 0 2: CE level 1	CEmodeA
PRACH-ParametersCE-r13[1] SEQUENCE {			
prach-ConfigIndex-r13[1]	3 4 53		RF SIG_FDD OR RRM_FDD SIG_TDD OR RRM_TDD
prach-FreqOffset-r13[1]	See subclause 4.6.8	Same as prach-FrequencyOffset	
prach-StartingSubframe-r13[1]	sf2		
maxNumPreambleAttemptCE-r13[1]	n5		
numRepetitionPerPreambleAttempt-r13[1]	n1		
mpdcch-NarrowbandsToMonitor-r13 SEQUENCE (SIZE(1..2)) OF INTEGER (1..maxAvailNarrowBands-r13)[1] {	1 entry		
mpdcch-NarrowbandsToMonitor-r13[1]	1 Value as specified in TS 36.523-3 clause 7.3.3.9		RF OR RRM SIG
}			
mpdcch-NumRepetition-RA-r13[1]	r1		
prach-HoppingConfig-r13[1]	off		
}			
PRACH-ParametersCE-r13[2] SEQUENCE {			
prach-ConfigIndex-r13[2]	3 4 53		RF SIG_FDD OR RRM_FDD SIG_TDD OR RRM_TDD
prach-FreqOffset-r13[2]	See subclause 4.6.8		
prach-StartingSubframe-r13[2]	sf128		
maxNumPreambleAttemptCE-r13[2]	n5		
numRepetitionPerPreambleAttempt-r13[2]	n128		
mpdcch-NarrowbandsToMonitor-r13 SEQUENCE (SIZE(1..2)) OF INTEGER (1..maxAvailNarrowBands-r13)[2] {	1 entry		
mpdcch-NarrowbandsToMonitor-r13[1]	1 Value as specified in TS 36.523-3 clause 7.3.3.9		RF OR RRM SIG
}			
mpdcch-NumRepetition-RA-r13[2]	r4		
prach-HoppingConfig-r13[2]	off		
}			
}			

initial-CE-level-r13	0		
}			

Condition	Explanation
FDD	FDD cell environment
TDD	TDD cell environment
RF	Used for RF, performance and RRM testing
RRM	Used for RRM testing
RRM_FDD	Used for RRM testing in FDD cell environment
RRM_TDD	Used for RRM testing in TDD cell environment
SIG	Used for protocol testing
SIG_FDD	Used for protocol testing in FDD cell environment
SIG_TDD	Used for protocol testing in TDD cell environment
CEmodeA	Used for CE mode A testing

– PRACH-Config-v1430-DEFAULT

Table 4.6.3-7B: PRACH-Config-v1430-DEFAULT

Derivation Path: 36.331 clause 6.3.2			
Information Element	Value/remark	Comment	Condition
PRACH-Config-v1430-DEFAULT ::= SEQUENCE { rootSequenceIndexHighSpeed-r14	See clause 4.4.2, Table 4.4.2-1A and clause 6.3.2.2 Table 6.3.2.2-2	See table 5.7.2-4 in TS 36.211 for PRACH format 0-3	FDD
	See clause 4.4.2, Table 4.4.2-1A and clause 6.3.2.2 Table 6.3.2.2-2	See table 5.7.2-4 in TS 36.211 for PRACH format 0-3	TDD
prach-ConfigIndexHighSpeed-r14	3	Typical value in real network for FDD (see table 5.7.1-1 and 5.7.1-2 in TS 36.211)	FDD
	33	Typical value in real network for TDD (see table 5.7.1-3 and 5.7.1-4 in TS 36.211)	TDD
zeroCorrelationZoneConfigHighSpeed-r14	11 (N_{cs} configuration = 118)	Restricted set type B is used	FDD
	11 (N_{cs} configuration = 118)	Restricted set type B is used	TDD
prach-FreqOffsetHighSpeed-r14	See subclause 4.6.8	Channel-bandwidth-dependent parameter	
}			

Condition	Explanation
FDD	FDD cell environment
TDD	TDD cell environment

- PRACH-ConfigSIB-DEFAULT

Table 4.6.3-7a: PRACH-ConfigSIB-DEFAULT

Derivation Path: 36.508 clause 4.6.3 Table 4.6.3-7 PRACH-Config-DEFAULT

- PRACH-ConfigSIB-v1310-DEFAULT

Table 4.6.3-7b: PRACH-ConfigSIB-v1310-DEFAULT

Derivation Path: 36.331 clause 6.3.2			
Information Element	Value/remark	Comment	Condition
PRACH-ConfigSIB-v1310-DEFAULT ::= SEQUENCE {			
rsrp-ThresholdsPrachInfoList-r13 SEQUENCE (SIZE(1..3)) OF {	1 entry	Threshold values to determine the CE level 1 for PRACH. RSRP-Range values according to mapping table in TS 36.133 Table 9.1.14.3.3-1.	CEmodeA PRACH_2CE
RSRP-Range[1]	40	-101dBm	
}			
rsrp-ThresholdsPrachInfoList-r13 SEQUENCE (SIZE(1..3)) OF {	2 entries	Threshold values to determine the CE level 1, 2 and 3 for PRACH. RSRP-Range values according to mapping table in TS 36.133 Table 9.1.14.3.3-1.	CEmodeB PRACH_3CE
RSRP-Range[1]	42	-99 dBm	
RSRP-Range[2]	34	-107 dBm	
}			
rsrp-ThresholdsPrachInfoList-r13 SEQUENCE (SIZE(1..3)) OF {	3 entries	Threshold values to determine the CE level 1, 2 and 3 for PRACH. RSRP-Range values according to mapping table in TS 36.133 Table 9.1.14.3.3-1.	CEmodeB PRACH_4CE
RSRP-Range[1]	49	-92 dBm	
RSRP-Range[2]	42	-99 dBm	
RSRP-Range[3]	34	-107 dBm	
}			
mpdcch-startSF-CSS-RA-r13 CHOICE {			
fdd-r13	v1		FDD
tdd-r13	v2		TDD
}			
prach-HoppingOffset-r13	Not present		
prach-ParametersListCE-r13 SEQUENCE (SIZE(1..maxCE-Level-r13)) OF SEQUENCE {	2 entries	1: CE level 0 2: CE level 1	CEmodeA PRACH_2CE
prach-ConfigIndex-r13[1]	3 4 53		RF SIG_FDD OR RRM_FDD SIG_TDD OR RRM_TDD
prach-FreqOffset-r13[1]	See subclause 4.6.8	Same as prach-FrequencyOffset	
prach-StartingSubframe-r13[1]	sf2		
maxNumPreambleAttemptCE-r13[1]	n5		
numRepetitionPerPreambleAttempt-r13[1]	n1		
mpdcch-NarrowbandsToMonitor-r13 SEQUENCE (SIZE(1..2)) OF INTEGER (1..maxAvailNarrowBands-r13)[1]	1 entry		

mpdcch-NarrowbandsToMonitor-r13[1]	1		RF
	Value as specified in TS 36.523-3 clause 7.3.3.9		SIG
mpdcch-NumRepetition-RA-r13[1]	r1		
prach-HoppingConfig-r13[1]	off		
prach-ConfigIndex-r13[2]	3		RF
	4		SIG_FDD OR RRM_FDD
	53		SIG_TDD OR RRM_TDD
prach-FreqOffset-r13[2]	See subclause 4.6.8		
prach-StartingSubframe-r13[2]	sf128		
maxNumPreambleAttemptCE-r13[2]	n5		
numRepetitionPerPreambleAttempt-r13[2]	n128		
mpdcch-NarrowbandsToMonitor-r13 SEQUENCE (SIZE(1..2)) OF INTEGER (1..maxAvailNarrowBands-r13)[2]	1 entry		
mpdcch-NarrowbandsToMonitor-r13[1]	1		RF
	Value as specified in TS 36.523-3 clause 7.3.3.9		SIG
mpdcch-NumRepetition-RA-r13[2]	r4		
prach-HoppingConfig-r13[2]	off		
}			
prach-ParametersListCE-r13 SEQUENCE (SIZE(1..maxCE-Level-r13)) OF SEQUENCE {	3 entries	1: CE level 0 2: CE level 1 3: CE level 2	PRACH_3C E
prach-ConfigIndex-r13[1]	3		RF
	4		SIG_FDD OR RRM_FDD
	53		SIG_TDD OR RRM_TDD
prach-FreqOffset-r13[1]	See subclause 4.6.8		
prach-StartingSubframe-r13[1]	sf2		
maxNumPreambleAttemptCE-r13[1]	n5		
numRepetitionPerPreambleAttempt-r13[1]	n1		
mpdcch-NarrowbandsToMonitor-r13 SEQUENCE (SIZE(1..2)) OF INTEGER (1..maxAvailNarrowBands-r13)[1]	1 entry		
mpdcch-NarrowbandsToMonitor-r13[1]	1		RF
	Value as specified in TS 36.523-3 clause 7.3.3.9		SIG
mpdcch-NumRepetition-RA-r13[1]	r1		
prach-HoppingConfig-r13[1]	Off		
prach-ConfigIndex-r13[2]	3		RF
	4		SIG_FDD OR RRM_FDD
	53		SIG_TDD OR RRM_TDD
prach-FreqOffset-r13[2]	See subclause 4.6.8		
prach-StartingSubframe-r13[2]	Sf64		
maxNumPreambleAttemptCE-r13[2]	n5		
numRepetitionPerPreambleAttempt-r13[2]	n64		
mpdcch-NarrowbandsToMonitor-r13 SEQUENCE (SIZE(1..2)) OF INTEGER (1..maxAvailNarrowBands-r13)[2]	1 entry		
mpdcch-NarrowbandsToMonitor-r13[1]	1		RF
	Value as specified in TS 36.523-3 clause 7.3.3.9		SIG
mpdcch-NumRepetition-RA-r13[2]	r16		
prach-HoppingConfig-r13[2]	Off		

prach-ConfigIndex-r13[3]	3		RF
	4		SIG_FDD OR RRM_FDD
	53		SIG_TDD OR RRM_TDD
prach-FreqOffset-r13[3]	See subclause 4.6.8		
prach-StartingSubframe-r13[3]	sf128		
maxNumPreambleAttemptCE-r13[3]	n5		
numRepetitionPerPreambleAttempt-r13[3]	n128		
mpdcch-NarrowbandsToMonitor-r13 SEQUENCE (SIZE(1..2)) OF INTEGER (1..maxAvailNarrowBands-r13)[3]	1 entry		
mpdcch-NarrowbandsToMonitor-r13[1]	1		RF
	Value as specified in TS 36.523-3 clause 7.3.3.9		SIG
mpdcch-NumRepetition-RA-r13[3]	r64		
prach-HoppingConfig-r13[3]	Off		
}			
prach-ParametersListCE-r13 SEQUENCE (SIZE(1..maxCE-Level-r13)) OF SEQUENCE {	4 entries	1: CE level 0 2: CE level 1 3: CE level 2 4: CE level 3	CEmodeB PRACH_4C E
prach-ConfigIndex-r13[1]	3		RF
	4		SIG_FDD OR RRM_FDD
	53		SIG_TDD OR RRM_TDD
prach-FreqOffset-r13[1]	See subclause 4.6.8		
prach-StartingSubframe-r13[1]	sf2		
maxNumPreambleAttemptCE-r13[1]	n5		
numRepetitionPerPreambleAttempt-r13[1]	n1		
mpdcch-NarrowbandsToMonitor-r13 SEQUENCE (SIZE(1..2)) OF INTEGER (1..maxAvailNarrowBands-r13)[1]	1 entry		
mpdcch-NarrowbandsToMonitor-r13[1]	1		RF
	Value as specified in TS 36.523-3 clause 7.3.3.9		SIG
mpdcch-NumRepetition-RA-r13[1]	r1		
prach-HoppingConfig-r13[1]	Off		
prach-ConfigIndex-r13[2]	3		RF
	4		SIG_FDD OR RRM_FDD
	53		SIG_TDD OR RRM_TDD
prach-FreqOffset-r13[2]	See subclause 4.6.8		
prach-StartingSubframe-r13[2]	sf32		
maxNumPreambleAttemptCE-r13[2]	n5		
numRepetitionPerPreambleAttempt-r13[2]	n32		
mpdcch-NarrowbandsToMonitor-r13 SEQUENCE (SIZE(1..2)) OF INTEGER (1..maxAvailNarrowBands-r13)[2]	1 entry		
mpdcch-NarrowbandsToMonitor-r13[1]	1		RF
	Value as specified in TS 36.523-3 clause 7.3.3.9		SIG
mpdcch-NumRepetition-RA-r13[2]	r4		
prach-HoppingConfig-r13[2]	Off		
prach-ConfigIndex-r13[3]	3		RF
	4		SIG_FDD OR RRM_FDD

	53		SIG_TDD OR RRM_TDD
prach-FreqOffset-r13[3]	See subclause 4.6.8		
prach-StartingSubframe-r13[3]	sf64		
maxNumPreambleAttemptCE-r13[3]	n5		
numRepetitionPerPreambleAttempt-r13[3]	n64		
mpdcch-NarrowbandsToMonitor-r13 SEQUENCE (SIZE(1..2)) OF INTEGER (1..maxAvailNarrowBands- r13)[3]	1 entry		
mpdcch-NarrowbandsToMonitor-r13[1]	1		RF
	Value as specified in TS 36.523-3 clause 7.3.3.9		SIG
mpdcch-NumRepetition-RA-r13[3]	r16		
prach-HoppingConfig-r13[3]	Off		
prach-ConfigIndex-r13[4]	3		RF
	4		SIG_FDD OR RRM_FDD
	53		SIG_TDD OR RRM_TDD
prach-FreqOffset-r13[4]	See subclause 4.6.8		
prach-StartingSubframe-r13[4]	sf128		
maxNumPreambleAttemptCE-r13[4]	n5		
numRepetitionPerPreambleAttempt-r13[4]	n128		
mpdcch-NarrowbandsToMonitor-r13 SEQUENCE (SIZE(1..2)) OF INTEGER (1..maxAvailNarrowBands- r13)[4]	1 entry		
mpdcch-NarrowbandsToMonitor-r13[1]	1		RF
	Value as specified in TS 36.523-3 clause 7.3.3.9		SIG
mpdcch-NumRepetition-RA-r13[4]	r64		
prach-HoppingConfig-r13[4]	Off		
}			
}			

Condition	Explanation
FDD	FDD cell environment
TDD	TDD cell environment
RF	Used for RF, performance and RRM testing
RRM	Used for RRM testing
RRM_FDD	Used for RRM testing in FDD cell environment
RRM_TDD	Used for RRM testing in TDD cell environment
SIG	Used for protocol testing
SIG_FDD	Used for protocol testing in FDD cell environment
SIG_TDD	Used for protocol testing in TDD cell environment
CEmodeA	Used for CE mode A testing using 2 CE levels
CEmodeB	Used for CE mode B testing using 4 CE levels
PRACH_2CE	Used for RRM testing using reference PRACH Configurations PRACH_2CE in TS 36.521-3 clause A.9
PRACH_3CE	Used for RRM testing using reference PRACH Configurations PRACH_3CE in TS 36.521-3 clause A.9
PRACH_4CE	Used for RRM testing using reference PRACH Configurations PRACH_4CE in TS 36.521-3 clause A.9

– PUCCH-ConfigCommon-DEFAULT

Table 4.6.3-8: PUCCH-ConfigCommon-DEFAULT

Derivation Path: 36.331 clause 6.3.2			
Information Element	Value/remark	Comment	Condition
PUCCH-ConfigCommon-DEFAULT ::= SEQUENCE {			
deltaPUCCH-Shift	ds2	Assuming typical values of the maximum delay spread	
nRB-CQI	See subclause 4.6.8	Channel-bandwidth-dependent parameter	
nCS-AN	6		
n1PUCCH-AN	0		
}			

- PUCCH-ConfigCommon-v1310-DEFAULT

Table 4.6.3-8A: PUCCH-ConfigCommon-v1310-DEFAULT

Derivation Path: 36.331 clause 6.3.2			
Information Element	Value/remark	Comment	Condition
PUCCH-ConfigCommon-v1310-DEFAULT ::= SEQUENCE {			
n1PUCCH-AN-InfoList-r13 SEQUENCE (SIZE(1..maxCE-Level-r13)) OF INTEGER (0..2047)	2 entries		CEmodeA
n1PUCCH-AN-InfoList-r13[1]	2		
n1PUCCH-AN-InfoList-r13[2]	2		
n1PUCCH-AN-InfoList-r13 SEQUENCE (SIZE(1..maxCE-Level-r13)) OF INTEGER (0..2047)	4 entries		CEmodeB
n1PUCCH-AN-InfoList-r13[1]	0	INTEGER (0..2047)	
n1PUCCH-AN-InfoList-r13[2]	0	INTEGER (0..2047)	
n1PUCCH-AN-InfoList-r13[3]	0	INTEGER (0..2047)	
n1PUCCH-AN-InfoList-r13[4]	0	INTEGER (0..2047)	
pucch-NumRepetitionCE-Msg4-Level0-r13	n4		
pucch-NumRepetitionCE-Msg4-Level1-r13	n4		
pucch-NumRepetitionCE-Msg4-Level2-r13	n16		CEmodeB
pucch-NumRepetitionCE-Msg4-Level3-r13	n16		CEmodeB
}			

Condition	Explanation
CEmodeA	Used for CE mode A testing
CEmodeB	Used for CE mode B testing

– PUCCH-ConfigDedicated-DEFAULT

Table 4.6.3-9: PUCCH-ConfigDedicated-DEFAULT

Derivation Path: 36.331 clause 6.3.2			
Information Element	Value/remark	Comment	Condition
PUCCH-ConfigDedicated-DEFAULT ::= SEQUENCE {			
ackNackRepetition CHOICE {			
release	NULL		
}			
tddAckNackFeedbackMode	Not present		FDD
	multiplexing	Multiplexing is selected as default to align with RAN4's assumptions in RF tests.	TDD
}			

Condition	Explanation
FDD	FDD cell environment
TDD	TDD cell environment

– PUCCH-ConfigDedicated-v1130-DEFAULT

Table 4.6.3-9AA: PUCCH-ConfigDedicated-v1130-DEFAULT

Derivation Path: 36.331 clause 6.3.2			
Information Element	Value/remark	Comment	Condition
PUCCH-ConfigDedicated-v1130-DEFAULT ::= SEQUENCE {			
n1PUCCH-AN-CS-v1130 CHOICE {			
release	NULL		
setup SEQUENCE {	2 entries		
n1PUCCH-AN-CS-ListP1-r11[1]	FFS		
n1PUCCH-AN-CS-ListP1-r11[2]	FFS		
}			
}			
nPUCCH-Param-r11 CHOICE {			
release	NULL		
setup SEQUENCE {			
nPUCCH-Identity-r11	FFS		
n1PUCCH-AN-r11	FFS		
}			
}			
}			

– PUCCH-ConfigDedicated-v1250-DEFAULT

Table 4.6.3-9AB: PUCCH-ConfigDedicated-v1250-DEFAULT

Derivation Path: 36.331 clause 6.3.2			
Information Element	Value/remark	Comment	Condition
PUCCH-ConfigDedicated-v1250-DEFAULT ::= SEQUENCE {			
nkaPUCCH-Param-r12 CHOICE {			
setup SEQUENCE {			
nkaPUCCH-AN-r12	FFS		
}			
}			
}			

– PUCCH-ConfigDedicated-r13-DEFAULT

Table 4.6.3-9AC: PUCCH-ConfigDedicated-r13-DEFAULT

Derivation Path: 36.331 clause 6.3.2			
Information Element	Value/remark	Comment	Condition
PUCCH-ConfigDedicated-r13-DEFAULT ::= SEQUENCE {			
ackNackRepetition-R13 CHOICE {			
release	NULL		
}			
tddAckNackFeedbackMode	Not present		FDD
	multiplexing	Multiplexing is selected as default to align with RAN4's assumptions in RF tests.	TDD
pucch-Format-r13 CHOICE {}	Not present		
twoAntennaPortActivatedPUCCH-Format1a1b-r13	Not present		
simultaneousPUCCH-PUSCH-r13	Not present		
n1PUCCH-AN-RepP1-r13	Not present		
nPUCCH-Param-r13 CHOICE {}	Not present		
nkaPUCCH-Param-r13 CHOICE {}	Not present		
spatialBundlingPUCCH	FALSE		
spatialBundlingPUSCH	FALSE		
harq-TimingTDD	FALSE		
codebooksizeDetermination-r13	Not present		
maximumPayloadCoderate-r13	0		
pucch-NumRepetitionCE-r13 CHOICE {}	Not present		
pucch-NumRepetitionCE-r13 CHOICE {			CEmodeA, CEmodeB
setup CHOICE {			
modeA SEQUENCE {			CEmodeA
pucch-NumRepetitionCE-format1-r13	r1	No repetitions used for protocol and performance testing to reduce the round trip time for large signaling messages.	
pucch-NumRepetitionCE-format2-r13	r1		
}			
modeB SEQUENCE {			CEmodeB
pucch-NumRepetitionCE-format1-r13	r4		
pucch-NumRepetitionCE-format2-r13	r4		
}			
}			
}			

Condition	Explanation
CEmodeA	Used for CE mode A testing
CEmodeB	Used for CE mode B testing

PUSCH-ConfigCommon-DEFAULT

Table 4.6.3-10: PUSCH-ConfigCommon-DEFAULT

Derivation Path: 36.331 clause 6.3.2			
Information Element	Value/remark	Comment	Condition
PUSCH-ConfigCommon-DEFAULT ::= SEQUENCE {			
pusch-ConfigBasic SEQUENCE {			
n-SB	1	Typical configuration in real network	
hoppingMode	interSubFrame	Typical configuration in real network	
pusch-HoppingOffset	See subclause 4.6.8	Channel-bandwidth-dependent parameter	
enable64QAM	FALSE		
	TRUE		UL64QAM
}			
ul-ReferenceSignalsPUSCH SEQUENCE {			
groupHoppingEnabled	TRUE	In accordance with "the RAN5 LTE UE Feature list".	
groupAssignmentPUSCH	0	Typical value in real network	
sequenceHoppingEnabled	FALSE	In accordance with "the RAN5 LTE UE Feature list".	
cyclicShift	0		
}			
}			

Condition	Explanation
UL64QAM	Used for UL 64QAM testing

PUSCH-ConfigCommon-v1310DEFAULT

Table 4.6.3-10A: PUSCH-ConfigCommon-v1310-DEFAULT

Derivation Path: 36.331 clause 6.3.2			
Information Element	Value/remark	Comment	Condition
PUSCH-ConfigCommon-v1310-DEFAULT ::= SEQUENCE {			
pusch-maxNumRepetitionCEmodeA-r13	Not present	Default value (r8) as defined in TS 36.213 [29, clause 8.0] apply (minimum value for CE Mode A)	CEmodeA
pusch-maxNumRepetitionCEmodeB-r13	r192	Set to minimum value for CE Mode B	CEmodeB
pusch-HoppingOffset-v13xy	Not present	No PUSCH frequency hopping	
}			

Condition	Explanation
-----------	-------------

CEmodeA	Used for CE mode A testing
CEmodeB	Used for CE mode B testing

– PUSCH-ConfigDedicated-r13DEFAULT

Table 4.6.3-11: PUSCH-ConfigDedicated-DEFAULT

Derivation Path: 36.331 clause 6.3.2			
Information Element	Value/remark	Comment	Condition
PUSCH-ConfigDedicated-DEFAULT ::= SEQUENCE {			
betaOffset-ACK-Index	9		
betaOffset-RI-Index	6		
betaOffset-CQI-Index	6		
}			

Table 4.6.3-11A: Void

– PUSCH-ConfigDedicated-v1130-DEFAULT

Table 4.6.3-11AA: PUSCH-ConfigDedicated-v1130-DEFAULT

Derivation Path: 36.331 clause 6.3.2			
Information Element	Value/remark	Comment	Condition
PUSCH-ConfigDedicated-v1130-DEFAULT ::= SEQUENCE {			
pusch-DMRS-r11 CHOICE {			
release	NULL		
setup SEQUENCE {			
nPUSCH-Identity-r11	FFS		
nDMRS-CSH-Identity-r11	FFS		
}			
}			
}			

– PUSCH-ConfigDedicated-v1250-DEFAULT

Table 4.6.3-11AB: PUSCH-ConfigDedicated-v1250-DEFAULT

Derivation Path: 36.331 clause 6.3.2			
Information Element	Value/remark	Comment	Condition
PUSCH-ConfigDedicated-v1250-DEFAULT ::= SEQUENCE {			
UciOnPUSCH CHOICE {			
setup SEQUENCE {			
betaOffset-ACK-Index-SubframeSet2-r12	9		
betaOffset-RI-Index-SubframeSet2-r12	6		
betaOffset-CQI-Index-SubframeSet2-r12	6		
betaOffsetMC-r12 SEQUENCE {			
betaOffset-ACK-Index-MC-SubframeSet2-r12	Not present		
betaOffset-RI-Index-MC-SubframeSet2-r12	Not present		
betaOffset-CQI-Index-MC-SubframeSet2-r12	Not present		
}			
}			
}			
}			

– PUSCH-ConfigDedicated--DEFAULT

Table 4.6.3-11AC: PUSCH-ConfigDedicated-r13-DEFAULT

Derivation Path: 36.331 clause 6.3.2			
Information Element	Value/remark	Comment	Condition
PUSCH-ConfigDedicated-r13-DEFAULT ::= SEQUENCE {			
betaOffset-ACK-Index-r13	9		
betaOffset2-ACK-Index-r13	Not present		
betaOffset-RI-Index-r13	6		
betaOffset-CQI-Index-r13	6		
betaOffsetMC-r13 SEQUENCE {}	Not present		
groupHoppingDisabled-r13	Not present		
dmrs-WithOCC-Activated-r13	Not present		
pusch-DMRS-r11	Not present		
uciOnPUSCH	Not present		
pusch-HoppingConfig-r13	Not Present	No PUSCH frequency hopping for BL UEs and UEs in CE	
}			

– PUSCH-EnhancementsConfig-r14-DEFAULT

Table 4.6.3-11AD: PUSCH-EnhancementsConfig-r14-DEFAULT

Derivation Path: 36.331 clause 6.3.2			
Information Element	Value/remark	Comment	Condition
PUSCH-EnhancementsConfig-r14-DEFAULT ::= CHOICE {			
Release	NULL		PuschEnhancement_Release
Setup SEQUENCE {			PuschEnhancement_Setup
pusch-HoppingOffsetPUSCH-Enh-r14	1		
interval-ULHoppingPUSCH-Enh-r14 CHOICE{			
interval-FDD-PUSCH-Enh-r14	int1	FDD	
interval-TDD-PUSCH-Enh-r14	int1	TDD	
}			
}			
}			

Condition	Explanation
PuschEnhancement_Release	UE is not allowed to apply PUSCH enhancement
PuschEnhancement_Setup	UE is allowed to apply PUSCH enhancement.

– RACH-ConfigCommon-DEFAULT

Table 4.6.3-12: RACH-ConfigCommon-DEFAULT

Derivation Path: 36.331 clause 6.3.2			
Information Element	Value/remark	Comment	Condition
RACH-ConfigCommon-DEFAULT ::= SEQUENCE {			
preambleInfo SEQUENCE {			
numberOfRA-Preambles	n52	Assuming the number of dedicated preambles is 12.	
preamblesGroupAConfig SEQUENCE {	Not present		
}			
powerRampingParameters SEQUENCE {			
powerRampingStep	dB2		
preambleInitialReceivedTargetPower	dBm-104 (default)	Thermal noise = -113 dBm NF = 5 dB IoT = 6 dB Required SNR = -8 dB (See table 8.4.2-1 in TS 36.104 [30]) -> -110 dB (default value is acceptable)	
}			
ra-SupervisionInfo SEQUENCE {			
preambleTransMax	n6	Under the condition of Case 1 in RAN1 simulation assumptions, an UE with pathloss of CDF = 90% reaches the maximum transmit power in 4 successive retransmissions. 6 has been selected considering the margin of 2.	
ra-ResponseWindowSize	sf10	The maximum value is preferable.	
mac-ContentionResolutionTimer	sf48	Allows for a sufficient number of msg3 retransmissions.	
}			
maxHARQ-Msg3Tx	4	Under the condition of Target SIR = 2 dB, the probability of 2 transmissions is less than 1%. 4 has been selected considering the margin of 2.	
preambleTransMax-CE-r13	Not present		
preambleTransMax-CE-r13	n6	Same as preambleTransMax	CEmodeA or CEmodeB
RACH-CE-LevelInfoList-r13	Not present		
RACH-CE-LevelInfoList-r13 SEQUENCE (SIZE (1..maxCE-Level-r13)) OF RACH-CE-LevelInfo-r13	2 entries	first two 2 entries [1] and [2] of list to be used	CEmodeA

RACH-CE-LevelInfoList-r13 SEQUENCE (SIZE (1..maxCE-Level-r13)) OF RACH-CE-LevelInfo-r13	4 entries		CEmodeB
RACH-CE-LevelInfo-r13[1] SEQUENCE {			
preambleMappingInfo-r13 SEQUENCE {			
firstPreamble-r13	0		
lastPreamble-r13	14		
}			
ra-ResponseWindowSize-r13	sf20		
mac-ContentionResolutionTimer-r13	sf80	Allows for a sufficient number of msg3 retransmissions. Longer time for increasing CE levels.	
rar-HoppingConfig-r13	off		
}			
RACH-CE-LevelInfo-r13[2] SEQUENCE {			
preambleMappingInfo-r13 SEQUENCE {			
firstPreamble-r13	15		
lastPreamble-r13	29		
}			
ra-ResponseWindowSize-r13	sf80		
mac-ContentionResolutionTimer-r13	sf120		
rar-HoppingConfig-r13	off		
}			
RACH-CE-LevelInfo-r13[3] SEQUENCE {			
PreambleMappingInfo-r13[3] SEQUENCE {			
firstPreamble-r13	30		
lastPreamble-r13	44		
}			
ra-ResponseWindowSize-r13	sf180		
mac-ContentionResolutionTimer-r13	sf200		
rar-HoppingConfig-r13	off		
}			
RACH-CE-LevelInfo-r13[4] SEQUENCE {			
preambleMappingInfo-r13 SEQUENCE {			
firstPreamble-r13	45		
lastPreamble-r13	60		
}			
ra-ResponseWindowSize-r13	sf320		
mac-ContentionResolutionTimer-r13	sf480		
rar-HoppingConfig-r13	off		
}			
}			
}			
}			

Condition	Explanation
CEmodeA	Used for CE mode A testing
CEmodeB	Used for CE mode B testing

– Rach-ConfigDedicated-DEFAULT

Table 4.6.3-12A: Rach-ConfigDedicated-DEFAULT

Derivation Path: 36.331 clause 6.3.2			
Information Element	Value/remark	Comment	Condition
Rach-ConfigDedicated-DEFAULT ::= SEQUENCE {			
ra-PreambleIndex	52		
ra-PRACH-MaskIndex	0		
}			

– RadioResourceConfigCommon-DEFAULT

Table 4.6.3-13: RadioResourceConfigCommon-DEFAULT

Derivation Path: 36.331 clause 6.3.2			
Information Element	Value/remark	Comment	Condition
RadioResourceConfigCommon-DEFAULT ::= SEQUENCE {			
rach-ConfigCommon	RACH-ConfigCommon-DEFAULT		
prach-Config	PRACH-Config-DEFAULT		
pdsch-ConfigCommon	Not present		
	PDSCH-ConfigCommon-DEFAULT		FullConfig, HO-to-EUTRA
pusch-ConfigCommon	PUSCH-ConfigCommon-DEFAULT		
phich-Config	Not present		
	PHICH-Config-DEFAULT		FullConfig, HO-to-EUTRA
pucch-ConfigCommon	Not present		SAME-BW
	PUCCH-ConfigCommon-DEFAULT		DIFF-BW, FullConfig, HO-to-EUTRA
soundingRSUL-ConfigCommon	SoundingRS-UL-ConfigCommon-DEFAULT		
uplinkPowerControlCommon	Not present		
	UplinkPowerControlCommon-DEFAULT		FullConfig, HO-to-EUTRA
antennaInfoCommon	Not present		
antennaInfoCommon SEQUENCE {			2TX
antennaPortsCount	an2		
}			
antennaInfoCommon SEQUENCE {			4TX
antennaPortsCount	an4		
}			
antennaInfoCommon SEQUENCE {			FullConfig, HO-to-EUTRA
antennaPortsCount	an1		
}			
p-Max	Not present		
tdd-Config	Not present		FDD or LAA SCell
	TDD-Config-DEFAULT		TDD
ul-CyclicPrefixLength	len1		
uplinkPowerControlCommon-v1020	UplinkPowerControlCommon-v1020-DEFAULT		CA
}	Not present		
tdd-Config-v1130	Not present		
pusch-ConfigCommon-v1270	Not present		
prach-Config-v1310	Not present		
	PRACH-Config-v1310-DEFAULT		CEmodeA, CEmodeB
freqHoppingParameters-r13	Not present		
	FreqHoppingParameters-r13-DEFAULT		(CEmodeA OR CEmodeB) AND SIG
pdsch-ConfigCommon-v1310	Not present		
	PDSCH-ConfigCommon-v1310-DEFAULT		CEmodeA, CEmodeB
pucch-ConfigCommon-v1310	Not present		
	PUCCH-ConfigCommon-v1310-DEFAULT		CEmodeA, CEmodeB

pusch-ConfigCommon-v1310	Not present		
	PUSCH-ConfigCommon-v1310-DEFAULT		CEmodeA, CEmodeB
uplinkPowerControlCommon-v1310	Not present		
highSpeedConfig-r14	Not present		
	HighSpeedConfig-r14-DEFAULT		HighSpeedEnhance
prach-Config-v1430	Not present		
	PRACH-Config-v1430-DEFAULT		HighSpeedEnhance
}			

Condition	Explanation
FDD	FDD cell environment
TDD	TDD cell environment
2TX	Used for cells with two antenna ports
4TX	Used for cells with four antenna ports
SAME-BW	Source and target cell are configured with same bandwidth
DIFF-BW	Source and target cell are configured with different bandwidth
UL CA	When UL Carrier Aggregation is used.
FullConfig	Handover with full configuration option (Rel-9 or later)
HO-to-EUTRA	Inter-RAT handover to E-UTRA
CA	For Carrier Aggregation Test cases
CEmodeA	Used for CE mode A testing
CEmodeB	Used for CE mode B testing
LAA SCell	For LAA SCell environment
SIG	For Signalling test cases
HighSpeedEnhance	High speed test environment

– RadioResourceConfigCommonSCell-r10-DEFAULT

Table 4.6.3-13A: RadioResourceConfigCommonSCell-r10-DEFAULT

Derivation Path: 36.331 clause 6.3.2			
Information Element	Value/remark	Comment	Condition
RadioResourceConfigCommonSCell-r10-DEFAULT ::= SEQUENCE {			
nonUL-Configuration-r10 SEQUENCE {			
dl-Bandwidth-r10	Same downlink bandwidth as used for target SCell		
antennaInfoCommon-r10 SEQUENCE {			
antennaPortsCount	an1		1TX
antennaPortsCount	an2		2TX
antennaPortsCount	an4		4TX
}			
mbsfn-SubframeConfigList-r10	Not present		
phich-Config-r10	PHICH-Config-DEFAULT		
pdsch-ConfigCommon-r10	PDSCH-ConfigCommon-DEFAULT		
tdd-Config-r10	Not present		FDD
}	TDD-Config-DEFAULT		TDD
}			
ul-Configuration-r10	Not present		
ul-Configuration-r10 SEQUENCE {			UL CA
ul-FreqInfo-r10 SEQUENCE {			
ul-CarrierFreq-r10	Not present		
ul-Bandwidth-r10	Not present		
additionalSpectrumEmissionSCell-r10	1 (CA_NS_01)		
}			
p-Max-r10	Not present		
uplinkPowerControlCommonSCell-r10	UplinkPowerControlCommonSCell-r10-DEFAULT		
soundingRS-UL-ConfigCommon-r10	SoundingRS-UL-ConfigCommon-DEFAULT		
ul-CyclicPrefixLength-r10	len1		
prach-ConfigSCell-r10	Not present		FDD
}	FFS		TDD
pusch-ConfigCommon-r10	PUSCH-ConfigCommon-DEFAULT		
}			
pusch-ConfigCommon-v1270	Not present		
pusch-ConfigCommon-v1270 SEQUENCE {			UL64QAM
enable64QAM-v1270	true		
}			
pucch-ConfigCommon-r13	Not present		
}	PUCCH-ConfigCommon-DEFAULT		PUCCH SCell
uplinkPowerControlCommonSCell-v1310	Not present		
}	UplinkPowerControlCommonSCell-v1310		PUCCH SCell
ul-Configuration-r14 SEQUENCE {			SRS-Switching
ul-FreqInfo-r14 SEQUENCE {			
ul-CarrierFreq-r14	Not present		
ul-Bandwidth-r14	Not present		
additionalSpectrumEmissionSCell-r14	1 (CA_NS_01)		
}			
p-Max-r14	Not present		
soundingRS-UL-ConfigCommon-r14	SoundingRS-UL-ConfigCommon-DEFAULT		
ul-CyclicPrefixLength-r14	len1		
prach-ConfigSCell-r14	Not Present		
uplinkPowerControlCommonPUSCH-LessCell-v14xy SEQUENCE {			

p0-Nominal-PeriodicSRS-r14	-85	Same as default PUSCH p0-Nominal	
p0-Nominal-AperiodicSRS-r14	-85	Same as default PUSCH p0-Nominal	
alpha-SRS-r14	al08		
}			
harq-ReferenceConfig-r14	Not Present		
soundingRS-FlexibleTiming-r14	Not Present		
}			
highSpeedConfigSCell-r14	Not Present		
	HighSpeedConfigSCell-r14-DEFAULT		HighSpeed Enhance
prach-Config-v1430	Not present		
	PRACH-Config-v1430-DEFAULT		HighSpeed Enhance
}			

Condition	Explanation
FDD	FDD cell environment
TDD	TDD cell environment
UL CA	When UL Carrier Aggregation is used.
1TX	Used for SCell with one antenna port
2TX	Used for SCell with two antenna ports
4TX	Used for SCell with four antenna ports
SRS-Switching	SRS transmission is switched to a PUSCH-less TDD SCell.
HighSpeedEnhance	High speed test environment
PUCCH-SCell	When this SCell is configured as PUCCH SCell
UL64QAM	Used for UL 64QAM testing for SCell

RadioResourceConfigCommonSIB-DEFAULT

Table 4.6.3-14: RadioResourceConfigCommonSIB-DEFAULT

Derivation Path: 36.331 clause 6.3.2			
Information Element	Value/remark	Comment	Condition
RadioResourceConfigCommonSIB-DEFAULT ::= SEQUENCE {			
rach-ConfigCommon	RACH-ConfigCommon-DEFAULT		
bcch-Config	BCCH-Config-DEFAULT		
pcch-Config	PCCH-Config-DEFAULT		
prach-Config	PRACH-ConfigSIB-DEFAULT		
pdsch-ConfigCommon	PDSCH-ConfigCommon-DEFAULT		
pusch-ConfigCommon	PUSCH-ConfigCommon-DEFAULT		
pucch-ConfigCommon	PUCCH-ConfigCommon-DEFAULT		
soundingRS-UL-ConfigCommon	SoundingRS-UL-ConfigCommon-DEFAULT		
uplinkPowerControlCommon	UplinkPowerControlCommon-DEFAULT		
ul-CyclicPrefixLength	len1		
uplinkPowerControlCommon-v1020	Not present		
	UplinkPowerControlCommon-v1020-DEFAULT		CA
rach-ConfigCommon-v1250	Not present		
pusch-ConfigCommon-v1270	Not present		
pusch-ConfigCommon-v1270 SEQUENCE {			UL64QAM
enable64QAM-v1270	true		
}			
bcch-Config-v1310	Not present		
pcch-Config-v1310	Not present		
	PCCH-Config-v1310-DEFAULT		CEmodeA, CEmodeB
freqHoppingParameters-r13	Not Present		
	FreqHoppingParameters-r13-DEFAULT		CEmodeA, CEmodeB
pdsch-ConfigCommon-v1310	Not present		
	PDSCH-ConfigCommon-v1310-DEFAULT		CEmodeA, CEmodeB
pusch-ConfigCommon-v1310	Not present		
	PUSCH-ConfigCommon-v1310-DEFAULT		CEmodeA, CEmodeB
prach-ConfigCommon-v1310	Not present		
	PRACH-ConfigSIB-v1310-DEFAULT		CEmodeA, CEmodeB
pucch-ConfigCommon-v1310	Not present		
	PUCCH-ConfigCommon-v1310-DEFAULT		CEmodeA, CEmodeB
highSpeedConfig-r14	Not present		
	HighSpeedConfig-r14-DEFAULT		HighSpeedEnhance
prach-Config-v1430	Not present		
	PRACH-Config-v1430-DEFAULT		HighSpeedEnhance
}			

Condition	Explanation
-----------	-------------

CA	For Carrier Aggregation test cases
CEmodeA	Used for CE mode A testing
CEmodeB	Used for CE mode B testing
HighSpeedEnhance	High speed test environment
UL64QAM	Used for UL 64QAM testing

– RadioResourceConfigDedicated-SRB1

Table 4.6.3-15: RadioResourceConfigDedicated-SRB1

Derivation Path: 36.331 clause 6.3.2			
Information Element	Value/remark	Comment	Condition
RadioResourceConfigDedicated-SRB1 ::= SEQUENCE {			
srb-ToAddModList SEQUENCE (SIZE (1..2)) OF SEQUENCE {	1 entry, with value SRB-ToAddMod-DEFAULT using condition SRB1		
drb-ToAddModList	Not present		
drb-ToReleaseList	Not present		
mac-MainConfig CHOICE {			
explicitValue	MAC-MainConfig-SRB	See subclause 4.8.2	
}			
sps-Config	Not present		
physicalConfigDedicated	PhysicalConfigDedicated-DEFAULT using condition SRB1	For signalling test cases see subclause 6.6B.1.1.1. Otherwise, see subclause 4.8.2	
}			

RadioResourceConfigDedicated-SRB2-DRB(n,m)

Table 4.6.3-16: RadioResourceConfigDedicated-SRB2-DRB(n,m)

Derivation Path: 36.331 clause 6.3.2			
Information Element	Value/remark	Comment	Condition
RadioResourceConfigDedicated-SRB2-DRB(n, m) ::= SEQUENCE {		n is the number of AM RLC DRBs (1..N) m is the number of UM RLC DRBs (0..M)	
srb-ToAddModList SEQUENCE (SIZE (1..2)) OF SEQUENCE {	1 entry		
srb-ToAddMod[1]	SRB-ToAddMod-DEFAULT using condition SRB2	See subclause 4.8.2	
}			
drb-ToAddModList SEQUENCE (SIZE (1..maxDRB)) OF SEQUENCE {	n+m entries		
drb-ToAddMod[k, k=1..n]	DRB-ToAddMod-DEFAULT (k) using condition AM	n AM RLC DRBs See subclause 4.8.2	
drb-ToAddMod[k, k=n+1..n+m]	DRB-ToAddMod-DEFAULT (k) using condition UM	m UM RLC DRBs See subclause 4.8.2	m>0
}			
drb-ToReleaseList	Not present		
mac-MainConfig CHOICE {			
explicitValue	MAC-MainConfig-RBC using condition DRX_L (note)	See subclause 4.8.2	m=0
	MAC-MainConfig-RBC using condition DRX_S (note)	See subclause 4.8.2	m>0
}			
sps-Config	Not present		
physicalConfigDedicated	PhysicalConfigDedicated-DEFAULT using condition RBC	For signalling test cases see subclause 6.6B.1.1.1. Otherwise, see subclause 4.8.2	
}			
NOTE: In cases where no RLC-UM bearer is configured, large DRX Cycle length is used. In cases where at least one RLC-UM bearer is configured, small DRX Cycle length is used.			

Condition	Explanation
m=0	m is equal to zero
m>0	m is greater than zero

RadioResourceConfigDedicated-DRB(n,m)

Table 4.6.3-17: RadioResourceConfigDedicated-DRB(n,m)

Derivation Path: 36.331 clause 6.3.2			
Information Element	Value/remark	Comment	Condition
RadioResourceConfigDedicated-DRB(n, m) ::= SEQUENCE {		n is the number of AM RLC DRBs (0..N) m is the number of UM RLC DRBs (0..M)	
srb-ToAddModList	Not present		
drb-ToAddModList SEQUENCE (SIZE (1..maxDRB)) OF SEQUENCE {	n+m entries	BID is the total number of established DRBs in the UE, before applying the contents of this IE	
drb-ToAddMod[k, k=BID+1..BID+n]	DRB-ToAddMod-DEFAULT (k) using condition AM	n AM RLC DRBs See subclause 4.8.2	n>0
drb-ToAddMod[k, k= BID+1+n.. BID+n+m]	DRB-ToAddMod-DEFAULT (k) using condition UM	m UM RLC DRBs See subclause 4.8.2	m>0
}			
drb-ToReleaseList	Not present		
mac-MainConfig	Not present (note)		m=0
mac-MainConfig CHOICE {			m>0
explicitValue	MAC-MainConfig-RBC using condition DRX_S (note)	See subclause 4.8.2	
}			
sps-Config	Not present		
physicalConfigDedicated	Not present		
}			
NOTE: In cases where no RLC-UM bearer is added, existing DRX configuration is used without modification. In cases where at least one RLC-UM bearer is added, small DRX Cycle length is used.			

Condition	Explanation
n>0	n is greater than zero
m=0	m is equal to zero
m>0	m is greater than zero

RadioResourceConfigDedicated-HO-TO-EUTRA(n,m)

Table 4.6.3-18: RadioResourceConfigDedicated-HO-TO-EUTRA(n,m)

Derivation Path: 36.331 clause 6.3.2			
Information Element	Value/remark	Comment	Condition
RadioResourceConfigDedicated-HO-TO-EUTRA(n, m) ::= SEQUENCE {		n is the number of AM RLC DRBs (1..N) m is the number of UM RLC DRBs (0..M)	
srb-ToAddModList SEQUENCE (SIZE (1..2)) OF SEQUENCE {	2 entries		
srb-ToAddMod[1]	SRB-ToAddMod-DEFAULT using condition SRB1	See subclause 4.8.2	
srb-ToAddMod[2]	SRB-ToAddMod-DEFAULT using condition SRB2	See subclause 4.8.2	
}			
drb-ToAddModList SEQUENCE (SIZE (1..maxDRB)) OF SEQUENCE {	n+m entries		
drb-ToAddMod[k, k=1..n]	DRB-ToAddMod-DEFAULT (k) using condition AM	n AM RLC DRBs See subclause 4.8.2	
drb-ToAddMod[k, k=n+1..n+m]	DRB-ToAddMod-DEFAULT (k) using condition UM	m UM RLC DRBs See subclause 4.8.2	m>0
}			
drb-ToReleaseList	Not present		
mac-MainConfig CHOICE {			
explicitValue	MAC-MainConfig-RBC using condition DRX_L (note)	See subclause 4.8.2	m=0
	MAC-MainConfig-RBC using condition DRX_S (note)	See subclause 4.8.2	m>0
}			
sps-Config	Not present		
physicalConfigDedicated	PhysicalConfigDedicated-DEFAULT using condition RBC	For signalling test cases see subclause 6.6B.1.1.1. Otherwise, see subclause 4.8.2	
}			
NOTE: In cases where no RLC-UM bearer is configured, large DRX Cycle length is used. In cases where at least one RLC-UM bearer is configured, small DRX Cycle length is used.			

Condition	Explanation
m=0	m is equal to zero
m>0	m is greater than zero

- RadioResourceConfigDedicated-AM-DRB-ADD(bid)

Table 4.6.3-18A: RadioResourceConfigDedicated-AM-DRB-ADD(bid)

Derivation Path: 36.331 clause 6.3.2			
Information Element	Value/remark	Comment	Condition
RadioResourceConfigDedicated-AM-DRB-ADD(bid) ::= SEQUENCE {		bid is the bearer identity	
srb-ToAddModList	Not present		
drb-ToAddModList SEQUENCE (SIZE (1..maxDRB)) OF SEQUENCE {	one entry		
drb-ToAddMod[1]	DRB-ToAddMod- DEFAULT (bid) using condition AM	See subclause 4.8.2	
}			
drb-ToReleaseList	Not present		
mac-MainConfig	Not present		
sps-Config	Not present		
physicalConfigDedicated	Not present		
}			

- RadioResourceConfigDedicated-UM-DRB-ADD(bid)

Table 4.6.3-18B: RadioResourceConfigDedicated-UM-DRB-ADD(bid)

Derivation Path: 36.331 clause 6.3.2			
Information Element	Value/remark	Comment	Condition
RadioResourceConfigDedicated-UM-DRB-ADD(bid) ::= SEQUENCE {		bid is the bearer identity	
srb-ToAddModList	Not present		
drb-ToAddModList SEQUENCE (SIZE (1..maxDRB)) OF SEQUENCE {	one entry		
drb-ToAddMod[1]	DRB-ToAddMod- DEFAULT (bid) using condition UM	See subclause 4.8.2	
}			
drb-ToReleaseList	Not present		
mac-MainConfig CHOICE {			
explicitValue	MAC-MainConfig-RBC using condition DRX_S (note)	See subclause 4.8.2	
}			
sps-Config	Not present		
physicalConfigDedicated	Not present		
}			
NOTE: Since one RLC-UM bearer is added, small DRX Cycle length is used.			

- RadioResourceConfigDedicated- DRB-REL(bid)

Table 4.6.3-18C: RadioResourceConfigDedicated-DRB-REL(bid)

Derivation Path: 36.331 clause 6.3.2			
Information Element	Value/remark	Comment	Condition
RadioResourceConfigDedicated-DRB-REL(bid) ::= SEQUENCE {		bid is the bearer identity	
srb-ToAddModList	Not present		
drb-ToAddModList	Not present		
drb-ToReleaseList SEQUENCE (SIZE (1..maxDRB)) OF	one entry		
drb-Identity[1]	bid		
mac-MainConfig	Not present		
sps-Config	Not present		
physicalConfigDedicated	Not present		
}			

- RadioResourceConfigDedicated-HO

Table 4.6.3-19: RadioResourceConfigDedicated-HO

Derivation Path: 36.331 clause 6.3.2			
Information Element	Value/remark	Comment	Condition
RadioResourceConfigDedicated-HO ::= SEQUENCE {			
srb-ToAddModList	Not present		
drb-ToAddModList	Not present		
drb-ToReleaseList	Not present		
mac-MainConfig	Not present		
sps-Config	Not present		
physicalConfigDedicated	PhysicalConfigDedicated-DEFAULT using condition RBC-HO	For signalling test cases see subclause 6.6B.1.1.1. Otherwise, see subclause 4.8.2	
}			

- RadioResourceConfigDedicatedSCell-r10-DEFAULT

Table 4.6.3-19AA: RadioResourceConfigDedicatedSCell-r10-DEFAULT

Derivation Path: 36.331 clause 6.3.2			
Information Element	Value/remark	Comment	Condition
RadioResourceConfigDedicatedSCell-r10 ::= SEQUENCE {			
physicalConfigDedicatedSCell-r10	PhysicalConfigDedicatedSCell-r10-DEFAULT		
}			

RadioResourceConfigDedicated-SCell_AddMod

Table 4.6.3-19AAA: RadioResourceConfigDedicated-SCell_AddMod

Derivation Path: 36.331 clause 6.3.2			
Information Element	Value/remark	Comment	Condition
RadioResourceConfigDedicated-SCell_AddMod ::= SEQUENCE {			
srb-ToAddModList	Not present		
drb-ToAddModList	Not present		
drb-ToReleaseList	Not present		
mac-MainConfig	MAC-MainConfig-RBC using condition SCell_AddMod	See subclause 4.8.2	
sps-Config	Not present		
physicalConfigDedicated	PhysicalConfigDedicated-DEFAULT using condition SCell_AddMod	For signalling test cases see subclause 6.6B.1.1.1. Otherwise, see subclause 4.8.2	
}			

Table 4.6.3-19AAAA: Void

RadioResourceConfigDedicated-V2X

Table 4.6.3-19AAAAA: RadioResourceConfigDedicated-V2X-SPS

Derivation Path: 36.331 clause 6.3.2			
Information Element	Value/remark	Comment	Condition
RadioResourceConfigDedicated-V2X-SPS ::= SEQUENCE {			
sps-Config-v1430 SEQUENCE {			
ul-SPS-V-RNTI-r14	Not Present		
sl-SPS-V-RNTI-r14	'1034'H		
sps-ConfigUL-ToAddModList-r14	Not Present		
sps-ConfigUL-ToReleaseList-r14	Not Present		
sps-ConfigSL-ToAddModList-r14 SEQUENCE (SIZE (1..maxConfigSPS-r14)) OF SEQUENCE {			SL_ADD
sps-ConfigIndex-r14	1	INTEGER (1..maxConfigSPS-r14)	
semiPersistSchedIntervalSL-r14	sf20	ENUMERATED { sf20 }	
}			
sps-ConfigSL-ToReleaseList-r14 SEQUENCE (SIZE (1..maxConfigSPS-r14)) OF SEQUENCE {			SL_RELEASE
SPS-ConfigIndex-r14	1		
}			
}			
}			

Condition	Explanation
SL_ADD	Add SPS configuration for V2X communication over Sidelink
SL_RELEASE	Release SPS configuration for V2X communication over Sidelink

RadioResourceConfigDedicated-EN-DC-Split

Table 4.6.3-19AAAAAB: RadioResourceConfigDedicated-EN-DC-Split

Derivation Path: 36.331 clause 6.3.2			
Information Element	Value/remark	Comment	Condition
RadioResourceConfigDedicated-EN-DC-Split ::= SEQUENCE {			
srb-ToAddModList SEQUENCE (SIZE (1..2)) OF SEQUENCE {	1 entry		
srb-ToAddMod[1]	SRB-ToAddMod-DEFAULT using condition SRB2	See subclause 4.8.2	
}			
drb-ToAddModList SEQUENCE (SIZE (1..maxDRB)) OF SEQUENCE {	2 entries		
drb-ToAddMod[1]	DRB-ToAddMod-DEFAULT (8) using condition AM	See subclause 4.8.2	
drb-ToAddMod[2]	DRB-ToAddMod-EN-DC-Split	See subclause 4.8.2	
}			
drb-ToAddModList SEQUENCE (SIZE (1..maxDRB)) OF SEQUENCE {	3 entries		MULTI_PDN
drb-ToAddMod[1]	DRB-ToAddMod-DEFAULT (1) using condition AM	See subclause 4.8.2	
drb-ToAddMod[2]	DRB-ToAddMod-DEFAULT (8) using condition AM	See subclause 4.8.2	
drb-ToAddMod[3]	DRB-ToAddMod-EN-DC-Split	See subclause 4.8.2	
}			
drb-ToReleaseList	Not present		
mac-MainConfig CHOICE {			
explicitValue	MAC-MainConfig-RBC using condition DRX_L	See subclause 4.8.2	
}			
sps-Config	Not present		
physicalConfigDedicated	PhysicalConfigDedicated-DEFAULT using condition RBC	For signalling test cases see subclause 6.6B.1.1.1. Otherwise, see subclause 4.8.2	
}			

- RadioResourceConfigDedicated-EN-DC_Split_DRB_Rel(bid)

Table 4.6.3-19AAAAAC: RadioResourceConfigDedicated-DRB-REL(bid)

Derivation Path: 36.331 clause 6.3.2			
Information Element	Value/remark	Comment	Condition
RadioResourceConfigDedicated-EN-DC_Split_DRB_Rel(bid) ::= SEQUENCE {		bid is the bearer identity of EN-DC Split DRB	
srb-ToAddModList	Not present		
drb-ToAddModList	Not present		
drb-ToReleaseList SEQUENCE (SIZE (1..maxDRB)) OF	one entry		
drb-Identity[1]	bid		
mac-MainConfig	Not present		
sps-Config	Not present		
physicalConfigDedicated	Not present		
}			

- RadioResourceConfigDedicated-EN-DC-SRB2-DRB

Table 4.6.3-19AAAAAD: RadioResourceConfigDedicated-EN-DC-SRB2-DRB

Derivation Path: 36.331 clause 6.3.2			
Information Element	Value/remark	Comment	Condition
RadioResourceConfigDedicated-SRB2-DRB ::= SEQUENCE {			
srb-ToAddModList SEQUENCE (SIZE (1..2)) OF SEQUENCE {	1 entry		
srb-ToAddMod[1]	SRB-ToAddMod-DEFAULT using condition SRB2	See subclause 4.8.2	
}			
drb-ToAddModList SEQUENCE (SIZE (1..maxDRB)) OF SEQUENCE {	1 entry		
drb-ToAddMod[1]	DRB-ToAddMod-DEFAULT (8) using condition AM	See subclause 4.8.2	
}			
drb-ToAddModList SEQUENCE (SIZE (1..maxDRB)) OF SEQUENCE {	2 entries		MULTI_PDN
drb-ToAddMod[1]	DRB-ToAddMod-DEFAULT (1) using condition AM	See subclause 4.8.2	
drb-ToAddMod[2]	DRB-ToAddMod-DEFAULT (8) using condition AM	See subclause 4.8.2	
}			
drb-ToReleaseList	Not present		
mac-MainConfig CHOICE {			
explicitValue	MAC-MainConfig-RBC using condition DRX_L	See subclause 4.8.2	
}			
sps-Config	Not present		
physicalConfigDedicated	PhysicalConfigDedicated-DEFAULT using condition RBC	For signalling test cases see subclause 6.6B.1.1.1. Otherwise, see subclause 4.8.2	
}			

– RLC-Config-DRB-AM-RECONFIG

Table 4.6.3-19A: RLC-Config-DRB-AM-RECONFIG

Derivation Path: 36.508 table 4.8.2.1.3.2-1: RLC-Config-DRB-AM			
Information Element	Value/remark	Comment	Condition
RLC-Config-DRB-AM-RECONFIG ::= CHOICE {			
am SEQUENCE {			
ul-AM-RLC SEQUENCE {			
t-PollRetransmit	ms85		
pollPDU	p64		
pollByte	kB250		
maxRetxThreshold	t8		
}			
dl-AM-RLC SEQUENCE {			
t-Reordering	ms85		
t-StatusProhibit	ms50		
}			
}			
}			

– RLC-Config-DRB-UM-RECONFIG

Table 4.6.3-19B: RLC-Config-DRB-UM-RECONFIG

Derivation Path: 36.508 table 4.8.2.1.3.1-1: RLC-Config-DRB-UM			
Information Element	Value/remark	Comment	Condition
RLC-Config-DRB-UM-RECONFIG ::= CHOICE {			
um-Bi-Directional SEQUENCE {			
ul-UM-RLC SEQUENCE {			
sn-FieldLength	Size10		
}			
dl-UM-RLC SEQUENCE {			
sn-FieldLength	Size10		
t-Reordering	ms55		
}			
}			
}			

– RLC-Config-SRB-AM-RECONFIG

Table 4.6.3-19C: RLC-Config-SRB-AM-RECONFIG

Derivation Path: 36.331 clause 6.3.2, 9.2.1			
Information Element	Value/remark	Comment	Condition
RLC-Config-SRB-AM-RECONFIG ::= CHOICE {			
am SEQUENCE {			
ul-AM-RLC SEQUENCE {			
t-PollRetransmit	ms50		
pollPDU	pInfinity	Default	
pollByte	kBinfinity	Default	
maxRetxThreshold	t6		
}			
dl-AM-RLC SEQUENCE {			
t-Reordering	ms40		
t-StatusProhibit	ms0	Default	
}			
}			
}			

– SCellToAddMod-r10-DEFAULT

Table 4.6.3-19D: SCellToAddMod-r10-DEFAULT

Derivation Path: 36.331 clause 6.2.2			
Information Element	Value/remark	Comment	Condition
SCellToAddMod-r10 ::= SEQUENCE {			
sCellIndex-r10	Set according to specific message content		
cellIdentification-r10 SEQUENCE {			
physCellId-r10	Set according to specific message content		
dl-CarrierFreq-r10	Set according to specific message content		
dl-CarrierFreq-r10	65535	maxEARFCN	Band > 64
}			
radioResourceConfigCommonSCell-r10	RadioResourceConfigCommonSCell-r10-DEFAULT		
radioResourceConfigDedicatedSCell-r10	RadioResourceConfigDedicatedSCell-r10-DEFAULT		
dl-CarrierFreq-v1090	Set according to specific message content		Band > 64
antennaInfoDedicatedSCell-v10i0 ::= SEQUENCE {			
maxLayersMIMO-r10	fourLayers		4Rx_SCC
}			
srs-SwitchFromServCellIndex-r14	0		SRS-Switching
}			

Condition	Explanation
Band > 64	If band > 64 is selected
4Rx_SCC	For 4Rx testcases with more than 2 Layers on SCC
SRS-Switching	SRS transmission is switched to a PUSCH-less TDD SCell.

– SCellToRelease-r10-DEFAULT

Table 4.6.3-19E: SCellToRelease-r10-DEFAULT

Derivation Path: 36.331 clause 6.2.2			
Information Element	Value/remark	Comment	Condition
sCellToReleaseList-r10 SEQUENCE (SIZE (1..maxSCell-r10) OF SEQUENCE {			
sCellIndex-r10[1]	1		
}			

– SCG-Configuration-r12-DEFAULT

Table 4.6.3-19F: SCG-Configuration-r12-DEFAULT

Derivation Path: 36.331 clause 6.3.2			
Information Element	Value/remark	Comment	Condition
scg-Configuration-r12 CHOICE {			
release	NULL		PSCell_Release
setup SEQUENCE {			PSCell_Mod, PSCell_Add_Split_DRB, PSCell_Add_SCG_DRB
scg-ConfigPartMCG-r12 SEQUENCE {			
scg-Counter-r12	0	INTEGER (0..65535)	
powerCoordinationInfo-r12 SEQUENCE {			
p-MeNB-r12	6 (30%)	INTEGER (1..16) mapped to 0..15 in Table 5.1.4.2-1 in TS 36.213 for power allocation for DC (0% - 100%)	
p-SeNB-r12	6 (30%)	INTEGER (1..16) mapped to 0..15 in Table 5.1.4.2-1 in TS 36.213 for power allocation for DC (0% - 100%)	
powerControlMode-r12	1	DC power control mode 1	
}			
}			
scg-ConfigPartSCG-r12 SEQUENCE {			PSCell_Add_Split_DRB, PSCell_Add_SCG_DRB
radioResourceConfigDedicatedSCG-r12 SEQUENCE {			
drb-ToAddModListSCG-r12 SEQUENCE (SIZE (1..maxDRB)) OF SEQUENCE {	1 entry		
DRB-ToAddModSCG-r12[1] SEQUENCE {			
drb-Identity-r12	Same DRB ID as used for the MCG		PSCell_Add_Split_DRB
drb-Identity-r12	BID+1	BID is the total number of established DRBs in the UE, before applying the contents of this IE	PSCell_Add_SCG_DRB
drb-Type-r12 CHOICE {			
split-r12	NULL		PSCell_Add_Split_DRB
scg-r12 SEQUENCE {			PSCell_Add_SCG_DRB
eps-BearerIdentity-r12	BID+5	drb-Identity-r12+4	
pdcp-Config-r12	PDCP-Config-DRB-AM		
}			
}			
rlc-ConfigSCG-r12	RLC-Config-DRB-AM		
rlc-Config-v1250	Not present		
logicalChannelIdentitySCG-r12	2	drb-Identity-r12+2	
logicalChannelConfigSCG-r12	LogicalChannelConfig-DRB using condition LO		
}			
}			
mac-MainConfigSCG-r12	Not present		
rlf-TimersAndConstantsSCG-r12	Not present		

}			
sCellToReleaseListSCG-r12	Not Present		
pSCellToAddMod-r12 SEQUENCE {			
sCellIndex-r12	Set according to specific message content		
cellIdentification-r12 SEQUENCE {			
physCellId-r12	Set according to specific message content		
dl-CarrierFreq-r12	Set according to specific message content		
}			
}			
radioResourceConfigCommonPSCell-r12 SEQUENCE {			
basicFields-r12	RadioResourceConfigCommonSCell-r10-DEFAULT		
pucch-ConfigCommon-r12	PUCCH-ConfigCommon-DEFAULT		
rach-ConfigCommon-r12	RACH-ConfigCommon-DEFAULT		
uplinkPowerControlCommonPSCell-r12 SEQUENCE {			
deltaF-PUCCH-Format3-r12	deltaF0	Same value as in UplinkPowerControlCommon-v1020-DEFAULT used for the PCell	RM coding
	deltaF4		Dual RM coding
deltaF-PUCCH-Format1bCS-r12	deltaF1	Same value as in UplinkPowerControlCommon-v1020-DEFAULT used for the PCell	
p0-NominalPUCCH-r12	-117 (-117 dBm)	Same value as in UplinkPowerControlCommon-DEFAULT used for the PCell	
deltaFList-PUCCH-r12 SEQUENCE {			
deltaF-PUCCH-Format1	deltaF0	Same value as in UplinkPowerControlCommon-DEFAULT used for the PCell	
deltaF-PUCCH-Format1b	deltaF3	Same value as in UplinkPowerControlCommon-DEFAULT used for the PCell	
deltaF-PUCCH-Format2	deltaF0	Same value as in UplinkPowerControlCommon-DEFAULT used for the PCell	
deltaF-PUCCH-Format2a	deltaF0	Same value as in UplinkPowerControlCommon-DEFAULT used for the PCell	
deltaF-PUCCH-Format2b	deltaF0	Same value as in UplinkPowerControlCommon-DEFAULT used for the PCell	
}			

}			
}			
radioResourceConfigDedicatedPSCell-r12 SEQUENCE {			
physicalConfigDedicatedPSCell-r12	PhysicalConfigDedicated-DEFAULT	For signalling test cases see subclause 6.6B.1.1.1. Otherwise, see subclause 4.8.2	
sps-Config-r12	Not present		
naics-Info-r12	Not present		
}			
antennaInfoDedicatedPSCell-v1280	Not present		
}			
sCellToAddModListSCG-r12	Not Present		
mobilityControlInfoSCG-r12			
t307-r12	ms2000	ENUMERATED {ms50, ms100, ms150, ms200, ms500,ms1000, ms2000}	
ue-IdentitySCG-r12	Any allowed value		
rach-ConfigDedicated-r12	Rach-ConfigDedicated-DEFAULT		
cipheringAlgorithmSCG-r12	Set according to PIXIT parameter for default ciphering algorithm		For SIG
	eea0		For RF
}			
}			

Condition	Explanation
PSCell_Mod	Modification of PSCell(s)
PSCell_Release	Release of PSCell
PSCell_Add_Split_DRB	Add PSCell(s) and setup of Split DRB
PSCell_Add_SCG_DRB	Add PSCell(s) and setup of SCG DRB
RM coding	Used for Reed-Muller coding
Dual RM coding	Used for Dual Reed-Muller coding
For SIG	Used for signalling test cases
For RF	Used for RF/RRM test cases

– SchedulingRequest-Config-DEFAULT

Table 4.6.3-20: SchedulingRequest-Config-DEFAULT

Derivation Path: 36.331 clause 6.3.2			
Information Element	Value/remark	Comment	Condition
SchedulingRequest-Config-DEFAULT ::= CHOICE { setup SEQUENCE {			
sr-PUCCH-ResourceIndex	See subclause 4.6.8	Channel-bandwidth-dependent parameter	
sr-ConfigIndex	30		FDD
	32		FDD and (CEmodeA or CEmodeB) and 3 MHz BW
	27		TDD
dsr-TransMax	n4		
}			
}			

Condition	Explanation
FDD	FDD cell environment
TDD	TDD cell environment
CEmodeA	Used for CE mode A testing
CEmodeB	Used for CE mode B testing
3 MHz BW	Used for cells with 3 MHz bandwidth

Table 4.6.3-20A: Void

– SchedulingRequestConfigSCell-r13-DEFAULT

Table 4.6.3-20B: SchedulingRequestConfigSCell-r13-DEFAULT

Derivation Path: 36.331 clause 6.3.2			
Information Element	Value/remark	Comment	Condition
SchedulingRequestConfigSCell-r13 ::= CHOICE { setup SEQUENCE {			
sr-PUCCH-ResourceIndex-r13	See subclause 4.6.8	Channel-bandwidth-dependent parameter	
sr-PUCCH-ResourceIndexP1-r13	Not present		
sr-ConfigIndex-r13	30		FDD
	27		TDD
dsr-TransMax-13	n4		
}			
}			

Condition	Explanation
FDD	FDD cell environment
TDD	TDD cell environment

Table 4.6.3-20B: Void

– SL-CommResourcePoolV2X-r14-DEFAULT

Table 4.6.3-20C: SL-CommResourcePoolV2X-r14-DEFAULT

Derivation Path: 36.331 clause 6.3.8			
Information Element	Value/remark	Comment	Condition
SL-CommResourcePoolV2X-r14-DEFAULT ::= SEQUENCE {			
sl-OffsetIndicator-r14	Not present		
sl-Subframe-r14 CHOICE {			
bs20-r14	11110000000000000000		BITMAP_1
	00001111000000000000		BITMAP_2
	00000000111100000000		BITMAP_3
	00000000000011110000		BITMAP_4
	00000000000000001111		BITMAP_5
	11111111111111111111		BITMAP_6
}			
adjacencyPSCCH-PSSCH-r14	true	BOOLEAN	
sizeSubchannel-r14	n5		BW10
	n10		BW20
numSubchannel-r14	n10		
startRB-Subchannel-r14	0		
startRB-PSCCH-Pool-r14	Not present		
rxParametersNCell-r14	Not present		
dataTxParameters-r14 {}	Not present		
dataTxParameters-r14 SEQUENCE {			COND_TX
alpha-r12	a10		
p0-r12	31		
}			
zoneID-r14	Not present	INTEGER (0..7)	
threshS-RSSI-CBR-r14	Not present	INTEGER (0..45)	
poolReportId-r14	Not present		
cbr-pssch-TxConfigList-r14	Not present		
resourceSelectionConfigP2X-r14	Not present		
syncAllowed-r14	Not present		
restrictResourceReservationPeriod-r14	Not present		
}			

Condition	Explanation
BW10	10 MHz channel bandwidth for V2X communication
BW20	20 MHz channel bandwidth for V2X communication

– SL-CommTxPoolSensingConfig-r14-DEFAULT

Table 4.6.3-20D: SL-CommTxPoolSensingConfig-r14-DEFAULT

Derivation Path: 36.331 clause 6.3.8			
Information Element	Value/remark	Comment	Condition
SL-CommTxPoolSensingConfig-r14-DEFAULT ::= SEQUENCE {			
pssch-TxConfigList-r14	SL-PSSCH-TxConfig-r14-DEFAULT		
thresPSSCH-RSRP-List-r14 SEQUENCE (SIZE (64)) OF SL-ThresPSSCH-RSRP-r14 {			
SL-ThresPSSCH-RSRP-r14[n]	1	For n=1,2,...,64, where n denotes the index for the threshold used for sensing based UE autonomous resource selection	
}			
restrictResourceReservationPeriod-r14 SEQUENCE (SIZE (1..maxReservationPeriod-r14)) OF SL-RestrictResourceReservationPeriod-r14 {			
SL-RestrictResourceReservationPeriod-r14[1]	v0dot2		
SL-RestrictResourceReservationPeriod-r14[2]	v0dot5		
SL-RestrictResourceReservationPeriod-r14[3]	v1		
SL-RestrictResourceReservationPeriod-r14[4]	v2		
SL-RestrictResourceReservationPeriod-r14[5]	v3		
SL-RestrictResourceReservationPeriod-r14[6]	v4		
SL-RestrictResourceReservationPeriod-r14[7]	v5		
SL-RestrictResourceReservationPeriod-r14[8]	v6		
SL-RestrictResourceReservationPeriod-r14[9]	v7		
SL-RestrictResourceReservationPeriod-r14[10]	v8		
SL-RestrictResourceReservationPeriod-r14[11]	v9		
SL-RestrictResourceReservationPeriod-r14[12]	v10		
}			
probResourceKeep-r14	v0		
p2x-SensingConfig-r14	Not present		
sl-ReselectAfter-r14	Not present		
}			

– SL-InterFreqInfoV2X-r14-DEFAULT

Table 4.6.3-20E: SL-InterFreqInfoV2X-r14-DEFAULT

Derivation Path: 36.331 clause 6.3.8			
Information Element	Value/remark	Comment	Condition
SL-InterFreqInfoV2X-r14-DEFAULT ::= SEQUENCE {			
plmn-IdentityList-r14	Not present		
v2x-CommCarrierFreq-r14	set according to the specific test configuration		
sl-MaxTxPower-r14	Not present	INTEGER (-30..33)	
sl-Bandwidth-r14	n50	ENUMERATED {n6, n15, n25, n50, n75, n100}	BW10
	n100		BW20
v2x-SchedulingPool-r14	SL-CommResourcePoolV2X-r14-DEFAULT using conditions BITMAP_4 and COND_TX		SCHEDULED
	Not present		SIB
v2x-UE-ConfigList-r14	SL-V2X-InterFreqUE-Config-r14-DEFAULT using condition SIB		SIB
	SL-V2X-InterFreqUE-Config-r14-DEFAULT using condition RRC		RRC
additionalSpectrumEmissionV2X-r14	Not present		
}			

Condition	Explanation
SIB	Inter-frequency V2X configuration for SIB21
RRC	Inter-frequency V2X configuration for RRCConnectionReconfiguration
BW10	10 MHz channel bandwidth for V2X communication
BW20	20 MHz channel bandwidth for V2X communication
SCHEDULED	The resources the UE can use are scheduled by the NW.

– SL-PSSCH-TxConfig-r14-DEFAULT

Table 4.6.3-20F: SL-PSSCH-TxConfig-r14-DEFAULT

Derivation Path: 36.331 clause 6.3.8			
Information Element	Value/remark	Comment	Condition
SL-PSSCH-TxConfig-r14-DEFAULT ::= SEQUENCE {			
typeTxSync-r14	enb		
thresUE-Speed-r14	kmph200		
parametersAboveThres-r14 SEQUENCE {			
minMCS-PSSCH-r14	0		
maxMCS-PSSCH-r14	15		
minSubChannel-NumberPSSCH-r14	1		
maxSubchannel-NumberPSSCH-r14	50		BW10
	100		BW20
allowedRetxNumberPSSCH-r14	both	ENUMERATED {n0, n1, both, spare1}	RF
	n0		SIG
maxTxPower-r14	Not present		
}			
parametersBelowThres-r14 SEQUENCE {			
minMCS-PSSCH-r14	4		
maxMCS-PSSCH-r14	25		
minSubChannel-NumberPSSCH-r14	1		
maxSubchannel-NumberPSSCH-r14	50		BW10
	100		BW20
allowedRetxNumberPSSCH-r14	n1	ENUMERATED {n0, n1, both, spare1}	RF
	n0		SIG
maxTxPower-r14	Not present		
}			
}			

Condition	Explanation
BW10	10 MHz channel bandwidth for V2X communication
BW20	20 MHz channel bandwidth for V2X communication
RF	For RF, performance and RRM testing
SIG	For protocol testing

– SL-TxPoolToAddMod-r14-DEFAULT

Table 4.6.3-20G: SL-TxPoolToAddMod-r14-DEFAULT

Derivation Path: 36.331 clause 6.3.8			
Information Element	Value/remark	Comment	Condition
SL-TxPoolToAddMod-r14-DEFAULT ::= SEQUENCE {			
poolIdentity-r14	1		
pool-r14	SL- CommResourcePoolV2X -r14-DEFAULT using conditions BITMAP_5 and COND_TX		
}			

– SL-TxPoolToReleaseListV2X-r14-DEFAULT

Table 4.6.3-20H: SL-TxPoolToReleaseListV2X-r14-DEFAULT

Derivation Path: 36.331 clause 6.3.8			
Information Element	Value/remark	Comment	Condition
SL-TxPoolToReleaseListV2X-r14-DEFAULT ::= SEQUENCE (SIZE (1..maxSL-V2X-TxPool-r14)) OF SL-V2X-TxPoolIdentity-r14 {			
SL-V2X-TxPoolIdentity-r14[1]	1		
}			

– SL-V2X-ConfigDedicated-r14-DEFAULT

Table 4.6.3-20HA: SL-V2X-ConfigDedicated-r14-DEFAULT

Derivation Path: 36.331 clause 6.3.8			
Information Element	Value/remark	Comment	Condition
SL-V2X-ConfigDedicated-r14-DEFAULT ::= SEQUENCE {			
commTxResources-r14 CHOICE {	Not present		
commTxResources-r14 CHOICE {			SCHEDULE D
release	NULL		RELEASE
setup CHOICE {			SETUP
scheduled-r14 SEQUENCE {			
sl-V-RNTI-r14	'1111'H	BIT STRING (SIZE (16))	
mac-MainConfig-r14 SEQUENCE {			
periodic-BSR-TimerSL	sf20		
retx-BSR-TimerSL	sf20		
}			
v2x-SchedulingPool-r14	Not present		
mcs-r14	Not present	INTEGER (0..31)	
logicalChGroupInfoList-r14 SEQUENCE (SIZE (1..maxLCG-r13)) OF SL-PriorityList-r13		4 entries	
SL-PriorityList-r13[1] ::= SEQUENCE (SIZE (1..maxSL-Prio-r13)) OF SL-Priority-r13 {			
SL-Priority-r13[1]	1		
SL-Priority-r13[2]	2		
}			
SL-PriorityList-r13[2] ::= SEQUENCE (SIZE (1..maxSL-Prio-r13)) OF SL-Priority-r13 {			
SL-Priority-r13[1]	3		
SL-Priority-r13[2]	4		
}			
SL-PriorityList-r13[3] ::= SEQUENCE (SIZE (1..maxSL-Prio-r13)) OF SL-Priority-r13 {			
SL-Priority-r13[1]	5		
SL-Priority-r13[2]	6		
}			
SL-PriorityList-r13[4] ::= SEQUENCE (SIZE (1..maxSL-Prio-r13)) OF SL-Priority-r13 {			
SL-Priority-r13[1]	7		
SL-Priority-r13[2]	8		
}			
}			
}			
ue-Selected-r14	Not present		
}			
}			
v2x-InterFreqInfoList-r14 SEQUENCE (SIZE (0..maxFreqV2X-1-r14)) OF SL-InterFreqInfoV2X-r14 {			
SL-InterFreqInfoV2X-r14[1]	SL-InterFreqInfoV2X-r14-DEFAULT using condition RRC		UE-SELECTED
SL-InterFreqInfoV2X-r14[1]	SL-InterFreqInfoV2X-r14-DEFAULT using condition RRC and SCHEDULED		SCHEDULE D
}			
thresSL-TxPrioritization-r14	Not present		
typeTxSync-r14	enb		
cbr-DedicatedTxConfigList-r14	Not present		
}			

Condition	Explanation
SCHEDULED	The resources the UE can use are scheduled by the NW.
UE-SELECTED	The resources the UE can use are to be selected by the UE from set of resources provided by the NW.
RELEASE	Release Communication Resources for V2X Sidelink communication
SETUP	Setup Communication Resources for V2X Sidelink communication

– SL-V2X-InterFreqUE-Config-r14-DEFAULT

Table 4.6.3-20I: SL-V2X-InterFreqUE-Config-r14-DEFAULT

Derivation Path: 36.331 clause 6.3.8			
Information Element	Value/remark	Comment	Condition
SL-V2X-InterFreqUE-Config-r14-DEFAULT ::= SEQUENCE {			
physCellIdList-r14	Not present		
typeTxSync-r14	enb		
v2x-SyncConfig-r14	Not present		
v2x-CommRxPool-r14 SEQUENCE (SIZE (1..maxSL-V2X-RxPool-r14)) OF SL-CommResourcePoolV2X-r14 {			
SL-CommResourcePoolV2X-r14[1]	SL-CommResourcePoolV2X-r14-DEFAULT using conditions BITMAP_1		
SL-CommResourcePoolV2X-r14[2]	SL-CommResourcePoolV2X-r14-DEFAULT using conditions BITMAP_2		
SL-CommResourcePoolV2X-r14[3]	SL-CommResourcePoolV2X-r14-DEFAULT using conditions BITMAP_3		
SL-CommResourcePoolV2X-r14[4]	SL-CommResourcePoolV2X-r14-DEFAULT using conditions BITMAP_4		
SL-CommResourcePoolV2X-r14[5]	SL-CommResourcePoolV2X-r14-DEFAULT using conditions BITMAP_5		
}			
v2x-CommTxPoolNormal-r14 SEQUENCE (SIZE (1..maxSL-V2X-TxPool-r14)) OF SL-CommResourcePoolV2X-r14 {			
SL-CommResourcePoolV2X-r14[1]	SL-CommResourcePoolV2X-r14-DEFAULT using conditions BITMAP_1 and COND_TX		SIB
	SL-CommResourcePoolV2X-r14-DEFAULT using conditions BITMAP_5 and COND_TX		RRC
}			
p2x-CommTxPoolNormal-r14	Not present		
v2x-CommTxPoolExceptional-r14	SL-CommResourcePoolV2X-r14-DEFAULT using conditions BITMAP_3 and COND_TX		
v2x-ResourceSelectionConfig-r14	SL-CommTxPoolSensingConfig-r14-DEFAULT		
zoneConfig-r14	Not present		
offsetDFN-r14	Not present		
}			

Condition	Explanation
SIB	UE configuration for Sidelink communication mode 4 for SIB21
RRC	UE configuration for Sidelink communication mode 4 for RRCConnectionReconfiguration

– SL-V2X-PreconfigCommPool-r14-DEFAULT

Table 4.6.3-20J: SL-V2X-PreconfigCommPool-r14-DEFAULT

Derivation Path: 36.331 clause 9.3.2			
Information Element	Value/remark	Comment	Condition
SL-V2X-PreconfigCommPool-r14-DEFAULT ::= SEQUENCE {			
sl-OffsetIndicator-r14	Not present		
sl-Subframe-r14 CHOICE {			
bs20-r14	11110000000000000000		BITMAP_1
	00001111000000000000		BITMAP_2
	00000000111100000000		BITMAP_3
	000000000000011110000		BITMAP_4
	000000000000000000001111		BITMAP_5
	11111111111111111111		BITMAP_6
}			
adjacencyPSCCH-PSSCH-r14	true	BOOLEAN	
sizeSubchannel-r14	n5		BW10
	n10		BW20
numSubchannel-r14	n10		
startRB-Subchannel-r14	0		
startRB-PSCCH-Pool-r14	Not present		
dataTxParameters-r14	31	p0-r12	
zoneID-r14	Not present	INTEGER (0..7)	
threshS-RSSI-CBR-r14	Not present	INTEGER (0..45)	
cbr-pssch-TxConfigList-r14	Not present		
resourceSelectionConfigP2X-r14	Not present		
syncAllowed-r14	Not present		
restrictResourceReservationPeriod-r14	Not present		
}			

Condition	Explanation
BW10	10 MHz channel bandwidth cell environment
BW20	20 MHz channel bandwidth cell environment

– SL-V2X-PreconfigFreqInfo-r14-DEFAULT

Table 4.6.3-20K: SL-V2X-PreconfigFreqInfo-r14-DEFAULT

Derivation Path: 36.331 clause 9.3.2			
Information Element	Value/remark	Comment	Condition
SL-V2X-PreconfigFreqInfo-r14-DEFAULT ::= SEQUENCE {			
v2x-CommPreconfigGeneral-r14 SEQUENCE {		SL-PreconfigGeneral-r12	
rohc-Profiles-r12 SEQUENCE {		-- PDCP configuration	
profile0x0001-r12	false		
profile0x0002-r12	false		
profile0x0004-r12	false		
profile0x0006-r12	false		
profile0x0101-r12	false		
profile0x0102-r12	false		
profile0x0104-r12	false		
}			
carrierFreq-r12	f1 as per table 6.2.3.5-1	ARFCN-ValueEUTRA-r9	
maxTxPower-r12	26		
additionalSpectrumEmission-r12	1(NS_01)	A-MPR doesn't apply by default. See TS 36.101 table 6.2.4-1	
sl-bandwidth-r12	Set according to specific message content		
tdd-ConfigSL-r12 SEQUENCE {		TDD-ConfigSL-r12	
subframeAssignment	none		
reserved-r12	'00000000000000000000'		
additionalSpectrumEmission-v1440	Not present		
}			
}			
v2x-CommPreconfigSync-r14	Not present		
v2x-CommRxPoolList-r14 SEQUENCE (SIZE (1..maxSL-V2X-RxPoolPreconf-r14)) OF SL-V2X-PreconfigCommPool-r14 {	1 entry		
SL-V2X-PreconfigCommPool-r14[1]	SL-V2X-PreconfigCommPool-r14-DEFAULT using condition BITMAP_6		
}			
v2x-CommTxPoolList-r14 SEQUENCE (SIZE (1..maxSL-V2X-TxPoolPreconf-r14)) OF SL-V2X-PreconfigCommPool-r14 {			
SL-V2X-PreconfigCommPool-r14[1]	SL-V2X-PreconfigCommPool-r14-DEFAULT using conditions BITMAP_6 and COND_TX		
}			
p2x-CommTxPoolList-r14	Not present		
v2x-ResourceSelectionConfig-r14	SL-CommTxPoolSensingConfig-r14-DEFAULT		
zoneConfig-r14	Not present		
syncPriority-r14	gnss		
thresSL-TxPrioritization-r14	Not present		
offsetDFN-r14	Not present		
}			

SoundingRS-UL-ConfigCommon-DEFAULT

Table 4.6.3-21: SoundingRS-UL-ConfigCommon-DEFAULT

Derivation Path: 36.331 clause 6.3.2			
Information Element	Value/remark	Comment	Condition
SoundingRS-UL-ConfigCommon-DEFAULT ::= SEQUENCE {			
setup SEQUENCE {			
-srs-BandwidthConfig	See subclause 4.6.8	Channel-bandwidth-dependent parameter	
srs-SubframeConfig	sc0	Assuming SRS density is high (see Table 5.5.3.3-1 in TS 36.211)	FDD
	sc4	Assuming SRS density is high (see Table 5.5.3.3-2 in TS 36.211)	TDD
ackNackSRS-SimultaneousTransmission	TRUE	Typical value in real network	
srs-MaxUpPts	Not Present		
}			
}			

Condition	Explanation
FDD	FDD cell environment
TDD	TDD cell environment

SoundingRS-UL-ConfigDedicated-DEFAULT

Table 4.6.3-22: SoundingRS-UL-ConfigDedicated-DEFAULT

Derivation Path: 36.331 clause 6.3.2			
Information Element	Value/remark	Comment	Condition
SoundingRS-UL-ConfigDedicated-DEFAULT ::= CHOICE {			
setup SEQUENCE {			
srs-Bandwidth	bw0		
	bw3		SRSFreqHopp
srs-HoppingBandwidth	hbw0		
freqDomainPosition	0		
duration	TRUE		
srs-ConfigIndex	20	See Table 8.2-1 in TS 36.213	FDD
	31	INTEGER (0..1023) See Table 8.2-2 in TS 36.213	TDD
transmissionComb	0		
cyclicShift	cs0		
}			
}			

Condition	Explanation
-----------	-------------

FDD	FDD cell environment
TDD	TDD cell environment
SRSFreqHopp	Used for SRS frequency hopping.

Table 4.6.3-22AA: Void

– SoundingRS-UL-ConfigDedicatedAperiodic-r10-DEFAULT

Table 4.6.3-22AB: SoundingRS-UL-ConfigDedicatedAperiodic-r10-DEFAULT

Derivation Path: 36.331 clause 6.3.2			
Information Element	Value/remark	Comment	Condition
SoundingRS-UL-ConfigDedicatedAperiodic-r10 ::= CHOICE {			
setup SEQUENCE {			
srs-ConfigIndexAp-r10	10		
srs-ConfigApDCI-Format4-r10	Not present		
srs-ActivateAp-r10	Not present		
}			
}			

– SRB-ToAddModList-RECONFIG

Table 4.6.3-22A: SRB-ToAddModList-RECONFIG

Derivation Path: 36.331 clause 6.3.2			
Information Element	Value/remark	Comment	Condition
SRB-ToAddModList ::= SEQUENCE (SIZE (1..2)) OF SEQUENCE {	2 Entries		
srb-Identity[1]	1		
rlc-Config[1] CHOICE {			
explicitValue	RLC-Config-SRB-AM-RECONFIG		
logicalChannelConfig[1] CHOICE {			
defaultValue	NULL		
}			
srb-Identity[2]	2		
rlc-Config[2] CHOICE {			
explicitValue	RLC-Config-SRB-AM-RECONFIG		
}			
logicalChannelConfig[2] CHOICE {			
defaultValue	NULL		
}			
}			

SRS-TPC-PDCCH-Config-r14-DEFAULT

Table 4.6.3-22B: SRS-TPC-PDCCH-Config-r14-DEFAULT

Derivation Path: 36.331 clause 6.3.2			
Information Element	Value/remark	Comment	Condition
SRS-TPC-PDCCH-Config-r14-DEFAULT ::= SEQUENCE {			
release	NULL		RELEASE
setup SEQUENCE {			SETUP
srs-TPC-RNTI-r14	'1100'H		
startingBitOfFormat3B-r14	0		
fieldTypeFormat3B-r14	4	1 bit SRS request, 2 bit TPC command	
srs-CC-SetIndexlist-	Not present		
}			
}			

Condition	Explanation
RELEASE	Release PDCCH configuration for SRS TPC
SETUP	Setup PDCCH configuration for SRS TPC

TDD-Config-DEFAULT

Table 4.6.3-23: TDD-Config-DEFAULT

Derivation Path: 36.331 clause 6.3.2			
Information Element	Value/remark	Comment	Condition
TDD-Config-DEFAULT ::= SEQUENCE {			
subframeAssignment	sa1		
specialSubframePatterns	Ssp6		
}			

TPC-PDCCH-Config-DEFAULT

Table 4.6.3-24: TPC-PDCCH-Config-DEFAULT

Derivation Path: 36.331 clause 6.3.2			
Information Element	Value/remark	Comment	Condition
TPC-PDCCH-Config-DEFAULT ::= CHOICE {			
setup SEQUENCE {			
tpc-RNTI	'03FF'H		PUCCH
	'01FA'H		PUSCH
tpc-Index CHOICE {			
indexOfFormat3	1		
}			
}			

Condition	Explanation
PUCCH	For PUCCH
PUSCH	For PUSCH

– TPC-PDCCH-ConfigSCell-r13-DEFAULT

Table 4.6.3-24A: TPC-PDCCH-ConfigSCell-r13-DEFAULT

Derivation Path: 36.331 clause 6.3.2			
Information Element	Value/remark	Comment	Condition
TPC-PDCCH-ConfigSCell-r13-DEFAULT ::= CHOICE			
{			
setup SEQUENCE {			
tpc-Index-PUCCH-SCell-r13 CHOICE {			
indexOfFormat3	1		
}			
}			
}			

– UplinkPowerControlCommon-DEFAULT

Table 4.6.3-25: UplinkPowerControlCommon-DEFAULT

Derivation Path: 36.331 clause 6.3.2			
Information Element	Value/remark	Comment	Condition
UplinkPowerControlCommon-DEFAULT ::= SEQUENCE {			
p0-NominalPUSCH	-85 (-85 dBm)	Typical value in real network	
alpha	alpha08 (0.8)	Typical value in real network	
p0-NominalPUCCH	-117 (-117 dBm)	Thermal noise = -121 dBm NF = 5 dB IoT = 6 dB Required SNR = -7.5 dB (1-bit A/N) -> -117 dB	
deltaFList-PUCCH SEQUENCE {			
deltaF-PUCCH-Format1	deltaF0	In accordance with RAN1 simulation results	
deltaF-PUCCH-Format1b	deltaF3	In accordance with RAN1 simulation results	
deltaF-PUCCH-Format2	deltaF0	In accordance with RAN1 simulation results	
deltaF-PUCCH-Format2a	deltaF0	In accordance with RAN1 simulation results	
deltaF-PUCCH-Format2b	deltaF0	In accordance with RAN1 simulation results	
}			
deltaPreambleMsg3	4		
}			

– UplinkPowerControlCommonSCell-r10-DEFAULT

Table 4.6.3-25A: UplinkPowerControlCommonSCell-r10-DEFAULT

Derivation Path: 36.331 clause 6.3.2			
Information Element	Value/remark	Comment	Condition
UplinkPowerControlCommonSCell-r10 ::= SEQUENCE {			
p0-NominalPUSCH-r10	-85 (-85 dBm)		
alpha-r10	al08 (0.8)		
}			

– UplinkPowerControlCommon-v1020-DEFAULT

Table 4.6.3-25AA: UplinkPowerControlCommon-v1020-DEFAULT

Derivation Path: 36.331 clause 6.3.2			
Information Element	Value/remark	Comment	Condition
UplinkPowerControlCommon-v1020-DEFAULT ::= SEQUENCE {			
deltaF-PUCCH-Format3-r10	deltaF0		RM coding
	deltaF4		Dual RM coding
deltaF-PUCCH-Format1bCS-r10	deltaF1		
}			

Condition	Explanation
RM coding	Used for Reed-Muller coding
Dual RM coding	Used for Dual Reed-Muller coding

– UplinkPowerControlCommonSCell-v1310-DEFAULT

Table 4.6.3-25AB: UplinkPowerControlCommonSCell-v1310-DEFAULT

Derivation Path: 36.331 clause 6.3.2			
Information Element	Value/remark	Comment	Condition
UplinkPowerControlCommonSCell-v1310-DEFAULT ::= SEQUENCE {			
p0-NominalPUCCH	-117 (-117 dBm)	Same value as in UplinkPowerControlCommon-DEFAULT used for the PCell	
deltaFList-PUCCH SEQUENCE {			
deltaF-PUCCH-Format1	deltaF0	Same value as in UplinkPowerControlCommon-DEFAULT used for the PCell	
deltaF-PUCCH-Format1b	deltaF3	Same value as in UplinkPowerControlCommon-DEFAULT used for the PCell	
deltaF-PUCCH-Format2	deltaF0	Same value as in UplinkPowerControlCommon-DEFAULT used for the PCell	
deltaF-PUCCH-Format2a	deltaF0	Same value as in UplinkPowerControlCommon-DEFAULT used for the PCell	
deltaF-PUCCH-Format2b	deltaF0	Same value as in UplinkPowerControlCommon-DEFAULT used for the PCell	
}			
deltaF-PUCCH-Format3-r12	Not present		
deltaF-PUCCH-Format1bCS-r12	Not present		
deltaF-PUCCH-Format4-r13	Not present		
deltaF-PUCCH-Format5-13	Not present		
}			

– UplinkPowerControlDedicated-DEFAULT

Table 4.6.3-26: UplinkPowerControlDedicated-DEFAULT

Derivation Path: 36.331 clause 6.3.2			
Information Element	Value/remark	Comment	Condition
UplinkPowerControlDedicated-DEFAULT ::= SEQUENCE {			
p0-UE-PUSCH	0		
deltaMCS-Enabled	en0		
accumulationEnabled	TRUE		
p0-UE-PUCCH	0		
pSRS-Offset	3 (-6 dB)		
filterCoefficient	fc4		
}			

UplinkPowerControlDedicated-v1020-DEFAULT

Table 4.6.3-26A: UplinkPowerControlDedicated-v1020-DEFAULT

Derivation Path: 36.331 clause 6.3.2			
Information Element	Value/remark	Comment	Condition
UplinkPowerControlDedicated-v1020 ::= SEQUENCE {			
deltaTxD-OffsetListPUCCH-r10	Not Present		
deltaTxD-OffsetListPUCCH-r10 SEQUENCE {			TxD
deltaTxD-OffsetPUCCH-Format1-r10	dB0		
deltaTxD-OffsetPUCCH-Format1a1b-r10	dB0		
deltaTxD-OffsetPUCCH-Format22a2b-r10	dB0		
deltaTxD-OffsetPUCCH-Format3-r10	dB0		
}			
pSRS-OffsetAp-r10	0		SRS _{Ap}
			Not present
}			

Condition	Explanation
TxD	When PUCCH Transmission Diversity is performed.
SRS _{Ap}	Aperiodic SRS configured

UplinkPowerControlDedicated-v1130-DEFAULT

Table 4.6.3-26BA: UplinkPowerControlDedicated-v1130-DEFAULT

Derivation Path: 36.331 clause 6.3.2			
Information Element	Value/remark	Comment	Condition
UplinkPowerControlDedicated-v1130 -DEFAULT ::= SEQUENCE {			
pSRS-Offset-v1130	FFS		
pSRS-OffsetAp-v1130	FFS		
deltaTxD-OffsetListPUCCH-v1130 = SEQUENCE {			
deltaTxD-OffsetPUCCH-Format1bCS-r11	FFS		
}			
}			

UplinkPowerControlDedicated-v1250-DEFAULT

Table 4.6.3-26BB: UplinkPowerControlDedicated-v1250-DEFAULT

Derivation Path: 36.331 clause 6.3.2			
Information Element	Value/remark	Comment	Condition
UplinkPowerControlDedicated-v1250 ::= SEQUENCE {			
set2PowerControlParameter CHOICE {			
setup SEQUENCE {			
tpc-SubframeSet-r12	0001100111		
p0-NominalPUSCH-SubframeSet2-r12	-85 (-85 dBm)		
alpha-SubframeSet2-r12	al08 (0.8)		
p0-UE-PUSCH-SubframeSet2-r12	0		
}			
}			
}			

– UplinkPowerControlDedicatedSCell-r10-DEFAULT

Table 4.6.3-26B: UplinkPowerControlDedicatedSCell-r10-DEFAULT

Derivation Path: 36.331 clause 6.3.2			
Information Element	Value/remark	Comment	Condition
UplinkPowerControlDedicatedSCell-r10 ::= SEQUENCE {			
p0-UE-PUSCH-r10	0		
deltaMCS-Enabled-r10	en0		
accumulationEnabled-r10	TRUE		
pSRS-Offset-r10	7		
pSRS-OffsetAp-r10	7		
filterCoefficient-r10	fc4		
pathlossReferenceLinking-r10	sCell		
}			

– UplinkPowerControlDedicatedSCell-v1310-DEFAULT

Table 4.6.3-26C: UplinkPowerControlDedicatedSCell-v1310-DEFAULT

Derivation Path: 36.331 clause 6.3.2			
Information Element	Value/remark	Comment	Condition
UplinkPowerControlDedicatedSCell-v1310 ::= SEQUENCE {			
p0-UE-PUCCH	0		
deltaTxD-OffsetListPUCCH-r10	Not present		
}			

- RadioResourceConfigDedicated-DRB-Mod

Table 4.6.3-27: RadioResourceConfigDedicated-DRB-Mod

Derivation Path: 36.331 clause 6.3.2			
Information Element	Value/remark	Comment	Condition
RadioResourceConfigDedicated-DRB ::= SEQUENCE {			
srb-ToAddModList	Not present		
drb-ToAddModList	DRB-ToAddModList-RECONFIG		
}			
drb-ToReleaseList	Not present		
mac-MainConfig	Not present		
sps-Config	Not present		
physicalConfigDedicated	Not present		
}			

- RadioResourceConfigDedicated-PCell-PATTERN

Table 4.6.3-28: RadioResourceConfigDedicated-PCell-PATTERN

Derivation Path: 36.331 clause 6.3.2			
Information Element	Value/remark	Comment	Condition
measSubframePatternPCell ::= CHOICE {			
MeasSubframePattern-r10 ::= CHOICE {			
subframePatternFDD-r10	'00110011001100110011 00110011001100110011' B		
subframePatternTDD-r10	FFS		
}			
}			

- OtherConfig-r9

Table 4.6.3-29: OtherConfig-r9

Derivation Path: 36.331 clause 6.3.6			
Information Element	Value/remark	Comment	Condition
OtherConfig-r9 ::= SEQUENCE {			
reportProximityConfig-r9 ::= SEQUENCE {			
proximityIndicationEUTRA-r9	Not Present		
proximityIndicationUTRA-r9	Not Present		
}			
IDC-Config-r11 SEQUENCE {			
idc-Indication-r11	Not Present		
autonomousDenialParameters-r11 ::= SEQUENCE {			
autonomousDenialSubframes-r11	Not Present		
autonomousDenialValidity-r11	Not Present		
}			
}			
PowerPrefIndicationConfig-r11 CHOICE {			
Release	NULL		Release
setup SEQUENCE {			Setup
powerPrefIndicationTimer-r11	s30		
}			
}			
delayBudgetReportingConfig-r14 CHOICE{			eVoLTE
Release	NULL		Release
setup SEQUENCE{			Setup
delayBudgetReportingProhibitTimer-r14	s0		
}			
}			
ObtainLocationConfig-r11 ::= SEQUENCE {			
obtainLocation-r11	Not present		
}			
sps-AssistanceInfoReport-r14	Not present		
}			

Condition	Explanation
eVoLTE	The UE is configured to setup or release delayBudgetReport in case of VoLTE enhancement
Setup	The UE is allowed to send power preference indications or send delaybudgetreport.
Release	The UE is not allowed to send power preference indications or send delay budgetreport.

WLAN-OffloadConfig-r12

Table 4.6.3-30: WLAN-OffloadConfig-DEFAULT

Derivation Path: 36.331 clause 6.3.6			
Information Element	Value/remark	Comment	Condition
WLAN-OffloadConfig-r12::= SEQUENCE {			
thresholdRSRP-r12	Not Present		
thresholdRSRP-r12::= SEQUENCE {			RSRP
thresholdRSRP-Low-r12	Set according to specific message content		
thresholdRSRP-High-r12	Set according to specific message content		
}			
thresholdRSRQ-r12	Not Present		RSRQ
thresholdRSRQ-r12::= SEQUENCE {			
thresholdRSRQ-Low-r12	Set according to specific message content		
thresholdRSRQ-High-r12	Set according to specific message content		
}			
thresholdRSRQ-OnAllSymbolsWithWB-r12	Not Present		
thresholdRSRQ-OnAllSymbols-r12	Not Present		
thresholdRSRQ-WB-r12	Not Present		
thresholdChannelUtilization-r12	Not Present		
thresholdChannelUtilization-r12::= SEQUENCE {			ChanUtilization
thresholdChannelUtilizationLow-r12	Set according to specific message content		
thresholdChannelUtilizationHigh-r12	Set according to specific message content		
}			
thresholdBackhaul-Bandwidth-r12	Not Present		
thresholdBackhaul-Bandwidth-r12::= SEQUENCE {			BackhaulBW
thresholdBackhaulDL-BandwidthLow-r12	Set according to specific message content		
thresholdBackhaulDL-BandwidthHigh-r12	Set according to specific message content		
thresholdBackhaulUL-BandwidthLow-r12	Set according to specific message content		
thresholdBackhaulUL-BandwidthHigh-r12	Set according to specific message content		
}			
thresholdBeaconRSSI-r12	Not Present		
thresholdBeaconRSSI-r12::= SEQUENCE {			BeaconRSSI
thresholdBeaconRSSI-Low-r12	Set according to specific message content		
thresholdBeaconRSSI-High-r12	Set according to specific message content		
}			
offloadPreferenceIndicator-r12	'1111 1111 1111 1111'B	All IP flows enabled	
t-SteeringWLAN-r12	0	Typical value in real networks	
}			

Condition	Explanation
RSRP	If RSRP based thresholds are to be used
RSRQ	If RSRQ based thresholds are to be used
ChanUtilization	If Channel Utilization based thresholds are to be used
BackhaulBW	If Backhaul bandwidth thresholds are to be used
BeaconRSSI	If Beacon RSSI Thresholds are to be used

– EIMTA-MainConfig-r12-DEFAULT

Table 4.6.3-31: EIMTA-MainConfig-r12-DEFAULT

Derivation Path: 36.331 clause 6.3.2			
Information Element	Value/remark	Comment	Condition
EIMTA-MainConfig-r12 ::= CHOICE {			
setup SEQUENCE {			
eimta-RNTI-r12	Set to the value of the C-RNTI of the UE		
eimta-CommandPeriodicity-r12	sf10		
eimta-CommandSubframeSet-r12	1111111111		FDD
	1100011000		TDD
}			
}			

Condition	Explanation
FDD	FDD cell environment
TDD	TDD cell environment

– EIMTA-MainConfigServCell-r12-DEFAULT

Table 4.6.3-32: EIMTA-MainConfigServCell-r12-DEFAULT

Derivation Path: 36.331 clause 6.3.2			
Information Element	Value/remark	Comment	Condition
EIMTA-MainConfigServCell-r12 ::= CHOICE {			
setup SEQUENCE {			
eimta-UL-DL-ConfigIndex-r12	1		
eimta-HARQ-ReferenceConfig-r12	Sa2		
mbsfn-SubframeConfigList-v1250	Not present		
mbsfn-SubframeConfigList-v1250 ::= CHOICE {			MBMS
setup SEQUENCE {			
mbsfn-SubframeConfigList	Not present		
mbsfn-SubframeConfigList SEQUENCE (SIZE (1..maxMBSFN-Allocations)) OF SEQUENCE {			MBMS
radioframeAllocationPeriod	n4		
radioframeAllocationOffset	1		FDD
	0		TDD
subframeAllocation CHOICE{			
oneFrame	'100000' B		FDD
	'000010' B		TDD
fourFrames	Not present		
}			
}			
}			
}			

Condition	Explanation
MBMS	MBMS cell environment
FDD	FDD cell environment
TDD	TDD cell environment

4.6.4 Security control information elements

– SecurityConfigHO-DEFAULT

Table 4.6.4-1: SecurityConfigHO-DEFAULT

Derivation Path: 36.331 clause 6.2.2, 6.3.3			
Information Element	Value/remark	Comment	Condition
SecurityConfigHO-DEFAULT ::= SEQUENCE {			
handoverType CHOICE {			
intraLTE SEQUENCE {			
securityAlgorithmConfig	Not present		
keyChangeIndicator	FALSE		
nextHopChainingCount	0		
}			
}			
}			

– SecurityConfigSMC-DEFAULT

Table 4.6.4-2: SecurityConfigSMC-DEFAULT

Derivation Path: 36.331 clause 6.2.2, 6.3.3			
Information Element	Value/remark	Comment	Condition
SecurityConfigSMC-DEFAULT ::= SEQUENCE {			
securityAlgorithmConfig SEQUENCE {			
cipheringAlgorithm	Set according to PIXIT parameter for default ciphering algorithm		For SIG
	eea0		For RF
integrityProtAlgorithm	Set according to PIXIT parameter for default integrity protection algorithm		For SIG
	spare1 or eia0-v920	This IE is set to one of the algorithms supported by the UE as indicated in the IE "UE network capability" in the ATTACH REQUEST message.	For RF
	eia1		
	eia2		
}			
}			

Condition	Explanation
For SIG	Used for signalling test cases
For RF	Used for RF/RRM test cases

4.6.5 Mobility control information elements

- MobilityControlInfo-HO

Table 4.6.5-1: MobilityControlInfo-HO

Derivation Path: 36.331 clause 6.3.4			
Information Element	Value/remark	Comment	Condition
MobilityControlInfo-HO ::= SEQUENCE {			
targetPhysCellId	Set according to specific message content		
carrierFreq SEQUENCE {			
dl-CarrierFreq	Set according to specific message content		
}			
carrierFreq SEQUENCE { }	Not present		Band > 64
carrierBandwidth	Not present		SAME-BW
carrierBandwidth SEQUENCE {			DIFF-BW
dl-Bandwidth	Same downlink bandwidth as used for target cell		
ul-Bandwidth	Not present		
}			
additionalSpectrumEmission	Not present		
	1		HO-to-EUTRA
t304	ms1000		
newUE-Identity	SS arbitrarily selects a value between '003C'H and 'FFF2'H.		
radioResourceConfigCommon	RadioResourceConfigCommon-DEFAULT		
rach-ConfigDedicated	Not present		
	Rach-ConfigDedicated-DEFAULT		FullConfig, HO-to-EUTRA
carrierFreq-v9e0 SEQUENCE {			Band > 64
dl-CarrierFreq-v9e0	Set according to specific message content		
}			
mobilityControlInfoV2X-r14 SEQUENCE {			HO-V2X
v2x-CommTxPoolExceptional-r14 SEQUENCE {			
sl-OffsetIndicator-r14	0	small-r12	
sl-Subframe-r14	00000000 11110000 0000	bs20-r14	
adjacencyPSCCH-PSSCH-r14	TRUE	BOOLEAN	
sizeSubchannel-r14	n5	ENUMERATED {n5}	BW10
	n10	ENUMERATED {n10}	BW20
numSubchannel-r14	n5	ENUMERATED {n5}	
startRB-Subchannel-r14	0		
startRB-PSCCH-Pool-r14	Not present		
rxParametersNCell-r14	Not present		
dataTxParameters-r14 SEQUENCE {			
alpha-r12	al0		
p0-r12	31		
}			
zoneID-r14	Not present		
}			
v2x-CommRxPool-r14 SEQUENCE {			
sl-OffsetIndicator-r14	0	small-r12	
sl-Subframe-r14	00001111 00000000 0000	bs20-r14	
adjacencyPSCCH-PSSCH-r14	TRUE	BOOLEAN	
sizeSubchannel-r14	n5	ENUMERATED {n5}	BW10

	n10	ENUMERATED {n10}	BW20
numSubchannel-r14	n5	ENUMERATED {n5}	
startRB-Subchannel-r14	0		
startRB-PSCCH-Pool-r14	Not present		
rxParametersNCell-r14	Not present		
dataTxParameters-r14	Not present		
zoneID-r14	Not present		
}			
v2x-CommSyncConfig-r14	Not present		
cbr-MobilityTxConfigList-r14	Not present		
}			
}			

Condition	Explanation
SAME-BW	Source and target cell are configured with same bandwidth
DIFF-BW	Source and target cell are configured with different bandwidth
Band > 64	If band > 64 is selected
HO-V2X	V2X sidelink communication handover
BW10	10 MHz channel bandwidth for V2X communication
BW20	20 MHz channel bandwidth for V2X communication

4.6.6 Measurement information elements

- MeasConfig-DEFAULT

Table 4.6.6-1: MeasConfig-DEFAULT

Derivation Path: 36.331, clause 6.3.5			
Information Element	Value/remark	Comment	Condition
MeasConfig-DEFAULT ::= SEQUENCE {			
measObjectToRemoveList	Not present		
measObjectToAddModList	Not present		
	MeasObjectEUTRA-GENERIC		RF
reportConfigToRemoveList	Not present		
reportConfigToAddModList	Not present		
	ReportConfigToAddModList_DEFAULT		RF
measIdToRemoveList	Not present		
measIdToAddModList	Not present		
	MeasIdToAddModList_DEFAULT		RF
quantityConfig	QuantityConfig-DEFAULT		
s-Measure	Not present		
preRegistrationInfoHRPD	Not present		
speedStatePars	Not present		
}			
measObjectToAddModList-v9e0 SEQUENCE {			Band > 64 and RF
measObjectEUTRA-v9e0 SEQUENCE {	N entries	N needs to be the same number of entries as in measObjectToAddModList	
carrierFreq-v9e0[n]	Downlink EARFCN for Freq		
}			
}			
measScaleFactor-r12	sf-EUTRA-cf1	specifies the factor for scaling the measurement performance requirements in TS 36.133	IncMon

Note: For signalling test, table 6.5.1-1 is applied.

Condition	Explanation
INTER-FREQ	For E-UTRA inter-freq measurements
INTER-RAT	For inter-RAT measurements with UTRAN and GERAN
Band > 64	If band > 64 is selected
intraFreq-CE-NeedForGaps	For UE having set pc_intraFreq-CE-NeedForGaps to TRUE.
RF	For RF, performance and RRM testing
IncMon	For IncMon RRM testing

- MeasGapConfig-GP1

Table 4.6.6-1A: MeasGapConfig-GP1

Derivation Path: 36.331, clause 6.3.5			
Information Element	Value/remark	Comment	Condition
MeasGapConfig-GP1 ::= CHOICE {			
setup SEQUENCE {			
gapOffset CHOICE {			
gp0	0	TGRP = 40 ms	
}			
}			
}			

- MeasGapConfig-CE

Table 4.6.6-1BA: MeasGapConfig-CE

Derivation Path: 36.331, clause 6.3.5			
Information Element	Value/remark	Comment	Condition
MeasGapConfig-CE ::= CHOICE {			
setup SEQUENCE {			
gapOffset CHOICE {			
gp0	20	TGRP = 40 ms	
}			
}			
}			

- MeasGapConfig-GP2

Table 4.6.6-1B: MeasGapConfig-GP2

Derivation Path: 36.331, clause 6.3.5			
Information Element	Value/remark	Comment	Condition
MeasGapConfig-GP2 ::= CHOICE {			
setup SEQUENCE {			
gapOffset CHOICE {			
gp1	0	TGRP = 80 ms	
}			
}			
}			

- MeasDS-Config-DEFAULT

Table 4.6.6-1CA: MeasDS-Config-DEFAULT

Derivation Path: 36.331, clause 6.3.5			
Information Element	Value/remark	Comment	Condition
MeasDS-Config-DEFAULT ::= CHOICE {			
release	NULL		
setup SEQUENCE {			
dmtc-PeriodOffset-r12 CHOICE {			
ms160-r12	10		
}			
ds-OccasionDuration-r12 CHOICE {			
durationFDD-r12	1		FDD
durationTDD-r12	2		TDD
}	1		LAA SCell
}			
measCSI-RS-ToRemoveList-r12	Not present		
measCSI-RS-ToAddModList-r12 SEQUENCE (SIZE (1..maxCSI-RS-Meas-r12)) OF MeasCSI-RS-Config-r12 {			
}	Not present		
}	MeasCSI-RS-Config-Default		CSI-RS
}			
}			

Condition	Explanation
FDD	FDD cell environment
TDD	TDD cell environment
CSI-RS	For CSI-RS measurements
LAA SCell	For LAA SCell environment

- MeasCSI-RS-Config-DEFAULT

Table 4.6.6-1CB: MeasCSI-RS-Config-DEFAULT

Derivation Path: 36.331, clause 6.3.5			
Information Element	Value/remark	Comment	Condition
MeasCSI-RS-Config-DEFAULT ::= SEQUENCE {			
measCSI-RS-Id-r12	Set according to specific message content		
physCellId-r12	Set according to specific message content		
scramblingIdentity-r12	1		
resourceConfig-r12	2		
subframeOffset-r12	0		
csi-RS-IndividualOffset-r12	0		
}			

MeasObjectCDMA2000-GENERIC

Table 4.6.6-1C: MeasObjectCDMA2000-GENERIC

Derivation Path: 36.331 clause 6.3.5			
Information Element	Value/remark	Comment	Condition
MeasObjectCDMA2000-GENERIC ::= SEQUENCE {			
cdma2000-Type	As per specific message content	[type1XRTT, typeHRPD]	
carrierFreq SEQUENCE {			
bandClass	As per specific message content	Should be one of the following: bc0, bc1, bc2, bc3, bc4, bc5, bc6, bc7, bc8, bc9, bc10, bc11, bc12, bc13, bc14, bc15, bc16, bc17, spare14, spare13, spare12, spare11, spare10, spare9, spare8, spare7, spare6, spare5, spare4, spare3, spare2, spare1, ...	
arfcn	Downlink channel number	INTEGER (0 to 2047)	
}			
searchWindowSize	As per specific message content	INTEGER (0..15)	
offsetFreq	0 (0 dB)		
cellsToRemoveList	Not present		
cellsToAddModList	[Not present]		
cellForWhichToReportCGI	Not present		
}			

ReportConfigToAddModList_DEFAULT

Table 4.6.6-1D: ReportConfigToAddModList_DEFAULT

Derivation Path: 36.331, clause 6.3.5			
Information Element	Value/remark	Comment	Condition
ReportConfigToAddModList_DEFAULT ::= SEQUENCE {	1 entry		
reportConfigId[1]	IdReportConfig-A3		
reportConfig[1]	ReportConfigEUTRA-A3		
}			

MeasIdToAddModList_DEFAULT

Table 4.6.6-1E: MeasIdToAddModList_DEFAULT

Derivation Path: 36.331, clause 6.3.5			
Information Element	Value/remark	Comment	Condition
MeasIdToAddModList_DEFAULT ::= SEQUENCE {	1 entry		
measId[1]	1		
measObjectId[1]	IdMeasObject-f1		
reportConfigId[1]	IdReportConfig-A3		
}			

- MeasObjectEUTRA-GENERIC

Table 4.6.6-2: MeasObjectEUTRA-GENERIC(Freq)

Derivation Path: 36.331 clause 6.3.5			
Information Element	Value/remark	Comment	Condition
MeasObjectEUTRA-GENERIC(Freq) ::= SEQUENCE {			
carrierFreq	Downlink EARFCN for Freq		
carrierFreq	65535	maxEARFCN	Band > 64
allowedmeasBandwidth	The number of the resource blocks for Freq		
presenceAntennaPort1	FALSE		
	TRUE	At least two cell-specific antenna ports are used in all neighbouring cells.	All neighCells with port1
neighbourCellConfig	'01'B (No MBSFN subframes are present in all neighbour cells)	MBSFN doesn't apply by default.	
offsetFreq	0 (dB 0)		
cellsToRemoveList	Not present		
cellsToAddModList	Not present		
blackCellsToRemoveList	Not present		
blackCellsToAddModList	Not present		
cellForWhichToReportCGI	Not present		
measCycleSCell-r10	sf512		SCell_EXIST
measSubframePatternConfigNeigh-r10	Not present		
measDS-Config-r12	MeasDS-Config-DEFAULT		DS_Meas
reducedMeasPerformance-r12	TRUE	For reduced measurement performance, otherwise it is normal measurement performance	IncMon
rmtc-Config-r13	Not present		
tx-ResourcePoolToRemoveList-r14	Not present		
tx-ResourcePoolToAddList-r14	Not present		
}			

Condition	Explanation
SCell_EXIST	When SCell exists on the carrier frequency indicated by carrierFreq
All neighCells with port1	Used for all neighbouring cells with at least two cell-specific antenna ports
DS_Meas	Used for discovery signals measurement on the carrier frequency indicated by carrierFreq
Band > 64	If band > 64 is selected
IncMon	For IncMon RRM testing

- MeasObjectGERAN-GENERIC

Table 4.6.6-2A: MeasObjectGERAN-GENERIC(Freq)

Derivation Path: 36.331 clause 6.3.5			
Information Element	Value/remark	Comment	Condition
MeasObjectGERAN-GENERIC(Freq) ::= SEQUENCE {			
carrierFreqs SEQUENCE {			
startingARFCN	Downlink GERAN ARFCN of Freq		
bandIndicator	Set according to the band used for GERAN cells under test		
followingARFCNs CHOICE {			
explicitListOfARFCNs	Set the corresponding ARFCN of GERAN cells under test		
}			
}			
offsetFreq	0 (dB 0)		
ncc-Permitted	'01000000'B	NCC=1 permitted	
cellForWhichToReportCGI	Not present		
}			

- MeasObjectNR-GENERIC

Table 4.6.6-2B: MeasObjectNR-GENERIC (Freq)

Derivation Path: 36.331 clause 6.3.5			
Information Element	Value/remark	Comment	Condition
MeasObjectNR-GENERIC(Freq) ::= SEQUENCE {			
carrierFreq-r15	Downlink ARFCN of ssbFrequency		
rs-ConfigSSB-r15 ::= SEQUENCE {			
measTimingConfig-r15 ::= SEQUENCE {			
periodicityAndOffset-r15 CHOICE {			
sf10-r15	0		
}			
ssb-Duration-r15	sf5		
}			
subcarrierSpacingSSB-r15	kHz15		FR1_FDD
	kHz30		FR1_TDD
	kHz120		FR2_TDD
}			
threshRS-Index-r15	Not present		
maxRS-IndexCellQual-r15	Not present		
offsetFreq-r15	0		
blackCellsToRemoveList-r15	Not present		
blackCellsToAddModList-r15	Not present		
quantityConfigSet-r15	1		
}			

Condition	Explanation
FR1_FDD	FDD frequency range < 6GHz
FR1_TDD	TDD frequency range < 6GHz
FR2_TDD	TDD frequency range > 6GHz

- MeasObjectUTRA-GENERIC

Table 4.6.6-3: MeasObjectUTRA-GENERIC(Freq)

Derivation Path: 36.331 clause 6.3.5			
Information Element	Value/remark	Comment	Condition
MeasObjectUTRA-GENERIC(Freq) ::= SEQUENCE {			
carrierFreq	Downlink UARFCN of Freq		
offsetFreq	0 (dB 0)		
cellsToRemoveList	Not present		
cellsToAddModList	Not present	For UTRA, the neighbouring cell list needs to be provided in specific test cases.	
cellForWhichToReportCGI	Not present		
}			

- QuantityConfig-DEFAULT

Table 4.6.6-3A: QuantityConfig-DEFAULT

Derivation Path: 36.331, clause 6.3.5			
Information Element	Value/remark	Comment	Condition
QuantityConfig-DEFAULT ::= SEQUENCE {			
quantityConfigEUTRA SEQUENCE {			
filterCoefficientRSRP	Not present	DEFAULT fc4	
filterCoefficientRSRQ	Not present	DEFAULT fc4	
}			
quantityConfigUTRA SEQUENCE {}	Not present		
quantityConfigUTRA SEQUENCE {			UTRAN
measQuantityUTRA-FDD	cpich-EcN0		
measQuantityUTRA-FDD	cpich-RSCP	For signalling test cases	
measQuantityUTRA-TDD	pccpch-RSCP		
filterCoefficient	Not present	DEFAULT fc4	
}			
quantityConfigGERAN SEQUENCE {}	Not present		
quantityConfigGERAN SEQUENCE {			GERAN
measQuantityGERAN	rssi		
filterCoefficient	Not present	DEFAULT fc2	
}			
quantityConfigCDMA2000 SEQUENCE {}	Not present		
quantityConfigCDMA2000 SEQUENCE {			CDMA2000
measQuantityCDMA2000	[FFS]		
}			
quantityConfigEUTRA-v1250 SEQUENCE {			
filterCoefficientCSI-RSRP-r12	Not present	DEFAULT fc4	CSI-RSRP
}			
}			

Condition	Explanation
UTRAN	For inter-RAT measurements with UTRAN
GERAN	For inter-RAT measurements with GERAN
CDMA2000	For inter-RAT measurements with CDMA2000
CSI-RSRP	For CSI-RSRP measurements

- ReportConfigEUTRA-A1

Table 4.6.6-4: ReportConfigEUTRA-A1(Thres)

Derivation Path: 36.331 clause 6.3.5			
Information Element	Value/remark	Comment	Condition
ReportConfigEUTRA-A1(Thres) ::= SEQUENCE {			
triggerType CHOICE {			
event SEQUENCE {			
eventId CHOICE {			
eventA1 SEQUENCE {			
a1-Threshold CHOICE {			
threshold-RSRP	Thres+140	Thres is actual threshold value in dBm	
}			
}			
}			
hysteresis	0 (0 dB)		
timeToTrigger	ms256		
}			
triggerQuantity	rsrp		
reportQuantity	both		
maxReportCells	1		
reportInterval	ms1024		
reportAmount	r1		
}			

- ReportConfigEUTRA-A2

Table 4.6.6-5: ReportConfigEUTRA-A2(Thres)

Derivation Path: 36.331 clause 6.3.5			
Information Element	Value/remark	Comment	Condition
ReportConfigEUTRA-A2(Thres) ::= SEQUENCE {			
triggerType CHOICE {			
event SEQUENCE {			
eventId CHOICE {			
eventA2 SEQUENCE {			
a2-Threshold CHOICE {			
threshold-RSRP	Thres+140	Thres is actual threshold value in dBm	
}			
}			
}			
hysteresis	0 (0 dB)		
timeToTrigger	ms320		
}			
triggerQuantity	rsrp		
reportQuantity	both		
maxReportCells	1		
reportInterval	ms1024		
reportAmount	r1		
}			

- ReportConfigEUTRA-A3

Table 4.6.6-6: ReportConfigEUTRA-A3

Derivation Path: 36.331 clause 6.3.5			
Information Element	Value/remark	Comment	Condition
ReportConfigEUTRA-A3 ::= SEQUENCE {			
triggerType CHOICE {			
event SEQUENCE {			
eventId CHOICE {			
eventA3 SEQUENCE {			
a3-Offset	0 (0 dB)	To reduce interference between intra-frequency multiple cells	
reportOnLeave	FALSE		
}			
}			
hysteresis	0 (0 dB)		
timeToTrigger	ms640		
}			
triggerQuantity	rsrp		
reportQuantity	both		
maxReportCells	1		
reportInterval	ms1024		
reportAmount	r1		
}			

- ReportConfigEUTRA-A4

Table 4.6.6-6AA: ReportConfigEUTRA-A4(Thres)

Derivation Path: 36.331 clause 6.3.5			
Information Element	Value/remark	Comment	Condition
ReportConfigEUTRA-A4 ::= SEQUENCE {			
triggerType CHOICE {			
event SEQUENCE {			
eventId CHOICE {			
eventA4 SEQUENCE {			
a4-Threshold CHOICE{			
threshold-RSRP	Thres + 140	Thres is actual threshold value in dBm	Not RSRQ
threshold-RSRQ	Thres * 2 + 40	Thres is actual threshold value in dB	RSRQ
}			
}			
hysteresis	0 (0 dB)		
timeToTrigger	ms0		
}			
}			
triggerQuantity	rsrp		Not RSRQ
	rsrq		RSRQ
reportQuantity	both		
maxReportCells	1		
reportInterval	ms1024		
reportAmount	r1		
si-RequestForHO-r9	Not Present		
ue-RxTxTimeDiffPeriodical-r9	Not Present		
}			

Condition	Explanation
RSRQ	When RSRQ based measurement is applied

- ReportConfigEUTRA-A5

Table 4.6.6-6AB: ReportConfigEUTRA-A5(Thres1, Thres2)

Derivation Path: 36.331 clause 6.3.5			
Information Element	Value/remark	Comment	Condition
ReportConfigEUTRA-A5 ::= SEQUENCE {			
triggerType CHOICE {			
event SEQUENCE {			
eventId CHOICE {			
eventA5 SEQUENCE {			
a5-Threshold1 CHOICE{			
threshold-RSRP	Thres1 + 140	Thres1 is actual threshold value in dBm	Not RSRQ
threshold-RSRQ	Thres1 * 2 + 40	Thres1 is actual threshold value in dB	RSRQ
}			
a5-Threshold2 CHOICE{			
threshold-RSRP	Thres2 + 140	Thres2 is actual threshold value in dBm	Not RSRQ
threshold-RSRQ	Thres2 * 2 + 40	Thres2 is actual threshold value in dB	RSRQ
}			
}			
hysteresis	0 (0 dB)		
timeToTrigger	ms0		
}			
}			
triggerQuantity	rsrp		Not RSRQ
	rsrq		RSRQ
reportQuantity	both		
maxReportCells	1		
reportInterval	ms1024		
reportAmount	r1		
si-RequestForHO-r9	Not Present		
ue-RxTxTimeDiffPeriodical-r9	Not Present		
}			

Condition	Explanation
RSRQ	See the definition below table 4.6.6-6AA.

- ReportConfigEUTRA-A6

Table 4.6.6-6A: ReportConfigEUTRA-A6

Derivation Path: 36.331 clause 6.3.5			
Information Element	Value/remark	Comment	Condition
ReportConfigEUTRA-A6 ::= SEQUENCE {			
triggerType CHOICE {			
event SEQUENCE {			
eventId CHOICE {			
eventA6-r10 SEQUENCE {			
a6-Offset-r10	0 (0 dB)		
a6-ReportOnLeave-r10	FALSE		
}			
}			
hysteresis	0 (0 dB)		
timeToTrigger	ms640		
}			
triggerQuantity	rsrp		
reportQuantity	both		
maxReportCells	1		
reportInterval	ms1024		
reportAmount	r1		
si-RequestForHO-r9	Not Present		
ue-RxTxTimeDiffPeriodical-r9	Not Present		
includeLocationInfo-r10	Not Present		
reportAddNeighMeas-r10	Not Present		
}			

- ReportConfigEUTRA-PERIODICAL

Table 4.6.6-7: ReportConfigEUTRA-PERIODICAL

Derivation Path: 36.331 clause 6.3.5			
Information Element	Value/remark	Comment	Condition
ReportConfigEUTRA-PERIODICAL ::= SEQUENCE {			
triggerType CHOICE {			
periodical SEQUENCE {			
purpose	reportStrongestCells		
}			
triggerQuantity	rsrp		
reportQuantity	both		
maxReportCells	1		
reportInterval	ms1024		
reportAmount	infinity		
}			

- ReportConfigInterRAT-B1-GERAN

Table 4.6.6-7A: ReportConfigInterRAT-B1-GERAN(GERAN-Thres)

Derivation Path: 36.331 clause 6.3.5			
Information Element	Value/remark	Comment	Condition
ReportConfigInterRAT-B1-GERAN(GERAN-Thres) ::= SEQUENCE {			
triggerType CHOICE {			
event SEQUENCE {			
eventId CHOICE {			
eventB1 SEQUENCE {			
b1-Threshold CHOICE {			
b1-ThresholdGERAN	(GERAN-Thres + 110)	GERAN-Thres is actual value in dBm	
}			
}			
}			
hysteresis	0	INTEGER(0..30)	
timeToTrigger	ms0		
}			
}			
maxReportCells	6	In line with RAN4 requirement	
reportInterval	ms1024		
reportAmount	r1		
}			

- ReportConfig-B1-NR-r15

Table 4.6.6-7AA: ReportConfig-B1-NR-r15(NR_Thres)

Derivation Path: 36.331 clause 6.3.5			
Information Element	Value/remark	Comment	Condition
ReportConfig-B1-NR ::= SEQUENCE {			
triggerType CHOICE {			
event SEQUENCE {			
eventId CHOICE {			
eventB1-NR-r15 SEQUENCE{			
b1-ThresholdNR-r15 CHOICE{			
nr-RSRP-r15	NR_Thres	NR_Thres is actual RSCP value in dBm	
}			
reportOnLeave-r15	FALSE		
}			
}			
hysteresis	0		
timeToTrigger	ms0		
}			
maxReportCells	6		
reportInterval	ms1024		
reportAmount	r1		
}			

- ReportConfigInterRAT-B1-UTRA

Table 4.6.6-7B: ReportConfigInterRAT-B1-UTRA(UTRA-Thres)

Derivation Path: 36.331 clause 6.3.5			
Information Element	Value/remark	Comment	Condition
ReportConfigInterRAT-B1-UTRA(UTRA-Thres) ::= SEQUENCE {			
triggerType CHOICE {			
event SEQUENCE {			
eventId CHOICE {			
eventB1 SEQUENCE {			
b1-Threshold CHOICE {			
b1-ThresholdUTRA CHOICE {			
utra-EcN0	(UTRA-Thres * 2 + 49)	UTRA-Thres is actual Ec/NO value in dB	UTRA-FDD
utra-RSCP	UTRA-Thres + 115	For signalling test cases UTRA-Thres is actual RSCP value in dBm	UTRA-FDD
utra-RSCP	UTRA-Thres + 115	UTRA-Thres is actual RSCP value in dBm	UTRA-TDD
}			
}			
}			
}			
hysteresis	3 (1.5 dB)		
timeToTrigger	ms0		
}			
}			
maxReportCells	6	In line with RAN4 requirement	
reportInterval	ms1024		
reportAmount	r1		
}			

Condition	Explanation
UTRA-FDD	UTRA FDD cell environment
UTRA-TDD	UTRA TDD cell environment

- ReportConfigInterRAT-B2-CDMA2000

Table 4.6.6-7C: ReportConfigInterRAT-B2-CDMA2000(EUTRA-Thres, CDMA2000-Thres)

Derivation Path: 36.331 clause 6.3.5			
Information Element	Value/remark	Comment	Condition
ReportConfigInterRAT-B2-CDMA2000(EUTRA-Thres, CDMA2000-Thres) ::= SEQUENCE {			
triggerType CHOICE {			
event SEQUENCE {			
eventId CHOICE {			
eventB2 SEQUENCE {			
b2-Threshold1 CHOICE {			
threshold-RSRP	EUTRA-Thres+140	EUTRA-Thres is actual threshold value in dBm	
}			
b2-Threshold2 CHOICE {			
b2-Threshold2CDMA2000	[30 (-15 dB)]	Integer (0..63)	
}			
}			
}			
hysteresis	[2 (1 dB)]	INTEGER(0..30)	
timeToTrigger	ms0		
}			
}			
maxReportCells	[8]		
reportInterval	[ms2048]	Range: ms120, ms240, ms480, ms640, ms1024, ms2048, ms5120, ms10240, min1, min6, min12, min30, min60, spare3, spare2, spare1	
reportAmount	[r1]	Range: r1, r2, r4, r8, r16, r32, r64, infinity	
}			

Table 4.6.6-7D: Void

- ReportConfigInterRAT-B2-GERAN

Table 4.6.6-7E: ReportConfigInterRAT-B2-GERAN(EUTRA-Thres, GERAN-Thres)

Derivation Path: 36.331 clause 6.3.5			
Information Element	Value/remark	Comment	Condition
ReportConfigInterRAT-B2-GERAN(EUTRA-Thres, GERAN-Thres) ::= SEQUENCE {			
triggerType CHOICE {			
event SEQUENCE {			
eventId CHOICE {			
eventB2 SEQUENCE {			
b2-Threshold1 CHOICE {			
threshold-RSRP	EUTRA-Thres+140	EUTRA-Thres is actual threshold value in dBm	
}			
b2-Threshold2 CHOICE {			
b2-Threshold2GERAN	GERAN-Thres + 110	GERAN-Thres is actual value in dBm	
}			
}			
}			
hysteresis	0	INTEGER(0..30)	
timeToTrigger	ms0		
}			
maxReportCells	6	In line with RAN4 requirement	
reportInterval	ms1024		
reportAmount	r1		
}			

ReportConfigInterRAT-B2-UTRA

Table 4.6.6-8: ReportConfigInterRAT-B2-UTRA(EUTRA-Thres, UTRA-Thres)

Derivation Path: 36.331 clause 6.3.5			
Information Element	Value/remark	Comment	Condition
ReportConfigInterRAT-B2-UTRA(EUTRA-Thres, UTRA-Thres) ::= SEQUENCE {			
triggerType CHOICE {			
event SEQUENCE {			
eventId CHOICE {			
eventB2 SEQUENCE {			
b2-Threshold1 CHOICE {			
threshold-RSRP	EUTRA-Thres+140	EUTRA-Thres is actual threshold value in dBm	
}			
b2-Threshold2 CHOICE {			
b2-Threshold2UTRA CHOICE {			
utra-EcN0	UTRA-Thres * 2 + 49	UTRA-Thres is actual Ec/NO value in dB	UTRA-FDD
utra-RSCP	UTRA-Thres + 115	For signalling test cases UTRA-Thres is actual RSCP value in dBm	UTRA-FDD
utra-RSCP	UTRA-Thres + 115	UTRA-Thres is actual RSCP value in dBm	UTRA-TDD
}			
}			
}			
hysteresis	3 (1.5 dB)		
timeToTrigger	ms0		
}			
maxReportCells	6	In line with RAN4 requirement	
reportInterval	ms1024		
reportAmount	r1		
}			

Condition	Explanation
UTRA-FDD	UTRA FDD cell environment
UTRA-TDD	UTRA TDD cell environment

- ReportConfigInterRAT-PERIODICAL

Table 4.6.6-9: ReportConfigInterRAT-PERIODICAL

Derivation Path: 36.331 clause 6.3.5			
Information Element	Value/remark	Comment	Condition
ReportConfigInterRAT-PERIODICAL ::= SEQUENCE {			
triggerType CHOICE {			
periodical SEQUENCE {			
purpose	reportStrongestCells		
}			
}			
maxReportCells	1		
reportInterval	ms1024		
reportAmount	infinity		
}			

- ReportConfigEUTRA-C1

Table 4.6.6-10: ReportConfigEUTRA-C1(Thres)

Derivation Path: 36.331 clause 6.3.5			
Information Element	Value/remark	Comment	Condition
ReportConfigEUTRA-C1 ::= SEQUENCE {			
triggerType CHOICE {			
event SEQUENCE {			
eventId CHOICE {			
eventC1-r12 SEQUENCE {			
c1-Threshold-r12	Thres+140	Thres is actual threshold value in dBm	
c1-ReportOnLeave-r12	FALSE		
}			
}			
}			
hysteresis	0 (0 dB)		
timeToTrigger	ms640		
}			
triggerQuantity	rsrp		
reportQuantity	sameAsTriggerQuantity		
maxReportCells	1		
reportInterval	ms1024		
reportAmount	r1		
si-RequestForHO-r9	Not Present		
ue-RxTxTimeDiffPeriodical-r9	Not Present		
includeLocationInfo-r10	Not Present		
reportAddNeighMeas-r10	Not Present		
alternativeTimeToTrigger-r12	Not Present		
useT312-r12	Not Present		
usePSCell-r12	Not Present		
aN-Threshold1-v1250	Not Present		
a5-Threshold2-v1250	Not Present		
reportStrongestCSI-RS-r12	false		
reportCRS-Meas-r12	false		
triggerQuantityCSI-RS-r12	true		
}			

- ReportConfigEUTRA-C2

Table 4.6.6-11: ReportConfigEUTRA-C2

Derivation Path: 36.331 clause 6.3.5			
Information Element	Value/remark	Comment	Condition
ReportConfigEUTRA-C2 ::= SEQUENCE {			
triggerType CHOICE {			
event SEQUENCE {			
eventId CHOICE {			
eventC2-r12 SEQUENCE {			
c2-RefCSI-RS-r12	1		
c2-Offset-r12	2	The actual value is IE value * 0.5 dB.	
c2-ReportOnLeave-r12	FALSE		
}			
}			
hysteresis	0 (0 dB)		
timeToTrigger	ms640		
}			
triggerQuantity	rsrp		
reportQuantity	sameAsTriggerQuantity		
maxReportCells	1		
reportInterval	ms1024		
reportAmount	r1		
si-RequestForHO-r9	Not Present		
ue-RxTxTimeDiffPeriodical-r9	Not Present		
includeLocationInfo-r10	Not Present		
reportAddNeighMeas-r10	Not Present		
alternativeTimeToTrigger-r12	Not Present		
useT312-r12	Not Present		
usePSCell-r12	Not Present		
aN-Threshold1-v1250	Not Present		
a5-Threshold2-v1250	Not Present		
reportStrongestCSI-RSs-r12	false		
reportCRS-Meas-r12	false		
triggerQuantityCSI-RS-r12	true		
}			

- ReportConfigEUTRA-PERIODICAL-CSI-RS

Table 4.6.6-12: ReportConfigEUTRA-PERIODICAL-CSI-RS

Derivation Path: 36.331 clause 6.3.5			
Information Element	Value/remark	Comment	Condition
ReportConfigEUTRA-PERIODICAL ::= SEQUENCE {			
triggerType CHOICE {			
periodical SEQUENCE {			
purpose	reportStrongestCells		
}			
}			
triggerQuantity	rsrp		
reportQuantity	both		
maxReportCells	1		
reportInterval	ms1024		
reportAmount	infinity		
si-RequestForHO-r9	Not Present		
ue-RxTxTimeDiffPeriodical-r9	Not Present		
includeLocationInfo-r10	Not Present		
reportAddNeighMeas-r10	Not Present		
alternativeTimeToTrigger-r12	Not Present		
useT312-r12	Not Present		
usePSCell-r12	Not Present		
aN-Threshold1-v1250	Not Present		
a5-Threshold2-v1250	Not Present		
reportStrongestCSI-RSs-r12	true		
reportCRS-Meas-r12	false		
triggerQuantityCSI-RS-r12	false		
}			

- ReportConfigEUTRA-V1

Table 4.6.6-13: ReportConfigEUTRA-V1

Derivation Path: 36.331 clause 6.3.5			
Information Element	Value/remark	Comment	Condition
ReportConfigEUTRA-V1 ::= SEQUENCE {			
triggerType CHOICE {			
event SEQUENCE {			
eventId CHOICE {			
eventV1-r14 SEQUENCE {			
v1-Threshold-r14	50		
}			
}			
}			
hysteresis	0 (0 dB)		
timeToTrigger	ms0		
}			
triggerQuantity	rsrp		Not RSRQ
reportQuantity	both		
maxReportCells	1		
reportInterval	ms1024		
reportAmount	r1		
purpose-v14xy	sidelink		
}			

- ReportConfigEUTRA-V2

Table 4.6.6-14: ReportConfigEUTRA-V2

Derivation Path: 36.331 clause 6.3.5			
Information Element	Value/remark	Comment	Condition
ReportConfigEUTRA-V2 ::= SEQUENCE {			
triggerType CHOICE {			
event SEQUENCE {			
eventId CHOICE {			
eventV2-r14 SEQUENCE {			
v2-Threshold-r14	10		
}			
}			
hysteresis	0 (0 dB)		
timeToTrigger	ms0		
}			
triggerQuantity	rsrp		Not RSRQ
reportQuantity	both		
maxReportCells	1		
reportInterval	ms1024		
reportAmount	r1		
purpose-v14xy	sidelink		
}			

4.6.7 Other information elements

- RRC-TransactionIdentifier-DL

Table 4.6.7-1: RRC-TransactionIdentifier-DL

Derivation Path: 36.331 clause 6.3.6			
Information Element	Value/remark	Comment	Condition
RRC-TransactionIdentifier-DL ::=	0..3		

- RRC-TransactionIdentifier-UL

Table 4.6.7-2: RRC-TransactionIdentifier-UL

Derivation Path: 36.331 clause 6.3.6			
Information Element	Value/remark	Comment	Condition
RRC-TransactionIdentifier-UL ::=	0..3	The same value as the value of RRC-TransactionIdentifier-DL in the downlink message initiating the procedure	

4.6.8 Channel-bandwidth-dependent parameters

The default values of parameters which depend on the channel bandwidth are defined in table 4.6.8-1.

Table 4.6.8-1: Channel-bandwidth-dependent parameters

Information Element	Channel bandwidth						Comment
	1.4 MHz	3 MHz	5 MHz	10 MHz	15 MHz	20MHz	
Prach-FrequencyOffset or prach-FreqOffsetHighSpeed-r14	0	1	2	4	6	8	Typical value in real network
nRB-CQI	0	0	2	4	6	8	Selected based on typical maximum number of UEs.
Pusch-HoppingOffset	0	2	4	8	12	16	Typical value in real network
sr-PUCCH-ResourceIndex	0	10	20	41	62	84	
srs-BandwidthConfig	FFS	FFS	bw3 ($m_{SRS,b}$, N_b) = (20, 1), (4, 5), (4, 1), (4, 1)	bw2 ($m_{SRS,b}$, N_b) = (40, 1), (20, 2), (4, 5), (4, 1)	bw2 ($m_{SRS,b}$, N_b) = (60, 1), (20, 3), (4, 5), (4, 1)	bw2 ($m_{SRS,b}$, N_b) = (80, 1), (40, 2), (20, 2), (4, 5)	Selected in accordance with pucch-ResourceSize.

4.7 Default NAS message and information element contents

This clause contains the default values of common NAS messages and information elements, which apply to all test cases unless otherwise specified. All the messages and information elements are listed in alphabetical order.

4.7.1 Security protected NAS messages

In subclauses 4.7.2 and 4.7.3 in this document, all the NAS messages are described in the plain NAS message format.

When a NAS message is security protected, the message shall be contained by SECURITY PROTECTED NAS MESSAGE unless contained by another NAS message.

The default contents of SECURITY PROTECTED NAS MESSAGE message are defined in table 4.7.1-1.

Table 4.7.1-1: SECURITY PROTECTED NAS MESSAGE

Derivation Path: 24.301 clause 8.2.23			
Information Element	Value/remark	Comment	Condition
Protocol discriminator	EMM		
Security header type	'0001'B	Integrity protected	UNCIPHERED
	'0010'B	Integrity protected and ciphered	CIPHERED
	'0011'B	Integrity protected with new EPS security context	UNCIPHERED-NEW
	'0100'B	Integrity protected and ciphered with new EPS security context	CIPHERED-NEW
	'0101'B	Integrity protected and partially ciphered NAS message	CIPHERED-PARTIALLY
Message authentication code	The calculated value of MAC-I for this message.	The value of MAC-I is calculated by SS using Sequence number sent by UE.	SENT-BY-SS
	The same value as the XMAC-I value calculated by SS.		SENT-BY-UE
Sequence number	The internal counter of the SS		SENT-BY-SS
	Any allowed value		SENT-BY-UE
NAS message	Set according to specific message content		

Condition	Explanation
UNCIPHERED	This condition applies to unciphered NAS message exchange
CIPHERED	This condition applies to ciphered NAS message exchange
UNCIPHERED-NEW	This condition applies to unciphered NAS message exchange with new EPS security context
CIPHERED-NEW	This condition applies to ciphered NAS message exchange with new EPS security context
CIPHERED-PARTIALLY	This condition applies to partially ciphered NAS message exchange
SENT-BY-SS	Use for the message sent from SS to UE
SENT-BY-UE	Use for the message sent from UE to SS

When a valid NAS security context exists, unless specified otherwise in other clauses of the present specification or in a test case, for every DL NAS message sent within SECURITY PROTECTED NAS MESSAGE message, the condition CIPHERED applies.

4.7.2 Contents of EMM messages

- ATTACH ACCEPT

This message is sent by the SS to the UE.

Table 4.7.2-1: ATTACH ACCEPT

Derivation Path: 24.301 clause 8.2.1			
Information Element	Value/remark	Comment	Condition
Protocol discriminator	EMM		
Security header type	'0000'B	Plain NAS message, not security protected	
Attach accept message identity	'0100 0010'B	Attach accept	
EPS attach result	'0001'B	EPS only	EPS_only
	'0010'B	combined EPS/IMSI attach	combined_EPS_IMSI
Spare half octet	'0000'B		
T3412 value			
Timer value	'0 0000'B		
Unit	'111'B	value indicates that the timer is deactivated.	
TAI list			
Length of tracking area identity list contents	'0000 0110'B	6 octets	
Partial tracking area identity list 1			
Number of elements	'0 0000'B	1 element	
Type of list	'00'B	list of TACs belonging to one PLMN, with non-consecutive TAC values	
MCC	See table 4.4.2-2 in this document	For NAS test cases, see table 6.3.2.2-1.	
MNC	See table 4.4.2-2 in this document	For NAS test cases, see table 6.3.2.2-1.	
TAC 1	See table 4.4.2-2 in this document	For NAS test cases, see table 6.3.2.2-1.	
ESM message container	ACTIVATE DEFAULT EPS BEARER CONTEXT REQUEST message to activate the default bearer		
ESM message container	ESM DUMMY MESSAGE		CIoT_Attach_WithoutPDN
GUTI			
Length of EPS mobile identity contents	'0000 1011'B	11 octets	
Type of identity	'110'B	GUTI	
Odd/even indication	'0'B	even number of identity digits and also when the GUTI is used	
MCC	See table 4.4.2-2 in this document	For NAS test cases, see table 6.3.2.2-1.	
MNC	See table 4.4.2-2 in this document	For NAS test cases, see table 6.3.2.2-1.	
MME Group ID	See table 4.4.2-2 in this document	For NAS test cases, see table 6.3.2.2-1.	
MME Code	See table 4.4.2-2 in this document	For NAS test cases, see table 6.3.2.2-1.	
M-TMSI	See table 4.4.2-2 in this document	For NAS test cases, see table 6.3.2.2-1.	
Location area identification	Not present		EPS_only
Location area identification			

MCC	MCC of the EUTRA cell from which this message is sent		combined_E PS_IMSI
MNC	MCC of the EUTRA cell from which this message is sent		
LAC	1		
MS identity	Not present		EPS_only
MS identity			combined_E PS_IMSI
Length of mobile identity contents	'0000 0101'B	5 octets	
Type of identity	'100'B	TMSI/P-TMSI/M-TMSI	
Odd/even indication	'0'B	even number of identity digits and also when the TMSI/P-TMSI or TMGI and optional MBMS Session Identity is used	
TMSI	TMSI-1		
EMM cause	Not present		
T3402 value	Not present		
T3423 value	Not present		
Equivalent PLMNs	Not present		
Emergency number list	Not present		
EPS network feature support	'0000 0001'B	IMS voice over PS session in S1 mode supported	
EPS network feature support	'0000 0011'B	IMS voice over PS session in S1 mode supported, emergency bearer services in S1 mode supported	Rel-9
EPS network feature support	'1000 0011 0000 1111'B	IMS voice over PS session in S1 mode, emergency bearer services in S1 mode, CP Clot, ePCO, HC-CP Clot, S1-U data and UP Clot supported	Clot
EPS network feature support	'1100 0000 0000 1100'B	Clot control plane optimization indicated, Attach Without PDN supported, ePCO supported, Header Compression for Clot control plane supported	Clot_CP AND pc_NB
EPS network feature support	'1000 0000 0000 1011'B	CP Clot supported, ePCO supported, S1-U data transfer supported, Clot user plane optimization indicated	Clot_UP AND pc_NB
EPS network feature support	'1000 0000 0000 1010'B	CP Clot supported, ePCO supported, S1-U data transfer only indicated	S1-U Only AND pc_NB

EPS network feature support	'0010 0000 0000 0000'B	EXTENDED SERVICE REQUEST for packet services indicated	ESRPS
Additional update result	Not present		
Additional update result	'0010' B	"SMS only"	additional_update_result_SMS OR CloT_SMSOnly
T3412 extended value	Not present		Rel-10
Extended DRX parameters	Not present		

Condition	Explanation
EPS_only	This condition applies if the UE is configured to initiate EPS attach or if explicitly specified.
combined_EPS_IMSI	This condition applies if the UE is configured to initiate combined EPS/IMSI attach or if explicitly specified. This condition does not apply for NB-S1.
additional_update_result_SMS	If the UE requested "SMS only" in the Additional update type IE and combined_EPS_IMSI condition applies
CloT_Attach_WithoutPDN	If the UE wants to attach without PDN for CloT optimization
CloT_CP	If test case requires control plane CloT optimization
CloT_SMSOnly	If SMS Only is indicated in the ATTACH REQ received earlier
CloT_UP	If test case requires user plane CloT optimization
S1-U data Only	If S1-U data transfer Only is indicated
CloT	If in the last ATTACH REQUEST, the UE network capability was included with the "CP CloT" (octet 8, bit 3) or the "UP CloT" and "S1-U data" (octet 8, bit 4 and bit 5). Note 1: This condition is only applicable for E-UTRA UEs (TS 36.523-2 A.4.1-1/1 or A.4.1-1/2).
ESRPS	If the test case requires the network to indicate support of EXTENDED SERVICE REQUEST for packet services (ESRPS)

NOTE: This message is always sent within SECURITY PROTECTED NAS MESSAGE message.

- ATTACH COMPLETE

This message is sent by the UE to the SS.

Table 4.7.2-2: ATTACH COMPLETE

Derivation Path: 24.301 clause 8.2.2			
Information Element	Value/remark	Comment	Condition
Protocol discriminator	EMM		
Security header type	'0000'B	Plain NAS message, not security protected	
Attach complete message identity	'0100 0011'B	Attach complete	
ESM message container	ACTIVATE DEFAULT EPS BEARER CONTEXT ACCEPT message		
ESM message container	ESM DUMMY MESSAGE		CloT_Attach_WithoutPDN

Condition	Explanation
CloT_Attach_WithoutPDN	If the UE wants to attach without PDN for CloT optimization

NOTE: This message is always sent within SECURITY PROTECTED NAS MESSAGE message.

- ATTACH REJECT

This message is sent by the SS to the UE.

Table 4.7.2-3: ATTACH REJECT

Derivation Path: 24.301 clause 8.2.3			
Information Element	Value/remark	Comment	Condition
Protocol discriminator	EMM		
Security header type	'0000'B	Plain NAS message, not security protected	
Attach reject message identity	'0100 0100'B	Attach reject	
EMM cause	Set according to specific message content.		
ESM message container	Set according to specific message content.		

NOTE: If this message includes the EMM cause set to #3, #6, #7, #8, #11, #12, #13, #14, #15, #25 or #35, it is sent within SECURITY PROTECTED NAS MESSAGE message. Otherwise this message is sent without integrity protection.

- ATTACH REQUEST

This message is sent by the UE to the SS.

Table 4.7.2-4: ATTACH REQUEST

Derivation Path: 24.301 clause 8.2.4			
Information Element	Value/remark	Comment	Condition
Protocol discriminator	EMM		
Security header type	'0000'B	Plain NAS message, not security protected	
Attach request message identity	'0100 0001'B	Attach request	
EPS attach type	'0001'B	EPS attach	EPS_only
	'0010'B	combined EPS/IMSI attach	combined_EPS_IMSI
NAS key set identifier	Any allowed value		
Old GUTI or IMSI	Any allowed value		
UE network capability	Any allowed value		
UE network capability			EN-DC
All octets with the exception of octet 9, bit 5	Any allowed value		
Dual connectivity with NR (DCNR) (octet 9, bit 5)	1	dual connectivity with NR supported	
ESM message container	PDN CONNECTIVITY REQUEST message to request PDN connectivity to the default PDN		
ESM message container	ESM DUMMY MESSAGE		CloT_Attach_WithoutPDN
Old P-TMSI signature	Not present or any allowed value		
Additional GUTI	Not present or any allowed value		
Last visited registered TAI	Not present or any allowed value		
DRX parameter	Not present or any allowed value		
MS network capability	Not present or any allowed value		
Old location area identification	Not present or any allowed value		
TMSI status	Not present or any allowed value		
Mobile station classmark 2	Not present or any allowed value		
Mobile station classmark 3	Not present or any allowed value		
Supported Codecs	Not present or any allowed value		
Additional update type	Not present		EPS_only
Additional update type	Any allowed value		EPS_only_with_SMS
Additional update type	Not present or any allowed value		combined_EPS_IMSI or CloT
Voice domain preference and UE's usage setting	Not present or any allowed value		
Device properties	Not present or any allowed value		
Old GUTI type	Not present or any allowed value		
MS network feature support	Not present or any allowed value		
TMSI based NRI container	Not present or any allowed value		
T3324 value	Not present or any allowed value		
T3412 extended value	Not present or any allowed value		
Extended DRX parameters	Not present or any allowed value		

UE additional security capability	Any allowed value (NOTE 1, NOTE 2)		EN-DC
NOTE 1: For a UE supporting dual connectivity with NR, if the UE supports one of the encryption algorithms for 5GS in bits 8 to 5 of octet 3, it shall support the same algorithms for E-UTRAN as specified in 3GPP TS 33.401 [41].			
NOTE 2: For a UE supporting dual connectivity with NR, if the UE supports one of the integrity protection algorithms for 5GS in bits 8 to 5 of octet 5, it shall support the same algorithms for E-UTRAN as specified in 3GPP TS 33.401 [41].			

Condition	Explanation
EPS_only	See the definition below table 4.7.2-1.
combined_EPS_IMSI	See the definition below table 4.7.2-1.
CloT_Attach_WithoutPDN	If the UE wants to attach without PDN for CloT optimization
EPS_only_with_SMS	If the UE wants to perform EPS attach with SMS only for CloT optimization
CloT	If UE supports CloT Optimisation
EN-DC	If the UE supports E-UTRA-NR dual connectivity ([71] pc_EN_DC)

NOTE: This message is sent integrity protected when a valid security context exists and without integrity protection otherwise.

- AUTHENTICATION FAILURE

This message is sent by the UE to the SS.

Table 4.7.2-5: AUTHENTICATION FAILURE

Derivation Path: 24.301 clause 8.2.5			
Information Element	Value/remark	Comment	Condition
Protocol discriminator	EMM		
Security header type	'0000'B	Plain NAS message, not security protected	
Authentication failure message type	'0101 1100'B	Authentication failure	
EMM cause	'0001 0100'B	Mac failure	
Authentication failure parameter	Not present	See TS 24.301 [28] subclause 8.2.5.2	

NOTE: The security protection of this message is the same as the previous AUTHENTICATION REQUEST message.

- AUTHENTICATION REJECT

This message is sent by the SS to the UE.

Table 4.7.2-6: AUTHENTICATION REJECT

Derivation Path: 24.301 clause 8.2.6			
Information Element	Value/remark	Comment	Condition
Protocol discriminator	EMM		
Security header type	'0000'B	Plain NAS message, not security protected	
Authentication reject message type	'0101 0100'B	Authentication reject	

NOTE: This message is sent without integrity protection.

- AUTHENTICATION REQUEST

This message is sent by the SS to the UE.

Table 4.7.2-7: AUTHENTICATION REQUEST

Derivation Path: 24.301 clause 8.2.7			
Information Element	Value/remark	Comment	Condition
Protocol discriminator	EMM		
Security header type	'0000'B	Plain NAS message, not security protected	
Authentication request message type	'0101 0010'B	Authentication request	
NAS key set identifier _{ASME}			
NAS key set identifier	An arbitrarily selected value between '000'B and '110'B, different from the valid NAS key set identifier of the UE if such a value exists.		
TSC	'0'B	native security context (for KSI _{ASME})	
Spare half octet	'0000'B		
Authentication parameter RAND (EPS challenge)	An arbitrarily selected 128 bits value		
Authentication parameter AUTN (EPS challenge)	See TS 24.301 [28] subclause 9.9.3.2		

NOTE: Within a test execution this message is sent without integrity protection before NAS security mode control procedure has been successfully completed; and sent integrity protected and ciphered within SECURITY PROTECTED NAS MESSAGE message after NAS security mode control procedure has been successfully completed. SS does not maintain information for NAS security mode control procedure after a TC is completed.

- AUTHENTICATION RESPONSE

This message is sent by the UE to the SS.

Table 4.7.2-8: AUTHENTICATION RESPONSE

Derivation Path: 24.301 clause 8.2.8			
Information Element	Value/remark	Comment	Condition
Protocol discriminator	EMM		
Security header type	'0000'B	Plain NAS message, not security protected	
Authentication response message type	'0101 0011'B	Authentication response	
Authentication response parameter	See TS 24.301 [28] subclause 9.9.3.4		

NOTE: When sent in response to an AUTHENTICATION REQUEST message which is not integrity protected and not ciphered, the AUTHENTICATION RESPONSE message may be sent integrity protected when a valid security context exists and without integrity protection otherwise.

- CS SERVICE NOTIFICATION

This message is sent by the SS to the UE.

Table 4.7.2-8A: CS SERVICE NOTIFICATION

Derivation Path: 24.301 clause 8.2.9			
Information Element	Value/remark	Comment	Condition
Protocol discriminator	EMM		
Security header type	'0000'B	Plain NAS message, not security protected	
CS service notification message identity	'01100100'B	CS Service notification	
Paging identity	'1'B	TMSI	
CLI	Not present		
SS Code	Not present		
LCS indicator	Not present		
LCS client identity	Not present		

NOTE: This message is always sent within SECURITY PROTECTED NAS MESSAGE message.

- CONTROL PLANE SERVICE REQUEST

This message is sent by the UE to the SS.

Table 4.7.2-28: CONTROL PLANE SERVICE REQUEST

Derivation Path: 24.301 clause 8.2.33			
Information Element	Value/remark	Comment	Condition
Protocol discriminator	EMM		
Security header type	'0000'B	Plain NAS message, not security protected	
Control plane service request message identity	'0100 1101'B	Control plane service request	
Data service type			
Data service type value	Any allowed value		
"Active" flag	'0'B	No radio bearer establishment requested	
NAS key set identifier			
NAS key set identifier	The valid NAS key set identifier of the UE		
TSC	'0'B	native security context (for KSI _{ASME})	
ESM message container	Not present or PDN CONNECTIVITY REQUEST message to request PDN connectivity to the default PDN		
NAS message container	Not present or set according to specific message content		
EPS bearer context status	Not present or (octet 3 = '00100000'B and octet 4 = '00000000'B)		
Device properties	Not present or Any allowed value		

NOTE: This message is always sent within SECURITY PROTECTED NAS MESSAGE message as an integrity protected message. If the ESM Message Container or NAS message container is present, this element is ciphered - so the whole message is then integrity protected and partially ciphered.

- DETACH ACCEPT (UE originating detach)

This message is sent by the SS to the UE.

Table 4.7.2-9: DETACH ACCEPT

Derivation Path: 24.301 clause 8.2.10.1			
Information Element	Value/remark	Comment	Condition
Protocol discriminator	EMM		
Security header type	'0000'B	Plain NAS message, not security protected	
Detach accept message identity	'0100 0110'B	Detach accept	

NOTE: This message is sent using the same security protection as in the previous DETACH REQUEST message received from the UE.

- DETACH ACCEPT (UE terminated detach)

This message is sent by the UE to the SS.

Table 4.7.2-10: DETACH ACCEPT

Derivation Path: 24.301 clause 8.2.10.2			
Information Element	Value/remark	Comment	Condition
Protocol discriminator	EMM		
Security header type	'0000'B	Plain NAS message, not security protected	
Detach accept message identity	'0100 0110'B	Detach accept	

NOTE: This message is sent without integrity protection before NAS security mode control procedure has been successfully completed and sent within SECURITY PROTECTED NAS MESSAGE message after NAS security mode control procedure has been successfully completed.

- DETACH REQUEST (UE originating detach)

This message is sent by the UE to the SS.

Table 4.7.2-11: DETACH REQUEST

Derivation Path: 24.301 clause 8.2.11.1			
Information Element	Value/remark	Comment	Condition
Protocol discriminator	EMM		
Security header type	'0000'B	Plain NAS message, not security protected	
Detach request message identity	'0100 0101'B	Detach request	
Detach type			
Type of detach	'001'B	EPS detach	EPS_only
	'011'B	combined EPS/IMSI detach	Combined_EPS_IMSI
Switch off	'1'B	switch off	
NAS key set identifier			
NAS key set identifier	The valid NAS key set identifier.		
TSC	Any Value		
GUTI or IMSI	If the UE has a valid GUTI, set to the GUTI, otherwise set to the IMSI of the UE.		

Condition	Explanation
EPS_only	See the definition below table 4.7.2-1.
Combined_EPS_IMSI	See the definition below table 4.7.2-1.

NOTE: This message is sent with integrity protection before SS has started the ciphering and integrity and ciphered protected after SS has started the ciphering.

- DETACH REQUEST (UE terminated detach)

This message is sent by the SS to the UE.

Table 4.7.2-12: DETACH REQUEST

Derivation Path: 24.301 clause 8.2.11.2			
Information Element	Value/remark	Comment	Condition
Protocol discriminator	EMM		
Security header type	'0000'B	Plain NAS message, not security protected	
Detach request message identity	'0100 0101'B	Detach request	
Detach type	Set according to specific message content.		
Spare half octet	'0000'B		
EMM cause	Set according to specific message content.		

NOTE: This message is always sent within SECURITY PROTECTED NAS MESSAGE message.

- DOWNLINK NAS TRANSPORT

This message is sent by the SS to the UE.

Table 4.7.2-12A: DOWNLINK NAS TRANSPORT

Derivation Path: 24.301 clause 8.2.12			
Information Element	Value/remark	Comment	Condition
Protocol discriminator	EMM		
Security header type	'0000'B	Plain NAS message, not security protected	
Downlink NAS transport message identity	'0110 0010'B	Downlink NAS transport	
NAS message container	Set according to specific message content		

NOTE: This message is always sent within SECURITY PROTECTED NAS MESSAGE message.

- EMM INFORMATION

This message is sent by the SS to the UE.

Table 4.7.2-13: EMM INFORMATION

Derivation Path: 24.301 clause 8.2.13			
Information Element	Value/remark	Comment	Condition
Protocol discriminator	EMM		
Security header type	'0000'B	Plain NAS message, not security protected	
EMM information message identity	'0110 0001'B	EMM information	
Full name for network	Set according to specific message content.		
Short name for network	Set according to specific message content.		
Local time zone	Set according to specific message content.		
Universal time and local time zone	Set according to specific message content.		
Network daylight saving time	Set according to specific message content.		

NOTE: This message is always sent within SECURITY PROTECTED NAS MESSAGE message.

- EMM STATUS

This message is sent by the UE or by the SS.

Table 4.7.2-14: EMM STATUS

Derivation Path: 24.301 clause 8.2.14			
Information Element	Value/remark	Comment	Condition
Protocol discriminator	EMM		
Security header type	'0000'B	Plain NAS message, not security protected	
EMM status message identity	'0110 0000'B	EMM status	
EMM cause	Set according to specific message content.		

NOTE: This message is always sent within SECURITY PROTECTED NAS MESSAGE message.

- EXTENDED SERVICE REQUEST

This message is sent by the UE to the SS.

Table 4.7.2-14A: EXTENDED SERVICE REQUEST

Derivation Path: 24.301 clause 8.2.15			
Information Element	Value/remark	Comment	Condition
Protocol discriminator	EMM		
Security header type	'0000'B	Plain NAS message, not security protected	
Extended service request message identity	'0100 1100'B	Extended service request	
Service type	'0001'B	mobile terminating CS fallback or 1xCS fallback	
NAS key set identifier			
NAS key set identifier	The valid NAS key set identifier.		
TSC	'0'B	native security context (for KSI _{ASME})	
M-TMSI	If the UE has a valid M-TMSI, set to the M-TMSI, otherwise set to the IMSI of the UE.		
CSFB response	'001'B	CS fallback accepted by the UE	

NOTE: This message is always sent within SECURITY PROTECTED NAS MESSAGE message.

- GUTI REALLOCATION COMMAND

This message is sent by the SS to the UE.

Table 4.7.2-15: GUTI REALLOCATION COMMAND

Derivation Path: 24.301 clause 8.2.16			
Information Element	Value/remark	Comment	Condition
Protocol discriminator	EMM		
Security header type	'0000'B	Plain NAS message, not security protected	
GUTI reallocation command message identity	'0101 0000'B	GUTI reallocation command	
GUTI	Set according to specific message content.		
TAI list	Set according to specific message content.		

NOTE: This message is always sent within SECURITY PROTECTED NAS MESSAGE message.

- GUTI REALLOCATION COMPLETE

This message is sent by the UE to the SS.

Table 4.7.2-16: GUTI REALLOCATION COMPLETE

Derivation Path: 24.301 clause 8.2.17			
Information Element	Value/remark	Comment	Condition
Protocol discriminator	EMM		
Security header type	'0000'B	Plain NAS message, not security protected	
GUTI reallocation complete message identity	'0101 0001'B	GUTI reallocation complete	

NOTE: This message is always sent within SECURITY PROTECTED NAS MESSAGE message.

- IDENTITY REQUEST

This message is sent by the SS to the UE.

Table 4.7.2-17: IDENTITY REQUEST

Derivation Path: 24.301 clause 8.2.18			
Information Element	Value/remark	Comment	Condition
Protocol discriminator	EMM		
Security header type	'0000'B	Plain NAS message, not security protected	
Identity request message identity	'0101 0101'B	Identity request	
Identity type	'0001'B	IMSI	
Spare half octet	'0000'B		

NOTE: This message is sent without integrity protection before NAS security mode control procedure has been successfully completed and sent within SECURITY PROTECTED NAS MESSAGE message after NAS security mode control procedure has been successfully completed.

- IDENTITY RESPONSE

This message is sent by the UE to the SS.

Table 4.7.2-18: IDENTITY RESPONSE

Derivation Path: 24.301 clause 8.2.19			
Information Element	Value/remark	Comment	Condition
Protocol discriminator	EMM		
Security header type	'0000'B	Plain NAS message, not security protected	
Identity response message	'0101 0110'B	Identity response	
Mobile identity	IMSI of the UE		

NOTE: This message is sent without integrity protection before NAS security mode control procedure has been successfully completed and sent within SECURITY PROTECTED NAS MESSAGE message after NAS security mode control procedure has been successfully completed.

SECURITY MODE COMMAND

This message is sent by the SS to the UE.

Table 4.7.2-19: SECURITY MODE COMMAND

Derivation Path: 24.301 clause 8.2.20			
Information Element	Value/remark	Comment	Condition
Protocol discriminator	EMM		
Security header type	'0000'B	Plain NAS message, not security protected	
Security mode command message identity	'0101 1101'B	Security mode command	
Selected NAS security algorithms			
Type of integrity protection algorithm	Set according to PIXIT parameter for default integrity protection algorithm		For SIG
	0(reserved or eia0)	This IE is set to one of the algorithms supported by the UE as indicated in the IE "UE network capability" in the ATTACH REQUEST message.	For RF
	eia1		
	eia2		
Type of ciphering algorithm	Set according to PIXIT parameter for default ciphering algorithm		For SIG
	eea0		For RF
NAS key set identifier			
NAS key set identifier	The valid NAS key set identifier.		
TSC	'0'B	native security context (for KSI _{ASME})	
Spare half octet	'0000'B		
Replayed UE security capabilities	Set according to the received UE security capabilities		
IMEISV request	Not present		
Replayed nonce _{UE}	Not present		
Nonce _{MME}	Not present		
Hash _{MME}	Not present		
Replayed UE additional security capability	Set to the value received in the Attach/TAU Request		EN-DC_duringRegistration

Condition	Explanation
For SIG	Used for signalling test cases
For RF	Used for RF/RRM test cases
EN-DC_duringRegistration	If the UE supports E-UTRA-NR dual connectivity NR ([71] pc_EN_DC) and this message is sent during an Attach or TAU procedure

NOTE: This message is always sent integrity protected with new EPS security context.

- SECURITY MODE COMPLETE

This message is sent by the UE to the SS.

Table 4.7.2-20: SECURITY MODE COMPLETE

Derivation Path: 24.301 clause 8.2.21			
Information Element	Value/remark	Comment	Condition
Protocol discriminator	EMM		
Security header type	'0000'B	Plain NAS message, not security protected	
Security mode complete message identity	'0101 1110'B	Security mode complete	
IMEISV	Not present		

NOTE: This message is always sent within SECURITY PROTECTED NAS MESSAGE message with new EPS security context.

- SECURITY MODE REJECT

This message is sent by the UE to the SS.

Table 4.7.2-21: SECURITY MODE REJECT

Derivation Path: 24.301 clause 8.2.22			
Information Element	Value/remark	Comment	Condition
Protocol discriminator	EMM		
Security header type	'0000'B	Plain NAS message, not security protected	
Security mode reject message identity	'0101 1111'B	Security mode reject	
EMM cause	The value is set according to specific message content.		

NOTE: This message is sent without integrity protection before NAS security mode control procedure has been successfully completed and sent within SECURITY PROTECTED NAS MESSAGE message after NAS security mode control procedure has been successfully completed.

- SERVICE ACCEPT

This message is sent by the SS to the UE.

Table 4.7.2-21A: SERVICE ACCEPT

Derivation Path: 24.301 clause 8.2.34			
Information Element	Value/remark	Comment	Condition
Protocol discriminator	EMM		
Security header type	'0000'B	Plain NAS message, not security protected	
Service accept message identity	'0100 1111'B	Service accept	
EPS bearer context status	The same value as the value set in CONTROL PLANE SERVICE REQUEST		

NOTE: This message is always sent within SECURITY PROTECTED NAS MESSAGE message.

- SERVICE REJECT

This message is sent by the SS to the UE.

Table 4.7.2-22: SERVICE REJECT

Derivation Path: 24.301 clause 8.2.24			
Information Element	Value/remark	Comment	Condition
Protocol discriminator	EMM		
Security header type	'0000'B	Plain NAS message, not security protected	
Service reject message identity	'0100 1110'B	Service reject	
EMM cause	Set according to specific message content.		
T3442 value	Not present		

NOTE: If this message includes the EMM cause set to #3, #6, #7, #8, #11, #12, #13, #14, #15, #25 or #35, it is sent within SECURITY PROTECTED NAS MESSAGE message. Otherwise this message is sent without integrity protection.

- SERVICE REQUEST

This message is sent by the UE to the SS.

Table 4.7.2-23: SERVICE REQUEST

Derivation Path: 24.301 clause 8.2.25			
Information Element	Value/remark	Comment	Condition
Protocol discriminator	EMM		
Security header type	'1100'B	Security header for the SERVICE REQUEST message	
KSI and sequence number			
Sequence number (short)	The 5 least significant bits of the NAS COUNT value applicable when this message is sent for sequence number.		
KSI	The effective KSI value.		
Message authentication code (short)	The 2 least significant octets of the resulting message authentication code		

- TRACKING AREA UPDATE ACCEPT

This message is sent by the SS to the UE.

Table 4.7.2-24: TRACKING AREA UPDATE ACCEPT

Derivation Path: 24.301 clause 8.2.26			
Information Element	Value/remark	Comment	Condition
Protocol discriminator	EMM		
Security header type	'0000'B	Plain NAS message, not security protected	
Tracking area update accept message identity	'0100 1001'B	Tracking area update accept	
EPS update result	'0000'B	TA updated	TA_only
	'0001'B	combined TA/LA updated	combined_TA_LA
Spare half octet	'0000'B		
T3412 value	Not present		Periodic
T3412 value			
Timer value	'0 0000'B		
Unit	'111'B	value indicates that the timer is deactivated.	
GUTI			
Length of EPS mobile identity contents	'0000 1011'B	11 octets	
Type of identity	'110'B	GUTI	
Odd/even indication	'0'B	even number of identity digits and also when the GUTI is used	
MCC	See table 4.4.2-2 in this document	For NAS test cases, see table 6.3.2.2-1.	
MNC	See table 4.4.2-2 in this document	For NAS test cases, see table 6.3.2.2-1.	
MME Group ID	See table 4.4.2-2 in this document	For NAS test cases, see table 6.3.2.2-1.	
MME Code	See table 4.4.2-2 in this document	For NAS test cases, see table 6.3.2.2-1.	
M-TMSI	See table 4.4.2-2 in this document	For NAS test cases, see table 6.3.2.2-1.	
TAI list			
Length of tracking area identity list contents	'0000 0110'B	6 octets	
Partial tracking area identity list 1			
Number of elements	'0 0000'B	1 element	
Type of list	'00'B	list of TACs belonging to one PLMN, with non-consecutive TAC values	
MCC	See table 4.4.2-2 in this document	For NAS test cases, see table 6.3.2.2-1.	
MNC	See table 4.4.2-2 in this document	For NAS test cases, see table 6.3.2.2-1.	
TAC 1	See table 4.4.2-2 in this document	For NAS test cases, see table 6.3.2.2-1.	
EPS bearer context status	The same value as the value set in TRACKING AREA UPDATE REQUEST message		
Location area identification	Not present		TA_only
Location area identification			combined_TA_LA
MCC	MCC of the EUTRA cell from which this message is sent		

MNC	MCC of the EUTRA cell from which this message is sent		
LAC	1		
MS identity	Not present		TA_only
MS identity			combined_TA_LA
Length of mobile identity contents	'0000 0101'B	5 octets	
Type of identity	'100'B	TMSI/P-TMSI/M-TMSI	
Odd/even indication	'0'B	even number of identity digits and also when the TMSI/P-TMSI or TMGI and optional MBMS Session Identity is used	
TMSI	TMSI-1		
EMM cause	Not present		
T3402 value	Not present		
T3423 value	Not present		
Equivalent PLMNs	Not present		
Emergency number list	Not present		
EPS network feature support	0000 0001'B	IMS voice over PS session in S1 mode supported	
EPS network feature support	'1100 0000 0000 1100'B	CloT control plane optimization indicated, Attach Without PDN supported, ePCO supported, Header Compression for CloT control plane supported	(CloT_CP OR CloT_CP_S MSONly) AND pc_NB
EPS network feature support	'1000 0000 0000 1011'B	CP CloT supported, ePCO supported, S1-U data transfer supported, CloT user plane optimization indicated	CloT_UP AND pc_NB
EPS network feature support	'1000 0000 0000 1010'B	CP CloT supported, ePCO supported, S1-U data transfer Only indicated	S1-U Only AND pc_NB
Additional update result	Not present		
Additional update result	'0010' B	"SMS only"	TAU_additional_update_result_SMS OR CloT_CP_S MSONly
T3412 extended value	Not present		Rel-10
Extended DRX parameters	Not present		
Header compression configuration status	Not present or set according to specific message content		

Condition	Explanation
-----------	-------------

TA_only	This condition applies if the UE is configured to initiate EPS attach or if explicitly specified.
combined_TA_LA	This condition applies if the UE is configured to initiate combined EPS/IMSI attach or if explicitly specified. This condition does not apply for NB-S1.
Periodic	This condition applies if in the last TRACKING AREA UPDATE REQUEST sent prior to this message, the EPS update type Value = '011'B (periodic updating).
TAU_additional_update_result_SMS	If the UE requested "SMS only" in the Additional update type IE and combined_TA_LA.
CloT_CP	If test case requires control plane CloT optimization
CloT_CP_SMSOnly	If test case requires control plane CloT optimization and SMS Only is indicated
CloT_UP	If test case requires user plane CloT optimization
S1-U data Only	If S1-U data transfer Only is indicated

NOTE: This message is always sent within SECURITY PROTECTED NAS MESSAGE message.

- TRACKING AREA UPDATE COMPLETE

This message is sent by the UE to the SS.

Table 4.7.2-25: TRACKING AREA UPDATE COMPLETE

Derivation Path: 24.301 clause 8.2.27			
Information Element	Value/remark	Comment	Condition
Protocol discriminator	EMM		
Security header type	'0000'B	Plain NAS message, not security protected	
Tracking area update complete message identity	'0100 1010'B	Tracking area update complete	

NOTE: This message is always sent within SECURITY PROTECTED NAS MESSAGE message.

- TRACKING AREA UPDATE REJECT

This message is sent by the SS to the UE.

Table 4.7.2-26: TRACKING AREA UPDATE REJECT

Derivation Path: 24.301 clause 8.2.28			
Information Element	Value/remark	Comment	Condition
Protocol discriminator	EMM		
Security header type	'0000'B	Plain NAS message, not security protected	
Tracking area update reject message identity	'0100 1011'B	Tracking area update reject	
EMM cause	Set according to specific message content.		

NOTE: If this message includes the EMM cause set to #3, #6, #7, #8, #11, #12, #13, #14, #15, #25 or #35, it is sent within SECURITY PROTECTED NAS MESSAGE message. Otherwise this message is sent without integrity protection.

- TRACKING AREA UPDATE REQUEST

This message is sent by the UE to the SS.

Table 4.7.2-27: TRACKING AREA UPDATE REQUEST

Derivation Path: 24.301 clause 8.2.29			
Information Element	Value/remark	Comment	Condition
Protocol discriminator	EMM		
Security header type	'0000'B	Plain NAS message, not security protected	
Tracking area update request message identity	'0100 1000'B	Tracking area update request	
EPS update type			
EPS update type Value	'000'B	TA updating	TA_only
	'001'B	Combined TA/LA updating	combined_TA_LA
"Active" flag	'0'B	No bearer establishment requested	
NAS key set identifier			
NAS key set identifier	The valid NAS key set identifier of the UE		
TSC	'0'B	native security context (for KSI _{ASME})	
Old GUTI	Any allowed value		
Non-current native NAS key set identifier	Not present		
GPRS ciphering key sequence number	Not present		
Old P-TMSI signature	Not present		
Additional GUTI	Not present		
Nonce _{UE}	Not present		
UE network capability	Not present or any allowed value		
UE network capability			EN-DC
All octets with the exception of octet 9, bit 5	Any allowed value		
Dual connectivity with NR (DCNR) (octet 9, bit 5)	1	dual connectivity with NR supported	
Last visited registered TAI	Not present or any allowed value		
DRX parameter	Not present or any allowed value		
UE radio capability information update needed	Not present or any allowed value		
EPS bearer context status	Not present or (octet 3 = '00100000'B and octet 4 = '00000000'B)		
MS network capability	Not present or any allowed value		
Old location area identification	Not present or any allowed value		
TMSI status	Not present or any allowed value		
Mobile station classmark 2	Not present or any allowed value		
Mobile station classmark 3	Not present or any allowed value		
Supported Codecs	Not present or any allowed value		
Additional update type	Not present		TA_only
Additional update type	Not present or any allowed value		combined_TA_LA
Additional update type	Any allowed value		TA_only_with_SMS
Additional update type	Not present or any allowed value		CloT
Voice domain preference and UE's usage setting	Not present or any allowed value		
Old GUTI type	Not present or any allowed value		
Device properties	Not present or any allowed value		

MS network feature support	Not present or any allowed value		
TMSI based NRI container	Not present or any allowed value		
T3324 value	Not present or any allowed value		
T3412 extended value	Not present or any allowed value		
Extended DRX parameters	Not present or any allowed value		
UE additional security capability	Any allowed value (NOTE 1, NOTE 2)		EN-DC
NOTE 1: For a UE supporting dual connectivity with NR, if the UE supports one of the encryption algorithms for 5GS in bits 8 to 5 of octet 3, it shall support the same algorithms for E-UTRAN as specified in 3GPP TS 33.401 [41].			
NOTE 2: For a UE supporting dual connectivity with NR, if the UE supports one of the integrity protection algorithms for 5GS in bits 8 to 5 of octet 5, it shall support the same algorithms for E-UTRAN as specified in 3GPP TS 33.401 [41].			

Condition	Explanation
TA_only	See the definition below table 4.7.2-24.
combined_TA_LA	See the definition below table 4.7.2-24.
EPS_only_with_SMS	If the UE wants to update for EPS attach with SMS only for Clot optimization
Clot	If UE supports Clot Optimisation
EN-DC	If the UE supports E-UTRA-NR dual connectivity ([71] pc_EN_DC)

NOTE: This message is always sent within SECURITY PROTECTED NAS MESSAGE message.

- UPLINK NAS TRANSPORT

This message is sent by the UE to the SS.

Table 4.7.2-27A: UPLINK NAS TRANSPORT

Derivation Path: 24.301 clause 8.2.30			
Information Element	Value/remark	Comment	Condition
Protocol discriminator	EMM		
Security header type	'0000'B	Plain NAS message, not security protected	
Uplink NAS transport message identity	'0100 0011'B	Uplink NAS transport	
NAS message container	Set according to specific message content		

NOTE: This message is always sent within SECURITY PROTECTED NAS MESSAGE message.

4.7.3 Contents of ESM messages

- ACTIVATE DEDICATED EPS BEARER CONTEXT ACCEPT

This message is sent by the UE to the SS.

Table 4.7.3-1: ACTIVATE DEDICATED EPS BEARER CONTEXT ACCEPT

Derivation Path: 24.301 clause 8.3.1			
Information Element	Value/remark	Comment	Condition
Protocol discriminator	ESM		
EPS bearer identity	The same value as the value set in ACTIVATE DEDICATED EPS BEARER CONTEXT REQUEST message		
Procedure transaction identity	'0000 0000'B	No procedure transaction identity assigned	
Activate dedicated EPS bearer context accept message identity	'1100 0110'B	Activate dedicated EPS bearer context accept	
Protocol configuration options	Not present or any allowed value		NOT (pc_NB or pc_NonIP_P DN)
Protocol configuration options	Not present		pc_NB or pc_NonIP_P DN
NBIFOM container	Not present or any allowed value		
Extended protocol configuration options	Not present or any allowed value		

NOTE: This message is always sent within SECURITY PROTECTED NAS MESSAGE message.

- ACTIVATE DEDICATED EPS BEARER CONTEXT REJECT

This message is sent by UE to the SS.

Table 4.7.3-2: ACTIVATE DEDICATED EPS BEARER CONTEXT REJECT

Derivation Path: 24.301 clause 8.3.2			
Information Element	Value/remark	Comment	Condition
Protocol discriminator	ESM		
EPS bearer identity	The same value as the value set in ACTIVATE DEDICATED EPS BEARER CONTEXT REQUEST message.		
Procedure transaction identity	'0000 0000'B	No procedure transaction identity assigned	
Activate dedicated EPS bearer context reject message identity	'1100 0111'B	Activate dedicated EPS bearer context reject	
ESM cause	The value is set according to specific message content.		
Protocol configuration options	Not present		
NBIFOM container	Not present or any allowed value		
Extended protocol configuration options	Not present or any allowed value		

NOTE: This message is always sent within SECURITY PROTECTED NAS MESSAGE message.

- ACTIVATE DEDICATED EPS BEARER CONTEXT REQUEST

This message is sent by the SS to the UE.

Table 4.7.3-3: ACTIVATE DEDICATED EPS BEARER CONTEXT REQUEST

Derivation Path: 24.301 clause 8.3.3			
Information Element	Value/remark	Comment	Condition
Protocol discriminator	ESM		
EPS bearer identity	Arbitrarily selected value between '0101'B and '1111'B.		
Procedure transaction identity	'0000 0000'B	No procedure transaction identity assigned	NETWORK-INITIATED
	The same value as the value set in BEARER RESOURCE MODIFICATION REQUEST message or BEARER RESOURCE ALLOCATION REQUEST message		UE-INITIATED
Activate dedicated EPS bearer context request message identity	'1100 0101'B	Activate dedicated EPS bearer context request	
Linked EPS bearer identity	The EPS bearer identity of the associated default bearer		
Spare half octet	'0000'B		
EPS QoS	See Reference dedicated EPS bearer context #1 in table 6.6.2-1		
TFT	See Reference dedicated EPS bearer context #1 in table 6.6.2-1		
Transaction identifier	Not present		
	Distinct value between 0 and 127 calculated on basis of the EPS bearer identity.		pc_UTRAN AND/OR pc_GERAN
Negotiated QoS	See Reference dedicated EPS bearer context #1 in table 6.6.2-1		
Negotiated LLC SAPI	See Reference dedicated EPS bearer context #1 in table 6.6.2-1		
Radio priority	See Reference dedicated EPS bearer context #1 in table 6.6.2-1		
Packet flow Identifier	Not present		
	'0000 0000'B	Best Effort	pc_GERAN
Protocol configuration options	See Reference dedicated EPS bearer context #1 in table 6.6.2-1		NOT (pc_NB or pc_NonIP_PDN)
Protocol configuration options	Not present		pc_NB or pc_NonIP_PDN
WLAN offload container	Not present		
NBIFOM container	Not present		
Extended protocol configuration options	Not present		NOT (pc_NB or pc_NonIP_PDN)
Extended protocol configuration options	See Reference dedicated EPS bearer context #1 in table 6.6.2-1		pc_NB or pc_NonIP_PDN

Condition	Explanation
-----------	-------------

NETWORK-INITIATED	Network initiated ESM procedures
UE-INITIATED	UE initiated ESM procedures

NOTE: This message is always sent within SECURITY PROTECTED NAS MESSAGE message.

- ACTIVATE DEFAULT EPS BEARER CONTEXT ACCEPT

This message is sent by the UE to the SS.

Table 4.7.3-4: ACTIVATE DEFAULT EPS BEARER CONTEXT ACCEPT

Derivation Path: 24.301 clause 8.3.4			
Information Element	Value/remark	Comment	Condition
Protocol discriminator	ESM		
EPS bearer identity	The same value as the value set in ACTIVATE DEFAULT EPS BEARER CONTEXT REQUEST message		
Procedure transaction identity	'0000 0000'B	No procedure transaction identity assigned	
Activate default EPS bearer context accept message identity	'1100 0010'B	Activate default EPS bearer context accept	
Protocol configuration options	Not present or any allowed value		NOT (pc_NB or pc_NonIP_P DN)
Protocol configuration options	Not present		pc_NB or pc_NonIP_P DN
Extended protocol configuration options	Not present or any allowed value		

NOTE: This message is always sent within SECURITY PROTECTED NAS MESSAGE message.

- ACTIVATE DEFAULT EPS BEARER CONTEXT REJECT

This message is sent by UE to the SS.

Table 4.7.3-5: ACTIVATE DEFAULT EPS BEARER CONTEXT REJECT

Derivation Path: 24.301 clause 8.3.5			
Information Element	Value/remark	Comment	Condition
Protocol discriminator	ESM		
EPS bearer identity	The same value as the value set in ACTIVATE DEFAULT EPS BEARER CONTEXT REQUEST message.		
Procedure transaction identity	'0000 0000'B	No procedure transaction identity assigned	
Activate default EPS bearer context reject message identity	'1100 0011'B	Activate default EPS bearer context reject	
ESM cause	The value is set according to specific message content.		
Protocol configuration options	Not present		
Extended protocol configuration options	Not present		

NOTE: This message is always sent within SECURITY PROTECTED NAS MESSAGE message.

- ACTIVATE DEFAULT EPS BEARER CONTEXT REQUEST

This message is sent by the SS to the UE.

Table 4.7.3-6: ACTIVATE DEFAULT EPS BEARER CONTEXT REQUEST

Derivation Path: 24.301 clause 8.3.6			
Information Element	Value/remark	Comment	Condition
Protocol discriminator	ESM		
EPS bearer identity	An arbitrarily selected value between '0101'B and '1111'B.		
Procedure transaction identity	The same value as the value set in the latest PDN CONNECTIVITY REQUEST message sent prior to this message.		
Activate default EPS bearer context request message identity	'1100 0001'B	Activate default EPS bearer context request	
EPS QoS	See Reference default EPS bearer context #1 in table 6.6.1-1		NOT IMS_PDN_ConnEstab
EPS QoS	See Reference default EPS bearer context #2 in table 6.6.1-1		IMS_PDN_ConnEstab
Access point name	The SS defines a Default APN		NOT IMS_PDN_ConnEstab AND NOT APN_Provided
Access point name	APN as provided in ESM INFORMATION RESPONSE or PDN CONNECTIVITY REQUEST		NOT IMS_PDN_ConnEstab AND APN_Provided
Access point name	IMS. mnc<MNC>.mcc<MCC>.gprs The <MNC> and <MCC> are set to the same values as in IMSI.		IMS_PDN_ConnEstab AND NOT APN_Provided
Access point name	Use APN Network Identifier provided in ESM INFORMATION RESPONSE or PDN CONNECTIVITY REQUEST message and the APN Operator Identifier mnc<MNC>.mcc<MCC>.gprs. The <MNC> and <MCC> are set to the same values as in IMSI.		IMS_PDN_ConnEstab AND APN_Provided
PDN address			IPv4
Length of PDN address contents	5 octets		
PDN type value	'001'B	IPv4	
PDN address information	IPv4 address	The SS provides a valid IPv4 address	NOT IPv4-DHCP
	0.0.0.0	DHCPv4 is to be used to allocate the IPv4 address	IPv4-DHCP
PDN address			IPv6
Length of PDN address contents	9 octets		
PDN type value	'010'B	IPv6	
PDN address information	IPv6 interface identifier	The SS provides a valid IPv6 interface identifier	
PDN address			IPv4v6
Length of PDN address contents	13 octets		
PDN type value	'011'B	IPv4v6	

PDN address information (Octets 4 to 11)	IPv6 interface identifier	The SS provides a valid IPv6 interface identifier	
PDN address information (Octets 12 to 15)	IPv4 address	The SS provides a valid IPv4 address	NOT IPv4-DHCP
	0.0.0.0	DHCPv4 is to be used to allocate the IPv4 address	IPv4-DHCP
PDN address			CloT_CP_N ON_IP
Length of PDN address contents	2 octets		
PDN type value	'101'B	Non-IP PDN	
PDN address information (Octets 4 to 7)	Coded as 0	spare	
Transaction identifier	Not present		
Transaction identifier	Distinct value between 0 and 127 calculated on basis of the EPS bearer identity.		pc_UTRAN AND/OR pc_GERAN
Negotiated QoS	See Reference default EPS bearer context #1 in table 6.6.1-1		
Negotiated LLC SAPI	See Reference default EPS bearer context #1 in table 6.6.1-1		
Radio priority	See Reference default EPS bearer context #1 in table 6.6.1-1		
Packet flow Identifier	Not present		
Packet flow Identifier	'0000 0000'B	Best Effort	pc_GERAN
APN-AMBR	See Reference default EPS bearer context #1 in table 6.6.1-1		
ESM cause	Not present		
Protocol configuration options	Not present		pc_NB or pc_NonIP_P DN
Protocol configuration options			NOT (pc_NB or pc_NonIP_P DN)
Configuration protocol	See Reference default EPS bearer context #1 in table 6.6.1-1		
Container ID 1	'0001'H		P-CSCF IPv6
Length of container ID 1 contents		Length value determined by the TTCN implementation	
Container ID 1 contents	IPv6 address	P-CSCF IPv6 Address	
Container ID 2	'000C'H		P-CSCF IPv4
Length of container ID 2 contents		Length value determined by the TTCN implementation	
Container ID 2 contents	IPv4 address	P-CSCF IPv4 Address	
Container ID n	'0003'H	n assigned to next available number	DNS IPv6
Length of container ID n contents		Length value determined by the TTCN implementation	
Container ID n contents	IPv6 address	DNS IPv6 Address	

Container ID n+1	'000D'H	n assigned to next available number	DNS IPv4
Length of container ID n+1 contents		Length value determined by the TTCN implementation	
Container ID n+1 contents	IPv4 address	DNS IPv4 Address	
WLAN offload indication	Not present		
WLAN offload indication			WLAN
WLAN offload acceptability	'0001'B	Offloading the traffic of the PDN connection via a WLAN when in S1 mode is acceptable	
NBIFOM container	Not present		
Header compression configuration	Not present or set according to specific message content		
Control plane only indication	Not present		
Control plane only indication	'0001'B		CloT_Contr olPlane_PD N
Extended protocol configuration options	Not present		NOT (pc_NB or pc_NonIP_P DN)
Extended protocol configuration options			pc_NB or pc_NonIP_P DN
Configuration protocol	See Reference default EPS bearer context #1 in table 6.6.1-1		
Container ID n	'0003'H	n assigned to next available number	DNS IPv6
Length of container ID n contents		Length value determined by the TTCN implementation	
Container ID n contents	IPv6 address	DNS IPv6 Address	
Container ID n+1	'000D'H	n assigned to next available number	DNS IPv4
Length of container ID n+1 contents		Length value determined by the TTCN implementation	
Container ID n+1 contents	IPv4 address	DNS IPv4 Address	
Serving PLMN rate control	Not present		
Serving PLMN rate control	'FFFF'H	Maximum number of ESM DATA TRANSPORT messages allowed per 6 min interval is not restricted	CloT_Contr olPlane_PD N

Condition	Explanation
IPv4	If in the last PDN CONNECTIVITY REQUEST sent prior to this message, the PDN type = '001'B
IPv6	If in the last PDN CONNECTIVITY REQUEST sent prior to this message, the PDN type = '010'B
IPv4v6	If in the last PDN CONNECTIVITY REQUEST sent prior to this message, the PDN type = '011'B
IPv4-DHCP	If in the last PDN CONNECTIVITY REQUEST or ESM INFORMATION RESPONSE sent prior to this message, the IE Protocol configuration options contains a configuration protocol option = '000B00H' ("IPv4 address allocation via DHCPv4", length of contents = 0). Note 1: This condition is used in conjunction with IPv4 or IPv4v6 as indicated in the "PDN address row" just above. Note 2: If both messages, PDN CONNECTIVITY REQUEST and ESM INFORMATION RESPONSE, are received and contain a Protocol configuration options IE then the IE from the message which is received later shall be used.
P-CSCF IPv6	If in the last PDN CONNECTIVITY REQUEST or ESM INFORMATION RESPONSE sent prior to this message, the Protocol configuration options and the additional parameter list was included with a "P-CSCF IPv6 Address Request" Note 1: This condition is only applicable for UEs with IMS support (TS 36.523-2 A.4.4-1/25). Note 2: If both messages, PDN CONNECTIVITY REQUEST and ESM INFORMATION RESPONSE, are received and contain a Protocol configuration options IE then the IE from the message which is received later shall be used.
P-CSCF IPv4	If in the last PDN CONNECTIVITY REQUEST or ESM INFORMATION RESPONSE sent prior to this message, the Protocol configuration options and the additional parameter list was included with a "P-CSCF IPv4 Address Request" Note 1: This condition is only applicable for UEs with IMS support (TS 36.523-2 A.4.4-1/25). Note 2: If both messages, PDN CONNECTIVITY REQUEST and ESM INFORMATION RESPONSE, are received and contain a Protocol configuration options IE then the IE from the message which is received later shall be used.
DNS IPv6	If in the last PDN CONNECTIVITY REQUEST or ESM INFORMATION RESPONSE sent prior to this message, the Protocol configuration options and the additional parameter list was included with a "DNS IPv6 Address Request". Note: If both messages, PDN CONNECTIVITY REQUEST and ESM INFORMATION RESPONSE, are received and contain a Protocol configuration options IE then the IE from the message which is received later shall be used.
DNS IPv4	If in the last PDN CONNECTIVITY REQUEST or ESM INFORMATION RESPONSE sent prior to this message, the Protocol configuration options and the additional parameter list was included with a "DNS IPv4 Address Request". Note: If both messages, PDN CONNECTIVITY REQUEST and ESM INFORMATION RESPONSE, are received and contain a Protocol configuration options IE then the IE from the message which is received later shall be used.
APN_Provided	If in the last PDN CONNECTIVITY REQUEST or ESM INFORMATION RESPONSE sent prior to this message an Access Point Name was included NOTE: APN_Provided is equivalent to pc_Provide_IMS_APN for establishment of the first PDN connectivity during initial registration and if the first PDN is IMS (see table 4.7.3-14)
IMS_PDN_ConnEstab	If this message refers to establishment of connectivity to the IMS PDN (only applicable if the UE supports IMS according to TS 36.523-2 A.4.4-1/25).
WLAN	If the message is being sent for RAN Assisted WLAN interworking.
CloT_ControlPlane_PDN	If the associated PDN connection is only for control plane CloT optimization
CloT_CP_NON_IP	If the UE requests a Non-IP type PDN

NOTE: This message is always sent within SECURITY PROTECTED NAS MESSAGE message.

- BEARER RESOURCE ALLOCATION REJECT

This message is sent by the SS to the UE.

Table 4.7.3-6A: BEARER RESOURCE ALLOCATION REJECT

Derivation Path: 24.301 clause 8.3.7			
Information Element	Value/remark	Comment	Condition
Protocol discriminator	ESM		
EPS bearer identity	'0000'B	No EPS bearer identity assigned	
Procedure transaction identity	The value indicated in BEARER RESOURCE ALLOCATION REQUEST message.		
Bearer resource allocation reject message identity	'1101 0101'B	Bearer resource allocation reject	
ESM cause	Set according to specific message content.		
Protocol configuration options	Not present		
NBIFOM container	Not present		
Extended protocol configuration options	Not present		

NOTE: This message is always sent within SECURITY PROTECTED NAS MESSAGE message.

- BEARER RESOURCE ALLOCATION REQUEST

This message is sent by the UE to the SS.

Table 4.7.3-6B: BEARER RESOURCE ALLOCATION REQUEST

Derivation Path: 24.301 clause 8.3.8			
Information Element	Value/remark	Comment	Condition
Protocol discriminator	ESM		
EPS bearer identity	'0000'B	No EPS bearer identity assigned	
Procedure transaction identity	Any value from 1 to 254		
Bearer resource allocation request message identity	'1101 0100'B	Bearer resource allocation request	
Linked EPS bearer identity	The EPS bearer identity of the associated default bearer.		
Spare half octet	'0000'B		
Traffic flow aggregate			
Number of packet filters	Greater than 0 and less than or equal to 16		
E bit	Any allowed value		
TFT operation code	'001'B	Create new TFT	
Packet filter list	Any allowed value		
Parameters list	Not present or any allowed value		
Required traffic flow QoS	Any allowed value		
Protocol configuration options	Not present or any allowed value		
NBIFOM container	Not present or any allowed value		
Extended protocol configuration options	Not present or any allowed value		

NOTE: This message is always sent within SECURITY PROTECTED NAS MESSAGE message.

- BEARER RESOURCE MODIFICATION REJECT

This message is sent by the SS to the UE.

Table 4.7.3-7: BEARER RESOURCE MODIFICATION REJECT

Derivation Path: 24.301 clause 8.3.9			
Information Element	Value/remark	Comment	Condition
Protocol discriminator	ESM		
EPS bearer identity	'0000'B	No EPS bearer identity assigned	
Procedure transaction identity	The value indicated in BEARER RESOURCE MODIFICATION REQUEST message.		
Bearer resource modification reject message identity	'1101 0111'B	Bearer resource modification reject	
ESM cause	Set according to specific message content.		
Protocol configuration options	Not present		
NBIFOM container	Not present		
Extended protocol configuration options	Not present		

NOTE: This message is always sent within SECURITY PROTECTED NAS MESSAGE message.

- BEARER RESOURCE MODIFICATION REQUEST

This message is sent by the UE to the SS.

Table 4.7.3-8: BEARER RESOURCE MODIFICATION REQUEST

Derivation Path: 24.301 clause 8.3.10			
Information Element	Value/remark	Comment	Condition
Protocol discriminator	ESM		
EPS bearer identity	'0000'B	No EPS bearer identity assigned	
Procedure transaction identity	Any value from 1 to 254		
Bearer resource modification request message identity	'1101 0110'B	Bearer resource modification request	
EPS bearer identity for packet filter	The EPS bearer identity of the associated dedicated EPS bearer related with packet filter.		
Spare half octet	'0000'B		
Traffic flow aggregate	Any allowed value		
Traffic flow aggregate			RELEASE-REQUESTED
Number of packet filters	Greater than 0 and less than or equal to 16		
E bit	Any allowed value		
TFT operation code	'101'B	Delete packet filters from existing TFT	
Packet filter list	Any allowed value		
Parameters list	Not present or any allowed value		
Required traffic flow QoS	Not present or any allowed value		
ESM cause	Not present		
	'0010 0100'B	Regular deactivation	RELEASE-REQUESTED
Protocol configuration options	Not present or any allowed value		
NBIFOM container	Not present or any allowed value		
Header compression configuration	Not present or any allowed value		
Extended protocol configuration options	Not present or any allowed value		

Condition	Explanation
RELEASE-REQUESTED	UE requests the release of bearer resources.

NOTE: This message is always sent within SECURITY PROTECTED NAS MESSAGE message.

Table 4.7.3-9: (Void)

Table 4.7.3-10: (Void)

- DEACTIVATE EPS BEARER CONTEXT ACCEPT

This message is sent by the UE to the SS.

Table 4.7.3-11: DEACTIVATE EPS BEARER CONTEXT ACCEPT

Derivation Path: 24.301 clause 8.3.9			
Information Element	Value/remark	Comment	Condition
Protocol discriminator	ESM		
EPS bearer identity	The same value as the value set in DEACTIVATE EPS BEARER CONTEXT REQUEST message.		
Procedure transaction identity	'0000 0000'B	No procedure transaction identity assigned	
Deactivate EPS bearer context accept message identity	'1100 1110'B	Deactivate EPS bearer context accept	
Protocol configuration options	Not present or any allowed value		
Extended protocol configuration options	Not present or any allowed value		

NOTE: This message is always sent within SECURITY PROTECTED NAS MESSAGE message.

- DEACTIVATE EPS BEARER CONTEXT REQUEST

This message is sent by the SS to the UE.

Table 4.7.3-12: DEACTIVATE EPS BEARER CONTEXT REQUEST

Derivation Path: 24.301 clause 8.3.10			
Information Element	Value/remark	Comment	Condition
Protocol discriminator	ESM		
EPS bearer identity	Set according to specific message content.		
Procedure transaction identity	'0000 0000'B	No procedure transaction identity assigned	NETWORK-INITIATED
	The same value as the value set in PDN DISCONNECT REQUEST message or BEARER RESOURCE MODIFICATION REQUEST message.		UE-INITIATED
Deactivate EPS bearer context request message identity	'1100 1101'B	Deactivate EPS bearer context request	
ESM cause	Set according to specific message content.		
Protocol configuration options	Not present		
NBIFOM container	Not present		
Extended protocol configuration options	Not present		

Condition	Explanation
NETWORK-INITIATED	Network initiated ESM procedures
UE-INITIATED	UE initiated ESM procedures

NOTE: This message is always sent within SECURITY PROTECTED NAS MESSAGE message.

- ESM DATA TRANSPORT

This message is sent by the UE or by the SS.

Table 4.7.3-12A: ESM DATA TRANSPORT

Derivation Path: 24.301 clause 8.3.25			
Information Element	Value/remark	Comment	Condition
Protocol discriminator	ESM		
EPS bearer identity	'0000'B	No EPS bearer identity assigned	
Procedure transaction identity	Any value from 1 to 254		
ESM data transport message identity	'1110 1011'B	ESM data transport	
User data container	set according to specific message content		
Release assistance indication	Not present or set according to specific message content		

NOTE: This message is always sent within SECURITY PROTECTED NAS MESSAGE message.

- ESM DUMMY MESSAGE

This message is sent by the SS to the UE or by the UE to the SS.

Table 4.7.3-12B: ESM DUMMY MESSAGE

Derivation Path: 24.301 clause 8.3.12A			
Information Element	Value/remark	Comment	Condition
Protocol discriminator	ESM		
EPS bearer identity	'0000'B	No EPS bearer identity assigned	
Procedure transaction identity	The value indicated in ESM DUMMY MESSAGE message.		
ESM information request message identity	'1101 1100'B	ESM dummy message	

NOTE: This message is always sent within SECURITY PROTECTED NAS MESSAGE message.

- ESM INFORMATION REQUEST

This message is sent by the SS to the UE.

Table 4.7.3-13: ESM INFORMATION REQUEST

Derivation Path: 24.301 clause 8.3.11			
Information Element	Value/remark	Comment	Condition
Protocol discriminator	ESM		
EPS bearer identity	'0000'B	No EPS bearer identity assigned	
Procedure transaction identity	The value indicated in PDN CONNECTIVITY REQUEST message.		
ESM information request message identity	'1101 1001'B	ESM information request	

NOTE: This message is always sent within SECURITY PROTECTED NAS MESSAGE message.

- ESM INFORMATION RESPONSE

This message is sent by the UE to the SS.

Table 4.7.3-14: ESM INFORMATION RESPONSE

Derivation Path: 24.301 clause 8.3.12			
Information Element	Value/remark	Comment	Condition
Protocol discriminator	ESM		
EPS bearer identity	'0000'B	No EPS bearer identity assigned	
Procedure transaction identity	The same value as the value set in ESM INFORMATION REQUEST message.		
ESM information response message identity	'1101 1010'B	ESM information response	
Access point name	Not present or any allowed value		Internet_AP_N
Access point name	Not present		IMS_APN_Default
Access point name	Any allowed value		IMS_APN_Provided
Protocol configuration options	Not present or any allowed value		NOT (pc_NB or pc_NonIP_PDN)
Protocol configuration options	Not present		pc_NB or pc_NonIP_PDN
Extended protocol configuration options	Not present or any allowed value		

Condition	Expression	Explanation
IMS_APN_Provided	pc_IMS AND NOT pc_Provide_IMS_as_second_APN AND pc_Provide_IMS_APN	IMS APN shall be provided by the UE:
IMS_APN_Default	pc_IMS AND NOT pc_Provide_IMS_as_second_APN AND NOT pc_Provide_IMS_APN	No IMS APN shall be provided by the UE; IMS APN is default APN
Internet_APN	NOT pc_IMS OR pc_Provide_IMS_as_second_APN	

NOTE: This message is always sent within SECURITY PROTECTED NAS MESSAGE message.

- **ESM STATUS**

This message is sent by the UE or by the SS.

Table 4.7.3-15: ESM STATUS

Derivation Path: 24.301 clause 8.3.13			
Information Element	Value/remark	Comment	Condition
Protocol discriminator	ESM		
EPS bearer identity	Set according to specific message content.		
Procedure transaction identity	'0000 0000'B	No procedure transaction identity assigned	
ESM status message identity	'1110 1000'B	ESM status	
ESM cause	Set according to specific message content.		

NOTE: This message is always sent within SECURITY PROTECTED NAS MESSAGE message.

- **MODIFY EPS BEARER CONTEXT ACCEPT**

This message is sent by the UE to the SS.

Table 4.7.3-16: MODIFY EPS BEARER CONTEXT ACCEPT

Derivation Path: 24.301 clause 8.3.14			
Information Element	Value/remark	Comment	Condition
Protocol discriminator	ESM		
EPS bearer identity	The same value as the value set in MODIFY EPS BEARER CONTEXT REQUEST message.		
Procedure transaction identity	'0000 0000'B	No procedure transaction identity assigned	
Modify EPS bearer context accept message identity	'1100 1010'B	Modify EPS bearer context accept	
Protocol configuration options	Not present or any allowed value		
NBIFOM container	Not present or any allowed value		
Extended protocol configuration options	Not present or any allowed value		

NOTE: This message is always sent within SECURITY PROTECTED NAS MESSAGE message.

- MODIFY EPS BEARER CONTEXT REJECT

This message is sent by the UE to the SS.

Table 4.7.3-17: MODIFY EPS BEARER CONTEXT REJECT

Derivation Path: 24.301 clause 8.3.15			
Information Element	Value/remark	Comment	Condition
Protocol discriminator	ESM		
EPS bearer identity	The same value as the value set in MODIFY EPS BEARER CONTEXT REQUEST message.		
Procedure transaction identity	'0000 0000'B	No procedure transaction identity assigned	
Modify EPS bearer context reject message identity	'1100 1011'B	Modify EPS bearer context reject	
ESM cause	The value is set according to specific message content.		
Protocol configuration options	Not present		
NBIFOM container	Not present		
Extended protocol configuration options	Not present		

NOTE: This message is always sent within SECURITY PROTECTED NAS MESSAGE message.

- MODIFY EPS BEARER CONTEXT REQUEST

This message is sent by the SS to the UE.

Table 4.7.3-18: MODIFY EPS BEARER CONTEXT REQUEST

Derivation Path: 24.301 clause 8.3.16			
Information Element	Value/remark	Comment	Condition
Protocol discriminator	ESM		
EPS bearer identity	Set according to specific message content.		
Procedure transaction identity	'0000 0000'B	No procedure transaction identity assigned	NETWORK-INITIATED
	The same value as the value set in BEARER RESOURCE MODIFICATION REQUEST message or BEARER RESOURCE ALLOCATION REQUEST message.		UE-INITIATED
Modify EPS bearer context request message identity	'1100 1001'B	Modify EPS bearer context request	
New EPS QoS	Use the same value as used in Activate EPS Bearer Context Request message		
TFT	According to reference dedicated EPS bearer context #2 except for TFT operation code which is set to '100'B and TFT identifier is set to '001 10000'B..		
New QoS	Not Present.		
Negotiated LLC SAPI	Not Present.		
Radio priority	Not Present.		
Packet flow Identifier	Not Present.		
	'0000 0000'B	Best Effort	pc_GERAN
APN-AMBR	Not Present.		
Protocol configuration options	Not present		
WLAN offload container	Not present		
NBIFOM container	Not present		
Header compression configuration	Not present		
Extended protocol configuration options	Not present		

Condition	Explanation
NETWORK-INITIATED	Network initiated ESM procedures
UE-INITIATED	UE initiated ESM procedures

NOTE: This message is always sent within SECURITY PROTECTED NAS MESSAGE message.

- NOTIFICATION

This message is sent by the SS to the UE.

Table 4.7.3-18A: NOTIFICATION

Derivation Path: 24.301 clause 8.3.18A			
Information Element	Value/remark	Comment	Condition
Protocol discriminator	ESM		
EPS bearer identity	'0000'B	No EPS bearer identity assigned	
	The same value as the value set in ACTIVATE DEFAULT EPS BEARER CONTEXT REQUEST message for IMS signalling.		SRVCC-HO-CANCELLED
Procedure transaction identity	'0000 0000'B	No procedure transaction identity assigned	
Notification message identity	'1101 1011'B	Notification	
Notification indicator	'0000 0001'B	SRVCC handover cancelled, IMS session re-establishment required	SRVCC-HO-CANCELLED

Condition	Explanation
SRVCC-HO-CANCELLED	Used if SRVCC handover is cancelled.

NOTE: This message is always sent within SECURITY PROTECTED NAS MESSAGE message.

- PDN CONNECTIVITY REJECT

This message is sent by the SS to the UE.

Table 4.7.3-19: PDN CONNECTIVITY REJECT

Derivation Path: 24.301 clause 8.3.17			
Information Element	Value/remark	Comment	Condition
Protocol discriminator	ESM		
EPS bearer identity	'0000'B	No EPS bearer identity assigned	
Procedure transaction identity	The same value as the value set in PDN CONNECTIVITY REQUEST message.		
PDN connectivity reject message identity	'1101 0001'B	PDN connectivity reject	
ESM cause	The value is set according to specific message content.		
Protocol configuration options	Not present		
NBIFOM container	Not present		
Extended protocol configuration options	Not present		

NOTE: This message is sent without integrity protection before NAS security mode control procedure has been successfully completed and sent within SECURITY PROTECTED NAS MESSAGE message after NAS security mode control procedure has been successfully completed.

- PDN CONNECTIVITY REQUEST

This message is sent by the UE to the SS.

Table 4.7.3-20: PDN CONNECTIVITY REQUEST

Derivation Path: 24.301 clause 8.3.20			
Information Element	Value/remark	Comment	Condition
Protocol discriminator	ESM		
EPS bearer identity	'0000'B	No EPS bearer identity assigned	
Procedure transaction identity	Any value from 1 to 254		
PDN connectivity request message identity	'1101 0000'B	PDN connectivity request	
Request type	'0001'B	initial request	
PDN type	Any value between '001'B, '010'B, '011'B and '100'B	The allowed values are respectively IPv4, IPv6, IPv4v6 and "unused but interpreted as IPv6 by the network"	
PDN type	'101'B	Non-IP	CloT_CP_NON_IP
ESM information transfer flag	Not present or any allowed value		
Access point name	Not present	The value is mandatory when the PDN CONNECTIVITY REQUEST message is sent together with an ATTACH REQUEST message.	
Protocol configuration options	Not present or any allowed value	The value received from the UE does not affect the possible verdict associated with the message when received by the SS. The SS shall remember if this IE is present and its contents because this affects subsequent SS behaviour, e.g. coding of ACTIVATE DEFAULT EPS BEARER CONTEXT REQUEST.	NOT (pc_NB or pc_NonIP_PDN)
Protocol configuration options	Not present		pc_NB or pc_NonIP_PDN
NBIFOM container	Not present or any allowed value		
Header compression configuration	Not present or any allowed value		
Extended protocol configuration options	Not present or any allowed value		

Condition	Explanation
CloT_CP_NON_IP	If the UE requests a Non-IP type PDN

NOTE: This message is sent without integrity protection before NAS security mode control procedure has been successfully completed and sent within SECURITY PROTECTED NAS MESSAGE message after NAS security mode control procedure has been successfully completed.

- PDN DISCONNECT REJECT

This message is sent by the SS to the UE.

Table 4.7.3-21: PDN DISCONNECT REJECT

Derivation Path: 24.301 clause 8.3.19			
Information Element	Value/remark	Comment	Condition
Protocol discriminator	ESM		
EPS bearer identity	'0000'B	No EPS bearer identity assigned	
Procedure transaction identity	The value indicated in PDN DISCONNECT REQUEST message.		
PDN disconnect reject message identity	'1101 0011'B	PDN disconnect reject	
ESM cause	Set according to specific message content.		
Protocol configuration options	Not present		
Extended protocol configuration options	Not present		

NOTE: This message is always sent within SECURITY PROTECTED NAS MESSAGE message.

- PDN DISCONNECT REQUEST

This message is sent by the UE to the SS.

Table 4.7.3-22: PDN DISCONNECT REQUEST

Derivation Path: 24.301 clause 8.3.20			
Information Element	Value/remark	Comment	Condition
Protocol discriminator	ESM		
EPS bearer identity	'0000'B	No EPS bearer identity assigned	
Procedure transaction identity	Any value from 1 to 254		
PDN disconnect request message identity	'1101 0010'B	PDN disconnect request	
Linked EPS bearer identity	The EPS bearer identity of the associated default bearer.		
Spare half octet	'0000'B		
Protocol configuration options	Not present or any allowed value		
Extended protocol configuration options	Not present or any allowed value		

NOTE: This message is always sent within SECURITY PROTECTED NAS MESSAGE message.

4.7A Default TC message and information element contents

This clause contains the default values of common TC (Test Control, see [38]) messages and information elements, which apply to all test cases unless otherwise specified. All the messages and information elements are listed in alphabetical order.

- ACTIVATE TEST MODE

This message is sent by the SS to the UE embedded in a RRC *DLInformationTransfer* message.

Table 4.7A-1: ACTIVATE TEST MODE

Derivation Path: 36.509 clause 6.5			
Information Element	Value/remark	Comment	Condition
Protocol discriminator	1 1 1 1		
Skip indicator	0 0 0 0		
Message type	1 0 0 0 0 1 0 0		
UE test loop mode	0 0 0 0 0 0 0 0	UE test loop mode A	UE TEST LOOP MODE A (default)
UE test loop mode	0 0 0 0 0 0 0 1	UE test loop mode B	UE TEST LOOP MODE B
UE test loop mode	0 0 0 0 0 0 1 0	UE test loop mode C	UE TEST LOOP MODE C
UE test loop mode	0 0 0 0 0 0 1 1	UE test loop mode D	UE TEST LOOP MODE D
UE test loop mode	0 0 0 0 0 1 0 0	UE test loop mode E	UE TEST LOOP MODE E
UE test loop mode	0 0 0 0 0 1 0 1	UE test loop mode F	UE TEST LOOP MODE F

Condition	Explanation
UE TEST LOOP MODE A	UE test loop function configured for UE test loop mode A operation.
UE TEST LOOP MODE B	UE test loop function configured for UE test loop mode B operation.
UE TEST LOOP MODE C	UE test loop function configured for UE test loop mode C operation.
UE TEST LOOP MODE D	UE test loop function configured for UE test loop mode D operation.
UE TEST LOOP MODE E	UE test loop function configured for UE test loop mode E operation.
UE TEST LOOP MODE F	UE test loop function configured for UE test loop mode F operation.

- ACTIVATE TEST MODE COMPLETE

This message is sent by the UE to the SS embedded in a RRC *ULInformationTransfer* message.

Table 4.7A-2: ACTIVATE TEST MODE COMPLETE

Derivation Path: 36.509 clause 6.6			
Information Element	Value/remark	Comment	Condition
Protocol discriminator	1 1 1 1		
Skip indicator	0 0 0 0		
Message type	1 0 0 0 0 1 0 1		

- CLOSE UE TEST LOOP

This message is sent by the SS to the UE embedded in a RRC *DLInformationTransfer* message.

Table 4.7A-3: CLOSE UE TEST LOOP

Derivation Path: 36.509 clause 6.1			
Information Element	Value/remark	Comment	Condition
Protocol discriminator	1 1 1 1		
Skip indicator	0 0 0 0		
Message type	1 0 0 0 0 0 0 0		
UE test loop mode	0 0 0 0 0 0 0 0	UE test loop mode A	UE TEST LOOP MODE A (default)
UE test loop mode A LB setup			
Length of UE test loop mode A LB setup list in bytes	0	No LB setup list. No scaling (UL RLC SDU size will be equal to the received DL SDU size)	
UE test loop mode B LB setup	Not present		
UE test loop mode C LB setup	Not present		
UE test loop mode D LB setup	Not present		
UE test loop mode E LB setup	Not present		
UE test loop mode F setup	Not present		
UE test loop mode	0 0 0 0 0 0 0 1	UE test loop mode B	UE TEST LOOP MODE B
UE test loop mode A LB setup	Not present		
UE test loop mode B LB setup			
IP PDU delay	0 0 0 0 0 0 0 0	No delay	
UE test loop mode C LB setup	Not present		
UE test loop mode D LB setup	Not present		
UE test loop mode E LB setup	Not present		
UE test loop mode F setup	Not present		
UE test loop mode	0 0 0 0 0 0 1 0	UE test loop mode C	UE TEST LOOP MODE C
UE test loop mode A LB setup	Not present		
UE test loop mode B LB setup	Not present		
UE test loop mode C LB setup		MTCH ID	
MBSFN area identity	0 0 0 0 0 0 0 0	0, same value as broadcasted in the default <i>SystemInformationBlock Type13</i> message	
MCH identity	0 0 0 0 0 0 0 0	0, same value as indicated in the default MBSFNAreaConfiguration message	
Logical channel identity	0 0 0 0 0 0 0 1	1, same value as indicated in the default MBSFNAreaConfiguration message	
UE test loop mode D LB setup	Not present		
UE test loop mode E LB setup	Not present		
UE test loop mode F setup	Not present		
UE test loop mode	0 0 0 0 0 0 1 1	UE test loop mode D	UE TEST LOOP MODE D
UE test loop mode A LB setup	Not present		
UE test loop mode B LB setup	Not present		
UE test loop mode C LB setup	Not present		
UE test loop mode D LB setup			
Discovery Announce or Monitor	0 0 0 0 0 0 0 0	0, triggered to monitor sidelink direct discovery by default.	
Length of UE test loop mode D Monitor list in bytes	0 0 0 0 0 0 0 0 0 0 0 0 0 0 0 0	0 byte because by default no specific App code is monitored individually. The UE will collectively monitor all App codes.	
UE test loop mode E LB setup	Not present		
UE test loop mode F setup	Not present		
UE test loop mode	0 0 0 0 0 1 0 0	UE test loop mode E	UE TEST LOOP MODE E
UE test loop mode A LB setup	Not present		
UE test loop mode B LB setup	Not present		
UE test loop mode C LB setup	Not present		
UE test loop mode D LB setup	Not present		
UE test loop mode E LB setup			

Length of UE test loop mode E Monitor setup contents in bytes	0 0 0 0 0 0 1	1 to account for first 1 octet which is always present. By default no specific Group Destination ID code is monitored individually. The UE will collectively monitor packets for all Group Destination IDs.	
Communication Transmit or Receive	0 0 0 0 0 0 0	0, triggered to receive sidelink direct communication by default.	
UE test loop mode F setup	Not present		
UE test loop mode	0 0 0 0 0 1 0 0	UE test loop mode E	UE TEST LOOP MODE E (V2X Reception)
UE test loop mode A LB setup	Not present		
UE test loop mode B LB setup	Not present		
UE test loop mode C LB setup	Not present		
UE test loop mode D LB setup	Not present		
UE test loop mode E LB setup			
Length of UE test loop mode E Monitor setup contents in bytes	0 0 0 0 0 0 1	1 to account for first 1 octet which is always present. By default no specific Group Destination ID code is monitored individually. The UE will collectively monitor packets for all Group Destination IDs.	
Communication Transmit or Receive	0 0 0 0 0 0 1 0	'10' indicates V2X UE triggered to receive V2X communication by default.	
UE test loop mode F setup	Not present		
UE test loop mode	0 0 0 0 0 1 0 0	UE test loop mode E	UE TEST LOOP MODE E (V2X Transmission)
UE test loop mode A LB setup	Not present		
UE test loop mode B LB setup	Not present		
UE test loop mode C LB setup	Not present		
UE test loop mode D LB setup	Not present		
UE test loop mode E LB setup			
Length of UE test loop mode E Monitor setup contents in bytes	0 0 0 0 0 0 1	1 to account for first 1 octet which is always present. By default no specific Group Destination ID code is monitored individually. The UE will collectively monitor packets for all Group Destination IDs.	
Communication Transmit or Receive	0 0 0 0 0 0 1 1	'11' indicates V2X UE triggered to transmit V2X communication by default.	
UE test loop mode F setup	Not present		
UE test loop mode	0 0 0 0 0 1 0 1	UE test loop mode F	UE TEST LOOP MODE F
UE test loop mode A LB setup	Not present		
UE test loop mode B LB setup	Not present		
UE test loop mode C LB setup	Not present		
UE test loop mode D LB setup	Not present		
UE test loop mode E LB setup	Not present		
UE test loop mode F setup		SC-MTCH ID	
g-RNTI	'0100'H	same value as indicated in the default SCPTM-Configuration message	

Condition	Explanation
UE TEST LOOP MODE A	UE test loop function configured for UE test loop mode A operation.
UE TEST LOOP MODE B	UE test loop function configured for UE test loop mode B operation.
UE TEST LOOP MODE C	UE test loop function configured for UE test loop mode C operation.
UE TEST LOOP MODE D	UE test loop function configured for UE test loop mode D operation.
UE TEST LOOP MODE E	UE test loop function configured for UE test loop mode E operation.
UE TEST LOOP MODE E (V2X Reception)	UE test loop function configured for UE test loop mode E operation with V2X reception.
UE TEST LOOP MODE E (V2X Transmission)	UE test loop function configured for UE test loop mode E operation with V2X transmission.
UE TEST LOOP MODE F	UE test loop function configured for UE test loop mode F operation.

- CLOSE UE TEST LOOP COMPLETE

This message is sent by the UE to the SS embedded in a RRC *ULInformationTransfer* message.

Table 4.7A-4: CLOSE UE TEST LOOP

Derivation Path: 36.509 clause 6.2			
Information Element	Value/remark	Comment	Condition
Protocol discriminator	1 1 1 1		
Skip indicator	0 0 0 0		
Message type	1 0 0 0 0 0 1		

- DEACTIVATE TEST MODE

This message is sent by the SS to the UE embedded in a RRC *DLInformationTransfer* message.

Table 4.7A-5: DEACTIVATE TEST MODE

Derivation Path: 36.509 clause 6.7			
Information Element	Value/remark	Comment	Condition
Protocol discriminator	1 1 1 1		
Skip indicator	0 0 0 0		
Message type	1 0 0 0 0 1 1 0		

- DEACTIVATE TEST MODE COMPLETE

This message is sent by the UE to the SS embedded in a RRC *ULInformationTransfer* message.

Table 4.7A-6: DEACTIVATE TEST MODE COMPLETE

Derivation Path: 36.509 clause 6.8			
Information Element	Value/remark	Comment	Condition
Protocol discriminator	1 1 1 1		
Skip indicator	0 0 0 0		
Message type	1 0 0 0 0 1 1 1		

- OPEN UE TEST LOOP

This message is sent by the SS to the UE embedded in a RRC *DLInformationTransfer* message.

Table 4.7A-7: OPEN UE TEST LOOP

Derivation Path: 36.509 clause 6.3			
Information Element	Value/remark	Comment	Condition
Protocol discriminator	1 1 1 1		
Skip indicator	0 0 0 0		
Message type	1 0 0 0 0 1 0		

- OPEN UE TEST LOOP COMPLETE

This message is sent by the UE to the SS embedded in a RRC *ULInformationTransfer* message.

Table 4.7A-8: OPEN UE TEST LOOP COMPLETE

Derivation Path: 36.509 clause 6.4			
Information Element	Value/remark	Comment	Condition
Protocol discriminator	1 1 1 1		
Skip indicator	0 0 0 0		
Message type	1 0 0 0 0 1 1		

- UE TEST LOOP MODE C MBMS PACKET COUNTER REQUEST

This message is sent by the SS to the UE embedded in a RRC *DLInformationTransfer* message.

Table 4.7A-9: UE TEST LOOP MODE C MBMS PACKET COUNTER REQUEST

Derivation Path: 36.509 clause 6.10			
Information Element	Value/remark	Comment	Condition
Protocol discriminator	1 1 1 1		
Skip indicator	0 0 0 0		
Message type	1 0 0 0 1 0 0 1		

- UE TEST LOOP MODE C MBMS PACKET COUNTER RESPONSE

This message is sent by the UE to the SS embedded in a RRC *ULInformationTransfer* message.

Table 4.7A-10: UE TEST LOOP MODE C MBMS PACKET COUNTER RESPONSE

Derivation Path: 36.509 clause 6.11			
Information Element	Value/remark	Comment	Condition
Protocol discriminator	1 1 1 1		
Skip indicator	0 0 0 0		
Message type	1 0 0 0 1 0 1 1		
MBMS Packet Counter Value			

- UE TEST LOOP PROSE PACKET COUNTER REQUEST

This message is sent by the SS to the UE embedded in a RRC *DLInformationTransfer* message.

Table 4.7A-11: UE TEST LOOP PROSE PACKET COUNTER REQUEST

Derivation Path: 36.509 clause 6.13			
Information Element	Value/remark	Comment	Condition
Protocol discriminator	1 1 1 1		
Skip indicator	0 0 0 0		
Message type	1 0 0 0 1 1 0 0		

- UE TEST LOOP PROSE PACKET COUNTER RESPONSE

This message is sent by the UE to the SS embedded in a RRC *ULInformationTransfer* message.

Table 4.7A-12: UE TEST LOOP PROSE PACKET COUNTER RESPONSE

Derivation Path: 36.509 clause 6.14			
Information Element	Value/remark	Comment	Condition
Protocol discriminator	1 1 1 1		
Skip indicator	0 0 0 0		
Message type	1 0 0 0 1 1 0 1		
ProSe Direct Discovery Packet Counter(s) Value			Mode D
ProSe Direct Communication PSCCH Packet Counter(s) Value			Mode E
ProSe Direct Communication STCH Packet Counter(s) Value			Mode E

Condition	Explanation
Mode D	This IE is present if UE test loop function is configured for UE test loop mode D operation else it shall be absent.
Mode E	This IE is present if UE test loop function is configured for UE test loop mode E operation else it shall be absent

- UE TEST LOOP MODE F SCPTM PACKET COUNTER REQUEST

This message is sent by the SS to the UE embedded in a RRC *DLInformationTransfer* message.

Table 4.7A-13: UE TEST LOOP MODE F SCPTM PACKET COUNTER REQUEST

Derivation Path: 36.509 clause 6.15			
Information Element	Value/remark	Comment	Condition
Protocol discriminator	1 1 1 1		
Skip indicator	0 0 0 0		
Message type	1 0 0 0 1 1 1 0		

- UE TEST LOOP MODE F SCPTM PACKET COUNTER RESPONSE

This message is sent by the UE to the SS embedded in a RRC *ULInformationTransfer* message.

Table 4.7A-14: UE TEST LOOP MODE F SCPTM PACKET COUNTER RESPONSE

Derivation Path: 36.509 clause 6.16			
Information Element	Value/remark	Comment	Condition
Protocol discriminator	1 1 1 1		
Skip indicator	0 0 0 0		
Message type	1 0 0 0 1 1 1 1		
SCPTM Packet Counter Value			

4.7B Default UTRA message and information element contents

4.7B.1 UTRA RRC messages

– HANDOVER TO UTRAN COMMAND

Table 4.7B.1-1: HANDOVER TO UTRAN COMMAND

Derivation Path: 25.331, clause 10.2.16a			
Information Element	Value/remark	Comment	Condition
New U-RNTI	U-RNTI-Short		
- SRNC identity	0000 0000 0001B		
- S-RNTI-2	00 0000 0001B		
Ciphering algorithm	UEA0 or UEA1. The indicated algorithm must be one of the algorithms supported by the UE.		
RNC support for change of UE capability	FALSE		
New H-RNTI	Not present		UTRA FDD PS RB, UTRA TDD PS RB, UTRA Speech, UTRA PS RB + Speech, UTRA Speech + Packet RAB Setup after Speech RAB Setup in CELL_DC H
	'1010 1010 1010 1010'		UTRA HSDPA RB, UTRA HSUPA/H SDPA RB
New Primary E-RNTI	Not present		UTRA FDD PS RB, UTRA TDD PS RB, UTRA HSDPA RB, UTRA Speech, UTRA PS RB + Speech. ,UTRA Speech + Packet RAB Setup after Speech RAB Setup in CELL_DC H
	'1010 1010 1010 1010'		UTRA HSUPA/H SDPA RB
New Secondary E-RNTI	Not present		
Default configuration for CELL_FACH	Not present		
CHOICE <i>specification mode</i>	Complete specification		

- Signalling RB information to setup List	<p>Same as the corresponding IE in the RRC CONNECTION SETUP message (Transition to CELL_DCH or HS-PDSCH in CELL_FACH) using condition A1 in TS 34.108 clause 9.1.1 for UTRA-FDD.</p> <p>Same as the corresponding IE in the RRC CONNECTION SETUP message in TS 34.108 clause 9.1.2 for UTRA-TDD.</p>		<p>UTRA FDD PS RB, UTRA HSDPA RB, UTRA Speech, UTRA PS RB + Speech, UTRA Speech + Packet RAB Setup after Speech RAB Setup in CELL_DCH</p>
	<p>Same as the corresponding IE in the RRC CONNECTION SETUP message in TS 34.108 clause 9.2.2</p>		<p>UTRA TDD PS RB</p>
	<p>Same as the corresponding IE in the RRC CONNECTION SETUP message (Transition to CELL_DCH or HS-PDSCH in CELL_FACH) using condition A3 in TS 34.108 clause 9.1.1 for UTRA-FDD.</p> <p>Same as the corresponding IE in the RRC CONNECTION SETUP (Transition to CELL_DCH) (1.28 Mcps TDD option) message in TS 34.108 clause 9.1.2 for UTRA-TDD.</p>		<p>UTRA HSUPA/H SDPA RB</p>
- RAB information to setup list	<p>Same as the corresponding IE in the RADIO BEARER SETUP message using condition A2 in TS 34.108 clause 9.1.1 for UTRA-FDD.</p> <p>Same as the corresponding IE in the RADIO BEARER SETUP message (1.28 Mcps TDD) using condition A2 in TS 34.108 clause 9.1.2 for UTRA-TDD.</p>		<p>UTRA Speech, UTRA PS RB + Speech, UTRA Speech + Packet RAB Setup after Speech RAB Setup in CELL_DCH</p>

	<p>Same as the corresponding IE in the RADIO BEARER SETUP message using condition A3 in TS 34.108 clause 9.1.1 for UTRA-FDD.</p> <p>Same as the corresponding IE in the RADIO BEARER SETUP message (1.28 Mcps TDD) using condition A3 in TS 34.108 clause 9.1.2 for UTRA-TDD.</p>		<p>UTRA FDD PS RB, UTRA PS RB + Speech</p>
	<p>Same as the corresponding IE in the RADIO BEARER SETUP message using condition A11 in TS 34.108 clause 9.1.1 for UTRA-FDD.</p> <p>Same as the corresponding IE in the RADIO BEARER SETUP message (1.28 Mcps TDD) using condition A11 in TS 34.108 clause 9.1.2 for UTRA-TDD.</p>		<p>UTRA Speech + Packet RAB Setup after Speech RAB Setup in CELL_DC H</p>
	<p>Same as the corresponding IE in the RADIO BEARER SETUP message (1.28 Mcps TDD) using condition A3 in TS 34.108 clause 9.2.2 for UTRA-TDD.</p>		<p>UTRA TDD PS RB</p>
	<p>Same as the corresponding IE in the RADIO BEARER SETUP message using condition A10 in TS 34.108 clause 9.1.1 for UTRA-FDD.</p> <p>Same as the corresponding IE in the RADIO BEARER SETUP message (1.28 Mcps TDD) using condition A10 in TS 34.108 clause 9.1.2 for UTRA-TDD.</p>		<p>UTRA HSDPA RB</p>
	<p>Same as the corresponding IE in the RADIO BEARER SETUP message using condition A14 in TS 34.108 clause 9.1.1 for UTRA-FDD.</p> <p>Same as the corresponding IE in the RADIO BEARER SETUP message (1.28 Mcps TDD) using condition A13 in TS 34.108 clause 9.1.2 for UTRA-TDD.</p>		<p>UTRA HSUPA/H SDPA RB</p>

<p>- UL Transport channel information common for all transport channels</p>	<p>Same as the corresponding IE in the RADIO BEARER SETUP message using condition A2 in TS 34.108 clause 9.1.1 for UTRA-FDD Same as the corresponding IE in the RADIO BEARER SETUP message (1.28 Mcps TDD) using condition A2 in TS 34.108 clause 9.1.2 for UTRA-TDD</p>		<p>UTRA Speech, UTRA PS RB + Speech, UTRA Speech + Packet RAB Setup after Speech RAB Setup in CELL_DCH</p>
	<p>Same as the corresponding IE in the RADIO BEARER SETUP message using condition A3 in TS 34.108 clause 9.1.1 UTRA-FDD. Same as the corresponding IE in the RADIO BEARER SETUP message (1.28 Mcps TDD) using condition A3 in TS 34.108 clause 9.2.2 UTRA-TDD.</p>		<p>UTRA FDD PS RB, UTRA TDD PS RB</p>
	<p>Same as the corresponding IE in the RADIO BEARER SETUP message using condition A10 in TS 34.108 clause 9.1.1 for UTRA-FDD. Same as the corresponding IE in the RADIO BEARER SETUP message (1.28 Mcps TDD) using condition A10 in TS 34.108 clause 9.1.2 for UTRA-TDD.</p>		<p>UTRA HSDPA RB</p>
	<p>Same content as the corresponding IE in the RADIO BEARER SETUP message using condition A14 in TS 34.108 clause 9.1.1 for UTRA-FDD. Same content as the corresponding IE in the RADIO BEARER SETUP message (1.28 Mcps TDD) using condition A13 in TS 34.108 clause 9.1.2 for UTRA-TDD.</p>		<p>UTRA HSUPA/HSDPA RB</p>

- Added or Reconfigured UL TrCH information	Same as the corresponding IE in the RADIO BEARER SETUP message using condition A2 in TS 34.108 clause 9.1.1 for UTRA-FDD. Same as the corresponding IE in the RADIO BEARER SETUP message (1.28 Mcps TDD) using condition A2 in TS 34.108 clause 9.1.2 for UTRA-TDD		UTRA Speech, UTRA PS RB + Speech, UTRA Speech + Packet RAB Setup after Speech RAB Setup in CELL_DCH
	Same as the corresponding IE in the RADIO BEARER SETUP message using condition A3 in TS 34.108 clause 9.1.1		UTRA FDD PS RB
	Same as the corresponding IE in the RADIO BEARER SETUP message using condition A10 in TS 34.108 clause 9.1.1 for UTRA-FDD. Same as the corresponding IE in the RADIO BEARER SETUP message (1.28 Mcps TDD) using condition A10 in TS 34.108 clause 9.1.2 for UTRA-TDD.		UTRA HSDPA RB
	Same as the corresponding IE in the RADIO BEARER SETUP message using condition A11 in TS 34.108 clause 9.1.1 for UTRA-FDD. Same as the corresponding IE in the RADIO BEARER SETUP message (1.28 Mcps TDD) using condition A11 in TS 34.108 clause 9.1.2 for UTRA-TDD.		UTRA Speech + Packet RAB Setup after Speech RAB Setup in CELL_DCH
	Same as the corresponding IE in the RADIO BEARER SETUP message using condition A14 in TS 34.108 clause 9.1.1 for UTRA-FDD. Same as the corresponding IE in the RADIO BEARER SETUP message (1.28 Mcps TDD) using condition A13 in TS 34.108 clause 9.1.2 for UTRA-TDD.		UTRA HSUPA/HSDPA RB
- Added or Reconfigured UL TrCH information	2 Entries		UTRA TDD PS RB
- Added or Reconfigured UL TrCH information[1]	Same as the corresponding IE in the RRC CONNECTION SETUP message (1.28 Mcps TDD) in TS 34.108 clause 9.2.2.		UTRA TDD PS RB

<p>- Added or Reconfigured UL TrCH information[2]</p>	<p>Same as the corresponding IE in the RADIO BEARER SETUP message (1.28 Mcps TDD) using condition A3 in TS 34.108 clause 9.2.2.</p>		<p>UTRA TDD PS RB</p>
<p>- DL Transport channel information common for all transport channels</p>	<p>Same as the corresponding IE in the RADIO BEARER SETUP message using condition A2 in TS 34.108 clause 9.1.1 for UTRA-FDD. Same as the corresponding IE in the RADIO BEARER SETUP message (1.28 Mcps TDD) using condition A2 in TS 34.108 clause 9.1.2 for UTRA-TDD.</p>		<p>UTRA Speech, UTRA PS RB + Speech, UTRA Speech + Packet RAB Setup after Speech RAB Setup in CELL_DC H</p>
	<p>Same as the corresponding IE in the RADIO BEARER SETUP message using condition A3 in TS 34.108 clause 9.1.1</p>		<p>UTRA FDD PS RB</p>
	<p>Same as the corresponding IE in the RADIO BEARER SETUP message (1.28 Mcps TDD) using condition A3 in TS 34.108 clause 9.2.2.</p>		<p>UTRA TDD PS RB</p>
	<p>Same as the corresponding IE in the RADIO BEARER SETUP message using condition A10 in TS 34.108 clause 9.1.1 for UTRA-FDD. Same as the corresponding IE in the RADIO BEARER SETUP message (1.28 Mcps TDD) using condition A10 in TS 34.108 clause 9.1.2 for UTRAT-TDD.</p>		<p>UTRA HSDPA RB</p>
	<p>Same content as the corresponding IE in the RADIO BEARER SETUP message using condition A14 in TS 34.108 clause 9.1.1 for UTRA-FDD. Same as the corresponding IE in the RADIO BEARER SETUP message (1.28 Mcps TDD) using condition A13 in TS 34.108 clause 9.1.2 for UTRA-TDD.</p>		<p>UTRA HSUPA/H SDPA RB</p>

<p>- Added or Reconfigured DL TrCH information</p>	<p>Same as the corresponding IE in the RADIO BEARER SETUP message using condition A2 in TS 34.108 clause 9.1.1 for UTRA-FDD. Same as the corresponding IE in the RADIO BEARER SETUP message (1.28 Mcps TDD) using condition A2 in TS 34.108 clause 9.1.2 for UTRA-TDD.</p>		<p>UTRA Speech, UTRA PS RB + Speech, UTRA Speech + Packet RAB Setup after Speech RAB Setup in CELL_DCH</p>
	<p>Same as the corresponding IE in the RADIO BEARER SETUP message using condition A3 in TS 34.108 clause 9.1.1</p>		<p>UTRA FDD PS RB</p>
	<p>Same as the corresponding IE in the RADIO BEARER SETUP message using condition A11 in TS 34.108 clause 9.1.1 for UTRA-FDD. Same as the corresponding IE in the RADIO BEARER SETUP message (1.28 Mcps TDD) using condition A11 in TS 34.108 clause 9.1.2 for UTRA-TDD.</p>		<p>UTRA Speech + Packet RAB Setup after Speech RAB Setup in CELL_DCH</p>
	<p>Same as the corresponding IE in the RADIO BEARER SETUP message using condition A10 in TS 34.108 clause 9.1.1 for UTRA-FDD. Same as the corresponding IE in the RADIO BEARER SETUP message (1.28 Mcps TDD) using condition A10 in TS 34.108 clause 9.1.2 for UTRA-TDD.</p>		<p>UTRA HSDPA RB</p>
	<p>Same as the corresponding IE in the RADIO BEARER SETUP message using condition A14 in TS 34.108 clause 9.1.1 for UTRA-FDD. Same as the corresponding IE in the RADIO BEARER SETUP message (1.28 Mcps TDD) using condition A13 in TS 34.108 clause 9.1.2 for UTRA-TDD.</p>		<p>UTRA HSUPA/HSDPA RB</p>
<p>- Added or Reconfigured DL TrCH information</p>	<p>2 Entries</p>		<p>UTRA TDD PS RB</p>
<p>- Added or Reconfigured DL TrCH information[1]</p>	<p>Same as the corresponding IE in the RRC CONNECTION SETUP message (1.28 Mcps TDD) in TS 34.108 clause 9.2.2.</p>		<p>UTRA TDD PS RB</p>

<p>- Added or Reconfigured DL TrCH information[2]</p>	<p>Same as the corresponding IE in the RADIO BEARER SETUP message (1.28 Mcps TDD) using condition A3 in TS 34.108 clause 9.2.2.</p>		<p>UTRA TDD PS RB</p>
<p>- Uplink DPCH info</p>	<p>Same as the corresponding IE in the RADIO BEARER SETUP message using condition A2 in TS 34.108 clause 9.1.1 for UTRA-FDD. Same as the corresponding IE in the RADIO BEARER SETUP message (1.28 Mcps TDD) using condition A13 in TS 34.108 clause 9.1.2 for UTRA-TDD.</p>		<p>UTRA Speech, UTRA PS RB + Speech, UTRA Speech + Packet RAB Setup after Speech RAB Setup in CELL_DC H</p>
	<p>Same as the corresponding IE in the RADIO BEARER SETUP message using condition A3 in TS 34.108 clause 9.1.1</p>		<p>UTRA FDD PS RB</p>
	<p>Same as the corresponding IE in the RADIO BEARER SETUP message (1.28 Mcps TDD) using condition A3 in TS 34.108 clause 9.2.2.</p>		<p>UTRA TDD PS RB</p>
	<p>Same as the corresponding IE in the RADIO BEARER SETUP message using condition A10 in TS 34.108 clause 9.1.1 for UTRA-FDD. Same as the corresponding IE in the RADIO BEARER SETUP message (1.28 Mcps TDD) using condition A10 in TS 34.108 clause 9.1.2 for UTRA-TDD.</p>		<p>UTRA HSDPA RB</p>
	<p>Same as the corresponding IE in the RADIO BEARER SETUP message using condition A14 in TS 34.108 clause 9.1.1 for UTRA-FDD. Same as the corresponding IE in the RADIO BEARER SETUP message (1.28 Mcps TDD) using condition A13 in TS 34.108 clause 9.1.2 for UTRA-TDD.</p>		<p>UTRA HSUPA/H SDPA RB</p>

- E-DCH Info	Not present		UTRA FDD PS RB, UTRA TDD PS RB, UTRA HSDPA RB, UTRA Speech, UTRA PS RB + Speech, UTRA Speech + Packet RAB Setup after Speech RAB Setup in CELL_DC H
	Same as the corresponding IE in the RADIO BEARER SETUP message using condition A14 in TS 34.108 clause 9.1.1 for UTRA-FDD. Same as the corresponding IE in the RADIO BEARER SETUP message (1.28 Mcps TDD) using condition A13 in TS 34.108 clause 9.1.2 for UTRA-TDD.		UTRA HSUPA/H SDPA RB
- Downlink HS-PDSCH Information	Not present		UTRA FDD PS RB, UTRA TDD PS RB, UTRA Speech, UTRA PS RB + Speech, UTRA Speech + Packet RAB Setup after Speech RAB Setup in CELL_DC H
	Same as the corresponding IE in the RADIO BEARER SETUP message using condition A10 in TS 34.108 clause 9.1.1 for UTRA-FDD. Same as the corresponding IE in the RADIO BEARER SETUP message (1.28 Mcps TDD) using condition A10 in TS 34.108 clause 9.1.2 for UTRA-TDD.		UTRA HSDPA RB

	Same as the corresponding IE in the RADIO BEARER SETUP message using condition A14 in TS 34.108 clause 9.1.1 for UTRA-FDD. Same as the corresponding IE in the RADIO BEARER SETUP message (1.28 Mcps TDD) using condition A13 in TS 34.108 clause 9.1.2 for UTRA-TDD.		UTRA HSUPA/H SDPA RB
- Downlink information common for all radio links	Same as the corresponding IE in the RADIO BEARER SETUP message using condition A2 in TS 34.108 clause 9.1.1 for UTRA-FDD. Same as the corresponding IE in the RADIO BEARER SETUP message (1.28 Mcps TDD) using condition A2 in TS 34.108 clause 9.1.2 for UTRA-TDD.		UTRA Speech, UTRA PS RB + Speech, UTRA Speech + Packet RAB Setup after Speech RAB Setup in CELL_DC H
	Same as the corresponding IE in the RADIO BEARER SETUP message using condition A4 in TS 34.108 clause 9.1.1		UTRA FDD PS RB
	Same as the corresponding IE in the RADIO BEARER SETUP message (1.28 Mcps TDD) using condition A3 in TS 34.108 clause 9.2.2.		UTRA TDD PS RB
	Same as the corresponding IE in the RADIO BEARER SETUP message using condition A10 in TS 34.108 clause 9.1.1 for UTRA-FDD. Same as the corresponding IE in the RADIO BEARER SETUP message (1.28 Mcps TDD) using condition A10 in TS 34.108 clause 9.1.2 for UTRA-TDD.		UTRA HSDPA RB
	Same as the corresponding IE in the RADIO BEARER SETUP message using condition A14 in TS 34.108 clause 9.1.1 for UTRA-FDD. Same as the corresponding IE in the RADIO BEARER SETUP message (1.28 Mcps TDD) using condition A13 in TS 34.108 clause 9.1.2 for UTRA-TDD.		UTRA HSUPA/H SDPA RB

- Downlink information for each radio link list	Same as the corresponding IE in the RADIO BEARER SETUP message using condition A2 in TS 34.108 clause 9.1.1 for UTRA-FDD. Same as the corresponding IE in the RADIO BEARER SETUP message (1.28 Mcps TDD) using condition A2 in TS 34.108 clause 9.1.2 for UTRA-TDD.		UTRA Speech, UTRA PS RB + Speech, UTRA Speech + Packet RAB Setup after Speech RAB Setup in CELL_DC H
	Same as the corresponding IE in the RADIO BEARER SETUP message using condition A3 in TS 34.108 clause 9.1.1		UTRA FDD PS RB
	Same as the corresponding IE in the RADIO BEARER SETUP message (1.28 Mcps TDD) using condition A3 in TS 34.108 clause 9.2.2.		UTRA TDD PS RB
	Same as the corresponding IE in the RADIO BEARER SETUP message using condition A10 in TS 34.108 clause 9.1.1 for UTRA-FDD. Same as the corresponding IE in the RADIO BEARER SETUP message (1.28 Mcps TDD) using condition A10 in TS 34.108 clause 9.1.2 for UTRA-TDD.		UTRA HSDPA RB
	Same as the corresponding IE in the RADIO BEARER SETUP message using condition A14 in TS 34.108 clause 9.1.1 for UTRA-FDD. Same as the corresponding IE in the RADIO BEARER SETUP message (1.28 Mcps TDD) using condition A13 in TS 34.108 clause 9.1.2 for UTRA-TDD.		UTRA HSUPA/H SDPA RB
Frequency info	Set according to the frequency of the target UTRA cell.		
Multi-frequency Info	Not present		
Maximum allowed UL TX power	21dBm		

Condition	Explanation
-----------	-------------

UTRA Speech	Establishment of the UTRA reference configuration as specified in Table 4.8.3-1 using the condition "UTRA Speech".
UTRA FDD PS RB	Establishment of the UTRA FDD reference configuration as specified in Table 4.8.3-1 using the condition "UTRA FDD PS RB".
UTRA TDD PS RB	Establishment of the UTRA TDD reference configuration as specified in Table 4.8.3-1 using the condition "UTRA TDD PS RB".
UTRA HSDPA RB	Establishment of the UTRA reference configuration as specified in Table 4.8.3-1 using the condition "UTRA HSDPA RB".
UTRA HSUPA/HSDPA RB	Establishment of the UTRA reference configuration as specified in Table 4.8.3-1 using the condition "UTRA HSUPA/HSDPA RB".
UTRA PS RB + Speech	Establishment of the UTRA reference configuration as specified in Table 4.8.3-1 using the condition "UTRA PS RB + Speech".
UTRA Speech + Packet RAB Setup after Speech RAB Setup in CELL_DCH	Establishment of the UTRA reference configuration as specified in Table 4.8.3-1 using the condition "UTRA Speech + Packet RAB Setup after Speech RAB Setup in Cell DCH".

HANDOVER FROM UTRAN COMMAND

Table 4.7B.1-2: HANDOVER FROM UTRAN COMMAND

Derivation Path: 25.331, clause 10.2.15			
Information Element	Value/remark	Comment	Condition
Message Type			
Integrity check info			
- Message authentication code	SS calculates the value of MAC-I for this message and writes to this IE. The first/ leftmost bit of the bit string contains the most significant bit of the MAC-I.		
- RRC Message sequence number	SS provides the value of this IE, from its internal counter.		
SR-VCC Info	Not present		
Activation time	Now		
RAB Info			
- RAB identity	0000 0101B The first/ leftmost bit of the bit string contains the most significant bit of the RAB identity.		
- CN domain identity	PS domain		
- NAS Synchronization Indicator	Not present		
- Re-establishment timer	Use T315		
Inter-system message			
- CHOICE System type	E-UTRA		
- E-UTRA message	RRConnectionReconfiguration using condition HO-TO-EUTRA(1,0)	See Table 4.6.1-8	

MEASUREMENT CONTROL

Table 4.7B.1-3: MEASUREMENT CONTROL

Derivation Path: 25.331, clause 10.2.17			
Information Element	Value/remark	Comment	Condition
Message Type			

RRC transaction identifier	Arbitrarily selects an unused integer between 0 to 3		
Integrity check info			
- Message authentication code	SS calculates the value of MAC-I for this message and writes to this IE. The first/ leftmost bit of the bit string contains the most significant bit of the MAC-I.		
- RRC message sequence number	SS provides the value of this IE, from its internal counter.		
Measurement Identity	3		
Measurement Command	Setup		
Measurement Reporting Mode			
- Measurement Report Transfer Mode	Acknowledged mode RLC		
- Periodical Reporting/Event Trigger Reporting Mode	Event trigger		
Additional measurement list	Not present		
CHOICE Measurement type	Inter-RAT measurement		
- CHOICE Inter-RAT measurement objects	E-UTRA frequency list		
- CHOICE E-UTRA frequency removal	Remove no frequencies		
- New frequencies			
- E-UTRA carrier frequency	Downlink EARFCN of E-UTRA Cell		
- E-UTRA carrier frequency	65535		Band > 64
- EARFCN extension	Downlink EARFCN of E-UTRA Cell		Band > 64
- Measurement bandwidth	Same downlink system bandwidth as used for E-UTRA Cell		
- Blacklisted cells list	Not present		
- Inter-RAT measurement quantity			
- Measurement quantity for UTRAN quality estimate			
- Filter coefficient	0		
- CHOICE mode	FDD		FDD_UTRA
- Measurement quantity	CPICH Ec/N0		
- Measurement quantity	CPICH RSCP	For signalling tests cases.	
- CHOICE mode	TDD		TDD_UTRA
- Measurement quantity	Primary CCPCH RSCP		
- CHOICE system	E-UTRA		
- Measurement quantity	RSRP		
- Filter coefficient	0		
- Inter-RAT reporting quantity			
- UTRAN estimated quality	FALSE		
- CHOICE system	E-UTRA		
- Reporting quantity	both		
- Reporting cell status	Not present		
- CHOICE report criteria	Inter-RAT measurement reporting criteria		
- Parameters required for each event	1 entry		
- Inter-RAT event identity	Set according to specific test.		
- Threshold own system	-66 dB		
- W	0		
- Threshold other system	-55 (-80 dBm)	When measurement quantity is RSRP, range should be (-115..-19), the actual value =	

		Threshold other system - 25 [dBm]	
- Hysteresis	0		
- Time to trigger	10 ms		
- Reporting cell status			
- CHOICE reported cell	Report cells within active set or within virtual active set or of the other RAT		
- Maximum number of reported cells	2		
- Idle Interval Information	Not present		
CELL_DCH measurement occasion info LCR			LCR_TDD_UTRA
- cellDCHMeasOccasionSequence	1 entry		
- Pattern sequence identifier	0		
- Status Flag	activate		
- Measurement purpose	'00001'		
- Measurement occasion pattern sequence parameters			
- k	3		
- Offset	0		
- M_Length	1		
- Timeslot Bitmap	Not Present		
DPCH Compressed mode status info	Not Present		FDD_UTRA AND NOT Compressed_mode
DPCH Compressed mode status info			FDD_UTRA AND Compressed_mode
- TGPS reconfiguration CFN	(Current CFN + (250 – TTI/10msec)) mod 256		
- Transmission gap pattern sequence	1 entry		
- TGPSI	1		
- TGPS Status Flag	activate		
- TGCFN	(Current CFN + (252 – TTI/10msec)) mod 256		
DPCH Compressed mode status info	Not present		TDD_UTRA

Condition	Explanation
FDD_UTRA	FDD UTRA cell environment
TDD_UTRA	TDD UTRA cell environment
LCR_TDD_UTRA	LCR TDD UTRA cell environment
Compressed_mode	The UE Support of Compressed mode (TS 36.523-2 table A.4.4-1/28).
Band > 64	If band > 64 is selected

MEASUREMENT REPORT

Table 4.7B.1-4: MEASUREMENT REPORT

Derivation Path: 25.331, clause 10.2.19			
Information Element	Value/remark	Comment	Condition
Message Type			
Integrity check info			
- Message authentication code	This IE is checked to see if it is present. The value is compared against the XMAC-I value computed by SS. The first/ leftmost bit of the bit string contains the most significant bit of the MAC-I.		

- RRC Message sequence number	This IE is checked to see if it is present. The value is used by SS to compute the XMAC-I value.		
Activation time	$(256 + CFN - (CFN \text{ MOD } 8 + 8)) \text{ MOD } 256$		
Measurement identity	3		
Measured Results	Not present		
Measured results on RACH	Not present		
Additional measured results	Not present		
Event results	Not present		
Inter-RAT cell info indication	Not present		
E-UTRA Measured Results			
- E-UTRA measured results list	1 entry		
- E-UTRA Carrier Frequency			
- Measured E-UTRA cells	1 entry		
- Physical Cell Identity	PhysicalCellIdentity of E-UTRA Cell		
- RSRP	Set according to specific test.		
- RSRQ	Set according to specific test.		
E-UTRA Event Results			
- Inter-RAT event identity	Set according to specific test.		
- E-UTRA events results list	1 entry		
- E-UTRA Carrier Frequency	Downlink EARFCN of E-UTRA Cell		
- E-UTRA Carrier Frequency	65535		Band > 64
- Reported cells	1 entry		
- Physical Cell Identity	PhysicalCellIdentity of E-UTRA Cell		
- E-UTRA events results extension list			Band > 64
- EARFCN extension	Downlink EARFCN of E-UTRA Cell		

Condition	Explanation
Band > 64	If band > 64 is selected

– PHYSICAL CHANNEL RECONFIGURATION

Table 4.7B.1-5: PHYSICAL CHANNEL RECONFIGURATION

Derivation Path: 25.331, clause 10.2.22			
Information Element	Value/remark	Comment	Condition
Message Type			
RRC transaction identifier	Arbitrarily selects an unused integer between 0 to 3		
Integrity check info			
- Message authentication code	SS calculates the value of MAC-I for this message and writes to this IE. The first/ leftmost bit of the bit string contains the most significant bit of the MAC-I.		
- RRC message sequence number	SS provides the value of this IE, from its internal counter.		
Integrity protection mode info	Not Present		
Ciphering mode info	Not Present		
Activation time	Not Present		

Delay restriction flag	Not Present		
New U-RNTI	Not Present		
New C-RNTI	Not Present		
New H-RNTI	Not Present		
New Primary E-RNTI	Not Present		
New Secondary E-RNTI	Not Present		
RRC State indicator	CELL_DCH		
UE Mobility State Indicator	Not Present		
UTRAN DRX cycle length coefficient	Not Present		
CN information info	Not Present		
URA identity	Not Present		
RNC support for change of UE capability	Not Present		
Reconfiguration in response to requested change of UE capability	Not Present		
Downlink counter synchronization info	Not Present		
Frequency info	Not Present		
DTX-DRX timing information	Not Present		
DTX-DRX Information	Not Present		
HS-SCCH less Information	Not Present		
MIMO parameters	Not Present		
HARQ Info	Not Present		
Maximum allowed UL TX power	Not Present		
CHOICE channel requirement	Not Present		
E-DCH Info	Not Present		
Downlink HS-PDSCH Information	Not Present		
Downlink information common for all radio links			
- Downlink DPCH info common for all RL	Not Present		
- DPCH compressed mode info	Not Present		TDD
- DPCH compressed mode info			FDD
- TGPSI	1		
- TGPS Status Flag	Deactivate		
- TGCFN	Not Present		
- Transmission gap pattern sequence configuration parameters			
- TGMP	E-UTRA measurement		
- TGPRC	Infinity		
- TGSN	8		
- TGL1	10		
- TGL2	Not Present		
- TGD	undefined		
- TGPL1	12		
- TGPL2	Not Present		
- RPP	Mode 0		
- ITP	Mode 0		
- CHOICE UL/DL Mode	UL and DL, UL only or DL only (depending on the UE capability)		
- Downlink compressed mode method	HLS(or not sent, depending on the UE capability)		
- Uplink compressed mode method	HLS(or not sent, depending on the UE capability)		
- Downlink frame type	B		
- DeltaSIR1	20 (2.0)		
- DeltaSIRAfter1	10 (1.0)		
- DeltaSIR2	Not Present		
- DeltaSIRAfter2	Not Present		
- N identify abort	Not Present		
- T Reconfirm abort	Not Present		
- TX Diversity mode	Not Present		
- SSDT information	Not Present		
- Default DPCH Offset Value	Not Present		
Downlink information for each radio link	Not Present		
MBMS PL Service Restriction Information	Not Present		

– PHYSICAL CHANNEL RECONFIGURATION COMPLETE

Table 4.7B.1-6: PHYSICAL CHANNEL RECONFIGURATION COMPLETE

Derivation Path: 25.331, clause 10.2.23			
Information Element	Value/remark	Comment	Condition
Message Type			
Integrity check info			
- Message authentication code	This IE is checked to see if it is present. The value is compared against the XMAC-I value computed by SS. The first/ leftmost bit of the bit string contains the most significant bit of the MAC-I.		
- RRC Message sequence number	This IE is checked to see if it is present. The value is used by SS to compute the XMAC-I value.		
Uplink integrity protection activation info	Not checked		
COUNT-C activation time	Not checked		
Uplink counter synchronization info	Not checked		

– RRC CONNECTION REQUEST

Table 4.7B.1-7: RRC CONNECTION REQUEST

Derivation Path: 25.331, clause 10.2.39			
Information Element	Value/remark	Comment	Condition
Message Type			
Predefined configuration status information	To be checked against requirement if specified		
Initial UE identity			
- CHOICE UE id type			
- TMSI and LAI (GSM-MAP)	Set to the UE's TMSI and LAI.		
Establishment cause	To be checked against requirement if specified		
Protocol error indicator	FALSE		
UE Specific Behaviour Information 1 idle	This IE will not be checked by default behaviour, but in specific test case.		
Domain indicator	Not checked		
Call type	Not checked		
UE capability indication	Not checked		
MBMS Selected Services	Not checked		
Support for F-DPCH	Not checked		
UE Mobility State Indicator	Not Present		
Support for Enhanced F-DPCH	Not checked		
HS-PDSCH in CELL_FACH	Not checked		
MAC-ehs support	Not checked		
DPCCH Discontinuous Transmission support	Not checked		
Support of common E-DCH	Not checked	REL-8	
Multi cell support	Not checked	REL-8	
Pre-redirectio n info	Not checked	REL-8	
Support of MAC-i/is	Not checked	REL-8	
Support of SPS operation	Not checked	REL-8	
Support for CS Voice over HSPA	Not checked	REL-8	
Dual cell MIMO support	Not checked	REL-9	
System Information Container Stored Indicator	Not checked	REL-9	

Measured results on RACH	Not checked		
Access stratum release indicator	Not checked		

– SECURITY MODE COMMAND

Table 4.7B.1-n: SECURITY MODE COMMAND

Derivation Path: 25.331, clause 10.2.43			
Information Element	Value/remark	Comment	Condition
FFS			

– SECURITY MODE COMPLETE

Table 4.7B.1-n: SECURITY MODE COMPLETE

Derivation Path: 25.331, clause 10.2.44			
Information Element	Value/remark	Comment	Condition
FFS			

– UTRAN MOBILITY INFORMATION

Table 4.7B.1-n: UTRAN MOBILITY INFORMATION

Derivation Path: 34.108 clause 9.1.1 (UTRAN MOBILITY INFORMATION message)			
Information Element	Value/remark	Comment	Condition
UTRAN MOBILITY INFORMATION			
CN information info			
- PLMN identity	Not present		
- CN common GSM-MAP NAS system information			
- GSM-MAP NAS system information	00 01H		
- CN domain related information			
- CN domain identity	PS		
- CN domain specific NAS system information			
- GSM-MAP NAS system information	01 00H		
- CN domain specific DRX cycle length coefficient	7		
- CN domain identity	CS		
- CN domain specific NAS system information			
- GSM-MAP NAS system information	1E 01H		
- CN domain specific DRX cycle length coefficient	7		

– UTRAN MOBILITY INFORMATION CONFIRM

Table 4.7B.1-n: UTRAN MOBILITY INFORMATION CONFIRM

Derivation Path: 34.108 clause 9.1.1 (UTRAN MOBILITY INFORMATION CONFIRM message)

4.7B.2 UTRA NAS messages

This section contains default message contents for UTRA NAS messages.

In 3GPP TS 36.523-1 [18]:

- UTRA NAS messages are defined as exceptions, IE by IE, to the messages defined in this section;
- UTRA NAS messages not defined in this section are specified completely.

The following messages are not specified in this section:

- AUTHENTICATION REQUEST (CS)
- AUTHENTICATION RESPONSE (CS)
- DETACH REQUEST (CS & PS)
- DETACH ACCEPT (CS & PS)
- IDENTITY REQUEST (CS & PS)
- IDENTITY RESPONSE (CS & PS)
- P-TMSI REALLOCATION COMMAND (PS)
- P-TMSI REALLOCATION COMPLETE (PS)
- SERVICE REQUEST (PS)

Table 4.7B.2-1: ROUTING AREA UPDATE REQUEST

Derivation path: 24.008 table 9.4.14			
Information Element	Value/Remark	Comment	Condition
Update type	000 'RA updating' or 001 'combined RA/LA updating' 010 'combined RA/LA updating with IMSI attach'	In NMO I, depending on capability and domain preference for voice and SMS, the UE may initiate either PS only or CS/PS registration procedures.	
GPRS ciphering key sequence number	Any allowed value		
Old routing area identification	Any allowed value		
MS Radio Access capability	Any allowed value	The checking of this IE is expected to be covered in UMTS test cases.	
Old P-TMSI signature	Not present or any allowed value	For test cases where no "UE" statement indicates that a P-TMSI signature was previously registered, whether or not the UE includes this IE depends on previous USIM contents.	
Requested READY timer value	Not present or any allowed value	The checking of this IE is expected to be covered in UMTS test cases.	
DRX parameter	Not present or any allowed value	The checking of this IE is expected to be covered in UMTS test cases.	
TMSI status	0 'no valid TMSI available' or not present		
P-TMSI	Not present or any allowed value		
MS network capability	Any allowed value	The checking of this IE is expected to be covered in UMTS test cases.	
PDP context status	Any allowed value	The checking of this IE is expected to be covered in UMTS test cases.	
PS LCS Capability	Not present or any allowed value	The checking of this IE is expected to be covered in UMTS test cases.	
MBMS context status	Not present		
UE network capability	Any allowed value (must be present)	No detailed checking by default but should be aligned with PICS	
Additional mobile identity	Not present or any allowed value		
Additional old routing area identification	Not present or any allowed value		

Mobile station classmark 2	Not present or any allowed value	This IE shall be included if the MS supports SRVCC to GERAN or UTRAN.	
Mobile station classmark 3	Not present or any allowed value	This IE shall be included if the MS supports SRVCC to GERAN.	
Supported Codecs	Not present or any allowed value		
Voice domain preference and UE's usage setting	Not present or any allowed value	Rel-9	
P-TMSI type	Any allowed value	Rel-10	

Table 4.7B.2-2: ROUTING AREA UPDATE ACCEPT

Derivation path: 24.008 table 9.4.15			
Information Element	Value/Remark	Comment	Condition
Force to standby	0 'Force to standby not indicated'		
Update result	000 'RA updated'		IF the UE indicated 000 'RA updating' in the previous RAU request message
	001 'combined RA/LA updated'		IF the UE indicated 001 'combined RA/LA updating' in the previous RAU request message
	1 'No follow-on proceed'		
Periodic RA update timer	111 (deactivated)		
Routing area identification	1	Value in table 4.4.4-2 for simulated UTRA cells.	
P-TMSI signature	Arbitrary value		
Allocated P-TMSI	Arbitrary value	2 most significant bits = 11 to indicate SGSN	
MS identity	Not present	Is never present in case of RA only procedure, and RA/LA procedures do not necessarily change TMSI	
List of Receive N PDU Numbers	Not present	Realistic network value	
Negotiated READY timer value	Not present		
GMM cause	Not present		
T3302 value	Not present		
Cell Notification	Not present	This IE is for A/Gb mode only.	
Equivalent PLMNs	Not present		
PDP context status	Same value as the one received in the RAU request message		UTRAN
PDP context status	0	NSAPI(0) - NSAPI(15) is set to 0, which means that the SM state of all PDP contexts is PDP-INACTIVE	GERAN
Network feature support	Not present		
Emergency Number List	Not present		
MBMS context status	Not present		
Requested MS Information	Not present		
T3319 value	Not present		
T3323 value	Not present		

Condition	Explanation
UTRAN	UTRAN cell environment
GERAN	GERAN cell environment

Table 4.7B.2-3: ROUTING AREA UPDATE COMPLETE

Derivation path: 24.008 table 9.4.16			
Information Element	Value/Remark	Comment	Condition
List of Receive N PDU Numbers	Not present		
Inter RAT handover information	Not present		
E-UTRAN inter RAT handover information	Not present		

Table 4.7B.2-4: LOCATION UPDATING REQUEST

Derivation path: 24.008 table 9.2.17			
Information Element	Value/Remark	Comment	Condition
Location updating type	Any allowed value		
Ciphering key sequence number	Any allowed value		
Location area identification	Any allowed value		
Mobile station classmark	Any allowed value		
Mobile identity	Any allowed value		
Mobile station classmark for UMTS	Any allowed value		
Additional update parameters	Not present or any allowed value		

Table 4.7B.2-5: LOCATION UPDATING ACCEPT

Derivation path: 24.008 table 9.2.15			
Information Element	Value/Remark	Comment	Condition
Location area identification	1		
Mobile identity			
TMSI	Arbitrary value	2 most significant bits = 00 to indicate VLR	
Follow on proceed	Present	This IE is unnecessary in non-CS fallback test cases.	
CTS permission	Absent		
Equivalent PLMNs	Absent		
Emergency Number List	Absent		

Table 4.7B.2-6: ATTACH REQUEST

Derivation path: 24.008 table 9.4.1			
Information Element	Value/Remark	Comment	Condition
MS network capability	Any allowed value		
Attach type	001 'GPRS attach' or 011 'Combiner GPRS/IMS attach'		
GPRS ciphering key sequence number	Any allowed value		
DRX parameter	Any allowed value		
P-TMSI or IMSI	Any allowed value		
Old routing area identification	Any allowed value		
MS Radio Access capability	Any allowed value		
Old P-TMSI signature	Not present or any allowed value		
Requested READY timer value	Not present or any allowed value		
TMSI status	0 'no valid TMSI available' or not present		
PS LCS Capability	Not present or any allowed value		
Mobile station classmark 2	Not present or any allowed value		
Mobile station classmark 3	Not present or any allowed value		
Supported Codecs	Not present or any allowed value		
UE network capability	Any allowed value (must be present)		
Additional mobile identity	Not present or any allowed value		
Additional old routing area identification	Not present or any allowed value		
Voice domain preference and UE's usage setting	Not present or any allowed value	Rel-9	
P-TMSI type	Not present or any allowed value	Rel-10	

Table 4.7B.2-7: ATTACH ACCEPT

Derivation path: 24.008 table 9.4.2			
Information Element	Value/Remark	Comment	Condition
Attach result	001 'GPRS only attached'		IF the UE indicated 001 'GPRS attach' in the previous attach request message
	011 'combined GPRS/IMSI attached'		IF the UE indicated 011 'Combined GPRS/IMS I attach' in the previous attach request message
Force to standby	000 'Force to standby not indicated'		
Periodic RA update timer	111 (deactivated)		
Radio priority for SMS	100 'priority level 4 (lowest)'		
Radio priority for TOM8	100 'priority level 4 (lowest)'		
Routing area identification	1		
P-TMSI signature	Arbitrary value		
Negotiated READY timer value	Not present		
Allocated P-TMSI	Arbitrary value	2 most significant bits = 11 to indicate SGSN	
MS identity	Not present		IF the UE indicated 001 'GPRS attach' in the previous attach request message
	Arbitrary value	2 most significant bits = 00 to indicate VLR	IF the UE indicated 011 'Combined GPRS/IMS I attach' in the previous attach request message
GMM cause	Not present		
T3302 value	Not present		
Cell Notification	Not present		
Equivalent PLMNs	Not present		
Network feature support	Not present		
Emergency Number List	Not present		
Requested MS Information	Not present		
T3319 value	Not present		
T3323 value	Not present		

Table 4.7B.2-8: ATTACH COMPLETE

Derivation path: 24.008 table 9.4.3			
Information Element	Value/Remark	Comment	Condition
Inter RAT handover information	Not present		
E-UTRAN inter RAT handover information	Not present		

Table 4.7B.2-9: AUTHENTICATION AND CIPHERING REQUEST

Derivation path: 24.008 table 9.4.9			
Information Element	Value/Remark	Comment	Condition
Ciphering algorithm	Any allowed value		
IMEISV request	000 'IMEISV not requested'		
Force to standby	000 'Force to standby not indicated'		
A&C reference number	Any allowed value		

Table 4.7B.2-10: AUTHENTICATION AND CIPHERING RESPONSE

Derivation path: 24.008 table 9.4.10			
Information Element	Value/Remark	Comment	Condition
A&C reference number	Arbitrary value		
Spare half octet	0000		

Table 4.7B.2-11: TMSI REALLOCATION COMMAND

Derivation path: 24.008 table 9.2.20			
Information Element	Value/Remark	Comment	Condition
Location area identification	Any allowed value		
Mobile identity	Any allowed value		

Table 4.7B.2-12: TMSI REALLOCATION COMPLETE

Derivation path: 24.008 table 9.2.21			
--------------------------------------	--	--	--

Table 4.7B.2-13: CM SERVICE REQUEST

Derivation path: 24.008 table 9.2.11			
Information Element	Value/Remark	Comment	Condition
CM service type	Any allowed value		
Ciphering key sequence number	Any allowed value		
Mobile station classmark	Any allowed value		
Mobile identity	Any allowed value		
Priority	Not present or any allowed value		
Additional update parameters	Not present or any allowed value		

4.7C Default DS-MIPv6 message and information element contents

4.7C.1 IKEv2 messages

- IKEv2 IKE_SA_INIT Request

This message is sent by the UE to the SS.

Table 4.7C.1-1: Message IKE_SA_INIT Request

Field	Value/remark	Comment	Condition
IKE Header			
Initiator's IKE_SA SPI	Set by the UE		
Responder's IKE_SA SPI	0	First message in IKE_SA_INIT exchange	
Next Payload	'00100001'B	SA	
Exchange Type	'00100010'B	IKE_SA_INIT	
Security Association Payload			
Next Payload	'00100010'B	KE	
More proposal	'00000010'B		
Proposal #	'00000001'B	First cryptographic suite (section 6.5 of TS 33.234)	
Protocol ID	'00000001'B	IKE	
SPI size	'00000000'B		
Number of transforms	'00000010'B		
More transform	'00000011'B	This is the transform for confidentiality	
Transform type	'00000001'B	Encryption	
Transform ID	'00000011'B	3DES in CBC mode (ENCR_3DES)	
More transform	'00000011'B	This is the transform for prf	
Transform type	'00000010'B	PRF	
Transform ID	'00000010'B	PRF_HMAC_SHA1 (HMAC-SHA1)	
More transform	'00000011'B	This is the transform for integrity	
Transform type	'00000011'B	Integrity	
Transform ID	'00000010'B	HMAC-SHA1-96 (AUTH_HMAC_SHA1_96)	
Last transform	'00000000'B	This is the transform for DH	
Transform type	'00000100'B	DH	
Transform ID	'00000010'B	Diffie-Hellman group 2 (1024-bit MODP)	
Last proposal	'00000000'B		
Proposal #	'00000010'B	Second cryptographic suite (section 6.5 of TS 33.234)	
Protocol ID	'00000001'B	IKE	
SPI size	'00000000'B		
Number of transforms	'00000010'B		
More transform	'00000011'B	This is the transform for confidentiality	
Transform type	'00000001'B	Encryption	
Transform ID	'00001011'B	AES with 128-bit keys in CBC mode (ENCR_AES_CBC)	
More transform	'00000011'B	This is the transform for prf	
Transform type	'00000010'B	PRF	
Transform ID	'00000100'B	PRF_AES128_XCBC_AES-XCBC-PRF-128	

More transform	'00000011'B	This is the transform for integrity	
Transform type	'00000011'B	Integrity	
Transform ID	'00000101'B	AES-XCBC-MAC-96 (AUTH_AES-XCBC -96)	
Last transform	'00000000'B	This is the transform for DH	
Transform type	'00000100'B	DH	
Transform ID	'00000010'B	Diffie-Hellman group 2 (1024-bit MODP)	
Key Exchange Payload			
Next Payload	'00101000'B	Nonce	
DH Group #	'0000000000000010'B	DH group 2	
Key Exchange data	Set by the UE		
Nonce Payload			
Next Payload	'00101001'B	Notify	UE IKE INIT HA
Nonce data	Random number set by the UE		
REDIRECT_SUPPORTED Notify Payload			UE IKE INIT HA
Next Payload	'00000000'B	No Next Payload	UE IKE INIT HA
Protocol ID	'00000000'B	Notification is not specific to a particular security association	UE IKE INIT HA
SPI size	'00000000'B	SPI field not present	UE IKE INIT HA
Notify Message Type	'0100000000010110'B	REDIRECT_SUPPORTED	UE IKE INIT HA
REDIRECT_FROM Notify Payload			UE IKE INIT HA Redirected
Next Payload	'00000000'B	No next payload	UE IKE INIT HA Redirected
Protocol ID	'00000000'B	Notification is not specific to a particular security association	UE IKE INIT HA Redirected
SPI size	'00000000'B	SPI field not present	UE IKE INIT HA Redirected
Notify Message Type	'0100000000010110'B	REDIRECT_FROM	UE IKE INIT HA Redirected
GW Ident Type	Any allowed value (IPv6 or IPv4 or HA FQDN)	Set depending on how the UE has discovered the HA in the preamble	UE IKE INIT HA Redirected
New Responder GW Identity	Depends on GW Ident type		UE IKE INIT HA Redirected

Condition	Explanation
UE IKE INIT HA	Part of IKE_INIT_SA request message sent to HA only
UE IKE INIT HA Redirected	Part of IKE_INIT_SA request message sent to HA only after a REDIRECT payload was received in a previous IKEV2 messages exchange

- IKE_SA_INIT Response

This message is sent by the SS to the UE.

Table 4.7C.1-2: Message IKE_SA_INIT Response

Field	Value/remark	Comment	Condition
IKE Header			
Initiator's IKE_SA SPI	Same as that set by the UE in IKE_SA_INIT request		
Responder's IKE_SA SPI	Set by the SS		
Next Payload	'00100001'B	SA	
Exchange Type	'00100010'B	IKE_SA_INIT	
Security Association Payload			
Next Payload	'00100010'B	KE	
Proposal	One of the 2 proposals included in IKE_SA_INIT at Step 1		
Key Exchange Payload			
Next payload	'00 101000'B	Nonce	
DH Group #	'0000000000000010'B	DH group 2	
Key Exchange data	Set by the SS		
Nonce Payload			
Next t payload	'00000000'B	No Next Payload	
Nonce data	Set by the SS		

- IKE_AUTH_Request

This message is sent by the UE to the SS.

Table 4.7C.1-3: Message IKE_AUTH Request

Field	Value/remark	Comment	Condition
IKE Header			
Initiator's IKE_SA SPI	Same as that set by the UE in IKE_INIT_SA Request		
Responder's IKE_SA SPI	Same as that set by the SS in IKE_INIT_SA Response		
Next Payload	'00101110'B	E	
Exchange Type	'00100011'B	IKE_AUTH	
Encrypted Payload			
Next Payload	'00100011'B	IDi	UE IKE AUTH1
Initialization Vector	Random value set by the UE		UE IKE AUTH1
Encrypted IKE Payloads			UE IKE AUTH1
Identification – Initiator Payload			UE IKE AUTH1
Next Payload	'00101111'B	CP	UE IKE AUTH1
ID Type	00000010B		UE IKE AUTH1
ID	Set to MN-NAI		UE IKE AUTH1
Configuration Payload			UE IKE AUTH1
Next Payload	'00100001'B	SA	UE IKE AUTH1
CFG Type	'00000001'B	Request	UE IKE AUTH1
Configuration Attribute	'00010000'B	MIP6_HOME_PR EFIX attribute	UE IKE AUTH1 HA
Length	'0000000000000000'B		UE IKE AUTH1 HA
Security Association Payload			UE IKE AUTH1
Next Payload	'00101100'B	TSi	UE IKE AUTH1
Proposals	Any set of allowed values		UE IKE AUTH1
Traffic Selector – Initiator Payload			UE IKE AUTH1
Next Payload	'00101100'B	TSr	UE IKE AUTH1
Traffic selector data	Any allowed set of values		UE IKE AUTH1
Traffic Selector – Responder Payload			UE IKE AUTH1
Next Payload	'00100100'B	IDr	UE IKE AUTH1
Traffic selector data	Any allowed set of values		UE IKE AUTH1
Identification – Responder Payload			UE IKE AUTH1
Next Payload	'00000000'B	No Next Payload	UE IKE AUTH1
ID Type	'00000010'B		UE IKE AUTH1
ID	APN		UE IKE AUTH1
Next Payload	'00110000'B	EAP	UE IKE AUTH2
Initialization Vector	Random value set by the UE		UE IKE AUTH2
Encrypted IKE Payloads			UE IKE AUTH2

Extensible Authentication Payload			UE IKE AUTH2
Next Payload	'00000000'B	No Next Payload	UE IKE AUTH2
Code	'00000010'B	Response	UE IKE AUTH2
Type	'00010111'B	AKA	UE IKE AUTH2
Subtype		AKA-Challenge	UE IKE AUTH2
Attribute type	'00000011'B	AT_RES	UE IKE AUTH2
AT_RES	See TS 24.301 [28] subclause 9.9.3.4		UE IKE AUTH2
Next Payload	'00100111'B	AUTH	UE IKE AUTH3
Initialization Vector	Random value set by the UE		UE IKE AUTH3
Encrypted IKE Payloads			UE IKE AUTH3
Authentication Payload			UE IKE AUTH3
Next Payload	'00000000'B	No Next Payload	UE IKE AUTH3
Auth Method	'00000010'B	Shared Key Integrity code	UE IKE AUTH3
Auth Data	derived from the MSK obtained from AKA exchange	RFC 4306 defines the function to derive this key (section 2.15)	UE IKE AUTH3
Padding	Set by the UE	Fields from Encrypted payload	
Pad Length	Set by the UE	Fields from Encrypted payload	
Integrity checksum data	Set by the UE	Fields from Encrypted payload	

Condition	Explanation
UE IKE AUTH1	Part of IKE_AUTH request message sent to HA or ePDG after the reception of IKE_INIT_SA response
UE IKE AUTH1 HA	Part of IKE_AUTH request message sent to HA after the reception of IKE_INIT_SA response
UE IKE AUTH2	Part of IKE_AUTH request message sent to HA or ePDG after the reception of IKE_SA response message containing the certificate payload CERT
UE IKE AUTH3	Part of IKE_AUTH request message sent to HA or ePDG after the reception of IKE_SA response containing EAP and encryption payloads only

- IKE_AUTH Response

This message is sent by the SS to the UE.

Table 4.7C.1-4: Message IKE_AUTH Response

Field	Value/remark	Comment	Condition
IKE Header			
Initiator's IKE_SA SPI	Same as that set by the UE in IKE_SA_INIT request		
Responder's IKE_SA SPI	Same as that set by the SS in IKE_SA_INIT response		
Next Payload	'00101110'B	E	
Exchange Type	'00100011'B	IKE_AUTH	
Encrypted Payload			
Next Payload	'00100100'B	IDr	SS IKE AUTH1
Initialization Vector	Set by the SS		SS IKE AUTH1
Encrypted IKE Payloads			SS IKE AUTH1
Identification – Responder Payload			SS IKE AUTH1
Next Payload	'00100101'B	CERT	SS IKE AUTH1
ID Type	'00000010'B		SS IKE AUTH1
ID	APN		SS IKE AUTH1
Certificate Payload			SS IKE AUTH1
Next Payload	'00110000'B	EAP	SS IKE AUTH1
Cert encoding	'00000100'B	X.509 certificate - signature	SS IKE AUTH1
Certificate data	Set by the SS	DER encoded X.509 certificate	SS IKE AUTH1
Extensible Authentication Payload			SS IKE AUTH1
Next Payload	'00000000'B	No Next Payload	SS IKE AUTH1
Code	'00000001'B	Request	SS IKE AUTH1
Type	'00010111'B	AKA	SS IKE AUTH1
Subtype		AKA-Challenge	SS IKE AUTH1
Attribute type	'00000001'B	AT_RAND	SS IKE AUTH1
AT_RAND	An arbitrarily selected 128 bits value		SS IKE AUTH1
Attribute Type	'00000010'B	AT_AUTN	SS IKE AUTH1
AT_AUTN	See TS 24.301 [28] subclause 9.9.3.2		SS IKE AUTH1
Next Payload	'00110000'B	EAP	SS IKE AUTH2
Initialization Vector	Set by the SS		SS IKE AUTH2
Encrypted IKE Payloads			SS IKE AUTH2
Extensible Authentication Payload			SS IKE AUTH2
Next Payload	'00000000'B	No Next Payload	SS IKE AUTH2
Code	'00000011'B	Success	SS IKE AUTH2
Next Payload	'00101111'B	CP	SS IKE AUTH3
Auth Method	'00000010'B	Shared Key Integrity code	SS IKE AUTH3

Auth Data	derived from the MSK obtained from AKA exchange	RFC 4306 defines the function to derive this key (section 2.15)	SS IKE AUTH3
Configuration Payload			SS IKE AUTH3
Next Payload	'00100001'B	SA	SS IKE AUTH3
CFG Type	'00000010'B	Reply	SS IKE AUTH3
Configuration Attribute	'00010000'B	MIP6_HOME_PR EFIX attribute	SS IKE AUTH3 HA
Length	'0000000000010101'B		SS IKE AUTH3 HA
Prefix lifetime	Any allowed value		SS IKE AUTH3 HA
Home Prefix	IPv6 prefix – 16 bytes		SS IKE AUTH3 HA
Prefix length	'10000000'B	Prefix length must be 64	SS IKE AUTH3 HA
Notify Payload			SS IKE AUTH3 HA redirect
Next Payload	'00100001'B	SA	SS IKE AUTH3 HA redirect
Protocol ID	'00000000'B	Notification is not specific to a particular security association	SS IKE AUTH3 HA redirect
SPI Size	'00000000'B	SPI field not present	SS IKE AUTH3 HA redirect
Notify Message Type Length	'0100000000010111'B	REDIRECT	SS IKE AUTH3 HA redirect
GW Ident Type	'00000101'B		SS IKE AUTH3 HA redirect
New Responder GW Identity	IPv6 address of the HA to relocate		SS IKE AUTH3 HA redirect
GW Ident Type	'00000001'B		SS IKE AUTH3 HA redirect
New Responder GW Identity	IPv4 address of the HA to relocate	Optional	SS IKE AUTH3 HA redirect
Security Association Payload			SS IKE AUTH3
Next Payload	'00101101'	TSi	SS IKE AUTH3
Proposal	One of the 2 proposals included in IKE_AUTH Request at Step 3		SS IKE AUTH3
Traffic Selector – Initiator Payload			SS IKE AUTH3
Next Payload	'00101100'B	TSr	SS IKE AUTH3
Traffic Selector data	Any allowed set of values		SS IKE AUTH3
Traffic Selector – Responder Payload			SS IKE AUTH3
Next Payload	'00000000'B	No Next Payload	SS IKE AUTH3

Padding	Set by the SS	Fields from Encryption payload	
Pad Length	Set by the SS	Fields from Encryption payload	
Integrity checksum data	Set by the SS	Fields from Encryption payload	

Condition	Explanation
SS IKE AUTH1	Part of IKE_AUTH request message sent to the UE as part of the first IKE_AUTH Response message
SS IKE AUTH2	Part of IKE_AUTH request message sent to the UE as part of the second IKE_AUTH Response message
SS IKE AUTH3	Part of IKE_AUTH request message sent to the UE as part of the third IKE_AUTH Response message
SS IKE AUTH3 HA	Part of IKE_AUTH request message sent to the UE as part of the third IKE_AUTH Response message when the UE interacts with HA
SS IKE AUTH3 HA_redirect	Part of IKE_AUTH request message sent to the UE as part of the third IKE_AUTH Response message when the UE interacts with HA and the UE gets redirected

4.7C.2 Messages used to perform DS-MIPv6 registration and deregistration

- Router Advertisement

This message is sent by the SS to the UE.

Table 4.7C.2-1: Message Router Advertisement

Field	Value/remark	Comment	Condition
Type	'10000110'B		
Code	'00000000'B		
Checksum	Set by SS	ICMP checksum	
Cur Hop Limit	'00000000'B	Unspecified	
M	Set by the SS		
O	Set by the SS	Depends on access network specific settings	
H	'0'B		
Prf	Set by the SS	Depends on access network specific settings	
Prf	Set by the SS	Depends on access network specific settings	
P	Set by the SS	Depends on access network specific settings	
Reserved	'00000'B		
Router Lifetime	Set by the SS		
Reachable Time	Set by the SS		
Retrans Timer	Set by the SS		
type	'00000011'B	Prefix Information Option	
Length	'00000100'B		
Prefix length	Set by the SS		
L	'1'B		
A	Set by the SS		
Valid Lifetime	Set by the SS		
Preferred Lifetime	Set by the SS		
Prefix	Set as per specific message content		

- Binding Update

This message is sent by the UE to the SS.

Table 4.7C.2-2: Message Binding Update

Information Element	Value/remark	Comment	Condition
IPv4 Source Address	UE IPv4 CoA (IPv4 address acquired by UE during network attachment)		UE IPv4
IPv4 Destination Address	IPv4 of Home Agent discovered during preamble		UE IPv4
UDP header			UE IPv4
Source Port	Set by UE		UE IPv4
Destination port	'0001000001011111'B		UE IPv4
IPv6 Source Address	UE IPv6 CoA (IPv6 address acquired by the UE during network attachment)		IPv6 visited
	IPv6 Home Address configured by the UE from Home Network Prefix assigned to UE during preamble		UE IPv6-home, UE IPv4
IPv6 Destination Address	IPv6 of Home Agent discovered during preamble		
Destination Header	IPv6 Home Address configured by the UE from Home Network Prefix assigned to the UE during preamble		IPv6 visited
Payload Proto	'00111011'B		
MH Type	'00000101'B	Binding Update message	
Sequence Number	Any allowed value		
Lifetime	Any allowed non-zero value		IPv6 visited
	'0000000000000000'B		UE IPv6-home
A	'1'B		
H	'1'B		
L	Not checked		
K	'1'B		
M	'0'B		
R	'1'B		
P	'0'B		
F	'0'B		
IPv4 Home Address option	Set to the value "0.0.0.0" to request allocation for the UE. The "P" flag is set to '0'B. The Prefix Length is set to the requested prefix length of '32'.	Optional	
Alternate Care-of Address option	Same IPv6 address as that inserted in the IP Source Address field		UE IPv6-visited

Condition	Explanation
-----------	-------------

UE IPv4	UE is in an IPv4 visited network (see RFC 5555)
UE IPv6-home	UE is in an IPv6 home network (see RFC 5555)
UE IPv6-visited	UE is in an IPv6 visited network (see RFC 5555)

- Binding Acknowledgement

This message is sent by the SS to the UE.

Table 4.7C.2-3: Message Binding Acknowledgement

Information Element	Value/remark	Comment	Condition
IPv4 Source Address	IPv4 Home Agent address		UE IPv4
IPv4 Destination Address	Same value as UE IPv4 CoA in IP Source Address from Binding Update		UE IPv4
UDP header			UE IPv4
Source Port	'0001000001011111'B		UE IPv4
Destination port	Same as Source port in Binding Update		UE IPv4
IPv6 Source Address	IPv6 Home Agent address		
IPv6 Destination Address	Same value as UE IPv6 CoA in IP Source Address from Binding Update		UE IPv6-visited
	IPv6 Home Address		UE IPv6-home, UE IPv4
Routing Header	Same value as UE IPv6 Home Address in Destination Header from Binding Update		UE IPv6-visited
Payload Proto	'00111011'B		
MH Type	'00000110'B	Binding Acknowledgement message	
Status	'00000000'B	Binding Update accepted	
K	Set by the SS		
R	'1'B		
P	'0'B		
Sequence Number	Same value as that sent by the UE in the Binding Update		
Lifetime	'0000000010010110'B	10 min	UE IPv6-visited, UE IPv4
	'0000000000000000'B		UE IPv6-home
IPv4 Address Acknowledgement option	IPv4 Home Address allocated to the UE	Present if IPv4 Home Address option was included by the UE in Binding Update	
Binding Refresh Advice option	'0000000010010110'B	10 min	

Condition	Explanation
UE IPv4	UE is in an IPv4 visited network (see RFC 5555)
UE IPv6-home	UE is in an IPv6 home network (see RFC 5555)
UE IPv6-visited	UE is in an IPv6 visited network (see RFC 5555)

- Binding Revocation Indication

This message is sent by the SS to the UE.

Table 4.7C.2-4: Binding Revocation Indication

Field	Value/remark	Comment	Condition
IPv4 Header			UE IPv4
IPv4 Source Address	UE IPv4 Home Agent address		UE IPv4
UDP header			UE IPv4
Source Port	Set by SS		UE IPv4
Destination port	'0001000001011111'B		UE IPv4
IPv6 Header			
IPv6 Source Address	IPv6 Home Agent address		
IPv6 Destination Address	IPv6 Home Address configured by UE from Home Network Prefix assigned to UE during preamble		UE IPv4
	IPv6 CoA		UE IPv6-visited
Routing Header	IPv6 Home Address configured by the UE from Home Network Prefix assigned to the UE during preamble		UE IPv6-visited
B.R. Type	'00000001'B	B.R.I	
Sequence Number	Set by the SS		
Revocation Trigger	'00000001'B		
P	'0'B		
G	'0'B		
V	'0'B		

Condition	Explanation
UE IPv4	UE is in an IPv4 visited network (see RFC 5555)
UE IPv6-visited	UE is in an IPv6 visited network (see RFC 5555)

- Binding Revocation Acknowledgement

This message is sent by the UE to the SS.

Table 4.7C.2-5: Binding Revocation Acknowledgement

Information Element	Value/remark	Comment	Condition
IPv4 Header			UE IPv4
IPv4 Source Address	IPv4 CoA		UE IPv4
IPv4 Destination Address	UE IPv4 Home Agent Address		UE IPv4
UDP header		UDP header	UE IPv4
Source Port	'0001000001011111'B	Source Port	UE IPv4
Destination port	Same as Source port in Binding Revocation	Destination port	UE IPv4
IPv6 Header			
IPv6 Source Address	IPv6 Home Address configured by UE		UE IPv4
	IPv6 CoA		UE IPv6-visited
IPv6 Destination Address	IPv6 of Home Agent address	IPv6 Destination Address	
Destination Header	IPv6 Home Address configured by the UE		UE IPv6-visited
B.R. Type	'00000010'B	B.R.A	
Sequence Number	Same value as Sequence Number sent by the SS in Binding Revocation		
Status	'00000000'B	Success	
P	'0'B		
G	'0'B		
V	'0'B		

Condition	Explanation
UE IPv4	UE is in an IPv4 visited network (see RFC 5555)
UE IPv6-visited	UE is in an IPv6 visited network (see RFC 5555)

4.7D Default GERAN message and information element contents

4.7D.1 GPRS message

– PS HANDOVER COMMAND

Table 4.7D.1-1: PS HANDOVER COMMAND

Derivation Path: 44.060 clause 11.2.43.1			
Information Element	Value/remark	Comment	Condition
PAGE_MODE	Default		
Global TFI	TFI of mobile station uplink TBF		
CONTAINER_ID	00		
PS Handover to A/Gb Mode Payload	00	PS Handover RR Info	
PS Handover RR Info flag	00		
PS Handover Radio Resources IE	Present		
Handover Reference	0		
ARFCN	default ARFCN for BCCH of GERAN cell		
SI	00	Non-synchronized	
NCI	0		
BSIC	BSIC of GERAN cell		
0 <CCN_ACTIVE>	not present		
0 <3G_CCN_ACTIVE>	not present		
0 <CCN Support Description>	not present		
Frequency Parameters	default PDTCH of GERAN cell		
NETWORK_CONTROL_ORDER	2		
0 <Global Packet Timing Advance>	not present		
EXTENDED_DYNAMIC_ALLOCATION	0		
RLC_RESET	1	RLC is reset	
0 <PO>	not present		
0 <Uplink Control Timeslot>	not present		
0 GPRS mode	Uplink TBF assignment for default PDTCH of GERAN cell		
0 <NAS Container for PS Handover IE>	not present		

4.7E Default HTTP messages for communication with the ProSe Function

- HTTP Request

This message is sent by the UE to the SS.

Table 4.7E-1: HTTP Request

Header/param	Value/remark	Comment	Condition
Request-Line Method Request-URI Version	"POST" Request-URI "HTTP 1.1"		
Content-Type media-type	"application/3gpp-prose+xml"		
Content-Length value	length of the message body		
Message-body	PC3 Control Protocol messages		
Note: HTTP request may contain further headers which are ignored.			

- HTTP Response

This message is sent by the SS to the UE.

Table 4.7E-2: HTTP Response

Header/param	Value/remark	Comment	Condition
Status-Line Version Code Reason	"HTTP 1.1" 200 "OK"		
Content-Type media-type	"application/3gpp-prose+xml"		
Content-Length value	length of the message body		
Message-body	PC3 Control Protocol messages		

4.7F Default ProSe messages

4.7F.1 ProSe discovery messages

- DISCOVERY_REQUEST

This message is sent by the UE to the SS.

Table 4.7F.1-1: DISCOVERY_REQUEST

Derivation path: 24.334 [57], clause 11.2.4.2.			
Information Element	Value/remark	Comment	Condition
discovery-request[1] {			
transaction-ID	Any allowed value		
command	2	monitor	
	1	announce	
UE-identity	IMSI		
ProSe-Application-ID	px_ProSeMonApplication Identity1		
application-identity	Any allowed value		
}			
...			
discovery-request[N]{} 	Any allowed value if present	A UE can include one or multiple transactions in one DISCOVERY_REQUEST message for one or more ProSe Application IDs	

- DISCOVERY_RESPONSE

This message is sent by the SS to the UE.

Table 4.7F.1-2: DISCOVERY_RESPONSE

Derivation path: 24.334 [57], clause 11.2.4.3.			
Information Element	Value/remark	Comment	Condition
Current-time	Current UTC time		
Max-Offset	32	32 seconds	
response-announce[1] {			
transaction-ID	Same as that included by UE in the relevant DISCOVERY_REQUEST message and the relevant discovery-request		
ProSe Application Code[1] {		184 bits See TS 23.003 [2], section 24.3.	
PLMN ID {		24 bits The PLMN ID of the ProSe Function that assigned the ProSe Application Code, i.e. Mobile Country Code (MCC) and Mobile Network Code (MNC).	
Scope	'10'	"country-specific scope", i.e. only MNC is wild carded	
Spare	'0'		
E	'1'	For Rel-12 MCC and the MNC of the ProSe Function that has assigned the ProSe Application Code are included in the PLMN ID in ProSe Application Code	
MCC	The MCC part of the The PLMN ID of the ProSe Function that assigned the ProSe Application Code (the relevant PLMN will be set in the TC)	fixed length of 10 bits and shall be coded as the binary representation of their decimal value	
MNC	The MNC part of the The PLMN ID of the ProSe Function that assigned the ProSe Application Code (the relevant PLMN will be set in the TC)	fixed length of 10 bits and shall be coded as the binary representation of their decimal value	
}			
TemporaryID	1111111100000000 0000000000000000 0000000000000000 0000000000000000 0000000000000000 0000000000000000 0000000000000000 0000000000000000 0000000000000000 0000000011111111	160 bits - see setting of bit 'E' above. A temporary identity that corresponds to the ProSe Application ID Name.	
}			

validity-timer-T4000	5	Indicating the time during which the Application Code is valid Integer in the 1-525600 range representing the timer value in unit of minutes	
discovery-key	1000100000001000 0100010000001000 0010001000001000 0001000100001000 0000100010001000 0000010001001000 0000001000101000 0000000100011000	128-bit As defined in TS 33.303 [60] and TS 33.220 [61]	
}			
response-monitor[1] {			
transaction-ID	Same as that included by UE in the relevant DISCOVERY_REQUEST message and the relevant discovery-request		
discovery-filter[1] {			
ProSe Application Code {		184 bits See TS 23.003 [2], section 24.3.	
PLMN ID {		24 bits The PLMN ID of the ProSe Function that assigned the ProSe Application Code, i.e. Mobile Country Code (MCC) and Mobile Network Code (MNC).	
Scope	'10'	"country-specific scope", i.e. only MNC is wild carded	
Spare	'0'		
E	'1'	For Rel-12 MCC and the MNC of the ProSe Function that has assigned the ProSe Application Code are included in the PLMN ID in ProSe Application Code	
MCC	The MCC part of the The PLMN ID of the ProSe Function that assigned the ProSe Application Code (the relevant PLMN will be set in the TC)	fixed length of 10 bits and shall be coded as the binary representation of their decimal value	

MNC	The MNC part of the The PLMN ID of the ProSe Function that assigned the ProSe Application Code (the relevant PLMN will be set in the TC)	fixed length of 10 bits and shall be coded as the binary representation of their decimal value	
}			
TemporaryID	1111111100000000 0000000000000000 0000000000000000 0000000000000000 0000000000000000 0000000000000000 0000000000000000 0000000000000000 0000000011111111	160 bits - see setting of bit 'E' above. A temporary identity that corresponds to the ProSe Application ID Name.	
}			
ProSe Application Mask[1]	0000111111111100 00000000 1111111111111111 0000000000000000 0000000000000000 0000000000000000 0000000000000000 0000000000000000 0000000000000000 0000000000000000 0000000000000000 0000000000000000 0000000000000000	184 bits - The length of the ProSe Application Mask is the same as the length of ProSe Application Code Full matching for the MCC part is required, as well as for the first 16 bits of the Temporary ID in order a received ProSe Application Code to result in a match	
ProSe Application Mask[2]	0000111111111100 00000000 0000000000000000 0000000000000000 0000000000000000 0000000000000000 0000000000000000 0000000000000000 0000000000000000 0000000000000000 0000000000000000 1111111111111111	184 bits - The length of the ProSe Application Mask is as same as the length of ProSe Application Code Full matching for the MCC part is required, as well as for the last 16 bits of the Temporary ID	
TTLTimer T4002	5	Indicating the time during which the filter is valid Integer in the 1-525600 range representing the timer value in unit of minutes	
}			
}			
response-reject	Not Present		

MATCH_REPORT

This message is sent by the UE to the SS.

Table 4.7F.1-3: MATCH_REPORT

Derivation path: 24.334 [57], clause 11.2.4.4.			
Information Element	Value/remark	Comment	Condition
transaction-ID	a new transaction ID		
ProSe-Application-Code	A code received in a PC5_DISCOVERY message for which there was a match event and for which the UE does not have an associated ProSe Application ID	The expected value will be set in the relevant TC.	
UE-identity	IMSI		
Monitored-PLMN-id	The monitored in the TC PLMN	The expected value will be set in the relevant TC.	
VPLMN-id	Not included		
MIC	MIC of the PC5_DISCOVERY message that contained the ProSe Application Code for which there was a match event		
UTC-based Counter	<ul style="list-style-type: none"> - the 28 most significant bits of the UTC-based counter shall be set to the 28 most significant bits of the UTC time provided by the lower layers for the PC5_DISCOVERY message that contained the ProSe Application Code for which there was a match event encoded as specified in TS 24.334 [57], subclause 12.2.2.18; and - the 4 least significant bits of the UTC-based counter shall be set to the 4 least significant bits of the UTC-based counter contained in the PC5_DISCOVERY message that contained the ProSe Application Code for which there was a match event, as specified in 3GPP TS 33.303 [60] 	The UTC is expressed in unit of seconds and coded in binary format as the 32 least significant bits of the Coordinated Universal Time as defined in 3GPP TS 36.331 [17]	
metadata-flag	Any allowed value		

- MATCH_REPORT_ACK

This message is sent by the SS to the UE.

Table 4.7F.1-4: MATCH_REPORT_ACK

Derivation path: 24.334 [57], clause 11.2.4.5.			
Information Element	Value/remark	Comment	Condition
Current-Time	Current UTC time		
match-ack {			
transaction-ID	the transaction ID received in the MATCH_REPORT		
ProSe-Application-ID		a ProSe Application ID which the UE does not have	
validity-timer-T4004	4	4 min	
metadata	Not Present		
match-report-refresh-timer-T4006	1	1 min	
}			

- PC5_DISCOVERY

This message is sent by the UE or by the SS-UE.

Table 4.7F.1-5: PC5_DISCOVERY for open ProSe direct discovery

Derivation path: 24.334 [57], Table 11.2.5.1.1.			
Information Element	Value/remark	Comment	Condition
ProSe Application Code {			
PLMN ID	Same as the PLMN ID provided in the DISCOVERY_RESPONSE message sent during the latest Monitor request procedure		
TemporaryID	Same as the TemporaryID provided in the DISCOVERY_RESPONSE message sent during the latest Monitor request procedure		
}			
MIC	Computed by UE based on Message Type, discovery-key and ProSe Application Code included by SS in DISCOVERY_RESPONSE sent during the latest Monitor request procedure, and UTC-based counter associated with the discovery slot. See TS 33.303 [60], A.2. The 32 least significant bits of the output of the KDF, TS 33.220 [61], Annex B.		
UTC-based Counter LSB	four least significant bits of the UTC-based counter associated with the discovery slot	The UTC is expressed in unit of seconds and coded in binary format as the 32 least significant bits of the Coordinated Universal Time as defined in 3GPP TS 36.331 [17]	

Table 4.7F.1-5A: PC5_DISCOVERY for Group Member Discovery Announcement

Derivation path: 24.334 [57], Table 11.2.5.1.7.			
Information Element	Value/remark	Comment	Condition
Message Type {			
Discovery type	'01'B	"Restricted discovery"	
Content type	'0110'	"Group Member Discovery Announcement or Group Member Discovery Response"	
Discovery model	'01'	"Model A"	
}			
Discovery Group ID	The configured Discovery Group ID parameter identifying the discovery group to be announced	24-bit long bit string	
User Info ID	The configured User Info ID for the group member discovery parameter	Announcer Info 48-bit long bit string	
ProSe UE ID	The configured Layer 2 ID used for unicast communication	24-bit long bit string	
Spare		The length of this parameter is variable and is indicated in a message where this parameter is included	
MIC	Computed in accordance with TS 33.303 [60], A.2.		
UTC-based Counter LSB		Set to the eight least significant bits of the UTC-based counter The UTC is expressed in unit of seconds and coded in binary format as the 32 least significant bits of the Coordinated Universal Time as defined in 3GPP TS 36.331 [17]	

Table 4.7F.1-5B: PC5_DISCOVERY for Group Member Discovery Solicitation

Derivation path: 24.334 [57], Table 11.2.5.1.8.			
Information Element	Value/remark	Comment	Condition
Message Type {			
Discovery type	'01'B	"Restricted discovery"	
Content type	'0111'	"Group Member Discovery Solicitation"	
Discovery model	'10'	"Model B"	
}			
Discovery Group ID	The configured Discovery Group ID parameter identifying the discovery group to be solicited	24-bit long bit string	
User Info ID	The configured User Info ID for the group member discovery parameter	Discoverer Info 48-bit long bit string	
GMDS Composition {			
TUII	Any value		
TGII	Any value		
}			
Target User Info	IF TUII='1' THEN the User Info ID of the targeted discoveree user - 48-bit long bit string ELSE Not present		
Target Group Info	IF TGII='1' THEN ProSe Layer 2 Group ID - 24-bit long bit string ELSE Not present		
Spare		The length of this parameter is variable and is indicated in a message where this parameter is included	
MIC	Computed in accordance with TS 33.303 [60], A.2.		
UTC-based Counter LSB		Set to the eight least significant bits of the UTC-based counter The UTC is expressed in unit of seconds and coded in binary format as the 32 least significant bits of the Coordinated Universal Time as defined in 3GPP TS 36.331 [17]	

Table 4.7F.1-5C: PC5_DISCOVERY for Group Member Discovery Response

Derivation path: 24.334 [57], Table 11.2.5.1.9.			
Information Element	Value/remark	Comment	Condition
Message Type {			
Discovery type	'01'B	"Restricted discovery"	
Content type	'0110'	"Group Member Discovery Announcement or Group Member Discovery Response"	
Discovery model	'10'	"Model B"	
}			
Discovery Group ID	The received Discovery Group ID parameter of the PC5_DISCOVERY message for Group Member Discovery Solicitation	24-bit long bit string	
User Info ID	The configured User Info ID for the group member discovery parameter	Discoveree Info 48-bit long bit string	
ProSe UE ID	The configured Layer 2 ID used for unicast communication	24-bit long bit string	
Spare		The length of this parameter is variable and is indicated in a message where this parameter is included	
MIC	Computed in accordance with TS 33.303 [60], A.2.		
UTC-based Counter LSB		Set to the eight least significant bits of the UTC-based counter The UTC is expressed in unit of seconds and coded in binary format as the 32 least significant bits of the Coordinated Universal Time as defined in 3GPP TS 36.331 [17]	

4.7F.2 Messages transmitted over the PC3ch interface

- USAGE_INFORMATION_REPORT_LIST

This message is sent by the UE to the SS.

Table 4.7F.2-1: USAGE_INFORMATION_REPORT_LIST

Derivation path: 24.334 [57], clause 11.3.4.2.			
Information Element	Value/remark	Comment	Condition
transaction-ID	Any allowed value		
UE-identity	IMSI		
usage-information-report[1] {	1 Report		
sequence-number	1	First report after power up	
coverage {			
in-coverage	FALSE	The UE was out of E-UTRAN coverage	
timestamp	Not Present or Any allowed Value		
location[1]	Not Present	UE was out of coverage i.e. the UE was not camping on nor the UE was in the EMM-CONNECTED mode on any E-UTRA cell	
}			
group[1] {		The UE is configured to report the group parameters, see EF _{PROSE_UIRC}	
prose-layer2-group-ID	As preconfigured in EF _{PROSE_POLICY}		
prose-group-IP-multicast-address	As preconfigured in EF _{PROSE_POLICY}		
first-transmission-timestamp	Any allowed Value		
first-reception-timestamp	Any allowed Value		
UE-source-IP-address	Any allowed Value		
prose-UE-id	As preconfigured in EF _{PROSE_POLICY}		
transmitter {			
source-IP-address	Any allowed Value		
prose-UE-id	Any allowed value		
}			
transmission {			
in-coverage	FALSE		
ECGI	Not Present		
amount	Any allowed Value		
timestamp	Any allowed Value		
radio-resources-ind	2	the configured radio resources were used	
radio-frequency	carrierFreq-r12, Table 6.8.1.1-1	the configured radio frequency	
}			
reception {			
in-coverage	FALSE		
ECGI	Not Present		
amount	Any allowed Value		
timestamp	Any allowed Value		
radio-resources-ind	2	the configured radio resources	
radio-frequency	carrierFreq-r12, Table 6.8.1.1-1	the configured radio frequency	
}			
..}			

radio-parameter-set {	2 entries in any order referring to SL-Preconfiguration-r12, Table 6.8.1.1-1 SLCONF1 and SLCONF2		
{	Entry 1		
params	the radio parameters used for ProSe direct communication, see SL-Preconfiguration-r12, Table 6.8.1.1-1 cond SLCONF1		
timestamp	Any allowed Value		
}			
{	Entry 2		
params	the radio parameters used for ProSe direct communication, see SL-Preconfiguration-r12, Table 6.8.1.1-1 cond SLCONF2		
timestamp	Any allowed Value		
}			
}			
app-specific-info	Any allowed Value		

USAGE_INFORMATION_REPORT_LIST_RESPONSE

This message is sent by the SS to the UE.

Table 4.7F.2-2: USAGE_INFORMATION_REPORT_LIST_RESPONSE

Derivation path: 24.334 [57], clause 11.3.4.3.			
Information Element	Value/remark	Comment	Condition
response-accept {			
transaction-ID	The value of the transaction ID of the related USAGE_INFORMATION_REPORT_LIST message		
}			
response-reject {	Not present		
transaction-ID			
cause-value			
}			

4.7F.3 ProSe Direct Communication Messages

- DIRECT_COMMUNICATION_ACCEPT

This message can be sent by the UE or the SS.

Table 4.7F.3-0A: DIRECT_COMMUNICATION_ACCEPT

Derivation path: 24.334 [57], clause 11.4.3.1.1.			
Information Element	Value/remark	Comment	Condition
Sequence Number	0	incremented for each outgoing new PC5 Signalling message	
IP Address Config	Any allowed value		
Link Local IPv6 Address	Present if the IP Address Config IE is set to 'address allocation not support' Not Present otherwise	128-bit IPv6 address	

- DIRECT_COMMUNICATION_KEEPALIVE

This message can be sent by the UE or the SS.

Table 4.7F.3-0B: DIRECT_COMMUNICATION_KEEPALIVE

Derivation path: 24.334 [57], clause 11.4.5.1.1.			
Information Element	Value/remark	Comment	Condition
Sequence Number	The Sequence number used in the previously sent PC5 Signalling message + 1		
Keepalive Counter	0 if this is the first keepalive message being sent otherwise - the value sent in the preceeding acknowledged DIRECT_COMMUNICATION_KEEPALIVE message + 1, or, - the same value if this is a retransmission		
Maximum Inactivity Period	Any allowed value or Not present		

- DIRECT_COMMUNICATION_KEEPALIVE_ACK

This message can be sent by the UE or the SS.

Table 4.7F.3-0C: DIRECT_COMMUNICATION_KEEPALIVE_ACK

Derivation path: 24.334 [57], clause 11.4.6.1.1.			
Information Element	Value/remark	Comment	Condition
Sequence Number	The Sequence number used in the previously sent PC5 Signalling message + 1		
Keepalive Counter	the same value as the one received in the preceeding DIRECT_COMMUNICATION_KEEPALIVE message		

- DIRECT_COMMUNICATION_RELEASE

This message can be sent by the UE or the SS.

Table 4.7F.3-0D: DIRECT_COMMUNICATION_RELEASE

Derivation path: 24.334 [57], clause 11.4.7.1.1.			
Information Element	Value/remark	Comment	Condition
Sequence Number	The Sequence number used in the previously sent PC5 Signalling message + 1		
Release Reason	Any allowed value		

- DIRECT_COMMUNICATION_RELEASE_ACCEPT

This message can be sent by the UE or the SS.

Table 4.7F.3-0E: DIRECT_COMMUNICATION_RELEASE_ACCEPT

Derivation path: 24.334 [57], clause 11.4.8.1.1.			
Information Element	Value/remark	Comment	Condition
Sequence Number	The Sequence number used in the previously sent PC5 Signalling message + 1		

- DIRECT_COMMUNICATION_REQUEST

This message can be sent by the UE or the SS.

Table 4.7F.3-0F: DIRECT_COMMUNICATION_REQUEST

Derivation path: 24.334 [57], clause 11.4.2.1.1.			
Information Element	Value/remark	Comment	Condition
Sequence Number	0	incremented for each outgoing new PC5 Signalling message	
User Info {			
Type of User Info	Any allowed value		
Odd/even indication	Any allowed value	Reflecting the number of identity digits	
Identity digits	Any allowed value		
}			
IP Address Config	Any allowed value		
Maximum Inactivity Period	Any allowed value		
Nonce_1	Any allowed value	128-bit nonce value generated by the UE which initiated the procedure	
UE Security Capabilities	Any allowed value		
MSB of K _{D-sess} ID	Any allowed value	the 8 most significant bits of the K _{D-sess} ID	
K _D ID	Any allowed value		
Relay Service Code	Not present		
Signature	Any allowed value	ECCSI signature content structure is specified in 3GPP TS 33.303 [60] IETF RFC 6507	
Link Local IPv6 Address	Present if the IP Address Config IE is set to 'address allocation not support' Not Present otherwise	128-bit IPv6 address	

- DIRECT_SECURITY_MODE_COMMAND

This message can be sent by the UE or the SS.

Table 4.7F.3-0G: DIRECT_SECURITY_MODE_COMMAND

Derivation path: 24.334 [57], clause 11.4.12.1.1.			
Information Element	Value/remark	Comment	Condition
Sequence Number	The Sequence number used in the previously sent PC5 Signalling message + 1		
UE Security Capabilities	Any allowed value		
Nonce 2	Any allowed value	128-bit nonce value generated by the UE which initiated the procedure	
Chosen Algorithms	Any allowed value		
LSB of K_{D-sess} ID	Any allowed value	the 8 least significant bits of the K_{D-sess} ID.	
MSB of K_D ID	Any allowed value or Not included	the 8 most significant bits of the K_{D-sess} ID	
K_D Freshness	Any allowed value or Not included	128-bit nonce value generated by initiating PKMF to ensure that any calculated K_D is fresh	
GPI	Any allowed value or Not included	the GBA Push Information as defined in 3GPP TS 33.223	
User Info {			
Type of User Info	Any allowed value		
Odd/even indication	Any allowed value	Reflecting the number of identity digits	
Identity digits	Any allowed value		
}			
Signature	Any allowed value	ECCSI signature content structure is specified in 3GPP TS 33.303 [60] IETF RFC 6507	
Encrypted Payload	Any allowed value	encrypted data encapsulating the shared secret key to be used for the established link The exact content structure is specified in 3GPP TS 33.303 [60]	

- DIRECT_SECURITY_MODE_COMPLETE

This message can be sent by the UE or the SS.

Table 4.7F.3-0H: DIRECT_SECURITY_MODE_COMPLETE

Derivation path: 24.334 [57], clause 11.4.13.1.			
Information Element	Value/remark	Comment	Condition
Sequence Number	The Sequence number used in the previously sent PC5 Signalling message + 1		
LSB of KD ID	Any allowed value or Not present	Optional 16 least significant bits of KD ID	

- KEY_REQUEST

This message is sent by the UE to the SS.

Table 4.7F.3-1: KEY_REQUEST

Derivation path: 33.303 [60], clause E.4.2.			
Information Element	Value/remark	Comment	Condition
transaction-ID	Any allowed value		
AlgorithmAvailable	Any allowed value	Encryption algorithm the UE supports for one-to-many communications	
GroupKeyReq {	One entry		
GroupId	Any allowed value	Group that the UE is requesting keys for (Range 0-167777215)	
PGKId	0	UE does not have any PGKs for this group	
anyExt	Not Present		
}			
PRUKId	Not Present		
KDRequest	Not Present		
Key Exchange Payload	Not Present		
GroupKeyStop	Not Present		
PSDiscoverySecurityCapabilities	Not Present		
RelayDiscoveryKeyRequest	Not Present		
RelayDiscoveryKeyStop	Not Present		
GroupMemberDiscoveryKeyRequest	Not Present		
GroupMemberDiscoveryKeyStop	Not Present		
anyExt	Not Present		

- KEY_RESPONSE

This message is sent by the SS to the UE.

Table 4.7F.3-2: KEY_RESPONSE

Derivation path: 33.303 [60], clause E.4.3.			
Information Element	Value/remark	Comment	Condition
transaction-ID	Same as that received in KEY_REQUEST		
GroupNotSupported	Not Present		
GroupResponse {	One entry		
GroupID	Same as that received in KEY_REQUEST		
GroupMemberID	1		
AlgorithmInfo	'001'B	EPS encryption algorithm 128-EEA1	
}			
Key-info {	One entry		
PMK-ID	'0000000000000001'H		
PMK	'00000000000000000000000000000001'H		
}			
PRUKInfo	Not Present		
PRUKErr	Not Present		
KDRResponse	Not Present		
KDErr	Not Present		
RelayNotSupported	Not Present		
RelayResponse	Not Present		
GroupMemberDiscoveryNotSupported	Not Present		
GroupMemberDiscoveryResponse	Not Present		
CurrentTime	Not Present		
MaxOffset	Not Present		
anyExt	Not Present		

- MIKEY Key Delivery Message

This message is sent by the SS to the UE.

Table 4.7F.3-3: MIKEY Key Delivery Message

Key data	'0000 0000 0000 0000 0000 0000 0000 0001'[OCT]	PGK	
KV data {			
VF length	FFS		
Valid from	FFS		
VT length	FFS		
Valid to	FFS		
}			
}			
Mac alg	'00000001'B	HMAC-SHA-1-160	
MAC	Message Authentication Code of the message		
}			

MIKEY Verification Message

This message is sent by the UE to the SS.

Table 4.7F.3-4: MIKEY Verification Message

Derivation path: 33.303 [60], clause D.3.			
Information Element	Value/remark	Comment	Condition
MIKEY Common Header {			
version	'00000001'B		
data type	'00000000'B	Pre-shared key message	
Next payload	'00000101'B	Next payload is timestamp	
V	'0'B		
PRF func	'0000001'B		
CSB ID	Same as sent by ProSe Function in the MIKEY message carrying PGK		
#CS	'00000000'B		
CS ID map type	'00000001'B	Empty map	
CS ID map Info	FFS		
}			
Timestamp Payload {			
Next payload	'00001011'B	Next payload is RAND	
TS Type	'00000010'B	Value 2 corresponds to Counter	
TS Value	'00000000000000000000000000000001'B	Replay counter.	
}			
IDr payload {			
Next payload	'00001001'B	Next payload is Verification Payload	
ID Type	0		
ID len	Length of ID data		
ID data	PMK identity of the PMK used to protect the MIKEY message @ the FQDN of the ProSe Key Management Function		
}			
Verification Message Payload {			
Next payload	'00000000'B	This is the last payload	
Auth alg	'00000001'B	AES-CM-128	
Verification data	Message Authentication Code		
}			

4.7G Default IKEv2 message and information element contents

- IKE_SA_INIT request

This message is sent by the UE to the SS.

Table 4.7G-1: IKE_SA_INIT request

Derivation path: IETF RFC 5996 [57]			
Information Element	Value/remark	Comment	Condition
IKE Header			
Initiator's IKE_SA SPI	Not checked		
Responder's IKE_SA SPI	0	First message in IKE_SA_INIT exchange	
Next Payload	'00100001'B	SA	
Exchange Type	'00100010'B	IKE_SA_INIT	
Security Association Payload		The presence of all Transform type and related Transform ID are checked. These are allowed in one or more Proposals in any combination.	
Next Payload	'00100010'B	KE	
More proposal	Not checked		
Proposal #	Not checked	Cryptographic suite	
Protocol ID	'00000001'B	IKE	
SPI size	Not checked		
Number of transforms	Not checked		
More transform or Last transform	Not checked		
Transform type	'00000001'B	Encryption Algorithm	
Transform ID	'00000011'B	ENCR_3DES	
More transform or Last transform	Not checked		
Transform type	'00000001'B	Encryption Algorithm	
Transform ID	'00001100'B	ENCR_AES_CBC	
More transform or Last transform	Not checked		
Transform type	'00000010'B	Pseudorandom Function	
Transform ID	'00000010'B	PRF_HMAC_SHA 1	
More transform or Last transform	Not checked		
Transform type	'00000011'B	Integrity Algorithm	
Transform ID	'00000010'B	AUTH_HMAC_SHA A1_96	
More transform or Last transform	Not checked		
Transform type	'00000011'B	Integrity Algorithm	
Transform ID	'00000101'B	AUTH_AES_XCBC_96	
More transform or Last transform	Not checked		
Transform type	'00000100'B	Diffie-Hellman group	
Transform ID	'00000010'B	1024-bit MODP	
Last transform or More transform	Not checked		
Transform type	'00000100'B	Diffie-Hellman group	
Transform ID	'00001110'B	2048-bit MODP	
Key Exchange Payload			
Next Payload	'00101000'B	Nonce	
Diffie-Hellman Group Num	'00000000000000010'B or '0000000000001110'B	DH group 2 or 14	
Key Exchange data	Not checked		
Nonce Payload			
Next Payload	'00000000'B	No Next Payload if Nonce is the last payload	
Nonce data	Not checked		

NOTE 1: The order of Payloads/fields is not checked, unless explicitly specified. Additional Payloads/fields are ignored.
 NOTE 2: The Check for Next Payload is to check the presence of (SA, KE, Nonce and No Next Payload). The SS shall not reject as invalid a message with those payloads in any other order.

- IKE_SA_INIT response

This message is sent by the SS to the UE.

Table 4.7G-2: IKE_SA_INIT response

Derivation path: IETF RFC 5996 [57]			
Information Element	Value/remark	Comment	Condition
IKE Header			
Initiator's IKE_SA SPI	Same as that set by the UE in IKE_SA_INIT request		
Responder's IKE_SA SPI	Set by the SS		
Next Payload	'00100001'B	SA	
Exchange Type	'00100010'B	IKE_SA_INIT	
Security Association Payload			
Next Payload	'00100010'B	KE	
Proposal	One of the proposals included in IKE_SA_INIT request		
Key Exchange Payload			
Next Payload	'00101000'B	Nonce	
Diffie-Hellman Group Num	One of the proposals included in IKE_SA_INIT request		
Key Exchange data	Set by the SS		
Nonce Payload			
Next Payload	'00000000'B	No Next Payload if Nonce is the last payload	
Nonce data	Set by the SS		

- IKE_AUTH_request

This message is sent by the UE to the SS.

Table 4.7G-3: IKE_AUTH request

Derivation path: IETF RFC 5996 [57]			
Information Element	Value/remark	Comment	Condition
IKE Header			
Next Payload	'00101111'B or '00110000'B or '00100111'B	CP or EAP or AUTH	
Exchange Type	'00100011'B	IKE_AUTH	
NOTE 1: The order of Payloads/fields is not checked, unless explicitly specified. Additional Payloads/fields are ignored.			

- IKE_AUTH response

This message is sent by the SS to the UE.

Table 4.7G-4: IKE_AUTH response

Derivation path: IETF RFC 5996 [57]			
Information Element	Value/remark	Comment	Condition
		The presence and values for applicable fields are provided according to the test model [see TS 36.523-3 [20] cl. 4.4.6].	

4.7H Default TLS message and information element contents

NOTE: Non handshake protocol details are ignored.

- ClientHello

This message is sent by the UE to the SS.

Table 4.7H-1: ClientHello

Field	Value/remark	Comment	Condition
Protocolversion	At least TLS 1.1	TLS protocol versions 1.1 is defined in RFCs 4346 [62].	
Random	Not checked		
SessionID	Empty		
CipherSuite	A list of supported cryptographic options including one or more PSK-based ciphersuites		
CompressionMethod	A list including CompressionMethod.null		

- ServerHello

This message is sent by the SS to the UE.

Table 4.7H-2: ServerHello

Field	Value/remark	Comment	Condition
Protocolversion	TLS 1.1		
Random	A SS generated random structure different from ClientHello		
SessionID	Identity of the TLS session generated by SS		
CipherSuite	One of the PSK-based ciphersuites listed in ClientHello	Ciphersuite according to PIXIT parameter (see TS 36.523-3 [20] cl. 9)	
CompressionMethod	CompressionMethod.null		

- ServerKeyExchange

This message is sent by the SS to the UE.

Table 4.7H-3: ServerKeyExchange

Field	Value/remark	Comment	Condition
psk identity hint	"3GPP-bootstrapping"		

- ServerHelloDone

This message is sent by the SS to the UE.

Table 4.7H-4: ServerHelloDone

Field	Value/remark	Comment	Condition
Note: No fields present.			

- ClientKeyExchange

This message is sent by the UE to the SS.

Table 4.7H-5: ClientKeyExchange

Field	Value/remark	Comment	Condition
psk identity	Concatenation of "3GPP-bootstrapping", "." and B-TID		

- **ChangeCipherSpec**

This message is sent by the UE or the SS.

Table 4.7H-6: ChangeCipherSpec

Field	Value/remark	Comment	Condition
Enum	1		

- **Finished**

This message is sent by the UE or the SS.

Table 4.7H-7: Finished

Field	Value/remark	Comment	Condition
opaque	Not checked		UE
opaque	SS generated verify_data	The verify data contains the hash of the handshake messages. For details, see the RFC for TLS defined in annex E of 3GPP TS 33.310 [63].	SS

Condition	Explanation
UE	Sent by the UE.
SS	Sent by the SS.

4.7I Default AT Command message and information element

- **AT Command +CATM**

This AT Command is sent by the SS to the UE.

Table 4.7I-1: +CATM

Derivation Path: 27.007 clause 15			
Field	Value/remark	Comment	Condition
+CATM=			
<status>	0		Activation
<status>	1		Deactivation

Condition	Explanation
-----------	-------------

Activation	Activate UE test loop mode.
Deactivation	Deactivate UE test loop mode

- AT Command +CCUTLE

This AT Command is sent by the SS to the UE.

Table 4.7I-2: +CCUTLE

Derivation Path: 27.007 clause 15			
Field	Value/remark	Comment	Condition
+ CCUTLE =			
<status>	1		Open
<status>	0		Close
<direction>	1		Transmit
<direction>	0		Receive
<format>	1		Receive
<length>	1		Receive
<monitor_list>	HEX '0000AA'		Receive

Condition	Explanation
Open	Open UE test loop back mode E.
Close	Close UE test loop back mode E
Transmit	UE is configured to transmit V2X communication packets
Receive	UE is configured to receive V2X communication packets

- AT Command +CUTCR

This AT Command is sent by the SS to the UE.

Table 4.7I-3: +CUTCR

Derivation Path: 27.007 clause 15			
Field	Value/remark	Comment	Condition
+CUTCR		This AT command has no additional fields	

- AT Command +CUSPCREQ

This AT Command is sent by the SS to the UE.

Table 4.7I-4: +CUSPCREQ

Derivation Path: 27.007 clause 15			
Field	Value/remark	Comment	Condition
+CUSPCREQ		This AT command has no additional fields	

4.8 Reference radio bearer configurations

4.8.1 General

4.8.2 SRB and DRB parameters and combinations

4.8.2.1 SRB and DRB parameters

4.8.2.1.1 SRB configurations

Table 4.8.2.1.1-1: SRB-ToAddMod-DEFAULT

Derivation Path: 36.331 clause 6.3.2			
Information Element	Value/remark	Comment	Condition
SRB-ToAddMod-DEFAULT ::= SEQUENCE {			
srb-Identity	1		SRB1
	2		SRB2
rlc-Config CHOICE {			
defaultValue			
}			
logicalChannelConfig CHOICE {			
defaultValue			
}			
}			

4.8.2.1.2 DRB PDCP configurations

4.8.2.1.2.1 DRB PDCP configurations for UM RLC

Table 4.8.2.1.2.1-1: PDCP-Config-DRB-UM

Derivation Path: 36.331 clause 6.3.2			
Information Element	Value/remark	Comment	Condition
PDCP-Config-DRB-UM ::= SEQUENCE {			
discardTimer	ms100	Suitable for real time services	
rlc-AM SEQUENCE {}	Not present		
rlc-UM SEQUENCE {			
pdcpc-SN-Size	Len12bits		
}			
headerCompression CHOICE {			
notUsed	NULL		
}			
}			

4.8.2.1.2.2 DRB PDCP configurations for AM RLC

Table 4.8.2.1.2.2-1: PDCP-Config-DRB-AM

Derivation Path: 36.331 clause 6.3.2			
Information Element	Value/remark	Comment	Condition
PDCP-Config-DRB-AM ::= SEQUENCE {			
discardTimer	Infinity		
rlc-AM SEQUENCE {			
statusReportRequired	TRUE		
}			
rlc-UM SEQUENCE {}	Not present		
headerCompression CHOICE {			
notUsed	NULL		
}			
ul-DataSplitDRB-ViaSCG-r12	TRUE	Uplink transmission of split DRB PDCP SDUs configured to be transmitted on the PSCell	DC_Setup_Split_DRB
t-Reordering-r12	ms200	ENUMERATED {ms0, ms20, ms40, ms60, ms80, ms100, ms120, ms140, ms160, ms180, ms200, ms220, ms240, ms260, ms280, ms300, ms500, ms750}	DC_Setup_Split_DRB
}			

Condition	Explanation
DC_Setup_Split_DRB	Setup of Split DRB

4.8.2.1.3 DRB RLC configurations

4.8.2.1.3.1 DRB UM RLC configurations

Table 4.8.2.1.3.1-1: RLC-Config-DRB-UM

Derivation Path: 36.331 clause 6.3.2			
Information Element	Value/remark	Comment	Condition
RLC-Config-DRB-UM ::= CHOICE {			
um-Bi-Directional SEQUENCE {			
ul-UM-RLC SEQUENCE {			
sn-FieldLength	Size10		
}			
dl-UM-RLC SEQUENCE {			
sn-FieldLength	Size10		
t-Reordering	ms50	ms50 provides sufficient margin	
}			
}			
}			

4.8.2.1.3.2 DRB AM RLC configurations

Table 4.8.2.1.3.2-1: RLC-Config-DRB-AM

Derivation Path: 36.331 clause 6.3.2			
Information Element	Value/remark	Comment	Condition
RLC-Config-DRB-AM ::= CHOICE {			
am SEQUENCE {			
ul-AM-RLC SEQUENCE {			
t-PollRetransmit	ms80		
pollPDU	p128		
pollByte	kB125		
maxRetxThreshold	t4		
}			
dl-AM-RLC SEQUENCE {			
t-Reordering	ms80	Is sufficient for 5 HARQ transmissions	
t-StatusProhibit	Ms60	Should be equal to or smaller than t-PollRetransmit.	
}			
}			
}			

4.8.2.1.4 DRB Logical Channel configurations

Table 4.8.2.1.4-1: LogicalChannelConfig-DRB

Derivation Path: 36.331 clause 6.3.2			
Information Element	Value/remark	Comment	Condition
LogicalChannelConfig-DRB ::= SEQUENCE {			
ul-SpecificParameters SEQUENCE {			
priority	6		HI
	13		LO
prioritisedBitRate	kBps0	PBR is disabled.	
bucketSizeDuration	ms100		
logicalChannelGroup	1		HI
	2		LO
}			
}			

Condition	Explanation
HI	Used for DRBs with high logical channel priority
LO	Used for DRBs with low logical channel priority

4.8.2.1.5 MAC configurations

Table 4.8.2.1.5-1: MAC-MainConfig-RBC

Derivation Path: 36.331 clause 6.3.2			
Information Element	Value/remark	Comment	Condition
MAC-MainConfig-RBC ::= SEQUENCE {			
ul-SCH-Config	Not present		SCell_AddMod
ul-SCH-Config SEQUENCE {			
maxHARQ-Tx	n5		
periodicBSR-Timer	sf20		
	Infinity		no_periodic_BSR_or_PHR
retxBSR-Timer	sf320		
	sf10240		no_periodic_BSR_or_PHR
ttiBundling	FALSE		
}			
drx-Config	Not present		NOT pc_FeatGrp_5 or SCell_AddMod
drx-Config CHOICE {			pc_FeatGrp_5 AND DRX_S
setup SEQUENCE {			
onDurationTimer	psf2		
	psf5		For SIG and HalfDuplex
drx-InactivityTimer	psf100		
drx-RetransmissionTimer	psf16		
longDRX-CycleStartOffset CHOICE {		sf40 typical value in real network for real-time services.	
sf40	4		For SIG
	0		For RF
}			
shortDRX	Not present		
}			
}			
drx-Config CHOICE {			pc_FeatGrp_5 AND DRX_L
setup SEQUENCE {			
onDurationTimer	psf6		
drx-InactivityTimer	psf1920		
drx-RetransmissionTimer	psf16		
longDRX-CycleStartOffset CHOICE {		sf1280 typical value in real network for best-effort services.	
sf1280	4		For SIG
	0		For RF
}			
shortDRX	Not present		
}			
}			
timeAlignmentTimerDedicated	sf750		
phr-Config CHOICE {			no_periodic_BSR_or_PHR
release	NULL		
}			
phr-Config	Not present		SCell_AddMod and RF

phr-Config CHOICE {			
setup SEQUENCE {			
periodicPHR-Timer	sf500		
prohibitPHR-Timer	sf200		
dl-PathlossChange	dB3		
}			
sr-ProhibitTimer-r9	Not present		
mac-MainConfig-v1020	Not present		
mac-MainConfig-v1020 SEQUENCE {			SCell_AddMod
sCellDeactivationTimer-r10	rf32		
extendedBSR-Sizes-r10	setup		
extendedPHR-r10	setup		
}			
stag-ToReleaseList-r11	Not present		
stag-ToAddModList-r11	Not present		
drx-Config-v1130	Not present		
e-HARQ-Pattern-r12	Not present		
dualConnectivityPHR CHOICE {}	Not present		
logicalChannelSR-Config-r12 CHOICE {}	Not present		
extendedPHR2-r13	Not present		
eDRX-Config-CycleStartOffset-r13 CHOICE {}	Not present		
eDRX-Config-CycleStartOffset-r13 CHOICE {}	Not present		
drx-Config-r13 CHOICE {}	Not present		
}			

Condition	Explanation
DRX_S	Used for DRX configuration with small DRX cycle length
DRX_L	Used for DRX configuration with large DRX cycle length
no_periodic_BSR_or_PHR	Used to disable BSR and PHR
For SIG	Used for DRX configuration in Protocol testing
For RF	Used for DRX configuration in RRM testing
SCell_AddMod	Addition or modification of SCell
HalfDuplex	Used during Type B HalfDuplexOperation

Table 4.8.2.1.5-2: MAC-MainConfig-SRB

Derivation Path: 36.331 clause 6.3.2			
Information Element	Value/remark	Comment	Condition
MAC-MainConfig-SRB ::= SEQUENCE {			
ul-SCH-Config SEQUENCE {			
maxHARQ-Tx	n5		
periodicBSR-Timer	sf20		
retxBSR-Timer	sf320		
ttiBundling	FALSE		
}			
drx-Config CHOICE {			
release	NULL		
}			
timeAlignmentTimerDedicated	sf750		
phr-Config CHOICE {			
setup SEQUENCE {			
periodicPHR-Timer	sf500		
prohibitPHR-Timer	sf200		
dl-PathlossChange	dB3		
}			
}			
}			

4.8.2.1.6 Physical Layer configurations

Table 4.8.2.1.6-1: PhysicalConfigDedicated-DEFAULT

Derivation Path: 36.331 clause 6.3.2			
Information Element	Value/remark	Comment	Condition
PhysicalConfigDedicated-DEFAULT ::= SEQUENCE { pdsch-ConfigDedicated	PDSCH-ConfigDedicated-DEFAULT	See subclause 4.6.3	SRB1 or HO-TO-EUTRA or PSCell_Mod or PSCell_Add_Split_DRB or PSCell_Add_SCG_DRB
	Not present		RBC or RBC-HO or SCell_AddMod
pucch-ConfigDedicated	PUCCH-ConfigDedicated-DEFAULT	See subclause 4.6.3	SRB1 and not (CE Mode A or CE Mode B)) or RBC-HO or HO-TO-EUTRA or PSCell_Mod or PSCell_Add_Split_DRB or PSCell_Add_SCG_DRB
	Not present		RBC or SCell_AddMod or CEmodeA or CEmodeB
pusch-ConfigDedicated	PUSCH-ConfigDedicated-DEFAULT	See subclause 4.6.3	SRB1 or HO-TO-EUTRA or PSCell_Mod or PSCell_Add_Split_DRB or PSCell_Add_SCG_DRB
	Not present		RBC or RBC-HO or SCell_AddMod
uplinkPowerControlDedicated	UplinkPowerControlDedicated-DEFAULT	See subclause 4.6.3	SRB1 or HO-TO-EUTRA or PSCell_Mod or PSCell_Add_Split_DRB or PSCell_Add_SCG_DRB
	Not present		RBC or RBC-HO or SCell_AddMod

tpc-PDCCH-ConfigPUCCH	Not present		SRB1 or SCell_AddMod
	TPC-PDCCH-Config-DEFAULT using condition PUCCH	See subclause 4.6.3	RBC or RBC-HO or HO-TO-EUTRA or PSCell_Mod or PSCell_Add_Split_DRB or PSCell_Add_SCG_DRB
tpc-PDCCH-ConfigPUSCH	Not present		SRB1 SCell_AddMod
	TPC-PDCCH-Config-DEFAULT using condition PUSCH	See subclause 4.6.3	RBC or RBC-HO or HO-TO-EUTRA or PSCell_Mod or PSCell_Add_Split_DRB or PSCell_Add_SCG_DRB
cqi-ReportConfig	CQI-ReportConfig-DEFAULT	See subclause 4.6.3	SRB1 or HO-TO-EUTRA or PSCell_Mod or PSCell_Add_Split_DRB or PSCell_Add_SCG_DRB
	CQI-ReportConfig-DEFAULT using condition CQI_PERIODIC	See subclause 4.6.3	(RBC or RBC-HO) and not RBC-HO-CA
	Not present		CA HalfDuplex
soundingRS-UL-ConfigDedicated	Not present		SRB1 or HO-TO-EUTRA SCell_AddMod PSCell_Add Mod HalfDuplex
	SoundingRS-UL-ConfigDedicated-DEFAULT	See subclause 4.6.3	RBC or RBC-HO
antennaInfo CHOICE {			
explicitValue SEQUENCE {			2TX or 4TX
transmissionMode	tm3		
codebookSubsetRestriction CHOICE {			
n2TxAntenna-tm3	'11'	BIT STRING (SIZE (2))	2TX
n4TxAntenna-tm3	'1111'	BIT STRING (SIZE (4))	4TX
}			
ue-TransmitAntennaSelection CHOICE {			
Release	NULL		
}			
}			

defaultValue	NULL		
}			
schedulingRequestConfig	SchedulingRequest-Config-DEFAULT	See subclause 4.6.3	SRB1 or RBC-H or HO-TO-EUTRA
	Not present		RBC SCell_AddMod or PSCell_AddMod
cqi-ReportConfig-v920	Not present		
antennaInfo-v920	Not present		
antennaInfo-r10	Not present		
antennaInfoUL-r10	Not present		
cif-Presence-r10	FALSE		SCell_AddMod
	Not present		
cqi-ReportConfig-r10	CQI-ReportConfig-r10-DEFAULT		SCell_AddMod or RBC-HO-CA
	Not present		
csi-RS-Config-r10	Not present		
pucch-ConfigDedicated-v1020	PUCCH-ConfigDedicated-v1020-DEFAULT		SCell_AddMod
pusch-ConfigDedicated-v1020	Not present		
schedulingRequestConfig-v1020	Not present		
soundingRS-UL-ConfigDedicated-v1020	Not present		
soundingRS-UL-ConfigDedicatedAperiodic-r10	Not present		
uplinkPowerControlDedicated-v1020	UplinkPowerControlDedicated-v1020-DEFAULT		SCell_AddMod and (TxD or SRSAP)
	Not present		
additionalSpectrumEmissionCA-r10	Not present		
additionalSpectrumEmissionCA-r10	Not present		SCell_AddMod and Intra-BC CA
additionalSpectrumEmissionCA-r10 CHOICE {			SCell_AddMod and Inter-B CA and UL CA
setup SEQUENCE {			
additionalSpectrumEmissionPCell-r10	Not present		
}			
}			
epdcch-Config-r11	EPDCCH-Config-r11-DEFAULT		ePDCCH or (Not(RBC) and (CE Mode A or CE Mode B))
	Not present		
csi-RS-ConfigNZPToReleaseList-r11	Not present		
csi-RS-ConfigNZPToAddModList-r11	Not present		
csi-RS-ConfigNZPToAddModList-r11 SEQUENCE (SIZE (1..maxCSI-RS-NZP-r11)) OF {	1 entry		DL_CoMP
CSI-RS-ConfigNZP-r11[1]	CSI-RS-ConfigNZP-r11-DEFAULT		
}			
csi-RS-ConfigZPToReleaseList-r11	Not present		
csi-RS-ConfigZPToAddModList-r11	Not present		
csi-RS-ConfigZPToAddModList-r11 SEQUENCE (SIZE (1..maxCSI-RS-ZP-r11)) OF {	1 entry		DL_CoMP
CSI-RS-ConfigZP-r11[1]	CSI-RS-ConfigZP-r11-DEFAULT		
}			

pdsch-ConfigDedicated-v1130	PDSCH-ConfigDedicated-v1130-DEFAULT		DL_CoMP
	Not present		
cqi-ReportConfig-v1130	CQI-ReportConfig-v1130-DEFAULT		DL_CoMP
	Not present		
pusch-EnhancementsConfig-r14	PUSCH-EnhancementsConfig-r14-DEFAULT		eVoLTE
	Not present		
pucch-ConfigDedicated-v1130	PUCCH-ConfigDedicated-v1130-DEFAULT		UL_CoMP
	Not present		
pusch-ConfigDedicated-v1130	PUSCH-ConfigDedicated-v1130-DEFAULT		UL_CoMP
	Not present		
uplinkPowerControlDedicated-v1130	UplinkPowerControlDedicated-v1130-DEFAULT		UL_CoMP
	Not present		
cqi-ReportConfigPCell-v1250	CQI-ReportConfig-v1250-DEFAULT		DL 256QAM
	Not present		
uplinkPowerControlDedicated-v1250	Not present		
pusch-ConfigDedicated-v1250	Not present		
csi-RS-Config-v1250	Not present		
pdsch-ConfigDedicated-v1280	Not present		
pdsch-ConfigDedicated-v1310	Not present		
pucch-ConfigDedicated-r13	Not present		
	PUCCH-ConfigDedicated-r13-DEFAULT		Not (RBC) and (CEmodeA or CemodeB)
pusch-ConfigDedicated-r13	Not present		
pdccch-CandidateReductions-r13	Not present		
cqi-ReportConfig-v1310	Not present		
soundingRS-UL-ConfigDedicated-v1310	Not present		
soundingRS-UL-ConfigDedicatedUpPTsExt-r13	Not present		
soundingRS-UL-ConfigDedicatedAperiodic-v1310	Not present		
soundingRS-UL-ConfigDedicatedAperiodicUpPTsExt-r13	Not present		
csi-RS-Config-v1310	Not present		
ce-Mode-r13 CHOICE {}	Not present		
ce-Mode-r13 CHOICE {			Not (RBC) and (CEmodeA OR CemodeB)
Setup	ce-ModeA		CEmodeA
setup	ce-ModeB		CEmodeB
}			
}			
Note: For signalling test, table 6.6B.1.1.1-1 is applied.			

Condition	Explanation
-----------	-------------

SRB1	Used at configuration of SRB1 during RRC connection (re-)establishment
RBC	Used at configuration of a radio bearer combination during SRB2+DRB establishment
2TX	Used for cells with two antenna ports
4TX	Used for cells with four antenna ports
RBC-HO	Used during Handover
RBC-HO-CA	Used during Handover when Carrier Aggregation is configured for the source cells
SCell_AddMod	Addition or modification of SCell
HO-TO-EUTRA	Inter-RAT handover to E-UTRA
ePDCCH	Used at configuration of ePDCCH
DL_CoMP	Used for DL CoMP
UL_CoMP	Used for UL CoMP
CA	For Carrier Aggregation Test cases
TxD	When PUCCH Transmission Diversity is performed.
SRSap	Aperiodic SRS configured
Intra-BC CA	Intra-band contiguous Carrier Aggregation
Inter-B CA	Inter-band Carrier Aggregation
UL CA	When UL Carrier Aggregation is used.
PSCell_Mod	Modification of PSCell
PSCell_Add_Split_DRB	Add PSCell(s) and setup of Split DRB
PSCell_Add_SCG_DRB	Add PSCell(s) and setup of SCG DRB
CEmodeA	Used for CE mode A testing
CEmodeB	Used for CE mode B testing
HalfDuplex	Used during Type B HalfDuplexOperation
DL 256QAM	When DL 256QAM is used
eVoLTE	When VoLTE enhancement is used.

Table 4.8.2.1.6-1A: PhysicalConfigDedicated-eIMTA

Derivation Path: 36.331 clause 6.3.2			
Information Element	Value/remark	Comment	Condition
PhysicalConfigDedicated-eIMTA ::= SEQUENCE {			
pdsch-ConfigDedicated	PDSCH-ConfigDedicated-DEFAULT	See subclause 4.6.3	SRB1 or HO-TO-EUTRA
	Not present		RBC or RBC-HO SCell_AddMod
pucch-ConfigDedicated	PUCCH-ConfigDedicated-DEFAULT	See subclause 4.6.3	SRB1 or RBC-HO or HO-TO-EUTRA
	Not present		RBC SCell_AddMod
pusch-ConfigDedicated	PUSCH-ConfigDedicated-DEFAULT	See subclause 4.6.3	SRB1 or HO-TO-EUTRA
	Not present		RBC or RBC-HO SCell_AddMod
uplinkPowerControlDedicated	UplinkPowerControlDedicated-DEFAULT	See subclause 4.6.3	SRB1 or HO-TO-EUTRA
	Not present		RBC or RBC-HO SCell_AddMod
tpc-PDCCH-ConfigPUCCH	Not present		SRB1 SCell_AddMod
	TPC-PDCCH-Config-DEFAULT using condition PUCCH	See subclause 4.6.3	RBC or RBC-HO or HO-TO-EUTRA
tpc-PDCCH-ConfigPUSCH	Not present		SRB1 SCell_AddMod
	TPC-PDCCH-Config-DEFAULT using condition PUSCH	See subclause 4.6.3	RBC or RBC-HO or HO-TO-EUTRA
cqi-ReportConfig	CQI-ReportConfig-DEFAULT	See subclause 4.6.3	SRB1 or HO-TO-EUTRA
	CQI-ReportConfig-DEFAULT using condition CQI_PERIODIC	See subclause 4.6.3	RBC or RBC-HO
	Not present		CA
soundingRS-UL-ConfigDedicated	Not present		SRB1 or HO-TO-EUTRA SCell_AddMod
	SoundingRS-UL-ConfigDedicated-DEFAULT	See subclause 4.6.3	RBC or RBC-HO
antennaInfo CHOICE {			
explicitValue SEQUENCE {			2TX
transmissionMode			tm3
codebookSubsetRestriction CHOICE {			
n2TxAntenna-tm3			'11' BIT STRING (SIZE (2))

}			
ue-TransmitAntennaSelection CHOICE {			
Release	NULL		
}			
defaultValue	NULL		
}			
schedulingRequestConfig	SchedulingRequest-Config-DEFAULT	See subclause 4.6.3	SRB1 or RBC-H or HO-TO-EUTRA
	Not present		RBC SCell_AddMod
cqi-ReportConfig-v920	Not present		
antennaInfo-v920	Not present		
antennaInfo-r10	Not present		
antennaInfoUL-r10	Not present		
cif-Presence-r10	FALSE		SCell_AddMod
	Not present		
cqi-ReportConfig-r10	CQI-ReportConfig-r10-DEFAULT		SCell_AddMod
	Not present		
csi-RS-Config-r10	Not present		
pucch-ConfigDedicated-v1020	PUCCH-ConfigDedicated-v1020-DEFAULT		SCell_AddMod
pusch-ConfigDedicated-v1020	Not present		
schedulingRequestConfig-v1020	Not present		
soundingRS-UL-ConfigDedicated-v1020	Not present		
soundingRS-UL-ConfigDedicatedAperiodic-r10	Not present		
uplinkPowerControlDedicated-v1020	UplinkPowerControlDedicated-v1020-DEFAULT		SCell_AddMod and (TxD or SRSAP)
	Not present		
additionalSpectrumEmissionCA-r10	Not present		
additionalSpectrumEmissionCA-r10	Not present		SCell_AddMod and Intra-BC CA
additionalSpectrumEmissionCA-r10 CHOICE {			SCell_AddMod and Inter-B CA and UL CA
setup SEQUENCE {			
additionalSpectrumEmissionPCell-r10	1 (CA_NS_01)		
}			
}			
epdcch-Config-r11	EPDCCH-Config-r11-eIMTA		ePDCCH
	Not present		
csi-RS-ConfigNZPToReleaseList-r11	Not present		
csi-RS-ConfigNZPToAddModList-r11	Not present		
csi-RS-ConfigNZPToAddModList-r11 SEQUENCE (SIZE (1..maxCSI-RS-NZP-r11)) OF {	1 entry		DL_CoMP
CSI-RS-ConfigNRP-r11[1]	CSI-RS-ConfigNRP-r11-DEFAULT		
}			
csi-RS-ConfigZPToReleaseList-r11	Not present		
csi-RS-ConfigZPToAddModList-r11	Not present		
csi-RS-ConfigZPToAddModList-r11 SEQUENCE (SIZE (1..maxCSI-RS-ZP-r11)) OF {	1 entry		DL_CoMP
CSI-RS-ConfigZP-r11[1]	CSI-RS-ConfigZP-r11-DEFAULT		

}			
pdsch-ConfigDedicated-v1130	PDSCH-ConfigDedicated-v1130-DEFAULT		DL_CoMP
	Not present		
cqi-ReportConfig-v1130	CQI-ReportConfig-v1130-eIMTA		DL_CoMP
	Not present		
pucch-ConfigDedicated-v1130	PUCCH-ConfigDedicated-v1130-DEFAULT		UL_CoMP
	Not present		
pusch-ConfigDedicated-v1130	PUSCH-ConfigDedicated-v1130-DEFAULT		UL_CoMP
	Not present		
uplinkPowerControlDedicated-v1130	UplinkPowerControlDedicated-v1130-DEFAULT		UL_CoMP
	Not present		
antennaInfo-v1250	Not present		
eimta-MainConfig-r12	EIMTA-MainConfig-r12-DEFAULT		eIMTA
	Not present		
eimta-MainConfigPCell-r12	EIMTA-MainConfigServCell-r12-DEFAULT		eIMTA
	Not present		
pucch-ConfigDedicated-v1250	PUCCH-ConfigDedicated-v1250-DEFAULT		eIMTA
	Not present		
cqi-ReportConfigPCell-v1250	CQI-ReportConfig-v1250-DEFAULT		eIMTA
	Not present		
uplinkPowerControlDedicated-v1250	UplinkPowerControlDedicated-v1250-DEFAULT		eIMTA
	Not present		
pusch-ConfigDedicated-v1250	PUSCH-ConfigDedicated-v1250-DEFAULT		eIMTA
	Not present		
csi-RS-Config-v1250	Not present		
}			

Condition	Explanation
SRB1	Used at configuration of SRB1 during RRC connection (re-)establishment
RBC	Used at configuration of a radio bearer combination during SRB2+DRB establishment
2TX	Used for cells with two antenna ports
RBC-HO	Used during Handover
RBC-HO-CA	Used during Handover when Carrier Aggregation is configured for the source cells
SCell_AddMod	Addition or modification of SCell
HO-TO-EUTRA	Inter-RAT handover to E-UTRA
ePDCCH	Used at configuration of ePDCCH
DL_CoMP	Used for DL CoMP
UL_CoMP	Used for UL CoMP
CA	For Carrier Aggregation Test cases
TxD	When PUCCH Transmission Diversity is performed.
SRSap	Aperiodic SRS configured
Intra-BC CA	Intra-band contiguous Carrier Aggregation
Inter-B CA	Inter-band Carrier Aggregation
UL CA	When UL Carrier Aggregation is used.
eIMTA	eIMTA cell environment

4.8.2.1.7 DRB configurations

Table 4.8.2.1.7-1: DRB-ToAddMod-DEFAULT(bid)

Derivation Path: 36.331 clause 6.3.2			
Information Element	Value/remark	Comment	Condition
DRB-ToAddMod-DEFAULT(bid) ::= SEQUENCE {		bid is the bearer identity (1..8)	
eps-BearerIdentity	bid+4		
drb-Identity	bid		
pdcp-Config	PDCP-Config-DRB-AM		AM
	PDCP-Config-DRB-UM		UM
rlc-Config	RLC-Config-DRB-AM		AM
	RLC-Config-DRB-UM		UM
logicalChannelIdentity	bid+2		
logicalChannelConfig	LogicalChannelConfig-DRB using condition LO		UM
	LogicalChannelConfig-DRB using condition HI		AM
}			

Condition	Explanation
AM	Used for AM DRB
UM	Used for UM DRB

Table 4.8.2.1.7-2: DRB-ToAddMod-EN-DC-Split

Derivation Path: 36.331 clause 6.3.2			
Information Element	Value/remark	Comment	Condition
DRB-ToAddMod-EN-DC-Split ::= SEQUENCE {			
eps-BearerIdentity	6		
drb-Identity	2		
pdcp-Config	Not present		
rlc-Config	RLC-Config-DRB-AM		
logicalChannelIdentity	Not present		
logicalChannelConfig	LogicalChannelConfig-DRB using condition HI		
}			

4.8.2.2 SRB and DRB combinations

4.8.2.2.1 Combinations on DL-SCH and UL-SCH

4.8.2.2.1.1 SRB1 and SRB2 for DCCH + n x AM DRB + m x UM DRB, where n=1..N and m=0..M

This SRB and DRB combination is setup with UE Registration procedure and the Generic Radio Bearer Establishment or Generic Radio Bearer Establishment, UE Test Mode Activated procedure using specific message content - the default *RRConnectionReconfiguration* message with condition SRB2-DRB(n, m).

4.8.3 UTRA reference radio parameters and combinations

Table 4.8.3-1 defines UTRA reference radio parameters and combinations to be used in E-UTRA and UTRA inter-RAT test cases.

Table 4.8.3-1: UTRA reference radio parameters and combinations

Condition	Reference configuration	Comment
UTRA Speech	TS 34.108 subclause 6.10.2.4.1.4	Conversational / speech / UL:12.2 DL:12.2 kbps / CS RAB + UL:3.4 DL:3.4 kbps SRBs for DCCH
UTRA FDD PS RB	TS 34.108 subclause 6.10.2.4.1.26	Interactive or background / UL:64 DL: 64 kbps / PS RAB + UL:3.4 DL:3.4 kbps SRBs for DCCH
UTRA HSDPA RB	TS 34.108 subclause 6.10.2.4.5.1	Interactive or background / UL:64 DL: [max bit rate depending on UE category] / PS RAB + UL:3.4 DL:3.4 kbps SRBs for DCCH
UTRA HSUPA/HSDPA RB	TS 34.108 subclause 6.10.2.4.6.3	Streaming or interactive or background / UL: [max bit rate depending on UE category and TTI] DL: [max bit rate depending on UE category] / PS RAB + UL: [max bit rate depending on UE category and TTI] DL: [max bit rate depending on UE category] SRBs for DCCH on E-DCH and HS-DSCH
UTRA PS RB + Speech	TS 34.108 subclause 6.10.2.4.1.40	Conversational / speech / UL:12.2 DL:12.2 kbps / CS RAB + Interactive or background / UL:64 DL:64 kbps / PS RAB+ UL:3.4 DL: 3.4 kbps SRBs for DCCH

4.8.4 GERAN reference PDP context parameters

Table 4.8.4-1 defines GERAN reference PDP context parameters to be used in E-UTRA and GERAN inter-RAT test cases.

Table 4.8.4-1: GERAN reference PDP context parameters

Condition	Reference configuration	Comment
GPRS	TS 51.010-1 subclause 40.5, Test PDP context3.	Test PDP context3 is the default Test PDP context which is used in the GERAN Inter-RAT GPRS test cases where no particular Test PDP contexts are specified. Compression is always turned off if nothing else is stated explicitly in the test case.

4.9 Common test USIM, CSIM and ISIM parameters

This clause defines default parameters for programming the elementary files of the test UICC when running conformance test cases defined in 3GPP TS 36.523-1[18].

4.9.1 General

See clause 8.1 in 3GPP TS 34.108 [5].

4.9.1.1 Definitions

See clause 8.1.1 in 3GPP TS 34.108 [5].

4.9.1.2 Definition of the test algorithm for authentication

Same as clause 8.1.2 in 3GPP TS 34.108[5].

4.9.1.2.1 Authentication and key derivation in the test USIM, CSIM and ISIM and SS

UE and SS calculate Ck, Ik, AUTN, RES[XRES] as in clause 8.1.2.1 in 3GPP TS 34.108 [5]. Derivation of K_{ASME} and other E-UTRA Keys shall be as defined in Annex A of 3GPP TS 33.401 [31], using Key derivation function HMAC-SHA-256 algorithm.

4.9.1.2.2 Generation of re-synchronization parameters in the USIM, CSIM and ISIM

Same as clause 8.1.2.1 in 3GPP TS 34.108[5].

4.9.1.2.3 Using the authentication test algorithm for UE conformance testing

See clause 8.1.2.3 in 3GPP TS 34.108 [5].

4.9.2 Default parameters for the test USIM, CSIM and ISIM

Same as clause 8.2 in 3GPP TS 34.108 [5].

4.9.3 Default settings for the Elementary Files (EFs)

The format and coding of elementary files of the USIM are defined in 3GPP TS 31.101 [32] and 3GPP TS 31.102 [33]. Those of the ISIM are defined in 3GPP TS 31.101 [32] and 3GPP TS 31.103 [45]. Those of the CSIM are defined in 3GPP2 C.S0065-B [48].

The settings of the elementary files at the MF and USIM ADF (Application DF) level resp. the ISIM ADF (Application DF) level are the same as section 8.3 in 3GPP TS 34.108 [5] resp. section 4.2 in 3GPP TS 34.229-1 Annex E [46] and 3GPP TS 34.229-3 Annex B.1 [47] with the exceptions listed below. The settings of the elementary files at the CSIM ADF (Application DF) level as specified below. Note that some files may be updated by the UE based on information received from the SS.

4.9.3.1 Modified contents of the USIM Elementary Files and additional USIM Elements files at the DF ProSe level

EF_{AD} (Administrative Data)

- Additional information:

Byte 3 (second byte of additional information):

b3 is used to indicate whether the USIM enables the Public Safety UE to use the ME provisioning parameters for Public Safety usage, in the cases described in TS 24.334 [57].

- b3=1: the ME is authorized to use the parameters stored in the USIM or in the ME for ProSe services for Public Safety usage, as described in TS 24.334 [57] without contacting the ProSe Function.

EF_{EPSLOC} (EPS location information)

File size: 18 Bytes

Default values: Bytes 1 to 12 (HEX): FF FF FF FF FF FF FF FF FF FF FF FF(GUTI)

Bytes 13 to 17 (HEX): 42 F6 18 FF FE (Last visited registered TAI)

Byte 18 (BIN): 00000001 (EPS update status = "not updated")

Bytes 13 to 17: TAI-MCC = 246 (bytes 13 to 14) and TAI-MNC = 81 (byte 15) are frequently used. The TAC (bytes 16 to 17) is set to "FF FE" since this, in conjunction with byte 18 setting of "01", is used to ensure that the UE performs Attach at the beginning of a test.

Bytes in this file (e.g. GUTI in bytes 1 to 12) may be updated as a result of a tracking area update attempt by the UE.

EF_{EPSNSC} (EPS NAS Security Context)

The programming of this EF follows default parameter written in 3GPP TS 31.102 [23], annex E.

EF_{NASCONFIG} (Non Access Stratum Configuration)

File size: 28 Bytes

Default values: Bytes 1 to 28 (HEX): FF FF ... FF

The programming of this EF follows the specific USIM requirements given in 3GPP TS 36.523-1 [18].

EF_{UST} (USIM Service Table):

Services		Activated	Version
Service n°101	ProSe	Optional	
Note: Only ProSe related services indicated.			

EF_{PROSE_ANN} (ProSe Announcing Parameters)

If service n°1 is "available" in the ProSe Service Table (EF_{PST}), this file shall be present.

Two PLMNs are authorised for restricted ProSe direct discovery for public safety. Consequently two records associated with each different PLMN are provided.

PLMN1

File size: 7 Bytes

Default values: Bytes 1 to 7 (HEX): A0 05 80 03 00 F1 10

The PLMN code of the operator in which the UE is authorized to use restricted ProSe direct discovery announcing for public safety consists of MCC = 001 and MNC = 01. An authorized announcing range is not specified.

PLMN2

File size: 7 Bytes

Default values: Bytes 1 to 7 (HEX): A0 07 80 03 00 F1 10

The PLMN code of the operator in which the UE is authorized to use restricted ProSe direct discovery announcing for public safety consists of MCC = 001 and MNC = 02. An authorized announcing range is not specified.

Model Tag '82'

Coding: Value = '03' (the UE is authorised for Restricted Model A announcing policy and for Restricted Model B discoverer policy)

EF_{PROSE_MON} (ProSe Monitoring Parameters)

If service n°1 is "available" in the ProSe Service Table (EF_{PST}), this file shall be present.

Two PLMNs are authorised for restricted ProSe direct discovery monitoring for public safety. Consequently two records associated with each different PLMN are provided.

PLMN1

File size: 7 Bytes

Default values: Bytes 1 to 7 (HEX): A0 05 80 03 00 F1 10

The PLMN code of the operator in which the UE is authorized to use restricted ProSe direct discovery monitoring for public safety consists of MCC = 001 and MNC = 01.

PLMN2

File size: 7 Bytes

Default values: Bytes 1 to 7 (HEX): A0 07 80 03 00 F1 10

The PLMN code of the operator in which the UE is authorized to use ProSe direct discovery monitoring for public safety consists of MCC = 001 and MNC = 02.

Model Tag '82'

Coding: Value = '03' (the UE is authorised for Restricted Model A monitoring policy and for Restricted Model B discoveree policy)

EF_{PROSEFUNC} (HPLMN ProSe Function)

If service n°2 is "available" in the ProSe Service Table (EF_{PST}), this file shall be present.

File size: 7 Bytes

Default values: Bytes 1 to 7 (HEX): 80 05 01 AC 16 02 67

The type of the HPLMN ProSe Function address is set to IPv4 and the address equals the IP address of the Internet PDN (= 172.22.2.103).

EF_{PROSE_RADIO_COM} (ProSe Direct Communication Radio Parameters)

If service n°3 is "available" in the ProSe Service Table (EF_{PST}), this file shall be present.

This EF contains the radio parameters to be used for ProSe direct communication for public safety when the UE is not served by E-UTRAN, as described in TS 24.334 [57].

File size: 100 Bytes

Default values: Bytes 1 to 12 (HEX): A0 FF 80 12 32 D9 4A 63 55 A3 32
 Bytes 13 to 24 (HEX): D2 D1 63 55 A3 32 D6 0D 63 59 47
 Bytes 25 to 36 (HEX): 81 25 00 13 1D DE 02 00 00 00 04 29
 Bytes 37 to 48 (HEX): 50 00 00 03 00 18 00 28 C0 00 00 00
 Bytes 48 to 60 (HEX): 03 F0 60 03 00 05 00 FF FF 00 00 00
 Bytes 61 to 72 (HEX): 1F 84 80 12 B2 D9 4A 63 55 A3 B2 D2
 Bytes 73 to 84 (HEX): D1 63 55 A3 B2 D6 0D 63 59 47 81 25
 Bytes 85 to 96 (HEX): 00 13 1D DE 02 00 00 00 04 29 50 00
 Bytes 97 to 108 (HEX): 00 03 00 18 00 28 30 00 00 00 03 F0
 Bytes 109 to 120 (HEX): 60 03 00 05 00 00 00 FF FF 00 00 1F
 Bytes 121 to 122 (HEX): 84

High level requirements

ProSe Direct Communication not served by E-UTRAN:

- Coding: Value = '03'; indicates that UE is authorised to perform one-to-many and one-to-one ProSe direct communication when not served by E-UTRAN

ProSe Radio parameters information:

First data object:

Geographical Area - Polygon Tag '80'

Point 1

Degrees of latitude: 35.753056

Degrees of longitude: 139.689167

Point 2

Degrees of latitude: 35.735278

Degrees of longitude: 139.689167

Point 3

Degrees of latitude: 35.744167

Degrees of longitude: 139.709167

Radio parameters Tag '81' (First data object)

Coded as *SL-Preconfiguration* in Table 6.8.1.1-1 condition SLCONF1 using Band 3 and 5MHz bandwidth as example.

Second data object:

Geographical Area - Polygon Tag '80'

Point 1

Degrees of latitude: -35.753056

Degrees of longitude: 139.689167

Point 2

Degrees of latitude: -35.735278

Degrees of longitude: 139.689167

Point 3

Degrees of latitude: -35.744167

Degrees of longitude: 139.669167

Radio parameters Tag '81' (First data object)

Coded as *SL-Preconfiguration* in Table 6.8.1.1-1 condition SLCONF2 using Band 3 and 5MHz bandwidth as example.

EF_{PROSE_RADIO_MON} (ProSe Direct Discovery Monitoring Radio Parameters)

If service n°4 is "available" in the ProSe Service Table (EF_{PST}), this file shall be present.

This EF contains the radio parameters to be used for ProSe direct communication for public safety when the UE is not served by E-UTRAN, as described in TS 24.334 [57].

High level requirements

ProSe Direct Discovery monitoring not served by E-UTRAN:

- Coding: Value = '03'; indicates that UE is authorised to perform ProSe direct discovery model A monitoring and ProSe direct discovery model B discoveree operation when not served by E-UTRAN

ProSe Radio parameters information same as the one in EF_{PROSE_RADIO_COM}

EF_{PROSE_RADIO_ANN} (ProSe Direct Discovery Announcing Radio Parameters)

If service n°5 is "available" in the ProSe Service Table (EF_{PST}), this file shall be present.

This EF contains the radio parameters to be used for ProSe direct communication for public safety when the UE is not served by E-UTRAN, as described in TS 24.334 [57].

High level requirements

ProSe Direct Discovery monitoring not served by E-UTRAN:

- Coding: Value = '03'; indicates that UE is authorised to perform ProSe direct discovery model A announcing and ProSe direct discovery model B discoverer operation when not served by E-UTRAN

ProSe Radio parameters information same as the one in EF_{PROSE_RADIO_COM}EF_{PROSE_POLICY} (ProSe Policy Parameters)

If service n°6 is "available" in the ProSe Service Table (EF_{PST}), this file shall be present.

This EF contains the policy parameters to be used for ProSe direct communication for public safety, as described in TS 24.334 [57].

File size: 63 Bytes

Default values: Bytes 1 to 12 (HEX): A0 3D 80 03 00 00 01 81 03 00 00 01
 Bytes 13 to 24 (HEX): 82 04 E0 00 00 02 83 01 01 84 04 AC
 Bytes 25 to 36 (HEX): 16 02 68 85 22 00 00 00 00 00 00
 Bytes 37 to 48 (HEX): 00 00 00 00 00 00 00 00 00 00 00
 Bytes 49 to 60 (HEX): 00 00 00 00 00 00 00 00 00 00 00
 Bytes 61 to 63 (HEX): 02 01 10

The value of the ProSe Layer-2 Group ID is 1.

The value of ProSe UE ID is 2.

The value of ProSe Group IP multicast address is 224.0.0.1

Address type value is '01' (indicates IPv4)

The IPv4 address of the source, i.e. Device Under Test is 172.22.2.104.

For the Group related security. The value of PGK is 2, the value of PGK Id is 1, and, the algorithm is 128-EEA1.

EF_{PROSE_PLMN} (ProSe PLMN Parameters)

If service n°3 is "available" in the ProSe Service Table (EF_{PST}), this file shall be present.

Specifies the PLMNs in which the UE is authorised to perform ProSe direct communication when served by E-UTRAN.

Two PLMNs are authorised for ProSe direct communication. Consequently two records associated with each different PLMN are provided.

PLMN1

File size: 7 Bytes

Default values: Bytes 1 to 7 (HEX): A0 05 80 03 00 F1 10

The PLMN code of the operator in which the UE is authorized to use ProSe direct communication consists of MCC = 001 and MNC = 01.

PLMN2

File size: 7 Bytes

Default values: Bytes 1 to 7 (HEX): A0 07 80 03 00 F1 10

The PLMN code of the operator in which the UE is authorized to use ProSe direct communication consists of MCC = 001 and MNC = 02.

EF_{PROSE_GC} (ProSe Group Counter)

If service n°7 is "available" in the ProSe Service Table (EF_{PST}), this file shall be present.

File size: 10 Bytes

Default values: Bytes 1 to 9 (HEX): 80 07 00 00 01 00 02 00 03

The value of the ProSe Layer-2 Group ID is 1.

The value of PTK ID is 2.

The Counter for the PGK used in the group is 3.

EF_{PST} (ProSe Service Table)

If service n°101 is "available" in the ProSe Service Table (EF_{UST}), this file shall be present.

File size: 2 Bytes

Default values: Bytes 1 to 2 (HEX): 24 00

This translates to:

Services		Activated	Version
Service n°1:	ProSe direct discovery parameters	Optional	
Service n°2:	HPLMN ProSe Function	Optional	
Service n°3:	ProSe Direct Communication radio parameters	Optional	
Service n°4:	ProSe Direct Discovery monitoring radio parameters	Optional	
Service n°5:	ProSe Direct Discovery announcing radio parameters	Optional	
Service n°6:	ProSe policy parameters	Optional	
Service n°7:	ProSe group counter	Optional	
Service n°8:	ProSe Usage Information Reporting configuration	Optional (Note 1)	
Service n°9:	UICC ProSe Direct Communication usage information reporting	Optional	
Service n°10:	ProSe Group Member Discovery parameters	Optional	
Service n°11:	ProSe Relay parameters	Optional (Note 2)	
Note 1: If service n°9 is "available", then service n°8 shall also be "available".			
Note 2: If service n°10 is "available", then service n°1 shall also be "available".			

EF_{PROSE_UIRC} (ProSe UsageInformationReportingConfiguration)

If service n°8 is "available" in the ProSe Service Table (EF_{PST}), this file shall be present.

This EF contains the description of the configuration to be used by the UE for reporting the usage information for direct communication for public safety, as described in TS 24.334 [57].

ProSe UsageInformationReportingConfiguration parameters information:

Description	Value	Comments
ProSe ServerAddress		No server address is provided, the UE shall upload the usage information reports to the IP address of the HPLMN ProSe Function.
ProSe CollectionPeriod	1	The time interval, in unit of minutes, at which the UE shall generate the usage information reports
ProSe ReportingWindow	5	The time window, in unit of minutes, during which the UE shall upload the usage information report to the server
ProSe ReportGroupParameters	1	The UE shall report the group parameters in the usage information
ProSe ReportTimeStampsFirstTransmissionAnd Reception	1	The UE shall report the time stamps of the first transmission/reception during the collection period in the usage information
ProSe ReportDataTransmitted	3	The UE shall report the amount of data transmitted during the collection period in the usage information with location information
ProSe ReportDataReceived	3	The UE shall report the amount of data received during the collection period in the usage information with location information
ProSe ReportTimeStampsOutOfCoverage	1	The UE shall report the time stamps when it went in and out of E-UTRAN coverage during the collection period in the usage information
ProSe ReportLocationInCoverage	1	The UE shall report the list of locations of the UE when in E-UTRAN coverage during the collection period in the usage information
ProSe ReportRadioParameters	1	The UE shall report the radio parameters used for ProSe direct communication (i.e. indicator of which radio resources used and radio frequency used) during the reporting period in the usage information

EF_{PROSE_GM_DISCOVERY} (ProSe Group Member Discovery Parameters)

If service n°10 is "available" in the ProSe Service Table, this file shall be present.

This EF contains the ProSe discovery parameters for public safety, as described in TS 24.334 [57]. This file shall be used only if the ME is authorized as per content of EFAD or received service authorization from the ProSe Function.

User Info ID = 1. Indicates the user information which is sent by the announcing or discoverer or discoveree UE over the air during Group Member Discovery procedures.

Discovery Group ID = 1. Indicates the group ID of the discovery group that the UE belongs to when group member discovery is performed.

Application Layer Group ID = 1. Indicates the Application Layer Group ID identifying an application layer group that the UE belongs to

EF_{PROSE_RELAY} (ProSe Relay Parameters)

If service n°11 is "available" in the ProSe Service Table, this file shall be present.

This EF contains the authorized PLMNs for ProSe UE-to-network relay for public safety, as described in TS 24.334 [57]. This file shall be used only if the ME is authorized as per content of EFAD or received service authorization from the ProSe Function.

PLMN1

File size: 7 Bytes

Default values: Bytes 1 to 7 (HEX): A0 05 80 03 00 F1 10

Relay type Value = '02' (the UE is not authorised to act as a ProSe UE-to-network relay, and, the UE is authorised to use a ProSe UE-to-network relay).

EF_{PROSE_RELAY_DISCOVERY} (ProSe Relay Discovery Parameters)

If service n°11 is "available" in the ProSe Service Table, this file shall be present.

This EF contains the ProSe direct discovery parameters when it is used for ProSe UE-to-network relay discovery for public safety, as described in TS 24.334 [37]. This file shall be used only if the ME is authorized as per content of EFAD or received service authorization from the ProSe Function.

User Info ID = 1. Indicates the user information which is sent by the announcing or discoverer or discoveree UE over the air during Group Member Discovery procedures.

Remote UE parameters information

Relay Service Code = 1. Indicates the connectivity service that the ProSe UE-to-network relay provides to public safety applications.

User Info ID of Relay = 2. Indicates the user information of the ProSe UE-to-network relay that the remote UE seeks to discover during ProSe UE-to-network relay discovery procedures.

IP Versions '01' (indicates IPv4)

For Security Content. The value of PSDK is 2.

Bitmask of keys = '07' DUSK, DUCK and DUIK are to be used

DUCK encryption bitmask - all bits set to '1'. 184-bit bitmask which uses bit "1" to mark the positions of the bits for which the DUCK encryption is applied

4.9.3.2 Modified contents of the CSIM Elementary Files

EF_{COUNT} (Call Count)

The programming of this EF follows default parameter written in 3GPP2 C.S0065-B [48], Annex E.

EF_{IMSI_M} (IMSI_M)

The programming of this EF follows default parameter written in 3GPP2 C.S0065-B [48], Annex E.

EF_{IMSI_T} (IMSI_T)

The programming of this EF follows default parameter written in 3GPP2 C.S0065-B [48], Annex E.

EF_{TMSI} (TMSI)

The programming of this EF follows default parameter written in 3GPP2 C.S0065-B [48], Annex E.

EF_{AH} (Analog Home SID)

The programming of this EF follows default parameter written in 3GPP2 C.S0065-B [48], Annex E.

EF_{AOP} (Analog Operational Parameters)

The programming of this EF is a test house option.

EF_{ALOC} (Analog Location and Registration Indicators)

The programming of this EF is a test house option.

EF_{CDMAHOME} (CDMA Home SID, NID)

Record size: 5 Bytes

Record count:6

Record 1:

Default values: Bytes 1 to 2 (HEX): E8 03 (CDMA Home SID (SIDp): 1000)

Bytes 3 to 4 (HEX): AE 08 (CDMA Home NID (NIDp): 2222)

Bytes 5 (HEX): 00 (Band Class: 0 (800 MHz cellular band))

Record 2:

Default values: Bytes 1 to 2 (HEX): E8 03 (CDMA Home SID (SIDp): 1000)

Bytes 3 to 4 (HEX): AE 08 (CDMA Home NID (NIDp): 2222)

Bytes 5 (HEX): 01 (Band Class: 1 (1.8 to 2.0 GHz PCS band))

Record 3:

Default values: Bytes 1 to 2 (HEX): E8 03 (CDMA Home SID (SIDp): 1000)

Bytes 3 to 4 (HEX): AE 08 (CDMA Home NID (NIDp): 2222)

Bytes 5 (HEX): 03 (Band Class: 3 (832 to 925 MHz JTACS band))

Record 4:

Default values: Bytes 1 to 2 (HEX): E8 03 (CDMA Home SID (SIDp): 1000)

Bytes 3 to 4 (HEX): AE 08 (CDMA Home NID (NIDp): 2222)

Bytes 5 (HEX): 04 (Band Class: 4 (1.75 to 1.87 GHz Korean PCS band))

Record 5:

Default values: Bytes 1 to 2 (HEX): E8 03 (CDMA Home SID (SIDp): 1000)

Bytes 3 to 4 (HEX): AE 08 (CDMA Home NID (NIDp): 2222)

Bytes 5 (HEX): 05 (Band Class: 5 (450 MHz NMT band))

Record 6:

Default values: Bytes 1 to 2 (HEX): E8 03 (CDMA Home SID (SIDp): 1000)

Bytes 3 to 4 (HEX): AE 08 (CDMA Home NID (NIDp): 2222)

Bytes 5 (HEX): 06 (Band Class: 6 (2 GHz IMT-2000 band))

EF_{ZNREGI} (CDMA Zone-Based Registration Indicators)

The programming of this EF follows default parameter written in 3GPP2 C.S0065-B [48], Annex E.

EF_{SNREGI} (CDMA System-Network Registration Indicators)

The programming of this EF is a test house option.

EF_{DISTREGI} (CDMA Distance-Based Registration Indicators)

The programming of this EF follows default parameter written in 3GPP2 C.S0065-B [48], Annex E.

EF_{ACCOLC} (Access Overload Class ACCOLCp)

The 4 LSB of this 1 byte file are der-bit access overload class indicator is derived from the last digit of the associated decimal representation of the IMSI_M via decimal to binary conversion.

File size: 1 byte

Default value: Bits 4 to 7 are reserved and set to '0000'. Bits 0 to 3 are derived from the last digit of the associated decimal representation of the IMSI_M via decimal to binary conversion.

EF_{TERM} (Call Termination Mode Preferences)

The programming of this EF is a test house option.

EF_{SSCI} (Suggested Slot Cycle Index)

The programming of this EF is a test house option.

EF_{ACP} (Analog Channel Preferences)

The programming of this EF is a test house option.

EF_{PRL} (Preferred Roaming List)

File size: 18 Bytes

Default values: Bytes 1 to 18 (HEX): 00 12 00 00 00 00 40 01 21 00 02 80 00 50 00 00 6E DB

The interpretation of the default values read as follows:

PRL ID – 0

Preferred only – 0

Default roaming indication – 0

Number of Acquisition Records – 1

Number of system records – 1

EF_{RUIMID} (Removable UIMID)

This EF stores a 32-bit electronic identification number (ID) unique to the CSIM or a 32-bit pseudo-UIMID of the CSIM. It is specified by the CSIM manufacturer.

EF_{CSIM_ST} (CSIM Service Table)

Services will be allocated and activated as follows.

Services		Activated	Version
Service n°1:	Local Phone Book	Option	
Service n°2:	Fixed Dialling Numbers (FDN)	Option	
Service n°3:	Extension 2	Option	
Service n°4:	Service Dialling Numbers (SDN)	Option	
Service n°5:	Extension3	Option	
Service n°6:	Short Message Storage	Yes	
Service n°7:	Short Message Parameters (SMP)	Yes	
Service n°8:	HRPD	Yes	
Service n°9:	Service Category Program for BC-SMS	Option	
Service n°10:	CDMA Home Service Provider Name	Yes	
Service n°11:	Data Download via SMS Broadcast (for CCAT)	Option	
Service n°12:	Data Download via SMS-PP (for CCAT)	Option	
Service n°13:	Call Control (for CCAT)	Option	
Service n°14:	3GPD-SIP	Option	

Services		Activated	Version
Service n°15:	3GPD-MIP	Option	
Service n°16:	AKA	Yes	
Service n°17:	IP-based Location Services (LCS)	Option	
Service n°18:	BCMCS	Option	
Service n°19:	Multimedia Messaging Service (MMS)	Option	
Service n°20:	Extension 8	Option	
Service n°21:	MMS User Connectivity Parameters	Option	
Service n°22:	Application Authentication	Option	
Service n°23:	Group Identifier Level 1	Option	
Service n°24:	Group Identifier Level 2	Option	
Service n°25:	De-Personalization Control Keys	Option	
Service n°26:	Cooperative Network List	Option	
Service n°27:	Outgoing Call Information (OCI)	Option	
Service n°28:	Incoming Call Information (ICI)	Option	
Service n°29:	Extension 5	Option	
Service n°30:	Multimedia Storage	Option	
Service n°31:	Image (EFIMG)	Option	
Service n°32:	Enabled Services Table	Yes	
Service n°33:	Capability Configuration Parameters (CCP)	Option	
Service n°34:	SF_EUIMID-based EUIMID	Option	
Service n°35:	Messaging and 3GPD Extensions	Option	
Service n°36:	Root Certificates	Option	
Service n°37:	WAP Browser	Option	
Service n°38:	Java	Option	
Service n°39:	Reserved for CDG	No	
Service n°40:	Reserved for CDG	No	
Service n°41:	IPv6	Option	
Service n°42:	Proactive CSIM (for CCAT)	Option	

EF_{SPC} (Service Programming Code)

The programming of this EF follows default parameter written in 3GPP2 C.S0065-B [48], Annex E.

EF_{OTAPASPC} (OTAPA/SPC_Enabled)

The programming of this EF follows default parameter written in 3GPP2 C.S0065-B [48], Annex E.

EF_{NAMLOCK} (NAM_LOCK)

The programming of this EF is a test house option.

EF_{OTA} (OTASP/OTAPA Features)

The programming of this EF is a test house option.

EF_{SP} (Service Preferences)

The programming of this EF is a test house option.

EF_{ESN_MEID_ME} (ESN_ME or MEID_ME)

The programming of this EF follows default parameter written in 3GPP2 C.S0065-B [48], Annex E.

EF_{LI} (Language Indication)

The programming of this EF is a test house option.

EF_{FDN} (Fixed Dialling Numbers)

The programming of this EF is a test house option.

EF_{SMS} (Short Messages)

The programming of this EF follows default parameter written in 3GPP2 C.S0065-B [48], Annex E.

EF_{SMSP} (Short Message Service Parameters)

Record size: 12 Bytes

Record count: 1

Record 1:

Default values: Bytes 1 to 23 (HEX): 00 02 10 02 5D FE FF FF 02 F5 FF FF FF FF FF FF FF
08 03 08 01 C0

The interpretation of the default values in this record read as follows:

Teleservice Identifier: CDMA Cellular Messaging Teleservice [CMT-95]

Parameter Indicators: MSG_ENCODING, Validity Period, Bearer Data

Message Encoding: 7-bit ASCII

Validity Period: Indefinite

Bearer Data:

Priority Indicator: Emergency

EF_{SMSS} (SMS Status)

The programming of this EF follows default parameter written in 3GPP2 C.S0065-B [48], Annex E.

EF_{SSFC} (Supplementary Services Feature Code Table)

The programming of this EF is a test house option.

EF_{SPN} (CDMA Home Service Provider Name)

File size: 35 Bytes

Default values: Bytes 1 to 35 (HEX): 01 02 01 44 65 66 61 75 6C 74 20 53 65 72 76 69 63 65 20 50 72 6F
76 69 64 65 72 20 4E 61 6D 65 FF FF FF

The interpretation of the default values read as follows:

Display Condition: Display of registered system is required

Character Encoding: 7-bit ASCII

Language Indicator: 1 (English)

Service Provider Name: "Default Service Provider Name"

EF_{USGIND} (UIMID/SF_EUIMID Usage Indicator)

The programming of this EF is a test house option.

EF_{AD} (Administrative Data)

The programming of this EF follows default parameter written in 3GPP2 C.S0065-B [48], Annex E.

EF_{MDN} (Mobile Directory Number)

The programming of this EF is a test house option.

EF_{MAXPRL} (Maximum PRL)

The programming of this EF is a test house option.

EF_{SPCS} (SPC Status)

If EF_{SPC} is set to default value of '00 00 00', then EF_{SPCS} shall be set to '00', otherwise it shall be set to '01'.

EF_{ECC} (Emergency Call Codes)

The programming of this EF follows default parameter written in 3GPP2 C.S0065-B [48], Annex E.

EF_{ME3GPDOPC} (ME 3GPD Operation Capability)

The programming of this EF follows default parameter written in 3GPP2 C.S0065-B [48], Annex E.

EF_{3GPDOPM} (3GPD Operation Mode)

The programming of this EF is a test house option.

EF_{SIPCAP} (SimpleIP Capability Parameters)

The programming of this EF is a test house option.

EF_{MIPCAP} (MobileIP Capability Parameters)

The programming of this EF is a test house option.

EF_{SIPUPP} (SimpleIP User Profile Parameters)

The programming of this EF is a test house option.

EF_{MIPUPP} (MobileIP User Profile Parameters)

The programming of this EF is a test house option.

EF_{SIPSP} (SimpleIP Status Parameters)

The programming of this EF is a test house option.

EF_{MIPSP} (MobileIP Status Parameters)

The programming of this EF is a test house option.

EF_{SIPPAPSS} (SimpleIP PAP SS Parameters)

The programming of this EF is a test house option.

EF_{PUZL} (Preferred User Zone List)

The programming of this EF is a test house option.

EF_{MAXPUZL} (Maximum PUZL)

The programming of this EF is a test house option.

EF_{MECRP} (ME-specific Configuration Request Parameters)

The programming of this EF follows default parameter written in 3GPP2 C.S0065-B [48], Annex E.

EF_{HRPDCAP} (HRPD Access Authentication Capability Parameters)

File size: 3 Bytes

Default values: Bytes 1 to 3 (HEX): 20 F8 80

The interpretation of the default values read as follows:

Maximum NAI Length: 32

Maximum Length of Shared Secret: 31

Authentication Algorithms: PPP CHAP

EF_{HRPDUUP} (HRPD Access Authentication User Profile Parameters)

File size: 14 Bytes

Default values: Bytes 1 to 14 (HEX): 0D 0B 61 62 63 40 78 79 7A 2E 63 6F 6D 10

The interpretation of the default values read as follows:

HRPD Profile NAI: "abc@xyz.com"

HRPD Profile Authentication Algorithm: CHAP

EF_{CSSPR} (CUR_SSPPR_P_REV)

The programming of this EF follows default parameter written in 3GPP2 C.S0065-B [48], Annex E.

EF_{ATC} (Access Terminal Class)

The programming of this EF is a test house option.

EF_{EPRL} (Extended Preferred Roaming List)

File size: 129 Bytes

Default values: Bytes 1 to 16 (HEX): 00 81 00 00 03 00 01 80 00 04 00 0A 04 01 64 03

Bytes 17 to 32 (HEX): 0B 0B 04 01 64 03 F5 0A 04 0A 58 08 19 0B 04 0A

Bytes 33 to 48 (HEX): 58 0C 97 0A 02 31 13 0B 02 30 C8 71 C0 02 00 10

Bytes 49 to 64 (HEX): 1F 01 00 C8 FF FF 00 80 00 38 E0 08 00 00 80 00

Bytes 65 to 80 (HEX): 71 E0 12 00 10 1F 01 00 C8 FF FF 00 80 00 38 E0

Bytes 81 to 96 (HEX): 18 00 00 80 00 71 C0 22 00 10 1F 01 00 C8 FF FF

Bytes 97 to 112 (HEX): 00 80 80 38 E0 28 00 00 80 80 71 E0 02 00 10 1F

Bytes 113 to 128 (HEX): 01 00 C8 FF FF 00 80 80 38 E0 08 00 00 80 80 2B

Byte 129 (HEX): 6B

The interpretation of the default values read as follows:

PRL ID – 0

List Type: IS-683D

Preferred only – 0

Default roaming indication – 0

Number of acquisition records – 6

- Index: 0, Type: CDMA Generic, Band: 0, Channel: 356 and 779
- Index: 1, Type: HDR Generic Band: 0, Channel: 356 and 1013
- Index: 2, Type: CDMA Generic, Band: 1, Channel: 600 and 25
- Index: 3, Type: HDR Generic, Band: 1, Channel: 600 and 1175
- Index: 4, Type: CDMA Generic, Band: 6, Channel: 275
- Index: 5, Type: HDR Generic, Band: 6, Channel: 200

Number of records in the Common Subnet Table – 0

Number of system records – 8

- Acquisition Index: 1, Type: IS-856, Roam Indicator: 0, Subnet ID: /0, Association Tag: 0
- Acquisition Index: 3, Type: IS-856, Roam Indicator: 0, Subnet ID: /0, Association Tag: 0
- Acquisition Index: 5, Type: IS-856, Roam Indicator: 0, Subnet ID: /0, Association Tag: 1
- Acquisition Index: 1, Type: IS-856, Roam Indicator: 0, Subnet ID: /0, Association Tag: 1
- Acquisition Index: 0, Type: MCC-MNC-based, Roam Indicator: 0, Subnet ID: MCC-MNC SID/NID, MCC: 001, MNC: 01, SID: 200, NID: 65535100, Association Tag: 0
- Acquisition Index: 2, Type: MCC-MNC-based, Roam Indicator: 0, Subnet ID: MCC-MNC SID/NID, MCC: 001, MNC: 01, SID: 200, NID: 65535100, Association Tag: 0
- Acquisition Index: 4, Type: MCC-MNC-based, Roam Indicator: 0, Subnet ID: MCC-MNC SID/NID, MCC: 001, MNC: 01, SID: 200, NID: 65535100, Association Tag: 1
- Acquisition Index: 0, Type: MCC-MNC-based, Roam Indicator: 0, Subnet ID: MCC-MNC SID/NID, MCC: 001, MNC: 01, SID: 200, NID: 65535, Association Tag: 1

EF_{MSPL} (Multimode system selection System Priority List)

File size: 18 Bytes

Default values: Bytes 1 to 18 (HEX): 00 0F 01 00 01 01 01 03 07 08 02 0C 00 3E 00 FF FF FF

The interpretation of the default values read as follows:

Current MMSS_P_REV – 1

MLPL Version ID – 1

MLPL Identification – 1

Number of MLPL Records – 1

- Index: 1, Location Parameter Type Value: default, MSPL Index: 1

EF_{MLPL} (Multimode system selection Location associated Priority List)

File size: 18 Bytes

Default values: Bytes 1 to 18 (HEX): 00 09 01 00 01 01 01 00 01 FF FF FF FF FF FF FF FF

The interpretation of the default values read as follows:

Current MMSS_P_REV – 1

MSPL Version ID – 1

MSPL Block 1:

MSPL Identification – 1,

Number of MSPL ID1 records – 3

- Index 1: System Type: EUTRA, Priority Class: Home Only, System Priority: 1, Higher Priority Search Time: 64 minutes, Network Capability Indicator: no Network CAP used
- Index 2: System Type: cdma2000 HRPD, Priority Class: Home + Preferred, System Priority: 1, Higher Priority Search Time: 64 minutes, Network Capability Indicator: no Network CAP used
- Index 3: System Type: cdma2000 AI, Priority Class: Any, System Priority: 1, Higher Priority Search Time: 64 minutes, Network Capability Indicator: no Network CAP used

EF_{BCSMScfg} (Broadcast Short Message Configuration)

The programming of this EF is a test house option.

EF_{BCSMSpref} (Broadcast Short Message Preference)

The programming of this EF follows default parameter written in 3GPP2 C.S0065-B [48], Annex E.

EF_{BCSMStable} (Broadcast Short Message Table)

The programming of this EF follows default parameter written in 3GPP2 C.S0065-B [48], Annex E.

EF_{BCSMSP} (Broadcast Short Message Parameter)

The programming of this EF follows default parameter written in 3GPP2 C.S0065-B [48], Annex E.

EF_{BAKPARA} (Currently used BAK Parameters)

The programming of this EF is a test house option.

EF_{UpBAKPARA} (Updated BAK Parameters)

The programming of this EF is a test house option.

EF_{MMSN} (MMS Notification)

The programming of this EF follows default parameter written in 3GPP2 C.S0065-B [48], Annex E.

EF_{EXT8} (Extension 8)

The programming of this EF follows default parameter written in 3GPP2 C.S0065-B [48], Annex E.

EF_{MMSICP} (MMS Issuer Connectivity Parameters)

The programming of this EF follows default parameter written in 3GPP2 C.S0065-B [48], Annex E.

EF_{MMSUP} (MMS User Preferences)

The programming of this EF follows default parameter written in 3GPP2 C.S0065-B [48], Annex E.

EF_{MMSUCP} (MMS User Connectivity Parameters)

The programming of this EF follows default parameter written in 3GPP2 C.S0065-B [48], Annex E.

EF_{AuthCapability} (Authentication Capability)

The programming of this EF follows default parameter written in 3GPP2 C.S0065-B [48], Annex E.

EF_{3GCIK} (3G Cipher and Integrity Keys)

The programming of this EF is a test house option.

EF_{DCK} (De-Personalization Control Keys)

The programming of this EF is a test house option.

EF_{GID1} (Group Identifier Level 1)

The programming of this EF is a test house option.

EF_{GID2} (Group Identifier Level 2)

The programming of this EF is a test house option.

EF_{CDMACNL} (CDMA Co-operative Network List)

The programming of this EF is a test house option.

EF_{HOME_TAG} (Home System Tag)

The programming of this EF is a test house option.

EF_{GROUP_TAG} (Group Tag List)

The programming of this EF is a test house option.

EF_{SPECIFIC_TAG} (Specific Tag List)

The programming of this EF is a test house option.

EF_{CALL_PROMPT} (Call Prompt List)

The programming of this EF is a test house option.

EF_{SF_EUIMID} (Short Form EUIMID)

Specified by CSIM Manufacturer.

EF_{EST} (Enabled Service Table)

The programming of this EF is a test house option.

EF_{HiddenKey} (Key for hidden phone book entries)

The programming of this EF is a test house option.

EF_{LCSVER} (LCS Protocol Version)

The programming of this EF is a test house option.

EF_{LCSCP} (LCS Connectivity Parameter)

The programming of this EF is a test house option.

EF_{SDN} (Service Dialling Numbers)

The programming of this EF is a test house option.

EF_{EXT2}(Extension2)

The programming of this EF is a test house option.

EF_{EXT3}(Extension3)

The programming of this EF is a test house option.

EF_{ICI} (Incoming Call Information)

The programming of this EF is a test house option.

EF_{OCI} (Outgoing Call Information)

The programming of this EF is a test house option.

EF_{EXT5} (Extension 5)

The programming of this EF is a test house option.

EF_{CCP2} (Capability Configuration Parameters 2)

The programming of this EF is a test house option.

EF_{AppLabels} (Application Labels)

The programming of this EF is a test house option.

EF_{Model} (Device Model Information)

The programming of this EF follows default parameter written in 3GPP2 C.S0065-B [48], Annex E.

EF_{RC} (Root Certificates)

The programming of this EF is a test house option.

EF_{SMSCAP} (SMS Capabilities)

File size: 4 Bytes

Default values: Bytes 1 to 4 (HEX): 3C 08 07 01

The interpretation of the default values read as follows:

SMS Retry Period: 60 seconds

SMS Retry Interval: 8 seconds

SMS Flags:

Send On Access: True

Send on Traffic: True

Send as Standard EMS: True

SMS Preferred Service Option: SO 6

EF_{MIPFlags} (MobileIP Flags)

The programming of this EF is a test house option.

EF_{3GPDUPPEExt} (3GPD User Profile Parameters Extension)

The programming of this EF is a test house option.

EF_{IPv6CAP} (IPv6 Capabilities)

The programming of this EF is a test house option.

EF_{TCPConfig} (TCp Configurations)

The programming of this EF is a test house option.

EF_{DGC} (Data Generic Configurations)

The programming of this EF is a test house option.

EF_{WAPBrowserCP} (WAP Browser Connectivity Parameters)

The programming of this EF is a test house option.

EF_{WAPBrowserBM} (WAP Browser Bookmarks)

The programming of this EF follows default parameter written in 3GPP2 C.S0065-B [48], Annex E.

EF_{MMSConfig} (MMS Configuration)

The programming of this EF is a test house option.

EF_{JDL} (Java Download URL)

The programming of this EF is a test house option.

4.9.3.3 Modified contents of the USIM Elementary Files and additional USIM Elements files at the MCPTT level

EF_{UST} (USIM Service Table)

Services	Description	Activated	Version
Service n°109	MCPTT	Optional	
Note: Only the relevant MCPTT related services indicated.			

EF_{MST} (MCPTT Service Table)

If service n°109 is "available" in the USIM Service Table or service n°15 is "available" in the ISIM Service Table, this file shall be present. This EF indicates the coding of the MCPTT management objects and which MCPTT services are available. If a service is not indicated as available in the MCPTT Service Table, the ME shall not select this service.

Coding of the MCPTT management objects = '00' (XML format).

Services	Description	Activated	Version
Service n°1:	UE configuration data		
Service n°2:	User configuration data		
Service n°3:	Group configuration data		
Service n°4:	Service configuration data		

EF_{MCPTT_CONFIG} (MCPTT configuration data)

If service n°1, 2, 3 or 4 is "available" in the MCPTT Service Table, this file shall be present.

Encoded in XML format (as specified in the MCPTT Service Table).

MCPTT configuration data objects	Tag Values	Condition
MCPTT UE configuration data	'80'	Shall be present if service n°1 is "available" in the MCPTT service table
MCPTT User configuration data	'81'	Shall be present if service n°2 is "available" in the MCPTT service table
MCPTT Group configuration data	'82'	Shall be present if service n°3 is "available" in the MCPTT service table
MCPTT Service configuration data	'83'	Shall be present if service n°4 is "available" in the MCPTT service table
Note: MCPTT configuration data objects, as specified in 3GPP TS 24.483 [66] Annex B.2, Annex B3, Annex B.4 and Annex B.5.		

4.9.3.4 Modified contents of the USIM Elementary Files and additional USIM Elements files at the DF_{V2X} level

EF_{UST} (USIM Service Table):

Services		Activated	Version
Service n°119	V2X	Optional	
Note: Only V2X related services indicated.			

EF_{VST} (V2X Service Table)

If service n°119 is "available" in the USIM Service Table, this file shall be present. This EF indicates the coding of the V2X management objects and which V2X services are available.

File size: 2 Bytes

Default values: Bytes 1 to 2 (HEX): 00 01

Coding of the V2X management objects is XML format described in TS 24.385 [97].

Service n°1 V2X configuration data is supported.

EF_{V2X_CONFIG} (V2X configuration data)

This EF contains zero, one or more V2X configuration data objects, as specified in TS 24.385 [97].

File size: 2+X Bytes

Default values: Bytes 1 to 2 (HEX): 00 80

Bytes 3 to X (HEX): Coding result of V2X management objects

Coding of the V2X management objects is XML format described in TS 24.385.

V2X configuration data object tag:

V2X configuration data objects	Tag Values	Condition
V2X configuration data	'80'	Shall be present if service n°1 is "available" in the V2X service table
Note: V2X configuration data objects, as specified in 4.10.2.		

4.9.3.5 Modified contents of the Elementary Files for eCall over IMS

For the eCall over IMS test cases EFs shall be extended as follows:

- Table 4.9.3.5-1 specifies the EF extensions for test cases for eCall capable supporting UEs,
- Table 4.9.3.5-2 specifies the EF extensions for test cases for eCall only supporting UEs.

Table 4.9.3.5-1: EF extensions eCall capable UEs

EF field	Value
EF _{UST}	Service n°4 Service Dialling Numbers (SDN), Service n°99 URI support by UICC, Service n°89 eCall Data and Service n°112 eCall Data over IMS are available
EF _{EST}	Services n°4 Service Dialling Numbers (SDN), Service n°99 URI support by UICC, Service n°89 eCall Data and Service n°112 eCall Data over IMS are enabled
EF _{SDN}	Two entries of SDNs, eCall Test Number (123456) and eCall reconfiguration number (345678)
EF _{SDNURI}	Two entries of SDNs, eCall Test Number (tel:123456) and eCall reconfiguration number (tel:345678)

Table 4.9.3.5-2: EF extensions for eCall only UEs

EF field	Value
EF _{UST}	Service n°2 Fixed Dialling Numbers (FDN), Service n°99 URI support by UICC, Service n°89 eCall Data and Service n°112 eCall Data over IMS are available
EF _{EST}	Service n°2 Fixed Dialling Numbers (FDN), Service n°99 URI support by UICC, Service n°89 eCall Data and Service n°112 eCall Data over IMS are enabled
EF _{FDN}	Two entries of FDNs, eCall Test Number (123456) and eCall reconfiguration number (345678)
EF _{FDNURI}	Two entries of FDNs, eCall Test Number (tel:123456) and eCall reconfiguration number (tel:345678)

4.10 V2X reference configuration

This clause contains the default reference pre-configurations, which apply to all V2X test cases unless otherwise specified.

4.10.1 Reference configuration for V2X Sidelink Communication

ROHC compression is not applied in test cases simulating in coverage and out-of-coverage scenarios.

Ciphering is not configured on SLRB.

4.10.1.1 V2X Sidelink Communication *Preconfiguration* for out-of-network coverage operation

The IE *SL-V2X-Preconfiguration* contains the resource pool information for V2X sidelink communication.

Table 4.10.1.1-1: SL-V2X-Preconfiguration

Derivation Path: 36.331 clause 9.3.2			
Information Element	Value/remark	Comment	Condition
SL-V2X-Preconfiguration-r14 ::= SEQUENCE {			
v2x-PreconfigFreqList-r14 SEQUENCE (SIZE (1..maxFreqV2X-r14)) OF SEQUENCE {			
SL-V2X-PreconfigFreqInfo-r14[1]	SL-V2X-PreconfigFreqInfo-r14-DEFAULT		
}			
anchorCarrierFreqList-r14	Not present		
cbr-PreconfigList-r14	Not present		
}			

Table 4.10.1.1-2: SL-V2X-Preconfiguration for V2X sidelink communication with MCC

Derivation Path: 36.331 clause 9.3.2			
Information Element	Value/remark	Comment	Condition
SL-V2X-Preconfiguration-r14 ::= SEQUENCE {			
v2x-PreconfigFreqList-r14 SEQUENCE (SIZE (1..maxFreqV2X-r14)) OF SEQUENCE {	2 entries of SL-V2X-PreconfigFreqInfo-r14		
SL-V2X-PreconfigFreqInfo-r14 [1]	SL-V2X-PreconfigFreqInfo-r14-DEFAULT		
SL-V2X-PreconfigFreqInfo-r14 [2]	SL-V2X-PreconfigFreqInfo-r14-DEFAULT		
}			
anchorCarrierFreqList-r14	Not present		
cbr-PreconfigList-r14	Not present		
}			

4.10.2 V2X management data object configuration

V2X management data object is specified in 3GPP TS 24.385. This subclause provides the default content of V2X management object for conformance testing.

The V2X management data object can be configured in USIM or pre-configured in ME.

Derivation Path: TS 24.385 clause 5		
V2X management objects	MO Values	Comment
<X>	N/A	
Name	Default Management Object for Conformance Testing	
V2XoverPC5	N/A	
Expiration	BIN'000000000000000001001111000110100000000'	31st January 2012 00:31:00 (GPS time) (UTC time: TBD)
ServedByEUTRAN	N/A	
AuthorizedPLMNs	N/A	
<X>	N/A	
PLMN	Set to the same Mobile Country Code and Mobile Network Code stored in EF _{IMSI} on the test USIM card	
NotServedByEUTRAN	N/A	
Authorized	1	Indicates that the UE is authorized to use V2X communication over PC5 when the UE is not served by E-UTRAN for V2X communication
RadioParameters	N/A	
<X>	N/A	
RadioParametersContents	Set as defined in <i>SL-V2X-Preconfiguration</i> in subclause 4.10	
GeographicalArea	N/A	
Polygon	N/A	
<X>	N/A	
Coordinates	N/A	
<X>	N/A	
Latitude	Set as defined in GNSS scenario used by specific test case	
Longitude	Set as defined in GNSS scenario used by specific test case	
OperatorManaged	0	Indicates that the radio parameters are "non-operator managed"
AuthorizedV2XServiceList	N/A	
<X>	N/A	
V2XServiceIdentifier	HEX '3000'	
DestinationLayer2ID	HEX '0000AA'	Same as default Destination Layer2ID defined in Table 4.71-2
PPPPtoPDBMappingRule	N/A	
<X>	N/A	1 st entry of PPPPtoPDBMappingRule
ProSePerPacketPriority	1	
PacketDelayBudget	100	
<X>	N/A	2 nd entry of PPPPtoPDBMappingRule
ProSePerPacketPriority	2	
PacketDelayBudget	100	
<X>	N/A	3 rd entry of PPPPtoPDBMappingRule
ProSePerPacketPriority	3	
PacketDelayBudget	100	
<X>	N/A	4 th entry of PPPPtoPDBMappingRule
ProSePerPacketPriority	4	
PacketDelayBudget	100	

<X>	N/A	5 th entry of PPPtoPDBMappingRule
ProSePerPacketPriority	5	
PacketDelayBudget	100	
<X>	N/A	6 th entry of PPPtoPDBMappingRule
ProSePerPacketPriority	6	
PacketDelayBudget	100	
<X>	N/A	7 th entry of PPPtoPDBMappingRule
ProSePerPacketPriority	7	
PacketDelayBudget	100	
<X>	N/A	8 th entry of PPPtoPDBMappingRule
ProSePerPacketPriority	8	
PacketDelayBudget	100	
DefaultDestinationLayer2ID	Not present	
PrivacyConfig	Not present	
V2XServiceIDtoV2XFrequencyMappingRule	Not present	
V2XoverLTEUu		
Expiration	BIN'00000000000000000001001111000110100000000'	31st January 2012 00:31:00 (GPS time) (UTC time: TBD)
AuthorizedPLMNs	N/A	
<X>	N/A	
PLMN	Set to the same Mobile Country Code and Mobile Network Code stored in EF _{IMSI} on the test USIM card	
V2XASMBMConfig	N/A	
TMGI	MBMS Service ID set to HEX '000000' MCC and MNC are the same Mobile Country Code and Mobile Network Code stored in EF _{IMSI} on the test USIM card	
SAIList	N/A	
<X>	N/A	
SAI	0	
Frequency	f1 as per table 6.2.3.3-2 using the same band as cell1	
SDPInV2XASMBMConfig	vnd.3gpp.v2x	
V2XServiceIdentifierUnrelated	N/A	
V2XMBMConfigs	N/A	
<X>	N/A	
V2XMBMConfig	N/A	
TMGI	MBMS Service ID set to HEX '000000' MCC and MNC are the same Mobile Country Code and Mobile Network Code stored in EF _{IMSI} on the test USIM card	
SAIList	N/A	
<X>	N/A	
SAI	0	
Frequency	f1 as per table 6.2.3.3-2 using the same band as cell1	

SDPInV2XASMBMSConfig	vnd.3gpp.v2x	
V2XServiceIdentifierRelated	N/A	
AuthorizedV2XServiceList	N/A	
<X>	N/A	
V2XServiceIdentifier	HEX '3000'	
V2XMBMSConfigs	N/A	
TMGI	MBMS Service ID set to HEX '000000' MCC and MNC are the same Mobile Country Code and Mobile Network Code stored in EF _{IMSI} on the test USIM card	
SAIList	N/A	
<X>	N/A	
SAI	0	
Frequency	f1 as per table 6.2.3.3-2 using the same band as cell1	
SDPInV2XASMBMSConfig	vnd.3gpp.v2x	

4.11 GNSS Requirements for V2X and MCS testing

4.11.1 General

This clause defines the GNSS scenarios and requirements which apply for all V2X and MCS test cases that require simulated GNSS signals, unless otherwise specified.

The term SV ID used in this clause is defined as the satellite PRN for GPS and Modernized GPS, as Code Number for Galileo, as the satellite Slot Number for GLONASS and as the Ranging Code Number for BDS.

4.11.2 GNSS Scenarios

The following GNSS scenarios shall be used.

- Yuma / Rinex Almanac data: the required file(s) available in the GNSS data sig zip file specified in TS 37.571-5 [68] Annex B are given in Table 4.11.2-1.

Table 4.11.2-1: Yuma / Rinex Almanac data files for V2X and MCS testing

GNSS supported by UE	Yuma / Rinex file(s) ⁽¹⁾
GPS	Sig GNSS 1-3 Yuma.txt
GLONASS	Sig GNSS 1-1 AGL.txt
Galileo	Sig GNSS 1-2 Yuma.txt
BDS	FFS
Note 1: Where the UE supports more than one GNSS then all the relevant Yuma / Rinex data files are used	

- UE location(s) and motion:

Latitude: the simulated latitude(s) are given in Table 4.11.2-3

Longitude: the simulated longitude(s) are given in Table 4.11.2-3

Height: the simulated height is 30m

Motion: the simulated motion(s) are given in Table 4.11.2-2

Table 4.11.2-2: UE location(s) and motion(s) for V2X and MCS testing

Scenario number and description	Step #	Action (Location details given in Table 4.11.2-3)	Notes
Scenario #1: static in Geographical area #1 Note 1	1	Static at location #1	
Scenario #2: move from inside Geographical area #1 to outside Geographical area #1 Note 1	1	Static at location #1	
	2	Trigger from test case to move in a straight line at 15m/s from current location to next location	Simulation leaves Geographical area #1 after 905 m, 60s after the trigger. An additional 1s is added to allow for UE position accuracy of +/- 15m. An additional 10s is added to allow for UE position update. Total time 71s
	3	Static at location #2	
Scenario #3: move from zone id0 to zone id1 to zone id3 to zone id2	1	Static at location #3	
	2	Trigger from test case to move in a straight line at 2m/s from current location to next location	Simulation crosses the boundary between zone id0 and zone id1 25s after the trigger. An additional 7.5s is added to allow for UE position accuracy of +/- 15m. An additional 10s is added to allow for UE position update. Total time 42.5s
	3	Static at location #4	
	4	Trigger from test case to move in a straight line at 2m/s from current location to next location	Simulation crosses the boundary between zone id1 and zone id3 42s after the trigger. An additional 7.5s is added to allow for UE position accuracy of +/- 15m. An additional 10s is added to allow for UE position update. Total time 59.5s
	5	Static at location #5	
	6	Trigger from test case to move in a straight line at 2m/s from current location to next location	Simulation crosses the boundary between zone id3 and zone id2 25s after the trigger. An additional 7.5s is added to allow for UE position accuracy of +/- 15m. An additional 10s is added to allow for UE position update. Total time 42.5s
	7	Static at location #6	
Scenario #4: move from inside Geographical area #1 to location #7 and then location #8 inside Geographical area #1 Note 1	1	Static at location #1	
	2	Trigger from test case to move in a straight line at 10m/s from current location to next location	Simulation takes approximately 10 secs to move from location #1 to location #7
	3	Static at location #7	
	4	Trigger from test case to move in a straight line at 10m/s from current location to next location	Simulation takes approximately 10 secs to move from location #7 to location #8
	5	Static at location #8	
Note 1: Geographical area #1 is defined in clause 4.9.3.1 and is defined by three points with the following coordinates: Point 1: latitude: 35.753056, longitude: 139.689167 Point 2: latitude: 35.735278, longitude: 139.689167 Point 3: latitude: 35.744167, longitude: 139.709167			

Table 4.11.2-3: Location descriptions for V2X and MCS testing

Location number	Description for information only	Latitude (degrees)	Longitude (degrees)
#1	Approximate centre of Geographical area #1	35.74428	139.69916
#2	Approximately 1720m due west of location #1, outside Geographical area #1	35.74428	139.68017
#3	Centre of zone id0 inside Geographical area #1, see Table 4.11.2-4 and Figure 4.11.2-1	35.74478	139.70333
#4	Centre of zone id1 inside Geographical area #1, see Table 4.11.2-4 and Figure 4.11.2-1	35.74478	139.70540
#5	Centre of zone id3 inside Geographical area #1, see Table 4.11.2-4 and Figure 4.11.2-1	35.74523	139.70716
#6	Centre of zone id2 inside Geographical area #1, see Table 4.11.2-4 and Figure 4.11.2-1	35.74523	139.70508
#7	Approximately 100m due west of location #1, inside Geographical area #1	35.74428	139.69806
#8	Approximately 100m due west of location #6, inside Geographical area #1	35.74428	139.69695

Table 4.11.2-4: Zone id calculations for V2X testing

Description	Latitude (degrees)	Longitude (degrees)	Long distance from 0,0 in m (x) Note 1	Lat distance from 0,0 in m (y) Note 1	Values for zone_id calculation (Nx, Ny = 2, L = 100, W = 50 Note 2) Note 3
Centre of zone id0	35.74478	139.70333	11061850	3957225	$y_1=0, x_1=0$
Centre of zone id1	35.74478	139.70540	11061950	3957225	$y_1=0, x_1=1$
Centre of zone id2	35.74523	139.70508	11061850	3957275	$y_1=1, x_1=0$
Centre of zone id3	35.74523	139.70716	11061950	3957275	$y_1=1, x_1=1$
<p>Note 1: all distances are +/- 1m</p> <p>Note 2: zone length (longitude) is set to 100m, zone width (latitude) is set to 50m in accordance with TS 36.523-1 [18] Table 24.1.8.3.3-1 and Table 24.1.9.3.3-1, this allows for the accuracy with which a UE can define its position which is assumed to be +/- 15m. Zone id longitude modulus and zone id latitude modulus are set to 2 in accordance with TS 36.523-1 [18] Table 24.1.8.3.3-1 and Table 24.1.9.3.3-1.</p> <p>Note 3: zone ids are calculated according to TS 36.331 [17] clause 5.10.13.2</p>					

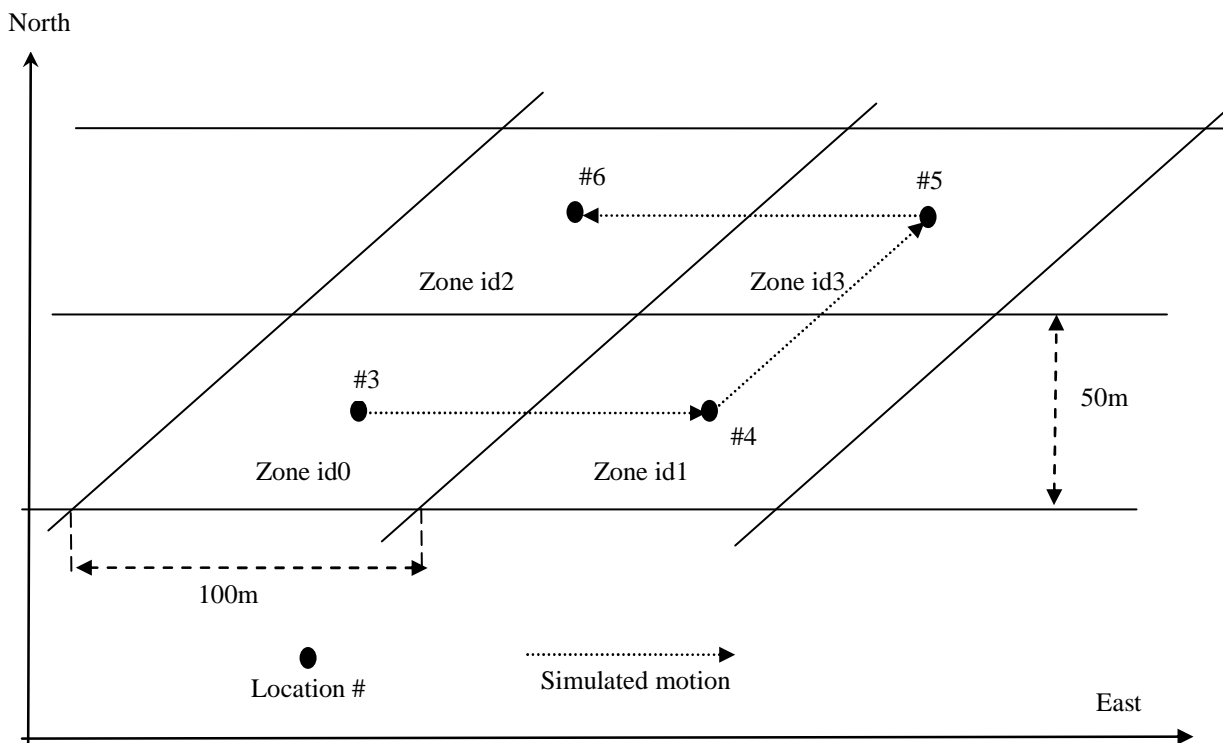

Figure 4.11.2-1: Zones and motions for scenario #3 for V2X testing (not to scale)

- Nominal start time:
1st January 2012 00:31:00 (GPS time) (UTC time: TBD).
- Visible satellites to be simulated are given in Table 4.11.2-5 and are above 15 degrees elevation with respect to the UE. These satellites have been selected to give a reasonable HDOP for the duration of the test.

Table 4.11.2-5: Satellites to be simulated for V2X and MCS testing

GNSS supported by UE	SV IDs of Satellites to be simulated ⁽¹⁾
GPS	1, 11, 17, 20, 23, 28
GLONASS	3, 4, 9, 10, 18, 20
Galileo	5, 10, 11, 18, 19, 20
BDS	FFS

Note 1: Where the UE supports more than one GNSS then all the relevant satellites are simulated

- The levels of the simulated satellites are given in Table 4.11.2-6 and shall be generated with an accuracy of +/- [1] dB. These conditions are defined for when there is no GNSS assistance data available at the UE and are specified in TS 36.133 [39] clause B.6.

Table 4.11.2-6: GNSS Reference Signal Power Requirements

System	Parameters	Unit	Value
	Number of generated satellites per system	-	6
GPS ⁽¹⁾	Reference signal power level for all satellites	dBm	-128.5
Galileo	Reference signal power level for all satellites	dBm	-127
GLONASS	Reference signal power level for all satellites	dBm	-131
BDS	Reference signal power level for all satellites	dBm	-133
NOTE 1: "GPS" here means GPS L1 C/A, Modernized GPS, or both, dependent on UE capabilities.			
NOTE 2: The DUT UE shall support at least one system and will be configured for the supported system(s).			

- Ionospheric model: simulated values are given in Tables 4.11.2-7 and 4.11.2-8.

Table 4.11.2-7: Klobuchar ionospheric model for GPS or GLONASS or BDS if supported by the UE

Model element	Units	Value/remark
alfa0	seconds	4.6566129 10E-9
alfa1	sec/semi-circle	1.4901161 10E-8
alfa2	sec/(semi-circle) ²	-5.96046 10E-8
alfa3	sec/(semi-circle) ³	-5.96046 10E-8
beta0	seconds	79872
beta1	sec/semi-circle	65536
beta2	sec/(semi-circle) ²	-65536
beta3	sec/(semi-circle) ³	-393216

Table 4.11.2-8: neQuick ionospheric model for Galileo if supported by the UE

Model Element	Units	Value/remark
ai0	solar flux unit	64.4
ai1	solar flux unit/degree	0
ai2	solar flux unit/degree ²	0

- Tropospheric model: STANAG with SRI equal to 324.8, as defined in STANAG 4294 [70].

5 Test environment for RF test

This section contains all the exceptions of the common test parameters specified in clause 4 for specific needs of test cases defined in TS 36.521-1 [21]. Exceptions specified in clause 5 overwrite the parameter settings of clause 4; exceptions defined within the test cases overwrite parameter settings of clause 4 and 5.

5.1 Requirements of test equipment

No common RF test environment requirements are specified in addition to the common requirements described in clause 4.2. Specific RF requirements are indicated within the test cases defined in TS 36.521-1 [21].

5.2 RF Reference system configurations

5.2.1 Common parameters for simulated E-UTRA cells

For BL/CE testing the same content of system information blocks SIB2, SIB3, SIB5 and SIB13 are used for broadcasting on BCCH and/or BCCH-BR.

5.2.1.1 Combinations of system information blocks

The combination of system information blocks required by a test case depends on the test case scenario. In this clause, the following combinations of system information blocks are defined.

Combination 1 is the default combination which applies to the following test case scenarios:

- E-UTRA FDD single cell scenario
- E-UTRA TDD single cell scenario
- E-UTRA FDD intra-frequency multi cell scenario
- E-UTRA TDD intra-frequency multi cell scenario

Combination 2 applies to the following test case scenarios:

- E-UTRA FDD + MBMS
- E-UTRA TDD + MBMS

Combination 3 applies to the following test case scenarios:

- E-UTRA FDD intra-band carrier aggregation component carriers cell scenario
- E-UTRA FDD inter-band carrier aggregation component carriers cell scenario
- E-UTRA TDD intra-band carrier aggregation component carriers cell scenario

The combinations of system information blocks for test cases in TS 36.521-1 [21] is defined in table 5.2.1.1-1.

Table 5.2.1.1-1: Combinations of system information blocks

Combination No.	System information block type											
	SIB2	SIB3	SIB4	SIB5	SIB6	SIB7	SIB8	SIB9	SIB10	SIB11	SIB12	SIB13
1	X	X										
2	X	X										X
3	X	X		X								

5.2.1.2 Scheduling of system information blocks

The scheduling configurations for combinations of system information blocks are defined in the following tables. SIB1 will be transmitted during subframes#5 which SFN mod 2 = 0, and SIB2+SIB3 will be transmitted during subframes#5 which SFN mod 2 = 1 with 8 radio frames periodicity. SIB5 will be transmitted during subframes#5 which SFN mod 2 = 1 with 64 radio frames periodicity

Table 5.2.1.2-1: Scheduling for combination 1

Scheduling Information No.	Periodicity [radio frames]	Mapping of system information blocks
1	8	SIB2, SIB3

Table 5.2.1.2-2: Scheduling for combination 2

Scheduling Information No.	Periodicity [radio frames]	Mapping of system information blocks
1	8	SIB2, SIB3
2	64	SIB13

Table 5.2.1.2-3: Scheduling for combination 3

Scheduling Information No.	Periodicity [radio frames]	Mapping of system information blocks
1	8	SIB2, SIB3
2	64	SIB5

5.2.1.3 Common contents of system information messages

- MasterInformationBlock

As defined in Table 4.4.3.2-1 without exceptions.

- SystemInformation

As defined in Table 5.2.1.3-1As defined in Table without exceptions.

Table 5.2.1.3-1: SystemInformation

Derivation Path: Clause 4.4.3.2 Table 4.4.3.2-2			
Information Element	Value/remark	Comment	Condition
SystemInformation ::= SEQUENCE {			
criticalExtensions CHOICE {			
systemInformation-r8 SEQUENCE {			
sib-TypeAndInfo SEQUENCE (SIZE (1..maxSIB)) OF CHOICE {}	See subclause 5.2.1.1 and 5.2.1.2		
criticalExtensionsFuture SEQUENCE {}	Not present		
}			
}			
}			

- SystemInformationBlockType1

As defined in Table 4.4.3.2-3 with the following exceptions:

Table 5.2.1.3-2: SystemInformationBlockType1 exceptions

Derivation Path: Clause 4.4.3.2 Table 4.4.3.2-3			
Information Element	Value/remark	Comment	Condition
SystemInformationBlockType1 ::= SEQUENCE {			
si-WindowLength	ms40		
}			

- SystemInformationBlockType1-BR-r13

As defined in Table 4.4.3.2-3 with the following exceptions:

Table 5.2.1.3-2A: SystemInformationBlockType1-BR-r13 exceptions

Derivation Path: Clause 4.4.3.2 Table 4.4.3.2-3A			
Information Element	Value/remark	Comment	Condition
SystemInformationBlockType1-BR-r13 ::= SEQUENCE {			
si-WindowLength-BR-r13	ms40		
}			

- SystemInformationBlockType2

As defined in Table 4.4.3.3-1 with the following exceptions:

Table 5.2.1.3-3: SystemInformationBlockType2 exceptions

Derivation Path: Clause 4.4.3.3 Table 4.4.3.3-1			
Information Element	Value/remark	Comment	Condition
SystemInformationBlockType2 ::= SEQUENCE {			
timeAlignmentTimerCommon	infinity		
}			

5.2A Generic RF procedures

The UE test state used for testing is specified in the individual test cases in the corresponding test specification TS 36.521-1 [21] or TS 36.521-3 [34].

This clause describes UE test states which can be used in the initial condition of many test cases defined in TS 36.521-1 [21] and TS 36.521-3 [34].

5.2A.1 UE RF test states

Table 5.2A.1-1: The E-UTRAN UE states

		RRC	ECM	EMM	ESM	UE Test Mode
State 2A-RF	Registered, Idle Mode, UE Test Mode Activated	RRC_IDLE	ECM-IDLE	EMM-REGISTERED	1 default EPS bearer context active	Active
State 2A-RF-CE	Registered, Idle Mode, Cell supporting BL/CE UE, UE Test Mode Activated	RRC_IDLE	ECM-IDLE	EMM-REGISTERED	1 default EPS bearer context active	Active
State 3A-RF	Generic Default RB Established, UE Test Mode Activated	RRC_CONNECTED 1 data radio bearer configured	ECM-CONNECTED	EMM-REGISTERED	1 default EPS bearer context active	Active
State 3A-RF-CE	Generic Default RB Established, Cell supporting BL/CE UE, UE Test Mode Activated	RRC_CONNECTED 1 data radio bearer configured	ECM-CONNECTED	EMM-REGISTERED	1 default EPS bearer context active	Active
State 3A-RF-DC1	DC MCG/SCG Dedicated RB established, UE Test Mode Activated	RRC_CONNECTED 2 data radio bearers configured	ECM_CONNECTED	EMM-REGISTERED	1 default EPS bearer context active on the PCell 1 dedicated EPS bearer context(s) active on the PSCell	Active
State 3A-RF-DC2	DC Split Default RB established, UE Test Mode Activated	RRC_CONNECTED 1 data radio bearer configured	ECM_CONNECTED	EMM-REGISTERED	1 default EPS bearer context active on the PCell and PSCell with UL transmission of PDCP SDUs on PSCell	Active
State 3A-RF-V2X	Generic Default RB Established, UE Test Mode Activated, V2X Setup	RRC_CONNECTED 1 data radio bearer configured	ECM-CONNECTED	EMM-REGISTERED	1 default EPS bearer context active	Active
State 3B-RF	Reserved for E-UTRAN UE state for RRM testing as described in Table 7.2A.1-1					
State 4A-RF	Loopback Activation without looped data	RRC_CONNECTED	ECM-CONNECTED	EMM-REGISTERED	1 default EPS bearer context active	Active
State 4A-RF-CE	Loopback Activation without looped data, Cell supporting BL/CE UE	RRC_CONNECTED	ECM-CONNECTED	EMM-REGISTERED	1 default EPS bearer context active	Active

State 4A-RF- DC1	DC MCG/SCG DRBs Loopback Activation without looped data	RRC_CONNECTED	ECM-CONNECTED	EMM-REGISTERED	1 default EPS bearer context active on the PCell 1 dedicated EPS bearer context(s) active on the PSCell	Active
State 4A-RF- DC2	DC Split DRB Loopback Activation without looped data	RRC_CONNECTED	ECM-CONNECTED	EMM-REGISTERED	1 default EPS bearer context active on the PCell and PSCell	Active
State 4A-RF- V2X	Loopback Activation without looped data, V2X Setup	RRC_CONNECTED	ECM-CONNECTED	EMM-REGISTERED	1 default EPS bearer context active	Active

5.2A.1A Registered, Idle Mode, UE Test Mode Activated (State 2A-RF)

5.2A.1A.1 Initial conditions

System Simulator:

- 1 cell, default parameters.
- The procedure shall be performed under ideal radio conditions as defined in clause 5

User Equipment:

- The Test USIM shall be inserted.

5.2A.1A.2 Definition of system information messages

The default system information messages are used.

5.2A.1A.3 Procedure

Table 5.2A.1A.3-1: UE registration with test mode activation procedure (state 1 to state 2A-RF)

Step	Procedure	Message Sequence	
		U - S	Message
1 to 9a2	Steps 1 to 9a2 as specified in the procedure in clause 4.5.2.3 take place	-	-
10	The SS transmits an ACTIVATE TEST MODE message to activate UE radio bearer test mode procedure.	<--	RRC: <i>DLInformationTransfer</i> TC: ACTIVATE TEST MODE
11	The UE transmits an ACTIVATE TEST MODE COMPLETE message.	-->	RRC: <i>ULInformationTransfer</i> TC: ACTIVATE TEST MODE COMPLETE
12	The SS transmits a <i>SecurityModeCommand</i> message to activate AS security.	<--	RRC: <i>SecurityModeCommand</i>
13	The UE transmits a <i>SecurityModeComplete</i> message and establishes the initial security configuration.	-->	RRC: <i>SecurityModeComplete</i>
14	The SS transmits a <i>UECapabilityEnquiry</i> message to initiate the UE radio access capability transfer procedure.	<--	RRC: <i>UECapabilityEnquiry</i>
15	The UE transmits a <i>UECapabilityInformation</i> message to transfer UE radio access capability.	-->	RRC: <i>UECapabilityInformation</i>
16	The SS transmits an <i>RRCCONNECTIONRECONFIGURATION</i> message to establish the default bearer with condition SRB2-DRB(1, 0) according to 4.8.2.2.1.1. This message includes the ATTACH ACCEPT message. The ACTIVATE DEFAULT EPS BEARER CONTEXT REQUEST message is piggybacked in ATTACH ACCEPT.	<--	RRC: <i>RRCCONNECTIONRECONFIGURATION</i> NAS: ATTACH ACCEPT NAS: ACTIVATE DEFAULT EPS BEARER CONTEXT REQUEST
17	The UE transmits an <i>RRCCONNECTIONRECONFIGURATIONCOMPLETE</i> message to confirm the establishment of default bearer.	-->	RRC: <i>RRCCONNECTIONRECONFIGURATIONCOMPLETE</i>
-	EXCEPTION: In parallel to the event described in step 18 below the generic procedure for IP address allocation in the U-plane specified in TS 36.508 subclause 4.5A.1 takes place performing IP address allocation in the U-plane if requested by the UE.		
18	This message includes the ATTACH COMPLETE message. The ACTIVATE DEFAULT EPS BEARER CONTEXT ACCEPT message is piggybacked in ATTACH COMPLETE.	-->	RRC: <i>ULInformationTransfer</i> NAS: ATTACH COMPLETE NAS: ACTIVATE DEFAULT EPS BEARER CONTEXT ACCEPT
-	EXCEPTION: Steps 18a1 to 18b6 describe behaviour that depends on UE configuration; the "lower case letter" identifies a step sequence that takes place if a particular configuration has been chosen	-	-
18a1	IF IMS voice not supported and pc_voice_PS_1_CS_2, pc_attach and pc_TAU_connected_in_IMS are set to TRUE (Note 1) THEN the UE transmits a TRACKING AREA UPDATE REQUEST message.	-->	RRC: <i>ULInformationTransfer</i> NAS: TRACKING AREA UPDATE REQUEST
18a2	The SS transmits a TRACKING AREA UPDATE ACCEPT message.	<--	RRC: <i>DLInformationTransfer</i> NAS: TRACKING AREA UPDATE ACCEPT
18a3	The UE transmits a TRACKING AREA UPDATE COMPLETE message.	-->	RRC: <i>ULInformationTransfer</i> NAS: TRACKING AREA UPDATE COMPLETE
18b1	ELSE IF IMS voice not supported and pc_voice_PS_1_CS_2, pc_attach and	<--	RRC: <i>RRCCONNECTIONRELEASE</i>

	pc_TAU_idle_in_IMS are set to TRUE (Note 2) THEN the SS transmits an <i>RRCCConnectionRelease</i> message to release the RRC connection.		
18b2	The UE transmits an <i>RRCCConnectionRequest</i> message.	-->	RRC: <i>RRCCConnectionRequest</i>
18b3	The SS transmit an <i>RRCCConnectionSetup</i> message.	<--	RRC: <i>RRCCConnectionSetup</i>
18b4	The UE transmits an <i>RRCCConnectionSetupComplete</i> message including a TRACKING AREA UPDATE REQUEST message.	-->	RRC: <i>RRCCConnectionSetupComplete</i> NAS: TRACKING AREA UPDATE REQUEST
18b5	The SS transmits a TRACKING AREA UPDATE ACCEPT message.	<--	RRC: <i>DLInformationTransfer</i> NAS: TRACKING AREA UPDATE ACCEPT
18b6	The UE transmits a TRACKING AREA UPDATE COMPLETE message.	-->	RRC: <i>ULInformationTransfer</i> NAS: TRACKING AREA UPDATE COMPLETE
19	The SS transmits an <i>RRCCConnectionRelease</i> message to release RRC connection and move to RRC_IDLE (State 2A-RF).	<--	RRC: <i>RRCCConnectionRelease</i>
NOTE 1: The procedure is used with specific message with no IMS voice network support. The UE is configured for voice domain preference IMS PS voice preferred, CS Voice as secondary and to initiate EPS attach. The UE implementation supports TAU in connected mode.			
NOTE 2: The procedure is used with specific message with no IMS voice network support. The UE is configured for voice domain preference IMS PS voice preferred, CS Voice as secondary and to initiate EPS attach. The UE implementation supports TAU in idle mode.			

5.2A.1A.4 Specific message contents

All specific message contents shall be referred to clause 4.6, 4.7 and 4.7A with the exceptions below.

Table 5.2A.1A.4-1: *RRCCConnectionRequest* (Step 2 and 19b2)

Derivation Path: Table 4.6.1-16			
Information Element	Value/remark	Comment	Condition
<i>RRCCConnectionRequest</i> ::= SEQUENCE {			
criticalExtensions CHOICE {			
<i>rrcConnectionRequest-r8</i> SEQUENCE {			
ue-Identity	Any allowed value		
}			
}			
}			

Table 5.2A.1A.4-2: *UECapabilityInformation* (Step 15)

Derivation Path: Table 4.6.1-23			
Information Element	Value/remark	Comment	Condition
<i>UECapabilityInformation</i> ::= SEQUENCE {			
criticalExtensions CHOICE {			
c1 CHOICE{			
<i>ueCapabilityInformation-r8</i>	Any allowed value		
}			
}			
}			

Table 5.2A.1A.4-3: ATTACH ACCEPT (Step 16)

Derivation Path: TS 36.508 Table 4.7.2-1			
Information Element	Value/remark	Comment	Condition
EPS network feature support	'0000 0000'B	IMS voice over PS session in S1 mode not supported	NON pc_Disable_ E- UTRA_NOI MSVoIP
	'0000 0001'B	IMS voice over PS session in S1 mode supported	pc_Disable_ E- UTRA_NOI MSVoIP
Additional update result	Not present		

Table 5.2A.1A.4-4: ACTIVATE DEFAULT EPS BEARER CONTEXT REQUEST (Step 16)

Derivation Path: Table 4.7.3-6			
Information Element	Value/remark	Comment	Condition
EPS QoS	See Reference default EPS bearer context #1 in table 6.6.1-1		NON pc_Disable_ E- UTRA_NOI MSVoIP
	See Reference default EPS bearer context #2 in table 6.6.1-1		pc_Disable_ E- UTRA_NOI MSVoIP
Access point name	The SS defines a Default APN or, if the UE transmits an ESM INFORMATION RESPONSE message providing an APN, the SS shall use this value if it is not the IMS APN. If it is the default IMS APN, the SS defines a Default APN.		NON pc_Disable_ E- UTRA_NOI MSVoIP
	IMS.apn.epc.mnc<MNC>.mcc<MCC>.3gppnetwork.org The <MNC> and <MCC> are set to the same values as in IMSI.		pc_Disable_ E- UTRA_NOI MSVoIP
PDN address			IPv4v6
Length of PDN address contents	5 octets		
PDN type value	'001'B	IPv4	
PDN address information	IPv4 address	The SS provides a valid IPv4 address	
ESM cause	IF "PDN type" IE in step 4 is 'IPv4v6' THEN '00110010'B ELSE Not present	"PDN type IPv4 only allowed"	

Table 5.2A.1A.4-5: TRACKING AREA UPDATE REQUEST (Steps 19a1 and 19b4)

Derivation Path: 36.508 Table 4.7.2-27 with condition combined_TA_LA
--

Table 5.2A.1A.4-6: TRACKING AREA UPDATE ACCEPT (Steps 19a2 and 19b5)

Derivation Path: 36.508 Table 4.7.2-24 with condition combined_TA_LA			
Information Element	Value/remark	Comment	Condition
EPS network feature support	'0000 0000'B	IMS voice over PS session in S1 mode not supported	
Additional update result	Not present		

5.2A.1AA Registered, Idle Mode, UE Test Mode Activated in cell supporting BL/CE UE (State 2A-RF-CE)

The same assumptions and definitions apply as in clause 5.2A.1A.

5.2A.1AA.1 Initial conditions

System Simulator:

- 1 cell, default parameters.
- The procedure shall be performed under ideal radio conditions as defined in clause 5

User Equipment:

- The Test USIM shall be inserted.

5.2A.1AA.2 Definition of system information messages

The default system information messages are used with the exceptions below.

Table 5.2A.1AA.2-1: *MasterInformationBlock*

Derivation Path: 36.508 Table 4.4.3.2-1 using condition CEmodeB if the test case specifically tests CE mode B else use condition CEmodeA.

Table 5.2A.1AA.2-2: *SystemInformation-BR-r13*

Derivation Path: 36.508 Table 4.4.3.2-2A.

Table 5.2A.1AA.2-3: *SystemInformationBlockType1-BR-r13*

Derivation Path: 36.508 Table 4.4.3.2-3A.

5.2A.1AA.3 Procedure

For RF testing of BL-UE use the same procedure as in clause 5.2A.1A.3 with the exception below:

- BR-BCCH replaces BCCH.

For RF testing of non-BL UE supporting CE use the procedure in Table 5.2A.1AA.3-1.

Table 5.2A.1AA.3-1: UE registration procedure (state 1 to state 2A-RF-CE)

Step	Procedure	Message Sequence	
		U - S	Message
1	In addition to the system information broadcasted on BCCH the SS broadcasts <i>SystemInformation-BR-r13</i> , <i>SystemInformationBlockType1-BR-r13</i> and other relevant system information blocks as required by the specified combinations of system information blocks specified for the test case on BCCH-BR.	<--	RRC: SYSTEM INFORMATION (BCCH and BCCH-BR)
2 to 9a2	Same procedure for steps 2 to 9a2 as specified in the procedure in clause 4.5.2.3	-	-
10 to 19	Same procedure for steps 10 to 19 as specified in the procedure in clause 5.2A.1A.3	-	-

5.2A.1AA.4 Specific message contents

Same specific message content as in clause 5.2A.1A.4 with the exception below:

- In addition to any other conditions use the condition CEmodeB if the test case specifically tests CE mode B else use condition CEmodeA.

5.2A.2 Generic Default Radio Bearer Establishment, UE Test Mode Activated (State 3A-RF)

In tests referring to test mode State 3A-RF, in order to avoid any uncontrollable transmission of uplink U-plane data, test mode State 4A-RF (specified in 5.2A.3) may be used and configured instead.

5.2A.2.1 Initial conditions

System Simulator:

- 1 cell, default parameters.
- The procedure shall be performed under ideal radio conditions as defined in clause 5

User Equipment:

- The Test USIM shall be inserted.

5.2A.2.2 Definition of system information messages

The default system information messages are used.

5.2A.2.3 Procedure

Table 5.2A.2.3-1: UE registration with default EPS bearer establishment and test mode activation procedures

Step	Procedure	Message Sequence	
		U - S	Message
1		<--	RRC: SYSTEM INFORMATION (BCCH)
2 to 18	Steps 2 to 18 as specified in the procedure in clause 5.2A.1A.3 take place.	-	-

For Rel-11 or higher UEs, that support *frequencyBandRetrieval_r11*, where the UE has not sent all supported [band combinations in UE Capability Information \(Step 15](#) of table 5.2A.2.3-1) the following procedure shall be executed after the completion of the procedure in table 5.2A.2.3-1:

Table 5.2A.2.3-2: Retrieval of additional UE capabilities for Rel-11 and higher UEs that support frequencyBandRetrieval_r11

Step	Procedure	Message Sequence	
		U - S	Message
1 to 3	Steps 1 to 3 as specified in the procedure in clause 5.2A.7.3 take place.	-	-

5.2A.2.4 Specific message contents

All specific message contents shall be referred to clause 5.2A.1A.4 with the exception below:

- In addition to any other conditions use the condition CEmodeB if the test case specifically tests CE mode B else use condition CEmodeA.

5.2A.2A DC MCG/SCG Dedicated RB established, UE Test Mode Activate (State 3A-RF-DC1)

5.2A.2A.1 Initial conditions

System Simulator:

- 2 cells, default parameters.
- The procedure shall be performed under ideal radio conditions as defined in clause 5

User Equipment:

- The UE shall be in Generic Default RB Established, UE Test Mode Activated (State 3A-RF).

5.2A.2A.2 Definition of system information messages

The default system information messages are used.

5.2A.2A.3 Procedure

The establishment of MCG/SCG dedicated radio bearer connection is assumed to always be mobile terminated.

Table 5.2A.2A.3-1: Procedure for MCG/SCG dedicated bearer establishment

Step	Procedure	Message Sequence	
		U - S	Message
1	The SS adds the PSCell and configures a new SCG data radio bearer and the associated dedicated EPS bearer context.	<--	RRC: RRCConnectionReconfiguration NAS: ACTIVATE DEDICATED EPS BEARER CONTEXT REQUEST
2	The UE transmits an RRCConnectionReconfigurationComplete message to confirm the establishment of the new SCG data radio bearer, associated with the dedicated EPS bearer context in the NAS message.	-->	RRC: RRCConnectionReconfigurationComplete
3	The UE transmits an ACTIVATE DEDICATED EPS BEARER CONTEXT ACCEPT message.	-->	NAS: ACTIVATE DEDICATED EPS BEARER CONTEXT ACCEPT

5.2A.2A.4 Specific message contents

All specific message contents shall be referred to clause 5.2A.1A.4, with exceptions as below.

Table 5.2A.2A.4-1: RRCConnectionReconfiguration (Step 1, Table 5.2A.2A.3-1)

Derivation Path: 36.508, Table 4.6.1-8 using condition PSCell_Add_SCG_DRB

5.2A.2AA Generic Default Radio Bearer Establishment, UE Test Mode Activated in cell supporting BL/CE UE (State 3A-RF-CE)

In tests referring to test mode State 3A-RF-CE, in order to avoid any uncontrollable transmission of uplink U-plane data, test mode State 4A-RF-CE (specified in 5.2A.3AA) may be used and configured instead.

5.2A.2AA.1 Initial conditions

System Simulator:

- 1 cell, default parameters.
- The procedure shall be performed under ideal radio conditions as defined in clause 5

User Equipment:

- The Test USIM shall be inserted.

5.2A.2AA.2 Definition of system information messages

The default system information messages are used with the exceptions below.

Table 5.2A.2AA.2-1: MasterInformationBlock

Derivation Path: 36.508 Table 4.4.3.2-1 using condition CEmodeB if the test case specifically tests CE mode B else use condition CEmodeA.

Table 5.2A.2AA.2-2: SystemInformation-BR-r13

Derivation Path: 36.508 Table 4.4.3.2-2A.

Table 5.2A.2AA.2-3: SystemInformationBlockType1-BR-r13

Derivation Path: 36.508 Table 4.4.3.2-3A			
Information Element	Value/remark	Comment	Condition
schedulingInfoList-BR-r13 SEQUENCE (SIZE (1..maxSI-Message)) OF SEQUENCE {	n entries	n is the same number of entries, and listed in the same order, as in SchedulingInfoList (without suffix)	
si-Narrowband-r13[1]	1	Narrowband index 0	1.4 MHz BW
si-Narrowband-r13[1]	2	Narrowband index 1	3 MHz BW
si-Narrowband-r13[1]	4	Narrowband index 3	5 MHz BW or 15 MHz BW or 20 MHz BW
si-Narrowband-r13[1]	6	Narrowband index 5	10 MHz BW
si-TBS-r13[1]	b712		
....			
si-Narrowband-r13[n]	1	Narrowband index 0	1.4 MHz BW
si-Narrowband-r13[n]	2	Narrowband index 1	3 MHz BW
si-Narrowband-r13[n]	4	Narrowband index 3	5 MHz BW or 15 MHz BW or 20 MHz BW
si-Narrowband-r13[n]	6	Narrowband index 5	10 MHz BW
si-TBS-r13[n]	b712		
}			

Condition	Explanation
1.4 MHz BW	Used for cells with 1.4 MHz bandwidth
3 MHz BW	Used for cells with 3 MHz bandwidth
5 MHz BW	Used for cells with 5 MHz bandwidth
10 MHz BW	Used for cells with 10 MHz bandwidth
15 MHz BW	Used for cells with 15 MHz bandwidth
20 MHz BW	Used for cells with 20 MHz bandwidth

5.2A.2AA.3 Procedure

For RF testing of BL-UE use the procedure in Table 5.2A.2AA.3-1. For RF testing of non-BL UE supporting CE use the procedure in Table 5.2A.2AA.3-2.

Table 5.2A.2AA.3-1: UE registration with default EPS bearer establishment and test mode activation procedures

Step	Procedure	Message Sequence	
		U - S	Message
1		<--	RRC: SYSTEM INFORMATION (BR-BCCH)
2 to 18	Steps 2 to 18 as specified in the procedure in clause 5.2A.1A.3 take place.	-	-

Table 5.2A.2AA.3-2: UE registration procedure (state 1 to state 2A-RF-CE)

Step	Procedure	Message Sequence	
		U - S	Message
1	In addition to the system information broadcasted on BCCH the SS broadcasts <i>SystemInformation-BR-r13</i> , <i>SystemInformationBlockType1-BR-r13</i> and other relevant system information blocks as required by the specified combinations of system information blocks specified for the test case on BCCH-BR.	<--	RRC: SYSTEM INFORMATION (BCCH and BCCH-BR)
2 to 18	Steps 2 to 18 as specified in the procedure in clause 5.2A.1A.3 take place.	-	-

5.2A.2AA.4 Specific message contents

All specific message contents shall be referred to clause 5.2A.1A.4 with the exceptions below:

- In addition to any other conditions use the condition CEmodeB if the test case specifically tests CE mode B else use condition CEmodeA.

Table 5.2A.2AA.4-1: MPDCCH-Config-r13

Derivation Path: 36.508 Table 4.6.3-2B			
Information Element	Value/remark	Comment	Condition
mpdcch-config-r13 CHOICE[1] {			
setup SEQUENCE {			
mpdcch-config-r13 CHOICE[1] {			
setup SEQUENCE {			
csi-NumRepetitionCE-r13	sf1		
mpdcch-pdsch-HoppingConfig-r13	off		
mpdcch-StartSF-U ESS-r13 CHOICE {			
fdd-r13	v1		FDD
tdd-r13	v1		TDD
}			
mpdcch-NumRepetition-r13	r1	No repetitions to reduce impact on legacy E-UTRA test cases for category M1 UEs.	
mpdcch-Narrowband-r13	1	Narrowband index 0	
}			
}			

Condition	Explanation
FDD	FDD cell environment
TDD	TDD cell environment

5.2A.2B DC Split Default RB established, UE Test Mode Activate (State 3A-RF-DC2)

5.2A.2B.1 Initial conditions

Same as in sub-clause 5.2A.2A.1.

5.2A.2B.2 Definition of system information messages

The default system information messages are used.

5.2A.2B.3 Procedure

The establishment of split dedicated radio bearer connection is assumed to always be mobile terminated.

Table 5.2A.2B.3-1: Procedure for Dual Connectivity Split default bearer establishment

Step	Procedure	Message Sequence	
		U - S	Message
4	The SS adds a PSCell and configures new split data radio bearer	<--	RRC: RRCConnectionReconfiguration
5	The UE transmits an RRCConnectionReconfigurationComplete message to confirm the establishment of the split data radio bearer with UL transmission of PDCP SDUs on the PSCell	-->	RRC: RRCConnectionReconfigurationComplete

5.2A.2B.4 Specific message contents

All specific message contents shall be referred to clause 5.2A.1A.4, with exceptions as below.

Table 5.2A.2B.4-1: RRCConnectionReconfiguration (Step 4, Table 5.2A.2A.3-1)

Derivation Path: 36.508, Table 4.6.1-8 using condition PSCell_Add_Split_DRB

5.2A.2C Generic Default Radio Bearer Establishment, UE Test Mode Activated, V2X Setup (State 3A-RF-V2X)

5.2A.2C.1 Initial conditions

System Simulator:

- 1 cell, default parameters.
- 1 V2V transmitter for receiver characteristics or 1 V2V receiver for transmitter characteristics
- The procedure shall be performed under ideal radio conditions as defined in clause 5

User Equipment:

- The Test USIM shall be inserted.

5.2A.2C.2 Definition of system information messages

The default system information messages are used with the exceptions below:

Table 5.2A.1B.2-1: SystemInformationBlockType21

Derivation Path: 36.508 Table 4.4.3.3-19.

5.2A.2C.3 Procedure

For RF testing of V2X Communication, use the same procedure as in clause 5.2A.2.3.

5.2A.2C.4 Specific message contents

All specific message contents shall be referred to clause 5.2A.1A.4, with exceptions as below:

Table 5.2A.2A.4-1: RRCConnectionReconfiguration (Step 16, Table 5.2A.1A.3-1)

Derivation Path: 36.508, Table 4.6.1-8B using conditions SETUP and SCHEDULED
--

5.2A.3 Loopback Activation without looped data (State 4A-RF)

Editor's note: Test mode State 4A-RF is used and configured as an alternative to test mode State 3A-RF, to avoid any uncontrollable transmission of uplink U-plane data.

5.2A.3.1 Initial conditions

System Simulator:

- 1 cell, default parameters.
- The procedure shall be performed under ideal radio conditions as defined in clause 5

User Equipment:

- The UE shall be in Generic RB Establishment state, UE Test Mode Activated (State 3A-RF).

5.2A.3.2 Definition of system information messages

The default system information messages are used.

5.2A.3.3 Procedure

Table 5.2A.3.3-1: UE registration with default EPS bearer establishment and test mode activation procedures

Step	Procedure	Message Sequence	
		U - S	Message
1	The SS transmits a CLOSE UE TEST LOOP message to enter the UE test loop mode.	<--	RRC: <i>DLInformationTransfer</i> TC: CLOSE UE TEST LOOP
2	The UE transmits a CLOSE UE TEST LOOP COMPLETE message to confirm that loopback entities for the radio bearer(s) have been created and loop back is activated.	-->	RRC: <i>ULInformationTransfer</i> TC: CLOSE UE TEST LOOP COMPLETE

5.2A.3.4 Specific message contents

All specific message contents shall be referred to clause 4.5.4.4, with the exceptions below.

Table 5.2A.3.4-1: CLOSE UE TEST LOOP (in the preamble) (Step 1 in Table 5.2A.3.3-1)

Derivation Path: 36.509 clause 6.1			
Information Element	Value/remark	Comment	Condition
Protocol discriminator	1 1 1 1		
Skip indicator	0 0 0 0		
Message type	1 0 0 0 0 0 0 0		
UE test loop mode	0 0 0 0 0 0 0 0	UE test loop mode A	
UE test loop mode A LB setup			
Length of UE test loop mode A LB setup list in bytes	0 0 0 0 0 0 1 1	Length of one LB setup DRB (3 bytes)	
LB setup DRB	0 0 0 0 0 0 0 0, 0 0 0 0 0 0 0 0, 0 0 0 Q4 Q3 Q2 Q1 Q0	UL PDCP SDU size = 0 bits (0 bytes) Q4..Q0 = Data Radio Bearer identity number for the default radio bearer. See 36.509 clause 6.1	
UE test loop mode B LB setup	Not present		
UE test loop mode B LB setup	Not present		

5.2A.3A DC MCG/SCG DRBs Loopback Activation without looped data (State 4A-RF-DC1)

Editor’s note: Test mode State 4B-RF is used and configured as an alternative to test mode State 3B-RF, to avoid any uncontrollable transmission of uplink U-plane data.

5.2A.3A.1 Initial conditions

System Simulator:

- 1 cell, default parameters.
- The procedure shall be performed under ideal radio conditions as defined in clause 5

User Equipment:

- The UE shall be in DC MCG/SCG Dedicated RB established, UE Test Mode Activated (State 3A-RF-DC1).

5.2A.3A.2 Definition of system information messages

Same as in sub-clause 5.2A.3.2.

5.2A.3A.3 Procedure

Same as in sub-clause 5.2A.3.3.

5.2A.3A.4 Specific message contents

Same as in sub-clause 5.2A.3.4.

5.2A.3AA Loopback Activation without looped data in cell supporting BL/CE UE (State 4A-RF-CE)

Editor's note: Test mode State 4A-RF-CE is used and configured as an alternative to test mode State 3A-RF-CE, to avoid any uncontrollable transmission of uplink U-plane data.

5.2A.3AA.1 Initial conditions

System Simulator:

- 1 cell, default parameters.
- The procedure shall be performed under ideal radio conditions as defined in clause 5

User Equipment:

- The UE shall be in Generic RB Establishment state, UE Test Mode Activated (State 3A-RF).

5.2A.3AA.2 Definition of system information messages

The default system information messages are used with the exceptions below.

Table 5.2A.3AA.2-1: *MasterInformationBlock*

Derivation Path: 36.508 Table 4.4.3.2-1 using condition CEmodeB if the test case specifically tests CE mode B else use condition CEmodeA.

Table 5.2A.3AA.2-2: *SystemInformation-BR-r13*

Derivation Path: 36.508 Table 4.4.3.2-2A.

Table 5.2A.2AA.2-3: *SystemInformationBlockType1-BR-r13*

Derivation Path: 36.508 Table 4.4.3.2-3A.

5.2A.3AA.3 Procedure

Table 5.2A.3.3-1: UE registration with default EPS bearer establishment and test mode activation procedures

Step	Procedure	Message Sequence	
		U - S	Message
1	The SS transmits a CLOSE UE TEST LOOP message to enter the UE test loop mode.	<--	RRC: <i>DLInformationTransfer</i> TC: CLOSE UE TEST LOOP
2	The UE transmits a CLOSE UE TEST LOOP COMPLETE message to confirm that loopback entities for the radio bearer(s) have been created and loop back is activated.	-->	RRC: <i>ULInformationTransfer</i> TC: CLOSE UE TEST LOOP COMPLETE

5.2A.3AA.4 Specific message contents

Same as in clause 5.2A.3.4.

5.2A.3B DC Split DRB Loopback Activation without looped data (State 4A-RF-DC2)

Editor's note: Test mode State 4C-RF is used and configured as an alternative to test mode State 3C-RF, to avoid any uncontrollable transmission of uplink U-plane data.

5.2A.3B.1 Initial conditions

System Simulator:

- 1 cell, default parameters.
- The procedure shall be performed under ideal radio conditions as defined in clause 5

User Equipment:

- The UE shall be in DC Split Default RB established, UE Test Mode Activated (State 3A-RF-DC2).

5.2A.3B.2 Definition of system information messages

Same as in sub-clause 5.2A.3.2.

5.2A.3B.3 Procedure

Same as in sub-clause 5.2A.3.3.

5.2A.3B.4 Specific message contents

Same as in sub-clause 5.2A.3.4.

5.2A.3C Loopback Activation without looped data, V2X Setup (State 4A-RF-V2X)

Editor's note: Test mode State 4A-RF-V2X is used and configured as an alternative to test mode State 3A-RF-V2X, to avoid any uncontrollable transmission of uplink U-plane data.

5.2A.3C.1 Initial conditions

System Simulator:

- 1 cell, default parameters.

- 1 GNSS simulator
- 1 V2V transmitter for receiver characteristics or 1 V2V receiver for transmitter characteristics
- The procedure shall be performed under ideal radio conditions as defined in clause 5

User Equipment:

- The UE shall be in Generic RB Establishment state, UE Test Mode Activated, V2X Setup (State 3A-RF-V2X).

5.2A.3C.2 Definition of system information messages

Same as in sub-clause 5.2A.3.2.

5.2A.3C.3 Procedure

Same as in sub-clause 5.2A.3.3.

5.2A.3C.4 Specific message contents

All specific message contents shall be referred to clause 5.2A.3.4, with exceptions as below:

Table 5.2A.3C.4-1: ACTIVATE TEST MODE: V2X Communication

Derivation Path: 36.508, Table 4.7A-1 using condition UE TEST LOOP MODE E

Table 5.2A.3C.4-2: CLOSE UE TEST LOOP: V2X Communication

Derivation Path: 36.508, Table 4.7A-3 using condition UE TEST LOOP MODE E

5.2A.4 Procedure to configure SCC

Table 5.2A.4.-1: UE RRC reconfiguration with sCELLToAdd

Step	Procedure	Message Sequence	
		U - S	Message
1	The SS transmits an <i>RRCConnectionReconfiguration(sCellToAdd ModList)</i> message to establish the SCC(s).	<--	RRC: <i>RRCConnectionReconfiguration</i>
2	The UE transmits an <i>RRCConnectionReconfigurationComplete</i>	-->	RRC: <i>RRCConnectionReconfigurationComplete</i>
3	If not all SCCs are established, then repeat step 1 and 2.		

5.2 A.41. Specific message contents

All specific message contents shall be referred to clause 4.5.2A.4, with exceptions as below.

5.2A.4.1.1 Exceptions for all CA tests

RRCConnectionReconfiguration

Table 5.2A.4.1.1-1: RRCConnectionReconfiguration

Derivation Path: Clause 4.6.1 Table 4.6.1-8, condition SCell_AddMod

MAC configurations

Table 5.2A.4.1.1-2: MAC-MainConfig-RBC

Derivation Path: Clause 4.8.2.1.5 Table 5.5.1.1-1, condition Scell_AddMod			
Information Element	Value/remark	Comment	Condition
MAC-MainConfig-RBC ::= SEQUENCE {			
mac-MainConfig-v1020SEQUENCE {			SCell_AddMod
sCellDeactivationTimer-r10	Not present		
extendedBSR-Sizes-r10	Not Present		
extendedPHR-r10	Not Present		UL CA
Setup			
}			
}			

Condition	Explanation
SCell_AddMod	Addition or modification of Scell
UL CA	This condition is used for UL CA.

5.2A.4.1.2 Exceptions for UL CA tests

RadioResourceConfigCommonSCell-r10-DEFAULT

Table 5.2A.4.1.2-1: RadioResourceConfigCommonSCell-r10-DEFAULT

Derivation Path: Clause 4.6.3 Table 4.6.3-13A			
Information Element	Value/remark	Comment	Condition
RadioResourceConfigCommonSCell-r10 ::= SEQUENCE {			
ul-Configuration-r10 SEQUENCE {			UL CA
ul-FreqInfo-r10 SEQUENCE {			
ul-CarrierFreq-r10	Not Present	For FDD: If absent, the (default) value determined from the default TX-RX frequency separation defined in 3GPP TS 36.101 [27], table 5.7.3-1 applies. For TDD: This parameter is absent and it is equal to the downlink frequency.	
ul-Bandwidth-r10	Not Present	Same downlink bandwidth as used for target SCell	
additionalSpectrumEmissionSCell-r10	31 (CA_NS_31)		Intra-B UL CA
additionalSpectrumEmissionSCell-r10	1 (NS_01)		Inter-B UL CA
}			
soundingRS-UL-ConfigCommon-r10	release		
}			
}			

Condition	Explanation
-----------	-------------

UL CA	When UL Carrier Aggregation is used.
Intra-B UL CA	Intra-band Carrier Aggregation
Inter-B UL CA	Inter-band Carrier Aggregation

PhysicalConfigDedicatedSCell-r10-DEFAULT

Table 5.2A.4.1.2-2: PhysicalConfigDedicatedSCell-r10-DEFAULT

Derivation Path: Clause 4.6.3 Table 4.6.3-6A			
Information Element	Value/remark	Comment	Condition
PhysicalConfigDedicatedSCell-r10 ::= SEQUENCE {			
ul-Configuration-r10	Present		
ul-Configuration-r10 SEQUENCE {			UL CA
antennaInfoUL-r10	Not Present		
pusch-ConfigDedicatedSCell-r10	Not present		
uplinkPowerControlDedicatedSCell-r10	UplinkPowerControlDedicatedSCell-r10-DEFAULT		
cgi-ReportConfigSCell-r10	Not present		
soundingRS-UL-ConfigDedicated-r10	Not present		
soundingRS-UL-ConfigDedicated-v1020	Not present		
soundingRS-UL-ConfigDedicatedAperiodic-r10	Not present		
}			
}			

Condition	Explanation
UL CA	When UL Carrier Aggregation is used.

5.2A.5 Exceptions for felCIC tests

5.2A.5.1 Specific message contents

All specific message contents shall be referred to clause 4.6, with exceptions as below.

5.2A.5.1.1 Neighbour cell info for all felCIC test cases

Table 5.2A.5.1.1-1: RRCConnectionReconfiguration

Derivation Path: clause 4.6.1, Table 4.6.1-8: RRCConnectionReconfiguration			
Information Element	Value/remark	Comment	Condition
RRCConnectionReconfiguration ::= SEQUENCE {			
rrc-TransactionIdentifier	RRC-TransactionIdentifier-DL		
criticalExtensions CHOICE {			
c1 CHOICE{			
rrcConnectionReconfiguration-r8 SEQUENCE {			
radioResourceConfigDedicated	RadioResourceConfigDedicated-SRB2-DRB(n, m)		SRB2-DRB(n, m)
securityConfigHO	Not present		
nonCriticalExtension SEQUENCE {}	Not present		
}			
}			
}			
}			

Table 5.2A.5.1.1-2: RadioResourceConfigDedicated-SRB2-DRB(n, m)

Derivation Path: clause 4.6.3, Table 4.6.3-16 RadioResourceConfigDedicated-SRB2-DRB(n,m)			
Information Element	Value/remark	Comment	Condition
RadioResourceConfigDedicated-SRB2-DRB(n, m) ::= SEQUENCE {			
neighCellsCRS-Info-r11 ::= CHOICE {			
setup SEQUENCE {			
CRS-AssistanceInfoList-r11 ::= SEQUENCE (SIZE (1..maxCellReport)) OF CRS-AssistanceInfo-r11			
CRS-AssistanceInfo-r11 ::= SEQUENCE {		CRS information for all the configured neighbour cells	
physCellId-r11	Based on simulated cell requirements		
antennaPortsCount-r11	Based on simulated cell requirements		
mbsfn-SubframeConfigList-r11	Based on simulated cell requirements		
}			
}			
}			
}			

5.2A.6 Exceptions for NAICS tests

5.2A.6.1 NAICS specific RRC Connection reconfiguration procedure

5.2A.6.1.1 Procedure

Table 5.2A.6.1.1-1: Procedure for RRC connection reconfiguration

Step	Procedure	Message Sequence	
		U - S	Message
1	The SS transmits and RRCConnectionReconfiguration message.	<--	RRC: RRCConnectionReconfiguration
2	The UE transmits an RRCConnectionReconfigurationComplete message	-->	RRC: RRCConnectionReconfigurationComplete

5.2A.6.1.1 Specific message contents

Same as in 5.2A.6.2 with the condition “NAICS_ONLY”.

5.2A.6.2 Specific message contents

All specific message contents shall be referred to clause 4.6, with exceptions as below.

5.2A.6.2.1 RRCConnectionReconfiguration for setting up and releasing NAICS configuration in NAICS test cases

Table 5.2A.6.2.1-1: RRCConnectionReconfiguration

Derivation Path: 36.331 clause 6.2.2			
Information Element	Value/remark	Comment	Condition
RRCConnectionReconfiguration ::= SEQUENCE {			
rrc-TransactionIdentifier	RRC-TransactionIdentifier-DL		
criticalExtensions CHOICE {			
c1 CHOICE{			
rrcConnectionReconfiguration-r8 SEQUENCE {			
dedicatedInfoNASList	Not present		NAICS_ONLY, NAICS_RELEASE
	Set according to specific message content		SRB2- DRB_NAICS(n, m)
radioResourceConfigDedicated	RadioResourceConfigDedicated-SRB2- DRB_NAICS_ONLY		NAICS_ONLY
	RadioResourceConfigDedicated-SRB2- DRB_NAICS(n, m)		SRB2- DRB_NAICS(n, m)
	RadioResourceConfigDedicated_NAICS_RELEASE		NAICS_RELEASE
securityConfigHO	Not present		
}			
}			
}			
}			

Condition	Explanation
SRB2-DRB_NAICS(n,m)	Establishment of a SRB and DRB combination with n x AM DRB and m x UM DRB (including establishment of SRB2) plus NAICS information
NAICS_ONLY	Stand alone NAICS set-up
NAICS_RELEASE	Standalone release of all NAICS configurations

Table 5.2A.6.2.1-2: RadioResourceConfigDedicated-SRB2-DRB_NAICS(n, m)

Derivation Path: clause 4.6.3, Table 4.6.3-16 RadioResourceConfigDedicated-SRB2-DRB(n,m)			
Information Element	Value/remark	Comment	Condition
RadioResourceConfigDedicated-SRB2- DRB_NAICS(n, m) ::= SEQUENCE {			
neighCellsCRS-Info-r11	NeighCellsCRS-Info_NAICS		
}			

Table 5.2A.6.2.1-3: RadioResourceConfigDedicated-SRB2-DRB_NAICS_ONLY

Derivation Path: 36.331 clause 6.3.2			
Information Element	Value/remark	Comment	Condition
RadioResourceConfigDedicated-SRB2- DRB_NAICS_ONLY ::= SEQUENCE {			
neighCellsCRS-Info-r11	NeighCellsCRS-Info_NAICS		
}			

Table 5.2A.6.2.1-4: *NeighCellsCRS-Info_NAICS*

Derivation Path: 36.331 clause 6.3.2			
Information Element	Value/remark	Comment	Condition
neighCellsCRS-Info-r11 ::= CHOICE {			
setup SEQUENCE {			
naics-Info-r12 ::= CHOICE {			
setup ::= SEQUENCE {			
neighCellsToReleaseList-r12	Not present		
neighCellsToAddModList-r12 SEQUENCE (SIZE (1..maxNeighCell-r12)) OF NeighCellsInfo-r12			
NeighCellsInfo-r12 ::= SEQUENCE {			
physCellId-r12	Based on simulated cell requirements		
p-b-r12	Based on simulated cell requirements		
crs-PortsCount-r12	Based on simulated cell requirements		
mbsfn-SubframeConfig-r12	Not present		
p-aList-r12 SEQUENCE (SIZE (1..maxP-a-PerNeighCell-r12)) OF P-a			
P-a	dB-6		
P-a	dB-3		
P-a	dB0		
transmissionModeList-r12	'01110110'B	Transmission modes 2,3,4,8 and 9	
resAllocGranularity-r12	1		
}			
servCellp-a-r12	Not present		
}			
}			
}			

Table 5.2A.6.2.1-5: *RadioResourceConfigDedicated_NAICS_RELEASE*

Derivation Path: 36.331 clause 6.3.2			
Information Element	Value/remark	Comment	Condition
RadioResourceConfigDedicated-SRB2-DRB_NAICS_ONLY ::= SEQUENCE {			
neighCellsCRS-Info-r11 ::= CHOICE {			
setup SEQUENCE {			
naics-Info-r12 ::= CHOICE {			
release	NULL		
}			
}			
}			
}			

5.2A.7 Procedure to retrieve additional UE Capabilities for Rel-11 and higher UEs that support frequencyBandRetrieval_r11

5.2A.7.1 Initial conditions

System Simulator:

- 1 cell, default parameters.
- The procedure shall be performed under ideal radio conditions as defined in clause 5

User Equipment:

- The Test USIM shall be inserted.

5.2A.7.2 Definition of system information messages

The default system information messages are used.

5.2A.7.3 Procedure

Table 5.2A.7.3-1: Procedure to retrieve additional UE capabilities

Step	Procedure	Message Sequence	
		U - S	Message
1	If the UE sent <i>freqBandretrieval-r11</i> in previous <i>UECapabilityInformation</i> , the SS transmits a <i>UECapabilityEnquiry</i> message to initiate the UE radio access capability transfer procedure	<--	RRC: <i>UECapabilityEnquiry</i>
2	The UE transmits a <i>UECapabilityInformation</i> message to transfer UE radio access capability.	-->	RRC: <i>UECapabilityInformation</i>
3	If the UE did not report all supported E-UTRA bands relevant to the tested bands, repeat steps 1 and 2.		

5.2A.7.4 Specific message contents

Table 5.2A.7.4-1: *UECapabilityEnquiry* (Step 1)

Derivation Path: Clause 6.2.2 Table 4.6.1-22			
Information Element	Value/remark	Comment	Condition
<i>UECapabilityEnquiry</i> ::= SEQUENCE {			
rrc-TransactionIdentifier	RRC-TransactionIdentifier-DL		
criticalExtensions CHOICE {			
c1 CHOICE {			
ueCapabilityEnquiry-r8 SEQUENCE {			
ue-CapabilityRequest	eutra		
nonCriticalExtension SEQUENCE {			
lateNonCriticalExtension	Not present		
nonCriticalExtension SEQUENCE {			
requestedFrequencyBands-r11 SEQUENCE (SIZE (1..16)) OF SEQUENCE{			
FreqBandIndicator-r11			
}			
nonCriticalExtension SEQUENCE {}	Not Present		
}			
}			
}			
}			
}			

5.2A.8 Exceptions for DL Control channel interference mitigation (Type A and Type B) tests

5.2A.8.1 Specific message contents

All specific message contents shall be referred to clause 4.6, with exceptions as below.

5.2A.8.1.1 Neighbour cell info for all CCIM test cases

Table 5.2A.5.1.1-1: RRCConnectionReconfiguration

Derivation Path: clause 4.6.1, Table 4.6.1-8: RRCConnectionReconfiguration			
Information Element	Value/remark	Comment	Condition
RRCConnectionReconfiguration ::= SEQUENCE {			
rrc-TransactionIdentifier	RRC-TransactionIdentifier-DL		
criticalExtensions CHOICE {			
c1 CHOICE{			
rrcConnectionReconfiguration-r8 SEQUENCE {			
radioResourceConfigDedicated	RadioResourceConfigDedicated-SRB2-DRB(n, m)		SRB2-DRB(n, m)
securityConfigHO	Not present		
nonCriticalExtension SEQUENCE {}	Not present		
}			
}			
}			
}			

Table 5.2A.5.1.1-2: RadioResourceConfigDedicated-SRB2-DRB(n, m)

Derivation Path: clause 4.6.3, Table 4.6.3-16 RadioResourceConfigDedicated-SRB2-DRB(n,m)			
Information Element	Value/remark	Comment	Condition
RadioResourceConfigDedicated-SRB2-DRB(n, m) ::= SEQUENCE {			
neighCellsCRS-Info-r13 ::= CHOICE {			
setup SEQUENCE {			
CRS-AssistanceInfoList-r13 ::= SEQUENCE (SIZE (1..maxCellReport)) OF CRS-AssistanceInfo-r13			
CRS-AssistanceInfo-r13 ::= SEQUENCE {		CRS information for all the configured neighbour cells	
physCellId-r13	Based on simulated cell requirements		
antennaPortsCount-r13	Based on simulated cell requirements		
}			
}			
}			
}			

5.3 Default RRC message and information elements contents

5.3.1 Radio resource control information elements

As defined in clause 4.6.3 with the following exceptions:

Table 5.3.1-1: TDD-Config-DEFAULT

Derivation Path: Clause 4.6.3 Table 4.6.3-23			
Information Element	Value/remark	Comment	Condition
TDD-Config-DEFAULT ::= SEQUENCE {			
subframeAssignment	sa1		
specialSubframePatterns	ssp4		RF
}			

Condition	Explanation
RF	For all the RF tests specified in 36.521-1

Table 5.3.1-2: RadioResourceConfigCommonSIB-DEFAULT

Derivation Path: Clause 4.6.3 Table 4.6.3-14			
Information Element	Value/remark	Comment	Condition
RadioResourceConfigCommonSIB-DEFAULT ::= SEQUENCE {			
rach-ConfigCommon	RACH-ConfigCommon-DEFAULT		
bcch-Config	BCCH-Config-DEFAULT		
pcch-Config	PCCH-Config-DEFAULT		
prach-Config	PRACH-ConfigSIB-DEFAULT		
pdsch-ConfigCommon	PDSCH-ConfigCommon-DEFAULT		
pusch-ConfigCommon	PUSCH-ConfigCommon-DEFAULT		
pucch-ConfigCommon	PUCCH-ConfigCommon-DEFAULT		
soundingRS-UL-ConfigCommon CHOICE {			
release	NULL		
}			
uplinkPowerControlCommon	UplinkPowerControlCommon-DEFAULT		
ul-CyclicPrefixLength	len1		
}			

Table 5.3.1-3: PRACH-Config-DEFAULT

Derivation Path: Clause 4.6.3 Table 4.6.3-7			
Information Element	Value/remark	Comment	Condition
PRACH-Config-DEFAULT ::= SEQUENCE {			
prach-ConfigInfo SEQUENCE {			
prach-ConfigIndex	3		TDD
}			
}			

Condition	Explanation
TDD	TDD cell environment

Table 5.3.1-4: RadioResourceConfigCommonSCell-r10-DEFAULT

Derivation Path: Clause 4.6.3 Table 4.6.3-13A			
Information Element	Value/remark	Comment	Condition
RadioResourceConfigCommonSCell-r10 ::= SEQUENCE {			
ul-Configuration-r10	Not Present		DL CA only
}			

Table 5.3.1-5: PhysicalConfigDedicatedSCell-r10-DEFAULT

Derivation Path: Clause 4.6.3 Table 4.6.3-6A			
Information Element	Value/remark	Comment	Condition
PhysicalConfigDedicatedSCell-r10 ::= SEQUENCE {			
ul-Configuration-r10	Not Present		DL CA only
}			

Condition	Explanation
DL CA only	When DL CA without UL CA is used.

5.3.2 Measurement information elements

As defined in clause 4.6.6 with the following exceptions:

Table 5.3.2-1: MeasDS-Config-DEFAULT

Derivation Path: clause 4.6.6 Table 4.6.6-1B			
Information Element	Value/remark	Comment	Condition
MeasDS-Config-DEFAULT ::= CHOICE {			
release	NULL		
setup SEQUENCE {			
dmtc-PeriodOffset-r12 CHOICE {			
ms40-r12	0		LAA_Receiver
ms80-r12	0		LAA_DemodCSI
}			
}			
}			

Condition	Explanation
LAA_Receiver	Used for LAA receiver characteristics test cases
LAA_DemodCSI	Used for LAA demodulation and CSI reporting test cases

5.4 Default NAS message and information elements contents

5.5 Reference radio bearer configurations

5.5.1 SRB and DRB parameters

5.5.1.1 MAC configurations

As defined in clause 4.8.2.1.5 with the following exceptions:

Table 5.5.1.1-1: MAC-MainConfig-RBC

Derivation Path: Clause 4.8.2.1.5, Table 4.8.2.1.5-1			
Information Element	Value/remark	Comment	Condition
MAC-MainConfig-RBC ::= SEQUENCE {			
ul-SCH-Config	Not present		SCell_AddMod
ul-SCH-Config SEQUENCE {			
maxHARQ-Tx	n1	Only one transmission per UL HARQ	
}			
drx-Config	Not present		SCell_AddMod
drx-Config CHOICE {			
release	NULL		
}			
timeAlignmentTimerDedicated	infinity		
}			

Condition	Explanation
SCell_AddMod	Addition or modification of Scell

5.5.1.2 Physical Layer configurations

Table 5.5.1.2-1: PhysicalConfigDedicated-DEFAULT

Derivation Path: Clause 4.8.2.1.6 Table 4.8.2.1.6-1			
Information Element	Value/remark	Comment	Condition
PhysicalConfigDedicated-DEFAULT ::= SEQUENCE {			
pdsch-ConfigDedicated	PDSCH-ConfigDedicated-DEFAULT	See subclause 4.6.3	SRB1
	Not present		RBC
pucch-ConfigDedicated	PUCCH-ConfigDedicated-DEFAULT	See subclause 4.6.3	SRB1
	Not present		RBC
pusch-ConfigDedicated	PUSCH-ConfigDedicated-DEFAULT	See subclause 4.6.3	SRB1
	Not present		RBC
uplinkPowerControlDedicated	UplinkPowerControlDedicated-DEFAULT	See subclause 4.6.3	SRB1
	Not present		RBC
tpc-PDCCH-ConfigPUCCH	Not present		SRB1
	TPC-PDCCH-Config-DEFAULT using condition PUCCH	See subclause 4.6.3	RBC
tpc-PDCCH-ConfigPUSCH	Not present		SRB1
	TPC-PDCCH-Config-DEFAULT using condition PUSCH	See subclause 4.6.3	RBC
cqi-ReportConfig	Not present		SRB1
	Not present		RBC
soundingRS-UL-ConfigDedicated	Not present		SRB1
	Not present		RBC
antennaInfo CHOICE {			
defaultValue	NULL		
}			
schedulingRequestConfig	Not present		SRB1
	SchedulingRequest-Config-DEFAULT	See subclause 4.6.3	SRB1 and HalfDuplex and (CEmodeA or CEmodeB)
	Not present	See subclause 4.6.3	RBC
}			
cqi-ReportConfig-r10	Not present		SCell_AddMod

Condition	Explanation
SRB1	Used at configuration of SRB1 during RRC connection (re-)establishment
RBC	Used at configuration of a radio bearer combination during SRB2+DRB establishment
SCell_AddMod	Addition or modification of SCell
CEmodeA	Used for CE mode A testing
CEmodeB	Used for CE mode B testing
HalfDuplex	Used during Type B HalfDuplex Operation

5.5.1.3 SRB and DRB combinations

5.5.1.3.1 Combinations on DL-SCH and UL-SCH

5.5.1.3.1.1 SRB1 and SRB2 for DCCH + n x AM DRB + m x UM DRB, where $n=1$ and $m=0$

This SRB and DRB combination is setup in UE Registration procedure and the Generic Radio Bearer Establishment with UE Test Mode Activated using specific message content - the default *RRConnectionReconfiguration* message with condition SRB2-DRB(n , m).

6 Test environment for Signalling test

6.1 Requirements of test equipment

The requirements of test equipment specified in this subclause apply to Signalling test cases defined in TS 36.523-1 [18], in addition to the common requirements of test equipment specified in clause 4.2 of this specification.

Test equipment shall be able to simulate cells of Radio Access Technology (RAT) E-UTRA, UTRA, GSM or HRPD / 1xRTT. Regardless of respective RAT, the overall number and configuration of cells to be simulated simultaneously by test equipment shall not exceed the resources specified in the following Table 6.1-1:

Table 6.1-1: Maximum resources in terms of number / configuration of cells to be simulated simultaneously in a test setup

Simulation of	Max. number / configuration of cells (SISO / SIMO)	Max. number / configuration of cells (MIMO)
E-UTRA single-mode networks (FDD or TDD)	3x cells	n/a
E-UTRA dual-mode networks (FDD and TDD)	3x cells	n/a
E-UTRA networks involving Carrier Aggregation	4x cells	n/a
Mixed E-UTRA / UTRA networks	3x cells	n/a
Mixed E-UTRA / GSM networks	3x cells	n/a
Mixed E-UTRA / HRPD or 1xRTT networks	3x cells	n/a
Mixed E-UTRA / UTRA / GSM networks	3x cells	n/a
Note 1:	No differentiation between cell configuration types (as defined in clause 6.3.3) here, because these types are relevant to specific test cases and their TTCN-3 implementation only.	
Note 2:	Only network scenarios specified in clause 4.4.1 and 6.3.2.1 have been covered.	
Note 3:	In case of Carrier Aggregation, each cell can act as a PCell, an SCell, or a standalone cell (not used as a CA component carrier). In Release 10 a maximum of 1 SCell can be aggregated with a PCell.	
Note 4:	Virtual Cells are not included in the maximum cell number as they do not require resources in the SS.	

Exceptions to the requirements outlined above are possible but need special evidence to be provided explicitly in the test case prose and should be allowed only if the test case purpose cannot be met otherwise.

Test equipment shall be able to simulate one or more UEs with PC5 interface for sidelink direct communication and/or sidelink direct discovery or V2X sidelink communication.

6.2 Reference test conditions

The reference test conditions specified in this subclause apply to all Signalling test cases defined in TS 36.523-1 [18] unless otherwise specified, in addition to the common reference test conditions specified in subclause 4.3 of this specification.

6.2.1 Physical channel allocations

6.2.1.1 Antennas

If the UE has two or more Rx antennas, the same downlink signal is applied to each one, except if MIMO is tested. All UE Rx antennas shall be connected.

If the UE has one Rx antenna, the downlink signal is applied to it.

6.2.1.2 Downlink physical channels and physical signals

Power allocation of downlink physical channels for Signalling test cases is specified in table 6.2.1.2-1.

Table 6.2.1.2-1: Power allocation for OFDM symbols and reference signals for Signalling test cases

Physical Channel	EPRE Ratio	Comment
PBCH	PBCH_RA = 0 dB	
	PBCH_RB = 0 dB	
PSS	PSS_RA = 0 dB	
SSS	SSS_RA = 0 dB	
PCFICH	PCFICH_RB = 0 dB	
PDCCH	PDCCH_RA = 0 dB	
	PDCCH_RB = 0 dB	
PDSCH (BCCH, BR-BCCH, CCCH, PCCH)	PDCCH_RA = 0 dB	To be consistent with default physical channel configuration in TS 36.331 [17], 9.2.4
	PDCCH_RB = 0 dB	
PDSCH (DCCH, DTCH)	PDSCH_RA = -3 dB	To reduce interference from PDSCH of intra-frequency neighbour cells
	PDSCH_RB = -3 dB	To reduce interference from PDSCH of intra-frequency neighbour cells
PHICH	PHICH_RB = 0 dB	
PMCH	PMCH_RA = 0 dB	
MBSFN RS	MBSFN_RS_RA = 0dB	

NOTE: MBSFN RS is not defined downlink physical channels in TS 36.211 [35].

6.2.1.3 Mapping of downlink physical channels and signals to physical resources

Same as clause 4.3.3.3

6.2.1.4 Uplink physical channels and physical signals

The SideLink Physical channels and Physical signals used and their powers relative to configured SS-UE power are specified in table 6.2.1.4-1.

Table 6.2.1.4-1: Relative power allocation for OFDM symbols and signals for SideLink test cases

Physical Channel	EPRE Ratio
PSSS	0 dB
SSSS	0 dB
PSDCH	0 dB
PSBCH	0 dB
PSCCH	0 dB
PSSCH	0 dB

6.2.1.5 Mapping of uplink physical channels and signals to physical resources

[FFS].

6.2.2 Signal levels

6.2.2.1 Downlink signal levels

The default settings of suitable cells and non-suitable cells for E-UTRA are specified in table 6.2.2.1-1.

Cells which are expected to be undetectable for UE under test shall fulfil the condition of non-suitable "Off" cell in table 6.2.2.1-1.

Table 6.2.2.1-1: Default settings of suitable / non-suitable cells

Power level type	E-UTRAN (Note 1-3)		UTRAN	GERAN
	Unit	Power level		
Serving cell	dBm/15kHz	-85	Table 6.1.1 (FDD) / 6.1.6a (TDD) [5]	Table 6.1.10 [5]
Suitable neighbour intra-frequency cell	dBm/15kHz	-91	Table 6.1.2 (FDD) / 6.1.7 (TDD) [5]	n/a
Suitable neighbour inter-frequency cell	dBm/15kHz	-97	Table 6.1.2 (FDD) / 6.1.7 (TDD) [5]	Table 6.1.10 [5]
Non-suitable cell	dBm/15kHz	-115	Table 6.1.3 (FDD) / 6.1.8 (TDD) [5]	Table 6.1.11 [5]
Non-suitable "Off" cell	dBm/15kHz	≤ -145	Table 6.1.4 (FDD) / 6.1.9 (TDD) [5]	Cell is switched-off
Note 1: The power level is specified in terms of cell-specific RS EPRE instead of RSRP as RSRP is a measured value and cannot be directly controlled by the SS.				
Note 2: Power levels are specified based on the precondition that q-Hyst, a3-Offset and hysteresis are 0 dB.				
Note 3: The power level is specified at each UE Rx antenna.				

The default signal level uncertainty is specified in table 6.2.2.1-2 for any level specified, unless a tighter uncertainty is specified by a test case in TS 36.523-1 [18].

Table 6.2.2.1-2: SS signal level uncertainty

	Absolute signal level uncertainty for each cell	Relative signal level uncertainty between multiple cells
Intra-frequency	+/-3 dB at each test port	+/-3 dB
Inter-frequency	+/-3 dB at each test port	See Note 1
Note 1: For Inter-frequency cells the relative signal level uncertainty between multiple cells is determined by the absolute uncertainty of each cell, and does not have any additional constraint.		

Cell-specific RS EPRE setting should be equal to or higher than -115 dBm except for Non-suitable "Off" cell. The figure is chosen to ensure that for all bands the DL signal is within the RSRP measurement range specified in TS 36.133 [39] clauses 9.1.2 and 9.1.3, taking into account the SS default absolute signal level uncertainty.

NOTE: (The power spectral density of a white noise source; specified in TS 36.133 [39]) can be assumed to be -Infinity [dBm/15kHz] for all intra and inter frequency test cases. It is applicable to both idle mode and connected mode in TS 36.523-1 [18], unless otherwise specified in specific test cases.

For test cases requiring AWGN (Noc), the default level uncertainty is specified in table 6.2.2.1-3 for any level specified, unless a tighter uncertainty is specified by a test case in TS 36.523-1 [18].

Table 6.2.2.1-3: SS AWGN level uncertainty

	Absolute AWGN level uncertainty for each frequency
Intra-frequency	+/-3 dB at each test port
Inter-frequency	+/-3 dB at each test port

6.2.2.2 Measurement accuracy and side conditions

Measurement accuracy shall be considered in setting downlink power levels.

RSRP measurement accuracy in E-UTRA RRC_IDLE state is specified in table 6.2.2.2-1, derived from TS 36.133 [39] clauses 4.2.2.3 and 4.2.2.4. This measurement accuracy is applicable to idle mode test cases specified in TS 36.523-1 [18]. For the serving cell and suitable neighbour cells, the following side conditions shall be satisfied including the effect of signal level uncertainty.

- RSRP \geq -121 dBm
- RSRP $\hat{E}_s/I_{ot} \geq$ -4 dB
- SCH_RP \geq -121 dBm
- SCH $\hat{E}_s/I_{ot} \geq$ -4 dB

Table 6.2.2.2-1: RSRP measurement accuracy in E-UTRA RRC_IDLE state

	Absolute RSRP measurement accuracy	Relative RSRP measurement accuracy
Intra-frequency	+/-6 dB	+/-3 dB
Inter-frequency	+/-6 dB	+/-5 dB

RSRP measurement accuracy in E-UTRA RRC_CONNECTED state is specified in table 6.2.2.2-2, derived from TS 36.133 [39] clauses 9.1.2 and 9.1.3 selecting Normal condition. The ranges and side conditions in TS 36.133 [39] clauses 9.1.2 and 9.1.3 apply. This measurement accuracy is applicable to connected mode test cases specified in TS 36.523-1 [18]. For the serving cell and suitable neighbour cells, the following side conditions shall be satisfied including the effect of signal level uncertainty.

- RSRP \geq -124 dBm
- RSRP $\hat{E}_s/I_{ot} >$ -6 dB- I_o : -118 dBm/15kHz ... -70 dBm/BWChannel (for absolute RSRP measurement accuracy)
- I_o : -118 dBm/15kHz ... -50 dBm/BWChannel (for relative RSRP measurement accuracy)

Table 6.2.2.2-2: RSRP measurement accuracy in E-UTRA RRC_CONNECTED state

	Absolute RSRP measurement accuracy	Relative RSRP measurement accuracy
Intra-frequency	+/-6 dB	+/-3 dB
Inter-frequency	+/-6 dB	+/-6 dB

Signal level difference between the serving cell and any suitable intra-frequency neighbour cell shall be nominally 6 dB to satisfy the measurement accuracy requirement and its side conditions specified in TS 36.133 [39]. This figure is chosen based on the following preconditions for intra-frequency cells.

- Interference to reference signals from reference signals of other cells is eliminated by Physical Cell Identity shifting as specified in TS 36.523-3 [20].
- Interference to reference signals from PDSCH with SI-RNTI of other cells is negligible because it's sparse enough.
- Interference to reference signals from PDSCH of the serving cell is controlled by satisfying the conditions of clauses 6.2.2.1 and 6.2.2.2.
- Interference to P-SS/S-SS from P-SS/S-SS of other cells is eliminated by frame timing shifting as specified in TS 36.523-3 [20].
- Interference to P-SS/S-SS from PDSCH of other cells is eliminated by PDSCH resource allocation as specified in TS 36.523-3 [20].

6.2.2.3 Uplink signal levels

The default settings of SS-UE is specified in table 6.2.2.3-1.

Table 6.2.2.3-1: Default settings of SS-UE power

Power level type	SS-UE (Note 1)		Absolute signal level uncertainty for each SS-UE
	Unit	Power level	
SS-UE (default value)	dBm/15kHz	-85	+/-3 dB
Note 1: The power level is specified at each Rx antenna of the UE under test.			

6.2.3 Default test frequencies

The default channel bandwidth of 5/10/20 MHz is applied to the signalling test. The test frequencies are defined so that no frequency overlapping takes place, in order to avoid unnecessary inter-frequency interference.

For sidelink direct discovery, the default channel bandwidth of 5/10/15/20 MHz is applied to the signalling test for all ProSe bands except band 14 and 31 where default bandwidth is 5/10 MHz and 5 Mhz respectively. For sidelink direct communication the default channel bandwidth of 10 MHz is applied to the signalling test except band 31 where bandwidth is 5 MHz.

For V2X communication, the default channel bandwidth of 10/20 MHz is applied to the signalling test for all V2X bands.

For Band 13, Band 18 and Band 31, only one test frequency f_1 is defined. All operating Bands except Band 13, Band 18 and Band 31 can accommodate at least two test frequencies f_1 and f_2 ($f_1 < f_2$). An additional test frequency f_3 can be defined for the operating Bands with at least triple of the default bandwidth. The fourth test frequency f_4 ($f_3 < f_1 < f_4 < f_2$) is applicable to the operating Bands which have at least quadruple of the default bandwidth.

To the single cell signalling test with channel bandwidth different from the default bandwidths of the operating bands, Mid Range defined in clause 4.3.1 is applied.

6.2.3.1 Test frequencies for signalling test

Test frequencies for signalling test are specified in table 6.2.3.1-1 and 6.2.3.1-1a for FDD and table 6.2.3.1-2 and 6.2.3.1-2a for TDD. Except f_4 and a few f_1 , f_5 which are specified according to EARFCN of the concerned operating Bands, the majority of the test frequencies in table 6.2.3.1-1, 6.2.3.1-1a, 6.2.3.1-2 and 6.2.3.1-2a are specified in terms of Low, Mid and High which are referred to the Low Range, Mid Range and High Range in clause 4.3.1.

Test frequencies for signalling test of MFBI are specified in table 6.2.3.1-1b and 6.2.3.1-1c for FDD and table 6.2.3.1-2b and 6.2.3.1-2c for TDD. Except f_4 and a few f_1 , f_5 which are specified according to EARFCN of the concerned operating Bands, the majority of the test frequencies in table 6.2.3.1-1b, 6.2.3.1-1c, 6.2.3.1-2b and 6.2.3.1-2c are specified in terms of Low, Mid and High which are referred to the Low Range, Mid Range and High Range in clause 4.3.1.

Table 6.2.3.1-1: Test frequencies for E-UTRA FDD(5MHz)

E-UTRA Operating Band	Bandwidth [MHz]	f1, f5		f2, f6		f3, f7		f4	
		N _{UL}	N _{DL}	N _{UL}	N _{DL}	N _{UL}	N _{DL}	N _{UL}	N _{DL}
1	60	Mid	Mid	High	High	Low	Low	18350	350
2	60	Mid	Mid	High	High	Low	Low	18950	950
3	75	Mid	Mid	High	High	Low	Low	19625	1625
4	45	Mid	Mid	High	High	Low	Low	20225	2225
5	25	Mid	Mid	High	High	Low	Low	20575	2575
6	10	Low	Low	High	High	N/A	N/A	N/A	N/A
7	70	Mid	Mid	High	High	Low	Low	21150	3150
8	35	Mid	Mid	High	High	Low	Low	21675	3675
9	35	Mid	Mid	High	High	Low	Low	22025	4025
10	60	Mid	Mid	High	High	Low	Low	22500	4500
12	17	Low	Low	High	High	Mid	Mid	N/A	N/A
14	10	Low	Low	High	High	N/A	N/A	N/A	N/A
...									
17	12	Low	Low	High	High	N/A	N/A	N/A	N/A
19	15	Mid	Mid	High	High	Low	Low	N/A	N/A
21	15	Mid	Mid	High	High	Low	Low	N/A	N/A
22	80	Mid	Mid	High	High	Low	Low	24950	6950
...									
23	20	25575	7575	High	High	Low	Low	25625	7625
24	34	Mid	Mid	High	High	Low	Low	25920	7920
25	65	Mid	Mid	High	High	Low	Low	26415	8415
26	35	Mid	Mid	High	High	Low	Low	26915	8915
27	17	Mid	Mid	High	High	Low	Low	N/A	N/A
28	45	Mid	Mid	High	High	Low	Low	27560	9560
30	10	Low	Low	High	High	N/A	N/A	N/A	N/A
31	5	Mid	Mid	N/A	N/A	N/A	N/A	N/A	N/A
...									
65	90	Mid	Mid	High	High	Low	Low	131422	65886
66	70+90 ¹	Mid	Mid	High	High	Low	Low	132272	66736
68	30	Mid	Mid	High	High	Low	Low	132867	67731
...									
70	15+25 ¹	Mid	Mid	High	High	Low	Low	N/A	N/A
71	35	Mid	Mid	High	High	Low	Low	133247	68711
72	5	Mid	Mid	N/A	N/A	N/A	N/A	N/A	N/A
...									
74	43	Mid	Mid	High	High	Low	Low	133882	69336

NOTE 1: Asymmetric operating band (UL + DL)

Table 6.2.3.1-1a: Test frequencies for E-UTRA FDD(10MHz)

E-UTRA Operating Band	Bandwidth [MHz]	f1, f5		f2, f6		f3, f7		f4	
		N _{UL}	N _{DL}	N _{UL}	N _{DL}	N _{UL}	N _{DL}	N _{UL}	N _{DL}
11	20	Low	Low	High	High	N/A	N/A	N/A	N/A
13	10	Mid	Mid	N/A	N/A	N/A	N/A	N/A	N/A
18	15	Low	Low	N/A	N/A	N/A	N/A	N/A	N/A
20	30	Mid	Mid	High	High	Low	Low	N/A	N/A
23	20	Low	Low	High	High	N/A	N/A	N/A	N/A

Table 6.2.3.1-1b: Test frequencies for E-UTRA FDD(5MHz) MFBI

E-UTRA Operating Band	MFBI Overlapping Band	Bandwidth [MHz]	f1, f5		f2, f6		f3, f7		f4	
			N _{UL}	N _{DL}	N _{UL}	N _{DL}	N _{UL}	N _{DL}	N _{UL}	N _{DL}
2	25	60	Mid	Mid	High	High	Low	Low	18950	950
3	9	35	Mid	Mid	High	High	Low	Low	19824	1824
4	10	45	Mid	Mid	High	High	Low	Low	20225	2225
4	66	45	Mid	Mid	High	High	Low	Low	20225	2225
5	18	6	Mid	Mid	N/A	N/A	N/A	N/A	N/A	N/A
5	19	25	Mid	Mid	High	High	Low	Low	20585	2585
5	26	25	Mid	Mid	High	High	Low	Low	20575	2575
9	3	35	Mid	Mid	High	High	Low	Low	22025	4025
10	4	45	Mid	Mid	High	High	Low	Low	22425	4425
10	66	60	Mid	Mid	High	High	Low	Low	22425	4425
12	17	12	Low	Low	High	High	N/A	N/A	N/A	N/A
17	12	12	Low	Low	High	High	N/A	N/A	N/A	N/A
19	5	15	Mid	Mid	High	High	Low	Low	N/A	N/A
19	26	15	Mid	Mid	High	High	Low	Low	N/A	N/A
25	2	60	Mid	Mid	High	High	Low	Low	26415	8415
26	5	25	Mid	Mid	High	High	Low	Low	26915	8915
26	18	15	Mid	Mid	High	High	Low	Low	N/A	N/A
26	19	15	Low	Low	High	High	N/A	N/A	N/A	N/A
26	27	10	Mid	Mid	High	High	Low	Low	N/A	N/A
27	18	9	Low	Low	High	High	N/A	N/A	N/A	N/A
27	26	10	Low	Low	High	High	N/A	N/A	N/A	N/A
66	4	45	Mid	Mid	High	High	Low	Low	132247	66711
66	10	60	Mid	Mid	High	High	Low	Low	132247	66711

Table 6.2.3.1-1c: Test frequencies for E-UTRA FDD(10MHz) MFBI

E-UTRA Operating Band	MFBI Overlapping Band	Bandwidth [MHz]	f1, f5		f2, f6		f3, f7		f4	
			N _{UL}	N _{DL}	N _{UL}	N _{DL}	N _{UL}	N _{DL}	N _{UL}	N _{DL}
18	5	6	Low	Low	N/A	N/A	N/A	N/A	N/A	N/A
18	26	15	Low	Low	N/A	N/A	N/A	N/A	N/A	N/A
18	27	9	Low	Low	N/A	N/A	N/A	N/A	N/A	N/A

Table 6.2.3.1-2: Test frequencies for E-UTRA TDD (5MHz)

E-UTRA Operating Band	Bandwidth [MHz]	f1, f5	f2, f6	F3, f7	f4
33	20	36075	High	Low	36125
34	15	Mid	High	Low	N/A
35	60	Mid	High	Low	36700
36	60	Mid	High	Low	37300
37	20	37625	High	Low	37675
...					
43	100	Mid	High	Low	44640
44	50	Mid	High	Low	46115
45	20	46665	High	Low	46715

Table 6.2.3.1-2a: Test frequencies for E-UTRA TDD(20MHz)

E-UTRA Operating Band	Bandwidth [MHz]	f1, f5	f2, f6	f3, f7	f4
38	50	Low	High	N/A	N/A
39	40	Low	High	N/A	N/A
40	100	Mid	High	Low	39350
41	194	Mid	High	Low	40970
42	200	Mid	High	Low	43040
...					
48	150	Mid	High	Low	56315

Table 6.2.3.1-2b: Test frequencies for E-UTRA TDD (5MHz) MFBI

E-UTRA Operating Band	MFBI Overlapping Band	Bandwidth [MHz]	f1, f5	f2, f6	F3, f7	f4
33	39	20	36075	High	Low	36125

Table 6.2.3.1-2c: Test frequencies for E-UTRA TDD(20MHz) MFBI

E-UTRA Operating Band	MFBI Overlapping Band	Bandwidth [MHz]	f1, f5	f2, f6	f3, f7	f4
38	41	50	Low	High	N/A	N/A
39	33	20	Low	High	N/A	N/A
41	38	50	High	Low	Mid	N/A

6.2.3.2 Test frequencies for CA signalling test

Test frequencies for CA signalling testing are specified in Table 6.2.3.2-1 for CA Intra-Band contiguous case; in Tables 6.2.3.2-2 for CA Inter-band case and in Table 6.2.3.2-4 for Intra-Band Non-Contiguous case.

NOTE 1: Alternative test frequencies for additional channel bandwidth combinations may need to be specified when new CA configurations or CA Bandwidth Combination Sets are introduced in TS 36.101 subclause 5.6A.

For CA Intra-Band contiguous scenarios then f1, f2 and f3 are used.

NOTE 2: f2 and f3 are not adjacent frequencies; hence those cannot be used simultaneously as Pcell and Scell for CA Intra-Band contiguous scenarios.

For CA Inter-Band scenarios then f1, f2, f5 and f6 are used.

NOTE 3: Table 6.2.3.2-2 specifies the test frequencies for operation with PCell in the frequency band mentioned first (= carrier 1) and SCell in the frequency band mentioned second (= carrier 2) in the E-UTRA CA Configuration name acc. to TS 36.101 subclause 5.6A (e.g. PCell in band 1 and SCell in band 5 for CA_1A-5A configuration), for operation with switched allocation of PCell and SCell. SCell in the frequency band mentioned first (= carrier 1) and PCell in the frequency band mentioned second (= carrier 2) in the E-UTRA CA Configuration name (given that UL is supported in both frequency bands in question).

NOTE 4: For operation with switched allocation f1 is mapped to f5, f2 is mapped to f6, f5 is mapped to f1, f6 is mapped to f2

For CA Intra-Band non-contiguous scenarios then f1, f2 and f3 are used.

Table 6.2.3.2-1: Test frequencies for E-UTRA PCell and SCell for CA contiguous Intra-band operation

E-UTRA CA Configuration	Width of Operating band [MHz]	CC Combination / N _{RB_agg}	Test Frequency	CC N _{RB}	N _{UL}	Frequency of Uplink [MHz]	N _{DL}	Frequency of Downlink [MHz]
CA_1C	60	100 + 100	f1	CC 100	18300	1950	300	2140
			f2	CC 100	18498	1969.8	498	2159.8
			f3	CC 100	18102	1930.2	102	2120.2
CA_2C	60	100 + 100	f1	CC 100	18901	1880.1	901	1960.1
			f2	CC 100	19099	1899.9	1099	1979.9
			f3	CC 100	18703	1860.3	703	1940.3
CA_3C	60	100 + 100	f1	CC 100	19505	1740.5	1505	1835.5
			f2	CC 100	19703	1760.3	1703	1855.3
			f3	CC 100	19307	1720.7	1307	1815.7
CA_5B	25	50+50	f1	CC_50	20476	831.6	2476	876.6
			f2	CC_50	20575	841.5	2575	886.5
			f3	N/A	N/A	N/A	N/A	N/A
CA_7B	70	75+25	f1	CC 100	21050	2530	3050	2650
			f2	CC 100	21248	2549.8	3248	2669.8
			f3	CC 100	20852	2510.2	2852	2630.2
CA_7C	70	100 + 100	f1	CC 100	21050	2530	3050	2650
			f2	CC 100	21248	2549.8	3248	2669.8
			f3	CC 100	20852	2510.2	2852	2630.2
CA_8B	35	50+50	f1	CC 50	21651	900.1	3651	945.1
			f2	CC_50	21750	910	3750	955
			f3	CC_50	21552	890.2	3552	935.2
CA_12B	17	25+25	f1	CC_25	23095	707.5	5095	737.5
			f2	CC_25	23143	712.3	5143	742.3
			f3	CC_25	23047	702.7	5047	732.7
CA_23B	20	50+50	f1	CC_50	25551	2005.1	7551	2185.1
			f2	CC_50	25650	2015	7650	2195
			f3	N/A	N/A	N/A	N/A	N/A
CA_27B	17	25+25	f1	CC_25	27100	813	9100	858
			f2	CC_25	27148	817.8	9148	862.8
			f3	CC_25	27050	808	9050	853
CA_38C	50	100 + 100	f1	CC 100	37901	2585.1	37901	2585.1
			f2	CC 100	38099	2604.9	38099	2604.9
			f3	N/A	N/A	N/A	N/A	N/A
CA_39C	40	100 + 50	f1	CC 100	38401	1895.1	38401	1895.1
			f2	CC 50	38545	1909.5	38545	1909.5
			f3	NA	NA	NA	NA	NA
CA_40C	100	100 + 100	f1	CC 100	39051	2340.1	39051	2340.1
			f2	CC 100	39249	2359.9	39249	2359.9
			f3	CC 100	38853	2320.3	38853	2320.3
CA_41C	194	100 + 100	f1	CC 100	40521	2583.1	40521	2583.1
			f2	CC 100	40719	2602.9	40719	2602.9
			f3	CC 100	40323	2563.3	40323	2563.3
CA_42C	200	100+100	f1	CC 100	42491	3490.1	42491	3490.1
			f2	CC 100	42689	3509.9	42689	3509.9
			f3	CC 100	42293	3470.3	42293	3470.3
CA_66B	70+90 ¹	50+50	f1	CC_50	132322	1745	66786	2145
			f2	CC_50	132421	1754.9	66885	2154.9
			f3	CC_50	132223	1735.1	66687	2135.1
CA_66C	70+90 ¹	100+100	f1	CC 100	132322	1745	66786	2145
			f2	CC 100	132520	1764.8	66984	2164.8
			f3	CC 100	132124	1725.2	66588	2125.2
CA_70C	15+25 ¹	75+50	f1	CC 75	133047	1702.5	68411	2002.5
			f2	CC 50	N/A	N/A	68531	2014.5
			f3	N/A	N/A	N/A	N/A	N/A

NOTE 1: Asymmetric operating band (UL + DL)

Table 6.2.3.2-2: Test frequencies for E-UTRA PCell and SCell for CA Inter-band operation and E-UTRA PCell and PSCell for DC Inter-band operation (two bands)

E-UTRA CA Configuration	Width of Operating bands [MHz+MHz]	CC Combination / N _{RB_agg}	Test Frequency	CC N _{RB}	N _{UL}	Frequency of Uplink [MHz]	N _{DL}	Frequency of Downlink [MHz]
CA_1A-3A, DC_1A-3A	60+75	50 + 50	f1	CC 50	18300	1950	300	2140
			f2	CC 50	18550	1975	550	2165
			f5	CC 50	19575	1747.5	1575	1842.5
			f6	CC 50	19900	1780	1900	1875
CA_1A-5A, DC_1A-5A	60+25	50 + 50	f1	CC 50	18300	1950	300	2140
			f2	CC 50	[18550]	[1975]	[550]	[2165]
			f5	CC 50	20450	829	2450	874
			f6	CC 50	20600	844	2600	889
CA_1A-7A, DC_1A-7A	60 + 70	50 + 50	f1	CC 50	18300	1950	300	2140
			f2	CC 50	18550	1975	550	2165
			f5	CC 50	21100	2535	3100	2655
			f6	CC 50	21400	2565	3400	2685
CA_1A-8A, DC_1A-8A	60 + 35	50 + 50	f1	CC 50	18300	1950	300	2140
			f2	CC 50	18550	1975	550	2165
			f5	CC 50	21625	897.5	3625	942.5
			f6	CC 50	21750	910	3750	955
CA_1A-11A	60 + 20	100 + 50	f1	CC 100	18300	1950	300	2140
			f2	CC 100	18500	1970	500	2160
			f5	CC 50	22800	1432.9	4800	1480.9
			f6	CC 50	22900	1442.9	4900	1490.9
CA_1A-18A	60 + 15	50 + 50	f1	CC 50	18300	1950	300	2140
			f2	CC 50	18550	1975	550	2165
			f5	CC 50	23900	820	5900	865
			f6	N/A	N/A	N/A	N/A	N/A
CA_1A-19A, DC_1A-19A	60+15	75 + 50	f1	CC 75	18324	1952.4	324	2142.4
			f2	CC 75	18525	1972.5	525	2162.5
			f5	CC 50	24100	840	6100	885
			f6	N/A	N/A	N/A	N/A	N/A
CA_1A-20A	60 + 30	50 + 50	f1	CC 50	18300	1950	300	2140
			f2	CC 50	18550	1975	550	2165
			f5	CC 50	24200	837	6200	796
			f6	CC 50	24400	857	6400	816
CA_1A-21A, DC_1A-21A	60+15	75 + 75	f1	CC 75	18324	1952.4	324	2142.4
			f2	CC 75	18525	1972.5	525	2162.5
			f5	CC 75	24525	1455.4	6525	1503.4
			f6	N/A	N/A	N/A	N/A	N/A
CA_1A-26A	60 + 35	50 + 50	f1	CC 50	18300	1950	300	2140
			f2	CC 50	18550	1975	550	2165
			f5	CC 50	26865	831.5	8865	876.5
			f6	CC 50	26990	844	8990	889
CA_1A-28A	60+45	50 + 50	f1	CC 50	18300	1950	300	2140
			f2	CC 50	18550	1975	550	2165
			f5	CC 50	27410	723	9410	778
			f6	CC 50	27610	743	9610	798
CA_1A-40A	60 + 100	50 + 100	f1	CC 50	18300	1950	300	2140
			f2	CC 50	18550	1975	550	2165
			f5	CC 100	39150	2350	39150	2350
			f6	CC 100	39550	2390	39550	2390
CA_1A-41A	60 + 194	50 + 100	f1	CC 50	18300	1950	300	2140
			f2	CC 50	18550	1975	550	2165
			f5	CC 100	40620	2593	40620	2593
			f6	CC 100	41490	2680	41490	2680
CA_1A-41C	60+194	50+100+100	f1	CC 50	18300	1950	300	2140
			f2	CC 50	18550	1975	550	2165
			f5	CC 100	40521	2583.1	40521	2583.1
			f6	CC 100	40719	2602.9	40719	2602.9
CA_1A-42A	60 + 200	75 + 100	f1	CC 75	18324	1952.4	324	2142.4

			f2	CC 75	18525	1972.5	525	2162.5
			f5	CC 100	42590	3500	42590	3500
			f6	CC 100	43490	3590	43490	3590
CA_1A-42C	60+200	50+100+100	f1	CC 50	18300	1950	300	2140
			f2	CC 50	18550	1975	550	2165
			f5	CC 100	42491	3490.1	42491	3490.1
			f6	CC 100	42689	3509.9	42689	3509.9
CA_1A-46A ³	60+775	50+100	f1	CC 50	18300	1950	300	2140
			f2	CC 50	18550	1975	550	2165
			f5	CC 100	50690	5540	50690	5540
			f6	CC 100	53940	5865	53940	5865
CA_2A-4A, DC_2A-4A	60 + 45	50 + 50	f1	CC 50	18900	1880	900	1960
			f2	CC 50	19150	1905	1150	1985
			f5	CC 50	20175	1732.5	2175	2132.5
			f6	CC 50	20350	1750	2350	2150
CA_2A-5A	60+25	50 + 50	f1	CC 50	18900	1880	900	1960
			f2	CC 50	19150	1905	1150	1985
			f5	CC 50	20450	829	2450	874
			f6	CC 50	20600	844	2600	889
CA_2A-7A, DC_2A-7A	60 + 70	50 + 50	f1	CC 50	18900	1880	900	1960
			f2	CC 50	19150	1905	1150	1985
			f5	CC 50	21100	2535	3100	2655
			f6	CC 50	21400	2565	3400	2685
CA_2A-12A	60 + 17	50 + 50	f1	CC 50	18900	1880	900	1960
			f2	CC 50	19150	1905	1150	1985
			f5	CC 50	23060	704	5060	734
			f6	N/A	N/A	N/A	N/A	N/A
CA_2A-13A, DC_2A-13A	60 + 10	50 + 50	f1	CC 50	18900	1880	900	1960
			f2	CC 50	19150	1905	1150	1985
			f5	CC 50	23230	782	5230	751
			f6	N/A	N/A	N/A	N/A	N/A
CA_2A-14A	60 + 10	50 + 50	f1	CC 50	18900	1880	900	1960
			f2	CC 50	19150	1905	1150	1985
			f5	CC 50	23330	793	5330	763
			f6	N/A	N/A	N/A	N/A	N/A
CA_2A-17A	60+12	50 + 50	f1	CC 50	18900	1880	900	1960
			f2	CC 50	19150	1905	1150	1985
			f5	CC 50	23790	710	5790	740
			f6	N/A	N/A	N/A	N/A	N/A
CA_2A-28A	60+45	50 + 50	f1	CC 50	18900	1880	900	1960
			f2	CC 50	19150	1905	1150	1985
			f5	CC 50	27410	723	9410	778
			f6	CC 50	27610	743	9610	798
CA_2A-29A	60+11	50 + 50	f1	CC 50	18900	1880	900	1960
			f2	CC 50	19150	1905	1150	1985
			f5	CC 50	N/A	N/A	9720	723
			f6	N/A	N/A	N/A	N/A	N/A
CA_2A-30A	60+10	50 + 50	f1	CC 50	18900	1880	900	1960
			f2	CC 50	19150	1905	1150	1985
			f5	CC 50	27710	2310	9820	2355
			f6	N/A	N/A	N/A	N/A	N/A
CA_2A-46A ³	60+775	50+100	f1	CC 50	18900	1880	900	1960
			f2	CC 50	19150	1905	1150	1985
			f5	CC 100	50690	5540	50690	5540
			f6	CC 100	53940	5865	53940	5865
CA_2A-66A	60+(70+90) ₂	50+100	f1	CC 50	18900	1880	900	1960
			f2	CC 50	19150	1905	1150	1985
			f5	CC 100	132422	1755	66886	2155
			f6	CC 100	132572	1770	67036	2170
CA_2A-71A	60+35	50+50	f1	CC 50	18900	1880	900	1960
			f2	CC 50	19150	1905	1150	1985
			f5	CC 50	133297	680.5	68761	634.5
			f6	CC 50	133422	693	68886	647
CA_3A-5A,	75+25	50 + 50	f1	CC 50	19575	1747.5	1575	1842.5

DC_3A-5A			f2	CC 50	[19900]	[1780]	[1900]	[1875]
			f5	CC 50	20450	829	2450	874
			f6	CC 50	20600	844	2600	889
CA_3C-5A	75+25	100+100+50	f1	CC 100	19475	1737.5	1475	1832.5
			f2	CC 100	19673	1757.3	1673	1852.3
			f5	CC 50	20450	829	2450	874
CA_3A-7A, DC_3A-7A	75+70	50 + 50	f6	CC 50	20600	844	2600	889
			f1	CC 50	19575	1747.5	1575	1842.5
			f2	CC 50	[19900]	[1780]	[1900]	[1875]
CA_3A-8A, DC_3A-8A	75+35	50+50	f5	CC 50	21100	2535	3100	2655
			f6	CC 50	21400	2565	3400	2685
			f1	CC 50	19575	1747.5	1575	1842.5
CA_3A-11A	75+20	75+50	f2	CC 50	19900	1780	1900	1875
			f5	CC 50	21625	897.5	3625	942.5
			f6	CC 50	21750	910	3750	955
CA_3A-19A, DC_3A-19A	75+15	100+50	f1	CC75	19674	1757.4	1674	1852.4
			f2	N/A	N/A	N/A	N/A	
			f5	CC50	22800	1432.9	4800	1480.9
CA_3A-20A, DC_3A-20A	75+30	50+50	f6	N/A	N/A	N/A	N/A	
			f1	CC 100	19575	1747.5	1575	1842.5
			f2	CC 100	19850	1775	1850	1870
CA_3A-26A, DC_3A-26A	75 + 35	50 + 50	f5	CC 50	24100	840	6100	885
			f6	N/A	N/A	N/A	N/A	
			f1	CC 50	19575	1747.5	1575	1842.5
CA_3A-27A	75 + 17	50 + 25	f2	CC 50	19900	1780	1900	1875
			f5	CC 50	24200	837	6200	796
			f6	CC 50	24400	857	6400	816
CA_3A-28A	75+45	50+50	f1	CC 50	19575	1747.5	1575	1842.5
			f2	CC 50	19900	1780	1900	1875
			f5	CC 50	27435	725.5	9435	780.5
CA_3A-69A	75 + 50	50 + 50	f6	CC 50	27610	743	9610	798
			f1	CC 50	19575	1747.5	1575	1842.5
			f2	CC 50	19900	1780	1900	1875
CA_3A-32A	75+44	50+50	f5	CC 50	N/A	N/A	68086	2595
			f6	CC 50	N/A	N/A	68286	2615
			f1	CC 50	19575	1747.5	1575	1842.5
CA_3A-40A	75 + 100	50 + 100	f2	CC 50	19900	1780	1900	1875
			f5	CC 50	N/A	N/A	10140	1474
			f6	CC 50	N/A	N/A	10310	1491
CA_3A-41A	75 + 194	100 + 100	f1	CC 50	19575	1747.5	1575	1842.5
			f2	CC 50	19900	1780	1900	1875
			f5	CC 100	39150	2350	39150	2350
CA_3A-42A	75 + 200	100 + 100	f6	CC 100	39550	2390	39550	2390
			f1	CC 100	19575	1747.5	1575	1842.5
			f2	CC 100	19850	1775	1850	1870
CA_3A-42C	75+200	50+100+100	f5	CC 100	42590	3500	42590	3500
			f6	CC 100	43490	3590	43490	3590
			f1	CC 50	19575	1747.5	1575	1842.5
CA_3A-46A ³	75+775	50+100	f2	CC 50	19900	1780	1900	1875
			f5	CC 100	42491	3490.1	42491	3490.1
			f6	CC 100	42689	3509.9	42689	3509.9
			f1	CC 50	19575	1747.5	1575	1842.5

			f2	CC 50	19900	1780	1900	1875
			f5	CC 100	50690	5540	50690	5540
			f6	CC 100	53940	5865	53940	5865
CA_4A-5A	45+25	50 + 50	f1	CC 50	20175	1732.5	2175	2132.5
			f2	CC 50	20350	1750	2350	2150
			f5	CC 50	20450	829	2450	874
			f6	CC 50	20600	844	2600	889
CA_4A-7A, DC_4A-7A	45+70	50+50	f1	CC 50	20175	1732.5	2175	2132.5
			f2	CC 50	20350	1750	2350	2150
			f5	CC 50	21100	2535	3100	2655
			f6	CC 50	21400	2565	3400	2685
CA_4A-12A, DC_4A-12A	45+17	50+50	f1	CC 50	20175	1732.5	2175	2132.5
			f2	CC 50	20350	1750	2350	2150
			f5	CC 50	23130	711	5130	741
			f6	N/A	N/A	N/A	N/A	N/A
CA_4A-13A, DC_4A-13A	45+10	50 + 50	f1	CC 50	20175	1732.5	2175	2132.5
			f2	CC 50	20350	1750	2350	2150
			f5	CC 50	23230	782	5230	751
			f6	N/A	N/A	N/A	N/A	N/A
CA_4A-17A, DC_4A-17A	45+12	50 + 50	f1	CC 50	20175	1732.5	2175	2132.5
			f2	CC 50	20350	1750	2350	2150
			f5	CC 50	23790	710	5790	740
			f6	N/A	N/A	N/A	N/A	N/A
CA_4A-28A	45+45	50 + 50	f1	CC 50	20175	1732.5	2175	2132.5
			f2	CC 50	20350	1750	2350	2150
			f5	CC 50	27410	723	9410	778
			f6	CC 50	27610	743	9610	798
CA_4A-29A	45+11	50 + 50	f1	CC 50	20175	1732.5	2175	2132.5
			f2	CC 50	20350	1750	2350	2150
			f5	CC 50	N/A	N/A	9720	723
			f6	N/A	N/A	N/A	N/A	N/A
CA_4A-30A	45+10	50 + 50	f1	CC 50	20175	1732.5	2175	2132.5
			f2	CC 50	20350	1750	2350	2150
			f5	CC 50	27710	2310	9820	2355
			f6	N/A	N/A	N/A	N/A	N/A
CA_4A-46A ³	54+775	50+100	f1	CC 50	20175	1732.5	2175	2132.5
			f2	CC 50	20350	1750	2350	2150
			f5	CC 100	50690	5540	50690	5540
			f6	CC 100	53940	5865	53940	5865
CA_4A-71A	45+35	50+50	f1	CC 50	20175	1732.5	2175	2132.5
			f2	CC 50	20350	1750	2350	2150
			f5	CC 50	133297	680.5	68761	634.5
			f6	CC 50	133422	693	68886	647
CA_5A-7A, DC_5A-7A	25+70	50 + 50	f1	CC 50	20450	829	2450	874
			f2	CC 50	20600	844	2600	889
			f5	CC 50	21100	2535	3100	2655
			f6	CC 50	21400	2565	3400	2685
CA_5A-12A, DC_5A-12A	25+17	50+50	f1	CC 50	20525	836.5	2525	881.5
			f2	CC 50	20600	844	2600	889
			f5	CC 50	23130	711	5130	741
			f6	N/A	N/A	N/A	N/A	N/A
CA_5A-13A	25+10	50 + 50	f1	CC 50	20450	829	2450	874
			f2	CC 50	20600	844	2600	889
			f5	CC 50	23230	782	5230	751
			f6	N/A	N/A	N/A	N/A	N/A
CA_5A-17A	25+12	50 + 50	f1	CC 50	20525	836.5	2525	881.5
			f2	CC 50	20600	844	2600	889
			f5	CC 50	23790	710	5790	740
			f6	N/A	N/A	N/A	N/A	N/A
CA_5A-25A	25+65	50 + 50	f1	CC 50	20525	836.5	2525	881.5
			f2	CC 50	20600	844	2600	889
			f5	CC 50	26363	1882.5	8365	1962.5
			f6	CC 50	26640	1910	8640	1990
CA_5A-29A	25 + 11	50 + 50	f1	CC 50	20525	836.5	2525	881.5

			f2	CC 50	20600	844	2600	889
			f5	CC 50	N/A	N/A	9720	723
			f6	N/A	N/A	N/A	N/A	N/A
CA_5A-30A	25+10	50 + 50	f1	CC 50	20525	836.5	2525	881.5
			f2	CC 50	20600	844	2600	889
			f5	CC 50	27710	2310	9820	2355
			f6	N/A	N/A	N/A	N/A	N/A
CA_5A-66A	25+(70+90) ²	50+100	f1	CC 50	20525	836.5	2525	881.5
			f2	CC 50	20600	844	2600	889
			f5	CC 100	132422	1755	66886	2155
			f6	CC 100	132572	1770	67036	2170
CA_7A-8A	70+35	50+50	f1	CC 50	21100	2535	3100	2655
			f2	CC 50	[21400]	[2565]	[3400]	[2685]
			f5	CC 50	21625	897.5	3625	942.5
			f6	CC 50	21750	910	3750	955
CA_7A-12A	70+17	50+50	f1	CC 50	21100	2535	3100	2655
			f2	CC 50	[21400]	[2565]	[3400]	[2685]
			f5	CC 50	23130	711	5130	741
			f6	N/A	N/A	N/A	N/A	N/A
CA_7A-20A, DC_7A-20A	70+30	50 + 50	f1	CC 50	21100	2535	3100	2655
			f2	CC 50	[21400]	[2565]	[3400]	[2685]
			f5	CC 50	24200	837	6200	796
			f6	CC 50	24400	857	6400	816
CA_7A-22A	70+80	50+50	f1	CC 50	21100	2535	3100	2655
			f2	CC 50	[21400]	[2565]	[3400]	[2685]
			f1	CC 50	24650	3415	6650	3515
			f2	CC 50	25350	3485	7350	3585
CA_7A-28A, DC_7A-28A	70+45	50+50	f1	CC 50	21100	2535	3100	2655
			f2	CC 50	[21400]	[2565]	[3400]	[2685]
			f5	CC 50	27410	723	9410	778
			f6	CC 50	27610	743	9610	798
CA_7A-46A ³	70+775	50+100	f1	CC 50	21100	2535	3100	2655
			f2	CC 50	[21400]	[2565]	[3400]	[2685]
			f5	CC 100	50690	5540	50690	5540
			f6	CC 100	53940	5865	53940	5865
CA_8A-11A	35 + 20	50 + 50	f1	CC 50	21750	910	3750	955
			f2	N/A	N/A	N/A	N/A	N/A
			f5	CC 50	22800	1432.9	4800	1480.9
			f6	N/A	N/A	N/A	N/A	N/A
CA_8A-20A	35 + 30	50 + 50	f1	CC 50	21625	897.5	3625	942.5
			f2	CC 50	21750	910	3750	955
			f5	CC 50	24200	837	6200	796
			f6	CC 50	24400	857	6400	816
CA_8A-27A	35 + 17	50 + 25	f1	CC 50	21625	897.5	3625	942.5
			f2	CC 50	21750	910	3750	955
			f5	CC 25	27125	815.5	9125	860.5
			f6	CC 25	27185	821.5	9185	866.5
CA_8A-28A	35 + 45	50 + 50	f1	CC 50	21625	897.5	3625	942.5
			f2	CC 50	21750	910	3750	955
			f5	CC 50	27410	723	9410	778
			f6	CC 50	27610	743	9610	798
CA_8A-40A	35 + 100	50 + 100	f1	CC 50	21625	897.5	3625	942.5
			f2	CC 50	21750	910	3750	955
			f5	CC 100	39150	2350	39150	2350
			f6	CC 100	39550	2390	39550	2390
CA_8A-41A	35 + 194	50 + 100	f1	CC 50	21651	900.1	3651	945.1
			f2	CC 50	21750	910	3750	955
			f5	CC 100	40521	2583.1	40521	2583.1
			f6	CC 100	40719	2602.9	40719	2602.9
CA_8A-41C	35 + 194	50 + 100+100	f1	CC 50	21651	900.1	3651	945.1
			f2	CC 50	21750	910	3750	955
			f5	CC 100	40521	2583.1	40521	2583.1
			f6	CC 100	40719	2602.9	40719	2602.9
CA_8A-42A	35+200	50 + 100	f1	CC 50	21625	897.5	3625	942.5

			f2	CC 50	21750	910	3750	955
			f5	CC 100	42590	3500	42590	3500
			f6	CC 100	43490	3590	43490	3590
CA_11A-18A	20+15	50 + 50	f1	CC 50	22800	1432.9	4800	1480.9
			f2	CC 50	22900	1442.9	4900	1490.9
			f5	CC 50	23900	820	5900	865
			f6	N/A	N/A	N/A	N/A	N/A
CA_11A-28A	20+30	50 + 50	f1	CC 50	22800	1432.9	4800	1480.9
			f2	CC 50	22900	1442.9	4900	1490.9
			f5	CC 50	27410	723	9410	778
			f6	CC 50	27610	743	9610	798
CA_12A-25A	17+65	50 + 50	f1	CC 50	23060	704	5060	734
			f2	N/A	N/A	N/A	N/A	N/A
			f5	CC 50	26363	1882.5	8365	1962.5
			f6	CC 50	26640	1910	8640	1990
CA_12A-30A	17+10	50 + 50	f1	CC 50	23060	704	5060	734
			f2	N/A	N/A	N/A	N/A	N/A
			f5	CC 50	27710	2310	9820	2355
			f6	N/A	N/A	N/A	N/A	N/A
CA_12A-66A	17+(70+90) ²	50 + 100	f1	CC 50	23060	704	5060	734
			f2	N/A	N/A	N/A	N/A	N/A
			f5	CC 100	132422	1755	66886	2155
			f6	CC 100	132572	1770	67036	2170
CA_13A-66A	10 + (70+90) ²	50 + 100	f1	CC 50	23230	782	5230	751
			f2	CC 50	N/A	N/A	N/A	N/A
			f5	CC 100	132422	1755	66886	2155
			f6	CC 100	132572	1770	67036	2170
CA_14A-30A	10+10	50 + 50	f1	CC 50	23330	793	5330	763
			f2	N/A	N/A	N/A	N/A	N/A
			f5	CC 50	27710	2310	9820	2355
			f6	N/A	N/A	N/A	N/A	N/A
CA_14A-66A	10+(70+90) ²	50 + 100	f1	CC 50	23330	793	5330	763
			f2	N/A	N/A	N/A	N/A	N/A
			f5	CC 100	132422	1755	66886	2155
			f6	CC 100	132572	1770	67036	2170
CA_18A-28A	15+30	50 + 50	f1	CC 50	23900	820	5900	865
			f2	N/A	N/A	N/A	N/A	N/A
			f5	CC 50	27360	718	9360	773
			f6	CC 50	27460	728	9460	783
CA_19A-21A, DC_19A-21A	15+15	50+75	f1	CC 50	24075	837.5	6075	882.5
			f2	N/A	N/A	N/A	N/A	N/A
			f5	CC 75	24525	1455.4	6525	1503.4
			f6	N/A	N/A	N/A	N/A	N/A
CA_19A-28A	15+30	50+50	f1	CC 50	24075	837.5	6075	882.5
			f2	N/A	N/A	N/A	N/A	N/A
			f5	CC 50	27360	718	9360	773
			f6	CC 50	27460	728	9460	783
CA_19A-42A	15 + 200	50 + 100	f1	CC 50	24075	837.5	6075	882.5
			f2	N/A	N/A	N/A	N/A	N/A
			f5	CC 100	42590	3500	42590	3500
			f6	CC 100	43490	3590	43490	3590
CA_19A-42C	15+200	50+100+100	f1	CC 50	24075	837.5	6075	882.5
			f2	N/A	N/A	N/A	N/A	N/A
			f5	CC 100	42491	3490.1	42491	3490.1
			f6	CC 100	42689	3509.9	42689	3509.9
CA_20A-28A	30+45	50 + 50	f1	CC 50	24300	847	6300	806
			f2	CC 50	24400	857	6400	816
			f5	CC 50	27410	723	9410	778
			f6	CC 50	27610	743	9610	798
CA_20A-31A	30+5	50 + 25	f1	CC 50	24300	847	6300	806
			f2	CC 50	24400	857	6400	816
			f5	CC 25	27785	455	9895	465
			f6	N/A	N/A	N/A	N/A	N/A
CA_20A-32A	30+44	50 + 50	f1	CC 50	24300	847	6300	806

			f2	CC 50	24400	857	6400	816
			f5	CC 50	N/A	N/A	10140	1474
			f6	CC 50	N/A	N/A	10310	1491
CA_20A-40A	30+100	50 + 100	f1	CC 50	24300	847	6300	806
			f2	CC 50	24400	857	6400	816
			f5	CC 100	39150	2350	39150	2350
			f6	CC 100	39550	2390	39550	2390
CA_20A-67A	30+20	50 + 50	f1	CC 50	24300	847	6300	806
			f2	CC 50	24400	857	6400	816
			f5	CC 50	N/A	N/A	67386	743
			f6	CC 50	N/A	N/A	67486	753
CA_21A-42C	15+200	75+100+100	f1	CC 75	24525	1455.4	6525	1503.4
			f2	N/A	N/A	N/A	N/A	N/A
			f5	CC 100	42491	3490.1	42491	3490.1
			f6	CC 100	42689	3509.9	42689	3509.9
CA_23A-29A	20+11	50 + 50	f1	CC 50	25550	2005	7550	2185
			f2	CC 50	25650	2015	7650	2195
			f5	CC 50	N/A	N/A	9720	723
			f6	N/A	N/A	N/A	N/A	N/A
CA_25A-26A	65+35	50 + 50	f1	CC 50	26365	1882.5	8365	1962.5
			f2	CC 50	26640	1910	8640	1990
			f5	CC 50	26865	831.5	8865	876.5
			f6	CC 50	26990	844	8990	889
CA_25A-41A	65+194	50 + 50	f1	CC 50	26365	1882.5	8365	1962.5
			f2	CC 50	26640	1910	8640	1990
			f5	CC 50	40620	2593	40620	2593
			f6	CC 50	41540	2685	41540	2685
CA_25A-41C	65+194	50+100+100	f1	CC 50	26363	1882.5	8365	1962.5
			f2	CC 50	26640	1910	8640	1990
			f5	CC 100	40521	2583.1	40521	2583.1
			f6	CC 100	40719	2602.9	40719	2602.9
CA_26A-41A	60 + 194	50 + 100	f1	CC 50	26865	831.5	8865	876.5
			f2	CC 50	26990	844	8990	889
			f5	CC 100	40620	2593	40620	2593
			f6	CC 100	41490	2680	41490	2680
CA_26A-41C	60+194	50+100+100	f1	CC 50	26865	831.5	8865	876.5
			f2	CC 50	26990	844	8990	889
			f5	CC 100	40521	2583.1	40521	2583.1
			f6	CC 100	40719	2602.9	40719	2602.9
CA_28A-41A	45+194	50 + 100	f1	CC 50	27410	723	9410	778
			f2	CC 50	27610	743	9610	798
			f5	CC 100	40620	2593	40620	2593
			f6	CC 100	41490	2680	41490	2680
CA_28A-41C	45+194	50+100+100	f1	CC 50	27410	723	9410	778
			f2	CC 50	27610	743	9610	798
			f5	CC 100	40521	2583.1	40521	2583.1
			f6	CC 100	40719	2602.9	40719	2602.9
CA_28A-42A	45+200	50 + 100	f1	CC 50	27410	723	9410	778
			f2	CC 50	27610	743	9610	798
			f5	CC 100	42590	3500	42590	3500
			f6	CC 100	43490	3590	43490	3590
CA_28A-42C	45+200	50+100+100	f1	CC 50	27410	723	9410	778
			f2	CC 50	27610	743	9610	798
			f5	CC 100	42491	3490.1	42491	3490.1
			f6	CC 100	42689	3509.9	42689	3509.9
CA_29A-30A ¹	11+10	50+50	f1	CC 50	N/A	N/A	9720	723
			f2	N/A	N/A	N/A	N/A	N/A
			f5	CC 50	27710	2310	9820	2355
			f6	N/A	N/A	N/A	N/A	N/A
CA_29A-66A ¹	11+(70+90) 2	50+100	f1	CC 50	N/A	N/A	9720	723
			f2	N/A	N/A	N/A	N/A	N/A
			f5	CC 100	132422	1755	66886	2155
			f6	CC 100	132572	1770	67036	2170
CA_29A-70A ¹	11+(15+25)	50+75	f1	CC 50	N/A	N/A	9720	723

	²		f2	N/A	N/A	N/A	N/A	N/A
			f5	CC 75	133047	1702.5	68411	2002.5
			f6	CC 75	N/A	N/A	N/A	N/A
CA_29A-70C ¹	$11+(15+25)$ ₂	50+75+50	f1	CC 50	N/A	N/A	9720	723
			f2	N/A	N/A	N/A	N/A	N/A
			f5	CC 75	133047	1702.5	68411	2002.5
			f6	CC 50	N/A	N/A	68531	2014.5
CA_30A-66A	$10+(70+90)$ ₂	50+100	f1	CC 50	27710	2310	9820	2355
			f2	N/A	N/A	N/A	N/A	N/A
			f5	CC 100	132422	1755	66886	2155
			f6	CC 100	132572	1770	67036	2170
CA_39A-41A, DC_39A-41A	40+194	100+100	f1	CC 100	38350	1890	38350	1890
			f2	CC 100	38550	1910	38550	1910
			f5	CC 100	40620	2593	40620	2593
			f6	CC 100	41490	2680	41490	2680
CA_41A-42A, DC_41A-42A	194+200	100 + 100	f1	CC 100	40620	2593	40620	2593
			f2	CC 100	41490	2680	41490	2680
			f5	CC 100	42590	3500	42590	3500
			f6	CC 100	43490	3590	43490	3590
CA_41A-42C	194+200	100+100+10 0	f1	CC100	40620	2593	40620	2593
			f2	CC 100	41490	2680	41490	2680
			f5	CC 100	42491	3490.1	42491	3490.1
			f6	CC 100	42689	3509.9	42689	3509.9
CA_41A-46A ³	194+775	100+100	f1	CC 100	40620	2593	40620	2593
			f2	CC 100	41490	2680	41490	2680
			f5	CC 100	50690	5540	50690	5540
			f6	CC 100	53940	5865	53940	5865
CA_41C-42A	194+200	100+100+10 0	f1	CC 100	40521	2583.1	40521	2583.1
			f2	CC 100	40719	2602.9	40719	2602.9
			f5	CC 100	42590	3500	42590	3500
			f6	CC 100	43490	3590	43490	3590
CA_42A-46A ³	200+775	100+100	f1	CC 100	42590	3500	42590	3500
			f2	CC 100	43490	3590	43490	3590
			f5	CC 100	50690	5540	50690	5540
			f6	CC 100	53940	5865	53940	5865
CA_46A-66A ^{1,3}	$775+(70+90)$ ²	100+100	f1	CC 100	50690	5540	50690	5540
			f2	CC 100	53940	5865	53940	5865
			f5	CC 100	132422	1755	66886	2155
			f6	CC 100	132572	1770	67036	2170
CA_46A-66C ^{1,3}	$775+(70+90)$ ²	100+100+10 0	f1	CC 100	50690	5540	50690	5540
			f2	CC 100	53940	5865	53940	5865
			f5	CC 100	132322	1745	66786	2145
			f6	CC 100	132520	1764.8	66984	2164.8
CA_46A-70A ^{1,3}	$775+(15+25)$ ²	100+75	f1	CC 100	50690	5540	50690	5540
			f2	CC 100	53940	5865	53940	5865
			f5	CC 75	133047	1702.5	68411	2002.5
			f6	CC 75	N/A	N/A	N/A	N/A
CA_46C-66A ^{1,3}	$775+(70+90)$ ²	100+100+10 0	f1	CC 100	50692	5540.2	50692	5540.2
			f2	CC 100	50890	5560	50890	5560
			f5	CC 100	132422	1755	66886	2155
			f6	CC 100	132572	1770	67036	2170
CA_66A-70A	$(70+90)^2 +$ $(15+25)^2$	100+75	f1	CC 100	132422	1755	66886	2155
			f2	CC 100	132572	1770	67036	2170
			f5	CC 75	133047	1702.5	68411	2002.5
			f6	CC 75	N/A	N/A	N/A	N/A
CA_66A-70C	$(70+90)^2 +$ $(15+25)^2$	100+75+50	f1	CC 100	132422	1755	66886	2155
			f2	CC 100	132572	1770	67036	2170
			f5	CC 75	133047	1702.5	68411	2002.5
			f6	CC 50	N/A	N/A	68531	2014.5
CA_66A-71A	$(70+90)^2 +$ 35	100+100+ 50	f1	CC 100	132422	1755	66886	2155
			f2	CC 100	132572	1770	67036	2170
			f5	CC 50	133297	680.5	68761	634.5
			f6	CC 50	133422	693	68886	647
CA_66C-70A	$(70+90)^2 +$	100+100+75	f1	CC 100	132322	1745	66786	2145

	$(15+25)^2$		f2	CC 100	132520	1764.8	66984	2164.8
			f5	CC 75	133047	1702.5	68411	2002.5
			f6	CC 75	N/A	N/A	N/A	N/A
CA_66C-70C	$(70+90)^2 + (15+25)^2$	100+100+75+50	f1	CC 100	132322	1745	66786	2145
			f2	CC 100	132520	1764.8	66984	2164.8
			f5	CC 75	133047	1702.5	68411	2002.5
			f6	CC 50	N/A	N/A	68531	2014.5
CA_66C-71A	$(70+90)^2 + 35$	100+100+ 50	f1	CC 100	132322	1745	66786	2145
			f2	CC 100	132520	1764.8	66984	2164.8
			f5	CC 50	133297	680.5	68761	634.5
			f6	CC 50	133422	693	68886	647
CA_70A-71A	$(15+25)^2 + 35$	75+50	f1	CC 75	133047	1702.5	68411	2002.5
			f2	CC 75	N/A	N/A	N/A	N/A
			f5	CC 50	133297	680.5	68761	634.5
			f6	CC 50	133422	693	68886	647
CA_70C-71A	$(15+25)^2 + 35$	75+50+50	f1	CC 75	133047	1702.5	68411	2002.5
			f2	CC 50	N/A	N/A	68531	2014.5
			f5	CC 50	133297	680.5	68761	634.5
			f6	CC 50	133422	693	68886	647

Note 1: Exceptionally the second band test frequencies of this CA combination shall be used for PCell and the first band test frequencies of this CA combination shall be used for the SCell respectively.

Note 2: Asymmetric operating band (UL + DL).

Note 3: Band 46 is restricted to E-UTRA operation when carrier aggregation is configured. In Rel-13 the downlink only operating band 46 is paired with the uplink operating band (external) of the carrier aggregation configuration that is supporting the configured Pcell.

Table 6.2.3.2-3: Void

Table 6.2.3.2-4: Test frequencies for E-UTRA PCell and SCell for CA non-contiguous Intra-band operation

E-UTRA CA Configuration	Width of Operating band [MHz]	CC Combination / N _{RB_agg}	Test Frequency	CC N _{RB}	N _{UL}	Frequency of Uplink [MHz]	N _{DL}	Frequency of Downlink [MHz]
CA_2A-2A	60	50 + 50	f1	CC 50	18650	1855	650	1935
			f2	CC 50	19150	1905	1150	1985
			f3	CC 50	18900	1880	900	1960
CA_3A-3A	75	50 + 50	f1	CC 50	19250	1715	1250	1810
			f2	CC 50	19900	1780	1900	1875
			f3	CC 50	19575	1747.5	1575	1842.5

CA_4A-4A	45	50 + 50	f1	CC 50	20000	1715	2000	2115
			f2	CC 50	20350	1750	2350	2150
			f3	CC 50	20175	1732.5	2175	2132.5
CA_5A-5A	25	50 + 50	f1	CC 50	20450	829	2450	874
			f2	CC 50	20600	844	2600	889
			f3	N/A	N/A	N/A	N/A	N/A
CA_7A-7A	70	50 + 50	f1	CC 50	20800	2505	2800	2625
			f2	CC 50	21400	2565	3400	2685
			f3	CC 50	21100	2535	3100	2655
CA_23A-23A	20	25 + 50	f1	CC 25	25525	2002.5	7525	2182.5
			f2	CC 50	25650	2015	7650	2195
			f3	N/A	N/A	N/A	N/A	N/A
CA_25A-25A	65	50 + 50	f1	CC 50	26090	1855	8090	1935
			f2	CC 50	26640	1910	8640	1990
			f3	CC 50	26365	1882,5	8365	1962.5
CA_41A-41A	194	100 + 100	f1	CC 100	39750	2506	39750	2506
			f2	CC 100	41490	2680	41490	2680
			f3	CC 100	40620	2593	40620	2593
CA_41A-41C	194 + 194	100 + 100	f1	CC 100	39750	2506	39750	2506
			f2	CC 100	41490	2680	41490	2680
			f3	CC 100	40620	2593	40620	2593
CA_42A-42A	200	100 + 100	f1	CC 100	41690	3410	41690	3410
			f2	CC 100	43490	3590	43490	3590
			f3	CC 100	42590	3500	42590	3500
CA_66A-66A	70+90 ¹	50 + 50	f1	CC 50	132022	1715	66486	2115
			f2	CC 50	132622	1775	67086	2175
			f3	CC 50	132322	1745	66786	2145

NOTE 1: Asymmetric operating band (UL + DL)

6.2.3.3 Test frequencies for ProSe signalling test

Test frequencies for proSe direct discovery and communication signalling testing are specified in Table 6.2.3.3-1 and Table 6.2.3.3-2, these are derived from section 4.3.1 using uplink mid range frequency (i.e. f1 in Table 6.2.3.1-1) for supported ProSe Bands as specified in TS 36.101 table 5.6D.

Table 6.2.3.3-1: Test frequencies for E-UTRA cells and Sidelink Discovery

E-UTRA ProSe Band	E-UTRA Operating Band	Default Operating BW MHz	f1		f2		f3		f4	
			N _{UL}	N _{DL}	N _{UL}	N _{DL}	N _{UL}	N _{DL}	N _{UL}	N _{DL}
2	2	5	Refer to Table 6.2.3.1-1							
3	3	5	Refer to Table 6.2.3.1-1							
4	4	5	Refer to Table 6.2.3.1-1							
7	7	5	Refer to Table 6.2.3.1-1							
14	14	5	Refer to Table 6.2.3.1-1							
20	20	10	Refer to Table 6.2.3.1-1a							
26	26	5	Refer to Table 6.2.3.1-1							
28	28	5	Refer to Table 6.2.3.1-1							
31	31	5	Refer to Table 6.2.3.1-1							
41	41	20	Refer to Table 6.2.3.1-2a							

Table 6.2.3.3-2: Test frequencies for E-UTRA cells and Sidelink Communication

E-UTRA ProSe Band	E-UTRA Operating Band	Default Operating BW MHz	f1		f2		f3		f4		
			N _{UL}	N _{DL}	N _{UL}	N _{DL}	N _{UL}	N _{DL}	N _{UL}	N _{DL}	
3	3	10	FFS	FFS	FFS	FFS	FFS	FFS	FFS	FFS	
7	7	10	FFS	FFS	FFS	FFS	FFS	FFS	FFS	FFS	
14	14	10	FFS	FFS	FFS	FFS	FFS	FFS	FFS	FFS	
20	20	10	Table 6.2.3.1-1a								
26	26	10	FFS	FFS	FFS	FFS	FFS	FFS	FFS	FFS	
28	28	10	FFS	FFS	FFS	FFS	FFS	FFS	FFS	FFS	
31	31	5	FFS	FFS	FFS	FFS	FFS	FFS	FFS	FFS	

6.2.3.4 Test frequencies for MFBI frequency band priority adjustment signalling test

Test frequencies for MFBI frequency band priority adjustment signalling testing are specified in Table 6.2.3.4-1, these are derived from section 4.3.1 using uplink mid range frequency.

Table 6.2.3.4-1: MFBI frequency band priority adjustment test frequency/Inter-band CA

E-UTRA CA Configuration	Width of Operating bands [MHz+MHz]	CC Combination / N _{RB_agg}	E-UTRA Operating Band	MFBI Operating Band	MFBI Overlapping Band	f1, f5
CA_39A-41A	40+194	100+100	39	38	41	Mid (Note)

Note: For f1, Mid refer to Table 4.3.1.2.7-1. For f5, Mid refer to Table 4.3.1.5.26-1.

6.2.3.5 Test frequencies for V2X Communication

Test frequencies for V2X communication signalling testing are specified in Table 6.2.3.5-1, these are derived from section 4.3.1 using uplink mid, low and high range frequency for supported V2X communication Bands as specified in TS 36.101 table 5.6G.

Table 6.2.3.5-1: Test frequencies for V2X Communication

E-UTRA V2X Communication Band	Bandwidth [MHz]	Default Operating BW MHz	f5		f6		f7	
			N _{UL}	N _{DL}	N _{UL}	N _{DL}	N _{UL}	N _{DL}
47	60	10	Mid	Mid	High	High	Low	Low
47	60	20	Mid	Mid	High	High	Low	Low

6.3 Reference system configurations

The reference system configurations specified in this subclause apply to all Signalling test cases defined in TS 36.523-1 [18] unless otherwise specified, in addition to the common reference system configurations specified in subclause 4.4 of this specification.

For Signalling testing, MIMO (Multiple Input Multiple Output) is not applied for all cell configurations regardless of UE MIMO functionality. Only one SS Tx antenna is used.

One or two UE antennas are used for all signalling test cases. (*1)

(*1) Two UE antennas configuration is possible for UE diversity case.

6.3.1 Default parameter specific for simulated cells

Default parameters specific for simulated cells are specified in this subclause.

6.3.1.1 Intra-frequency neighbouring cell list in SIB4 for E-UTRA cells

Intra-frequency neighbouring cell list for signalling test cases is defined in table 6.3.1.1-1. This table is referred to in the default contents of IE *intraFreqNeighbouringCellList* in *SystemInformationBlockType4* defined in table 4.4.3.3-3.

Table 6.3.1.1-1: Intra-frequency neighbouring cell lists for E-UTRA cells

cell ID	Test Frequency	intra-frequency neighbouring cell list						
		number of entries	physCellId[n]			q-OffsetCell [n]		
			1	2	3	1	2	3
Cell 1	f1	3	Cell 2	Cell 4	Cell 11	dB0	dB0	dB0
Cell 2	f1	3	Cell 1	Cell 4	Cell 11	dB0	dB0	dB0
Cell 4	f1	3	Cell 1	Cell 2	Cell 11	dB0	dB0	dB0
Cell 11	f1	3	Cell 1	Cell 2	Cell 4	dB0	dB0	dB0
Cell 3	f2	1	Cell 23	-	-	dB0	-	-
Cell 23	f2	1	Cell 3	-	-	dB0	-	-

NOTE: The intra-frequency E-UTRA neighbouring cell list for signalling NAS test cases when cells are on same PLMN is defined in table 6.3.2.3.1-1.

6.3.1.2 Inter-frequency carrier frequency list in SIB5 for E-UTRA cells

Inter-frequency E-UTRA carrier frequency list for signalling test cases is defined in table 6.3.1.2-1. This table is referred to in the default contents of IE *interFreqCarrierFreqList* in *SystemInformationBlockType5* defined in table 4.4.3.3-4.

Table 6.3.1.2-1: Inter-frequency carrier frequency lists for E-UTRA cells

cell ID	Test Frequency	interFreqCarrierFreqList			
		number of entries	dl-CarrierFreq[n]		
			1	2	3
Cell 1 Cell 2 Cell 4 Cell 11	f1	3	f2	f3	f5
Cell 3 Cell 23	f2	3	f1	f3	f5
Cell 6	f3	3	f1	f2	f5
Cell 10	f5	3	f1	f2	f3
Note 1:	The inter-frequency E-UTRA carrier frequency list for signalling NAS test cases when cells are on same PLMN is defined in table 6.3.2.3.2-1.				
Note 2:	Depending on the Band under test, f3 may not be applicable.				
Note 3:	In case of Test frequency f1, f2 and f3, dl-CarrierFreq f5 as part of inter-frequency list is applicable only in case of multi-band scenarios.				
Note 4:	In case of Test frequency f5, dl-CarrierFreq f1 as part of inter-frequency list is applicable only in case of multi-band scenarios.				

In the case of dual mode multi-cell network scenarios as defined in subclause 4.4.1.3, inter-frequency E-UTRA carrier frequency list for signalling test cases is defined in table 6.3.1.2-2.

Table 6.3.1.2-2: Inter-frequency carrier frequency lists for E-UTRA cells in dual mode scenario

cell ID	Test Frequency	interFreqCarrierFreqList			
		number of entries	dl-CarrierFreq[n]		
			1	2	3

Cell 1 Cell 2 Cell 4	f1	3	f2	f5	f6
Cell 3	f2	3	f1	f5	f6
Cell 10, Cell 30, Cell 31	f5	3	f1	f2	f6
Cell 28, Cell 29	f6	3	f1	f2	f5

6.3.1.3 UTRA carrier frequency list in SIB6 for E-UTRA cells

UTRA carrier frequency list for signalling test cases is defined in table 6.3.1.3-1. This table is referred to in the default contents of IE *carrierFreqListUTRA-FDD* and *carrierFreqListUTRA-TDD* in *SystemInformationBlockType6* defined in table 4.4.3.3-5.

Table 6.3.1.3-1: UTRA carrier frequency lists for E-UTRA cells

interFreqCarrierFreqList			
number of entries	carrierFreq[n]		
	1	2	3
3	f8	f9	f10
Note: Band VI has two entries.			

Table 6.3.1.3-2: Mapping of UTRA cell with TS 34.108 [5]

UTRA cell	Frequency	UTRA cell in TS 34.108, clause 6.1	UTRA frequency in TS 34.108
Cell 5	f8	Cell 1	High (Note 2)
Cell 7	f8	Cell 2	High (Note 2)
Cell 8	f9	Cell 4	Mid (Note 2)
Cell 9	f10	Cell 7	Low
Note 1: The following simultaneous co-existences in the test are not allowed: <ul style="list-style-type: none"> - cells on f1 (eUTRA cell 1, cell 2, cell 4, cell 11) and f9 (UTRA cell 8); - cells on f2 (eUTRA cell 3, cell 12, cell 23) and f8 (UTRA cell 5, cell 7); - cells on f3 (eUTRA cell 6, Cell 13) and f10 (UTRA cell 9). Note 2: On UTRA Band VI, the Low range test frequency is applied to f9 for Cell 8, and f8 for Cell 5 and Cell 7. Note 3: The combinations of the referred TS 34.108 UTRA Cell index and frequency in this table override that specified in TS 34.108.			

6.3.1.4 GERAN carrier frequency group list in SIB7 for E-UTRA cells

GERAN carrier frequency group list for signalling test cases is defined in table 6.3.1.4-1. This table is referred to in the default contents of IE *carrierFreqsInfoList* in *SystemInformationBlockType7* defined in table 4.4.3.3-6.

Table 6.3.1.4-1: GERAN carrier frequency group list for E-UTRA cells

carrierFreqsInfoList				
number of entries	index (n)	carrierFreqs[n]		
		startingARFCN[n]	explicitListOfARFCNs[n]	
			number of entries	ARFCN-ValueGERAN
1	1	f11	2	f12, f13

Table 6.3.1.4-2: Mapping of GERAN cells with TS 51.010-1 [25]

GERAN cell	Frequency	GERAN cell in TS 51.010-1, clause 40
Cell 24	f11	Cell A
Cell 25	f12	Cell D
Cell 26	f13	Cell B

NOTE 2: Unless otherwise stated, GERAN cells 24/25/26 take the default values of GERAN cells A/B/D as defined in TS 51.010 clause 40.

6.3.1.5 CDMA2000 HRPD carrier frequency list in SIB8 for E-UTRA cells

CDMA2000 HRPD carrier frequency list for signalling test cases is defined in table 6.3.1.5-1. This table is referred to in the default contents of IE *cellReselectionParametersHRPD* in *SystemInformationBlockTyp8* defined in table 4.4.3.3-7.

Table 6.3.1.5-1: CDMA2000 HRPD carrier frequency list for E-UTRA cells

neighCellsPerFreqList					
number of entries	index (n)	arfcn[n]	physCellIdList[n]		
			number of entries	index	PhysCellIdCDMA2000
3	1	f14	2	1	Cell 15
				2	Cell 16
	2	f15	1	1	Cell 17
				3	f16

6.3.1.6 CDMA2000 1xRTT carrier frequency list in SIB8 for E-UTRA cells

CDMA2000 1xRTT carrier frequency list for signalling test cases is defined in table 6.3.1.6-1. This table is referred to in the default contents of IE *cellReselectionParameters1XRTT* in *SystemInformationBlockTyp8* defined in table 4.4.3.3-7.

Table 6.3.1.6-1: CDMA2000 1xRTT carrier frequency list for E-UTRA cells

neighCellsPerFreqList					
number of entries	index (n)	arfcn[n]	physCellIdList[n]		
			number of entries	index	PhysCellIdCDMA2000
3	1	f17	2	1	Cell 19
				2	Cell 20
	2	f18	1	1	Cell 21
				3	f19

6.3.1.7 E-UTRA carrier frequency list in SIB19 for UTRA cells

E-UTRA carrier frequency list for signalling test cases is defined in table 6.3.1.7-1. This table is referred to in the default contents of IE *eutra-FrequencyAndPriorityInfoList* in *System Information Block type 19* defined in table 4.4.4.1-1.

Table 6.3.1.7-1: E-UTRA carrier frequency list for UTRA cells

eutra-FrequencyAndPriorityInfoList					
number of entries	earfcn[n]				
	1	2	3	4	-
4	f1	f2	f3	f4	-
Note: Depending on the Band under test, f2, f3 and f4 may not be applicable.					

6.3.2 Default configurations for NAS test cases

The default configurations specified in this subclause apply only to NAS test cases. They apply to all NAS test cases unless otherwise specified.

6.3.2.1 Simulated network scenarios for NAS test cases

Simulated network scenarios for NAS test cases to be tested are specified in the pre-test conditions of each individual test case.

NOTE: The number of cells specified does not necessarily correspond to the maximum number of resources to be configured simultaneously in test equipment. Please refer to Table 6.1-1 for such information.

Any combination is allowed with the following restrictions:

- Cell E should not be used if Cell G or Cell H is used, otherwise two different PLMNs will be operated on the same frequency
- a maximum 3 cells on the same frequency can be used, i.e. only 3 cells out of cells A, B, C, D and M may be used simultaneously in each individual test case when cells in the test case are in different PLMNs (refer to Table 6.3.2.2-3).

6.3.2.2 Simulated NAS cells

Simulated NAS cells and default parameters are specified in table 6.3.2.2-1.

Unless otherwise specified, the default parameters specified in section 4 also apply to all NAS cells.

Table 6.3.2.2-1: Default parameters for simulated NAS cells

NAS cell ID	Tracking Area			TA# list (Note 1)	GUTI (Note 2)		M-TMSI	
	TA#	PLMN			MME Identifier			
		MCC	MNC		MME Group ID	MME Code		
Cell A	TAI-1	(Note 3)		1	TAI-1	32769	1	Arbitrarily selected according to TS 23.003 subclause 2.8 [2].
Cell B	TAI-2	(Note 3)		2	TAI-2	32770	1	
Cell C	TAI-3	(Note 3)		3	TAI-3	32771	1	
Cell D	TAI-4	(Note 3)		4	TAI-4	32772	1	
Cell E	TAI-12	002	101	3	TAI-12	32777	1	
Cell F								
Cell G	TAI-7	(Note 4)	02	1	TAI-7	32775	1	
Cell H	TAI-8	(Note 4)	02	2	TAI-8	32776	1	
Cell I	TAI-9	002	101	1	TAI-9	32777	1	
Cell J	TAI-10	003	101	1	TAI-10	32778	1	
Cell K	TAI-9	002	101	1	TAI-9	32777	1	
Cell L	TAI-11	002	101	2	TAI-11	32779	1	
Cell M	TAI-1	(Note 3)		1	TAI-1	32769	1	
Note 1: The value(s) in the column TA# list indicates TAI(s) included in the response messages of the registration procedure (ATTACH ACCEPT or TRACKING AREA UPDATE ACCEPT) when the UE performs the registration procedure on a corresponding cell. Note 2: The value in the column GUTI indicates GUTI included in the response messages of the registration procedure (ATTACH ACCEPT or TRACKING AREA UPDATE ACCEPT) when the UE performs the registration procedure on a corresponding cell. Note 3: Set to the same Mobile Country Code and Mobile Network Code stored in EF _{IMSI} on the test USIM card (subclause 4.9.3). Note 4: Set to the same Mobile Country Code stored in EF _{IMSI} on the test USIM card (subclause 4.9.3). Note 5: Cell A is a serving cell and the other cells are suitable neighbour cells. The definitions are specified in subclause 6.2.2.1.								

Table 6.3.2.2-2: Default cell identifiers for simulated NAS cells when cells are in same PLMN

NAS cell ID	Frequency	E-UTRAN Cell Identifier		Physical layer cell identity	rootSequenceIndex FDD	rootSequenceIndex TDD
		eNB Identifier	Cell Identity			

Cell A	f1	'0000 0000 0000 0001 0001'B	'0000 0001'B	1	22	0
Cell B	f1	'0000 0000 0000 0001 0001'B	'0000 0010'B	2	86	8
Cell C	f2	'0000 0000 0000 0001 0010'B	'0000 0011'B	3	22	0
Cell D	f1	'0000 0000 0000 0001 0001'B	'0000 0100'B	4	150	16
Cell E	NA	NA	NA	NA	NA	NA
Cell F	NA	NA	NA	NA	NA	NA
Cell G	NA	NA	NA	NA	NA	NA
Cell H	NA	NA	NA	NA	NA	NA
Cell I	NA	NA	NA	NA	NA	NA
Cell J	NA	NA	NA	NA	NA	NA
Cell M	f2	'0000 0000 0000 0010 0001'B	'0001 0001'B	17	86	8

Table 6.3.2.2-3: Default cell identifiers for simulated NAS cells when cells are in different PLMNs

NAS cell ID	PLMN	Frequency	E-UTRAN Cell Identifier		Physical layer cell identity	rootSequenceIndex FDD	rootSequenceIndex TDD
			eNB Identifier	Cell Identity			
Cell A	MCC/MNC= MCC/MNC in USIM	f1	'0000 0000 0000 0010 0001'B	'0000 0001'B	1	22	0
Cell B	MCC/MNC= MCC/MNC in USIM	f1	'0000 0000 0000 0010 0001'B	'0000 0010'B	2	86	8
Cell C	MCC/MNC= MCC/MNC in USIM	f1	'0000 0000 0000 0010 0001'B	'0000 0011'B	3	150	16
Cell D	MCC/MNC= MCC/MNC in USIM	f1	'0000 0000 0000 0010 0001'B	'0000 0100'B	4	214	24
Cell E	MCC=002 MNC=101	f2	'0000 0000 0000 0011 0101'B	'0001 0111'B	23	22	0
Cell F	NA	NA	NA	NA	NA	NA	NA
Cell G	MCC = MCC in USIM MNC=02	f2	'0000 0000 0000 0010 0010'B	'0000 1011'B	11	86	8
Cell H	MCC= MCC in USIM MNC=02	f2	'0000 0000 0000 0010 0010'B	'0000 1100'B	12	150	16
Cell I	MCC=002 MNC=101	f3 (Note 1)	'0000 0000 0000 0010 0011'B	'0000 1101'B	13	22	0
Cell J	MCC=003 MNC=101	f4 (Note 1)	'0000 0000 0000 0010 0100'B	'0000 1110'B	14	22	0
Cell K	MCC=002 MNC=101	f3 (Note 1)	'0000 0000 0000 0010 0011'B	'0000 1111'B	15	86	8
Cell L	MCC=002 MNC=101	f3 (Note 1)	'0000 0000 0000 0010 0011'B	'0001 0000'B	16	150	16
Cell M	MCC/MNC= MCC/MNC in USIM	f1	'0000 0000 0000 0010 0001'B	'0001 0001'B	17	278	32

Note 1: The test frequency f3 or f4 is allocated to the cell if f1 and f2 are already allocated to the cells in the test. Otherwise, f1 or f2 is allocated, instead.

6.3.2.3 Broadcast system information

6.3.2.3.1 Intra-frequency neighbouring cell list in SIB4 for E-UTRA NAS cells

Intra-frequency neighbouring cell list of the same PLMN for the NAS signalling test is defined in table 6.3.2.3.1-1 when SIB4 to be broadcast.

Table 6.3.2.3.1-1: Intra-freq. lists in SIB4 for NAS test cases (same PLMN)

NAS cell ID	Test Frequency	Intra-frequency neighbouring cell list		
		number of entries	physCellId[n]	
			1	2
Cell A	f1	2	Cell B	Cell D
Cell B	f1	2	Cell A	Cell D
Cell D	f1	2	Cell A	Cell B
Cell C	f2	1	Cell M	N/A
Cell M	f2	1	Cell C	N/A

6.3.2.3.2 Inter-frequency carrier frequency list in SIB5 for E-UTRA NAS cells

Inter-frequency neighbouring carrier and cell lists for NAS signalling test cases are defined in table 6.3.2.3.2-1 for same PLMN and table 6.3.2.3.2-2 for different PLMN.

Table 6.3.2.3.2-1: Inter-freq. lists in SIB5 for NAS test cases (same PLMN)

NAS cell ID	Test Frequency	interFreqCarrierFreqList		
		number of entries	dl-CarrierFreq[n]	
			1	2
Cell A Cell B Cell D	f1	1	f2	NA
Cell C Cell M	f2	1	f1	NA

NOTE: Operating on Band 13, SIB5 is not broadcast.

Table 6.3.2.3.2-2: Inter-freq. lists in SIB5 for NAS test cases (different PLMN)

NAS cell ID	Test Frequency	interFreqCarrierFreqList			Condition
		number of entries	dl-CarrierFreq[n]		
			1	2	
Cell A Cell B Cell C Cell D Cell M	f1	0	NA	NA	
Cell G Cell H	f2	0	NA	NA	
Cell I Cell K Cell L	f3	0	NA	NA	E-NOT-CONF
		1	f2		E-CONF
Cell J	f4	0	NA	NA	
Cell E	f2	1	f3	NA	

Condition	Explanation
E-NOT-CONF	cell E is not configured in the test
E-CONF	cell E is configured in the test

6.3.3 Cell configurations

For the purpose of test not involving Carrier Aggregation, three types of SS cell configurations are defined, full (Active) cell configuration, broadcast only cell configuration and minimum uplink cell configuration.

The abovementioned configurations can also be used in Carrier Aggregation test cases, either for PCells or SCells. However another configuration, the virtual cell configuration, can additionally be used for an SCell that is not active.

6.3.3.1 Full cell configuration

Full cell configuration is also called active cell configuration. The cell configuration, in minimum, has all defined DL and UL physical channels configured, i.e.

in DL: PBCH, PCFICH, PDCCH, PDSCH, PHICH,

in UL: PRACH, PUCCH, PUSCH.

The DL and UL Reference and synchronization (both primary and secondary) signals are also configured.

6.3.3.2 Minimum uplink cell configuration

In this cell configuration,

in DL: physical channels capable of transmission, i.e. PBCH, PCFICH, PDCCH, PDSCH are configured;

DL physical reference and synchronization (both primary and secondary) signals are also configured.

In UL: PRACH is configured. SS shall report any detection of PRACH preambles, in order to assign test verdicts. Decoding the preambles is not required.

6.3.3.3 Broadcast only cell configuration

In this cell configuration,

in DL: physical channels capable of transmission, i.e. PBCH, PCFICH, PDCCH, PDSCH are configured;

DL physical reference and synchronization (both primary and secondary) signals are also configured.

in UL: no physical resources are configured, neither channels, nor signals.

6.3.3.3A Virtual cell configuration

In this cell configuration,

in DL: no physical resources are configured, neither channels, nor signals;

in UL: no physical resources are configured, neither channels, nor signals.

6.3.3.4 Application of different cell configurations

By default, the cells specified in 36.523-1 are defined with the full cell configuration, unless it is explicitly specified as either the broadcast only, minimum uplink, or virtual cell configuration. The full cell configuration is suitable for UE to start camping, establish RRC connection or hand over from another active cell.

The broadcast only cells identified as 'DL only' can be applied in some RRC measurement test cases to those neighbour cells which UE shall not camp on during the test case execution.

The capability of a minimum uplink cell is much weaker than a full cell, but stronger than a broadcast only cell in UL. This cell configuration identified as 'min UL' can be applied in the idle mode test cases to those neighbour cells which a conformant UE shall not camp on during the test case execution.

The virtual cell configuration can only be used in Carrier Aggregation test cases as an SCell which is not active, i.e. the UE has it configured via RRC signalling but does not need to send or receive anything in this SCell.

If a cell configuration is specified in a test case it shall remain unchanged throughout the test case specification. In addition, there shall not be any requirement in the test specification or test implementation for a cell reconfiguration from one of the above configurations to the other.

For the UE conformance test, the broadcast only cell configuration can be replaced and implemented with the minimum uplink or full cell configurations. The minimum uplink cell configuration can also be implemented with the full cell configuration. The replacements in the implementation have no impact on the test purposes and the test requirements. The implementation guidelines are referred to 36.523-3.

6.3.4 SCell configurations

For the purpose of System Simulator resource management for Carrier Aggregation testing the following types of SCell configurations are defined:

- Active SCell: A cell that becomes an SCell at any point of time during the test case and which, while being an SCell, is activated.
- Inactive SCell: A cell that becomes an SCell at any point of time during the test case, but is never activated while being an SCell.

SCell activation is defined as sending an Activation/Deactivation MAC Control Element (ref. 36.321 cl. 6.1.3.8) to the UE to activate the SCell.

The SCell type does not depend on what the cell is used for in the test case while not being an SCell, and does not directly relate to the cell type specified in section 6.3.3. In particular an Inactive SCell can still be used as full cell or broadcast only cell (e.g. for measurements to be performed on such a cell), and may be used for UE dedicated traffic while not acting as an SCell.

Also note that an Active SCell will not become an Inactive SCell if the SCell is deactivated via Activation/Deactivation MAC Control Element or after the *sCellDeactivationTimer* timer expires.

6.4 Generic procedures

This clause describes UE test states which can be used in the initial condition of many test cases defined in TS 36.523-1 [18] in addition to the states already specified in clause 4.5 of this specification.

6.4.1 Initial UE states and setup procedures

6.4.1.1 Initial UE states and setup procedures

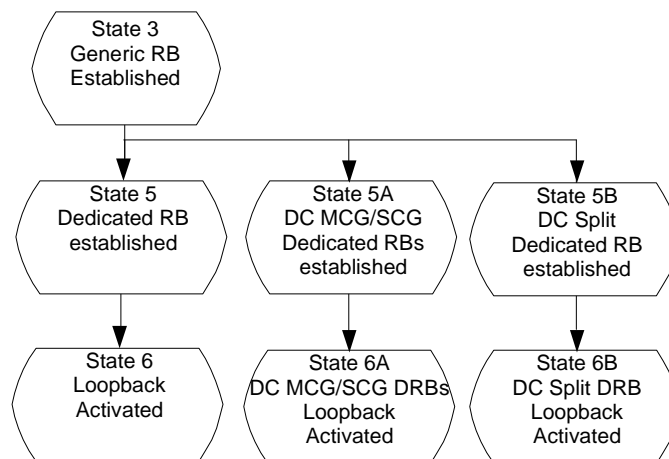

Figure 6.4.1.1-1: Initial UE states

In order that the UE can set up a call or session in E-UTRAN, there are a number of setup procedures to be undertaken in a hierarchical sequence to move between known states. The sequences are shown in figure 6.4.1.1-1 and the status of the relevant protocols in the UE in the different states are given in table 6.4.1.1-1. State 3 is defined in clause 4.5.1.

Table 6.4.1.1-1: Protocol state for each initial UE state

		RRC	ECM	EMM	ESM
State 5	Dedicated RB established	RRC_CONNECTED	ECM_CONNECTED	EMM-REGISTERED	1 default EPS bearer context active N dedicated EPS bearer context(s) active
State 5A	DC MCG/SCG Dedicated RB established	RRC_CONNECTED	ECM_CONNECTED	EMM-REGISTERED	1 default EPS bearer context active on the PCell 1 dedicated EPS bearer context(s) active on the PCell 1 dedicated EPS bearer context(s) active on the PSCell
State 5B	DC Split Dedicated RB established	RRC_CONNECTED	ECM_CONNECTED	EMM-REGISTERED	1 default EPS bearer context active on the PCell 1 dedicated EPS bearer context(s) active as a Split DRB on the PCell and the PSCell with UL transmission of PDCP SDUs on PSCell
State 6	Loopback Activated	RRC_CONNECTED	ECM_CONNECTED	EMM-REGISTERED	1 default EPS bearer context active N dedicated EPS bearer context(s) active
State 6A	DC MCG/SCG DRB Loopback Activated	RRC_CONNECTED	ECM_CONNECTED	EMM-REGISTERED	1 default EPS bearer context active 1 dedicated EPS bearer context(s) active on the PCell 1 dedicated EPS bearer context(s) active on the PSCell
State 6B	DC Split DRB Loopback Activated	RRC_CONNECTED	ECM_CONNECTED	EMM-REGISTERED	1 default EPS bearer context active 1 dedicated EPS bearer context(s) active as a Split DRB on the PCell and the PSCell with UL transmission of PDCP SDUs on PSCell

6.4.1.2 Dedicated Bearer Establishment (to state 5)

6.4.1.2.1 Initial conditions

System Simulator:

- Parameters are set to the default parameters for the basic single cell environment, as defined in subclause 4.4, unless otherwise specified in the test case.

User Equipment:

- The UE shall be in Generic RB established (State 3).

6.4.1.2.2 Definition of system information messages

The default system information messages are used.

6.4.1.2.3 Procedure

The establishment of dedicated radio bearer connection is assumed to always be mobile terminated.

Table 6.4.1.2.3-1: Procedure for dedicated bearer establishment

Step	Procedure	Message Sequence	
		U - S	Message
1	The SS configures new data radio bearer(s) and the associated dedicated EPS bearer context(s).	<--	RRC: RRCConnectionReconfiguration NAS: ACTIVATE DEDICATED EPS BEARER CONTEXT REQUEST
2	The UE transmits an <i>RRCConnectionReconfigurationComplete</i> message to confirm the establishment of the new data radio bearer(s), associated with the dedicated EPS bearer context(s) in the NAS message.	-->	RRC: RRCConnectionReconfigurationComplete
3	The UE transmits an ACTIVATE DEDICATED EPS BEARER CONTEXT ACCEPT message.	-->	NAS: ACTIVATE DEDICATED EPS BEARER CONTEXT ACCEPT

6.4.1.2.4 Specific message contents

All specific message contents shall be referred to clause 4.6 and 4.7.

6.4.1.2A DC MCG/SCG Dedicated Bearer Establishment (to state 5A)

6.4.1.2A.1 Initial conditions

System Simulator:

- Parameters are set to the default parameters for the basic single cell environment, as defined in subclause 4.4, unless otherwise specified in the test case.

User Equipment:

- The UE shall be in Generic RB established (State 3).

6.4.1.2A.2 Definition of system information messages

The default system information messages are used.

6.4.1.2A.3 Procedure

The establishment of MCG/SCG dedicated radio bearer connection is assumed to always be mobile terminated.

Table 6.4.1.2A.3-1: Procedure for MCG/SCG dedicated bearer establishment

Step	Procedure	Message Sequence	
		U - S	Message
1	The SS configures new MCG data radio bearer and the associated dedicated EPS bearer context.	<--	RRC: RRCConnectionReconfiguration NAS: ACTIVATE DEDICATED EPS BEARER CONTEXT REQUEST
2	The UE transmits an <i>RRCConnectionReconfigurationComplete</i> message to confirm the establishment of the new MCG data radio bearer, associated with the dedicated EPS bearer context in the NAS message.	-->	RRC: RRCConnectionReconfigurationComplete
3	The UE transmits an ACTIVATE DEDICATED EPS BEARER CONTEXT ACCEPT message.	-->	NAS: ACTIVATE DEDICATED EPS BEARER CONTEXT ACCEPT
4	The SS adds a PSCell and configures new SCG data radio bearer and the associated dedicated EPS bearer context.	<--	RRC: RRCConnectionReconfiguration NAS: ACTIVATE DEDICATED EPS BEARER CONTEXT REQUEST
5	The UE transmits an <i>RRCConnectionReconfigurationComplete</i> message to confirm the establishment of the new SCG data radio bearer(s), associated with the dedicated EPS bearer context in the NAS message.	-->	RRC: RRCConnectionReconfigurationComplete
6	The UE transmits an ACTIVATE DEDICATED EPS BEARER CONTEXT ACCEPT message.	-->	NAS: ACTIVATE DEDICATED EPS BEARER CONTEXT ACCEPT

6.4.1.2A.4 Specific message contents

All specific message contents shall be referred to clause 4.6 and 4.7 with the following exceptions:

Table 6.4.1.2A.4-1: RRCConnectionReconfiguration (Step 1, Table 6.4.1.2A.3-1)

Derivation Path: 36.508, Table 4.6.1-8 using conditions AM-DRB-ADD(1)

Table 6.4.1.2A.4-2: RRCConnectionReconfiguration (Step 4, Table 6.4.1.2A.3-1)

Derivation Path: 36.508, Table 4.6.1-8 using conditions PSCell_Add_SCG_DRB
--

6.4.1.2B DC Split Dedicated Bearer Establishment (to state 5B)

6.4.1.2B.1 Initial conditions

System Simulator:

- Parameters are set to the default parameters for the basic single cell environment, as defined in subclause 4.4, unless otherwise specified in the test case.

User Equipment:

- The UE shall be in Generic RB established (State 3).

6.4.1.2B.2 Definition of system information messages

The default system information messages are used.

6.4.1.2B.3 Procedure

The establishment of split dedicated radio bearer connection is assumed to always be mobile terminated.

Table 6.4.1.2B.3-1: Procedure for Dual Connectivity Split dedicated bearer establishment

Step	Procedure	Message Sequence	
		U - S	Message
1	The SS configures new MCG data radio bearer and the associated dedicated EPS bearer context.	<--	RRC: RRCConnectionReconfiguration NAS: ACTIVATE DEDICATED EPS BEARER CONTEXT REQUEST
2	The UE transmits an <i>RRCConnectionReconfigurationComplete</i> message to confirm the establishment of the new MCG data radio bearer, associated with the dedicated EPS bearer context in the NAS message.	-->	RRC: RRCConnectionReconfigurationComplete
3	The UE transmits an ACTIVATE DEDICATED EPS BEARER CONTEXT ACCEPT message.	-->	NAS: ACTIVATE DEDICATED EPS BEARER CONTEXT ACCEPT
4	The SS adds a PSCell and configures a split data radio bearer with UL transmission of PDCP SDUs on the PSCel.	<--	RRC: RRCConnectionReconfiguration
5	The UE transmits an <i>RRCConnectionReconfigurationComplete</i> message to confirm the establishment of the split data radio bearer	-->	RRC: RRCConnectionReconfigurationComplete
6	Void	-	-

6.4.1.2B.4 Specific message contents

All specific message contents shall be referred to clause 4.6 and 4.7 with the following exceptions:

Table 6.4.1.2B.4-1: RRCConnectionReconfiguration (Step 1, Table 6.4.1.2A.3-1)

Derivation Path: 36.508, Table 4.6.1-8 using conditions AM-DRB-ADD(1)

Table 6.4.1.2B.4-2: RRCConnectionReconfiguration (Step 4, Table 6.4.1.2A.3-1)

Derivation Path: 36.508, Table 4.6.1-8 using conditions PSCell_Add_Split_DRB
--

6.4.1.3 Loopback Activation (to state 6)

6.4.1.3.1 Initial conditions

System Simulator:

- Parameters are set to the default parameters for the basic single cell environment, as defined in subclause 4.4, unless otherwise specified in the test case.

User Equipment:

- The UE shall be in Dedicated Radio Bearer Established (State 5).

6.4.1.3.2 Definition of system information messages

The default system information messages are used.

6.4.1.3.3 Procedure

Table 6.4.1.3.3-1: Procedure for loopback activation

Step	Procedure	Message Sequence	
		U - S	Message
1	The SS transmits an ACTIVATE RB TEST MODE message to activate UE radio bearer test mode procedure.	<--	RRC: DLInformationTransfer TC: ACTIVATE RB TEST MODE
2	The UE transmits an ACTIVATE RB TEST MODE COMPLETE message.	-->	RRC: ULInformationTransfer TC: ACTIVATE RB TEST MODE COMPLETE
3	The SS transmits a CLOSE UE TEST LOOP message to enter the UE test loop mode.	<--	RRC: DLInformationTransfer TC: CLOSE UE TEST LOOP
4	The UE transmits a CLOSE UE TEST LOOP COMPLETE message to confirm that loopback entities for the radio bearer(s) have been created and loop back is activated (State 6).	-->	RRC: ULInformationTransfer TC: CLOSE UE TEST LOOP COMPLETE

6.4.1.3.4 Specific message contents

All specific message contents shall be referred to clause 4.6, 4.7 and 4.7A.

6.4.1.3A DC MCG/SCG DRB Loopback Activation (to state 6A)

6.4.1.3A.1 Initial conditions

System Simulator:

- Parameters are set to the default parameters for the basic single cell environment, as defined in subclause 4.4, unless otherwise specified in the test case.

User Equipment:

- The UE shall be in DC MCG/SCG Dedicated Radio Bearer Established (State 5A).

6.4.1.3A.2 Definition of system information messages

The default system information messages are used.

6.4.1.3A.3 Procedure

Same procedure as in sub-clause 6.4.1.3.3.

6.4.1.3A.4 Specific message contents

All specific message contents shall be referred to clause 4.6, 4.7 and 4.7A.

6.4.1.3B DC Split DRB Loopback Activation (to state 6B)

6.4.1.3B.1 Initial conditions

System Simulator:

- Parameters are set to the default parameters for the basic single cell environment, as defined in subclause 4.4, unless otherwise specified in the test case.

User Equipment:

- The UE shall be in DC Split Dedicated Radio Bearer Established (State 5B).

6.4.1.3B.2 Definition of system information messages

The default system information messages are used.

6.4.1.3B.3 Procedure

Same procedure as in sub-clause 6.4.1.3.3.

6.4.1.3B.4 Specific message contents

All specific message contents shall be referred to clause 4.6, 4.7 and 4.7A.

6.4.2 Test procedures

6.4.2.1 Introduction

This section defines test procedures which can be used within test procedure sequences for test steps where checking the UE state is needed.

For each test procedure,

- at the start of the test procedure,
 - the System Simulator condition and the value of system information messages are the ones applicable in the test case referring to this test procedure, as they are after the execution of the test step immediately preceding the test step where the test procedure is used;
 - the initial UE condition is one indicated in the test case referring to this procedure, as it is after the execution of the test step immediately preceding the test step where the test procedure is used.
- at the end of the test procedure,
 - the System Simulator condition after the test procedure execution is complete is the same as before it is started (this should not be changed by the test procedure).

6.4.2.2 Test procedure to check RRC_IDLE state

This procedure aims at checking whether the UE is in RRC_IDLE on a certain cell of a test case or not.

Table 6.4.2.2-1: Test procedure sequence

St	Procedure	Message Sequence		TP	Verdict
		U - S	Message/PDU/SDU		
0	The SS waits 1 second.	-	-	-	-
1	The SS sends RRC <i>Paging</i> message with UE S-TMSI on the cell(s) specified in the test case.	<--	RRC: <i>Paging</i> (PCCH)	-	-
2	Check: Does the UE send an <i>RRCConnectionRequest</i> message on the cell specified in the test case ?	-->	RRC: <i>RRCConnectionRequest</i>		P
3	The SS transmits a <i>RRCConnectionSetup</i> message	<--	RRC: <i>RRCConnectionSetup</i>	-	-
4	The UE transmits an <i>RRCConnectionSetupComplete</i> message to confirm the successful completion of the connection establishment and to initiate the session management procedure by including the SERVICE REQUEST message.	-->	RRC: <i>RRCConnectionSetupComplete</i> NAS: SERVICE REQUEST	-	-
5 - 6	Void	-	-	-	-
7	The SS transmits a <i>SecurityModeCommand</i> message to activate AS security.	<--	RRC: <i>SecurityModeCommand</i>	-	-
8	The UE transmits a <i>SecurityModeComplete</i> message.	-->	RRC: <i>SecurityModeComplete</i>	-	-
9	The SS transmits a <i>RRCConnectionReconfiguration</i> message to establish the default bearer with condition SRB2-DRB(1, 0) according to 4.8.2.2.1.1,	<--	RRC: <i>RRCConnectionReconfiguration</i>	-	-
10	The UE transmits an <i>RRCConnectionReconfigurationComplete</i> message.	-->	RRC: <i>RRCConnectionReconfigurationComplete</i>	-	-
11	The SS release the RRC connection.	<--	RRC: <i>RRCConnectionRelease</i>	-	-

6.4.2.3 Test procedure to check RRC_CONNECTED state

Table 6.4.2.3-1: Test procedure sequence

St	Procedure	Message Sequence		TP	Verdict
		U - S	Message/PDU/SDU		
1	The SS sends <i>UECapabilityEnquiry</i> message to the UE.	<--	<i>UECapabilityEnquiry</i>	-	-
2	Check: Does the UE send a <i>UECapabilityInformation</i> message?	-->	<i>UECapabilityInformation</i>		P

6.4.2.4 Test procedure Paging (for NAS testing)

This procedure aims at checking whether the UE is in registered with a certain S-TMSI.

For the PS domain this procedure is identical to the procedure in 6.4.2.2 except that the S-TMSI as indicated in step 1 is the one explicitly specified in the test step calling this procedure.

For the CS domain the test procedure is FFS (i.e. it shall be avoided to make use of CS paging in the test case design).

6.4.2.5 Test procedure for no response to paging (for NAS testing)

This procedure aims at checking that the UE ignores paging messages with a specified identity.

The procedure is defined in table 6.4.2.5-1.

Table 6.4.2.5-1: Test procedure sequence

St	Procedure	Message Sequence		TP	Verdict
		U - S	Message		
0	The SS waits 1 second.	-	-	-	-
1	The SS transmits a paging message using the UE identity and the CN domain which are both specified in the referring test step, and on the cell which is specified in the referring test step.	<--	Paging	-	-
2	Check: Does the UE send an <i>RRCCONNECTIONREQUEST</i> message on the cell where the paging was transmitted within the next 3s?	-->	<i>RRCCONNECTIONREQUEST</i>		F

6.4.2.6 Test procedure to check that a dedicated EPS bearer context is active (for NAS testing)

This procedure aims at checking that a dedicated EPS bearer context is active.

The procedure is defined in table 6.4.2.6-1.

Table 6.4.2.6-1: Test procedure sequence

St	Procedure	Message Sequence		TP	Verdict
		U - S	Message		
1	The SS modifies existing data radio bearer(s) and the associated EPS bearer context(s) with Bearer QoS update.	<--	RRC: <i>RRCCONNECTIONRECONFIGURATION</i> NAS: MODIFY EPS BEARER CONTEXT REQUEST	-	-
2	The UE transmits an <i>RRCCONNECTIONRECONFIGURATIONCOMPLETE</i> message to confirm the modification of the existing data radio bearer(s), associated with the EPS bearer context(s) in the NAS message.	-->	RRC: <i>RRCCONNECTIONRECONFIGURATIONCOMPLETE</i>	-	-
3	Check: Does the UE transmit a MODIFY EPS BEARER CONTEXT ACCEPT message?	-->	RRC: <i>ULINFORMATIONTRANSFER</i> NAS: MODIFY EPS BEARER CONTEXT ACCEPT		P

6.4.2.7 Test procedure to check that UE is camped on a new E-UTRAN cell

This procedure aims at checking whether the UE is camping on a new E-UTRAN cell with different TAI of a test case or not.

The procedure is defined in table 6.4.2.7-1.

Table 6.4.2.7-1: Test procedure sequence

St	Procedure	Message Sequence		TP	Verdict
		U - S	Message		
1	The UE transmits an <i>RRCConnectionRequest</i> message on the cell specified in the test case.	-->	RRC: <i>RRCConnectionRequest</i>	-	-
2	SS transmit an <i>RRCConnectionSetup</i> message.	<--	RRC: <i>RRCConnectionSetup</i>	-	-
3	The UE transmits an <i>RRCConnectionSetupComplete</i> message to confirm the successful completion of the connection establishment and a TRACKING AREA UPDATE REQUEST message is sent to update the registration of the actual tracking area.	-->	RRC: <i>RRCConnectionSetupComplete</i> NAS: TRACKING AREA UPDATE REQUEST	-	-
4	SS responds with TRACKING AREA UPDATE ACCEPT message.	<--	RRC: <i>DLInformationTransfer</i> NAS: TRACKING AREA UPDATE ACCEPT	-	-
5	Check: Does the UE send a TRACKING AREA UPDATE COMPLETE on the cell specified in the test case?	-->	RRC: <i>ULInformationTransfer</i> NAS: TRACKING AREA UPDATE COMPLETE	-	P
6	The SS transmits an <i>RRCConnectionRelease</i> message to release RRC connection and move to RRC_IDLE.	<--	RRC: <i>RRCConnectionRelease</i>	-	-

NOTE 1: The periodic tracking area updating timer T3412 is deactivated by default during the attach procedure (TS 36.508 clause 4.7.2).

NOTE 2: The SS does not initiate authentication and NAS SECURITY MODE COMMAND are not performed (reuse of keys allocated during the attach procedure).

6.4.2.7A Test procedure to check that UE is camped on E-UTRAN cell upon mobility from another RAT

This procedure aims at checking whether the UE is camping on a E-UTRAN cell upon mobility from another RAT after Inter RAT reselection.

The procedure if PDP context was established before inter RAT reselection, is defined in table 6.4.2.7A-1.

Table 6.4.2.7A-1: Test procedure sequence

St	Procedure	Message Sequence		TP	Verdict
		U - S	Message		
1	The UE transmits a <i>RRCConnectionRequest</i> message on the cell specified in the test case.	-->	RRC: <i>RRCConnectionRequest</i>	-	-
2	SS transmit an <i>RRCConnectionSetup</i> message.	<--	RRC: <i>RRCConnectionSetup</i>	-	-
3	The UE transmits a <i>RRCConnectionSetupComplete</i> message to confirm the successful completion of the connection establishment and a TRACKING AREA UPDATE REQUEST message is sent to update the registration of the actual tracking area.	-->	RRC: <i>RRCConnectionSetupComplete</i> NAS: TRACKING AREA UPDATE REQUEST	-	-
4	The SS transmits a NAS SECURITY MODE COMMAND message to activate NAS security (mapped security context) (Note 1).	<--	RRC: <i>DLInformationTransfer</i> NAS: SECURITY MODE COMMAND	-	-
5	The UE transmits a NAS SECURITY MODE COMPLETE message and establishes the initial security configuration.	-->	RRC: <i>ULInformationTransfer</i> NAS: SECURITY MODE COMPLETE	-	-
6	SS responds with TRACKING AREA UPDATE ACCEPT message.	<--	RRC: <i>DLInformationTransfer</i> NAS: TRACKING AREA UPDATE ACCEPT	-	-
7	Check: Does the UE send a TRACKING AREA UPDATE COMPLETE on the cell specified in the test case?	-->	RRC: <i>ULInformationTransfer</i> NAS: TRACKING AREA UPDATE COMPLETE	-	P
8	The SS transmits an <i>RRCConnectionRelease</i> message to release RRC connection and move to RRC_IDLE.	<--	RRC: <i>RRCConnectionRelease</i>	-	-
Note 1: Step 4 and 5 are executed only when UE and SS does not have a native security context.					

The procedure if PDP context was not established before inter RAT reselection, is defined in table 6.4.2.7A-2.

Table 6.4.2.7A-2: Test procedure sequence

St	Procedure	Message Sequence		TP	Verdict
		U - S	Message		
-	EXCEPTION: For Rel-8 and Rel-9 steps 1 to 6 are optional and depend on UE implementation. A Rel-10 UE directly starts attach procedure from step 6.	-	-	-	-
1	The UE transmits a <i>RRCConnectionRequest</i> message on the cell specified in the test case.	-->	RRC: <i>RRCConnectionRequest</i>	-	-
2	SS transmit an <i>RRCConnectionSetup</i> message.	<--	RRC: <i>RRCConnectionSetup</i>	-	-
3	The UE transmits a <i>RRCConnectionSetupComplete</i> message to confirm the successful completion of the connection establishment and a TRACKING AREA UPDATE REQUEST message is sent to update the registration of the actual tracking area.	-->	RRC: <i>RRCConnectionSetupComplete</i> NAS: TRACKING AREA UPDATE REQUEST	-	-
4	The SS transmits a TRACKING AREA UPDATE REJECT message with cause #40 (No EPS bearer context activated) to force attach the UE	<--	RRC: <i>DLInformationTransfer</i> NAS: TRACKING AREA UPDATE REJECT	-	-
-	EXCEPTION: Step 5 describes the behaviour that depends on UE behaviour (Note 1).	-	-	-	-
5	The SS transmits an <i>RRCConnectionRelease</i> message to release RRC connection and move to RRC_IDLE.	<--	RRC: <i>RRCConnectionRelease</i>	-	-
-	EXCEPTION: Step 6 describes a behaviour which depends on the UE capability	-	-	-	-
6	IF NOT <i>pc_Auto_PDN_Connectivity</i> , the user initiates an attach by MMI or by AT command. (Note 2)	-	-	-	-
7-22	Steps 2 to 17 of the generic UE Registration procedure (4.5.2.3-1) are executed to successfully complete the Attach procedure.	-	-	-	-
Note 1: SS waits for 1.5 second to receive the Attach Request on the existing RRC Connection. In case Attach Request is not received within 1.5 second, existing RRC Connection is released.					
Note 2: The request is assumed to be triggered by AT command AT+CGDCONT=1,"IP" followed by AT+CGACT=1					

6.4.2.7A.1 Specific message contents

Table 6.4.2.7A.1-1: TRACKING AREA UPDATE REQUEST (Step 3, table 6.4.2.7A-1, 6.4.2.7A-2)

Derivation Path: 36.508 clause 4.7.2			
Information Element	Value/remark	Comment	Condition
EPS update type			
EPS update type Value	'000'B	TA updating	TA_only
	'001'B or '010'B	Combined TA/LA updating or combined TA/LA updating with IMSI attach	No_LAU_CombinedRAU_GERAN_UTRA
	'010'B	Combined TA/LA updating with IMSI attach	LAU_CombinedRAU_GERAN_UTRA
"Active" flag	Any allowed value		
NAS key set identifier			
NAS key set identifier	The valid NAS key set identifier of the UE		
TSC	'0'B	native security context (for KSI _{ASME})	Native_Security_Context
	'1'B	mapped security context (for KSI _{SGSN})	Mapped_Security_Context
GPRS ciphering key sequence number	Not present or any allowed value		
Old P-TMSI signature	Any allowed value		
Additional GUTI	Not present or any allowed value		
Nonce _{UE}	Not present or any allowed value		
UE radio capability information update needed	Not present or any allowed value		
EPS bearer context status	Not present or (octet 3 = '00100000'B or '01100000'B) and octet 4 = '00000000'B)		Bearer_Established
	Not present or (octet 3 = '00000000'B and octet 4 = '00000000'B)		No_Bearer_Established

Condition	Explanation
TA_only	See the definition below table 4.7.2-24.
combined_TA_LA	See the definition below table 4.7.2-24.
Native_Security_Context	UE has performed AKA on the EUTRA Cell
Mapped_Security_Context	UE has performed AKA on the UTRA/GERAN Cell
No_LAU_CombinedRAU_GERAN_UTRA	UE has not performed location area update procedure or a combined routing area update procedure in A/Gb or lu mode
LAU_CombinedRAU_GERAN_UTRA	UE has performed location area update procedure or a combined routing area update procedure in A/Gb or lu mode
Bearer_Established	Bearer is Established when UE earlier camped at UTRAN/GERAN cell or UE previously successfully camped in EUTRA cell.
No_Bearer_Established	Bearer is not Established when UE earlier camped at UTRAN/GERAN cell and UE did not previously camped in EUTRA cell.

This message is sent integrity protected when a valid security context exists and without integrity protection otherwise.

6.4.2.7B Test procedure to check that UE is camped on a new E-UTRAN cell / UP Clot

This procedure aims at checking whether the UE is camping on a new E-UTRAN cell with different TAI of a test case or not.

The procedure is defined in table 6.4.2.7B-1.

Table 6.4.2.7B-1: Test procedure sequence

St	Procedure	Message Sequence		TP	Verdict
		U - S	Message		
1	The UE transmits an <i>RRCCONNECTIONRESUMEREQUEST</i> message on the cell specified in the test case.	-->	RRC: <i>RRCCONNECTIONRESUMEREQUEST</i>	-	-
2	SS transmit an <i>RRCCONNECTIONRESUME</i> message.	<--	RRC: <i>RRCCONNECTIONRESUME</i>	-	-
3	The UE transmits an <i>RRCCONNECTIONRESUMECOMplete</i> message to confirm the successful completion of the connection establishment and a TRACKING AREA UPDATE REQUEST message is sent to update the registration of the actual tracking area.	-->	RRC: <i>RRCCONNECTIONRESUMECOMplete</i> NAS: TRACKING AREA UPDATE REQUEST	-	-
4	SS responds with TRACKING AREA UPDATE ACCEPT message.	<--	RRC: <i>DLInformationTransfer</i> NAS: TRACKING AREA UPDATE ACCEPT	-	-
5	Check: Does the UE send a TRACKING AREA UPDATE COMPLETE on the cell specified in the test case?	-->	RRC: <i>ULInformationTransfer</i> NAS: TRACKING AREA UPDATE COMPLETE	-	P
6	The SS transmits an <i>RRCCONNECTIONRELEASE</i> message to release RRC connection and move to RRC_IDLE.	<--	RRC: <i>RRCCONNECTIONRELEASE</i>	-	-

Table 6.4.2.7B-2: *RRCCONNECTIONRELEASE* (Step 6)

Derivation Path: 36.331 clause 6.2.2			
Information Element	Value/remark	Comment	Condition
<i>RRCCONNECTIONRELEASE</i> ::= SEQUENCE {			
<code>rrc-TransactionIdentifier</code>	RRC-TransactionIdentifier-DL		
criticalExtensions CHOICE {			
c1 CHOICE {			
<code>rrcConnectionRelease-r8</code> SEQUENCE {			
<code>releaseCause</code>	other		
<code>redirectedCarrierInfo</code>	Not present		
<code>idleModeMobilityControlInfo</code>	Not present		
nonCriticalExtension SEQUENCE {}	Not present		
}			
}			
}			
}			

6.4.2.8 Test procedure to check that UE is camped on a new UTRAN cell

This procedure aims at checking whether the UE is camping on a new UTRAN cell of a test case or not.

The procedure is defined in table 6.4.2.8-1.

Table 6.4.2.8-1: Test procedure sequence

St	Procedure	Message Sequence		TP	Verdict
		U - S	Message		
1	The UE transmits a RRC CONNECTION REQUEST message on the cell specified in the test case.	-->	RRC: RRC CONNECTION REQUEST	-	-
2	The SS transmits an RRC CONNECTION SETUP message.	<--	RRC: RRC CONNECTION SETUP	-	-
3	The UE transmits an RRC CONNECTION SETUP COMPLETE message.	-->	RRC: RRC CONNECTION SETUP COMPLETE	-	-
4	The UE transmits a ROUTING AREA UPDATE REQUEST message.	-->	RRC: INITIAL DIRECT TRANSFER NAS: ROUTING AREA UPDATE REQUEST	-	-
5	The SS transmits a SECURITY MODE COMMAND message.	<--	RRC: SECURITY MODE COMMAND	-	-
6	The UE transmits a SECURITY MODE COMPLETE message.	-->	RRC: SECURITY MODE COMPLETE	-	-
7	The SS transmits a ROUTING AREA UPDATE ACCEPT message.	<--	RRC: DOWNLINK DIRECT TRANSFER NAS: ROUTING AREA UPDATE ACCEPT	-	-
8	The UE transmits a ROUTING AREA UPDATE COMPLETE message.	-->	RRC: UPLINK DIRECT TRANSFER NAS: ROUTING AREA UPDATE COMPLETE	-	-
9	The SS transmits a RRC CONNECTION RELEASE message.	<--	RRC: RRC CONNECTION RELEASE	-	-
10	Check: Does the UE transmit an RRC CONNECTION RELEASE COMPLETE message on the cell specified in the test?	-->	RRC: RRC CONNECTION RELEASE COMPLETE	-	P

NOTE: The TS 34.108 [5] and TS 34.123-1 [7] use Network Mode of Operation I as default, for this reason a combined MM/GMM procedure is performed.

6.4.2.9 Test procedure to check that UE is camped on a new GERAN cell

This procedure aims at checking whether the UE is camping on a new GERAN cell of a test case or not.

The procedure is defined in table 6.4.2.9-1.

Table 6.4.2.9-1: Test procedure sequence

St	Procedure	Message Sequence		TP	Verdict
		U - S	Message		
1	Check: Does the UE send a CHANNEL REQUEST message on the cell(s) specified in the test case?	-->	CHANNEL REQUEST	-	-
2	An uplink TBF is established in order to allow the UE to transmit a ROUTING AREA UPDATE REQUEST message signalling.	-	-	-	-
3	The UE transmits a ROUTING AREA UPDATE REQUEST message.	-->	ROUTING AREA UPDATING REQUEST	-	-
4	A downlink TBF is established by the SS in order to transmit the AUTHENTICATION AND CIPHERING REQUEST message	-	-	-	-
5	The SS transmits an AUTHENTICATION AND CIPHERING REQUEST message.	<--	AUTHENTICATION AND CIPHERING REQUEST	-	-
6	An uplink TBF is established in order to allow the UE to transmit an AUTHENTICATION AND CIPHERING RESPONSE message	-	-	-	-
7	The UE transmits an AUTHENTICATION AND CIPHERING RESPONSE message.	-->	AUTHENTICATION AND CIPHERING RESPONSE	-	-
8	A downlink TBF is established by the SS in order to transmit the ROUTING AREA UPDATE ACCEPT message	-	-	-	-
9	The SS transmits a ROUTING AREA UPDATE ACCEPT message.	<--	ROUTING AREA UPDATING ACCEPT	-	-
10	An uplink TBF is established in order to allow the UE to transmit a ROUTING AREA UPDATE COMPLETE message	-	-	-	-
11	The UE transmits a ROUTING AREA UPDATE COMPLETE message.	-->	ROUTING AREA UPDATING COMPLETE	-	P

NOTE: The TS 51.010-1 [25] uses Network Mode of Operation I as default, for this reason a combined MM/GMM procedure is performed.

6.4.2.10 Test procedure to check that UE performs tracking area updating procedure without ISR and security reconfiguration after successful completion of handover from UTRA

This procedure aims at checking whether the UE performs tracking area updating procedure where ISR is not activated and security reconfiguration after successful completion of handover from UTRA.

The procedure is defined in table 6.4.2.10-1.

Table 6.4.2.10-1: Test procedure sequence

St	Procedure	Message Sequence		TP	Verdict
		U - S	Message		
1	The UE transmits an <i>ULInformationTransfer</i> message on the cell specified in the test case. This message includes a TRACKING AREA UPDATE REQUEST message.	-->	RRC: <i>ULInformationTransfer</i> NAS: TRACKING AREA UPDATE REQUEST	-	-
2	The SS transmits a <i>DLInformationTransfer</i> message on the cell specified in the test case. This message includes a TRACKING AREA UPDATE ACCEPT message.	<--	RRC: <i>DLInformationTransfer</i> NAS: TRACKING AREA UPDATE ACCEPT	-	-
3	The UE transmits an <i>ULInformationTransfer</i> message on the cell specified in the test case. This message includes a TRACKING AREA UPDATE COMPLETE message.	-->	RRC: <i>ULInformationTransfer</i> NAS: TRACKING AREA UPDATE COMPLETE	-	-
-	EXCEPTION: Steps 4a1 to 4a2 describe behaviour that depends on the IE included in TRACKING AREA UPDATE REQUEST in step 1.	-	-	-	-
4a1	IF TRACKING AREA UPDATE REQUEST transmitted in step 1 does not contain a valid <i>KSI_{ASME}</i> THEN the SS transmits a <i>DLInformationTransfer</i> message on the cell specified in the test case. This message includes an AUTHENTICATION REQUEST message.	<--	RRC: <i>DLInformationTransfer</i> NAS: AUTHENTICATION REQUEST	-	-
4a2	The UE transmits an <i>ULInformationTransfer</i> message on the cell specified in the test case. This message includes an AUTHENTICATION RESPONSE message.	-->	RRC: <i>ULInformationTransfer</i> NAS: AUTHENTICATION RESPONSE	-	-
5	The SS transmits a <i>DLInformationTransfer</i> message on the cell specified in the test case. This message includes a SECURITY MODE COMMAND message to take the native EPS security context into use.	<--	RRC: <i>DLInformationTransfer</i> NAS: SECURITY MODE COMMAND	-	-
6	The UE transmits an <i>ULInformationTransfer</i> message on the cell specified in the test case. This message includes a SECURITY MODE COMPLETE message.	-->	RRC: <i>ULInformationTransfer</i> NAS: SECURITY MODE COMPLETE	-	-
7	The SS transmits an <i>RRCConnectionReconfiguration</i> message to perform intra cell handover and security reconfiguration on the cell specified in the test case.	<--	RRC: <i>RRCConnectionReconfiguration</i>	-	-
8	Check: Does the UE transmit an <i>RRCConnectionReconfigurationComplete</i> message on the cell specified in the test case?	-->	RRC: <i>RRCConnectionReconfigurationComplete</i>	-	P

Table 6.4.2.10-2: Message TRACKING AREA UPDATE REQUEST (step 1, Table 6.4.2.10-1)

Derivation Path: 36.508 clause 4.7.2-27			
Information Element	Value/remark	Comment	Condition
NAS key set identifier			
NAS key set identifier	The valid NAS key set identifier of the UE	mapped security context (for KSI _{SGSN})	
TSC	1		
Non-current native NAS key set identifier			
NAS key set identifier	The valid NAS key set identifier of the UE	native security context (for KSI _{ASME})	
TSC	0		
Old P-TMSI signature	any allowed value		
Additional GUTI	any allowed value		

Table 6.4.2.10-3: RRCConnectionReconfiguration (step 7, Table 6.4.2.10-1)

Derivation Path: 36.508, Table 4.6.1-8
--

Table 6.4.2.10-4: SecurityConfigHO (IE in RRCConnectionReconfiguration, Table 6.4.2.10-3)

Derivation Path: 36.508, Table 4.6.4-1			
Information Element	Value/remark	Comment	Condition
SecurityConfigHO ::= SEQUENCE {			
handoverType CHOICE {			
intraLTE SEQUENCE {			
keyChangeIndicator	TRUE		
nextHopChainingCount	0		
}			
}			
}			

6.4.3 Reference test procedures for TTCN development

This clause describes reference test procedures for the purpose of TTCN development.

6.4.3.1 UE triggered establishment of a dedicated EPS bearer context

Table 6.4.3.1-1: Test procedure sequence

St	Procedure	Message Sequence	
		U - S	Message
1	Cause the UE to request bearer resource allocation of dedicated EPS bearer associated with first PDN connectivity. (see Note 1)	-	-
-	EXCEPTION: Steps 2a1 to 2a7 describe behaviour that depends on RRC state; the "lower case letter" identifies a step sequence that takes place if the UE is in RRC_IDLE state.	-	-
2a1	IF the UE is in RRC_IDLE state THEN the UE transmits an <i>RRCCONNECTIONREQUEST</i> message.	-->	RRC: <i>RRCCONNECTIONREQUEST</i>
2a2	The SS transmits an <i>RRCCONNECTIONSETUP</i> message.	<--	RRC: <i>RRCCONNECTIONSETUP</i>
2a3	The UE transmits an <i>RRCCONNECTIONSETUPCOMPLETE</i> including the SERVICE REQUEST message.	-->	RRC: <i>RRCCONNECTIONSETUPCOMPLETE</i> NAS: SERVICE REQUEST
2a4	The SS transmits a <i>SECURITYMODECOMMAND</i> message to activate AS security.	<--	RRC: <i>SECURITYMODECOMMAND</i>
2a5	The UE transmits a <i>SECURITYMODECOMPLETE</i> message and establishes the initial security configuration.	-->	RRC: <i>SECURITYMODECOMPLETE</i>
2a6	The SS transmits an <i>RRCCONNECTIONRECONFIGURATION</i> message to configure data radio bearer(s) associated with the existing EPS bearer context. The <i>RRCCONNECTIONRECONFIGURATION</i> message is using condition SRB2-DRB(n, m) where n and m are the number of DRBs associated with existing EPS bearer contexts and configured respectively with RLC-AM and RLC-UM.	<--	RRC: <i>RRCCONNECTIONRECONFIGURATION</i>
2a7	The UE transmits an <i>RRCCONNECTIONRECONFIGURATIONCOMPLETE</i> message.	-->	RRC: <i>RRCCONNECTIONRECONFIGURATIONCOMPLETE</i>
3	The UE transmits an <i>ULINFORMATIONTRANSFER</i> message including the BEARER RESOURCE ALLOCATION REQUEST message.	-->	RRC: <i>ULINFORMATIONTRANSFER</i> NAS: BEARER RESOURCE ALLOCATION REQUEST
4	The SS transmits an <i>RRCCONNECTIONRECONFIGURATION</i> message including the ACTIVATE DEDICATED EPS BEARER CONTEXT REQUEST message to establish the dedicated EPS bearer context.	<--	RRC: <i>RRCCONNECTIONRECONFIGURATION</i> NAS: ACTIVATE DEDICATED EPS BEARER CONTEXT REQUEST
5	The UE transmits an <i>RRCCONNECTIONRECONFIGURATIONCOMPLETE</i> message.	-->	RRC: <i>RRCCONNECTIONRECONFIGURATIONCOMPLETE</i>
6	The UE transmits an <i>ULINFORMATIONTRANSFER</i> message including the ACTIVATE DEDICATED EPS BEARER CONTEXT ACCEPT message.	-->	RRC: <i>ULINFORMATIONTRANSFER</i> NAS: ACTIVATE DEDICATED EPS BEARER CONTEXT ACCEPT
Note 1: The request is assumed to be triggered by AT command +CGDSCONT, and +CGACT (activated).			
Note 2: If UE sends IP related data this shall be handled by the SS.			

6.4.3.2 UE triggered establishment of a default EPS bearer context associated with an additional PDN

Table 6.4.3.2-1: Test procedure sequence

St	Procedure	Message Sequence	
		U - S	Message
1	Cause the UE to request connectivity to an additional PDN. (see Note 1)	-	-
-	EXCEPTION: Steps 2a1 to 2a7 describe behaviour that depends on RRC state; the "lower case letter" identifies a step sequence that takes place if the UE is in RRC_IDLE state.	-	-
2a1	IF the UE is in RRC_IDLE state THEN the UE transmits an <i>RRCCONNECTIONREQUEST</i> message.	-->	RRC: <i>RRCCONNECTIONREQUEST</i>
2a2	The SS transmits an <i>RRCCONNECTIONSETUP</i> message.	<--	RRC: <i>RRCCONNECTIONSETUP</i>
2a3	The UE transmits an <i>RRCCONNECTIONSETUPCOMPLETE</i> including the SERVICE REQUEST message.	-->	RRC: <i>RRCCONNECTIONSETUPCOMPLETE</i> NAS: SERVICE REQUEST
2a4	The SS transmits a <i>SECURITYMODECOMMAND</i> message to activate AS security.	<--	RRC: <i>SECURITYMODECOMMAND</i>
2a5	The UE transmits a <i>SECURITYMODECOMPLETE</i> message and establishes the initial security configuration.	-->	RRC: <i>SECURITYMODECOMPLETE</i>
2a6	The SS transmits an <i>RRCCONNECTIONRECONFIGURATION</i> message to configure data radio bearer(s) associated with the existing EPS bearer context. The <i>RRCCONNECTIONRECONFIGURATION</i> message is using condition SRB2-DRB(n, m) where n and m are the number of DRBs associated with existing EPS bearer contexts and configured respectively with RLC-AM and RLC-UM.	<--	RRC: <i>RRCCONNECTIONRECONFIGURATION</i>
2a7	The UE transmits an <i>RRCCONNECTIONRECONFIGURATIONCOMPLETE</i> message.	-->	RRC: <i>RRCCONNECTIONRECONFIGURATIONCOMPLETE</i>
3	The UE transmits an <i>ULINFORMATIONTRANSFER</i> message including the PDN CONNECTIVITY REQUEST message.	-->	RRC: <i>ULINFORMATIONTRANSFER</i> NAS: PDN CONNECTIVITY REQUEST
4	The SS transmits an <i>RRCCONNECTIONRECONFIGURATION</i> message including the ACTIVATE DEFAULT EPS BEARER CONTEXT REQUEST message to establish the default EPS bearer context.	<--	RRC: <i>RRCCONNECTIONRECONFIGURATION</i> NAS: ACTIVATE DEFAULT EPS BEARER CONTEXT REQUEST
5	The UE transmits an <i>RRCCONNECTIONRECONFIGURATIONCOMPLETE</i> message.	-->	RRC: <i>RRCCONNECTIONRECONFIGURATIONCOMPLETE</i>
-	EXCEPTION: In parallel to the event described in step 6 below, the generic procedure for IP address allocation in the U-plane specified in TS 36.508 subclause 4.5A.1 takes place performing IP address allocation in the U-plane.	-	-
6	The UE transmits an <i>ULINFORMATIONTRANSFER</i> message including the ACTIVATE DEFAULT EPS BEARER CONTEXT ACCEPT message.	-->	RRC: <i>ULINFORMATIONTRANSFER</i> NAS: ACTIVATE DEFAULT EPS BEARER CONTEXT ACCEPT

Note 1: The request is assumed to be triggered by AT command +CGDCONT and +CGACT (activated).
Note 2: If UE sends IP related data this shall be handled by the SS.

Table 6.4.3.2-2: Message PDN CONNECTIVITY REQUEST (step 3, Table 6.4.3.2-1)

Derivation Path: TS 36.508 Table 4.7.3-20			
Information Element	Value/remark	Comment	Condition
EPS bearer identity	0000	No EPS bearer identity assigned	
Procedure transaction identity	PTI-1	UE assigns a particular PTI not yet used between 1 and 254	
ESM information transfer flag	Not present	This IE is only used during an attach procedure.	
Access point name	APN-1(New PDN name)	The requested PDN is different from default PDN	

6.4.3.3 UE triggered modification of an EPS bearer context

Table 6.4.3.3-1: Test procedure sequence

St	Procedure	Message Sequence	
		U - S	Message
1	Cause the UE to request bearer resource modification of EPS bearer associated with first PDN connectivity. (see Note 1)	-	-
-	EXCEPTION: Steps 2a1 to 2a7 describe behaviour that depends on RRC state; the "lower case letter" identifies a step sequence that takes place if the UE is in RRC_IDLE state.	-	-
2a1	IF the UE is in RRC_IDLE state THEN the UE transmits an <i>RRCCONNECTIONREQUEST</i> message.	-->	RRC: <i>RRCCONNECTIONREQUEST</i>
2a2	The SS transmits an <i>RRCCONNECTIONSETUP</i> message.	<--	RRC: <i>RRCCONNECTIONSETUP</i>
2a3	The UE transmits an <i>RRCCONNECTIONSETUPCOMPLETE</i> including the SERVICE REQUEST message.	-->	RRC: <i>RRCCONNECTIONSETUPCOMPLETE</i> NAS: SERVICE REQUEST
2a4	The SS transmits a <i>SECURITYMODECOMMAND</i> message to activate AS security.	<--	RRC: <i>SECURITYMODECOMMAND</i>
2a5	The UE transmits a <i>SECURITYMODECOMPLETE</i> message and establishes the initial security configuration.	-->	RRC: <i>SECURITYMODECOMPLETE</i>
2a6	The SS transmits an <i>RRCCONNECTIONRECONFIGURATION</i> message to configure data radio bearer(s) associated with the existing EPS bearer context. The <i>RRCCONNECTIONRECONFIGURATION</i> message is using condition SRB2-DRB(n, m) where n and m are the number of DRBs associated with existing EPS bearer contexts and configured respectively with RLC-AM and RLC-UM.	<--	RRC: <i>RRCCONNECTIONRECONFIGURATION</i>
2a7	The UE transmits an <i>RRCCONNECTIONRECONFIGURATIONCOMPLETE</i> message.	-->	RRC: <i>RRCCONNECTIONRECONFIGURATIONCOMPLETE</i>
3	The UE transmits an <i>ULINFORMATIONTRANSFER</i> message including the BEARER RESOURCE MODIFICATION REQUEST message.	-->	RRC: <i>ULINFORMATIONTRANSFER</i> NAS: BEARER RESOURCE MODIFICATION REQUEST
4	The SS transmits an <i>RRCCONNECTIONRECONFIGURATION</i> message including the MODIFY EPS BEARER CONTEXT REQUEST message to modify the EPS bearer context.	<--	RRC: <i>RRCCONNECTIONRECONFIGURATION</i> NAS: MODIFY EPS BEARER CONTEXT REQUEST
5	The UE transmits an <i>RRCCONNECTIONRECONFIGURATIONCOMPLETE</i> message.	-->	RRC: <i>RRCCONNECTIONRECONFIGURATIONCOMPLETE</i>
6	Check: Does the UE transmit an <i>ULINFORMATIONTRANSFER</i> message including the MODIFY EPS BEARER CONTEXT ACCEPT message?	-->	RRC: <i>ULINFORMATIONTRANSFER</i> NAS: MODIFY EPS BEARER CONTEXT ACCEPT
Note 1: The request is assumed to be triggered by AT command +CGCMOD.			
Note 2: If UE sends IP related data this shall be handled by the SS.			

6.4.3.4 UE triggered deletion of an EPS bearer context

Table 6.4.3.4-1: Test procedure sequence

St	Procedure	Message Sequence	
		U - S	Message
1	Cause the UE to request bearer resource release of dedicated EPS bearer associated with first PDN connectivity. (see Note 1)	-	-
-	EXCEPTION: Steps 2a1 to 2a7 describe behaviour that depends on RRC state; the "lower case letter" identifies a step sequence that takes place if the UE is in RRC_IDLE state.	-	-
2a1	IF the UE is in RRC_IDLE state THEN the UE transmits an <i>RRCCConnectionRequest</i> message.	-->	RRC: <i>RRCCConnectionRequest</i>
2a2	The SS transmits an <i>RRCCConnectionSetup</i> message.	<--	RRC: <i>RRCCConnectionSetup</i>
2a3	The UE transmits an <i>RRCCConnectionSetupComplete</i> including the SERVICE REQUEST message.	-->	RRC: <i>RRCCConnectionSetupComplete</i> NAS: SERVICE REQUEST
2a4	The SS transmits a <i>SecurityModeCommand</i> message to activate AS security.	<--	RRC: <i>SecurityModeCommand</i>
2a5	The UE transmits a <i>SecurityModeComplete</i> message and establishes the initial security configuration.	-->	RRC: <i>SecurityModeComplete</i>
2a6	The SS transmits an <i>RRCCConnectionReconfiguration</i> message to configure data radio bearer(s) associated with the existing EPS bearer context. The <i>RRCCConnectionReconfiguration</i> message is using condition SRB2-DRB(n, m) where n and m are the number of DRBs associated with existing EPS bearer contexts and configured respectively with RLC-AM and RLC-UM.	<--	RRC: <i>RRCCConnectionReconfiguration</i>
2a7	The UE transmits an <i>RRCCConnectionReconfigurationComplete</i> message.	-->	RRC: <i>RRCCConnectionReconfigurationComplete</i>
3	The UE transmits an <i>ULInformationTransfer</i> message including the BEARER RESOURCE MODIFICATION REQUEST message.	-->	RRC: <i>ULInformationTransfer</i> NAS: BEARER RESOURCE MODIFICATION REQUEST
4	The SS transmits an <i>RRCCConnectionReconfiguration</i> message including the DEACTIVATE EPS BEARER CONTEXT REQUEST message to delete EPS bearer context.	<--	RRC: <i>RRCCConnectionReconfiguration</i> NAS: DEACTIVATE EPS BEARER CONTEXT REQUEST
5	The UE transmits an <i>RRCCConnectionReconfigurationComplete</i> message	-->	RRC: <i>RRCCConnectionReconfigurationComplete</i>
6	The UE transmits an <i>ULInformationTransfer</i> message including the DEACTIVATE EPS BEARER CONTEXT ACCEPT message.	-->	RRC: <i>ULInformationTransfer</i> NAS: DEACTIVATE EPS BEARER CONTEXT ACCEPT
Note 1: The request is assumed to be triggered by AT command +CGACT (deactivated).			
Note 2: If UE sends IP related data this shall be handled by the SS.			

6.4.3.5 UE triggered CS call

Table 6.4.3.5-1: Test procedure sequence

St	Procedure	Message Sequence	
		U - S	Message
1	Cause the UE to originate CS call. (see Note 1)	-	-
-	EXCEPTION: Steps 2a1 to 2b1 describe behaviour that depends on RRC state; the "lower case letter" identifies a step sequence that takes place depending on RRC state.	-	-
2a1	IF the UE is in RRC_IDLE state THEN the UE transmits an <i>RRCCoordinateRequest</i> message.	-->	RRC: <i>RRCCoordinateRequest</i>
2a2	The SS transmits an <i>RRCCoordinateSetup</i> message.	<--	RRC: <i>RRCCoordinateSetup</i>
2a3	The UE transmits an <i>RRCCoordinateSetupComplete</i> including the EXTENDED SERVICE REQUEST message.	-->	RRC: <i>RRCCoordinateSetupComplete</i> NAS: EXTENDED SERVICE REQUEST
2b1	ELSE The UE transmits an <i>ULInformationTransfer</i> message including the EXTENDED SERVICE REQUEST message.	-->	RRC: <i>ULInformationTransfer</i> NAS: EXTENDED SERVICE REQUEST
Note 1: The request is assumed to be triggered by AT command D.			

6.4.3.6 UE triggered MO SMS over SGs

Table 6.4.3.6-1: Test procedure sequence

St	Procedure	Message Sequence	
		U - S	Message
1	Cause the UE to originate SMS message. (see Note 1)	-	-
-	EXCEPTION: Steps 2a1 to 2a7 describe behaviour that depends on RRC state; the "lower case letter" identifies a step sequence that takes place if the UE is in RRC_IDLE state.	-	-
2a1	IF the UE is in RRC_IDLE state THEN the UE transmits an <i>RRCCConnectionRequest</i> message.	-->	RRC: <i>RRCCConnectionRequest</i>
2a2	The SS transmits an <i>RRCCConnectionSetup</i> message.	<--	RRC: <i>RRCCConnectionSetup</i>
2a3	The UE transmits an <i>RRCCConnectionSetupComplete</i> including the SERVICE REQUEST message.	-->	RRC: <i>RRCCConnectionSetupComplete</i> NAS: SERVICE REQUEST
2a4	The SS transmits a <i>SecurityModeCommand</i> message to activate AS security.	<--	RRC: <i>SecurityModeCommand</i>
2a5	The UE transmits a <i>SecurityModeComplete</i> message and establishes the initial security configuration.	-->	RRC: <i>SecurityModeComplete</i>
2a6	The SS transmits an <i>RRCCConnectionReconfiguration</i> message to configure data radio bearer(s) associated with the existing EPS bearer context. The <i>RRCCConnectionReconfiguration</i> message is using condition SRB2-DRB(n, m) where n and m are the number of DRBs associated with existing EPS bearer contexts and configured respectively with RLC-AM and RLC-UM.	<--	RRC: <i>RRCCConnectionReconfiguration</i>
2a7	The UE transmits an <i>RRCCConnectionReconfigurationComplete</i> message.	-->	RRC: <i>RRCCConnectionReconfigurationComplete</i>
3	The UE transmits an <i>ULInformationTransfer</i> message including the UPLINK NAS TRANSPORT message to send the SMS message.	-->	RRC: <i>ULInformationTransfer</i> NAS: UPLINK NAS TRANSPORT
4	The SS transmits a <i>DLInformationTransfer</i> message including the DOWNLINK NAS TRANSPORT message to acknowledge receipt of the SMS message.	<--	RRC: <i>DLInformationTransfer</i> NAS: DOWNLINK NAS TRANSPORT
5	The SS transmits a <i>DLInformationTransfer</i> message including the DOWNLINK NAS TRANSPORT message to send the delivery report.	<--	RRC: <i>DLInformationTransfer</i> NAS: DOWNLINK NAS TRANSPORT
6	The UE transmits an <i>ULInformationTransfer</i> message including the UPLINK NAS TRANSPORT message to acknowledge receipt of the delivery report.	-->	RRC: <i>ULInformationTransfer</i> NAS: UPLINK NAS TRANSPORT
Note 1: The request is assumed to be triggered by AT command +CMGW and +CMSS.			

6.4.3.7 CS fallback to UTRAN procedures (LAI of UTRAN cell same as the LAI received in combined Attach procedure in EUTRA cell)

All procedures specified in this clause are referred to the UTRA target cell where the UE has been redirected or handed over from the EUTRA cell after a CS call requested. The default message contents are found in TS 34.108 [5], clause 9.

The procedures in 6.4.3.7.1 – 6.4.3.7.4 are applied if the UE supports (EUTRA) RRC connection release with redirection and Multi Cell System Information to UTRAN. The procedures in 6.4.3.7.5 - 6.4.3.7.7 are applied if the UE supports PS HO from EUTRA to UTRAN.

6.4.3.7.1 CS fallback to UTRAN with redirection / MT call (PS bearers not established)

Table 6.4.3.7.1-1: Test procedure sequence

St	Procedure	Message Sequence		TP	Verdict
		U - S	Message		
1	The UE transmits an RRC CONNECTION REQUEST message.	-->	RRC CONNECTION REQUEST	-	-
2	The SS transmits an RRC CONNECTION SETUP message.	<--	RRC CONNECTION SETUP	-	-
3	The UE transmits an RRC CONNECTION SETUP COMPLETE message.	-->	RRC CONNECTION SETUP COMPLETE	-	-
-	EXCEPTION: In parallel to the events described in step 4 to 15 the step specified in Table 6.4.3.7.1-2 takes place.	-	-	-	-
4	Check: Does the UE transmit a PAGING RESPONSE message?	-->	PAGING RESPONSE	-	P
5-15	Steps 7 to 17 of the generic test procedure in TS 34.108 [5] subclause 7.2.3.1.3 are performed using the UTRA reference radio bearer parameters and combination "UTRA Speech" according to subclause 4.8.3 and Table 4.8.3-1. NOTE: Mobile terminating CS call is established.	-	-	-	-
16	The SS transmits a SECURITY MODE COMMAND message for the PS domain. See Note 1.	<--	SECURITY MODE COMMAND	-	-
17	The UE transmits a SECURITY MODE COMPLETE message.	-->	SECURITY MODE COMPLETE	-	-
18	The SS transmits a ROUTING AREA UPDATE ACCEPT message.	<--	ROUTING AREA UPDATE ACCEPT	-	-
19	The UE transmits a ROUTING AREA UPDATE COMPLETE message.	-->	ROUTING AREA UPDATE COMPLETE	-	-
Note 1: A real network will initiate the security mode command procedure for the PS domain immediately after receiving the ROUTING AREA UPDATE REQUEST, but in this test procedure it was chosen to complete the procedure for CS domain first, in order to avoid the possibility of a security mode command procedure running in parallel with another RRC procedure.					

Table 6.4.3.7.1-2: Parallel behaviour

St	Procedure	Message Sequence		TP	Verdict
		U - S	Message		
1	The UE transmits a ROUTING AREA UPDATE REQUEST message.	-->	ROUTING AREA UPDATE REQUEST	-	-

6.4.3.7.2 CS fallback to UTRAN with redirection / MO call (PS bearers not established)

Table 6.4.3.7.2-1: Test procedure sequence

St	Procedure	Message Sequence		TP	Verdict
		U - S	Message		
1	The UE transmits an RRC CONNECTION REQUEST message.	-->	RRC CONNECTION REQUEST	-	-
2	The SS transmits an RRC CONNECTION SETUP message.	<--	RRC CONNECTION SETUP	-	-
3	The UE transmits an RRC CONNECTION SETUP COMPLETE message.	-->	RRC CONNECTION SETUP COMPLETE	-	-
-	EXCEPTION: In parallel to the events described in step 4 to 15 the step specified in Table 6.4.3.7.2-2 takes place.	-	-	-	-
4	Check: Does the UE transmit a CM SERVICE REQUEST message?	-->	CM SERVICE REQUEST	-	P
5-15	Steps 6 to 16 of the generic test procedure in TS 34.108 [5] subclause 7.2.3.2.3 are performed using the UTRA reference radio bearer parameters and combination "UTRA Speech" according to subclause 4.8.3 and Table 4.8.3-1. NOTE: Mobile originating CS call is established.	-	-	-	-
16	The SS transmits a SECURITY MODE COMMAND message for the PS domain. See Note 1.	<--	SECURITY MODE COMMAND	-	-
17	The UE transmits a SECURITY MODE COMPLETE message.	-->	SECURITY MODE COMPLETE	-	-
18	The SS transmits a ROUTING AREA UPDATE ACCEPT message.	<--	ROUTING AREA UPDATE ACCEPT	-	-
19	The UE transmits a ROUTING AREA UPDATE COMPLETE message.	-->	ROUTING AREA UPDATE COMPLETE	-	-
Note 1: A real network will initiate the security mode command procedure for the PS domain immediately after receiving the ROUTING AREA UPDATE REQUEST, but in this test procedure it was chosen to complete the procedure for CS domain first, in order to avoid the possibility of a security mode command procedure running in parallel with another RRC procedure.					

Table 6.4.3.7.2-2: Parallel behaviour

St	Procedure	Message Sequence		TP	Verdict
		U - S	Message		
1	The UE transmits a ROUTING AREA UPDATE REQUEST message.	-->	ROUTING AREA UPDATE REQUEST	-	-

6.4.3.7.3 CS fallback to UTRAN with redirection / MT call (PS bearer established)

Table 6.4.3.7.3-1: Test procedure sequence

St	Procedure	Message Sequence		TP	Verdict
		U - S	Message		
1-19	Steps 1-19 of table 6.4.3.7.1-1. NOTE: Mobile terminating CS call is established and Routing Area Update procedure is performed			-	-
20	Check: Does the UE transmit a SERVICE REQUEST message?	-->	SERVICE REQUEST	-	P
21	SS transmits a RADIO BEARER SETUP message, using the UTRA reference radio bearer parameters and combination "UTRA PS RB + Speech" according to subclause 4.8.3 and Table 4.8.3-1. NOTE: Mobile originating packet switched session is established.	<--	RADIO BEARER SETUP	-	-
22	The UE transmits a RADIO BEARER SETUP COMPLETE message	-->	RADIO BEARER SETUP COMPLETE	-	-

6.4.3.7.4 CS fallback to UTRAN with redirection / MO call (PS bearer established)

Table 6.4.3.7.4-1: Test procedure sequence

St	Procedure	Message Sequence		TP	Verdict
		U - S	Message		
1-19	Steps 1-19 of table 6.4.3.7.2-1. NOTE: Mobile originating CS call is set up and Routing Area Update procedure is performed	-	-	-	-
20	Check: Does the UE transmit a SERVICE REQUEST message?	-->	SERVICE REQUEST	-	P
21	SS transmits a RADIO BEARER SETUP message, using the UTRA reference radio bearer parameters and combination "UTRA PS RB + Speech" according to subclause 4.8.3 and Table 4.8.3-1. NOTE: Mobile originating packet switched session is established.	<--	RADIO BEARER SETUP	-	-
22	The UE transmits a RADIO BEARER SETUP COMPLETE message	-->	RADIO BEARER SETUP COMPLETE	-	-

6.4.3.7.5 CS fallback to UTRAN with Handover / MT call

Table 6.4.3.7.5-1: Test procedure sequence

St	Procedure	Message Sequence		TP	Verdict
		U - S	Message		
1	Check: Does the UE transmit a HANDOVER TO UTRAN COMPLETE message?	-->	HANDOVER TO UTRAN COMPLETE	-	P
-	EXCEPTION: In parallel to the events described in step 2a1 to 9 the steps specified in table 6.4.3.7.5-2 takes place.	-	-	-	-
-	Exception: Steps 2a1 to 2a10 and 2b1 to 2b9 describe behaviour that depends on the UE capability; the "lower case letter" identifies a step sequence that takes place if a capability is supported. Note: One sequence of steps 2a1 to 2a10 or 2b1 to 2b9 are executed	-	-	-	-
2a1	IF the UE does not determine the LAI of the new UTRAN cell, THEN Check: Does the UE transmit a LOCATION UPDATING REQUEST message?	-->	LOCATION UPDATING REQUEST	-	P
2a2	The SS transmits AUTHENTICATION REQUEST	<--	AUTHENTICATION REQUEST	-	-
2a3	The UE transmits AUTHENTICATION RESPONSE	-->	AUTHENTICATION RESPONSE	-	-
2a4	The SS transmits a SECURITY MODE COMMAND message for the CS domain.	<--	SECURITY MODE COMMAND	-	-
2a5	The UE transmits a SECURITY MODE COMPLETE message.	-->	SECURITY MODE COMPLETE	-	-
2a6	The SS transmits a LOCATION UPDATING ACCEPT message.	<--	LOCATION UPDATING ACCEPT	-	-
2a7	The SS transmits a SECURITY MODE COMMAND message for the PS domain.	<--	SECURITY MODE COMMAND	-	-
2a8	The UE transmits a SECURITY MODE COMPLETE message.	-->	SECURITY MODE COMPLETE	-	-
2a9	The SS transmits an UTRAN MOBILITY INFORMATION message to notify CN information.	<--	UTRAN MOBILITY INFORMATION	-	-
2a10	The UE transmits an UTRAN MOBILITY INFORMATION CONFIRM message.	-->	UTRAN MOBILITY INFORMATION CONFIRM	-	-
	Exception: Steps 2b1 to 2b4 takes place if pc_UMI_ProcNeeded_DuringCSFB				
2b1	The SS transmits a SECURITY MODE COMMAND message for the PS domain.	<--	SECURITY MODE COMMAND	-	-
2b2	The UE transmits a SECURITY MODE COMPLETE message.	-->	SECURITY MODE COMPLETE	-	-
2b3	The SS transmits an UTRAN MOBILITY INFORMATION message to notify CN information.	<--	UTRAN MOBILITY INFORMATION	-	-
2b4	The UE transmits an UTRAN MOBILITY INFORMATION CONFIRM message.	-->	UTRAN MOBILITY INFORMATION CONFIRM	-	-
2b5	Check: Does the UE transmit a PAGING RESPONSE?	-->	PAGING RESPONSE	-	P
2b6	The SS transmits AUTHENTICATION REQUEST	<--	AUTHENTICATION REQUEST	-	-
2b7	The UE transmits AUTHENTICATION RESPONSE	-->	AUTHENTICATION RESPONSE	-	-
2b8	The SS transmits a SECURITY MODE COMMAND message for the CS domain.	<--	SECURITY MODE COMMAND	-	-
2b9	The UE transmits a SECURITY MODE COMPLETE message.	-->	SECURITY MODE COMPLETE	-	-
3-9	Steps 11 to 17 of the generic test procedure in TS 34.108 subclause 7.2.3.1.3 are performed using the UTRA reference radio bearer parameters and combination "UTRA PS RB + Speech" according to subclause 4.8.3 and	-	-	-	-

	Table 4.8.3-1. NOTE: Mobile terminating CS call is established.				
10	The SS transmits a ROUTING AREA UPDATE ACCEPT.	<--	ROUTING AREA UPDATE ACCEPT	-	-
11	The UE sends ROUTING AREA UPDATE COMPLETE.	-->	ROUTING AREA UPDATE COMPLETE	-	-

Table 6.4.3.7.5-2: Parallel behaviour

St	Procedure	Message Sequence		TP	Verdict
		U - S	Message		
1	The UE transmits a ROUTING AREA UPDATE REQUEST message.	-->	ROUTING AREA UPDATE REQUEST	-	-

6.4.3.7.5.1 Specific message contents

Table 6.4.3.7.5.1-1: Void**Table 6.4.3.7.5.1-2: LOCATION UPDATING ACCEPT (step 2a6 of table 6.4.3.7.5-1)**

Derivation Path: TS 36.508 Table 4.7B.2-5			
Information Element	Value/remark	Comment	Condition
Mobile identity	Not present		

6.4.3.7.6 CS fallback to UTRAN with Handover / MO call

Table 6.4.3.7.6-1: Test procedure sequence

St	Procedure	Message Sequence		TP	Verdict
		U - S	Message		
1	Check: Does the UE transmit a HANDOVER TO UTRAN COMPLETE message?	-->	HANDOVER TO UTRAN COMPLETE	-	P
-	EXCEPTION: In parallel to the events described in step 2a1 to 9 the steps specified in table 6.4.3.7.6-2 takes place.	-	-	-	-
-	Exception: Steps 2a1 to 2a12 and 2b1 to 2b9 describe behaviour that depends on the UE capability; the "lower case letter" identifies a step sequence that takes place if a capability is supported. Note: One sequence of steps 2a1 to 2a12 or 2b1 to 2b9 are executed	-	-	-	-
2a1	IF the UE does not determine the LAI of the new UTRAN cell, THEN Check: Does the UE transmit a LOCATION UPDATING REQUEST message?	-->	LOCATION UPDATING REQUEST	-	P
2a2	The SS transmits AUTHENTICATION REQUEST	<--	AUTHENTICATION REQUEST	-	-
2a3	The UE transmits AUTHENTICATION RESPONSE	-->	AUTHENTICATION RESPONSE	-	-
2a4	The SS transmits a SECURITY MODE COMMAND message for the CS domain.	<--	SECURITY MODE COMMAND	-	-
2a5	The UE transmits a SECURITY MODE COMPLETE message.	-->	SECURITY MODE COMPLETE	-	-
2a6	The SS transmits a LOCATION UPDATING ACCEPT message.	<--	LOCATION UPDATING ACCEPT	-	-
2a7	Check: Does the UE transmit a CM SERVICE REQUEST?	-->	CM SERVICE REQUEST	-	P
2a8	The SS transmits a SECURITY MODE COMMAND message for the PS domain.	<--	SECURITY MODE COMMAND	-	-
2a9	The UE transmits a SECURITY MODE COMPLETE message.	-->	SECURITY MODE COMPLETE	-	-
2a10	The SS transmits an UTRAN MOBILITY INFORMATION message to notify CN information.	<--	UTRAN MOBILITY INFORMATION	-	-
2a11	The UE transmits an UTRAN MOBILITY INFORMATION CONFIRM message.	-->	UTRAN MOBILITY INFORMATION CONFIRM	-	-
2a12	The SS transmits a CM SERVICE ACCEPT message.	<--	CM SERVICE ACCEPT	-	-
	Exception: Steps 2b1 to 2b4 takes place if pc_UMI_ProcNeeded_DuringCSFB				
2b1	The SS transmits a SECURITY MODE COMMAND message for the PS domain.	<--	SECURITY MODE COMMAND	-	-
2b2	The UE transmits a SECURITY MODE COMPLETE message.	-->	SECURITY MODE COMPLETE	-	-
2b3	The SS transmits an UTRAN MOBILITY INFORMATION message to notify CN information.	<--	UTRAN MOBILITY INFORMATION	-	-
2b4	The UE transmits an UTRAN MOBILITY INFORMATION CONFIRM message.	-->	UTRAN MOBILITY INFORMATION CONFIRM	-	-
2b5	Check: Does the UE transmit a CM SERVICE REQUEST?	-->	CM SERVICE REQUEST	-	P
2b6	The SS transmits AUTHENTICATION REQUEST	<--	AUTHENTICATION REQUEST	-	-
2b7	The UE transmits AUTHENTICATION RESPONSE	-->	AUTHENTICATION RESPONSE	-	-
2b8	The SS transmits a SECURITY MODE COMMAND message for the CS domain.	<--	SECURITY MODE COMMAND	-	-
2b9	The UE transmits a SECURITY MODE COMPLETE message.	-->	SECURITY MODE COMPLETE	-	-
3	The UE transmits a SETUP message.	-->	SETUP	-	-

4-9	Steps 11 to 16 of the generic test procedure in TS 34.108 subclause 7.2.3.2.3 are performed using the UTRA reference radio bearer parameters and combination "UTRA PS RB + Speech" according to subclause 4.8.3 and Table 4.8.3-1. NOTE: Mobile originating CS call is established.	-	-	-	-
10	The SS transmits a ROUTING AREA UPDATE ACCEPT.	<--	ROUTING AREA UPDATE ACCEPT	-	-
11	The UE sends ROUTING AREA UPDATE COMPLETE.	-->	ROUTING AREA UPDATE COMPLETE	-	-

Table 6.4.3.7.6-2: Parallel behaviour

St	Procedure	Message Sequence		TP	Verdict
		U - S	Message		
1	The UE transmits a ROUTING AREA UPDATE REQUEST message.	-->	ROUTING AREA UPDATE REQUEST	-	-

6.4.3.7.6.1 Specific message contents

None.

Table 6.4.3.7.6.1-1: LOCATION UPDATING ACCEPT (step 2a6 of table 6.4.3.7.6-1)

Derivation Path: TS 36.508 Table 4.7B.2-5			
Information Element	Value/remark	Comment	Condition
Mobile identity	Not present		

6.4.3.7.7 CS fallback to UTRAN with Handover / emergency call

Table 6.4.3.7-1: Test procedure sequence

St	Procedure	Message Sequence		TP	Verdict
		U - S	Message		
1	Check: Does the UE transmit a HANDOVER TO UTRAN COMPLETE message?	-->	HANDOVER TO UTRAN COMPLETE	-	P
-	EXCEPTION: In parallel to the events described in step 2a1 to 9 the steps specified in table 6.4.3.7-2 takes place.	-	-	-	-
-	Exception: Steps 2a1 to 2a12 and 2b1 to 2b9 describe behaviour that depends on the UE capability; the "lower case letter" identifies a step sequence that takes place if a capability is supported. Note: One sequence of steps 2a1 to 2a12 or 2b1 to 2b9 are executed	-	-	-	-
2a1	IF the UE does not determine the LAI of the new UTRAN cell, THEN Check: Does the UE transmit a LOCATION UPDATING REQUEST message?	-->	LOCATION UPDATING REQUEST	-	P
2a2	The SS transmits AUTHENTICATION REQUEST	<--	AUTHENTICATION REQUEST	-	-
2a3	The UE transmits AUTHENTICATION RESPONSE	-->	AUTHENTICATION RESPONSE	-	-
2a4	The SS transmits a SECURITY MODE COMMAND message for the CS domain.	<--	SECURITY MODE COMMAND	-	-
2a5	The UE transmits a SECURITY MODE COMPLETE message.	-->	SECURITY MODE COMPLETE	-	-
2a6	The SS transmits a LOCATION UPDATING ACCEPT message.	<--	LOCATION UPDATING ACCEPT	-	-
2a7	Check: Does the UE transmit a CM SERVICE REQUEST?	-->	CM SERVICE REQUEST	-	P
2a8	The SS transmits a SECURITY MODE COMMAND message for the PS domain.	<--	SECURITY MODE COMMAND	-	-
2a9	The UE transmits a SECURITY MODE COMPLETE message.	-->	SECURITY MODE COMPLETE	-	-
2a10	The SS transmits an UTRAN MOBILITY INFORMATION message to notify CN information.	<--	UTRAN MOBILITY INFORMATION	-	-
2a11	The UE transmits an UTRAN MOBILITY INFORMATION CONFIRM message.	-->	UTRAN MOBILITY INFORMATION CONFIRM	-	-
2a12	The SS transmits a CM SERVICE ACCEPT message.	<--	CM SERVICE ACCEPT	-	-
	Exception: Steps 2b1 to 2b4 takes place if pc_UMI_ProcNeeded_DuringCSFB				
2b1	The SS transmits a SECURITY MODE COMMAND message for the PS domain.	<--	SECURITY MODE COMMAND	-	-
2b2	The UE transmits a SECURITY MODE COMPLETE message.	-->	SECURITY MODE COMPLETE	-	-
2b3	The SS transmits an UTRAN MOBILITY INFORMATION message to notify CN information.	<--	UTRAN MOBILITY INFORMATION	-	-
2b4	The UE transmits an UTRAN MOBILITY INFORMATION CONFIRM message.	-->	UTRAN MOBILITY INFORMATION CONFIRM	-	-
2b5	Check: Does the UE transmit a CM SERVICE REQUEST?	-->	CM SERVICE REQUEST	-	P
2b6	The SS transmits AUTHENTICATION REQUEST	<--	AUTHENTICATION REQUEST	-	-
2b7	The UE transmits AUTHENTICATION RESPONSE	-->	AUTHENTICATION RESPONSE	-	-
2b8	The SS transmits a SECURITY MODE COMMAND message for the CS domain.	<--	SECURITY MODE COMMAND	-	-
2b9	The UE transmits a SECURITY MODE COMPLETE message.	-->	SECURITY MODE COMPLETE	-	-
3	The UE transmits an EMERGENCY SETUP	-->	EMERGENCY SETUP	-	-

	message.				
4-9	Steps 12 to 17 of the test procedure in TS 34.123-1 [7] subclause 13.2.1.1 are performed using the UTRA reference radio bearer parameters and combination "UTRA PS RB + Speech" according to subclause 4.8.3 and Table 4.8.3-1. NOTE: Emergency call is established..	-	-	-	-
10	The SS transmits a ROUTING AREA UPDATE ACCEPT.	<--	ROUTING AREA UPDATE ACCEPT	-	-
11	The UE sends ROUTING AREA UPDATE COMPLETE.	-->	ROUTING AREA UPDATE COMPLETE	-	-

Table 6.4.3.7.7-2: Parallel behaviour

St	Procedure	Message Sequence		TP	Verdict
		U - S	Message		
1	The UE transmits a ROUTING AREA UPDATE REQUEST message.	-->	ROUTING AREA UPDATE REQUEST	-	-

6.4.3.7.7.1 Specific message contents

UTRAN MOBILITY INFORMATION (step 2a10 & 2b1 of table 6.4.3.7.7-1): same as Table 6.4.3.7.5.1-1

Table 6.4.3.7.7.1-1: LOCATION UPDATING ACCEPT (step 2a6 of table 6.4.3.7.7-1)

Derivation Path: TS 36.508 Table 4.7B.2-5			
Information Element	Value/remark	Comment	Condition
Mobile identity	Not present		

6.4.3.8 CS fallback to GERAN procedures (LAI of GERAN cell same as the LAI received in combined Attach procedure in EUTRA cell)

All procedures specified in this clause are referred to the GERAN target cell where the UE has been redirected or handed over from the EUTRA cell after a CS call requested. The default message contents are found in TS 34.108 [5], clause 9.

The procedures in 6.4.3.8.1 – 6.4.3.8.4 are applied if the UE supports (EUTRA) RRC connection release with redirection or Cell Change order and Multi Cell System Information to GERAN.

6.4.3.8.1 CS fallback to GERAN with redirection or CCO / MT call (DTM not supported)

Table 6.4.3.8.1-1: Test procedure sequence

St	Procedure	Message Sequence		TP	Verdict
		U - S	Message		
1	The UE transmits a CHANNEL REQUEST message.	-->	CHANNEL REQUEST	-	-
2	The SS transmits an IMMEDIATE ASSIGNMENT message.	<--	IMMEDIATE ASSIGNMENT	-	-
3	Void	-	-	-	-
-	EXCEPTION: In parallel to the events described in step 4 to 19 the steps specified in table 6.4.3.8.1-2 takes place	-	-	-	-
4	Check: Does the UE transmit a PAGING RESPONSE message?	-->	PAGING RESPONSE	-	P
4A	The UE transmits a <i>Classmark Change</i> message	-->	CLASSMARK CHANGE	-	-
-	EXCEPTION: Step 4B describes behaviour that depends on the UE capability.	-	-	-	-
4B	IF <i>pc_UTRA</i> then the UE transmits a <i>Utran Classmark</i> message	-->	UTRAN CLASSMARK CHANGE	-	-
5-19	Steps 5 to 19 of the generic test procedure in TS 51.010-1 sub clause 10.3.3 are performed NOTE: Mobile terminating CS call is established.	-	-	-	-
20	The SS transmits DISCONNECT.	<--	DISCONNECT	-	-
21	The UE transmits RELEASE..	-->	RELEASE	-	-
22	The SS transmits RELEASE COMPLETE.	<--	RELEASE COMPLETE	-	-
23	The SS transmits CHANNEL RELEASE, with GPRS Resumption Field set to 1	<--	CHANNEL RELEASE	-	-
24-34	Steps 1 to 11 of the generic test procedure in sub clause 6.4.2.9 are performed.	-	-	-	-

Table 6.4.3.8.1-2: Parallel behaviour

St	Procedure	Message Sequence		TP	Verdict
		U - S	Message		
1	The UE transmits a GPRS SUSPENSION REQUEST message.	-->	GPRS SUSPENSION REQUEST	-	-

6.4.3.8.2 CS fallback to GERAN with redirection or CCO / MO call (DTM not supported)

Table 6.4.3.8.2-1: Test procedure sequence

St	Procedure	Message Sequence		TP	Verdict
		U - S	Message		
1	The UE transmits a CHANNEL REQUEST message.	-->	CHANNEL REQUEST	-	-
2	The SS transmits an IMMEDIATE ASSIGNMENT message.	<--	IMMEDIATE ASSIGNMENT	-	-
3	Void	-	-	-	-
-	EXCEPTION: In parallel to the events described in step 4 to 17 the steps specified in table 6.4.3.8.2-2 takes place	-	-	-	-
4	Check: Does the UE transmit a CM SERVICE REQUEST message?	-->	CM SERVICE REQUEST	-	P
4A	The UE transmits a <i>Classmark Change</i> message	-->	CLASSMARK CHANGE	-	-
-	EXCEPTION: Step 4B describes behaviour that depends on the UE capability.	-	-	-	-
4B	IF <i>pc_UTRA</i> then the UE transmits a Utran <i>Classmark</i> message	-->	UTRAN CLASSMARK CHANGE	-	-
5-17	Steps 5 to 17 of the generic test procedure in TS 51.010-1 sub clause 10.2.3 are performed NOTE: Mobile originating CS call is established.	-	-	-	-
18	The SS transmits DISCONNECT.	<--	DISCONNECT	-	-
19	The UE transmits RELEASE..	-->	RELEASE	-	-
20	The SS transmits RELEASE COMPLETE.	<--	RELEASE COMPLETE	-	-
21	The SS transmits CHANNEL RELEASE, with GPRS Resumption Field set to 1	<--	CHANNEL RELEASE	-	-
22-32	Steps 1 to 11 of the generic test procedure in sub clause 6.4.2.9 are performed.	-	-	-	-

Table 6.4.3.8.2-2: Parallel behaviour

St	Procedure	Message Sequence		TP	Verdict
		U - S	Message		
1	The UE transmits a GPRS SUSPENSION REQUEST message.	-->	GPRS SUSPENSION REQUEST	-	-

6.4.3.8.3 CS fallback to GERAN with PS Handover / MT call (EDTM not supported)

Same as test procedure sequence in 36.523-1 [18] clause 13.1.11.3.2 from steps 11 to end.

6.4.3.8.4 CS fallback to GERAN with PS Handover / MO call (EDTM not supported)

Same as test procedure sequence in 36.523-1 [18] clause 13.1.12.3.2 from steps 4 to end.

6.4.3.8.5 CS fallback to GERAN with PS Handover / MT call (EDTM supported)

Same as test procedure sequence in 36.523-1 [18] clause 13.1.13.3.2 from steps 7 to end.

6.4.3.9 SRVCC Handover to UTRA

The procedure specified in this clause are referred to the UTRA target cell where the UE has been SRVCC handed over from the EUTRA cell. The default message contents are found in TS 34.108 [5], clause 9.

Table 6.4.3.9-1: Test procedure sequence

St	Procedure	Message Sequence		TP	Verdict
		U - S	Message		
1	Check: Does the UE transmit a HANDOVER TO UTRAN COMPLETE message?	-->	HANDOVER TO UTRAN COMPLETE	-	P
-	EXCEPTION: In parallel to the events described in step 2 to 7 the steps specified in table 6.4.3.9-2 takes place.	-	-	-	-
2	The SS transmits a SECURITY MODE COMMAND message for the CS domain.	<--	SECURITY MODE COMMAND	-	-
3	The UE transmits a SECURITY MODE COMPLETE message.	-->	SECURITY MODE COMPLETE	-	-
4	The SS transmits an UTRAN MOBILITY INFORMATION message to notify CN information.	<--	UTRAN MOBILITY INFORMATION	-	-
5	The UE transmits an UTRAN MOBILITY INFORMATION CONFIRM message.	-->	UTRAN MOBILITY INFORMATION CONFIRM	-	-
6	The SS transmits a TMSI REALLOCATION COMMAND message.	<--	TMSI REALLOCATION COMMAND	-	-
7	The UE transmits a TMSI REALLOCATION COMPLETE message.	-->	TMSI REALLOCATION COMPLETE	-	-
8	The SS transmits a ROUTING AREA UPDATE ACCEPT.	<--	ROUTING AREA UPDATE ACCEPT	-	-
9	The UE sends ROUTING AREA UPDATE COMPLETE.	-->	ROUTING AREA UPDATE COMPLETE	-	-

Table 6.4.3.9-2: Parallel behaviour

St	Procedure	Message Sequence		TP	Verdict
		U - S	Message		
1	The UE transmits a ROUTING AREA UPDATE REQUEST message.	-->	ROUTING AREA UPDATE REQUEST	-	-

6.4.3.9.1 Specific message contents

Table 6.4.3.9.1-1: SECURITY MODE COMMAND (step 2, Table 8.4.1.2.3.2-1)

Derivation Path: 34.108 clause 9.1.1 (SECURITY MODE COMMAND message)		
Information Element	Condition	Value/remark
Ciphering mode info		Not Present

6.4.3.10 Offload to WLAN

The procedure specified in this clause is referred to the WLAN target AP where the UE has been offloaded from the EUTRA cell.

Table 6.4.3.10-1: Test procedure sequence

St	Procedure	Message Sequence		TP	Verdict
		U - S	Message		
1	UE associates with the WLAN AP and obtains the local IP address if it has not already done. Note 1	-	-	-	-
-	EXCEPTION: Step 2 is optional, and is executed if initiated by UE	-	-	-	-
2	UE performs a dynamic selection of ePDG using DNS query	-	-	-	-
3	UE initiates Authentication and Authorization (EAP-AKA) using CHAP as defined in 33.402 [55] clause 6.5.3	-	-	-	-
4-9	Check: The UE establishes IPsec tunnel using the IKEv2 protocol as defined in 3GPP TS 33.402 [55] clause 8.2.2, Figure 8.2.2-1; Procedure as defined in 23.402 [41] clause 8.2.3 steps 4-9	-	-	-	P
	Exception: Steps 10a1 to 10a3 takes place if UE is in RRC Connected state. Note 2			-	-
10a1 - 10a3	The generic test procedure in TS 36.508 subclause 4.5A.15.3 is executed.	-	-	-	P
-	EXCEPTION: Steps 11a1 to 11a2b1 describes a transaction that depends on offload of IMS PDN.				
11a1	IF IMS PDN is offloaded SS starts timer Timer_1 = 10 s (Note 3)				
-	EXCEPTION: Steps 11a2a1 to 11a2a2 describe a transaction that depends on offload of IMS PDN and UE implementation				
11a2 a1- 11a2 a2	IF initiated by the UE, Re-Registration procedure according to TS 34.229-1 [43] sub clause C.XX takes place on WLAN AP.				
11a2 b1	The SS waits for Timer_1 expiry				
<p>Note 1: If the UE has not already associated with WLAN AP it may take long time (up to 60 seconds) to associate with WLAN AP as it may need to scan, authenticate, obtain IP address etc.</p> <p>Note 2: If UE is in RRC Idle state then as per 24.301[28] clause 6.4.2.2, the offloaded PDN is implicitly released.</p> <p>Note 3: A guarding time of [10] sec is suggested within which the procedure is expected to start. If the timer expires then the test procedure, from which the Procedure for IMS Re-Registration is called, shall advance to the next specified step.</p>					

6.4.3.10.1 Specific message contents

None

6.4.3.11 Offload from WLAN

The procedure specified in this clause is referred to the EUTRA cell where the UE has been previously offloaded from the EUTRA cell and now the Offload from WLAN AP back to EUTRA cell happens.

Table 6.4.3.11-1: Test procedure sequence

St	Procedure	Message Sequence		TP	Verdict
		U - S	Message		
	Exception: Steps 1 to 9 are executed if the UE is in RRC Idle state in EUTRA cell.			-	-
1	Check: Does UE transmit an <i>RRCConnectionRequest</i> message with <i>establishmentCause</i> set to 'mo-Data' followed by a SERVICE REQUEST message?	-->	SERVICE REQUEST	-	
2-9	The SS establishes SRB2 and DRB associated with non offloaded default EPS bearer context by executing steps 3-10a7 in the generic test procedure in TS 36.508 subclause 4.5.3.3	-	-	-	-
10	Check: Does the UE establish additional PDN connection for offloaded PDN by executing the generic test procedure in TS 36.508 subclause 4.5A.16.3.	-	-	-	P
11	Network initiated IPsec tunnel disconnection procedures defined by the IKEv2 protocol in IETF RFC 5996 [57] is executed on WLAN AP	-	-	-	-

6.4.3.11.1 Specific message contents

None

6.4.3.12 Check UE does not offload to WLAN

The procedure specified in this clause is referred to the WLANAP.

Table 6.4.3.12-1: Test procedure sequence

St	Procedure	Message Sequence		TP	Verdict
		U - S	Message		
-	Exception: In parallel to step 1 parallel behaviour in table 6.4.3.12-2 may be optionally executed.	-	-	-	-
1	Check: IF UE initiates Authentication and Authorization (EAP-AKA) using CHAP as defined in 33.402 [55] clause 6.5.3 in the next 60 seconds	-	-	-	F

Table 6.4.3.12-2: Parallel Behaviour

St	Procedure	Message Sequence		TP	Verdict
		U - S	Message		
1	UE associates with the WLAN AP and obtains the local IP address if it has not already done	-	-	-	-

6.4.3.12.1 Specific message contents

None

6.4.3.13 Check UE does not Offload to E-UTRAN

The procedure specified in this clause are referred to the EUTRA cell.

Table 6.4.3.13-1: Test procedure sequence

St	Procedure	Message Sequence			TP	Verdict
		U - S	Message			
	Exception: Steps 1a to 1b describe behaviour that depends on the state; the "lower case letter" identifies a step sequence that take place. IF UE is in 'Idle' state step 1a takes and if in 'Connected' state step 1b takes				-	-
1a	Check: Does UE transmit an <i>RRConnectionRequest</i> in the next 15 seconds	-->	<i>RRConnectionRequest</i>		-	F
1b	Check: Does the UE transmits a PDN CONNECTIVITY REQUEST message to request an additional PDN. In the next 15 seconds	-->	RRC: <i>ULInformationTransfer</i> NAS: PDN CONNECTIVITY REQUEST		-	F

6.4.3.14 Procedure for UE initiated detach at non-switch-off

The purpose of this procedure is to allow a UE to perform UE initiated detaching.

Table 6.4.3.14-1: Procedure for optional UE initiated detaching

Step	Procedure	Message Sequence			
		U - S	Message		
1	The UE transmits a DETACH REQUEST message with the Detach type IE indicating "EPS detach" to regain normal service.	-->	DETACH REQUEST	-	-
2	The SS responds the DETACH ACCEPT message.	<--	DETACH ACCEPT	-	-

6.4.3.13.1 Specific message contents

None

6.4.3A Test case postambles

6.4.3A.1 Introduction

In order to make test cases perfectly reproducible, the UE under test is switched off after the test procedure sequence of a test case is complete. In order to make it possible to run a number of test cases without any manual operation, it is important that the SS can properly handle any possible signalling from the UE between the end of the test procedure sequence and until the UE is off.

After the last verdict of a test procedure sequence is assigned, it is necessary to:

- terminate any ongoing signalling procedure,
- switch off the UE.

Usually, this can be performed by completing necessary TAU/LAU/RAU procedures, completing any ongoing voice call (CS or IMS), and switching off the UE with a detach procedure.

6.4.3A.2 Reference end states

Test procedures in TS 36.523-1 may only partially terminate ongoing signalling procedures, provided they indicate a reference end state at the end of the test procedure sequence, so that a matching procedure in TS 36.523-3 can be executed to switch off the UE.

Reference end states definitions include the necessary pieces of information to predict UE behaviour during the postambles.

If any extra information was stored in the UE or the USIM due to the test procedure sequence, it should be removed explicitly by the test procedure sequence, before the UE can be left in a reference end state.

Table 6.4.3A.2-1: Reference end states

Name	Description	Optional information
E-UTRA idle (E1)	The UE: - is camped on an E-UTRA cell, and RRC idle and - registered for EPS services and EPS update status is "updated" and - is registered for non-EPS services and update status is updated (if CS fallback or SMS over SGs is supported) and - has one or more default EPS bearer context are active, zero or more dedicated EPS bearer contexts are active.	The test case may indicate that the UE is not registered for non-EPS services, though the UE supports CS fallback or SMS over SGs.
E-UTRA connected (E2)	Same as E-UTRA idle , except that: - the UE is RRC connected and - DRBs for all active EPS bearer contexts are established.	Same as for E-UTRA idle .
E-UTRA connected, T3440 started (E2_T3440)	Same as E-UTRA idle , except that: - the UE is RRC connected and - Timer T3440 is started in UE.	Same as for E-UTRA idle
E-UTRA test mode (E3)	Same as E-UTRA connected and - test mode is active and - test loop is closed.	Same as for E-UTRA idle
E-UTRA deregistered (E4)	The UE is: - camped on an E-UTRA cell, and idle and - not registered of EPS services and - not registered for non-EPS services.	
E-UTRA manual selection (E5)	Same as E-UTRA idle , except that: - the UE is in manual PLMN selection mode	Same as for E-UTRA idle
UTRA idle (U1)	The UE is: - camped on a UTRA cell, RRC idle and - IMSI attached and update status is "updated" (if the UE supports CS domain) and - GPRS attached, GPRS update state is "updated", and zero or one or several PDP context(s) with interactive or background QoS are active.	The test case may indicate that the UE is not IMSI attached though the UE supports CS domain
UTRA connected (U2)	Same as UTRA idle , except that: - the UE is in CELL_DCH state and - a RAB associated with the active PDP context is established.	The test case may indicate that the UE is not IMSI attached though the UE supports CS domain.
UTRA handover (U3)	The UE: - was E-UTRA connected and - has completed a handover to UMTS and - hasn't yet sent or received any NAS signalling on the target UTRAN cell.	Same as for UTRA connected
UTRA CS fallback (U4)	The UE: - was E-UTRA idle or E-UTRA connected and - has transmitted an EXTENDED SERVICE REQUEST message due to MO or MT CS fallback call and - either the UE has completed a handover to UMTS or the UE has been redirected to UMTS and has established the RRC connection to a UTRA cell, and the target UTRA cell has activated security and RABs for all previously active EPS bearer contexts were established and - the UE hasn't yet sent or received any NAS signalling on the target UTRAN cell	
UTRA CS call (U5)	The UE was in UTRAN CS fallback and the UE has completed LAU/RAU procedure if necessary and has established a CS call or the UE was in E-UTRAN connected and the UE has completed LAU/RAU procedure if necessary and has performed a handover to UTRAN with SRVCC.	
UTRA deregistered (U6)	The UE is: - camped on a UTRA cell, and idle and - not registered GPRS/non-GPRS services	
GERAN idle (G1)	The UE: - is camped on an GERAN cell, in idle mode and GPRS idle state and - is registered for PS services and GPRS update status is "updated" and zero or one or several PDP context(s) with interactive or background QoS are active. - is IMSI attached (if CS domain is supported)	

GERAN PS handover (G2)	The UE: - was E-UTRA connected and - has performed a PS handover procedure to a GERAN cell and - hasn't yet sent or received any NAS signalling on the target GERAN cell.	
GERAN CS fallback (G3)	The UE: - was E-UTRA idle or E-UTRA connected and - has transmitted an EXTENDED SERVICE REQUEST message due to MO or MT CS fallback call and - either the UE has completed a PS handover to GERAN or a CCO to GERAN or the UE has been redirected to GERAN and has entered dedicated mode, and if DTM is supported, - the UE hasn't yet sent or received any NAS signalling on the target GERAN cell	
GERAN CS call (G4)	The UE was in GERAN CS fallback and the UE has established a CS call or the UE was in E-UTRAN connected and has performed a handover to GERAN with SRVCC.	
GERAN deregistered (G5)	The UE is: - camped on a GERAN cell, and idle and - not registered GPRS/non-GPRS services	
1xRTT state 1 (1x1)	FFS	
...	...	
HRPD state 1 (H1)	FFS	
...	...	

6.5 Default RRC message and information element contents

The default RRC message and information element contents specified in this subclause apply to all Signalling test cases defined in TS 36.523-1 [18] unless otherwise specified, in addition to the default RRC message and information element contents specified in subclause 4.6 of this specification.

6.5.1 Measurement information elements

- MeasConfig-DEFAULT

Table 6.5.1-1: MeasConfig-DEFAULT

Derivation Path: 36.331, clause 6.3.5			
Information Element	Value/remark	Comment	Condition
MeasConfig-DEFAULT ::= SEQUENCE {			
measObjectToRemoveList	Not present		
measObjectToAddModList	Not present		
reportConfigToRemoveList	Not present		
reportConfigToAddModList	Not present		
measIdToRemoveList	Not present		
measIdToAddModList	Not present		
quantityConfig	QuantityConfig-DEFAULT		
measGapConfig	Not present		
	MeasGapConfig-GP1		INTER-FREQ, UTRAN
	MeasGapConfig-GP2		GERAN, INTER-RAT
	MeasGapConfig-CE		intraFreq-CE-NeedForGaps
s-Measure	Not present		
preRegistrationInfoHRPD	Not present		
speedStatePars	Not present		
}			

Condition	Explanation
INTER-FREQ	For E-UTRA inter-freq measurements
UTRAN	For inter-RAT measurements with UTRAN
GERAN	For inter-RAT measurements with GERAN
INTER-RAT	For inter-RAT measurements with UTRAN and GERAN
intraFreq-CE-NeedForGaps	For UE having set pc_intraFreq-CE-NeedForGaps to TRUE.

- MeasGapConfig-GP1

Table 6.5.1-2: MeasGapConfig-GP1

Derivation Path: 36.331, clause 6.3.5			
Information Element	Value/remark	Comment	Condition
MeasGapConfig-GP1 ::= CHOICE {			
setup SEQUENCE {			
gapOffset CHOICE {			
gp0	30	TGRP = 40 ms	
}			
}			
}			

- MeasGapConfig-GP2

Table 6.5.1-3: MeasGapConfig-GP2

Derivation Path: 36.331, clause 6.3.5			
Information Element	Value/remark	Comment	Condition
MeasGapConfig-GP2 ::= CHOICE {			
setup SEQUENCE {			
gapOffset CHOICE {			
gp1	30	TGRP = 80 ms	
}			
}			
}			

- MeasGapConfig-CE

Table 6.5.1-4: MeasGapConfig-CE

Derivation Path: 36.331, clause 6.3.5			
Information Element	Value/remark	Comment	Condition
MeasGapConfig-CE ::= CHOICE {			
setup SEQUENCE {			
gapOffset CHOICE {			
gp0	20	TGRP = 40 ms	
}			
}			
}			

6.6 Default NAS message and information element contents

The default NAS message and information element contents specified in this subclause apply to all Signalling test cases defined in TS 36.523-1 [18] unless otherwise specified, in addition to the default NAS message and information element contents specified in subclause 4.7 of this specification.

6.6.1 Reference default EPS bearer contexts

The following table defines Reference default EPS bearer contexts. Default EPS bearer context1 is the default "default EPS bearer context" which is used in the common procedures and test cases where no particular default EPS bearer context is specified.

Table 6.6.1-1: Reference default EPS bearer contexts

Parameters	Reference default EPS bearer context #1	Reference default EPS bearer context #2	Reference default EPS bearer context #3
EPS QoS			
QCI (Note 1)	9 (non-GBR QCI)	5 (non-GBR QCI)	69 (Note 5) (non-GBR QCI)
Maximum bit rate for uplink	64 kbps (Note 2)	64 kbps (Note 2)	64 kbps (Note 2)
Maximum bit rate for downlink	64 kbps (Note 2)	64 kbps (Note 2)	64 kbps (Note 2)
Guaranteed bit rate for uplink	64 kbps (Note 2)	64 kbps (Note 2)	64 kbps (Note 2)
Guaranteed bit rate for downlink	64 kbps (Note 2)	64 kbps (Note 2)	64 kbps (Note 2)
Maximum bit rate for uplink (extended)	0	0	0
Maximum bit rate for downlink (extended)	0	0	0
Guaranteed bit rate for uplink (extended)	0	0	0
Guaranteed bit rate for downlink (extended)	0	0	0
Negotiated QoS	Note 3, Note 4	Note 3, Note 4	Note 3, Note 4
Negotiated LLC SAPI	Note 4	Note 4	Note 4
Radio priority	Note 4	Note 4	Note 4
APN-AMBR	Not present	Not present	Not present
Configuration protocol	PPP	PPP	PPP
Note 1: For all non-GBR QCIs, the maximum and guaranteed bit rates shall be ignored. Note 2: According to TS 24.301, the UE ignores these parameters for a non-GBR QCI. Note 3: Parameters included for UEs capable of UTRAN according to TS 34.123-3 clause 8.10. Note 4: Parameters included for UEs capable of GERAN according to TS 51.010 subclause 40.5. Note 5: QCI 69 is used for MCPTT delay sensitive signalling			

6.6.2 Reference dedicated EPS bearer contexts

The following table defines Reference dedicated EPS bearer contexts. Dedicated EPS bearer context #1 is the default "dedicated EPS bearer context" which is used in the common procedures and test cases where no particular dedicated EPS bearer context is specified.

Table 6.6.2-1: Reference dedicated EPS bearer contexts, first set

Parameters	Reference dedicated EPS bearer context #1	Reference dedicated EPS bearer context #2	Reference dedicated EPS bearer context #3	Reference dedicated EPS bearer context #4	Reference dedicated EPS bearer context #5
Linked EPS bearer identity	Reference default EPS bearer #1	Reference default EPS bearer #1	Reference default EPS bearer #2	Reference default EPS bearer #2	Reference default EPS bearer #3
EPS QoS					
QCI (Note 1)	1 (GBR QCI)	5 (non-GBR QCI)	2 (GBR QCI)	1 (GBR QCI)	65 (Note 8) (GBR QCI)
Maximum bit rate for uplink	384 kbps	384 kbps (Note 2)	2104 (Note 7)	384 kbps	384 kbps
Maximum bit rate for downlink	384 kbps	384 kbps (Note 2)	2104 (Note 7)	384 kbps	384 kbps
Guaranteed bit rate for uplink	128 kbps	128 kbps (Note 2)	2104 (Note 7)	128 kbps	128 kbps
Guaranteed bit rate for downlink	128 kbps	128 kbps (Note 2)	2104 (Note 7)	128 kbps	128 kbps
Maximum bit rate for uplink (extended)	0	0	0	0	0
Maximum bit rate for downlink (extended)	0	0	0	0	0
Guaranteed bit rate for uplink (extended)	0	0	0	0	0
Guaranteed bit rate for downlink (extended)	0	0	0	0	0
TFT					
TFT operation code	"create new TFT"	"create new TFT"	"create new TFT"	"create new TFT"	"create new TFT"
E bit	0	0	0	0	0
Packet filters (Note 5)	1, 2	3	5	4	1, 2
Negotiated QoS					
Traffic Class	conversational	See "PDP ContextDchForLTE" (Note 3); See "PDP context3" (Note 6)	conversational	conversational	conversational
Delivery Order	'no'	See "PDP ContextDchForLTE" (Note 3); See "PDP context3" (Note 6)	'no'	'no'	'no'
Delivery of erroneous SDU	'no'	See "PDP ContextDchForLTE" (Note 3); See "PDP context3" (Note 6)	'no'	'no'	'no'
Maximum SDU size	150	See "PDP ContextDchForLTE" (Note 3); See "PDP context3" (Note 6)	1400	150	150
Maximum bit rate for uplink	384 kbps	See "PDP ContextDchForLTE" (Note 3); See "PDP context3" (Note 6)	432 kbps	384 kbps	384 kbps
Maximum bit rate for	384 kbps	See "PDP	432 kbps	384 kbps	384 kbps

downlink		ContextDchForLTE" (Note 3); See "PDP context3" (Note 6)			
Residual BER	$5 \cdot 10^{-2}$	See "PDP ContextDchForLTE" (Note 3); See "PDP context3" (Note 6)	10^{-5}	$5 \cdot 10^{-2}$	$5 \cdot 10^{-2}$
SDU error ratio	10^{-2}	See "PDP ContextDchForLTE" (Note 3); See "PDP context3" (Note 6)	$7 \cdot 10^{-3}$	10^{-2}	10^{-2}
Transfer delay	80 ms	See "PDP ContextDchForLTE" (Note 3); See "PDP context3" (Note 6)	130 ms	80 ms	80 ms
Traffic Handling priority	0	See "PDP ContextDchForLTE" (Note 3); See "PDP context3" (Note 6)	0	0	0
Guaranteed bit rate for uplink	0	See "PDP ContextDchForLTE" (Note 3); See "PDP context3" (Note 6)	0	0	0
Guaranteed bit rate for downlink	0	See "PDP ContextDchForLTE" (Note 3); See "PDP context3" (Note 6)	0	0	0
Signalling Indication	0	See "PDP ContextDchForLTE" (Note 3); See "PDP context3" (Note 6)	0	0	0
Source Statistics Descriptor	0	See "PDP ContextDchForLTE" (Note 3); See "PDP context3" (Note 6)	0	1	0
Maximum bit rate for downlink (extended)	0	See "PDP ContextDchForLTE" (Note 3); See "PDP context3" (Note 6)	0	0	0
Guaranteed bit rate for downlink (extended)	0	See "PDP ContextDchForLTE" (Note 3); See "PDP context3" (Note 6)	0	0	0
Maximum bit rate for uplink (extended)	0	See "PDP ContextDchForLTE" (Note 3);	0	0	0

		See "PDP context3" (Note 6)			
Guaranteed bit rate for uplink (extended)	0	See "PDP ContextDchForLTE" (Note 3); See "PDP context3" (Note 6)	0	0	0
Negotiated LLC SAPI	3 (Note 6)	See "PDP context3" (Note 6)	-	3 (Note 6)	-
Radio priority	1 (Note 6)	See "PDP context3" (Note 6)	-	1 (Note 6)	-
Protocol configuration options	-	-	-	-	-
<p>Note 1: For all non-GBR QCIs, the maximum and guaranteed bit rates shall be ignored.</p> <p>Note 2: According to TS 24.301, the UE ignores these parameters for a non-GBR QCI.</p> <p>Note 3: Parameters included for UEs capable of UTRAN according to TS 34.123-3 clause 8.10 (table 8.10.1 and 8.10.2).</p> <p>Note 5: This row refers to the reference packet filters defined in the tables below. For each reference dedicated EPS bearer context, a list of reference packet filter numbers is provided.</p> <p>Note 6: Parameter included for UEs capable of GERAN; when value is not provided then value from TS 51.010 subclause 40.5 is applied.</p> <p>Note 7: This value shall reflect the highest possible bandwidth requirement of the H.264 codec to EPS bearer mappings as specified in Appendix E of TS 26.114 [64].</p> <p>Note 8: QCI 65 is used for MCPTT voice.</p>					

Table 6.6.2-1A: Reference dedicated EPS bearer contexts, second set

Parameters	Reference dedicated EPS bearer context #6	Reference dedicated EPS bearer context #7	Reference dedicated EPS bearer context #8		
Linked EPS bearer identity	Reference default EPS bearer #1	Reference default EPS bearer #2	Reference default EPS bearer #2		
EPS QoS					
QCI (Note 1)	8 (non-GBR QCI)	79 (non-GBR QCI)	66 (GBR QCI)		
Maximum bit rate for uplink	384 kbps (Note 2)	384 kbps (Note 2)	384 kbps		
Maximum bit rate for downlink	384 kbps (Note 2)	384 kbps (Note 2)	384 kbps		
Guaranteed bit rate for uplink	128 kbps (Note 2)	128 kbps (Note 2)	128 kbps		
Guaranteed bit rate for downlink	128 kbps (Note 2)	128 kbps (Note 2)	128 kbps		
Maximum bit rate for uplink (extended)	0	0	0		
Maximum bit rate for downlink (extended)	0	0	0		
Guaranteed bit rate for uplink (extended)	0	0	0		
Guaranteed bit rate for downlink (extended)	0	0	0		
TFT					
TFT operation code	"create new TFT"	"create new TFT"	"create new TFT"		
E bit	0	0	0		
Packet filters (Note 3)	6, 7	8	9		
Negotiated QoS					
Traffic Class	-	-	Conversational		
Delivery Order	-	-	'no'		
Delivery of erroneous SDU	-	-	'no'		
Maximum SDU size	-	-	150		
Maximum bit rate for uplink	-	-	384 kbps		
Maximum bit rate for downlink	-	-	384 kbps		
Residual BER	-	-	$5 \cdot 10^{-2}$		
SDU error ratio	-	-	10^{-2}		
Transfer delay	-	-	75 ms		
Traffic Handling priority	-	-	0		
Guaranteed bit rate for uplink	-	-	0		
Guaranteed bit rate for downlink	-	-	0		
Signalling Indication	-	-	0		
Source Statistics Descriptor	-	-	0		
Maximum bit rate for downlink (extended)	-	-	0		
Guaranteed bit rate for downlink (extended)	-	-	0		
Maximum bit rate for uplink (extended)	-	-	0		
Guaranteed bit rate for uplink (extended)	-	-	0		
Negotiated LLC SAPI	-	-	-		

Radio priority	-	-	-		
Protocol configuration options	-	-	-		
<p>Note 1: For all non-GBR QCI, the maximum and guaranteed bit rates shall be ignored.</p> <p>Note 2: According to TS 24.301, the UE ignores these parameters for a non-GBR QCI.</p> <p>Note 3: This row refers to the reference packet filters defined in the tables below. For each reference dedicated EPS bearer context, a list of reference packet filter numbers is provided.</p>					

Table 6.6.2-2: Reference packet filter #1

Derivation path: 24.008 table 10.5.162			
Information Element	Value/Remark	Comment	Condition
Identifier	0 0 0 1 0 0 0 0	DL only filter, ID=0	
Evaluation precedence	(0 0 0 0 0 0 0 0) + EPS Bearer ID - 6	0 to 7	
Component type 1 ID	0 0 0 1 0 0 0 0	IPv4 remote address type	remotelPv4
	0 0 1 0 0 0 0 0	IPv6 remote address type	remotelPv6
Component type 1 Value	remoteAddress 255.255.255.255	See note 1	remotelPv4
	remoteAddress ff:ff:ff:ff:ff:ff:ff:ff:ff:ff:ff:ff:ff:ff:ff:ff	See note 1	remotelPv6
Component type 2 ID	0 1 0 1 0 0 0 0	Single remote port type	
Component type 2 Value	31 160 + EPS Bearer ID - 6		
Component type 3 ID	0 0 1 1 0 0 0 0	Protocol identifier/Next header type	
Component type 3 Value	17	UDP	
<p>Note 1: remoteAddress should be set to the address of an IP server able to send a flow of downlink IP/UDP packets to the UE. remotelPv4 applies if the UE has acquired an IPv4 address only, remotelPv6 applies if the UE has acquired an IPv6 address only, or both an IPv6 and an IPv4 address.</p>			

Table 6.6.2-3: Reference packet filter #2

Derivation path: 24.008 table 10.5.162			
Information Element	Value/Remark	Comment	Condition
Identifier	0 0 1 0 0 0 0 1	UL only filter, ID=1	
Evaluation precedence	(0 0 0 0 0 0 0 0) + EPS Bearer ID - 6 + 8	8 to 15	
Component type 1 ID	0 0 0 1 0 0 0 0	IPv4 remote address type	remotelPv 4
	0 0 1 0 0 0 0 0	IPv6 remote address type	remotelPv 6
Component type 1 Value	remoteAddress 255.255.255.255	See note 1	remotelPv 4
	remoteAddress ff:ff:ff:ff:ff:ff: ff:ff:ff:ff:ff:ff:ff	See note 1	remotelPv 6
Component type 2 ID	0 1 0 1 0 0 0 0	Single remote port type	
Component type 2 Value	61 000 + EPS Bearer ID - 6		
Component type 3 ID	0 0 1 1 0 0 0 0	Protocol identifier/Next header type	
Component type 3 Value	17	UDP	
Note 1: remoteAddress should be set to the address of an IP server able to process a flow of uplink IP/UDP packets received from the UE. When configured together with packet filter #1, remoteAddress is the same as that for packet filter #1. remotelPv4 applies if the UE has acquired an IPv4 address only, remotelPv6 applies if the UE has acquired an IPv6 address only, or both an IPv6 and an IPv4 address.			

Table 6.6.2-4: Reference packet filter #3

Derivation path: 24.008 table 10.5.162			
Information Element	Value/Remark	Comment	Condition
Identifier	0 0 1 1 0 0 1 0	Bidirectional filter, ID=2	
Evaluation precedence	0 0 0 0 1 1 1 1	Lowest priority	
Component type 1 ID	0 0 0 1 0 0 0 0	IPv4 remote address type	remotelPv 4
	0 0 1 0 0 0 0 0	IPv6 remote address type	remotelPv 6
Component type 1 Value	remoteAddress 255.255.255.255	See note 1	remotelPv 4
	remoteAddress ff:ff:ff:ff:ff:ff: ff:ff:ff:ff:ff:ff:ff	See note 1	remotelPv 6
Note 1: remoteAddress should be set to the address of an IP server able to process a uplink IP packets from the UE and transmit downlink IP packets to the UE. remotelPv4 applies if the UE has acquired an IPv4 address only, remotelPv6 applies if the UE has acquired an IPv6 address only, or both an IPv6 and an IPv4 address.			

Table 6.6.2-5: Reference packet filter #4

Derivation path: 24.008 table 10.5.162			
Information Element	Value/Remark	Comment	Condition
Identifier	0 0 1 1 0 0 1 1	Bidirectional, ID=3	
Evaluation precedence	(0 0 0 0 0 0 0 0) + EPS Bearer ID – 6	0 to 7	
Component type 1 ID	0 1 0 1 0 0 0 1	Remote port range type	
Component type 1 Value	media port	SS speech media port as used in the SDP negotiation (RTP remote port); see Note 1	
	media port + 1	RTCP remote port; see Note 1	
Component type 2 ID	0 0 1 1 0 0 0 0	Protocol identifier/Next header type	
Component type 2 Value	17	UDP	
Note 1: Acc. to TS 26.114 and RFC 4566 a "media port" can be understood as the transport port to which a media stream is sent.			

Table 6.6.2-6: Reference packet filter #5

Derivation path: 24.008 table 10.5.162			
Information Element	Value/Remark	Comment	Condition
Identifier	0 0 1 1 0 1 0 0	Bidirectional, ID=4	
Evaluation precedence	(0 0 0 0 0 0 0 0) + EPS Bearer ID – 6	0 to 7	
Component type 1 ID	0 1 0 1 0 0 0 1	Remote port range type	
Component type 1 Value	media port	SS video media port as used in the SDP negotiation (RTP remote port); see Note 1	
	media port + 1	RTCP remote port; see Note 1	
Component type 2 ID	0 0 1 1 0 0 0 0	Protocol identifier/Next header type	
Component type 2 Value	17	UDP	
Note 1: Acc. to TS 26.114 and RFC 4566 a "media port" can be understood as the transport port to which a media stream is sent.			

Table 6.6.2--7: Reference packet filter #6

Derivation path: 24.008 table 10.5.162			
Information Element	Value/Remark	Comment	Condition
Identifier	0 0 0 1 0 0 0 0	DL only filter, ID=0	
Evaluation precedence	(0 0 0 0 0 0 0 0) + EPS Bearer ID - 6	0 to 7	
Component type 1 ID	0 0 0 1 0 0 0 0	IPv4 remote address type	remoteIPv4
	0 0 1 0 0 0 0 0	IPv6 remote address type	remoteIPv6
Component type 1 Value	remoteAddress 255.255.255.255	See note 1	remoteIPv4
	remoteAddress ff:ff:ff:ff:ff:ff: ff:ff:ff:ff:ff:ff	See note 1	remoteIPv6
Component type 2 ID	0 1 0 1 0 0 0 0	Single remote port type	
Component type 2 Value	31 160 + EPS Bearer ID - 6		
Component type 3 ID	0 0 1 1 0 0 0 0	Protocol identifier/Next header type	
Component type 3 Value	17	UDP	
Component type 3 Value	1	ICMP (See note 2)	remote IPv4 AND Ping
Component type 3 Value	58	ICMPv6 (See note 2)	remote IPv6 AND Ping
Note 1: remoteAddress should be set to the address of an IP server able to send a flow of downlink IP/UDP packets to the UE. remoteIPv4 applies if the UE has acquired an IPv4 address only, remoteIPv6 applies if the UE has acquired an IPv6 address only, or both an IPv6 and an IPv4 address.			
Note 2: Component type 3 value of ICMP or ICMPv6 applies if TS 38.508-2 [5] pc_IP_Ping is true.			

Table 6.6.2-8: Reference packet filter #7

Derivation path: 24.008 table 10.5.162			
Information Element	Value/Remark	Comment	Condition
Identifier	0 0 1 0 0 0 0 1	UL only filter, ID=1	
Evaluation precedence	(0 0 0 0 0 0 0 0) + EPS Bearer ID - 6 + 8	8 to 15	
Component type 1 ID	0 0 0 1 0 0 0 0	IPv4 remote address type	remotelPv 4
	0 0 1 0 0 0 0 0	IPv6 remote address type	remotelPv 6
Component type 1 Value	remoteAddress 255.255.255.255	See note 1	remotelPv 4
	remoteAddress ff:ff:ff:ff:ff:ff:ff:ff: ff:ff:ff:ff:ff:ff:ff:ff	See note 1	remotelPv 6
Component type 2 ID	0 1 0 1 0 0 0 0	Single remote port type	
Component type 2 Value	61 000 + EPS Bearer ID - 6		
Component type 3 ID	0 0 1 1 0 0 0 0	Protocol identifier/Next header type	
Component type 3 Value	17	UDP	
Component type 3 Value	1	ICMP (See note 2)	Ping AND remotelPv 4
Component type 3 Value	58	ICMPv6 (See note 2)	Ping AND remotelPv 6
<p>Note 1: remoteAddress should be set to the address of an IP server able to process a flow of uplink IP/UDP packets received from the UE. When configured together with packet filter #1, remoteAddress is the same as that for packet filter #6. remotelPv4 applies if the UE has acquired an IPv4 address only, remotelPv6 applies if the UE has acquired an IPv6 address only, or both an IPv6 and an IPv4 address.</p> <p>Note 2: Component type 3 value of ICMP or ICMPv6 applies if TS 38.508-2 [5] pc_IP_Ping is true.</p>			

Table 6.6.2-9: Reference packet filter #8

Derivation path: 24.008 table 10.5.162			
Information Element	Value/Remark	Comment	Condition
Identifier	0 0 1 0 0 0 0 1	UL only filter, ID=1	
Evaluation precedence	(0 0 0 0 0 0 0 0) + EPS Bearer ID - 6 + 8	8 to 15	
Component type 1 ID	0 0 0 1 0 0 0 0	IPv4 remote address type	remotelPv 4
	0 0 1 0 0 0 0 0	IPv6 remote address type	remotelPv 6
Component type 1 Value	remoteAddress 255.255.255.255	See note 1	remotelPv 4
	remoteAddress ff:ff:ff:ff:ff:ff:ff:ff: ff:ff:ff:ff:ff:ff:ff:ff	See note 1	remotelPv 6
Component type 2 ID	0 0 1 1 0 0 0 0	Protocol identifier/Next header type	
Component type 2 Value	17	UDP	
<p>Note 1: remoteAddress should be set to the address of an IP server able to process a flow of uplink IP/UDP packets received from the UE. When configured together with packet filter #1, remoteAddress is the same as that for packet filter #1. remotelPv4 applies if the UE has acquired an IPv4 address only, remotelPv6 applies if the UE has acquired an IPv6 address only, or both an IPv6 and an IPv4 address.</p>			

Table 6.6.2-10: Reference packet filter #9

Derivation path: 24.008 table 10.5.162			
Information Element	Value/Remark	Comment	Condition
Identifier	0 0 1 1 0 1 0 1	Bidirectional filter, ID=5	
Evaluation precedence	(0 0 0 0 0 0 0 0) + EPS Bearer ID – 6	0 to 7	
Component type 1 ID	0 1 0 1 0 0 0 1	Remote port range type	
Component type 1 Value	media port	SS video media port as used in the SDP negotiation (RTP remote port); see Note 1	
	media port + 1	RTCP remote port; see Note 1	
Component type 2 ID	0 0 1 1 0 0 0 0	Protocol identifier/Next header type	
Component type 2 Value	17	UDP	
Note 1: Acc. to TS 26.114 and RFC 4566 a "media port" can be understood as the transport port to which a media stream is sent.			

6.6A Default SMS over SGs message and information element contents

The default SMS over SGs message and information element contents specified in this subclause apply to all SMS over SGs Signalling test cases defined in TS 36.523-1 [18] unless otherwise specified. All the messages and information elements are listed in alphabetical order.

6.6A.1 CM-sublayer messages

- CP-ACK

This message is sent between the SS and the UE, in both directions.

Table 6.6A.1-1: Message CP-ACK

Derivation Path: 24.011 clause 7.2.2			
Information Element	Value/remark	Comment	Condition
Protocol discriminator	'1001'B	SMS messages	
Transaction identifier	Any allowed value		
Message type	'00000100'B	CP-ACK	

- CP-DATA

This message is sent between the SS and the UE, in both directions.

Table 6.6A.1-2: Message CP-DATA

Derivation Path: 24.011 clause 7.2.1			
Information Element	Value/remark	Comment	Condition
Protocol discriminator	'1001'B	SMS messages	
Transaction identifier	Any allowed value		
Message type	'00000001'B	CP-DATA	
CP-User data	RP-ACK RPDU or RP-DATA RPDU (as specified in the test case)		

6.6A.2 Short Message Relay Layer (SM-RL) messages

- RP-ACK RPDU

This message is sent between the SS and the UE, in both directions.

Table 6.6A.2-1: Message RP-ACK RPDU

Derivation Path: 24.011 clause 7.3.3			
Information Element	Value/remark	Comment	Condition
RP-Message Type	'010'B	RP-ACK_PDU uplink	Uplink_SMS
	'011'B	RP-ACK_PDU downlink	Downlink_S MS
RP-Message Reference	Same as in associated (preceding) RP-DATA RPDU		
RP-User Data	Not present or any allowed value		Uplink_SMS
	Not present		Downlink_S MS

Condition	Explanation
Uplink_SMS	This condition applies when the message is sent by the UE to the SS.
Downlink_SMS	This condition applies when the message is sent by the SS to the UE.

- RP-DATA RPDU

This message is sent between the SS and the UE, in both directions.

Table 6.6A.2-2: Message RP-DATA RPDU

Derivation Path: 24.301 clause 8.2.23			
Information Element	Value/remark	Comment	Condition
RP-Message Type	'001'B	RP-DATA_PDU downlink	Downlink_S MS
	'000'B	RP-DATA_PDU uplink	Uplink_SMS
RP-Message Reference	Any allowed value		
RP-Originator Address	Any allowed value	originating Service Centre address	Downlink_S MS
	Not present		Uplink_SMS
RP-Destination Address	Not present		Downlink_S MS
	Any allowed value	destination Service Centre address	Uplink_SMS
RP-User Data	SMS-SUBMIT or SMS- DELIVER (as set in the test case)		

Condition	Explanation
Uplink_SMS	See the definition below table 6.6A.2-1.
Downlink_SMS	See the definition below table 6.6A.2-1.

6.6A.3 Short Message Transfer Layer (SM-TL) messages

- SMS-DELIVER

This message is sent by the SS to the UE.

Table 6.6A.3-1: Message SMS-DELIVER

Derivation Path: 23.040 clause 9.2.2.1			
Information Element	Value/remark	Comment	Condition
TP-MTI	'00'B	SMS-DELIVER	
TP-MMS	'1'B	No more messages are waiting for the MS in this SC	
TP-RP	Any allowed value		
TP-UDHI	'0'B		
TP-SRI	'0'B		
TP-OA	Any allowed value		
TP-PID	'00000000'B		
TP-DCS	Any allowed value		
TP-SCTS	Any allowed value		
TP-UDL	160		
TP-UD (140 octets)	text of message (160 characters)	The 160 characters in TP-UD shall include at least one occurrence of each character in the default alphabet (see 3GPP TS 23.038, clause 6.2.1).	

- SMS-SUBMIT

This message is sent by the UE to the SS.

Table 6.6A.3-2: Message SMS-SUBMIT

Derivation Path: 23.040 clause 9.2.2.2			
Information Element	Value/remark	Comment	Condition
TP-MTI	'01'B	SMS-SUBMIT	
TP-RD	Any allowed value		
TP-VPF	Any allowed value		
TP-RP	Any allowed value		
TP-UDHI	Not present or any allowed value		
TP-SRR	Not present or any allowed value		
TP-MR	Any allowed value		
TP-DA	Any allowed value		
TP-PID	'00000000'B		
TP-DCS	Any allowed value		
TP-VP	Not present or any allowed value		
TP-UDL	160		
TP-UD (140 octets)	text of message (160 characters)		

6.6B Reference radio bearer configurations

6.6B.1 SRB and DRB parameters and combinations

6.6B.1.1 SRB and DRB parameters

6.6B.1.1.1 Physical Layer configurations

Table 6.6B.1.1.1-1: PhysicalConfigDedicated-DEFAULT

Derivation Path: TS 36.508 clause 4.8.2.1.6, Table 4.8.2.1.6-1			
Information Element	Value/remark	Comment	Condition
PhysicalConfigDedicated-DEFAULT ::= SEQUENCE {			
cqi-ReportConfig	CQI-ReportConfig-DEFAULT using condition CQI_PERIODIC	See subclause 4.6.3	SRB1 or RBC or RBC-HO or HO-TO-EUTRA
soundingRS-UL-ConfigDedicated	SoundingRS-UL-ConfigDedicated-DEFAULT	See subclause 4.6.3	(SRB1 or RBC or RBC-HO or HO-TO-EUTRA) and not (CEmodeA or CEmodeB)
	Not present	Not applicable for CAT M1	CEmodeA or CEmodeB
}			

Condition	Explanation
SRB1	Used at configuration of SRB1 during RRC connection (re-)establishment
RBC	Used at configuration of a radio bearer combination during SRB2+DRB establishment
2TX	Used for cells with two antenna ports
RBC-HO	Used during Handover
HO-TO-EUTRA	Inter-RAT handover to E-UTRA
CEmodeA	CE mode A test environment
CEmodeB	CE mode B test environment

6.7 Timer Tolerances

The timer tolerances specified for the test environment in this subclause apply to all Signalling test cases defined in TS 36.523-1 [18] unless otherwise specified

All the timers used during testing are within a tolerance margin given by the equation below. If for a specific test a different tolerance value is required then this should be specified in the relevant test document (i.e. the document where the test is described).

Timer tolerance = 10%, or $5 \times \text{RTT}$, whichever value is the greater.

Where $\text{RTT} = 8 \text{ TTIs}$ for FDD, and $\text{RTT} = \text{Maximum RTT}$ from Table 6.7-1 for TDD (see Note).

NOTE: Since the exact RTT for TDD varies depending on the UL/DL configurations and subframe number [29], the maximum RTT is defined in Table 6.7-1.

Table 6.7-1: Maximum RTT for TDD UL/DL configurations

UL/DL Configuration	Maximum RTT (TTIs)
0	10
1*	11
2	12
3	15
4	16
5	TBD
6	11
*Note: Default UL/DL configuration defined in Table 4.6.3-23 of TS 36.508	

6.8 SideLink reference configuration

The reference test configurations specified in 6.8.1 apply to all SideLink Signalling test cases defined in TS 36.523-1 [18].

The reference test configurations specified in 6.8.2 apply to all V2X SideLink Signalling test cases defined in TS 36.523-1 [18].

6.8.1 Reference configuration for Direct Communication

ROHC compression is not applied in the signalling test cases simulating in coverage and out-of-coverage scenarios.

Unless otherwise specified, ciphering is not configured on SLRB.

6.8.1.1 ProSe Direct Communication *Preconfiguration* for out-of-network coverage operation

The IE *SL-Preconfiguration* contains the resource pool information for sidelink direct communication.

Table 6.8.1.1-1: SL-Preconfiguration

Derivation Path: 36.331 clause 9.3.2			
Information Element	Value/remark	Comment	Condition
SL-Preconfiguration-r12 ::= SEQUENCE {			
preconfigGeneral-r12 SEQUENCE {		SL-PreconfigGeneral-r12	
rohc-Profiles-r12 SEQUENCE {		-- PDCP configuration	
profile0x0001-r12	false		
profile0x0002-r12	false		
profile0x0004-r12	false		
profile0x0006-r12	false		
profile0x0101-r12	false		
profile0x0102-r12	false		
profile0x0104-r12	false		
}			
carrierFreq-r12	f1 as per table 6.2.3.3-2 using the same band as cell1	ARFCN-ValueEUTRA-r9	
maxTxPower-r12	0		
additionalSpectrumEmission-r12	1		
sl-bandwidth-r12	see table 6.2.3.3-2 using the same bandwidth as cell1		
tdd-ConfigSL-r12 SEQUENCE {		TDD-ConfigSL-r12	
subframeAssignment	none	FDD	
}			
reserved-r12	'00000000000000000000'		
}	B		
preconfigSync-r12 SEQUENCE {		SL-PreconfigSync-r12	
syncCP-Len-r12	normal	SL-CP-Len-r12	
syncOffsetIndicator1-r12	1	SL-OffsetIndicatorSync-r12	
		Synchronisation resources are present in those SFN and subframes which satisfy the relation: (SFN*10+ Subframe Number) mod 40 = SL-OffsetIndicatorSync	
syncOffsetIndicator2-r12	2	SL-OffsetIndicatorSync-r12	
syncTxParameters-r12	23	P0-SL-r12	
syncTxThreshOoC-r12	0	(-110dBm/15kHz)	
filterCoefficient-r12	fc0		
syncRefMinHyst-r12	dB0		
syncRefDiffHyst-r12	dB0		
}			
preconfigComm-r12 SEQUENCE (SIZE (1..maxSL-TxPool-r12)) OF SL-PreconfigCommPool-r12 {	1 entry	SL-PreconfigCommPoolList4-r12	
SL-PreconfigCommPool-r12 SEQUENCE {		-- This IE is same as SL-CommResourceP	

		ool with rxParametersNCelI absent	
sc-CP-Len-r12	normal	SL-CP-Len-r12	
sc-Period-r12	sf40	SL-PeriodComm-r12	
sc-TF-ResourceConfig-r12 SEQUENCE {		SL-TF-ResourceConfig-r12	
prb-Num-r12	13		BW5
	25		BW10
prb-Start-r12	0		
prb-End-r12	24		BW5
	49		BW10
offsetIndicator-r12	0	SL-OffsetIndicator-r12	
subframeBitmap-r12	00011000 00000000 00000000 00000000 00000000	bs40-r12	SLCONF1
	00000110 00000000 00000000 00000000 00000000		SLCONF2
}			
sc-TxParameters-r12	0	INTEGER (-126..31)	
data-CP-Len-r12	Normal	SL-CP-Len-r12	
data-TF-ResourceConfig-r12 SEQUENCE {		SL-TF-ResourceConfig-r12	
prb-Num-r12	13		BW5
	25		BW10
prb-Start-r12	0		
prb-End-r12	24		BW5
	49		BW10
offsetIndicator-r12	0	SL-OffsetIndicator-r12	
subframeBitmap-r12	00000000 11111111 11111111 00000000 00000000	bs40-r12	SLCONF1
	00000000 00000000 00000000 11111111 11111111		SLCONF2
}			
dataHoppingConfig-r12 SEQUENCE {		SL-HoppingConfigComm-r12	
hoppingParameter-r12	0	INTEGER (0..504),	
numSubbands-r12	ns1	ENUMERATED {ns1, ns2, ns4}	
rb-Offset-r12	0	INTEGER (0..110)	
}			
dataTxParameters-r12	0	INTEGER (-126..31)	
trpt-Subset-r12	010		
}			
}			
}			

Condition	Explanation
BW5	when sl-bandwidth-r12 is set to 5 MHz
BW10	when sl-bandwidth-r12 is set to 10 MHz
SLCONF1	SideLink Configuration 1
SLCONF2	SideLink Configuration 2 (a limited number of Radio Parameters which differ to those in SLCONF1 are provided to allow means for easily recognisable different UE transmissions when UE respects them).

6.8.2 Reference configuration for V2X Sidelink Communication

ROHC compression is not applied in the signalling test cases simulating in coverage and out-of-coverage scenarios.

Ciphering is not configured on SLRB.

6.8.2.1 V2X Sidelink Communication *Preconfiguration* for out-of-network coverage operation

The V2X Sidelink communication preconfigurations for single V2X component carrier or V2X intra-band contiguous multi-carrier are defined in Table 4.10.1.1-1 and Table 4.10.1.1-2 respectively.

7 Test environment for RRM tests

This section contains all the exceptions of the common test parameters specified in clause 4 for specific needs of test cases defined in TS 36.521-3 [34], TS 34.121-1 [50] and TS 34.122 [51]. Exceptions specified in clause 7 overwrite the parameter settings of clause 4; exceptions defined within the test cases overwrite parameter settings of clause 4 and 7.

This clause describes UE test states which can be used in the initial condition for TS 36.521-3 [34], TS 34.121-1 [50] and TS 34.122 [51].

7.1 Requirements of *test* equipment

<void>

7.2 RRM Reference system configurations

7.2.1 Common parameters for simulated E-UTRA cells

7.2.1.1 Combinations of system information blocks

<void>

7.2.1.2 Scheduling of system information blocks

<void>

7.2.1.3 Common contents of system information messages

- SystemInformationBlockType2

As defined in Table 4.4.3.3-1 with the following exceptions:

Table 7.2.1.3-1: SystemInformationBlockType2 exceptions

Derivation Path: Clause 4.4.3.3, Table 4.4.3.3-1 SystemInformationBlockType2			
Information Element	Value/remark	Comment	Condition
mbsfn-SubframeConfigList SEQUENCE	Not Present	MBSFN not applicable for eMTC RRM Test cases	CEmodeA, CEmodeB
mbsfn-SubframeConfigList ::= SEQUENCE (SIZE (1..maxMBSFN-Allocations)) OF SEQUENCE {			FDD
radioframeAllocationPeriod	n1	Every radio frame is with MBSFN subframe	
radioframeAllocationOffset	0		
subframeAllocation CHOICE {			
oneFrame	'111111'B	Subframe 1, 2, 3, 6, 7, 8 is used for MBSFN	
}			
}			

Condition	Explanation
FDD	FDD cell environment
CEmodeA	CE mode A test environment
CEmodeB	CE mode B test environment

- SystemInformationBlockType3

As defined in Table 4.4.3.3-2 with the following exceptions:

Table 7.2.1.3-2: SystemInformationBlockType3 exceptions

Derivation Path: Clause 4.4.3.3, Table 4.4.3.3-2 SystemInformationBlockType3			
Information Element	Value/remark	Comment	Condition
neighCellConfig	'10'B (The MBSFN subframe allocations of all neighbour cells are identical to or subsets of that in the serving cell)		FDD with E-UTRA FDD neighbour cell
	'01'B (No MBSFN subframes are present in all neighbor cells)		CEmodeA, CEmodeB

Condition	Explanation
FDD with E-UTRA FDD neighbour cell	FDD cell environment with a E-UTRA FDD neighbour cell
CEmodeA	CE mode A test environment
CEmodeB	CE mode B test environment

- SystemInformationBlockType5

As defined in Table 4.4.3.3-3 with the following exceptions:

Table 7.2.1.3-3: SystemInformationBlockType5 exceptions

Derivation Path: Clause 4.4.3.3, Table 4.4.3.3-4 SystemInformationBlockType5			
Information Element	Value/remark	Comment	Condition
neighCellConfig[n]	'10'B (The MBSFN subframe allocations of all neighbour cells are identical to or subsets of that in the serving cell)		FDD with E-UTRA FDD neighbour cell
	'11'B (Different UL/DL allocation in neighbouring cells for TDD compared to the serving cell)		FDD with E-UTRA TDD neighbour cell, TDD with E-UTRA FDD neighbour cell
	'01'B (No MBSFN sub frames are present in all neighbor cells)		CEmodeA, CEmodeB

Condition	Explanation
FDD with E-UTRA FDD neighbour cell	FDD cell environment with a E-UTRA FDD neighbour cell
FDD with E-UTRA TDD neighbour cell	FDD cell environment with a E-UTRA TDD neighbour cell
TDD with E-UTRA FDD neighbour cell	TDD cell environment with a E-UTRA FDD neighbour cell
CEmodeA	CE mode A test environment
CEmodeB	CE mode B test environment

- SystemInformationBlockType7

As defined in Table 4.4.3.3-6 with the following exceptions:

Table 7.2.1.3-4: SystemInformationBlockType7 exceptions

Derivation Path: Clause 4.4.3.3, Table 4.4.3.3-6 SystemInformationBlockType7			
Information Element	Value/remark	Comment	Condition
commonInfo SEQUENCE {			
p-MaxGERAN	33 (33 dBm)		GSM 400 & GSM 900 & GSM 850 & GSM 700
	30 (30 dBm)		DCS 1800 & PCS 1900
}			

7.2.2 Common parameters for simulated GERAN cells

7.2.2.1 Mapping of GERAN cells

Unless otherwise stated, GERAN cells take the default values defined in Table 7.2.2.1-1.

Table 7.2.2.1-1: Mapping of GERAN cells with TS 51.010-1 [25]

GERAN cell	Frequency	GERAN cell in TS 51.010-1, clause 40
Cell 24	f11	Cell A
Cell 25	f12	Cell D
Cell 26	f13	Cell B

7.2A Generic RRM procedures

7.2A.1 UE RRM test states

Table 7.2A.1-1: The E-UTRAN UE states

		RRC	ECM	EMM	ESM	UE Test Mode
State 2A-RF	Registered, Idle Mode, UE Test Mode Activated	Refer to Table 5.2A.1-1	Refer to Table 5.2A.1-1	Refer to Table 5.2A.1-1	Refer to Table 5.2A.1-1	Refer to Table 5.2A.1-1
State 2A-RF-CE	Registered, Idle Mode, Cell supporting BL/CE UE, UE Test Mode Activated	Refer to Table 5.2A.1-1AA	Refer to Table 5.2A.1-1AA	Refer to Table 5.2A.1-1AA	Refer to Table 5.2A.1-1AA	Refer to Table 5.2A.1-1AA
State 3A-RF	Generic Default RB Established, UE Test Mode Activated	Refer to Table 5.2A.1-1	Refer to Table 5.2A.1-1	Refer to Table 5.2A.1-1	Refer to Table 5.2A.1-1	Refer to Table 5.2A.1-1
State 3A-RF-CE	Generic Default RB Established, Cell supporting BL/CE UE, UE Test Mode Activated	Refer to Table 5.2A.2AA	Refer to Table 5.2A.2AA	Refer to Table 5.2A.2AA	Refer to Table 5.2A.2AA	Refer to Table 5.2A.2AA
State 3A-RF-DC1	DC MCG/SCG Dedicated RB established, UE Test Mode Activated	Refer to Table 5.2A.1-1	Refer to Table 5.2A.1-1	Refer to Table 5.2A.1-1	Refer to Table 5.2A.1-1	Refer to Table 5.2A.1-1
State 3A-RF-DC2	DC Split Default RB established, UE Test Mode Activated	Refer to Table 5.2A.1-1	Refer to Table 5.2A.1-1	Refer to Table 5.2A.1-1	Refer to Table 5.2A.1-1	Refer to Table 5.2A.1-1
State 3B-RF	Generic Default RB Established, UE Test Mode Activated, pre-registered on HRPD	RRC_CONNECTED 1 data radio bearer configured	ECM-CONNECTED	EMM-REGISTERED	1 default EPS bearer context active	Active

7.2A.2 UE Registration, UE Test Mode Activated (State 2A-RF)

As described in clause 5.2A.1A.

7.2A.2A UE Registration, UE Test Mode Activated in cell supporting BL/CE UE (State 2A-RF-CE)

As described in clause 5.2A.1AA.

7.2A.3 Generic Default Radio Bearer Establishment, UE Test Mode Activated (State 3A-RF)

As described in clause 5.2A.2.

7.2A.3A DC MCG/SCG Dedicated RB established, UE Test Mode Activated (State 3A-RF-DC1)

As described in clause 5.2A.2A.

7.2A.3AA Generic Default Radio Bearer Establishment, UE Test Mode Activated in cell supporting BL/CE UE (State 3A-RF-CE)

As described in clause 5.2A.2AA.

7.2A.3B DC Split Default RB established, UE Test Mode Activated (State 3A-RF-DC2)

As described in clause 5.2A.2B.

7.2A.3C Generic Default Radio Bearer Establishment, UE Test Mode Activated, V2X Setup (State 3A-RF-V2X)

As described in clause 5.2A.2C.

7.2A.4 Generic Default Radio Bearer Establishment, UE Test Mode Activated, pre-registration on HRPD (State 3B-RF)

Editor's note: This section is incomplete. The following aspects are either missing or not yet determined: Other than UATI Request message and UATI Assignment message are FFS

7.2A.4.1 Initial conditions

System Simulator:

- Cell 1
- Cell 1 is transmitting SystemInformationBlockType8

User Equipment:

- The Test USIM shall be inserted.

7.2A.4.2 Definition of system information messages

As described in clause 4.5.2B.2.

7.2A.4.3 Procedure

Table 7.2A.4.3-1: UE registration with default EPS bearer establishment, test mode activation and HRPD pre-registration procedures (state 1 to state 3B-RF)

Step	Procedure	Message Sequence	
		U - S	Message
1 to 18	Steps 1 to 18 as specified in the procedure in clause 5.2A.1A.3 take place.	-	-
19 to 36	Same procedure for steps 17 to 30D as specified in the procedure in clause 4.5.2B.3.		

7.2A.4.4 Specific message contents

As described in clauses 4.5.2B.4 and 7.2A.2.

7.2A.5 Procedure to configure SCC

As described in clause 5.2A.4.

7.2A.6 Exceptions for feICIC tests

As described in clause 5.2A.5.

7.2B Other generic RRM procedures

7.2B.1 Tracking area updating procedure

The procedure is defined in table 7.2B.1-1.

Table 7.2B.1-1: Tracking area updating procedure

Step	Procedure	Message Sequence	
		U - S	Message
1	The SS transmits system information on the cell specified in the test case.	<--	RRC: SYSTEM INFORMATION (BCCH, BCCH-BR) Note 5.
-	EXCEPTION: If all EPS bearer contexts are inactive in UE, for Rel-8 and Rel-9, steps 2 to 8a are optional and depend on UE implementation. If all EPS bearer contexts are inactive in UE, a Rel-10 or higher UE directly starts attach procedure from step 9a.	-	-
2	The UE transmits an <i>RRCConnectionRequest</i> message on the cell specified in the test case.	-->	RRC: <i>RRCConnectionRequest</i>
3	The SS transmits an <i>RRCConnectionSetup</i> message.	<--	RRC: <i>RRCConnectionSetup</i>
4	The UE transmits an <i>RRCConnectionSetupComplete</i> message to confirm the successful completion of the connection establishment and a TRACKING AREA UPDATE REQUEST message is sent to update the registration of the actual tracking area.	-->	RRC: <i>RRCConnectionSetupComplete</i> NAS: TRACKING AREA UPDATE REQUEST
-	EXCEPTION: If all EPS bearer contexts are marked as inactive in the EPS bearer context status IE included in the TRACKING AREA UPDATE REQUEST message then, events described in steps 5a to 26a. Otherwise, events described in steps 5 to 7.	-	-
5	The SS responds with TRACKING AREA UPDATE ACCEPT message.	<--	RRC: <i>DLInformationTransfer</i> NAS: TRACKING AREA UPDATE ACCEPT
6	The UE transmits a TRACKING AREA UPDATE COMPLETE	-->	RRC: <i>ULInformationTransfer</i> NAS: TRACKING AREA UPDATE COMPLETE
7	The SS transmits an <i>RRCConnectionRelease</i> message to release RRC connection and move to RRC_IDLE.	<--	RRC: <i>RRCConnectionRelease</i>
5a	The SS responds with TRACKING AREA UPDATE REJECT message with cause #40 (No EPS bearer context activated) to force attach the UE.	<--	RRC: <i>DLInformationTransfer</i> NAS: TRACKING AREA UPDATE REJECT
6a	EXCEPTION: Step 7a describes the behaviour that depends on UE behaviour (Note 3).	-	-
7a	The SS transmits an <i>RRCConnectionRelease</i> message to release RRC connection and move to RRC_IDLE.	<--	RRC: <i>RRCConnectionRelease</i>
-	EXCEPTION: Step 8a describes a behaviour which depends on the UE capability	-	-
8a	IF NOT <i>pc_Auto_PDN_Connectivity</i> , the user initiates an attach by MMI or by AT command (NOTE 4).	-	-
9a to 27a	Steps 2 to 20 of the generic UE Registration procedure (5.2A.1A.3) take place to complete the Attach procedure	-	-
<p>NOTE 1: The periodic tracking area updating timer T3412 is deactivated by default during the attach procedure (TS 36.508 clause 4.7.2).</p> <p>NOTE 2: The SS does not initiate authentication and NAS SECURITY MODE COMMAND are not performed (reuse of keys allocated during the attach procedure).</p> <p>NOTE 3: The SS waits for 1.5 second to receive the Attach Request on the existing RRC Connection. In case Attach Request is not received within 1.5 second, existing RRC Connection is released.</p> <p>NOTE 4: The request is assumed to be triggered by AT command AT+CGDCONT=1,"IP" followed by AT+CGACT=1.</p> <p>NOTE 5: For BL UE testing and for non-BL UE enhanced coverage testing the SS shall broadcast SystemInformation-BR-r13, SystemInformationBlockType1-BR-r13 and other relevant system information blocks as required by the specified combinations of system information blocks</p>			

specified for the test case on BCCH-BR. For non-BL UE normal coverage testing the SS may exclude broadcasting of system information on BCCH-BR.

Specific message contents

Table 7.2B.1-1a: MasterInformationBlock (Step 1 and following steps)

Derivation Path: 36.508 Table 4.4.3.2-1 using condition CEmodeB if the test case specifically tests CE mode B else use condition CEmodeA.

Table 7.2B.1-1a1: SystemInformation-BR-r13 (Step 1 and following steps)

Derivation Path: 36.508 Table 4.4.3.2-2A.

Table 7.2B.1-1a2: SystemInformationBlockType1-BR-r13 (Step 1 and following steps)

Derivation Path: 36.508 Table 4.4.3.2-3A.

Table 7.2B.1-2: TRACKING AREA UPDATE ACCEPT (Step 5)

Derivation Path: 36.508 Table 4.7.2-24			
Information Element	Value/remark	Comment	Condition
EPS network feature support	'0000 0000'B	IMS voice over PS session in S1 mode not supported	
Additional update result	Not present		

7.3 Default RRC message and information elements contents

7.3.1 Contents of RRC messages

FFS.

7.3.2 Radio resource control information elements

Editor's note: Unless otherwise stated in the test parameters or messages exceptions in the respective test cases in TS 36.521-3 [34], PRACH configuration index and exceptional message as specified in Table 7.3.2-1 is used.

As defined in clause 4.6.3 with the following exceptions:

Table 7.3.2-1: PRACH-Config-DEFAULT

Derivation Path: Clause 4.6.3 Table 4.6.3-7			
Information Element	Value/remark	Comment	Condition
PRACH-Config-DEFAULT ::= SEQUENCE {			
prach-ConfigIndex	3		TDD
}			

Condition	Explanation
TDD	TDD cell environment

Table 7.3.2-2: RadioResourceConfigCommonSCell-r10-DEFAULT

Derivation Path: Clause 4.6.3 Table 4.6.3-13A			
Information Element	Value/remark	Comment	Condition
RadioResourceConfigCommonSCell-r10 ::= SEQUENCE {			
mbsfn-SubframeConfigList-r10 SEQUENCE (SIZE (1..maxMBSFN-Allocations)) OF SEQUENCE {			FDD
radioframeAllocationPeriod	n1	Every radio frame is with MBSFN subframe	
radioframeAllocationOffset	0		
subframeAllocation CHOICE {			
oneFrame	'111111'B	Subframe 1, 2, 3, 6, 7, 8 is used for MBSFN	
}			
}			
ul-Configuration-r10	Not Present		
}			

Condition	Explanation
FDD	FDD cell environment

Table 7.3.2-3: PhysicalConfigDedicatedSCell-r10-DEFAULT

Derivation Path: Clause 4.6.3 Table 4.6.3-6A			
Information Element	Value/remark	Comment	Condition
PhysicalConfigDedicatedSCell-r10 ::= SEQUENCE {			
ul-Configuration-r10	Not Present		
}			

7.3.3 Measurement information elements

As defined in clause 4.6.6 with the following exceptions:

Table 7.3.3-0: MeasDS-Config-DEFAULT

Derivation Path: clause 4.6.6 Table 4.6.6-1B			
Information Element	Value/remark	Comment	Condition
MeasDS-Config-DEFAULT ::= CHOICE {			
release	NULL		
setup SEQUENCE {			
dmtc-PeriodOffset-r12 CHOICE {			
ms40-r12	10		LAA_Meas Proc
ms40-r12	0		LAA_Meas Perf
}			
}			
}			

Condition	Explanation
LAA_MeasProc	Used for LAA measurements procedures test cases
LAA_MeasPerf	Used for LAA measurement performance test cases

Table 7.3.3-1: MeasObjectEUTRA-GENERIC (Freq)

Derivation Path: Clause 4.6.6, Table 4.6.6-2			
Information Element	Value/remark	Comment	Condition
neighCellConfig	10'B (The MBSFN subframe allocations of all neighbour cells are identical to or subsets of that in the serving cell)		FDD with E-UTRA FDD neighbour cell
	'11'B (Different UL/DL allocation in neighbouring cells for TDD compared to the serving cell)		FDD with E-UTRA TDD neighbour cell, TDD with E-UTRA FDD neighbour cell
	'01'B (No MBSFN sub frames are present in all neighbor cells)		CEmodeA, CEmodeB

Condition	Explanation
FDD with E-UTRA FDD neighbour cell	FDD cell environment with a E-UTRA FDD neighbour cell
FDD with E-UTRA TDD neighbour cell	FDD cell environment with a E-UTRA TDD neighbour cell
TDD with E-UTRA FDD neighbour cell	TDD cell environment with a E-UTRA FDD neighbour cell
CEmodeA	CE mode A test environment
CEmodeB	CE mode B test environment

7.3A Default UTRA message and information element contents

7.3A.1 UTRA RRC messages

As defined in 4.7B with the following exceptions:

Contents of RRC CONNECTION SETUP message: UM

Information Element	Condition	Value/remark	Version	Index
- System specific capability update requirement list		1 entry		RCSU-019
- System specific capability update requirement		GSM		RCSU-019a
CHOICE <i>specification mode</i>		Complete specification	Rel-5	RCSU-020
- Complete specification			Rel-5	RCSU-021

7.4 Default NAS message and information elements contents

7.5 Reference radio bearer configurations

7.5.1 SRB and DRB parameters

7.5.1.1 MAC configurations

As defined in clause 4.8.2.1.5 with the following exceptions:

Table 7.5.1.1-1: MAC-MainConfig-RBC

Derivation Path: Clause 4.8.2.1.5 Table 4.8.2.1.5-1			
Information Element	Value/remark	Comment	Condition
MAC-MainConfig-RBC ::= SEQUENCE {			
mac-MainConfig-v1020SEQUENCE {			SCell_AddMod
sCellDeactivationTimer-r10	Not present		
extendedBSR-Sizes-r10	Not Present		
extendedPHR-r10	Not Present		
}	Setup		UL CA
}			

Condition	Explanation
SCell_AddMod	Addition or modification of SCell
UL CA	This condition is used for UL CA.

8 NB-IoT test environment

8.1 NB-IoT Common test environment

8.1.1 NB-IoT Environmental conditions

Same environmental conditions as the ones described in section 4.1 apply to NB-IoT UEs.

8.1.2 NB-IoT Common requirements of test equipment

Same common requirements of test equipment as the ones described in section 4.2 apply to NB-IoT with the following exceptions:

- Only FDD Mode is required for Rel-13 NB-IoT
- Supported physical channels for NB-IoT are:

Physical channel	Minimum number	Comments
NPBCH	1	Narrowband Physical Broadcast Channel
NPDCCH	1	The Narrowband Physical Downlink Control channel carries control information.
NPDSCH	1	Narrowband Physical Downlink Shared Channel
NPUSCH	1	Narrowband Physical Uplink Shared Channel
NPRACH	1	Narrowband Physical Random Access Channel

- Supported physical signals for NB-IoT are:

Physical signal	Minimum number	Comments
Narrowband Reference Signal	NA	DL
Narrowband Primary Synchronization Signal	NA	DL
Narrowband Secondary Synchronization Signal	NA	DL
Demodulation Reference Signal	NA	UL

8.1.3 NB-IoT Reference test conditions

This clause contains the reference test conditions, which apply to all NB-IoT test cases unless otherwise specified.

8.1.3.1 NB-IoT Test frequencies

NB-IoT is designed to operate in the E-UTRA operating bands 1, 2, 3, 4, 5, 8, 11, 12, 13, 14, 17, 18, 19, 20, 21, 25, 26, 28, 31, 66, 70, 71, 72, 73, 74 and 85 which are defined in Table 5.5-1 in [21]. NB-IoT system operates in HD-FDD duplex mode.

The test frequencies are based on the E-UTRA frequency bands defined in the core specifications.

The raster spacing is 100 KHz.

E-UTRA/FDD is designed to operate in paired bands of 3GPP TS 36.101 [27]. The reference test frequencies for the RF and Signalling test environment for each of the operating bands are defined in sub clause 8.1.3.1.1.

8.1.3.1.1 NB-IoT FDD Mode Test frequencies

8.1.3.1.1.1 NB-IoT FDD reference test frequencies for operating band 1

Table 8.1.3.1.1.1-1: NB-IoT standalone Test frequencies for operating band 1

Test Frequency ID	N _{UL}	M _{UL}	Frequency of Uplink [MHz]	N _{DL}	M _{DL}	Frequency of Downlink [MHz]
Low Range	18001	0	1920.1	1	-0.5	2110.1
Mid Range	18300	0	1950.0	300	-0.5	2140.0
High Range	18599	0	1979.9	599	-0.5	2169.9

NOTE 1: Applicable to either 3.75 kHz or 15 kHz NB-IoT UL subcarrier spacing

Table 8.1.3.1.1.1-2: NB-IoT in-band Test frequencies for operating band 1

Test Frequency ID	N _{UL}	M _{UL}	Frequency of Uplink [MHz]	N _{DL}	M _{DL}	Frequency of Downlink [MHz]
Low Range ¹	18007	0	1920.7000	7	-2	2110.6925
Low Range ²	18060	-2	1925.9900	60	-1	2115.9975
Low Range ³	18069	-2	1926.8900	69	-1	2116.8975
Mid Range ¹	18291	0	1949.1000	291	-2	2139.0925
Mid Range ²	18310	-2	1950.9900	310	-1	2140.9975
Mid Range ³	18319	-2	1951.8900	319	-1	2141.8975
High Range ¹	18593	0	1979.3000	593	1	2169.3075
High Range ²	18560	-2	1975.9900	560	-1	2165.9975
High Range ³	18569	-2	1976.8900	569	-1	2166.8975

NOTE 1: Related to LTE channel BW 5 MHz
NOTE 2: Related to LTE channel BW 10 MHz and NB-IoT PRB 30
NOTE 3: Related to LTE channel BW 10 MHz and NB-IoT PRB 35
NOTE 4: Defined for NB-IoT UL subcarrier spacing 15 kHz. Also applicable for 3.75 kHz UL sub-carrier spacing

Table 8.1.3.1.1.1-3: NB-IoT guard-band Test frequencies for operating band 1

Test Frequency ID	LTE Cell Bandwidth [MHz]	N _{UL}	M _{UL}	Frequency of Uplink [MHz]	N _{DL}	M _{DL}	Frequency of Downlink [MHz]
Low Range	Any	18001	0	1920.1000	1	1	2110.1075
Mid Range	5	18276	0	1947.6000	276	1	2137.6075
	10	18346	0	1954.5900	346	1	2144.5975
High Range	Any	18599	0	1979.9000	599	-2	2169.8925

NOTE 1: Void
NOTE 2: Defined for NB-IoT UL subcarrier spacing 15 kHz. Also applicable for 3.75 kHz UL sub-carrier spacing

8.1.3.1.1.2 NB-IoT FDD reference test frequencies for operating band 2

Table 8.1.3.1.1.2-1: NB-IoT standalone Test frequencies for operating band 2

Test Frequency ID	N _{UL}	M _{UL}	Frequency of Uplink [MHz]	N _{DL}	M _{DL}	Frequency of Downlink [MHz]
Low Range	18601	0	1850.1	601	-0.5	1930.1
Mid Range	18900	0	1880.0	900	-0.5	1960.0
High Range	19199	0	1909.9	1199	-0.5	1989.9

NOTE 1: Applicable to either 3.75 kHz or 15 kHz NB-IoT UL subcarrier spacing

Table 8.1.3.1.1.2-2: NB-IoT in-band Test frequencies for operating band 2

Test Frequency ID	N _{UL}	M _{UL}	Frequency of Uplink [MHz]	N _{DL}	M _{DL}	Frequency of Downlink [MHz]
Low Range ¹	18606	0	1850.6000	606	-2	1930.5925
Low Range ²	18660	-2	1855.9900	660	-1	1935.9975
Low Range ³	18669	-2	1856.8900	669	-1	1936.8975
Mid Range ¹	18891	0	1879.1000	891	-2	1959.0925
Mid Range ²	18910	-2	1880.9900	910	-1	1960.9975
Mid Range ³	18919	-2	1881.8900	919	-1	1961.8975
High Range ¹	19194	0	1909.4000	1194	1	1989.4075
High Range ²	19160	-2	1905.9900	1160	-1	1985.9975
High Range ³	19169	-2	1906.8900	1169	-1	1986.8975

NOTE 1: Related to LTE channel BW 3 MHz
NOTE 2: Related to LTE channel BW 10 MHz and NB-IoT PRB 30
NOTE 3: Related to LTE channel BW 10 MHz and NB-IoT PRB 35
NOTE 4: Defined for NB-IoT UL subcarrier spacing 15 kHz. Also applicable for 3.75 kHz UL sub-carrier spacing

Table 8.1.3.1.1.2-3: NB-IoT guard-band Test frequencies for operating band 2

Test Frequency ID	LTE Cell Bandwidth [MHz]	N _{UL}	M _{UL}	Frequency of Uplink [MHz]	N _{DL}	M _{DL}	Frequency of Downlink [MHz]
Low Range	Any	18601	0	1850.1000	601	1	1930.1075
Mid Range	5	18876	0	1877.6000	876	1	1957.6075
	10	18946	0	1884.5900	946	1	1964.5975
High Range	Any	19199	0	1909.9000	1199	-2	1989.8925

NOTE 1: Void
NOTE 2: Defined for NB-IoT UL subcarrier spacing 15 kHz. Also applicable for 3.75 kHz UL sub-carrier spacing

8.1.3.1.1.3 NB-IoT FDD reference test frequencies for operating band 3

Table 8.1.3.1.1.3-1: NB-IoT standalone Test frequencies for operating band 3

Test Frequency ID	N _{UL}	M _{UL}	Frequency of Uplink [MHz]	N _{DL}	M _{DL}	Frequency of Downlink [MHz]
Low Range	19201	0	1710.1	1201	-0.5	1805.1
Mid Range	19575	0	1747.5	1575	-0.5	1842.5
High Range	19949	0	1784.9	1949	-0.5	1879.9

NOTE 1: Applicable to either 3.75 kHz or 15 kHz NB-IoT UL subcarrier spacing

Table 8.1.3.1.1.3-2: NB-IoT in-band Test frequencies for operating band 3

Test Frequency ID	N _{UL}	M _{UL}	Frequency of Uplink [MHz]	N _{DL}	M _{DL}	Frequency of Downlink [MHz]
Low Range ¹	19206	0	1710.6000	1206	-2	1805.5925
Low Range ²	19260	-2	1715.9900	1260	-1	1810.9975
Low Range ³	19269	-2	1716.8900	1269	-1	1811.8975
Mid Range ¹	19566	0	1746.6000	1566	-2	1841.5925
Mid Range ²	19585	-2	1748.4900	1585	-1	1843.4975
Mid Range ³	19594	-2	1749.3900	1594	-1	1844.3975
High Range ¹	19944	0	1784.4000	1944	1	1879.4075
High Range ²	19910	-2	1780.9900	1910	-1	1875.9975
High Range ³	19919	-2	1781.8900	1919	-1	1876.8975

NOTE 1: Related to LTE channel BW 3 MHz
NOTE 2: Related to LTE channel BW 10 MHz and NB-IoT PRB 30
NOTE 3: Related to LTE channel BW 10 MHz and NB-IoT PRB 35
NOTE 4: Defined for NB-IoT UL subcarrier spacing 15 kHz. Also applicable for 3.75 kHz UL sub-carrier spacing

Table 8.1.3.1.1.3-3: NB-IoT guard-band Test frequencies for operating band 3

Test Frequency ID	LTE Cell Bandwidth [MHz]	N _{UL}	M _{UL}	Frequency of Uplink [MHz]	N _{DL}	M _{DL}	Frequency of Downlink [MHz]
Low Range	Any	19201	0	1710.1000	1201	1	1805.1075
Mid Range	5	19551	0	1745.1000	1551	1	1840.1075
	10	19621	0	1752.0900	1621	1	1847.0975
High Range	Any	19949	0	1784.9000	1949	-2	1879.8925

NOTE 1: Void
NOTE 2: Defined for NB-IoT UL subcarrier spacing 15 kHz. Also applicable for 3.75 kHz UL sub-carrier spacing

8.1.3.1.1.4 NB-IoT FDD reference test frequencies for operating band 4

Table 8.1.3.1.1.4-1: NB-IoT standalone Test frequencies for operating band 4

Test Frequency ID	N _{UL}	M _{UL}	Frequency of Uplink [MHz]	N _{DL}	M _{DL}	Frequency of Downlink [MHz]
Low Range	19951	0	1710.1	1951	-0.5	2110.1
Mid Range	20175	0	1732.5	2175	-0.5	2132.5
High Range	20399	0	1754.9	2399	-0.5	2154.9

NOTE 1: Applicable to either 3.75 kHz or 15 kHz NB-IoT UL subcarrier spacing

Table 8.1.3.1.1.4-2: NB-IoT in-band Test frequencies for operating band 4

Test Frequency ID	N _{UL}	M _{UL}	Frequency of Uplink [MHz]	N _{DL}	M _{DL}	Frequency of Downlink [MHz]
Low Range ¹	19957	0	1710.7000	1957	-2	2110.6925
Low Range ²	20010	-2	1715.9900	2010	-1	2115.9975
Low Range ³	20019	-2	1716.8900	2019	-1	2116.8975
Mid Range ¹	20166	0	1731.6000	2166	-2	2131.5925
Mid Range ²	20185	-2	1733.4900	2185	-1	2133.4975
Mid Range ³	20194	-2	1734.3900	2194	-1	2134.3975
High Range ¹	20393	0	1754.3000	2393	1	2154.3075
High Range ²	20360	-2	1750.9900	2360	-1	2150.9975
High Range ³	20369	-2	1751.8900	2369	-1	2151.8975

NOTE 1: Related to LTE channel BW 3 MHz
NOTE 2: Related to LTE channel BW 10 MHz and NB-IoT PRB 30
NOTE 3: Related to LTE channel BW 10 MHz and NB-IoT PRB 35
NOTE 4: Defined for NB-IoT UL subcarrier spacing 15 kHz. Also applicable for 3.75 kHz UL sub-carrier spacing

Table 8.1.3.1.1.4-3: NB-IoT guard-band Test frequencies for operating band 4

Test Frequency ID	LTE Cell Bandwidth [MHz]	N _{UL}	M _{UL}	Frequency of Uplink [MHz]	N _{DL}	M _{DL}	Frequency of Downlink [MHz]
Low Range	Any	19951	0	1710.1000	1951	1	2110.1075
Mid Range	5	20151	0	1730.1000	2151	1	2130.1075
	10	20221	0	1737.0900	2221	1	2137.0975
High Range	Any	20399	0	1754.9000	2399	-2	2154.8925

NOTE 1: Void
NOTE 2: Defined for NB-IoT UL subcarrier spacing 15 kHz. Also applicable for 3.75 kHz UL sub-carrier spacing

8.1.3.1.1.5 NB-LoT FDD reference test frequencies for operating band 5

Table 8.1.3.1.1.5-1: NB-LoT standalone Test frequencies for operating band 5

Test Frequency ID	N _{UL}	M _{UL}	Frequency of Uplink [MHz]	N _{DL}	M _{DL}	Frequency of Downlink [MHz]
Low Range	20401	0	824.1	2401	-0.5	869.1
Mid Range	20525	0	836.5	2525	-0.5	881.5
High Range	20649	0	848.9	2649	-0.5	893.9

NOTE 1: Applicable to either 3.75 kHz or 15 kHz NB-LoT UL subcarrier spacing

Table 8.1.3.1.1.5-2: NB-LoT in-band Test frequencies for operating band 5

Test Frequency ID	N _{UL}	M _{UL}	Frequency of Uplink [MHz]	N _{DL}	M _{DL}	Frequency of Downlink [MHz]
Low Range ¹	20406	0	824.6000	2406	-2	869.5925
Low Range ²	20460	-2	829.9900	2460	-1	874.9975
Low Range ³	20469	-2	830.8900	2469	-1	875.8975
Mid Range ¹	20516	0	835.6000	2516	-2	880.5925
Mid Range ²	20535	-2	837.4900	2535	-1	882.4975
Mid Range ³	20544	-2	838.3900	2544	-1	883.3975
High Range ¹	20644	0	848.4000	2644	1	893.4075
High Range ²	20610	-2	844.9900	2610	-1	889.9975
High Range ³	20619	-2	845.8900	2619	-1	890.8975

NOTE 1: Related to LTE channel BW 3 MHz
NOTE 2: Related to LTE channel BW 10 MHz and NB-LoT PRB 30
NOTE 3: Related to LTE channel BW 10 MHz and NB-LoT PRB 35
NOTE 4: Applicable to either 3.75 kHz or 15 kHz UL sub-carrier spacing

Table 8.1.3.1.1.5-3: NB-LoT guard-band Test frequencies for operating band 5

Test Frequency ID	LTE Cell Bandwidth [MHz]	N _{UL}	M _{UL}	Frequency of Uplink [MHz]	N _{DL}	M _{DL}	Frequency of Downlink [MHz]
Low Range	Any	20401	0	824.1000	2401	1	869.1075
Mid Range	5	20501	0	834.1000	2501	1	879.1075
	10	20571	0	841.0900	2571	1	886.0975
High Range	Any	20649	0	848.9000	2649	-2	893.8925

NOTE 1: Void
NOTE 2: Applicable to either 3.75 kHz or 15 kHz UL sub-carrier spacing

8.1.3.1.1.6 to 8.1.3.1.1.7 Void

8.1.3.1.1.8 NB-LoT FDD reference test frequencies for operating band 8

Table 8.1.3.1.1.8-1: NB-LoT standalone Test frequencies for operating band 8

Test Frequency ID	N _{UL}	M _{UL}	Frequency of Uplink [MHz]	N _{DL}	M _{DL}	Frequency of Downlink [MHz]
Low Range	21451	0	880.1	3451	-0.5	925.1
Mid Range	21625	0	897.5	3625	-0.5	942.5
High Range	21799	0	914.9	3799	-0.5	959.9

NOTE 1: Applicable to either 3.75 kHz or 15 kHz NB-LoT UL subcarrier spacing

Table 8.1.3.1.1.8-2: NB-IoT in-band Test frequencies for operating band 8

Test Frequency ID	N _{UL}	M _{UL}	Frequency of Uplink [MHz]	N _{DL}	M _{DL}	Frequency of Downlink [MHz]
Low Range ¹	21456	0	880.6000	3456	-2	925.5925
Low Range ²	21510	-2	885.9900	3510	-1	930.9975
Low Range ³	21519	-2	886.8900	3519	-1	931.8975
Mid Range	21616	0	896.6000	3616	-2	941.5925
Mid Range ²	21635	-2	898.4900	3635	-1	943.4975
Mid Range ³	21644	-2	899.3900	3644	-1	944.3975
High Range	21794	0	914.4000	3794	1	959.4075
High Range ²	21760	-2	910.9900	3760	-1	955.9975
High Range ³	21769	-2	911.8900	3769	-1	956.8975

NOTE 1: Related to LTE channel BW 3 MHz
NOTE 2: Related to LTE channel BW 10 MHz and NB-IoT PRB 30
NOTE 3: Related to LTE channel BW 10 MHz and NB-IoT PRB 35
NOTE 4: Applicable to either 3.75 kHz or 15 kHz UL sub-carrier spacing

Table 8.1.3.1.1.8-3: NB-IoT guard-band Test frequencies for operating band 8

Test Frequency ID	LTE Cell Bandwidth [MHz]	N _{UL}	M _{UL}	Frequency of Uplink [MHz]	N _{DL}	M _{DL}	Frequency of Downlink [MHz]
Low Range	Any	21451	0	880.1000	3451	1	925.1075
Mid Range	5	21601	0	895.1000	3601	1	940.1075
	10	21671	0	902.0900	3671	1	947.0975
High Range	Any	21799	0	914.9000	3799	-2	959.8925

NOTE 1: Void
NOTE 2: Applicable to either 3.75 kHz or 15 kHz UL sub-carrier spacing

8.1.3.1.1.9 to 8.1.3.1.1.10 Void

8.1.3.1.1.11 NB-IoT FDD reference test frequencies for operating band 11

Table 8.1.3.1.1.11-1: NB-IoT standalone Test frequencies for operating band 11

Test Frequency ID	N _{UL}	M _{UL}	Frequency of Uplink [MHz]	N _{DL}	M _{DL}	Frequency of Downlink [MHz]
Low Range	22751	0	1428.0	4751	-0.5	1476.0
Mid Range	22850	0	1437.9	4850	-0.5	1485.9
High Range	22949	0	1447.8	4949	-0.5	1495.8

NOTE 1: Applicable to either 3.75 kHz or 15 kHz NB-IoT UL subcarrier spacing

Table 8.1.3.1.1.11-2: NB-IoT in-band Test frequencies for operating band 11

Test Frequency ID	N _{UL}	M _{UL}	Frequency of Uplink [MHz]	N _{DL}	M _{DL}	Frequency of Downlink [MHz]
Low Range ¹	22757	0	1428.6000	4757	-2	1476.5925
Low Range ²	22810	-2	1433.8900	4810	-1	1481.8975
Low Range ³	22819	-2	1434.7900	4819	-1	1482.7975
Mid Range ¹	22841	0	1437.0000	4841	-2	1484.9925
Mid Range ²	22860	-2	1438.8900	4860	-1	1486.8975
Mid Range ³	22869	-2	1439.7900	4869	-1	1487.7975
High Range ¹	22943	0	1447.2000	4943	1	1495.2075
High Range ²	22910	-2	1443.8900	4910	-1	1491.8975
High Range ³	22919	-2	1444.7900	4919	-1	1492.7975

NOTE 1: Related to LTE channel BW 5 MHz
NOTE 2: Related to LTE channel BW 10 MHz and NB-IoT PRB 30
NOTE 3: Related to LTE channel BW 10 MHz and NB-IoT PRB 35
NOTE 4: Applicable to either 3.75 kHz or 15 kHz UL sub-carrier spacing

Table 8.1.3.1.1.11-3: NB-IoT guard-band Test frequencies for operating band 11

Test Frequency ID	N _{UL}	M _{UL}	Frequency of Uplink [MHz]	N _{DL}	M _{DL}	Frequency of Downlink [MHz]
Low Range	22751	0	1428.0000	4751	1	1476.0075
Mid Range	22826	0	1435.5000	4826	1	1483.5075
High Range	22949	0	1447.8000	4949	-2	1495.7925

NOTE 1: Related to LTE channel BW 5 MHz
NOTE 2: Applicable to either 3.75 kHz or 15 kHz UL sub-carrier spacing

8.1.3.1.1.12 NB-IoT FDD reference test frequencies for operating band 12

Table 8.1.3.1.1.12-1: NB-IoT standalone Test frequencies for operating band 12

Test Frequency ID	N _{UL}	M _{UL}	Frequency of Uplink [MHz]	N _{DL}	M _{DL}	Frequency of Downlink [MHz]
Low Range	23011	0	699.1	5011	-0.5	729.1
Mid Range	23095	0	707.5	5095	-0.5	737.5
High Range	23179	0	715.9	5179	-0.5	745.9

NOTE 1: Applicable to either 3.75 kHz or 15 kHz NB-IoT UL subcarrier spacing

Table 8.1.3.1.1.12-2: NB-IoT in-band Test frequencies for operating band 12

Test Frequency ID	N _{UL}	M _{UL}	Frequency of Uplink [MHz]	N _{DL}	M _{DL}	Frequency of Downlink [MHz]
Low Range ¹	23016	0	699.6000	5016	-2	729.5925
Low Range ²	23070	-2	704.9900	5070	-1	734.9975
Low Range ³	23079	-2	705.8900	5079	-1	735.8975
Mid Range ¹	23086	0	706.6000	5086	-2	736.5925
Mid Range ²	23105	-2	708.4900	5105	-1	738.4975
Mid Range ³	23114	-2	709.3900	5114	-1	739.3975
High Range ¹	23174	0	715.4000	5174	1	745.4075
High Range ²	23140	-2	711.9900	5140	-1	741.9975
High Range ³	23149	-2	712.8900	5149	-1	742.8975

NOTE 1: Related to LTE channel BW 3 MHz
NOTE 2: Related to LTE channel BW 10 MHz and NB-IoT PRB 30
NOTE 3: Related to LTE channel BW 10 MHz and NB-IoT PRB 35
NOTE 4: Applicable to either 3.75 kHz or 15 kHz UL sub-carrier spacing

Table 8.1.3.1.1.12-3: NB-IoT guard-band Test frequencies for operating band 12

Test Frequency ID	LTE Cell Bandwidth [MHz]	N _{UL}	M _{UL}	Frequency of Uplink [MHz]	N _{DL}	M _{DL}	Frequency of Downlink [MHz]
Low Range	Any	23011	0	699.1000	5011	1	729.1075
Mid Range	5	23071	0	705.1000	5071	1	735.1075
	10	23141	0	712.0900	5141	1	742.0975
High Range	Any	23179	0	715.9000	5179	-2	745.8925

NOTE 1: Void
NOTE 2: Applicable to either 3.75 kHz or 15 kHz UL sub-carrier spacing

8.1.3.1.1.13 NB-IoT FDD reference test frequencies for operating band 13

Table 8.1.3.1.1.13-1: NB-IoT standalone Test frequencies for operating band 13

Test Frequency ID	N _{UL}	M _{UL}	Frequency of Uplink [MHz]	N _{DL}	M _{DL}	Frequency of Downlink [MHz]
Low Range	23181	0	777.1	5181	-0.5	746.1
Mid Range	23230	0	782.0	5230	-0.5	751.0
High Range	23279	0	786.9	5279	-0.5	755.9

NOTE 1: Applicable to either 3.75 kHz or 15 kHz NB-IoT UL subcarrier spacing

Table 8.1.3.1.1.13-2: NB-IoT in-band Test frequencies for operating band 13

Test Frequency ID	N _{UL}	M _{UL}	Frequency of Uplink [MHz]	N _{DL}	M _{DL}	Frequency of Downlink [MHz]
Low Range ¹	23187	0	777.7000	5187	-2	746.6925
Low Range ²	23240	-2	782.9900	5240	-1	751.9975
Low Range ³	23249	-2	783.8900	5249	-1	752.8975
Mid Range ¹	23221	0	781.1000	5221	-2	750.0925
Mid Range ²	23240	-2	782.9900	5240	-1	751.9975
Mid Range ³	23249	-2	783.8900	5249	-1	752.8975
High Range ¹	23273	0	786.3000	5273	1	755.3075
High Range ²	23240	-2	782.9900	5240	-1	751.9975
High Range ³	23249	-2	783.8900	5249	-1	752.8975

NOTE 1: Related to LTE channel BW 5 MHz
NOTE 2: Related to LTE channel BW 10 MHz and NB-IoT PRB 30
NOTE 3: Related to LTE channel BW 10 MHz and NB-IoT PRB 35
NOTE 4: Applicable to either 3.75 kHz or 15 kHz UL sub-carrier spacing

Table 8.1.3.1.1.13-3: NB-IoT guard-band Test frequencies for operating band 13

Test Frequency ID	LTE Cell Bandwidth [MHz]	N _{UL}	M _{UL}	Frequency of Uplink [MHz]	N _{DL}	M _{DL}	Frequency of Downlink [MHz]
Low Range	Any	23181	3	777.1150	5181	1	746.1075
Mid Range	5	23206	3	779.6150	5206	1	748.6075
	10	23276	3	786.6050	5276	1	755.5975
High Range	Any	23279	-3	786.8850	5279	-2	755.8925

NOTE 1: Void
NOTE 2: Applicable to either 3.75 kHz or 15 kHz UL sub-carrier spacing

8.1.3.1.1.14 NB-IoT FDD reference test frequencies for operating band 14

Table 8.1.3.1.1.14-1: NB-IoT standalone Test frequencies for operating band 14

Test Frequency ID	N _{UL}	M _{UL}	Frequency of Uplink [MHz]	N _{DL}	M _{DL}	Frequency of Downlink [MHz]
Low Range	23281	0	788.1	5281	-0.5	758.1
Mid Range	23330	0	793.0	5330	-0.5	763.0
High Range	23379	0	797.9	5379	-0.5	767.9

NOTE 1: Applicable to either 3.75 kHz or 15 kHz NB-IoT UL subcarrier spacing

Table 8.1.3.1.1.14-2: NB-IoT in-band Test frequencies for operating band 14

Test Frequency ID	N _{UL}	M _{UL}	Frequency of Uplink [MHz]	N _{DL}	M _{DL}	Frequency of Downlink [MHz]
Low Range ¹	23287	0	788.7000	5287	-2	758.6925
Low Range ²	23340	-2	793.9900	5340	-1	763.9975
Low Range ³	23349	-2	794.8900	5349	-1	764.8975
Mid Range ¹	23321	0	792.1000	5321	-2	762.0925
Mid Range ²	23340	-2	793.9900	5340	-1	763.9975
Mid Range ³	23349	-2	794.8900	5349	-1	764.8975
High Range ¹	23373	0	797.3000	5373	1	767.3075
High Range ²	23340	-2	793.9900	5340	-1	763.9975
High Range ³	23349	-2	794.8900	5349	-1	764.8975

NOTE 1: Related to LTE channel BW 5 MHz
NOTE 2: Related to LTE channel BW 10 MHz and NB-IoT PRB 30
NOTE 3: Related to LTE channel BW 10 MHz and NB-IoT PRB 35
NOTE 4: Applicable to either 3.75 kHz or 15 kHz UL sub-carrier spacing

Table 8.1.3.1.1.14-3: NB-IoT guard-band Test frequencies for operating band 14

Test Frequency ID	LTE Cell Bandwidth [MHz]	N _{UL}	M _{UL}	Frequency of Uplink [MHz]	N _{DL}	M _{DL}	Frequency of Downlink [MHz]
Low Range	Any	23281	3	788.1000	5281	1	758.1075
Mid Range	5	23306	3	790.6000	5306	1	760.6075
	10	23376	3	797.5900	5376	1	767.5975
High Range	Any	23379	-3	797.9000	5379	-2	767.8925

NOTE 1: Void
NOTE 2: Applicable to either 3.75 kHz or 15 kHz UL sub-carrier spacing

8.1.3.1.1.15 to 8.1.3.1.1.16 Void

8.1.3.1.1.17 NB-IoT FDD reference test frequencies for operating band 17

Table 8.1.3.1.1.17-1: NB-IoT standalone Test frequencies for operating band 17

Test Frequency ID	N _{UL}	M _{UL}	Frequency of Uplink [MHz]	N _{DL}	M _{DL}	Frequency of Downlink [MHz]
Low Range	23731	0	704.1	5731	-0.5	734.1
Mid Range	23790	0	710.0	5790	-0.5	740.0
High Range	23849	0	715.9	5849	-0.5	745.9

NOTE 1: Applicable to either 3.75 kHz or 15 kHz NB-IoT UL subcarrier spacing

Table 8.1.3.1.1.17-2: NB-IoT in-band Test frequencies for operating band 17

Test Frequency ID	N _{UL}	M _{UL}	Frequency of Uplink [MHz]	N _{DL}	M _{DL}	Frequency of Downlink [MHz]
Low Range ¹	23737	0	704.7000	5737	-2	734.6925
Low Range ²	23790	-2	709.9900	5790	-1	739.9975
Low Range ³	23799	-2	710.8900	5799	-1	740.8975
Mid Range ¹	23781	0	709.1000	5781	-2	739.0925
Mid Range ²	23800	-2	710.9900	5800	-1	740.9975
Mid Range ³	23809	-2	711.8900	5809	-1	741.8975
High Range ¹	23843	0	715.3000	5843	1	745.3075
High Range ²	23810	-2	711.9900	5810	-1	741.9975
High Range ³	23819	-2	712.8900	5819	-1	742.8975

NOTE 1: Related to LTE channel BW 5 MHz
NOTE 2: Related to LTE channel BW 10 MHz and NB-IoT PRB 30
NOTE 3: Related to LTE channel BW 10 MHz and NB-IoT PRB 35
NOTE 4: Applicable to either 3.75 kHz or 15 kHz UL sub-carrier spacing

Table 8.1.3.1.1.17-3: NB-IoT guard-band Test frequencies for operating band 17

Test Frequency ID	N _{UL}	M _{UL}	Frequency of Uplink [MHz]	N _{DL}	M _{DL}	Frequency of Downlink [MHz]
Low Range	23731	0	704.1000	5731	1	734.1075
Mid Range	23766	0	707.6000	5766	1	737.6075
High Range	23849	0	715.9000	5849	-2	745.8925

NOTE 1: Related to LTE channel BW 5 MHz
NOTE 2: Applicable to either 3.75 kHz or 15 kHz UL sub-carrier spacing

8.1.3.1.1.18 NB-IoT FDD reference test frequencies for operating band 18

Table 8.1.3.1.1.18-1: NB-IoT standalone Test frequencies for operating band 18

Test Frequency ID	N _{UL}	M _{UL}	Frequency of Uplink [MHz]	N _{DL}	M _{DL}	Frequency of Downlink [MHz]
Low Range	23851	0	815.1	5851	-0.5	860.1
Mid Range	23925	0	822.5	5925	-0.5	867.5
High Range	23999	0	829.9	5999	-0.5	874.9

NOTE 1: Applicable to either 3.75 kHz or 15 kHz NB-IoT UL subcarrier spacing

Table 8.1.3.1.1.18-2: NB-IoT in-band Test frequencies for operating band 18

Test Frequency ID	N _{UL}	M _{UL}	Frequency of Uplink [MHz]	N _{DL}	M _{DL}	Frequency of Downlink [MHz]
Low Range ¹	23857	0	815.7000	5857	-2	860.6925
Low Range ²	23910	-2	820.9900	5910	-1	865.9975
Low Range ³	23919	-2	821.8900	5919	-1	866.8975
Mid Range ¹	23916	0	821.6000	5916	-2	866.5925
Mid Range ²	23935	-2	823.4900	5935	-1	868.4975
Mid Range ³	23944	-2	824.3900	5944	-1	869.3975
High Range ¹	23993	0	829.3000	5993	1	874.3075
High Range ²	23960	-2	825.9900	5960	-1	870.9975
High Range ³	23969	-2	826.8900	5969	-1	871.8975

NOTE 1: Related to LTE channel BW 5 MHz
NOTE 2: Related to LTE channel BW 10 MHz and NB-IoT PRB 30
NOTE 3: Related to LTE channel BW 10 MHz and NB-IoT PRB 35
NOTE 4: Applicable to either 3.75 kHz or 15 kHz UL sub-carrier spacing

Table 8.1.3.1.1.18-3: NB-IoT guard-band Test frequencies for operating band 18

Test Frequency ID	N _{UL}	M _{UL}	Frequency of Uplink [MHz]	N _{DL}	M _{DL}	Frequency of Downlink [MHz]
Low Range	23851	0	815.1000	5851	1	860.1075
Mid Range	23901	0	820.1000	5901	1	865.1075
High Range	23999	0	829.9000	5999	-2	874.8925

NOTE 1: Related to LTE channel BW 5 MHz
NOTE 2: Applicable to either 3.75 kHz or 15 kHz UL sub-carrier spacing

8.1.3.1.1.19 NB-IoT FDD reference test frequencies for operating band 19

Table 8.1.3.1.1.19-1: NB-IoT standalone Test frequencies for operating band 19

Test Frequency ID	N _{UL}	M _{UL}	Frequency of Uplink [MHz]	N _{DL}	M _{DL}	Frequency of Downlink [MHz]
Low Range	24001	0	830.1	6001	-0.5	875.1
Mid Range	24075	0	837.5	6075	-0.5	882.5
High Range	24149	0	844.9	6149	-0.5	889.9

NOTE 1: Applicable to either 3.75 kHz or 15 kHz NB-IoT UL subcarrier spacing

Table 8.1.3.1.1.19-2: NB-IoT in-band Test frequencies for operating band 19

Test Frequency ID	N _{UL}	M _{UL}	Frequency of Uplink [MHz]	N _{DL}	M _{DL}	Frequency of Downlink [MHz]
Low Range ¹	24007	0	830.7000	6007	-2	875.6925
Low Range ²	24060	-2	835.9900	6060	-1	880.9975
Low Range ³	24069	-2	836.8900	6069	-1	881.8975
Mid Range ¹	24066	0	836.6000	6066	-2	881.5925
Mid Range ²	24085	-2	838.4900	6085	-1	883.4975
Mid Range ³	24094	-2	839.3900	6094	-1	884.3975
High Range ¹	24143	0	844.3000	6143	1	889.3075
High Range ²	24110	-2	840.9900	6110	-1	885.9975
High Range ³	24119	-2	841.8900	6119	-1	886.8975

NOTE 1: Related to LTE channel BW 5 MHz
NOTE 2: Related to LTE channel BW 10 MHz and NB-IoT PRB 30
NOTE 3: Related to LTE channel BW 10 MHz and NB-IoT PRB 35
NOTE 4: Applicable to either 3.75 kHz or 15 kHz UL sub-carrier spacing

Table 8.1.3.1.1.19-3: NB-IoT guard-band Test frequencies for operating band 19

Test Frequency ID	N _{UL}	M _{UL}	Frequency of Uplink [MHz]	N _{DL}	M _{DL}	Frequency of Downlink [MHz]
Low Range	24001	0	830.1000	6001	1	875.1075
Mid Range	24051	0	835.1000	6051	1	880.1075
High Range	24149	0	844.9000	6149	-2	889.8925

NOTE 1: Related to LTE channel BW 5 MHz
NOTE 2: Applicable to either 3.75 kHz or 15 kHz UL sub-carrier spacing

8.1.3.1.1.20 NB-IoT FDD reference test frequencies for operating band 20

Table 8.1.3.1.1.20-1: NB-IoT standalone Test frequencies for operating band 20

Test Frequency ID	N _{UL}	M _{UL}	Frequency of Uplink [MHz]	N _{DL}	M _{DL}	Frequency of Downlink [MHz]
Low Range	24151	0	832.1	6151	-0.5	791.1
Mid Range	24300	0	847.0	6300	-0.5	806.0
High Range	24449	0	861.9	6449	-0.5	820.9

NOTE 1: Applicable to either 3.75 kHz or 15 kHz NB-IoT UL subcarrier spacing

Table 8.1.3.1.1.20-2: NB-IoT in-band Test frequencies for operating band 20

Test Frequency ID	N _{UL}	M _{UL}	Frequency of Uplink [MHz]	N _{DL}	M _{DL}	Frequency of Downlink [MHz]
Low Range ¹	24157	0	832.7000	6157	-2	791.6925
Low Range ²	24210	-2	837.9900	6210	-1	796.9975
Low Range ³	24219	-2	838.8900	6219	-1	797.8975
Mid Range ¹	24291	0	846.1000	6291	-2	805.0925
Mid Range ²	24310	-2	847.9900	6310	-1	806.9975
Mid Range ³	24319	-2	848.8900	6319	-1	807.8975
High Range ¹	24443	0	861.3000	6443	1	820.3075
High Range ²	24410	-2	857.9900	6410	-1	816.9975
High Range ³	24419	-2	858.8900	6419	-1	817.8975

NOTE 1: Related to LTE channel BW 5 MHz
NOTE 2: Related to LTE channel BW 10 MHz and NB-IoT PRB 30
NOTE 3: Related to LTE channel BW 10 MHz and NB-IoT PRB 35
NOTE 4: Applicable to either 3.75 kHz or 15 kHz UL sub-carrier spacing

Table 8.1.3.1.1.20-3: NB-IoT guard-band Test frequencies for operating band 20

Test Frequency ID	LTE Cell Bandwidth [MHz]	N _{UL}	M _{UL}	Frequency of Uplink [MHz]	N _{DL}	M _{DL}	Frequency of Downlink [MHz]
Low Range	Any	24151	3	832.1150	6151	1	791.1075
Mid Range	5	24276	3	844.6150	6276	1	803.6075
	10	24346	3	851.6050	6346	1	810.5975
High Range	Any	24449	-3	861.8850	6449	-2	820.8925

NOTE 1: Void
NOTE 2: Applicable to either 3.75 kHz or 15 kHz UL sub-carrier spacing

8.1.3.1.1.21 NB-IoT FDD reference test frequencies for operating band 21

Table 8.1.3.1.1.21-1: NB-IoT standalone Test frequencies for operating band 21

Test Frequency ID	N _{UL}	M _{UL}	Frequency of Uplink [MHz]	N _{DL}	M _{DL}	Frequency of Downlink [MHz]
Low Range	24451	0	1448,00	6451	-0.5	1496,00
Mid Range	24525	0	1455,40	6525	-0.5	1503,40
High Range	24599	0	1462,80	6599	-0.5	1510,80

NOTE 1: Applicable to either 3.75 kHz or 15 kHz NB-IoT UL subcarrier spacing

Table 8.1.3.1.1.21-2: NB-IoT in-band Test frequencies for operating band 21

Test Frequency ID	N _{UL}	M _{UL}	Frequency of Uplink [MHz]	N _{DL}	M _{DL}	Frequency of Downlink [MHz]
Low Range	24457	-3	1448,5850	6457	-2	1496,5925
Low Range ²	24510	-2	1453.8900	6510	-1	1501.8975
Low Range ³	24519	-2	1454.7900	6519	-1	1502.7975
Mid Range	24516	-3	1454,4850	6516	-2	1502,4925
Mid Range ²	24535	-2	1456.3900	6535	-1	1504.3975
Mid Range ³	24544	-2	1457.2900	6544	-1	1505.2975
High Range	24593	3	1462,2150	6593	1	1510,2075
High Range ²	24560	-2	1458.8900	6560	-1	1506.8975
High Range ³	24569	-2	1459.7900	6569	-1	1507.7975

NOTE 1: Related to LTE channel BW 5 MHz
NOTE 2: Related to LTE channel BW 10 MHz and NB-IoT PRB 30
NOTE 3: Related to LTE channel BW 10 MHz and NB-IoT PRB 35
NOTE 4: Applicable to either 3.75 kHz or 15 kHz UL sub-carrier spacing

Table 8.1.3.1.1.21-3: NB-IoT guard-band Test frequencies for operating band 21

Test Frequency ID	LTE Cell Bandwidth [MHz]	N _{UL}	M _{UL}	Frequency of Uplink [MHz]	N _{DL}	M _{DL}	Frequency of Downlink [MHz]
Low Range	Any	24451	0	1448.0000	6451	1	1496.0075
Mid Range	5	24501	0	1453.0000	6501	1	1501.0075
	10	24571	0	1459.9900	6571	1	1507.9975
High Range	Any	24599	0	1462.8000	6599	-2	1510.7925

NOTE 1: Void
NOTE 2: Applicable to either 3.75 kHz or 15 kHz UL sub-carrier spacing

8.1.3.1.1.22 to 8.1.3.1.1.24 Void

8.1.3.1.1.25 NB-IoT FDD reference test frequencies for operating band 25

Table 8.1.3.1.1.25-1: NB-IoT standalone Test frequencies for operating band 25

Test Frequency ID	N _{UL}	M _{UL}	Frequency of Uplink [MHz]	N _{DL}	M _{DL}	Frequency of Downlink [MHz]
Low Range	26041	0	1850.10	8041	-0.5	1930.1
Mid Range	26365	0	1882.50	8365	-0.5	1962.5
High Range	26689	0	1914.90	8689	-0.5	1994.9

NOTE 1: Applicable to either 3.75 kHz or 15 kHz NB-IoT UL subcarrier spacing

Table 8.1.3.1.1.25-2: NB-IoT in-band Test frequencies for operating band 25

Test Frequency ID	N _{UL}	M _{UL}	Frequency of Uplink [MHz]	N _{DL}	M _{DL}	Frequency of Downlink [MHz]
Low Range ¹	26046	0	1850.6000	8046	-2	1930.5925
Low Range ²	26100	-2	1855.9900	8100	-1	1935.9975
Low Range ³	26109	-2	1856.8900	8109	-1	1936.8975
Mid Range ¹	26356	0	1881.6000	8356	-2	1961.5925
Mid Range ²	26375	-2	1883.4900	8375	-1	1963.4975
Mid Range ³	26384	-2	1884.3900	8384	-1	1964.3975
High Range ¹	26684	0	1914.4000	8684	1	1994.4075
High Range ²	26650	-2	1910.99	8650	-1	1990.9975
High Range ³	26659	-2	1911.89	8659	-1	1991.8975

NOTE 1: Related to LTE channel BW 3 MHz
NOTE 2: Related to LTE channel BW 10 MHz and NB-IoT PRB 30
NOTE 3: Related to LTE channel BW 10 MHz and NB-IoT PRB 35
NOTE 4: Applicable to either 3.75 kHz or 15 kHz UL sub-carrier spacing

Table 8.1.3.1.1.25-3: NB-IoT guard-band Test frequencies for operating band 25

Test Frequency ID	N _{UL}	M _{UL}	Frequency of Uplink [MHz]	N _{DL}	M _{DL}	Frequency of Downlink [MHz]
Low Range	26041	0	1850,1000	8041	1	1930,1075
Mid Range	26341	0	1880,1000	8341	1	1960,1075
High Range	26689	0	1914,9000	8689	-2	1994,8925

NOTE 1: Related to LTE channel BW 5 MHz
NOTE 2: Applicable to either 3.75 kHz or 15 kHz UL sub-carrier spacing

8.1.3.1.1.26 NB-IoT FDD reference test frequencies for operating band 26

Table 8.1.3.1.1.26-1: NB-IoT standalone Test frequencies for operating band 26

Test Frequency ID	N _{UL}	M _{UL}	Frequency of Uplink [MHz]	N _{DL}	M _{DL}	Frequency of Downlink [MHz]
Low Range	26691	0	814.1	8691	-0.5	859.1
Mid Range	26865	0	831.5	8865	-0.5	876.5
High Range	27039	0	848.9	9039	-0.5	893.9

NOTE 1: Applicable to either 3.75 kHz or 15 kHz NB-IoT UL subcarrier spacing

Table 8.1.3.1.1.26-2: NB-IoT in-band Test frequencies for operating band 26

Test Frequency ID	N _{UL}	M _{UL}	Frequency of Uplink [MHz]	N _{DL}	M _{DL}	Frequency of Downlink [MHz]
Low Range ¹	26696	0	814.6000	8696	-2	859.5925
Low Range ²	26750	-2	819.9900	8750	-1	864.9975
Low Range ³	26759	-2	820.8900	8759	-1	865.8975
Mid Range ¹	26856	0	830.6000	8856	-2	875.5925
Mid Range ²	26875	-2	832.4900	8875	-1	877.4975
Mid Range ³	26884	-2	833.3900	8884	-1	878.3975
High Range ¹	27034	0	848.4000	9034	1	893.4075
High Range ²	27000	-2	844.9900	9000	-1	889.9975
High Range ³	27009	-2	845.8900	9009	-1	890.8975

NOTE 1: Related to LTE channel BW 3 MHz
NOTE 2: Related to LTE channel BW 10 MHz and NB-IoT PRB 30
NOTE 3: Related to LTE channel BW 10 MHz and NB-IoT PRB 35
NOTE 4: Applicable to either 3.75 kHz or 15 kHz UL sub-carrier spacing

Table 8.1.3.1.1.26-3: NB-IoT guard-band Test frequencies for operating band 26

Test Frequency ID	N _{UL}	M _{UL}	Frequency of Uplink [MHz]	N _{DL}	M _{DL}	Frequency of Downlink [MHz]
Low Range	26691	0	814.1000	8691	1	859.1075
Mid Range	26841	0	829.1000	8841	1	874.1075
High Range	27039	0	848.9000	9039	-2	893.8925

NOTE 1: Related to LTE channel BW 5 MHz
NOTE 2: Applicable to either 3.75 kHz or 15 kHz UL sub-carrier spacing

8.1.3.1.1.27 Void

8.1.3.1.1.28 NB-IoT FDD reference test frequencies for operating band 28

Table 8.1.3.1.1.28-1: NB-IoT standalone Test frequencies for operating band 28

Test Frequency ID	N _{UL}	M _{UL}	Frequency of Uplink [MHz]	N _{DL}	M _{DL}	Frequency of Downlink [MHz]
Low Range	27211	0	703.1	9211	-0.5	758.1
Mid Range	27435	0	725.5	9435	-0.5	780.5
High Range	27659	0	747.9	9659	-0.5	802.9

NOTE 1: Applicable to either 3.75 kHz or 15 kHz NB-IoT UL subcarrier spacing

Table 8.1.3.1.1.28-2: NB-IoT in-band Test frequencies for operating band 28

Test Frequency ID	N _{UL}	M _{UL}	Frequency of Uplink [MHz]	N _{DL}	M _{DL}	Frequency of Downlink [MHz]
Low Range ¹	27216	0	703.6000	9216	-2	758.5925
Low Range ²	27270	-2	708.9900	9270	-1	763.9975
Low Range ³	27279	-2	709.8900	9279	-1	764.8975
Mid Range ¹	27426	0	724.6000	9426	-2	779.5925
Mid Range ²	27420	-2	723.9900	9420	-1	778.9975
Mid Range ³	27429	-2	724.8900	9429	-1	779.8975
High Range ¹	27654	0	747.4000	9654	1	802.4075
High Range ²	27620	-2	743.9900	9620	-1	798.9975
High Range ³	27629	-2	744.8900	9629	-1	799.8975

NOTE 1: Related to LTE channel BW 3 MHz
NOTE 2: Related to LTE channel BW 10 MHz and NB-IoT PRB 30
NOTE 3: Related to LTE channel BW 10 MHz and NB-IoT PRB 35
NOTE 4: Applicable to either 3.75 kHz or 15 kHz UL sub-carrier spacing

Table 8.1.3.1.1.28-3: NB-IoT guard-band Test frequencies for operating band 28

Test Frequency ID	LTE Cell Bandwidth [MHz]	N _{UL}	M _{UL}	Frequency of Uplink [MHz]	N _{DL}	M _{DL}	Frequency of Downlink [MHz]
Low Range	Any	27211	0	703.1000	9211	1	758.1075
Mid Range	5	27411	0	723.1000	9411	1	778.1075
	10	27456	0	727.5900	9456	1	782.5975
High Range	Any	27659	0	747.9000	9659	-2	802.8925

NOTE 1: Void
NOTE 2: Applicable to either 3.75 kHz or 15 kHz UL sub-carrier spacing

8.1.3.1.1.29 to 8.1.3.1.1.30 Void

8.1.3.1.1.31 NB-IoT FDD reference test frequencies for operating band 31

Table 8.1.3.1.1.31-1: NB-IoT standalone Test frequencies for operating band 31

Test Frequency ID	N _{UL}	M _{UL}	Frequency of Uplink [MHz]	N _{DL}	M _{DL}	Frequency of Downlink [MHz]
Low Range	27761	0	452,60	9871	-0.5	462,6
Mid Range	27785	0	455,00	9895	-0.5	465
High Range	27809	0	457,40	9919	-0.5	467,4

NOTE 1: Applicable to either 3.75 kHz or 15 kHz NB-IoT UL subcarrier spacing

Table 8.1.3.1.1.31-2: NB-IoT in-band Test frequencies for operating band 31

Test Frequency ID	N _{UL}	M _{UL}	Frequency of Uplink [MHz]	N _{DL}	M _{DL}	Frequency of Downlink [MHz]
Low Range ¹	27766	-3	453,0850	9876	-2	463,0925
Low Range ²	27794	0	455.9000	9904	1	465.9075
Low Range ³	27803	0	456.8000	9913	1	466.8075
Mid Range ¹	27776	-3	454,0850	9886	-2	464,0925
Mid Range ²	27794	0	455.9000	9904	1	465.9075
Mid Range ³	27803	0	456.8000	9913	1	466.8075
High Range ¹	27804	3	456,9150	9914	1	466,9075
High Range ²	27794	0	455.9000	9904	1	465.9075
High Range ³	27803	0	456.8000	9913	1	466.8075

NOTE 1: Related to LTE channel BW 3 MHz
NOTE 2: Related to LTE channel BW 5 MHz and NB-IoT PRB 17
NOTE 3: Related to LTE channel BW 5 MHz and NB-IoT PRB 22
NOTE 4: Applicable to either 3.75 kHz or 15 kHz UL sub-carrier spacing

Table 8.1.3.1.1.31-3: NB-IoT guard-band Test frequencies for operating band 31

Test Frequency ID	N _{UL}	M _{UL}	Frequency of Uplink [MHz]	N _{DL}	M _{DL}	Frequency of Downlink [MHz]
Low Range	27761	0	452,6000	9871	1	462,6075
Mid Range	27761	0	452,6000	9871	1	462,6075
High Range	27809	0	457,4000	9919	-2	467,3925

NOTE 1: Related to LTE channel BW 5 MHz
NOTE 2: Applicable to either 3.75 kHz or 15 kHz UL sub-carrier spacing

8.1.3.1.1.32 to 8.1.3.1.1.65 Void

8.1.3.1.1.66 NB-IoT FDD reference test frequencies for operating band 66

Table 8.1.3.1.1.66-1: NB-IoT standalone Test frequencies for operating band 66

Test Frequency ID	N _{UL}	M _{UL}	Frequency of Uplink [MHz]	N _{DL}	M _{DL}	Frequency of Downlink [MHz]
Low Range	131973	0	1710.1	66437	-0.5	2110.1
Mid Range	132322	0	1745.0	66786	-0.5	2145.0
High Range	132671	0	1779.9	67135	-0.5	2179.9

NOTE 1: Applicable to either 3.75 kHz or 15 kHz NB-IoT UL subcarrier spacing
NOTE 2: Only paired part of the band considered for NB-IoT

Table 8.1.3.1.1.66-2: NB-IoT in-band Test frequencies for operating band 66

Test Frequency ID	N _{UL}	M _{UL}	Frequency of Uplink [MHz]	N _{DL}	M _{DL}	Frequency of Downlink [MHz]
Low Range ¹	131978	0	1710.6000	66442	-2	2110.5925
Low Range ²	132032	-2	1715.9900	66496	-1	2115.9975
Low Range ³	132041	-2	1716.8900	66505	-1	2116.8975
Mid Range ¹	132313	0	1744.1000	66777	-2	2144.0925
Mid Range ²	132432	-2	1755.9900	66896	-1	2155.9975
Mid Range ³	132441	-2	1756.8900	66905	-1	2156.8975
High Range ¹	132666	0	1779.4000	67130	1	2179.4075
High Range ²	132632	-2	1775.9900	67096	-1	2175.9975
High Range ³	132641	-2	1776.8900	67105	-1	2176.8975

NOTE 1: Related to LTE channel BW 3 MHz
NOTE 2: Related to LTE channel BW 10 MHz and NB-IoT PRB 30
NOTE 3: Related to LTE channel BW 10 MHz and NB-IoT PRB 35
NOTE 4: Applicable to either 3.75 kHz or 15 kHz UL sub-carrier spacing
NOTE 3: Only paired part of the band considered for NB-IoT

Table 8.1.3.1.1.66-3: NB-IoT guard-band Test frequencies for operating band 66

Test Frequency ID	LTE Cell Bandwidth [MHz]	N _{UL}	M _{UL}	Frequency of Uplink [MHz]	N _{DL}	M _{DL}	Frequency of Downlink [MHz]
Low Range	Any	131973	0	1710.1000	66437	1	2110.1075
Mid Range	5	132298	0	1742.6000	66762	1	2142.6075
	10	132468	0	1759.5900	66932	1	2159.5975
High Range	Any	132671	0	1779.9000	67135	-2	2179.8925

NOTE 1: Void
NOTE 2: Applicable to either 3.75 kHz or 15 kHz UL sub-carrier spacing
NOTE 3: Only paired part of the band considered for NB-IoT

8.1.3.1.1.67 to 8.1.3.1.1.69 Void

8.1.3.1.1.70 NB-IoT FDD reference test frequencies for operating band 70

Table 8.1.3.1.1.70-1: NB-IoT standalone Test frequencies for operating band 70

Test Frequency ID	N _{UL}	M _{UL}	Frequency of Uplink [MHz]	N _{DL}	M _{DL}	Frequency of Downlink [MHz]
Low Range	132973	0	1695.1	68337	-0.5	1995.1
Mid Range	133047	0	1702.5	68411	-0.5	2002.5
High Range	133121	0	1709.9	68485	-0.5	2009.9

NOTE 1: Applicable to either 3.75 kHz or 15 kHz NB-IoT UL subcarrier spacing

Table 8.1.3.1.1.70-2: NB-IoT in-band Test frequencies for operating band 70

Test Frequency ID	N _{UL}	M _{UL}	Frequency of Uplink [MHz]	N _{DL}	M _{DL}	Frequency of Downlink [MHz]
Low Range	132979	-3	1695.6850	68343	-2	1995.6925
Mid Range	133038	-3	1701.5850	68402	-2	2001.5925
High Range	133115	3	1709.3150	68479	1	2009.3075

NOTE 1: Related to LTE channel BW 3 MHz
NOTE 2: Applicable to either 3.75 kHz or 15 kHz UL sub-carrier spacing

Table 8.1.3.1.1.70-3: NB-IoT guard-band Test frequencies for operating band 70

Test Frequency ID	LTE Cell Bandwidth [MHz]	N _{UL}	M _{UL}	Frequency of Uplink [MHz]	N _{DL}	M _{DL}	Frequency of Downlink [MHz]
Low Range	Any	132973	0	1695.1000	68337	1	1995.1075
Mid Range	5	133023	0	1700.1000	68387	1	2000.1075
	10	133093	0	1707.0900	68457	1	2007.0975
High Range	Any	133121	0	1709.9000	68485	-2	2009.8925

NOTE 1: Void
NOTE 2: Applicable to either 3.75 kHz or 15 kHz UL sub-carrier spacing
NOTE 3: Only paired part of the band considered for NB-IoT

8.1.3.1.1.71 NB-IoT FDD reference test frequencies for operating band 71

Table 8.1.3.1.1.71-1: NB-IoT standalone Test frequencies for operating band 71

Test Frequency ID	N _{UL}	M _{UL}	Frequency of Uplink [MHz]	N _{DL}	M _{DL}	Frequency of Downlink [MHz]
Low Range	133123	0	663.1000	68587	-0.5	617.1000
Mid Range	133297	0	680.5000	68761	-0.5	634.5000
High Range	133471	0	697.9000	68935	-0.5	651.9000

NOTE 1: Defined for NB-IoT UL subcarrier spacing 15 kHz. Also applicable for 3.75 kHz UL sub-carrier spacing

Table 8.1.3.1.1.71-2: NB-IoT in-band Test frequencies for operating band 71

Test Frequency ID	N _{UL}	M _{UL}	Frequency of Uplink [MHz]	N _{DL}	M _{DL}	Frequency of Downlink [MHz]
Low Range ¹	133129	0	663.7000	68593	-2	617.6925
Low Range ²	133182	-2	668.9900	68646	-1	622.9975
Low Range ³	133191	-2	669.8900	68655	-1	623.8975
Mid Range ¹	133288	0	679.6000	68752	-2	633.5925
Mid Range ²	133307	-2	681.4900	68771	-1	635.4975
Mid Range ³	133316	-2	682.4000	68780	-1	636.3975
High Range ¹	133465	0	697.3000	68929	1	651.2975
High Range ²	133432	-2	693.9900	68896	-1	647.9975
High Range ³	133441	-2	694.8900	68905	-1	648.8975

NOTE 1: Related to LTE channel BW 3 MHz
NOTE 2: Related to LTE channel BW 10 MHz and NB-IoT PRB 30
NOTE 3: Related to LTE channel BW 10 MHz and NB-IoT PRB 35
NOTE 4: Defined for NB-IoT UL subcarrier spacing 15 kHz. Also applicable for 3.75 kHz UL sub-carrier spacing

Table 8.1.3.1.1.71-3: NB-IoT guard-band Test frequencies for operating band 71

Test Frequency ID	LTE Cell Bandwidth [MHz]	N _{UL}	M _{UL}	Frequency of Uplink [MHz]	N _{DL}	M _{DL}	Frequency of Downlink [MHz]
Low Range	Any	133123	0	663.1000	68587	1	617.1075
Mid Range	5	133273	0	678.1000	68737	1	632.1075
	10	133343	0	685.0900	68807	1	639.0975
High Range	Any	133471	0	697.9000	68935	-2	651.8925

NOTE 1: Void.
NOTE 2: Defined for NB-IoT UL subcarrier spacing 15 kHz. Also applicable for 3.75 kHz UL sub-carrier spacing

8.1.3.2 NB-IoT Radio conditions

8.1.3.2.1 NB-IoT Normal propagation condition

Same normal propagation condition as defined in clause 4.3.2.1 apply.

8.1.3.3 NB-IoT Physical channel allocations

8.1.3.3.1 NB-IoT Antennas

As the UE has one Rx antenna, the downlink signal is applied to it.

8.1.3.3.2 NB-IoT Downlink physical channels and physical signals

The Downlink Physical channels and Physical signals used and their relative powers are specified for either single or two SS Tx antenna in table 8.1.3.3.2-1. According to this table, no boosting needs to be signalled (as power ratios are fixed between NRS EPRE and all DL channels for a given number of DL antenna ports).

According to TS 36.213 [29] clause 16.2.2, if higher layer parameter *operationModeInfo* indicates '00' for a cell, the ratio of NRS EPRE to CRS EPRE is given by the parameter *nrs-CRS-PowerOffset* if the parameter *nrs-CRS-EPRE-Ratio* is provided by higher layers, and the ratio of NRS EPRE to CRS EPRE may be assumed to be 0 dB if the parameter *nrs-CRS-EPRE-Ratio* is not provided by higher layers.

Table 8.1.3.3.2-1: NB-IoT Power allocation for OFDM symbols and reference signals (1 or 2 SS Tx antenna)

Physical Channel	EPRE Ratio
NPBCH	According to TS 36.213 [29] clause 16.2.2, a UE may assume the ratio of NPBCH EPRE to NRS EPRE among NPBCH REs (not applicable to NPBCH REs with zero EPRE) is 0 dB for an NB-IoT cell with one NRS antenna port and -3 dB for an NB-IoT cell with two NRS antenna ports.
NPSS	Power allocation for NPSS is defined as equal to NRS EPRE = -85 dBm/15 kHz in order to have a constant EPRE (an absolute value is used as there is no NRS transmission when NPSS is transmitted).
NSSS	Power allocation for NSSS is defined as equal to NRS EPRE = -85 dBm/15 kHz in order to have a constant EPRE (an absolute value is used as there is no NRS transmission when NPSS is transmitted).
NPDCCH	According to TS 36.213 [29] clause 16.2.2, a UE may assume the ratio of NPDCCH EPRE to NRS EPRE among NPDCCH REs (not applicable to NPDCCH REs with zero EPRE) is 0 dB for an NB-IoT cell with one NRS antenna port and -3 dB for an NB-IoT cell with two NRS antenna ports.
NPDSCH	According to TS 36.213 [29] clause 16.2.2, a UE may assume the ratio of NPDSCH EPRE to NRS EPRE among NPDSCH REs (not applicable to NPDSCH REs with zero EPRE) is 0 dB for an NB-IoT cell with one NRS antenna port and -3 dB for an NB-IoT cell with two NRS antenna ports.
NRS	<ul style="list-style-type: none"> - If the number of NRS antenna ports is one, the EPRE of NRS and the EPRE of all NB-IoT DL channels is the same - If the number of NRS antenna ports is two, the EPRE per antenna port of NRS port is 3dB larger compared to the EPRE per antenna port of all NB-IoT DL channels - This means no signalling support of power offsets - The set of values for power offset between NRS and LTE CRS is {-6, -4.77, -3, -1.77, 0, 1, 1.23, 2, 3, 4, 4.23, 5, 6, 7, 8, 9} dB.

8.1.3.3.3 NB-IoT Mapping of downlink physical channels and signals to physical resources

Parameters for mapping of NB-IoT downlink physical channels and signals are specified as follows:

Normal Cyclic Prefix

N_{ID}^{cell} , Physical layer cell identity = 0 is used as the default physical layer cell identity

For RF testing, the mapping of DL physical channels to resource element is defined TS 36.521-1 [21] Annex C.1.

Table 8.1.3.3-1: NB-IoT Mapping of DL Physical Channels to Resource Elements (FDD)

Physical channel	Time Domain Location	Frequency Domain Location	Note
NPBCH	<ul style="list-style-type: none"> - NPBCH is transmitted in subframe 0 in every radio frame - NPBCH consists of 8 independently decodable blocks of 80 ms duration - The time interval where MIB remains unchanged is 640 ms - NPBCH does not use the first 3 symbols in a subframe in in-band operation. - For stand-alone and guard-band, the first 3 symbols (of the subframe transmitting NPBCH) contain no NPBCH. 	Occupies any of the 12 subcarriers not reserved for transmission of reference signals	Mapping rule is specified in TS36.211 [35] sub clause 10.2.4.4
NPSS	<ul style="list-style-type: none"> - NPSS is transmitted in subframe 5 - NPSS uses the last 11 OFDM symbols of subframes in which NB-PSS occurs for normal CP - NB-IoT PSS/SSS do not use: <ul style="list-style-type: none"> - the LTE PDCCH control region - REs used by LTE CRS - The periodicity of NPSS transmission is 10ms. 	NPSS is mapped to subcarriers #0-10 of the NB-IoT carrier	Mapping rule is specified in TS36.211 [35] sub clause 10.2.7.1.2
NSSS	<ul style="list-style-type: none"> - NSSS is transmitted in subframe 9 - NSSS uses the last 11 OFDM symbols of subframes in which NB-SSS occurs for normal CP - NB-IoT PSS/SSS do not use: <ul style="list-style-type: none"> - the LTE PDCCH control region - REs used by LTE CRS - NSSS periodicity is 20ms 	The number of subcarriers for NSSS is 12	Mapping rule is specified in TS36.211 [35] sub clause 10.2.7.2.2
NPDCCH	<ul style="list-style-type: none"> - NPDCCH on a given NB-IoT carrier are not mapped to the subframes containing NPSS/NSSS/PBCH on that carrier - NPDCCH are not be mapped onto resources elements used for NRS - NPDCCH are not overlapped with PBCH, PSS, SSS, or CRS - One or two NPDCCHs can be transmitted in a subframe. - In in-band, first three OFDM symbols are not used for NPDCCH - In stand-alone and guard-band, all OFDM symbols are available for NPDCCH - NPDCCH and NPDSCH are multiplexed only based on TDM at subframe level - It means that only cross subframe scheduling is supported - The start of an NPDCCH search space is ≥ 4ms after the end of the last NPDCCH search space 	<ul style="list-style-type: none"> - NPDCCH is transmitted on an aggregation of one or two consecutive narrowband control channel elements (NCCEs), where a narrowband control channel element corresponds to 6 consecutive subcarriers in a subframe where NCCE 0 occupies subcarriers 0 through 5 and NCCE 1 occupies subcarriers 6 through 11. - <i>REG is not defined for NPDCCH</i> 	Mapping rule is specified in TS36.211 [35] sub clause 10.2.5.5
NPDSCH	<ul style="list-style-type: none"> - The start of NB-PDSCH transmission is ≥ 4ms later than the end of its associated DL assignment - NPDSCH on a given NB-IoT carrier are not mapped to the subframes containing NPSS/NSSS/PBCH on that carrier - NPDSCH resources elements should be different from the ones used for NRS - NPDSCH resources elements should be different from the ones used for CRS 	Occupies any of the 12 subcarriers not reserved for transmission of reference signals	Mapping rule is specified in TS36.211 [35] sub clause 10.2.3.4
NRS	<ul style="list-style-type: none"> - Narrowband reference signals are transmitted in all NB-IoT downlink subframes in a cell supporting NPDSCH transmission. - NRS is not transmitted in subframes that are not NB-IoT downlink subframes, except if these subframes contain NPBCH or NPDSCH carrying SystemInformationBlockType1-NB 	2 subcarriers per antenna port in any OFDM symbols where NRS is transmitted	

	where NRS shall be transmitted. - Narrowband reference signals are transmitted in subframes #0 and #4 and in subframes #9 not containing NSSS [when no NB-IoT downlink subframes configuration has not been established]. - The narrowband reference signals shall not be mapped to subframes containing NPSS or NSSS. - NRS are transmitted on one or two antenna ports 0 to 1 (refer to Figure 10.2.6.2-1 in TS 36.211 [35]).		
--	--	--	--

8.1.3.3.4 NB-IoT Uplink physical channels and physical signals

The NB-IoT uplink setting in table 8.1.3.3.4-1 is used unless otherwise specified in a test case.

Table 8.1.3.3.4-1: NB-IoT Default Uplink setting

	Unit	Channel bandwidth
		200 kHz
Number of Tones		1
Sub-carrier spacing	kHz	15

8.1.3.3.5 NB-IoT Mapping of uplink physical channels and signals to physical resources [FFS]

8.1.3.4 NB-IoT Signal levels

8.1.3.4.1 NB-IoT Downlink signal levels

The downlink power settings in table 8.1.3.4.1-1 are used unless otherwise specified in a test case.

Table 8.1.3.4.1-1: NB-IoT Default Downlink power levels

	Unit	Channel bandwidth
		200 kHz
Number of Tones		12
Channel BW Power	dBm	-74
NRS EPRE	dBm/15kHz	-85
Note 1: The channel bandwidth powers are informative, based on -85dBm/15kHz NRS_EPRES, then scaled according to the number of tones in DL and rounded to the nearest integer dBm value. Note 2: The power level is specified at the UE Rx antenna		

It is [FFS] whether there is a requirement to specify constant power throughout all OFDM symbols, and if so how unallocated Resource elements should be treated.

The default signal level uncertainty is +/-3dB at each test port, for any level specified. If the uncertainty value is critical for the test purpose a tighter uncertainty is specified for the related test case in TS 36.521-1 [21] Annex F or in TS 36.521-3 [34] Annex F

8.1.3.4.2 NB-IoT Uplink signal levels

[FFS]

8.1.3.5 NB-IoT Standard test signals

8.1.3.5.1 NB-IoT Downlink test signals

[FFS]

8.1.3.5.2 NB-IoT Uplink test signals

[FFS]

8.1.3.6 NB-IoT Physical layer parameters

8.1.3.6.1 NB-IoT Downlink physical layer parameters

8.1.3.6.1.1 NB-IoT Physical layer parameters for DCI format N0

Default NB-IoT physical layer parameters for DCI format N0 are specified in table 8.1.3.6.1.1-1.

Table 8.1.3.6.1.1-1: NB-IoT Physical layer parameters for DCI format N0

Parameter	Value	Value in binary
Flag for format N0/format N1 differentiation	format N0	"0"
Subcarrier indication	0 if not specified otherwise depending on test case (6 bits as defined in section 16.5.1.1 of 36.213 [29])	-
Resource assignment	Depending on test parameters (3 bits as defined in section 16.5.1.1 of 36.213 [29])	-
Scheduling delay	0 (2 bits as defined in section 16.5.1 of 36.213 [29])	"00"
Modulation and coding scheme	Depending on test parameters (4 bits as defined in section 16.5.1.2 of 36.213 [29])	-
Redundancy version	0 (1 bit as defined in clause 16.5.1.2 of 36.213 [29])	"0"
Repetition number	NRep = 1 (3 bits as defined in clause 16.5.1.2 of 36.213 [29])	"000"
New data indicator	Set for every data transmission/retransmission according to the rules specified in TS 36.321 [14] (1 bit)	-
DCI subframe repetition number	R = 2 (according to NPDCCH configuration of Table 8.1.6.3-3)(2 bits as defined in section 16.6 in 36.213 [29])	"00"

8.1.3.6.1.2 NB-IoT Physical layer parameters for DCI format N1

Default NB-IoT physical layer parameters for DCI format N1 are specified in table 8.1.3.6.1.2-1 for random access procedure initiated by a NPDCCH order and in table 8.1.3.6.1.2-2 for the scheduling of one NPDSCH codeword in one cell.

Table 8.1.3.6.1.2-1: NB-IoT Physical layer parameters for DCI format N1 (for random access procedure initiated by a NPDCCH order)

Parameter	Value	Value in binary
Flag for format N0/format N1 differentiation	format N1	"1"
NPDCCH order indicator	1	"1"
Starting number of NPRACH repetitions	n1 <i>(2 bits as defined in section 16.3.1 of 36.213 [29])</i>	"00"
Subcarrier indication of NPRACH	12 <i>(6 bits as defined in section 16.3.1 of 36.213 [29])</i>	"001100"
NOTE 1: All the remaining bits in format N1 are set to one		

Table 8.1.3.6.1.2-2: NB-IoT Physical layer parameters for DCI format N1 (for the scheduling of one NPDSCH codeword in one cell)

Parameter	Value	Value in binary
Flag for format N0/format N1 differentiation	format N1	"1"
NPDCCH order indicator	0	"0"
Scheduling delay	0 <i>(3 bits as defined in clause 16.4.1 of 36.213 [29])</i>	"000"
Resource assignment	Depending on test parameters <i>(3 bits as defined in section 16.4.1.3 of 36.213 [29])</i>	-
Modulation and coding scheme	Depending on test parameters <i>(4 bits as defined in section 16.4.1.5 of 36.213 [29])</i>	-
Repetition number	NRep = 1 <i>(4 bits as defined in section 16.4.1.3 of 36.213 [29])</i>	"0000"
New data indicator	Set for every data transmission/retransmission according to the rules specified in TS 36.321 [14] <i>(1 bit)</i>	-
HARQ-ACK resource	0 if not specified otherwise depending on test case <i>(4 bits as defined in section 16.4.2 of 36.213 [29])</i>	-
DCI subframe repetition number	R = 2 (according to NPRACH configuration of Table 8.1.6.3-5) <i>(2 bits as defined in section 16.6 in 36.213 [29])</i>	"00"

8.1.3.6.1.3 (Void)

8.1.3.6.1.4 (Void)

8.1.3.6.1.5 NB-IoT Physical layer parameters for DCI format N2

Default NB-IoT physical layer parameters for DCI format N2 are specified in table 8.1.3.6.1.5-1 for paging and in table 8.1.3.6.1.5-2 for direct indication.

Table 8.1.3.6.1.5-1: NB-IoT Physical layer parameters for DCI format N2 (for paging)

Parameter	Value	Value in binary
Flag for paging/direct indication differentiation	1	"1"
Resource assignment	Depending on test parameters (3 bits as defined in section 16.4.1.3 of 36.213 [29])	-
Modulation and coding scheme (transport block 1)	Depending on test parameters (4 bits as defined in section 16.4.1.5 of 36.213 [29])	-
Repetition number	NRep = 1 (4 bits as defined in section 16.4.1.3 of 36.213 [29])	"0000"
DCI subframe repetition number	R = 1 (according to PCCH configuration of Table 8.1.6.3-2) (3 bits as defined in section 16.6 of 36.213 [29])	"000"

Table 8.1.3.6.1.5-2: NB-IoT Physical layer parameters for DCI format N2 (for direct indication)

Parameter	Value	Value in binary
Flag for paging/direct indication differentiation	0	"0"
Direct Indication information	1 (8 bits provide direct indication of system information update and other fields, as defined in 36.331 [17])	"00000001"
NOTE 1: Reserved information bits are added until the size is equal to that of format N2 with Flag=1		

8.1.4 NB-IoT Reference system configurations

The reference system configurations specified in this sub clause apply to all NB-IoT test cases unless otherwise specified.

8.1.4.1 NB-IoT Simulated network scenarios

Simulated network scenarios to be tested are listed in this sub clause.

NOTE 1: The number of cells specified does not necessarily correspond to the maximum number of resources to be configured simultaneously in test equipment. Please refer to clause 8.3.1 for such information.

NOTE 2: Void.

8.1.4.1.1 NB-IoT Single cell network scenarios

For NB-IoT basic single cell environment, Ncell 1 is used.

8.1.4.1.2 NB-IoT single mode multi cell network scenarios

For NB-IoT basic intra-frequency multi cell environment, Ncell 1, Ncell 2 and Ncell 4 are used.

For NB-IoT basic inter-frequency multi cell environment, Ncell 1 Ncell 3 and Ncell 6 are used.

For NB-IoT basic inter-band cell environment, Ncell 1 and Ncell 10 are used.

For NB-IoT multi tracking area intra-frequency multi cell environment, Ncell 1 and Ncell 11 are used.

For NB-IoT multi tracking area inter-frequency multi cell environment, Ncell 1 and Ncell 23 are used.

For NB-IoT multi PLMN inter-frequency multi cell environment, Ncell 1, Ncell 12, Ncell 13 and Ncell 14 are used.

8.1.4.2 NB-IoT Simulated cells

NOTE 1: Void

NOTE 2: Test frequency and range defined in table 8.1.4.2-1 do not apply to 36.521-1 test cases.

Test frequencies and simulated cells are defined in table 8.1.4.2-1. For NB-IoT cells, f1 is the default test frequency.

Default parameters for simulated cells are specified in table 8.1.4.2-1A and table 8.1.4.2-2.

Common parameters for simulated cells are specified in subclauses 8.1.4.3.

Table 8.1.4.2-1: Definition of test frequencies and simulated NB-IoT cells – Batch1

Test frequency	RAT	Operating band	Range	Simulated cells
f1	NB-IoT	Operating band under test	Mid (Note 1)	Ncell 1, Ncell 1a, Ncell 2, Ncell 4, Ncell5, Ncell 11 (Note 2), Ncell 18
f2	NB-IoT	Operating band under test	High (Note 1)	Ncell 3, Ncell 12, Ncell 23
f3	NB-IoT	Operating band under test	Low (Note 1)	Ncell 6, Ncell 13
f4	NB-IoT	Operating band under test	(Note 1)	Ncell 14
f5	NB-IoT	Operating band for inter-band cells	Mid (Note 1)	Ncell 10
Note 1:	For signalling test, see clause 8.3.2.3 (note that f4 is not defined for signalling tests).			
Note 2:	For signalling test, simultaneous co-existence of Ncell 2 with Ncell 11 is not allowed.			

Table 8.1.4.2-1A: Default NB-IoT parameters for simulated NB-IoT cells – Batch1

cell ID	NB-IoT Cell Identifier		Physical layer cell identity
	eNB Identifier	Cell Identity	
Ncell 1	'0000 0000 0000 0000 0001'B	'0000 0000'B	0
Ncell 1a	'0000 0000 0000 0000 0001'B	'0000 0001'B	1
Ncell 2	'0000 0000 0000 0000 0001'B	'0000 0010'B	2
Ncell 3	'0000 0000 0000 0000 0010'B	'0000 0011'B	3
Ncell 4	'0000 0000 0000 0000 0011'B	'0000 0100'B	4
Ncell 5	'0000 0000 0000 0000 0011'B	'0000 0101'B	5
Ncell 6	'0000 0000 0000 0000 0100'B	'0000 0110'B	6
Ncell 10	'0000 0000 0000 0000 0101'B	'0000 1010'B	10
Ncell 11	'0000 0000 0000 0000 0110'B	'0000 1011'B	11
Ncell 12	'0000 0000 0000 0000 0010'B	'0000 1100'B	12
Ncell 13	'0000 0000 0000 0000 0100'B	'0000 1101'B	13
Ncell 14	'0000 0000 0000 0000 0111'B	'0000 1110'B	14
Ncell 18	'0000 0000 0000 0000 0100'B	'0001 0010'B	18
Ncell 23	'0000 0000 0000 0000 0110'B	'0001 0111'B	23

Table 8.1.4.2-2: Default NAS parameters for simulated NB-IoT cells – Batch1

cell ID	Tracking Area			TA# list (Note 1)	GUTI (Note 2)		M-TMSI	
	TA#	PLMN			TAC	MME Identifier		
		MCC	MNC			MME Group ID		MME Code
Ncell 1	TAI-1	(Note 3)		1	TAI-1	32769	1	Arbitrarily selected according to TS 23.003 subclause 2.8 [2].
Ncell 1a	TAI-1	(Note 3)		1	TAI-1	32769	1	
Ncell 2	TAI-1	(Note 3)		1	TAI-1	32769	1	
Ncell 3	TAI-1	(Note 3)		1	TAI-1	32769	1	
Ncell 4	TAI-1	(Note 3)		1	TAI-1	32769	1	
Ncell 5	TAI-2	(Note 3)		2	TAI-2	32769	1	
Ncell 6	TAI-1	(Note 3)		1	TAI-1	32769	1	
Ncell 10	TAI-10	(Note 3)		1	TAI-1	32769	1	
Ncell 11	TAI-2	(Note 3)		2	TAI-2	32769	1	
Ncell 12	TAI-3	002	11	1	TAI-3	32769	1	
Ncell 13	TAI-4	003	21	1	TAI-4	32769	1	
Ncell 14	TAI-5	004	31	1	TAI-5	32769	1	
Ncell 18	TAI-1	(Note 3)		1	TAI-1	32769	1	
Ncell 23	TAI-2	(Note 3)		2	TAI-2	32769	1	

Note 1: The value(s) in the column TA# list indicates TAI(s) included in the response messages of the registration procedure (ATTACH ACCEPT or TRACKING AREA UPDATE ACCEPT) when the UE performs the registration procedure on a corresponding cell.

Note 2: The value in the column GUTI indicates GUTI included in the response messages of the registration procedure (ATTACH ACCEPT or TRACKING AREA UPDATE ACCEPT) when the UE performs the registration procedure on a corresponding cell.

Note 3: Set to the same Mobile Country Code and Mobile Network Code stored in EF_{IMS} on the test USIM card (subclause 4.9.3).

Table 8.1.4.2-3: Default NAS parameters for simulated NB-IoT cells – Batch2

NAS cell ID	Tracking Area				TA# list (Note 1)	GUTI (Note 2)		M-TMSI
	TA#	PLMN		TAC		MME Identifier		
		MCC	MNC			MME Group ID	MME Code	
Ncell 50	TAI-1	(Note 3)		1	TAI-1	32769	1	Arbitrarily selected according to TS 23.003 subclause 2.8 [2].
Ncell 51	TAI-2	(Note 3)		2	TAI-2	32770	1	
Ncell 52	TAI-3	(Note 3)		3	TAI-3	32771	1	
Ncell 53	TAI-4	(Note 3)		4	TAI-4	32772	1	
Ncell 54	TAI-12	002	101	3	TAI-12	32777	1	
Ncell 55	TAI-7	(Note 4)	02	1	TAI-7	32775	1	
Ncell 56	TAI-8	(Note 4)	02	2	TAI-8	32776	1	
Ncell 57	TAI-9	002	101	1	TAI-9	32777	1	
Ncell 58	TAI-10	003	101	1	TAI-10	32778	1	
Ncell 59	TAI-9	002	101	1	TAI-9	32777	1	
Ncell 60	TAI-11	002	101	2	TAI-11	32779	1	
Ncell 61	TAI-1	(Note 3)		1	TAI-1	32769	1	
Ncell 62	TAI-7	(Note 4)	02	1	TAI-7	32775	1	
Ncell 63	TAI-13	(Note 4)	03	1	TAI-13	32770	1	

Note 1: The value(s) in the column TA# list indicates TAI(s) included in the response messages of the registration procedure (ATTACH ACCEPT or TRACKING AREA UPDATE ACCEPT) when the UE performs the registration procedure on a corresponding cell.

Note 2: The value in the column GUTI indicates GUTI included in the response messages of the registration procedure (ATTACH ACCEPT or TRACKING AREA UPDATE ACCEPT) when the UE performs the registration procedure on a corresponding cell.

Note 3: Set to the same Mobile Country Code and Mobile Network Code stored in EF_{IMSI} on the test USIM card (subclause 4.9.3).

Note 4: Set to the same Mobile Country Code stored in EF_{IMSI} on the test USIM card (subclause 4.9.3).

Note 5: Ncell 50 is a serving cell and the other cells are suitable neighbour cells. The definitions are specified in subclause 8.3.2.2.1.

Table 8.1.4.2-4: Default cell identifiers for simulated NB-IoT cells – Batch2 when cells are in same PLMN

cell ID	Frequency	NB-IoT Cell Identifier		Physical layer cell identity
		eNB Identifier	Cell Identity	
Ncell 50	f1	'0000 0000 0000 0001 0001'B	'0000 0001'B	1
Ncell 51	f1	'0000 0000 0000 0001 0001'B	'0000 0010'B	2
Ncell 52	f2	'0000 0000 0000 0001 0010'B	'0000 0011'B	3
Ncell 53	f1	'0000 0000 0000 0001 0001'B	'0000 0100'B	4
Ncell 54	NA	NA	NA	NA
Ncell 55	NA	NA	NA	NA
Ncell 56	NA	NA	NA	NA
Ncell 57	NA	NA	NA	NA
Ncell 58	NA	NA	NA	NA
Ncell 61	f2	'0000 0000 0000 0010 0001'B	'0001 0001'B	17

Table 8.1.4.2-5: Default cell identifiers for simulated NB-IoT cells – Batch2 when cells are in different PLMNs

NAS cell ID	PLMN	Frequency	NB-IoT Cell Identifier		Physical layer cell identity
			eNB Identifier	Cell Identity	
Ncell 50	MCC/MNC= MCC/MNC in USIM	f1	'0000 0000 0000 0010 0001'B	'0000 0001'B	1
Ncell 51	MCC/MNC= MCC/MNC in USIM	f1	'0000 0000 0000 0010 0001'B	'0000 0010'B	2
Ncell 52	MCC/MNC= MCC/MNC in USIM	f1	'0000 0000 0000 0010 0001'B	'0000 0011'B	3
Ncell 53	MCC/MNC= MCC/MNC in USIM	f1	'0000 0000 0000 0010 0001'B	'0000 0100'B	4
Ncell 54	MCC=002 MNC=101	f2	'0000 0000 0000 0011 0101'B	'0001 0111'B	23
Ncell 55	MCC = MCC in USIM MNC=02	f2	'0000 0000 0000 0010 0010'B	'0000 1011'B	11
Ncell 56	MCC= MCC in USIM MNC=02	f2	'0000 0000 0000 0010 0010'B	'0000 1100'B	12
Ncell 57	MCC=002 MNC=101	f3 (Note 1)	'0000 0000 0000 0010 0011'B	'0000 1101'B	13
Ncell 58	MCC=003 MNC=101	f4 (Note 1)	'0000 0000 0000 0010 0100'B	'0000 1110'B	14
Ncell 59	MCC=002 MNC=101	f3 (Note 1)	'0000 0000 0000 0010 0011'B	'0000 1111'B	15
Ncell 60	MCC=002 MNC=101	f3 (Note 1)	'0000 0000 0000 0010 0011'B	'0001 0000'B	16
Ncell 61	MCC/MNC= MCC/MNC in USIM	f1	'0000 0000 0000 0010 0001'B	'0001 0001'B	17
Ncell 62	MCC = MCC in USIM MNC=02	f1	'0000 0000 0000 0010 0010'B	'0001 0010'B	18
Ncell 63	MCC = MCC in USIM MNC=03	f1	'0000 0000 0000 0010 0010'B	'0001 0011'B	19
Note 1: The test frequency f3 or f4 is allocated to the cell if f1 and f2 are already allocated to the cells in the test. Otherwise, f1 or f2 is allocated instead. Note that f4 is not defined for signalling tests (see clause 8.3.2.3).					

Table 8.1.4.2-6 defines TAC values only for Idle Mode Test Cases defined in TS 36.523-1 section 22.2.

Table 8.1.4.2-6: Tracking Area Code (TAC) for NB-IoT cells – Batch1 for Idle Mode test cases

cell ID	TAC
Ncell 1	1
Ncell 2	2
Ncell 3	3
Ncell 4	4
Ncell 6	6
Ncell 11	11
Ncell 12	12
Ncell 13	13
Ncell 14	14
Ncell 23	23

8.1.4.3 NB-IoT Common parameters for simulated cells

The parameters specified in this sub clause apply to all simulated cells unless otherwise specified.

8.1.4.3.1 NB-IoT Common configurations of system information blocks

8.1.4.3.1.1 NB-IoT Combinations of system information blocks

The combination of system information blocks required by a test case depends on the test case scenario. In this clause, the following combinations of system information blocks are defined.

Combination 1 is the default combination which applies to the following test case scenarios:

- single cell scenario

Combination 2 applies to the following test case scenarios:

- intra-frequency multi cell scenario
- intra-frequency multi cell scenario with neighbouring cell related information

Combination 3 applies to the following test case scenarios:

- inter-frequency multi cell scenario

Combination 4 applies to the following test case scenarios:

- access barring single cell scenario

Combination 5 applies to the following test case scenarios:

- SC-PTM single cell scenario (SC-PTM cell broadcasting SIB20-NB)

Combination 6 applies to the following test case scenarios:

- single cell on multi carriers scenario

Table 8.1.4.3.1.1-1: Combinations of system information blocks

Combination No.	System information block type							
	SIB2-NB	SIB3-NB	SIB4-NB	SIB5-NB	SIB 14-NB	SIB 16-NB	SIB 20-NB	SIB 22-NB
1	X							
2	X	X	X					
3	X	X		X				
4	X	X			X			
5	X						X	
6	X							X

8.1.4.3.1.2 NB-IoT Scheduling of system information blocks

The scheduling configurations for combinations of system information blocks are defined in the following tables.

Table 8.1.4.3.1.2-1: Scheduling for combination 1

Scheduling Information No.	Periodicity [radio frames]	Repetition pattern [radio frames]	TB size [bits]	Mapping of system information blocks
1	64	every8thRF	552	SIB2-NB

Table 8.1.4.3.1.2-2: Scheduling for combination 2

Scheduling Information No.	Periodicity [radio frames]	Repetition pattern [radio frames]	TB size [bits]	Mapping of system information blocks
1	64	every8thRF	552	SIB2-NB
2	64	every16thRF	256	SIB3-NB
3	64	every16thRF	256	SIB4-NB

Table 8.1.4.3.1.2-3: Scheduling for combination 3

Scheduling Information No.	Periodicity [radio frames]	Repetition pattern [radio frames]	TB size [bits]	Mapping of system information blocks
1	64	every8thRF	552	SIB2-NB
2	64	every16thRF	256	SIB3-NB
3	64	every16thRF	256	SIB5-NB

Table 8.1.4.3.1.2-4: Scheduling for combination 4

Scheduling Information No.	Periodicity [radio frames]	Repetition pattern [radio frames]	TB size [bits]	Mapping of system information blocks
1	64	every8thRF	552	SIB2-NB
2	64	every16thRF	256	SIB3-NB
3	64	every16thRF	256	SIB14-NB

Table 8.1.4.3.1.2-5: Scheduling for combination 5

Scheduling Information No.	Periodicity [radio frames]	Repetition pattern [radio frames]	TB size [bits]	Mapping of system information blocks
1	64	every8thRF	552	SIB2-NB
2	64	every16thRF	256	SIB20-NB

Table 8.1.4.3.1.2-6: Scheduling for combination 6

Scheduling Information No.	Periodicity [radio frames]	Repetition pattern [radio frames]	TB size [bits]	Mapping of system information blocks
1	64	every8thRF	552	SIB2-NB
2	64	every16thRF	256	SIB22-NB

8.1.4.3.2 NB-IoT Common contents of system information messages

- MasterInformationBlock-NB

The *MasterInformationBlock-NB* includes the system information transmitted on BCH.

Table 8.1.4.3.2-1: MasterInformationBlock-NB

Derivation Path: 36.331 clause 6.7.2			
Information Element	Value/remark	Comment	Condition
MasterInformationBlock-NB ::= SEQUENCE {			
systemFrameNumber-MSB-r13	A valid value as defined in TS 36.331 [17]		
hyperSFN-LSB-r13	A valid value as defined in TS 36.331 [17]		
schedulingInfoSIB1-r13	2	TBS = 208 bits, 16 repetitions	
systemInfoValueTag-r13	0		
ab-Enabled-r13	FALSE		
operationModeInfo-r13 CHOICE {			
inband-SamePCI-r13 SEQUENCE {			Inband-Same
eutra-CRS-SequenceInfo-r13	23	As specified in TS 36.213 [29] Clause 16.8	PRB30
	24	As specified in TS 36.213 [29] Clause 16.8	PRB35
	7	As specified in TS 36.213 [29] Clause 16.8	PRB17
	8	As specified in TS 36.213 [29] Clause 16.8	PRB22
}			
inband-DifferentPCI-r13 SEQUENCE {			Inband_Different
eutra-NumCRS-Ports-r13	same	same number of ports as NRS	
rasterOffset-r13	2.5*(2M _{DL} +1) kHz	M _{DL} See subclause 8.1.3.1	
spare	'00'B		
}			
guardband-r13 SEQUENCE {			Guardband
rasterOffset-r13	2.5*(2M _{DL} +1) kHz	M _{DL} See subclause 8.1.3.1	
spare	'000'B		
}			
standalone-r13 SEQUENCE {			Standalone
spare	'0000 0'B		
}			
}			
}			

Condition	Explanation
Inband-Same	In-band with same PCI test environment
Inband-Different	In-band with different PCI test environment
PRB30	For 10 MHz LTE Cell with In-Band NB-IoT in PRB 30
PRB35	For 10 MHz LTE Cell with In-Band NB-IoT in PRB 35
PRB17	For 5 MHz LTE Cell with In-Band NB-IoT in PRB 17
PRB22	For 5 MHz LTE Cell with In-Band NB-IoT in PRB 22
Standalone	Standalone test environment
Guardband	Guard-band test environment

- SystemInformation-NB

The *SystemInformation-NB* message is used to convey one or more System Information Blocks. All the SIBs included are transmitted with the same periodicity.

Table 8.1.4.3.2-2: SystemInformation-NB

Derivation Path: 36.331 clause 6.7.2			
Information Element	Value/remark	Comment	Condition
SystemInformation-NB ::= SEQUENCE {			
criticalExtensions CHOICE {			
systemInformation-r13 SEQUENCE {			
sib-TypeAndInfo-r13 SEQUENCE (SIZE (1..maxSIB)) OF CHOICE {}	See subclause 8.1.4.3.1		
lateNonCriticalExtension	Not present		
nonCriticalExtension SEQUENCE {}	Not present		
}			
}			
}			

- SystemInformationBlockType1-NB

SystemInformationBlockType1-NB contains information relevant when evaluating if a UE is allowed to access a cell and defines the scheduling of other system information.

Table 8.1.4.3.2-3: SystemInformationBlockType1-NB

Derivation Path: 36.331 clause 6.7.2			
Information Element	Value/remark	Comment	Condition
SystemInformationBlockType1-NB ::= SEQUENCE {			
hyperSFN-MSB-r13	A valid value as defined in TS 36.331 [17]		
cellAccessRelatedInfo-r13 SEQUENCE {			
plmn-IdentityList-r13 SEQUENCE (SIZE (1.. maxPLMN-r11)) OF SEQUENCE {	1 entry		
plmn-Identity-r13[1] SEQUENCE {			
mcc	See table 8.1.4.2-2		
mnc	See table 8.1.4.2-2		
}			
cellReservedForOperatorUse-r13[1]	notReserved		
attachWithoutPDN-Connectivity-r13[1]	true		ATTACH_WITHOUT_PDN
	Not present		ATTACH_WITH_PDN
}			
trackingAreaCode-r13	See table 8.1.4.2-2		
cellIdentity-r13	Cell ID for the simulated cell		
cellBarred-r13	notBarred		
intraFreqReselection-r13	notAllowed		
}			
cellSelectionInfo-r13 SEQUENCE {			
q-RxLevMin-r13	-70 (-140 dBm)	For RF/RRM test cases	RF
	-106 dBm	For signalling test cases	Signaling
q-QualMin-r13	-20 (-20dB)		
}			
p-Max-r13	Not Present		
freqBandIndicator-r13	Operating band under test.		
freqBandInfo-r13	Not Present		
multiBandInfoList-r13	Not Present		
downlinkBitmap-r13	Not Present		
eutraControlRegionSize-r13	n2		Inband-Same, Inband- Different
	Not Present		Standalone, Guard
nrs-CRS-PowerOffset-r13	dB0		Inband- Same
	Not Present		Inband-Different, Standalone, Guardband
schedulingInfoList-r13	See subclause 8.1.4.3.1		
si-WindowLength-r13	ms160		
si-RadioFrameOffset-r13	Not Present		
systemInfoValueTagList-r13	Not Present		
lateNonCriticalExtension	Not Present		
nonCriticalExtension SEQUENCE {	Not Present		
}			

Condition	Explanation
-----------	-------------

ATTACH_WITH_PDN	If the UE shall perform ATTACH with PDN connectivity procedure.
ATTACH_WITHOUT_PDN	If the UE may perform ATTACH without PDN connectivity procedure.
Inband_Same	In-band with same PCI test environment
Inband_Different	In-band with different PCI test environment
Standalone	Standalone test environment
Guardband	Guard-band test environment
RF	For RF/RRM test cases
Signaling	For Signaling test cases

8.1.4.3.3 NB-IoT Common contents of system information blocks

- SystemInformationBlockType2-NB

The IE *SystemInformationBlockType2-NB* contains radio resource configuration information that is common for all UEs.

Table 8.1.4.3.3-1: SystemInformationBlockType2-NB

Derivation Path: 36.331 clause 6.7.3.1			
Information Element	Value/remark	Comment	Condition
SystemInformationBlockType2-NB-r13 ::= SEQUENCE {			
radioResourceConfigCommon-r13 SEQUENCE {}	RadioResourceConfigCommonSIB-NB-DEFAULT	See subclause 8.1.6	
ue-TimersAndConstants-r13 SEQUENCE {			
t300-r13	ms10000		
t301-r13	ms10000		
t310-r13	ms1000		
n310-r13	n2		
t311-r13	ms1000		
n311-r13	n1		
}			
freqInfo-r13 SEQUENCE {			
ul-CarrierFreq-r13	Not present	Default UL EARFCN applies	Standalone
ul-CarrierFreq-r13	See subclause 8.1.3.1		Inband_Same, Inband_Different, Guardband
additionalSpectrumEmission-r13	1 (NS_01)	A-MPR doesn't apply by default. See TS 36.101 table 6.2.4-1.	
}			
timeAlignmentTimerCommon-r13	infinity		
multiBandInfoList-r13 SEQUENCE {}	Not present		
lateNonCriticalExtension SEQUENCE {}	Not present		
}			

Condition	Explanation
Inband_Same	In-band with same PCI test environment
Inband_Different	In-band with different PCI test environment
Standalone	Standalone test environment
Guardband	Guard-band test environment

- SystemInformationBlockType3-NB

The IE *SystemInformationBlockType3-NB* contains cell re-selection information common for intra-frequency, inter-frequency as well as intra-frequency cell re-selection information other than neighbouring cell related.

Table 8.1.4.3.3-2: SystemInformationBlockType3-NB

Derivation Path: 36.331 clause 6.7.3.1			
Information Element	Value/remark	Comment	Condition
SystemInformationBlockType3-NB-r13 ::= SEQUENCE {			
cellReselectionInfoCommon-r13 SEQUENCE {			
q-Hyst-r13	dB0	To reduce interference between intra-frequency multiple cells	
}			
cellReselectionServingFreqInfo SEQUENCE-r13 {			
s-NonIntraSearch-r13	31 (62dB)		
}			
intraFreqCellReselectionInfo-r13 SEQUENCE {			
q-RxLevMin-r13	-70 (-140 dBm)	For RF/RRM test cases	
	-106 dBm	For signalling test cases	
q-QualMin-r13	Not present		
p-Max-r13	Not present		
s-IntraSearchP-r13	31 (62dB)		
t-Reselection-r13	0		
}			
freqBandInfo-r13	Not present		
multiBandInfoList-r1	Not present		
lateNonCriticalExtension	Not present		
}			

- SystemInformationBlockType4-NB

The IE *SystemInformationBlockType4-NB* contains neighbouring cell related information relevant only for intra-frequency cell re-selection. The IE includes cells with specific re-selection parameters.

Table 8.1.4.3.3-3: SystemInformationBlockType4-NB

Derivation Path: 36.331 clause 6.7.3.1			
Information Element	Value/remark	Comment	Condition
SystemInformationBlockType4-NB-r13 ::= SEQUENCE {			
intraFreqNeighCellList-r13 SEQUENCE (SIZE (1..maxCellIntra)) OF SEQUENCE {}	Not present	Not required unless Qoffset configuration is tested. When Qoffset configuration is tested, see table 8.3.3.1.1-1	
intraFreqBlackCellList SEQUENCE-r13 (SIZE (1..maxCellBlack)) OF SEQUENCE {}	Not present	Not required unless Blacklisted cell list configuration is tested. When Blacklisted cell list configuration is tested, see table FFS.	
lateNonCriticalExtension	Not present		
}			

- SystemInformationBlockType5-NB

The IE *SystemInformationBlockType5-NB* contains information relevant only for inter-frequency cell re-selection i.e. information about other NB-IOT frequencies and inter-frequency neighbouring cells relevant for cell re-selection. The IE includes cell re-selection parameters common for a frequency.

Table 8.1.4.3.3-4: *SystemInformationBlockType5-NB*

Derivation Path: 36.331 clause 6.7.3.1			
Information Element	Value/remark	Comment	Condition
SystemInformationBlockType5-NB-r13 ::= SEQUENCE {			
interFreqCarrierFreqList-r13 SEQUENCE (SIZE (1..maxFreq)) OF SEQUENCE {	The same number of entries as the configured inter-freq carriers. For Signalling test cases see clause 8.3.2.3	n denotes the index of the entry	
dl-CarrierFreq-r13[n]	Downlink EARFCN under test. For Signalling test cases see clause 8.3.2.3		
q-RxLevMin-r13[n]	-65 (-130 dBm)	For RF/RRM test cases	
	-106 dBm	For signalling test cases	
q-QualMin-r13[n]	Not present		
p-Max-r13[n]	Not present		
q-OffsetFreq-r13[n]	dB0	Q_{offset} doesn't apply by default.	
interFreqNeighCellList-r13[n] SEQUENCE (SIZE (1..maxCellInter)) OF SEQUENCE {}	Not present	Not required unless Q_{offset} configuration is tested	
interFreqBlackCellList-r13[n] SEQUENCE (SIZE (1..maxCellBlack)) OF SEQUENCE {}	Not present	Not required unless Blacklisted cell list configuration is tested	
multiBandInfoList-r13	Not present		
}			
t-Reselection-r13	s0		
lateNonCriticalExtension	Not present		
}			

- SystemInformationBlockType14-NB

The IE *SystemInformationBlockType14-NB* contains the AB parameters.

Table 8.1.4.3.3-5: *SystemInformationBlockType14-NB*

Derivation Path: 36.331 clause 6.7.3.1			
Information Element	Value/remark	Comment	Condition
SystemInformationBlockType14-NB-r13 ::= SEQUENCE {			
ab-Param-r13 CHOICE {			
ab-Common-r13 SEQUENCE {			
ab-Category-r13	a	AB applies to all UEs	
ab-BarringBitmap-r13	'111111111'B	All UE classes 0-9	
ab-BarringExceptionData-r13	Not present		
ab-BarringForSpecialAC-r13	'11111'B	All UE classes 11-15	
}			
}			
lateNonCriticalExtension	Not present		
}			

- SystemInformationBlockType15-NB

The IE *SystemInformationBlockType15-NB* contains the MBMS Service Area Identities (SAI) of the current and/ or neighbouring carrier frequencies.

Table 8.1.4.3.3-5A: SystemInformationBlockType15-NB

FFS

- SystemInformationBlockType16-NB

The IE *SystemInformationBlockType16-NB* contains information related to GPS time and Coordinated Universal Time (UTC). The UE may use the parameters provided in this system information block to obtain the UTC, the GPS and the local time.

Table 8.1.4.3.3-6: SystemInformationBlockType16-NB

FFS

- SystemInformationBlockType20-NB

The IE *SystemInformationBlockType20-NB* contains the information required to acquire the control information associated with transmission of MBMS using SC-PTM.

Table 8.1.4.3.3-7: SystemInformationBlockType20-NB

Derivation Path: 36.331 clause 6.7.3.1			
Information Element	Value/remark	Comment	Condition
SystemInformationBlockType20-NB-r14 ::= SEQUENCE {			
npdcch-SC-MCCH-Config-r14 SEQUENCE {			
npdcch-NumRepetitions-SC-MCCH-r14	r8		
npdcch-StartSF-SC-MCCH-r14	v1dot5		
npdcch-Offset-SC-MCCH-r14	zero		
}			
sc-mcch-CarrierConfig-r14 CHOICE {			
dl-CarrierIndex-r14	0		
}			
sc-mcch-RepetitionPeriod-r14	rf32		
sc-mcch-Offset-r14	1		
sc-mcch-ModificationPeriod-r14	rf512		
sc-mcch-SchedulingInfo-r14	Not present		
lateNonCriticalExtension			
}			

- SystemInformationBlockType22-NB

The IE *SystemInformationBlockType22-NB* contains radio resource configuration for paging and random access procedure on non-anchor carriers.

Table 8.1.4.3.3-8: *SystemInformationBlockType22-NB*

Derivation Path: 36.331 clause 6.7.3.1			
Information Element	Value/remark	Comment	Condition
SystemInformationBlockType22-NB-r14 ::= SEQUENCE {			
dl-ConfigList-r14 SEQUENCE (SIZE (1.. maxNonAnchorCarriers-NB-r14)) OF DL-ConfigCommon-NB-r14 SEQUENCE {			
DL-ConfigCommon-NB-r14[1] SEQUENCE {			
dl-CarrierConfig-r14	DL-CarrierConfigCommon-NB-DEFAULT		
pcch-Config-r14	Not present		
}			
}			
ul-ConfigList-r14 SEQUENCE (SIZE (1.. maxNonAnchorCarriers-NB-r14)) OF UL-ConfigCommon-NB-r14 SEQUENCE {			
UL-ConfigCommon-NB-r14[1] SEQUENCE {			
ul-CarrierFreq-r14	See subclause 8.1.3.1		
nprach-ParametersList-r14	Not present		
}			
}			
pagingWeightAnchor-r14	Not present		
nprach-ProbabilityAnchorList-r14	Not present		
lateNonCriticalExtension	Not present		
}			

8.1.5 NB-IoT Generic procedures

8.1.5.0 General

This clause describes NB-IoT UE test states which can be used in the initial condition of many test cases defined in TS 36.521-1 [21], TS 36.523-1 [18] and TS 36.521-3 [34] or other procedures defined in this specification. This section also defines a set of procedures to bring the UE into these states.

8.1.5.1 NB-IoT UE test states

NB-IoT UE test states defined in this section support Control Plane CIoT EPS Optimization (CP) and User Plane CIoT EPS Optimization (UP).

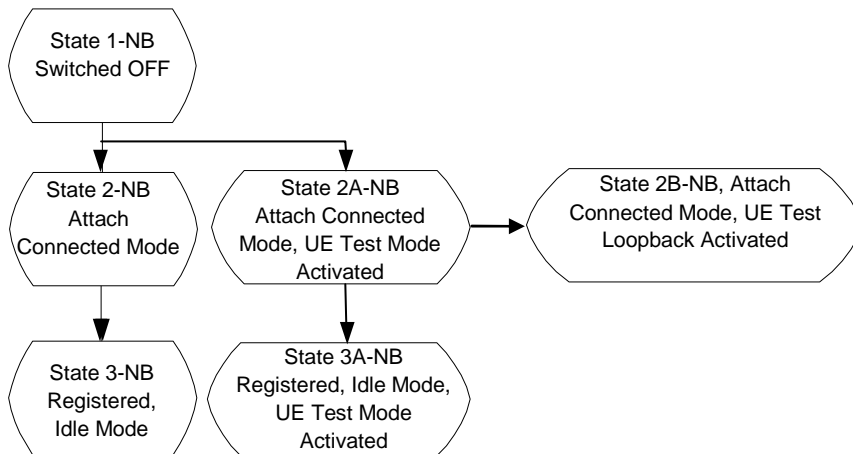

Figure 8.1.5.1-1: NB-IoT UE Test States for Basic Generic Procedures

Table 8.1.5.1-1: The NB-IoT UE states

		RRC	ECM	EMM	ESM	UE Test Mode
State 1-NB	Switched OFF	-----	-----	-----	-----	-----
State 2-NB	Attach, Connected Mode	RRC_CONNECT ED 0, 1 or 2 data radio bearers configured as specified in the test cases	ECM-CONNECTED	EMM-REGISTERED	0 or 1 default EPS bearer context active and N (0 ≤ N ≤ 1) dedicated EPS bearer active as specified in the test cases.	Not active
State 2A-NB	Attach, Connected Mode, UE Test Mode Activated	RRC_CONNECT ED 0, 1 or 2 data radio bearers configured as specified in the test cases	ECM-CONNECTED	EMM-REGISTERED	0 or 1 default EPS bearer context active and N (0 ≤ N ≤ 1) dedicated EPS bearer active as specified in the test cases.	Active
State 2B-NB	Attach, Connected Mode, UE Loopback Activated UL User data transmission pending	RRC_CONNECT ED 0,1 or 2 data radio bearers configured as specified in the test cases	ECM-CONNECTED	EMM-REGISTERED	0 or 1 default EPS bearer context active and N (0 ≤ N ≤ 1) dedicated EPS bearer active as specified in the test cases.	Active and Closed
State 3-NB	Registered, Idle Mode	RRC_IDLE	ECM-IDLE	EMM-REGISTERED	0 or 1 default EPS bearer context active as specified in the test cases.	Not active
State 3A-NB	Registered, Idle Mode, UE Test Mode Activated	RRC_IDLE	ECM-IDLE	EMM-REGISTERED	0 or 1 default EPS bearer context active as specified in the test cases.	Active

NOTE 1: Refer to TS 24.301 [28] subclause 5.5.1.1 for more details on the ESM state.

NOTE 2: Refer to TS 36.509 [38] for details regarding UE test mode and UE Loopback.

8.1.5.2 NB-IoT UE Attach, Connected mode (State 2-NB)

8.1.5.2.0 General

UE registration depends on the specific configuration of a UE, which is expressed by PICS according to TS 36.523-2 [19], and specific test case conditions.

The following UE configurations and test case conditions are used in this procedure.

Configuration	Condition	Explanation	Default
S1_U_DataTransfer	UE_S1_U_CIoT_Optimisation AND TC_Require_S1_U_DataTransfer	User Plane ClIoT Optimisation or S1_U is supported by UE (UE capability), pc_User_Plane_CIoT_Optimisation or pc_S1_U_DataTransfer, and both the Network and test case require Attach with S1_U Data Transfer	UE_S1_U_DataTr =pc_User_Plane_ n or pc_S1_U_Da TC_Require_S1_U =FALSE

8.1.5.2.1 Initial conditions

System Simulator:

- 1 NB-IoT cell, default parameters.
- The procedure shall be performed under ideal radio conditions as defined in clause 8.2

User Equipment:

- The Test UICC shall be inserted. This shall contain a USIM application on UICC.
- UE is in State 1-NB switched off.

8.1.5.2.2 Definition of system information messages

The default system information messages are used with the exception(s) below.

Table 8.1.5.2.2-1: SystemInformationBlockType1-NB

Derivation Path: Table 8.1.4.3.2-3, condition ATTACH_WITHOUT_PDN for NOT S1_U_DataTransfer and ATTACH_WITH_PDN for S1_U_DataTransfer.

8.1.5.2.3 Procedure

Table 8.1.5.2.3-1: NB-IoT UE connected mode procedure (state 1-NB to state 2-NB)

Step	Procedure	Message Sequence	
		U - S	Message
1	SS transmits system information.	<--	RRC: SYSTEM INFORMATION-NB (BCCH)
1A	Switch-on the UE	-	-
2	UE transmits an <i>RRCConnectionRequest-NB</i> message.	-->	RRC: <i>RRCConnectionRequest-NB</i>
3	SS transmits an <i>RRCConnectionSetup-NB</i> message.	<--	RRC: <i>RRCConnectionSetup-NB</i>
-	EXCEPTION: Steps 4a1 and 4b1 describe behaviour that depends on UE capabilities; the "lower case letter" identifies a step sequence that take place depending on whether the UE is configured to do Attach Without PDN or not.	-	-
4a1	IF (NOT S1_U_DataTransfer AND px_Do AttachWithoutPDN) THEN The UE transmits an <i>RRCConnectionSetupComplete-NB</i> message to confirm the successful completion of the connection establishment and to initiate the Attach procedure by including the ATTACH REQUEST message. An ESM DUMMY MESSAGE is piggybacked in ATTACH REQUEST.	-->	RRC: <i>RRCConnectionSetupComplete-NB</i> NAS: ATTACH REQUEST NAS: ESM DUMMY MESSAGE
4b1	ELSE The UE transmits an <i>RRCConnectionSetupComplete-NB</i> message to confirm the successful completion of the connection establishment and to initiate the Attach procedure by including the ATTACH REQUEST message. A PDN CONNECTIVITY REQUEST message is piggybacked in ATTACH REQUEST.	-->	RRC: <i>RRCConnectionSetupComplete-NB</i> NAS: ATTACH REQUEST NAS: PDN CONNECTIVITY REQUEST
5	The SS transmits an AUTHENTICATION REQUEST message to initiate the EPS authentication and AKA procedure.	<--	RRC: <i>DLInformationTransfer-NB</i> NAS: AUTHENTICATION REQUEST
6	The UE transmits an AUTHENTICATION RESPONSE message and establishes mutual authentication.	-->	RRC: <i>ULInformationTransfer-NB</i> NAS: AUTHENTICATION RESPONSE
7	The SS transmits a NAS SECURITY MODE COMMAND message to activate NAS security.	<--	RRC: <i>DLInformationTransfer-NB</i> NAS: SECURITY MODE COMMAND
8	The UE transmits a NAS SECURITY MODE COMPLETE message and establishes the initial security configuration.	-->	RRC: <i>ULInformationTransfer-NB</i> NAS: SECURITY MODE COMPLETE
-	EXCEPTION: Steps 9a1 to 9a2 describe behaviour that depends on UE configuration; the "lower case letter" identifies a step sequence that take place if the UE has ESM information which needs to be transferred.	-	-
9a1	IF the UE sets the ESM information transfer flag in the PDN CONNECTIVITY REQUEST message sent in step 4b1 THEN the SS transmits an ESM INFORMATION REQUEST message to initiate exchange of protocol configuration options and/or APN.	<--	RRC: <i>DLInformationTransfer-NB</i> NAS: ESM INFORMATION REQUEST
9a2	The UE transmits an ESM INFORMATION RESPONSE message to transfer protocol configuration options and/or APN.	-->	RRC: <i>ULInformationTransfer-NB</i> NAS: ESM INFORMATION RESPONSE
-	EXCEPTION: Steps 10a1 to 10a2 describe behaviour that depends on UE configuration and test case condition; the "lower case letter"	-	-

	identifies a step sequence that take place if S1_U_DataTransfer condition is evaluated as true.		
10a1	IF S1_U_DataTransfer THEN the SS transmits a <i>SecurityModeCommand</i> message to activate AS security.	<--	RRC: <i>SecurityModeCommand</i>
10a2	The UE transmits a <i>SecurityModeComplete</i> message and establishes the initial security configuration.	-->	RRC: <i>SecurityModeComplete</i>
11	The SS transmits a <i>UECapabilityEnquiry-NB</i> message to initiate the UE radio access capability transfer procedure.	<--	RRC: <i>UECapabilityEnquiry-NB</i>
12	The UE transmits a <i>UECapabilityInformation-NB</i> message to transfer UE radio access capability.	-->	RRC: <i>UECapabilityInformation-NB</i>
-	EXCEPTION: Steps 13a1 to 13c1 describe behaviour that depends on UE capabilities; the "lower case letter" identifies a step sequence that take place depending on whether the UE is configured for S1_U_DataTransfer and if not then if it is configured to do Attach Without PDN or not.	-	-
13a1	IF S1_U_DataTransfer THEN the SS transmits a <i>RRCConnectionReconfiguration-NB</i> message to establish the default bearer with condition DRB(1) according to [8.1.8]. This message includes the ATTACH ACCEPT message and the ACTIVATE DEFAULT EPS BEARER CONTEXT REQUEST message is piggybacked in the ATTACH ACCEPT	<--	RRC: <i>RRCConnectionReconfiguration-NB</i> NAS: ATTACH ACCEPT NAS: ACTIVATE DEFAULT EPS BEARER CONTEXT REQUEST
13a2	The UE transmits an <i>RRCConnectionReconfigurationComplete-NB</i> message to confirm the establishment of default bearer,	-->	RRC: <i>RRCConnectionReconfigurationComplete-NB</i>
13b1	ELSE IF px_DoAttachWithoutPDN THEN SS transmits an ATTACH ACCEPT message and an ESM DUMMY MESSAGE is piggybacked in the ATTACH ACCEPT.	<--	RRC: <i>DLInformationTransfer-NB</i> NAS: ATTACH ACCEPT NAS: ESM DUMMY MESSAGE
13c1	ELSE SS transmits an ATTACH ACCEPT message and an ACTIVATE DEFAULT EPS BEARER CONTEXT REQUEST message is piggybacked in the ATTACH ACCEPT If PDN type "IP" was included in the PDN CONNECTIVITY REQUEST step 4b1 then the network shall include the PDN type and the PDN address information within the PDN address IE in the ACTIVATE DEFAULT EPS BEARER CONTEXT REQUEST message sent to the UE	<--	RRC: <i>DLInformationTransfer-NB</i> NAS: ATTACH ACCEPT NAS: ACTIVATE DEFAULT EPS BEARER CONTEXT REQUEST
-	EXCEPTION: Steps 14a1 to 14b1 describe behaviour which depends on UE capabilities; the "lower case letter" identifies a step sequence that take place depending on whether the UE is configured to do Attach Without PDN or not.	-	-
14a1	IF px_DoAttachWithoutPDN THEN The UE transmit an ATTACH COMPLETE message and an ESM DUMMY MESSAGE is piggybacked in the ATTACH COMPLETE.	-->	RRC: <i>ULInformationTransfer-NB</i> NAS: ATTACH COMPLETE NAS: ESM DUMMY MESSAGE
-	EXCEPTION: IF not all IP address information was allocated in the ACTIVATE DEFAULT EPS BEARER CONTEXT REQUEST	-	-

	<p>message sent in steps 13a1 or 13c1 THEN</p> <p>IF pc_User_Plane_CIoT_Optimisation or pc_S1_U_DataTransfer THEN In parallel to the event described in step 14b1 below the generic procedure for IP address allocation in the U-plane specified in TS 36.508 [18] subclause 4.5A.1 takes place performing IP address allocation in the U-plane.</p> <p>ELSE In parallel to the events described in step 14b1 below the Generic 'Procedure for IP address allocation in the CP Clot' described in TS 36.508 [18], clause 8.1.5A.1 takes place.</p>		
14 b1	<p>ELSE</p> <p>UE transmits and ATTACH COMPLETE message and an ACTIVATE DEFAULT EPS BEARER CONTEXT ACCEPT message is piggybacked in the ATTACH COMPLETE.</p>	-->	<p>RRC: <i>ULInformationTransfer-NBNAS</i>: ATTACH COMPLETE</p> <p>NAS: ACTIVATE DEFAULT EPS BEARER CONTEXT ACCEPT</p>

8.1.5.2.4 Specific message contents

All specific message contents shall be referred to clause 8.1.6 and 8.1.7 with the exceptions below.

Table 8.1.5.2.4-1: RRCConnectionRequest-NB (step 2, Table 8.1.5.2.3-1)

Derivation Path: Table 8.1.6.1-10			
Information Element	Value/remark	Comment	Condition
RRCConnectionRequest-NB ::= SEQUENCE {			
criticalExtensions CHOICE {			
rrcConnectionRequest-r13 SEQUENCE {			
ue-Identity-r13	Any allowed value		
}			
}			
}			

8.1.5.2A NB-IoT UE Attach, Connected mode, UE Test Mode Activated (State 2A-NB)

8.1.5.2A.0 General

UE registration depends on the specific configuration of a UE, which is expressed by PICS according to TS 36.523-2 [19], and specific test case conditions.

The UE configurations and test case conditions described in clause 8.1.5.2 are used in this procedure.

8.1.5.2A.1 Initial conditions

System Simulator:

- 1 NB-IoT cell, default parameters.
- The procedure shall be performed under ideal radio conditions as defined in clause 8.2

User Equipment:

- The Test UICC shall be inserted. This shall contain a USIM application on UICC.
- UE is in State 1-NB switched off.

8.1.5.2A.2 Definition of system information messages

The same default system information messages are used as in clause 8.1.5.2.2.

NOTE: Loopback mode A/B is applicable only IF S1_U_DataTransfer; loopback mode G/H/I is applicable only IF NOT S1_U_DataTransfer.

8.1.5.2A.3 Procedure

Table 8.1.5.2A.3-1: NB-IoT UE Attach, connected mode and test mode activated procedure (state 2-NB to state 2A-NB)

Step	Procedure	U - S	Message Sequence Message
0	Switch-on the UE	-	-
1-9a2	Same procedure for steps 0 to 9a2 as specified in the procedure in clause 8.1.5.2.3	-	-
10	The SS transmits an ACTIVATE TEST MODE message to activate test mode procedure.	<--	RRC: <i>DLInformationTransfer-NB</i> TC: ACTIVATE TEST MODE
11	The UE transmits an ACTIVATE TEST MODE COMPLETE message.	-->	RRC: <i>ULInformationTransfer-NB</i> TC: ACTIVATE TEST MODE COMPLETE
12a1-16b1	Same procedure for steps 10a1 to 14b1 as specified in the procedure in clause 8.1.5.2.3	-	-

8.1.5.2A.4 Specific message contents

All specific message contents shall be referred to clause 8.1.6 and 8.1.7 with the exceptions below.

Table 8.1.5.2A.4-1: ACTIVATE TEST MODE (step 10, Table 8.1.5.2A.3-1)

Derivation Path: Table 4.7A-1			
Information Element	Value/remark	Comment	Condition
UE test loop mode	'00000110'B		UE TEST LOOP MODE G (NOTE 1)
	'00000111'B		UE TEST LOOP MODE H (NOTE 1)
	'00001000'B		UE TEST LOOP MODE I (NOTE 1)
	'00000000'B		UE TEST LOOP MODE A (NOTE 2)
	'00000001'B		UE TEST LOOP MODE B (NOTE 2)
	'00000101'B		UE TEST LOOP MODE F
NOTE 1: UE TEST LOOP MODE G/H/I is applicable only IF NOT S1_U_DataTransfer.			
NOTE 2: UE TEST LOOP MODE A/B is applicable only IF S1_U_DataTransfer.			

8.1.5.2B NB-IoT UE Attach, Connected Mode, UE Test Loopback Activated (State 2B-NB)

8.1.5.2B.1 Initial conditions

System Simulator:

- Parameters are set to the default parameters for the basic single cell environment, as defined in subclause 8.1.4.4, unless otherwise specified in the test case.
- The procedure shall be performed under ideal radio conditions as defined in clause 8.2

User Equipment:

- The NB-IoT UE shall be in NB-IoT UE Connected mode, NB-IoT UE Test Mode Activated (State 2A-NB).

8.1.5.2B.2 Definition of system information messages

The same default system information messages are used as in clause 8.1.5.2.2.

NOTE: Loopback mode A/B is applicable only IF S1_U_DataTransfer; loopback mode G/H/I is applicable only IF NOT S1_U_DataTransfer.

8.1.5.2B.3 Procedure

Table 8.1.5.2B.3-1: NB-IoT UE Attach, Connected Mode, UE Test Loopback Activated procedure (state 2A-NB to state 2B-NB)

Step	Procedure	Direction	Message Sequence
		UE - SS	Message
1	The SS transmits a CLOSE UE TEST LOOP message to enter the UE test loop mode.	<--	RRC: <i>DLInformationTransfer-NB</i> TC: CLOSE UE TEST LOOP
2	The UE transmits a CLOSE UE TEST LOOP COMPLETE message.	-->	RRC: <i>ULInformationTransfer-NB</i> TC: CLOSE UE TEST LOOP COMPLETE

8.1.5.2B.4 Specific message contents

All specific message contents shall be referred to clause 8.1.6 and 8.1.7 and 4.7 with the exceptions below for Test loop mode G/H/I/F (for test loop A/B the default message content according to clause 4.7A shall be applied).

Table 8.1.5.2B.4-1: CLOSE UE TEST LOOP (step 1, Table 8.1.5.2B.3-1) for test loop mode G/H/I/F

Derivation path: Table 4.7A-3			
Information Element	Value/Remark	Comment	Condition
UE test loop mode	'00000110'B	UE test loop mode G setup	TL_MODE_G
	'00000111'B	UE test loop mode H setup	TL_MODE_H
	'00001000'B	UE test loop mode I setup	TL_MODE_I
	'00000101'B	UE test loop mode F setup	TL_MODE_F
Operation mode and repetitions			TL_MODE_G, TL_MODE_H
M0	0		return_via_EMM_SMC
	1		NBIOT_return_via_RLC
R6..R0	'0000001'B	1 The received DL message in uplink shall be looped back 1 time (once)	
Uplink data delay	'00000000'B	T_delay_modeG timer=0 sec	
SC-MTCH ID	'0100'H	same value as g-RNTI indicated in the default SCPTMConfiguration-NB message	TL_MODE_F

Condition	Explanation
TL_MODE_G	Test loop mode G is applied
TL_MODE_H	Test loop mode H is applied
TL_MODE_I	Test loop mode I is applied
TL_MODE_F	Test loop mode F is applied
return_via_EMM_SMC	data is returned in uplink at the EMM entity for UE test loop mode G or the SMC SAP for UE test loop mode H
NBIOT_return_via_RLC	data is returned in uplink at the RLC AM-SAP of SRB1bis for NB-IoT UE used in MAC and RLC test cases

8.1.5.3 NB-IoT UE Registered, Idle Mode (State 3-NB)

8.1.5.3.1 Initial conditions

System Simulator:

- Parameters are set to the default parameters for the basic single cell environment, as defined in subclause 8.1.4.4, unless otherwise specified in the test case.
- The procedure shall be performed under ideal radio conditions as defined in clause 8.2

User Equipment:

- The NB-IoT UE shall be in NB-IoT UE Attach, Connected mode (State 2-NB).

8.1.5.3.2 Definition of system information messages

The same default system information messages are used as in clause 8.1.5.2.2.

8.1.5.3.3 Procedure

Table 8.1.5.3.3-1: NB-IoT Registered Idle Mode procedure (state 2-NB to state 3-NB)

Step	Procedure	Direction	Message Sequence
		UE - SS	Message
1	The SS transmits an <i>RRCConnectionRelease-NB</i> message to release RRC connection and move to RRC_IDLE.	<--	RRC: <i>RRCConnectionRelease-NB</i>

8.1.5.3.4 Specific message contents

None.

8.1.5.3A NB-IoT UE Registered, Idle Mode, UE Test Mode Activated (State 3A-NB)

8.1.5.3A.1 Initial conditions

System Simulator:

- Parameters are set to the default parameters for the basic single cell environment, as defined in subclause 8.1.4.4, unless otherwise specified in the test case.
- The procedure shall be performed under ideal radio conditions as defined in clause 8.2

User Equipment:

- The NB-IoT UE shall be in NB-IoT UE Attach, Connected mode (State 2A-NB).

8.1.5.3A.2 Definition of system information messages

The same default system information messages are used as in clause 8.1.5.2.2.

8.1.5.3A.3 Procedure

Table 8.1.5.3A.3-1: NB-IoT Registered, Idle Mode, NB-IoT UE Test Mode Activated (state 2A-NB to state 3A-NB)

Step	Procedure	Direction	Message Sequence
		UE - SS	Message
1	The SS transmits an <i>RRCConnectionRelease-NB</i> message to release RRC connection and move to RRC_IDLE.	<--	RRC: <i>RRCConnectionRelease-NB</i>

8.1.5.3A.4 Specific message contents

None.

8.1.5.4 Void

8.1.5A Other generic procedures

8.1.5A.1 Procedure for IP address allocation in the CP CIoT

The purpose of this procedure is to allow the successful completion of IP address allocation if it is initiated by the UE therefore the result from the execution of the Procedure for IP address allocation in the CP CIoT shall not lead to assignment of a verdict.

Depending on the UE configuration there may be unpredictable delay in the start of the procedure. A guarding time of 1.2 sec is suggested within which the procedure is expected to start. If the timer expires then the test procedure, from which the Procedure for IP address allocation in the CP CIoT is called, shall advance to the next specified step.

The procedure only applies for IP data. The procedure is not applicable for Non IP type data and SMS.

Table 8.1.5A.1-1: Procedure for IP address allocation in the CP CIoT

Step	Procedure	Message Sequence	
		U - S	Message
-	EXCEPTION: Steps 1 to 2 below describe behaviour that depends on the contents of the latest PDN CONNECTIVITY REQUEST message sent by the UE prior to this procedure.	-	-
1	If the "PDN type" in the latest PDN CONNECTIVITY REQUEST message prior to this procedure was 'IPv6' or 'IPv4v6' then stateless address auto configuration may occur over SRB1bis, UE may send an ICMPv6 Router Solicitation	-->	RRC: <i>ULInformationTransfer-NB</i> NAS: ESM DATA TRANSPORT
2	The SS sends an ICMPv6 Router Advertisement containing the IPv6 prefix.	<--	RRC: <i>DLInformationTransfer-NB</i> NAS: ESM DATA TRANSPORT

8.1.5A.2 Test procedure to check UE response to Paging for Control Plane CIoT MT access

8.1.5A.2.1 Initial conditions

System Simulator:

- 1 NB-IoT cell, default parameters.
- The procedure shall be performed under ideal radio conditions as defined in clause 8.2.

User Equipment:

- The UE is in RRC-IDLE.

8.1.5A.2.2 Definition of system information messages

The default system information messages are used with the exception(s) below.

Table 8.1.5A.2.2-1: SystemInformationBlockType1-NB

Derivation Path: Table 8.1.4.3.2-3, Condition ATTACH_WITHOUT_PDN.

8.1.5A.2.3 Procedure

Table 8.1.5A.2.3-1: UE response to Paging for Control Plane ClOT MT access

St	Procedure	Message Sequence		TP	Verdict
		U - S	Message/PDU/SDU		
1	SS sends a <i>Paging</i> message to the UE on the appropriate paging block, and including the UE identity in one entry of the IE <i>pagingRecordLists</i> .	<--	RRC: <i>Paging-NB</i>	-	-
2	Check: Does the UE transmit an <i>RRCConnectionRequest-NB</i> message "mt-access"?	-->	RRC: <i>RRCConnectionRequest-NB</i>	-	P
3	SS transmits an <i>RRCConnectionSetup-NB</i> message.	<--	RRC: <i>RRCConnectionSetup-NB</i>	-	-
-	EXCEPTION: Steps 4a1a1 to 4a1b3b1 describe behaviour which depends on UE implementation; the "lower case letter" identifies a step sequence which takes place depending on whether the UE is configured or not to establish PDN upon establishing RRC connection and whether UE has pending data to transmit.	-	-	-	-
4a1a 1	IF UE is configured to establish PDN upon establishing RRC connection and UE has pending data to transmit THEN Check: Does the UE transmit an <i>RRCConnectionSetupComplete-NB</i> message and a CONTROL PLANE SERVICE REQUEST message containing a ESM DATA TRANSPORT message in the ESM message container IE?	-->	RRC: <i>RRCConnectionSetupComplete-NB</i> NAS: CONTROL PLANE SERVICE REQUEST NAS: ESM DATA TRANSPORT	-	P
4a1b 1	ELSE Check: Does the UE transmit an <i>RRCConnectionSetupComplete-NB</i> message and a CONTROL PLANE SERVICE REQUEST message not containing user data (there is not yet a PDN) not containing a PDN CONNECTIVITY REQUEST message?	-->	RRC: <i>RRCConnectionSetupComplete-NB</i> NAS: CONTROL PLANE SERVICE REQUEST	-	P
4a1b 2	SS starts wait timer 2 sec. Note: The Service request procedure success is guarded in the UE by timer T3417 = 5 sec after which expiry without any DL action the UE will consider the procedure as failed.	-	-	-	-
-	EXCEPTION: Steps 4a1b3a1 to 4a1b3a4 describe behaviour which depends on UE implementation; the "lower case letter" identifies a step sequence which takes place depending on whether the UE is configured or not to establish PDN in RRC-CONNECTED after it sends the CONTROL PLANE SERVICE REQUEST message.	-	-	-	-
4a1b 3a1	The UE transmits a PDN CONNECTIVITY REQUEST message.	-->	RRC: <i>ULInformationTransfer-NB</i> NAS: PDN CONNECTIVITY REQUEST	-	-
4a1b 3a2	Stop timer wait timer 2 sec.	-	-	-	-
4a1b 3a3	The SS transmits an ACTIVATE DEFAULT EPS BEARER CONTEXT REQUEST message.	<--	RRC: <i>DLInformationTransfer-NB</i> NAS: ACTIVATE DEFAULT EPS BEARER CONTEXT REQUEST	-	-
-	EXCEPTION: IF <i>pc_IP_PDN</i> AND not all IP address information was allocated in the ACTIVATE DEFAULT EPS BEARER CONTEXT REQUEST message sent in step 4a1b3a3 TNEN	-	-	-	-

	In parallel to the events described in steps 4a1b3a4 the Generic 'Procedure for IP address allocation in the CP CIoT' described in TS 36.508 [18], clause 8.1.5A.1 takes place.				
4a1b3a4	The UE transmits an ACTIVATE DEFAULT EPS BEARER CONTEXT ACCEPT message.	-->	RRC: <i>ULInformationTransfer-NB</i> NAS:ACTIVATE DEFAULT EPS BEARER CONTEXT ACCEPT	-	-
4a1b3b1	Timer 2 sec expires	-	-	-	-
5	The SS transmits a SERVICE ACCEPT message.	<--	RRC: <i>DLInformationTransfer-NB</i> NAS: SERVICE ACCEPT	-	-

8.1.5A.2.4 Specific message contents

All specific message contents shall be referred to clause 8.1.6 and 4.7 with the exceptions below.

Table 8.1.5A.2.4-1: Message *RRCConnectionRequest-NB* (step 2, Table 8.1.5A.2.3-1)

Derivation path: Table 8.1.6.1-10			
Information Element	Value/Remark	Comment	Condition
RRCConnectionRequest-NB ::= SEQUENCE {			
criticalExtensions CHOICE {			
rrcConnectionRequest-r13 SEQUENCE {			
establishmentCause-r13	mt-Access		
}			
}			
}			

Table 8.1.5A.2.4-2: Message *RRCConnectionSetupComplete-NB* (steps 4a1a1, 4a1b1, Table 8.1.5A.2.3-1)

Derivation path: Table 8.1.6.1-15			
Information Element	Value/Remark	Comment	Condition
RRCConnectionSetupComplete-NB ::= SEQUENCE {			
rrc-TransactionIdentifier	the same value as included in the <i>RRCConnectionSetup-NB</i> message received from SS		
criticalExtensions CHOICE {			
rrcConnectionSetupComplete-r13 SEQUENCE {			
attachWithoutPDN-Connectivity-r13	True		px_DoAttachWithoutPDN
	Not Present		NOT px_DoAttachWithoutPDN
}			
}			
}			

Table 8.1.5A.2.4-3: PDN CONNECTIVITY REQUEST (steps 4a1a1, 4a1b3a1, Table 8.1.5A.2.3-1)

Derivation path: Table 4.7.3-20			
Information Element	Value/Remark	Comment	Condition
Access point name	Not Present or Any allowed value		
Protocol configuration options	Not Present		
Header compression configuration	Any allowed value		pc_HCCP Clot AND pc_IP_PD N
Extended protocol configuration options	Not Present or Any allowed value		

Table 8.1.5A.2.4-4: Message ACTIVATE DEFAULT EPS BEARER CONTEXT REQUEST (step 4a1b3a3, Table 8.1.5A.2.3-1)

Derivation path: Table 4.7.3-6			
Information Element	Value/Remark	Comment	Condition
Protocol configuration options	Not present		
Header compression configuration	0000H	No Compression profile NOTE: For the purposes of CloT (NAS) testing regardless of the Compression files supported by the UE and indicated in the PDN CONNECTIVITY REQUEST, the SS does not agree header compression to be applied.	pc_HCCP CloT AND pc_IP_PD N
Control plane only indication	'0001'B	PDN connection can be used for control plane CloT EPS optimization only	
Extended protocol configuration options		The content of the IE below uses the same fields and Conditions (and their meaning) as those defined in TS 36.508 [18] for the IE 'Protocol configuration options'	
Container ID n	'0003'H	n assigned to next available number	DNS IPv6
Length of container ID n contents		Length value determined by the TTCN implementation	
Container ID n contents	IPv6 address	DNS IPv6 Address	
Container ID n+1	'000D'H	n assigned to next available number	DNS IPv4
Length of container ID n+1 contents		Length value determined by the TTCN implementation	
Container ID n+1 contents	IPv4 address	DNS IPv4 Address	
Serving PLMN rate control	'11111111 11111111'B	Unrestricted Max number of uplink ESM DATA TRANSPORT messages including User data container IEs the UE is allowed to send via a PDN connection per 6 minute interval	

Table 8.1.5A.2.4-5: Message ACTIVATE DEFAULT EPS BEARER CONTEXT ACCEPT (step 4a1b3a4, Table 8.1.5A.2.3-1)

Derivation path: Table 4.7.3-4			
Information Element	Value/Remark	Comment	Condition
Protocol configuration options	Not present		
Extended protocol configuration options	Not present or any allowed value		

8.1.5A.3 Test procedure to check UE initiation of Control Plane Clot MO user data transfer non-SMS transport

8.1.5A.3.1 Initial conditions

System Simulator:

- 1 NB-IoT cell, default parameters.
- The procedure shall be performed under ideal radio conditions as defined in clause 8.2.

User Equipment:

- The UE is in RRC-IDLE.

8.1.5A.3.2 Definition of system information messages

The default system information messages are used with the exception(s) below.

Table 8.1.5A.3.2-1: SystemInformationBlockType1-NB

Derivation Path: Table 8.1.4.3.2-3, condition ATTACH_WITHOUT_PDN.

8.1.5A.3.3 Procedure

Table 8.1.5A.3.3-1: Control Plane CIoT MO user data transfer non-SMS transport

St	Procedure	Message Sequence		TP	Verdict
		U - S	Message/PDU/SDU		
1	Check: Does the UE transmit an <i>RRCConnectionRequest-NB</i> message?	-->	RRC: <i>RRCConnectionRequest-NB</i>	-	P
2	SS transmits an <i>RRCConnectionSetup-NB</i> message.	<--	RRC: <i>RRCConnectionSetup-NB</i>	-	-
-	EXCEPTION: Steps 3a1 to 3b1 describe behaviour that depends on UE capabilities; the "lower case letter" identifies a step sequence that take place depending on whether the UE is configured to do Attach Without PDN or not.	-	-	-	-
3a1a 1	Void.	-	-	-	-
3a1b 1	IF <i>px_DoAttachWithoutPDN</i> THEN Check: Does the UE transmit an <i>RRCConnectionSetupComplete-NB</i> message and a CONTROL PLANE SERVICE REQUEST message?	-->	RRC: <i>RRCConnectionSetupComplete-NB</i> NAS: CONTROL PLANE SERVICE REQUEST	-	P
3a1b 2	Check: Does the UE transmit a PDN CONNECTIVITY REQUEST message?	-->	RRC: <i>ULInformationTransfer-NB</i> NAS: PDN CONNECTIVITY REQUEST	-	P
3a2	The SS transmits an ACTIVATE DEFAULT EPS BEARER CONTEXT REQUEST message.	<--	RRC: <i>DLInformationTransfer-NB</i> NAS: ACTIVATE DEFAULT EPS BEARER CONTEXT REQUEST	-	-
-	EXCEPTION: IF <i>pc_IP_PDN</i> AND not all IP address information was allocated in the ACTIVATE DEFAULT EPS BEARER CONTEXT REQUEST message sent in step 3a2 THEN In parallel to the events described in steps 3a3 the Generic 'Procedure for IP address allocation in the CP CIoT' described in TS 36.508 [18], clause 8.1.5A.1 takes place.	-	-	-	-
3a3	Check: Does the UE transmit an ACTIVATE DEFAULT EPS BEARER CONTEXT ACCEPT message?	-->	RRC: <i>ULInformationTransfer-NB</i> NAS:ACTIVATE DEFAULT EPS BEARER CONTEXT ACCEPT	-	P
3a4	Check: Does the UE send an ESM DATA TRANSPORT message containing user data?	-->	RRC: <i>ULInformationTransfer-NB</i> NAS: ESM DATA TRANSPORT	-	P
3b1	ELSE (NOT <i>px_DoAttachWithoutPDN</i>) Check: Does the UE transmit an <i>RRCConnectionSetupComplete-NB</i> message and a CONTROL PLANE SERVICE REQUEST message containing user data encapsulated in an ESM DATA TRANSPORT message included in the ESM message container IE?	-->	RRC: <i>RRCConnectionSetupComplete-NB</i> NAS: CONTROL PLANE SERVICE REQUEST NAS: ESM DATA TRANSPORT	-	P
4	The SS transmits a SERVICE ACCEPT message.	<--	RRC: <i>DLInformationTransfer-NB</i> NAS: SERVICE ACCEPT	-	-

8.1.5A.3.4 Specific message contents

All specific message contents shall be referred to clause 8.1.6 and 4.7 with the exceptions below.

Table 8.1.5A.3.4-1: Message *RRCConnectionRequest-NB* (step 1, Table 8.1.5A.3.3-1)

Derivation path: Table 8.1.6.1-10			
Information Element	Value/Remark	Comment	Condition
<i>RRCConnectionRequest-NB</i> ::= SEQUENCE {			
criticalExtensions CHOICE {			
rrcConnectionRequest-r13 SEQUENCE {			
establishmentCause-r13	mo-data		
}			
}			
}			

Table 8.1.5A.3.4-2: Message *RRCConnectionSetupComplete-NB* (steps 3a1a1, 3a1b1, Table 8.1.5A.3.3-1)

Derivation path: Table 8.1.6.1-15			
Information Element	Value/Remark	Comment	Condition
<i>RRCConnectionSetupComplete-NB</i> ::= SEQUENCE {			
rrc-TransactionIdentifier	the same value as included in the <i>RRCConnectionSetup-NB</i> message received from SS		
criticalExtensions CHOICE {			
rrcConnectionSetupComplete-r13 SEQUENCE {			
attachWithoutPDN-Connectivity-r13	True		px_DoAttachWithoutPDN
	Not Present		NOT px_DoAttachWithoutPDN
}			
}			
}			

Table 8.1.5A.3.4-3: Message CONTROL PLANE SERVICE REQUEST (step 3b1, Table 8.1.5A.3.3-1)

Derivation path: Table 4.7.2-28.			
Information Element	Value/Remark	Comment	Condition
Data service type			
..Data service type value	mobile originating request		
ESM message container	ESM DATA TRANSPORT message, User data container not checked	If the ESM DATA TRANSPORT message 'User data container' IE needs to be checked and then its content shall be specified in TC	

Table 8.1.5A.3.4-4: PDN CONNECTIVITY REQUEST (steps 3a1a1, 3a1b2, Table 8.1.5A.3.3-1)

Derivation path: Table 4.7.3-20			
Information Element	Value/Remark	Comment	Condition
Access point name	Not Present or Any allowed value		
Protocol configuration options	Not Present		
Header compression configuration	Any allowed value		pc_HCCP Clot AND pc_IP_PD N
Extended protocol configuration options	Not Present or Any allowed value		

Table 8.1.5A.3.4-5: Message ACTIVATE DEFAULT EPS BEARER CONTEXT REQUEST (step 3a2, Table 8.1.5A.3.3-1)

Derivation path: Table 4.7.3-6			
Information Element	Value/Remark	Comment	Condition
Protocol configuration options	Not present		
Header compression configuration	0000H	No Compression profile NOTE: For the purposes of Clot (NAS) testing regardless of the Compression files supported by the UE and indicated in the PDN CONNECTIVITY REQUEST, the SS does not agree header compression to be applied.	pc_HCCP Clot AND pc_IP_PD N
Control plane only indication	'0001'B	PDN connection can be used for control plane Clot EPS optimization only	
Extended protocol configuration options		The content of the IE below uses the same fields and Conditions (and their meaning) as those defined in TS 36.508 [18] for the IE 'Protocol configuration options'	
Container ID n	'0003'H	n assigned to next available number	DNS IPv6
Length of container ID n contents		Length value determined by the TTCN implementation	
Container ID n contents	IPv6 address	DNS IPv6 Address	
Container ID n+1	'000D'H	n assigned to next available number	DNS IPv4
Length of container ID n+1 contents		Length value determined by the TTCN implementation	
Container ID n+1 contents	IPv4 address	DNS IPv4 Address	
Serving PLMN rate control	'11111111 11111111'B	Unrestricted Max number of uplink ESM DATA TRANSPORT messages including User data container IEs the UE is allowed to send via a PDN connection per 6 minute interval	

Table 8.1.5A.3.4-6: Message ACTIVATE DEFAULT EPS BEARER CONTEXT ACCEPT (step 3a3, Table 8.1.5A.3.3-1)

Derivation path: Table 4.7.3-4			
Information Element	Value/Remark	Comment	Condition
Protocol configuration options	Not present		
Extended protocol configuration options	Not present or any allowed value		

8.1.5A.3A Test procedure to check UE initiation of Control Plane ClOT MO user data transfer SMS transport

8.1.5A.3A.1 Initial conditions

System Simulator:

- 1 NB-IoT cell, default parameters.
- The procedure shall be performed under ideal radio conditions as defined in clause 8.2.

User Equipment:

- The UE is in RRC-IDLE.

8.1.5A.3A.2 Definition of system information messages

The default system information messages are used with the exception(s) below.

Table 8.1.5A.3A.2-1: SystemInformationBlockType1-NB

Derivation Path: Table 8.1.4.3.2-3, condition ATTACH_WITHOUT_PDN.

8.1.5A.3A.3 Procedure

Table 8.1.5A.3A.3-1: Control Plane ClOT MO user data transfer SMS transport

St	Procedure	Message Sequence		TP	Verdict
		U - S	Message/PDU/SDU		
1	Check: Does the UE transmit an <i>RRCConnectionRequest-NB</i> message?	-->	RRC: <i>RRCConnectionRequest-NB</i>	-	P
2	SS transmits an <i>RRCConnectionSetup-NB</i> message.	<--	RRC: <i>RRCConnectionSetup-NB</i>	-	-
3a1	Void.	-	-	-	-
3a2	Void.	-	-	-	-
3a3	Void.	-	-	-	-
3b1	Check: Does the UE transmit an <i>RRCConnectionSetupComplete-NB</i> message and a CONTROL PLANE SERVICE REQUEST message, data service type="mobile originating request", integrity protected and partially ciphered and including the SMS in the NAS message container IE, and, not containing a PDN CONNECTIVITY REQUEST message?	-->	RRC: <i>RRCConnectionSetupComplete-NB</i> NAS: CONTROL PLANE SERVICE REQUEST	-	P
3b2	SS starts wait timer 2 sec. Note: The Service request procedure success is guarded in the UE by timer T3417 = 5 sec after which expiry without any DL action the UE will consider the procedure as failed.	-	-	-	-
-	EXCEPTION: Steps 3b3a1 to 3b3b1 describe behaviour which depends on UE implementation; the "lower case letter" identifies a step sequence which takes place depending on whether the UE is configured or not to establish PDN in RRC-CONNECTED after it sends the CONTROL PLANE SERVICE REQUEST message.	-	-	-	-
3b3a 1	IF <i>px_nonSMSTransport_CP_CIoT</i> AND <i>px_DoAttachWithoutPDN</i> THEN The UE transmits a PDN CONNECTIVITY REQUEST message.	-->	RRC: <i>ULInformationTransfer-NB</i> NAS: PDN CONNECTIVITY REQUEST	-	-
3b3a 2	Stop timer wait timer 2 sec.	-	-	-	-
3b3a 3	The SS transmits an ACTIVATE DEFAULT EPS BEARER CONTEXT REQUEST message.	<--	RRC: <i>DLInformationTransfer-NB</i> NAS: ACTIVATE DEFAULT EPS BEARER CONTEXT REQUEST	-	-
-	EXCEPTION: IF <i>pc_IP_PDN</i> AND not all IP address information was allocated in the ACTIVATE DEFAULT EPS BEARER CONTEXT REQUEST message sent in step 3b3a3 THEN In parallel to the events described in steps 3b3a4 the Generic 'Procedure for IP address allocation in the CP ClOT' described in TS 36.508 [18], clause 8.1.5A.1 takes place.	-	-	-	-
3b3a 4	The UE transmits an ACTIVATE DEFAULT EPS BEARER CONTEXT ACCEPT message.	-->	RRC: <i>ULInformationTransfer-NB</i> NAS:ACTIVATE DEFAULT EPS BEARER CONTEXT ACCEPT	-	-
3b3b 1	Timer 2 sec expires	-	-	-	-
4	The SS transmits a SERVICE ACCEPT message.	<--	RRC: <i>DLInformationTransfer-NB</i> NAS: SERVICE ACCEPT	-	-

8.1.5A.3A.4 Specific message contents

All specific message contents shall be referred to clause 8.1.6 and 4.7 with the exceptions below.

Table 8.1.5A.3A.4-1: Message *RRCCONNECTIONREQUEST-NB* (step 1, Table 8.1.5A.3A.3-1)

Derivation path: Table 8.1.6.1-10			
Information Element	Value/Remark	Comment	Condition
RRCCONNECTIONREQUEST-NB ::= SEQUENCE {			
criticalExtensions CHOICE {			
rrcConnectionRequest-r13 SEQUENCE {			
establishmentCause-r13	mo-data		
}			
}			
}			

Table 8.1.5A.3A.4-2: Message *RRCCONNECTIONSETUPCOMPLETE-NB* (steps 3a1, 3b1, Table 8.1.5A.3A.3-1)

Derivation path: Table 8.1.6.1-15			
Information Element	Value/Remark	Comment	Condition
RRCCONNECTIONSETUPCOMPLETE-NB ::= SEQUENCE {			
rrc-TransactionIdentifier	the same value as included in the <i>RRCCONNECTIONSETUP-NB</i> message received from SS		
criticalExtensions CHOICE {			
rrcConnectionSetupComplete-r13 SEQUENCE {			
attachWithoutPDN-Connectivity-r13	True		px_DoAttachWithoutPDN
	Not Present		NOT px_DoAttachWithoutPDN
}			
}			
}			

Table 8.1.5A.3A.4-3: Message CONTROL PLANE SERVICE REQUEST (steps 3a1, 3b1, Table 8.1.5A.3A.3-1)

Derivation path: Table 4.7.2-28.			
Information Element	Value/Remark	Comment	Condition
Data service type			
..Data service type value	mobile originating request		
NAS message container	SMS - content not checked	If the SMS needs to be checked and then its content shall be specified in TC	

Table 8.1.5A.3A.4-4: PDN CONNECTIVITY REQUEST (steps 3a1, 3b3a1, Table 8.1.5A.3A.3-1)

Derivation path: Table 4.7.3-20			
Information Element	Value/Remark	Comment	Condition
Access point name	Not Present or Any allowed value		
Protocol configuration options	Not Present		
Header compression configuration	Any allowed value		pc_HCCP Clot AND pc_IP_PD N
Extended protocol configuration options	Not Present or Any allowed value		

Table 8.1.5A.3A.4-5: Message ACTIVATE DEFAULT EPS BEARER CONTEXT REQUEST (steps 3a2, 3b3a3, Table 8.1.5A.3A.3-1)

Derivation path: Table 4.7.3-6			
Information Element	Value/Remark	Comment	Condition
Protocol configuration options	Not present		
Header compression configuration	0000H	No Compression profile NOTE: For the purposes of Clot (NAS) testing regardless of the Compression files supported by the UE and indicated in the PDN CONNECTIVITY REQUEST, the SS does not agree header compression to be applied.	pc_HCCP Clot AND pc_IP_PD N
Control plane only indication	'0001'B	PDN connection can be used for control plane Clot EPS optimization only	
Extended protocol configuration options		The content of the IE below uses the same fields and Conditions (and their meaning) as those defined in TS 36.508 [18] for the IE 'Protocol configuration options'	
Container ID n	'0003'H	n assigned to next available number	DNS IPv6
Length of container ID n contents		Length value determined by the TTCN implementation	
Container ID n contents	IPv6 address	DNS IPv6 Address	
Container ID n+1	'000D'H	n assigned to next available number	DNS IPv4
Length of container ID n+1 contents		Length value determined by the TTCN implementation	
Container ID n+1 contents	IPv4 address	DNS IPv4 Address	
Serving PLMN rate control	'11111111 11111111'B	Unrestricted Max number of uplink ESM DATA TRANSPORT messages including User data container IEs the UE is allowed to send via a PDN connection per 6 minute interval	

Table 8.1.5A.3A.4-6: Message ACTIVATE DEFAULT EPS BEARER CONTEXT ACCEPT (steps 3a3, 3b3a4, Table 8.1.5A.3A.3-1)

Derivation path: Table 4.7.3-4			
Information Element	Value/Remark	Comment	Condition
Protocol configuration options	Not present		
Extended protocol configuration options	Not present or any allowed value		

8.1.5A.4 Test procedure to check release of PDN connectivity before leaving RRC-CONNECTED for attach without PDN

8.1.5A.4.1 Initial conditions

- 1 NB-IoT cell, default parameters.
- The procedure shall be performed under ideal radio conditions as defined in clause 8.2.

User Equipment:

- The UE is in RRC-CONNECTED.
- px_DoAttachWithoutPDN=TRUE

8.1.5A.4.2 Definition of system information messages

The default system information messages are used with the exception(s) below.

Table 8.1.5A.4.2-1: SystemInformationBlockType1-NB

Derivation Path: Table 8.1.4.3.2-3, condition ATTACH_WITHOUT_PDN.

8.1.5A.4.3 Procedure

Table 8.1.5A.4.3-1: Release of PDN connectivity before leaving RRC-CONNECTED for attach without PDN

St	Procedure	Message Sequence		TP	Verdict
		U - S	Message/PDU/SDU		
-	EXCEPTION: Steps 1a1 and 1b2 describe behaviour that depends on UE implementation; the "lower case letter" identifies a step sequence which may take place depending on whether the UE is configured to do Attach Without PDN or not.	-	-	-	-
1	SS starts timer 60 sec	-	-	-	-
-	EXCEPTION: Steps 2a1-2b3 describe behaviour that depends on UE implementation; the "lower case letter" identifies a step sequence which may take place depending on whether the UE will initiate PDN deactivation.	-	-	-	-
2a1	Check: Does the UE transmit a PDN DISCONNECT REQUEST message?	-->	RRC: <i>ULInformationTransfer</i> NAS: PDN DISCONNECT REQUEST	-	P
2a2	The SS transmits a DEACTIVATE EPS BEARER CONTEXT REQUEST message.	<--	RRC: <i>DLInformationTransfer-NB</i> NAS: DEACTIVATE EPS BEARER CONTEXT REQUEST	-	-
2a3	Check: Does the UE transmit a DEACTIVATE EPS BEARER CONTEXT ACCEPT message?	-->	RRC: <i>ULInformationTransfer</i> NAS: DEACTIVATE EPS BEARER CONTEXT ACCEPT	-	P
2a4	SS stops 60 sec timer.	-	-	-	-
2b1	60 sec timer expires.	-	-	-	-
2b2	SS releases the PDN connectivity by transmitting a DEACTIVATE EPS BEARER CONTEXT REQUEST message.	<--	RRC: <i>DLInformationTransfer-NB</i> NAS: DEACTIVATE EPS BEARER CONTEXT REQUEST	-	-
2b3	Check: Does the UE transmit a DEACTIVATE EPS BEARER CONTEXT ACCEPT message?	-->	RRC: <i>ULInformationTransfer-NB</i> NAS: DEACTIVATE EPS BEARER CONTEXT ACCEPT	-	P

8.1.5A.4.4 Specific message contents

All specific message contents shall be referred to clause 8.1.6 and 4.7 with the exceptions below.

Table 8.1.5A.4.4-1: DEACTIVATE EPS BEARER CONTEXT REQUEST (step 2a2, Table 8.1.5A.4.3-1)

Derivation Path: Table 4.7.3-12, Condition UE-INITIATED			
Information Element	Value/remark	Comment	Condition
ESM cause	00100100	regular deactivation	

Table 8.1.5A.4.4-2: DEACTIVATE EPS BEARER CONTEXT REQUEST (step 2b2, Table 8.1.5A.4.3-1)

Derivation Path: Table 4.7.3-12, Condition NETWORK-INITIATED			
Information Element	Value/remark	Comment	Condition
ESM cause	00100100	regular deactivation	

8.1.5A.5 Test procedure to check that NB-IoT UE is camped on a new NB-IOT cell

This procedure verifies whether the UE has camped on a new NB-IoT cell with different TAI.

The procedure is defined in table 8.1.5A.5-1.

Table 8.1.5A.5-1: Test procedure sequence

St	Procedure	Message Sequence		TP	Verdict
		U - S	Message		
1	The UE transmits an <i>RRCConnectionRequest-NB</i> message on the cell specified in the test case.	-->	RRC: <i>RRCConnectionRequest-NB</i>	-	-
2	SS transmit an <i>RRCConnectionSetup-NB</i> message.	<--	RRC: <i>RRCConnectionSetup-NB</i>	-	-
3	The UE transmits an <i>RRCConnectionSetupComplete-NB</i> message to confirm the successful completion of the connection establishment and a TRACKING AREA UPDATE REQUEST message is sent to update the registration of the actual tracking area.	-->	RRC: <i>RRCConnectionSetupComplete-NB</i> NAS: TRACKING AREA UPDATE REQUEST	-	-
4	SS responds with TRACKING AREA UPDATE ACCEPT message.	<--	RRC: <i>DLInformationTransfer-NB</i> NAS: TRACKING AREA UPDATE ACCEPT	-	-
5	Check: Does the UE send a TRACKING AREA UPDATE COMPLETE on the cell specified in the test case?	-->	RRC: <i>ULInformationTransfer-NB</i> NAS: TRACKING AREA UPDATE COMPLETE	-	P
6	The SS transmits an <i>RRCConnectionRelease-NB</i> message to release RRC connection and move to RRC_IDLE.	<--	RRC: <i>RRCConnectionRelease-NB</i>	-	-

8.1.5A.6 Test procedure to check that NB-IoT UE resume RRC connection on a new NB-IOT cell

This procedure verifies whether the UE resumes RRC connection on a new NB-IoT cell with different TAI.

The procedure is defined in table 8.1.5A.6-1.

Table 8.1.5A.6-1: Test procedure sequence

St	Procedure	Message Sequence		TP	Verdict
		U - S	Message		
1	The UE transmits an <i>RRCConnectionResumeRequest-NB</i> message on the cell specified in the test case.	-->	RRC: <i>RRCConnectionResumeRequest-NB</i>	-	-
2	SS transmits an <i>RRCConnectionResume-NB</i> message.	<--	RRC: <i>RRCConnectionResume-NB</i>	-	-
3	The UE transmits an <i>RRCConnectionResumeComplete-NB</i> message to confirm the successful completion of the connection establishment and a TRACKING AREA UPDATE REQUEST message is sent to update the registration of the actual tracking area.	-->	RRC: <i>RRCConnectionResumeComplete-NB</i> NAS: TRACKING AREA UPDATE REQUEST	-	-
4	SS responds with TRACKING AREA UPDATE ACCEPT message.	<--	RRC: <i>DLInformationTransfer-NB</i> NAS: TRACKING AREA UPDATE ACCEPT	-	-
5	Check: Does the UE send a TRACKING AREA UPDATE COMPLETE on the cell specified in the test case?	-->	RRC: <i>ULInformationTransfer-NB</i> NAS: TRACKING AREA UPDATE COMPLETE	-	P
6	The SS transmits an <i>RRCConnectionRelease-NB</i> message to release RRC connection and move to RRC_IDLE.	<--	RRC: <i>RRCConnectionRelease-NB</i>	-	-

8.1.5A.7

8.1.5A.8 Test procedure to check RRC_CONNECTED state for NB-IoT

Table 8.1.5A.8-1: Test procedure sequence

St	Procedure	Message Sequence		TP	Verdict
		U - S	Message/PDU/SDU		
1	The SS sends <i>UECapabilityEnquiry-NB</i> message to the UE.	<--	<i>UECapabilityEnquiry-NB</i>	-	-
2	Check: Does the UE send a <i>UECapabilityInformation-NB</i> message?	-->	<i>UECapabilityInformation-NB</i>	-	P

8.1.5A.9 Test Procedure to establish radio bearers in User Plane

8.1.5A.9.1 Initial conditions

System Simulator:

- Parameters are set to the default parameters for the NB-IoT single cell environment, as defined in subclause 8.1.4.1.1, unless otherwise specified in the test case.
- The procedure shall be performed under ideal radio conditions as defined in clause 8.2

User Equipment:

- The NB-IoT UE shall be in NB-IoT Registered, Idle mode (State 3-NB) for condition S1_U_DataTransfer.

8.1.5A.9.2 Definition of system information messages

The default system information messages are used with the exception(s) below.

Table 8.1.5A.9.2-1: SystemInformationBlockType1-NB

Derivation Path: Table 8.1.4.3.2-3, condition ATTACH_WITH_PDN.
--

8.1.5A.9.3 Procedure

The establishment of generic radio bearer connection is assumed to always be mobile terminated.

Table 8.1.5A.9.3-1: Generic Radio Bearer establishment procedure

Step	Procedure	U - S	Message Sequence Message
1	SS sends a <i>Paging</i> message to the UE on the appropriate paging block, and including the UE identity in one entry of the IE <i>pagingRecordLists</i> .	<--	RRC: <i>Paging-NB</i>
2	UE transmits an <i>RRCCONNECTIONREQUEST-NB</i> message.	-->	RRC: <i>RRCCONNECTIONREQUEST-NB</i>
3	SS transmit an <i>RRCCONNECTIONSETUP-NB</i> message.	<--	RRC: <i>RRCCONNECTIONSETUP-NB</i>
4	The UE transmits an <i>RRCCONNECTIONSETUPCOMPLETE-NB</i> message to confirm the successful completion of the connection establishment and to initiate the session management procedure by including the CONTROL PLANE SERVICE REQUEST message.	-->	RRC: <i>RRCCONNECTIONSETUPCOMPLETE-NB</i> NAS: CONTROL PLANE SERVICE REQUEST
5	The SS transmits a <i>SecurityModeCommand</i> message to activate AS security.	<--	RRC: <i>SecurityModeCommand</i>
6	The UE transmits a <i>SecurityModeComplete</i> message and establishes the initial security configuration.	-->	RRC: <i>SecurityModeComplete</i>
7	The SS configures a new data radio bearer, associated with the default EPS bearer context. The <i>RRCCONNECTIONRECONFIGURATION-NB</i> message is using condition DRB(1).	<--	RRC: <i>RRCCONNECTIONRECONFIGURATION-NB</i>
8	The UE transmits an <i>RRCCONNECTIONRECONFIGURATIONCOMPLETE-NB</i> message to confirm the establishment of the new data radio bearer, associated with the default EPS bearer context.	-->	RRC: <i>RRCCONNECTIONRECONFIGURATIONCOMPLETE-NB</i>

8.1.5A.9.4 Specific message contents

All specific message contents shall be referred to clause 4.6, 4.7 and 8.1.6.

8.1.6 NB-IoT Default RRC message and information elements contents

This clause contains the default values of common RRC messages and information elements, which unless indicated otherwise in specific clauses of TS 36.521-1 [21], TS 36.521-3 [34], TS 36.523-1 [18] and other clauses in this specification. All the messages and information elements are listed in alphabetical order.

8.1.6.1 NB-IoT Contents of RRC messages

– *DLInformationTransfer-NB***Table 8.1.6.1-1: *DLInformationTransfer-NB***

Derivation Path: 36.331 clause 6.7.2			
Information Element	Value/remark	Comment	Condition
DLInformationTransfer-NB ::= SEQUENCE {			
rrc-TransactionIdentifier	RRC-TransactionIdentifier-DL		
criticalExtensions CHOICE {			
c1 CHOICE {			
dlInformationTransfer-r13 SEQUENCE {			
dedicatedInfoNAS-r13	Set according to specific message content		
lateNonCriticalExtension	Not present		
nonCriticalExtension SEQUENCE {}	Not present		
}			
}			
}			
}			

– *Paging-NB***Table 8.1.6.1-2: *Paging-NB***

Derivation Path: 36.331 clause 6.7.2			
Information Element	Value/remark	Comment	Condition
Paging-NB ::= SEQUENCE {			
pagingRecordList-r13 SEQUENCE (SIZE (1..maxPageRec)) OF SEQUENCE {	1 entry		
ue-Identity-r13[1] CHOICE {			
s-TMSI	Set to the value of the S-TMSI of the UE		
}			
}			
systemInfoModification-r13	Not present		
systemInfoModification-eDRX-r13	Not present		
nonCriticalExtension SEQUENCE {}	Not present		
}			

RRCConnectionReconfiguration-NB

Table 8.1.6.1-3: RRCConnectionReconfiguration-NB

Derivation Path: 36.331 clause 6.7.2			
Information Element	Value/remark	Comment	Condition
RRCConnectionReconfiguration-NB ::= SEQUENCE {			
rrc-TransactionIdentifier	RRC-TransactionIdentifier-DL		
criticalExtensions CHOICE {			
c1 CHOICE{			
rrcConnectionReconfiguration-r13 SEQUENCE {			
dedicatedInfoNASList-r13	Not present		
	Set according to specific message content		NB-DRB(n)
radioResourceConfigDedicated-r13	Not present		
	RadioResourceConfigDedicated-NB-DRB(n)		NB-DRB(n)
fullConfig-r13	Not present		
	Present		Reestab
lateNonCriticalExtension	Not present		
nonCriticalExtension SEQUENCE {}	Not present		
}			
}			
}			
}			

Condition	Explanation
NB-DRB	Establishment of additional n x AM DRB:s (maximum number of AM DRBs: 2)
Reestab	This field is optionally present, need ON upon the first reconfiguration after RRC connection re-establishment; otherwise the field is not present

RRCConnectionReconfigurationComplete-NB

Table 8.1.6.1-4: RRCConnectionReconfigurationComplete-NB

Derivation Path: 36.331 clause 6.7.2			
Information Element	Value/remark	Comment	Condition
RRCConnectionReconfigurationComplete-NB ::= SEQUENCE {			
rrc-TransactionIdentifier	RRC-TransactionIdentifier-UL		
criticalExtensions CHOICE {			
rrcConnectionReconfigurationComplete-r13 SEQUENCE {			
lateNonCriticalExtension	Not checked		
nonCriticalExtension SEQUENCE {}	Not checked		
}			
}			
}			

– *RRCCONNECTIONREESTABLISHMENT-NB***Table 8.1.6.1-5: *RRCCONNECTIONREESTABLISHMENT-NB***

Derivation Path: 36.331 clause 6.7.2			
Information Element	Value/remark	Comment	Condition
RRCCONNECTIONREESTABLISHMENT-NB ::= SEQUENCE {			
rrc-TransactionIdentifier	RRC-TransactionIdentifier-DL		
criticalExtensions CHOICE {			
c1 CHOICE {			
rrcConnectionReestablishment-r13 SEQUENCE {			
radioResourceConfigDedicated-r13	RadioResourceConfigDedicated-NB-SRB		
nextHopChainingCount	0		
lateNonCriticalExtension	Not present		
nonCriticalExtension SEQUENCE {}	Not present		
}			
}			
}			
}			

– *RRCCONNECTIONREESTABLISHMENTCOMPLETE-NB***Table 8.1.6.1-6: *RRCCONNECTIONREESTABLISHMENTCOMPLETE-NB***

Derivation Path: 36.331 clause 6.7.2			
Information Element	Value/remark	Comment	Condition
RRCCONNECTIONREESTABLISHMENTCOMPLETE-NB ::= SEQUENCE {			
rrc-TransactionIdentifier	RRC-TransactionIdentifier-UL		
criticalExtensions CHOICE {			
rrcConnectionReestablishmentComplete-r13 SEQUENCE {			
lateNonCriticalExtension	Not checked		
nonCriticalExtension SEQUENCE {}	Not checked		
}			
}			
}			

– *RRCCONNECTIONREESTABLISHMENTREQUEST-NB***Table 8.1.6.1-7: RRCCONNECTIONREESTABLISHMENTREQUEST-NB**

Derivation Path: 36.331 clause 6.7.2			
Information Element	Value/remark	Comment	Condition
RRCCONNECTIONREESTABLISHMENTREQUEST-NB ::= SEQUENCE {			
criticalExtensions CHOICE {			
rrcConnectionReestablishmentRequest-r13 SEQUENCE {			
ue-Identity-r13	Set according to specific message content		
reestablishmentCause-r13	Set according to specific message content		
spare	Present but contents not checked		
}			
}			
}			

– *RRCCONNECTIONREJECT-NB***Table 8.1.6.1-8: RRCCONNECTIONREJECT-NB**

Derivation Path: 36.331 clause 6.7.2			
Information Element	Value/remark	Comment	Condition
RRCCONNECTIONREJECT-NB ::= SEQUENCE {			
criticalExtensions CHOICE {			
c1 CHOICE {			
rrcConnectionReject-r13 SEQUENCE {			
extendedWaitTime	3(seconds)		
rrc-SuspendIndication-r13	Not present		
lateNonCriticalExtension	Not present		
nonCriticalExtension SEQUENCE {}	Not present		
}			
}			
}			
}			

– *RRCConnectionRelease-NB***Table 8.1.6.1-9: RRCConnectionRelease-NB**

Derivation Path: 36.331 clause 6.7.2			
Information Element	Value/remark	Comment	Condition
RRCConnectionRelease-NB ::= SEQUENCE {			
rrc-TransactionIdentifier	RRC-TransactionIdentifier-DL		
criticalExtensions CHOICE {			
c1 CHOICE {			
rrcConnectionRelease-r13 SEQUENCE {			
releaseCause-r13	other		
resumeldentity-r13	Not present		
extendedWaitTime-r13	Not present		
redirectedCarrierInfo	Not present		
lateNonCriticalExtension	Not present		
nonCriticalExtension SEQUENCE {}	Not present		
}			
}			
}			
}			

– *RRCConnectionRequest-NB***Table 8.1.6.1-10: RRCConnectionRequest-NB**

Derivation Path: 36.331 clause 6.7.2			
Information Element	Value/remark	Comment	Condition
RRCConnectionRequest-NB ::= SEQUENCE {			
criticalExtensions CHOICE {			
rrcConnectionRequest-r13 SEQUENCE {			
ue-Identity-r13 CHOICE {			
s-TMSI	Any allowed value		
}			
establishmentCause-r13	Present but contents not checked		
multiToneSupport-r13	Not checked		
multiCarrierSupport-r13	Not checked		
spare	Present but contents not checked		
}			
}			

– *RRCCONNECTIONRESUME-NB***Table 8.1.6.1-11: RRCCONNECTIONRESUME-NB**

Derivation Path: 36.331 clause 6.7.2			
Information Element	Value/remark	Comment	Condition
RRCCONNECTIONRESUME-NB ::= SEQUENCE {		(Note 1)	
rrc-TransactionIdentifier	RRC-TransactionIdentifier-DL		
criticalExtensions CHOICE {			
c1 CHOICE {			
rrcConnectionResume-r13 SEQUENCE {			
radioResourceConfigDedicated-r13	RadioResourceConfigDedicated-NB-DRB(n)		
nextHopChainingCount-r13	0		
drb-ContinueROHC-r13	Not present		
lateNonCriticalExtension	Not present		
nonCriticalExtension SEQUENCE {}	Not present		
}			
}			
}			
}			
Note 1: The RRCCONNECTIONRESUME-NB (SRB-1 DCCH message) is sent on the same MAC PDU as Contention Resolution (RA Msg4).			

– *RRCCONNECTIONRESUMECOMPLETE-NB***Table 8.1.6.1-12: RRCCONNECTIONRESUMECOMPLETE-NB**

Derivation Path: 36.331 clause 6.7.2			
Information Element	Value/remark	Comment	Condition
RRCCONNECTIONRESUMECOMPLETE-NB ::= SEQUENCE {			
rrc-TransactionIdentifier	RRC-TransactionIdentifier-UL		
criticalExtensions CHOICE {			
rrcConnectionResumeComplete-r13 SEQUENCE {			
selectedPLMN-Identity-r13	Not checked		
dedicatedInfoNAS-r13	Not checked		
lateNonCriticalExtension	Not checked		
nonCriticalExtension SEQUENCE {}	Not checked		
}			
}			
}			

– *RRCCONNECTIONRESUMEREQUEST-NB***Table 8.1.6.1-13: RRCCONNECTIONRESUMEREQUEST-NB**

Derivation Path: 36.331 clause 6.7.2			
Information Element	Value/remark	Comment	Condition
RRCCONNECTIONRESUMEREQUEST-NB ::= SEQUENCE {			
criticalExtensions CHOICE {			
rrcConnectionResumeRequest-r13 SEQUENCE {			
resumeID-r13	Present but contents not checked		
resumeMAC-I-r13	Present but contents not checked		
resumeCause-r13	Present but contents not checked		
spare	Present but contents not checked		
}			
}			
}			

– *RRCCONNECTIONSETUP-NB***Table 8.1.6.1-14: RRCCONNECTIONSETUP-NB**

Derivation Path: 36.331 clause 6.7.2			
Information Element	Value/remark	Comment	Condition
RRCCONNECTIONSETUP-NB ::= SEQUENCE {			
rrc-TransactionIdentifier	RRC-TransactionIdentifier-DL		
criticalExtensions CHOICE {			
c1 CHOICE {			
rrcConnectionSetup-r13 SEQUENCE {			
radioResourceConfigDedicated-r13	RadioResourceConfigDedicated-NB-SRB		
lateNonCriticalExtension	Not present		
nonCriticalExtension SEQUENCE {	Not present		
}			
}			
}			
}			

– *RRCConnectionSetupComplete-NB***Table 8.1.6.1-15: *RRCConnectionSetupComplete-NB***

Derivation Path: 36.331 clause 6.7.2			
Information Element	Value/remark	Comment	Condition
RRCConnectionSetupComplete-NB ::= SEQUENCE {			
rrc-TransactionIdentifier	RRC-TransactionIdentifier-UL		
criticalExtensions CHOICE {			
rrcConnectionSetupComplete-r13 SEQUENCE {			
selectedPLMN-Identity	1		
s-TMSI-r13	Not checked		
registeredMME	Not checked		
dedicatedInfoNAS	Present but contents not checked		
attachWithoutPDN-Connectivity-r13	Not checked		
up-CIoT-EPS-Optimisation-r13	Not checked		
lateNonCriticalExtension	Not checked		
nonCriticalExtension SEQUENCE {}	Not checked		
}			
}			
}			

– SCPTMConfiguration-NB

Table 8.1.6.1-15a: SCPTMConfiguration-NB

Derivation Path: 36.331 clause 6.7.2			
Information Element	Value/remark	Comment	Condition
SCPTMConfiguration-NB-r14 ::= SEQUENCE {			
sc-mtch-InfoList-r14 SEQUENCE (SIZE (0.. maxSC-MTCH-NB-r14)) OF SEQUENCE {	1 entry		
sc-mtch-CarrierConfig-r14 CHOICE {			
dl-CarrierConfig-r14	DL-CarrierConfigCommon-NB-DEFAULT		
dl-CarrierIndex-r14	0	INTEGER (0.. maxNonAnchorCarriers-NB-r14)	
}			
mbmsSessionInfo-r14 SEQUENCE {			
tmgi-r13 SEQUENCE {			
plmn-Id-r9 CHOICE {			
plmn-Index-r9	1		
}			
}			
serviceld-r9	'000001'H	OCTET STRING (SIZE (3))	
}			
sessionId-r13	Not present		
}			
g-RNTI-r14	'0100'H		
sc-mtch-SchedulingInfo-r14	Not present		
sc-mtch-neighbourCell-r14	Not present		
npdcch-NPDSCH-MaxTBS-SC-MTCH-r14	n680		
npdcch-NumRepetitions-SC-MTCH-r14	r16		
npdcch-StartSF-SC-MTCH-r14	v4		
npdcch-Offset-SC-MTCH-r14	zero		
}			
scptm-NeighbourCellList-r14	Not present		
lateNonCriticalExtension	Not present		
nonCriticalExtension SEQUENCE {}	Not present		
}			
}			
}			
}			
}			

– UECapabilityEnquiry-NB

Table 8.1.6.1-16: UECapabilityEnquiry-NB

Derivation Path: 36.331 clause 6.7.2			
Information Element	Value/remark	Comment	Condition
UECapabilityEnquiry-NB ::= SEQUENCE {			
rrc-TransactionIdentifier	RRC-TransactionIdentifier-DL		
criticalExtensions CHOICE {			
c1 CHOICE {			
ueCapabilityEnquiry-r13 SEQUENCE {			
lateNonCriticalExtension	Not present		
nonCriticalExtension SEQUENCE {}	Not present		
}			
}			
}			
}			
}			
}			

– *UECapabilityInformation-NB***Table 8.1.6.1-17: UECapabilityInformation-NB**

Derivation Path: 36.331 clause 6.7.2			
Information Element	Value/remark	Comment	Condition
UECapabilityInformation-NB ::= SEQUENCE {			
rrc-TransactionIdentifier	RRC-TransactionIdentifier-UL		
criticalExtensions CHOICE {			
ueCapabilityInformation-r13 SEQUENCE {			
ue-Capability-Container-r13 SEQUENCE {			
accessStratumRelease-r13	Same as indicated in TC applicability in TS 36.523-2 [19]		
ue-Category-NB-r13	Not checked		
multipleDRB-r13	Not checked		
pdcp-Parameters-r13	Not checked		
phyLayerParameters-r13 SEQUENCE {			
multiTone-r13	Not checked		
multiCarrier-r13	Not checked		
}			
rf-Parameters-r13	Not checked		
nonCriticalExtension SEQUENCE {}	Not checked		
}			
ue-RadioPagingInfo-r13 SEQUENCE {			
ue-Category-NB-r13	Not checked		
}			
lateNonCriticalExtension	Not checked		
nonCriticalExtension SEQUENCE {}	Not checked		
}			
}			

– *ULInformationTransfer-NB***Table 8.1.6.1-18: ULInformationTransfer-NB**

Derivation Path: 36.331 clause 6.7.2			
Information Element	Value/remark	Comment	Condition
ULInformationTransfer-NB ::= SEQUENCE {			
criticalExtensions CHOICE {			
ulInformationTransfer-r13 SEQUENCE {			
dedicatedInfoNAS-r13	Present but contents not checked		
lateNonCriticalExtension	Not checked		
nonCriticalExtension SEQUENCE {}	Not checked		
}			
}			
}			

8.1.6.2 NB-IoT System information blocks

See subclause 8.1.4.3.3 in this document.

8.1.6.3 NB-IoT Radio resource control information elements

– BCCH-Config-NB-DEFAULT

Table 8.1.6.3-1: BCCH-Config-NB-DEFAULT

Derivation Path: 36.331 clause 6.7.3			
Information Element	Value/remark	Comment	Condition
BCCH-Config-NB-DEFAULT ::= SEQUENCE {			
modificationPeriodCoeff-r13	n32	To provide reliable delivery of SI change notifications.	
}			

– DL-CarrierConfigCommon-NB-DEFAULT

Table 8.1.6.3-1A: DL-CarrierConfigCommon-NB-DEFAULT

Derivation Path: 36.331 clause 6.7.3.2			
Information Element	Value/remark	Comment	Condition
DL-CarrierConfigCommon-NB-DEFAULT ::= SEQUENCE {			
dl-CarrierFreq-r14	See subclause 8.1.3.1		
downlinkBitmapNonAnchor-r14 CHOICE {			
useNoBitmap	NULL		
}			
dl-GapNonAnchor-r14 CHOICE {			
useNoGap-r14	NULL		
}			
inbandCarrierInfo-r14 SEQUENCE {			NON-ANCHOR-INBAND
samePCI-Indicator-r14	Not present		
eutraControlRegionSize-r14	n2		
}			
nrs-PowerOffsetNonAnchor-r14	dB0		
}			

Condition	Explanation
NON-ANCHOR-INBAND	The non-anchor carrier is an inband carrier

– PCCH-Config-NB-DEFAULT

Table 8.1.6.3-2: PCCH-Config-NB-DEFAULT

Derivation Path: 36.331 clause 6.7.3			
Information Element	Value/remark	Comment	Condition
PCCH-Config-NB-DEFAULT ::= SEQUENCE {			
defaultPagingCycle-r13	rf128	Typical value in real network.	
nB-r13	oneT		
npdcch-NumRepetitionPaging-r13	r8		
}			

– NPDCCH-ConfigDedicated-NB-DEFAULT

Table 8.1.6.3-3: NPDCCH-ConfigDedicated-NB-DEFAULT

Derivation Path: 36.331 clause 6.7.3			
Information Element	Value/remark	Comment	Condition
NPDCCH-ConfigDedicated-NB-DEFAULT ::= SEQUENCE {			
npdcch-NumRepetitions-r13	r16		
npdcch-StartSF-USS-r13	v4		
npdcch-Offset-USS-r13	zero		
}			

– NPDSCH-ConfigCommon-NB-DEFAULT

Table 8.1.6.3-4: NPDSCH-ConfigCommon-NB-DEFAULT

Derivation Path: 36.331 clause 6.7.3			
Information Element	Value/remark	Comment	Condition
NPDSCH-ConfigCommon-NB-DEFAULT ::= SEQUENCE {			
nrs-Power-r13	44 (dBm)		
}			

– NPRACH-ConfigSIB-NB-DEFAULT

Table 8.1.6.3-5: NPRACH-ConfigSIB-NB-DEFAULT

Derivation Path: 36.331 clause 6.7.3			
Information Element	Value/remark	Comment	Condition
NPRACH-ConfigSIB-NB-DEFAULT ::= SEQUENCE {			
nprach-CP-Length-r13	us66dot7		
rsrp-ThresholdsPrachInfoList-r13	Not present	Only one resource	
nprach-ParametersList-r13 SEQUENCE (SIZE (1.. maxNPRACH-Resources-NB-r13)) OF SEQUENCE {	1 entry		
nprach-Periodicity-r13	ms80		
nprach-StartTime-r13	ms32		
nprach-SubcarrierOffset-r13	n12		
nprach-NumSubcarriers-r13	n12		
nprach-SubcarrierMSG3-RangeStart-r13	oneThird		
maxNumPreambleAttemptCE-r13	n6		
numRepetitionsPerPreambleAttempt-r13	n1		
npdcch-NumRepetitions-RA-r13	r16		
npdcch-StartSF-CSS-RA-r13	v4		
npdcch-Offset-RA-r13	zero		
}			
}			

– NPUSCH-ConfigCommon-NB-DEFAULT

Table 8.1.6.3-6: NPUSCH-ConfigCommon-NB-DEFAULT

Derivation Path: 36.331 clause 6.7.3			
Information Element	Value/remark	Comment	Condition
NPUSCH-ConfigCommon-NB-DEFAULT ::= SEQUENCE {			
ack-NACK-NumRepetitions-Msg4-r13 SEQUENCE (SIZE (1.. maxNPRACH-Resources-NB-r13)) OF { ACK-NACK-NumRepetitions-NB-r13 }	r8	1 entry	
srs-SubframeConfig-r13	Not present		
dmrs-Config-r13 SEQUENCE {			
threeTone-BaseSequence-r13	Not present		
threeTone-CyclicShift-r13	0		
sixTone-BaseSequence-r13	Not present		
sixTone-CyclicShift-r13	0		
twelveTone-BaseSequence-r13	Not present		
}			
ul-ReferenceSignalsNPUSCH-r13 SEQUENCE {			
groupHoppingEnabled-r13	FALSE		
groupAssignmentPUSCH-13	0		
}			
}			

– NPUSCH-ConfigDedicated-NB-DEFAULT

Table 8.1.6.3-7: NPUSCH-ConfigDedicated-NB-DEFAULT

Derivation Path: 36.331 clause 6.7.3			
Information Element	Value/remark	Comment	Condition
NPUSCH-ConfigDedicated-NB-DEFAULT ::= SEQUENCE {			
ack-NACK-NumRepetitions-r13	r8	Default	
npusch-AllSymbols-r13	TRUE	Default	
groupHoppingDisabled-r13	Not present	Default	
}			

– RACH-ConfigCommon-NB-DEFAULT

Table 8.1.6.3-8: RACH-ConfigCommon-NB-DEFAULT

Derivation Path: 36.331 clause 6.7.3			
Information Element	Value/remark	Comment	Condition
RACH-ConfigCommon-NB-DEFAULT ::= SEQUENCE {			
preambleTransMax-CE-r13	n6		
powerRampingParameters-r13 SEQUENCE {			
powerRampingStep	dB2		
preambleInitialReceivedTargetPower	dBm-104		
}			
rach-InfoList-r13 (SIZE (1.. maxNPRACH-Resources-NB-r13)) OF SEQUENCE {	1 entry		
ra-ResponseWindowSize-r13	pp10		
mac-ContentionResolutionTimer-r13	pp8		
}			
connEstFailOffset-r13	Not present		
}			

– RadioResourceConfigCommonSIB-NB-DEFAULT

Table 8.1.6.3-9: RadioResourceConfigCommonSIB-NB-DEFAULT

Derivation Path: 36.331 clause 6.7.3			
Information Element	Value/remark	Comment	Condition
RadioResourceConfigCommonSIB-NB-DEFAULT ::= SEQUENCE {			
rach-ConfigCommon-r13	RACH-ConfigCommon-NB-DEFAULT		
bcch-Config-r13	BCCH-Config-NB-DEFAULT		
pcch-Config-r13	PCCH-Config-NB-DEFAULT		
nprach-Config-r13	NPRACH-ConfigSIB-NB-DEFAULT		
npdsch-ConfigCommon-r13	NPDSCH-ConfigCommon-NB-DEFAULT		
npusch-ConfigCommon-r13	NPUSCH-ConfigCommon-NB-DEFAULT		
dl-Gap-r13	Not present		
uplinkPowerControlCommon-r13	UplinkPowerControlCommon-NB-DEFAULT		
nprach-Config-v1330	Not present		
}			

– RadioResourceConfigDedicated-NB-SRB

Table 8.1.6.3-10: RadioResourceConfigDedicated-NB-SRB

Derivation Path: 36.331 clause 6.7.3			
Information Element	Value/remark	Comment	Condition
RadioResourceConfigDedicated-NB-SRB ::= SEQUENCE {			
srb-ToAddModList-r13 SEQUENCE (SIZE (1)) OF SEQUENCE {}	1 entry, with value SRB-ToAddMod-NB-DEFAULT	See subclause 8.1.8.2	
drb-ToAddModList-r13	Not present		
drb-ToReleaseList-r13	Not present		
mac-MainConfig CHOICE {			
explicitValue-r13	MAC-MainConfig-NB-SRB	See subclause 8.1.8.2	
}			
physicalConfigDedicated-r13	PhysicalConfigDedicated-NB-DEFAULT	See subclause 8.1.8.2	
rlf-TimersAndConstants-r13	Not present		
}			

– RadioResourceConfigDedicated-NB-DRB(n)

Table 8.1.6.3-11: RadioResourceConfigDedicated-NB-DRB(n)

Derivation Path: 36.331 clause 6.7.3			
Information Element	Value/remark	Comment	Condition
RadioResourceConfigDedicated-NB-DRB(n) ::= SEQUENCE {		n is the number of AM RLC DRBs (0..2)	
srb-ToAddModList-r13	Not present		
drb-ToAddModList-r13 SEQUENCE (SIZE (1.. maxDRB-NB-r13)) OF SEQUENCE {	n		
drb-ToAddMod[n]-r13	DRB-ToAddMod-NB-DEFAULT (n)	n AM RLC DRBs See subclause 8.1.8.2	n>0
}			
drb-ToReleaseList-r13	Not present		
mac-MainConfig-r13	Not present		
physicalConfigDedicated-r13	Not present		
rlf-TimersAndConstants-r13	Not present		
}			

- RadioResourceConfigDedicated-NB-DRB-ADD(bid)

Table 8.1.6.3-11A: RadioResourceConfigDedicated-NB-DRB-ADD(bid)

Derivation Path: 36.331 clause 6.7.3			
Information Element	Value/remark	Comment	Condition
RadioResourceConfigDedicated-NB-DRB-ADD(bid) ::= SEQUENCE {		bid is the bearer identity	
srb-ToAddModList-r13	Not present		
drb-ToAddModList-r13 SEQUENCE (SIZE (1.. maxDRB-NB-r13)) OF SEQUENCE {	one entry		
drb-ToAddMod-r13[1]	DRB-ToAddMod-NB-DEFAULT (bid)	See subclause 8.1.8.2	
}			
drb-ToReleaseList-r13	Not present		
mac-MainConfig-r13	Not present		
physicalConfigDedicated-r13	Not present		
rlf-TimersAndConstants-r13	Not present		
}			

- RadioResourceConfigDedicated-NB-DRB-REL(bid)

Table 8.1.6.3-11B: RadioResourceConfigDedicated-NB-DRB-REL(bid)

Derivation Path: 36.331 clause 6.7.3			
Information Element	Value/remark	Comment	Condition
RadioResourceConfigDedicated-NB-DRB-REL(bid) ::= SEQUENCE {		bid is the bearer identity	
srb-ToAddModList-r13	Not present		
drb-ToAddModList-r13	Not present		
drb-ToReleaseList-r13 SEQUENCE (SIZE (1.. maxDRB-NB-r13)) OF	one entry		
drb-Identity[1]	bid		
mac-MainConfig-r13	Not present		
physicalConfigDedicated-r13	Not present		
rlf-TimersAndConstants-r13	Not present		
}			

– RLC-Config-NB-SRB-RECONFIG

Table 8.1.6.3-12: RLC-Config-NB-SRB-RECONFIG

Derivation Path: 36.331 clause 6.7.3, 9.2.1.1			
Information Element	Value/remark	Comment	Condition
RLC-Config-NB-SRB-RECONFIG ::= CHOICE {			
am SEQUENCE {			
ul-AM-RLC-r13 SEQUENCE {			
t-PollRetransmit-r13	ms15000		
maxRetxThreshold-r13	t6		
}			
dl-AM-RLC-r13 SEQUENCE {			
enableStatusReportSN-Gap-r13	Not present	Default	
}			
}			
}			

– SRB-ToAddModList-NB-RECONFIG

Table 8.1.6.3-13: SRB-ToAddModList-NB-RECONFIG

Derivation Path: 36.331 clause 6.7.3			
Information Element	Value/remark	Comment	Condition
SRB-ToAddModList-NB ::= SEQUENCE (SIZE (1)) OF SEQUENCE {	1 Entries		
rlc-Config-r13 CHOICE {			
explicitValue-r13	RLC-Config-NB-SRB-RECONFIG		
logicalChannelConfig-r13 CHOICE {			
defaultValue	NULL		
}			
}			

– UplinkPowerControlCommon-NB-DEFAULT

Table 8.1.6.3-14: UplinkPowerControlCommon-NB-DEFAULT

Derivation Path: 36.331 clause 6.7.3			
Information Element	Value/remark	Comment	Condition
UplinkPowerControlCommon-NB-DEFAULT ::= SEQUENCE {			
p0-NominalNPUSCH-r13	-85 (-85 dBm)		
alpha-r13	al1 (1)		
deltaPreambleMsg3-r13	4		
}			

– UplinkPowerControlDedicated-NB-DEFAULT

Table 8.1.6.3-15: UplinkPowerControlDedicated-NB-DEFAULT

Derivation Path: 36.331 clause 6.7.3			
Information Element	Value/remark	Comment	Condition
UplinkPowerControlDedicated-NB-DEFAULT ::= SEQUENCE {			
p0-UE-NPUSCH-r13	0	Default	
}			

- RadioResourceConfigDedicated-NB-DRB-Mod

Table 8.1.6.3-16: RadioResourceConfigDedicated-NB-DRB-Mod

Derivation Path: 36.331 clause 6.7.3			
Information Element	Value/remark	Comment	Condition
RadioResourceConfigDedicated-NB-DRB ::= SEQUENCE {			
srb-ToAddModList-r13	Not present		
drb-ToAddModList-r13	DRB-ToAddModList-NB-RECONFIG		
}			
drb-ToReleaseList-r13	Not present		
mac-MainConfig-r13	Not present		
physicalConfigDedicated-r13	Not present		
rlf-TimersAndConstants-r13	Not present		
}			

8.1.6.4 NB-IoT Security control information elements

See subclause 4.6.4 in this document.

8.1.6.5 NB-IoT Other information elements

- RRC-TransactionIdentifier-DL

Table 8.1.6.5-1: RRC-TransactionIdentifier-DL

Derivation Path: 36.331 clause 6.3.6			
Information Element	Value/remark	Comment	Condition
RRC-TransactionIdentifier-DL ::=	0..3		

- RRC-TransactionIdentifier-UL

Table 8.1.6.5-2: RRC-TransactionIdentifier-UL

Derivation Path: 36.331 clause 6.3.6			
Information Element	Value/remark	Comment	Condition
RRC-TransactionIdentifier-UL ::=	0..3	The same value as the value of RRC-TransactionIdentifier-DL in the downlink message initiating the procedure	

8.1.7 NB-IoT Default NAS message and information element contents

Default values and common NAS messages and information elements are defined in section 4.7 of this document.

8.1.7A NB-IoT Default TC message and information element contents

Default values of common TC (Test Control, see [38]) messages and information elements are defined in section 4.7A of this document.

8.1.8 NB-IoT Reference radio bearer configurations

8.1.8.1 General

8.1.8.2 NB-IoT SRB and DRB parameters and combinations

8.1.8.2.1 NB-IoT SRB and DRB parameters

8.1.8.2.1.1 NB-IoT SRB configurations

Table 8.1.8.2.1.1-1: SRB-ToAddMod-NB-DEFAULT

Derivation Path: 36.331 clause 6.7.3			
Information Element	Value/remark	Comment	Condition
SRB-ToAddMod-NB-DEFAULT ::= SEQUENCE {			
rlc-Config-r13 CHOICE {			
defaultValue		Default values defined in subclause 9.2.1.1 of TS 36.331	
}			
logicalChannelConfig CHOICE {			
defaultValue		Default values defined in subclause 9.2.1.1 of TS 36.331	
}			
}			

8.1.8.2.1.2 NB-IoT DRB PDCP configurations

8.1.8.2.1.2.1 DRB PDCP configurations for AM RLC

Table 8.1.8.2.1.2.1-1: PDCP-Config-NB-DRB

Derivation Path: 36.331 clause 6.7.3			
Information Element	Value/remark	Comment	Condition
PDCP-Config-NB-DRB ::= SEQUENCE {			
discardTimer-r13	Infinity		
headerCompression-r13 CHOICE {			
notUsed	NULL		
}			
}			

8.1.8.2.1.3 NB-IoT DRB RLC configurations

8.1.8.2.1.3.1 NB-IoT DRB AM RLC configurations

Table 8.1.8.2.1.3.1-1: RLC-Config-NB-DRB

Derivation Path: 36.331 clause 6.7.3			
Information Element	Value/remark	Comment	Condition
RLC-Config-NB-DRB ::= CHOICE {			
am SEQUENCE {			
ul-AM-RLC-r13 SEQUENCE {			
t-PollRetransmit-r13	ms25000		
maxRetxThreshold-r13	t8		
}			
dl-AM-RLC-r13 SEQUENCE {			
enableStatusReportSN-Gap-r13	Not present		
}			
}			
}			

8.1.8.2.1.4 NB-IoT DRB Logical Channel configurations

Table 8.1.8.2.1.4-1: LogicalChannelConfig-NB-DRB

Derivation Path: 36.331 clause 6.7.3			
Information Element	Value/remark	Comment	Condition
LogicalChannelConfig-NB-DRB ::= SEQUENCE {			
priority-r13	13	low logical channel priority	
logicalChannelSR-Prohibit-r13	TRUE		
}			

8.1.8.2.1.5 NB-IoT MAC configurations

Table 8.1.8.2.1.5-1: MAC-MainConfig-NB-SRB

Derivation Path: 36.331 clause 6.7.3			
Information Element	Value/remark	Comment	Condition
MAC-MainConfig-NB-SRB ::= SEQUENCE {			
ul-SCH-Config-r13 SEQUENCE {			
periodicBSR-Timer-r13	pp8	Default	
retxBSR-Timer-r13	infinity	Default	
}			
drx-Config-r13 CHOICE {			
release	NULL		
}			
timeAlignmentTimerDedicated-r13	infinity		
logicalChannelSR-Config-r13 CHOICE {			
logicalChannelSR-ProhibitTimer-r13	pp2048		
}			
}			

8.1.8.2.1.6 NB-IoT Physical Layer configurations

Table 8.1.8.2.1.6-1: PhysicalConfigDedicated-NB-DEFAULT

Derivation Path: 36.331 clause 6.7.3			
Information Element	Value/remark	Comment	Condition
PhysicalConfigDedicated-NB-DEFAULT ::= SEQUENCE {			
carrierConfigDedicated-r13	Not present	Anchor carrier	
npdcch-ConfigDedicated-r13	NPDCCH-ConfigDedicated-NB-DEFAULT	See subclause 8.1.6.3	
npusch-ConfigDedicated-r13	NPUSCH-ConfigDedicated-NB-DEFAULT	See subclause 8.1.6.3	
uplinkPowerControlDedicated-r13	UplinkPowerControlDedicated-NB-DEFAULT	See subclause 8.1.6.3	
}			

8.1.8.2.1.7 NB-IoT DRB configurations

Table 8.1.8.2.1.7-1: DRB-ToAddMod-NB-DEFAULT(bid)

Derivation Path: 36.331 clause 6.7.3			
Information Element	Value/remark	Comment	Condition
DRB-ToAddMod-NB-DEFAULT(bid) ::= SEQUENCE {		bid is the bearer identity (1..2)	
eps-BearerIdentity-r13	bid+4		
drb-Identity-r13	Bid		
pdcp-Config-r13	PDCP-Config-NB-DRB		
rlc-Config-r13	RLC-Config-NB-DRB		
logicalChannelIdentity-r13	bid+3		
logicalChannelConfig-r13	LogicalChannelConfig-NB-DRB		
}			

8.1.9 NB-IoT Common test USIM parameters

8.1.9.1 General

As defined in clause 4.9; i.e. there are no specific NB-IoT requirements in addition to the default test USIM parameters, unless specified otherwise in a test case defined in TS 36.523-1 [18].

For PLMN (re-)selection, the UE will decide on the PLMN to select based on 'E-UTRA' as Access Technology in the PLMN selector of USIM Elementary Files PLMNwAcT, OPLMNwAcT and HPLMNwAcT and then use its device category (= NB-IoT) to properly access the NB-IoT network.

8.2 NB-IoT Test environment for RF test

This section contains all the exceptions of the NB-IoT common test parameters specified in clause 8.1 for specific needs of test cases defined in TS 36.521-1 [21]. Exceptions specified in clause 8.2 overwrite the parameter settings of clause 8.1; exceptions defined within the test cases overwrite parameter settings of clause 8.1 and 8.2.

8.2.1 NB-IoT Requirements of test equipment

No NB-IoT common RF test environment requirements are specified in addition to the NB-IoT common requirements described in clause 8.1.2. Specific RF requirements are indicated within the test cases defined in TS 36.521-1 [21].

8.2.2 NB-IoT RF Reference system configurations

8.2.2.1 NB-IoT Common parameters for simulated E-UTRA cells

8.2.2.1.1 NB-IoT Combinations of system information blocks

The NB-IoT combination of system information blocks required by a test case depends on the test case scenario. In clause 8.1.4 of this document, the NB-IoT combinations of system information blocks are defined.

Combination 1, defined in clause 8.1.4, is used by default in test cases defined in TS 36.521-1 [21].

8.2.2.1.2 NB-IoT Scheduling of system information blocks

Same NB-IoT scheduling of system information blocks as defined in clause 8.1.4.3.1.2.

8.2.2.1.3 NB-IoT Common contents of system information messages

MasterInformationBlock-NB

As defined in Table 8.1.4.3.2-1.

SystemInformation-NB

As defined in Table 8.1.4.3.2-2 without exceptions.

SystemInformationBlockType1-NB

As defined in Table 8.1.4.3.2-3 without exceptions.

SystemInformationBlockType2-NB

As defined in Table 8.1.4.3.3-1 without exceptions.

8.2.2A NB-IoT Generic RF procedures

The NB-IoT UE test state used for testing is specified in the individual test cases in the corresponding test specification TS 36.521-1 [21] or TS 36.521-3 [34].

RF NB-IoT UE test states are covered by common NB-IoT UE test states defined in clause 8.1.5 of this document.

8.2.3 NB-IoT Default RRC message and information elements contents

8.2.3.1 NB-IoT Radio resource control information elements

As defined in clause 8.1.6.3 with the following exceptions.

Table 8.2.3.1-1: NPDCCH-ConfigDedicated-NB-DEFAULT

Derivation Path: Clause 8.1.6.3 Table 8.1.6.3-3			
Information Element	Value/remark	Comment	Condition
NPDCCH-ConfigDedicated-NB-DEFAULT ::= SEQUENCE {			
npdcch-NumRepetitions-r13	r1		
npdcch-StartSF-USS-r13	v8		
npdcch-Offset-USS-r13	oneFourth		
}			

Table 8.2.3.1-2: NPUSCH-ConfigDedicated-NB-DEFAULT

Derivation Path: Clause 8.1.6.3 Table 8.1.6.3-7			
Information Element	Value/remark	Comment	Condition
NPUSCH-ConfigDedicated-NB-DEFAULT ::= SEQUENCE {			
ack-NACK-NumRepetitions-r13	r1		
npusch-AllSymbols-r13	TRUE	Default	
groupHoppingDisabled-r13	Not present	Default	
}			

8.2.4 NB-IoT Default NAS message and information elements contents

As defined in clause 8.1.7 without exceptions.

8.2.5 NB-IoT Reference radio bearer configurations

8.2.5.1 NB-IoT SRB and DRB parameters

As defined in clause 8.1.8.2.1 without exception.

8.3 NB-IoT Test environment for Signalling test

8.3.1 NB-IoT Requirements of test equipment

The requirements of test equipment specified in this subclause apply to NB-IoT Signalling test cases defined in TS 36.523-1 [18], in addition to the common NB-IoT requirements of test equipment specified in clause 8.1.2 and 8.1.3 of this specification. Test equipment shall be able to simulate NB-IoT cells, based on the E-UTRA platform as Radio Access Technology (RAT), in the following deployment scenarios:

- In-band operation with E-UTRA
- Guard-band operation with E-UTRA
- Standalone operation

Depending on the respective deployment scenario, the overall number and configuration of cells to be simulated simultaneously by test equipment shall not exceed the resources specified in the following Table 8.3.1-1:

Table 8.3.1-1: Maximum resources in terms of number / configuration of Ncells to be simulated simultaneously in a test setup

Simulation of	Max. number / configuration of cells (SISO)
NB-IoT network in standalone operation	4x cells
NB-IoT network in E-UTRA guard-band operation (Note 1)	4x cells
NB-IoT network in E-UTRA in-band operation (Note 1)	4x cells
Note 1: E-UTRA cells are <u>not</u> configured.	

Exceptions to the requirements outlined above are possible but need special evidence to be provided explicitly in the test case prose and should be allowed only if the test case purpose cannot be met otherwise.

8.3.2 NB-IoT Reference test conditions

8.3.2.1 NB-IoT Physical channel allocations

As defined in clause 8.1.3.3.

8.3.2.2 NB-IoT Signal levels

8.3.2.2.1 NB-IoT Downlink signal levels

The default settings of suitable cells and non-suitable cells for NB-IoT are specified in table 8.3.2.2.1-1. Cells which are expected to be undetectable for UE under test shall fulfil the condition of non-suitable "Off" cell.

Table 8.3.2.2.1-1: Default settings of suitable / non-suitable cells

Power level type	NB-IoT (Note 1-3)	
	Unit	Power level
Serving cell	dBm/15kHz	-85
Suitable neighbour intra-frequency cell	dBm/15kHz	-91
Suitable neighbour inter-frequency cell	dBm/15kHz	-97
Non-suitable cell	dBm/15kHz	-120 (Note 4)
Non-suitable "Off" cell	dBm/15kHz	≤ -150
Note 1: The power level is specified in terms of cell-specific NRS EPRE.		
Note 2: Power levels are specified based on the precondition that q-Hyst, a3-Offset and hysteresis are 0 dB.		
Note 3: The power level is specified at the UE Rx antenna (assumption = single UE Rx antenna).		
Note 4: Calculation of non-suitable cell power level is based on the reference sensitivity (without repetitions) for UE category NB1 as per the minimum requirements specified in TS 36.101 [27] clause 7.3.1F.1.		

The default signal level uncertainty is specified in table 8.3.2.2.1-2 for any level specified, unless a tighter uncertainty is specified by a test case in TS 36.523-1 [18].

Table 8.3.2.2.1-2: SS signal level uncertainty

	Absolute signal level uncertainty for each cell	Relative signal level uncertainty between multiple cells
Intra-frequency	+/-3 dB at each test port	+/-3 dB
Inter-frequency	+/-3 dB at each test port	See Note 1
Note 1: For Inter-frequency cells the relative signal level uncertainty between multiple cells is determined by the absolute uncertainty of each cell, and does not have any additional constraint.		

8.3.2.3 NB-IoT Default test frequencies

The default channel bandwidth of 200 kHz is applied to the signalling test. The test frequencies are defined so that no frequency overlapping takes place, in order to avoid unnecessary inter-frequency interference.

All operating bands can accommodate at least three test frequencies f_1 , f_2 and f_3 ($f_3 < f_1 < f_2$).

For NB-IoT in-band and guard-band signalling testing, the NB-IoT frequency to be tested are low/mid/high range and are associated to the LTE frequency low/mid/high range as specified in tables 4.3.1.1.x. The E-UTRA channel bandwidth to be tested is 10MHz for in-band and 5 MHz for guard-band for all operating bands for all test cases; unless the specific channel bandwidth is specified for the operating band below:

For Band 31 in-band testing, the E-UTRA channel bandwidth to be tested is 5 MHz.

8.3.2.3.1 NB-IoT Test frequencies for signalling test

Test frequencies for signalling test are specified in table 8.3.2.3.1-1 in terms of Low, Mid and High which are referred to the Low Range, Mid Range and High Range in clause 8.1.3.1.

Table 8.3.2.3.1-1: Test frequencies for NB-IoT FDD (200 kHz)

NB-IoT Operating	Bandwidth [MHz]	f1, f5		f2		f3	
		N _{UL}	N _{DL}	N _{UL}	N _{DL}	N _{UL}	N _{DL}

Band								
1	60	Mid	Mid	High	High	Low	Low	
2	60	Mid	Mid	High	High	Low	Low	
3	75	Mid	Mid	High	High	Low	Low	
4	45	Mid	Mid	High	High	Low	Low	
5	25	Mid	Mid	High	High	Low	Low	
...								
8	35	Mid	Mid	High	High	Low	Low	
...								
11	20	Mid	Mid	High	High	Low	Low	
12	17	Mid	Mid	High	High	Low	Low	
13	10	Mid	Mid	High	High	Low	Low	
14	10	Mid	Mid	High	High	Low	Low	
...								
17	12	Mid	Mid	High	High	Low	Low	
18	15	Mid	Mid	High	High	Low	Low	
19	15	Mid	Mid	High	High	Low	Low	
20	30	Mid	Mid	High	High	Low	Low	
21	15	Mid	Mid	High	High	Low	Low	
...								
25	65	Mid	Mid	High	High	Low	Low	
26	35	Mid	Mid	High	High	Low	Low	
...								
28	45	Mid	Mid	High	High	Low	Low	
...								
31	5	Mid	Mid	High	High	Low	Low	
...								
66	70+90 ¹	Mid	Mid	High	High	Low	Low	
70	15	Mid	Mid	High	High	Low	Low	
71	35	Mid	Mid	High	High	Low	Low	

NOTE 1: Asymmetric operating band (UL + DL).

Test frequencies for signalling test of MFBI are specified in Table 8.3.2.3.1-1a for FDD in terms of Low, Mid and High which are referred to as Low Range, Mid Range and High range in clause 8.1.3.1.

Table 8.3.2.3.1-1a: Test frequencies for NB-IoT FDD MFBI (200 kHz)

NB-IoT Operating Band	MFBI Overlapping Band	Bandwidth [MHz]	f1, f5		f2		f3	
			N _{UL}	N _{DL}	N _{UL}	N _{DL}	N _{UL}	N _{DL}
2	25	60	Mid	Mid	High	High	Low	Low
5	18	15	Mid	Mid	High	High	Low	Low
5	19	15	Mid	Mid	High	High	Low	Low
5	26	25	Mid	Mid	High	High	Low	Low
12	17	12	Mid	Mid	High	High	Low	Low
17	12	12	Mid	Mid	High	High	Low	Low
19	5	15	Mid	Mid	High	High	Low	Low
19	26	15	Mid	Mid	High	High	Low	Low
25	2	60	Mid	Mid	High	High	Low	Low
26	5	25	Mid	Mid	High	High	Low	Low
26	18	15	Mid	Mid	High	High	Low	Low
26	19	15	Mid	Mid	High	High	Low	Low

8.3.3 NB-IoT Reference system configurations

The reference system configurations specified in this subclause apply to all Signalling test cases defined in TS 36.523-1 [18] unless otherwise specified, in addition to the common reference system configurations specified in subclause 8.1.4 of this specification.

Only one SS Tx antenna is used.

One UE antenna is used for all signalling test cases.

8.3.3.1 NB-IoT Default parameters specific for simulated cells

Default parameters specific for simulated cells are specified in this subclause.

8.3.3.1.1 Intra-frequency neighbouring cell list in SIB4-NB for NB-IoT cells

Intra-frequency neighbouring cell list for signalling test cases is defined in table 8.3.3.1.1-1. This table is referred to in the default contents of IE *intraFreqNeighbouringCellList* in *SystemInformationBlockType4-NB* defined in table 8.1.4.3.3-3.

Table 8.3.3.1.1-1: Intra-frequency neighbouring cell lists for NB-IoT cells

cell ID	Test Frequency	intra-frequency neighbouring cell list						
		number of entries	physCellId[n]			q-OffsetCell[n]		
			1	2	3	1	2	3
Ncell 1	f1	3	Ncell 2	Ncell 4	Ncell 11	dB0	dB0	dB0
Ncell 2	f1	3	Ncell 1	Ncell 4	Ncell 11	dB0	dB0	dB0
Ncell 4	f1	3	Ncell 1	Ncell 2	Ncell 11	dB0	dB0	dB0
Ncell 11	f1	3	Ncell 1	Ncell 2	Ncell 4	dB0	dB0	dB0
Ncell 3	f2	1	Ncell 23	-	-	dB0	-	-
Ncell 23	f2	1	Ncell 3	-	-	dB0	-	-

Intra-frequency neighbouring cell list of the same PLMN for the NAS signalling test is defined in table 8.3.3.1.1-2 when SIB4-NB is broadcast.

Table 8.3.3.1.1-2: Intra-freq. lists in SIB4 for NAS test cases (same PLMN)

NAS cell ID	Test Frequency	Intra-frequency neighbouring cell list		
		number of entries	physCellId[n]	
			1	2
Ncell 50	f1	2	Ncell 51	Ncell 53
Ncell 51	f1	2	Ncell 50	Ncell 53
Ncell 53	f1	2	Ncell 50	Ncell 51
Ncell 52	f2	1	Ncell 61	N/A
Ncell 61	f2	1	Ncell 52	N/A

8.3.3.1.2 Inter-frequency carrier frequency list in SIB5-NB for NB-IoT cells

Inter-frequency E-UTRA carrier frequency list for signalling test cases is defined in table 8.3.3.1.2-1. This table is referred to in the default contents of IE *interFreqCarrierFreqList* in *SystemInformationBlockType5-NB* defined in table 8.1.4.3.3-4.

Table 8.3.3.1.2-1: Inter-frequency carrier frequency lists for NB-IoT cells

cell ID	Test Frequency	interFreqCarrierFreqList			
		number of entries	dl-CarrierFreq[n]		
			1	2	3
Ncell 1 Ncell 2 Ncell 4 Ncell 11	f1	3	f2	f3	f5
Ncell 3 Ncell 23	f2	3	f1	f3	f5
Ncell 6	f3	3	f1	f2	f5
Ncell 10	f5	3	f1	f2	f3
Note 1:	The inter-frequency carrier frequency list for signalling NAS test cases when cells are on same PLMN is defined in table 8.3.3.1.2-2.				
Note 2:	In case of Test frequency f1, f2 and f3, dl-CarrierFreq f5 as part of inter-frequency list is applicable only in case of multi-band scenarios.				
Note 3:	In case of Test frequency f5, dl-CarrierFreq f1 as part of inter-frequency list is applicable only in case of multi-band scenarios.				

Inter-frequency neighbouring carrier and cell lists for NAS signalling test cases are defined in table 8.3.3.1.2-2 for same PLMN and table 8.3.3.1.2-3 for different PLMN.

Table 8.3.3.1.2-2: Inter-freq. lists in SIB5-NB for NAS test cases (same PLMN)

NAS cell ID	Test Frequency	interFreqCarrierFreqList		
		number of entries	dl-CarrierFreq[n]	
			1	2
Ncell 50 Ncell 51 Ncell 53	f1	1	f2	NA
Ncell 52 Ncell 61	f2	1	f1	NA

Table 8.3.3.1.2-3: Inter-freq. lists in SIB5-NB for NAS test cases (different PLMN)

NAS cell ID	Test Frequency	interFreqCarrierFreqList			Condition
		number of entries	dl-CarrierFreq[n]		
			1	2	
Ncell 50 Ncell 51 Ncell 52 Ncell 53 Ncell 62	f1	0	NA	NA	
Ncell 55 Ncell 56	f2	0	NA	NA	
Ncell 57 Ncell 59 Ncell 60	f3	0	NA	NA	54-NOT-CONF
		1	f2		54-CONF
Ncell 54	f2	1	f3	NA	

Condition	Explanation
54-NOT-CONF	Ncell 54 is not configured in the test
54-CONF	Ncell 54 is configured in the test

8.3.3.2 NB-IoT Default configurations for NAS test cases

As defined in clause 8.1.4.

8.3.3.3 NB-IoT Cell configurations

All Ncells are assumed to be full cells unless specified otherwise in a test case defined in TS 36.523-1 [18].

8.3.4 NB-IoT Generic signalling procedures

8.3.4.1 NB-IoT Initial UE states and setup procedures

As defined in clause 8.1.5.

8.3.4.2 NB-IoT Reference procedures and test procedures for TTCN development

As defined in clause 8.1.5A.

8.3.4.3 NB-IoT Test case postambles for TTCN development

As defined in clause 10.5 of TS 36.523-3 [20].

8.3.5 NB-IoT Default RRC message and information element contents

As defined in clause 8.1.6.

8.3.6 NB-IoT Default NAS message and information element contents

As defined in clause 8.1.7.

8.3.7 NB-IoT Timer tolerances

The timer tolerances specified for the test environment in this subclause apply to all Signalling test cases defined in TS 36.523-1 [18] unless otherwise specified.

All the timers used during testing are within a tolerance margin given in Table 8.3.7-1 below. For NB-IoT and its typically longer timer values across all protocol layers, common timer tolerances are applicable independently from protocol layer resp. test case group. If for a specific test a different tolerance value is required then this should be specified in the relevant test document (i.e. the document where the test is described).

Table 8.3.7-1: Timer tolerances for protocol timers

	timer value < 500 ms	not applicable
500 ms ≤	timer value < 10000 ms	timer tolerance = 10 %
10000 ms ≤	timer value < 40000 ms	timer tolerance = 5 %
40000 ms ≤	timer value	timer tolerance = 2.5 %

8.4 NB-IOT Test environment for RRM tests

This section contains all the exceptions of the common test parameters specified in clause 8.1 for specific needs of NB-IoT test cases defined in TS 36.521-3 [34]. Exceptions specified in clause 8.4 overwrite the parameter settings of clause 8.1; exceptions defined within the test cases overwrite parameter settings of clause 8.1 and 8.4.

8.4.1 NB-IoT Requirements of test equipment

No NB-IoT common RRM test environment requirements are specified in addition to the NB-IoT common requirements described in clause 8.1.2. Specific RRM requirements are indicated within the test cases defined in TS 36.521-3 [34].

8.4.2 NB-IoT RRM Reference system configurations

8.4.2.1 NB-IoT Common parameters for simulated NB-IoT cells

8.4.2.1.1 NB-IoT Combinations of system information blocks

The NB-IoT combination of system information blocks required by a test case depends on the test case scenario. In clause 8.1.4 of this document, the NB-IoT combinations of system information blocks are defined.

8.4.2.1.2 NB-IoT Scheduling of system information blocks

Same NB-IoT scheduling of system information blocks as defined in clause 8.1.4.3.1.2.

8.4.2.1.3 NB-IoT Common contents of system information messages

- MasterInformationBlock-NB

As defined in Table 8.1.4.3.2-1 with the following exceptions.

Table 8.4.2.1.3-1: MasterInformationBlock-NB

Derivation Path: 36.331 clause 6.7.2			
Information Element	Value/remark	Comment	Condition
MasterInformationBlock-NB ::= SEQUENCE {			
operationModeInfo-r13 CHOICE {			
inband-SamePCI-r13 SEQUENCE {			Inband-Same
eutra-CRS-SequenceInfo-r13	0		
}			
}			
}			

- SystemInformation-NB

As defined in Table 8.1.4.3.2-2 without exceptions.

- SystemInformationBlockType1-NB

As defined in Table 8.1.4.3.2-3 without exceptions.

- SystemInformationBlockType2-NB

As defined in Table 8.1.4.3.3-1 without exceptions.

8.4.2A NB-IoT Generic RRM procedures

The NB-IoT UE test state used for testing is specified in the individual test cases in the corresponding test specification TS 36.521-3 [34].

RRM NB-IoT UE test states are covered by common NB-IoT UE test states defined in clause 8.1.5 of this document.

8.4.3 NB-IoT Default RRC message and information elements contents

8.4.3.1 NB-IoT Radio resource control information elements

As defined in clause 8.1.6.3 without exceptions.

8.4.4 NB-IoT Default NAS message and information elements contents

As defined in clause 8.1.7 without exceptions.

8.4.5 NB-IoT Reference radio bearer configurations

8.4.5.1 NB-IoT SRB and DRB parameters

As defined in clause 8.1.8.2.1 without exception.

Annex A (informative): Connection Diagrams

Definition of Terms

System Simulator or SS – A device or system, that is capable of generating simulated Node B signalling and analysing UE signalling responses on one or more RF channels, in order to create the required test environment for the UE under test. It will also include the following capabilities:

1. Measurement and control of the UE Tx output power through TPC commands
2. Measurement of Throughput
3. Measurement of signalling timing and delays
4. Ability to simulate UTRAN and/or E-UTRAN and/or GERAN signalling

GNSS System Simulator or GSS: A device or system, that is capable of generating simulated GNSS satellite transmissions in order to create the required test environment for the UE under test. It will also include the following capabilities:

1. Control of the output power of individual satellites and the simulation of atmospheric delays.
2. Ability to synchronize with E-UTRAN timing in the SS.

Test System – A combination of devices brought together into a system for the purpose of making one or more measurements on a UE in accordance with the test case requirements. A test system may include one or more System Simulators if additional signalling is required for the test case. The following diagrams are all examples of Test Systems.

NOTE 1: The above terms are logical definitions to be used to describe the test methods used in the documents TS36.521-1, TS 36.523-1 and TS36.521-3 in practice, real devices called 'System Simulators' may also include additional measurement capabilities or may only support those features required for the test cases they are designed to perform.

NOTE 2: Components in the connection diagrams:

The components in the connection diagrams represent ideal components. They are intended to display the wanted signal flow. They don't mandate real implementations. An alternative to Figure A3 is shown below as an example: It is nearer to real implementations. The signal levels are the same as in Figure A3. The signal flow cannot be displayed as detailed as in Figure A.3.

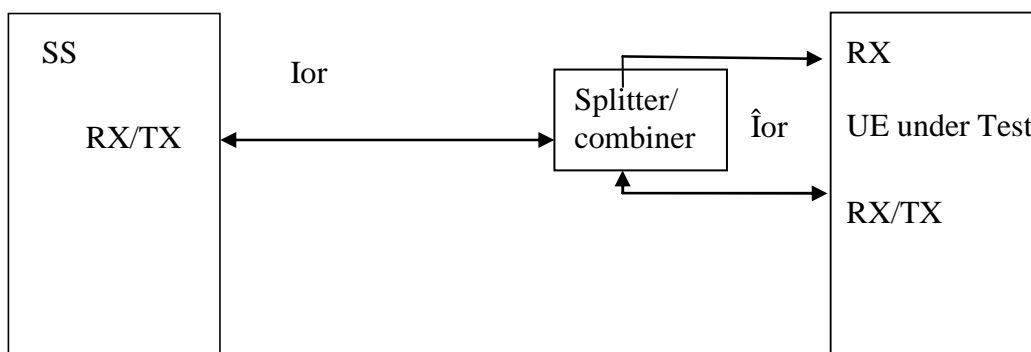

Alternative to Figure A.3

Connection: Each connection is displayed as a one or two sided arrow, showing the intended signal flow. In some cases, for some tests, some connections shown may not be necessary (for example UL RX connection for a second cell).

Circulator: The signal, entering one port, is conducted to the adjacent port, indicated by the arrow. The attenuation among the above mentioned ports is ideally 0 and the isolation among the other ports is ideally ∞ .

Splitter: a splitter has one input and 2 or more outputs. The signal at the input is equally divided to the outputs. The attenuation from input to the outputs is ideally 0 and the isolation between the outputs is ideally ∞ .

Combiner: a combiner has one output and 2 or more inputs. The signals at the inputs are conducted to the output, all with the same, ideally 0 attenuation. The isolation between the inputs is ideally ∞ .

Switch: contacts a sink (or source) alternatively to two or more sources (or sinks).

Fader: The fader has one input and one output. The MIMO fading channel is represented by several single faders (e.g. 8 in case of a MIMO antenna configuration 4x2) The correlation among the faders is described in TS 36.521-1 clause B.2.2. In some cases, for some tests, diagrams with fader(s) are referenced when no fading is required; in this case the fader(s) is omitted.

Attenuator: TBD

General considerations on connections for CA testing

Figures A.32<x> to A.37<x> and A.41<x> to A.46<x> contain connection diagrams for CA testing with 2 CCs. Different options (<x> = a, b, c) have been defined for each connection, to consider different UE employments with respect to UE antenna connectors and signal mapping:

- a: Separate antenna connectors for each CC. An optional *Combiner* may be used in case the UE employs one common wide band antenna only for the receive diversity for both CC-s.
- b: Common antenna connectors for both CC-s with same UL transmit antenna connector.
- c: Common antenna connectors for both CC-s with different UL transmit antenna connectors.

The connections are referred in tests as *Figure group* which imply figures with the same Arabic numeral in the number, but different Latin letter extension (e.g. Figure A.32a, A.32b etc.). The selection of the connection option for testing is done according to the UE employment as appropriate.

Connection diagrams for CA testing with ≥ 3 CCs have been defined in other figures.

- The connections represent the case of a DUT with separate antenna connectors per CC. For other DUT antenna connector configurations, the necessary signal combining is done accordingly.
- The number of secondary CC is n with $n = 2, 3, \dots$ as applicable to the individual test case for $n+1$ CCs testing.

Following symbolic is used in the connection diagrams to distinguish CC-s and paths:

- p : primary CC
- s : secondary CC (in case of CA with 2CCs)
- $s1$: first secondary CC (in case of CA with >2CCs)
- sn : n -th secondary CC with $n = 2, 3, \dots$ (in case of CA with >2CCs)
- $\langle j \rangle$: (integer) defines the receive antenna and the path to it $\langle j \rangle$ for a given CC
- $\langle i \rangle \langle j \rangle$: (integer) defines the path between transmit antenna $\langle i \rangle$ and receive antenna $\langle j \rangle$ for a given CC

The connections are general and support CA both in DL and UL. According to the test conditions, if the UL CA is not used, the "secondary CCs of UL" in the connections may be ignored.

For contiguous CA, single AWGN _{k} sources with $k = \{p, s, s1, s2, \dots\}$ affecting the same UE antenna connector can be unified to AWGN sources with higher bandwidth.

Connections for UE category 0 and category M1 testing

For UE category 0 and category M1, if the connection is referred with the additional clarification “using only main UE Tx/Rx antenna”, then all the links and blocks in the connection serving to supply other UE Rx antennas with signal, are not used.

The example below in Figure A.0 shows the resulting connection to be used, after removing the unnecessary parts (red coloured) to connection of Figure A.10, assuming it is referred in a UE category 0 or a category M1 test as mentioned above.

Connections for ProSe testing

TBD

Connections for 4 Rx antenna ports in transmitter tests

For UE supporting 4 Rx antenna ports on at least one of the bands under test, in transmitter tests the connection is referred to connection diagrams showing only 2 UE Rx antenna ports. For such cases, the SS fed only two of the four antennas from the UE, which are connected depending on UE capability. The remaining two antenna ports of the UE are not connected to the SS.

Considerations for CA testing on 4Rx capable UEs

Figures A.80, A.82, A.85 to A.87, A.90, A.91, A.94 and A.95 contain connection diagrams that shall be used to enable CA testing on 4Rx capable UEs. Such connection diagrams are only applicable to UEs that support 4Rx on at least one of the bands under test. In such cases, the following rules apply to the connection diagram:

- 1 For nDL CA with x CCs on a 4Rx supported band and $(n-x)$ CCs on a 2Rx supported band, the 4Rx Module shall be replicated x times and 2Rx Module shall be replicated $(n-x)$ times. These modules are specified on the connection diagrams.
- 2 UE is assumed to support 2Rx in {Rx1, Rx3} and 4Rx in {Rx1, Rx2, Rx3, Rx4}. Depending on UE capability these ports can be interchanged.
- 3 For all 2Rx supported band the 2-Rx CCs are fed only on two ports and the remaining two ports have zero-input in this band.
- 4 SS shall configure Rx1, Rx2, Rx3, Rx4 based on UE capability.
- 5 UE Tx will be placed in one of the 4 UE antenna ports and shall feed either SS_4Rx or SS_2Rx depending on UE capability. SS_4Rx and SS_2Rx are specified on the connection diagrams.

The connections represent the case of a DUT with common antenna connectors for both CC-s with same UL transmit antenna connector. For other DUT antenna connector configurations, the necessary signal combining is done accordingly.

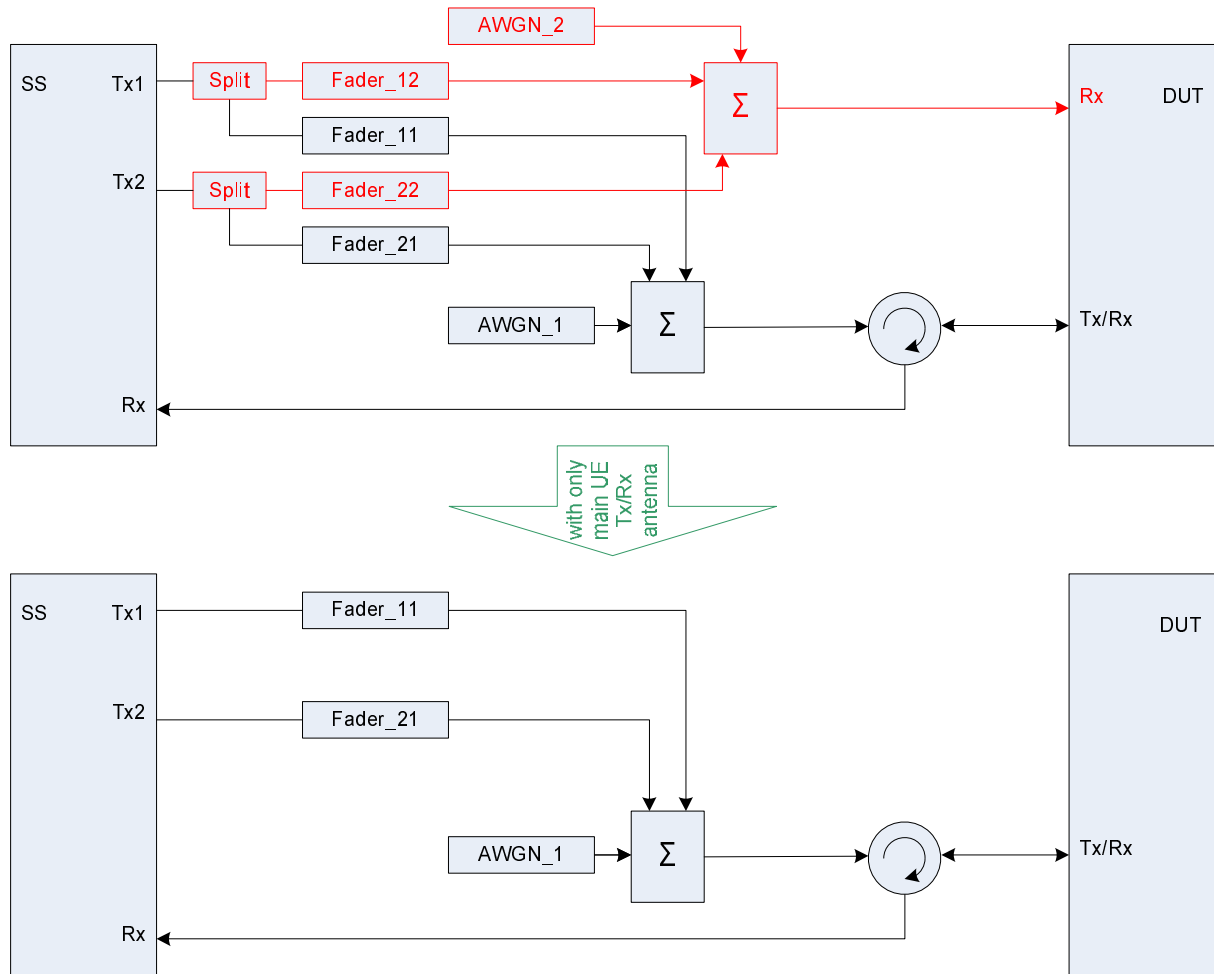

Figure A.0: Reduced implementation of connections for UE category 0 and category M1 testing (example of Figure A.10)

Figure A.1: Void

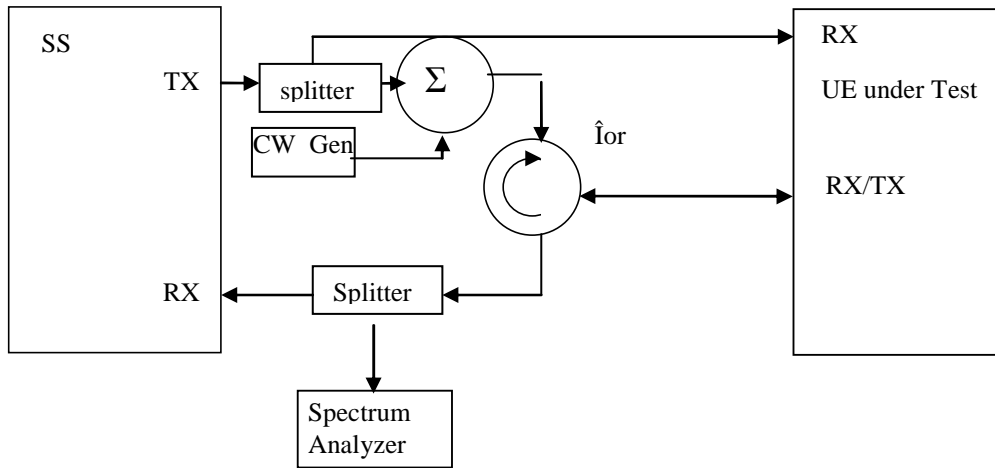

Figure A.2: Connection for Transmitter Intermodulation tests

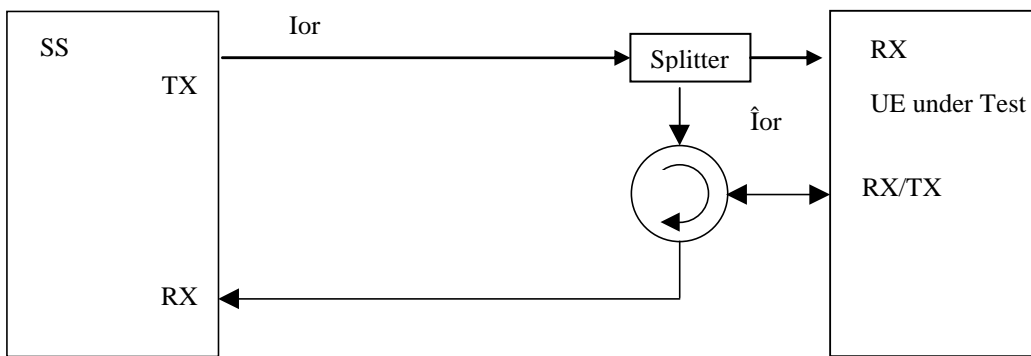

Figure A.3: Connection for basic single cell, RX and TX tests

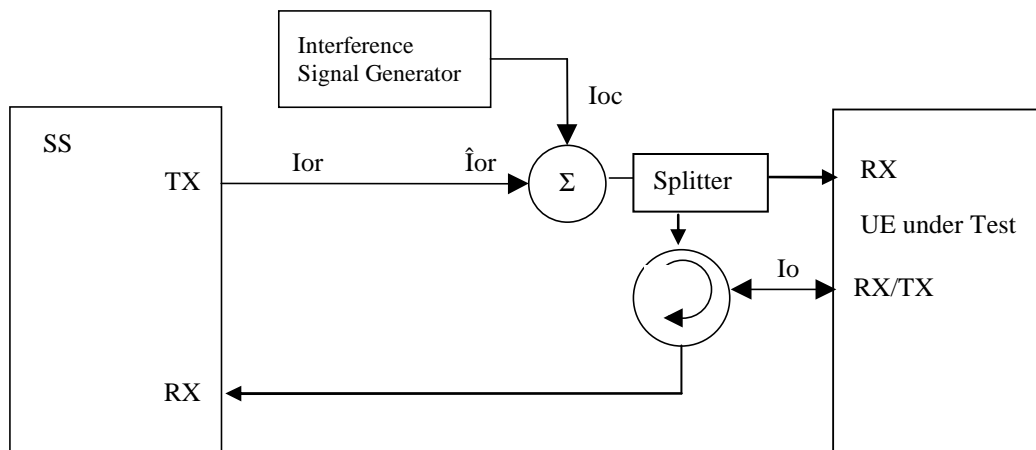

Figure A.4: Connection for Receiver tests with E-UTRA-Interference

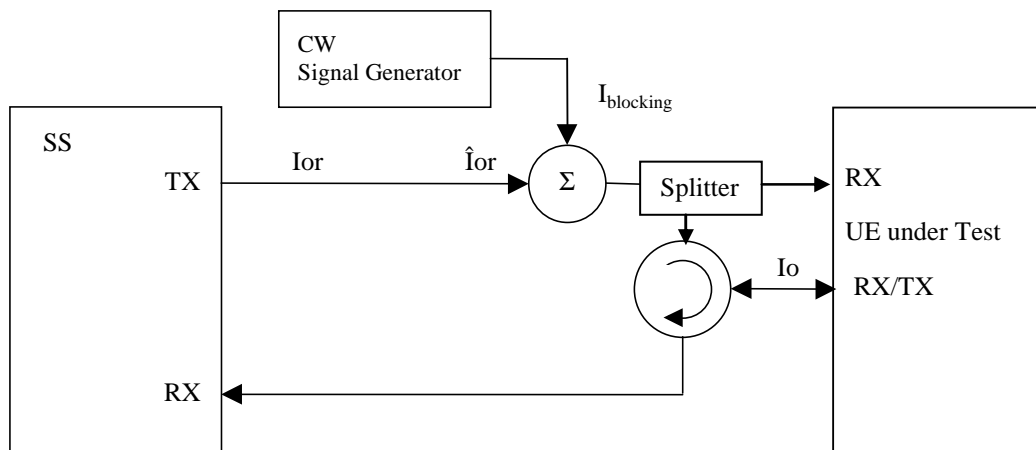

Figure A.5: Connection for Receiver tests with CW interferer

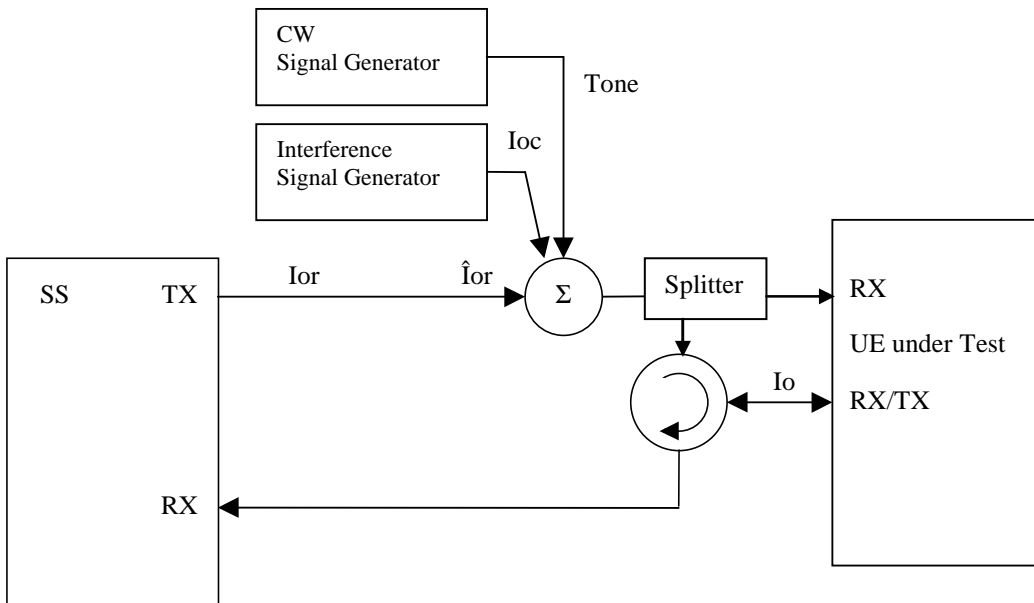

Figure A.6: Connection for Receiver tests with both E-UTRA Interference and additional CW signal

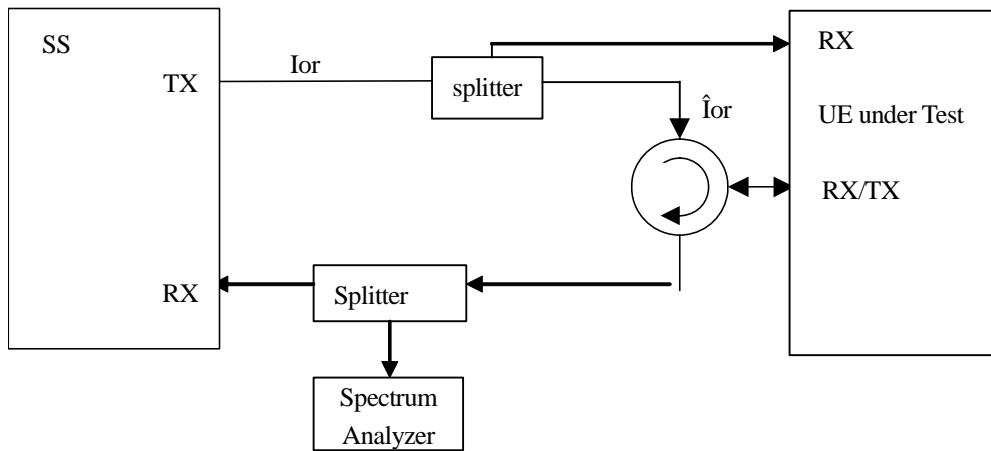

Figure A.7: Connection for TX-tests with additional Spectrum Analyzer

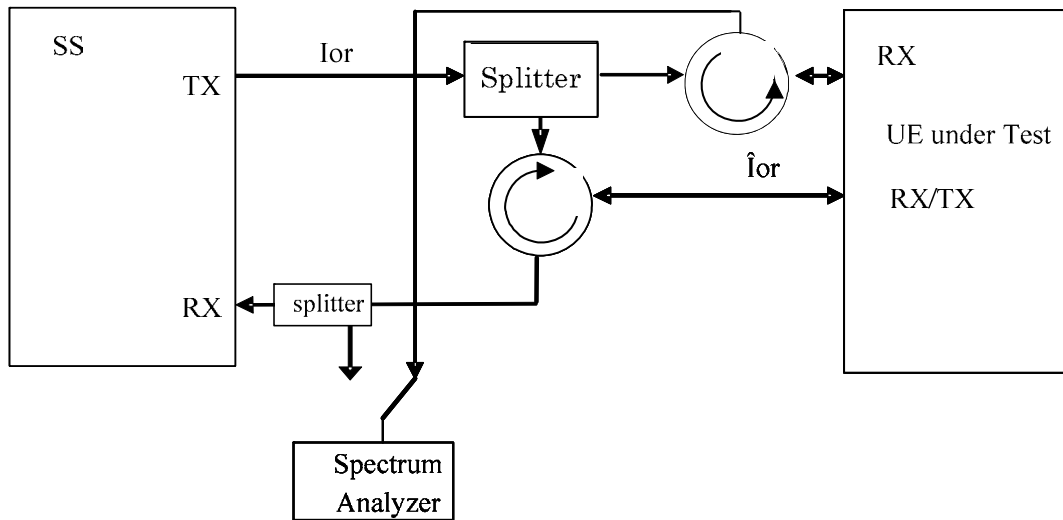

Figure A.8: Connection for RX-tests with additional Spectrum Analyzer

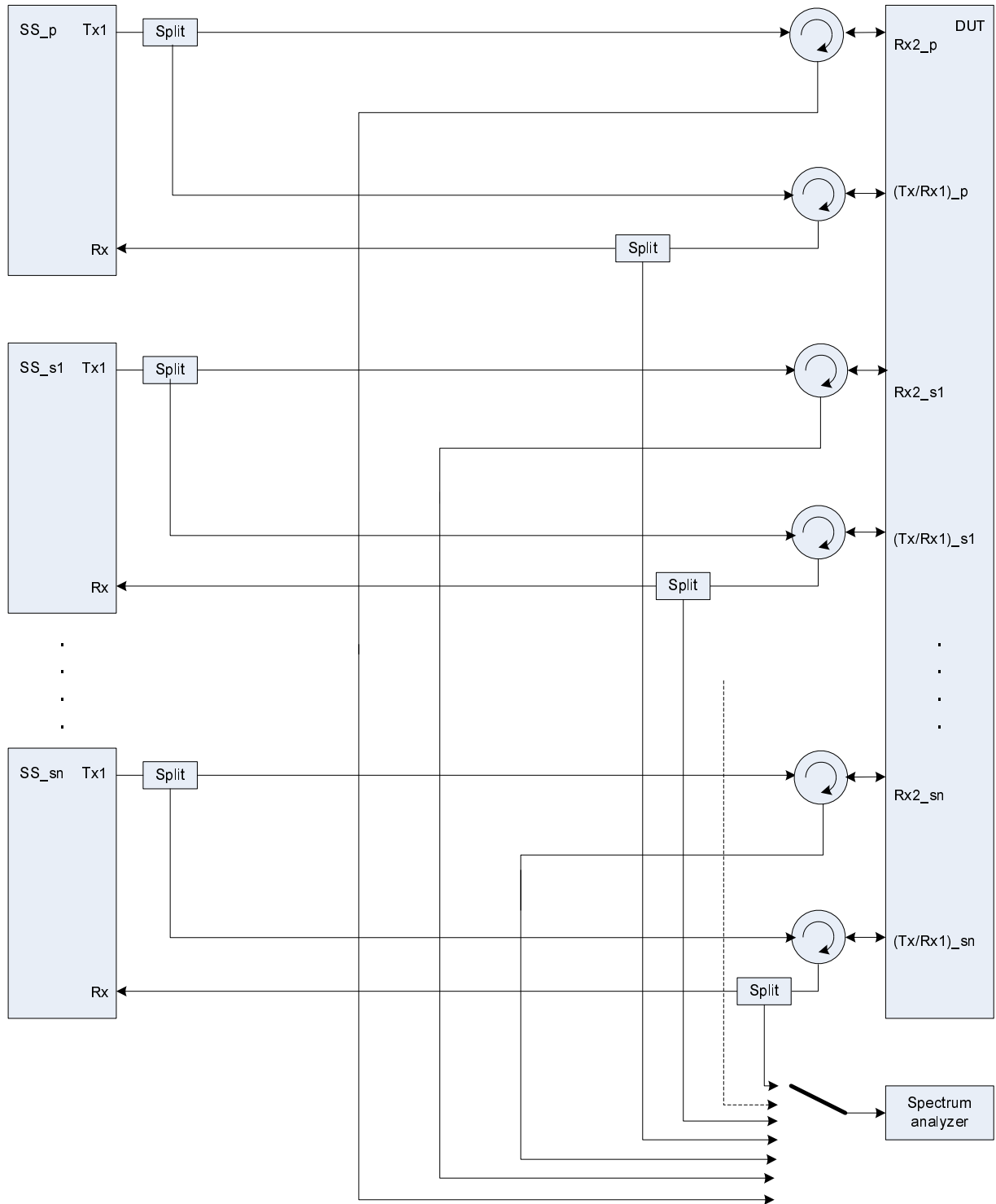

Figure A.8a: Connection for RX tests for CA (≥ 2CCs) with additional Spectrum Analyzer

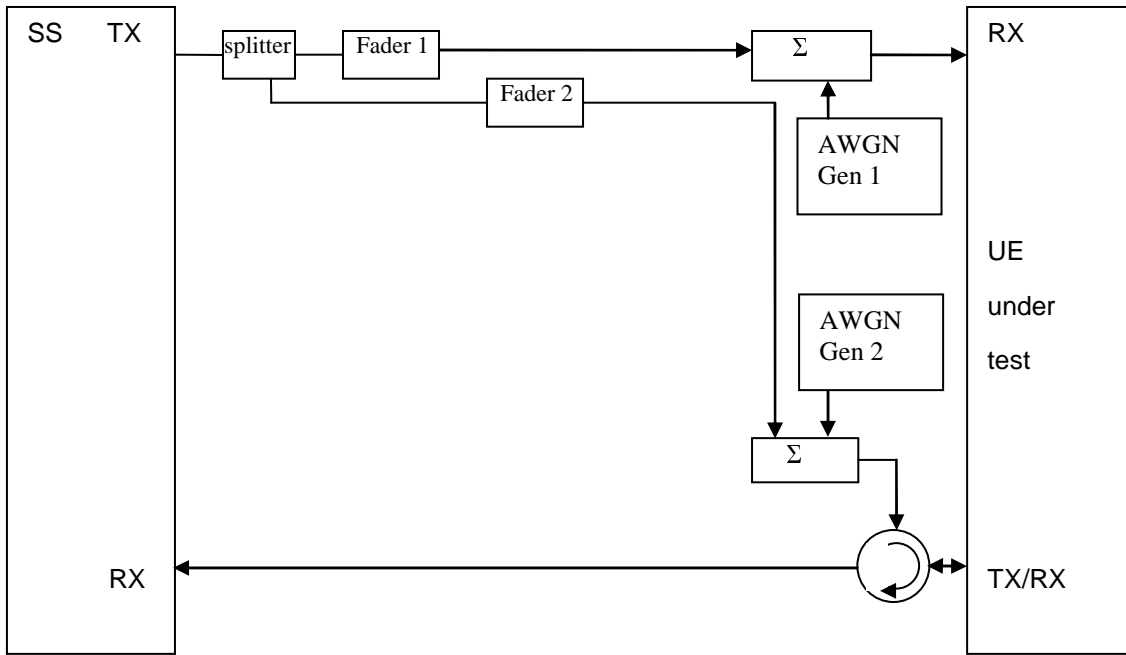

Figure A.9: Connection for RX performance tests with antenna configuration 1x2 (single antenna port)

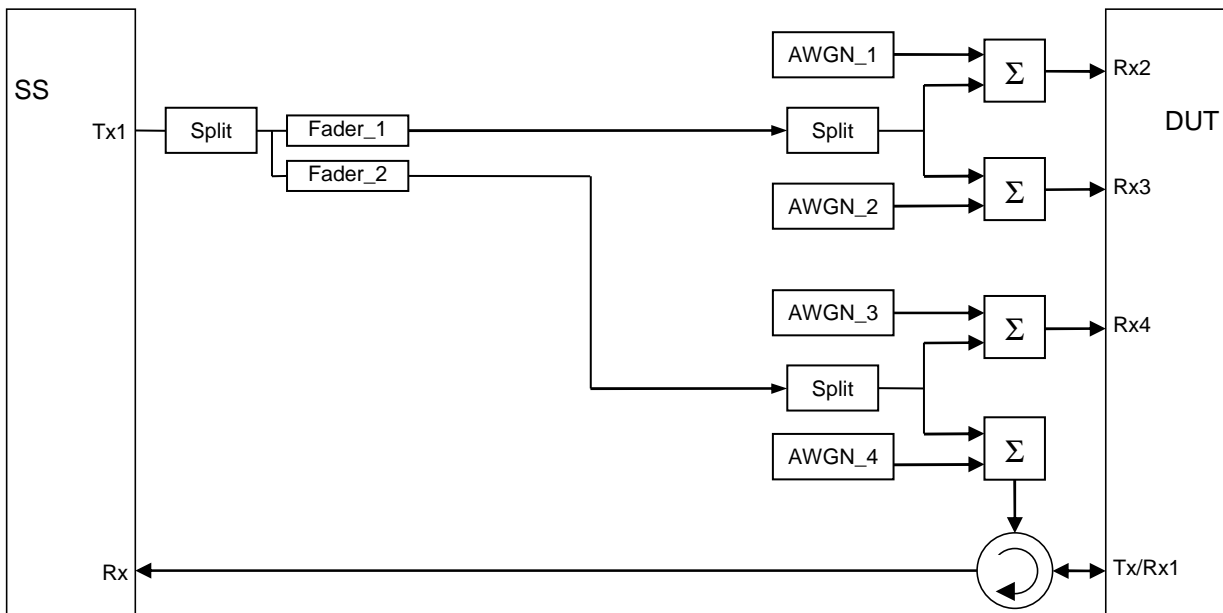

Figure A.9a: Connection for RX performance tests with antenna configuration 1x2 (single antenna port) for 4Rx capable UEs without any 2Rx RF bands

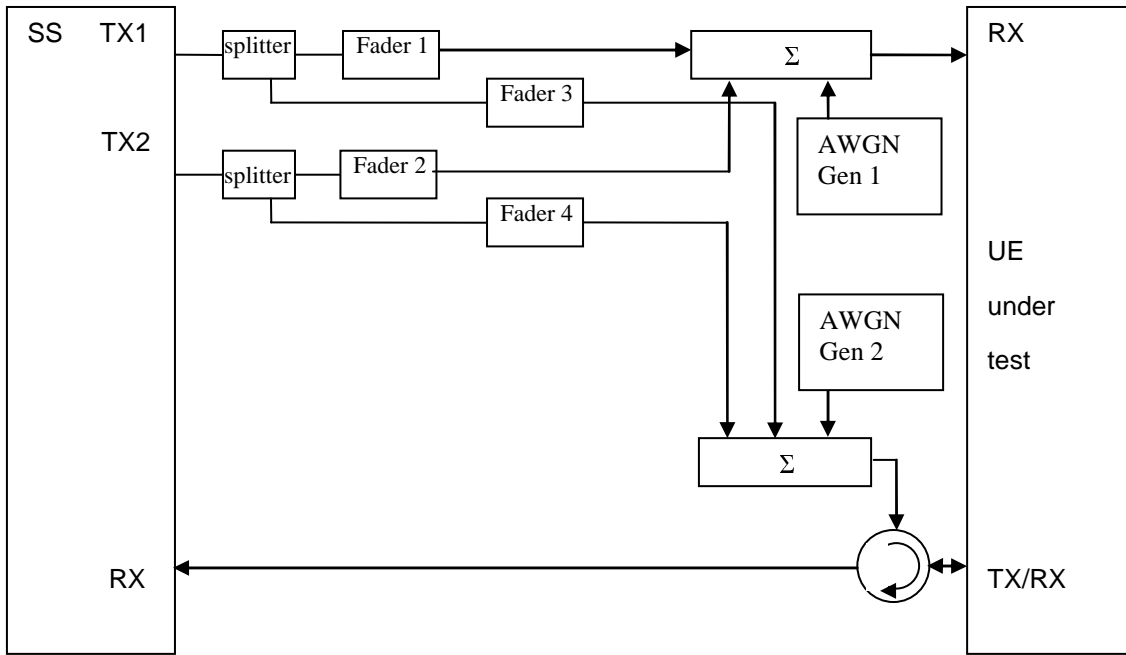

Figure A.10: Connection for RX performance tests with antenna configuration 2x2

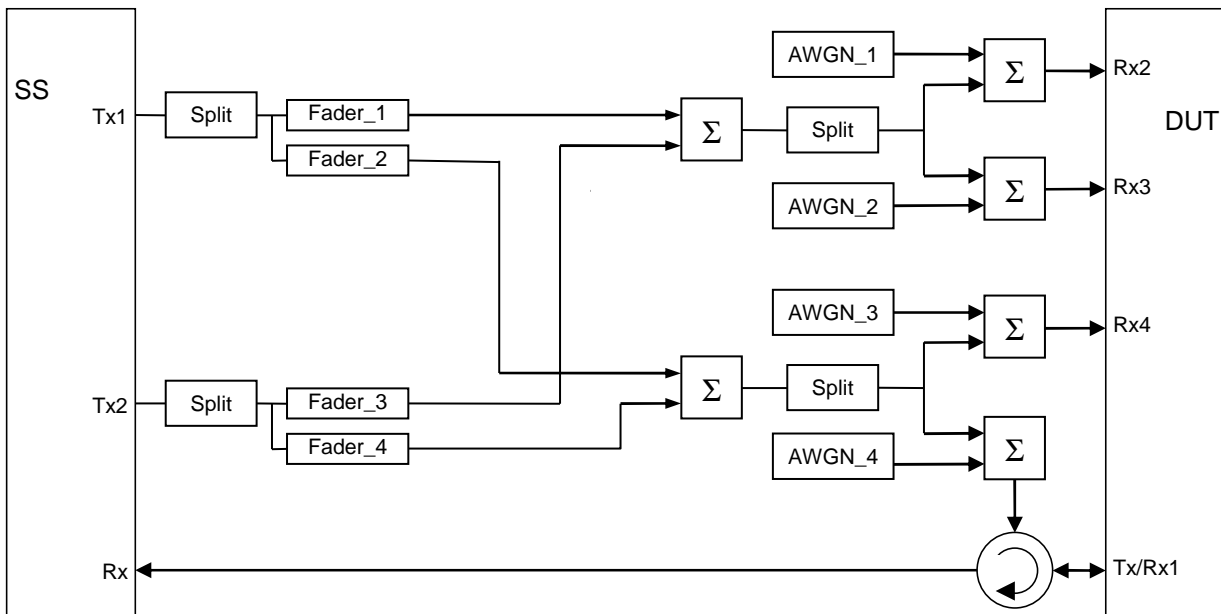

Figure A.10a: Connection for RX performance tests with antenna configuration 2x2 for 4Rx capable UEs without any 2Rx RF bands

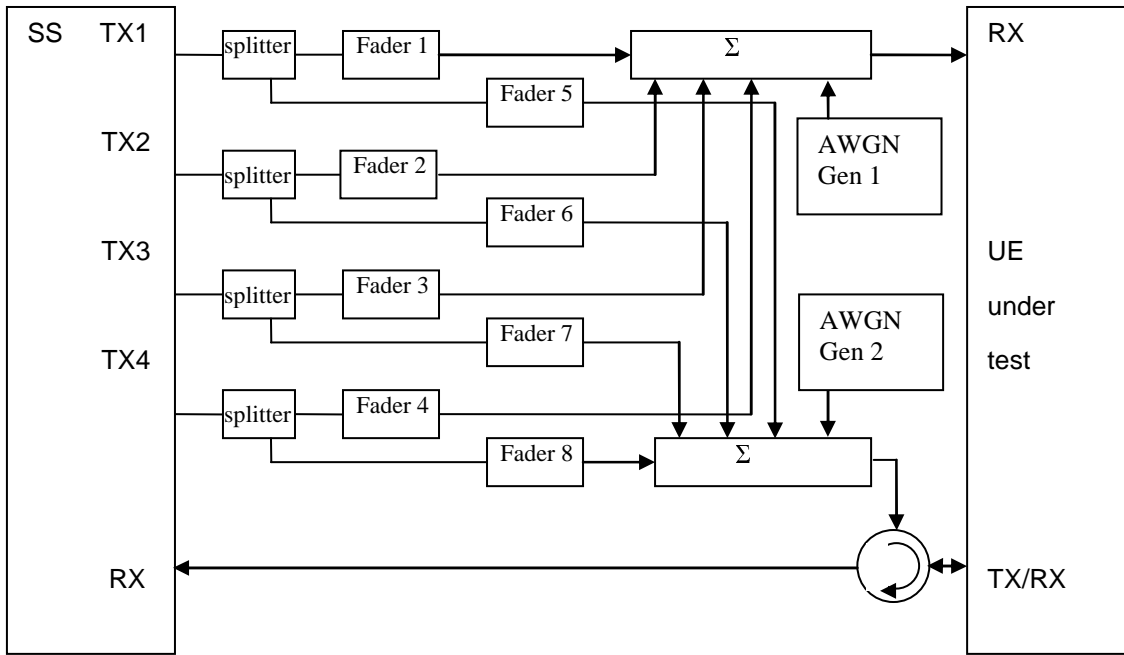

Figure A.11: Connection for RX performance tests with antenna configuration 4x2

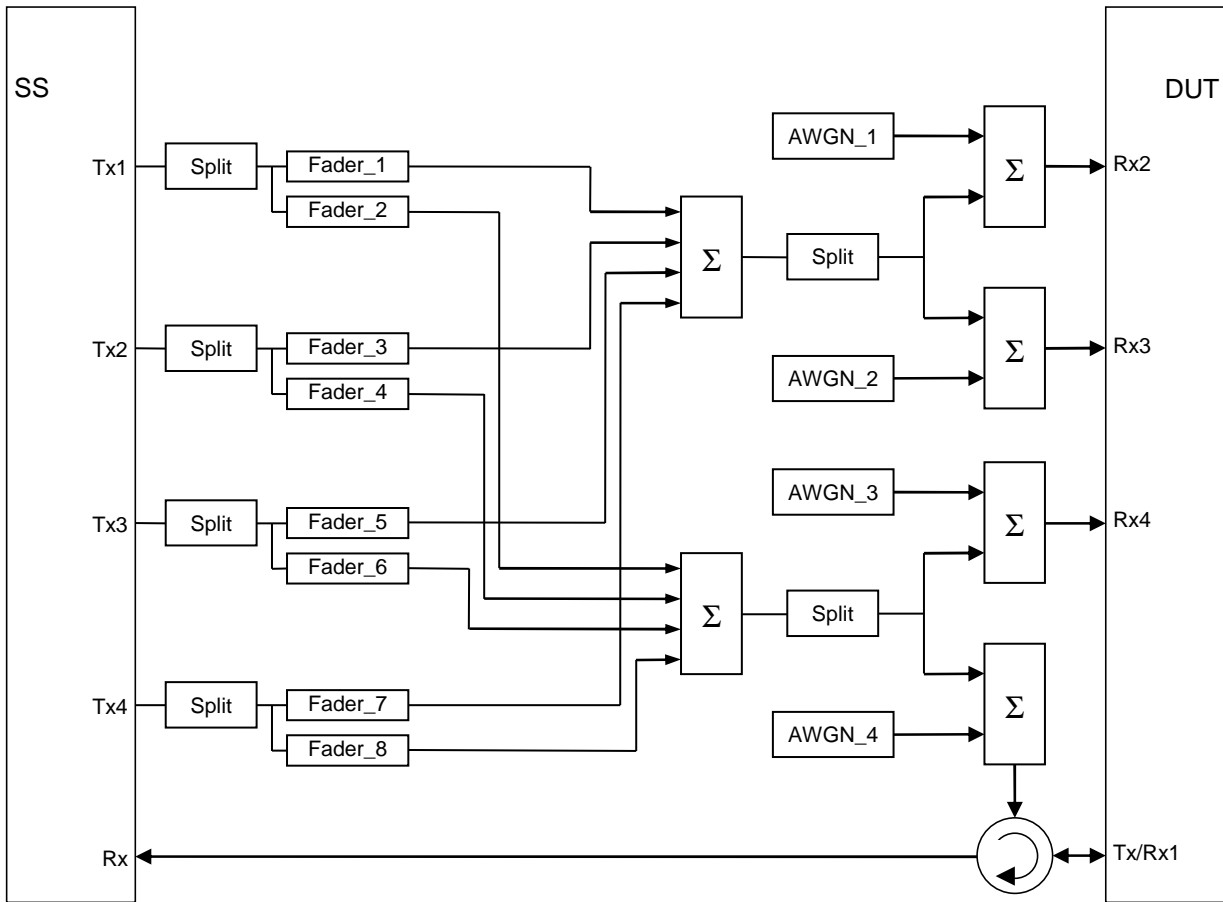

Figure A.11a: Connection for RX performance tests with antenna configuration 4x2 for 4Rx capable UEs without any 2Rx RF bands

Figure A.12: Void

Figure A.13: Void

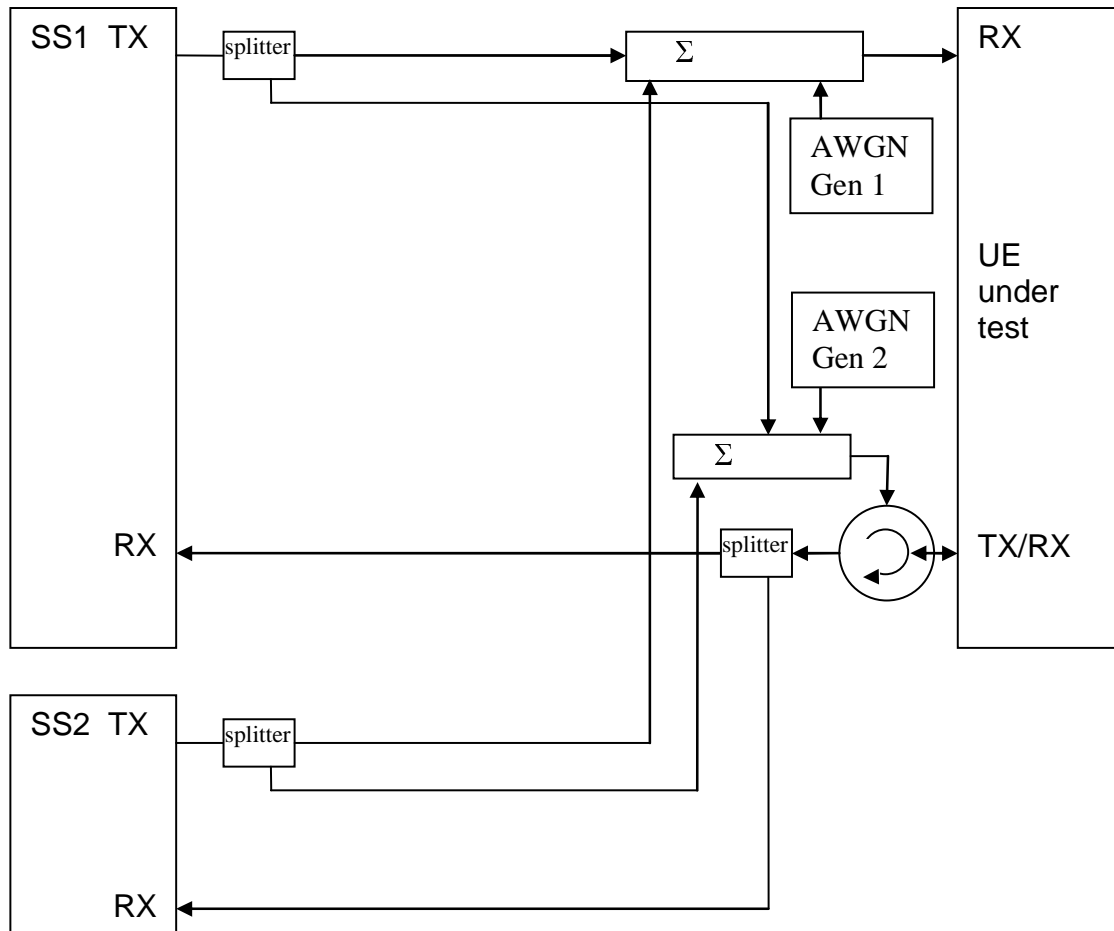

Figure A.14: Connection for 2 cells with static propagation and receive diversity

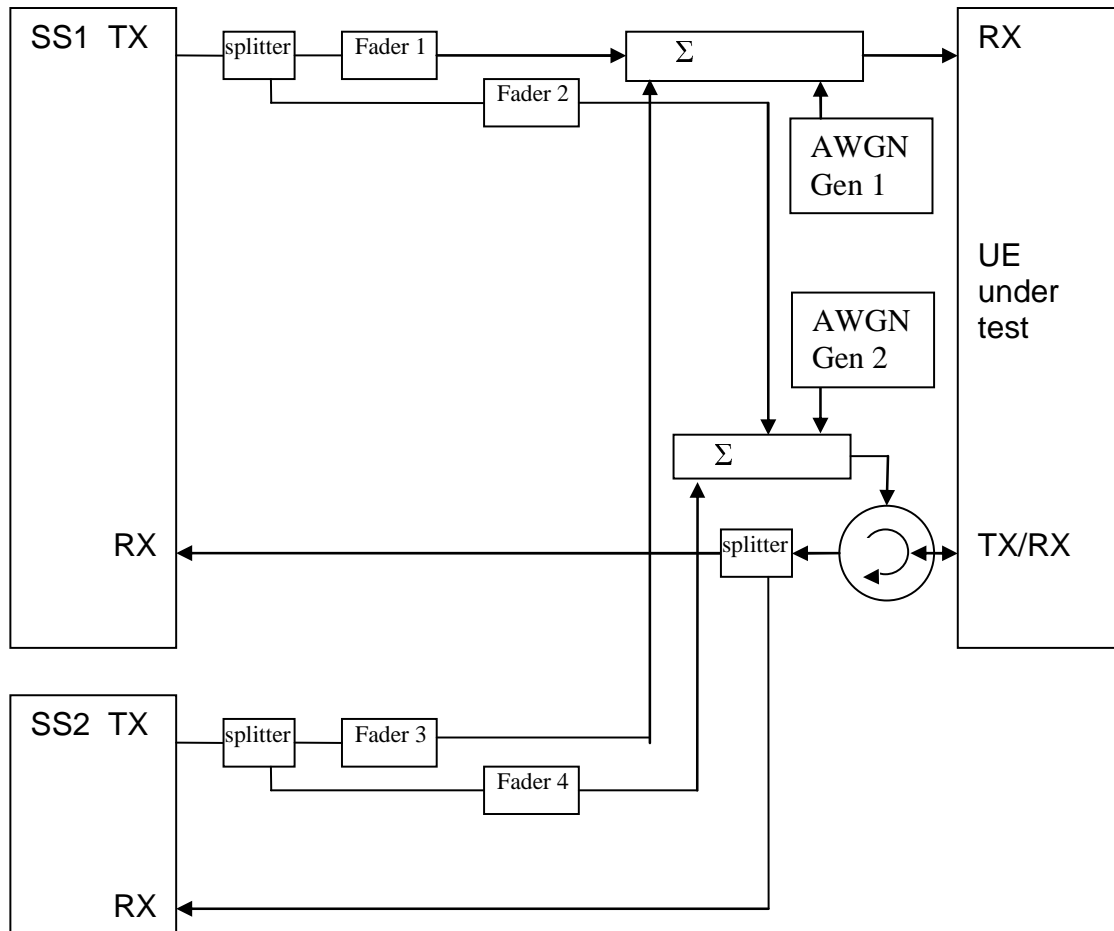

Figure A.15: Connection for 2 cells with multipath fading propagation and receive diversity

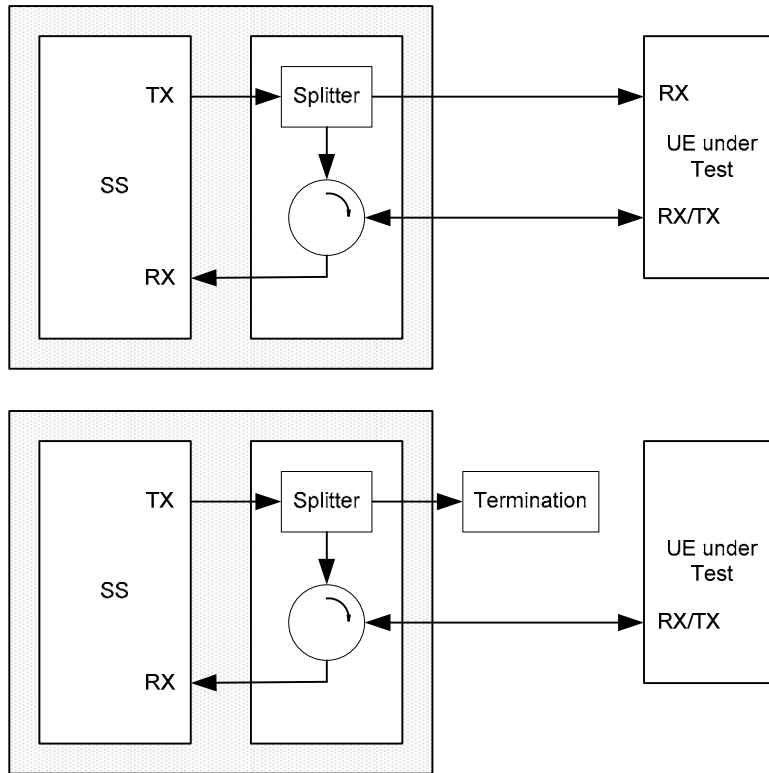

Figure A.16: Connection for single cell Signalling tests
 (Note: only one Rx/Tx antenna port in case of NB-IoT UE)

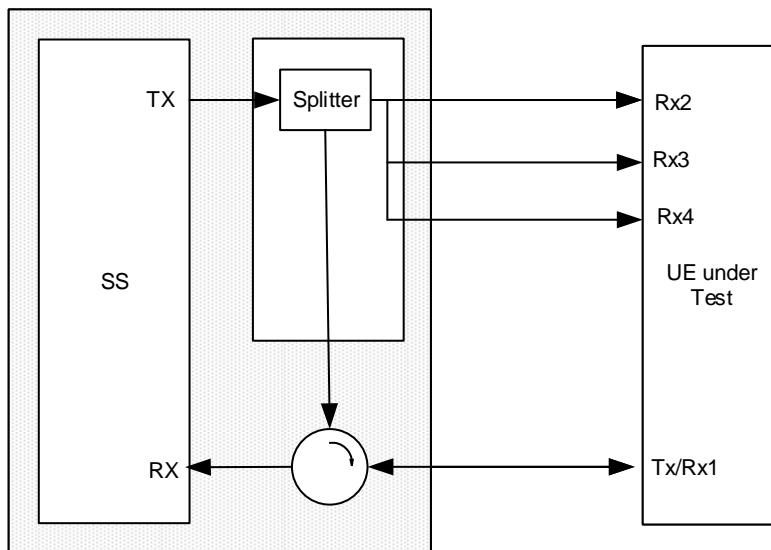
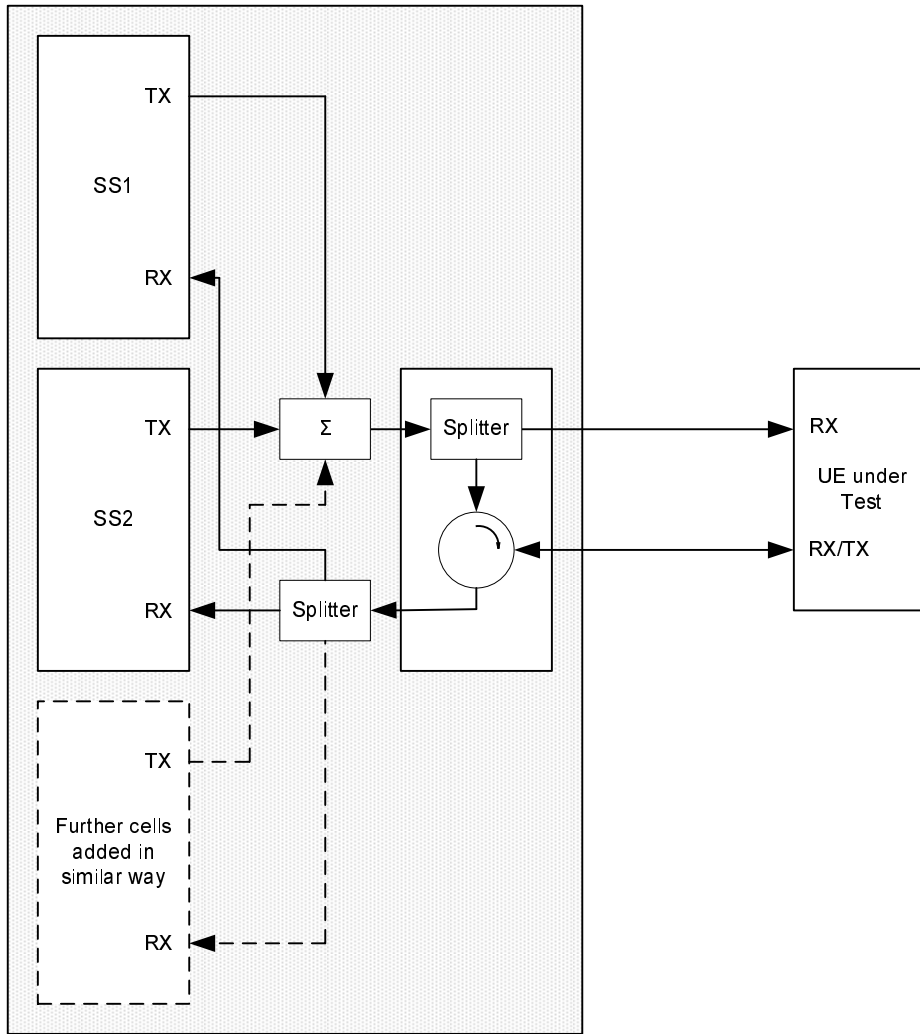

Figure A.16a: Connection for single cell Signalling tests for 4Rx Capable UE



**Figure A.17: Connection for multiple cells Signalling tests
(Note: only one Rx/Tx antenna port in case of NB-IoT UE)**

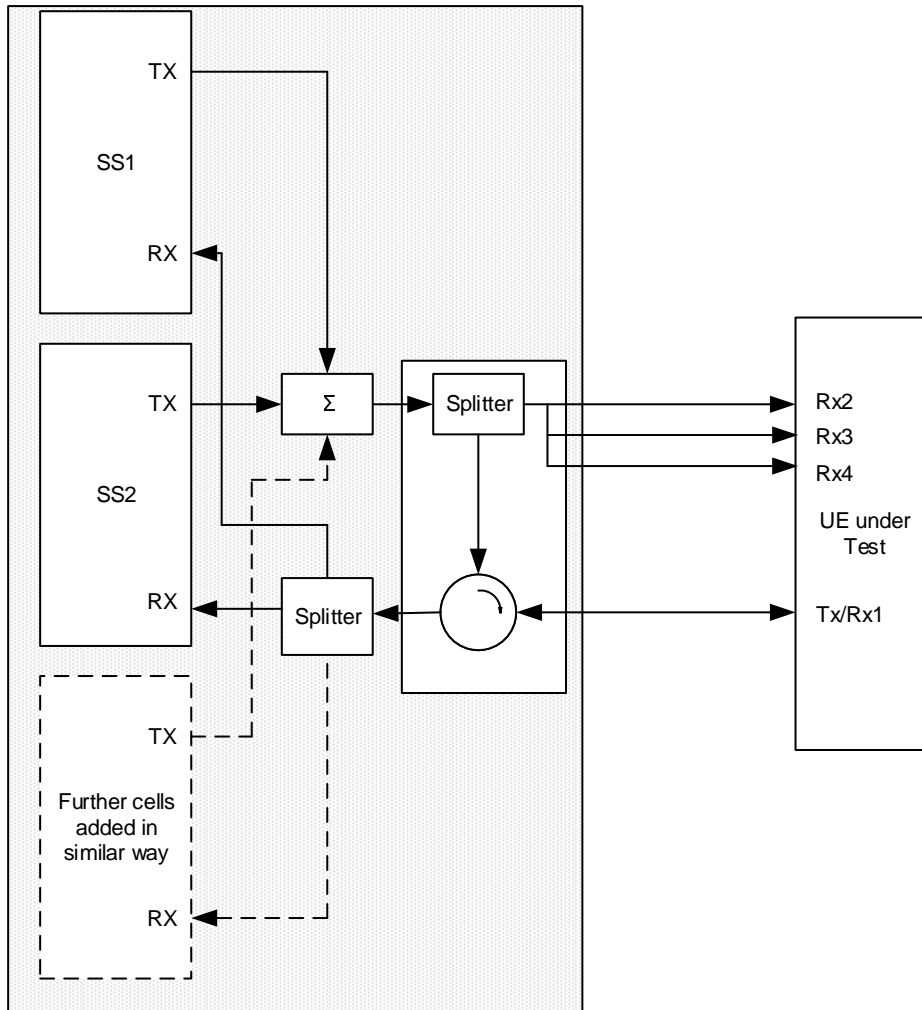

Figure A.17a: Connection for multiple cells Signalling tests for 4Rx capable UE

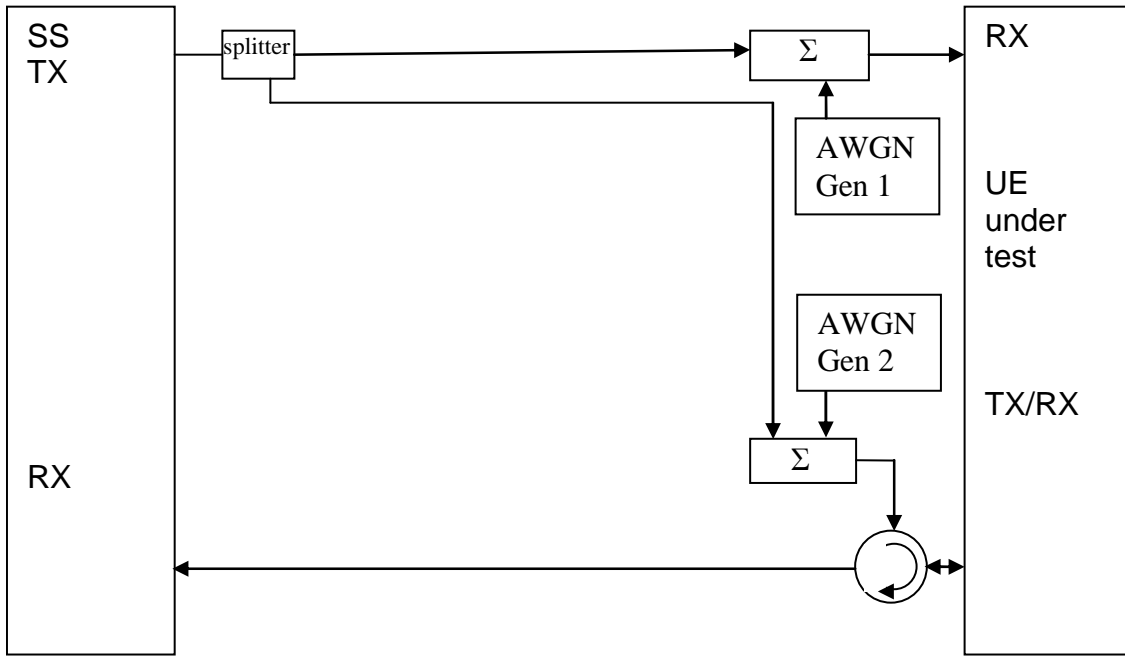

Figure A.18: Connection for 1 cell with antenna configuration 1x2 in static propagation conditions

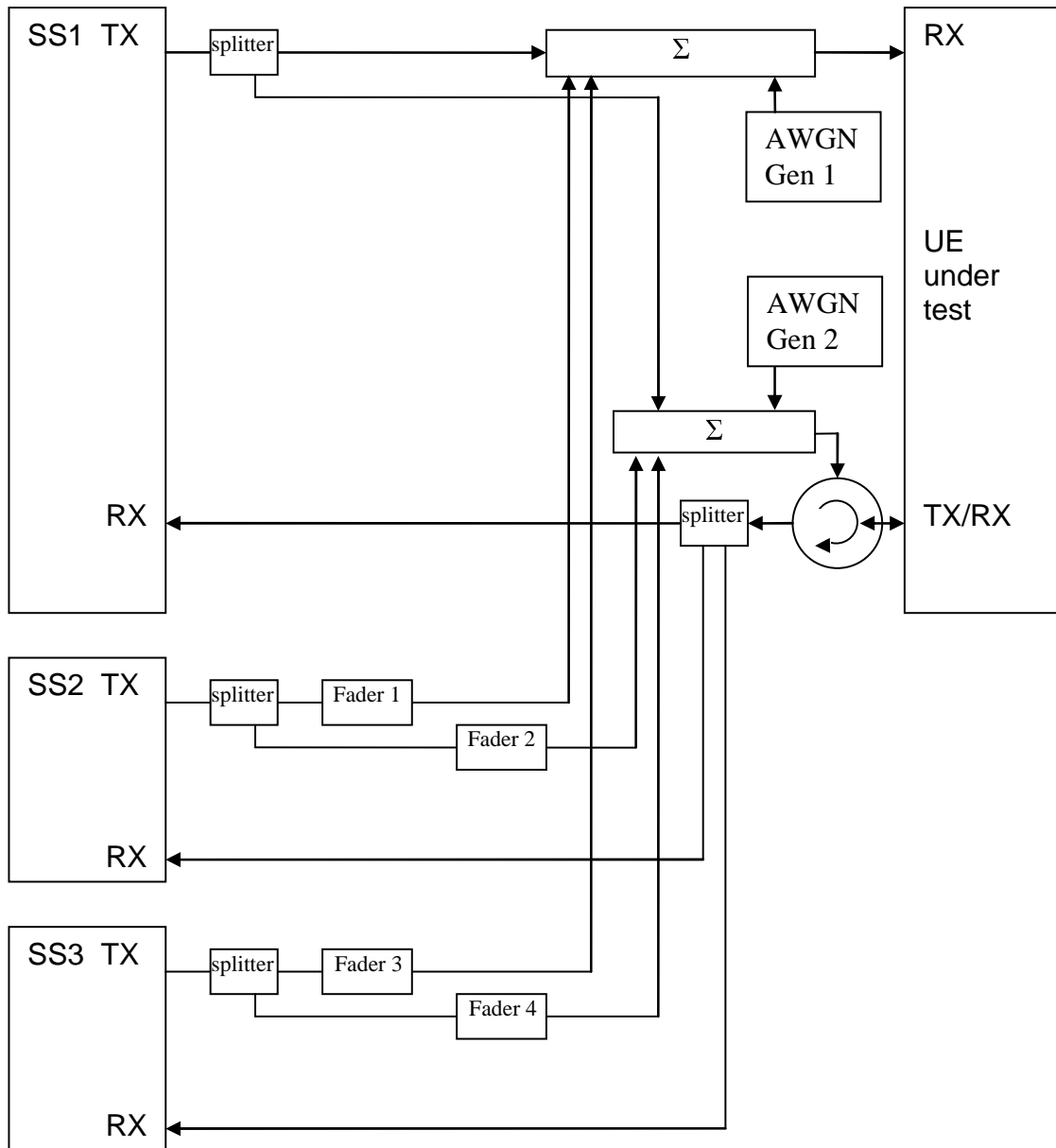

Figure A.19: Connection for 3 cells with antenna configuration 1x2 in static (cell 1) and multipath fading (cell 2 and 3) propagation conditions and receive diversity

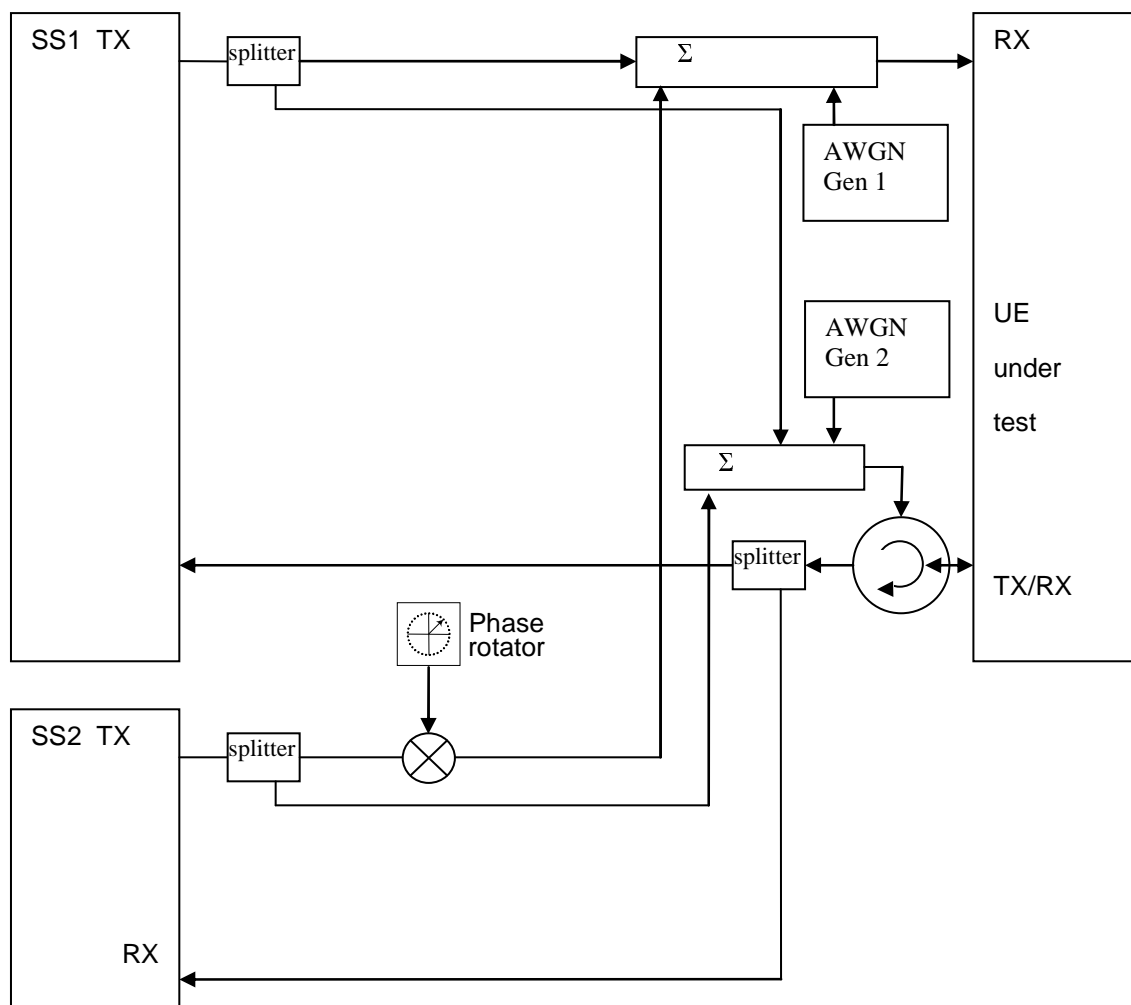

Figure A.20: Connection for 2 cells with static propagation and receive diversity with phase rotator (The frequency offset used in phase rotator is 5 Hz)

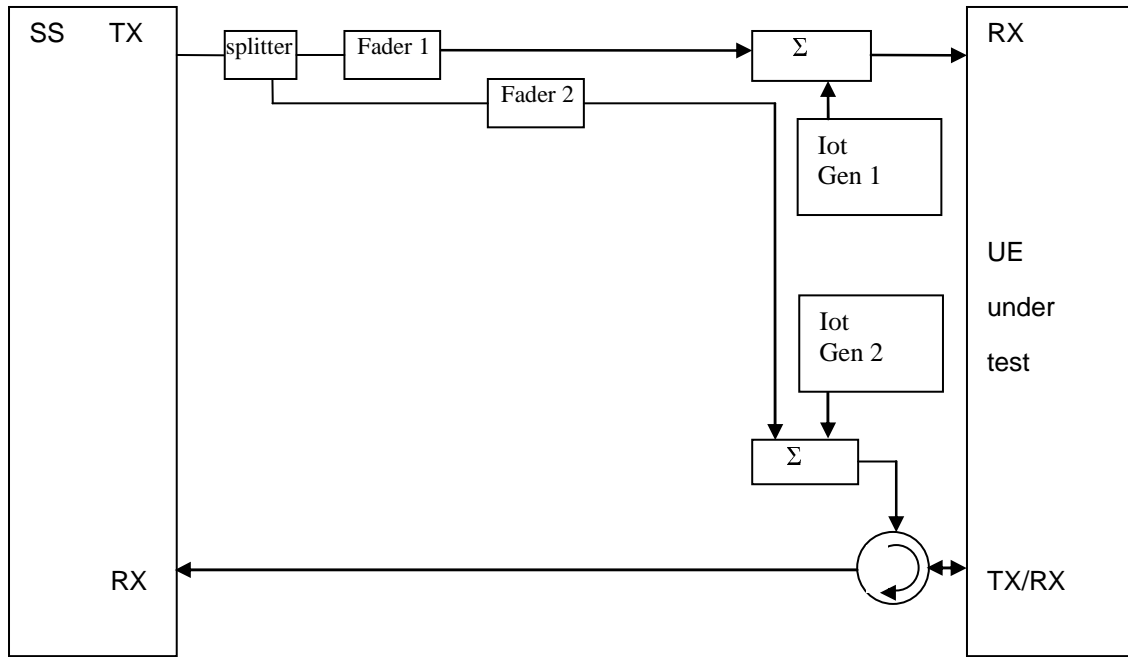

Figure A.21: Connection for frequency-selective interference with multipath fading propagation and receive diversity

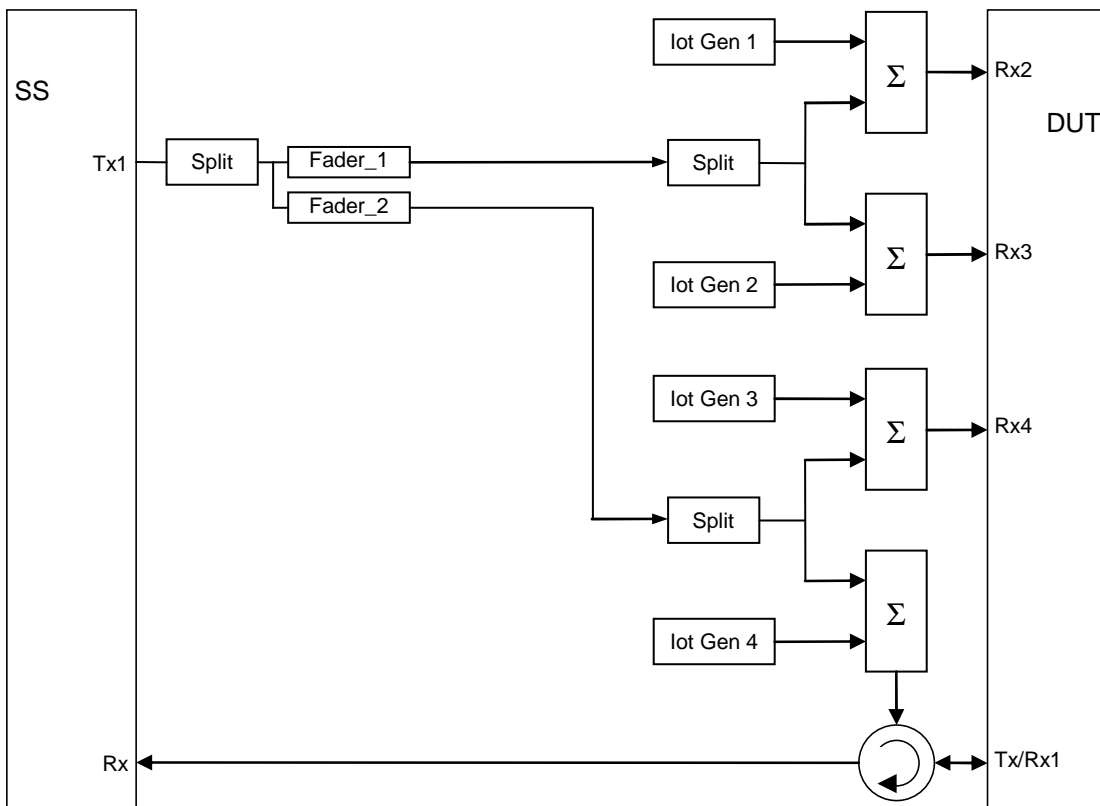

Figure A.21a: Connection for frequency-selective interference with multipath fading propagation and receive diversity for 4Rx capable UEs without any 2Rx RF bands

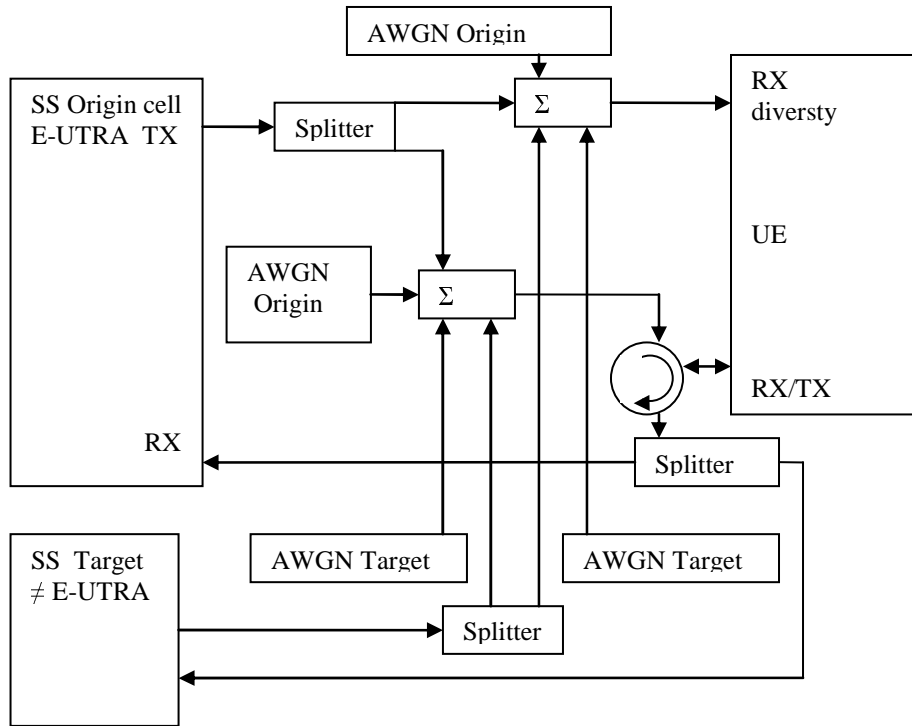

Figure A.22: Connection for 2 cells with static propagation condition. Origin (E-UTRAN) and target cell (≠ E-UTRAN) received with RX diversity

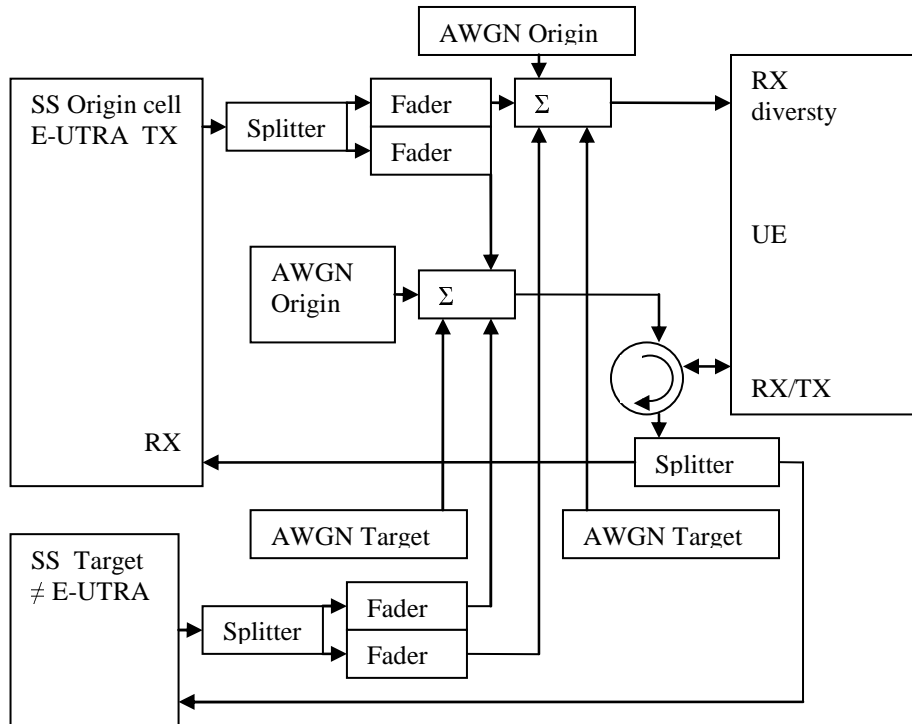

Figure A.23: Connection for 2 cells with multipath fading propagation condition. Origin (E-UTRAN) and target cell (\neq E-UTRAN) received with RX diversity

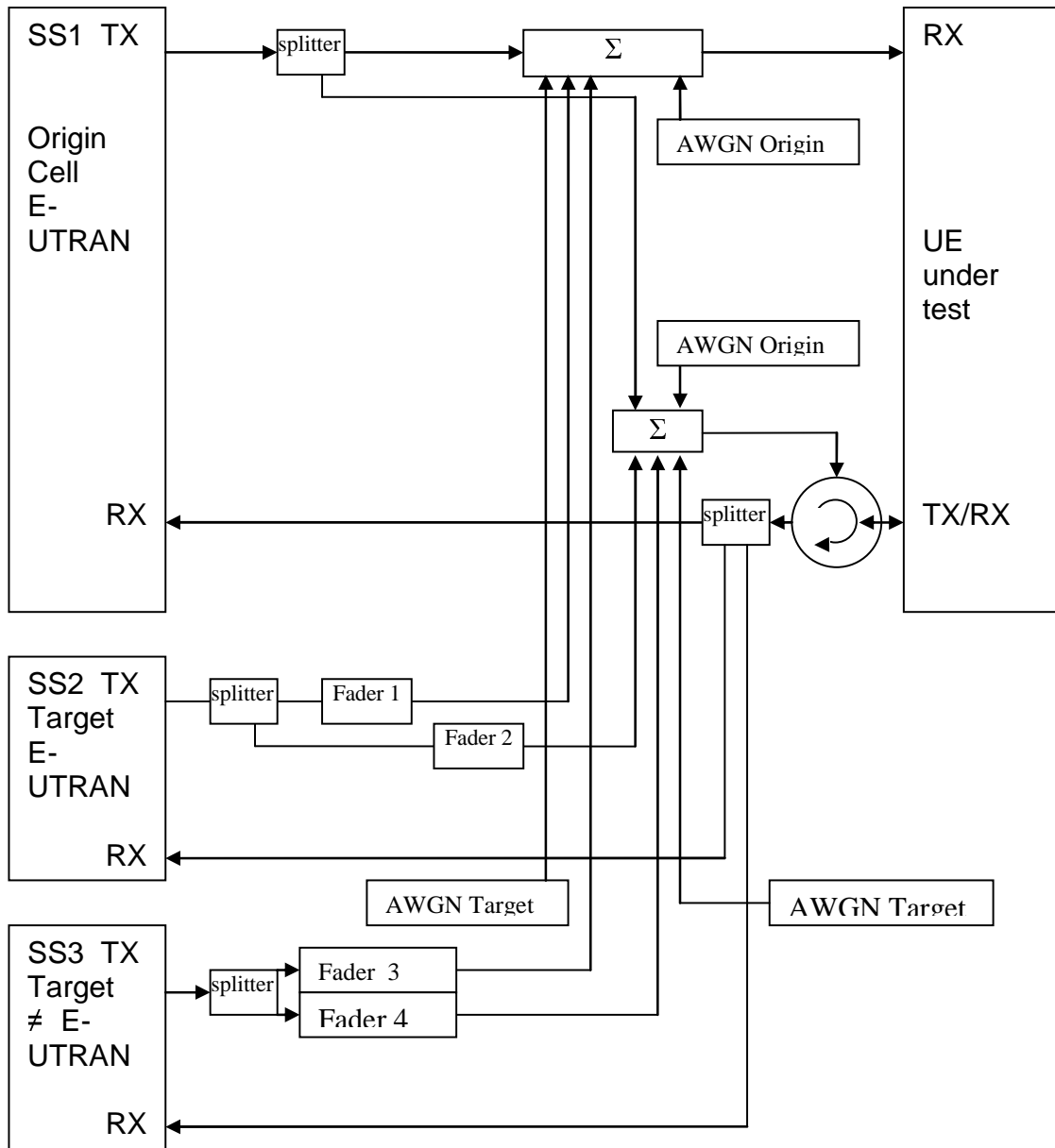

Figure A.24: Connection for 3 cells with antenna configuration 1x2 in static (cell 1) and multipath fading conditions (cell 2 and 3) and multiple RAT and receive diversity

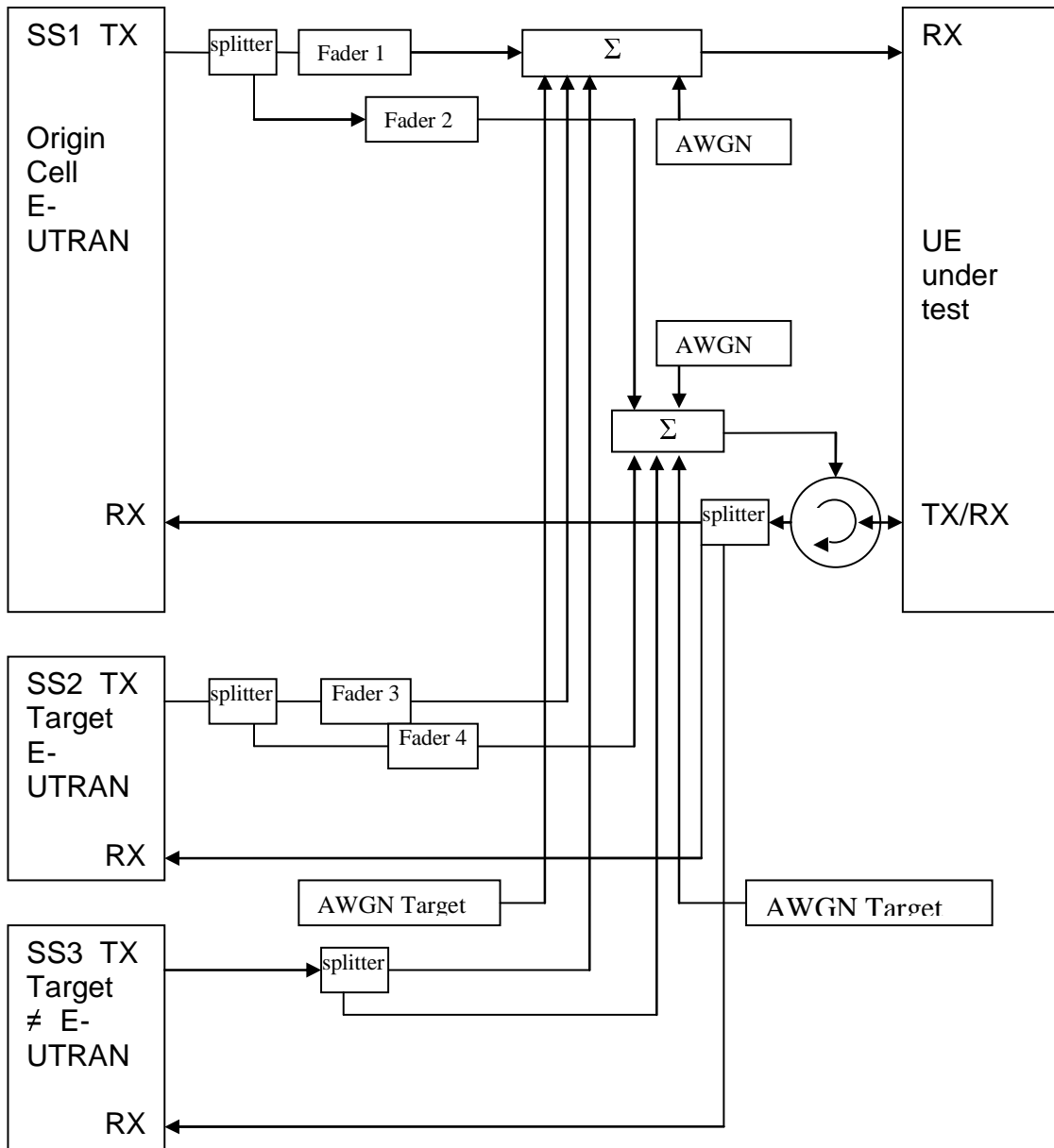

Figure A.25: Connection for 3 cells with antenna configuration 1x2 in multipath fading (cell 1 and 2) and multiple RAT (cell 3 static) and receive diversity

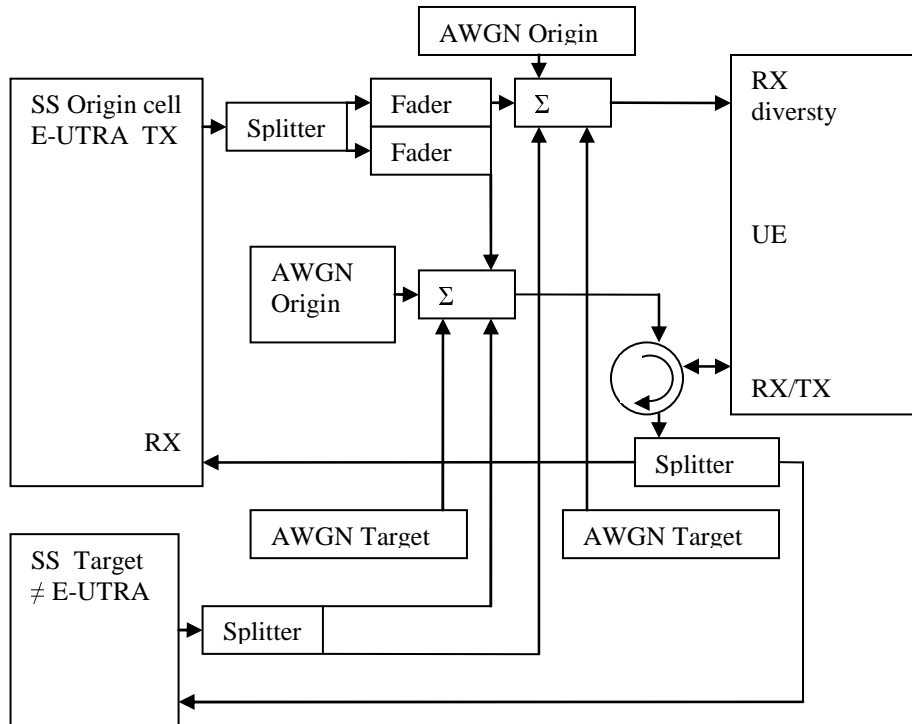

Figure A.26: Connection for 2 cells. Origin (E-UTRAN, multipath fading) and target cell (\neq E-UTRAN, static) received with RX diversity

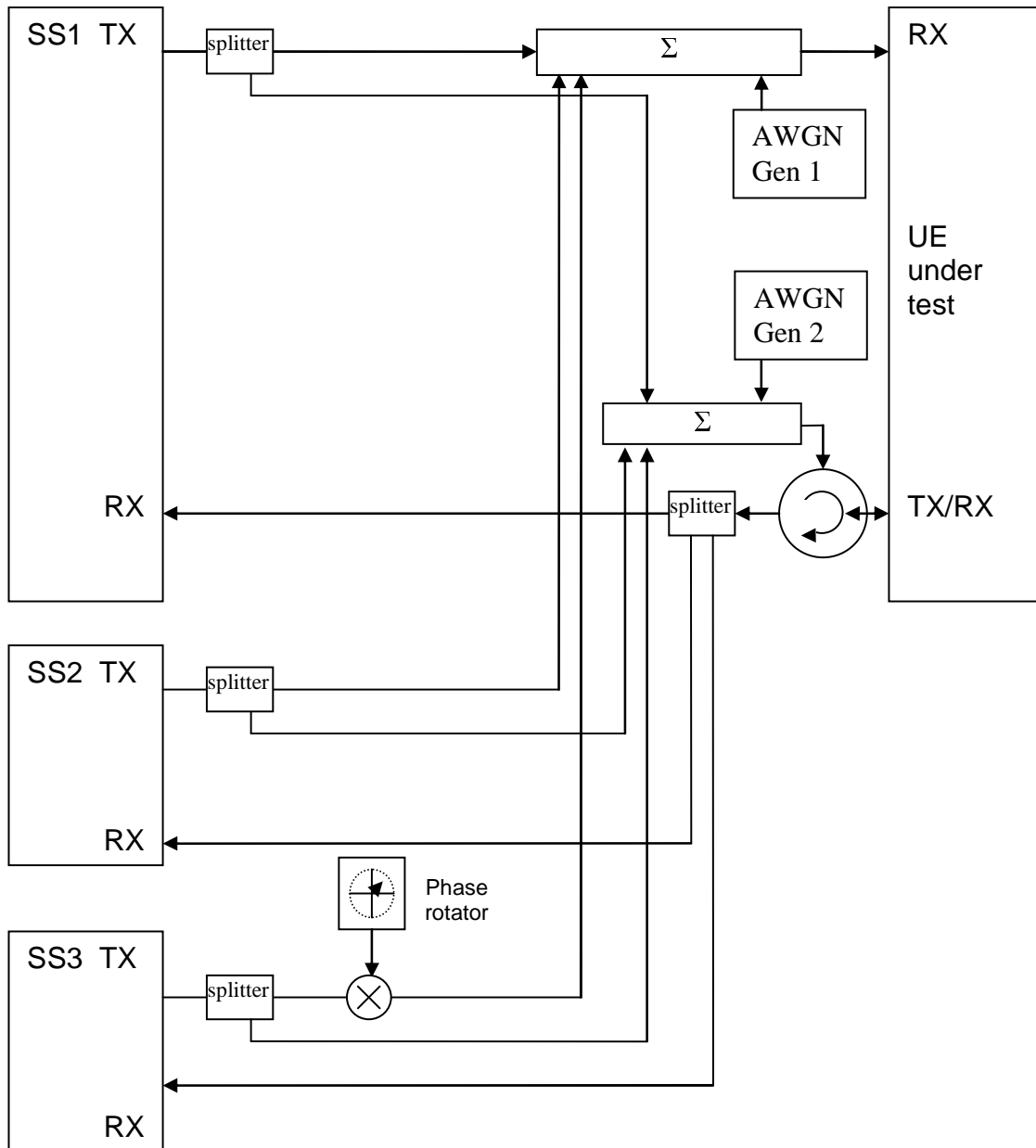

Figure A.27: Connection for 3 cells with static propagation and receive diversity

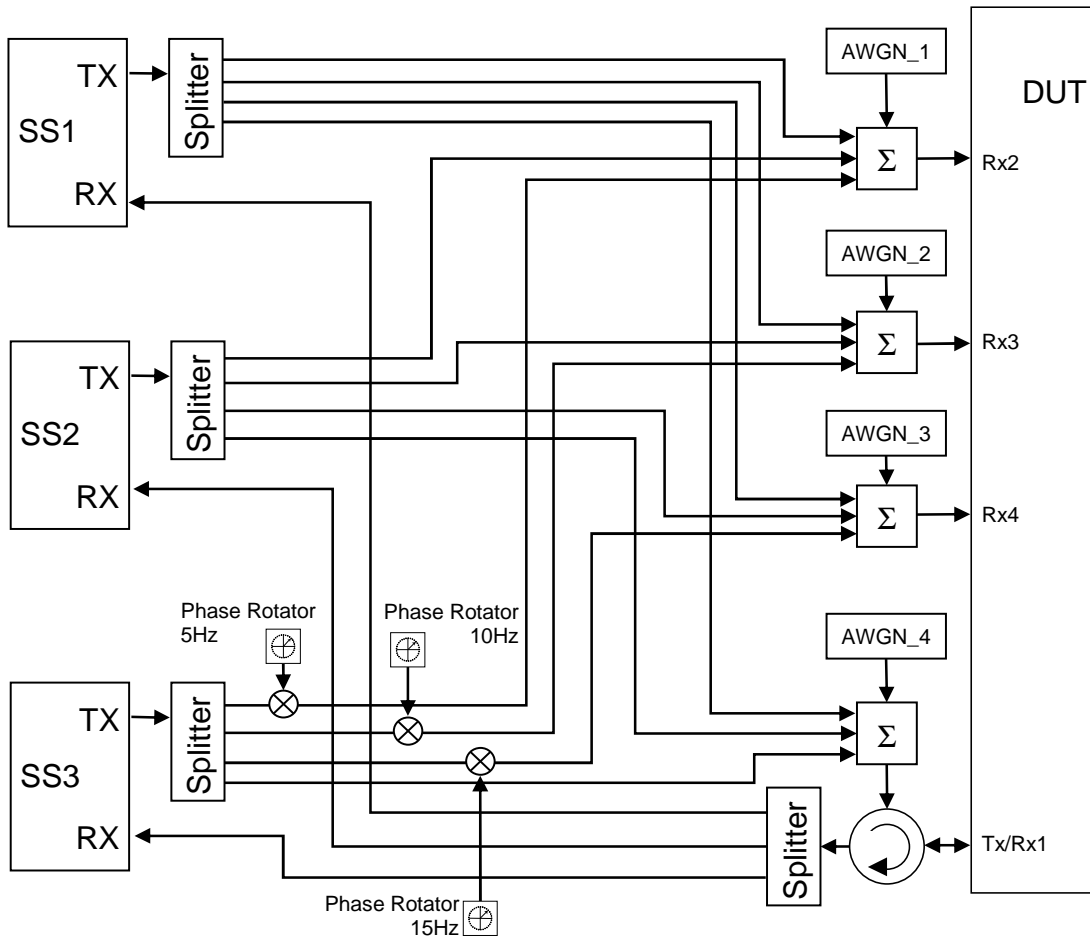

Figure A.27a: Connection for 3 cells with static propagation and 1x4 receive diversity

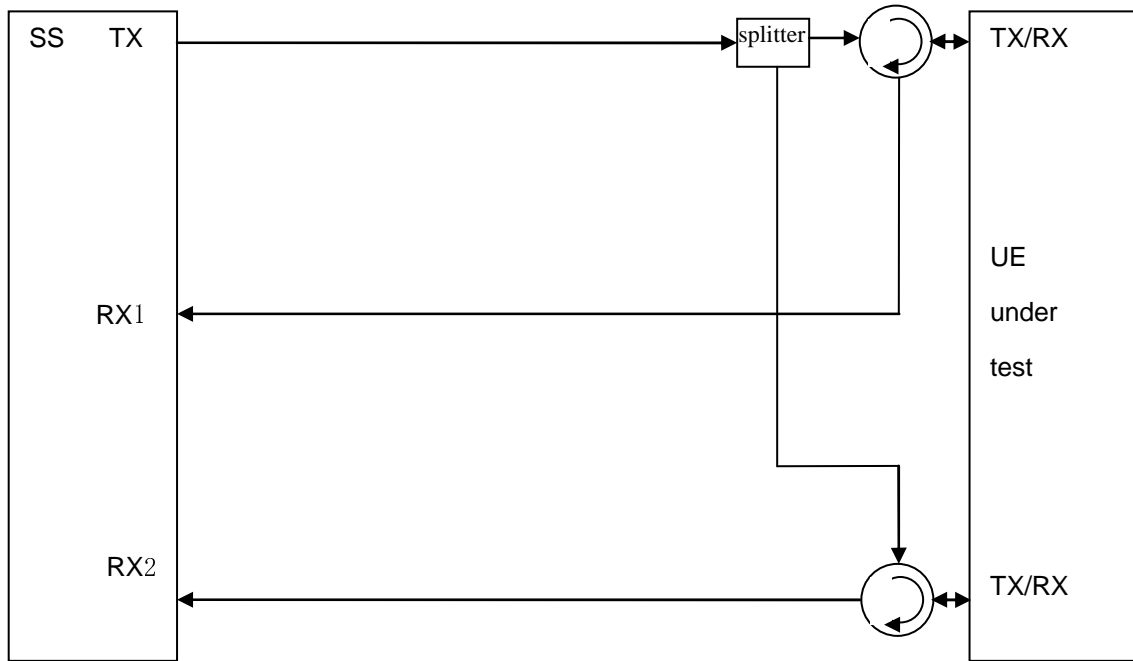

Figure A.28: Connection for basic UL MIMO with receive diversity

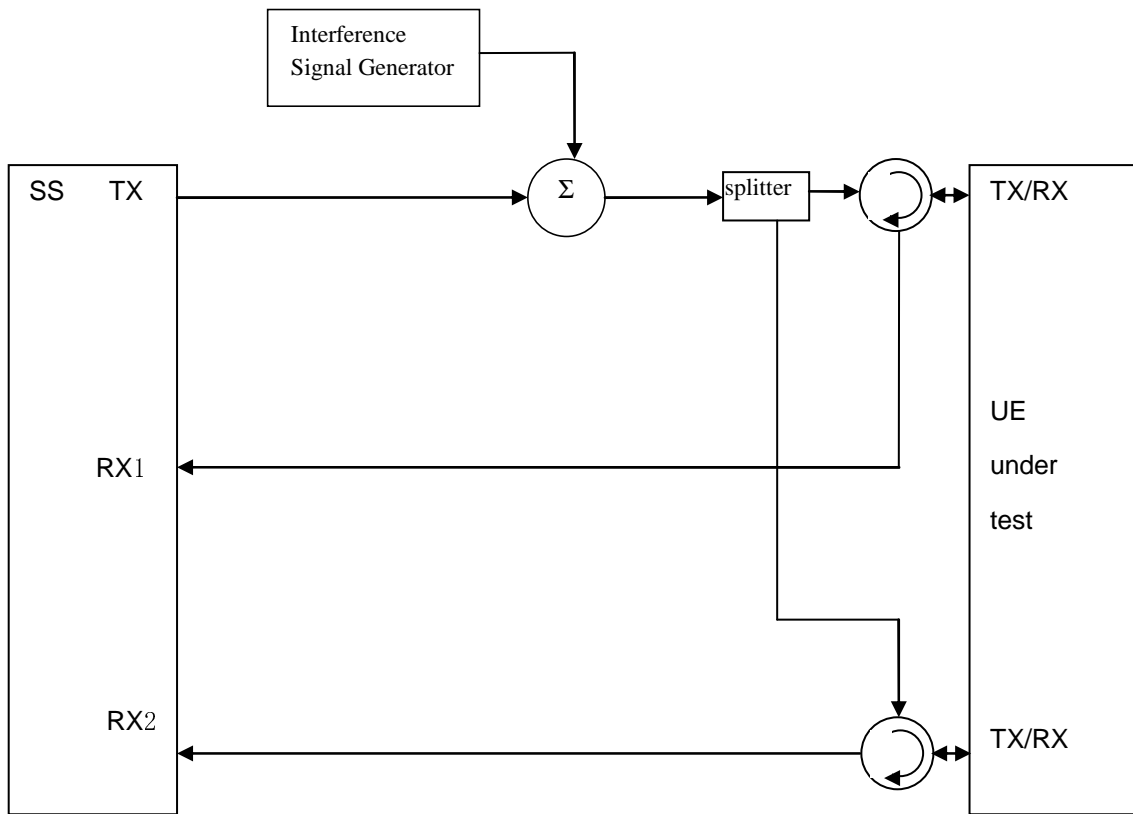

Figure A.29: Connection for UL MIMO Receiver tests with E-UTRA-Interference

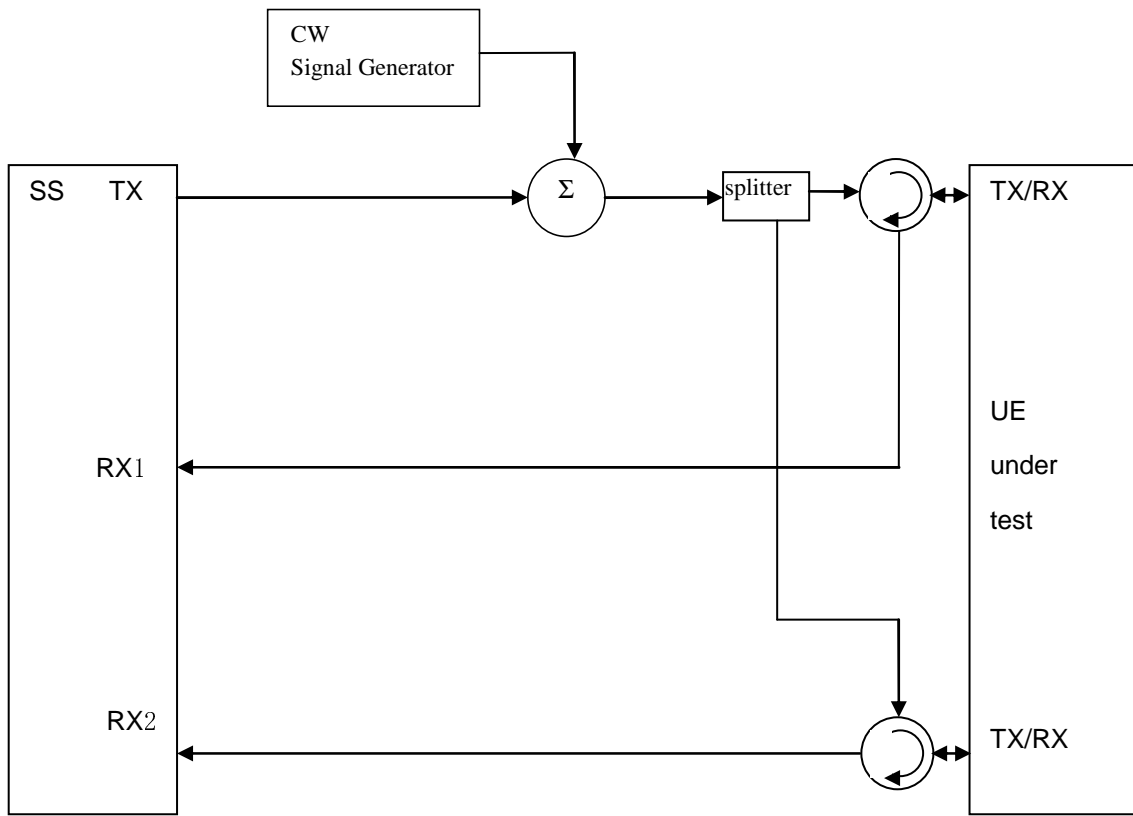

Figure A.30: Connection for UL MIMO Receiver tests with CW Interference

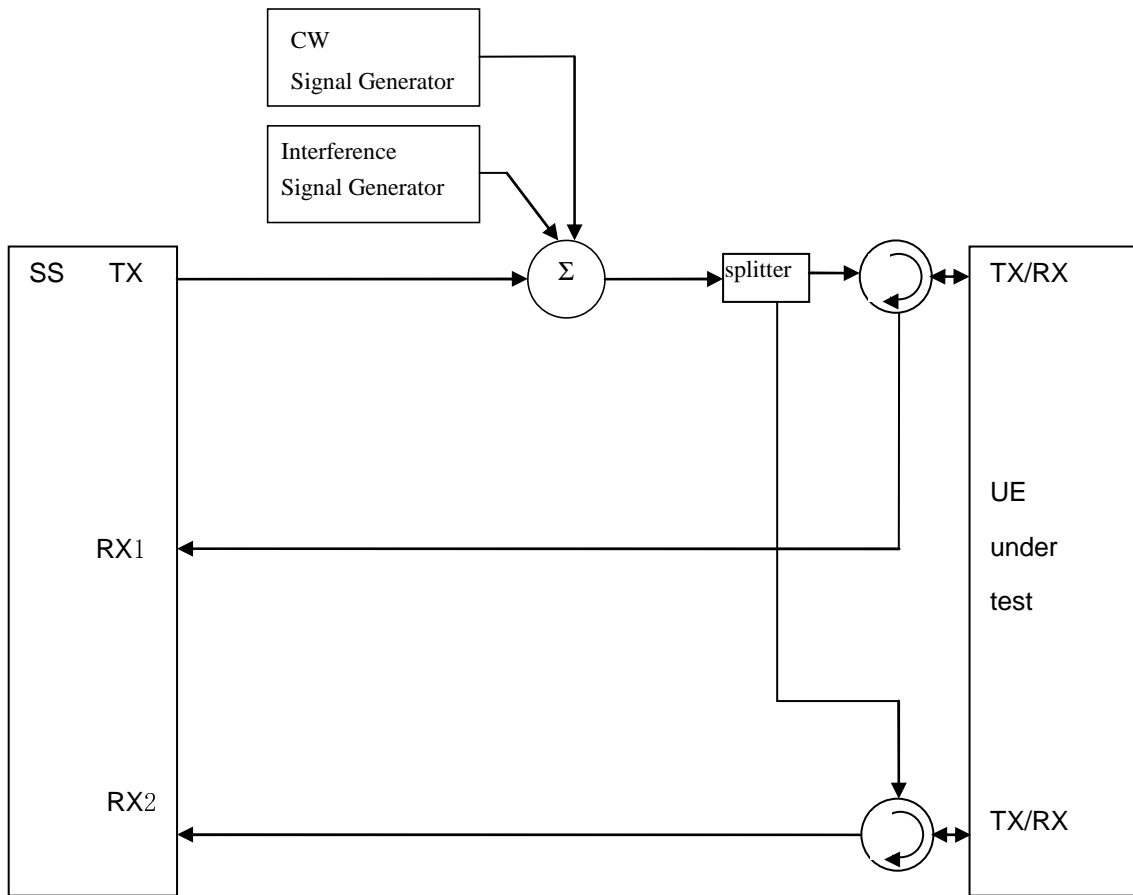

Figure A.31: Connection for UL MIMO Receiver tests with both E-UTRA-Interference and additional CW signal

Figure group A.32: Connections for basic Tx and Rx tests for CA

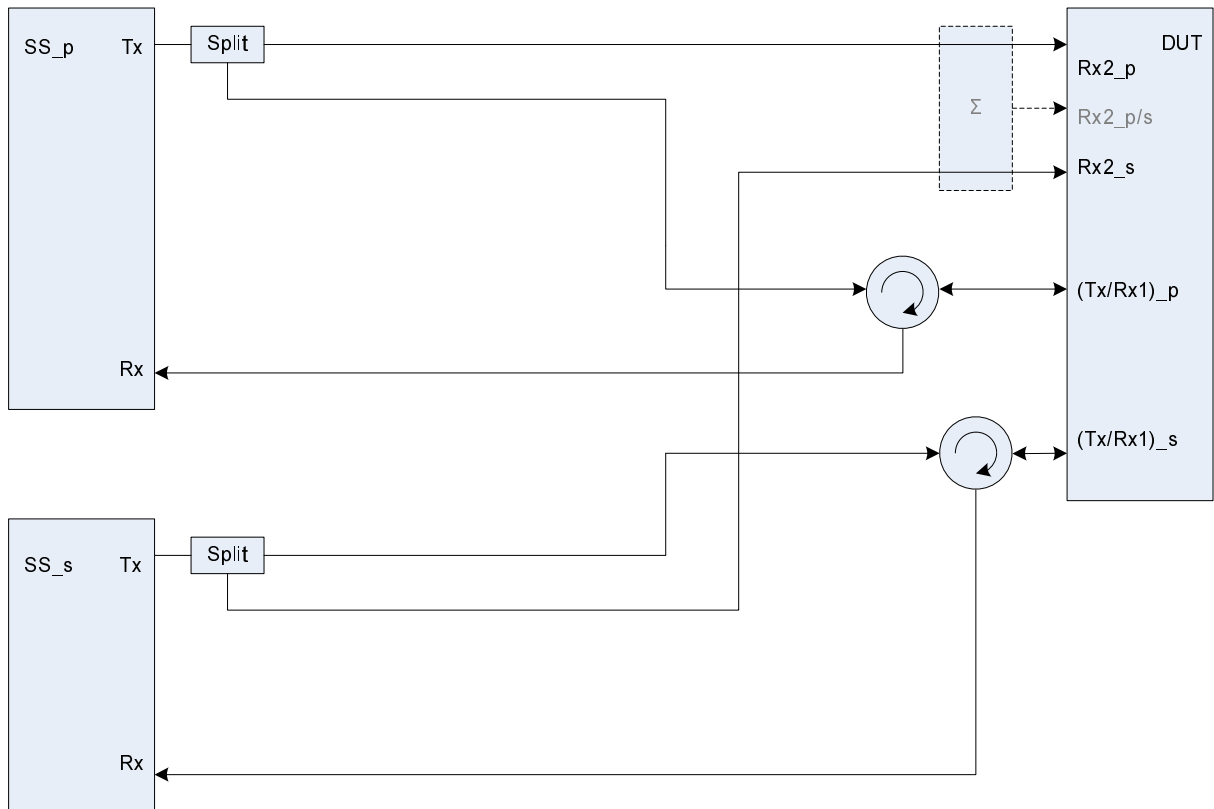

Figure A.32a: Connection for basic Tx and Rx tests for CA (separate connectors)

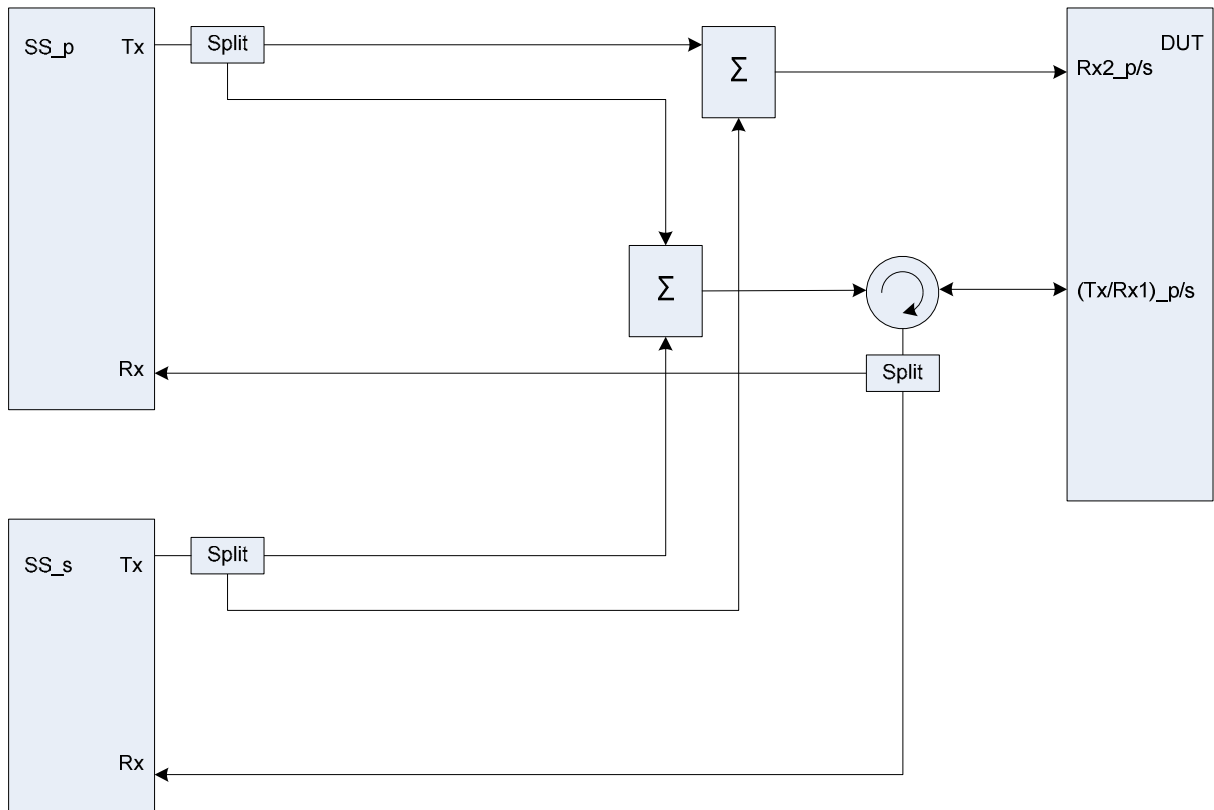

Figure A.32b: Connection for basic Tx and Rx tests for CA (common connectors, same UL antenna)

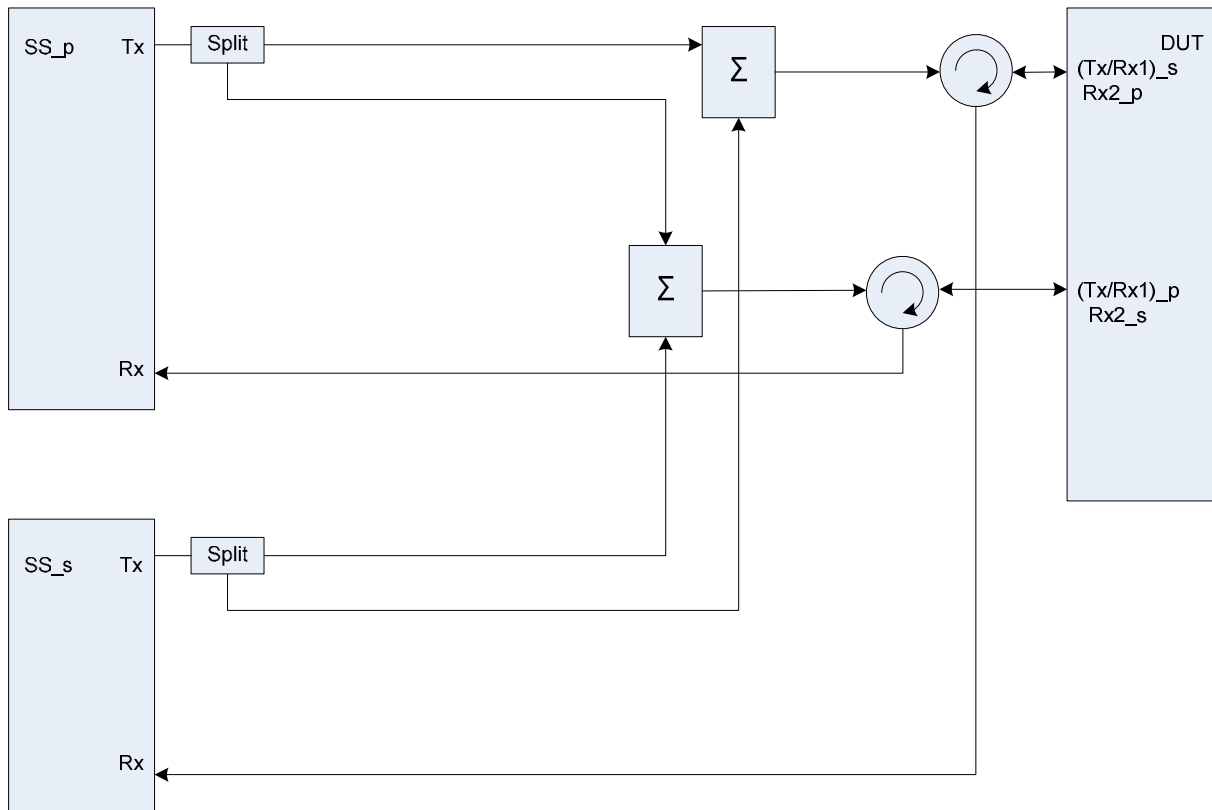

Figure A.32c: Connection for basic Tx and Rx tests for CA (common connectors, different UL antennas)

Figure group A.33: Connection for Tx tests for CA with additional Spectrum Analyzer

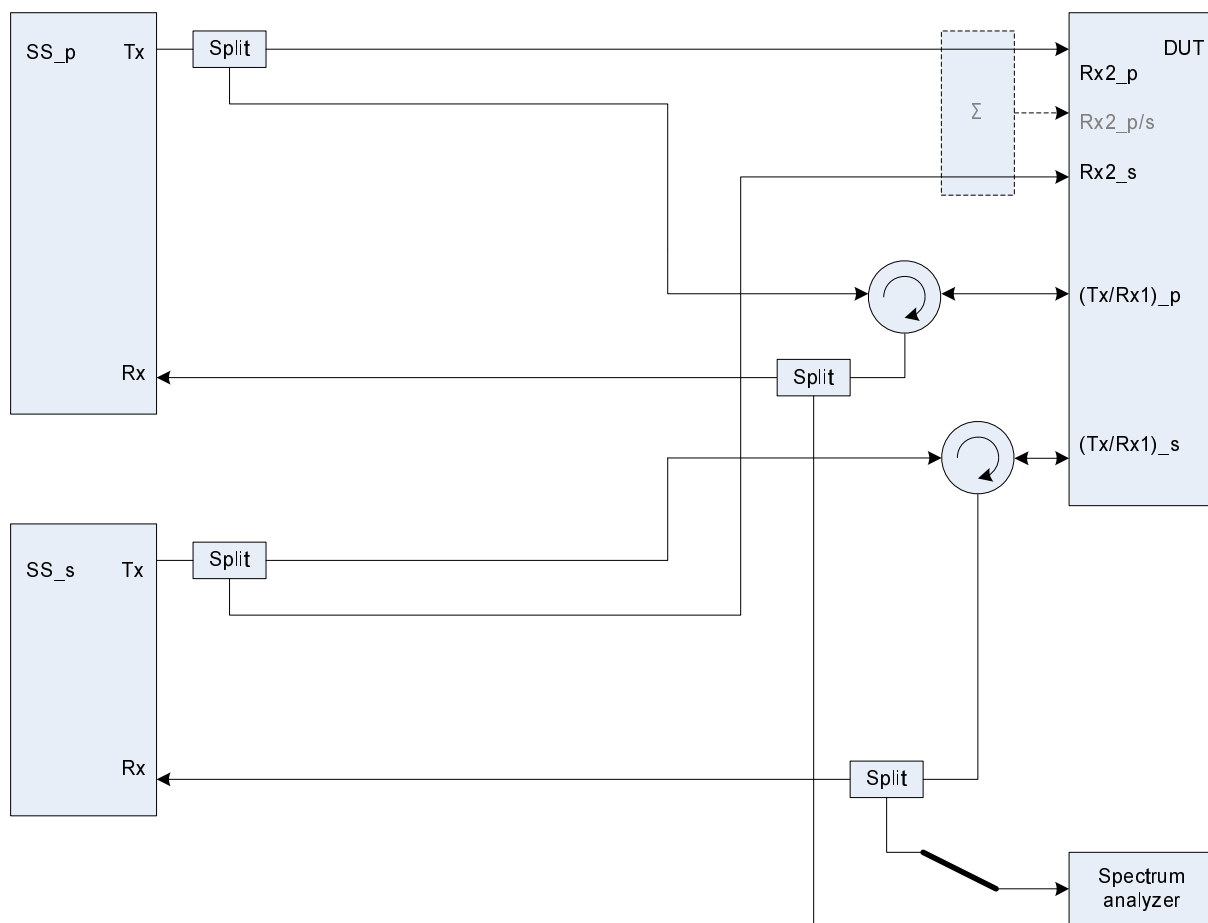

Figure A.33a: Connection for Tx tests for CA with additional Spectrum Analyzer (separate connectors)

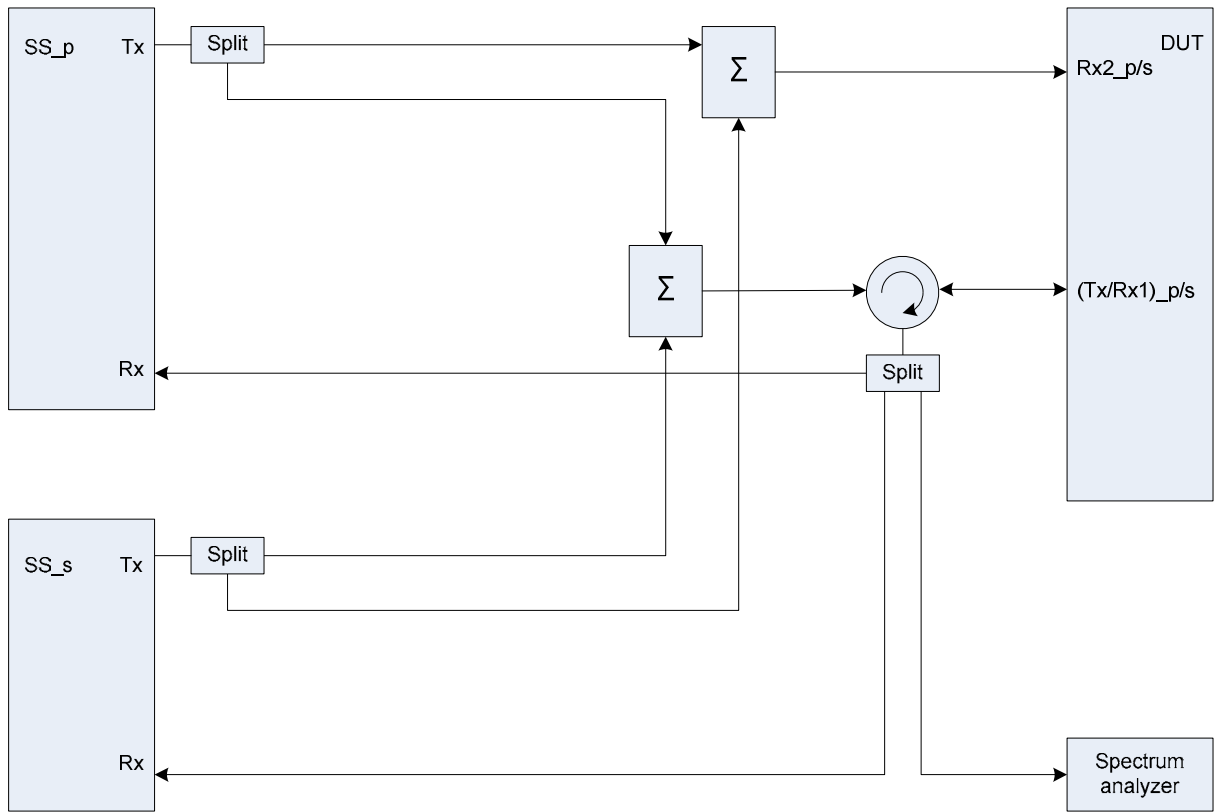

Figure A.33b: Connection for Tx tests for CA with additional Spectrum Analyzer (common connectors, same UL antenna)

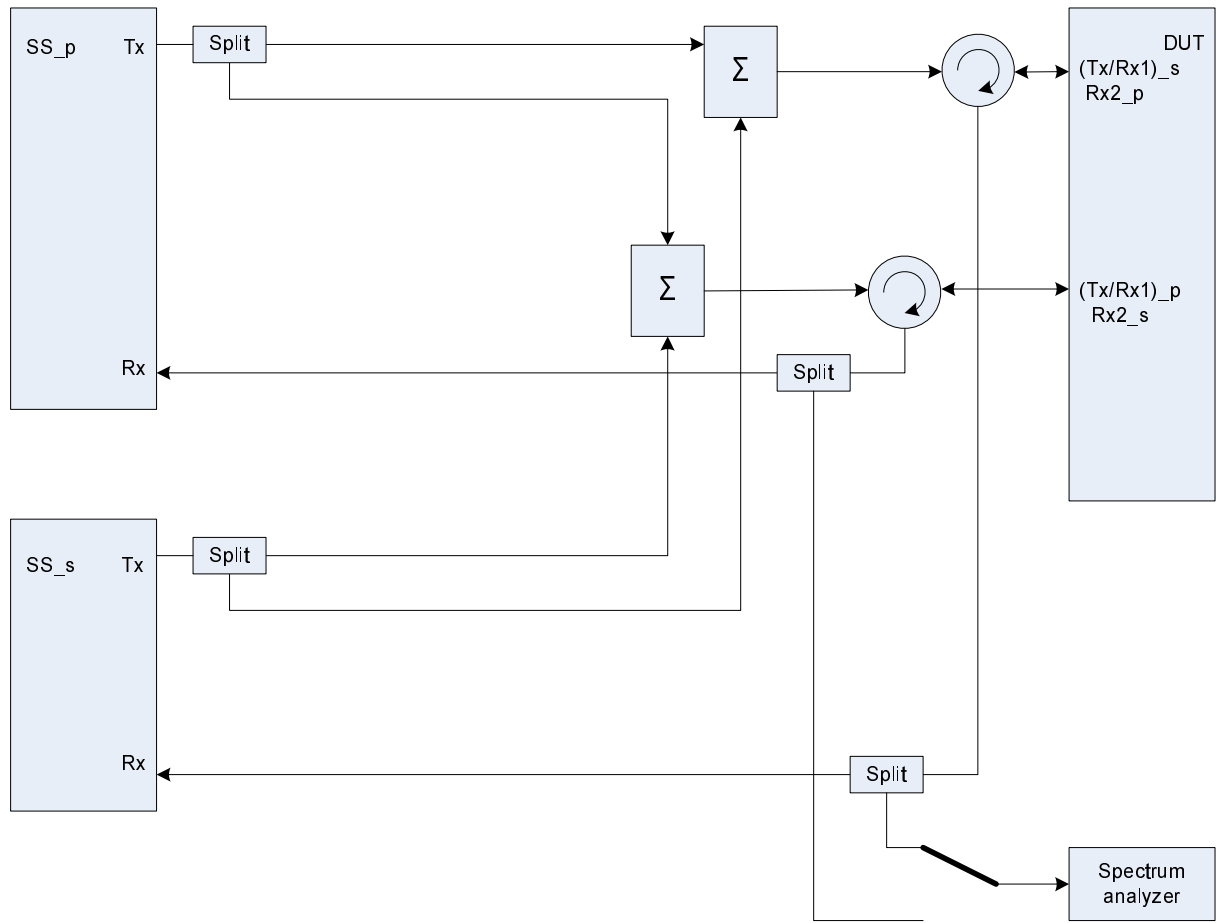

Figure A.33c: Connection for Tx tests for CA with additional Spectrum Analyzer (common connectors, different UL antennas)

Figure group A.34: Connection for Rx tests for CA with additional Interferer / CW

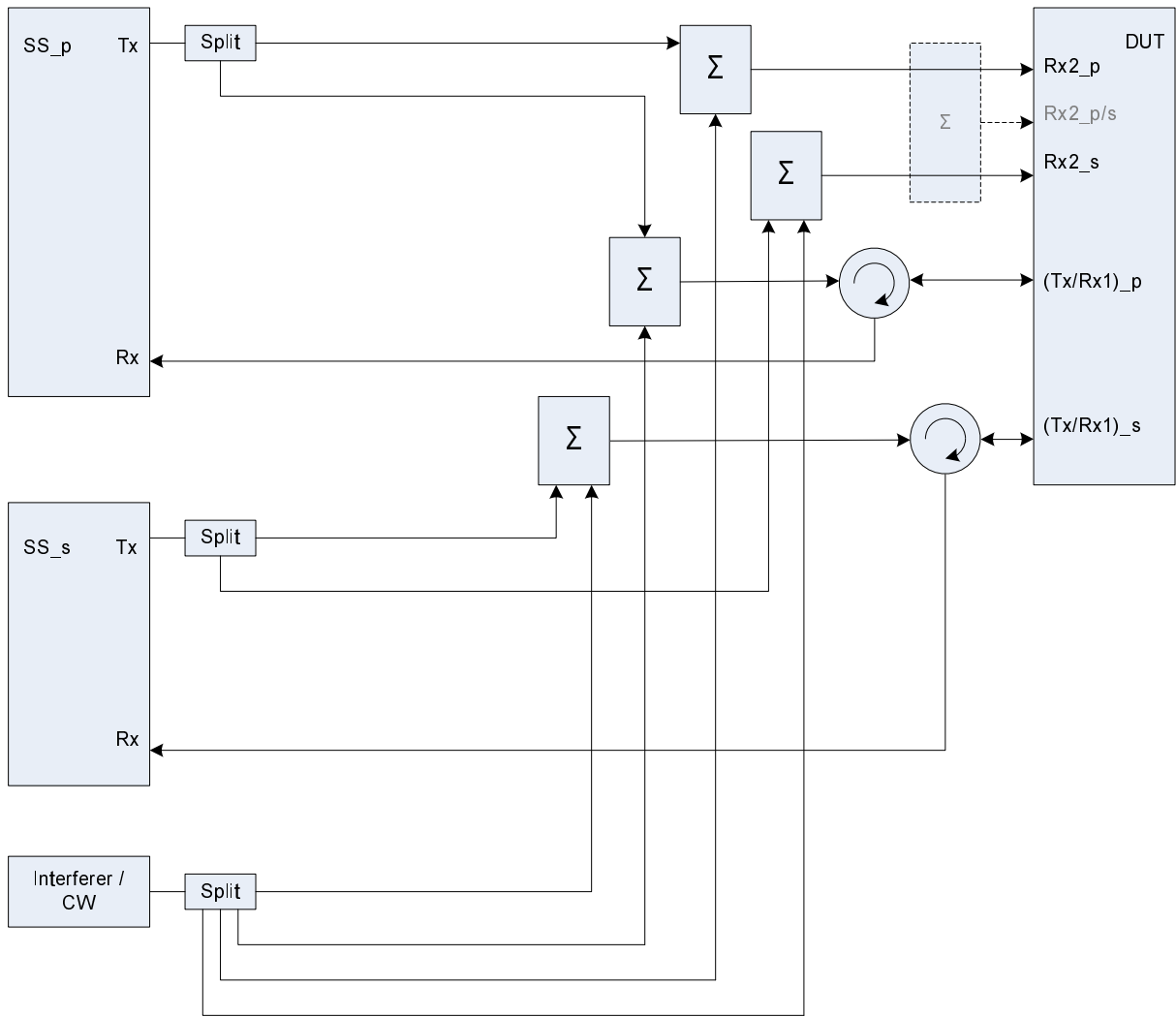

Figure A.34a: Connection for Rx tests for CA with additional Interferer / CW (separate connectors)

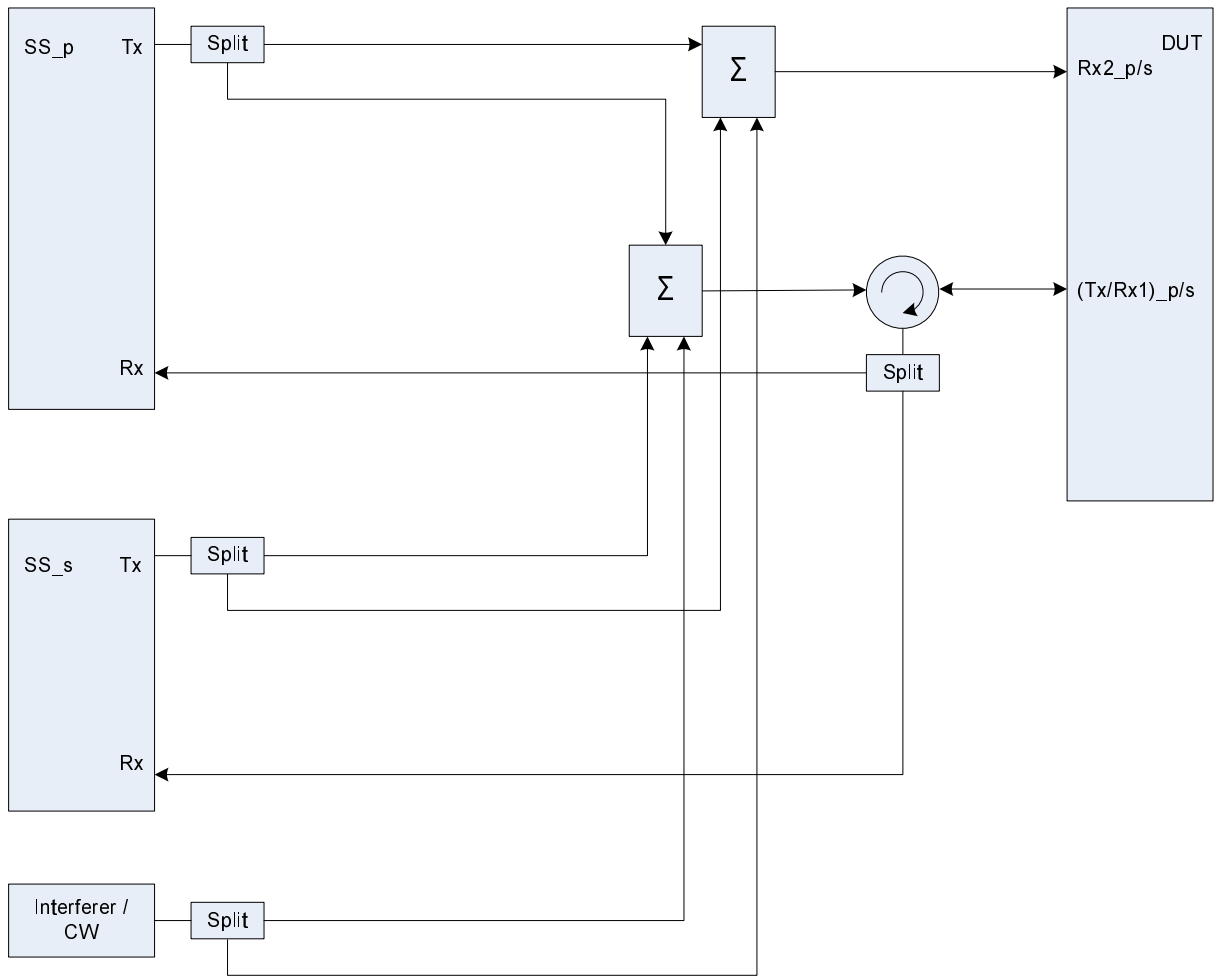

Figure A.34b: Connection for Rx tests for CA with additional Interferer / CW (common connectors, same UL antenna)

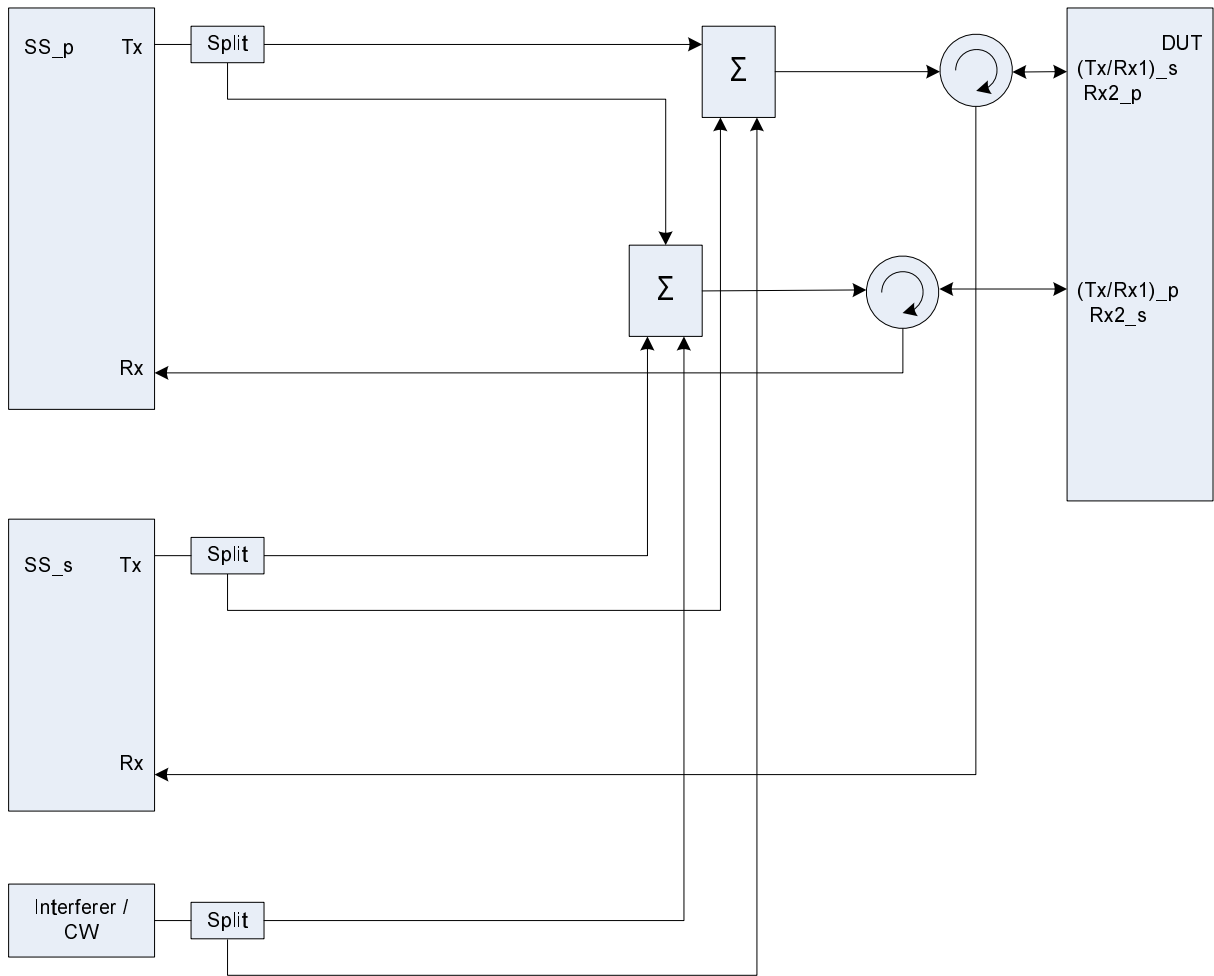

Figure A.34c: Connection for Rx tests for CA with additional Interferer / CW (common connectors, different UL antennas)

Figure group A.35: Connection for Rx performance tests for CA with antenna configuration 1x2

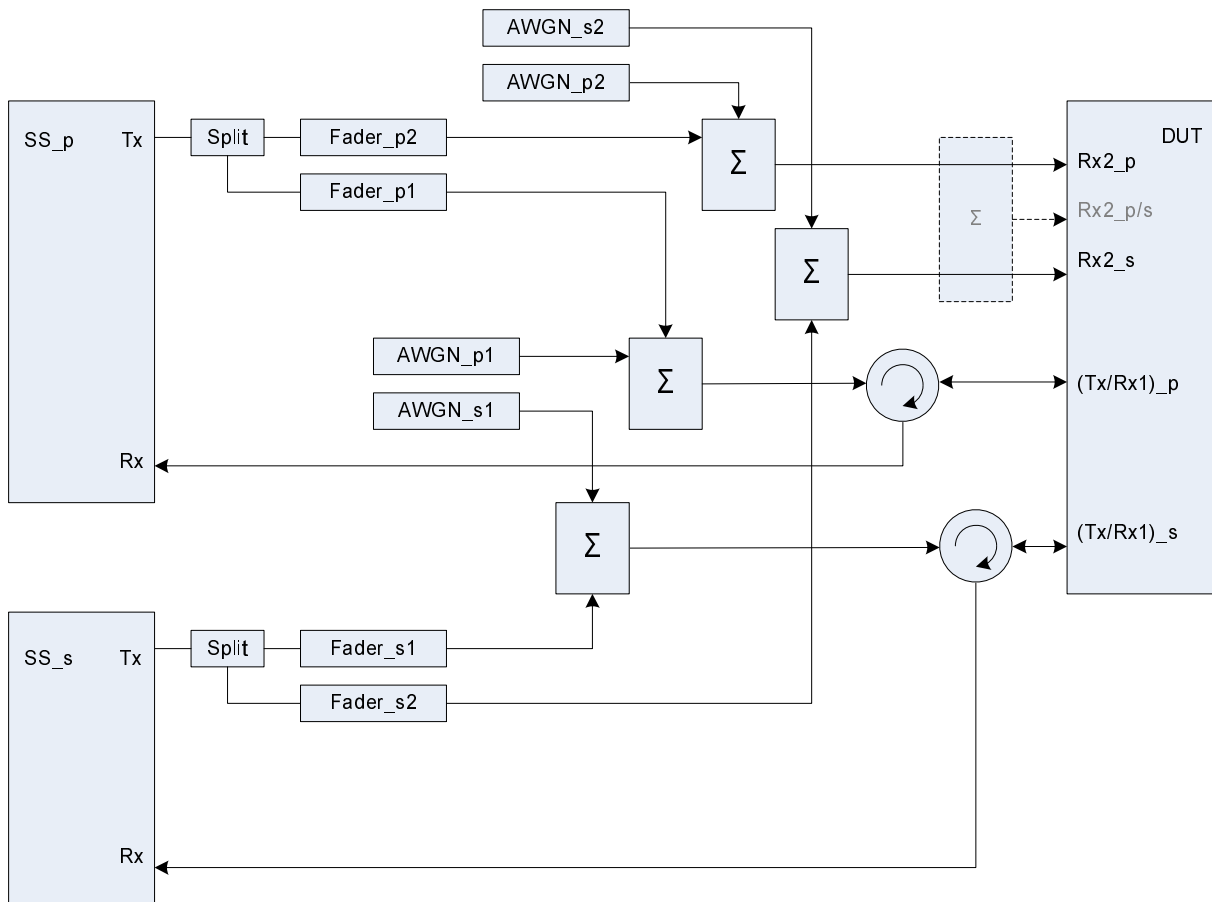

Figure A.35a: Connection for Rx performance tests for CA with antenna configuration 1x2 (separate connectors)

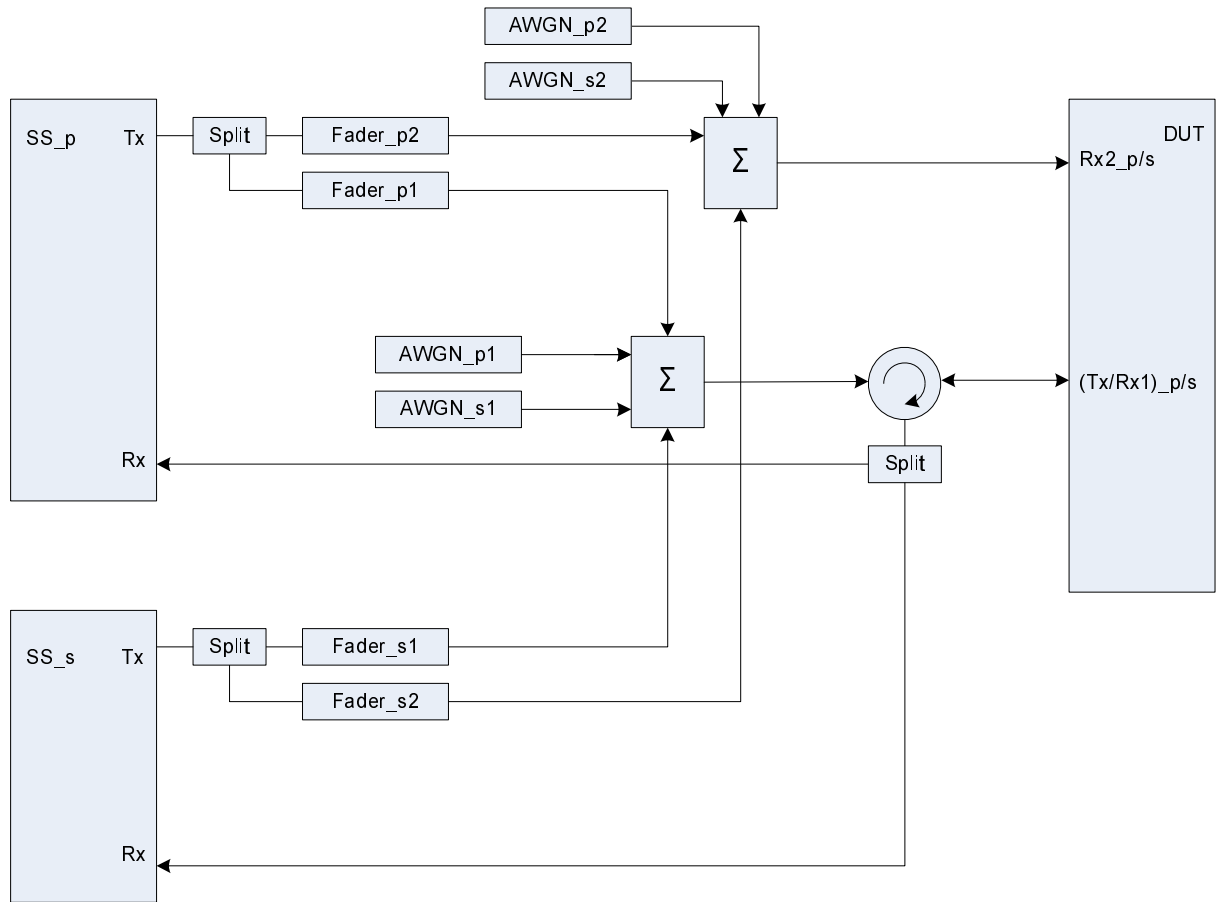

Figure A.35b: Connection for Rx performance tests for CA with antenna configuration 1x2 (common connectors, same UL antenna)

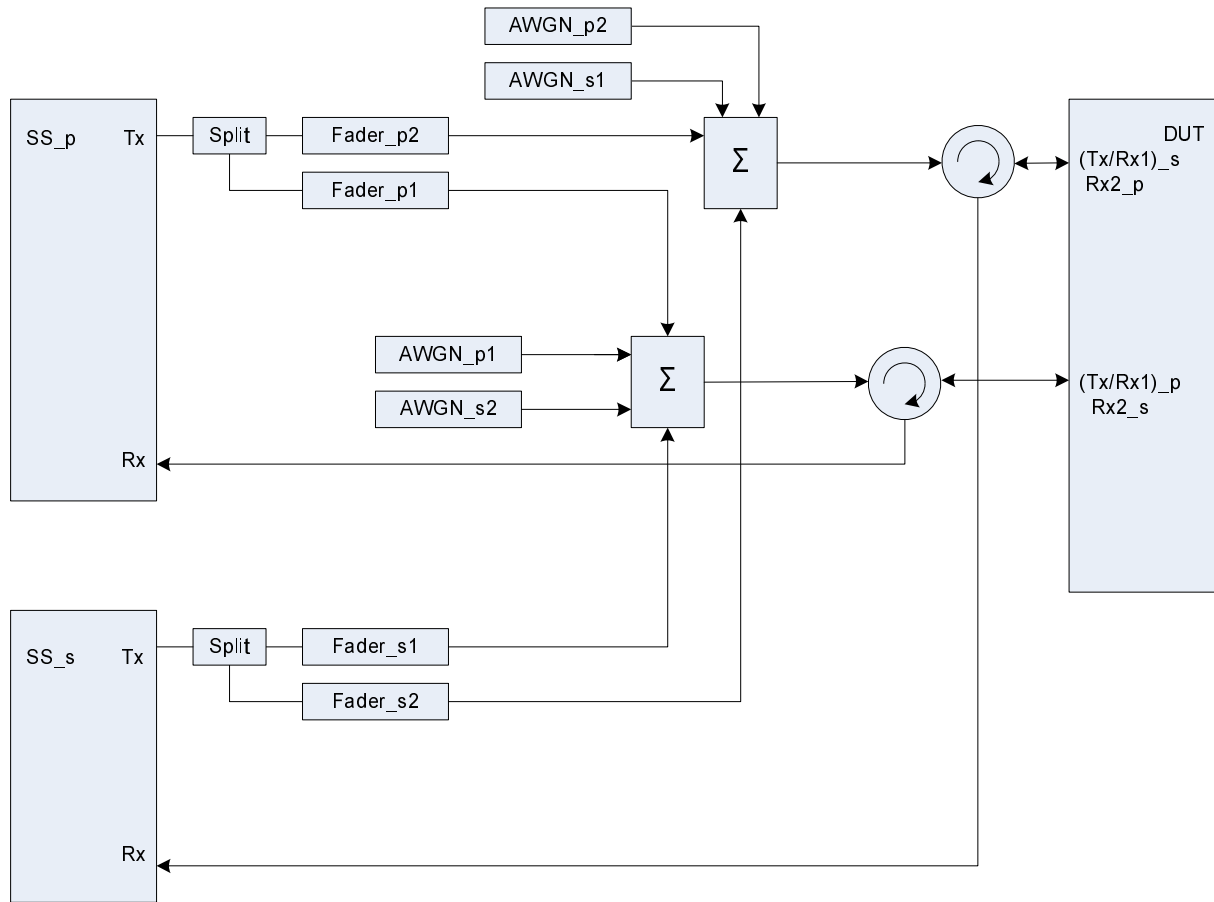

Figure A.35c: Connection for Rx performance tests for CA with antenna configuration 1x2 (common connectors, different UL antennas)

Figure group A.36: Connection for Rx performance tests for CA with antenna configuration 2x2

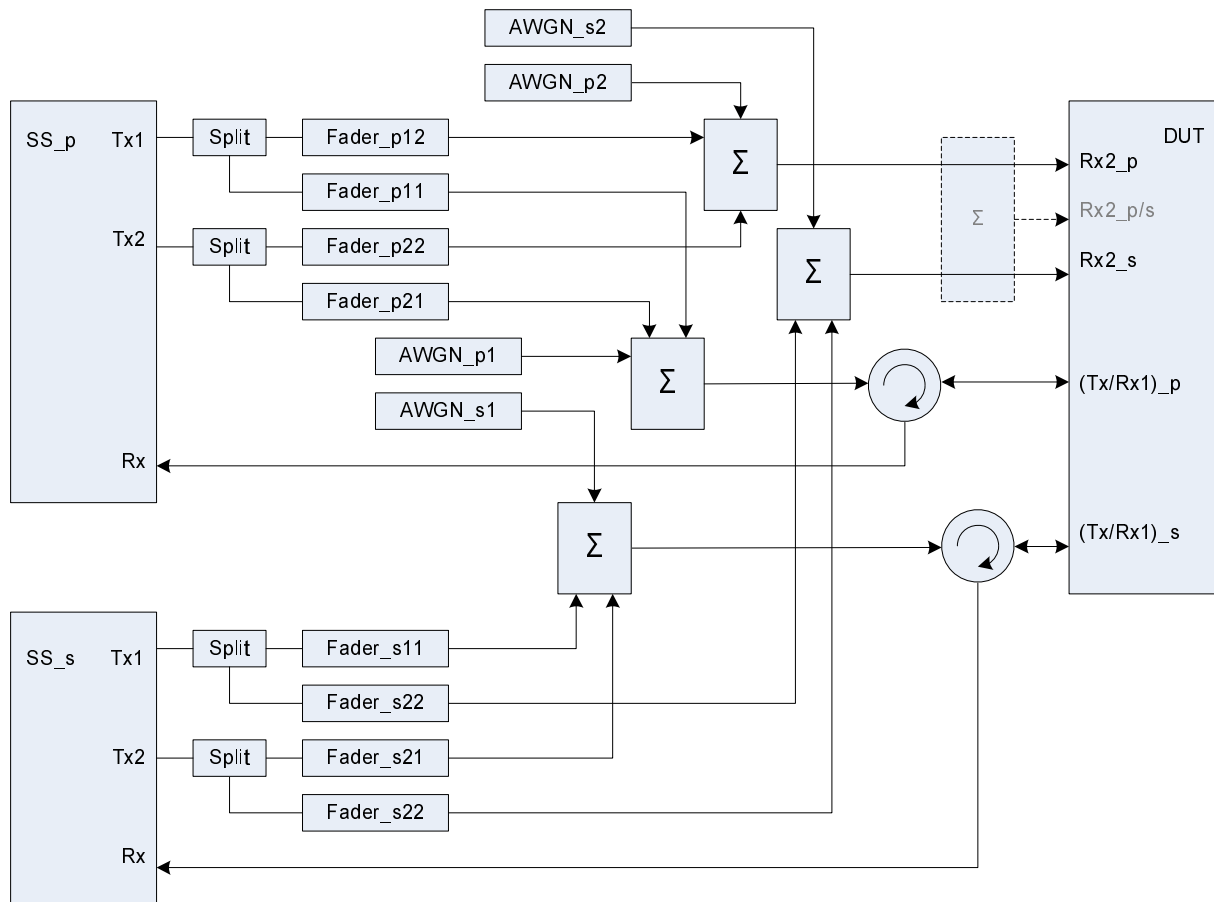

Figure A.36a: Connection for Rx performance tests for CA with antenna configuration 2x2 (separate connectors)

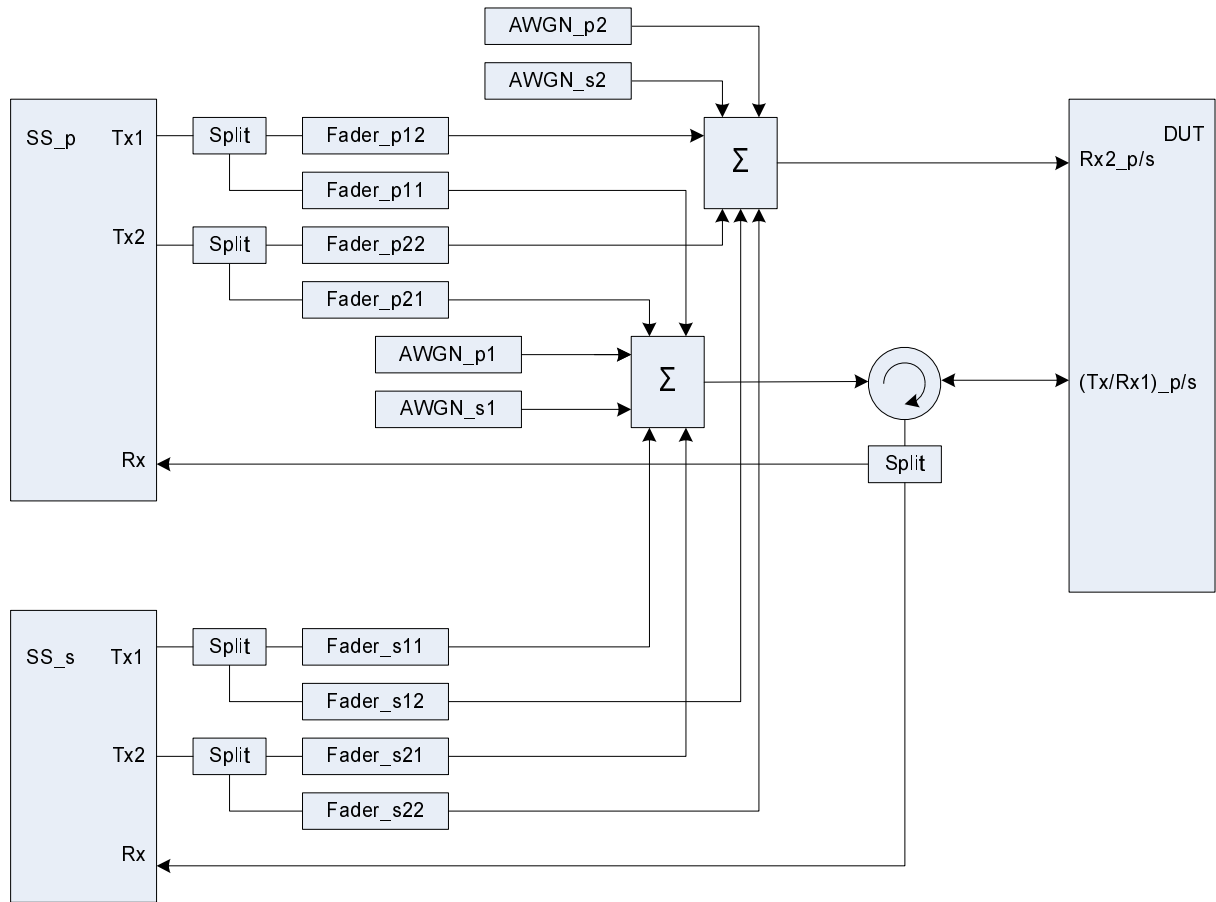

Figure A.36b: Connection for Rx performance tests for CA with antenna configuration 2x2 (common connectors, same UL antenna)

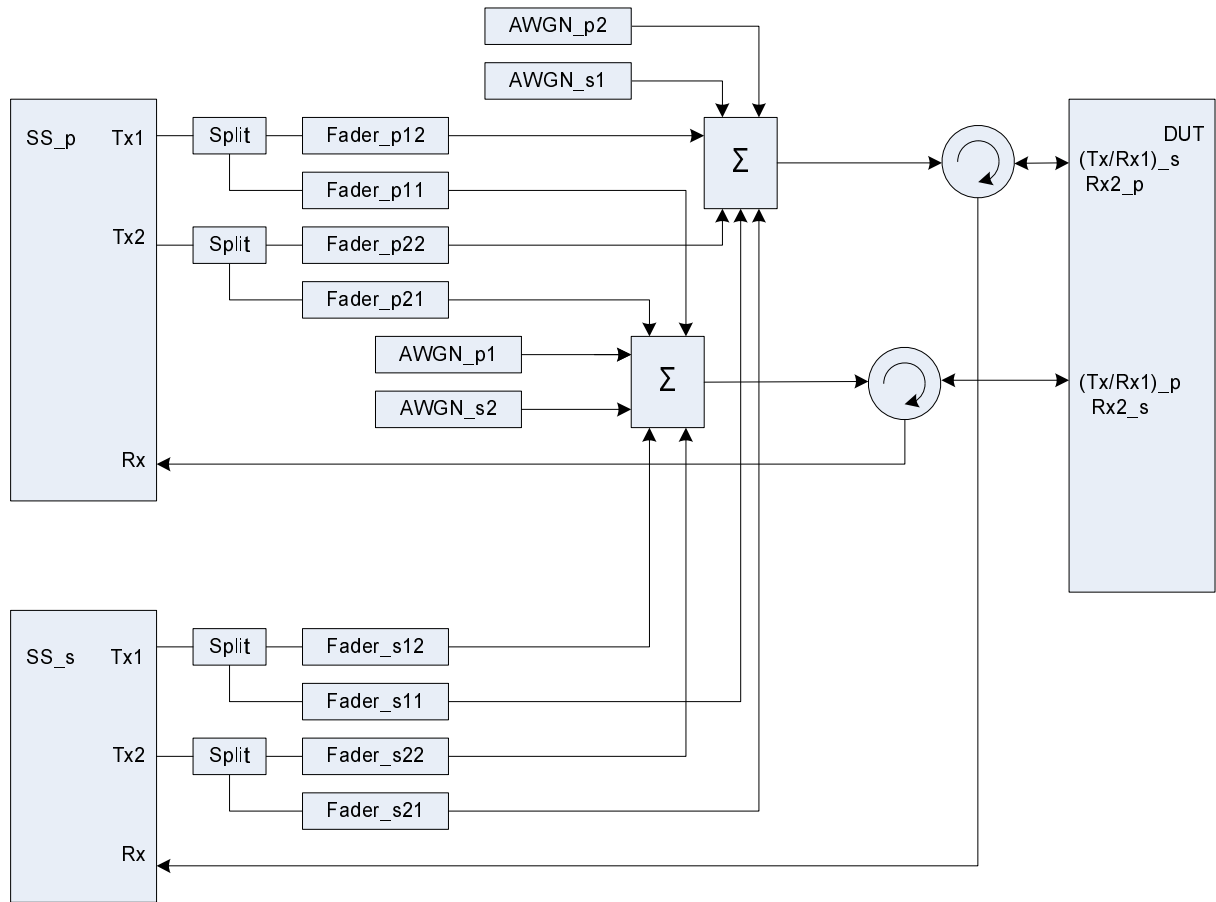

Figure A.36c: Connection for Rx performance tests for CA with antenna configuration 2x2 (common connectors, different UL antennas)

Figure group A.37: Connection for Tx tests for CA with additional CW and Spectrum Analyzer

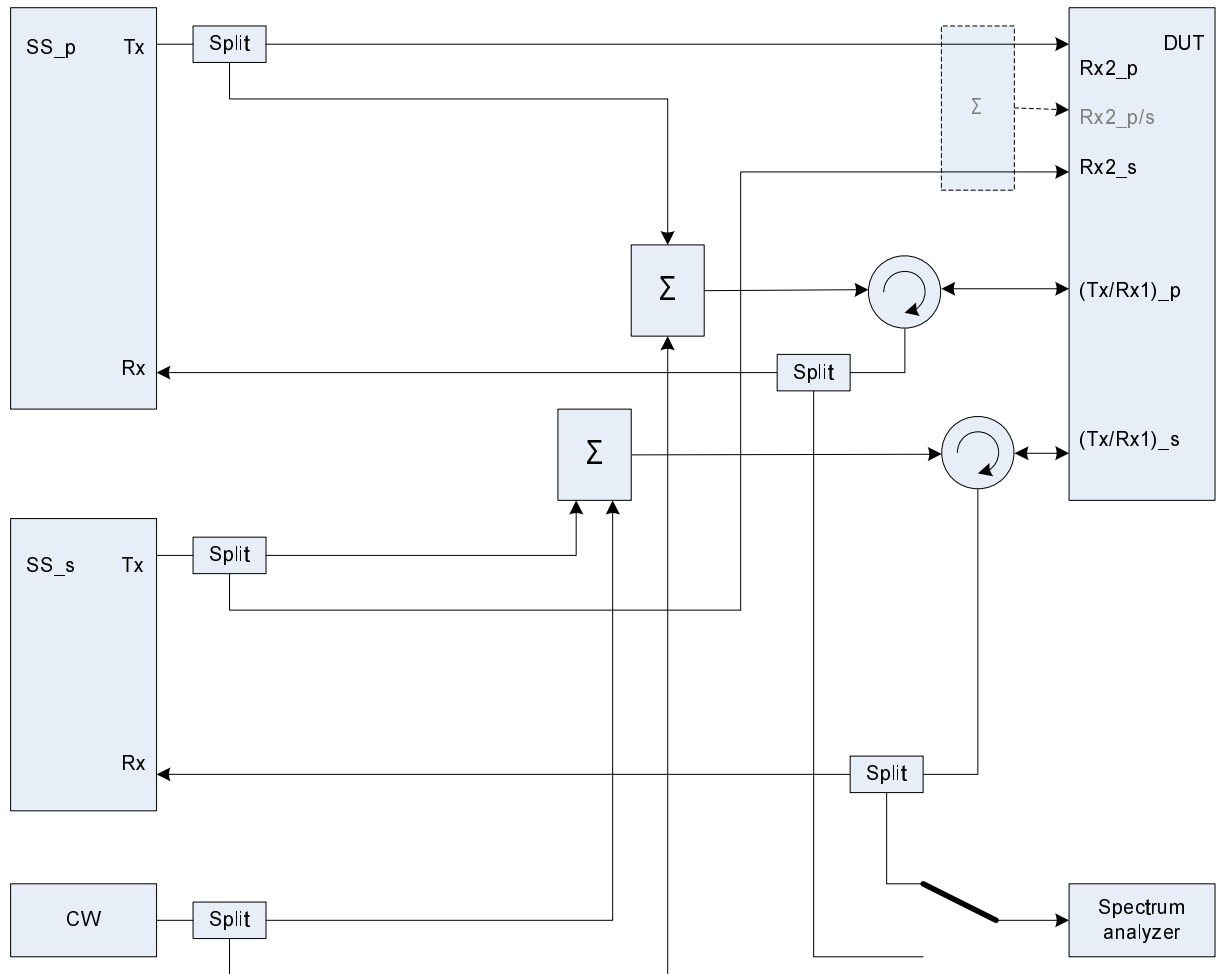

Figure A.37a: Connection for Tx tests for CA with additional CW and Spectrum Analyzer (separate connectors)

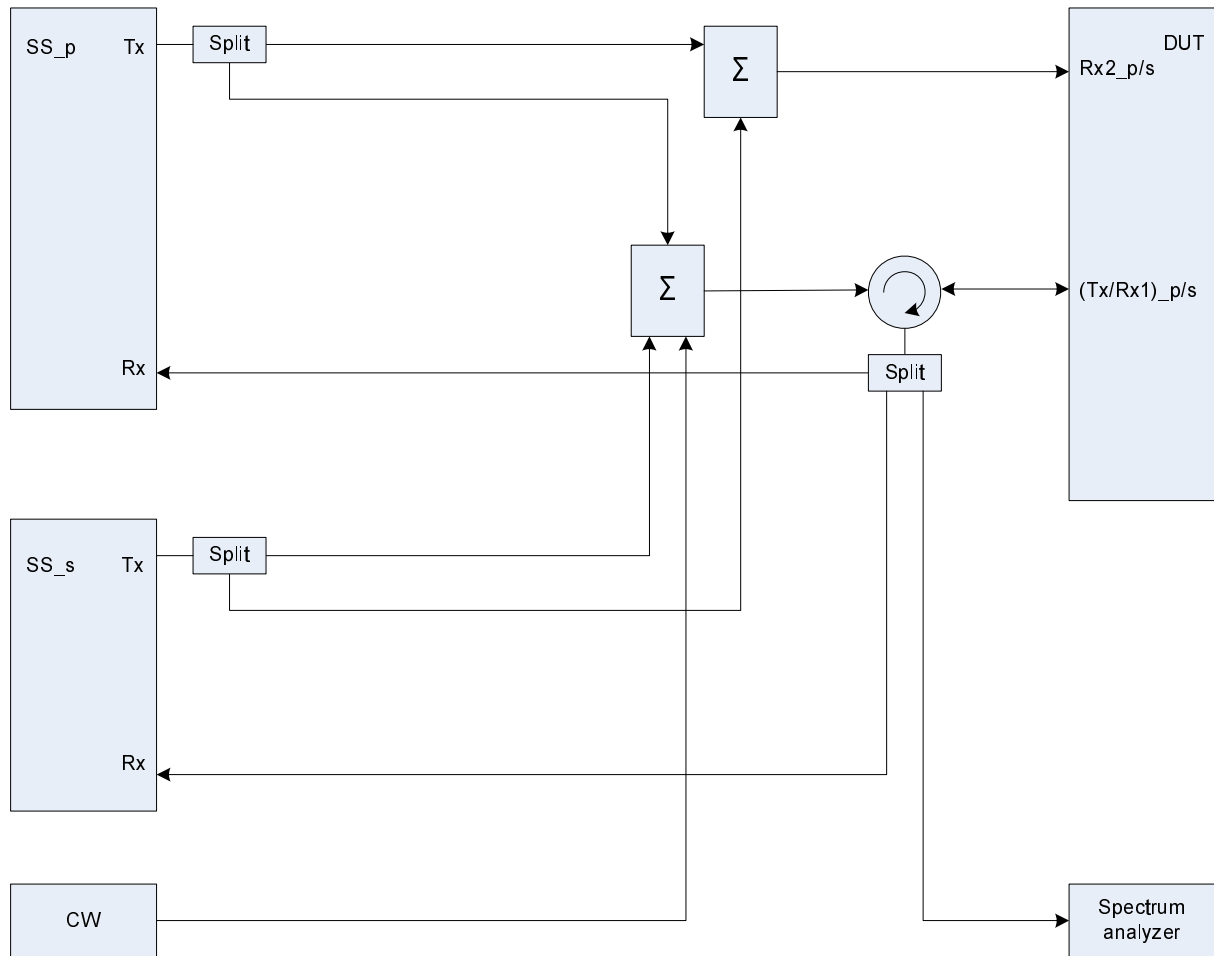

Figure A.37b: Connection for Tx tests for CA with additional CW and Spectrum Analyzer (common connectors, same UL antenna)

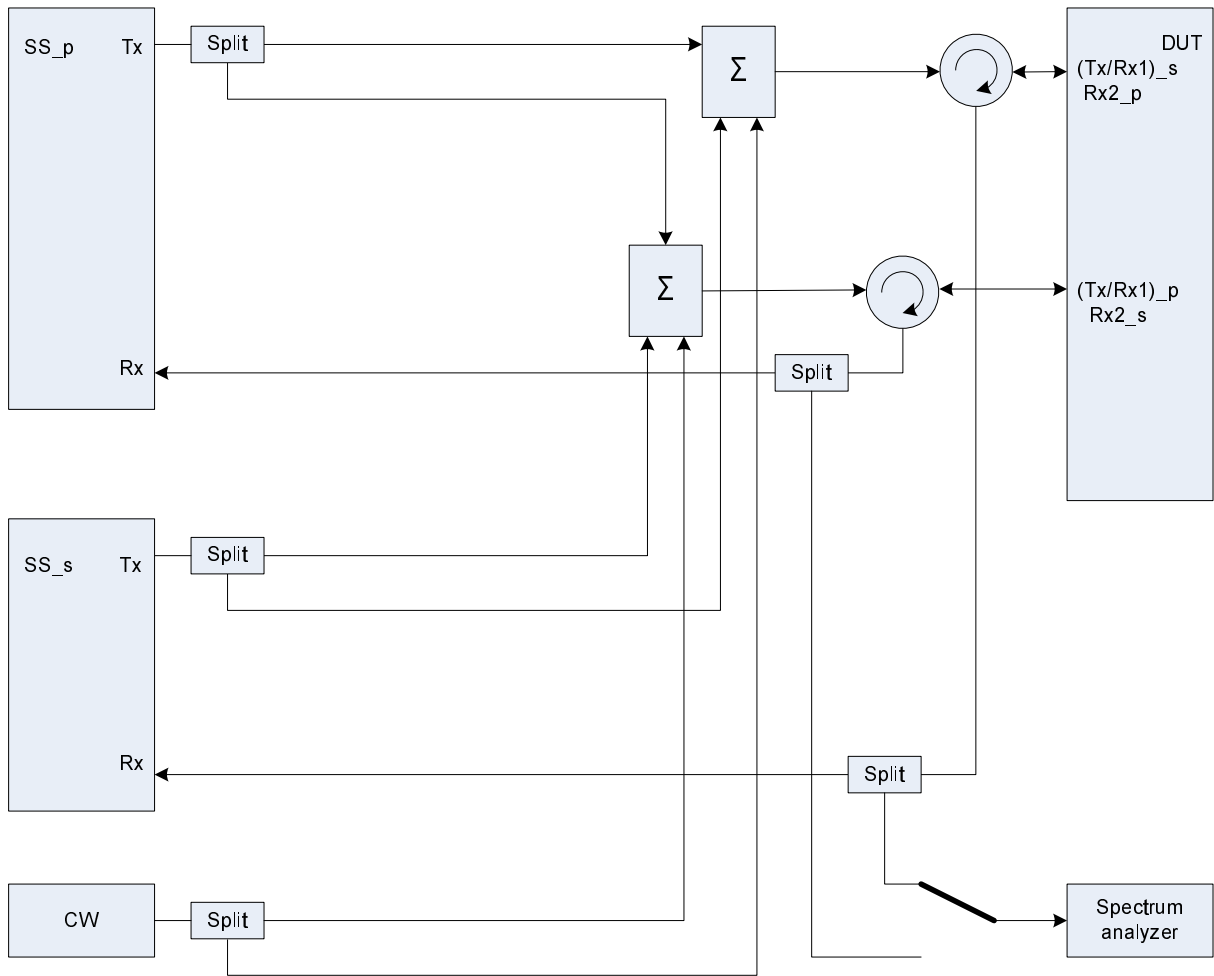

Figure A.37c: Connection for Tx tests for CA with additional CW and Spectrum Analyzer (common connectors, different UL antennas)

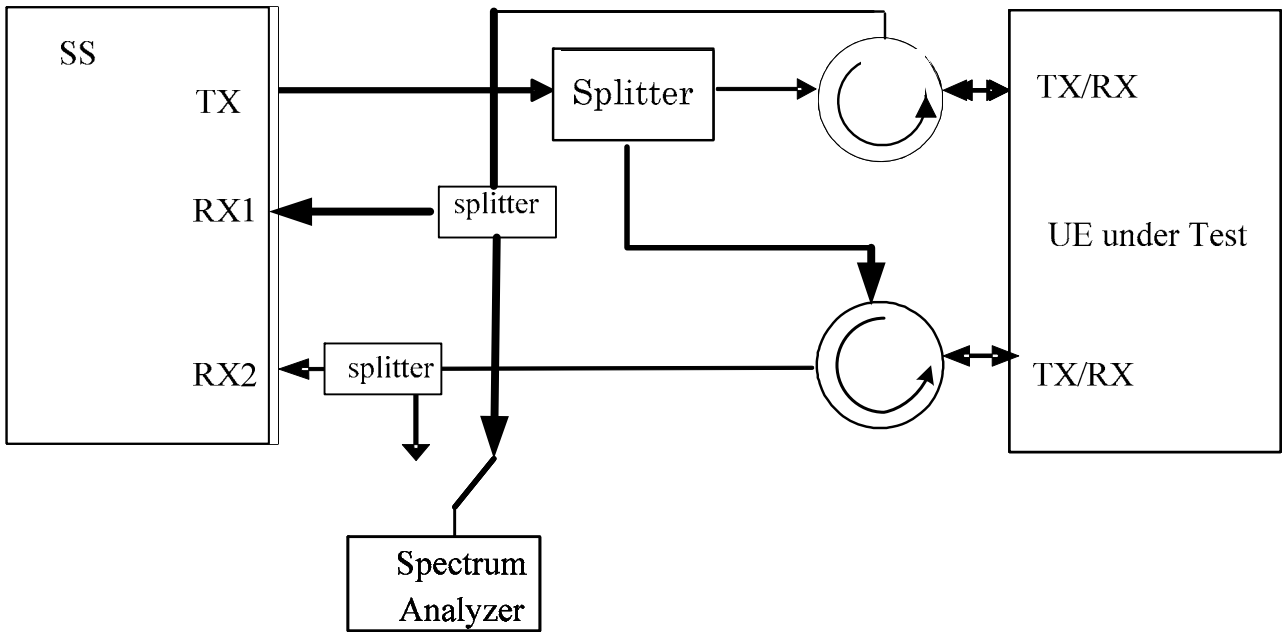

Figure A.38: Connection for UL MIMO tests with additional Spectrum Analyzer

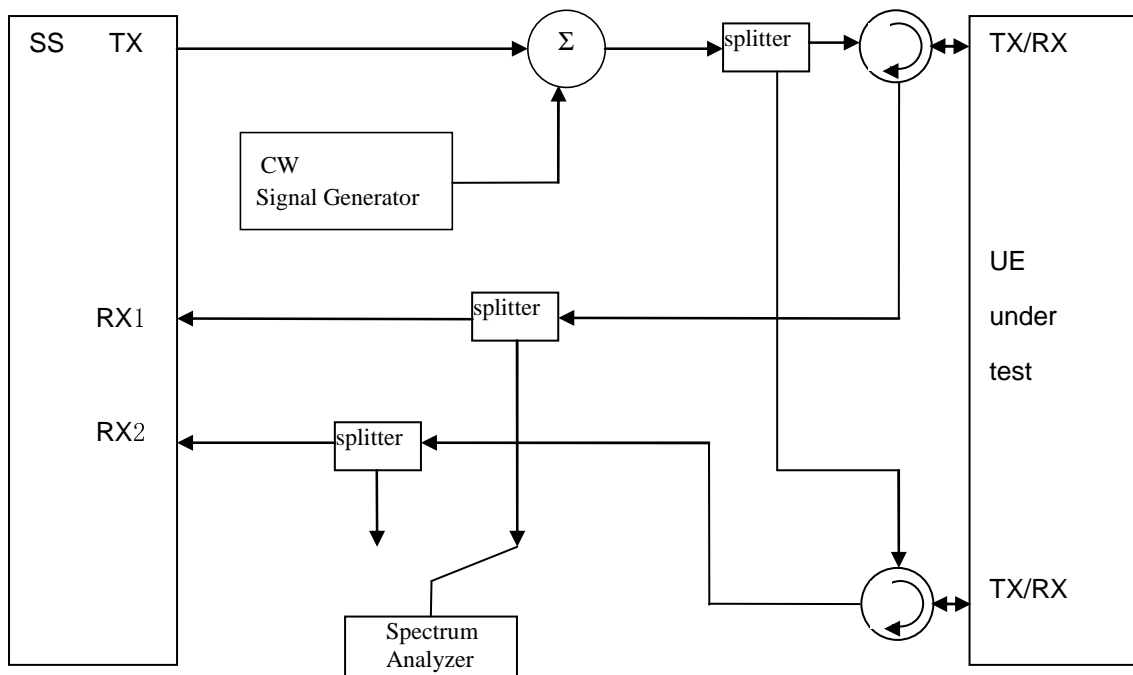

Figure A.39: Connection for Transmitter Intermodulation tests for UL-MIMO

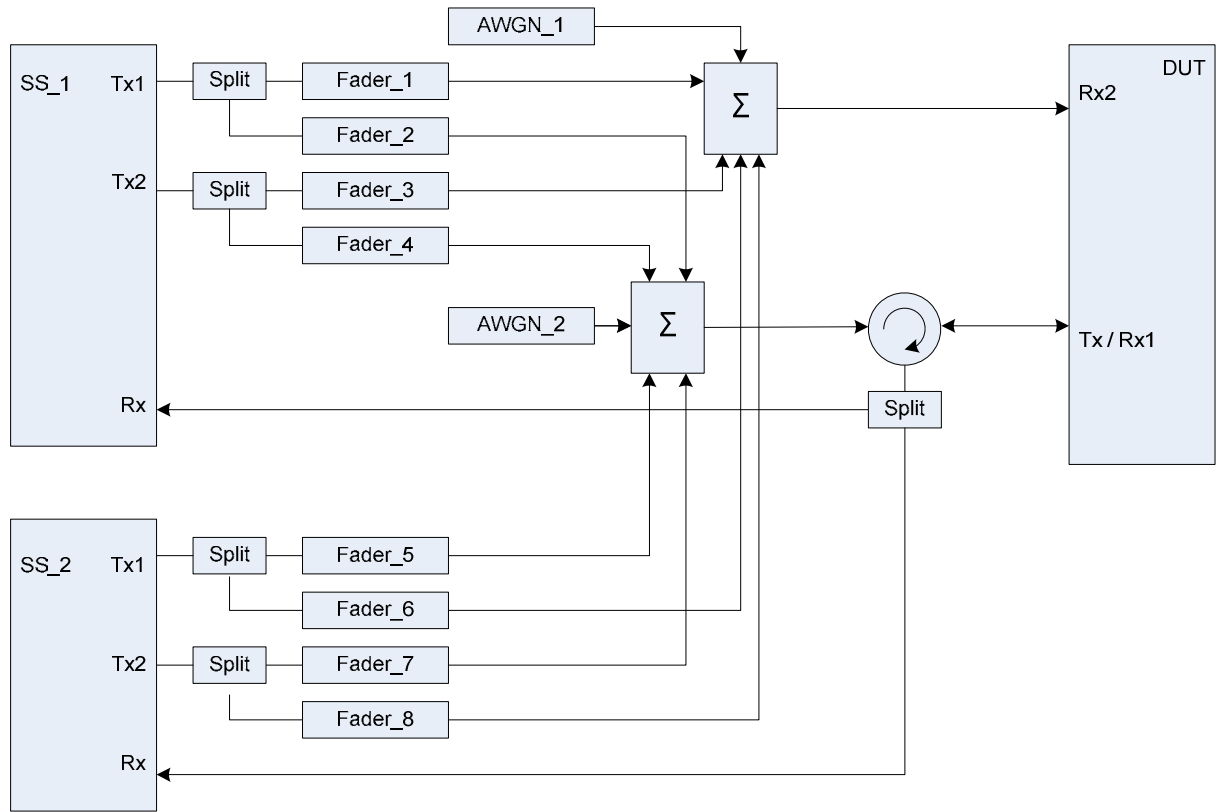

Figure A.40: Connection for 2 cells, antenna configuration 2x2, multipath fading and receive diversity

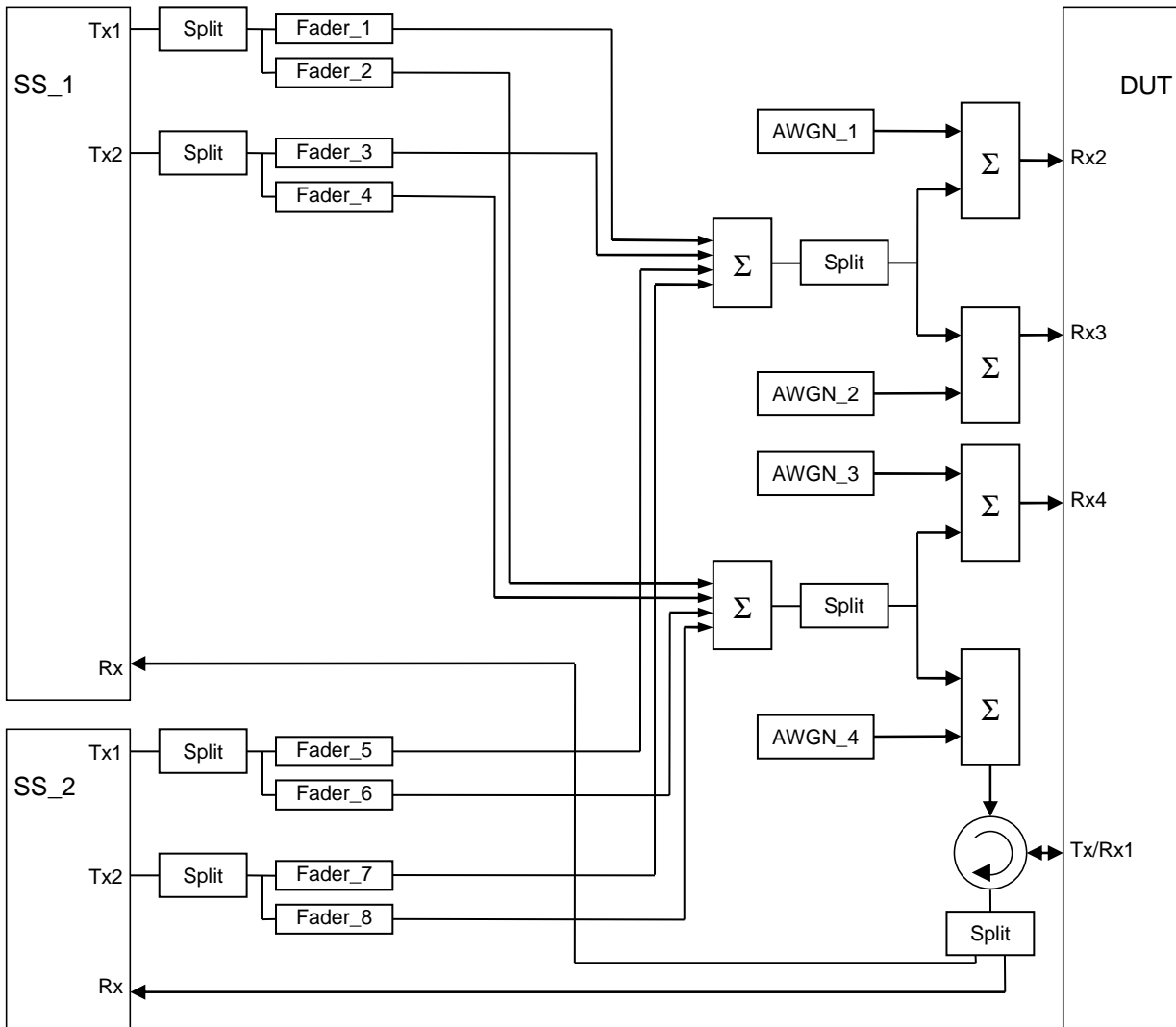

Figure A.40a: Connection for 2 cells, antenna configuration 2x2, multipath fading and receive diversity for 4Rx capable UEs without any 2Rx RF bands

Figure group A.41: Connection for CA with additional intra-frequency cell and static propagation channel

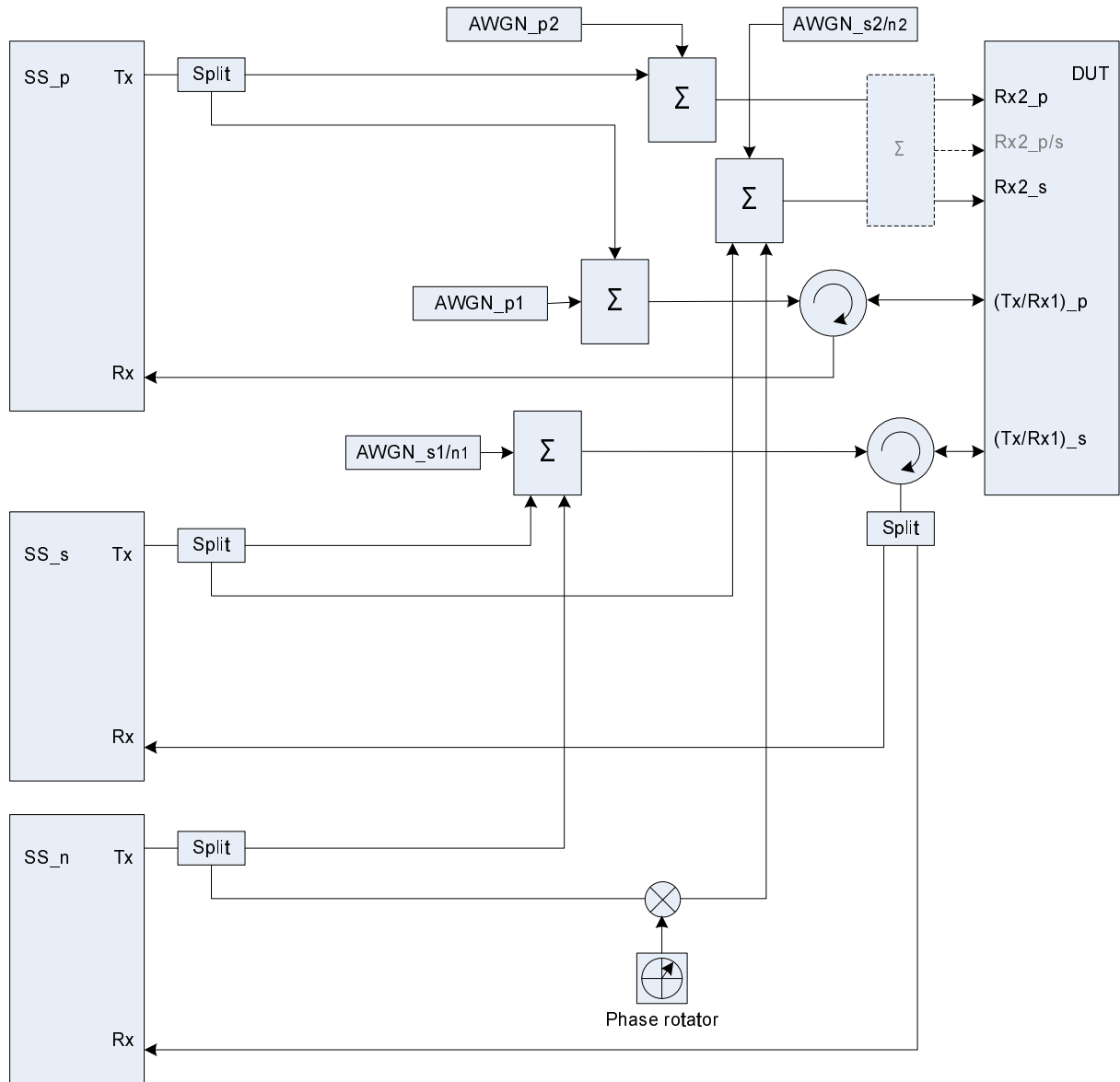

Figure A.41a: Connection for CA with additional intra-frequency cell and static propagation channel (separate connectors) (The frequency offset used in phase rotator is 5 Hz)

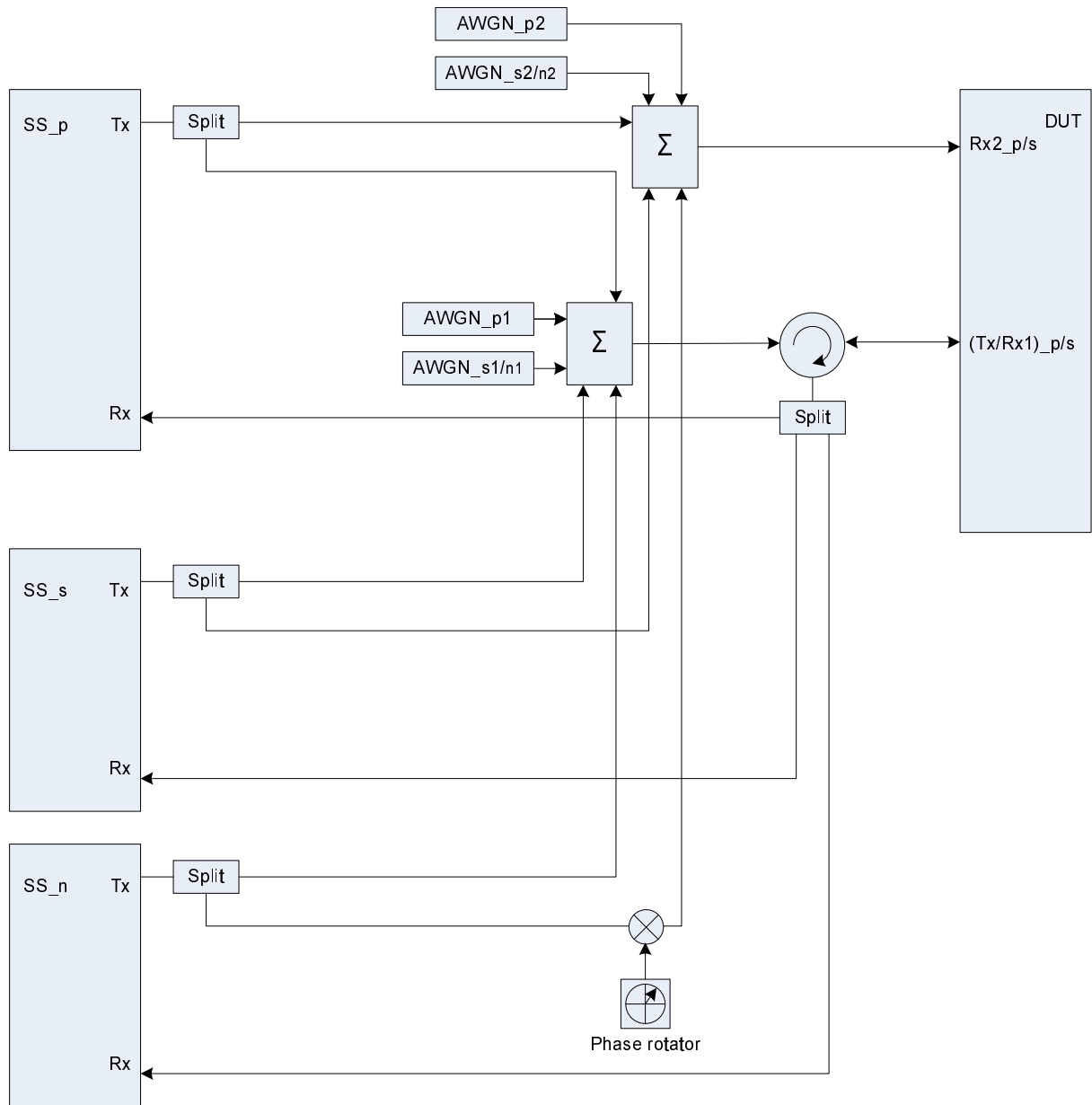

Figure A.41b: Connection for CA with additional intra-frequency cell and static propagation channel (common connectors, same UL antenna) (The frequency offset used in phase rotator is 5 Hz)

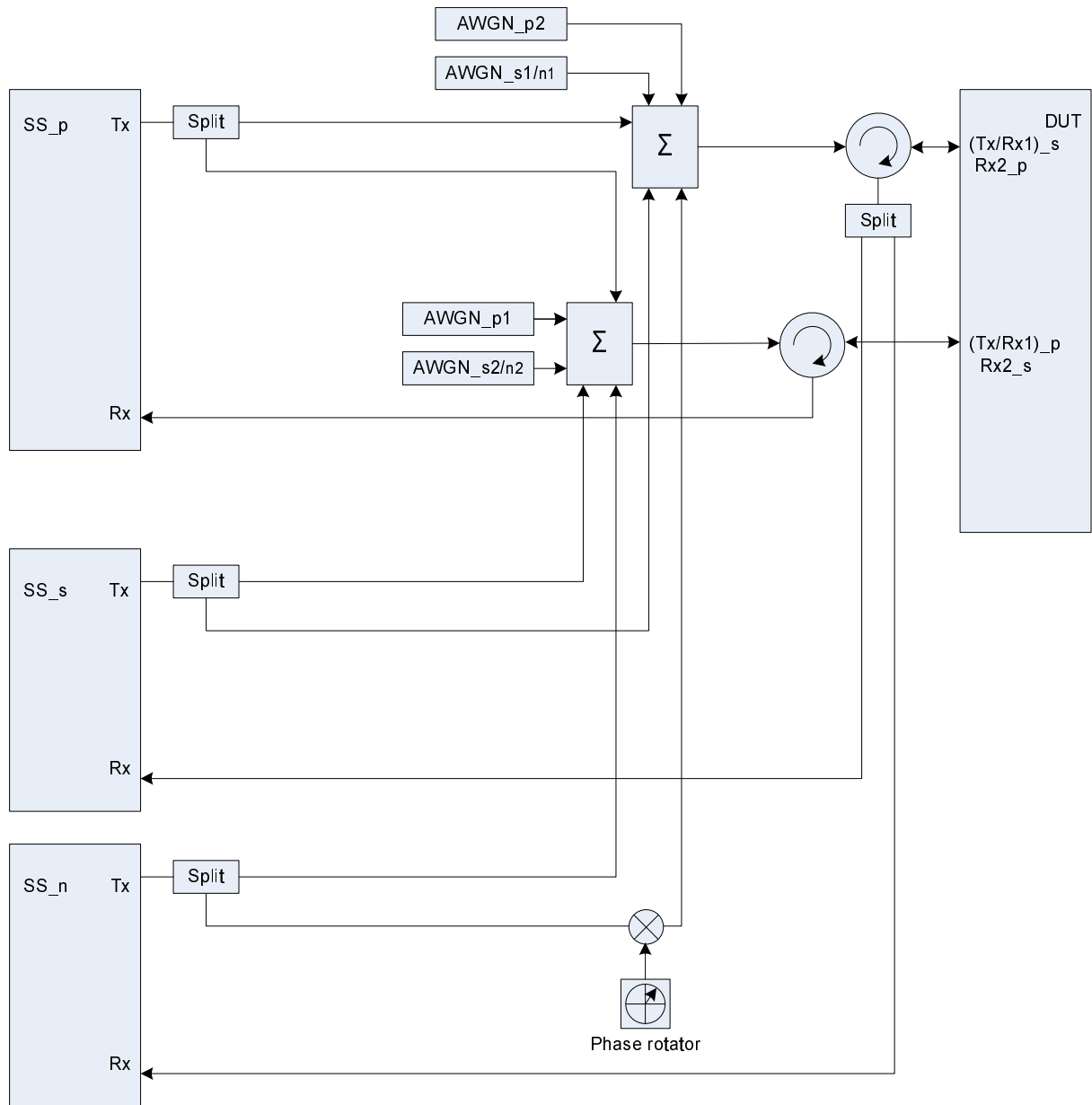

Figure A.41c: Connection for CA with additional intra-frequency cell and static propagation channel (common connectors, different UL antennas) (The frequency offset used in phase rotator is 5 Hz)

Figure group A.42: Connection for CA with additional intra-frequency cell and multipath fading propagation

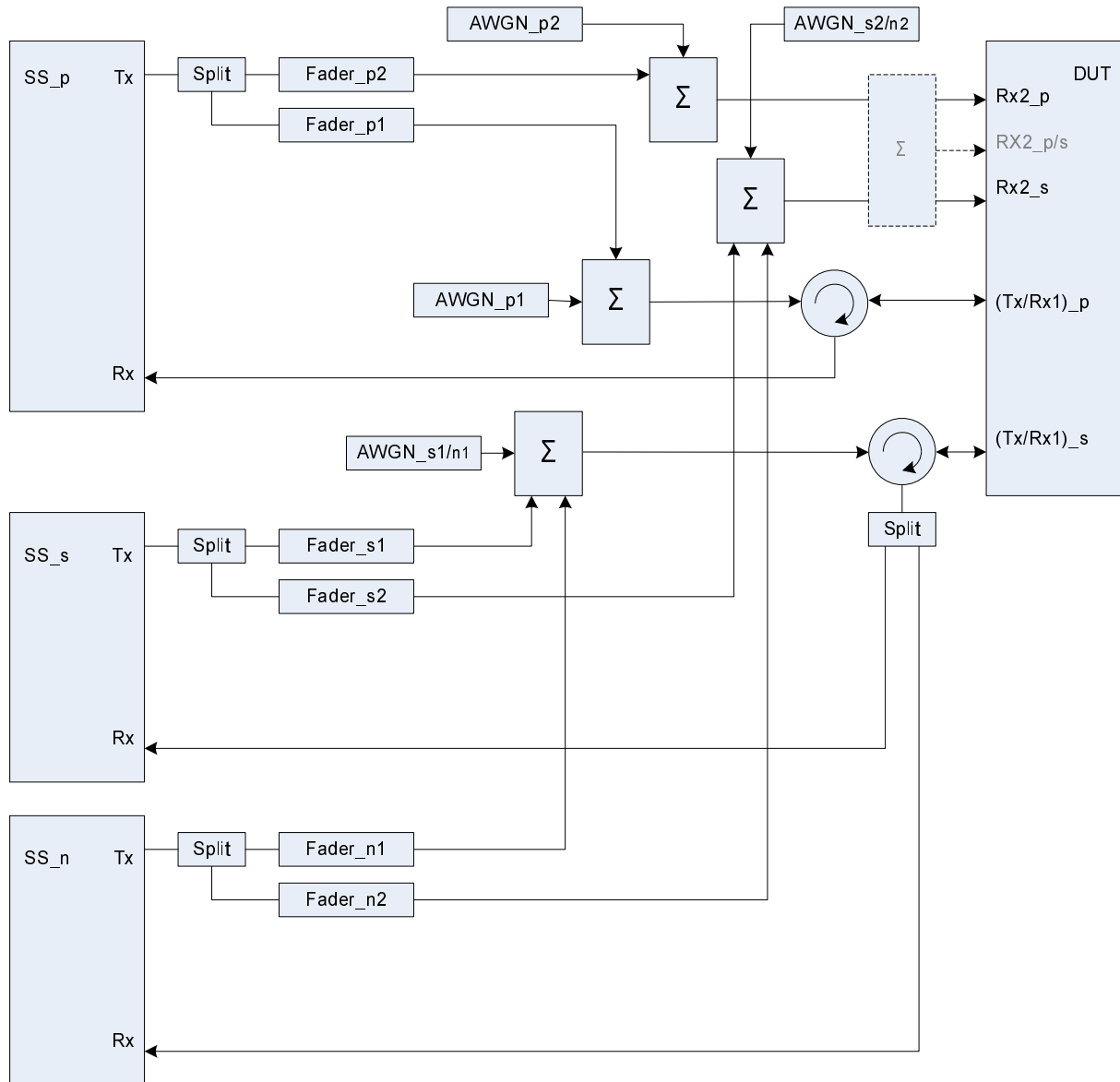

Figure A.42a: Connection for CA with additional intra-frequency cell and multipath fading propagation (separate connectors)

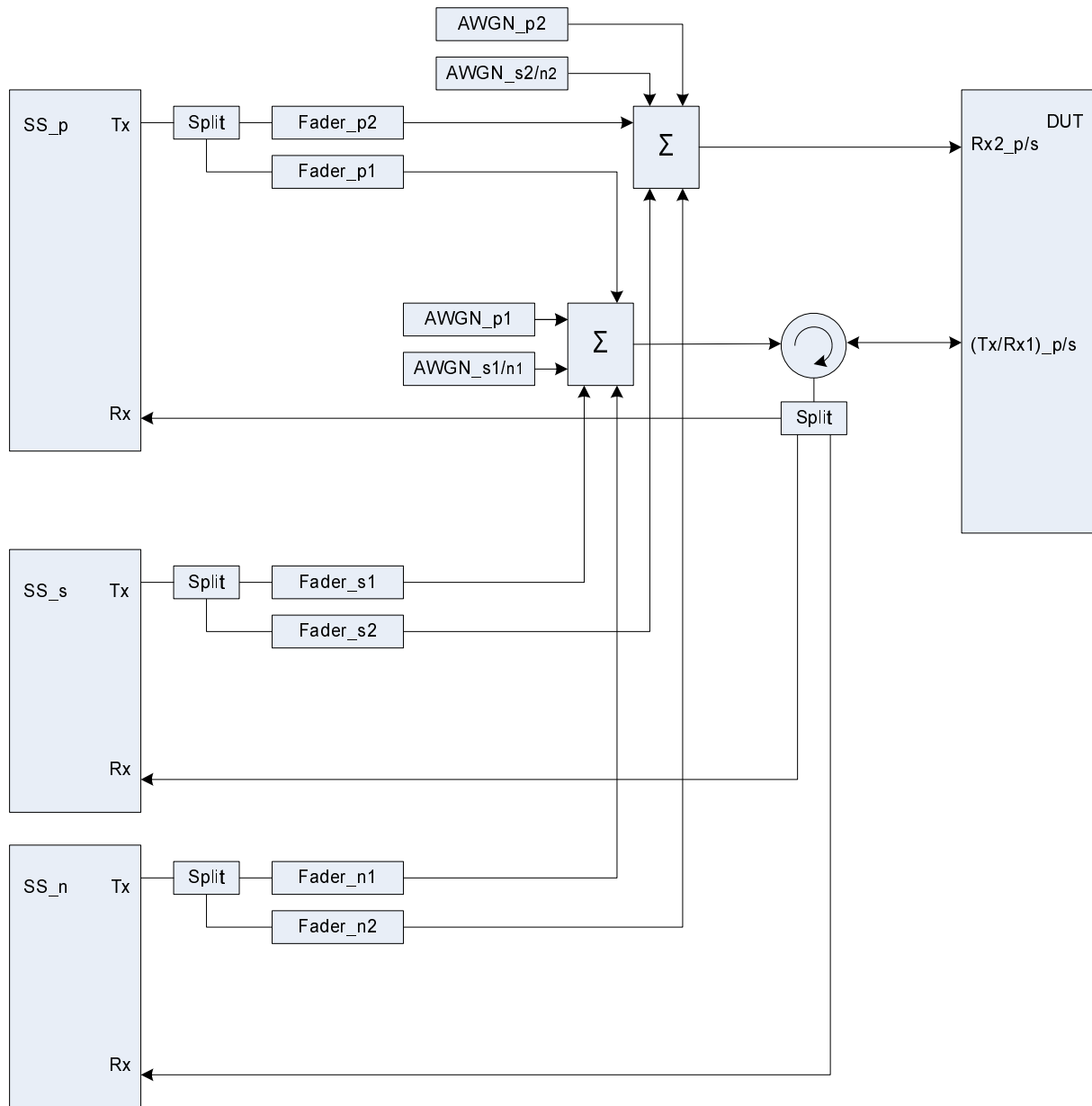

Figure A.42b: Connection for CA with additional intra-frequency cell and multipath fading propagation (common connectors, same UL antenna)

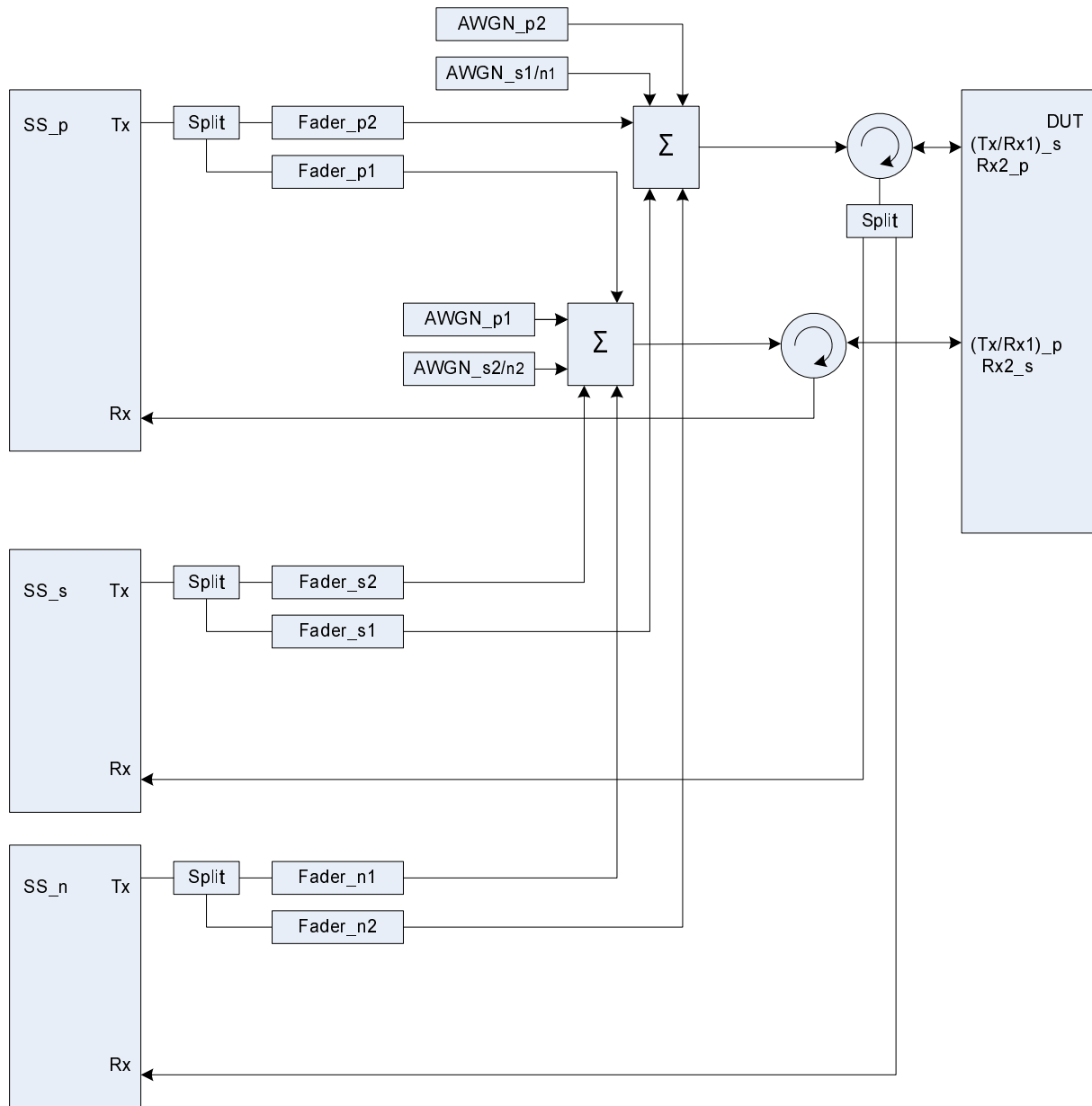

Figure A.42c: Connection for CA with additional intra-frequency cell and multipath fading propagation (common connectors, different UL antennas)

Figure group A.43: Connection for CA with additional inter-frequency cell and multipath fading propagation

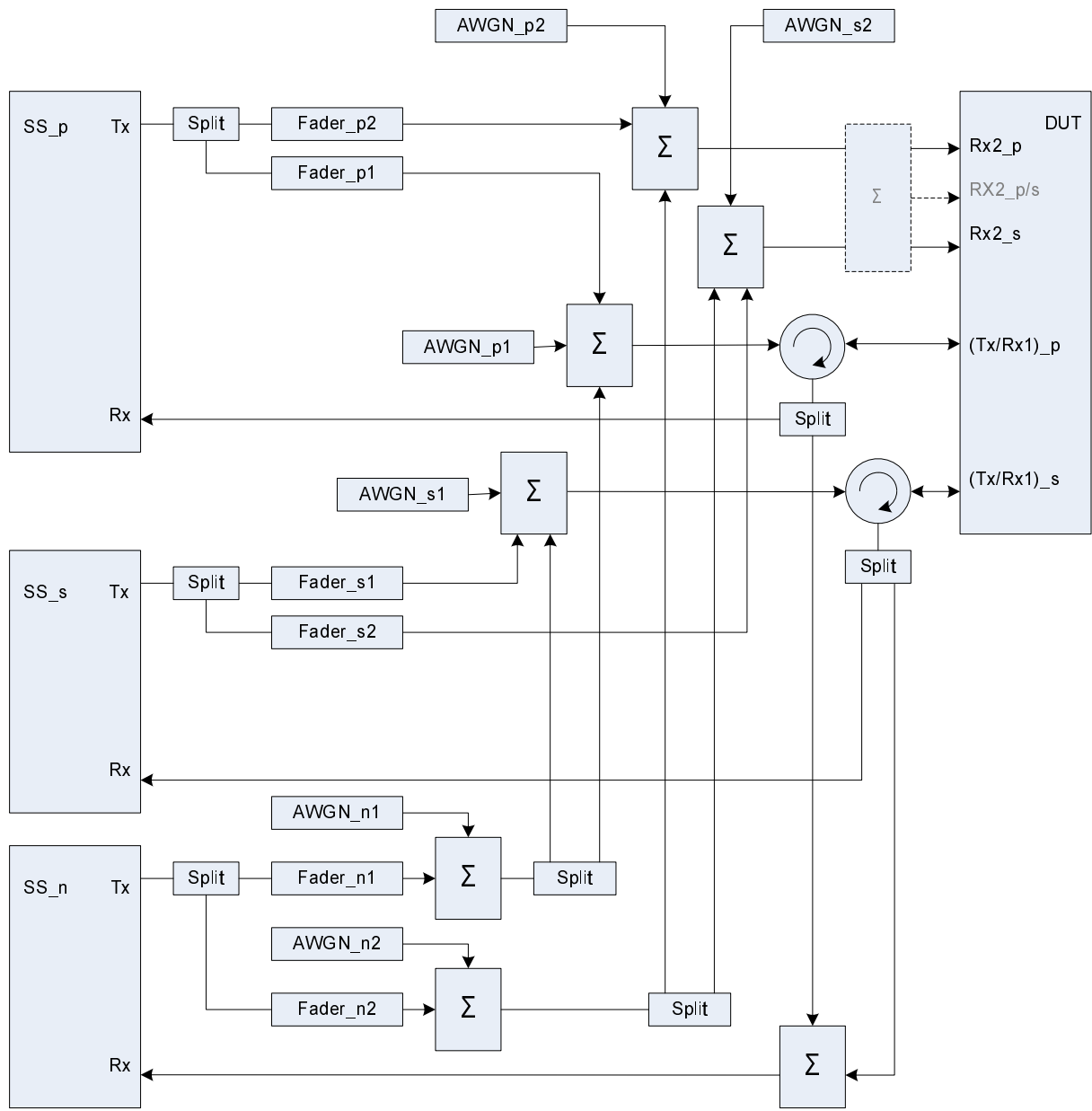

Figure A.43a: Connection for CA with additional inter-frequency cell and multipath fading propagation (separate connectors)

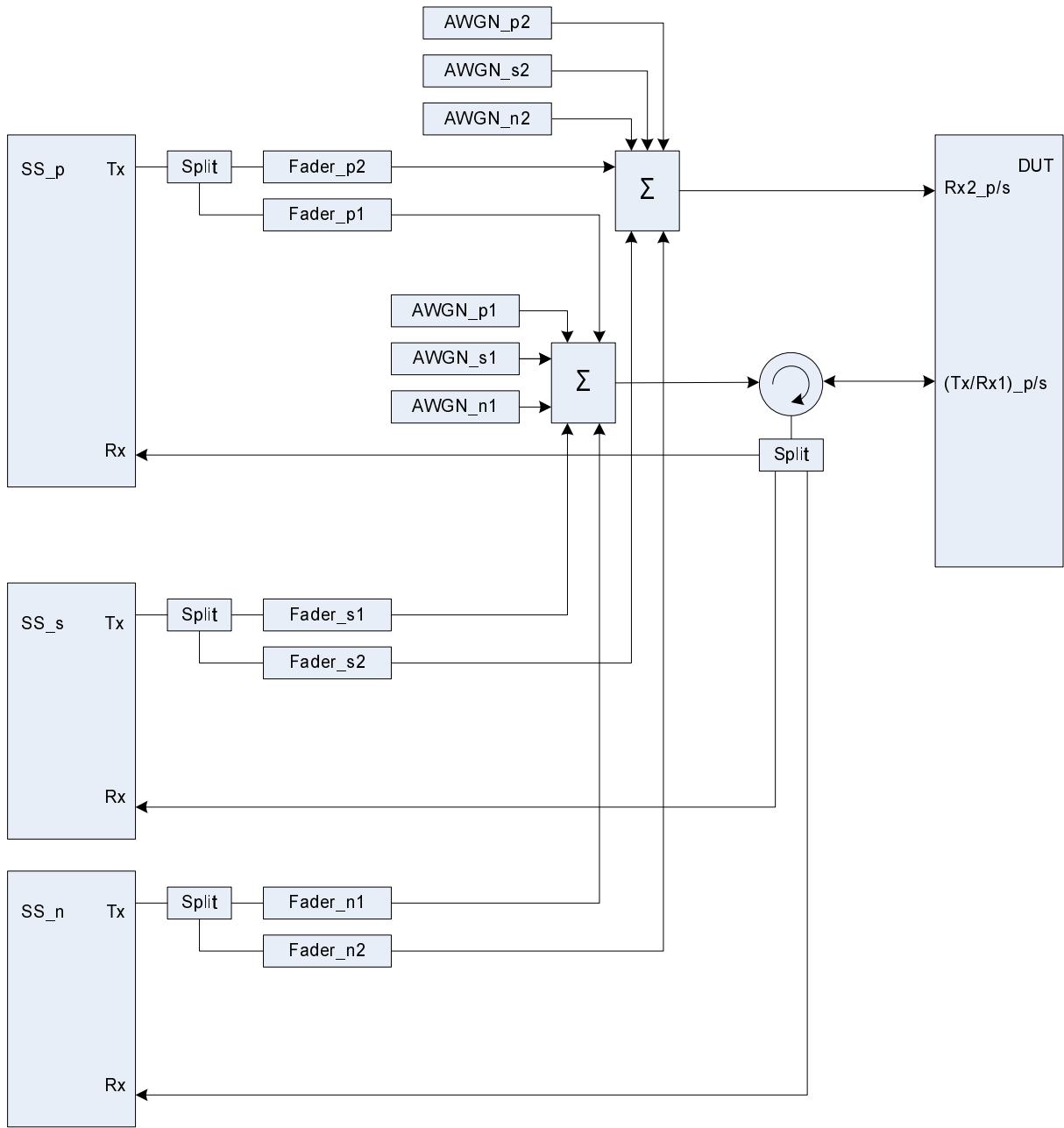

Figure A.43b: Connection for CA with additional inter-frequency cell and multipath fading propagation (common connectors, same UL antenna)

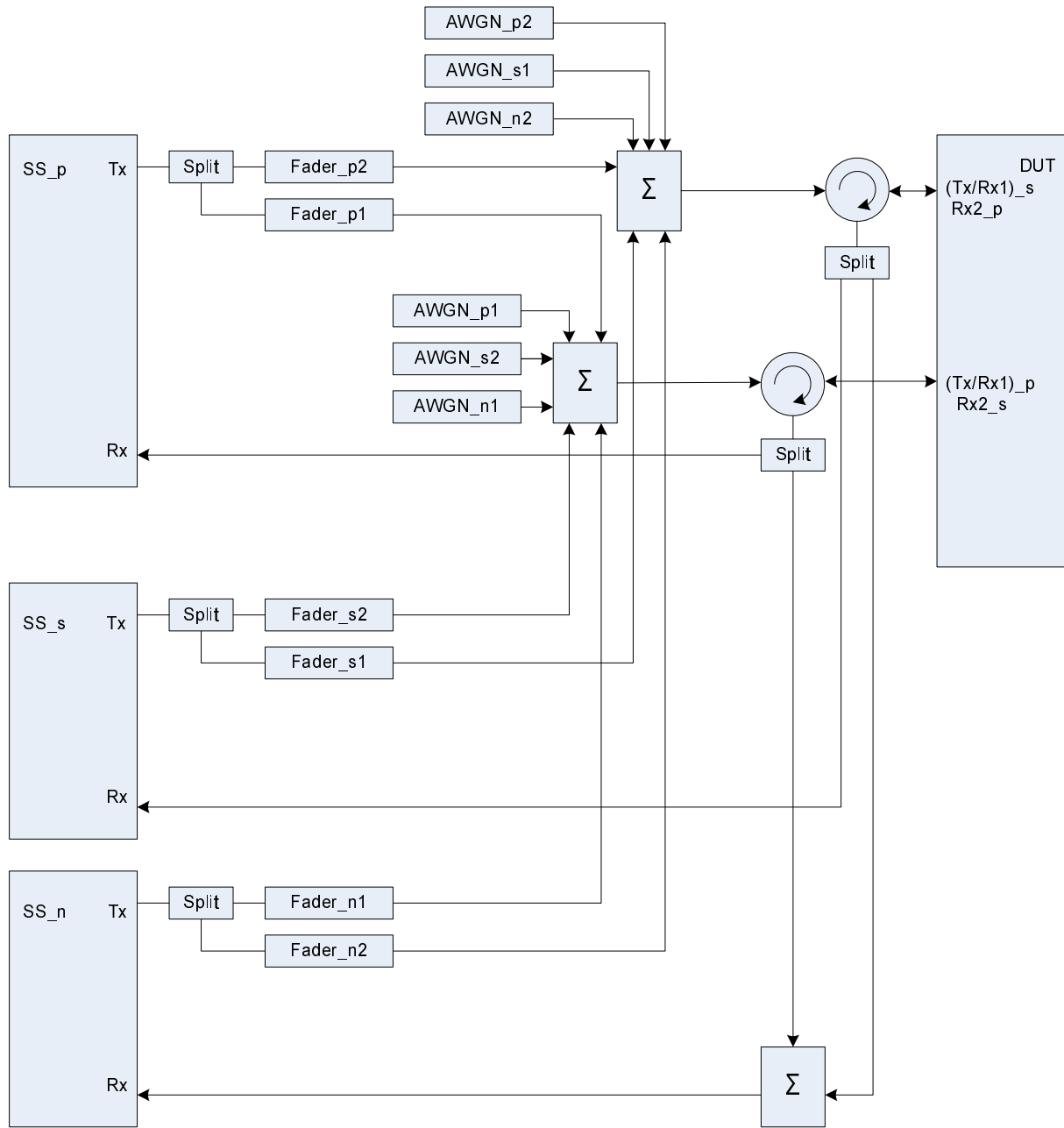

Figure A.43c: Connection for CA with additional inter-frequency cell and multipath fading propagation (common connectors, different UL antennas)

Figure group A.44: Connection for CA with additional inter-RAT cell and multipath fading propagation

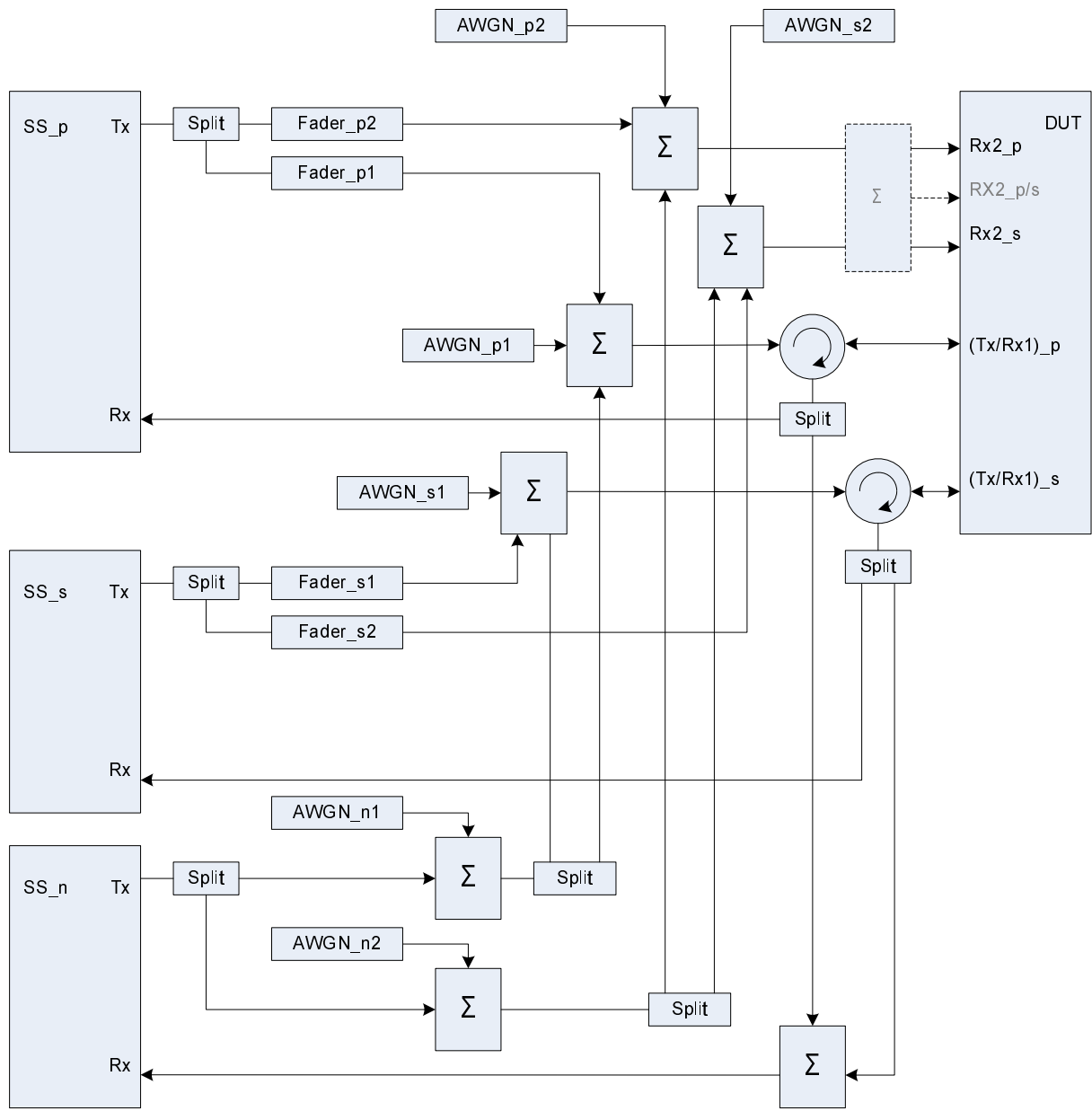

Figure A.44a: Connection for CA with additional inter-RAT cell and multipath fading propagation (separate connectors)

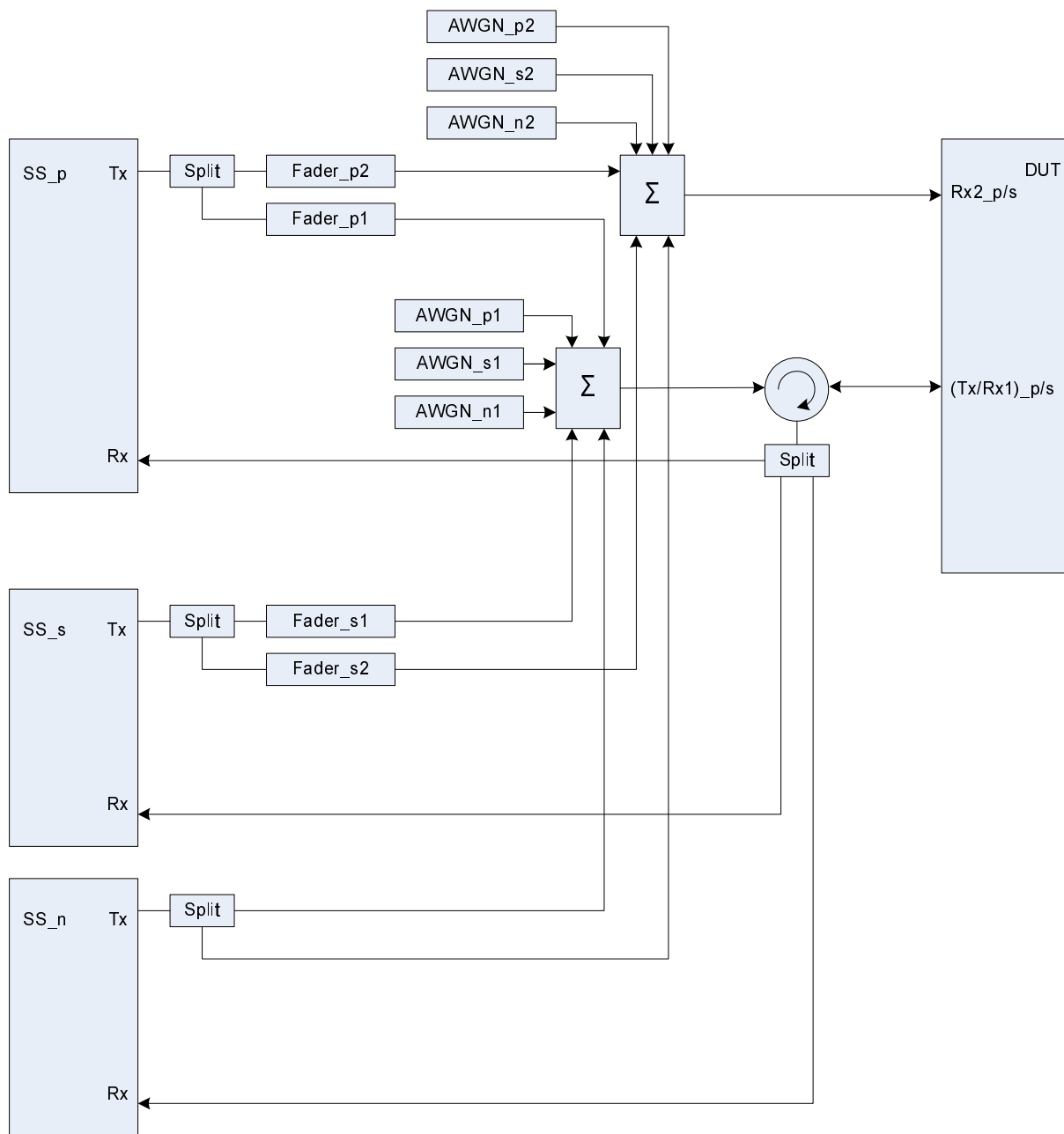

Figure A.44b: Connection for CA with additional inter-RAT cell and multipath fading propagation (common connectors, same UL antenna)

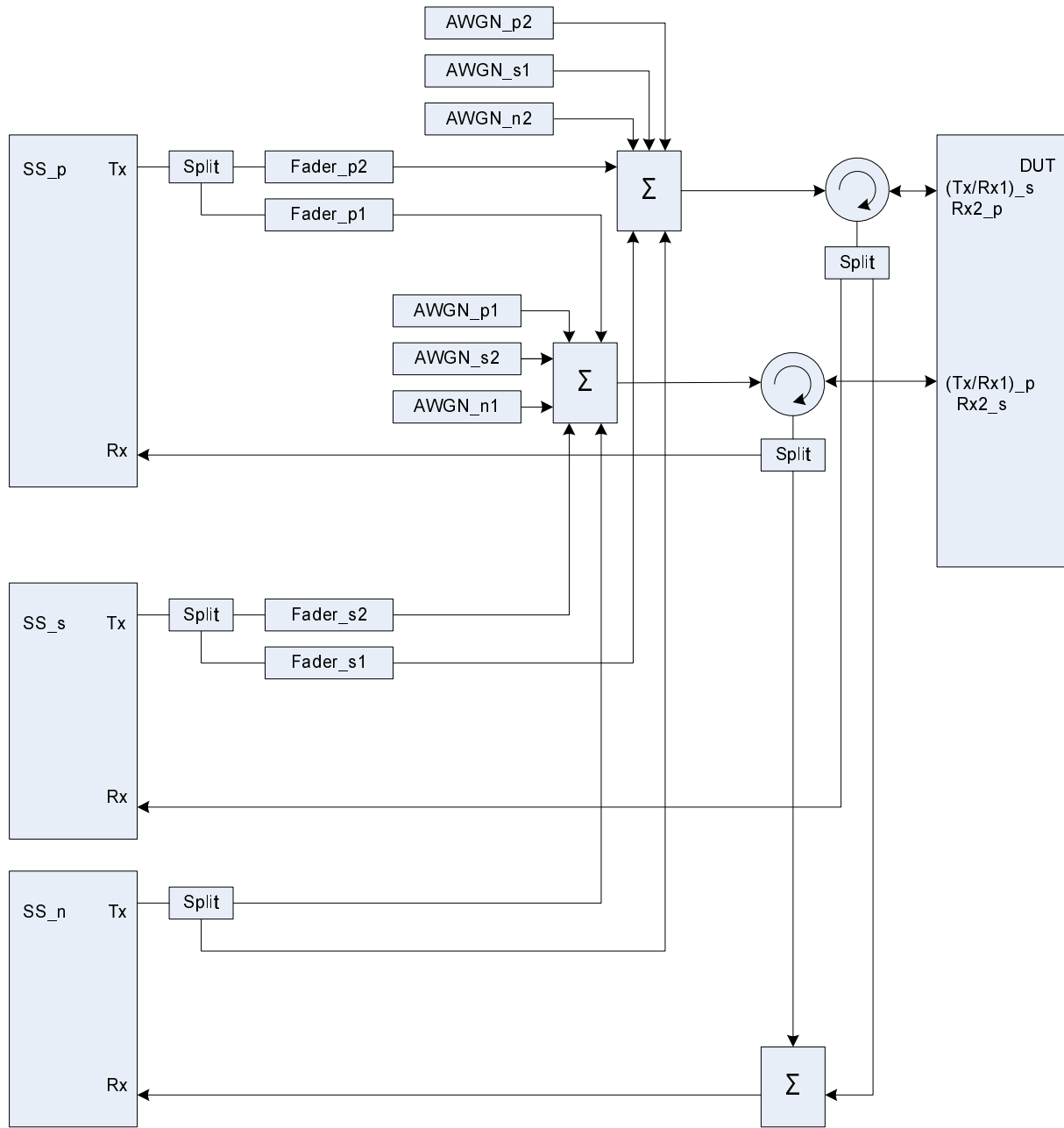

Figure A.44c: Connection for CA with additional inter-RAT cell and multipath fading propagation (common connectors, different UL antennas)

Figure group A.45: Connection for 2 cells with antenna configuration 1x2 and static propagation

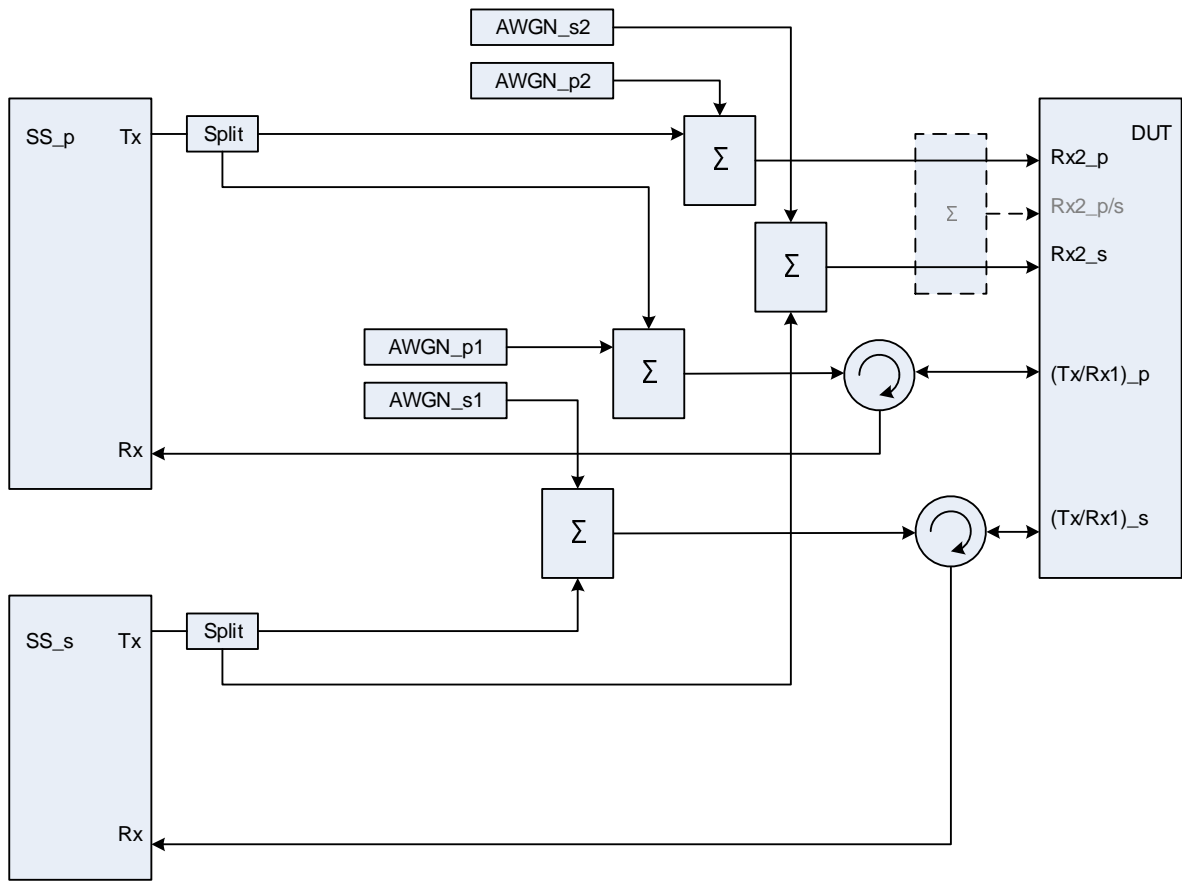

Figure A.45a: Connection for 2 cells with antenna configuration 1x2 and static propagation (separate connectors)

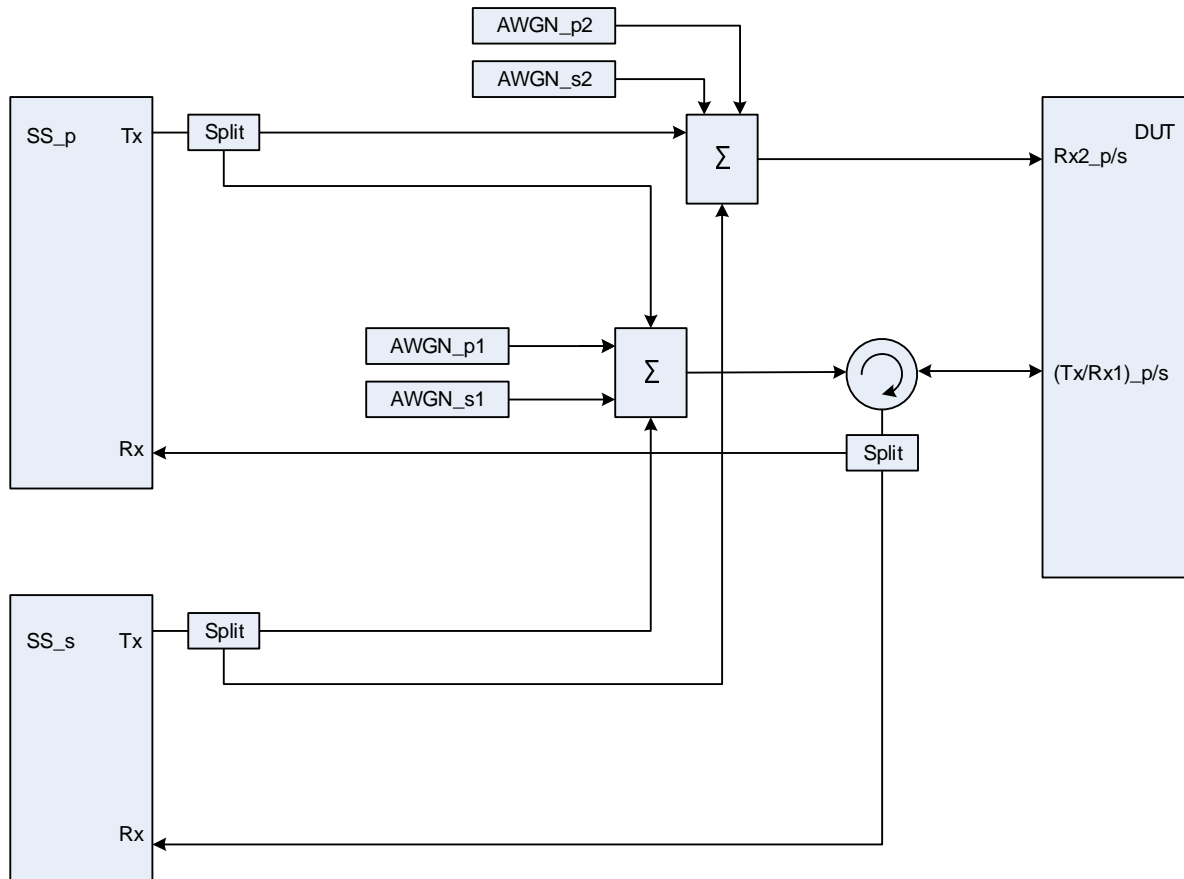

Figure A.45b: Connection for 2 cells with antenna configuration 1x2 and static propagation (common connectors, same UL antenna)

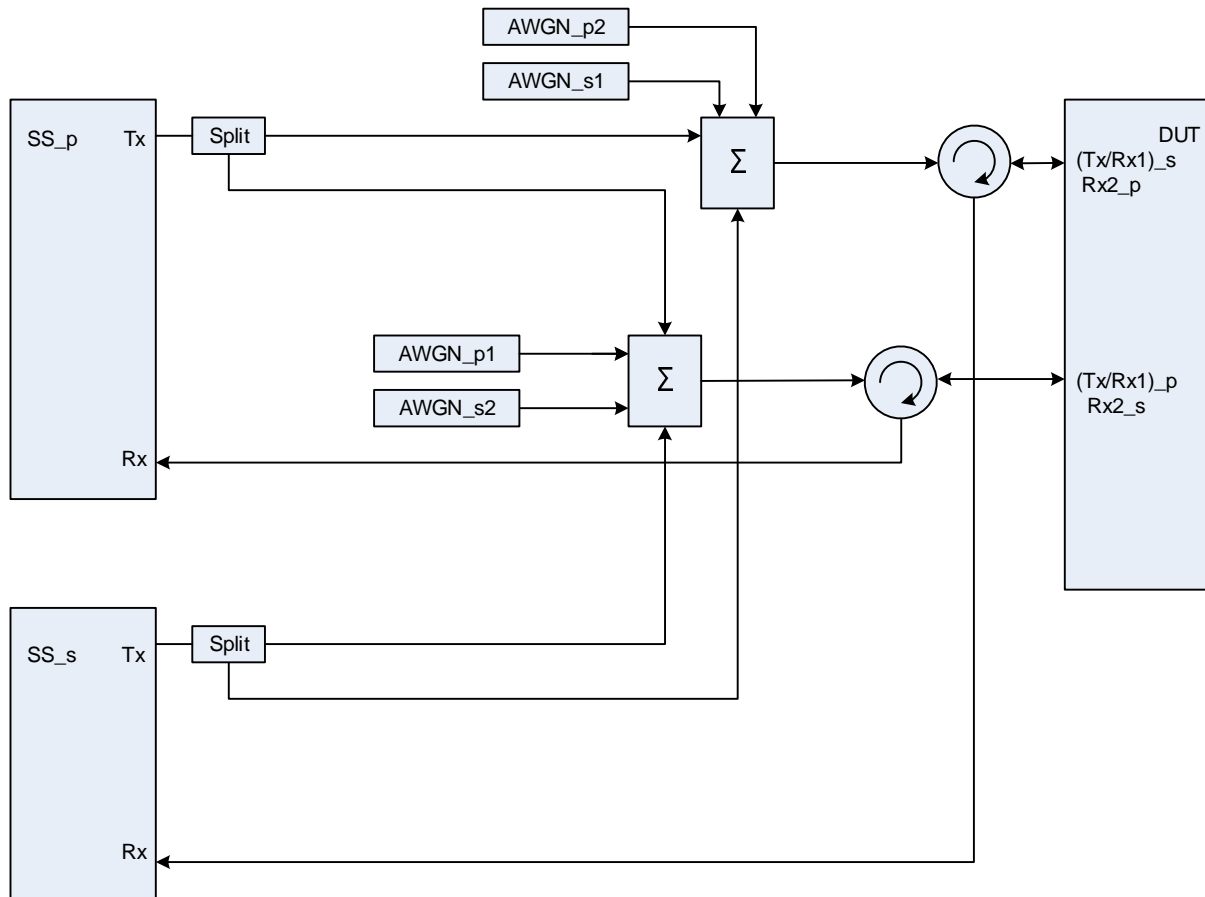

Figure A.45c: Connection for 2 cells with antenna configuration 1x2 and static propagation (common connectors, different UL antennas)

Figure group A.46: Connection for Rx performance tests for CA with antenna configuration 4x2

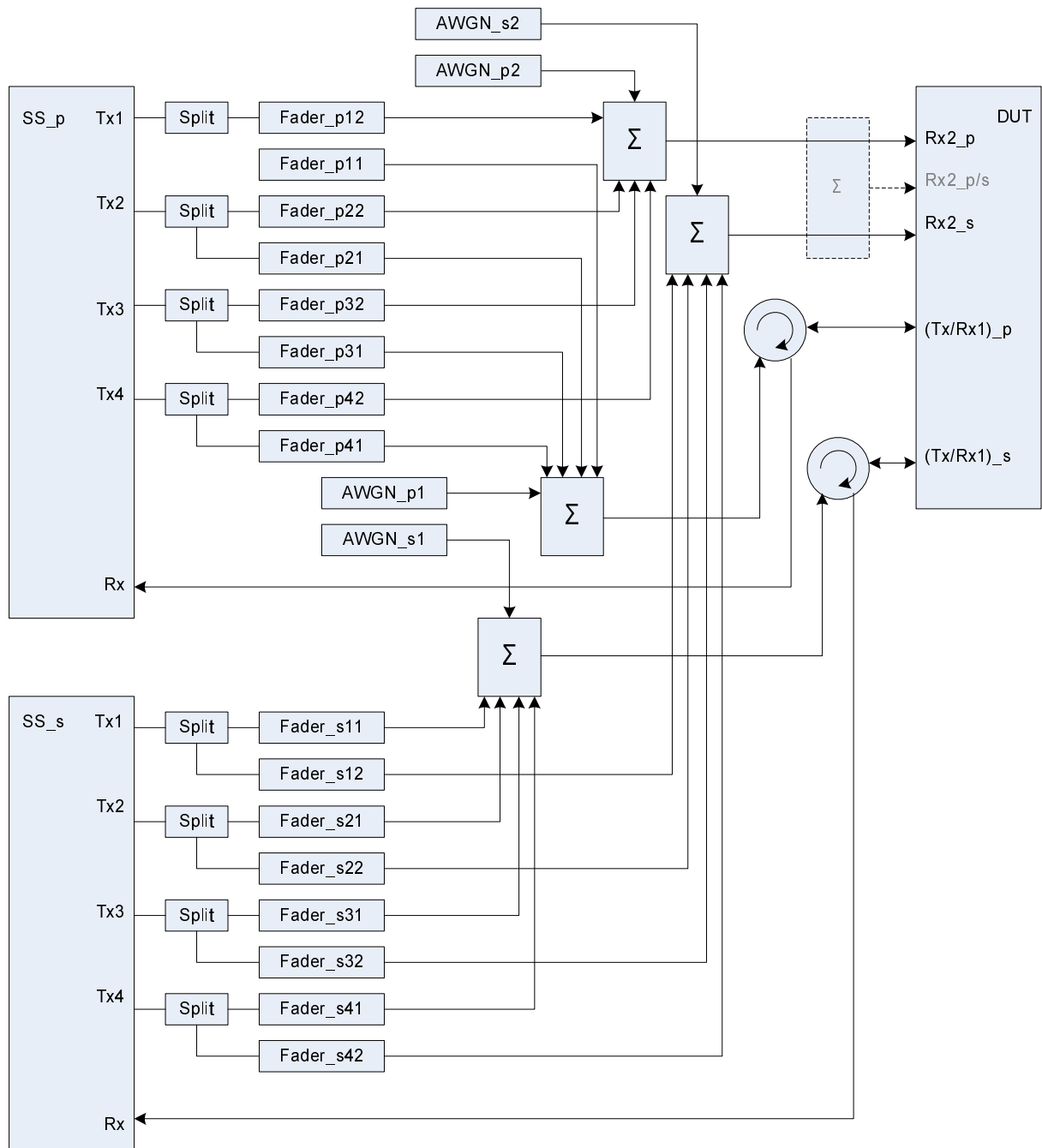

Figure A.46a: Connection for Rx performance tests for CA with antenna configuration 4x2 (separate connectors)

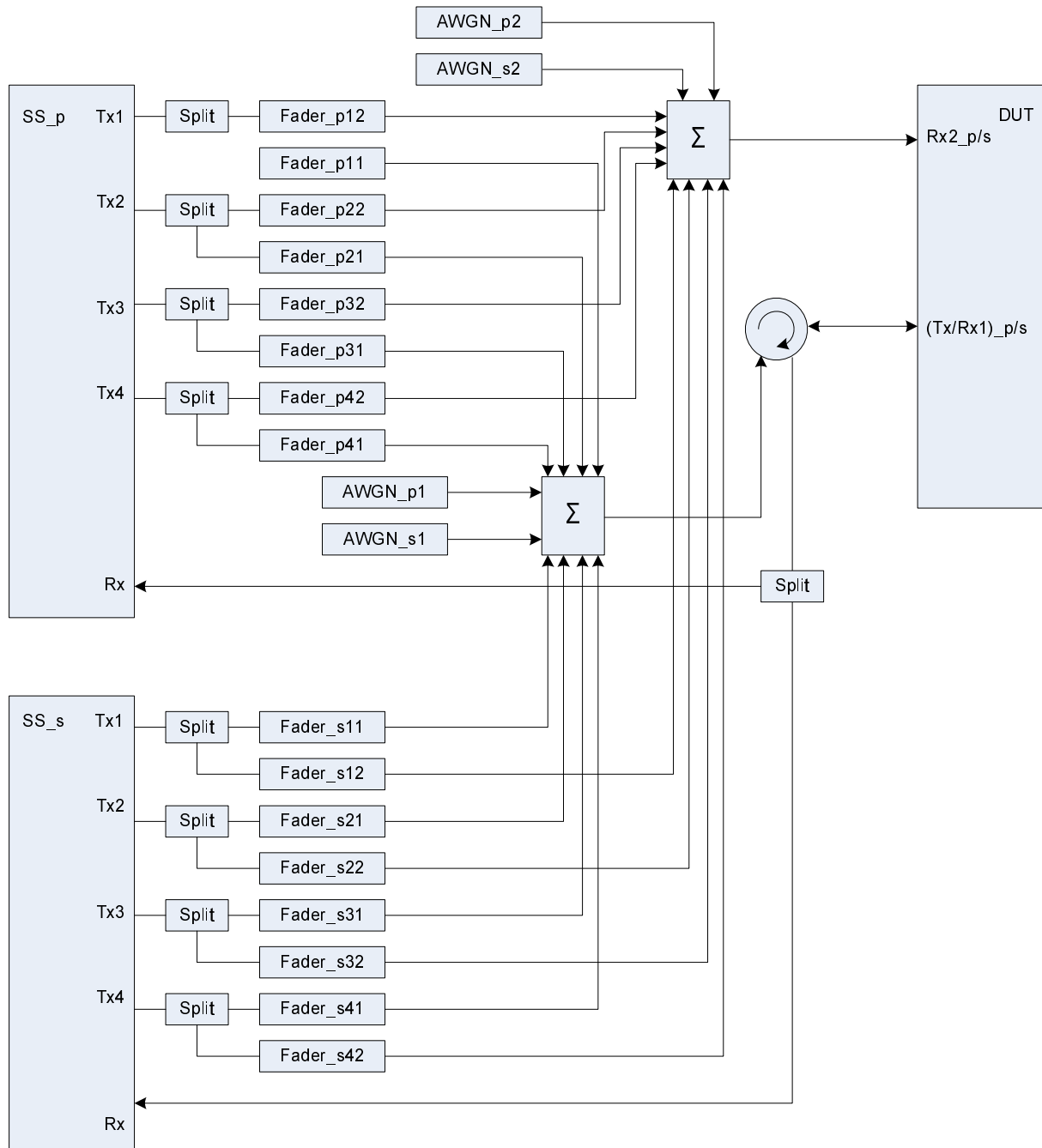

Figure A.46b: Connection for Rx performance tests for CA with antenna configuration 4x2 (common connectors, same UL antenna)

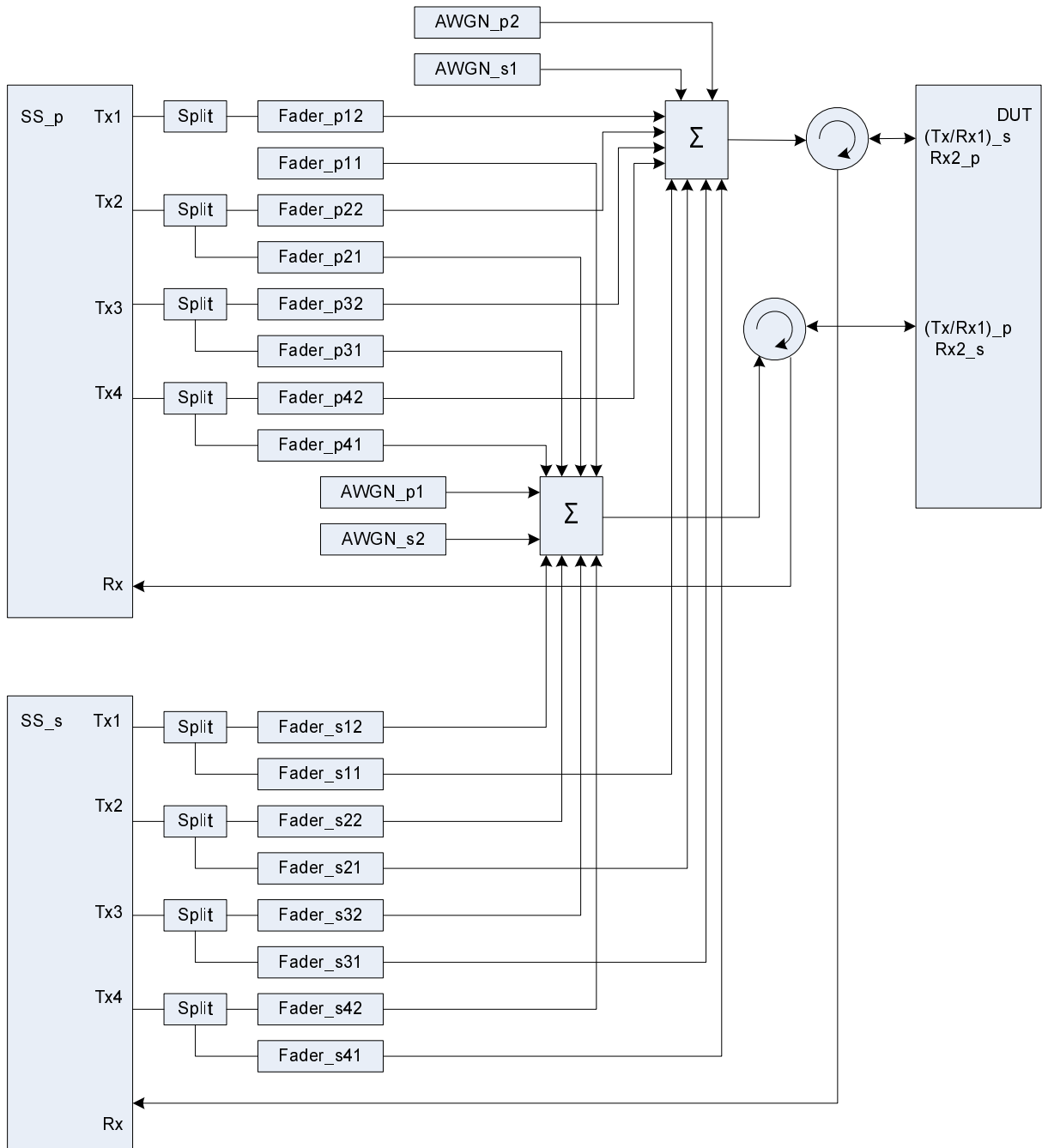

Figure A.46c: Connection for Rx performance tests for CA with antenna configuration 4x2 (common connectors, different UL antennas)

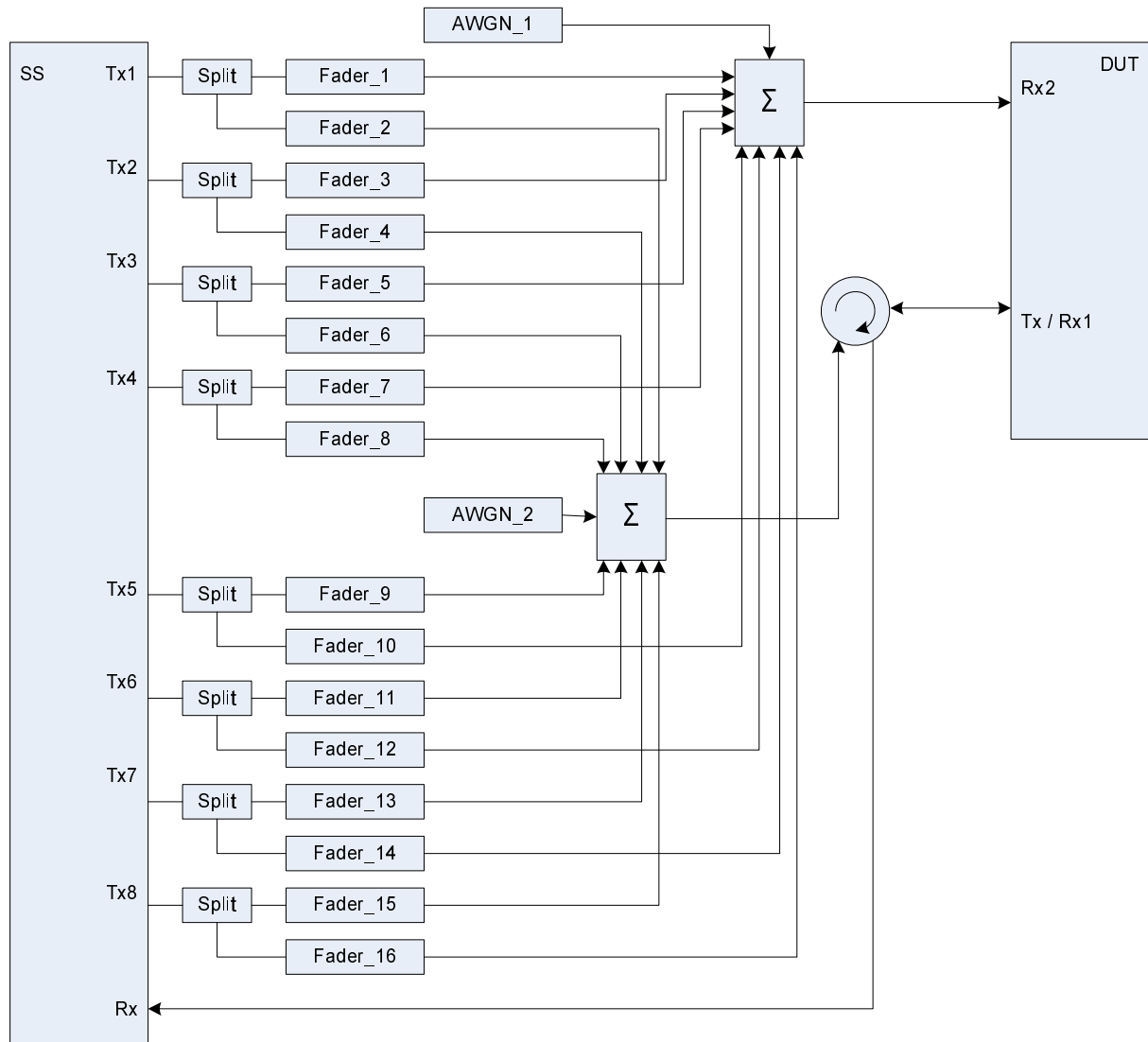

Figure A.47: Connection for RX performance tests with antenna configuration 8x2

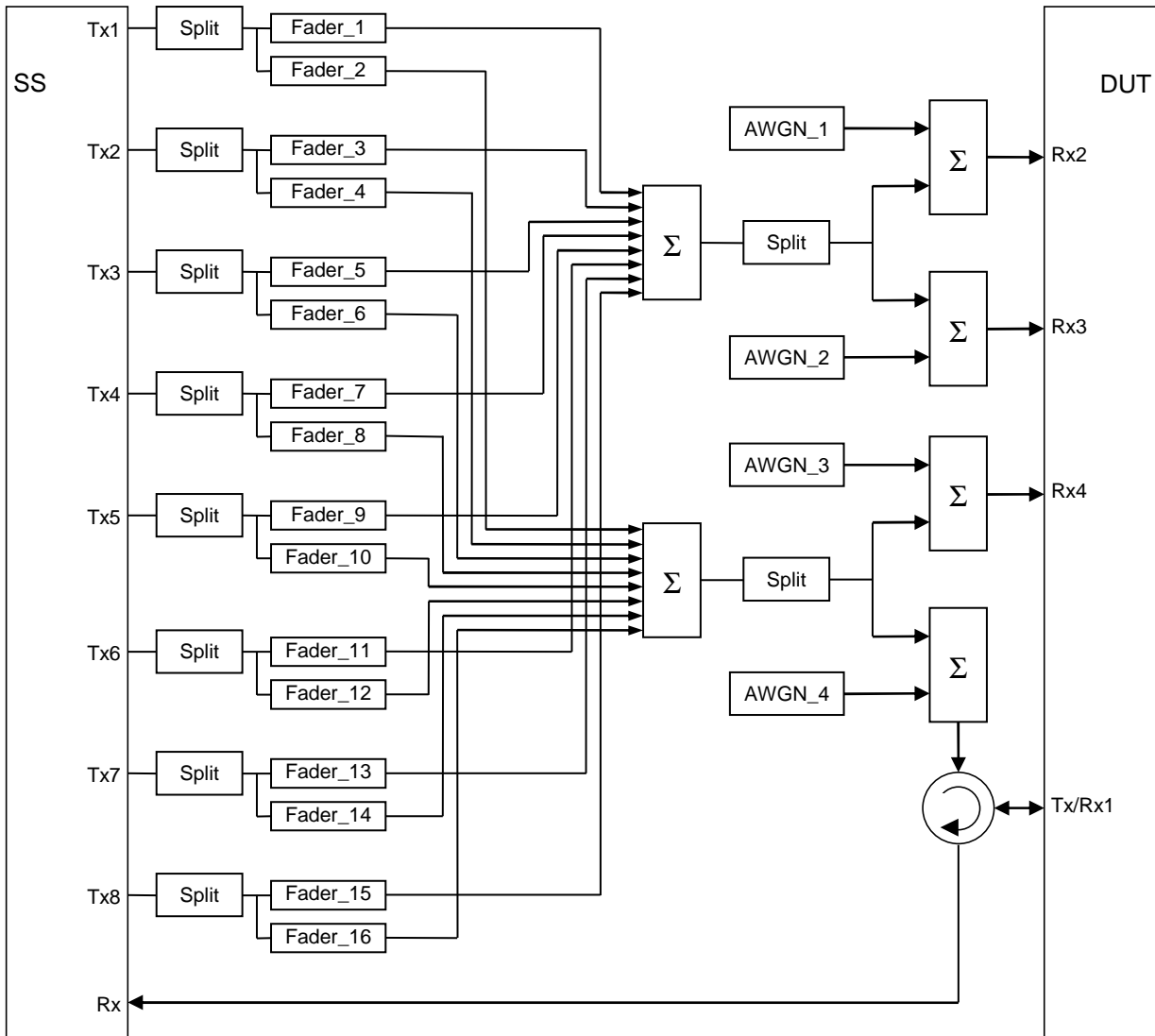

Figure A.47a: Connection for RX performance tests with antenna configuration 8x2 for 4Rx capable UEs without any 2Rx RF bands

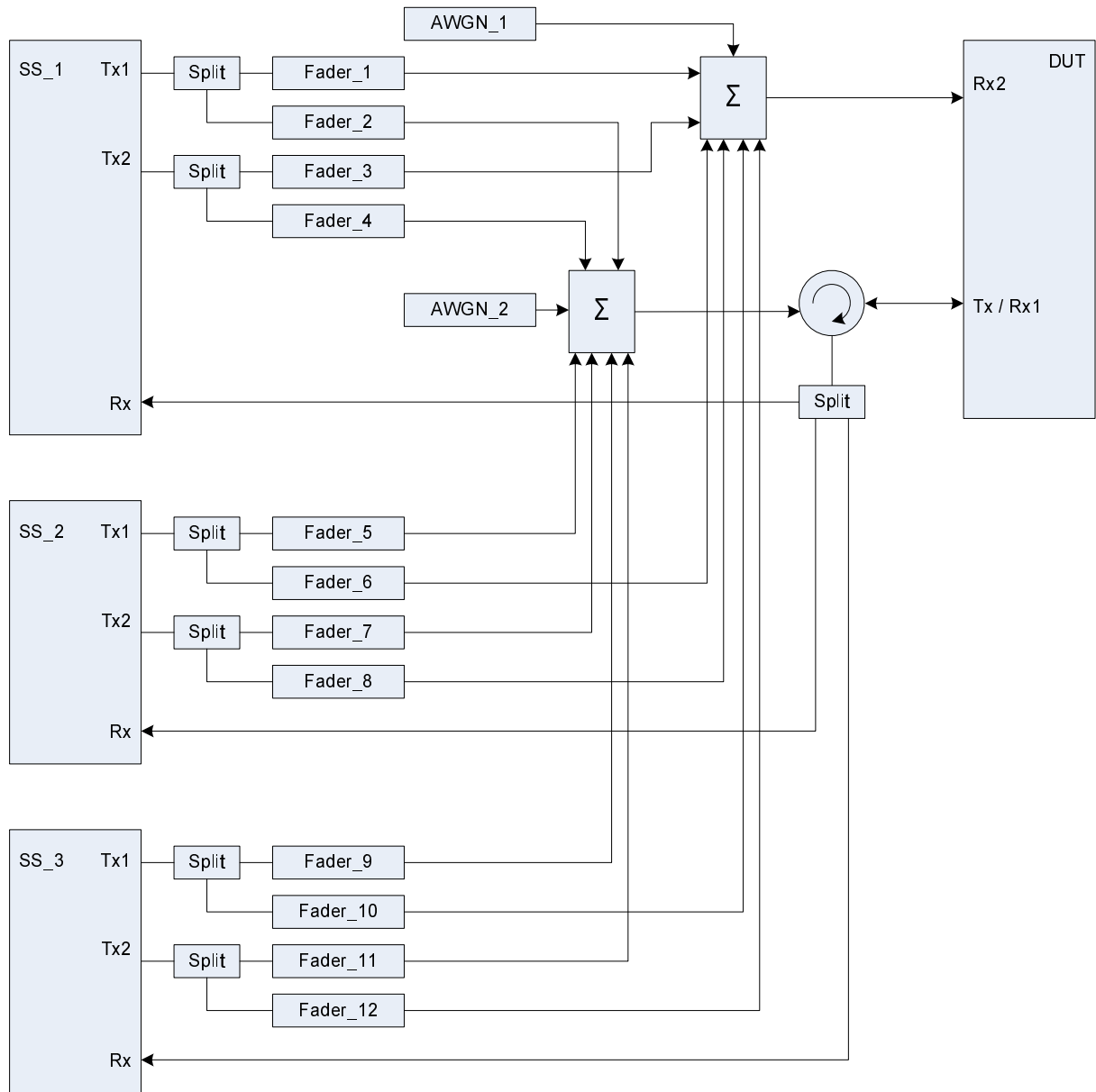

Figure A.48: Connection for 3 Cells (TPs) with antenna configuration 2x2 and fading

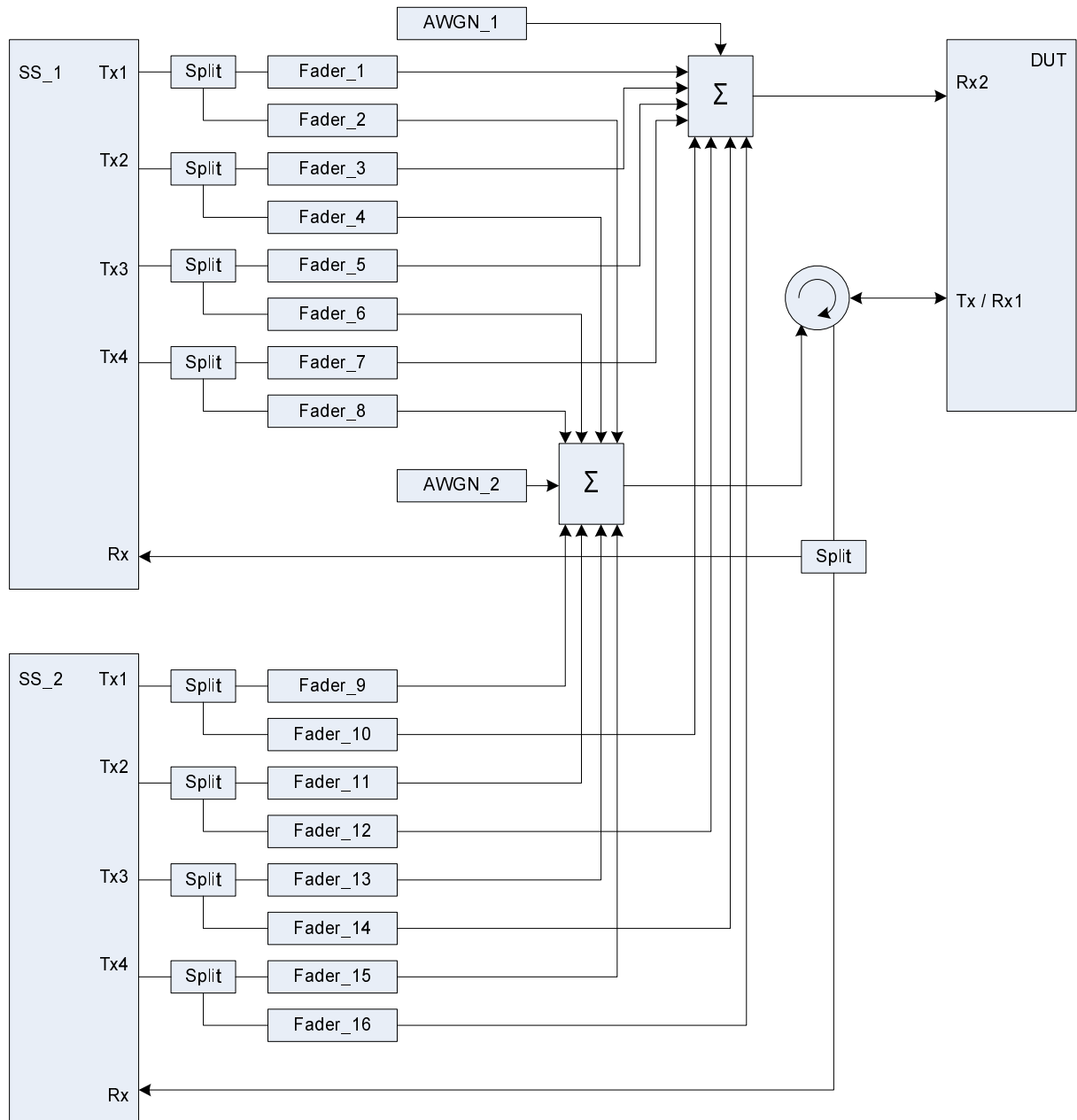

Figure A.49: Connection for 2 Cells (TPs) with antenna configuration 4x2 and fading

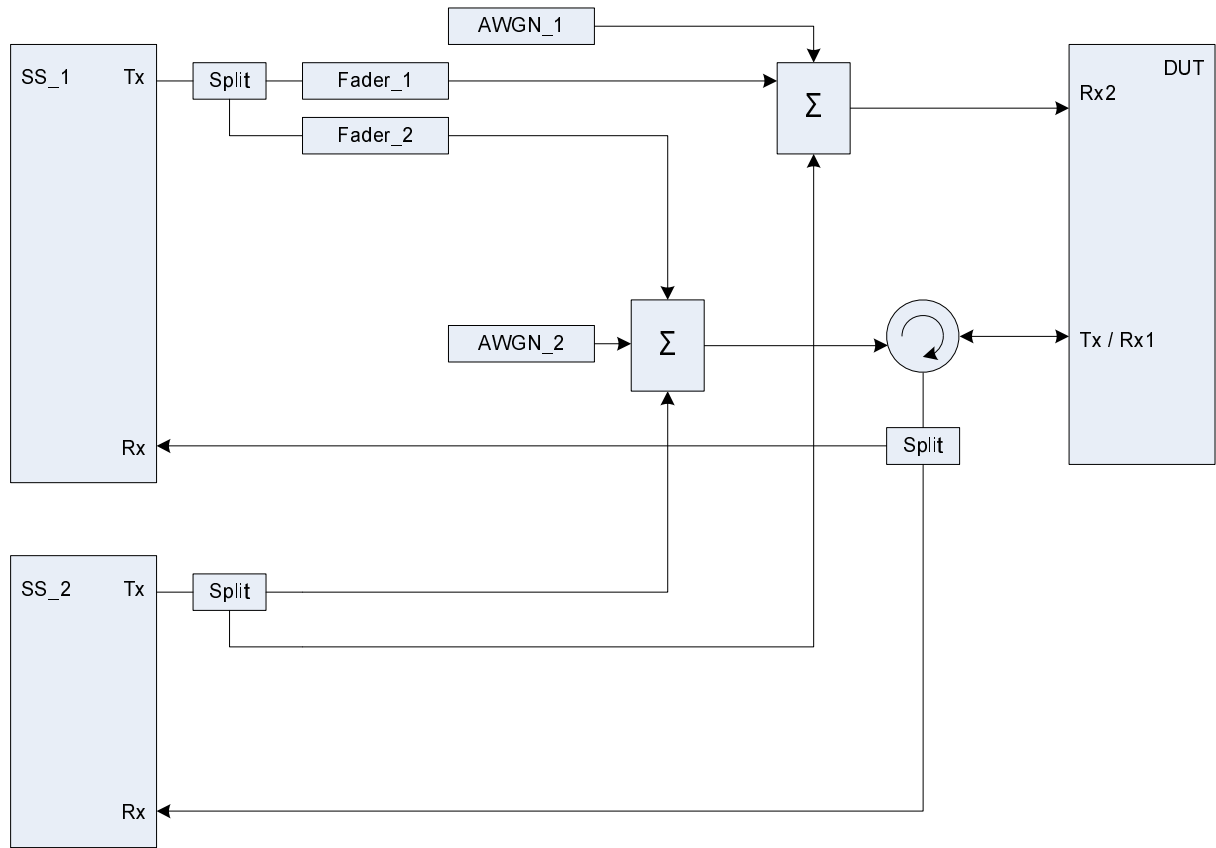

Figure A.50: Connection for 2 Cells (TPs) with antenna configuration 1x2 and fading for one Cell (TP)

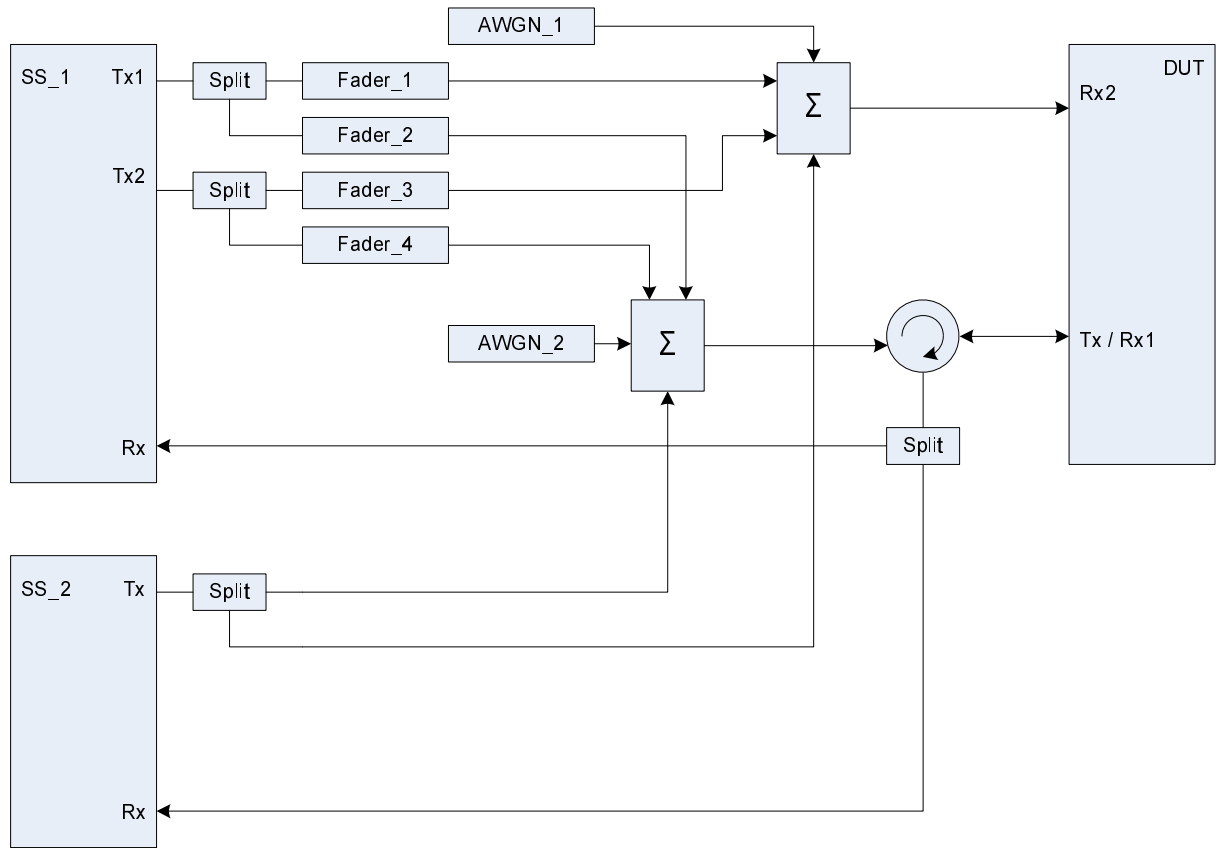

Figure A.51: Connection for 2 Cells (TPs) with antenna configuration 2x2 / 1x2 and fading for the 2x2 Cell (TP)

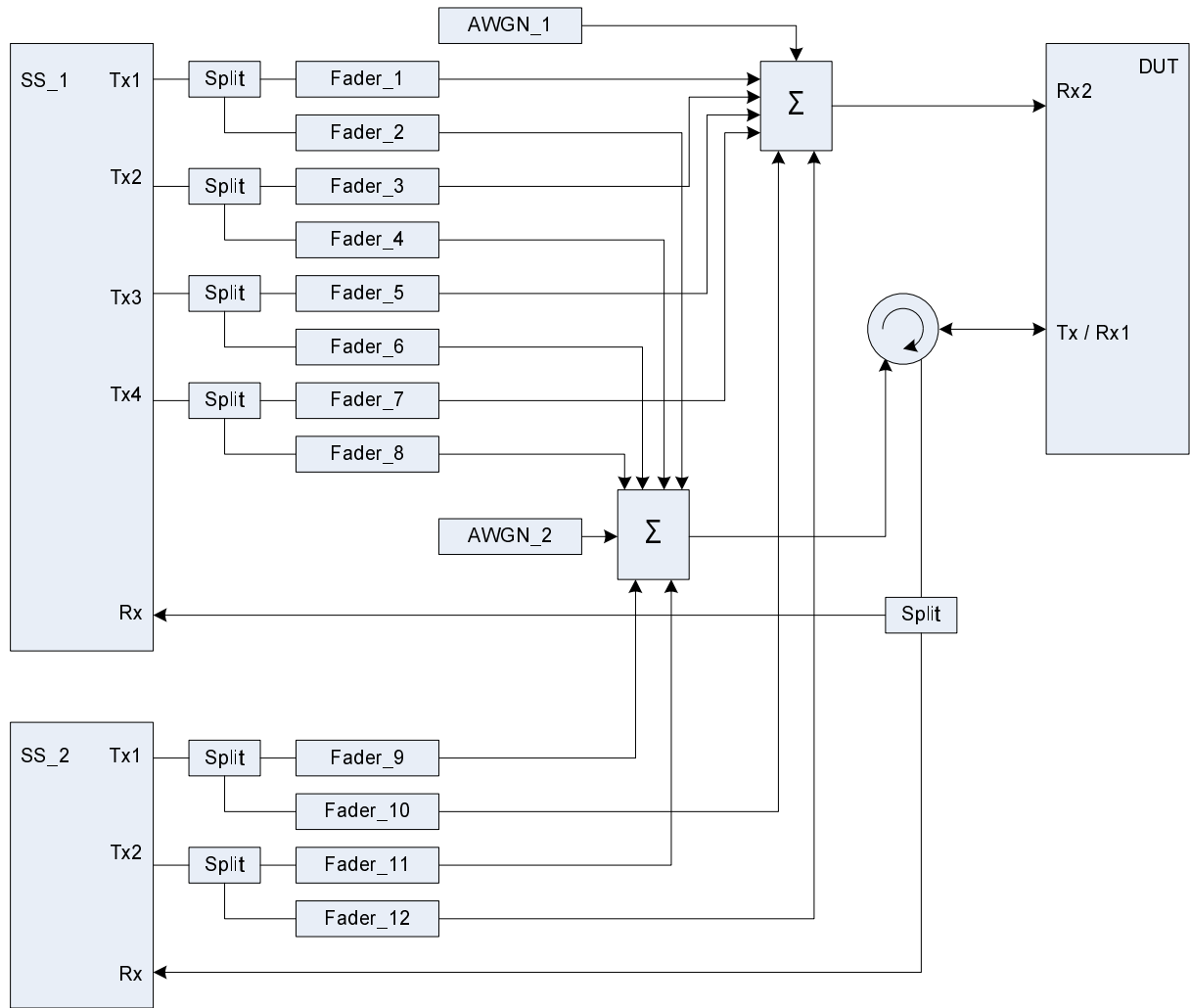

Figure A.52: Connection for 2 Cells (TPs) with antenna configuration 4x2 / 2x2 and fading

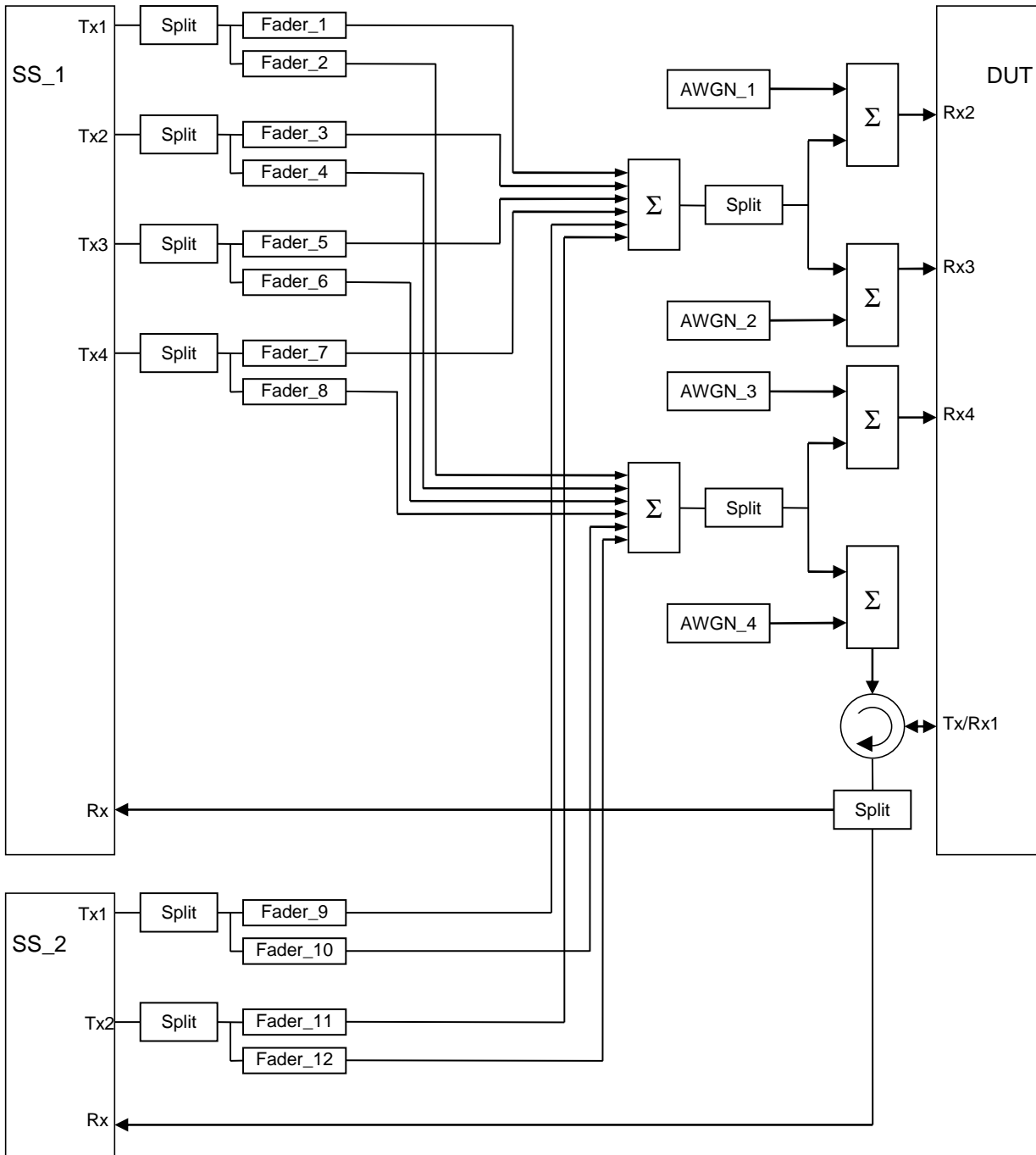

Figure A.52a: Connection for 2 Cells (TPs) with antenna configuration 4x2 / 2x2 and fading for 4Rx capable UEs without any 2Rx RF bands

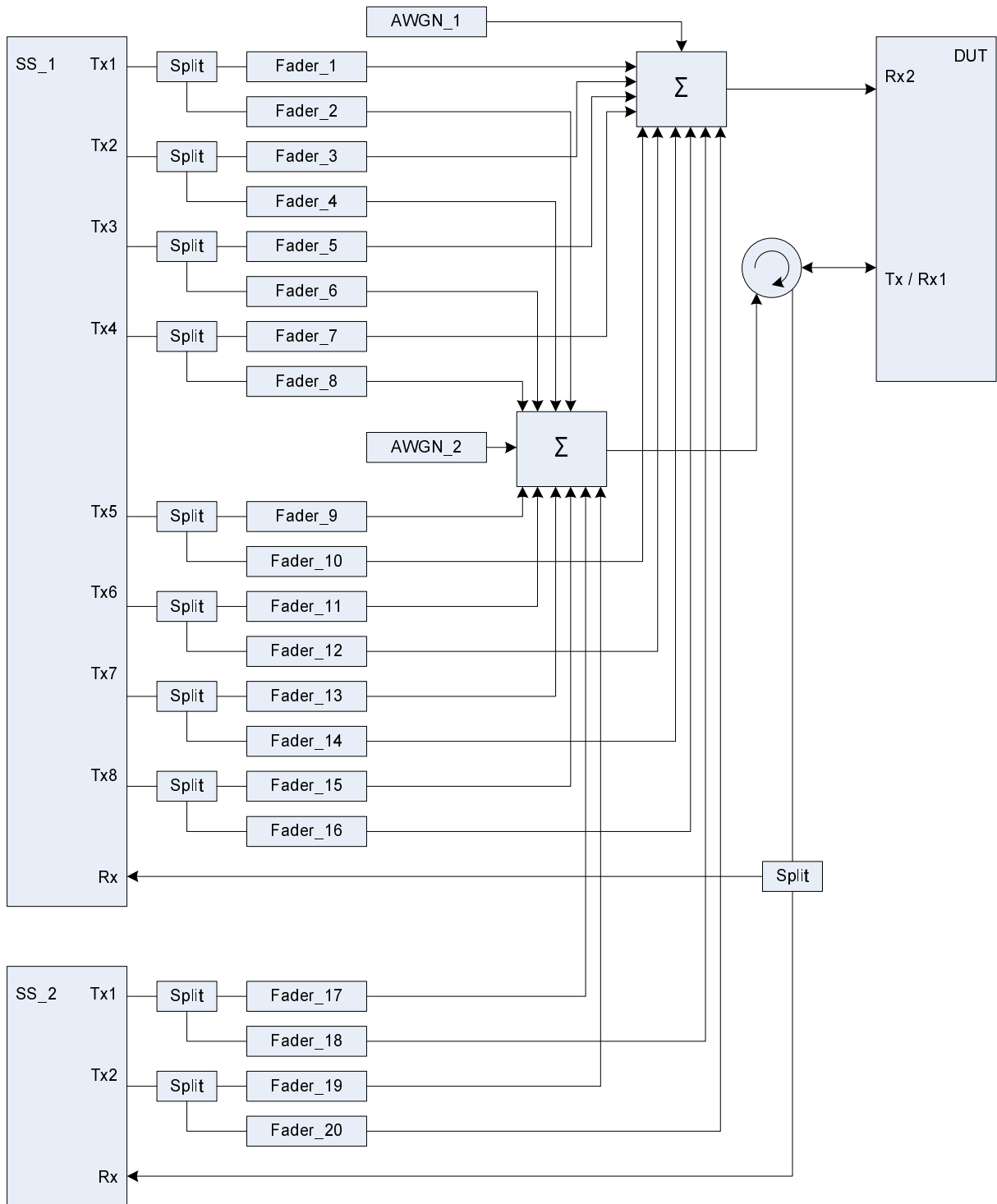

Figure A.53: Connection for 2 Cells (TPs) with antenna configuration 8x2 / 2x2 and fading

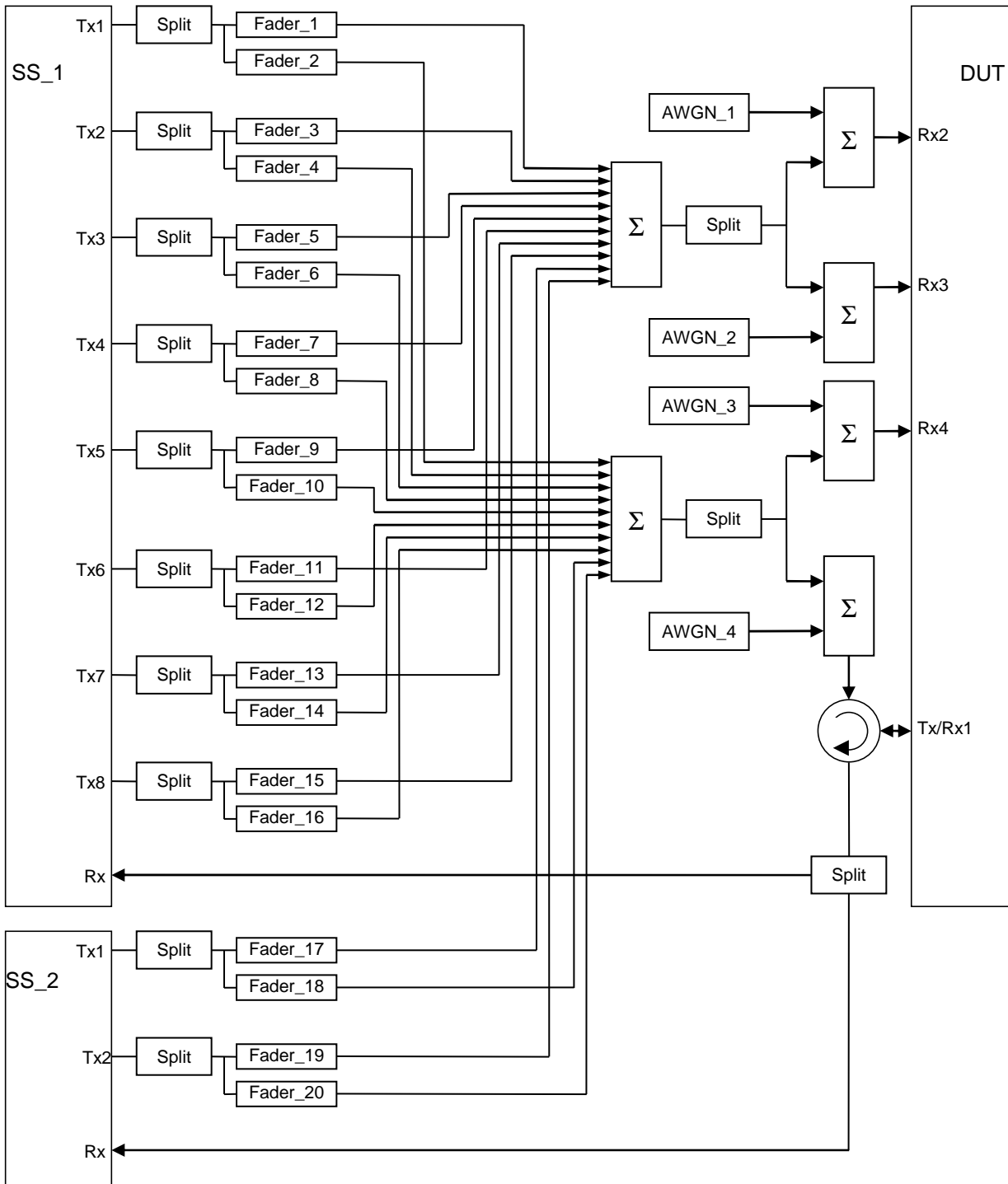

Figure A.53a: Connection for 2 Cells (TPs) with antenna configuration 8x2 / 2x2 and fading for 4Rx capable UEs without any 2Rx RF bands

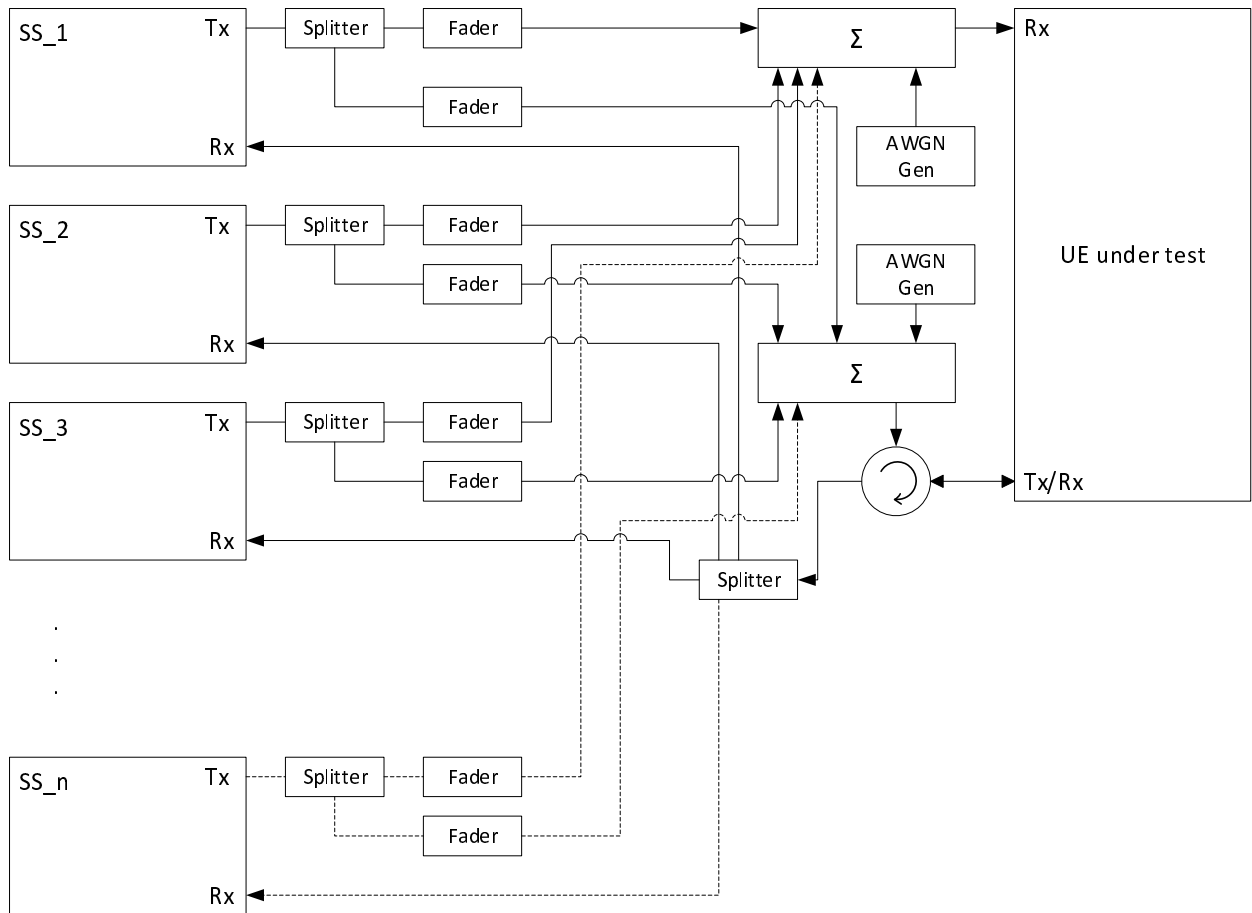

Figure A.54: Connection for 3 or more Cells (TPs) with antenna configuration 1x2 and fading

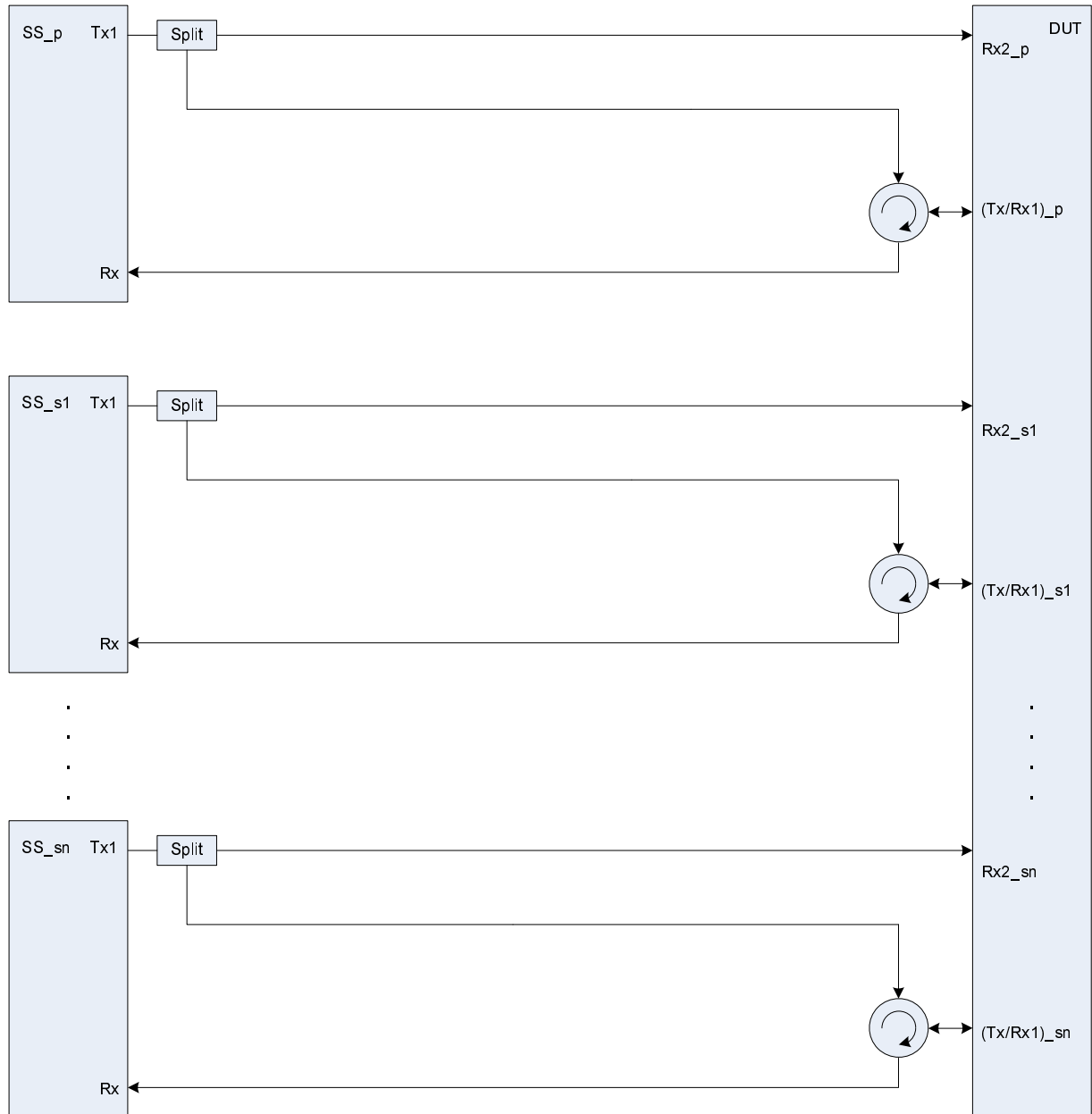

Figure A.55: Connection for basic Tx and Rx tests for CA (≥ 3 CCs)

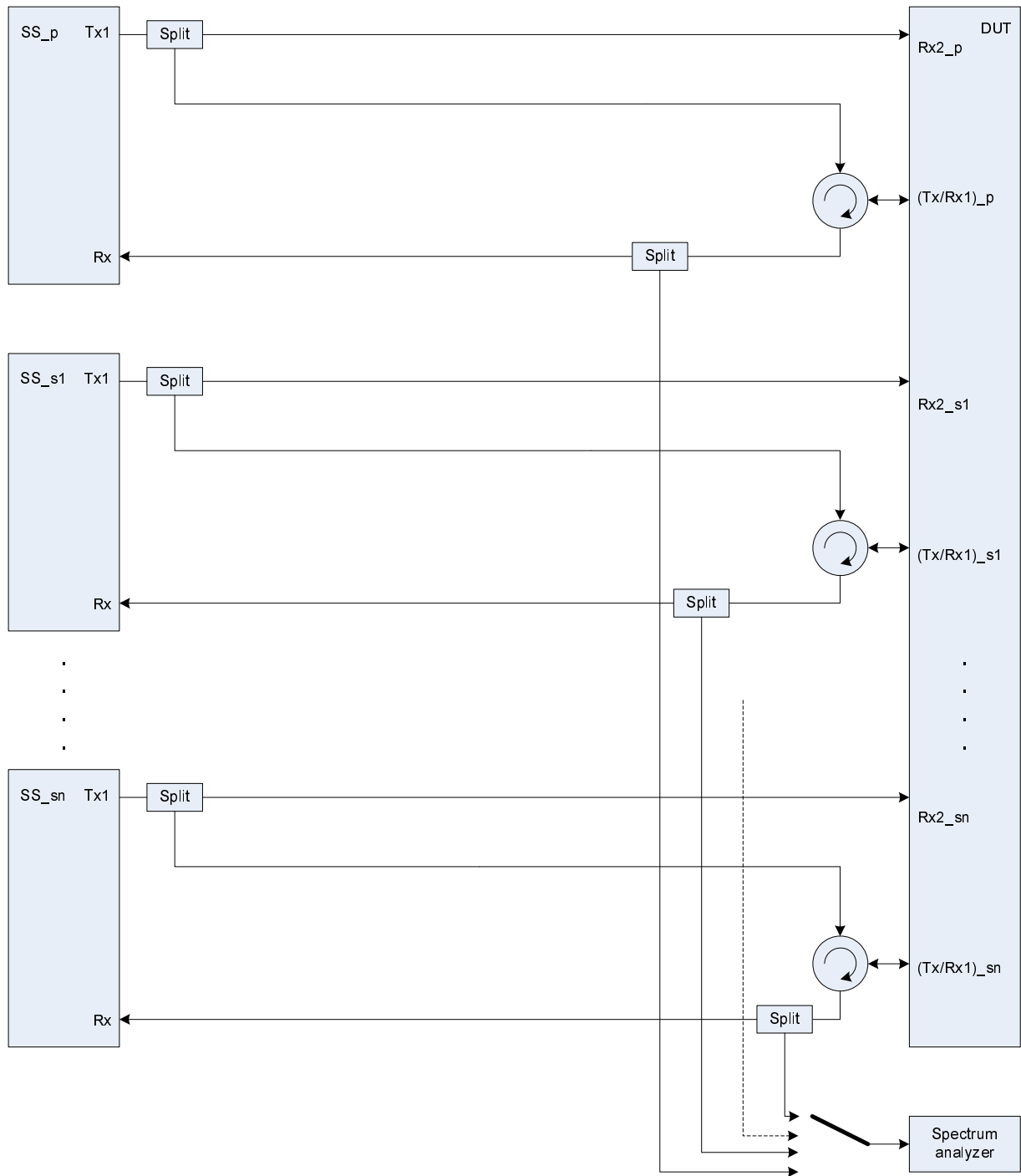

Figure A.56: Connection for Tx tests for CA (≥ 3 CCs) with additional Spectrum Analyzer

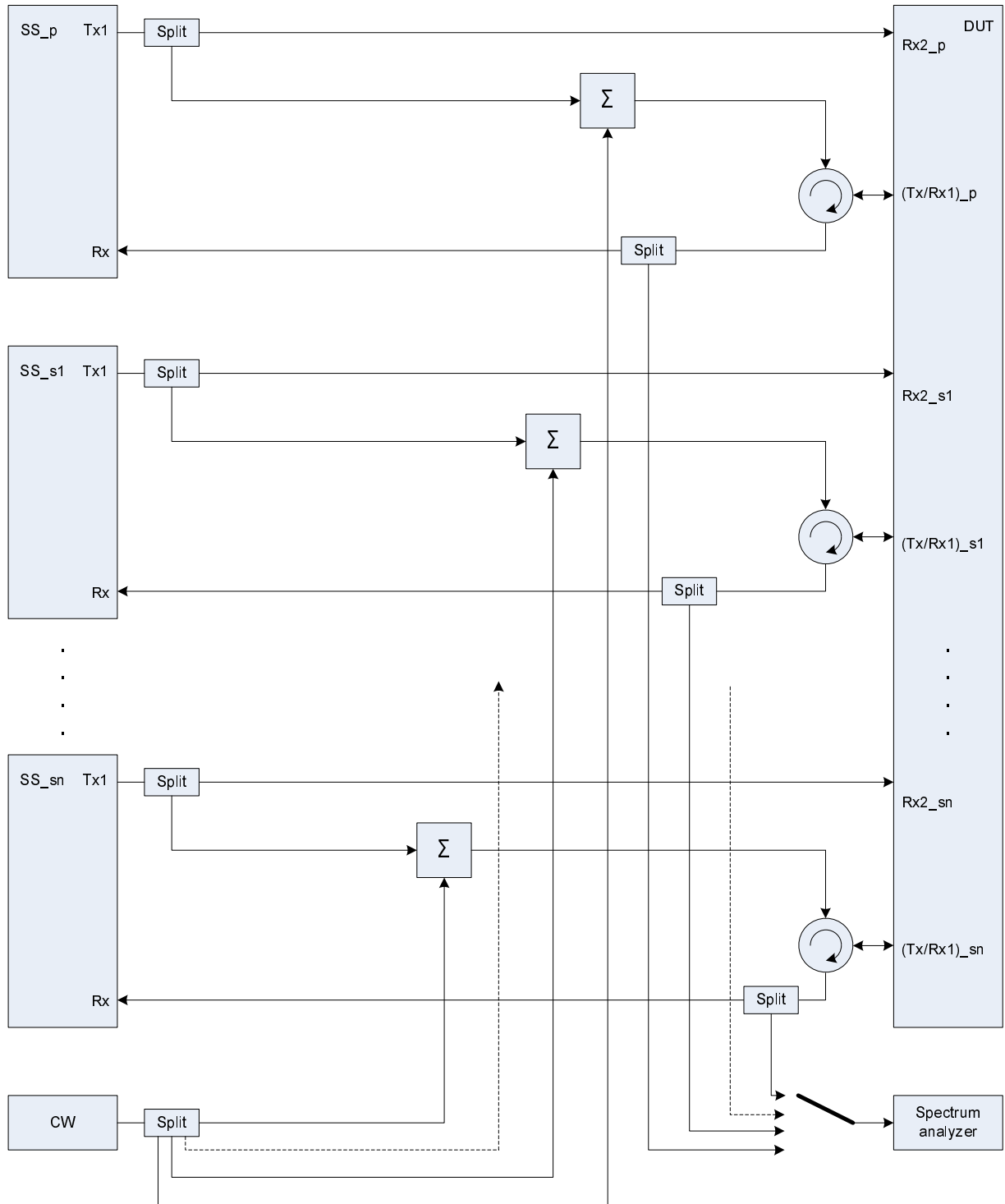

Figure A.57: Connection for Tx tests for CA (≥ 3CCs) with additional CW and Spectrum Analyzer

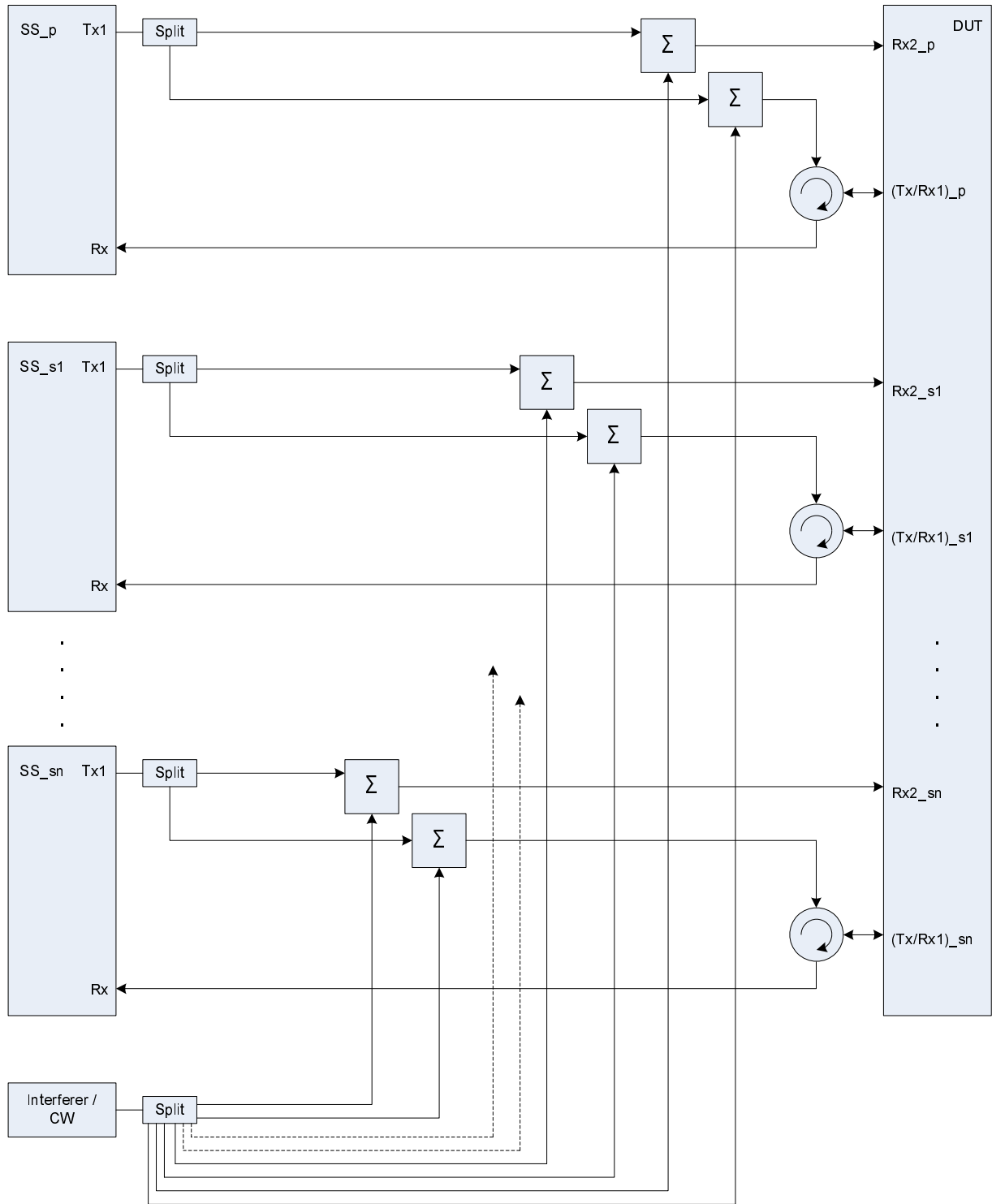

Figure A.58: Connection for Rx tests for CA (≥ 3CCs) with additional Interferer / CW

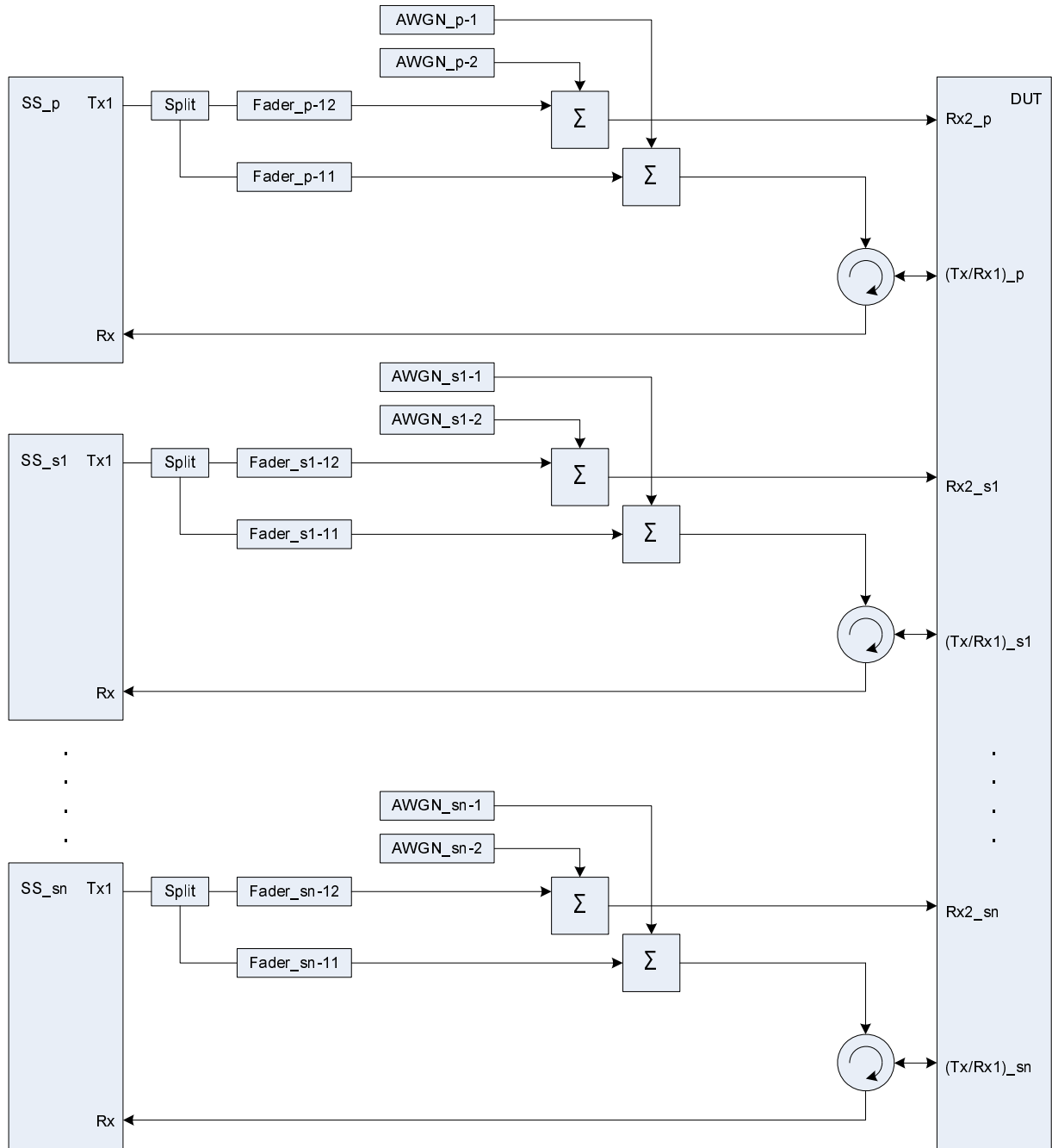

Figure A.59: Connection for Rx performance tests for CA (≥ 3CCs) with antenna configuration 1x2

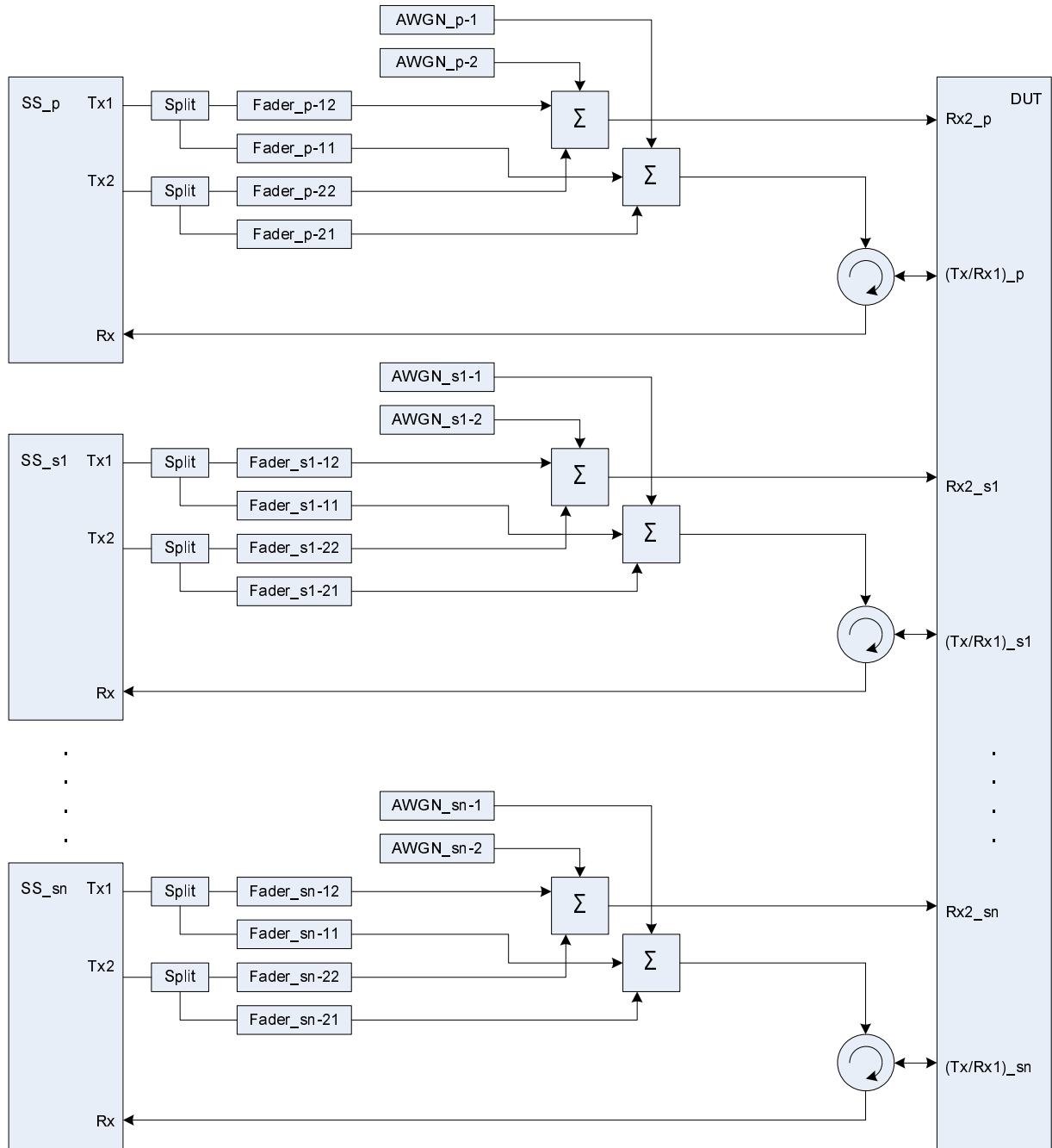

Figure A.60: Connection for Rx performance tests for CA (≥ 3CCs) with antenna configuration 2x2

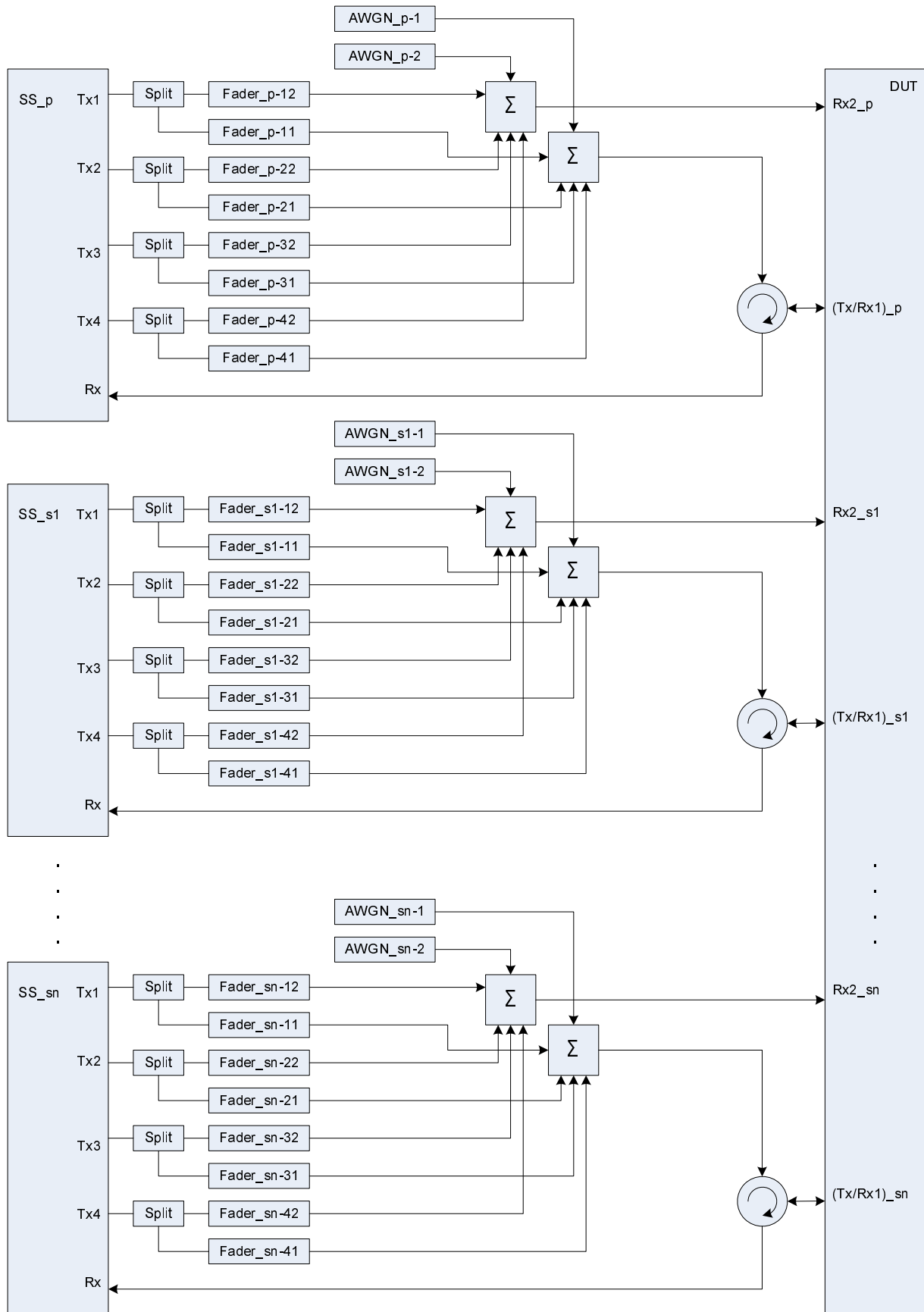

Figure A.61: Connection for Rx performance tests for CA (≥ 3CCs) with antenna configuration 4x2

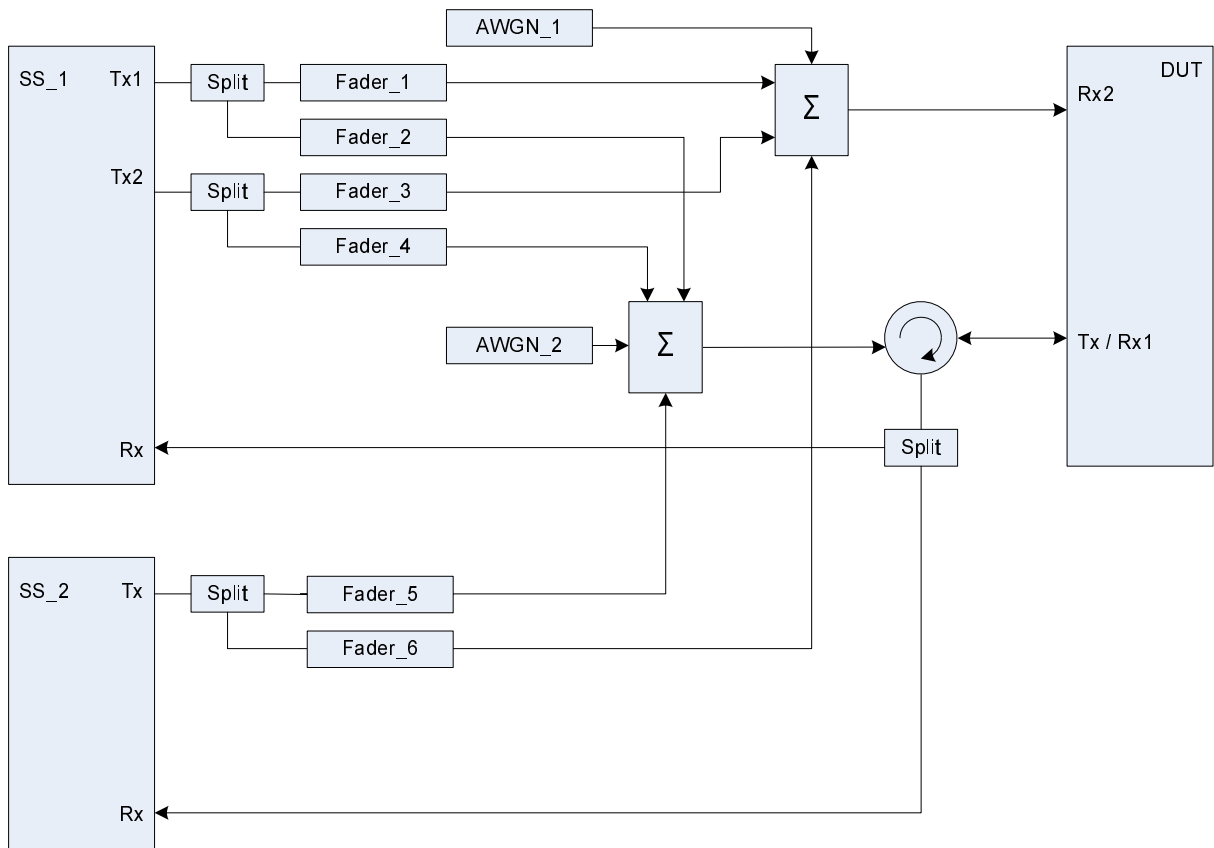

Figure A.62: Connection for 2 Cells with antenna configuration 2x2 / 1x2 and fading

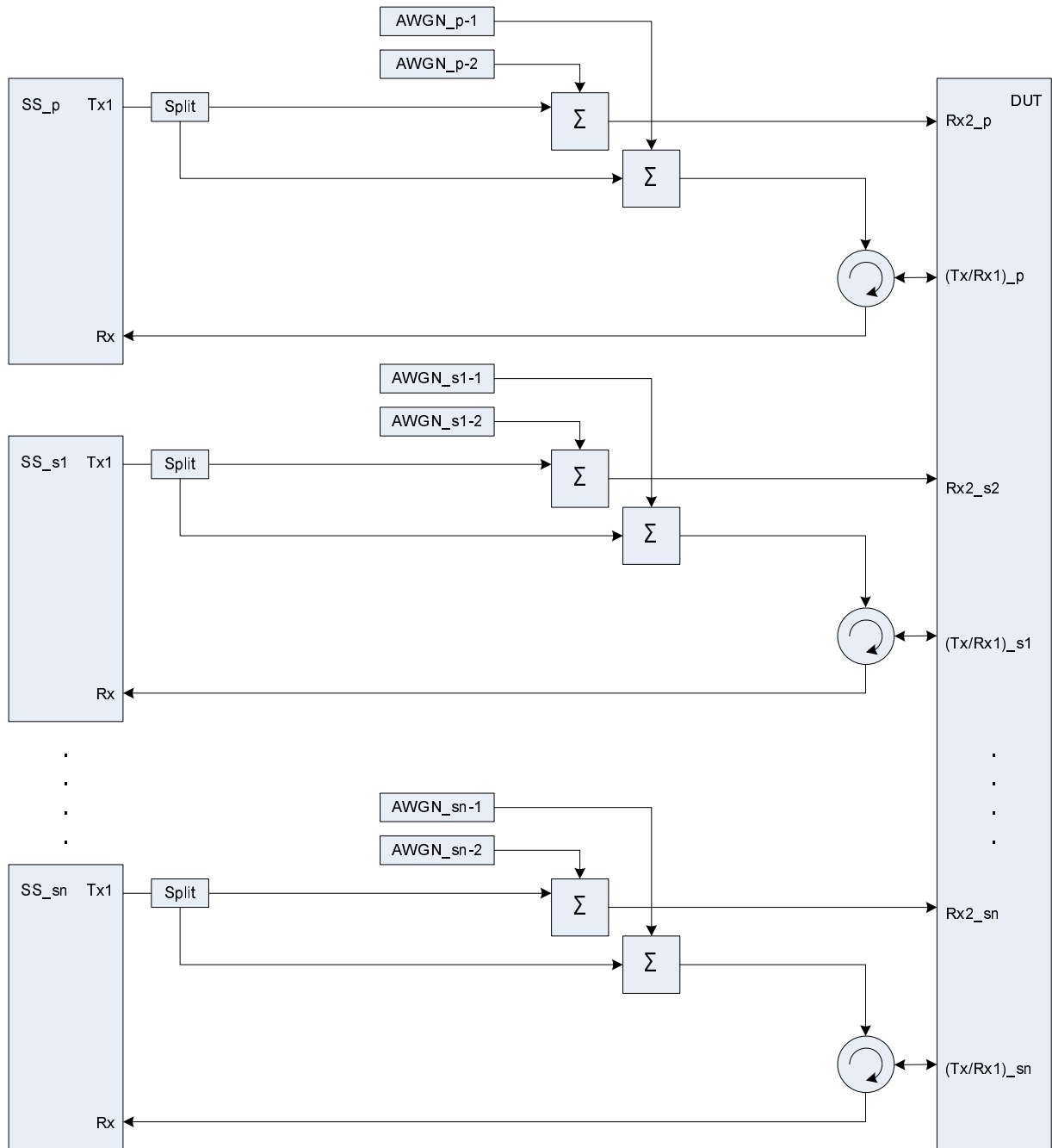

Figure A.63: Connection for CA testing (≥ 3 CCs) with antenna configuration 1x2 and static propagation conditions

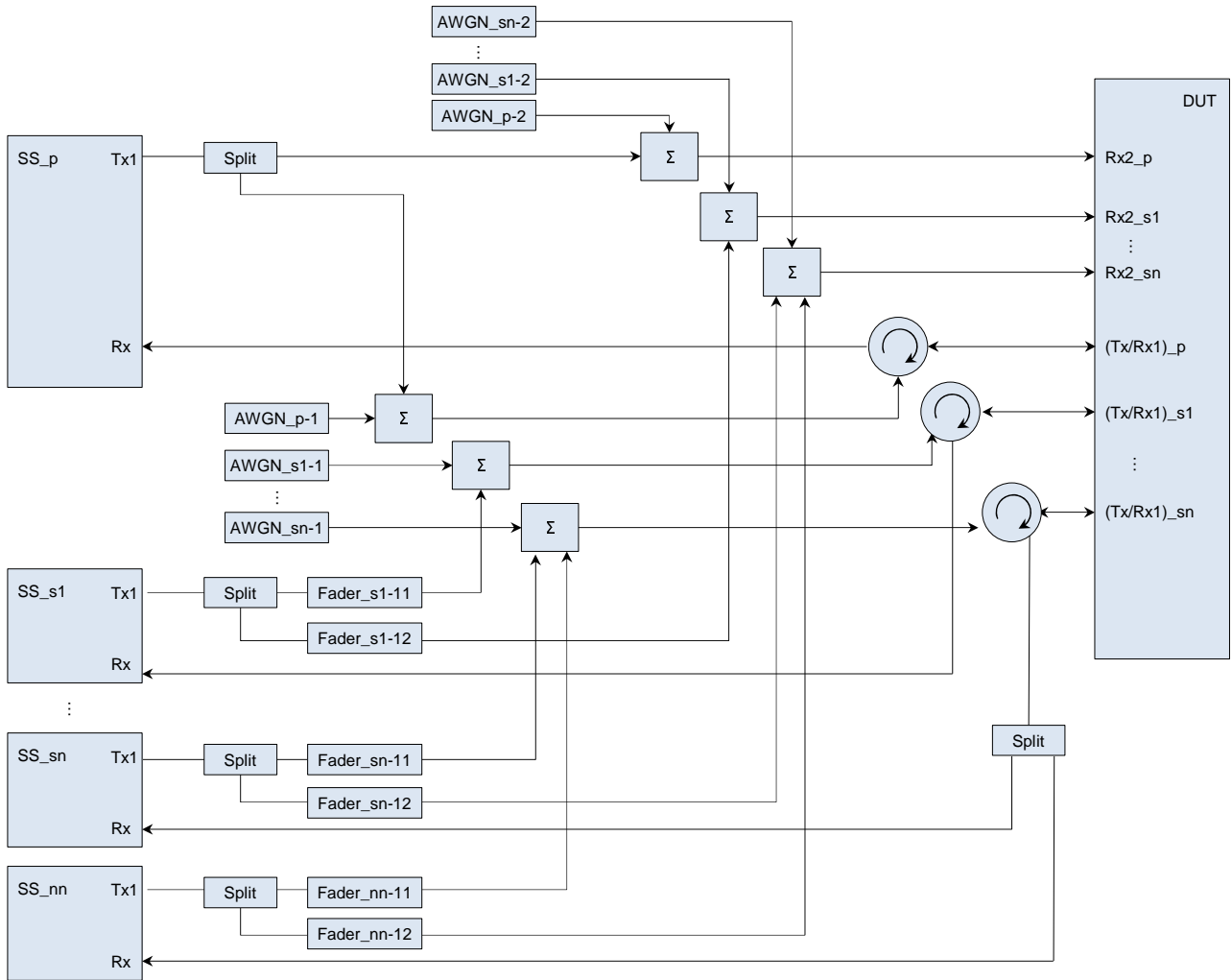

Figure A.64: Connection for CA(≥ 3CCs) with static PCC propagation channel, SCCs multipath fading propagation channels and additional intra-frequency cell on one SCC

Figure A.64a: Void

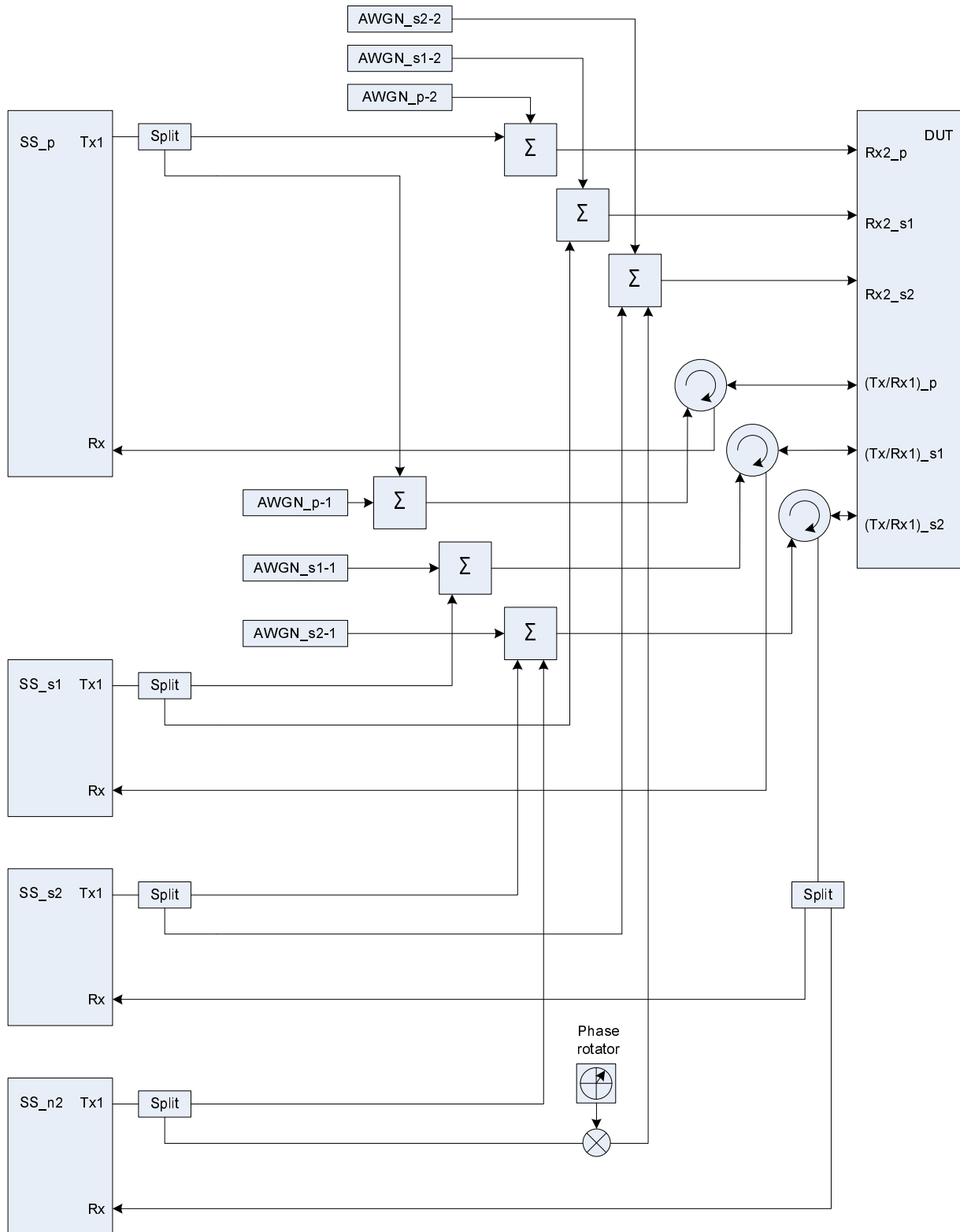

Figure A.65: Connection for 3DL CA with static propagation channels and additional intra-frequency cell on one SCC (the frequency offset used in phase rotator is 5 Hz)

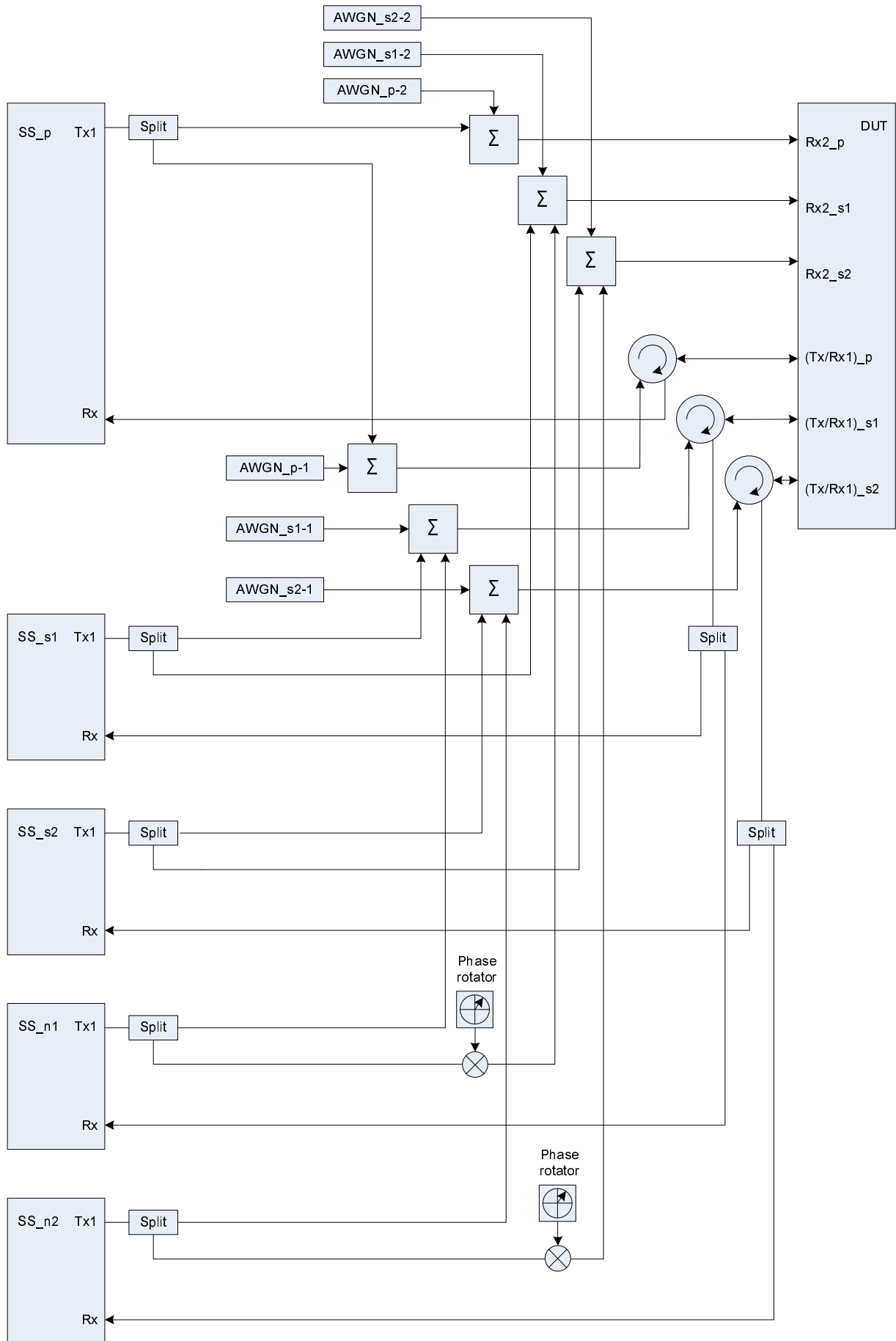

Figure A.66: Connection for 3DL CA with static propagation channels and additional intra-frequency cell(s) on both SCCs (the frequency offset used in phase rotators is 5 Hz)

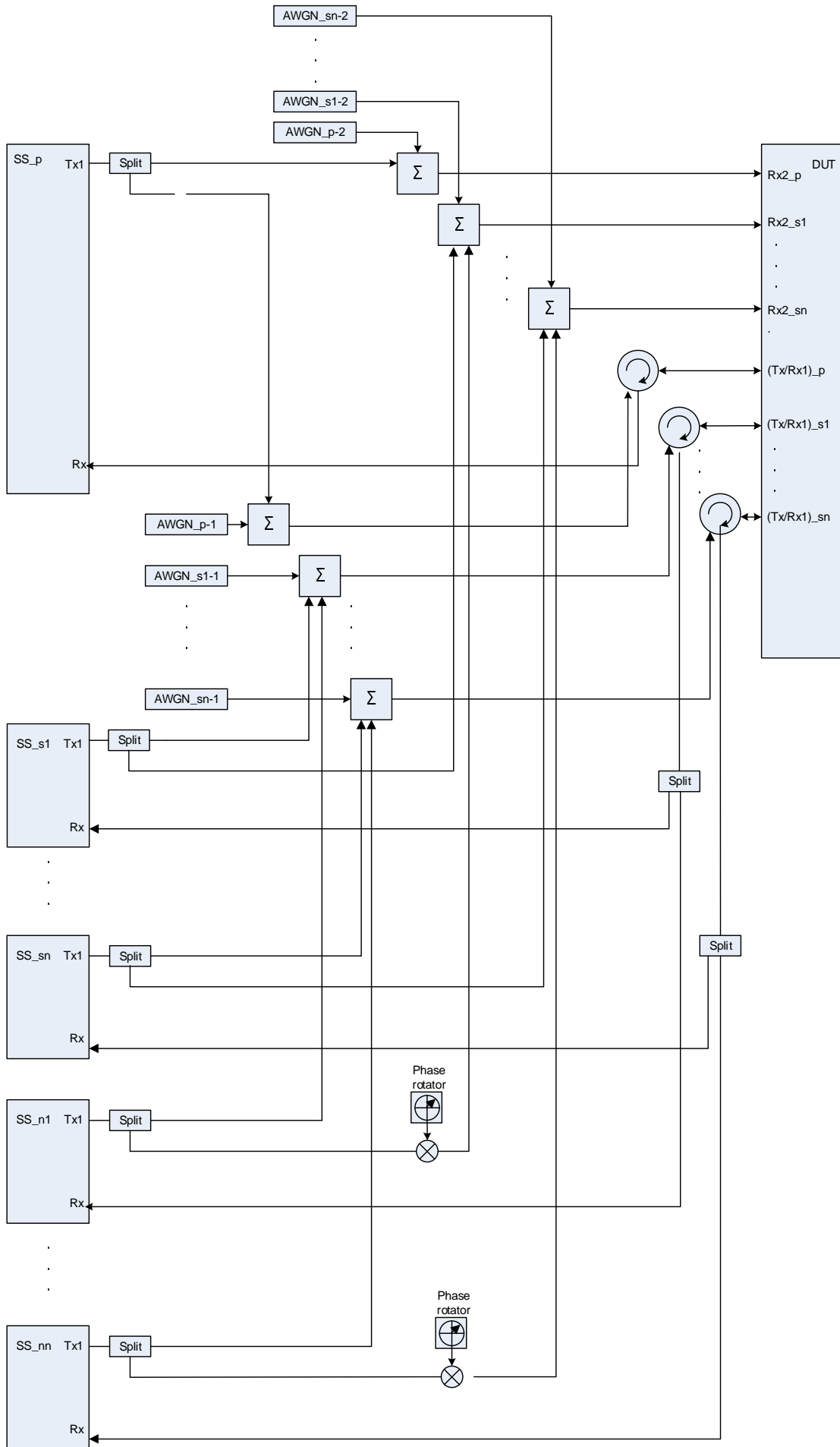

Figure A.66a: Connection for more than 3DL CA with static propagation channels and additional intra-frequency cell(s) on each SCC (the frequency offset used in phase rotators is 5 Hz)

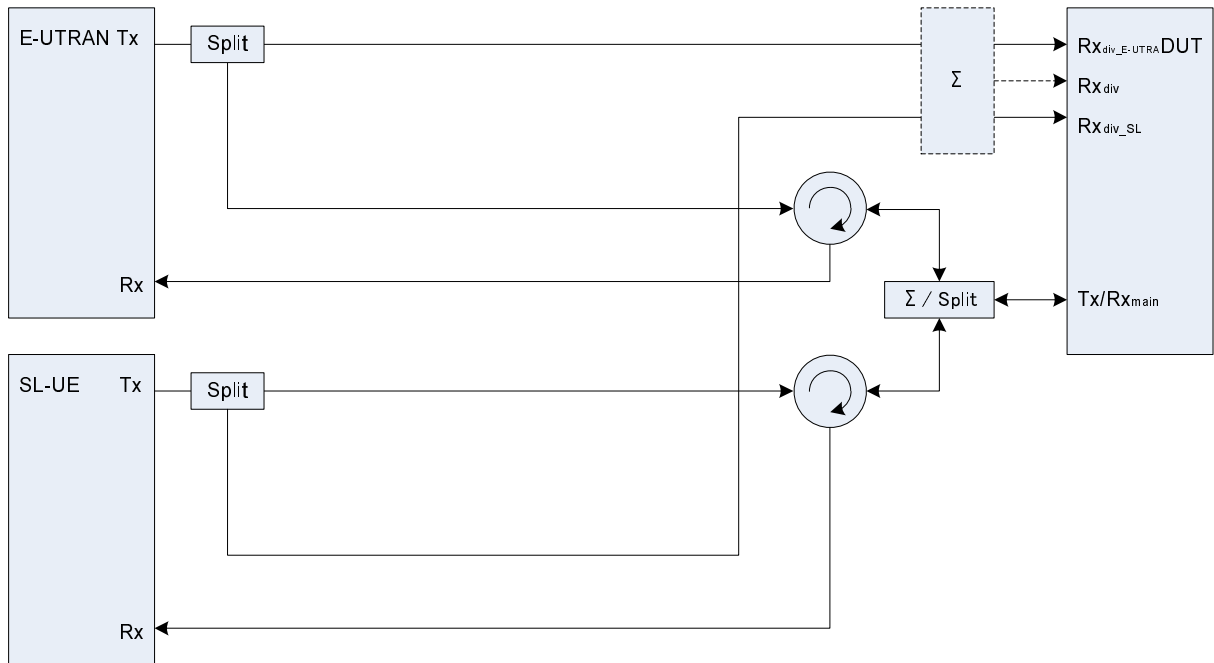

Figure A.67: Connection for Sidelink basic Tx/Rx testing

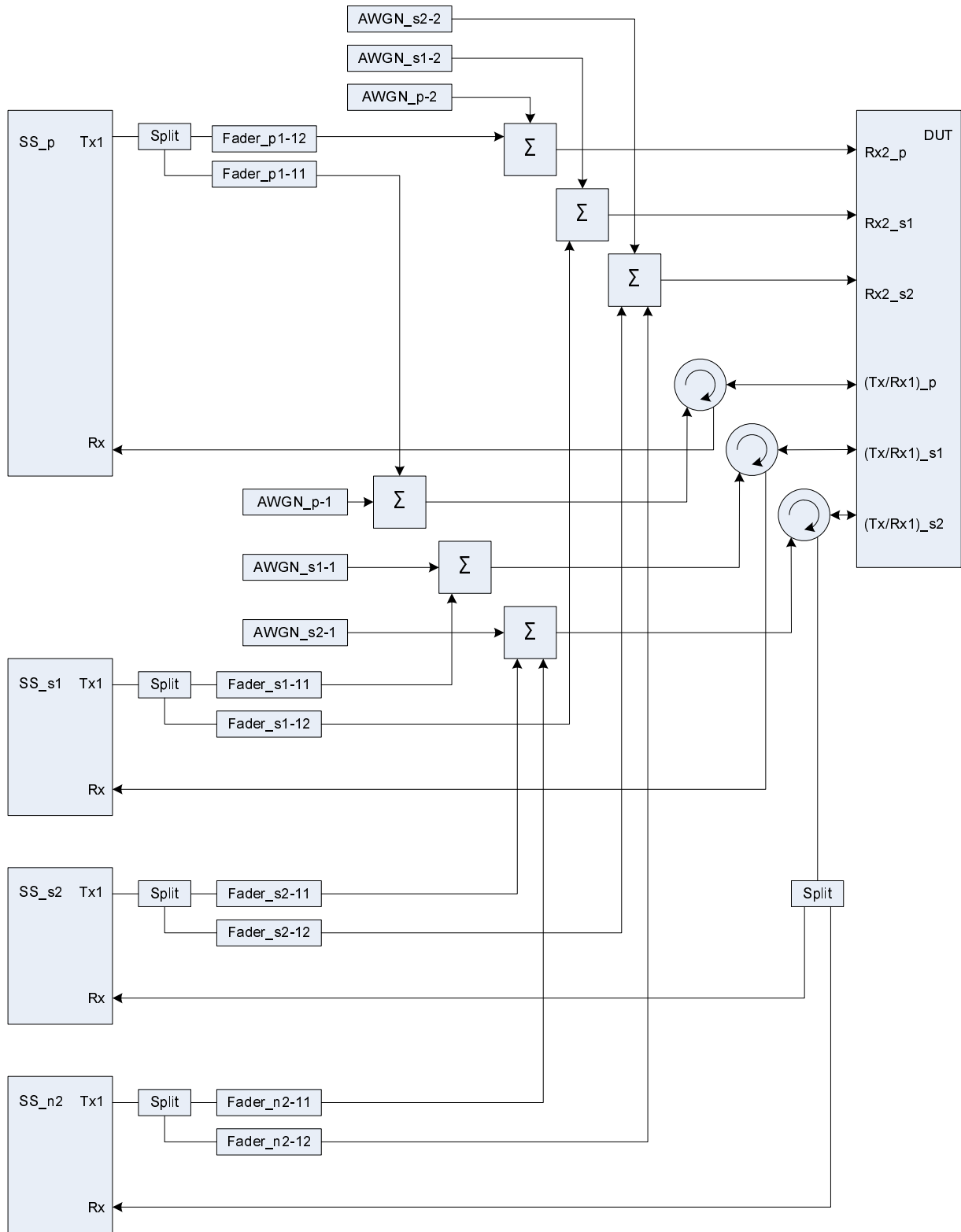

Figure A.68: Connection for 3DL CA with PCC and SCCs multipath fading propagation channels and additional intra-frequency cell on one SCC

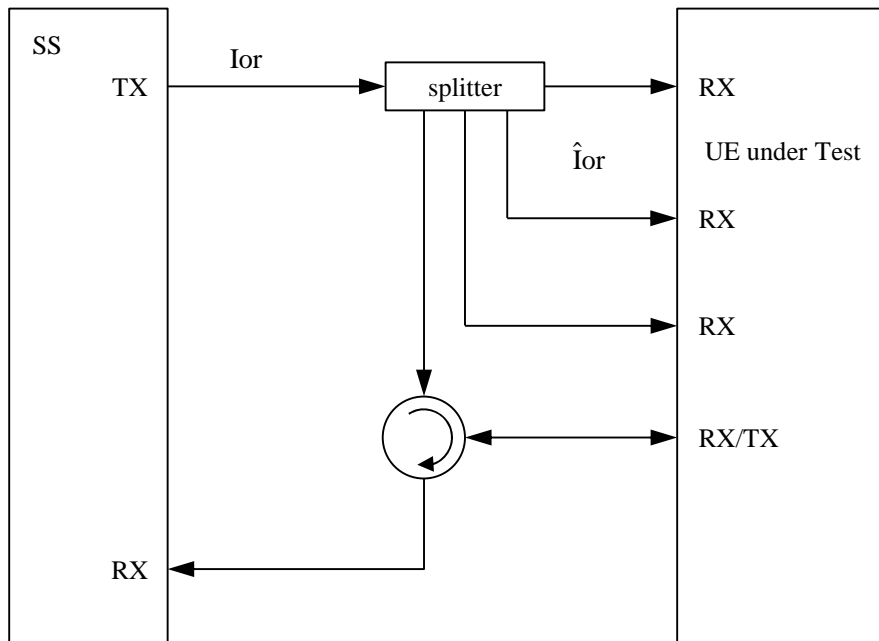

Figure A.69: Connection for Receiver test with 4 Rx antenna ports

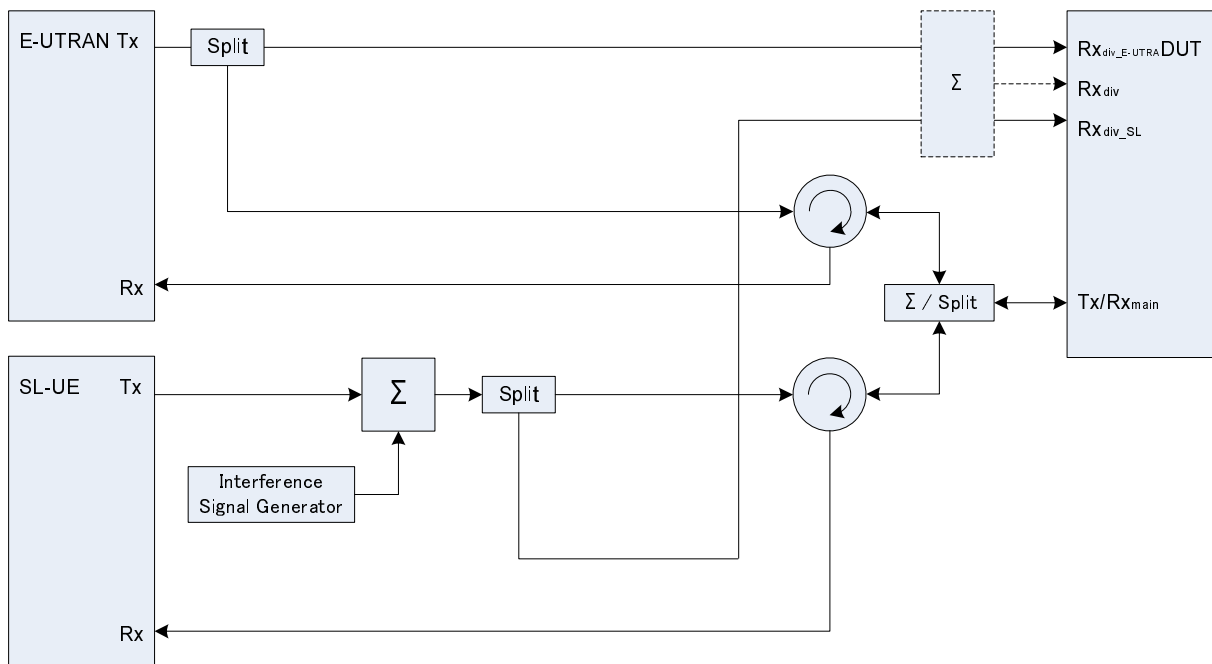

Figure A.70: Connection for Sidelink Receiver tests with E-UTRA-Interference

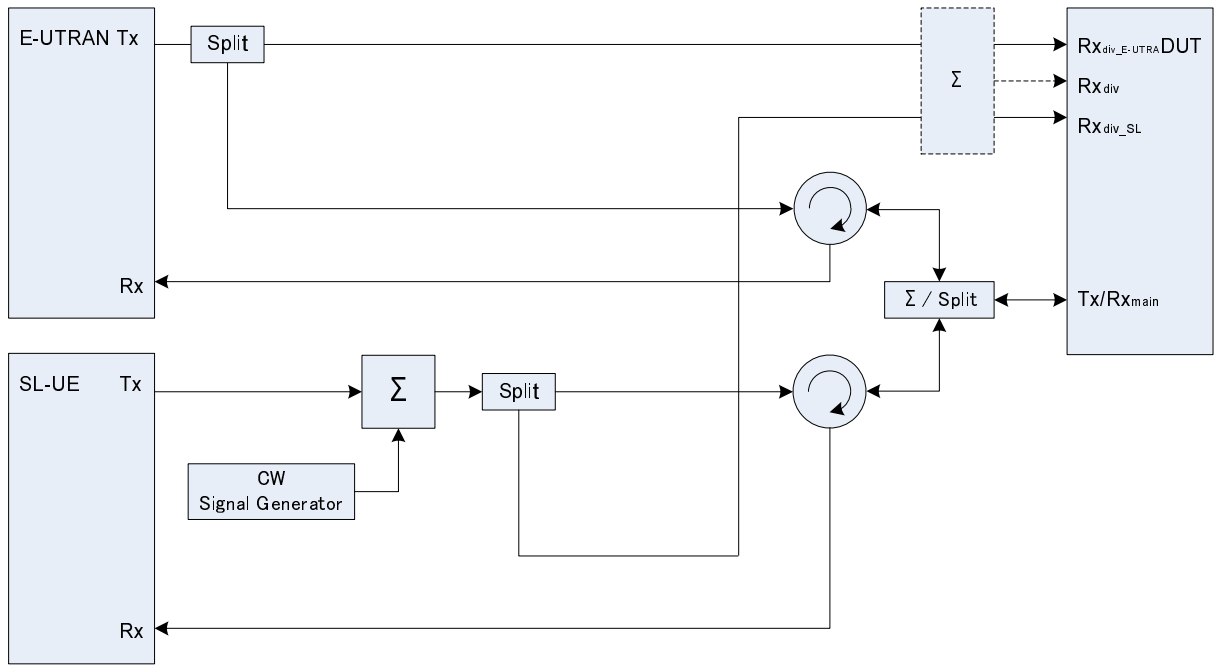

Figure A.71: Connection for Sidelink Receiver tests with CW interferer

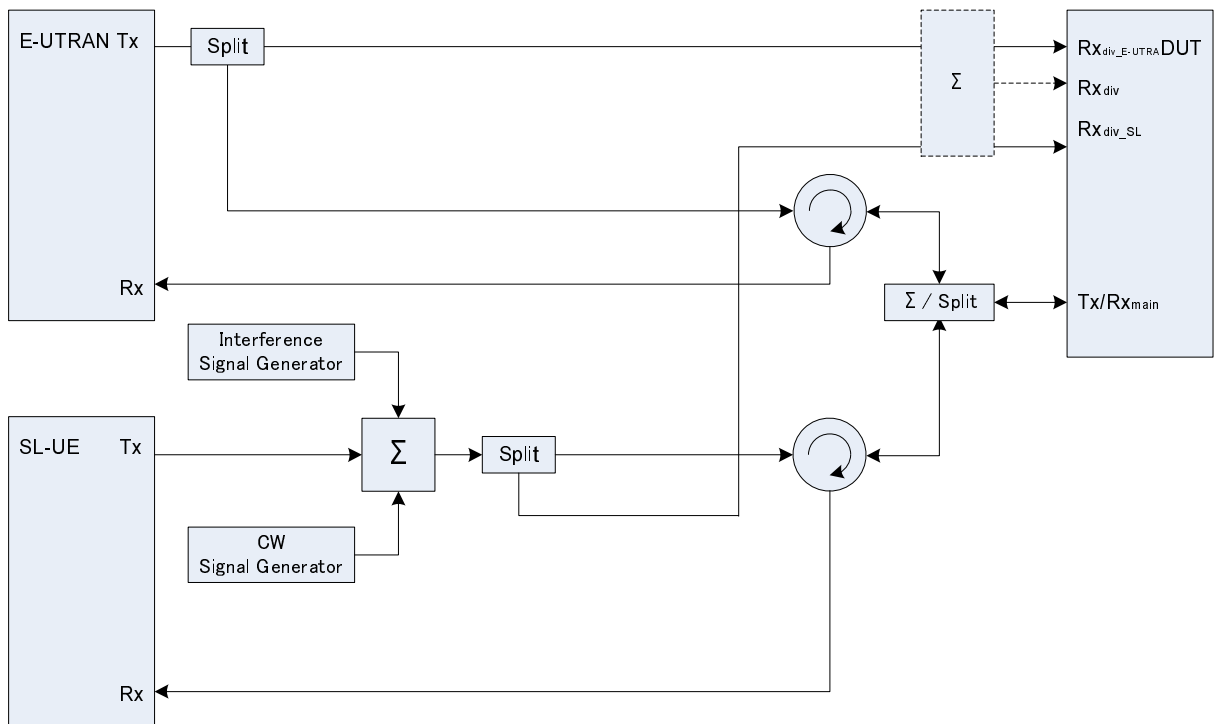

Figure A.72: Connection for Sidelink Receiver tests with both E-UTRA Interference and additional CW interferer

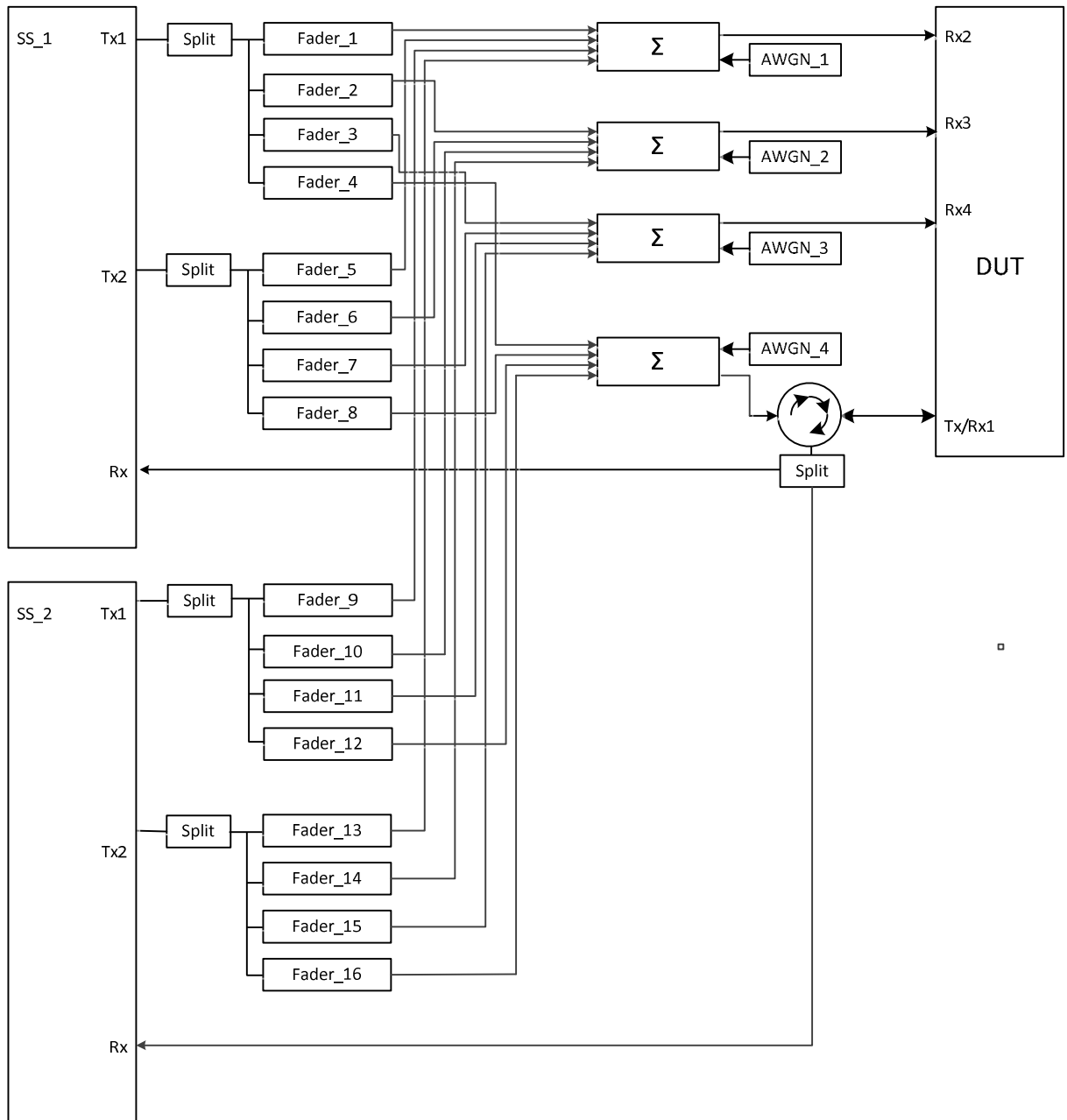

Figure A.73: Connection for 2 Cells (TPs) with antenna configuration 2x4 and fading

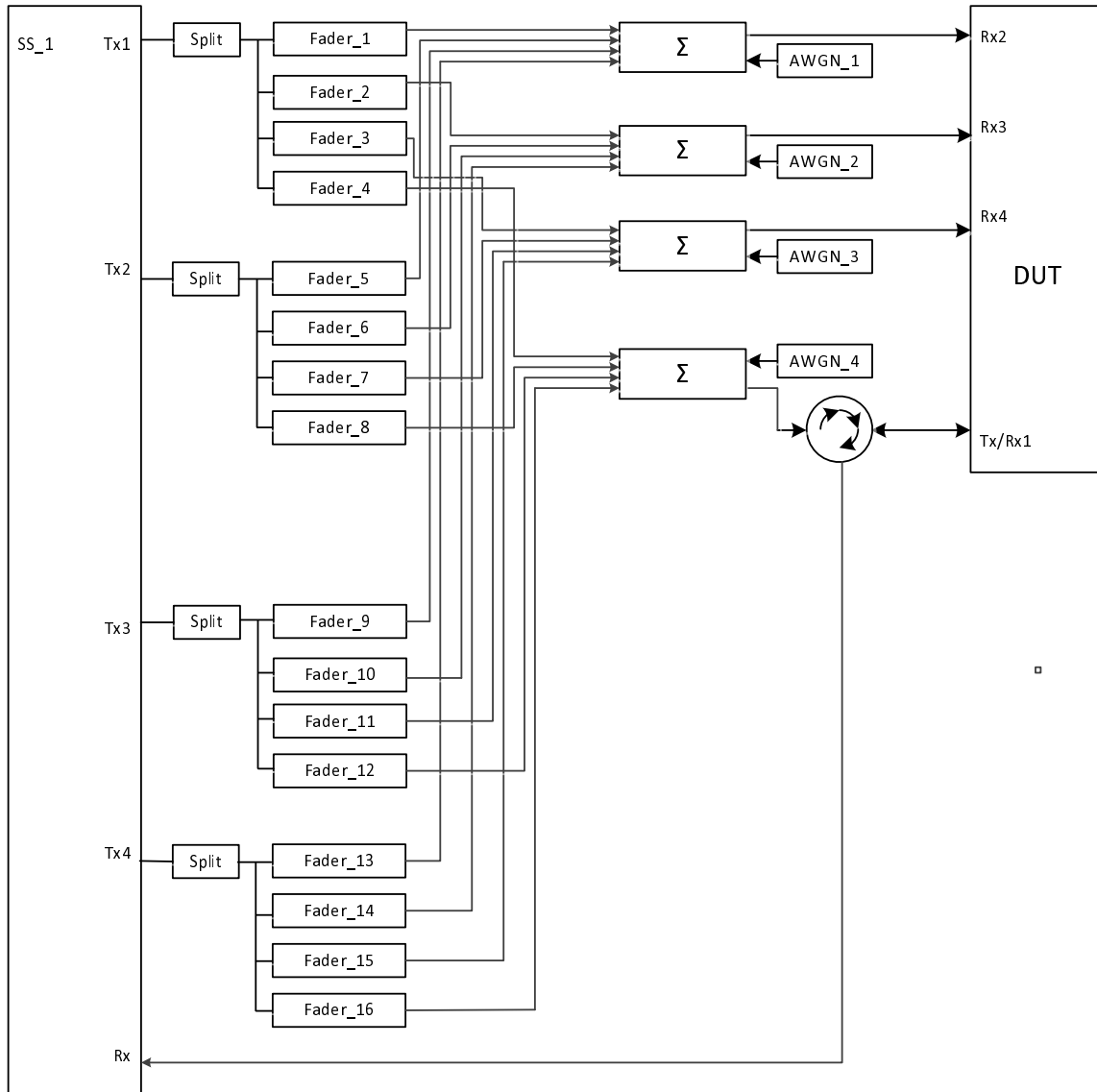

Figure A.74: Connection for RX performance tests with antenna configuration 4x4

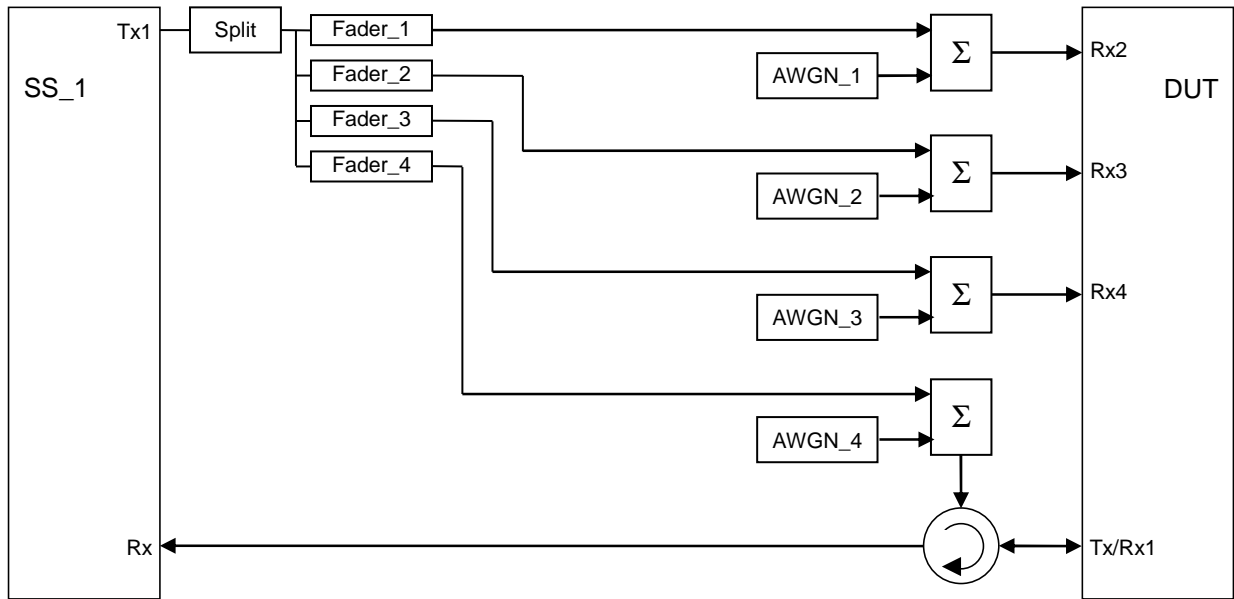

Figure A.75: Connection for RX performance tests with antenna configuration 1x4

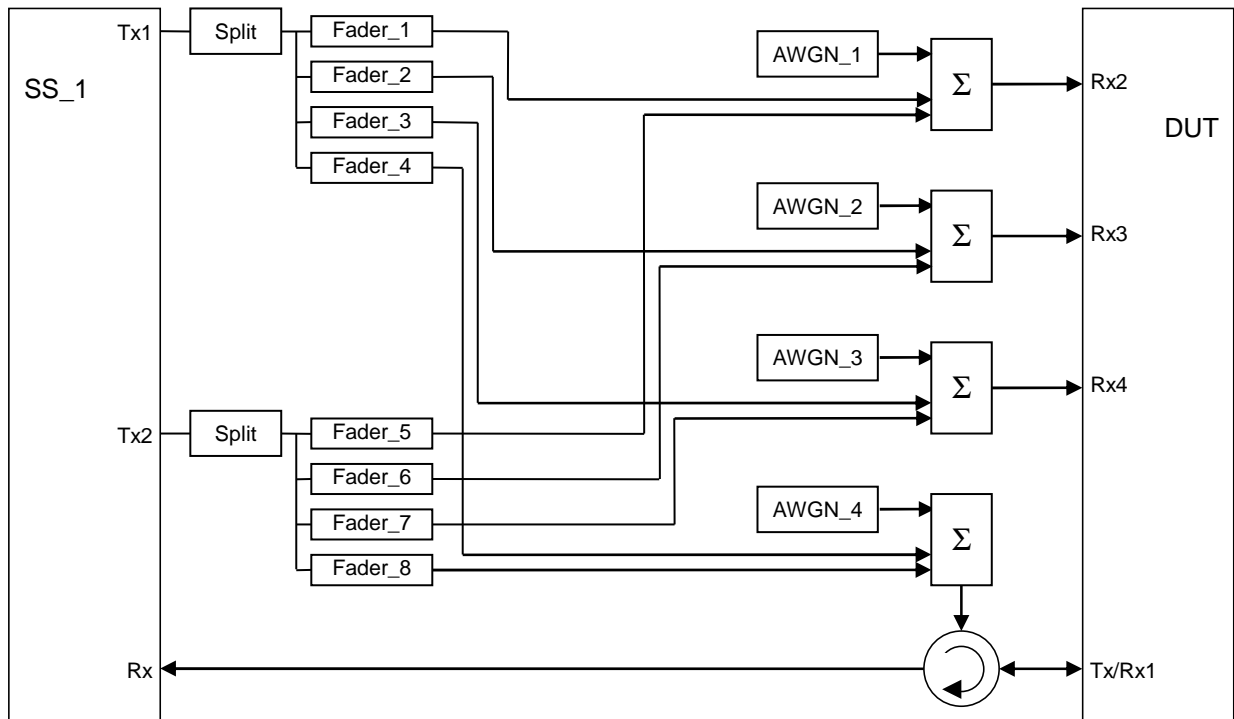

Figure A.76: Connection for RX performance tests with antenna configuration 2x4

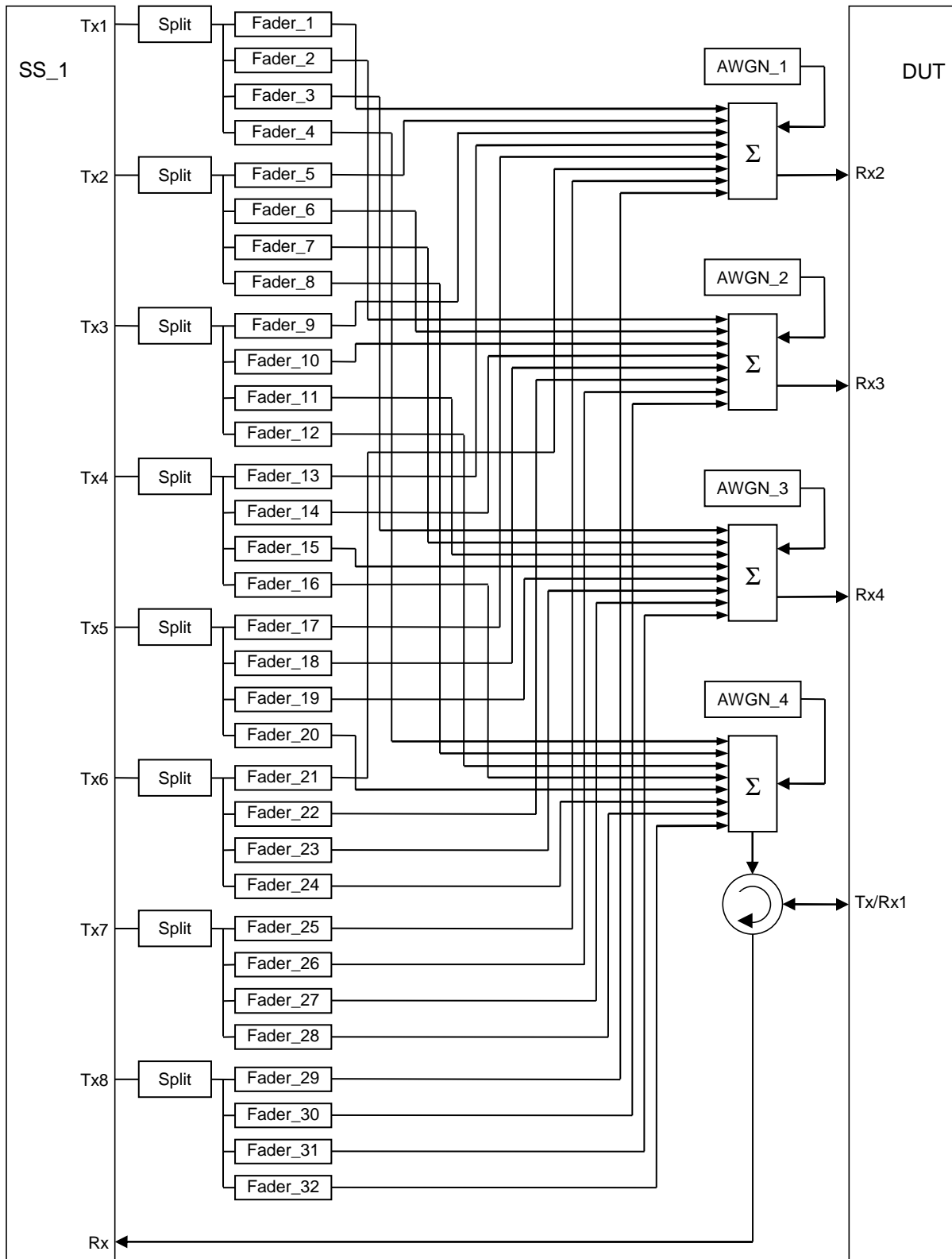

Figure A.77: Connection for RX performance tests with antenna configuration 8x4

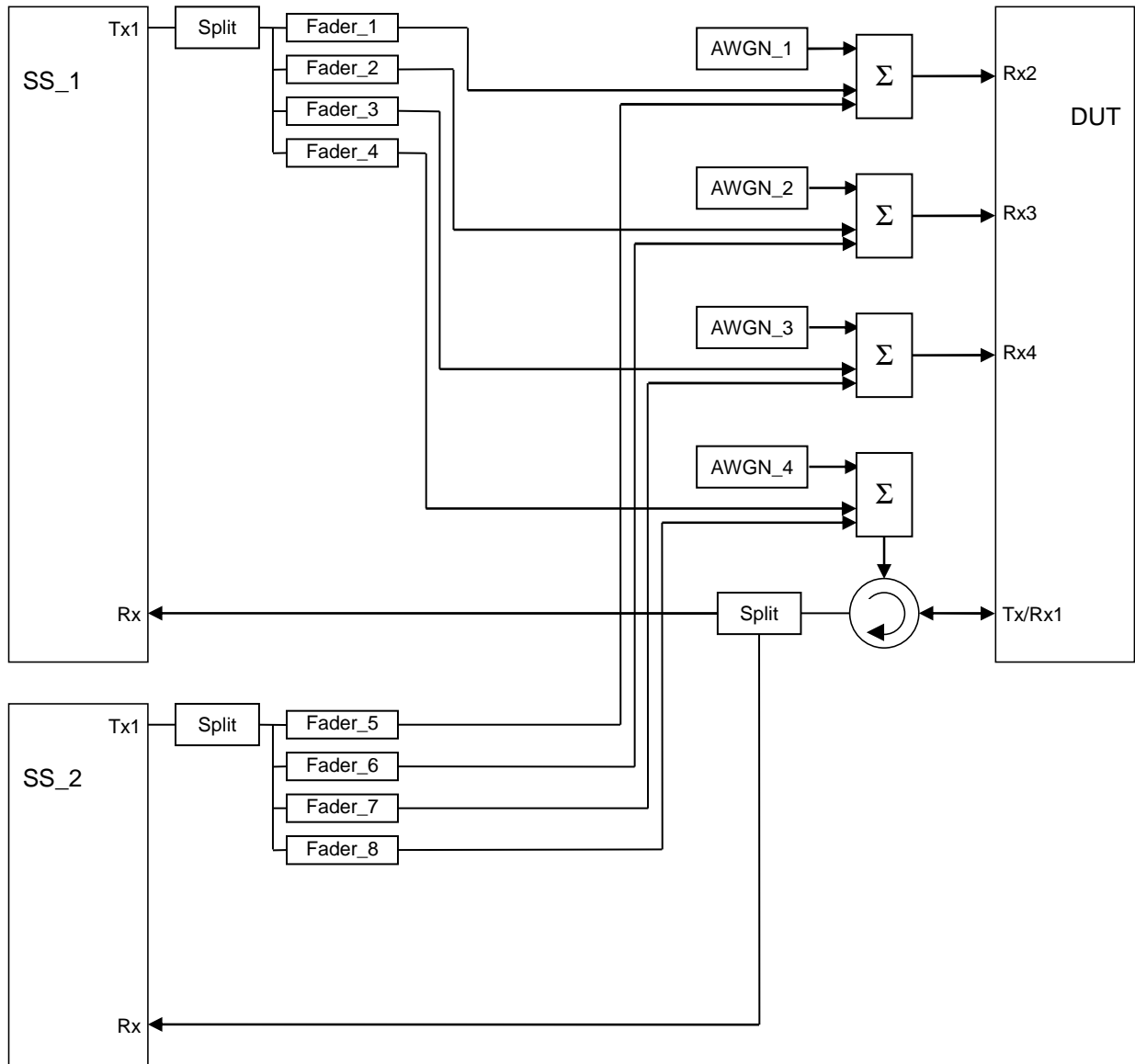

Figure A.78: Connection for 2 Cells (TPs) with antenna configuration 1x4 and fading

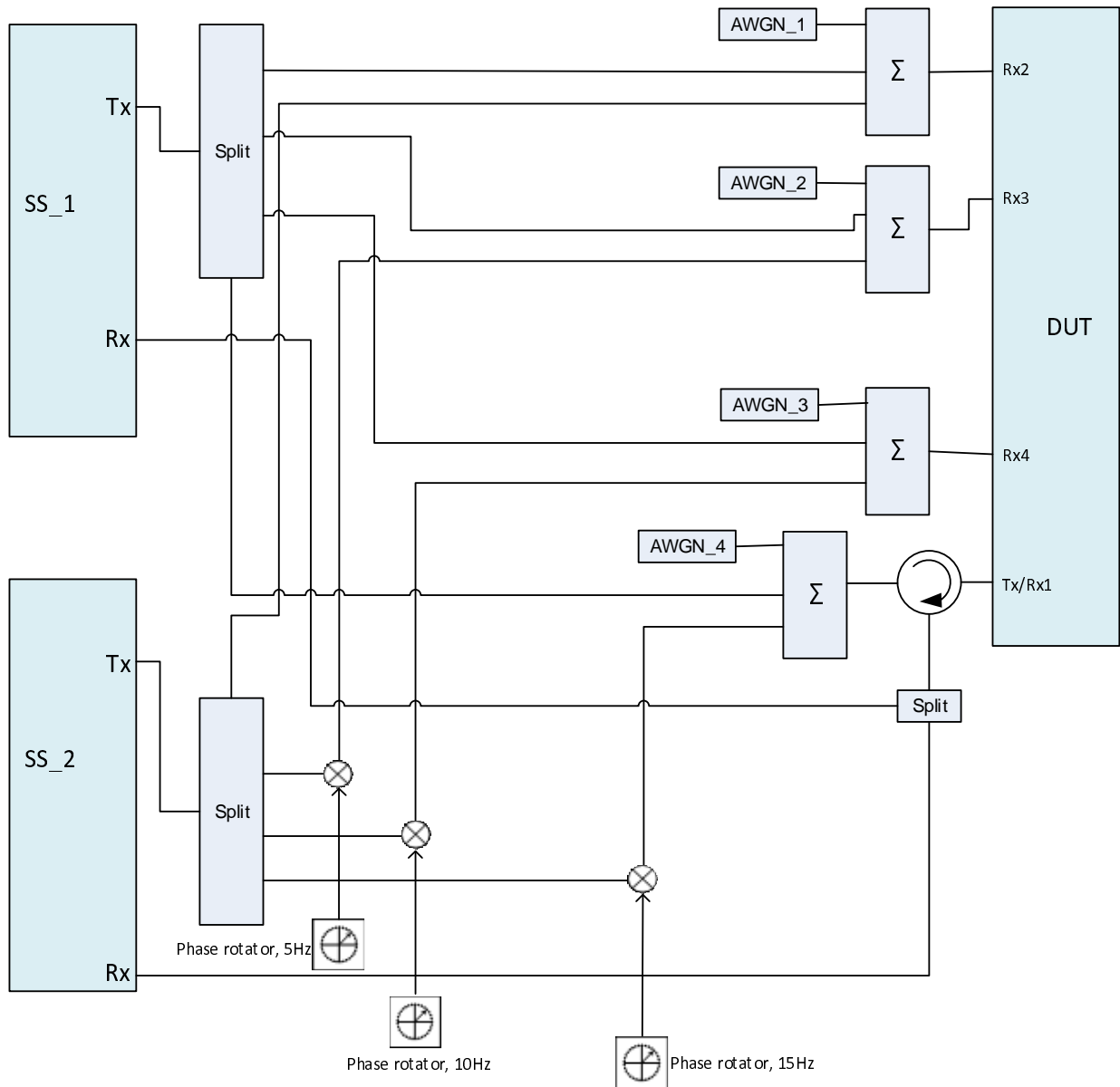

Figure A.78a: Connection for 2 Cells (TPs) with antenna configuration 1x4 and phase rotators (The frequency offset used in the phase rotators is 5, 10 and 15 Hz respectively)

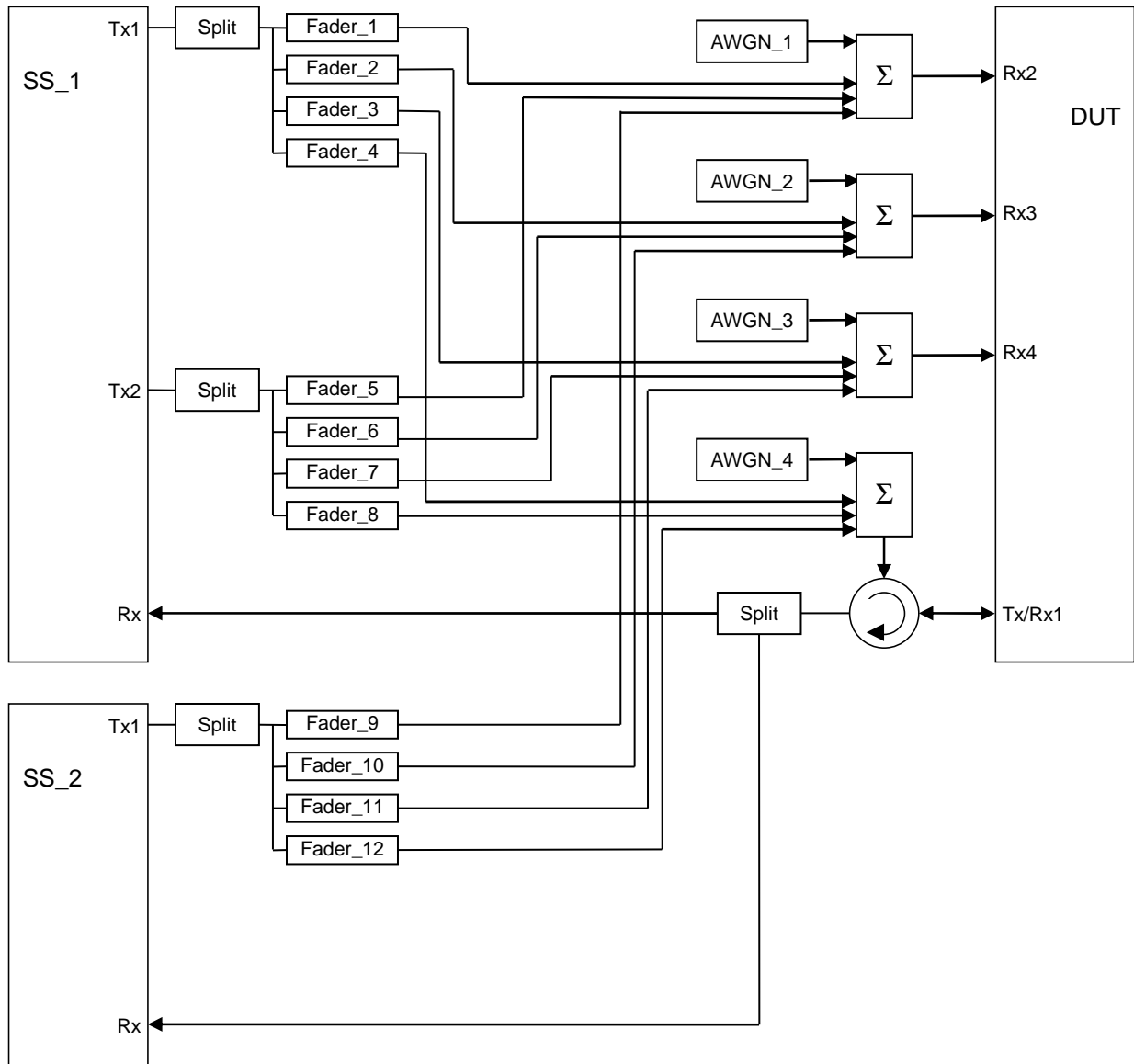

Figure A.79: Connection for 2 Cells (TPs) with antenna configuration 2x4 / 1x4 and fading

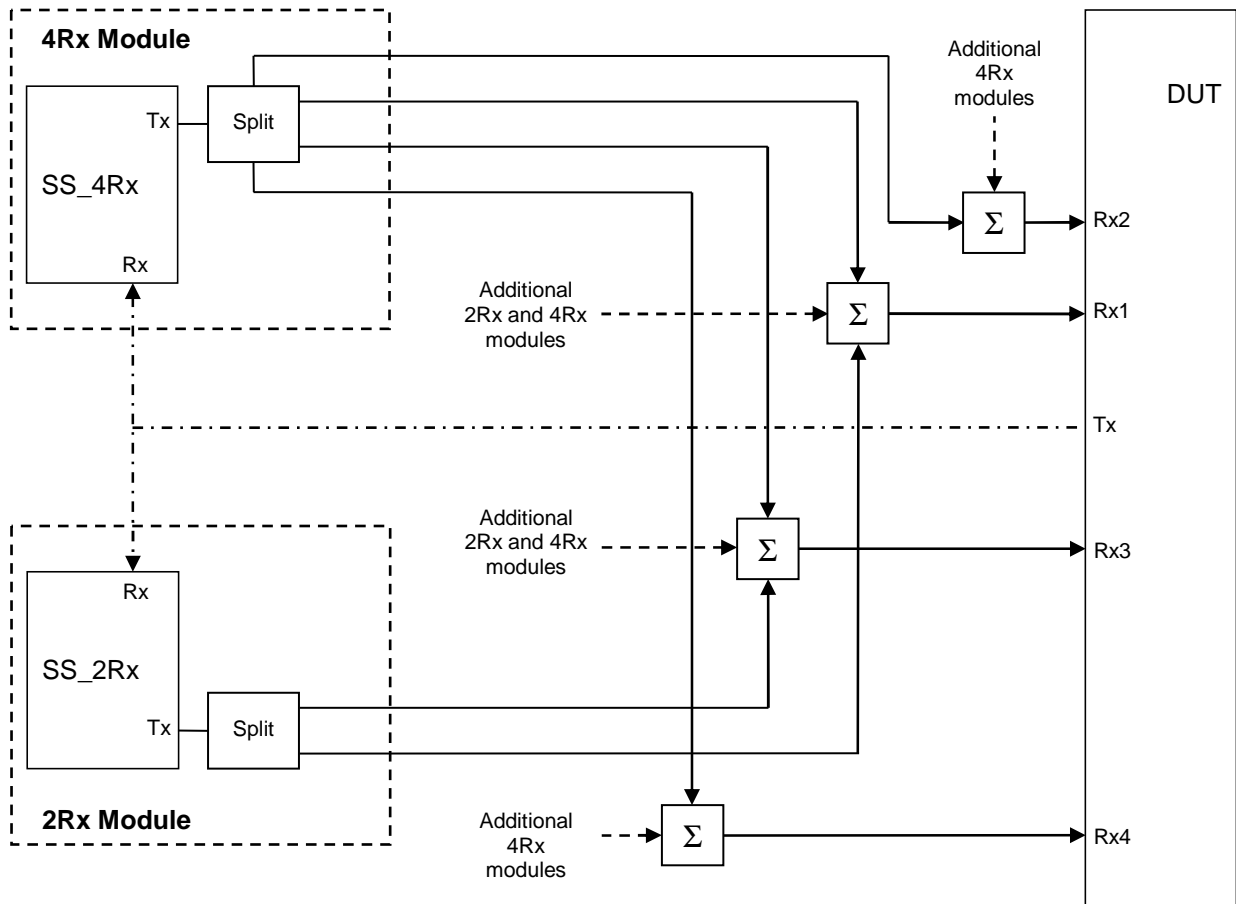

Figure A.80: Connection to enable Receiver tests for CA on a 4Rx-capable UE with CCs on both 4Rx-supported RF bands and 2Rx-supported RF bands

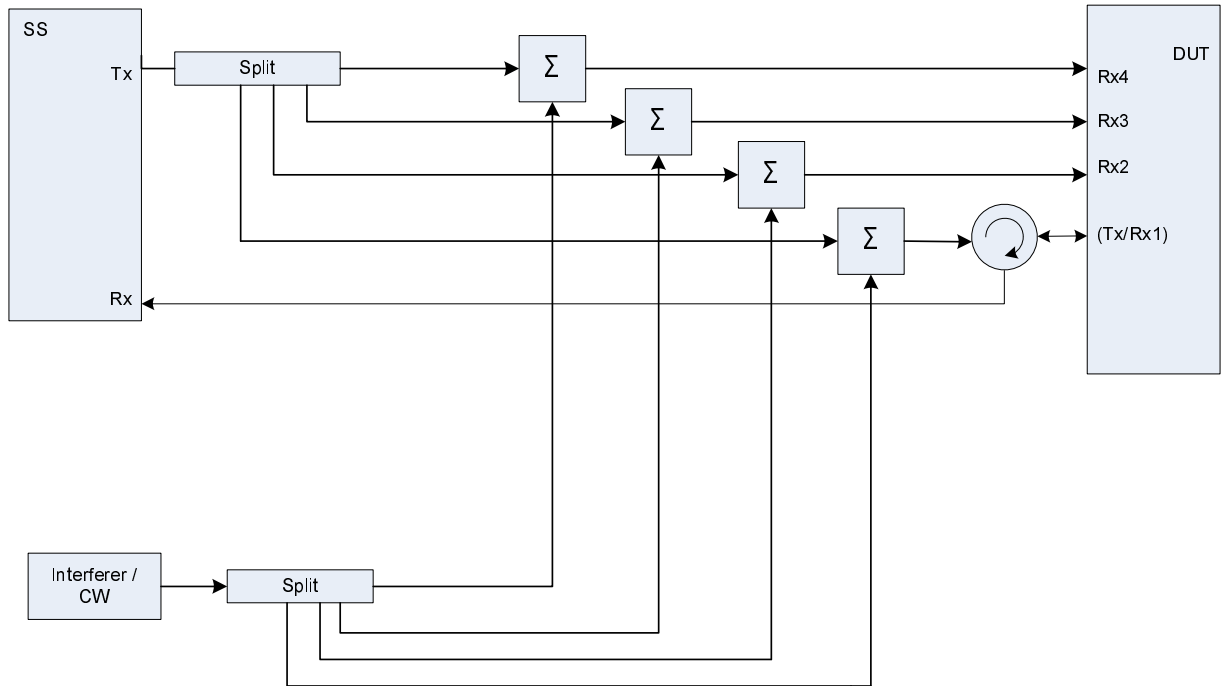

Figure A.81: Connection for Receiver tests with interferer(s) and 4 Rx antenna ports

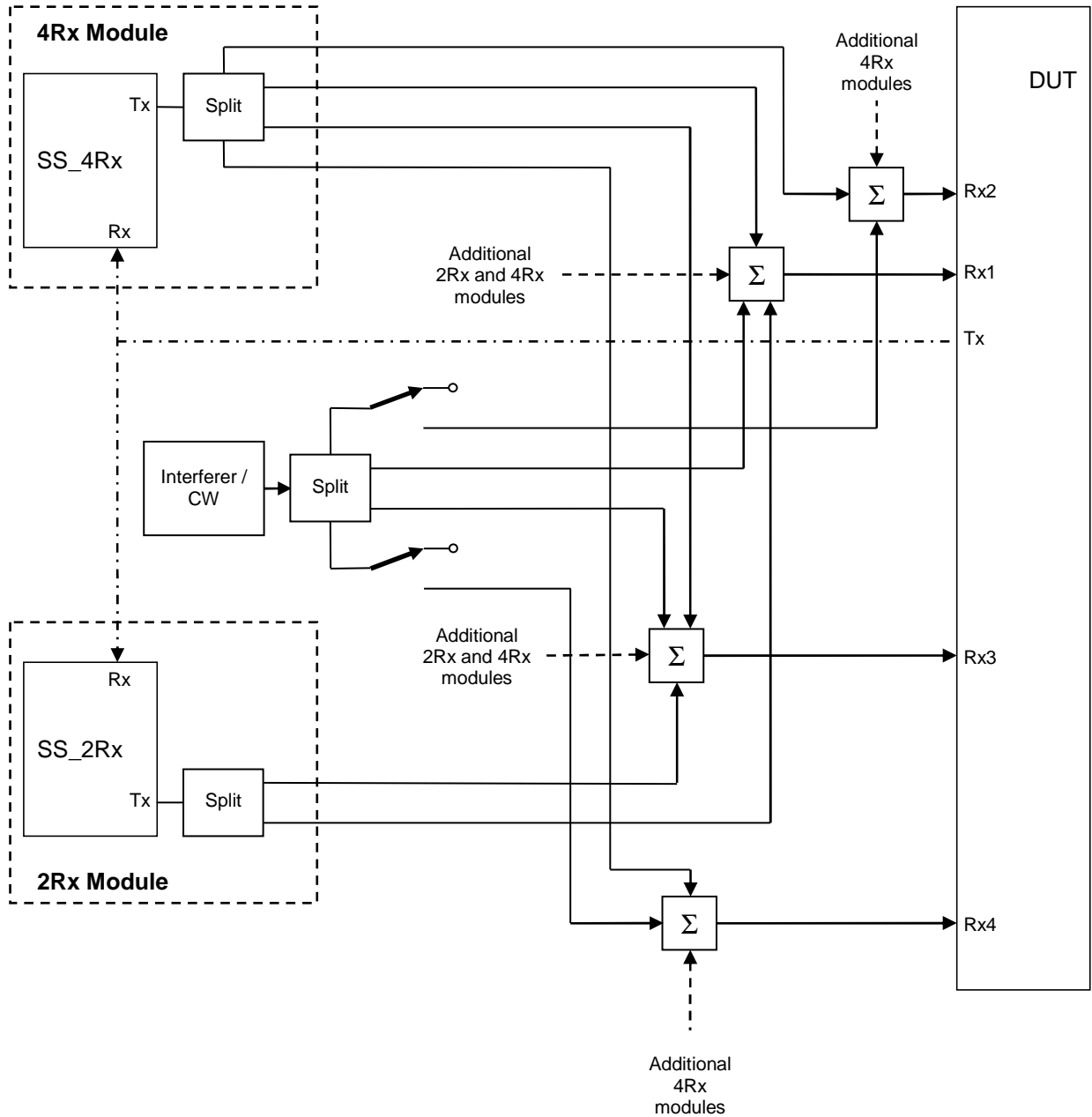

Figure A.82: Connection to enable Receiver tests for CA with additional Interferer on a 4Rx-capable UE with CCs on both 4Rx-supported RF bands and 2Rx-supported RF bands

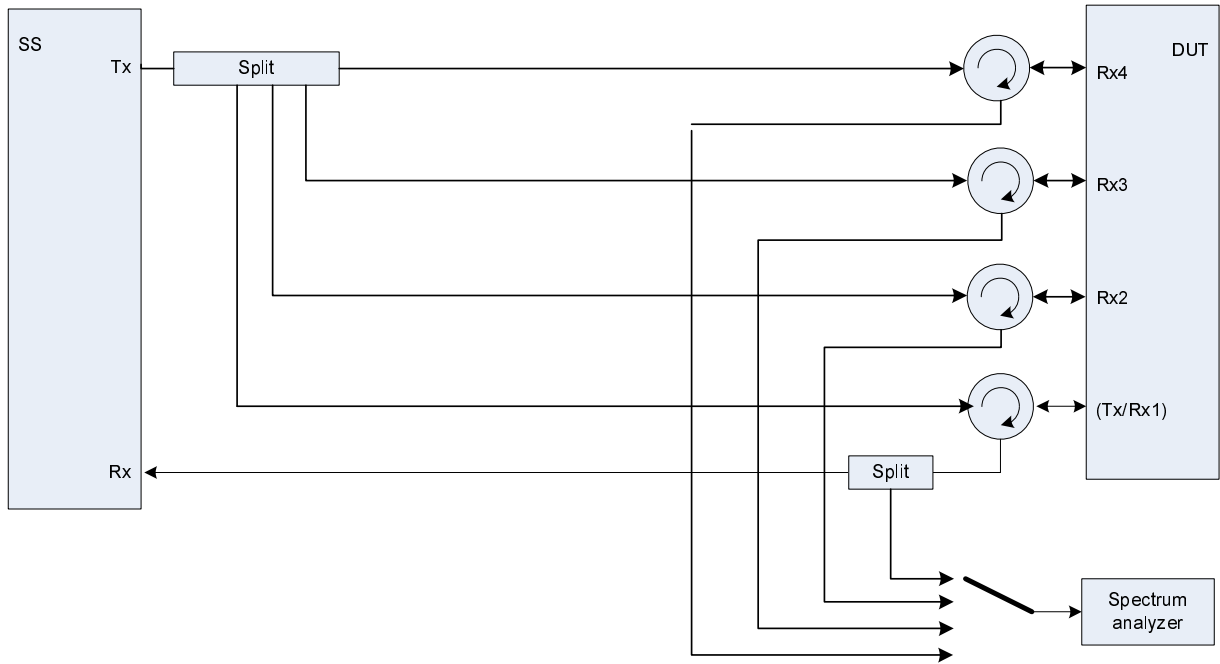

Figure A.83: Connection for Receiver tests with 4 Rx antenna ports and additional spectrum analyzer

Figure A.84: Void

Figure A.84a: Void

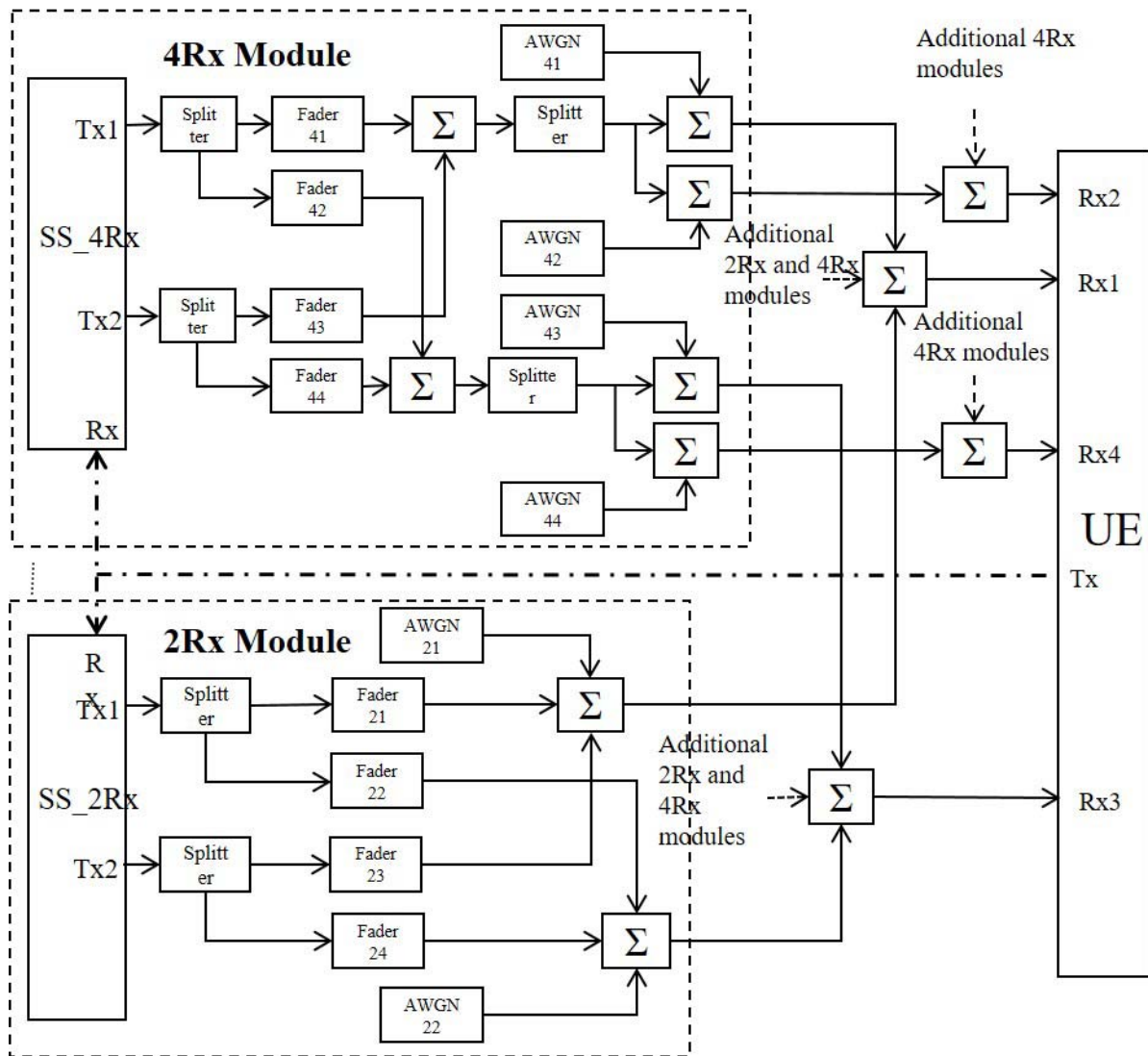

Figure A.85: Connection Diagram to enable Carrier Aggregation tests (with 2x2 channel) on a 4Rx-capable UE with CCs on both 4Rx-supported RF bands and 2Rx-supported bands

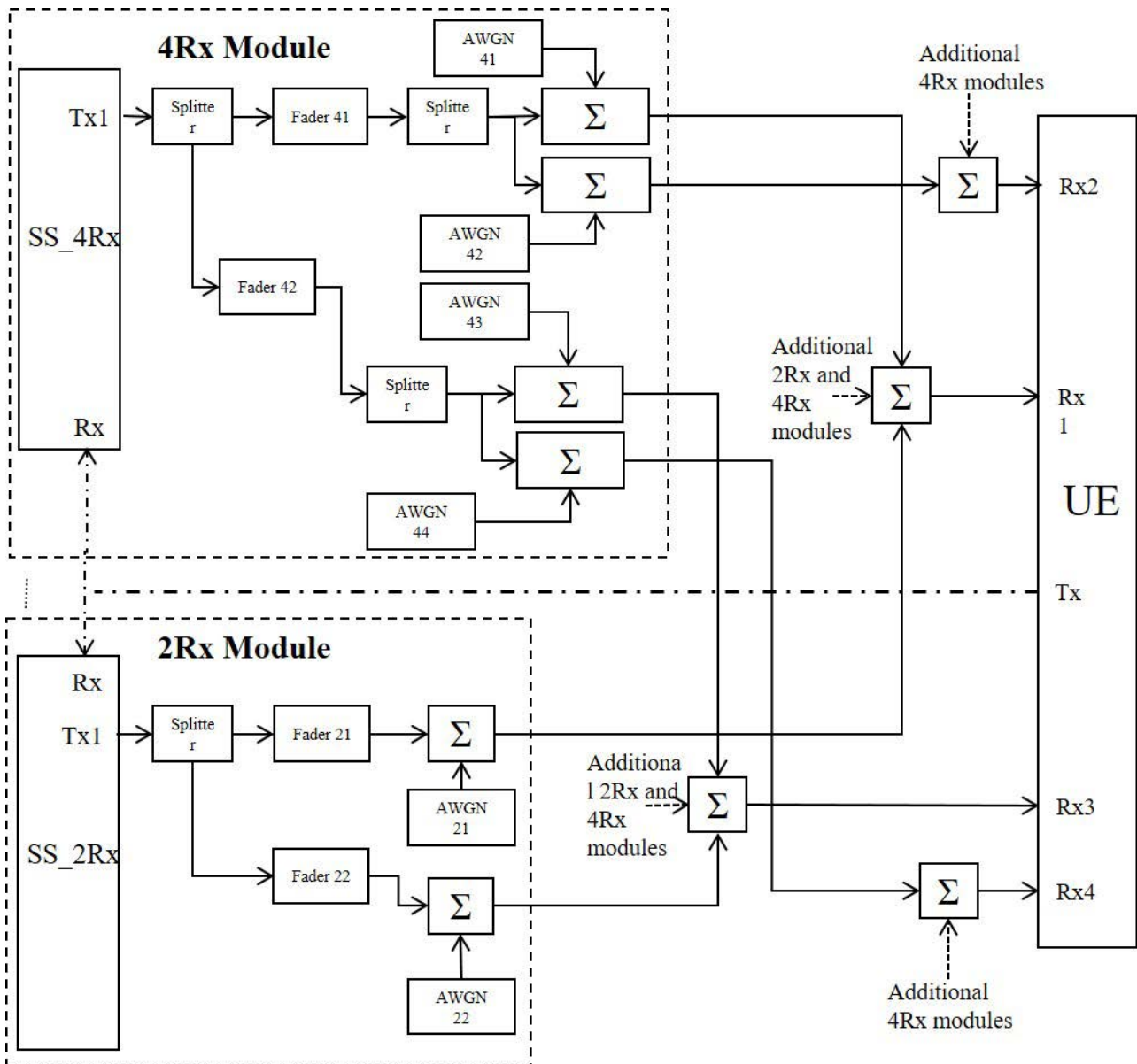

Figure A.86: Connection Diagram to enable Carrier Aggregation tests (with 1x2 channel) on a 4Rx-capable UE with CCs on both 4Rx-supported RF bands and 2Rx-supported bands

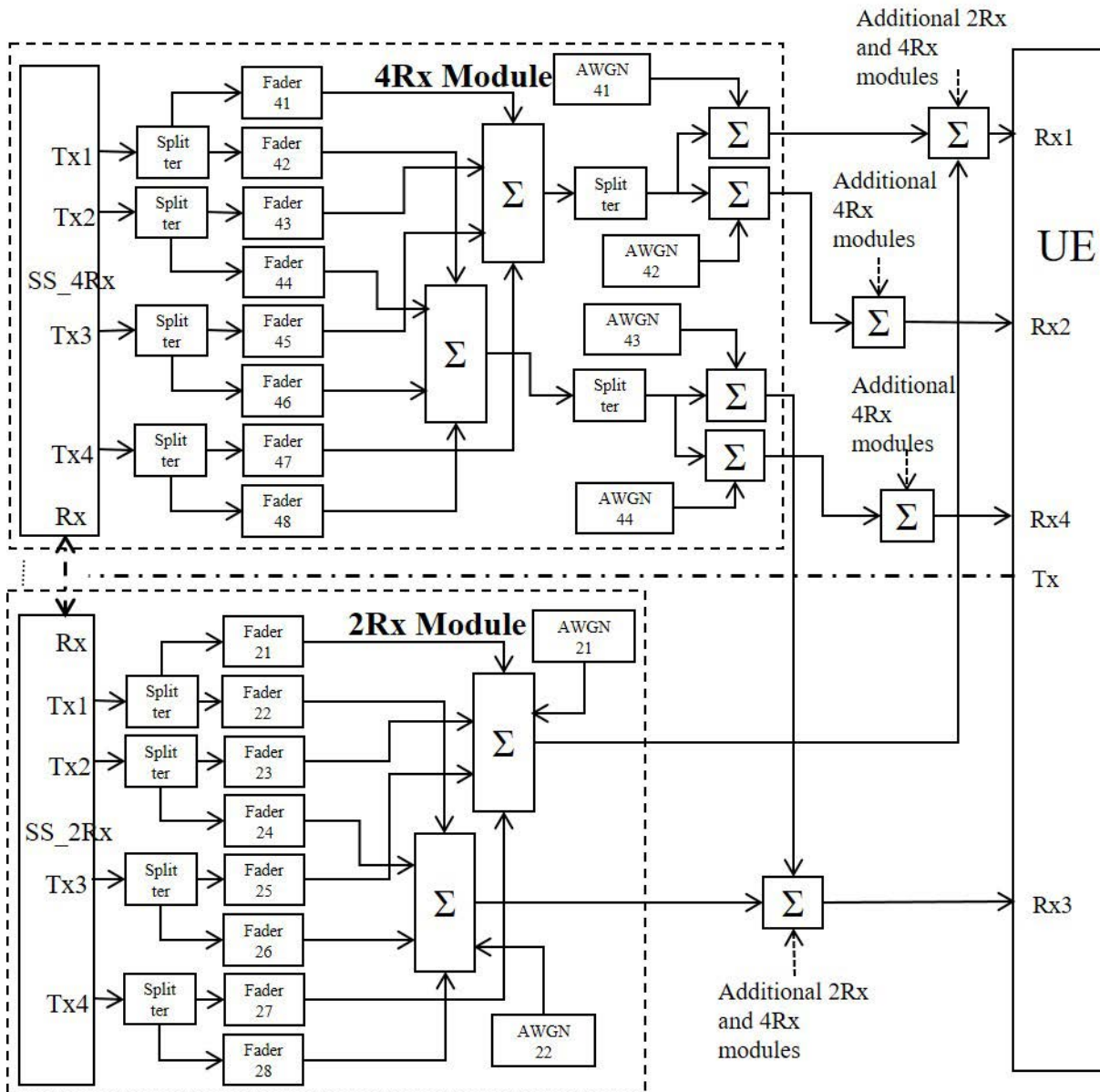

Figure A.87: Connection Diagram to enable Carrier Aggregation tests (with 4x2 channel) on a 4Rx-capable UE with CCs on both 4Rx-supported RF bands and 2Rx-supported bands

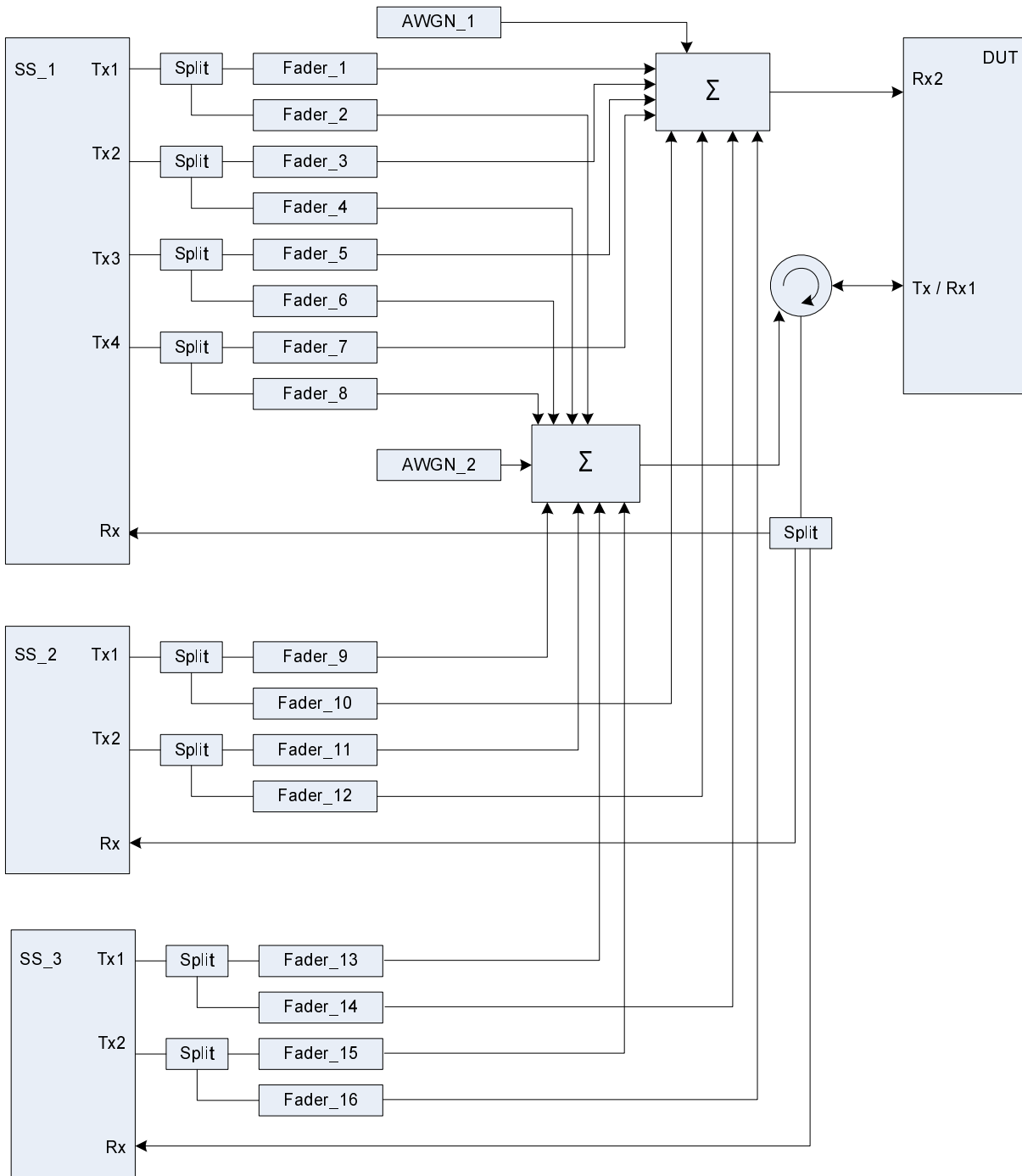

Figure A.88: Connection for 3 Cells (TPs) with antenna configuration 4x2 / 2x2 / 2x2 and fading

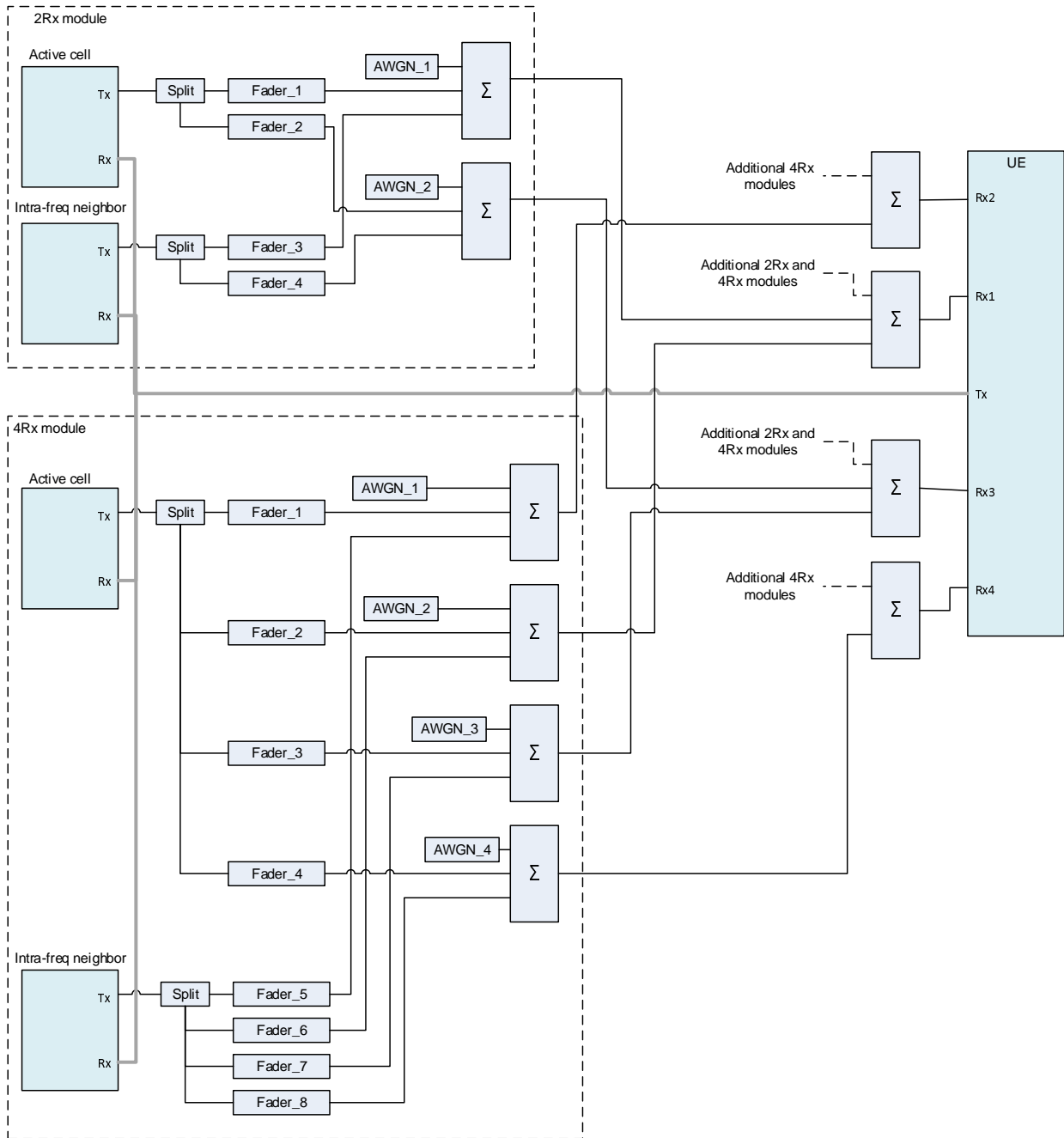

Figure A.89: Connection for CA with Fading and additional intra-frequency cell for 4Rx antenna ports

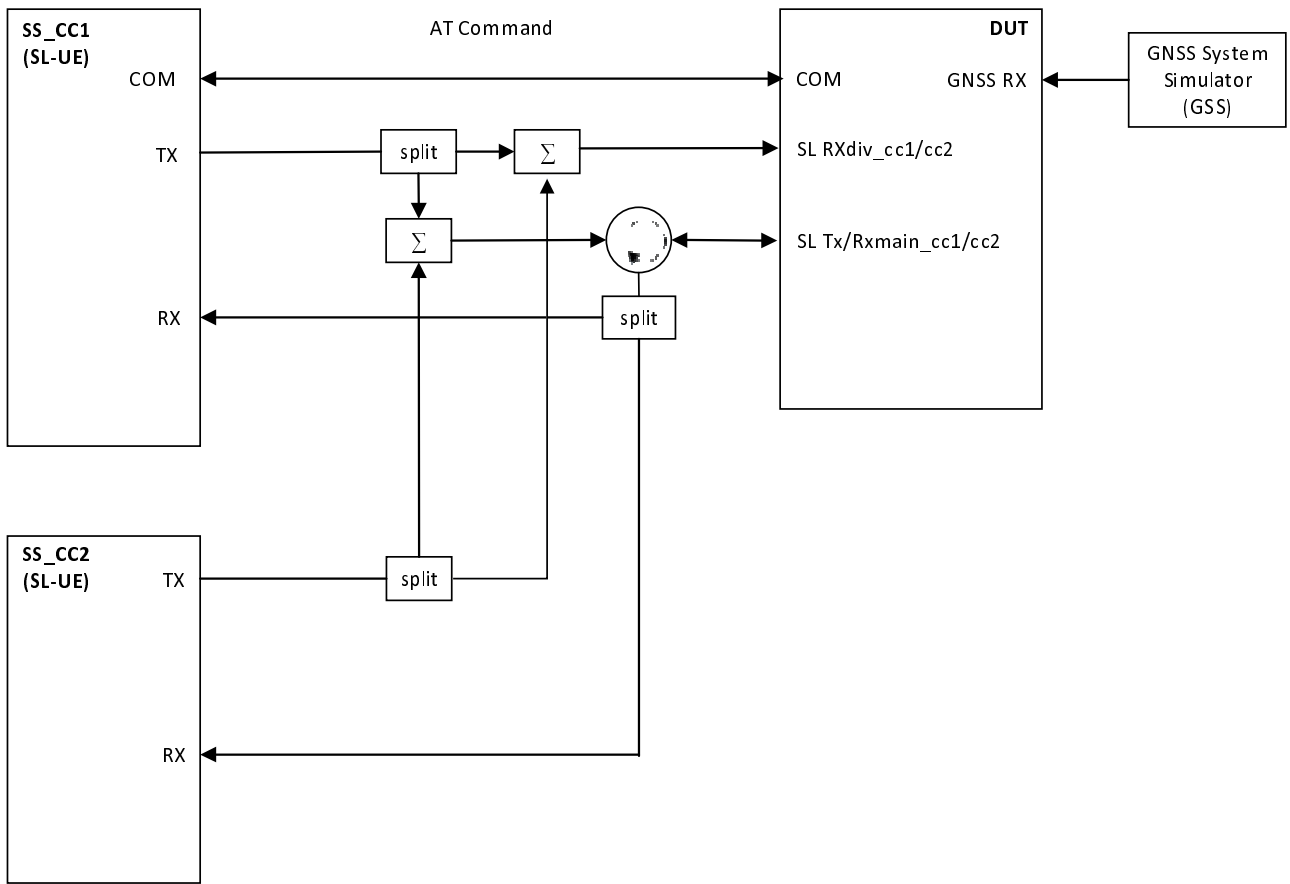

Figure A.89a: Connection for V2X Communication / Intra-band contiguous multi-carrier operation (common connectors, same UL antenna)

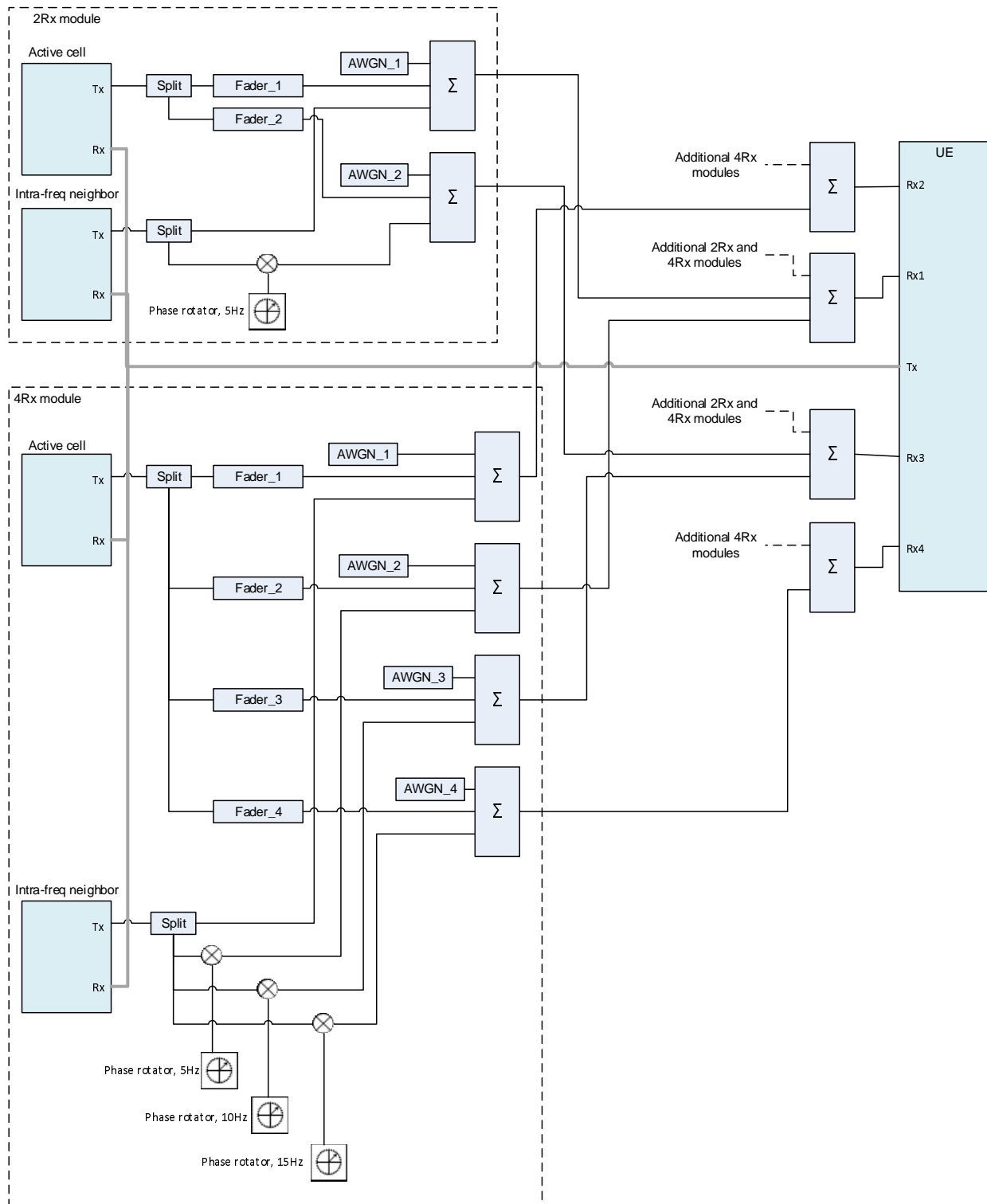

Figure A.90: Connection for CA with Fading and additional Static intra-frequency cell with phase rotators for 4Rx antenna ports

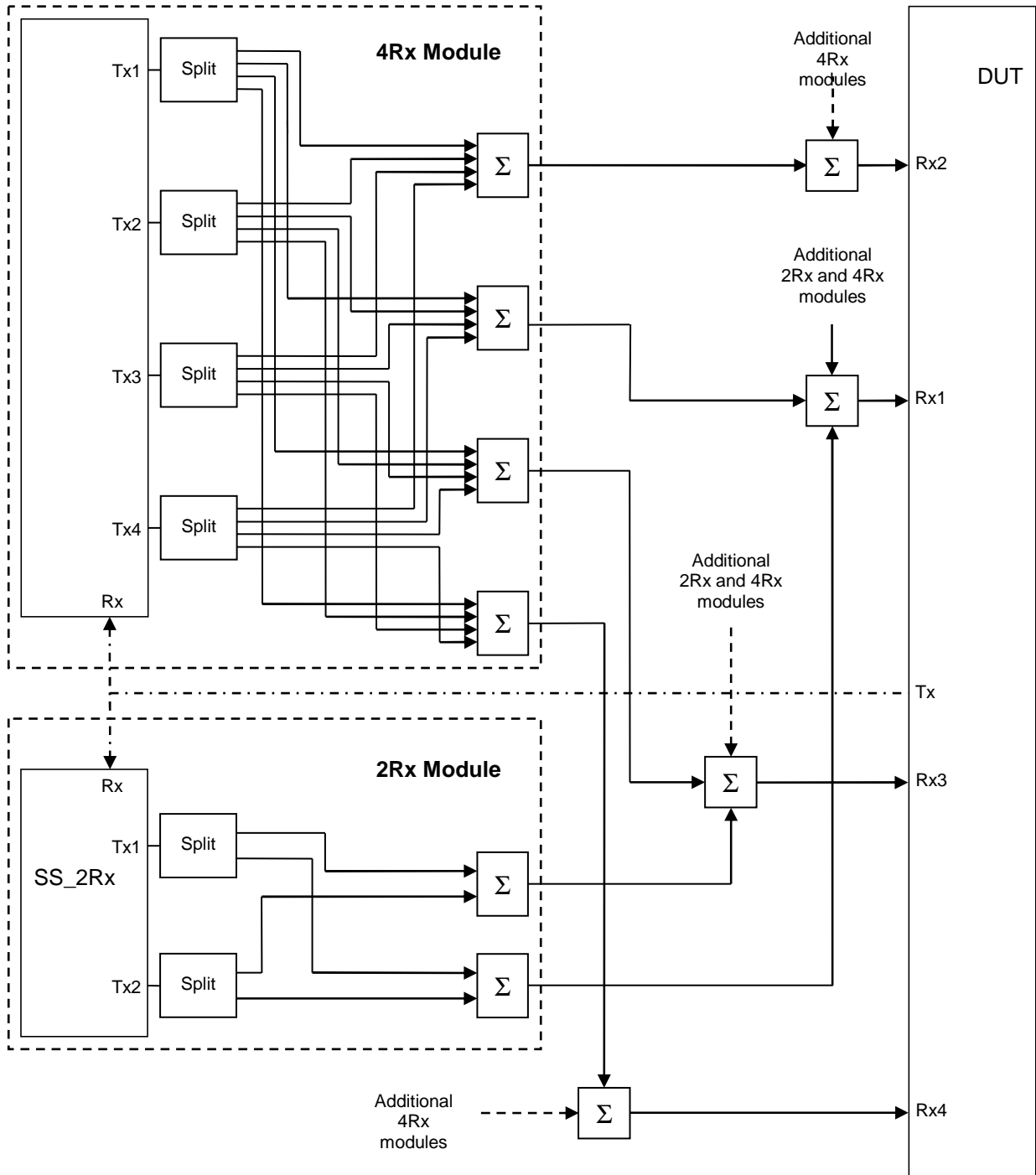

Figure A.91: Connection for CA SDR tests on a 4Rx-capable UE with CCs on both 4Rx-supported RF bands and 2Rx-supported RF bands

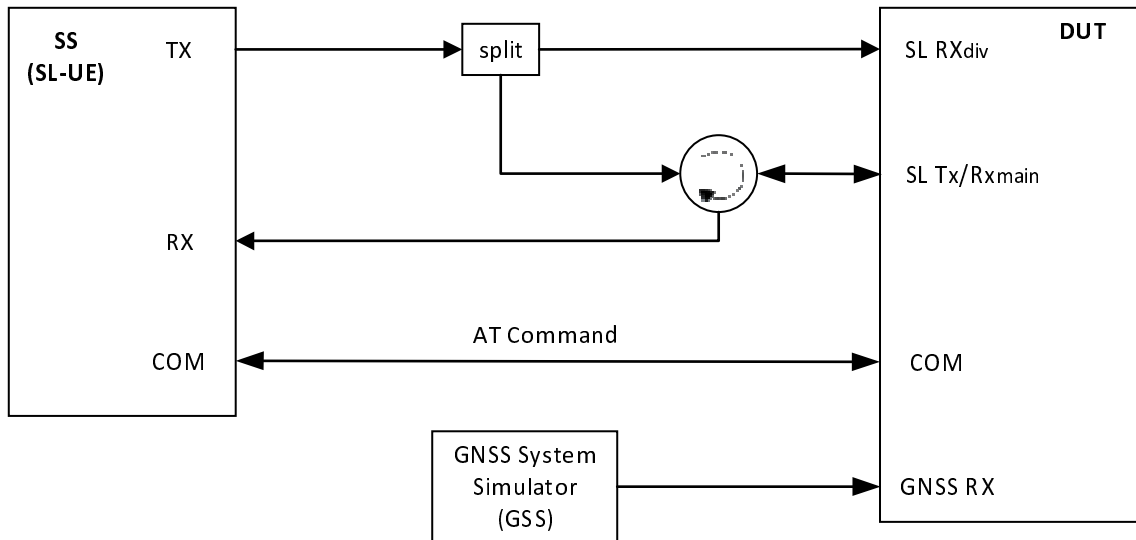

Figure A.92: Connection for basic Tx/Rx testing of V2X sidelink transmissions non-concurrent with E-UTRAN uplink transmissions

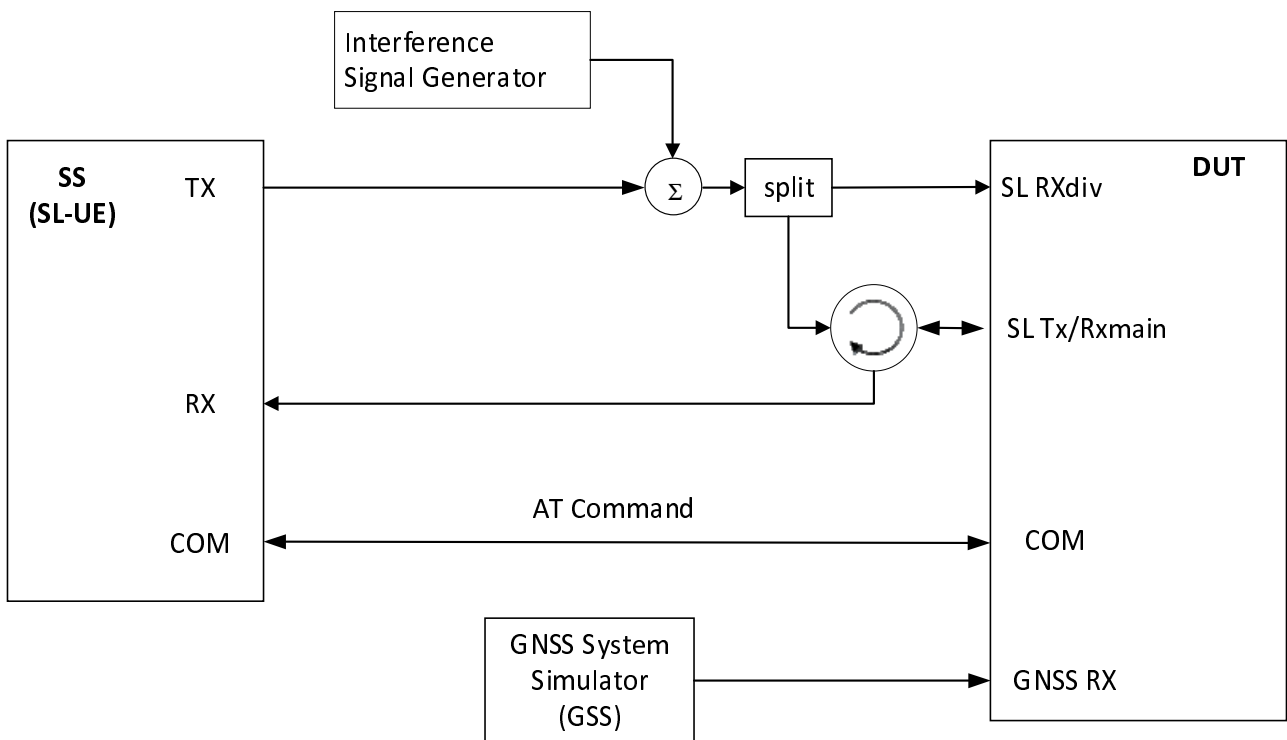

Figure A.92a: Connection for basic Tx/Rx testing of V2X sidelink transmissions non-concurrent with E-UTRAN uplink transmission with E-UTRA-Interference

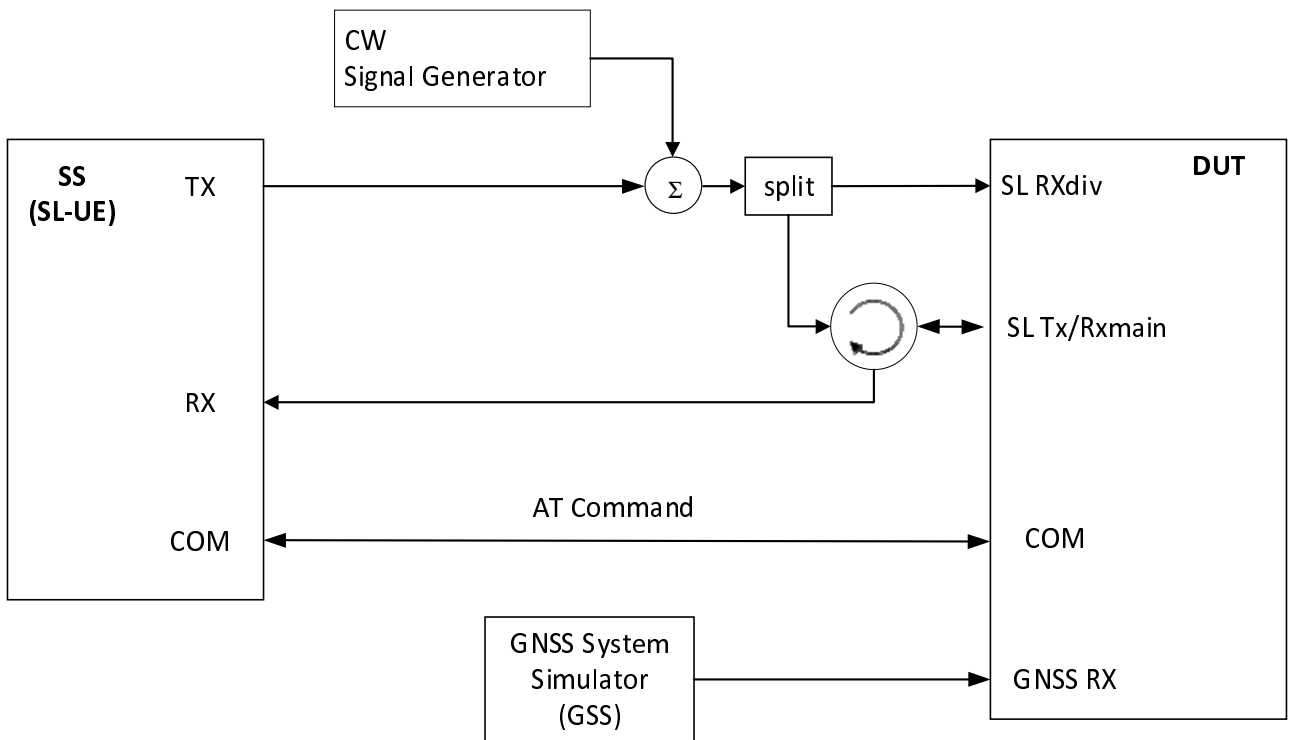

Figure A.92b: Connection for basic Tx/Rx testing of V2X sidelink transmissions non-concurrent with E-UTRAN uplink transmission with CW Interference

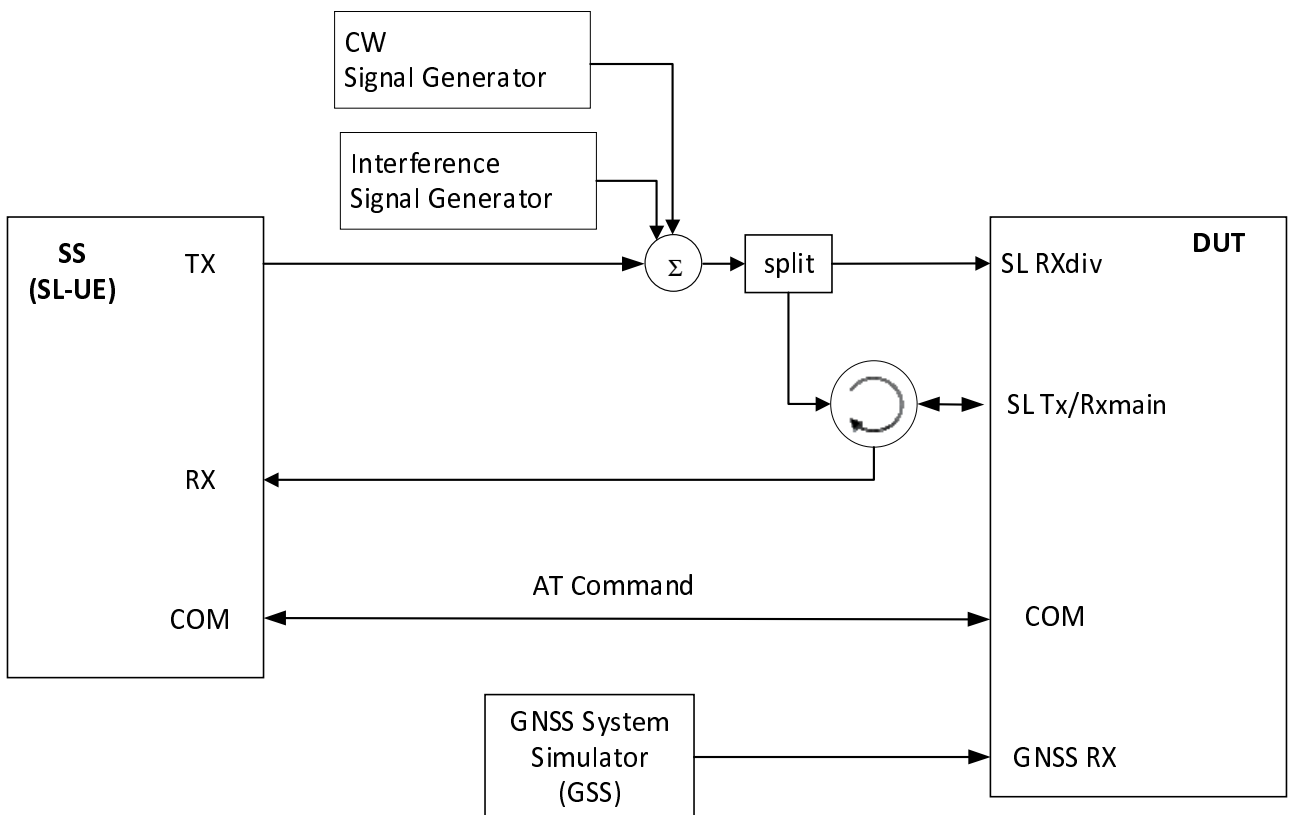

Figure A.92c: Connection for basic Tx/Rx testing of V2X sidelink transmissions non-concurrent with E-UTRAN uplink transmission with both E-UTRA Interference and additional CW signal

Figure A.93: Void

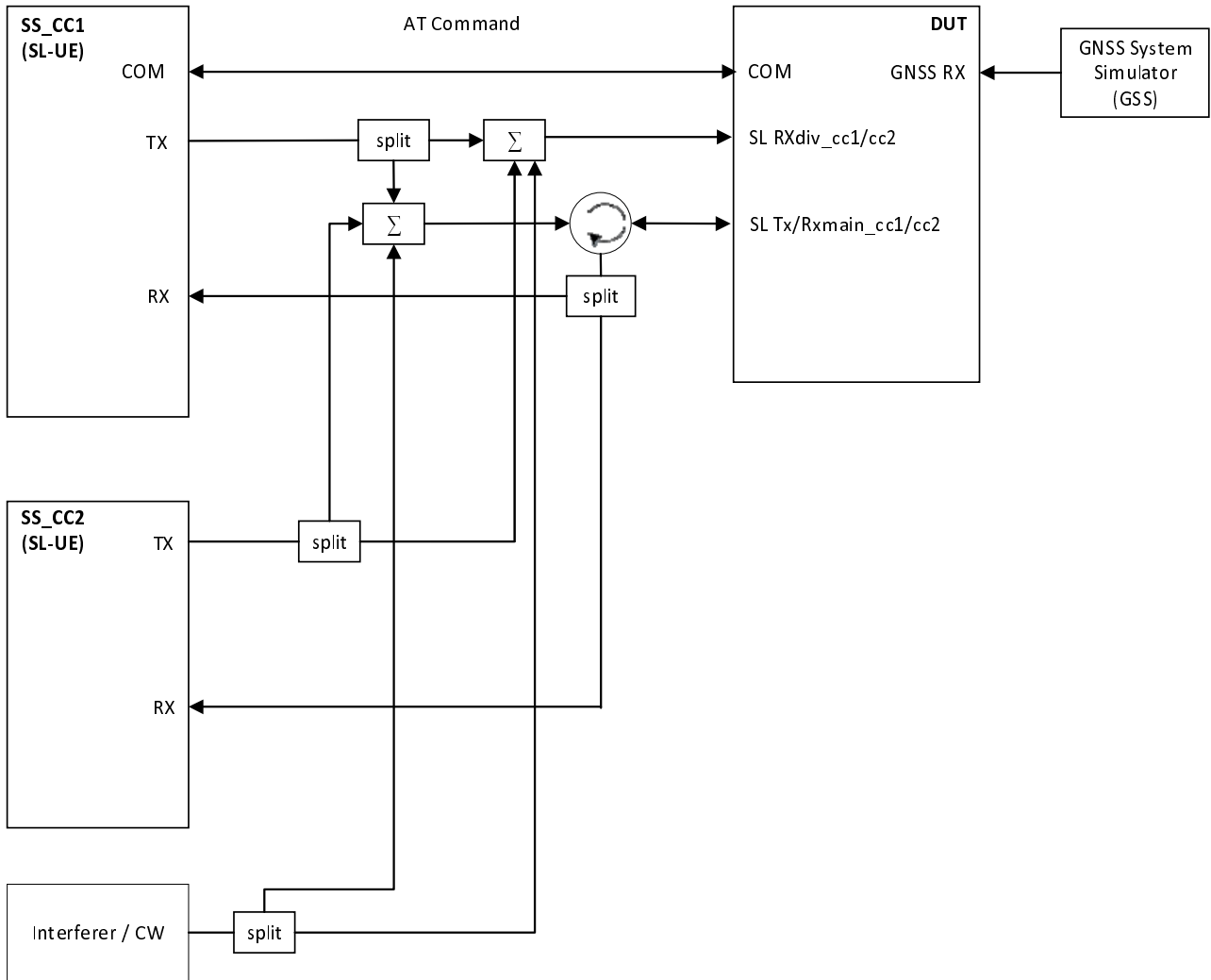

Figure A.92d: Connection for V2X Communication / Intra-band contiguous multi-carrier operation with additional Interferer / CW (common connectors, same UL antenna)

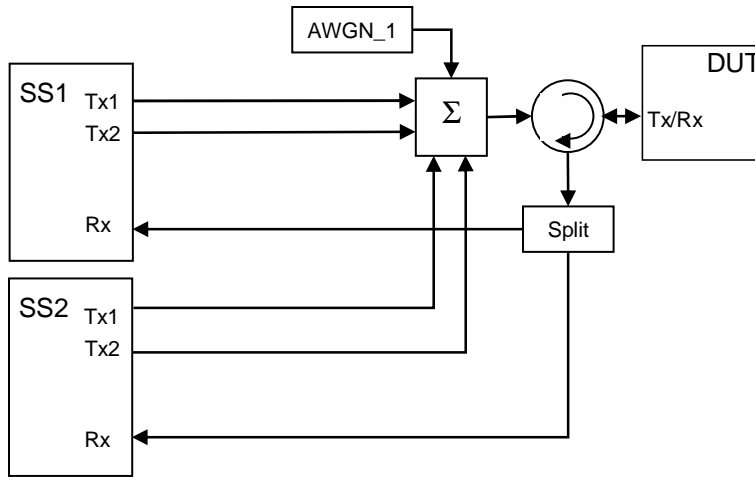

Figure A.93: Connection for RRM tests with antenna configuration 2x1 and 2 Cells

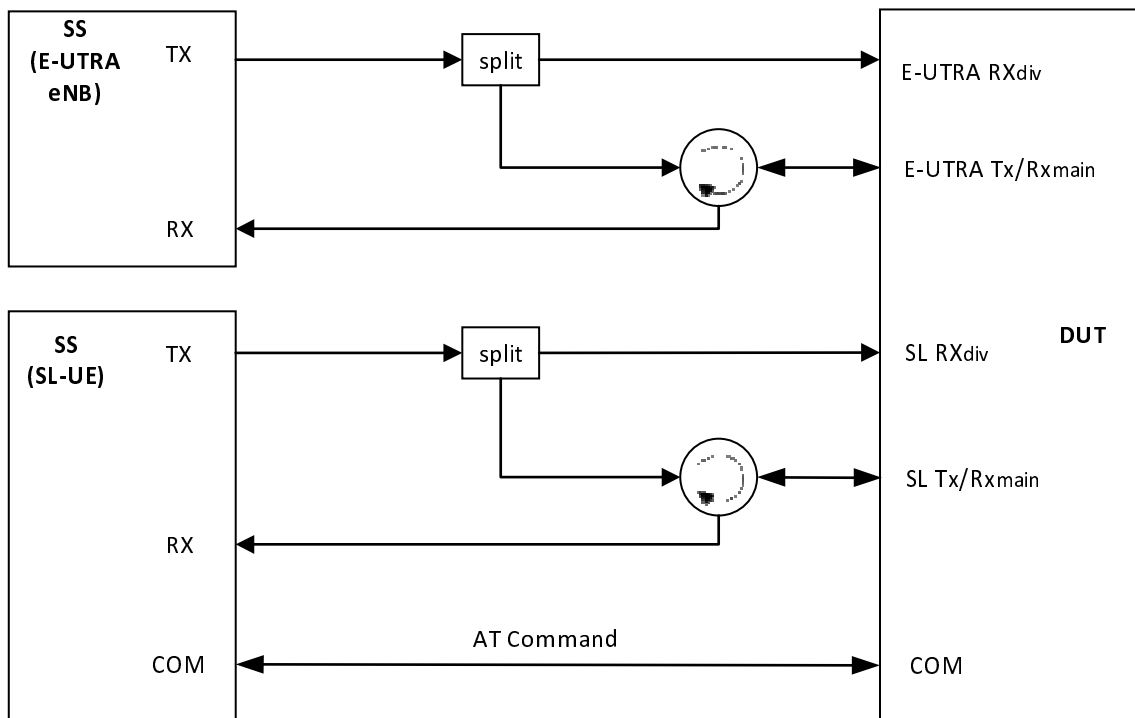

Figure A.93a: Connection for basic Tx/Rx testing of simultaneous E-UTRA V2X sidelink and E-UTRA uplink transmission

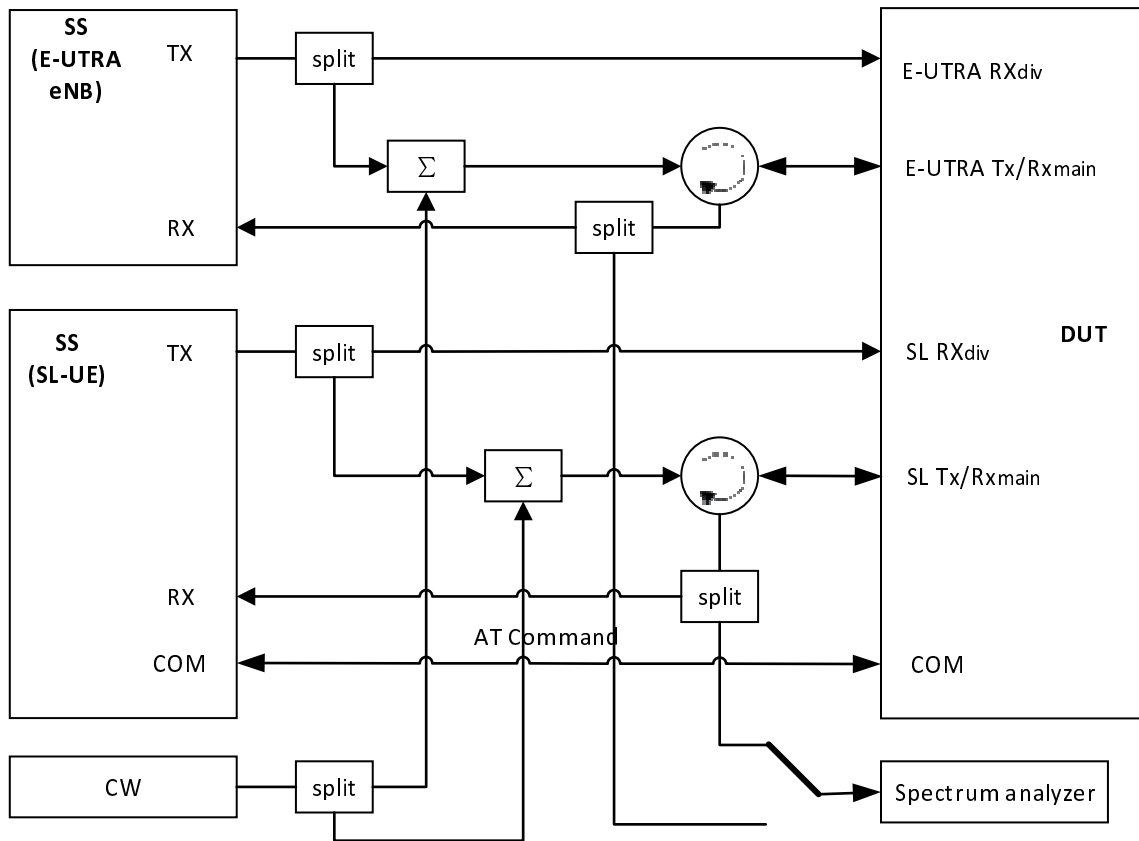

Figure A.93b: Connection for V2X testing of simultaneous E-UTRA V2X sidelink and E-UTRA uplink transmission with additional CW and Spectrum Analyzer

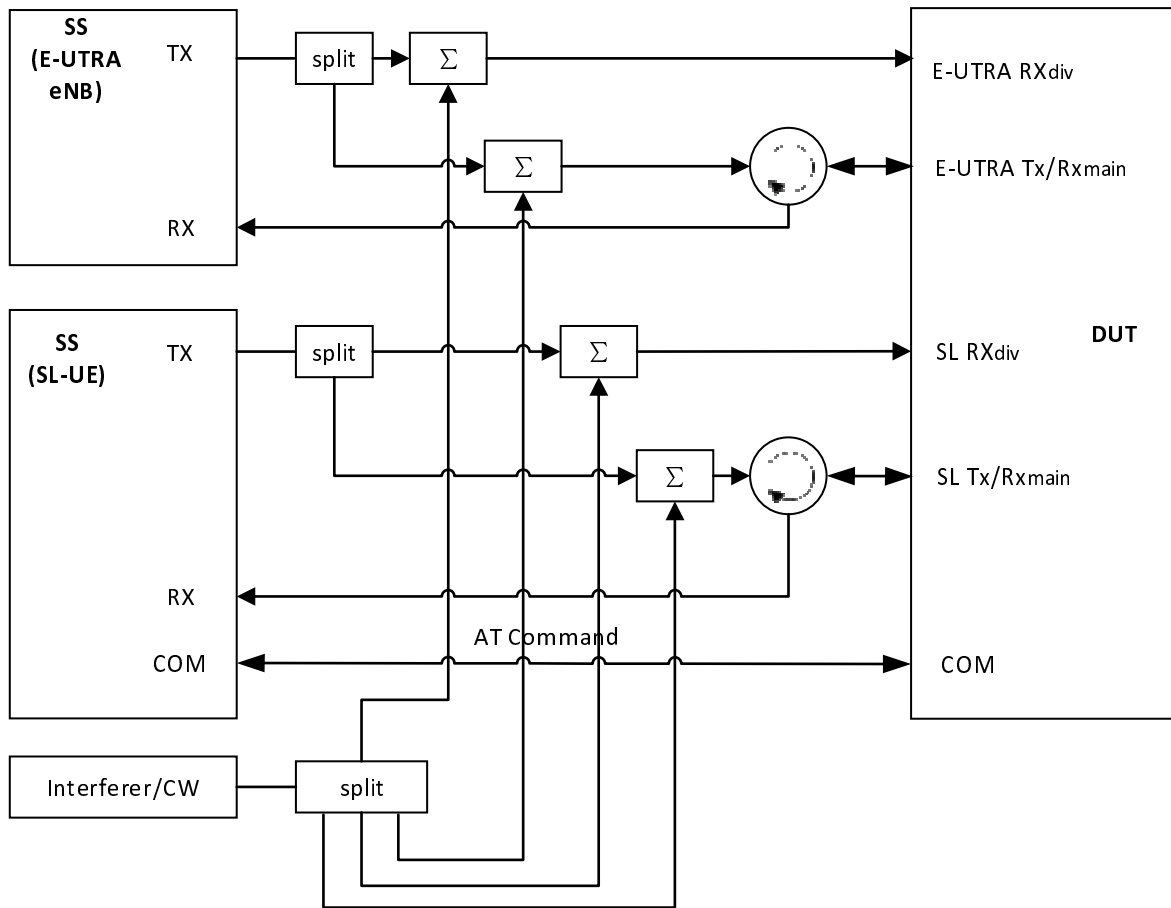

Figure A.93c: Connection for V2X testing of simultaneous E-UTRA V2X sidelink and E-UTRA uplink transmission with additional Interferer / CW

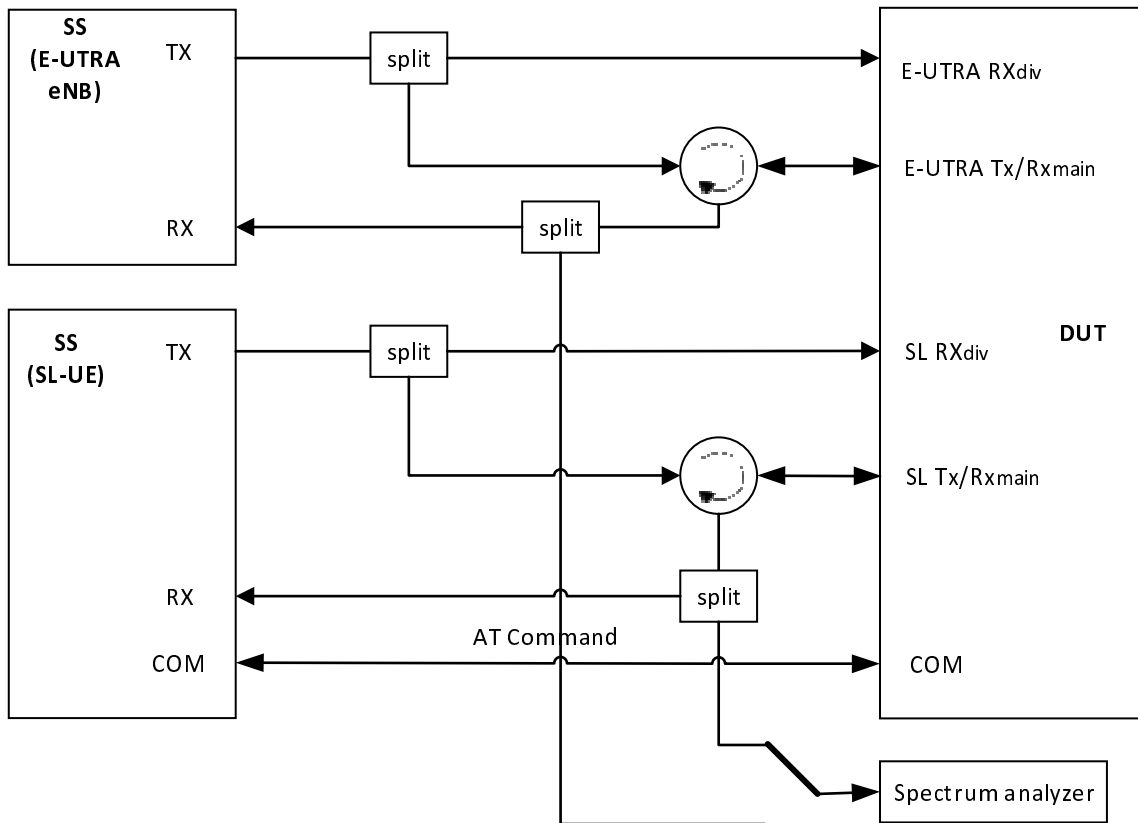

Figure A.93d: Connection for V2X Tx testing of simultaneous E-UTRA V2X sidelink and E-UTRA uplink transmission with additional Spectrum Analyzer

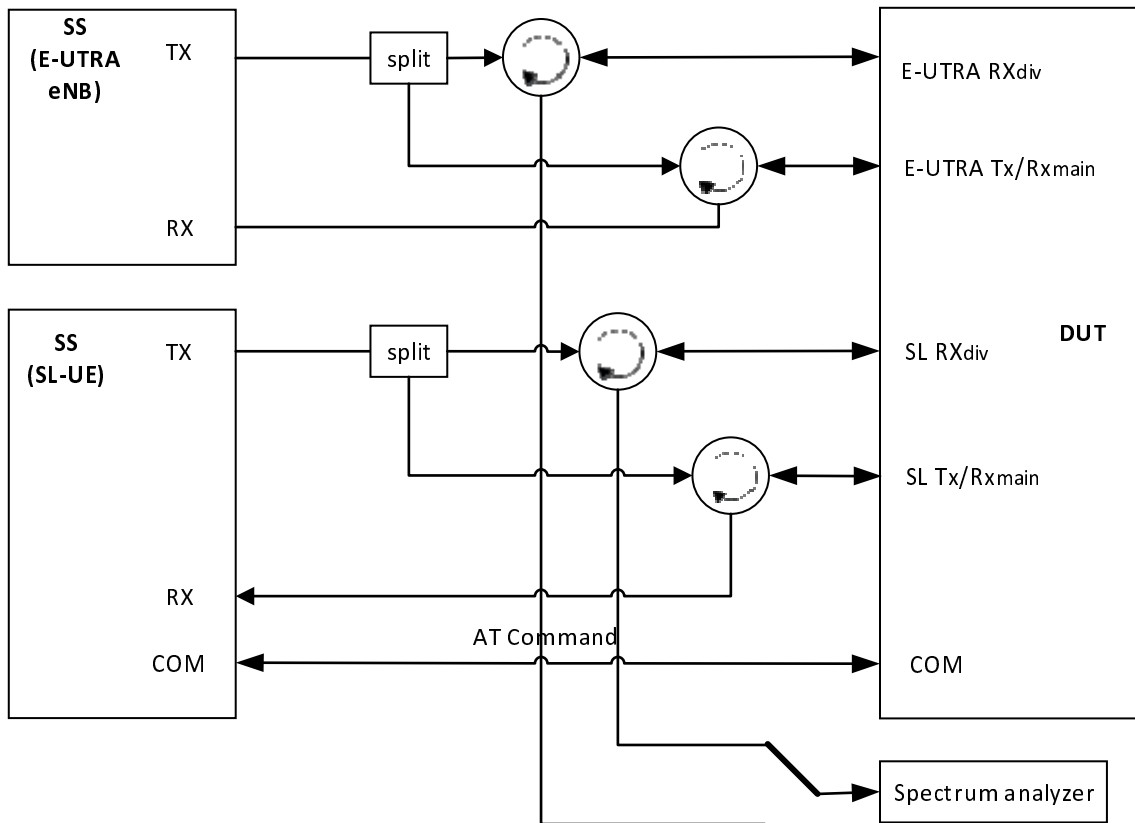

Figure A.93e: Connection for V2X Rx testing of simultaneous E-UTRA V2X sidelink and E-UTRA uplink transmission with additional Spectrum Analyzer

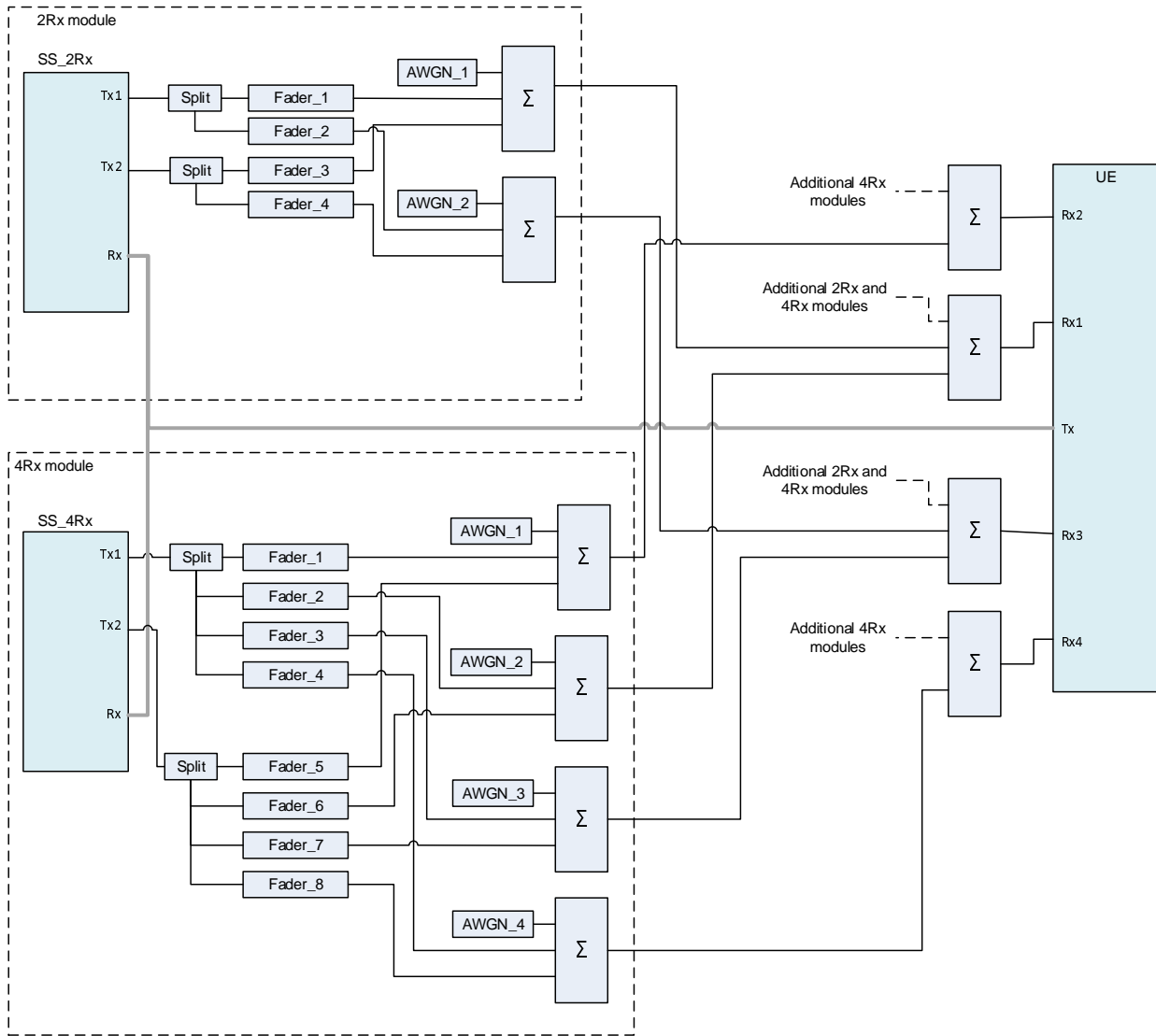

Figure A.94: Connection Diagram to enable Carrier Aggregation tests (with 2x4 channel) on a 4Rx-capable UE with CCs on both 4Rx-supported RF bands and 2Rx-supported bands

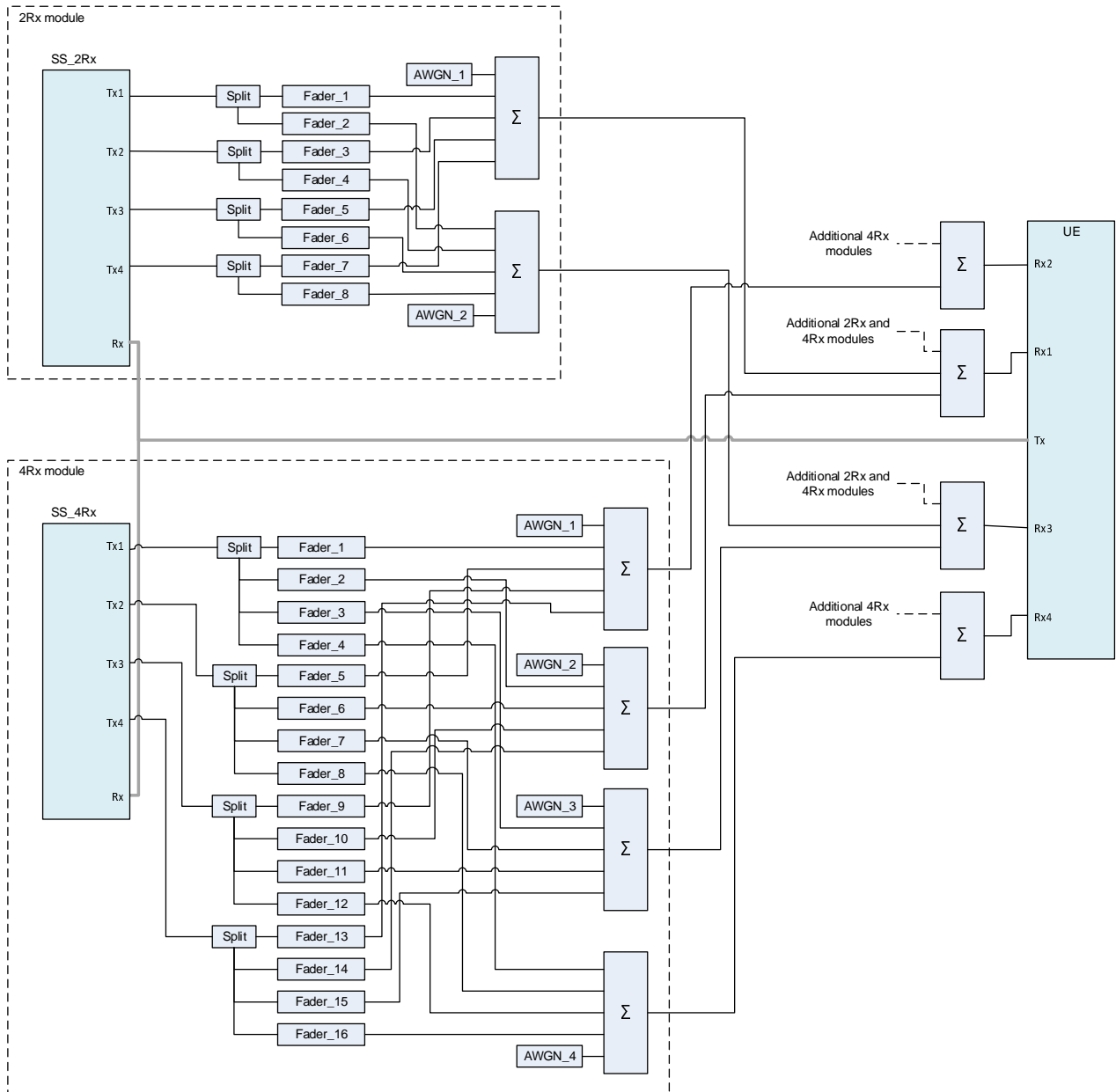

Figure A.95: Connection Diagram to enable Carrier Aggregation tests (with 4x4 channel) on a 4Rx-capable UE with CCs on both 4Rx-supported RF bands and 2Rx-supported bands

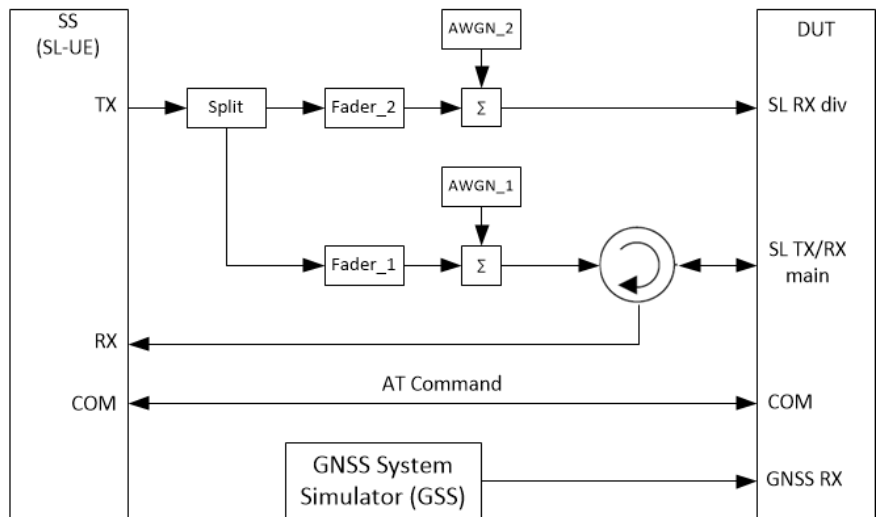

Figure A.96: Connection for performance testing of V2V/V2X sidelink communications in 1x2 faded channel and non-concurrent with E-UTRAN uplink transmission

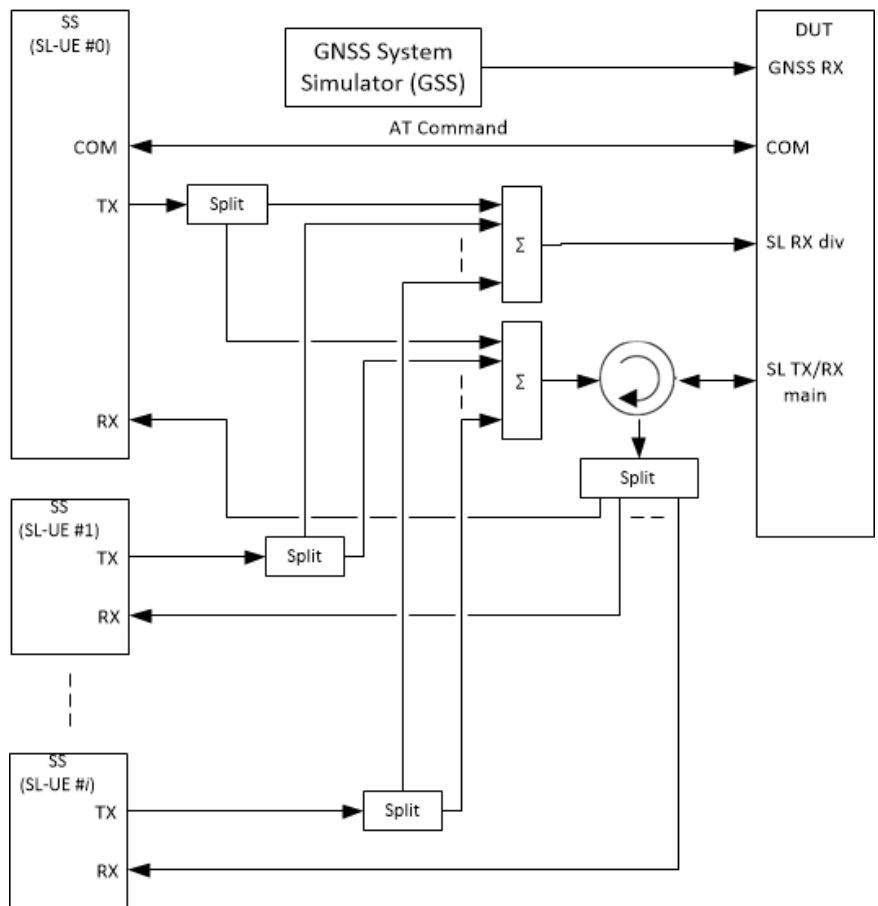

Figure A.97: Connection for performance decoding capability testing of V2V/V2X sidelink communications in 1x2 static channel and non-concurrent with E-UTRAN uplink transmission

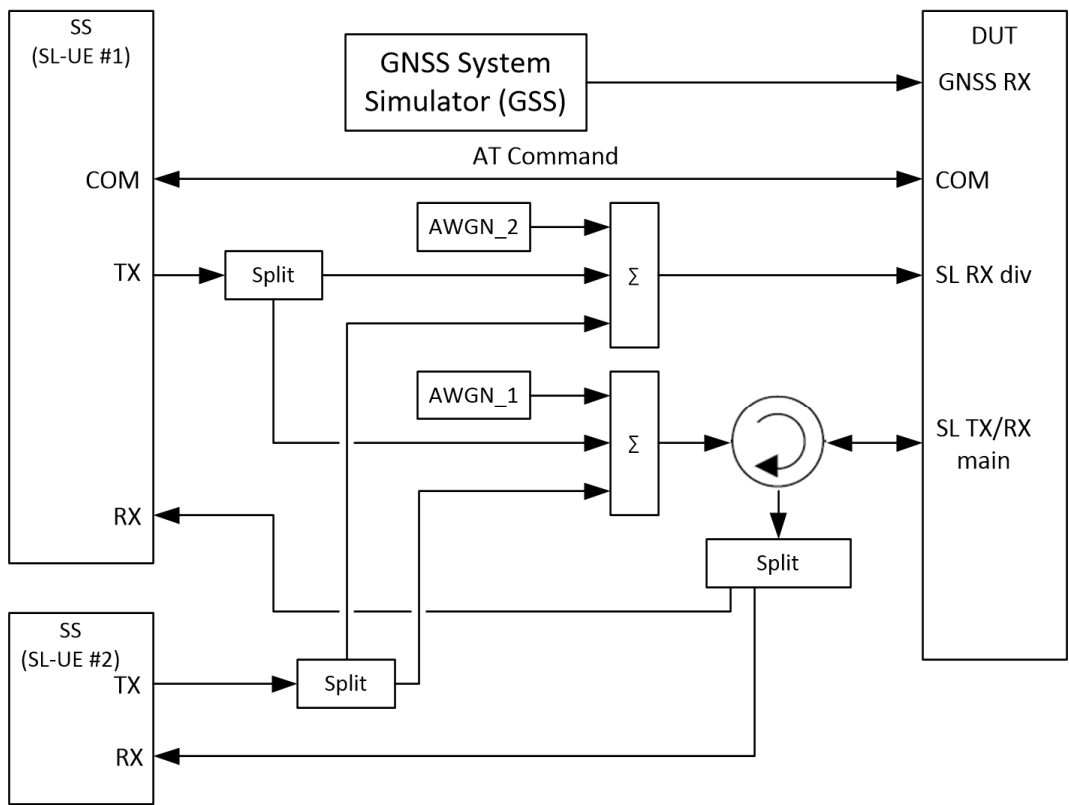

Figure A.98: Connection for power imbalance performance testing of V2V sidelink communications with two links in 1x2 AWGN channel and non-concurrent with E-UTRAN uplink transmission

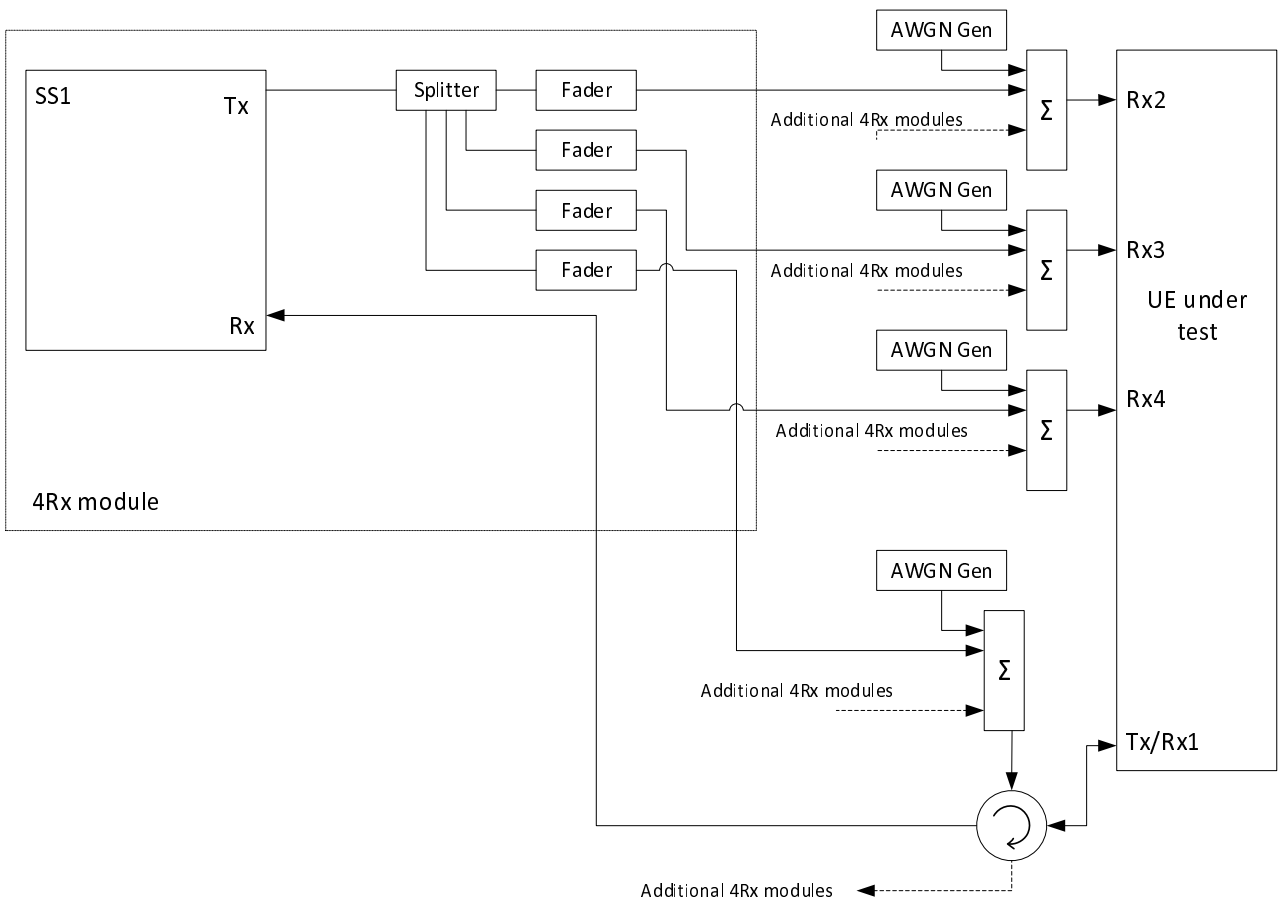

Figure A.99: Connection for more than 1 Cell with multipath fading propagation for 4Rx Capable UE

Annex B (informative): Change history

Meeting-1st-Level	Doc-1st-Level	CR	Rev	Subject	Cat	Version-Current	Version-New	Doc-2nd-Level
RAN5 #37	R5-073107			Skeleton proposed for RAN5#37 Jeju			0.0.1	
RAN5 LTE workshop	R5w080007			Proposed for RAN5 LTE workshop, Sophia Antipolis		0.0.1	0.0.2	
RAN5 #39	R5-081167			Following proposals have been incorporated: R5w080046 R5w080026 R5w080036		0.0.2	0.0.3	
RAN5 #39	R5-081615			Following proposals and many editorial corrections have been incorporated: R5-081564, R5-081561, R5-081248, R5-081530, R5-081126, R5-081443, R5-081382, R5-081200		0.0.3	0.1.0	
RAN5 #39bis	R5-082141			Following proposals and many editorial corrections have been incorporated: R5-082149, "Updates of reference test conditions for TS 36.508" R5-082148, "Addition of E-UTRA TDD Test frequencies for TS36.508" R5-082150, "Default downlink signal channel powers for LTE UE test" R5-082146, "Addition of Cell Environment for multi Cell Configuration" R5-082140, "Proposal of LTE reference system configurations for TS 36.508" R5-082204, "Addition of Cell and UE configuration for TS 36.508" R5-082090, "Update of default RRC message contents" R5-082100, "Proposal on Structure of Default Message Contents for TS 36.508" R5-082091, "Addition of SRB and DRB radio bearer combinations to 36.508" R5-082173, "Connection Diagrams for TX and RX tests"		0.1.0	0.2.0	
RAN5 #40	R5-083399			Following proposals have been incorporated: R5-083800, "Mapping of DL physical channels to physical resources for TS 36.508", NEC R5-083403, "Addition of New Cell Environment for multi Cell Configuration", NTT DOCOMO R5-083529, "Proposal on default system information contents for TS 36.508", NTT DOCOMO R5-083395, "Corrections to generic procedures in TS 36.508", NTT DOCOMO R5-083623, "Update of RRC default message contents and RB combination parameters", Ericsson R5-083622, "Radio Resource Configuration specification for TS 36.508", NEC R5-083397, "Addition of Default NAS message contents in TS 36.508", NTT DOCOMO		0.2.0	1.0.0	
RAN5 #40bis	R5-084102			Following proposals have been incorporated: R5-084101, "Missing corrections to TS 36.508" R5-084110, "Updates of Test frequencies for TS 36.508" R5-084144, "The mapping of DL physical channels to physical resources for TS 36.508" R5-084198, "Update of RA and RB power ratios definition in TS 36.508" R5-084199, "Update of Reference System Configuration in 36.508" R5-084109, "Addition of default RRC message contents to TS 36.508" R5-084202, "Update of RRC Message Contents and RB Configurations in 36.508" R5-084265, "Addition of default RRC message contents for handover" R5-084162, "Connection Diagrams for performance		1.0.0	1.1.0	

Meeting-1st-Level	Doc-1st-Level	CR	Rev	Subject	Cat	Version-Current	Version-New	Doc-2nd-Level
				tests"				
RAN5 #41	R5-085145			Following proposals have been incorporated: R5-085087, "Updates of Test frequencies for TS 36.508" R5-085701, "Cleaning up section 5 in TS 36.508" R5-085252, "Correction to Section 4.3.3.2 of TS 36.508" R5-085315, "Connection Diagrams: delete the editorial note" R5-085454, "Addition of timer tolerances" R5-085566, "Addition of default settings of suitable / non-suitable cells in TS 36.508" R5-085541, "Update to default configurations of simulated cells in TS 36.508" R5-085514, "Update to default configurations of system information blocks in TS 36.508" R5-085472, "Addition of default settings of suitable / non-suitable cells in TS 36.508" R5-085394, "Update of Reference system configurations in 36.508" R5-085457, "Update to generic procedure in TS 36.508" R5-085458, "Addition of new generic procedure to check the UE does not answer to paging" R5-085523, "Update of default RRC message contents" R5-085381, "Addition to default RRC IE contents for measurement configuration" R5-085469, "Update to default NAS message contents in TS 36.508" R5-085451, "Parameter settings for reference RB configurations" R5-085556, "Common test USIM parameters for EPS testing"		1.1.0	2.0.0	
RAN#42	RP-085145			Approval of version 2.0.0 at RAN#42, then updated to v 8.0.0.		2.0.0	8.0.0	
				Editorial corrections.		8.0.0	8.0.1	
RAN5 #41bis	R5-086021	0001	-	Introduction of half cell configurations in eUTRA SS		8.0.1	8.1.0	
RAN5 #41bis	R5-086166	0002	-	Removal of Redundant Environmental Conditions		8.0.1	8.1.0	
RAN5 #41bis	R5-086221	0003	-	CR to 36.508: correction of EARFCN		8.0.1	8.1.0	
RAN5 #41bis	R5-086226	0004	-	Correction to the default system informations in TS 36.508		8.0.1	8.1.0	
RAN5 #41bis	R5-086236	0005	-	Connection diagrams for RRM		8.0.1	8.1.0	
RAN5 #41bis	R5-086346	0006	-	Update of the default message AUTHENTICATION FAILURE		8.0.1	8.1.0	
RAN5 #41bis	R5-086362	0007	-	update of reference configuration systems for CDMA2000 in 36.508		8.0.1	8.1.0	
RAN5 #41bis	R5-086363	0008	-	Updated of common and default parameters for CDMA2000 cells		8.0.1	8.1.0	
RAN5 #41bis	R5-086364	0009	-	Update of SystemInformationBlockType8 in 36.508		8.0.1	8.1.0	
RAN5 #41bis	R5-086369	0010	-	Addition of reference EPS bearer contexts		8.0.1	8.1.0	
RAN5 #41bis	R5-086370	0011	-	Mapping of default DL Physical Channels for TDD in 36.508		8.0.1	8.1.0	
RAN5 #41bis	R5-086400	0012	-	Addition of RS_EPRES powers to default DL signal levels		8.0.1	8.1.0	
RAN5 #42	R5-090084	0013	-	Test procedure to verify that an EPS bearer context is active		8.0.1	8.1.0	
RAN5 #42	R5-090362	0014	-	Correction to the definition of simulated NAS cells in TS 36.508		8.0.1	8.1.0	
RAN5 #42	R5-090464	0015	-	Clean up the test algorithm for authentication		8.0.1	8.1.0	
RAN5 #42	R5-090586	0016	-	Add specific information elements for RRC reconfiguration		8.0.1	8.1.0	
RAN5 #42	R5-090630	0017	-	Introduction of alternative DRX configurations		8.0.1	8.1.0	
RAN5 #42	R5-090681	0018	-	Correction to the default NAS message contents in TS 36.508		8.0.1	8.1.0	
RAN5 #42	R5-090682	0019	-	Correction to the definition of simulated cells in TS 36.508		8.0.1	8.1.0	
RAN5	R5-090698	0020	-	Update of 4.5 generic procedures in 36.508		8.0.1	8.1.0	

Meeting-1st-Level	Doc-1st-Level	CR	Rev	Subject	Cat	Version-Current	Version-New	Doc-2nd-Level
#42								
RAN5 #42	R5-090699	0021	-	TDD RTT correction for timer tolerance		8.0.1	8.1.0	
RAN5 #42	R5-090759	0022	-	Correction to the default RRC message contents in TS 36.508		8.0.1	8.1.0	
RAN5 #42	R5-091000	0023	-	Correction to clause 4.3.3.3		8.0.1	8.1.0	
RAN5 #42	R5-091001	0024	-	LTE-RF: Clarification to 36.508 Simulated Cells for RF tests		8.0.1	8.1.0	
RAN5 #43	RP-090447	0025	-	Correction to Cell off power		8.1.0	8.2.0	R5-092086
RAN5 #43	RP-090447	0026	-	LTE Signalling Tests: UE Rx antenna connection		8.1.0	8.2.0	R5-092087
RAN5 #43	RP-090448	0027	-	CR to 36.508 for subclause 4.3.1 channel bandwidth clarification for RF tests (re-submit no changes)		8.1.0	8.2.0	R5-092124
RAN5 #43	RP-090448	0028	-	Text for 4.2.2: Minimum functional requirements		8.1.0	8.2.0	R5-092128
RAN5 #43	RP-090448	0029	-	Annex A: transition from 1 to 2 RX antenna		8.1.0	8.2.0	R5-092132
RAN5 #43	RP-090447	0030	-	Update of SN length in UM RLC default configuration		8.1.0	8.2.0	R5-092202
RAN5 #43	RP-090448	0031	-	TP for simulated UTRA TDD cell parameter		8.1.0	8.2.0	R5-092275
RAN5 #43	RP-090447	0032	-	Correction to specific message contents in setup procedure in TS 36.508		8.1.0	8.2.0	R5-092349
RAN5 #43	RP-090447	0033	-	Correction to the definition of simulated NAS cells in TS 36.508		8.1.0	8.2.0	R5-092352
RAN5 #43	RP-090447	0034	-	CR on 6.7 TDD Timer Tolerance in 36.508		8.1.0	8.2.0	R5-092363
RAN5 #43	RP-090448	0044	-	Update of 4.5.2A in 36.508 (Re-submit not change)		8.1.0	8.2.0	R5-092457
RAN5 #43	RP-090448	0035	-	Default value of q-RxLevMin for RF TCs		8.1.0	8.2.0	R5-092458
RAN5 #43	RP-090598	0045	-	CR to 36.508 Addition of test frequencies for band 18 and band 19		8.1.0	8.2.0	R5-092535
RAN5 #43	RP-090447	0036	-	Update of the default NAS message contents in TS 36.508		8.1.0	8.2.0	R5-092708
RAN5 #43	RP-090447	0037	-	Correction to reference radio bearer configurations		8.1.0	8.2.0	R5-092721
RAN5 #43	RP-090447	0038	-	Definition of default Test Control (TC) messages		8.1.0	8.2.0	R5-092734
RAN5 #43	RP-090448	0039	-	Modification of procedures in section 4.5.2.3 /4.5.2A		8.1.0	8.2.0	R5-092735
RAN5 #43	RP-090447	0040	-	Addition of default physical layer parameters		8.1.0	8.2.0	R5-092736
RAN5 #43	RP-090447	0041	-	Correction to default RRC message contents		8.1.0	8.2.0	R5-092738
RAN5 #43	RP-090447	0042	-	Introduction in 36.508 of a common tracking/routing area update procedure for Idle mode and RRC connection release test cases		8.1.0	8.2.0	R5-092765
RAN5 #43	RP-090447	0043	-	Corrections to default system configurations in TS 36.508		8.1.0	8.2.0	R5-092773
RAN5 #43	RP-090447	0046	-	Max. resources for signalling test cases		8.1.0	8.2.0	R5-092723
-	-	-	-	Editorial corrections and merging of all sections together		8.2.0	8.2.1	-
RAN5 #44	RP-090802	0047	-	Correction to the default value of ul-Bandwidth in TS 36.508	F	8.2.1	8.3.0	R5-094059
RAN5 #44	RP-090802	0048	-	UTRAN SIB scheduling for LTE interRAT test	F	8.2.1	8.3.0	R5-094072
RAN5 #44	RP-090802	0049	-	Correction to the default NAS message contents	F	8.2.1	8.3.0	R5-094141
RAN5 #44	RP-090802	0050	-	TDD fields in default physical layer parameters	F	8.2.1	8.3.0	R5-094279
RAN5 #44	RP-090802	0051	-	Addition of UTRA reference radio bearer parameters and GERAN reference PDP context parameters for E-UTRA Inter-RAT testing	F	8.2.1	8.3.0	R5-094304
RAN5 #44	RP-090801	0052	-	System information scheduling for RF testing	F	8.2.1	8.3.0	R5-094311
RAN5 #44	RP-090801	0053	-	Connection for 1 cell with antenna configuration 1x2 in static propagation conditions	F	8.2.1	8.3.0	R5-094364
RAN5 #44	RP-090801	0054	-	Correction to 4.3.1.2.5 TDD reference test frequencies for Operating Band 37	F	8.2.1	8.3.0	R5-094373

Meeting-1st-Level	Doc-1st-Level	CR	Rev	Subject	Cat	Version-Current	Version-New	Doc-2nd-Level
RAN5 #44	RP-090801	0055	-	LTE RF: Physical Layer configurations for RF/RRM testing	F	8.2.1	8.3.0	R5-094421
RAN5 #44	RP-090802	0056	-	Update of SN length in PDCP default configuration	F	8.2.1	8.3.0	R5-094533
RAN5 #44	RP-090802	0057	-	Corrections to default RRC message and IE contents	F	8.2.1	8.3.0	R5-094639
RAN5 #44	RP-090801	0058	-	Update of TDD reference test frequencies for operating band 40	F	8.2.1	8.3.0	R5-094786
RAN5 #44	RP-090810	0059	-	TDD special subframe pattern update	F	8.2.1	8.3.0	R5-094901
RAN5 #44	RP-090802	0060	-	corrections to reference RB configurations	F	8.2.1	8.3.0	R5-095064
RAN5 #44	RP-090802	0061	-	Correction of test procedure 6.4.2.7 in TS 36.508	F	8.2.1	8.3.0	R5-095093
RAN5 #44	RP-090802	0062	-	Adding new elementary files to the default USIM settings	F	8.2.1	8.3.0	R5-095100
RAN5 #44	RP-090802	0063	-	Correction to the Test procedure to check RRC_IDLE state	F	8.2.1	8.3.0	R5-095102
RAN5 #44	RP-090802	0064	-	Introduction of UE mode of operation into NAS default message contents	F	8.2.1	8.3.0	R5-095138
RAN5 #44	RP-090802	0065	-	TDD ACK/NACK feedback mode update	F	8.2.1	8.3.0	R5-095152
RAN5 #44	RP-090802	0066	-	Corrections to default signal levels	F	8.2.1	8.3.0	R5-095206
RAN5 #44	RP-090802	0067	-	Update to default messages in regard to IP address allocation	F	8.2.1	8.3.0	R5-095218
RAN5 #45	RP-091121	0068	-	Correction to 4.3.1.2.6 TDD reference test frequencies for Operating Band 38	F	8.3.0	8.4.0	R5-095486
RAN5 #45	RP-091121	0069	-	Correction CR to 36.508: Set the default parameter for offsetFreq in MeasObjectGERAN Information Element	F	8.3.0	8.4.0	R5-095514
RAN5 #45	RP-091470	0070	-	Addition of HSPA UTRA reference radio bearer parameters for E-UTRA Inter-RAT testing	F	8.3.0	8.4.0	R5-095555
RAN5 #45	RP-091122	0071	-	Introduction of RS power boosting to reduce interference	F	8.3.0	8.4.0	R5-095594
RAN5 #45	RP-091122	0072	-	Corrections to default RRC message contents	F	8.3.0	8.4.0	R5-095651
RAN5 #45	RP-091122	0073	-	Clarification for Cell Configuration Identifiers in 36.508	F	8.3.0	8.4.0	R5-096005
RAN5 #45	RP-091122	0074	-	Correction to the generic procedure for IP allocation and more	F	8.3.0	8.4.0	R5-096114
RAN5 #45	RP-091122	0075	-	Addition of new generic procedure for TAU after inter-RAT HO from UTRA	F	8.3.0	8.4.0	R5-096115
RAN5 #45	RP-091122	0076	-	Update of header chapter 5.2 in 36.508	F	8.3.0	8.4.0	R5-096202
RAN5 #45	RP-091122	0077	-	Correction to the default NAS message contents	F	8.3.0	8.4.0	R5-096403
RAN5 #45	RP-091122	0078	-	cell frequency allocation	F	8.3.0	8.4.0	R5-096440
RAN5 #45	RP-091122	0079	-	Correction for IP address allocation	F	8.3.0	8.4.0	R5-096447
RAN5 #45	RP-091122	0080	-	LAI and TMSI in ATTACH ACCEPT and TAU ACCEPT messages	F	8.3.0	8.4.0	R5-096449
RAN5 #45	RP-091122	0081	-	Addition of generic procedure for IP address allocation / configuration in U-plane	F	8.3.0	8.4.0	R5-096455
RAN5 #45	RP-091122	0082	-	Correction of test procedures in TS 36.508	F	8.3.0	8.4.0	R5-096456
RAN5 #45	RP-091122	0083	-	Update of MAC configuration for disabling PHR and BSR for L2 test cases	F	8.3.0	8.4.0	R5-096458
RAN5 #45	RP-091122	0084	-	Addition of default UTRA message contents to TS 36.508	F	8.3.0	8.4.0	R5-096461
RAN5 #45	RP-091122	0085	-	Clarification to the mapping of GERAN cells and the default parameter values	F	8.3.0	8.4.0	R5-096462
RAN5 #45	RP-091122	0086	-	Correction of TFTs for reference dedicated EPS bearer contexts	F	8.3.0	8.4.0	R5-096464
RAN5 #45	RP-091122	0087	-	Cleanup of default NAS message contents	F	8.3.0	8.4.0	R5-096465
RAN5 #45	RP-091122	0088	-	LTE-Sig: Assignment of different rootSequenceIndex for cells at the same frequency	F	8.3.0	8.4.0	R5-096641
RAN5 #46	RP-100143	0089	-	Correction of SIB19 scheduling position in the neighbouring UTRA cell	F	8.4.0	8.5.0	R5-100086
RAN5 #46	RP-100143	0091	-	Correction of Quantity Configuration for EUTRA	F	8.4.0	8.5.0	R5-100110

Meeting-1st-Level	Doc-1st-Level	CR	Rev	Subject	Cat	Version-Current	Version-New	Doc-2nd-Level
RAN5 #46	RP-100143	0092	-	Correction for the offset value of RSRP in EUTRA	F	8.4.0	8.5.0	R5-100111
RAN5 #46	RP-100143	0093	-	SIB10 and SIB11 periodicity	F	8.4.0	8.5.0	R5-100112
RAN5 #46	RP-100143	0094	-	Assignment of rootSequenceIndex for simulated NAS cells in different PLMNs	F	8.4.0	8.5.0	R5-100260
RAN5 #46	RP-100143	0095	-	Editorial correction to the default value of 'p-a'	F	8.4.0	8.5.0	R5-100261
RAN5 #46	RP-100142	0096	-	New chapter: Test environment for RRM tests	F	8.4.0	8.5.0	R5-100396
RAN5 #46	RP-100143	0097	-	Remove UM in DRB reconfiguration	F	8.4.0	8.5.0	R5-100487
RAN5 #46	RP-100143	0098	-	Addition of default power allocation for two TX antennas	F	8.4.0	8.5.0	R5-100518
RAN5 #46	RP-100143	0099	-	Correction to TFT parameters used in ACTIVATE DEDICATED EPS BEARER CONTEXT REQUEST message	F	8.4.0	8.5.0	R5-100771
RAN5 #46	RP-100143	0100	-	Update to RRC common messages for support of test cases for MIMO	F	8.4.0	8.5.0	R5-100786
RAN5 #46	RP-100152	0101	-	Adding band 20 in 36.508	F	8.4.0	8.5.0	R5-100846
RAN5 #46	RP-100154	0102	-	CR to 36.508: Update test frequencies with extended LTE1500 operating bands	F	8.4.0	8.5.0	R5-100847
RAN5 #46	RP-100143	0103	-	Defining default message contents for ATTACH/TAU REQUEST/ACCEPT messages according to UE capability	F	8.4.0	8.5.0	R5-101021
RAN5 #46	RP-100143	0104	-	Limitation of simultaneous co-existence of intra-freq cells to reduce interference	F	8.4.0	8.5.0	R5-101029
RAN5 #46	RP-100143	0105	-	An additional option for IP address allocation in test cases using UE test mode	F	8.4.0	8.5.0	R5-101045
RAN5 #46	RP-100143	0106	-	Specify default UL NAS check	F	8.4.0	8.5.0	R5-101051
RAN5 #46	RP-100143	0107	-	Correct default requirement for some mandatory information elements	F	8.4.0	8.5.0	R5-101052
RAN5 #46	RP-100142	0108	-	Addition of Tracking area updating procedure	F	8.4.0	8.5.0	R5-101136
RAN5 #46	RP-100143	0109	-	Clarification of Security Protection for NAS Messages	F	8.4.0	8.5.0	R5-101147
RAN5 #46	RP-100143	0110	-	Update to layer 2 UM test cases to increase the drx-Inactivity Timer to psf200	F	8.4.0	8.5.0	R5-101178
RAN5 #46	RP-100143	0111	-	Addition of new generic procedure for bearer establishment for MO call.	F	8.4.0	8.5.0	R5-101187
RAN5 #46	RP-100143	0112	-	update of default bandwidth configuration for signalling	F	8.4.0	8.5.0	R5-101207
RP#47	-	-	-	Moved to v9.0.0 with no change	-	8.5.0	9.0.0	-
RP#48	RP-100510	0143	-	Clarification of security protection when NAS security mode procedure has taken place outside of a TC sequence	F	9.0.0	9.1.0	R5-103085
RP#48	RP-100523	0113	-	CR to 36.508: Update of EARFCN for band 21	F	9.0.0	9.1.0	R5-103101
RP#48	RP-100510	0114	-	Correction to the default message contents of EXTENDED SERVICE REQUEST	F	9.0.0	9.1.0	R5-103128
RP#48	RP-100510	0115	-	Removal of unrealistic network behaviour from generic procedures	F	9.0.0	9.1.0	R5-103223
RP#48	RP-100510	0116	-	Correction of table numbers in clause 6.2.3.1	F	9.0.0	9.1.0	R5-103232
RP#48	RP-100510	0117	-	Correction to default values for PhysicalConfigDedicated and MIMO	F	9.0.0	9.1.0	R5-103287
RP#48	RP-100510	0118	-	Correction to SR-ConfigIndex for LTE TDD signalling test cases	F	9.0.0	9.1.0	R5-103290
RP#48	RP-100510	0119	-	Correction to MME Group ID to set MSB to 1	F	9.0.0	9.1.0	R5-103298
RP#48	RP-100500	0144	-	Connection diagram for test 8.11.2 (3 cells)	F	9.0.0	9.1.0	R5-103311
RP#48	RP-100510	0120	-	New combination of system information blocks for CSG Cell in TS 36.508	F	9.0.0	9.1.0	R5-103363
RP#48	RP-100510	0121	-	Clarification of security protection for detach request message	F	9.0.0	9.1.0	R5-103368
RP#48	RP-100510	0122	-	Corrections to cell numbers for 3GPP2 Inter-RAT network scenarios	F	9.0.0	9.1.0	R5-103374

Meeting-1st-Level	Doc-1st-Level	CR	Rev	Subject	Cat	Version-Current	Version-New	Doc-2nd-Level
RP#48	RP-100510	0140	-	Clarification to default message content for Modify EPS Bearer Context Request message	F	9.0.0	9.1.0	R5-103625
RP#48	RP-100510	0141	-	Clarification to default message content for RRC Connection Reconfiguration message	F	9.0.0	9.1.0	R5-103626
RP#48	RP-100524	0123	-	Addition of WLAN test cell	F	9.0.0	9.1.0	R5-103647
RP#48	RP-100524	0124	-	Addition of default message contents for mobility management based on DSMIPv6 testing	F	9.0.0	9.1.0	R5-103648
RP#48	RP-100510	0125	-	Update default message contents for EPS attach conditions	F	9.0.0	9.1.0	R5-103673
RP#48	RP-100510	0126	-	Update default message with network support for IMS voice	F	9.0.0	9.1.0	R5-103674
RP#48	RP-100510	0127	-	Correction to Generic Test Procedure in TS 36.508	F	9.0.0	9.1.0	R5-103675
RP#48	RP-100510	0128	-	Default settings of suitable - non-suitable cells for UTRAN/GERAN	F	9.0.0	9.1.0	R5-103677
RP#48	RP-100510	0129	-	Correction to IE schedulingRequestConfig during Handover	F	9.0.0	9.1.0	R5-103678
RP#48	RP-100510	0130	-	Update generic procedures for IMS	F	9.0.0	9.1.0	R5-103679
RP#48	RP-100510	0131	-	Aligning E-UTRAN USIM parameters for multi-RAT devices	F	9.0.0	9.1.0	R5-103680
RP#48	RP-100510	0132	-	Adding Additional Update Result handling to the default messages	F	9.0.0	9.1.0	R5-103681
RP#48	RP-100509	0133	-	Connection diagram update for intra-freq measurement with phase rotator	F	9.0.0	9.1.0	R5-103770
RP#48	RP-100509	0134	-	Update of default bandwidth configuration for Signalling for Band 38	F	9.0.0	9.1.0	R5-103813
RP#48	RP-100524	0135	-	Addition of generic procedures for mobility management based on DSMIPv6 testing	F	9.0.0	9.1.0	R5-103858
RP#48	RP-100510	0136	-	Addition of new generic procedure for MO SMS over SGs and clarifications	F	9.0.0	9.1.0	R5-103869
RP#48	RP-100510	0137	-	Addition of generic procedures for HRPD and 1xRTT pre-registration	F	9.0.0	9.1.0	R5-103870
RP#48	RP-100510	0138	-	Introduction of reference information for test case postambles	F	9.0.0	9.1.0	R5-103875
RP#48	RP-100509	0139	-	Physical layer parameter correction to DCI formats used in RF tests	F	9.0.0	9.1.0	R5-103885
RP#49	RP-100812	0145	-	Update of tested channel bandwidths for Bands 13, 14 and 17	F	9.1.0	9.2.0	R5-104089
RP#49	RP-100816	0146	-	Correction to remove special configurations for UM Bearer test cases	F	9.1.0	9.2.0	R5-104106
RP#49	RP-100816	0147	-	Clarification to the procedure: UE triggered establishment of a default EPS bearer context associated with an additional PDN	F	9.1.0	9.2.0	R5-104128
RP#49	RP-100816	0148	-	Correction to Inter-frequency carrier frequency list in SIB5 and E-UTRA carrier frequency list in SIB19	F	9.1.0	9.2.0	R5-104169
RP#49	RP-100816	0149	-	Update of 6.2.3 of 36.508 - description of default frequency for the single cell signalling test	F	9.1.0	9.2.0	R5-104220
RP#49	RP-100831	0150	-	Update of default message contents for DSMIPv6 testing	F	9.1.0	9.2.0	R5-104392
RP#49	RP-100837	0151	-	Addition of UE test state model for HRPD	F	9.1.0	9.2.0	R5-104454
RP#49	RP-100812	0152	-	Correction to Qrxlevmin in SIB 1 for RF and RRM	F	9.1.0	9.2.0	R5-104503
RP#49	RP-100816	0153	-	Specification of HRPD specific values in SIB8	F	9.1.0	9.2.0	R5-104547
RP#49	RP-100816	0154	-	Update of default bandwidth configuration for signalling	F	9.1.0	9.2.0	R5-104685
RP#49	RP-100816	0155	-	Clarification to packet filter identifier and precedence in TFT	F	9.1.0	9.2.0	R5-104702
RP#49	RP-100816	0156	-	Add P-CSCF method II for IMS	F	9.1.0	9.2.0	R5-104703
RP#49	RP-100816	0157	-	Update generic procedures for IMS	F	9.1.0	9.2.0	R5-104704
RP#49	RP-100816	0158	-	Correction of clause 4.3.3.4	F	9.1.0	9.2.0	R5-104705
RP#49	RP-100816	0159	-	Correction to Downlink Frequency for N_DL 4850	F	9.1.0	9.2.0	R5-104706
RP#49	RP-100816	0160	-	Default message contents for UTRAN and GERAN	F	9.1.0	9.2.0	R5-104707

Meeting-1st-Level	Doc-1st-Level	CR	Rev	Subject	Cat	Version-Current	Version-New	Doc-2nd-Level
RP#49	RP-100812	0161	-	Addition of the new connection diagram for the CSI test case	F	9.1.0	9.2.0	R5-104884
RP#49	RP-100816	0162	-	Correction to reference end states	F	9.1.0	9.2.0	R5-105003
RP#49	RP-100837	0163	-	Correction for Timer Tolerances	F	9.1.0	9.2.0	R5-105050
RP#49	RP-100885	0165	-	Introduction of default message contents for HRPD overhead messages	F	9.1.0	9.2.0	-
GP#49	GP-101743	0166	-	Update of Common parameters for simulated GERAN cells for supporting GERAN-EUTRAN Inter-RAT cell reselection	F	9.2.0	9.3.0	GP-101743
RP#50	RP-101138	0167	-	MBSFN configuration for RRM tests using E-UTRA FDD cells	F	9.2.0	9.3.0	R5-106070
RP#50	RP-101155	0169	-	CR to 36.508: Update test frequencies for EUTRA TDD LTE band 41.	F	9.2.0	9.3.0	R5-106105
RP#50	RP-101142	0168	-	CR to 36.508: Correction to HRPD Overhead messages (subclause 4.4.7.1)	F	9.2.0	9.3.0	R5-106116
RP#50	RP-101142	0170	-	Addition of test frequencies for LTE-C2k interworking test cases	F	9.2.0	9.3.0	R5-106298
RP#50	RP-101142	0172	-	Addition of UTRA reference radio parameters and combination for PS RB and Speech	F	9.2.0	9.3.0	R5-106383
RP#50	RP-101142	0175	-	Correction to EUTRA carrier frequency list in SIB19	F	9.2.0	9.3.0	R5-106421
RP#50	RP-101142	0171	-	Correction to the IDENTITY RESPONSE (with IMSI) message	F	9.2.0	9.3.0	R5-106551
RP#50	RP-101142	0178	-	Correction for DRX offset start time	F	9.2.0	9.3.0	R5-106552
RP#50	RP-101142	0177	-	Correction of specific message content for generic procedures (state 2 and state 2A)	F	9.2.0	9.3.0	R5-106596
RP#50	RP-101138	0180	-	LTE-RF state 3A	F	9.2.0	9.3.0	R5-106597
RP#50	RP-101142	0176	-	Correction to security protection header for Identity Request message	F	9.2.0	9.3.0	R5-106611
RP#50	RP-101142	0173	-	Addition of new system information combinations	F	9.2.0	9.3.0	R5-106616
RP#50	RP-101142	0174	-	Remove SS requirement for IMS in UTRA	F	9.2.0	9.3.0	R5-106690
RP#50	RP-101159	0179	-	Corrections to default settings for Elementary Files (EFs) on Test USIM	F	9.2.0	9.3.0	R5-106819
RP#50	RP-101138	0181	-	Update of the RF exceptional RRC message	F	9.2.0	9.3.0	R5-106820
RP#51	RP-110161	0182	-	Update of HRPD overhead message parameters AccessSignature, SectorSignature	F	9.3.0	9.4.0	R5-110069
RP#51	RP-110161	0183	-	Add a new eUTRA sub-end state E2_T3440	F	9.3.0	9.4.0	R5-110105
RP#51	RP-110161	0184	-	Correction for NAS message NOTE	F	9.3.0	9.4.0	R5-110229
RP#51	RP-110161	0185	-	Addition of CSIM default contents	F	9.3.0	9.4.0	R5-110331
RP#51	RP-110161	0186	-	Update of Table 4.4.2-1 with HRPD/1xRTT frequency range info	F	9.3.0	9.4.0	R5-110332
RP#51	RP-110157	0187	-	Update of the RF exceptional RRC message	F	9.3.0	9.4.0	R5-110410
RP#51	RP-110161	0188	-	Editorial correction for IMS signalling	F	9.3.0	9.4.0	R5-110433
RP#51	RP-110161	0189	-	Correction to SIB combinations related to HeNB Cells	F	9.3.0	9.4.0	R5-110471
RP#51	RP-110161	0190	-	Correction to default message content for Detach Request message	F	9.3.0	9.4.0	R5-110472
RP#51	RP-110157	0191	-	Removal of Lower Humidity Limit in Normal Conditions	F	9.3.0	9.4.0	R5-110534

Meeting-1st-Level	Doc-1st-Level	CR	Rev	Subject	Cat	Version-Current	Version-New	Doc-2nd-Level
RP#51	RP-110157	0192	-	Correction of EARFCN numbers for band 41	F	9.3.0	9.4.0	R5-110542
RP#51	RP-110161	0193	-	Removal of "Modified contents of the EFs at the ISIM ADF (application DF) level"	F	9.3.0	9.4.0	R5-110593
RP#51	RP-110161	0194	-	Correction of the IEs for compressed mode in table 4.7B.1-5	F	9.3.0	9.4.0	R5-110601
RP#51	RP-110161	0195	-	Update to default message content for TRACKING AREA UPDATE REQUEST message	F	9.3.0	9.4.0	R5-110703
RP#51	RP-110161	0196	-	Add default APN for IMS	F	9.3.0	9.4.0	R5-110708
RP#51	RP-110161	0197	-	Introduction of over head messages for CDMA2000 1XRTT	F	9.3.0	9.4.0	R5-110710
RP#51	RP-110161	0198	-	Addition of default SMS over SGs message contents	F	9.3.0	9.4.0	R5-110875
RP#51	RP-110161	0199	-	Correction to 'Test procedure to check that UE is camped on E-UTRAN cell upon mobility from another RAT'	F	9.3.0	9.4.0	R5-110746
RP#51	RP-110161	0200	-	Correction of frequency allocations	F	9.3.0	9.4.0	R5-110788
RP#51	RP-110161	0201	-	Update of Reference packet filters contents	F	9.3.0	9.4.0	R5-110789
RP#51	RP-110157	0202	-	Correction to FDD Reference Test Frequencies for Operating Band 12	F	9.3.0	9.4.0	R5-110846
RP#51	RP-110157	0203	-	LTE RF: state 3A-RF update	F	9.3.0	9.4.0	R5-110937
RP#51	RP-110172	0204	-	Add test frequencies for bands 42, 43 (3500MHz)	F	9.3.0	9.4.0	R5-110968
RP#52	RP-110647	0205	-	Correction to default message content of LOCATION UPDATING REQUEST message	F	9.4.0	9.5.0	R5-112114
RP#52	RP-110647	0206	-	Correction to default message content of TRACKING AREA UPDATE REQUEST message	F	9.4.0	9.5.0	R5-112120
RP#52	RP-110643	0207	-	PRACH-Config-DEFAULT for RF-tests TDD: Correction to derivation path	F	9.4.0	9.5.0	R5-112146
RP#52	RP-110643	0208	-	Correction to connection diagram for CQI with uneven interference test (A.21)	F	9.4.0	9.5.0	R5-112147
RP#52	RP-110647	0209	-	Update to Common contents of system information blocks	F	9.4.0	9.5.0	R5-112161
RP#52	RP-110647	0210	-	Addition of missing labels in Figure 4.5.1-1	F	9.4.0	9.5.0	R5-112278
RP#52	RP-110647	0211	-	Corrections to Table 4.3.7-6	F	9.4.0	9.5.0	R5-112279
RP#52	RP-110647	0212	-	Update of CSIM default contents	F	9.4.0	9.5.0	R5-112285
RP#52	RP-110660	0213	-	Add emergency bearer support	F	9.4.0	9.5.0	R5-112289
RP#52	RP-110667	0214	-	Band 24 Addition to TS 36.508	F	9.4.0	9.5.0	R5-112381
RP#52	RP-110643	0215	-	New connection diagrams to Annex A	F	9.4.0	9.5.0	R5-112458
RP#52	RP-110647	0216	-	Correction to Derivation Path for RB Setup on UTRA side (condition UTRA PS RB)	F	9.4.0	9.5.0	R5-112571
RP#52	RP-110647	0217	-	Update APN check at attach	F	9.4.0	9.5.0	R5-112598
RP#52	RP-110647	0218	-	Update of SIB7 default message contents	F	9.4.0	9.5.0	R5-112599
RP#52	RP-110647	0219	-	Clarification to conditions for IP address configuration over user plane	F	9.4.0	9.5.0	R5-112600
RP#52	RP-110666	0220	-	Introduction of UE Test Loop Mode C for LTE MBMS testing	F	9.4.0	9.5.0	R5-112675

Meeting-1st-Level	Doc-1st-Level	CR	Rev	Subject	Cat	Version-Current	Version-New	Doc-2nd-Level
RP#52	RP-110647	0222	-	Update 36.508 QoS definition for InterRat test cases	F	9.4.0	9.5.0	R5-112698
RP#52	RP-110666	0221	-	Addition of some MBMS related message definitions in TS36.508	F	9.4.0	9.5.0	R5-112748
RP#52	RP-110647	0223	-	Introduction of generic CS fall back procedures for UTRAN and GERAN	F	9.4.0	9.5.0	R5-112751
RP#52	RP-110643	0224	-	Default Bandwidth Configuration for RF Testing	F	9.4.0	9.5.0	R5-112760
RP#52	RP-110643	0225	-	Update for PRACH-Config-DEFAULT for the default TDD RRM message	F	9.4.0	9.5.0	R5-112872
RP#52	RP-110647	0205	-	Correction to default message content of LOCATION UPDATING REQUEST message	F	9.4.0	9.5.0	R5-112114
RP#52	RP-110647	0206	-	Correction to default message content of TRACKING AREA UPDATE REQUEST message	F	9.4.0	9.5.0	R5-112120
RP#52	RP-110643	0207	-	PRACH-Config-DEFAULT for RF-tests TDD: Correction to derivation path	F	9.4.0	9.5.0	R5-112146
RP#52	RP-110643	0208	-	Correction to connection diagram for CQI with uneven interference test (A.21)	F	9.4.0	9.5.0	R5-112147
RP#52	RP-110647	0209	-	Update to Common contents of system information blocks	F	9.4.0	9.5.0	R5-112161
RP#52	RP-110647	0210	-	Addition of missing labels in Figure 4.5.1-1	F	9.4.0	9.5.0	R5-112278
RP#52	RP-110647	0211	-	Corrections to Table 4.3.7-6	F	9.4.0	9.5.0	R5-112279
RP#52	RP-110647	0212	-	Update of CSIM default contents	F	9.4.0	9.5.0	R5-112285
RP#52	RP-110660	0213	-	Add emergency bearer support	F	9.4.0	9.5.0	R5-112289
RP#52	RP-110667	0214	-	Band 24 Addition to TS 36.508	F	9.4.0	9.5.0	R5-112381
RP#52	RP-110643	0215	-	New connection diagrams to Annex A	F	9.4.0	9.5.0	R5-112458
RP#52	RP-110647	0216	-	Correction to Derivation Path for RB Setup on UTRA side (condition UTRA PS RB)	F	9.4.0	9.5.0	R5-112571
RP#52	RP-110647	0217	-	Update APN check at attach	F	9.4.0	9.5.0	R5-112598
RP#52	RP-110647	0218	-	Update of SIB7 default message contents	F	9.4.0	9.5.0	R5-112599
RP#52	RP-110647	0219	-	Clarification to conditions for IP address configuration over user plane	F	9.4.0	9.5.0	R5-112600
RP#52	RP-110647	0222	-	Update 36.508 QoS definition for InterRat test cases	F	9.4.0	9.5.0	R5-112698
RP#52	RP-110666	0221	-	Addition of some MBMS related message definitions in TS36.508	F	9.4.0	9.5.0	R5-112748
RP#52	RP-110647	0223	-	Introduction of generic CS fall back procedures for UTRAN and GERAN	F	9.4.0	9.5.0	R5-112751
RP#52	RP-110643	0224	-	Default Bandwidth Configuration for RF Testing	F	9.4.0	9.5.0	R5-112760
RP#52	RP-110643	0225	-	Update for PRACH-Config-DEFAULT for the default TDD RRM message	F	9.4.0	9.5.0	R5-112872
RP#53	RP-111138	0226	-	Correction for generic CS fallback procedures for UTRAN	F	9.5.0	9.6.0	R5-113033
RP#53	RP-111138	0227	-	Correction to paging test procedure	F	9.5.0	9.6.0	R5-113163
RP#53	RP-111138	0228	-	Deletion of 'EPSONlyAttachForced' in common part	F	9.5.0	9.6.0	R5-113195
RP#53	RP-111135	0229	-	Deletion of 'EPSONlyAttachForced' in RF part	F	9.5.0	9.6.0	R5-113213

Meeting-1st-Level	Doc-1st-Level	CR	Rev	Subject	Cat	Version-Current	Version-New	Doc-2nd-Level
RP#53	RP-111135	0230	-	Correction to PhysicalConfigDedicated-DEFAULT for HO case	F	9.5.0	9.6.0	R5-113450
RP#53	RP-111138	0231	-	Addition of the 'Expanded 1900 MHz band' as operating band 25 to TS 36.508	F	9.5.0	9.6.0	R5-113500
RP#53	RP-111153	0232	-	Band 24 Details for Signalling part of 36.508	F	9.5.0	9.6.0	R5-113521
RP#53	RP-111138	0233	-	Add new SI combination	F	9.5.0	9.6.0	R5-113658
RP#53	RP-111138	0234	-	Update of HRPD/1xRTT test frequencies, pre-registration procedures and message contents	F	9.5.0	9.6.0	R5-113659
RP#53	RP-111138	0235	-	Correction to test procedures specific message contents	F	9.5.0	9.6.0	R5-113660
RP#53	RP-111138	0236	-	Correction to 'Test procedure to check that UE is camped on E-UTRAN cell upon mobility from another RAT'	F	9.5.0	9.6.0	R5-113661
RP#53	RP-111138	0237	-	Correction for the default NAS message contents	F	9.5.0	9.6.0	R5-113662
RP#53	RP-111138	0238	-	Update UTRA RRC messages	F	9.5.0	9.6.0	R5-113663
RP#53	RP-111138	0239	-	Update UTRA NAS messages	F	9.5.0	9.6.0	R5-113664
RP#53	RP-111138	0240	-	Addition of default GERAN message PS HANDOVER COMMAND	F	9.5.0	9.6.0	R5-113665
RP#53	RP-111138	0241	-	Update test procedure 6.4.3.7.6	F	9.5.0	9.6.0	R5-113666
RP#53	RP-111138	0242	-	Update test procedure 6.4.3.7.5	F	9.5.0	9.6.0	R5-113667
RP#53	RP-111155	0243	-	Update test frequencies for FDD LTE Band 23 in 36.508	F	9.5.0	9.6.0	R5-113749
RP#53	RP-111138	0244	-	Correction on the IE ReportConfigEUTRA-PERIODICAL definition	F	9.5.0	9.6.0	R5-113751
RP#53	RP-111148	0245	-	Correction to TS36.508 subclause 4.6.1	F	9.5.0	9.6.0	R5-113761
RP#53	RP-111145	0246	-	Combined parallel procedures between EUTRA/EPC and IMS emergency call	F	9.5.0	9.6.0	R5-113801
RP#53	RP-111135	0247	-	RF/RRM State 3A-RF: Editors note	F	9.5.0	9.6.0	R5-114037
RP#54	RP-111579	0248	-	Correction of the default message contents of Transaction Identifiers in Activate Default EPS Bearer Context and Activate Dedicated EPS Bearer Context messages	F	9.6.0	9.7.0	R5-115091
RP#54	RP-111596	0250	-	Adding band 22 (3500MHz FDD) to 36.508	F	9.6.0	9.7.0	R5-115185
RP#54	RP-111579	0251	-	Update of UE Registration pre-registration on 1xRTT registrationPeriod	F	9.6.0	9.7.0	R5-115264
RP#54	RP-111579	0252	-	Update UTRA RRC message for handover to UTRAN	F	9.6.0	9.7.0	R5-115533
RP#54	RP-111579	0253	-	Add reference default EPS bearer context for QCI 5	F	9.6.0	9.7.0	R5-115537
RP#54	RP-111579	0254	-	Correction of EPS Bearer Contexts	F	9.6.0	9.7.0	R5-115585
RP#54	RP-111579	0255	-	Correction to ESM default messages	F	9.6.0	9.7.0	R5-115618
RP#54	RP-111579	0256	-	Introduction of Combined Generic test procedure for IMS Speech call	F	9.6.0	9.7.0	R5-115619
RP#54	RP-111576	0257	-	default band configuration for RF testing in band 25	F	9.6.0	9.7.0	R5-115633
RP#54	RP-111579	0258	-	Complete the system configuration for dual mode network scenario	F	9.6.0	9.7.0	R5-115694
RP#54	RP-111579	0259	-	Correction to IE PhysicalConfigDedicated-DEFAULT definition in Table 4.8.2.1.6-1	F	9.6.0	9.7.0	R5-115696

Meeting-1st-Level	Doc-1st-Level	CR	Rev	Subject	Cat	Version-Current	Version-New	Doc-2nd-Level
RP#54	RP-111579	0260	-	Updates for 1xRTT pre-registration scenario	F	9.6.0	9.7.0	R5-115708
RP#54	RP-111579	0261	-	Update of UE 1xRTT registrationPeriod in SystemInformationBlock type8	F	9.6.0	9.7.0	R5-115750
RP#54	RP-111579	0262	-	Correction to 1xRTT Overhead Message contents	F	9.6.0	9.7.0	R5-115791
RP#55	RP-120176	0263	-	Correction to measurement control and report in default UTRA message	F	9.7.0	9.8.0	R5-120311
RP#55	RP-120176	0264	-	Update of E-UTRAN_QRXLEVMIN in SIB19 and SI2 Quarter	F	9.7.0	9.8.0	R5-120312
RP#55	RP-120176	0265	-	Update of RF Reference system configurations	F	9.7.0	9.8.0	R5-120313
RP#55	RP-120179	0266	-	Correction of Physical Layer configurations	F	9.7.0	9.8.0	R5-120497
RP#55	RP-120179	0267	-	Correction of E2_T3440 state definition	F	9.7.0	9.8.0	R5-120566
RP#55	RP-120179	0268	-	Correction of default PCO value in some ESM messages	F	9.7.0	9.8.0	R5-120572
RP#55	RP-120179	0269	-	Correction to the default message content of GERAN carrier frequency group list for E-UTRA cells	F	9.7.0	9.8.0	R5-120604
RP#55	RP-120179	0270	-	Update of SystemInformationBlockType1	F	9.7.0	9.8.0	R5-120616
RP#55	RP-120179	0271	-	Update the default configuration of channel bandwidth for Band 39 for signalling testing	F	9.7.0	9.8.0	R5-120617
RP#55	RP-120179	0272	-	Correction for UE pre-registration on CDMA2000 system	F	9.7.0	9.8.0	R5-120618
RP#55	RP-120179	0273	-	Update to Reference default EPS bearer context #2	F	9.7.0	9.8.0	R5-120619
RP#55	RP-120179	0274	-	Correction to the default (UTRA) Physical Channel Reconfiguration message	F	9.7.0	9.8.0	R5-120620
RP#55	RP-120179	0275	-	Correction of default measurement gap offset	F	9.7.0	9.8.0	R5-120621
RP#55	RP-120179	0276	-	Correction to carrier bandwidth	F	9.7.0	9.8.0	R5-120677
RP#55	RP-120192	0277	-	Update generic procedure 4.5A.4	F	9.7.0	9.8.0	R5-120693
RP#55	RP-120192	0278	-	Update generic procedure 4.5A.5	F	9.7.0	9.8.0	R5-120694
RP#55	RP-120200	0280	-	Addition of the default value of Carrier Aggregation parameters	F	9.7.0	9.8.0	R5-120726
RP#55	RP-120179	0282	-	Correction of UE Release in UE capability	F	9.7.0	9.8.0	R5-120752
RP#55	RP-120179	0283	-	Introduction of generic test procedure for SRVCC call handover to UTRA	F	9.7.0	9.8.0	R5-120753
RP#55	RP-120179	0284	-	Correction to test procedure sequence 6.4.2.7A for check that UE is camped on E-UTRAN cell upon mobility from another RAT	F	9.7.0	9.8.0	R5-120754
RP#55	RP-120179	0285	-	Addition of Default UTRA RRC Connection Request message	F	9.7.0	9.8.0	R5-120756
RP#55	RP-120176	0286	-	TS 36.508: Band 23 test frequencies correction	F	9.7.0	9.8.0	R5-120800
RP#55	RP-120179	0287	-	Remove IPv4viaNAS_TestMode	F	9.7.0	9.8.0	R5-120908
RP#55	GP-120009	0288	-	Section 4.4.5 Common parameters for simulated GERAN cells – Correction to SI2 Quarter	F	9.7.0	9.8.0	GP-120009
RP#55	RP-120203	0279	-	Addition of two MBMS counting related messages in TS 36.508	F	9.8.0	10.0.0	R5-120723
RP#55	RP-120199	0281	-	Introduction of new RRC default messages for Rel-10	F	9.8.0	10.0.0	R5-120737

Meeting-1st-Level	Doc-1st-Level	CR	Rev	Subject	Cat	Version-Current	Version-New	Doc-2nd-Level
				and MDT				
RP#56	RP-120644	0290	-	Correction of power ratio allocation on PDSCH for common logical channels	F	10.0.0	10.1.0	R5-121089
RP#56	RP-120644	0291	-	Correction to default mobilityParameters message contents	F	10.0.0	10.1.0	R5-121121
RP#56	RP-120644	0292	-	Corrections to default overhead messages for HRPD	F	10.0.0	10.1.0	R5-121122
RP#56	RP-120644	0293	-	Corrections to default overhead messages for 1xRTT	F	10.0.0	10.1.0	R5-121123
RP#56	RP-120644	0294	-	Update of CSFBParametersRequest/ResponseCDMA2000 process in Registration	F	10.0.0	10.1.0	R5-121276
RP#56	RP-120641	0295	-	RRM: Definition of parameters for simulated GSM cells	F	10.0.0	10.1.0	R5-121357
RP#56	RP-120662	0296	-	SIB Combination for CA test scenarios	F	10.0.0	10.1.0	R5-121383
RP#56	RP-120644	0297	-	Addition of default value of RSRQ Cell Reselection parameters	F	10.0.0	10.1.0	R5-121384
RP#56	RP-120641	0298	-	Test frequencies for inter-band cells in RRM tests	F	10.0.0	10.1.0	R5-121407
RP#56	RP-120644	0299	-	Update generic procedure 4.5A.6	F	10.0.0	10.1.0	R5-121413
RP#56	RP-120644	0300	-	Update generic procedure 4.5A.7	F	10.0.0	10.1.0	R5-121414
RP#56	RP-120644	0301	-	Update generic procedure 4.5A.3	F	10.0.0	10.1.0	R5-121439
RP#56	RP-120644	0302	-	Correction to RadioResourceConfigCommon-DEFAULT	F	10.0.0	10.1.0	R5-121447
RP#56	RP-120641	0304	-	Removing 5.2A.3 for State 2A	F	10.0.0	10.1.0	R5-121521
RP#56	RP-120641	0305	-	Addition of A-GNSS testing to Test frequencies clause 4.3.1	F	10.0.0	10.1.0	R5-121543
RP#56	RP-120641	0306	-	Ensuring all SS TX antennas are in use for whole test sequence	F	10.0.0	10.1.0	R5-121544
RP#56	RP-120641	0307	-	Connection diagram for RRM 3 cell TCs with static propagation	F	10.0.0	10.1.0	R5-121556
RP#56	RP-120644	0308	-	Correction of Physical Layer configurations tables	F	10.0.0	10.1.0	R5-121665
RP#56	RP-120644	0309	-	Update of default bandwidth configuration for E-UTRA FDD band 11 and 18	F	10.0.0	10.1.0	R5-121712
RP#56	RP-120644	0310	-	Correction to default SIB4 contents for CSG cells	F	10.0.0	10.1.0	R5-121733
RP#56	RP-120644	0311	-	Update of CDMA2000 Band Class data and addition of CDMA2000 Band Class 10	F	10.0.0	10.1.0	R5-121734
RP#56	RP-120644	0312	-	Update to Reference dedicated EPS bearer context #3	F	10.0.0	10.1.0	R5-121735
RP#56	RP-120644	0313	-	Add generic procedure MO video call	F	10.0.0	10.1.0	R5-121736
RP#56	RP-120644	0314	-	Add generic procedure MT video call	F	10.0.0	10.1.0	R5-121737
RP#56	RP-120644	0315	-	Clarifications to UICC requirements for LTE-C2K testing	F	10.0.0	10.1.0	R5-121809
RP#56	RP-120644	0316	-	Update UE capability information	F	10.0.0	10.1.0	R5-121847
RP#56	RP-120658	0317	-	Introduction of System information for PWS	F	10.0.0	10.1.0	R5-121854
RP#56	RP-120662	0318	-	Update of the default value of Carrier Aggregation parameters	F	10.0.0	10.1.0	R5-121856
RP#56	RP-120644	0319	-	Correction to reference system configurations for dual mode scenarios	F	10.0.0	10.1.0	R5-121888

Meeting-1st-Level	Doc-1st-Level	CR	Rev	Subject	Cat	Version-Current	Version-New	Doc-2nd-Level
RP#56	RP-120667	0320	-	Adding operating band 26 to TS 36.508	F	10.0.0	10.1.0	R5-121905
RP#56	RP-120641	0321	-	Addition of State 3B-RF in 36.508	F	10.0.0	10.1.0	R5-121919
RP#56	RP-120641	0322	-	Correction to Tracking area updating procedure in 36.508	F	10.0.0	10.1.0	R5-121936
RP#56	RP-120662	0323	-	Addition of Test mode call procedure for CA test cases	F	10.0.0	10.1.0	R5-121982
RP#56	RP-120641	0303	-	Correction to Handover to UTRAN commands for UTRA RRC messages in 36.508	F	10.0.0	10.1.0	R5-122018
RP#56	RP-120662	0324	-	36.508 - Test frequencies for CA_1C and CA_40C	F	10.0.0	10.1.0	R5-122134
RP#56	RP-120649	0289	-	Removal of technical content in 36.508 v9.8.0 and substitution with pointer to the next Release	F	10.0.0	10.1.0	R5-121078
RP#56	RP-120644	0290	-	Correction of power ratio allocation on PDSCH for common logical channels	F	10.0.0	10.1.0	R5-121089
RP#56	RP-120644	0291	-	Correction to default mobilityParameters message contents	F	10.0.0	10.1.0	R5-121121
RP#56	RP-120644	0292	-	Corrections to default overhead messages for HRPD	F	10.0.0	10.1.0	R5-121122
RP#56	RP-120644	0293	-	Corrections to default overhead messages for 1xRTT	F	10.0.0	10.1.0	R5-121123
RP#56	RP-120644	0294	-	Update of CSFBParametersRequest/ResponseCDMA2000 process in Registration	F	10.0.0	10.1.0	R5-121276
RP#56	RP-120641	0295	-	RRM: Definition of parameters for simulated GSM cells	F	10.0.0	10.1.0	R5-121357
RP#56	RP-120662	0296	-	SIB Combination for CA test scenarios	F	10.0.0	10.1.0	R5-121383
RP#56	RP-120644	0297	-	Addition of default value of RSRQ Cell Reselection parameters	F	10.0.0	10.1.0	R5-121384
RP#56	RP-120641	0298	-	Test frequencies for inter-band cells in RRM tests	F	10.0.0	10.1.0	R5-121407
RP#56	RP-120644	0299	-	Update generic procedure 4.5A.6	F	10.0.0	10.1.0	R5-121413
RP#56	RP-120644	0300	-	Update generic procedure 4.5A.7	F	10.0.0	10.1.0	R5-121414
RP#56	RP-120644	0301	-	Update generic procedure 4.5A.3	F	10.0.0	10.1.0	R5-121439
RP#56	RP-120644	0302	-	Correction to RadioResourceConfigCommon-DEFAULT	F	10.0.0	10.1.0	R5-121447
RP#56	RP-120641	0304	-	Removing 5.2A.3 for State 2A	F	10.0.0	10.1.0	R5-121521
RP#56	RP-120641	0305	-	Addition of A-GNSS testing to Test frequencies clause 4.3.1	F	10.0.0	10.1.0	R5-121543
RP#56	RP-120641	0306	-	Ensuring all SS TX antennas are in use for whole test sequence	F	10.0.0	10.1.0	R5-121544
RP#56	RP-120641	0307	-	Connection diagram for RRM 3 cell TCs with static propagation	F	10.0.0	10.1.0	R5-121556
RP#56	RP-120644	0308	-	Correction of Physical Layer configurations tables	F	10.0.0	10.1.0	R5-121665
RP#56	RP-120644	0309	-	Update of default bandwidth configuration for E-UTRA FDD band 11 and 18	F	10.0.0	10.1.0	R5-121712
RP#56	RP-120644	0310	-	Correction to default SIB4 contents for CSG cells	F	10.0.0	10.1.0	R5-121733
RP#56	RP-120644	0311	-	Update of CDMA2000 Band Class data and addition of CDMA2000 Band Class 10	F	10.0.0	10.1.0	R5-121734
RP#56	RP-120644	0312	-	Update to Reference dedicated EPS bearer context #3	F	10.0.0	10.1.0	R5-121735
RP#56	RP-120644	0313	-	Add generic procedure MO video call	F	10.0.0	10.1.0	R5-121736

Meeting-1st-Level	Doc-1st-Level	CR	Rev	Subject	Cat	Version-Current	Version-New	Doc-2nd-Level
RP#56	RP-120644	0314	-	Add generic procedure MT video call	F	10.0.0	10.1.0	R5-121737
RP#56	RP-120644	0315	-	Clarifications to UICC requirements for LTE-C2K testing	F	10.0.0	10.1.0	R5-121809
RP#56	RP-120644	0316	-	Update UE capability information	F	10.0.0	10.1.0	R5-121847
RP#56	RP-120658	0317	-	Introduction of System information for PWS	F	10.0.0	10.1.0	R5-121854
RP#56	RP-120662	0318	-	Update of the default value of Carrier Aggregation parameters	F	10.0.0	10.1.0	R5-121856
RP#56	RP-120644	0319	-	Correction to reference system configurations for dual mode scenarios	F	10.0.0	10.1.0	R5-121888
RP#56	RP-120667	0320	-	Adding operating band 26 to TS 36.508	F	10.0.0	10.1.0	R5-121905
RP#56	RP-120641	0321	-	Addition of State 3B-RF in 36.508	F	10.0.0	10.1.0	R5-121919
RP#56	RP-120641	0322	-	Correction to Tracking area updating procedure in 36.508	F	10.0.0	10.1.0	R5-121936
RP#56	RP-120662	0323	-	Addition of Test mode call procedure for CA test cases	F	10.0.0	10.1.0	R5-121982
RP#56	RP-120641	0303	-	Correction to Handover to UTRAN commands for UTRA RRC messages in 36.508	F	10.0.0	10.1.0	R5-122018
RP#56	RP-120662	0324	-	36.508 - Test frequencies for CA_1C and CA_40C	F	10.0.0	10.1.0	R5-122134
RP#57	RP-121098	0325	-	Correction to default message content of UTRA NAS attach accept message	F	10.1.0	10.2.0	R5-123114
RP#57	RP-121098	0326	-	Correction default message content for Tracking Area Update Request message	F	10.1.0	10.2.0	R5-123117
RP#57	RP-121095	0327	-	RF: Addition of messages and SIB combination informations for RF MBMS tests	F	10.1.0	10.2.0	R5-123211
RP#57	RP-121098	0328	-	Clarify requirements for ROHC	F	10.1.0	10.2.0	R5-123259
RP#57	RP-121098	0329	-	Updates to cl 6.x regarding use of MIMO	F	10.1.0	10.2.0	R5-123304
RP#57	RP-121113	0330	-	Update of default parameters for Carrier Aggregation	F	10.1.0	10.2.0	R5-123305
RP#57	RP-121098	0331	-	Addition of default value of Additional update parameters	F	10.1.0	10.2.0	R5-123306
RP#57	RP-121098	0332	-	Addition of default value of Explicit Signalling Indication parameters	F	10.1.0	10.2.0	R5-123307
RP#57	RP-121095	0333	-	Update of NeighCellConfig for RRM tests	F	10.1.0	10.2.0	R5-123328
RP#57	RP-121095	0334	-	Correction to HO commands for UTRAN TDD	F	10.1.0	10.2.0	R5-123329
RP#57	RP-121116	0335	-	Addition of new connection diagrams for UL-MIMO Testing	F	10.1.0	10.2.0	R5-123390
RP#57	RP-121098	0336	-	Correction to generic test procedure CS fallback to GERAN with redirection or CCO / MT call(DTM not supported)	F	10.1.0	10.2.0	R5-123629
RP#57	RP-121098	0337	-	Correction to RRC Connection Reconfiguration message during Handover from UTRA to EUTRA	F	10.1.0	10.2.0	R5-123630
RP#57	RP-121098	0338	-	Update to Reference dedicated EPS bearer context #3	F	10.1.0	10.2.0	R5-123632
RP#57	RP-121098	0339	-	Update generic procedure 4.5A.6	F	10.1.0	10.2.0	R5-123633
RP#57	RP-121098	0340	-	Update generic procedure 4.5A.7	F	10.1.0	10.2.0	R5-123634
RP#57	RP-121098	0341	-	Update generic procedure 4.5A.8	F	10.1.0	10.2.0	R5-123635
RP#57	RP-121098	0342	-	Update generic procedure 4.5A.9	F	10.1.0	10.2.0	R5-123636

Meeting-1st-Level	Doc-1st-Level	CR	Rev	Subject	Cat	Version-Current	Version-New	Doc-2nd-Level
RP#57	RP-121098	0343	-	Update the default value of IE RadioResourceConfigCommon and IE additionalSpectrumEmission	F	10.1.0	10.2.0	R5-123712
RP#57	RP-121098	0344	-	Correction to test procedure 6.4.2.10	F	10.1.0	10.2.0	R5-123720
RP#57	RP-121098	0345	-	Corrections to CDMA2000 message sequences	F	10.1.0	10.2.0	R5-123728
RP#57	RP-121098	0346	-	Update of UE Capability Information	F	10.1.0	10.2.0	R5-123729
RP#57	RP-121098	0347	-	Update of Paging test procedure (for NAS test cases)	F	10.1.0	10.2.0	R5-123730
RP#57	RP-121098	0348	-	Addition of guard timer to the procedure for IMS signalling	F	10.1.0	10.2.0	R5-123731
RP#57	RP-121098	0349	-	Update to cl. 6.4.2.7A and 7.2B.1	F	10.1.0	10.2.0	R5-123734
RP#57	RP-121113	0351	-	Extension of cell configurations for Carrier Aggregation	F	10.1.0	10.2.0	R5-123751
RP#57	RP-121113	0352	-	Maximum number of cells simultaneously used in Carrier Aggregation test cases	F	10.1.0	10.2.0	R5-123752
RP#57	RP-121098	0353	-	Update of default MSPL and MLPL contents in Test UICC	F	10.1.0	10.2.0	R5-123767
RP#57	RP-121113	0354	-	Correction to the CA test state references	F	10.1.0	10.2.0	R5-123949
RP#58	RP-121681	0356	-	Addition of new connection diagram for UL-MIMO testing	F	10.2.0	10.3.0	R5-125107
RP#58	RP-121659	0357	-	Update to test procedure sequence 6.4.2.7A for check that UE is camped on E-UTRAN cell upon mobility from another RAT	F	10.2.0	10.3.0	R5-125116
RP#58	RP-121677	0358	-	Introduction of connection diagrams for CA tests	F	10.2.0	10.3.0	R5-125187
RP#58	RP-121685	0359	-	Addition of default message contents for ESM NOTIFICATION message	F	10.2.0	10.3.0	R5-125219
RP#58	RP-121659	0360	-	Modification of measurement configuration for UTRAN FDD SIG	F	10.2.0	10.3.0	R5-125283
RP#58	RP-121659	0361	-	Clarification of table 6.6.2-1	F	10.2.0	10.3.0	R5-125287
RP#58	RP-121656	0362	-	Addition of channel bandwidth tested for E-UTRA FDD band 19	F	10.2.0	10.3.0	R5-125303
RP#58	RP-121656	0363	-	Correction of circulator in connection diagrams	F	10.2.0	10.3.0	R5-125370
RP#58	RP-121656	0364	-	Correction to test channel numbers for Band 26	F	10.2.0	10.3.0	R5-125372
RP#58	RP-121656	0365	-	Update of Chw Bw Parameters for 1.4MHz and 3MHz	F	10.2.0	10.3.0	R5-125373
RP#58	RP-121659	0366	-	Update generic procedure 4.5A.7	F	10.2.0	10.3.0	R5-125530
RP#58	RP-121659	0367	-	Update of default ROUTING AREA UPDATE REQUEST message	F	10.2.0	10.3.0	R5-125545
RP#58	RP-121690	0368	-	CA_38: Addition of new test frequency for CA band 38	F	10.2.0	10.3.0	R5-125573
RP#58	RP-121689	0369	-	Addition of Band 28 definition	F	10.2.0	10.3.0	R5-125778
RP#58	RP-121685	0370	-	Add generic procedure for IMS MO speech and aSRVCC	F	10.2.0	10.3.0	R5-125792
RP#58	RP-121677	0371	-	Modification to state 3A-RF-CA initial conditions of clause 5.2A.4	F	10.2.0	10.3.0	R5-125800
RP#58	RP-121688	0372	-	Introduction of Band 27 to TS 36.508	F	10.2.0	10.3.0	R5-125832
RP#58	RP-121677	0373	-	Update of RF Reference system configurations in 36.508	F	10.2.0	10.3.0	R5-125933

Meeting-1st-Level	Doc-1st-Level	CR	Rev	Subject	Cat	Version-Current	Version-New	Doc-2nd-Level
RP#58	RP-121659	0374	-	Using not null integrity protection and ciphering algorithms by default	F	10.2.0	10.3.0	R5-126020
RP#58	RP-121677	0375	-	Introducing default channel bandwidth for CA signalling testing	F	10.2.0	10.3.0	R5-126053
RP#59	RP-130156	0377	-	Addition of new connection diagram for UL-MIMO testing	F	10.3.0	10.4.0	R5-130136
RP#59	RP-130145	0378	-	AWGN Level uncertainty for Signalling test cases	F	10.3.0	10.4.0	R5-130201
RP#59	RP-130144	0379	-	Correction to CDMA2000Parameters message contents	F	10.3.0	10.4.0	R5-130202
RP#59	RP-130167	0380	-	Addition of SCell configuration type	F	10.3.0	10.4.0	R5-130311
RP#59	RP-130145	0382	-	Addition of default message contents of measurement information elements for event A4 and A5 measurement test cases	F	10.3.0	10.4.0	R5-130363
RP#59	RP-130144	0383	-	Correction to ncc-Permitted value to TS 36.508	F	10.3.0	10.4.0	R5-130453
RP#59	RP-130167	0384	-	Correction to EARFCN definition for CA_40C	F	10.3.0	10.4.0	R5-130477
RP#59	RP-130144	0385	-	Addition of combination A2+A11 and condition "UTRA Speech + Packet RAB Setup after Speech RAB Setup in CELL_DCH in Table 4.7B.1-1: HANDOVER TO UTRAN COMMAND	F	10.3.0	10.4.0	R5-130561
RP#59	RP-130144	0386	-	Update of Band 18 configuration	F	10.3.0	10.4.0	R5-130619
RP#59	RP-130144	0387	-	Update generic procedure 4.5.2	F	10.3.0	10.4.0	R5-130620
RP#59	RP-130144	0388	-	Update generic procedure 4.5.2A	F	10.3.0	10.4.0	R5-130621
RP#59	RP-130144	0389	-	Add generic procedure MO add video	F	10.3.0	10.4.0	R5-130622
RP#59	RP-130144	0390	-	Add generic procedure MT add video	F	10.3.0	10.4.0	R5-130623
RP#59	RP-130167	0391	-	Correction of test frequencies for CA signalling tests	F	10.3.0	10.4.0	R5-130692
RP#59	RP-130146	0395	-	Addition of simulated cell for E-UTRA dual mode multi cell network scenarios	F	10.3.0	10.4.0	R5-130709
RP#59	RP-130167	0397	-	Corrections to Annex A general considerations on connections for CA testing	F	10.3.0	10.4.0	R5-130900
RP#59	RP-130165	0376	-	Addition of test frequencies of CA_1A-19A and CA_1A-21A for CA signalling testing	F	10.4.0	11.0.0	R5-130087
RP#59	RP-130165	0381	-	Addition of test frequencies for CA_7C and CA_41C signalling test	F	10.4.0	11.0.0	R5-130343
RP#59	RP-130165	0392	-	Addition of test frequencies of CA_38, CA_3-7 and CA_7-20 for CA signalling test	F	10.4.0	11.0.0	R5-130694
RP#59	RP-130165	0393	-	Addition of test frequencies of CA_4A-5A and CA_4A-13A for CA signalling testing	F	10.4.0	11.0.0	R5-130695
RP#59	RP-130165	0394	-	Updates of 6.2.3.2 Test frequency for CA_1A-18A and 11A-18A	F	10.4.0	11.0.0	R5-130696
RP#59	RP-130164	0396	-	Adding operating band 44 to TS36.508	F	10.4.0	11.0.0	R5-130710
RP#59	RP-130165	0398	-	Addition of new test frequencies for CA band 7 and band 41	F	10.4.0	11.0.0	R5-130955
RP#60	RP-130609	0399	-	Update of CDMA2000 specification references: TS 36.508	F	10.4.0	11.1.0	R5-131067
RP#60	RP-130609	0401	-	Editorial Fix Hysteris values for event B1&B2 ReportConfigInterRAT for GERAN	F	10.4.0	11.1.0	R5-131090

Meeting-1st-Level	Doc-1st-Level	CR	Rev	Subject	Cat	Version-Current	Version-New	Doc-2nd-Level
RP#60	RP-130622	0402	-	eICIC: Connection diagram for 2x2 antenna configuration scenarios	F	10.4.0	11.1.0	R5-131116
RP#60	RP-130636	0403	-	CA: Connection diagrams for RRM tests	F	10.4.0	11.1.0	R5-131117
RP#60	RP-130609	0404	-	Clarification to ncc-Permitted value interpretation in TS 36.508	F	10.4.0	11.1.0	R5-131322
RP#60	RP-130626	0405	-	Maintenance of Band 23 Requirements in TS 36.508	F	10.4.0	11.1.0	R5-131462
RP#60	RP-130626	0406	-	Adding IE T3412 extended value	F	10.4.0	11.1.0	R5-131474
RP#60	RP-130611	0408	-	Addition of exception for p-MaxGERAN of SIB7	F	10.4.0	11.1.0	R5-131583
RP#60	RP-130627	0409	-	Correction of test bandwidth for band 44	F	10.4.0	11.1.0	R5-131611
RP#60	RP-130631	0410	-	Addition of default parameters for ePDCCH	F	10.4.0	11.1.0	R5-131638
RP#60	RP-130630	0411	-	Addition of default parameters for CoMP	F	10.4.0	11.1.0	R5-131667
RP#60	RP-130628	0412	-	Addition of test frequencies for CA_2A-17A and CA_4A-17A for signalling testing	F	10.4.0	11.1.0	R5-131704
RP#60	RP-130611	0413	-	Editorial update of generic procedure 4.5.2	F	10.4.0	11.1.0	R5-131804
RP#60	RP-130611	0414	-	Editorial update of generic procedure 4.5.2A	F	10.4.0	11.1.0	R5-131805
RP#60	RP-130609	0415	-	Correction of DRB Logical Channel configuration	F	10.4.0	11.1.0	R5-131806
RP#60	RP-130611	0416	-	Add generic procedure for XCAP establishment	F	10.4.0	11.1.0	R5-131807
RP#60	RP-130611	0417	-	Corrections to default messages for eMBMS testing	F	10.4.0	11.1.0	R5-131809
RP#60	RP-130611	0418	-	Complete the default MEASUREMENT CONTROL MESSAGE for LCR_TDD_UTRAN	F	10.4.0	11.1.0	R5-131872
RP#60	RP-130636	0419	-	Carrier Aggregation: PCC and SCC Configuration Update	F	10.4.0	11.1.0	R5-131885
RP#60	RP-130609	0420	-	Update of UE Capability Information for Rel-11 UEs	F	10.4.0	11.1.0	R5-131888
RP#60	RP-130636	0421	-	Modifications to Common Section CA settings	F	10.4.0	11.1.0	R5-132002
RP#60	RP-130636	0422	-	Correction to test frequencies for CA signalling test	F	10.4.0	11.1.0	R5-132027
RP#60	RP-130629	0423	-	Modification of default contents for UE Information Request message	F	10.4.0	11.1.0	R5-132029
RP#60	RP-130628	0424	-	Addition of test frequencies of CA_4-12, CA_5-12 for CA signalling test	F	10.4.0	11.1.0	R5-132041
RP#60	RP-130611	0426	-	Addition of generic procedure for IMS call release	F	10.4.0	11.1.0	R5-132066
RP#60	RP-130609	0425	-	Update of CSIM and USIM EFs	F	10.4.0	11.1.0	R5-132082
RP#60	RP-130609	0427	-	Corrections to setup of dedicated EPS bearer contexts in IMS generic procedures	F	10.4.0	11.1.0	R5-132085
RP#60	RP-130636	0428	-	Modifications to RF Section CA settings	F	10.4.0	11.1.0	R5-132106
RP#60	RP-130610	0429	-	Correction to generic MO CSFB procedures	F	10.4.0	11.1.0	R5-131496
RP#60	-	-	-	Correction in history table from v11.0.0 to v11.1.0	F	11.0.0	11.1.1	
RP#61	RP-131115	0460	-	Addition of frequency f2 to band combinations CA_2A-17A and CA_4A-17A	F	11.1.1	11.2.0	R5-133094
RP#61	RP-131115	0430	-	Addition of test frequencies of CA_3-8 for CA signaling test	F	11.1.1	11.2.0	R5-133113
RP#61	RP-131103	0431	-	Addition of option to use IP addresses from PCO IE in ESM INFORMATION RESPONSE	F	11.1.1	11.2.0	R5-133116

Meeting-1st-Level	Doc-1st-Level	CR	Rev	Subject	Cat	Version-Current	Version-New	Doc-2nd-Level
RP#61	RP-131101	0432	-	Update of CSIM Elementary File for EPRL	F	11.1.1	11.2.0	R5-133118
RP#61	RP-131103	0433	-	Correction to SystemInformationBlockType13 message (eMBMS testing)	F	11.1.1	11.2.0	R5-133159
RP#61	RP-131114	0434	-	Correction to default MBMS Counting messages	F	11.1.1	11.2.0	R5-133160
RP#61	RP-131111	0435	-	CA RRM: Phase rotator for intra-frequency static scenarios	F	11.1.1	11.2.0	R5-133224
RP#61	RP-131125	0436	-	Addition of Band 31 to 36.508	F	11.1.1	11.2.0	R5-133246
RP#61	RP-131111	0437	-	Test frequencies for RF intra-band contiguous CA tests	F	11.1.1	11.2.0	R5-133270
RP#61	RP-131115	0438	-	Update of PUCCH-ConfigDedicated-v1020-DEFAULT for TDD	F	11.1.1	11.2.0	R5-133275
RP#61	RP-131101	0439	-	Default Bandwidth Configuration for E-UTRA Band 2 RF Testing	F	11.1.1	11.2.0	R5-133306
RP#61	RP-131116	0440	-	Modification of default contents for UEInformationRequest message	F	11.1.1	11.2.0	R5-133321
RP#61	RP-131115	0441	-	Correction of reference to cell frequencies for CA signalling test cases	F	11.1.1	11.2.0	R5-133348
RP#61	RP-131101	0442	-	Correction to SID value	F	11.1.1	11.2.0	R5-133365
RP#61	RP-131101	0443	-	Update of generic procedure 4.5A.7	F	11.1.1	11.2.0	R5-133366
RP#61	RP-131101	0444	-	Update of generic procedure 4.5A.14	F	11.1.1	11.2.0	R5-133367
RP#61	RP-131111	0445	-	Update of Generic RRM procedures for CA	F	11.1.1	11.2.0	R5-133451
RP#61	RP-131113	0446	-	Default Message Contents for eCIC PCell Pattern	F	11.1.1	11.2.0	R5-133453
RP#61	RP-131103	0447	-	Corrections to the reference dedicated EPS bearer contexts	F	11.1.1	11.2.0	R5-133509
RP#61	RP-131101	0448	-	Extension of default contents of ACTIVATE DEFAULT EPS BEARER CONTEXT REQUESTS message	F	11.1.1	11.2.0	R5-133554
RP#61	RP-131101	0449	-	Corrections to allow ISIM or USIM to be used in test cases using IMS	F	11.1.1	11.2.0	R5-133582
RP#61	RP-131101	0450	-	Correction of Feature Group Indicators in Table 4.6.1-23	F	11.1.1	11.2.0	R5-133583
RP#61	RP-131101	0451	-	Correction to ROUTING AREA UPDATE ACCEPT default message contents	F	11.1.1	11.2.0	R5-133584
RP#61	RP-131115	0452	-	Addition of test frequencies of CA_3A-5A for CA signalling test	F	11.1.1	11.2.0	R5-133614
RP#61	RP-131115	0453	-	Extension of EUTRA CA test frequency configurations	F	11.1.1	11.2.0	R5-133615
RP#61	RP-131113	0454	-	Update of Measurement information element	F	11.1.1	11.2.0	R5-133645
RP#61	RP-131117	0455	-	Introduction of new default messages for eMBMS service continuity testing	F	11.1.1	11.2.0	R5-133661
RP#61	RP-131117	0456	-	Introduction of system information combinations for eMBMS service continuity testing	F	11.1.1	11.2.0	R5-133662
RP#61	RP-131118	0457	-	Addition of specific message formats for eDDA test cases.	F	11.1.1	11.2.0	R5-133674
RP#61	RP-131101	0458	-	Missing agreed change in 36.508	F	11.1.1	11.2.0	R5-133704
RP#61	RP-131101	0459	-	Clean up of 36.508	F	11.1.1	11.2.0	R5-133714
RP#62	RP-131864	0461	-	Correction of MBSFNAreaConfiguration and SIB combination 15	F	11.2.0	11.3.0	R5-134152

Meeting-1st-Level	Doc-1st-Level	CR	Rev	Subject	Cat	Version-Current	Version-New	Doc-2nd-Level
RP#62	RP-131874	0465	-	Correction to MeasConfig-DEFAULT	F	11.2.0	11.3.0	R5-134459
RP#62	RP-131876	0466	-	General clarification to CA test frequency tables for signalling	F	11.2.0	11.3.0	R5-134642
RP#62	RP-131861	0467	-	Update to MeasConfig-DEFAULT	F	11.2.0	11.3.0	R5-134645
RP#62	RP-131861	0469	-	Editorial correction to generic MO CSFB procedures	F	11.2.0	11.3.0	R5-134726
RP#62	RP-131864	0470	-	Corrections to default message contents of MBMSCountingRequest	F	11.2.0	11.3.0	R5-134727
RP#62	RP-131876	0471	-	Extension of default settings for the Elementary Files on Test UICC	F	11.2.0	11.3.0	R5-134730
RP#62	RP-131877	0472	-	Addition of CA band combinations CA_2A_29A, CA_4A_29A and CA_5A_17A	F	11.2.0	11.3.0	R5-134786
RP#62	RP-131873	0475	-	Addition of connection diagrams for CA CSI tests	F	11.2.0	11.3.0	R5-134803
RP#62	RP-131873	0477	-	Correction to PhysicalConfigDedicated-DEFAULT for SCell_AddMod	F	11.2.0	11.3.0	R5-134903
RP#62	RP-131873	0478	-	Clarification of multi antenna ports for all neighboring cells	F	11.2.0	11.3.0	R5-134904
RP#62	RP-131877	0480	-	Addition of B29 test frequencies to 36.508	F	11.2.0	11.3.0	R5-134986
RP#62	RP-131861	0481	-	Corrections to procedures for State 3A-RF	F	11.2.0	11.3.0	R5-135013
RP#62	RP-131864	0468	-	Correction to Generic Test Procedure for IMS Emergency call establishment in EUTRA: Limited Service	F	11.2.0	11.3.0	R5-135069
RP#62	RP-131864	0479	-	Correction of generic test procedure for IMS Emergency Call establishment in EUTRA limited service	F	11.2.0	11.3.0	R5-135070
RP#62	RP-131890	0462	-	Addition of test frequencies for CA_3C	F	11.3.0	12.0.0	R5-134336
RP#62	RP-131890	0463	-	Updates of 6.2.3.2 Test frequencies for CA_1A-26A	F	11.3.0	12.0.0	R5-134368
RP#62	RP-131890	0464	-	Addition of CA band combination CA_2A_5A	F	11.3.0	12.0.0	R5-134426
RP#62	RP-131873	0473	-	Addition of test frequencies of CA_3A-19A and CA_19A-21A for CA signalling testing	F	11.3.0	12.0.0	R5-134790
RP#62	RP-131890	0474	-	Addition of test frequencies for CA_3C signalling test	F	11.3.0	12.0.0	R5-134791
RP#63	RP-140329	0482	-	Adding default message content for SystemInformationBlockType14	F	12.0.0	12.1.0	R5-140075
RP#63	RP-140307	0484	-	Correction of UTRA cell carrier frequency in Table 6.3.1.3-2	F	12.0.0	12.1.0	R5-140136
RP#63	R5-140319	0485	-	CA RF: Adding connection diagram for CA 4x2 MIMO with fading scenarios	F	12.0.0	12.1.0	R5-140242
RP#63	R5-140319	0486	-	eDL-MIMO RF: Adding connection diagram for 8x2 MIMO scenarios	F	12.0.0	12.1.0	R5-140243
RP#63	RP-140307	0487	-	Correction to Table 6.4.2.7A.1-1 for TAU Request	F	12.0.0	12.1.0	R5-140325
RP#63	RP-140308	0488	-	Update of MBMS configurations	F	12.0.0	12.1.0	R5-140394
RP#63	RP-140332	0489	-	Addition of test frequencies for CA_1A-8A	F	12.0.0	12.1.0	R5-140406
RP#63	R5-140319	0490	-	Correction to UL CA message exceptions	F	12.0.0	12.1.0	R5-140503
RP#63	RP-140308	0492	-	Correction to Generic Test Procedure for IMS Emergency call establishment in EUTRA: Limited Service	F	12.0.0	12.1.0	R5-140536

Meeting-1st-Level	Doc-1st-Level	CR	Rev	Subject	Cat	Version-Current	Version-New	Doc-2nd-Level
RP#63	R5-140319	0493	-	Update to QuantityConfig in MeasConfig DEFAULT	F	12.0.0	12.1.0	R5-140743
RP#63	RP-140331	0494	-	Correction of CA band combinations CA_1A_18A and CA_11A_18A	F	12.0.0	12.1.0	R5-140744
RP#63	R5-140319	0495	-	Adding test frequencies for CA reverse inter band combination for bands 4 and 13	F	12.0.0	12.1.0	R5-140745
RP#63	RP-140307	0496	-	Update to Generic test procedure in TS 36.508 Table 6.4.2.7A-2	F	12.0.0	12.1.0	R5-140746
RP#63	RP-140307	0497	-	Addition of procedure for EPS Bearer Deactivation and deletion of procedure for MT release of IMS call	F	12.0.0	12.1.0	R5-140747
RP#63	RP-140332	0498	-	Addition of Rel12 reverse band combination CA_2A-5A	F	12.0.0	12.1.0	R5-140789
RP#63	RP-140325	0499	-	Addition of neighbour cell CRS and dedicated SIB-1 IE for fEICIC test cases	F	12.0.0	12.1.0	R5-140830
RP#63	R5-140319	0500	-	Addition of transmissionMode-r10 for SCC	F	12.0.0	12.1.0	R5-140928
RP#63	RP-140331	0501	-	Addition of Rel11 reverse band combinations CA_2A-29A, CA_4A-5A, CA_4A-29A, CA_5A-17A	F	12.0.0	12.1.0	R5-140998
RP#63	RP-140302	0502	-	Change of test frequencies for Band 28	F	12.0.0	12.1.0	R5-141039
RP#64	RP-140838	0503	-	Addition of CA 3A-28A to 36.508	F	12.1.0	12.2.0	R5-142114
RP#64	RP-140812	0504	-	Update to MEASUREMENT CONTROL	F	12.1.0	12.2.0	R5-142126
RP#64	RP-140815	0505	-	Update to default non-MBSFNregionLength in SystemInformationBlockType13	F	12.1.0	12.2.0	R5-142127
RP#64	RP-140815	0506	-	Editorial Update to Table 4.6.1-4A: MBSFNAreaConfiguration	F	12.1.0	12.2.0	R5-142128
RP#64	RP-140837	0507	-	Correction to default SystemInformationBlockType15 message for eMBMS testing	F	12.1.0	12.2.0	R5-142254
RP#64	RP-140838	0508	-	Updates of 6.2.3.2 Test frequency for CA_3A-26A and CA_3A-27A	F	12.1.0	12.2.0	R5-142299
RP#64	RP-140832	0509	-	Adding connection diagrams for RF/RRM Rel-11 WI-s tests	F	12.1.0	12.2.0	R5-142318
RP#64	RP-140832	0510	-	Addition of exceptions for fEICIC RRM test cases	F	12.1.0	12.2.0	R5-142336
RP#64	RP-140812	0511	-	Correction to NAS UTRA Routing Area Update Accept message	F	12.1.0	12.2.0	R5-142397
RP#64	RP-140812	0512	-	Correction to the exception of SIB2	F	12.1.0	12.2.0	R5-142602
RP#64	RP-140812	0513	-	Addition of 4Tx for RF demodulation test cases	F	12.1.0	12.2.0	R5-142603
RP#64	RP-140838	0514	-	Addition of test frequencies for CA_2A-4A and CA_5A-7A	F	12.1.0	12.2.0	R5-142768
RP#64	RP-140837	0515	-	Correction to system information combination 16 and 19 for eMBMS testing	F	12.1.0	12.2.0	R5-142844
RP#64	RP-140817	0516	-	Update to ri-ConfigIndex in Table 4.6.3-2AC CQI-ReportPeriodic-r10-DEFAULT	F	12.1.0	12.2.0	R5-142845
RP#64	RP-140815	0517	-	Correction to MFBI Frequencies in 36.508	F	12.1.0	12.2.0	R5-142846
RP#64	RP-140838	0518	-	Addition of test frequencies of CA_39A-41A for CA signalling testing in TS 36.508	F	12.1.0	12.2.0	R5-142928
RP#64	RP-140838	0519	-	Updates to TS 36.508 for CA_27B signalling test frequencies defined in section 6.2.3.2	F	12.1.0	12.2.0	R5-142930
RP#64	RP-140817	0520	-	Clarification of RRC message definitions	F	12.1.0	12.2.0	R5-143001

Meeting-1st-Level	Doc-1st-Level	CR	Rev	Subject	Cat	Version-Current	Version-New	Doc-2nd-Level
RP#64	RP-140817	0521	-	Corrections to MBMS information elements in SIB2 and SIB13	F	12.1.0	12.2.0	R5-143002
RP#64	RP-140838	0522	-	Addition of new test frequency for CA_39C	F	12.1.0	12.2.0	R5-143132
RP#64	RP-140838	0523	-	Updates to TS 36.508 for CA_27B test frequencies defined in section 4.3.1.1	F	12.1.0	12.2.0	R5-143171
RP#65	RP-141573	0524	-	Correction to notificationSF-Index-r9 in Sib13	F	12.2.0	12.3.0	R5-144185
RP#65	RP-141571	0525	-	IMS APN pre-configured IR.92 devices	F	12.2.0	12.3.0	R5-144370
RP#65	RP-141571	0526	-	Removal of transition period for Band 28 test frequency definition in 36.508	F	12.2.0	12.3.0	R5-144459
RP#65	RP-141593	0527	-	Addition of Rel11 reverse band combinations CA_1A-18A, CA_11A-18A	F	12.2.0	12.3.0	R5-144543
RP#65	RP-141594	0528	-	Addition of Rel12 reverse band combination CA_1A-26A	F	12.2.0	12.3.0	R5-144544
RP#65	RP-141593	0529	-	Editorial correction to Table 6.2.3.2-2	F	12.2.0	12.3.0	R5-144644
RP#65	RP-141594	0530	-	Addition of reverse band combinations, CA_1A-19A, CA_1A-21A, CA_3A-19A and CA_19A-21A	F	12.2.0	12.3.0	R5-144685
RP#65	RP-141587	0531	-	Addition of default parameters for Enhanced downlink control channel(s) for LTE Advanced	F	12.2.0	12.3.0	R5-144711
RP#65	RP-141593	0532	-	Removal of FFS from IEs triggered by CoMP related TCs specification	F	12.2.0	12.3.0	R5-144712
RP#65	RP-141571	0533	-	Clarification on the default setting of Security header type in SECURITY PROTECTED NAS MESSAGE	F	12.2.0	12.3.0	R5-144750
RP#65	RP-141571	0534	-	Support of 2nd PDN connectivity at UE registration	F	12.2.0	12.3.0	R5-144797
RP#65	RP-141575	0535	-	CA: New structure for test frequencies for intra-band contiguous CA	F	12.2.0	12.3.0	R5-144890
RP#65	RP-141575	0536	-	Correction to 7.2B.1 Tracking Area Updating procedure	F	12.2.0	12.3.0	R5-144929
RP#65	-	-	-	Correction concerning R5-144797 to resolve the 4.5A.X, 4.5A.Y, 4.5A.Z reference in Table 4.5.2.3-1	-	12.3.0	12.3.1	-
RP#66	RP-142075	0538	-	New CA band combination CA_1A-3A - Updates of 6.2.3.2 Test Frequency		12.3.1	12.4.0	R5-145181
RP#66	RP-142076	0539	-	Addition of E-UTRA FDD Band 30 to TS 36.508, subclause 6.2.3.1.		12.3.1	12.4.0	R5-145606
RP#66	RP-142054	0540	-	Correction to SIB8 Default Message Contents for LTE<>1XRTT		12.3.1	12.4.0	R5-145657
RP#66	RP-142057	0541	-	Correction to Test frequencies for E-UTRA FDD(5MHz) for MFBI		12.3.1	12.4.0	R5-145658
RP#66	RP-142057	0542	-	Updating dataCodingScheme of CMAS TC in 36.508		12.3.1	12.4.0	R5-145659
RP#66	RP-142074	0543	-	Correction of default parameters for Enhanced downlink control channel(s) for LTE Advanced		12.3.1	12.4.0	R5-145661
RP#66	RP-142074	0544	-	Correction to eMBMS multiband test cases		12.3.1	12.4.0	R5-145662
RP#66	RP-142059	0545	-	Harmonization of CA terminology (36.508)		12.3.1	12.4.0	R5-145663
RP#66	RP-142054	0546	-	Correction to Test Frequencies for FDD Band 12->17 for 5MHZ		12.3.1	12.4.0	R5-145686
RP#66	RP-142075	0547	-	Addition of CA_1A-28A in 36.508		12.3.1	12.4.0	R5-145715
RP#66	RP-142075	0548	-	Introduction of 1+11 and 8+11 in 36.508		12.3.1	12.4.0	R5-145716

Meeting-1st-Level	Doc-1st-Level	CR	Rev	Subject	Cat	Version-Current	Version-New	Doc-2nd-Level
RP#66	RP-142075	0549	-	Addition of Intra-Band Non-Contiguous Default Frequencies to 36.508 Chapter 6		12.3.1	12.4.0	R5-145717
RP#66	RP-142078	0550	-	Addition of CA_18A-28A in 36.508		12.3.1	12.4.0	R5-145718
RP#66	RP-142075	0551	-	Existing CA band combination CA_39C: update test frequencies for CA_39C signalling test		12.3.1	12.4.0	R5-145739
RP#66	RP-142054	0552	-	Correction to generic procedure for EPS Bearer Deactivation		12.3.1	12.4.0	R5-145774
RP#66	RP-142054	0553	-	Corrections for Generic Test Procedure for IMS MO/MT add video establishment in E-UTRA (clause 4.5A.11 and 4.5A.12)		12.3.1	12.4.0	R5-145779
RP#66	RP-142054	0554	-	Support of 2nd PDN connectivity at UE registration - XCAP		12.3.1	12.4.0	R5-145787
RP#66	RP-142054	0555	-	Correction of CSIM Elementary File for EPRL		12.3.1	12.4.0	R5-145792
RP#66	RP-142059	0556	-	Correction of SCell_AddMod condition in MAC Configurations		12.3.1	12.4.0	R5-145793
RP#66	RP-142059	0557	-	Addition of CA_4A-7A and CA_3A-20A Test Frequencies		12.3.1	12.4.0	R5-145799
RP#66	RP-142076	0558	-	Addition of operating band 30 to TS 36.508, subclause 4.3.1.1.30		12.3.1	12.4.0	R5-145850
RP#66	RP-142059	0559	-	Addition of editor's note for MFBI Test frequencies		12.3.1	12.4.0	R5-145879
RP#66	RP-142079	0560	-	Clarifications to connection diagrams		12.3.1	12.4.0	R5-145897
RP#66	RP-142059	0562	-	Correction to message exceptions for felCIC tests		12.3.1	12.4.0	R5-145916
RP#66	RP-142075	0563	-	CA: Test frequencies for intra-band non-contiguous		12.3.1	12.4.0	R5-145923
RP#66	RP-142075	0564	-	Introduction of CA_42C for TS36.508		12.3.1	12.4.0	R5-145959
RP#66	RP-142059	0565	-	TS 36.508: Correction to CA intra-band contiguous test frequencies		12.3.1	12.4.0	R5-145962
RP#66	RP-142054	0566	-	Correction to generic procedure for UE Registration, pre-registration on 1xRTT (State 2C)		12.3.1	12.4.0	R5-145971
RP#66	RP-142054	0561	-	UE registration for RF and RRM testing		12.3.1	12.4.0	R5-145979
-	-	-	-	correction of closing bracket in Table 5.2A.5.1.1-2 of R5-145916		12.4.0	12.4.1	-
-	-	-	-	correction of missing changes of R5-145787		12.4.0	12.4.1	-
RP#67	RP-150342	0567	-	Correction to CA_19A-21A, CA_39A-41A	F	12.4.1	12.5.0	R5-150103
RP#67	RP-150323	0568	-	Support of 2nd PDN connectivity at UE registration - Corrections for C2K	F	12.4.1	12.5.0	R5-150127
RP#67	RP-150326	0570	-	Correction of MFBI Test Frequencies for Band 38->41	F	12.4.1	12.5.0	R5-150273
RP#67	RP-150341	0571	-	Addition of CA_8A-20A to Clause 6.2.3.2 of TS 36.508	F	12.4.1	12.5.0	R5-150367
RP#67	RP-150343	0572	-	Addition of CA_1A-20A to Clause 6.2.3.2 of TS 36.508	F	12.4.1	12.5.0	R5-150480
RP#67	RP-150342	0575	-	Correction to TDD CA contiguous Intra-band setting for signalling test	F	12.4.1	12.5.0	R5-150679
RP#67	RP-150342	0576	-	Addition of Signalling test frequencies to 36.508 for CA_1A-7A	F	12.4.1	12.5.0	R5-150680
RP#67	RP-150343	0577	-	Addition of CA_2A-30A to Clause 6.2.3.2 of TS 36.508.	F	12.4.1	12.5.0	R5-150682
RP#67	RP-150343	0578	-	Addition of CA_4A-30A to Clause 6.2.3.2 of TS 36.508.	F	12.4.1	12.5.0	R5-150683

Meeting-1st-Level	Doc-1st-Level	CR	Rev	Subject	Cat	Version-Current	Version-New	Doc-2nd-Level
RP#67	RP-150343	0579	-	Addition of CA_5A-30A to Clause 6.2.3.2 of TS 36.508.	F	12.4.1	12.5.0	R5-150684
RP#67	RP-150342	0580	-	Addition of Signalling test frequencies to 36.508 for CA_5A-25A and CA_12A-25A	F	12.4.1	12.5.0	R5-150722
RP#67	RP-150343	0581	-	Correction to CA_18A-28A SIG test frequency in 36.508	F	12.4.1	12.5.0	R5-150743
RP#67	RP-150342	0582	-	Addition of test frequency table for Band 23B to 36.508	F	12.4.1	12.5.0	R5-150859
RP#67	RP-150343	0583	-	Addition of test frequencies for CA_18A-28A in 36.508	F	12.4.1	12.5.0	R5-150864
RP#67	RP-150343	0584	-	Addition of 3DL Intra-band Contiguous and Non-contiguous Test Frequencies	F	12.4.1	12.5.0	R5-150895
RP#67	RP-150342	0585	-	Addition of further test frequencies for Intra-band Non-contiguous 2DL CA	F	12.4.1	12.5.0	R5-150896
RP#67	RP-150343	0586	-	Update of SCC configuration for 3DL CA RF/RRM tests	F	12.4.1	12.5.0	R5-150912
RP#67	RP-150345	0569	-	Addition of UE Positioning testing to State 3A	F	12.4.1	12.5.0	R5-150933
RP#67	RP-150342	0573	-	Addition of Signalling test frequencies to 36.508 for CA_23B	F	12.4.1	12.5.0	R5-150936
RP#67	RP-150342	0574	-	Addition of Signalling test frequencies to 36.508 for CA_23A-29A	F	12.4.1	12.5.0	R5-150937
RP#68	RP-150886	0587	-	APN IE requirements for IMS emergency PDN	F	12.5.0	12.6.0	R5-151104
RP#68	RP-150900	0588	-	CA RF: Connection diagrams for 3DL CA (RF) testing	F	12.5.0	12.6.0	R5-151113
RP#68	RP-150905	0592	-	Addition of band 32 to 36.508	F	12.5.0	12.6.0	R5-151327
RP#68	RP-150912	0594	-	Updates to 36.508 for CA_7C, CA_40C, CA_41C, CA_41D	F	12.5.0	12.6.0	R5-151365
RP#68	RP-150888	0595	-	Change of default Network Signalling Value for Uplink Carrier aggregation test cases	F	12.5.0	12.6.0	R5-151423
RP#68	RP-150900	0602	-	Addition of test frequencies for CA_1A-18A-28A in 36.508	F	12.5.0	12.6.0	R5-151582
RP#68	RP-150900	0604	-	Correction to test frequencies for CA_18A-28A in 36.508	F	12.5.0	12.6.0	R5-151626
RP#68	RP-150900	0607	-	36.508: Test frequencies definition for CA_12B	F	12.5.0	12.6.0	R5-151658
RP#68	RP-150900	0608	-	36.508: Signalling test frequencies definition for CA_12B	F	12.5.0	12.6.0	R5-151660
RP#68	RP-150888	0601	1	Addition of Carrier Aggregation band combination 2 to 13	F	12.5.0	12.6.0	R5-151737
RP#68	RP-150912	0603	1	Removal of SIB1 transmission in 5.2A.5 Exceptions for feICIC tests	F	12.5.0	12.6.0	R5-151801
RP#68	RP-150888	0600	1	Addition of exception of RRC Connection Setup(UTRA)	F	12.5.0	12.6.0	R5-151804
RP#68	RP-150900	0591	1	Addition of 2DL CA and 3DL CA Frequencies to 36.508 Chapter 6	F	12.5.0	12.6.0	R5-151967
RP#68	RP-150909	0590	1	Update of default SIB1 for Low Cost MTC testing	F	12.5.0	12.6.0	R5-151975
RP#68	RP-150906	0596	2	Add generic procedure for IMS MO speech for EVS	F	12.5.0	12.6.0	R5-151976
RP#68	RP-150903	0598	1	Introduction of EUTRA-WLAN interworking test environment parameters and message contents	F	12.5.0	12.6.0	R5-151995
RP#68	RP-150908	0589	1	Addition of Device to Device Proximity Services Test Environment	F	12.5.0	12.6.0	R5-152058
RP#68	RP-150903	0599	1	Introduction of generic procedures for EUTRA-WLAN	F	12.5.0	12.6.0	R5-152117

Meeting-1st-Level	Doc-1st-Level	CR	Rev	Subject	Cat	Version-Current	Version-New	Doc-2nd-Level
				interworking				
RP#68	RP-150888	0609	1	Correction to default E-UTRA channel bandwidth combination for CA_39C	F	12.5.0	12.6.0	R5-152140
RP#68	RP-150903	0610	1	Update to registration procedure to support multi PDN for RAN assisted WLAN interworking	F	12.5.0	12.6.0	R5-152141
RP#69	RP-151409	0612	-	Prevent unnecessary IMS signalling over GERAN for non-IMS related test cases	F	12.6.0	12.7.0	R5-153114
RP#69	RP-151409	0613	-	Correct the IMS APN format	F	12.6.0	12.7.0	R5-153149
RP#69	RP-151429	0614	-	Introduction of new RRC default message - SidelinkUEInformation	F	12.6.0	12.7.0	R5-153188
RP#69	RP-151412	0623	-	Correction to Table 4.4.2-1A to change root sequence index for Cell 30	F	12.6.0	12.7.0	R5-153408
RP#69	RP-151427	0631	-	Add generic procedure for IMS MT speech for EVS	F	12.6.0	12.7.0	R5-153539
RP#69	RP-151412	0625	1	Update the default configuration of channel bandwidth for Band 42 for signalling testing	F	12.6.0	12.7.0	R5-153715
RP#69	RP-151409	0628	1	New generic procedure 4.5A.21 Generic Test Procedure for IMS MO Customized Alerting Tones and speech establishment in E-UTRA	F	12.6.0	12.7.0	R5-153716
RP#69	RP-151412	0630	1	Correction to PhysicalConfigDedicated-DEFAULT	F	12.6.0	12.7.0	R5-153717
RP#69	RP-151423	0624	1	Addition and modification of 2DL CA Frequencies and CA Channel Bandwidth combination	F	12.6.0	12.7.0	R5-153749
RP#69	RP-151423	0640	-	Introduction of test environment information for intra-band Carrier Aggregation combinations CA_2C	F	12.6.0	12.7.0	R5-153751
RP#69	RP-151423	0636	1	Introduction of Default E-UTRA channel bandwidth combinations for CA Signalling testing with three component carriers	F	12.6.0	12.7.0	R5-153752
RP#69	RP-151423	0638	1	Introduction of test environment and test frequency information for several new 3DL inter-band Carrier Aggregation combinations with two different bands to 36.508.	F	12.6.0	12.7.0	R5-153753
RP#69	RP-151423	0627	1	Addition of CA_2C to Chapter 4	F	12.6.0	12.7.0	R5-153820
RP#69	RP-151433	0629	1	Introduce connection diagram for multi-cell Enhanced requirements Type C tests	F	12.6.0	12.7.0	R5-153835
RP#69	RP-151430	0616	1	UE Cat 0: Connection diagrams for RF/RRM testing	F	12.6.0	12.7.0	R5-153850
RP#69	RP-151423	0611	1	CA RF: Update of connection diagrams for 3CCs (RF) testing for more than 3CCs	F	12.6.0	12.7.0	R5-153875
RP#69	RP-151423	0621	1	Update of 4.4.2 Simulated cells for CA RRM test cases	F	12.6.0	12.7.0	R5-153876
RP#69	RP-151409	0618	1	Update to Loopback activation procedure for IMS enabled UE	F	12.6.0	12.7.0	R5-153971
RP#69	RP-151429	0615	2	Update to Device to Device Proximity Services Test Environment	F	12.6.0	12.7.0	R5-153998
RP#69	-	-	-	update of the "non-specific references" in section 2 according to the approved R5-153582 and an action point on ETSI MCC	-	12.6.0	12.7.0	-
RP#70	RP-151703	0641	-	Update generic procedures 4.5A.19 and 4.5A.20	F	12.7.0	12.8.0	R5-155083
RP#70	RP-151685	0642	-	Editor notes correction in clause 5.2A.1A	F	12.7.0	12.8.0	R5-155111
RP#70	RP-151705	0643	-	Editorial correction to Device to Device Proximity	F	12.7.0	12.8.0	R5-155130

Meeting-1st-Level	Doc-1st-Level	CR	Rev	Subject	Cat	Version-Current	Version-New	Doc-2nd-Level
				Services Test Environment				
RP#70	RP-151710	0644	-	Introduction of combinations of system information blocks for Dual Connectivity	F	12.7.0	12.8.0	R5-155234
RP#70	RP-151710	0651	-	Introduction of generic test procedures for Dual Connectivity for signalling testing	F	12.7.0	12.8.0	R5-155419
RP#70	RP-151710	0652	-	Introduction of default messages for Dual Connectivity	F	12.7.0	12.8.0	R5-155434
RP#70	RP-151685	0655	-	Correction to procedure for UE triggered establishment of a default EPS bearer context associated with an additional PDN	F	12.7.0	12.8.0	R5-155490
RP#70	RP-151705	0659	-	Addition of default Test UICC contents for DF_ProSe	F	12.7.0	12.8.0	R5-155647
RP#70	RP-151713	0662	1	Removal of incorrect test frequencies for CA_12B	F	12.7.0	12.8.0	R5-155800
RP#70	RP-151700	0654	1	Connections for 3DL CA RRM test cases	F	12.7.0	12.8.0	R5-155865
RP#70	RP-151700	0658	1	3DL carrier aggregation combination corrections to Table 6.2.3.2-2 "Test frequencies for E-UTRA PCell and SCell for CA Inter-band operation (two bands)"	F	12.7.0	12.8.0	R5-155910
RP#70	RP-151705	0663	1	Clarification of SIB18/19 Table	F	12.7.0	12.8.0	R5-155922
RP#70	RP-151699	0661	1	Add generic procedures for IMS over WLAN	F	12.7.0	12.8.0	R5-155958
RP#70	RP-151701	0650	1	Addition of new generic procedures to check UE does not offload	F	12.7.0	12.8.0	R5-155961
RP#70	RP-151701	0657	1	Update of WLAN Offload procedures to and from EUTRA	F	12.7.0	12.8.0	R5-155962
RP#70	RP-151705	0648	1	ProSe: Connection diagram for basic Tx/Rx testing	F	12.7.0	12.8.0	R5-156012
RP#70	RP-151712	0645	1	Adding default message contents for NAICS test cases	F	12.7.0	12.8.0	R5-156088
RP#70	RP-151685	0653	1	Correction to UE test states for RF/RRM testing	F	12.7.0	12.8.0	R5-156094
RP#70	RP-151705	0647	1	Add generic procedures for ProSe UE registration	F	12.7.0	12.8.0	R5-156159
RP#71	RP-160107	0675	-	Correction of generic setup procedures for Dual Connectivity protocol testing	F	12.8.0	12.9.0	R5-160406
RP#71	RP-160107	0676	-	Introduction of generic RF procedures for Dual Connectivity	F	12.8.0	12.9.0	R5-160407
RP#71	RP-160111	0678	-	CA_20A-67A: Add test frequencies to sub-clause 6.2.3.2	F	12.8.0	12.9.0	R5-160413
RP#71	RP-160099	0679	-	Addition of default power level for WLAN AP beacon RSSI	F	12.8.0	12.9.0	R5-160471
RP#71	RP-160110	0680	-	Addition of reference message definitions for eIMTA	F	12.8.0	12.9.0	R5-160476
RP#71	RP-160103	0682	-	Addition of ProSe Test Frequencies and update to Band and Bandwidth capabilities	F	12.8.0	12.9.0	R5-160503
RP#71	RP-160117	0683	-	Addition of missing E-UTRA manual selection (E5) -end state	F	12.8.0	12.9.0	R5-160562
RP#71	RP-160105	0686	-	Correction of PhysicalConfigDedicated-DEFAULT	F	12.8.0	12.9.0	R5-160646
RP#71	RP-160128	0687	-	Correction of test frequencies for CA_3C and CA_7C	F	12.8.0	12.9.0	R5-160647
RP#71	RP-160103	0689	-	Addition of default Test UICC contents for DF_ProSe	F	12.8.0	12.9.0	R5-160699
RP#71	RP-160117	0673	1	UTRAN Registration procedure for LTE-IRAT test cases	F	12.8.0	12.9.0	R5-160730
RP#71	RP-160117	0684	1	Correction to CDMA Frequency range for E25-CDMA BC1 band combination	F	12.8.0	12.9.0	R5-160731

Meeting-1st-Level	Doc-1st-Level	CR	Rev	Subject	Cat	Version-Current	Version-New	Doc-2nd-Level
RP#71	RP-160103	0670	1	Update generic procedures 4.5A.22	F	12.8.0	12.9.0	R5-160765
RP#71	RP-160103	0685	1	Update for SIB18 and SIB19	F	12.8.0	12.9.0	R5-160767
RP#71	RP-160117	0690	-	Correction to UE registration procedure State 2	F	12.8.0	12.9.0	R5-160784
RP#71	RP-160098	0691	-	Add new antenna diagram for 3DL CA RSTD test cases	F	12.8.0	12.9.0	R5-160789
RP#71	RP-160111	0672	1	Addition of Test frequency for CA_19A-28A and CA_1A-19A-28A	F	12.8.0	12.9.0	R5-160809
RP#71	RP-160111	0677	1	CA_20A-67A: Add test frequencies to sub-clause 4.3.1	F	12.8.0	12.9.0	R5-160810
RP#71	RP-160109	0664	1	Adding new specific message content to release NAICS configuration	F	12.8.0	12.9.0	R5-160848
RP#71	RP-160112	0667	1	Connection diagram for Receiver test with 4 Rx antenna ports	F	12.8.0	12.9.0	R5-160895
RP#71	RP-160107	0674	1	Corrections to default RRC messages for Dual Connectivity	F	12.8.0	12.9.0	R5-160950
RP#71	RP-160117	0671	1	Corrections to bit rates for video calls	F	12.8.0	12.9.0	R5-160980
RP#71	RP-160128	0681	1	Correction to extendedPHR-r10 for UL CA	F	12.8.0	12.9.0	R5-161003
RP#71	RP-160106	0669	1	Addition of the default messages in 36.508 for the small cell enhancements for physical layer test	F	12.8.0	12.9.0	R5-161057
RP#72	RP-160858	0717	1	Defining SIB combination for TDD-FDD CA	F	12.9.0	12.10.0	R5-163012
RP#72	RP-160843	0708	2	Addition of test frequencies for band 66	F	12.9.0	12.10.0	R5-163193
RP#72	RP-160835	0734	-	Addition of test frequencies for intra-band non-contiguous Low WGap test points	F	12.9.0	12.10.0	R5-162889
RP#72	RP-160837	0695	1	Correction to generic RF procedures for Dual Connectivity	F	12.9.0	12.10.0	R5-162883
RP#72	RP-160833	0692	-	Clarifications to the D2D ProSe test environment for signalling tests	F	12.9.0	12.10.0	R5-162028
RP#72	RP-160833	0698	-	Update generic procedures 4.5A.22	F	12.9.0	12.10.0	R5-162133
RP#72	RP-160833	0723	-	Update of 36508 USIM for D2D	F	12.9.0	12.10.0	R5-162611
RP#72	RP-160833	0699	1	Add TLS default messages	F	12.9.0	12.10.0	R5-162902
RP#72	RP-160833	0719	1	Update of 36508 adding Default ProSe messages D2D	F	12.9.0	12.10.0	R5-162903
RP#72	RP-160833	0720	1	Update of 36508 References for D2D	F	12.9.0	12.10.0	R5-162904
RP#72	RP-160833	0721	1	Update of 36508 SIB19 D2D	F	12.9.0	12.10.0	R5-162906
RP#72	RP-160833	0722	1	Update of 36508 SIB18 D2D	F	12.9.0	12.10.0	R5-162907
RP#72	RP-160837	0694	-	Correction to generic default messages for Dual Connectivity	F	12.9.0	12.10.0	R5-162073
RP#72	RP-160837	0710	-	Introduction of test frequencies for protocol testing of Dual Connectivity	F	12.9.0	12.10.0	R5-162394
RP#72	RP-160837	0704	1	Correction to generic procedures for protocol testing of Dual Connectivity	F	12.9.0	12.10.0	R5-163025
RP#72	RP-160831	0700	1	Add IKEv2 default messages	F	12.9.0	12.10.0	R5-163077
RP#72	RP-160839	0724	1	Modification of reference message definitions for eIMTA	F	12.9.0	12.10.0	R5-163081
RP#72	RP-160846	0693	-	Removing outdated Editor's Notes	F	12.9.0	12.10.0	R5-162042
RP#72	RP-160858	0718	-	New CA band combination CA_8A-40A – Updates of	F	12.9.0	12.10.0	R5-162558

Meeting-1st-Level	Doc-1st-Level	CR	Rev	Subject	Cat	Version-Current	Version-New	Doc-2nd-Level
				6.2.3.2 Test Frequency				
RP#72	RP-160858	0705	1	Correction to Tracking area update request message (mobility from another RAT)	F	12.9.0	12.10.0	R5-162764
RP#72	RP-160846	0730	1	Updates to bitrate values for the dedicated EPS video bearer	F	12.9.0	12.10.0	R5-162766
RP#72	RP-160858	0732	-	Editorial correction to the test procedure of 6.4.3.10	F	12.9.0	12.10.0	R5-162767
RP#72	RP-160858	0709	2	Updates to handle IMS registration in WLAN offloading procedures	F	12.9.0	12.10.0	R5-163053
RP#72	RP-160847	0729	1	Introduction of Generic Test Procedure for optional UE initiated detaching	F	12.9.0	12.10.0	R5-163079
RP#72	RP-160858	0703	1	[Common] Updates to WLAN offloading procedures to allow IMS PDN	F	12.9.0	12.10.0	R5-163080
RP#72	RP-160841	0716	-	Add test frequencies for CA_42D in 36.508	F	12.10.0	13.0.0	R5-162541
RP#72	RP-160841	0711	1	Addition of RF test frequencies for CA_5B, CA_5A-5A & CA_3C-5A to Section 4.3.1	F	12.10.0	13.0.0	R5-163117
RP#72	RP-160863	0727	1	Band 65 test frequencies for 36.508 clause 4.3	F	12.10.0	13.0.0	R5-162972
RP#72	RP-160841	0701	-	Updates of 6.2.3.2 Test Frequency for CA_3A-41A for CA signalling test	F	12.10.0	13.0.0	R5-162170
RP#72	RP-160841	0702	-	Updates of CA Channel Bandwidth combination for CA signalling test in sub-clause 4.3.1	F	12.10.0	13.0.0	R5-162171
RP#72	RP-160841	0712	1	Addition of signalling test frequencies for CA_5B, CA_5A-5A & CA_3C-5A to Section 6.2.3.2	F	12.10.0	13.0.0	R5-162795
RP#72	RP-160841	0733	-	Update of Rel-13 CA test frequency CA_19A-28A and CA_21A-42C	F	12.10.0	13.0.0	R5-163052
RP#72	RP-160863	0728	1	Band 65 signalling test frequencies for 36.508 clause 6.2.3	F	12.10.0	13.0.0	R5-162796
RP#72	RP-160861	0726	2	Introduction of default messages for testing of CAT-M1 UE and UE in enhanced coverage	F	12.10.0	13.0.0	R5-163156
RP#72	RP-160864	0714	1	Addition of some SC-PTM related message definitions in TS36.508	F	12.10.0	13.0.0	R5-163038
RP#72	RP-160862	0697	1	Updates to Common parameter in EUTRA (SIB1) and NAS Default Messages and informational elements contents to include Extended DRX parameters	F	12.10.0	13.0.0	R5-162797
RP#72	RP-160866	0713	1	Addition of LAA related message definitions in TS36.508	F	12.10.0	13.0.0	R5-163001
RP#72	-	-	-	restoring deleted Table 4.3.1.1.66A-3 of R5-163193	F	13.0.0	13.0.1	-
RP#73	RP-161427	0749	-	Correction to DRB configuration	F	13.0.1	13.1.0	R5-165110
RP#73	RP-161407	0754	-	Introduction of test frequencies for CA_8A-42A and editorial corrections to clause 6.2.3.2	F	13.0.1	13.1.0	R5-165242
RP#73	RP-161427	0755	-	Prevent unnecessary IMS signalling over GERAN for non-IMS test cases	F	13.0.1	13.1.0	R5-165266
RP#73	RP-161399	0756	-	Update to generic test procedure 4.5A.22	F	13.0.1	13.1.0	R5-165267
RP#73	RP-161407	0761	-	TS36.508_Addition of signalling test frequencies for CA_8B and CA_8A-41C	F	13.0.1	13.1.0	R5-165448
RP#73	RP-161399	0762	-	Update of 36508 adding Default ProSe messages D2D	F	13.0.1	13.1.0	R5-165457
RP#73	RP-161399	0763	-	Update of 36508 SIB19 D2D	F	13.0.1	13.1.0	R5-165458

Meeting-1st-Level	Doc-1st-Level	CR	Rev	Subject	Cat	Version-Current	Version-New	Doc-2nd-Level
RP#73	RP-161399	0764	-	Update of 36508 SIB18 D2D	F	13.0.1	13.1.0	R5-165459
RP#73	RP-161400	0765	-	Correction to PhysicalConfigDedicated-DEFAULT IE for HalfDuplex Type B mode operation	F	13.0.1	13.1.0	R5-165478
RP#73	RP-161410	0771	-	Addition of LAA CA band 46 combination test frequencies for signalling test cases	F	13.0.1	13.1.0	R5-165519
RP#73	RP-161410	0772	-	Addition of LAA band 46 test frequencies	F	13.0.1	13.1.0	R5-165521
RP#73	RP-161407	0773	-	Update of Rel-13 CA test frequency and CA Channel Bandwidth combination	F	13.0.1	13.1.0	R5-165609
RP#73	RP-161428	0758	1	Update SystemInformationBlockType1 for band 65 and higher	F	13.0.1	13.1.0	R5-165892
RP#73	RP-161439	0759	1	Introduction of test frequencies for MFBI enhancement	F	13.0.1	13.1.0	R5-165893
RP#73	RP-161437	0769	1	Correction of test frequencies for CA intra band combinations CA_2C, CA_3C, CA_7C and CA_12B	F	13.0.1	13.1.0	R5-165894
RP#73	RP-161407	0746	1	Updates of 6.2.3.2 Test Frequency for CA_2A-28A for CA signalling test	F	13.0.1	13.1.0	R5-165921
RP#73	RP-161407	0752	1	New CA band combination CA_1A-40A and CA_3A-40A - Updates of 6.2.3.2 Test Frequency	F	13.0.1	13.1.0	R5-165922
RP#73	RP-161407	0783	1	Updates of 6.2.3.2 Test Frequency for CA_4A-28A and CA_20A-31A for CA signalling test	F	13.0.1	13.1.0	R5-165923
RP#73	RP-161413	0747	1	Correction of default messages for testing of CAT-M1 UE and UE in enhanced coverage	F	13.0.1	13.1.0	R5-165932
RP#73	RP-161399	0753	1	Addition of default content for KEY_REQUEST, KEY_RESPONSE and MIKEY messages	F	13.0.1	13.1.0	R5-165960
RP#73	RP-161421	0777	1	NB-IoT test frequencies definition	F	13.0.1	13.1.0	R5-165985
RP#73	RP-161421	0779	1	Addition basic NB-IoT UE test states to TS 36.508	F	13.0.1	13.1.0	R5-165986
RP#73	RP-161421	0780	1	Introduction default NAS messages and Reference bearer configurations for NB-IoT	F	13.0.1	13.1.0	R5-165987
RP#73	RP-161421	0781	1	Introduction default RRC messages for NB-IoT	F	13.0.1	13.1.0	R5-165988
RP#73	RP-161421	0784	1	Definition of NB-IoT environmental conditions and NB-IoT common test requirements of test equipment	F	13.0.1	13.1.0	R5-165989
RP#73	RP-161421	0785	1	Definition of NB-IoT physical layer parameters	F	13.0.1	13.1.0	R5-165990
RP#73	RP-161421	0786	1	Definition of NB-IoT signal levels and standard test signals	F	13.0.1	13.1.0	R5-165991
RP#73	RP-161421	0787	1	Definition of NB-IoT radio conditions and physical channel allocation	F	13.0.1	13.1.0	R5-165992
RP#73	RP-161437	0796	-	36.508: Addition of test frequencies for band CA_7B	F	13.0.1	13.1.0	R5-166015
RP#73	RP-161402	0775	1	Addition of message exceptions for DL 256QAM	F	13.0.1	13.1.0	R5-166021
RP#73	RP-161407	0760	1	TS36.508_Additional new Test Frequency for CA_8B	F	13.0.1	13.1.0	R5-166026
RP#73	RP-161409	0795	1	Addition of connection diagram for 4Rx test cases	F	13.0.1	13.1.0	R5-166095
RP#73	RP-161421	0782	1	Introduction Test environment for RF test for NB-IoT	F	13.0.1	13.1.0	R5-166124
RP#73	RP-161419	0770	1	Introduction of Band 45 into 36.508	F	13.0.1	13.1.0	R5-166128
RP#73	RP-161411	0766	1	Correction to test frequencies for Band 66	F	13.0.1	13.1.0	R5-166131
RP#73	RP-161411	0776	1	Correction to Band 66 test frequencies	F	13.0.1	13.1.0	R5-166132

Meeting-1st-Level	Doc-1st-Level	CR	Rev	Subject	Cat	Version-Current	Version-New	Doc-2nd-Level
RP#73	RP-161399	0767	1	Addition of connection diagrams for ProSe	F	13.0.1	13.1.0	R5-166140
RP#73	RP-161437	0791	1	36.508 UL CA correction for RF test cases	F	13.0.1	13.1.0	R5-166142
RP#73	RP-161423	0789	2	Introduction of Indoor Positioning Enhancements (MBS)	F	13.0.1	13.1.0	R5-166184
RP#73	RP-161397	0778	1	Correction to Default IKEv2 message definitions.	F	13.0.1	13.1.0	R5-166260
RP#73	RP-161413	0748	1	Introduction of test environment for testing of CAT-M1 UE and UE in enhanced coverage	F	13.0.1	13.1.0	R5-166261
RP#73	RP-161421	0790	1	Addition of definition of simulated network cells for NB-IoT	F	13.0.1	13.1.0	R5-166285
RP#73	RP-161421	0797	1	Add default NAS messages for NB-IoT and Rel-13 updates	F	13.0.1	13.1.0	R5-166331
RP#74	RP-162076	0798	-	Update of default message contents for ProSe Direct Communication	F	13.1.0	13.2.0	R5-168072
RP#74	RP-162075	0801	-	Update IKEv2 default messages	F	13.1.0	13.2.0	R5-168094
RP#74	RP-162085	0802	-	Addition of connection diagrams for new SC demod and CSI Test Cases for 4Rx	F	13.1.0	13.2.0	R5-168120
RP#74	RP-162083	0805	-	Editorial correction to aggregated number of resource blocks for CA Inter-band combination CA_8A-42A	F	13.1.0	13.2.0	R5-168319
RP#74	RP-162083	0811	-	Addition of new test frequencies for intra-band non-contiguous CA	F	13.1.0	13.2.0	R5-168367
RP#74	RP-162097	0812	-	Common test frequencies for Band 70	F	13.1.0	13.2.0	R5-168398
RP#74	RP-162104	0815	-	Update SCellToAddMod for band 65 and higher	F	13.1.0	13.2.0	R5-168447
RP#74	RP-162104	0816	-	Update MobilityControlInfo for band 65 and higher	F	13.1.0	13.2.0	R5-168454
RP#74	RP-162091	0819	-	Addition of Procedure for IP address allocation in the CP CIoT	F	13.1.0	13.2.0	R5-168472
RP#74	RP-162079	0820	-	Correction of ReportConfigEUTRA-C2	F	13.1.0	13.2.0	R5-168567
RP#74	RP-162096	0824	-	CA_20A-28A: Add test frequencies to sub-clause 6.2.3.2	F	13.1.0	13.2.0	R5-168618
RP#74	RP-162103	0834	-	Correction to EUTRA band 2 and band 25 <> CDMA BC 1 for LTE<>HRPD/1xRTT	F	13.1.0	13.2.0	R5-168775
RP#74	RP-162113	0835	-	Addition of test frequencies for CA_7C	F	13.1.0	13.2.0	R5-168778
RP#74	RP-162091	0837	-	Addition NB-IoT test environment for RRM test	F	13.1.0	13.2.0	R5-168833
RP#74	RP-162097	0840	-	Signalling Test environment for CA_70C	F	13.1.0	13.2.0	R5-168843
RP#74	RP-162087	0845	-	Add generic procedure for control plane CIoT connection request	F	13.1.0	13.2.0	R5-168885
RP#74	RP-162087	0846	-	Add generic procedure for user plane CIoT connection request	F	13.1.0	13.2.0	R5-168886
RP#74	RP-162080	0847	-	Correction to Table 6.2.3.2-2 for DC_7A-20A	F	13.1.0	13.2.0	R5-168890
RP#74	RP-162080	0848	-	Editorial correction to clause 5.2A.2A.1	F	13.1.0	13.2.0	R5-168891
RP#74	RP-162083	0851	-	Add test frequencies to sub-clause 6.2.3.2 for CA_7A-22A, CA_7B and CA_20A-40A	F	13.1.0	13.2.0	R5-168922
RP#74	RP-162091	0806	1	Addition of various CIoT generic procedures for PDN establishment-release	F	13.1.0	13.2.0	R5-169009
RP#74	RP-162087	0844	1	Update UE test states	F	13.1.0	13.2.0	R5-169032

Meeting-1st-Level	Doc-1st-Level	CR	Rev	Subject	Cat	Version-Current	Version-New	Doc-2nd-Level
RP#74	RP-162104	0814	1	Update SystemInformationBlockType5 for band 65 and higher	F	13.1.0	13.2.0	R5-169034
RP#74	RP-162103	0843	1	EPS bearer mapping updates	F	13.1.0	13.2.0	R5-169035
RP#74	RP-162097	0813	1	Signalling Test environment for Band 70	F	13.1.0	13.2.0	R5-169047
RP#74	RP-162075	0800	1	Update generic procedure 4.5A.23	F	13.1.0	13.2.0	R5-169074
RP#74	RP-162087	0825	1	Correction of default DCI formats and messages for testing of CAT-M1 UE and UE in enhanced coverage	F	13.1.0	13.2.0	R5-169087
RP#74	RP-162091	0838	1	Addition default values in NB-IoT RRC messages and IEs	F	13.1.0	13.2.0	R5-169088
RP#74	RP-162104	0817	1	Update measurement information for band 65 and higher	F	13.1.0	13.2.0	R5-169116
RP#74	RP-162083	0832	1	Introduction of test frequencies for CA_5A-29A	F	13.1.0	13.2.0	R5-169125
RP#74	RP-162091	0799	1	Update to default NAS messages for NB-IoT	F	13.1.0	13.2.0	R5-169126
RP#74	RP-162091	0807	1	Update of NB-IoT Generic procedures	F	13.1.0	13.2.0	R5-169127
RP#74	RP-162091	0818	1	TAU Procedure for NB-IoT UE's	F	13.1.0	13.2.0	R5-169128
RP#74	RP-162091	0833	1	Addition of Default configurations for NB-IoT NAS and Idle Mode test cases	F	13.1.0	13.2.0	R5-169129
RP#74	RP-162091	0808	1	Correction to NB-IOT System configuration IE	F	13.1.0	13.2.0	R5-169144
RP#74	RP-162103	0827	1	Correction to Procedure for IMS signalling	F	13.1.0	13.2.0	R5-169150
RP#74	RP-162091	0852	1	Default NB-IoT uplink configuration	F	13.1.0	13.2.0	R5-169164
RP#74	RP-162091	0841	1	Update of common test environment sections and Annex for NB-IoT UEs	F	13.1.0	13.2.0	R5-169169
RP#74	RP-162113	0830	1	Correction to test frequencies for CA_66C	F	13.1.0	13.2.0	R5-169500
RP#74	RP-162115	0831	1	Correction to default messages for TDD FDD CA	F	13.1.0	13.2.0	R5-169501
RP#74	RP-162113	0810	1	New connection diagram for TC7.9A	F	13.1.0	13.2.0	R5-169503
RP#74	RP-162113	0829	1	Correction to test frequencies for CA_12B	F	13.1.0	13.2.0	R5-169504
RP#74	RP-162101	0836	1	Correction of lower test frequencies for Band 26	F	13.1.0	13.2.0	R5-169505
RP#74	RP-162085	0809	1	New connection diagrams for 4Rx Receiver TCs	F	13.1.0	13.2.0	R5-169618
RP#74	RP-162085	0826	1	Addition of 4-Rx connection diagrams	F	13.2.0	14.0.0	R5-169619
RP#74	RP-162098	0821	1	Addition of V2X Sidelink Communication Test Environment	F	13.2.0	14.0.0	R5-169647
RP#74	RP-162097	0839	1	Common test frequencies for CA_70C	F	13.2.0	14.0.0	R5-169649
RP#74	RP-162114	0822	1	Addition of UE Capability Enquiry message for RF tests	F	13.2.0	14.0.0	R5-169661
RP#74	RP-162085	0803	1	Addition of connection diagram for new CA SDR Test Case for 4Rx	F	13.2.0	14.0.0	R5-169673
RP#74	RP-162085	0804	1	Addition of connection diagrams for 2Rx Test Cases with 4Rx capable UEs	F	13.2.0	14.0.0	R5-169674

Change history							
Date	Meeting	TDoc	CR	Rev	Cat	Subject/Comment	New version
2017-03	RAN#75	RP-170082	0856	-	F	Update to default NAS messages for NB-IoT	14.1.0
2017-03	RAN#75	RP-170072	0857	-	F	To add Figure A.64a for 4DL CA connection with static PCC propagation channel, SCCs multipath fading propagation channels and additional intra-frequency cell on one SCC.	14.1.0
2017-03	RAN#75	RP-170077	0858	-	F	Update generic procedure control plane CIoT connection request	14.1.0
2017-03	RAN#75	RP-170082	0859	-	F	Corrections for TA and ul-carrierFreq-r13 in SIB2	14.1.0
2017-03	RAN#75	RP-170082	0862	-	F	Add generic procedure to check RRC Connected state for NB-IoT	14.1.0
2017-03	RAN#75	RP-170097	0872	-	F	Update SystemInformationBlockType5	14.1.0
2017-03	RAN#75	RP-170070	0875	-	F	NAICS: Addition of new connction diagram	14.1.0
2017-03	RAN#75	RP-170107	0876	-	F	New generic procedure for IMS emergency call in EPC / WLAN	14.1.0
2017-03	RAN#75	RP-170082	0879	-	F	NPDCCH config dedicated update for RF test cases	14.1.0
2017-03	RAN#75	RP-170106	0880	-	F	Addition of test frequencies for 10+15MHz and 15+10MHz in CA_41C	14.1.0
2017-03	RAN#75	RP-170082	0882	-	F	Correction to default values of NB-IoT RRC UECapabilityInformation-NB message	14.1.0
2017-03	RAN#75	RP-170076	0883	-	F	Update of Rel-13 LAA related IE content in MeasObjectEURA	14.1.0
2017-03	RAN#75	RP-170091	0884	-	F	Update of V2X Sidelink Communication Test Environment	14.1.0
2017-03	RAN#75	RP-170082	0886	-	F	Update of various CIoT generic procedures	14.1.0
2017-03	RAN#75	RP-170072	0888	-	F	Correction to test frequencies for CA_5A-5A	14.1.0
2017-03	RAN#75	RP-170082	0889	-	F	NPRACH-ConfigSIB-NB-DEFAULT updated	14.1.0
2017-03	RAN#75	RP-170082	0895	-	F	Correction to NB-IoT Physical layer parameters for DCI	14.1.0
2017-03	RAN#75	RP-170095	0896	-	F	Correction to Generic Test Procedure for network initiated release of additional PDN connectivity	14.1.0
2017-03	RAN#75	RP-170095	0897	-	F	Correction to generic procedure for preventing IMS signalling over GERAN	14.1.0
2017-03	RAN#75	RP-170108	0900	-	F	Add missing condition description in Table 4.6.3-9A	14.1.0
2017-03	RAN#75	RP-170095	0902	1	F	Update MobilityControllInfo	14.1.0
2017-03	RAN#75	RP-170097	0903	1	F	Update MeasConfig-DEFAULT	14.1.0
2017-03	RAN#75	RP-170089	0864	1	F	Introduction of test frequencies for CA_3A-11A to section 6	14.1.0
2017-03	RAN#75	RP-170089	0865	1	F	Introduction of test frequencies for CA_8A-28A to section 6	14.1.0
2017-03	RAN#75	RP-170089	0866	1	F	Introduction of test frequencies for CA_11A-28A to section 6	14.1.0
2017-03	RAN#75	RP-170089	0893	1	F	CA_29A-66A, CA_29A-66A-66A, CA_29A-66C, CA_46A-66A test frequencies for signalling test	14.1.0
2017-03	RAN#75	RP-170108	0869	1	F	Introduction of new combination of SIBs for OTDOA 3DL CA test cases	14.1.0
2017-03	RAN#75	RP-170082	0854	1	F	[Common] Correction to default parameters for Ncells and SIB-NB	14.1.0
2017-03	RAN#75	RP-170077	0905	-	F	Correction to eMTC generic procedures	14.1.0
2017-03	RAN#75	RP-170077	0885	1	F	Correction of default messages for testing of CAT-M1 UE and UE in enhanced coverage	14.1.0
2017-03	RAN#75	RP-170082	0899	1	F	TAU Procedure for NB-IoT UEs performing Suspend-Resume	14.1.0

2017-03	RAN#75	RP-170076	0898	1	F	Correction to test frequencies for Band 46 and Test frequencies for CA signalling test	14.1.0
2017-03	RAN#75	RP-170089	0874	1	F	Updates to Band 66 test frequencies	14.1.0
2017-03	RAN#75	RP-170076	0894	1	F	Update of Rel-13 LAA related IE content in the test environment for RF and RRM test	14.1.0
2017-03	RAN#75	RP-170076	0873	1	F	LAA: Test frequencies for Band 46	14.1.0
2017-03	RAN#75	RP-170077	0863	1	F	Correction of PRACH configuration for RF tests	14.1.0
2017-03	RAN#75	RP-170072	0887	1	F	Addition of Low Wgap frequencies for CA_4A-4A	14.1.0
2017-03	RAN#75	RP-170093	0853	1	F	Update TS 36.508 with Addition of LTE Band 48	14.1.0
2017-03	RAN#75	RP-170077	0871	1	F	MBSFN information in SIB2 should not be mandatory for eMTC RRM test cases	14.1.0
2017-03	RAN#75	RP-170082	0877	2	F	Correction to NB-IoT test environment for SIG	14.1.0
2017-03	RAN#75	RP-170082	0904	1	F	Updates to NB-IoT generic procedures to add User-Plane mode support	14.1.0
2017-03	RAN#75	RP-170077	0878	3	F	Correction to default message contents for eMTC testing	14.1.0
2017-03	RAN#75	RP-170082	0856	-	F	Update to default NAS messages for NB-IoT	14.1.0
2017-03	RAN#75	RP-170072	0857	-	F	To add Figure A.64a for 4DL CA connection with static PCC propagation channel, SCCs multipath fading propagation channels and additional intra-frequency cell on one SCC.	14.1.0
2017-03	RAN#75	RP-170077	0858	-	F	Update generic procedure control plane CIoT connection request	14.1.0
2017-03	RAN#75	RP-170082	0859	-	F	Corrections for TA and ul-carrierFreq-r13 in SIB2	14.1.0
2017-03	RAN#75	RP-170082	0862	-	F	Add generic procedure to check RRC Connected state for NB-IoT	14.1.0
2017-03	RAN#75	RP-170082	0880	-	F	Update SystemInformationBlockType5	14.1.0
2017-03	RAN#75	RP-170070	0875	-	F	NAICS: Addition of new connction diagram	14.1.0
2017-03	RAN#75	RP-170107	0876	-	F	New generic procedure for IMS emergency call in EPC / WLAN	14.1.0
2017-03	RAN#75	RP-170082	0879	-	F	NPDCCH config dedicated update for RF test cases	14.1.0
2017-03	RAN#75	RP-170106	0880	-	F	Addition of test frequencies for 10+15MHz and 15+10MHz in CA_41C	14.1.0
2017-03	RAN#75	RP-170082	0882	-	F	Correction to default values of NB-IoT RRC UECapabilityInformation-NB message	14.1.0
2017-03	RAN#75	RP-170076	0883	-	F	Cor Update of Rel-13 LAA related IE content in MeasObjectEURA	14.1.0
2017-03	RAN#75	RP-170091	0884	-	F	Update of V2X Sidelink Communication Test Environment	14.1.0
2017-03	RAN#75	RP-170082	0886	-	F	Update of various CIoT generic procedures	14.1.0
2017-03	RAN#75	RP-170072	0888	-	F	Correction to test frequencies for CA_5A-5A	14.1.0
2017-03	RAN#75	RP-170082	0889	-	F	NPRACH-ConfigSIB-NB-DEFAULT updated	14.1.0
2017-03	RAN#75	RP-170082	0895	-	F	Correction to NB-IoT Physical layer parameters for DCI Renumbering of clauses 8.1.3.6.1.5 (and associated tables) not implemented: clause renumbering is strongly deprecated; instead, empty padding clauses 8.1.3.6.1.3 & 8.1.3.6.1.4 added.	14.1.0
2017-03	RAN#75	RP-170095	0896	-	F	Correction to Generic Test Procedure for network initiated release of additional PDN connectivity	14.1.0
2017-03	RAN#75	RP-170095	0897	-	F	Correction to generic procedure for preventing IMS signalling over GERAN	14.1.0
2017-03	RAN#75	RP-170108	0900	-	F	Add missing condition description in Table 4.6.3-9A	14.1.0
2017-03	RAN#75	RP-170095	0902	-	F	Update MobilityControllInfo	14.1.0
2017-03	RAN#75	RP-170097	0903	-	F	Update MeasConfig-DEFAULT	14.1.0
2017-03	RAN#75	RP-170089	0864	-	F	Introduction of test frequencies for CA_3A-11A to section 6	14.1.0

2017-03	RAN#75	RP-170089	0865	-	F	Introduction of test frequencies for CA_8A-28A to section 6	14.1.0
2017-03	RAN#75	RP-170089	0866	-	F	Introduction of test frequencies for CA_11A-28A to section 6	14.1.0
2017-03	RAN#75	RP-170089	0893	-	F	CA_29A-66A, CA_29A-66A-66A, CA_29A-66C, CA_46A-66A test frequencies for signalling test	14.1.0
2017-03	RAN#75	RP-170108	0869	1	F	Introduction of new combination of SIBs for OTDOA 3DL CA test cases	14.1.0
2017-03	RAN#75	RP-170108	0854	1	F	[Common] Correction to default parameters for Ncells and SIB-NB	14.1.0
2017-03	RAN#75	RP-170077	0905	1	F	Correction to eMTC generic procedures	14.1.0
2017-03	RAN#75	RP-170077	0885	1	F	Correction of default messages for testing of CAT-M1 UE and UE in enhanced coverage	14.1.0
2017-03	RAN#75	RP-170082	0899	1	F	TAU Procedure for NB-IoT UEs performing Suspend-Resume	14.1.0
2017-03	RAN#75	RP-170076	0898	1	F	Correction to test frequencies for Band 46 and Test frequencies for CA signalling test	14.1.0
2017-03	RAN#75	RP-170089	0874	1	F	Updates to Band 66 test frequencies	14.1.0
2017-03	RAN#75	RP-170076	0894	1	F	Update of Rel-13 LAA related IE content in the test environment for RF and RRM test	14.1.0
2017-03	RAN#75	RP-170076	0873	1	F	LAA: Test frequencies for Band 46	14.1.0
2017-03	RAN#75	RP-170077	0863	1	F	Correction of PRACH configuration for RF tests	14.1.0
2017-03	RAN#75	RP-170072	0887	-	F	Addition of Low Wgap frequencies for CA_4A-4A	14.1.0
2017-03	RAN#75	RP-170093	0853	1	F	Update TS 36.508 with Addition of LTE Band 48	14.1.0
2017-03	RAN#75	RP-170093	0871	1	F	MBSFN information in SIB2 should not be mandatory for eMTC RRM test cases	14.1.0
2017-03	RAN#75	RP-170093	0872	2	F	Correction to NB-IoT test environment for SIG	14.1.0
2017-03	RAN#75	RP-170077	0878	3	F	Correction to default message contents for eMTC testing	14.1.0
2017-03	RAN#75	RP-170082	0904	1	F	Updates to NB-IoT generic procedures to add User-Plane mode support	14.1.0
2017-06	RAN#76	R5-172049	0908		F	Updates to D2D ProSe default message contents	14.2.0
2017-06	RAN#76	R5-172061	0910		F	Editorial update to references to PhysicalConfigDedicated-DEFAULT for SIG	14.2.0
2017-06	RAN#76	R5-172115	0915		F	NB-IoT test frequencies for Band 70	14.2.0
2017-06	RAN#76	R5-172227	0925		F	CA_46C-66A test frequencies for signalling test and correction to CA_46A-66A	14.2.0
2017-06	RAN#76	R5-172324	0933		F	MobilityControlInfo-HO correction for bands > 64 (Editorial)	14.2.0
2017-06	RAN#76	R5-172427	0938		F	Update to e-MTC SIB-2 Signalling	14.2.0
2017-06	RAN#76	R5-172507	0944		F	Correction to PhysicalConfigdedicated Parameters for LAA	14.2.0
2017-06	RAN#76	R5-172561	0947		F	Update of test frequencies for 2DL/1UL of CA_3A-3A and CA_7A-7A due to new REFSENS test points addition.	14.2.0
2017-06	RAN#76	R5-172567	0948		F	Addition of SRS switching common test environment	14.2.0
2017-06	RAN#76	R5-172582	0950		F	Addition of test frequencies with Low Wgap for CA_66A-66A	14.2.0
2017-06	RAN#76	R5-172636	0952		F	Correction to scheduling request parameters for CatM1 using HD-FDD	14.2.0
2017-06	RAN#76	R5-172672	0953		F	Introduction of test frequencies for Band 48 for protocol testing	14.2.0
2017-06	RAN#76	R5-172756	0955		F	Addition of Rel-14 NB-IoT operating bands	14.2.0
2017-06	RAN#76	R5-172776	0957		F	NB-IoT test frequencies update for inband operation mode	14.2.0
2017-06	RAN#76	R5-172786	0959		F	Editorial correction to Clause and Table numbers in generic procedure 4.5A.3B	14.2.0
2017-06	RAN#76	R5-172850	0906	1	F	Update SRB reconfiguration for NB-IoT	14.2.0
2017-06	RAN#76	R5-172851	0909	1	F	NB-IoT: Add new generic procedure for generic RB establishment for UP	14.2.0
2017-06	RAN#76	R5-172853	0963		F	Correction to EPS network feature support for ATTACH ACCEPT and TRACKING AREA UPDATE ACCEPT	14.2.0

2017-06	RAN#76	R5-172875	0911	1	F	Update SystemInformationBlockType2	14.2.0
2017-06	RAN#76	R5-172876	0916	1	F	Update generic procedure control plane CIoT connection request	14.2.0
2017-06	RAN#76	R5-172877	0917	1	F	Add generic procedure control plane CIoT with test mode	14.2.0
2017-06	RAN#76	R5-172878	0964		F	Update SystemInformationBlockType3-NB	14.2.0
2017-06	RAN#76	R5-172879	0919	1	F	Update generic procedure user plane CIoT connection request	14.2.0
2017-06	RAN#76	R5-172880	0922	1	F	Add messages for resuming an RRC connection	14.2.0
2017-06	RAN#76	R5-172895	0926	1	F	Addition of Band 66 Frequencies	14.2.0
2017-06	RAN#76	R5-172896	0927	1	F	Update System Information Block type 19 for Band > 64	14.2.0
2017-06	RAN#76	R5-172941	0934	1	F	Addition of CA_2A-66A, CA_5A-66A and CA_13A-66A test frequencies for signalling test	14.2.0
2017-06	RAN#76	R5-172944	0940	1	F	Correction of test frequency selection of band 20 in Table 6.2.3.2-2	14.2.0
2017-06	RAN#76	R5-172946	0965		F	Introduction of test frequencies for 2UL/2DL of DC_41A-42A to section 6	14.2.0
2017-06	RAN#76	R5-172961	0961	1	F	Update for Antenna configuration for 4 Rx UE antenna	14.2.0
2017-06	RAN#76	R5-172962	0966		F	Correction to RACH-ConfigCommon-DEFAULT	14.2.0
2017-06	RAN#76	R5-172981	0949	1	F	Update of V2X related message contents in 36.508	14.2.0
2017-06	RAN#76	R5-172999	0913	1	F	Update RRCConnectionSetupComplete	14.2.0
2017-06	RAN#76	R5-173000	0912	1	F	Update ATTACH ACCEPT	14.2.0
2017-06	RAN#76	R5-173001	0918	1	F	Update RRCConnectionRelease	14.2.0
2017-06	RAN#76	R5-173002	0920	1	F	Add generic procedure user plane CIoT with test mode	14.2.0
2017-06	RAN#76	R5-173003	0921	1	F	Update UE test state	14.2.0
2017-06	RAN#76	R5-173006	0960	1	F	Correction to DRB logical channel configurations	14.2.0
2017-06	RAN#76	R5-173028	0943	1	F	LAA band 46 clarification on DL only operation	14.2.0
2017-06	RAN#76	R5-173035	0929	1	F	Correction to SIB21	14.2.0
2017-06	RAN#76	R5-173227	0942	1	F	Addition of Figure Connection for more than 3DL CA with static propagation channels and additional intra-frequency cell(s) on each SCC	14.2.0
2017-06	RAN#76	R5-173315	0932	1	F	RadioResourceConfigCommon-DEFAULT correction for eMTC (Editorial)	14.2.0
2017-06	RAN#76	R5-173352	0931	1	F	Introduction of the generic procedures for V2X Communication	14.2.0
2017-06	RAN#76	R5-173353	0956	1	F	Addition of reference test frequencies for V2X 47B	14.2.0
2017-06	RAN#76	R5-173406	0923	1	F	Update to NB-IOT RRM cell configuration	14.2.0
2017-06	RAN#76	R5-173408	0936	1	F	Separation of Narrowband Index for SI message and Data (PDSCH/MPDCCH/PUSCH) for eMTC test cases	14.2.0
2017-06	RAN#76	R5-173416	0924	1	F	New connection diagrams for RX tests with 2Rx and 4Rx and clarification for TX tests	14.2.0
2017-09	RAN#77	R5-173636	0974	-	F	Remove editor's note for ATTACH ACCEPT	14.3.0
2017-09	RAN#77	R5-173669	0976	-	F	Update to SI2Quater for LTE Bands>64	14.3.0
2017-09	RAN#77	R5-173670	0977	-	F	Updates to UTRAN MEASUREMENT CONTROL & REPORT for LTE Bands>64	14.3.0
2017-09	RAN#77	R5-173686	0978	-	F	Clarify the use of system information in generic procedures	14.3.0
2017-09	RAN#77	R5-173765	0983	-	F	Add new Ncells for RRM Test Cases	14.3.0
2017-09	RAN#77	R5-173783	0984	-	F	Correction to 4Rx connection diagram for CSI 9.3.3	14.3.0
2017-09	RAN#77	R5-173794	0985	-	F	Correction to default messages for Cat M1	14.3.0
2017-09	RAN#77	R5-173805	0986	-	F	Correction to System Information Block Type 19 for Band > 64	14.3.0

2017-09	RAN#77	R5-173839	0987	-	F	Remove editor's note for RRC Connection Release	14.3.0
2017-09	RAN#77	R5-173842	0988	-	F	Add generic procedure to check that UE is camped on a new E-UTRAN cell / UP Clot	14.3.0
2017-09	RAN#77	R5-173859	0991	-	F	Addition of Test Frequencies for NB-IoT FDD MFBI (180 kHz)	14.3.0
2017-09	RAN#77	R5-173914	0996	-	F	Introduction of default message configurations for eHST	14.3.0
2017-09	RAN#77	R5-173927	0999	-	F	Editorial: Update of NB-IOT RadioResourceConfigCommonSIB-NB message in 36.508	14.3.0
2017-09	RAN#77	R5-173973	1004	-	F	Introduction of test frequencies for CA configuration CA_2A-7A	14.3.0
2017-09	RAN#77	R5-174071	1008	-	F	Addition of Physical layer parameters for DCI format 0C	14.3.0
2017-09	RAN#77	R5-174151	1010	-	F	Addition of 1.4 and 3 MHz test frequencies for Band 65	14.3.0
2017-09	RAN#77	R5-174173	1014	-	F	Introduction of test frequencies for CA_3A-32A to section 6.2.3.2	14.3.0
2017-09	RAN#77	R5-174266	1016	-	F	Addition of FDD reference test frequencies for band 69	14.3.0
2017-09	RAN#77	R5-174291	1017	-	F	Update to UECapabilityInformation-NB message	14.3.0
2017-09	RAN#77	R5-174299	1018	-	F	Update to V2X message contents	14.3.0
2017-09	RAN#77	R5-174403	1027	-	F	Correction to generic procedures for Rel-12 DC	14.3.0
2017-09	RAN#77	R5-174456	1019	1	F	Correction to Generic Test Procedure for NB-IoT Control Plane Clot	14.3.0
2017-09	RAN#77	R5-174457	1028	1	F	Addition of test loop mode I	14.3.0
2017-09	RAN#77	R5-174498	0969	1	F	New generic test procedure for XCAP establishment in EPC / WLAN	14.3.0
2017-09	RAN#77	R5-174499	0973	1	F	WLAN power level	14.3.0
2017-09	RAN#77	R5-174500	0975	1	F	Corrections to UTRAN SIB19 for LTE Bands>64	14.3.0
2017-09	RAN#77	R5-174501	1024	1	F	Update REJECT message security header	14.3.0
2017-09	RAN#77	R5-174502	0980	1	F	Update of Default ProSe messages 36508	14.3.0
2017-09	RAN#77	R5-174565	1011	1	F	CA_29A-70A, CA_46A-66C, CA_46A-70A signalling test frequencies	14.3.0
2017-09	RAN#77	R5-174580	1006	2	F	Correction to RadioResourceConfigCommonSIB-DEFAULT IE	14.3.0
2017-09	RAN#77	R5-174593	0979	1	F	New default ProSe messages Rel-13 36508	14.3.0
2017-09	RAN#77	R5-174594	0994	1	F	36.508 Section 6.6.1 - Update for QCI 69	14.3.0
2017-09	RAN#77	R5-174595	0995	1	F	36.508 Section 6.6.2 - Update for QCI 65	14.3.0
2017-09	RAN#77	R5-174640	0990	1	F	Update UP Clot for ATTACH ACCEPT	14.3.0
2017-09	RAN#77	R5-174649	0968	1	F	Update IMS speech procedures for UE category M1	14.3.0
2017-09	RAN#77	R5-174660	0971	2	F	Addition of the SIB1 eCall over IMS Release 14 related IEs and condition	14.3.0
2017-09	RAN#77	R5-174666	0997	1	F	Addition of PUCCH SCell common test environment	14.3.0
2017-09	RAN#77	R5-174667	1009	1	F	Update of Clot conditions in NAS messages	14.3.0
2017-09	RAN#77	R5-174681	0972	1	F	Addition of Generic Test Procedure for eCall over IMS establishment in EUTRA: Normal Service	14.3.0
2017-09	RAN#77	R5-175016	1003	1	F	Updates to test frequencies for CA combinations	14.3.0
2017-09	RAN#77	R5-175050	1007	1	F	Sending of MaxLayersMimo-r10 IE for 4Rx TCs with more than 2 Layers	14.3.0
2017-09	RAN#77	R5-175051	1023	1	F	Addition of connection diagrams for 4Rx test cases	14.3.0
2017-09	RAN#77	R5-175074	1005	1	F	New connection diagram for SDR tests with 2Rx and 4Rx	14.3.0
2017-09	RAN#77	R5-175083	1000	1	F	Update of V2V related connection diagram	14.3.0
2017-09	RAN#77	R5-175099	0970	1	F	Addition of SL-V2X-Preconfiguration for V2X MCC case in 4.6.3 and 6.8.2.1	14.3.0

2017-09	RAN#77	R5-175100	1002	1	F	Update of V2X related message contents in 36.508	14.3.0
2017-09	RAN#77	R5-175101	1020	1	F	Addition of connection diagram for V2X Communication / Intra-band contiguous MCC operation	14.3.0
2017-09	RAN#77	R5-175110	1012	1	F	Correction of NB-IOT MasterInformationBlock	14.3.0
2017-09	RAN#77	R5-175112	0967	2	F	Correct srs-Bandwidth comment for Frequency Hopping tests (Editorial Change)	14.3.0
2017-09	RAN#77	R5-175124	1025	1	F	Addition of rel-14 NB-IoT test frequencies	14.3.0
2017-09	RAN#77	R5-175159	1013	1	F	Correction to PRACH-Config-v1310-DEFAULT for eMTC TC	14.3.0
2017-09	RAN#77	R5-175218	1001	2	F	Addition of new generic test procedures State 5-V2X and State 5A-V2X	14.3.0
2017-12	RAN#78	R5-176083	1033	-	F	Addition of MFBI Test Frequencies for operation Bands 4 and 10 overlapping with Band 66	14.4.0
2017-12	RAN#78	R5-176104	1034	-	F	New Connection diagram for RRM eMTC MISO tests	14.4.0
2017-12	RAN#78	R5-176106	1036	-	F	Correction of SIB2-NB (complete implementation of CR0859)	14.4.0
2017-12	RAN#78	R5-176132	1037	-	F	Correction to eCalloverIMS condition in SysinfoType1	14.4.0
2017-12	RAN#78	R5-176136	1038	-	F	Correction to support of User Plane Clot Optimisation and S1-U Data Transfer	14.4.0
2017-12	RAN#78	R5-176137	1039	-	F	Corrections to NB-IoT generic test procedure to establish RB(s) in UP	14.4.0
2017-12	RAN#78	R5-176145	1040	-	F	Correction to RRC Connection Release message	14.4.0
2017-12	RAN#78	R5-176146	1041	-	F	Update to Tracking Area Update procedure for UP Clot	14.4.0
2017-12	RAN#78	R5-176421	1058	-	F	Addition of test frequencies for CA signalling test	14.4.0
2017-12	RAN#78	R5-176450	1060	-	F	Update of PUCCH SCell common test environment	14.4.0
2017-12	RAN#78	R5-176487	1064	-	F	Correction to test frequencies for CA_41D-41A	14.4.0
2017-12	RAN#78	R5-176491	1065	-	F	Correction to NB-IoT Test frequencies for in-band mode	14.4.0
2017-12	RAN#78	R5-176575	1071	-	F	Update to SECURITY REJECT message security header	14.4.0
2017-12	RAN#78	R5-176607	1074	-	F	Editorial correction to the FDD reference test frequencies for operating band 30	14.4.0
2017-12	RAN#78	R5-176680	1076	-	F	Correction to startSymbolBR-r13 IE in SystemInformationBlockType1-BR-r13	14.4.0
2017-12	RAN#78	R5-176683	1078	-	F	Correction to PRACH-ConfigSIB-v1310-DEFAULT IE	14.4.0
2017-12	RAN#78	R5-176703	1079	-	F	New Connection diagram for RRM 4Rx	14.4.0
2017-12	RAN#78	R5-176758	1080	-	F	Allow retransmissions in IMS registration procedure over UTRA	14.4.0
2017-12	RAN#78	R5-176802	1085	-	F	Correction of Generic Test Procedure for eCall over IMS establishment in EUTRA: Normal Service	14.4.0
2017-12	RAN#78	R5-176872	1044	1	F	Updates to ATTACH REQUEST and TRACKING AREA REQUEST for Clot Optimisation	14.4.0
2017-12	RAN#78	R5-176887	1042	1	F	Corrections to IMS over WLAN procedures and default messages	14.4.0
2017-12	RAN#78	R5-176888	1061	1	F	Addition of 4 antenna ports default message contents	14.4.0
2017-12	RAN#78	R5-176892	1083	1	F	Addition of default IE contents for MeasGapConfig-CE	14.4.0
2017-12	RAN#78	R5-176950	1032	1	F	Addition of Generic Test Procedure for eCall over IMS establishment in EUTRA: eCall Only Support	14.4.0
2017-12	RAN#78	R5-176958	1043	1	F	Introduction of default message configuration for LTE_VoLTE_ViLTE_enhancement	14.4.0
2017-12	RAN#78	R5-176961	1030	1	F	Correction to 4.5.9.4 and 4.71	14.4.0
2017-12	RAN#78	R5-176962	1054	1	F	Correct the order of Table 4.6.3-20J and Table 4.6.3-20K	14.4.0
2017-12	RAN#78	R5-176965	1059	1	F	Update to V2V and V2X default message definitions.	14.4.0
2017-12	RAN#78	R5-176991	1082	1	F	Corrections for NPRACH-ConfigSIB-NB-DEFAULT	14.4.0
2017-12	RAN#78	R5-176998	1031	1	F	Correction to raster offset in MIB	14.4.0

2017-12	RAN#78	R5-177040	1051	1	F	Update of default ProSe discovery messages	14.4.0
2017-12	RAN#78	R5-177041	1052	1	F	Update of USIM for ProSe discovery	14.4.0
2017-12	RAN#78	R5-177053	1089	-	F	Addition of new generic procedure for User or Network Initiated EPS Bearer Deactivation	14.4.0
2017-12	RAN#78	R5-177058	1077	1	F	Corrections to Generic Test Procedure for user initiated release of additional PDN connectivity	14.4.0
2017-12	RAN#78	R5-177062	1090	-	F	Correction to RadioResourceConfigCommon-DEFAULT IE	14.4.0
2017-12	RAN#78	R5-177084	1050	1	F	Adding generic procedures for Converged IP Communications	14.4.0
2017-12	RAN#78	R5-177090	1068	1	F	Correction to MeasConfig-DEFAULT for Band > 64	14.4.0
2017-12	RAN#78	R5-177128	1073	2	F	Correction to UE registration procedure for an IMS enabled multi-PDN UE when Network does not support IMS VoPS	14.4.0
2017-12	RAN#78	R5-177334	1088	1	F	Sending of MaxLayersMimo-r10 IE on SCC for 4Rx TCs with more than 2 Layers	14.4.0
2017-12	RAN#78	R5-177351	1056	1	F	Addition of connection diagrams for V2V RX test cases	14.4.0
2017-12	RAN#78	R5-177361	1057	1	F	Addition of connection diagrams for V2V RX Intra-band contiguous MCC operation	14.4.0
2017-12	RAN#78	R5-177378	1035	1	F	Correction of MIB for NB-IOT InBand	14.4.0
2017-12	RAN#78	R5-176210	1046	-	F	Signaling Test environment for Band 72	15.0.0
2017-12	RAN#78	R5-176216	1047	-	F	Common test frequencies for Band 68	15.0.0
2017-12	RAN#78	R5-176220	1048	-	F	Signaling Test environment for Band 68	15.0.0
2017-12	RAN#78	R5-176557	1069	-	F	Addition of test frequencies for Band 71	15.0.0
2017-12	RAN#78	R5-176817	1087	-	F	Band 71 Signaling Test environment	15.0.0
2017-12	RAN#78	R5-176919	1072	2	F	Update RRCConnectionReconfiguration for 5GS	15.0.0
2017-12	RAN#78	R5-177316	1045	1	F	Common test frequencies for Band 72	15.0.0
2017-12	RAN#78	R5-177375	1075	1	F	Correction to SystemInformationBlockType2 for NS value > 32	15.0.0
2018-03	RAN#79	R5-180317	1093	-	F	New Cells for NB-IOT OTDOA tests - LTE Cell	15.1.0
2018-03	RAN#79	R5-180377	1095	-	F	Correction to DRX onDurationTimer for FDD-HD operation in MAC configuration	15.1.0
2018-03	RAN#79	R5-180395	1097	-	F	Addition of default configuration of DCI 3B to TS 36.508	15.1.0
2018-03	RAN#79	R5-180396	1098	-	F	Update of SRS switching test environment	15.1.0
2018-03	RAN#79	R5-180407	1101	-	F	Addition of connection diagram of simultaneous E-UTRA V2X sidelink and E-UTRA uplink transmission	15.1.0
2018-03	RAN#79	R5-180715	1111	-	F	Addition of new Enhanced LAA IE in PhysicalConfigDedicatedSCell-r10-DEFAULT message	15.1.0
2018-03	RAN#79	R5-180749	1116	-	F	Added R14 CA combination to Test frequencies for CA signalling test	15.1.0
2018-03	RAN#79	R5-180753	1117	-	F	Added R15 CA combination to Test frequencies for CA signalling test	15.1.0
2018-03	RAN#79	R5-180780	1118	-	F	Addition of CA_29A-70C, CA_66A-70A, CA_66A-70C, CA_66C-70A, CA_66C-70C to 36.508	15.1.0
2018-03	RAN#79	R5-180918	1120	-	F	Addition of Band 74 Signaling Test environment	15.1.0
2018-03	RAN#79	R5-180934	1121	-	F	Correction to test frequencies for CA_7A-7A	15.1.0
2018-03	RAN#79	R5-180939	1122	-	F	Correction to interval-ULHoppingConfigCommonModeA/B-r13	15.1.0
2018-03	RAN#79	R5-180940	1123	-	F	Correction to sr-ConfigIndex for CatM1 with 3MHz BW	15.1.0
2018-03	RAN#79	R5-181054	1126	-	F	Addition of the Band 74 information into TS 36.508	15.1.0
2018-03	RAN#79	R5-181066	1127	-	F	Correction to test frequency f4 for E-UTRA FDD bands 25 and 26	15.1.0
2018-03	RAN#79	R5-181101	1130	-	F	Connection diagrams for new 4Rx CA demodulation test cases	15.1.0
2018-03	RAN#79	R5-181141	1096	1	F	Corrections to the generic test procedures for IMS MT calls in E-UTRA	15.1.0

2018-03	RAN#79	R5-181142	1128	1	F	Correction to MeasConfig-DEFAULT	15.1.0
2018-03	RAN#79	R5-181143	1129	1	F	Correction to UE registration with test mode activation procedure 4.5.2A.3	15.1.0
2018-03	RAN#79	R5-181196	1103	1	F	Addition of default USIM settings for IMS eCall test cases	15.1.0
2018-03	RAN#79	R5-181197	1113	1	F	Update to generic procedure 36.508 4.5A.27 for eCall Only Supporting UE	15.1.0
2018-03	RAN#79	R5-181216	1099	1	F	Update the USIM EFs configuration for V2X.	15.1.0
2018-03	RAN#79	R5-181217	1100	1	F	Editorial, clean up of V2X default message definitions.	15.1.0
2018-03	RAN#79	R5-181218	1119	1	F	Changes and additions to GNSS requirements for V2X testing	15.1.0
2018-03	RAN#79	R5-181293	1104	1	F	Addition of new Generic Test Procedure for IPsec Tunnel Disconnection in EPC / WLAN	15.1.0
2018-03	RAN#79	R5-181295	1106	1	F	Updates to default NB-IoT messages to support the in-band operation mode in protocol test cases	15.1.0
2018-03	RAN#79	R5-181309	1131	-	F	Correction to RRCConnectionResume-NB specific message contents.	15.1.0
2018-03	RAN#79	R5-181601	1094	1	F	New Cells for NB-IOT OTDOA tests - NB-IOT Cell	15.1.0
2018-03	RAN#79	R5-181607	1102	1	F	Include AdditionalSpectrumEmission for V2X as per RAN2 spec	15.1.0
2018-03	RAN#79	R5-181616	1114	1	F	Test frequencies for Rel-13 LTE CA configurations	15.1.0
2018-03	RAN#79	R5-181357	1115	1	F	Test frequencies for Rel-14 LTE CA configurations	15.1.0
2018-03	RAN#79	R5-181666	1112	1	F	Addition of Connection Diagrams for V2X and V2V Sidelink Communication Performance Test Cases	15.1.0
2018-06	RAN#80	R5-182376	1142	-	F	Removal of square brackets for GNSS for V2X setups	15.2.0
2018-06	RAN#80	R5-182415	1144	-	F	Addition of GNSS information for MCS tests	15.2.0
2018-06	RAN#80	R5-182425	1145	-	F	Update of default NAS messages to add ENDC IEs	15.2.0
2018-06	RAN#80	R5-182460	1146	-	F	Correction to Attach request and Tracking Area Update request message	15.2.0
2018-06	RAN#80	R5-182608	1154	-	F	Addition of connection diagrams for power imbalance performance V2V test	15.2.0
2018-06	RAN#80	R5-182636	1155	-	F	Update SIB2 message for NR	15.2.0
2018-06	RAN#80	R5-182654	1156	-	F	Addition of SIB22-NB definition	15.2.0
2018-06	RAN#80	R5-182660	1157	-	F	Update of V2X USIM configuration to add service ID	15.2.0
2018-06	RAN#80	R5-182666	1158	-	F	Addition of test frequency of CA_40E	15.2.0
2018-06	RAN#80	R5-182668	1159	-	F	Addition of test frequency of CA_41F	15.2.0
2018-06	RAN#80	R5-182811	1163	-	F	Addition of test frequencies for CA signalling test	15.2.0
2018-06	RAN#80	R5-182878	1167	-	F	Exceptions for DL Control Channel Interference Mitigation (Type A and Type B) Tests	15.2.0
2018-06	RAN#80	R5-183038	1173	-	F	Addition of test frequency of CA_66A-66A-66A	15.2.0
2018-06	RAN#80	R5-183055	1174	-	F	Corrections to 4.5A.24	15.2.0
2018-06	RAN#80	R5-183056	1139	1	F	Update to UECapabilityInformation-NB message	15.2.0
2018-06	RAN#80	R5-183057	1150	1	F	Correction to t-PollRetransmit value in Table 4.6.3-19A	15.2.0
2018-06	RAN#80	R5-183058	1170	1	F	Correction to PRACH Config for CAT-M1 UEs	15.2.0
2018-06	RAN#80	R5-183076	1172	1	F	Correction to Band 66 CA band combinations	15.2.0
2018-06	RAN#80	R5-183091	1166	1	F	Addition of NR and MRDC details for UECapabilityEnquiry RRC message	15.2.0
2018-06	RAN#80	R5-183092	1169	1	F	Add ULInformationTransferMRDC message contents	15.2.0
2018-06	RAN#80	R5-183125	1136	1	F	Addition of MeasObject and MeasReport for NR	15.2.0
2018-06	RAN#80	R5-183170	1161	1	F	Introduction of DCI0A/0B for eLAA	15.2.0

2018-06	RAN#80	R5-183171	1162	1	F	Introduction of DCI4A/4B for eLAA	15.2.0
2018-06	RAN#80	R5-183182	1149	1	F	Addition of V2XoverLTEUu in V2X management data object configuration	15.2.0
2018-06	RAN#80	R5-183238	1138	1	F	Update RRCConnectionReconfiguration message for EN-DC	15.2.0
2018-06	RAN#80	R5-183239	1147	1	F	Update TFT configuration in Dedicated Bearer to Allow IP Ping Operation	15.2.0
2018-06	RAN#80	R5-183247	1140	1	F	Update to the generic registration procedure for Multi-PDNs UEs	15.2.0
2018-06	RAN#80	R5-183786	1153	1	F	Update on AT commands for V2V/X Sidelink communications	15.2.0
2018-06	RAN#80	R5-183864	1151	1	F	Definition of additional simulated cells for IncMon RRM Test Cases	15.2.0
2018-06	RAN#80	R5-183867	1141	1	F	Addition of Rel-15 NB-IoT test frequencies	15.2.0
2018-06	RAN#80	R5-183894	1143	1	F	Addition of WLAN and BLE to test frequencies	15.2.0
2018-09	RAN#81	R5-184054	1177	-	F	Add SRB with NR PDCP	15.3.0
2018-09	RAN#81	R5-184075	1178	-	F	NB-IoT timer tolerances: extension of timer value range	15.3.0
2018-09	RAN#81	R5-184110	1180	-	F	Correction to NB-IOT In-Band Test Frequencies	15.3.0
2018-09	RAN#81	R5-184234	1182	-	F	Correction to message contents for UL64QAM	15.3.0
2018-09	RAN#81	R5-184235	1183	-	F	Correction to default message for UL CA tests	15.3.0
2018-09	RAN#81	R5-184236	1184	-	F	Editorial correction to FDD Mode test frequencies	15.3.0
2018-09	RAN#81	R5-184268	1186	-	F	Cleaning up the default message contents and test states of V2X	15.3.0
2018-09	RAN#81	R5-184282	1187	-	F	Update of test frequencies for CA_42A-42A	15.3.0
2018-09	RAN#81	R5-184569	1193	-	F	Add Band 31 Test Frequencies for NB-IoT Inter-frequency Test cases	15.3.0
2018-09	RAN#81	R5-184668	1195	-	F	Editorial correction of reference document	15.3.0
2018-09	RAN#81	R5-184771	1197	-	F	Addition of test frequencies for CA_66A-71A, CA_66C-71A, CA_70A-71A, CA_70C-71A to 36.508	15.3.0
2018-09	RAN#81	R5-184820	1199	-	F	Addition of default laa-SCellConfiguration setting for eLAA	15.3.0
2018-09	RAN#81	R5-184884	1200	-	F	Update to NB-IoT test conditions for in-band / guard band	15.3.0
2018-09	RAN#81	R5-185002	1179	1	F	Correction to ATTACH ACCEPT message for SMS only	15.3.0
2018-09	RAN#81	R5-185003	1190	1	F	Correction of 6.2.3.2 Test Frequency for CA_3A-27A	15.3.0
2018-09	RAN#81	R5-185023	1189	1	F	Updates of 6.2.3.2 Test Frequency for CA_8A-27A	15.3.0
2018-09	RAN#81	R5-185103	1196	1	F	Specifying content for SCGFailureInformationNR	15.3.0
2018-09	RAN#81	R5-185104	1201	1	F	Addition of reference dedicated EPS bearer context #7 for V2X testing	15.3.0
2018-09	RAN#81	R5-185113	1198	1	F	Addition of NB_IOTenh-UEConTest test case scenarios and default SIB content	15.3.0
2018-09	RAN#81	R5-185158	1176	1	F	Update Reference Table 6.6.2-1A dedicated EPS bearer contexts	15.3.0
2018-09	RAN#81	R5-185164	1175	1	F	Update RRCConnectionReconfiguration message for EN-DC	15.3.0
2018-09	RAN#81	R5-185166	1188	1	F	Modification of EPS & Data Radio Bearer ID mapping for EN-DC Test cases	15.3.0
2018-09	RAN#81	R5-185409	1181	1	F	Addition of NB-IOT Guardband Test Frequencies for 10 MHz	15.3.0
2018-09	RAN#81	R5-185449	1185	1	F	Correction to Figure A.64 to cater for CC >= 3	15.3.0
2018-09	RAN#81	R5-185454	1191	1	F	Addition of antenna diagrams for IncMon RRM test cases	15.3.0
2018-09	RAN#81	R5-185455	1192	1	F	Addition of message content for RRM IncMon test cases	15.3.0

History

Document history		
V15.2.0	September 2018	Publication
V15.3.0	October 2018	Publication