

ETSI TS 136 523-3 V8.5.0 (2011-04)

Technical Specification

**LTE;
Evolved Universal Terrestrial Radio Access (E-UTRA) and
Evolved Packet Core (EPC);
User Equipment (UE) conformance specification;
Part 3: Test suites
(3GPP TS 36.523-3 version 8.5.0 Release 8)**



Reference

RTS/TSGR-0536523-3v850

Keywords

LTE

ETSI

650 Route des Lucioles
F-06921 Sophia Antipolis Cedex - FRANCE

Tel.: +33 4 92 94 42 00 Fax: +33 4 93 65 47 16

Siret N° 348 623 562 00017 - NAF 742 C
Association à but non lucratif enregistrée à la
Sous-Préfecture de Grasse (06) N° 7803/88

Important notice

Individual copies of the present document can be downloaded from:

<http://www.etsi.org>

The present document may be made available in more than one electronic version or in print. In any case of existing or perceived difference in contents between such versions, the reference version is the Portable Document Format (PDF). In case of dispute, the reference shall be the printing on ETSI printers of the PDF version kept on a specific network drive within ETSI Secretariat.

Users of the present document should be aware that the document may be subject to revision or change of status. Information on the current status of this and other ETSI documents is available at

<http://portal.etsi.org/tb/status/status.asp>

If you find errors in the present document, please send your comment to one of the following services:

http://portal.etsi.org/chaicor/ETSI_support.asp

Copyright Notification

No part may be reproduced except as authorized by written permission.
The copyright and the foregoing restriction extend to reproduction in all media.

© European Telecommunications Standards Institute 2011.
All rights reserved.

DECT[™], **PLUGTESTS**[™], **UMTS**[™], **TIPHON**[™], the TIPHON logo and the ETSI logo are Trade Marks of ETSI registered for the benefit of its Members.

3GPP[™] is a Trade Mark of ETSI registered for the benefit of its Members and of the 3GPP Organizational Partners.

LTE[™] is a Trade Mark of ETSI currently being registered

for the benefit of its Members and of the 3GPP Organizational Partners.

GSM[®] and the GSM logo are Trade Marks registered and owned by the GSM Association.

Intellectual Property Rights

IPRs essential or potentially essential to the present document may have been declared to ETSI. The information pertaining to these essential IPRs, if any, is publicly available for **ETSI members and non-members**, and can be found in ETSI SR 000 314: *"Intellectual Property Rights (IPRs); Essential, or potentially Essential, IPRs notified to ETSI in respect of ETSI standards"*, which is available from the ETSI Secretariat. Latest updates are available on the ETSI Web server (<http://webapp.etsi.org/IPR/home.asp>).

Pursuant to the ETSI IPR Policy, no investigation, including IPR searches, has been carried out by ETSI. No guarantee can be given as to the existence of other IPRs not referenced in ETSI SR 000 314 (or the updates on the ETSI Web server) which are, or may be, or may become, essential to the present document.

Foreword

This Technical Specification (TS) has been produced by ETSI 3rd Generation Partnership Project (3GPP).

The present document may refer to technical specifications or reports using their 3GPP identities, UMTS identities or GSM identities. These should be interpreted as being references to the corresponding ETSI deliverables.

The cross reference between GSM, UMTS, 3GPP and ETSI identities can be found under <http://webapp.etsi.org/key/queryform.asp>.

Contents

Intellectual Property Rights	2
Foreword.....	2
Foreword.....	9
Introduction	9
1 Scope	10
2 References	10
3 Definitions and abbreviations.....	12
3.1 Definitions	12
3.2 Abbreviations	12
4 E-UTRAN/SAE system architecture and test models	12
4.1 Test system architecture	12
4.1.1 General system architecture	12
4.1.2 Component architecture	13
4.2 E-UTRAN test models	15
4.2.1 Layer 2 test models	15
4.2.1.1 MAC test model	15
4.2.1.2 RLC test model	16
4.2.1.3 PDCP test model	17
4.2.1.3.1 PDCP ROHC test model	17
4.2.1.3.2 PDCP test model (Non ROHC)	18
4.2.2 RRC test model.....	19
4.2.3 DRB test model.....	20
4.2.4 IP Test Model	21
4.2.4.1 IP user data.....	21
4.2.4.2 Configuration of Sockets.....	22
4.2.4.2.1 Socket Establishment.....	22
4.2.4.2.2 Socket Release.....	23
4.2.4.3 Handling of IP data	23
4.2.4.4 Routing of IP Data	24
4.2.5 IMS test model handling registration signalling	24
4.2.5.1 Requirements of the IP test model extension	24
4.2.5.2 IMS Test model.....	25
4.2.5.2.1 IMS Registration/Authentication function	25
4.2.5.2.2 Necessary IP network server functions.....	25
4.2.5.2.3 IPsec protocol.....	26
4.2.5.2.4 Transport and IP-CAN bearer.....	28
4.2.5.2.5 SIP Compression	28
4.2.5.2.6 SIP TTCN-3 Codec	28
4.2.6 Support DSMIPv6	29
4.3 SAE Test Model	29
4.3.1 NAS Test Model.....	29
4.4 Inter RAT Test Model	30
4.4.1 E-UTRAN-UTRAN Inter RAT Test Model	30
4.4.2 E-UTRAN-GERAN Inter RAT Test Model	31
4.4.3 E-UTRAN-CDMA2000 Inter RAT Test Model.....	32
4.4.3.1 E-UTRAN-CDMA2000 HRPD Inter RAT Test Model.....	32
4.4.3.2 E-UTRAN-CDMA2000 1xRTT Inter RAT test model.....	35
4.4.4 E-UTRAN FDD-TDD Inter RAT Test Model.....	37
4.4.5 E-UTRAN-UTRAN-GERAN Inter RAT Test Model	38
5 Upper Tester Interface.....	38
6 ASP specifications.....	40

6.1	General Requirements and Assumptions.....	40
6.1.1	IP ASP requirements.....	41
6.1.2	Enhancement of IP ASP for handling IMS signalling	41
6.2	E-UTRAN ASP Definitions	41
6.2.1	Configuration Primitives.....	42
6.2.2	Signalling Primitives.....	42
6.2.3	Co-ordination Messages between NAS Emulation PTC and EUTRA PTC	42
6.3	UTRAN ASP Definitions.....	44
6.3.1	ASPs for Control Primitive Transmission	44
6.3.2	ASPs for Data Transmission and Reception	45
6.4	GERAN ASP Definitions.....	46
6.4.1	ASPs for Control Primitive Transmission	46
6.4.2	ASPs for Data Transmission and Reception	47
7	Test Methods and Design Considerations	49
7.1	Channel Mapping	49
7.1.1	PDCCH Candidate Selection	49
7.1.1.1	FDD candidates selection.....	50
7.1.1.2	TDD candidates selection	53
7.2	Uplink Grant.....	55
7.2.1	Exception TC list	56
7.3	Downlink Resource Allocation	57
7.3.1	PDCCH DCI default formats.....	57
7.3.2	Radio parameters configured.....	57
7.3.3	General DL scheduling scheme	58
7.3.3.1	Additional rules for BCCH scheduling scheme	58
7.3.3.1.1	BCCH with DCI combination 1	59
7.3.3.1.2	BCCH with DCI combination 2	59
7.3.3.2	Additional rules for PCCH specific scheduling scheme	59
7.3.3.2.1	PCCH with DCI combination 1.....	59
7.3.3.2.2	PCCH with DCI combination 2.....	59
7.3.3.3	Additional rules for RAR specific scheduling scheme.....	60
7.3.3.3.1	RAR with DCI combination 1	60
7.3.3.3.2	RAR with DCI combination 2	60
7.3.3.4	Additional rules for UE-dedicated scheduling scheme in normal mode	60
7.3.3.5	DL Resource allocation bitmaps	62
7.3.3.5.1	DCI combination 1	62
7.3.3.5.2	DCI combination 2	63
7.3.3.6	UE-dedicated scheduling scheme in explicit mode.....	65
7.3.3.6.1	DL Scheduling in Transport Block Size Selection Test Cases	66
7.3.3.7	Resource allocation sheets	66
7.4	Cell Configurations	67
7.4.1	Cell Configuration Types.....	67
7.4.2	Cell Power Change	68
7.4.3	E-UTRAN cell identity	68
7.4.3.1	Timing parameters of cells.....	68
7.4.4	Cell configurations for NAS test cases	70
7.4.5	Configuration of Multi-Cell Environment	70
7.5	TDD Considerations.....	71
7.5.1	FDD vs. TDD implementation.....	71
7.6	Special RLC Modes.....	71
7.6.1	Suppression of RLC Acknowledgements	71
7.6.2	Modification of VT(S).....	71
7.7	System information	72
7.7.1	System information broadcasting	72
7.7.2	Scheduling information.....	72
7.7.3	System information modification	77
7.8	Timers and Timing Restrictions	77
7.8.1	Auxiliary timers	78
7.8.2	RRC timers reconfiguration.....	78
7.8.3	MAC TA timer reconfiguration	78
7.9	Error Indication	78

7.10	Race Conditions	78
7.11	Radio Link Failure.....	79
7.12	Test method for RRC signalling latency	79
7.12.1	Procedure delays in PUCCH synchronized state	79
7.12.2	Procedure delays when RACH procedure required	80
7.13	RLC test method for scheduled data.....	81
7.14	IP packets for Loopback Mode.....	82
7.14.1	IP packets used for Loopback Mode A.....	82
7.14.2	IP packets used for Loopback Mode B	82
7.15	Connected Mode DRX	82
7.16	Handover Sequences	84
7.16.1	Sequence of inter-cell handover.....	84
7.16.2	Sequence of intra-cell handover.....	84
7.16.3	UL Grants used in RA procedure during handover	85
8	External Function Definitions	85
9	IXIT Proforma.....	87
9.1	E-UTRAN PIXIT	88
9.2	MultiRAT PIXIT	89
10	Postambles.....	91
10.1	Postambles for E-UTRA to UTRA tests.....	91
10.1.1	UE postamble states and procedures for E-UTRA to UTRA.....	91
10.1.2	Switch/Power off procedure	93
10.1.2.1	Procedure	93
10.1.3	CC disconnect procedure	94
10.1.3.1	Procedure	94
10.1.4	PS Routing Area Update procedure.....	95
10.1.4.1	Procedure	95
10.1.5	CS fallback procedure.....	97
10.1.5.1	Procedure	97
10.2	Postambles for E-UTRAN to GERAN tests.....	98
10.2.1	UE postamble states and procedures for E-UTRA to GERAN test cases.....	99
10.2.2	Switch/Power off procedure	100
10.2.2.1	Procedure	100
10.2.3	PS Handover procedure	101
10.2.3.1	Procedure	101
10.2.4	CC disconnect procedure	102
10.2.4.1	Procedure	102
10.2.5	CS fallback procedure.....	103
10.2.5.1	Procedure	103
10.3	Postambles for E-UTRA test cases.....	104
10.3.1	UE postamble states and procedures for E-UTRA test cases.....	104
10.3.2	Switch/Power off procedure in State 2E1	104
10.3.2.1	Procedure	104
10.3.3	Switch/Power off procedure in State E2 and E3.....	105
10.3.3.1	Procedure	105
10.3.4	Switch/Power off procedure in State E4.....	105
10.3.4.1	Procedure	105
10.4	Postambles for E-UTRA to HRPD test cases.....	105
10.4.1	UE postamble procedures for E-UTRA to HRPD (No Pre-Registration).....	106
10.4.1.1	Registration on HRPD Cell.....	106
10.4.1.2	Detach on HRPD Cell	107
11	Guidelines on test execution.....	107
11.1	Guidelines for different operating Bands	107
Annex A (normative): Test Suites.....		109
A.1	Baseline of specifications.....	109
A.2	E-UTRA Test Suites.....	109

Annex B (informative):	Style Guides	115
B.1	Introduction	115
B.2	General Requirements for TTCN-3 Implementations	115
B.3	Naming Conventions	116
B.3.1	Prefixes and Restrictions for TTCN-3 Objects.....	116
B.3.2	Void.....	117
B.3.3	Void.....	117
B.3.4	Identifiers consisting of more than one Name	117
B.4	Implementation Issues	117
B.4.1	Control part	117
B.4.2	Top Level Test Case Definitions	117
B.4.3	Inter Component Communication	118
B.4.4	Encoding Information.....	118
B.4.5	Verdict Assignment.....	118
B.4.5.1	PASS verdict assignment.....	119
B.4.5.2	FAIL or INCONC verdict assignment.....	119
B.4.5.3	Verdict assignment in default behaviour	119
B.4.6	Default Behaviour	120
B.4.7	Templates for Sending and Receiving.....	121
B.4.8	Logging	121
B.4.8.1	Prose Step Numbers.....	121
B.4.9	Top level comments	122
B.4.10	Mapping of DRBs	122
B.5	Modularisation	122
Annex C (informative):	Design Principles.....	124
C.1	ASP Design	124
C.2	SS State Model	125
Annex D (informative)	TTCN-3 Definitions	128
D.1	EUTRA_ASP_TypeDefs.....	128
D.1.1	ASN1_Container	128
D.1.2	System_Configuration.....	131
D.1.3	Cell_Configuration.....	133
D.1.3.1	Cell_Configuration_Common.....	133
D.1.3.2	Downlink_Physical_Layer_Configuration	138
D.1.3.2.1	Antenna_Configuration.....	138
D.1.3.2.2	Physical_Channels	139
D.1.3.2.3	Physical_Signals	141
D.1.3.3	Uplink_Physical_Layer_Configuration	142
D.1.3.4	Common_MAC_Configuration	143
D.1.3.5	Random_Access_Procedure	149
D.1.3.6	System_Information_Control	155
D.1.3.7	Paging_Control	157
D.1.3.8	UE_Specific_Channel_Configuration	157
D.1.3.8.1	UE_Specific_Channel_Configuration_DL	157
D.1.3.8.1.1	MIMO_Configuration	158
D.1.3.8.2	UE_Specific_Channel_Configuration_UL	159
D.1.4	Cell_Power_Attenuation	161
D.1.5	Radio_Bearer_Configuration	161
D.1.5.1	PDCP_Configuration.....	161
D.1.5.2	RLC_Configuration	163
D.1.5.3	MAC_Configuration.....	165
D.1.6	AS_Security	168
D.1.7	Semi_Persistent_Scheduling	170
D.1.8	Paging_Trigger.....	172
D.1.9	L1_MAC_Indication_Control	172

D.1.10	Rlc_Indication_Control.....	173
D.1.11	PDCP_Count.....	173
D.1.12	PDCP_Handover.....	174
D.1.13	L1_MAC_Test_Mode.....	175
D.1.14	PDCCH_Order.....	175
D.1.15	System_Indications.....	176
D.1.16	System_Interface.....	178
D.2	EUTRA_ASP_DrbDefs.....	179
D.2.1	PDU_TypeDefs.....	180
D.2.1.1	MAC_PDU.....	180
D.2.1.2	RLC_PDU.....	182
D.2.1.2.1	Common.....	182
D.2.1.2.2	TM_Data.....	183
D.2.1.2.3	UM_Data.....	184
D.2.1.2.4	AM_Data.....	185
D.2.1.2.5	AM_Status.....	186
D.2.1.3	PDCP.....	188
D.2.2	DRB_Primitive_Definitions.....	189
D.2.2.1	DRB_Common.....	190
D.2.2.2	Downlink.....	191
D.2.2.3	Uplink.....	192
D.2.3	System_Interface.....	193
D.3	IP_ASP_TypeDefs.....	194
D.3.1	IP_Common.....	194
D.3.2	IP_Config.....	195
D.3.3	IP_SocketHandling.....	198
D.3.3.1	Socket_Common.....	199
D.3.3.2	TCP_Socket.....	199
D.3.3.3	UDP_Socket.....	203
D.3.3.4	ICMP_Socket.....	205
D.3.3.5	Socket_Primitives.....	208
D.3.4	System_Interface.....	208
D.4	NasEmu_AspTypes.....	210
D.4.1	System_Interface.....	210
D.5	EUTRA_CommonDefs.....	211
D.5.1	Common_Types.....	211
D.5.2	Common_Constants.....	213
D.5.3	RRC_Nested_Types.....	213
D.5.4	ASP_CommonPart.....	213
D.5.4.1	ASP_CommonPart_Definitions.....	214
D.5.4.1.1	Routing_Info.....	214
D.5.4.1.2	Timing_Info.....	215
D.5.4.2	REQ_ASP_CommonPart.....	216
D.5.4.3	CNF_ASP_CommonPart.....	216
D.5.4.4	IND_ASP_CommonPart.....	217
D.6	CDMA2000_ASP_TypeDefs.....	217
D.6.1	CDMA2000_Common.....	217
D.6.1.1	CDMA2000_SystemContants.....	218
D.6.1.2	CDMA2000_Routing.....	218
D.6.1.3	CDMA2000_TimingInfo.....	218
D.6.1.4	CDMA2000_ReqAspCommonPart.....	219
D.6.1.5	CDMA2000_IndAspCommonPart.....	220
D.6.1.6	CDMA2000_CnfAspCommonPart.....	220
D.6.2	CDMA2000_PowerLevel.....	221
D.6.3	CDMA2000_Data.....	222
D.6.4	CDMA2000_CellConfiguration.....	224
D.6.5	CDMA2000_HRPD.....	226
D.6.5.1	CDMA2000_PDN_Defs.....	226
D.6.5.2	CDMA2000_SubProtocols.....	227

D.6.5.3	HRPD_Indications	228
D.6.5.4	HRPD_Commands	230
D.6.6	CDMA2000_RTT1X	232
D.6.6.1	RTT1X_Indications	232
D.6.6.2	RTT1X_Commands	235
D.6.7	System_Interface	235
D.7	CDMA2000_CommonDefs	238
D.8	HRPD_MsgTypeDefs	241
D.9	CommonDefs	241
D.10	References to TTCN-3	242
Annex E (informative):	Change history	243
History		255

Foreword

This Technical Specification has been produced by the 3rd Generation Partnership Project (3GPP).

The contents of the present document are subject to continuing work within the TSG and may change following formal TSG approval. Should the TSG modify the contents of the present document, it will be re-released by the TSG with an identifying change of release date and an increase in version number as follows:

Version x.y.z

where:

- x the first digit:
 - 1 presented to TSG for information;
 - 2 presented to TSG for approval;
 - 3 or greater indicates TSG approved document under change control.
- y the second digit is incremented for all changes of substance, i.e. technical enhancements, corrections, updates, etc.
- z the third digit is incremented when editorial only changes have been incorporated in the document.

Introduction

The present document is part 3 of a multi-part conformance test specification for the 3GPP evolved User Equipment (UE). The specification contains a TTCN-3 design frame work and the detailed test specifications in TTCN-3 for evolved UE at the UE-E-UTRAN radio interface.

- 3GPP TS 36.523-1 [1]: "User Equipment (UE) conformance specification; Part 1: Protocol conformance specification".
- 3GPP TS 36.523-2 [2]: "User Equipment (UE) conformance specification; Part 2: Implementation Conformance Statement (ICS) proforma specification".
- **3GPP TS 36.523-3: "Test Suites"** (the present document).

1 Scope

The present document specifies the protocol and signalling conformance testing in TTCN-3 for the 3GPP UE at the UE-E-UTRAN radio interface.

The following TTCN test specification and design considerations can be found in the present document:

- the test system architecture;
- the overall test suite structure;
- the test models and ASP definitions;
- the test methods and usage of communication ports definitions;
- the test configurations;
- the design principles and assumptions;
- TTCN styles and conventions;
- the partial PIXIT proforma;
- the test suites.

The Abstract Test Suites designed in the document are based on the test cases specified in prose (3GPP TS 36.523-1 [1]). The applicability of the individual test cases is specified in the test ICS proforma specification (3GPP TS 36.523-2 [1]).

The present document is valid for UE implemented according to 3GPP Rel-8 upwards.

2 References

The following documents contain provisions which, through reference in this text, constitute provisions of the present document.

- References are either specific (identified by date of publication, edition number, version number, etc.) or non-specific.
- For a specific reference, subsequent revisions do not apply.
- For a non-specific reference, the latest version applies. In the case of a reference to a 3GPP document (including a GSM document), a non-specific reference implicitly refers to the latest version of that document *in the same Release as the present document*.

- [1] 3GPP TS 36.523-1: "User Equipment (UE) conformance specification; Part 1: Protocol conformance specification".
- [2] 3GPP TS 36.523-2: "User Equipment (UE) conformance specification; Part 2: Implementation Conformance Statement (ICS) proforma specification".
- [3] 3GPP TS 36.508: "Common test environments for User Equipment (UE) conformance testing".
- [4] 3GPP TS 36.509: "Terminal logical test interface; Special conformance testing functions".
- [5] 3GPP TS 34.123-1: "User Equipment (UE) conformance specification; Part 1: Protocol conformance specification".
- [6] 3GPP TS 34.123-2: "User Equipment (UE) conformance specification; Part 2: Implementation Conformance Statement (ICS) proforma specification".

- [7] 3GPP TS 34.123-3: "User Equipment (UE) conformance specification; Part 3: Abstract Test Suite (ATS)".
- [8] 3GPP TS 34.108: "Common test environments for User Equipment (UE) conformance testing".
- [9] 3GPP TS 34.109: "Terminal logical test interface; Special conformance testing functions".
- [10] 3GPP TS 51.010-1: "Mobile Station (MS) conformance specification; Part 1: Conformance Specification".
- [11] 3GPP TS 51.010-2: "Mobile Station (MS) conformance specification; Part 2: Protocol Implementation Conformance Statement (PICS) proforma specification".
- [12] 3GPP TS 51.010-5: "Mobile Station (MS) conformance specification; Part 5: Inter-RAT (GERAN to UTRAN) Abstract Test Suite (ATS)".
- [13] ETSI ES 201 873-1: "Methods for Testing and Specification (MTS); The Tree and Tabular Combined Notation version 3; Part 1: TTCN-3 Core Language".
- [14] 3GPP TS 36.304: "Evolved Universal Terrestrial Radio Access (E-UTRA); "UE Procedures in Idle Mode".
- [15] 3GPP TS 36.306 "Evolved Universal Terrestrial Radio Access (E-UTRA); "UE Radio Access Capabilities".
- [16] 3GPP TS 36.321: "Evolved Universal Terrestrial Radio Access (E-UTRA); "Medium Access Control (MAC) protocol specification".
- [17] 3GPP TS 36.322: "Evolved Universal Terrestrial Radio Access (E-UTRA); "Radio Link Control (RLC) protocol specification".
- [18] 3GPP TS 36.323: "Evolved Universal Terrestrial Radio Access (E-UTRA); "Packet Data Convergence Protocol (PDCP) Specification".
- [19] 3GPP TS 36.331: "Evolved Universal Terrestrial Radio Access (E-UTRA) Radio Resource Control (RRC); Protocol Specification".
- [20] 3GPP TS 24.008: "Mobile Radio Interface Layer 3 specification; Core Network Protocols; Stage 3".
- [21] 3GPP TS 24.301: "Non-Access-Stratum (NAS) Protocol for Evolved Packet System (EPS); Stage 3".
- [22] 3GPP TS 24.303: "Mobility Management based on DSMIPv6; User Equipment (UE) to network protocols; Stage 3".
- [23] 3GPP TS 24.304: "Mobility management based on Mobile IPv4; User Equipment (UE) - foreign agent interface; Stage 3".
- [24] 3GPP TS 33.401: "3GPP System Architecture Evolution (SAE); Security architecture".
- [25] 3GPP TS 33.402: "3GPP System Architecture Evolution (SAE); Security aspects of non-3GPP accesses".
- [26] 3GPP TR 21.905: "Vocabulary for 3GPP Specifications".
- [27] ETSI ES 201 873-4: "Methods for Testing and Specification (MTS); The Testing and Test Control Notation version 3; Part 4: TTCN-3 Operational Semantics".
- [28] ETSI ES 201 873-5: "Methods for Testing and Specification (MTS); The Testing and Test Control Notation version 3; Part 5: TTCN-3 Runtime Interface (TRI)".
- [29] ETSI ES 201 873-6: "Methods for Testing and Specification (MTS); The Testing and Test Control Notation version 3; Part 6: TTCN-3 Control Interface (TCI)".
- [30] 3GPP TS 36.213: "Evolved Universal Terrestrial Radio Access (E-UTRA); Physical layer procedures".

- [31] 3GPP TS 27.005: "Use of Data Terminal Equipment - Data Circuit terminating Equipment (DTE-DCE) interface for Short Message Service (SMS) and Cell Broadcast Service (CBS)".
- [32] 3GPP TS 27.007: "AT command set for 3G User Equipment (UE)".
- [33] 3GPP TS 27.060: "Packet domain; Mobile Station (MS) supporting Packet Switched services".
- [34] 3GPP TS 36.101: "Evolved Universal Terrestrial Radio Access (E-UTRA); User Equipment (UE) radio transmission and reception".
- [35] 3GPP TS 36.211: "Evolved Universal Terrestrial Radio Access (E-UTRA); Physical channels and modulation".
- [36] 3GPP TS 25.331: "RRC Protocol Specification".
- [37] 3GPP TS 36.133: "Evolved Universal Terrestrial Radio Access (E-UTRA); Requirements for support of radio resource management".
- [38] 3GPP2 TSG-C C.S0024_C: "cdma2000 High Rate Packet Data Air Interface Specification".
- [39] 3GPP2 TSG-C C.S0057_D:" Band Class Specification for cdma2000 Spread Spectrum Systems"
- [40] 3GPP TS 34.229-1: "Internet Protocol (IP) multimedia call control protocol based on Session Initiation Protocol (SIP) and Session Description Protocol (SDP); User Equipment (UE) conformance specification; Part 1: Protocol conformance specification".
- [41] 3GPP TS 33.203: "3G security; Access security for IP-based services".
- [42] 3GPP TS 24.229: "IP Multimedia Call Control Protocol based on Session Initiation Protocol (SIP) and Session Description Protocol (SDP); Stage 3".

3 Definitions and abbreviations

3.1 Definitions

For the purposes of the present document, the terms and definitions given in 3GPP TR 21.905 [26] apply.

3.2 Abbreviations

For the purposes of the present document, the abbreviations given in 3GPP TR 21.905 [26] apply.

4 E-UTRAN/SAE system architecture and test models

4.1 Test system architecture

4.1.1 General system architecture

The general system architecture is shown in figure 4.1.1-1.

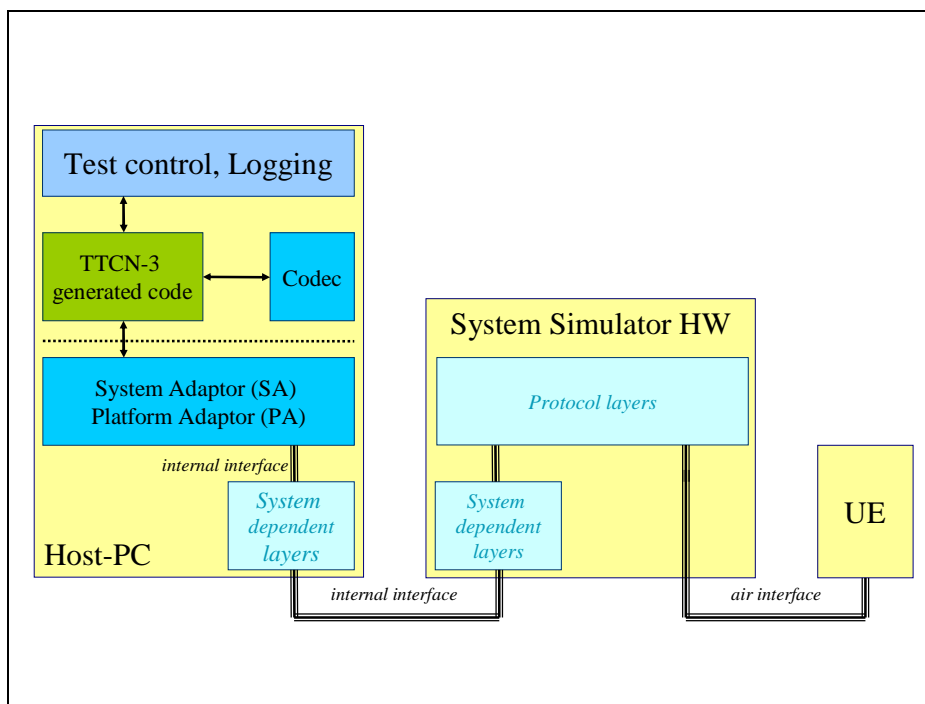

Figure 4.1.1-1: Architecture of system simulator

The scope of the present document is the TTCN-3 implementation of conformance tests. Specifications and definitions of the present document affect the codec and the system adaptor (SA). Test control and logging are out of scope as well as the interface between the TTCN-3 generated code and the system adaptor which can be either standardised TRI or proprietary.

The main assumptions regarding the system architecture are:

- TTCN-3 code runs on the host system only:
- No TTCN-3 components are downloaded to system simulator HW.
- Layer 2 tests (MAC, RLC) are controlled by appropriate configuration primitives in TTCN-3 but neither layer 2 nor parts of it are implemented in TTCN-3; the system simulator performs low layer procedure autonomously but all system simulator implementations shall result in the same test pattern at the air interface.
- Proprietary interfaces e.g. instead of the TRI are not considered in the test model.
- The timing considerations of the conformance tests shall be supported by appropriate timing information (e.g. system frame number) provided from/to the system simulator rather than by timing measurements in TTCN-3.

4.1.2 Component architecture

For E-UTRAN conformance tests each access technology (RAT) is hosted by a separate TTCN-3 parallel component (PTC):

- E-UTRAN.
- UTRAN.
- GERAN.
- Other technologies like 3GPP2 UTRAN.

The PTCs are controlled by the TTCN-3 master test component (MTC) which:

- is independent from the RAT;
- may host the upper tester for MMI and AT commands;
- creates, synchronises and terminates the PTCs;
- starts and terminates test cases.

Figure 4.1.2-1 shows this component architecture for a E-UTRAN and UTRAN scenario.

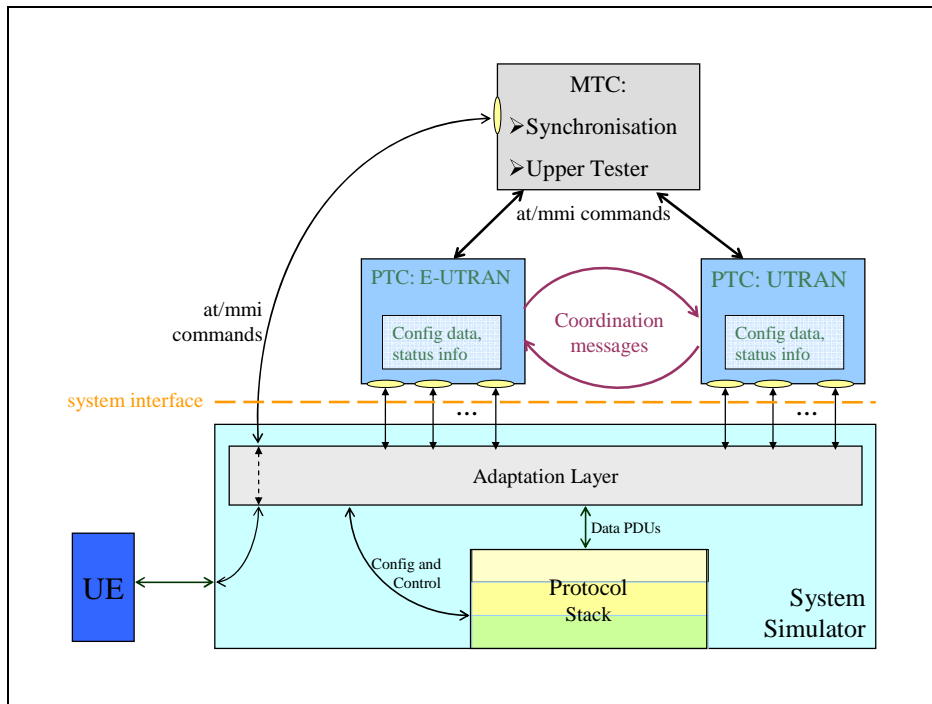

Figure 4.1.2-1: E-UTRAN-UTRAN component model

According to this model there are different interfaces to be considered:

MTC - PTC:

- common synchronisation of PTCs;
- upper tester primitives.

MTC - System Interface:

- upper tester primitives.

PTC - PTC:

- primitives containing information for IRAT handover.

PTC - System Interface:

- primitives containing peer-to-peer message;
- configuration primitives.

4.2 E-UTRAN test models

4.2.1 Layer 2 test models

When test loop mode is used for the Layer 2 tests the DRB ports at the SS side is referred to the raw DRB ones. At the SS side, DRBs are initially configured with default modes and parameters. For the purpose of L2-testing the DRBs may be reconfigured later on as indicated in the subsequent test models (see below).

4.2.1.1 MAC test model

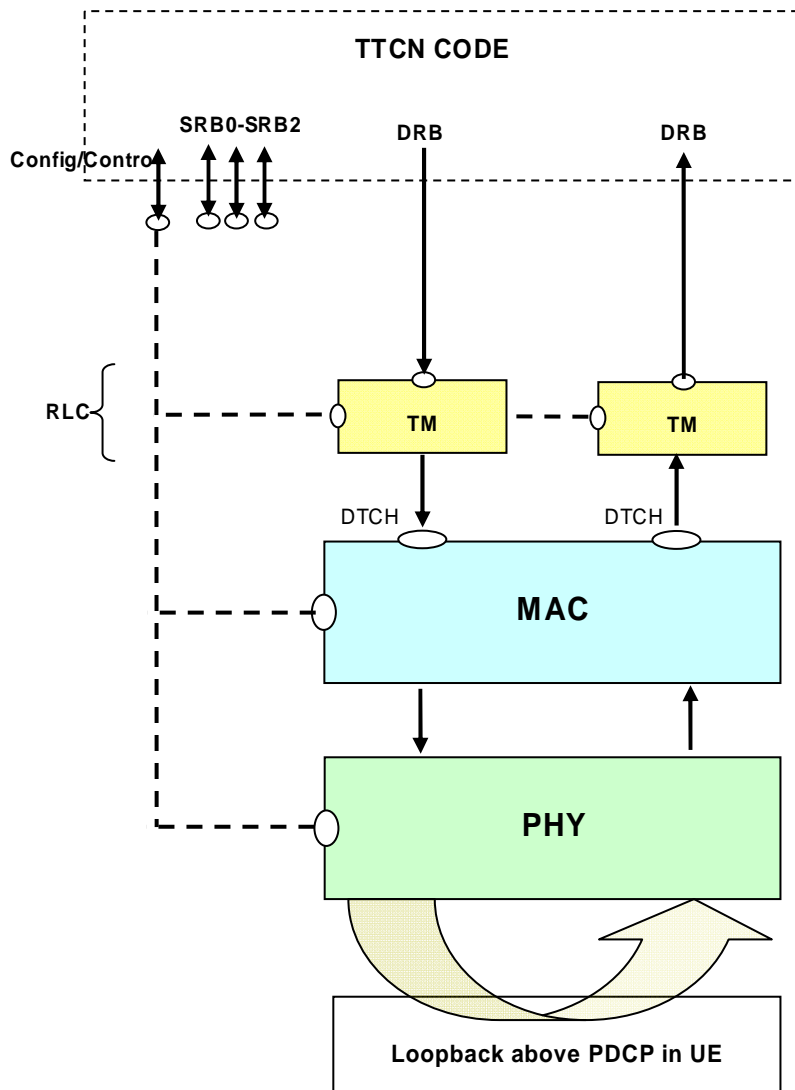

Figure 4.2.1.1-1: Test model for MAC testing

The UE is configured in Test Loop Mode, to loop back the user domain data above PDCP layer. On UE side Ciphering is enabled (since Mandatory) but with dummy ciphering algorithm, which is equivalent to not using ciphering. ROHC is not configured on UE Side.

On the SS Side, L1 is configured in the normal way. MAC is configured in a special mode, where it does not add any MAC headers in DL and not remove any MAC headers on UL directions respectively. In this case, the TTCN shall provide the final PDU, including padding. Except for this, the MAC layer shall perform all of its other functions.

The RLC is configured in transparent mode. Hence with this configuration PDU's out of SS RLC are same as the SDU's in it. There is no PDCP configured on SS Side. The ports are directly above RLC.

The PDU's exchanged between TTCN and SS, shall be the final MAC PDU's consisting of MAC, RLC and PDCP headers. TTCN code shall take care in DL of building MAC header, RLC headers and PDCP headers and in UL handle MAC, RLC and PDCP headers. TTCN code shall take care of maintaining sequence numbers and state variables for MAC, RLC and PDCP layers. During testing of Multiple DRBs on UE side, it shall still be possible to configure only one DRB on SS side with configuration in the figure 4.2.1.1-1. Other DRBs will not be configured, to facilitate routing UL TBSs. Multiplexing/de-multiplexing of PDU's meant/from different DRB's shall be performed in TTCN.

The UL Scheduling Grant and DL Scheduling assignments are configured from TTCN over system control port. SS reports PUCCH scheduling information over system indication port, if configured. In a similar way the reception of RACH preambles is reported by SS over the same port.

4.2.1.2 RLC test model

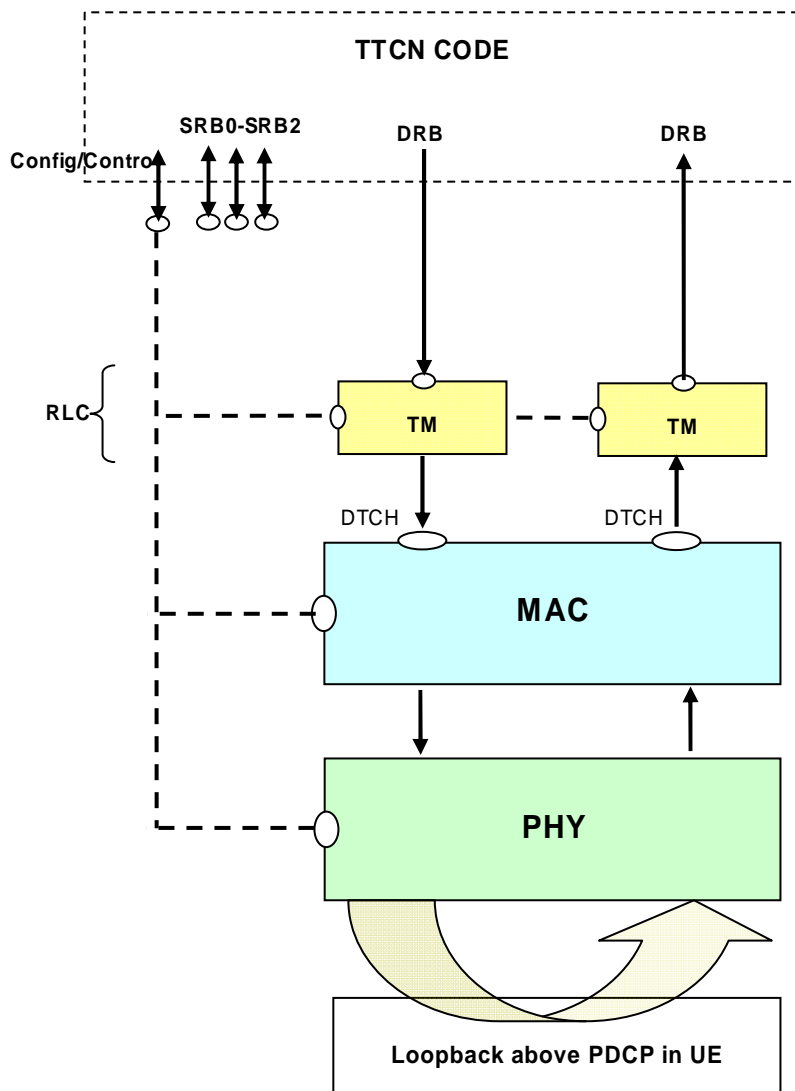

Figure 4.2.1.2.3-1: Test model for RLC AM/UM testing

This model is suitable for testing both UM/AM mode of operation of DRBs on UE side.

The UE is configured in Test Loop Mode, to loop back the user domain data above PDCP layer. On UE side Ciphering is enabled (since mandatory) but with dummy ciphering algorithm, which is equivalent to not using ciphering. ROHC is not configured on UE Side.

On the SS Side, L1 and MAC are configured in the normal way. The RLC is configured in transparent mode. Hence with this configuration PDUs out of SS RLC are same as the SDUs in it. There is no PDCP configured on SS Side. The ports are directly above RLC.

The PDUs exchanged between TTCN and SS, shall be the final RLC PDUs consisting of RLC and PDCP headers. TTCN code shall take care in DL of building RLC headers and PDCP headers and in UL handle RLC and PDCP headers. TTCN code shall take care of maintaining sequence numbers and state variables for RLC and PDCP layers. If RLC on UE side is in AM mode, TTCN shall take care of generating polls in DL and responding with RLC control PDUs on reception of UL Poll.

The UL Scheduling Grant and DL Scheduling assignments are configured from TTCN over system control port.

4.2.1.3 PDCP test model

4.2.1.3.1 PDCP ROHC test model

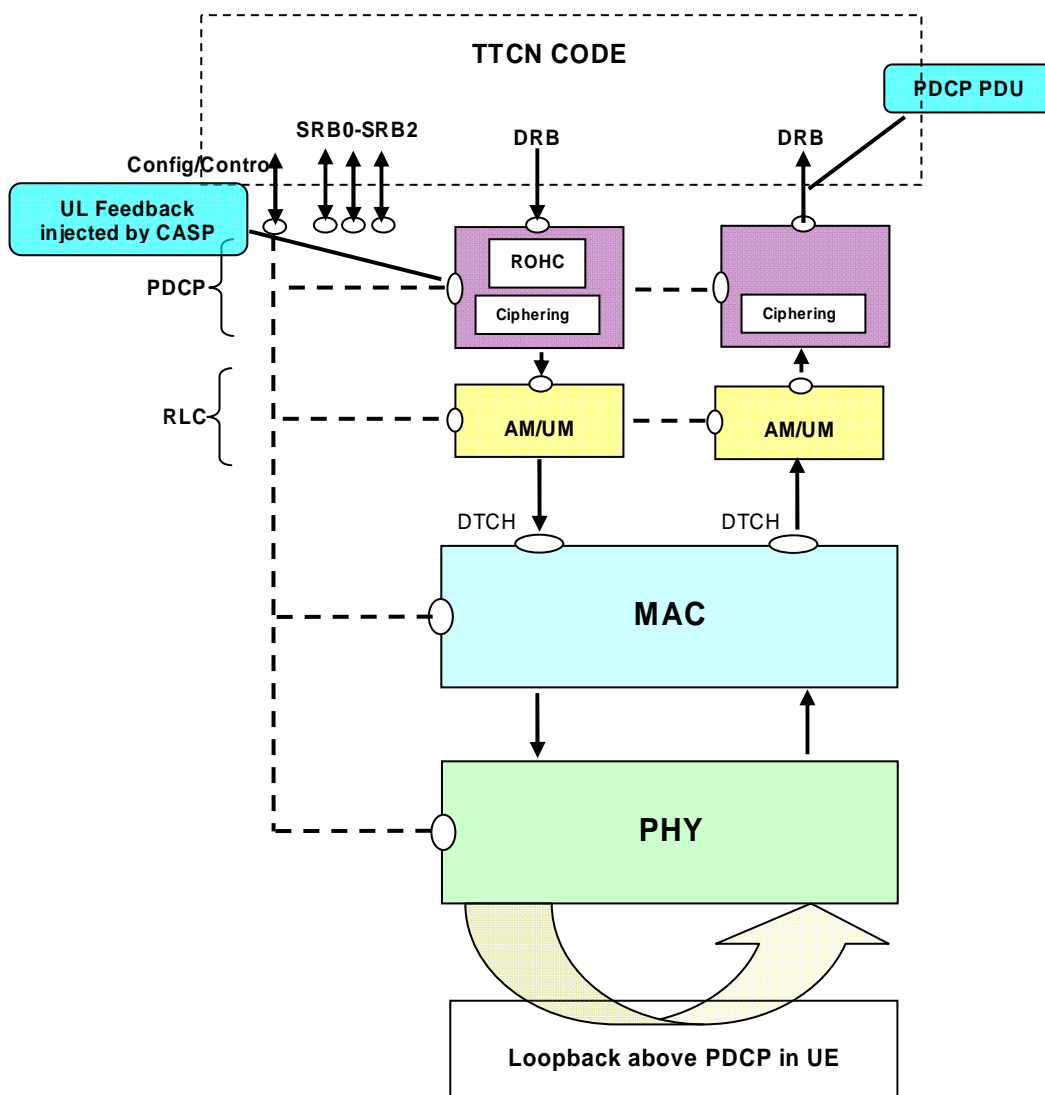

Figure 4.2.1.3.1-1: Test model for PDCP ROHC testing

The UE is configured in Test Loop Mode, to loop back the user domain data above PDCP layer. On UE side Ciphering is enabled and ROHC is configured.

On the SS Side L1, MAC and RLC are configured in normal way. They shall perform all of their functions. The ports are above PDCP.

The PDCP is configured in special mode, with no header manipulation. Ciphering is configured in both directions. ROHC is configured in DL direction only. UL ROHC feedback can be injected by control ASP. It shall be possible to configure 'no header manipulation' mode independently in UL and DL directions. When configured in special mode, SS shall not add PDCP header (DL) and remove PDCP Header (UL). PDCP state variables shall be maintained by SS PDCP layer. It shall be possible for SS PDCP to update state variables based on the PDU's in both directions, even though headers are not added/removed. Also, it shall be possible to read or set the PDCP internal state variables, by control primitives.

The UL Scheduling Grant and DL Scheduling assignments are configured from TTCN over system control port. SS reports PUCCH scheduling information reception over system indication port, if configured.

4.2.1.3.2 PDCP test model (Non ROHC)

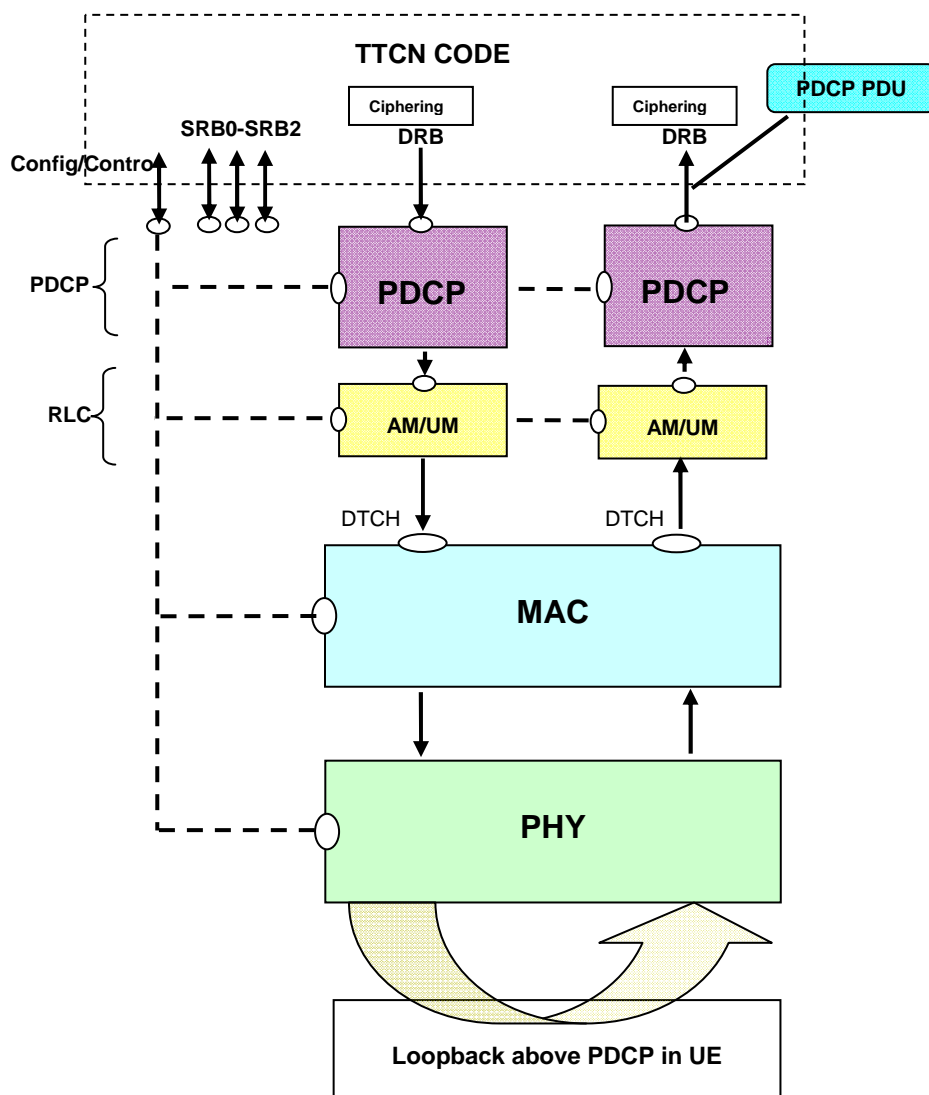

Figure 4.2.1.3.2-1: Test model for PDCP (Non ROHC) testing

The UE is configured in Test Loop Mode, to loop back the user domain data above PDCP layer. On UE side Ciphering is enabled and ROHC is not configured.

On the SS Side L1, MAC and RLC are configured in normal way. They shall perform all of their functions. The ports are above PDCP.

The PDCP is configured in a special mode, named transparent mode. In this mode, SS shall not add PDCP header (DL) and remove PDCP Header (UL). The TTCN maintains sequence numbers and state variables for the PDCP layer. The TTCN makes use of the AS ciphering functionality in both directions, employing the dummy ciphering algorithm. Ciphering/deciphering are performed using TTCN external functions. ROHC is not configured.

The UL Scheduling Grant and DL Scheduling assignments are configured from TTCN over system control port. SS reports PUCCH scheduling information reception over system indication port, if configured.

4.2.2 RRC test model

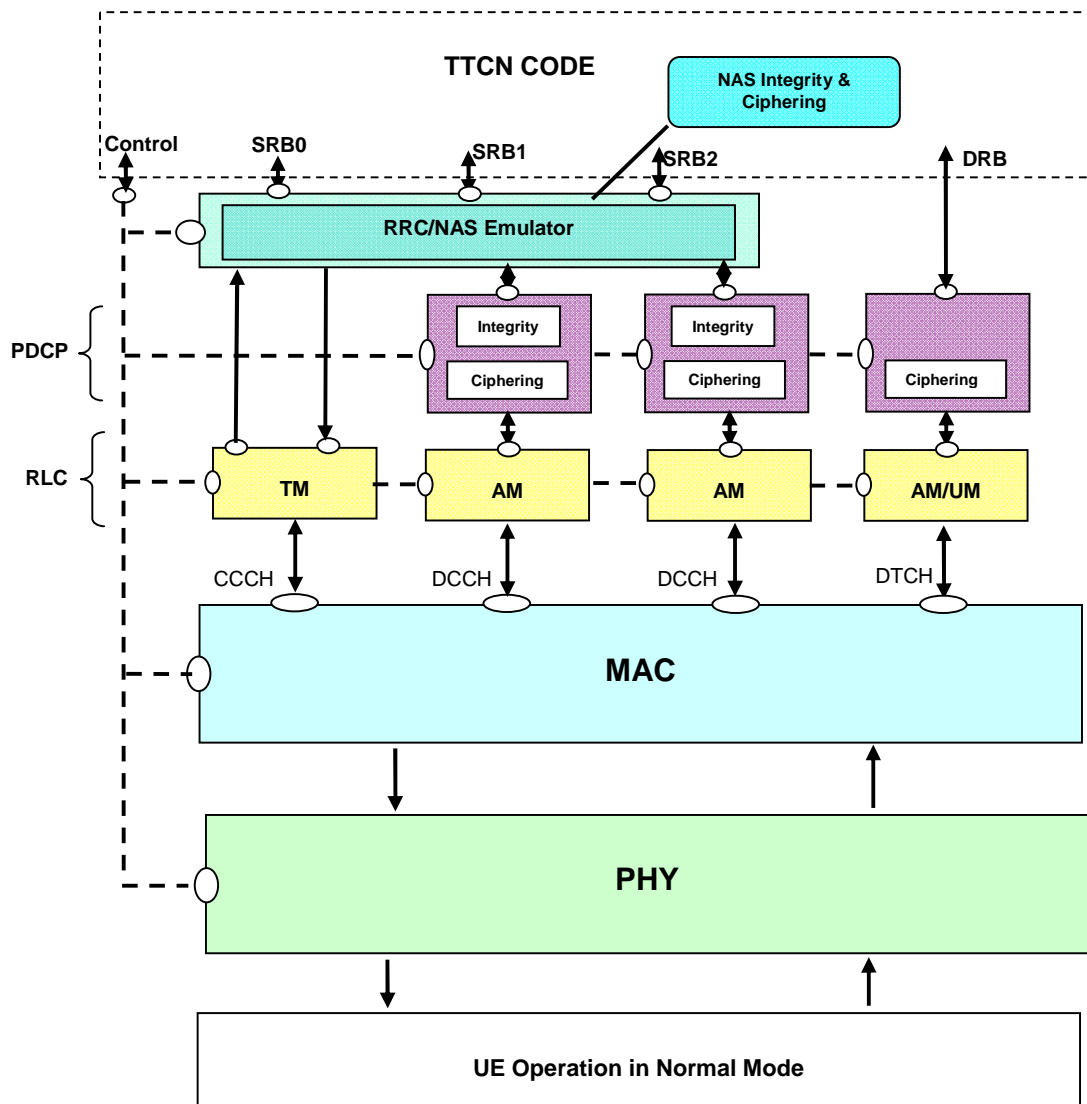

Figure 4.2.2-1: Test model for RRC testing

The UE is configured in normal mode. On UE side Ciphering/Integrity (PDCP and NAS) is enabled and ROHC is not configured.

On the SS Side L1, MAC, RLC and PDCP are configured in normal way. They shall perform all of their functions. For SRB0 the DL and UL port is above RLC. For SRB1 and SRB2 the port is above/below the RRC and NAS emulator, which may be implemented as a parallel test component. For DRB, the port is above PDCP. PDCP Ciphering/Integrity is enabled. NAS integrity/Ciphering is enabled.

The RRC/NAS emulator for SRB1 and SRB2 shall provide the Ciphering and integrity functionality for the NAS messages. In UL direction, SS shall report RRC messages, still containing (where appropriate) the secure and encoded

NAS message, to the RRC port. In DL, RRC and NAS messages with same timing information shall be embedded in one PDU after integrity and ciphering for NAS messages.

The UL Scheduling Grant and DL Scheduling assignments are configured from TTCN over system control port. SS reports PUCCH scheduling information reception over system indication port, if configured.

4.2.3 DRB test model

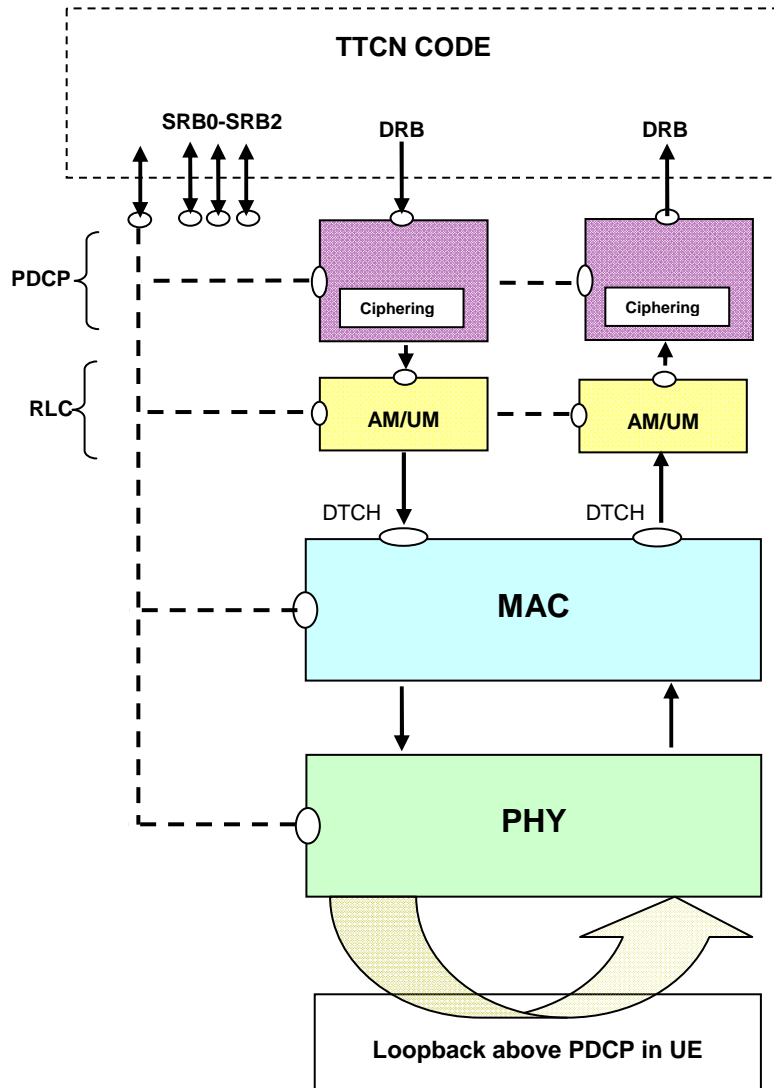

Figure 4.2.3-1: Test model for DRB testing

The UE is configured in Test Loop Mode, to loop back the user domain data above PDCP layer. Ciphering is optionally configured on UE side. In TTCN the DRB data is considered as raw data and there is no IP handling while the UE is in loopback mode.

On the SS Side L1, MAC, RLC and PDCP are configured in normal way. They shall perform all of their functions. The ports are above PDCP. When test loop mode is used for the DRB, the ports at the SS side refer to the raw DRB ones. Ciphering is enabled and ROHC is not configured on SS Side.

SS shall send in DL all PDU's received from different RB's but with same timing control information in one MAC PDU and in one TTI.

The UL Scheduling Grant and DL Scheduling assignments are configured from TTCN over system control port. SS reports PUCCH scheduling information reception over system indication port, if configured.

4.2.4 IP Test Model

Depending on different test scenarios user plane data can be distinguished in:

- Raw user data upon EUTRA PDCP (Raw mode);
- IP user data (IP mode).

The raw user data are applied for L2 or DRB tests, no IP protocols are involved. The UL user data is directly routed to the EUTRA_PTC.

The IP user data are applied when IP packets data are handled in TTCN. A DRB can have one or more Transport and Internet protocols configured.

Whether a DRB is in IP or in raw mode depends on the configuration of the routing table in the DRB-Mux. This is controlled by the IP_CTRL port and independent from the configuration of the IP connections (IP_SOCKET).

4.2.4.1 IP user data

To allow the usage of common protocol implementations at the system adaptor the related interfaces in TTCN-3 are based on the Sockets API.

There can be one or several sockets (server or client) for each DRB: TCP, UDP and ICMP.

Each socket can be clearly identified by the IP address, port number and the protocol (tcp|udp|icmp). It implies that a TCP socket can be either server or client.

It is assumed that:

- Different DRBs are not using the same sockets.
- The UE behaviour of a single IP-based protocol on a specific socket like DHCP can be included in conformance tests.
- Other protocols like ESP are not considered but can easily be introduced later, if necessary, by using the same socket approach.

The routing of IP packets from the IP stack to the DRBs in DL and from the DRBs either to the DRB port (E_DRB in case of EUTRA) or to the IP stack in UL is done by the DRB-Mux. This behaviour is controlled by the DRB-Mux's routing table.

The general architecture of the IP test model is shown in figure 4.2.4.1-1 (with a DHCP server as example for IP handling).

NOTE 1: In figure 4.2.4.1-1 DHCP is one example for a protocol above the IP stack; other protocols like DNS can also be implemented but this a pure TTCN implementation issue and independent from the system interface

NOTE 2: In general IMS can also be an application above the IP_PTC, but this is out of scope for this document.

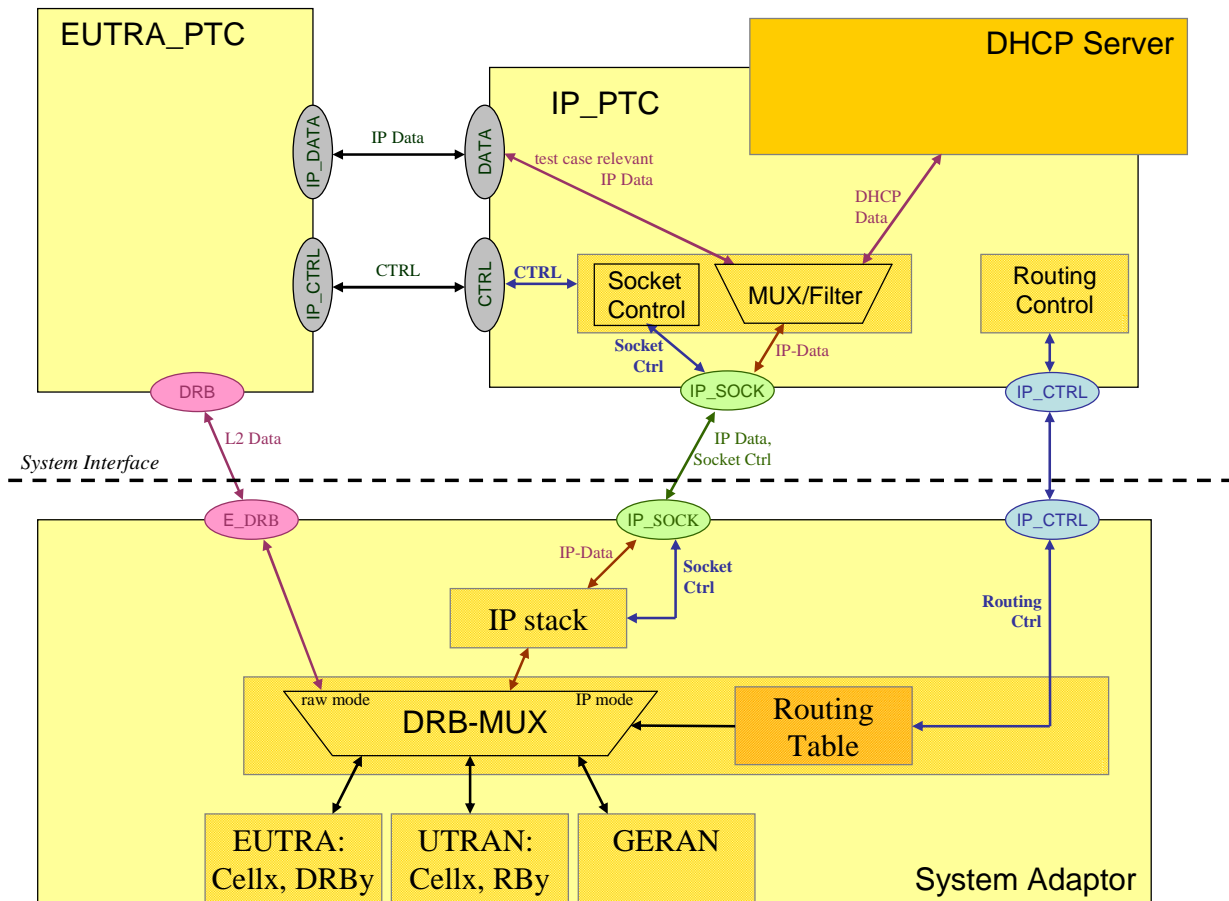

Figure 4.2.4.1-1: Example of IP test model with a DHCP server

4.2.4.2 Configuration of Sockets

The following configurations are controlled by the IP_PTC (IP_SOCKET_REQ). The socket configuration and the sending/receiving of data are done with the same ASP on the system port IP_SOCKET.

NOTE: Support and configuration of IPsec is FFS.

4.2.4.2.1 Socket Establishment

TCP server

TCP socket configured as server: the socket 'listens' to a 'connect' from the UE. The socket can be configured by using the following system calls of the Berkeley Sockets API:

- socket (AF_INET | AF_INET6, SOCK_STREAM, 0);
- setsockopt;
- bind (local IP address Port);
- listen.

NOTE: 'setsockopt' can be used e.g. in case of IPsec (FFS).

When the UE connects to the server the connection is accepted with the 'accept' system call.

TCP client

A TCP connection is established to an existing TCP server at the UE side. This can be done with the following system calls:

- socket (AF_INET|AF_INET6, SOCK_STREAM, 0);
- setsockopt;
- connect (remote Server Addr of the UE = IP-Addr + Port).

NOTE: 'setsockopt' can be used e.g. in case of IPsec (FFS).

UDP socket

A UDP socket can be established with the system calls

- socket (AF_INET|AF_INET6, SOCK_DGRAM, 0);
- setsockopt;
- bind (local IP address Port);
- connect.

NOTE 1: 'setsockopt' can be used to set the option SO_BROADCAST to allow broadcast messages (e.g. for DHCP).

NOTE 2: Usage of 'connect' depends on implementation of the system adaptor.

4.2.4.2.2 Socket Release

A socket is released:

- in case of TCP when the remote entity closes the connection;
- when it is closed explicitly by the IP_PTC (system call 'close').

NOTE: In general the sockets are independent from the configuration of the DRBs. Especially in case of UDP or ICMP the sockets can exist even without any DRB being configured.

4.2.4.3 Handling of IP data

Sending and receiving of IP data is done by the same ASPs as the socket establishment on IP SOCK. In TTCN the IP data are handled by a separate TTCN component: IP_PTC. This PTC can deal with the data according to the respective protocol, e.g. DHCP. In general, this is out of scope for the (signalling conformance) test case in terms of pass/fail assignment.

The IP_PTC will receive data from sockets being configured for the corresponding IP protocols. Any unrecognised IP packets are discarded by the IP stack in the system adaptor.

When the IP data is relevant for the test purpose, e.g. the test purpose is to test DHCP, the IP data are routed to the EUTRA_PTC. This allows generic protocol implementations for the common case, i.e. IP_PTC and DHCP server are independent from test case specific implementations.

The interface between EUTRA_PTC and IP_PTC is a pure TTCN implementation issue and independent of the system interface. Furthermore it is irrelevant for the system interface whether e.g. the DHCP server is part of the IP_PTC or implemented as a separate PTC.

- For TCP, the primitives to send and receive data correspond to the 'send' and 'recv' system calls.
- For UDP and ICMP, the primitives correspond to the 'sendto' and 'recvfrom' system calls.
- For both UDP and TCP the system adaptor may send ("in-band") error indications in case of system errors. That results in an assignment of inconc by the IP_PTC.

4.2.4.4 Routing of IP Data

The routing of IP data is done in the DRB-Mux which gets a routing table configured. This table associates the address and protocol information of IP packets (protocol, local IP address, local port, remote IP address, remote port) with the radio bearer (RAT, cell, DRB id).

In UL a DRB is considered being in raw mode when there is no entry found in the routing table. It is considered being in IP mode when there is any entry regardless of the protocol and address information being stored (i.e. SS does not need to evaluate the IP header what would cause problems in case of loopback data).

In DL the IP packets of the IP stack are routed to the DRBs acc. to the routing information in the routing table (see annex D for details).

NOTE: Only the IP PTC can re-configure the Routing Table; if that needs to be triggered by a RAT specific PTC, this is done by appropriate coordination messages but the RAT specific PTCs don't have a direct access to the routing tables.

4.2.5 IMS test model handling registration signalling

An UE supporting IMS will initiate the initial REGISTRATION after it has acquired an IP address, discovered a P-CSCF, and established an IP-CAN bearer (default DRB) that can be use for SIP signalling. This will happen during the testing preamble of EUTRA test cases. The test model defined in clause 4.2.4 and Figure 4.2.4.1-1 is extended to handle IMS signalling. The extensions include:

Introduce IPsec into the IP stack and add SigComp layer above IP stack,

Expand the IP_PTC test component and to include IMS registration/authentication function.

The ASP on system port IP SOCK carries both IP data and IP stack configuration/control commands, which are multiplexed. A box for data and control below port IP SOCK is drawn in the system adaptor of figure 4.2.5.2-1 to make such multiplexing more visible.

4.2.5.1 Requirements of the IP test model extension

For the IMS purpose, the IP test model extension fulfils the following requirements.

Handle IMS Registration signalling on the LTE default DRB while the UE is attached in an eUTRA cell

Perform necessary IP network server functions, e.g. IMS registration/authentication, DNS, DHCP. These functions are simulated in TTCN-3.

The IP_PTC is made independent from the different access technologies

The extension can be applied to support DSMIPv6 test

4.2.5.2 IMS Test model

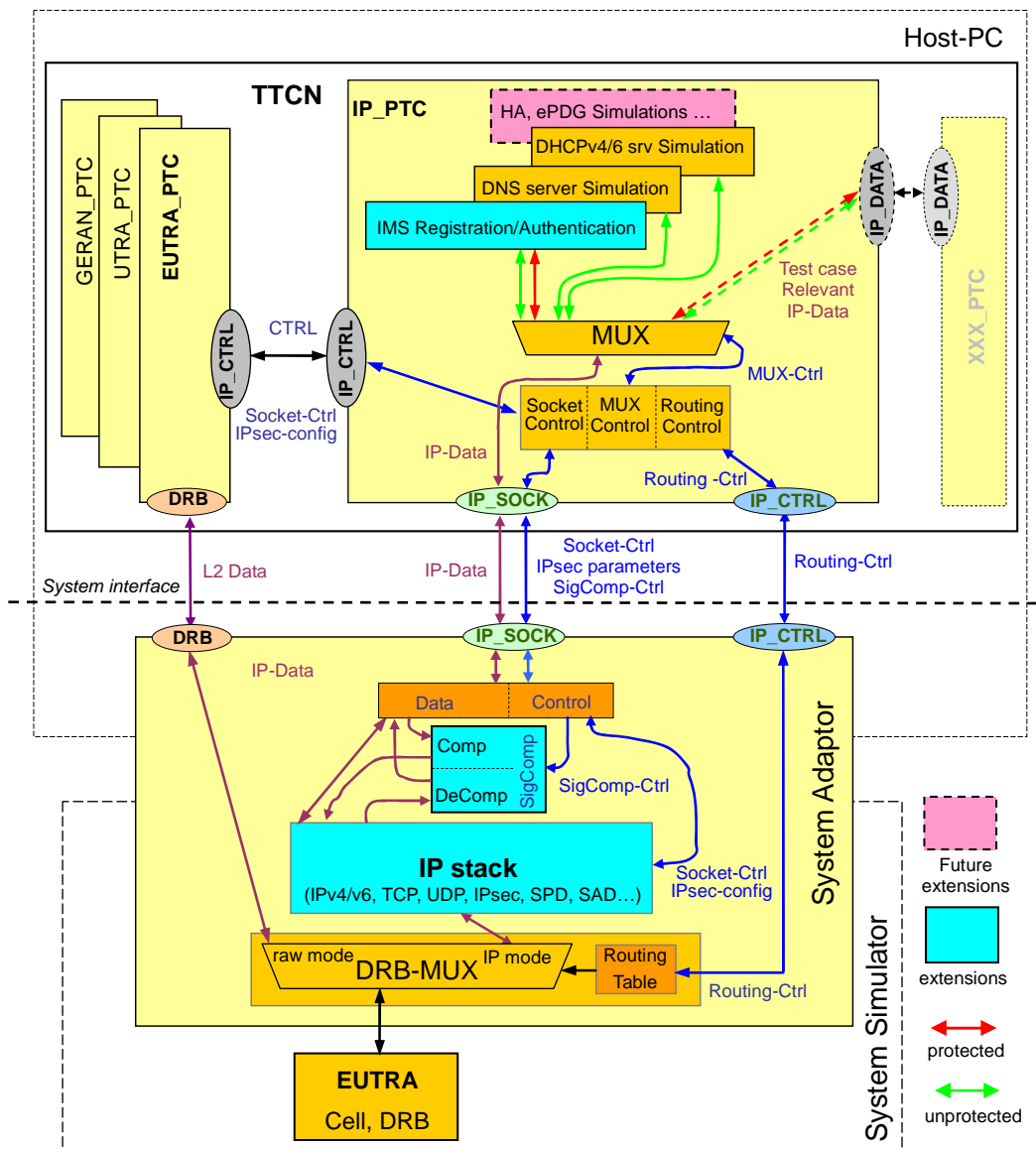

Fig. 4.2.5.2-1 IMS test model for registration handling

4.2.5.2.1 IMS Registration/Authentication function

IMS Registration/Authentication function emulates the SIP behaviour in P_CSCF side, it communicates with the UE under test via four ports: SIP server port and SIP secure server port (after security association established), SIP client port and SIP secure client port (after security association established). It is implemented in TTCN-3 on a parallel test component IP_PTC. Running this function is controlled by coordination messages from EUTRA_PTC via port IP_CTRL. The IMS Registration/Authentication function is able to receive from the UE the IMS signalling messages via TCP, UDP or alternated TCP/UDP when performing the IMS Registration procedure. The IMS Registration/Authentication function shall be able to handling both initial registration using IMS AKA and initial registration using GIBA (Ref. TS 36.508-920[3]).

4.2.5.2.2 Necessary IP network server functions

The necessary IP network server functions such as DHCP, DNS are implemented in TTCN-3 for running in IP_PTC. The implemented codes contain only the IP server functions required for testing. The IP_PTC is made as radio access technologies - independent.

4.2.5.2.3 IPsec protocol

IPsec protocol involves security policy database (SPD) and security association database (SAD) (Ref. RFC4301). The entries in the databases are configured by security parameters within IP connection request ASPs via control port IP SOCK. The SS shall clean the entries related to a particular connection when a close connection ASP for that connection is received. The SS shall clean all entries when abortion of a test case is detected or after the system reboots. Packets that are not match the security polices shall bypass the IPsec processing as if there is no IPsec.

4.2.5.2.3.1 Security Association, SA

During the IMS signalling handling two pairs of SAs consisting of four unidirectional SAs will be used, one pair of SAs (SA2 and SA4) is between the server port of UE and the client port of the SS, another pair of SAs (SA1 and SA3) is between the client port of UE and the server port of the SS, see figure 4.2.5.2.3.1-1.

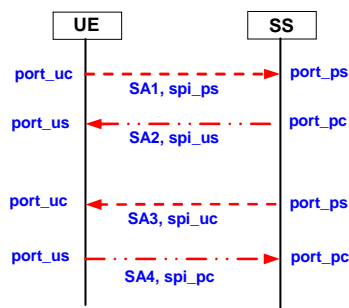

Figure 4.2.5.2.3.1-1 Two pairs of SAs

SA1 used for data flow from port_uc to port_ps is an inbound SA for protected server port of P-CSCF, its Security Parameter Index spi_ps is selected by P-CSCF (IMS Registration/Authentication function in IP_PTC) and presented in 401 Unauthorised; SA2 used for data flow from port_pc to port_us is an inbound SA for protected server port of UE, its Security Parameter Index spi_us is selected by UE and presented in initial REGISTER message; SA3 used for data flow from port_ps to port_uc is an inbound SA for protected client port of UE, its Security Parameter Index spi_uc is selected by UE and presented in initial REGISTER message; SA4 used for data flow from port_us to port_pc via an inbound SA for client port of P-CSCF, its Security Parameter Index spi_pc is selected by P-CSCF (IMS Registration/Authentication function in IP_PTC) and presented in 401 Unauthorised message. The pair of SA1 and SA3 is for bidirectional traffic between port_uc and port_ps. The pair of SA2 and SA4 is for bidirectional traffic between port_pc and port_us. Those four spi_xx and other security parameters are negotiated during security association set up procedure and shall be passed to IPsec protocol layer in the SS. See “SAD and SPD” and clause 7.2 of TS 33.203 [41].

These four unidirectional SA and relevant ports are shared by TCP and UDP. TCP transport will use all four SAs, UDP transport uses only two SAs, because there is no traffic from port_ps to port_uc, nor from port_us to port_pc. Figure 4.2.5.2.3.1-2 shows the usage of ports and SAs under UDP and TCP transport in a generic registration procedure. (Ref. Annex C2 of TS 34.229-1[40]).

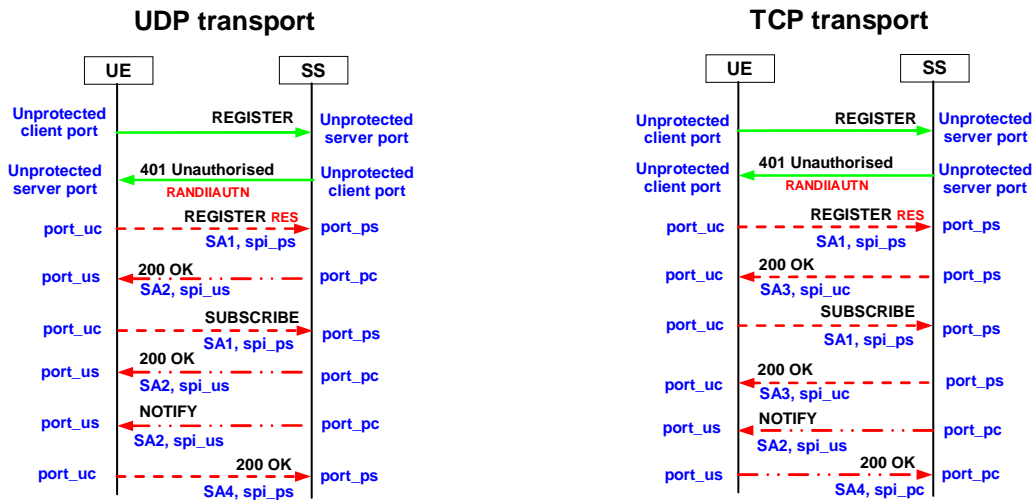

Figure 4.2.5.2.3.1-2: Usage of ports and SAs in UDP and TCP transport

4.2.5.2.3.2 SAD and SPD

SAD and SPD are used by IPsec to store various security parameters (per Security Association). During IMS AKA, the UE and the IMS Registration/Authentication function in IP_PTC negotiates the negotiable parameters for security association setup, this negotiation is carried out at the SIP level in TTCN-3, and the resulting security association parameters are maintained in TTCN-3. The involved parameters are:

- spi_uc; spi_us; spi_pc; spi_ps
- encryption algorithm
- integrity algorithm

The IMS AKA will generate key IK_{IM} , the security parameters IK_{ESP} and CK_{ESP} are derived from IK_{IM} and CK_{IM} in TTCN-3 (Ref. Annex I of TS 33.203[41]). ASPs are used to pass these parameters (per security association and with its selectors) from TTCN-3 to SAD and SPD of IPsec layer in the SS.

The same IK_{ESP} and CK_{ESP} will be used for the four unidirectional SAs. All of the four unidirectional SAs will use the same negotiated encryption algorithm and integrity algorithm.

In addition to those negotiable security parameters, other security parameters are fixed in IMS environment (Ref. clause 7.1 of TS 33.203 [41]):

- Life type: second
- SA duration: $2^{32}-1$
- Mode: transport
- IPsec protocol: ESP, ESP integrity applied
- Key length: 192 bits for DES-EDES_CBC, 128 bits for AES-CBC and HMAC-MD5-96; 160 bits for HMAC-SHA-1-96

These parameters are hard coded with IPsec implementation in the SS, not passed from TTCN-3.

An SA have to be bound to selectors (specific parameters) of the data flows between UE and P-CSCF (IMS Registration/Authentication function in IP_PTC), the selectors are:

- source IP address
- destination IP address
- source port

destination port

transport protocols that share the SA

IP addresses bound to the two pairs of SAs are:

For inbound SAs at the P-CSCF (the SS side):

The source and destination IP addresses associated with the SA are identical to those in the header of the IP packet in which the initial SIP REGISTER message was received by the P-CSCF.

For outbound SAs at the P-CSCF (the SS side):

The source IP address bound to the outbound SA equals the destination IP address bound to the inbound SA; the destination IP address bound to the outbound SA equals the source IP address bound to the inbound SA.

Ports bound to the two pairs of SAs are depicted in figure 4.2.5.2.3.1-1, port_ps and port_pc shall be different from the default SIP ports 5060 and 5061. The number of the ports port_ps and port_pc are communicated to the UE during the security association setup procedure.

The transport protocol selector shall allow UDP and TCP.

The selectors are passed to the SS IPsec layer together with the security parameters related to an SA bound to the selectors.

4.2.5.2.4 Transport and IP-CAN bearer

From protocol stack point of view, SIP is an application layer protocol located above transport layer (TCP or UDP protocol). Below transport layer we need IP/IPsec layer and IP-CAN bearer. In the testing model we depicted four kinds of IP-CAN bearers: UTRA bearers, EUTRA bearers, GERAN bearers and possible further extension of WLAN bearers. The emulations of these protocol layers are implemented in the SS and shall be compliant with the relevant core specifications (IETF and 3GPP). They are not parts of TTCN-3 codes, but the TTCN-3 codes shall be able to control their configuration and provide necessary parameters to them through ASPs. The IMS registration signalling using IMS AKA or the IMS registration signalling using GIBA will occur on the default EUTRA bearer. The transport layer shall deliver a whole SIP message (not segments of the message) to the IMS Registration/Authentication located in IP_PTC no matter what segmentation happened in the transport layer on the IP-CAN bearer.

4.2.5.2.5 SIP Compression

SIP compression is mandatory (Ref. clause 8 of TS 24.229[42]) and Signalling compression (RFC3320, RFC3485, RFC 3486, RFC4896, RFC5049) protocol is used for SIP compression. SigComp entity in the model is used to carry out the compression/decompression functions. In receiving direction of the SS the SigComp entity will detect whether the incoming SIP message is compressed, and decompress the message if it is compressed. In the SS transmitting direction, the TTCN, via ASP, controls when the compression of outgoing SIP message is started. Stateless compression is not used in the SIP environment. For statefull operation of SigComp the ASP passing compartment ID to SigComp is applied. The SS shall clean all states related to a connection in SigComp when an ASP for closing the connection is received. The SS shall also clean all states in the SigComp when abortion of a test case is detected or after the system reboots. If decompression failure occurs while decompressing a message, the message shall be discarded. The SigComp entity in the SS shall automatically find if a secure port or un-secure port is being used for transmission or reception of messages. If an un-secure port is used for transmission, it shall not include state creation instructions. If the state creation command is received in a compressed message on an un-secured port, a decompression failure shall be generated.

4.2.5.2.6 SIP TTCN-3 Codec

SIP is a text-based protocol, the messages exchanged between the UE and the SS are character strings. In TTCN-3 the messages are structured to take the advantages of TTCN-3 functionalities, and to make the debugging and maintenance easier. When TTCN-3 sends a SIP message to the UE, the SIP codec (not shown in Figure 4.2.5.2-1) converts (encvalue function of codec) the structured message to the corresponding character string to be transferred to the UE. When the SS receives a SIP message from the UE the TTCN-3 codec converts (decvalue function of codec) the received character string to the structured message to be delivered to the TTCN-3.

4.2.6 Support DSMIPv6

The extension to support DSMIPv6 is depicted in dotted lines and dotted boxes in Figure 4.2.5.2-1. The functions of HA and ePDG are FFS.

4.3 SAE Test Model

4.3.1 NAS Test Model

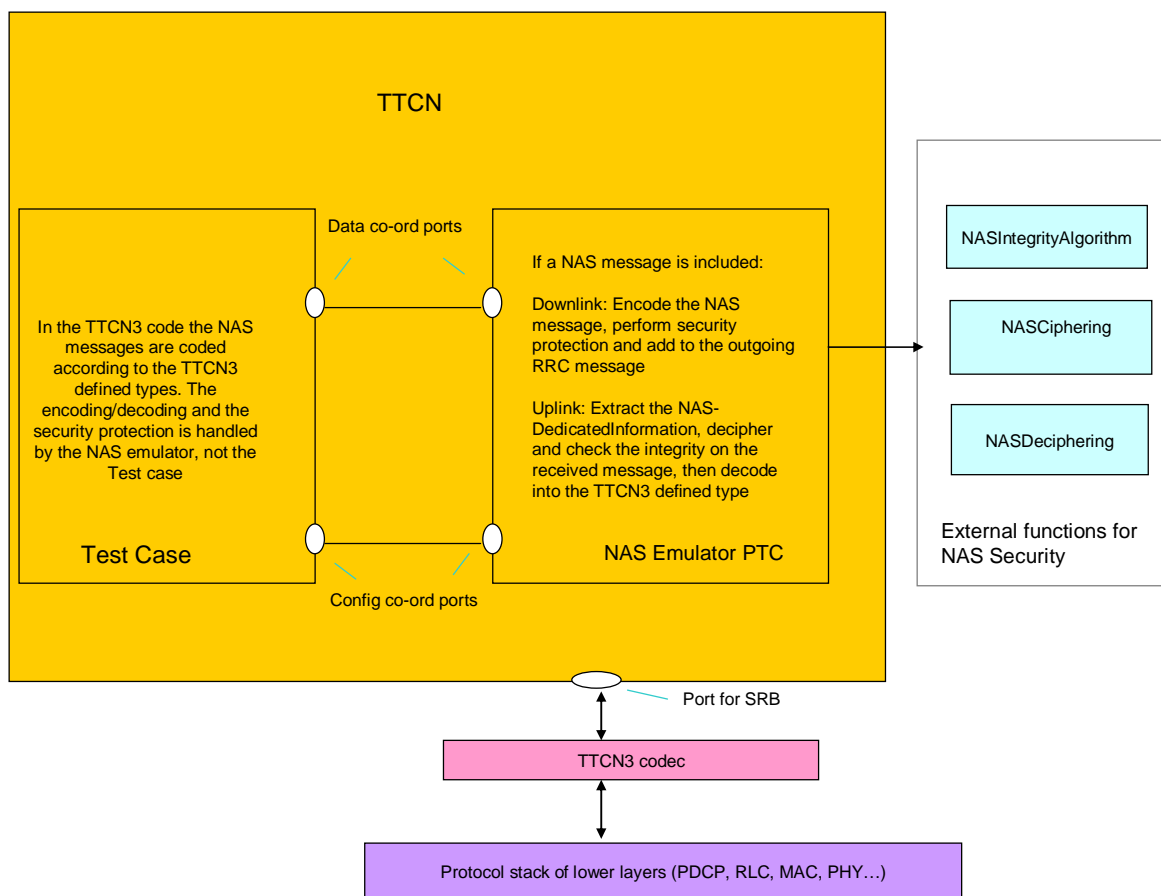

Figure 4.3.1-1: NAS Test Model

The NAS emulator is a parallel test component which handles NAS security, with the help of external functions to perform the integrity and (de)ciphering.

The interface between the emulator and the TTCN (co-ordination messages) handle data as TTCN-3 values. The interface between the emulator and the SS handles the RRC messages as TTCN-3 values, containing (where applicable) secure, encoded NAS messages.

The NAS emulator is not part of the test case in terms of verdict assignment (i.e. it does not check the correctness of any protocol message). Nevertheless, in case of fatal errors such as encode/decode errors, the NAS emulator sets the verdict to inconclusive and terminates immediately - which causes the test case to terminate. i.e. the NAS emulator does not resolve error situations.

4.4 Inter RAT Test Model

4.4.1 E-UTRAN-UTRAN Inter RAT Test Model

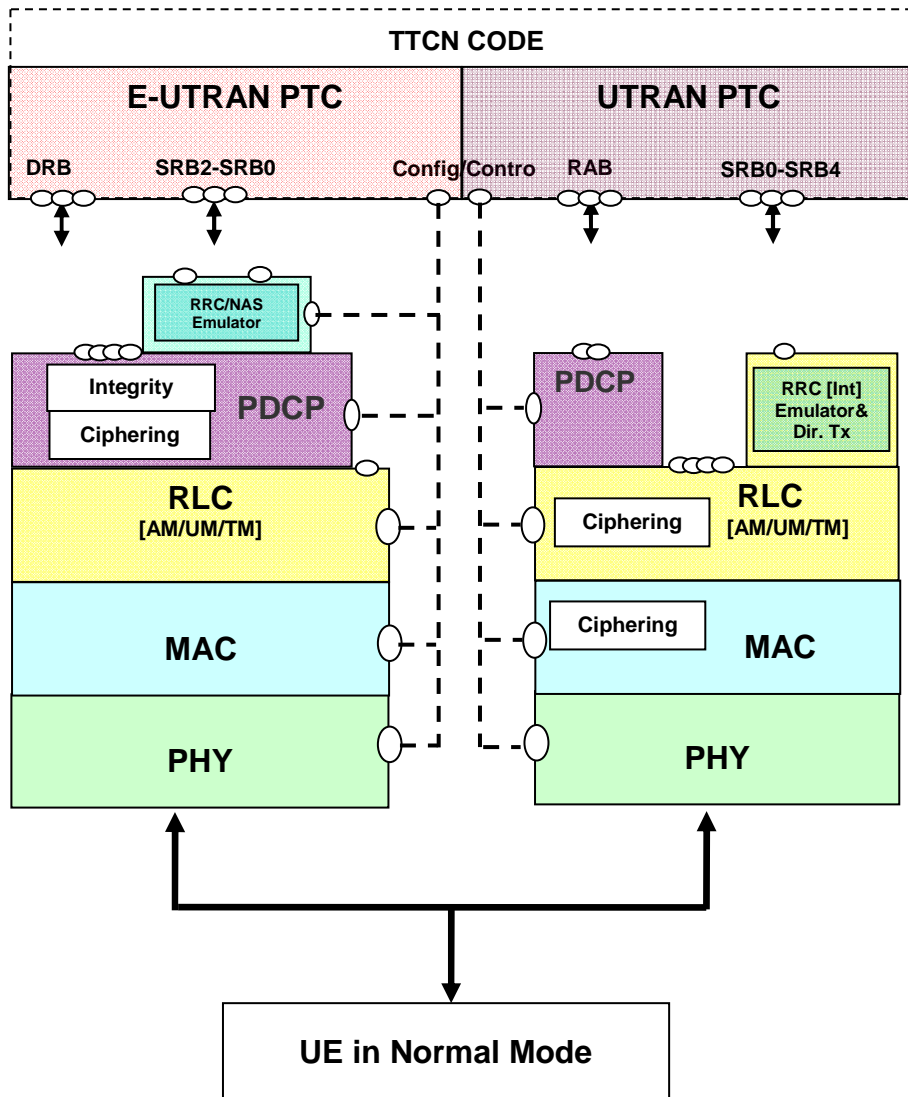

Figure 4.4.1-1: Test model for Inter RAT E-UTRAN-UTRAN testing

The model consists of dual protocol stack one for E-UTRAN and one for UTRAN. The TTCN implementation for E-UTRAN and UTRAN functionalities will be in separate Parallel Test Components. The SS E-UTRAN part is same as the model defined in clause 4.2.2 for RRC testing.

The SS UTRAN part consist of L1, MAC, RLC and PDCP (IF PS user RB established only), are configured in normal mode. They shall perform all of their functions normally. Ciphering is enabled and shall be performed in RLC (AM/UM) and MAC (TM RLC). Integrity is enabled, and SS shall provide RRC emulator for integrity protection calculation and checking and 'Direct transfer' adaptation. Ports are above RLC (CS RAB and SRB0), PDCP (PS RAB) and RRC Emulator (SRB1 to SRB4).

The UE is configured in normal mode. Ciphering/Integrity (PDCP and NAS) are enabled and ROHC is not configured in E-UTRAN. Ciphering is enabled in UTRAN.

4.4.2 E-UTRAN-GERAN Inter RAT Test Model

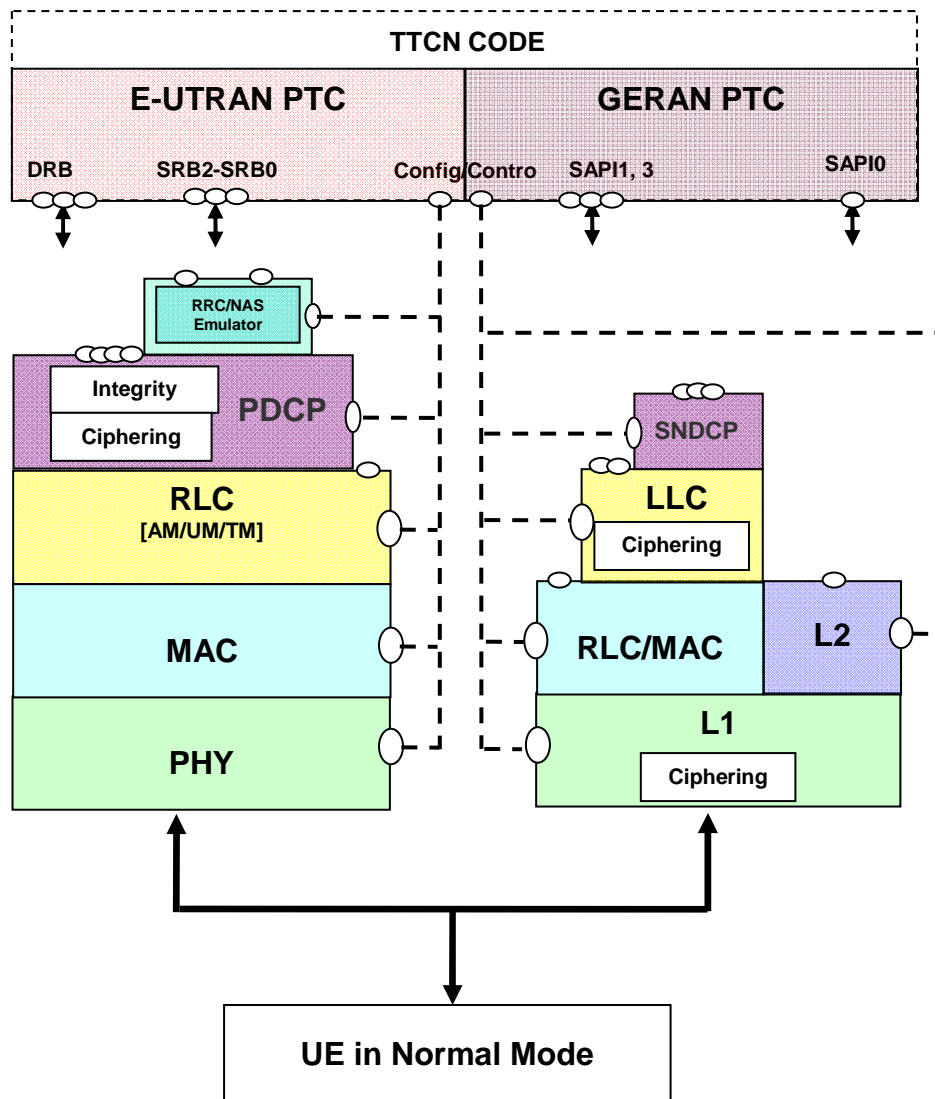

Figure 4.4.2-1: Test model for Inter RAT E-UTRAN-GERAN testing

The model consists of dual protocol stack one for E-UTRAN and one for GERAN. The TTCN implementation for E-UTRAN and GERAN functionalities will be in separate Parallel Test Components. The SS E-UTRAN part is the same as the model defined in clause 4.2.2 for RRC testing.

The SS GERAN model for GPRS consists of L1, MAC/ RLC and LLC, configured in normal mode. SNDCP may also be configured. They shall perform all of their functions normally. Ciphering is enabled and shall be performed in LLC. Ports are above RLC (GRR messages), LLC (NAS and Data) and SNDCP (User Data).

The SS GERAN model for GSM consists of L1, L2 (MAC/ RLC), configured in normal mode. They shall perform all of their functions normally. Ciphering is enabled and shall be performed in L1. Ports are above L2.

The UE is configured in normal mode. Ciphering/Integrity (PDCP and NAS) is enabled and ROHC is not configured in E-UTRAN. Ciphering is enabled in GERAN.

4.4.3 E-UTRAN-CDMA2000 Inter RAT Test Model

4.4.3.1 E-UTRAN-CDMA2000 HRPD Inter RAT Test Model

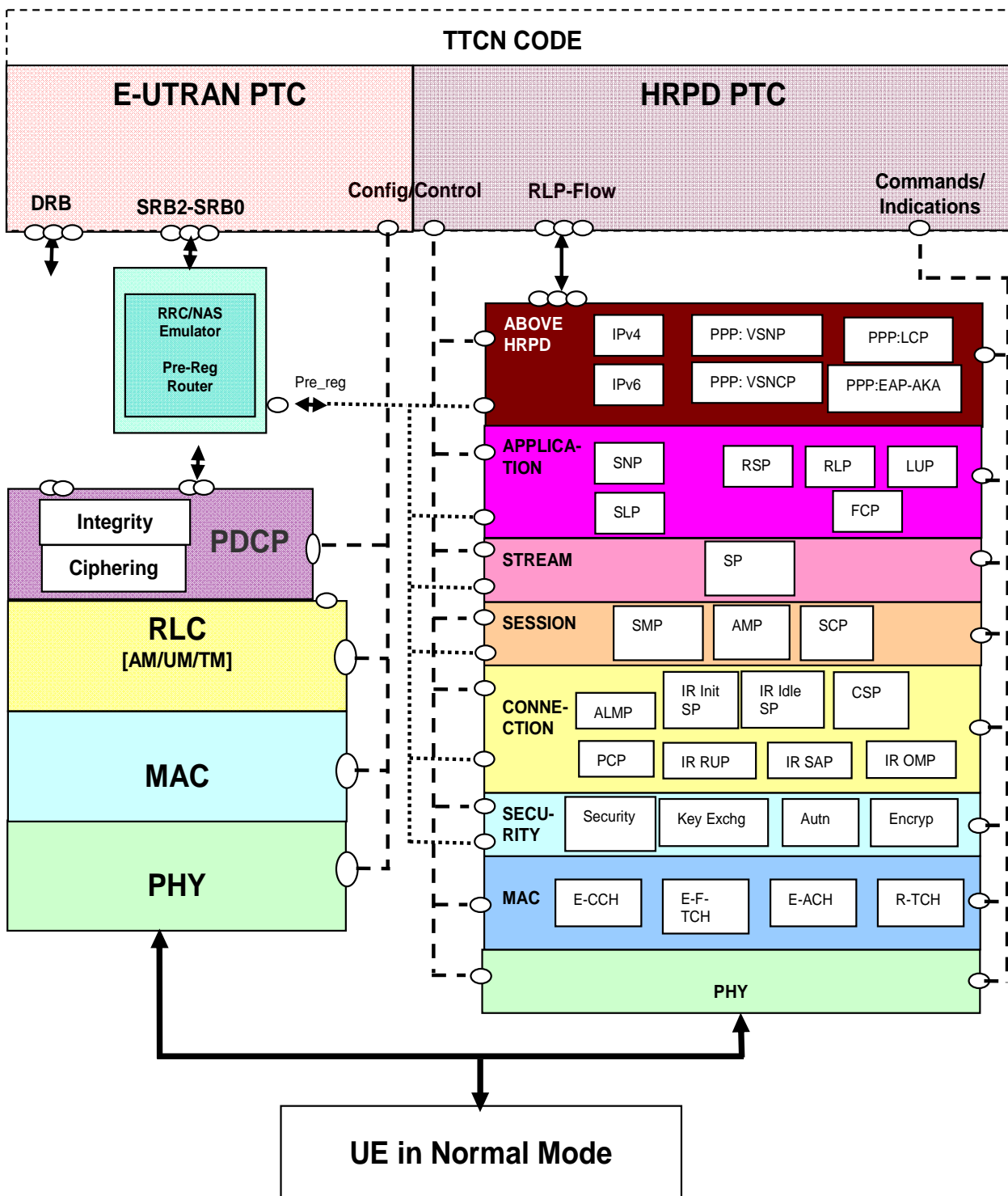

Figure 4.4.3-1: Test model for InterRAT E-UTRAN-CDMA2000 HRPD testing

The model consists of a dual protocol stack, one for E-UTRAN and one for HRPD. The TTCN implementation for E-UTRAN and HRPD functionalities will be in separate Parallel Test Components. The SS E-UTRAN part is same as the model defined in clause 4.2.2 for RRC testing.

The HRPD part emulation in SS is considered as a black box. The commands/Indications port is used for commanding the SS to bring the UE into the desired state and monitoring the progress. The Pre-Reg port is used for routing encapsulated pre-registration messages in the EUTRAN cell to the HRPD.

The SS HRPD part consists of Physical, MAC, Security, Connection, Session, Stream, Application and Layers for PPP and IP configured in normal mode. They shall perform all of their functions normally. Encryption may be enabled and performed in security layer.

The CDMA2000 HRPD emulation in the SS supports the following layers and protocols:

- Physical layer (Subtype 2)
- MAC layer
 - Enhanced (Subtype 0, Subtype 1) Control Channel MAC Protocol (ECH)
 - Enhanced (Subtype 1) Forward Traffic Channel MAC Protocol (E-F-TCH)
 - Enhanced (Subtype 1) Access Channel MAC Protocol (E-ACH)
 - Subtype 3 Reverse Traffic Channel MAC Protocol (R-TCH)
- Security Layer
 - Default Security Protocol (Security)
- Connection Layer
 - Default Air Link Management Protocol (ALMP)
 - Default Connected State Protocol (CSP)
 - Default Packet Consolidation Protocol (PCP)
 - Inter-RAT Signalling Adaptation Protocol (IR-SAP) (required only for optimized handover)
 - Inter-RAT Initialization State Protocol (IR-Init SP) (required only for optimized handover)
 - Inter-RAT Idle State Protocol (IR-Idle SP) (required only for optimized handover)
 - Inter-RAT Route Update Protocol (IR-RUP) (required only for optimized handover)
 - Inter-RAT Overhead Messages Protocol (IR-OMP) (required only for optimized handover)
- Session Layer
 - Default Session Management Protocol (SMP)
 - Default Address Management Protocol (AMP)
 - Default Session Configuration Protocol (SCP)
- Stream Layer
 - Default Stream Protocol (DSP)
- Application Layer
 - Default Signalling Application
 - Signalling Network Protocol (SNP)
 - Signalling Link Protocol (SLP)

- Enhanced Multi-Flow Packet Application
 - Route Selection Protocol (RSP)
 - Radio Link Protocol (RLP)
 - Location Update Protocol (LUP)
 - Flow Control Protocol (FCP)
- Above HRPD
 - PPP: Vendor Specific Network Control Protocol (PPP:VSNCP)
 - PPP: Vendor Specific Network Protocol (PPP:VSNP)
 - PPP: Link Control Protocol (PPP:LCP);
 - PPP: Extensible Authentication protocol-Authentication and key agreement (PPP:EAP-AKA)
 - IPv4
 - IPv6

The UE is configured in normal mode. Ciphering/Integrity (PDCP and NAS) are enabled and ROHC is not configured in E-UTRAN. Encryption is enabled in HRPD.

4.4.3.2 E-UTRAN-CDMA2000 1xRTT Inter RAT test model

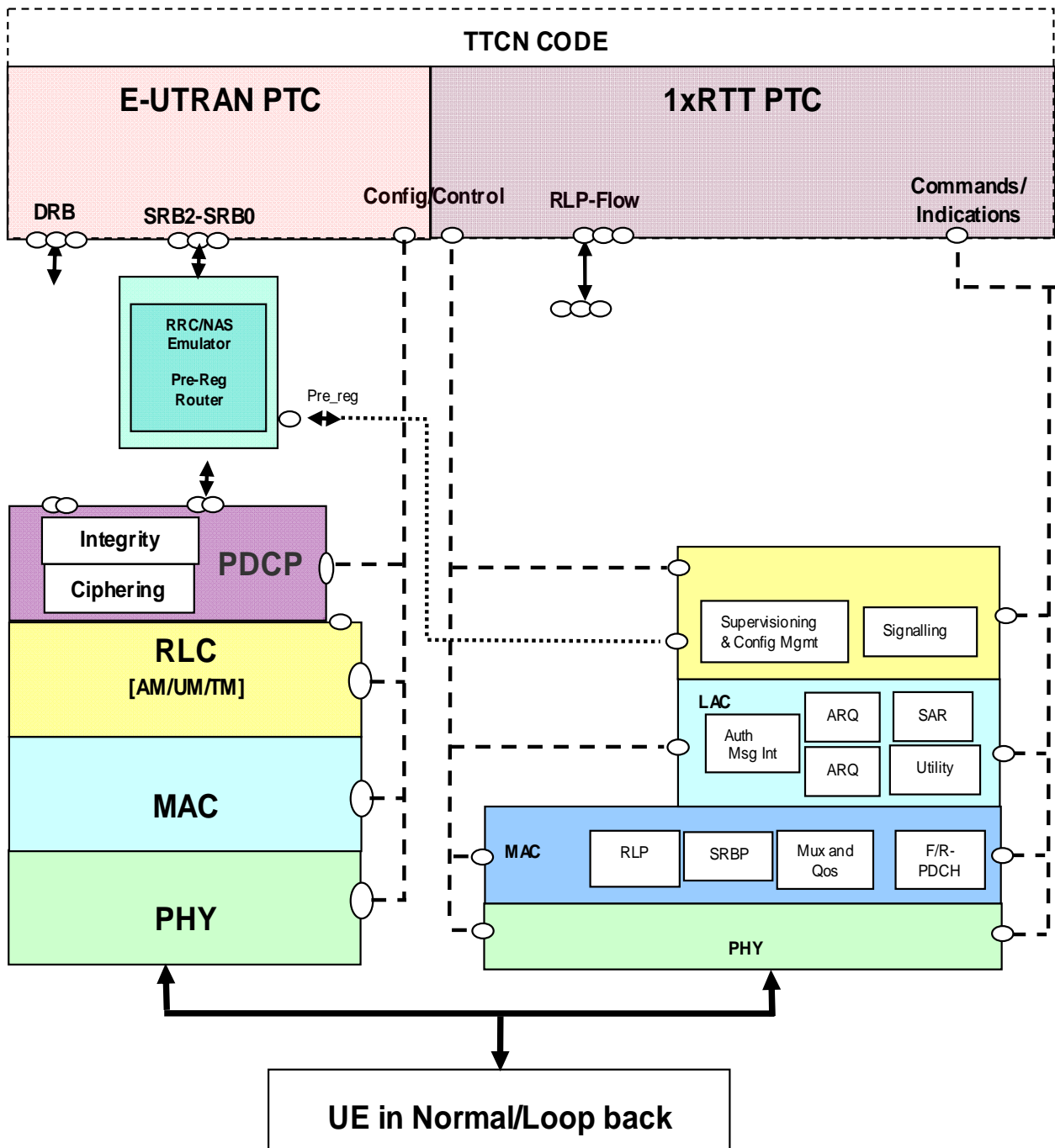

Figure 4.4.3.2-1: Test model for InterRAT E-UTRAN-CDMA2000 1xRTT testing

The 1xRTT test model consists of a dual protocol stack, one for E-UTRAN and one for 1xRTT. The TTCN implementation for E-UTRAN and 1xRTT functionalities are in separate Parallel Test Components. The SS E-UTRAN part is same as the model defined in clause 4.2.2 for RRC testing.

The 1xRTT part emulation in SS is considered as a black box. The commands/Indications port is used for commanding the SS to bring the UE into the desired state and monitoring the progress. The Pre-Reg port is used for routing encapsulated pre-registration messages in the EUTRAN cell to the 1xRTT.

The SS 1xRTT part consists of Physical, MAC, LAC, Session, Stream, Application and Layers for PPP and IP configured in normal mode. They shall perform all of their functions normally. Encryption may be enabled and performed in security layer.

The CDMA2000 1xRTT emulation in the SS supports the following layers and protocols:

- Physical layer
- MAC layer
 - Signalling Radio Burst protocol
 - Radio Link Protocol for Data services
 - Forward and Reverse Packet Data Channel functions
 - Multiplexing and QoS Delivery
- Link Access Control
 - Authentication and Message Integrity sublayer [optional]
 - ARQ sublayer
 - Addressing
 - Utility
 - Segmentation and Reassembly
- Layer 3
 - Super visioning and Configuration Management
 - Signalling Protocol

The UE is configured in normal mode or loop back mode. Ciphering/Integrity (PDCP and NAS) are enabled and ROHC is not configured in E-UTRAN. Encryption may be enabled in 1xRTT.

4.4.4 E-UTRAN FDD-TDD Inter RAT Test Model

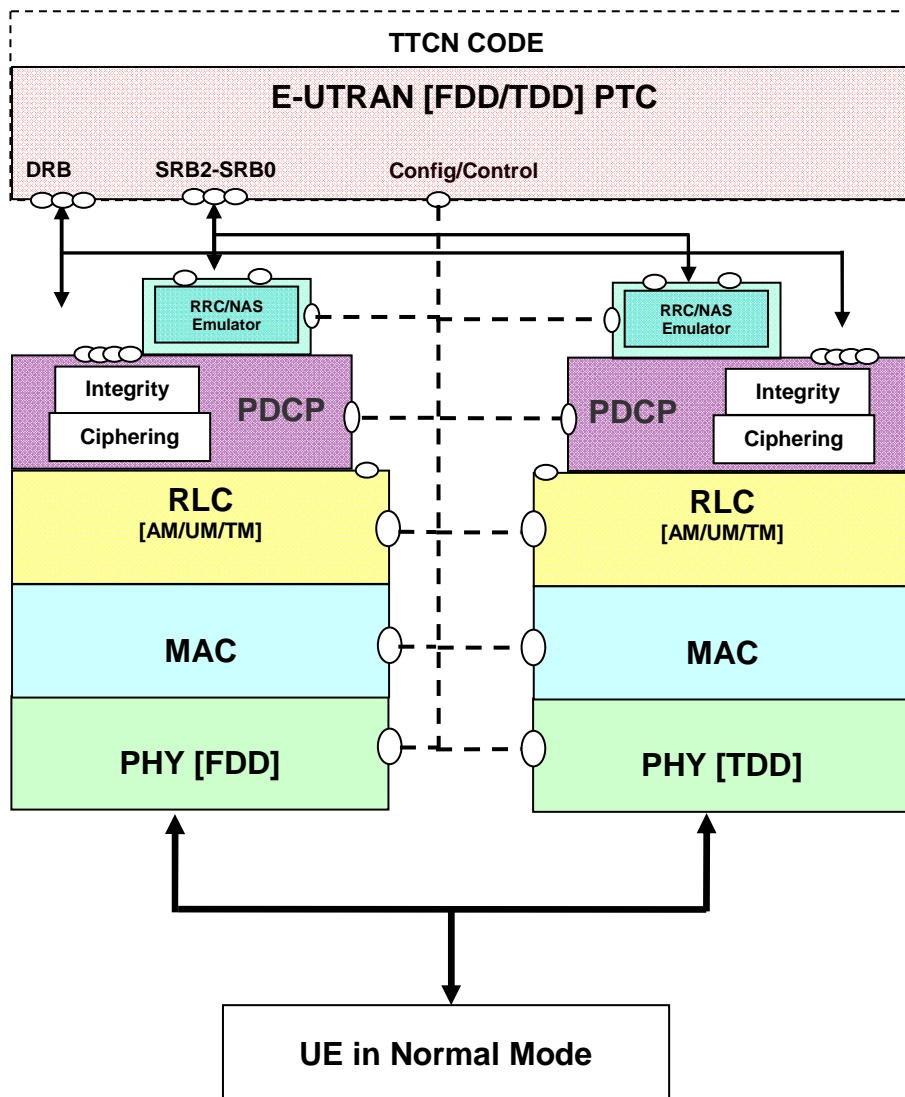

Figure 4.4.4-1: Test model for Inter RAT E-UTRANFDD-TDD testing

The model consists of dual protocol stack one for E-UTRANFDD and one for E-UTRANTDD. The TTCN implementation for E-UTRANFDD and TDD functionalities will be in the same Parallel Test Component. The SS E-UTRAN (both FDD and TDD) part is the same as the model defined in clause 4.2.2 for RRC testing. SS E-UTRANFDD and TDD shall be configured as separate cells.

The UE is configured in normal mode. Ciphering/Integrity (PDCP and NAS) are enabled and ROHC is not configured for both FDD and TDD.

4.4.5 E-UTRAN-UTRAN-GERAN Inter RAT Test Model

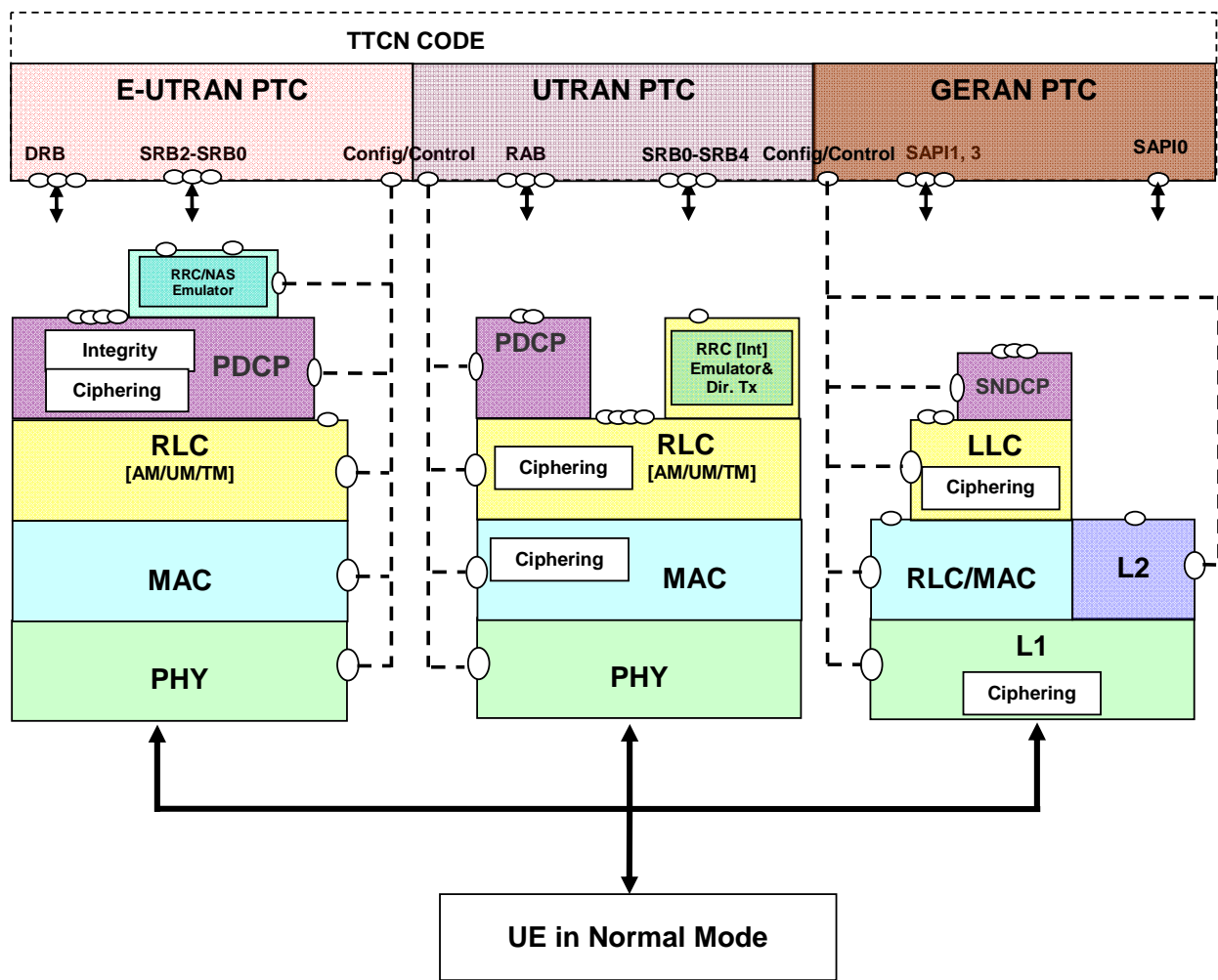

Figure 4.4.5-1: Test model for Inter RAT E-UTRANFDD-TDD testing

The model consists of integrated protocol stack supporting E-UTRAN, UTRAN and GERAN. The TTCN implementation for E-UTRAN, UTRAN and GERAN functionalities will be in separate Parallel Test Components. The SS E-UTRAN part is the same as the model defined in clause 4.2.2 for RRC testing. The SS UTRAN part is the same as the model defined in clause 4.4.1. The SS GERAN part is same as the model defined in clause 4.4.2.

The UE is configured in normal mode. Ciphering/Integrity (PDCP and NAS) are enabled and ROHC is not configured in E-UTRAN. Ciphering/Integrity are enabled in UTRAN. Ciphering is enabled in GERAN.

5 Upper Tester Interface

This clause describes the handling of AT commands and MMI Commands at the system interface. The internal handling of those commands in TTCN is out of scope.

In the TTCN, the Upper Tester is located at the MTC; therefore there is one interface to the system adaptor common for all RATs.

There is one primitive defined carrying either an MMI or an AT command to be sent to the system adaptor and one common confirmation primitive to be sent by the system adaptor.

TTCN-3 ASP Definition		
Type Name	UT_SYSTEM_REQ	
TTCN-3 Type	Record	
Cmd	TTCN-3 Type	union
AT	charstring carrying the AT command as defined in TS 27.007 [32], TS 27.005 [31] and TS 27.060 [33]	
MMI	<ul style="list-style-type: none"> • Cmd (charstring) • List of parameters: <ul style="list-style-type: none"> ○ Name (charstring) ○ Value (charstring) 	
CnfRequired	TTCN-3 Type	boolean
	true: system adaptor shall reply with confirmation received from the UE false: SS shall swallow any confirmation generated by the UE Note: In the TTCN, a confirmation shall only be requested in cases when there is no signalling from the UE being triggered by the MMI/AT command	

TTCN-3 ASP Definition		
Type Name	UT_COMMON_CNF	
TTCN-3 Type	Record	
Result	TTCN-3 Type	boolean
	true: success false: failure	
ResultString	TTCN-3 Type	charstring
	response by the UE for commands which request the UE to return a result, optional	

All mandatory and optional AT commands are sent as AT command strings as defined above. If an optional AT command is not implemented in the UE, the system adaptor needs to parse the AT command and map it to an appropriate MMI command (which is out of scope for this document).

The following MMI commands are defined.

Table 5-1: MMI commands

Command	Parameters	
	Name	Value
"SWITCH_ON"	(none)	
"SWITCH_OFF"	(none)	
"POWER_ON"	(none)	
"POWER_OFF"	(none)	
"INSERT_USIM"	(none)	
"REMOVE_USIM"	(none)	
"CHECK_PLMN"	"PLMN"	<PLMN ID>
PRE_CONFIGURE_FOR_EPS_ATTACH	(none)	
PRE_CONFIGURE_FOR_COMBINED_EPS_IMSI_ATTACH	(none)	
"CHECK_SMS_LENGTH_CONTENTS"	"Length"	<Length>
	"Msg"	<Msg>
"DISABLE_EPS_CAPABILITY"	(none)	
"SELECT_CSG"	"PLMN"	<PLMN ID>
	"CSG"	<CSG ID>

The following AT commands are applied in TTCN.

Table 5-2: AT Commands

Command	Reference
ATD	3GPP TS 27.007
AT+CGEQOS	3GPP TS 27.007
AT+CGTFT	3GPP TS 27.007
AT+CGDSCONT	3GPP TS 27.007
AT+CGACT	3GPP TS 27.007
AT+CGCMOD	3GPP TS 27.007
AT+CGDCONT	3GPP TS 27.007
AT+CMGD	3GPP TS 27.005
AT+CSMS	3GPP TS 27.005
AT+CPMS	3GPP TS 27.005
AT+CMGF	3GPP TS 27.005
AT+CSCS	3GPP TS 27.007
AT+CSCA	3GPP TS 27.005
AT+CMGW	3GPP TS 27.005
AT+CMSS	3GPP TS 27.005
AT+CSMP	3GPP TS 27.005
AT+CGEQREQ	3GPP TS 27.007
AT+CCLK	3GPP TS 27.007
AT+COPS	3GPP TS 27.007
AT+CGATT	3GPP TS 27.007
AT+CEMODE	3GPP TS 27.007

AT commands are referred to TS 27.005 [31], TS 27.007 [32] and TS 27.060 [33].

6 ASP specifications

6.1 General Requirements and Assumptions

The following common requirements affect ASP definitions:

- The definition of ASPs shall have no impact on the common system architecture or on the performance.
- The codec implementation is out of scope of the present document.
- For peer-to-peer PDUs contained in an ASP encoding rules need to be considered acc. to the respective protocol:
 - ASN.1 BER and PER.
 - Tabular notation for NAS PDUs or layer 2 data PDUs.

There are no encoding rules being defined for top level ASP definitions and information exchanged between the test executable and the System Adaptor (SA) only. Instead encoding depends on implementation of the codec and the SA.

There are no encoding rules being defined for ASPs between TTCN-3 components. This is implementation dependent.

Info elements defined in the protocol specifications (e.g. RRC) shall be re-used in configuration ASPs as far as possible.

For optional fields within the configuration ASPs, the following rules will be applied:

- For ASN.1 fields - these will follow the same rules as defined in the RRC specification [19].
- For TTCN-3 fields - when the current configuration of an optional field is to be 'kept as it is' then the field will be set to omit.
- For TTCN-3 fields - when the current configuration of an optional field is to be released/deleted then a separate option is provided in a union.

6.1.1 IP ASP requirements

6.1.2 Enhancement of IP ASP for handling IMS signalling

The IMS test model handling registration signalling introduces IPsec and SigComp layers into the IP test model in Figure 4.2.5.2-1. The ASP on system port IP_SOCK needs to be enhanced to provide additional configuration/control functions for IPsec and SigComp. The enhanced IP ASP should contain:

1. Function to clean all IPsec and SigComp configurations and to put the IPsec and SigComp in the initial state.
2. Function to return SigComp layer a Compartment Id instructing SigComp layer to save the state of a received message which was compressed.
3. Function to start or stop signalling compression in sending direction (the SS to the UE) of SigComp.
4. Function to set security parameters (per security association) in IPsec layer.
5. A flag indicating whether SigComp layer shall be included in the data path when establishing a connection.
6. A flag indicating whether the received message was compressed by SigComp.
7. A parameter to point to a compartment used by SigComp to send a message.

6.2 E-UTRAN ASP Definitions

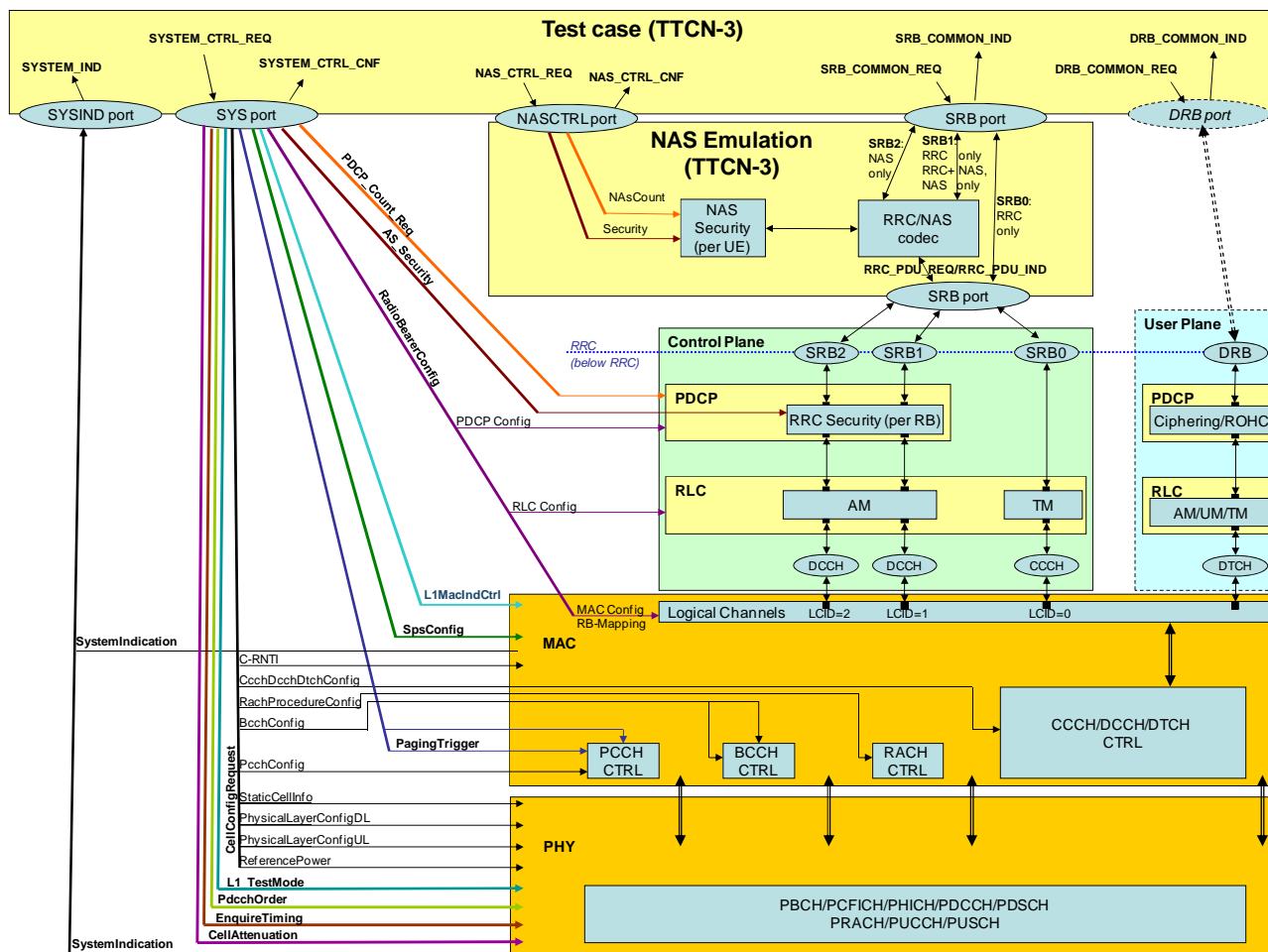

Figure 6.2-1: E-UTRAN ASP Test Model

6.2.1 Configuration Primitives

Annex D contains the ASP definitions for configurations.

6.2.2 Signalling Primitives

Annex D contains the ASP definitions for configurations.

6.2.3 Co-ordination Messages between NAS Emulation PTC and EUTRA PTC

TTCN-3 ASP Definition		
Type Name	SRB_COMMON_REQ	
TTCN-3 Type	Record	
Common Part	TTCN-3 Type	record
CellId	cell id	
RoutingInfo	SRB0, SRB1, SRB2	
TimingInfo	system frame number and sub-frame number or "Now"	
ControllInfo	CnfFlag: (normally false) FollowOnFlag: true: Indicates that the message(s) to be sent on the same TTI will follow NOTE: If the same TimingInfo is not used in the messages to be sent on the same TTI, the SS shall produce an error false: Indicates that no more message(s) will follow.	
Signalling Part	TTCN-3 Type	record
Rrc	TTCN-3 Type	union
	omit: NAS message shall be present; NAS message shall be sent in DLInformationTransfer present, NAS message present: (piggybacked) NAS PDU shall be security protected (if necessary) and inserted in RRC PDU's NAS_DedicatedInformation present, NAS message omit: (RRC message does not contain NAS information)	
Ccch	DL_CCCH_Message as define in TS 36.331 [19], clause 6.2.1	
Dcch	DL_DCCH_Message as define in TS 36.331 [19], clause 6.2.1	
Nas	TTCN-3 Type	record
	omit: RRC message shall be present; RRC message does not contain (piggybacked) NAS PDU present, RRC message omit: NAS message shall be sent embedded in DLInformationTransfer present, RRC message present: NAS message is piggybacked in RRC message NOTE: In case of RRC message being sent on CCCH or does not have IE NAS_DedicatedInformation NAS message shall be omitted.	
SecurityProtectionInfo	security status (if protected with integrity and/or ciphering, if at all)	
NAS message	union of all NAS messages define for DL except SECURITY PROTECTED NAS MESSAGE	

TTCN-3 ASP Definition		
Type Name	SRB_COMMON_IND	
TTCN-3 Type	Record	
Common Part	TTCN-3 Type	record
CellId	cell id	
RoutingInfo	SRB0, SRB1, SRB2	
TimingInfo	system frame number; sub-frame number when PDU has been received	
Signalling Part	TTCN-3 Type	record
Rrc	TTCN-3 Type	union
	omit: NAS message shall be present; NAS message is received in	

TTCN-3 ASP Definition	
	ULInformationTransfer present, NAS message present: NAS_DedicatedInformation contains unstructured and security protected NAS PDU and the NAS message contains the deciphered message in structured format present, NAS message omit: (RRC message does not contain NAS information)
Ccch	UL_CCCH_Message as define in TS 36.331 [19], clause 6.2.1
Dcch	UL_DCCH_Message as define in TS 36.331 [19], clause 6.2.1
Nas	TTCN-3 Type record
	omit RRC message shall be present; RRC message does not contain (piggybacked) NAS PDU present, RRC message omit NAS message has been received in ULInformationTransfer present, RRC message present NAS message is piggybacked in RRC message
SecurityProtectionInfo	security status (if protected with integrity and/or ciphering, if at all), nas count
NAS message	union of all NAS messages define for UL except SECURITY PROTECTED NAS MESSAGE

TTCN-3 ASP Definition	
Type Name	NAS_CTRL_REQ
TTCN-3 Type	Record
Common Part	TTCN-3 Type record
CellId	cell id
RoutingInfo	(not used for configuration)
TimingInfo	current system frame number; sub-frame number (always provided by the SS)
Result	Success or error (in case of error an SS specific error code shall be provided; this will not be evaluated by TTCN but may be useful for validation)
Primitive specific Part	TTCN-3 Type union
Security	Start/Restart Integrity Ciphering NasCountReset Release
NAS Count	get set

TTCN-3 ASP Definition	
Type Name	NAS_CTRL_CNF
TTCN-3 Type	Record
Common Part	TTCN-3 Type record
CellId	cell id
RoutingInfo	(not used for configuration)
TimingInfo	current system frame number; sub-frame number (always provided by the SS)
Result	Success or error (in case of error an SS specific error code shall be provided; this will not be evaluated by TTCN but may be useful for validation)
Primitive specific Part	TTCN-3 Type union
Security	(contains no further information)
NAS Count	get set

6.3 UTRAN ASP Definitions

6.3.1 ASPs for Control Primitive Transmission

TTCN-3 ASP Definition		
Type Name	U_CPHY_CONFIG_REQ	
TTCN-3 Type	union	
Port	UTRAN_CPHY	
CPHY_RL_Setup_FDD_REQ		TS 34.123-3, clause 7.3.2.2.11
CPHY_RL_Setup_TDD_REQ		TS 34.123-3, clause 7.3.2.3.1
CPHY_RL_Modify_FDD_REQ		TS 34.123-3, clause 7.3.2.2.9
CPHY_RL_Modify_TDD_REQ		TS 34.123-3, clause 7.3.2.3.1
CPHY_RL_Release_REQ		TS 34.123-3, clause 7.3.2.2.10
CPHY_TrCH_Config_FDD_REQ		TS 34.123-3, clause 7.3.2.2.13
CPHY_TrCH_Config_TDD_REQ		TS 34.123-3, clause 7.3.2.2.13
CPHY_TrCH_Release_REQ		TS 34.123-3, clause 7.3.2.2.14
CPHY_Cell_Config_FDD_REQ		TS 34.123-3, clause 7.3.2.2.2
CPHY_Cell_Config_TDD_REQ		TS 34.123-3, clause 7.3.2.3.1
CPHY_Cell_Release_REQ		TS 34.123-3, clause 7.3.2.2.3
CPHY_Ini_REQ		TS 34.123-3, clause 7.3.2.2.4
CPHY_Cell_TxPower_Modify_REQ		TS 34.123-3, clause 7.3.2.2.5
CPHY_Frame_Number_REQ		TS 34.123-3, clause 7.3.2.2.6

TTCN-3 ASP Definition		
Type Name	U_CPHY_CONFIG_CNF	
TTCN-3 Type	union	
Port	UTRAN_CPHY	
CPHY_RL_Setup_CNF		TS 34.123-3, clause 7.3.2.2.11
CPHY_RL_Modify_CNF		TS 34.123-3, clause 7.3.2.2.9
CPHY_RL_Release_CNF		TS 34.123-3, clause 7.3.2.2.10
CPHY_TrCH_Config_CNF		TS 34.123-3, clause 7.3.2.2.13
CPHY_TrCH_Release_CNF		TS 34.123-3, clause 7.3.2.2.14
CPHY_Cell_Config_CNF		TS 34.123-3, clause 7.3.2.2.2
CPHY_Cell_Release_CNF		TS 34.123-3, clause 7.3.2.2.3
CPHY_Ini_CNF		TS 34.123-3, clause 7.3.2.2.4
CPHY_Cell_TxPower_Modify_CNF		TS 34.123-3, clause 7.3.2.2.5
CPHY_Frame_Number_CNF		TS 34.123-3, clause 7.3.2.2.6
CPHY_Sync_IND		TS 34.123-3, clause 7.3.2.2.12
CPHY_Out_of_Sync_IND		TS 34.123-3, clause 7.3.2.2.7

TTCN-3 ASP Definition		
Type Name	U_CMACE_CONFIG_REQ	
TTCN-3 Type	union	
Port	UTRAN_CMACE	
CMAC_Config_FDD_REQ		TS 34.123-3, clause 7.3.2.2.17
CMAC_Config_TDD_REQ		TS 34.123-3, clause 7.3.2.2.17
CMAC_SYSINFO_Config_REQ		TS 34.123-3, clause 7.3.2.2.22
CMAC_SecurityMode_Config_REQ		TS 34.123-3, clause 7.3.2.2.20
CMAC_Ciphering_Activate_REQ		TS 34.123-3, clause 7.3.2.2.16
CMAC_PAGING_Config_FDD_REQ		TS 34.123-3, clause 7.3.2.2.18
CMAC_PAGING_Config_TDD_REQ		TS 34.123-3, clause 7.3.2.2.18
CMAC_MACes_Config_REQ		TS 34.123-3, clause 7.3.2.2.17d
CMAC_MACe_Config_FDD_REQ		TS 34.123-3, clause 7.3.2.2.17b
CMAC_MACe_Config_TDD_REQ		TS 34.123-3, clause 7.3.2.2.17b
CMAC_MACe_NodeB_CellMapping_REQ		TS 34.123-3, clause 7.3.2.2.17c
CMAC_MACHs_MACehs_TFRCconfigure_FDD_REQ		TS 34.123-3, clause 7.3.2.2.17a
CMAC_MACHs_MACehs_TFRCconfigure_TDD_REQ		TS 34.123-3, clause 7.3.2.3.1

TTCN-3 ASP Definition	
Type Name	U_CMACE_CONFIG_CNF
TTCN-3 Type	union
Port	UTRAN_CMACE
CMACE_Config_CNF	TS 34.123-3, clause 7.3.2.2.17
CMACE_SYSINFO_Config_CNF	TS 34.123-3, clause 7.3.2.2.22
CMACE_SecurityMode_Config_CNF	TS 34.123-3, clause 7.3.2.2.20
CMACE_Ciphering_Activate_CNF	TS 34.123-3, clause 7.3.2.2.16
CMACE_PAGING_Config_CNF	TS 34.123-3, clause 7.3.2.2.18
CMACE_MACes_Config_CNF	TS 34.123-3, clause 7.3.2.2.17d
CMACE_MACe_Config_CNF	TS 34.123-3, clause 7.3.2.2.17b
CMACE_MACe_NodeB_CellMapping_CNF	TS 34.123-3, clause 7.3.2.2.17c
CMACE_MAChs_MACehs_TFRConfigure_CNF	TS 34.123-3, clause 7.3.2.2.17a

TTCN-3 ASP Definition	
Type Name	U_CRLC_CONFIG_REQ
TTCN-3 Type	union
Port	UTRAN_CRLC
CRLC_Config_REQ	TS 34.123-3, clause 7.3.2.2.24
CRLC_Sequence_Number_REQ	TS 34.123-3, clause 7.3.2.2.29
CRLC_SecurityMode_Config_REQ	TS 34.123-3, clause 7.3.2.2.28
CRLC_Ciphering_Activate_REQ	TS 34.123-3, clause 7.3.2.2.23
CRLC_Integrity_Activate_REQ	TS 34.123-3, clause 7.3.2.2.25
CRLC_SetRRC_MessageSN_REQ	TS 34.123-3, clause 7.3.2.2.28a
CRLC_RRC_MessageSN_REQ	TS 34.123-3, clause 7.3.2.2.27a
CRLC_Resume_REQ	TS 34.123-3, clause 7.3.2.2.27
CRLC_Suspend_REQ	TS 34.123-3, clause 7.3.2.2.31
CRLC_ProhibitRLC_Ack_REQ	TS 34.123-3, clause 7.3.2.2.26a

TTCN-3 ASP Definition	
Type Name	U_CRLC_CONFIG_CNF
TTCN-3 Type	union
Port	UTRAN_CRLC
CRLC_Config_CNF	TS 34.123-3, clause 7.3.2.2.24
CRLC_Sequence_Number_CNF	TS 34.123-3, clause 7.3.2.2.29
CRLC_SecurityMode_Config_CNF	TS 34.123-3, clause 7.3.2.2.28
CRLC_Ciphering_Activate_CNF	TS 34.123-3, clause 7.3.2.2.23
CRLC_integrity_Activate_CNF	TS 34.123-3, clause 7.3.2.2.25
CRLC_Integrity_Failure_IND	TS 34.123-3, clause 7.3.2.2.26
CRLC_SetRRC_MessageSN_CNF	TS 34.123-3, clause 7.3.2.2.28a
CRLC_RRC_MessageSN_CNF	TS 34.123-3, clause 7.3.2.2.27a
CRLC_Resume_CNF	TS 34.123-3, clause 7.3.2.2.27
CRLC_Suspend_CNF	TS 34.123-3, clause 7.3.2.2.31
CRLC_ProhibitRLC_Ack_CNF	TS 34.123-3, clause 7.3.2.2.26a

6.3.2 ASPs for Data Transmission and Reception

TTCN-3 ASP Definition	
Type Name	U_RLC_AM_REQ
TTCN-3 Type	union
Port	UTRAN_AM
RLC_AM_DATA_REQ	TS 34.123-3, clause 7.3.2.2.34
RLC_AM_TestDataReq	TS 34.123-3, clause 7.3.3.1

TTCN-3 ASP Definition	
Type Name	U_RLC_AM_IND
TTCN-3 Type	union
Port	UTRAN_AM
RLC_AM_DATA_CNF	TS 34.123-3, clause 7.3.2.2.34
RLC_AM_DATA_IND	TS 34.123-3, clause 7.3.2.2.34
RLC_AM_TestDataInd	TS 34.123-3, clause 7.3.3.1

TTCN-3 ASP Definition	Port	Defined in
UTRAN_RLC_AM_REQ	UTRAN_AM	TS 34.123-3, clause 7.3.2.2.34
UTRAN_RLC_AM_IND	UTRAN_AM	TS 34.123-3, clause 7.3.2.2.34
UTRAN_RLC_TR_REQ	UTRAN_TM	TS 34.123-3, clause 7.3.2.2.33
UTRAN_RLC_TR_IND	UTRAN_TM	TS 34.123-3, clause 7.3.2.2.33
UTRAN_RLC_UM_REQ	UTRAN_UM	TS 34.123-3, clause 7.3.2.2.35
UTRAN_RLC_UM_IND	UTRAN_UM	TS 34.123-3, clause 7.3.2.2.35
RRC_DataReq	UTRAN_Dc	TS 34.123-3, clause 7.1.2
RRC_DataReqInd	UTRAN_Dc	TS 34.123-3, clause 7.1.2

The Invalid_DL_DCCH_Message type is replaced with:

Type Name	Invalid_DL_DCCH_Message
TTCN-3 Type	NULL

6.4 GERAN ASP Definitions

6.4.1 ASPs for Control Primitive Transmission

TTCN-3 ASP Definition	
Type Name	G_CPHY_CONFIG_REQ
TTCN-3 Type	Union
Port	GERAN_CL1
G_CL1_CreateCell_REQ	TS 34.123-3, clause 7.3.4.3.2.1
G_CL1_DeleteCell_REQ	TS 34.123-3, clause 7.3.4.3.2.1
G_CL1_CreateBasicPhyCh_REQ	TS 34.123-3, clause 7.3.4.3.2.1
G_CL1_CreateMultiSlotConfig_REQ	TS 34.123-3, clause 7.3.4.3.2.1
G_CL1_DeleteChannel_REQ	TS 34.123-3, clause 7.3.4.3.2.1
G_CL1_ChangePowerLevel_REQ	TS 34.123-3, clause 7.3.4.3.2.1
G_CL1_CipheringControl_REQ	TS 34.123-3, clause 7.3.4.3.2.1
G_CL1_CipherModeModify_REQ	TS 34.123-3, clause 7.3.4.3.2.1
G_CL1_ChModeModify_REQ	TS 34.123-3, clause 7.3.4.3.2.1
G_CL1_ComingFN_REQ	TS 34.123-3, clause 7.3.4.3.2.1
G_CL2_HoldPhyInfo_REQ	TS 34.123-3, clause 7.3.4.3.2.2
G_CL1_L1Header_REQ	TS 34.123-3, clause 7.3.4.3.2.1
G_CL2_MeasRptControl_REQ	TS 34.123-3, clause 7.3.4.3.2.2
G_CL2_NoUAforSABM_REQ	TS 34.123-3, clause 7.3.4.3.2.2
G_CL2_ResumeUAforSABM_REQ	TS 34.123-3, clause 7.3.4.3.2.2
G_CL2_Release_REQ	TS 34.123-3, clause 7.3.4.3.2.2
G_CL1_SetNewKey_REQ	TS 34.123-3, clause 7.3.4.3.2.1

TTCN-3 ASP Definition	
Type Name	G_CPHY_CONFIG_CNF
TTCN-3 Type	Union
Port	GERAN_CL1
ComingFN	RFN
L1Header	L1Header
None	This choice used when neither of the other choices are selected

TTCN-3 ASP Definition	
Type Name	G_CRLC_CONFIG_REQ
TTCN-3 Type	Union
Port	GERAN_CRLC
G_CRLC_CreateRLC_MAC_REQ	TS 34.123-3, clause 7.3.4.3.2.3
G_CRLC_DeleteRLC_MAC_REQ	TS 34.123-3, clause 7.3.4.3.2.3
G_CRLC_DL_TBF_Config_REQ	TS 34.123-3, clause 7.3.4.3.2.3
G_CRLC_UL_TBF_Config_REQ	TS 34.123-3, clause 7.3.4.3.2.3

TTCN-3 ASP Definition	
Type Name	G_CRLC_CONFIG_CNF
TTCN-3 Type	empty record
Port	GERAN_CRLC

TTCN-3 ASP Definition	
Type Name	G_CLLC_CONFIG_REQ
TTCN-3 Type	Union
Port	GERAN_CLLC
G_CLLC_Assign_REQ	TS 34.123-3, clause 7.3.4.3.2.4
G_CLLC_Reassign_REQ	TS 34.123-3, clause 7.3.4.3.2.4
G_CLLC_CreateLLE_REQ	TS 34.123-3, clause 7.3.4.3.2.4
G_CLLC_DeleteLLE_REQ	TS 34.123-3, clause 7.3.4.3.2.4

TTCN-3 ASP Definition	
Type Name	G_CLLC_CONFIG_CNF
TTCN-3 Type	empty record
Port	GERAN_CLLC

6.4.2 ASPs for Data Transmission and Reception

TTCN-3 ASP Definition	
Type Name	G_L2_DATAMESSAGE_REQ
TTCN-3 Type	Union
Port	GERAN_L2
G_L2_UNITDATA_REQ	TS 34.123-3, clause 7.3.4.3.1.1
G_L2_Release_REQ	TS 34.123-3, clause 7.3.4.3.1.1
G_L2_SYSINFO_REQ	TS 34.123-3, clause 7.3.4.3.1.1
G_L2_Paging_REQ	TS 34.123-3, clause 7.3.4.3.1.1
G_L2_PagingGPRS_REQ	TS 34.123-3, clause 7.3.4.3.1.1
G_L2_DATA_REQ	TS 34.123-3, clause 7.3.4.3.1.1
G_L2_GTP_REQ	TS 34.123-3, clause 7.3.4.3.1.1

The SysInfoType is replaced with:

Type Name	SysInfoMsg
TTCN-3 Type	union
	SYSTEMINFORMATIONTYPE1
	SYSTEMINFORMATIONTYPE2
	SYSTEMINFORMATIONTYPE3
	SYSTEMINFORMATIONTYPE4
	SYSTEMINFORMATIONTYPE5
	SYSTEMINFORMATIONTYPE6
	SYSTEMINFORMATIONTYPE13
	SYSTEMINFORMATIONTYPE15
	SYSTEMINFORMATIONTYPE2bis
	SYSTEMINFORMATIONTYPE2ter
	SYSTEMINFORMATIONTYPE2quater
	SYSTEMINFORMATIONTYPE5bis

TTCN-3 ASP Definition	
Type Name	G_L2_DATAMESSAGE_IND
TTCN-3 Type	Union
Port	GERAN_L2
G_L2_UNITDATA_IND	TS 34.123-3, clause 7.3.4.3.1.1
G_L2_Release_CNF	TS 34.123-3, clause 7.3.4.3.1.1
G_L2_Release_IND	TS 34.123-3, clause 7.3.4.3.1.1
G_L2_Estab_IND	TS 34.123-3, clause 7.3.4.3.1.1
G_L2_GTP_IND	TS 34.123-3, clause 7.3.4.3.1.1
G_L2_DATA_IND	TS 34.123-3, clause 7.3.4.3.1.1
G_L2_ACCESS_IND	TS 34.123-3, clause 7.3.4.3.1.1

TTCN-3 ASP Definition	
Type Name	G_RLC_DATAMESSAGE_REQ
TTCN-3 Type	Union
Port	GERAN_RLC
G_RLC_ControlMsg_REQ	TS 34.123-3, clause 7.3.4.3.1.2

TTCN-3 ASP Definition	
Type Name	G_RLC_DATAMESSAGE_IND
TTCN-3 Type	Union
Port	GERAN_RLC
G_RLC_ControlMsg_IND	TS 34.123-3, clause 7.3.4.3.1.2

TTCN-3 ASP Definition	
Type Name	G_LLC_DATAMESSAGE_REQ
TTCN-3 Type	Union
Port	GERAN_LLC
G_LLC_UNITDATA_REQ	TS 34.123-3, clause 7.3.4.3.1.3
G_LLC_XID_RES	TS 34.123-3, clause 7.3.4.3.1.3

TTCN-3 ASP Definition	
Type Name	G_LLC_DATAMESSAGE_IND
TTCN-3 Type	Union
Port	GERAN_LLC
G_LLC_UNITDATA_IND	TS 34.123-3, clause 7.3.4.3.1.3
G_LLC_XID_IND	TS 34.123-3, clause 7.3.4.3.1.3

7 Test Methods and Design Considerations

7.1 Channel Mapping

Figure 7.1 shows the channel type mapping that is used for the configuration of the SS. In layer 2 test cases non default channel mapping can be applied on SS, as explained in clause 4.2.1.

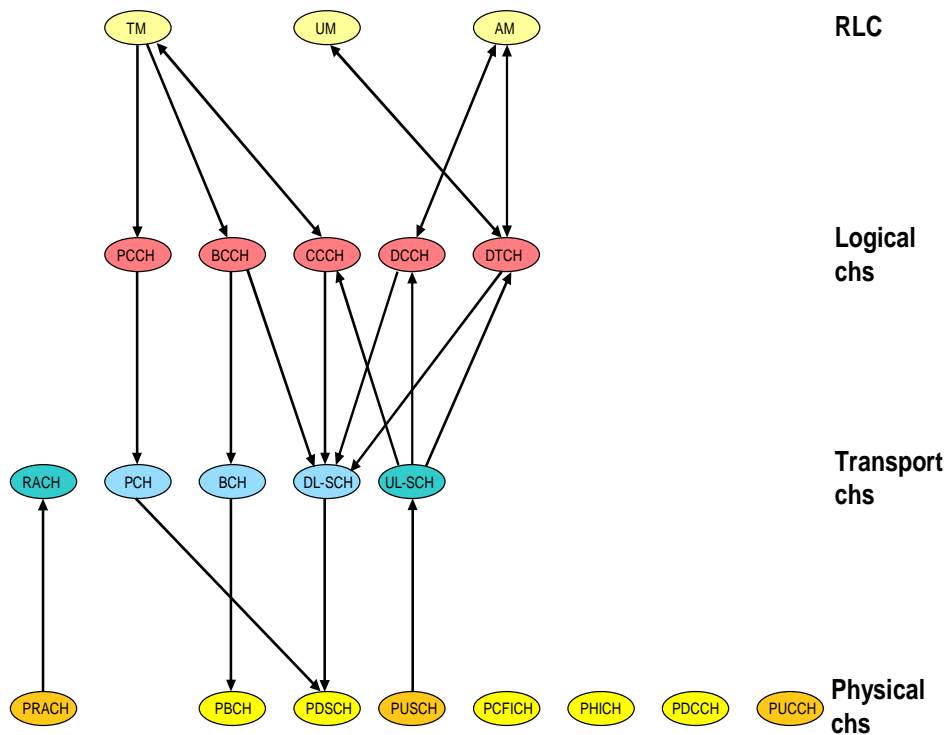

7.1-1: Channel type mapping for the default configuration of the SS

Figure

7.1.1 PDCCH Candidate Selection

In this clause following abbreviations are used:

- Common search Space Aggregation: CS_Agr.
- UE-Specific Search Space Aggregation: UE_Agr.
- Total number of CCEs available in a subframe: Max_CCE.

SS shall apply defined rules below in a DL subframe for PDCCH candidates' selection.

- Scheduled transmissions on SI-RNTI / P-RNTI / RA-RNTI, use Common Search Space. UL and DL Scheduled transmissions on C-RNTI/ SPS C-RNTI, and DL Scheduled transmissions on Temp. C-RNTI, use UE-Specific Search Space. Transmissions on TPC-PUCCH-RNTI / TPC-PUSCH-RNTI and UL Scheduled transmissions on Temp. C-RNTI is not considered for default CCE management.
- If a transmission on SI-RNTI is scheduled, PDCCH candidate corresponding to CCEs between 0 and (CS_Agr-1) is used. This PDCCH candidate is reserved for SI-RNTI, and left vacant if no SI-RNTI transmission is scheduled.
- PDCCH candidates corresponding to CCEs between CS_Agr and (2*CS_Agr-1) can be used either for the transmission on P-RNTI or RA-RNTI. In conformance test cases with single UE, there is no requirement for transmissions scheduled for both P-RNTI and RA-RNTI in one DL subframe.
- For DL transmission for C-RNTI/SPS-RNTI/Temp C-RNTI the lowest value of $m = m'$ which has a PDCCH available from CCEs between $2*CS_Agr$ and (Max_CCE-1) shall be used. 'm' is defined in TS 36.213 [30], clause 9.1.1.
- For UL transmission for C-RNTI/SPS-RNTI the lowest value of $m = m'' > m'$ which has a PDCCH available from CCEs between $2*CS_Agr$ and (Max_CCE-1) shall be used, irrespective of PDCCH candidate corresponding to m' is used or not.

NOTE: If m' or m'' cannot be allocated in any TTI, it is a TTCN error due to X-RNTI not properly allocated. The error shall be reported to TTCN. The TTCN will exit the test case assigning an inconclusive verdict.

7.1.1.1 FDD candidates selection

Table 7.1.1.1-1 gives the CCE resources utilized for m' and m'' for default values of common search space aggregation level =4, UE-specific search space aggregation L=2 resulting in 6 PDCCH candidates $m=0..5$ and channel Bandwidth of 5 MHz. This give Max_CCE =20 for FDD. The table also gives the corresponding CCE start indices of PDCCH candidates for m' and m'' .

Table 7.1.1.1-1: CCE Start indices(m' & m'' to be used for various C-RNTIs (5 MHz)

C-RNTI	Value		SF0	SF1	SF2	SF3	SF4	SF5	SF6	SF7	SF8	SF9
tsc_C_RNTI_Def	'1001'H 4097	m'	0	1	0	0	0	3	4	0	0	0
		CCE_St_Ind'	12	8	14	8	12	8	8	8	14	10
		m''	1	2	1	1	1	4	5	1	1	1
		CCE_St_Ind''	14	10	16	10	14	10	10	10	16	12
tsc_C_RNTI_Def2	'1034'H 4148	m'	0	0	2	0	0	4	4	1	0	0
		CCE_St_Ind'	12	16	8	14	10	8	8	8	18	16
		m''	1	1	3	1	1	5	5	2	5	1
		CCE_St_Ind''	14	18	10	16	12	10	10	10	8	18
tsc_C_RNTI_Def3	'1111'H 4369	m'	0	0	0	2	3	0	0	0	0	4
		CCE_St_Ind'	16	10	14	8	8	10	14	8	18	8
		m''	1	1	1	3	4	1	1	1	5	5
		CCE_St_Ind''	18	12	16	10	10	12	16	10	8	10
tsc_C_RNTI_Def4	'1FF1'H 8177	m'	0	0	0	0	3	0	0	0	2	4
		CCE_St_Ind'	12	12	18	16	8	18	18	18	8	8
		m''	1	1	5	1	4	5	5	5	3	5
		CCE_St_Ind''	14	14	8	18	10	8	8	8	10	10
tsc_C_RNTI_Def5	'04D2'H 1234	m'	0	2	0	4	0	2	3	0	1	0
		CCE_St_Ind'	10	8	10	8	14	8	8	14	8	10
		m''	1	3	1	5	1	3	4	1	2	1
		CCE_St_Ind''	12	10	12	10	16	10	10	16	10	12
tsc_C_RNTI_Def6	'0929'H 2345	m'	4	0	4	0	0	1	3	3	4	2
		CCE_St_Ind'	8	10	8	12	14	8	8	8	8	8
		m''	5	1	5	1	1	2	4	4	5	3
		CCE_St_Ind''	10	12	10	14	16	10	10	10	10	10
tsc_C_RNTI_Def7	'0D80'H 3456	m'	2	0	2	0	0	0	3	0	0	2
		CCE_St_Ind'	8	16	8	18	14	14	8	16	14	8
		m''	3	1	3	5	1	1	4	1	1	3
		CCE_St_Ind''	10	18	10	8	16	16	10	18	16	10
tsc_C_RNTI_Def8	'11D7'H 4567	m'	0	0	0	2	0	0	3	2	0	2
		CCE_St_Ind'	8	16	8	8	14	16	8	8	8	8
		m''	1	1	1	3	1	1	4	3	1	3
		CCE_St_Ind''	10	18	10	10	16	18	10	10	10	10
tsc_C_RNTI_Def9	'162E'H 5678	m'	0	3	0	0	0	2	0	0	3	2
		CCE_St_Ind'	12	8	12	16	8	8	16	18	8	8
		m''	1	4	1	1	1	3	1	5	4	3
		CCE_St_Ind''	14	10	14	18	10	10	18	8	10	10
tsc_C_RNTI_Def10	'1A85'H 6789	m'	0	0	0	3	0	1	0	1	3	2
		CCE_St_Ind'	16	8	16	8	8	8	16	8	8	8
		m''	1	1	1	4	1	2	1	2	4	3
		CCE_St_Ind''	18	10	18	10	10	10	18	10	10	10

Tables 7.1.1.1-2, 7.1.1.1-3, 7.1.1.1-4 give the CCE resources utilized for m' and m'' for default values of common search space aggregation level =4, UE-specific search space aggregation L=2 resulting in 6 PDCCH candidates m=0..5 and bandwidths of 10/15/20 MHz respectively. This gives Max_CCE =25(10 MHz)/37(15 MHz)/50(20 MHz) for FDD. The tables also give the corresponding CCE start indices of PDCCH candidates for m' and m''. These are in general to be applied in MAC Transport block size test cases defined in clause 7.1.7 of 36.523-1 [1].

Table 7.1.1.1-2: CCE Start indices (m' & m'') to be used for default C-RNTI (10 MHz)

C-RNTI	Value		SF0	SF1	SF2	SF3	SF4	SF5	SF6	SF7	SF8	SF9
tsc_C_RNTI_Def	'1001'H 4097	m'	0	3	3	0	0	0	0	0	0	0
		CCE_St_Ind'	12	8	8	20	16	18	16	8	14	18
		m''	1	4	4	1	1	1	1	1	1	1
		CCE_St_Ind''	14	10	10	22	18	20	18	10	16	20
tsc_C_RNTI_Def2	'1034'H 4148	m'	0	4	0	0	0	4	0	0	0	0
		CCE_St_Ind'	8	8	20	10	14	8	20	22	18	8
		m''	1	5	1	1	1	5	1	5	1	1
		CCE_St_Ind''	10	10	22	12	16	10	22	8	20	10
tsc_C_RNTI_Def3	'1111'H 4369	m'	0	0	0	4	0	0	0	2	0	0
		CCE_St_Ind'	16	10	10	8	22	22	22	8	10	16
		m''	1	1	1	5	5	5	5	3	1	1
		CCE_St_Ind''	18	12	12	10	8	8	8	10	12	18
tsc_C_RNTI_Def4	'1FF1'H 8177	m'	2	0	0	4	0	0	3	0	2	0
		CCE_St_Ind'	8	20	14	8	10	18	8	22	8	12
		m''	3	1	1	5	1	1	4	5	3	1
		CCE_St_Ind''	10	22	16	10	12	20	10	8	10	14
tsc_C_RNTI_Def5	'04D2'H 1234	m'	3	0	0	0	0	2	3	3	1	0
		CCE_St_Ind'	8	16	22	12	22	8	8	8	8	22
		m''	4	1	5	1	5	3	4	4	2	5
		CCE_St_Ind''	10	18	8	14	8	10	10	10	10	8
tsc_C_RNTI_Def6	'0929'H 2345	m'	0	0	2	2	0	1	0	0	0	2
		CCE_St_Ind'	20	18	8	8	18	8	18	22	12	8
		m''	1	1	3	3	1	2	1	5	1	3
		CCE_St_Ind''	22	20	10	10	20	10	20	8	14	10
tsc_C_RNTI_Def7	'0D80'H 3456	m'	4	0	0	1	0	0	0	0	0	4
		CCE_St_Ind'	8	20	20	8	14	22	10	8	18	8
		m''	5	1	1	2	1	5	1	1	1	5
		CCE_St_Ind''	10	22	22	10	16	8	12	10	20	10
tsc_C_RNTI_Def8	'11D7'H 4567	m'	2	0	0	0	0	4	3	2	4	0
		CCE_St_Ind'	8	8	12	8	10	8	8	8	8	20
		m''	3	1	1	1	1	5	4	3	5	1
		CCE_St_Ind''	10	10	14	10	12	10	10	10	10	22
tsc_C_RNTI_Def9	'162E'H 5678	m'	0	0	2	4	0	0	2	0	1	0
		CCE_St_Ind'	8	10	8	8	16	16	8	14	8	16
		m''	1	1	3	5	1	1	3	1	2	1
		CCE_St_Ind''	10	12	10	10	18	18	10	16	10	18
tsc_C_RNTI_Def10	'1A85'H 6789	m'	0	0	0	3	0	0	0	0	3	0
		CCE_St_Ind'	12	12	20	8	12	18	20	10	8	12
		m''	1	1	1	4	1	1	1	1	4	1
		CCE_St_Ind''	14	14	22	10	14	20	22	12	10	14

Table 7.1.1.1-3: CCE Start indices (m' & m'') to be used for default C-RNTI (15 MHz)

C-RNTI	Value		SF0	SF1	SF2	SF3	SF4	SF5	SF6	SF7	SF8	SF9
tsc_C_RNTI_Def	'1001'H 4097	m'	4	0	0	0	0	0	0	0	0	0
		CCE_St_Ind'	8	14	14	20	16	18	28	20	26	30
		m''	5	1	1	1	1	1	1	1	1	1
		CCE_St_Ind''	10	16	16	22	18	20	30	22	28	32

Table 7.1.1.1-4: CCE Start indices (m' & m'') to be used for default C-RNTI (20 MHz)

C-RNTI	Value		SF0	SF1	SF2	SF3	SF4	SF5	SF6	SF7	SF8	SF9
tsc_C_RNTI_Def	'1001'H 4097	m'	3	0	0	0	0	0	0	0	2	0
		CCE_St_Ind'	8	36	34	38	42	22	10	8	8	20
		m''	4	1	1	1	1	1	1	1	3	1
		CCE_St_Ind''	10	38	36	40	44	24	12	10	10	22

7.1.1.2 TDD candidates selection

The default TDD subframe configuration 1 is applied to this clause.

Considering that each TDD subframe having different PHICH group number, and only two symbols being present for PDCCH in the special subframes 1 and 6 for bandwidth of 5 MHz, two symbols for PDCCH in all subframes for bandwidth of 10/15/20 MHz [3], each subframe has, therefore, different number of MAX_CCE.

Table 7.1.1.2-1 gives the PDCCH candidates of m' and m'' for default values of common search space aggregation level =4, UE-specific search space aggregation $L=2$ resulting in 6 PDCCH candidates $m=0..5$ and the corresponding CCE start indices for channel bandwidth of 5MHz. SF0 and SF5 cannot be used for UL grant. SF1 and SF6 are not used for DL assignment. SF2, SF3, SF7 and SF8 are not applicable to PDCCH CCE allocation since they are uplink subframes.

Table 7.1.1.2-1: CCE Start indices (m' & m'') to be used for various C-RNTIs (5 MHz)

C-RNTI	Value		SF0	SF1	SF2	SF3	SF4	SF5	SF6	SF7	SF8	SF9
tsc_C_RNTI_Def	'1001'H 4097	Max_CCE	21	12	-	-	20	21	12	-	-	20
		m'	0	-	-	-	0	3	-	-	-	0
		CCE_St_Ind'	12	-	-	-	12	8	-	-	-	10
		m''	-	4	-	-	1	-	3	-	-	1
tsc_C_RNTI_Def2	'1034'H 4148	CCE_St_Ind''	-	10	-	-	14	-	10	-	-	12
		m'	0	-	-	-	0	4	-	-	-	0
		CCE_St_Ind'	12	-	-	-	10	8	-	-	-	16
		m''	-	5	-	-	1	-	1	-	-	1
tsc_C_RNTI_Def3	'1111'H 4369	CCE_St_Ind''	-	10	-	-	12	-	10	-	-	18
		m'	0	-	-	-	3	0	-	-	-	4
		CCE_St_Ind'	16	-	-	-	8	10	-	-	-	8
		m''	-	0	-	-	4	-	5	-	-	5
tsc_C_RNTI_Def4	'1FF1'H 8177	CCE_St_Ind''	-	10	-	-	10	-	8	-	-	10
		m'	0	-	-	-	3	0	-	-	-	4
		CCE_St_Ind'	12	-	-	-	8	18	-	-	-	8
		m''	-	1	-	-	4	-	4	-	-	5
tsc_C_RNTI_Def5	'04D2'H 1234	CCE_St_Ind''	-	10	-	-	10	-	10	-	-	10
		m'	0	-	-	-	0	2	-	-	-	0
		CCE_St_Ind'	10	-	-	-	14	8	-	-	-	10
		m''	-	3	-	-	1	-	4	-	-	1
tsc_C_RNTI_Def6	'0929'H 2345	CCE_St_Ind''	-	10	-	-	16	-	10	-	-	12
		m'	4	-	-	-	0	1	-	-	-	2
		CCE_St_Ind'	8	-	-	-	14	8	-	-	-	8
		m''	-	2	-	-	2	-	1	-	-	3
tsc_C_RNTI_Def7	'0D80'H 3456	CCE_St_Ind''	-	10	-	-	16	-	10	-	-	10
		m'	2	-	-	-	0	0	-	-	-	2
		CCE_St_Ind'	8	-	-	-	14	14	-	-	-	8
		m''	-	1	-	-	1	-	5	-	-	3
tsc_C_RNTI_Def8	'11D7'H 4567	CCE_St_Ind''	-	10	-	-	16	-	8	-	-	11
		m'	0	-	-	-	0	0	-	-	-	2
		CCE_St_Ind'	8	-	-	-	14	16	-	-	-	8
		m''	-	0	-	-	1	-	4	-	-	3
tsc_C_RNTI_Def9	'162E'H 5678	CCE_St_Ind''	-	10	-	-	16	-	10	-	-	10
		m'	0	-	-	-	0	2	-	-	-	2
		CCE_St_Ind'	12	-	-	-	8	8	-	-	-	8
		m''	-	5	-	-	1	-	3	-	-	3
tsc_C_RNTI_Def10	'1A85'H 6789	CCE_St_Ind''	-	8	-	-	10	-	10	-	-	10
		m'	0	-	-	-	0	1	-	-	-	2
		CCE_St_Ind'	16	-	-	-	8	8	-	-	-	8
		m''	-	5	-	-	1	-	1	-	-	3
		CCE_St_Ind''	-	10	-	-	10	-	10	-	-	10

Tables 7.1.1.2-2, 7.1.1.2-3, 7.1.1.2-4 give the PDCCH candidates of m' and m'' for default values of common search space aggregation level =4, UE-specific search space aggregation $L=2$ resulting in 6 PDCCH candidates $m=0..5$ and the corresponding CCE start indices for bandwidths of 10/15/20 MHz respectively, with the different Max_CCE number for each subframe.

Table 7.1.1.2-2: CCE Start indices (m' & m'') to be used for default C-RNTI (10 MHz)

C-RNTI	Value		SF0	SF1	SF2	SF3	SF4	SF5	SF6	SF7	SF8	SF9
		Max_CCE	27	25	-	-	25	27	25	-	-	25
tsc_C_RNTI_Def	'1001'H 4097	m'	0	-	-	-	0	2	-	-	-	0
		CCE_St_Ind'	10	-	-	-	16	8	-	-	-	18
		m''	-	4	-	-	1	-	1	-	-	1
		CCE_St_Ind''	-	10	-	-	18	-	18	-	-	20

Table 7.1.1.2-3: CCE Start indices (m' & m'') to be used for default C-RNTI (15 MHz)

C-RNTI	Value		SF0	SF1	SF2	SF3	SF4	SF5	SF6	SF7	SF8	SF9
		Max_CCE	41	37	-	-	37	41	37	-	-	37
tsc_C_RNTI_Def	'1001'H 4097	m'	0	-	-	-	0	3	-	-	-	0
		CCE_St_Ind'	12	-	-	-	16	8	-	-	-	30
		m''	-	1	-	-	1	-	1	-	-	1
		CCE_St_Ind''	-	16	-	-	18	-	30	-	-	32

Table 7.1.1.2-4: CCE Start indices (m' & m'') to be used for default C-RNTI (20 MHz)

C-RNTI	Value		SF0	SF1	SF2	SF3	SF4	SF5	SF6	SF7	SF8	SF9
		Max_CCE	55	50	-	-	50	55	50	-	-	50
tsc_C_RNTI_Def	'1001'H 4097	m'	4	-	-	-	0	4	-	-	-	0
		CCE_St_Ind'	8	-	-	-	42	8	-	-	-	20
		m''	-	1	-	-	1	-	1	-	-	1
		CCE_St_Ind''	-	38	-	-	44	-	12	-	-	22
tsc_C_RNTI_Def	'1034'H 4148	m'	0	-	-	-	0	4	-	-	-	1
		CCE_St_Ind'	32	-	-	-	20	8	-	-	-	8
		m''	-	1	-	-	1	-	1	-	-	2
		CCE_St_Ind''	-	48	-	-	22	-	12	-	-	10
tsc_C_RNTI_Def	'1111'H 4369	m'	0	-	-	-	3	2	-	-	-	0
		CCE_St_Ind'	52	-	-	-	8	8	-	-	-	20
		m''	-	1	-	-	4	-	3	-	-	1
		CCE_St_Ind''	-	22	-	-	10	-	10	-	-	22
tsc_C_RNTI_Def	'1FF1'H 8177	m'	0	-	-	-	0	0	-	-	-	0
		CCE_St_Ind'	22	-	-	-	42	18	-	-	-	20
		m''	-	1	-	-	1	-	1	-	-	1
		CCE_St_Ind''	-	14	-	-	44	-	30	-	-	22
tsc_C_RNTI_Def	'04D2'H 1234	m'	0	-	-	-	0	0	-	-	-	0
		CCE_St_Ind'	26	-	-	-	44	10	-	-	-	20
		m''	-	1	-	-	1	-	1	-	-	1
		CCE_St_Ind''	-	36	-	-	46	-	14	-	-	22
tsc_C_RNTI_Def	'0929'H 2345	m'	0	-	-	-	0	4	-	-	-	2
		CCE_St_Ind'	26	-	-	-	14	8	-	-	-	8
		m''	-	1	-	-	1	-	1	-	-	3
		CCE_St_Ind''	-	22	-	-	16	-	24	-	-	10
tsc_C_RNTI_Def	'0D80'H 3456	m'	0	-	-	-	0	0	-	-	-	0
		CCE_St_Ind'	42	-	-	-	34	28	-	-	-	14
		m''	-	2	-	-	1	-	1	-	-	1
		CCE_St_Ind''	-	10	-	-	36	-	34	-	-	16
tsc_C_RNTI_Def	'11D7'H 4567	m'	2	-	-	-	2	0	-	-	-	0
		CCE_St_Ind'	8	-	-	-	8	18	-	-	-	24
		m''	-	1	-	-	3	-	1	-	-	1
		CCE_St_Ind''	-	18	-	-	10	-	44	-	-	26
tsc_C_RNTI_Def	'162E'H 5678	m'	0	-	-	-	0	0	-	-	-	0
		CCE_St_Ind'	20	-	-	-	48	46	-	-	-	34
		m''	-	4	-	-	5	-	1	-	-	1
		CCE_St_Ind''	-	10	-	-	8	-	28	-	-	36
tsc_C_RNTI_Def	'1A85'H 6789	m'	0	-	-	-	0	0	-	-	-	0
		CCE_St_Ind'	36	-	-	-	18	36	-	-	-	44
		m''	-	1	-	-	1	-	1	-	-	1
		CCE_St_Ind''	-	40	-	-	20	-	38	-	-	46

7.2 Uplink Grant

The Network/SS informs the UE if it is allowed to make Uplink Data transmission by transmitting 'DCI format 0' on PDCCH. The UE shall transmit (4 TTI later for FDD or variable for TDD) a Transport block of exactly the same size as specified in DCI format 0. The UE has no control of its own on TB size, and has to merely follow the network, even if that means lots of MAC padding or resource starving.

The UE has the following means to communicate if it has UL data ready for transmission and subsequently the estimate of quantity of data to be transmitted.

RACH procedure: UE in idle mode, handed over to a new cell or connected mode but PUCCH is unsynchronized (sometimes referred to as PUCCH is not configured) will trigger RACH procedure on data ready for transmission in UL.

Scheduling Request: UE in connected mode, no grant configured, PUCCH is synchronized and has data ready for transmission in UL, will transmit a scheduling request on PUCCH.

Buffer Status Reports: UE in connected mode, PUCCH synchronized, has a configured grant for current TTI, but grant is not sufficient to transmit all the data will include MAC control element BSR in the UL MAC PDU.

RACH and SR indicate on data availability and BSR provides an estimate of data available for transmission.

Hence to determine the exact need of the grant requirement of the UE a network/SS needs to act on all three of the above. This eventually complicates the SS implementation and hence the grant allocation procedure is simplified such that SS needs only to react on reception of SR.

The SS, if configured for maintaining PUCCH synchronization at UE, shall periodically transmit automatically MAC PDUs containing the MAC control element 'Timing Advance'. The period as configured by the TTCN is set to 80 % of the 'Time Alignment Timer' default value (750 ms) configured at UE.

Additionally the SS can be configured to automatically transmit a 'configured' UL grant at every reception of a Scheduling Request. This grant should be selected under the following restrictions:

- All UE categories can handle this i.e. ($TBS < 5160$).
- It is sufficiently large that most of uplink signalling messages can be transmitted. In case the grant is not sufficient to fit the whole UL data, the UE will have to wait for the expiry of RETX_BSR_TIMER and retransmit a SR. And hence the procedure is repeated.

The following 4 types of grant allocation configurations are possible. Grant allocation Types 1 to 3 are applicable, when the UE is in connected state. Grant allocation Type 4 is applicable when UE is establishing /re-establishing the RRC Connection, or during handover or in connected state but PUCCH is not synchronised.

Grant Allocation Type 1:

- SS is configured to maintain PUCCH Synch.
- SS is configured to send an automatically 'configured Grant' (in terms of I_{MCS} and N_{PRB}) to the UE on every reception of a Scheduling Request, within 10 subframes. The default configured grant is $I_{MCS} = 9$ and $N_{PRB} = 25$, unless explicitly specified in test cases.
- By default this type of grant allocation is applied. The majority of Idle mode, RRC and NAS test cases, the preambles of all tests and the postambles of those tests for which UE is still PUCCH synchronised at the end of test body. A few Layer 2 tests also use this type of grant.

Grant Allocation Type 2:

- Configure SS to maintain PUCCH Synch.
- Configure SS to periodically transmit a grant (I_{MCS} and N_{PRB}). Number of grants (1 or more) and period configured by TTCN. First grant transmitted as specified in timing information.
- This type of grant allocation is applicable to the majority of RLC, PDCP and a few MAC test cases.

- No additional grant is allocated on reception of any SRs.

Grant Allocation Type 3:

- SS may or may not be configured to maintain PUCCH Synch.
- Configure SS to transmit a one time grant (I_{MCS} and N_{PRB}) in the time requested by TTCN. The one time transmission is achieved by setting Number of grants=1 and period =Only once
- This type of grant allocation is suitable for MAC and DRB tests when UE is in UL Synchronised state

Grant Allocation Type 4 (RACH configuration):

- In addition to the 3 types of UL grant allocations, a fourth type of grant allocation during the RACH procedure is also possible, where the SS behaves as per the RACH procedure configured and allocates the configured grant during the RACH procedure. This UL Grant type is used in the configuration for the preamble in many situations, basically in MAC test cases. This type of grant is further used when UE is establishing/re-establishing the RRC connection or during handover, or when the UE is not PUCCH synchronised;

All the UL grant allocation methods define grant allocation in terms of I_{MCS} and N_{PRB} to be used. The SS shall allocate RBs corresponding to PRB indices 0..(N_{PRB} -1).

7.2.1 Exception TC list

This clause contains the exception test case list where the explicit uplink grant types other than UL grant type 1 are specified.

Table 7.2.1-1: Exception test case list with explicit uplink grant types other than UL grant type 1

Group	Test Case	Uplink Grant Type 2	Uplink Grant Type 3
RLC	7.2.2.6	X	
	7.2.2.7	X	
	7.2.3.1		X
	7.2.3.2	X	
	7.2.3.4		X
	7.2.3.5		X
	7.2.3.6	X	
	7.2.3.7	X	
	7.2.3.9	X	
	7.2.3.10	X	X
	7.2.3.13	X	X
	7.2.3.15	X	
	7.2.3.18		X
MAC	7.1.4.1	X	
	7.1.4.2		X
	7.1.4.3	X	
	7.1.4.4		X
	7.1.4.7		X
	7.1.4.8	X	X
	7.1.4.10		X
	7.1.4.11		X
	7.1.4.14		X
	7.1.4.15	X	
	7.1.4.16	X	
	7.1.5.1	X	
	7.1.5.2	X	
	7.1.5.3	X	
	7.1.5.4	X	
7.1.5.5	X		

	7.1.6.1		X
RRC	8.2.1.5	X	
DRB	12.1.1		X
	12.1.2		X

7.3 Downlink Resource Allocation

The DL resource allocation is an SS emulation function. In order to ensure similar DL behaviours (within defined tolerances) on the different SS platforms in the timing stringent requirements, all downlink resource allocation schemes specified in the present clause shall be supported by the SS.

When the DL data is to be sent with a specific scheduling requirement, for instance, in a TTI in advance rather than "now", the TTCN shall ensure that the data is scheduled 100 ms in advance. The 100 ms time covers all time delays, from the time DL data is sent by the TTCN to the completion of the transmission at the SS (TTCN delays, codec delays, adaptor delays and SS processing delays at various protocol Layers).

NOTE: The DL data means DL signalling and/or data in the present clause.

7.3.1 PDCCH DCI default formats

Two types of DCI combinations are identified as default formats for the signalling and protocol test.

DCI combination 1 uses:

- DCI format 1A, resource allocation type 2 localised, for all DL scheduling types.

DCI combination 2 uses:

- DCI format 1C, resource allocation type 2 distributed, for scheduling of PCCH/BCCH/RAR; and
- DCI format 1 resource allocation type 0, for UE dedicated scheduling.

7.3.2 Radio parameters configured

The SS shall support DL QPSK, 16QAM and 64QAM modulation schemes. The configured radio parameters, including DCI format, resource allocation types, maximum allowed modulation scheme, first virtual / physical resource block to be used, maximum available resource blocks and redundancy version, are provided to the SS.

In the normal signalling test condition, DL RLC and HARQ retransmissions are rare. The redundancy version is provided to allow the occasional HARQ retransmissions. For those MAC, RLC tests contained in Table 7.3.1-1 where timing requirements are involved the DL or UL HARQ retransmissions are not tolerable.

NOTE: If the test is expecting the reporting of UL ACK/NACK for the DL MAC PDUs, or is configuring the PHICH in a certain mode, HARQ retransmissions other than those that are already specified in the prose will have an impact on the test sequence. If test cases perform scheduling of data transmissions and/or receptions, or the testing timers in the test cases are less than 900 ms (i.e. the tolerance for 90 ms), HARQ retransmissions will make it difficult to continue testing.

Table 7.3.2-1: TC list of HARQ retransmissions not tolerable

Test case	Comment
MAC	
7.1.3.1, 7.1.3.2, 7.1.3.4, 7.1.3.5, 7.1.3.6, 7.1.3.9, 7.1.6.1, 7.1.6.2	HARQ feedback reporting enabled or DL CRC errors introduced; DL HARQ unspecified (re)transmissions will result in 'Fail' in test body, UL HARQ retransmissions are allowed;
7.1.4.8	Strict relationship between grant and UL data
7.1.4.3	Up to 104 PDUs to be sent in DL every TTI;
7.1.4.2, 7.1.4.11, 7.1.4.12, 7.1.4.14, 7.1.5.4	HARQ feedback transmission specified or PHICH errors introduced
RLC	
7.2.2.6, 7.2.2.7, 7.2.2.8, 7.2.2.10, 7.2.3.1, 7.2.3.2, 7.2.3.4, 7.2.3.5, 7.2.3.6, 7.2.3.7, 7.2.3.8, 7.2.3.9, 7.2.3.10, 7.2.3.13, 7.2.3.14, 7.2.3.15, 7.2.3.17, 7.2.3.18	Testing timer < 900 ms

7.3.3 General DL scheduling scheme

The rules in the present clause, unless particularly specified, are applied to both default DCI combinations.

The bandwidth of 5/10/20 MHz makes 25/50/100 available physical resource blocks respectively. The 25/50/100 resource blocks are divided into three distinct sets. Exact set sizes and the elements contained in the individual sets depend upon the DCI combination to be applied.

- The first set is reserved for BCCH mapped to DL-SCH (SI-RNTI).
- The second set is reserved for PCCH mapped to DL-SCH (P-RNTI).
- The third set is used for one of mutually exclusive transmissions of:
 - 'Random Access Response' mapped to DL-SCH (RA-RNTI); or
 - UE-dedicated scheduling mapped to DL-SCH (C-RNTI/ SPS C-RNTI/ Temp C-RNTI).

For each subframe for which data of one or more types is scheduled, the SS shall select a Transport Block Size (TBS), independently for each type of data scheduled, such that:

- All the scheduled data is transmitted respecting the timing information. More details on the timing information can be found in clause 7.8.
- .- Not more than $MaxRbCnt$ resource blocks are used, for DCI format 1C, $N_{PRB} = MaxRbCnt$.
- Minimum MAC Padding is performed.
- If all scheduled Data cannot be transmitted in the indicated subframe, for example due to TDD and half duplex configuration, it shall be transmitted in the next available subframe.

7.3.3.1 Additional rules for BCCH scheduling scheme

This scheme is applicable for Data transmission on logical channel BCCH mapped to DL-SCH, PDCCH scrambled by SI-RNTI. For both DCI combinations 4 physical resource blocks are reserved for BCCH transmission. The maximum modulation scheme is restricted to QPSK.

Following additional rules are applied for TBS selection:

- The Max TBS, the maximum TBS allowed for the scheduling scheme, is restricted to 600. (nearest value achievable for $I_{TBS} = 9$ and $N_{PRB} = 4$, as per table 7.1.7.2.1-1 of TS 36.213 [30]).
- If the scheduled Data cannot fit into a TBS smaller or equal to Max TBS, SS generates an error (it's a TTCN error). TTCN should gracefully exit the test case as a fatal error, assigning inconclusive verdict.
- Rules in clause 7.3.3.1.1 for DCI combination 1 and in clause 7.3.3.1.2 for DCI combination 2 shall be applied.

7.3.3.1.1 BCCH with DCI combination 1

TS 36.213 [30], table 7.1.7.2.1-1, rows with $I_{TBS} = 0..26$ and columns with $N_{PRB} = 2$ (corresponding to TPC LSB = 0) and $N_{PRB} = 3$ (corresponding to TPC LSB = 1), $TBS \leq \text{Max TBS}$ are applicable.

Distinct TBSs and all (TPC LSB, I_{TBS}) combinations for each distinct TBS are listed in the sheet.

If a TBS can have two (TPC LSB, I_{TBS}) combinations, the combination with TPC LSB = 0 is selected.

RIV indicates 4 PRBs with index 0..3 allocated.

7.3.3.1.2 BCCH with DCI combination 2

TS 36.213 [30], table 7.1.7.2.3-1, $I_{TBS} = 0..17$ with $TBS \leq \text{Max TBS}$ are applicable.

RIV indicates 4 virtual RBs with index 0..3 allocated. These virtual RBs correspond to the physical RBs

- with index 0, 6, 12, 18 in even slots and 12, 18, 0, 6 in odd slots for 5 MHz bandwidth,
- with index 0, 12, 27, 39 in even slots and 27, 39, 0, 12 in odd slots for 10 MHz bandwidth,
- with index 0, 24, 48, 72 in even slots and 48, 72, 0, 24 in odd slots for 20 MHz bandwidth.

7.3.3.2 Additional rules for PCCH specific scheduling scheme

This scheme is applicable for Data transmission on logical channel PCCH mapped to DL-SCH, PDCCH scrambled by P-RNTI. For DCI combination 1, one physical resource block is reserved. For DCI combination 2, two physical resource blocks are reserved for 5 MHz bandwidth, and four physical resource blocks are reserved for 10 or 20 MHz bandwidth. The maximum modulation scheme is restricted to QPSK.

Following additional rules are applied for TBS selection:

- If the scheduled Data cannot fit into Max TBS, SS generates an error (it's a TTCN error). TTCN should gracefully exit the test case as a fatal error, assigning inconclusive verdict.
- Rules in clause 7.3.3.2.1 for DCI combination 1 and clause 7.3.3.2.2 for DCI combination 2 shall be applied.

7.3.3.2.1 PCCH with DCI combination 1

TS 36.213 [30], table 7.1.7.2.1-1, rows with $I_{TBS} = 0..26$ and columns with $N_{PRB} = 2$ (corresponding to TPC LSB = 0) and $N_{PRB} = 3$ (corresponding to TPC LSB = 1) $TBS \leq \text{Max TBS}$ are applicable.

The Max TBS is restricted to 120 (nearest value achievable for $I_{TBS} = 9$ and $N_{PRB} = 1$, as per table 7.1.7.2.1-1 of TS 36.213 [30]).

Distinct TBSs and all (TPC LSB, I_{TBS}) combinations for each distinct TBS are listed in the sheet.

If a TBS can have two (TPC LSB, I_{TBS}) combinations, the combination with TPC LSB = 0 is selected.

RIV indicates 1 PRBs with index 4 allocated.

7.3.3.2.2 PCCH with DCI combination 2

TS 36.213 [30], table 7.1.7.2.3-1, $I_{TBS} = 0..11$ for 5 MHz/ $I_{TBS} = 0..17$ for 10 or 20 MHz with $TBS \leq \text{Max TBS}$ are applicable.

The Max TBS is restricted to

- 296 bits (nearest value achievable for $I_{TBS} = 9$ and $N_{PRB} = 2$) for 5 MHz bandwidth,
- 600 bits (nearest value achievable for $I_{TBS} = 9$ and $N_{PRB} = 4$) for 10 or 20 MHz bandwidth.

RIV indicates either two virtual RBs with index 4 and 5 allocated, or four virtual RBs with index 4 to 7 allocated. These virtual RBs correspond to physical RBs:

- with index 1 and 7 in even slots and 13 and 19 in odd slots for 5 MHz bandwidth,
- with index 1, 13, 28, 40 in even slots and 28, 40, 1, 13 in odd slots for 10 MHz bandwidth,
- with index 1, 25, 49, 73 in even slots and 49, 73, 1, 25 in odd slots for 20 MHz bandwidth.

7.3.3.3 Additional rules for RAR specific scheduling scheme

This scheme is applicable for transmission of Random Access Response mapped to DL-SCH, PDCCH scrambled by RA-RNTI. For both DCI combinations four physical resource blocks are reserved. The maximum modulation scheme is restricted to QPSK.

Following additional rules are applied for TBS selection:

- The Max TBS is restricted to 600 bits (nearest value achievable for $I_{TBS} = 9$ and $N_{PRB} = 4$, as per table 7.1.7.2.1-1 of TS 36.213 [30]).
- If the scheduled Data cannot fit into Max TBS, SS generates an error (it's a TTCN error). TTCN should gracefully exit the test case as a fatal error, assigning inconclusive verdict.
- Rules in clause 7.3.3.3.1 for DCI combination 1 and clause 7.3.3.3.2 for DCI combination 2 shall be applied.

7.3.3.3.1 RAR with DCI combination 1

TS 36.213 [30], table 7.1.7.2.1-1, rows with $I_{TBS} = 0..26$ and columns with $N_{PRB} = 2$ (corresponding to TPC LSB = 0) and 3 (corresponding to TPC LSB = 1) $TBS \leq \text{Max TBS}$ are applicable

Distinct TBSs and all (TPC LSB, I_{TBS}) combinations for each distinct TBS are listed in the sheet.

If a TBS can have two (TPC LSB, I_{TBS}) combinations, the combination with TPC LSB = 0 is selected.

RIV indicates 4 PRBs with index 5..8 allocated.

7.3.3.3.2 RAR with DCI combination 2

TS 36.213 [30], table 7.1.7.2.3-1, $I_{TBS} = 0..17$ with $TBS \leq \text{Max TBS}$ are applicable.

RIV indicates 4 virtual RBs are allocated. These corresponds to physical RB

- with index 13, 19, 2, 8 in even slots and 1, 7, 14, 20 in odd slots for 5 MHz bandwidth,
- with index 2, 14, 29, 41 in even slots and 29, 41, 2, 14 in odd slots for 10 MHz bandwidth,
- with index 2, 26, 50, 74 in even slots and 50, 74, 2, 26 in odd slots for 20 MHz bandwidth.

7.3.3.4 Additional rules for UE-dedicated scheduling scheme in normal mode

The UE-dedicated DL scheduling can work in the normal mode or in the explicit mode. The two resource allocation schemes shall be reconfigurable from each other when the UE and SS are not sending and receiving data, for instance, at end of the test preamble and before the beginning of the test body.

The present clause is specified for the use of the normal mode. The explicit mode is referred to clause 7.3.3.6.

The scheme specified in the present clause is applicable for transmission of data dedicated to a UE in a DL subframe, mapped to DL-SCH, PDCCH scrambled by C-RNTI/ SPS C-RNTI/ Temp C-RNTI when spatial multiplexing MIMO mode is not configured. The maximum modulation scheme is restricted to 64QAM. For the DCI combination 1, 20 physical resource blocks (5 to 24), and for the DCI combination 2, 17 physical resource blocks are reserved. In the case when three intra frequency cells are applied to the test in the DCI combination 1, for the purpose of interference reduction, only 9 PRBs (16 to 24) are reserved.

In TDD normal TBS selection mode, no data is transmitted in DwPTS of the special subframe. For FDD, data can be transmitted in any subframe.

The following additional rules are applied for TBS selection:

- Multiple ASPs can also carry same explicit timing information; indicating different ASP payloads, eventually needs to be transmitted in 1 TTI.
- The Max TBS is restricted to 10296 bits (Max supported by UE category type 1).

For 5 MHz bandwidth and the DCI combination 1 with 20 PRBs or DCI combination 2, the TBS 8248, 8760, and 9528 are blocked as they result in coding rates higher than 0.93.

For 5 MHz bandwidth and special DCI combination 1 with 9 PRBs, the TBS 2216, 5992 and 6712 are blocked as they result in coding rates higher than 0.93.

For 10 and 20 MHz bandwidths none of TBSs are blocked as no TBS combination result in coding rates higher than 0.93.

The blocked TBS are considered to be not available for selection.

- Data pending for transmission in a given sub-frame consists of (listed in transmission priority order):
 - MAC Control Elements that the SS needs to send.
 - AMD STATUS PDU(s) that the SS needs to send.
 - Data not sent in previous subframe(s).
 - Fresh Data scheduled for transmission in this subframe for all logical channels.
- Distinct TBSs and all $(N_{\text{PRB}}, I_{\text{TBS}})$ combinations for each distinct TBS are listed in the sheet.
- If a TBS size can be achieved with more than one combination of $I_{\text{MCS}}(I_{\text{TBS}})$ and N_{PRB} :
 - Select combination with lowest delta between N_{PRB} and I_{MCS} .
 - If still more than one combination remain, select combination with highest N_{PRB} .
- Not more than one RLC Data PDU shall be placed in a MAC PDU per logical channel (i.e. minimize RLC segmentation).
- In a subframe, in case there is data pending for transmission from more than one logical channel, for each type of data pending for transmission as defined above, priority shall be given to the logical channel with the lowest logical channel priority value. In case of more than one logical channel with the same logical channel priority value, these logical channels should be served equally. Data pending for transmission from more than one logical channel will rarely happen for the signalling and protocol test.
- Data not transmitted within a subframe is scheduled as pending for transmission in the next available subframe according to the priorities given above. Pending data for transmission will rarely happen for the signalling and protocol test.
- TBS selected in a context by various platforms shall be within an allowed deterministic tolerance of:
 - 2 bytes for potential Timing Advance Command MAC Control Element (1 byte data + 1 byte MAC sub header).
 - 4 bytes each for AMD STATUS PDU (2 bytes data + 2 bytes MAC subheader).
 - Therefore in the worst case the SS may add up to $(2 + 4 \times N_{\text{AMRB}})$ bytes to the data scheduled for transmission in a certain subframe, where N_{AMRB} is the number of AM radio bearers (SRB or DRB) actively sending DL data in the test, in any subframe.
- For DCI combination 1 RIV is calculated based on physical resource blocks corresponding to N_{PRB} of the selected TBS and $(N_{\text{PRB}}, I_{\text{TBS}})$ combination. The physical resource blocks that can be allocated are the first N_{PRB} resources of index range

- 5..24 for 5 MHz bandwidth,
- 28..49 for 10 MHz bandwidth,
- 9..30 for 20 MHz bandwidth.

- For DCI combination 2, RBG assignment is calculated based on physical resource blocks corresponding to N_{PRB} of the selected TBS and (N_{PRB}, I_{TBS}) combination. The size of RBG is 2 for 5 MHz, 3 for 10 MHz and 4 for 20 MHz. The available physical resource blocks for allocation are:

For 5 MHz bandwidth, RBG1(2,3), RBG2(4,5), RBG4(8,9), RBG5(10,11), RBG7(14,15), RBG8(16,17), RBG10(20,21), RBG11(22,23) and RBG12(24). If N_{PRB} is even, the first $N_{PRB} / 2$ available RBGs are allocated. If N_{PRB} is odd, then first $(N_{PRB} - 1) / 2$ RBGs and RBG 12 are allocated.

For 10 MHz bandwidth, RBG1(3,4,5), RBG2(6,7,8), RBG3(9,10,11), RBG5(15,16,17), RBG6(18,19,20), RBG10(30,31,32), RBG11(33,34,35), RBG12(36,37,38) and RBG16(48,49). If $N_{PRB} \bmod 3$ is 0, the first $N_{PRB} / 3$ RBGs are allocated. If mod 3 is 2, then first $(N_{PRB} - 2) / 3$ available RBGs and RBG 16 are allocated.

For 20 MHz bandwidth, RBG1(4,5,6,7), RBG2(8,9,10,11), RBG3(12,13,14,15), RBG4(16,17,18,19), RBG5(20,21,22,23), RBG7(28,29,30,31), RBG8(32,33,34,35), RBG9(36,37,38,39), RBG10(40,41,42,43), RBG14(56,57,58,59), RBG15(60,61,62,63), RBG16(64,65,66,67), RBG17(68,69,70,71), RBG19(76,77,78,79) and RBG20(80,81,82,83). The first $N_{PRB} / 4$ RBGs are allocated.

7.3.3.5 DL Resource allocation bitmaps

7.3.3.5.1 DCI combination 1

Table 7.3.3.5.1-1: Physical resource allocation bitmap for DCI combination 1 (5 MHz) with 20 PRBs

N_{PRB}	0	1	2	3	4	5	6	7	8	9	10	11	12	13	14	15	16	17	18	19	20	21	22	23	24
BCCH																									
PCCH																									
RAR																									
UE-Dedicated																									

Table 7.3.3.5.1-2: Physical resource allocation bitmap for DCI combination 1 (5 MHz) with 9 PRBs

N_{PRB}	0	1	2	3	4	5	6	7	8	9	10	11	12	13	14	15	16	17	18	19	20	21	22	23	24
BCCH																									
PCCH																									
RAR																									
UE-Dedicated																									

Table 7.3.3.5.1-3 (columns 0–34): Physical resource allocation bitmap for DCI combination 1 (10 MHz)

N_{PRB}	0	1	2	3	4	5	6	7	8	9..22	23..27	28	29	30	31	32	33	34
BCCH										Not Used								
PCCH											Used for PBCH and other common signals							
RAR																		
UE-Specific																		

Table 7.3.3.5.1-3 (columns 35–49): Physical resource allocation bitmap for DCI combination 1 (10 MHz)

N_{PRB}	35	36	37	38	39	40	41	42	43	44	45	46	47	48	49
BCCH															
PCCH															
RAR															
UE-Specific															

Table 7.3.3.5.1-4 (columns 0–20): Physical resource allocation bitmap for DCI combination 1 (20 MHz)

N_{PRB}	0	1	2	3	4	5	6	7	8	9	10	11	12	13	14	15	16	17	18	19	20
BCCH	1	1	1	1																	
PCCH					1																
RAR						1	1	1	1												
UE-Specific										1	1	1	1	1	1	1	1	1	1	1	1

Table 7.3.3.5.1-4 (columns 21–30): Physical resource allocation bitmap for DCI combination 1 (20 MHz)

N_{PRB}	21	22	23	24	25	26	27	28	29	30	31..46	47..52	53..99
BCCH											Not Used	Used for PBCH and other common signals	Not Used
PCCH													
RAR													
UE-Specific	1	1	1	1	1	1	1	1	1				

7.3.3.5.2 DCI combination 2

Table 7.3.3.5.2-1: Physical resource allocation bitmap for DCI combination 2 (5 MHz)

N_{PRB}	0	1	2	3	4	5	6	7	8	9	10	11	12	13	14	15	16	17	18	19	20	21	22	23	24
BCCH-Even	0					1						2						3							
BCCH-Odd	2					3						0						1							
PCCH-Even		4						5																	
PCCH-Odd													4								5				
RAR-Even			8						9				6								7				
RAR-Odd		6						7							8							9			
UE-Dedicated			1	1	1	1		1	1	1	1			1	1	1	1				1	1	1	1	

Table 7.3.3.5.2-2 (columns 0-20): Physical resource allocation bitmap for DCI combination 2 (10 MHz)

N_{PRB}	0	1	2	3	4	5	6	7	8	9	10	11	12	13	14	15	16	17	18	19	20
BCCH-Even	0												1								
BCCH-Odd	2												3								
PCCH-Even			4												5						
PCCH-Odd			6												7						
RAR-Even					8												9				
RAR-Odd					10												11				
UE-Specific	x	x													x	x					
RBGs		0				1			2			3			4		5			6	

Table 7.3.3.5.2-2 (columns 21-41): Physical resource allocation bitmap for DCI combination 2 (10 MHz)

N_{PRB}	21	22	23	24	25	26	27	28	29	30	31	32	33	34	35	36	37	38	39	40	41
BCCH-Even							2												3		
BCCH-Odd							0												1		
PCCH-Even										6											7
PCCH-Odd										4											5
RAR-Even											10										11
RAR-Odd											8										9
UE-Specific		x	x	x	x	x	x	x											x	x	
RBGs		7				8			9			10			11						13

Table 7.3.3.5.2-2 (columns 42-49): Physical resource allocation bitmap for DCI combination 2 (10 MHz)

N_{PRB}	42	43	44	45	46	47	48	49
BCCH-Even					Not Used			
BCCH-Odd								
PCCH-Even								
PCCH-Odd								
RAR-Even								
RAR-Odd								
UE-Specific								
RBG's	14			15			16	

Table 7.3.3.5.2-3 (columns 0-19): Physical resource allocation bitmap for DCI combination 2 (20 MHz)

N_{PRB}	0	1	2	3	4	5	6	7	8	9	10	11	12	13	14	15	16	17	18	19
BCCH-Even	0																			
BCCH-Odd	2																			
PCCH-Even		4																		
PCCH-Odd		6																		
RAR-Even			8																	
RAR-Odd			10																	
UE-Specific	x	x																		
RBG's	0			1			2			3			4							

Table 7.3.3.5.2-3 (columns 20-39): Physical resource allocation bitmap for DCI combination 2 (20 MHz)

N_{PRB}	20	21	22	23	24	25	26	27	28	29	30	31	32	33	34	35	36	37	38	39
BCCH-Even					1															
BCCH-Odd					3															
PCCH-Even						5														
PCCH-Odd						7														
RAR-Even							9													
RAR-Odd								11												
UE-Specific					x	x														
RBG's	5				6				7				8				9			

Table 7.3.3.5.2-3 (columns 40-59): Physical resource allocation bitmap for DCI combination 2 (20 MHz)

N_{PRB}	40	41	42	43	44	45	46	47	48	49	50	51	52	53	54	55	56	57	58	59
BCCH-Even									2											
BCCH-Odd									0											
PCCH-Even										6										
PCCH-Odd										4										
RAR-Even											10									
RAR-Odd											8									
UE-Specific									x	x	x									
RBG's	10				11				12				13				14			

Table 7.3.3.5.2-3 (columns 60-79): Physical resource allocation bitmap for DCI combination 2 (20 MHz)

N_{PRB}	60	61	62	63	64	65	66	67	68	69	70	71	72	73	74	75	76	77	78	79
BCCH-Even													3							
BCCH-Odd													1							
PCCH-Even														7						
PCCH-Odd														5						
RAR-Even																11				
RAR-Odd																9				
UE-Specific													x	x						
RBGs	15			16			17			18			19							

Table 7.3.3.5.2-3 (columns 80-99): Physical resource allocation bitmap for DCI combination 2 (20 MHz)

N_{PRB}	80	81	82	83	84	85	86	87	88	89	90	91	92	93	94	95	96	97	98	99
BCCH-Even																	Not Used			
BCCH-Odd																				
PCCH-Even																				
PCCH-Odd																				
RAR-Even																				
RAR-Odd																				
UE-Specific																				
RBGs	20			21			22			23			24							

NOTE: Odd and even refer to slots.

7.3.3.6 UE-dedicated scheduling scheme in explicit mode

This scheme applies to MIMO configurations or to non-MIMO configuration where the normal mode scheduling scheme is inappropriate.

SS is configured with an exact TBS (modulation and coding scheme, I_{mcs} , and number of resource blocks, N_{prb}) to use.

Other parameters, such as the HARQ process number and redundancy version to use for each transmission, are also configured by the TTCN.

All data scheduled for a certain subframe shall be transmitted in the single indicated subframe, using configured parameters. The TTCN shall ensure that the configured parameters are consistent, in particular that the scheduled data size and the configured TBS match each other. Data scheduled by the prose, and hence also by the TTCN, provides possible space for the Timing Advance MAC control element and the RLC Status PDU. The SS shall include one of these if so triggered, else the bits reserved for these are filled by MAC padding.

Additionally, in the case of MIMO data scheduled for transmission in a given sub-frame, this consists of (listed in transmission priority order):

- MAC Control Elements that the SS needs to send (if triggered)
- AMD STATUS PDU(s) that the SS needs to send (if triggered)
- Fresh data scheduled for transmission in this subframe for one or more logical channels, as per logical channel priority [lower value = higher priority]; if data is available for more than one logical channel with the same priority, then the logical channel corresponding to the DRB-ID with the lower value has the higher priority
- MAC padding

The following additional rules need to be applied on data scheduled for transmission to be mapped on two transport blocks corresponding to two code words:

- Higher priority data (as stated above) maps on to Transport Block 1 and lower priority data maps on Transport Block 2 (if Transport Block 1 gets full); and

- Minimum MAC padding is performed in Transport Block 1; and
- If data from one logical channel needs to be mapped on to two transport blocks, the PDCP PDUs with lower PDCP sequence numbers get mapped on to Transport Block 1.

7.3.3.6.1 DL Scheduling in Transport Block Size Selection Test Cases

The MAC transport block size selection test cases defined in clause 7.1.7 of 36.523-1 [1], use bandwidths of 10/15/20MHz. For the preamble and postamble in these tests, the default scheduling rules defined in clauses 7.3.3.1 to 7.3.3.4 for 10/10/20 MHz and DCI combination 1A are applied respectively. During the test body, when the actual TB sizes with appropriate DCI and resource allocation formats needed are to be tested, the SS is configured in explicit mode for UE-dedicated scheduling.

7.3.3.7 Resource allocation sheets

Attached with this Technical Specification, the DL resource allocation tables can be found, providing physical resource allocations for various transport block sizes, developed as per rules specified in clause 7.3.3, in Microsoft Excel format. Each individual sheet in the workbook represents various scheduling schemes as per table 7.3.3.7-1.

Table 7.3.3.7-1: DL resource allocation sheets

S. No	Sheet Name	Description
1	DCI-1A-PCCH	DL Resource scheduling for DCI format 1A and PDCCH is scrambled by P-RNTI (5, 10 & 20 MHz)
2	DCI-1A-BCCH	DL Resource scheduling for DCI format 1A and PDCCH is scrambled by SI-RNTI (5, 10 & 20 MHz)
3	DCI-1A-RAR	DL Resource scheduling for DCI format 1A and PDCCH is scrambled by RA-RNTI (5, 10 & 20 MHz)
4	DCI-1A-UE-Specific	DL Resource scheduling for DCI format 1A and PDCCH is scrambled by C-RNTI/ SPS C-RNTI/ Temp C-RNTI (5 MHz)
5	DCI-1A-3-IntraFreq-UE-Specific	DL Resource scheduling for DCI format 1A and PDCCH is scrambled by C-RNTI/ SPS C-RNTI/ Temp C-RNTI and three Intra Freq cells are configured (5 MHz)
6	DCI-1A-UE-Specific-10MHz	DL Resource scheduling for DCI format 1A and PDCCH is scrambled by C-RNTI/ SPS C-RNTI/ Temp C-RNTI (10 MHz)
7	DCI-1A-UE-Specific-20MHz	DL Resource scheduling for DCI format 1A and PDCCH is scrambled by C-RNTI/ SPS C-RNTI/ Temp C-RNTI (20 MHz)
8	DCI-1C-PCCH	DL Resource scheduling for DCI format 1C and PDCCH is scrambled by P-RNTI (5 MHz)
9	DCI-1C-BCCH	DL Resource scheduling for DCI format 1C and PDCCH is scrambled by SI-RNTI (5 MHz)
10	DCI-1C-RAR	DL Resource scheduling for DCI format 1C and PDCCH is scrambled by RA-RNTI (5 MHz)
11	DCI-1-UE-Specific	DL Resource scheduling for DCI format 1, Resource allocation 0 and PDCCH is scrambled by C-RNTI/ SPS C-RNTI/ Temp C-RNTI (5 MHz)
12	DCI-1C-PCCH-10MHz-Gap1	DL Resource scheduling for DCI format 1C and PDCCH is scrambled by P-RNTI (10 MHz)
13	DCI-1C-BCCH-10MHz-Gap1	DL Resource scheduling for DCI format 1C and PDCCH is scrambled by SI-RNTI (10 MHz)
14	DCI-1C-RAR-10MHz-Gap1	DL Resource scheduling for DCI format 1C and PDCCH is scrambled by RA-RNTI (10 MHz)
15	DCI-1-UE-Specific-10MHz-Gap1	DL Resource scheduling for DCI format 1, Resource allocation 0 and PDCCH is scrambled by C-RNTI/ SPS C-RNTI/ Temp C-RNTI (10 MHz)
16	DCI-1C-PCCH-20MHz-Gap1	DL Resource scheduling for DCI format 1C and PDCCH is scrambled by P-RNTI (20 MHz)
17	DCI-1C-BCCH-20MHz-Gap1	DL Resource scheduling for DCI format 1C and PDCCH is scrambled by SI-RNTI (20 MHz)
18	DCI-1C-RAR-20MHz-Gap1	DL Resource scheduling for DCI format 1C and PDCCH is scrambled by RA-RNTI (20 MHz)
19	DCI-1-UE-Specific-20MHz-Gap1	DL Resource scheduling for DCI format 1, Resource allocation 0 and PDCCH is scrambled by C-RNTI/ SPS C-RNTI/ Temp C-RNTI (20 MHz)
20	MAC-TBS-DCI-1-RA0	DL Resource scheduling for DCI format 1, Resource allocation 0 and PDCCH is scrambled by C-RNTI
21	MAC-TBS-DCI-1-RA1	DL Resource scheduling for DCI format 1, Resource allocation 1 and PDCCH is scrambled by C-RNTI
22	MAC-TBS-DCI1A	DL Resource scheduling for DCI format 1A, Resource allocation 2(localised & distributed) and PDCCH is scrambled by C-RNTI

7.4 Cell Configurations

7.4.1 Cell Configuration Types

Three cell configurations are defined in 3GPP TS 36.508 [3] clause 6.3.3: Full Cell, Minimum Uplink Cell and Broadcast Only Cell; however the TTCN always considers all cells as Full Cells, and thus always provides the complete cell configuration parameters.

The SS may:

- always configure a cell as a 'Full Cell' based on the complete information; or
- configure the cell based on the 'CellConfig_Type' flag taking only the required configuration parameters and ignoring the others.

For a given value of the 'CellConfig_Type' flag, the TTCN shall:

- For Full Cell Configuration:
 - expect normal SS behaviour.
- For Minimum Uplink Cell Configuration:
 - Configure the SS to report Preamble detection.
 - Assign verdicts based on the PRACH Preamble Indications.
 - Consume any uplink SRB0 messages (if the SS is configured as a Full Cell).
- For Broadcast Only Cell Configuration:
 - Not configure the SS to report Preamble detection.
 - Consume any uplink SRB0 messages (if the SS is configured as a Full Cell).

7.4.2 Cell Power Change

To set and adjust the cell power at the two test ports, Reference Power and Attenuation, are provided in the record Reference Power.

The field Reference Power is only set when the cell is created and is not updated during the test case execution. The SS applies the Reference Power when the cell is fully configured.

To adjust the power level in the test case, the field Attenuation is used. After initial configuration of a cell the attenuation corresponds to the value "off". When the power is changed for more than one cell, the power changes must happen at the same time for all the cells according to the time instances for power level changes specified in TS 36.523-1 [1]. The time it takes to complete the power change for all the cells shall be done:

- within a maximum of 700 ms when changing the power of a cell from "off" to a certain value, or
- within a maximum of 100 ms (10 frames) otherwise.

When adjusting the power level in the test case, separate templates will be used in order to improve code readability.

The SS shall ensure the power level at the test ports conform to the required downlink signal levels specified in clause 6.2.2.1 of TS 36.508 [3].

7.4.3 E-UTRAN cell identity

7.4.3.1 Timing parameters of cells

For RRC and Idle mode test, the timing parameters in table 7.4.3.1-1 are applied. The specification of Cell 1 - Cell 23 can be found in TS 36.508 [3].

Table 7.4.3.1-1: Timing parameters of simulated cells

cell ID	SFN offset	FDD Tcell (Ts)	TDD Tcell (Ts)
Cell 1	0	0	0
Cell 2	124	30720	155792
Cell 3	257	150897	0
Cell 4	1000	61440	157984
Cell 6	657	524	0
Cell 10	129	43658	0
Cell 11	957	92160	155792
Cell 12	1015	181617	155792
Cell 13	890	31244	155792
Cell 14	680	300501	0
Cell 23	383	212337	155792

Table 7.4.3.1-2 is applied to the NAS test when more than one PLMN exists in a test case. Further cell parameters can be found in table 7.4.4-1.

Table 7.4.3.1-2: Timing parameters of simulated cells for NAS TCs in different PLMNs

cell ID	SFN offset	FDD Tcell (Ts)	TDD Tcell (Ts)
Cell A	0	0	0
Cell B	124	30720	155792
Cell C	257	61440	157984
Cell D	1000	92160	155792
Cell E	752	32047	0
Cell F	NA	NA	NA
Cell G	957	631	0
Cell H	1015	31351	155792
Cell I	890	127200	0
Cell J	680	1327	0
Cell K	383	157920	155792
Cell L	562	188640	157984
Cell M	471	122880	157984

Figure 7.4.3.1-1 illustrates shifting DL transmission timing offset by Tcell = 1 subframe, between multiple NAS FDD cells on the same frequency (table 7.4.3.1-2) in the same PLMN.

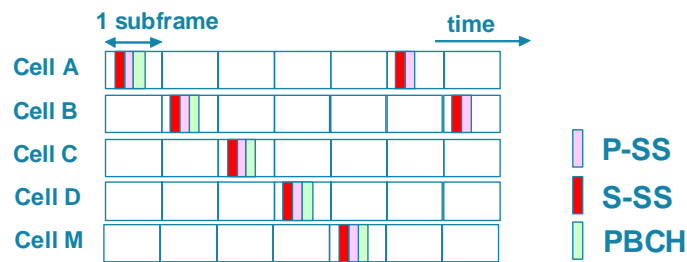

Figure 7.4.3.1-1: Timing offset between FDD cells on the same frequency

Figure 7.4.3.1-2 illustrates shifting DL transmission timing offset for three TDD cells operated on the same frequency (table 7.4.3.1-1) in the same PLMN.

Timing shift between Cell 0 and Cell 1: Tcell = 5 subframes + 2192 Ts

Timing shift between Cell 0 and Cell 2: Tcell = 5 subframes + 4384 Ts

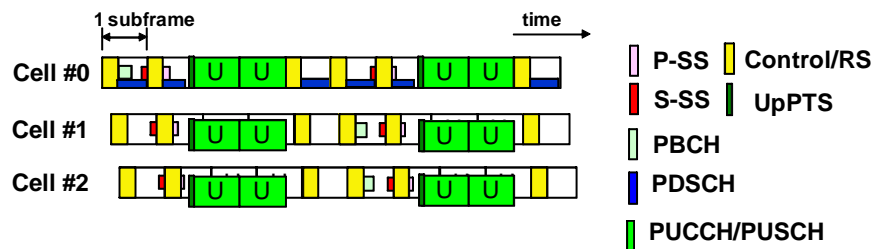

Figure 7.4.3.1-2: Timing offset between TDD cells on the same frequency

Table 7.4.3.1-3 is applied to the NAS test when all NAS cells in a test case belong to the same PLMN. Further cell parameters can be found in table 7.4.4-2.

Table 7.4.3.1-3: Timing parameters of simulated cells for NAS TCs in same PLMN

cell ID	SFN offset	FDD Tcell (Ts)	TDD Tcell (Ts)
Cell A	0	0	0
Cell B	124	30720	155792
Cell C	257	150897	0
Cell D	1000	61440	157984
Cell E	NA	NA	NA
Cell F	NA	NA	NA
Cell G	NA	NA	NA
Cell H	NA	NA	NA
Cell I	NA	NA	NA
Cell J	NA	NA	NA
Cell K	NA	NA	NA
Cell L	NA	NA	NA
Cell M	471	31244	155792

Shifting radio frame transmission timing can eliminate the following interference between intra frequency cells:

- P-SS/S-SS to P-SS/S-SS, RS, PBCH, PCFICH, PDCCH and PHICH.
- PBCH to PBCH.
- PBCH to PCFICH, PDCCH and PHICH.
- PDSCH to PCFICH, PDCCH, PHICH.

As TDD UL and DL are on same frequency, to avoid interference between DL and UL, the Random Access Response Timing Advance (RAR TA) is related to the Tcell:

$RAR\ TA = [T_{cell} - [30720 * 5]] / 16$ where $30720 * 5$ is time period of a 5 sub frames in Ts
For example for cell 2, $RAR\ TA = [155792 - 153600] / 16 = 137$

NOTE: TDD default combination periodicity is 5 sub frames; sub frame 6 in cell 1 can correspond to SF $6+5 \bmod 10 = SF 1$ in cell 2.

For FDD, the Random Access Response Timing Advance is set to 0.

7.4.4 Cell configurations for NAS test cases

The default cell identifiers for NAS cells are defined in 36.508[3] clause 6.3.2.2.

The allocation of Physical layer cell identifiers to the individual cells is according to (*PCI mode 6*) being differential for the cells working on the same radio frequency. The way of PCI allocation can reduce the interference between the intra-frequency cells for reference signal to reference signal, PCFICH to PCFICH and PHICH to PHICH. The definition of Cell A - Cell M can be found in TS 36.508 [3].

7.4.5 Configuration of Multi-Cell Environment

When there is more than one EUTRA cell in a test case the following rules are applied in TTCN:

- At the beginning of the preamble, before initial attachment of the UE, all EUTRA cells are configured but switched off.
- In the preamble only the serving cell is switched on; all other cells remain switched off.
- At the end of the preamble the cells are configured according to the initial power level settings (T0) of the test case.

The mapping of cells to physical resources and management of the physical resources are out of TTCN scope. The following principles can be applied to the system simulator:

- Cells being switched off need not to be mapped to physical resources.

- When a cell is switched off mapping to a physical resource may be kept and reused when the cell is switched on again.
- When a cell is switched on it can either already been mapped to a physical resource or it needs to be mapped to a free resource.
- When there are less physical resources than cells it is up to SS implementation to find strategies to dynamically map the cells to the resources.

Independent from the strategies being used the system simulator shall obey timing restrictions for changing power-levels of one or several cells as stated in clause 7.4.2.

7.5 TDD Considerations

LTE options of FDD and TDD will be contained in the same common FDD and TDD test cases, similar to the prose in TS 36.523-1 [1].

The TDD Uplink-downlink configuration 1 in 3GPP TS 36.211 [35], Table 4.2-2 is applied.

7.5.1 FDD vs. TDD implementation

FDD/TDD differences are introduced in the common FDD and TDD test cases using branches at a low level in the test case. The branches are used either:

- to assign a variable;
- to implement a different behaviour;
- to change an FDD or TDD parameter in a template sent to the UE or SS.

The mode under test (FDD or TDD) is based on the value of the bands under test.

7.6 Special RLC Modes

7.6.1 Suppression of RLC Acknowledgements

Two different modes, both applicable per radio bearer, are defined as:

- General suppression:
 - If this mode is activated, no RLC acknowledgements will be generated by the SS. This mode can be switched on and will persist until it is switched off. Afterwards the SS will continue handling the RLC acknowledgements as normal.
- One time suppression
 - If this mode is activated, no RLC acknowledgement will be generated by SS for the next RLC message data PDU received. Once this has been done, the SS continues handling RLC acknowledgements as normal.

In case of a handover the modes continue to be active.

7.6.2 Modification of VT(S)

This mode allows to manipulate the RLC state variable VT(S) so that the SS can generate an RLC sequence number as needed during a test. The input to the special test mode is an integer (0..1023) as value of ModifyVTS, The SS shall set variable VT(S) as follows:

VT(S):= ModifyVTS.

The purpose of this special test mode is to force an incorrect RLC sequence number to be used by the SS. Once VT(S) has been modified in the RLC entity at the SS side, this RLC entity will be inconsistent. One possibility to bring the

RLC entity back to normal is to re-establish the RLC peer connection. This is done in the only use case of this special RLC test mode by performing an RRC Connection reconfiguration immediately after the test mode has been applied.

Users of this test mode should ensure that the RLC AM PDU carrying the incorrect sequence number will reach the peer RLC entity. It is therefore recommended to activate the RRC Connection reconfiguration only after some delay. This delay shall be short enough to ensure that the UE will not yet request the retransmission of the RLC PDU corresponding to the skipped sequence numbers.

7.7 System information

7.7.1 System information broadcasting

The rules for the transmission of BCCH messages are specified in 3GPP TS 36.331 [19], clause 5.2. The current clause provides the implementation guidelines.

The ASPs SYSTEM_CTRL_REQ and SYSTEM_CTRL_CNF are used as interface to SS; the following rules apply:

- The complete system information is provided to SS by using a single ASP.
- SS starts scheduling all system information from the same SFN.
- The scheduling information sent to SS is the same as the scheduling information sent to the UE. For each SI message, the subframeOffset in SYSTEM_CTRL_REQ indicates the exact point in time in the SI window at which SS shall start the transmission of the related SI.
- SS shall set the systemFrameNumber in the MIB to the 8 most significant bits of the SFN. A dummy value is provided by TTCN.
- The system information is sent to SS using the asn.1 types, SS shall encode in unaligned PER and add the necessary padding bits as specified in TS 36.331 [19] clause 9.1.1.1.
- In the E-UTRAN-CDMA2000 Inter RAT configuration, SS shall set the CDMA2000 synchronousSystemTime in SystemInformationBlockType8 to the SFN boundary at or after the ending boundary of the SI-window in which SystemInformationBlockType8 is transmitted (see TS 36.331[19] clause 6.3.4). The changes of synchronousSystemTime will not result in system information change notification, nor in a modification of systemInfoValueTag in SIB1 in TTCN as specified in TS 36.331[19] clause 6.3.1.

7.7.2 Scheduling information

The maximum number of resource blocks as defined in table 7.7.2-1 are used to broadcast the system information.

Table 7.7.2-1: Maximum number of resource blocks

	Maximum number of resource blocks assigned
SIB1	4
for all SIs	4

The subframe offset values used for SI messages are according to table 7.7.2-2.

Table 7.7.2-2: SubframeOffset values

Scheduling Information No. Acc to TS 36.508 [3], clause 4.4.3.1.2	subframeOffset (FDD)	subframeOffset (TDD)
SI1	1	4
SI2	1	4
SI3	3	9
SI4	7	9

All System Information messages are sent only once within the SI-window.

Table 7.7.2-3 (FDD) and 7.7.2-4(TDD) give the SFN's and subframe numbers in which the MIB, SI1, SI2, SI3 & SI4 are actually scheduled as per default parameters for si-WindowLength(20sf), periodicity for SI1(16), SI2(32), SI3(64) and SI4(64) for bandwidths 5/10/15/20 MHz defined in 36.508 [3]:

Table 7.7.2-3: System Information Scheduling (FDD)

SFN\SUBFrame	0	1	2	3	4	5	6	7	8	9
0	MIB	SI1				SIB1				
1	MIB									
2	MIB	SI2				SIB1				
3	MIB									
4	MIB			SI3		SIB1				
5	MIB									
6	MIB					SIB1		SI4		
7	MIB									
8	MIB					SIB1				
9	MIB									
10	MIB					SIB1				
11	MIB									
12	MIB					SIB1				
13	MIB									
14	MIB					SIB1				
15	MIB									
16	MIB	SI1				SIB1				
17	MIB									
18	MIB					SIB1				
19	MIB									
20	MIB					SIB1				
21	MIB									
22	MIB					SIB1				
23	MIB									
24	MIB					SIB1				
25	MIB									
26	MIB					SIB1				
27	MIB									
28	MIB					SIB1				
29	MIB									
30	MIB					SIB1				
31	MIB									
32	MIB	SI1				SIB1				
33	MIB									
34	MIB	SI2				SIB1				
35	MIB									
36	MIB					SIB1				
37	MIB									
38	MIB					SIB1				
39	MIB									
40	MIB					SIB1				
41	MIB									
42	MIB					SIB1				
43	MIB									
44	MIB					SIB1				
45	MIB									
46	MIB					SIB1				
47	MIB									
48	MIB	SI1				SIB1				
49	MIB									
50	MIB					SIB1				

51	MIB									
52	MIB					SIB1				
53	MIB									
54	MIB					SIB1				
55	MIB									
56	MIB					SIB1				
57	MIB									
58	MIB					SIB1				
59	MIB									
60	MIB					SIB1				
61	MIB									
62	MIB					SIB1				
63	MIB									
64	MIB	SI1				SIB1				
65	MIB									
66	MIB	SI2				SIB1				
67	MIB									
68	MIB			SI3		SIB1				
69	MIB									
70	MIB					SIB1		SI4		
71	MIB									
72	MIB					SIB1				

Table 7.7.2-4: System Information Scheduling (TDD)

SFN/SUBFrame	0	1	2	3	4	5	6	7	8	9
0	MIB				SI1	SIB1				
1	MIB									
2	MIB				SI2	SIB1				
3	MIB									
4	MIB					SIB1				SI3
5	MIB									
6	MIB					SIB1				
7	MIB									SI4
8	MIB					SIB1				
9	MIB									
10	MIB					SIB1				
11	MIB									
12	MIB					SIB1				
13	MIB									
14	MIB					SIB1				
15	MIB									
16	MIB				SI1	SIB1				
17	MIB									
18	MIB					SIB1				
19	MIB									
20	MIB					SIB1				
21	MIB									
22	MIB					SIB1				
23	MIB									
24	MIB					SIB1				
25	MIB									
26	MIB					SIB1				
27	MIB									
28	MIB					SIB1				
29	MIB									
30	MIB					SIB1				
31	MIB									
32	MIB				SI1	SIB1				
33	MIB									
34	MIB				SI2	SIB1				
35	MIB									
36	MIB					SIB1				
37	MIB									
38	MIB					SIB1				
39	MIB									
40	MIB					SIB1				
41	MIB									
42	MIB					SIB1				
43	MIB									
44	MIB					SIB1				
45	MIB									
46	MIB					SIB1				
47	MIB									
48	MIB				SI1	SIB1				
49	MIB									
50	MIB					SIB1				

51	MIB									
52	MIB					SIB1				
53	MIB									
54	MIB					SIB1				
55	MIB									
56	MIB					SIB1				
57	MIB									
58	MIB					SIB1				
59	MIB									
60	MIB					SIB1				
61	MIB									
62	MIB					SIB1				
63	MIB									
64	MIB				SI1	SIB1				
65	MIB									
66	MIB				SI2	SIB1				
67	MIB									
68	MIB					SIB1				SI3
69	MIB									
70	MIB					SIB1				
71	MIB									SI4
72	MIB					SIB1				

7.7.3 System information modification

For system information modification, the same rules as defined in clause 7.7.1 are applied.

The SFN for the start of modification period is calculated by TTCN. The modified system information and the calculated SFN are provided in the ASP SYSTEM_CTRL_REQ.

7.8 Timers and Timing Restrictions

A timer is set at the beginning of each test case to guard against system failure. Behaviour on expiry of this guard timer shall be consistent for all test cases.

A watchdog timer can be specified for receive statements in order to reduce blocking time when a test case has already failed. Watchdog timers are a kind of TTCN auxiliary timer. When a watchdog timer is used to control a receive event, its expiry does not need to be handled explicitly in the test case, but will lead to a fail or inconclusive verdict due to handling in the default behaviour

In idle mode operations, an idle mode generic timer is specified for receive statements if the test case specification does not explicitly specify a wait time for the specific test step or test purpose. The expiry of this idle mode generic timer is at least 6 minutes to safely cover most test scenarios.

The watchdog timer and the idle mode generic timer are only to be used inside the test case test body; if the timer expires a fail verdict is applied.

It is the TTCN responsibility to ensure that appropriate timer values are being used.

Tolerances (as described in TS 36.508 [3]) are not applicable to guard timers, idle mode generic timers and watchdog timers.

In general timers of less than 500ms shall not be implemented by TTCN timers but controlled by usage of the timing information provided by the SS (This is based on an estimate of the system delay). To achieve this, there will be cases when a DL message is scheduled at a specific point in time. This shall be done by adding at least 100ms to the current time.

If Timing is 'now' the SS shall schedule the data transmission or the (re)configuration in the next available sub-frame, but will ensure that this period is less than 80ms.

7.8.1 Auxiliary timers

For practical reasons, the TTCN can include timers that are not specified as part of the expected sequence. These timers are documented below.

RLC and PDCP watchdog timer

7.8.2 RRC timers reconfiguration

Considering the allowed UE accuracy for the RRC timer T3xx being between 100ms and 2.5% of T3xx (Ref. TS.36.133[37]), the TTCN applies the RRC net timers tolerance as MAX (10% of T3xx, (100 ms + 5 RTT)), whereby:

FDD: 10% of T3xx or 140 ms whichever is higher

TDD: 10% of T3xx or 155 ms whichever is higher

7.8.3 MAC TA timer reconfiguration

Considering that the UE applies new values for MAC timers not before restart of the timer (Ref. TS 36.321 [16] clause 5.8), when the TA timer is changed at the UE, a delay in TTCN will be added so as to allow SS to transmit Timing advance MCE (based on current periodic Timing advance configuration) and hence resulting in restart of TA timer at UE with new value.

7.9 Error Indication

There are several situations on lower layer in which SS shall raise an error rather than trying to resolve the problem. This is done by sending a SystemIndication.Error to the test case. SS shall raise an error in the following cases:

- HARQ retransmissions (applicable when SS is configured to indicate HARQ retransmissions as errors)
 - HARQ CRC error for UL data
 - HARQ NACK from the UE unless SS is configured to report HARQ ACK/NACK
- Paging, System information exceeds max. number of resource blocks.
- Configuration: max. number of resource blocks specified for a channel exceeds system bandwidth.
- When in User-Plane a DL PDCP PDU or SDU not fitting into one TTI is sent with Harq Process being explicitly specified
- SS gets invalid TimingInfo for TDD from the test case
- SS detects contradiction of periodic UL grants and TDD configuration
- Data scheduled for the same TTI does not fit into an available transport block

Further error conditions are specified in annex D.

7.10 Race Conditions

When two uplink messages are sent from the UE within a very small amount of time, they may be received in either order in the TTCN if they are received on different ports. This may cause a race condition which is due to the snapshot mechanism in TTCN. In these cases, the TTCN will accept the messages in either order and then compare the timestamps of both messages to ensure they were sent in the correct order.

For UL messages received at a single port, there are normally no race conditions, with the exception of the SRB port where the following rules shall be fulfilled, in order to achieve an ordered UL message queue:

- UL messages are queued according to the timing information

- UL messages with the same timing information are queued according to the logical channel priority with the "higher-first-in" principle.

7.11 Radio Link Failure

A radio link failure shall be triggered by switching the downlink power level of the source cell to the value for non-suitable "Off" for the time period of least T_{310} + time it takes to receive N_{310} consecutive out-of-sync indications from lower layers (non-suitable "Off" is defined in 36.508 [3], whereas T_{310} and N_{310} are defined in 36.331 [19]).

If the RRC re-establishment procedure is used in a radio link failure context, it shall be realised by using two cells.

7.12 Test method for RRC signalling latency

Test cases testing RRC signalling latency will need special test method. The PUCCH synchronisation state of UE influences the test method. Following 2 different ways in which the UE's completeness of procedure can be probed are considered:

1. UE is still PUCCH synchronized and can respond to uplink grants
2. UE needs a RACH procedure and hence RACH procedural delays add upon the actual procedure delay.

7.12.1 Procedure delays in PUCCH synchronized state

Figure 7.12.1-1 demonstrates the latency check procedure that will be applied when UE is in PUCCH synchronized state and can respond to uplink grants.

SS is configured to report ACK/NACK received from UE, to TTCN.

By default SS is configured to retransmit any DL MAC PDU max 4 times (1 transmission and 4 retransmissions).

Round trip time (RTT) is considered as (Note)

8 subframes for FDD,

10 or 11 subframes for TDD.

Let N be the max allowed delay for procedure.

TTCN schedules at time T_1 a DL message to the UE. This is achieved using Time stamps in sending ASPs.

TTCN is configured to send UL grants continuously every UL subframe from T_1+N-1 ,

for 4 RTT (32) subframes for FDD,

$4 \max_{RTT}$ (44) subframes for [TDD], where $\max_{RTT}=11$.

The time difference between the received ACK and the reception of UL PDU will be checked against N . the test is passed when $(Y-X) \leq N + \Delta$, where Δ is considered as possible UL subframe uncertainty.

$\Delta = 0$ for FDD,

$\Delta = 3TTI$ for TDD.

NOTE: RTT here is meant, on reception of a NACK, SS shall schedule the retransmission at 4th FDD TTI for FDD or 6th TTI for TDD since reception of NACK.

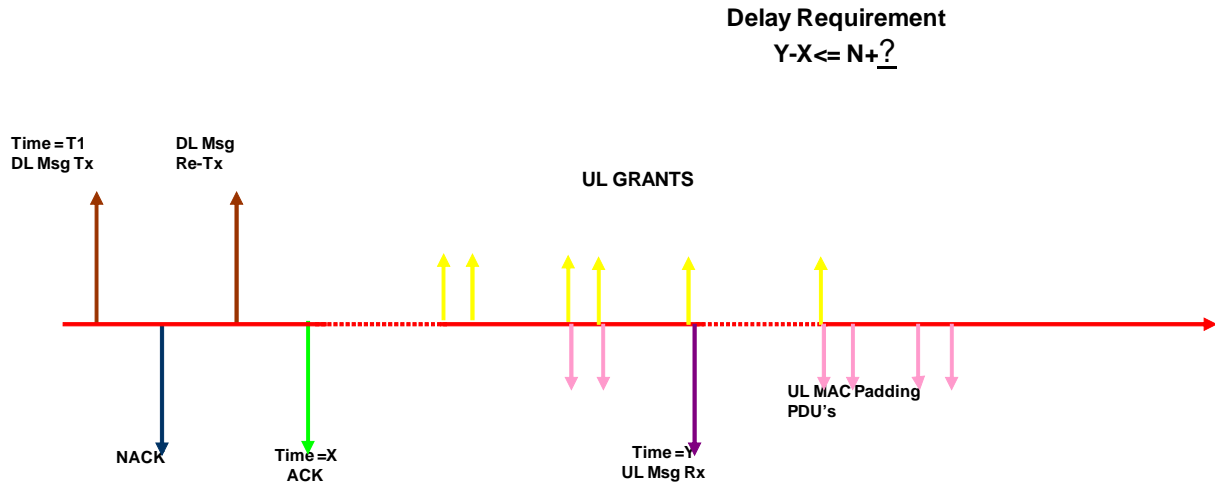

Figure 7.12.1-1: Delays in PUCCH synchronized state

Table 7.12.1-1: TDD configuration 1

Subframe	0	1	2	3	4	5	6	7	8	9
Configuration 1	D	S	U	U	D	D	S	U	U	D
Delay from DL to Ack/Nack [TTIs]			6,7	4				6,7	4	
Delay from NCK to re tx [TTIs]			4	6				4	6	
RTT	11	10			10	11	10			10

7.12.2 Procedure delays when RACH procedure required

Figure 7.12.2-1 demonstrates the latency check procedure that will be applied when UE is not PUCCH synchronized state needs RACH procedure.

PRACH configuration index is set as 14 for FDD, 12 for TDD which allows UE to send Preamble in any frame at any subframe.

SS is configured to report ACK/NACK, PRACH preambles received from UE.

By default SS is configured to retransmit any DL MAC PDU max 4 times [1 Transmission and 4 Retransmission].

Let N be the max allowed delay for procedure.

TTCN schedules at time T1, DL message to the UE. This is achieved using Time stamps in send ASP's.

The time difference between the ACK and the reception of PRACH preamble will be checked against N plus any Interruption time (TS 36.133 [37]) and verdict is assigned, when $(Y-X) <= N + T_{interruption} + \Delta$

$\Delta = 0$ for FDD,

$\Delta = 3TTI$ for TDD, where 3TTI is UL subframe uncertainty.

If cell change occurs, cell timing differences, Frame number offsets need to be included for procedural delay evaluations.

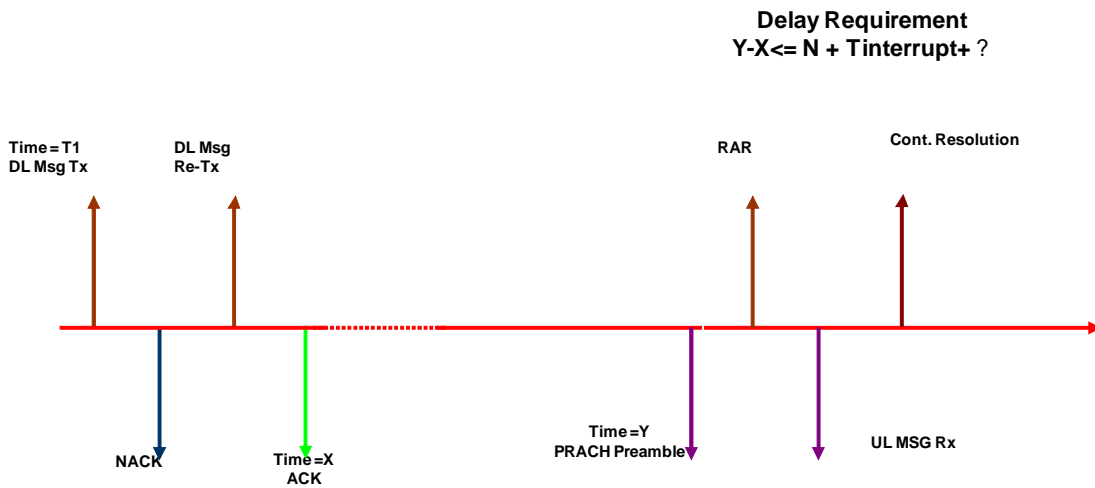

Figure 7.12.2-1: Delays when RACH procedure needed

7.13 RLC test method for scheduled data

The test loop mode is applied to the RLC tests. The allowed SS delay for sending data (< 80 ms) is comparable to the default values of the RLC timers. In order to ensure a unique TTCN implementation of the RLC test cases and the deterministic test result, independent from the SS platforms and UEs, scheduled data method can be applied to the test.

The scheduled data method is suitable to the RLC test if

Receiving multiple UL RLC SDUs is expected in the test; the UE may send a STATUS PDU in addition,

Time measurement is required for the looped back RLC SDUs,

DL RLC PDUs are sent on consecutive TTIs; the subframe numbers to be applied are relevant in TDD.

The table 7.13-1 illustrates the data scheduling in the RLC test.

Table 7.13-1: Scheduled RLC test events

Scheduled timing		t0 (Note 1)	t1 (Note 1)	t2
Test event descriptions	Multiple SDUs	Obtain the reference time	Send DL data	Provide UL grant (Note 2)
	Time measurement		Send DL data	Receive UL data
	DL data in TDD		Send 1 st DL data	Send subsequent data (Note 3)

Note 1: $(t1-t0) \geq 100$ ms which is greater than the allowed SS max. delay time, 80ms.
 Note 2: $(t2-t1) = 60$ ms, this duration will allow the UE transmitting max. 3 scheduling requests (every 20 ms once) after the UL data to be looped back being available at the UE without going onto PRACH.
 Note 3: The applied TDD subframe numbers 4, 5, 9, 10, 14, 15, 19, 20, 24, 25, ...

If the test case prose does not indicate timely restrictions for the scheduling, sequential sending events are scheduled in consecutive TTIs.

NOTE 1: For TDD configuration 1, the subframes 0, 4, 5 and 9 are considered as consecutive.

NOTE 2: Scheduling may imply to execute the test steps in the TTCN in an order different from the order given in the test case prose. However, the sequence of the events over the air follows the prose description.

7.14 IP packets for Loopback Mode

7.14.1 IP packets used for Loopback Mode A

It is irrelevant which kind of data is used in loopback mode A. Some PDCP test cases however specify to use IP packets. In these cases, an ICMPv4 ECHO REPLY shall be used with a valid IP header checksum and valid ICMP checksum.

7.14.2 IP packets used for Loopback Mode B

According to TS 36.509 [4], the UE performs loopback mode B above the UL TFT entity. Therefore IP packets need to match the packet filters signalled to the UE according to TS 36.508 clause 6.6.2 [3]:

When the UE gets configured via NAS signalling with packet filter #1 and #2 according to TS 36.508 clause 6.6.2 the IP packets shall fulfil the following requirements:

Protocol:

UDP referred to packet filter #1 and #2

IP addresses:

Referred to TS 36.508 Table 6.6.2-3 Note 1 source and destination IP address are the same.

Ports:

packet filter #1 specifies DL filter \Rightarrow IP packet's source port shall match remote port of packet filter #1

packet filter #2 specifies UL filter \Rightarrow IP packet's destination port shall match remote port of packet filter #2

To summarize, on dedicated bearers for loopback mode B, UDP packets used shall match the packet filters configured at the UE side. The UDP packets, having no specific content, shall have the correct header checksum and UDP checksum. On the default bearer, any other packets can be used, as an example, ICMPv4 ECHO REPLY similar as for loopback mode A.

7.15 Connected Mode DRX

The SS shall support connected mode DRX according to TS 36.321, i.e. the SS shall not send any data to the UE while the UE is not monitoring the PDCCH. To achieve this, the SS needs to estimate the UE's Active Time by considering the on-duration as well as the drx-inactivity timer:

- on-duration
The on-duration can be derived from the SS' DRX configuration.
- drx-inactivity timer
According to TS 36.321 clause 5.7 at the UE the drx-inactivity timer is started or restarted during the Active Time whenever PDCCH indicates a new transmission (DL or UL)

There is no activation time for the configuration of DRX at the UE and it is not acceptable just to consider the on-duration after re-configuration of the UE (for DRX_L according to TS 36.508 the DRX cycle is 1.28s); instead the drx-inactivity timer needs to be taken in account after DRX reconfiguration as well.

The following rules shall be applied to achieve synchronisation of SS and UE:

1. SS shall consider drx-inactivity timer as restarted at the UE whenever the UE is addressed on the PDCCH (DL data or UL grant)
2. When there is a scheduling request sent by the UE, SS assigns a grant independent of DRX; when sending out that grant on PDCCH SS considers drx-inactivity timer as (re-)started (as per 1. above)
3. For all DL messages scheduled with specific timing information SS shall send the data at the given time irrespective of current DRX configuration
4. DRX (re-)configuration:

- a) when DRX has not been configured at the UE yet
 - a1) TTCN will configure the SS just before the sending out the RRCConnectionReconfiguration message configuring DRX at the UE; no other send-events between the reconfiguration of the SS and sending the RRC message shall be scheduled in TTCN.
 - a2) TTCN will schedule sending of the RRCConnectionReconfiguration message configuring DRX with specific timing information.
- b) Reconfiguration of DRX at the UE:
 - Same as a) but
 - b1) TTCN shall schedule sending of the RRCConnectionReconfiguration according to the old DRX configuration (i.e. the SS does not need to cache the new configuration)
- c) RRC connection release
 - c1) TTCN will release DRX at the SS just after the RRC connection release procedure

5. There shall be no parallel data on any DRBs during DRX reconfiguration.

NOTE: Timing requirements in the DRX test cases

- a) The drx-Inactivity Timer shall be long compared to the duration between sending RRCConnectionReconfiguration and receiving RRCConnectionReconfigurationComplete (> 50ms.)It ensures the SS in-time sending of the RLC STATUS PDU.

or

- b) the drx-cycle shall be short compared to the RLC timers applied for SRB1

Figure 7.15-1 illustrates DRX (re)configuration at the SS and the UE.

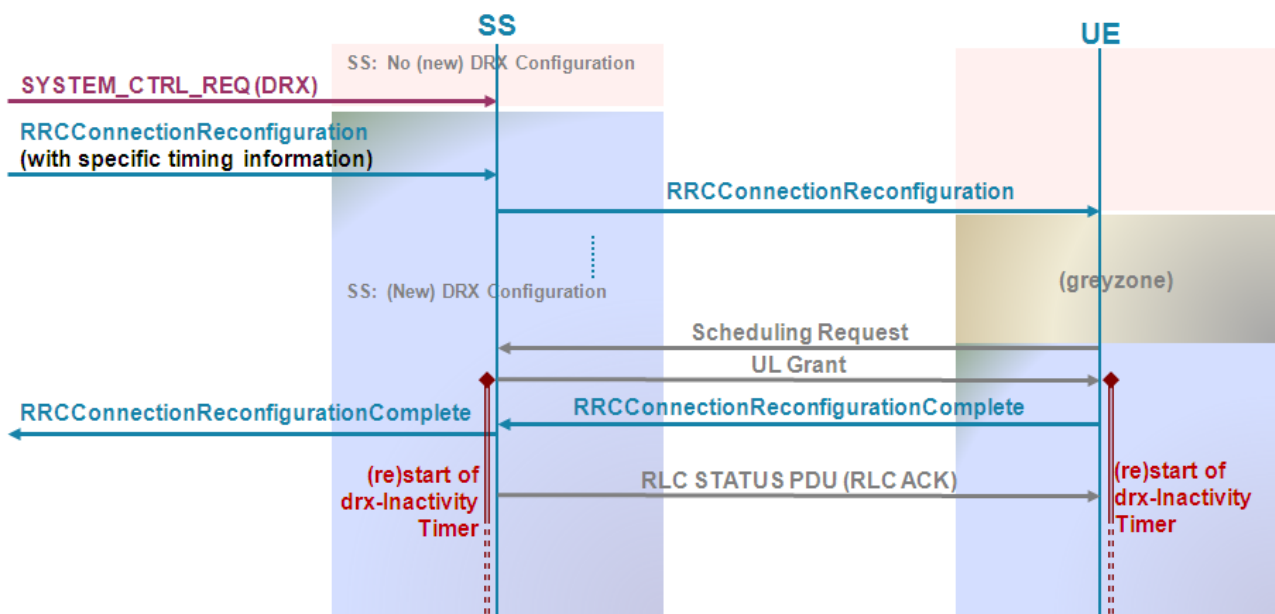

Figure 7.15-1: DRX (Re)configuration

NOTE 1: Between RRCConnectionReconfiguration and RRCConnectionReconfigurationComplete the UE may send a separate RLC STATUS PDU to acknowledge the RRCConnectionReconfiguration, but that does not affect the principle as long as SS applies rule 2.

NOTE 2: During the “greyzone” SS does not know about DRX configuration at the UE; during that period according to rule 4a1 and rule 5 there is no data to be sent by SS

The TTCN (re)configures the connected mode DRX in SS for the test cases if DRX_S is applied (Ref. TS 36.508 [3]. The (re)configuration of DRX_L in SS is FFS.

For test case 7.1.6.1 and 7.1.6.2, DRX will not be activated at the SS. Periodic UL grants every 4ms will be allocated to the UE during the preamble and postamble of the test case to prevent UE from activating DRX; These grants may result in padding MAC PDU's transmitted by UE, which will be received by SS MAC and discarded.

7.16 Handover Sequences

7.16.1 Sequence of inter-cell handover

In general, the Inter-Cell handover is done without activation time, i.e. the timing information for configuration of the SS and sending of the RRCConnectionReconfiguration is 'Now'.

1. Transfer of the PDCP Count for AM DRBs from source to target cell (optional)

- a) Source Cell: Get PDCP COUNT

- b) Target Cell: Set PDCP COUNT

NOTE 1: There shall be no further sending/receiving of AM DRB data before the HO has been done.

NOTE 2: This sequence is called in TTCN only if there has been any AM DRB data before HO (if there has been no data yet, COUNT is zero at both cells)

2. Target Cell: Inform the SS about the HO and about the source cell id
3. Target Cell: Configure RACH procedure either dedicated or C-RNTI based
4. Target Cell: Activate security
5. Target Cell: configure DRX

NOTE: As long as the DRX configuration is not modified by the RRCConnectionReconfiguration the target cell gets the same DRX configuration as the source cell

6. Source Cell: Stop periodic TA

NOTE: UL grant configuration keeps configured as per default at the source cell

7. Target Cell: Configure UL grant configuration ("OnSR", periodic TA is not started)
8. Source Cell: Send RRCConnectionReconfiguration
9. Target Cell: Receive RRCConnectionReconfigurationComplete
10. Target Cell: Start periodic TA
11. Target Cell: Inform the SS about completion of the HO (e.g. to trigger PDCP STATUS PDU)
12. Target Cell: Re-configure RACH procedure as for initial access
13. Source Cell: Reset SRBs and DRBs
14. Source Cell: Release DRX configuration

7.16.2 Sequence of intra-cell handover

For Intra-Cell handover dedicated timing information is used: the sequence starts at time T with sending of the RRCConnectionReconfiguration. T is ranged from 100 - 500 ms, with default value 300ms, in advance of the handover.

1. At T: Send RRCConnectionReconfiguration
2. At T + 5ms: Release SRBs and DRBs
3. At T + 5ms: Configure RACH procedure either dedicated or C-RNTI based

NOTE: Since the RACH procedure may require a new C-RNTI to be used it cannot be configured before sending out the RRCConnectionReconfiguration.

4. At T + 10ms: (Re-) configure SRBs and DRBs
5. At T + 10ms: Reestablish security
6. (after step 5) Receive RRCConnectionReconfigurationComplete
7. (after step 6) Re-configure RACH procedure as for initial access

7.16.3 UL Grants used in RA procedure during handover

In the Random Access Procedure a grant is assigned to the UE by the Random Access Response and another grant, as initial grant, is assigned for contention resolution.

When UL data is pending, the UE will try to put as much data into given grants as possible, i.e. it will segment the user data and send it e.g. with the initial grant if possible. To avoid this segmentation of user data, the grants assigned during handover will be set in TTCN to:

Grant assigned by Random Access Response: 56 bits

Initial grant: 104 bits

NOTE 1: According to TS 36.321 [14], clause 5.1.4, 56 bits are the minimum grant which can be assigned by the Random Access Response. That is sufficient to convey C-RNTI (3 bytes) and short BSR (2 bytes) or long BSR (4 bytes) but even with short BSR the remaining 2 bytes are not sufficient to convey any segment of the RRCConnectionReconfigurationComplete (at least 4 bytes).

NOTE 2: The RRCConnectionReconfigurationComplete (9 bytes) shall completely be conveyed in the initial grant of RA procedure. This requires a minimum of 10 bytes (1 byte MAC header + 2 bytes RLC header + 5 bytes PDCP header + 2 bytes payload). Additionally an optional PHR MAC element (2 bytes) needs to be considered since the PHR has higher priority than the MAC SDU. Any further user data would require a minimum of 5 additional bytes (2 bytes MAC header + 2 bytes RLC header + 1 byte payload).

8 External Function Definitions

The following external functions are required to be implemented by the SS:

TTCN-3 External Function							
Name	<code>fx_KeyDerivationFunction</code>						
Description	Hashing function for Hashing algorithms as defined in TS 33.401 [24] SHA-256 encoding algorithm is used as KEY Description Function						
Parameters	<table border="1"> <tr> <td>KDF</td> <td>KDF_HMAC_SHA_256 (no other KDF defined yet)</td> </tr> <tr> <td>Key</td> <td>256 bit key</td> </tr> <tr> <td>String</td> <td>string being constructed acc. to TS 33.401 [24], annex A</td> </tr> </table>	KDF	KDF_HMAC_SHA_256 (no other KDF defined yet)	Key	256 bit key	String	string being constructed acc. to TS 33.401 [24], annex A
KDF	KDF_HMAC_SHA_256 (no other KDF defined yet)						
Key	256 bit key						
String	string being constructed acc. to TS 33.401 [24], annex A						
Return Value	256 bit derived key						

TTCN-3 External Function		
Name	fx_NasIntegrityAlgorithm	
Description	Apply integrity protection algorithm on a given octetstring	
Parameters	NAS PDU	octetstring according to TS 24.301 [21], clause 4.4.3.3 this shall include octet 6 to n of the security protected NAS message, i.e. the sequence number IE and the NAS message IE
	Integrity Algorithm	3 bits as defined in TS 24.301 [21], clause 9.9.3.23
	KNAS _{int}	Integrity key
	NAS COUNT	as documented in TS 24.301
	BEARER Id	fix value ('00000'B) acc. TS 33.401 [24], clause 8.1
	Direction	UL: 0 DL: 1 (acc. to TS 33.401 [24], Annex B.1)
Return Value	Message Authentication Code (4 octets)	

TTCN-3 External Function		
Name	fx_NasCipherng	
Description	Apply cipherng on a given octetstring	
Parameters	NAS PDU	octetstring
	Cipherng Algorithm	3 bits as defined in TS 24.301 [21], clause 9.9.3.23
	KNAS _{enc}	Cipherng Key
	NAS COUNT	as documented in TS 24.301
	BEARER Id	fixed value ('00000'B) acc. TS 33.401 [24], clause 8.1
Return Value	cipherng octet string	

TTCN-3 External Function		
Name	fx_NasDecipherng	
Description	Apply decipherng on a given octetstring	
Parameters	cipherng NAS PDU	octetstring
	Cipherng Algorithm	3 bits as defined in TS 24.301 [21], clause 9.9.3.23
	KNAS _{enc}	Cipherng Key
	NAS COUNT	as documented in TS 24.301 [21]
	BEARER Id	fixed value ('00000'B) acc. TS 33.401 [24], clause 8.1
Return Value	decipherng octet string	

TTCN-3 External Function		
Name	fx_GetCurrentTestcaseName	
Description	external function giving back the name of the test case currently running	
Parameters	None	
Return Value	char string	

TTCN-3 External Function		
Name	fx_AsIntegrityAlgorithm	
Description	Apply integrity protection algorithm on a given octetstring	
Parameters	PDCP PDU	octetstring
	Integrity Algorithm	3 bits as defined in TS 33.401 [24]
	KRRC _{int}	Integrity key
	PDCP COUNT	octetstring, length 4
	BEARER Id	the value of the DRB identity minus one
	Direction	UL: 0 DL: 1 (acc. to TS 33.401 [24], Annex B.2)
Return Value	Message Authentication Code (4 octets)	

TTCN-3 External Function		
Name	fx_AsCiphering	
Description	Apply ciphering on a given octetstring	
Parameters	SDU	octetstring
	Ciphering Algorithm	3 bits as defined in TS 33.401 [24]
	KRRC _{enc}	Ciphering Key
	PDCP COUNT	octetstring, length 4
	BEARER Id	the value of the DRB identity minus one
Return Value	ciphered octet string	

TTCN-3 External Function		
Name	fx_AsDeciphering	
Description	Apply deciphering on a given octetstring	
Parameters	ciphered SDU	octetstring
	Ciphering Algorithm	3 bits as defined in TS 33.401 [24]
	KRRC _{enc}	Ciphering Key
	PDCP COUNT	octetstring, length 4
	BEARER Id	the value of the DRB identity minus one
Return Value	deciphered octet string	

TTCN-3 External Function		
Name	fx_GetSystemTime	
Description	Function to get the system time: Implementation is based on C standard library (time.h)	
Parameters	p_Struct_tm (out)	<p>p_Struct_tm returns local system time equivalent to "struct tm" as defined for C standard library (time.h or ctime):</p> <pre> type record Struct_tm_Type { integer tm_sec, // seconds after the minute // (0..61; see NOTE) integer tm_min, // minutes after the hour (0..59) integer tm_hour, // hours since midnight (0..23) integer tm_mday, // day of the month (1..31) integer tm_mon, // months since January (0..11) integer tm_year, // years since 1900 integer tm_wday, // days since Sunday (0..6) integer tm_yday, // days since January 1 (0..365) integer tm_isdst // Daylight Saving Time flag }; </pre> <p>NOTE: tm_sec is generally 0-59. Extra range to accommodate for leap seconds in certain systems</p> <p>C implementation:</p> <pre> time_t v_Now = time(NULL); struct tm *v_Tm = localtime(&v_Now); </pre>
	p_TimezoneInfo (out)	<p>p_TimezoneInfo returns the difference (in seconds) between the UTC time (GMT) and the local time (integer value);</p> <p>C implementation:</p> <pre> int timezone = (int)difftime(mktime(gmtime(&v_Now)), v_Now); </pre> <p>NOTE:</p> <p>p_TimezoneInfo does not consider daylight saving e.g. it is always 3600 for CET independent of summer/winter</p>
Return Value	None	

9 IXIT Proforma

This partial IXIT proforma contained in the present document is provided for completion, when the related Abstract Test Suite is to be used against the Implementation Under Test (IUT).

Text in *italics* is a comment for guidance for the production of an IXIT, and is not to be included in the actual IXIT.

The completed partial IXIT will normally be used in conjunction with the completed ICS, as it adds precision to the information provided by the ICS.

9.1 E-UTRAN PIXIT

Table 9.1-1: CommonPIXIT

Parameter Name	Parameter Type	Default Value	Supported Values	Description
px_AccessPointName	octetstring			Access Point Name, as defined in 23.003 and used in 24.008, section 10.5.6.1
px_AttachTypeTested	EUTRA_ATTACH_TESTED_Type	EPS_ATTACH_ONLY	EPS_ATTACH_ONLY, COMBINED_ATTACH	Attach Type to be tested, if UE supports both pc_Attach and pc_Combined_Attach
px_eAuthRAND	B128_Type	oct2bit('A3DE0C6D363E30C364A4078F1BF8D577'O)		Random Challenge
px_ePrimaryBandChannelBandwidth	DI_Bandwidth_Type	n25		E-UTRA primary band channel bandwidth
px_eJapanMCC_Band6	NAS_Mcc	'442'H		Japan MCC code to be used for Band 6. The same value will be used for E-UTRA and Inter-RAT cells. Type is different to that defined in TS 34.123-3 [7].
px_ePrimaryFrequencyBand	FrequencyBand_Type	1		E-UTRA primary frequency band
px_eSecondaryFrequencyBand	FrequencyBand_Type	2		E-UTRA secondary frequency band
px_IPv4_Address	charstring			IPv4 Address
px_IPv4_RemoteAddress	charstring			IPv4 Remote Address
px_IPv6_Address	charstring			IPv6 Address
px_IPv6_RemoteAddress	charstring			IPv6 Remote Address
px_SMS_ChkMsgReceived	boolean	true		Whether the operator can check an MT Short Message received
px_SMS_PrefMem1	charstring	"SM"		SMS Preferred Memory 1 <mem1> of TS 27.005 cl. 3.2.2
px_SMS_PrefMem2	charstring	"SM"		SMS Preferred Memory 2 <mem1> of TS 27.005 cl. 3.2.2
px_SMS_PrefMem3	charstring	"MT"		SMS Preferred Memory 3 <mem1> of TS 27.005 cl. 3.2.2
px_SMS_Service	charstring	"0"		SMS Service <service> of TS 27.005 cl. 3.2.1
px_IPv4viaNAS_TestMode	boolean	FALSE		This parameter can be set to TRUE so as to force allocation of IPv4 only PDN connection and IP address allocation via NAS signalling in the preamble of test cases using test mode (see TS 36.508 [3] clause 4.5.2A).

Table 9.1-2: E-UTRAN PIXIT

Parameter Name	Parameter Type	Default Value	Supported Values	Description
px_eTDDsubframeConfig	TDD_SubframeAssignment_Type	1		TDD uplink-downlink subframe configuration
px_eUE_Category_Type	UE_Category_Type	1		UE Category values 1..5 as defined in 36.306 clause 4.1
px_eSecondaryBandChannelBandwidth	DL_Bandwidth_Type	n25		E-UTRA secondary band channel bandwidth
px_NAS_CipheringAlgorithm	B3_Type	001'B		NAS Ciphering Algorithm
px_NAS_IntegrityProtAlgorithm	B3_Type	001'B		NAS Integrity Algorithm
px_RRC_CipheringAlgorithm	CipheringAlgorithm	eea0		Ciphering Algorithm
px_RRC_IntegrityProtAlgorithm	IntegrityProtAlgorithm	eia1		Integrity Algorithm
px_MaxNumberROHC_ContextSessions	MaxNumberROHC_ContextSessions_Type	Cs16		Maximum number of ROHC context sessions

9.2 MultiRAT PIXIT

Table 9. 2-1: GERAN PIXIT

Parameter Name	Parameter Type	Default Value	Supported Values	Description
px_GERAN_BandUnderTest	GERAN_BandUnderTestType	GSM_P900		Indicates which band is under test.

Table 9. 2-2: UTRAN PIXIT

Parameter Name	Parameter Type	Default Value	Supported Values	Description
px_UTRAN_CipheringAlgorithm	CipheringAlgorithm_r7	uea2	uea0, uea1, uea2	UTRAN Ciphering algorithm

Table 9. 2-3: CDMA2000 HRPD PIXIT

Parameter Name	Parameter Type	Default Value	Supported Values	Description
px_HRPD_BandClass	BandclassCDMA2000_Type	1		Band Class; Table 1.5-1 of C.S0057_D Default value corresponds to 1.8 to 2.0 GHz PCS band
px_HRPD_ChannelNum_F14	ARFCN_ValueCDMA2000_Type	225		Channel number of frequency 14
px_HRPD_KChannelNum_F15	ARFCN_ValueCDMA2000_Type	525		Channel number of frequency 15
px_HRPD_KChannelNum_F16	ARFCN_ValueCDMA2000_Type	825		Channel number of frequency 16
px_HRPD_SectorID_Cell15	SectorID_HRPD_Type	oct2bit('FEA0000000000000000000000000000000000000001'O)		Sector ID of Cell 15; Clause 13.9 of C.S0024_B
px_HRPD_SectorID_Cell16	SectorID_HRPD_Type	oct2bit('FEA0000000000000000000000000000000000000002'O)		Sector ID of Cell 16; Clause 13.9 of C.S0024_B
px_HRPD_SectorID_Cell17	SectorID_HRPD_Type	oct2bit('FEA0000000000000000000000000000000000000003'O)		Sector ID of Cell 17; Clause 13.9 of C.S0024_B
px_HRPD_SectorID_Cell18	SectorID_HRPD_Type	oct2bit('FEA0000000000000000000000000000000000000004'O)		Sector ID of Cell 18; Clause 13.9 of C.S0024_B
px_ColorCode	ColorCode_Type	64		Colour code of the subnet to which the sectors belong; Same for all HRPD cells
px_OpenLoopAdjust	OpenLoopAdjust_Type	10		The value of open loop adjust to be used by access terminals in the open loop power estimate, expressed as an unsigned value in units of 1 dB. The value used by the access terminal is -1 times the value of this field

Table 9.2-4: CDMA2000 1xRTT PIXIT

Parameter Name	Parameter Type	Default Value	Supported Values	Description
px_1XRTT_Baseld_Cell19	B16_Type	int2bit (39,16)		Base ID of Cell 19
px_1XRTT_Baseld_Cell20	B16_Type	int2bit (40,16)		Base ID of Cell 20
px_1XRTT_Baseld_Cell21	B16_Type	int2bit (41,16)		Base ID of Cell 21
px_1XRTT_Baseld_Cell22	B16_Type	int2bit (42,16)		Base ID of Cell 22
px_1XRTT_NID	B16_Type	int2bit (100,16)		default Network ID of 1xRTT Cells
px_1XRTT_SID	B15_Type	int2bit (200,15)		default System ID of 1xRTT Cells
px_1XRTT_TMSI_Def	O4_Type	'1234ABCD'O		TMSI to be used in 1XRTT
px_1XRTT_MinProtRev	ProtRev_Type	0		Minimum Protocol revision supported by Base Station
px_1XRTT_UserInfo_EncMode	EncryptionMode_Type	2		Encryption Mode Rijndael algorithm
px_1XRTT_Sig_EncMode	EncryptionMode_Type	2		Encryption Mode Rijndael algorithm
px_1XRTT_BandClass	BandclassCDMA2000_Type	1		Band Class; Table 1.5-1 of C.S0057_D. Default value corresponds to 1.8 to 2.0 GHz PCS band
px_1XRTT_ChannelNum_F17	ARFCN_ValueCDMA2000_Type	225		Channel number of frequency 17
px_1XRTT_ChannelNum_F18	ARFCN_ValueCDMA2000_Type	525		Channel number of frequency 18
px_1XRTT_ChannelNum_F19	ARFCN_ValueCDMA2000_Type	825		Channel number of frequency 19

10 Postambles

The purpose of this clause is to specify postambles to bring the UE to a well defined state regardless of the UE state at the termination of main test body or of the SS conditions and values of the system information inherited from the test.

10.1 Postambles for E-UTRA to UTRA tests

This clause describes UE postamble procedures which are used at the end of inter-RAT test cases specified in TS 36.508 [3] so as to switch off the UE.

UE LTE and UTRAN postamble conditions are specified in Table 10.1-1.

Table 10.1-1: UE postamble conditions

LTE UE attach type	UE UTRA CS/PS domain	Postamble condition
attach	pc_CS AND pc_PS	C1
	pc_PS AND NOT (pc_CS)	C2
combined_attach	pc_CS AND pc_PS	C3
	pc_CS AND NOT (pc_PS)	C4

10.1.1 UE postamble states and procedures for E-UTRA to UTRA

In order to bring the UE to the switched/powering off state, a number of procedures need to be executed in a hierarchical sequence, according to the reference end state specified in each test procedure sequence. The sequences and the identified procedures are shown in figure 10.1.1-1.

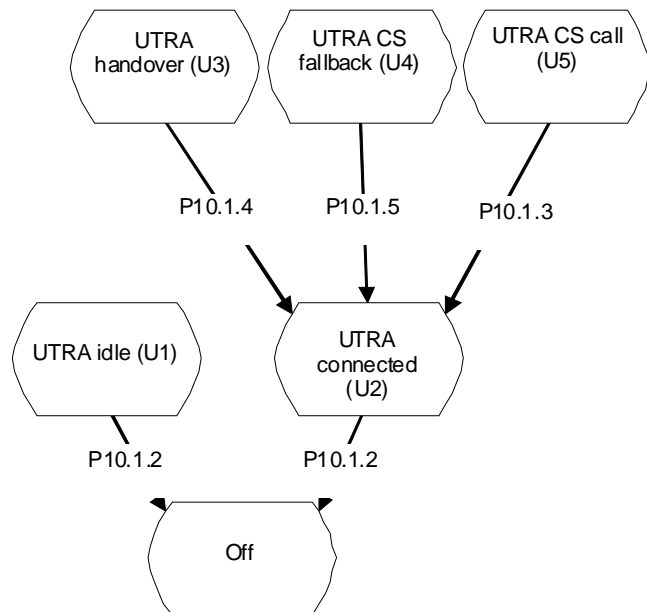

Figure 10.1.1-1: UE postamble procedures for E-UTRA / UTRA test cases

NOTE: Depending on the test case specifications the termination of a test case can be in any state of this diagram.

UE in UTRA state U2, U3, U4 and U5 may send data on the established radio bearer and shall be accepted and handled.

NOTE: NAS and AS security procedures during routing area update and handover are performed according to 3GPP TS 33.401[24] clauses 9.1.1 and 9.2.1 and 3GPP TS 25.331[36] clause 8.3.6.3.

10.1.2 Switch/Power off procedure

10.1.2.1 Procedure

Table 10.1.2.1-1: Switch/Power off procedure

Step	Procedure	U - S	Message Sequence Message
1	The UE is powered off or switched off, (see ICS)	-	-
-	EXCEPTION: Steps 2 to 7 specify the behaviour if UE supports <code>pc_SwitchOnOff</code> .	-	-
-	EXCEPTION: Steps 2 to 4 are used only when the UE is in UTRA idle end state (U1).		
2	The UE transmits RRC CONNECTION REQUEST	-->	RRC CONNECTION REQUEST
3	The SS transmit a RRC CONNECTION SETUP	<--	RRC CONNECTION SETUP
4	The UE transmits an RRC CONNECTION SETUP COMPLETE message	-->	RRC CONNECTION SETUP COMPLETE
-	EXCEPTION: Step 5a1 specifies behaviour when the current UTRA cell is in NMO I and the UE is in condition: - C1 or - C3	-	-
5a1	The UE transmits an INITIAL DIRECT TRANSFER message including a DETACH REQUEST message with the detach type='power switched off, GPRS/IMSI combined detach'	-->	DETACH REQUEST
-	EXCEPTION: Step 5b1 specifies behaviour when the current UTRA cell is in (NMO I or NMO II) and the UE is in condition C4	-	-
5b1	The UE transmits an INITIAL DIRECT TRANSFER message. This message includes an IMSI DETACH INDICATION message	-->	IMSI DETACH INDICATION
-	EXCEPTION: Step 5c1 specifies behaviour when the current UTRA cell is in (NMO I or NMO II) and the UE is in condition C2	-	-
5c1	The UE transmits an INITIAL DIRECT TRANSFER message. This message includes a DETACH REQUEST message with detach type='power switched off, PS detach'	-->	DETACH REQUEST
-	EXCEPTION: Steps 5d1 and 5d2 specify behaviour when the current UTRA cell is in NMO II and the UE is in condition: - C1 or - C3. Both detach messages (in steps 5d1 and 5d2) can be sent by UE in any order.	-	-
5d1	The UE transmits an INITIAL DIRECT TRANSFER message. This message includes a DETACH REQUEST message with the detach type='power switched off, PS detach'	-->	DETACH REQUEST
5d2	The UE transmits an INITIAL DIRECT TRANSFER message. This message includes an IMSI DETACH INDICATION message	-->	IMSI DETACH INDICATION
6	The SS transmits an RRC CONNECTION RELEASE message	<--	RRC CONNECTION RELEASE
7	The UE transmits a RRC CONNECTION RELEASE COMPLETE message	-->	RRC CONNECTION RELEASE COMPLETE

10.1.3 CC disconnect procedure

10.1.3.1 Procedure

Table 10.1.3.1-1: CC disconnect procedure

Step	Procedure	U - S	Message Sequence Message
1	The SS transmits a DOWNLINK DIRECT TRANSFER message. This message includes a DISCONNECT message.	<--	DISCONNECT
2	The UE transmits an UPLINK DIRECT TRANSFER message. This message includes a RELEASE message.	-->	RELEASE
3	The SS transmits a DOWNLINK DIRECT TRANSFER message. This message includes a RELEASE COMPLETE message.	<--	RELEASE COMPLETE

10.1.4 PS Routing Area Update procedure

10.1.4.1 Procedure

Table 10.1.4.1-1: PS Routing Area Update procedure

Step	Procedure	U - S	Message Sequence Message
-	EXCEPTION: steps 1a1 to 1a5 specify the UE behaviour when the current UTRA cell is in NMO I and the UE is in condition: - C1 or - C3 and the UE is not registered to the LAC of the current UTRA cell	-	-
1a1	The UE transmits an UPLINK DIRECT TRANSFER message. This message includes a ROUTING AREA UPDATE REQUEST message with Update type = 'Combined RA/LA Updated'	-->	ROUTING AREA UPDATE REQUEST
1a2	The SS transmits a SECURITY MODE COMMAND message.	<--	SECURITY MODE COMMAND
1a3	The UE transmits a SECURITY MODE COMPLETE message.	-->	SECURITY MODE COMPLETE
1a4	The SS transmits a DOWNLINK DIRECT TRANSFER message. This message includes a ROUTING AREA UPDATE ACCEPT message.	<--	ROUTING AREA UPDATE ACCEPT
1a5	The UE transmits an UPLINK DIRECT TRANSFER message. This message includes a ROUTING AREA UPDATE COMPLETE message.	-->	ROUTING AREA UPDATE COMPLETE
-	EXCEPTION: steps 1b1 to 1b5 specify the UE behaviour when the current UTRA cell is in (NMO I or NMO II) and the UE is in condition: - C2 or - C3 and the UE is registered to the LAC of the current UTRA cell	-	-
1b1	The UE transmits an UPLINK DIRECT TRANSFER message. This message includes a ROUTING AREA UPDATE REQUEST message with Update type = 'RA Update'	-->	ROUTING AREA UPDATE REQUEST
1b2	The SS transmits a SECURITY MODE COMMAND message.	<--	SECURITY MODE COMMAND
1b3	The UE transmits a SECURITY MODE COMPLETE message.	-->	SECURITY MODE COMPLETE
1b4	The SS transmits a DOWNLINK DIRECT TRANSFER message. This message includes a ROUTING AREA UPDATE ACCEPT message.	<--	ROUTING AREA UPDATE ACCEPT
1b5	The UE transmits an UPLINK DIRECT TRANSFER message. This message includes a ROUTING AREA UPDATE COMPLETE message.	-->	ROUTING AREA UPDATE COMPLETE
-	EXCEPTION: steps 1c1 to 1c9 specify the UE behaviour when the current UTRA cell is in NMO II and the UE is in condition: - C1 or - C3 and the UE is not registered to the LAC of the current UTRA cell. The LOCATION UPDATE REQUEST message (step 1c6) can be received during the routing area updating procedure (steps 1c1 to 1c4).	-	-

1c1	The UE transmits an UPLINK DIRECT TRANSFER message. This message includes a ROUTING AREA UPDATE REQUEST message with Update type = 'RA Update'.	-->	ROUTING AREA UPDATE REQUEST
1c2	The SS transmits a SECURITY MODE COMMAND message.	<--	SECURITY MODE COMMAND
1c3	The UE transmits a SECURITY MODE COMPLETE message.	-->	SECURITY MODE COMPLETE
1c4	The SS transmits a DOWNLINK DIRECT TRANSFER message. This message includes a ROUTING AREA UPDATE ACCEPT message.	<--	ROUTING AREA UPDATE ACCEPT
1c5	The UE transmits an UPLINK DIRECT TRANSFER message. This message includes a ROUTING AREA UPDATE COMPLETE message.	-->	ROUTING AREA UPDATE COMPLETE
1c6	The UE transmits an UPLINK DIRECT TRANSFER message. This message includes a LOCATION UPDATING REQUEST message.	-->	LOCATION UPDATING REQUEST
1c7	The SS transmits a SECURITY MODE COMMAND message.	<--	SECURITY MODE COMMAND
1c8	The UE transmits a SECURITY MODE COMPLETE message.	-->	SECURITY MODE COMPLETE
1c9	The SS transmits a DOWNLINK DIRECT TRANSFER message. This message includes a LOCATION UPDATING ACCEPT	<--	LOCATION UPDATING ACCEPT
1c10	The EU transmits a UPLINK DIRECT TRANSFER message. This message includes a TMSI REALLOCATION COMPLETE	-->	TMSI REALLOCATION COMPLETE

10.1.5 CS fallback procedure

10.1.5.1 Procedure

Table 10.1.5.1-1: CS fallback procedure

Step	Procedure	U - S	Message Sequence Message
-	EXCEPTION: Steps 1a1 and 1a2 specify the MO call procedure.	-	-
1a1	The UE transmits an INITIAL DIRECT TRANSFER message including a CM SERVICE REQUEST message.	-->	CM SERVICE REQUEST
1a2	The SS transmits an UPLINK DIRECT TRNASFER message including a CM SERVICE REJECT with the reject cause #32 (Service option not supported)	<--	CM SERVICE REJECT
-	EXCEPTION: Step 1b1 specifies the MT call procedure.	-	-
1b1	The UE transmits an INITIAL DIRECT TRANSFER message including a PAGING RESPONSE message.	-->	PAGING RESPONSE
2	The SS transmits an RRC CONNECTION RELEASE message.	<--	RRC CONNECTION RELEASE
3	The UE transmits an RRC CONNECTION RELEASE COMPLETE message.	-->	RRC CONNECTION RELEASE COMPLETE
4	The UE transmits an RRC CONNECTION REQUEST message.	-->	RRC CONNECTION REQUEST
5	The SS transmits an RRC CONNECTION SETUP message		RRC CONNECTION SETUP
6	The UE transmits an RRC CONNECTION SETUP COMPLETE message	-->	RRC CONNECTION SETUP COMPLETE
-	EXCEPTION: Steps 7a1 and 7a5 specify the the routing area update procedure when the current UTRA cell is in NMO I and the UE is in condition C3 and the UE is not registered to the LAC of the current UTRA cell.	-	-
7a1	The UE transmits an UPLINK DIRECT TRANSFER message. This message includes a ROUTING AREA UPDATE REQUEST message with Update type = 'Combined RA/LA Updated'.	-->	ROUTING AREA UPDATE REQUEST
7a2	The SS transmits a SECURITY MODE COMMAND message.	<--	SECURITY MODE COMMAND
7a3	The UE transmits a SECURITY MODE COMPLETE message.	-->	SECURITY MODE COMPLETE
7a4	The SS transmits a DOWNLINK DIRECT TRANSFER message. This message includes a ROUTING AREA UPDATE ACCEPT message.	<--	ROUTING AREA UPDATE ACCEPT
7a5	The UE transmits an UPLINK DIRECT TRANSFER message. This message includes a ROUTING AREA UPDATE COMPLETE message.	-->	ROUTING AREA UPDATE COMPLETE
-	EXCEPTION: Steps 7b1 and 7b4 specify the location updating procedure when the current UTRA cell is in network mode (NMO I or NMO II) and the UE is in condition C4 and the UE is not registered to the LAC of the current UTRA cell.	-	-
7b1	The UE transmits an UPLINK DIRECT TRANSFER message. This message includes a LOCATION UPDATING REQUEST message.	-->	LOCATION UPDATING REQUEST
7b2	The SS transmits a SECURITY MODE	<--	SECURITY MODE COMMAND

	COMMAND message.		
7b3	The UE transmits a SECURITY MODE COMPLETE message.	-->	SECURITY MODE COMPLETE
7b4	The SS transmits a DOWNLINK DIRECT TRANSFER message. This message includes a LOCATION UPDATING ACCEPT	<--	LOCATION UPDATING ACCEPT
7b5	The EU transmits a UPLINK DIRECT TRANSFER message. This message includes a TMSI REALLOCATION COMPLETE	-->	TMSI REALLOCATION COMPLETE
-	EXCEPTION: steps 7c1 to 7c9 specify the UE behaviour when the current UTRA cell is in NMO II and the UE is in condition C3 and the UE is registered to the LAC of the current UTRA cell. The LOCATION UPDATE REQUEST message (step 7c6) can be received during the routing area updating procedure (steps 7c1 to 7c4).	-	-
7c1	The UE transmits an UPLINK DIRECT TRANSFER message. This message includes a ROUTING AREA UPDATE REQUEST message with Update type ='RA Update'.	-->	ROUTING AREA UPDATE REQUEST
7c2	The SS transmits a SECURITY MODE COMMAND message.	<--	SECURITY MODE COMMAND
7c3	The UE transmits a SECURITY MODE COMPLETE message.	-->	SECURITY MODE COMPLETE
7c4	The SS transmits a DOWNLINK DIRECT TRANSFER message. This message includes a ROUTING AREA UPDATE ACCEPT message.	<--	ROUTING AREA UPDATE ACCEPT
7c5	The UE transmits an UPLINK DIRECT TRANSFER message. This message includes a ROUTING AREA UPDATE COMPLETE message.	-->	ROUTING AREA UPDATE COMPLETE
7c6	The UE transmits an UPLINK DIRECT TRANSFER message. This message includes a LOCATION UPDATING REQUEST message.	-->	LOCATION UPDATING REQUEST
7c7	The SS transmits a SECURITY MODE COMMAND message.	<--	SECURITY MODE COMMAND
7c8	The UE transmits a SECURITY MODE COMPLETE message.	-->	SECURITY MODE COMPLETE
7c9	The SS transmits a DOWNLINK DIRECT TRANSFER message. This message includes a LOCATION UPDATING ACCEPT	<--	LOCATION UPDATING ACCEPT
7c10	The EU transmits a UPLINK DIRECT TRANSFER message. This message includes a TMSI REALLOCATION COMPLETE	-->	TMSI REALLOCATION COMPLETE
8	The SS transmits an RRC CONNECTION RELEASE message.	<--	RRC CONNECTION RELEASE
9	The UE transmits an RRC CONNECTION RELEASE COMPLETE message.	-->	RRC CONNECTION RELEASE COMPLETE

10.2 Postambles for E-UTRAN to GERAN tests

This clause describes UE postamble procedures which are used at the end of inter-RAT test cases defined in TS 36.508 [3] so as to switch off the UE. UE LTE and GERAN postamble transitions are specified in Table 10.2-1.

Table 10.2-1: UE postamble conditions

LTE UE attach type	UE GERAN CS/PS domain	Postamble condition
attach	pc_GPRS	C1
combined attach	pc_GPRS	C2
	NOT pc_GPRS	C3

10.2.1 UE postamble states and procedures for E-UTRA to GERAN test cases

In order to bring the UE to the switched/powered off state there are a number of procedures that need to be executed in a hierarchical sequence, according to the reference end state specified in each test procedure sequence. The sequences and the identified procedures are shown in figure 10.2.1-1

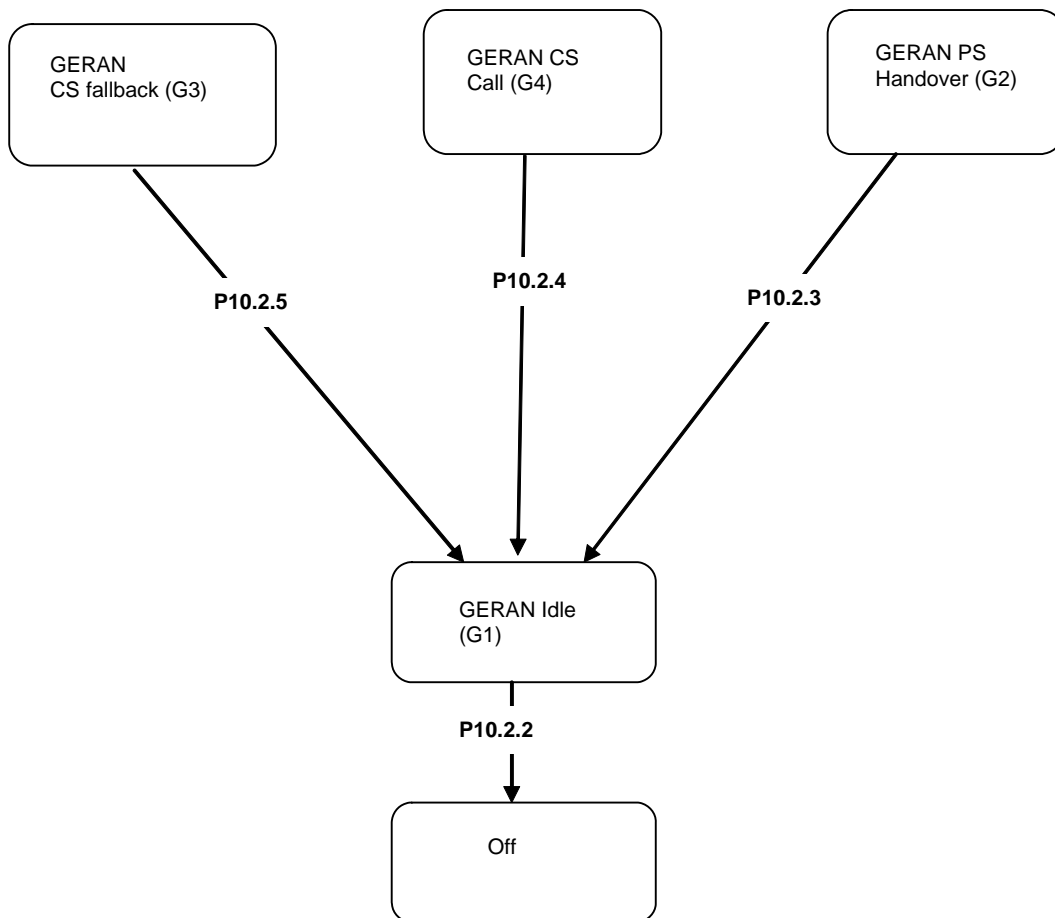

Figure 10.2.1-1: UE postamble procedures for E-UTRA / GERAN test cases

NOTE 1: Depending on the test case specifications the termination of a test case can be in any state of this diagram.

NOTE 2: The security procedures for interworking to GERAN are according to 3GPP TS 33.401[24] clauses 10.2.1 and 10.3.1.

10.2.2 Switch/Power off procedure

10.2.2.1 Procedure

Table 10.2.2.1-1: Switch/Power off procedure

Step	Procedure	U - S	Message Sequence Message
1	The UE is powered off or switched off, (see ICS)	-	-
-	EXCEPTION: Steps 2a1 to 2c2 specify the behaviour if UE supports <code>pc_SwitchOnOff</code> .	-	-
-	EXCEPTION: Step 2a1 specifies behaviour when the GERAN cell is in (NMO I or NMO II) and UE is in condition C1	-	-
2a1	The UE transmits a DETACH REQUEST message	-->	DETACH REQUEST
-	EXCEPTION: Step 2b1 specifies behaviour when the GERAN cell is in (NMO I or NMO II) and UE is in condition C3	-	-
2b1	The UE transmits an IMSI DETACH INDICATION message	-->	IMSI DETACH INDICATION
-	EXCEPTION: Steps 2c1 and 2c2 specify behaviour when the GERAN cell is in NMO II and UE is in condition C2. The messages can be sent in any order	-	-
2c1	The UE transmits an IMSI DETACH INDICATION message	-->	IMSI DETACH INDICATION
2c2	The UE transmits a DETACH REQUEST message	-->	DETACH REQUEST

10.2.3 PS Handover procedure

10.2.3.1 Procedure

Table 10.2.3.1-1: PS handover procedure

Step	Procedure	U - S	Message Sequence Message
-	EXCEPTION: Steps 1a1 and 1a3 specify the UE behaviour when GERAN cell is in NMO I and the UE is in condition C2 and the UE is not registered to the LAC of this cell.	-	-
1a1	The UE transmits a ROUTING AREA UPDATE REQUEST message with update type='Combined RA/LA Update'.	-->	ROUTING AREA UPDATE REQUEST
1a2	The SS transmits a ROUTING AREA UPDATE ACCEPT message.	<--	ROUTING AREA UPDATE ACCEPT
1a3	The UE transmits a ROUTING AREA UPDATE COMPLETE message.	-->	ROUTING AREA UPDATE COMPLETE
-	EXCEPTION: Steps 1b1 and 1b3 specify the location updating procedure when GERAN cell is in (NMO I or NMO II) and the UE is in condition C2 and the UE is registered to the LAC of this cell.	-	-
1b1	The UE transmits a ROUTING AREA UPDATE REQUEST message with update type='RA Update'.	-->	ROUTING AREA UPDATE REQUEST
1b2	The SS transmits a ROUTING AREA UPDATE ACCEPT message.	<--	ROUTING AREA UPDATE ACCEPT
1b3	The UE transmits a ROUTING AREA UPDATE COMPLETE message.	-->	ROUTING AREA UPDATE COMPLETE
-	EXCEPTION: Steps 1c1 and 1c6 specify the location updating procedure when GERAN cell is in NMO II and the UE is in condition C2 and the UE is not registered to the LAC of this cell.	-	-
1c1	The UE transmits a ROUTING AREA UPDATE REQUEST message with update type='RA Update'.	-->	ROUTING AREA UPDATE REQUEST
1c2	The SS transmits a ROUTING AREA UPDATE ACCEPT message.	<--	ROUTING AREA UPDATE ACCEPT
1c3	The UE transmits a ROUTING AREA UPDATE COMPLETE message.	-->	ROUTING AREA UPDATE COMPLETE
1c4	The UE transmits a LOCATION UPDATING REQUEST message.	-->	LOCATION UPDATING REQUEST
1c5	The SS transmits a LOCATION UPDATING ACCEPT	<--	LOCATION UPDATING ACCEPT
1c6	The UE transmits a TMSI REALLOCATION COMPLETE		TMSI REALLOCATION COMPLETE

10.2.4 CC disconnect procedure

10.2.4.1 Procedure

Table 10.2.4.1-1: CC disconnect procedure

Step	Procedure	U - S	Message Sequence Message
1	The SS transmits a DISCONNECT message.	<--	DISCONNECT
2	The UE transmits a RELEASE message.	-->	RELEASE
3	The SS transmits a RELEASE COMPLETE message.	<--	RELEASE COMPLETE
4	The SS transmits a CHANNEL RELEASE message.	<--	CHANNEL RELEASE

10.2.5 CS fallback procedure

10.2.5.1 Procedure

Table 10.2.5.1-1: CS fallback procedure MO call

Step	Procedure	U - S	Message Sequence Message
-	EXCEPTION: Steps 1a1 and 1a2 specify the MO call procedure.	-	-
1a1	The UE transmits a CM SERVICE REQUEST message.	-->	CM SERVICE REQUEST
1a2	The SS transmits a CM SERVICE REJECT with the reject cause #32 (Service option not supported)	<--	CM SERVICE REJECT
-	EXCEPTION: Step 1b1 specifies the MT call procedure.	-	-
1b1	The UE transmits a PAGING RESPONSE message.	-->	PAGING RESPONSE
-	EXCEPTION: Steps 2a1 to 2a6 specify the procedure when GERAN cell is in NMO II and if the UE is in condition C2 and the UE is registered to the LAC of the current GERAN cell.	-	-
2a1	The UE transmits a LOCATION UPDATING REQUEST message.	-->	LOCATION UPDATING REQUEST
2a2	The SS transmits a LOCATION UPDATING ACCEPT	<--	LOCATION UPDATING ACCEPT
2a3	The UE transmits a TMSI REALLOCATION COMPLETE		TMSI REALLOCATION COMPLETE
2a4	The UE transmits a ROUTING AREA UPDATE REQUEST message.	-->	ROUTING AREA UPDATE REQUEST
2a5	The SS transmits a ROUTING AREA UPDATE ACCEPT message.	<--	ROUTING AREA UPDATE ACCEPT
2a6	The UE transmits a ROUTING AREA UPDATE COMPLETE message.	-->	ROUTING AREA UPDATE COMPLETE
-	EXCEPTION: Steps 2b1 to 2b3 specify the location updating procedure when GERAN cell is in (NMO I or NMO II) and if the UE is in condition C3 and the UE is not registered to the LAC of the current GERAN cell	-	-
2b1	The UE transmits a LOCATION UPDATING REQUEST message.	-->	LOCATION UPDATING REQUEST
2b2	The SS transmits a LOCATION UPDATING ACCEPT	<--	LOCATION UPDATING ACCEPT
2b3	The UE transmits a TMSI REALLOCATION COMPLETE		TMSI REALLOCATION COMPLETE
-	EXCEPTION: Steps 2c1 to 2c3 specify the routing area updating procedure when the GERAN cell is in NMO I and the UE is in condition C2 and the UE is not registered to the LAC of the current GERAN cell	-	-
2c1	The UE transmits a ROUTING AREA UPDATE REQUEST message with update type = 'Combined RA/LA update'.	-->	ROUTING AREA UPDATE REQUEST
2c2	The SS transmits a ROUTING AREA UPDATE ACCEPT message.	<--	ROUTING AREA UPDATE ACCEPT
2c3	The UE transmits a ROUTING AREA UPDATE COMPLETE message.	-->	ROUTING AREA UPDATE COMPLETE

10.3 Postambles for E-UTRA test cases

This clause describes UE postamble states which can be used in the post condition of E-UTRA test cases defined in TS 36.523-1[1]. The clause also specifies a set of procedures to bring the UE into these states.

10.3.1 UE postamble states and procedures for E-UTRA test cases

In order to bring the UE to switched/powered off state there are some procedures that need to be executed. The identified procedures are shown in figure 10.3.1-1.

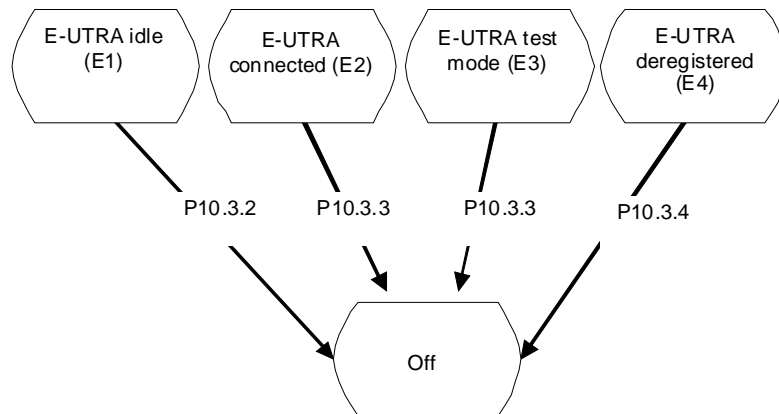

Figure 10.3.1-1: UE postamble states and procedures for E-UTRA

10.3.2 Switch/Power off procedure in State 2E1

10.3.2.1 Procedure

Table 10.3.2.1-1: Switch/Power off procedure

Step	Procedure	U - S	Message Sequence Message
1	The UE is powered off or switched off, (see ICS)	-	-
-	EXCEPTION: Steps 2a1 to 2a4 specify behaviour if the UE supports pc_SwitchOnOff	-	-
2a1	UE transmits an <i>RRConnectionRequest</i> message.	-->	RRC: <i>RRConnectionRequest</i>
2a2	SS transmit an <i>RRConnectionSetup</i> message.	<--	RRC: <i>RRConnectionSetup</i>
2a3	The UE transmits an <i>RRConnectionSetupComplete</i> message to confirm the successful completion of the connection establishment and to initiate the Detach procedure by including the DETACH REQUEST message.	-->	RRC: <i>RRConnectionSetupComplete</i> NAS: DETACH REQUEST
2a4	The SS transmits an RRC CONNECTION RELEASE message	<--	RRC CONNECTION RELEASE

10.3.3 Switch/Power off procedure in State E2 and E3

10.3.3.1 Procedure

Table 10.3.3.1-1: Switch/Power off procedure

Step	Procedure	U - S	Message Sequence Message
1	The UE is powered off or switched off (see ICS)	-	-
-	EXCEPTION: Steps 2a1 to 2a2 specify behaviour if the UE supports <code>pc_SwitchOnOff</code>	-	-
2a1	The UE transmits DETACH REQUEST	-->	DETACH REQUEST
2a2	The SS transmits an RRC CONNECTION RELEASE message	<--	RRC CONNECTION RELEASE

10.3.4 Switch/Power off procedure in State E4

10.3.4.1 Procedure

Table 10.3.4.1-1: Switch/Power off procedure

Step	Procedure	U - S	Message Sequence Message
1	The UE is powered off or switched off (see ICS)	-	-

10.4 Postambles for E-UTRA to HRPD test cases

This clause describes UE postamble states which can be used in the post condition of E-UTRA test cases defined in TS 36.523-1[1]. The clause also specifies a set of procedures to bring the UE into these states.

10.4.1 UE postamble procedures for E-UTRA to HRPD (No Pre-Registration)

10.4.1.1 Registration on HRPD Cell

Table 10.4.1.1: Registration on HRPD Cell procedure

Step	Procedure	Message Sequence	
		U - S	Message
1	The UE transmits a <i>UATIRequest</i> message.	-->	<i>UATIRequest</i>
2	The SS transmits <i>UATIAssignment</i> message	<--	<i>UATIAssignment</i>
3	The UE transmits <i>UATIComplete</i> message	-->	<i>UATIComplete</i>
4	The UE transmits <i>ConnectionRequest</i> message .	-->	<i>ConnectionRequest</i>
5	The SS transmits a <i>TrafficChannelAssignment</i> message .	<--	<i>TrafficChannelAssignment</i>
6	The UE transmits <i>TrafficChannelcomplete</i> .	-->	<i>TrafficChannelcomplete</i>
7	The UE transmits <i>ConfigurationRequest</i> message for SCP configuration .	-->	<i>SCP:ConfigurationRequest</i>
8	The SS transmits a <i>ConfigurationResponse</i> message for SCP configuration .	<--	<i>SCP:ConfigurationResponse</i>
9	The UE transmits <i>ConfigurationRequest</i> message for Stream protocol .	-->	<i>Stream:ConfigurationRequest</i>
10	The SS transmits a <i>ConfigurationResponse</i> message for Stream protocol accepting EMPA bound to service network .	<--	<i>Stream: ConfigurationResponse</i>
11	The UE transmits <i>EMPA ConfigurationRequest</i> message .	-->	<i>EMPA:ConfigurationRequest</i>
12	The SS transmits an <i>EMPA ConfigurationResponse</i> message .	<--	<i>EMPA: ConfigurationResponse</i>
13	The UE transmits <i>ConfigurationComplete</i> message .	-->	<i>ConfigurationComplete</i>
14	Optionally session negotiation initiated by the SS might take place	<-->	-
15	Optionally device level authentication may take place .	<-->	-
16	Optionally Location Update procedure may take place if the SS is configured to support it.	<-->	-
17	PPP LCP negotiation is performed between the UE and the SS. EAP-AKA is selected as the authentication protocol.	<-->	-
18	Tunnelled EAP-AKA is performed between the UE and the SS.	<-->	-
19	The UE transmits <i>VSNCP Configure-Request</i> message, including a PDN-ID, PDN Type, APN, PDN Address with empty content, Protocol Configuration Options, and Attach Type = "handover". The Address Allocation Preference option contained in the Protocol Configuration Options indicates whether the UE wants to perform the IP address allocation during the attach procedure or deferred IPv4 address allocation. PDN Type indicates the UE's IP capability (IPv4, IPv6 or IPv4/v6)	-->	<i>VSNCP: Configure-Request</i>
20	The SS transmits a <i>VSNCP Configure-Ack</i> message.	<--	<i>VSNCP: Configure-Ack</i>
21	The SS transmits a <i>VSNCP Configure-Request</i> message including the PDN-ID configuration option.	<--	<i>VSNCP: Configure-Request</i>
22	The UE transmits <i>VSNCP Configure-Ack</i> message.	-->	<i>VSNCP :Configure-Ack</i>
23	Optionally IPv4 address allocation by DHCPv4 may occur (depending on the Address Allocation Preference indicated by	<-->	-

	the UE at Step 19).		
24	Optionally Link global IPv6 address configuration by ICMPv6 may occur (depending on the Address Allocation Preference indicated by the UE at Step 19). <i>solicitation</i> message.	<-->	-

10.4.1.2 Detach on HRPD Cell

Table 10.4.1.2: Detach on HRPD Cell procedure

Step	Procedure	Message Sequence	
		U - S	Message
1	The UE transmits PPP:LCP Terminate-Request	-->	LCP:Terminate-Request
2	The SS transmits PPP: LCP Terminate-Ack	<--	LCP:Terminate-Ack
3	the UE and SS perform Session update to release the reservations;	<-->	-

11 Guidelines on test execution

This clause provides the guidelines on test executions.

11.1 Guidelines for different operating Bands

The restriction on test case execution as listed in this clause is due to the restriction of bandwidth to accommodate the necessary number of radio frequencies for the specific operating Band as used by the test cases.

A test case using more than one radio frequency, i.e. using the radio frequencies f2 or f3 or f4 specified in TS 36.508 [3], shall avoid to be executed on operating

Band 12 with 10MHz bandwidth,

Band 13,

Band 17 with 10MHz bandwidth.

The list containing such test cases is given below:

6.1.1.1, 6.1.1.4, 6.1.1.6, 6.1.1.10, 6.1.2.5, 6.1.2.7, 6.1.2.8, 6.1.2.9, 6.1.2.11, 6.1.2.15, 6.2.1.1, 6.2.1.2, 6.2.1.3, 6.2.1.4, 6.3.6,

8.1.3.4, 8.1.3.5, 8.2.4.6, 8.3.1.3, 8.3.1.4, 8.3.1.6, 8.3.1.9, 8.3.1.10, 8.3.1.11,

9.1.2.6, 9.2.1.1.1a, 9.2.1.1.7, 9.2.1.1.9, 9.2.1.1.10, 9.2.1.1.11, 9.2.1.1.12, 9.2.1.1.13, 9.2.1.1.15, 9.2.1.1.16, 9.2.1.1.17, 9.2.1.1.18, 9.2.1.2.1, 9.2.1.2.9, 9.2.1.2.10, 9.2.1.2.11, 9.2.1.2.12, 9.2.1.2.13, 9.2.1.2.14, 9.2.3.1.1, 9.2.3.1.4, 9.2.3.1.9a, 9.2.3.1.10, 9.2.3.1.11, 9.2.3.1.12, 9.2.3.1.15, 9.2.3.1.16, 9.2.3.1.17, 9.2.3.1.18, 9.2.3.1.19, 9.2.3.1.25, 9.2.3.1.27, 9.2.3.2.1, 9.2.3.2.5, 9.2.3.2.6, 9.2.3.2.7, 9.2.3.2.8, 9.2.3.2.11, 9.2.3.2.12, 9.2.3.2.14, 9.2.3.2.15, 9.2.3.2.16.

A test case using more than two radio frequencies, i.e. using the radio frequencies f3 or f4 specified in TS 36.508 [3], shall avoid to be executed on operating

Band 6,

Band 14,

Band 17 with 5MHz bandwidth.,

Band 38

The list containing such test cases is given below:

6.1.1.1, 6.1.1.4, 6.1.1.6, 6.1.2.7, 6.1.2.8, 6.1.2.9, 6.1.2.15, 6.2.1.1,

8.1.3.5, 8.3.1.4,

9.1.2.6, 9.2.1.1.1a, 9.2.1.1.7, 9.2.1.1.13, 9.2.1.1.15, 9.2.1.1.16, 9.2.1.2.9, 9.2.1.2.11, 9.2.1.2.12, 9.2.3.1.4, 9.2.3.1.15,
9.2.3.1.17, 9.2.3.1.18, 9.2.3.2.11, 9.2.3.2.14.

A test case using more than three radio frequencies, i.e. using the radio frequency f_4 specified in TS 36.508 [3], shall avoid to be executed on operating

Band 12 with 5MHz bandwidth,

Band 18,

Band 19,

Band 20,

Band 21,

Band 34.

The list containing such test cases is given below:

6.1.1.1, 6.1.1.6

9.2.1.1.7, 9.2.1.2.12, 9.2.3.1.4, 9.2.3.2.14.

Annex A (normative): Test Suites

This annex contains the approved TTCN Test Suites. The test suites have been produced using the Testing and Test Control Notation version 3 (TTCN3) according to ES 201 873-1 [13].

A.1 Baseline of specifications

Table A.1 shows the baseline of the relevant cores specifications and the test specifications which the delivered TTCN test suites are referred to.

Table A.1: References of the test and Core specifications

Core specifications baseline	3GPP TS 36.331 [19]
	3GPP TS 24.301 [21]
Test specifications	3GPP TS 36.508 [3]
	3GPP TS 36.509 [4]
	3GPP TS 36.523-1 [1]
	3GPP TS 36.523-2 [2]

A.2 E-UTRA Test Suites

The following table lists all approved test cases. An “X” in columns FDD or TDD indicates the test case approved for the respective variant.

Table A.2: E-UTRA / EPS TTCN test cases

Test case	Description	FDD	TDD
6.1.1.1	PLMN selection of RPLMN, HPLMN/EHPLMN, UPLMN and OPLMN / Automatic mode	X	
6.1.2.2	Cell selection, Qrxlevmin	X	X
6.1.2.3	Cell selection / Intra E-UTRAN / Serving cell becomes non-suitable (S<0 or barred)	X	X
6.1.2.4	Cell reselection	X	X
6.1.2.5	Cell reselection for inter-band operation	X	
6.1.2.6	Cell reselection using Qhyst, Qoffset and Tselection	X	X
6.1.2.7	Cell reselection / Equivalent PLMN	X	
6.1.2.8	Cell reselection using cell status and cell reservations / Access control class 0 to 9	X	X
6.1.2.9	Cell reselection using cell status and cell reservations / Access control class 11 to15	X	
6.1.2.11	Inter-frequency cell reselection	X	X
6.1.2.15	Inter-frequency cell reselection according to cell reselection priority provided by SIBs	X	
7.1.1.1	CCCH mapped to UL SCH/ DL-SCH / Reserved LCID (Logical Channel ID)	X	X
7.1.1.2	DTCH or DCCH mapped to UL SCH/ DL-SCH / Reserved Logical Channel ID	X	X
7.1.2.1	Correct selection of RACH parameters / Random access preamble and PRACH resource explicitly signalled to the UE by RRC / Non-contention based random access procedure	X	X
7.1.2.2	Correct selection of RACH parameters / Random access preamble and PRACH resource explicitly signalled to the UE in PDCCH Order / Non-contention based random access procedure	X	X
7.1.2.3	Correct selection of RACH parameters / Preamble selected by MAC itself / Contention based random access procedure	X	X
7.1.2.4	Random access procedure / Successful	X	
7.1.2.5	Random access procedure / MAC PDU containing multiple RARs	X	X
7.1.2.6	Maintenance of uplink time alignment	X	X
7.1.2.7	MAC contention resolution / Temporary C-RNTI	X	X
7.1.2.8	MAC contention resolution / C-RNTI	X	X
7.1.2.9	MAC backoff indicator	X	X
7.1.3.1	Correct handling of DL assignment / Dynamic case	X	X
7.1.3.3	MAC PDU header handling	X	X
7.1.3.4	Correct HARQ process handling / DCCH and DTCH	X	X
7.1.3.5	Correct HARQ process handling / CCCH	X	X
7.1.3.6	Correct HARQ process handling / BCCH	X	X
7.1.3.7	MAC padding	X	X
7.1.4.1	Correct handling of UL assignment / Dynamic case	X	X
7.1.4.3	Logical channel prioritization handling	X	
7.1.4.4	Correct handling of MAC control information / Scheduling requests and PUCCH	X	X
7.1.4.5	Correct handling of MAC control information / Scheduling requests and random access procedure	X	X
7.1.4.6	Correct handling of MAC control information / Buffer status / UL data arrive in the UE Tx buffer and retransmission of BSR / Regular BSR	X	X
7.1.4.7	Correct handling of MAC control information / Buffer Status / UL resources are allocated / Padding BSR	X	X
7.1.4.8	Correct handling of MAC control information / Buffer status / Periodic BSR timer expires	X	X
7.1.4.10	MAC padding	X	X
7.1.4.11	Correct HARQ process handling	X	X
7.1.4.12	MAC reset UL	X	
7.1.4.13	MAC PDU header handling	X	X
7.1.4.15	UE power headroom reporting / Periodic reporting	X	X
7.1.4.16	UE power headroom Reporting / DL pathloss change reporting	X	X
7.1.6.1	DRX operation / Short cycle not configured / Parameters configured by RRC	X	
7.1.6.2	DRX operation / Short cycle not configured / DRX command MAC control element reception	X	
7.1.7.1.1	DL-SCH transport block size selection / DCI format 1 / RA type 0	X	X
7.1.7.1.2	DL-SCH transport block size selection / DCI format 1 / RA type 1	X	X
7.1.7.1.3	DL-SCH transport block size selection / DCI format 1A / RA type 2 / Localised VRB	X	X

7.1.7.1.4	DL-SCH transport block size selection / DCI format 1A / RA type 2 / Distributed VRB	X	X
7.1.7.2.1	UL-SCH transport block size selection / DCI format 0	X	X
7.2.2.1	UM RLC / Segmentation and reassembly / 5-bit SN / Framing info field	X	X
7.2.2.2	UM RLC / Segmentation and reassembly / 10-bit SN / Framing info field	X	X
7.2.2.3	UM RLC / Reassembly / 5-bit SN / LI value > PDU size	X	X
7.2.2.4	UM RLC / Reassembly / 10-bit SN / LI value > PDU size	X	X
7.2.2.5.1	UM RLC / 5-bit SN / Correct use of sequence numbering	X	X
7.2.2.5.2	UM RLC / 5-bit SN / Correct use of sequence numbering	X	X
7.2.2.6	UM RLC / Concatenation, segmentation and reassembly	X	X
7.2.2.7	UM RLC / In sequence delivery of upper layer PDUs without residual loss of RLC PDUs / Maximum re-ordering delay below t-Reordering	X	X
7.2.2.8	UM RLC / In sequence delivery of upper layer PDUs without residual loss of RLC PDUs / Maximum re-ordering delay exceeds t-Reordering	X	X
7.2.2.9	UM RLC / In sequence delivery of upper layer PDUs with residual loss of RLC PDUs / Maximum re-ordering delay exceeds t-Reordering	X	X
7.2.2.10	UM RLC / Duplicate detection of RLC PDUs	X	X
7.2.2.11	UM RLC / RLC re-establishment procedure	X	X
7.2.3.1	AM RLC / Concatenation and reassembly	X	X
7.2.3.2	AM RLC / Segmentation and reassembly / No PDU segmentation	X	X
7.2.3.3	AM RLC / Segmentation and reassembly / Framing info field	X	X
7.2.3.4	AM RLC / Segmentation and reassembly / Different numbers of length indicators	X	X
7.2.3.5	AM RLC / Reassembly / LI value > PDU size	X	X
7.2.3.6	AM RLC / Correct use of sequence numbering	X	X
7.2.3.7	AM RLC / Control of transmit window	X	X
7.2.3.8	AM RLC / Control of receive window	X	X
7.2.3.9	AM RLC / Polling for status	X	X
7.2.3.10	AM RLC / Receiver status triggers	X	X
7.2.3.13	AM RLC / Reconfiguration of RLC parameters by upper layers	X	X
7.2.3.14	AM RLC / In sequence delivery of upper layers PDUs	X	X
7.2.3.15	AM RLC / Re-ordering of RLC PDU segments	X	X
7.2.3.16	AM RLC / Re-transmission of RLC PDU without re-segmentation	X	X
7.2.3.17	AM RLC / Re-segmentation RLC PDU / SO, FI, LSF	X	X
7.2.3.18	AM RLC / Reassembly / AMD PDU reassembly from AMD PDU segments, Segmentation Offset and Last Segment Flag fields	X	X
7.2.3.20	AM RLC / Duplicate detection of RLC PDUs	X	X
7.2.3.21	AM RLC / RLC re-establishment at RRC connection reconfiguration including mobilityControlInfo IE	X	X
7.3.1.1	Maintenance of PDCP sequence numbers / User plane / RLC AM	X	X
7.3.1.2	Maintenance of PDCP sequence numbers / User plane / RLC UM / Short PDCP SN (7 bits)	X	X
7.3.1.3	Maintenance of PDCP sequence numbers / User plane / RLC UM / Long PDCP SN (12 bits)	X	X
7.3.3.1	Ciphering and deciphering / Correct functionality of EPS AS encryption algorithms / SNOW 3G	X	X
7.3.3.2	Ciphering and deciphering / Correct functionality of EPS UP encryption algorithms / SNOW 3G	X	X
7.3.3.3	Ciphering and deciphering / Correct functionality of EPS AS encryption algorithms / AES	X	X
7.3.3.4	Ciphering and deciphering / Correct functionality of EPS UP encryption algorithms / AES	X	X
7.3.4.1	Integrity protection / Correct functionality of EPS AS integrity algorithms / SNOW 3G	X	X
7.3.4.2	Integrity protection / Correct functionality of EPS AS integrity algorithms / AES	X	X
7.3.5.2	PDCP handover / Lossless handover / PDCP sequence number maintenance	X	
7.3.5.3	PDCP handover / Non-lossless handover / PDCP sequence number maintenance	X	
7.3.5.4	PDCP handover / Lossless handover / PDCP status report to convey the information on missing or acknowledged PDCP SDUs at handover	X	X
7.3.5.5	PDCP handover / In-order delivery and duplicate elimination in the downlink	X	X
7.3.6.1	PDCP discard	X	X
8.1.1.1	RRC / Paging for connection in idle mode	X	X
8.1.1.2	RRC / Paging for notification of BCCH modification in idle mode	X	
8.1.1.6	RRC / BCCH modification in connected mode	X	X
8.1.2.1	RRC connection establishment / Success	X	X
8.1.2.3	RRC connection establishment / Return to idle state after T300 timeout	X	
8.1.2.5	RRC connection establishment / 0% access probability for MO calls, no restriction for MO	X	X

	signalling		
8.1.2.7	RRC connection establishment / 0% access probability for AC 0 to 9, AC 10 is barred, AC 11 to 15 are not barred, access for UE with access class in the range 11 to 15 is allowed	X	
8.1.3.1	RRC connection release / Success	X	X
8.1.3.4	RRC connection release / Redirection to another E-UTRAN frequency	X	
8.1.3.5	RRC connection release / Success / With priority information	X	
8.2.1.1	RRC connection reconfiguration / Radio bearer establishment for transition from RRC_IDLE to RRC_CONNECTED / Success / Default bearer / Early bearer establishment	X	X
8.2.1.3	RRC connection reconfiguration / Radio bearer establishment / Success / Dedicated bearer	X	X
8.2.1.7	RRC connection reconfiguration / Radio bearer establishment / Success / SRB2	X	
8.2.2.1	RRC connection reconfiguration / Radio resource reconfiguration / Success	X	X
8.2.2.2	RRC connection reconfiguration / SRB/DRB reconfiguration / Success	X	X
8.2.3.1	RRC connection reconfiguration / Radio bearer release / Success	X	X
8.2.4.1	RRC connection reconfiguration / Handover / Success / Dedicated preamble	X	X
8.2.4.2	RRC connection reconfiguration / Handover / Success / Common preamble	X	X
8.2.4.3	RRC connection reconfiguration / Handover / Success / Intra-cell / Security reconfiguration	X	X
8.2.4.4	RRC connection reconfiguration / Handover / Failure / Intra-cell / Security reconfiguration	X	
8.2.4.5	RRC connection reconfiguration / Handover / All parameters included	X	X
8.2.4.6	RRC connection reconfiguration / Handover / Success / Inter-frequency	X	
8.2.4.7	RRC connection reconfiguration / Handover / Failure / Re-establishment successful	X	
8.3.1.1	Measurement configuration control and reporting / Intra E-UTRAN measurements / Event A1	X	X
8.3.1.2	Measurement configuration control and reporting / Intra E-UTRAN measurements / Event A2	X	X
8.3.1.3	Measurement configuration control and reporting / Intra E-UTRAN measurements / Two simultaneous events A3 (intra and inter-frequency measurements)	X	X
8.3.1.5	Measurement configuration control and reporting / Intra E-UTRAN measurements / Two simultaneous event A3 (intra-frequency measurements)	X	X
8.3.1.7	Measurement configuration control and reporting / Intra E-UTRAN measurements / Blacklisting	X	X
8.3.1.8	Measurement configuration control and reporting / Intra E-UTRAN measurements / Handover / IE measurement configuration present	X	X
8.3.1.9	Measurement configuration control and reporting / Intra E-UTRAN measurements / Intra-frequency handover / IE measurement configuration not present	X	X
8.3.1.10	Measurement configuration control and reporting / Intra E-UTRAN measurements / Inter-frequency handover / IE measurement configuration not present	X	
8.5.1.1	Radio link failure / RRC connection re-establishment Success	X	X
8.5.1.2	Radio link failure / T301 expiry	X	
8.5.1.3	Radio link failure / T311 expiry	X	X
8.5.1.5	Radio link failure / Radio link recovery while T310 is running	X	X
8.5.4.1	UE capability transfer / Success	X	X
9.1.2.1	Authentication accepted	X	X
9.1.2.3	Authentication not accepted by the network, GUTI used, authentication reject and re-authentication	X	X
9.1.2.4	Authentication not accepted by the UE / MAC code failure	X	X
9.1.2.5	Authentication not accepted by the UE / SQN failure	X	X
9.1.3.1	NAS security mode command accepted by the UE	X	X
9.1.3.2	NAS security mode command not accepted by the UE	X	X
9.1.4.2	Identification procedure / IMEI requested	X	X
9.2.1.1.1	Attach Procedure / Success / Valid GUTI	X	X
9.2.1.1.1a	Attach / Success / Last visited TAI, TAI list and equivalent PLMN list handling	X	X
9.2.1.1.2	Attach Procedure / Success / With IMSI / GUTI reallocation	X	X
9.2.1.1.7	Attach / Success / List of equivalent PLMNs in the ATTACH ACCEPT message	X	X
9.2.1.1.9	Attach / Rejected / IMSI invalid	X	X
9.2.1.1.10	Attach / Rejected / Illegal ME	X	X
9.2.1.1.13	Attach / Rejected / PLMN not allowed	X	X
9.2.1.1.14	Attach / Rejected / Tracking area not allowed	X	X
9.2.1.1.15	Attach / Rejected / Roaming not allowed in this tracking area	X	X
9.2.1.1.16	Attach / Rejected / EPS services not allowed in this PLMN	X	X

9.2.1.1.17	Attach / Rejected / No suitable cells in tracking area	X	X
9.2.1.1.19	Attach / Abnormal case / Failure due to non integrity protection	X	X
9.2.1.1.20	Attach / Abnormal case / Access barred because of access class barring or NAS signalling connection establishment rejected by the network	X	X
9.2.1.1.21	Attach / Abnormal case / Success after several attempts due to no network response	X	X
9.2.1.1.22	Attach / Abnormal case / Unsuccessful attach after 5 attempts	X	X
9.2.1.1.23	Attach / Abnormal case / Repeated rejects for network failures	X	X
9.2.1.2.1	Combined attach / Success / EPS and non-EPS services	X	X
9.2.1.2.4	Combined attach / Success / EPS services only / CS domain not available	X	X
9.2.2.1.1	UE initiated detach / UE switched off	X	X
9.2.2.1.2	UE initiated detach / USIM removed from the UE	X	X
9.2.2.1.6	UE initiated detach / Abnormal case / Local detach after 5 attempts due to no network response	X	X
9.2.2.2.1	NW initiated detach / Re-attach required	X	X
9.2.2.2.2	NW initiated detach / IMSI detach	X	X
9.2.3.1.1	Normal tracking area update / Accepted	X	X
9.2.3.1.2	Normal tracking area update / Accepted / "Active" flag set	X	X
9.2.3.1.4	Normal tracking area update / List of equivalent PLMNs in the TRACKING AREA UPDATE ACCEPT message	X	X
9.2.3.1.5	Periodic tracking area update / Accepted	X	X
9.2.3.1.8	UE receives an indication that the RRC connection was released with cause "load balancing TAU required"	X	X
9.2.3.1.13	Normal tracking area update / Rejected / UE identity cannot be derived by the network	X	X
9.2.3.1.14	Normal tracking area update / Rejected / UE implicitly detached	X	X
9.2.3.2.1	Combined tracking area update / Successful	X	X
9.3.1.1	Service request initiated by UE for user data	X	X
9.3.1.7	Service request / Rejected / UE identity cannot be derived by the network	X	X
9.3.1.7a	Service request / Rejected / UE implicitly detached	X	X
9.3.1.16	Service request / Abnormal case / Switch off	X	X
9.3.1.17	Service request / Abnormal case / Procedure collision	X	X
9.3.2.1	Paging procedure	X	X
9.4.1	Integrity protection / Correct functionality of EPS NAS integrity algorithm / SNOW3G	X	X
9.4.2	Integrity protection / Correct functionality of EPS NAS integrity algorithm / AES	X	X
9.4.3	Ciphering and deciphering / Correct functionality of EPS NAS encryption algorithm / SNOW3G	X	X
9.4.4	Ciphering and deciphering / Correct functionality of EPS NAS encryption algorithm / AES	X	X
10.2.1	Dedicated EPS bearer context activation / Success	X	X
10.3.1	EPS bearer context modification / Success	X	X
10.4.1	EPS bearer context deactivation / Success	X	X
10.5.1	UE requested PDN connectivity procedure accepted by the network	X	X
10.5.3	UE requested PDN connectivity procedure not accepted	X	X
10.6.1	UE requested PDN disconnect procedure accepted by the network	X	X
10.7.1	UE requested bearer resource allocation, accepted by the network / New EPS bearer context	X	X
10.7.2	UE requested bearer resource allocation accepted by the network / Existing EPS bearer context	X	X
10.7.3	UE requested bearer resource allocation not accepted by the network	X	X
10.7.4	UE requested bearer resource allocation / Expiry of timer T3480	X	X
10.8.1	UE requested bearer resource modification accepted by the network / New EPS bearer context	X	X
10.8.2	UE requested bearer resource modification accepted by the network / Existing EPS bearer context	X	X
10.8.3	UE requested bearer resource modification not accepted by the network	X	X
11.1.1	MT-SMS over SGs / Idle mode	X	
11.1.2	MT-SMS over SGs / Active mode	X	
11.1.3	MO-SMS over SGs / Idle mode	X	
11.1.4	MO-SMS over SGs / Active mode	X	
12.2.1	Data transfer of E-UTRA radio bearer combinations 1, 3, 6 and 9	X	X

12.2.2	Data transfer of E-UTRA radio bearer combinations 2, 4, 7 and 10	X	X
12.2.3	Data transfer of E-UTRA radio bearer combinations 5, 6, 8, 11 and 12	X	
13.1.1	Activation and deactivation of additional data radio bearer in E-UTRA	X	X
13.2.1	RRC connection reconfiguration / E-UTRA to E-UTRA	X	X
13.3.1.1	Intra-system connection re-establishment / Radio link recovery while T310 is running	X	
13.3.1.2	Intra-system connection re-establishment / Re-establishment of a new connection when further data is to be transferred	X	

The Test Suite in TTCN3 is contained in multiple ASCII files which accompany the present document.

Annex B (informative): Style Guides

B.1 Introduction

This annex is based on the style guide given in TS 34.123-3 [7], annex E but the language for UE conformance tests is TTCN-3.

B.2 General Requirements for TTCN-3 Implementations

The TTCN-3 implementation for UE conformance tests shall be based on the following general design considerations:

- Even though it is not reflected in TTCN-3 anymore in UE conformance tests ASPs and PDUs will still be distinguished. This has impact on type definitions and naming conventions.
- In general, templates for UE conformance tests shall be separated for sending and receiving.
- Modified templates shall not be modified again.
- All local variables shall be declared at the beginning of a function;
the order of declarations is
 - local constants
 - local variables
 - local timers
- The purpose of the test case implementation is conformance testing.
- The common RAN5 approval process needs to be considered.

The TTCN-3 implementation for UE conformance tests shall fulfil the following requirements.

The implementation shall:

- follow ES 201 873-1 [13] (TTCN-3 Core Language) and ES 201 873-4 [27] (TTCN-3 Operational Semantics);
- be independent from interface specifications like TRI (ES 201 873-5 [28]) and TCI (ES 201 873-6 [29]) as well as from proprietary approaches;
- not use or rely on tool dependent features;
- support maintainability and extendibility;
- follow the naming conventions as defined below.

Further requirements:

- Usage of external functions should be avoided.
- Type definitions:
 - Existing ASN.1 type definitions contained in protocol specifications are imported from the respective standards. All other type definitions shall be done within TTCN-3.

B.3 Naming Conventions

Even though these are being used for TTCN-3 the naming conventions provided in the present document are mainly backward compatible to TTCN-2 as defined in TS 34.123-3 [7].

B.3.1 Prefixes and Restrictions for TTCN-3 Objects

Table B.3.1: Prefixes used for TTCN-3 objects

TTCN object	Initial Letter	Prefix/ Postfix	Comment
TTCN module	upper case	(none)	
TTCN group	upper case	(none)	
function parameter	upper case	p_	
function running on a component	upper case	f_	
local function (tree) not to be used by other modules	upper case	fl_	local function not to be used by other modules
external function	upper case	fx_	
altstep	upper case	a_	(including defaults)
test case selection expression			name as specified in TS 36.523-2 [2] shall be used
global constant	upper case	tsc_	(see note 1)
local constant	upper case	const_	local constant being defined in a function
Enumerated		(none)	there are no restrictions regarding enumerated types
type definition	upper case	_Type	(see note 7)
local variable	upper case	v_	(see note 6)
global (component) variable	upper case	vc_	(see note 2)
port type	upper case		
port name	upper case		
local timer	upper case	t_	
ASP template	upper case	cas_ cads_ car_ cadr_	send ASP modified (derived) send ASP receive ASP modified (derived) receive ASP
PDU template	upper case	cs_ cds_ cr_ cdr_	send PDU modified (derived) send PDU receive PDU modified (derived) receive PDU (see note 3)
CM template	upper case	cms_ cmr_	send coordination message receive coordination message
Template (neither ASP nor PDU nor CM)	upper case	cs_ cds_ cr_ cdr_ crs_	send template modified (derived) send template receive template modified (derived) receive template templates for IEs used in both directions (see note 5)
test suite parameter (PICS)	upper case	pc_	
test suite parameter (PIXIT)	upper case	px_	
test case		TC_	(see note 4)

<p>NOTE 1: Global constants may be defined differently in imported modules (e.g. without any prefix and with lower case initial letter).</p> <p>NOTE 2: Global variables or timers are those defined within the TTCN-3 components. They are visible to all the functions run in the component.</p> <p>NOTE 3: Base template may have a second prefix:</p> <ul style="list-style-type: none">- 508: PDU as defined in TS 36.508 [3];- 108: PDU as defined in TS 34.108 [8]. <p>NOTE 4: Test case names will correspond to the clause in the prose that specifies the test purpose. E.g. TC_8_1.</p> <p>NOTE 5: Applicable only in case of "quasi-constant" definitions, e.g. to define a (constant) random pattern to be used for sending and receiving when the UE is configured in loopback mode.</p> <p>NOTE 6: Counter variables do not need to have a prefix.</p> <p>NOTE 7: Exceptions for type definitions:</p> <ul style="list-style-type: none">- ASP names are fully upper case letters and typically have postfix "_REQ", "_CNF" or "_IND".- RRC protocol type definitions are extracted and imported from TS 36.331/25.331 and are therefore out of scope.- NAS protocol type definitions follow the names provided in the tabular notion of the standards and therefore do not have a "_Type" postfix.

B.3.2 Void

B.3.3 Void

B.3.4 Identifiers consisting of more than one Name

When identifiers are a concatenation of several words the words shall start with capital letters:

e.g.: "px" + "Cell" + "A" + "Cell" + "Id" -> px_CellACellId.

Further details are described in TS 34.123-3 [7], clause E.2.1.

B.4 Implementation Issues

B.4.1 Control part

Even though the control part may not be used in a test campaign but be overruled by the test management system it is used to provide the following information:

- All test cases contained in the test suite.
- For each test case:
 - Test case selection expression.

For maintenance reasons it shall be possible to generate the control part automatically by an appropriate tool.

B.4.2 Top Level Test Case Definitions

The top level test case definitions run on the MTC exclusively. The tasks of these test case definitions are generally the same for each test case:

- Start guard timer.
- Create PTCs.
- Connect PTCs.
- Start PTCs.

- Wait for PTCs having finished.

Additionally the MTC may host the upper tester but this is left open to implementation.

For maintenance reasons it shall be possible to generate the top level test case definitions defined for the MTC automatically by an appropriate tool. To achieve this, the name of a function to be started on particular PTC need derived from the test case name:

e.g. the function for PTC_A in test case TC_XX_YY_ZZ shall be f_TC_XX_YY_ZZ_A.

Cells are created in an off-state in the preambles of the corresponding PTCs while UE is in the switched off-state.

B.4.3 Inter Component Communication

Communication between PTCs or PTCs and the MTC can be done by messages or by build-in mechanisms as *done* and *kill*. For maintenance reasons and extendibility the inter component communication shall be encapsulated by TTCN-3 implementation.

B.4.4 Encoding Information

For UE conformance tests several encoding rules need to be applied by the TTCN-3 codec. Even though the codec is out of scope of the present document there are aspects with impact on TTCN-3 implementation depending on different type definitions.

Table B.4.4-1

Type definitions	Encoding
ASN.1 types used for RRC signalling	ASN.1 PER
ASN.1 types used by NAS protocols	ASN.1 BER
NAS types	Tabular notated (see note)
DRB types	Tabular notated (see note)
DHCPv4 types	Tabular notated (see note)
ICMPv6 types	Tabular notated (see note)
GPRS Padding	see TS 34.123-3, clause 6.10.2.9.1
GSM Spare Padding	see TS 34.123-3, clause 6.10.2.9.2
LowHigh Rule	see TS 34.123-3, clause 6.10.2.9.3
SACCHSysInfo Spare Padding	see TS 34.123-3, clause 6.10.2.9.5
TTCN-3 types not used at the air interface: <ul style="list-style-type: none"> - Configuration of system simulator - Coordination between components - Types used internally in TTCN-3 	(no specific encoding required)
NOTE: Tabular notated is performed by concatenation of all the present fields in the TTCN-3 template.	

Encoding information may be provided and supported in TTCN-3 by grouping of type definitions and using the *encode* attribute.

B.4.5 Verdict Assignment

In general the following rules shall be applied.

Table B.4.5-1: Rules for verdict assignment

Verdict	Rule
Pass	shall be assigned for each step defined in the prose of the test case
Fail	shall be assigned when there is a non-conformant signalling by the UE within the test body
Inconc	shall be assigned outside the test body and when it is not unequivocal whether a misbehaviour is caused by non-conformity of the UE signalling
Error	In case of obvious programming or parameterisation errors (e.g. missing <i>case</i> in a <i>select</i> statement)

B.4.5.1 PASS verdict assignment

The PASS verdicts are assigned by test cases or test case specific functions.

For generic test procedures as specified in 36.508 cl. 6.4.2, the preliminary pass is assigned directly after the procedure if all described in the procedure UL messages have been successfully received; this allows re-usage of these procedures for other purposes.

B.4.5.2 FAIL or INCONC verdict assignment

The verdict FAIL or INCONC can be assigned in test cases, in the test case-specific function, in the common functions and in the default behaviour.

Test case or test case-specific function

In normal cases the common function `f_EUTRA_SetVerdictFailOrInconc` shall be used to assign FAIL or INCONC depending on whether it is in the test body or outside of the body.

If in test cases a verdict FAIL shall be assigned for watchdog timer timeouts this needs to be done explicitly.

Common Functions

The majority of the common functions have no verdict assignment. If a verdicts assignment is required in some common functions, the common function `f_EUTRA_SetVerdictFailOrInconc` shall be used to assign FAIL or INCONC.

As an exception in the altstep `a_EUTRA_RacingCond_AwaitRrcMessage` an INCONC is assigned when the RRC message and the L1/MAC indication are in the wrong order.

B.4.5.3 Verdict assignment in default behaviour

The default behaviour handles all events not being handled in test cases or functions. Whether the verdict FAIL or INCONC to be assigned in the default behaviour it depends very much on the port where the event occurs.

Table B.4.5.3-1: Verdict assignment in default behaviour upon test ports

Test port	Message	Comment	Verdict
SYS	SYSTEM_CTRL_CNF	unexpected confirmation	INCONC
SYSIND	SYSTEM_IND: Error indication	unspecific error at SS	INCONC
	SYSTEM_IND: MAC indication	(NOTE 1)	FAIL in the test body INCONC outside the test body
	SYSTEM_IND: L1 indication	RachPreamble, SchedReq, UL_HARQ may be repeated by the UE in case of transmission errors (NOTE 1)	INCONC
SRB	SRB_COMMON_IND	Any unexpected L3 signalling (NOTE 3)	FAIL in the test body INCONC outside the test body
NASCTRL	NAS_CTRL_CNF	unexpected confirmation	INCONC
DRB	DRB_COMMON_IND	L2 and combined tests (NOTE 2)	FAIL in the test body INCONC outside the test body
		pure signalling tests (NOTE 2)	INCONC
UT	UT_COMMON_CNF	unexpected confirmation	INCONC
<p>Note 1: L1/MAC indications need to be enabled by the test case therefore they occur only when being relevant for the test case.</p> <p>Note 2: L2 and combined tests can be distinguished from pure signalling tests by additional global information controlled by f_EUTRA_TestBody_Set.</p> <p>Note3: Layer 3 signalling by definition covers NAS and RRC signalling i.e. in general unexpected RRC messages will cause a FAIL in the body of any NAS test case as well as unexpected NAS messages will cause a FAIL in the body of any RRC test case.</p>			

Table B.4.5.3-2: Verdict assignment in default behaviour when time-out

Timeout	Comment	Verdict
any timer	unspecific timeout (NOTE)	INCONC
NOTE: Local timers of test cases or functions cannot be distinguished in the default behaviour.		

B.4.6 Default Behaviour

As experience from UMTS conformance tests there shall be one standard default behaviour for each component.

The following rules shall be applied:

- The standard default behaviour is activated during initialisation of the respective component. In normal cases a TTCN writer does not need to care about the default.
- In general there is only one default behaviour activated (i.e. the standard default behaviour).
- The standard default behaviour shall cover all ports and timers of the component.
- Whenever possible deviations from the standard default behaviour shall be implemented locally rather than by introducing a new default behaviour.

If for exceptional cases the standard default behaviour needs to be replaced by another default behaviour or another default behaviour needs to be activated on top, the TTCN writer is responsible:

- to avoid side effects;

- to restore the standard behaviour.

B.4.7 Templates for Sending and Receiving

Templates used for sending and receiving shall be separated in general:

- A template shall be either for sending or for receiving; this shall be reflected in the prefix of the identifier.
- Send templates shall use no receive templates and vice versa.
- All parameters of a send template shall be restricted to:
 - values;
 - template (value);
 - template (omit).
- Parameters of receive templates may allow wildcards. They can be:
 - values;
 - unrestricted template parameters;
 - template parameters restricted to be present.
- The only exception to the above rule is for "quasi-constant" definitions, as described in note 5 of table B.3.1. Otherwise, even when the same data is expected for sending and receiving templates, there shall be different templates and the following rule shall be applied.
- The receive template is assigned the send template e.g.:
 - template My_Type cr_Template := cs_Template
- This results in separate definitions for sending and receiving and improves maintainability.

NOTE 1: For maintenance reasons, a send template shall never be derived from a receive template; and also a receive template shall never be assigned to a send template.

NOTE 2: When a send template is assigned to a receive template, the formal parameters of the receive template must follow the rules of send templates (i.e. it shall only contain 'template (value)', 'template (omit)' or values only).

B.4.8 Logging

In general no explicit log statements shall be used. As an exception log may be used to report unexpected situations in TTCN-3 like fatal programming error.

B.4.8.1 Prose Step Numbers

Informative comments containing the prose steps defined in 36.523-1 should be implemented according to the following guidelines:

- They relate to the Expected Sequence steps in the prose
- They should not be placed in common functions
- They should only be placed in functions containing the test case body
- They should always start with //@siclog
- They should always finish with siclog@
- For single steps they should be in the form //@siclog "Step 1" siclog@

- For multiple steps (where several steps are completed in a common function), they should be in the form `//@siclog "Steps 1 - 3" siclog@` - i.e. Steps, space, first number, space, dash, space, second number
- They should be placed as close as possible, but always BEFORE, the line send/receive/function call
- The step number should also be included in any pass/fail verdict specified in the test case body
- If the step is listed as Void (or a group of steps) in the expected sequence, include the word Void in the comment.

Therefore the format of the comment should be:

```
//@siclog "Step[s] X [- Y] [Void]" siclog@
```

B.4.9 Top level comments

No restriction is specified for the top level comments.

B.4.10 Mapping of DRBs

LTE DRBs are mapped in TTCN according to the following rules:

- DRB1 is exclusively reserved for the default DRB and hence is always AM
- additional DRBs (AM or UM) may be assigned from DRB2 onward in any order
- there shall be no reconfiguration of a DRB from AM to UM or vice versa (unless a test case explicitly requires this); this especially means that DRB1 is never reconfigured to UM
- in general at the SS all DRBs needed by a test case may be configured at the beginning of the test case.

B.5 Modularisation

Even though there are no specific rules how to apply modularisation in general some principles can be defined:

- Maintainability and extendibility:
 - Maintainability and extendibility are essential for definition of the modular structure.
- Granularity of modules:
 - Cyclic imports are forbidden in TTCN-3; this has impact on the extendibility:
 - The granularity of modules shall not be too small.
 - Too big modules are hard to handle and may cause increase of compilation time:
 - The granularity of modules shall not be too rough.

NOTE: These are only vague principles since there is no way to define what small or huge modules are.

- General module structure:
 - The following modularisation can be applied independent from the internal structure:
 - Type definitions: TTCN-3, ASN.1.
 - Component definitions.
 - Common Templates: component dependent, component independent.
 - Common behaviour: MTC, PTCs.

- Test case specific templates.
- Test case specific behaviour.
- Whether or how these module groups can further be sub-divided is implementation dependent and therefore out of scope of the present document.

Annex C (informative): Design Principles

C.1 ASP Design

All ASPs consist of a common part (defined as a TTCN-3 type) and a specific part.

All ASPs sent by the SS include timing information (SFN, subframe number) in the common part.

Only one ASP is defined per direction per port, but this ASP may contain a union of several sub-ASPs in the specific part.

In general a small number of common ASPs cover all functionality, although other ASPs may be introduced to simplify TTCN-3 implementation and improve readability. Recurrent SS changes, such as power level changes, security activation and MAC scheduling are handled in dedicated ASPs. In addition, special purpose ASPs are used to control special behaviour, for example in L2 tests.

Configuration ASPs re-use ASN.1 definitions defined in the core specs.

No encoding rules are specified for the configuration ASPs; how they are encoded is left up to the SS implementation.

Configuration ASPs are 'procedure-based', rather than 'protocol layer-based' and reflect the state transitions of the SS. The same ASPs are used for reconfiguration and for initial configuration. In the case of reconfiguration the semantics of omit is to keep the configuration as it is; therefore when an IE in a configuration may be left out this is done e.g. by setting the respective field to a special value "None".

Data ASPs for sending/receiving peer-to-peer PDUs and user data all have different ASPs for the different SAPs.

The common part includes (at least):

- Timing Info:
 - SFN.
 - Subframe number (optional).
 - Which timing to use will depend on the test procedure and ASP purpose.
- Control Info:
 - Confirmation Flag.

The RRC ASN.1 IEs used in the specific part of the configuration ASPs:

- are imported using the granularity at the channel structure level or below;
- allow the ASP to be organised according to SS requirements;
- have a name that relates to SS configuration.

The SS specific IEs used in the specific part of the configuration ASPs (i.e. those elements not imported from the RRC ASN.1):

- use a naming convention such that they are easily distinguishable from the RRC ASN.1 IEs;
- are defined in TTCN-3 (i.e. not in ASN.1).

C.2 SS State Model

Figure C.2 shows the basic SS state model. It is basic in the sense that internally the SS may have more states; however, (re)configuration actions (state transitions in the model) should cause the SS to transit between the states defined below.

The following assumptions have been made about this state model:

- It presents a model of states in scope of a single cell. Hence, all configuration activities shall be performed in scope of a single cell.
- It depicts only SS states and SS (re)configuration actions between these states:
 - It does not show events which may trigger state transitions, e.g. L3 messages or procedures - i.e. it is test case and L3 procedure agnostic.
 - It does not show any peer-to-peer (i.e. between SS and UE) messages.
- Triggers for state transitions are always SS configuration messages (ASPs) coming from the test suite:
 - L2 messages coming from the UE can only trigger internal SS sub-state transitions and semi-autonomous procedures.
- L1 and L2 procedures (e.g. random access procedure, scheduling, security activation steps) are semi-autonomously handled by the SS and after being pre-configured do not require interaction with the test case:
 - The majority of test cases do not need to worry about e.g. RA procedure and letting the SS handle it would greatly simplify test case definition and implementation.
 - There may be stringent time requirements in case of some procedures that can be hard to meet in a generic way in the test suite.
 - Semi-autonomous procedures should be flexibly configurable and should have a "manual" mode in which they are handled by the test suite in order to enable testing them. What is the desired level and way of control is FFS.

Most states are stationary states, i.e. the SS can stay in them for a long time or, after performing some procedures, returns to these states. However, there is one state (indicated by dashed lines) which is part of the AS security activation procedure and is transitional, i.e. the SS can only stay in it for a short time until a transition to the next stationary state is triggered.

To make the diagram more readable, a separate state called *ANY_STATE* has been introduced, together with some transitions. It shows which transitions are allowed at any point of time in any state.

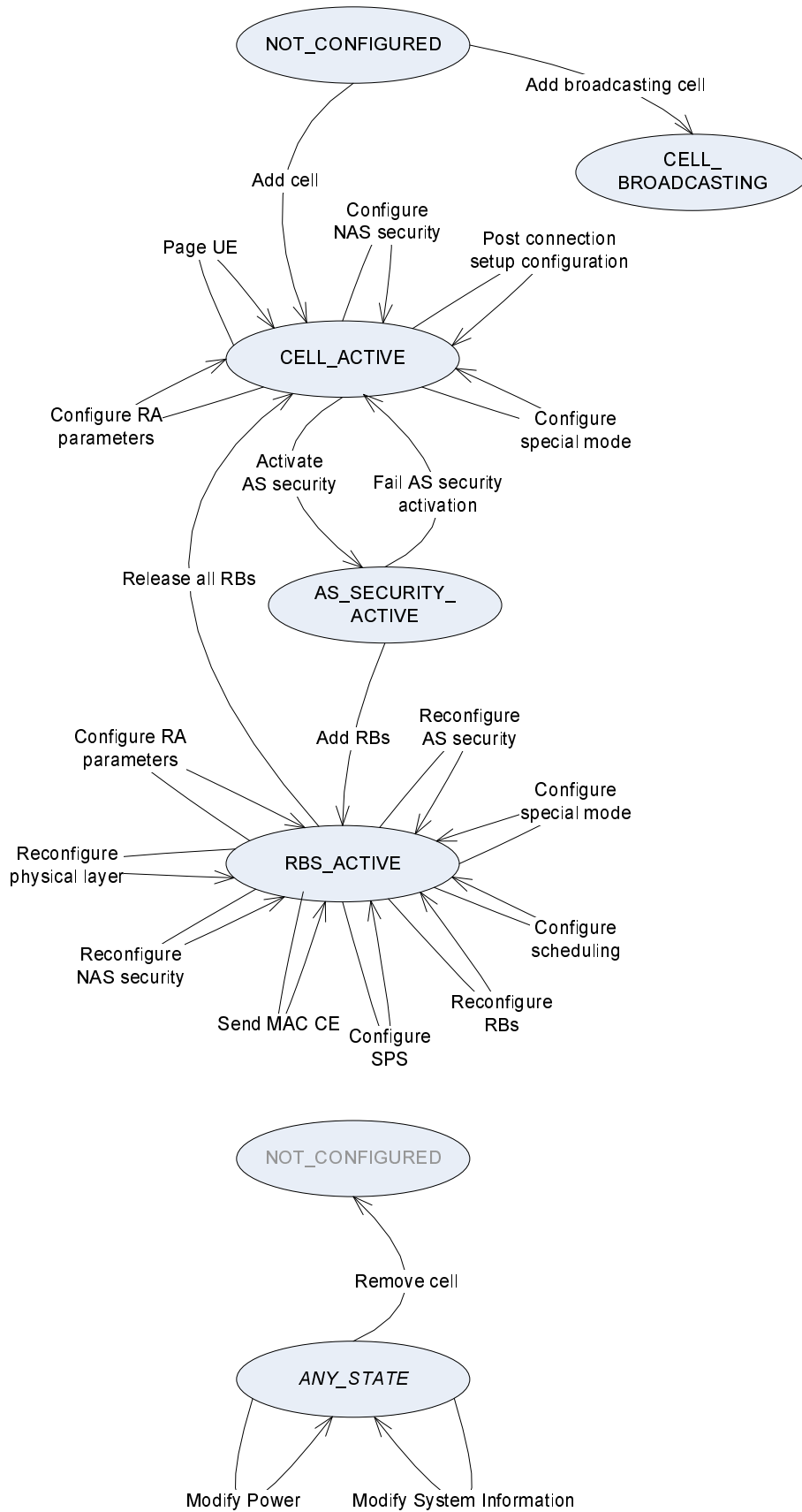

Figure C.2-1: Basic SS state model

Description of states.

Table C.2-1: Description of states

State	Description
NOT_CONFIGURED	The cell does not exist (is not configured) in the SS
CELL_BROADCASTING	Physical DL channels and signals configured Initial cell configuration done: freq, BW, antennas, MIMO mode, power, etc. Transport and logical channels configured for SI broadcast Cell is broadcasting SI and downlink signals NOTE 1: This type of cell is needed only to serve as a neighbouring cell for measurement purposes, where full cell configuration does not need to be specified. There is no need to be able to promote a broadcasting cell to a full cell. NOTE 2: It is currently open whether a separate cell type with limited PRACH/RACH Rx capability is needed - this depends on whether a justified use case is defined for such a cell type.
CELL_ACTIVE	Cell configured to send and receive data from UE (fully functional) SRB0 defined (default configuration specified in TS 36.508 [3]) SRB1 defined (default configuration specified in TS 36.508 [3])
AS_SECURITY_ACTIVE	The SS has AS security (integrity protection and ciphering) active NOTE: The SS needs to autonomously take care of a temporary state in which integrity protection is applied to an outgoing SMC message, but ciphering is not.
RBS_ACTIVE	SRB2 and/or DRBs are configured for the UE (in addition to SRB0 and SRB1)
ANY_STATE	Represents any of the above states (except NOT_CONFIGURED)

Annex D (informative)

TTCN-3 Definitions

D.1 EUTRA_ASP_TypeDefs

Type definitions for configuration of the system simulator;

Common design principles:

Semantics of OMIT: for all TTCN-3 type definitions used in ASPs omit means "keep as it is" =>

- on initial configuration in general all fields shall be provided
- no default values for fields are foreseen
- if necessary non-existence of information shall be explicitly configured (e.g. with a union of "no configuration" and "configuration parameters")
- fields within structures imported from the core spec are excepted from this rule

D.1.1 ASN1_Container

Definitions containing ASN.1 types for backward compatibility;

NOTE 1: PCCH_Message and BCCH_DL_SCH_Message already have a critical extension mechanism by RRC type definition

NOTE 2: BCCH_BCH_Message contains the MIB and therefore is considered to be not extendable

NOTE 3: "simple types" are not considered: C_RNTI, PhysCellId, CellIdentity, ARFCN_ValueEUTRA

TDD_Config_Type

TTCN-3 Union Type	
Name	TDD_Config_Type
Comment	
R8	TDD_Config

AntennaInfoCommon_Type

TTCN-3 Union Type	
Name	AntennaInfoCommon_Type
Comment	
R8	AntennaInfoCommon

AntennaInfoDedicated_Type

TTCN-3 Union Type	
Name	AntennaInfoDedicated_Type
Comment	
R8	AntennaInfoDedicated

PHICH_Config_Type

TTCN-3 Union Type	
Name	PHICH_Config_Type
Comment	
R8	PHICH_Config

PRACH_Config_Type

TTCN-3 Union Type		
Name	PRACH_Config_Type	
Comment		
R8	PRACH_Config	

PUCCH_ConfigCommon_Type

TTCN-3 Union Type		
Name	PUCCH_ConfigCommon_Type	
Comment		
R8	PUCCH_ConfigCommon	

PUCCH_ConfigDedicated_Type

TTCN-3 Union Type		
Name	PUCCH_ConfigDedicated_Type	
Comment		
R8	PUCCH_ConfigDedicated	

PUSCH_ConfigCommon_Type

TTCN-3 Union Type		
Name	PUSCH_ConfigCommon_Type	
Comment		
R8	PUSCH_ConfigCommon	

PUSCH_ConfigDedicated_Type

TTCN-3 Union Type		
Name	PUSCH_ConfigDedicated_Type	
Comment		
R8	PUSCH_ConfigDedicated	

SoundingRS_UL_ConfigCommon_Type

TTCN-3 Union Type		
Name	SoundingRS_UL_ConfigCommon_Type	
Comment		
R8	SoundingRS_UL_ConfigCommon	

SoundingRS_UL_ConfigDedicated_Type

TTCN-3 Union Type		
Name	SoundingRS_UL_ConfigDedicated_Type	
Comment		
R8	SoundingRS_UL_ConfigDedicated	

SchedulingRequestConfig_Type

TTCN-3 Union Type		
Name	SchedulingRequestConfig_Type	
Comment		
R8	SchedulingRequestConfig	

CQI_ReportConfig_Type

TTCN-3 Union Type	
Name	CQI_ReportConfig_Type
Comment	
R8	CQI_ReportConfig

RACH_ConfigCommon_Type

TTCN-3 Union Type	
Name	RACH_ConfigCommon_Type
Comment	
R8	RACH_ConfigCommon

RACH_ConfigDedicated_Type

TTCN-3 Union Type	
Name	RACH_ConfigDedicated_Type
Comment	
R8	RACH_ConfigDedicated

MeasGapConfig_Type

TTCN-3 Union Type	
Name	MeasGapConfig_Type
Comment	
R8	MeasGapConfig

PDCP_Config_Type

TTCN-3 Union Type	
Name	PDCP_Config_Type
Comment	
R8	PDCP_Config

UL_AM_RLC_Type

TTCN-3 Union Type	
Name	UL_AM_RLC_Type
Comment	
R8	UL_AM_RLC

DL_AM_RLC_Type

TTCN-3 Union Type	
Name	DL_AM_RLC_Type
Comment	
R8	DL_AM_RLC

UL_UM_RLC_Type

TTCN-3 Union Type	
Name	UL_UM_RLC_Type
Comment	
R8	UL_UM_RLC

DL_UM_RLC_Type

TTCN-3 Union Type		
Name	DL_UM_RLC_Type	
Comment		
R8	DL_UM_RLC	

TTI_BundlingConfig_Type

TTCN-3 Union Type		
Name	TTI_BundlingConfig_Type	
Comment		
R8	boolean	

DRX_Config_Type

TTCN-3 Union Type		
Name	DRX_Config_Type	
Comment		
R8	DRX_Config	

SpsConfigurationDL_Type

TTCN-3 Union Type		
Name	SpsConfigurationDL_Type	
Comment		
R8	SPS_ConfigDL.setup	

SpsConfigurationUL_Type

TTCN-3 Union Type		
Name	SpsConfigurationUL_Type	
Comment		
R8	SPS_ConfigUL.setup	

UplinkPowerControlCommon_Type

TTCN-3 Union Type		
Name	UplinkPowerControlCommon_Type	
Comment		
R8	UplinkPowerControlCommon	

UplinkPowerControlDedicated_Type

TTCN-3 Union Type		
Name	UplinkPowerControlDedicated_Type	
Comment		
R8	UplinkPowerControlDedicated	

D.1.2 System_Configuration

Formal ASP Definitions for system configuration

SystemRequest_Type

TTCN-3 Union Type		
Name	SystemRequest_Type	
Comment		
Cell	CellConfigRequest_Type	configure/release a cell
CellAttenuation List	CellAttenuationList_Type	power attenuation for one or several cells; all cells included in the list shall be changed at the same time; all cells in the list shall reach the new cell power within a maximum of 100ms (10 frames) acc. to the tolerances given in TS 36.508 NOTE: In the common ASP part the CellId shall be set - to the cell the timing information refers to if activation time shall be applied - to extra_Cell_NonSpecific when there is no activation time
RadioBearerList	RadioBearerList_Type	configure/release one or several SRBs and/or DRBs
EnquireTiming	Null_Type	get SFN and sub-frame number for this cell
AS_Security	AS_Security_Type	StartRestart/Release of AS security
Sps	SpsConfig_Type	to configure/activate or release semi-persistent scheduling
Paging	PagingTrigger_Type	to trigger SS to send paging at the given paging occasion (as calculated in TTCN)
L1MacIndCtrl	L1Mac_IndicationControl_Type	to configure SS to generate indications for L1/MAC events
RlcIndCtrl	Rlc_IndicationControl_Type	to configure SS to generate indications for RLC events
PdcpCount	PDCP_CountReq_Type	to set or enquire PDCP COUNT for one ore more RBs
PdcpHandover Control	PDCP_HandoverControlReq_Type	to inform the target cell about the handover
L1_TestMode	L1_TestMode_Type	To Set L1/MAC in special Test modes eg. DL CRC, PHICH etc
PdcchOrder	RA_PDCCH_Order_Type	to configure SS to transmit a PDCCH order with configured C-RNTI to the UE to trigger RA procedure; result in DCI Format 1A transmission as in TS 36.212, clause 5.3.3.1.3

SystemConfirm_Type

TTCN-3 Union Type		
Name	SystemConfirm_Type	
Comment	confirmations for system configuration; in general to be sent after the configuration has been done	
Cell	Null_Type	(no further parameters from SS)
CellAttenuation List	Null_Type	(no further parameters from SS) NOTE 1: the confirmation shall be sent when all cells have changed power levels NOTE 2: for the CellId in the common ASP part the same rules are applied as for the SYSTEM REQ
RadioBearerList	Null_Type	(no further parameters from SS)
EnquireTiming	Null_Type	SFN and sub-frame number are included in the TimingInfo
AS_Security	Null_Type	(no further parameters from SS)
Sps	Null_Type	(no further parameters from SS)
Paging	Null_Type	normally not needed but defined for completeness
L1MacIndCtrl	Null_Type	(no further parameters from SS)
RlcIndCtrl	Null_Type	(no further parameters from SS)
PdcpCount	PDCP_CountCnf_Type	as response to 'Get' a list is returned containing COUNT information for the requested RBs
PdcpHandover Control	Null_Type	confirmation for PDCP handover control
L1_TestMode	Null_Type	confirmation for L1 test mode
PdcchOrder	Null_Type	confirmation for PDCCH Order

SystemIndication_Type

TTCN-3 Union Type		
Name	SystemIndication_Type	
Comment		
Error	charstring	indicates an error situation in SS; is not explicitly handled in TTCN but causes an INCONC due to default behaviour; an additional error code can be signalled in the common part of the ASP; SS shall raise an error in case of - Invalid TimingInfo for TDD - Contradiction of periodic UL grants and TDD configuration - Data scheduled for the same TTI does not fit into an available transport block (NOTE: additional cases may occur)
RachPreamble	RachPreamble_Type	RACH preamble being sent by the UE
SchedReq	Null_Type	indication for scheduling request sent by the UE
BSR	BSR_Type	to report the Buffer status report being received
UL_HARQ	HARQ_Type	to report the UL HARQ as received on PUCCH[TTI] for corresponding DL transmission in TTI-x, where x is normally 4
C_RNTI	C_RNTI	indicates C-RNTI being contained in a MAC PDU sent by the UE
PHR	PHR_Type	to report the Power headroom report received
HarqError	HarqError_Type	indicates detection of HARQ error: 1. HARQ CRC error for UL data 2. HARQ NACK from the UE unless SS is configured to report HARQ ACK/NACK
RlcDiscardInd	RlcDiscardInd_Type	indicates e.g. discarded PDUs

D.1.3 Cell_Configuration

Specific Info for Cell Configuration Primitive

D.1.3.1 Cell_Configuration_Common

EUTRA_ASP_TypeDefs: Constant Definitions

TTCN-3 Basic Types			
tsc_CellAttenuation_Off	Attenuation_Type	{Off:=true}	

Cell_Configuration_Common: Basic Type Definitions

TTCN-3 Basic Types		
EUTRA_FDD_Info_Type	Null_Type	no further parameters defined for FDD
EutraBand_Type	integer (1..40)	E-UTRA Band acc. to TS 36.101, clause 5.2 (common for UL/DL)
CfiValue_Type	integer (1..3)	
AbsoluteCellPower_Type	integer (-145..0)	absolute cell power (dBm)
InitialAttenuation_Type	Attenuation_Type (tsc_CellAttenuation_Off)	Attenuation restricted to 'Off'
ToRS_EPRES_Ratio_Type	integer (-35..0)	any-resource-element to RS ratio in dB (e.g. PDSCH-to-RS ratio; see TS 36.213, clause 5.2)

CellConfigRequest_Type

TTCN-3 Union Type		
Name	CellConfigRequest_Type	
Comment		
AddOrReconfigure	CellConfigInfo_Type	for cell configuration: CellId : identifier of the cell to be configured RoutingInfo : None TimingInfo : Now (for initial configuration and for reconfiguration in general) ControlInfo : CnfFlag:=true; FollowOnFlag:=false (in general)
Release	Null_Type	to remove a cell completely - CellId : identifier of the cell to be released; extra_Cell_NonSpecific, in case all cells shall be released RoutingInfo : None TimingInfo : Now ControlInfo : CnfFlag:=true; FollowOnFlag:=false (in general)

CellConfigInfo_Type

TTCN-3 Record Type			
Name	CellConfigInfo_Type		
Comment	common information for initial cell configuration or reconfiguration; in case of reconfiguration OMIT means 'keep configuration as it is'		
Basic	BasicCellConfig_Type	opt	basic information for a cell (e.g. broadcasting)
Active	ActiveCellConfig_Type	opt	add. configuration for active cell (i.e. cell being capable to receive RACH preamble)

CellConfigCapability_Type

TTCN-3 Enumerated Type	
Name	CellConfigCapability_Type
Comment	capabilities of a cell acc. to the initial condition of a test case
broadcastOnlyCell	no detection of RACH preables required; cell is only broadcasting
minimumUplinkCell	detection of RACH preables required but not any further RX capability
fullCell	full TX and RX capabilities

BasicCellConfig_Type

TTCN-3 Record Type			
Name	BasicCellConfig_Type		
Comment			
ConfigCapability	CellConfigCapability_Type	opt	mandatory for the initial configuration; to be omitted afterwards
StaticCellInfo	StaticCellInfo_Type	opt	Common information which does not change during a test
PhysicalLayerConfigDL	PhysicalLayerConfigDL_Type	opt	default settings regarding physical control channels: PCFICH, PHICH, PDCCH
InitialCellPower	InitialCellPower_Type	opt	reference cell power for the RS of each antenna in DL NOTE 1: the power of the RS of an antenna may be reduced by antenna specific configuration NOTE 2: in general the power may be adjusted on a per resource element basis => all physical channel/signal power settings shall be adjusted relatively to the RS; if there are more than one TX antennas each one may have its own attenuation; independently from those relative power settings the cell power can easily be adjusted by just changing the reference power
BcchConfig	BcchConfig_Type	opt	configuration of BCCH/BCH; SS is triggered to configure RLC/MAC regardingly; BCCH data on the PDSCH is distinguished by the SI-RNTI PBCH: MIB; PDSCH: scheduling and resource allocation; SIBs
PcchConfig	PcchConfig_Type	opt	configuration of PCCH/PCH; SS is triggered to configure RLC/MAC regardingly; PCCH data on the PDSCH is distinguished by the P-RNTI (needed even to modify SI => shall be configured for CELL_BROADCASTING)

ActiveCellConfig_Type

TTCN-3 Record Type			
Name	ActiveCellConfig_Type		
Comment			
C_RNTI	C_RNTI	opt	(pre-)configured C-RNTI; affects scrambling of PDSCH/PUSCH and CRC of PDCCH(s); shall be used implicitly in RACH procedure (i.e. as CE in RAR)
PhysicalLayerConfigUL	PhysicalLayerConfigUL_Type	opt	parameters for PRACH, PUCCH, PUSCH
RachProcedureConfig	RachProcedureConfig_Type	opt	to configure the SS's behaviour for the RACH procedure
CcchDcchDtchConfig	CcchDcchDtchConfig_Type	opt	Parameters related to CCCH/DCCH/DTCH in UL and DL

StaticCellInfo_Type

TTCN-3 Record Type			
Name	StaticCellInfo_Type		
Comment	Common information which (normally) does not change during a test; therefore all fields are mandatory		
Common	CommonStaticCellInfo_Type		
Downlink	DownlinkStaticCellInfo_Type		
Uplink	UplinkStaticCellInfo_Type	opt	NOTE: for TDD UL and DL are using the same parameters

CommonStaticCellInfo_Type

TTCN-3 Record Type			
Name	CommonStaticCellInfo_Type		
Comment	information common for UL and DL; all fields are mandatory		
RAT	EUTRA_RAT_Type		FDD or TDD; FDD/TDD specific parameters
PhysicalCellId	PhysCellId		N(cell, ID): imported from core spec; -> cell specific reference signals (non-MBSFN) -> scrambling of all DL physical channels: PBCH, PCFICH, PDCCH, PHICH and PDSCH (together with nRNTI)
eNB_CellId	CellIdentity	opt	Placeholder for Cell identity (28 bits): eNB (20bits) and cell identity (8bits). The use of that field is for future usage and omit for the time being
EutraBand	EutraBand_Type		NOTE: in 3G there are overlapping bands therefore the band needs to be provided; in EUTRA it is provided as well to be extendable in the future
CellTimingInfo	CellTimingInfo_Type		

EUTRA_TDD_Info_Type

TTCN-3 Record Type			
Name	EUTRA_TDD_Info_Type		
Comment			
Configuration	TDD_Config_Type		TDD_Config acc. to RRC ASN.1 (acc. TS 36.331, clause 6.3.2)

EUTRA_HalfDuplexFDD_Info_Type

TTCN-3 Record Type			
Name	EUTRA_HalfDuplexFDD_Info_Type		
Comment	NOTE: for the time being there is no test case or test configuration using half duplex FDD; (type definition is used as place holder only)		

EUTRA_RAT_Type

TTCN-3 Union Type			
Name	EUTRA_RAT_Type		
Comment	specifies RAT type and frame structure (TS 36.211, clause 4)		
FDD	EUTRA_FDD_Info_Type		
TDD	EUTRA_TDD_Info_Type		
HalfDuplexFDD	EUTRA_HalfDuplexFDD_Info_Type		

CellTimingInfo_Type

TTCN-3 Record Type			
Name	CellTimingInfo_Type		
Comment	Cell Timing		
Tcell	integer (0..307199)		frame duration $T_f = 307200 * T_s = 10\text{ms}$; System Time Unit $T_s = 1/(15000 * 2048)$
SfnOffset	integer (0..1023)		(assuming 10 bit SFN)

DownlinkStaticCellInfo_Type

TTCN-3 Record Type		
Name	DownlinkStaticCellInfo_Type	
Comment	DL Static Info	
Earfcn	ARFCN_ValueEUTRA	DL-EARFCN as defined in TS 36.101
Bandwidth	DL_Bandwidth_Type	$N(DL, RB) = 6..110$ (6, 15, 25, 50, 75, 100)
RBSIZE	EUTRA_RBSIZE_Type	may be skipped assuming normal sub-carrier spacing => $N(RB, SC) = 12$
CyclicPrefix	EUTRA_CyclicPrefix_Type	

UplinkStaticCellInfo_Type

TTCN-3 Record Type		
Name	UplinkStaticCellInfo_Type	
Comment	UL Static Info	
Earfcn	ARFCN_ValueEUTRA	UL-EARFCN as defined in TS 36.101
Bandwidth	UI_Bandwidth_Type	$N(DL, RB) = 6..110$ (6, 15, 25, 50, 75, 100)
CyclicPrefix	EUTRA_CyclicPrefix_Type	

EUTRA_RBSIZE_Type

TTCN-3 Enumerated Type	
Name	EUTRA_RBSIZE_Type
Comment	Resource Block Size in freq domain; $N(RB, SC)$ is 12 for normal sub-carrier spacing
n_RB_SC_12	
n_RB_SC_24	

EUTRA_CyclicPrefix_Type

TTCN-3 Enumerated Type	
Name	EUTRA_CyclicPrefix_Type
Comment	NOTE: in DL extended cyclic prefix depends on sub-carrier spacing
normal	
extended	

Modulation_Type

TTCN-3 Enumerated Type	
Name	Modulation_Type
Comment	'unused' e.g. for 2nd codeword when there is no spatial multiplexing
unused	
qpsk	
qam16	
qam64	

Attenuation_Type

TTCN-3 Union Type		
Name	Attenuation_Type	
Comment	attenuation of the reference power	
Value	integer (0..144)	cell power reference power reduced by the given attenuation (value is in dB)
Off	Null_Type	even though in TS 36.508 -145dBm is given for a non suitable cell we specify an explicit "Off" value here

ToRS_EPRES_Ratios_Type

TTCN-3 Record Type			
Name	ToRS_EPRES_Ratios_Type		
Comment	RA and RB ratios according to see TS 36.213, clause 5.2		
RA	ToRS_EPRES_Ratio_Type	opt	
RB	ToRS_EPRES_Ratio_Type	opt	

InitialCellPower_Type

TTCN-3 Record Type			
Name	InitialCellPower_Type		
Comment			
MaxReference Power	AbsoluteCellPower_Type		maximum value of cell reference power (RS EPRE in dBm/15kHz as per TS 36.508, clause 4.3.4.1); a cell is initialised with this reference power; its value is the upper bound of the cell power during the test case
Attenuation	InitialAttenuation_Type		initial attenuation

D.1.3.2 Downlink_Physical_Layer_Configuration

Downlink physical layer configuration:

- DL antenna configuration
- control region (PCFICH, PHICH, PDCCH)
- primary/secondary sync signals
- power control for physical channels and signals

D.1.3.2.1 Antenna_Configuration

Antenna_Configuration: Basic Type Definitions

TTCN-3 Basic Types		
AntennaPortId_Type	integer (0, 1, 2, 3)	

AntennaPortInfo_Type

TTCN-3 Record Type			
Name	AntennaPortInfo_Type		
Comment	NOTE: for conformance tests it may not be necessary to consider propagation pathes for different antennas; => fields of AntennaPortInfo_Type are used as place holders for future usage and are of 'Dummy_Type' for the time being		
PowerAttenuation	Dummy_Type		even though eNb shall send with the same power on all antennas at the UE there may be different signal strength => RS will have reduced power NOTE: the EPRE ratios (e.g. PDSCH-to-RS ratio) are assumed to be equal for all antennas
PropagationDelay	Dummy_Type		signal from different antennas may have different propagation delay

AntennaPortConfig_Type

TTCN-3 Union Type		
Name	AntennaPortConfig_Type	
Comment		
AddOrReconfigure	AntennaPortInfo_Type	add / re-configure antenna port
Release	Null_Type	release antenna port

AntennaPort_Type

TTCN-3 Record Type			
Name	AntennaPort_Type		
Comment			
Id	AntennaPortId_Type		
Config	AntennaPortConfig_Type		

DownlinkAntennaGroupConfig_Type

TTCN-3 Record Type			
Name	DownlinkAntennaGroupConfig_Type		
Comment			
AntennaInfoCommon	AntennaInfoCommon_Type		acc. to TS 36.331, clause 6.3.2; contains antennaPortsCount = an1, an2, an4; static parameter; will (normally) not be modified whilst a test; NOTE: information is redundant since number of antenna ports may implicitly be determined by the number of ports being configured
AntennaPort	record length (1..4) of AntennaPort_Type		1, 2 or 4 antennas; from the UE's point of view each antenna may have a different power level and a different propagation delay

D.1.3.2.2 Physical_Channels

PbchConfig_Type

TTCN-3 Record Type			
Name	PbchConfig_Type		
Comment			
RelativeTxPower	ToRS_EPRES_Ratios_Type	opt	power ratio for PBCH's resource elements relative to the RS

PcfichConfig_Type

TTCN-3 Record Type			
Name	PcfichConfig_Type		
Comment			
CfiValue	CfiValue_Type	opt	control format indicator signalled on PCFICH
RelativeTxPower	ToRS_EPRES_Ratios_Type	opt	power ratio for PCFICH's resource elements relative to the RS

PhichConfig_Type

TTCN-3 Record Type			
Name	PhichConfig_Type		
Comment			
PhichConfig	PHICH_Config_Type	opt	parameters acc. TS 36.331, clause 6.3.2: phich-Duration, phich-Resource; may have impact on Cfi
RelativeTxPower	ToRS_EPRES_Ratios_Type	opt	power ratio for PHICH's resource elements relative to the RS

CCE_StartIndex_DL_UL_Type

TTCN-3 Record Type			
Name	CCE_StartIndex_DL_UL_Type		
Comment	CCE_St_Ind' or CCE_St_Ind" acc. to table 7.1.1-1 in TS 36.523-3		
CCE_StartIndex_DL	integer		
CCE_StartIndex_UL	integer		

CCE_StartIndexList_Type

TTCN-3 Record of Type			
Name	CCE_StartIndexList_Type		
Comment	describes PDCCH candidates for all sub-frames		
record length(10) of CCE_StartIndex_DL_UL_Type			

PdcchCandidate_Type

TTCN-3 Record Type			
Name	PdcchCandidate_Type		
Comment	CCE start indeces for a given RNTI value acc. to table 7.1.1-1 in TS 36.523-3		
RNTI	C_RNTI		RNTI value as per table 7.1.1-1
CCE_StartIndexList	CCE_StartIndexList_Type		CCE Start Indices corresponding to the RNTI

PdcchCandidateList_Type

TTCN-3 Record of Type			
Name	PdcchCandidateList_Type		
Comment	list of RNTIs and their corresponding CCE Start Indices		
record of PdcchCandidate_Type			

PdcchConfig_Type

TTCN-3 Record Type			
Name	PdcchConfig_Type		
Comment	UE performs blind detection for common and UE specific search spaces for different aggregation levels (PDCCH formats acc. TS 36.211, clause 6.8.1) content of the PDCCHs (DCI formats acc. TS 36.212, clause 5.3.3) shall be controlled together with scheduling and resource allocation		
CommonSearchSpaceFormat	integer (2, 3)	opt	PDCCH format for common search space; acc. to TS 36.213, clause 9.1.1 only aggregation level 4 and 8 are allowed (i.e. PDCCH format 2 and 3)
UeSpecificSearchSpaceFormat	integer (0, 1, 2, 3)	opt	UE specific search space: corresponding aggregation levels 1, 2, 4, 8
PdcchCandidateList	PdcchCandidateList_Type	opt	PDCCH candidate list acc. to table 7.1.1-1 in TS 36.523-3
RelativeTxPower	ToRS_EPRES Ratios_Type	opt	power ratio for PDCCH's resource elements relative to the RS

PdschRelativeTxPower_Type

TTCN-3 Record Type			
Name	PdschRelativeTxPower_Type		
Comment	NOTE 1: the power control for the PDSCH is assumed to be (semi-)static for signalling conformance tests acc. to TS 36.323; nevertheless for different channels and purposes with the PDSCH there may be different power settings; NOTE 2: acc. to TS 36.213, clause 5.2 the EPRE ratio is different in time domain for OFDM symbols containing or not containing reference signals; this needs to be considered by SS		
RachResponse	ToRS EPRE Ratios_Type	opt	
BcchOnPdsch	ToRS EPRE Ratios_Type	opt	
PcchOnPdsch	ToRS EPRE Ratios_Type	opt	
CcchDcchDtch	ToRS EPRE Ratios_Type	opt	

PdschConfig_Type

TTCN-3 Record Type			
Name	PdschConfig_Type		
Comment			
RelativeTxPower	PdschRelativeTxPower_Type	opt	

D.1.3.2.3 Physical_Signals

PrimarySyncSignal_Type

TTCN-3 Record Type			
Name	PrimarySyncSignal_Type		
Comment			
RelativeTxPower	ToRS EPRE Ratios_Type	opt	power ratio for PSS's resource elements relative to the RS

SecondarySyncSignal_Type

TTCN-3 Record Type			
Name	SecondarySyncSignal_Type		
Comment			
RelativeTxPower	ToRS EPRE Ratios_Type	opt	power ratio for PSS's resource elements relative to the RS

SRS_UL_Config_Type

TTCN-3 Record Type			
Name	SRS_UL_Config_Type		
Comment			
Common	SoundingRS_UL_ConfigCommon_Type		
Dedicated	SoundingRS_UL_ConfigDedicated_Type		

PhysicalLayerConfigDL_Type

TTCN-3 Record Type			
Name	PhysicalLayerConfigDL_Type		
Comment	all fields are declared as optional to allow single reconfigurations; in this case omit means "keep as it is"		
AntennaGroup	DownlinkAntennaGroupConfig_Type	opt	
Pbch	PbchConfig_Type	opt	
Pcfich	PcfichConfig_Type	opt	
Phich	PhichConfig_Type	opt	
Pdcch	PdcchConfig_Type	opt	
Pdsch	PdschConfig_Type	opt	
Pss	PrimarySyncSignal_Type	opt	
Sss	SecondarySyncSignal_Type	opt	

D.1.3.3 Uplink_Physical_Layer_Configuration

Uplink physical channel configuration: PRACH, PUCCH, PUSCH and UL RS

PUCCH_Configuration_Type

TTCN-3 Record Type			
Name	PUCCH_Configuration_Type		
Comment			
Common	PUCCH_ConfigCommon_Type	opt	
Dedicated	PUCCH_ConfigDedicated_Type	opt	

PUSCH_Configuration_Type

TTCN-3 Record Type			
Name	PUSCH_Configuration_Type		
Comment			
Common	PUSCH_ConfigCommon_Type	opt	
Dedicated	PUSCH_ConfigDedicated_Type	opt	

SS_TimingAdvanceConfig_Type

TTCN-3 Union Type			
Name	SS_TimingAdvanceConfig_Type		
Comment			
InitialValue	RACH_TimingAdvance_Type		initial value corresponding to what is sent to the UE in RACH response (range acc. 11 bit value; 0 in normal cases)
Relative	TimingAdvanceIndex_Type		timing advance command to adjust changes of timing advance acc. to TS 36.213, clause 4.2.3; (range acc. 6 bit value: -31..32)

PhysicalLayerConfigUL_Type

TTCN-3 Record Type			
Name	PhysicalLayerConfigUL_Type		
Comment	NOTE: For the time being there is no requirement to configure the SS with TPC-PDCCH-Config; In general SS is required to keep the UE's UL power constant		
Prach	PRACH_Config_Type	opt	parameters acc. TS 36.331, clause 6.3.2; in general depending on FDD/TDD (see TS 36.211, clause 5.7)
Pucch	PUCCH_Configuration_Type	opt	parameters acc. TS 36.331, clause 6.3.2
Pusch	PUSCH_Configuration_Type	opt	parameters acc. TS 36.331, clause 6.3.2 (including configuration of RS)
TimingAdvance	SS_TimingAdvanceConfig_Type	opt	to adjust timing advance; normally timing advance is configured as 0 at the beginning and never changed during the test case; in some MAC test cases timing advance may be configured to a non-zero (11 bit value) at the beginning and modified by (6 bit) timing advance commands during the test
SRS_UL_Config	SRS_UL_Config_Type	opt	sounding reference symbol (SRS); -> TS 36.213, clause 8.2, TS 36.211, clause 5.5.3
SR_Config	SchedulingRequestConfig_Type	opt	PUCCH resources for scheduling requests acc. to TS 36.213 table 10.15; as signalled to the UE acc. to TS 36.331, clause 6.3.2
CQI_ReportConfig	CQI_ReportConfig_Type	opt	
UplinkPowerControlCommon	UplinkPowerControlCommon_Type	opt	
UplinkPowerControlDedicated	UplinkPowerControlDedicated_Type	opt	

D.1.3.4 Common_MAC_Configuration

Transport channel and MAC related procedures and configuration

Common_MAC_Configuration: Basic Type Definitions

TTCN-3 Basic Types		
ImcsValue_Type	integer (0..31)	Modulation and coding scheme index coding
TimingAdvanceIndex_Type	integer (0..63)	acc. to TS 36.321, clause 6.1.3.5 "Timing Advance Command MAC Control Element" and TS 36.213, clause 4.2.3 "Transmission timing adjustments"
TimingAdvance_Period_Type	integer (400, 600, 1020, 1530, 2040, 4090, 8190)	the values correspond to 80 % of TimeAlignmentTimer (acc. to TS 36.523-3, clause 7.2) (TS 36.331, clause 6.3.2: sf500, sf750, sf1280, sf1920, sf2560, sf5120, sf10240) rounded to nearest multiple of 10

RedundancyVersionListDL_Type

TTCN-3 Record of Type	
Name	RedundancyVersionListDL_Type
Comment	NOTE: in general the list shall contain maxHARQ-Tx elements; if there are not enough elements specified SS shall raise an error; per default the list is configured to 0,2,3,1,0 (TS 36.321, clause 5.4.2.2)
record length (1..28) of RedundancyVersion_Type	

UL_TransRetransmission_Type

TTCN-3 Union Type		
Name	UL_TransRetransmission_Type	
Comment		
NewTransmission	Null_Type	new transmission of data with redundancy version RV=0 (acc. to TS 36.321 clause 5.4.2.2); NDI is toggled
RetransmissionAdaptive	RedundancyVersion_Type	SS assigns grant to requests retransmission of data with given redundancy version; NDI is not toggled
RetransmissionNonAdaptive	Null_Type	place holder for non-adaptive retransmissions; SS does not send any grant

UL_TransRetransmissionList_Type

TTCN-3 Record of Type	
Name	UL_TransRetransmissionList_Type
Comment	list of transmission and subsequent retransmissions: in UL retransmissions are synchronous (every 8 TTIs for FDD); independent from the HARQ_ModelList SS shall send grants for every adaptive retransmissions; in case of non-adaptive retransmissions SS simply does not send a grant (i.e. RetransmissionNonAdaptive elements are used to adjust timing of the adaptive retransmissions only)
record length (1..28) of UL_TransRetransmission_Type	

Imcs_Type

TTCN-3 Union Type		
Name	Imcs_Type	
Comment		
Value	ImcsValue_Type	
NotUsed	Null_Type	

ULGrant_Period_Type

TTCN-3 Union Type		
Name	ULGrant_Period_Type	
Comment		
OnlyOnce	Null_Type	grant is sent out only once; no period
Duration	integer (-1,1..infinity)	duration of the grant period (TTI=1ms)

TransmissionRepetition_Type

TTCN-3 Union Type		
Name	TransmissionRepetition_Type	
Comment		
Continuous	Null_Type	
NumOfCycles	integer (1..infinity)	

PUCCH_AutoSynch_Type

TTCN-3 Record Type		
Name	PUCCH_AutoSynch_Type	
Comment		
TimingAdvance	TimingAdvanceIndex_Type	
TA_Period	TimingAdvance_Period_Type	time period after which TA MAC control elements need to be automatically transmitted
TA_Repetition	TransmissionRepetition_Type	number of TA MAC control element repetitions to be automatically transmitted or 'Continuous'

PUCCH_Synch_Type

TTCN-3 Union Type		
Name	PUCCH_Synch_Type	
Comment		
None	Null_Type	no PUCCH Synchronisation applied
Auto	PUCCH_AutoSynch_Type	SS automatically maintains PUCCH synchronization at UE

FreqDomainSchedulCommon_Type

TTCN-3 Record Type		
Name	FreqDomainSchedulCommon_Type	
Comment	<p>common type to specify restrictions for frequency domain scheduling by a start index and a maximum range of RBs; in general the resource allocation refers to virtual resource blocks:</p> <ul style="list-style-type: none"> - format 1A (localised): FirstRbIndex refers to the first physical RB; the RBs are subsequent (upto MaxRbCnt RBs); may be applied for all kind of channels - format 1C (distributed): FirstRbIndex refers to the first virtual RB; the virtual RBs are subsequent (upto MaxRbCnt RBs) but mapped (distributed) to physical resource; typically applied on BCCH, PCCH and RAR - format 1 (localised): FirstRbIndex refers to the first physical RB; RBs are not consecutive; SS needs to provided bitmap of RBs (see TS 36.523-3) to cope with mapping of virtual resource allocation (format 1C) applied on other channels; typically there are either <ul style="list-style-type: none"> - all channels having format 1A (localised) - BCCH, PCCH and RAR having format 1C (distributed) + DTCH/DCCH having format 1 	
FirstRbIndex	integer	<p>index of the first (virtual) resource block in frequency domain; 0 .. N(UL/DL, RB) - 1; NOTE: DCI format 1C refers to a virtual RB allocation i.e. the resource block index; differs from the physical resource allocation where the RBs are distributed over the whole frequency bandwidth (TS 36.213, clause 7.1.6.3)</p>
MaxRbCnt	integer	<p>max. number of resource blocks to be assigned; FirstRbIndex + MaxRbCnt <= N(UL/DL, RB); SS shall not assigned more than the given resource blocks to the respective channel (i.e. MaxRbCnt is the upper bound); if the the configuration for a channel exceeds the total bandwidth this is a TTCN error (=> SS shall raise an error)</p>

FreqDomainSchedulExplicit_Type

TTCN-3 Record Type		
Name	FreqDomainSchedulExplicit_Type	
Comment	type used for explicit DL scheduling; Nprb is the exact number of RBs whereas in FreqDomainSchedulCommon_Type MaxRbCnt is the upper bound	
FirstRbIndex	integer	index of the first resource block in frequency domain; 0 .. N(UL/DL, RB) - 1
Nprb	integer	number of resource blocks to be assigned;

PdcchDciFormat_Type

TTCN-3 Enumerated Type	
Name	PdcchDciFormat_Type
Comment	DCI format acc. to TS 36.212, clause 5.3.3.1; SS shall apply physical parameters accordingly as specified in TS 36.508, clause 4.3.6
dci_0	physical layer parameters acc. TS 36.508 Table 4.3.6.1.1-1
dci_1	physical layer parameters acc. TS 36.508 Table 4.3.6.1.2-1
dci_1A	physical layer parameters acc. TS 36.508 Table 4.3.6.1.3-1
dci_1B	
dci_1C	physical layer parameters acc. TS 36.508 Table 4.3.6.1.4-1
dci_1D	
dci_2	physical layer parameters acc. TS 36.508 Table 4.3.6.1.5-1
dci_2A	physical layer parameters acc. TS 36.508 Table 4.3.6.1.6-1
dci_3	
dci_3A	

PdcchResourceAllocation_Type

TTCN-3 Enumerated Type	
Name	PdcchResourceAllocation_Type
Comment	Resource allocation acc. TS 36.213, clause 7.1.6
ra_0	
ra_1	
ra_2_Localised	=> physical and virtual RB index are identical
ra_2_Distributed	=> virtual resource allocation

MIMO_PrecodingBits_Type

TTCN-3 Union Type		
Name	MIMO_PrecodingBits_Type	
Comment	Number of bits for precoding information acc. TS 36.212, table 5.3.3.1.5-3 and 5.3.3.1.5A-1	
None	Null_Type	DCI 2A: 2 antenna ports at eNodeB (table 5.3.3.1.5A-1)
Bit2	B2_Type	DCI 2A: 4 antenna ports at eNodeB (table 5.3.3.1.5A-1)
Bit3	B3_Type	DCI 2: 2 antenna ports at eNodeB (table 5.3.3.1.5-3)
Bit6	B6_Type	DCI 2: 4 antenna ports at eNodeB (table 5.3.3.1.5-3)

MIMO_DciDlInfo_Type

TTCN-3 Record Type			
Name	MIMO_DciDlInfo_Type		
Comment	additional information for DL DCI in case of MIMO (i.e. when a 2nd CW is specified)		
RedundancyVersionList_2ndCW	RedundancyVersionListDL_Type	opt	list of Redundancy version for 2nd code word; shall have the same length as RedundancyVersionList_1stCW; if omit, for the 2nd CW the same RedundancyVersionList shall be applied as for the 1st CW
CodeWordSwapFlag	B1_Type		transport block to codeword mapping acc. to TS 36.212 Table 5.3.3.1.5-1
PrecodingBits	MIMO_PrecodingBits_Type		precoding information acc. TS 36.212, table 5.3.3.1.5-3 and 5.3.3.1.5A-1

DciDlInfoCommon_Type

TTCN-3 Record Type			
Name	DciDlInfoCommon_Type		
Comment	used for normal DL scheduling acc. to TS 36.523-3, clause 7.3		
Format	PdcchDciFormat_Type		BCCH, PCCH and RACH Response: 1A or 1C (TS 36.213, clause 7.1) CCCH: 1A since transmission mode is not (may not be) configured at the UE yet (TS 36.213, clause 7.1) DTCH/DCCH: depending on transmission mode
ResourceAlloc Type	PdcchResourceAllocation_Type		depends on DCI format, e.g. ra_2_Localised or ra_2_Distributed for DCI format 1A
Modulation_1st CW	Modulation_Type		max. modulation scheme for the 1st code word; depending on the amount of data a lower modulation scheme may be by SS but not a higher one; BCCH, PCCH and RACH Response: QPSK only
Modulation_2nd CW	Modulation_Type		modulation scheme for 2nd code word in case of spatial multiplexing; can be different than 1st code word (see TS 36.211, clause 6.3.2; TS 36.212, clause 5.3.3.1.5); 'unused' when there is no spatial multiplexing; NOTE: Acc. to 36.523-3 cl. 7.3.3.4 in normal mode MIMO shall not be used => for the time being Modulation_2ndCW is always "unused"
FreqDomainScheduling	FreqDomainScheduling_Type		index of 1st RB; max. number of RBs per TTI; NOTE: in case of DCI format 1C the first RB index has no meaning since distributed virtual resource blocks assigned in this case (TS 36.213, clause 7.1.6.3)
RedundancyVersionList	RedundancyVersionListDL_Type		list of Redundancy version to be used in case of retransmission; the number of elements in the list provides the maxHARQ-Tx

DciDlInfoExplicit_Type

TTCN-3 Record Type			
Name	DciDlInfoExplicit_Type		
Comment	used for explicit DL scheduling acc. to TS 36.523-3, clause 7.3		
Imcs_1stCW	Imcs_Type		MCS index of table 7.1.7.1-1 of TS 36.213
Imcs_2ndCW	Imcs_Type		MCS index for the 2nd code word in case of MIMO; 'NotUsed' when MIMO is not used
Format	PdcchDciFormat_Type		
ResourceAlloc Type	PdcchResourceAllocation_Type		
FreqDomainScheduling	FreqDomainSchedulingExplicit_Type		
RedundancyVersionList	RedundancyVersionListDL_Type		list of Redundancy version to be used in case of retransmission the number of elements in the list provides the maxHARQ-Tx
MimoInfo	MIMO DciDlInfo_Type	opt	shall be present when Imcs_2ndCW specifies a 2nd CW to be used; shall be omit when Imcs_2ndCW is 'NotUsed'

DciDlInfo_Type

TTCN-3 Union Type			
Name	DciDlInfo_Type		
Comment			
Auto	DciDlInfoCommon_Type		SS shall chose the appropriate TBS up to the maximim number of resource blocks
Explicit	DciDlInfoExplicit_Type		used in MAC or RAB tests where exact TBS needs to be specified

DciUlInfo_Type

TTCN-3 Record Type		
Name	DciUlInfo_Type	
Comment		
Imcs	Imcs_Type	MCS index of table 8.6.1-1 of TS 36.213
TransRetransmissionList	UL_TransRetransmissionList_Type	list of possible retransmissions and their redundancy versions (depending on being adaptive or non-adaptive); the list shall <ul style="list-style-type: none"> - start with <ul style="list-style-type: none"> - "New Transmission" (normal case) or - "Adaptive Retransmission" (e.g. to request a retransmission even when the data has been acknowledged with a HARQ ACK) - end with "Adaptive Retransmission" (if there are retransmissions) NOTE1: TTCN implementation shall ensure that a reconfiguration is done not before the previous list has been fully processed NOTE2: for normal operation the list contains only one NewTransmission element (i.e. possible retransmissions are non-adaptive)
FreqDomainSchedule	FreqDomainScheduleExplicit_Type	

PeriodicGrant_Type

TTCN-3 Record Type		
Name	PeriodicGrant_Type	
Comment		
Period	ULGrant_Period_Type	time period after which UL Grant need to be automatically transmitted or 'OnlyOnce'
NoOfRepetitions	TransmissionRepetition_Type	number of UL Grant repetitions to be automatically transmitted or continuous repetition

UL_GrantConfig_Type

TTCN-3 Union Type		
Name	UL_GrantConfig_Type	
Comment		
OnSR_Reception	Null_Type	SS transmits UL Grant as configured by CommonDciInfoUL_Type at every reception of SR; to be used in non L2 Test
Periodic	PeriodicGrant_Type	SS transmits UL Grant as configured by CommonDciInfoUL_Type periodically; to be used in L2 tests; MAC tests testing Grants might set the period as infinite and num grant as 1
None	Null_Type	disable any grant transmission

D.1.3.5 Random_Access_Procedure

EUTRA_ASP_TypeDefs: Constant Definitions

TTCN-3 Basic Types			
tsc_RandomAccessResponseListSize	integer	10	arbitrary value (needs to be extended, if necessary); in case of RACH in idle, UE will keep on making RACH attempts until t300 expires => number of PRACH preambles maybe even greater than maximum value of PREAMBLE_TRANS_MAX

Random_Access_Procedure: Basic Type Definitions

TTCN-3 Basic Types		
RACH_TimingAdvance_Type	integer (0..2047)	11 bit timing advance as used in RACH response (absolute value)

UplinkGrant_Type

TTCN-3 Record Type			
Name	UplinkGrant_Type		
Comment	TS 36.213, clause 6.2		
HoppingFlag	B1_Type		Hopping flag
RB_Allocation	B10_Type		Fixed size resource block assignment
ModAndCodScheme	B4_Type		Truncated modulation and coding scheme
TPC_Command	B3_Type		TPC command for scheduled PUSCH
UL_Delay	B1_Type		UL delay
CQI_Req	B1_Type		CQI request

ContentionResolution_ContainedRlcPdu_Type

TTCN-3 Union Type		
Name	ContentionResolution_ContainedRlcPdu_Type	
Comment		
RlcPdu	octetstring	octetstring of an RLC PDU containing e.g. the RRC Connection Setup; to be sent in the same MAC PDU as the MAC Contention Resolution Control Element
None	Null_Type	MAC PDU containing the MAC Contention Resolution Control Element does not contain an RLC PDU (i.e. RRC Connection Setup is sent in another PDU)

ContentionResolution_ContainedId_Type

TTCN-3 Union Type		
Name	ContentionResolution_ContainedId_Type	
Comment		
XorMask	ContentionResolutionId_Type	When SS receives Contention Resolution ID from the UE, SS shall XOR it with the given mask and use this as Contention Resolution ID; this allows to get an unmatching Contention Resolution ID; in normal cases mask shall be set to tsc_ContentionResolutionId_Unchanged (i.e. the Contention Resolution ID remains unchanged)
None	Null_Type	MAC Contention Resolution Control Element is not contained in the MAC PDU sent out as response on Msg3

TCRNTI_ContentionResolutionMacPdu_Type

TTCN-3 Record Type		
Name	TCRNTI_ContentionResolutionMacPdu_Type	
Comment	NOTE: Either ContainedId or ContainedRlcPdu (or both) shall not be 'none'; (if no Contention Resolution Mac Pdu shall be sent, TCRNTI_ContentionResolutionCtrl_Type.NoContResolID shall be used instead)	
ContainedId	ContentionResolution_ContainedId_Type	Either the Contention Resolution ID as received from the UE or a modified Contention Resolution ID (XorMask != tsc_ContentionResolutionId_Unchanged) or no Contention Resolution ID at all
ContainedRlcPdu	ContentionResolution_ContainedRlcPdu_Type	the MAC PDU containing the MAC Contention Resolution Control Element may contain the RRC Connection Setup; in this case the RRC PDU shall be completely encoded been contained in an RLC PDU

TCRNTI_ContentionResolutionCtrl_Type

TTCN-3 Union Type		
Name	TCRNTI_ContentionResolutionCtrl_Type	
Comment	when the UE responds on a Random Access Response with a RRC Connection Request on CCCH and not with a C-RNTI SS shall assume initial Random Access Procedure (TS 36.300, clause 10.1.5.1), i.e. sends a ContentionResolutionId back to the UE	
MacPdu	TCRNTI_ContentionResolutionMacPdu_Type	MAC PDU containing the Contention Resolution ID and optionally an RRC PDU (RRC Connection Setup)
MacPdu_CRC_Error	TCRNTI_ContentionResolutionMacPdu_Type	same as MacPdu (see above), but SS shall generate CRC error by toggling CRC bits; no retransmissions shall be made as UE shall not send a NACK
NoContResolID	Null_Type	SS shall not include contention resolution ID (i.e. no MAC PDU shall be sent); used for contention resolution fail case

CRNTI_ContentionResolutionCtrl_Type

TTCN-3 Union Type		
Name	CRNTI_ContentionResolutionCtrl_Type	
Comment	configuration for Random Access Procedure in RRC_CONNECTED (see TS 36.300, clause 10.1.5.1); when SS receives C-RNTI MAC element sent by the UE after Random Access Response, SS shall deal with the C-RNTI as specified in this structure	
AutomaticGrant	DciUlInfo_Type	before expiry of the contention resolution timer SS shall automatically address PDCCH using C-RNTI as sent by the UE; the UL grant is specified acc. to DciUlInfo_Type
None	Null_Type	Used in case of dedicated preamble transmission or to simulate failure cases; SS shall not address PDCCH using C-RNTI => expiry of contention resolution timer on UE side

ContentionResolutionCtrl_Type

TTCN-3 Union Type		
Name	ContentionResolutionCtrl_Type	
Comment	NOTE: SS only needs to consider one kind of contention resolution at one time; in the initial configuration of a cell TCRNTI_Based shall be configured and the common assumption is that in RRC_CONNECTED normally there are no RACH procedures (i.e. no CRNTI_Based configuration needed) whereas e.g. in case of handover scenarios CRNTI_Based shall be configured	
TCRNTI_Based	TCRNTI_ContentionResolutionCtrl_Type	TCRNTI based contention resolution (e.g. initial access), hence involves inclusion contention resolution identity in DL message 4 of RACH procedure
CRNTI_Based	CRNTI_ContentionResolutionCtrl_Type	CRNTI based contention resolution (e.g. in case UE is being in RRC_CONNECTED): hence uplink message in step 3 (of RACH procedure) is followed by PDCCH transmission with UE C-RNTI to end procedure

RapidCtrl_Type

TTCN-3 Union Type		
Name	RapidCtrl_Type	
Comment		
Automatic	Null_Type	SS shall automatically use same RAPID as received from the UE
Unmatched	Null_Type	SS shall use RAPID being different from preamble sent by the UE; SS shall calculate this RAPID acc. to $RAPID := (RAPID + 3..63) \bmod 64$ if single RAR is transmitted in a MAC PDU then only 3 is added if multiple RAR's are transmitted in MAC PDU, then for first unmatched RAR 3 is added, second unmatched 4 is added, third unmatched 5 is added and so on

TempC_RNTI_Type

TTCN-3 Union Type		
Name	TempC_RNTI_Type	
Comment		
SameAsC_RNTI	Null_Type	in the RA response SS shall use the same C-RNTI as configured in ActiveCellConfig_Type; this is useful for initial random access
Explicit	C_RNTI	in the RA response SS shall use different value as configured in ActiveCellConfig_Type; this can be used when the UE already is in RRC_CONNECTED to have a temporary C-RNTI different from the one used by the UE; NOTE: when the UE is not in RRC_CONNECTED there shall be no explicit temp. C-RNTI since then the UE would assume this value as C-RNTI

RandomAccessResponseParameters_Type

TTCN-3 Record Type		
Name	RandomAccessResponseParameters_Type	
Comment	parameters to control content of RAR sent to the UE	
Rapld	RapldCtrl_Type	to control Random Access Preamble Id to be sent back to the UE; used in RAR MAC sub-header
InitialGrant	UplinkGrant_Type	initial UL grant
TimingAdvance	RACH_TimingAdvance_Type	timing advance: granularity of 0.52 micro sec (16*Ts); see TS 36.300, clause 5.2.7.3, TS 36.321, clause 6.1.3.5; NOTE: timing advance has impact not only on the RA procedure; SS in general needs to adjust its timing accordingly
TempC_RNTI	TempC_RNTI_Type	NOTE: For initial Random Access Procedure at network (SS) side there is no temporary C-RNTI: network assigns the C-RNTI which is used by any UE as being temporary; the UE which 'wins' the contention resolution keeps the (temporary) C-RNTI; other UEs need to repeat the RACH procedure; => at the SS the TempC_RNTI shall be 'SameAsC_RNTI' For Random Access Procedure in RRC_CONNECTED state the NW assigns a temporary C-RNTI which is replaced by the one stored at the UE; => TempC_RNTI may be 'SameAsC_RNTI' (in this case temp. C-RNTI and C-RNTI are equal what is not likely in a real network), or there is an explicit temp. C-RNTI what is used during RA procedure only (as in a real network)

RarList_Type

TTCN-3 Record of Type	
Name	RarList_Type
Comment	in general MAC PDU may contain one or several RARs; normally only one RAR is contained
record of RandomAccessResponseParameters_Type	

RandomAccessResponse_Type

TTCN-3 Union Type		
Name	RandomAccessResponse_Type	
Comment		
None	Null_Type	used for unsuccessful RA procedure
List	RarList_Type	normally one RAR to be sent to the UE; in general there can be more than one RAR

RandomAccessBackoffIndicator_Type

TTCN-3 Union Type		
Name	RandomAccessBackoffIndicator_Type	
Comment		
None	Null_Type	normal case, no back off indicator included
Index	integer (0..15)	Backoff Parameter values acc. TS 36.321, clause 7.2; values 0..12 are defined, 13..15 may be used in error case

RandomAccessResponseCtrl_Type

TTCN-3 Record Type		
Name	RandomAccessResponseCtrl_Type	
Comment	configuration for Random Access Response mapped to DL-SCH mapped to PDSCH TransmissionMode: single antenna mode when there is only one antenna configured, transmit diversit else; RNTI: RA-RNTI (TS 36.321, clause 7.1); if both RAR msg and backoff indicator are 'None' SS shall not respond on RAP	
DciInfo	DciDlInfoCommon_Type	DCI format: 1A or 1C (TS 36.213, clause 7.1) ResourceAllocType: 2 (acc. to DCI format) Modulation: QPSK Frequency domain schedule: index of 1st RB; max. number of RBs per TTI
Rar	RandomAccessResponse_Type	RAR to be sent to the UE
BackoffInd	RandomAccessBackoffIndicator_Type	possible backoff indicator; 'None' for normal cases

RandomAccessResponseConfig_Type

TTCN-3 Union Type		
Name	RandomAccessResponseConfig_Type	
Comment		
Ctrl	RandomAccessResponseCtrl_Type	contains information to control sending of RAR
Ctrl_CRC_Error	RandomAccessResponseCtrl_Type	same as Ctrl (see above), but MAC PDU transmitted will contain CRC bits (0-3) being toggled; no retransmissions shall be made as UE shall not send a NACK
None	Null_Type	to be used when there is no RAR to be sent at all

RachProcedure_Type

TTCN-3 Record Type	
Name	RachProcedure_Type
Comment	
RAResponse	RandomAccessResponseConfig_Type control of how the SS shall react on RA preamble; this may be - the RAP id as expected by the UE - a RAP id not matching to the UE's RAP - a backoff indicator - nothing at all
ContentionResolutionCtrl	ContentionResolutionCtrl_Type

RachProcedureList_Type

TTCN-3 Record of Type	
Name	RachProcedureList_Type
Comment	<p>to simulate RACH procedure with one or more than one attempt by the UE:</p> <p>1. Normal cases: one single RandomAccessResponse is sent to the UE matching the UE's RACH preamble; contention resolution is successful immediately => list contains only one element which is used for any RA procedure (Even if a RACH procedure is repeated by the UE for any reason this element shall be used; e.g. it needs not to be handled as error when the UE sends another RACH preamble instead of the RRC connection request message)</p> <p>2. Special cases: there are upto tsc_RandomAccessResponseListSize preambles sent by the UE => there are upto tsc_RandomAccessResponseListSize responses to be configured as elements of the list; SS shall start with the first element in the list and use the RAR as specified in this element; if the RAR matches at the UE side the UE will send UL data and contention resolution is performed as configured for this element; if the RAR does not match the UE sends another RAP and SS continues with the next element in the list; in this case the contention resolution of the respective element is not used; if the end of the list is reached and further RACH preambles are sent by the UE SS shall repeatedly apply the last element of the list (this is necessary because there might be not enough time to reconfigure SS after the end of the list has been reached and there shall be well-defined behaviour after the list has been processed);</p> <p>to change from a special mode to normal mode the RachProcedureList is reconfigured by TTCN to achieve transparency and readability of the code;</p> <p>NOTE: when there are RACH_ConfigDedicated configured (see below) and the RA preamble matches with one the configured ones the contention resolution ctrl is obsolete (non contention based random access procedure)</p>
record length(1..tsc_RandomAccessResponseListSize) of RachProcedure_Type	

RachProcedureConfig_Type

TTCN-3 Record Type			
Name	RachProcedureConfig_Type		
Comment	parameters to control the random access procedure; TS 36.321, clause 5.1		
RACH_ConfigCommon	RACH_ConfigCommon_Type	opt	acc. TS 36.331, clause 6.3.2; may not be necessary for SS; omit: "keep as it is"
RACH_ConfigDedicated	RACH_ConfigDedicated_Type	opt	acc. TS 36.331, clause 6.3.2; when random access preamble sent by the UE matches with the configured one, SS shall assume the random access procedure being non-contention based; initial configuration: no RACH_ConfigDedicated are configured; omit means "keep as it is"
RachProcedureList	RachProcedureList_Type	opt	in normal cases there is one element which is used for any RA procedure; special cases are used in MAC test cases; omit means "keep as it is"

D.1.3.6 System_Information_Control

Primitive to configuration BCCH/BCH

System_Information_Control: Basic Type Definitions

TTCN-3 Basic Types		
BcchToPbchConfig_Type	Null_Type	place holder for BCCH mapped to BCH mapped to PBCH; MIB using fixed scheduling (periodicity: 40ms); transmission mode: single antenna port configuration (layer mapping acc. TS 36.211, clause 6.3.3.1) or transmit diversity (layer mapping acc. TS 36.211, clause 6.3.3.3) depending on antenna configuration

Sib1Schedul_Type

TTCN-3 Record Type			
Name	Sib1Schedul_Type		
Comment	SIB1: fixed scheduling in time domain acc. TS 36.331, clause 5.2.1.2 (periodicity: 80ms; repetitions every 20ms)		
DciInfo	DciDlInfoCommon_Type	opt	DCI format: 1A or 1C (TS 36.213, clause 7.1) ResourceAllocType: 2 (acc. to DCI format) Modulation: QPSK Frequency domain schedule: index of 1st RB; max. number of RBs per TTI

SingleSiSchedul_Type

TTCN-3 Record Type			
Name	SingleSiSchedul_Type		
Comment	specifies scheduling for a single SI in freq and time domain		
DciInfo	DciDlInfoCommon_Type	opt	DCI format: 1A or 1C (TS 36.213, clause 7.1) ResourceAllocType: 2 (acc. to DCI format) Modulation: QPSK Frequency domain schedule: index of 1st RB; max. number of RBs per TTI
SubframeOffset	integer	opt	offset within the SI-window; NOTE: SI-window may span more than one frame

SiSchedul_Type

TTCN-3 Record Type			
Name	SiSchedul_Type		
Comment	specifies for a specific SI scheduling and repetitions within as SI window		
Periodicity	SiPeriodicity_Type	opt	
Window	record of SingleSiSchedul_Type	opt	NOTE: acc. to TS 36.331, clause 5.2.1.2 the same SI may occur more than once in an SI-window; to allow this there is a "record of" even though acc. to TS 36.508, clause 4.4.3.3 all SIs are sent only once within the window

SiSchedulList_Type

TTCN-3 Record of Type	
Name	SiSchedulList_Type
Comment	record length(1..maxSI_Message) of SiSchedul_Type

AllSiSchedul_Type

TTCN-3 Record Type			
Name	AllSiSchedul_Type		
Comment			
WindowLength	SiWindowLength_Type	opt	to calculate start of each SI window acc. TS 36.331, clause 5.2.3
SiList	SiSchedulList_Type	opt	list of SIs containing one ore more SIBs

BcchToPdschConfig_Type

TTCN-3 Record Type			
Name	BcchToPdschConfig_Type		
Comment	configuration for BCCH mapped to DL-SCH mapped to PDSCH TransmissionMode: single antenna mode when there is only one antenna configured, transmit diversity else; RNTI: SI-RNTI (TS 36.321, clause 7.1)		
Sib1Schedul	Sib1Schedul_Type	opt	scheduling of SIB1 in frequency domain
SiSchedul	AllSiSchedul_Type	opt	scheduling of SIs in frequency and time domain

SI_List_Type

TTCN-3 Record of Type	
Name	SI_List_Type
Comment	TS 36.331, clause 6.2.1 BCCH-DL-SCH-Message and clause 6.2.2 SystemInformation
record of BCCH_DL_SCH_Message	

BcchInfo_Type

TTCN-3 Record Type			
Name	BcchInfo_Type		
Comment	all fields are declared as optional to allow modification of single field; acc. to TS 36.331, clause 9.1.1.1 "RRC will perform padding, if required due to the granularity of the TF signalling, as defined in 8.5."; therefore this needs to be done by the system simulator		
MIB	BCCH_BCH_Message	opt	TS 36.331, clause 6.2.1 BCCH-BCH-Message and clause 6.2.2 MasterInformationBlock; NOTE: the sequence number included in MIB needs to be handled and maintained by the system simulator; that means that the sequence number being setup by TTCN will be overwritten by SS
SIB1	BCCH_DL_SCH_Message	opt	TS 36.331, clause 6.2.1 BCCH-DL-SCH-Message and clause 6.2.2 SystemInformationBlockType1
SIs	SI_List_Type	opt	

BcchConfig_Type

TTCN-3 Record Type			
Name	BcchConfig_Type		
Comment	all fields are optional to allow single modifications; activation time may be applied in the common part of the ASP; NOTE 1: acc. to TS 36.331, clause 9.1.1.1 there is no PDCP and RLC/MAC are in TM NOTE 2: mapping/scheduling and contents of the System Information in general is done in one go (i.e. there are no separate ports for SIB data and configuration)		
Pbch	BcchToPbchConfig_Type	opt	
Pdsch	BcchToPdschConfig_Type	opt	
BcchInfo	BcchInfo_Type	opt	

D.1.3.7 Paging_Control

Primitive to configuration PCCH/PCH

PcchConfig_Type

TTCN-3 Record Type			
Name	PcchConfig_Type		
Comment	configuration for PCCH mapped to PCH mapped to PDSCH TransmissionMode: single antenna mode when there is only one antenna configured, transmit diversity else; RNTI: P-RNTI (TS 36.321, clause 7.1) NOTE: acc. to TS 36.331, clause 9.1.1.3 there is no PDCP and RLC/MAC are in TM		
DciInfo	DciDlInfoCommon_Type	opt	DCI format: 1A or 1C (TS 36.213, clause 7.1) ResourceAllocType: 2 (acc. to DCI format) Modulation: QPSK Frequency domain schedule: index of 1st RB; max. number of RBs per TTI

D.1.3.8 UE_Specific_Channel_Configuration**D.1.3.8.1 UE_Specific_Channel_Configuration_DL**

Scheduling and other information for CCCH/DCCH/DTCH mapped to DL-SCH mapped to PDSCH

D.1.3.8.1.1 MIMO_Configuration

Precoding information for spatial multiplexing (DCI format 2)

PrecodingInfoForOneCodeWord_Type

TTCN-3 Union Type		
Name	PrecodingInfoForOneCodeWord_Type	
Comment	NOTE: not all index values may make sense (e.g. the indices referring to the values reported by the UE)	
TwoAntennasClosedLoop	integer (0..6)	index acc. to TS 36.212 Table 5.3.3.1.5-2; RI = 1; transmit diversity or code book index 0..3 acc. TS 36.211 Table 6.3.4.2.3-1
FourAntennasClosedLoop	integer (0..34)	index acc. to TS 36.212 Table 5.3.3.1.5-3; RI = 1..2; transmit diversity or code book index 0..15 acc. TS 36.211 Table 6.3.4.2.3-2
TwoAntennasOpenLoop	Null_Type	no precoding info; RI=1 when only codeword 1 is enabled
FourAntennasOpenLoop	integer (0..1)	index acc. to TS 36.212 Table 5.3.3.1.5-4 RI = 1..2; RI=1 => transmit diversity; RI=2 => large delay CDD

PrecodingInfoForTwoCodeWords_Type

TTCN-3 Union Type		
Name	PrecodingInfoForTwoCodeWords_Type	
Comment	NOTE: not all index values may make sense (e.g. the indices referring to the values reported by the UE)	
TwoAntennasClosedLoop	integer (0..2)	index acc. to TS 36.212 Table 5.3.3.1.5-2; RI = 2; code book index 1, 2 acc. TS 36.211 Table 6.3.4.2.3-1
FourAntennasClosedLoop	integer (0..50)	index acc. to TS 36.212 Table 5.3.3.1.5-3; RI = 2..4; code book index 0..15 acc. TS 36.211 Table 6.3.4.2.3-2
TwoAntennasOpenLoop	Null_Type	no precoding info; RI=2 when both codewords are enabled
FourAntennasOpenLoop	integer (0..2)	index acc. to TS 36.212 Table 5.3.3.1.5-4 RI = 2..4; large delay CDD

PrecodingInfoIndex_Type

TTCN-3 Union Type		
Name	PrecodingInfoIndex_Type	
Comment		
OneCodeWord	PrecodingInfoForOneCodeWord_Type	only codeword 1 shall be enabled in the DCI
TwoCodeWords	PrecodingInfoForTwoCodeWords_Type	both codewords shall be enabled in the DCI

PrecodingOperationMode_Type

TTCN-3 Enumerated Type		
Name	PrecodingOperationMode_Type	
Comment	how to determine precoding information for spatial multiplexing is signalled on PDCCH with DCI format 2 and 2A (TS 36.212, clause 5.3.3.1.5)	
hardcoded	SS shall apply configured precoding info as configured regardless RI and PMI reported by the UE	
automatic	SS shall apply configured precoding info as long as there are no RI and PMI reported by the UE; when there are RI and PMI reported by the UE these shall be used	

SpatialMultiplexingInfo_Type

TTCN-3 Record Type			
Name	SpatialMultiplexingInfo_Type		
Comment	NOTE: there may be codebookSubsetRestriction as signalled to the UE (TS 36.331, clause 6.3.2 AntennaInfoDedicated) to be considered		
OperationMode	PrecodingOperationMode_Type		
PrecodingIndex	PrecodingInfoIndex_Type		NOTE: contains information about number of code words to be used in DCI format 2

MimoInfo_Type

TTCN-3 Union Type			
Name	MimoInfo_Type		
Comment			
NoMimo	Null_Type		
Spatial	SpatialMultiplexingInfo_Type		

HarqProcessConfigDL_Type

TTCN-3 Union Type			
Name	HarqProcessConfigDL_Type		
Comment	HARQ processes to be used automatically for DL assignments		
AllProcesses	Null_Type		all HARQ processes shall be used for automatic assignment; this is the normal case
SpecificSubset	HarqProcessList_Type		only the HARQ processes of this list shall be used automatically, other processes are excluded from automatic assignments; nevertheless all HARQ processes may be addressed explicitly by DRB_DataPerSubframe_DL_Type.HarqProcess

CcchDcchDtchConfigDL_Type

TTCN-3 Record Type			
Name	CcchDcchDtchConfigDL_Type		
Comment	configuration for CCCH/DCCH/DTCH mapped to DL-SCH mapped to PDSCH TransmissionMode: as signalled to the UE (AntennaInfoDedicated in RRCConnectionSetup); RNTI: C-RNTI (TS 36.321, clause 7.1); all fields optional (omit = "keep as it is") since DCI format and modulation may be changed during a test; for initial configuration all fields are mandatory		
DciInfo	DciDlInfo_Type	opt	DCI format: 1A per default since for CCCH mimo cannot be applied in general ResourceAllocType: (depending on DCI format) Modulation: QPSK for signalling Frequency domain schedule: index of 1st RB; max. number of RBs per TTI; in case of spatial multiplexing if there are 2 code words FreqDomainSchedul shall be applied to both
AntennaInfo	AntennaInfoDedicated_Type	opt	as signalled to the UE (TS 36.331, clause 6.3.2): transmissionMode, codebookSubsetRestriction
MimoInfo	MimoInfo_Type	opt	when spatial multiplexing is applied (transmissionMode 3, 4): precoding information, number of code words
HarqProcessConfig	HarqProcessConfigDL_Type	opt	HARQ processes automatically used by the SS in DL

D.1.3.8.2 UE_Specific_Channel_Configuration_UL

Scheduling information for CCCH/DCCH/DTCH mapped to UL-SCH mapped to PUSCH

PucchHoppingBits_Type

TTCN-3 Union Type		
Name	PucchHoppingBits_Type	
Comment	Number of hopping bits acc. to TS 36.213 table 8.4-2	
OneBit	B1_Type	N(UL, RB) = 6..49 i.e. default system bandwidth is less than 10 MHz (does not include 10 MHz)
TwoBits	B2_Type	N(UL, RB) = 50..110 i.e. default system bandwidth is 10 MHz or above

UplinkHoppingResourceParameters_Type

TTCN-3 Record Type		
Name	UplinkHoppingResourceParameters_Type	
Comment		
PucchHopping	PucchHoppingBits_Type	to control hopping resource allocation as signalled in DCI format 0 (TS 36.212, clause 5.3.3.1.1)

UplinkHoppingControl_Type

TTCN-3 Union Type		
Name	UplinkHoppingControl_Type	
Comment	shall be considered by SS to fill in the information needed for DCI format 0 (TS 36.213, clause 7.1)	
Deactivated	Null_Type	
Activated	UplinkHoppingResourceParameters_Type	

CcchDcchDtchConfigUL_Type

TTCN-3 Record Type		
Name	CcchDcchDtchConfigUL_Type	
Comment	scheduling for CCCH/DCCH/DTCH mapped to UL-SCH mapped to PUSCH NOTE 1: for definition of the possible UL grants the location of the PUCCH (TS 36.211, clause 5.4.3) and the PRACH (TS 36.211, clause 5.7.3) need to be taken into account; NOTE 2: In contrast to the DL where the scheduling can be done (with consideration of some restrictions) by SS on a per need basis in the UL the scheduling depends on information provided by the UE: e.g. BSR (buffer status report), SR (scheduling request) see TS 36.523-3 clause 7.2 for further information.	
DciInfo	DciUInfo_Type	opt DCI format: 0 (TS 36.213, clause 7.1) ResourceAllocType: 2 (acc. to DCI format) Modulation: QPSK per default Frequency domain schedule: index of 1st RB; max. number of RBs per TTI (upper bound up to which SS may assign grants to the UE)
Hopping	UplinkHoppingControl_Type	opt when Hopping = 'Activated' SS shall set hopping flag in DCI format 0
PUCCH_Synch	PUCCH_Synch_Type	opt parameters to control automatic control of timing advance
UL_GrantConfig	UL_GrantConfig_Type	opt UL grant allocation to be applied

DrxCtrl_Type

TTCN-3 Union Type		
Name	DrxCtrl_Type	
Comment	DRX configuration for connected mode (TS 36.321, clause 5.7)	
None	Null_Type	DRX not configured
Config	DRX_Config_Type	DRX is configured as signalled to the UE

TimeDomainRestriction_Type

TTCN-3 Record Type			
Name	TimeDomainRestriction_Type		
Comment			
MeasGapConfig	MeasGapConfig_Type		measurement gap configuration acc. to TS 36.331, clause 6.3.5 and gap pattern acc. TS 36.133 Table 8.1.2.1-1

CcchDcchDtchConfig_Type

TTCN-3 Record Type			
Name	CcchDcchDtchConfig_Type		
Comment			
TimeDomainRestriction	TimeDomainRestriction_Type	opt	to tell the SS when no assignments/grants shall be assigned to the UE
DL	CcchDcchDtchConfigDL_Type	opt	Scheduling, parameters related to CCCH, DCCH and DTCH in DL
UL	CcchDcchDtchConfigUL_Type	opt	Scheduling, parameters related to CCCH, DCCH and DTCH in UL
DrxCtrl	DrxCtrl_Type	opt	DRX configuration as sent to the UE (or 'None' when the UE does not support connected mode DRX)
TtiBundling	TTI_BundlingConfig_Type	opt	TTI bundling as configured at the UE

D.1.4 Cell_Power_Attenuation**CellAttenuationConfig_Type**

TTCN-3 Record Type			
Name	CellAttenuationConfig_Type		
Comment			
CellId	CellId_Type		
Attenuation	Attenuation_Type		

CellAttenuationList_Type

TTCN-3 Record of Type			
Name	CellAttenuationList_Type		
Comment			
record length(1.. tsc_EUTRA_MaxNumberOfCells) of CellAttenuationConfig_Type			

D.1.5 Radio_Bearer_Configuration

Radio Bearer Configuration: SRBs/DRBs

D.1.5.1 PDCP_Configuration**PDCP_SNLength_Type**

TTCN-3 Enumerated Type	
Name	PDCP_SNLength_Type
Comment	PDCP Sequence Number
PDCP_SNLength5	TS 36.323 clause 6.2.2
PDCP_SNLength7	TS 36.323 clause 6.2.3
PDCP_SNLength12	TS 36.323 clause 6.2.4

PDCP_ROHC_Mode_Type

TTCN-3 Record Type	
Name	PDCP_ROHC_Mode_Type
Comment	
SN_Size	PDCP_SNLength_Type

PDCP_NonROHC_Mode_Type

TTCN-3 Record Type	
Name	PDCP_NonROHC_Mode_Type
Comment	
SN_Size	PDCP_SNLength_Type

PDCP_TestModelInfo_Type

TTCN-3 Union Type		
Name	PDCP_TestModelInfo_Type	
Comment		
PDCP_ROHC_Mode	PDCP_ROHC_Mode_Type	ROHC test mode acc. to TS 36.523-3, clause 4.2.1.3.1; requires PDCP to be configured for this RB => - SS applies ciphering in UL and DL - SS maintains PDCP sequence numbers and state variables Furthermore in this mode - SS does not add/remove PDCP headers (in UL the PDCP PDUs are decoded depending on SN_Size) - SS applies ROHC in DL only
PDCP_NonROHC_Mode	PDCP_NonROHC_Mode_Type	PDCP test mode acc. to TS 36.523-3, clause 4.2.1.3.2 (non-ROHC test mode); requires PDCP to be configured as transparent => - SS does not apply ciphering in UL and DL - SS does not interpret, insert or remove PDCP headers (in UL PDCP PDUs are decoded depending on SN_Size) - SS does not maintain PDCP sequence numbers and state variables

PDCP_TestModeConfig_Type

TTCN-3 Union Type	
Name	PDCP_TestModeConfig_Type
Comment	
None	Null_Type
Info	PDCP_TestModelInfo_Type

PDCP_RbConfig_Type

TTCN-3 Union Type		
Name	PDCP_RbConfig_Type	
Comment		
Srb	Null_Type	for SRB1/2 there are no PDCP_Parameters; SN is always 5 bits
Drb	PDCP_Config_Type	PDCP-Configuration acc. to TS 36.331, clause 6.3.2; among others for UM here pdcp-SN-Size is configured to be either len7bits or len12bits; for AM it always is 12bit
Transparent	Null_Type	used for PDCP tests (TS 36.523-3, clause 4.2.1.3.2): the SS does not apply ciphering and does not maintain PDCP sequence numbers and state variables; in UL the PDCP PDUs are decoded acc. to the TestMode; Note: a reconfiguration of a RB from transparent mode to 'normal' mode is not foreseen (i.e. there is no mechanism to restore Ciphering, PDCP sequence numbers and state variables at the SS)

PDCP_ConfigInfo_Type

TTCN-3 Record Type			
Name	PDCP_ConfigInfo_Type		
Comment			
Rb	PDCP_RbConfig_Type	opt	mandatory for initial configuration; omit means "keep as it is"
TestMode	PDCP_TestModeConfig_Type	opt	mandatory for initial configuration; omit means "keep as it is"

PDCP_Configuration_Type

TTCN-3 Union Type		
Name	PDCP_Configuration_Type	
Comment		
None	Null_Type	for SRB0 no PDCP is configured; furthermore the PDCP may not be configured e.g. for DRBs tested in MAC test cases
Config	PDCP_ConfigInfo_Type	

D.1.5.2 RLC_Configuration

RLC configuration: radio bearer specific

RLC_Configuration: Basic Type Definitions

TTCN-3 Basic Types		
RLC_AM_SequenceNumber_Type	integer (0..1023)	RLC AM sequence number
SS_RLC_TM_Type	Null_Type	TM to configure SRB0; no parameters to be defined

RLC_ACK_Prohibit_Type

TTCN-3 Enumerated Type	
Name	RLC_ACK_Prohibit_Type
Comment	
Prohibit	cause SS RLC layer to stop any ACK transmission for UL PDU's received from UE
Continue	bring back the SS RLC in normal mode, where ACK/NACK are transmitted at polling

RLC_NotACK_NextRLC_PDU_Type

TTCN-3 Enumerated Type	
Name	RLC_NotACK_NextRLC_PDU_Type
Comment	
Start	cause SS RLC layer not to ACK the next received RLC PDU; this is done regardless of whether the poll bit is set or not; Example [from UMTS]: when the UE gets new security information in a SECURITY MODE COMMAND the response (SECURITY MODE COMPLETE) sent by the UE is not acknowledged at the RLC level; this causes the UE to continue using the "old" security information

RLC_TestModelInfo_Type

TTCN-3 Union Type		
Name	RLC_TestModelInfo_Type	
Comment		
AckProhibit	RLC_ACK_Prohibit_Type	valid only when the RLC is configured in AM
NotACK_NextRLC_PDU	RLC_NotACK_NextRLC_PDU_Type	valid only when the RLC is configured in AM
ModifyVTS	RLC_AM_SequenceNumber_Type	to modify the VT(S) at SS: VT(S) at the SS side is set to this (absolute) value; valid only when the RLC is configured in AM
TransparentMode_UMDwith5BitSN	Null_Type	shall be set when TTCN expects RLC PDUs as UMD in UL with an SN of 5 bits; valid only when the RLC is configured in TM
TransparentMode_UMDwith10BitSN	Null_Type	shall be set when TTCN expects RLC PDUs as UMD in UL with an SN of 10 bits; valid only when the RLC is configured in TM
TransparentMode_AMD	Null_Type	shall be set when TTCN expects RLC PDUs as AMD in UL; valid only when the RLC is configured in TM

RLC_TestModeConfig_Type

TTCN-3 Union Type		
Name	RLC_TestModeConfig_Type	
Comment		
None	Null_Type	
Info	RLC_TestModelInfo_Type	

SS_RLC_AM_Type

TTCN-3 Record Type			
Name	SS_RLC_AM_Type		
Comment			
Tx	UL_AM_RLC_Type	opt	the UE's UL setting to be used in SS's tx direction
Rx	DL_AM_RLC_Type	opt	the UE's DL setting to be used in SS's rx direction

SS_RLC_UM_Bi_Directional_Type

TTCN-3 Record Type			
Name	SS_RLC_UM_Bi_Directional_Type		
Comment			
Tx	UL_UM_RLC_Type	opt	the UE's UL setting to be used in SS's tx direction
Rx	DL_UM_RLC_Type	opt	the UE's DL setting to be used in SS's rx direction

SS_RLC_UM_Uni_Directional_UL_Type

TTCN-3 Record Type			
Name	SS_RLC_UM_Uni_Directional_UL_Type		
Comment			
Rx	DL_UM_RLC_Type	opt	the UE's DL setting to be used in SS's rx direction

SS_RLC_UM_Uni_Directional_DL_Type

TTCN-3 Record Type			
Name	SS_RLC_UM_Uni_Directional_DL_Type		
Comment			
Tx	UL_UM_RLC_Type	opt	the UE's UL setting to be used in SS's tx direction

RLC_RbConfig_Type

TTCN-3 Union Type			
Name	RLC_RbConfig_Type		
Comment			
AM	SS_RLC_AM_Type		
UM	SS_RLC_UM_Bi_Directional_Type		
UM_OnlyUL	SS_RLC_UM_Uni_Directional_UL_Type		
UM_OnlyDL	SS_RLC_UM_Uni_Directional_DL_Type		
TM	SS_RLC_TM_Type		normally SRB0 only; may be used for test purposes also

RLC_Configuration_Type

TTCN-3 Record Type			
Name	RLC_Configuration_Type		
Comment			
Rb	RLC_RbConfig_Type	opt	mandatory for initial configuration; omit means "keep as it is"
TestMode	RLC_TestModeConfig_Type	opt	mandatory for initial configuration; omit means "keep as it is"

D.1.5.3 MAC_Configuration

MAC configuration: radio bearer specific configuration

EUTRA_ASP_TypeDefs: Constant Definitions

TTCN-3 Basic Types			
tsc_MaxHarqRetransmission	integer	28	maximum value for maxHARQ-Msg3Tx as being signalled to the UE

MAC_Test_DLLogChID_Type

TTCN-3 Union Type		
Name	MAC_Test_DLLogChID_Type	
Comment		
LogChId	TestLogicalChannelId_Type	Specifies to over write the logical channel ID in MAC header in all the DL messages sent on the configured logical channel
ConfigLchId	Null_Type	Specifies that the normal mode of correct logical channel ID to be used in DL Mac header. This will be the default mode, when SS is initially configured.

MAC_Test_DL_SCH_CRC_Mode_Type

TTCN-3 Enumerated Type	
Name	MAC_Test_DL_SCH_CRC_Mode_Type
Comment	
Normal	default mode, the CRC generation is correct
Erroneous	SS shall generate CRC error by toggling CRC bits; the CRC error shall be applied for all PDUs of the given RNTI and their retransmission until SS is configured back to 'normal' operation
Error1AndNormal	the SS generates wrong CRC for first transmission and correct CRC on first retransmission. Later SS operates in normal mode. The retransmission is automatically triggered by reception of HARQ NACK

MAC_Test_SCH_NoHeaderManipulation_Type

TTCN-3 Enumerated Type	
Name	MAC_Test_SCH_NoHeaderManipulation_Type
Comment	
NormalMode	MAC header is fully controlled by the SS
DL_SCH_Only	TTCN can submit a final MAC PDU including header and payloads; SS does not do anything with this MAC PDU i.e. no header is added for the DL SCH transport channel. It is possible that data belonging to multiple DRBs is sent in one MAC PDU and from one special RB configured. NOTE: whether/how SRBs can be used on DL-SCH when DL-SCH MAC is configured in this mode is FFS.
DL_UL_SCH	In UL and DL the SS' MAC layer is transparent i.e. SS does not add or remove any MAC header

HARQ_ModeList_Type

TTCN-3 Record of Type	
Name	HARQ_ModeList_Type
Comment	
record length (1.. tsc_MaxHargRetransmission) of HARQ_Type	

PhichTestMode_Type

TTCN-3 Union Type		
Name	PhichTestMode_Type	
Comment		
NormalMode	Null_Type	PHICH is configured to operate in normal mode
ExplicitMode	HARQ_ModeList_Type	the number of elements in explicit list shall match the number of retransmissions being expected

MAC_TestModelInfo_Type

TTCN-3 Record Type			
Name	MAC_TestModelInfo_Type		
Comment	Parameters/Configuration for MAC tests		
DiffLogChId	MAC_Test_DLLogChID_Type		to be used in test cases 7.1.1.1 and 7.1.1.2 for using a different logical channel ID in MAC-header on DL-SCH channel
No_HeaderManipulation	MAC_Test_SCH_NoHeaderManipulation_Type		to configure mode for no header manipulation in SS MAC layer for DL/UL SCH

MAC_TestModeConfig_Type

TTCN-3 Union Type		
Name	MAC_TestModeConfig_Type	
Comment		
None	Null_Type	
Info	MAC_TestModeInfo_Type	

MAC_LogicalChannelConfig_Type

TTCN-3 Record Type			
Name	MAC_LogicalChannelConfig_Type		
Comment			
Priority	integer		logical channel priority for the DL as described in TS 36.321, clause 5.4.3.1 for the UL
PrioritizedBitRate	PrioritizedBitRate_Type		PBR as described for the UL; probably not needed at SS

MAC_Configuration_Type

TTCN-3 Record Type			
Name	MAC_Configuration_Type		
Comment			
LogicalChannel	MAC_LogicalChannelConfig_Type	opt	mandatory for initial configuration; omit means "keep as it is"
TestMode	MAC_TestModeConfig_Type	opt	mandatory for initial configuration; omit means "keep as it is"; for none MAC tests "TestMode.None:=true"

Radio_Bearer_Configuration: Basic Type Definitions

TTCN-3 Basic Types		
LogicalChannelId_Type	integer (0..10)	acc. TS 36.331, clause 6.3.2 for DRBs DTCH-LogicalChannelIdentity is INTEGER (3..10); additionally we have 0..2 for the SRBs
TestLogicalChannelId_Type	integer (0..31)	To be used in MAC test mode for reserved values of Logical channels;

RadioBearerConfigInfo_Type

TTCN-3 Record Type			
Name	RadioBearerConfigInfo_Type		
Comment	semantics of omit: "keep as it is"		
Pdcp	PDCP_Configuration_Type	opt	for SRB0: "Pdcp.None:=true" mandatory for initial configuration; omit means "keep as it is"
Rlc	RLC_Configuration_Type	opt	mandatory for initial configuration; omit means "keep as it is"
LogicalChannelId	LogicalChannelId_Type	opt	DRBs: DTCH-LogicalChannelIdentity as for rb-MappingInfo in DRB-ToAddModifyList; SRBs: for SRBs specified configurations acc. to TS 36.331, clause 9.1.2 shall be applied: SRB1: ul-LogicalChannel-Identity = dl-LogicalChannel-Identity = 1 SRB2: ul-LogicalChannel-Identity = dl-LogicalChannel-Identity = 2 for SRB0 being mapped to CCCH the LCID is '00000'B acc. to TS 36.321, clause 6.2.1; mandatory for initial configuration; omit means "keep as it is"
Mac	MAC_Configuration_Type	opt	

RadioBearerConfig_Type

TTCN-3 Union Type		
Name	RadioBearerConfig_Type	
Comment		
AddOrReconfigure	RadioBearerConfigInfo_Type	add / re-configure RB - CellId : identifier of the cell being configured RoutingInfo : None TimingInfo : 'Now' in common cases ControlInfo : CnfFlag:=true; FollowOnFlag:=false (in general)
Release	Null_Type	release RB - CellId : identifier of the cell being configured RoutingInfo : None TimingInfo : 'Now' in common cases ControlInfo : CnfFlag:=true; FollowOnFlag:=false (in general)

RadioBearer_Type

TTCN-3 Record Type		
Name	RadioBearer_Type	
Comment		
Id	RadioBearerId_Type	either for SRB or DRB
Config	RadioBearerConfig_Type	

RadioBearerList_Type

TTCN-3 Record of Type	
Name	RadioBearerList_Type
Comment	array of SRBs and/or DRBs (DRBs + 3 SRBs)
record length (1.. tsc_MaxRB) of RadioBearer_Type	

D.1.6 AS_Security

Primitive for control of AS security

PdcpSQN_Type

TTCN-3 Record Type		
Name	PdcpSQN_Type	
Comment		
Format	PdcpCountFormat_Type	5 bit, 7 bit or 12 bit SQN
Value	integer	SQN value (5 bit, 7 bit or 12 bit SQN) NOTE: in TTCN the test case writer is responsible to deal with potential overflows (e.g. there shall be a "mod 32", "mod 128" or "mod 4096" according to the format)

PDCP_ActTime_Type

TTCN-3 Union Type		
Name	PDCP_ActTime_Type	
Comment	The sequence number in UL and DL for SRB1 should be one more than the present SQN, as Cipherring starts in UL and DL soon after SMC and SMComp; For other SRB/DRB it should be the present SQN.	
None	Null_Type	No Activation time; to be used if Cipherring is not applied
SQN	PdcpSQN_Type	PDCP sequence number

SecurityActTime_Type

TTCN-3 Record Type			
Name	SecurityActTime_Type		
Comment			
RadioBearerId	RadioBearerId_Type		
UL	PDCP_ActTime_Type		
DL	PDCP_ActTime_Type		

SecurityActTimeList_Type

TTCN-3 Record of Type			
Name	SecurityActTimeList_Type		
Comment			
record length (1.. tsc_MaxRB) of SecurityActTime_Type			

AS_IntegrityInfo_Type

TTCN-3 Record Type			
Name	AS_IntegrityInfo_Type		
Comment	for initial configuration activation time is not needed for integrity protection as all messages in DL after security activation are integrity protected; this means this ASP is invoked before transmission of Security mode command; if there is a integrity violation in UL SS shall set the IndicationStatus in the common ASP part to flag the integrity error (IndicationStatus.Error.Integrity.Pdcp := true); integrity to be provided for each SRB as per core spec		
Algorithm	IntegrityProtAlgorithm_Type		IntegrityProtAlgorithm_Type being defined in RRC ASN.1
KRRRCint	B128_Key_Type		
ActTimeList	SecurityActTimeList_Type	opt	omit for initial configuration (i.e. all SRBs to be integrity protected immediately); in HO scenarios activation time may be needed e.g. for SRB1

AS_CipheringInfo_Type

TTCN-3 Record Type			
Name	AS_CipheringInfo_Type		
Comment			
Algorithm	CipheringAlgorithm_Type		CipheringAlgorithm_Type being defined in RRC ASN.1
KRRRCenc	B128_Key_Type		
KUPenc	B128_Key_Type		KUPenc is mandatory; and SS uses it when DRB are configured
ActTimeList	SecurityActTimeList_Type		

AS_SecStartRestart_Type

TTCN-3 Record Type			
Name	AS_SecStartRestart_Type		
Comment			
Integrity	AS_IntegrityInfo_Type	opt	optional to allow separated activation of integrity and ciphering; omit: keep as it is
Ciphering	AS_CipheringInfo_Type	opt	optional to allow separated activation of integrity and ciphering; omit: keep as it is

AS_Security_Type

TTCN-3 Union Type		
Name	AS_Security_Type	
Comment	Security mode command procedure (TS 36.331, clause 5.3.4): both SMC and SMComp are integrity protected (nevertheless SS shall be able to cope with unprotected SM reject); ciphering is started just after SMComp (acc. to TS 36.331, clause 5.3.4.3 and 5.3.1.1)	
StartRestart	AS_SecStartRestart_Type	information to start/restart AS security protection in the PDCP
Release	Null_Type	to release AS security protection in the PDCP

D.1.7 Semi_Persistent_Scheduling

Semi-persistent scheduling (SPS)

NOTE 1:

configuration of SPS cannot be done completely in advance but needs to be activated by PDCCH signalling
=> SPS is configured/activated in an own primitive which may be sent to SS during RBs are being configured

NOTE 2:

semi-persistent (configured) scheduling is per UE (as well as 'normal' scheduling; see e.g. TS 36.300, clause 11.1)

SpsAssignmentUL_Type

TTCN-3 Record Type			
Name	SpsAssignmentUL_Type		
Comment	information to assign semi-persistent scheduls in UL		
DciInfo	DciUlInfo_Type	opt	to apply a grant
SchedulInterval	SpsConfigurationUL_Type	opt	as in TS 36.331, clause 6.3.2 SPS-ConfigUL
SetNDI_1	Null_Type	opt	if present then NDI is set as 1 indicating a retransmission; If absent then NDI is set as 0 indicating a new transmission

SpsAssignmentDL_Type

TTCN-3 Record Type			
Name	SpsAssignmentDL_Type		
Comment	information to assign semi-persistent scheduls in DL		
DciInfo	DciDlInfo_Type	opt	to apply a assignment
SchedulInterval	SpsConfigurationDL_Type	opt	as in TS 36.331, clause 6.3.2 SPS-ConfigDL
SetNDI_1	Null_Type	opt	if present then NDI is set as 1 indicating a retransmission; If absent then NDI is set as 0 indicating a new transmission

SpsActivateInfo_Type

TTCN-3 Record Type			
Name	SpsActivateInfo_Type		
Comment	<p>Semi-persistent scheduling (SPS): Even though SPS is pre-configured at the UE (e.g. RRCConnectionSetup->RadioResourceConfiguration->MAC_MainConfig) it needs to be activated by L1 signalling => SS shall 'activate' SPS by sending appropriate assignments/grants to the UE; this shall be done with an activation time. If SPS is already configured and new Activate command is received, at the activation time SS locally deactivates old SPS configuration, sends UE an PDCCH assignment for new SPS assignment and locally activates new SPS configuration. In DL, in addition to SS SPS assignment configuration with activation time 'T', TTCN writer shall also schedule a DL MAC PDU with same activation time 'T' and at every SPS ScheduleInterval (NOTE: in general it is an error when TTCN does not provide data for a ScheduleInterval; SS shall send no data in this case). Special fields of PDCCH assignment are filled as per table 9.2-1 of 36.213</p>		
SPS_C_RNTI	C_RNTI		SPS C-RNTI as signalled to UE
UplinkGrant	SpsAssignmentUL_Type	opt	
DownlinkAssignment	SpsAssignmentDL_Type	opt	

SpsPdcchRelease_Type

TTCN-3 Record Type			
Name	SpsPdcchRelease_Type		
Comment	<p>On reception of this information SS shall send an SPS release indicated by PDCCH transmission with indicated DCI format (0 or 1A) at the activation time. Special fields of PDCCH assignment are filled as per table 9.2-1A of 36.213</p>		
SPS_C_RNTI	C_RNTI		
DCI_Format	PdcchDciFormat_Type		only formats 0 (UL release) and 1A (DL release) are applicable. It is a TTCN error if any other formats are used.

SpsDeactivateInfo_Type

TTCN-3 Union Type			
Name	SpsDeactivateInfo_Type		
Comment			
LocalRelease	Null_Type		SPS configuration shall be released at the SS, that means as well that the SS shall not address SPS_C_RNTI anymore from the given TimingInfo onward; NOTE: there is no SPS release to be signalled on PDCCH (this is done with PdcchExplicitRelease - see below)
PdcchExplicitRelease	SpsPdcchRelease_Type		SS transmits PDCCH content indicating SPS release but holds the local SPS configuration until it is locally released

SpsConfig_Type

TTCN-3 Union Type			
Name	SpsConfig_Type		
Comment			
Activate	SpsActivateInfo_Type		CellId : identifier of the cell where the UE is active RoutingInfo : None TimingInfo : activation time for SPS assignment/grant transmission; NOTE: the first SPS DL data packet shall be sent with the same timing information ControllInfo : CnfFlag:=false; FollowOnFlag:=false
Deactivate	SpsDeactivateInfo_Type		CellId : identifier of the cell where the UE is active RoutingInfo : None TimingInfo : activation time for SPS release indicated by PDCCH transmission or SS local deactivation ControllInfo : CnfFlag:=false; FollowOnFlag:=false

D.1.8 Paging_Trigger

PagingTrigger_Type

TTCN-3 Record Type			
Name	PagingTrigger_Type		
Comment	CellId : identifier of the cell where the UE is active RoutingInfo : None TimingInfo : Calculated paging occasion ControllInfo : CnfFlag:=false; FollowOnFlag:=false primitive to trigger transmission of a paging on the PCCH at a calculated paging occasion (TS 36.304, clause 7); the paging occasion is calculated by TTCN and activation time is applied; as for BCCH Infor acc. to TS 36.331, clause 9.1.1.3 "RRC will perform padding, if required due to the granularity of the TF signalling, as defined in 8.5."; therefore this needs to be done by the system simulator		
Paging	PCCH_Message		paging to be send out at paging occasion and being announced on PDCCH using P-RNTI

D.1.9 L1_MAC_Indication_Control

Primitive for control of L1/MAC indication for special purposes

L1Mac_IndicationMode_Type

TTCN-3 Enumerated Type	
Name	L1Mac_IndicationMode_Type
Comment	
enable	
disable	

L1Mac_IndicationControl_Type

TTCN-3 Record Type			
Name	L1Mac_IndicationControl_Type		
Comment	NOTE: Initially all indications are disabled in SS (i.e. it shall not be necessary in 'normal' test cases to use this primitive but only if a specific indication is needed); omit means indication mode is not changed		
RachPreamble	L1Mac_IndicationMode_Type	opt	To enable/disable reporting of PRACH preamble received.
SchedReq	L1Mac_IndicationMode_Type	opt	To enable/disable reporting of reception of Scheduling Request on PUCCH.
BSR	L1Mac_IndicationMode_Type	opt	To enable/disable reporting of Buffer Status Report. NOTE: this is applicable only when MAC is configured in normal mode in UL; MAC configured in test mode, results in over writing the report.
UL_HARQ	L1Mac_IndicationMode_Type	opt	To enable/disable reporting of reception of HARQ ACK/NACK.
C_RNTI	L1Mac_IndicationMode_Type	opt	To enable/disable reporting of C-RNTI sent by the UE within MAC PDU
PHR	L1Mac_IndicationMode_Type	opt	To enable/disable reporting of Power Headroom Report. NOTE: this is applicable only when MAC is configured in normal mode in UL; MAC configured in test mode, results in over writing the report.
HarqError	L1Mac_IndicationMode_Type	opt	To enable/disable reporting of HARQ errors

D.1.10 Rlc_Indication_Control

Primitive for control of RLC indication for special purposes

Rlc_IndicationMode_Type

TTCN-3 Enumerated Type	
Name	Rlc_IndicationMode_Type
Comment	
enable	
disable	

Rlc_IndicationControl_Type

TTCN-3 Record Type			
Name	Rlc_IndicationControl_Type		
Comment			
Discard	Rlc_IndicationMode_Type	opt	To enable/disable reporting of discarded RLC PDUs

D.1.11 PDCP_Count

Primitives to enquire PDCP COUNT

PDCP_Count: Basic Type Definitions

TTCN-3 Basic Types		
PdcpCountValue_Type	B32_Type	

PdcpCountFormat_Type

TTCN-3 Enumerated Type	
Name	PdcpCountFormat_Type
Comment	
PdcpCount_Srb	27 bit HFN; 5 bit SQF
PdcpCount_DrbLong SQN	20 bit HFN; 12 bit SQF
PdcpCount_DrbShort SQN	25 bit HFN; 7 bit SQF

PdcpCount_Type

TTCN-3 Record Type			
Name	PdcpCount_Type		
Comment			
Format	PdcpCountFormat_Type		
Value	PdcpCountValue_Type		

PdcpCountInfo_Type

TTCN-3 Record Type			
Name	PdcpCountInfo_Type		
Comment			
RadioBearerId	RadioBearerId_Type		
UL	PdcpCount_Type	opt	omit: keep as it is
DL	PdcpCount_Type	opt	omit: keep as it is

PdcpCountInfoList_Type

TTCN-3 Record of Type	
Name	PdcpCountInfoList_Type
Comment	
record length (1..tsc_MaxRB) of PdcpCountInfo_Type	

PdcpCountGetReq_Type

TTCN-3 Union Type	
Name	PdcpCountGetReq_Type
Comment	
AllRBs	Null_Type return COUNT values for all RBs being configured
SingleRB	RadioBearerId_Type

PDCP_CountReq_Type

TTCN-3 Union Type	
Name	PDCP_CountReq_Type
Comment	
Get	PdcpCountGetReq_Type Request PDCP count for one or all RBs being configured at the PDCP
Set	PdcpCountInfoList_Type Set PDCP count for one or all RBs being configured at the PDCP; list for RBs which's COUNT shall be manipulated

PDCP_CountCnf_Type

TTCN-3 Union Type	
Name	PDCP_CountCnf_Type
Comment	
Get	PdcpCountInfoList_Type RBs in ascending order; SRBs first
Set	Null_Type

D.1.12 PDCP_Handover

Primitives to control PDCP regarding handover

PDCP_HandoverInit_Type

TTCN-3 Record Type	
Name	PDCP_HandoverInit_Type
Comment	
SourceCellId	CellId_Type

PDCP_HandoverControlReq_Type

TTCN-3 Union Type		
Name	PDCP_HandoverControlReq_Type	
Comment		
HandoverInit	PDCP_HandoverInit_Type	to inform SS that a handover will follow: in the common ASP part the CellId shall be set to the id of the target cell
HandoverComplete	Null_Type	to inform SS that the handover has successfully been performed by the UE; this shall trigger the SS to sent a PDCP Status Report to the UE; in the common ASP part the CellId shall be set to the id of the target cell

D.1.13 L1_MAC_Test_Mode

Primitive for control of L1/MAC Test Modes

L1_TestMode_Type

TTCN-3 Record Type		
Name	L1_TestMode_Type	
Comment	L1 test mode; in general RACH is handled separately	
DL_SCH_CRC	DL_SCH_CRC_Type	Manipulation of CRC bit generation for DL-SCH
Phich	PhichTestMode_Type	HARQ feedback mode on the PHICH

DL_SCH_CRC_Type

TTCN-3 Union Type		
Name	DL_SCH_CRC_Type	
Comment	NOTE: CRC error mode for RA_RNTI is not addressed as it will be configured in RACHProcedureConfig	
C_RNTI	MAC_Test_DL_SCH_CRC_Mode_Type	to configure mode for CRC bit for all MAC PDU's for which C-RNTI is used in PDCCH transmission
SI_RNTI	MAC_Test_DL_SCH_CRC_Mode_Type	to configure mode for CRC bit for all MAC PDU's for which SI-RNTI is used in PDCCH transmission
SPS_RNTI	MAC_Test_DL_SCH_CRC_Mode_Type	to configure mode for CRC bit for all MAC PDU's for which SPS-RNTI is used in PDCCH transmission

D.1.14 PDCCH_Order

Primitive to trigger SS to send PDCCH order to initiate RA procedure (TS 36.321, clause 5.1.1)

PDCCH_Order: Basic Type Definitions

TTCN-3 Basic Types		
PrachPreambleIndex_Type	Ra_PreambleIndex_Type	
PrachMaskIndex_Type	integer (0..15)	TS 36.321, clause 7.3

RA_PDCCH_Order_Type

TTCN-3 Record Type		
Name	RA_PDCCH_Order_Type	
Comment	see also TS 36.212, clause 5.3.3.1.3	
PreambleIndex	PrachPreambleIndex_Type	naming acc. TS 36.212, clause 5.3.3.1.3
PrachMaskIndex	PrachMaskIndex_Type	naming acc. TS 36.212, clause 5.3.3.1.3

D.1.15 System_Indications

Primitives for System indications

System_Indications: Basic Type Definitions

TTCN-3 Basic Types		
PRTPower_Type	Dummy_Type	needs to define appropriately the power level report of PREAMBLE_RECEIVED_TARGET_POWER; NOTE: for the time being this is just a place holder for enhancements in the future.
LogicalChannelGroup_Type	integer (0..3)	
BSR_Value_Type	integer (0..63)	
PHR_Type	integer (0..63)	

HarqError_Type

TTCN-3 Union Type		
Name	HarqError_Type	
Comment		
UL	HarqProcessId_Type	indicates HARQ error detected at the SS side (error at UL transmission)
DL	HarqProcessId_Type	indicates HARQ NACK sent by the UE (error at DL transmission)

RachPreamble_Type

TTCN-3 Record Type		
Name	RachPreamble_Type	
Comment		
RAPID	PrachPreambleIndex_Type	indicates the RAPID of the preamble used (integer (0..63))
PRTPower	PRTPower_Type	represents the PREAMBLE_RECEIVED_TARGET_POWER

Short_BSR_Type

TTCN-3 Record Type		
Name	Short_BSR_Type	
Comment		
LCG	LogicalChannelGroup_Type	Logical channel Group
Value	BSR_Value_Type	BSR value

Long_BSR_Type

TTCN-3 Record Type		
Name	Long_BSR_Type	
Comment		
Value_LCG1	BSR_Value_Type	BSR value for LCG 1
Value_LCG2	BSR_Value_Type	BSR value for LCG 2
Value_LCG3	BSR_Value_Type	BSR value for LCG 3
Value_LCG4	BSR_Value_Type	BSR value for LCG 4

BSR_Type

TTCN-3 Union Type	
Name	BSR_Type
Comment	
Short	Short_BSR_Type
Truncated	Short_BSR_Type
Long	Long_BSR_Type

HARQ_Type

TTCN-3 Enumerated Type	
Name	HARQ_Type
Comment	ack represents HARQ ACK; nack represents HARQ_NACK
ack	
nack	

RlcDiscardInd_Type

TTCN-3 Record Type	
Name	RlcDiscardInd_Type
Comment	SS shall send this indication if it discards a received RLC AMD PDU as specified in TS 36.322 cl. 5.1.3.2.2.
SequenceNumber	integer
ber	sequence number of the PDU being discarded

D.1.16 System_Interface

SYSTEM_CTRL_REQ

TTCN-3 Record Type		
Name	SYSTEM_CTRL_REQ	
Comment		
Common	ReqAspCommonPart_Type	TimingInfo depends on respective primitive:
Request	SystemRequest_Type	<ul style="list-style-type: none"> - Cell TimingInfo: 'now' (in general) - CellAttenuationList TimingInfo: 'now' (in general, but activation time may be used also) - RadioBearerList TimingInfo: 'now' in general; activation time may be used in special case for release and/or reconfiguration of one or several RBs; the following rules shall be considered: <ul style="list-style-type: none"> - release/Reconfiguration of an RB shall not be scheduled earlier than 5ms after a previous data transmission on this RB - subsequent release and reconfiguration(s) shall be scheduled with an interval of at least 5ms - a subsequent data transmission on an RB shall not be scheduled earlier than 5ms after the last reconfiguration of the RB the configuration shall be performed exactly at the given time - EnquireTiming TimingInfo: 'now' - AS_Security TimingInfo: 'now'; NOTE: "activation time" may be specified in the primitive based on PDCP SQN - Sps TimingInfo: activation time for SPS assignment transmission - Paging TimingInfo: Calculated paging occasion - L1MacIndCtrl TimingInfo: 'now' (in general) - Pdcpcount TimingInfo: 'now' - L1_TestMode TimingInfo: depends on the test mode; activation time is used e.g. for manipulation of the CRC - PdcchOrder TimingInfo: 'now' (in general)

SYSTEM_CTRL_CNF

TTCN-3 Record Type		
Name	SYSTEM_CTRL_CNF	
Comment		
Common	CnfAspCommonPart_Type	TimingInfo is ignored by TTCN (apart from EnquireTiming) => SS may set TimingInfo to "None"
Confirm	SystemConfirm_Type	

SYSTEM_IND

TTCN-3 Record Type			
Name	SYSTEM_IND		
Comment			
Common	IndAspCommonPart_Type		The SS shall provide TimingInfo (SFN + subframe number) depending on the respective indication:
Indication	SystemIndication_Type		<ul style="list-style-type: none"> - Error/HarqError TimingInfo: related to the error (if available) - RachPreamble TimingInfo: shall indicate start of the RACH preamble - SchedReq TimingInfo: subframe containing the SR - BSR TimingInfo: subframe in which the MAC PDU contains the BSR - UL_HARQ TimingInfo: subframe containing the UL HARQ - C_RNTI TimingInfo: subframe in which the MAC PDU contains the C_RNTI - PHR TimingInfo: subframe in which the MAC PDU contains the PHR

EUTRA_SYSTEM_PORT

TTCN-3 Port Type			
Name	EUTRA_SYSTEM_PORT		
Comment	EUTRA PTC: Port for system configuration		
out	SYSTEM_CTRL_REQ		
in	SYSTEM_CTRL_CNF		

EUTRA_SYSIND_PORT

TTCN-3 Port Type			
Name	EUTRA_SYSIND_PORT		
Comment	EUTRA PTC: Port for system indications		
in	SYSTEM_IND		

D.2 EUTRA_ASP_DrbDefs

ASP interface for DRBs

D.2.1 PDU_TypeDefs

D.2.1.1 MAC_PDU

MAC_PDU: Basic Type Definitions

TTCN-3 Basic Types		
MAC_CTRL_C_RNTI_Type	C_RNTI	TS 36.321, clause 6.1.3.2
MAC_CTRL_ContentionResolutionId_Type	ContentionResolutionId_Type	TS 36.321, clause 6.1.3.4 fix 48-bit size; consists of a single field defined UE Contention Resolution Identity (uplink CCCH SDU transmitted by MAC)
MAC_CTRL_TimingAdvance_Type	B8_Type	TS 36.321, clause 6.1.3.5 indicates the amount of timing adjustment in 0.5 ms that the UE has to apply; the length of the field is [8] bits
MAC_SDU_Type	octetstring	

MAC_PDU_Length_Type

TTCN-3 Record Type		
Name	MAC_PDU_Length_Type	
Comment	NOTE: since F and L field are either both present or both omitted they are put into this record; to allow homogeneous (direct) encoding the PDU length is not defined as union; TTCN-3 does allow length restrictions to one length or a range of length but not to two specific lengths; further restriction may be achieved by appropriate templates (parameter either 7 or 15 bit)	
Format	B1_Type	F: The Format field indicates the size of the Length field as indicated in table 6.2.1-3. There is one F field per MAC PDU subheader except for the last subheader and sub-headers corresponding to fixed-sized MAC control elements. The size of the F field is 1 bit. If the size of the MAC SDU or MAC control element is less than 128 bytes, the UE shall set the value of the F field to 0, otherwise the UE shall set it to 1
Value	B7_15_Type	L: The Length field indicates the length of the corresponding MAC SDU or MAC control element in bytes. There is one L field per MAC PDU subheader except for the last subheader and sub-headers corresponding to fixed-sized MAC control elements. The size of the L field is indicated by the F field

MAC_PDU_SubHeader_Type

TTCN-3 Record Type			
Name	MAC_PDU_SubHeader_Type		
Comment			
Reserved	B2_Type		Reserved bits
Extension	B1_Type		E: The Extension field is a flag indicating if more fields are present in the MAC header or not. The E field is set to "1" to indicate another set of at least R/R/E/LCID fields. The E field is set to "0" to indicate that either a MAC SDU, a MAC control element or padding starts at the next byte
LCID	B5_Type		LCID: The Logical Channel ID field identifies the logical channel instance of the corresponding MAC SDU or the type of the corresponding MAC control element or padding as described in tables 6.2.1-1 and 6.2.1-2 for the DL and UL-SCH respectively. There is one LCID field for each MAC SDU, MAC control element or padding included in the MAC PDU. The LCID field size is 5 bits; NOTE: In case of DRX command the sub-header corresponds to a control element of length zero (i.e. there is no control element)
Length	MAC_PDU_Length_Type	opt	

MAC_Header_Type

TTCN-3 Record of Type	
Name	MAC_Header_Type
Comment	
record of MAC_PDU_SubHeader_Type	

MAC_CTRL_ShortBSR_Type

TTCN-3 Record Type			
Name	MAC_CTRL_ShortBSR_Type		
Comment	TS 36.321, clause 6.1.3.1		
LCG	B2_Type		
Value	B6_Type		

MAC_CTRL_LongBSR_Type

TTCN-3 Record Type			
Name	MAC_CTRL_LongBSR_Type		
Comment	TS 36.321, clause 6.1.3.1		
Value_LCG1	B6_Type		
Value_LCG2	B6_Type		
Value_LCG3	B6_Type		
Value_LCG4	B6_Type		

MAC_CTRL_PowerHeadRoom_Type

TTCN-3 Record Type			
Name	MAC_CTRL_PowerHeadRoom_Type		
Comment	TS 36.321, clause 6.1.3.6		
Reserved	B2_Type		
Value	B6_Type		

MAC_CTRL_ElementList_Type

TTCN-3 Set Type			
Name	MAC_CTRL_ElementList_Type		
Comment	NOTE 1: for simplication UL and DL are not distiguished even though the control elements are either UL or DL NOTE 2: type is defined as set: the ordering is not significant; nevertheless the ordering is well-defined by the sub-headers; for codec implementations it is in any case necessary to evaluate the sub-header information in order to encode/decode the payload		
ShortBSR	MAC_CTRL_ShortBSR_Type	opt	UL only
LongBSR	MAC_CTRL_LongBSR_Type	opt	UL only
C_RNTI	MAC_CTRL_C_RNTI_Type	opt	UL only
ContentionResolutionID	MAC_CTRL_ContentionResolutionId_Type	opt	DL only
TimingAdvance	MAC_CTRL_TimingAdvance_Type	opt	DL only
PowerHeadRoom	MAC_CTRL_PowerHeadRoom_Type	opt	UL only

MAC_SDUList_Type

TTCN-3 Record of Type	
Name	MAC_SDUList_Type
Comment	record of MAC_SDU_Type

MAC_PDU_Type

TTCN-3 Record Type			
Name	MAC_PDU_Type		
Comment			
Header	MAC_Header_Type		list of MAC PDU SubHeaders corresponding to MAC control elements and MAC SDUs
CtrlElementList	MAC_CTRL_ElementList_Type	opt	Mac control elements; acc. to TS 36.321, clause 6.1.2 "MAC control elements, are always placed before any MAC SDU."
SduList	MAC_SDUList_Type	opt	MAC SDUs, which can typically be RLC PDUs
Padding	octetstring	opt	Octet aligned Padding if more than or equal to 2 bytes

MAC_PDUList_Type

TTCN-3 Record of Type	
Name	MAC_PDUList_Type
Comment	record of MAC_PDU_Type

D.2.1.2 RLC_PDU

D.2.1.2.1 Common

RLC PDU definition: common AM/UM field definitions

Common: Basic Type Definitions

TTCN-3 Basic Types		
RLC_FramingInfo_Type	B2_Type	00 - First byte of the Data field corresponds to the first byte of a RLC SDU. Last byte of the Data field corresponds to the last byte of a RLC SDU. 01 - First byte of the Data field corresponds to the first byte of a RLC SDU. Last byte of the Data field does not correspond to the last byte of a RLC SDU. 10 - First byte of the Data field does not correspond to the first byte of a RLC SDU. Last byte of the Data field corresponds to the last byte of a RLC SDU. 11 - First byte of the Data field does not correspond to the first byte of a RLC SDU. Last byte of the Data field does not correspond to the last byte of a RLC SDU.

RLC_LengthIndicator_Type

TTCN-3 Record Type		
Name	RLC_LengthIndicator_Type	
Comment		
Extension	B1_Type	0 - Data field follows from the octet following the LI field following this E field 1 - A set of E field and LI field follows from the bit following the LI field following this E field
LengthIndicator	B11_Type	Length Indicator

RLC_LI_List_Type

TTCN-3 Record of Type	
Name	RLC_LI_List_Type
Comment	
record of RLC_LengthIndicator_Type	

RLC_PDU_Header_FlexPart_Type

TTCN-3 Record Type		
Name	RLC_PDU_Header_FlexPart_Type	
Comment	Flexible part of the header with a number of K LIs	
LengthIndicator	RLC_LI_List_Type	List of E, LI fields
Padding	B4_Type	opt optional 4 bit padding present in case of odd number of LI's

D.2.1.2.2 TM_Data

RLC PDU definition: UM (TS 36.322, clause 6.2.1.2)

TM_Data: Basic Type Definitions

TTCN-3 Basic Types		
RLC_TMD_PDU_Type	octetstring	TS 36.322, clause 6.2.1.2

D.2.1.2.3 UM_Data

RLC PDU definition: UM (TS 36.322, clause 6.2.1.3)

NOTE:

To allow direct encoding the definition for RLC UM Data PDU is split into data PDU with 5/10 bit sequence number

UM_Data: Basic Type Definitions

TTCN-3 Basic Types		
RLC_DataField_Type	octetstring	restrictions imposed from LI size of 11 bits is not applicable when the LI's are not present

RLC_UMD_Header_FixPartShortSN_Type

TTCN-3 Record Type			
Name	RLC_UMD_Header_FixPartShortSN_Type		
Comment	TS 36.322, clause 6.2.1.3 Figure 6.2.1.3-1, 6.2.1.3-3 and 6.2.1.3-4); one octet		
FramingInfo	RLC_FramingInfo_Type		2 bits FI
Extension	B1_Type		1 bit E
SequenceNumber	B5_Type		5 bits SN

RLC_UMD_Header_FixPartLongSN_Type

TTCN-3 Record Type			
Name	RLC_UMD_Header_FixPartLongSN_Type		
Comment	TS 36.322, clause 6.2.1.3 Figure 6.2.1.3-2, 6.2.1.3-5 and 6.2.1.3-6); two octets		
Reserved	B3_Type		3 bits reserved
FramingInfo	RLC_FramingInfo_Type		2 bits FI
Extension	B1_Type		1 bit E
SequenceNumber	B10_Type		10 bits SN

RLC_UMD_HeaderShortSN_Type

TTCN-3 Record Type			
Name	RLC_UMD_HeaderShortSN_Type		
Comment			
FixPart	RLC_UMD_Header_FixPartShortSN_Type		
FlexPart	RLC_PDU_Header_FlexPart_Type	opt	

RLC_UMD_HeaderLongSN_Type

TTCN-3 Record Type			
Name	RLC_UMD_HeaderLongSN_Type		
Comment			
FixPart	RLC_UMD_Header_FixPartLongSN_Type		
FlexPart	RLC_PDU_Header_FlexPart_Type	opt	

RLC_DataFieldList_Type

TTCN-3 Record of Type	
Name	RLC_DataFieldList_Type
Comment	One to one correspondence with sub headers (LengthIndicatorList_Type)
record of RLC_DataField_Type	

RLC_UMD_PDU_ShortSN_Type

TTCN-3 Record Type	
Name	RLC_UMD_PDU_ShortSN_Type
Comment	
Header	RLC_UMD_HeaderShortSN_Type
Data	RLC_DataFieldList_Type

RLC_UMD_PDU_LongSN_Type

TTCN-3 Record Type	
Name	RLC_UMD_PDU_LongSN_Type
Comment	
Header	RLC_UMD_HeaderLongSN_Type
Data	RLC_DataFieldList_Type

RLC_UMD_PDU_Type

TTCN-3 Union Type	
Name	RLC_UMD_PDU_Type
Comment	
ShortSN	RLC_UMD_PDU_ShortSN_Type
LongSN	RLC_UMD_PDU_LongSN_Type

D.2.1.2.4 AM_Data

RLC PDU definition: AM (TS 36.322, clause 6.2.1.4 and 6.2.1.5)

RLC_AMD_Header_FixPart_Type

TTCN-3 Record Type	
Name	RLC_AMD_Header_FixPart_Type
Comment	TS 36.322, clause 6.2.1.4 Figure 6.2.1.4-1, 6.2.1.4-2 and 6.2.1.4-3); 2 or 4 octets
D_C	B1_Type 0 - Control PDU 1 - Data PDU
ReSeg	B1_Type 0 - AMD PDU 1 - AMD PDU segment
Poll	B1_Type 0 - Status report not requested 1 - Status report is requested
FramingInfo	RLC_FramingInfo_Type 2 bit FI
Extension	B1_Type 1 bit E
SN	B10_Type Sequence numbers

RLC_AMD_Header_SegmentPart_Type

TTCN-3 Record Type			
Name	RLC_AMD_Header_SegmentPart_Type		
Comment	AMD PDU segment related info in PDU header acc. TS 36.322, clause 6.2.1.5		
LastSegmentFlag	B1_Type		0 - Last byte of the AMD PDU segment does not correspond to the last byte of an AMD PDU 1 - Last byte of the AMD PDU segment corresponds to the last byte of an AMD PDU
SegOffset	B15_Type		The SO field indicates the position of the AMD PDU segment in bytes within the original AMD PDU. Specifically, the SO field indicates the position within the Data field of the original AMD PDU to which the first byte of the Data field of the AMD PDU segment corresponds to.

RLC_AMD_Header_Type

TTCN-3 Record Type			
Name	RLC_AMD_Header_Type		
Comment			
FixPart	RLC_AMD_Header_FixPart_Type		
SegmentPart	RLC_AMD_Header_SegmentPart_Type	opt	present in case of AMD Seg PDU only
FlexPart	RLC_PDU_Header_FlexPart_Type	opt	

RLC_AMD_PDU_Type

TTCN-3 Record Type			
Name	RLC_AMD_PDU_Type		
Comment			
Header	RLC_AMD_Header_Type		
Data	RLC_DataFieldList_Type		

D.2.1.2.5 AM_Status

AM Status PDU (TS 36.322, clause 6.2.1.6)

AM_Status: Basic Type Definitions

TTCN-3 Basic Types		
RLC_Status_Padding_Type	bitstring length (1..7)	NOTE: in TTCN-3 length restriction cannot be done inline in record definition => explicit type definition necessary

RLC_Status_ACK_Type

TTCN-3 Record Type			
Name	RLC_Status_ACK_Type		
Comment			
ACK_SN	B10_Type		Acknowledgement SN (TS 36.322, clause 6.2.2.14)
Extn1	B1_Type		0 - a set of NACK_SN, E1 and E2 does not follow. 1 - a set of NACK_SN, E1 and E2 follows.

RLC_Status_SegOffset_Type

TTCN-3 Record Type			
Name	RLC_Status_SegOffset_Type		
Comment			
Start	B15_Type		SOstart field indicates the position of the first byte of the portion of the AMD PDU in bytes within the Data field of the AMD PDU
End	B15_Type		SOend field indicates the position of the last byte of the portion of the AMD PDU in bytes within the Data field of the AMD PDU. The special SOend value '1111111111111111'B is used to indicate that the missing portion of the AMD PDU includes all bytes to the last byte of the AMD PDU

RLC_Status_NACK_Type

TTCN-3 Record Type			
Name	RLC_Status_NACK_Type		
Comment			
NACK_SN	B10_Type		
Extn1	B1_Type		0 - A set of NACK_SN, E1 and E2 does not follow. 1 - A set of NACK_SN, E1 and E2 follows.
Extn2	B1_Type		0 - A set of SOstart and SOend does not follow for this NACK_SN. 1 - A set of SOstart and SOend follows for this NACK_SN.
SO	RLC_Status_SegOffset_Type	opt	

RLC_Status_NACK_List_Type

TTCN-3 Record of Type	
Name	RLC_Status_NACK_List_Type
Comment	
record of RLC_Status_NACK_Type	

RLC_AM_StatusPDU_Type

TTCN-3 Record Type			
Name	RLC_AM_StatusPDU_Type		
Comment			
D_C	B1_Type		0 - Control PDU 1 - Data PDU
Type	B3_Type		000 - STATUS PDU 001..111 - Reserved (=> PDU to be discarded by the receiving entity for this release of the protocol)
Ack	RLC_Status_ACK_Type		ACK_SN and E1 bit
NackList	RLC_Status_NACK_List_Type	opt	presence depends on Extn1 bit of Ack filed (RLC_Status_ACK_Type)
Padding	RLC_Status_Padding_Type	opt	1..7 bit padding if needed for octet alignment

RLC_PDU_Type

TTCN-3 Union Type	
Name	RLC_PDU_Type
Comment	
TMD	RLC_TMD_PDU_Type
UMD	RLC_UMD_PDU_Type
AMD	RLC_AMD_PDU_Type
Status	RLC_AM_StatusPDU_Type

RLC_PDUList_Type

TTCN-3 Record of Type	
Name	RLC_PDUList_Type
Comment	
record of RLC_PDU_Type	

D.2.1.3 PDCP

PDCP user plane SDU and PDU definitions

NOTE:

To allow direct encoding the definition for PDCP Data PDU is split into data PDU with long/short sequence number

PDCP: Basic Type Definitions

TTCN-3 Basic Types	
PDCP_SDU_Type	octetstring

PDCP_SDUList_Type

TTCN-3 Record of Type	
Name	PDCP_SDUList_Type
Comment	
record of PDCP_SDU_Type	

PDCP_DataPdu_LongSN_Type

TTCN-3 Record Type		
Name	PDCP_DataPdu_LongSN_Type	
Comment	User plane PDCP Data PDU with long sequence number (TS 36.323, clause 6.2.3)	
D_C	B1_Type	0 - Control PDU 1 - Data PDU
Reserved	B3_Type	
SequenceNumber	B12_Type	12 bit sequence number
SDU	PDCP_SDU_Type	content (octetstring)

PDCP_DataPdu_ShortSN_Type

TTCN-3 Record Type		
Name	PDCP_DataPdu_ShortSN_Type	
Comment	User plane PDCP Data PDU with short sequence number (TS 36.323, clause 6.2.4)	
D_C	B1_Type	0 - Control PDU 1 - Data PDU
SequenceNumber	B7_Type	7 bit sequence number
SDU	PDCP_SDU_Type	content (octetstring)

PDCP_Ctrl_ROHC_FB_PDU_Type

TTCN-3 Record Type			
Name	PDCP_Ctrl_ROHC_FB_PDU_Type		
Comment	PDCP Control PDU for interspersed ROHC feedback packet (TS 36.323, clause 6.2.5)		
D_C	B1_Type		0 - Control PDU 1 - Data PDU
Type	B3_Type		000 - PDCP status report 001 - Header Compression Feedback Information 010..111 - reserved
Reserved	B4_Type		
ROHC_FB	octetstring		Contains one ROHC packet with only feedback, i.e. a ROHC packet that is not associated with a PDCP

PDCP_Ctrl_StatusReport_Type

TTCN-3 Record Type			
Name	PDCP_Ctrl_StatusReport_Type		
Comment	PDCP Control PDU for PDCP status report (TS 36.323, clause 6.2.6)		
D_C	B1_Type		0 - Control PDU 1 - Data PDU
Type	B3_Type		000 - PDCP status report 001 - Header Compression Feedback Information 010..111 - reserved
FMS	B12_Type		PDCP SN of the first missing PDCP SDU.
Bitmap	octetstring	opt	The MSB of the first octet of the type "Bitmap" indicates whether or not the PDCP SDU with the SN (FMS + 1) modulo 4096 has been received and, optionally decompressed correctly. 0 - PDCP SDU with PDCP SN = (FMS + bit position) modulo 4096 is missing in the receiver. The bit position of Nth bit in the Bitmap is N, i.e. the bit position of the first bit in the Bitmap is 1. 1 - PDCP PSU with PDCP SN = (FMS + bit position) modulo 4096 does not need to be retransmitted. The bit position of Nth bit in the Bitmap is N, i.e. the bit position of the first bit in the Bitmap is 1.

PDCP_PDU_Type

TTCN-3 Union Type			
Name	PDCP_PDU_Type		
Comment			
DataLongSN	PDCP_DataPdu_LongSN_Type		user plane PDCP data PDU with 12 Bit Seq Number
DataShortSN	PDCP_DataPdu_ShortSN_Type		user plane PDCP data PDU with 7 Bit Seq Number
RohcFeedback	PDCP_Ctrl_ROHC_FB_PDU_Type		PDCP Control PDU for interspersed ROHC feedback packet
StatusReport	PDCP_Ctrl_StatusReport_Type		PDCP Control PDU for PDCP status report

PDCP_PDUList_Type

TTCN-3 Record of Type	
Name	PDCP_PDUList_Type
Comment	
record of PDCP_PDU_Type	

D.2.2 DRB_Primitive_Definitions

Primitive definitions to send/receive data PDUs over DRB's

D.2.2.1 DRB_Common

U_PlaneDataList_Type

TTCN-3 Union Type		
Name	U_PlaneDataList_Type	
Comment	MAC: acc. to rel-8 protocols there is not more than one MAC PDU per TTI; any MAC PDU is completely included in one subframe RLC: one or more RLC PDUs per TTI (e.g. RLC Data + Status PDU on a logical channel; more than one RLC Data PDU in one MAC PDU is valid too) any RLC PDU is completely included in one subframe PDCP: one or more PDUs per TTI; one PDCP PDU may be included in more than one subframe	
MacPdu	MAC_PDUList_Type	SS configuration: RLC TM mode, MAC no header removal (PDCP is not configured)
RlcPdu	RLC_PDUList_Type	SS configuration: RLC TM mode, MAC header removal (PDCP is not configured)
PdcpPdu	PDCP_PDUList_Type	SS configuration: RLC AM/UM mode, PDCP no header removal
PdcpSdu	PDCP_SDUList_Type	SS configuration: RLC AM/UM mode, PDCP header removal

HarqProcessAssignment_Type

TTCN-3 Union Type		
Name	HarqProcessAssignment_Type	
Comment	in DL the HARQ process id may be specified by the test case or automatically assigned by SS	
Id	HarqProcessId_Type	HARQ process as specified by the test case NOTE1: the scope of this type is only for data being sent in one TTI; if data needs more than one TTI the HarqProcessId is undefined for the 2nd TTI onward what shall be handled as an error at the SS; SS may send a SYSTEM_IND indicating an error in this case; NOTE2: The initial value of the NDI shall be the same for all HARQ processes and cells
Automatic	Null_Type	HARQ process id automatically assigned by SS

D.2.2.2 Downlink

DRB_DataPerSubframe_DL_Type

TTCN-3 Record Type			
Name	DRB_DataPerSubframe_DL_Type		
Comment	<p>common definition for one or several PDUs/SDUs to be sent in the subframe given by the subframe offset;</p> <p>NOTE 1: For MAC and RLC PDUs a single PDU is always sent in one subframe; SS shall raise an error indication (using SYSTEM_IND) when that is not possible</p> <p>NOTE 2: For PDCP the data may be spread over more than one subframe (segmented by the RLC); the TTCN implementation is responsible to calculate appropriate offsets accordingly; the exact timing depends on (and is exactly specified by) configuration of the DL scheduling; SS shall raise an error when there is any conflict</p>		
SubframeOffset	integer		<p>subframe offset relative to the absolute timing information given in the common part of the ASP;</p> <p>NOTE 1: Notes: Acc. to TS 36.523-3, clause 7.3.3 in case of TDD or half-duplex configuration only subframes available for DL are taken into consideration</p> <p>NOTE 2: if a PDCP PDU or SDU takes more than one subframe, SubframeOffset specifies the first TTI</p>
HarqProcess	HarqProcessAssignment_Type		<p>HARQ process to be used: specific value (0..7) or automatically assigned by SS;</p> <p>in automatic mode SS chooses HARQ process out of the set configured by CcchDcchDtchConfigDL_Type.HarqProcessConfig</p> <p>NOTE: for PDCP SDUs or PDUs automatic mode shall be used; otherwise SS shall raise an error</p>
PduSduList	U_PlaneDataList_Type		list of PDUs/SDUs to be sent in one TTI

DRB_DataPerSubframeList_DL_Type

TTCN-3 Record of Type			
Name	DRB_DataPerSubframeList_DL_Type		
Comment	<p>list of user plane data to be sent in sub-frames given by the SubframeOffset in the single elements of the list;</p> <p>Timing: the start time for the whole sequence is given by the timing info of the ASP (common information); the timing for the respective data pdus is given by the SubframeOffset relative to the common timing info;</p> <p>design consideration: repetitions of this sequence are not foreseen (in which case the subframe offset could not be related to the timing info of the ASP)</p>		
record of DRB_DataPerSubframe_DL_Type			

U_Plane_Request_Type

TTCN-3 Record Type			
Name	U_Plane_Request_Type		
Comment	<p>NOTE: formal type definition to allow later enhancements; U_Plane_Request_Type defines a sequence of subframes in which data shall be sent</p>		
SubframeDataList	DRB_DataPerSubframeList_DL_Type		

D.2.2.3 Uplink

DRB_DataPerSubframe_UL_Type

TTCN-3 Record Type			
Name	DRB_DataPerSubframe_UL_Type		
Comment	common definition for one or several PDUs/SDUs being received in one subframe or to receive one PDCP PDU or SDU being spread over more than one TTI; NOTE: There is a fix relation between HARQ process id and subframe in UL => it is not necessary to include HARQ process id for UL data		
PduSduList	U_PlaneDataList_Type		list of PDUs/SDUs being received in one TTI; elements of the list appear in the same order as the PDUs/SDUs in the MAC PDU; for PDCP when a PDU or SDU takes more than one TTI the list only contains this PDU or SDU
NoOfTTIs	integer		in case of PDCP: number of TTIs the SDU or PDU has taken NOTE 1: for the time being the NoOfTTIs is not checked by TTCN-3 and may be set to 1 by SS; NOTE 2: the timing info in common part of the ASP refers to the last TTI NOTE 3: when NoOfTTIs > 1 => PduSduList shall only contain one PDCP PDU or SDU in case of MAC or RLC PDUs: NoOfTTIs shall always be 1 (acc. to TS 36.321 MAC is not doing segmentation of RLC PDUs and acc. to TS 36.322, clause 6.2.2.2 the maximum RLC data is calculated to fit into a MAC PDU and RLC does segmentation accordingly)

U_Plane_Indication_Type

TTCN-3 Record Type			
Name	U_Plane_Indication_Type		
Comment	NOTE: formal type definition to allow later enhancements; U_Plane_Indication_Type defines data being received in a single subframe i.e. PDUs of subsequent TTIs are indicated in separated ASPs		
SubframeData	DRB_DataPerSubframe_UL_Type		

D.2.3 System_Interface

DRB_COMMON_REQ

TTCN-3 Record Type			
Name	DRB_COMMON_REQ		
Comment	common ASP to send PDUs to DRBs		
Common	ReqAspCommonPart_Type		CellId : identifier of the cell RoutingInfo : DRB id TimingInfo : starting point when to start sending sequence of data PDUs e.g. SFN = X, subframe number = x; U_Plane.SubframeDataList[j].SubframeOffset := offset_i; => U_Plane.SubframeDataList[j].PduSduList shall be sent out at at SFN = X + ((x + offset_i) / 10); subframe number = (x + offset_i) % 10 ControllInfo : CnfFlag:=false; FollowOnFlag:=false
U_Plane	U_Plane_Request_Type		
SuppressPdcch ForC_RNTI	Null_Type	opt	By default all DRB_COMMON_REQ scheduled DL PDU's are associated with an appropriate explicit configured or SS selected DL assignment allocation on PDCCH. For SuppressPdcch:=true in the sub frame in which DL PDU's are transmitted, there is no associated DL assignment allocation for configured C-RNTI. This will be used for SPS assignment based transmission or in any error scenarios; NOTE: this flag has no impact on PDCCH messages required for SPS activation

DRB_COMMON_IND

TTCN-3 Record Type			
Name	DRB_COMMON_IND		
Comment	common ASP to receive PDUs from DRBs		
Common	IndAspCommonPart_Type		CellId : identifier of the cell RoutingInfo : DRB id TimingInfo : time when message has been received NOTE 1: For MAC and RCL PDUs per definition U_Plane_Indication_Type correspond to exactly one subframe => TimingInfo refers to this subframe NOTE 2: For PDCP a single PDU or SDU may take more than one TTI => TimingInfo refers to the end of the PDU/SDU and the length is given by NoOfTTIs in U_Plane_Indication_Type (the end of the PDU/SDU is the last RLC PDU being received; in case of retransmissions this is not necessarily the RLC PDU with the last SN)
U_Plane	U_Plane_Indication_Type		

EUTRA_DRB_PORT

TTCN-3 Port Type			
Name	EUTRA_DRB_PORT		
Comment			
out	DRB_COMMON_REQ		
in	DRB_COMMON_IND		

D.3 IP_ASP_TypeDefs

General Notes:

NOTE 1:

In general the handling of IP data shall be independent from the RAT being used on lower layers.

NOTE 2:

It shall be possible for SS implementation to reuse existing IP stack implementations in the system adaptor; therefore the well-known concept of socket programming shall be supported (regardless of whether those are used in the system adaptor implementation or not)

NOTE 3:

Since in general at the network side there are several different IP addresses the SS needs to simulate more than one IP address;

that can be based on a concept of multiple virtual network adaptors

NOTE 4:

There is no easy way to control the routing of IP data for an IP connection from above the IP stack

i.e. there are no parameters at the socket interface to determine e.g. cell id and DRB id

=> another independent logical entity (DRB-MUX) is needed below the IP stack which is responsible to control the routing of IP packets from/to DRBs in different cells of different RATs

Reference:

An introduction to socket programming can be found in

UNIX Network Programming Volume 1, Third Edition: The Sockets Networking API

by W. Richard Stevens, Bill Fenner, Andrew M. Rudoff

D.3.1 IP_Common

IP_Common: Basic Type Definitions

TTCN-3 Basic Types	
PortNumber_Type	UInt16_Type

IPv4_AddrInfo_Type

TTCN-3 Record Type	
Name	IPv4_AddrInfo_Type
Comment	IPv4 specific info of the socket addr (AF_INET)
Addr	charstring
	IP Address as string (IP v4 dot notation) to be converted to 32-bit unsigned integer

IPv6_AddrInfo_Type

TTCN-3 Record Type	
Name	IPv6_AddrInfo_Type
Comment	IPv6 specific info of the socket addr (AF_INET6); NOTE: sin6_flowinfo can be ignored and set to 0
Addr	charstring
	to be converted to sin6_addr
Scopeld	UInt32_Type
	opt sin6_scope_id in general an IPv6 address is like "fe80::1%eth0" with eth0 being the network adaptor mapped to a scope id (Unix) assumption: for UE conformance testing it is not necessary to distinguish different scopes and the scope id in general can be determined by the system adaptor => omit

IP_AddrInfo_Type

TTCN-3 Union Type	
Name	IP_AddrInfo_Type
Comment	
V4	IPv4_AddrInfo_Type
V6	IPv6_AddrInfo_Type

IP_Socket_Type

TTCN-3 Record Type			
Name	IP_Socket_Type		
Comment	Socket		
IpAddr	IP_AddrInfo_Type	opt	IP address
Port	PortNumber_Type	opt	port number

InternetProtocol_Type

TTCN-3 Enumerated Type	
Name	InternetProtocol_Type
Comment	
udp	
tcp	
icmp	
icmpv6	

IP_Connection_Type

TTCN-3 Record Type			
Name	IP_Connection_Type		
Comment	A connection between peer-to-peer entities is unambiguously defined by the protocol (udp/tcp/icmp/icmpv4), the local socket and the remote socket		
Protocol	InternetProtocol_Type		
Local	IP_Socket_Type	opt	
Remote	IP_Socket_Type	opt	

D.3.2 IP_Config

Configuration of the routing table managed by the system adaptor's DRB-MUX:
foreach IP connection it is specified which

- RAT
- Cell
- DRB

to be used.

The IP connection does not need to be fully specified depending on the role SS plays (e.g. in case of a server role the port number of the remote side is not known in advance).

The configurations of DRBs within the same cell shall be mutual exclusive.

With the configuration of the IP routing the DRB is configured either in IP or in raw mode:
either there are entries for the DRB in the routing table (IP mode) or not (raw mode)
=> It is not necessary to reconfigure this for the respective RAT.

Behaviour of the DRB-MUX in UL:

- SS gets data packet from the lower layers (e.g. PDCP SDU)
- SS checks whether there is any IP connection configured for this DRB (identified by {RAT, CellId, DrbId})
 - if YES => packet is routed to the IP stack (IP mode)
 - if NO => packet is handed over to the DRB port (raw mode)

NOTE 1:

If there is any entry for the DRB in the routing table the DRB is considered as being in IP mode and all UL IP packets are sent to the IP stack regardless of whether their addresses match the DRB's routing entries or not (in general 'unknown' packets are discarded by the IP stack)

=> a DRB can be either in IP or in raw mode

NOTE 2:

=> SS does not need to evaluate the IP packets (i.e. there is no conflict with loopback data)

Behaviour of the DRB-MUX in DL:

- SS gets IP packets from the IP stack for an IP connection
 - SS compares the IP connection (protocol, local/remote IP Addr) against the IP routing table and checks whether the corresponding protocol stack is configured at the lower layers =>

1. no match:

no entry in the routing table fits to the address in the IP packet
 or the corresponding RB is not configured

=> SS shall raise an error (DRBMUX_COMMON_IND_CNF.Error)

2. one match:

There is exactly one possibility to route the IP packet

=> SS shall send the packet to this RB

3. several matches:

There are more than one DRBs, cells or RATs to which the packet may be routed

=> SS shall raise an error if there is more than one DRB in one cell matching;
 if the DRBs belong to different cells or RATS SS shall send the data to all of them
 (whether this may occur in test cases is FFS)

General notes:

NOTE 1:

SS may use the information of the routing table to determine which network adaptors it needs to simulate (implementation dependent);

in general there will be more than one IP address at the network side.

=> it seems to be helpful to pre-configure all possible IP connections at the very beginning of a test case

NOTE 2:

In general the routing table is a simplified DL TFT implementation

NOTE 3:

When the routing table is empty all DRBs are in raw mode; this shall be the initial condition at the DRB-MUX;

=> for L2 testing in general (and apart from the preamble) there is no need to use/configure the IP_PTC; the configuration of the RAT specific U-plane stacks is not affected

IP_Config: Basic Type Definitions

TTCN-3 Basic Types		
IP_DrbIdType	integer	DRB identity type common for all RATs: - for EUTRA it corresponds to the ASN.1 type DRB-Identity - for UTRAN/GERAN it corresponds the NSAPI value (type record NSAPI) NOTE: this is introduced to simplify the dependencies (i.e. to keep IP_ASP_TypeDefs independent from any RAT specific type definitions)

IP_EUTRA_Cell_Type

TTCN-3 Union Type		
Name	IP_EUTRA_Cell_Type	
Comment		
Any	Null_Type	if this option is used, in all EUTRA cells the same DRB is used for this IP connection; in general there is only a DRB stack on one cell, i.e. in DL the data is routed to the cell which actually has the DRB configured
Id	CellId_Type	with this option the data is routed to a specific cell regardless of whether the same DRB is configured in any other cell; CellId_Type is defined in EUTRA_CommonDefs

IP_EUTRA_DrbInfo_Type

TTCN-3 Record Type		
Name	IP_EUTRA_DrbInfo_Type	
Comment		
Cell	IP_EUTRA_Cell_Type	
DrbId	IP_DrbIdType	

IP_UTRAN_Cell_Type

TTCN-3 Union Type		
Name	IP_UTRAN_Cell_Type	
Comment		
Any	Null_Type	(see IP_EUTRA_Cell_Type)
Id	UTRAN_CellId_Type	(see IP_EUTRA_Cell_Type) UTRAN_CellId_Type is defined in UTRAN_ASP_definitions

IP_UTRAN_DrbInfo_Type

TTCN-3 Record Type		
Name	IP_UTRAN_DrbInfo_Type	
Comment		
Cell	IP_UTRAN_Cell_Type	
DrbId	IP_DrbIdType	

IP_GERAN_Cell_Type

TTCN-3 Union Type		
Name	IP_GERAN_Cell_Type	
Comment		
Any	Null_Type	(see IP_EUTRA_Cell_Type)
Id	GERAN_CellId_Type	(see IP_EUTRA_Cell_Type) GERAN_CellId_Type is defined in GERAN_TypeDefs

IP_GERAN_DrbInfo_Type

TTCN-3 Record Type		
Name	IP_GERAN_DrbInfo_Type	
Comment		
Cell	IP_GERAN_Cell_Type	
DrbId	IP_DrbIdType	

IP_DrbInfo_Type

TTCN-3 Union Type	
Name	IP_DrbInfo_Type
Comment	
Eutra	IP_EUTRA_DrbInfo_Type
Utran	IP_UTRAN_DrbInfo_Type
Geran	IP_GERAN_DrbInfo_Type

IP_RoutingInfo_Type

TTCN-3 Record Type	
Name	IP_RoutingInfo_Type
Comment	
IpInfo	<p>IP_Connection_Type</p> <p>IP connection tuple: protocol, local socket, remote socket depending on the role the SS plays the following information may be provided (informative; even less information can be sufficient):</p> <ol style="list-style-type: none"> TCP/UDP server <ul style="list-style-type: none"> - local IP addr -- provided - local port -- provided - remote IP addr -- omit - remote port -- omit TCP/UDP client <ul style="list-style-type: none"> - local IP addr -- provided (to inform SS about the local IP addr for this service) - local port -- omit; for UDP a well-defined port may be defined (protocol dependent, e.g. DHCP) - remote IP addr -- provided - remote port -- provided ICMP (in general ICMP may be mapped only to a single DRB) <ul style="list-style-type: none"> - local IP addr -- provided (to inform SS about the local IP addr for this service) - local port -- n/a (shall be set to omit) - remote IP addr -- omit - remote port -- n/a (shall be set to omit) <p>NOTE: In case of broadcasts in UL the broadcast address shall match any local IP address; in DL for broadcast services typically no remote IP address is specified in the routing table</p>
DRB	IP_DrbInfo_Type

IP_RoutingTable_Type

TTCN-3 Record of Type	
Name	IP_RoutingTable_Type
Comment	NOTE: configurations of DRBs within the same cell shall be mutual exclusive
record of IP_RoutingInfo_Type	

D.3.3 IP_SocketHandling

Handling of IP data and IP connections

NOTE 1:

In general IP connections are distinguished by the tuple {protocol, local socket, remote socket}; this information is used at the interface between TTCN and the system adaptor.

It is up to the system adaptor implementation to associate the IP connection with the internal socket (file descriptor; implementation dependent)

NOTE 2:

In general the association of the IP connections to (internal) sockets and the routing table for the DRB mpping (as configured with IP_RoutingTable_Type) are independent from each other

D.3.3.1 Socket_Common

IP_SockOpt_Type

TTCN-3 Union Type		
Name	IP_SockOpt_Type	
Comment	socket options acc. to the setsockopt system call (i.e. for level=SOL_SOCKET in case of Berkeley socket API); NOTE: only options being relevant for a specific applications (upon a socket) are configured by TTCN other options (e.g. SO_REUSEADDR) are out of TTCN and therefore a matter of system adaptor implementation	
SO_BROADCAST	boolean	set to true when IP broadcast messages shall be allowed for a port; this is required e.g. in case of DHCP

IP_SockOptList_Type

TTCN-3 Record of Type	
Name	IP_SockOptList_Type
Comment	record of IP_SockOpt_Type

IP_SocketError_Type

TTCN-3 Union Type		
Name	IP_SocketError_Type	
Comment	used to indicate errors related to sockets; the IP_Connection shall contain as much address information as available at the system adaptor	
InvalidAddress	Null_Type	TTCN error: e.g. invalid or incomplete address information
System	integer	system error caused by system call; the integer value may be used for validation but shall not be evaluated by TTCN

D.3.3.2 TCP_Socket

TCP primitives used on the IP port

TCP_Socket: Basic Type Definitions

TTCN-3 Basic Types		
TCP_Data_Type	octetstring	data as sent/received with send()/recv() on a TCP socket

TCP_ConnectRequest_Type

TTCN-3 Record Type		
Name	TCP_ConnectRequest_Type	
Comment	TCP client: -> 'connect' system call	
SockOptList	IP_SockOptList_Type	when there are no options to configure the list is empty

TCP_Listen_Type

TTCN-3 Record Type	
Name	TCP_Listen_Type
Comment	TCP server: -> 'listen' system call
SockOptList	IP_SockOptList_Type when there are no options to configure the list is empty

TCP_CtrlRequest_Type

TTCN-3 Union Type	
Name	TCP_CtrlRequest_Type
Comment	
ConnectReq	<p>TCP_ConnectRequest_Type</p> <p>request a 'connect' to a remote server</p> <p>system calls (informative) socket -- get file descriptor (setsockopt) -- normally not needed bind -- assign local IP addr (to cope with multiple IP addresses) connect -- connect to the client</p> <p>IP_Connection: protocol -- tcp local IP addr -- mandatory to distinguish different network adaptors local port -- omit (ephemeral port will be assigned by the system) remote IP addr -- mandatory remote port -- mandatory</p>
Listen	<p>TCP_Listen_Type</p> <p>establish a server at the local (SS) side</p> <p>system calls (informative) socket -- get file descriptor (setsockopt) -- if needed bind -- assign local IP addr and port listen -- await incoming connection</p> <p>IP_Connection: protocol -- tcp local IP addr -- mandatory to distinguish different network adaptors local port -- mandatory remote IP addr -- omit remote port -- omit</p>
Close	<p>Null_Type</p> <p>close a connection</p> <p>system calls (informative): close</p> <p>IP_Connection: protocol -- tcp local IP addr -- mandatory local port -- mandatory remote IP addr -- mandatory remote port -- mandatory</p>

TCP_DataRequest_Type

TTCN-3 Union Type		
Name	TCP_DataRequest_Type	
Comment		
Send	TCP_Data_Type	send data system calls (informative): send or write IP_Connection: protocol -- tcp local IP addr -- mandatory local port -- mandatory remote IP addr -- mandatory remote port -- mandatory

TCP_CtrlIndication_Type

TTCN-3 Union Type		
Name	TCP_CtrlIndication_Type	
Comment		
ConnectCnf	Null_Type	<p>confirm a 'connect' to a remote server</p> <p>system calls (informative): getsockname -- get local port (ephemeral port assigned by the system)</p> <p>IP_Connection: protocol -- tcp local IP addr -- mandatory (as in corresponding TCP_ConnectRequest) local port -- mandatory (if there is more than one connection to the same server the local port is necessary to distinguish the connections) remote IP addr -- mandatory (as in corresponding TCP_ConnectRequest) remote port -- mandatory (as in corresponding TCP_ConnectRequest)</p>
Accept	Null_Type	<p>sent by the SS when it 'accepts' an incoming connection</p> <p>system calls (informative): accept</p> <p>IP_Connection: protocol -- tcp local IP addr -- mandatory (as in corresponding TCP_ListenRequest) local port -- mandatory (as in corresponding TCP_ListenRequest) remote IP addr -- mandatory (as gotten from 'accept') remote port -- mandatory (as gotten from 'accept')</p>
Close	Null_Type	<p>indicate 'close' by the remote side</p> <p>system calls (informative): indicated by recv or read</p> <p>IP_Connection: protocol -- tcp local IP addr -- mandatory local port -- mandatory remote IP addr -- mandatory remote port -- mandatory</p>
CloseCnf	Null_Type	<p>Confirmation for 'close' request; necessary since for TCP there are IP packets to release the connection</p> <p>system calls (informative): close</p> <p>IP_Connection: protocol -- tcp local IP addr -- mandatory local port -- mandatory remote IP addr -- mandatory remote port -- mandatory</p>

TCP_DataIndication_Type

TTCN-3 Union Type		
Name	TCP_DataIndication_Type	
Comment		
Recv	TCP_Data_Type	receive data system calls (informative): recv or read IP_Connection: protocol -- tcp local IP addr -- mandatory local port -- mandatory remote IP addr -- mandatory remote port -- mandatory

D.3.3.3 UDP_Socket

UDP primitives used on the IP port

NOTE:

In principle a UDP socket may communicate with different remote entities;
 therefore the system adaptor may associate the socket handle with the local socket only
 (local IP address and local port)

UDP_Socket: Basic Type Definitions

TTCN-3 Basic Types		
UDP_Data_Type	octetstring	data as sent/received with sendto()/recvfrom() on a UDP socket

UDP_SocketReq_Type

TTCN-3 Record Type		
Name	UDP_SocketReq_Type	
Comment	to establish a UDP server or to bind local port number	
SockOptList	IP_SockOptList_Type	e.g. to allow broadcast messages; when there are no options to configure the list is empty

UDP_CtrlRequest_Type

TTCN-3 Union Type		
Name	UDP_CtrlRequest_Type	
Comment		
SocketReq	UDP_SocketReq_Type	<p>request the system adaptor to bind a socket to a local address; this is needed in general when the system adaptor acts as</p> <ol style="list-style-type: none"> 1. UDP server 2. UDP client when it uses a well-known port rather than an ephemeral port (this is e.g. for DHCP) 3. UDP client when a local address needs to be bond (e.g. when there are several local addresses) <p>system calls (informative): socket -- get file descriptor (setsockopt) -- needed e.g. to allow broad cast message bind -- assign local IP address (to cope with multiple IP addresses) and local port (in case of well-known local port)</p> <p>IP_Connection: protocol -- udp local IP addr -- mandatory (to distiguish multiple IP addresses) local port -- optional (mandatory in case of a UDP server) remote IP addr -- omit remote port -- omit</p>
Close	Null_Type	<p>release local socket</p> <p>system calls (informative): close</p> <p>IP_Connection: protocol -- udp local IP addr -- mandatory (to identify local socket) local port -- mandatory (to identify local socket) remote IP addr -- omit remote port -- omit</p>

UDP_DataRequest_Type

TTCN-3 Union Type		
Name	UDP_DataRequest_Type	
Comment		
SendTo	UDP_Data_Type	<p>send data to (any) remote socket; NOTE: To simplify implementation of the system adaptor the local socket shall be bond in any case (using 'SocketReq') to specify the local IP address before sending data; (in general the sendto system call can be used without explicitly binding the socket before; in this case the port gets implicitly bond to an ephemeral port and the default IP address is used)</p> <p>system calls (informative): sendto</p> <p>IP_Connection: protocol -- udp local IP addr -- mandatory (to identify local socket) local port -- mandatory (to identify local socket) remote IP addr -- mandatory (to address remote socket) remote port -- mandatory (to address remote socket)</p>

UDP_CtrlIndication_Type

TTCN-3 Union Type		
Name	UDP_CtrlIndication_Type	
Comment		
SocketCnf	Null_Type	confirm 'SocketReq' and tell TTCN about assignment of ephemeral port; system calls (informative): getsockname -- get local port (ephemeral port assigned by the system; not needed if local port is well-known) IP_Connection: protocol -- udp local IP addr -- mandatory local port -- mandatory (well-known or ephemeral port assigned by the system) remote IP addr -- omit remote port -- omit

UDP_DataIndication_Type

TTCN-3 Union Type		
Name	UDP_DataIndication_Type	
Comment		
RecvFrom	UDP_Data_Type	receive data; system calls (informative): recvfrom -- get data and src addr IP_Connection: protocol -- udp local IP addr -- mandatory (see note) local port -- mandatory remote IP addr -- mandatory (as gotten from recvfrom) remote port -- mandatory (as gotten from recvfrom) NOTE: The UE may send a UDP packet as broadcast (IP Addr 255.255.255.255 - e.g. in case of DHCP) SS shall consider a broadcast address as matching every IP for UL and DL example: - SS gets DHCPDISCOVER with DEST_Addr=255.255.255.255 DEST_Port=67, SRC_Addr=0.0.0.0 SRC_Port=68 - TTCN gets DHCPDISCOVER with local Addr=(255.255.255.255 Port=67), remote Addr=(0.0.0.0 Port=68) - TTCN sends DHCPOFFER with local Addr=(local IP Addr Port=67), remote Addr=(255.255.255.255 Port=68)

D.3.3.4 ICMP_Socket

ICMP primitives used on the IP port

NOTE:

the local side is identified by the protocol and in general by the local IP address

ICMP_Socket: Basic Type Definitions

TTCN-3 Basic Types		
ICMP_Data_Type	octetstring	data as sent/received with sendto()/recvfrom() on the raw socket; NOTE: the data may depend on the socket options (FFS); in general it does not include the IP header and the checksum of the ICMP packet needs to be calculated/checked in TTCN

ICMP_SocketReq_Type

TTCN-3 Record Type		
Name	ICMP_SocketReq_Type	
Comment	to establish a raw socket to send/receive ICMP packets	
SockOptList	IP_SockOptList_Type	e.g. to set the IP_HDRINCL socket option (to include the IP header in the data buffer) -> FFS when there are no options to configure the list is empty

ICMP_CtrlRequest_Type

TTCN-3 Union Type		
Name	ICMP_CtrlRequest_Type	
Comment		
SocketReq	ICMP_SocketReq_Type	request the system adaptor to open a raw socket (IPv4 or IPv6) system calls (informative): socket -- get file descriptor (IPPROTO_ICMP or IPPROTO_IPV6); (setsockopt) -- optional; to set socket options bind -- assign local IP address (to cope with multiple IP addresses) IP_Connection: protocol -- icmp or icmpv6 local IP addr -- mandatory (to distinguish multiple IP addresses) local port -- omit (not applicable for ICMP) remote IP addr -- omit remote port -- omit (not applicable for ICMP)
Close	Null_Type	release local socket system calls (informative): close IP_Connection: protocol -- icmp or icmpv6 local IP addr -- mandatory (to identify local socket) local port -- omit remote IP addr -- omit remote port -- omit

ICMP_DataRequest_Type

TTCN-3 Union Type		
Name	ICMP_DataRequest_Type	
Comment		
SendTo	ICMP_Data_Type	<p>send datagram</p> <p>system calls (informative): sendto</p> <p>IP_Connection: protocol -- icmp or icmpv6 local IP addr -- mandatory (to identify local socket) local port -- omit remote IP addr -- mandatory remote port -- omit</p>

ICMP_CtrlIndication_Type

TTCN-3 Union Type		
Name	ICMP_CtrlIndication_Type	
Comment		
SocketCnf	Null_Type	<p>confirm 'SocketReq'</p> <p>system calls (informative): (SocketCnf is sent when all system calls for SocketReq have been successful)</p> <p>IP_Connection: protocol -- icmp or icmpv6 local IP addr -- mandatory local port -- omit remote IP addr -- omit remote port -- omit</p>

ICMP_DataIndication_Type

TTCN-3 Union Type		
Name	ICMP_DataIndication_Type	
Comment		
RecvFrom	ICMP_Data_Type	<p>receive datagram</p> <p>system calls (informative): recvfrom -- get data and src addr</p> <p>IP_Connection: protocol -- icmp or icmpv6 local IP addr -- mandatory local port -- omit remote IP addr -- mandatory (as gotten from recvfrom) remote port -- omit</p>

D.3.3.5 Socket_Primitives

IP_CtrlRequest_Type

TTCN-3 Union Type	
Name	IP_CtrlRequest_Type
Comment	
TCP	TCP_CtrlRequest_Type
UDP	UDP_CtrlRequest_Type
ICMP	ICMP_CtrlRequest_Type

IP_DataRequest_Type

TTCN-3 Union Type	
Name	IP_DataRequest_Type
Comment	
TCP	TCP_DataRequest_Type
UDP	UDP_DataRequest_Type
ICMP	ICMP_DataRequest_Type

IP_CtrlIndication_Type

TTCN-3 Union Type	
Name	IP_CtrlIndication_Type
Comment	
TCP	TCP_CtrlIndication_Type
UDP	UDP_CtrlIndication_Type
ICMP	ICMP_CtrlIndication_Type
Error	IP_SocketError_Type

IP_DataIndication_Type

TTCN-3 Union Type	
Name	IP_DataIndication_Type
Comment	
TCP	TCP_DataIndication_Type
UDP	UDP_DataIndication_Type
ICMP	ICMP_DataIndication_Type

D.3.4 System_Interface

DRBMUX_CONFIG_REQ

TTCN-3 Union Type	
Name	DRBMUX_CONFIG_REQ
Comment	<p>NOTE 1: There is just one primitive to configure the whole routing table. It is not foreseen to add, remove or manipulate single entries but the table is managed in TTCN and completely configured on any change; (otherwise it might get complicated to identify single entries)</p> <p>NOTE 2: the SS's routing table shall be empty at the beginning and can be cleared by an empty record (DRBMUX_CONFIG_REQ.RoutingInfo = {})</p> <p>NOTE 3: In general a reconfiguration of the routing table during a test case would be necessary only if an ephemeral port is needed to distinguish different routing (e.g. when there are several TCP connections of the same service routed to different DRBs)</p>
RoutingInfo	IP_RoutingTable_Type

DRBMUX_COMMON_IND_CNF

TTCN-3 Union Type		
Name	DRBMUX_COMMON_IND_CNF	
Comment		
Confirm	Null_Type	confirm DRBMUX_CONFIG_REQ
Error	Null_Type	<p>indication of errors at the DRB-MUX: An Error shall be raised by the DRB-MUX e.g. in the following cases:</p> <ul style="list-style-type: none"> - in DL when there are IP packets which cannot be routed to any DRB <ul style="list-style-type: none"> i.e. the IP packet does not match to any entry in the routing table or the corresponding RB is not configured - in DL when there are several DRBs possible for routing in the same cell

IP_SOCKET_CTRL_REQ

TTCN-3 Record Type			
Name	IP_SOCKET_CTRL_REQ		
Comment			
ConnectionId	IP_Connection_Type		
Req	IP_CtrlRequest_Type		

IP_SOCKET_DATA_REQ

TTCN-3 Record Type			
Name	IP_SOCKET_DATA_REQ		
Comment			
ConnectionId	IP_Connection_Type		
Req	IP_DataRequest_Type		

IP_SOCKET_CTRL_IND

TTCN-3 Record Type			
Name	IP_SOCKET_CTRL_IND		
Comment			
ConnectionId	IP_Connection_Type		
Ind	IP_CtrlIndication_Type		

IP_SOCKET_DATA_IND

TTCN-3 Record Type			
Name	IP_SOCKET_DATA_IND		
Comment			
ConnectionId	IP_Connection_Type		
Ind	IP_DataIndication_Type		

IP_SOCKET_REQ

TTCN-3 Union Type		
Name	IP_SOCKET_REQ	
Comment		
CTRL	IP_SOCKET_CTRL_REQ	
DATA	IP_SOCKET_DATA_REQ	

IP_SOCKET_IND

TTCN-3 Union Type		
Name	IP_SOCKET_IND	
Comment		
CTRL	IP_SOCKET_CTRL_IND	
DATA	IP_SOCKET_DATA_IND	

IP_CONTROL_PORT

TTCN-3 Port Type		
Name	IP_CONTROL_PORT	
Comment		
out	DRBMUX_CONFIG_REQ	
in	DRBMUX_COMMON_IND_CNF	

IP_SOCKET_PORT

TTCN-3 Port Type		
Name	IP_SOCKET_PORT	
Comment		
out	IP_SOCKET_REQ	
in	IP_SOCKET_IND	

D.4 NasEmu_AspTypes

System interface between NAS emulation and system adaptor

D.4.1 System_Interface

RRC_PDU_REQ

TTCN-3 Record Type		
Name	RRC_PDU_REQ	
Comment		
Common	ReqAspCommonPart_Type	<p>CellId : identifier of the cell RoutingInfo : SRB0, SRB1, SRB2 TimingInfo : Now in normal cases; For latency tests TimingInfo can be set to the SFN/subframe in which the RRC messages shall be sent out NOTE 1: if the RRC PDU is too long to be sent in one TTI the TimingInfo corresponds to the first TTI NOTE 2: the TimingInfo is not changed by the NAS Emu (i.e. the timing info as coming from the test case (SRB_COMMON_REQ) is handed through by the NAS Emu) ControllInfo Cnfflag:=false; FollowOnFlag true: Indicates that the message(s) to be sent on the same TTI will follow NOTE 1: If the TimingInfo is not the same for messages to be sent on the same TTI, the SS shall produce an error NOTE 2: the follow on flag applies only for messages of the same SRB false: Indicates that no more message(s) will follow</p>
RrcPdu	RRC_MSG_Request_Type	

RRC_PDU_IND

TTCN-3 Record Type		
Name	RRC_PDU_IND	
Comment	common ASP to receive PDUs from SRB0, SRB1 or SRB2	
Common	IndAspCommonPart_Type	CellId : identifier of the cell RoutingInfo : SRB0, SRB1, SRB2 TimingInfo : time when message has been received (frame and sub-frame number); this is handed through to the test case by the NAS emulation NOTE: normally an RRC PDU is expected in one TTI; nevertheless if it is spread over more than one TTIs TimingInfo shall refer to the end of the PDU i.e. to the last RLC PDU being received; Status : OK or RRC integrity error
RrcPdu	RRC_MSG_Indication_Type	

NASEMU_SYSTEM_PORT

TTCN-3 Port Type		
Name	NASEMU_SYSTEM_PORT	
Comment	NASEMU PTC: Port for Sending/Receiving data to/from the SYSTEM Interface	
out	RRC_PDU_REQ	
in	RRC_PDU_IND	

D.5 EUTRA_CommonDefs

D.5.1 Common_Types

Common_Types: Basic Type Definitions

TTCN-3 Basic Types		
HarqProcessId_Type	integer (0..14)	The values 0..7 represent the ID of HARQ process ID; value range 0..14 is for TDD
RedundancyVersion_Type	integer (0..3)	used in EUTRA_ASP_DrbDefs and EUTRA_ASP_Typedefs
ContentionResolutionId_Type	bitstring length(48)	used in EUTRA_ASP_DrbDefs and EUTRA_ASP_Typedefs

CellId_Type

TTCN-3 Enumerated Type	
Name	CellId_Type
Comment	
eutra_Cell_NonSpecific	
eutra_Cell1	
eutra_Cell2	
eutra_Cell3	
eutra_Cell4	
eutra_Cell6	
eutra_Cell10	
eutra_Cell11	
eutra_Cell12	
eutra_Cell13	
eutra_Cell14	
eutra_Cell23	
eutra_CellA	
eutra_CellB	
eutra_CellC	
eutra_CellD	
eutra_CellE	
eutra_CellG	
eutra_CellH	
eutra_CellI	
eutra_CellJ	
eutra_CellK	
eutra_CellL	
eutra_CellM	

HarqProcessList_Type

TTCN-3 Record of Type	
Name	HarqProcessList_Type
Comment	list of HARQ processes: each element shall be unique
record length(0..14) of	HarqProcessId_Type

RRC_MSG_Request_Type

TTCN-3 Union Type	
Name	RRC_MSG_Request_Type
Comment	DL RRC PDU on CCCH or DCCH
Ccch	DL_CCCH_Message
Dcch	DL_DCCH_Message

RRC_MSG_Indication_Type

TTCN-3 Union Type	
Name	RRC_MSG_Indication_Type
Comment	UL RRC PDU on CCCH or DCCH
Ccch	UL_CCCH_Message
Dcch	UL_DCCH_Message

D.5.2 Common_Constants

EUTRA_CommonDefs: Constant Definitions

TTCN-3 Basic Types			
tsc_EUTRA_MaxNumberOfCells	integer	20	Maximum number of cells; in TS 36.508 in, clause 4.4.2 and 6.3.2.2 there are tables for cells being used in non-NAS and NAS test cases; in both cases less than 20 cells are listed

D.5.3 RRC_Nested_Types

RRC_Nested_Types: Basic Type Definitions

TTCN-3 Basic Types		
SiWindowLength_Type	SystemInformationBlockType1.si_WindowLength	
SiPeriodicity_Type	SchedulingInfoList[0].si_Periodicity	
M_TMSI_Type	S_TMSI.m_TMSI	
MME_GroupId_Type	RegisteredMME.mmegi	
PrioritizedBitRate_Type	LogicalChannelConfig.ul_SpecificParameters.prioritisedBitRate	
DL_Bandwidth_Type	CarrierBandwidthEUTRA.dl_Bandwidth	
UL_Bandwidth_Type	CarrierBandwidthEUTRA.ul_Bandwidth	
Ra_PreambleIndex_Type	RACH_ConfigDedicated.ra_PreambleIndex	
CipheringAlgorithm_Type	SecurityAlgorithmConfig.cipheringAlgorithm	
IntegrityProtAlgorithm_Type	SecurityAlgorithmConfig.integrityProtAlgorithm	
SearchWindowSize_Type	SystemInformationBlockType8.searchWindowSize	

D.5.4 ASP_CommonPart

Definition of ASP common parts for REQ-, CNF- and IND-ASPs

D.5.4.1 ASP_CommonPart_Definitions

D.5.4.1.1 Routing_Info

EUTRA_CommonDefs: Constant Definitions

TTCN-3 Basic Types			
tsc_MaxRB	integer	maxDRB + 3	DRBs + 3 SRBs
tsc_SRB0	integer	0	
tsc_SRB1	integer	1	
tsc_SRB2	integer	2	
tsc_DRB1	DRB_Identity	1	
tsc_DRB2	DRB_Identity	2	
tsc_DRB3	DRB_Identity	3	
tsc_DRB4	DRB_Identity	4	
tsc_DRB5	DRB_Identity	5	
tsc_DRB6	DRB_Identity	6	
tsc_DRB7	DRB_Identity	7	
tsc_DRB8	DRB_Identity	8	

Routing_Info: Basic Type Definitions

TTCN-3 Basic Types		
SRB_Identity_Type	integer (tsc_SRB0 , tsc_SRB1 , tsc_SRB2)	SRB0 to be covered as well

DRB_IdentityList_Type

TTCN-3 Record of Type	
Name	DRB_IdentityList_Type
Comment	
record of DRB_Identity	

RadioBearerId_Type

TTCN-3 Union Type	
Name	RadioBearerId_Type
Comment	
Srb	SRB_Identity_Type
Drb	DRB_Identity

RoutingInfo_Type

TTCN-3 Union Type	
Name	RoutingInfo_Type
Comment	
None	Null_Type
RadioBearerId	RadioBearerId_Type

D.5.4.1.2 Timing_Info

Timing_Info: Basic Type Definitions

TTCN-3 Basic Types		
SystemFrameNumber_Type	integer (0..1023)	
SubFrameNumber_Type	integer (0..9)	

SubFrameInfo_Type

TTCN-3 Union Type		
Name	SubFrameInfo_Type	
Comment		
Number	SubFrameNumber_Type	
Any	Null_Type	no specific sub-frame (valid for REQ ASPs only)

SystemFrameNumberInfo_Type

TTCN-3 Union Type		
Name	SystemFrameNumberInfo_Type	
Comment		
Number	SystemFrameNumber_Type	
Any	Null_Type	no specific frame number (valid for REQ ASPs only)

SubFrameTiming_Type

TTCN-3 Record Type		
Name	SubFrameTiming_Type	
Comment		
SFN	SystemFrameNumberInfo_Type	
Subframe	SubFrameInfo_Type	

TimingInfo_Type

TTCN-3 Union Type		
Name	TimingInfo_Type	
Comment		
SubFrame	SubFrameTiming_Type	
Now	Null_Type	to be used in REQ ASPs when there is no 'activation time'
None	Null_Type	only to be used in SYSTEM_CTRL_CNF but not for EnquireTiming

D.5.4.2 REQ_ASP_CommonPart

ReqAspControllInfo_Type

TTCN-3 Record Type			
Name	ReqAspControllInfo_Type		
Comment			
CnfFlag	boolean		<p>true => SS shall send CNF: when the REQ is with no timing information (no activation time), SS shall send the confirmation when the configuration is done, i.e. when the test case may continue. Example: when there is a configuration follow by a send event it shall not be necessary to have a wait timer in between but the CNF triggers the send event. If there are other triggers e.g. like the UE sending a message, CnfFlag shall be set to false by the test case to avoid racing conditions with the CNF and the signalling message. When there is an activation time SS shall send the CNF after the configuration has been scheduled; that means SS shall not wait until the activation time has been expired.</p>
FollowOnFlag	boolean		<p>false => no further (related) information true: further related information will be sent to SS (semantics depending on respective ASP)</p>

ReqAspCommonPart_Type

TTCN-3 Record Type			
Name	ReqAspCommonPart_Type		
Comment			
CellId	CellId_Type		
RoutingInfo	RoutingInfo_Type		
TimingInfo	TimingInfo_Type		
ControllInfo	ReqAspControllInfo_Type		

D.5.4.3 CNF_ASP_CommonPart

ConfirmationResult_Type

TTCN-3 Union Type			
Name	ConfirmationResult_Type		
Comment			
Success	Null_Type		
Error	integer		may contain SS specific error code; this will not be evaluated by TTCN

CnfAspCommonPart_Type

TTCN-3 Record Type			
Name	CnfAspCommonPart_Type		
Comment			
CellId	CellId_Type		
RoutingInfo	RoutingInfo_Type		
TimingInfo	TimingInfo_Type		
Result	ConfirmationResult_Type		

D.5.4.4 IND_ASP_CommonPart

IntegrityErrorIndication_Type

TTCN-3 Record Type			
Name	IntegrityErrorIndication_Type		
Comment			
Nas	boolean		NAS Integrity: received MAC does not match calculated MAC
Pdcp	boolean		PDCP Integrity: received MAC does not match calculated MAC

ErrorIndication_Type

TTCN-3 Record Type			
Name	ErrorIndication_Type		
Comment			
Integrity	IntegrityErrorIndication_Type		Integrity error: received MAC does not match calculated MAC
System	integer		any other error: may be SS specific error code; this will not be evaluated by TTCN; e.g. an error shall be raised when the UE requests retransmission of an RLC PDU

IndicationStatus_Type

TTCN-3 Union Type			
Name	IndicationStatus_Type		
Comment			
Ok	Null_Type		
Error	ErrorIndication_Type		

IndAspCommonPart_Type

TTCN-3 Record Type			
Name	IndAspCommonPart_Type		
Comment			
CellId	CellId_Type		
RoutingInfo	RoutingInfo_Type		
TimingInfo	TimingInfo_Type		
Status	IndicationStatus_Type		

D.6 CDMA2000_ASP_TypeDefs

D.6.1 CDMA2000_Common

Common definitions for CDMA2000 and CDMA2000 ASPs

D.6.1.1 CDMA2000_SystemContants

CDMA2000_ASP_TypeDefs: Constant Definitions

TTCN-3 Basic Types			
tsc_CDMA2000_MaxNumberOfCells	integer	8	Maximum number of CDMA2000 cells; in TS 36.508 in, clause 6.3.1.5 and 6.3.1.6 define 4 cells each for HRPD and 1XRTT; hence total is 8

D.6.1.2 CDMA2000_Routing

CDMA2000_Routing: Basic Type Definitions

TTCN-3 Basic Types		
RLP_FlowId_Type	integer (0..30)	As per S.0024, clause 4.8.2.10 both MaxNumRLPFlowsFwd and MaxNumRLPFlowsRvs need to be in the range of 0x06[6] to 0x1F[31] As per x.s007 clause 10, the PDN ID and Flow ID identify a flow

RLP_FlowIdList_Type

TTCN-3 Record of Type	
Name	RLP_FlowIdList_Type
Comment	
record of RLP_FlowId_Type	

CDMA2000_RoutingInfo_Type

TTCN-3 Union Type	
Name	CDMA2000_RoutingInfo_Type
Comment	
None	Null_Type
RLP_FlowId	RLP_FlowId_Type

D.6.1.3 CDMA2000_TimingInfo

CDMA2000_TimingInfo: Basic Type Definitions

TTCN-3 Basic Types		
TimeStampLong_Type	B64_Type	The duration of time specified by 16 slots or 26.66 ms.

CDMA2000_SubFrameInfo_Type

TTCN-3 Union Type	
Name	CDMA2000_SubFrameInfo_Type
Comment	
Number	SubFrameNumber_Type
Any	Null_Type no specific sub-frame (valid for REQ ASPs only)

SystemTimeStamp_Type

TTCN-3 Union Type		
Name	SystemTimeStamp_Type	
Comment		
TimeStampLong	TimeStampLong_Type	
Any	Null_Type	no specific TimeStamp (valid for REQ ASPs only)

CDMA2000_SubFrameTiming_Type

TTCN-3 Record Type		
Name	CDMA2000_SubFrameTiming_Type	
Comment		
SystemTimeStamp	SystemTimeStamp_Type	
Subframe	CDMA2000_SubFrameInfo_Type	

CDMA2000_TimingInfo_Type

TTCN-3 Union Type		
Name	CDMA2000_TimingInfo_Type	
Comment		
SubFrame	CDMA2000_SubFrameTiming_Type	
Now	Null_Type	to be used in REQ ASPs when there is no 'activation time'
None	Null_Type	only to be used in SYSTEM_CTRL_CNF but not for EnquireTiming

D.6.1.4 CDMA2000_ReqAspCommonPart**CDMA2000_ReqAspControllInfo_Type**

TTCN-3 Record Type		
Name	CDMA2000_ReqAspControllInfo_Type	
Comment		
CnfFlag	boolean	true => SS shall send CNF: when the REQ is with no timing information (no activation time), SS shall send the confirmation when the configuration is done, i.e. when the test case may continue. Example: when there is a configuration follow by a send event it shall not be necessary to have a wait timer in between but the CNF triggers the send event or system Command. If there are other triggers e.g. like the UE sending a message, CnfFlag shall be set to false by the test case to avoid racing conditions with the CNF and the signalling message. When there is an activation time SS shall send the CNF after the configuration has been scheduled; that means SS shall not wait until the activation time has been expired.
FollowOnFlag	boolean	false => no further (related) information true: further related information will be sent to SS ; Currently this value is not foreseen to be used.

CDMA2000_ReqAspCommonPart_Type

TTCN-3 Record Type			
Name	CDMA2000_ReqAspCommonPart_Type		
Comment			
CellId	CDMA2000_CellId_Type		
RoutingInfo	CDMA2000_RoutingInfo_Type		
TimingInfo	CDMA2000_TimingInfo_Type		
ControllInfo	CDMA2000_ReqAspControllInfo_Type		

D.6.1.5 CDMA2000_IndAspCommonPart

CDMA2000_ErrorIndication_Type

TTCN-3 Record Type			
Name	CDMA2000_ErrorIndication_Type		
Comment			
System	integer		any other error: may be SS specific error code; this will not be evaluated by TTCN; e.g. an error shall be raised when the UE requests retransmission of an RLC PDU

CDMA2000_IndicationStatus_Type

TTCN-3 Union Type			
Name	CDMA2000_IndicationStatus_Type		
Comment			
Ok	Null_Type		
Error	CDMA2000_ErrorIndication_Type		

CDMA2000_IndAspCommonPart_Type

TTCN-3 Record Type			
Name	CDMA2000_IndAspCommonPart_Type		
Comment			
CellId	CDMA2000_CellId_Type		
RoutingInfo	CDMA2000_RoutingInfo_Type		
TimingInfo	CDMA2000_TimingInfo_Type		
Status	CDMA2000_IndicationStatus_Type		

D.6.1.6 CDMA2000_CnfAspCommonPart

CDMA2000_ConfirmationResult_Type

TTCN-3 Union Type			
Name	CDMA2000_ConfirmationResult_Type		
Comment			
Success	Null_Type		
Error	integer		may contain SS specific error code; this will not be evaluated by TTCN

CDMA2000_CnfAspCommonPart_Type

TTCN-3 Record Type			
Name	CDMA2000_CnfAspCommonPart_Type		
Comment			
CellId	CDMA2000_CellId_Type		
RoutingInfo	CDMA2000_RoutingInfo_Type		
TimingInfo	CDMA2000_TimingInfo_Type		
Result	CDMA2000_ConfirmationResult_Type		Similar definition as EUTRA

D.6.2 CDMA2000_PowerLevel

CDMA2000_ASP_TypeDefs: Constant Definitions

TTCN-3 Basic Types			
tsc_CDMA2000_Attenuation_Off	CDMA2000_Attenuation_Type	{Off:=true}	

CDMA2000_PowerLevel: Basic Type Definitions

TTCN-3 Basic Types		
CDMA2000_InitialAttenuation_Type	CDMA2000_Attenuation_Type (tsc_CDMA2000_Attenuation_Off)	Attenuation restricted to 'Off'

CDMA2000_Attenuation_Type

TTCN-3 Union Type		
Name	CDMA2000_Attenuation_Type	
Comment	attenuation of the reference power	
Value	Attenuation_Type	cell power reference power reduced by the given attenuation (value is in dB)
Off	Null_Type	for non suitable off cell we specify an explicit "Off" value here

CDMA2000_CellAttenuation_Type

TTCN-3 Record Type			
Name	CDMA2000_CellAttenuation_Type		
Comment			
CellId	CDMA2000_CellId_Type		
Attenuation	CDMA2000_Attenuation_Type		

CDMA2000_CellAttenuationList_Type

TTCN-3 Record of Type	
Name	CDMA2000_CellAttenuationList_Type
Comment	
record length(1.. tsc_CDMA2000_MaxNumberOfCells) of CDMA2000_CellAttenuation_Type	

CDMA2000_AbsoluteCellPower_Type

TTCN-3 Record Type			
Name	CDMA2000_AbsoluteCellPower_Type		
Comment			
Powerloc	Powerloc_Type		TTCN writer Shall set same vale in all cells; SS shall have only one AWGN channel for all configured cells per frequency SS shall create a AWGN channel in first cell per frequency and ignore this in later cell creations on the same frequency; i.e. this channel is created along once for Cell 15 or 16 and one each per 17 and 19 similary for RTT1X once for 19 or 20 and one each per 21 and 22
Powerlor	Powerlor_Type		Total Transmit power in cell before attenuation
PilotOffset	PilotOffset_Type		Default -7

CDMA2000_InitialCellPower_Type

TTCN-3 Record Type			
Name	CDMA2000_InitialCellPower_Type		
Comment			
MaxReference Power	CDMA2000_AbsoluteCellPower_Type		maximum value of cell reference power corresponding to Max lor/loc in power level table; a cell is initialised with this reference power; its value is the upper bound of the cell power during the test case
Attenuation	CDMA2000_InitialAttenuation_Type		initial attenuation Cell is off

D.6.3 CDMA2000_Data

Data primitives sent/received at CDMA2000_RLP_FLOW_PORT

CDMA2000_Data: Basic Type Definitions

TTCN-3 Basic Types		
RLP_SDU_Type	octetstring	

RLP_SDUList_Type

TTCN-3 Record of Type	
Name	RLP_SDUList_Type
Comment	
record of RLP_SDU_Type	

CDMA2000_U_PlaneData_Type

TTCN-3 Union Type		
Name	CDMA2000_U_PlaneData_Type	
Comment	Union structure is provided for future possible enhancements	
RLP_Sdu	RLP_SDUList_Type	RLP SDU's

RLPFlow_DataPerSubframe_DL_Type

TTCN-3 Record Type	
Name	RLPFlow_DataPerSubframe_DL_Type
Comment	common definition for one or several SDUs to be sent in the subframe given by the subframe offset; SS shall raise an error indication (using SYSTEM_IND) when that is not possible NOTE 1: For RLP the data may be spread over more than one subframe ; the TTCN implementation is responsible to calculate appropriate offsets accordingly
SubframeOffset	integer subframe offset relative to the absolute timing information given in the common part of the ASP; NOTE : if a RLP SDU takes more than one subframe, SubframeOffset specifies the first TTI
SduList	CDMA2000_U_PlaneData_Type list of PDUs/SDUs to be sent in one subframe

RLPFlow_DataPerSubframeList_DL_Type

TTCN-3 Record of Type	
Name	RLPFlow_DataPerSubframeList_DL_Type
Comment	list of user plane data to be sent in sub-frames given by the SubframeOffset in the single elements of the list; Timing: the start time for the whole sequence is given by the timing info of the ASP (common information); the timing for the respective data pdus is given by the SubframeOffset relative to the common timing info; design consideration: repetitions of this sequence are not foreseen (in which case the subframe offset could not be related to the timing info of the ASP)
record of RLPFlow_DataPerSubframe_DL_Type	

CDMA2000_U_Plane_Request_Type

TTCN-3 Record Type	
Name	CDMA2000_U_Plane_Request_Type
Comment	NOTE: formal type definition to allow later enhancements; CDMA2000_U_Plane_Request_Type defines a sequence of subframes in which data shall be sent
SubframeDataList	RLPFlow_DataPerSubframeList_DL_Type

D.6.4 CDMA2000_CellConfiguration

HRPD_CellParameters_Type

TTCN-3 Record Type			
Name	HRPD_CellParameters_Type		
Comment	Parameters specific to HRPD		
SystemType	SystemType_Type		Specifies the system type of Channel As per Table 13.1-1 of C.S0024 0, 1, 2 are defined values and 3 to 255 are reserved
SubNetMask	B8_Type		7.11.6.2.2 of C.S0024 Sector Subnet identifier set this field to the number of consecutive 1s in the subnet mask of the subnet to which this sector belongs
ColorCode	ColorCode_Type		7.11.6.2.1 of C.S0024 set to the color code corresponding to this sector part of QuickConfig Over head message
CountryCode	MCC_Type		7.11.6.2.2 of C.S0024 three-digit BCD (binary coded decimal) encoded representation of the Mobile Country Code associated with this sector
OpenLoopAdjust	OpenLoopAdjust_Type		9.4.6.2.6 of C.S0024; The negative of the nominal power to be used by access terminals in the open loop power estimate, expressed as an unsigned value in units of 1 dB. The value used by the access terminal is -1 times the value of this field
ReverseRateLimit	ReverseRateLimit_Type		Table 9.9.6.3-2 of C.S0024; set to the highest data rate that the access terminal is allowed to use on the Reverse Traffic Channel
MACIndex	ReverseLinkMACIndex_Type		C.S0024 clause 12.4.1.3.2.2 Forward channel MAC is derived from this based on table 12.4.1.3.2.2-1
PacketApp	PacketApplication_Type		Multi Flow Packet Application to be used Enhanced Multi-Flow Packet Application subtype(0x0009) defined in C.S0087 or alternate Enhanced Multi-Flow Packet Application subtype (0xFFFE) in C.R1001
ControlChannelRate	ControlChannelRate_Type		MAC index to be used for the Control Channel

RTT1X_CellParameters_Type

TTCN-3 Record Type		
Name	RTT1X_CellParameters_Type	
Comment	Parameters specific to 1XRTT	
Reg_Zone	B12_Type	C.S005 clause 3.7.2.3.2.1 and 2.6.5.1.5 Registration Zone of the base station Reg_Zone, SID and NID shall be unique for each base station
Base_Class	B4_Type	C.S0005 clause 3.7.2.3.2.1 Base station class. The base station shall set this field as follows: For Band Class 1 and 4, the base station shall set this field to '0001'; otherwise, the base station shall set this field to '0000'
MCC	B10_Type	3.7.2.3.2.13 and 2.3.1.1 of C.S0005 encoding is int2bit (100*D1+10*D2+D3 -111,10) with digit 0 being mapped to 10 binary representation of the Mobile Country Code associated with this sector
IMSI_11_12	B7_Type	3.7.2.3.2.13 and 2.3.1.2 of C.S0005 encoding is int2bit (10*D2+D3 -11,7) with digit 0 being mapped to 10 binary representation of the Mobile Network Code associated with this sector
TMSI	TMSI_Type	the TMSI to be assigned to the MS
ProtRev	ProtRev_Type	Protocol Revision
Min_ProtRev	ProtRev_Type	the minimum protocol revision supported by Base station
Sig_Encryption Mode	EncryptionMode_Type	Encryption mode for Common and dedicated signalling
USerInfo_EncryptionMode	EncryptionMode_Type	User information Encryption mode

ModeSpecificCellParams_Type

TTCN-3 Union Type		
Name	ModeSpecificCellParams_Type	
Comment		
RTT1X	RTT1X_CellParameters_Type	
HRPD	HRPD_CellParameters_Type	

CDMA2000_CellParameters_Type

TTCN-3 Record Type		
Name	CDMA2000_CellParameters_Type	
Comment		
Type	CDMA2K_Type	Gives if cell is EHRPD or RTT1X
CarrierFreq	CarrierFreqCDMA2000_Type	Contains bandclass [5 bit] and arfcn i.e. 11 bit channel number
PhysCellId	PhysCellIdCDMA2000_Type	PN offset of pilot 0..511
CellGlobalId	CellGlobalIdCDMA2000_Type	Contains the 128 bit cell ID for HRPD and 47 bit cell ID for 1XRTT
SearchWindow	SearchWindowSizeRecord_Type	contains the SearchWindow for Active, Neighbor & Remaining cells

CDMA2000_CellConfigInfo_Type

TTCN-3 Record Type		
Name	CDMA2000_CellConfigInfo_Type	
Comment		
CellParameters	CDMA2000_CellParameters_Type	Parameters common to HRPD and RTT1X
InitialCellPower	CDMA2000_InitialCellPower_Type	Power level parameters
ModeSpecificCellParams	ModeSpecificCellParams_Type	Parameters specific to RTT1X or HRPD

CDMA2000_CellConfigRequest_Type

TTCN-3 Union Type		
Name	CDMA2000_CellConfigRequest_Type	
Comment		
AddOrReconfigure	CDMA2000_CellConfigInfo_Type	for cell configuration: CellId : identifier of the cell to be configured RoutingInfo : None TimingInfo : Now (for initial configuration and for reconfiguration in general) ControlInfo : CnfFlag:=true; FollowOnFlag:=false (in general)
Release	Null_Type	to remove a cell completely - CellId : identifier of the cell to be released; extra_Cell_NonSpecific, in case all cells shall be released RoutingInfo : None TimingInfo : Now ControlInfo : CnfFlag:=true; FollowOnFlag:=false (in general)

D.6.5 CDMA2000_HRPD

D.6.5.1 CDMA2000_PDN_Defs

CDMA2000_PDN_Defs: Basic Type Definitions

TTCN-3 Basic Types		
CDMA2000_AttachType	O3_Type	Defined values: 1: Initial Attach to a PDN, 3: Handover attach to a PDN. Rest undefined and not used
IPv4_Address_Type	O4_Type	represents the IPv4 address as per 24.301 clause 9.9.4.9
IPv6_Address_Type	O8_Type	represents the IPv6 interface identifier as per 24.301 clause 9.9.4.9
PDN_Id_Type	B4_Type	indicates the PDN Id associated with the bearer PDN Identifier of the PDN for which the user data is sent. it is the low order 4 bits of, containing the PDN-ID identifies the PDN [i.e. one per default bearer] Reference x.s0057 clause 10.1.5; gives only low order 4 bits, and high order 4 bits are added as all zero's
Flow_Id_Type	B4_Type	the lower 4 bits of the Flow Identifier, as defined in Table 15 of x.s0057 identify each reservation that is requested to be added or deleted the complete 8 bit flow Identifier is formed by PDN-ID and Flow-Id

IPv4v6_Address_Type

TTCN-3 Record Type			
Name	IPv4v6_Address_Type		
Comment			
IPv4	IPv4_Address_Type		IP v4 address to be allocated
IPv6	IPv6_Address_Type		IP v6 interface identifier to be allocated

PDN_Address_Type

TTCN-3 Union Type			
Name	PDN_Address_Type		
Comment	based on 24.301 cl. 9.9.4.9		
IPv4	IPv4_Address_Type		only IP v4 address to be allocated
IPv6	IPv6_Address_Type		only IP v6 interface identifier to be allocated
IPv4v6	IPv4v6_Address_Type		both IP v4 address and IP v6 interface identifier to be allocated

Flow_IdList_Type

TTCN-3 Record of Type	
Name	Flow_IdList_Type
Comment	
record of Flow_Id_Type	

D.6.5.2 CDMA2000_SubProtocols

LCP_DetachInit_Type

TTCN-3 Enumerated Type	
Name	LCP_DetachInit_Type
Comment	
networkInitiated	x.s0057 clause 11.2
UEInitiated	x.s0057 clause 11.1.2

DHCP_Ind_Type

TTCN-3 Record Type			
Name	DHCP_Ind_Type		
Comment			
RapidCommit	boolean		indicates if Rapid Comit option of DHCP is used

UATI104_Type

TTCN-3 Union Type			
Name	UATI104_Type		
Comment			
Value	O13_Type		
None	Null_Type		

UATI_Type

TTCN-3 Record Type			
Name	UATI_Type		
Comment			
UATI24	O3_Type		Represents UATI[0:23], as per clause 6.3.7.2.2 of C.S0024
UATI104	UATI104_Type		Represents UATI[127:24], as per clause 6.3.7.2.2 of C.S0024 if has to be assigned

D.6.5.3 HRPD_Indications

RegAndDefBearerEstInd_Type

TTCN-3 Record Type			
Name	RegAndDefBearerEstInd_Type		
Comment			
UATI_Assignm entCmpl	Null_Type		UATIAssignment is received UATIComplete is received
ChAssignCmpl	Null_Type		Traffic/Extended Channel Assignment procedure started UE has sent ConnectionRequest Traffic/Extended Channel assignment is completed UE has sent TrafficChannelComplete Route update protocol
SCP_ConfigC mpl	Null_Type		SCP (Session Configuration Protocol)ConfigurationRequest message is received SCP (Session Configuration Protocol)ConfigurationResponse message is transmitted
Stream_Config Cmpl	Null_Type		Stream Protocol Configuration ConfigurationRequest message is received Stream Protocol Configuration ConfigurationResponse message is transmitted
EMPA_ConfigC mpl	Null_Type		Enhanced Multi flow Packet application ConfigurationRequest message is received Enhanced Multi flow Packet application ConfigurationComplete message is received
SessionNegotia tionCmpl	Null_Type	opt	Session Negotiation has started; Session Negotiation has completed
DeviceAuthCm pl	Null_Type	opt	Device level authentication has started; Device level authentication has completed
LocationUpdate Cmpl	Null_Type	opt	Location Update started; Location Update completed
EAP_AKA_Cm pl	Null_Type		Improved Extensible Authentication protocol for Authentication and Key agreement started RFC 5448 Message flow in x.s0057 clause 5.2.5.1 Authentication and Key agreement Completed
VSNCPConfig Cmpl	Null_Type		PDN connection establishment started and UE has sent PPP Vendor Specific Network Control Protocol Configuration Request PDN Connection and default bearer establishment is completed with possible IPV4 address [optional] and or IPV6 interface ID [Mandatory] provided Attach type shall be Handover Attach
DHCP_ConfigC mpl	DHCP_Ind_Type	opt	UE and SS decided for IPV4 address allocation by DHCP IPV4 address allocation completed by UE and SS Completion of IP Address through DHCP

DedicatedBearerRelInd_Type

TTCN-3 Record Type			
Name	DedicatedBearerRelInd_Type		
Comment			
VSNP_TerminateCmpl	Null_Type		Dedicated bearers are deactivated/ released
SCP_ReleaseCmpl	Null_Type	opt	Session Configuration Protocol to relase the reservations exclusively associated with the deleted bearer Reservation deletion completed

DefaultBearerRelDetachInd_Type

TTCN-3 Record Type			
Name	DefaultBearerRelDetachInd_Type		
Comment			
VSNCP_TerminateCmpl	Null_Type	opt	To Released configured default bearer and hense associated Dedicated bearer x.s0057 clause 11.3 and 11.1.1 To indicate the default bearer is released
LCP_TerminateCmpl	Null_Type		To detach the UE x.s0057 clause 11.2 Detach completed

HRPD_SystemIndication_Type

TTCN-3 Union Type			
Name	HRPD_SystemIndication_Type		
Comment			
Error	Null_Type		Used by SS to indicate any error; the Actual Error types reported in ASP common part in CDMA2000_IndicationStatus_Type
InitialAccessProbeRcvd	Null_Type		Initial Access probe is received;
RegAndDefBearerEstInd	RegAndDefBearerEstInd_Type		UE has succesfully performed registration and default bearer establishment
DedicatedBearerEstInd	Null_Type		Vendor specific network protocol [RFC 3772] procedures to re-establish Dedicated bearer as defined in S.0057 clause 5.5.3.1 [BCM is MS/NW] or clause 5.5.4.1.1 [BCM = MS-Only] Bearer Configuration Mode Dedicated bearers are [re] established
DedicatedBearerRelInd	DedicatedBearerRelInd_Type		To indicate the Dedicated bearer is released
DefaultBearerRelDetachInd	DefaultBearerRelDetachInd_Type		To Release configured default bearer and hense associated Dedicated bearer x.s0057 clause 11.3 and 11.1.1 Dedicated bearers are deactivated/released To detach the UE x.s0057 clause 11.2 Detach completed
MovedToDormantMode	Null_Type		The channels are released and UE is moved to PPP dormant mode/Air interface Idle.

D.6.5.4 HRPD_Commands

HRPD_UE_InitStateType

TTCN-3 Enumerated Type	
Name	HRPD_UE_InitStateType
Comment	HRPD UE states as defined in C.S0057 clause 3.1
idle_Null	In the Inactive/Null State, 1. there is no physical traffic channel between the UE and the eAN, and no connection exists between the eAN and the ePCF 2. no PPP link between the UE and the HSGW . 3. The UE may have a Universal Access Terminal Identifier (UATI) that has been assigned by an eHRPD eAN
dormant	In the Dormant State, 1. no physical traffic channel exists between the UE and the eAN and no connection exists between the eAN and the ePCF. 2. PPP link between the UE and the HSGW 3. eHRPD DORMANT state equates to the "idle" state referred to in TS 23.402
active_Connected	In the Active/Connected State, 1. a physical traffic channel exists between the UE and the eAN over which data may be sent. A connection exists between the eAN and the ePCF, and between the ePCF and the HSGW, 2. there is a PPP link between the UE and the HSGW
preregister	The UE is performing pre-register though a different Access network

RegAndDefBearerEst_Type

TTCN-3 Record Type	
Name	RegAndDefBearerEst_Type
Comment	
InitState	HRPD_UE_InitStateType
PDN_Id	PDN_Id_Type PDN_ID of the bearer
PDN_Address	PDN_Address_Type the PDN Address to be provided to the UE in VSNCP ConfigAck
RLP_FlowId	RLP_FlowId_Type Associated RLP Flow ID
UATI	UATI_Type UATI to be Assigned to the UE
AttachType	CDMA2000_AttachType The Attach Type to be expected in VSNCP procedure

DefaultBearerRelDetach_Type

TTCN-3 Record Type	
Name	DefaultBearerRelDetach_Type
Comment	
InitState	HRPD_UE_InitStateType
PDN_Id	PDN_Id_Type PDN_ID of the bearer
RLP_FlowId	RLP_FlowId_Type Associated RLP Flow ID
UE_NW_Initiated	LCP_DetachInit_Type If initiated by UE or Network

DedicatedBearerEstRel_Type

TTCN-3 Record Type			
Name	DedicatedBearerEstRel_Type		
Comment			
InitState	HRPD_UE_InitStateType		PPP and Air Interface state of UE when the procedure is being executed
AssociatedDefaultBearer	PDN_Id_Type		the PDN ID of the associated default bearer; Gives the APN with which additional Dedicated Bearer needs to be established
Flow_Ids	Flow_IdList_Type		Flow_ID's of the multiple dedicated bearers to be Activated/Deactivated
RLP_FlowIds	RLP_FlowIdList_Type		Associated RLP Flow ID; There is one to one association between elements in Flow_IdList_Type and RLP_FlowIdList_Type; ITs a TTCN programing error otherwise

HRPD_SystemCommand_Type

TTCN-3 Union Type		
Name	HRPD_SystemCommand_Type	
Comment		
ReportInitialAccessProbe	Null_Type	SS is expected to report any possible Access probes received on HRPD Cell; will be used in situations where UE is not expected to camp on a HRPD Cell
RegAndDefBearerEst	RegAndDefBearerEst_Type	To complete registration and establish Default bearer; Initial UE State is Idle_Null State Indications upto VSNCP protocol and possible IP signalling over DHCPv4 and/or ICMPv6 is performed At the end of procedure, UE is still in Active/Connected state; SS is expected to send InitialAccessProbeRcvd and RegAndDefBearerEstInd as an indication for succesful completion of procedure
DedicatedBearerEst	DedicatedBearerEstRel_Type	Dedicated bearers are established/Activated by VSNP/EMPA protocol; PDN ID and RLP flow ID pairs are provided for each Dedicated bearer At the end of procedure, UE is still in Active/Connected state SS is expected to send InitialAccessProbeRcvd[only if initial state is not Active] and DedicatedBearerEstInd as an indication for succesful completion of procedure
MoveToDormantState	Null_Type	UE is Active_Connected state and is moved to Dormant state SS is expected to send MovedToDormantMode
MoveToActiveState	RLP_FlowIdList_Type	UE is initially Dormant state; UE is made to Move to Active_Connected State List of RLP flow Id's [associated with default + dedicated bearer], need to be established are provided SS is expected to send InitialAccessProbeRcvd
DedicatedBearerRel	DedicatedBearerEstRel_Type	Dedicated bearers are released/De-Activated by VSNP terminate and SCP release protocol; At the end of procedure, UE is still in Active/Connected state SS is expected to send InitialAccessProbeRcvd[only if initial state is not Active] and DedicatedBearerRelInd as an indication for succesful completion of procedure
DefaultBearerRelDetach	DefaultBearerRelDetach_Type	Default bearer is released by VSNCP terminate and SCP release protocol UE is made to detach by LCP protocol and Possible Channels are released At the end of procedure, UE is in Idle_Null state Notes: When Detach is network initiated the sequence is 1. Default bearer [and hence all associated Dedicated bearers] released by VSNCP terminate 2. UE is detached by LCP terminate procedure When Detach is UE initiated, UE may only perform LCP terminate procedure SS is expected to send InitialAccessProbeRcvd[only if initial state is not Active] and DefaultBearerRelDetachInd as an indication for succesful completion of procedure

D.6.6 CDMA2000_RTT1X

D.6.6.1 RTT1X_Indications

RTT1X call flows in RTT1x cell

Expected Sequence for Attach [Power Up Attach]

1. Initial AccessProbeRcvd
2. CS_RegistrationStart[Powerup]
3. CS_RegistrationCmpl

Expected Sequence for Detach [Power Down Attach]

- 1. Initial AccessProbeRcvd
 - 2. CS_RegistrationStart [PowerDown]
 - 3. CS_RegistrationCmpl
- Expected Sequence for CSFB Call Establishment
- 1. Initial AccessProbeRcvd
 - 2. CS_CallEstStart [Origination/ PageResponse]
 - 3. ChAssignCmpl [Extended Channel Assignment is sent]
 - 4. CS_CallEstCompleted [Acknowledgement Order Sent, Service Connect sent, Service Connect Completion received, Alert Sent/Received and ConnectOrder is received]
- Expected Sequence for SRVCC call handover
- 1. Initial AccessProbeRcvd
 - 2. HandoffCmpl

RTT1X_CS_CallType

TTCN-3 Enumerated Type	
Name	RTT1X_CS_CallType
Comment	
mo	Call is UE originated
mt	Call is UE Terminated

RTT1XAttachType

TTCN-3 Enumerated Type	
Name	RTT1XAttachType
Comment	
powerUpAttach	UE is doing Power up attach it was not previously attached
powerDownAttach	UE is doing power down attach; it was previously attached

CS_RegCmplInd_Type

TTCN-3 Record Type	
Name	CS_RegCmplInd_Type
Comment	
CS_Registratio nCmpl	RTT1XAttachType CS power up/down registration is completed UE Sent Registration message and received an L2 Acknowledgement Optionally SS can perform Authentication and and has sent Registration Accepted order

CS_Reg_CallCmplInd_Type

TTCN-3 Record Type			
Name	CS_Reg_CallCmplInd_Type		
Comment			
CS_Registratio nCmpl	RTT1XAttachType	opt	CS power up/down registration is completed; This is omit if implicit registration is done UE Sent Registration message and received an L2 Acknowledgement Optionally SS can perform Authentication and and has sent Registration Accepted order UE can also do a implicit registration; i.e. reception of Origination/reconnect/CallRecovery/Page message by Base station is treated as implicit registration
CS_CallEstStar ted	RTT1X_CS_CallType		Received Origination message for MO and Page Response for MT
ChAssignCmpl	Null_Type		[Extended] Channel Assignment procedure started UE has sent ConnectionRequestTraffic Extended Channel assignment is completedUE has sent TrafficChannelComplete
CS_CallEstCo mpleted	Null_Type		SS received Service Connect Completion[Mo] or ConnectOrder[MT] [i.e User Accepted call]

CS_CallCmplInd_Type

TTCN-3 Record Type			
Name	CS_CallCmplInd_Type		
Comment			
CS_CallEstStar ted	RTT1X_CS_CallType		Received Origination message for MO and Page Response for MT
ChAssignCmpl	Null_Type		[Extended] Channel Assignment procedure started UE has sent ConnectionRequestTraffic Extended Channel assignment is completedUE has sent TrafficChannelComplete
CS_CallEstCo mpleted	Null_Type		SS received Service Connect Completion[Mo] or ConnectOrder[MT] [i.e User Accepted call]

RTT1X_SystemIndication_Type

TTCN-3 Union Type			
Name	RTT1X_SystemIndication_Type		
Comment			
Error	Null_Type		Used by SS to indicate any error; the Actual Error types reported in ASP common part in CDMA2000_IndicationStatus_Type
InitialAccessPr obeRcvd	Null_Type		Initial Access probe is received
CS_Registratio nCmpl	CS_RegCmplInd_Type		CS power up/down registration is completed As registration message, and possible Authentication Registration accepted order are all sent received on f/r-csch UE at end is in Idle state
CS_Reg_CallC mplInd	CS_Reg_CallCmplInd_Type		CS Registration /implicit registration and Call Indication MO or MT UE is in connected state with f/r dtch configured
CS_CallCmplIn d	CS_CallCmplInd_Type		CS Call Indication MO or MT UE is in connected state with f/r dtch configured
HandoffCmpl	Null_Type		needed for SRVCC handover of an IMS voice call on LTE to 1XRTT indicates SS has received HandoffComplete message and the call is established
MovedToIdleSt ate	Null_Type		The channels are released and UE is moved to Idle state. CS Call is released by exchange of Release order in both directions C.S0005 figure B3 and B4

D.6.6.2 RTT1X_Commands

CS_Registration_Type

TTCN-3 Record Type		
Name	CS_Registration_Type	
Comment		
AttachType	RTT1XAttachType	
IsPreRegistration	boolean	Indicates if it is done as pre registration Value is ignored if Attach Type is Power down (Assumption detach happens only in 1XRTT cell)

RTT1X_SystemCommand_Type

TTCN-3 Union Type		
Name	RTT1X_SystemCommand_Type	
Comment		
ReportInitialAccessProbe	Null_Type	SS is expected to report any possible Access probes received on 1XRTT Cell; will be used in situations where UE is not expected to camp on a 1XRTT Cell
CS_Registration	CS_Registration_Type	Power up attach/ power down attach in 1xRTT cell or Pre registration [Power up attach] through a different RAT
CSFB_Call	RTT1X_CS_CallType	CSFB_Call by a [pre-]registered UE
CS_Reg_CSFB_Call	RTT1X_CS_CallType	UE not previously pre-registered hence performs registration [Power up attach] and CSFB call Registration can be implicit registration as

D.6.7 System_Interface

CDMA2000_SystemRequest_Type

TTCN-3 Union Type		
Name	CDMA2000_SystemRequest_Type	
Comment		
Cell	CDMA2000_CellConfigRequest_Type	configure/release a cell
CellAttenuationList	CDMA2000_CellAttenuationList_Type	

CDMA2000_SystemConfirm_Type

TTCN-3 Union Type		
Name	CDMA2000_SystemConfirm_Type	
Comment	confirmations for system configuration; in general to be sent after the configuration has been done	
Cell	Null_Type	(no further parameters from SS)
CellAttenuationList	Null_Type	(no further parameters from SS) NOTE 1: the confirmation shall be sent when all cells have changed power levels NOTE 2: for the CellId in the common ASP part the same rules are applied as for the CDMA2000 SYSTEM REQ

CDMA2000_SYSTEM_CTRL_REQ

TTCN-3 Record Type			
Name	CDMA2000_SYSTEM_CTRL_REQ		
Comment			
Common	CDMA2000_ReqAspComm onPart_Type		TimingInfo depends on respective primitive:
Request	CDMA2000_SystemReque st_Type		- Cell TimingInfo: 'now' (in general) - CellAttenuationList TimingInfo: 'now' (in general, but activation time may be used also)

CDMA2000_SYSTEM_CTRL_CNF

TTCN-3 Record Type			
Name	CDMA2000_SYSTEM_CTRL_CNF		
Comment			
Common	CDMA2000_CnfAspComm onPart_Type		TimingInfo is ignored by TTCN => SS may set TimingInfo to "None"
Confirm	CDMA2000_SystemConfir m_Type		

CDMA2000_SystemCommand_Type

TTCN-3 Union Type		
Name	CDMA2000_SystemCommand_Type	
Comment		
HRPD	HRPD_SystemCommand_Type	HRPD Specific System commands
RTT1X	RTT1X_SystemCommand_Type	1XRTT specific System commands

CDMA2000_SYSTEM_CMD

TTCN-3 Record Type			
Name	CDMA2000_SYSTEM_CMD		
Comment			
Common	CDMA2000_ReqAspComm onPart_Type		Routing info will be none generally; TimingInfo is generally now but activation time may be used also for all System commands Cnf and Follow on flags are both false
Command	CDMA2000_SystemComm and_Type		HRPD or 1XRTT System commands

CDMA2000_SystemIndication_Type

TTCN-3 Union Type		
Name	CDMA2000_SystemIndication_Type	
Comment		
HRPD	HRPD_SystemIndication_Type	
RTT1X	RTT1X_SystemIndication_Type	

CDMA2000_SYSTEM_IND

TTCN-3 Record Type			
Name	CDMA2000_SYSTEM_IND		
Comment			
Common	CDMA2000_IndAspCommonPart_Type		The SS shall provide TimingInfo (SFN + subframe number) depending on the respective indication:
Indication	CDMA2000_SystemIndication_Type		- Error TimingInfo: related to the error (if available) - HRPD/RTT1X Procedure completion The timing info corresponding to logical completion of the complete procedure includes completion of all sub protocols

CDMA2000_RLP_FLOW_COMMON_IND

TTCN-3 Record Type			
Name	CDMA2000_RLP_FLOW_COMMON_IND		
Comment	ASP to receive PDUs from RLP Packet Flows		
Common	CDMA2000_IndAspCommonPart_Type		CellId : identifier of the cell RoutingInfo : RLP Flow id TimingInfo : time when RLP SDU's has been completely received
Data	CDMA2000_U_PlaneData_Type		

CDMA2000_RLP_FLOW_COMMON_REQ

TTCN-3 Record Type			
Name	CDMA2000_RLP_FLOW_COMMON_REQ		
Comment	ASP to send PDUs to RLP Packet flows		
Common	CDMA2000_ReqAspCommonPart_Type		CellId : identifier of the cell RoutingInfo : RLP Flow id TimingInfo : starting point when to start sending sequence of data PDUs e.g. TimeStampLong_Type = X, subframe number = x; U_Plane.SubframeDataList[i].SubframeOffset := offset_i; => U_Plane.SubframeDataList[i].PduSduList shall be sent out at TimeStampLong_Type = X + ((x + offset_i) / 4); subframe number = (x + offset_i) mod 4 ControlInfo : CnfFlag:=false; FollowOnFlag:=false
U_Plane	CDMA2000_U_Plane_Request_Type		

CDMA2000_SYSTEM_PORT

TTCN-3 Port Type			
Name	CDMA2000_SYSTEM_PORT		
Comment	CDMA2000 PTC: Port for system configuration		
out	CDMA2000_SYSTEM_CTRL_REQ		
in	CDMA2000_SYSTEM_CTRL_CONF		

CDMA2000_SYSCMD_IND_PORT

TTCN-3 Port Type	
Name	CDMA2000_SYSCMD_IND_PORT
Comment	CDMA2000 PTC: Port for system indications/Commands
out	CDMA2000_SYSTEM_CMD
in	CDMA2000_SYSTEM_IND

CDMA2000_RLP_FLOW_PORT

TTCN-3 Port Type	
Name	CDMA2000_RLP_FLOW_PORT
Comment	CDMA2000 PTC: Port for RLP SDU's to be sent on RLP packet data streams
out	CDMA2000_RLP_FLOW_COMM ON_REQ
in	CDMA2000_RLP_FLOW_COMM ON_IND

D.7 CDMA2000_CommonDefs

type definitions used by CDMA2000 and EUTRA

CDMA2000_CommonDefs: Basic Type Definitions

TTCN-3 Basic Types		
BandclassCDMA2000_Type	integer (0..31)	Band class defined as in 36.331 ASN.1 definition for BandclassCDMA2000
ARFCN_ValueCDMA2000_Type	integer (0..2047)	ARFCN for CDMA2000 cell as in 36.331 ASN.1 definition for ARFCN_ValueCDMA2000
PhysCellIdCDMA2000_Type	integer (0..511)	PN offset for CDMA2000 cell as in 36.331 ASN.1 definition for PhysCellIdCDMA2000
ProtRev_Type	integer (0..255)	protocol revision
OpenLoopAdjust_Type	integer (0..255)	9.4.6.2.6 of C.S0024
BCD_Digit_Type	integer (0..9)	To represent BCD digit of MCC
TMSI_Code_Type	O4_Type	
EncryptionMode_Type	integer (0..7)	C.S0005 table 3.7.4.5-1 & 3.7.5.7-3 0 ... Encryption disabled 1 ... Encryption with ORYX algorithm for User Info and Enhanced Cellular Msg Encryption Algorithm for Signalling 2 ... Encryption with Rijndael algorithm 3-7 ... reserved
TMSI_ZoneLen_Type	integer (1..8)	TMSI Zone Length; On encoding this is encoded to B4_Type
SectorID_HRPD_Type	B128_Type	Sector ID for HRPD as in 36.331 ASN.1 definition for CellGlobalIdCDMA2000.cellGlobalIdHRPD
PilotOffset_Type	integer (-31..0)	Represents the offset i.e. Pilot Channel power to total cell power(dB); By default shall be set to -7 127 selected Max value by 7 bits
Powerlor_Type	integer (-127..0)	Represents the cell total Tx power lor (dBm/1.23 MHz)
Powerloc_Type	integer (-127..0)	Represents the cell total AWGN power loc (dBm/1.23 MHz) which is independent of cell
SystemType_Type	integer (0..255)	0 to 2 are allowed and 3 to 255 are reserved 13.1 of C.S0024
ColorCode_Type	integer (0..255)	7.11.6.2.1 of C.S0024
ReverseLinkMACIndex_Type	integer (0..383)	C.S0024 clause 12.4.1.3.2.2

MCC_Type

TTCN-3 Record of Type	
Name	MCC_Type
Comment	Represents Mobile Country Code
record length (3) of BCD_Digit_Type	

TMSI_Zone_Type

TTCN-3 Record of Type	
Name	TMSI_Zone_Type
Comment	TMSI Zone 1 to 8 octets
record length (1..8) of B8_Type	

TMSI_Type

TTCN-3 Record Type		
Name	TMSI_Type	
Comment	Globally unique TMSI as defined in C.s0005 clause 3.7.2.3.2.19	
TMSI_ZoneLen	TMSI_ZoneLen_Type	Length of TMSI_Zone 1..8
TMSI_Zone	TMSI_Zone_Type	TMSI_ZoneLen octets of TMSI_Zone
TMSI_Code	TMSI_Code_Type	TMSI code

SectorID_RTT1X_Type

TTCN-3 Record Type		
Name	SectorID_RTT1X_Type	
Comment	Sector ID for 1XRTT acc. to C.S0005 clause 3.7.2.3.2.1 and as in 36.331 ASN.1 clause 6.3.4, definition of CellGlobalIdCDMA2000.cellGlobalId1XRTT	
BaselId	B16_Type	Base station identification. The base station shall set this field to its identification number
NID	B16_Type	Network identification This field serves as a sub-identifier of a system as defined by the owner of the SID. The base station shall set this field to the network identification number for this network
SID	B15_Type	System identification. set to the system identification number for this system

CarrierFreqCDMA2000_Type

TTCN-3 Record Type		
Name	CarrierFreqCDMA2000_Type	
Comment	Carrier Frequency for CDMA2000 cell as in 36.331 ASN.1 definition for CarrierFreqCDMA2000; contains Band class 5 bit and Channel number 11 bit part of Sector Channel over head message contained in 24 bit Channel IE	
BandClass	BandclassCDMA2000_Type	
ARFCN	ARFCN_ValueCDMA2000_Type	

CDMA2K_Type

TTCN-3 Enumerated Type	
Name	CDMA2K_Type
Comment	CDMA 2000 Type for CDMA2000 cell as in 36.331 ASN.1 definition for CDMA2000-Type
type1XRTT	
typeHRPD	

CellGlobalIdCDMA2000_Type

TTCN-3 Union Type	
Name	CellGlobalIdCDMA2000_Type
Comment	CDMA 2000 Type Sector ID of the Cell as in 36.331 ASN.1 definition CellGlobalIdCDMA2000
RTT1X	SectorID_RTT1X_Type
HRPD	SectorID_HRPD_Type

ReverseRateLimit_Type

TTCN-3 Enumerated Type	
Name	ReverseRateLimit_Type
Comment	Table 9.9.6.3-2 of C.S0024; set to the highest data rate that the access terminal is allowed to use on the Reverse Traffic Channel; 10 Reserved values
kbps0	
kbps9_6	
kbps19_2	
kbps38_4	
kbps76_8	
kbps153_6	
resrv1	
resrv2	
resrv3	
resrv4	
resrv5	
resrv6	
resrv7	
resrv8	
resrv9	
resrv10	

PacketApplication_Type

TTCN-3 Enumerated Type	
Name	PacketApplication_Type
Comment	Type of Packet Application
enhMultiFlowPacketApp	
altEnhMultiFlowPacketApp	

ControlChannelRate_Type

TTCN-3 Enumerated Type	
Name	ControlChannelRate_Type
Comment	Determines the MAC configuration for Control Channel
macIndex2	
macIndex3	

CDMA2000_CellId_Type

TTCN-3 Enumerated Type	
Name	CDMA2000_CellId_Type
Comment	
cdma2000_Cell_Non Specific	
cdma2000_Cell15	HRDP Cell
cdma2000_Cell16	HRDP Cell
cdma2000_Cell17	HRDP Cell
cdma2000_Cell18	HRDP Cell
cdma2000_Cell19	RTT1X Cell
cdma2000_Cell20	RTT1X Cell
cdma2000_Cell21	RTT1X Cell
cdma2000_Cell22	RTT1X Cell

SearchWindowSizeRecord_Type

TTCN-3 Record Type			
Name	SearchWindowSizeRecord_Type		
Comment			
SearchWindow_Active	SearchWindowSize_Type		Search Window for Active Cells
SearchWindow_Neighbor	SearchWindowSize_Type		Search Window for Neighbor Cells
SearchWindow_Remaining	SearchWindowSize_Type		Search Window for Rest Cells

D.8 HRPD_MsgTypeDefs

HRPD_MsgTypeDefs: Basic Type Definitions

TTCN-3 Basic Types		
MessageId_Type	B8_Type	
TransactionId_Type	B8_Type	

D.9 CommonDefs

CommonDefs: Constant Definitions

TTCN-3 Basic Types			
tsc_UInt8Max	integer	255	
tsc_UInt16Max	integer	65535	
tsc_UInt32Max	integer	4294967295	

CommonDefs: Basic Type Definitions

TTCN-3 Basic Types		
B1_Type	bitstring length(1)	
B2_Type	bitstring length(2)	
B3_Type	bitstring length(3)	
B4_Type	bitstring length(4)	
B5_Type	bitstring length(5)	
B6_Type	bitstring length(6)	
B7_Type	bitstring length(7)	
B7_15_Type	bitstring length(7..15)	NOTE: length restriction can only be a range but not two distinct lengths
B8_Type	bitstring length(8)	
B10_Type	bitstring length(10)	
B11_Type	bitstring length(11)	
B12_Type	bitstring length(12)	
B15_Type	bitstring length(15)	
B16_Type	bitstring length(16)	
B24_Type	bitstring length(24)	
B32_Type	bitstring length(32)	
B64_Type	bitstring length(64)	
B128_Type	bitstring length(128)	
B256_Type	bitstring length(256)	
B128_Key_Type	B128_Type	128 bit security key
O3_Type	octetstring length(3)	
O4_Type	octetstring length(4)	
O8_Type	octetstring length(8)	
O13_Type	octetstring length(14)	
Null_Type	boolean (true)	dummy type for 'typeless' fields in unions
Dummy_Type	boolean (true)	dummy type for temporary purposes only
UInt16_Type	integer (0 .. tsc UInt16Max)	
UInt32_Type	integer (0 .. tsc UInt32Max)	
Char1_Type	charstring length (1)	

D.10 References to TTCN-3

References to TTCN-3		
EUTRA_ASP_TypeDefs	CommonEUTRA_Defs/EUTRA_ASP_TypeDefs.ttcn	Rev 4308
EUTRA_ASP_DrbDefs	CommonEUTRA_Defs/EUTRA_ASP_DrbDefs.ttcn	Rev 4092
IP_ASP_TypeDefs	IP_PTC/IP_ASP_TypeDefs.ttcn	Rev 4092
NasEmu_AspTypes	NasEmulation/NasEmu_AspTypes.ttcn	Rev 1800
EUTRA_CommonDefs	CommonEUTRA_Defs/EUTRA_CommonDefs.ttcn	Rev 4214
CDMA2000_ASP_TypeDefs	C2K/CDMA2000_ASP_TypeDefs.ttcn	Rev 4258
CDMA2000_CommonDefs	C2K/CDMA2000_CommonDefs.ttcn	Rev 4258
HRPD_MsgTypeDefs	C2K/HRPD_MsgTypeDefs.ttcn	Rev 3724
CommonDefs	Common/CommonDefs.ttcn	Rev 4263

Annex E (informative): Change history

Change history								
Date	TSG #	TSG Doc.	CR	Rev	Subject/Comment	Old	New	
2008-05					Creation of draft TS		0.0.2	
2008-08					Add test models	0.0.2	0.1.0	
2008-10					Add ASPs and state model	0.1.1	0.3.0	
2008-12					Add details of UL/DL scheduling and cell configurations	0.4.0	0.5.0	
2009-02					Change naming conventions, add more design considerations	0.5.0	1.0.0	
2009-03	RAN#43	RP-090271			Presentation for Information	1.0.0	1.0.2	
2009-03					Add Upper tester interface	1.0.2	1.1.0	
2009-04					Improved DL scheduling	1.1.0	1.2.0	
2009-06					Add normative annex D for ASP definitions	1.2.0	1.3.0	
2009-08					General update	1.3.0	1.4.0	
2009-09					Style /format check from ETSI EditHelp	1.4.0	1.4.1	
2009-09	RAN#45	RP-090753			Presentation of v2.0.0 for approval	1.4.1	2.0.0	
2009-09					Updated to 8.0.0 with no change	2.0.0	8.0.0	
2009-12	RAN#46	RP-091122	0001	-	LTE ASP clarifications and update	8.0.0	8.1.0	
2009-12	RAN#46	RP-091119	0002	-	CR to 36.523-3: Add new e-mail agreed LTE TTCN test cases in the TC list of Annex A and update Annex D	8.0.0	8.1.0	
2009-12	RAN#46	R5s090180	0003	-	Resubmission of GCF WI 81 LTE RRC test case 8.1.2.1 on wk42 TTCN	8.0.0	8.1.0	
2009-12	RAN#46	R5s090139	0004	-	Addition of GCF WI 81 LTE RRC test case 8.1.1.1	8.0.0	8.1.0	
2009-12	RAN#46	R5s090144	0005	-	Addition of GCF WI 81 LTE RRC test case 8.1.3.1	8.0.0	8.1.0	
2009-12	RAN#46	R5s090163	0006	-	Addition of GCF WI 82 EUTRA NAS test case 9.2.1.1.2	8.0.0	8.1.0	
2009-12	RAN#46	R5s090141	0007	-	Addition of GCF WI 81 LTE MAC test case 7.1.1.1	8.0.0	8.1.0	
2009-12	RAN#46	R5s090160	0008	-	Addition of GCF WI 81 EUTRA RLC test case 7.2.3.1	8.0.0	8.1.0	
2009-12	RAN#46	R5s090156	0009	-	Addition of GCF WI 81 EUTRA RLC test case 7.2.3.2	8.0.0	8.1.0	
2009-12	RAN#46	R5s090154	0010	-	Addition of GCF WI 82 EPC test case 9.2.2.2.1	8.0.0	8.1.0	
2009-12	RAN#46	R5s090165	0011	-	Addition of GCF WI 81 EUTRA RLC test case 7.2.3.3	8.0.0	8.1.0	
2009-12	RAN#46	R5s090171	0012	-	Addition of GCF WI 81 EUTRA MAC test case 7.1.3.3	8.0.0	8.1.0	
2009-12	RAN#46	R5s090176	0013	-	Addition of GCF WI 82 EPC test case 9.3.2.1	8.0.0	8.1.0	
2009-12	RAN#46	R5s090174	0014	-	Addition of GCF WI 81 EUTRA MAC test case 7.1.3.7	8.0.0	8.1.0	
2009-12	RAN#46	R5s090178	0015	-	Addition of GCF WI 81 EUTRA MAC test case 7.1.3.6	8.0.0	8.1.0	
2009-12	RAN#46	R5s090198	0016	-	Addition of GCF WI 81 EUTRA PDCP test case 7.3.3.1	8.0.0	8.1.0	
2009-12	RAN#46	R5s090204	0017	-	Addition of GCF WI 81 EUTRA PDCP test case 7.3.3.4	8.0.0	8.1.0	
2009-12	RAN#46	R5s090202	0018	-	Addition of GCF WI 81 EUTRA PDCP test case 7.3.3.3	8.0.0	8.1.0	
2009-12	RAN#46	R5s090200	0019	-	Addition of GCF WI 81 EUTRA PDCP test case 7.3.3.2	8.0.0	8.1.0	
2009-12	RAN#46	R5s090196	0020	-	Addition of GCF WI 81 EUTRA PDCP test case 7.3.4.2	8.0.0	8.1.0	
2009-12	RAN#46	R5s090194	0021	-	Addition of GCF WI 81 EUTRA PDCP test case 7.3.4.1	8.0.0	8.1.0	
2010-03	RAN#47	R5-100103	0090	-	An additional option for IP address allocation in test cases using UE test mode	8.1.0	8.2.0	
2010-03	RAN#47	R5-101049	0081	-	Add a new clause for postamble in a UTRA/GERAN cell	8.1.0	8.2.0	
2010-03	RAN#47	R5-101050	0082	2	Routine maintenance of TS 36.523-3	8.1.0	8.2.0	
2010-03	RAN#47	RP-100147	0022	1	CR to 36.523-3: Add new verified and e-mail agreed TTCN test cases in the TC lists in 36.523-3 (prose), Annex A	8.1.0	8.2.0	
2010-03	RAN#47	R5s090209	0076	-	Addition of GCF WI 81 LTE Idle Mode test case 6.1.2.2 on wk42 TTCN	8.1.0	8.2.0	
2010-03	RAN#47	R5s090210	0075	-	Addition of GCF WI 82 EPC test case 9.1.3.1	8.1.0	8.2.0	
2010-03	RAN#47	R5s090212	0078	-	Addition of GCF WI 82 EPC test case 9.2.3.1.5	8.1.0	8.2.0	
2010-03	RAN#47	R5s090214	0077	-	Addition of GCF WI 81 EUTRA MAC test case 7.1.4.15	8.1.0	8.2.0	
2010-03	RAN#47	R5s090217	0072	-	Addition of GCF WI 81 EUTRA RLC test case 7.2.3.5	8.1.0	8.2.0	
2010-03	RAN#47	R5s090219	0073	-	Addition of GCF WI 81 EUTRA RLC test case 7.2.3.17	8.1.0	8.2.0	
2010-03	RAN#47	R5s090222	0074	-	Addition of GCF WI 81 EUTRA RLC test case 7.2.3.20	8.1.0	8.2.0	
2010-03	RAN#47	R5s090306	0045	-	Addition of GCF WI 81 LTE RRC test case 8.5.4.1	8.1.0	8.2.0	
2010-03	RAN#47	R5s090310	0038	-	Addition of GCF WI-82 EPC test case 9.1.2.1	8.1.0	8.2.0	

2010-03	RAN#47	R5s090314	0030	-	Addition of GCF WI 81 EUTRA RLC test case 7.2.2.1	8.1.0	8.2.0
2010-03	RAN#47	R5s090316	0049	-	Addition of GCF WI 81 EUTRA RLC test case 7.2.2.2	8.1.0	8.2.0
2010-03	RAN#47	R5s090318	0042	-	Addition of GCF WI 81 EUTRA RLC test case 7.2.2.3	8.1.0	8.2.0
2010-03	RAN#47	R5s090320	0041	-	Addition of GCF WI 81 EUTRA RLC test case 7.2.2.4	8.1.0	8.2.0
2010-03	RAN#47	R5s090322	0028	-	Correction to test step f_GetPDNAddress	8.1.0	8.2.0
2010-03	RAN#47	R5s090331	0024	-	Resubmission of GCF WI-81 LTE RRC test case 8.2.2.1 on ATS_wk47	8.1.0	8.2.0
2010-03	RAN#47	R5s090333	0025	-	Resubmission of GCF WI-81 LTE RRC test case 8.2.2.2 on ATS_wk47	8.1.0	8.2.0
2010-03	RAN#47	R5s090335	0023	-	Resubmission of GCF WI-81 LTE RRC test case 8.2.3.1 on ATS_wk47	8.1.0	8.2.0
2010-03	RAN#47	R5s090337	0027	-	Correction to EUTRA MAC test cases 7.1.3.3 and 7.1.3.7	8.1.0	8.2.0
2010-03	RAN#47	R5s090340	0040	-	Addition of GCF WI 81 EUTRA RLC test case 7.2.2.5.1	8.1.0	8.2.0
2010-03	RAN#47	R5s090342	0039	-	Addition of GCF WI 81 EUTRA RLC test case 7.2.2.5.2	8.1.0	8.2.0
2010-03	RAN#47	R5s090345	0043	-	Addition of GCF WI 81 EUTRA MAC test case 7.1.1.2	8.1.0	8.2.0
2010-03	RAN#47	R5s090347	0048	-	Addition of GCF WI 81 EUTRA MAC test case 7.1.2.2	8.1.0	8.2.0
2010-03	RAN#47	R5s090349	0033	-	Addition of GCF WI 81 EUTRA MAC test case 7.1.2.3	8.1.0	8.2.0
2010-03	RAN#47	R5s090351	0034	-	Addition of GCF WI 81 EUTRA MAC test case 7.1.2.4	8.1.0	8.2.0
2010-03	RAN#47	R5s090353	0035	-	Addition of GCF WI 81 EUTRA MAC test case 7.1.2.5	8.1.0	8.2.0
2010-03	RAN#47	R5s090355	0047	-	Addition of GCF WI 81 EUTRA MAC test case 7.1.2.7	8.1.0	8.2.0
2010-03	RAN#47	R5s090357	0032	-	Addition of GCF WI 81 EUTRA MAC test case 7.1.2.9	8.1.0	8.2.0
2010-03	RAN#47	R5s090359	0050	-	Addition of GCF WI 81 EUTRA MAC test case 7.1.4.4	8.1.0	8.2.0
2010-03	RAN#47	R5s090361	0026	-	Correction of GCF WI 81 EUTRA RLC test case 7.2.3.2	8.1.0	8.2.0
2010-03	RAN#47	R5s090362	0031	-	Addition of GCF WI 81 EUTRA MAC test case 7.1.4.13	8.1.0	8.2.0
2010-03	RAN#47	R5s090364	0054	-	Addition of GCF WI 81 EUTRA MAC test case 7.1.3.1	8.1.0	8.2.0
2010-03	RAN#47	R5s090366	0046	-	Addition of GCF WI 82 EPC test case 9.3.1.1	8.1.0	8.2.0
2010-03	RAN#47	R5s090368	0029	-	Addition of GCF WI 81 EUTRA MAC test case 7.1.4.5	8.1.0	8.2.0
2010-03	RAN#47	R5s090373	0037	-	TTCN corrections from LTE ATS_wk51 regression testing	8.1.0	8.2.0
2010-03	RAN#47	R5s090375	0056	-	Addition of GCF WI 81 EUTRA RLC test case 7.2.3.8	8.1.0	8.2.0
2010-03	RAN#47	R5s090377	0055	-	Addition of GCF WI 81 EUTRA MAC test case 7.1.4.6	8.1.0	8.2.0
2010-03	RAN#47	R5s090379	0036	-	Correction to EPC test case 9.2.3.1.5	8.1.0	8.2.0
2010-03	RAN#47	R5s100001	0044	-	Correction to EUTRA RLC test case 7.2.3.17	8.1.0	8.2.0
2010-03	RAN#47	R5s100002	0052	-	Addition of GCF WI 81 EUTRA RLC test case 7.2.3.14	8.1.0	8.2.0
2010-03	RAN#47	R5s100004	0059	-	Addition of GCF WI 81 EUTRA RLC test case 7.2.2.6	8.1.0	8.2.0
2010-03	RAN#47	R5s100006	0050	-	Addition of GCF WI 81 EUTRA RLC test case 7.2.2.7	8.1.0	8.2.0
2010-03	RAN#47	R5s100008	0056	-	Addition of GCF WI 82 LTE NAS test case 9.2.1.1.1	8.1.0	8.2.0
2010-03	RAN#47	R5s100012	0053	-	Addition of GCF WI 81 EUTRA PDCP test case 7.3.1.1	8.1.0	8.2.0
2010-03	RAN#47	R5s100014	0051	-	Addition of GCF WI 81 EUTRA RLC test case 7.2.2.9	8.1.0	8.2.0
2010-03	RAN#47	R5s100016	0058	-	Addition of GCF WI 81 EUTRA RLC test case 7.1.4.1	8.1.0	8.2.0

2010-03	RAN#47	R5s100018	0053	-	Addition of GCF WI 81 EUTRA RLC test case 7.2.3.4	8.1.0	8.2.0
2010-03	RAN#47	R5s100020	0052	-	Summary of regression errors in wk51 LTE ATS	8.1.0	8.2.0
2010-03	RAN#47	R5s100021	0051	-	Addition of GCF WI 81 EUTRA MAC test case 7.1.3.4	8.1.0	8.2.0
2010-03	RAN#47	R5s100024	0054	-	Addition of GCF WI-082 EPC test case 13.1.1	8.1.0	8.2.0
2010-03	RAN#47	R5s100029	0057	-	Addition of GCF WI 81 EUTRA Idle Mode test case 6.1.2.4	8.1.0	8.2.0
2010-03	RAN#47	R5s100031	0058	-	Addition of GCF WI 81 EUTRA RLC test case 7.2.3.10	8.1.0	8.2.0
2010-03	RAN#47	R5s100039	0055	-	Addition of GCF WI 81 EUTRA RLC test case 7.2.3.18	8.1.0	8.2.0
2010-03	RAN#47	R5s100041	0057	-	Addition of GCF WI 81 EUTRA MAC test case 7.1.4.7	8.1.0	8.2.0
2010-03	RAN#47	R5s100043	0070	-	Addition of GCF WI 81 LTE MAC test case 7.1.4.10	8.1.0	8.2.0
2010-03	RAN#47	R5s100047	0071	-	Corrections of GCF WI 81 EUTRA RLC test cases 7.2.3.1, 7.2.3.4, and 7.2.3.5.	8.1.0	8.2.0
2010-03	RAN#47	R5s100049	0059	-	Regression CR for LTE wk03 ATS	8.1.0	8.2.0
2010-03	RAN#47	R5s100053	0079	-	Correction of GCF WI 81 EUTRA RLC test case 7.2.3.8	8.1.0	8.2.0
2010-03	RAN#47	R5s100054	0080	-	Addition of GCF WI 81 EUTRA RLC test case 7.2.3.15	8.1.0	8.2.0
2010-06	RAN#48	RP-100515	0084	-	CR to 36.523-3: Add new verified and e-mail agreed TTCN test cases in the TC lists in 36.523-3 (prose), Annex A	8.2.0	8.3.0
2010-06	RAN#48	R5-103845	0141	-	Specification of default UL grant type and exception TC list	8.2.0	8.3.0
2010-06	RAN#48	R5-103846	0142	-	Routine maintenance of TS 36.523-3	8.2.0	8.3.0
2010-06	RAN#48	R5-103847	0143	-	Align the postambles with the new specified UTRA test end states and UE attach implementation capabilities	8.2.0	8.3.0
2010-06	RAN#48	R5s100057	0085	-	Addition of GCF WI-081 RRC test case 8.2.1.1	8.2.0	8.3.0
2010-06	RAN#48	R5s100065	0086	-	Correction of GCF WI 81 EUTRA RLC test case 7.2.2.5.2	8.2.0	8.3.0
2010-06	RAN#48	R5s100068	0092	-	Regression CR for LTE wk07 ATS	8.2.0	8.3.0
2010-06	RAN#48	R5s100072	0091	-	Correction to EPC test case 9.2.2.2.1	8.2.0	8.3.0
2010-06	RAN#48	R5s100073	0090	-	Correction to LTE MAC test case 7.1.2.3 and 7.1.4.5	8.2.0	8.3.0
2010-06	RAN#48	R5s100074	0087	-	Addition of GCF WI 81 EUTRA MAC test case 7.1.3.5	8.2.0	8.3.0
2010-06	RAN#48	R5s100076	0089	-	Corrections to GCF WI-81 EUTRA RLC test cases 7.2.2.1, 7.2.2.3 and 7.2.2.5.1.	8.2.0	8.3.0
2010-06	RAN#48	R5s100077	0088	-	Correction to 'EUTRA_NASSteps.ttcn' module (here: APN IE)	8.2.0	8.3.0
2010-06	RAN#48	R5s100078	0113	-	Addition of GCF WI 81 EUTRA RLC test case 7.2.2.8	8.2.0	8.3.0
2010-06	RAN#48	R5s100080	0112	-	Addition of GCF WI 81 EUTRA NAS test case 7.2.3.16	8.2.0	8.3.0
2010-06	RAN#48	R5s100082	0109	-	Addition of GCF WI 81 EUTRA PDCP test case 7.3.1.2	8.2.0	8.3.0
2010-06	RAN#48	R5s100086	0108	-	Addition of GCF WI 82 EPC test case 9.1.2.4	8.2.0	8.3.0
2010-06	RAN#48	R5s100088	0107	-	Addition of GCF WI 82 EPC test case 9.1.2.5	8.2.0	8.3.0
2010-06	RAN#48	R5s100090	0106	-	Addition of GCF WI 82 EPC test case 9.2.3.1.8	8.2.0	8.3.0
2010-06	RAN#48	R5s100092	0110	-	Addition of GCF WI 82 EPC test case 9.1.4.2	8.2.0	8.3.0
2010-06	RAN#48	R5s100094	0105	-	Addition of GCF WI 82 EPC test case 9.3.1.7a	8.2.0	8.3.0
2010-06	RAN#48	R5s100096	0104	-	Addition of GCF WI 82 EPC test case 9.3.1.7	8.2.0	8.3.0
2010-06	RAN#48	R5s100098	0111	-	Addition of GCF WI 82 EPC test case 9.1.3.2	8.2.0	8.3.0
2010-06	RAN#48	R5s100100	0093	-	Addition of GCF WI 81 EUTRA RAB test case 12.2.1	8.2.0	8.3.0

2010-06	RAN#48	R5s100102	0103	-	Addition of GCF WI 81 EUTRA MAC test case 7.1.4.16	8.2.0	8.3.0
2010-06	RAN#48	R5s100104	0099	-	Addition of GCF WI 81 EUTRA RLC test case 7.2.2.10	8.2.0	8.3.0
2010-06	RAN#48	R5s100106	0102	-	Addition of GCF WI -081 test case 8.2.1.3	8.2.0	8.3.0
2010-06	RAN#48	R5s100109	0131	-	Addition of GCF WI-082 EUTRA EPS test case 9.4.1	8.2.0	8.3.0
2010-06	RAN#48	R5s100111	0101	-	Addition of GCF WI 82 EPC NAS test case 9.4.3	8.2.0	8.3.0
2010-06	RAN#48	R5s100113	0100	-	Addition of GCF WI 82 EPC test case 9.4.4	8.2.0	8.3.0
2010-06	RAN#48	R5s100116	0094	-	Regression CR for LTE wk11 ATS	8.2.0	8.3.0
2010-06	RAN#48	R5s100117	0098	-	Addition of GCF WI 82 EPC test case 9.4.2	8.2.0	8.3.0
2010-06	RAN#48	R5s100127	0097	-	Resubmission of GCF WI 82 EPC test case 9.1.2.3	8.2.0	8.3.0
2010-06	RAN#48	R5s100130	0095	-	Resubmission of GCF WI 81 EUTRA MAC test case 7.1.4.8	8.2.0	8.3.0
2010-06	RAN#48	R5s100132	0096	-	Addition of GCF WI 82 EPC test case 9.2.2.1.6	8.2.0	8.3.0
2010-06	RAN#48	R5s100135	0136	-	Baseline upgrade to December-09 Rel-8	8.2.0	8.3.0
2010-06	RAN#48	R5s100136	0130	-	Correction to the test step f_TestcasesL2Testcase	8.2.0	8.3.0
2010-06	RAN#48	R5s100137	0129	-	Correction to PDCCH candidate selection based on channel bandwidth under test	8.2.0	8.3.0
2010-06	RAN#48	R5s100138	0127	-	Addition of GCF WI-081 MAC test case 7.1.2.1	8.2.0	8.3.0
2010-06	RAN#48	R5s100140	0128	-	Regression CR for LTE/SAE ATS_10wk11	8.2.0	8.3.0
2010-06	RAN#48	R5s100141	0125	-	Correction to GCF WI 81 EUTRA MAC test case 7.1.3.5	8.2.0	8.3.0
2010-06	RAN#48	R5s100142	0126	-	Correction to EUTRA RLC test case 7.2.3.10	8.2.0	8.3.0
2010-06	RAN#48	R5s100143	0118	-	Addition of GCF WI 81 EUTRA RLC test case 7.2.3.9	8.2.0	8.3.0
2010-06	RAN#48	R5s100145	0119	-	Addition of GCF WI 81 EUTRA RLC test case 7.2.3.13	8.2.0	8.3.0
2010-06	RAN#48	R5s100147	0122	-	Addition of GCF WI 81 EUTRA PDCP test case 7.3.6.1	8.2.0	8.3.0
2010-06	RAN#48	R5s100149	0120	-	Addition of GCF WI 81 EUTRA RRC test case 8.3.1.1	8.2.0	8.3.0
2010-06	RAN#48	R5s100151	0121	-	Addition of GCF WI 81 EUTRA RRC test case 8.5.1.5	8.2.0	8.3.0
2010-06	RAN#48	R5s100153	0123	-	Addition of GCF WI 82 EPC EMM test case 9.2.2.1.1	8.2.0	8.3.0
2010-06	RAN#48	R5s100155	0117	-	Addition of GCF WI 81 EUTRA MAC test case 7.1.7.1.1	8.2.0	8.3.0
2010-06	RAN#48	R5s100157	0116	-	Addition of GCF WI 81 EUTRA MAC test case 7.1.7.1.2	8.2.0	8.3.0
2010-06	RAN#48	R5s100159	0114	-	Addition of GCF WI 81 EUTRA MAC test case 7.1.7.1.3	8.2.0	8.3.0
2010-06	RAN#48	R5s100161	0115	-	Addition of GCF WI 81 EUTRA MAC test case 7.1.7.1.4	8.2.0	8.3.0
2010-06	RAN#48	R5s100163	0124	-	Correction to MME Group ID to set MSB to 1	8.2.0	8.3.0
2010-06	RAN#48	R5s100169	0132	-	Correction of GCF WI-082 EPC test cases 9.1.2.3, 9.1.2.4 and 9.1.2.5	8.2.0	8.3.0
2010-06	RAN#48	R5s100172	0133	-	Further regression CR for LTE/SAE 10wk11 ATS	8.2.0	8.3.0
2010-06	RAN#48	R5s100176	0135	-	Addition of GCF WI 81 EUTRA RRC test case 8.3.1.2	8.2.0	8.3.0
2010-06	RAN#48	R5s100178	0137	-	Addition of GCF WI 81 EUTRA RRC test case 8.2.4.3	8.2.0	8.3.0
2010-06	RAN#48	R5s100180	0138	-	Addition of GCF WI 81 EUTRA RLC test case 7.2.2.11	8.2.0	8.3.0
2010-06	RAN#48	R5s100182	0139	-	Regression CR for LTE wk11 ATS	8.2.0	8.3.0
2010-06	RAN#48	R5s100183	0134	-	Corrections to EUTRA RLC and PDCP test cases	8.2.0	8.3.0
2010-09	RAN#49	R5-104796	0145	-	Routine maintenance of TS 36.523-3	8.3.0	8.4.0

2010-09	RAN#49	R5-104197	0144	-	Addition of MMI command 'DISABLE EPS CAPABILITY'	8.3.0	8.4.0
2010-09	RAN#49	RP-100826	0146	-	CR to 36.523-3: Add new verified and e-mail agreed TTCN test cases in the TC lists in 36.523-3 (prose), Annex A	8.3.0	8.4.0
2010-09	-	-	-	-	Updated the lists of approved test cases for FDD and LCR TDD in Annex A to align with TTCN.	8.3.0	8.4.0
2010-09	RAN#49	R5s100198	0175	-	LTE_TDD : Addition of GCF WI 91 EUTRA RRC test case 8.2.3.1	8.3.0	8.4.0
2010-09	RAN#49	R5s100302	0200	-	Regression CR for LTE/SAE iwd_10wk22 ATS	8.3.0	8.4.0
2010-09	RAN#49	R5s100268	0281	-	Addition of GCF WI 81 EUTRA MAC test case 7.1.6.1	8.3.0	8.4.0
2010-09	RAN#49	R5s100298	0206	-	Addition of GCF WI 81 EUTRA PDCP test case 7.3.5.3	8.3.0	8.4.0
2010-09	RAN#49	R5s100260	0187	-	LTE_TDD : Addition of GCF WI 91 EUTRA MAC test case 7.1.1.2	8.3.0	8.4.0
2010-09	RAN#49	R5s100300	0205	-	Correction to EPC test case 9.3.1.1	8.3.0	8.4.0
2010-09	RAN#49	R5s100226	0194	-	LTE_TDD: Addition of GCF WI 91 EUTRA RLC test case 7.2.3.5	8.3.0	8.4.0
2010-09	RAN#49	R5s100274	0155	-	Regression CR for LTE wk17 ATS	8.3.0	8.4.0
2010-09	RAN#49	R5s100249	0191	-	LTE_TDD: Addition of GCF WI 91 EUTRA RLC test case 7.2.2.1	8.3.0	8.4.0
2010-09	RAN#49	R5s100228	0163	-	LTE_TDD : Addition of GCF WI 91 EUTRA RLC test case 7.2.3.17	8.3.0	8.4.0
2010-09	RAN#49	R5s100293	0279	-	Addition of GCF WI 81 EUTRA DRB test case 12.2.2	8.3.0	8.4.0
2010-09	RAN#49	R5s100224	0195	-	LTE_TDD: Addition of GCF WI 81 EUTRA RLC test case 7.2.3.4	8.3.0	8.4.0
2010-09	RAN#49	R5s100270	0280	-	Addition of GCF WI 81 EUTRA MAC test case 7.1.6.2	8.3.0	8.4.0
2010-09	RAN#49	R5s100266	0152	-	Addition of GCF WI 81 EUTRA RLC test case 7.2.3.7	8.3.0	8.4.0
2010-09	RAN#49	R5s100295	0207	-	Addition of GCF WI 82 ESM test case 10.2.1	8.3.0	8.4.0
2010-09	RAN#49	R5s100210	0170	-	LTE_TDD : Addition of GCF WI 91 EUTRA MAC test case 7.1.2.7	8.3.0	8.4.0
2010-09	RAN#49	R5s100287	0182	-	Correction to TFT filter identifier and precedence values	8.3.0	8.4.0
2010-09	RAN#49	R5s100222	0164	-	LTE_TDD : Addition of GCF WI 91 EUTRA RLC test case 7.2.3.3	8.3.0	8.4.0
2010-09	RAN#49	R5s100214	0168	-	LTE_TDD : Addition of GCF WI 91 EUTRA RLC test case 7.2.2.3	8.3.0	8.4.0
2010-09	RAN#49	R5s100189	0150	-	Regression CR for LTE wk17 ATS	8.3.0	8.4.0
2010-09	RAN#49	R5s100220	0165	-	LTE_TDD : Addition of GCF WI 91 EUTRA RLC test case 7.2.3.2	8.3.0	8.4.0
2010-09	RAN#49	R5s100272	0157	-	Corrections to EUTRA MAC test case.	8.3.0	8.4.0
2010-09	RAN#49	R5s100187	0149	-	Addition of GCF WI 81 EUTRA RRC test case 8.3.1.5	8.3.0	8.4.0
2010-09	RAN#49	R5s100273	0156	-	Corrections to EUTRA RLC test case 7.2.2.6 and 7.2.2.10	8.3.0	8.4.0
2010-09	RAN#49	R5s100279	0181	-	Regression CR for LTE wk22 ATS	8.3.0	8.4.0
2010-09	RAN#49	R5s100208	0171	-	LTE_TDD : Addition of GCF WI 91 EUTRA MAC test case 7.1.2.5	8.3.0	8.4.0
2010-09	RAN#49	R5s100256	0154	-	Addition of GCF WI 81 EUTRA RLC test case 7.2.3.21	8.3.0	8.4.0
2010-09	RAN#49	R5s100283	0184	-	Addition of GCF WI 81 EUTRA PDCP test case 7.3.1.3	8.3.0	8.4.0
2010-09	RAN#49	R5s100291	0180	-	Addition of GCF WI 81 EUTRA MAC test case 7.1.2.6	8.3.0	8.4.0
2010-09	RAN#49	R5s100301	0204	-	Correction to EUTRA test case 7.1.4.6	8.3.0	8.4.0
2010-09	RAN#49	R5s100196	0176	-	LTE_TDD: Addition of GCF WI 91 EUTRA RRC test case 8.2.2.2	8.3.0	8.4.0
2010-09	RAN#49	R5s100258	0188	-	LTE_TDD: Addition of GCF WI 91 EUTRA RLC test case 7.2.3.1	8.3.0	8.4.0
2010-09	RAN#49	R5s100234	0160	-	LTE_TDD : Addition of GCF WI 91 EUTRA PDCP test case 7.3.3.3	8.3.0	8.4.0
2010-09	RAN#49	R5s100303	0217	-	Addition of GCF WI 81 EUTRA MAC test case 7.1.7.2.1	8.3.0	8.4.0

2010-09	RAN#49	R5s100285	0220	-	LTE_TDD : Addition of GCF WI 92 EUTRA Multi layer test case 13.1.1	8.3.0	8.4.0
2010-09	RAN#49	R5s100247	0192	-	LTE_TDD: Addition of GCF WI 81 EUTRA PDCP test case 7.3.3.4	8.3.0	8.4.0
2010-09	RAN#49	R5s100238	0158	-	LTE_TDD : Addition of GCF WI 91 EUTRA PDCP test case 7.3.4.2	8.3.0	8.4.0
2010-09	RAN#49	R5s100240	0148	-	Addition of GCF WI 81 EUTRA RRC test case 8.2.4.2	8.3.0	8.4.0
2010-09	RAN#49	R5s100236	0159	-	LTE_TDD : Addition of GCF WI 91 EUTRA PDCP test case 7.3.4.1	8.3.0	8.4.0
2010-09	RAN#49	R5s100262	0186	-	LTE_TDD : Addition of GCF WI 91 EUTRA MAC test case 7.1.3.5	8.3.0	8.4.0
2010-09	RAN#49	R5s100305	0203	-	Addition of GCF WI 81 EUTRA PDCP test case 7.3.5.2	8.3.0	8.4.0
2010-09	RAN#49	R5s100216	0167	-	LTE_TDD : Addition of GCF WI 91 EUTRA RLC test case 7.2.2.4	8.3.0	8.4.0
2010-09	RAN#49	R5s100218	0166	-	LTE_TDD : Addition of GCF WI 91 EUTRA RLC test case 7.2.2.9	8.3.0	8.4.0
2010-09	RAN#49	R5s100264	0153	-	Addition of GCF WI 81 EUTRA RLC test case 7.2.3.6	8.3.0	8.4.0
2010-09	RAN#49	R5s100281	0185	-	Addition of GCF WI 81 EUTRA Idle Mode test case 6.1.2.3	8.3.0	8.4.0
2010-09	RAN#49	R5s100194	0177	-	LTE_TDD: Addition of GCF WI 91 EUTRA RRC test case 8.2.2.1	8.3.0	8.4.0
2010-09	RAN#49	R5s100190	0179	-	LTE_TDD : Addition of GCF WI 91 EUTRA RRC test case 8.1.1.1	8.3.0	8.4.0
2010-09	RAN#49	R5s100202	0173	-	LTE_TDD : Addition of GCF WI 91 EUTRA MAC test case 7.1.1.1	8.3.0	8.4.0
2010-09	RAN#49	R5s100204	0172	-	LTE_TDD : Addition of GCF WI 91 EUTRA MAC test case 7.1.2.2	8.3.0	8.4.0
2010-09	RAN#49	R5s100253	0189	-	LTE_TDD: Addition of GCF WI 91 EUTRA RRC test case 8.1.3.1	8.3.0	8.4.0
2010-09	RAN#49	R5s100251	0190	-	LTE_TDD: Addition of GCF WI 91 EUTRA RLC test case 7.2.2.2	8.3.0	8.4.0
2010-09	RAN#49	R5s100245	0193	-	LTE_TDD: Addition of GCF WI 91 EUTRA PDCP test case 7.3.3.2	8.3.0	8.4.0
2010-09	RAN#49	R5s100200	0174	-	LTE_TDD : Addition of GCF WI 81 EUTRA RRC test case 8.5.4.1	8.3.0	8.4.0
2010-09	RAN#49	R5s100288	0183	-	Addition of GCF WI 82 EPC Multi-layer test case 13.2.1	8.3.0	8.4.0
2010-09	RAN#49	R5s100192	0178	-	LTE_TDD : Addition of GCF WI 91 EUTRA RRC test case 8.1.2.1	8.3.0	8.4.0
2010-09	RAN#49	R5s100230	0162	-	LTE_TDD : Addition of GCF WI 91 EUTRA RLC test case 7.2.3.20	8.3.0	8.4.0
2010-09	RAN#49	R5s100242	0147	-	Addition of GCF WI 81 EUTRA RRC test case 8.2.4.5	8.3.0	8.4.0
2010-09	RAN#49	R5s100307	0202	-	Addition of GCF WI 81 EUTRA PDCP test case 7.3.5.4	8.3.0	8.4.0
2010-09	RAN#49	R5s100309	0201	-	Addition of GCF WI 81 EUTRA PDCP test case 7.3.5.5	8.3.0	8.4.0
2010-09	RAN#49	R5s100311	0197	-	Addition of GCF WI-081 EUTRA RRC test case 8.1.2.5	8.3.0	8.4.0
2010-09	RAN#49	R5s100313	0199	-	Addition of GCF WI 82 ESM test case 10.5.1	8.3.0	8.4.0
2010-09	RAN#49	R5s100317	0198	-	Addition of GCF WI 81 EUTRA RRC test case 8.1.2.7	8.3.0	8.4.0
2010-09	RAN#49	R5s100319	0196	-	Addition of GCF WI 81 EUTRA RRC test case 8.5.1.3	8.3.0	8.4.0
2010-09	RAN#49	R5s100321	0219	-	Correction to EUTRA MAC 7.1.7.1.x test cases	8.3.0	8.4.0
2010-09	RAN#49	R5s100322	0218	-	Addition of GCF WI 82 EPC test case 9.2.1.1.20	8.3.0	8.4.0
2010-09	RAN#49	R5s100324	0216	-	Addition of GCF WI 81 EUTRA RRC test case 8.5.1.1	8.3.0	8.4.0
2010-09	RAN#49	R5s100326	0215	-	Addition of GCF WI 82 EPC test case 10.6.1	8.3.0	8.4.0
2010-09	RAN#49	R5s100329	0211	-	LTE_TDD: Addition of GCF WI 91 EUTRA MAC test case 7.1.2.3	8.3.0	8.4.0
2010-09	RAN#49	R5s100331	0210	-	LTE_TDD: Addition of GCF WI 91 EUTRA MAC test case 7.1.2.9	8.3.0	8.4.0
2010-09	RAN#49	R5s100333	0209	-	LTE_TDD: Addition of GCF WI 91 EUTRA MAC test case 7.1.4.1	8.3.0	8.4.0
2010-09	RAN#49	R5s100335	0244	-	LTE_TDD: Addition of GCF WI 91 EUTRA MAC test case 7.1.7.1.2	8.3.0	8.4.0
2010-09	RAN#49	R5s100337	0243	-	LTE_TDD: Addition of GCF WI 91 EUTRA MAC test case 7.1.7.1.4	8.3.0	8.4.0

2010-09	RAN#49	R5s100339	0208	-	LTE_TDD: Addition of GCF WI 91 EUTRA RLC-UM test case 7.2.2.5.1	8.3.0	8.4.0
2010-09	RAN#49	R5s100341	0212	-	LTE_TDD: Addition of GCF WI 91 EUTRA RLC-UM test case 7.2.2.6	8.3.0	8.4.0
2010-09	RAN#49	R5s100343	0213	-	LTE_TDD: Addition of GCF WI 91 EUTRA RLC test case 7.2.2.7	8.3.0	8.4.0
2010-09	RAN#49	R5s100345	0242	-	LTE_TDD: Addition of GCF WI 91 EUTRA DRB test case 12.2.1	8.3.0	8.4.0
2010-09	RAN#49	R5s100347	0214	-	Correction of GCF WI-081 E-UTRA PDCP test case 7.3.6.1	8.3.0	8.4.0
2010-09	RAN#49	R5s100348	0221	-	Addition of GCF WI-081 E-UTRA RRC test case 8.1.3.4	8.3.0	8.4.0
2010-09	RAN#49	R5s100350	0264	-	Addition of GCF WI-082 EMM test case 9.2.1.1.9	8.3.0	8.4.0
2010-09	RAN#49	R5s100184	0151	-	TTCN Correction to 36.523-3 LTE/SAE NAS definition of LAIList	8.3.0	8.4.0
2010-09	RAN#49	R5s100232	0161	-	LTE_TDD : Addition of GCF WI 91 EUTRA PDCP test case 7.3.3.1	8.3.0	8.4.0
2010-09	RAN#49	R5s100352	0263	-	Addition of GCF WI-082 EMM test case 9.2.1.1.10	8.3.0	8.4.0
2010-09	RAN#49	R5s100354	0233	-	Corrections to EUTRA MAC test case 7.1.3.1	8.3.0	8.4.0
2010-09	RAN#49	R5s100356	0232	-	Corrections to EUTRA Idle Mode Testcases 6.1.2.3	8.3.0	8.4.0
2010-09	RAN#49	R5s100358	0241	-	Addition of GCF WI 82 EPC test case 9.2.1.1.14	8.3.0	8.4.0
2010-09	RAN#49	R5s100360	0286	-	Addition of GCF WI 82 ESM test case 10.3.1	8.3.0	8.4.0
2010-09	RAN#49	R5s100362	0285	-	Addition of GCF WI 82 ESM test case 10.7.1	8.3.0	8.4.0
2010-09	RAN#49	R5s100364	0293	-	Addition of GCF WI 82 ESM test case 10.7.2	8.3.0	8.4.0
2010-09	RAN#49	R5s100366	0240	-	LTE_TDD: Addition of GCF WI 91 EUTRA MAC test case 7.1.3.1	8.3.0	8.4.0
2010-09	RAN#49	R5s100368	0239	-	LTE_TDD: Addition of GCF WI 91 EUTRA MAC test case 7.1.3.3	8.3.0	8.4.0
2010-09	RAN#49	R5s100370	0238	-	LTE_TDD: Addition of GCF WI 91 EUTRA MAC test case 7.1.3.4	8.3.0	8.4.0
2010-09	RAN#49	R5s100372	0237	-	LTE_TDD: Addition of GCF WI 91 EUTRA MAC test case 7.1.3.6	8.3.0	8.4.0
2010-09	RAN#49	R5s100374	0236	-	LTE_TDD: Addition of GCF WI 91 EUTRA MAC test case 7.1.3.7	8.3.0	8.4.0
2010-09	RAN#49	R5s100376	0235	-	LTE_TDD: Addition of GCF WI 91 EUTRA MAC test case 7.1.4.4	8.3.0	8.4.0
2010-09	RAN#49	R5s100378	0234	-	LTE_TDD: Addition of GCF WI 91 EUTRA MAC test case 7.1.4.13	8.3.0	8.4.0
2010-09	RAN#49	R5s100380	0231	-	Corrections to EUTRA EMM Testcases 9.2.1.1.20	8.3.0	8.4.0
2010-09	RAN#49	R5s100381	0227	-	LTE_TDD: Addition of GCF WI 91 EUTRA MAC test case 7.1.2.6	8.3.0	8.4.0
2010-09	RAN#49	R5s100383	0226	-	LTE_TDD: Addition of GCF WI 91 EUTRA RLC test case 7.2.3.18	8.3.0	8.4.0
2010-09	RAN#49	R5s100385	0230	-	Correction to EUTRA DRB test cases 12.2.1, 12.2.2, 12.2.3, 12.2.4	8.3.0	8.4.0
2010-09	RAN#49	R5s100386	0229	-	Correction to GCF WI-081 EUTRA RLC Testcase 7.2.3.10	8.3.0	8.4.0
2010-09	RAN#49	R5s100387	0228	-	Correction to GCF WI-081 EUTRA RLC Testcase 7.2.3.16	8.3.0	8.4.0
2010-09	RAN#49	R5s100388	0224	-	LTE_TDD: Addition of GCF WI 91 EUTRA RLC test case 7.2.2.5.2	8.3.0	8.4.0
2010-09	RAN#49	R5s100390	0223	-	LTE_TDD: Addition of GCF WI 91 EUTRA RRC test case 8.2.1.1	8.3.0	8.4.0
2010-09	RAN#49	R5s100392	0225	-	Correction to the function fl_EUTRA_InitPhysicalCellId	8.3.0	8.4.0
2010-09	RAN#49	R5s100394	0222	-	Addition of GCF WI 82 EPC test case 9.2.3.1.2	8.3.0	8.4.0
2010-09	RAN#49	R5s100398	0262	-	Regression CR for LTE wk26 ATS	8.3.0	8.4.0
2010-09	RAN#49	R5s100400	0300	-	LTE_TDD: Addition of GCF WI 91 EUTRA Idle Mode test case 6.1.2.2	8.3.0	8.4.0
2010-09	RAN#49	R5s100402	0299	-	LTE_TDD: Addition of GCF WI 91 EUTRA PDCP test case 7.3.1.1	8.3.0	8.4.0
2010-09	RAN#49	R5s100405	0253	-	LTE_TDD:Corrections to EUTRA RLC test cases regarding subframe offset calculation for TDD	8.3.0	8.4.0
2010-09	RAN#49	R5s100406	0261	-	LTE_TDD: Addition of GCF WI 91 EUTRA RLC AM test case 7.2.3.6	8.3.0	8.4.0

2010-09	RAN#49	R5s100212	0169	-	LTE_TDD : Addition of GCF WI 91 EUTRA MAC test case 7.1.4.15	8.3.0	8.4.0
2010-09	RAN#49	R5s100408	0260	-	LTE_TDD: Addition of GCF WI 91 EUTRA RLC AM test case 7.2.3.7	8.3.0	8.4.0
2010-09	RAN#49	R5s100412	0259	-	LTE_TDD: Addition of GCF WI 91 EUTRA RLC AM test case 7.2.3.8	8.3.0	8.4.0
2010-09	RAN#49	R5s100414	0258	-	LTE_TDD: Addition of GCF WI 91 EUTRA RLC AM test case 7.2.3.9	8.3.0	8.4.0
2010-09	RAN#49	R5s100416	0257	-	LTE_TDD: Addition of GCF WI 91 EUTRA RLC AM test case 7.2.3.14	8.3.0	8.4.0
2010-09	RAN#49	R5s100418	0256	-	LTE_TDD: Addition of GCF WI 91 EUTRA RLC AM test case 7.2.3.15	8.3.0	8.4.0
2010-09	RAN#49	R5s100420	0278	-	LTE_TDD: Addition of GCF WI 91 EUTRA MAC test case 7.1.4.8	8.3.0	8.4.0
2010-09	RAN#49	R5s100422	0277	-	LTE_TDD: Addition of GCF WI 91 EUTRA MAC test case 7.1.7.1.1	8.3.0	8.4.0
2010-09	RAN#49	R5s100424	0275	-	LTE_TDD: Addition of GCF WI 91 EUTRA RLC UM test case 7.2.2.8	8.3.0	8.4.0
2010-09	RAN#49	R5s100426	0274	-	LTE_TDD: Addition of GCF WI 91 EUTRA RLC AM test case 7.2.3.13	8.3.0	8.4.0
2010-09	RAN#49	R5s100430	0289	-	LTE_TDD: Addition of GCF WI 91 EUTRA RLC AM test case 7.2.3.21	8.3.0	8.4.0
2010-09	RAN#49	R5s100432	0273	-	LTE_TDD: Addition of GCF WI 91 EUTRA PDCP test case 7.3.1.2	8.3.0	8.4.0
2010-09	RAN#49	R5s100434	0272	-	LTE_TDD: Addition of GCF WI 91 EUTRA PDCP test case 7.3.6.1	8.3.0	8.4.0
2010-09	RAN#49	R5s100436	0271	-	LTE_TDD: Addition of GCF WI 91 EUTRA RRC test case 8.2.1.3	8.3.0	8.4.0
2010-09	RAN#49	R5s100438	0270	-	LTE_TDD: Addition of GCF WI 91 EUTRA RRC test case 8.3.1.1	8.3.0	8.4.0
2010-09	RAN#49	R5s100440	0269	-	LTE_TDD: Addition of GCF WI 91 EUTRA RRC test case 8.3.1.2	8.3.0	8.4.0
2010-09	RAN#49	R5s100442	0268	-	LTE_TDD: Addition of GCF WI 91 EUTRA RRC test case 8.5.1.5	8.3.0	8.4.0
2010-09	RAN#49	R5s100444	0267	-	LTE_TDD: Addition of GCF WI 91 EUTRA DRB test case 12.2.2	8.3.0	8.4.0
2010-09	RAN#49	R5s100446	0276	-	LTE_TDD: Addition of GCF WI 91 EUTRA MAC test case 7.1.7.2.1	8.3.0	8.4.0
2010-09	RAN#49	R5s100457	0255	-	Correction of GCF WI-081 E-UTRA MAC test case 7.1.2.4	8.3.0	8.4.0
2010-09	RAN#49	R5s100458	0254	-	Correction of GCF WI-081 E-UTRA MAC test case 7.1.2.7	8.3.0	8.4.0
2010-09	RAN#49	R5s100459	0250	-	Corrections to GCF WI-081EUTRA RRC Testcase 8.5.1.1	8.3.0	8.4.0
2010-09	RAN#49	R5s100461	0249	-	Corrections to GCF WI-082 EUTRA ESM Testcase 10.6.1	8.3.0	8.4.0
2010-09	RAN#49	R5s100462	0252	-	Correction of GCF WI-081 E-UTRA MAC test case 7.1.3.1	8.3.0	8.4.0
2010-09	RAN#49	R5s100463	0251	-	Correction of GCF WI-081 E-UTRA MAC test case 7.1.3.4	8.3.0	8.4.0
2010-09	RAN#49	R5s100464	0288	-	Addition of GCF WI 82 ESM test case 10.4.1	8.3.0	8.4.0
2010-09	RAN#49	R5s100466	0247	-	Regression CR for LTE wk26 ATS	8.3.0	8.4.0
2010-09	RAN#49	R5s100468	0248	-	Corrections to GCF WI-081EUTRA RLC Testcase 7.2.3.4	8.3.0	8.4.0
2010-09	RAN#49	R5s100469	0265	-	Corrections to GCF WI-081EUTRA DRB Testcase 12.2.1 and 12.2.2	8.3.0	8.4.0
2010-09	RAN#49	R5s100472	0287	-	LTE_TDD: Addition of GCF WI 91 EUTRA RLC test case 7.2.2.11	8.3.0	8.4.0
2010-09	RAN#49	R5s100475	0266	-	Addition of GCF WI 81 EUTRA Idle Mode test case 6.1.2.6	8.3.0	8.4.0
2010-09	RAN#49	R5s100477	0298	-	Addition of GCF WI-081 E-UTRA RRC test case 8.2.4.6	8.3.0	8.4.0
2010-09	RAN#49	R5s100479	0246	-	Corrections to GCF WI-082 EUTRA ESM Testcase 10.6.1	8.3.0	8.4.0
2010-09	RAN#49	R5s100485	0245	-	Regression CR for LTE/SAE 10wk26 ATS [Revision of R5s100485]	8.3.0	8.4.0
2010-09	RAN#49	R5s100487	0284	-	Addition of GCF WI 82 EMM test case 9.2.3.1.1	8.3.0	8.4.0
2010-09	RAN#49	R5s100489	0283	-	LTE_TDD: Addition of GCF WI 91 EUTRA PDCP test case 7.3.1.3	8.3.0	8.4.0
2010-09	RAN#49	R5s100491	0282	-	Addition of GCF WI-081 E-UTRA RRC test case 8.3.1.8	8.3.0	8.4.0
2010-09	RAN#49	R5s100495	0290	-	Addition of GCF WI-081 E-UTRA RRC test case 8.3.1.3	8.3.0	8.4.0

2010-09	RAN#49	R5s100496	0292	-	Addition of GCF WI 81 EUTRA RRC test case 8.2.4.1	8.3.0	8.4.0
2010-09	RAN#49	R5s100498	0291	-	Addition of GCF WI 81 EUTRA RRC test case 8.2.4.7	8.3.0	8.4.0
2010-09	RAN#49	R5s100500	0297	-	Addition of GCF WI 81 EUTRA IDLE MODE test case 6.1.2.8	8.3.0	8.4.0
2010-09	RAN#49	R5s100503	0295	-	Addition of GCF WI-081 E-UTRA Idle Mode test case 6.1.2.11	8.3.0	8.4.0
2010-09	RAN#49	R5s100505	0294	-	Addition of GCF WI-081 E-UTRA Idle Mode test case 6.1.2.15	8.3.0	8.4.0
2010-09	RAN#49	R5s100507	0296	-	Addition of GCF WI 81 EUTRA IDLE MODE test case 6.1.2.9	8.3.0	8.4.0
2010-12	RAN#50	R5-106578	0301	-	Clarification on cell power change time	8.4.0	8.5.0
2010-12	RAN#50	R5-106675	0302	-	LTE test model updates	8.4.0	8.5.0
2010-12	RAN#50	RP-101151	0303	-	CR to 36.523-3: Add new verified and e-mail agreed TTCN test cases in the TC lists in 36.523-3 (prose), Annex A	8.4.0	8.5.0
2010-12	RAN#50	R5s100399	0307	-	Corrections to EUTRA RLC test case 7.2.3.2, 7.2.3.5, 7.2.3.18, 7.2.3.10	8.4.0	8.5.0
2010-12	RAN#50	R5s100448	0381	-	LTE_TDD: Addition of GCF WI 91 EUTRA Idle Mode test case 6.1.2.4	8.4.0	8.5.0
2010-12	RAN#50	R5s100450	0380	-	LTE_TDD: Addition of GCF WI 91 EUTRA MAC test case 7.1.2.1	8.4.0	8.5.0
2010-12	RAN#50	R5s100454	0379	-	LTE_TDD: Addition of GCF WI 92 EUTRA Multi-layer test case 13.2.1	8.4.0	8.5.0
2010-12	RAN#50	R5s100470	0305	-	Addition of GCF WI 82 ESM test case 10.8.1	8.4.0	8.5.0
2010-12	RAN#50	R5s100473	0309	-	Addition of GCF WI 81 EUTRA MAC test case 7.1.4.3	8.4.0	8.5.0
2010-12	RAN#50	R5s100493	0306	-	Addition of GCF WI-081 E-UTRA RRC test case 8.3.1.9	8.4.0	8.5.0
2010-12	RAN#50	R5s100513	0304	-	LTE_TDD: Correction to f_EUTRA_SS_ConfigureActiveCell to configure Tcell and sfn offset	8.4.0	8.5.0
2010-12	RAN#50	R5s100515	0320	-	Correction to GCF WI-081 E-UTRA RRC test case 8.2.4.5	8.4.0	8.5.0
2010-12	RAN#50	R5s100516	0319	-	Addition of GCF WI 81 EUTRA RRC test case 8.3.1.10	8.4.0	8.5.0
2010-12	RAN#50	R5s100520	0318	-	Regression CR for LTE wk33 ATS	8.4.0	8.5.0
2010-12	RAN#50	R5s100522	0308	-	Addition of GCF WI 81 EUTRA MAC test case 7.1.4.11	8.4.0	8.5.0
2010-12	RAN#50	R5s100524	0316	-	Correction to GCF WI-081 E-UTRA RRC test cases 8.2.4.x	8.4.0	8.5.0
2010-12	RAN#50	R5s100525	0317	-	Addition of GCF WI 81 EUTRA MAC test case 7.1.2.8	8.4.0	8.5.0
2010-12	RAN#50	R5s100527	0315	-	Addition of GCF WI 81 EUTRA Idle Mode test case 6.1.2.7	8.4.0	8.5.0
2010-12	RAN#50	R5s100529	0314	-	Addition of GCF WI 81 EUTRA MAC test case 7.1.4.12	8.4.0	8.5.0
2010-12	RAN#50	R5s100531	0310	-	Correction of GCF WI-081 E-UTRA RLC test case 7.2.3.9	8.4.0	8.5.0
2010-12	RAN#50	R5s100532	0325	-	Corrections to GCF WI-081 EUTRA MAC Testcase 7.1.1.1	8.4.0	8.5.0
2010-12	RAN#50	R5s100533	0313	-	Corrections to GCF WI-081 EUTRA MAC Testcase 7.1.4.10	8.4.0	8.5.0
2010-12	RAN#50	R5s100535	0312	-	Corrections to Usage of Float Values in LTE TTCN ATS	8.4.0	8.5.0
2010-12	RAN#50	R5s100536	0311	-	Correction to GCF WI-082 E-UTRA EMM test case 9.2.3.1.5	8.4.0	8.5.0
2010-12	RAN#50	R5s100538	0321	-	Regression CR for LTE wk37 ATS	8.4.0	8.5.0
2010-12	RAN#50	R5s100539	0324	-	Correction to GCF WI-081 E-UTRA RRC test cases 8.1.2.7	8.4.0	8.5.0
2010-12	RAN#50	R5s100541	0323	-	Addition of GCF WI 81 EUTRA RRC test case 8.1.3.5	8.4.0	8.5.0
2010-12	RAN#50	R5s100545	0322	-	Addition of GCF WI 82 EMM test case 9.2.1.1.1a	8.4.0	8.5.0
2010-12	RAN#50	R5s100548	0328	-	Correction of GCF WI-081 EUTRA RRC test case 8.2.4.6	8.4.0	8.5.0
2010-12	RAN#50	R5s100549	0327	-	Correction of GCF WI-082 EPC test case 10.7.2	8.4.0	8.5.0
2010-12	RAN#50	R5s100550	0326	-	Correction of GCF WI-082 EPC test case 10.3.1	8.4.0	8.5.0
2010-12	RAN#50	R5s100555	0338	-	Correction to GCF WI-082 EMM test case 9.2.3.1.8	8.4.0	8.5.0

2010-12	RAN#50	R5s100556	0329	-	Regression TTCN CR for IWD D10_wk37 ATS	8.4.0	8.5.0
2010-12	RAN#50	R5s100557	0337	-	Correction to AT commands used in LTE ATS	8.4.0	8.5.0
2010-12	RAN#50	R5s100558	0336	-	Correction of GCF WI-081 EUTRA MAC test case 7.1.4.16	8.4.0	8.5.0
2010-12	RAN#50	R5s100559	0335	-	Correction to L2 test cases to allow HARQ retransmissions	8.4.0	8.5.0
2010-12	RAN#50	R5s100560	0334	-	Correction to GCF WI-081 EUTRA PDCP test cases 7.3.5.x	8.4.0	8.5.0
2010-12	RAN#50	R5s100561	0333	-	Correction to GCF WI-081 EUTRA RRC test case 8.2.4.5	8.4.0	8.5.0
2010-12	RAN#50	R5s100562	0332	-	Correction to GCF WI-081 EUTRA PDCP test case 7.3.5.4	8.4.0	8.5.0
2010-12	RAN#50	R5s100563	0330	-	Correction to GCF WI-081 EUTRA MAC test case 7.1.3.7	8.4.0	8.5.0
2010-12	RAN#50	R5s100564	0331	-	Correction to GCF WI-081 EUTRA RRC test case 8.5.1.1	8.4.0	8.5.0
2010-12	RAN#50	R5s100566	0341	-	Correction to GCF WI-081 EUTRA RLC test case 7.2.3.14	8.4.0	8.5.0
2010-12	RAN#50	R5s100571	0386	-	Correction of GCF WI-081 E-UTRA MAC test case 7.1.4.5	8.4.0	8.5.0
2010-12	RAN#50	R5s100572	0340	-	Correction of GCF WI-081 E-UTRA MAC test case 7.1.2.3	8.4.0	8.5.0
2010-12	RAN#50	R5s100573	0347	-	Correction to GCF WI-081 EUTRA RRC Testcase 8.2.4.3	8.4.0	8.5.0
2010-12	RAN#50	R5s100576	0339	-	Correction to GCF WI-081 EUTRA RRC Testcase 8.2.4.1	8.4.0	8.5.0
2010-12	RAN#50	R5s100579	0343	-	Correction to GCF WI-081 EUTRA PDCP test case 7.3.5.5	8.4.0	8.5.0
2010-12	RAN#50	R5s100580	0342	-	Correction to GCF WI-081 EUTRA RRC Testcase 8.3.1.10	8.4.0	8.5.0
2010-12	RAN#50	R5s100582	0352	-	Addition of GCF WI 82 EMM test case 9.2.1.1.15	8.4.0	8.5.0
2010-12	RAN#50	R5s100584	0351	-	Addition of GCF WI 82 EMM test case 9.2.1.1.17	8.4.0	8.5.0
2010-12	RAN#50	R5s100586	0385	-	Addition of GCF WI 82 EMM SMS test case 11.1.1	8.4.0	8.5.0
2010-12	RAN#50	R5s100588	0384	-	Addition of GCF WI 82 EMM SMS test case 11.1.2	8.4.0	8.5.0
2010-12	RAN#50	R5s100590	0350	-	Addition of GCF WI 81 EUTRA test case 6.1.2.5	8.4.0	8.5.0
2010-12	RAN#50	R5s100592	0349	-	Correction to GCF WI-081 EUTRA MAC Testcase 7.1.3.6	8.4.0	8.5.0
2010-12	RAN#50	R5s100593	0348	-	Correction to GCF WI-081 EUTRA MAC Testcase 7.1.4.13	8.4.0	8.5.0
2010-12	RAN#50	R5s100595	0346	-	Correction to GCF WI-081 EUTRA RLC Testcase 7.2.2.11	8.4.0	8.5.0
2010-12	RAN#50	R5s100597	0345	-	Addition of GCF WI 81 EUTRA RRC test case 9.2.1.1.13	8.4.0	8.5.0
2010-12	RAN#50	R5s100604	0383	-	Addition of GCF WI 82 EMM SMS test case 11.1.3	8.4.0	8.5.0
2010-12	RAN#50	R5s100606	0382	-	Addition of GCF WI 82 EMM SMS test case 11.1.4	8.4.0	8.5.0
2010-12	RAN#50	R5s100608	0344	-	Correction of GCF WI-081 E-UTRA TAU	8.4.0	8.5.0
2010-12	RAN#50	R5s100610	0367	-	Addition of GCF WI 82 EMM test case 9.2.1.1.7	8.4.0	8.5.0
2010-12	RAN#50	R5s100614	0364	-	LTE_TDD: Addition of GCF WI 91 EUTRA Idle Mode test case 6.1.2.3	8.4.0	8.5.0
2010-12	RAN#50	R5s100616	0363	-	LTE_TDD: Addition of GCF WI 91 EUTRA MAC test case 7.1.2.8	8.4.0	8.5.0
2010-12	RAN#50	R5s100618	0362	-	LTE_TDD: Addition of GCF WI 91 EUTRA MAC test case 7.1.4.5	8.4.0	8.5.0
2010-12	RAN#50	R5s100620	0361	-	LTE_TDD: Addition of GCF WI 91 EUTRA MAC test case 7.1.4.6	8.4.0	8.5.0
2010-12	RAN#50	R5s100622	0360	-	LTE_TDD: Addition of GCF WI 91 EUTRA MAC test case 7.1.4.7	8.4.0	8.5.0
2010-12	RAN#50	R5s100624	0366	-	Addition of GCF WI 82 EMM test case 9.2.3.1.4	8.4.0	8.5.0
2010-12	RAN#50	R5s100626	0359	-	LTE_TDD: Addition of GCF WI 91 EUTRA MAC test case 7.1.4.10	8.4.0	8.5.0
2010-12	RAN#50	R5s100628	0358	-	LTE_TDD: Addition of GCF WI 91 EUTRA MAC test case 7.1.4.16	8.4.0	8.5.0
2010-12	RAN#50	R5s100632	0357	-	LTE_TDD: Addition of GCF WI 91 EUTRA RLC test case 7.2.3.10	8.4.0	8.5.0

2010-12	RAN#50	R5s100634	0356	-	LTE_TDD: Addition of GCF WI 91 EUTRA RLC test case 7.2.3.16	8.4.0	8.5.0
2010-12	RAN#50	R5s100636	0355	-	LTE_TDD: Addition of GCF WI 91 EUTRA RRC test case 8.2.4.3	8.4.0	8.5.0
2010-12	RAN#50	R5s100638	0354	-	LTE_TDD: Addition of GCF WI 91 EUTRA RRC test case 8.5.1.1	8.4.0	8.5.0
2010-12	RAN#50	R5s100640	0365	-	Addition of GCF WI 82 EMM test case 9.2.1.2.4	8.4.0	8.5.0
2010-12	RAN#50	R5s100642	0353	-	LTE_TDD: Addition of GCF WI 91 EUTRA MAC test case 7.1.7.1.3	8.4.0	8.5.0
2010-12	RAN#50	R5s100644	0378	-	LTE_TDD: Addition of GCF WI 91 EUTRA Idle Mode test case 6.1.2.6	8.4.0	8.5.0
2010-12	RAN#50	R5s100646	0377	-	LTE_TDD: Addition of GCF WI 91 EUTRA RRC test case 8.1.2.5	8.4.0	8.5.0
2010-12	RAN#50	R5s100648	0376	-	LTE_TDD: Addition of GCF WI 91 EUTRA RRC test case 8.2.4.2	8.4.0	8.5.0
2010-12	RAN#50	R5s100650	0375	-	LTE_TDD: Addition of GCF WI 91 EUTRA RRC test case 8.2.4.5	8.4.0	8.5.0
2010-12	RAN#50	R5s100652	0374	-	LTE_TDD: Addition of GCF WI 91 EUTRA RRC test case 8.3.1.5	8.4.0	8.5.0
2010-12	RAN#50	R5s100654	0373	-	LTE_TDD: Addition of GCF WI 91 EUTRA RRC test case 8.3.1.8	8.4.0	8.5.0
2010-12	RAN#50	R5s100656	0372	-	LTE_TDD: Addition of GCF WI 91 EUTRA RRC test case 8.5.1.3	8.4.0	8.5.0
2010-12	RAN#50	R5s100658	0368	-	LTE_TDD: Addition of GCF WI 91 EUTRA MAC test case 7.1.4.11	8.4.0	8.5.0
2010-12	RAN#50	R5s100660	0371	-	Addition of GCF WI 82 EMM test case 9.2.2.2.2	8.4.0	8.5.0
2010-12	RAN#50	R5s100662	0370	-	Addition of GCF WI 82 EMM test case 9.2.1.2.1	8.4.0	8.5.0
2010-12	RAN#50	R5s100664	0369	-	Addition of GCF WI 82 EMM test case 9.2.3.2.1	8.4.0	8.5.0
2010-12	RAN#50	R5s100669	0390	-	LTE_TDD: Addition of GCF WI 91 EUTRA PDCP test case 7.3.5.4	8.4.0	8.5.0
2010-12	RAN#50	R5s100671	0389	-	LTE_TDD: Addition of GCF WI 91 EUTRA RRC test case 8.2.4.1	8.4.0	8.5.0
2010-12	RAN#50	R5s100673	0388	-	LTE_TDD: Addition of GCF WI 91 EUTRA RRC test case 8.3.1.9	8.4.0	8.5.0
2010-12	RAN#50	R5s100675	0398	-	Addition of GCF WI 81 EUTRA IDLE MODE test case 6.1.1.1	8.4.0	8.5.0
2010-12	RAN#50	R5s100678	0401	-	Addition of GCF WI 81 RRC test case 8.3.1.7	8.4.0	8.5.0
2010-12	RAN#50	R5s100680	0400	-	Addition of GCF WI 81 EUTRA RRC test case 8.1.2.3	8.4.0	8.5.0
2010-12	RAN#50	R5s100682	0399	-	Addition of GCF WI 81 EUTRA RRC test case 8.1.1.2	8.4.0	8.5.0
2010-12	RAN#50	R5s100688	0397	-	Addition of GCF WI 82 EMM test case 9.2.1.1.21	8.4.0	8.5.0
2010-12	RAN#50	R5s100690	0396	-	Addition of GCF WI 84 EMM test case 9.2.1.1.22	8.4.0	8.5.0
2010-12	RAN#50	R5s100692	0402	-	Regression CR for LTE wk42 ATS	8.4.0	8.5.0
2010-12	RAN#50	R5s100693	0393	-	Addition of GCF WI 82 ESM test case 10.8.2	8.4.0	8.5.0
2010-12	RAN#50	R5s100695	0392	-	Addition of GCF WI 82 ESM test case 10.8.3	8.4.0	8.5.0
2010-12	RAN#50	R5s100697	0391	-	Addition of GCF WI 82 EMM test case 9.3.1.17	8.4.0	8.5.0
2010-12	RAN#50	R5s100699	0395	-	Addition of GCF WI 82 EUTRA DRB test case 12.2.3	8.4.0	8.5.0
2010-12	RAN#50	R5s100701	0394	-	Addition of GCF WI 82 EMM test case 9.2.1.1.19	8.4.0	8.5.0
2010-12	RAN#50	R5s100703	0387	-	Addition of GCF WI 81 EUTRA RRC test case 8.1.1.6	8.4.0	8.5.0
2010-12	RAN#50	R5s100705	0408	-	Addition of GCF Priority 3 E-UTRA RRC test case 8.2.1.7	8.4.0	8.5.0
2010-12	RAN#50	R5s100707	0407	-	Addition of GCF Priority 3 E-UTRA RRC test case 8.5.1.2	8.4.0	8.5.0
2010-12	RAN#50	R5s100709	0406	-	Correction of GCF WI-081 Test Case 7.1.4.5	8.4.0	8.5.0
2010-12	RAN#50	R5s100712	0405	-	Addition of GCF WI 82 ESM test case 10.7.3	8.4.0	8.5.0
2010-12	RAN#50	R5s100714	0404	-	Addition of GCF WI 81 EUTRA RRC test case 8.2.4.4	8.4.0	8.5.0
2010-12	RAN#50	R5s100720	0403	-	Addition of GCF WI 82 Multilayer test case 13.3.1.1	8.4.0	8.5.0

2010-12	RAN#50	R5s100722	0409	-	Addition of GCF WI 82 EMM test case 9.2.1.1.23	8.4.0	8.5.0
2010-12	RAN#50	R5s100724	0414	-	Correction to IP address allocation and ESM cause for condition IPv4viaNAS_TestMode	8.4.0	8.5.0
2010-12	RAN#50	R5s100725	0413	-	Correction of the q-RxLevMin value in the sib5 interFreqCarrierFreqList	8.4.0	8.5.0
2010-12	RAN#50	R5s100726	0411	-	LTE_TDD: Resubmission of GCF WI 91 EUTRA RLC test case 7.2.2.10	8.4.0	8.5.0
2010-12	RAN#50	R5s100728	0412	-	Addition of GCF WI 82 EMM test case 9.3.1.16	8.4.0	8.5.0
2010-12	RAN#50	R5s100730	0410	-	Addition of GCF WI 82 EMM test case 9.2.2.1.2	8.4.0	8.5.0
2010-12	RAN#50	R5s100732	0422	-	LTE_TDD: Addition of GCF WI 91 EUTRA Idle mode test case 6.1.2.11	8.4.0	8.5.0
2010-12	RAN#50	R5s100734	0421	-	LTE_TDD: Addition of GCF WI 91 EUTRA Idle mode test case 6.1.2.8	8.4.0	8.5.0
2010-12	RAN#50	R5s100738	0419	-	LTE_TDD: Addition of GCF WI 91 EUTRA RRC test case 8.3.1.3	8.4.0	8.5.0
2010-12	RAN#50	R5s100740	0418	-	LTE_TDD: Addition of GCF WI 93 EUTRA RRC test case 8.3.1.7	8.4.0	8.5.0
2010-12	RAN#50	R5s100742	0417	-	LTE_TDD: Addition of GCF WI 91 EUTRA PDCP test case 7.3.5.5	8.4.0	8.5.0
2010-12	RAN#50	R5s100744	0416	-	Addition of GCF WI 82 Multilayer test case 13.3.1.2	8.4.0	8.5.0
2010-12	RAN#50	R5s100746	0415	-	Addition of GCF WI 82 ESM test case 10.7.4	8.4.0	8.5.0
2010-12	RAN#50	R5s100748	0423	-	Addition of GCF P3 E-UTRA ESM test case 10.5.3	8.4.0	8.5.0
2010-12	RAN#50	R5s100750	0424	-	Addition of GCF P3 E-UTRA EMM test case 9.2.3.1.13	8.4.0	8.5.0
2010-12	RAN#50	R5s100754	0425	-	Correction of GCF WI-081 EPC test case 9.1.2.5	8.4.0	8.5.0
2010-12	RAN#50	R5s100755	0426	-	Correction of GCF WI-081 EMM test case 9.2.3.1.5 and 9.2.3.1.8	8.4.0	8.5.0
2010-12	RAN#50	R5s100758	0434	-	Addition of GCF WI-82 P3 E-UTRA EMM test case 9.2.3.1.14	8.4.0	8.5.0
2010-12	RAN#50	R5s100760	0432	-	Correction of GCF WI-081 EPC test case 12.2.1 and 12.2.2	8.4.0	8.5.0
2010-12	RAN#50	R5s100761	0433	-	Correction of GCF WI-081 ESM test case 10.6.1, 10.4.1, 10.5.1, 10.5.3	8.4.0	8.5.0
2010-12	RAN#50	R5s100766	0431	-	Correction to GCF WI 81 EUTRA IDLE MODE test case 6.1.2.9	8.4.0	8.5.0
2010-12	RAN#50	R5s100767	0430	-	Correction to GCF WI 81 EUTRA MAC test case 7.1.4.1	8.4.0	8.5.0
2010-12	RAN#50	R5s100768	0429	-	Correction to GCF WI 82 EPC SMS test cases 11.1.3 and 11.1.4	8.4.0	8.5.0
2010-12	RAN#50	R5s100769	0428	-	Correction to GCF WI 81 EUTRA MAC test case 7.1.2.8	8.4.0	8.5.0
2010-12	RAN#50	R5s100784	0427	-	Addition of GCF WI 82 EMM test case 9.2.1.1.16	8.4.0	8.5.0
2010-12	RAN#50	R5s100787	0420	-	LTE_TDD: Addition of GCF WI 91 EUTRA RRC test case 8.1.1.6	8.4.0	8.5.0

History

Document history		
V8.0.0	November 2009	Publication
V8.1.0	April 2010	Publication
V8.2.0	July 2010	Publication
V8.3.0	July 2010	Publication
V8.4.0	November 2010	Publication
V8.5.0	April 2011	Publication