

ETSI TS 136 523-3 V14.0.0 (2017-08)



**LTE;
Evolved Universal Terrestrial Radio Access (E-UTRA) and
Evolved Packet Core (EPC);
User Equipment (UE) conformance specification;
Part 3: Test suites
(3GPP TS 36.523-3 version 14.0.0 Release 14)**



Reference

RTS/TSGR-0536523-3ve00

Keywords

LTE

ETSI

650 Route des Lucioles
F-06921 Sophia Antipolis Cedex - FRANCE

Tel.: +33 4 92 94 42 00 Fax: +33 4 93 65 47 16

Siret N° 348 623 562 00017 - NAF 742 C
Association à but non lucratif enregistrée à la
Sous-Préfecture de Grasse (06) N° 7803/88

Important notice

The present document can be downloaded from:

<http://www.etsi.org/standards-search>

The present document may be made available in electronic versions and/or in print. The content of any electronic and/or print versions of the present document shall not be modified without the prior written authorization of ETSI. In case of any existing or perceived difference in contents between such versions and/or in print, the only prevailing document is the print of the Portable Document Format (PDF) version kept on a specific network drive within ETSI Secretariat.

Users of the present document should be aware that the document may be subject to revision or change of status.

Information on the current status of this and other ETSI documents is available at

<https://portal.etsi.org/TB/ETSIDeliverableStatus.aspx>

If you find errors in the present document, please send your comment to one of the following services:

<https://portal.etsi.org/People/CommiteeSupportStaff.aspx>

Copyright Notification

No part may be reproduced or utilized in any form or by any means, electronic or mechanical, including photocopying and microfilm except as authorized by written permission of ETSI.

The content of the PDF version shall not be modified without the written authorization of ETSI.

The copyright and the foregoing restriction extend to reproduction in all media.

© ETSI 2017.

All rights reserved.

DECT™, **PLUGTESTS™**, **UMTS™** and the ETSI logo are trademarks of ETSI registered for the benefit of its Members.

3GPP™ and **LTE™** are trademarks of ETSI registered for the benefit of its Members and of the 3GPP Organizational Partners.

oneM2M logo is protected for the benefit of its Members.

GSM® and the GSM logo are trademarks registered and owned by the GSM Association.

Intellectual Property Rights

IPRs essential or potentially essential to the present document may have been declared to ETSI. The information pertaining to these essential IPRs, if any, is publicly available for **ETSI members and non-members**, and can be found in ETSI SR 000 314: "*Intellectual Property Rights (IPRs); Essential, or potentially Essential, IPRs notified to ETSI in respect of ETSI standards*", which is available from the ETSI Secretariat. Latest updates are available on the ETSI Web server (<https://ipr.etsi.org>).

Pursuant to the ETSI IPR Policy, no investigation, including IPR searches, has been carried out by ETSI. No guarantee can be given as to the existence of other IPRs not referenced in ETSI SR 000 314 (or the updates on the ETSI Web server) which are, or may be, or may become, essential to the present document.

Foreword

This Technical Specification (TS) has been produced by ETSI 3rd Generation Partnership Project (3GPP).

The present document may refer to technical specifications or reports using their 3GPP identities, UMTS identities or GSM identities. These should be interpreted as being references to the corresponding ETSI deliverables.

The cross reference between GSM, UMTS, 3GPP and ETSI identities can be found under <http://webapp.etsi.org/key/queryform.asp>.

Modal verbs terminology

In the present document "**shall**", "**shall not**", "**should**", "**should not**", "**may**", "**need not**", "**will**", "**will not**", "**can**" and "**cannot**" are to be interpreted as described in clause 3.2 of the [ETSI Drafting Rules](#) (Verbal forms for the expression of provisions).

"**must**" and "**must not**" are **NOT** allowed in ETSI deliverables except when used in direct citation.

Contents

Intellectual Property Rights	2
Foreword.....	2
Modal verbs terminology.....	2
Foreword.....	14
Introduction	14
1 Scope	15
2 References	15
3 Definitions and abbreviations.....	18
3.1 Definitions	18
3.2 Abbreviations	18
4 E-UTRAN/SAE system architecture and test models	18
4.1 Test system architecture	18
4.1.1 General system architecture	18
4.1.2 Component architecture	19
4.2 E-UTRAN test models	21
4.2.1 Layer 2 test models	21
4.2.1.1 MAC test model	21
4.2.1.2 RLC test model	23
4.2.1.3 PDCP test model	24
4.2.1.3.1 PDCP ROHC test model	24
4.2.1.3.2 PDCP test model (Non ROHC)	25
4.2.2 RRC test model.....	26
4.2.3 DRB test model.....	27
4.2.4 IP Test Model	27
4.2.4.1 IP user data.....	28
4.2.4.2 Configuration of Sockets.....	29
4.2.4.2.1 Socket Establishment.....	29
4.2.4.2.2 Socket Release.....	30
4.2.4.3 Handling of IP data	30
4.2.4.4 Routing of IP Data	31
4.2.4.5 Multiple PDNs	31
4.2.4.6 IP Addresses Guidelines	32
4.2.4.6.1 Common Structure of IP Addresses	32
4.2.4.6.2 Common Requirements regarding IP Addresses	33
4.2.4.6.3 Network Entities and their IP addresses	33
4.2.4.7 User Plane Signalling for Address Allocation.....	34
4.2.4.7.1 DHCP	34
4.2.4.7.2 DHCPv6	37
4.2.4.7.3 ICMPv6	37
4.2.4.7.4 DNS	38
4.2.4A LTE-Carrier Aggregation test Models	41
4.2.4A.1 CA-MAC test model	41
4.2.4A.2 CA-RRC test model	43
4.2.4A.3 LAA-MAC test model.....	44
4.2.4A.4 LAA-RRC test model.....	45
4.2.4B Dual Connectivity test models	46
4.2.4B.1 DC MAC test model.....	46
4.2.4B.2 DC PDCP test model.....	47
4.2.4B.3 DC RRC test model.....	48
4.2.5 IP model extension for IMS	49
4.2.5.1 IPsec	50
4.2.5.1.1 Security Association	50
4.2.5.1.2 SAD and SPD	51

4.2.5.2	Signalling Compression (SigComp).....	52
4.2.5.3	SIP TTCN-3 Codec	52
4.2.6	Support of DSMIPv6	52
4.2.7	MBMS test model.....	53
4.2.8	OCNG test model	53
4.2.9	Device-to-Device Proximity Services test model	55
4.2.9.1	ProSe Function test model	56
4.2.9.2	Direct Discovery test model.....	56
4.2.9.3	Direct Communication test model.....	57
4.2.10	SC-PTM test model	58
4.3	SAE Test Model.....	59
4.3.1	NAS Test Model.....	59
4.4	Inter RAT Test Model	60
4.4.1	E-UTRAN-UTRAN Inter RAT Test Model	60
4.4.1.1	User data over UTRAN.....	60
4.4.1.1.1	Raw user data over UTRAN.....	61
4.4.1.1.2	IP data over UTRAN	61
4.4.1.1.3	Routing IP data.....	62
4.4.2	E-UTRAN-GERAN Inter RAT Test Model	63
4.4.2.1	User data over GERAN.....	63
4.4.2.1.1	Raw user data over GERAN.....	64
4.4.2.1.2	IP data over GERAN	64
4.4.2.1.3	Routing IP data	65
4.4.3	E-UTRAN-CDMA2000 Inter RAT Test Model.....	66
4.4.3.1	E-UTRAN-CDMA2000 HRPD Inter RAT Test Model.....	66
4.4.3.2	E-UTRAN-CDMA2000 1xRTT Inter RAT test model.....	68
4.4.4	E-UTRAN FDD-TDD Inter RAT Test Model.....	71
4.4.5	E-UTRAN-UTRAN-GERAN Inter RAT Test Model	72
4.4.6	3GPP-WLAN Inter working Test Model.....	73
4.4.6.1	E-UTRAN-WLAN Inter working Test Model.....	73
4.4.6.2	UTRAN-WLAN Inter working Test Model.....	75
4.5	Generic WLAN Test Model	76
4.5.1	WLAN Access Point.....	76
4.5.2	ePDG/AAA-Server Emulation.....	76
4A	NB-IoT system architecture and test models.....	79
4A.1	Test system architecture	79
4A.2	NB-IoT test models	79
4A.2.1	Layer 2 test models	79
4A.2.1.1	Layer 2 loopback mode for CP mode.....	79
4A.2.1.2	MAC test model (CP mode).....	81
4A.2.1.3	RLC test model (CP mode).....	82
4A.2.1.4	PDCP test model	83
4A.2.2	RRC / NAS test model.....	84
5	Upper Tester Interface.....	85
5.1	Definitions	85
5.2	Upper Tester ASPs	85
6	ASP specifications.....	91
6.1	General Requirements and Assumptions.....	91
6.1.1	IP ASP requirements.....	91
6.1.2	Enhancement of IP ASP for handling IMS signalling	91
6.2	E-UTRAN ASP Definitions	92
6.2.1	Configuration Primitives.....	92
6.2.2	Signalling Primitives.....	92
6.2.3	Co-ordination Messages between NAS Emulation PTC and EUTRA PTC	93
6.3	UTRAN ASP Definitions	94
6.3.1	Void	95
6.3.2	ASPs for Data Transmission and Reception	95
6.4	GERAN ASP Definitions	96
6.4.1	ASPs for Control Primitive Transmission	96
6.4.2	ASPs for Data Transmission and Reception	98

6.5	NB-IoT ASP Definitions	101
6.5.1	Configuration Primitives.....	101
6.5.2	Signalling Primitives.....	101
6.5.3	Co-ordination Messages between NAS Emulation PTC and NBIOT PTC	102
7	E-UTRAN/SAE Test Methods and Design Considerations	104
7.1	Channel Mapping	104
7.1.1	PDCCH Candidate Selection	104
7.1.1.1	FDD candidates selection.....	105
7.1.1.2	TDD candidates selection	109
7.1.1.2.1	TDD candidates selection in special subframes	112
7.1.2	ePDCCH Candidate Selection	112
7.1.2.1	FDD candidates selection.....	112
7.1.2.2	TDD candidates selection	113
7.1.3	MPDCCH Candidate Selection.....	113
7.2	Uplink Grant.....	114
7.2.1	Exception TC list	117
7.3	Downlink Resource Allocation	117
7.3.1	PDCCH DCI default formats	118
7.3.1.1	Default DCI Format to be used in test cases configuring MIMO.....	118
7.3.2	Radio parameters configured	118
7.3.2.1	HARQ Retransmission when MIMO is configured.....	119
7.3.3	General DL scheduling scheme	119
7.3.3.1	Additional rules for BCCH scheduling scheme	119
7.3.3.1.1	BCCH with DCI combination 1	120
7.3.3.1.2	BCCH with DCI combination 2	120
7.3.3.2	Additional rules for PCCH specific scheduling scheme	120
7.3.3.2.1	PCCH with DCI combination 1.....	120
7.3.3.2.2	PCCH with DCI combination 2.....	120
7.3.3.3	Additional rules for RAR specific scheduling scheme.....	121
7.3.3.3.1	RAR with DCI combination 1	121
7.3.3.3.2	RAR with DCI combination 2	121
7.3.3.4	Additional rules for UE-dedicated scheduling scheme in normal mode	121
7.3.3.5	DL Resource allocation bitmaps	123
7.3.3.5.1	DCI combination 1	123
7.3.3.5.2	DCI combination 2	125
7.3.3.6	UE-dedicated scheduling scheme in explicit mode.....	128
7.3.3.6.1	DL Scheduling in Transport Block Size Selection Test Cases	129
7.3.3.7	Resource allocation sheets	129
7.3.3.8	MPDCCH DL DCI formats	130
7.3.3.8.1	BCCH.....	130
7.3.3.8.2	PCCH	131
7.3.3.8.3	RAR.....	131
7.3.3.8.4	UE-dedicated scheduling.....	131
7.3.3.9	DL Resource allocation bitmaps for BL/CE UE.....	132
7.3.3.9.1	DCI combination 1	132
7.4	Cell Configurations	134
7.4.1	Cell Configuration Types.....	134
7.4.2	Cell Power Change	134
7.4.3	E-UTRAN cell identity	134
7.4.3.1	Timing parameters of cells.....	134
7.4.4	Cell configurations for NAS test cases	136
7.4.5	Configuration of Multi-Cell Environment	137
7.5	TDD Considerations.....	137
7.5.1	FDD vs. TDD implementation.....	137
7.5.2	Guideline for FDD vs. TDD verification	137
7.6	Special RLC Modes.....	138
7.6.1	Suppression of RLC Acknowledgements	138
7.6.2	Modification of VT(S).....	138
7.7	System information	138
7.7.1	System information broadcasting	138
7.7.2	Scheduling information.....	139

7.7.2a	Scheduling information for BR System information	142
7.7.3	System information modification	153
7.7.3.1	Non-PWS System Information modification	153
7.7.3.1.1	UE in Idle_mode.....	153
7.7.3.1.2	UE in connected mode.....	154
7.7.3.2	PWS System Information modification	155
7.8	Timers and Timing Restrictions	155
7.8.1	Auxiliary timers	156
7.8.2	RRC timers reconfiguration.....	156
7.8.3	MAC TA timer reconfiguration	156
7.8.4	Non-protocol timers	156
7.9	Error Indication	156
7.10	Race Conditions	157
7.11	Radio Link Failure.....	157
7.12	Test method for RRC signalling latency	157
7.12.1	Procedure delays in PUCCH synchronized state	157
7.12.2	Procedure delays when RACH procedure required	159
7.13	RLC test method for scheduled data.....	159
7.14	IP packets for Loopback Mode.....	160
7.14.1	IP packets used for Loopback Mode A.....	160
7.14.2	IP packets used for Loopback Mode B	160
7.15	Connected Mode DRX	161
7.16	Handover Sequences	162
7.16.1	Sequence of inter-cell handover.....	162
7.16.1a	Sequence of inter-cell CA handover (more than one CC before and after handover).....	163
7.16.2	Sequence of intra-cell handover.....	164
7.16.3	UL Grants used in RA procedure during handover	165
7.17	Simulation of PDCP MAC-I Failure in UE.....	165
7.17.1	Integrity and ciphering not yet activated.....	165
7.17.2	Integrity and/or ciphering already activated	166
7.18	RRC Connection Release Sequence	166
7.18a	RRC Connection Release Sequence for BL/CE UE.....	166
7.19	DL CCCH Message and Contention Resolution MAC Control Element transmission in one MAC PDU or in separate MAC PDUs.....	167
7.20	RRC Connection Reconfiguration Sequence (Measurement Control)	167
7.21	Inter-RAT - GERAN special issues.....	168
7.21.1	Timeslot assigned for GERAN CS traffic.....	168
7.21.2	Subchannel used in GERAN L2 access message.....	168
7.21.3	Paging in GERAN	168
7.22	EUTRAN RSRQ Calculations	168
7.22.1	Assumptions	168
7.22.2	The Ideal Calculation.....	168
7.22.3	Additional RSRQ Calculations For Fixing Boundary Values	169
7.23	Test method for eICIC and feICIC	169
7.24	Carrier Aggregation Signalling Sequences.....	170
7.24.1	Initial configuration of Pcell	170
7.24.2	Initial configuration of SCell	170
7.24.3	Scell Addition and/or release	171
7.25	Test method for MBMS	171
7.25.1	Schedule transmission of MCCH messages.....	171
7.25.2	MCCH change notification	172
7.25.3	MTCH data scheduling	172
7.26	Type B FDD Half-Duplex Considerations	172
7.27	Test method for Device-to-Device Proximity Services	173
7.27.1	Direct Discovery test method.....	173
7.27.2	Direct Communication test method	174
7.27.2.1	Synchronisation and SBCCH transmission.....	174
7.27.2.2	Sidelink data transmission/reception.....	174
7.28	Test method for SC-PTM.....	174
7.28.1	Schedule transmission of SC-MCCH messages	174
7.28.2	SC-MCCH information change	175
7.28.3	SC-MTCH data scheduling.....	175

7A	NB-IoT Test Methods and Design Considerations	175
7A.1	Physical signals and channels.....	175
7A.2	System information	176
7A.2.1	System information broadcasting in general.....	176
7A.2.2	System information scheduling and synchronisation signals.....	176
7A.2.2.1	MIB-NB, NPSS, NSSS	176
7A.2.2.2	SIB1-NB	176
7A.2.2.3	SI-messages containing SIB3-NB, SIB4-NB, SIB5-NB, SIB14-NB, SIB16-NB	177
7A.2.2.3.1	SI combination 1 scheduling	177
7A.2.2.3.2	SI combination 2/3/4 scheduling	178
7A.2.3	System information modification	179
7A.3	Search space configurations	179
7A.3.1	Type1CSS - Paging.....	180
7A.3.2	Type2CSS – Random access	180
7A.3.3	UESS	180
7A.4	Timing considerations	181
7A.4.1	Random access procedure.....	181
7A.4.2	Uplink transmissions.....	182
7A.4.3	Downlink transmissions.....	183
7A.4.4	Half-duplex mode	183
7A.4.5	Conclusions.....	184
7A.5	Scheduling requests and scheduling of UL grants.....	184
7A.5.1	RACH procedure mode	184
7A.5.2	Polling mode	184
7A.6	Scheduling requirements	184
7A.6.1	Random access procedure.....	185
7A.6.2	Downlink transmissions.....	185
7A.6.3	Periodic uplink grants	186
7A.6.4	HARQ re-transmissions	187
7A.6.4.1	Uplink	187
7A.6.4.2	Downlink.....	187
7A.6.5	Timing info for UL messages	188
7A.6.6	Uplink time alignment	188
7A.7	RRC Connection Release Sequence	188
7A.8	DL CCCH Message and Contention Resolution MAC Control Element transmission in one MAC PDU or in separate MAC PDUs.....	189
7A.9	Cell Configuration	189
7A.9.1	Cell Power Change	189
7A.9.2	Timing Parameters of Cells	189
7A.9.3	Configuration of Multi-Cell Environment	190
7A.10	Timers and Timing Restrictions	190
7A.11	Error Indication	190
7A.12	NBIOT RSRQ Calculations	190
8	External Function Definitions	190
9	IXIT Proforma.....	193
9.1	E-UTRAN PIXIT	193
9.2	MultiRAT PIXIT	197
9.3	NB-IoT PIXIT	201
10	Postambles.....	201
10.1	Postambles for E-UTRA to UTRA tests.....	201
10.1.1	UE postamble states and procedures for E-UTRA to UTRA.....	201
10.1.2	Switch/Power off procedure	203
10.1.2.1	Procedure	203
10.1.3	CC disconnect procedure	205
10.1.3.1	Procedure	205
10.1.4	PS Routing Area Update procedure.....	206
10.1.4.1	Procedure	206
10.1.5	CS fallback procedure.....	207
10.1.5.1	Procedure	207
10.2	Postambles for E-UTRAN to GERAN tests.....	209

10.2.1	UE postamble states and procedures for E-UTRA to GERAN test cases	209
10.2.2	Switch/Power off procedure	211
10.2.2.1	Procedure	211
10.2.3	PS Handover procedure	212
10.2.3.1	Procedure	212
10.2.4	CC disconnect procedure	213
10.2.4.1	Procedure	213
10.2.5	CS fallback procedure.....	213
10.2.5.1	Procedure	213
10.3	Postambles for E-UTRA test cases.....	214
10.3.1	UE postamble states and procedures for E-UTRA test cases.....	214
10.3.2	Switch/Power off procedure in State E1	215
10.3.2.1	Procedure	215
10.3.3	Switch/Power off procedure in State E2 and E3	216
10.3.3.1	Procedure for E2 and E3	216
10.3.3.2	Procedure for E2_T3440	217
10.3.4	Switch/Power off procedure in State E4	218
10.3.4.1	Procedure	218
10.3.5	Automatic selection mode procedure in State E5 (current cell, neighbour cell).....	218
10.3.5.1	Procedure	218
10.4	Postambles for E-UTRA to HRPD test cases	218
10.4.1	UE postamble procedures for E-UTRA to HRPD (No Pre-Registration).....	218
10.4.1.1	Registration on HRPD Cell	218
10.4.1.2	Detach on HRPD Cell	220
10.5	Postambles for NB-IoT test cases.....	220
10.5.1	UE postamble states and procedures for NB-IoT test cases.....	220
10.5.2	Switch/Power off procedure in State N1.....	221
10.5.2.1	Procedure	221
10.5.3	Switch/Power off procedure in State N2 and N3	221
10.5.3.1	Procedure for N2 and N3	221
10.5.4	Switch/Power off procedure in State N4.....	221
10.5.4.1	Procedure	221
10.5.5	Automatic selection mode procedure in State N5 (current cell, neighbour cell)	222
10.5.5.1	Procedure	222
11	Guidelines on test execution.....	222
11.1	EUTRA single technology	222
11.1.1	Replacement of test case execution	223
11.2	EUTRA - UTRA - GERAN	224
11.2.1	UTRA configured – GERAN not configured	224
11.2.1.1	EUTRA band overlapping UTRA band	224
11.2.1.2	EUTRA band not overlapping UTRA band	225
11.2.2	GERAN configured - UTRA not configured	226
11.2.3	Neither UTRA nor GERAN configured	227
11.2.4	Both UTRA and GERAN configured	227
11.2.4.1	EUTRA band overlapping UTRA band	227
11.2.4.2	EUTRA band not overlapping UTRA band	228
11.2.5	Replacement of test case execution	228
11.3	EUTRA inter-band	228
11.3.1	Primary operating band.....	229
11.3.2	Secondary operating band for inter-band cells.....	229
11.3.3	Replacement of test case execution	229
11.4	EUTRA CA	229
11.4.1	CA contiguous Intra-band operation.....	229
11.4.2	CA Inter-band operation	230
11.4.3	CA non-contiguous Intra-band operation	233
11.5	EUTRA MFBI.....	233
11.6	EUTRA DC	234
Annex A (normative): Test Suites.....		236
A.1	Baseline of specifications	236

A.2	E-UTRA Test Suites.....	236
Annex B (informative): Style Guides.....		256
B.1	Introduction	256
B.2	General Requirements for TTCN-3 Implementations	256
B.3	Naming Conventions.....	257
B.3.1	Prefixes and Restrictions for TTCN-3 Objects.....	257
B.3.2	Void.....	258
B.3.3	Void.....	258
B.3.4	Identifiers consisting of more than one Name	258
B.4	Implementation Issues	258
B.4.1	Control part	258
B.4.2	Top Level Test Case Definitions	258
B.4.3	Inter Component Communication	259
B.4.4	Encoding Information.....	259
B.4.5	Verdict Assignment.....	259
B.4.5.1	PASS verdict assignment.....	260
B.4.5.2	FAIL or INCONC verdict assignment.....	260
B.4.5.3	Verdict assignment in default behaviour	261
B.4.6	Default Behaviour	261
B.4.7	Templates for Sending and Receiving.....	262
B.4.8	Logging	262
B.4.8.1	Prose Step Numbers.....	262
B.4.9	Top level comments	263
B.4.10	Mapping of DRBs	263
B.5	Modularisation	263
Annex C (informative): Design Principles.....		265
C.1	ASP Design	265
C.2	SS State Model.....	266
Annex D (informative) TTCN-3 Definitions		269
D.1	EUTRA_ASP_TypeDefs.....	269
D.1.1	ASN1_Container	269
D.1.2	System_Configuration.....	278
D.1.3	Cell_Configuration.....	281
D.1.3.1	Cell_Configuration_Common.....	282
D.1.3.2	Downlink_Physical_Layer_Configuration	286
D.1.3.2.1	Antenna_Configuration.....	287
D.1.3.2.2	Physical_Channels	288
D.1.3.2.3	Physical_Signals	290
D.1.3.3	Uplink_Physical_Layer_Configuration	291
D.1.3.4	Common_MAC_Configuration	292
D.1.3.5	Random_Access_Procedure	299
D.1.3.6	System_Information_Control	304
D.1.3.7	Paging_Control	309
D.1.3.8	UE_Specific_Channel_Configuration	309
D.1.3.8.1	UE_Specific_Channel_Configuration_DL	309
D.1.3.8.2	UE_Specific_Channel_Configuration_UL	310
D.1.3.9	Carrier_Aggregation	313
D.1.3.10	OCNG_Config.....	315
D.1.3.11	EIMTA_Config.....	316
D.1.4	Cell_Power_Attenuation	316
D.1.5	Radio_Bearer_Configuration	317
D.1.5.1	PDCP_Configuration.....	317
D.1.5.2	RLC_Configuration	318
D.1.5.3	MAC_Configuration.....	320

D.1.6	AS_Security	323
D.1.7	Semi_Persistent_Scheduling	325
D.1.8	Paging_Trigger	327
D.1.9	L1_MAC_Indication_Control	327
D.1.10	Rlc_Indication_Control	328
D.1.11	PDCP_Count	329
D.1.12	PDCP_Handover	330
D.1.13	L1_MAC_Test_Mode	330
D.1.14	PDCCH_Order	331
D.1.15	System_Indications	331
D.1.16	System_Interface	334
D.1.17	MBMS_Configuration	335
D.1.18	SCPTM_Configuration	338
D.1.19	DirectIndicationInfo_Trigger	340
D.2	EUTRA_ASP_DrbDefs	340
D.2.1	MBMS_MRB_Primitive_Definitions	340
D.2.2	System_Interface	341
D.3	EUTRA_NB_ASP_L2DataDefs	342
D.3.1	PDU_TypeDefs	342
D.3.1.1	MAC_PDU	342
D.3.1.2	RLC_PDU	345
D.3.1.2.1	Common	345
D.3.1.2.2	TM_Data	346
D.3.1.2.3	UM_Data	346
D.3.1.2.4	AM_Data	348
D.3.1.2.5	AM_Status	350
D.3.1.3	PDCP	353
D.3.2	DRB_Primitive_Definitions	359
D.3.2.1	DRB_Common	359
D.3.2.2	Downlink	360
D.3.2.3	Uplink	361
D.4	EUTRA_ASP_SrbDefs	362
D.4.1	SRB_DATA_ASAPs	362
D.4.2	Port_Definitions	364
D.5	IP_ASP_TypeDefs	364
D.5.1	IP_Common	364
D.5.2	IP_Config	366
D.5.3	IPsec_Config	367
D.5.4	IP_SocketHandling	369
D.5.4.1	Socket_Common	369
D.5.4.2	Socket_Datagram	370
D.5.4.3	TCP_Socket	371
D.5.4.4	UDP_Socket	376
D.5.4.5	ICMP_Socket	378
D.5.4.6	Socket_Primitives	380
D.5.5	System_Interface	381
D.6	NasEmu_AspTypes_EUTRA	383
D.6.1	System_Interface	384
D.7	EUTRA_CommonDefs	385
D.7.1	Common_Types	385
D.7.2	Common_Constants	385
D.7.3	RRC_Nested_Types	386
D.7.4	ASP_CommonPart	387
D.7.4.1	ASP_CommonPart_Definitions	387
D.7.4.1.1	Routing_Info	387
D.7.4.2	REQ_ASP_CommonPart	388
D.7.4.3	CNF_ASP_CommonPart	388
D.7.4.4	IND_ASP_CommonPart	388

D.7.5	MBMS_CommonDefs.....	388
D.8	CDMA2000_ASP_TypeDefs.....	389
D.8.1	CDMA2000_Common.....	389
D.8.1.1	CDMA2000_SystemContants.....	389
D.8.1.2	CDMA2000_Routing.....	389
D.8.1.3	CDMA2000_TimingInfo.....	390
D.8.1.4	CDMA2000_ReqAspCommonPart.....	391
D.8.1.5	CDMA2000_IndAspCommonPart.....	392
D.8.1.6	CDMA2000_CnfAspCommonPart.....	392
D.8.2	CDMA2000_PowerLevel.....	393
D.8.3	CDMA2000_Data.....	394
D.8.4	CDMA2000_CellConfiguration.....	396
D.8.5	CDMA2000_HRPD.....	398
D.8.5.1	CDMA2000_PDN_Defs.....	398
D.8.5.2	CDMA2000_SubProtocols.....	399
D.8.5.3	HRPD_Indications.....	401
D.8.5.4	HRPD_Commands.....	404
D.8.6	CDMA2000_RTT1X.....	407
D.8.6.1	RTT1X_Indications.....	407
D.8.6.2	RTT1X_Commands.....	410
D.8.7	System_Interface.....	412
D.9	CDMA2000_CommonDefs.....	415
D.10	EUTRA_ASP_CDMA2000TunnellingDefs.....	419
D.11	EUTRA_ASP_VirtualNoiseDefs.....	420
D.12	UTRAN_ASP_VirtualNoiseDefs.....	421
D.13	WLAN_ASP_TypeDefs.....	422
D.14	SideLinkUE_ASP_TypeDefs.....	434
D.14.1	SideLinkUE_Data.....	434
D.14.2	SideLinkUE_Configuration.....	436
D.14.2.1	SL_Routing_Timing.....	436
D.14.2.2	SL_SystemRequestAsp.....	438
D.14.2.2.1	SL_RequestAspCommon_Part.....	438
D.14.2.2.2	Discovery_Specific.....	441
D.14.2.2.3	Communication_Specific.....	443
D.14.2.2.4	SL_Security.....	449
D.14.2.3	SL_SystemConfirmAsp.....	450
D.14.2.4	SL_SystemIndicationAsp.....	450
D.14.2.5	SL_System_Interface.....	452
D.15	CommonDefs.....	453
D.16	EUTRA_NB_ASP_TypeDefs.....	456
D.16.1	Cell_Configuration.....	456
D.16.1.1	Cell_Configuration_Common.....	456
D.16.1.2	Uplink_Physical_Layer_Configuration.....	457
D.16.1.3	Common_MAC_Configuration.....	457
D.16.1.4	Random_Access_Procedure.....	459
D.16.2	System_Indications.....	461
D.17	EUTRA_NB_CommonDefs.....	461
D.17.1	Common_Types.....	461
D.17.2	RRC_Nested_Types.....	462
D.17.3	ASP_CommonPart.....	462
D.17.3.1	ASP_CommonPart_Definitions.....	462
D.17.3.1.1	Routing_Info.....	462
D.17.3.1.2	Timing_Info.....	462
D.17.3.2	REQ_ASP_CommonPart.....	463
D.17.3.3	CNF_ASP_CommonPart.....	463

D.17.3.4	IND_ASP_CommonPart.....	464
D.17.4	L2Data_CommonDefs.....	464
D.18	References to TTCN-3	466
Annex E (informative): Upper Tester Scenarios		467
E.1	No confirmation	467
E.2	Immediate confirmation	467
E.3	Late response.....	469
E.4	Multiple responses.....	470
Annex F (informative): TTCN-3 Definitions		473
F.1	NBIOT_ASP_TypeDefs.....	473
F.1.1	ASN1_Container	473
F.1.2	System_Configuration.....	474
F.1.3	Cell_Configuration.....	477
F.1.3.1	Cell_Configuration_Common.....	477
F.1.3.2	Downlink_Physical_Layer_Configuration	479
F.1.3.2.1	Physical_Channels	479
F.1.3.2.2	Physical_Signals	482
F.1.3.3	Uplink_Physical_Layer_Configuration	483
F.1.3.4	Common_MAC_Configuration	484
F.1.3.5	Random_Access_Procedure	487
F.1.3.6	System_Information_Control	490
F.1.3.7	Paging_Control.....	492
F.1.3.8	UE_Specific_Channel_Configuration	492
F.1.3.8.1	UE_Specific_Channel_Configuration_DL	492
F.1.3.8.2	UE_Specific_Channel_Configuration_UL	493
F.1.4	Cell_Power_Attenuation	494
F.1.5	Radio_Bearer_Configuration	494
F.1.5.1	RLC_Configuration	494
F.1.5.2	MAC_Configuration.....	495
F.1.6	AS_Security	498
F.1.7	Paging_Trigger.....	499
F.1.8	RLC_Counts.....	500
F.1.9	PDCP_Count.....	500
F.1.10	L1_MAC_Test_Mode.....	502
F.1.11	System_Interface.....	502
F.2	NBIOT_ASP_SrbDefs	503
F.2.1	SRB_DATA_ASPs	503
F.2.2	Port_Definitions	505
F.3	NBIOT_ASP_L2DataDefs.....	505
F.3.1	System_Interface.....	505
F.4	EUTRA_NB_ASP_L2DataDefs	506
F.4.1	PDU_TypeDefs	506
F.4.1.1	MAC_PDU	506
F.4.1.2	RLC_PDU.....	509
F.4.1.2.1	Common.....	509
F.4.1.2.2	TM_Data.....	510
F.4.1.2.3	UM_Data.....	510
F.4.1.2.4	AM_Data.....	512
F.4.1.2.5	AM_Status	514
F.4.1.3	PDCP	517
F.4.2	DRB_Primitive_Definitions.....	523
F.4.2.1	DRB_Common	523
F.4.2.2	Downlink	524
F.4.2.3	Uplink	525

F.5	NasEmu_AspTypes_NBIOT	526
F.5.1	System_Interface	526
F.6	NBIOT_CommonDefs	528
F.6.1	NBIOT_Common_Types	528
F.6.2	NBIOT_RRC_Nested_Types	529
F.6.3	NBIOT_ASP_CommonPart	529
F.6.3.1	NBIOT_ASP_CommonPart_Definitions	529
F.6.3.1.1	NBIOT_Routing_Info	529
F.6.3.2	REQ_ASP_CommonPart	530
F.6.3.3	NBIOT_CNF_ASP_CommonPart	530
F.6.3.4	NBIOT_IND_ASP_CommonPart	531
F.7	NBIOT_Imported_EUTRA_ASN1_Types	531
F.8	NBIOT_ASP_VirtualNoiseDefs	531
F.9	CommonDefs	533
F.10	EUTRA_NB_ASP_TypeDefs	533
F.10.1	Cell_Configuration	533
F.10.1.1	Cell_Configuration_Common	534
F.10.1.2	Uplink_Physical_Layer_Configuration	535
F.10.1.3	Common_MAC_Configuration	535
F.10.1.4	Random_Access_Procedure	536
F.10.2	System_Indications	538
F.11	EUTRA_NB_CommonDefs	538
F.11.1	Common_Types	538
F.11.2	RRC_Nested_Types	538
F.11.3	ASP_CommonPart	538
F.11.3.1	ASP_CommonPart_Definitions	538
F.11.3.1.1	Routing_Info	538
F.11.3.1.2	Timing_Info	539
F.11.3.2	REQ_ASP_CommonPart	540
F.11.3.3	CNF_ASP_CommonPart	540
F.11.3.4	IND_ASP_CommonPart	540
F.11.4	L2Data_CommonDefs	541
F.12	References to TTCN-3	543
Annex G (informative):	Change history	544
History		643

Foreword

This Technical Specification has been produced by the 3rd Generation Partnership Project (3GPP).

The contents of the present document are subject to continuing work within the TSG and may change following formal TSG approval. Should the TSG modify the contents of the present document, it will be re-released by the TSG with an identifying change of release date and an increase in version number as follows:

Version x.y.z

where:

- x the first digit:
 - 1 presented to TSG for information;
 - 2 presented to TSG for approval;
 - 3 or greater indicates TSG approved document under change control.
- y the second digit is incremented for all changes of substance, i.e. technical enhancements, corrections, updates, etc.
- z the third digit is incremented when editorial only changes have been incorporated in the document.

Introduction

The present document is part 3 of a multi-part conformance test specification for the 3GPP evolved User Equipment (UE). The specification contains a TTCN-3 design frame work and the detailed test specifications in TTCN-3 for evolved UE at the UE-E-UTRAN radio interface.

- 3GPP TS 36.523-1 [1]: "User Equipment (UE) conformance specification; Part 1: Protocol conformance specification".
- 3GPP TS 36.523-2 [2]: "User Equipment (UE) conformance specification; Part 2: Implementation Conformance Statement (ICS) proforma specification".
- **3GPP TS 36.523-3: "Test Suites"** (the present document).

1 Scope

The present document specifies the protocol and signalling conformance testing in TTCN-3 for the 3GPP UE at the UE-E-UTRAN radio interface.

The following TTCN test specification and design considerations can be found in the present document:

- the test system architecture;
- the overall test suite structure;
- the test models and ASP definitions;
- the test methods and usage of communication ports definitions;
- the test configurations;
- the design principles and assumptions;
- TTCN styles and conventions;
- the partial PIXIT proforma;
- the test suites.

The Abstract Test Suites designed in the document are based on the test cases specified in prose (3GPP TS 36.523-1 [1]). The applicability of the individual test cases is specified in the test ICS proforma specification (3GPP TS 36.523-2 [1]).

The present document is valid for TTCN development for LTE, LTE-Advanced and LTE-Advanced Pro (including NB-IoT) UE conformance test according to 3GPP Releases starting from Release 8 up to the Release indicated on the cover page of the present document.

In the remainder of the present document, unless explicitly stated otherwise, the term E-UTRA(N) implicitly refers to the Wideband part of E-UTRA(N) known as WB-E-UTRA(N). The Narrowband part of E-UTRA(N) is always explicitly referred to as NB-IoT.

2 References

The following documents contain provisions which, through reference in this text, constitute provisions of the present document.

- References are either specific (identified by date of publication, edition number, version number, etc.) or non-specific.
- For a specific reference, subsequent revisions do not apply.
- For a non-specific reference, the latest version applies. In the case of a reference to a 3GPP document (including a GSM document), a non-specific reference implicitly refers to the latest version of that document in the same Release as the present document unless the context in which the reference is made suggests a different Release is relevant (information on the applicable release in a particular context can be found in e.g. test case title, description or applicability, message description or content).

- [1] 3GPP TS 36.523-1: "User Equipment (UE) conformance specification; Part 1: Protocol conformance specification".
- [2] 3GPP TS 36.523-2: "User Equipment (UE) conformance specification; Part 2: Implementation Conformance Statement (ICS) proforma specification".
- [3] 3GPP TS 36.508: "Common test environments for User Equipment (UE) conformance testing".
- [4] 3GPP TS 36.509: "Terminal logical test interface; Special conformance testing functions".

- [5] 3GPP TS 34.123-1: "User Equipment (UE) conformance specification; Part 1: Protocol conformance specification".
- [6] 3GPP TS 34.123-2: "User Equipment (UE) conformance specification; Part 2: Implementation Conformance Statement (ICS) proforma specification".
- [7] 3GPP TS 34.123-3: "User Equipment (UE) conformance specification; Part 3: Abstract Test Suite (ATS)".
- [8] 3GPP TS 34.108: "Common test environments for User Equipment (UE) conformance testing".
- [9] 3GPP TS 34.109: "Terminal logical test interface; Special conformance testing functions".
- [10] 3GPP TS 51.010-1: "Mobile Station (MS) conformance specification; Part 1: Conformance Specification".
- [11] 3GPP TS 51.010-2: "Mobile Station (MS) conformance specification; Part 2: Protocol Implementation Conformance Statement (PICS) proforma specification".
- [12] 3GPP TS 51.010-5: "Mobile Station (MS) conformance specification; Part 5: Inter-RAT (GERAN to UTRAN) Abstract Test Suite (ATS)".
- [13] ETSI ES 201 873-1: "Methods for Testing and Specification (MTS); The Testing and Test Control Notation version 3; Part 1: TTCN-3 Core Language".
- [14] 3GPP TS 36.304: "Evolved Universal Terrestrial Radio Access (E-UTRA); "UE Procedures in Idle Mode".
- [15] 3GPP TS 36.306 "Evolved Universal Terrestrial Radio Access (E-UTRA); "UE Radio Access Capabilities".
- [16] 3GPP TS 36.321: "Evolved Universal Terrestrial Radio Access (E-UTRA); "Medium Access Control (MAC) protocol specification".
- [17] 3GPP TS 36.322:"Evolved Universal Terrestrial Radio Access (E-UTRA); "Radio Link Control (RLC) protocol specification".
- [18] 3GPP TS 36.323: "Evolved Universal Terrestrial Radio Access (E-UTRA); "Packet Data Convergence Protocol (PDCP) Specification".
- [19] 3GPP TS 36.331: "Evolved Universal Terrestrial Radio Access (E-UTRA) Radio Resource Control (RRC); Protocol Specification".
- [20] 3GPP TS 24.008: "Mobile Radio Interface Layer 3 specification; Core Network Protocols; Stage 3".
- [21] 3GPP TS 24.301: "Non-Access-Stratum (NAS) Protocol for Evolved Packet System (EPS); Stage 3".
- [22] 3GPP TS 24.303: "Mobility Management based on DSMIPv6; User Equipment (UE) to network protocols; Stage 3".
- [23] 3GPP TS 24.304: "Mobility management based on Mobile IPv4; User Equipment (UE) – foreign agent interface; Stage 3".
- [24] 3GPP TS 33.401: "3GPP System Architecture Evolution (SAE); Security architecture".
- [25] 3GPP TS 33.402: "3GPP System Architecture Evolution (SAE); Security aspects of non-3GPP accesses".
- [26] 3GPP TR 21.905: "Vocabulary for 3GPP Specifications".
- [27] ETSI ES 201 873-4: "Methods for Testing and Specification (MTS); The Testing and Test Control Notation version 3; Part 4: TTCN-3 Operational Semantics".
- [28] ETSI ES 201 873-5: "Methods for Testing and Specification (MTS); The Testing and Test Control Notation version 3; Part 5: TTCN-3 Runtime Interface (TRI)".

- [29] ETSI ES 201 873-6: "Methods for Testing and Specification (MTS); The Testing and Test Control Notation version 3; Part 6: TTCN-3 Control Interface (TCI)".
- [30] 3GPP TS 36.213: "Evolved Universal Terrestrial Radio Access (E-UTRA); Physical layer procedures".
- [31] 3GPP TS 27.005: "Use of Data Terminal Equipment – Data Circuit terminating Equipment (DTE-DCE) interface for Short Message Service (SMS) and Cell Broadcast Service (CBS)".
- [32] 3GPP TS 27.007: "AT command set for 3G User Equipment (UE)".
- [33] 3GPP TS 27.060: "Packet domain; Mobile Station (MS) supporting Packet Switched services".
- [34] 3GPP TS 36.101: "Evolved Universal Terrestrial Radio Access (E-UTRA); User Equipment (UE) radio transmission and reception".
- [35] 3GPP TS 36.211: "Evolved Universal Terrestrial Radio Access (E-UTRA); Physical channels and modulation".
- [36] 3GPP TS 25.331: "RRC Protocol Specification".
- [37] 3GPP TS 36.133: "Evolved Universal Terrestrial Radio Access (E-UTRA); Requirements for support of radio resource management".
- [38] 3GPP2 TSG-C C.S0024_C v2.0: "cdma2000 High Rate Packet Data Air Interface Specification".
- [39] 3GPP2 TSG-C C.S0057-E v1.0: "Band Class Specification for cdma2000 Spread Spectrum Systems".
- [40] 3GPP TS 34.229-1: "Internet Protocol (IP) multimedia call control protocol based on Session Initiation Protocol (SIP) and Session Description Protocol (SDP); User Equipment (UE) conformance specification; Part 1: Protocol conformance specification".
- [41] 3GPP TS 33.203: "3G security; Access security for IP-based services".
- [42] 3GPP TS 24.229: "IP Multimedia Call Control Protocol based on Session Initiation Protocol (SIP) and Session Description Protocol (SDP); Stage 3".
- [43] IETF RFC 3320: "Signalling Compression (SigComp)".
- [44] IETF RFC 3485: "The Session Initiation Protocol (SIP) and Session Description Protocol (SDP) Static Dictionary for Signalling Compression (SigComp)".
- [45] IETF RFC 3486: "Compressing the Session Initiation Protocol (SIP)".
- [46] IETF RFC 4896: "Signalling Compression (SigComp) Corrections and Clarifications".
- [47] IETF RFC 5049: "Applying Signalling Compression (SigComp) to the Session Initiation Protocol (SIP)".
- [48] 3GPP TS 23.003: "Numbering, addressing and identification".
- [49] 3GPP TS 23.060: "General Packet Radio Service (GPRS) Service description; Stage 2".
- [50] 3GPP TS 29.061: "Interworking between the Public Land Mobile Network (PLMN) supporting packet based services and Packet Data Networks (PDN)".
- [51] 3GPP TS 34.229-3: "Internet Protocol (IP) multimedia call control protocol based on Session Initiation Protocol (SIP) and Session Description Protocol (SDP); User Equipment (UE) conformance specification; Part 3: Abstract Test Suite ".
- [52] 3GPP TS 37.571-4: "User Equipment (UE) conformance specification for UE positioning; Part 4: Test Suites"
- [53] 3GPP TS 36.214: " Evolved Universal Terrestrial Radio Access (E-UTRA);Physical layer; Measurements".

- [54] IETF RFC 1144: "Compressing TCP/IP headers for low-speed serial links".
- [55] IETF RFC 2507: "IP Header Compression".
- [56] ITU-T Recommendation V.42bis: "Data compression procedures for data circuit-terminating equipment (DCE) using error correction procedures".
- [57] ITU-T Recommendation V.44: "Data compression procedures".
- [58] IETF RFC 1035: "DOMAIN NAMES - IMPLEMENTATION AND SPECIFICATION"
- [59] IETF RFC 3596: "DNS Extensions to Support IP Version 6"
- [60] ITU-T Recommendation V.250: " Serial asynchronous automatic dialling and control"
- [61] 3GPP TS 24.334: "Proximity-service (ProSe) User Equipment (UE) to ProSe function protocol aspects; Stage 3"
- [62] 3GPP TS 25.307: "Requirements on User Equipments (UEs) supporting a release-independent frequency band"
- [63] 3GPP TS 23.402: "Architecture enhancements for non-3GPP accesses"
- [64] IETF RFC 5996: "Internet Key Exchange Protocol Version 2 (IKEv2)".
- [65] IETF RFC 3948: "UDP Encapsulation of IPsec ESP Packets".
- [66] IETF RFC 4187 (January 2006): "Extensible Authentication Protocol Method for 3rd Generation Authentication and Key Agreement (EAP-AKA)".
- [67] 3GPP TS 24.302: "Access to the 3GPP Evolved Packet Core (EPC) via non-3GPP access networks"
- [68] ITU-T Recommendation V.42: " Error-Correcting Procedures for DCEs using Asynchronous-to-synchronous conversion".

3 Definitions and abbreviations

3.1 Definitions

For the purposes of the present document, the terms and definitions given in TR 21.905 [26] apply.

3.2 Abbreviations

For the purposes of the present document, the abbreviations given in TR 21.905 [26] apply.

4 E-UTRAN/SAE system architecture and test models

4.1 Test system architecture

4.1.1 General system architecture

The general system architecture is shown in figure 4.1.1-1.

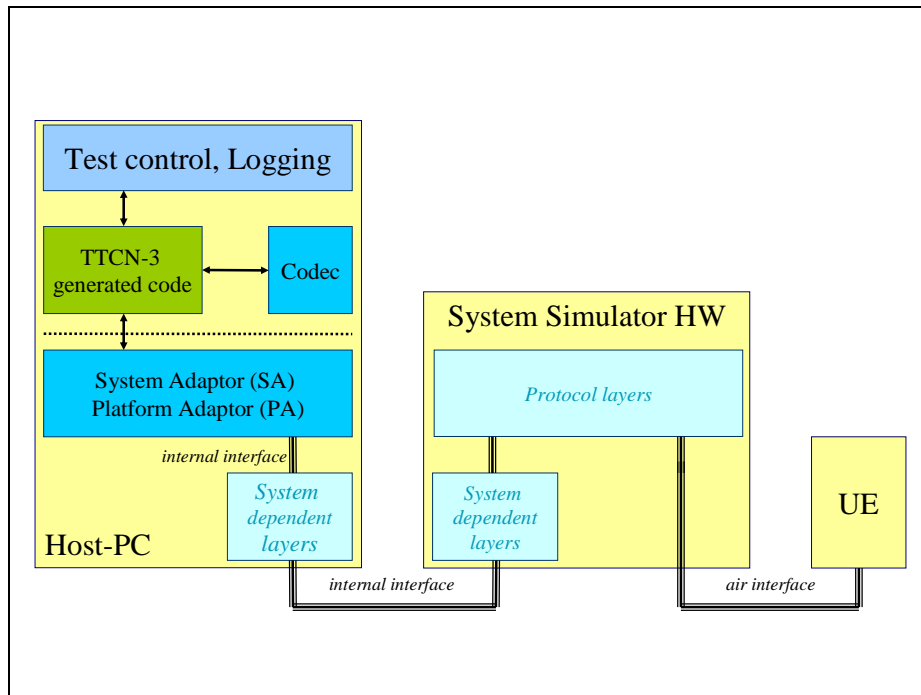

Figure 4.1.1-1: Architecture of system simulator

The scope of the present document is the TTCN-3 implementation of conformance tests. Specifications and definitions of the present document affect the codec and the system adaptor (SA). Test control and logging are out of scope as well as the interface between the TTCN-3 generated code and the system adaptor which can be either standardised TRI or proprietary.

The main assumptions regarding the system architecture are:

- TTCN-3 code runs on the host system only:
- No TTCN-3 components are downloaded to system simulator HW.
- Layer 2 tests (MAC, RLC) are controlled by appropriate configuration primitives in TTCN-3 but neither layer 2 nor parts of it are implemented in TTCN-3; the system simulator performs low layer procedure autonomously but all system simulator implementations shall result in the same test pattern at the air interface.
- Proprietary interfaces e.g. instead of the TRI are not considered in the test model.
- The timing considerations of the conformance tests shall be supported by appropriate timing information (e.g. system frame number) provided from/to the system simulator rather than by timing measurements in TTCN-3.

4.1.2 Component architecture

For E-UTRAN conformance tests each access technology (RAT) is hosted by a separate TTCN-3 parallel component (PTC):

- E-UTRAN.
- UTRAN.
- GERAN.
- Other technologies like 3GPP2 UTRAN.

The PTCs are controlled by the TTCN-3 master test component (MTC) which:

- is independent from the RAT;
- may host the upper tester for MMI and AT commands;
- creates, synchronises and terminates the PTCs;
- starts and terminates test cases.

Figure 4.1.2-1 shows this component architecture for a E-UTRAN and UTRAN scenario.

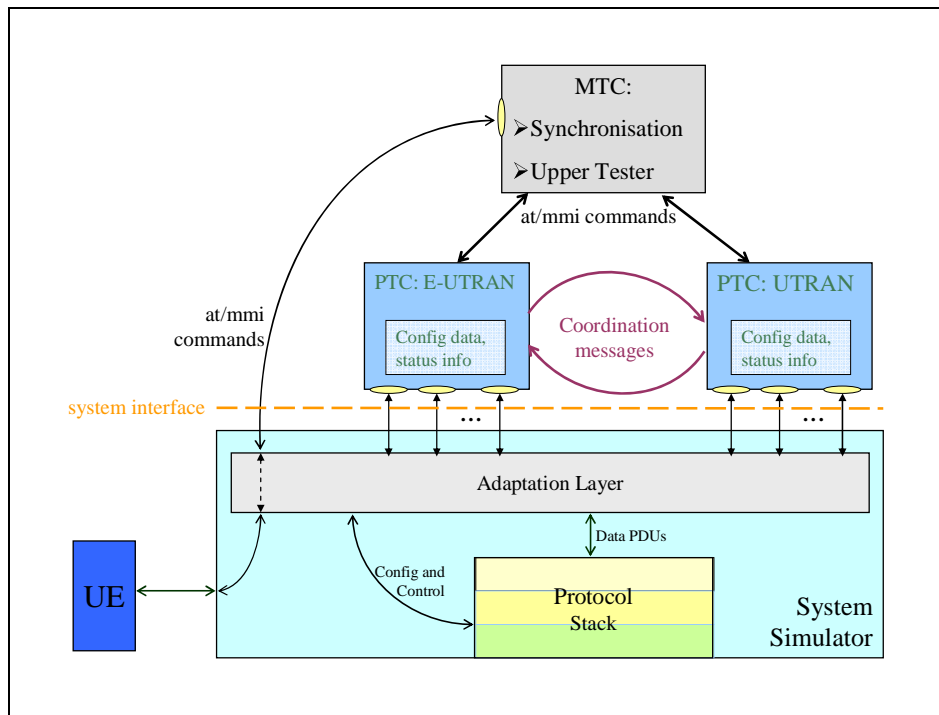

Figure 4.1.2-1: E-UTRAN-UTRAN component model

According to this model there are different interfaces to be considered:

MTC - PTC:

- common synchronisation of PTCs;
- upper tester primitives.

MTC - System Interface:

- upper tester primitives.

PTC - PTC:

- primitives containing information for IRAT handover.

PTC - System Interface:

- primitives containing peer-to-peer message;
- configuration primitives.

4.2 E-UTRAN test models

4.2.1 Layer 2 test models

When test loop mode is used for the Layer 2 tests the DRB ports at the SS side is referred to the raw DRB ones. At the SS side, DRBs are initially configured with default modes and parameters. For the purpose of L2-testing the DRBs may be reconfigured later on as indicated in the subsequent test models (see below).

4.2.1.1 MAC test model

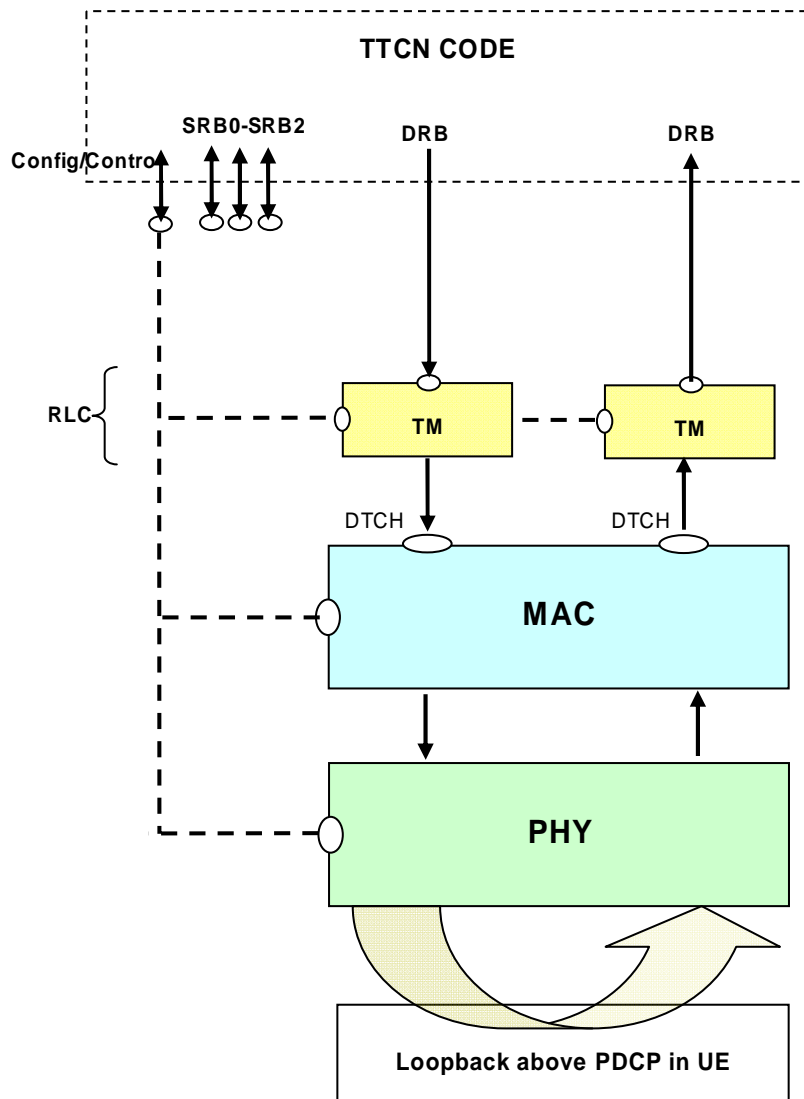

Figure 4.2.1.1-1: Test model for MAC testing

The UE is configured in Test Loop Mode, to loop back the user domain data above PDCP layer. On UE side Ciphering is enabled (since Mandatory) but with dummy ciphering algorithm, which is equivalent to not using ciphering. ROHC is not configured on UE Side.

On the SS Side, Layer 1 is configured in the normal way. MAC is configured in a special mode, where it does not add any MAC headers in DL and /or not remove any MAC headers in UL directions respectively at DRB port. In this case, the TTCN shall provide the final PDU, including padding. Except for this, the MAC layer shall perform all of its other functions.

On DRBs the RLC is configured in transparent mode. Hence with this configuration PDU's out of SS RLC are same as the SDU's in it. There is no PDCP configured on SS Side. The ports are directly above RLC.

There are two different test modes in which MAC header addition/removal can be configured:

DL/UL header-transparent mode: no header addition in DL and no header removal in UL.

DL only header-transparent mode: no header addition in DL; UL MAC is configured in normal mode to remove MAC header and dispatch the MAC SDUs according to the logical channel Ids.

If SS MAC is configured in DL/UL header-transparent mode, the PDU's exchanged at the DRB port between TTCN and SS, shall be the final MAC PDU's consisting of MAC, RLC and PDCP headers. TTCN code shall take care in DL of building MAC header, RLC headers and PDCP headers and in UL handle MAC, RLC and PDCP headers. TTCN code shall take care of maintaining sequence numbers and state variables for RLC and PDCP layers. During testing of multiple DRBs at the UE side, it shall still be possible to configure only one DRB on SS side with configuration in the figure 4.2.1.1-1. Other DRBs will not be configured, to facilitate routing UL TBSs. Multiplexing/de-multiplexing of PDUs meant/from different DRBs shall be performed in TTCN. Since the MAC layer does not evaluate the MAC headers in UL it cannot distinguish between SRB and DRB data in UL. Therefore there shall be no SRB traffic while MAC is configured in this test mode. The SS MAC shall take care of automatic repetitions in UL and DL, based on normal MAC HARQ behaviour.

If SS MAC is configured in DL only header-transparent mode, the UL PDUs exchanged at the DRB port between TTCN and SS, shall be final RLC PDUs consisting of RLC and PDCP headers. SS shall route these PDUs based on logical channel IDs. In DL, TTCN sends fully encoded MAC PDUs at the DRB port (consisting of MAC, RLC and PDCP headers). In this case TTCN needs to take care of maintaining sequence numbers and state variables for RLC and PDCP layers. Furthermore in UL and DL the SS MAC layer shall be capable of dealing with SRB data (i.e. it shall handle DL RLC PDUs coming from SRBs RLC layer or dispatch UL RLC PDUs to SRBs) as in normal mode. The SS MAC shall take care of automatic repetitions in UL and DL, based on normal MAC HARQ behaviour.

NOTE: TTCN shall ensure that no DL MAC SDUs in normal mode and DL MAC PDUs in test mode are mixed for the same TTI.

The UL Scheduling Grant and DL Scheduling assignments are configured from TTCN over system control port. SS reports PUCCH scheduling information reception over system indication port, if configured. In a similar way the reception of RACH preambles is reported by SS over the same port.

4.2.1.2 RLC test model

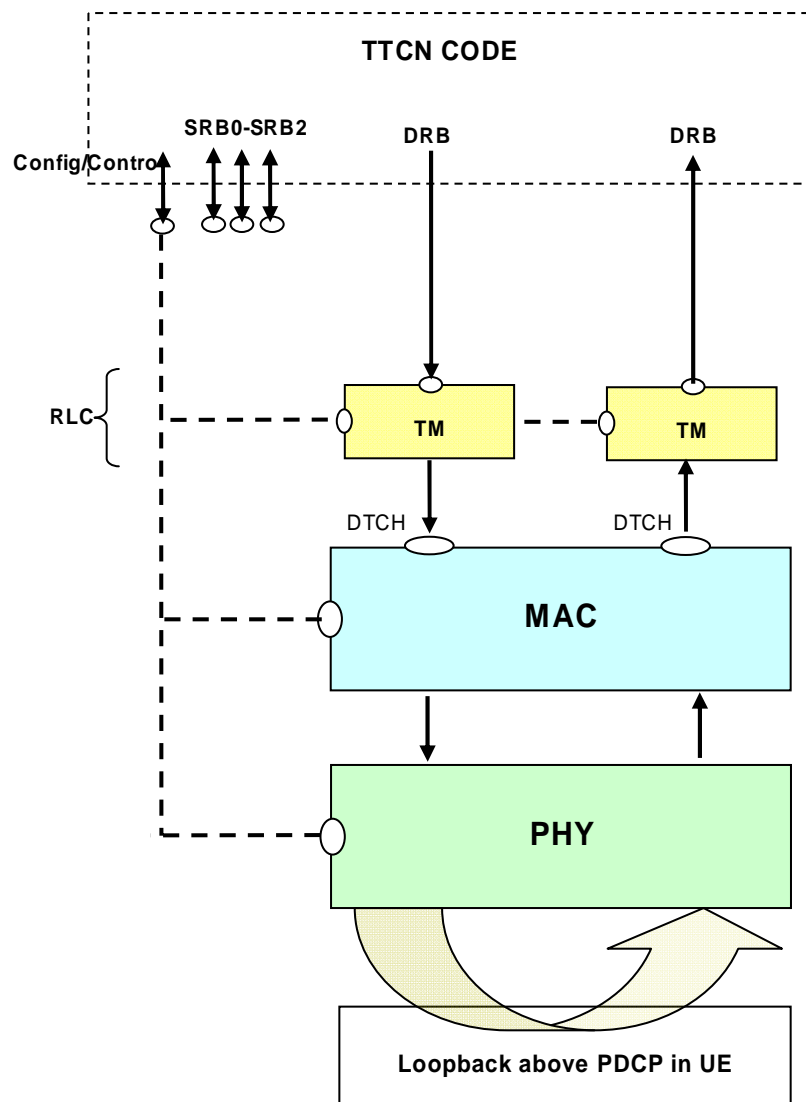

Figure 4.2.1.2.3-1: Test model for RLC AM/UM testing

This model is suitable for testing both UM/AM mode of operation of DRBs on UE side.

The UE is configured in Test Loop Mode, to loop back the user domain data above PDCP layer. On UE side Ciphering is enabled (since mandatory) but with dummy ciphering algorithm, which is equivalent to not using ciphering. ROHC is not configured on UE Side.

On the SS Side, L1 and MAC are configured in the normal way. The RLC is configured in transparent mode. Hence with this configuration PDUs out of SS RLC are same as the SDUs in it. There is no PDCP configured on SS Side. The ports are directly above RLC.

The PDUs exchanged between TTCN and SS, shall be the final RLC PDUs consisting of RLC and PDCP headers. TTCN code shall take care in DL of building RLC headers and PDCP headers and in UL handle RLC and PDCP headers. TTCN code shall take care of maintaining sequence numbers and state variables for RLC and PDCP layers. If RLC on UE side is in AM mode, TTCN shall take care of generating polls in DL and responding with RLC control PDUs on reception of UL Poll.

The UL Scheduling Grant and DL Scheduling assignments are configured from TTCN over system control port.

4.2.1.3 PDCP test model

4.2.1.3.1 PDCP ROHC test model

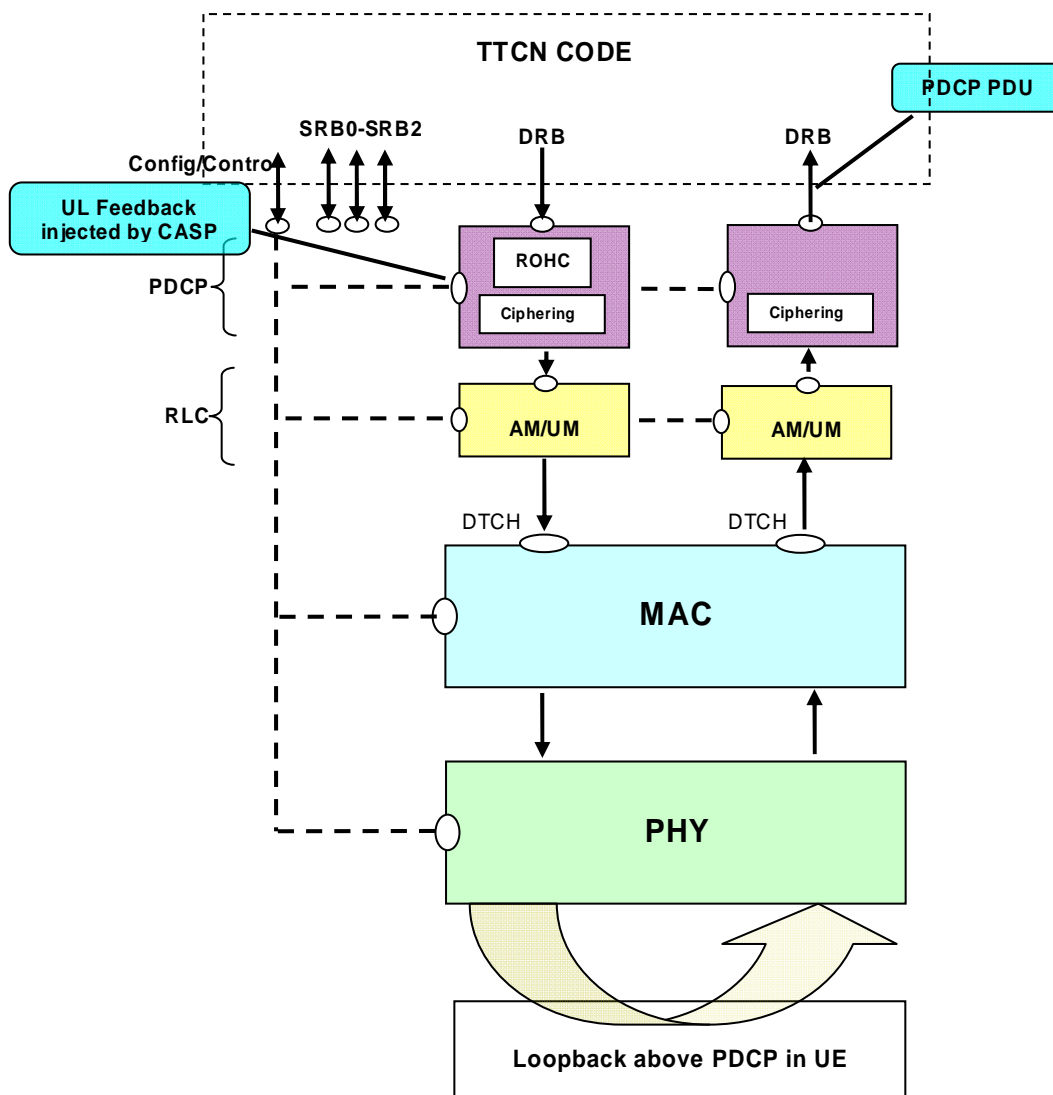

Figure 4.2.1.3.1-1: Test model for PDCP ROHC testing

The UE is configured in Test Loop Mode, to loop back the user domain data above PDCP layer. On UE side Cipherring is enabled and ROHC is configured.

On the SS Side L1, MAC and RLC are configured in normal way. They shall perform all of their functions. The ports are above PDCP.

The PDCP is configured in special mode, with no header manipulation. Cipherring is configured in both directions. ROHC is configured in DL direction only. UL ROHC feedback can be injected by control ASP. It shall be possible to configure 'no header manipulation' mode independently in UL and DL directions. When configured in special mode, SS shall not add PDCP header (DL) and remove PDCP Header (UL). PDCP state variables shall be maintained by SS PDCP layer. It shall be possible for SS PDCP to update state variables based on the PDU's in both directions, even though headers are not added/removed. Also, it shall be possible to read or set the PDCP internal state variables, by control primitives.

The UL Scheduling Grant and DL Scheduling assignments are configured from TTCN over system control port. SS reports PUCCH scheduling information reception over system indication port, if configured.

4.2.1.3.2 PDCP test model (Non ROHC)

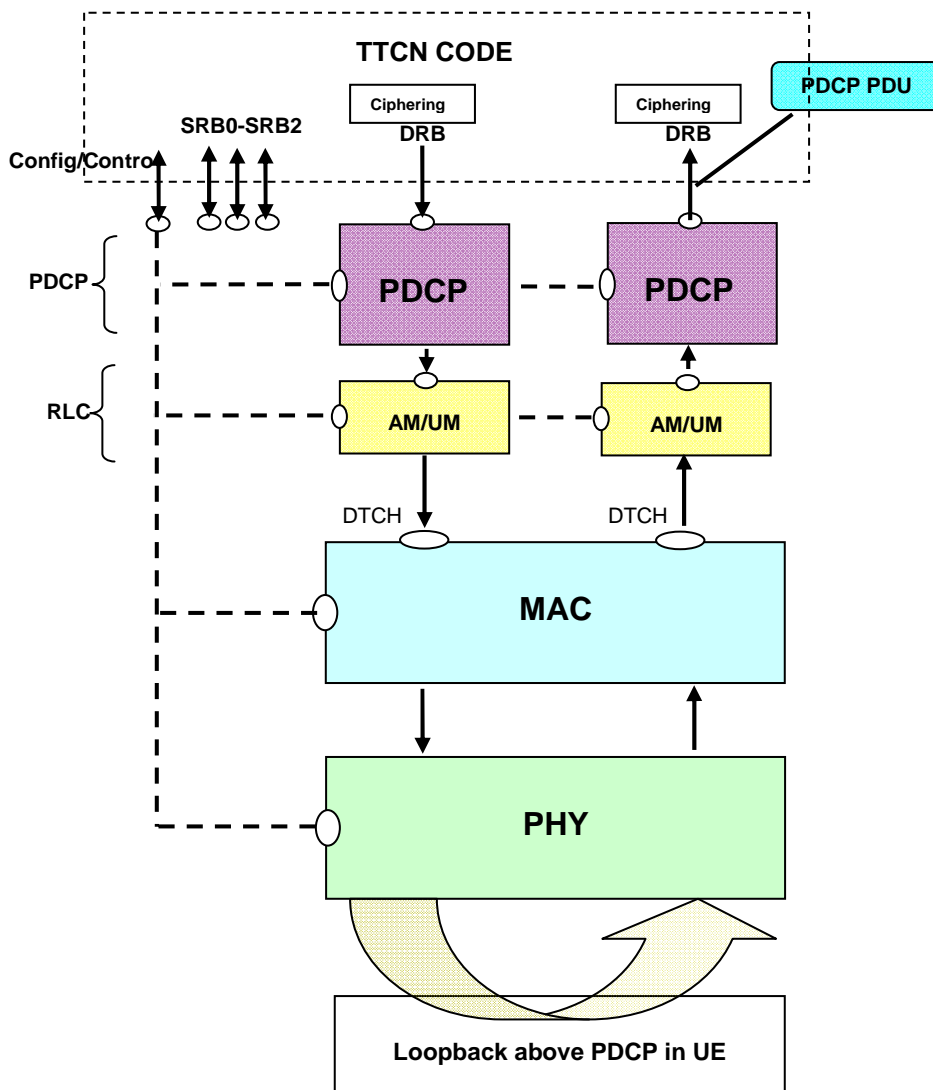

Figure 4.2.1.3.2-1: Test model for PDCP (Non ROHC) testing

The UE is configured in Test Loop Mode, to loop back the user domain data above PDCP layer. On UE side Ciph. is enabled and ROHC is not configured.

On the SS Side L1, MAC and RLC are configured in normal way. They shall perform all of their functions. The ports are above PDCP.

The PDCP is configured in a special mode, named transparent mode. In this mode, SS shall not add PDCP header (DL) and remove PDCP Header (UL). The TTCN maintains sequence numbers and state variables for the PDCP layer. The TTCN makes use of the AS ciph. functionality in both directions, employing the dummy ciph. algorithm. Ciph./deciph. are performed using TTCN external functions. ROHC is not configured.

The UL Scheduling Grant and DL Scheduling assignments are configured from TTCN over system control port. SS reports PUCCH scheduling information reception over system indication port, if configured.

4.2.2 RRC test model

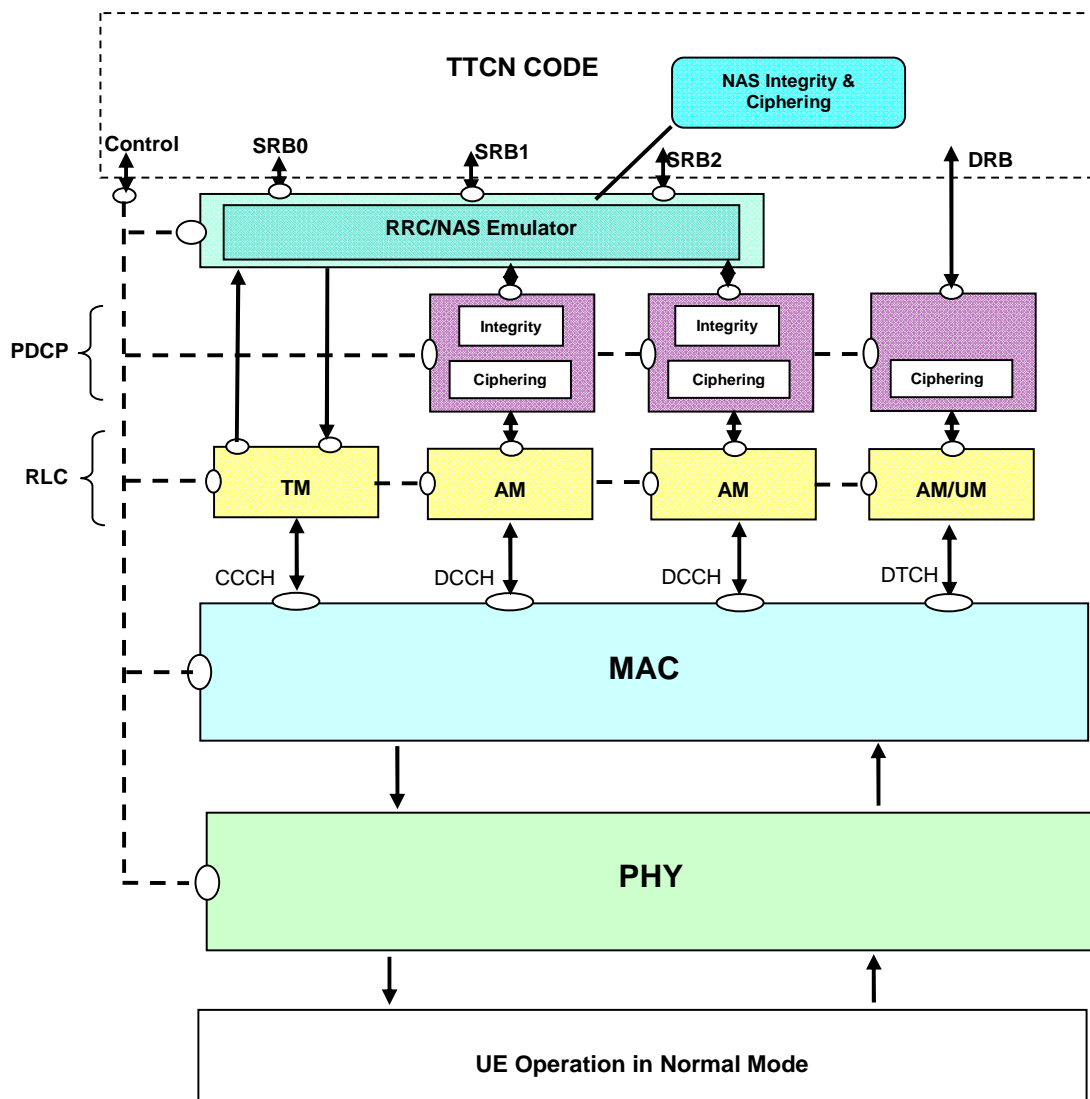

Figure 4.2.2-1: Test model for RRC testing

The UE is configured in normal mode. On UE side Ciphering/Integrity (PDCP and NAS) is enabled and ROHC is not configured.

On the SS Side L1, MAC, RLC and PDCP are configured in normal way. They shall perform all of their functions. For SRB0 the DL and UL port is above RLC. For SRB1 and SRB2 the port is above/below the RRC and NAS emulator, which may be implemented as a parallel test component. For DRB, the port is above PDCP. PDCP Ciphering/Integrity is enabled. NAS integrity/Ciphering is enabled.

The RRC/NAS emulator for SRB1 and SRB2 shall provide the Ciphering and integrity functionality for the NAS messages. In UL direction, SS shall report RRC messages, still containing (where appropriate) the secure and encoded NAS message, to the RRC port. In DL, RRC and NAS messages with same timing information shall be embedded in one PDU after integrity and ciphering for NAS messages.

The UL Scheduling Grant and DL Scheduling assignments are configured from TTCN over system control port. SS reports PUCCH scheduling information reception over system indication port, if configured.

4.2.3 DRB test model

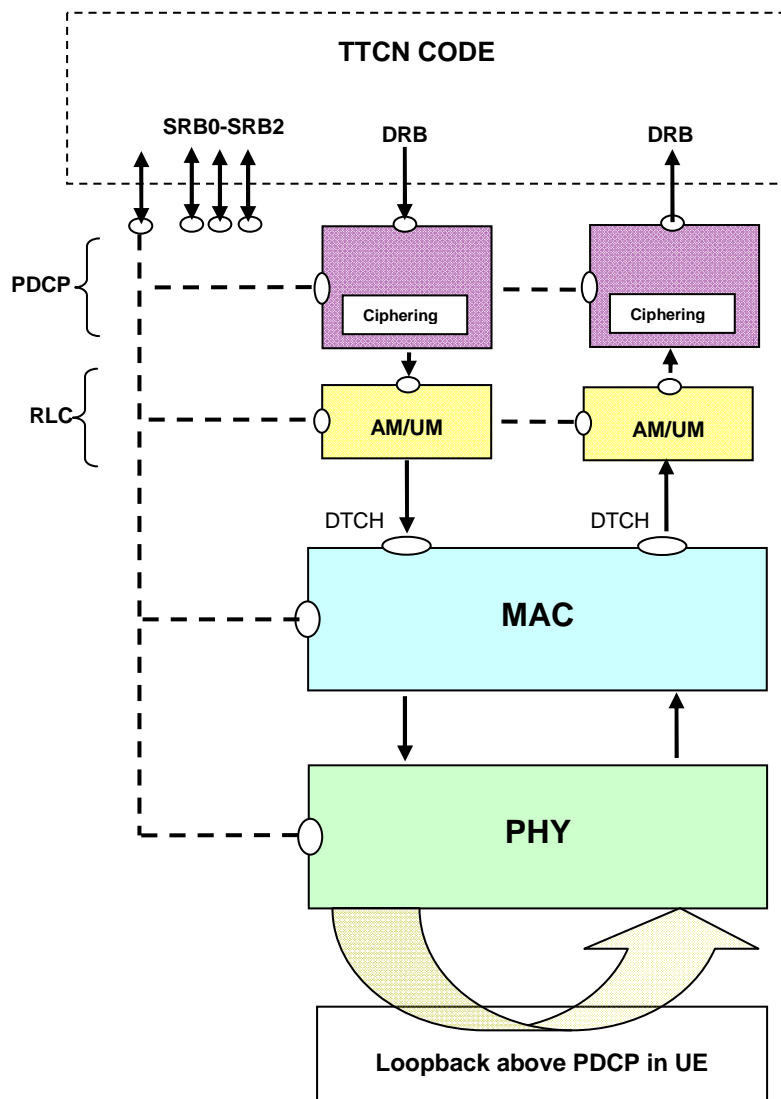

Figure 4.2.3-1: Test model for DRB testing

The UE is configured in Test Loop Mode, to loop back the user domain data above PDCP layer. Ciphering is optionally configured on UE side. In TTCN the DRB data is considered as raw data and there is no IP handling while the UE is in loopback mode.

On the SS Side L1, MAC, RLC and PDCP are configured in normal way. They shall perform all of their functions. The ports are above PDCP. When test loop mode is used for the DRB, the ports at the SS side refer to the raw DRB ones. Ciphering is enabled and ROHC is not configured on SS Side.

SS shall send in DL all PDU's received from different RB's but with same timing control information in one MAC PDU and in one TTI.

The UL Scheduling Grant and DL Scheduling assignments are configured from TTCN over system control port. SS reports PUCCH scheduling information reception over system indication port, if configured.

4.2.4 IP Test Model

Depending on different test scenarios user plane data can be distinguished in:

- Raw user data upon EUTRA PDCP (Raw mode);

- IP user data (IP mode).

The raw user data are applied for L2 or DRB tests, no IP protocols are involved. The UL user data is directly routed to the EUTRA_PTC.

The IP user data are applied when IP packets data are discarded, looped back or handled in TTCN. A DRB can have one or more Transport and Internet protocols configured.

Whether a DRB is in IP or in raw mode depends on the configuration of the routing table in the DRB-Mux. This is controlled by the IP_CTRL port and independent from the configuration of the IP connections (IP_SOCKET).

4.2.4.1 IP user data

To allow the usage of common protocol implementations at the system adaptor the related interfaces in TTCN-3 are based on the Sockets API.

There can be one or several sockets (server or client) for each DRB: TCP, UDP and ICMP.

Each socket can be clearly identified by the IP address, port number and the protocol (tcp|udp|icmp). It implies that a TCP socket can be either server or client.

It is assumed that:

- Different DRBs are not using the same sockets.
- The UE behaviour of a single IP-based protocol on a specific socket like DHCP can be included in conformance tests.
- Other protocols like ESP are not considered but can easily be introduced later, if necessary, by using the same socket approach.

The routing of IP packets from the IP stack to the DRBs in DL, and from the DRBs either to the DRB port (E_DRB in case of EUTRA) or to the IP stack or discard/loopback in UL is done by the DRB-Mux. This behaviour is controlled by the DRB-Mux's routing table.

The general architecture of the IP test model is shown in figure 4.2.4.1-1 (with a DHCP server as example for IP handling).

- NOTE: In figure 4.2.4.1-1 DHCP is one example for a protocol above the IP stack; other protocols like DNS can also be implemented but this a pure TTCN implementation issue and independent from the system interface.

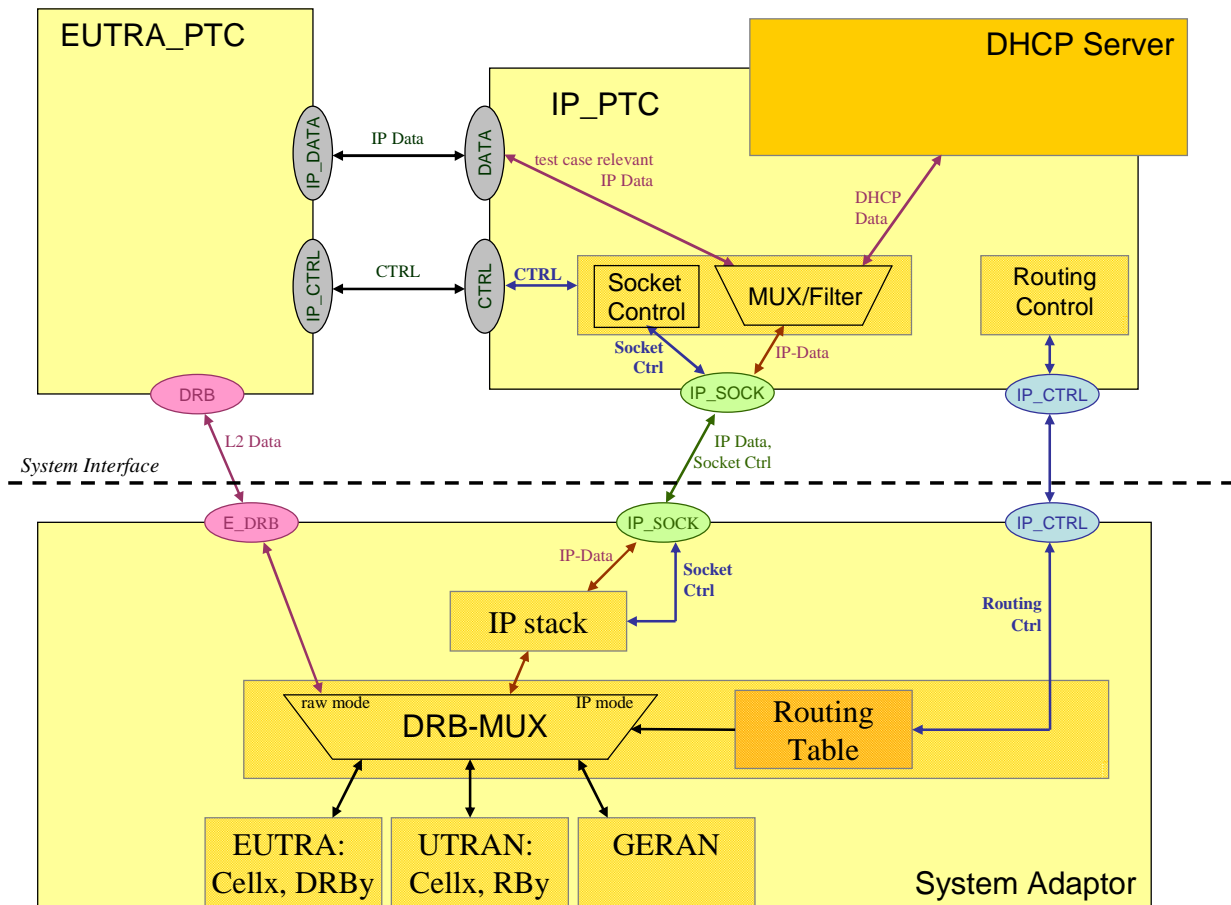

Figure 4.2.4.1-1: Example of EUTRA IP test model with a DHCP server

4.2.4.2 Configuration of Sockets

The following configurations are controlled by the IP_PTC (IP_SOCKET_REQ). The socket configuration and the sending/receiving of data are done with the same ASP on the system port IP_SOCK.

4.2.4.2.1 Socket Establishment

TCP server

TCP socket configured as server: the socket 'listens' to a 'connect' from the UE. The socket can be configured by using the following system calls of the Berkeley Sockets API:

- socket (AF_INET | AF_INET6, SOCK_STREAM, 0);
- setsockopt;
- bind (local IP address Port);
- listen.

NOTE: Currently the only socket option being defined is SO_BROADCAST

When the UE connects to the server the connection is accepted with the 'accept' system call.

TCP client

A TCP connection is established to an existing TCP server at the UE side. This can be done with the following system calls:

- socket (AF_INET|AF_INET6, SOCK_STREAM, 0);
- setsockopt;
- connect (remote Server Addr of the UE = IP-Addr + Port).

UDP socket

A UDP socket can be established with the system calls

- socket (AF_INET|AF_INET6, SOCK_DGRAM, 0);
- setsockopt;
- bind (local IP address, Port);
- connect.

NOTE 1: 'setsockopt' can be used to set the option SO_BROADCAST to allow broadcast messages (e.g. for DHCP).

NOTE 2: Usage of 'connect' depends on implementation of the system adaptor.

4.2.4.2.2 Socket Release

A socket is released:

- in case of TCP when the remote entity closes the connection;
- when it is closed explicitly by the IP_PTC (system call 'close').

NOTE 1: In general the sockets are independent from the configuration of the DRBs. Especially in case of UDP or ICMP the sockets can exist even without any DRB being configured.

NOTE 2: For IMS, TCP close happens for unprotected ports after initial registration and for protected ports after deregistration or re-registration: Any protected TCP connections are kept as long as the UE is registered independent of whether the RRC connection is released in between. In general TCP close is expected to be done from the client's end.

In detail

- after initial registration TTCN waits ΔT seconds for the UE to close any TCP connection on the unprotected port
- after de-registration TTCN waits ΔT seconds for the UE to close its client TCP connection; after this is done the TTCN closes any remaining TCP connection (independently of the server/client role)
- after re-registration when there is a new security context TTCN waits ΔT seconds for the UE to close its client TCP connection of the old security context.
- as special case after an emergency call the same procedure is applied as for de-registration ΔT is 3s.

4.2.4.3 Handling of IP data

Sending and receiving of IP data is done by the same ASPs as the socket establishment on IP_SOCKET. In TTCN the IP data are handled by a separate TTCN component: IP_PTC. This PTC can deal with the data according to the respective protocol, e.g. DHCP. In general, this is out of scope for the (signalling conformance) test case in terms of pass/fail assignment.

The IP_PTC will receive data from sockets being configured for the corresponding IP protocols. Any unrecognised IP packets are discarded by the IP stack in the system adaptor.

When the IP data is relevant for the test purpose, e.g. the test purpose is to test DHCP, the IP data are routed to the EUTRA_PTC. This allows generic protocol implementations for the common case, i.e. IP_PTC and DHCP server are independent from test case specific implementations.

The interface between EUTRA_PTC and IP_PTC is a pure TTCN implementation issue and independent of the system interface. Furthermore it is irrelevant for the system interface whether e.g. the DHCP server is part of the IP_PTC or implemented as a separate PTC.

- For TCP, the primitives to send and receive data correspond to the 'send' and 'recv' system calls.
- For UDP and ICMP, the primitives correspond to the 'sendto' and 'recvfrom' system calls.
- For both UDP and TCP the system adaptor may send ("in-band") error indications in case of system errors. That results in an assignment of inconc by the IP_PTC.

4.2.4.4 Routing of IP Data

The routing of IP data is done in the DRB-Mux which gets a routing table configured. This table associates the address and protocol information of IP packets (protocol, local IP address, local port, remote IP address, remote port) with the radio bearer (RAT, cell, DRB id).

In UL a DRB is considered being in raw mode when there is no entry found in the routing table. It is considered being in IP mode when there is any entry regardless of the protocol and address information being stored, i.e. in UL, the SS does not need to evaluate the IP header to route the data (in raw mode this would cause problems in the case of loopback data). In addition for the IP mode, specific entries of the routing table can be flagged to discard or loopback IP packets matching this entry.

The discard mode can be used e.g. for rSRVCC to suppress RTP/RTCP data on the default AM DRB during HO. The major purpose is to discard the data silently (i.e. to suppress any error reporting like ICMP error messages).

NOTE: It is up to system implementation how packets are discarded (explicitly or implicitly by the IP stack) as long as it done silently.

The loopback mode can be configured for RTP and/or RTCP, and depending on the protocol the SS shall manipulate the packets as follows :

- swapping of source and destination address and port .

NOTE: Further manipulation of the RTP header and/or RTCP header is not considered in the present document. Beyond the aforementioned requirements, it is up to system implementation how packets are looped back.

In DL the IP packets of the IP stack are routed to the DRBs acc. to the routing information in the routing table (see annex D for details).

NOTE: Only the IP PTC can re-configure the Routing Table; if that needs to be triggered by a RAT specific PTC, this is done by appropriate coordination messages but the RAT specific PTCs don't have a direct access to the routing tables.

4.2.4.5 Multiple PDNs

In case multiple PDNs broadcast, or multicast datagrams sent by the UE, need to assigned to the respective PDN:

IPv4

When the UE does not get a valid IPv4 address assigned via NAS signalling it will request the IP address via DHCP. In this case there are DHCP broadcast messages in UL.

In the case of multiple PDNs, it cannot be distinguished by evaluating the IP address to which PDN the message belongs but additional information is necessary:

The network side needs to know which interface (i.e. network) the broadcast comes from; in case of LTE this is associated with the default bearer of the particular PDN.

NOTE: In principle the 'chaddr' field or the 'client identifier' option of the DHCP messages may be used to distinguish different interfaces (e.g. for Ethernet this would be the MAC address) but it is not specified how these fields are to be used by the UE (or how to configure them at the UE); RFCs (e.g. RFC 2131) only require the client identifier to be unique in a given subnet.

IPv6

The UE gets an interface identifier assigned via NAS signalling (TS 24.301 [21] clause 6.2.2) which is used as link-local address during stateless address auto configuration (TS 23.060 [43] clause 9.2.1.1 and TS 29.061 [44] clause 11.2):

The UE may send a ROUTER SOLICITATION message (multicast) to which the network responds with a ROUTER ADVERTISEMENT.

Since the ROUTER SOLICITATION message contains the interface identifier as assigned via NAS signalling, even in the case of multiple PDNs it can distinguish which PDN is concerned, as long as the interface identifiers are different for different PDNs (for UE side as well as for network side).

NOTE: According to TS 23.060 [43] clause 9.2.1.1 and RFC 3314 a real network (PDN-GW) itself shall send an (unsolicited) ROUTER ADVERTISEMENT after it has assigned the interface identifier.

Conclusions and Requirements:

In the case of broadcast or multicast messages TTCN needs additional information about the PDN being addressed.

When a socket connection is configured to allow broadcasts and there is a broadcast or multicast message in UL the SS shall provide information about on which bearer the datagram has been sent (RAT, cell, DRB id).

NOTE: From the socket programming point of view multiple PDNs for the SS are like a multi-homed host: Servers for different interfaces are bound to different interfaces (e.g. using the 'bind' system call with a specific IP address instead of IPADDR_ANY) or a server may retrieve the interface id for a received datagram from the IP stack with an appropriate system call.

Even though the details are implementation dependent, the SS shall be capable of:

determining RAT, cell, DRB id for any broadcast or multicast datagram in UL

avoiding any duplication of messages in UL even when multiple servers are listening to broadcast/multicast messages (what is a possible SS implementation)

4.2.4.6 IP Addresses Guidelines

4.2.4.6.1 Common Structure of IP Addresses

IPv4:

Network prefix (subnet address)	n bits
Host part	32-n bits

with 'n' e.g. depending on the network class

IPv6:

Network prefix	
Global routing prefix	64 – n bits
Subnet ID	n bits
Interface ID	64 bits

Addresses within one network (PDN) have all the same subnet address (IPv4) or global routing prefix (IPv6)

NOTE: As a consequence at the system simulator, routing can be done based on appropriate network masks, but that is dependent on SS implementation and therefore is out of scope for this document.

4.2.4.6.2 Common Requirements regarding IP Addresses

IP addresses are configured via PIXIT parameters as defined in clause 9.1.

These PIXIT parameters shall fulfil the following requirements:

Network and UE addresses shall be different from each other

Network entities (DHCP server, DNS server, P-CSCF etc.) of a given PDN shall all have the same global routing prefix (IPv6) or subnet address (IPv4).

The IP address assigned to the UE shall have the same global routing prefix (IPv6) or subnet address (IPv4) as the corresponding network.

Requirements for IPv6: according to TS 23.401, cl. 5.3.1.2.2

The 64 bit network prefix of a UE's IPv6 address is unique

The UE may change its interface id during auto configuration

The UE must use the given interface id in the link local address for router solicitation but may use any other interface id in the global address

NOTE: As a consequence, the SS implementation needs to cope with the changing of the UE address and cannot rely on static IP address assignment to the UE.

Global routing prefix (IPv6) and subnet address (IPv4) shall be different for different PDNs

Home agent address:

The home agent is located in the UE's home network (which shall be considered to find an appropriate network prefix for the home agent's IP address)

In order to simplify implementations, the following rules shall be applied:

The IPv6 interface identifier as assigned to the UE via NAS signalling shall be unique, i.e.

It shall be different for different PDNs

It shall differ from the interface ids of the other entities on the link (in general the interface id of the PDN-GW)

Multiple PDNs shall have different IPv6 interface identifier for the PDN-GW

NOTE: Consistency checks for addresses of different PDNs can be done based on an appropriate network mask (IPv4, e.g. 255.255.255.0) and global routing prefix (IPv6, e.g. 2001:db8:1234::/48).

4.2.4.6.3 Network Entities and their IP addresses

In general and in accordance of IMS test cases in TS 36.523-1 [1] and TS 34.229-1 [40] the simulated network architecture can be illustrated as in Figure 4.2.4.6.3-1.

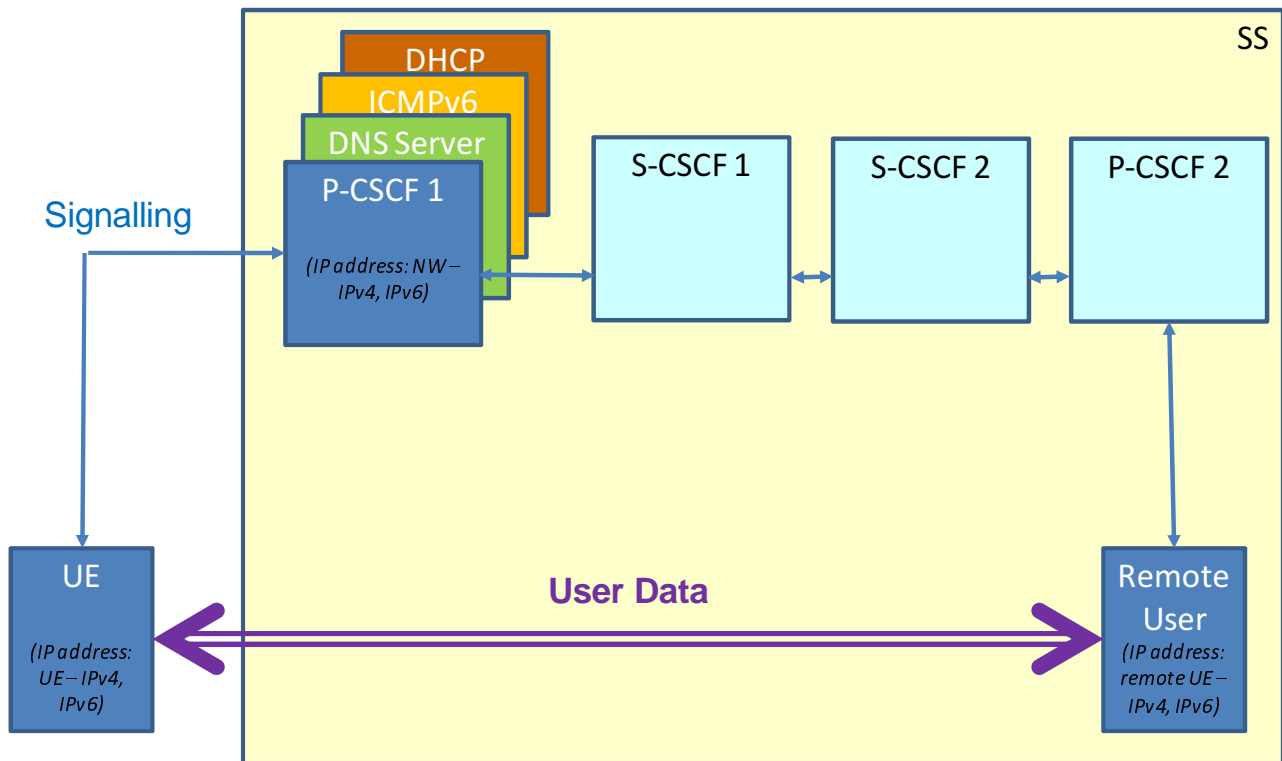

Figure 4.2.4.6.3-1: Simulated Network Architecture

For simplification and to keep the number of PIXITs small , several network entities share the same PIXIT:

- px_IPv4_AddressXX_NW: P-CSCF 1 (IPv4 address), DNS Server (IPv4 address), DHCP Server
 - px_IPv6_AddressXX_NW: P-CSCF 1 (IPv6 address), DNS Server (IPv6 address), ICMPv6 Server
- (“XX” refers to the respective PDN)

In general , in test cases according to TS 36.523-1 [1] and TS 34.229-1 [40] no IP addresses are needed for S-CSCF 1, S-CSCF 2 or P-CSCF 2.

4.2.4.7 User Plane Signalling for Address Allocation

For IPv4, the UE gets assigned the IP address via NAS signalling unless it explicitly requests to use DHCP.

For IPv6, the UE gets assigned a unique interface identifier to be used until it has successfully performed the auto-configuration procedure (Ref. to RFC 2462).

NOTE: This clause specifies behaviour of the SS (TTCN) to achieve successful IP signalling; but in general, IP signalling is out of scope for conformance tests as defined in TS 36.523-1 [1].

4.2.4.7.1 DHCP

When the UE supports IPv4 and does not get an IPv4 address via NAS signalling it will request the address via DHCP (Ref. to RFC2131).

The UE may send a **DHCPDISCOVER** with or without Rapid Commit Option (Ref. to RFC 4039):

UE sends **DHCPDISCOVER** according to table 4.2.4.7.1-1 with Rapid Commit Option.

TTCN sends **DHCPACK** according to table 4.2.4.7.1-4

UE sends **DHCPDISCOVER** according to table 4.2.4.7.1-1 without Rapid Commit Option.

TTCN sends **DHCPOFFER** according to table 4.2.4.7.1-2

When the Rapid Commit option is not used the UE sends a DHCPREQUEST as response to the DHCPOFFER:

UE sends **DHCPREQUEST** according to table 4.2.4.7.1-3

TTCN sends **DHCPACK** according to table 4.2.4.7.1-4

Any other DHCP messages shall be ignored by TTCN.

Table 4.2.4.7.1-1: DHCPDISCOVER

UDP		
SRC ADDR	0.0.0.0	any address
SRC Port	68	not checked
DEST ADDR	255.255.255.255	broadcast
DEST Port	67	
DHCP		
op	'01'O	BOOTREQUEST
htype	any value	
hlen	any value	
hops	any value	
xid	any value	
secs	any value	
flags	any value	
ciaddr	any value	0 according to RFC 2131 Table 5
yiaddr	any value	0 according to RFC 2131 Table 5
siaddr	any value	0 according to RFC 2131 Table 5
giaddr	any value	0 according to RFC 2131 Table 5
chaddr	any value	client's hardware address
sname	any value	(may be overloaded with further options)
file	any value	(may be overloaded with further options)
options		NOTE
magic cookie	'63825363'O	
message type	'01'O	DHCPDISCOVER
rapid commit	present	shortened address assignment by 2-message exchange acc. to RFC 4039
	not present	address assignment by 4-message exchange
NOTE: Any further options are not evaluated and ignored by TTCN		

Table 4.2.4.7.1-2: DHCPOFFER

UDP		
SRC ADDR	valid server address	address as configured by PIXIT
SRC Port	67	
DEST ADDR	255.255.255.255	broadcast
DEST Port	68	
DHCP		
op	'02'O	BOOTREPLY
htype	as in corresponding DHCPDISCOVER	NOTE 1
hlen	as in corresponding DHCPDISCOVER	NOTE 1
hops	'00'O	NOTE 2
xid	as in corresponding DHCPDISCOVER	NOTE 2
secs	'0000'O	NOTE 2
flags	as in corresponding DHCPDISCOVER	NOTE 2
ciaddr	'00000000'O	NOTE 2
yiaddr	valid UE address	address to be assigned to the UE (as configured by PIXIT)
siaddr	0	the UE does not need to retrieve any operating system executable image
giaddr	as in corresponding DHCPDISCOVER	NOTE 2
chaddr	as in corresponding DHCPDISCOVER	NOTE 2
sname	'0000000000000000'O	
file	'00000000000000000000000000000000'O	
options		
magic cookie	'63825363'O	
message type	'02'O	DHCPOFFER
lease time	86400	one day; mandatory (NOTE 2)
server identifier	server address	server address as used in the UDP header
NOTE 1: To get any valid value		
NOTE 2: According to table 3 in RFC 2131		

Table 4.2.4.7.1-3: DHCPREQUEST

UDP		
SRC ADDR	0.0.0.0	any address
SRC Port	68	not checked
DEST ADDR	255.255.255.255	broadcast
DEST Port	67	
DHCP		
op	'01'O	BOOTREQUEST
htype	any value	
hlen	any value	
hops	any value	
xid	any value	
secs	any value	
flags	any value	
ciaddr	any value	0 according to RFC 2131 Table 5
yiaddr	any value	0 according to RFC 2131 Table 5
siaddr	any value	0 according to RFC 2131 Table 5
giaddr	any value	0 according to RFC 2131 Table 5
chaddr	any value	client's hardware address
sname	any value	(may be overloaded with further options)
file	any value	(may be overloaded with further options)
options		NOTE
magic cookie	'63825363'O	
message type	'02'O	DHCPREQUEST
NOTE: Any further options are not evaluated and ignored by TTCN		

Table 4.2.4.7.1-4: DHCPACK

UDP		
SRC ADDR	valid server address	address as configured by PIXIT
SRC Port	67	not checked
DEST ADDR	255.255.255.255	broadcast
DEST Port	68	
DHCP		
op	'02'O	BOOTREPLY
htype	'01'O	
hlen	as in corresponding DHCPREQUEST or DHCPDISCOVER	NOTE
hops	'00'O	NOTE
xid	as in corresponding DHCPREQUEST or DHCPDISCOVER	NOTE
secs	'0000'O	NOTE
flags	as in corresponding DHCPREQUEST or DHCPDISCOVER	NOTE
ciaddr	'00000000'O	NOTE
yiaddr	valid UE address	address to be assigned to the UE (as configured by PIXIT)
siaddr	0	the UE does not need to retrieve any operating system executable image
giaddr	as in corresponding DHCPREQUEST or DHCPDISCOVER	NOTE
chaddr	as in corresponding DHCPREQUEST or DHCPDISCOVER	NOTE
sname	'0000000000000000'O	
file	'00000000000000000000000000000000'O	
options		
magic cookie	'63825363'O	
message type	'05'O	DHCPACK
lease time	86400	one day; mandatory (NOTE)
server identifier	server address	server address as used in the UDP header
NOTE: According to table 3 in RFC 2131		

4.2.4.7.2 DHCPv6

DHCPv6 is not needed for E-UTRA conformance tests as defined in 36.523-1[1]

4.2.4.7.3 ICMPv6

When the UE supports IPv6 it will perform IPv6 Stateless Address Auto configuration according to RFC 4862. The UE sends an **ICMPv6 Router Solicitation** message according to table 4.2.4.7.3-1; as response the TTCN sends an **ICMPv6 Router Advertisement** message according to table 4.2.4.7.3-2.

NOTE: The TTCN does not send any (periodic) unsolicited Router Advertisement, i.e. the UE is expected to ask for an immediate advertisement whenever it is needed.

Any other ICMPv6 messages are ignored by the TTCN (especially in accordance to TS 23.060, clause 9.2.1.1, the TTCN silently discards Neighbour Solicitation).

Table 4.2.4.7.3-1: ICMPv6 Router Solicitation

IPv6		
SRC ADDR	link local address	NOTE 1
DEST ADDR	multicast address	NOTE 2
ICMPv6 (Ref. to RFC 4861)		
type	133	Router Solicitation
code	0	
checksum	not checked	
reserved	ignored	
options		
source link-layer address	ignored if present	
other options	ignored	
NOTE 1: The UE shall use the interface identifier as assigned via NAS signalling (but this is not checked in TTCN).		
NOTE 2: TTCN detects the multicast address by checking it to start with FF02 but accepts any of these addresses.		

Table 4.2.4.7.3-2: ICMPv6 Router Advertisement

IPv6		
SRC ADDR	link local address (NW)	NOTE 1
DEST ADDR	link local address (UE)	NOTE 2
ICMPv6 (Ref. to RFC 4861)		
type	134	Router Advertisement
code	0	
checksum	calculated by TTCN	
current hop limit	64	arbitrarily selected
m-flag	'0'B	no "Managed address configuration"; NOTE 3
o-flag	'0'B	no "Other configuration"
reserved	'000000'B	
router lifetime	65535	max. value
reachable time	0	unspecified
retrans timer	0	unspecified
options		
source link-layer address	not present	
mtu	not present	
prefix information		
type	'03'O	
length	4	
prefix length	64	/64 IPv6 prefix acc. to TS 23.401
on-link flag	'0'B	no "On-link detection"; NOTE 3
autonomous address configuration flag	'0'B	
reserved1	'000000'B	
valid lifetime	'FFFFFFFF'O	infinity; NOTE 3
preferred lifetime	'FFFFFFFF'O	infinity; NOTE 3
reserved2	'00000000'B	
prefix	globally unique /64 IPv6 prefix to be assigned to the UE	NOTE 4, 5
NOTE 1: The server's link local address is derived from the server's global IPV6 address (PIXIT parameter)		
NOTE 2: As received as SRC address of the corresponding Router Solicitation		
NOTE 3: Acc. to TS 29.062 clause 11.2.1.3.2		
NOTE 4: The routing prefix of the UE's global IPv6 address is derived from the respective PIXIT parameter		
NOTE 5: Since the UE may change its interface identifier after successful auto configuration to any value in general the IPv6 address used by the UE differs from the PIXIT		

4.2.4.7.4 DNS

In general DNS is not needed for E-UTRA conformance tests as defined in 36.523-1[1].

Nevertheless as the IP test model is also applicable for test suites other than 36.523-1[1] handling of certain DNS queries (according to RFC 1035 [58]) is supported over UDP:

Table 4.2.4.7.4-1: Supported DNS Queries

DNS Header		
id	any value	2 octets; id to be used in response
qr	'0'B	query
opcode	'0000'B	standard query
aa	'?'B	Authoritative Answer: any value in query
tc	'0'B	no truncation
rd	'?'B	Recursion Desired: any value
ra	'?'B	Recursion Available: any value in query
z	'000'B	must be '000'B according to RFC 1035 [58]
rcode	'????'B	Response code: na for query
qdcnt	1	unsigned 16 bit integer: number of questions
ancnt	0	unsigned 16 bit integer: number of answers
nscount	0	unsigned 16 bit integer: number of authority records
arcount	0	unsigned 16 bit integer: number of additional records
Questions		
DNS Question: only one question per query is supported		
qname	any value	octetstring with encoded domain name according to RFC 1035 clause 4.1.2 [58]
qtype	'0001'O or '001C'O	Type A (IPv4 Address according to RFC 1035 clause 3.2.2 [58]) or Type AAAA (IPv6 Address according to RFC 3596 clause 2.1 [59])
qclass	'0001'O	IN (internet)

Table 4.2.4.7.4-2: Corresponding DNS Responses

DNS Header		
id	same value as in corresponding query	
qr	'1'B	response
opcode	same value as in corresponding query	
aa	'1'B	Authoritative Answer
tc	'0'B	no truncation
rd	'0'B	no recursion
ra	'0'B	no recursion
z	'000'B	
rcode	'0000'B	no error
qdcount	1	unsigned 16 bit integer: number of questions
ancount	1	unsigned 16 bit integer: number of answers
nscount	0	unsigned 16 bit integer: number of authority records
arcount	0	unsigned 16 bit integer: number of additional records
Questions		
DNS Question	same value as in corresponding query	
Answers		
DNS Answer		
qname	same value as in corresponding query/question	
qtype	same value as in corresponding query/question	
qclass	'0001'O	IN (internet)
ttd	86400	one day
rddlength	4 for IPv4 16 for IPv6	
rddata	octetstring containing IPv4 or IPv6 address	

4.2.4A LTE-Carrier Aggregation test Models

4.2.4A.1 CA-MAC test model

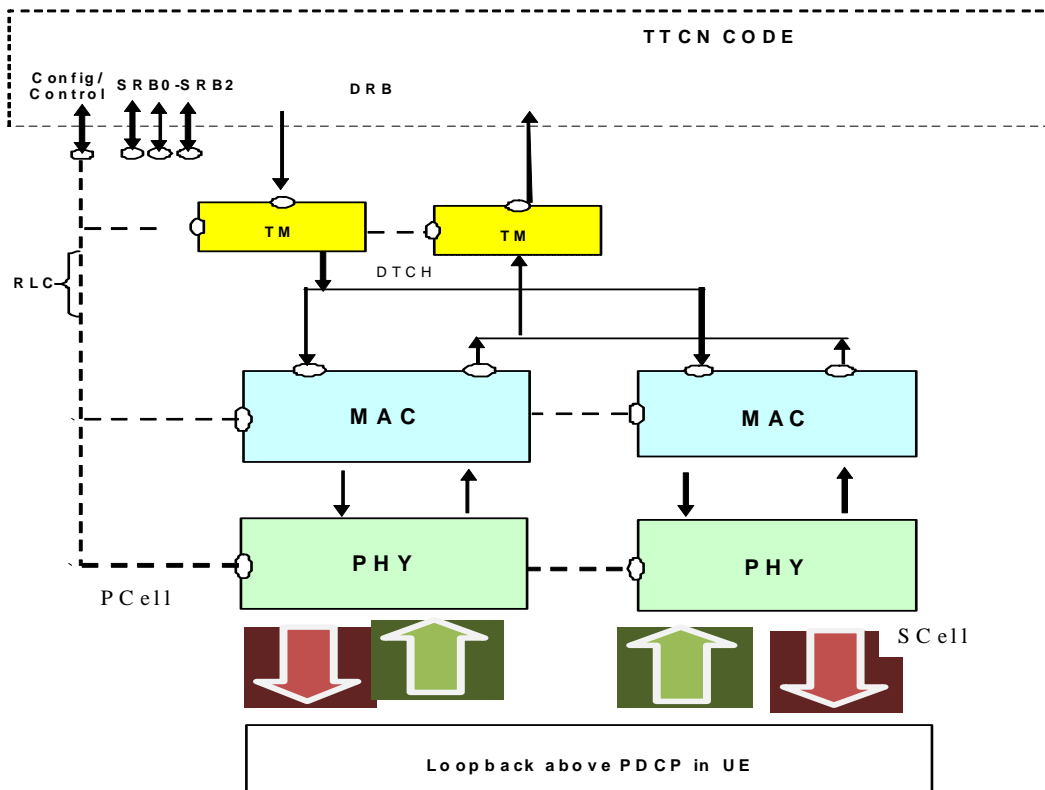

Figure 4.2.4A.1-1: Test model for CA-MAC testing

The UE is configured in Test Loop Mode, to loop back the user domain data above PDCP layer. On UE side Ciphering is enabled (since Mandatory) but with dummy ciphering algorithm, which is equivalent to not using ciphering. ROHC is not configured on UE Side.

On the SS Side,

Pcell only: On DRBs the RLC is configured in transparent mode. Hence with this configuration PDU's out of SS RLC are same as the SDU's in it. There is no PDCP configured on SS Side. The ports are directly above RLC.

Pcell/Scell: Layer 1 is configured in the normal way. MAC is configured in a special mode, where it does not add any MAC headers in DL and /or not remove any MAC headers in UL directions respectively at DRB port. In this case, the TTCN shall provide the final PDU, including padding. Except for this, the MAC layer shall perform all of its other functions. For SRB's/BCCH/PCCH the configuration is same as in CA-RRC test model.

There are two different test modes in which MAC header addition/removal can be configured:

DL/UL header-transparent mode: no header addition in DL and no header removal in UL.

DL only header-transparent mode: no header addition in DL; UL MAC is configured in normal mode to remove MAC header and dispatch the MAC SDUs according to the logical channel Ids.

If SS MAC is configured in DL/UL header-transparent mode, the PDU's exchanged at the DRB port between TTCN and SS, shall be the final MAC PDU's consisting of MAC, RLC and PDCP headers. TTCN code shall take care in DL of building MAC header, RLC headers and PDCP headers and in UL handle MAC, RLC and PDCP headers. TTCN code shall take care of maintaining sequence numbers and state variables for RLC and PDCP layers. During testing of multiple DRBs at the UE side, it shall still be possible to configure only one DRB on SS side with configuration in the figure 4.2.4A.1-1. Other DRBs will not be configured, to facilitate routing UL TBs. Multiplexing/de-multiplexing of

PDU's meant/from different DRBs shall be performed in TTCN. Since the MAC layer does not evaluate the MAC headers in UL it cannot distinguish between SRB and DRB data in UL. Therefore there shall be no SRB traffic while MAC is configured in this test mode.

If SS MAC is configured in DL only header-transparent mode, the UL PDU's exchanged at the DRB port between TTCN and SS, shall be final RLC PDU's consisting of RLC and PDCP headers. SS shall route these PDU's based on logical channel IDs. In DL, TTCN sends fully encoded MAC PDU's at the DRB port (consisting of MAC, RLC and PDCP headers). In this case TTCN needs to take care of maintaining sequence numbers and state variables for RLC and PDCP layers. Furthermore in UL and DL the SS MAC layer shall be capable of dealing with SRB data (i.e. it shall handle DL RLC PDU's coming from SRBs RLC layer or dispatch UL RLC PDU's to SRBs) as in normal mode.

NOTE: TTCN shall ensure that no DL MAC SDUs in normal mode and DL MAC PDU's in test mode are mixed for the same TTI.

The UL Scheduling Grant and DL Scheduling assignments are configured from TTCN over system control port. SS reports PUCCH scheduling information reception in Pcell over system indication port, if configured. In a similar way the reception of RACH preambles in Pcell/Scell is reported by SS over the same port, if configured.

The RACH Procedure configured in active Scell controls the RACH procedure in Scell. The PDCCH order is sent on PDCCH controlling the Scell. PRACH preamble is received in the Scell. RAR is transmitted in the associated Pcell as per RACH procedure in active Scell.

4.2.4A.2 CA-RRC test model

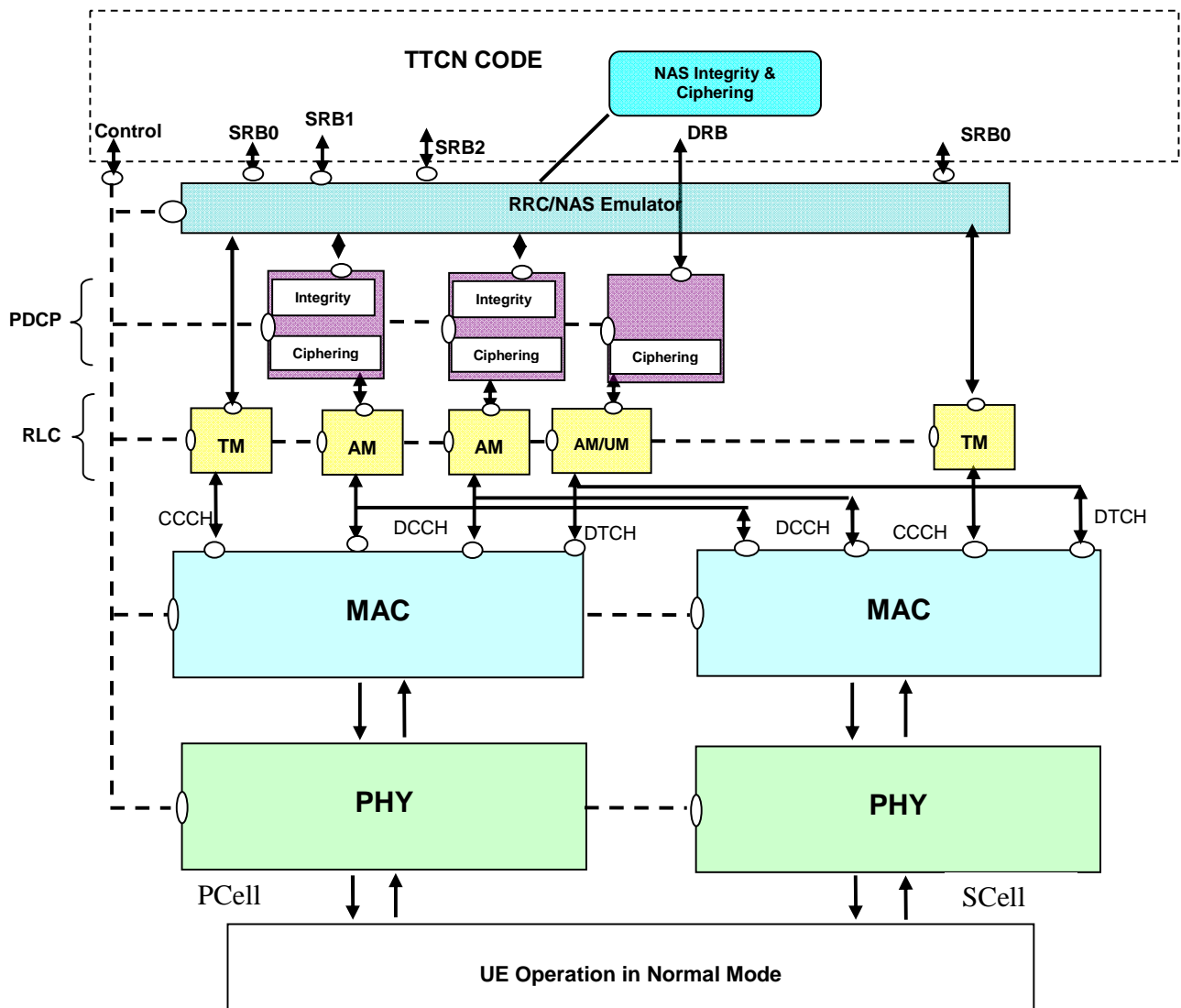

Figure 4.2.4A.2-1: Test model for CA-RRC testing

The UE is configured in normal mode. On UE side Ciphering/Integrity (PDCP and NAS) is enabled and ROHC is not configured.

On the SS Side L1 (Pcell/Scell), MAC (Pcell/Scell), RLC (Pcell) and PDCP (Pcell) are configured in normal way. They shall perform all of their functions. For SRB0 the DL and UL port is above RLC. For SRB1 and SRB2 the port is above/below the RRC and NAS emulator, which may be implemented as a parallel test component. For DRB, the port is above PDCP. PDCP Ciphering/Integrity is enabled. NAS integrity/Ciphering is enabled.

Note: RLC for BCCH/ PCCH/CCH are configured per serving cell; RLC and PDCP for DCCH/DTCH are configured only in Pcell and are additionally multiplexed on MAC of associated Scells.

The RRC/NAS emulator for SRB1 and SRB2 shall provide the Ciphering and integrity functionality for the NAS messages. In UL direction, SS shall report RRC messages, still containing (where appropriate) the secure and encoded NAS message, to the RRC port. In DL, RRC and NAS messages with same timing information shall be embedded in one PDU after integrity and ciphering for NAS messages.

The UL Scheduling Grant and DL Scheduling assignments are configured from TTCN over system control port. SS reports PUCCH scheduling information reception in Pcell over system indication port, if configured. In a similar way the reception of RACH preambles in Pcell/Scell is reported by SS over the same port, if configured.

4.2.4B Dual Connectivity test models

4.2.4B.1 DC MAC test model

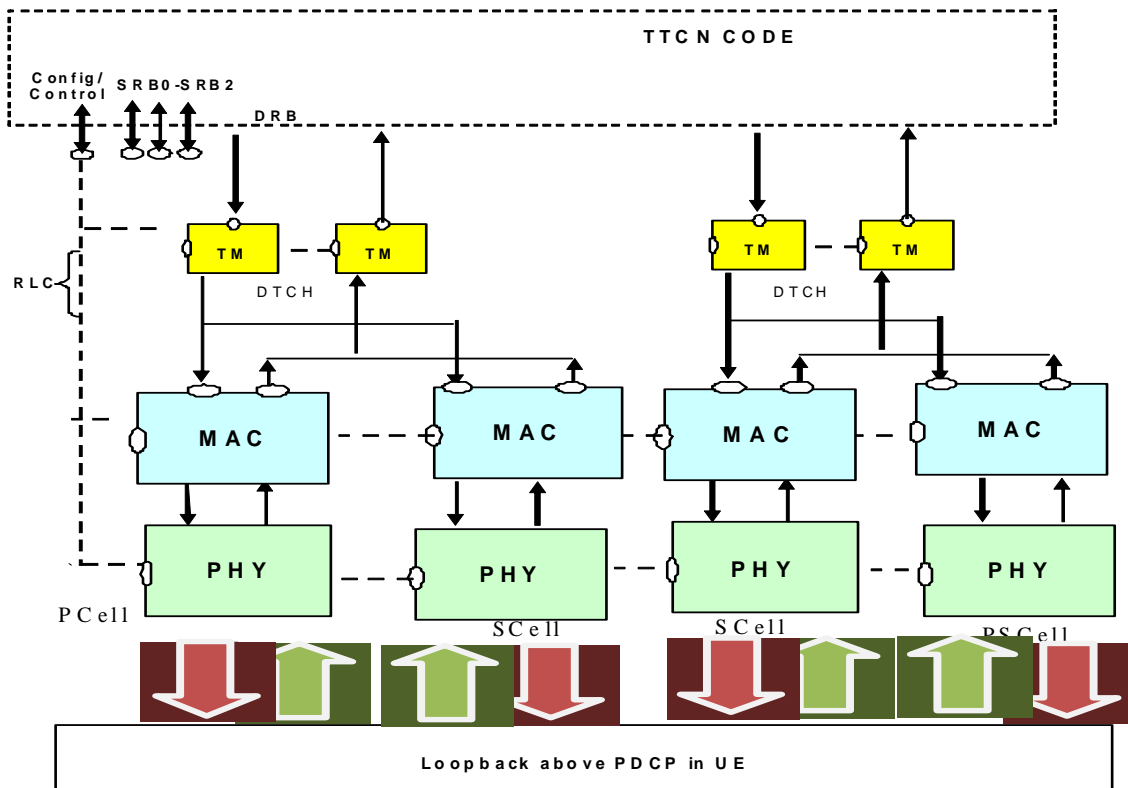

Figure 4.2.4B.1-1: Test model for DC MAC testing

The UE is configured in Test Loop Mode, to loop back the user domain data above PDCP layer. On UE side Ciphering is enabled (since mandatory) with dummy ciphering algorithm, which is equivalent to not using ciphering. ROHC is not configured on UE Side.

On the SS Side, zero or more SCell's associated with PCell/PSCell may be configured.

PCell/PSCell only: On DRBs the RLC is configured in transparent mode. Hence with this configuration PDU's out of SS RLC are same as the SDU's in it. There is no PDCP configured on SS Side. The ports are directly above RLC.

PCell/PSCell/SCell: Layer 1 is configured in the normal way. MAC is configured in a special mode, where it does not add any MAC headers in DL and /or not remove any MAC headers in UL directions respectively at DRB port. In this case, the TTCN shall provide the final PDU, including padding. Except for this, the MAC layer shall perform all of its other functions. For SRB's/BCCH/PCCH the configuration is same as in Dual connectivity-RRC test model.

For Split DRB's the TM DRB from the CG will be used to send/receive PDU's in that CG.

There are two different test modes in which MAC header addition/removal can be configured:

- DL/UL header-transparent mode: no header addition in DL and no header removal in UL.
- DL only header-transparent mode: no header addition in DL; UL MAC is configured in normal mode to remove MAC header and dispatch the MAC SDUs according to the logical channel Ids.

If SS MAC is configured in DL/UL header-transparent mode, the PDU's exchanged at the DRB port between TTCN and SS, shall be the final MAC PDU's consisting of MAC, RLC and PDCP headers. TTCN code shall take care in DL of building MAC header, RLC headers and PDCP headers and in UL handle MAC, RLC and PDCP headers. TTCN code shall take care of maintaining sequence numbers and state variables for RLC and PDCP layers. During testing of

multiple DRBs at the UE side, it shall still be possible to configure only one DRB on SS side per CG with configuration in the figure 4.2.4B.1-1. Other DRBs will not be configured, to facilitate routing UL TBs. Multiplexing/de-multiplexing of PDUs meant/from different DRBs shall be performed in TTCN. Since the MAC layer does not evaluate the MAC headers in UL it cannot distinguish between SRB and DRB data in UL. Therefore there shall be no SRB traffic while MAC is configured in this test mode.

If SS MAC is configured in DL only header-transparent mode, the UL PDUs exchanged at the DRB port between TTCN and SS shall be final RLC PDUs consisting of RLC and PDCP headers. SS shall route these PDUs based on logical channel IDs. In DL, TTCN sends fully encoded MAC PDUs at the DRB port (consisting of MAC, RLC and PDCP headers). In this case TTCN needs to take care of maintaining sequence numbers and state variables for RLC and PDCP layers. Furthermore in UL and DL the SS MAC layer shall be capable of dealing with SRB data (i.e. it shall handle DL RLC PDUs coming from SRBs RLC layer or dispatch UL RLC PDUs to SRBs) as in normal mode.

NOTE: TTCN ensures that no DL MAC SDUs in normal mode and DL MAC PDUs in test mode are mixed for the same TTI.

The UL Scheduling Grant and DL Scheduling assignments are configured from TTCN over system control port. SS reports PUCCH scheduling information reception in PCell over system indication port, if configured. In a similar way the reception of RACH preambles in PCell/SCell is reported by SS over the same port, if configured.

The RACH Procedure configured in active SCell controls the RACH procedure in SCell. The PDCCH order is sent on PDCCH controlling the SCell. PRACH preamble is received in the SCell. RAR is transmitted in the associated PCell as per RACH procedure in active SCell.

4.2.4B.2 DC PDCP test model

The PDCP test model is based on DC RRC test model except for the following.

The UE is configured in Test Loop Mode, to loop back the user domain data above PDCP layer. On UE side Ciphering is enabled and ROHC is not configured.

The PDCP is configured in a special mode, named transparent mode. In this mode, SS shall not add PDCP header (DL) and remove PDCP Header (UL). The TTCN maintains sequence numbers and state variables for the PDCP layer. The TTCN makes use of the AS ciphering functionality in both directions, employing the dummy ciphering algorithm. Ciphering/deciphering are performed using TTCN external functions. ROHC is not configured.

4.2.4B.3 DC RRC test model

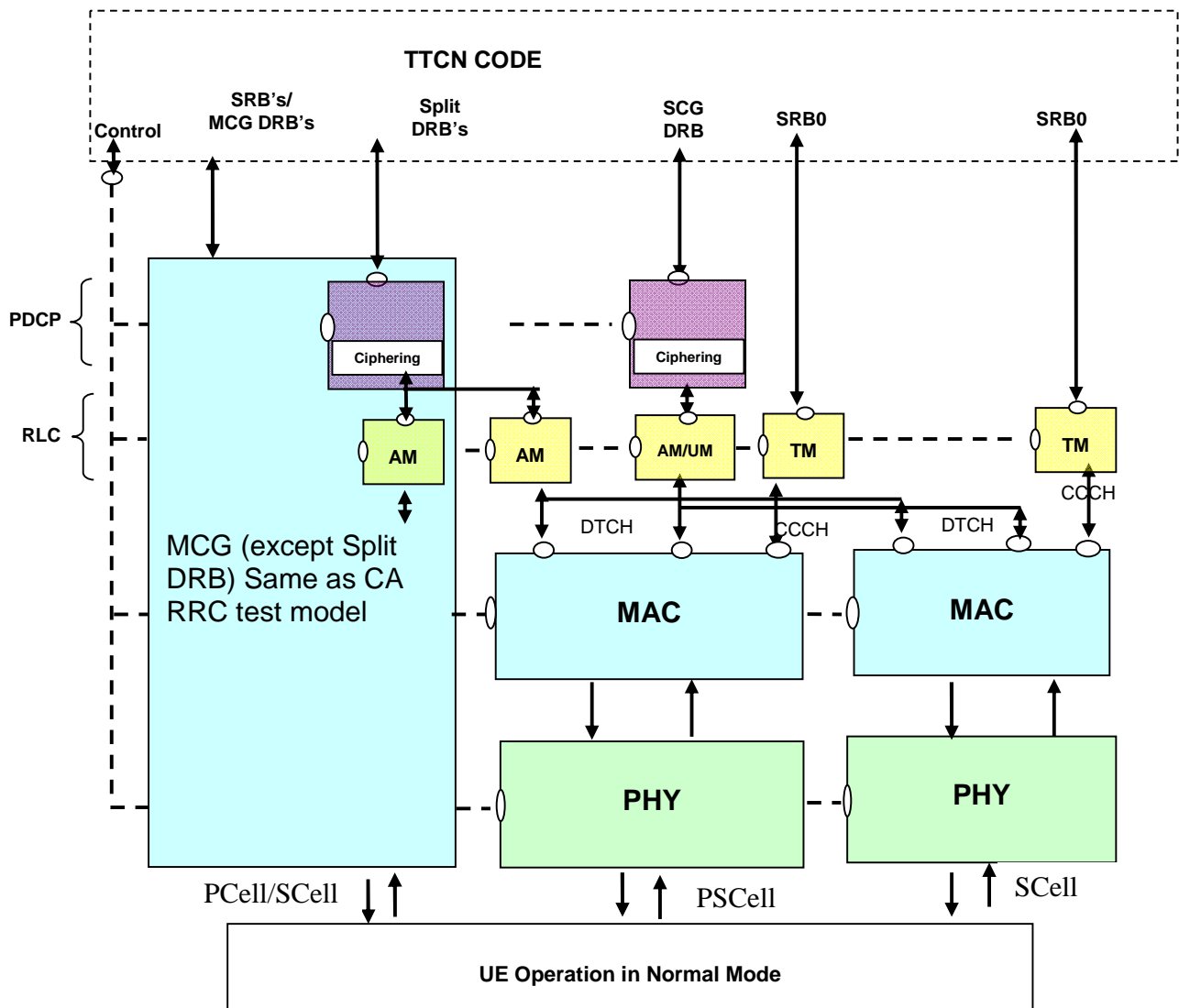

Figure 4.2.4B.3-1: Test model for DC RRC testing

The UE is configured in normal mode. On UE side Ciphering/Integrity (PDCP and NAS) is enabled and ROHC is not configured. Zero or more SCell's associated with PCell/PSCell may be configured.

On the SS Side L1 (PCell/PSCell/SCell), MAC (PCell/PSCell/SCell), RLC (PCell/PSCell) and PDCP (PCell/PSCell) are configured in normal way. They shall perform all of their functions. SRB's are configured only in PCell. For SRB0 the DL and UL port is above RLC. For SRB1 and SRB2 the port is above/below the RRC and NAS emulator, which may be implemented as a parallel test component. For DRB, the port is above PDCP. PDCP Ciphering/Integrity is enabled. NAS integrity/Ciphering is enabled.

NOTE: RLC for BCCH/PCCH/CCCH are configured per serving cell; RLC and PDCP for DCCH/DTCH are configured only in PCell/PSCell and are additionally multiplexed on MAC of associated SCells in the CG (carrier group).

For Split DRB's PDCP is not configured in PSCell. If UL traffic on split DRB will be steered through SCG (i.e. *ul-DataSplitDRB-ViaSCG* is true), the IE *ul-DataSplitDRB-ViaSCG* will only be provided in PDCP-Info in PSCell.

The PCell and SCell (associated with either PCell or PSCell) are same as in CA RRC test model in clause 4.2.4A.2.

The RRC/NAS emulator for SRB1 and SRB2 shall provide the Ciphering and Integrity functionality for the NAS messages. In UL direction, SS shall report RRC messages, still containing (where appropriate) the secure and encoded

NAS message, to the RRC port. In DL, RRC and NAS messages with same timing information shall be embedded in one PDU after integrity and ciphering for NAS messages.

The UL Scheduling Grant and DL Scheduling assignments are configured from TTCN over system control port. SS reports PUCCH scheduling information reception in PCell/PSCell over system indication port, if configured. In a similar way the reception of RACH preambles in PCell/PSCell/SCell is reported by SS over the same port, if configured.

4.2.5 IP model extension for IMS

The IMS test model is based on the IP Test Model with extensions to support IPsec. Support of Signalling Compression (SigComp) may be added in the future if needed.

IMS in general may use TCP, UDP or alternated TCP/UDP as transport layer for signalling messages.

At TTCN-3 system interface level there are no IMS specific ports or ASPs, i.e. IMS specific issues are purely handled in TTCN and therefore out of scope for this document.

NOTE: Even though the main intention to introduce the IMS test model is to support the initial IMS registration procedure, the IMS test model is independent of any specific IMS procedures.

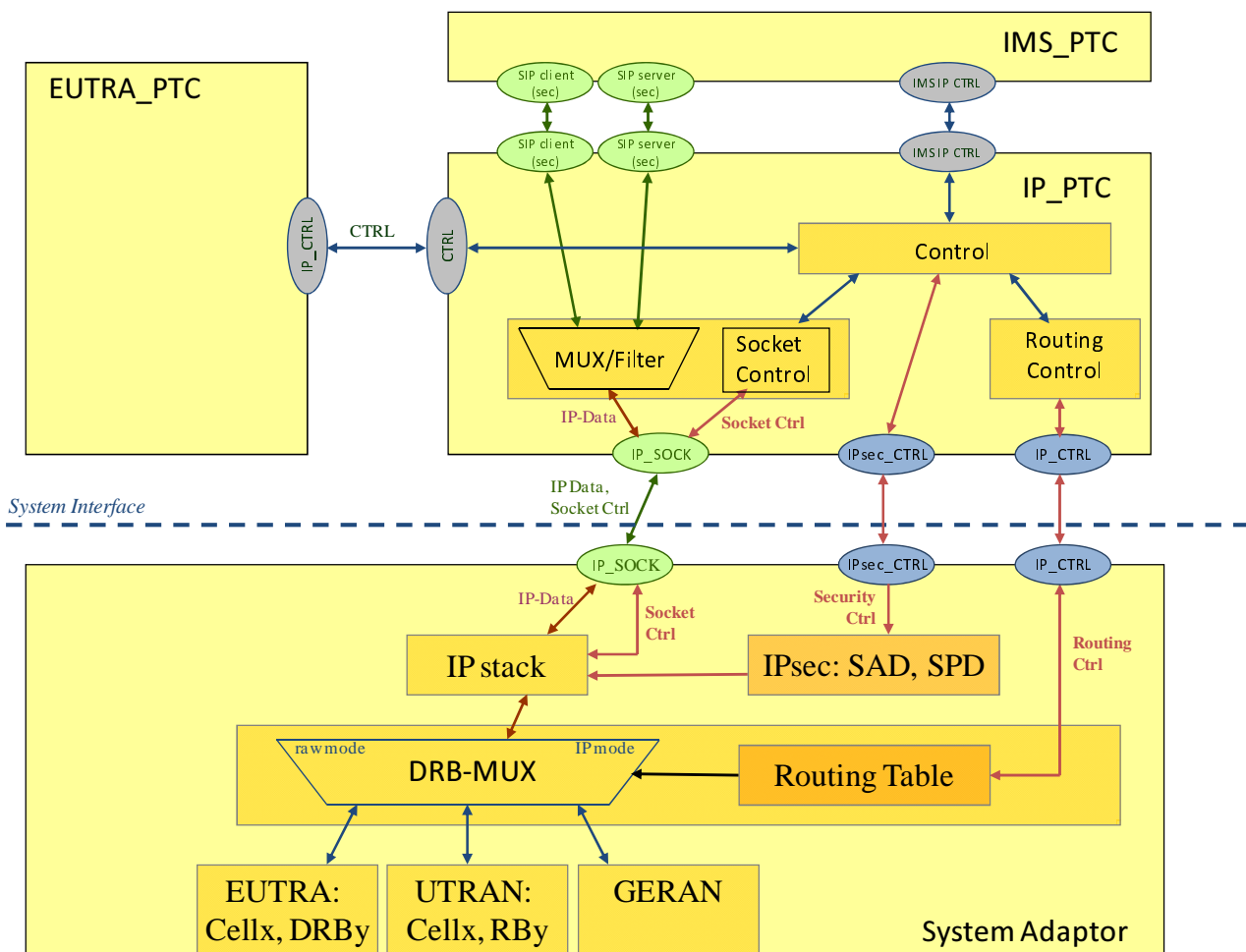

Figure 4.2.5-1: Example for IP model supporting IMS

NOTE 1: At the system interface IPsec is the only difference compared to the IP model of clause 4.2.4

NOTE 2: It is a working assumption to have a separate PTC for IMS as shown in figure 4.2.5-1

NOTE 3: Ports between the IP_PTC and the IMS_PTC are for illustration only

4.2.5.1 IPsec

IPsec involves security policy database (SPD) and security association database (SAD) (Ref. RFC4301). The entries in the databases are configured with security parameters by ASPs at the IPsec_CTRL port.

NOTE: IPsec is not directly associated to a given socket but IPsec is applied to IP packets matching a configured security association. ⇒ configuration of IPsec in general is independent of the existence of sockets but typically the IPsec configuration is done just before establishment of a corresponding socket.

The SS shall cleanup all IPsec database entries which has been setup by TTCN during a test case at the end of the test case independent of how the test case terminates (normal termination, run-time error etc.)

4.2.5.1.1 Security Association

NOTE: Within this clause SA is used as abbreviation of 'Security Association' (i.e. not as abbreviation for 'System Adaptor' as usual)

During the IMS signalling handling two pairs of SAs consisting of four unidirectional SAs will be used, one pair of SAs (SA2 and SA4) is between the server port of UE and the client port of the SS, another pair of SAs (SA1 and SA3) is between the client port of UE and the server port of the SS, see figure 4.2.5.2.3.1-1.

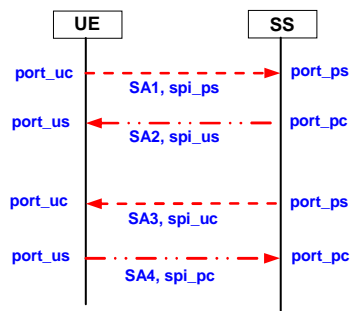

Figure 4.2.5.2.3.1-1 Two pairs of SAs

SA1 used for data flow from port_uc to port_ps is an inbound SA for protected server port of P-CSCF, its Security Parameter Index spi_ps is selected by P-CSCF (IMS Registration/Authentication function in IP_PTC) and presented in 401 Unauthorised; SA2 used for data flow from port_pc to port_us is an inbound SA for protected server port of UE, its Security Parameter Index spi_us is selected by UE and presented in initial REGISTER message; SA3 used for data flow from port_ps to port_uc is an inbound SA for protected client port of UE, its Security Parameter Index spi_uc is selected by UE and presented in initial REGISTER message; SA4 used for data flow from port_us to port_pc via an inbound SA for client port of P-CSCF, its Security Parameter Index spi_pc is selected by P-CSCF (IMS Registration/Authentication function in IP_PTC) and presented in 401 Unauthorised message. The pair of SA1 and SA3 is for bidirectional traffic between port_uc and port_ps. The pair of SA2 and SA4 is for bidirectional traffic between port_pc and port_us. Those four spi_xx and other security parameters are negotiated during security association set up procedure and shall be passed to IPsec protocol layer in the SS. See "SAD and SPD" and clause 7.2 of TS 33.203 [41].

These four unidirectional SA and relevant ports are shared by TCP and UDP. TCP transport will use all four SAs, UDP transport uses only two SAs, because there is no traffic from port_ps to port_uc, nor from port_us to port_pc. Figure 4.2.5.2.3.1-2 shows the usage of ports and SAs under UDP and TCP transport in a generic registration procedure (see clause C.2 of TS 34.229-1 [40]).

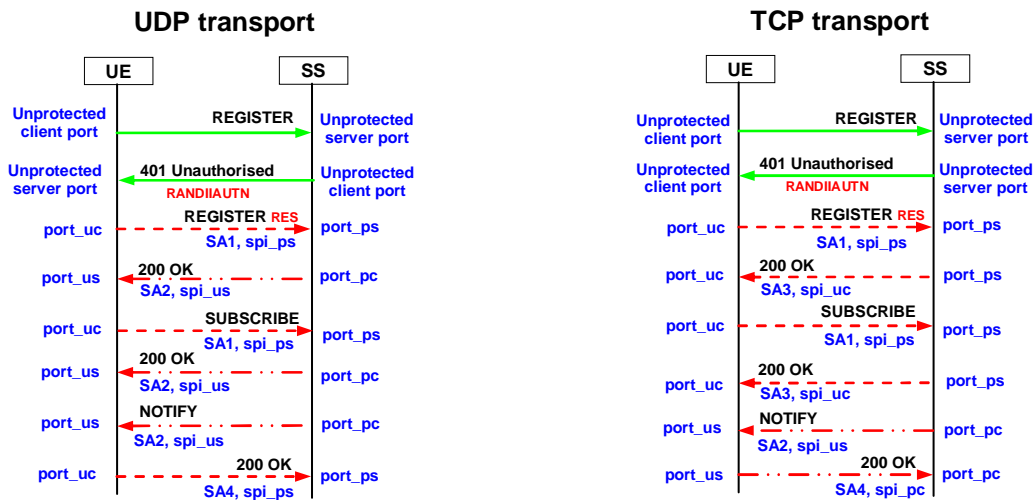

Figure 4.2.5.2.3.1-2: Usage of ports and SAs in UDP and TCP transport

4.2.5.1.2 SAD and SPD

SAD and SPD are used by IPsec to store various security parameters (per Security Association). During IMS AKA, the UE and the IMS Registration/Authentication function in IP_PTC negotiates the negotiable parameters for security association setup, this negotiation is carried out at the SIP level in TTCN-3, and the resulting security association parameters are maintained in TTCN-3. The involved parameters are:

- spi_uc; spi_us; spi_pc; spi_ps
- encryption algorithm
- integrity algorithm

The IMS AKA will generate key IK_{IM} , the security parameters IK_{ESP} and CK_{ESP} are derived from IK_{IM} and CK_{IM} in TTCN-3 (Ref. Annex I of TS 33.203[41]). ASPs are used to pass these parameters (per security association and with its selectors) from TTCN-3 to SAD and SPD of IPsec layer in the SS.

The same IK_{ESP} and CK_{ESP} will be used for the four unidirectional SAs. All of the four unidirectional SAs will use the same negotiated encryption algorithm and integrity algorithm.

In addition to those negotiable security parameters, other security parameters are fixed in IMS environment (see clause 7.1 of TS 33.203 [41]):

- Life type: second
- SA duration: $2^{32}-1$
- Mode: transport
- IPsec protocol: ESP, ESP integrity applied
- Key length: 192 bits for DES-EDES_CBC, 128 bits for AES-CBC and HMAC-MD5-96; 160 bits for HMAC-SHA-1-96

These parameters are hard coded with IPsec implementation in the SS, not passed from TTCN-3.

An SA have to be bound to selectors (specific parameters) of the data flows between UE and P-CSCF (IMS Registration/Authentication function in IP_PTC), the selectors are:

- source IP address
- destination IP address
- source port

destination port

transport protocols that share the SA

IP addresses bound to the two pairs of SAs are:

For inbound SAs at the P-CSCF (the SS side):

- The source and destination IP addresses associated with the SA are identical to those in the header of the IP packet in which the initial SIP REGISTER message was received by the P-CSCF.

For outbound SAs at the P-CSCF (the SS side):

- The source IP address bound to the outbound SA equals the destination IP address bound to the inbound SA; the destination IP address bound to the outbound SA equals the source IP address bound to the inbound SA.

Ports bound to the two pairs of SAs are depicted in figure 4.2.5.2.3.1-1, port_ps and port_pc shall be different from the default SIP ports 5060 and 5061. The number of the ports port_ps and port_pc are communicated to the UE during the security association setup procedure.

The transport protocol selector shall allow UDP and TCP.

The selectors are passed to the SS IPsec layer together with the security parameters related to an SA bound to the selectors.

4.2.5.2 Signalling Compression (SigComp)

Signalling compression is mandatory (see clause 8 of TS 24.229 [42]) and Signalling compression (RFC 3320 [43], RFC 3485 [44], RFC 3486 [45], RFC 4896 [46], RFC 5049 [47]) protocol is used for SIP compression. SigComp entity in the model is used to carry out the compression/decompression functions. In receiving direction of the SS the SigComp entity will detect whether the incoming SIP message is compressed, and decompress the message if it is compressed. In the SS transmitting direction, the TTCN, via ASP, controls when the compression of outgoing SIP message is started. Stateless compression is not used in the SIP environment. For state full operation of SigComp the ASP passing compartment ID to SigComp is applied. The SS shall clean all states related to a connection in SigComp when an ASP for closing the connection is received. The SS shall also clean all states in the SigComp when abortion of a test case is detected or after the system reboots. If decompression failure occurs while decompressing a message, the message shall be discarded. The SigComp entity in the SS shall automatically find if a secure port or un-secure port is being used for transmission or reception of messages. If an un-secure port is used for transmission, it shall not include state creation instructions. If the state creation command is received in a compressed message on an un-secured port, a decompression failure shall be generated.

4.2.5.3 SIP TTCN-3 Codec

SIP is a text-based protocol, the messages exchanged between the UE and the SS are character strings. In TTCN-3 the messages are structured to take the advantages of TTCN-3 functionalities, and to make the debugging and maintenance easier.

Even though there is no encoding/decoding of SIP messages at the TTCN-3 system interface, the IMS_PTC uses the SIP codec by means of the TTCN-3 build-in functions encvalue and decvalue.

The SIP codec is specified in TS 34.229-3 [45] clause 7.

4.2.6 Support of DSMIPv6

For testing of DSMIPv6 IP packets being relevant for the test cases may be routed by the IP_PTC to the PTCs with specific test case implementation. There are not specific requirements for the system interface.

The functions of HA and ePDG are FFS.

4.2.7 MBMS test model

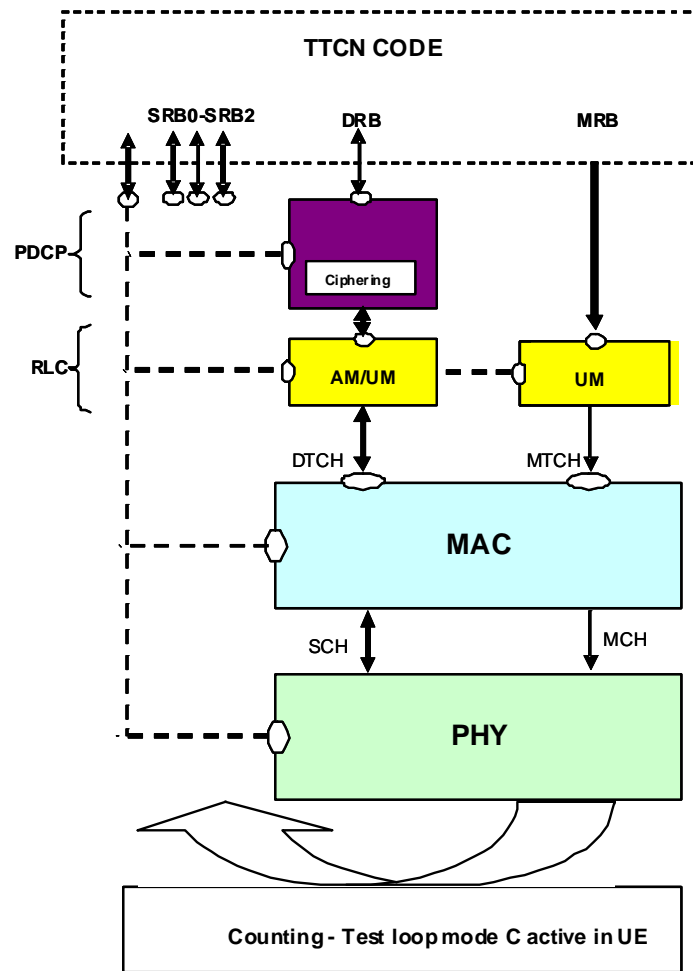

Figure 4.2.7-1: Test model for MBMS testing

The UE is configured in Test Loop Mode C to count the successfully received MBMS Packets. On the UE side, Ciphering/Integrity (PDCP and NAS) are enabled on SRBs/DRB. No security is configured on MCCH/MTCH.

On the SS side, the cell is configured as a normal cell, the MBMS parameters are configured by using an additional call of `SYSTEM_CTRL_REQ.L1`, MAC and RLC are configured for MCCH/MTCH in normal mode; they shall perform all of their functions. The MRB ports are above RLC. For MTCH data transmission, the SS shall set the MCH Scheduling Information (MSI) in the MAC PDU in the first subframe allocated to the MCH within the MCH scheduling period to indicate the position of each MTCH and unused subframes on the MCH according to TS 36.321[16] clause 6.1.3.7 The SS will be explicitly configured by the TTCN for MSI MAC control element. SS shall repeat the same configured MSI in the first subframe allocated to the MCH within each new MCH scheduling period.

The MRB data is considered as raw data and is scheduled with explicit timing control information from TTCN on MTCH.

4.2.8 OCNG test model

The OCNG generator is a logical block in the SS MAC layer, activated/deactivated by TTCN. There is one OCNG generator per cell, and OCNG may be activated by TTCN in any cell (i.e. serving or neighbour).

When OCNG is activated in a cell, the SS shall automatically transmit uncorrelated pseudo random data in an arbitrary number of DL MAC TB's on PDSCH's, in each non-ABS (Almost Blank Subframe) identified by *MeasSubFramePattern*, identified by an arbitrary number of virtual (non existing) UE's with C-RNTI's set different

from the C-RNTI of the UE under test. The SS shall treat these MAC TB's in a special way, i.e. shall not expect any HARQ feedback and shall not make any HARQ retransmissions. The SS shall select the number of virtual UE's to achieve the following conditions in each non-ABS subframe:

- Load all CCE's unused by any scheduled RNTI (SI-RNTI, C-RNTI, P-RNTI, RA-RNTI, Temp C-RNTI, SPS C-RNTI, M-RNTI) transmissions.
- Utilize all PRB's un-assigned by any scheduled RNTI.
- The modulation is restricted to QPSK.

The DCI combination 1 defined in clause 7.3.3.5.1 is used to facilitate maximum utilization of un-assigned PRB's.

While activating OCNG on a non-PCell, TTCN shall take care of timing information for the cell such that the SFN and subframe number should result in the corresponding PCell $SFN \bmod x = 0$, where x is the size of the subframePattern bit string divided by 10 and the corresponding subframe number of Pcell =0.

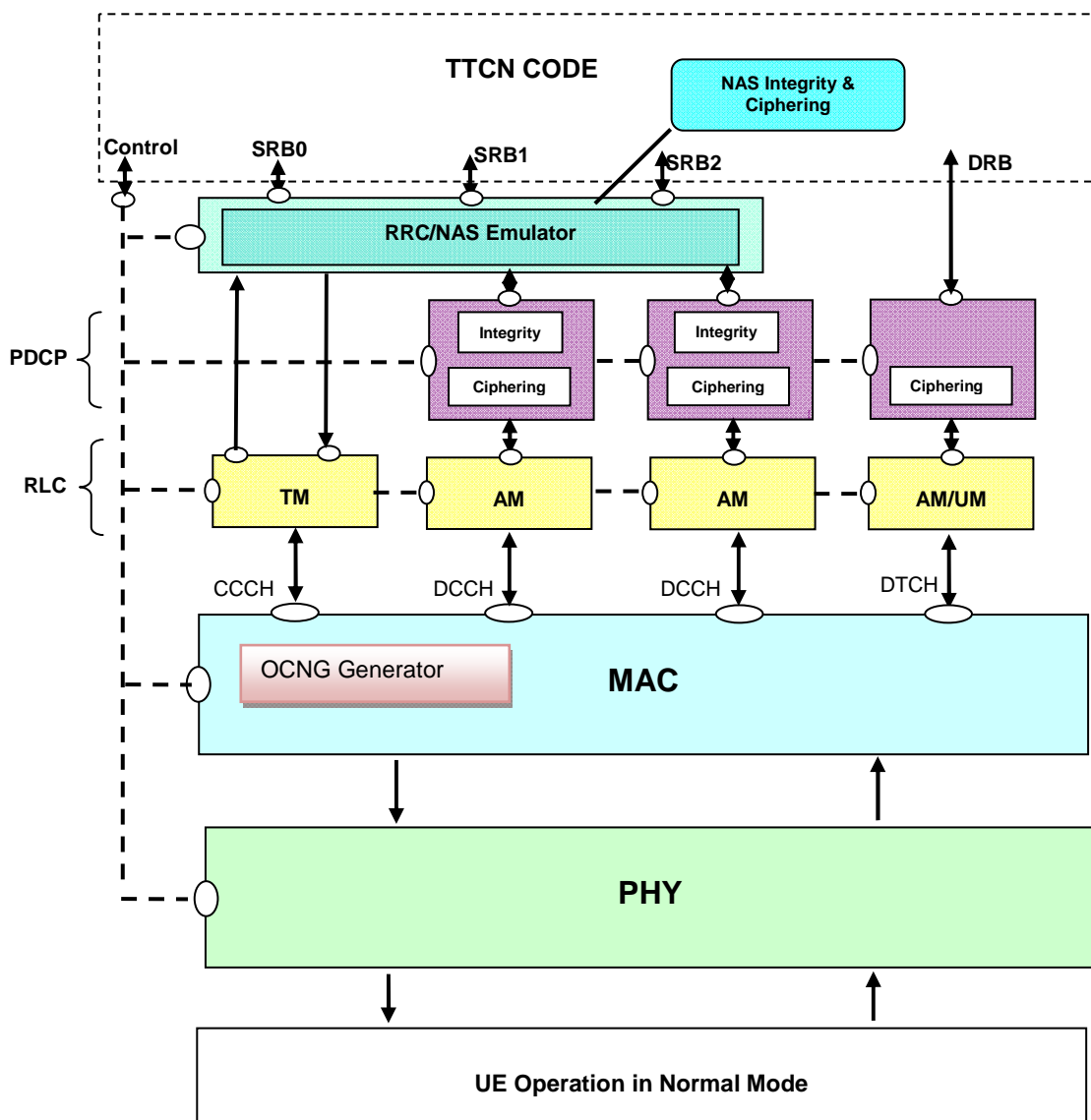

Figure 4.2.8-1: Test model for testing with OCNG

4.2.9 Device-to-Device Proximity Services test model

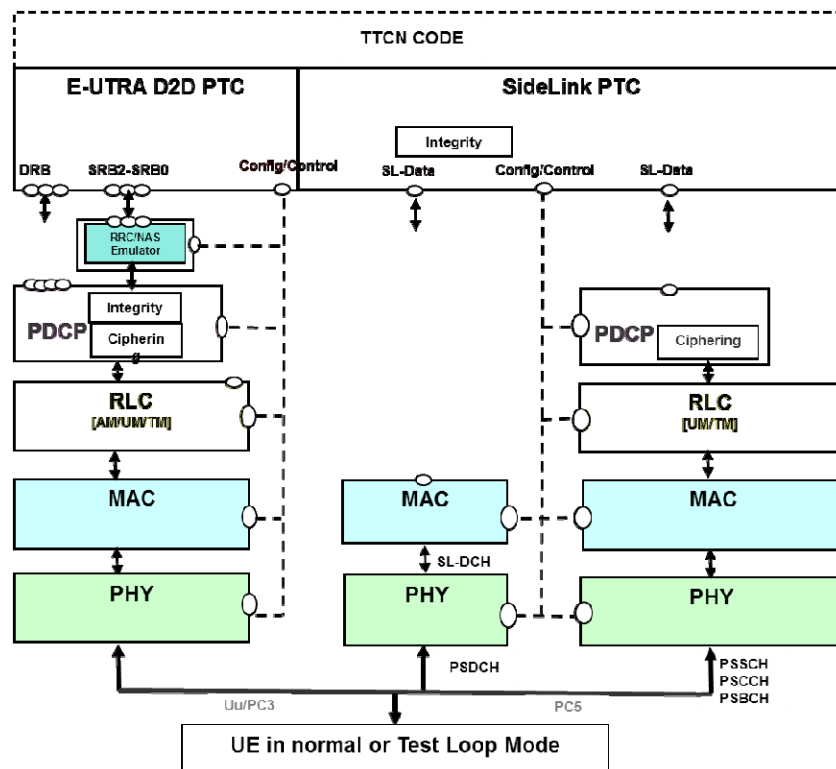

Figure 4.2.9-1: D2D ProSe test model

For testing of Device-to-Device Proximity Services (D2D ProSe), the system simulator (SS) shall implement, in addition to one or several simulated E-UTRA cells (L1/L2), one or several simulated UEs (L1/L2), called hereafter SS-UE. An SS-UE is used to send/receive data with the UE under test over the PC5 interface. This is depicted in the D2D ProSe test model of Figure 4.2.9-1.

From a TTCN architecture point of view Figure 4.2.9-2 depicts the TTCN component model used for D2D ProSe.

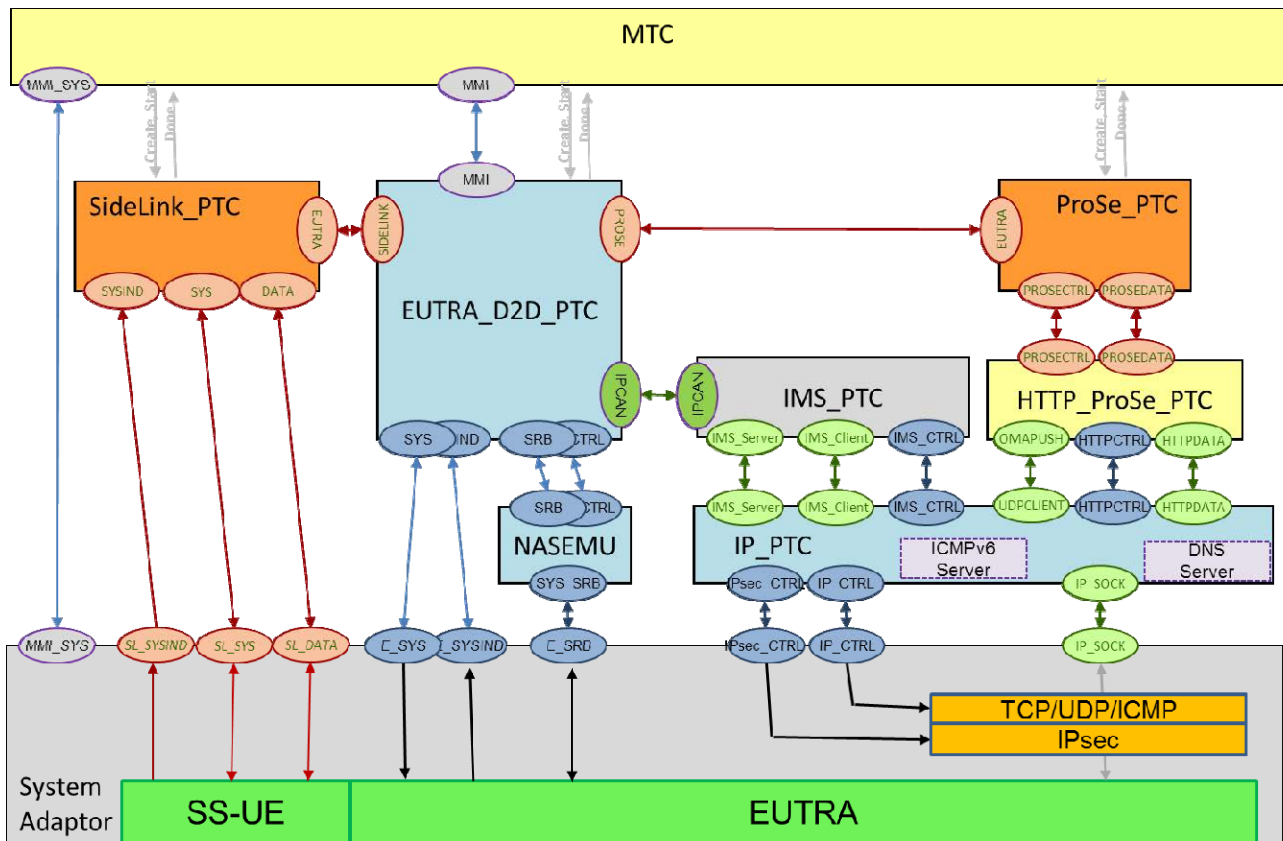

Figure 4.2.9-2: D2D ProSe component model

An SS-UE is controlled by TTCN in the SideLink PTC and is configured for Direct Discovery or Direct Communication by TTCN over sidelink system control SL_SYS port.

The ProSe Function is simulated in the ProSe_PTC. The HTTP_ProSe_PTC takes care about extracting and embedding PC3 messages from/into HTTP requests and responses and to generate the trigger for network-initiated procedures (OMA PUSH). There are no PC3 interface specific system ports, i.e. PC3 messages are IP user data in terms of clause 4.2.4.

4.2.9.1 ProSe Function test model

The PC3 Control Protocol procedures between the UE and the ProSe Function can be tested by TTCN at the ProSe_PTC. The ProSe_PTC handles ProSe discovery messages and procedures as defined in TS 24.334 [61].

The purpose of the HTTP_ProSe_PTC is to emulate the transport protocol for PC3 Control Protocol messages. It is responsible to receive HTTP requests addressing the ProSe function in UL, for encoding and decoding of the ProSe discovery messages and to provide the HTTP responses with all relevant headers in DL.

In addition the HTTP_ProSe_PTC provides means to trigger network-initiated procedures (e.g. OMA PUSH) and is used for HTTP based authentication (e.g. GBA).

4.2.9.2 Direct Discovery test model

The UE under test is configured in normal mode.

The SS-UE is configured in coverage. L1 and MAC are configured in normal way, they shall perform all of their functions. The SL_DATA port for transmission and reception of SL-DCH message, i.e. PC5_DISCOVERY messages, is above MAC.

On UE side integrity in SL-DCH message is applied. TTCN in SL_UE PTC provides the integrity functionality for the SL-DCH messages:

- In reception, SS-UE shall report to TTCN the SL-DCH message, containing the Message Code Integrity (MIC), with the SFN/Subframe at which the message was received. TTCN shall check the MIC field.
- In transmission, TTCN computes the MIC before sending the SL-DCH messages to SS-UE.

The SS-UE is configured by TTCN over sidelink system control port to receive/transmit SLSS. The SS-UE shall report SLSS reception over the sidelink system indication port.

4.2.9.3 Direct Communication test model

The UE under test is configured in normal mode or in Test loop mode E, ciphering (PDCP on STCH) is not enabled unless specified otherwise in the test case and ROHC is not configured.

The SS-UE is configured in coverage or out of coverage. L1, MAC and RLC are configured in normal way, they shall perform all of their functions. PDCP is configured in normal mode or in 'no header manipulation' special mode in STCH security test cases:

- When configured in normal mode, PDCP shall perform all of its functions. PDCP ciphering is not enabled unless specified otherwise in the test case and ROHC is not configured.
- When configured in 'no header manipulation' mode, no header manipulation shall be performed in PDCP layer in both directions: the SS-UE shall not add PDCP header (in transmission) and remove PDCP Header (in reception). PDCP state variables shall be maintained by SS-UE PDCP layer. PDCP ciphering is enabled when specified in the test and ROHC is not configured.

The SL_DATA port for transmission and reception of STCH data is above PDCP. The STCH data is considered as raw data.

4.2.10 SC-PTM test model

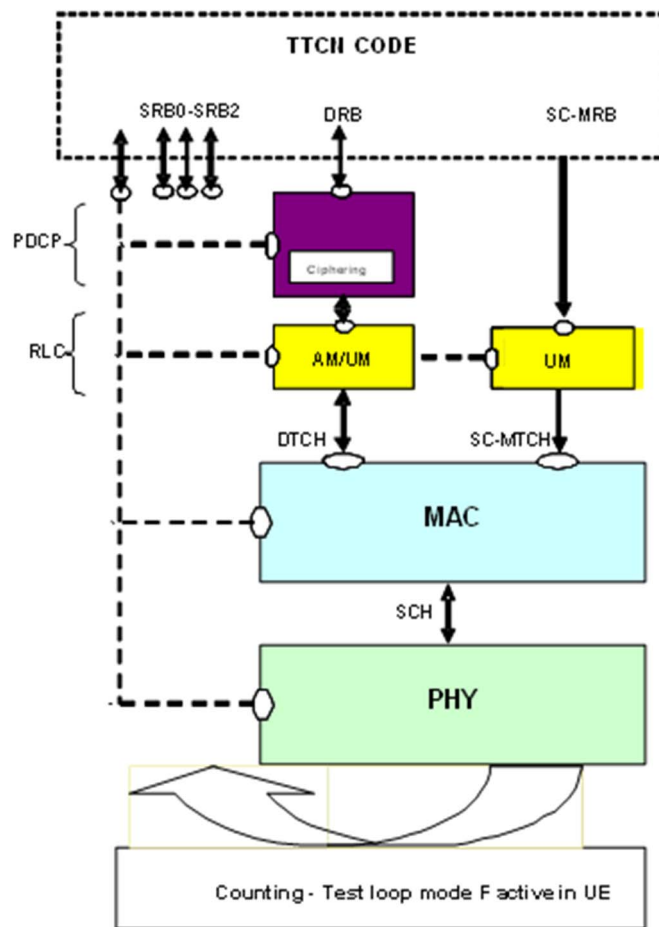

Figure 4.2.10-1: Test model for SC-PTM testing

The UE is configured in Test Loop Mode F to count the successfully received MBMS Packets. On the UE side, Ciphering/Integrity (PDCP and NAS) are enabled on SRBs/DRB. No security is configured on SC-MCCH/SC-MTCH.

On the SS side, the cell is configured as a normal cell, the SC-PTM parameters are configured by using an additional call of SYSTEM_CTRL_REQ. L1, MAC and RLC are configured for SC-MCCH/SC-MTCH in normal mode; they shall perform all of their functions. Existing MRB port will be reused for routing SC-MRB data.

The SC-MRB data is considered as raw data that shall not be multiplexed with the data from other RBs and shall be sent in one MAC PDU and in one TTI. DL Scheduling assignments are configured from TTCN over system control port.

4.3 SAE Test Model

4.3.1 NAS Test Model

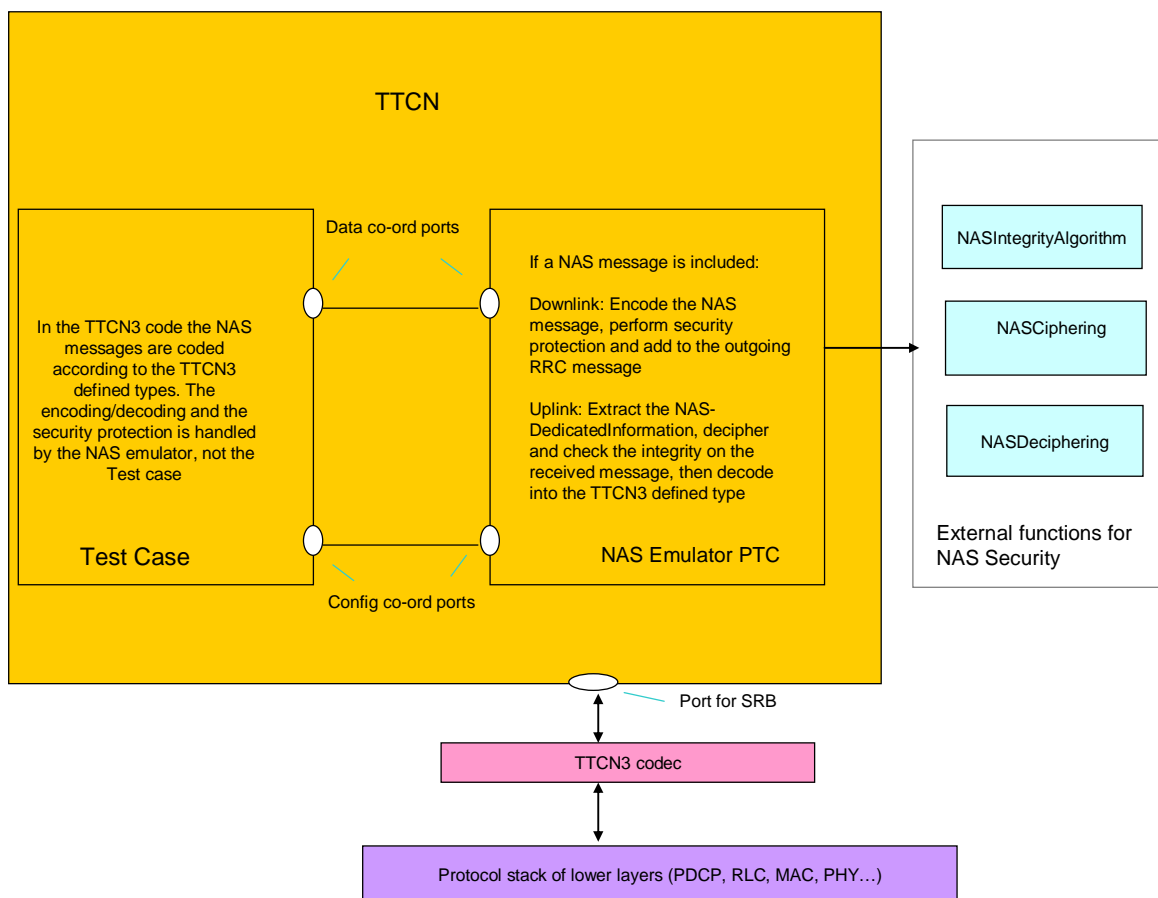

Figure 4.3.1-1: NAS Test Model

The NAS emulator is a parallel test component which handles NAS security, with the help of external functions to perform the integrity and (de)ciphering.

The interface between the emulator and the TTCN (co-ordination messages) handle data as TTCN-3 values. The interface between the emulator and the SS handles the RRC messages as TTCN-3 values, containing (where applicable) secure, encoded NAS messages.

The NAS emulator is not part of the test case in terms of verdict assignment (i.e. it does not check the correctness of any protocol message). Nevertheless, in case of fatal errors such as encode/decode errors, the NAS emulator sets the verdict to inconclusive and terminates immediately - which causes the test case to terminate. I.e. the NAS emulator does not resolve error situations.

4.4 Inter RAT Test Model

4.4.1 E-UTRAN-UTRAN Inter RAT Test Model

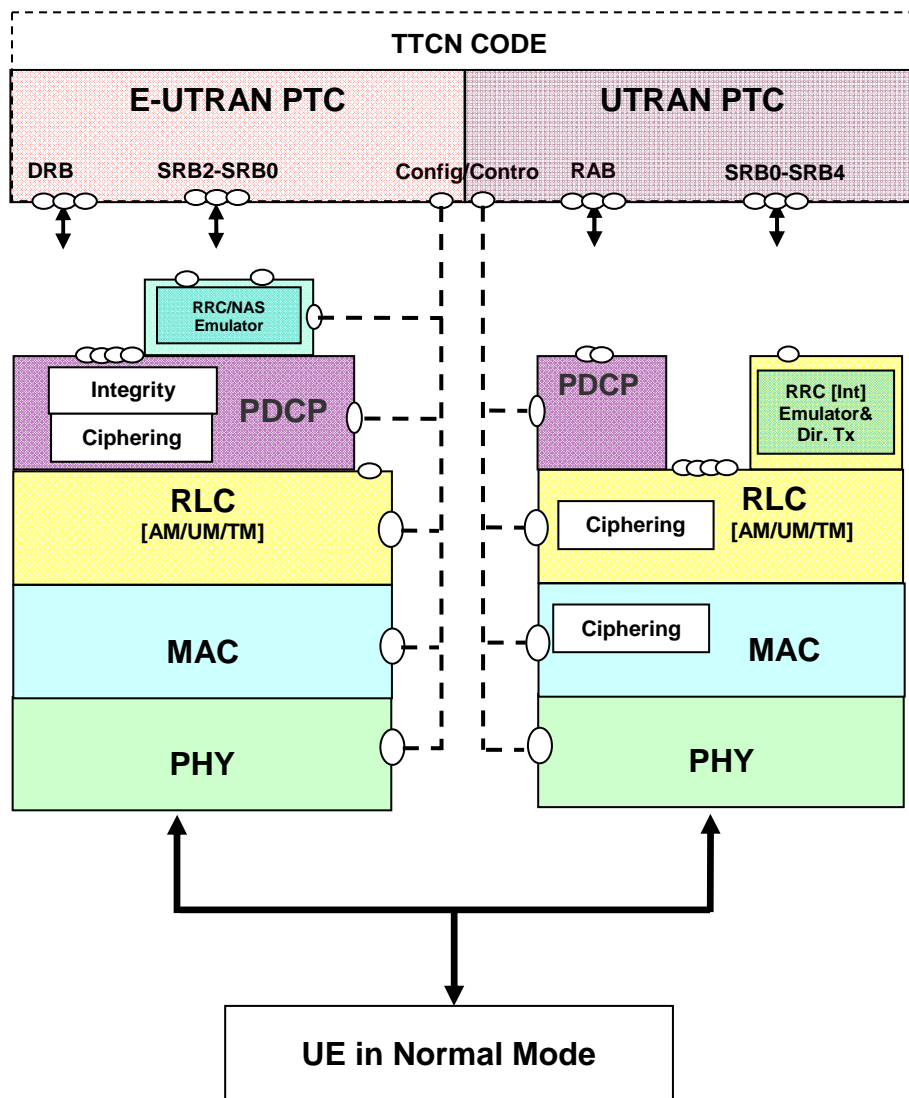

Figure 4.4.1-1: Test model for Inter RAT E-UTRAN-UTRAN testing

The model consists of dual protocol stack one for E-UTRAN and one for UTRAN. The TTCN implementation for E-UTRAN and UTRAN functionalities will be in separate Parallel Test Components. The SS E-UTRAN part is same as the model defined in clause 4.2.2 for RRC testing.

The SS UTRAN part consisting of PHY, MAC, RLC and PDCP (optionally) (IF PS user RB established only), are configured in normal mode. They shall perform all of their functions normally. Ciphering is enabled and shall be performed in RLC (AM/UM) and MAC (TM RLC). Integrity is enabled, and SS shall provide RRC emulator for integrity protection calculation and checking and 'Direct transfer' adaptation. Ports are above RLC (CS RAB and SRB0), PDCP (PS RAB) and RRC Emulator (SRB1 to SRB4).

The UE is configured in normal mode. Ciphering/Integrity (PDCP and NAS) are enabled and ROHC is not configured in E-UTRAN. Ciphering is enabled in UTRAN.

4.4.1.1 User data over UTRAN

User data transferred over UTRAN is distinguished between:

Raw user data (raw mode),

IP data (IP mode).

Depending upon whether the user data is relevant for the purpose of test, several scenarios are listed:

Raw user data relevant for the purpose of test,

IP data relevant for the purpose of test,

IP data, considered as IP signalling, not directly relevant for the purpose of test.

4.4.1.1.1 Raw user data over UTRAN

The raw user data can be as RLC SDUs and PDCP SDUs. The DL and UL user data are routed to UTRAN_PTC (Fig. 4.4.1.1.2-1). The IP stack in SS is not involved for all raw user data applications.

RLC SDUs is applied if the test loop mode 1 with loopback of RLC SDUs in TS 34.109 [9] is activated. PDCP in SS is not configured in this case; the DL and UL user data are routed to UTRAN_PTC via the RLC port.

The raw user data as PDCP SDUs is applied in the following cases:

the test loop mode 4 (TS 34.109 [9]) is activated,

the test loop mode 1 is activated with loopback of PDCP SDUs (TS 34.109 [9]),

the test loop mode B (TS 36.509 [4]) is activated and raw data is looped back on UTRAN,

IP raw data is another type of raw user data. The test loop mode is not activated. This case is applied when sending uplink data is triggered by the upper tester.

PDCP and optional RoHC are configured in SS, the DL and UL user data are routed to UTRAN_PTC via the PDCP port.

Feeding raw user data is largely used in the pure UTRAN test in TS 34.123-3 [7].

4.4.1.1.2 IP data over UTRAN

The IP data over UTRAN is applied to E-UTRA-UTRAN I-RAT and UTRAN test cases. The IP stack in SS is involved. IP data is considered as:

IP packets data (IP mode) relevant for the purpose of test,

IP signalling (IP mode), to be handled in TTCN at IP Layer

One of the IP signalling handling is the stateless address auto configuration for IPv6, illustrated in Fig. 4.4.1.1.2-1.

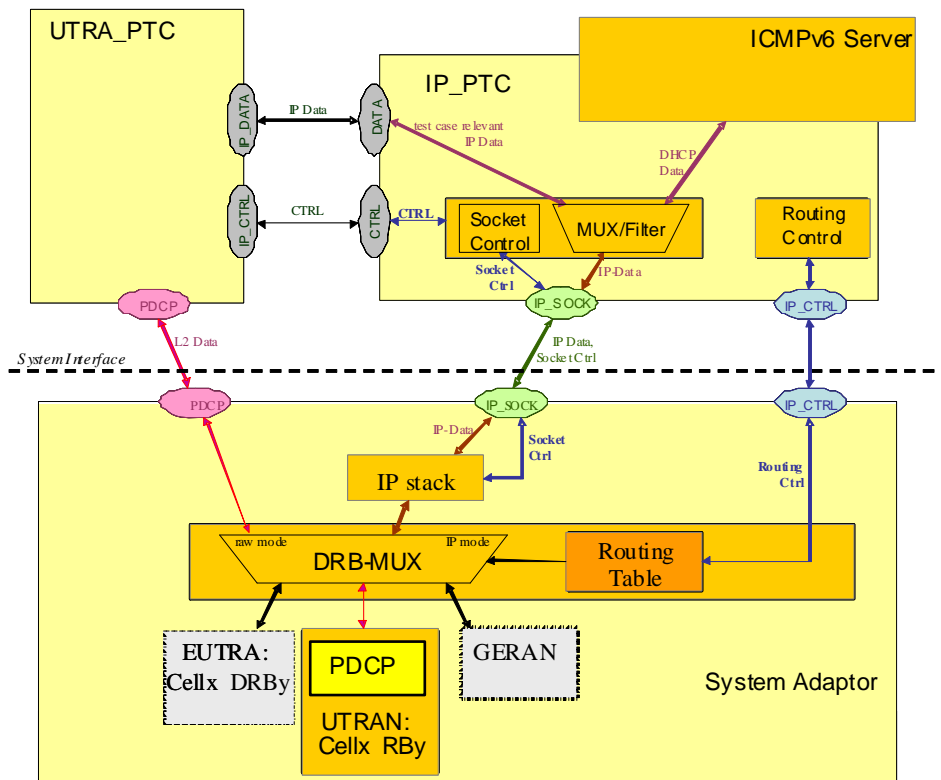

Figure 4.4.1.1.2-1: UTRAN IP test model with an ICMPv6 server

4.4.1.1.3 Routing IP data

The routing of user data is the function of DRB-Mux and controlled by a routing table.

If there is no entry in the routing table for a given RB, it is considered being in raw mode, raw user data is routed to or from the UTRAN PDCP port.

If there is an entry in the routing table for a given RB, it is considered being in IP mode, IP data is routed to or from the IP stack.

For EUTRA-UTRAN or UTRAN test, the routing entry parameters in the DRB-Mux's routing table are specified as (RAT=Utran, cell-id=-1, RB id). SS PDCP entity does not belong to a particular cell; the cellId shall be assigned to the value -1. Consequently, the UTRAN cell id provided in DRB-Mux is set to cell-id=-1.

IP protocol information of IP data (protocol, local IP address, local port, remote IP address, and remote port) is also provided in the routing table. More information can be found in 4.2.4.

4.4.2 E-UTRAN-GERAN Inter RAT Test Model

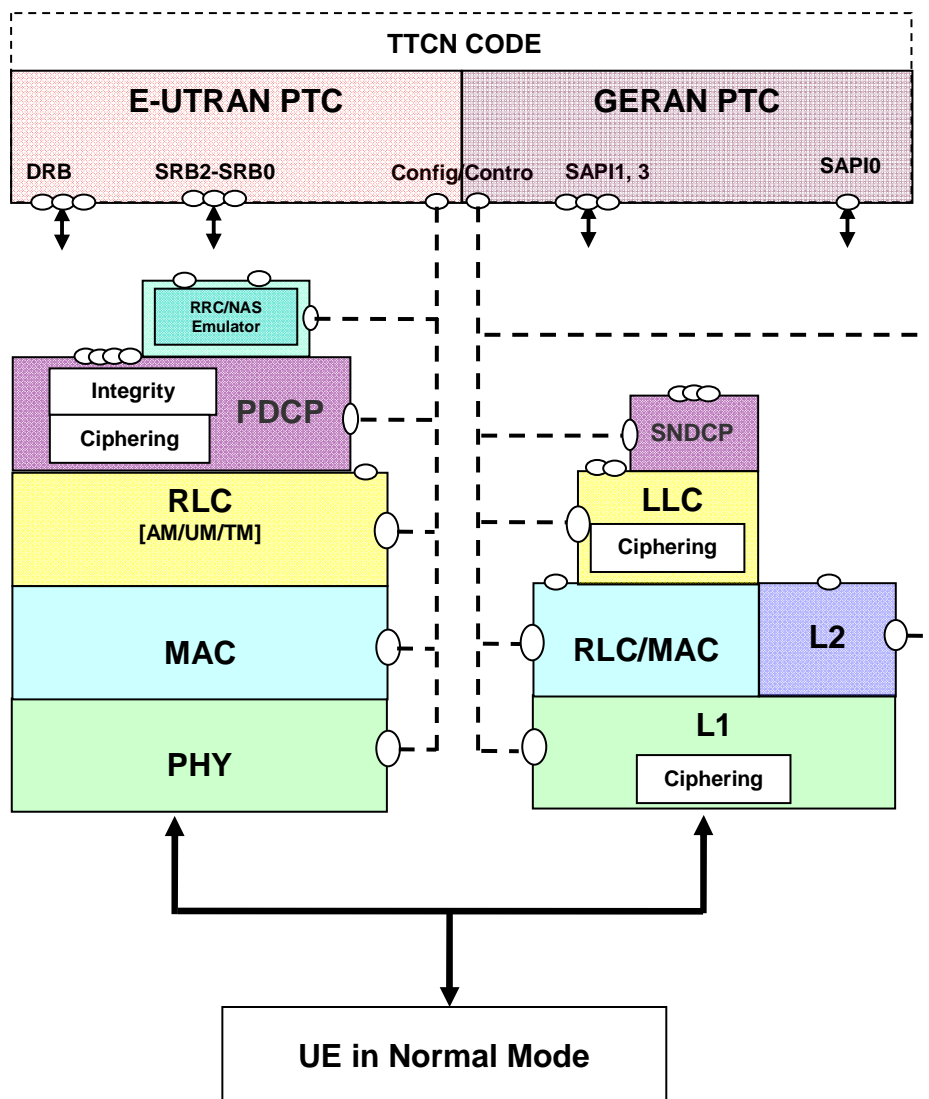

Figure 4.4.2-1: Test model for Inter RAT E-UTRAN-GERAN testing

The model consists of dual protocol stack one for E-UTRAN and one for GERAN. The TTCN implementation for E-UTRAN and GERAN functionalities will be in separate Parallel Test Components. The SS E-UTRAN part is the same as the model defined in clause 4.2.2 for RRC testing.

The SS GERAN model for GPRS consists of L1, MAC/ RLC and LLC, configured in normal mode. SNDCP may also be configured. If SNDCP is configured, this shall reference the LL Entity by the LLMEId. They shall perform all of their functions normally. Ciphering is enabled and shall be performed in LLC. XIDs shall be sent/received by the TTCN and the TTCN will then send the XID information to the SS using the G_CLLC_XID_Config_REQ ASP. Ports are above RLC (GRR messages), LLC (NAS and Data) and SNDCP (User Data).

The SS GERAN model for GSM consists of L1, L2 (MAC/ RLC), configured in normal mode. They shall perform all of their functions normally. Ciphering is enabled and shall be performed in L1. Ports are above L2.

The UE is configured in normal mode. Ciphering/Integrity (PDCP and NAS) are enabled and ROHC is not configured in E-UTRAN. Ciphering is enabled in GERAN.

4.4.2.1 User data over GERAN

User data transferred over GERAN is distinguished between:

Raw user data (raw mode),

IP data (IP mode).

Depending upon whether the user data is relevant for the purpose of test, several scenarios are listed:

Raw user data relevant for the purpose of test,

IP data relevant for the purpose of test,

IP data, considered as IP signalling, not directly relevant for the purpose of test.

4.4.2.1.1 Raw user data over GERAN

The raw user data can be as RLC blocks and SNDCP SDUs. The DL and UL user data are routed to GERAN PTC (Fig. 4.4.2.1.2-1). The IP stack in the SS is not involved for all raw user data applications.

RLC blocks are applied if testloop mode B (TS 36.509 [4]) is activated and raw data is looped back on GERAN.

IP raw data is another type of raw data. The testloop mode is not activated. This case is applied when sending uplink data is triggered by the upper tester.

SNDCP and optionally RoHC are configured in the SS, DL and UL user data are routed to GERAN_PTC via the SNDCP port.

4.4.2.1.2 IP data over GERAN

The IP data over GERAN is applied to EUTRA – GERAN I-RAT test cases. The IP stack in the SS is involved. IP data is considered as:

- IP packets data (IP mode) relevant for the purpose of the test,
- IP signalling (IP mode), to be handled in the TTCN at IP layer.

One of the IP signalling handling is the stateless address auto configuration for IPv6, illustrated in Figure 4.4.2.1.2-1.

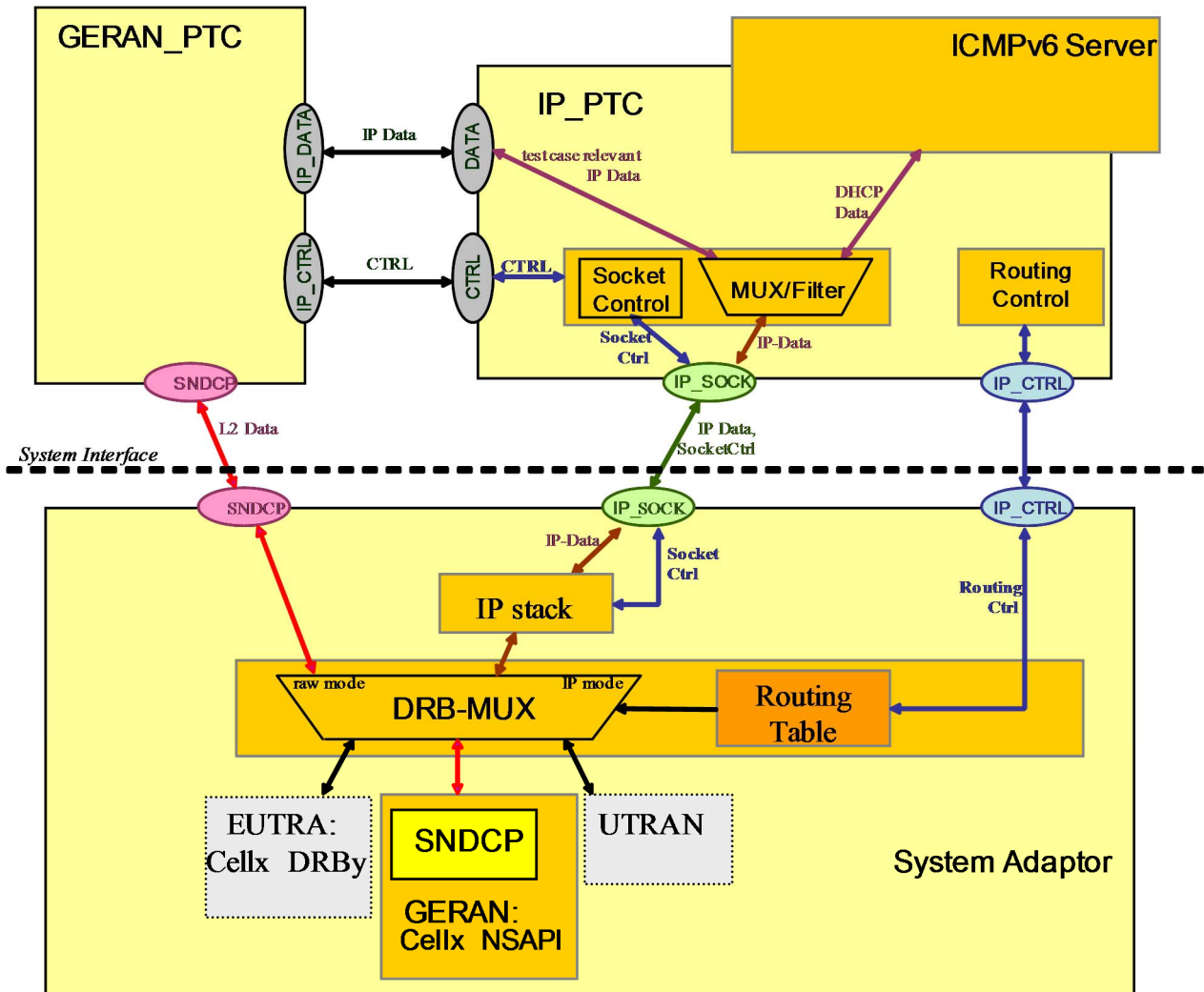

Figure 4.4.2.1.2-1: GERAN IP test model with an ICMPv6 server

4.4.2.1.3 Routing IP data

The routing of user data is the function of the DRB-Mux and is controlled by a routing table.

If there is no entry in the routing table for a given NSAPI, it is considered to be in raw mode, raw user data is routed to or from the GERAN SNDSCP port.

If there is an entry in the routing table for a given NSAPI, it is considered to be in IP mode, IP data is routed to or from the IP stack.

For EUTRA-GERAN, the routing entry parameters in the DRB-Mux's routing table are specified as (RAT = GERAN, cell-id, NSAPI). IP protocol information of IP data (protocol, local IP address, local port, remote IP address, and remote port) is also provided in the routing table. More information can be found in clause 4.2.4.

4.4.3 E-UTRAN-CDMA2000 Inter RAT Test Model

4.4.3.1 E-UTRAN-CDMA2000 HRPD Inter RAT Test Model

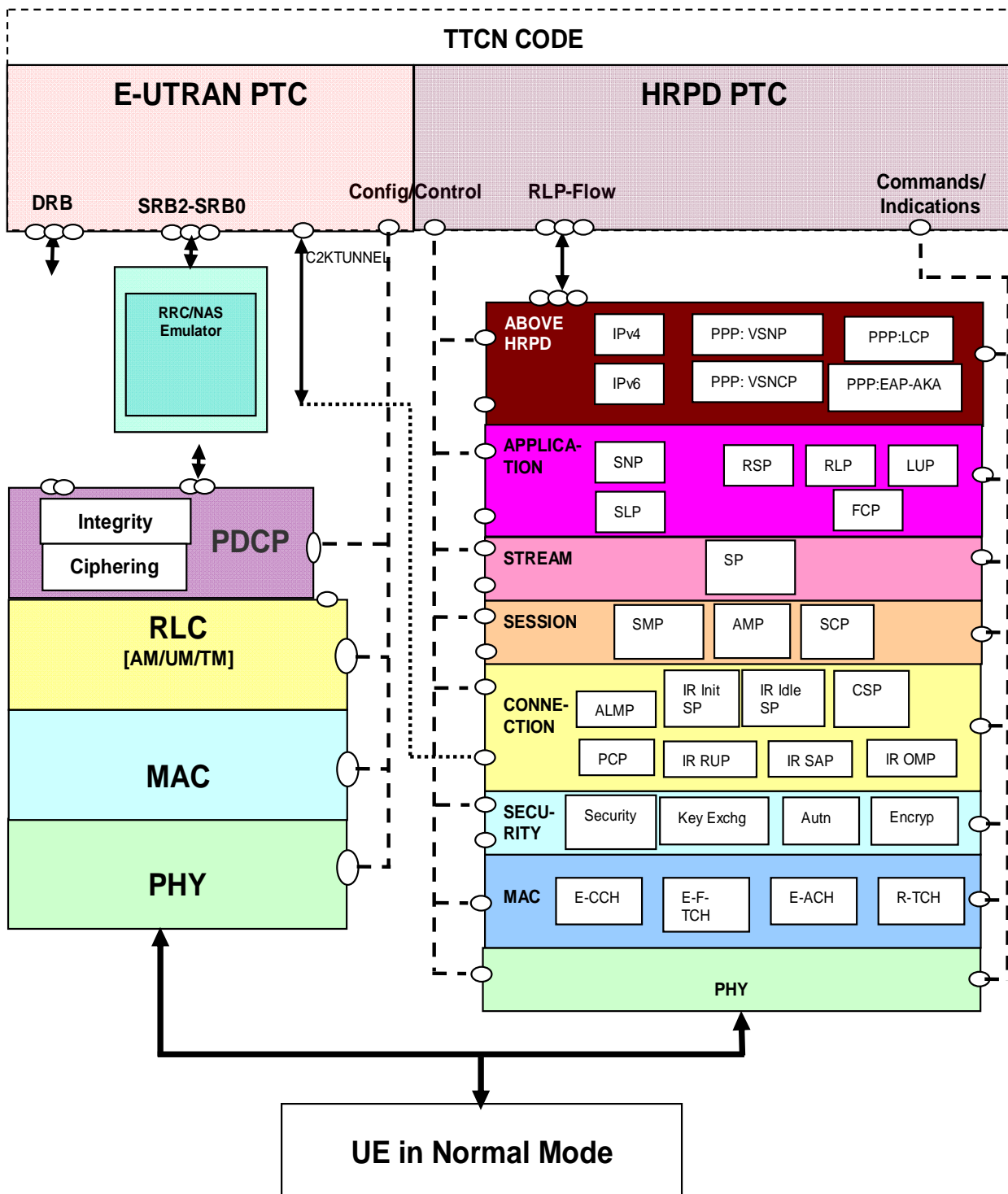

Figure 4.4.3-1: Test model for InterRAT E-UTRAN-CDMA2000 HRPD testing

The model consists of a dual protocol stack, one for E-UTRAN and one for eHRPD. The TTCN implementation for E-UTRAN and eHRPD functionalities will be in separate Parallel Test Components. The SS E-UTRAN part is same as the model defined in clause 4.2.2 for RRC testing.

The eHRPD part emulation in SS is considered as a black box. The commands/Indications port is used for commanding the SS to bring the UE into the desired state and monitoring the progress. The System commands and indications are designed with principle of having minimum command/indication per eHRPD procedure hence avoid racing conditions and timing issues. By default, the execution order of sub procedures (e.g. protocol negotiations) cannot be monitored by TTCN. The SS emulations shall be compliant with respective 3GPP/3GPP2 core specifications and guarantee execution order of respective eHRPD procedures as per relevant 3GPP/3GPP2 test/core specifications.

The C2KTUNNEL port is used for routing encapsulated

1. pre-registration messages (i.e. messages encapsulated in *ULInformationTransfer* and *DLInformationTransfer*) in the EUTRAN cell to the eHRPD and
2. handover related eHRPD messages (i.e. messages encapsulated in *HandoverFromEUTRAPreparationRequest/ULHandoverPreparationTransfer/MobilityFromEUTRACommand*).

The SS eHRPD part consists of Physical, MAC, Security, Connection, Session, Stream, Application and Layers for PPP and IP configured in normal mode. They shall perform all of their functions normally. Encryption may be enabled and performed in security layer.

The CDMA2000 eHRPD emulation in the SS supports the following layers and protocols:

- Physical layer (Subtype 2).
- MAC layer:
 - Enhanced (Subtype 0, Subtype 1) Control Channel MAC Protocol (ECH).
 - Enhanced (Subtype 1) Forward Traffic Channel MAC Protocol (E-F-TCH).
 - Enhanced (Subtype 1) Access Channel MAC Protocol (E-ACH).
 - Subtype 3 Reverse Traffic Channel MAC Protocol (R-TCH).
- Security Layer:
 - Default Security Protocol (Security).
- Connection Layer:
 - Default Air Link Management Protocol (ALMP).
 - Default Connected State Protocol (CSP).
 - Default Packet Consolidation Protocol (PCP).
 - Inter-RAT Signalling Adaptation Protocol (IR-SAP) (required only for optimized handover).
 - Inter-RAT Initialization State Protocol (IR-Init SP) (required only for optimized handover).
 - Inter-RAT Idle State Protocol (IR-Idle SP) (required only for optimized handover).
 - Inter-RAT Route Update Protocol (IR-RUP) (required only for optimized handover).
 - Inter-RAT Overhead Messages Protocol (IR-OMP) (required only for optimized handover).
- Session Layer:
 - Default Session Management Protocol (SMP).
 - Default Address Management Protocol (AMP).
 - Default Session Configuration Protocol (SCP).
- Stream Layer:
 - Default Stream Protocol (DSP).
- Application Layer:

- Default Signalling Application:
 - Signalling Network Protocol (SNP).
 - Signalling Link Protocol (SLP).
- Enhanced Multi-Flow Packet Application:
 - Route Selection Protocol (RSP).
 - Radio Link Protocol (RLP).
 - Location Update Protocol (LUP).
 - Flow Control Protocol (FCP).
- Alternate Enhanced Multi-Flow Packet Application (to be listed along with EMPA during SCP negotiation)
- Above eHRPD:
 - PPP: Vendor Specific Network Control Protocol (PPP:VSNCP).
 - PPP: Vendor Specific Network Protocol (PPP:VSNP).
 - PPP: Link Control Protocol (PPP:LCP).
 - PPP: Extensible Authentication protocol-Authentication and Key Agreement' (PPP:EAP-AKA').
 - IPv4.
 - IPv6.

During pre-registration phase, one cell per preRegistrationZoneID (ColorCode) to be simulated will be configured by TTCN with power level as 'off', or as specified by the test case. The SS will be issued System commands for pre-registration and expect the appropriate system indications.

The UE is configured in normal mode. Ciphering/Integrity (PDCP and NAS) are enabled and ROHC is not configured in E-UTRAN. Encryption is enabled in HRPD.

4.4.3.2 E-UTRAN-CDMA2000 1xRTT Inter RAT test model

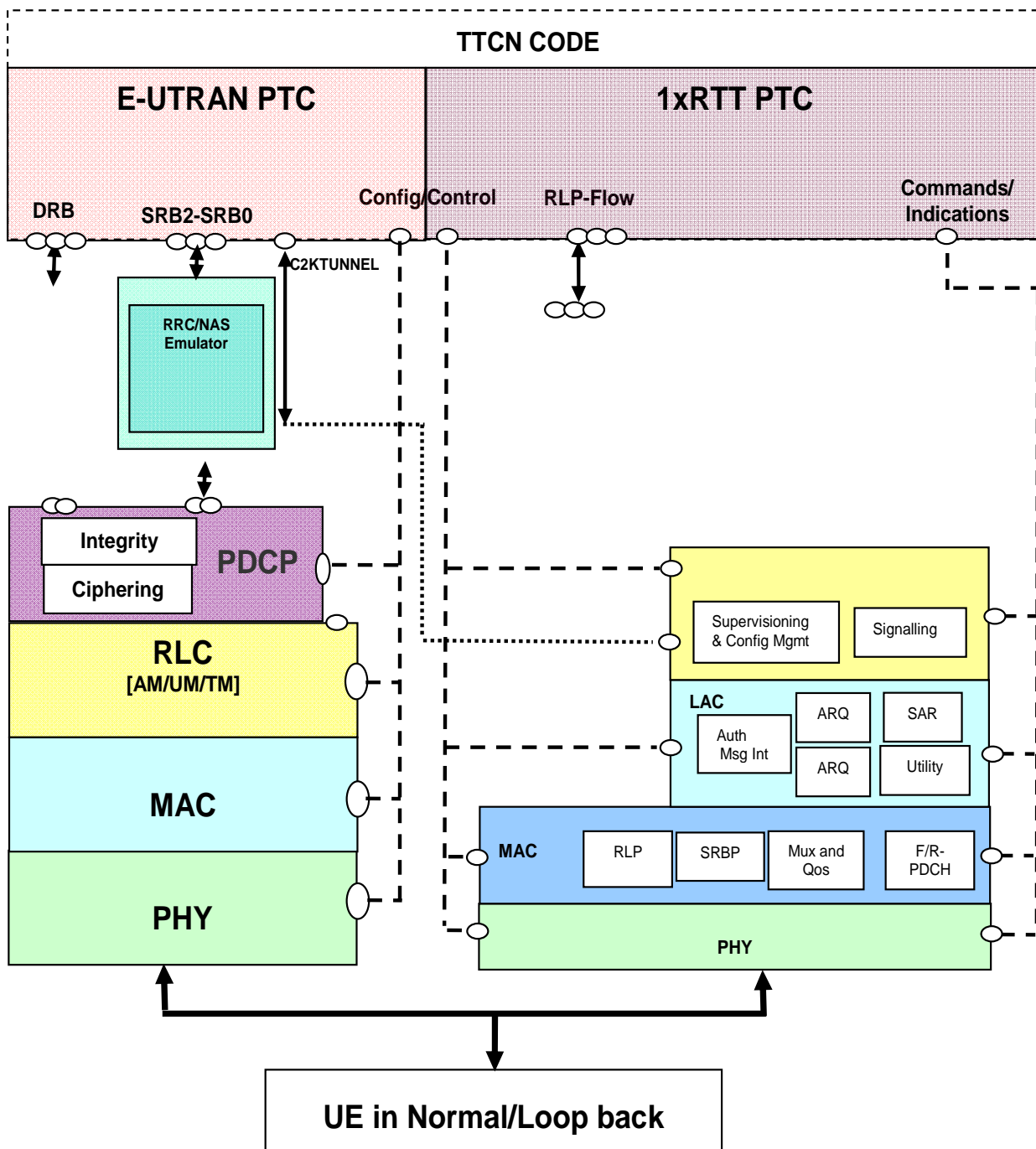

Figure 4.4.3.2-1: Test model for InterRAT E-UTRAN-CDMA2000 1xRTT testing

The 1xRTT test model consists of a dual protocol stack, one for E-UTRAN and one for 1xRTT. The TTCN implementation for E-UTRAN and 1xRTT functionalities are in separate Parallel Test Components. The SS E-UTRAN part is same as the model defined in clause 4.2.2 for RRC testing.

The 1xRTT part emulation in SS is considered as a black box. The commands/Indications port is used for commanding the SS to bring the UE into the desired state and monitoring the progress. The System commands and indications are designed with principle of having minimum command/indication per 1xRTT procedures hence avoid racing conditions and timing issues. By default, the execution order of sub procedures(e.g. protocol negotiations) cannot be monitored by TTCN. The SS emulations shall be compliant with respective 3GPP/3GPP2 core specifications and guarantee execution order of respective 1xRTT procedures as per relevant 3GPP/3GPP2 test/core specifications.

The C2KTUNNEL port is used for routing encapsulated

1. pre-registration messages (i.e. messages encapsulated in *CSFBParametersResponseCDMA2000*, *ULInformationTransfer* and *DLInformationTransfer*) in the EUTRAN cell to the 1xRTT and
2. handover, e-CSFB related 1xRTT messages (i.e. messages encapsulated in *HandoverFromEUTRAPreparationRequest*/*ULHandoverPreparationTransfer*/*MobilityFromEUTRACCommand*).

The SS 1xRTT part consists of Physical, MAC, LAC, Session, Stream, Application and Layers for PPP and IP configured in normal mode. They shall perform all of their functions normally. Encryption may be enabled and performed in security layer.

The CDMA2000 1xRTT emulation in the SS supports the following layers and protocols:

- Physical layer.
- MAC layer:
 - Signalling Radio Burst protocol.
 - Radio Link Protocol for Data services.
 - Forward and Reverse Packet Data Channel functions.
 - Multiplexing and QoS Delivery.
- Link Access Control:
 - Authentication and Message Integrity sublayer [optional].
 - ARQ sublayer.
 - Addressing.
 - Utility.
 - Segmentation and Reassembly.
- Layer 3:
 - Super visioning and Configuration Management.
 - Signalling Protocol.

During pre-registration phase, one cell per *preRegistrationZoneID* (*ColourCode*) to be simulated will be configured by TTCN with power level as 'off', or as specified by the test case. The SS will be issued System commands for pre-registration and expect the appropriate system indications.

The UE is configured in normal mode or loop back mode. Ciphering/Integrity (PDCP and NAS) are enabled and ROHC is not configured in E-UTRAN. Encryption may be enabled in 1xRTT.

4.4.4 E-UTRAN FDD-TDD Inter RAT Test Model

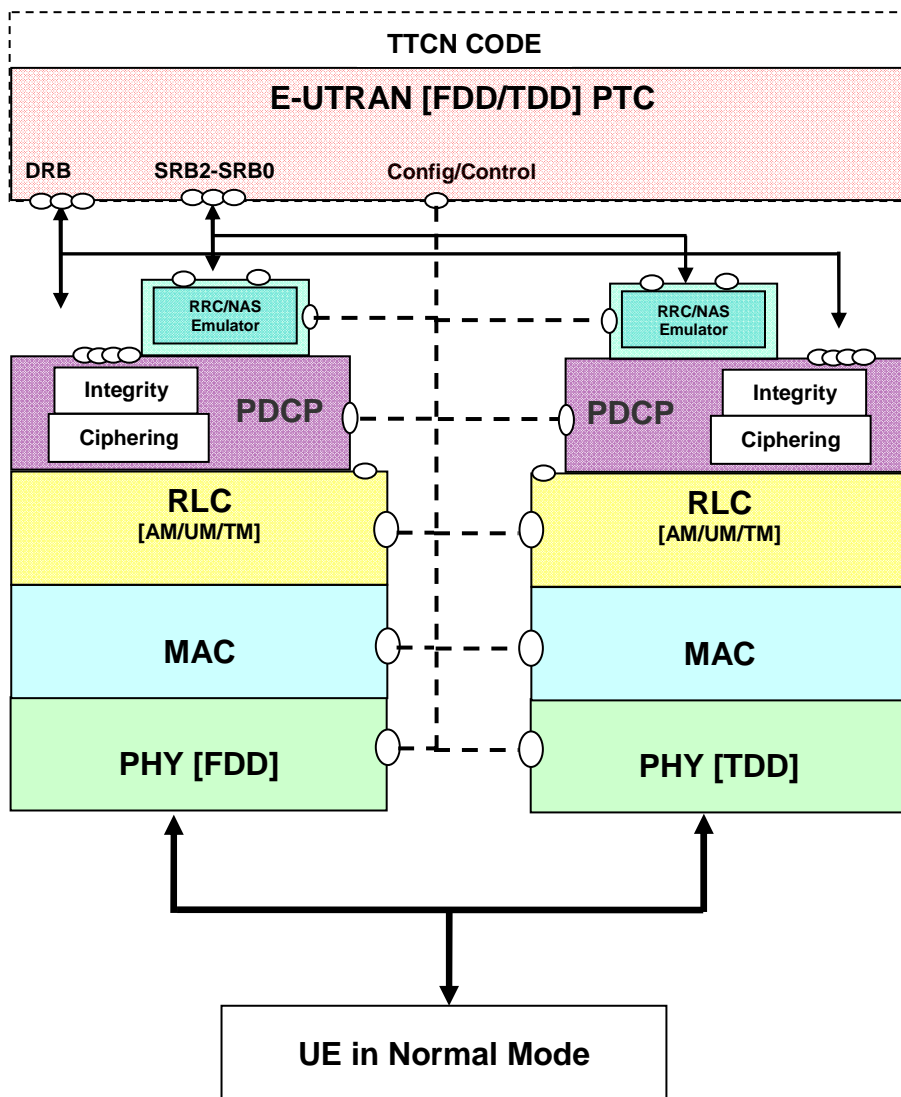

Figure 4.4.4-1: Test model for Inter RAT E-UTRANFDD-TDD testing

The model consists of dual protocol stack one for E-UTRANFDD and one for E-UTRANTDD. The TTCN implementation for E-UTRANFDD and TDD functionalities will be in the same Parallel Test Component. The SS E-UTRAN (both FDD and TDD) part is the same as the model defined in clause 4.2.2 for RRC testing. SS E-UTRANFDD and TDD shall be configured as separate cells.

The UE is configured in normal mode. Ciphering/Integrity (PDCP and NAS) are enabled and ROHC is not configured for both FDD and TDD.

4.4.5 E-UTRAN-UTRAN-GERAN Inter RAT Test Model

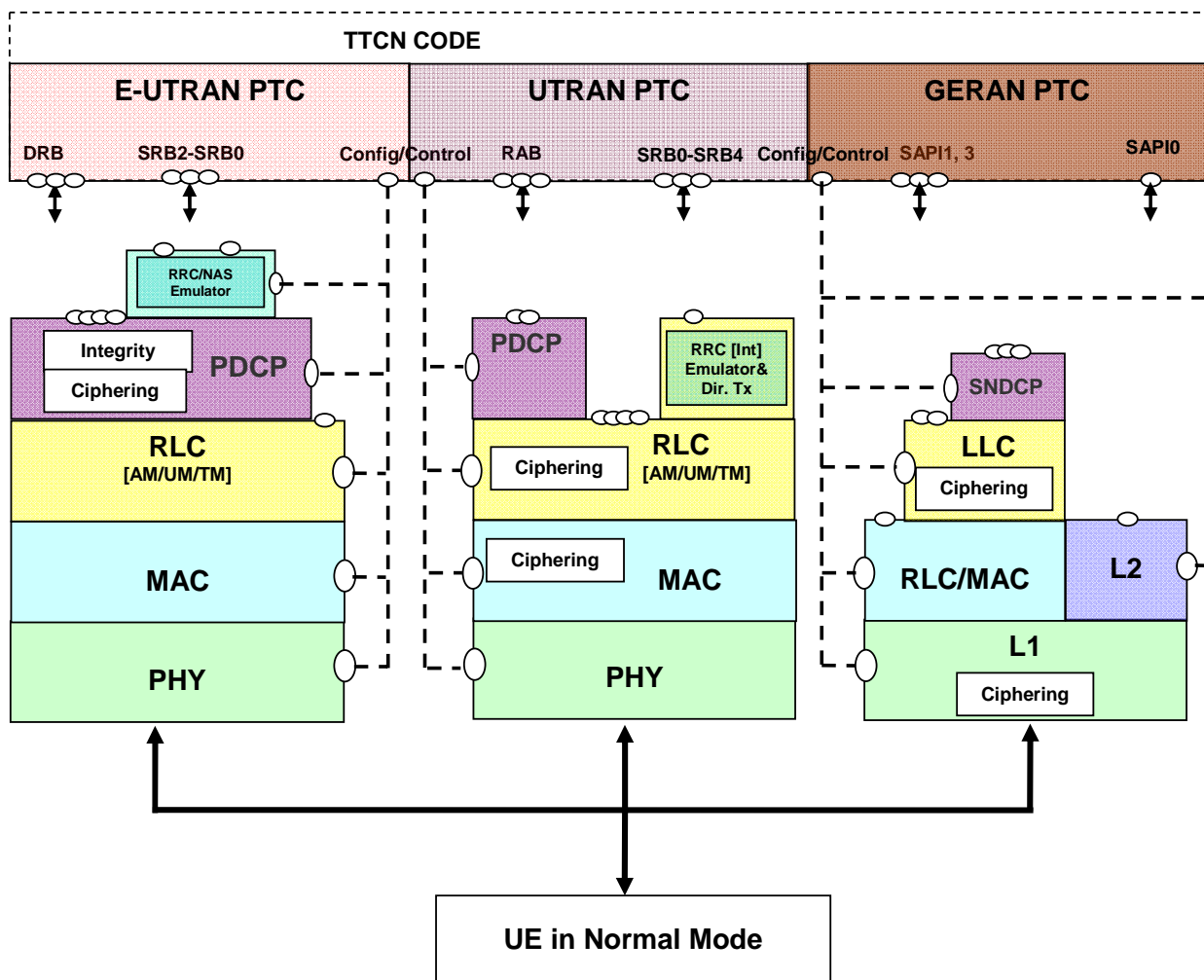

Figure 4.4.5-1: Test model for Inter RAT E-UTRANFDD-TDD testing

The model consists of integrated protocol stack supporting E-UTRAN, UTRAN and GERAN. The TTCN implementation for E-UTRAN, UTRAN and GERAN functionalities will be in separate Parallel Test Components. The SS E-UTRAN part is the same as the model defined in clause 4.2.2 for RRC testing. The SS UTRAN part is the same as the model defined in clause 4.4.1. The SS GERAN part is same as the model defined in clause 4.4.2.

The UE is configured in normal mode. Ciphering/Integrity (PDCP and NAS) are enabled and ROHC is not configured in E-UTRAN. Ciphering/Integrity are enabled in UTRAN. Ciphering is enabled in GERAN.

4.4.6 3GPP-WLAN Inter working Test Model

4.4.6.1 E-UTRAN-WLAN Inter working Test Model

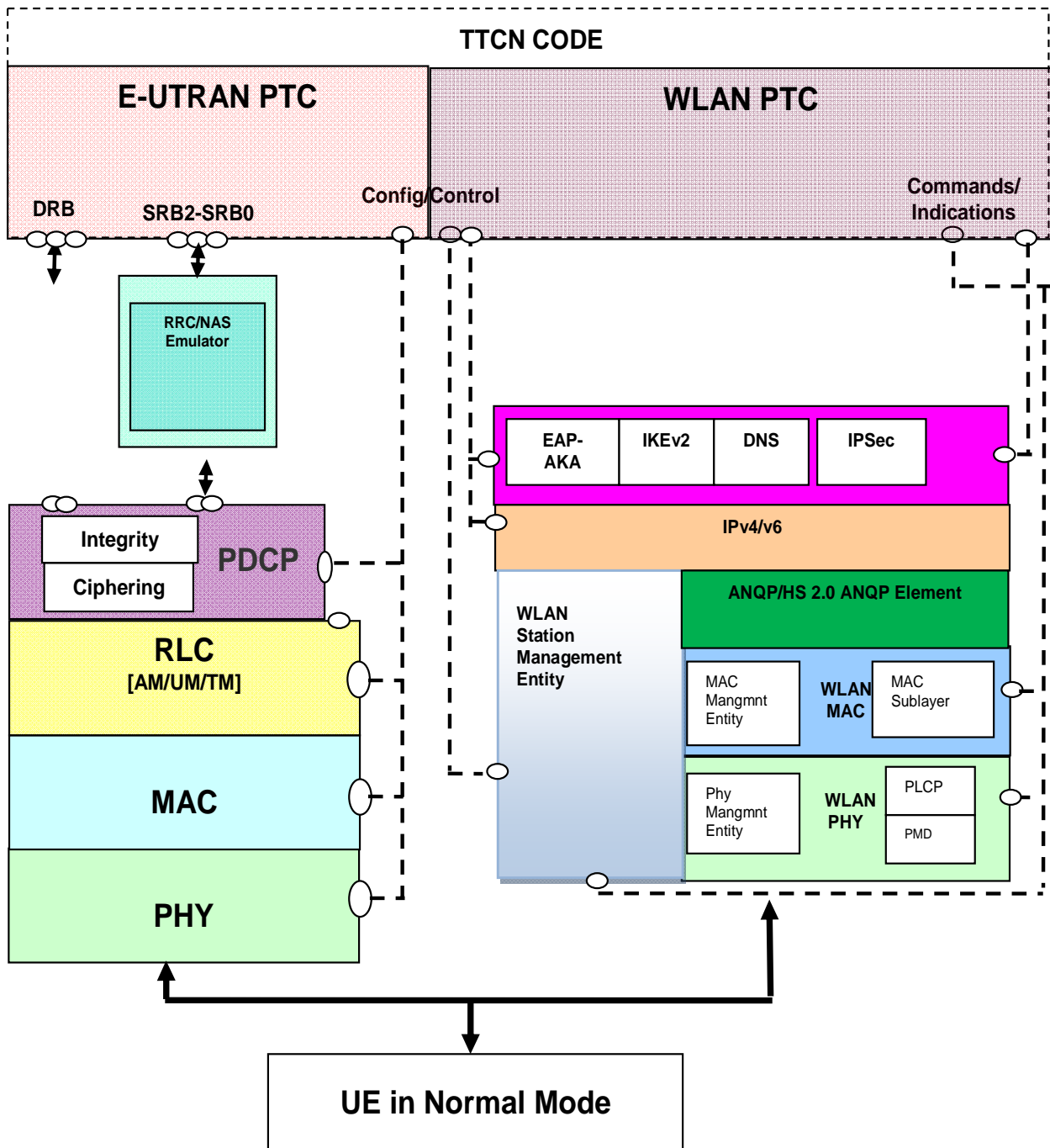

Figure 4.4.6.1-1: Test model for E-UTRAN-WLAN interworking testing

The model consists of a dual protocol stack, one for E-UTRAN and one for WLAN. E-UTRAN and WLAN functionalities are implemented in separate Parallel Test Components in the TTCN. The SS E-UTRAN part is the same as the model defined in clause 4.2.2 for RRC testing. The WLAN part is specified in clause 4.5.

The UE is configured in normal mode. Ciphering/Integrity (PDCP and NAS) are enabled and ROHC is not configured in E-UTRAN.

NOTE: The working assumption is that the UE supports IP address preservation. Therefore the UE includes INTERNAL_IP4_ADDRESS or the INTERNAL_IP6_ADDRESS attribute or both in the CFG_REQUEST Configuration Payload within the IKE_AUTH request message. The ePDG then relays in the IKEv2 Configuration Payload (CFG_REPLY) of the final IKE_AUTH response message the remote IP address information to the UE. Reference 24.302 [67] clause 7.2.2(UE) and 7.3.1(ePDG).

4.4.6.2 UTRAN-WLAN Inter working Test Model

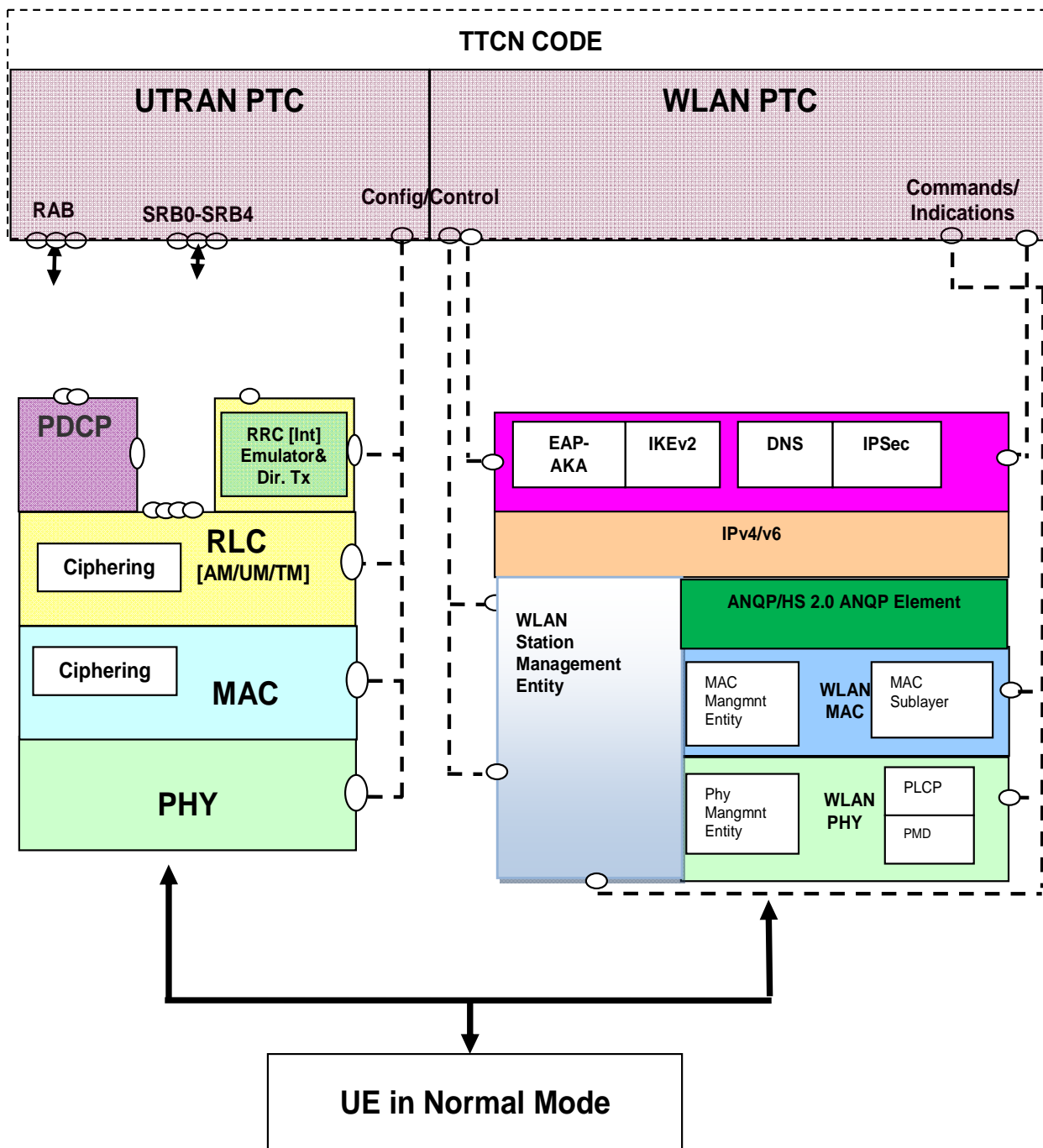

Figure 4.4.6.2-1: Test model for UTRAN-WLAN interworking testing

The model consists of a dual protocol stack, one for UTRAN and one for WLAN. UTRAN and WLAN functionalities are implemented in separate Parallel Test Components in the TTCN. The SS UTRAN part is the same as the model defined in clause 4.4.1. The SS WLAN part is defined in clause 4.5.

4.5 Generic WLAN Test Model

The generic WLAN test model is applicable for IMS over WLAN testing, as well as for E-UTRAN/UTRAN-WLAN interworking testing. The TTCN and SS implementations emulate an untrusted Non-3GPP IP Access as specified in TS 23.402 [63]: There is the WLAN access point (WLAN AP) and the emulation of ePDG and AAA-server.

4.5.1 WLAN Access Point

The WLAN access point emulation is done at the SS with a few configuration parameters provided by TTCN. The following layers need to be supported:

- Station Management Entity
- Physical layer:
 - Physical Sublayer Management Entity
 - Physical layer Convergence procedure
 - Physical Medium Dependent
- MAC layer:
 - MAC Management Entity
 - MAC sublayer
 - Also contains security services
- ANQP element and HS 2.0 ANQP Network elements

WLAN security protocol using WPA/WPA2 algorithms shall be supported.

4.5.2 ePDG/AAA-Server Emulation

An IPsec tunnel is established between the UE being in the untrusted network and the ePDG: Establishment, maintenance and release of the IPsec tunnel requires IP signalling between the tunnel end-points (UE, ePDG) according to RFC 5996 [64] and TS 33.402 [25]. IP data between the UE and the emulated 3GPP network is transferred through the IPsec tunnel by using UDP Encapsulation of IPsec ESP Packets according to RFC 3948 [65].

Figure 4.5.2-1 shows the principle of the IPsec tunnel. Note that the IP addresses of 3GPP and non-3GPP network shall be different.

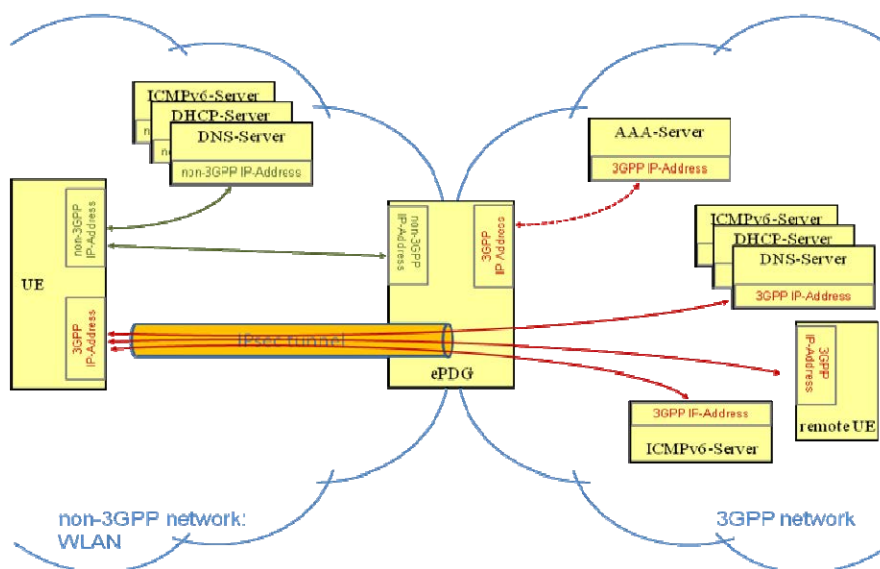

Figure 4.5.2-1: IPsec tunnel for untrusted Non-3GPP IP Access to 3GPP network

During establishment of the IPsec tunnel, parameters for authentication and authorization (EAP AKA) are exchanged between the ePDG and the AAA-server (see TS 33.402 [25] clause 8).

The means for establishment, maintenance and release of the IPsec tunnel shall be provided by the SS. The TTCN does not deal with IKE messages as such. In addition to the IP test model of clause 4.2.4 there are the following requirements for SS implementation:

- IPsec tunnelling according to RFC 5996 [64] (IKEv2) and RFC 3948 [65]
- Emulation of EAP AKA according to RFC 4187 [66] i.e. interworking between IPsec (ePDG) and emulated AAA-server

The enhancement of the common IP test model of clause 4.2.4 is shown in figure 4.5.2-2.

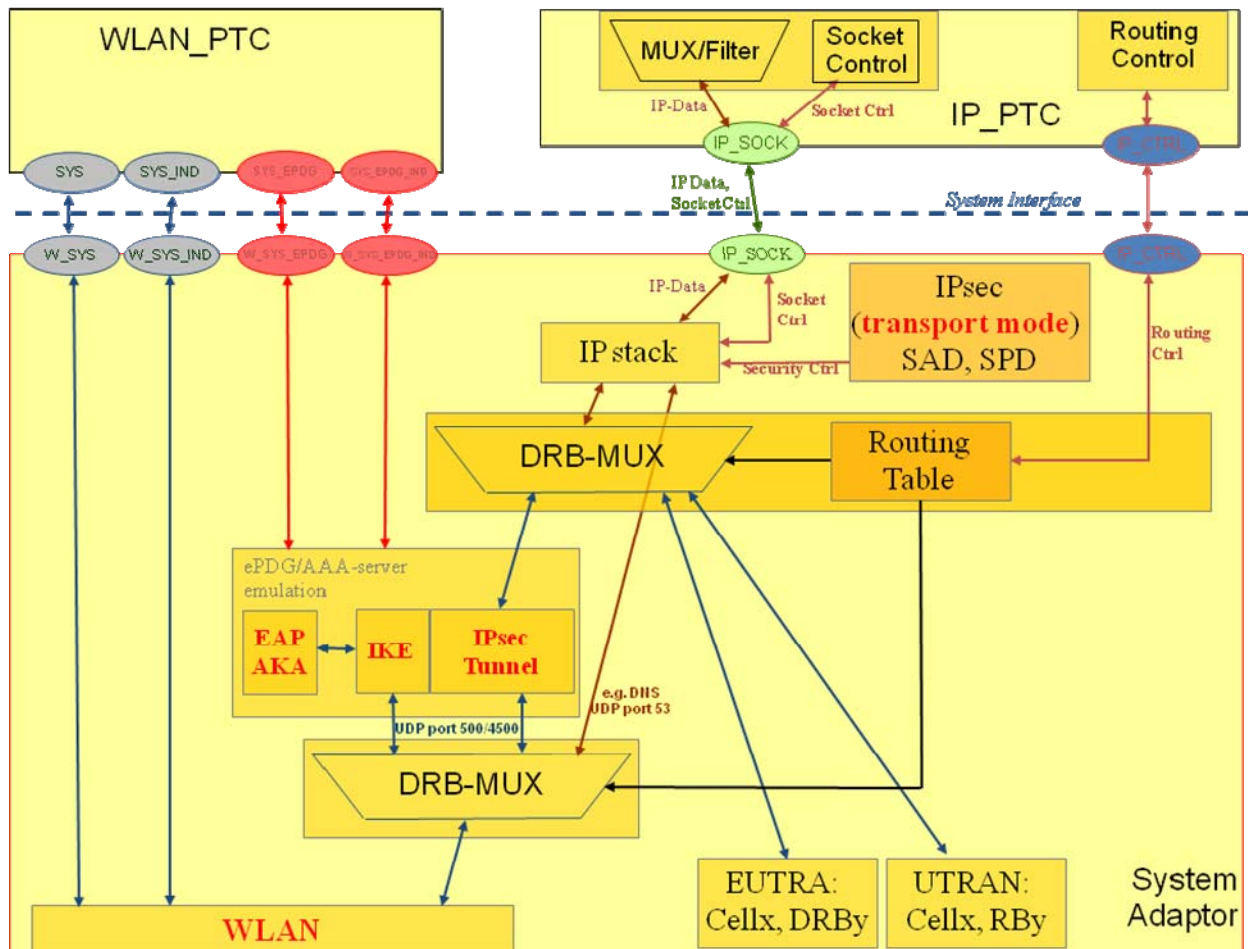

Figure 4.5.2-2: Generic WLAN Test Model

Further implementation requirements:

IPsec tunnel handling is controlled by the TTCN with static parameters

- DNS for dynamic selection of the ePDG is handled in the TTCN according to the common IP test model
- DHCP and ICMPv6 can be handled in the TTCN when needed (as for E-UTRA or UTRAN)
- IMS SIP/SDP signalling is handled in the TTCN as for E-UTRA or UTRAN
- RTP/RTCP loopback model can be configured in the same way as for E-UTRA
- Routing of IP packets from and to WLAN is controlled by the DRB-Mux in the same way as for E-UTRA or UTRAN

In the context of the IPsec tunnel, logically two instances of the DRB-Mux can be considered:

- Uplink
 - lower DRB-Mux to distinguish whether a UDP packet is IKE or ESP data
 - an IKE or ESP packet needs to be routed to the IPsec tunnel
 - upper DRB-Mux to handle IP packets coming out of the IPsec tunnel
- Downlink
 - upper DRB-Mux to distinguish whether an IP packet shall be sent into the IPsec tunnel

- lower DRB-Mux to determine routing of IKE/ESP packets (i.e. the packets inside the tunnel)

4A NB-IoT system architecture and test models

4A.1 Test system architecture

The principles outlined in clause 4.1 apply also to the case of NB-IoT.

For NB-IoT conformance tests, NB-IoT is considered as a separate radio access technology (RAT) and is hosted by a separate TTCN-3 parallel component (PTC).

4A.2 NB-IoT test models

4A.2.1 Layer 2 test models

4A.2.1.1 Layer 2 loopback mode for CP mode

Layer 2 test cases for control plane mode (CP mode) are using UE test loop mode G or H according to TS 36.509 [4] with `GH_RLC_SDU_loopback` set to true. In this mode the UE is still able to receive RRC and NAS messages but in case of ESM DATA TRANSPORT (UE test loop mode G) or CP DATA (UE test loop mode H) the UE takes the user data of the DL NAS message and uses it as RLC SDU in UL.

At the SS, depending on the requirements of the particular test case, RLC layer and MAC layer may be configured in transparent mode to allow TTCN the control over RLC and MAC layers. This requires that the RRC message *DLInformationTransfer-NB* and the contained ESM DATA TRANSPORT or CP DATA are fully encoded (including NAS security protection). To avoid inconsistencies of the NAS COUNTs, TTCN still uses the NAS emulator. But in the DL instead of sending the messages to the SS, the NAS emulator encodes and ciphers a message and gives the encoded octetstring back to the test case implementation at the NBIOT PTC. The exchange of the respective L2 PDUs happens at the L2DATA port instead of the SRB port. Therefore the SS gets configured for an L2TestMode in which the L2 UL and DL messages shall be routed to/from L2DATA port and there is no signalling via the SRB port anymore as long as the L2TestMode is activated.

In contrast to L2 tests on DRBs the RLC counts VTS and VRR need to be:

- retrieved from the SS before configuring the RLC into transparent mode,
- maintained in TTCN while the test mode is active,
- restored at the SS after the RLC layer gets re-configured back to normal operation.

NOTE: For NB-IoT in CP mode there is no PDCP.

Figure 4A.2.1.1-1 illustrates the layer 2 loopback mode.

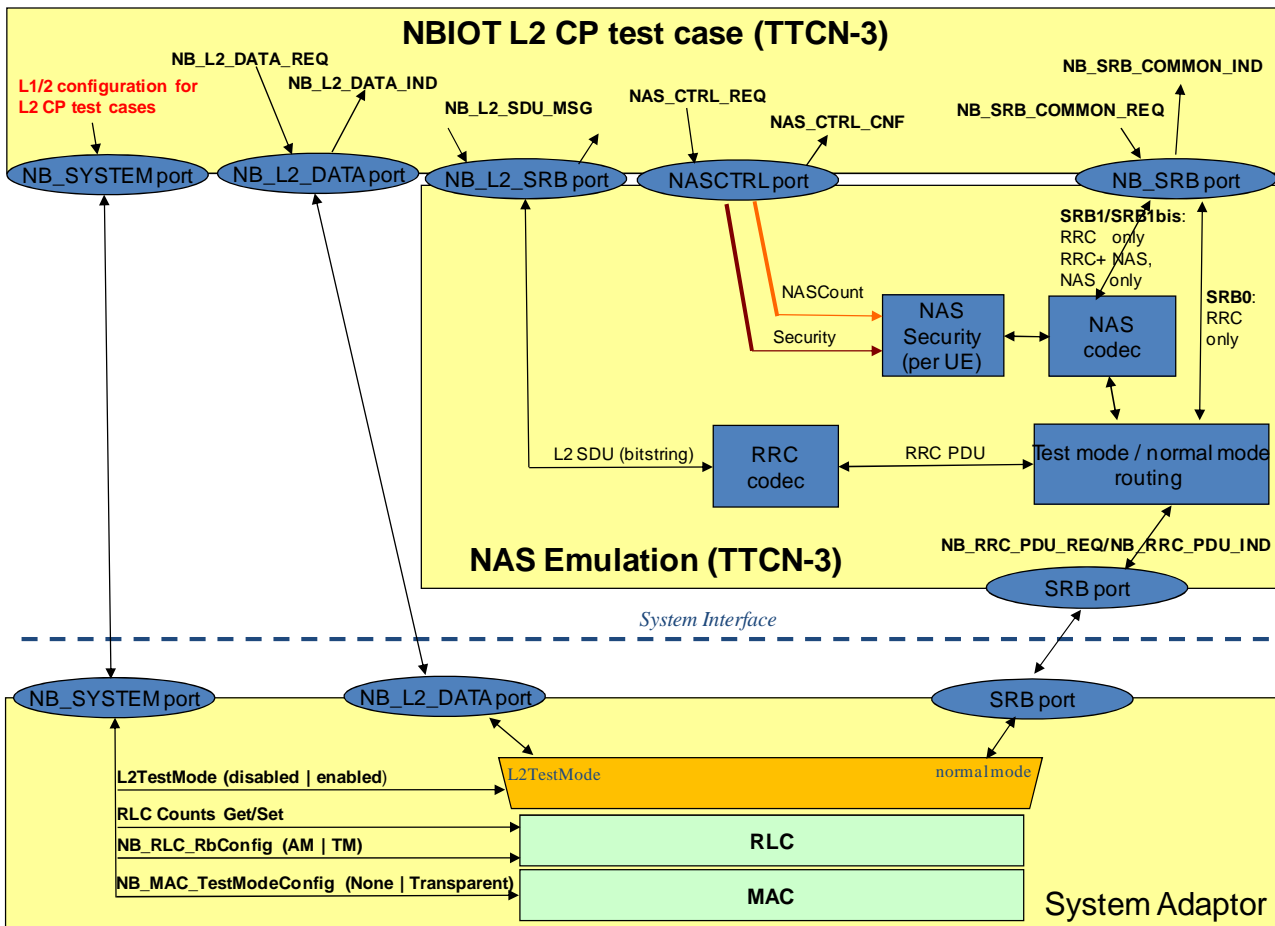

Figure 4A.2.1.1-1: Layer 2 loopback mode

4A.2.1.2 MAC test model (CP mode)

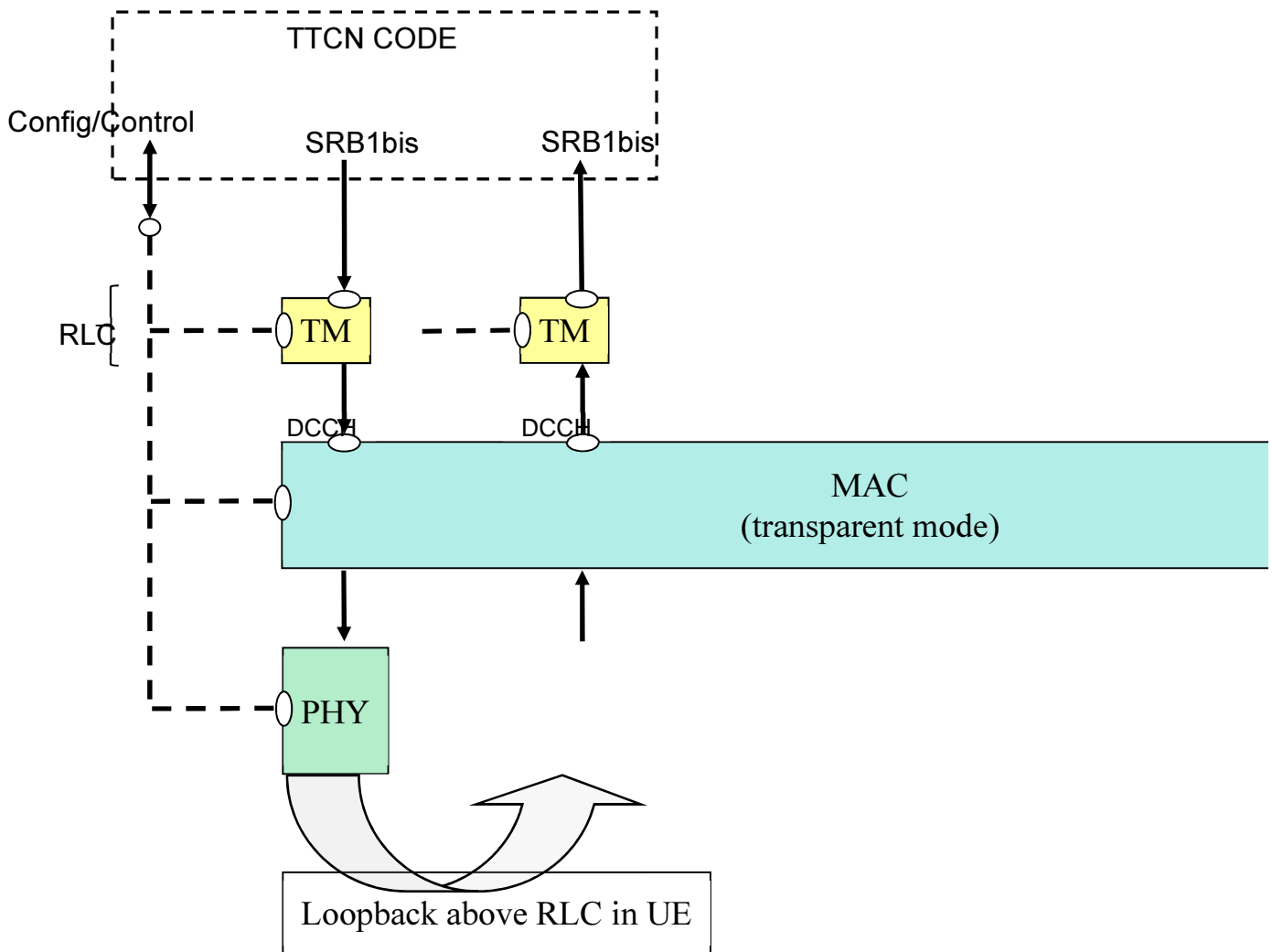

Figure 4A.2.1.2-1: Test model for MAC testing in NB-IoT CP mode

In general NB-IoT MAC test cases are implemented for control plane mode using loopback mode as described in clause 4A.2.1.1. At the SS RLC and MAC layer are configured in transparent mode with L2TestMode enabled. Transparent mode means that the TTCN fully controls processing of the RLC and MAC PDUs including padding and the SS is responsible for encoding and decoding of the MAC PDUs only.

4A.2.1.3 RLC test model (CP mode)

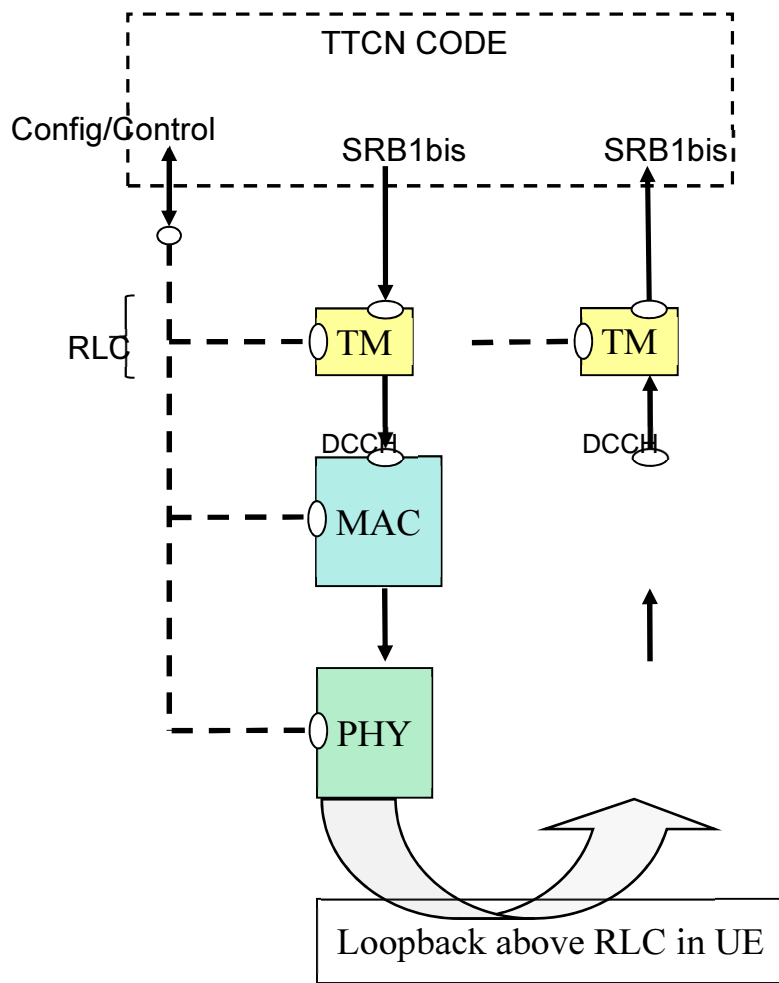

Figure 4A.2.1.3-1: Test model for RLC testing in NB-IoT CP mode

In general NB-IoT RLC test cases are implemented for control plane mode using loopback mode as described in clause 4A.2.1.1. At the SS RLC layer is configured in transparent mode with L2TestMode enabled. Transparent mode means that the TTCN fully controls processing of the RLC PDUs and the SS is responsible for encoding and decoding of the RLC PDUs only.

Only RLC AM mode of operation is used. On the SS Side, L1 and MAC are configured in the normal way. The UL Scheduling Grant and DL Scheduling assignments are configured from TTCN over the SRB1bis port.

4A.2.1.4 PDCP test model

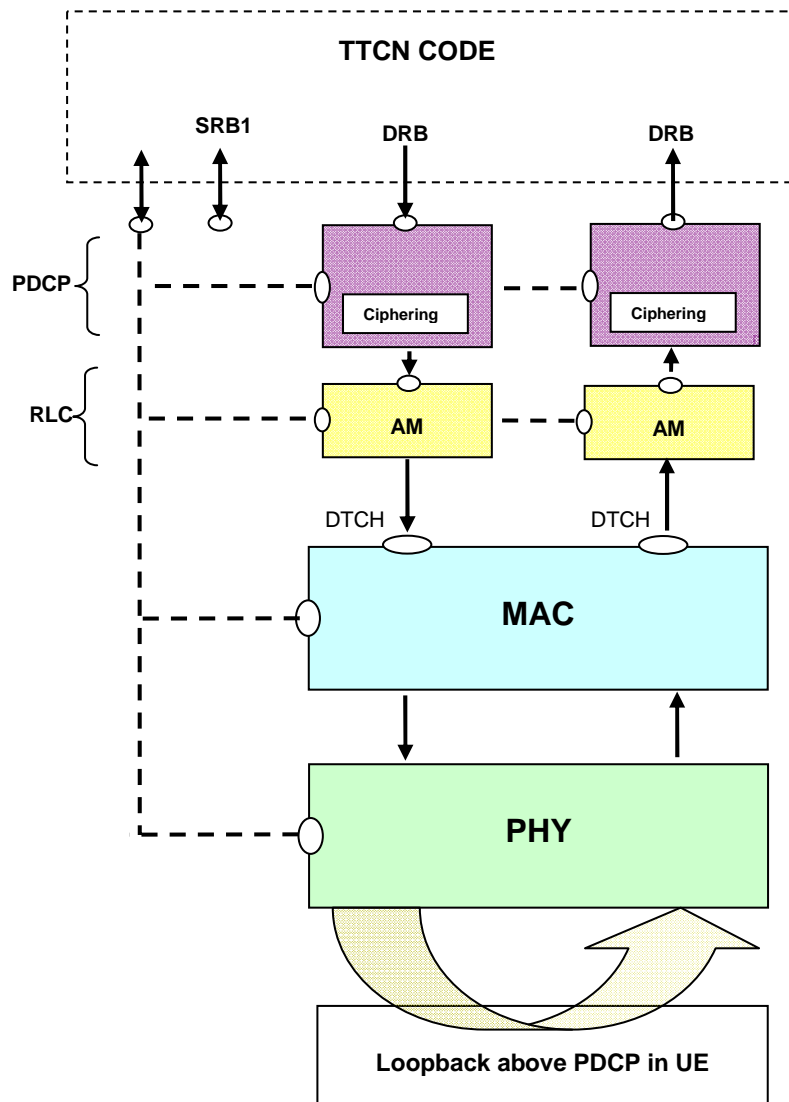

Figure 4A.2.1.4-1: Test model for PDCP testing

In general the UE is configured in Test Loop Mode A, to loop back the user domain data above PDCP layer. Ciphering is optionally configured on UE side. PDCP test cases require the UE to support NB-IoT user plane mode.

4A.2.2 RRC / NAS test model

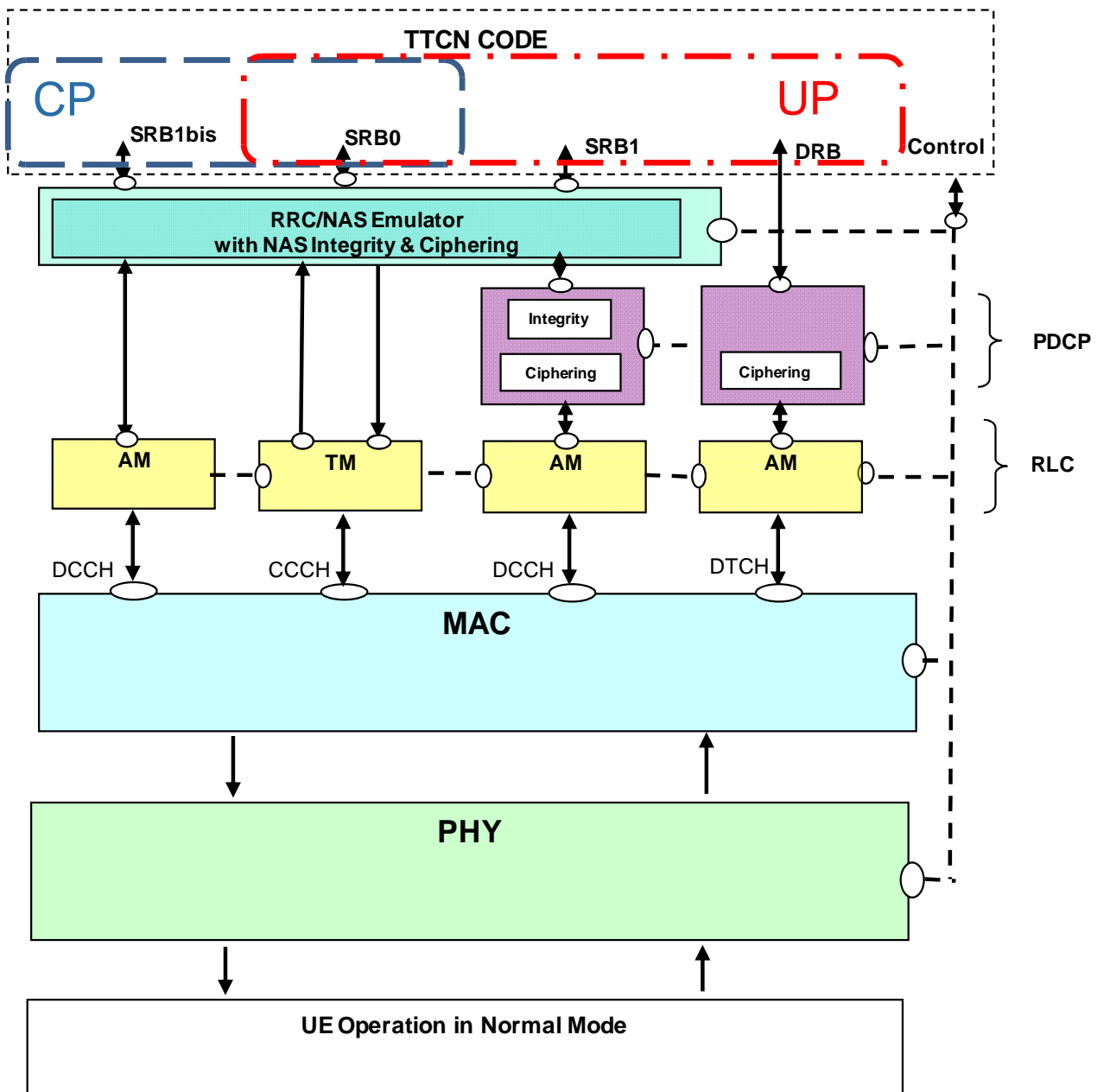

Figure 4A.2.2-1: Test model for NB-IoT RRC/NAS testing

The UE is configured in normal mode. On UE side NAS security (ciphering/integrity) is enabled and ROHC is not configured. For UP, PDCP and AS security (ciphering/integrity) are enabled.

On the SS Side L1, MAC and RLC are configured in normal mode. They shall perform all of their functions. For SRB0 the DL and UL port is above RLC. For SRB1/SRB1bis the port is above/below the RRC and NAS emulator, which is implemented as a parallel test component. NAS security (integrity/ciphering) is enabled. For UP, PDCP is configured in normal mode and the DRB port is above PDCP. AS security (ciphering/integrity) is enabled.

The NAS emulator for SRB1/SRB1bis shall provide the ciphering and integrity functionality for the NAS messages. In the UL direction, the SS shall report RRC messages, still containing (where appropriate) the secure and encoded NAS message, to the RRC port. In DL, RRC and NAS messages with same timing information shall be embedded in one PDU after integrity and ciphering for NAS messages.

The UL Scheduling Grant and DL Scheduling Assignments are configured from TTCN over the system control port.

5 Upper Tester Interface

This clause describes the handling of Upper Tester Commands at the system interface. The internal handling of those commands in TTCN is out of scope.

In the TTCN, the Upper Tester is located at the MTC; therefore there is one interface to the system adaptor common for all RATs.

5.1 Definitions

Upper test (UT) commands are commands at the UT interface and can be distinguished as:

- AT commands:
Well-defined commands specified in 3GPP core specifications like TS 27.007 [32].
At the UT interface AT commands shall be used as defined in the core specifications. It is out of scope of the TTCN implementation whether or not an AT command is supported by the UE and whether automatic operation or manual intervention is used.
All AT commands are sent as AT command strings as defined in clause 5.2. If an AT command is not implemented in the UE, the system adaptor needs to parse the AT command and map it to an appropriate proprietary command (which is out of scope for this document). If required, the system adaptor then also needs to provide a response appropriately formatted as an AT string, as expected by the TTCN.
- MMI commands:
In context of this specification MMI commands are commands for which there is no AT command defined in any core specification. This is independent from the operation (manual or automatic).

For each UT command the interactions between the system adaptor and the UE can be distinguished as either an automatic operation or requiring manual intervention.

- Automatic operation:
There is no interaction needed by the test operator i.e. the UT command is performed automatically (e.g. by using the UE's AT command interface). It is up to the system adaptor implementation to use the given UT command or map it to proprietary UE command(s) depending on each UE implementation (see clause 5.2).
- Manual intervention:
The UT command is performed by a test operator (e.g. by manual handling of the UE). The interaction between the SS and the operator, and the operator and the UE is up to the system adaptor implementation and out of scope for TTCN.

The TTCN implementation shall be the same for both modes. There shall be no difference between automatic operation and manual intervention.

- NOTE: Annex E shows message flows for manual intervention and automatic operation in different scenarios. This illustrates the behaviour at the system adapter and shows that the behaviour is the same in TTCN for both modes.

5.2 Upper Tester ASPs

There is one primitive defined carrying either an MMI or an AT command to be sent to the system adaptor and one common confirmation primitive to be sent by the system adaptor.

TTCN-3 ASP Definition			
Type Name	UT_SYSTEM_REQ		
TTCN-3 Type	Record		
Cmd	TTCN-3 Type	union	
AT	charstring carrying the AT command as defined in TS 27.007 [32], TS 27.005 [31] and TS 27.060 [33]		
MMI	<ul style="list-style-type: none"> - Cmd (charstring) - List of parameters: <ul style="list-style-type: none"> - Name (charstring) - Value (charstring) 		
CnfRequired	TTCN-3 Type	Ut_CnfReq_Type	
	<p>CNF_REQUIRED: SS shall reply with one confirmation (NOTE)</p> <p>NO_CNF_REQUIRED: SS shall swallow any confirmation generated</p> <p>LOCAL_CNF_REQUIRED: SS shall immediately send one confirmation when the command is submitted to the UE i.e. in case of operator interaction when the operator has confirmed the command, but SS shall not wait for the UE responding(NOTE)</p>		
NOTE:	In the TTCN, a confirmation shall only be requested in cases when there is no signalling from the UE being triggered by the MMI/AT command		

TTCN-3 ASP Definition			
Type Name	UT_COMMON_CNF		
TTCN-3 Type	Record		
Result	TTCN-3 Type	boolean	
	<p>true: success</p> <p>false: failure</p> <p>NOTE: In case of AT commands, the SS shall return false if and only if the UE comes back with "ERROR" as result code according to ITU-T Rec V.250 clause 5.7 [60]. In case of e.g. "+CME ERROR" the SS shall return true and put the UE's response into the ResultString</p>		
ResultString	TTCN-3 Type	charstring	
	<p>response by the UE for commands which request the UE to return a result, optional</p> <p>In case of AT commands, ResultString shall contain the complete line according to the specification of the AT command.</p>		

The following MMI commands are defined.

Table 5.1: MMI commands

Command	Parameters	
	Name	Value
"SWITCH_ON"	(none)	
"SWITCH_OFF"	(none)	
"POWER_ON"	(none)	
"POWER_OFF"	(none)	
"INSERT_USIM"	"USIM"	<USIM>
"REMOVE_USIM"	(none)	
"CHECK_PLMN"	"PLMN"	<PLMN ID>
"CHECK_ETWS_INDICATION"	"WARNING1"	<WARNING1>
	"WARNING2"	<WARNING2>
"CHECK_ETWS_ALERT"	(none)	
"CHECK_ETWS_NO_ALERT"	(none)	
"CHECK_CMAS_INDICATION"	"WARNING1"	<WARNING1>
	"WARNING2"	<WARNING2>
"CHECK_CMAS_ALERT"	(none)	
"CHECK_CMAS_NO_ALERT"	(none)	
"HRPD_PDN_CONNECTION"	(none)	
"CHECK_MESSAGE_DISPLAYED"	"Length"	<Length>
	"Msg"	<Msg>
"CHECK_SMS_LENGTH_CONTENTS"	"Length"	<Length>
	"Msg"	<Msg>
"CONFIGURE_SMS_ONLY"	(none)	
"DISABLE_EPS_CAPABILITY"	(none)	
"DETACH_NON_EPS"	(none)	
"CLEAR_STORED_ASSISTANCE_DATA"	(none)	
"CHECK_DTCH_THROUGHCONNECTED"	(none)	
"GERAN_UPLINK_DATA"	(none)	
"SELECT_CSG"	"PLMN"	<PLMN ID>
	"CSG"	<CSG ID>
"TRIGGER_USER_RESELECTION"	(none)	
"REQUEST_NON_CALL_RELATED_SS"	(none)	
"MBMS_SERVICE_INTEREST"	"PLMN"	<PLMN ID>
	"Service"	<MBMS Service ID>
	"Interest"	"ON" / "OFF"
	"SAI"	<MBMS SAI>
"MBMS_SERVICE_ACTIVE"	"Service"	<MBMS Service ID>
	"SAI"	<MBMS SAI>
	"Active"	"ON" / "OFF"
"MBMS_PRIORITY_OVER_UNICAST"	"Priority Over Unicast"	"FALSE" / "TRUE"
"CHECK_ETWS_NO_INDICATION"	"WARNING1"	<WARNING1>
	"WARNING2"	<WARNING2>
"CHECK_CMAS_NO_INDICATION"	"WARNING1"	<WARNING1>
	"WARNING2"	<WARNING2>
"CHECK_CALL_DISPLAY"	"ToDisplay"	<NAME>/<NUMBER>
"CHECK_CSG"	"CSG"	< CSG ID >
	"Included"	"FALSE" / "TRUE"
"CHECK_NITZ_DST"	"DaylightSaving Time:"	DST
"CHECK_RESPONSE_DISPLAY"	"ToDisplay"	<STRING>
"CHECK_SS_USER_IND"	"Supplementary Service"	<SUPPLEMENTARY SERVICE>
	"ToDisplay"	<STRING>
"CHECK_SS_USER_IND_FAILURE"	(none)	

"CONFIGURE_OPERATIONMODE"	"OPERATION MODE"	<OPERATION MODE>
"CONFIGURE_ANDSF_RULE"	"ANDSF Rule"	<ANDSF RULE>
"WLAN_ANDSF_CONFIGURED"	(none)	
"WLAN_ANDSF_NOT_CONFIGURED"	(none)	
"CMTLR_DUMMY" (see Note)	"Notification Type"	<NOTIFICATION TYPE>
"CCFC_DUMMY" (see Note)	"Status"	<STATUS>
"CNAP_DUMMY" (see Note)	"Testname"	<TESTNAME>
"CTZE_DUMMY" (see Note)	"Year"	<YEAR>
	"Month"	<MONTH>
	"Day"	<DAY>
	"Hour"	<HOUR>
	"Minutes"	<MINUTES>
	"Seconds"	<SECONDS>
	"Daylight SavingTime"	<DAYLIGHT SAVING TIME>
"TimeZone"	<TIMEZONE>	
"CMWN_DUMMY" (see Note)	(none)	
"D2D_DISCOVERY_CLEAR"	(none)	
"D2D_DISCOVERY_CONFIGURATION"	"ProSeApplicationID"	<charstring>
	"PLMN_List"	<PLMN ID_List>
	T4005	<T4005>
"D2D_DISCOVERY"	"ProSeApplicationID"	<charstring>
	"Announce"	"ON" / "OFF"
	"Monitor"	"ON" / "OFF"
"D2D_COMMUNICATION"	"ProSe Layer-2 Group ID"	<charstring>
	"Transmit"	"ON" / "OFF"
	"Receive"	"ON" / "OFF"
	"Max size of UE transmitted Direct Communication data"	<bytes>
"D2D_COMMUNICATION_CONFIGURATION"	"ProSe Layer-2 Group ID"	<charstring>
	"PLMN_List"	<PLMN ID_List>
	T4005_Minutes	<T4005>
	"Security Lifetime timer in minutes" (Default: 0)	<SecurityTimer >
"CONFIGURE_EDRX"	"EDRX"	"ON" / "OFF"
"CONFIGURE_PSM"	"PSM"	"ON" / "OFF"
"TRIGGER_MO_EXCEPTIONDATA"	(none)	
Note:	These MMI commands are used to indicate to the SS that a UT response is expected by the TTCN in the case when the AT command is not supported. They can be ignored if the UE supports the AT command. The prefix of these commands matches the start of the AT response expected by the TTCN	

The following AT commands are applied in TTCN.

Table 5.2: AT Commands

Command	Reference
ATD	TS 27.007 [32]
ATA	TS 27.007 [32]
ATH	TS 27.007 [32]
AT+CGEQOS	TS 27.007 [32]
AT+CGTFT	TS 27.007 [32]
AT+CGDSCONT	TS 27.007 [32]
AT+CGACT	TS 27.007 [32]
AT+CGCMOD	TS 27.007 [32]
AT+CGDCONT	TS 27.007 [32]
AT+CMGD	TS 27.005 [31]
AT+CSMS	TS 27.005 [31]
AT+CPMS	TS 27.005 [31]
AT+CMGF	TS 27.005 [31]
AT+CSCS	TS 27.007 [32]
AT+CSCA	TS 27.005 [31]
AT+CMGW	TS 27.005 [31]
AT+CMSS	TS 27.005 [31]
AT+CMMS	TS 27.005 [31]
AT+CSMP	TS 27.005 [31]
AT+CGEQREQ	TS 27.007 [32]
AT+CCLK	TS 27.007 [32]
AT+COPS	TS 27.007 [32]
AT+CGATT	TS 27.007 [32]
AT+CEMODE	TS 27.007 [32]
AT+CEN	TS 27.007 [32]
AT+CLIP	TS 27.007 [32]
AT+CLIR	TS 27.007 [32]
AT+COLP	TS 27.007 [32]
AT+CCFC	TS 27.007 [32]
AT+CHLD	TS 27.007 [32]
AT+CEPPI	TS 27.007 [32]
AT+CDU	TS 27.007 [32]
AT+CHCCS	TS 27.007 [32]
AT+COLR	TS 27.007 [32]
AT+CCWA	TS 27.007 [32]
AT+CNAP	TS 27.007 [32]
AT+CLCK	TS 27.007 [32]
AT+CPWD	TS 27.007 [32]
AT+CTZR	TS 27.007 [32]
AT+CTZU	TS 27.007 [32]
AT+CUSD	TS 27.007 [32]
AT+CMWI	TS 27.007 [32]
AT+CPSMS	TS 27.007 [32]

AT commands are referred to TS 27.005 [31], TS 27.007 [32] and TS 27.060 [33].

The setting in TTCN of the AT command elements listed in Table 5-3 may require adaptation to the UE dependent interpretation of the element. It shall be handled by the system adaptor.

Table 5-3: AT commands elements

Element	Reference	TTCN Setting
<cid>	TS 27.007 [32]	EPS Bearer Identity or PDP Context Identity

6 ASP specifications

6.1 General Requirements and Assumptions

The following common requirements affect ASP definitions:

- The definition of ASPs shall have no impact on the common system architecture or on the performance.
- The codec implementation is out of scope of the present document.
- For peer-to-peer PDUs contained in an ASP encoding rules need to be considered acc. to the respective protocol:
 - ASN.1 BER and PER.
 - Tabular notation for NAS PDUs or layer 2 data PDUs.

There are no encoding rules being defined for top level ASP definitions and information exchanged between the test executable and the System Adaptor (SA) only. Instead encoding depends on implementation of the codec and the SA.

There are no encoding rules being defined for ASPs between TTCN-3 components. This is implementation dependent.

Info elements defined in the protocol specifications (e.g. RRC) shall be re-used in configuration ASPs as far as possible.

For optional fields within the configuration ASPs, the following rules will be applied:

- For ASN.1 fields - these will follow the same rules as defined in the RRC specification [19].
- For TTCN-3 fields - when the current configuration of an optional field is to be 'kept as it is' then the field will be set to omit.
- For TTCN-3 fields - when the current configuration of an optional field is to be released/deleted then a separate option is provided in a union.

6.1.1 IP ASP requirements

6.1.2 Enhancement of IP ASP for handling IMS signalling

The IMS test model handling registration signalling introduces IPsec and SigComp layers into the IP test model in Figure 4.2.5.2-1. The ASP on system port IP_SOCK needs to be enhanced to provide additional configuration/control functions for IPsec and SigComp. The enhanced IP ASP should contain:

1. Function to clean all IPsec and SigComp configurations and to put the IPsec and SigComp in the initial state.
2. Function to return SigComp layer a Compartment Id instructing SigComp layer to save the state of a received message which was compressed.
3. Function to start or stop signalling compression in sending direction (the SS to the UE) of SigComp.
4. Function to set security parameters (per security association) in IPsec layer.
5. A flag indicating whether SigComp layer shall be included in the data path when establishing a connection.
6. A flag indicating whether the received message was compressed by SigComp.
7. A parameter to point to a compartment used by SigComp to send a message.

6.2 E-UTRAN ASP Definitions

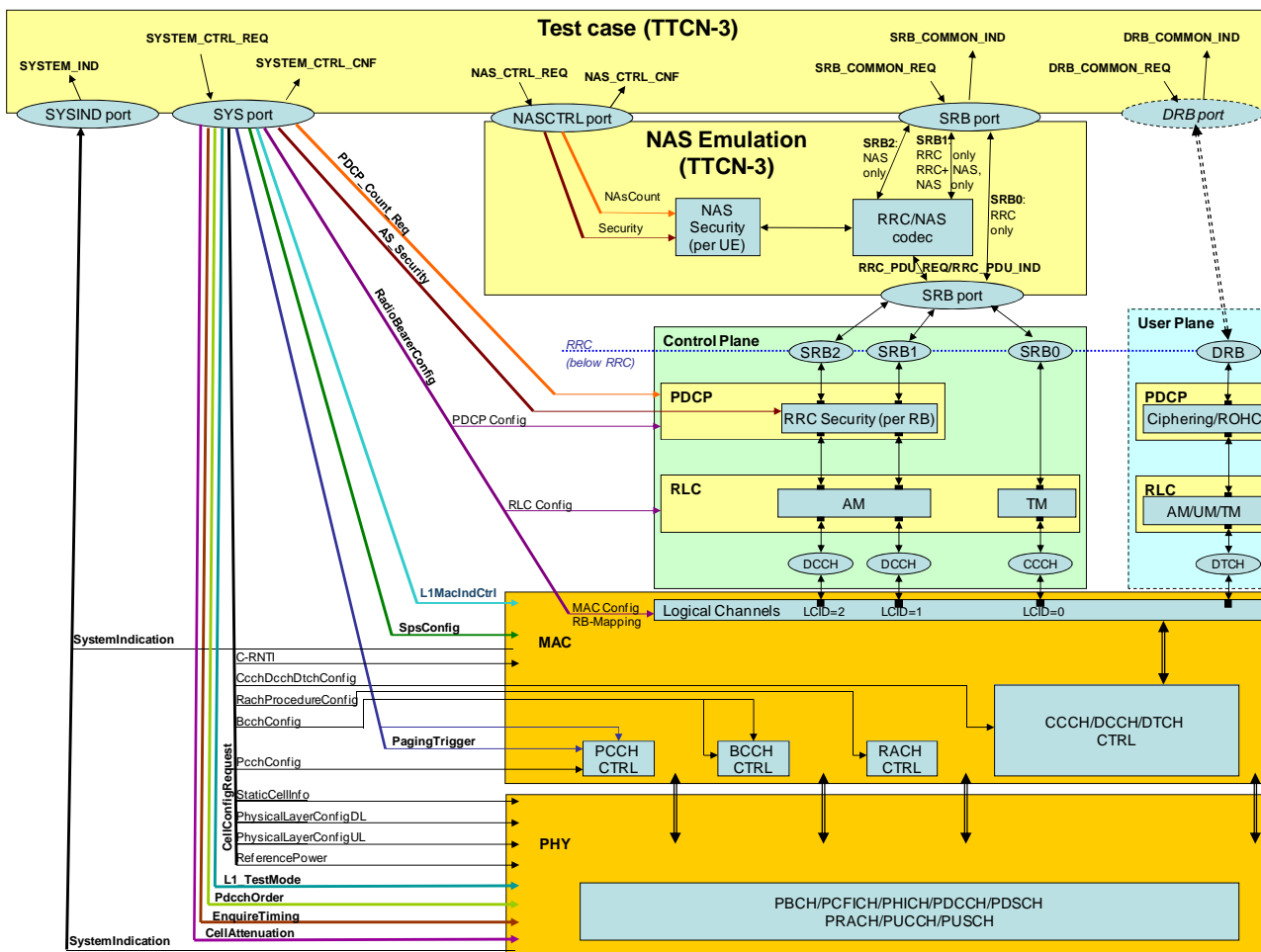

Figure 6.2-1: E-UTRAN ASP Test Model

6.2.1 Configuration Primitives

Annex D contains the ASP definitions for configurations.

6.2.2 Signalling Primitives

Annex D contains the ASP definitions for configurations.

6.2.3 Co-ordination Messages between NAS Emulation PTC and EUTRA PTC

TTCN-3 ASP Definition	
Type Name	SRB_COMMON_REQ
TTCN-3 Type	Record
Common Part	TTCN-3 Type record
CellId	cell id
RoutingInfo	SRB0, SRB1, SRB2
TimingInfo	system frame number and sub-frame number or "Now"
ControllInfo	CnfFlag: (normally false) FollowOnFlag: true: Indicates that the message(s) to be sent on the same TTI will follow NOTE 1: If the same TimingInfo is not used in the messages to be sent on the same TTI, the SS shall produce an error. false: Indicates that no more message(s) will follow.
Signalling Part	TTCN-3 Type record
Rrc	TTCN-3 Type union
	omit: NAS message shall be present; NAS message shall be sent in DLInformationTransfer present, NAS message present: (piggybacked) NAS PDU shall be security protected (if necessary) and inserted in RRC PDU's NAS_DedicatedInformation present, NAS message omit: (RRC message does not contain NAS information)
Ccch	DL_CCCH_Message as define in TS 36.331 [19], clause 6.2.1
Dcch	DL_DCCH_Message as define in TS 36.331 [19], clause 6.2.1
Nas	TTCN-3 Type record
	omit: RRC message shall be present; RRC message does not contain (piggybacked) NAS PDU present, RRC message omit: NAS message shall be sent embedded in DLInformationTransfer present, RRC message present: NAS message is piggybacked in RRC message NOTE 2: In case of RRC message being sent on CCCH or does not have IE NAS_DedicatedInformation NAS message shall be omitted.
SecurityProtectionInfo	security status (if protected with integrity and/or ciphering, if at all)
NAS message	union of all NAS messages define for DL except SECURITY PROTECTED NAS MESSAGE

TTCN-3 ASP Definition	
Type Name	SRB_COMMON_IND
TTCN-3 Type	Record
Common Part	TTCN-3 Type record
CellId	cell id
RoutingInfo	SRB0, SRB1, SRB2
TimingInfo	system frame number; sub-frame number when PDU has been received
Signalling Part	TTCN-3 Type record
Rrc	TTCN-3 Type union
	omit: NAS message shall be present; NAS message is received in ULInformationTransfer present, NAS message present: NAS_DedicatedInformation contains unstructured and security protected NAS PDU and the NAS message contains the deciphered message in structured format present, NAS message omit: (RRC message does not contain NAS information)
Ccch	UL_CCCH_Message as define in TS 36.331 [19], clause 6.2.1
Dcch	UL_DCCH_Message as define in TS 36.331 [19], clause 6.2.1

TTCN-3 ASP Definition		
Nas	TTCN-3 Type	record
	omit RRC message shall be present; RRC message does not contain (piggybacked) NAS PDU present, RRC message omit NAS message has been received in ULInformationTransfer present, RRC message present NAS message is piggybacked in RRC message	
SecurityProtectionInfo	security status (if protected with integrity and/or ciphering, if at all), nas count	
NAS message	union of all NAS messages define for UL except SECURITY PROTECTED NAS MESSAGE	

TTCN-3 ASP Definition		
Type Name	NAS_CTRL_REQ	
TTCN-3 Type	Record	
Common Part	TTCN-3 Type	record
CellId	cell id	
RoutingInfo	(not used for configuration)	
TimingInfo	current system frame number; sub-frame number (always provided by the SS)	
Result	Success or error (in case of error an SS specific error code shall be provided; this will not be evaluated by TTCN but may be useful for validation)	
Primitive specific Part	TTCN-3 Type	union
Security	Start/Restart Integrity Ciphering NasCountReset Release	
NAS Count	get set	

TTCN-3 ASP Definition		
Type Name	NAS_CTRL_CNF	
TTCN-3 Type	Record	
Common Part	TTCN-3 Type	record
CellId	cell id	
RoutingInfo	(not used for configuration)	
TimingInfo	current system frame number; sub-frame number (always provided by the SS)	
Result	Success or error (in case of error an SS specific error code shall be provided; this will not be evaluated by TTCN but may be useful for validation)	
Primitive specific Part	TTCN-3 Type	union
Security	(contains no further information)	
NAS Count	get set	

6.3 UTRAN ASP Definitions

The UTRAN ASP definitions are specified according to 3GPP TS 34.123 [7], clause 6A.3.

6.3.1 Void

6.3.2 ASPs for Data Transmission and Reception

TTCN-3 ASP Definition	
Type Name	U_RLC_AM_REQ
TTCN-3 Type	union
Port	UTRAN_AM
RLC_AM_DATA_REQ	TS 34.123-3, clause 7.3.2.2.34
RLC_AM_TestDataReq	TS 34.123-3, clause 7.3.3.1

TTCN-3 ASP Definition	
Type Name	U_RLC_AM_IND
TTCN-3 Type	union
Port	UTRAN_AM
RLC_AM_DATA_CNF	TS 34.123-3, clause 7.3.2.2.34
RLC_AM_DATA_IND	TS 34.123-3, clause 7.3.2.2.34
RLC_AM_TestDataInd	TS 34.123-3, clause 7.3.3.1

TTCN-3 ASP Definition	Port	Defined in
UTRAN_RLC_AM_REQ	UTRAN_AM	TS 34.123-3, clause 7.3.2.2.34
UTRAN_RLC_AM_IND	UTRAN_AM	TS 34.123-3, clause 7.3.2.2.34
UTRAN_RLC_TR_REQ	UTRAN_TM	TS 34.123-3, clause 7.3.2.2.33
UTRAN_RLC_TR_IND	UTRAN_TM	TS 34.123-3, clause 7.3.2.2.33
UTRAN_RLC_UM_REQ	UTRAN_UM	TS 34.123-3, clause 7.3.2.2.35
UTRAN_RLC_UM_IND	UTRAN_UM	TS 34.123-3, clause 7.3.2.2.35
RRC_DataReq	UTRAN_Dc	TS 34.123-3, clause 7.1.2
RRC_DataReqInd	UTRAN_Dc	TS 34.123-3, clause 7.1.2

The Invalid_DL_DCCH_Message type is replaced with:

Type Name	Invalid_DL_DCCH_Message
TTCN-3 Type	NULL

6.4 GERAN ASP Definitions

6.4.1 ASPs for Control Primitive Transmission

TTCN-3 ASP Definition	
Type Name	G_CPHY_CONFIG_REQ
TTCN-3 Type	Union
Port	GERAN_CL1
G_CL1_CreateCell_REQ	TS 34.123-3, clause 7.3.4.3.2.1
G_CL1_DeleteCell_REQ	TS 34.123-3, clause 7.3.4.3.2.1
G_CL1_CreateBasicPhyCh_REQ	TS 34.123-3, clause 7.3.4.3.2.1
G_CL1_CreateMultiSlotConfig_REQ	TS 34.123-3, clause 7.3.4.3.2.1
G_CL1_DeleteChannel_REQ	TS 34.123-3, clause 7.3.4.3.2.1
G_CL1_ChangePowerLevel_REQ	TS 34.123-3, clause 7.3.4.3.2.1
G_CL1_CipheringControl_REQ	TS 34.123-3, clause 7.3.4.3.2.1
G_CL1_CipherModeModify_REQ	TS 34.123-3, clause 7.3.4.3.2.1
G_CL1_ChModeModify_REQ	TS 34.123-3, clause 7.3.4.3.2.1
G_CL1_ComingFN_REQ	TS 34.123-3, clause 7.3.4.3.2.1
G_CL2_HoldPhyInfo_REQ	TS 34.123-3, clause 7.3.4.3.2.2
G_CL1_L1Header_REQ	TS 34.123-3, clause 7.3.4.3.2.1
G_CL2_MeasRptControl_REQ	TS 34.123-3, clause 7.3.4.3.2.2
G_CL2_NoUAforSABM_REQ	TS 34.123-3, clause 7.3.4.3.2.2
G_CL2_ResumeUAforSABM_REQ	TS 34.123-3, clause 7.3.4.3.2.2
G_CL2_Release_REQ	TS 34.123-3, clause 7.3.4.3.2.2
G_CL1_SetNewKey_REQ	TS 34.123-3, clause 7.3.4.3.2.1

TTCN-3 ASP Definition	
Type Name	G_CPHY_CONFIG_CNF
TTCN-3 Type	Union
Port	GERAN_CL1
ComingFN	RFN
L1Header	L1Header
None	This choice used when neither of the other choices are selected

TTCN-3 ASP Definition	
Type Name	G_CRLC_CONFIG_REQ
TTCN-3 Type	Union
Port	GERAN_CRLC
G_CRLC_CreateRLC_MAC_REQ	TS 34.123-3, clause 7.3.4.3.2.3
G_CRLC_DeleteRLC_MAC_REQ	TS 34.123-3, clause 7.3.4.3.2.3
G_CRLC_DL_TBF_Config_REQ	TS 34.123-3, clause 7.3.4.3.2.3
G_CRLC_UL_TBF_Config_REQ	TS 34.123-3, clause 7.3.4.3.2.3

TTCN-3 ASP Definition	
Type Name	G_CRLC_CONFIG_CNF
TTCN-3 Type	empty record
Port	GERAN_CRLC

TTCN-3 ASP Definition	
Type Name	G_LL_C_CONFIG_REQ
TTCN-3 Type	Union
Port	GERAN_CLLC
G_CLLC_Assign_REQ	TS 34.123-3, clause 7.3.4.3.2.4
G_CLLC_ReassignLLE_REQ	See below
G_CLLC_CreateLLE_REQ	TS 34.123-3, clause 7.3.4.3.2.4
G_CLLC_DeleteLLE_REQ	TS 34.123-3, clause 7.3.4.3.2.4
G_CLLC_XID_Config_REQ	See below
G_CLLC_DoNotCheckSequenceNumber_REQ	See below

TTCN-3 ASP Definition	
Type Name	G_CLLC_CONFIG_CNF
TTCN-3 Type	empty record
Port	GERAN_CLLC

ASP Name	G_CSNDTCP_Activate_REQ	
PCO Type	G_CSAP	
Comments	The ASP is used to activate the SNDTCP entity	
Parameter Name	Parameter Type	Comments
sNDTCPid	SNDTCPid	The SNDTCP entity identifier of the cell
LLMEId	LLMEId	Logical link management entity Id
nSAPI	integer	The Network Service Access Point Identifier
sAPI	SAPI	LLC SAPI
PCI_Compression	INTEGER	0 - RFC 1144 [54] compress; 1 - RFC 2507 [55] compression; 32 - no compression
dataCompression	INTEGER	0 - ITU-T Recommendation V.42bis [56] compression; 1 - ITU-T Recommendation V.44 [57] compression; 32 - no compression
nPDUNumberSync	INTEGER	0 - Asynchronous 1 - Synchronous
Detailed Comments		

ASP Name	G_CSNDTCP_Activate_CNF	
PCO Type	G_CSAP	
Comments	The ASP is used to get the confirmation of a G_CSNDTCP_Activate_REQ	
Parameter Name	Parameter Type	Comments
sNDTCPid	SNDTCPid	SNDTCPentity identifier
nSAPI	NSAPI	The Network Service Access Point Identifier
Detailed Comments		

ASP Name	G_CSNDTCP_Release_REQ	
PCO Type	G_CSAP	
Comments	This ASP is used to inform that the NSAPI is in use and the acknowledge mode peer to peer LLC operation for the requested SAPI is established.	
Parameter Name	Parameter Type	Comments
sNDTCPid	SNDTCPid	The SNDTCP entity identifier
nSAPI	integer	The Network Service Access Point Identifier
Detailed Comments		

TTCN-3 ASP Definition	
Type Name	G_SNDTCP_CONFIG_CNF
TTCN-3 Type	Record
Port	GERAN_CSNDTCP

TTCN-3 ASP Definition	
Type Name	G_SNDTCP_CONFIG_REQ
TTCN-3 Type	Union
Port	GERAN_CSNDTCP
G_CSNDTCP_Activate_REQ	
G_CSNDTCP_Release_REQ	

ASP Name	G_CLLC_ReassignLLE_REQ	
PCO Type	G_CSAP	
Comments	The ASP is used to reassign RLC/MAC entity to the specified LLME identity. This ASP allows simulation of Intra-SGSN operations in tests.	
Parameter Name	Parameter Type	Comments
ILMEId	LLMEId	Logical Layer Management Entity Id
rLC_MAC_MappingInfo	integer	This parameter indicates the RLC/MAC emulation module in the cell, not the cell itself
tLLI	TLLI	

ASP Name	G_CLLC_XID_Config_REQ	
PCO Type	G_CSAP	
Comments	The ASP is used to inform the SS of the XID information responded to the UE by TTCN	
Parameter Name	Parameter Type	Comments
ILMEId	LLMEId	
tLLI	TLLI	
sAPI	SAPI	
xID_Info	XID_Info	the XID parameters responded to the UE/MS
Detailed Comments		

ASP Name	G_CLLC_DoNotCheckSequenceNumber_REQ	
PCO Type	G_CSAP	
Comments	The ASP commands the SS to not check the N(U) sequence number of the next LLC message to be received on the connection specified by the ASP parameters. The SS should however use this value to update its value of N(U).	
Parameter Name	Parameter Type	Comments
ILMEId	LLMEId	The identifier of the cell Logical Layer Management Entity Id
tLLI	TLLI	
sAPI	SAPI	
Detailed Comments		

6.4.2 ASPs for Data Transmission and Reception

TTCN-3 ASP Definition	
Type Name	G_L2_DATAMESSAGE_REQ
TTCN-3 Type	Union
Port	GERAN_L2
G_L2_UNITDATA_REQ	TS 34.123-3, clause 7.3.4.3.1.1
G_L2_Release_REQ	TS 34.123-3, clause 7.3.4.3.1.1
G_L2_SYSINFO_REQ	TS 34.123-3, clause 7.3.4.3.1.1
G_L2_Paging_REQ	TS 34.123-3, clause 7.3.4.3.1.1
G_L2_PagingGPRS_REQ	TS 34.123-3, clause 7.3.4.3.1.1
G_L2_DATA_REQ	TS 34.123-3, clause 7.3.4.3.1.1
G_L2_GTP_REQ	TS 34.123-3, clause 7.3.4.3.1.1

The SysInfoType is replaced with:

Type Name	SysInfoMsg
TTCN-3 Type	Union
	SYSTEMINFORMATIONTYPE1
	SYSTEMINFORMATIONTYPE2
	SYSTEMINFORMATIONTYPE3
	SYSTEMINFORMATIONTYPE4
	SYSTEMINFORMATIONTYPE5
	SYSTEMINFORMATIONTYPE6
	SYSTEMINFORMATIONTYPE13
	SYSTEMINFORMATIONTYPE15
	SYSTEMINFORMATIONTYPE2bis
	SYSTEMINFORMATIONTYPE2ter
	SYSTEMINFORMATIONTYPE2quater
	SYSTEMINFORMATIONTYPE5bis

TTCN-3 ASP Definition	
Type Name	G_L2_DATAMESSAGE_IND
TTCN-3 Type	Union
Port	GERAN_L2
G_L2_UNITDATA_IND	TS 34.123-3, clause 7.3.4.3.1.1
G_L2_Release_CNF	TS 34.123-3, clause 7.3.4.3.1.1
G_L2_Release_IND	TS 34.123-3, clause 7.3.4.3.1.1
G_L2_Estab_IND	TS 34.123-3, clause 7.3.4.3.1.1
G_L2_GTP_IND	TS 34.123-3, clause 7.3.4.3.1.1
G_L2_DATA_IND	TS 34.123-3, clause 7.3.4.3.1.1
G_L2_ACCESS_IND	TS 34.123-3, clause 7.3.4.3.1.1

TTCN-3 ASP Definition	
Type Name	G_RLC_DATAMESSAGE_REQ
TTCN-3 Type	Union
Port	GERAN_RLC
G_RLC_ControlMsg_REQ	TS 34.123-3, clause 7.3.4.3.1.2

TTCN-3 ASP Definition	
Type Name	G_RLC_DATAMESSAGE_IND
TTCN-3 Type	Union
Port	GERAN_RLC
G_RLC_ControlMsg_IND	TS 34.123-3, clause 7.3.4.3.1.2

TTCN-3 ASP Definition	
Type Name	G_LLC_DATAMESSAGE_REQ
TTCN-3 Type	Union
Port	GERAN_LLC
G_LLC_UNITDATA_REQ	TS 34.123-3, clause 7.3.4.3.1.3
G_LLC_XID_RES	TS 34.123-3, clause 7.3.4.3.1.3

ASP Name	G_LLC_NULL_IND		
PCO Type	G_DSAP		
Comments	The ASP is used to receive the LLC NULL frame, sent by the UE for Cell Update.		
	Parameter Name	Parameter Type	Comments
	ILMEId	LLMEId	
	tLLI	TLLI	
	sAPI	SAPI	
	Detailed Comments		

TTCN-3 ASP Definition	
Type Name	G_LL_C_DATAMESSAGE_IND
TTCN-3 Type	Union
Port	GERAN_LL_C
G_LL_C_UNITDATA_IND	TS 34.123-3, clause 7.3.4.3.1.3
G_LL_C_XID_IND	TS 34.123-3, clause 7.3.4.3.1.3
G_LL_C_NULL_IND	

ASP Name	G_SN_UNITDATA_REQ	
PCO Type	G_DSAP	
Comments	The ASP is used to send a valid IP datagram on the specified NSAPI to the UE/MS by unacknowledged transmission.	
Parameter Name	Parameter Type	Comments
sNDCPIId	SNDCPIId	
nSAPI	integer	5 to 15
n_PDU	N_PDU	Valid IPv4 or IPv6 datagram
Detailed Comments	Unacknowledged transmission mode	

ASP Name	G_SN_UNITDATA_IND	
PCO Type	G_DSAP	
Comments	The ASP is used to receive an IP datagram on the specified NASPI from the UE/MS in unacknowledged transmission mode.	
Parameter Name	Parameter Type	Comments
sNDCPIId	SNDCPIId	
nSAPI	integer	5 to 15
n_PDU	N_PDU	IPv4 or IPv6 datagram
Detailed Comments	Unacknowledged transmission mode	

Type Name	SNDCPIId
Type Definition	INTEGER
Type Encoding	
Comments	The identifier of the SMDCP entity in SGSN

TTCN-3 ASP Definition	
Type Name	G_SN_DATAMESSAGE_REQ
TTCN-3 Type	Union
Port	GERAN_SMDCP
G_SN_UNITDATA_REQ	

TTCN-3 ASP Definition	
Type Name	G_SN_DATAMESSAGE_IND
TTCN-3 Type	Union
Port	GERAN_SMDCP
G_SN_UNITDATA_IND	

6.5 NB-IoT ASP Definitions

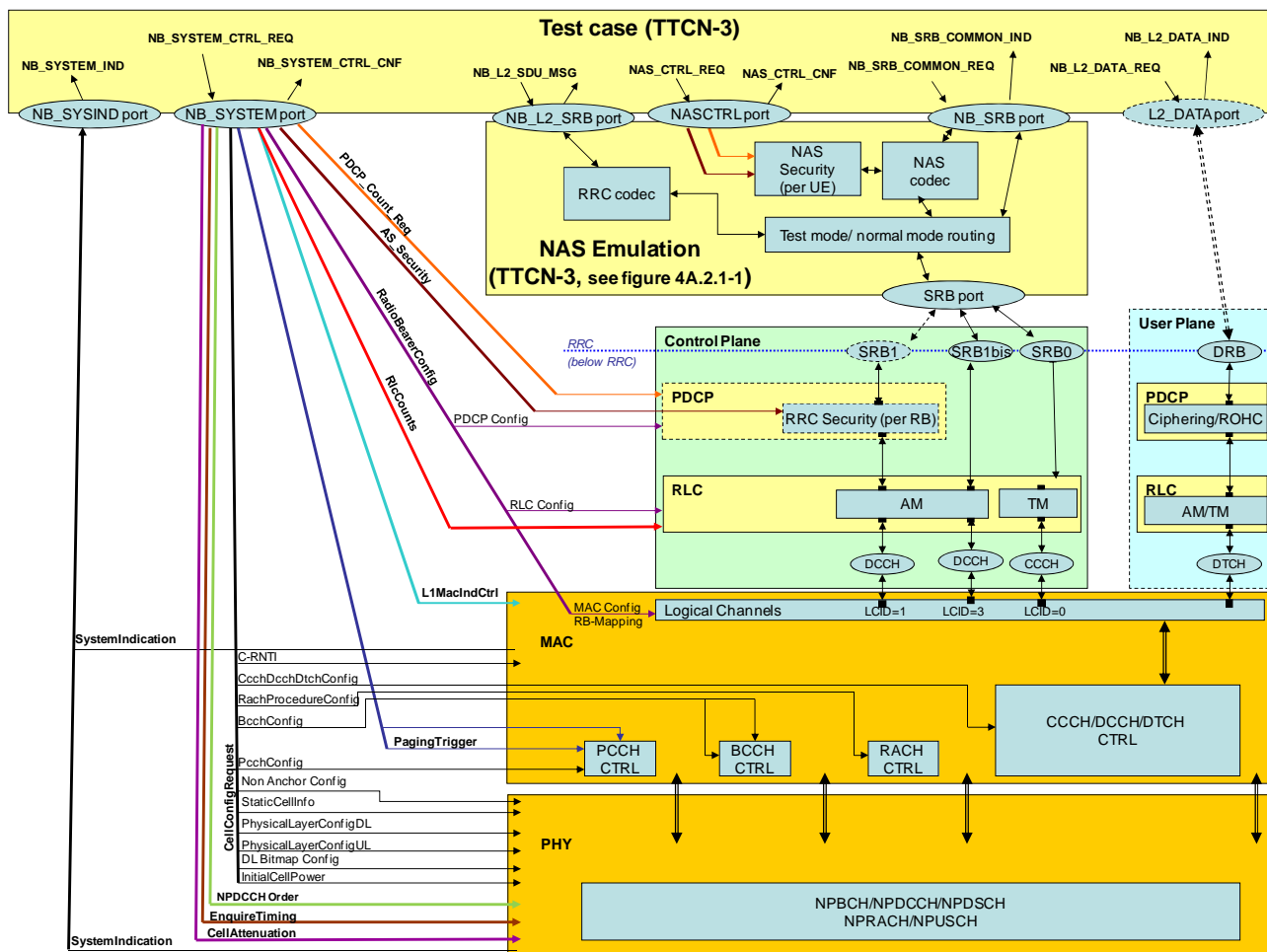

Figure 6.5-1: NB-IoT ASP Test Model

6.5.1 Configuration Primitives

Annex F contains the ASP definitions for configurations.

6.5.2 Signalling Primitives

Annex F contains the ASP definitions for configurations.

6.5.3 Co-ordination Messages between NAS Emulation PTC and NBIOT PTC

TTCN-3 ASP Definition	
Type Name	NB_SRB_COMMON_REQ
TTCN-3 Type	Record
Common Part	TTCN-3 Type record
CellId	cell id
RoutingInfo	SRB0, SRB1, SRB1bis
TimingInfo	H-SFN, system frame number and sub-frame number or "Now"
ControllInfo	CnfFlag: (normally false) FollowOnFlag: true: Indicates that the message(s) to be sent on the same TTI will follow NOTE 1: If the same TimingInfo is not used in the messages to be sent on the same TTI, the SS shall produce an error. false: Indicates that no more message(s) will follow.
Signalling Part	TTCN-3 Type record
Rrc	TTCN-3 Type union
	omit: NAS message shall be present; NAS message shall be sent in DLInformationTransfer_NB present, NAS message present: (piggybacked) NAS PDU shall be security protected (if necessary) and inserted in RRC PDU's NAS_DedicatedInformation present, NAS message omit: (RRC message does not contain NAS information)
Ccch	DL_CCCH_Message_NB as define in TS 36.331 [19], clause 6.7.1
Dcch	DL_DCCH_Message_NB as define in TS 36.331 [19], clause 6.7.1
Nas	TTCN-3 Type record
	omit: RRC message shall be present; RRC message does not contain (piggybacked) NAS PDU present, RRC message omit: NAS message shall be sent embedded in DLInformationTransfer_NB present, RRC message present: NAS message is piggybacked in RRC message NOTE 2: In case of RRC message being sent on CCCH or does not have IE NAS_DedicatedInformation NAS message shall be omitted.
SecurityProtectionInfo	security status (if protected with integrity and/or cipherng, if at all)
NAS message	union of all NAS messages define for DL except SECURITY PROTECTED NAS MESSAGE

TTCN-3 ASP Definition	
Type Name	NB_SRB_COMMON_IND
TTCN-3 Type	Record
Common Part	TTCN-3 Type record
CellId	cell id
RoutingInfo	SRB0, SRB1, SRB1bis
TimingInfo	H-SFN, system frame number; sub-frame number when PDU has been received
Signalling Part	TTCN-3 Type record
Rrc	TTCN-3 Type union
	omit: NAS message shall be present; NAS message is received in ULInformationTransfer_NB present, NAS message present: NAS_DedicatedInformation contains unstructured and security protected NAS PDU and the NAS message contains the deciphered message in structured format present, NAS message omit: (RRC message does not contain NAS information)
Ccch	UL_CCCH_Message_NB as define in TS 36.331 [19], clause 6.7.1
Dcch	UL_DCCH_Message_NB as define in TS 36.331 [19], clause 6.7.1

TTCN-3 ASP Definition		
Nas	TTCN-3 Type	record
	omit RRC message shall be present; RRC message does not contain (piggybacked) NAS PDU present, RRC message omit NAS message has been received in ULInformationTransfer_NB present, RRC message present NAS message is piggybacked in RRC message	
SecurityProtectionInfo	security status (if protected with integrity and/or ciphering, if at all), nas count	
NAS message	union of all NAS messages define for UL except SECURITY PROTECTED NAS MESSAGE	

For other ASPs, please refer to 6.2.3

7 E-UTRAN/SAE Test Methods and Design Considerations

7.1 Channel Mapping

Figure 7.1 shows the channel type mapping that is used for the configuration of the SS. In layer 2 test cases non default channel mapping can be applied on SS, as explained in clause 4.2.1.

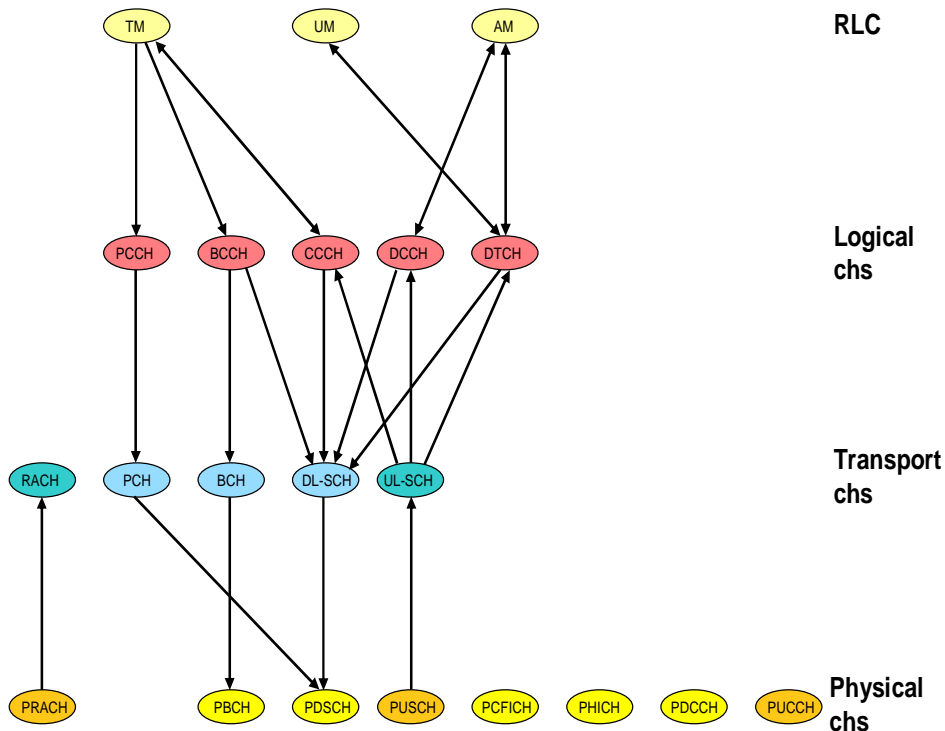

Figure 7.1-1: Channel type mapping for the default configuration of the SS

7.1.1 PDCCH Candidate Selection

In this clause following abbreviations are used:

- Common search Space Aggregation: CS_Agr.
- UE-Specific Search Space Aggregation: UE_Agr.
- Total number of CCEs available in a subframe: Max_CCE.

SS shall apply defined rules below in a DL subframe for PDCCH candidates selection.

- Scheduled transmissions on SI-RNTI, P-RNTI, RA-RNTI, M-RNTI, G-RNTI, SC-RNTI, SC-N-RNTI and eIMTA-RNTI, use Common Search Space. UL and DL Scheduled transmissions on C-RNTI / SPS C-RNTI, DL Scheduled transmissions on Temp. C-RNTI and UL Scheduled transmission on SL-RNTI, use UE-Specific Search Space. Transmissions on TPC-PUCCH-RNTI / TPC-PUSCH-RNTI and UL Scheduled transmissions on Temp. C-RNTI is not considered for default CCE management.
- If a transmission on SI-RNTI is scheduled, PDCCH candidate corresponding to CCEs between 0 and (CS_Agr-1) is used. For FDD, this PDCCH candidate is reserved for SI-RNTI, and left vacant if no SI-RNTI transmission is scheduled. For TDD the default UL/DL configuration type 1, this PDCCH candidate is reserved for SI-RNTI in subframes 0 & 5 (i.e. subframes where PDCCH for UL grant for C-RNTI / SPS C-RNTI is not scheduled).

- PDCCH candidates corresponding to CCEs between CS_Agr and $(2*CS_Agr-1)$ can be used for the transmission on P-RNTI, RA-RNTI, M-RNTI, G-RNTI, SC-RNTI, SC-N-RNTI or eIMTA-RNTI. In conformance test cases with single UE, there is no requirement for transmissions scheduled for more than one of P-RNTI, RA-RNTI, M-RNTI, G-RNTI, SC-RNTI, SC-N-RNTI or eIMTA-RNTI in one DL subframe. As per TS 36.331 [19] clause 5.8.1.3, the MCCH change notification indicator shall be transmitted on MBSFN subframes only.

For FDD:

- For DL transmission for C-RNTI / SPS C-RNTI / Temp C-RNTI the lowest value of $m = m'$ which has a PDCCH available from CCEs between $2*CS_Agr$ and (Max_CCE-1) shall be used. ' m ' is defined in TS 36.213 [30], clause 9.1.1.
- For UL transmission for C-RNTI / SPS C-RNTI / SL-RNTI the lowest value of $m = m'' > m'$ which has a PDCCH available from CCEs between $2*CS_Agr$ and (Max_CCE-1) shall be used, irrespective of PDCCH candidate corresponding to m' is used or not. In conformance test cases with single UE, there is no requirement for transmissions scheduled for more than one of C-RNTI / SPS C-RNTI or SL-RNTI in one DL subframe.

For TDD:

- For DL transmission, for C-RNTI / SPS C-RNTI / Temp C-RNTI the lowest value of $m = m'$ which has a PDCCH available from CCEs between $1*CS_Agr$ and (Max_CCE-1) shall be used. ' m ' is defined in TS 36.213 [30] clause 9.1.1. In conformance test cases with single UE, there is no requirement for transmissions scheduled for more than one of C-RNTI / SPS C-RNTI / Temp C-RNTI, P-RNTI, RA-RNTI or eIMTA-RNTI in one DL sub frame.
- For UL transmission, for C-RNTI / SPS C-RNTI / SL-RNTI the lowest value of $m = m''$ and if in the sub frame m' is also used, $m'' \neq m'$ has a PDCCH available from CCEs between 0 and (Max_CCE-1) shall be used. In conformance test cases with single UE, there is no requirement for transmissions scheduled for more than one of C-RNTI / SPS C-RNTI, SL-RNTI or eIMTA-RNTI in one DL subframe.

NOTE: If m' or m'' cannot be allocated in any TTI, it is a TTCN error due to X-RNTI not properly allocated. The error shall be reported to TTCN. The TTCN will exit the test case assigning an inconclusive verdict.

7.1.1.1 FDD candidates selection

Table 7.1.1.1-1 gives the CCE resources utilized for m' and m'' for default values of common search space aggregation level $=4$, UE-specific search space aggregation $L=2$ resulting in 6 PDCCH candidates $m=0..5$ and channel Bandwidth of 5 MHz. This give $Max_CCE = 20$ for FDD. The table also gives the corresponding CCE start indices of PDCCH candidates for m' and m'' .

Table 7.1.1.1-1: CCE Start indices(m' & m'') to be used for various C-RNTIs (5 MHz)

C-RNTI	Value		SF0	SF1	SF2	SF3	SF4	SF5	SF6	SF7	SF8	SF9
tsc_C_RNTI_Def	'1001'H 4097	m'	0	1	0	0	0	3	4	0	0	0
		CCE_St_Ind'	12	8	14	8	12	8	8	8	14	10
		m''	1	2	1	1	1	4	5	1	1	1
		CCE_St_Ind''	14	10	16	10	14	10	10	10	16	12
tsc_C_RNTI_Def2	'1034'H 4148	m'	0	0	2	0	0	4	4	1	0	0
		CCE_St_Ind'	12	16	8	14	10	8	8	8	18	16
		m''	1	1	3	1	1	5	5	2	5	1
		CCE_St_Ind''	14	18	10	16	12	10	10	10	8	18
tsc_C_RNTI_Def3	'1111'H 4369	m'	0	0	0	2	3	0	0	0	0	4
		CCE_St_Ind'	16	10	14	8	8	10	14	8	18	8
		m''	1	1	1	3	4	1	1	1	5	5
		CCE_St_Ind''	18	12	16	10	10	12	16	10	8	10
tsc_C_RNTI_Def4	'1FF1'H 8177	m'	0	0	0	0	3	0	0	0	2	4
		CCE_St_Ind'	12	12	18	16	8	18	18	18	8	8
		m''	1	1	5	1	4	5	5	5	3	5
		CCE_St_Ind''	14	14	8	18	10	8	8	8	10	10
tsc_C_RNTI_Def5	'04D2'H 1234	m'	0	2	0	4	0	2	3	0	1	0
		CCE_St_Ind'	10	8	10	8	14	8	8	14	8	10
		m''	1	3	1	5	1	3	4	1	2	1
		CCE_St_Ind''	12	10	12	10	16	10	10	16	10	12
tsc_C_RNTI_Def6	'0929'H 2345	m'	4	0	4	0	0	1	3	3	4	2
		CCE_St_Ind'	8	10	8	12	14	8	8	8	8	8
		m''	5	1	5	1	1	2	4	4	5	3
		CCE_St_Ind''	10	12	10	14	16	10	10	10	10	10
tsc_C_RNTI_Def7	'0D80'H 3456	m'	2	0	2	0	0	0	3	0	0	2
		CCE_St_Ind'	8	16	8	18	14	14	8	16	14	8
		m''	3	1	3	5	1	1	4	1	1	3
		CCE_St_Ind''	10	18	10	8	16	16	10	18	16	10
tsc_C_RNTI_Def8	'11D7'H 4567	m'	0	0	0	2	0	0	3	2	0	2
		CCE_St_Ind'	8	16	8	8	14	16	8	8	8	8
		m''	1	1	1	3	1	1	4	3	1	3
		CCE_St_Ind''	10	18	10	10	16	18	10	10	10	10
tsc_C_RNTI_Def9	'162E'H 5678	m'	0	3	0	0	0	2	0	0	3	2
		CCE_St_Ind'	12	8	12	16	8	8	16	18	8	8
		m''	1	4	1	1	1	3	1	5	4	3
		CCE_St_Ind''	14	10	14	18	10	10	18	8	10	10
tsc_C_RNTI_Def10	'1A85'H 6789	m'	0	0	0	3	0	1	0	1	3	2
		CCE_St_Ind'	16	8	16	8	8	8	16	8	8	8
		m''	1	1	1	4	1	2	1	2	4	3
		CCE_St_Ind''	18	10	18	10	10	10	18	10	10	10

Table 7.1.1.1-1a gives the CCE resources utilized for m' and m'' for default values of common search space aggregation level =4, UE-specific search space aggregation L=2 resulting in 6 PDCCH candidates m=0..5 and channel Bandwidth of 5 MHz and CFI=2, suitable for eMBMS test cases. This give Max_CCE =12 for FDD. The table also gives the corresponding CCE start indices of PDCCH candidates for m' and m''.

Table 7.1.1.1-1a: CCE Start indices(m' & m'') to be used for various C-RNTIs with CFI=2 (5 MHz)

C-RNTI	Value		SF0	SF1	SF2	SF3	SF4	SF5	SF6	SF7	SF8	SF9
tsc_C_RNTI_Def	'1001'H 4097	m'	4	3	3	0	2	1	2	0	3	1
		CCE_St_Ind'	8	8	8	8	8	8	8	8	8	8
		m''	5	4	4	1	3	2	3	1	4	2
		CCE_St_Ind''	10	10	10	10	10	10	10	10	10	10
tsc_C_RNTI_Def2	'1034'H 4148	m'	0	4	0	0	3	4	0	0	1	0
		CCE_St_Ind'	8	8	8	10	8	8	8	10	8	8
		m''	1	5	1	5	4	5	1	5	2	1
		CCE_St_Ind''	10	10	10	8	10	10	10	8	10	10
tsc_C_RNTI_Def3	'1111'H 4369	m'	2	0	0	4	0	0	0	2	0	2
		CCE_St_Ind'	8	10	10	8	10	10	10	8	10	8
		m''	3	5	5	5	5	5	5	3	5	3
		CCE_St_Ind''	10	8	8	10	8	8	8	10	8	10

Tables 7.1.1.1-2, 7.1.1.1-3 and 7.1.1.1-4 give the CCE resources utilized for m' and m'' for default values of common search space aggregation level =4, UE-specific search space aggregation L=2 resulting in 6 PDCCH candidates m=0..5 and bandwidths of 10/15/20 MHz respectively. This gives Max_CCE =25(10 MHz)/37(15 MHz)/50(20 MHz) for FDD. The tables also give the corresponding CCE start indices of PDCCH candidates for m' and m''. These are in general to be applied in MAC Transport block size test cases defined in clause 7.1.7 of TS 36.523-1 [1].

Table 7.1.1.1-2: CCE Start indices (m' & m'') to be used for default C-RNTI (10 MHz)

C-RNTI	Value		SF0	SF1	SF2	SF3	SF4	SF5	SF6	SF7	SF8	SF9
tsc_C_RNTI_Def	'1001'H 4097	m'	0	3	3	0	0	0	0	0	0	0
		CCE_St_Ind'	12	8	8	20	16	18	16	8	14	18
		m''	1	4	4	1	1	1	1	1	1	1
		CCE_St_Ind''	14	10	10	22	18	20	18	10	16	20
tsc_C_RNTI_Def2	'1034'H 4148	m'	0	4	0	0	0	4	0	0	0	0
		CCE_St_Ind'	8	8	20	10	14	8	20	22	18	8
		m''	1	5	1	1	1	5	1	5	1	1
		CCE_St_Ind''	10	10	22	12	16	10	22	8	20	10
tsc_C_RNTI_Def3	'1111'H 4369	m'	0	0	0	4	0	0	0	2	0	0
		CCE_St_Ind'	16	10	10	8	22	22	22	8	10	16
		m''	1	1	1	5	5	5	5	3	1	1
		CCE_St_Ind''	18	12	12	10	8	8	8	10	12	18
tsc_C_RNTI_Def4	'1FF1'H 8177	m'	2	0	0	4	0	0	3	0	2	0
		CCE_St_Ind'	8	20	14	8	10	18	8	22	8	12
		m''	3	1	1	5	1	1	4	5	3	1
		CCE_St_Ind''	10	22	16	10	12	20	10	8	10	14
tsc_C_RNTI_Def5	'04D2'H 1234	m'	3	0	0	0	0	2	3	3	1	0
		CCE_St_Ind'	8	16	22	12	22	8	8	8	8	22
		m''	4	1	5	1	5	3	4	4	2	5
		CCE_St_Ind''	10	18	8	14	8	10	10	10	10	8
tsc_C_RNTI_Def6	'0929'H 2345	m'	0	0	2	2	0	1	0	0	0	2
		CCE_St_Ind'	20	18	8	8	18	8	18	22	12	8
		m''	1	1	3	3	1	2	1	5	1	3
		CCE_St_Ind''	22	20	10	10	20	10	20	8	14	10
tsc_C_RNTI_Def7	'0D80'H 3456	m'	4	0	0	1	0	0	0	0	0	4
		CCE_St_Ind'	8	20	20	8	14	22	10	8	18	8
		m''	5	1	1	2	1	5	1	1	1	5
		CCE_St_Ind''	10	22	22	10	16	8	12	10	20	10
tsc_C_RNTI_Def8	'11D7'H 4567	m'	2	0	0	0	0	4	3	2	4	0
		CCE_St_Ind'	8	8	12	8	10	8	8	8	8	20
		m''	3	1	1	1	1	5	4	3	5	1
		CCE_St_Ind''	10	10	14	10	12	10	10	10	10	22
tsc_C_RNTI_Def9	'162E'H 5678	m'	0	0	2	4	0	0	2	0	1	0
		CCE_St_Ind'	8	10	8	8	16	16	8	14	8	16
		m''	1	1	3	5	1	1	3	1	2	1
		CCE_St_Ind''	10	12	10	10	18	18	10	16	10	18
tsc_C_RNTI_Def10	'1A85'H 6789	m'	0	0	0	3	0	0	0	0	3	0
		CCE_St_Ind'	12	12	20	8	12	18	20	10	8	12
		m''	1	1	1	4	1	1	1	1	4	1
		CCE_St_Ind''	14	14	22	10	14	20	22	12	10	14

Table 7.1.1.1-3: CCE Start indices (m' & m'') to be used for default C-RNTI (15 MHz)

C-RNTI	Value		SF0	SF1	SF2	SF3	SF4	SF5	SF6	SF7	SF8	SF9
tsc_C_RNTI_Def	'1001'H 4097	m'	4	0	0	0	0	0	0	0	0	0
		CCE_St_Ind'	8	14	14	20	16	18	28	20	26	30
		m''	5	1	1	1	1	1	1	1	1	1
		CCE_St_Ind''	10	16	16	22	18	20	30	22	28	32
tsc_C_RNTI_Def2	'1034'H 4148	m'	0	0	0	0	0	4	0	0	0	0
		CCE_St_Ind'	32	12	20	34	14	8	8	10	30	32
		m''	1	1	1	5	1	5	1	1	1	1
		CCE_St_Ind''	34	14	22	8	16	10	10	12	32	34
tsc_C_RNTI_Def3	'1111'H 4369	m'	0	0	0	4	0	0	0	0	0	0
		CCE_St_Ind'	16	22	22	8	10	22	34	28	34	28
		m''	1	1	1	5	1	1	5	1	5	1
		CCE_St_Ind''	18	24	24	10	12	24	8	30	8	30

Table 7.1.1.1-4: CCE Start indices (m' & m'') to be used for default C-RNTI (20 MHz)

C-RNTI	Value		SF0	SF1	SF2	SF3	SF4	SF5	SF6	SF7	SF8	SF9
tsc_C_RNTI_Def	'1001'H 4097	m'	3	0	0	0	0	0	0	0	2	0
		CCE_St_Ind'	8	36	34	38	42	22	10	8	8	20
		m''	4	1	1	1	1	1	1	1	3	1
		CCE_St_Ind''	10	38	36	40	44	24	12	10	10	22
tsc_C_RNTI_Def2	'1034'H 4148	m'	0	0	2	0	0	0	0	0	0	1
		CCE_St_Ind'	12	46	8	34	20	10	10	26	28	8
		m''	1	1	3	1	1	1	1	1	1	2
		CCE_St_Ind''	14	48	10	36	22	12	12	28	30	10
tsc_C_RNTI_Def3	'1111'H 4369	m'	1	0	0	0	3	0	2	0	0	0
		CCE_St_Ind'	8	20	24	34	8	10	8	38	48	20
		m''	2	1	1	1	4	1	3	1	5	1
		CCE_St_Ind''	10	22	26	36	10	12	10	40	8	22

7.1.1.2 TDD candidates selection

The default TDD subframe configuration 1 is applied to this clause. By default no DL data is scheduled in special subframes 1 and 6.

Considering that each TDD subframe having different PHICH group number, and only two symbols being present for PDCCH in the special subframes 1 and 6 for bandwidth of 5 MHz, two symbols for PDCCH in all subframes for bandwidth of 10/15/20 MHz (TS 36.508 [3]), each subframe has, therefore, different number of MAX_CCE.

Table 7.1.1.2-1 gives the PDCCH candidates of m' and m'' for default values of common search space aggregation level =8, UE-specific search space aggregation L=8 resulting in 2 PDCCH candidates m=0,1 and the corresponding CCE start indices for channel bandwidth of 5MHz. SF0 and SF5 cannot be used for UL grant. SF1 and SF6 are not used for DL assignment. SF2, SF3, SF7 and SF8 are not applicable to PDCCH CCE allocation since they are uplink subframes.

Table 7.1.1.2-1: CCE Start indices (m' & m'') to be used for various C-RNTIs (5 MHz)

C-RNTI	Value		SF0	SF1	SF2	SF3	SF4	SF5	SF6	SF7	SF8	SF9
		Max_CCE	21	12	-	-	20	21	12	-	-	20
tsc_C_RNTI_Def	'1001'H 4097	m'	1	-	-	-	1	0	-	-	-	0
		CCE_St_Ind'	8	-	-	-	8	8	-	-	-	8
		m''	-	0	-	-	0	-	0	-	-	1
		CCE_St_Ind''	-	0	-	-	0	-	0	-	-	0
tsc_C_RNTI_Def2	'1034'H 4148	m'	1	-	-	-	0	1	-	-	-	1
		CCE_St_Ind'	8	-	-	-	8	8	-	-	-	8
		m''	-	0	-	-	1	-	0	-	-	0
		CCE_St_Ind''	-	0	-	-	0	-	0	-	-	0
tsc_C_RNTI_Def3	'1111'H 4369	m'	1	-	-	-	0	0	-	-	-	1
		CCE_St_Ind'	8	-	-	-	8	8	-	-	-	8
		m''	-	0	-	-	1	-	0	-	-	0
		CCE_St_Ind''	-	0	-	-	0	-	0	-	-	0
tsc_C_RNTI_Def4	'1FF1'H 8177	m'	1	-	-	-	0	0	-	-	-	1
		CCE_St_Ind'	8	-	-	-	8	8	-	-	-	8
		m''	-	0	-	-	1	-	0	-	-	0
		CCE_St_Ind''	-	0	-	-	0	-	0	-	-	0
tsc_C_RNTI_Def5	'04D2'H 1234	m'	0	-	-	-	0	1	-	-	-	0
		CCE_St_Ind'	8	-	-	-	8	8	-	-	-	8
		m''	-	0	-	-	1	-	0	-	-	1
		CCE_St_Ind''	-	0	-	-	0	-	0	-	-	0
tsc_C_RNTI_Def6	'0929'H 2345	m'	1	-	-	-	0	0	-	-	-	1
		CCE_St_Ind'	8	-	-	-	8	8	-	-	-	8
		m''	-	0	-	-	1	-	0	-	-	0
		CCE_St_Ind''	-	0	-	-	0	-	10	-	-	0
tsc_C_RNTI_Def7	'0D80'H 3456	m'	1	-	-	-	0	0	-	-	-	1
		CCE_St_Ind'	8	-	-	-	8	8	-	-	-	8
		m''	-	0	-	-	1	-	0	-	-	0
		CCE_St_Ind''	-	0	-	-	0	-	0	-	-	0
tsc_C_RNTI_Def8	'11D7'H 4567	m'	1	-	-	-	0	0	-	-	-	1
		CCE_St_Ind'	8	-	-	-	8	8	-	-	-	8

C-RNTI	Value		SF0	SF1	SF2	SF3	SF4	SF5	SF6	SF7	SF8	SF9
		m''	-	0	-	-	1	-	0	-	-	0
		CCE_St_Ind''	-	0	-	-	0	-	0	-	-	0
tsc_C_RNTI_Def9	'162E'H 5678	m'	1	-	-	-	0	0	-	-	-	1
		CCE_St_Ind'	8	-	-	-	8	8	-	-	-	8
		m''	-	0	-	-	1	-	0	-	-	0
		CCE_St_Ind''	-	0	-	-	0	-	0	-	-	0
tsc_C_RNTI_Def1 0	'1A85'H 6789	m'	1	-	-	-	0	0	-	-	-	1
		CCE_St_Ind'	8	-	-	-	8	8	-	-	-	8
		m''	-	0	-	-	1	-	0	-	-	0
		CCE_St_Ind''	-	0	-	-	0	-	0	-	-	0

Table 7.1.1.2-1a gives the PDCCH candidates of m' and m'' for default values of common search space aggregation level =4, UE-specific search space aggregation L=4 resulting in 2 PDCCH candidates m=0,1 and the corresponding CCE start indices for channel bandwidth of 5MHz and CFI=2, suitable for eMBMS test cases. SF0 and SF5 cannot be used for UL grant. SF1 and SF6 are not used for DL assignment. SF2, SF3, SF7 and SF8 are not applicable to PDCCH CCE allocation since they are uplink subframes.

Note: With Max-CCE=13 or 12, aggregation level of 8 results in only 1 PDCCH candidate. Hence aggregation level of 4 is used.

Table 7.1.1.2-1a: CCE Start indices (m' & m'') to be used for various C-RNTIs with CFI=2 (5 MHz)

C-RNTI	Value		SF0	SF1	SF2	SF3	SF4	SF5	SF6	SF7	SF8	SF9
		Max_CCE	13	12	-	-	12	13	12	-	-	12
tsc_C_RNTI_Def	'1001'H 4097	m'	1	-	-	-	0	1	-	-	-	1
		CCE_St_Ind'	4	-	-	-	8	4	-	-	-	4
		m''	-	0	-	-	1	-	0	-	-	0
		CCE_St_Ind''	-	4	-	-	0	-	8	-	-	0
tsc_C_RNTI_Def2	'1034'H 4148	m'	0	-	-	-	0	1	-	-	-	0
		CCE_St_Ind'	4	-	-	-	4	4	-	-	-	4
		m''	-	0	-	-	1	-	0	-	-	1
		CCE_St_Ind''	-	0	-	-	8	-	4	-	-	8
tsc_C_RNTI_Def3	'1111'H 4369	m'	0	-	-	-	0	0	-	-	-	0
		CCE_St_Ind'	8	-	-	-	8	8	-	-	-	8
		m''	-	0	-	-	1	-	0	-	-	1
		CCE_St_Ind''	-	8	-	-	0	-	8	-	-	0

Tables 7.1.1.2-2, 7.1.1.2-3 and 7.1.1.2-4 give the PDCCH candidates of m' and m'' for default values of common search space aggregation level =8, UE-specific search space aggregation L=8 resulting in 2 PDCCH candidates m=0,1 and the corresponding CCE start indices for bandwidths of 10/15/20 MHz respectively, with the different Max_CCE number for each subframe.

Table 7.1.1.2-2: CCE Start indices (m' & m'') to be used for default C-RNTI (10 MHz)

C-RNTI	Value		SF0	SF1	SF2	SF3	SF4	SF5	SF6	SF7	SF8	SF9
		Max_CCE	27	25	-	-	25	27	25	-	-	25
tsc_C_RNTI_Def	'1001'H 4097	m'	1	-	-	-	0	1	-	-	-	1
		CCE_St_Ind'	8	-	-	-	16	8	-	-	-	8
		m''	-	0	-	-	1	-	0	-	-	0
		CCE_St_Ind''	-	8	-	-	0	-	16	-	-	0
tsc_C_RNTI_Def 2	'1034'H 4148	m'	0	-	-	-	0	1	-	-	-	0
		CCE_St_Ind'	8	-	-	-	8	8	-	-	-	8
		m''	-	0	-	-	1	-	0	-	-	1
		CCE_St_Ind''	-	0	-	-	16	-	8	-	-	16
tsc_C_RNTI_Def 3	'1111'H 4369	m'	0	-	-	-	0	0	-	-	-	0
		CCE_St_Ind'	16	-	-	-	16	16	-	-	-	16
		m''	-	0	-	-	1	-	0	-	-	1
		CCE_St_Ind''	-	16	-	-	0	-	16	-	-	0

Table 7.1.1.2-3: CCE Start indices (m' & m'') to be used for default C-RNTI (15 MHz)

C-RNTI	Value		SF0	SF1	SF2	SF3	SF4	SF5	SF6	SF7	SF8	SF9
		Max_CCE	41	37	-	-	37	41	37	-	-	37
tsc_C_RNTI_Def 1	'1001'H 4097	m'	0	-	-	-	1	0	-	-	-	0
		CCE_St_Ind'	8	-	-	-	8	8	-	-	-	8
		m''	-	0	-	-	0	-	0	-	-	1
		CCE_St_Ind''	-	8	-	-	0	-	0	-	-	16
tsc_C_RNTI_Def 2	'1034'H 4148	m'	0	-	-	-	0	1	-	-	-	1
		CCE_St_Ind'	8	-	-	-	24	8	-	-	-	8
		m''	-	0	-	-	1	-	0	-	-	0
		CCE_St_Ind''	-	0	-	-	0	-	16	-	-	0
tsc_C_RNTI_Def 3	'1111'H 4369	m'	0	-	-	-	0	1	-	-	-	1
		CCE_St_Ind'	24	-	-	-	24	8	-	-	-	8
		m''	-	0	-	-	1	-	0	-	-	0
		CCE_St_Ind''	-	8	-	-	0	-	24	-	-	0

Table 7.1.1.2-4: CCE Start indices (m' & m'') to be used for default C-RNTI (20 MHz)

C-RNTI	Value		SF0	SF1	SF2	SF3	SF4	SF5	SF6	SF7	SF8	SF9
		Max_CCE	55	50	-	-	50	55	50	-	-	50
tsc_C_RNTI_Def 1	'1001'H 4097	m'	1	-	-	-	0	0	-	-	-	0
		CCE_St_Ind'	8	-	-	-	16	24	-	-	-	24
		m''	-	0	-	-	1	-	0	-	-	1
		CCE_St_Ind''	-	8	-	-	24	-	16	-	-	32
tsc_C_RNTI_Def 2	'1034'H 4148	m'	0	-	-	-	0	1	-	-	-	0
		CCE_St_Ind'	32	-	-	-	8	8	-	-	-	32
		m''	-	0	-	-	1	-	0	-	-	1
		CCE_St_Ind''	-	0	-	-	16	-	32	-	-	40
tsc_C_RNTI_Def 3	'1111'H 4369	m'	0	-	-	-	0	0	-	-	-	0
		CCE_St_Ind'	16	-	-	-	40	40	-	-	-	16
		m''	-	0	-	-	1	-	0	-	-	1
		CCE_St_Ind''	-	40	-	-	0	-	40	-	-	24
tsc_C_RNTI_Def 4	'1FF1'H 8177	m'	0	-	-	-	0	0	-	-	-	1
		CCE_St_Ind'	16	-	-	-	40	24	-	-	-	8
		m''	-	0	-	-	1	-	0	-	-	0
		CCE_St_Ind''	-	32	-	-	0	-	8	-	-	0
tsc_C_RNTI_Def 5	'04D2'H 1234	m'	0	-	-	-	0	0	-	-	-	0
		CCE_St_Ind'	8	-	-	-	40	16	-	-	-	40
		m''	-	0	-	-	1	-	0	-	-	1
		CCE_St_Ind''	-	16	-	-	0	-	8	-	-	0
tsc_C_RNTI_Def 6	'0929'H 2345	m'	0	-	-	-	0	0	-	-	-	0
		CCE_St_Ind'	32	-	-	-	24	24	-	-	-	16
		m''	-	0	-	-	1	-	0	-	-	1
		CCE_St_Ind''	-	24	-	-	32	-	24	-	-	24
tsc_C_RNTI_Def 7	'0D80'H 3456	m'	1	-	-	-	0	0	-	-	-	1
		CCE_St_Ind'	8	-	-	-	8	40	-	-	-	8
		m''	-	0	-	-	1	-	0	-	-	0
		CCE_St_Ind''	-	32	-	-	16	-	40	-	-	0
tsc_C_RNTI_Def 8	'11D7'H 4567	m'	0	-	-	-	0	1	-	-	-	0
		CCE_St_Ind'	16	-	-	-	40	8	-	-	-	32
		m''	-	0	-	-	1	-	0	-	-	1
		CCE_St_Ind''	-	32	-	-	0	-	8	-	-	40
tsc_C_RNTI_Def 9	'162E'H 5678	m'	0	-	-	-	0	0	-	-	-	0
		CCE_St_Ind'	32	-	-	-	16	16	-	-	-	16
		m''	-	0	-	-	1	-	0	-	-	1
		CCE_St_Ind''	-	40	-	-	24	-	16	-	-	24
tsc_C_RNTI_Def 10	'1A85'H 6789	m'	1	-	-	-	1	0	-	-	-	1
		CCE_St_Ind'	8	-	-	-	8	24	-	-	-	8
		m''	-	0	-	-	0	-	0	-	-	0
		CCE_St_Ind''	-	0	-	-	0	-	32	-	-	0

7.1.1.2.1 TDD candidates selection in special subframes

In test cases (7.1.3.12/13) testing DL data transmission in special subframes following CCE tables will be used

Table 7.1.1.2.1-1: CCE Start indices (m' & m'') to be used for various default C-RNTI (5 MHz)

C-RNTI	Value		SF0	SF1	SF2	SF3	SF4	SF5	SF6	SF7	SF8	SF9
		Max_CCE	21	12	-	-	20	21	12	-	-	20
tsc_C_RNTI_Def	'1001'H 4097	m'	1	1	-	-	1	0	1	-	-	0
		CCE_St_Ind'	8	0	-	-	8	8	0	-	-	8
		m''	-	0	-	-	0	-	0	-	-	1
		CCE_St_Ind''	-	0	-	-	0	-	0	-	-	0
tsc_C_RNTI_Def2	'1034'H 4148	m'	1	1	-	-	0	1	1	-	-	1
		CCE_St_Ind'	8	0	-	-	8	8	0	-	-	8
		m''	-	0	-	-	1	-	0	-	-	0
		CCE_St_Ind''	-	0	-	-	0	-	0	-	-	0

NOTE: Special subframes with Max CCE =12 and aggregation of 8 result in only 1 PDCCH. Hence either only UL grant or DL allocation is possible.

Table 7.1.1.2.1-2: CCE Start indices (m' & m'') to be used for default C-RNTI (20 MHz)

C-RNTI	Value		SF0	SF1	SF2	SF3	SF4	SF5	SF6	SF7	SF8	SF9
		Max_CCE	55	50	-	-	50	55	50	-	-	50
tsc_C_RNTI_Def	'1001'H 4097	m'	1	0	-	-	0	0	0	-	-	0
		CCE_St_Ind'	8	8	-	-	16	24	16	-	-	24
		m''	-	1	-	-	1	-	1	-	-	1
		CCE_St_Ind''	-	16	-	-	24	-	24	-	-	32
tsc_C_RNTI_Def 2	'1034'H 4148	m'	0	1	-	-	0	1	0	-	-	0
		CCE_St_Ind'	32	8	-	-	8	8	32	-	-	32
		m''	-	0	-	-	1	-	1	-	-	1
		CCE_St_Ind''	-	0	-	-	16	-	40	-	-	40

7.1.2 ePDCCH Candidate Selection

Total number of eREGs available in a subframe: Max_eREG.

Total number of eCCEs available in a subframe: Max_eCCE.

The value of numberPRB-Pairs=8 to be used in ePDCCH signalling test cases result in MAX_eREG=128 as per TS 36.211 [35] clause 6.2.4A. As per TS 36.211 [35] clause 6.8A.1 results in MAX_eCCE=32.

7.1.2.1 FDD candidates selection

The UE specific search space aggregation L=2 same as in clause 7.1.1.1 is used. For DL transmission for C-RNTI / SPS C-RNTI value of m=0 (m') in set config ID 0 shall be used. 'm' is defined in TS 36.213 [30], clause 9.1.4. For UL transmission for C-RNTI / SPS C-RNTI the lowest value of m=1 (m'') shall be used.

Table 7.1.2.1-1: eCCE Start indices (m' & m'') to be used for various C-RNTIs

C-RNTI	Value		SF0	SF1	SF2	SF3	SF4	SF5	SF6	SF7	SF8	SF9
tsc_C_RNTI_Def	'1001'H 4097	m'	0	0	0	0	0	0	0	0	0	0
		CCE_St_Ind'	20	2	10	28	0	26	16	8	22	2
		m''	1	1	1	1	1	1	1	1	1	1
		CCE_St_Ind''	4	18	26	12	16	10	0	24	6	18
tsc_C_RNTI_Def2	'1034'H 4148	m'	0	0	0	0	0	0	0	0	0	0
		CCE_St_Ind'	8	24	4	26	14	0	4	22	26	8
		m''	1	1	1	1	1	1	1	1	1	1
		CCE_St_Ind''	24	8	20	10	30	16	20	6	10	24

NOTE: eCCE start indices are independent of bandwidth.

7.1.2.2 TDD candidates selection

The search space aggregation $L=8$ same as in clause 7.1.1.2 is used. For DL transmission for C-RNTI / SPS C-RNTI value of $m=0$ (m') in set config ID 0 shall be used. ' m' ' is defined in TS 36.213 [30], clause 9.1.4. For UL transmission for C-RNTI / SPS C-RNTI the lowest value of $m=1$ (m'') shall be used.

Table 7.1.2.2-1: CCE Start indices (m' & m'') to be used for various C-RNTIs

C-RNTI	Value		SF0	SF1	SF2	SF3	SF4	SF5	SF6	SF7	SF8	SF9
tsc_C_RNTI_Def	'1001'H 4097	Max_CCE	21	12	-	-	20	21	12	-	-	20
		m'	0	-	-	-	0	0	-	-	-	0
		CCE_St_Ind'	16	-	-	-	0	8	-	-	-	8
		m''	-	0	-	-	1	-	0	-	-	1
tsc_C_RNTI_Def2	'1034'H 4148	CCE_St_Ind''	-	8	-	-	16	-	0	-	-	24
		m'	0	-	-	-	0	0	-	-	-	0
		CCE_St_Ind'	0	-	-	-	24	0	-	-	-	0
		m''	-	0	-	-	1	-	0	-	-	1
		CCE_St_Ind''	-	0	-	-	8	-	0	-	-	16

7.1.3 MPDCCH Candidate Selection

The value of numberPRB-Pairs=2+4 (numberPRB-Pairs-v1310= n6) is to be used for MPDCCH in signalling test cases. The DCI format 6-2 used for P-RNTI will be sent in Type1-common search space. The DCI format 6-1A and 6-1B scrambled with RA-RNTI will be sent in Type2-common search space. The DCI format 6-1A and 1B scrambled by C-RNTI and DCI format 6-0A and 6-0B can be sent either in Type0-common (CE Mode A only) or UE Specific by C-RNTI search space. For simplicity and to be applicable for both CE Modes, they will always be sent on UE Specific by C-RNTI search space.

It is assumed that transmissions based on P-RNTI, C-RNTI and RA-RNTI are mutually exclusive in a one UE test environment. In a subframe any one of following will happen:

- 1 DCI for P-RNTI- 1 DCI for RA-RNTI- 1 or 2 DCI for C-RNTI

For TDD with default 'specialSubframePatterns' = ssp6, as per 36.213[30] clause 9.1.5, UE is not required to monitor MPDCCH in special subframes for both CE Mode's A and B.

For Type1-common search space for P-RNTI, as per 36.213[30] clause 9.1.5 only one MPDCCH with Aggregation $L' = 24$ is defined. This requires all 6 PRB's to be used. For this eCCE's with 0 to 23 (i.e. all eCCE's) are used.

For Type2-common search space for RA-RNTI, Aggregation L' of 24 results in only one MPDCCH utilising all 6 PRB's. For this eCCE's with 0 to 23 (i.e. all eCCE's) are used.

For UE Specific by C-RNTI search space, if only one of DCI 6-1x and 6-0x is to be sent, then Aggregation L' of 24 results in only one MPDCCH utilising all 6 PRB's. For this eCCE's with 0 to 23 (i.e. all eCCE's) are used.

For UE Specific by C-RNTI search space, if both UL and DL DCI (6-1x and 6-0x) are to be sent then:

- For CE Mode B with $R=r1$, aggregation level $L'=8$ on 2 PRB's (the lowest 2 PRB's in Narrow band), resulting in only one MPDCCH utilising all 8 eCCE's with 0 to 7 are used. This is used for DCI 6-1x (36.213[30] table 9.1.5-2b).
- For CE Mode B with $R=r1$, aggregation level $L'=16$ on 4 PRB's (the highest 4 PRB's in Narrow band), resulting in only one MPDCCH utilising all 16 eCCE's with 0 to 15 are used. This is used for DCI 6-0x(36.213[30] table 9.1.5-2b).
- For CE Mode A with $R=r1$, level $L'=8$ on 4 PRB's (the highest 4 PRB's in Narrow band), resulting in two MPDCCH, MPDCCH 1 with CCE's 0-7 are used for DCI 6- 1x and MPDCCH 2 with CCE's 8-15 are used for DCI 6- 0x(36.213[30] table 9.1.5-2a).

MPDCCH is repeated based on semi-statically configured higher layer parameter `mpdcch-NumRepetition` and dynamically selected by network. Each value of `mpdcch-NumRepetition = rmax` maps into max 4 allowed values of repetitions $R = r1, r2, r3, r4$. UE is required to monitor all $r1, r2, r3$ & $r4$ as per 36.213[30] table 9.1.5-2a for CE Mode A and table 9.1.5-2b for CE mode B.

Following values shall be used for DCI subframe repetition number R based on $rmax = mpdcch-NumRepetition$ default values:

- Type1-common search space for P-RNTI, `mpdcch-NumRepetition-Paging-r13 = r16`, $R=r1=1$ for both CE-Modes A & B.
- Type2-common search space for RA-RNTI, `mpdcch-NumRepetition-RA-r13 = r1`, $R=r1=1$, resulting in no retransmissions is used for both CE-Modes A & B.
 - Type2-common search space for RA-RNTI, `mpdcch-NumRepetition-RA-r13 = r4`, $R=r1=1$, resulting in no retransmissions is used for both CE-Modes A & B.
 - Type2-common search space for RA-RNTI, `mpdcch-NumRepetition-RA-r13 = r16`, $R=r1=2$, resulting in 2 transmissions is used for both CE-Modes A & B.
 - Type2-common search space for RA-RNTI, `mpdcch-NumRepetition-RA-r13 = r64`, $R=r1=2$, resulting in 8 transmissions is used for both CE-Modes A & B.
- UE Specific by C-RNTI search space, `mpdcch-NumRepetition-r13 = r16`, $R=r1=2$ resulting in 2 transmissions.
- UE Specific by C-RNTI search space, `mpdcch-NumRepetition-r13 = r1`, $R=r1=1$ resulting in 1 transmission.

7.2 Uplink Grant

The Network/SS informs the UE if it is allowed to make Uplink Data transmission by transmitting 'DCI format 0' on PDCCH. The UE shall transmit (4 TTI later for FDD or variable for TDD) a Transport block of exactly the same size as specified in DCI format 0. The UE has no control of its own on TB size, and has to merely follow the network, even if that means lots of MAC padding or resource starving.

The UE has the following means to communicate if it has UL data ready for transmission and subsequently the estimate of quantity of data to be transmitted.

RACH procedure: UE in idle mode, handed over to a new cell or connected mode but PUCCH is unsynchronized (sometimes referred to as PUCCH is not configured) will trigger RACH procedure on data ready for transmission in UL.

Scheduling Request: UE in connected mode, no grant configured, PUCCH is synchronized and has data ready for transmission in UL, will transmit a scheduling request on PUCCH.

Buffer Status Reports: UE in connected mode, PUCCH synchronized, has a configured grant for current TTI, but grant is not sufficient to transmit all the data will include MAC control element BSR in the UL MAC PDU.

RACH and SR indicate on data availability and BSR provides an estimate of data available for transmission.

CQI/PMI/RI feedback from the UE which indicates the channel conditions and recommended number of layers.

Hence to determine the exact need of the grant requirement of the UE a network/SS needs to act on all four of the above. This eventually complicates the SS implementation and hence the grant allocation procedure is simplified such that SS needs only to react on reception of SR and grant allocation configured from the TTCN.

The SS disables aperiodic CQI/PMI/RI feedback from the UE by setting the 'CQI request field' to 0 in DCI format 0/RAR grant.

When request for periodic CQI/PMI/RI feedback is requested due to TTCN configuration, the SS does not react on periodic CQI/PMI/RI feedback received and still allocates grants as configured from TTCN.

The SS, if configured for maintaining PUCCH synchronization at UE, shall periodically transmit automatically MAC PDUs containing the MAC control element 'Timing Advance'. The period as configured by the TTCN is set to 80 % of the 'Time Alignment Timer' default value (750 ms) configured at UE.

Additionally the SS can be configured to automatically transmit a 'configured' UL grant at every reception of a Scheduling Request. This grant should be selected under the following restrictions:

- All UE categories can handle this i.e. (for UEs Cat 1 and above TBS \leq 5160, for Cat 0/M1 TBS \leq 1000).
- It is sufficiently large that most of uplink signalling messages can be transmitted. In case the grant is not sufficient to fit the whole UL data, the UE will have to wait for the expiry of RETX_BSR_TIMER and retransmit a SR. And hence the procedure is repeated.

The following 5 types of grant allocation configurations are possible. Grant allocation Types 1 to 3 are applicable, when the UE is in connected state. Grant allocation Type 4 is applicable when UE is establishing /re-establishing the RRC Connection, or during handover or in connected state but PUCCH is not synchronised. Grant allocation type 5 is applicable when the UE is in connected state and is used for lower category UEs when the UL grants greater than Max TBS supported by the UE is needed.

Grant Allocation Type 1:

- SS is configured to maintain PUCCH Synch.
- SS is configured to send an automatically 'configured Grant' (in terms of I_{MCS} and N_{PRB}) to the UE on every reception of a Scheduling Request, within 10 subframes. The default configured grant is $I_{MCS} = 9$ and $N_{PRB} = 25$ for test cases without IMS signalling within the test body and $I_{MCS} = 20$ and $N_{PRB} = 25$ for test cases with IMS signalling within the test body, unless explicitly specified in test cases.
- By default this type of grant allocation is applied. The majority of Idle mode, RRC and NAS test cases, the preambles of all tests and the postambles of those tests for which UE is still PUCCH synchronised at the end of test body. A few Layer 2 tests also use this type of grant.

Grant Allocation Type 2:

- Configure SS to maintain PUCCH Synch.
- Configure SS to periodically transmit a grant (I_{MCS} and N_{PRB}). Number of grants (1 or more) and period (in ms) configured by TTCN.
- The first grant transmitted is as specified in the explicit timing information. If timing information is "now" the SS selects the first suitable subframe for UL transmission.
- The grant allocation period for TDD shall be assigned without conflict with the allowed UL subframes in the TDD subframe configurations. As example of allocation period, the TDD UL Grant allocation can be assigned as in multiples of 5 ms.
- This type of grant allocation is applicable to the majority of RLC, PDCP and a few MAC test cases.
- No additional grant is allocated on reception of any SRs.

Grant Allocation Type 3:

- SS may or may not be configured to maintain PUCCH Synch.

- Configure SS to transmit a one time grant (I_{MCS} and N_{PRB}) in the time requested by TTCN. The one time transmission is achieved by setting Number of grants=1 and period =Only once
- This type of grant allocation is suitable for MAC and DRB tests when UE is in UL Synchronised state

Grant Allocation Type 4 (RACH configuration):

- In addition to the 3 types of UL grant allocations, a fourth type of grant allocation during the RACH procedure is also possible, where the SS behaves as per the RACH procedure configured and allocates the configured grant during the RACH procedure. This UL Grant type is used in the configuration for the preamble in many situations, basically in MAC test cases. This type of grant is further used when UE is establishing/re-establishing the RRC connection or during handover, or when the UE is not PUCCH synchronised;

Grant Allocation Type 5:

- SS is configured to maintain PUCCH Synch.
- Configure SS to periodically transmit a grant (I_{MCS} and N_{PRB}) on reception of SR. Number of grants (1 or more) and period (in ms) configured by TTCN. The first grant is sent within 10 subframes of SR. Reception of SR starts/restarts periodic grant transmission. The default configured grant is $I_{MCS} = 12$ and $N_{PRB} = 25$ for UE Cat 1 and $I_{MCS} = 14$ and $N_{PRB} = 4$ for UE Cat 0/CAT M1 (CE Mode A), unless explicitly specified in test cases.
- This type of grant allocation is suitable when the UE category is lower than 2. The majority of Idle mode, RRC and NAS test cases, the preambles of all tests and the postambles of those tests which UE is still PUCCH synchronised at the end of the test body. A few Layer 2 tests also use this type of grant.

All the UL grant allocation methods define grant allocation in terms of I_{MCS} and N_{PRB} to be used. The SS shall allocate RBs corresponding to PRB indices $0..(N_{PRB}-1)$.

7.2.1 Exception TC list

This clause contains the exception test case list where the explicit uplink grant types other than UL grant type 1 are specified.

Table 7.2.1-1: Exception test case list with explicit uplink grant types other than UL grant type 1

Group	Test Case	Uplink Grant Type 2	Uplink Grant Type 3
RLC	7.2.2.6	X	
	7.2.2.7	X	
	7.2.3.1		X
	7.2.3.2	X	
	7.2.3.4		X
	7.2.3.5		X
	7.2.3.6	X	
	7.2.3.7	X	
	7.2.3.9	X	
	7.2.3.10	X	X
	7.2.3.13	X	X
	7.2.3.15	X	
	7.2.3.17	X	
7.2.3.18		X	
7.2.3.21		X	
MAC	7.1.4.1	X	
	7.1.4.2		X
	7.1.4.3	X	
	7.1.4.4		X
	7.1.4.7		X
	7.1.4.8	X	X
	7.1.4.10		X
	7.1.4.11		X
	7.1.4.14		X
	7.1.4.15	X	
	7.1.4.16	X	
	7.1.5.1	X	
	7.1.5.2	X	
	7.1.5.3	X	
	7.1.5.4	X	
	7.1.5.5	X	
7.1.6.1		X	
PDCP	7.3.5.4		X
RRC	8.2.1.5	X	
NAS	9.2.1.1.24		X
DRB	12.1.1		X
	12.1.2		X

7.3 Downlink Resource Allocation

The DL resource allocation is an SS emulation function. In order to ensure similar DL behaviours (within defined tolerances) on the different SS platforms in the timing stringent requirements, all downlink resource allocation schemes specified in the present clause shall be supported by the SS.

When the DL data is to be sent with a specific scheduling requirement, for instance, in a TTI in advance rather than “now”, the TTCN shall ensure that the data is scheduled at least 100 ms in advance. The 100 ms time in general covers all time delays, from the time DL data is sent by the TTCN at the EUTRA PTC to the completion of the transmission at the SS (TTCN delays, codec delays, adaptor delays and SS processing delays at various protocol Layers). In the case of more than one NAS PDU is piggy-backed in a scheduled RRC PDU, 20ms shall be added per additional NAS PDU: $100\text{ms} + ((\text{NoOfNASPDUs} - 1) * 20\text{ms})$; this calculation is based on the assumption that there are not more than 7 piggy-backed NAS messages; this is valid for LTE.

NOTE: The DL data means DL signalling and/or data in the present clause.

7.3.1 PDCCH DCI default formats

Two types of DCI combinations are identified as default formats for the signalling and protocol test.

DCI combination 1 uses:

- DCI format 1A, resource allocation type 2 localised, for all DL scheduling types.

DCI combination 2 uses:

- DCI format 1C, resource allocation type 2 distributed, for scheduling of PCCH/BCCH/RAR; and
- DCI format 1 resource allocation type 0, for UE dedicated scheduling.

7.3.1.1 Default DCI Format to be used in test cases configuring MIMO

Transmission mode 3 will be used in MIMO test cases configuring 2 Transmit antenna SS environment. As per 36.213 Table 7.1-5, in Transmission mode 3, UE is expected to decode only DCI formats 2A and 1A. Similarly for Transmission mode 4, UE is expected to decode only DCI formats 2 and 1A. Hence for all test cases configuring 2TX (2 antenna ports) at SS, DCI combination 1 is the default DCI combination to be applied. This allows DCI format 1A to be used as default DL scheduling scheme for test sequences not explicitly specified to use DCI formats 2A or 2(i.e. preamble, postamble etc.)

7.3.2 Radio parameters configured

The SS shall support DL QPSK, 16QAM and 64QAM modulation schemes. The configured radio parameters, including DCI format, resource allocation types, maximum allowed modulation scheme, first virtual / physical resource block to be used, maximum available resource blocks and redundancy version, are provided to the SS.

In the normal signalling test condition, DL RLC and HARQ retransmissions are rare. The redundancy version is provided to allow the occasional HARQ retransmissions. For those MAC, RLC tests contained in table 7.3.2-1 where timing requirements are involved the DL or UL HARQ retransmissions are not tolerable. Table 7.3.2-2 lists the RLC tests where timing requirements are involved, only one DL or UL HARQ retransmission per transport block is tolerable. Unless otherwise specified, if HARQ retransmissions occur in the test cases contained in table 7.3.2-1 or more than one HARQ retransmission occurs in the test cases of table 7.3.2-2, the test cases will be terminated with verdict inconclusive.

NOTE: If the test is expecting the reporting of UL ACK/NACK for the DL MAC PDUs, or is configuring the PHICH in a certain mode, HARQ retransmissions other than those that are already specified in the prose will have an impact on the test sequence. If test cases perform scheduling of data transmissions and/or receptions, or the testing timers in the test cases are less than 900 ms (i.e. the tolerance for 90 ms), HARQ retransmissions will make it difficult to continue testing.

Table 7.3.2-1: TC list intolerable of HARQ retransmissions

Test case	Comment
MAC	
7.1.3.1, 7.1.3.2, 7.1.3.4, 7.1.3.5, 7.1.3.6, 7.1.3.9, 7.1.6.1, 7.1.6.2	HARQ feedback reporting enabled or DL CRC errors introduced; DL HARQ un specified (re)transmissions will result in 'Fail' in test body, UL HARQ retransmissions are allowed;
7.1.4.8	Strict relationship between grant and UL data
7.1.4.3	Up to 104 PDUs to be sent in DL every TTI;
7.1.4.2, 7.1.4.11, 7.1.4.12, 7.1.4.14, 7.1.5.4	HARQ feedback transmission specified or PHICH errors introduced
7.1.4.15, 7.1.4.16	Periodic UL grants
RLC	
7.2.2.6, 7.2.2.7, 7.2.2.8, 7.2.2.10, 7.2.3.1, 7.2.3.2, 7.2.3.4, 7.2.3.5, 7.2.3.10, 7.2.3.13, 7.2.3.14, 7.2.3.15, 7.2.3.18	Tolerating HARQ retransmissions is not feasible due to rigid timing and scheduling conditions. Testing timer < 900 ms

Table 7.3.2-2: TC list intolerable of more than one HARQ retransmission per transport block

Test case	Comment
7.2.3.6, 7.2.3.7, 7.2.3.8, 7.2.3.9, 7.2.3.17	Tolerating more than one HARQ retransmission is not feasible due to rigid timing and scheduling conditions. Testing timer < 900 ms

7.3.2.1 HARQ Retransmission when MIMO is configured

For test cases configuring MIMO, if in a TTI more than one transport blocks are scheduled (DCI format 2/ 2A/2B), the HARQ retransmission is handled independently for each transport block by SS. In case UE ACKs one Transport block and NACKs the other and there is no fresh data scheduled for transmission, SS only schedules the NACKed transport block for retransmission, using same I_{mcs} as used in initial transmission, mapped to codeword 0. Aced Transport block (and hence codeword 1) is disabled by setting corresponding $I_{MCS} = 0$ and $r_{vidx} = 1$. Resource allocation (N_{prb}) used in retransmission is same as in initial transmission.

It is assumed that retransmission and fresh data scheduled in one TTI will not happen.

7.3.3 General DL scheduling scheme

The rules in the present clause, unless particularly specified, are applied to both default DCI combinations.

The bandwidth of 5/10/15/20 MHz makes 25/50/75/100 available physical resource blocks respectively. The 25/50/75/100 resource blocks are divided into three distinct sets. Exact set sizes and the elements contained in the individual sets depend upon the DCI combination to be applied.

- The first set is reserved for BCCH mapped to DL-SCH (SI-RNTI).
- The second set is reserved for PCCH mapped to DL-SCH (P-RNTI).
- The third set is used for one of mutually exclusive transmissions of:
 - 'Random Access Response' mapped to DL-SCH (RA-RNTI); or
 - UE-dedicated scheduling mapped to DL-SCH (C-RNTI/ SPS C-RNTI/ Temp C-RNTI).

For each subframe for which data of one or more types is scheduled, the SS shall select a Transport Block Size (TBS), independently for each type of data scheduled, such that:

- All the scheduled data is transmitted respecting the timing information. More details on the timing information can be found in clause 7.8.
- Not more than $MaxRbCnt$ resource blocks are used, for DCI format 1C, $N_{PRB} = MaxRbCnt$.
- Minimum MAC Padding is performed.
- If all scheduled Data cannot be transmitted in the indicated subframe, for example due to TDD and half duplex configuration, it shall be transmitted in the next available subframe.

7.3.3.1 Additional rules for BCCH scheduling scheme

This scheme is applicable for Data transmission on logical channel BCCH mapped to DL-SCH, PDCCH scrambled by SI-RNTI. For both DCI combinations 4 physical resource blocks are reserved for BCCH transmission. The maximum modulation scheme is restricted to QPSK.

Following additional rules are applied for TBS selection:

- The Max TBS, the maximum TBS allowed for the scheduling scheme, is restricted to 600. (nearest value achievable for $I_{TBS} = 9$ and $N_{PRB} = 4$, as per table 7.1.7.2.1-1 of TS 36.213 [30]).

- If the scheduled Data cannot fit into a TBS smaller or equal to Max TBS, SS generates an error (it's a TTCN error). TTCN should gracefully exit the test case as a fatal error, assigning inconclusive verdict.
- Rules in clause 7.3.3.1.1 for DCI combination 1 and in clause 7.3.3.1.2 for DCI combination 2 shall be applied.

7.3.3.1.1 BCCH with DCI combination 1

TS 36.213 [30], table 7.1.7.2.1-1, rows with $I_{TBS} = 0..26$ and columns with $N_{PRB} = 2$ (corresponding to TPC LSB = 0) and $N_{PRB} = 3$ (corresponding to TPC LSB = 1), $TBS \leq \text{Max TBS}$ are applicable.

Distinct TBSs and all (TPC LSB, I_{TBS}) combinations for each distinct TBS are listed in the sheet.

If a TBS can have two (TPC LSB, I_{TBS}) combinations, the combination with TPC LSB = 0 is selected.

RIV indicates 4 PRBs with index 0..3 allocated.

7.3.3.1.2 BCCH with DCI combination 2

TS 36.213 [30], table 7.1.7.2.3-1, $I_{TBS} = 0..17$ with $TBS \leq \text{Max TBS}$ are applicable.

RIV indicates 4 virtual RBs with index 0..3 allocated. These virtual RBs correspond to the physical RBs

- with index 0, 6, 12, 18 in even slots and 12, 18, 0, 6 in odd slots for 5 MHz bandwidth;
- with index 0, 12, 27, 39 in even slots and 27, 39, 0, 12 in odd slots for 10 MHz bandwidth;
- with index 0, 16, 48, 64 in even slots and 48, 64, 0, 16 in odd slots for 15 MHz bandwidth;
- with index 0, 24, 48, 72 in even slots and 48, 72, 0, 24 in odd slots for 20 MHz bandwidth.

7.3.3.2 Additional rules for PCCH specific scheduling scheme

This scheme is applicable for Data transmission on logical channel PCCH mapped to DL-SCH, PDCCH scrambled by P-RNTI. For DCI combination 1, one physical resource block is reserved. For DCI combination 2, two physical resource blocks are reserved for 5 MHz bandwidth, and four physical resource blocks are reserved for 10 MHz, 15 MHz or 20 MHz bandwidth. The maximum modulation scheme is restricted to QPSK.

Following additional rules are applied for TBS selection:

- If the scheduled Data cannot fit into Max TBS, SS generates an error (it's a TTCN error). TTCN should gracefully exit the test case as a fatal error, assigning inconclusive verdict.
- Rules in clause 7.3.3.2.1 for DCI combination 1 and clause 7.3.3.2.2 for DCI combination 2 shall be applied.

7.3.3.2.1 PCCH with DCI combination 1

TS 36.213 [30], table 7.1.7.2.1-1, rows with $I_{TBS} = 0..26$ and columns with $N_{PRB} = 2$ (corresponding to TPC LSB = 0) and $N_{PRB} = 3$ (corresponding to TPC LSB = 1) $TBS \leq \text{Max TBS}$ are applicable.

The Max TBS is restricted to 120 (nearest value achievable for $I_{TBS} = 9$ and $N_{PRB} = 1$, as per table 7.1.7.2.1-1 of TS 36.213 [30]).

Distinct TBSs and all (TPC LSB, I_{TBS}) combinations for each distinct TBS are listed in the sheet.

If a TBS can have two (TPC LSB, I_{TBS}) combinations, the combination with TPC LSB = 0 is selected.

RIV indicates 1 PRBs with index 4 allocated.

7.3.3.2.2 PCCH with DCI combination 2

TS 36.213 [30], table 7.1.7.2.3-1, $I_{TBS} = 0..11$ for 5 MHz/ $I_{TBS} = 0..17$ for 10, 15 or 20 MHz with $TBS \leq \text{Max TBS}$ are applicable.

The Max TBS is restricted to

296 bits (nearest value achievable for $I_{TBS} = 9$ and $N_{PRB} = 2$) for 5 MHz bandwidth,

600 bits (nearest value achievable for $I_{TBS} = 9$ and $N_{PRB} = 4$) for 10, 15 or 20 MHz bandwidth.

RIV indicates either two virtual RBs with index 4 and 5 allocated, or four virtual RBs with index 4 to 7 allocated. These virtual RBs correspond to physical RBs:

with index 1 and 7 in even slots and 13 and 19 in odd slots for 5 MHz bandwidth;

with index 1, 13, 28, 40 in even slots and 28, 40, 1, 13 in odd slots for 10 MHz bandwidth;

with index 1, 17, 49, 65 in even slots and 49, 65, 1, 17 in odd slots for 15 MHz bandwidth;

with index 1, 25, 49, 73 in even slots and 49, 73, 1, 25 in odd slots for 20 MHz bandwidth.

7.3.3.3 Additional rules for RAR specific scheduling scheme

This scheme is applicable for transmission of Random Access Response mapped to DL-SCH, PDCCH scrambled by RA-RNTI. For both DCI combinations four physical resource blocks are reserved. The maximum modulation scheme is restricted to QPSK.

Following additional rules are applied for TBS selection:

- The Max TBS is restricted to 600 bits (nearest value achievable for $I_{TBS} = 9$ and $N_{PRB} = 4$, as per table 7.1.7.2.1-1 of TS 36.213 [30]).
- If the scheduled Data cannot fit into Max TBS, SS generates an error (it's a TTCN error). TTCN should gracefully exit the test case as a fatal error, assigning inconclusive verdict.
- Rules in clause 7.3.3.3.1 for DCI combination 1 and clause 7.3.3.3.2 for DCI combination 2 shall be applied.

7.3.3.3.1 RAR with DCI combination 1

TS 36.213 [30], table 7.1.7.2.1-1, rows with $I_{TBS} = 0..26$ and columns with $N_{PRB} = 2$ (corresponding to TPC LSB = 0) and 3 (corresponding to TPC LSB = 1) $TBS \leq \text{Max TBS}$ are applicable

Distinct TBSs and all (TPC LSB, I_{TBS}) combinations for each distinct TBS are listed in the sheet.

If a TBS can have two (TPC LSB, I_{TBS}) combinations, the combination with TPC LSB = 0 is selected.

RIV indicates 4 PRBs with index 5..8 allocated.

7.3.3.3.2 RAR with DCI combination 2

TS 36.213 [30], table 7.1.7.2.3-1, $I_{TBS} = 0..17$ with $TBS \leq \text{Max TBS}$ are applicable.

RIV indicates 4 virtual RBs are allocated. These corresponds to physical RB

with index 13, 19, 2, 8 in even slots and 1, 7, 14, 20 in odd slots for 5 MHz bandwidth;

with index 2, 14, 29, 41 in even slots and 29, 41, 2, 14 in odd slots for 10 MHz bandwidth;

with index 2, 18, 50, 66 in even slots and 50, 66, 2, 18 in odd slots for 15 MHz bandwidth;

with index 2, 26, 50, 74 in even slots and 50, 74, 2, 26 in odd slots for 20 MHz bandwidth.

7.3.3.4 Additional rules for UE-dedicated scheduling scheme in normal mode

The UE-dedicated DL scheduling can work in the normal mode or in the explicit mode. The two resource allocation schemes shall be reconfigurable from each other when the UE and SS are not sending and receiving data, for instance, at end of the test preamble and before the beginning of the test body.

The present clause is specified for the use of the normal mode. The explicit mode is referred to clause 7.3.3.6.

The scheme specified in the present clause is applicable for transmission of data dedicated to a UE in a DL subframe, mapped to DL-SCH, PDCCH scrambled by C-RNTI/ SPS C-RNTI/ Temp C-RNTI when spatial multiplexing MIMO mode is not configured. The maximum modulation scheme is restricted to 64QAM. For the DCI combination 1, 20 physical resource blocks (5 to 24), and for the DCI combination 2, 17 physical resource blocks are reserved. In the case when three intra frequency cells are applied to the test in the DCI combination 1, for the purpose of interference reduction, only 9 PRBs (16 to 24) are reserved.

In TDD normal TBS selection mode, no data is transmitted in DwPTS of the special subframe. For FDD, data can be transmitted in any subframe, except for half-duplex Type B UEs for which scheduling restrictions are specified in clause 7.26. In addition for BL/CE UEs, only valid subframes, according to *fdd-DownlinkOrTddSubframeBitmapBR* (when configured in the SS), shall be considered as suitable.

The following additional rules are applied for TBS selection:

- Multiple ASPs can also carry same explicit timing information; indicating different ASP payloads, eventually needs to be transmitted in 1 TTI.
- For UE Category $\neq 0$ the Max TBS is restricted to 10296 bits (Max supported by UE category type 1).
- For UE Category = 0 and M1, the Max TBS is restricted to 1000 bits. Hence in all TBS sheets only TB combinations with $TBS_{Size} \leq 1000$ are used.

For 5 MHz bandwidth and the DCI combination 1 with 20 PRBs or DCI combination 2, the TBS 8248, 8760, and 9528 are blocked as they result in coding rates higher than 0.93.

For 5 MHz bandwidth and special DCI combination 1 with 9 PRBs, the TBS 2216, 5992 and 6712 are blocked as they result in coding rates higher than 0.93.

For 10 MHz, 15 MHz and 20 MHz bandwidths none of TBSs are blocked due to coding rates higher than 0.93.

TBS 280 is blocked for all bandwidths as it can be achieved by only $N_{prb} = 1$ and $I_{tbs} = 15$, requiring 64 QAM modulation scheme. This TBS would normally be used for "RACH procedure MSG4+RRCconnectionSetup".

The blocked TBS are considered to be not available for selection.

- Data pending for transmission in a given sub-frame consists of (listed in transmission priority order):
 - MAC Control Elements that the SS needs to send.
 - AMD STATUS PDU(s) that the SS needs to send.
 - Data not sent in previous subframe(s).
 - Fresh Data scheduled for transmission in this subframe for all logical channels.
- Distinct TBSs and all (N_{PRB}, I_{TBS}) combinations for each distinct TBS are listed in the sheet.
- If a TBS size can be achieved with more than one combination of $I_{MCS}(I_{TBS})$ and N_{PRB} :
 - Select combination with lowest delta between N_{PRB} and I_{MCS} .
 - If still more than one combination remain, select combination with highest N_{PRB} .
- Not more than one RLC Data PDU shall be placed in a MAC PDU per logical channel (i.e. minimize RLC segmentation).
- In a subframe, in case there is data pending for transmission from more than one logical channel, for each type of data pending for transmission as defined above, priority shall be given to the logical channel with the lowest logical channel priority value. In case of more than one logical channel with the same logical channel priority value, these logical channels should be served equally. Data pending for transmission from more than one logical channel will rarely happen for the signalling and protocol test.
- Data not transmitted within a subframe is scheduled as pending for transmission in the next available subframe according to the priorities given above. Pending data for transmission will rarely happen for the signalling and protocol test.
- TBS selected in a context by various platforms shall be within an allowed deterministic tolerance of:

- 2 bytes for potential Timing Advance Command MAC Control Element (1 byte data + 1 byte MAC sub header).
- 4 bytes each for AMD STATUS PDU (2 bytes data + 2 bytes MAC subheader).
- Therefore in the worst case the SS may add up to $(2 + 4 \times N_{AMRB})$ bytes to the data scheduled for transmission in a certain subframe, where N_{AMRB} is the number of AM radio bearers (SRB or DRB) actively sending DL data in the test, in any subframe.
- For DCI combination 1 RIV is calculated based on physical resource blocks corresponding to N_{PRB} of the selected TBS and (N_{PRB}, I_{TBS}) combination. The physical resource blocks that can be allocated are the first N_{PRB} resources of index range
 - 5..24 for 5 MHz bandwidth,
 - 28..49 for 10 MHz bandwidth,
 - 9..30 for 15 & 20 MHz bandwidth.
- For DCI combination 2, RBG assignment is calculated based on physical resource blocks corresponding to N_{PRB} of the selected TBS and (N_{PRB}, I_{TBS}) combination. The size of RBG is 2 for 5 MHz, 3 for 10 MHz and 4 for 15 & 20 MHz. The available physical resource blocks for allocation are:
 - For 5 MHz bandwidth, RBG1(2,3), RBG2(4,5), RBG4(8,9), RBG5(10,11), RBG7(14,15), RBG8(16,17), RBG10(20,21), RBG11(22,23) and RBG12(24). If N_{PRB} is even, the first $N_{PRB} / 2$ available RBGs are allocated. If N_{PRB} is odd, then first $(N_{PRB} - 1) / 2$ RBGs and RBG 12 are allocated.
 - For 10 MHz bandwidth, RBG1(3,4,5), RBG2(6,7,8), RBG3(9,10,11), RBG5(15,16,17), RBG6(18,19,20), RBG10(30,31,32), RBG11(33,34,35), RBG12(36,37,38) and RBG16(48,49). If $N_{PRB} \bmod 3$ is 0, the first $N_{PRB} / 3$ RBGs are allocated. If $N_{PRB} \bmod 3$ is 2, then first $(N_{PRB} - 2) / 3$ available RBGs and RBG 16 are allocated.
 - For 15 MHz bandwidth, RBG1(4,5,6,7), RBG2(8,9,10,11), RBG3(12,13,14,15), RBG5(20,21,22,23), RBG6(24,25,26,27), RBG7(28,29,30,31), RBG11(44,45,46,47), RBG13(52,53,54,55), RBG14(56,57,58,59), RBG15(60,61,62,63), RBG17(68,69,70,71), RBG18(72,73,74). If $N_{PRB} \bmod 4$ is 0, the first $N_{PRB} / 4$ RBGs are allocated. If $N_{PRB} \bmod 4$ is 3, then first $(N_{PRB} - 3) / 4$ available RBGs and RBG 18 are allocated.
 - For 20 MHz bandwidth, RBG1(4,5,6,7), RBG2(8,9,10,11), RBG3(12,13,14,15), RBG4(16,17,18,19), RBG5(20,21,22,23), RBG7(28,29,30,31), RBG8(32,33,34,35), RBG9(36,37,38,39), RBG10(40,41,42,43), RBG14(56,57,58,59), RBG15(60,61,62,63), RBG16(64,65,66,67), RBG17(68,69,70,71), RBG19(76,77,78,79) and RBG20(80,81,82,83). The first $N_{PRB} / 4$ RBGs are allocated.

7.3.3.5 DL Resource allocation bitmaps

7.3.3.5.1 DCI combination 1

Table 7.3.3.5.1-1: Physical resource allocation bitmap for DCI combination 1 (5 MHz) with 20 PRBs

N_{PRB}	0	1	2	3	4	5	6	7	8	9	10	11	12	13	14	15	16	17	18	19	20	21	22	23	24	
BCCH																										
PCCH																										
RAR																										
UE-Dedicated																										

Table 7.3.3.5.1-2: Physical resource allocation bitmap for DCI combination 1 (5 MHz) with 9 PRBs

N_{PRB}	0	1	2	3	4	5	6	7	8	9	10	11	12	13	14	15	16	17	18	19	20	21	22	23	24
BCCH	█	█	█	█																					
PCCH					█																				
RAR						█	█	█	█																
UE-Dedicated																		█	█	█	█	█	█	█	█

Table 7.3.3.5.1-3 (columns 0–34): Physical resource allocation bitmap for DCI combination 1 (10 MHz)

N_{PRB}	0	1	2	3	4	5	6	7	8	9..22	23..27						28	29	30	31	32	33	34					
BCCH	█	█	█	█						Not Used	Used for PBCH and other common signals																	
PCCH					█																							
RAR						█	█	█	█																			
UE-Specific																		█	█	█	█	█	█	█				

Table 7.3.3.5.1-3 (columns 35–49): Physical resource allocation bitmap for DCI combination 1 (10 MHz)

N_{PRB}	35	36	37	38	39	40	41	42	43	44	45	46	47	48	49
BCCH															
PCCH															
RAR															
UE-Specific	█	█	█	█	█	█	█	█	█	█	█	█	█	█	█

Table 7.3.3.5.1-3A (columns 0–20): Physical resource allocation bitmap for DCI combination 1 (15 MHz)

N_{PRB}	0	1	2	3	4	5	6	7	8	9	10	11	12	13	14	15	16	17	18	19	20
BCCH	█	█	█	█																	
PCCH					█																
RAR						█	█	█	█												
UE-Specific										█	█	█	█	█	█	█	█	█	█	█	█

Table 7.3.3.5.1-3B (columns 21-74): Physical resource allocation bitmap for DCI combination 1 (15 MHz)

N_{PRB}	21	22	23	24	25	26	27	28	29	30	31..33	34..41			42..74						
BCCH											Not Used	Used for PBCH and other common signals			Not Used						
PCCH																					
RAR																					
UE-Specific	█	█	█	█	█	█	█	█	█	█											

Table 7.3.3.5.1-4 (columns 0–20): Physical resource allocation bitmap for DCI combination 1 (20 MHz)

N_{PRB}	0	1	2	3	4	5	6	7	8	9	10	11	12	13	14	15	16	17	18	19	20
BCCH	█	█	█	█																	
PCCH					█																
RAR						█	█	█	█												
UE-Specific										█	█	█	█	█	█	█	█	█	█	█	█

Table 7.3.3.5.1-5 (columns 21-99): Physical resource allocation bitmap for DCI combination 1 (20 MHz)

N_{PRB}	21	22	23	24	25	26	27	28	29	30	31..46	47..52	53..99
BCCH											Not Used	Used for PBCH and other common signals	Not Used
PCCH													
RAR													
UE-Specific													

7.3.3.5.2 DCI combination 2

Table 7.3.3.5.2-1: Physical resource allocation bitmap for DCI combination 2 (5 MHz)

N_{PRB}	0	1	2	3	4	5	6	7	8	9	10	11	12	13	14	15	16	17	18	19	20	21	22	23	24	
BCCH-Even	0						1						2						3							
BCCH-Odd	2						3						0						1							
PCCH-Even		4						5																		
PCCH-Odd													4							5						
RAR-Even			8						9				6							7						
RAR-Odd		6						7							8						9					
UE-Dedicated																										

Table 7.3.3.5.2-2 (columns 0-20): Physical resource allocation bitmap for DCI combination 2 (10 MHz)

N_{PRB}	0	1	2	3	4	5	6	7	8	9	10	11	12	13	14	15	16	17	18	19	20				
BCCH-Even	0												1												
BCCH-Odd	2												3												
PCCH-Even		4												5											
PCCH-Odd		6												7											
RAR-Even			8													9									
RAR-Odd			10													11									
UE-Specific	x	x												x	x										
RBGs		0					1			2			3		4			5			6				

Table 7.3.3.5.2-2 (columns 21-41): Physical resource allocation bitmap for DCI combination 2 (10 MHz)

N_{PRB}	21	22	23	24	25	26	27	28	29	30	31	32	33	34	35	36	37	38	39	40	41	
BCCH-Even							2												3			
BCCH-Odd							0												1			
PCCH-Even								6													7	
PCCH-Odd								4													5	
RAR-Even									10													11
RAR-Odd									8													9
UE-Specific		x	x	x	x	x	x	x											x	x		
RBGs		7			8			9			10			11			12				13	

Table 7.3.3.5.2-2 (columns 42-49): Physical resource allocation bitmap for DCI combination 2 (10 MHz)

N_{PRB}	42	43	44	45	46	47	48	49
BCCH-Even					Not Used			
BCCH-Odd								
PCCH-Even								
PCCH-Odd								
RAR-Even								
RAR-Odd								
UE-Specific								
RBG's	14			15			16	

Table 7.3.3.5.2-2a (columns 0-19): Physical resource allocation bitmap for DCI combination 2 (15 MHz)

nprb	0	1	2	3	4	5	6	7	8	9	10	11	12	13	14	15	16	17	18	19
BCCH-Even	0																1			
BCCH-Odd	2																3			
PCCH-Even		4																5		
PCCH-Odd		6																	7	
RAR-Even			8																	9
RAR-Odd			10																	11
UE-Specific	x	x															x	x		
RBG's	0			1			2			3			4							

Table 7.3.3.5.2-2a (columns 20-39): Physical resource allocation bitmap for DCI combination 2 (15 MHz)

nprb	20	21	22	23	24	25	26	27	28	29	30	31	32	33	34	35	36	37	38	39
BCCH-Even																				
BCCH-Odd																				
PCCH-Even																				
PCCH-Odd																				
RAR-Even																				
RAR-Odd																				
UE-Specific																				
RBG's	5				6				7				8				9			

Table 7.3.3.5.2-2a (columns 40-59): Physical resource allocation bitmap for DCI combination 2 (15 MHz)

nprb	40	41	42	43	44	45	46	47	48	49	50	51	52	53	54	55	56	57	58	59
BCCH-Even								2												
BCCH-Odd								0												
PCCH-Even										6										
PCCH-Odd										4										
RAR-Even											10									
RAR-Odd											8									
UE-Specific										x	x									

RBG's	10	11	12	13	14
-------	----	----	----	----	----

Table 7.3.3.5.2-2a (columns 60-74): Physical resource allocation bitmap for DCI combination 2 (15 MHz)

nprb	60	61	62	63	64	65	66	67	68	69	70	71	72	73	74
BCCH-Even					3										
BCCH-Odd					1										
PCCH-Even						7									
PCCH-Odd						5									
RAR-Even							11								
RAR-Odd							9								
UE-Specific	x	x	x	x	x	x	x	x	x	x	x	x	x	x	x
RBG's	15				16				17				18		

Table 7.3.3.5.2-3 (columns 0-19): Physical resource allocation bitmap for DCI combination 2 (20 MHz)

N _{PRB}	0	1	2	3	4	5	6	7	8	9	10	11	12	13	14	15	16	17	18	19
BCCH-Even	0																			
BCCH-Odd	2																			
PCCH-Even		4																		
PCCH-Odd		6																		
RAR-Even			8																	
RAR-Odd			10																	
UE-Specific	x	x	x	x	x	x	x	x	x	x	x	x	x	x	x	x	x	x	x	
RBGs	0			1			2			3			4							

Table 7.3.3.5.2-3 (columns 20-39): Physical resource allocation bitmap for DCI combination 2 (20 MHz)

N _{PRB}	20	21	22	23	24	25	26	27	28	29	30	31	32	33	34	35	36	37	38	39
BCCH-Even					1															
BCCH-Odd					3															
PCCH-Even						5														
PCCH-Odd						7														
RAR-Even							9													
RAR-Odd							11													
UE-Specific	x	x	x	x	x	x	x	x	x	x	x	x	x	x	x	x	x	x	x	
RBGs	5				6				7				8				9			

Table 7.3.3.5.2-3 (columns 40-59): Physical resource allocation bitmap for DCI combination 2 (20 MHz)

N _{PRB}	40	41	42	43	44	45	46	47	48	49	50	51	52	53	54	55	56	57	58	59			
BCCH-Even								2															
BCCH-Odd								4															
PCCH-Even										6													
PCCH-Odd										4													
RAR-Even											10												
RAR-Odd											8												
UE-Specific	x	x	x	x	x	x	x	x	x	x	x	x	x	x	x	x	x	x	x				
RBG's	10						11						12						13			14	

Table 7.3.3.5.2-3 (columns 60-79): Physical resource allocation bitmap for DCI combination 2 (20 MHz)

N_{PRB}	60	61	62	63	64	65	66	67	68	69	70	71	72	73	74	75	76	77	78	79
BCCH-Even													3							
BCCH-Odd													1							
PCCH-Even														7						
PCCH-Odd														5						
RAR-Even															11					
RAR-Odd															9					
UE-Specific													x	x						
RBGs	15			16			17			18			19							

Table 7.3.3.5.2-3 (columns 80-99): Physical resource allocation bitmap for DCI combination 2 (20 MHz)

N_{PRB}	80	81	82	83	84	85	86	87	88	89	90	91	92	93	94	95	96	97	98	99
BCCH-Even																	Not Used			
BCCH-Odd																				
PCCH-Even																				
PCCH-Odd																				
RAR-Even																				
RAR-Odd																				
UE-Specific																				
RBGs	20			21			22			23			24							

NOTE: Odd and even refer to slots.

7.3.3.6 UE-dedicated scheduling scheme in explicit mode

This scheme applies to:

1. *spatial multiplexing MIMO* configurations or
2. *transmit diversity MIMO configurations* and non-MIMO configuration where the normal mode scheduling scheme is inappropriate.

SS is configured with an exact TBS (modulation and coding scheme, I_{mcs} , and number of resource blocks, N_{prb}) to use. Other parameters, such as the HARQ process number and redundancy version to use for each transmission, are also configured by the TTCN. SS shall use TBS sheets with matching DCI format and Resource allocation Type. If the parameter 'FirstRbIndex' is configured different than specified in respective TBS sheet, the resource block bit maps in TBS sheet s are shifted by ' FirstRbIndex' and applied, with an exception for Resource allocation type 0 where only the full size 'Resource block groups' are shifted by ' FirstRbIndex'; if the last Resource block group is not full size, and is part of resource block bitmap, it is applied without any shift.

All data scheduled for a certain subframe shall be transmitted in the single indicated subframe, using configured parameters. The TTCN shall ensure that the configured parameters are consistent, in particular that the scheduled data size and the configured TBS match each other. Data scheduled by the prose, and hence also by the TTCN, provides possible space for the Timing Advance MAC control element and the RLC Status PDU. The SS shall include one of these if so triggered, else the bits reserved for these are filled by MAC padding.

Additionally, in the case of MIMO data scheduled for transmission in a given sub-frame, this consists of (listed in transmission priority order):

- MAC Control Elements that the SS needs to send (if triggered).
- AMD STATUS PDU(s) that the SS needs to send (if triggered).
- Fresh data scheduled for transmission in this subframe for one or more logical channels, as per logical channel priority [lower value = higher priority]; if data is available for more than one logical channel with the same priority, then the logical channel corresponding to the DRB-ID with the lower value has the higher priority.
- MAC padding.

The following additional rules need to be applied on data scheduled for transmission to be mapped on two transport blocks corresponding to two code words:

- Higher priority data (as stated above) maps on to Transport Block 1 and lower priority data maps on Transport Block 2 (if Transport Block 1 gets full); and
- Minimum MAC padding is performed in Transport Block 1; and
- If data from one logical channel needs to be mapped on to two transport blocks, the PDCP PDUs with lower PDCP sequence numbers get mapped on to Transport Block 1.

By default no data is scheduled in TDD special subframes (i.e. subframes 1 and 6 for default TDD subframe configuration). For testing DL data reception in TDD special subframe, explicit mode TBS selection shall be used. The TTCN shall ensure that the configured parameters are consistent, in particular that the scheduled data size and the configured TBS match each other. As per TS36.213 [30] clause 7.1.7, for special subframe configuration 9 with normal cyclic prefix or special subframe configuration 7 with extended cyclic prefix, the actual Nprb used for TB size calculation will be a $\max(\text{floor}\{\text{Nprb in DCI command} * 0.375\}, 1)$. Tables 7.3.3.6-1/2 give the mapping for Nprb in DCI command and Nprb used for TB size determination.

Table 7.3.3.6-1: Nprb DCI to Nprb TBS mapping for 20 Mhz

Nprb in DCI command (configured by TTCN)	4	8	12	16	20	24	28	32	36	40	44	48	54	60
Nprb used for TBS determination	1	3	4	6	7	9	10	12	13	15	16	18	20	22

Table 7.3.3.6-2: Nprb DCI to Nprb TBS mapping for 5 Mhz

Nprb in DCI command (configured by TTCN)	4	6	8	12	14	16
Nprb used for TBS determination	1	2	3	4	5	6

7.3.3.6.1 DL Scheduling in Transport Block Size Selection Test Cases

The MAC transport block size selection test cases defined in clause 7.1.7 of TS 36.523-1 [1], use bandwidths of 5/10/15/20MHz. For the preamble and postamble in these tests, the default scheduling rules defined in clauses 7.3.3.1 to 7.3.3.4 for 5/10/15/20 MHz and DCI combination 1A are applied respectively. During the test body, when the actual TB sizes with appropriate DCI and resource allocation formats needed are to be tested, the SS is configured in explicit mode for UE-dedicated scheduling.

7.3.3.7 Resource allocation sheets

Attached with this Technical Specification, the DL resource allocation tables can be found, providing physical resource allocations for various transport block sizes, developed as per rules specified in clause 7.3.3, in Microsoft Excel format. Each individual sheet in the workbook represents various scheduling schemes as per table 7.3.3.7-1.

Table 7.3.3.7-1: DL resource allocation sheets

S. No	Sheet Name	Description
1	DCI-1A-PCCH	DL Resource scheduling for DCI format 1A and PDCCH is scrambled by P-RNTI (5 MHz, 10 MHz, 15 MHz and 20 MHz)
2	DCI-1A-BCCH	DL Resource scheduling for DCI format 1A and PDCCH is scrambled by SI-RNTI (5 MHz, 10 MHz, 15 MHz and 20 MHz)
3	DCI-1A-RAR	DL Resource scheduling for DCI format 1A and PDCCH is scrambled by RA-RNTI (5 MHz, 10 MHz, 15 MHz and 20 MHz)
4	DCI-1A-UE-Specific	DL Resource scheduling for DCI format 1A and PDCCH is scrambled by C-RNTI/ SPS C-RNTI/ Temp C-RNTI (5 MHz)
5	DCI-1A-3-IntraFreq-UE-Specific	DL Resource scheduling for DCI format 1A and PDCCH is scrambled by C-RNTI/ SPS C-RNTI/ Temp C-RNTI and three Intra Freq cells are configured (5 MHz)

S. No	Sheet Name	Description
6	DCI-1A-UE-Specific-10MHz	DL Resource scheduling for DCI format 1A and PDCCH is scrambled by C-RNTI/ SPS C-RNTI/ Temp C-RNTI (10 MHz)
6A	DCI-1A-UE-Specific-15MHz	DL Resource scheduling for DCI format 1A and PDCCH is scrambled by C-RNTI/ SPS C-RNTI/ Temp C-RNTI (15 MHz)
7	DCI-1A-UE-Specific-20MHz	DL Resource scheduling for DCI format 1A and PDCCH is scrambled by C-RNTI/ SPS C-RNTI/ Temp C-RNTI (20 MHz) Also in preamble/postamble phase of MAC TBS test cases with 15 MHz bandwidth configured
8	DCI-1C-PCCH	DL Resource scheduling for DCI format 1C and PDCCH is scrambled by P-RNTI (5 MHz)
9	DCI-1C-BCCH	DL Resource scheduling for DCI format 1C and PDCCH is scrambled by SI-RNTI (5 MHz)
10	DCI-1C-RAR	DL Resource scheduling for DCI format 1C and PDCCH is scrambled by RA-RNTI (5 MHz)
11	DCI-1-UE-Specific	DL Resource scheduling for DCI format 1, Resource allocation 0 and PDCCH is scrambled by C-RNTI/ SPS C-RNTI/ Temp C-RNTI (5 MHz)
12	DCI-1C-PCCH-10MHz-Gap1	DL Resource scheduling for DCI format 1C and PDCCH is scrambled by P-RNTI (10 MHz)
13	DCI-1C-BCCH-10MHz-Gap1	DL Resource scheduling for DCI format 1C and PDCCH is scrambled by SI-RNTI (10 MHz)
14	DCI-1C-RAR-10MHz-Gap1	DL Resource scheduling for DCI format 1C and PDCCH is scrambled by RA-RNTI (10 MHz)
15	DCI-1-UE-Specific-10MHz-Gap1	DL Resource scheduling for DCI format 1, Resource allocation 0 and PDCCH is scrambled by C-RNTI/ SPS C-RNTI/ Temp C-RNTI (10 MHz)
15A	DCI-1C-PCCH-15MHz-Gap1	DL Resource scheduling for DCI format 1C and PDCCH is scrambled by P-RNTI (15 MHz)
15B	DCI-1C-BCCH-15MHz-Gap1	DL Resource scheduling for DCI format 1C and PDCCH is scrambled by SI-RNTI (15 MHz)
15C	DCI-1C-RAR-15MHz-Gap1	DL Resource scheduling for DCI format 1C and PDCCH is scrambled by RA-RNTI (15 MHz)
15D	DCI-1-UE-Specific-15MHz-Gap1	DL Resource scheduling for DCI format 1, Resource allocation 0 and PDCCH is scrambled by C-RNTI/ SPS C-RNTI/ Temp C-RNTI (15 MHz)
16	DCI-1C-PCCH-20MHz-Gap1	DL Resource scheduling for DCI format 1C and PDCCH is scrambled by P-RNTI (20 MHz)
17	DCI-1C-BCCH-20MHz-Gap1	DL Resource scheduling for DCI format 1C and PDCCH is scrambled by SI-RNTI (20 MHz)
18	DCI-1C-RAR-20MHz-Gap1	DL Resource scheduling for DCI format 1C and PDCCH is scrambled by RA-RNTI (20 MHz)
19	DCI-1-UE-Specific-20MHz-Gap1	DL Resource scheduling for DCI format 1, Resource allocation 0 and PDCCH is scrambled by C-RNTI/ SPS C-RNTI/ Temp C-RNTI (20 MHz)
20	DCI-1-RA0-ExplicitConfig	DL Resource scheduling for DCI format 1, Resource allocation 0 and PDCCH is scrambled by C-RNTI
21	DCI-1-RA1-ExplicitConfig	DL Resource scheduling for DCI format 1, Resource allocation 1 and PDCCH is scrambled by C-RNTI
22	DCI1A-ExplicitConfig	DL Resource scheduling for DCI format 1A, Resource allocation 2(localised & distributed) and PDCCH is scrambled by C-RNTI
23	DCI-2A-RA0-ExplicitConfig	DL Resource scheduling for DCI format 2A, Resource allocation 0 and PDCCH is scrambled by C-RNTI
24	DCI-2A-RA1-ExplicitConfig	DL Resource scheduling for DCI format 2A, Resource allocation 1 and PDCCH is scrambled by C-RNTI

7.3.3.8 MPDCCH DL DCI formats

The PRB scheduling is for the PRB's within a selected Narrow Band consisting of 6 resources. Hence all PRB selection is restricted to these 6 PRB's in the 'X' selected narrow band.

7.3.3.8.1 BCCH

There is no MPDCCH transmitted for BCCH hence no DCI format. All six contiguously allocated localized virtual resource blocks within a narrowband are used. The Ibs is configured by RRC.

7.3.3.8.2 PCCH

DCI format 6-2 is used for PCCH scheduling. All six contiguously allocated localized virtual resource blocks within a narrowband are used. The I_{TBS} to TB size mapping is in table 7.3.3.8.2-1 derived from TS 36.213 [30] table 7.1.7.2.3-1. The $I_{TBS} = I_{MCS}$ in the DCI 6-2. The $I_{MCS} = I_{TBS}$ shall be less than or equal to 7.

Table 7.3.3.8.2-1: Transport Block Size (TBS) table for PCCH, DCI 6-2

I_{TBS}	0	1	2	3	4	5	6	7
TBS	40	56	72	120	136	144	176	208

7.3.3.8.3 RAR

7.3.3.8.3.1 RAR with DCI format 6-1A for CE ModeA UE

TS 36.213 [30], table 7.1.7.2.1-1, rows with $I_{TBS} = 0..15$ and columns with $N_{PRB} = 2$ (corresponding to TPC LSB = 0) and 3 (corresponding to TPC LSB = 1) $TBS \leq \text{Max TBS}$ are applicable

Distinct TBSs and all (TPC LSB, I_{TBS}) combinations for each distinct TBS are listed in the sheet.

If a TBS can have two (TPC LSB, I_{TBS}) combinations, the combination with TPC LSB = 0 is selected.

RIV = 18, indicates 4 localised virtual RBs (0,1,2,3) are allocated. These correspond to physical RB (0,1,2,3) in the indicated narrow band. Resource allocation sheet 'DCI-6-1A-RAR' gives the transport block sizes.

RAR length is 7 bytes, 1 byte header and 6 bytes Payload. Needing 1 byte for Back off indicator if included.

Tbsize of 600, allows max upto 10 RAR messages to be sent in one MAC PDU [$8*7*10=560$ bits]

7.3.3.8.3.2 RAR with DCI format 6-1B for CE ModeB UE

TS 36.213 [30], clause 7.1.7.2.6 $I_{MCS}=I_{TBS} = 0..9$.

Resource allocation bit is set to 0 in the indicated narrowband, indicates RBs with PRB index {0, 1, 2, 3} are allocated. The TB sizes are given by table 7.3.3.8.3.2-1.

Table 7.3.3.8.3.2-1: Transport Block Size (TBS) table for RAR, DCI 6-1B

I_{TBS}	0	1	2	3	4	5	6	7	8	9
TBS	88	144	176	208	256	328	392	472	536	616

RAR length is 6 bytes, 1 byte header and 5 bytes Payload. Needing 1 byte for Back off indicator if included.

Max Tbsize of 616, allows max up to 11 RAR messages to be sent in one MAC PDU ($8*7*11=616$ bits).

7.3.3.8.4 UE-dedicated scheduling

7.3.3.8.4.1 UE-dedicated scheduling with DCI format 6-1A for CE ModeA UE

TS 36.213 [30], table 7.1.7.2.3-1, $I_{TBS} = 0..15$ with $TBS \leq \text{Max TBS}=1000$ are applicable. The rules applied are same as clause 7.3.3.4. Resource allocation sheet 'UE-Specific-DCI-6-1A' gives the transport block sizes.

7.3.3.8.4.2 UE-dedicated scheduling with DCI format 6-1B for CE ModeB UE

TS 36.213 [30], clause 7.1.7.2.6 $I_{MCS}=I_{TBS} = 0..9$, Modulation is always QPSK.

Resource allocation bit is set to 0 in the indicated narrowband, indicates RBs with PRB index {0, 1, 2, 3} are allocated and 1 indicates all 6 PRB's are allocated. If a TB size can be achieved by both $n_{PRB}=4$ and 6, then the rules to select TBS combination are same as clause 7.3.3.4. Resource allocation sheet 'UE-Specific-DCI-6-1A' gives the transport block sizes.

7.3.3.9 DL Resource allocation bitmaps for BL/CE UE

7.3.3.9.1 DCI combination 1

For simplicity of scheduling, it is proposed to restrict DCI combination 1 for WB-EUTRA operation in test cases also applicable for BL/CE UE and executed against BL/CE UE.

UE-specific below includes all other transmission C-RNTI/T-CRNTI/P-RNTI/RA-RNTI on PDSCH.

Table 7.3.3.9.1-1: Physical resource allocation bitmap for DCI combination 1 (5 MHz)

N_{PRB}	0	1	2	3	4	5	6	7	8	9-15	16	17	18	19-24	
BCCH										Used for PBCH and other common signals					
SIB1-BR	NB 0														NB 3
SIX-BR	NB 0														
UE-Specific															NB 3
MPDCCH/P-RNTI	NB 0														NB 3
MPDCCH							NB 1								

NOTE: The allocation assumes that SIB1-BR/SIX-BR/SIX are not transmitted in same subframe.

It is unavoidable to use NB 3 for both SIB1-BR and UE-specific. This means that UE-specific transmission cannot be used in (frame number mod 2=0 in even physical layer cell Id and frame number mod 2 =1 in odd physical layer cell Id, subframe =4). NB 1 and 2 need to be avoided so as to avoid central 72 carriers carrying MIB and reduce interference between intra frequency cells.

Table 7.3.3.9.1-2: Narrow band allocation per cell (5 MHz)

Physical cell ID mod 2	SIB1-BR set	SIX-BR	UE-specific	MPDCCH	MPDCCH associated with the P-RNTI
0	NB 0,NB 3	NB 0	NB 3	NB 1	NB 0
1	NB 3,NB 0	NB 0	NB 3	NB 1	NB 3

Table 7.3.3.9.1-3 (columns 0–30): Physical resource allocation bitmap for DCI combination 1 (10 MHz)

N_{PRB}	0	1	2	3	4	5	6	7-12	13-18	19..21	22..27	28-30
BCCH										Not Used	Used for PBCH and other common signals	Not Used
SIB1-BR	NB 0						NB 1	NB 2				
SIX-BR	NB 0											
UE-Specific												
MPDCCH/P-RNTI	NB 0						NB 1	NB 2				
MPDCCH							NB1	NB2				

Table 7.3.3.9.1-3 (columns 31–49): Physical resource allocation bitmap for DCI combination 1 (10 MHz)

N_{PRB}	31-36	37-42	43-48	49
BCCH				Not Used
SIB1-BR	NB 5	NB 6	NB 7	
SIX-BR				
UE-Specific		NB 6	NB 7	
MPDCCH/P-RNTI	NB 5	NB 6	NB 7	
MPDCCH				

Table 7.3.3.9.1-4: Narrow band allocation per cell (10 MHz)

Physical cell ID mod 6	SIB1-BR set	Six-BR	UE-specific	MPDCCH	MPDCCH associated with the P-RNTI
0	NB 0,NB 5	NB 0	NB 6	NB 1	NB 0
1	NB 1,NB 6	NB 0	NB 7	NB 2	NB 1
2	NB 2,NB 7	NB 0	NB 6	NB 1	NB 2
3	NB 5,NB 0	NB 0	NB 6	NB 1	NB 5
4	NB 6,NB 1	NB 0	NB 7	NB 2	NB 6
5	NB 7,NB 2	NB 0	NB 6	NB 1	NB 7

NOTE 1: The allocation assumes that SIB1-BR/Six-BR and SIB1-BR/Six are not transmitted in same subframe.

NOTE 2: The setting of NBs does not consider the case of bandwidth 10MHz for TDD.

Table 7.3.3.9.1-5 (columns 0–43): Physical resource allocation bitmap for DCI combination 1 (20 MHz)

N_{PRB}	0	1	2	3	4	5	6	7	8-13	14-19	20-25	26-31	32-37	38-43
BCCH														
SIB1-BR			NB 0						NB 1	NB 2	NB 3	NB 4	NB 5	NB 6
Six-BR									NB 1					
UE-Specific														
MPDCCH/P-RNTI			NB 0						NB 1	NB 2	NB 3	NB 4	NB 5	NB 6

Table 7.3.3.9.1-5 (columns 44-99): Physical resource allocation bitmap for DCI combination 1 (20 MHz)

N_{PRB}	44-46	47..52	53-54	56-61	62-67	68-73	64-79	80-85	86-91	92-97	98..99
BCCH	Not Used	Used for PBCH and other common signals	Not Used								Not Used
SIB1-BR				NB 9	NB 10	NB11	NB 12	NB 13	NB14	NB 15	
Six-BR											
UE-Specific									NB 14		
MPDCCH/P-RNTI				NB 9	NB 10	NB11	NB 12	NB 13	NB 14	NB 15	
MPDCCH	NB 7										

Table 7.3.3.9.1-6: Narrow band allocation per cell (20 MHz)

Physical cell ID mod 14	SIB1-BR set	Six-BR	UE-specific	MPDCCH	MPDCCH associated with the P-RNTI
0	NB 0, NB 3, NB 6, NB 11	NB 1	NB 14	NB 7	NB 0
1	NB 1, NB 4, NB 9, NB 12	NB 1	NB 14	NB 7	NB 1
2	NB 2, NB 5, NB 10, NB 13	NB 1	NB 14	NB 7	NB 2
3	NB 3, NB 6, NB 11, NB 14	NB 1	NB 15	NB 7	NB 3
4	NB 4,NB 9, NB 12, NB 15	NB 1	NB 14	NB 7	NB 4
5	NB 5, NB 10, NB 13, NB 0	NB 1	NB 14	NB 7	NB 5
6	NB 6, NB 11, NB 14, NB 1	NB 1	NB 15	NB 7	NB 6
7	NB 9, NB 12, NB 15, NB 2	NB 1	NB 14	NB 7	NB 9
8	NB 10, NB13, NB 0, NB 3	NB 1	NB 14	NB 7	NB 10
9	NB 11, NB 14, NB 1, NB 4	NB 1	NB 15	NB 7	NB 11
10	NB 12, NB 15, NB 2, NB 5	NB 1	NB 14	NB 7	NB 12
11	NB 13, NB 0, NB 3, NB 6	NB 1	NB 14	NB 7	NB 13
12	NB 14, NB 1, NB 4, NB 9	NB 1	NB 15	NB 7	NB 14
13	NB 15, NB 2, NB 5, NB 10	NB 1	NB 14	NB 7	NB 15

NOTE: The allocation assumes that SIB1-BR/Six and SIB1-BR/Six-BR are not transmitted in same subframe.

7.4 Cell Configurations

7.4.1 Cell Configuration Types

Three cell configurations are defined in TS 36.508 [3] clause 6.3.3: Full Cell, Minimum Uplink Cell and Broadcast Only Cell; however the TTCN always considers all cells as Full Cells, and thus always provides the complete cell configuration parameters.

The SS may:

- always configure a cell as a 'Full Cell' based on the complete information; or
- configure the cell based on the 'CellConfig_Type' flag taking only the required configuration parameters and ignoring the others.

For a given value of the 'CellConfig_Type' flag, the TTCN shall:

- For Full Cell Configuration:
 - expect normal SS behaviour.
- For Minimum Uplink Cell Configuration:
 - Configure the SS to report Preamble detection.
 - Assign verdicts based on the PRACH Preamble Indications.
 - Consume any uplink SRB0 messages (if the SS is configured as a Full Cell).
- For Broadcast Only Cell Configuration:
 - Not configure the SS to report Preamble detection.
 - Consume any uplink SRB0 messages (if the SS is configured as a Full Cell).

7.4.2 Cell Power Change

To set and adjust the cell power at the two test ports, Reference Power and Attenuation, are provided in the record Reference Power.

The field Reference Power is only set when the cell is created and is not updated during the test case execution. The SS applies the Reference Power when the cell is fully configured.

To adjust the power level in the test case, the field Attenuation is used. After initial configuration of a cell the attenuation corresponds to the value "off". When the power is changed for more than one cell, the power changes must happen at the same time for all the cells according to the time instances for power level changes specified in TS 36.523-1 [1]. The time it takes to complete the power change for all the cells shall be done:

- within a maximum of 700 ms when changing the power of a cell from "off" to a certain value; or
- within a maximum of 100 ms (10 frames) otherwise.

The SS shall ensure the power level at the test ports conform to the required downlink signal levels specified in clause 6.2.2.1 of TS 36.508 [3].

7.4.3 E-UTRAN cell identity

7.4.3.1 Timing parameters of cells

For RRC and Idle mode test, the timing parameters in table 7.4.3.1-1 are applied. The specification of Cell 1 - Cell 30 can be found in TS 36.508 [3].

Table 7.4.3.1-1: Timing parameters of simulated cells

cell ID	SFN offset	FDD Tcell (Ts)	TDD Tcell (Ts)	
			Synchronous	Non synchronous
Cell 1	0	0	0	0
Cell 2	124	30720	154	30720
Cell 3	257	150897	77	150897
Cell 4	1000	61440	307	61440
Cell 6	657	524	77	524
Cell 10	129	43658	77	43658
Cell 11	957	92160	154	92160
Cell 12	1015	181617	154	181617
Cell 13	890	31244	154	31244
Cell 14	680	300501	77	300501
Cell 23	383	212337	154	212337
Cell 28	890	31244	154	31244
Cell 29	680	300501	77	300501
Cell 30	1015	181617	154	181617

NOTE: For TDD, synchronous Tcell values are applied unless specified otherwise in the test cases.

Table 7.4.3.1-2 is applied to the NAS test when more than one PLMN exists in a test case. Further cell parameters can be found in TS 36.508 [3], table 6.3.2.2-3.

Table 7.4.3.1-2: Timing parameters of simulated cells for NAS TCs in different PLMNs

cell ID	SFN offset	FDD Tcell (Ts)	TDD Tcell (Ts)	
			Synchronous	Non synchronous
Cell A	0	0	0	0
Cell B	124	30720	154	30720
Cell C	257	61440	307	61440
Cell D	1000	92160	154	92160
Cell E	752	32047	77	32047
Cell F	NA	NA	NA	NA
Cell G	957	631	77	631
Cell H	1015	31351	154	31351
Cell I	890	127200	77	127200
Cell J	680	1327	77	1327
Cell K	383	157920	154	157920
Cell L	562	188640	307	188640
Cell M	471	122880	307	122880

NOTE: For TDD, synchronous Tcell values are applied unless specified otherwise in the test cases.

Figure 7.4.3.1-3 illustrates shifting DL transmission timing offset by Tcell = 1 subframe, between multiple NAS FDD cells on the same frequency (table 7.4.3.1-4) in the same PLMN.

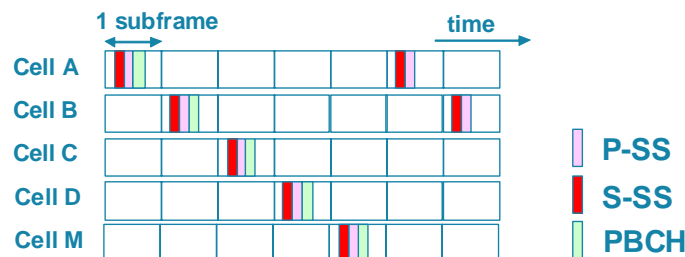

Figure 7.4.3.1-3: Timing offset between FDD cells on the same frequency

Table 7.4.3.1-4 is applied to the NAS test when all NAS cells in a test case belong to the same PLMN. Further cell parameters can be found in TS 36.508 [3], table 6.3.2.2-2.

Table 7.4.3.1-4: Timing parameters of simulated cells for NAS TCs in same PLMN

cell ID	SFN offset	FDD Tcell (Ts)	TDD Tcell (Ts)	
			Synchronous	Non synchronous
Cell A	0	0	0	0
Cell B	124	30720	154	30720
Cell C	257	150897	77	150897
Cell D	1000	61440	307	61440
Cell E	NA	NA	NA	NA
Cell F	NA	NA	NA	NA
Cell G	NA	NA	NA	NA
Cell H	NA	NA	NA	NA
Cell I	NA	NA	NA	NA
Cell J	NA	NA	NA	NA
Cell K	NA	NA	NA	NA
Cell L	NA	NA	NA	NA
Cell M	471	31244	154	31244

NOTE: For TDD, synchronous Tcell values are applied unless specified otherwise in the test cases.

Shifting radio frame transmission timing can eliminate the following interference between intra frequency cells:

- P-SS/S-SS to P-SS/S-SS, RS, PBCH, PCFICH, PDCCH and PHICH.
- PBCH to PBCH.
- PBCH to PCFICH, PDCCH and PHICH.
- PDSCH to PCFICH, PDCCH, PHICH.

As TDD UL and DL are on same frequency, to avoid interference between DL and UL, the Random Access Response Timing Advance (RAR TA) is related to the Tcell:

For TDD cells:

$$\text{RAR TA} = [\text{FLOOR} ((\text{Tcell}) \bmod 30720 / 16)] \bmod 1282$$

For FDD, the Random Access Response Timing Advance is set to 0.

In MBMS test cases, cells belonging to the same MBSFN Area have a synchronized radio frame timing: the SFN offset and Tcell values are set to the values of the cell having the lower cellId value.

In Carrier Aggregation signalling test cases, the SFN offset and Tcell of configured cells has to be same.

Editor's note: More clarification in terms of tables representing configured cells may be needed. Cell 1, Cell 2, Cell3, Cell12 & Cell 6 are configured in CA test cases.

The HFSN Offset shall be set to 0 for all cells.

7.4.4 Cell configurations for NAS test cases

The default cell identifiers for NAS cells are defined in 36.508 [3] clause 6.3.2.2.

The allocation of Physical layer cell identifiers to the individual cells is according to (*PCI mode 6*) being differential for the cells working on the same radio frequency. The way of PCI allocation can reduce the interference between the intra-frequency cells for reference signal to reference signal, PCFICH to PCFICH and PHICH to PHICH. The definition of Cell A - Cell M can be found in TS 36.508 [3].

7.4.5 Configuration of Multi-Cell Environment

When there is more than one EUTRA cell in a test case the following rules are applied in TTCN:

- At the beginning of the preamble, before initial attachment of the UE, all EUTRA cells are configured but switched off.
- In the preamble only the serving cell is switched on; all other cells remain switched off.
- At the end of the preamble the cells are configured according to the initial power level settings (T0) of the test case.

The mapping of cells to physical resources and management of the physical resources are out of TTCN scope. The following principles can be applied to the system simulator:

- Cells being switched off need not to be mapped to physical resources.
- When a cell is switched off mapping to a physical resource may be kept and reused when the cell is switched on again.
- When a cell is switched on it can either already been mapped to a physical resource or it needs to be mapped to a free resource.
- When there are less physical resources than cells it is up to SS implementation to find strategies to dynamically map the cells to the resources.

Independent from the strategies being used the system simulator shall obey timing restrictions for changing power-levels of one or several cells as stated in clause 7.4.2.

7.5 TDD Considerations

LTE options of FDD and TDD will be contained in the same common FDD and TDD test cases, similar to the prose in TS 36.523-1 [1].

The TDD Uplink-downlink configuration 1 in 3GPP TS 36.211 [35], table 4.2-2 is applied.

7.5.1 FDD vs. TDD implementation

FDD/TDD differences are introduced in the common FDD and TDD test cases using branches at a low level in the test case. The branches are used either:

- to assign a variable;
- to implement a different behaviour;
- to change an FDD or TDD parameter in a template sent to the UE or SS.

The mode under test (FDD or TDD) is based on the value of the bands under test.

7.5.2 Guideline for FDD vs. TDD verification

With respect to EUTRA FDD vs. TDD technologies, it is recommended that separate verifications for FDD and TDD are required for the TCs in TS 36.523-1 [1]:

- clause 6, 7, 8, 12, 13;
- with MultiRAT involved.

7.6 Special RLC Modes

7.6.1 Suppression of RLC Acknowledgements

Two different modes, both applicable per radio bearer, are defined as:

- General suppression:
 - If this mode is activated, no RLC acknowledgements will be generated by the SS. This mode can be switched on and will persist until it is switched off. Afterwards the SS will continue handling the RLC acknowledgements as normal.
- One time suppression:
 - If this mode is activated, no RLC acknowledgement will be generated by SS for the next RLC message data PDU received. Once this has been done, the SS continues handling RLC acknowledgements as normal.

In case of a handover the modes continue to be active.

7.6.2 Modification of VT(S)

This mode allows to manipulate the RLC state variable VT(S) so that the SS can generate an RLC sequence number as needed during a test. The input to the special test mode is an integer (0..1023) as value of ModifyVTS, The SS shall set variable VT(S) as follows:

$$VT(S) := \text{ModifyVTS.}$$

The purpose of this special test mode is to force an incorrect RLC sequence number to be used by the SS. Once VT(S) has been modified in the RLC entity at the SS side, this RLC entity will be inconsistent. One possibility to bring the RLC entity back to normal is to re-establish the RLC peer connection. This is done in the only use case of this special RLC test mode by performing an RRC Connection reconfiguration immediately after the test mode has been applied.

Users of this test mode should ensure that the RLC AM PDU carrying the incorrect sequence number will reach the peer RLC entity. It is therefore recommended to activate the RRC Connection reconfiguration only after some delay. This delay shall be short enough to ensure that the UE will not yet request the retransmission of the RLC PDU corresponding to the skipped sequence numbers.

7.7 System information

7.7.1 System information broadcasting

The rules for the transmission of BCCH messages are specified in TS 36.331 [19], clause 5.2. The current clause provides the implementation guidelines.

The ASPs SYSTEM_CTRL_REQ and SYSTEM_CTRL_CNF are used as interface to SS; the following rules apply:

- The complete system information is provided to SS by using a single ASP.
- SS starts scheduling all system information from the same SFN.
- The scheduling information sent to SS is the same as the scheduling information sent to the UE. For each SI message, the subframeOffset in SYSTEM_CTRL_REQ indicates the exact point in time in the SI window at which SS shall start the transmission of the related SI.
- SS shall set the systemFrameNumber in the MIB to the 8 most significant bits of the SFN. A dummy value is provided by TTCN.
- If the HFSN value is included in SIB1 sent from the TTCN, the SS shall set the hyperSFN in this message to the current HSFN. In this case, a dummy value is provided by TTCN.
- If the HFSN is not included in the SIB1 sent from the TTCN, it shall not be added by the SS.

- The system information is sent to SS using the asn.1 types, SS shall encode in unaligned PER and add the necessary padding bits as specified in TS 36.331 [19], clause 9.1.1.1.
- In the E-UTRAN-CDMA2000 Inter RAT configuration, SS shall set the CDMA2000 synchronousSystemTime in SystemInformationBlockType8 to the SFN boundary at or after the ending boundary of the SI-window in which SystemInformationBlockType8 is transmitted (see TS 36.331 [19], clause 6.3.4). The changes of synchronousSystemTime will not result in system information change notification, nor in a modification of systemInfoValueTag in SIB1 in TTCN as specified in TS 36.331 [19], clause 6.3.1. If 1xRTT is being tested, then SS shall overwrite the longCodeState1XRTT in SystemInformationBlockType8 to the state of long code generation registers in CDMA2000 1xRTT system as defined in C.S0002-A [12, Section 1.3] at $\lceil t/10 \rceil \times 10 + 320$ ms, where t equals to the *cdma-SystemTime*. The changes of longCodeState1XRTT will not result in system information change notification, nor in a modification of systemInfoValueTag in SIB1 in TTCN as specified in TS 36.331 [19], clause 6.3.1.

7.7.2 Scheduling information

The maximum number of resource blocks as defined in table 7.7.2-1 are used to broadcast the system information.

Table 7.7.2-1: Maximum number of resource blocks

	Maximum number of resource blocks assigned
SIB1	4
for all SIs	4

The subframe offset values used for SI messages are according to table 7.7.2-2.

Table 7.7.2-2: SubframeOffset values

Scheduling Information No. Acc to TS 36.508 [3], clause 4.4.3.1.2	subframeOffset (FDD)	subframeOffset (TDD)
SI1	1	0
SI2	1	0
SI3	3	15
SI4	7	15
SI5	7	15

All System Information messages are sent only once within the SI-window.

Table 7.7.2-3 (FDD) and 7.7.2-4(TDD) give the SFN's and subframe numbers in which the MIB, SI1, SI2, SI3, SI4 & SI5 are actually scheduled as per default parameters for si-WindowLength(20sf), periodicity for SI1(16), SI2(32), SI3(64) , SI4(64) and SI5(64) for bandwidths 5/10/15/20 MHz defined in TS 36.508 [3]:

Table 7.7.2-3: System Information Scheduling (FDD)

SFN\SubFrame	0	1	2	3	4	5	6	7	8	9
0	MIB	SI1				SIB1				
1	MIB									
2	MIB	SI2				SIB1				
3	MIB									
4	MIB			SI3		SIB1				
5	MIB									
6	MIB					SIB1		SI4		
7	MIB									
8	MIB					SIB1		SI5		
9	MIB									
10	MIB					SIB1				
11	MIB									
12	MIB					SIB1				
13	MIB									
14	MIB					SIB1				
15	MIB									

SFNSubFrame	0	1	2	3	4	5	6	7	8	9
16	MIB	SI1				SIB1				
17	MIB									
18	MIB					SIB1				
19	MIB									
20	MIB					SIB1				
21	MIB									
22	MIB					SIB1				
23	MIB									
24	MIB					SIB1				
25	MIB									
26	MIB					SIB1				
27	MIB									
28	MIB					SIB1				
29	MIB									
30	MIB					SIB1				
31	MIB									
32	MIB	SI1				SIB1				
33	MIB									
34	MIB	SI2				SIB1				
35	MIB									
36	MIB					SIB1				
37	MIB									
38	MIB					SIB1				
39	MIB									
40	MIB					SIB1				
41	MIB									
42	MIB					SIB1				
43	MIB									
44	MIB					SIB1				
45	MIB									
46	MIB					SIB1				
47	MIB									
48	MIB	SI1				SIB1				
49	MIB									
50	MIB					SIB1				
51	MIB									
52	MIB					SIB1				
53	MIB									
54	MIB					SIB1				
55	MIB									
56	MIB					SIB1				
57	MIB									
58	MIB					SIB1				
59	MIB									
60	MIB					SIB1				
61	MIB									
62	MIB					SIB1				
63	MIB									
64	MIB	SI1				SIB1				
65	MIB									
66	MIB	SI2				SIB1				
67	MIB									
68	MIB			SI3		SIB1				
69	MIB									
70	MIB					SIB1		SI4		
71	MIB									
72	MIB					SIB1		SI5		

Table 7.7.2-4: System Information Scheduling (TDD)

SFNSubFrame	0	1	2	3	4	5	6	7	8	9
0	MIB, SI1					SIB1				
1	MIB									

SFN/SubFrame	0	1	2	3	4	5	6	7	8	9
2	MIB, SI2					SIB1				
3	MIB									
4	MIB					SIB1				
5	MIB					SI3				
6	MIB					SIB1				
7	MIB					SI4				
8	MIB					SIB1				
9	MIB					SI5				
10	MIB					SIB1				
11	MIB									
12	MIB					SIB1				
13	MIB									
14	MIB					SIB1				
15	MIB									
16	MIB, SI1					SIB1				
17	MIB									
18	MIB					SIB1				
19	MIB									
20	MIB					SIB1				
21	MIB									
22	MIB					SIB1				
23	MIB									
24	MIB					SIB1				
25	MIB									
26	MIB					SIB1				
27	MIB									
28	MIB					SIB1				
29	MIB									
30	MIB					SIB1				
31	MIB									
32	MIB, SI1					SIB1				
33	MIB									
34	MIB, SI2					SIB1				
35	MIB									
36	MIB					SIB1				
37	MIB									
38	MIB					SIB1				
39	MIB									
40	MIB					SIB1				
41	MIB									
42	MIB					SIB1				
43	MIB									
44	MIB					SIB1				
45	MIB									
46	MIB					SIB1				
47	MIB									
48	MIB, SI1					SIB1				
49	MIB									
50	MIB					SIB1				
51	MIB									
52	MIB					SIB1				
53	MIB									
54	MIB					SIB1				
55	MIB									
56	MIB					SIB1				
57	MIB									
58	MIB					SIB1				
59	MIB									
60	MIB					SIB1				
61	MIB									
62	MIB					SIB1				
63	MIB									
64	MIB, SI1					SIB1				
65	MIB									

SFN\SubFrame	0	1	2	3	4	5	6	7	8	9
66	MIB, SI2					SIB1				
67	MIB									
68	MIB					SIB1				
69	MIB					SI3				
70	MIB					SIB1				
71	MIB					SI4				
72	MIB					SIB1				
73	MIB					SI5				

NOTE: Subframes 4 and 9 are avoided so as to facilitate availability of PDCCHs in the UE specific search space for transmission of PDCCH for both UL C-RNTI/SPS-RNTI and DL C-RNTI/SPS-RNTI/Temp C-RNTI.

7.7.2a Scheduling information for BR System information

The scheduling of BR System Information is based upon the following conditions (Ref: 36.211 [44] clause 6.4.1):

- $N_{\text{PDSCH}}^{\text{SIB1-BR}} = 4$ i.e. the schedulingInfoSIB1-BR-r13 values are selected from {1,4,7,10,13,16} which as per 36.213[30] table 7.1.6-1 would result in 4 repetitions.
- si-WindowLength-BR-r13 = 20 ms (same value as si-WindowLength)
- si-RepetitionPattern-r13 = every2ndRF (hence results eventually in only transmission in first frame of window)
- Except for SIB1-BR (mandated for SIB1-BR by 36.211) hopping is assumed to be not enabled for anything else.
- The current test plan excludes inter frequency and inter rat test cases due to limitations in RAN4. Inter frequency, inter RAT system information combinations are not considered.
- The typical size of SIB1/2/3/4 is less than 700 bits, the Max TB size for SIx-BR is 936 bits, 36.213 [30] table 7.1.7.2.7-1, hence no segmentation is assumed. For SIB1-BR schedulingInfoSIB1-BR-r13 = 10, and for SIB 2,3,4 the si-TBS-r13 is set as b712.
- If MIB needs to be repeated as per 36.331[19] clause 5.2.1.2 in subframe#9 of the previous radio frame for FDD and sub frame #5 of the same radio frame for TDD, the same can be achieved in the below schedule.
- System information broadcasting rules defined in clause 7.7.1 apply with the exception that SIB1 is replaced with SIB1 & SIB1-BR and SI is replaced with SI & SI-BR.

The sub frame offset values used for SI messages are according to table 7.7.2a-1.

Table 7.7.2a-1: SubframeOffset values

Scheduling Information No. Acc to TS 36.508 [3], clause 4.4.3.1.2	subframeOffset (FDD)	subframeOffset (TDD DL bandwidth > 5 MHz)	subframeOffset (TDD DL bandwidth = 5 MHz)
SI1	1	0	10
SI2	1	0	10
SI3	3	0	10
SI4	3	0	10
SI1-BR	0	0	0
SI2-BR	0	0	0
SI3-BR	0	0	0
SI4-BR	0	0	0

NOTE: The subframe offsets for SIx/SIx-BR of 0 and 10 are suitable for all TDD uplink-downlink configurations.

The following tables give the SFN and subframe numbers in which MIB, SIs and SI-BRs are actually scheduled as per default parameters defined in TS 36.508 [3] for:

Table 7.7.2a-2 for FDD with even physical layer cell IDs

Table 7.7.2a-4 for FDD with odd physical layer cell IDs

Table 7.7.2a -3 for TDD for DL bandwidth > 5 MHz and even physical layer cell Id

Table 7.7.2a-5 for TDD for DL bandwidth > 5 MHz and odd physical layer cell Id

Table 7.7.2a-6 for TDD for DL bandwidth = 5 MHz.

Table 7.7.2a-2: BR System Information Scheduling (FDD) for even physical layer cell

$$IDs_{[N_{ID}^{cell} \bmod 2 = 0]}$$

SFN/SubFrame	0	1	2	3	4	5	6	7	8	9
0	MIB SI1-BR	SI1			SIB1-BR	SIB1				
1	MIB									
2	MIB SI2-BR	SI2			SIB1-BR	SIB1				
3	MIB									
4	MIB SI3-BR			SI3	SIB1-BR	SIB1				
5	MIB									
6	MIB SI4-BR			SI4	SIB1-BR	SIB1				
7	MIB									
8	MIB				SIB1-BR	SIB1				
9	MIB									
10	MIB				SIB1-BR	SIB1				
11	MIB									
12	MIB				SIB1-BR	SIB1				
13	MIB									
14	MIB				SIB1-BR	SIB1				
15	MIB									
16	MIB SI1-BR	SI1			SIB1-BR	SIB1				
17	MIB									
18	MIB				SIB1-BR	SIB1				
19	MIB									
20	MIB				SIB1-BR	SIB1				
21	MIB									
22	MIB				SIB1-BR	SIB1				
23	MIB									
24	MIB				SIB1-BR	SIB1				
25	MIB									
26	MIB				SIB1-BR	SIB1				
27	MIB									
28	MIB				SIB1-BR	SIB1				
29	MIB									
30	MIB				SIB1-BR	SIB1				
31	MIB									
32	MIB SI1-BR	SI1			SIB1-BR	SIB1				
33	MIB									
34	MIB SI2-BR	SI2			SIB1-BR	SIB1				
35	MIB									
36	MIB				SIB1-BR	SIB1				
37	MIB									
38	MIB				SIB1-BR	SIB1				
39	MIB									
40	MIB				SIB1-BR	SIB1				
41	MIB									
42	MIB				SIB1-BR	SIB1				
43	MIB									
44	MIB				SIB1-BR	SIB1				
45	MIB									
46	MIB				SIB1-BR	SIB1				
47	MIB									
48	MIB SI1-BR	SI1			SIB1-BR	SIB1				
49	MIB									
50	MIB				SIB1-BR	SIB1				
51	MIB									
52	MIB				SIB1-BR	SIB1				

SFNSubFrame	0	1	2	3	4	5	6	7	8	9
53	MIB									
54	MIB				SIB1-BR	SIB1				
55	MIB									
56	MIB				SIB1-BR	SIB1				
57	MIB									
58	MIB				SIB1-BR	SIB1				
59	MIB									
60	MIB				SIB1-BR	SIB1				
61	MIB									
62	MIB				SIB1-BR	SIB1				
63	MIB									
64	MIB SI1-BR	SI1			SIB1-BR	SIB1				
65	MIB									
66	MIB SI2-BR	SI2			SIB1-BR	SIB1				
67	MIB									
68	MIB SI3-BR			SI3	SIB1-BR	SIB1				
69	MIB									
70	MIB SI4-BR			SI4	SIB1-BR	SIB1				
71	MIB									
72	MIB				SIB1-BR	SIB1				

Table 7.7.2a-3: BR System Information Scheduling (TDD) for DL bandwidth > 5 MHz [$N_{RB}^{DL} > 15$] and even physical layer cell Id [$N_{ID}^{cell} \bmod 2 = 0$]

SFN\SubFrame	0	1	2	3	4	5	6	7	8	9
0	MIB, SI1, SI1-BR					SIB1				
1	MIB					SIB1-BR				
2	MIB, SI2, SI2-BR					SIB1				
3	MIB					SIB1-BR				
4	MIB, SI3, SI3-BR					SIB1				
5	MIB					SIB1-BR				
6	MIB, SI4, SI4-BR					SIB1				
7	MIB					SIB1-BR				
8	MIB					SIB1				
9	MIB					SIB1-BR				
10	MIB					SIB1				
11	MIB					SIB1-BR				
12	MIB					SIB1				
13	MIB					SIB1-BR				
14	MIB					SIB1				
15	MIB					SIB1-BR				
16	MIB, SI1, SI1-BR					SIB1				
17	MIB					SIB1-BR				
18	MIB					SIB1				
19	MIB					SIB1-BR				
20	MIB					SIB1				
21	MIB					SIB1-BR				
22	MIB					SIB1				
23	MIB					SIB1-BR				
24	MIB					SIB1				
25	MIB					SIB1-BR				
26	MIB					SIB1				
27	MIB					SIB1-BR				
28	MIB					SIB1				
29	MIB					SIB1-BR				
30	MIB					SIB1				
31	MIB					SIB1-BR				
32	MIB, SI1, SI1-BR					SIB1				
33	MIB					SIB1-BR				
34	MIB, SI2, SI2-BR					SIB1				
35	MIB					SIB1-BR				
36	MIB					SIB1				
37	MIB					SIB1-BR				
38	MIB					SIB1				
39	MIB					SIB1-BR				
40	MIB					SIB1				
41	MIB					SIB1-BR				
42	MIB					SIB1				
43	MIB					SIB1-BR				
44	MIB					SIB1				
45	MIB					SIB1-BR				
46	MIB					SIB1				
47	MIB					SIB1-BR				
48	MIB, SI1, SI1-BR					SIB1				
49	MIB					SIB1-BR				
50	MIB					SIB1				
51	MIB					SIB1-BR				
52	MIB					SIB1				

SFN/SubFrame	0	1	2	3	4	5	6	7	8	9
53	MIB					SIB1-BR				
54	MIB					SIB1				
55	MIB					SIB1-BR				
56	MIB					SIB1				
57	MIB					SIB1-BR				
58	MIB					SIB1				
59	MIB					SIB1-BR				
60	MIB					SIB1				
61	MIB					SIB1-BR				
62	MIB					SIB1				
63	MIB					SIB1-BR				
64	MIB, SI1, SI1-BR					SIB1				
65	MIB					SIB1-BR				
66	MIB, SI2, SI2-BR					SIB1				
67	MIB					SIB1-BR				
68	MIB, SI3, SI3-BR					SIB1				
69	MIB					SIB1-BR				
70	MIB, SI4, SI4-BR					SIB1				
71	MIB					SIB1-BR				
72	MIB					SIB1				
73	MIB					SIB1-BR				

Table 7.7.2a-4: BR System Information Scheduling (FDD) for odd physical layer cell IDs[$N_{ID}^{cell} \bmod 2 = 1$]

SFNSubFrame	0	1	2	3	4	5	6	7	8	9
0	MIB SI1-BR	SI1				SIB1				
1	MIB				SIB1-BR					
2	MIB SI2-BR	SI2				SIB1				
3	MIB				SIB1-BR					
4	MIB SI3-BR			SI3		SIB1				
5	MIB				SIB1-BR					
6	MIB SI4-BR			SI4		SIB1				
7	MIB				SIB1-BR					
8	MIB					SIB1				
9	MIB				SIB1-BR					
10	MIB					SIB1				
11	MIB				SIB1-BR					
12	MIB					SIB1				
13	MIB				SIB1-BR					
14	MIB					SIB1				
15	MIB				SIB1-BR					
16	MIB SI1-BR	SI1				SIB1				
17	MIB				SIB1-BR					
18	MIB					SIB1				
19	MIB				SIB1-BR					
20	MIB					SIB1				
21	MIB				SIB1-BR					
22	MIB					SIB1				
23	MIB				SIB1-BR					
24	MIB					SIB1				
25	MIB				SIB1-BR					
26	MIB					SIB1				
27	MIB				SIB1-BR					
28	MIB					SIB1				
29	MIB				SIB1-BR					
30	MIB					SIB1				
31	MIB				SIB1-BR					
32	MIB SI1-BR	SI1				SIB1				
33	MIB				SIB1-BR					
34	MIB SI2-BR	SI2				SIB1				
35	MIB				SIB1-BR					
36	MIB					SIB1				
37	MIB				SIB1-BR					
38	MIB					SIB1				
39	MIB				SIB1-BR					
40	MIB					SIB1				
41	MIB				SIB1-BR					
42	MIB					SIB1				
43	MIB				SIB1-BR					
44	MIB					SIB1				
45	MIB				SIB1-BR					
46	MIB					SIB1				
47	MIB				SIB1-BR					
48	MIB SI1-BR	SI1				SIB1				
49	MIB				SIB1-BR					
50	MIB					SIB1				
51	MIB				SIB1-BR					
52	MIB					SIB1				
53	MIB				SIB1-BR					

SFNSubFrame	0	1	2	3	4	5	6	7	8	9
54	MIB					SIB1				
55	MIB				SIB1-BR					
56	MIB					SIB1				
57	MIB				SIB1-BR					
58	MIB					SIB1				
59	MIB				SIB1-BR					
60	MIB					SIB1				
61	MIB				SIB1-BR					
62	MIB					SIB1				
63	MIB				SIB1-BR					
64	MIB SI1-BR	SI1				SIB1				
65	MIB				SIB1-BR					
66	MIB SI2-BR	SI2				SIB1				
67	MIB				SIB1-BR					
68	MIB SI3-BR			SI3		SIB1				
69	MIB				SIB1-BR					
70	MIB SI4-BR			SI4		SIB1				
71	MIB				SIB1-BR					
72	MIB					SIB1				

Table 7.7.2a-5: BR System Information Scheduling (TDD) for DL bandwidth > 5 MHz [$N_{RB}^{DL} > 15$] and odd physical layer cell Id [$N_{ID}^{cell} \bmod 2 = 1$]

SFN\SubFrame	0	1	2	3	4	5	6	7	8	9
0	MIB, SI1, SI1-BR					SIB1				
1	MIB, SIB1-BR									
2	MIB, SI2, SI2-BR					SIB1				
3	MIB, SIB1-BR									
4	MIB, SI3, SI3-BR					SIB1				
5	MIB, SIB1-BR									
6	MIB, SI4, SI4-BR					SIB1				
7	MIB, SIB1-BR									
8	MIB					SIB1				
9	MIB, SIB1-BR									
10	MIB					SIB1				
11	MIB, SIB1-BR									
12	MIB					SIB1				
13	MIB, SIB1-BR									
14	MIB					SIB1				
15	MIB, SIB1-BR									
16	MIB, SI1, SI1-BR					SIB1				
17	MIB, SIB1-BR									
18	MIB					SIB1				
19	MIB, SIB1-BR									
20	MIB					SIB1				
21	MIB, SIB1-BR									
22	MIB					SIB1				
23	MIB, SIB1-BR									
24	MIB					SIB1				
25	MIB, SIB1-BR									
26	MIB					SIB1				
27	MIB, SIB1-BR									
28	MIB					SIB1				
29	MIB, SIB1-BR									
30	MIB					SIB1				
31	MIB, SIB1-BR									
32	MIB, SI1, SI1-BR					SIB1				
33	MIB, SIB1-BR									
34	MIB, SI2, SI2-BR					SIB1				
35	MIB, SIB1-BR									
36	MIB					SIB1				
37	MIB, SIB1-BR									
38	MIB					SIB1				
39	MIB, SIB1-BR									
40	MIB					SIB1				
41	MIB, SIB1-BR									
42	MIB					SIB1				
43	MIB, SIB1-BR									
44	MIB					SIB1				
45	MIB, SIB1-BR									
46	MIB					SIB1				
47	MIB, SIB1-BR									
48	MIB, SI1, SI1-BR					SIB1				
49	MIB, SIB1-BR									
50	MIB					SIB1				
51	MIB, SIB1-BR									
52	MIB					SIB1				

SFN/SubFrame	0	1	2	3	4	5	6	7	8	9
53	MIB, SIB1-BR									
54	MIB					SIB1				
55	MIB, SIB1-BR									
56	MIB					SIB1				
57	MIB, SIB1-BR									
58	MIB					SIB1				
59	MIB, SIB1-BR									
60	MIB					SIB1				
61	MIB, SIB1-BR									
62	MIB					SIB1				
63	MIB, SIB1-BR									
64	MIB, SI1, SI1-BR					SIB1				
65	MIB, SIB1-BR									
66	MIB, SI2, SI2-BR					SIB1				
67	MIB, SIB1-BR									
68	MIB, SI3, SI3-BR					SIB1				
69	MIB, SIB1-BR									
70	MIB, SI4, SI4-BR					SIB1				
71	MIB, SIB1-BR									
72	MIB					SIB1				
73	MIB, SIB1-BR									

Table 7.7.2a-6: BR System Information Scheduling (TDD) for DL bandwidth = 5 MHz

SFN/SubFrame	0	1	2	3	4	5	6	7	8	9
0	MIB, SI1-BR					SIB1				
1	MIB, SI1					SIB1-BR				
2	MIB, SI2-BR					SIB1				
3	MIB, SI2					SIB1-BR				
4	MIB, SI3-BR					SIB1				
5	MIB, SI3					SIB1-BR				
6	MIB, SI4-BR					SIB1				
7	MIB, SI4					SIB1-BR				
8	MIB					SIB1				
9	MIB					SIB1-BR				
10	MIB					SIB1				
11	MIB					SIB1-BR				
12	MIB					SIB1				
13	MIB					SIB1-BR				
14	MIB					SIB1				
15	MIB					SIB1-BR				
16	MIB, SI1-BR					SIB1				
17	MIB, SI1					SIB1-BR				
18	MIB					SIB1				
19	MIB					SIB1-BR				
20	MIB					SIB1				
21	MIB					SIB1-BR				
22	MIB					SIB1				
23	MIB					SIB1-BR				
24	MIB					SIB1				
25	MIB					SIB1-BR				
26	MIB					SIB1				
27	MIB					SIB1-BR				
28	MIB					SIB1				
29	MIB					SIB1-BR				
30	MIB					SIB1				
31	MIB					SIB1-BR				
32	MIB, SI1-BR					SIB1				
33	MIB, SI1					SIB1-BR				
34	MIB, SI2-BR					SIB1				
35	MIB, SI2					SIB1-BR				
36	MIB					SIB1				
37	MIB					SIB1-BR				
38	MIB					SIB1				
39	MIB					SIB1-BR				
40	MIB					SIB1				
41	MIB					SIB1-BR				
42	MIB					SIB1				
43	MIB					SIB1-BR				
44	MIB					SIB1				
45	MIB					SIB1-BR				
46	MIB					SIB1				
47	MIB					SIB1-BR				
48	MIB, SI1-BR					SIB1				
49	MIB, SI1					SIB1-BR				
50	MIB					SIB1				
51	MIB					SIB1-BR				
52	MIB					SIB1				
53	MIB					SIB1-BR				
54	MIB					SIB1				

SFN\SubFrame	0	1	2	3	4	5	6	7	8	9
55	MIB					SIB1-BR				
56	MIB					SIB1				
57	MIB					SIB1-BR				
58	MIB					SIB1				
59	MIB					SIB1-BR				
60	MIB					SIB1				
61	MIB					SIB1-BR				
62	MIB					SIB1				
63	MIB					SIB1-BR				
64	MIB, SI1-BR					SIB1				
65	MIB, SI1					SIB1-BR				
66	MIB, SI2-BR					SIB1				
67	MIB, SI2					SIB1-BR				
68	MIB, SI3-BR					SIB1				
69	MIB, SI3					SIB1-BR				
70	MIB, SI4-BR					SIB1				
71	MIB, SI4					SIB1-BR				
72	MIB					SIB1				
73	MIB					SIB1-BR				

7.7.3 System information modification

For system information modification, the same rules as defined in clause 7.7.1 are applied.

The SFN and the HSFN for the start of modification period are calculated by TTCN. The modified system information and the calculated SFN, HSFN are provided in the ASP SYSTEM_CTRL_REQ.

7.7.3.1 Non-PWS System Information modification

The modification of system information is notified by paging messages containing the *systemInfoModification* (normal DRX) or *systemInfoModification-eDRX* (extended DRX). The paging messages are sent during one modification period before broadcasting the modified system information for normal DRX, and within a Paging Time Window (PTW) for extended DRX. The paging messages are sent on paging occasions (PO) within the paging frames (PF). With the default paging and sysinfo parameters provided in TS 36.508 [3] PO is set to 9 for FDD and 0 for TDD.

In case the UE is configured by the SS with an extended DRX cycle and the cell indicates support for eDRX in System Information, eDRX is performed. See to TS 36.304 [14], clause 7.3

7.7.3.1.1 UE in Idle_mode

7.7.3.1.1.1 Paging in DRX when P-RNTI transmitted on PDCCH

In the case of normal DRX, the paging frames calculation is based on the UE identity (see to TS 36.304 [14], clause 7). With:

defaultPagingCycle=128

nB=oneT

modificationPeriodCoeff=n4

it results in 4 paging messages to be sent on the paging occasions during the modification period in the frames of:

$$\text{SFN mod } 128 = (\text{UE_ID}) \text{ mod } 128.$$

7.7.3.1.1.2 Paging in extended DRX

In the case of eDRX, the DRX cycle is longer than the modification period and the parameter is the Paging Hyperframe (PH) and refers to the hyper SFN (H-SFN) in which the UE starts monitoring POs during a Paging Time Window (PTW). The H-SFN is broadcasted by the cell and increments by one when the SFN wraps around. When a change notification is received, the UE acquires the updated system information at the next H-SFN boundary defined by:

$$\text{H-SFN mod } 256 = 0$$

If the UE is configured with a T_{eDRX} cycle of 512 radio frames, it monitors POs as defined on normal DRX with parameter $T = 512$, otherwise it will monitor POs calculated as normal DRX only (as per clause 7.7.3.1.1.1 or 7.7.3.1.1.3) within the periodic PTW configured for the UE. The calculation of the bounds for the PTW are UE-specific and described on TS 36.304 [14] clause 7.3.

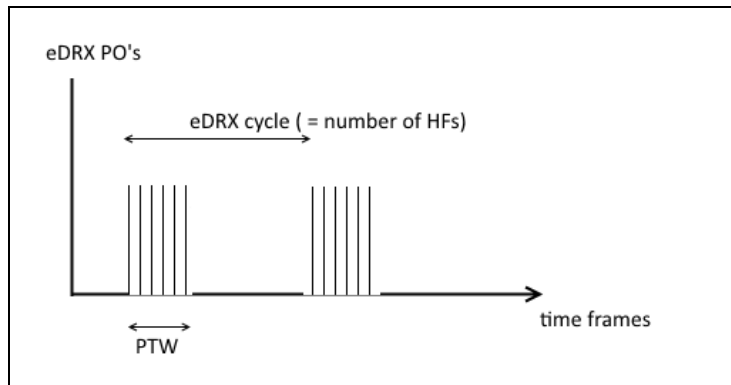

Figure 7.7.3.1.1-1: Paging cycles in eDRX idle mode

7.7.3.1.1.3 Paging in DRX when P-RNTI transmitted on MPDCCH

BL/CE UEs can be notified using Direct Indication information or paging message.

For BL/CE UEs, the paging frames calculation is based on the UE identity (see to TS 36.304 [14], clause 7.1). With:

```
defaultPagingCycle=128
nB=oneT
modificationPeriodCoeff=n4
number of paging narrowbands=1
SystemInformationBlockType1-BR modification period = 512 frames
SIs-BR modification period = 512 frames
```

The paging occasion calculation is resulting in the frames of: $\text{SFN mod } 128 = (\text{UE_ID}) \text{ mod } 128$. The Paging Narrowband (PNB) is resulting in $\text{PNB}=0$ and then resulting in the Narrow Band used for MPDCCH defined in clause 7.3.3.9.1.

One paging message is sent on the calculated paging occasion before the start of SystemInformationBlockType1-BR modification period. When both SystemInformationBlockType1-BR and SIs-BR are modified, their respective modification period starts may not match:

- When they match, SS is configured with the modified SystemInformationBlockType1-BR and SIs-BR in one ASP
- When they do not match, SS is configured with the modified SystemInformationBlockType1-BR and SIs-BR in two different ASPs with activation time set to the start of the respective modification periods.

7.7.3.1.2 UE in connected mode

When the UE is in connected mode, paging messages are sent on the paging occasions of each frame within the paging cycle throughout a modification period. This results in 128×4 consecutive paging messages to be sent during the modification period.

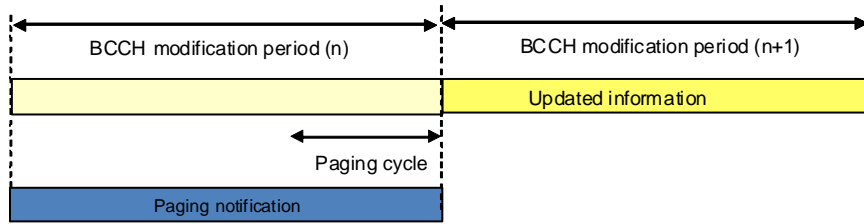

Figure 7.7.3.1.2-1: Paging notification UE in connected mode

For ETWS and/or CMAS capable UEs in connected mode, paging messages are sent on the paging occasions of each frame within the last paging cycle of the modification period. This results in 128 consecutive paging messages to be sent during the modification period.

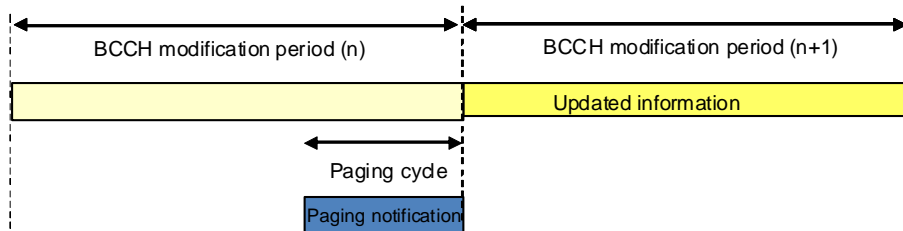

Figure 7.7.3.1.2-2: Paging notification for ETWS and/or CMAS capable UE in connected mode

7.7.3.2 PWS System Information modification

The modification of system information for ETWS and CMAS notification is notified by paging messages. The transmission of system information notification is not necessarily at the beginning of a modification period.

When the UE is in idle mode, the paging frames calculation is the same as defined in clause 7.7.3.1.1.

When the UE is in connected mode, paging messages are sent on the paging occasions of each frame during a paging cycle. This results in 128 consecutive paging messages to be sent. The transmission of the first paging message and the first system information notification are simultaneous and are sent at the beginning of a paging cycle.

7.8 Timers and Timing Restrictions

A timer is set at the beginning of each test case to guard against system failure. Behaviour on expiry of this guard timer shall be consistent for all test cases.

A watchdog timer can be specified for receive statements in order to reduce blocking time when a test case has already failed. Watchdog timers are a kind of TTCN auxiliary timer. When a watchdog timer is used to control a receive event, its expiry does not need to be handled explicitly in the test case, but will lead to a fail or inconclusive verdict due to handling in the default behaviour.

In idle mode operations, an idle mode generic timer is specified for receive statements if the test case specification does not explicitly specify a wait time for the specific test step or test purpose. The expiry of this idle mode generic timer is at least 6 minutes to safely cover most test scenarios.

The watchdog timer and the idle mode generic timer are only to be used inside the test case test body; if the timer expires a fail verdict is applied.

It is the TTCN responsibility to ensure that appropriate timer values are being used.

Tolerances (as described in TS 36.508 [3]) are not applicable to guard timers, idle mode generic timers and watchdog timers.

In general timers of less than 500 ms shall not be implemented by TTCN timers but controlled by usage of the timing information provided by the SS (This is based on an estimate of the system delay). To achieve this, there will be cases when a DL message is scheduled at a specific point in time. This shall be done by adding at least 100 ms to the current time.

If Timing is 'now' the SS shall schedule the data transmission or the (re)configuration in the next available sub-frame, but will ensure that this period is less than 80 ms.

7.8.1 Auxiliary timers

For practical reasons, the TTCN can include timers that are not specified as part of the expected sequence. These timers are documented below.

RLC and PDCP watchdog timer.

7.8.2 RRC timers reconfiguration

Considering the allowed UE accuracy for the RRC timer T3xx being between 100 ms and 2.5 % of T3xx (see TS 36.133 [37]), the TTCN applies the RRC net timers tolerance as MAX (10% of T3xx, (100 ms + 5 RTT)), whereby:

FDD: 10 % of T3xx or 140 ms whichever is higher.

TDD: 10 % of T3xx or 155 ms whichever is higher.

7.8.3 MAC TA timer reconfiguration

Considering that the UE applies new values for MAC timers not before restart of the timer (see TS 36.321 [16], clause 5.8), when the TA timer is changed at the UE, a delay in TTCN will be added so as to allow SS to transmit Timing advance MCE (based on current periodic Timing advance configuration) and hence resulting in restart of TA timer at UE with new value.

7.8.4 Non-protocol timers

Time durations or periods in the test specification without corresponding references in the core specifications are considered as non-protocol timers for which no timer tolerances are applied in the TTCN.

7.9 Error Indication

There are several situations on lower layer in which SS shall raise an error rather than trying to resolve the problem. This is done by sending a SystemIndicationError to the test case. SS shall raise an error in the following cases:

- HARQ retransmissions (applicable when SS is configured to indicate HARQ retransmissions as errors):
 - HARQ CRC error for UL data;
 - HARQ NACK from the UE unless SS is configured to report HARQ ACK/NACK.
- Paging, System information exceeds max. number of resource blocks.
- Configuration: max. number of resource blocks specified for a channel exceeds system bandwidth.
- When in User-Plane a DL PDCP PDU or SDU not fitting into one TTI is sent with Harq Process being explicitly specified.
- SS gets invalid TimingInfo for TDD from the test case.
- SS detects contradiction of UL grant(s) and TDD configuration.
- Data scheduled for the same TTI does not fit into an available transport block.

Further error conditions are specified in annex D.

7.10 Race Conditions

When two uplink messages are sent from the UE within a very small amount of time, they may be received in either order in the TTCN if they are received on different ports. This may cause a race condition which is due to the snapshot mechanism in TTCN. In these cases, the TTCN will accept the messages in either order and then compare the timestamps of both messages to ensure they were sent in the correct order.

For UL messages received at a single port, there are normally no race conditions, with the exception of the SRB port where the following rules shall be fulfilled, in order to achieve an ordered UL message queue:

- UL messages are queued according to the timing information.
- UL messages with the same timing information are queued according to the logical channel priority with the "higher-first-in" principle.

7.11 Radio Link Failure

A radio link failure shall be triggered by switching the downlink power level of the source cell to the value for non-suitable "Off" for the time period of least T_{310} + time it takes to receive N_{310} consecutive out-of-sync indications from lower layers (non-suitable "Off" is defined in TS 36.508 [3], whereas T_{310} and N_{310} are defined in TS 36.331 [19]).

If the RRC re-establishment procedure is used in a radio link failure context, it shall be realised by using two cells.

7.12 Test method for RRC signalling latency

Test cases testing RRC signalling latency will need special test method. The PUCCH synchronisation state of UE influences the test method. Following 2 different ways in which the UE's completeness of procedure can be probed are considered:

1. UE is still PUCCH synchronized and can respond to uplink grants.
2. UE needs a RACH procedure and hence RACH procedural delays add upon the actual procedure delay.

7.12.1 Procedure delays in PUCCH synchronized state

For latency tests there may be up to 4 HARQ retransmissions in DL (corresponding to the default configuration of the SS) but HARQ retransmissions in UL cannot be compensated, i.e. any HARQ error in UL shall result in an inconclusive verdict for the test case (otherwise a UE may get fail due to a HARQ error).

Figure 7.12.1-1 demonstrates the latency check procedure that will be applied when UE is in PUCCH synchronized state and can respond to uplink grants.

SS is configured to report ACK/NACK received from UE, to TTCN.

NOTE: Due to L2 signalling (e.g. RLC STATUS PDUs) it is necessary to limit the reporting of UL HARQ ACK/NACK to the time between sending of the RRC message and receiving the ACK.

By default SS is configured to retransmit any DL MAC PDU max 4 times.

To avoid unexpected side effects the Time Alignment timer needs to be set to infinity and the SS shall be configured to not send any Timing Advance MAC control elements during the latency tests (since this may result in additional ACK/NACK)

The SS shall be configured to report HARQ errors and in the case of an UL HARQ error, an inconclusive verdict is assigned.

In the case of HARQ retransmissions in DL the HARQ RTT Timer according to TS 36.321 clause 7.7 [16] is

- 8 for FDD
- 10 for TDD configuration 1 in case the DL PDU is sent in subframe 4 (as per default; see Table 7.12.1-1).

The SS shall schedule DL retransmission at 4th TTI for FDD and TDD since reception of the NACK.

Let N be the max allowed delay for procedure.

TTCN schedules at time T1 a DL message to the UE.

TTCN schedules UL grants at

$$T_2(k) = T_1 + N + 1 + \Delta_1 + k * RTT;$$

with

k = 0..4; number of HARQ retransmission in DL

RTT = 8 (FDD)

RTT = 10 (TDD)

$\Delta_1 = 0$ (FDD)

$\Delta_1 = 0..3$ (TDD; possible UL subframe uncertainty since not all subframes can be used for UL)

Example:

given TDD; DL PDU sent at subframe 4; N=10

$\Rightarrow \Delta_1 = 1$ since UL grant cannot be scheduled for subframe 5 but needs subframe 6 (36.213 [30] cl.8.0)

The UL data is sent by the UE at

$$T_3(K) = T_2(K) + 4 + \Delta_2 \text{ with } \Delta_2 = 0 \text{ for FDD and } \Delta_2 = 0..3 \text{ for TDD and K is the value of k corresponding to which a HARQ Ack is received}$$

The latency requirements are fulfilled when

$$T_3(K) - T_1 = N + 5 + \Delta_1 + \Delta_2 + K * RTT$$

Looking at TDD configuration 1 in detail it can be shown that $\Delta = \Delta_1 + \Delta_2 = 0..3$

$$\Rightarrow T_3(K) - T_1 = N + 5 + \Delta + k * RTT; \text{ with } \Delta = 0..3$$

NOTE:

as long as N is a multiple of 5ms, given T1 is at 4th TTI for TDD configuration 1 we get $\Delta = 3$ ($\Delta_1 = 1$ and $\Delta_2 = 2$, 36.213 [30] cl.8.0)

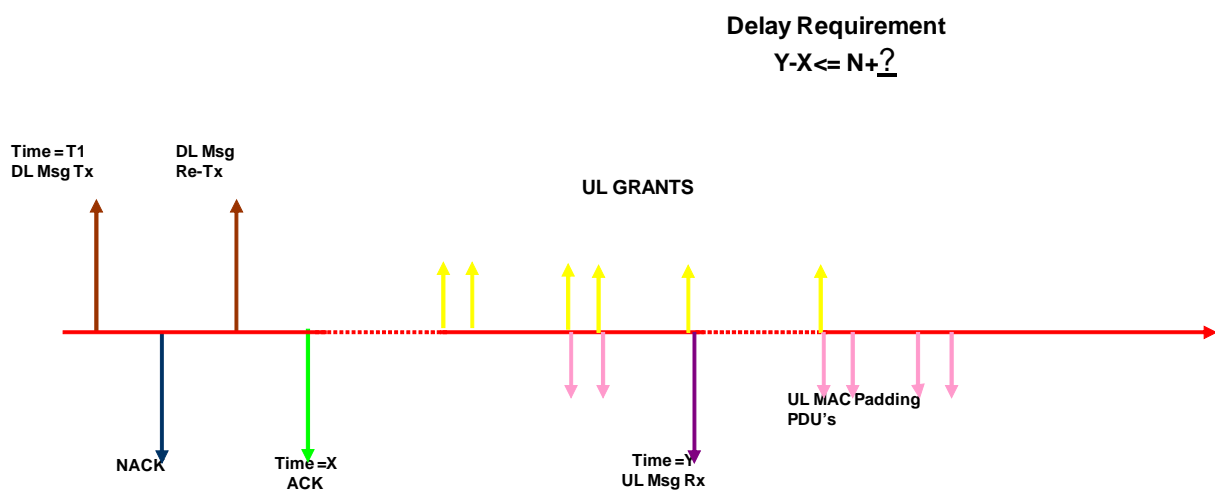

Figure 7.12.1-1: Delays in PUCCH synchronized state

Table 7.12.1-1: TDD configuration 1

Subframe	0	1	2	3	4	5	6	7	8	9
Configuration 1	D	S	U	U	D	D	S	U	U	D
Delay from DL to Ack/Nack [TTIs]			6,7	4				6,7	4	
Delay from NCK to re tx [TTIs]			4	6				4	6	
RTT	11	10			10	11	10			10

7.12.2 Procedure delays when RACH procedure required

Figure 7.12.2-1 demonstrates the latency check procedure that will be applied when UE is not PUCCH synchronized state needs RACH procedure.

PRACH configuration index is set as 14 for FDD, 12 for TDD which allows UE to send Preamble in any frame at any subframe.

SS is configured to report ACK/NACK, PRACH preambles received from UE.

By default SS is configured to retransmit any DL MAC PDU max 4 times [1 Transmission and 4 Retransmission].

Let N be the max allowed delay for procedure.

TTCN schedules at time T1, DL message to the UE. This is achieved using Time stamps in send ASP's.

The time difference between the ACK and the reception of PRACH preamble will be checked against N plus any Interruption time (TS 36.133 [37]) and verdict is assigned, when $(Y-X) \leq N + T_{interrupt} + \Delta$:

$\Delta = 0$ for FDD;

$\Delta = 3TTI$ for TDD, where 3TTI is UL subframe uncertainty.

If cell change occurs, cell timing differences, Frame number offsets need to be included for procedural delay evaluations.

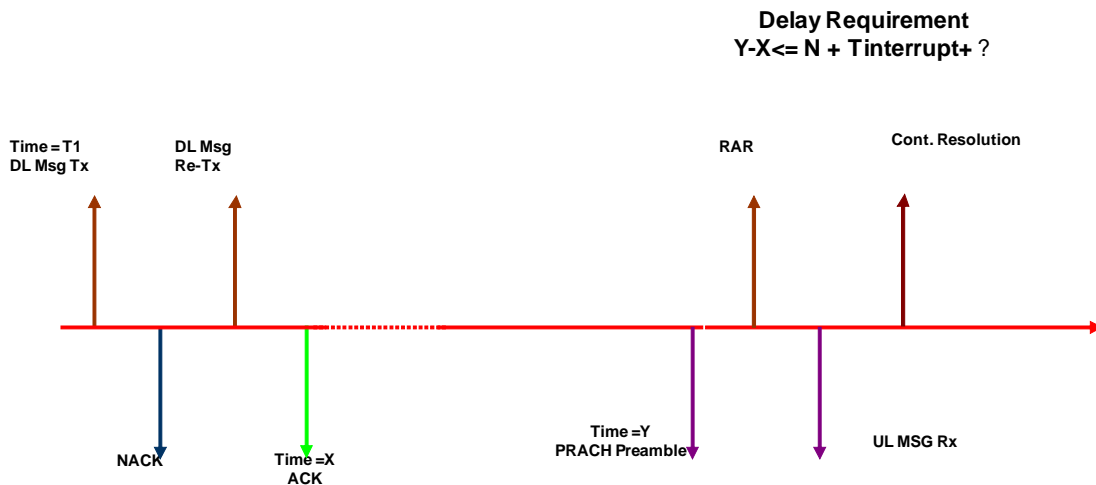

Figure 7.12.2-1: Delays when RACH procedure needed

7.13 RLC test method for scheduled data

The test loop mode is applied to the RLC tests. The allowed SS delay for sending data (< 80 ms) is comparable to the default values of the RLC timers. In order to ensure a unique TTCN implementation of the RLC test cases and the deterministic test result, independent from the SS platforms and UEs, scheduled data method can be applied to the test.

The scheduled data method is suitable to the RLC test if:

Receiving multiple UL RLC SDUs is expected in the test; the UE may send a STATUS PDU in addition.

Time measurement is required for the looped back RLC SDUs.

DL RLC PDUs are sent on consecutive TTIs; the subframe numbers to be applied are relevant in TDD.

Table 7.13-1 illustrates the data scheduling in the RLC test.

Table 7.13-1: Scheduled RLC test events

Scheduled timing		t0 (see note 1)	t1 (see note 1)	t2
Test event descriptions	Multiple SDUs	Obtain the reference time	Send DL data	Provide UL grant (see note 2)
	Time measurement		Send DL data	Receive UL data
	DL data in TDD		Send 1 st DL data	Send subsequent data (see note 3)
NOTE 1: $(t1-t0) \geq 100$ ms which is greater than the allowed SS max. delay time, 80 ms.				
NOTE 2: $(t2-t1) = 60$ ms, this duration will allow the UE transmitting max. 3 scheduling requests (every 20 ms once) after the UL data to be looped back being available at the UE without going onto PRACH.				
NOTE 3: The applied TDD subframe numbers 4, 5, 9, 10, 14, 15, 19, 20, 24, 25,...				

If the test case prose does not indicate timely restrictions for the scheduling, sequential sending events are scheduled in consecutive TTIs.

NOTE 1: For TDD configuration 1, the subframes 0, 4, 5 and 9 are considered as consecutive.

NOTE 2: Scheduling may imply to execute the test steps in the TTCN in an order different from the order given in the test case prose. However, the sequence of the events over the air follows the prose description.

7.14 IP packets for Loopback Mode

7.14.1 IP packets used for Loopback Mode A

It is irrelevant which kind of data is used in loopback mode A. Some PDCP test cases however specify to use IP packets. In these cases, an ICMPv4 ECHO REPLY shall be used with a valid IP header checksum and valid ICMP checksum.

7.14.2 IP packets used for Loopback Mode B

According to TS 36.509 [4], the UE performs loopback mode B above the UL TFT entity. Therefore IP packets need to match the packet filters signalled to the UE according to TS 36.508 [3], clause 6.6.2:

When the UE gets configured via NAS signalling with packet filter #1 and #2 according to TS 36.508 clause 6.6.2 the IP packets shall fulfil the following requirements:

Protocol:

UDP referred to packet filter #1 and #2

IP addresses:

Referred to TS 36.508 [3], table 6.6.2-3, note 1 source and destination IP address are the same.

Ports:

packet filter #1 specifies DL filter \Rightarrow IP packet's source port shall match remote port of packet filter #1.

packet filter #2 specifies UL filter \Rightarrow IP packet's destination port shall match remote port of packet filter #2.

To summarize, on dedicated bearers for loopback mode B, UDP packets used shall match the packet filters configured at the UE side. The UDP packets, having no specific content, shall have the correct header checksum and UDP checksum. On the default bearer, any other packets can be used, as an example, ICMPv4 ECHO REPLY similar as for loopback mode A.

7.15 Connected Mode DRX

The SS shall support connected mode DRX according to TS 36.321 [16], i.e. the SS shall not send any data to the UE while the UE is not monitoring the PDCCH. To achieve this, the SS needs to estimate the UE's Active Time by considering the on-duration as well as the drx-inactivity timer:

on-duration:

The on-duration can be derived from the SS' DRX configuration.

drx-inactivity timer:

According to TS 36.321 [16], clause 5.7 at the UE the drx-inactivity timer is started or restarted during the Active Time whenever PDCCH indicates a new transmission (DL or UL).

There is no activation time for the configuration of DRX at the UE and it is not acceptable just to consider the on-duration after re-configuration of the UE (for DRX_L according to TS 36.508 [3] the DRX cycle is 1.28 s); instead the drx-inactivity timer needs to be taken in account after DRX reconfiguration as well.

The following rules shall be applied to achieve synchronisation of SS and UE:

1. SS shall consider drx-inactivity timer as restarted at the UE whenever the UE is addressed on the PDCCH (DL data or UL grant).
2. When there is a scheduling request sent by the UE, SS assigns a grant independent of DRX; when sending out that grant on PDCCH SS considers drx-inactivity timer as (re-)started (as per 1. above).
3. For all DL messages scheduled with specific timing information SS shall send the data at the given time irrespective of current DRX configuration.
4. DRX (re-)configuration:
 - a) when DRX has not been configured at the UE yet:
 - a1) TTCN will configure the SS just before the sending out the RRCConnectionReconfiguration message configuring DRX at the UE; no other send-events between the reconfiguration of the SS and sending the RRC message shall be scheduled in TTCN.
 - a2) TTCN will schedule sending of the RRCConnectionReconfiguration message configuring DRX with specific timing information.
 - b) Reconfiguration of DRX at the UE: Same as a) but:
 - b1) TTCN shall schedule sending of the RRCConnectionReconfiguration according to the old DRX configuration (i.e. the SS does not need to cache the new configuration).
 - c) RRC connection release:
 - c1) TTCN will release DRX at the SS just after the RRC connection release procedure.
5. There shall be no parallel data on any DRBs during DRX reconfiguration.

NOTE: Timing requirements in the DRX test cases:

- a) The drx-Inactivity Timer shall be long compared to the duration between sending RRCConnectionReconfiguration and receiving RRCConnectionReconfigurationComplete (> 50 ms). It ensures the SS in-time sending of the RLC STATUS PDU.
- or
- b) The drx-cycle shall be short compared to the RLC timers applied for SRB1.

Figure 7.15-1 illustrates DRX (re)configuration at the SS and the UE.

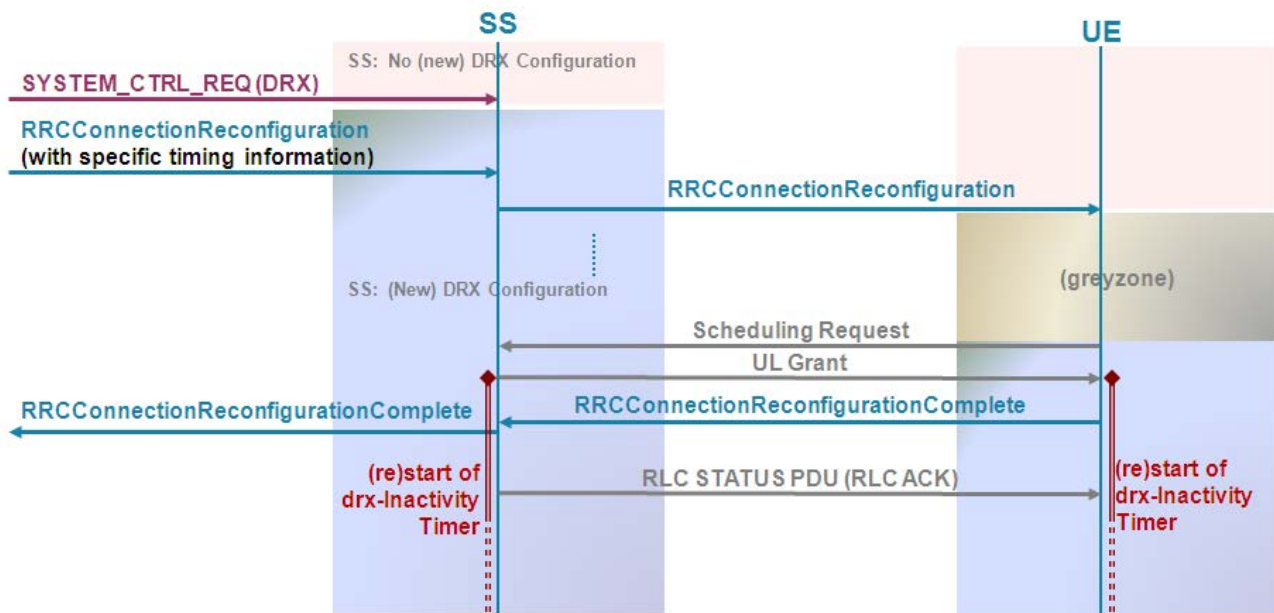

Figure 7.15-1: DRX (Re)configuration

NOTE 1: Between RRCConnectionReconfiguration and RRCConnectionReconfigurationComplete the UE may send a separate RLC STATUS PDU to acknowledge the RRCConnectionReconfiguration, but that does not affect the principle as long as SS applies rule 2.

NOTE 2: During the "greyzone" SS does not know about DRX configuration at the UE; during that period according to rule 4a1 and rule 5 there is no data to be sent by SS.

The TTCN (re)configures the connected mode DRX in SS for the test cases if DRX_S is applied (Ref. TS 36.508 [3]). The (re)configuration of DRX_L in SS is FFS.

Together with DRX, the SS shall implement eDRX for which an extended longDRX-Cycle can be configured. The values of eDRX cycle can be of 5.12 and 10.24s for connected mode. When TTCN configures the eDRX cycle on the SS alongside the DRX configuration, the SS shall apply it.

For test case 7.1.6.1 and 7.1.6.2, DRX will not be activated at the SS. Periodic UL grants every 5ms (suitable for both FDD and TDD and less than drx-InactivityTimer 6ms) will be allocated to the UE during the steps configuring test case specific DRX parameters of the test case to prevent UE from activating DRX; These grants may result in padding MAC PDU's transmitted by UE, which will be received by SS MAC and discarded.

7.16 Handover Sequences

7.16.1 Sequence of inter-cell handover

In general, the Inter-Cell handover is done without activation time, i.e. the timing information for configuration of the SS and sending of the RRCConnectionReconfiguration is 'Now'.

The sequence may be interrupted if other events need to be handled. E.g. when a TAU procedure is performed in the target cell and there are procedures left to be executed on the source cell.

1. Transfer of the PDCP Count for AM DRBs from source to target cell:
 - a) Source Cell: Get PDCP COUNT.
 - b) Target Cell: Set PDCP COUNT.

NOTE 1: There shall be no further sending/receiving of AM DRB data before the HO has been done.

2. Target Cell: Inform the SS about the HO and about the source cell id.
3. Target Cell: Configure RACH procedure either dedicated or C-RNTI based.
4. Target Cell: Activate security.

NOTE 2: For AM DRBs the PDCP count is maintained (for SRBs and UM DRBs the PDCP count is reset).

5. Target Cell: configure DRX (if necessary).

NOTE 3: As long as the DRX configuration is not modified by the RRCConnectionReconfiguration the target cell gets the same DRX configuration as the source cell.

NOTE 3A: According to TS 36.331 clause 5.5.6.1 the measurement gap configuration is released at the UE due to the handover, therefore nothing needs to be configured at the target cell regarding measurement gaps.

6. Source Cell: Stop periodic TA.

NOTE 4: Unless explicitly specified UL grant configuration keeps configured as per default at the source cell.

7. Target Cell: Configure UL grant configuration ("OnSR", periodic TA is not started).
8. Source Cell: Send RRCConnectionReconfiguration.
9. Target Cell: Receive RRCConnectionReconfigurationComplete.
10. Target Cell: Start periodic TA.
11. Target Cell: Inform the SS about completion of the HO (e.g. to trigger PDCP STATUS PDU).
12. Target Cell: Re-configure RACH procedure as for initial access.
- 12a. Target Cell: Configure measurement gap configuration (if necessary).
13. Source Cell: Reset SRBs and release DRBs.
14. Source Cell: Release DRX and MeasGapConfig configuration.

7.16.1a Sequence of inter-cell CA handover (more than one CC before and after handover)

The Inter-Cell handover is done with activation time, i.e. the timing information for configuration of the SS and sending of the RRCConnectionReconfiguration is explicit. Time 'T' is set to 700 ms in advance of the handover, time T1 = T + 10 ms and time T2 = T + 20 ms.

At Time T, steps 1-3:

1. Source Pcell: Configure source primary cell for stop of automatic Time alignment MCE transmission by SS
2. Target Pcell: Configure target pcell for no RACH response transmission
3. Source Pcell: Schedule the transmission of RRC Connection Reconfiguration message to UE requesting Handover to target Pcell and Scell

At time T2, steps 4-5:

4. Target Pcell: If target Pcell is same as source Scell, configure SS for target Pcell to be converted from a Scell to Pcell
- 4a. Configuration of DRBs at the target PCell
5. Transfer of the PDCP Count for AM DRBs from source to target Pcell:
 - a) Source PCell: Get PDCP COUNT.
 - b) Target PCell: Set PDCP COUNT.

NOTE 1: There shall be no further sending/receiving of AM DRB data before the HO has been done.

At time T1, steps 6-12:

6. Target PCell: Inform the SS about the HO and about the source Pcell id.
7. Target PCell: Configure RACH procedure either dedicated or C-RNTI based.
8. Target PCell: Activate security.

NOTE 2: For AM DRBs the PDCP count is maintained (for SRBs and UM DRBs the PDCP count is reset).

9. Target PCell & Target Scell: configure DRX.

NOTE 3: As long as the DRX configuration is not modified by the RRCConnectionReconfiguration the target cell gets the same DRX configuration as the source cell.

NOTE 4: According to TS 36.331 clause 5.5.6.1 the measurement gap configuration is released at the UE due to the handover, therefore nothing needs to be configured at the target cell regarding measurement gaps.

10. Target PCell: Configure UL grant configuration ("OnSR", periodic TA is not started).
11. Target PCell: Configure Target Pcell as Pcell.
12. Target SCell: Configure Target Scell for
 - 12.1 Configure RACH procedure C-RNTI based.
 - 12.2 Configure UL grant configuration ("OnSR", periodic TA is not started).
 - 12.3 Configure target SCell as Scell with new Pcell association.

After time T2 (without activation time):

13. Target PCell: Receive RRCConnectionReconfigurationComplete.
14. Target PCell: Start periodic TA.
15. Target PCell: Inform the SS about completion of the HO (e.g. to trigger PDCP STATUS PDU).
16. Target PCell: Re-configure RACH procedure as for initial access.
- 16a. Target Pcell & TargetScell: Configure measurement gap configuration (if necessary).
17. Source PCell: If source Pcell is not target Scell, reset SRBs and release DRBs.
18. Source Pcell: If source Pcell is not target Scell, configure from Pcell to normal cell.
19. Source Pcell: If source Pcell is not target Scell, Release DRX and MeasGap configuration
20. Source SCell: If source Scell is neither target Pcell or Scell, Release DRX and MeasGapConfig configuration.
21. Source Scell: If source Scell is neither target Pcell or Scell, configure from Scell to normal cell.
22. Source Scell: If source Scell is neither target Pcell or Scell, Configure UL grant configuration ("OnSR", periodic TA is not started).

7.16.2 Sequence of intra-cell handover

For Intra-Cell handover dedicated timing information is used: the sequence starts at time T with sending of the RRCConnectionReconfiguration. T is set to 300 ms in advance of the handover.

0. Before T: Get PDCP count for AM DRBs.
1. At T: Send RRCConnectionReconfiguration.
2. At T + 5ms: Release SRBs and DRBs.

3. At T + 5ms: Configure RACH procedure either dedicated or C-RNTI based.

NOTE 1: Since the RACH procedure may require a new C-RNTI to be used it cannot be configured before sending out the RRCConnectionReconfiguration.

- 3A At T + 5ms: Release MeasGapConfig configuration.

NOTE 2: According to TS 36.331, clause 5.5.6.1 the measurement gap configuration is released at the UE due to the handover, therefore MeasGapConfig is released unless a new measurement gap configuration is explicitly given in the RRCConnectionReconfiguration.

4. At T + 10ms: (Re-) configure SRBs and DRBs.
5. At T + 10ms: Re-establish security, disable TA transmission.

NOTE 3: For AM DRBs the PDCP count is maintained while for SRBs and UM DRBs the PDCP count is reset.

6. (after step 5) Receive RRCConnectionReconfigurationComplete.
7. (after step 6) Re-configure RACH procedure as for initial access, enable TA transmissions.
8. (after step 7) Restore the PDCP count for AM DRBs.

7.16.3 UL Grants used in RA procedure during handover

In the Random Access Procedure a grant is assigned to the UE by the Random Access Response and another grant, as initial grant, is assigned for contention resolution.

When UL data is pending, the UE will try to put as much data into given grants as possible, i.e. it will segment the user data and send it e.g. with the initial grant if possible. To avoid this segmentation of user data, the grants assigned during handover will be set in TTCN to:

Grant assigned by Random Access Response: 56 bits.

Initial grant: 104 bits.

NOTE 1: According to TS 36.321 [16], clause 5.1.4, 56 bits are the minimum grant which can be assigned by the Random Access Response. That is sufficient to convey C-RNTI (3 bytes) and short BSR (2 bytes) or long BSR (4 bytes) but even with short BSR the remaining 2 bytes are not sufficient to convey any segment of the RRCConnectionReconfigurationComplete (at least 4 bytes).

NOTE 2: The RRCConnectionReconfigurationComplete (9 bytes) shall completely be conveyed in the initial grant of RA procedure. This requires a minimum of 10 bytes (1 byte MAC header + 2 bytes RLC header + 5 bytes PDCP header + 2 bytes payload). Additionally an optional PHR MAC element (2 bytes) needs to be considered since the PHR has higher priority than the MAC SDU. Any further user data would require a minimum of 5 additional bytes (2 bytes MAC header + 2 bytes RLC header + 1 byte payload).

7.17 Simulation of PDCP MAC-I Failure in UE

PDCP integrity protection test cases 7.3.4.x have the requirement to trigger MAC-I failures in UE for downlink messages; to achieve the MAC-I failure in UE two methods are specified in the subsequent sub clauses.

7.17.1 Integrity and ciphering not yet activated

UE has not yet started Integrity protection and it is required to trigger MAC-I failure for the PDCP PDU carrying RRC SecurityModeCommand starting integrity with one of integrity protection algorithms. Further a conformant UE will respond with SecurityModeFailure without any integrity protection.

This is achieved by:

Not configuring SS PDCP to start integrity and ciphering with selected algorithm.

RRC SecurityModeCommand is sent indicating Integrity protection through the desired algorithm.

Normal behaviour of PDCP layer in SS will include all zeros in MAC-I.

This results in MAC-I failure as UE will calculate the XMAC-I with indicated algorithm.

7.17.2 Integrity and/or ciphering already activated

UE has started Integrity protection (ciphering configured with possibly non null algorithm) and it is required to trigger MAC-I failure for the PDCP PDU carrying an RRC UE Capability Enquiry message. A conformant UE will trigger an RRC Connection Reestablishment procedure.

This is achieved by:

Configuring SS PDCP to use a different Integrity algorithm other than used by UE (i.e. if UE is configured to use AES, SS is configured to use SNOW3G and vice versa).

Ciphering is configured at SS side same as in UE side.

The MAC-I included by SS PDCP will be as per new algorithm.

UE will calculate XMAC-I based on its own algorithm which is different from the algorithm SS has used and will result in MAC-I failure.

7.18 RRC Connection Release Sequence

According to TS 36.331 [19], clause 5.3.8.3, after reception of the RRC Connection Release the UE may either wait 60 ms or for indication of acknowledgement from lower layer. After the RRC connection release there are cases where the UE may immediately come up with an RRC connection request. This requires scheduled release of resources at the SS:

1. At T: Send RRC Connection Release, stop UL grants.
2. At T + 5ms: Release security.
3. At T + 10ms: Release DRX configuration at the SS.
- 3A At T + 15ms: Release measurement gap configuration at the SS.
4. At T + 50ms: no action.
5. At T + 55ms: Release SRBs and DRBs.
6. At T + 60ms: (Re-)configure SRBs.
7. Delay of 840ms (NOTE)

T is set to 300ms in advance of RRC connection release.

NOTE: The delay ensures that the UE is camping on the serving cell again to avoid side effects e.g. due to subsequent power level changes. It does not affect any sending of messages by the UE. The delay 840ms is chosen to ensure the UE is re-camping on the cell and has read relevant system information, MIB, SIB1, SIB2 and all other SIs.

7.18a RRC Connection Release Sequence for BL/CE UE

According to TS 36.331 [19], clause 5.3.8.3, after reception of the RRC Connection Release the UE may either wait 1250 ms for a BL/CE UE or for indication of acknowledgement from lower layer. After the RRC connection release there are cases where the UE may immediately come up with an RRC connection request. This requires scheduled release of resources at the SS:

1. At T: Send RRC Connection Release,.
2. At T + 5ms: Release security.

3. At T + 10ms: Release DRX configuration at the SS.
- 3A At T + 15ms: Release measurement gap configuration at the SS.
4. At T + 200ms: stop UL grants (NOTE 1).
5. At T + 205ms: Release SRBs and DRBs.
6. At T + 210ms: (Re-)configure SRBs.
7. Delay of 1880ms(1040 +840) (NOTE 2)

T is set to 300ms in advance of RRC connection release.

NOTE 1: The delay of 200ms added for release of UL grant is to allow UE to send an UL RLC Ack for *RRCCONNECTIONRELEASE*. It is selected to be small enough so as to not impact successive cell selection and long enough that both CE mode A and B type UE's can be catered.

NOTE 2: The delay ensures that the UE is camping on the serving cell again to avoid side effects e.g. due to subsequent power level changes. It does not affect any sending of messages by the UE. The delay 840ms is chosen to ensure the UE is re-camping on the cell and has read relevant system information, MIB, SIB1, SIB2 and all other SIs. The 1880 ms is 1.25s - 210ms.

7.19 DL CCCH Message and Contention Resolution MAC Control Element transmission in one MAC PDU or in separate MAC PDUs

When the contention based RACH procedure is being executed (RRC Connection Establishment or RRC Connection Reconfiguration), in general the contention resolution MAC control element and the DL RRC PDU (RRC Connection Setup/RRC Connection Reject/RRC Connection Re-establishment/RRC Connection Re-establishment Reject) are sent in one MAC PDU. This is achieved by pre-configuring the SS (before the start of the RRC procedure) to send the encoded DL message and contention resolution MCE in one MAC PDU.

Nevertheless, due to specific test purposes there are still many cases where it is necessary to send the DL CCCH message separately:

RRC connection establishment

When RRC connection establishment is part of the test purpose

Special cases: , e.g. when no contention resolution shall be sent according to the test purpose

RRC Connection Reestablishment is part of the test purpose

RRC Connection Reject is part of the test purpose

RRC Connection Reestablishment Reject is part of the test purpose

NOTE: The way contention resolution is applied has impact on the DCI format being used in a test case: when the DL CCCH message is sent separately DCI combination 1 according to clause 7.3.1 shall be used.

7.20 RRC Connection Reconfiguration Sequence (Measurement Control)

When an RRC Connection Reconfiguration message contains information to configure measurement gaps at the UE according to TS 36.331 [19] clause 5.5.2.9, the SS needs to be configured accordingly:

IF MeasConfig contains measGapConfig:

1. At T: Send RRC Connection Reconfiguration.
2. At T + 5ms: Configure measurement gaps at the SS.

3. (after step 2) Receive RRC Connection Reconfiguration Complete

ELSE

1. Send RRC Connection Reconfiguration (without scheduling)
2. Receive RRC Connection Reconfiguration Complete.

T in general is set to 100ms in advance of the RRC connection reconfiguration.

7.21 Inter-RAT - GERAN special issues

7.21.1 Timeslot assigned for GERAN CS traffic

Timeslot 3 shall be used as the timeslot assigned for GERAN CS traffic, in order to avoid conflicts with timeslots reserved for other purposes (e.g. the GPRS channel which is assigned to timeslot 4).

7.21.2 Subchannel used in GERAN L2 access message

The subchannel is valid only for the following logical channel types: FACCH/H, SDCCH/8, SDCCH/4. For other logical channel types this field is not applicable and shall be coded as 15 for compatibility with TTCN2 test cases. The SS shall ignore it if this field is coded as 15.

7.21.3 Paging in GERAN

The system paging parameter BS_PA_MFRMS is set to a value of 2 multi frames, in order to ensure the next paging occasion is as soon as possible.

7.22 EUTRAN RSRQ Calculations

7.22.1 Assumptions

- As per 36.214 [53] clause 5.1.1 and 5.12, the RSRP and RSSI shall be averaged over the same set of resource blocks. It is assumed that the power calculations made over one symbol are good enough for RSRQ calculations. This is based on the assumption that the power levels remain the same across the symbols on which the UE is calculating the average. The contribution of Nprb and the OFDM symbols carrying cell specific reference symbols per PRB contribute equally in numerator and denominator, hence RSRQ calculations in dB with aggregation over cell DL bandwidth and without aggregation result in the same output.
- As per table 7.4.3.1.1-1, for FDD the timing offset between the intra frequency cells is always a multiple of sub frame duration i.e. 3072 Ts, hence in the symbols carrying cell-specific reference signals in one cell, the other cell (interference) is also carrying a cell-specific reference signal, even though in a different subframe. Hence from an interference calculation perspective, we can safely assume that the cells contributing an interference shall also transmit the same cell specific reference signal in the symbol/
- The noise source is treated as a dummy cell transmitting on all resource elements with equal EPRE. Hence to switch off the noise source, a value of non-suitable "Off" cell, as per 36.508 [3] table 6.2.2.1-1 shall be used (<-145), and the signal level uncertainties similar to configured cells in 36.508 [3] clause 6.2.2.1 will also be applied to the noise source.
- When the Noc value remains 'off' during the test case execution, the Virtual Noise Generator is not configured in the SS.

7.22.2 The Ideal Calculation

The test case specifies the RS-EPRE (dBm/15kHz) which is the cell absolute power-cell attenuation in dBm per carrier of 15 kHz; the linear average over few measurements will give the RRP value.

It is assumed that the power levels of all contributors is fluctuating hence in the typical test environment RS-EPRE will be the RSRP over a single carrier frequency.

The RS-EPRE_{mW}(mW/15kHz) = 10 power (RSRP/10).

The energy in noise source [Noc] for the frequency is also specified in the same units of dBm/15kHz.

The RSSI_{mW} calculation(mW over a resource block frequency of 180 kHz) = 2 (the sum over all intra frequency configured cells RS-EPRE_{mW}) + 10 power ((Noc/10)*12).

The cell inference is multiplied by 2 as in a RB, cell specific reference is transmitted in only 2 carriers. But the AWGN transmits on all 12 carriers in the resource block.

The RSRQ in dB will be the 10*log (RS-EPRE_{mW}/RSSI_{mW}).

7.22.3 Additional RSRQ Calculations For Fixing Boundary Values

In addition to the ideal calculation, various RSRQ calculations take into consideration the combinations of the SS signal uncertainties and possibly all 12 carriers being used for DL transmission.

The 12 carriers being used can happen when the UE makes the measurement in a subframe when a DL PDSCH is scheduled or measurement is in subframe zero and the UE measures in OFDM symbol carrying PBCH i.e. slot 1, symbol 0.

The Min and Max RSRQ values are identified from 6 different RSRQ calculations:

RSRQ Ideal: RSRQ calculated in ideal conditions as given above

RSRQ Min: RSRQ calculation applying –ve signal uncertainty to all configured cells and noise source

RSRQ Max: RSRQ calculation applying +ve signal uncertainty to all configured cells and noise source

RSRQ Max Worst Case: RSRQ calculation applying +ve signal uncertainty for measured cell and –ve signal uncertainty to all remaining configured cells and noise source. This shall be the Max RSRQ possible

RSRQ Max And 12 Carriers: RSRQ calculation applying +ve signal uncertainty to all configured cells and noise source and cell interference considered over all 12 carriers

RSRQ Min Worst Case And 12 Carriers: RSRQ calculation applying -ve signal uncertainty for measured cell and +ve signal uncertainty to all others; and cell interference considered over all 12 carriers. This shall be the Min RSRQ possible

Applying UE measurement accuracy 36.133 [37], Table 9.1.6.2-1, +/-4dB normal conditions and side conditions of RSRQ when $RSRP \hat{E}_s/I_{ot} \geq -6$ dB & $RSRP \geq -124$ dBm the final boundary value for RSRQ is

Min RSRQ With UE Meas Acc := Min RSRQ -4 dB

Max RSRQ With UE Meas Acc := Max RSRQ + 4 dB

For conditions to fulfil desired cell selection or reselection, the respective conditions shall be satisfied for both the boundary values Min RSRQ RSRQ With UE Measurement Accuracy and Max RSRQ With UE Measurement Accuracy.

As the Boundary conditions also consider the worst scenario of all 12 carriers being transmitted, the requirement for OCNB is removed. There is no need to restrict measurement bandwidth and will be applicable for both DCI formats.

7.23 Test method for eICIC and feICIC

When periodic CQI feedback is requested due to TTCN configuration, the SS reports the periodic CQI to the TTCN. SS does not react on periodic CQI received and still allocates grants as configured from TTCN.

In the selected ABS no DL/UL user data (SRB/DRB) is scheduled, nor paging is transmitted; this is controlled by TTCN.

For feICIC testing, the SS may be configured to temporarily stop the transmission of SIB1 and its associated DCI.

7.24 Carrier Aggregation Signalling Sequences

7.24.1 Initial configuration of Pcell

Cell is configured as a normal cell by using function `f_EUTRA_CellConfig_Def`. The missing CA default parameters (e.g. UL power control Common) are configured by using additional ASP call(s).

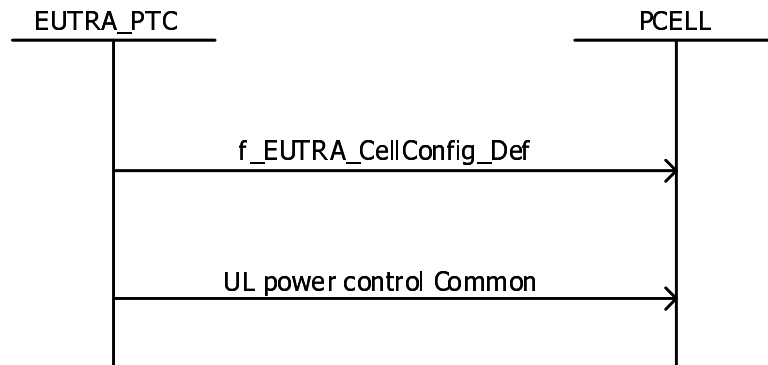

Figure 7.24.1-1: CA sequence of an initial cell configuration for a cell to be used as Pcell

7.24.2 Initial configuration of SCell

Cell is configured as a normal cell except for SRB/DRB configuration by function `f_EUTRA_SS_ConfigureActiveCell`. SRB0 not yet configured in step 1 is then configured.

The missing CA default parameters (e.g. UL power control (Common + Dedicated), PUSCH config Dedicated, SRS UL Dedicated) are configured by using additional ASP call(s).

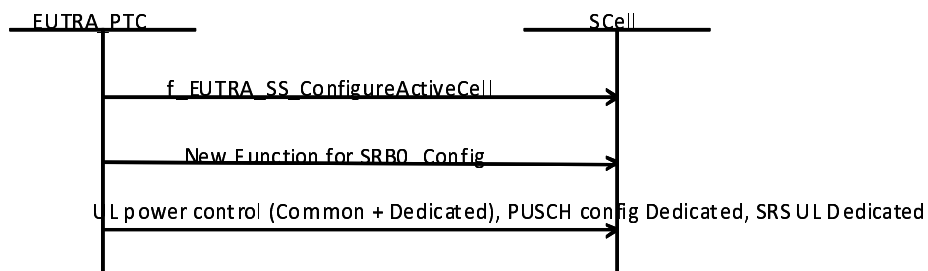

Figure 7.24.2-1: CA sequence of an initial cell configuration for a cell to be used as SCell

7.24.3 Scell Addition and/or release

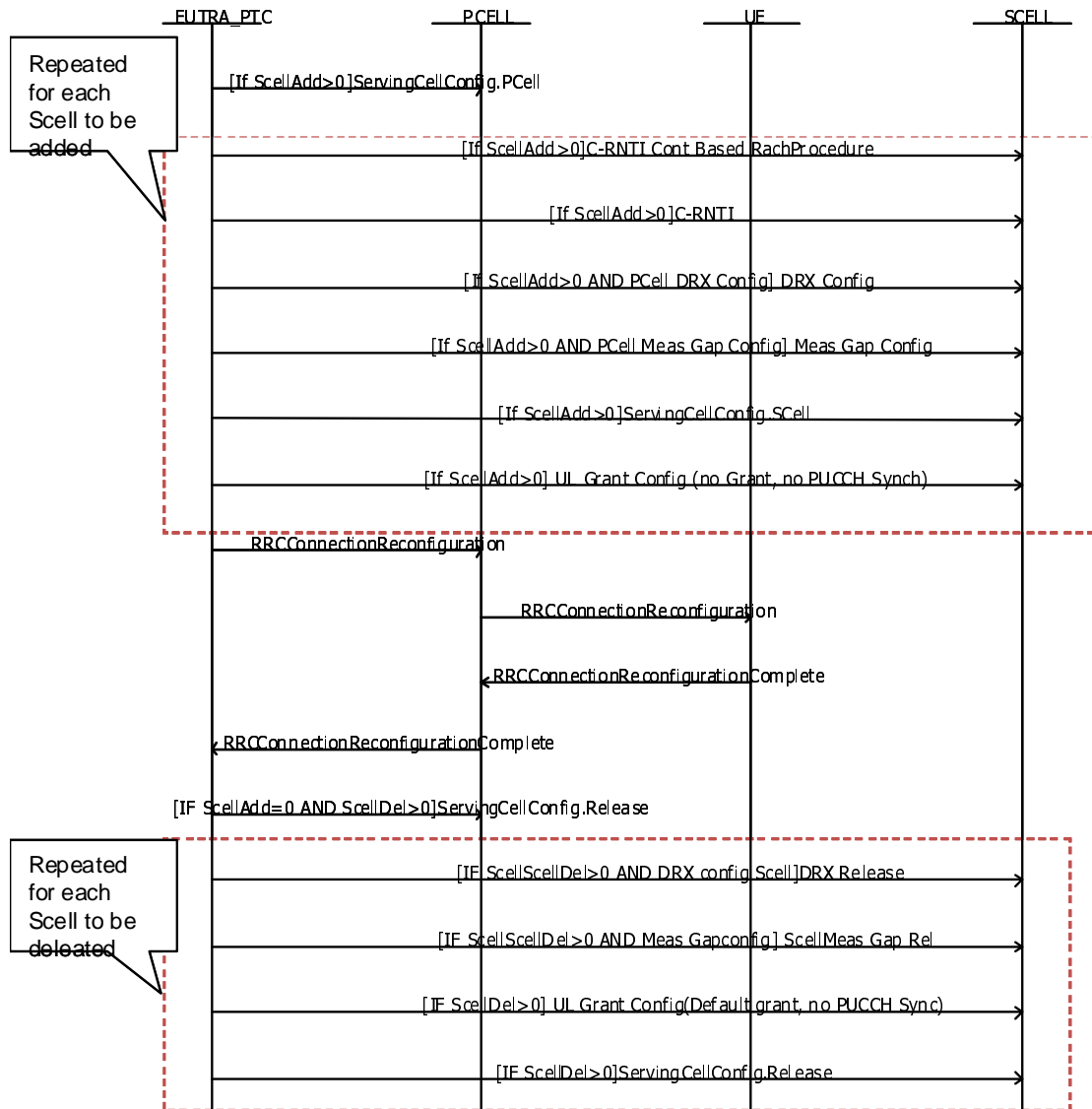

Figure 7.24.3-1: CA sequence of Scell Addition and/or release

7.25 Test method for MBMS

7.25.1 Schedule transmission of MCCH messages

The rules for the transmission of MCCH messages are specified in TS 36.331 [19], clause 5.8.1.2. The ASPs SYSTEM_CTRL_REQ and SYSTEM_CTRL_CNF are used as interface to SS; the following rules apply:

The complete MCCH information is provided to SS by using a single ASP. The MCCH carries the *MBSFNAreaConfiguration* and may also carry the *MBMSCountingRequest* message.

The scheduling information sent to SS is the same as the scheduling information sent to the UE.

The MCCH information is sent to SS using the asn.1 types, SS shall encode in unaligned PER and add the necessary padding bits as specified in TS 36.331 [19], clause 9.1.1.1.

Segmentation occurs when the MCCH message size is larger than the TBS of the MCH. SS starts scheduling all MCCH information blocks from the same SFN.

NOTE: With the default values $NPRB=NRBDL=25$ for 5 MHz and default signalling $Imcs=2$; then $Itbs=2$ and the TB size will be 1096 bits, hence segmentation may never happen.

7.25.2 MCCH change notification

A change notification is used to indicate the modification of MCCH information. The notification is transmitted on PDCCH, it includes the notification indicator provided in the ASP and is transmitted using the M-RNTI (defined in 3GPP TS 36.321 [16] Table 7.1-1).

The notification messages are sent during one modification period before transmitting the modified MCCH information. The SFN for the start of modification period is calculated by TTCN. The modified MCCH information and the calculated SFN are provided in the ASP SYSTEM_CTRL_REQ. The notification messages are sent on SFN/subframes calculated by TTCN according to 36.331 [19] clause 6.3.7.

7.25.3 MTCH data scheduling

The SS is configured with configuration parameters for CSA, PMCH, MRBs, MSI and scheduling information for MTCH data transmission.

The TTCN shall ensure that:

- For each configured MCH, the routing & timing information of the scheduled MRB data is consistent with the configured MSI.
- The size of all MRB data scheduled in the same subframe shall fit within the resource allocation of that subframe.

The SS shall ensure that:

- In subframes belonging to the CSA and for which no MCCH/MTCH/MSI data is scheduled by the TTCN, no MCH data shall be sent in MBMS subframes not used as per MSI.

If an MTCH packet is scheduled from TTCN in a subframe in which MCCH will be automatically transmitted by SS and/or MSI is configured and needs to be included, the MTCH packet and MCCH data along with possible MSI are included in one MAC PDU and *signallingMCS* is used.

When data is sent on MTCH the SS shall set the MSI in the MAC header according to TS 36.321 [16] clause 6.1.3.7. The periodicity of the MSI is defined by the MCH scheduling period i.e. the MSI is not necessarily included in the subframe where the RLC SDU is transmitted.

7.26 Type B FDD Half-Duplex Considerations

Type B FDD half-duplex UE has limitations in receiving a DL subframe preceding or following a UL subframe for the same UE hence a blank subframe is needed. In [non TTI bundling considerations] max 3 contiguous subframes UL or DL can be scheduled. And after and before any contiguous DL/UL subframes block a blank subframe is needed.

If the UE under test is a Type B FDD half-duplex UE:

- SS will be configured per cell by providing UE category info and FDD half-duplex operation.
- When explicit timing info is provided in any DL transmission, the SS shall ignore the UE capability and shall follow the explicit scheduling. It will be TTCN responsibility to schedule UL/DL transmissions based on UE capability. Paging is always explicitly scheduled and hence SS follows explicit scheduling for paging.
- For UE Category 0, SI scheduling will be configured as per TDD SI scheduling (Table 7.7.2-4) restricting system info transmissions in sub frames 0 and 5. For non-explicitly scheduled new DL transmissions/ new UL grant allocations, the SS shall restrict UL/DL operations as per table below:

Table 7.26-1: Scheduling pattern for type B half-duplex FDD Cat.0 UE (non-explicitly scheduled)

SFN/ SubFrame	0	1	2	3	4	5	6	7	8	9
X (any)	MIB/SI	Blank	New UL Data/ HARQ	Blank	Blank	SIB1/SI	DL HARQ	Blank	New DL Data/ UL Grant	Blank

- For BL/CE UE, SI scheduling is specified in clause 7.7.2a. BL/CE UE acquires sysinfo in RRC_IDLE. In RRC_CONNECTED BL/CE UE acquires MIB/SIB1-BR only when T311 is running. For non-explicitly scheduled new DL transmissions/ new UL grant allocations:
 - No subframe restriction using *fdd-DownlinkOrTddSubframeBitmapBR* nor *fdd-UplinkSubframeBitmapBR* are provided by TTCN to SS,
 - The SS shall restrict UL/DL operations as per table below:

Table 7.26-2: Scheduling pattern for type B half-duplex FDD BL/CE UE (non-explicitly scheduled)

SFN/ SubFrame	0	1	2	3	4	5	6	7	8	9
X (any)	MIB/SI- BR	Blank	New UL Data/ HARQ	Blank	SIB1-BR	Blank	DL HARQ	Blank	New DL Data/ UL Grant	Blank

- If HARQ retransmissions are required:
 - DL retransmissions being asynchronous in nature shall be scheduled by the SS as per above schedule (i.e. subframe 8).
 - UL retransmissions being synchronous will not be limited to subframe 2. i.e. the first UL retransmission will be in frame X+1, subframe 0, second retransmission in frame X+1, subframe 8 and so on.
 - HARQ retransmissions shall be prioritised over new transmissions.

7.27 Test method for Device-to-Device Proximity Services

7.27.1 Direct Discovery test method

SS-UE is configured in coverage, i.e. it is associated with a EUTRA-cell (as specified in clause 7.27.2.1).

SS-UE can be configured for sidelink data transmission and/or reception:

- When UE under test is configured in sidelink discovery type 1 (i.e. ue-Selected), the SS-UE is configured in reception with the same pool(s) of resource.
- When UE under test is configured in sidelink discovery type 2B (i.e. scheduled), the SS-UE is configured in reception with the same pool of resource and same indexes.
- For transmission, TTCN configures the SS-UE with a pool of resources and provides the SL_DATA_REQ ASP including:
 - the SL-DCH message to be transmitted,
 - the timing info indicating the SFN/Subframe of the first discovery period,
 - the number of discovery periods in which the message shall be transmitted,
 - the selected PSDCH resource value (n_{PSDCH}), this value is incremented by TTCN after each transmission cycle. To avoid clashes when multiple PC5_DISCOVERY messages are transmitted within the same discovery period, TTCN will provide different n_{PSDCH} values.

7.27.2 Direct Communication test method

7.27.2.1 Synchronisation and SBCCH transmission

When configured in coverage, the SS-UE is associated with a EUTRA-cell, it is configured with the same configuration parameters i.e. Band, Bandwidth, UL frequency, Cell timing, TDD Frame structure of the associated EUTRA cell.

When out of coverage, SS-UE is configured explicitly by TTCN, e.g. Band, Bandwidth, TDD Frame structure. For timing synchronisation SS-UE can be configured either:

- To synchronise from UE under test transmitted SLSS/MIB-SL: UE under test is the synchronisation source. The SS-UE shall use the received SLSS and MIB-SL including the DirectFrameNumber/DirectSubframeNumber as synchronisation source as specified in TS 36.331 [19], clause 5.10.9.2
- To be the synchronisation source: SS-UE shall initiate autonomously the DirectFrameNumber/DirectSubframeNumber and transmit SLSS/MIB-SL.

When the SS-UE is configured by TTCN over sidelink system control port to receive/transmit SLSS and MIB-SL, the following rules apply:

- For transmission, the complete MIB-SL message is provided to SS-UE. SS-UE shall set the DirectFrameNumber and DirectSubframeNumber in the MIB-SL, a dummy value is provided by TTCN.
- The MIB-SL is sent to SS-UE using asn.1 types. The rules for encoding and transmission of SBCCH messages (MIB-SL) are specified in TS 36.331 [19].
- For reception, SS-UE shall report SLSS or MIB-SL over the sidelink system indication port.

7.27.2.2 Sidelink data transmission/reception

When UE is in coverage and configured in transmission mode 1 (i.e. scheduled), the sidelink Scheduling Grant is configured in SS by TTCN over system control port. On PDCCH, the SS informs the UE under test if it is allowed to make sidelink data transmission by transmitting 'DCI format 5' including 'SCI format 0' with the CRC scrambled by SL-RNTI (acc. to TS 36.213 [30] clause 14.2). The UE under test will transmit on PSCCH/PSSCH as specified in the received DCI format 5 and 'SCI format 0'. SS shall only react on reception of SR and grant allocation configured from the TTCN. The following sidelink grant allocation is configured:

- SS is configured to maintain PUCCH Synchronisation.
- SS is configured to send automatically a 'configured Grant' (in terms of N_{PSCCH} , I_{TRP} and N_{PRB}) to the UE on every reception of a Scheduling Request, within 10 subframes.
 - The default resource for PSCCH is $N_{\text{PSCCH}} = 11$,
 - The default configured grant for PSSCH in SCI format 0 is $I_{\text{TRP}} = 36$ and $N_{\text{PRB}} = 25$. The SS shall allocate resource allocation RBs corresponding to PRB indices $0..(N_{\text{PRB}}-1)$.- SS-UE is configured with the same pool(s) of resources as UE under test.

When UE is out of coverage or configured in transmission mode 2 (i.e. ue-Selected), UE selects autonomously the resources on PSCCH/PSSCH. SS-UE is configured with the same pool(s) of resources as UE under test.

The SS-UE, when triggered to transmit data, is configured with $I_{\text{MCS}}=0$ and the same N_{PSCCH} , I_{TRP} and N_{PRB} as specified above.

7.28 Test method for SC-PTM

7.28.1 Schedule transmission of SC-MCCH messages

The rules for the transmission of SC-MCCH messages are specified in TS 36.331 [19], clause 5.8a.1.2. The ASPs SYSTEM_CTRL_REQ and SYSTEM_CTRL_CNF are used as interface to SS; the following rules apply:

- The complete SC-MCCH information is provided to SS by using a single ASP. The SC-MCCH carries the *SPCTMConfiguration* message.
- The scheduling information sent to SS is the same as the scheduling information sent to the UE.
- The SC-MCCH information is sent to SS using the *asn.1* types, SS shall encode in unaligned PER and add the necessary padding bits as specified in TS 36.331 [19], clause 9.1.1.7.
- Segmentation occurs when the SC-MCCH message size is larger than the TBS of the DL-SCH. SS starts scheduling all SC-MCCH information blocks from the same SFN.

NOTE: With the default values $NPRB=NRBDL=25$ for 5 MHz and default signalling $Imcs=2$; then $Itbs=2$ and the TB size will be 1096 bits, hence segmentation may never happen.

7.28.2 SC-MCCH information change

There are two possibilities to update SC-MCCH information. One is to transmit modified SC-MCCH information at the beginning of the modification period. Alternatively, notification mechanism can be used. The notification is transmitted using the DCI format 1C with SC-N-RNTI (defined in 3GPP TS 36.321 [16] Table 7.1-1) and one bit within the 8-bit bitmap. The notification is sent in the first subframe, which can be used for SC-MCCH transmission in a repetition period. Modified SC-MCCH message is to be transmitted starting from the same subframe, as defined in TS 36.300 clause 15.3.5a.

The SFN for the start of modification to SC-MCCH is calculated by TTCN according to TS 36.331 [19] clause 6.3.1 as defined for *SystemInformationBlockType20*. The modified SC-MCCH information, the calculated SFN and a flag, pointing on if a notification mechanism has to be used, are provided in the ASP `SYSTEM_CTRL_REQ`.

7.28.3 SC-MTCH data scheduling

The SS may be configured with scheduling information for SC-MTCH data transmission. The TTCN shall ensure that SC-MTCH packets will be scheduled for the transmission only during the Active Time for a PDCCH subframe as defined in TS 36.321 [16] clause 5.7a.

7A NB-IoT Test Methods and Design Considerations

NOTE: Unless explicitly stated otherwise, the present clause and its subclauses apply to the NB-IoT anchor carrier.

7A.1 Physical signals and channels

For Signalling testing, single Tx antenna shall be used by the SS, unless specified otherwise in a test case.

The SS shall transmit all NB-IoT physical signals and channels according to TS 36.211 [35], with the following additional requirements, unless specified otherwise in a test case:

- The NRS shall be transmitted on one antenna port.
- The NPSS and NSSS shall be transmitted on one and the same antenna port.

No (WB-E-UTRA) LTE signals and channels shall be transmitted by the SS, except for the case of 'in-band same PCI' operation mode where the SS shall transmit the LTE CRS. For the in-band operation modes, TTCN will provide the necessary LTE CRS configuration to the SS ; for the case of 'in-band different PCI' operation mode, the SS shall use this information to skip the resource elements, which should be occupied by the LTE CRS, when transmitting NB-IoT downlink physical channels.

7A.2 System information

7A.2.1 System information broadcasting in general

TTCN provides separately the BCCH (MIB-NB, SIB-NB's) messages to transmit, and the scheduling of how and when to transmit them. However the complete information is provided to the SS by using a single ASP.

The SS shall transmit all BCCH messages according to TS 36.331 [19], with the following additional requirements:

- SS shall start scheduling all BCCH messages from the same timing (H-SFN, SFN).
- SS shall set and maintain the SFN-MSB and the HSFN-LSB in the MIB-NB message provided by TTCN, according to its internal timing. A dummy value is provided by TTCN.
- SS shall set and maintain the HSFN-MSB in the SIB1-NB message provided by TTCN, according to its internal timing. A dummy value is provided by TTCN.
- TTCN provides the BCCH messages to the SS using the ASN.1 types. The SS shall encode them in unaligned PER and add the necessary padding bits as specified in TS 36.331 [19], clause 8.5.

7A.2.2 System information scheduling and synchronisation signals

For NB-IoT the scheduling of UL and DL data strongly depends on the scheduling of system information and synchronisation signals: The SS can schedule DL assignments and UL grants only in subframes which are not used by system information or synchronisation signals.

This clause shows the allocation of system information and synchronisation signals according to core specifications and for cases of common system information scheduling according to TS 36.508 [3] clause 8.1.4.3.

NOTE: Unless explicitly stated otherwise, the present clause and its subclauses apply to downlinkBitmap-r13 not being specified in SIB1-NB.

7A.2.2.1 MIB-NB, NPSS, NSSS

NPSS is transmitted in subframe 5 of every radio frame (TS 36.211 [35] clause 10.2.7.1.2).

NSSS is transmitted in subframe 9 of every radio frame with even frame number (TS 36.211 [35] clause 10.2.7.2.2).

MIB-NB is sent on NPBCH: It is split into 8 blocks, each of which is repeated 8 times in the first subframe of a frame (TS 36.331 [19] clause 5.2.1.2a) ⇒ MIB uses first subframe of every frame, periodicity is 640ms.

Table 7A.2.2.1-1: MIB-NB, NPSS, NSSS scheduling

...	SFN mod 2 = 0									SFN mod 2 = 1									...			
...	0	1	2	3	4	5	6	7	8	9	0	1	2	3	4	5	6	7	8	9	...	
...	N P B C H					N P S S				N S S S	N P B C H					N P S S						...

7A.2.2.2 SIB1-NB

SIB1-NB scheduling depends on

- schedulingInfoSIB1-r13 contained in MasterInformationBlock-NB:
TBS of 208, 328, 440 or 680 and 4, 8 or 16 repetitions (TS 36.213 [30] Tables 16.4.1.3-3 & 16.4.1.5-2-1)
- Physical Cell ID (PCID) derived by the UE from the NSSS:
Starting radio frame number for NB-SIB1 repetitions depends on the PCID and the number of repetitions (TS 36.213 [30] Table 16.4.1.3-4)

According to TS 36.331 [19] clause 5.2.1.2a independent from the TBS a single SIB1-NB transmission takes every second of 16 sub-sequent frames and the parts of the SIB1-NB are sent at subframe #4.

Table 7A.2.2.2-1 shows SIB1-NB scheduling for the 16 repetitions for the case that the radio frame of the first transmission is 0 ($N_{ID}^{Ncell} \bmod 4 = 0$ in Table 16.4.1.3-4 of TS 36.213 [30]); frames with SIB1-NB are shown in green.

Table 7A.2.2.2-1: SIB1-NB scheduling with 16 repetitions

frame 0	frame 1	frame 2	frame 3	frame 4	frame 5	frame 6	frame 7	frame 8	frame 9	frame 10	frame 11	frame 12	frame 13	frame 14	frame 15
frame 0	frame 1	frame 2	frame 3	frame 4	frame 5	frame 6	frame 7	frame 8	frame 9	frame 10	frame 11	frame 12	frame 13	frame 14	frame 15
frame 16	frame 17	frame 18	frame 19	frame 20	frame 21	frame 22	frame 23	frame 24	frame 25	frame 26	frame 27	frame 28	frame 29	frame 30	frame 31
frame 32	frame 33	frame 34	frame 35	frame 36	frame 37	frame 38	frame 39	frame 40	frame 41	frame 42	frame 43	frame 44	frame 45	frame 46	frame 47
frame 48	frame 49	frame 50	frame 51	frame 52	frame 53	frame 54	frame 55	frame 56	frame 57	frame 58	frame 59	frame 60	frame 61	frame 62	frame 63
frame 64	frame 65	frame 66	frame 67	frame 68	frame 69	frame 70	frame 71	frame 72	frame 73	frame 74	frame 75	frame 76	frame 77	frame 78	frame 79
frame 80	frame 81	frame 82	frame 83	frame 84	frame 85	frame 86	frame 87	frame 88	frame 89	frame 90	frame 91	frame 92	frame 93	frame 94	frame 95
frame 96	frame 97	frame 98	frame 99	frame 100	frame 101	frame 102	frame 103	frame 104	frame 105	frame 106	frame 107	frame 108	frame 109	frame 110	frame 111
frame 112	frame 113	frame 114	frame 115	frame 116	frame 117	frame 118	frame 119	frame 120	frame 121	frame 122	frame 123	frame 124	frame 125	frame 126	frame 127
frame 128	frame 129	frame 130	frame 131	frame 132	frame 133	frame 134	frame 135	frame 136	frame 137	frame 138	frame 139	frame 140	frame 141	frame 142	frame 143
frame 144	frame 145	frame 146	frame 147	frame 148	frame 149	frame 150	frame 151	frame 152	frame 153	frame 154	frame 155	frame 156	frame 157	frame 158	frame 159
frame 160	frame 161	frame 162	frame 163	frame 164	frame 165	frame 166	frame 167	frame 168	frame 169	frame 170	frame 171	frame 172	frame 173	frame 174	frame 175
frame 176	frame 177	frame 178	frame 179	frame 180	frame 181	frame 182	frame 183	frame 184	frame 185	frame 186	frame 187	frame 188	frame 189	frame 190	frame 191
frame 192	frame 193	frame 194	frame 195	frame 196	frame 197	frame 198	frame 199	frame 200	frame 201	frame 202	frame 203	frame 204	frame 205	frame 206	frame 207
frame 208	frame 209	frame 210	frame 211	frame 212	frame 213	frame 214	frame 215	frame 216	frame 217	frame 218	frame 219	frame 220	frame 221	frame 222	frame 223
frame 224	frame 225	frame 226	frame 227	frame 228	frame 229	frame 230	frame 231	frame 232	frame 233	frame 234	frame 235	frame 236	frame 237	frame 238	frame 239
frame 240	frame 241	frame 242	frame 243	frame 244	frame 245	frame 246	frame 247	frame 248	frame 249	frame 250	frame 251	frame 252	frame 253	frame 254	frame 255

7A.2.2.3 SI-messages containing SIB3-NB, SIB4-NB, SIB5-NB, SIB14-NB, SIB16-NB

Scheduling of SI messages is specified in TS 36.331 [19] clauses 5.2.1.2a and 5.2.3a.

As SI messages are sent on NPDSCH, only "NB-IoT DL subframes" can be used according to TS 36.213 [30] clause 16.4: In case of SIB1-NB not specifying *downlinkBitmap-r13* NB-IoT DL subframes are subframes not containing NPSS/NSSS/NPBCH/NB-SIB1 transmissions.

The parameters for SI scheduling are contained in SystemInformationBlockType1-NB:

Configuration common for all SI messages:

- Window size
- Frame offset for scheduling

Configuration per SI message:

- SI window:
According to TS 36.331 [19] clause 5.2.3a the position of an SI-window depends on the order of the corresponding SI-message in the list, the window size and the periodicity.
- Repetitions of the SI-message:
Within an SI-window repetitions are specified by the repetition-pattern.
- SIBs mapped to the SI-message
- Transport block size (TBS) and number of subframes (N_{SF}) used for transmission:
According to clause 6.7.2 of TS 36.331 [19] N_{SF} is either 2 (for TBS = 56, 120) or N_{SF} is 8 (for TBS = 208, 256, 328, 440, 552, 680).

7A.2.2.3.1 SI combination 1 scheduling

TS 36.508 [3] clause 8.1.4.3 specifies configuration of SI combination 1 scheduling as shown in table 7A.2.1.3.1-1 with

- 16 Repetitions of SIB1-NB \Rightarrow SIB1-NB in every second frame at subframe 4
- si-WindowLength-r13: ms160
- si-RadioFrameOffset-r13: 0 (not present in SystemInformationBlockType1-NB)
- 1 SI-message:
 - SI-Window 1
 - si-Periodicity-r13 rf64

si-RepetitionPattern-r13 every16thRF
 si-TB-r13 256 ⇒ N_{SF} = 8

- According to TS 36.331 [19] clause 5.2.3a the SI-windows start at subframe 0 of frame
 - (H-SFN * 1024 + SFN) mod T_{SI1} = 0; with T_{SI1} = 64
 - (H-SFN * 1024 + SFN) mod T_{SI2} = 16; with T_{SI2} = 64
 - (H-SFN * 1024 + SFN) mod T_{SI3} = 32; with T_{SI3} = 64

Table 7A.2.2.3-2: SI combination 2/3/4 scheduling (SIB2-NB + SIB3-NB + SIB4/5/14-NB)

SI Window	K	SFN = K										SFN = K + 1										SFN = K + 2										SFN = K + 3									
		0	1	2	3	4	5	6	7	8	9	0	1	2	3	4	5	6	7	8	9	0	1	2	3	4	5	6	7	8	9	0	1	2	3	4	5	6	7	8	9
SI-1	0	NPBCH	NPSS	NPSS	NPSS	NPSS	NPSS	NPSS	NPSS	NPSS	NPSS	NPSS	NPSS	NPSS	NPSS	NPSS	NPSS	NPSS	NPSS	NPSS	NPSS	NPSS	NPSS	NPSS	NPSS	NPSS	NPSS	NPSS	NPSS	NPSS	NPSS	NPSS	NPSS	NPSS	NPSS	NPSS	NPSS	NPSS	NPSS	NPSS	
	4	NPBCH	NPSS	NPSS	NPSS	NPSS	NPSS	NPSS	NPSS	NPSS	NPSS	NPSS	NPSS	NPSS	NPSS	NPSS	NPSS	NPSS	NPSS	NPSS	NPSS	NPSS	NPSS	NPSS	NPSS	NPSS	NPSS	NPSS	NPSS	NPSS	NPSS	NPSS	NPSS	NPSS	NPSS	NPSS	NPSS	NPSS	NPSS	NPSS	
	8	NPBCH	NPSS	NPSS	NPSS	NPSS	NPSS	NPSS	NPSS	NPSS	NPSS	NPSS	NPSS	NPSS	NPSS	NPSS	NPSS	NPSS	NPSS	NPSS	NPSS	NPSS	NPSS	NPSS	NPSS	NPSS	NPSS	NPSS	NPSS	NPSS	NPSS	NPSS	NPSS	NPSS	NPSS	NPSS	NPSS	NPSS	NPSS	NPSS	
	12	NPBCH	NPSS	NPSS	NPSS	NPSS	NPSS	NPSS	NPSS	NPSS	NPSS	NPSS	NPSS	NPSS	NPSS	NPSS	NPSS	NPSS	NPSS	NPSS	NPSS	NPSS	NPSS	NPSS	NPSS	NPSS	NPSS	NPSS	NPSS	NPSS	NPSS	NPSS	NPSS	NPSS	NPSS	NPSS	NPSS	NPSS	NPSS	NPSS	
	16	NPBCH	NPSS	NPSS	NPSS	NPSS	NPSS	NPSS	NPSS	NPSS	NPSS	NPSS	NPSS	NPSS	NPSS	NPSS	NPSS	NPSS	NPSS	NPSS	NPSS	NPSS	NPSS	NPSS	NPSS	NPSS	NPSS	NPSS	NPSS	NPSS	NPSS	NPSS	NPSS	NPSS	NPSS	NPSS	NPSS	NPSS	NPSS	NPSS	
SI-2	20	NPBCH	NPSS	NPSS	NPSS	NPSS	NPSS	NPSS	NPSS	NPSS	NPSS	NPSS	NPSS	NPSS	NPSS	NPSS	NPSS	NPSS	NPSS	NPSS	NPSS	NPSS	NPSS	NPSS	NPSS	NPSS	NPSS	NPSS	NPSS	NPSS	NPSS	NPSS	NPSS	NPSS	NPSS	NPSS	NPSS	NPSS	NPSS		
	24	NPBCH	NPSS	NPSS	NPSS	NPSS	NPSS	NPSS	NPSS	NPSS	NPSS	NPSS	NPSS	NPSS	NPSS	NPSS	NPSS	NPSS	NPSS	NPSS	NPSS	NPSS	NPSS	NPSS	NPSS	NPSS	NPSS	NPSS	NPSS	NPSS	NPSS	NPSS	NPSS	NPSS	NPSS	NPSS	NPSS	NPSS	NPSS		
	28	NPBCH	NPSS	NPSS	NPSS	NPSS	NPSS	NPSS	NPSS	NPSS	NPSS	NPSS	NPSS	NPSS	NPSS	NPSS	NPSS	NPSS	NPSS	NPSS	NPSS	NPSS	NPSS	NPSS	NPSS	NPSS	NPSS	NPSS	NPSS	NPSS	NPSS	NPSS	NPSS	NPSS	NPSS	NPSS	NPSS	NPSS	NPSS		
	32	NPBCH	NPSS	NPSS	NPSS	NPSS	NPSS	NPSS	NPSS	NPSS	NPSS	NPSS	NPSS	NPSS	NPSS	NPSS	NPSS	NPSS	NPSS	NPSS	NPSS	NPSS	NPSS	NPSS	NPSS	NPSS	NPSS	NPSS	NPSS	NPSS	NPSS	NPSS	NPSS	NPSS	NPSS	NPSS	NPSS	NPSS	NPSS		
	36	NPBCH	NPSS	NPSS	NPSS	NPSS	NPSS	NPSS	NPSS	NPSS	NPSS	NPSS	NPSS	NPSS	NPSS	NPSS	NPSS	NPSS	NPSS	NPSS	NPSS	NPSS	NPSS	NPSS	NPSS	NPSS	NPSS	NPSS	NPSS	NPSS	NPSS	NPSS	NPSS	NPSS	NPSS	NPSS	NPSS	NPSS	NPSS		
SI-3	40	NPBCH	NPSS	NPSS	NPSS	NPSS	NPSS	NPSS	NPSS	NPSS	NPSS	NPSS	NPSS	NPSS	NPSS	NPSS	NPSS	NPSS	NPSS	NPSS	NPSS	NPSS	NPSS	NPSS	NPSS	NPSS	NPSS	NPSS	NPSS	NPSS	NPSS	NPSS	NPSS	NPSS	NPSS	NPSS	NPSS	NPSS	NPSS		
	44	NPBCH	NPSS	NPSS	NPSS	NPSS	NPSS	NPSS	NPSS	NPSS	NPSS	NPSS	NPSS	NPSS	NPSS	NPSS	NPSS	NPSS	NPSS	NPSS	NPSS	NPSS	NPSS	NPSS	NPSS	NPSS	NPSS	NPSS	NPSS	NPSS	NPSS	NPSS	NPSS	NPSS	NPSS	NPSS	NPSS	NPSS	NPSS		
	48	NPBCH	NPSS	NPSS	NPSS	NPSS	NPSS	NPSS	NPSS	NPSS	NPSS	NPSS	NPSS	NPSS	NPSS	NPSS	NPSS	NPSS	NPSS	NPSS	NPSS	NPSS	NPSS	NPSS	NPSS	NPSS	NPSS	NPSS	NPSS	NPSS	NPSS	NPSS	NPSS	NPSS	NPSS	NPSS	NPSS	NPSS	NPSS		
	52	NPBCH	NPSS	NPSS	NPSS	NPSS	NPSS	NPSS	NPSS	NPSS	NPSS	NPSS	NPSS	NPSS	NPSS	NPSS	NPSS	NPSS	NPSS	NPSS	NPSS	NPSS	NPSS	NPSS	NPSS	NPSS	NPSS	NPSS	NPSS	NPSS	NPSS	NPSS	NPSS	NPSS	NPSS	NPSS	NPSS	NPSS	NPSS		
	56	NPBCH	NPSS	NPSS	NPSS	NPSS	NPSS	NPSS	NPSS	NPSS	NPSS	NPSS	NPSS	NPSS	NPSS	NPSS	NPSS	NPSS	NPSS	NPSS	NPSS	NPSS	NPSS	NPSS	NPSS	NPSS	NPSS	NPSS	NPSS	NPSS	NPSS	NPSS	NPSS	NPSS	NPSS	NPSS	NPSS	NPSS	NPSS		
SI-1	60	NPBCH	NPSS	NPSS	NPSS	NPSS	NPSS	NPSS	NPSS	NPSS	NPSS	NPSS	NPSS	NPSS	NPSS	NPSS	NPSS	NPSS	NPSS	NPSS	NPSS	NPSS	NPSS	NPSS	NPSS	NPSS	NPSS	NPSS	NPSS	NPSS	NPSS	NPSS	NPSS	NPSS	NPSS	NPSS	NPSS	NPSS	NPSS		
	64	NPBCH	NPSS	NPSS	NPSS	NPSS	NPSS	NPSS	NPSS	NPSS	NPSS	NPSS	NPSS	NPSS	NPSS	NPSS	NPSS	NPSS	NPSS	NPSS	NPSS	NPSS	NPSS	NPSS	NPSS	NPSS	NPSS	NPSS	NPSS	NPSS	NPSS	NPSS	NPSS	NPSS	NPSS	NPSS	NPSS	NPSS	NPSS		
	68	NPBCH	NPSS	NPSS	NPSS	NPSS	NPSS	NPSS	NPSS	NPSS	NPSS	NPSS	NPSS	NPSS	NPSS	NPSS	NPSS	NPSS	NPSS	NPSS	NPSS	NPSS	NPSS	NPSS	NPSS	NPSS	NPSS	NPSS	NPSS	NPSS	NPSS	NPSS	NPSS	NPSS	NPSS	NPSS	NPSS	NPSS	NPSS		
	72	NPBCH	NPSS	NPSS	NPSS	NPSS	NPSS	NPSS	NPSS	NPSS	NPSS	NPSS	NPSS	NPSS	NPSS	NPSS	NPSS	NPSS	NPSS	NPSS	NPSS	NPSS	NPSS	NPSS	NPSS	NPSS	NPSS	NPSS	NPSS	NPSS	NPSS	NPSS	NPSS	NPSS	NPSS	NPSS	NPSS	NPSS	NPSS		
	76	NPBCH	NPSS	NPSS	NPSS	NPSS	NPSS	NPSS	NPSS	NPSS	NPSS	NPSS	NPSS	NPSS	NPSS	NPSS	NPSS	NPSS	NPSS	NPSS	NPSS	NPSS	NPSS	NPSS	NPSS	NPSS	NPSS	NPSS	NPSS	NPSS	NPSS	NPSS	NPSS	NPSS	NPSS	NPSS	NPSS	NPSS	NPSS		
SI-2	80	NPBCH	NPSS	NPSS	NPSS	NPSS	NPSS	NPSS	NPSS	NPSS	NPSS	NPSS	NPSS	NPSS	NPSS	NPSS	NPSS	NPSS	NPSS	NPSS	NPSS	NPSS	NPSS	NPSS	NPSS	NPSS	NPSS	NPSS	NPSS	NPSS	NPSS	NPSS	NPSS	NPSS	NPSS	NPSS	NPSS	NPSS	NPSS		
	84	NPBCH	NPSS	NPSS	NPSS	NPSS	NPSS	NPSS	NPSS	NPSS	NPSS	NPSS	NPSS	NPSS	NPSS	NPSS	NPSS	NPSS	NPSS	NPSS	NPSS	NPSS	NPSS	NPSS	NPSS	NPSS	NPSS	NPSS	NPSS	NPSS	NPSS	NPSS	NPSS	NPSS	NPSS	NPSS	NPSS	NPSS	NPSS		
	88	NPBCH	NPSS	NPSS	NPSS	NPSS	NPSS	NPSS	NPSS	NPSS	NPSS	NPSS	NPSS	NPSS	NPSS	NPSS	NPSS	NPSS	NPSS	NPSS	NPSS	NPSS	NPSS	NPSS	NPSS	NPSS	NPSS	NPSS	NPSS	NPSS	NPSS	NPSS	NPSS	NPSS	NPSS	NPSS	NPSS	NPSS	NPSS		
	92	NPBCH	NPSS	NPSS	NPSS	NPSS	NPSS	NPSS	NPSS	NPSS	NPSS	NPSS	NPSS	NPSS	NPSS	NPSS	NPSS	NPSS	NPSS	NPSS	NPSS	NPSS	NPSS	NPSS	NPSS	NPSS	NPSS	NPSS	NPSS	NPSS	NPSS	NPSS	NPSS	NPSS	NPSS	NPSS	NPSS	NPSS	NPSS		
	96	NPBCH	NPSS	NPSS	NPSS	NPSS	NPSS	NPSS	NPSS	NPSS	NPSS	NPSS	NPSS	NPSS	NPSS	NPSS	NPSS	NPSS	NPSS	NPSS	NPSS	NPSS	NPSS	NPSS	NPSS	NPSS	NPSS	NPSS	NPSS	NPSS	NPSS	NPSS	NPSS	NPSS	NPSS	NPSS	NPSS	NPSS	NPSS		
SI-3	100	NPBCH	NPSS	NPSS	NPSS	NPSS	NPSS	NPSS	NPSS	NPSS	NPSS	NPSS	NPSS	NPSS	NPSS	NPSS	NPSS	NPSS	NPSS	NPSS	NPSS	NPSS	NPSS	NPSS	NPSS	NPSS	NPSS	NPSS	NPSS	NPSS	NPSS	NPSS	NPSS	NPSS	NPSS	NPSS	NPSS	NPSS	NPSS		
	104	NPBCH	NPSS	NPSS	NPSS	NPSS	NPSS	NPSS	NPSS	NPSS	NPSS	NPSS	NPSS	NPSS	NPSS	NPSS	NPSS	NPSS	NPSS	NPSS	NPSS	NPSS	NPSS	NPSS	NPSS	NPSS	NPSS	NPSS	NPSS	NPSS	NPSS	NPSS	NPSS	NPSS	NPSS	NPSS	NPSS	NPSS	NPSS		
	108	NPBCH	NPSS	NPSS	NPSS	NPSS	NPSS	NPSS	NPSS	NPSS	NPSS	NPSS	NPSS	NPSS	NPSS	NPSS	NPSS	NPSS	NPSS	NPSS	NPSS	NPSS	NPSS	NPSS	NPSS	NPSS	NPSS	NPSS	NPSS	NPSS	NPSS	NPSS	NPSS	NPSS	NPSS	NPSS	NPSS	NPSS	NPSS		
	112	NPBCH	NPSS	NPSS	NPSS	NPSS	NPSS	NPSS	NPSS	NPSS	NPSS	NPSS	NPSS	NPSS	NPSS	NPSS	NPSS	NPSS	NPSS	NPSS	NPSS	NPSS	NPSS	NPSS	NPSS	NPSS	NPSS	NPSS	NPSS	NPSS	NPSS	NPSS	NPSS	NPSS	NPSS	NPSS	NPSS	NPSS	NPSS		
	116	NPBCH	NPSS	NPSS	NPSS	NPSS	NPSS	NPSS	NPSS	NPSS	NPSS	NPSS	NPSS	NPSS	NPSS	NPSS	NPSS	NPSS	NPSS	NPSS	NPSS	NPSS	NPSS	NPSS	NPSS	NPSS	NPSS	NPSS	NPSS	NPSS	NPSS	NPSS	NPSS	NPSS	NPSS	NPSS	NPSS	NPSS	NPSS		
SI-1	120	NPBCH	NPSS	NPSS	NPSS	NPSS	NPSS	NPSS	NPSS	NPSS	NPSS	NPSS	NPSS	NPSS	NPSS	NPSS	NPSS	NPSS	NPSS	NPSS	NPSS	NPSS	NPSS	NPSS	NPSS	NPSS	NPSS	NPSS	NPSS	NPSS	NPSS	NPSS	NPSS	NPSS	NPSS	NPSS	NPSS	NPSS	NPSS		
	124	NPBCH	NPSS	NPSS	NPSS	NPSS	NPSS	NPSS	NPSS	NPSS	NPSS	NPSS	NPSS	NPSS	NPSS	NPSS	NPSS	NPSS	NPSS	NPSS	NPSS	NPSS	NPSS	NPSS	NPSS	NPSS	NPSS	NPSS	NPSS	NPSS	NPSS	NPSS	NPSS	NPSS	NPSS	NPSS	NPSS	NPSS	NPSS		
	128	NPBCH	NPSS	NPSS	NPSS	NPSS	NPSS	NPSS	NPSS	NPSS	NPSS	NPSS	NPSS	NPSS	NPSS	NPSS	NPSS	NPSS	NPSS	NPSS	NPSS	NPSS	NPSS	NPSS	NPSS	NPSS	NPSS	NPSS	NPSS	NPSS	NPSS	NPSS	NPSS	NPSS	NPSS	NPSS	NPSS	NPSS	NPSS		
	132	NPBCH	NPSS	NPSS	NPSS	NPSS	NPSS	NPSS	NPSS	NPSS	NPSS	NPSS	NPSS	NPSS	NPSS	NPSS	NPSS	NPSS	NPSS	NPSS	NPSS	NPSS	NPSS	NPSS	NPSS	NPSS	NPSS	NPSS	NPSS	NPSS	NPSS	NPSS	NPSS	NPSS	NPSS	NPSS	NPSS	NPSS	NPSS		
	136	NPBCH	NPSS	NPSS	NPSS	NPSS	NPSS	NPSS	NPSS	NPSS	NPSS	NPSS	NPSS	NPSS	NPSS	NPSS	NPSS	NPSS	NPSS	NPSS	NPSS	NPSS	NPSS	NPSS	NPSS	NPSS	NPSS	NPSS	NPSS	NPSS	NPSS	NPSS	NPSS	NPSS	NPSS	NPSS	NPSS	NPSS	NPSS		
140	NPBCH	NPSS	NPSS	NPSS	NPSS	NPSS	NPSS	NPSS	NPSS	NPSS	NPSS	NPSS	NPSS	NPSS	NPSS	NPSS	NPSS	NPSS	NPSS	NPSS	NPSS	NPSS	NPSS	NPSS	NPSS	NPSS	NPSS	NPSS	NPSS	NPSS	NPSS	NPSS	NPSS	NPSS	NPSS	NPSS	NPSS	NPSS			

With

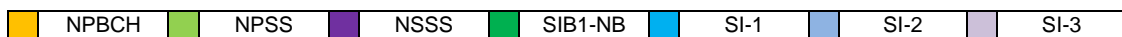

7A.2.3 System information modification

According to TS 36.331 [19] for normal DRX the modification period for change of system information is

$$\text{ModificationPeriod} = \text{modificationPeriodCoeff} * \text{defaultPagingCycle}$$

(modificationPeriodCoeff, defaultPagingCycle are given by SIB signalling).

Editor's note: eDRX is FFS

TTCN implementation is responsible to wait long enough to ensure that the UE has acquired the new system information. With modificationPeriodCoeff=n32 and defaultPagingCycle=rf128 this means that TTCN needs to wait more than 40s to be sure that the UE has got the change.

As working assumption it is sufficient to schedule just one paging message or one direct indication in a modification period to indicate change of system information in the next modification period.

7A.3 Search space configurations

There are 3 kinds of search spaces in NB-IoT (TS 36.213 [30] clause 16.6):

- Type1-NPDCCH common search space (Type1CSS): Paging
- Type2-NPDCCH common search space (Type2CSS): Random access
- NPDCCH UE-specific search space (UESS): UL grants and DL assignments for UE in connected mode

The search spaces define in which time windows the network may schedule DL assignments and UL grants.

Scheduling of DL assignments and UL grants is not possible in subframes occupied by system information or synchronisation signals or in subframes outside the respective search space.

- Timing of NB-IoT conformance test cases strongly depends on the system information scheduling (see clause 7A.2.2) and the search space configurations described in this clause.

In addition it is the responsibility of the SS to determine the exact timing for scheduling of DL assignments and UL grants.

Table 7A.3-1 shows the relevant parameters for search space calculations.

Table 7A.3-1: Parameters for search space calculations

R_{max}	Type1CSS	configured in SIB2-NB (PCCH-Config-NB-r13)
	Type2CSS	configured in SIB2-NB (NPRACH-Parameters-NB-r13)
	UESS	configured in RadioResourceConfigDedicated-NB-r13 (NPDCCH-ConfigDedicated-NB-r13)
G	Type1CSS	(not applicable)
	Type2CSS	configured in SIB2-NB (NPRACH-Parameters-NB-r13)
	UESS	configured in RadioResourceConfigDedicated-NB-r13 (NPDCCH-ConfigDedicated-NB-r13)
α_{offset}	Type1CSS	(not applicable)
	Type2CSS	configured in SIB2-NB (NPRACH-Parameters-NB-r13)
	UESS	configured in RadioResourceConfigDedicated-NB-r13 (NPDCCH-ConfigDedicated-NB-r13)
T	Type1CSS	DRX cycle according to PCCH-Config-NB-r13.defaultPagingCycle-r13
	Type2CSS	search space cycle: $R_{max} * G$
	UESS	search space cycle: $R_{max} * G$
R	Type1CSS	depends on R_{max} and the "DCI subframe repetition number" in the DCI format N2 as shown in TS 36.213 [30] table 16.6-2
	Type2CSS	depends on R_{max} and the "DCI subframe repetition number" in the DCI format N1 as shown in TS 36.213 [30] table 16.6-3
	UESS	depends on R_{max} and the "DCI subframe repetition number" in the DCI format N0/N1 as shown in TS 36.213 [30] table 16.6-1

7A.3.1 Type1CSS - Paging

For NB-IoT the same calculations for paging are applied as for WB-E-UTRA (TS 36.304 [14] clause 7), but in contrast to WB-E-UTRA the paging does not happen at the paging occasion itself, but the Type1-NPDCCH common search space starts at the paging occasion according to TS 36.213 [30] clause 16.6: DCI with format N2 is sent out on NPDCCH from the next suitable subframe onward (starting at the paging occasion).

As for WB-E-UTRA the paging occasion is calculated by TTCN and provided to SS as timing information of the system request. The SS shall schedule the DCI and the corresponding paging message (if any) according to the given configuration of the Type1CSS, PCCH configuration and according to the rules provided by core specifications (mainly TS 36.213 [30] clause 16).

7A.3.2 Type2CSS – Random access

In principle the same considerations can be applied as for the UESS (see below).

7A.3.3 UESS

Taking into account the SIB scheduling as described in clause 7A.2 and applying parameters for the UESS as per TS 36.508 [3] UESS configuration results in

Table 7A.3.3-1: Parameters for UESS

R_{max}	16	according to TS 36.508 [3] table 8.1.6.3-3
G	4	according to TS 36.508 [3] table 8.1.6.3-3
α_{offset}	0	according to TS 36.508 [3] table 8.1.6.3-3
T	64	$R_{max} * G$
R	2	according to DCI subframe repetition number in TS 36.508 [3] Table 8.1.3.6.1.2-2 and parameters as above

- according to TS 36.213 [30] clause 16.6

the search spaces start at $k_0 = 0, 64, 128, 192, 256, \dots$

the candidates within a search space start at $b = R * u = 0, 2, 4, 6, 8, 10, 12, 14.$

Table 7A.3.3-2: Scheduling of UESS

K	SFN = K									SFN = K + 1									SFN = K + 2									SFN = K + 3																					
	0	1	2	3	4	5	6	7	8	9	0	1	2	3	4	5	6	7	8	9	0	1	2	3	4	5	6	7	8	9	0	1	2	3	4	5	6	7	8	9									
0	NPBCH	NPBCH	NPBCH	NPBCH	NPBCH	NPBCH	NPBCH	NPBCH	NPBCH	NPBCH	NPBCH	NPBCH	NPBCH	NPBCH	NPBCH	NPBCH	NPBCH	NPBCH	NPBCH	NPBCH	NPBCH	NPBCH	NPBCH	NPBCH	NPBCH	NPBCH	NPBCH	NPBCH	NPBCH	NPBCH	NPBCH	NPBCH	NPBCH	NPBCH	NPBCH	NPBCH	NPBCH	NPBCH	NPBCH	NPBCH	NPBCH	NPBCH	NPBCH	NPBCH	NPBCH	NPBCH	NPBCH	NPBCH	
4																																																	
8																																																	
12																																																	
16																																																	
20																																																	
24																																																	
28																																																	
32																																																	
36																																																	
40																																																	
44																																																	
48																																																	
52																																																	
56																																																	
60																																																	
64																																																	
68																																																	
72																																																	
76																																																	

With

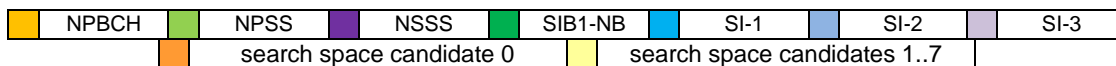

NOTE 1: Depending on SS configuration in general the first search space candidate can be used for the transmission of the DCI. Therefore the first search space candidate is highlighted in table 7A.3.3-2.

7A.4 Timing considerations

Based on SIB scheduling and search space configuration as described in the previous clauses timing considerations are made as below.

7A.4.1 Random access procedure

Details regarding random access procedure in NB-IoT are specified in clause 16.3 of TS 36.213 [30] and clause 5.1 of TS 36.321 [16]. The timing of a random access procedure in NB-IoT is illustrated in table 7A.4.1-1.

Table 7A.4.1-1: Timing of random access procedure

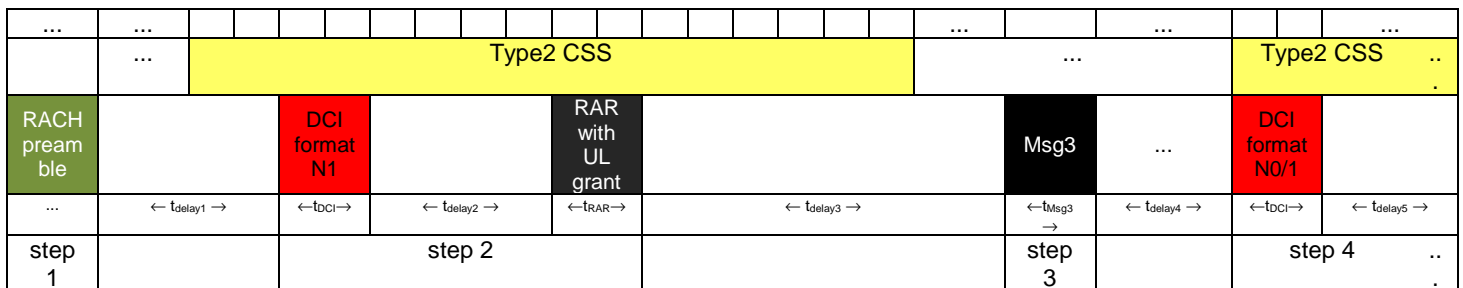

with

steps 1-4	Random access procedure according to TS 36.300 [69] clause 10.1.5.1: step 2: RAR is addressed to RA-RNTI step 3: Msg3 contains either a CCCH SDU (a) or the C-RNTI (b) step 4: a) temporary C-RNTI based contention resolution (DL assignment for Msg4) b) C-RNTI based contention resolution (UL grant) NOTE: According to TS 36.213 [30] clause 16.5.1, Table 16.5.1-4 and clause 16.4.1, Table 16.4.1-5 the DCI for step 4 is sent on NPDCCH in the Type2 common search space	
t_{delay1}	$\geq 3\text{ms}$ (but up to $\geq 50\text{ms}$)	depends on Type2-CSS configuration, start of RA response window according to TS 36.321 [16] clause 5.1.4 and when the RACH preamble happens
t_{DCI}	$\geq 2\text{ms}$	for $R_{\text{max}} = 16$ and DCI subframe repetition number = 0 (TS 36.213 [30] clause 16.6)
t_{delay2}	$\geq 4\text{ms}$	scheduling delay according to DCI (TS 36.213 [30] clause 16.4.1 and table 16.4.1-1)
t_{RAR}	$\geq 1\text{ms}$	depending on TBS and number of repetitions (TS 36.213 [30] clause 16.4.1)
t_{delay3}	$\geq 12\text{ms}$	scheduling delay according to RAR grant (TS 36.213 [30] clause 16.3.3)
t_{Msg3}	$\geq 1\text{ms}$	depending on MSC index and number of repetitions according to RAR grant; the TBS is 88 bits in all cases (TS 36.213 [30] clause 16.3.3)
t_{delay4}	$\geq 3\text{ms}$	delay before the UE monitors NPDCCH again (TS 36.213 [30] clause 16.6)
t_{delay5}	$\geq 13\text{ms}$	depending on whether UL or DL transmission follows, see clause 7A.4.2 and 7A.4.3

NOTE 1: In addition to the delay in table 7A.4.1-1 there is further delay caused by PBCH, NPSS, NSSS, SI transmissions.

NOTE 2: Assuming a search space configuration as per clause 7A.3 in general a random access procedure needs more than two search space cycles.

7A.4.2 Uplink transmissions

Table 7A.4.2-1: Timing of uplink transmissions

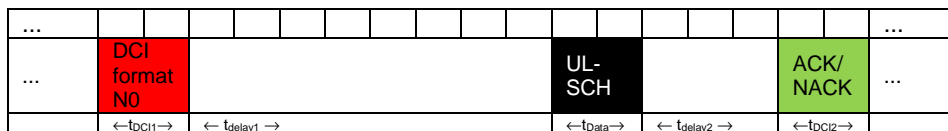

with

t_{DCI1}	$\geq 2\text{ms}$	for $R_{\text{max}} = 16$ and DCI subframe repetition number = 0 (TS 36.213 [30] clause 16.6)
t_{delay1}	$\geq 8\text{ms}$	according to TS 36.213 [30] table 16.5.1-1
t_{Data}	$\geq 1\text{ms}$	depending on TBS and number of repetitions (TS 36.213 [30] clause 16.5.1 and TS 36.211 Table 10.1.2.3-1) (NOTE 4)
t_{delay2}	$\geq 3\text{ms}$	according to TS 36.213 [30] clause 16.5.2
t_{DCI2}	$\geq 2\text{ms}$	(same as t_{DCI1})

NOTE 1: In addition to the delay in table 7A.4.2-1 there is further delay caused by PBCH, NPSS, NSSS, SI transmissions.

NOTE 2: Assuming a search space configuration as per clause 7A.3 in general an uplink transmission takes one search space cycle.

NOTE 3: Even when in case of necessary UL re-transmission the grant for the re-transmission is sent immediately using adaptive HARQ NACK it is hardly predictable how many search space cycles the complete successful transmission takes. Nevertheless one re-transmission may still be finished in the same search space cycle in which the initial UL has been scheduled.

NOTE 4: For single tone ($N_{sc}^{RU} = 1$) according to TS 36.213 [30] Table 16.5.1.2-1 the maximum value of I_{TBS} is 10. Therefore according to table 16.5.1.2-2 the maximum grant of 1000 bits requires at least $I_{RU} = 5$ i.e. $t_{Data} \geq 6ms$ for maximum grant.

7A.4.3 Downlink transmissions

Table 7A.4.3-1: Timing of downlink transmissions

...																			...
...	DCI format N1				DL-SCH													ACK/NACK	...
	← t _{DCI} →	← t _{delay1} →			← t _{Data} →	← t _{delay2} →			← t _{ACK/NACK} →										

with

t _{DCI}	≥ 2ms	for $R_{max} = 16$ and DCI subframe repetition number = 0 (TS 36.213 [30] clause 16.6)
t _{delay1}	≥ 4ms	scheduling delay according to DCI (TS 36.213 [30] clause 16.4.1 and table 16.4.1-1)
t _{Data}	≥ 1ms	depending on TBS and number of repetitions (TS 36.213 [30] clause 16.4.1)
t _{delay2}	≥ 12ms	depending HARQ-ACK resource allocation according to TS 36.213 [30] clause 16.4.2
t _{ACK/NACK}	≥ 2ms	multiples of 2ms according to TS 36.211 [35] Table 10.1.2.3-1; depending on number of repetitions configured by RRC signalling (NPUSCH-ConfigCommon-NB-r13, NPUSCH-ConfigDedicated-NB-r13; $N_{Rep} \geq 1$)

NOTE 1: In addition to the delay in table 7A.4.3-1 there is further delay caused by PBCH, NPSS, NSSS, SI transmissions.

NOTE 2: Assuming a search space configuration as per clause 7A.3 in general a downlink transmission takes one search space cycle.

NOTE 3: Assuming a search space configuration as per clause 7A.3 in case of a HARQ NACK from the UE a re-transmission needs to be scheduled in the next search space cycle (as even when the DL transmission has been scheduled using the first search space candidate, at the point in time the SS detects the NACK there is no search space candidate in the current search space cycle anymore).

7A.4.4 Half-duplex mode

According to TS 36.211 [35] for NB-IoT only type-B half-duplex FDD operation is supported (clause 10.2.2.3) in which according to clause 4.1 the UE cannot transmit and receive at the same time.

In addition in clause 16.6 of TS 36.213 [30] there are further rules further restricting the timing of UL/DL transmissions summarised in table 7A.4.4-1 and table 7A.4.4-2.

Table 7A.4.4-1: Uplink transmissions

	n	n+1	...	n+k-1	n+k			n ₁	n ₁ +1	n ₁ +2	n ₁ +3		
DCI Format N0					NPUSCH transmission							ACK/NA CK (NPDCCH)	
	UL-SCH transmission: NPDCCH not monitored by the UE												

Table 7A.4.4-2: Downlink transmissions

	n	n+1											n+k-1	n+k			n _i	n _i +1	n _i +2	n _i +3
DCI Format N1																				
	DL-SCH transmission: NPDCCH not monitored by the UE																			

7A.4.5 Conclusions

Based on the system information scheduling as in clause 7A.2 and search space configuration as in clause 7A.3 the following conclusions are made:

- Random access procedure:
After detection of the random access preamble steps 2-4 of the random access procedure take at least two search space cycles.
- Uplink and downlink transmissions:
In general an UL or DL transmission takes one search space cycle and UL/DL transmission are mutually exclusive, i.e. a search space cycle can be either for UL or for DL.

7A.5 Scheduling requests and scheduling of UL grants

As there is no NPUCCH in NB-IoT the UE cannot directly indicate scheduling requests to the network. Instead according to TS 36.321 [16] clause 5.4.4 the UE starts with a RACH procedure, unless an SR-ProhibitTimer is configured by RRC signalling.

- NOTE 1: It seems not to be reliable that, when no SR-ProhibitTimer is configured, the UE will use an UL grant being scheduled in advance.
- NOTE 2: It seems not to be reliable that a UE uses an UL grant addressed with C-RNTI when it has already started a RACH procedure and is waiting for the RA response being addressed by the RA-RNTI. Furthermore there is no core spec reference about the UE to abort the RACH procedure in this case.
- In terms of UL scheduling there are two modes for the UE in RRC connected mode: RACH procedure mode and polling mode.

7A.5.1 RACH procedure mode

UL grant scheduling is triggered by a RACH procedure and the subsequent evaluation of BSRs. There is no explicit scheduling of UL grants in advance.

The SS assigns UL grants according to RACH procedure configuration and common MAC configuration (DCI format N0 configuration of UL grants).

- NOTE: In case of uncorrelated UL and DL transmissions there may be race conditions resulting in the UE having started a random access procedure already when the SS schedules the DL transmission. In this case the UE may not read the DL assignment anymore and therefore not receive the DL data.

7A.5.2 Polling mode

SR-ProhibitTimer (logicalChannelSR-Prohibit-r13 according to release 13 ASN.1, TS 36.331 [19]) is configured at the UE (for each logical channel) and the SS polls the UE with UL grants: When the UE has UL data pending it will use a given grant; the UE in connected mode will not start any RACH procedure while SR-ProhibitTimer is running.

The SS gets configured with periodic UL grants to be assigned to the UE: grant size, periodicity, total number of grants.

7A.6 Scheduling requirements

As conclusion of the above timing and scheduling considerations this clause defines SS requirements about how to schedule UL grants and DL assignments.

7A.6.1 Random access procedure

The SS gets configured with:

- configuration of the Type2 common search space (R_{\max} , G , α_{offset})
- Type 2 common search space candidate to schedule RAR
- Type 2 common search space candidate to schedule DL assignment or UL grant at step 4 of the random access procedure
- UL grant to be provided in RAR
- DCI for DL assignment of Msg4 in case of temporary C-RNTI based contention resolution
- For C-RNTI based contention resolution (RACH procedure mode):
DCI for UL grants to be used at step 4 of the random access procedure and for any subsequent UL transmissions (if any)

The SS shall:

- when it has detected a RACH preamble, wait until start of the next Type2 common search space within the RA response window and schedule the Random Access Response containing the UL grant for Msg3 by using the Type2 common search space candidate as configured
- after it has received Msg3, schedule a DL assignment or UL grant in the next Type2 common search space by using the search space candidate as configured
- in case of RACH procedure with C-RNTI based contention resolution (i.e. UE in connected mode), check whether the UL MAC PDU sent at step 4 of the random access procedure contains a BSR element indicating that the UE needs more UL grant. If so, the SS shall use the ACK/NACK response corresponding to step 4's UL transmission as specified in clause 16.5.2 of TS 36.213 [30] to schedule another UL grant as configured at the SS (\Rightarrow the SS shall not do any dynamic calculation for the UL grant based on the details of the BSR); this shall be repeated until the UE does not indicate need for further UL grant anymore. Pending DL transmissions shall be postponed until after all UL data has been received.
NOTE: This rule applies for RACH procedure mode according to clause 7A.5.1.
- in case of RACH procedure with C-RNTI based contention resolution (i.e. UE in connected mode), not use any adaptive HARQ ACK to schedule a DL transmission.

7A.6.2 Downlink transmissions

The SS gets configured with:

- configuration of the UE specific search space (R_{\max} , G , α_{offset})
- search space candidate to be used for DL assignments within the search space
- DCI to be used for DL assignments:
normal mode: transport block size, I_{TBS} and I_{SF} to be automatically determined by the SS
explicit mode: DCI with I_{TBS} , I_{SF} provided by TTCN

When the SS gets a message from TTCN to be sent in DL it shall:

- when the timing info is now, schedule the DL assignment in the next search space not being used for HARQ re-transmissions.
- when a specific timing info is given, schedule the DL assignment by using the configured search space candidate in the next NPDCCH period starting at or after the given point in time. If for any reason there is an ongoing UL or DL transmission so that the UE may not monitor the NPDCCH, the SS shall raise an error.
NOTE: The search space candidate is given as index (0..7) in the configuration of the UE specific search space corresponding to u in the calculations of clause 16.6 in TS 36.213 [30].
- when timing info is "now" and a previous DL transmission is still pending, schedule the DL assignment of the 2nd message in the search space starting after the HARQ ACK of the 1st message.

- when e.g. an RRC message containing user data needs to be segmented by the RLC layer transmission of the resulting transport blocks shall be scheduled in consecutive search space cycles and the given timing info is applied for the first transmission.
- when TBS, I_{TBS} and I_{SF} shall be determined by the SS, use the mapping according to table 7A.6.2-1, otherwise use I_{TBS} and I_{SF} as provided by TTCN.

Table 7A.6.2-1: DL Resource allocation in normal mode

amount of pending DL data (bits): N_{Data}	TBS to be chosen by the SS	I_{TBS} (NOTE)	I_{SF} (NOTE)	Comment
$N_{Data} \leq 16$	16	0	0	
$16 < N_{Data} \leq 24$	24	1	0	
$24 < N_{Data} \leq 32$	32	2	0	
$32 < N_{Data} \leq 40$	40	3	0	
$40 < N_{Data} \leq 56$	56	4	0	
$56 < N_{Data} \leq 72$	72	5	0	
$72 < N_{Data} \leq 88$	88	6	0	
$88 < N_{Data} \leq 104$	104	7	0	
$104 < N_{Data} \leq 120$	120	8	0	
$120 < N_{Data} \leq 136$	136	9	0	
$136 < N_{Data} \leq 144$	144	10	0	TBS=152 skipped as it would require $I_{SF}=5$ (NOTE 1)
$144 < N_{Data} \leq 176$	176	6	1	NOTE 2
$176 < N_{Data} \leq 208$	208	4	2	NOTE 2
$208 < N_{Data} \leq 224$	224	4	2	NOTE 2
$224 < N_{Data} \leq 256$	256	8	1	
$256 < N_{Data} \leq 296$	296	9	1	
$296 < N_{Data} \leq 328$	328	10	1	TBS=344 skipped as it would require $I_{SF}=7$ (NOTE 1)
$328 < N_{Data} \leq 392$	392	8	2	TBS=376 skipped as it would require $I_{TBS}=11$ (NOTE 2) TBS=408 skipped as it would require $I_{SF}=5$ (NOTE 1) TBS=424 skipped as it would require $I_{SF}=4$ (NOTE 1) TBS=440 skipped as it would require either $I_{TBS}=12$ (NOTE 2) or $I_{SF}=6$ (NOTE 1)
$392 < N_{Data} \leq 456$	456	9	2	
$456 < N_{Data} \leq 472$	472	7	3	
$472 < N_{Data} \leq 504$	504	10	2)
$504 < N_{Data} \leq 536$	536	8	3	TBS=552 skipped as it would require $I_{SF}=6$ (NOTE 1) TBS=568 skipped as it would require $I_{SF}=7$ (NOTE 1)
$536 < N_{Data} \leq 616$	616	9	3	TBS=584 skipped as it would require either $I_{TBS}=11$ (NOTE 2) or $I_{SF}=4$ (NOTE 1) TBS=600 skipped as it would require $I_{SF}=5$ (NOTE 1)
$616 < N_{Data}$	680	10	3	NOTE 2
NOTE 1: According to TS 36.213 [30] Table 16.4.1.5.1-1				
NOTE 2: According to TS 36.213 [30] clause 16.4.1.5.1 for <i>operationModeInfo</i> set to '00' or '01' (Inband Operation Mode) I_{TBS} is $0 \leq I_{TBS} \leq 10$				

- $I_{SF} \leq 3$ for all DL transmission (i.e. a DL transmission needs not more than 4 NB-IoT DL subframes, which is needed for maximum TBS of 680)

7A.6.3 Periodic uplink grants

Periodic scheduling of UL grants applies for polling mode according to clause 7A.5.2, i.e. in general the UE is configured with SR-ProhibitTimer(s) to be prevented from triggering RACH procedures in connected mode.

The SS gets configured with:

- configuration of the UE specific search space (R_{max} , G , α_{offset})
- search space candidate to be used for UL grants within the search space
- configuration of grant scheduling:

- DCI of the UL grants
- number of UL grants to be scheduled: one grant only, several, continuous
- periodicity: every search space, every 2nd search space, ...

When the SS gets configured for periodic scheduling of uplink grants, the SS shall:

- start UL grant scheduling with the next available search space candidate as configured for the UE specific search space after the given timing information (which can be "now" or a specific point in time).
- not give any additional grants base on buffer status reporting by the UE.
- not use the adaptive HARQ ACK to schedule another transmission.
- when DL transmission is scheduled, postpone any UL grant which would be scheduled for the same search space by one search space cycle.
NOTE: the periodicity is related to beginning of the UL grant scheduling i.e. independent from whether or not a single grant is postponed.

Table 7A.6.3-1 gives an example for periodic UL grant scheduling for a periodicity of every 3rd search space cycle: at UESS cycle 7 the UL grant is postponed to cycle 8 due to DL transmission.

Table 7A.6.3-1: Periodic UL grant scheduling – Example for UL and DL transmissions

...	UESS cycle 1	UESS cycle 2	UESS cycle 3	UESS cycle 4	UESS cycle 5	UESS cycle 6	UESS cycle 7	UESS cycle 8	UESS cycle 9	UESS cycle 10	...
UL grant configuration	UL		DL	UL			DL	UL		UL	

7A.6.4 HARQ re-transmissions

NOTE: HARQ re-transmission are considered being rare in a RF cabled test environment. Nevertheless depending on test requirements HARQ re-transmissions may be tolerated at least for some test cases.

The SS shall report HARQ errors to TTCN if HARQ error reporting is configured by TTCN.

7A.6.4.1 Uplink

When the SS needs to request a re-transmission in uplink, it shall use adaptive HARQ ACK/NACK to indicate the NACK to the UE. ⇒ The re-transmission shall be scheduled immediately by using the ACK/NACK response corresponding to the UL transmission as specified in clause 16.5.2 of TS 36.213 [30] independent from any UL grant scheduling.

If the re-transmission is not successfully finished within the search cycle in which the transmission has been started, i.e. a second search space cycle is needed to complete the UL transmission, the SS shall:

- if a DL transmission is pending with timing info "now":
postpone the DL transmission
- if DL transmission is scheduled explicitly for the second search space cycle:
raise an error
- if an UL grant is scheduled for the second search space cycle:
postpone this UL grant for one cycle.

7A.6.4.2 Downlink

When the UE indicates a HARQ NACK to the SS for a DL transmission in search space cycle N, the SS shall re-schedule the DL assignment in search space cycle N+1.

The SS shall:

- if a another DL transmission is pending with timing info "now":
postpone the DL transmission
- if DL transmission is scheduled explicitly for the second search space cycle:
raise an error
- if an UL grant is scheduled for the second search space cycle:
postpone this UL grant for one cycle.

Depending on test requirements, the SS may get configured to generate a CRC error for a DL transmission corresponding to a configured DCI. In this case the DCI may be reconfigured before the retransmission happens. Therefore the SS shall not re-use the DCI of the initial transmission but shall consider a possible reconfiguration of the DCI.

7A.6.5 Timing info for UL messages

The SS shall provide the H-SFN, SFN and subframe number of the subframe corresponding to the first RU of the NPUSCH transmission. It is up to TTCN implementation to derive other timing information if needed (e.g. the start of the corresponding search space).

NOTE: E.g. in case of IP data a layer 3 message carrying the user data on the control plane may be segmented by the RLC layer. In this case the timing info shall be related to the first segment.

7A.6.6 Uplink time alignment

As for legacy LTE the SS can be configured to periodically send Timing Advance Commands to the UE to prevent the UE from starting a RACH procedure due to expiry of the Time Alignment Timer. When the Time Alignment Timer at the UE is set to infinity, the SS is configured not to do any automatic transmission of Timing Advance Commands.

7A.7 RRC Connection Release Sequence

According to TS 36.331 [19], clause 5.3.8.3, after reception of the RRCConnectionRelease the UE may either wait 10s or for indication of acknowledgement from lower layer. Furthermore according to TS 36.331 [19], clause 5.3.12, upon leaving RRC_CONNECTED the UE resets layer 2.

- As the UE resets layer 2 anyway after 60ms there is no need to provide the UE with UL grants for layer 2 signalling (e.g. RLC ACK).

Assuming search space cycles of 64ms as described in clause 7A.3 and with a given search space cycle N starting at time T being at least 100ms in advance, TTCN scheduled schedules the RRC Connection Release Sequence as

1. At T: Start of search space cycle N:
Send RRCConnectionRelease, stop UL grants.
2. At T + 64ms: Start of search space cycle N+1:
Release security (optional; only when security has been configured).
3. At T + 80ms: Release SRBs and DRBs (if configured).
4. At T + 96ms: (Re-) configure SRBs.
5. Delay of 11000ms from T onward (NOTE)

NOTE: The delay 11000ms is 10s delay according to TS 36.331 [19] + 10% to ensure the UE is re-camping on the cell and has read relevant system information, MIB, SIB1, SIB2 and all other SIs.

7A.8 DL CCCH Message and Contention Resolution MAC Control Element transmission in one MAC PDU or in separate MAC PDUs

As the UE needs to know the configuration of the UE-specific search space to receive further DL messages being addressed with the C-RNTI, in case of temporary C-RNTI based contention resolution Msg4 of the random access procedure shall contain the DL CCCH message together with the Contention Resolution MAC Control Element transmission, i.e. in NB-IoT the DL CCCH cannot be sent in a separate DL message after contention resolution.

7A.9 Cell Configuration

7A.9.1 Cell Power Change

Please refer to clause 7.4.2

7A.9.2 Timing Parameters of Cells

To reduce interference for cells with same frequency the timing for these cells is shifted to avoid that NPSS and NSSS are transmitted at the same time. This is done by T_S values in multiples of 30720 (one subframe).

Table 7A.9.2-1 shows timing parameters for cells with frequencies according to Table 8.1.4.2-1 in TS 36.508 [3], Table 7A.9.2-2 shows timing parameters for cells with frequencies according to Table 8.1.4.2-4 in TS 36.508 [3], Table 7A.9.2-3 shows timing parameters for cells with frequencies according to Table 8.1.4.2-5 in TS 36.508 [3]; cells with same frequency are marked with the same colour.

Table 7A.9.2-1: Timing parameters of simulated NB-IoT cells – Batch1

Cell ID	SFN offset	Tcell (T_s)	Frequency (Table 8.1.4.2-1 in TS 36.508 [3])
Ncell 1	0	0	f1
Ncell 2	124	184320	f1
Ncell 3	257	150897	f2
Ncell 4	1000	61440	f1
Ncell 6	657	524	f3
Ncell 10	129	43658	f5
Ncell 11	957	92160	f1
Ncell 12	1015	181617	f2
Ncell 13	890	31244	f3
Ncell 14	680	300501	f4
Ncell 23	383	212337	f2

Table 7A.9.2-2: Timing parameters of simulated NB-IoT cells – Batch2 in same PLMN

Cell ID	SFN offset	Tcell (T_s)	Frequency (Table 8.1.4.2-4 in TS 36.508 [3])
Ncell 50	0	0	f1
Ncell 51	124	30720	f1
Ncell 52	257	150897	f2
Ncell 53	1000	61440	f1
Ncell 61	471	31244	f2

Table 7A.9.2-2: Timing parameters of simulated NB-IoT cells –Batch2 in different PLMNs

Cell ID	SFN offset	Tcell (Ts)	Frequency (Table 8.1.4.2-5 in TS 36.508 [3])
Ncell 50	0	0	f1
Ncell 51	124	30720	f1
Ncell 52	257	61440	f1
Ncell 53	1000	92160	f1
Ncell 54	752	32047	f2
Ncell 55	957	631	f2
Ncell 56	1015	31351	f2
Ncell 57	890	127200	f3/f1
Ncell 58	680	1327	f4/f2
Ncell 59	383	157920	f3/f1
Ncell 60	562	188640	f3/f1
Ncell 61	471	122880	f1
Ncell 62	595	153600	f1
Ncell 63	728	184320	f1

The Random Access Response Timing Advance is set to 0.

7A.9.3 Configuration of Multi-Cell Environment

Please refer to clause 7.4.5

7A.10 Timers and Timing Restrictions

Please refer to clause 7.8

7A.11 Error Indication

The SS shall raise an error indication in all cases of system errors or other unforeseen events at lower layers.

In addition the SS may get configured for HARQ error reporting, e.g. in cases when HARQ retransmissions would have unacceptable impact on the test behaviour.

Any error indication results in an "inconc" verdict in TTCN.

7A.12 NBIOT RSRQ Calculations

Please refer to clause 7.22

8 External Function Definitions

The following external functions are required to be implemented by the SS.

TTCN-3 External Function		
Name	fx_KeyDerivationFunction	
Description	Hashing function for Hashing algorithms as defined in TS 33.401 [24] SHA-256 encoding algorithm is used as KEY Description Function	
Parameters	KDF	KDF_HMAC_SHA_256 (no other KDF defined yet)
	Key	bit key
	String	string being constructed acc. to TS 33.401 [24], annex A
Return Value	256 bit derived key	

TTCN-3 External Function		
Name	fx_NasIntegrityAlgorithm	
Description	Apply integrity protection algorithm on a given octetstring	
Parameters	NAS PDU	octetstring according to TS 24.301 [21], clause 4.4.3.3 this shall include octet 6 to n of the security protected NAS message, i.e. the sequence number IE and the NAS message IE
	Integrity Algorithm	3 bits as defined in TS 24.301 [21], clause 9.9.3.23
	KNAS _{int}	Integrity key
	NAS COUNT	as documented in TS 24.301
	BEARER Id	fix value ('00000'B) acc. TS 33.401 [24], clause 8.1
	Direction	UL: 0 DL: 1 (acc. to TS 33.401 [24], clause B.1)
Return Value	Message Authentication Code (4 octets)	

TTCN-3 External Function		
Name	fx_NasCipherng	
Description	Apply cipherng on a given octetstring	
Parameters	NAS PDU	octetstring
	Cipherng Algorithm	3 bits as defined in TS 24.301 [21], clause 9.9.3.23
	KNAS _{enc}	Cipherng Key
	NAS COUNT	as documented in TS 24.301
	BEARER Id	fixed value ('00000'B) acc. TS 33.401 [24], clause 8.1
Return Value	cipherng octet string	

TTCN-3 External Function		
Name	fx_NasDecipherng	
Description	Apply decipherng on a given octetstring	
Parameters	cipherng NAS PDU	octetstring
	Cipherng Algorithm	3 bits as defined in TS 24.301 [21], clause 9.9.3.23
	KNAS _{enc}	Cipherng Key
	NAS COUNT	as documented in TS 24.301 [21]
	BEARER Id	fixed value ('00000'B) acc. TS 33.401 [24], clause 8.1
Return Value	decipherng octet string	

TTCN-3 External Function		
Name	fx_AsIntegrityAlgorithm	
Description	Apply integrity protection algorithm on a given octetstring	
Parameters	PDCP PDU	octetstring
	Integrity Algorithm	3 bits as defined in TS 33.401 [24]
	KRRC _{int}	Integrity key
	PDCP COUNT	octetstring, length 4
	BEARER Id	the value of the DRB identity minus one
	Direction	UL: 0 DL: 1 (acc. to TS 33.401 [24], clause B.2)
Return Value	Message Authentication Code (4 octets)	

TTCN-3 External Function		
Name	fx_AsCipherng	
Description	Apply cipherng on a given octetstring	
Parameters	SDU	octetstring
	Cipherng Algorithm	3 bits as defined in TS 33.401 [24]
	KRRC _{enc}	Cipherng Key
	PDCP COUNT	octetstring, length 4
	BEARER Id	the value of the DRB identity minus one
Return Value	cipherng octet string	

TTCN-3 External Function		
Name	fx_AsDeciphering	
Description	Apply deciphering on a given octetstring	
Parameters	ciphersed SDU	octetstring
	Ciphering Algorithm	3 bits as defined in TS 33.401 [24]
	KRRC _{enc}	Ciphering Key
	PDCP COUNT	octetstring, length 4
	BEARER Id	the value of the DRB identity minus one
Return Value	deciphered octet string	

TTCN-3 External Function		
Name	fx_GetSystemTime	
Description	Function to get the system time: Implementation is based on C standard library (time.h)	
Parameters	p_Struct_tm (out)	<p>p_Struct_tm returns local system time equivalent to "struct tm" as defined for C standard library (time.h or ctime):</p> <pre> type record Struct_tm_Type { integer tm_sec, // seconds after the minute // (0..61; see NOTE) integer tm_min, // minutes after the hour (0..59) integer tm_hour, // hours since midnight (0..23) integer tm_mday, // day of the month (1..31) integer tm_mon, // months since January (0..11) integer tm_year, // years since 1900 integer tm_wday, // days since Sunday (0..6) integer tm_yday, // days since January 1 (0..365) integer tm_isdst // Daylight Saving Time flag }; </pre> <p>NOTE: tm_sec is generally 0-59. Extra range to accommodate for leap seconds in certain systems</p> <p>C implementation:</p> <pre> time_t v_Now = time(NULL); struct tm *v_Tm = localtime(&v_Now); </pre>
	p_TimezoneInfo (out)	<p>p_TimezoneInfo returns the difference (in seconds) between the UTC time (GMT) and the local time (integer value);</p> <p>C implementation:</p> <pre> int timezone = (int)difftime(mktime(gmtime(&v_Now)), v_Now); </pre> <p>NOTE: p_TimezoneInfo does not consider daylight saving e.g. it is always 3600 for CET independent of summer/winter</p>
Return Value	None	

TTCN-3 External Function		
Name	fx_MD5_Hex	
Description	external function to calculate the MD5 Message-Digest Algorithm according to RFC 1321	
Parameters	Data	octetstring
Return Value	octetstring	

TTCN-3 External Function		
Name	fx_CalculateFCS32	
Description	32-bit frame check sequence (FCS) calculation according to ITU-T Recommendation V.42 [68] section 8.1.1.6.2 and TS36.304 [14] section 7.3.	
Parameters	p_Input	bitstring
Return Value	bitstring, length 32	

9 IXIT Proforma

This partial IXIT proforma contained in the present document is provided for completion, when the related Abstract Test Suite is to be used against the Implementation Under Test (IUT).

Text in *italics* is a comment for guidance for the production of an IXIT, and is not to be included in the actual IXIT.

The completed partial IXIT will normally be used in conjunction with the completed ICS, as it adds precision to the information provided by the ICS.

9.1 E-UTRAN PIXIT

Table 9.1-1: Common PIXIT

Parameter Name	Parameter Type	Default Value	Supported Values	Description
px_AccessPointName	octetstring			Access Point Name, as defined in TS 23.003 [48] and used in TS 24.008 [20], clause 10.5.6.1
px_AttachTypeTested	EUTRA_ATTACH_TESTED_Type	EPS_ATTACH_ONLY	EPS_ATTACH_ONLY, COMBINED_ATTACH	Attach Type to be tested, if UE supports both pc_Attach and pc_Combined_Attach
px_eAuthRAND	B128_Type	oct2bit('A3DE0C6D363E30C364A4078F1BF8D577'O)		Random Challenge
px_EllipsoidPointWithAltitude	O8_Type			Ellipsoid Point With Altitude value to be provided in Update UE location information (see 36.509 cl. 6.12)
px_HorizontalVelocity	O3_Type			Horizontal Velocity value to be provided in Update UE location information (see 36.509 cl. 6.12)
px_eJapanMCC_Band6	NAS_Mcc	'442'H		Japan MCC code to be used for Band 6. The same value will be used for E-UTRA and Inter-RAT cells. Type is different to that defined in TS 34.123-3 [7]
px_PWS_CB_DataPage1	charstring			ETWS or CMAS Page 1 warning data message
px_PWS_CB_DataPage2	charstring			ETWS or CMAS Page 2 warning data message
px_PWS_CB_DataPage3	charstring			ETWS or CMAS Page 3 warning data message
px_PWS_CB_DataPage4	charstring			ETWS or CMAS Page 4 warning data message
px_PWS_CB_DataCodingScheme	bitstring			ETWS or CMAS data coding scheme of the alphabet/coding and the applied language [see TS 23.041]
px_ETWS_DigitalSignature	O43_Type			ETWS Digital Signature
px_IPv4_Address1_UE	charstring			IPv4 Address connected to PDN1
px_IPv4_Address2_UE	charstring			IPv4 Address connected to PDN2
px_IPv4_Address2a_UE	charstring			IPv4 Address connected to PDN2a
px_IPv4_Address1_NW	charstring			IPv4 Gateway Address in PDN1
px_Ipv4_Address2_NW	charstring			Ipv4 Gateway Address in PDN2
px_IPv4_Address1_RemoteUE	charstring			IPv4 Address of remote UE connected to PDN1
px_IPv4_Address2_RemoteUE	charstring			IPv4 Address of remote UE connected to PDN2
px_Ipv4_Address_HomeAgent	charstring			Ipv4 Home Agent Address
px_IPv6_Address1_UE	charstring			IPv6 Address connected to PDN1
px_IPv6_Address2_UE	charstring			IPv6 Address connected to PDN2

Parameter Name	Parameter Type	Default Value	Supported Values	Description
px_IPv6_Address2a_UE	charstring			IPv6 Address connected to PDN2a
px_IPv6_Address1_NW	charstring			IPv6 Gateway Address in PDN1
px_Ipv6_Address2_NW	charstring			Ipv6 Gateway Address in PDN2
px_IPv6_Address1_RemoteUE	charstring			IPv6 Address of remote UE connected to PDN1
px_IPv6_Address2_RemoteUE	charstring			IPv6 Address of remote UE connected to PDN2
px_Ipv6_Address_HomeAgent	charstring			Ipv6 Home Agent Address
px_SMS_ChkMsgReceived	boolean	true		Whether the operator can check an MT Short Message received
px_SMS_MsgFrmt	charstring	"1"		SMS message format <mode> (see TS 27.005 [31] cl. 3.2.3). NOTE: Default value is for text mode. Change value to "0" to execute tests with PDU mode.
px_RATComb_Tested	RATComb_Test ed_Type	EUTRA_UTRA	EUTRA_UTRA, EUTRA_GERAN, EUTRA_Only	This parameter represents the network RAT capability / preference and indicates which, if any is supported, RAT combination is to be tested.
px_SinglePLMN_Test ed	SinglePLMN_Test ed_Type	MultiPLMN	SinglePLMN, MultiPLMN, MultiPLMNi nPrimaryBand, MultiPLMNi nSecondary Band	This parameter represents the network capability/preference to support multi PLMNs on the same test Band and indicates the preference of multi PLMNs or single PLMN test environment. This PIXIT shall be set to SinglePLMN when only one frequency is defined for the test band.
px_UE_CS_PS_UsageSetting_Test ed	CS_PS_MODE	VOICE_CENTRIC	VOICE_CENTRIC, DATA_CENTRIC	Specifies which CS/PS mode is under test
px_UE_PS_UsageSetting_Test ed	PS_MODE	VOICE_CENTRIC	VOICE_CENTRIC, DATA_CENTRIC	Specifies which PS mode is under test
px_UTRAN_ModeUnderTest	UTRAN_FDD_TDD	UTRAN_FDD	UTRAN_FDD, UTRAN_TDD	Specifies which radio access technology is being tested in UTRAN
px_TestLoopModeB_Delay	O1_Type	'5A'		This parameter represents the IP_PDU_delay to be used for UE test loop mode B in test cases, where long delay may be needed e.g. because of user interaction.
px_IP_MTU_Size	integer	65535		MTU Size. This value is specific to the SS.
px_UTRAN_OverlappingNotSupportedFrequencyBandMFBI	integer			A not supported UTRAN frequency band that is overlapping with a supported band (px_MFBI_UTRAN_FrequencyBand). This PIXIT shall be set also in accordance with the values of the 3 PIXIT items: px_UARFCN_D_High, px_UARFCN_D_Mid, px_UARFCN_L_Mid. Applied to MFBI test case scenario.
px_MFBI_UTRAN_FrequencyBand	integer			A supported UTRAN frequency band overlapping with

Parameter Name	Parameter Type	Default Value	Supported Values	Description
				px_UTRAN_OverlappingNotSupportedFrequencyBandMFBI. Applied to MFBI test case scenario.

Table 9.1-2: E-UTRAN PIXIT

Parameter Name	Parameter Type	Default Value	Supported Values	Description
px_EllipsoidPointWithAltitude_ProSe_Area1	O8_Type			Ellipsoid Point With Altitude value corresponding to geographical area 1 provided in EF _{PROSE_RADIO_COM} to be provided in Update UE location information (see 36.509 cl. 6.12)
px_EllipsoidPointWithAltitude_ProSe_Area2	O8_Type			Ellipsoid Point With Altitude value corresponding to geographical area 2 provided in EF _{PROSE_RADIO_COM} to be provided in Update UE location information (see 36.509 cl. 6.12)
px_EllipsoidPointWithAltitude_NotProSe	O8_Type			Ellipsoid Point With Altitude value not corresponding to geographical area provided in EF _{PROSE_RADIO_COM} to be provided in Update UE location information (see 36.509 cl. 6.12)
px_eTDDsubframeConfig	TDD_SubframeAssignment_Type	1		TDD uplink-downlink subframe configuration
px_ePrimaryBandChannelBandwidth	DI_Bandwidth_Type	n25		Channel bandwidth used on px_ePrimaryFrequencyBand
px_ePrimaryFrequencyBand	integer	1		E-UTRA primary frequency band
px_eSecondaryFrequencyBand	integer	2		E-UTRA secondary frequency band
px_eSecondaryBandChannelBandwidth	DI_Bandwidth_Type	n25		Channel bandwidth used on px_eSecondaryFrequencyBand
px_EUTRA_CA_BandCombination	CA_BandCombination_Type	CA_1C		Band combination for CA test cases
px_EUTRA_DC_BandCombination	DC_BandCombination_Type	DC_1A-3A		Band combination for DC test cases
px_NAS_CipheringAlgorithm	B3_Type	001'B		NAS Ciphering Algorithm (eea1, see NOTE)
px_NAS_IntegrityProtAlgorithm	B3_Type	001'B		NAS Integrity Algorithm (eia1, see NOTE)
px_RRC_CipheringAlgorithm	CipheringAlgorithm_r12	eea1		Ciphering Algorithm (see NOTE)
px_RRC_IntegrityProtAlgorithm	IntegrityProtAlgorithm	eia1		Integrity Algorithm (see NOTE)
px_eMaxNumberROHC_ContextSessions	MaxNumberROHC_ContextSessions_Type	Cs16		Maximum number of ROHC context sessions
px_MFBI_FrequencyBand	integer	26		A supported E-UTRA frequency band overlapping with px_OverlappingNotSupportedFrequencyBand_MFBI. Applied to MFBI test case scenario.
px_MFBI_BandChannelBandwidth	DI_Bandwidth_Type	n25		E-UTRAN channel bandwidth used on px_MFBI_FrequencyBand. Applied to MFBI test case scenario.
px_OverlappingNotSupportedFrequencyBand_MFBI	integer	27		A not supported E-UTRA frequency band that is overlapping with a supported band (px_MFBI_FrequencyBand). Applied to MFBI test case scenario.
px_OverlappingSupportedFrequencyBand_MFBI	integer	26		A supported E-UTRA frequency band overlapping with px_OverlappingNotSupportedFrequencyBand_MFBI. Applied to MFBI enhancement test case

				scenario.
px_ProSeAnnApplicationIdentity1	charstring	mcc345.mnc012.ProSeApp.Food.Restaurants.Italian		A ProSe Application ID with which data structure the UE is preconfigured and for which the UE can request and perform Direct Discovery Announcing. TS 23.003, section 24.2.
px_ProSeMonApplicationIdentity1	charstring	mcc300.mnc165.ProSeApp.*.Sports.Surfing		A ProSe Application ID with which data structure the UE is preconfigured and for which the UE can request and perform Direct Discovery Monitoring. TS 23.003, section 24.2
px_ProSeMonApplicationIdentityNot1	charstring	mcc208.mnc*.ProSeApp.Shops.Food.Wine		A ProSe Application ID with which data structure the UE is NOT preconfigured to request and perform Direct Discovery Monitoring. TS 23.003, section 24.2
px_ProSe_TLS_CipherSuite	TLS_CIPHER_Type	TLS_PSK_WITH_3DES_EDE_CBC_SHA		TLS cipher suite to be used for ProSe communication
px_SL_AdditionalSupportedBandwidth	UI_Bandwidth_Type	n25		Supported sidelink bandwidth different from px_ePrimaryBandChannelBandwidth
NOTE: Unless specified otherwise in the test case prose, the null algorithm shall not be used for verification.				

9.2 MultiRAT PIXIT

Table 9.2-1: GERAN PIXIT

Parameter Name	Parameter Type	Default Value	Supported Values	Description
px_GERAN_BandUnderTest	GERAN_BandUnderTestType	GSM_P900		Indicates which band is under test

Table 9.2-2: UTRAN PIXIT

Parameter Name	Parameter Type	Default Value	Supported Values	Description
px_UTRAN_CipheringAlgorithm	CipheringAlgorithm_r7	uea2	uea0, uea1, uea2	UTRAN Ciphering algorithm
px_UARFCN_Low_TDD	integer			Low Range downlink UARFCN value for LCR TDD
px_UARFCN_Mid_TDD	integer			Mid Range downlink UARFCN value for LCR TDD
px_UARFCN_High_TDD	integer			High Range downlink UARFCN value for LCR TDD
px_TDD_OperationBandCharstring	charstring	a	px_UARFCN_Mid_TDD, px_UARFCN_Low_TDD and px_UARFCN_High_TDD shall take the values according to the value of px_TDD_OperationBandCharstring	Applicable for TDD The operation band under test as defined in 34.108 clause 5.1.2
px_NoTDD_LCR_onLTE	boolean	false		Only applicable to UE supporting (at least) LTE and LCR TDD. If set to true, the UE is configured not to report support of LCR TDD (IE ultraTDD128 in UECapabilityInformation) when being camped on an LTE cell with no detectable LCR TDD cell in the environment

Table 9.2-4: CDMA2000 1xRTT PIXIT

Parameter Name	Parameter Type	Default Value	Supported Values	Description
px_1XRTT_Baseld_Cell19	B16_Type	int2bit (39,16)		Base ID of Cell 19
px_1XRTT_Baseld_Cell20	B16_Type	int2bit (40,16)		Base ID of Cell 20
px_1XRTT_Baseld_Cell21	B16_Type	int2bit (41,16)		Base ID of Cell 21
px_1XRTT_Baseld_Cell22	B16_Type	int2bit (42,16)		Base ID of Cell 22
px_1XRTT_NID	B16_Type	int2bit (100,16)		default Network ID of 1xRTT Cells
px_1XRTT_SID	B15_Type	int2bit (200,15)		default SystemID of 1xRTT Cells
px_1XRTT_TMSI_Def	O4_Type	'1234ABCD'O		TMSI to be used in 1XRTT
px_1XRTT_MinProtRev	ProtRev_Type	0		Minimum Protocol revision supported by Base Station
px_1XRTT_UserInfo_EncMode	EncryptionMode_Type	2		Encryption Mode Rijndael algorithm
px_1XRTT_Sig_EncMode	EncryptionMode_Type	2		Encryption Mode Rijndael algorithm
px_1XRTT_BandClass	BandclassCDMA2000_Type	1		Band Class; Table 1.5-1 of C.S0057 E v1.0. Default value corresponds to 1.8 GHz to 2.0 GHz PCS band
px_PowerDownRegEnabled	boolean	true		Parameter for power down reg in 1xRTT
px_1XRTT_Zone_Timer	B3_Type	'000'B		Zone timer sent in 'System Parameters Message' overhead message
px_RAND	B32_Type	'00001111000011110000111100001111'B		Random Challenge Data to be included along with mobility parameters in CSFBParametersResponseCDMA2000 or HandoverFromEUTRAPreparationRequest
px_RAND2	B32_Type	'00001111000011110000111100001111'B		Random Challenge Data to be included along with mobility parameters in CSFBParametersResponseCDMA2000 or HandoverFromEUTRAPreparationRequest

Table 9.2-5: WLAN PIXIT

Parameter Name	Parameter Type	Default Value	Supported Values	Description
px_ePDG_Ipsec_CipheringAlgorithm	IPsec_CipheringAlgorithm_Type	des_ede3_cbc	des_ede3_cbc, aes_cbc, nociph	Ipsec Ciphering Algorithm used in ePDG
px_ePDG_Ipsec_IntegrityAlgorithm	IPsec_IntegrityAlgorithm_Type	hmac_sha_1_96	hmac_md5_96, hmac_sha_1_96	Ipsec Integrity Algorithm used in ePDG
px_WLANBand	WLAN_Band_Type	Band2_4Ghz	Band2_4Ghz, Band5Ghz, Band3_6Ghz	WLAN ISM Band
px_WLAN_RulesToBeTested	WLAN_RulesToBeTested	"ANDSF_Rules"	"ANDSF_Rules", "RAN_Rules"	Rules to be tested in WLAN test cases
px_WLAN_PDN1_ToOffload	boolean	true		If set to true, the first PDN connection is offloaded to WLAN. If set to false, the second PDN connection is offloaded to WLAN.
px_WLAN_UE_AddrIPv4	charstring			IPv4 WLAN UE Address
px_WLAN_UE_AddrIPv6	charstring			IPv6 WLAN UE Address
px_WLAN_NetworkAddrIPv4	charstring			IPv4 WLAN Network Address

px_WLAN_NetworkAddrIPv6	charstring			IPv6 WLAN Network Address
-------------------------	------------	--	--	---------------------------

9.3 NB-IoT PIXIT

Table 9.3-1: NB-IoT PIXIT

Parameter Name	Parameter Type	Default Value	Supported Values	Description
px_NB_OperationMode	NB_OperationMode_Type	standalone	inband_samePCI, inband_differentPCI, guardband, standalone	NB-IoT Operation Mode
px_DoAttachWithoutPDN	boolean	false		UE is configured to do Attach without PDN; if the value is FALSE it is assumed that the UE is configured to do Attach with PDN
px_SMSTransport_CP_CIoT	boolean	false		NB-IoT UE configured to utilise the SMS service as transport mechanism for user data for Control Plane Clot Optimisation
px_nonSMSTransport_CP_CIoT	boolean	false		NB-IoT UE configured to utilise non-SMS services as transport mechanism for user data for Control Plane Clot Optimisation
px_ModifyBearerResources	boolean	false		NB-IoT UE configured to handle modification of bearer resources including dedicated bearers (PDN of type "IP")

10 Postambles

The purpose of this clause is to specify postambles to bring the UE to a well defined state regardless of the UE state at the termination of main test body or of the SS conditions and values of the system information inherited from the test.

10.1 Postambles for E-UTRA to UTRA tests

This clause describes UE postamble procedures which are used at the end of inter-RAT test cases specified in TS 36.508 [3] so as to switch off the UE.

UE LTE and UTRAN postamble conditions are specified in table 10.1-1.

Table 10.1-1: UE postamble conditions

LTE UE attach type	UE UTRA CS/PS domain	Postamble condition
attach	pc_CS AND pc_PS	C1
	pc_PS AND NOT (pc_CS)	C2
combined_attach	pc_CS AND pc_PS	C3
	pc_CS AND NOT (pc_PS)	C4

10.1.1 UE postamble states and procedures for E-UTRA to UTRA

In order to bring the UE to the switched/powering off state, a number of procedures need to be executed in a hierarchical sequence, according to the reference end state specified in each test procedure sequence. The sequences and the identified procedures are shown in figure 10.1.1-1.

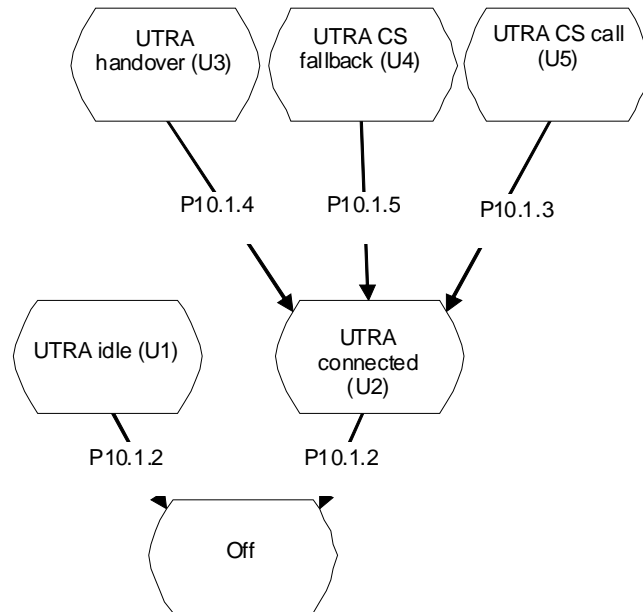

Figure 10.1.1-1: UE postamble procedures for E-UTRA / UTRA test cases

NOTE 1: Depending on the test case specifications the termination of a test case can be in any state of figure 10.1.1-1.

UE in UTRA state U2, U3, U4 and U5 may send data on the established radio bearer and shall be accepted and handled.

NOTE 2: NAS and AS security procedures during routing area update and handover are performed according to TS 33.401 [24], clauses 9.1.1 and 9.2.1 and TS 25.331 [36], clause 8.3.6.3.

10.1.2 Switch/Power off procedure

10.1.2.1 Procedure

Table 10.1.2.1-1: Switch/Power off procedure

Step	Procedure	Message Sequence	
		U - S	Message
1	The UE is powered off or switched off, (see ICS)	-	-
-	EXCEPTION: Steps 2 to 7 specify the behaviour if UE supports pc_SwitchOnOff.	-	-
-	EXCEPTION: Steps 2 to 4 are used only when the UE is in UTRA idle end state (U1).		
2	The UE transmits RRC CONNECTION REQUEST	-->	RRC CONNECTION REQUEST
3	The SS transmit a RRC CONNECTION SETUP	<--	RRC CONNECTION SETUP
4	The UE transmits an RRC CONNECTION SETUP COMPLETE message	-->	RRC CONNECTION SETUP COMPLETE
-	EXCEPTION: Step 4Aa1 to 4Aa6 specifies optional behaviour if the UE is registered to IMS services. UE may perform IMS-deregistration procedure.		
4Aa1	The UE transmits UPLINK DIRECT TRANSFER message or INITIAL DIRECT TRANSFER message when the UE is in UTRA idle end state (U1). This message includes a GMM SERVICE REQUEST message with service type=Data.	-->	GMM SERVICE REQUEST
4Aa2	The SS transmits a SECURITY MODE COMMAND message for the ps domain.		SECURITY MODE COMMAND
4Aa3	The UE transmits a SECURITY MODE COMPLETE message.		SECURITY MODE COMPLETE
4Aa4	The SS transmits a RADIO BEARER SETUP message using the UTRA reference radio bearer parameters and combination "UTRA PS RB" according to TS 36.508 subclause 4.8.3 and Table 4.8.3-1.		RADIO BEARER SETUP
4Aa5	The UE transmits a RADIO BEARER SETUP COMPLETE		RADIO BEARER SETUP COMPLETE
4Aa6	IMS de-registration is performed using the generic procedure defined in 34.229-1 [40] Annex C.30.		
-	EXCEPTION: Step 4Aa7a1 to 4Aa7a2 specifies optional behaviour depending on the UE implementation. The UE may perform PDP context deactivation procedure before Detach.		
4Aa7a1	The UE transmits DEACTIVATE PDP CONTEXT REQUEST	-->	DEACTIVATE PDP CONTEXT REQUEST
4Aa7a2	The SS transmits DEACTIVATE PDP CONTEXT ACCEPT	<--	DEACTIVATE PDP CONTEXT ACCEPT
-	EXCEPTION: Step 5a1 specifies behaviour when the current UTRA cell is in NMO I and the UE is in condition: - C1 or - C3	-	-
5a1	The UE transmits an UPLINK DIRECT TRANSFER message or INITIAL DIRECT TRANSFER message when the UE is in UTRA idle end state (U1). This message includes a DETACH REQUEST message with the detach type='power switched off, GPRS/IMSI combined detach'	-->	DETACH REQUEST

Step	Procedure	Message Sequence	
		U - S	Message
-	EXCEPTION: Step 5b1 specifies behaviour when the current UTRA cell is in (NMO I or NMO II) and the UE is in condition C4	-	-
5b1	The UE transmits an UPLINK DIRECT TRANSFER message or INITIAL DIRECT TRANSFER message when the UE is in UTRA idle end state (U1). This message includes an IMSI DETACH INDICATION message	-->	IMSI DETACH INDICATION
-	EXCEPTION: Step 5c1 specifies behaviour when the current UTRA cell is in (NMO I or NMO II) and the UE is in condition C2	-	-
5c1	The UE transmits an UPLINK DIRECT TRANSFER message or INITIAL DIRECT TRANSFER message when the UE is in UTRA idle end state (U1). This message includes a DETACH REQUEST message with detach type='power switched off, PS detach'	-->	DETACH REQUEST
-	EXCEPTION: Steps 5d1 and 5d2 specify behaviour when the current UTRA cell is in NMO II and the UE is in condition: - C1 or - C3. Both detach messages (in steps 5d1 and 5d2) can be sent by UE in any order.	-	-
5d1	The UE transmits an UPLINK DIRECT TRANSFER message or INITIAL DIRECT TRANSFER message when the UE is in UTRA idle end state (U1) and this is the first message received. This message includes a DETACH REQUEST message with the detach type='power switched off, PS detach'	-->	DETACH REQUEST
5d2	The UE transmits an UPLINK DIRECT TRANSFER message or INITIAL DIRECT TRANSFER message when the UE is in UTRA idle end state (U1) and this is the first message received. This message includes an IMSI DETACH INDICATION message	-->	IMSI DETACH INDICATION
6	The SS transmits an RRC CONNECTION RELEASE message	<--	RRC CONNECTION RELEASE
7	The UE transmits a RRC CONNECTION RELEASE COMPLETE message	-->	RRC CONNECTION RELEASE COMPLETE

10.1.3 CC disconnect procedure

10.1.3.1 Procedure

Table 10.1.3.1-1: CC disconnect procedure

Step	Procedure	Message Sequence	
		U - S	Message
1	The SS transmits a DOWNLINK DIRECT TRANSFER message. This message includes a DISCONNECT message.	<--	DISCONNECT
2	The UE transmits an UPLINK DIRECT TRANSFER message. This message includes a RELEASE message.	-->	RELEASE
3	The SS transmits a DOWNLINK DIRECT TRANSFER message. This message includes a RELEASE COMPLETE message.	<--	RELEASE COMPLETE
4	Void		
5a	The SS transmits an RRC CONNECTION RELEASE message	<--	RRC CONNECTION RELEASE
5b	The UE transmits a RRC CONNECTION RELEASE COMPLETE message	-->	RRC CONNECTION RELEASE COMPLETE
5c	The UE transmits RRC CONNECTION REQUEST	-->	RRC CONNECTION REQUEST
5d	The SS transmit a RRC CONNECTION SETUP	<--	RRC CONNECTION SETUP
5e	The UE transmits an RRC CONNECTION SETUP COMPLETE message	-->	RRC CONNECTION SETUP COMPLETE
6	The UE transmits an UPLINK DIRECT TRANSFER message. This message includes a ROUTING AREA UPDATE REQUEST message with Update type = 'Combined RA/LA Updated'	-->	ROUTING AREA UPDATE REQUEST
7	The SS transmits a DOWNLINK DIRECT TRANSFER message. This message includes a ROUTING AREA UPDATE ACCEPT message.	<--	ROUTING AREA UPDATE ACCEPT
8	The UE transmits an UPLINK DIRECT TRANSFER message. This message includes a ROUTING AREA UPDATE COMPLETE message.	-->	ROUTING AREA UPDATE COMPLETE

10.1.4 PS Routing Area Update procedure

10.1.4.1 Procedure

Table 10.1.4.1-1: PS Routing Area Update procedure

Step	Procedure	Message Sequence	
		U - S	Message
-	EXCEPTION: steps 1a1 to 1a5 specify the UE behaviour when the current UTRA cell is in NMO I and the UE is in condition: - C1 or - C3 and the UE is not registered to the LAC of the current UTRA cell	-	-
1a1	The UE transmits an UPLINK DIRECT TRANSFER message. This message includes a ROUTING AREA UPDATE REQUEST message with Update type = 'Combined RA/LA Updated'	-->	ROUTING AREA UPDATE REQUEST
1a2	Void	-	-
1a3	Void	-	-
1a4	The SS transmits a DOWNLINK DIRECT TRANSFER message. This message includes a ROUTING AREA UPDATE ACCEPT message.	<--	ROUTING AREA UPDATE ACCEPT
1a5	The UE transmits an UPLINK DIRECT TRANSFER message. This message includes a ROUTING AREA UPDATE COMPLETE message.	-->	ROUTING AREA UPDATE COMPLETE
-	EXCEPTION: steps 1b1 to 1b5 specify the UE behaviour when the current UTRA cell is in (NMO I or NMO II) and the UE is in condition: - C2 or - C3 and the UE is registered to the LAC of the current UTRA cell	-	-
1b1	The UE transmits an UPLINK DIRECT TRANSFER message. This message includes a ROUTING AREA UPDATE REQUEST message with Update type = 'RA Update'	-->	ROUTING AREA UPDATE REQUEST
1b2	Void	-	-
1b3	Void	-	-
1b4	The SS transmits a DOWNLINK DIRECT TRANSFER message. This message includes a ROUTING AREA UPDATE ACCEPT message.	<--	ROUTING AREA UPDATE ACCEPT
1b5	The UE transmits an UPLINK DIRECT TRANSFER message. This message includes a ROUTING AREA UPDATE COMPLETE message.	-->	ROUTING AREA UPDATE COMPLETE
-	EXCEPTION: steps 1c1 to 1c9 specify the UE behaviour when the current UTRA cell is in NMO II and the UE is in condition: - C1 or - C3 and the UE is not registered to the LAC of the current UTRA cell. The LOCATION UPDATE REQUEST message (step 1c6) can be received during the routing area updating procedure (steps 1c1 to 1c4).	-	-
1c1	The UE transmits an UPLINK DIRECT TRANSFER message. This message includes a ROUTING AREA UPDATE REQUEST message with Update type = 'RA Update'.	-->	ROUTING AREA UPDATE REQUEST

Step	Procedure	Message Sequence	
		U - S	Message
1c2	Void	-	-
1c3	Void	-	-
1c4	The SS transmits a DOWNLINK DIRECT TRANSFER message. This message includes a ROUTING AREA UPDATE ACCEPT message.	<--	ROUTING AREA UPDATE ACCEPT
1c5	The UE transmits an UPLINK DIRECT TRANSFER message. This message includes a ROUTING AREA UPDATE COMPLETE message.	-->	ROUTING AREA UPDATE COMPLETE
1c6	The UE transmits an UPLINK DIRECT TRANSFER message. This message includes a LOCATION UPDATING REQUEST message.	-->	LOCATION UPDATING REQUEST
1c7	The SS transmits a SECURITY MODE COMMAND message.	<--	SECURITY MODE COMMAND
1c8	The UE transmits a SECURITY MODE COMPLETE message.	-->	SECURITY MODE COMPLETE
1c9	The SS transmits a DOWNLINK DIRECT TRANSFER message. This message includes a LOCATION UPDATING ACCEPT message.	<--	LOCATION UPDATING ACCEPT
1c10	The UE transmits a UPLINK DIRECT TRANSFER message. This message includes a TMSI REALLOCATION COMPLETE message.	-->	TMSI REALLOCATION COMPLETE

10.1.5 CS fallback procedure

10.1.5.1 Procedure

Table 10.1.5.1-1: CS fallback procedure

Step	Procedure	Message Sequence	
		U - S	Message
-	EXCEPTION: In parallel to the events described in step 1a1 to 2a5 the steps specified in table 10.1.5.1-2 takes place.	-	-
-	EXCEPTION: Steps 1a1 and 1a2 specify the MO call procedure and step 1b1 specifies the MT call procedure.	-	-
1a1	The UE transmits an INITIAL DIRECT TRANSFER message including a CM SERVICE REQUEST message.	-->	CM SERVICE REQUEST
1a2	The SS transmits an UPLINK DIRECT TRNASFER message including a CM SERVICE REJECT with the reject cause #32 (Service option not supported)	<--	CM SERVICE REJECT
-	EXCEPTION: Step 1b1 specifies the MT call procedure.	-	-
1b1	The UE transmits an INITIAL DIRECT TRANSFER message including a PAGING RESPONSE message.	-->	PAGING RESPONSE
-	EXCEPTION: Steps 2a1 and 2a5 specify the location area update procedure when the current UTRA cell is in NMO II and the UE is in condition C3 and the UE is not registered to the LAC of the current UTRA cell.	-	-
2a1	The UE transmits an UPLINK DIRECT TRANSFER message. This message includes a LOCATION UPDATING REQUEST message.	-->	LOCATION UPDATING REQUEST

Step	Procedure	Message Sequence	
		U - S	Message
2a2	The SS transmits a SECURITY MODE COMMAND message.	<--	SECURITY MODE COMMAND
2a3	The UE transmits a SECURITY MODE COMPLETE message.	-->	SECURITY MODE COMPLETE
2a4	The SS transmits a DOWNLINK DIRECT TRANSFER message. This message includes a LOCATION UPDATING ACCEPT	<--	LOCATION UPDATING ACCEPT
2a5	The EU transmits a UPLINK DIRECT TRANSFER message. This message includes a TMSI REALLOCATION COMPLETE	-->	TMSI REALLOCATION COMPLETE
3	The SS transmits a SECURITY MODE COMMAND message.	<--	SECURITY MODE COMMAND
4	The UE transmits a SECURITY MODE COMPLETE message.	-->	SECURITY MODE COMPLETE
5	The SS transmits a DOWNLINK DIRECT TRANSFER message. This message includes a ROUTING AREA UPDATE ACCEPT message.	<--	ROUTING AREA UPDATE ACCEPT
6	The UE transmits an UPLINK DIRECT TRANSFER message. This message includes a ROUTING AREA UPDATE COMPLETE message.	-->	ROUTING AREA UPDATE COMPLETE
-	EXCEPTION: Steps 7a1 and 7a5 specify the combined routing updating procedure when the initial RAU procedure was for RA Only. This may occur either before, or after, steps 8 and 9	-	-
7a1	The UE transmits a ROUTING AREA UPDATE REQUEST message.	-->	ROUTING AREA UPDATE REQUEST
7a2	The SS transmits a SECURITY MODE COMMAND message.	<--	SECURITY MODE COMMAND
7a3	The UE transmits a SECURITY MODE COMPLETE message.	-->	SECURITY MODE COMPLETE
7a4	The SS transmits a DOWNLINK DIRECT TRANSFER message. This message includes a ROUTING AREA UPDATE ACCEPT message.	<--	ROUTING AREA UPDATE ACCEPT
7a5	The UE transmits an UPLINK DIRECT TRANSFER message. This message includes a ROUTING AREA UPDATE COMPLETE message.	-->	ROUTING AREA UPDATE COMPLETE
-	EXCEPTION: Steps 7b1 and 7b4 specify the location updating procedure when the current UTRA cell is in network mode (NMO I or NMO II) and the UE is in condition C4 and the UE is not registered to the LAC of the current UTRA cell.	-	-
7b1	The UE transmits an UPLINK DIRECT TRANSFER message. This message includes a LOCATION UPDATING REQUEST message.	-->	LOCATION UPDATING REQUEST
7b2	The SS transmits a SECURITY MODE COMMAND message.	<--	SECURITY MODE COMMAND
7b3	The UE transmits a SECURITY MODE COMPLETE message.	-->	SECURITY MODE COMPLETE
7b4	The SS transmits a DOWNLINK DIRECT TRANSFER message. This message includes a LOCATION UPDATING ACCEPT	<--	LOCATION UPDATING ACCEPT
7b5	The EU transmits a UPLINK DIRECT TRANSFER message. This message includes a TMSI REALLOCATION COMPLETE	-->	TMSI REALLOCATION COMPLETE

Step	Procedure	Message Sequence	
		U - S	Message
8	The SS transmits an RRC CONNECTION RELEASE message.	<--	RRC CONNECTION RELEASE
9	The UE transmits an RRC CONNECTION RELEASE COMPLETE message.	-->	RRC CONNECTION RELEASE COMPLETE

Table 10.1.5.1-2: Parallel behaviour

St	Procedure	Message Sequence		TP	Verdict
		U - S	Message		
1	The UE transmits a ROUTING AREA UPDATE REQUEST message.	-->	ROUTING AREA UPDATE REQUEST	-	-

10.2 Postambles for E-UTRAN to GERAN tests

This clause describes UE postamble procedures which are used at the end of inter-RAT test cases defined in TS 36.508 [3] so as to switch off the UE. UE LTE and GERAN postamble transitions are specified in table 10.2-1.

Table 10.2-1: UE postamble conditions

LTE UE attach type	UE GERAN CS/PS domain	Postamble condition
attach	pc_GPRS	C1
combined attach	pc_GPRS	C2
	NOT pc_GPRS	C3

10.2.1 UE postamble states and procedures for E-UTRA to GERAN test cases

In order to bring the UE to the switched/powered off state there are a number of procedures that need to be executed in a hierarchical sequence, according to the reference end state specified in each test procedure sequence. The sequences and the identified procedures are shown in figure 10.2.1-1.

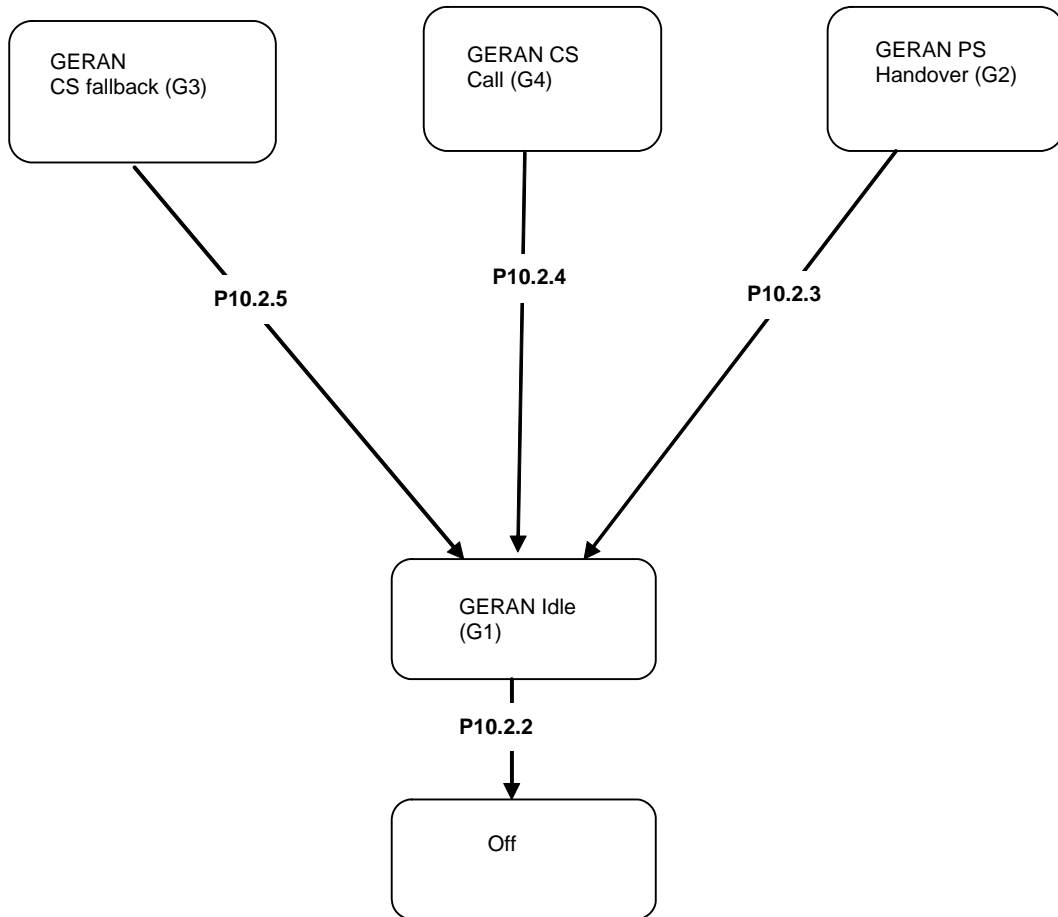

Figure 10.2.1-1: UE postamble procedures for E-UTRA / GERAN test cases

NOTE 1: Depending on the test case specifications the termination of a test case can be in any state of figure 10.2.1-1.

NOTE 2: The security procedures for interworking to GERAN are according to TS 33.401 [24] clauses 10.2.1 and 10.3.1.

10.2.2 Switch/Power off procedure

10.2.2.1 Procedure

Table 10.2.2.1-1: Switch/Power off procedure

Step	Procedure	Message Sequence	
		U - S	Message
1	The UE is powered off or switched off, (see ICS)	-	-
-	EXCEPTION: Steps 2a1 to 2c2 specify the behaviour if UE supports <i>pc_SwitchOnOff</i> .	-	-
-	EXCEPTION: Step 2a1 specifies behaviour when the GERAN cell is in (NMO I or NMO II) and UE is in condition C1	-	-
2a1	The UE transmits a DETACH REQUEST message	-->	DETACH REQUEST
-	EXCEPTION: Step 2b1 specifies behaviour when the GERAN cell is in (NMO I or NMO II) and UE is in condition C3	-	-
2b1	The UE transmits an IMSI DETACH INDICATION message	-->	IMSI DETACH INDICATION
-	EXCEPTION: Steps 2c1 – 2c1A3 and step 2c2 specify behaviour when the GERAN cell is in NMO II and UE is in condition C2. The messages can be sent in any order	-	-
2c1	The UE transmits an IMSI DETACH INDICATION message	-->	IMSI DETACH INDICATION
2c1A1	The UE transmits a <i>Classmark Change</i> message	-->	CLASSMARK CHANGE
-	EXCEPTION: Steps 2c1A2 and 2cA3 can occur in any order	-	-
2c1A2	IF <i>pc_UTRA</i> THEN the UE transmits a <i>Utran Classmark Change</i> message.	-->	UTRAN CLASSMARK CHANGE.
2c1A3	IF UE is still attached for GPRS (step 2c2 has not yet occurred) THEN the UE transmits a <i>GPRS Suspension Request</i> message	-->	GPRS SUSPENSION REQUEST
2c2	The UE transmits a DETACH REQUEST message	-->	DETACH REQUEST

10.2.3 PS Handover procedure

10.2.3.1 Procedure

Table 10.2.3.1-1: PS handover procedure

Step	Procedure	Message Sequence	
		U - S	Message
-	EXCEPTION: Steps 1a1 and 1a3 specify the UE behaviour when GERAN cell is in NMO I and the UE is in condition C2 and the UE is not registered to the LAC of this cell.	-	-
1a1	The UE transmits a ROUTING AREA UPDATE REQUEST message with update type='Combined RA/LA Update'.	-->	ROUTING AREA UPDATE REQUEST
1a2	The SS transmits a ROUTING AREA UPDATE ACCEPT message.	<--	ROUTING AREA UPDATE ACCEPT
1a3	The UE transmits a ROUTING AREA UPDATE COMPLETE message.	-->	ROUTING AREA UPDATE COMPLETE
-	EXCEPTION: Steps 1b1 and 1b3 specify the location updating procedure when GERAN cell is in (NMO I or NMO II) and the UE is in condition C2 and the UE is registered to the LAC of this cell.	-	-
1b1	The UE transmits a ROUTING AREA UPDATE REQUEST message with update type='RA Update'.	-->	ROUTING AREA UPDATE REQUEST
1b2	The SS transmits a ROUTING AREA UPDATE ACCEPT message.	<--	ROUTING AREA UPDATE ACCEPT
1b3	The UE transmits a ROUTING AREA UPDATE COMPLETE message.	-->	ROUTING AREA UPDATE COMPLETE
-	EXCEPTION: Steps 1c1 and 1c6 specify the location updating procedure when GERAN cell is in NMO II and the UE is in condition C2 and the UE is not registered to the LAC of this cell.	-	-
1c1	The UE transmits a ROUTING AREA UPDATE REQUEST message with update type='RA Update'.	-->	ROUTING AREA UPDATE REQUEST
1c2	The SS transmits a ROUTING AREA UPDATE ACCEPT message.	<--	ROUTING AREA UPDATE ACCEPT
1c3	The UE transmits a ROUTING AREA UPDATE COMPLETE message.	-->	ROUTING AREA UPDATE COMPLETE
1c4	The UE transmits a LOCATION UPDATING REQUEST message.	-->	LOCATION UPDATING REQUEST
1c4A1	The UE transmits a <i>Classmark Change</i> message	-->	CLASSMARK CHANGE
-	EXCEPTION: The next step describes behaviour that depends on UE capability.	-	-
1c4A2	IF pc_UTRA THEN the UE transmits a <i>Utran Classmark Change</i> message.	-->	UTRAN CLASSMARK CHANGE.
1c5	The SS transmits a LOCATION UPDATING ACCEPT	<--	LOCATION UPDATING ACCEPT
1c6	The UE transmits a TMSI REALLOCATION COMPLETE		TMSI REALLOCATION COMPLETE

10.2.4 CC disconnect procedure

10.2.4.1 Procedure

Table 10.2.4.1-1: CC disconnect procedure

Step	Procedure	Message Sequence	
		U - S	Message
1	The SS transmits a DISCONNECT message.	<--	DISCONNECT
2	The UE transmits a RELEASE message.	-->	RELEASE
3	The SS transmits a RELEASE COMPLETE message.	<--	RELEASE COMPLETE
4	The SS transmits a CHANNEL RELEASE message.	<--	CHANNEL RELEASE

10.2.5 CS fallback procedure

10.2.5.1 Procedure

Table 10.2.5.1-1: CS fallback procedure MO call

Step	Procedure	Message Sequence	
		U - S	Message
-	EXCEPTION: Steps 1a1 and 1a2 specify the MO call procedure.	-	-
1a1	The UE transmits a CM SERVICE REQUEST message.	-->	CM SERVICE REQUEST
1a2	The SS transmits a CM SERVICE REJECT with the reject cause #32 (Service option not supported)	<--	CM SERVICE REJECT
-	EXCEPTION: Step 1b1 specifies the MT call procedure.	-	-
1b1	The UE transmits a PAGING RESPONSE message.	-->	PAGING RESPONSE
-	EXCEPTION: Steps 2a1 to 2a6 specify the procedure when GERAN cell is in NMO II and if the UE is in condition C2 and the UE is registered to the LAC of the current GERAN cell.	-	-
2a1	The UE transmits a LOCATION UPDATING REQUEST message.	-->	LOCATION UPDATING REQUEST
2a1A1	The UE transmits a <i>Classmark Change</i> message	-->	CLASSMARK CHANGE
-	EXCEPTION: The next step describes behaviour that depends on UE capability.	-	-
2a1A2	IF pc_UTRA THEN the UE transmits a <i>Utran Classmark Change</i> message.	-->	UTRAN CLASSMARK CHANGE.
2a2	The SS transmits a LOCATION UPDATING ACCEPT	<--	LOCATION UPDATING ACCEPT
2a3	The UE transmits a TMSI REALLOCATION COMPLETE		TMSI REALLOCATION COMPLETE
2a4	The UE transmits a ROUTING AREA UPDATE REQUEST message.	-->	ROUTING AREA UPDATE REQUEST
2a5	The SS transmits a ROUTING AREA UPDATE ACCEPT message.	<--	ROUTING AREA UPDATE ACCEPT
2a6	The UE transmits a ROUTING AREA UPDATE COMPLETE message.	-->	ROUTING AREA UPDATE COMPLETE
-	EXCEPTION: Steps 2b1 to 2b3 specify the location updating procedure when GERAN cell is in (NMO I or NMO II) and if the UE is in condition C3 and the UE is not registered to the LAC of the current GERAN cell	-	-
2b1	The UE transmits a LOCATION UPDATING	-->	LOCATION UPDATING REQUEST

Step	Procedure	Message Sequence	
		U - S	Message
	REQUEST message.		
2b1A1	The UE transmits a <i>Classmark Change</i> message	-->	CLASSMARK CHANGE
-	EXCEPTION: The next step describes behaviour that depends on UE capability.	-	-
2b1A2	IF pc_UTRA THEN the UE transmits a <i>Utran Classmark Change</i> message.	-->	UTRAN CLASSMARK CHANGE.
2b2	The SS transmits a LOCATION UPDATING ACCEPT	<--	LOCATION UPDATING ACCEPT
2b3	The UE transmits a TMSI REALLOCATION COMPLETE		TMSI REALLOCATION COMPLETE
-	EXCEPTION: Steps 2c1 to 2c3 specify the routing area updating procedure when the GERAN cell is in NMO I and the UE is in condition C2 and the UE is not registered to the LAC of the current GERAN cell	-	-
2c1	The UE transmits a ROUTING AREA UPDATE REQUEST message with update type = 'Combined RA/LA update'.	-->	ROUTING AREA UPDATE REQUEST
2c2	The SS transmits a ROUTING AREA UPDATE ACCEPT message.	<--	ROUTING AREA UPDATE ACCEPT
2c3	The UE transmits a ROUTING AREA UPDATE COMPLETE message.	-->	ROUTING AREA UPDATE COMPLETE

10.3 Postambles for E-UTRA test cases

This clause describes UE postamble states which can be used in the post condition of E-UTRA test cases defined in TS 36.523-1 [1]. The clause also specifies a set of procedures to bring the UE into these states.

10.3.1 UE postamble states and procedures for E-UTRA test cases

In order to bring the UE to switched/powering off state there are some procedures that need to be executed. The identified procedures are shown in figure 10.3.1-1.

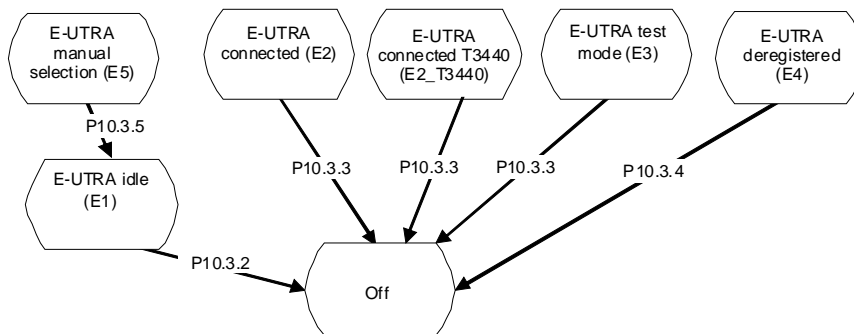

Figure 10.3.1-1: UE postamble states and procedures for E-UTRA

10.3.2 Switch/Power off procedure in State E1

10.3.2.1 Procedure

Table 10.3.2.1-1: Switch/Power off procedure

Step	Procedure	Message Sequence	
		U - S	Message
1	The UE is powered off or switched off, (see ICS)	-	-
-	EXCEPTION: Steps 2a1 to 2a4 specify behaviour if the UE supports <i>pc_SwitchOnOff</i>	-	-
2a1	UE transmits an <i>RRCConnectionRequest</i> message.	-->	RRC: <i>RRCConnectionRequest</i>
2a2	SS transmit an <i>RRCConnectionSetup</i> message.	<--	RRC: <i>RRCConnectionSetup</i>
-	EXCEPTION: Steps 2a3Aa1 to 2a3Aa6 specify optional behaviour if the UE has previously performed IMS registration	-	-
2a3Aa 1	The UE transmits an <i>RRCConnectionSetupComplete</i> message to confirm the successful completion of the connection establishment and to initiate the IMS signalling procedure by including the SERVICE REQUEST message.	-->	RRC: <i>RRCConnectionSetupComplete</i> NAS: SERVICE REQUEST
2a3Aa 2	The SS transmits a <i>SecurityModeCommand</i> message to activate AS security.	<--	RRC: <i>SecurityModeCommand</i>
2a3Aa 3	The UE transmits a <i>SecurityModeComplete</i> message and establishes the initial security configuration.	-->	RRC: <i>SecurityModeComplete</i>
2a3Aa 4	The SS configures a new data radio bearer, associated with the default EPS bearer context. The <i>RRCConnectionReconfiguration</i> message is using condition SRB2-DRB(1, 0). The DRB associated with default EPS bearer context obtained during the attach procedure is established	<--	RRC: <i>RRCConnectionReconfiguration</i>
	EXCEPTION: In parallel to the event described in step 2a3Aa5 below, the behaviour in TS 34.229-1 [40] Annex C.30 may occur. (IMS de-registration)	-	-
2a3Aa 5	The UE transmits an <i>RRCConnectionReconfigurationComplete</i> message to confirm the establishment of the new data radio bearer, associated with the default EPS bearer context.	-->	RRC: <i>RRCConnectionReconfigurationComplete</i>
2a3Aa 6	The UE initiates the Detach procedure by sending DETACH REQUEST	-->	NAS: DETACH REQUEST
	EXCEPTION : Step 2a3Ba1 below specifies the behaviour if the UE has not previously performed IMS registration		
2a3 Ba1	The UE transmits an <i>RRCConnectionSetupComplete</i> message to confirm the successful completion of the connection establishment and to initiate the Detach procedure by including the DETACH REQUEST message.	-->	RRC: <i>RRCConnectionSetupComplete</i> NAS: DETACH REQUEST
2a4	The SS transmits an RRC CONNECTION RELEASE message	<--	RRC CONNECTION RELEASE

10.3.3 Switch/Power off procedure in State E2 and E3

10.3.3.1 Procedure for E2 and E3

Table 10.3.3.1-1: Switch/Power off procedure

Step	Procedure	Message Sequence	
		U - S	Message
-	EXCEPTION: In parallel to the events described in steps 1 to 2a2, the steps described: - in Table 10.3.3.1-2 may take place if UE supports pc_eMBMS_SC and SIB15 is broadcasted in the cell, - in Table 10.3.3.1-3 may take place if UE supports pc_discSupportedBands and SIB19 is broadcasted in the cell or if UE supports pc_commSupportedBands and SIB18 is broadcasted in the cell.		
1	The UE is powered off or switched off (see ICS)	-	-
-	EXCEPTION: Steps 2a1 to 2a2 specify behaviour if the UE supports pc_SwitchOnOff	-	-
-	EXCEPTION : Step 2a1Aa1 to 2a1Aa2 below specifies optional behaviour if the UE has previously performed IMS registration	-	-
2a1Aa1 – 2a1Aa2	The UE may perform the procedure described in TS 34.229-1 [40] Annex C.30 (IMS de-registration)	-	-
2a1	The UE transmits DETACH REQUEST	-->	DETACH REQUEST
2a2	The SS transmits an RRC CONNECTION RELEASE message	<--	RRC CONNECTION RELEASE

Table 10.3.3.1-2: Parallel behaviour

St	Procedure	Message Sequence	
		U - S	Message
1	UE transmits a <i>MBMSInterestIndication</i> message.	-->	<i>MBMSInterestIndication</i>

Table 10.3.3.1-3: Parallel behaviour

St	Procedure	Message Sequence	
		U - S	Message
1	UE transmits a <i>SidelinkUEInformation</i> message.	-->	<i>SidelinkUEInformation</i>

10.3.3.2 Procedure for E2_T3440

Table 10.3.3.2-1: RRC release and switch/power off procedure

Step	Procedure	Message Sequence	
		U - S	Message
1	The SS transmits an RRC CONNECTION RELEASE message	<--	RRC CONNECTION RELEASE
2	The SS waits for 5s to ensure that the UE goes to RRC_IDLE state.	-	
3	The UE is powered off or switched off (see ICS)	-	-
-	EXCEPTION: Steps 4a1 to 4a4 specify behaviour if the UE supports pc_SwitchOnOff	-	-
4a1	UE transmits an <i>RRCConnectionRequest</i> message.	-->	RRC: <i>RRCConnectionRequest</i>
4a2	SS transmit an <i>RRCConnectionSetup</i> message.	<--	RRC: <i>RRCConnectionSetup</i>
-	EXCEPTION: Steps 4a3Aa1 to 4a3Aa6 specify optional behaviour if the UE has previously performed IMS registration	-	-
4a3Aa 1	The UE transmits an <i>RRCConnectionSetupComplete</i> message to confirm the successful completion of the connection establishment and to initiate the IMS signalling procedure by including the SERVICE REQUEST message.	-->	RRC: <i>RRCConnectionSetupComplete</i> NAS: SERVICE REQUEST
4a3Aa 2	The SS transmits a <i>SecurityModeCommand</i> message to activate AS security.	<--	RRC: <i>SecurityModeCommand</i>
4a3Aa 3	The UE transmits a <i>SecurityModeComplete</i> message and establishes the initial security configuration.	-->	RRC: <i>SecurityModeComplete</i>
4a3Aa 4	The SS configures a new data radio bearer, associated with the default EPS bearer context. The <i>RRCConnectionReconfiguration</i> message is using condition SRB2-DRB(1, 0). The DRB associated with default EPS bearer context obtained during the attach procedure is established	<--	RRC: <i>RRCConnectionReconfiguration</i>
-	EXCEPTION: In parallel to the event described in step 4a3Aa5 below, the behaviour in TS 34.229-1 [40] Annex C.30 may occur. (IMS de-registration)	-	-
4a3Aa 5	The UE transmits an <i>RRCConnectionReconfigurationComplete</i> message to confirm the establishment of the new data radio bearer, associated with the default EPS bearer context.	-->	RRC: <i>RRCConnectionReconfigurationComplete</i>
4a3Aa 6	The UE initiates the Detach procedure by sending DETACH REQUEST	-->	NAS: DETACH REQUEST
-	EXCEPTION : Step 4a3Ba1 below specifies the behaviour if the UE has not previously performed IMS registration	-	
4a3 Ba1	The UE transmits an <i>RRCConnectionSetupComplete</i> message to confirm the successful completion of the connection establishment and to initiate the Detach procedure by including the DETACH REQUEST message.	-->	RRC: <i>RRCConnectionSetupComplete</i> NAS: DETACH REQUEST
4a4	The SS transmits an RRC CONNECTION RELEASE message	<--	RRC CONNECTION RELEASE

10.3.4 Switch/Power off procedure in State E4

10.3.4.1 Procedure

Table 10.3.4.1-1: Switch/Power off procedure

Step	Procedure	Message Sequence	
		U - S	Message
1	The UE is powered off or switched off (see ICS)	-	-

10.3.5 Automatic selection mode procedure in State E5 (current cell, neighbour cell)

10.3.5.1 Procedure

Table 10.3.5.1-1: Automatic selection mode procedure

Step	Procedure	Message Sequence	
		U - S	Message
1	Set UE to Automatic PLMN selection mode.	-	-
2	The SS configures: - the current cell as a "Non-Suitable Off cell" - the neighbour cell as a "Serving cell"	-	-
3	Generic test procedure in TS 36.508 subclause 6.4.2.7-1 is performed on the neighbour cell	-	-
-	At the end of this test procedure sequence, the UE is in end state E-UTRA idle (E1)	-	-

10.4 Postambles for E-UTRA to HRPD test cases

This clause describes UE postamble states which can be used in the post condition of E-UTRA test cases defined in TS 36.523-1 [1]. The clause also specifies a set of procedures to bring the UE into these states.

10.4.1 UE postamble procedures for E-UTRA to HRPD (No Pre-Registration)

10.4.1.1 Registration on HRPD Cell

Table 10.4.1.1: Registration on HRPD Cell procedure

Step	Procedure	Message Sequence	
		U - S	Message
1	The UE transmits a <i>UATIRequest</i> message.	-->	<i>UATIRequest</i>
2	The SS transmits <i>UATIAssignment</i> message	<--	<i>UATIAssignment</i>
3	The UE transmits <i>UATIComplete</i> message	-->	<i>UATIComplete</i>
4	The UE transmits <i>ConnectionRequest</i> message.	-->	<i>ConnectionRequest</i>
5	The SS transmits a <i>TrafficChannelAssignment</i> message.	<--	<i>TrafficChannelAssignment</i>
6	The UE transmits <i>TrafficChannelcomplete</i> .	-->	<i>TrafficChannelcomplete</i>
7	The UE transmits <i>ConfigurationRequest</i> message for SCP configuration.	-->	<i>SCP:ConfigurationRequest</i>
8	The SS transmits a <i>ConfigurationResponse</i>	<--	<i>SCP:ConfigurationResponse</i>

Step	Procedure	Message Sequence	
		U - S	Message
	message for SCP configuration.		
9	The UE transmits <i>ConfigurationRequest</i> message for Stream protocol.	-->	<i>Stream:ConfigurationRequest</i>
10	The SS transmits a <i>ConfigurationResponse</i> message for Stream protocol accepting EMPA bound to service network.	<--	<i>Stream: ConfigurationResponse</i>
11	The UE transmits <i>EMPA ConfigurationRequest</i> message.	-->	<i>EMPA:ConfigurationRequest</i>
12	The SS transmits an <i>EMPA ConfigurationResponse</i> message.	<--	<i>EMPA: ConfigurationResponse</i>
13	The UE transmits <i>ConfigurationComplete</i> message.	-->	<i>ConfigurationComplete</i>
14	Optionally session negotiation initiated by the SS might take place	<-->	-
15	Optionally device level authentication may take place.	<-->	-
16	Optionally Location Update procedure may take place if the SS is configured to support it.	<-->	-
17	PPP LCP negotiation is performed between the UE and the SS. EAP-AKA is selected as the authentication protocol.	<-->	-
18	Tunnelled EAP-AKA is performed between the UE and the SS.	<-->	-
19	The UE transmits <i>VSNCP Configure-Request</i> message, including a PDN-ID, PDN Type, APN, PDN Address with empty content, Protocol Configuration Options, and Attach Type = "handover". The Address Allocation Preference option contained in the Protocol Configuration Options indicates whether the UE wants to perform the IP address allocation during the attach procedure or deferred IPv4 address allocation. PDN Type indicates the UE's IP capability (IPv4, IPv6 or IPv4/v6)	-->	<i>VSNCP: Configure-Request</i>
20	The SS transmits a <i>VSNCP Configure-Ack</i> message.	<--	<i>VSNCP: Configure-Ack</i>
21	The SS transmits a <i>VSNCP Configure-Request</i> message including the PDN-ID configuration option.	<--	<i>VSNCP: Configure-Request</i>
22	The UE transmits <i>VSNCP Configure-Ack</i> message.	-->	<i>VSNCP :Configure-Ack</i>
23	Optionally IPv4 address allocation by DHCPv4 may occur (depending on the Address Allocation Preference indicated by the UE at Step 19).	<-->	-
24	Optionally Link global IPv6 address configuration by ICMPv6 may occur (depending on the Address Allocation Preference indicated by the UE at Step 19). <i>solicitation</i> message.	<-->	-

10.4.1.2 Detach on HRPD Cell

Table 10.4.1.2: Detach on HRPD Cell procedure

Step	Procedure	Message Sequence	
		U - S	Message
1	The UE transmits PPP:LCP Terminate-Request	-->	LCP:Terminate-Request
2	The SS transmits PPP: LCP Terminate-Ack	<--	LCP:Terminate-Ack
3	the UE and SS perform Session update to release the reservations	<-->	-

10.5 Postambles for NB-IoT test cases

This clause describes UE postamble states which can be used in the post condition of NB-IoT test cases defined in TS 36.523-1 [1]. The clause also specifies a set of procedures to bring the UE into these states.

10.5.1 UE postamble states and procedures for NB-IoT test cases

In order to bring the UE to switched/powering off state there are some procedures that need to be executed. The identified procedures are shown in figure 10.5.1-1.

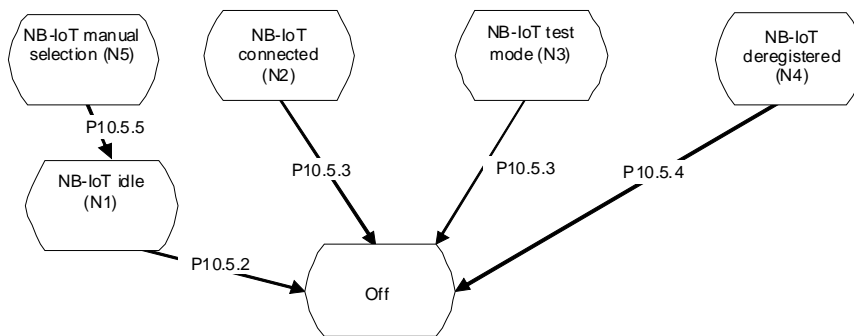

Figure 10.5.1-1: UE postamble states and procedures for NB-IoT

10.5.2 Switch/Power off procedure in State N1

10.5.2.1 Procedure

Table 10.5.2.1-1: Switch/Power off procedure

Step	Procedure	Message Sequence	
		U - S	Message
1	The UE is powered off or switched off, (see ICS)	-	-
-	EXCEPTION: Steps 2a1 to 2a4 specify behaviour if the UE supports <i>pc_SwitchOnOff</i>	-	-
2a1	UE transmits an <i>RRCCONNECTIONREQUEST-NB</i> message.	-->	RRC: <i>RRCCONNECTIONREQUEST-NB</i>
2a2	SS transmit an <i>RRCCONNECTIONSETUP-NB</i> message.	<--	RRC: <i>RRCCONNECTIONSETUP-NB</i>
2a3	The UE transmits an <i>RRCCONNECTIONSETUPCOMPLETE-NB</i> message to confirm the successful completion of the connection establishment and to initiate the Detach procedure by including the DETACH REQUEST message.	-->	RRC: <i>RRCCONNECTIONSETUPCOMPLETE-NB</i> NAS: DETACH REQUEST
2a4	The SS transmits an <i>RRCCONNECTIONRELEASE-NB</i> message	<--	<i>RRCCONNECTIONRELEASE-NB</i>

10.5.3 Switch/Power off procedure in State N2 and N3

10.5.3.1 Procedure for N2 and N3

Table 10.5.3.1-1: Switch/Power off procedure

Step	Procedure	Message Sequence	
		U - S	Message
1	The UE is powered off or switched off (see ICS)	-	-
2	The UE transmits DETACH REQUEST	-->	DETACH REQUEST
3	The SS transmits an <i>RRCCONNECTIONRELEASE-NB</i> message	<--	<i>RRCCONNECTIONRELEASE-NB</i>

10.5.4 Switch/Power off procedure in State N4

10.5.4.1 Procedure

Table 10.5.4.1-1: Switch/Power off procedure

Step	Procedure	Message Sequence	
		U - S	Message
1	The UE is powered off or switched off (see ICS)	-	-

10.5.5 Automatic selection mode procedure in State N5 (current cell, neighbour cell)

10.5.5.1 Procedure

Table 10.5.5.1-1: Automatic selection mode procedure

Step	Procedure	Message Sequence	
		U - S	Message
1	Set UE to Automatic PLMN selection mode.	-	-
2	The SS configures: - the current cell as a "Non-Suitable Off cell" - the neighbour cell as a "Serving cell"	-	-
3	Generic test procedure in TS 36.508 subclause 8.1.5A.X is performed on the neighbour cell	-	-
-	At the end of this test procedure sequence, the UE is in end state NB-IoT idle (N1)	-	-

Editors Note: Subclause of generic test procedure introduced in R5-167185.

11 Guidelines on test execution

This clause provides the guidelines on test executions.

The restriction on test case execution as listed in this clause is due to the restriction of bandwidth to accommodate the necessary number of radio frequencies for the specific operating Band as used by the test cases.

11.1 EUTRA single technology

This clause provides the guidelines for the test cases to be executed on the pure EUTRA test configuration.

A test case using more than one radio frequency, i.e. using the radio frequencies f2 or f3 or f4 specified in TS 36.508 [3], shall avoid to be executed on operating:

Band 12 with 10MHz bandwidth,

Band 13,

Band 17 with 10MHz bandwidth,

Band 18,

Band 31.

The list containing such test cases is given below:

6.1.1.1, 6.1.1.2, 6.1.1.3, 6.1.1.6, 6.1.1.7, 6.1.1.8, 6.1.2.6b, 6.1.2.7, 6.1.2.8, 6.1.2.9, 6.1.2.11, 6.1.2.13, 6.1.2.15, 6.1.2.17, 6.1.2.18, 6.3.1, 6.3.5, 6.3.6, 6.3.9, 6.4.1, 6.4.2,

8.1.3.4, 8.1.3.5, 8.2.4.6, 8.2.4.26, 8.3.1.3, 8.3.1.3a, 8.3.1.4, 8.3.1.6, 8.3.1.9, 8.3.1.10, 8.3.1.11, 8.3.1.26, 8.3.1.27, 8.3.1.31, 8.3.4.2, 8.3.4.3, 8.3.4.5, 8.6.2.2, 8.6.2.3a, 8.6.2.8, 8.6.2.10, 8.6.2.11, 8.6.2.12, 8.6.4.2, 8.6.4.3, 8.6.4.4, 8.6.4.8, 8.6.4.9, 8.6.4.10, 8.6.6.2, 8.6.6.5, 8.6.6.6, 8.6.6.7, 8.6.8.2, 8.6.8.6,

9.2.1.1.1a, 9.2.1.1.7, 9.2.1.1.13, 9.2.1.1.15, 9.2.1.1.16, 9.2.1.2.1, 9.2.1.2.10, 9.2.1.2.12, 9.2.1.2.14, 9.2.3.2.1, 9.2.3.2.12, 9.2.3.2.15, 9.2.3.2.16,

11.2.6, 11.2.7,

13.4.1.2,
17.4.1, 17.4.2, 17.4.3,
21.3.1, 21.3.2, 21.3.3, 21.3.7, 21.3.10, 21.3.11, 21.3.12.

A test case using more than two radio frequencies, i.e. using the radio frequencies f3 or f4 specified in TS 36.508 [3], shall avoid to be executed on operating:

Band 6,
Band 11,
Band 14,
Band 17 with 5MHz bandwidth,
Band 23 with 10MHz bandwidth,
Band 30,
Band 38,
Band 39

The list containing such test cases is given below:

6.1.1.1, 6.1.1.2, 6.1.1.3, 6.1.1.6, 6.1.1.7, 6.1.1.8, 6.1.2.7, 6.1.2.8, 6.1.2.9, 6.1.2.15, 6.3.5
8.1.3.5, 8.3.1.4, 8.6.4.3,
9.2.1.1.1a, 9.2.1.1.7, 9.2.1.1.15,
11.2.7.

A test case using more than three radio frequencies, i.e. using the radio frequency f4 specified in TS 36.508 [3], shall avoid to be executed on operating:

Band 12 with 5MHz bandwidth,
Band 19,
Band 20,
Band 21,
Band 27,
Band 34,
Band 70.

The list containing such test cases is given below:

6.1.1.1, 6.1.1.2, 6.1.1.6, 6.1.1.8,
9.2.1.1.7.

11.1.1 Replacement of test case execution

In case of bandwidth limitation for accommodation of more frequencies, a number of test cases can be replaced with the corresponding mirror test cases without affecting the test coverage. The table 11.1.1-1 shows the possible replacements. Only one of the paired test cases is required for execution.

Table 11.1.1-1: Replacement of test cases

Original test case	Replacing test case
6.1.1.1	6.1.1.1b
6.1.1.2	6.1.1.2a
6.1.1.3	6.1.1.3b
6.1.1.6	6.1.1.6a
6.1.2.7	6.1.2.7a
6.1.2.8	6.1.2.8a
6.1.2.9	6.1.2.9a
8.3.1.9	8.3.1.9a
8.3.1.11	8.3.1.11a
9.2.1.1.1a	9.2.1.1.1b
9.2.1.1.7	9.2.1.1.7a
9.2.1.1.13	9.2.1.1.13a
9.2.1.1.15	9.2.1.1.15a
9.2.1.1.16	9.2.1.1.16a

11.2 EUTRA - UTRA - GERAN

This clause contains the guidelines for the EUTRA interRAT test cases to be executed on the different test configurations: with only UTRA configured, with only GERAN configured or with UTRA-GERAN both configured. Whether or not an EUTRA frequency band overlaps the UTRA band, the dependency will affect the restrictions of the test execution on this band.

NOTE: The case where an EUTRA band overlaps a GSM band is not considered.

11.2.1 UTRA configured – GERAN not configured

This clause provides the guidelines for the EUTRA interRAT test cases where UTRA is configured, while GERAN is either not needed or not configured.

11.2.1.1 EUTRA band overlapping UTRA band

The restriction on test case execution as listed in this clause is due to the bandwidth of an EUTRA Band accommodating the necessary number of EUTRA or UTRA radio frequencies if an E-UTRA band overlaps the UTRA Band. A test case using more than one radio frequency, on the same EUTRA and UTRA band, shall avoid to be executed on operating

Band 12 with 10MHz bandwidth,

Band 13,

Band 17 with 10MHz bandwidth,

Band 18,

Band 31.

The list containing such test cases is given below:

6.2.1.2, 6.2.1.3, 6.2.2.1, 6.2.2.5, 6.2.2.8, 6.2.3.3, 6.2.3.3a, 6.2.3.4, 6.2.3.4a, 6.2.3.5, 6.2.3.5a, 6.2.3.6, 6.2.3.13, 6.2.3.31, 6.2.3.32, 6.2.3.33, 6.2.4.1, 6.2.4.2, 6.2.4.3, 6.2.4.4, 6.2.4.5, 6.2.4.6, 6.2.4.7, 6.3.3, 6.3.4, 6.3.7, 6.4.3, 6.4.4, 6.4.5, 6.4.6,

8.1.3.6, 8.1.3.6a, 8.1.3.7, 8.3.2.3, 8.3.2.3a, 8.3.2.4, 8.3.3.2, 8.3.4.4, 8.4.1.2, 8.4.1.4, 8.4.1.5, 8.4.2.2, 8.4.2.4, 8.5.2.1, 8.6.3.1, 8.6.3.4, 8.6.5.1, 8.6.5.1a, 8.6.5.4, 8.6.7.1, 8.6.7.4, 8.6.9.1, 8.6.9.2, 8.6.10.1, 8.7.1,

9.2.1.1.11, 9.2.1.1.12, 9.2.1.2.1b, 9.2.1.2.1c, 9.2.1.2.1d, 9.2.1.2.5, 9.2.1.2.8, 9.2.1.2.9, 9.2.1.2.11, 9.2.1.2.13, 9.2.1.2.15, 9.2.2.1.3, 9.2.2.1.10, 9.2.3.1.6, 9.2.3.1.10, 9.2.3.1.11, 9.2.3.1.12, 9.2.3.1.15, 9.2.3.1.15a, 9.2.3.1.17, 9.2.3.1.18, 9.2.3.1.18a, 9.2.3.2.1a, 9.2.3.2.1b, 9.2.3.2.1c, 9.2.3.2.3, 9.2.3.2.5, 9.2.3.2.6, 9.2.3.2.7, 9.2.3.2.8,

9.2.3.2.9, 9.2.3.2.11, 9.2.3.2.13, 9.2.3.2.14, 9.2.3.3.1, 9.2.3.3.2, 9.2.3.3.3, 9.2.3.3.4, 9.2.3.3.5, 9.2.3.3.5a, 9.3.1.4, 9.3.1.5, 9.3.1.6,

11.2.10, 11.2.11,

13.1.2, 13.1.2a, 13.1.3, 13.1.4, 13.1.5, 13.1.15, 13.1.16, 13.3.2.1, 13.4.2.1, 13.4.2.4, 13.4.3.1, 13.4.3.2, 13.4.3.4, 13.4.3.6, 13.4.3.7, 13.4.3.8, 13.4.3.9, 13.4.3.10, 13.4.3.11, 13.4.3.13, 13.4.3.14, 13.4.3.15, 13.4.3.16, 13.4.3.18, 13.4.3.19, 13.4.3.20.

A test case using more than two radio frequencies on the same EUTRA and UTRA band shall avoid to be executed on operating:

Band 6,

Band 11,

Band 14,

Band 17 with 5MHz bandwidth,

Band 23 with 10MHz bandwidth,

Band 38,

Band 39.

The list containing such test cases is given below:

6.2.1.2, 6.2.1.3,

8.6.3.4, 8.6.5.1a, 8.6.7.4,

9.2.1.2.9, 9.2.1.2.11, 9.2.1.2.13, 9.2.3.1.15, 9.2.3.1.18, 9.2.3.2.5, 9.2.3.2.6, 9.2.3.2.7, 9.2.3.2.8, 9.2.3.2.11, 9.2.3.2.13, 9.2.3.2.14.

A test case using more than three radio frequencies, on the same EUTRA and UTRA band shall avoid to be executed on operating

Band 12 with 5MHz bandwidth,

Band 19,

Band 20,

Band 21,

Band 27,

Band 34,

Band 70.

The list containing such test cases is given below:

9.2.1.2.13, 9.2.3.2.13.

11.2.1.2 EUTRA band not overlapping UTRA band

The restriction on test case execution as listed in this clause is due to the bandwidth of an EUTRA Band accommodating the necessary number of EUTRA radio frequencies. A test case using more than one radio frequency shall avoid to be executed on E-UTRA operating

Band 12 with 10MHz bandwidth,

Band 13,

Band 17 with 10MHz bandwidth,

Band 18,

Band 31.

The list containing such test cases is given below:

6.2.1.2, 6.2.1.3,

8.6.3.4, 8.6.5.1a, 8.6.7.4,

9.2.1.2.9, 9.2.1.2.11, 9.2.1.2.13, 9.2.3.1.15, 9.2.3.1.18, 9.2.3.2.5, 9.2.3.2.6, 9.2.3.2.7, 9.2.3.2.8, 9.2.3.2.11, 9.2.3.2.13,
9.2.3.2.14,

A test case using more than two radio frequencies shall avoid to be executed on E-UTRA operating

Band 6,

Band 11,

Band 14,

Band 17 with 5MHz bandwidth,

Band 23 with 10MHz bandwidth,

Band 30,

Band 38,

Band 39.

The list containing such test cases is given below:

9.2.1.2.13, 9.2.3.2.13.

11.2.2 GERAN configured - UTRA not configured

This clause provides the guidelines for the EUTRA/GERAN test cases where UTRA is either not needed or not configured. The restriction on test case execution as listed in this clause is due to the restriction of bandwidth of an EUTRA Band accommodating the necessary number of EUTRA radio frequencies.

A test case using more than one radio frequency shall avoid to be executed on E-UTRA operating

Band 12 with 10MHz bandwidth,

Band 13,

Band 17 with 10MHz bandwidth,

Band 18,

Band 31

The list containing such test cases is given below:

6.2.1.4, 6.2.3.17, 6.2.3.18,

8.3.2.2,

9.2.1.2.9, 9.2.1.2.11, 9.2.1.2.13, 9.2.3.1.15, 9.2.3.1.18, 9.2.3.2.5, 9.2.3.2.6, 9.2.3.2.7, 9.2.3.2.8, 9.2.3.2.11, 9.2.3.2.13,
9.2.3.2.14.

A test case using more than two radio frequencies, i.e. using the radio frequencies f3 or f4 specified in TS 36.508 [3], shall avoid to be executed on operating:

Band 6,

Band 11,
Band 14,
Band 17 with 5MHz bandwidth,
Band 23 with 10MHz bandwidth,
Band 30,
Band 38,
Band 39

The list containing such test cases is given below:

9.2.1.2.13, 9.2.3.2.13.

11.2.3 Neither UTRA nor GERAN configured

Certain EMM test cases can be executed as EUTRA_Only configuration despite of UTRA or GERAN test branches included in the test cases. The restriction on test case execution as listed in this clause is due to the bandwidth of an EUTRA Band accommodating the necessary number of EUTRA radio frequencies.

A test case using more than one radio frequency shall avoid to be executed on E-UTRA operating

Band 12 with 10MHz bandwidth,
Band 13,
Band 17 with 10MHz bandwidth,
Band 18,
Band 31.

The list containing such test cases is given below:

9.2.3.1.15, 9.2.3.1.18.

11.2.4 Both UTRA and GERAN configured

This clause provides the guidelines for the EUTRA - UTRA - GERAN test cases where three RAT technologies are simultaneously configured.

11.2.4.1 EUTRA band overlapping UTRA band

The restriction on test case execution as listed in this clause is due to the bandwidth of an EUTRA Band accommodating the necessary number of EUTRA or UTRA, UTRA radio frequencies if an E-UTRA band overlaps the UTRA Band.

A test case using more than one radio frequency shall avoid to be executed on E-UTRA operating

Band 12 with 10MHz bandwidth,
Band 13,
Band 17 with 10MHz bandwidth,
Band 18,
Band 31.

The list containing such test cases is given below:

6.2.1.1, 8.3.2.5, 8.3.2.6,

9.2.1.2.6, 9.2.1.2.7,

11.2.8

A test case using more than two radio frequencies, i.e. using the radio frequencies f3 or f4 specified in TS 36.508 [3], shall avoid to be executed on operating:

Band 6,

Band 11,

Band 14,

Band 17 with 5MHz bandwidth,

Band 23 with 10MHz bandwidth,

Band 38

Band 39

The list containing such test cases is given below:

6.2.1.1.

11.2.4.2 EUTRA band not overlapping UTRA band

The restriction on test case execution as listed in this clause is due to the restriction of bandwidth of an EUTRA Band accommodating the necessary number of EUTRA radio frequencies.

A test case using more than one radio frequency shall avoid to be executed on E-UTRA operating

Band 12 with 10MHz bandwidth,

Band 13,

Band 17 with 10MHz bandwidth,

Band 18,

Band 31.

The list containing such test cases is given below:

6.2.1.1

11.2.5 Replacement of test case execution

In case of bandwidth limitation for accommodation of more frequencies, a number of test cases can be replaced with the corresponding mirror test cases without affecting the test coverage. The table 11.2.1.5-1 shows the possible replacements. Only one of the paired test cases is required for execution.

Table 11.2.5-1: Replacement of interRAT test cases

Original test case	Replacing test case
9.2.3.1.15	9.2.3.1.15a
9.2.3.1.18	9.2.3.1.18a

11.3 EUTRA inter-band

The restriction on test case execution as listed in this clause is due to the restriction of bandwidth of an EUTRA band accommodating the necessary number of EUTRA radio frequencies. The inter-band test includes also EUTRA FDD-TDD and inter-band carrier aggregation tests.

11.3.1 Primary operating band

A test case using more than one radio frequency on the first operating band, shall avoid to be executed on operating

Band 12 with 10MHz bandwidth,

Band 13,

Band 17 with 10MHz bandwidth,

Band 18,

Band 31.

The list containing such test cases is given below:

6.1.2.15a, 8.1.3.12.

11.3.2 Secondary operating band for inter-band cells

Test case using more than one radio frequency, on the second operating band, shall avoid to be executed on operating

Band 12 with 10MHz bandwidth,

Band 13,

Band 17 with 10MHz bandwidth,

Band 18,

Band 31.

The list containing such test cases is given below:

6.1.1.1a, 6.1.1.3a, 6.1.1.4a, 6.1.2.16, 8.1.3.11a, 8.1.3.12b, 8.2.4.13a, 8.2.4.14a, 8.3.1.12a, 8.3.1.14a

11.3.3 Replacement of test case execution

In case of bandwidth limitation for accommodation of more frequencies, a number of test cases can be replaced with the corresponding mirror test cases without affecting the test coverage. The table 11.3.3-1 shows the possible replacements. Only one of the paired test cases is required for execution.

Table 11.3.3-1: Replacement of test cases

Original test case	Replacing test case
8.1.3.12	8.1.3.12b

11.4 EUTRA CA

The restriction on CA test case execution as listed in this clause is due to the restriction of bandwidth of an EUTRA CA band accommodating the necessary number of EUTRA radio frequencies.

11.4.1 CA contiguous Intra-band operation

Test case using more than two radio frequencies, i.e. using the radio frequencies f3 or f4 specified in TS 36.508 [3], shall avoid to be executed on E-UTRA CA Configuration:

CA_5B,

CA_23B,

CA_38C,

CA_39C,

CA_70C.

The list containing such test cases is given below:

8.2.4.19.1, 8.2.4.21.1

The following test cases using SCell on f2 are not applicable to be run when executed in the band combinations CA_70C:

7.1.2.10.1,

7.1.2.11.1,

7.1.4.20.1,

8.2.2.7.1,

8.2.4.17.1,

8.2.4.20.1,

8.2.4.23.1,

8.3.1.17.1,

8.3.1.18.1

11.4.2 CA Inter-band operation

Test case using more than one radio frequency on the primary band, i.e. using the radio frequency f2 specified in TS 36.508 [3], shall avoid to be executed on E-UTRA CA Configuration:

CA_3A-11A,

CA_5A-29A,

CA_8A-11A,

CA_12A-25A,

CA_12A-30A,

CA_18A-28A,

CA_19A-21A,

CA_19A-28A,

CA_19A-42A,

CA_19A-42C,

CA_21A-42C,

and on E-UTRA CA switched configuration

CA_1A-18A,

CA_1A-19A,

CA_1A-21A,

CA_2A-12A,

CA_2A-13A,

CA_2A-17A,
CA_2A-29A,
CA_2A-30A,
CA_3A-11A,
CA_3A-19A,
CA_4A-12A,
CA_4A-13A,
CA_4A-17A,
CA_4A-29A,
CA_4A-30A,
CA_5A-12A,
CA_5A-13A,
CA_5A-17A,
CA_5A-30A,
CA_7A-12A,
CA_8A-11A,
CA_11A-18A,
CA_12A-30A,
CA_19A-21A,
CA_20A-31A,
CA_29A-30A

The list containing such test cases is given below:

8.2.4.19.2

Test case using more than one radio frequency on the primary band, i.e. using the radio frequency f2 or f6 (depending upon the Cell being used) specified in TS 36.508 [3], shall avoid to be executed on E-UTRA CA Configuration:

CA_3A-11A,
CA_8A-11A,
CA_19A-21A,
CA_12A_30A

and on E-UTRA CA switched configuration

CA_3A-11A,
CA_8A-11A,
CA_19A-21A,
CA_12A_30A,
CA_29A-30A

The list containing such test cases is given below:

8.2.4.21.2

These test cases can be run with switched allocation of PCell and SCell as specified in TS 36.508 [3] clause 6.2.3.2 (NOTE 3 and 4).

These test cases with switched allocation of PCell and SCell shall avoid to be executed on E-UTRA CA Configuration with a band having no UL frequency

CA_2A-29A,

CA_4A-29A,

CA_5A-29A,

CA_20A-32A,

CA_23A-29A,

CA_20A-67A

and on E-UTRA CA switched configuration

CA_29A-30A,

CA_29A-66A

with an LAA unlicensed band

CA_1A-46A,

CA_2A-46A,

CA_3A-46A,

CA_4A-46A,

CA_7A-46A,

CA_41A-46A,

CA_42A-46A

and on E-UTRA CA switched configuration

CA_46A-66A,

7.1.2.10.2,

7.1.2.11.2,

7.1.4.20.2,

8.2.2.7.2,

8.2.4.17.2,

8.2.4.20.2,

8.2.4.23.2,

17.4.11.2,

21.3.12.2

The 3DL CA test cases can be run on 3CCs FDD-TDD band combinations, they are using more than one radio frequency on the primary band, i.e. using the radio frequency f2 specified in TS 36.508 [3], shall avoid to be executed on E-UTRA CA Configuration:

CA_19A-42C,

CA_21A-42C

The list containing such test cases is given below:

7.1.2.11.4

11.4.3 CA non-contiguous Intra-band operation

Test case using more than two radio frequencies, i.e. using the radio frequencies f3 specified in TS 36.508 [3], shall avoid to be executed on E-UTRA CA Configuration:

CA_5A-5A,

CA_23A-23A

The list containing such test cases is given below:

8.2.4.19.3

8.2.4.21.3

11.5 EUTRA MFBI

The following EUTRA MFBI test cases shall be executed using the combinations specified in Table 11.5-1 for px_OverlappingNotSupportedFrequencyBand_MFBI and px_MFBI_FrequencyBand:

6.1.2.19, 6.1.2.20, 6.1.2.21, 6.1.2.22, 6.2.3.34, 6.2.3.35

Table 11.5-1: Operating and MFBI EUTRA bands combinations

px_OverlappingNotSupportedFrequencyBand and_MFBI	px_MFBI_FrequencyBand (Note)
2	25
3	9
4	10, 66
5	18, 19, 26
9	3
10	4, 66
12	17
17	12
18	5, 26, 27
19	5, 26
25	2
26	5, 18, 19, 27
27	18, 26
33	39
38	41
39	33
41	38
66	4, 10
Note: The UE supports one or more of the listed MFBI bands and does not support at least one overlapping band. If the UE supports all overlapping bands, these test cases are not applicable.	

Test case 6.1.2.20 is not applicable to be run when executed in the band combination 5 & 18.

For test case 6.2.3.34 additionally the UTRA band combinations specified in Table 11.5-2 for px_UTRAN_OverlappingNotSupportedFrequencyBandMFBI and px_MFBI_UTRAN_FrequencyBand shall also be applicable

Table 11.5-2: Operating and MFBI UTRA bands combinations

px_UTRAN_OverlappingNotSupportedFrequencyBandMFBI	px_MFBI_UTRAN_FrequencyBand (Note)
2	25
3	9
4	10
5	18, 19, 26
9	3
10	4
18	5, 26
19	5, 26
25	2
26	5, 18, 19
Note: The UE supports one or more of the listed MFBI bands and does not support at least one overlapping band. If the UE supports all overlapping bands, these test cases are not applicable.	

The MFBI test case 6.1.2.23 shall be executed using the combinations specified in Table 11.5-3 for px_ePrimaryFrequencyBand, px_MFBI_FrequencyBand and px_OverlappingSupportedFrequencyBand_MFBI

Table 11.5-3: Operating and MFBI EUTRA bands combinations

px_ePrimaryFrequencyBand	px_MFBI_FrequencyBand	px_OverlappingSupportedFrequencyBand_MFBI
39	38	41

11.6 EUTRA DC

The restriction on DC test case execution as listed in this clause is due to the restriction of bandwidth of an EUTRA DC band accommodating the necessary number of EUTRA radio frequencies.

Test case using more than one radio frequency on the primary band, i.e. using the radio frequency f2 specified in TS 36.508 [3], shall avoid to be executed on E-UTRA DC inter-band configuration:

DC_19A-21A,

and on E-UTRA DC switched configuration

DC_1A-19A,

DC_1A-21A,

DC_2A-13A,

DC_3A-19A,

DC_4A-12A,

DC_4A-13A,

DC_4A-17A,

DC_5A-12A,

DC_19A-21A

The list containing such test cases is given below:

8.2.4.25.1, 8.2.4.25.2, 8.2.4.25.3, 8.2.4.25.4, 8.2.4.25.5, 8.2.4.25.6, 8.2.4.25.7

Test cases using more than one radio frequency on the secondary band, i.e. using the radio frequency f_6 specified in TS 36.508 [3], shall avoid to be executed on E-UTRA DC inter-band configurations:

DC_1A-19A,

DC_1A-21A,

DC_2A-13A,

DC_3A-19A,

DC_4A-12A,

DC_4A-13A,

DC_4A-17A,

DC_5A-12A,

DC_19A-21A

and on E-UTRA DC switched configuration

DC_19A-21A

The list containing such test cases is given below:

8.5.1.8.1, 8.5.1.8.2

Annex A (normative): Test Suites

This annex contains the approved TTCN Test Suites. The test suites have been produced using the Testing and Test Control Notation version 3 (TTCN3) according to ES 201 873-1 [13].

A.1 Baseline of specifications

Table A.1 shows the baseline of the relevant cores specifications and the test specifications which the delivered TTCN test suites are referred to.

Table A.1: References of the test and Core specifications

Core specifications baseline	TS 36.331 [19]
	TS 24.301 [21]
Test specifications	TS 36.508 [3]
	TS 36.509 [4]
	TS 36.523-1 [1]
	TS 36.523-2 [2]

A.2 E-UTRA Test Suites

Table A.2 lists all approved test cases.

For a given test case, the following variants are distinguished (if applicable):

- FDD: E-UTRA FDD mode; and UTRA FDD mode in case the test case is Inter-RAT with UTRA cell(s).
- TDD: E-UTRA TDD mode; and UTRA TDD mode in case the test case is Inter-RAT with UTRA cell(s).
- T/F: E-UTRA TDD mode and UTRA FDD mode; only applicable to Inter-RAT test cases with UTRA cell(s).

An "X" in columns FDD, TDD or T/F indicates the test case is approved for the respective variant.

An "-" in columns FDD, TDD or T/F indicates the test case is not applicable to the respective variant.

Table A.2: E-UTRA/EPS TTCN test cases

Test case	Description	FDD	TDD	T/F
6.1.1.1	PLMN selection of RPLMN, HPLMN/EHPLMN, UPLMN and OPLMN/Automatic mode	X	X	-
6.1.1.1a	PLMN selection / Automatic mode / between FDD and TDD	X	X	-
6.1.1.1b	PLMN selection of RPLMN, HPLMN/EHPLMN, UPLMN and OPLMN / Automatic mode / Single Frequency operation	X	X	-
6.1.1.2	PLMN selection of "Other PLMN/access technology combinations" / Automatic mode	X	X	-
6.1.1.2a	PLMN selection of "Other PLMN/access technology combinations" / Automatic mode / Single Frequency operation	X	X	-
6.1.1.3	Cell reselection of ePLMN in manual mode	X	X	-
6.1.1.3a	Cell reselection of ePLMN in manual mode / between FDD and TDD	X	X	-
6.1.1.3b	Cell reselection of ePLMN in manual mode / Single Frequency operation	X	X	-
6.1.1.4	PLMN selection in shared network environment / Automatic mode	X	X	-
6.1.1.4a	PLMN selection in shared network environment / Automatic mode / between FDD and TDD	X	X	-
6.1.1.6	PLMN selection of RPLMN, HPLMN/EHPLMN, UPLMN and OPLMN / Automatic mode / User reselection	X	X	-
6.1.1.6a	PLMN selection of RPLMN, HPLMN/EHPLMN, UPLMN and OPLMN / Automatic mode / User reselection / Single Frequency operation	X	X	-
6.1.1.7	PLMN selection / Periodic reselection / MinimumPeriodicSearchTimer	X	X	-
6.1.1.7a	PLMN selection / Periodic reselection / MinimumPeriodicSearchTimer / Single Frequency	X	X	-

Test case	Description	FDD	TDD	T/F
	operation			
6.1.1.8	PLMN selection of RPLMN or (E)HPLMN / Automatic mode	X	X	-
6.1.1.9	PLMN selection of RPLMN or (E)HPLMN; Manual mode	X	X	-
6.1.2.2	Cell selection, Qrxlevmin	X	X	-
6.1.2.2a	Cell selection / Qqualmin	X	X	-
6.1.2.2b	Cell selection / UE Cat 0 not allowed	X		-
6.1.2.2.c	Cell selection / Qrxlevmin / Enhanced coverage	X		-
6.1.2.2.d	Cell selection / Qqualmin / Enhanced coverage	X		-
6.1.2.3	Cell selection/Intra E-UTRAN/Serving cell becomes non-suitable (S<0 or barred)	X	X	-
6.1.2.3a	Cell selection / Intra E-UTRAN / Serving cell becomes non-suitable (Srxlev > 0 and Squal <0)	X	X	-
6.1.2.4	Cell reselection	X	X	-
6.1.2.5	Cell reselection for inter-band operation	X	X	-
6.1.2.5a	Cell reselection for interband operation/ Power Class 2 UE operation/ Between FDD and TDD	X	-	-
6.1.2.6	Cell reselection using Qhyst, Qoffset and Treselection	X	X	-
6.1.2.6a	Cell reselection using Treselection / Enhanced coverage	X		-
6.1.2.7	Cell reselection/Equivalent PLMN	X	X	-
6.1.2.7a	Cell reselection / Equivalent PLMN / Single Frequency operation	X	X	-
6.1.2.8	Cell reselection using cell status and cell reservations/Access control class 0 to 9	X	X	-
6.1.2.8a	Cell reselection using cell status and cell reservations / Access control class 0 to 9 / Single Frequency operation	X	X	-
6.1.2.9	Cell reselection using cell status and cell reservations/Access control class 11 to15	X	X	-
6.1.2.9a	Cell reselection using cell status and cell reservations / Access control class 11 to 15 / Single Frequency operation	X	X	-
6.1.2.10	Cell reselection in shared network environment	X	X	-
6.1.2.11	Inter-frequency cell reselection	X	X	-
6.1.2.12	Cell reselection / Cell-specific reselection parameters provided by the network in a neighbouring cell list	X	X	-
6.1.2.13	Cell re-selection, Sintrasearch, Snonintrasearch	X	X	-
6.1.2.14	Speed-dependent cell reselection	X	X	-
6.1.2.15	Inter-frequency cell reselection according to cell reselection priority provided by SIBs	X	X	-
6.1.2.15a	Inter-frequency cell reselection according to cell reselection priority provided by SIBs / Between FDD and TDD	X	X	-
6.1.2.15b	Inter-band cell reselection according to cell reselection priority provided by SIBs	X	X	-
6.1.2.16	Cell reselection / interband operation / Between FDD and TDD	X	X	-
6.1.2.17	Cell reselection for Squal to check against SIntraSearchQ and SnonIntraSearchQ	X	X	-
6.1.2.18	Inter-frequency cell reselection based on common priority information with parameters ThreshX, HighQ, ThreshX, LowQ and ThreshServing, LowQ	X	X	-
6.1.2.19	Intra-frequency cell reselection / MFBI	X	X	-
6.1.2.20	Inter-frequency cell reselection / MFBI	X	X	-
6.1.2.21	Inter-band cell reselection / MFBI	X	X	-
6.1.2.22	Cell reselection / MFBI / UE does not support multiBandInfoList	X		-
6.1.2.23	Inter-Band cell reselection / MFBI frequency band priority adjustment/inter-band CA	X		
6.2.1.1	Inter-RAT PLMN selection / Selection of correct RAT for OPLMN / Automatic mode	X	X	X
6.2.1.2	Inter-RAT PLMN selection / Selection of correct RAT for UPLMN / Automatic mode	X	X	X
6.2.1.3	Inter-RAT PLMN selection / Selection of correct PLMN and RAT in shared network environment / Automatic mode	X	X	X
6.2.1.4	Inter-RAT PLMN selection / Selection of correct RAT from the OPLMN list / Manual mode	X	X	-
6.2.1.6	Inter-RAT background HPLMN search / Search for correct RAT for HPLMN / Automatic mode	X	X	-
6.2.2.1	Inter-RAT cell selection/From E-UTRA RRC_IDLE to UTRA_Idle/Serving cell becomes non-suitable	X	X	X
6.2.2.2	Inter-RAT cell selection / From E-UTRA RRC_IDLE to GSM_Idle/GPRS Packet_idle / Serving cell becomes non-suitable	X	X	-
6.2.2.3	Inter-RAT cell selection / From E-UTRA RRC_IDLE to HRPD Idle / Serving cell becomes non-suitable	X	X	-
6.2.2.4	Inter-RAT cell selection / From E-UTRA RRC_IDLE to 1xRTT Dormant / Serving cell becomes non-suitable	X	X	-
6.2.2.5	Cell selection / No USIM	X	X	X
6.2.2.6	Inter-RAT Cell selection / From GSM_Idle/GPRS Packet_idle to E-UTRA RRC_IDLE / Serving cell becomes non-suitable	X	X	-
6.2.2.7	Inter-RAT Cell selection / From GSM_Idle/GPRS Packet_idle to E-UTRA RRC_IDLE / Serving cell is barred	X	X	-

Test case	Description	FDD	TDD	T/F
6.2.2.8	Inter-RAT cell selection / From UTRA_Idle to E-UTRA RRC_IDLE / Serving cell becomes non-suitable	X	X	X
6.2.3.1	Inter-RAT cell reselection / From E-UTRA RRC_IDLE to GSM_Idle/GPRS Packet_Idle	X	X	-
6.2.3.1a	Inter-RAT cell reselection / From E-UTRA RRC_IDLE to GSM_Idle/GPRS Packet_Idle (Squal < ThreshServing, LowQ, Srxlev > ThreshX, LowP and Srxlev > ThreshX, HighP)	X	X	-
6.2.3.3	Inter-RAT cell reselection/From UTRA_Idle to E-UTRA RRC_IDLE	X	X	X
6.2.3.3a	Inter-RAT cell reselection / From UTRA_Idle to E-UTRA RRC_IDLE (QqualminEUTRA, SqualServingCell < Threshserving,low2, SqualnonServingCell,x > Threshx, low2 and SqualnonServingCell,x > Threshx, high2)	X	-	-
6.2.3.4	Inter-RAT cell reselection / From UTRA CELL_PCH state to E-UTRA RRC_IDLE	X	X	X
6.2.3.4a	Inter-RAT cell reselection / From UTRA_CELL_PCH state to E-UTRA RRC_IDLE based on RSRQ+RSRP evaluation	X	X	X
6.2.3.5	Inter-RAT cell reselection/From E-UTRA RRC_IDLE to UTRA_Idle	X	X	X
6.2.3.5a	Inter-RAT cell reselection / From E-UTRA RRC_IDLE to UTRA_Idle (Squal > ThreshX, HighQ, Squal < ThreshServing, LowQ, Squal > ThreshX, LowQ and SnonIntraSearchQ)	X	-	-
6.2.3.6	Inter-RAT cell reselection / From E-UTRA RRC_IDLE to UTRA_Idle according to RAT priority provided by dedicated signalling	X	X	X
6.2.3.7	Inter-RAT cell reselection / From E-UTRA RRC_IDLE to HRPD Idle / HRPD cell is higher reselection priority than E-UTRA	X	X	-
6.2.3.7a	Inter-RAT cell reselection / From E-UTRA RRC_IDLE to HRPD Idle / HRPD cell is higher reselection priority than E-UTRA (Srxlev > ThreshX, HighP)	X	X	-
6.2.3.8	Inter-RAT cell reselection / From E-UTRA RRC_IDLE to HRPD Idle / HRPD cell is lower reselection priority than E-UTRA	X	X	-
6.2.3.8a	Inter-RAT cell reselection / From E-UTRA RRC_IDLE to HRPD Idle / HRPD cell is lower reselection priority than E-UTRA (Squal < ThreshServing, LowQ and Srxlev > ThreshX, LowP)	X	X	-
6.2.3.9	Inter-RAT cell reselection / From E-UTRA RRC_IDLE to 1xRTT Dormant / 1xRTT cell is higher reselection priority than E-UTRA	X	X	-
6.2.3.9a	Inter-RAT cell reselection / From E-UTRA RRC_IDLE to 1xRTT Dormant / 1xRTT cell is higher reselection priority than E-UTRA (Srxlev > ThreshX, HighP)	X	X	-
6.2.3.10	Inter-RAT cell reselection / From E-UTRA RRC_IDLE to 1xRTT Dormant / 1xRTT cell is lower reselection priority than E-UTRA	X	X	-
6.2.3.10a	Inter-RAT cell reselection / From E-UTRA RRC_IDLE to 1xRTT Dormant / 1xRTT cell is lower reselection priority than E-UTRA (Squal < ThreshServing, LowQ and Srxlev > ThreshX, LowP)	X	X	-
6.2.3.13	Inter-RAT cell reselection / From UTRA_Idle to E-UTRA RRC_IDLE according to RAT priority provided by dedicated signalling	X	X	X
6.2.3.14	Inter-RAT cell reselection / From GSM_Idle/GPRS Packet_Idle to E-UTRA / Priority of E-UTRA cells are higher than the serving cell	X	X	-
6.2.3.15	Inter-RAT cell reselection / From GSM_Idle/GPRS Packet_Idle to E-UTRA / Priority of E-UTRA cells are lower than the serving cell	X	X	-
6.2.3.16	Inter-RAT cell reselection / From GSM_Idle to E-UTRAN /based on H_Prio criteria	X	X	-
6.2.3.17	Inter-RAT cell reselection / From GSM_Idle/GPRS Packet_Idle to E-UTRA / Priority E-UTRA cells	X	X	-
6.2.3.18	Inter-RAT cell reselection / From GSM_Idle/GPRS Packet_Idle to E-UTRA / Blacklisted E-UTRA cells	X	X	-
6.2.3.19	Inter-RAT cell redirection to E-UTRA cell from GSM TCH mode	X	X	-
6.2.3.21	Inter-RAT autonomous cell reselection GPRS Packet_transfer NC0 mode to E-UTRA	X	X	-
6.2.3.23	Inter-RAT cell reselection from GPRS Packet_transfer to E-UTRA in CCN mode / PACKET CELL CHANGE CONTINUE	X	X	-
6.2.3.24	Inter-RAT cell reselection from GPRS Packet_transfer to E-UTRA in CCN mode / PACKET CELL CHANGE ORDER	X	X	-
6.2.3.26	Inter-RAT autonomous cell reselection GPRS Packet_transfer NC1 mode to E-UTRA Cell	X	X	-
6.2.3.27	Inter-RAT cell selection from GPRS Packet_transfer to E-UTRA (NC2 mode)	X	X	-
6.2.3.28	Inter-RAT cell reselection from GPRS Packet_transfer to E-UTRA	X	X	-
6.2.3.29	Inter-RAT Cell Reselection from GPRS Packet_transfer NC1 mode to E-UTRA in CCN mode (PACKET MEASUREMENT ORDER)	X	X	-
6.2.3.31	Inter-RAT cell reselection / From UTRA_Idle (low priority) to E-UTRA RRC_IDLE (high priority) according to RAT priority provided by dedicated signalling	X	X	X
6.2.3.32	Inter-RAT cell re-selection / From E-UTRA RRC_IDLE to UTRA_Idle, Snonintrasearch	X	X	X
6.2.3.33	Inter-RAT cell reselection / From E-UTRA RRC_IDLE to UTRA_Idle / Squal based cell reselection parameters are broadcasted in E-UTRAN / UE does not support Squal based cell reselection in UTRAN	X	X	X
6.2.3.34	Inter-RAT cell reselection from E-UTRA to UTRA / MFBI	X		
6.2.3.35	Inter-RAT cell reselection from UTRA to E-UTRA / MFBI	X		

Test case	Description	FDD	TDD	T/F
6.2.4.1	Inter-RAT absolute priority based reselection in UTRA CELL_FACH to E-UTRA RRC_IDLE (Higher Priority Layers, $Srxlev,x > Threshx,high$ and $Srxlev,serv > Sprioritysearch1$ and $SqualServ > Sprioritysearch2$)	X	-	X
6.2.4.2	Inter-RAT absolute priority based reselection in UTRA CELL_FACH (Higher Priority Layers, no cell reselection to E-UTRA RRC_IDLE when $Srxlev,serv < Sprioritysearch1$)	X	-	X
6.2.4.3	Inter-RAT absolute priority based reselection in UTRA CELL_FACH to E-UTRA RRC_IDLE (Higher Priority Layers, $Squal,x > Threshx,high2$ and $Srxlev,serv > Sprioritysearch1$ and $SqualServ > Sprioritysearch2$)	X	-	X
6.2.4.4	Inter-RAT absolute priority based reselection in UTRA CELL_FACH (lower priority) to E-UTRA RRC_IDLE (higher priority) (All Layers, $Srxlev,x > Threshx,high$)	X	-	X
6.2.4.5	Inter-RAT absolute priority based reselection in UTRA CELL_FACH (lower priority) to E-UTRA RRC_IDLE (higher priority) (All Layers, $Squal,x > ThreshX,high2$)	X	-	X
6.2.4.6	Inter-RAT absolute priority based reselection in UTRA CELL_FACH (higher priority) to E-UTRA RRC_IDLE (lower priority) (All Layers, $Srxlev,serv < Sprioritysearch1$, $Srxlev,serv < Thresh serv,low$ and $Srxlev,x > ThreshX,low$)	X	-	X
6.2.4.7	Inter-RAT absolute priority based reselection in UTRA CELL_FACH (higher priority) to E-UTRA RRC_IDLE (lower priority) (All Layers, $Srxlev,serv < Sprioritysearch1$, $Squal,serv < Thresh serv,low2$ && $Squal,x > ThreshX,low2$)	X	-	X
6.3.1	Inter-frequency cell reselection / From E-UTRA RRC_IDLE non-CSG cell to E-UTRA RRC_IDLE CSG cell	X	X	
6.3.2	Inter-RAT cell reselection / From GSM_Idle/GPRS Packet_Idle to E-UTRA idle CSG cell	X		-
6.3.3	Inter-RAT cell reselection / From UTRA_Idle to E-UTRA RRC_IDLE CSG cell	X	X	X
6.3.4	Inter-RAT cell reselection / From UTRA CELL_PCH state to E-UTRA RRC_IDLE CSG cell	X		
6.3.5	Manual support for CSG ID selection	X	X	-
6.3.6	Ignoring CSG cells in cell selection/reselection when allowed CSG list is empty or not supported	X	X	-
6.3.7	Inter-RAT Cell reselection from E-UTRA idle non-CSG cell to a UTRA CSG cell	X	X	X
6.3.9	Manual CSG ID selection across PLMNs	X	X	-
6.4.1	Manual CSG ID selection / Hybrid cell whose CSG ID is not in the Allowed CSG list nor Operator's list	X	X	-
6.4.2	Inter-frequency cell reselection / From E-UTRA RRC_IDLE non-CSG cell to E-UTRA RRC_IDLE member hybrid cell	X	X	-
6.4.3	Inter-RAT cell reselection / From E-UTRA RRC_IDLE non-CSG cell to UTRA_Idle member hybrid cell	X	X	X
6.4.4	Inter-RAT cell reselection / From E-UTRA RRC_IDLE non-member hybrid cell to UTRA_Idle member hybrid cell	X		X
6.4.5	Inter-RAT cell reselection / From UTRA_Idle to E-UTRA RRC_IDLE member hybrid cell	X	X	X
6.4.6	Inter-RAT cell reselection / From UTRA CELL_PCH to E-UTRA RRC_IDLE member hybrid cell	X		
6.4.7	Inter-RAT cell reselection / From GSM_Idle/GPRS Packet_Idle to E-UTRA RRC_IDLE member hybrid cell	X		-
7.1.1.1	CCCH mapped to UL SCH/ DL-SCH/Reserved LCID (Logical Channel ID)	X	X	-
7.1.1.1a	CCCH mapped to UL SCH/ DL-SCH / UE Cat 0	X		-
7.1.1.2	DTCH or DCCH mapped to UL SCH/ DL-SCH/Reserved Logical Channel ID	X	X	-
7.1.2.1	Correct selection of RACH parameters/Random access preamble and PRACH resource explicitly signalled to the UE by RRC/Non-contention based random access procedure	X	X	-
7.1.2.2	Correct selection of RACH parameters/Random access preamble and PRACH resource explicitly signalled to the UE in PDCCH Order/Non-contention based random access procedure	X	X	-
7.1.2.3	Correct selection of RACH parameters/Preamble selected by MAC itself/Contention based random access procedure	X	X	-
7.1.2.4	Random access procedure/Successful	X	X	-
7.1.2.5	Random access procedure/MAC PDU containing multiple RARs	X	X	-
7.1.2.6	Maintenance of uplink time alignment	X	X	-
7.1.2.7	MAC contention resolution/Temporary C-RNTI	X	X	-
7.1.2.8	MAC contention resolution/C-RNTI	X	X	-
7.1.2.9	MAC backoff indicator	X	X	-
7.1.2.10.1	CA / Random access procedure / SCell / Intra-band Contiguous CA	X	X	-
7.1.2.10.2	CA / Random access procedure / SCell / Inter-band CA	X	X	-
7.1.2.10.3	CA / Random access procedure / SCell / Intra-band non-contiguous CA	X		-
7.1.2.11.2	CA / Maintenance of uplink time alignment / Multiple TA / Inter-band CA	X	X	-
7.1.3.1	Correct handling of DL assignment/Dynamic case	X	X	-
7.1.3.2	Correct handling of DL assignment / Semi-persistent case	X	X	-
7.1.3.3	MAC PDU header handling	X	X	-
7.1.3.3a	MAC PDU header handling / UE with limited TB size	X		-
7.1.3.4	Correct HARQ process handling/DCCH and DTCH	X	X	-

Test case	Description	FDD	TDD	T/F
7.1.3.5	Correct HARQ process handling/CCCH	X	X	-
7.1.3.6	Correct HARQ process handling/BCCH	X	X	-
7.1.3.7	MAC padding	X	X	-
7.1.3.9	MAC reset DL	X	X	-
7.1.3.11.1	CA / Correct HARQ process handling / DCCH and DTCH / P cell and Scell / Intra-band Contiguous CA	X	X	-
7.1.3.11.2	CA / Correct HARQ process handling / DCCH and DTCH / P cell and Scell / Inter-band CA	X	X	-
7.1.3.11.3	CA / Correct HARQ process handling / DCCH and DTCH / P cell and Scell / Intra-band non-Contiguous CA	X		-
7.1.3.11.4	FDD-TDD CA / Correct HARQ process handling / DCCH and DTCH / FDD PCell and TDD SCell	X		-
7.1.3.11.5	FDD-TDD CA / Correct HARQ process handling / DCCH and DTCH / TDD PCell and FDD SCell	X		-
7.1.3.12	TDD additional special subframe configuration / Special subframe pattern 9 with Normal Cyclic Prefix / CRS based transmission scheme	-	X	-
7.1.3.12a	TDD additional special subframe configuration / Special subframe pattern 7 with Extended Cyclic Prefix / CRS based transmission scheme	-	X	-
7.1.3.13	TDD additional special subframe configuration / Special subframe pattern 9 with Normal Cyclic Prefix / UE-specific reference signals based transmission scheme	-	X	-
7.1.3.13a	TDD additional special subframe configuration / Special subframe pattern 7 with Extended Cyclic Prefix / UE-specific reference signals based transmission scheme	-	X	-
7.1.4.1	Correct handling of UL assignment/Dynamic case	X	X	-
7.1.4.2	Correct handling of UL assignment / Semi-persistent case	X	X	-
7.1.4.3	Logical channel prioritization handling	X	X	-
7.1.4.4	Correct handling of MAC control information/Scheduling requests and PUCCH	X	X	-
7.1.4.5	Correct handling of MAC control information/Scheduling requests and random access procedure	X	X	-
7.1.4.6	Correct handling of MAC control information/Buffer status/UL data arrive in the UE Tx buffer and retransmission of BSR/Regular BSR	X	X	-
7.1.4.7	Correct handling of MAC control information/Buffer Status/UL resources are allocated/Padding BSR	X	X	-
7.1.4.7a	Correct handling of MAC control information / Buffer Status / UL resources are allocated / Cancellation of Padding BSR	X	X	-
7.1.4.8	Correct handling of MAC control information/Buffer status/Periodic BSR timer expires	X	X	-
7.1.4.10	MAC padding	X	X	-
7.1.4.11	Correct HARQ process handling	X	X	-
7.1.4.12	MAC reset UL	X	X	-
7.1.4.13	MAC PDU header handling	X	X	-
7.1.4.14	Correct HARQ process handling / TTI bundling	X	X	-
7.1.4.15	UE power headroom reporting/Periodic reporting	X	X	-
7.1.4.16	UE power headroom Reporting/DL pathloss change reporting	X	X	-
7.1.4.18	CA / Correct handling of MAC control information / Buffer Status / UL data arrive in the UE Tx buffer / Extended buffer size	X	X	-
7.1.4.19.1	CA / UE power headroom reporting / SCell activation and DL pathloss change reporting / Extended PHR / Intra-band Contiguous	X	X	-
7.1.4.19.2	CA / UE power headroom reporting / SCell activation and DL pathloss change reporting / Extended PHR / Inter-band CA	X	X	-
7.1.4.20.1	CA / Correct handling of MAC control information / Buffer status / Intra-band Contiguous CA	X	X	-
7.1.4.20.2	CA / Correct handling of MAC control information / Buffer status / Inter-band CA	X	X	-
7.1.4.20.3	CA / Correct handling of MAC control information / Buffer status / Intra-band non-Contiguous CA	X		-
7.1.4.21	CA / UE power headroom reporting / Extended PHR	X	X	-
7.1.4.23	Correct HARQ process handling / TTI bundling with enhanced HARQ pattern	X		-
7.1.4.24	Correct HARQ process handling / TTI bundling without resource allocation restriction	X	X	-
7.1.5.1	Inter-TTI PUSCH hopping by uplink grant	X	X	-
7.1.5.2	Predefined intra-TTI PUSCH hopping (N_sb=1)	X	X	-
7.1.5.3	Predefined intra-TTI PUSCH hopping (N_sb=2/3/4)	X	X	-
7.1.5.4	Predefined inter-TTI PUSCH hopping (N_sb=1)	X	X	-
7.1.5.5	Predefined inter-TTI PUSCH hopping (N_sb=2/3/4)	X	X	-
7.1.6.1	DRX operation/Short cycle not configured/Parameters configured by RRC	X	X	-
7.1.6.2	DRX operation/Short cycle not configured/DRX command MAC control element reception	X	X	-
7.1.6.3	DRX operation / Short cycle configured / Parameters configured by RRC	X	X	-
7.1.6.4	DRX Operation / Short cycle configured / DRX command MAC control element reception	X	X	-
7.1.7.1.1	DL-SCH transport block size selection/DCI format 1/RA type 0	X	X	-
7.1.7.1.2	DL-SCH transport block size selection/DCI format 1/RA type 1	X	X	-
7.1.7.1.3	DL-SCH transport block size selection/DCI format 1A/RA type 2/Localised VRB	X	X	-

Test case	Description	FDD	TDD	T/F
7.1.7.1.4	DL-SCH transport block size selection/DCI format 1A/RA type 2/Distributed VRB	X	X	-
7.1.7.1.5	DL-SCH transport block size selection / DCI format 2A / RA type 0 / Two transport blocks enabled / Transport block to codeword swap flag value set to 0	X	X	-
7.1.7.1.6	DL-SCH transport block size selection / DCI format 2A / RA type 1/ Two transport blocks enabled / Transport block to codeword swap flag value set to 1	X	X	-
7.1.7.1.7	DL-SCH transport block size selection / DCI format 1 / RA type 0 / 256QAM	X	X	-
7.1.7.1.8	DL-SCH transport block size selection / DCI format 1 / RA type 1 / 256QAM	X	X	-
7.1.7.1.11	DL-SCH transport block size selection / DCI format 2A / RA type 0 / Two transport blocks enabled / Transport block to codeword swap flag value set to '0' / 256QAM	X		-
7.1.7.1.12	DL-SCH Transport Block Size selection / DCI format 2A / RA type 1 / Two transport blocks enabled / Transport block to codeword swap flag value set to '1' / 256QAM	X	X	-
7.1.7.1.13	DL-SCH transport block size selection / DCI format 6-1A / RA type 2 / Localised VRB	X		-
7.1.7.2.1	UL-SCH transport block size selection/DCI format 0	X	X	-
7.1.7.2.2	UL-SCH transport block size selection / DCI format 6-0A	X		-
7.1.8.1	Periodic RI reporting using PUCCH / Category 1 UE / Transmission mode 3/4	X	X	-
7.1.9.1.1	CA / Activation/Deactivation of SCells / Activation/Deactivation MAC control element reception / sCellDeactivationTimer/ Intra-band Contiguous CA	X	X	-
7.1.9.1.2	CA / Activation/Deactivation of SCells / Activation/Deactivation MAC control element reception / sCellDeactivationTimer/ Inter-band CA	X	X	-
7.1.9.1.3	CA / Activation/Deactivation of SCells / Activation/Deactivation MAC control element reception / sCellDeactivationTimer / Intra-band non-Contiguous CA	X	X	-
7.1.10.1	Sending SR on PUCCH with DMRS generated by using virtual cell identity / nPUCCH-Identity	X	X	-
7.1.10.2	7.1.10.2 Transmitting data on PUSCH with DMRS generated by using virtual cell identity / nPUSCH-Identity	X	X	-
7.2.2.1	UM RLC/Segmentation and reassembly/5-bit SN/Framing info field	X	X	-
7.2.2.2	UM RLC/Segmentation and reassembly/10-bit SN/Framing info field	X	X	-
7.2.2.3	UM RLC/Reassembly/5-bit SN/LI value > PDU size	X	X	-
7.2.2.4	UM RLC/Reassembly/10-bit SN/LI value > PDU size	X	X	-
7.2.2.5.1	UM RLC/5-bit SN/Correct use of sequence numbering	X	X	-
7.2.2.5.2	UM RLC/5-bit SN/Correct use of sequence numbering	X	X	-
7.2.2.6	UM RLC/Concatenation, segmentation and reassembly	X	X	-
7.2.2.7	UM RLC/In sequence delivery of upper layer PDUs without residual loss of RLC PDUs/Maximum re-ordering delay below t-Reordering	X	X	-
7.2.2.8	UM RLC/In sequence delivery of upper layer PDUs without residual loss of RLC PDUs/Maximum re-ordering delay exceeds t-Reordering	X	X	-
7.2.2.9	UM RLC/In sequence delivery of upper layer PDUs with residual loss of RLC PDUs/Maximum re-ordering delay exceeds t-Reordering	X	X	-
7.2.2.10	UM RLC/Duplicate detection of RLC PDUs	X	X	-
7.2.2.11	UM RLC/RLC re-establishment procedure	X	X	-
7.2.3.1	AM RLC/Concatenation and reassembly	X	X	-
7.2.3.2	AM RLC/Segmentation and reassembly/No PDU segmentation	X	X	-
7.2.3.3	AM RLC/Segmentation and reassembly/Framing info field	X	X	-
7.2.3.4	AM RLC/Segmentation and reassembly/Different numbers of length indicators	X	X	-
7.2.3.5	AM RLC/Reassembly/LI value > PDU size	X	X	-
7.2.3.6	AM RLC/Correct use of sequence numbering	X	X	-
7.2.3.7	AM RLC/Control of transmit window	X	X	-
7.2.3.8	AM RLC/Control of receive window	X	X	-
7.2.3.9	AM RLC/Polling for status	X	X	-
7.2.3.10	AM RLC/Receiver status triggers	X	X	-
7.2.3.13	AM RLC/Reconfiguration of RLC parameters by upper layers	X	X	-
7.2.3.14	AM RLC/In sequence delivery of upper layers PDUs	X	X	-
7.2.3.15	AM RLC/Re-ordering of RLC PDU segments	X	X	-
7.2.3.16	AM RLC/Re-transmission of RLC PDU without re-segmentation	X	X	-
7.2.3.17	AM RLC/Re-segmentation RLC PDU/SO, FI, LSF	X	X	-
7.2.3.18	AM RLC/Reassembly/AMD PDU reassembly from AMD PDU segments, Segmentation Offset and Last Segment Flag fields	X	X	-
7.2.3.20	AM RLC/Duplicate detection of RLC PDUs	X	X	-
7.2.3.21	AM RLC/RLC re-establishment at RRC connection reconfiguration including mobilityControlInfo IE	X	X	-
7.3.1.1	Maintenance of PDCP sequence numbers/User plane/RLC AM	X	X	-
7.3.1.2	Maintenance of PDCP sequence numbers/User plane/RLC UM/Short PDCP SN (7 bits)	X	X	-
7.3.1.3	Maintenance of PDCP sequence numbers/User plane/RLC UM/Long PDCP SN (12 bits)	X	X	-
7.3.3.1	Ciphering and deciphering/Correct functionality of EPS AS encryption algorithms/SNOW 3G	X	X	-
7.3.3.2	Ciphering and deciphering/Correct functionality of EPS UP encryption algorithms/SNOW 3G	X	X	-

Test case	Description	FDD	TDD	T/F
7.3.3.3	Ciphering and deciphering/Correct functionality of EPS AS encryption algorithms/AES	X	X	-
7.3.3.4	Ciphering and deciphering/Correct functionality of EPS UP encryption algorithms/AES	X	X	-
7.3.3.5	Ciphering and deciphering / Correct functionality of EPS AS encryption algorithms / ZUC	X	X	-
7.3.3.6	Ciphering and deciphering / Correct functionality of EPS AS encryption algorithms / ZUC	X	X	-
7.3.4.1	Integrity protection/Correct functionality of EPS AS integrity algorithms/SNOW 3G	X	X	-
7.3.4.2	Integrity protection/Correct functionality of EPS AS integrity algorithms/AES	X	X	-
7.3.4.3	Integrity protection / Correct functionality of EPS AS integrity algorithms / ZUC	X	X	-
7.3.5.2	PDCP handover/Lossless handover/PDCP sequence number maintenance	X	X	-
7.3.5.3	PDCP handover/Non-lossless handover/PDCP sequence number maintenance	X	X	-
7.3.5.4	PDCP handover/Lossless handover/PDCP status report to convey the information on missing or acknowledged PDCP SDUs at handover	X	X	-
7.3.5.5	PDCP handover/In-order delivery and duplicate elimination in the downlink	X	X	-
7.3.6.1	PDCP discard	X	X	-
8.1.1.1	RRC/Paging for connection in idle mode	X	X	-
8.1.1.1a	RRC / Direct Indication Information / Notification of BCCH modification in idle mode	X		-
8.1.1.2	RRC/Paging for notification of BCCH modification in idle mode	X	X	-
8.1.1.3	RRC / Paging for connection in idle mode / Multiple paging records	X	X	-
8.1.1.4	RRC / Paging for connection in idle mode / Shared network environment	X	X	-
8.1.1.6	RRC/BCCH modification in connected mode	X	X	-
8.1.1.7	RRC / Paging / EAB active	X	X	-
8.1.2.2	RRC connection establishment/Reject with wait time	X	X	-
8.1.2.3	RRC connection establishment/Return to idle state after T300 timeout	X	X	-
8.1.2.5	RRC connection establishment/0% access probability for MO calls, no restriction for MO signalling	X	X	-
8.1.2.6	RRC connection establishment / Non-zero percent access probability for MO calls, no restriction for MO signalling	X	X	-
8.1.2.7	RRC connection establishment/0% access probability for AC 0 to 9, AC 10 is barred, AC 11 to 15 are not barred, access for UE with access class in the range 11 to 15 is allowed	X	X	-
8.1.2.8	RRC connection establishment / Range of access barring time	X	X	-
8.1.2.9	RRC Connection Establishment / 0% access probability for MO calls, non-zero percent access probability for MO signalling	X	X	-
8.1.2.11	RRC connection establishment of emergency call	X	X	-
8.1.2.12	RRC connection establishment of emergency call / Limited Service	X	X	-
8.1.2.13	RRC connection establishment / 0% access probability for MO calls, 0% access probability for MO signalling	X	X	-
8.1.2.14	RRC connection establishment / High speed flag	X	X	-
8.1.3.1	RRC connection release/Success	X	X	-
8.1.3.4	RRC connection release/Redirection to another E-UTRAN frequency	X	X	-
8.1.3.5	RRC connection release/Success/With priority information	X	X	-
8.1.3.6	RRC connection release/Redirection from E-UTRAN to UTRAN	X	X	X
8.1.3.6a	RRC connection release / Redirection from E-UTRAN to UTRAN / Pre-redirection info	X	X	X
8.1.3.7	RRC connection release / Redirection from UTRAN to E-UTRAN	X	X	X
8.1.3.8	RRC connection release / Redirection from E-UTRAN to GERAN	X	X	-
8.1.3.9	RRC connection release / Redirection from E-UTRAN to HRPD	X	X	-
8.1.3.10	RRC connection release / Redirection from E-UTRAN to 1xRTT	X	X	-
8.1.3.11	RRC connection release / Redirection to another E-UTRAN band	X	X	-
8.1.3.11a	RRC connection release / Redirection to another E-UTRAN band / Between FDD and TDD	X	X	-
8.1.3.12	RRC connection release / Success / With priority information / Inter-band	X	X	-
8.1.3.12a	RRC connection release / Success / With priority information / Inter-band / Between FDD and TDD	X	X	-
8.1.3.12b	RRC connection release / Success / With priority information / Inter-band(Single frequency operation in source band)	X	X	-
8.2.1.1	RRC connection reconfiguration/Radio bearer establishment for transition from RRC_IDLE to RRC_CONNECTED/Success/Default bearer/Early bearer establishment	X	X	-
8.2.1.3	RRC connection reconfiguration/Radio bearer establishment/Success/Dedicated bearer	X	X	-
8.2.1.5	RRC connection reconfiguration / Radio bearer establishment for transition from RRC_IDLE to RRC_CONNECTED / Success / Latency check	X	X	-
8.2.1.6	RRC connection reconfiguration / Radio bearer establishment for transition from RRC_IDLE to RRC_CONNECTED / Success / Latency check / SecurityModeCommand and RRCConnectionReconfiguration transmitted in the same TTI	X	X	-
8.2.1.7	RRC connection reconfiguration/Radio bearer establishment/Success/SRB2	X	X	-
8.2.1.8	RRC connection reconfiguration / Radio bearer establishment / Success / Dedicated bearer / ROHC configured	X	X	-
8.2.2.1	RRC connection reconfiguration/Radio resource reconfiguration/Success	X	X	-

Test case	Description	FDD	TDD	T/F
8.2.2.2	RRC connection reconfiguration/SRB/DRB reconfiguration/Success	X	X	-
8.2.2.3.1	CA / RRC connection reconfiguration / SCell addition/ modification/release / Success / Intra-band contiguous CA	X	X	-
8.2.2.3.2	CA / RRC connection reconfiguration / SCell addition/ modification/release / Success / Inter-band CA	X	X	-
8.2.2.3.3	CA / RRC connection reconfiguration / SCell addition/ modification/release / Success / Intra-band non-contiguous CA	X	X	-
8.2.2.4.1	CA / RRC connection reconfiguration / SCell SI change / Success / Intra-band Contiguous CA	X	X	-
8.2.2.4.2	CA / RRC connection reconfiguration / SCell SI change / Success / Inter-band CA	X	X	-
8.2.2.4.3	CA / RRC connection reconfiguration / SCell SI change / Success / Intra-band non-contiguous CA	X	X	-
8.2.2.5.1	CA / RRC connection reconfiguration / SCell addition without UL / Success / Intra-band contiguous CA	X	X	-
8.2.2.5.2	CA / RRC connection reconfiguration / SCell addition without UL / Success / Inter-band CA	X	X	-
8.2.2.5.3	CA / RRC connection reconfiguration / SCell addition without UL / Success / Intra-band non-contiguous CA	X	X	-
8.2.2.6.1	RRC connection reconfiguration/ UE Assistance Information/power preference indication setup and release	X	X	-
8.2.2.6.2	RRC connection reconfiguration/ UE Assistance Information/power preference indication release on connection re-establishment	X	X	-
8.2.2.6.3	RRC connection reconfiguration/ UE Assistance Information/T340 running	X	X	-
8.2.2.7.1	CA / RRC connection reconfiguration / sTAG addition/ modification/release / Success / Intra-band Contiguous CA	X	X	X
8.2.2.7.2	CA / RRC connection reconfiguration / sTAG addition/ modification/release / Success / Inter-band CA	X	X	-
8.2.2.7.3	CA / RRC connection reconfiguration / sTAG addition/ modification/release / Success / Intra-band non-contiguous CA		X	-
8.2.2.8	RRC connection reconfiguration / SIB1 information / Success	X	X	-
8.2.3.1	RRC connection reconfiguration/Radio bearer release/Success	X	X	-
8.2.4.1	RRC connection reconfiguration/Handover/Success/Dedicated preamble	X	X	-
8.2.4.2	RRC connection reconfiguration/Handover/Success/Common preamble	X	X	-
8.2.4.3	RRC connection reconfiguration/Handover/Success/Intra-cell/Security reconfiguration	X	X	-
8.2.4.4	RRC connection reconfiguration/Handover/Failure/Intra-cell/Security reconfiguration	X	X	-
8.2.4.5	RRC connection reconfiguration/Handover/All parameters included	X	X	-
8.2.4.6	RRC connection reconfiguration/Handover/Success/Inter-frequency	X	X	-
8.2.4.7	RRC connection reconfiguration/Handover/Failure/Re-establishment successful	X	X	-
8.2.4.8	RRC connection reconfiguration / Handover / Failure / Re-establishment failure	X	X	-
8.2.4.9	RRC connection reconfiguration/Handover/Inter-band blind handover/Success	X	X	-
8.2.4.10	RRC connection reconfiguration / Handover / Between FDD and TDD	X	X	-
8.2.4.12	RRC connection reconfiguration / Handover / Setup and release of MIMO	X	X	-
8.2.4.13	RRC connection reconfiguration / Handover / Success (with measurement) / Inter-band	X	X	-
8.2.4.13a	RRC connection reconfiguration / Handover / Success (with measurement) / Inter-band / between FDD and TDD	X	X	-
8.2.4.14	RRC connection reconfiguration / Handover / Failure / Re-establishment successful / Inter-band	X	X	-
8.2.4.14a	RRC connection reconfiguration / Handover / Failure / Re-establishment successful / Inter-band / between FDD and TDD	X	X	-
8.2.4.15	RRC connection reconfiguration / Handover / Failure / Re-establishment failure / Inter-band	X	X	-
8.2.4.15a	RRC connection reconfiguration / Handover / Failure / Re-establishment failure / Inter-band / Between FDD and TDD	X	X	-
8.2.4.16.1	CA / RRC connection reconfiguration / Setup and Change of MIMO / Intra-band Contiguous CA	X	X	-
8.2.4.16.2	CA / RRC connection reconfiguration / Setup and Change of MIMO / Inter-band CA	X	X	-
8.2.4.16.3	CA / RRC connection reconfiguration / Setup and Change of MIMO / Intra-band non-contiguous CA	X	X	-
8.2.4.17.1	CA / RRC connection reconfiguration / Handover / Success / PCell Change and SCell addition / Intra-band contiguous CA	X	X	-
8.2.4.17.2	CA / RRC connection reconfiguration / Handover / Success / PCell Change and SCell addition / Inter-band CA	X	X	-
8.2.4.17.3	CA / RRC connection reconfiguration / Handover / Success / PCell Change and SCell addition / Intra-band non-contiguous CA	X	X	-
8.2.4.18.1	CA / RRC connection reconfiguration / Handover / Success / SCell release / Intra-band contiguous CA	X	X	-

Test case	Description	FDD	TDD	T/F
8.2.4.18.2	CA / RRC connection reconfiguration / Handover / Success / SCell release / Inter- band CA	X	X	-
8.2.4.18.3	CA / RRC connection reconfiguration / Handover / Success / SCell release / Intra- band non-contiguous CA	X	X	-
8.2.4.19.1	CA / RRC connection reconfiguration / Handover / Success / PCell Change/ Scell no Change / Intra-band contiguous CA	X	X	-
8.2.4.19.2	CA / RRC connection reconfiguration / Handover / Success / PCell Change/ Scell no Change / Inter-band CA	X	X	-
8.2.4.19.3	CA / RRC connection reconfiguration / Handover / Success / PCell Change/ Scell no Change / Intra-band non-contiguous CA	X	X	-
8.2.4.20.1	CA / RRC connection reconfiguration / Handover / Success / Scell Change / Intra-band Contiguous CA	X	X	-
8.2.4.20.2	CA / RRC connection reconfiguration / Handover / Success / Scell Change / Inter-band CA	X	X	-
8.2.4.20.3	CA / RRC connection reconfiguration / Handover / Success / SCell Change / Intra-band non-Contiguous CAChange / Intra-band non-contiguous CA	X	X	-
8.2.4.21.1	CA / RRC connection reconfiguration / Handover / Success / SCell release / Intra-band Contiguous CA	X	X	-
8.2.4.21.2	CA / RRC connection reconfiguration / Handover / Success / SCell release / Inter-band CA	X	X	-
8.2.4.21.3	CA / RRC connection reconfiguration / Handover / Success / SCell release / Intra-band non-contiguous CA	X	X	-
8.2.4.22	RRC connection reconfiguration / Handover / MFBI / Target cell broadcasting information disregarded by the UE	X	X	-
8.2.4.23.1	CA / RRC connection reconfiguration / Handover / Failure / Re-establishment successful / Intra-band Contiguous CA	X	X	-
8.2.4.23.2	CA / RRC connection reconfiguration / Handover / Failure / Re-establishment successful / Inter-band CA	X	X	-
8.2.4.23.3	CA / RRC connection reconfiguration / Handover / Failure / Re-establishment successful / Intra-band non-Contiguous CA	X	X	-
8.3.1.1	Measurement configuration control and reporting/Intra E-UTRAN measurements/Event A1	X	X	-
8.3.1.2	Measurement configuration control and reporting/Intra E-UTRAN measurements/Event A2	X	X	-
8.3.1.3	Measurement configuration control and reporting/Intra E-UTRAN measurements/Two simultaneous events A3 (intra and inter-frequency measurements)	X	X	-
8.3.1.3a	Measurement configuration control and reporting / Intra E-UTRAN measurements / Two simultaneous events A3 (intra and inter-frequency measurements) / RSRQ based measurements	X	X	-
8.3.1.4	Measurement configuration control and reporting/Intra E-UTRAN measurements/Periodic reporting (intra and inter-frequency measurements)	X	X	-
8.3.1.5	Measurement configuration control and reporting/Intra E-UTRAN measurements/Two simultaneous event A3 (intra-frequency measurements)	X	X	-
8.3.1.6	Measurement configuration control and reporting / Intra E-UTRAN measurements / Two simultaneous events A2 and A3 (inter-frequency measurements)	X	X	-
8.3.1.7	Measurement configuration control and reporting/Intra E-UTRAN measurements/Blacklisting	X	X	-
8.3.1.8	Measurement configuration control and reporting/Intra E-UTRAN measurements/Handover/IE measurement configuration present	X	X	-
8.3.1.9	Measurement configuration control and reporting/Intra E-UTRAN measurements/Intra-frequency handover/IE measurement configuration not present	X	X	-
8.3.1.9a	Measurement configuration control and reporting / Intra E-UTRAN measurements / Intra-frequency handover / IE measurement configuration not present / Single Frequency operation	X	X	-
8.3.1.10	Measurement configuration control and reporting/Intra E-UTRAN measurements/Inter-frequency handover/IE measurement configuration not present	X	X	-
8.3.1.11	Measurement configuration control and reporting/Intra E-UTRAN measurements/Continuation of the measurements after RRC connection re-establishment	X	X	-
8.3.1.11a	Measurement configuration control and reporting / Intra Frequency measurements / Continuation of the measurements after RRC connection re-establishment / Single Frequency operation	X	X	-
8.3.1.12	Measurement configuration control and reporting / Intra E-UTRAN measurements / Two simultaneous events A3 (Inter-band measurements)	X	X	-
8.3.1.12a	Measurement configuration control and reporting / Intra E-UTRAN measurements / Two simultaneous events A3 (inter-band measurements) / Between FDD and TDD	X	X	-
8.3.1.13	Measurement configuration control and reporting / Intra E-UTRAN measurements / Periodic reporting (intra-frequency and inter-band measurements)	X	X	-
8.3.1.13a	Measurement configuration control and reporting / Intra E-UTRAN measurements / Periodic reporting (intra-frequency and inter-band measurements) / Between FDD and TDD	X	X	-

Test case	Description	FDD	TDD	T/F
8.3.1.14	Measurement configuration control and reporting / Intra E-UTRAN measurements / Two simultaneous events A2 and A3 (Inter-band measurements)	X	X	-
8.3.1.14a	Measurement configuration control and reporting / Intra E-UTRAN measurements / Two simultaneous events A2 and A3 (inter-band measurements) / Between FDD and TDD	X	X	-
8.3.1.15	Measurement configuration control and reporting / Intra E-UTRAN measurements / Inter-band handover / IE measurement configuration not present	X	X	-
8.3.1.15a	Measurement configuration control and reporting / Intra E-UTRAN measurements / Inter-band handover / IE measurement configuration not present / Between FDD and TDD	X	X	-
8.3.1.16	Measurement configuration control and reporting / Intra E-UTRAN measurements / Continuation of the measurements after RRC connection re-establishment / Inter-band	X	X	-
8.3.1.16a	Measurement configuration control and reporting / Intra E-UTRAN measurements / Continuation of the measurements after RRC connection re-establishment / Inter-band / Between FDD and TDD	X	X	-
8.3.1.17.1	CA / Measurement configuration control and reporting / Intra E-UTRAN measurements / Event A6 / Intra-band contiguous CA	X	X	-
8.3.1.17.2	CA / Measurement configuration control and reporting / Intra E-UTRAN measurements / Event A6 / Inter-band CA	X	X	-
8.3.1.17.3	CA / Measurement configuration control and reporting / Intra E-UTRAN measurements / Event A6 / Intra-band non-contiguous CA	X	X	-
8.3.1.18.1	CA / Measurement configuration control and reporting / Intra E-UTRAN measurements / Additional measurement reporting / Intra-band contiguous CA	X	X	-
8.3.1.18.2	CA / Measurement configuration control and reporting / Intra E-UTRAN measurements / Additional measurement reporting / Inter-band CA	X	X	-
8.3.1.18.3	CA / Measurement configuration control and reporting / Intra E-UTRAN measurements / Additional measurement reporting / Intra-band non-contiguous CA	X	X	-
8.3.1.19	eICIC / Measurement configuration control and reporting / CSI change	X	X	-
8.3.1.21	eICIC / Measurement configuration control and reporting/Event A3 Handover / Neighbor RSRP measurement configuration change	X	X	-
8.3.1.22.1	CA / Measurement configuration control and reporting / Intra E-UTRAN measurements / Event A1 / Event A2 / Intra-band Contiguous CA	X	X	-
8.3.1.22.2	CA / Measurement configuration control and reporting / Intra E-UTRAN measurements / Event A1 / Event A2 / Inter-band CA	X	X	-
8.3.1.22.3	CA / Measurement configuration control and reporting / Intra E-UTRAN measurements / Event A1/Event A2 / Intra-band non-contiguous CA	X	X	-
8.3.1.23	Measurement configuration control and reporting / Intra E-UTRAN measurements / Event A4	X	X	-
8.3.1.24	Measurement configuration control and reporting / Intra E-UTRAN measurements / Event A5	X	X	-
8.3.1.25	Measurement configuration control and reporting / Intra E-UTRAN measurements / Event A5 / RSRQ based measurements	X	X	-
8.3.1.26	Measurement configuration control and reporting / Intra E-UTRAN measurements / Event A5 (Inter-frequency measurements)	X	X	-
8.3.1.27	Measurement configuration control and reporting / Intra E-UTRAN measurements / Event A5 (Inter-frequency measurements) / RSRQ based measurements	X	X	-
8.3.1.28	eICIC / Measurement configuration control and reporting/Event A1 / RSRP and RSRQ measurement / Serving ABS	X	X	-
8.3.2.1	Measurement configuration control and reporting / Inter-RAT measurements / Event B2 / Measurement of GERAN cells	X	X	-
8.3.2.2	Measurement configuration control and reporting / Inter-RAT measurements / Periodic reporting / Measurement of GERAN cells	X	X	-
8.3.2.3	Measurement configuration control and reporting/Inter-RAT measurements/Event B2/Measurement of UTRAN cells	X	X	X
8.3.2.3a	Measurement configuration control and reporting / Inter-RAT measurements / Event B2 / Measurement of UTRAN cells / RSRQ based measurements	X	X	X
8.3.2.4	Measurement configuration control and reporting / Inter-RAT measurements / Periodic reporting / Measurement of UTRAN cells	X	X	X
8.3.2.5	Measurement configuration control and reporting / Inter-RAT measurements / Periodic reporting / Measurements of E-UTRAN, UTRAN and GERAN cells	X	X	X
8.3.2.6	Measurement configuration control and reporting / Inter-RAT measurements / Simultaneous A2 and two B2 / Measurements of E-UTRAN, UTRAN and GERAN cells	X	X	X
8.3.2.7	Measurement configuration control and reporting/Inter-RAT measurements/Event B2/Measurement of HRPD cells	X	X	-
8.3.2.8	Measurement configuration control and reporting / Inter-RAT measurements / Periodic reporting / Measurement of HRPD cells	X	X	-
8.3.2.9	Measurement configuration control and reporting / Inter-RAT measurements / Event B2 /	X	X	-

Test case	Description	FDD	TDD	T/F
	Measurement of 1xRTT cells			
8.3.2.10	Measurement configuration control and reporting / Inter-RAT measurements / Periodic reporting / Measurement of 1xRTT cells	X	X	-
8.3.2.11	Measurement configuration control and reporting / Inter-RAT Measurements / Event B1 / Measurement of UTRAN cells	X	X	X
8.3.3.1	Measurement configuration control and reporting/SON/ANR/CGI reporting of E-UTRAN cell	X	X	-
8.3.3.2	Measurement configuration control and reporting / SON / ANR / CGI reporting of UTRAN cell	X		X
8.3.3.3	Measurement configuration control and reporting / SON / ANR / CGI reporting of GERAN cell	X	X	-
8.3.3.4	Measurement configuration control and reporting / SON / ANR / CGI reporting of HRPD cell	X	X	-
8.3.4.1	Intra-frequency SI acquisition / CSG cell and non-CSG cell	X	X	-
8.3.4.2	Inter-freq SI acquisition / Non-member hybrid cell	X	X	-
8.3.4.3	Inter-freq SI acquisition / Member hybrid cell	X	X	-
8.3.4.4	Inter-RAT SI acquisition / RRC_CONNECTED / UMTS member CSG cell	X	X	X
8.3.4.5	Inter-frequency E-UTRAN FDD – FDD / CSG Proximity Indication	X	-	-
8.4.1.2	Inter-RAT handover / From E-UTRA to UTRA PS / Data	X	X	X
8.4.1.4	Inter-RAT handover / From E-UTRA to UTRA HSPA / Data	X	X	X
8.4.1.5	Inter-RAT handover / from E-UTRA to UTRA HSUPA/HSDPA / Data	X		X
8.4.2.2	Inter-RAT handover / From UTRA PS to E-UTRA / Data	X	X	X
8.4.2.4	Inter-RAT handover / From UTRA HSPA to E-UTRA / Data	X	X	X
8.4.2.7.1	CA / RRC connection reconfiguration / Handover UTRAN to E-UTRAN/ Success / SCell addition / Intra-band Contiguous CA	X	X	X
8.4.2.7.2	CA / RRC connection reconfiguration / Handover UTRAN to E-UTRAN/ Success / SCell addition / Inter-band CA	X	X	X
8.4.2.7.3	CA / RRC connection reconfiguration / Handover UTRAN to E-UTRAN/ Success / SCell addition / Intra-band non-contiguous CA	X	X	X
8.4.3.2	Inter-RAT cell change order / From E-UTRA data RRC_CONNECTED to GPRS / Without NACC	X	X	-
8.4.3.3	Inter-RAT cell change order / From E-UTRA data to GPRS / With NACC	X	X	-
8.4.7.3	Pre-registration at 1xRTT and inter-RAT handover / CS fallback from E-UTRA RRC_IDLE to 1xRTT	X	X	-
8.4.7.4	Pre-Registration at 1xRTT and inter-RAT handover / CS fallback caused by addition of CS service / From E-UTRA Data to 1xRTT	X	X	-
8.4.7.5	Pre-registration at 1xRTT and inter-RAT handover / Enhanced CS fallback from E-UTRA RRC_IDLE to 1xRTT / MT call	X		
8.4.7.6	Pre-registration at 1xRTT and inter-RAT handover / Enhanced CS fallback from E-UTRA RRC_CONNECTED to 1xRTT / MO call	X	X	-
8.4.7.7	Pre-registration at 1xRTT and inter-RAT handover / Enhanced CS fallback from E-UTRA RRC_CONNECTED to e1XCSFB ECAM-based 1xRTT / MO call	X	X	-
8.4.7.8	Pre-registration at 1xRTT and inter-RAT Handover / Enhanced CS fallback from E-UTRA RRC_CONNECTED to 1xRTT / ECAM-based MT call	X	X	-
8.4.7.9	Pre-registration at 1xRTT and inter-RAT Handover / Enhanced CS fallback from E-UTRA RRC_CONNECTED to 1xRTT / Extended Service Reject / MO call	X	X	-
8.4.7.10	Pre-registration at 1xRTT and inter-RAT Handover / Enhanced CS fallback from E-UTRA call failure – GCSNA with Reorder Order	X	X	-
8.5.1.1	Radio link failure/RRC connection re-establishment Success	X	X	-
8.5.1.2	Radio link failure/T301 expiry	X	X	-
8.5.1.3	Radio link failure/T311 expiry	X	X	-
8.5.1.4	Radio link failure / RRC connection re-establishment reject	X	X	-
8.5.1.5	Radio link failure/Radio link recovery while T310 is running	X	X	-
8.5.1.6	Radio link failure / T311 expiry / Dedicated RLF timer	X	X	-
8.5.1.7.1	CA / No Radio link failure on Scell/ RRC Connection Continues on PCell / Intra-band Contiguous CA	X	X	-
8.5.1.7.2	CA / No Radio link failure on Scell/ RRC Connection Continues on PCell / Inter-band CA	X	X	-
8.5.1.7.3	CA / No Radio link failure on Scell/ RRC Connection Continues on PCell / Intra-band non-contiguous CA	X	X	-
8.5.2.1	Redirection to E-UTRAN / From UTRAN upon reception of RRC CONNECTION REJECT	X	X	X
8.5.4.1	UE capability transfer/Success	X	X	-
8.5.4.2	Network-requested CA Band Combination Capability Signalling / Number of UE supported CA band combinations less than or equal to 128	X	X	-
8.5.4.3	Network-requested CA Band Combination Capability Signalling / Number of UE supported CA band combinations exceeds 128	X	X	-
8.5.4.4	UE Capability Transfer/ Success/ UE Cat 0/ UE Paging Info	X		-

Test case	Description	FDD	TDD	T/F
8.6.1.1	Immediate MDT / Reporting / Location information	X	X	-
8.6.1.2	Immediate MDT / Reporting / Location information / Request from eNB / Event A2	X	X	-
8.6.2.1	Logged MDT / Intra-frequency measurement, logging and reporting	X	X	-
8.6.2.2	Logged MDT / Inter-frequency measurement, logging and reporting	X	X	-
8.6.2.3	Logged MDT / Logging and reporting / Limiting area scope	X	X	-
8.6.2.3a	Logged MDT / Logging and reporting / Limiting area scope / TAC list with PLMN identity	X	X	-
8.6.2.4	Logged MDT / Logging and reporting / Indication of logged measurements at E-UTRA handover	X	X	-
8.6.2.5	Logged MDT / Logging and reporting / Indication of logged measurements at E-UTRA re-establishment	X	X	-
8.6.2.6	Logged MDT / Release of logged MDT measurement configuration / Expire of duration timer	X	X	-
8.6.2.7	Logged MDT / Release of logged MDT measurement configuration / Reception of new logged measurement configuration, Detach or UE power off	X	X	-
8.6.2.8	Logged MDT / Maintaining logged measurement configuration / UE state transitions and mobility	X	X	-
8.6.2.9	Logged MDT / Location information	X	X	-
8.6.2.10	Logged MDT / Logging and reporting / Reporting at RRC connection establishment / PLMN list	X	X	-
8.6.2.11	Logged MDT / Logging and reporting / Reporting at intra LTE handover / PLMN list	X	X	-
8.6.2.12	Logged MDT / Logging and reporting / Reporting at RRC connection re-establishment / PLMN list	X	X	-
8.6.3.1	Logged MDT / UTRAN Inter-RAT measurement, logging and reporting	X		X
8.6.3.4	Logged MDT / Logging and reporting / Reporting at UTRAN Inter-RAT handover / PLMN list	X		X
8.6.4.1	Radio Link Failure logging / Reporting of Intra-frequency measurements	X	X	-
8.6.4.2	Radio Link Failure logging / Reporting of Inter-frequency measurements	X	X	-
8.6.4.3	Radio Link Failure logging / Reporting at RRC connection establishment and reestablishment	X	X	-
8.6.4.4	Radio Link Failure logging / Reporting at E-UTRA handover	X	X	-
8.6.4.5	Radio Link Failure logging / Reporting of ECGI of the PCell	X	X	-
8.6.4.7	Radio Link Failure logging / Location information	X	X	-
8.6.4.8	Radio Link Failure logging / Logging and reporting / Reporting at RRC connection establishment / PLMN list	X	X	-
8.6.4.9	Radio Link Failure logging / Logging and reporting / Reporting at intra LTE handover / PLMN list	X	X	-
8.6.4.10	Radio Link Failure logging / Logging and reporting / Reporting at RRC connection re-establishment / PLMN list	X	X	-
8.6.5.1	Radio Link Failure logging / Reporting at UTRAN Inter-RAT handover	X	X	X
8.6.5.1a	Radio Link Failure logging / Reporting at UTRAN Inter-RAT handover / PLMN list	X		X
8.6.5.4	Radio Link Failure logging / Reporting of selected UTRA cell	X	X	X
8.6.6.1	Handover Failure logging / Reporting of Intra-frequency measurements	X	X	-
8.6.6.2	Handover Failure logging / Reporting of Inter-frequency measurements	X	X	-
8.6.6.4	Handover Failure logging / Location information	X	X	-
8.6.6.5	Handover Failure logging / Logging and reporting / Reporting at RRC connection establishment / PLMN list	X	X	-
8.6.6.6	Handover Failure logging / Logging and reporting / Reporting at intra LTE handover / PLMN list	X	X	-
8.6.6.7	Handover Failure logging / Logging and reporting / Reporting at RRC connection re-establishment / PLMN list	X	X	-

Test case	Description	FDD	TDD	T/F
8.6.7.1	Handover Failure logging / Reporting of UTRAN Inter-RAT measurements	X	X	X
8.6.7.2	Handover Failure logging / Reporting of GERAN Inter-RAT measurements	X	X	-
8.6.7.3	Handover Failure logging / Reporting of CDMA2000 Inter-RAT measurements	X		-
8.6.7.4	Handover Failure logging / Reporting at UTRAN Inter-RAT handover / PLMN list	X	X	
8.6.8.1	Connection Establishment Failure logging / Logging and reporting / T300 expiry	X	X	-
8.6.8.2	Connection Establishment Failure logging / Logging and reporting / Reporting at intra-LTE handover	X	X	-
8.6.8.3	Connection Establishment Failure logging / Logging and reporting / Reporting at RRC connection re-establishment	X	X	-
8.6.8.4	Connection Establishment Failure logging / Logging and reporting / Location Information	X	X	-
8.6.8.5	Connection Establishment Failure logging / Logging and reporting / Reporting of Intra-frequency measurements	X	X	-
8.6.8.6	Connection Establishment Failure logging / Logging and reporting / Reporting of Inter-frequency measurements	X	X	-
8.6.9.1	Connection Establishment Failure logging / Logging and reporting / Reporting at UTRAN Inter-RAT handover	X	X	X
8.6.9.2	Connection Establishment Failure logging / Logging and reporting / Reporting of UTRAN Inter-RAT measurements	X	X	X
8.6.9.3	Connection Establishment Failure logging / Logging and reporting / Reporting of GERAN Inter-RAT measurements	X	X	-
8.6.10.1	Inter-RAT Immediate MDT / Reporting / Location information / Event B2	X	X	X
8.6.11.1	RACH Optimisation	X	X	-
8.7.1	Inter-RAT / ANR measurement, logging and reporting / E-UTRAN cell	X		
9.1.2.1	Authentication accepted	X	X	-
9.1.2.3	Authentication not accepted by the network, GUTI used, authentication reject and re-authentication	X	X	-
9.1.2.4	Authentication not accepted by the UE/MAC code failure	X	X	-
9.1.2.5	Authentication not accepted by the UE/SQN failure	X	X	-
9.1.2.6	Abnormal cases/Network failing the authentication check	X	X	-
9.1.2.7	Authentication not accepted by the UE/ non-EPS authentication unacceptable	X	X	-
9.1.3.1	NAS security mode command accepted by the UE	X	X	-
9.1.3.2	NAS security mode command not accepted by the UE	X	X	-
9.1.3.3	No emergency bearer service / NAS security mode command with EIA0 not accepted by the UE	X	X	-
9.1.4.2	Identification procedure/IMEI requested	X	X	-
9.1.5.1	EMM information procedure	X	X	-
9.2.1.1.1	Attach Procedure/Success/Valid GUTI	X	X	-
9.2.1.1.1a	Attach/Success/Last visited TAI, TAI list and equivalent PLMN list handling	X	X	-
9.2.1.1.1b	Attach Procedure / Success / Last visited TAI, TAI list and equivalent PLMN list handling / Single Frequency operation	X	X	-
9.2.1.1.2	Attach Procedure/Success/With IMSI/GUTI reallocation	X	X	-
9.2.1.1.2a	AttachWithIMSI configured / Selected PLMN is neither the registered PLMN nor in the list of equivalent PLMNs / Success	X	X	-
9.2.1.1.7	Attach/Success/List of equivalent PLMNs in the ATTACH ACCEPT message	X	X	-
9.2.1.1.7a	Attach Procedure / Success / List of equivalent PLMNs in the ATTACH ACCEPT message / Single Frequency operation	X	X	-
9.2.1.1.7b	Attach / Success / native GUMMEI	X	X	-
9.2.1.1.7c	Attach / Success / PSM	X	X	-
9.2.1.1.9	Attach/Rejected/IMSI invalid	X	X	-
9.2.1.1.10	Attach/Rejected/Illegal ME	X	X	-
9.2.1.1.11	Attach / Rejected / EPS services and non-EPS services not allowed	X	X	X
9.2.1.1.12	Attach / Rejected / EPS services not allowed	X	X	X
9.2.1.1.13	Attach/Rejected/PLMN not allowed	X	X	-
9.2.1.1.13a	Attach / Rejected / PLMN not allowed / Single Frequency operation	X	X	-
9.2.1.1.14	Attach/Rejected/Tracking area not allowed	X	X	-
9.2.1.1.15	Attach/Rejected/Roaming not allowed in this tracking area	X	X	-
9.2.1.1.15a	Attach / Rejected / Roaming not allowed in this tracking area / Single Frequency operation	X	X	-
9.2.1.1.16	Attach/Rejected/EPS services not allowed in this PLMN	X	X	-
9.2.1.1.16a	Attach / Rejected / EPS services not allowed in this PLMN / Single Frequency operation	X	X	--
9.2.1.1.17	Attach/Rejected/No suitable cells in tracking area	X	X	-
9.2.1.1.18	Attach / Rejected / Not authorized for this CSG	X	X	-
9.2.1.1.19	Attach/Abnormal case/Failure due to non integrity protection	X	X	-
9.2.1.1.20	Attach/Abnormal case/Access barred because of access class barring or NAS signalling connection establishment rejected by the network	X	X	-

Test case	Description	FDD	TDD	T/F
9.2.1.1.21	Attach/Abnormal case/Success after several attempts due to no network response	X	X	-
9.2.1.1.22	Attach/Abnormal case/Unsuccessful attach after 5 attempts	X	X	-
9.2.1.1.23	Attach/Abnormal case/Repeated rejects for network failures	X	X	-
9.2.1.1.24	Attach/Abnormal case/Change of cell into a new tracking area	X	X	-
9.2.1.1.25	Attach/Abnormal case/Mobile originated detach required	X	X	-
9.2.1.1.26	Attach/Abnormal case/Detach procedure collision	X	X	-
9.2.1.1.27	Attach / Abnormal case / Network reject with Extended Wait Timer	X	X	-
9.2.1.1.27a	Attach Procedure / EAB broadcast handling / ExtendedAccessBarring configured in the UE	X	X	-
9.2.1.1.28	Attach / Success / IMS	X	X	-
9.2.1.1.28a	Attach / Success / IMS / Second PDN	X	X	-
9.2.1.1.29	Attach / Rejected / IMEI not accepted	X	X	-
9.2.1.1.30	Attach / Abnormal case / ESM failure	X	X	-
9.2.1.2.1	Combined attach/Success/EPS and non-EPS services	X	X	-
9.2.1.2.1b	Combined attach / Success / SMS only	X	X	X
9.2.1.2.1c	Combined attach procedure / Success / CS Fallback not preferred	X	X	X
9.2.1.2.1d	Combined attach procedure / Success / EPS and CS Fallback not preferred / data centric UE	X	X	X
9.2.1.2.2	Combined attach / Success / EPS services only / IMSI unknown in HSS	X	X	-
9.2.1.2.3	Combined attach / Success / EPS services only / MSC temporarily not reachable	X	X	-
9.2.1.2.4	Combined attach/Success/EPS services only/CS domain not available	X	X	-
9.2.1.2.4a	Successful combined attach procedure / EPS service only / congestion	X	X	-
9.2.1.2.5	Combined attach / Rejected / IMSI invalid	X	X	X
9.2.1.2.6	Combined attach / Rejected / Illegal ME	X	X	X
9.2.1.2.7	Combined attach / Rejected / EPS services and non-EPS services not allowed	X	X	X
9.2.1.2.8	Combined attach / Rejected / EPS services not allowed	X	X	X
9.2.1.2.9	Combined attach / Rejected / PLMN not allowed	X	X	X
9.2.1.2.10	Combined attach / Rejected / Tracking area not allowed	X	X	-
9.2.1.2.11	Combined attach / Rejected / Roaming not allowed in this tracking area	X	X	X
9.2.1.2.12	Combined attach / Rejected / EPS services not allowed in this PLMN	X	X	-
9.2.1.2.13	Combined attach / Rejected / No suitable cells in tracking area	X	X	X
9.2.1.2.14	Combined attach / Rejected / Not authorized for this CSG	X	X	-
9.2.1.2.15	Combined attach / Abnormal case / Handling of the EPS attach attempt counter	X	X	X
9.2.2.1.1	UE initiated detach/UE switched off	X	X	-
9.2.2.1.2	UE initiated detach/USIM removed from the UE	X	X	-
9.2.2.1.3	UE initiated detach/EPS capability of the UE is disabled	X	X	X
9.2.2.1.4	UE initiated detach / detach for non-EPS services	X	X	-
9.2.2.1.6	UE initiated detach/Abnormal case/Local detach after 5 attempts due to no network response	X	X	-
9.2.2.1.7	UE initiated detach/Abnormal case/Detach procedure collision	X	X	-
9.2.2.1.8	UE initiated detach/Abnormal case/Detach and EMM common procedure collision	X	X	-
9.2.2.1.9	UE initiated detach/Abnormal case/Change of cell into a new tracking area	X	X	-
9.2.2.1.10	UE initiated detach / Mapped security context	X	X	X
9.2.2.2.1	NW initiated detach/Re-attach required	X	X	-
9.2.2.2.2	NW initiated detach/IMSI detach	X	X	-
9.2.2.2.14	NW initiated detach/Abnormal case/EMM cause not included	X	X	-
9.2.3.1.1	Normal tracking area update/Accepted	X	X	-
9.2.3.1.1a	Normal tracking area update / Accepted / PSM	X	X	-
9.2.3.1.4	Normal tracking area update/List of equivalent PLMNs in the TRACKING AREA UPDATE ACCEPT message	X	X	-
9.2.3.1.5	Periodic tracking area update/Accepted	X	X	-
9.2.3.1.5a	Periodic tracking area update / Accepted / Per-device timer	X	X	-
9.2.3.1.5b	Periodic tracking area update / Accepted / PSM / T3312 Extended Value	X	X	-
9.2.3.1.6	Normal tracking area update / UE with ISR active moves to E-UTRAN	X	X	X
9.2.3.1.8	UE receives an indication that the RRC connection was released with cause "load balancing TAU required"	X	X	-
9.2.3.1.8a	Normal tracking area update / low priority override	X	X	-
9.2.3.1.8b	Normal tracking area update / EAB active	X	X	-
9.2.3.1.9	Normal tracking area update / Correct handling of CSG list	X	X	-
9.2.3.1.9a	Normal tracking area update/NAS signalling connection recovery	X	X	-
9.2.3.1.10	Normal tracking area update / Rejected / IMSI invalid	X	X	X
9.2.3.1.11	Normal tracking area update / Rejected / Illegal ME	X	X	X
9.2.3.1.12	Normal tracking area update / Rejected / EPS service not allowed	X	X	X
9.2.3.1.13	Normal tracking area update/Rejected/UE identity cannot be derived by the network	X	X	-

Test case	Description	FDD	TDD	T/F
9.2.3.1.14	Normal tracking area update/Rejected/UE implicitly detached	X	X	-
9.2.3.1.15	Normal tracking area update / Rejected / PLMN not allowed	X	X	X
9.2.3.1.15a	Normal tracking area update / Rejected / PLMN not allowed / Single Frequency operation	X	X	X
9.2.3.1.16	Normal tracking area update/Rejected/Tracking area not allowed	X	X	-
9.2.3.1.17	Normal tracking area update / Rejected / Roaming not allowed in this tracking area	X	X	X
9.2.3.1.18	Normal tracking area update / Rejected / EPS services not allowed in this PLMN	X	X	X
9.2.3.1.18a	Normal tracking area update / Rejected / EPS services not allowed in this PLMN / Single Frequency operation	X	X	X
9.2.3.1.19	Normal tracking area update/Rejected/No suitable cells in tracking area	X	X	-
9.2.3.1.20	Normal tracking area update / Rejected / Not authorized for this CSG	X	X	-
9.2.3.1.20a	Normal tracking area update / Rejected / Congestion	X	X	-
9.2.3.1.22	Normal tracking area update / Abnormal case / access barred due to access class control or NAS signalling connection establishment rejected by the network	X	X	-
9.2.3.1.23	Normal tracking area update/Abnormal case/Success after several attempts due to no network response/TA belongs to TAI list and status is UPDATED	X	X	-
9.2.3.1.25	Normal tracking area update/Abnormal case/Failure after 5 attempts due to no network response	X	X	-
9.2.3.1.26	Normal tracking area update/Abnormal case/TRACKING AREA UPDATE REJECT	X	X	-
9.2.3.1.27	Normal tracking area update/Abnormal case/Change of cell into a new tracking area	X	X	-
9.2.3.1.28	Normal tracking area update/Abnormal case/Tracking area updating and detach procedure collision	X	X	-
9.2.3.2.1	Combined tracking area update/Successful	X	X	-
9.2.3.2.1a	Combined tracking area update / Successful / Check of last visited TAI and handling of TAI list, LAI and TMSI	X	X	X
9.2.3.2.1b	Combined tracking area update / Success / SMS only	X	X	X
9.2.3.2.1c	Combined tracking area update / Success / CS Fallback not preferred	X	X	X
9.2.3.2.2	Combined tracking area update / Successful for EPS services only / IMSI unknown in HSS	X	X	-
9.2.3.2.3	Combined tracking area update / Successful for EPS services only / MSC temporarily not reachable	X	X	X
9.2.3.2.4	Combined tracking area update / Successful for EPS services only / CS domain not available	X	X	-
9.2.3.2.4a	Combined tracking area update / Successful for EPS services only / congestion	X	X	-
9.2.3.2.5	Combined tracking area update / Rejected / IMSI invalid	X	X	X
9.2.3.2.6	Combined tracking area update / Rejected / Illegal ME	X	X	X
9.2.3.2.7	Combined tracking area update / Rejected / EPS services and non-EPS services not allowed	X	X	X
9.2.3.2.8	Combined tracking area update / Rejected / EPS services not allowed	X	X	X
9.2.3.2.9	Combined tracking area update / Rejected / UE identity cannot be derived by the network	X	X	X
9.2.3.2.10	Combined tracking area update / Rejected / UE implicitly detached	X	X	-
9.2.3.2.11	Combined tracking area update / Rejected / PLMN not allowed	X	X	X
9.2.3.2.12	Combined tracking area update / Rejected / Tracking area not allowed	X	X	-
9.2.3.2.13	Combined tracking area update / Rejected / Roaming not allowed in this tracking area	X	X	X
9.2.3.2.14	Combined tracking area update / Rejected / EPS services not allowed in this PLMN	X	X	X
9.2.3.2.15	Combined tracking area update / Rejected / No suitable cells in tracking area	X	X	-
9.2.3.2.16	Combined tracking area update / Rejected / Not authorized for this CSG	X	X	-
9.2.3.2.17	Combined tracking area update / Abnormal case / handling of the EPS tracking area updating attempt counter	X	X	-
9.2.3.3.1	First lu mode to S1 mode inter-system change after attach	X	X	X
9.2.3.3.2	lu mode to S1 mode intersystem change / ISR is active / Expiry of T3312 in E-UTRAN or T3412 in UTRAN and further intersystem change	X	X	X
9.2.3.3.3	lu mode to S1 mode intersystem change / Periodic TAU and RAU / ISR activated, T34xx expired	X	X	X
9.2.3.3.4	First S1 mode to lu mode inter-system change after attach	X	X	X
9.2.3.3.5	Periodic routing area update	X	X	X
9.2.3.3.5a	Periodic location update	X	X	X
9.2.3.4.1	TAU/RAU procedure for inter-system cell reselection between A/Gb and S1 modes	X	X	-
9.2.4.1.1	Attach and Normal tracking area update Procedure / Success / With and without Idle eDRX parameters	X	X	-
9.2.4.1.2	Attach & Normal tracking area update Procedure / Success / With and without Idle eDRX and PSM parameters	X	X	-
9.3.1.1	Service request initiated by UE for user data	X	X	-
9.3.1.3	Service request / Mobile originating CS fallback	X	X	-
9.3.1.4	Service request / Rejected / IMSI invalid	X	X	X
9.3.1.5	Service request / Rejected / Illegal ME	X	X	X

Test case	Description	FDD	TDD	T/F
9.3.1.6	Service request / Rejected / EPS services not allowed	X	X	X
9.3.1.7	Service request/Rejected/UE identity cannot be derived by the network	X	X	-
9.3.1.7a	Service request/Rejected/UE implicitly detached	X	X	-
9.3.1.12a	Extended service request / Rejected / CS domain temporarily not available	X	X	-
9.3.1.16	Service request/Abnormal case/Switch off	X	X	-
9.3.1.17	Service request/Abnormal case/Procedure collision	X	X	-
9.3.1.18	Service request / Rejected / Not authorized for this CSG	X	X	-
9.3.2.1	Paging procedure	X	X	-
9.3.2.2	Paging for CS fallback/Idle mode	X	X	-
9.3.2.2a	Paging for CS fallback/Connected mode	X	X	-
9.4.1	Integrity protection/Correct functionality of EPS NAS integrity algorithm/SNOW3G	X	X	-
9.4.2	Integrity protection/Correct functionality of EPS NAS integrity algorithm/AES	X	X	-
9.4.3	Ciphering and deciphering/Correct functionality of EPS NAS encryption algorithm/SNOW3G	X	X	-
9.4.4	Ciphering and deciphering/Correct functionality of EPS NAS encryption algorithm/AES	X	X	-
9.4.5	Integrity protection / Correct functionality of EPS NAS integrity algorithm / ZUC	X	X	-
9.4.6	Ciphering and deciphering / Correct functionality of EPS NAS encryption algorithm / ZUC	X	X	-
10.2.1	Dedicated EPS bearer context activation/Success	X	X	-
10.3.1	EPS bearer context modification/Success	X	X	-
10.4.1	EPS bearer context deactivation/Success	X	X	-
10.4.2	EPS bearer context deactivation / Re-establishment	X	X	-
10.5.1	UE requested PDN connectivity procedure accepted by the network	X	X	-
10.5.1a	UE requested PDN connectivity accepted / Dual priority / T3396 override	X	X	-
10.5.1b	UE requested PDN connectivity accepted / Dual priority / T3346 override	X	X	-
10.5.3	UE requested PDN connectivity procedure not accepted	X	X	-
10.5.4	UE requested PDN connectivity not accepted / Network reject with Extended Wait Timer	X	X	-
10.6.1	UE requested PDN disconnect procedure accepted by the network	X	X	-
10.7.1	UE requested bearer resource allocation, accepted by the network/New EPS bearer context	X	X	-
10.7.2	UE requested bearer resource allocation accepted by the network/Existing EPS bearer context	X	X	-
10.7.3	UE requested bearer resource allocation not accepted by the network	X	X	-
10.7.4	UE requested bearer resource allocation/Expiry of timer T3480	X	X	-
10.7.5	UE requested bearer resource allocation / BEARER RESOURCE ALLOCATION REJECT message including cause #43 "unknown EPS bearer context"	X	X	-
10.8.1	UE requested bearer resource modification accepted by the network/New EPS bearer context	X	X	-
10.8.2	UE requested bearer resource modification accepted by the network/Existing EPS bearer context	X	X	-
10.8.3	UE requested bearer resource modification not accepted by the network	X	X	-
10.8.4	UE requested bearer resource modification / Cause #36 "regular deactivation"	X	X	-
10.8.5	UE requested bearer resource modification / BEARER RESOURCE MODIFICATION REJECT message including cause #43 "unknown EPS bearer context"	X	X	-
10.8.6	UE requested bearer resource modification / Collision of a UE requested bearer resource modification procedure and EPS bearer context deactivation procedure	X	X	-
10.8.7	UE requested bearer resource modification / Expiry of timer T3481	X	X	-
10.8.8	UE requested bearer resource modification / Dual priority / low priority override	X	X	-
10.9.1	UE routing of uplinks packets	X	X	-
11.1.1	MT-SMS over SGs/Idle mode	X	X	-
11.1.2	MT-SMS over SGs/Active mode	X	X	-
11.1.3	MO-SMS over SGs/Idle mode	X	X	-
11.1.4	MO-SMS over SGs/Active mode	X	X	-
11.1.5	Multiple MO-SMS over SGs / Idle mode	X	X	-
11.1.6	Multiple MO-SMS over SGs / Active mode	X	X	-
11.2.1	Emergency bearer services / Normal cell / NORMAL-SERVICE / Local Emergency Numbers List sent in the Attach / PDN connect new emergency EPS bearer context / Service request / Emergency PDN disconnect	X	X	-
11.2.2	Emergency bearer services / Normal cell / LIMITED-SERVICE / Attach / PDN connect / Service request / PDN disconnect / Detach / Temporary storage of EMM information	X	X	-
11.2.3	Emergency bearer services / CSG cell / LIMITED-SERVICE / Attach / Security mode control procedure without prior authentication / PDN connect / Service request / PDN disconnect / Detach upon UE switched off / Temporary storage of EMM information	X	X	-
11.2.4	Emergency bearer services / Normal cell / NO-IMSI / Attach / No EPS security context / PDN connect / Service request / Timer T3412 expires	X	X	-

Test case	Description	FDD	TDD	T/F
11.2.5	Emergency bearer services / Normal cell / NORMAL-SERVICE / Local Emergency Numbers List NOT sent in the Attach / PDN connect new emergency EPS bearer context / Authentication SQN code failure – MME aborts authentication continues using current security context / Service request / Emergency PDN disconnect	X	X	-
11.2.6	Handling of Local Emergency Numbers List provided during Attach and Normal tracking area update procedures	X	X	-
11.2.7	UE has PDN connection only for emergency bearer services / Normal tracking area update / Accepted / Local Emergency Numbers List is not sent by the network / Handling of the lists of forbidden tracking areas	X	X	-
11.2.8	Attach for emergency bearer services / Rejected / No suitable cells in tracking area / Emergency call using the CS domain / UTRA or GERAN	X	X	X
11.2.10	LIMITED-SERVICE / EPS does not support IMS Emergency / Emergency call using the CS domain	X	X	X
11.2.11	LIMITED-SERVICE / Inter-system mobility / E-UTRA to UTRA CS / SRVCC Emergency Call Handover to UTRAN	X	X	X
11.2.12	LIMITED-SERVICE / Inter-system mobility / E-UTRA to GSM CS / SRVCC Emergency Call Handover to GERAN	X	X	-
12.2.1	Data transfer of E-UTRA radio bearer combinations 1, 3, 6 and 9	X	X	-
12.2.2	Data transfer of E-UTRA radio bearer combinations 2, 4, 7 and 10	X	X	-
12.2.3	Data transfer of E-UTRA radio bearer combinations 5, 6, 8, 11 and 12	X	X	-
12.2.4	Data transfer of E-UTRA radio bearer combination 13	X	X	-
12.3.1	Data transfer of E-UTRA radio bearer combinations 1, 3, 6 and 9 / MIMO	X	X	-
12.3.2	Data transfer of E-UTRA radio bearer combinations 2, 4, 7 and 10 / MIMO	X	X	-
12.3.3	Data transfer of E-UTRA radio bearer combinations 5, 6, 8, 11 and 12 / MIMO	X	X	-
12.3.4	Data transfer of E-UTRA radio bearer combination 13 / MIMO	X	X	-
13.1.1	Activation and deactivation of additional data radio bearer in E-UTRA	X	X	-
13.1.2	Call setup from E-UTRAN RRC_IDLE / CS fallback to UTRAN with redirection / MO call	X	X	X
13.1.2a	Call setup from E-UTRAN RRC_IDLE / CS fallback to UTRAN with redirection including System Information / MO call	X	X	X
13.1.3	Call setup from E-UTRAN RRC_CONNECTED / CS fallback to UTRAN with redirection / MT call	X	X	X
13.1.4	Call setup from E-UTRAN RRC_IDLE / CS fallback to UTRAN with handover / MT call	X	X	X
13.1.5	Call setup from E-UTRAN RRC_CONNECTED / CS fallback to UTRAN with handover / MO call	X	X	X
13.1.7	Call setup from E-UTRA RRC_IDLE / CS fallback to GSM with redirection / MT call	X	X	-
13.1.8	Call setup from E-UTRA RRC_CONNECTED / CS fallback to GSM with redirection / MO call	X	X	-
13.1.9	Call setup from E-UTRA RRC_IDLE / CS fallback to GSM with CCO without NACC / MO call	X	X	-
13.1.10	Call setup from E-UTRA RRC_CONNECTED / CS fallback to GSM with CCO without NACC / MT call	X	X	-
13.1.15	Call setup from E-UTRAN RRC_IDLE / CS fallback to UTRAN with redirection / MT call / UTRAN cell is barred	X	X	X
13.1.16	Emergency call setup from E-UTRAN RRC_IDLE / CS fallback to UTRAN with handover	X	X	X
13.1.17	Call setup from E-UTRAN RRC_IDLE / mobile originating 1xCS fallback emergency call to 1xRTT	X	X	-
13.1.18	Call setup from E-UTRAN RRC_IDLE / mobile originating enhanced 1xCS fallback emergency call to 1xRTT	X	X	-
13.1.19	Emergency call setup from E-UTRAN RRC_IDLE / IMS VoPS supported / EMC BS not supported / CS fallback to UTRAN or GERAN with redirection	X	X	X
13.1.20	Emergency call setup from E-UTRAN RRC_IDLE / IMS VoPS not supported / EMC BS supported / CS fallback to UTRAN or GERAN with redirection	X	X	X
13.2.1	RRC connection reconfiguration/E-UTRA to E-UTRA	X	X	-
13.3.1.1	Intra-system connection re-establishment/Radio link recovery while T310 is running	X	X	-
13.3.1.2	Intra-system connection re-establishment/Re-establishment of a new connection when further data is to be transferred	X	X	-
13.3.1.3	RRC connection reconfiguration / Full configuration / DRB establishment	X	X	-
13.3.2.1	Inter-system connection re-establishment / E-UTRAN to UTRAN / Further data are to be transferred	X	X	X
13.3.2.2	Inter-system connection re-establishment / E-UTRAN to GPRS / Further data are to be transferred	X	X	-
13.4.1.2	Inter-frequency mobility/E-UTRA to E-UTRA packet	X	X	-
13.4.1.3	Intra-system mobility / E-UTRA FDD to E-UTRA TDD to E-UTRA FDD packet	X	X	-
13.4.1.4	Inter-band mobility / E-UTRA to E-UTRA packet	X	X	-
13.4.1.5	RRC connection reconfiguration / Handover / Full configuration / DRB establishment	X	X	-

Test case	Description	FDD	TDD	T/F
13.4.2.1	Inter-system mobility / E-UTRA to UTRA packet	X	X	X
13.4.2.4	Inter-system mobility / Service based redirection from UTRA to E-UTRA	X	X	X
13.4.2.5	Inter-system mobility / Service based redirection from GSM/GPRS to E-UTRA	X	X	-
13.4.3.1	Inter-system mobility / E-UTRA voice to UTRA CS voice / SRVCC	X		
13.4.3.2	Inter-system mobility / E-UTRA PS voice + PS data to UTRA CS voice + PS data / SRVCC	X		
13.4.3.3	Inter-system mobility / E-UTRA voice to GSM CS voice / SRVCC	X	X	-
13.4.3.4	Inter-system mobility / E-UTRA voice to UTRA CS voice / Unsuccessful case / Retry on old cell / SRVCC	X		
13.4.3.5	Inter-system mobility / E-UTRA voice to GSM CS voice / Unsuccessful case / Retry on old cell / SRVCC	X	X	-
13.4.3.6	Inter-system mobility / E-UTRA PS voice + PS Data / HO cancelled / Notification procedure / SRVCC	X		X
13.4.3.7	Inter-system mobility / E-UTRA voice to UTRA CS voice / aSRVCC / MO call	X		X
13.4.3.8	Inter-system mobility / E-UTRA voice to UTRA CS voice / aSRVCC / MO call / Forked responses	X		X
13.4.3.9	Inter-system mobility / E-UTRA voice to UTRA CS voice / aSRVCC / MO call / SRVCC HO failure	X	X	X
13.4.3.10	Inter-system mobility / E-UTRA voice to UTRA CS voice / aSRVCC / MT call	X		X
13.4.3.11	Inter-system mobility / E-UTRA voice to UTRA CS voice / aSRVCC / MT call / SRVCC HO failure	X	X	X
13.4.3.13	Inter-system mobility / E-UTRA voice to UTRA CS voice / aSRVCC / MT call / User answers in PS domain / SRVCC HO cancelled	X	X	X
13.4.3.14	Inter-system mobility / E-UTRA PS voice + PS data to UTRA CS voice + PS data / aSRVCC / MO call	X		X
13.4.3.15	Inter-system mobility / E-UTRA PS voice + PS data to UTRA CS voice + PS data / aSRVCC / MO call / SRVCC HO cancelled	X		X
13.4.3.16	Inter-system mobility / E-UTRA PS voice + PS data to UTRA CS voice + PS data / aSRVCC / MT call	X		X
13.4.3.18	Inter-system mobility / E-UTRA PS voice + PS data to UTRA CS voice + PS data / bSRVCC / MO call	X		
13.4.3.19	Inter-system mobility / E-UTRA PS voice + PS data to UTRA CS voice + PS data / bSRVCC / MO call / SRVCC HO cancelled	X		X
13.4.3.20	Inter-system mobility / E-UTRA voice to UTRA CS voice / bSRVCC / MO call / SRVCC HO failure	X		X
13.4.3.21	Inter-system mobility / E-UTRA PS voice to GSM CS voice / bSRVCC / MO call	X	X	-
13.4.3.22	Inter-system mobility / E-UTRA PS voice to GSM CS voice / bSRVCC / MO call / SRVCC HO cancelled	X	X	-
13.4.3.23	Inter-system mobility / E-UTRA voice to GSM CS voice / bSRVCC / MO call / SRVCC HO failure	X	X	-
13.4.3.24	Inter-system mobility / E-UTRA voice to GSM CS voice / aSRVCC / MO call	X	X	-
13.4.3.25	Inter-system mobility / E-UTRA voice to GSM CS voice / aSRVCC / MO call / Forked responses	X	X	-
13.4.3.26	Inter-system mobility / E-UTRA voice to GSM CS voice / aSRVCC / MO call / SRVCC HO failure	X	X	-
13.4.3.27	Inter-system mobility / E-UTRA voice to GSM CS voice / aSRVCC / MT call	X	X	-
13.4.3.28	Inter-system mobility / E-UTRA voice to GSM CS voice / aSRVCC / MT call / SRVCC HO failure	X	X	-
13.4.3.30	Inter-system mobility / E-UTRA voice to GSM CS voice / aSRVCC / MT call / User answers in PS domain/ SRVCC HO cancelled	X	X	-
13.4.3.32	Inter-system mobility / UTRA CS voice to E-UTRA voice / rSRVCC	X		
13.4.3.34	Inter-system mobility / UTRA CS voice to E-UTRA voice / alerting / rSRVCC / MO call	X		
13.4.3.41	Inter-system mobility / E-UTRA PS voice to GSM CS voice / HO cancelled / Notification procedure / SRVCC	X	X	-
13.4.4.1	Pre-registration at 1xRTT and Cell reselection / 1x Zone Registration	X	X	-
13.4.4.2	Pre-registration at 1xRTT and Cell reselection / 1x Ordered Registration	X		
13.4.4.5	Pre-Registration at 1xRTT / Power Down Registration	X	X	-
13.5.1	MTSI MO speech call / SSAC / 0% access probability for MTSI MO speech call	X	X	-
13.5.1a	MTSI MO speech call / SSAC in Connected mode / 0% access probability for MTSI MO speech call	X	X	-
13.5.2	MTSI MO video call / SSAC / 0% access probability for MTSI MO video call	X	X	-
13.5.2a	MTSI MO video call / SSAC in connected mode / 0% access probability for MTSI MO video call	X	X	-
13.5.3	Emergency call / Success / SSAC / 0% access probability for MTSI MO speech call	X	X	-
13.5.3a	Emergency call / Success / SSAC in connected mode / 0% access probability for MTSI MO speech call	X	X	-

Test case	Description	FDD	TDD	T/F
13.5.4	MTSI MO speech call / SCM / 0% access probability skip for MTSI MO speech call	X	X	-
13.5.5	MTSI MO video call / SCM / 0% access probability skip for MTSI MO video call	X	X	-
13.5.6	MTSI MO SMS / SCM / 0% access probability skip for MTSI MO SMS over IP	X	X	-
14.1	ETWS reception in RRC_IDLE state / Duplicate detection	X		-
14.2	ETWS reception in RRC_CONNECTED state / Duplicate detection	X		-
17.1.1	MCCH information acquisition/ UE is switched on	X	X	-
17.1.2	MCCH information acquisition/UE cell reselection to a cell in a new MBSFN area	X	X	-
17.1.3	MCCH information acquisition/UE handover to a cell in a new MBSFN area	X	X	-
17.1.4	MCCH information acquisition/ UE is receiving an MBMS service	X	X	-
17.1.5	MCCH information acquisition/UE is not receiving MBMS data	X	X	-
17.2.1	UE acquire the MBMS data based on the SIB13 and MCCH message / MCCH and MTCH are on the same MCH	X	X	-
17.2.2	UE acquire the MBMS data based on the SIB13 and MCCH message / MCCH and MTCH are on different MCHs	X	X	-
17.2.3	UE receives the MBMS data when this data is in the beginning of the MSAP	X	X	-
17.2.4	Reception of PDCCH DCI format 0 and PHICH in MBSFN subframes.	X	X	-
17.3.1	MBMS Counting / UE not receiving MBMS service	X	X	-
17.3.2	MBMS Counting / UE receiving MBMS service	X	X	-
17.4.1	Cell reselection to intra-frequency cell to start MBMS service	X	X	-
17.4.1a	Cell reselection to intra-frequency cell to continue MBMS service reception / Single Frequency operation (inter-band neighbouring cell)	X	X	-
17.4.2	Cell reselection to inter- frequency cell to start MBMS service	X	X	-
17.4.2a	Cell reselection to inter- band cell to start MBMS service reception	X	X	-
17.4.3	Handover to inter-frequency cell to start MBMS service reception	X	X	-
17.4.3a	Handover to inter-band cell to start MBMS service reception	X	X	-
17.4.4	MBMS service continuity / Handover to inter-frequency cell / MBMS Interest Indication on cell not broadcasting SIB15	X	X	-
17.4.5	Conditional retransmission of MBMS Interest Indication after handover	X	X	-
17.4.6	MBMS service continuity / E-UTRAN release of unicast bearer	X	X	-
17.4.7	MBMS Interest Indication after Radio Link Failure	X	X	-
17.4.8	Continue MBMS service reception after E-UTRAN release of unicast bearer	X	X	-
17.4.9.1	CA / Start MBMS reception on Non-Serving Cell / Continue MBMS reception on SCell after SCell addition / Intra-band Contiguous CA	X		-
17.4.9.2	CA / Start MBMS reception on Non-Serving Cell / Continue MBMS reception on SCell after SCell addition / Inter-band CA	X		-
17.4.10.1	CA / Start MBMS reception on SCell / Continue MBMS reception on Non-Serving after SCell release / Intra-band Contiguous CA	X	X	-
17.4.10.2	CA / Start MBMS reception on SCell / Continue MBMS reception on Non-Serving after SCell release / Inter-band CA	X	X	-
17.4.11.1	CA / Start MBMS reception on PCell / Continue MBMS reception after swap of SCell and PCell / Intra-band Contiguous CA	X	X	-
17.4.11.2	CA / Start MBMS reception on PCell / Continue MBMS reception after swap of SCell and PCell / Inter-band CA	X	X	-
18.1.1	PWS reception in RRC_IDLE state / Duplicate detection	X	-	-
18.1.2	PWS reception in RRC_CONNECTED state / Duplicate detection	X	-	-
18.1.3	PWS reception in RRC_CONNECTED State/Power On	X	-	-
22.2.8	NB-IoT / Cell reselection in shared network environment	X	-	-
22.3.1.3	NB-IoT / Correct Handling of UL MAC PDU/Assignment/HARQ process/Padding	X	-	-
22.3.1.4	NB-IoT / Correct handling of MAC control information / Buffer status	X	-	-
22.3.1.6	NB-IoT / DL-SCH /UL-SCH transport block size selection / DCI format N1/ N0	X	-	-
22.3.2.1	NB-IoT / AM RLC / Correct use of sequence numbering / Concatenation and reassembly /Polling for status	X	-	-
22.3.2.2	NB-IoT / AM RLC / Receiver status triggers	X	-	-
22.3.2.3	NB-IoT / AM RLC / In sequence delivery of upper layers PDUs/ Different numbers of length indicators	X	-	-
22.3.3.1	NB-IoT / Maintenance of PDCP sequence numbers / User plane / RLC AM	X	-	-
22.3.3.2	NB-IoT / Integrity protection / Ciphering and deciphering / Correct functionality of EPS AS and UP encryption algorithms / SNOW3G	X	-	-
22.3.3.3	NB-IoT / Integrity protection / Ciphering and deciphering / Correct functionality of EPS AS and UP encryption algorithms / AES	X	-	-
22.4.2	NB-IoT / Paging for connection in idle mode / Multiple paging records	X	-	-
22.4.6	NB-IoT / Paging for notification of BCCH modification in idle mode / Direct indication for SI update	X	-	-
22.4.11	NB-IoT / RRC connection release / Redirection to another NB-IoT frequency	X	-	-
22.4.12	NB-IoT / RRC connection release / Redirection to another NB-IoT band	X	-	-

Test case	Description	FDD	TDD	T/F
22.4.13	NB-IoT / UE capability transfer / Success	X	-	-
22.4.21	NB-IoT / Radio link failure / Radio link recovery while T310 is running	X	-	-
22.5.1	NB-IoT / Authentication not accepted by the network, GUTI used / Authentication not accepted by the UE, SQN failure / Authentication not accepted by the UE, non-EPS authentication unacceptable / Network failing the authentication check	X	-	-
22.5.2	NB-IoT / NAS Security / Handling of null integrity protection and null ciphering algorithms / NAS count reset to zero / Security mode command with not matching replayed security capabilities / Provision of IMEISV and IMEI	X	-	-
22.5.3	NB-IoT / NW initiated detach Re-attach required / UE initiated detach Abnormal case EMM common procedure collision / UE initiated detach Abnormal case Local detach after 5 attempts due to no network response	X	-	-
22.5.4	NB-IoT / Attach to new PLMN GUTI reallocation / Network reject with Extended Wait Timer / Paging with IMSI / Attach Rejected Illegal ME/UE / Detach upon switch-off	X	-	-
22.5.10	NB-IoT / EPS NAS integrity and encryption / SNOW 3G	X	-	-
22.5.11	NB-IoT / EPS NAS integrity and encryption / AES	X	-	-
22.5.12	NB-IoT / EPS NAS integrity and encryption / ZUC	X	-	-

The Test Suite in TTCN3 is contained in multiple ASCII files which accompany the present document.

Annex B (informative): Style Guides

B.1 Introduction

This annex is based on the style guide given in TS 34.123-3 [7], annex E but the language for UE conformance tests is TTCN-3.

B.2 General Requirements for TTCN-3 Implementations

The TTCN-3 implementation for UE conformance tests shall be based on the following general design considerations:

- Even though it is not reflected in TTCN-3 anymore in UE conformance tests ASPs and PDUs will still be distinguished. This has impact on type definitions and naming conventions.
- In general, templates for UE conformance tests shall be separated for sending and receiving.
- Modified templates shall not be modified again.
- All local variables shall be declared at the beginning of a function; the order of declarations is:
 - local constants
 - local variables
 - local timers
- The purpose of the test case implementation is conformance testing.
- The common RAN5 approval process needs to be considered.

The TTCN-3 implementation for UE conformance tests shall fulfil the following requirements.

The implementation shall:

- follow ES 201 873-1 [13] (TTCN-3 Core Language) and ES 201 873-4 [27] (TTCN-3 Operational Semantics);
- be independent from interface specifications like TRI (ES 201 873-5 [28]) and TCI (ES 201 873-6 [29]) as well as from proprietary approaches;
- not use or rely on tool dependent features;
- support maintainability and extendibility;
- follow the naming conventions as defined below.

Further requirements:

- Usage of external functions should be avoided.
- Type definitions:
 - Existing ASN.1 type definitions contained in protocol specifications are imported from the respective standards. All other type definitions shall be done within TTCN-3.

B.3 Naming Conventions

Even though these are being used for TTCN-3 the naming conventions provided in the present document are mainly backward compatible to TTCN-2 as defined in TS 34.123-3 [7].

B.3.1 Prefixes and Restrictions for TTCN-3 Objects

Table B.3.1: Prefixes used for TTCN-3 objects

TTCN object	Initial Letter	Prefix/Postfix	Comment
TTCN module	upper case	(none)	
TTCN group	upper case	(none)	
function parameter	upper case	p_	
function running on a component	upper case	f_	
local function (tree) not to be used by other modules	upper case	fl_	local function not to be used by other modules
external function	upper case	fx_	
altstep	upper case	a_	(including defaults)
test case selection expression			name as specified in TS 36.523-2 [2] shall be used
global constant	upper case	tsc_	(see note 1)
local constant	upper case	const_	local constant being defined in a function
Enumerated		(none)	there are no restrictions regarding enumerated types
type definition	upper case	_Type	(see note 7)
local variable	upper case	v_	(see note 6)
global (component) variable	upper case	vc_	(see note 2)
port type	upper case		
port name	upper case		
local timer	upper case	t_	
ASP template	upper case	cas_ cads_ car_ cadr_	send ASP modified (derived) send ASP receive ASP modified (derived) receive ASP
PDU template	upper case	cs_ cds_ cr_ cdr_	send PDU modified (derived) send PDU receive PDU modified (derived) receive PDU (see note 3)
CM template	upper case	cms_ cmr_	send coordination message receive coordination message
Template (neither ASP nor PDU nor CM)	upper case	cs_ cds_ cr_ cdr_ crs_	send template modified (derived) send template receive template modified (derived) receive template templates for IEs used in both directions (see note 5)
test suite parameter (PICS)	upper case	pc_	(see note 8)
test suite parameter (PIXIT)	upper case	px_	(see note 8)
test case		TC_	(see note 4)

NOTE 1: Global constants may be defined differently in imported modules (e.g. without any prefix and with lower case initial letter).
NOTE 2: Global variables or timers are those defined within the TTCN-3 components. They are visible to all the functions run in the component.
NOTE 3: Base template may have a second prefix: <ul style="list-style-type: none">- 508: PDU as defined in TS 36.508 [3];- 108: PDU as defined in TS 34.108 [8].
NOTE 4: Test case names will correspond to the clause in the prose that specifies the test purpose. E.g. TC_8_1.
NOTE 5: Applicable only in case of "quasi-constant" definitions, e.g. to define a (constant) random pattern to be used for sending and receiving when the UE is configured in loopback mode.
NOTE 6: Counter variables do not need to have a prefix.
NOTE 7: Exceptions for type definitions: <ul style="list-style-type: none">- ASP names are fully upper case letters and typically have postfix "_REQ", "_CNF" or "_IND".- RRC protocol type definitions are extracted and imported from TS 36.331 [19]/TS 25.331 [36] and are therefore out of scope.- NAS protocol type definitions follow the names provided in the tabular notion of the standards and therefore do not have a "_Type" postfix.
NOTE 8: For clarification an additional postfix _FDD/_TDD can be added.

B.3.2 Void

B.3.3 Void

B.3.4 Identifiers consisting of more than one Name

When identifiers are a concatenation of several words the words shall start with capital letters:

e.g.: "px" + "Cell" + "A" + "Cell" + "Id" -> px_CellACellId.

Further details are described in TS 34.123-3 [7], clause E.2.1.

B.4 Implementation Issues

B.4.1 Control part

Even though the control part may not be used in a test campaign but be overruled by the test management system it is used to provide the following information:

- All test cases contained in the test suite.
- For each test case:
 - Test case selection expression.

For maintenance reasons it shall be possible to generate the control part automatically by an appropriate tool.

B.4.2 Top Level Test Case Definitions

The top level test case definitions run on the MTC exclusively. The tasks of these test case definitions are generally the same for each test case:

- Start guard timer.
- Create PTCs.
- Connect PTCs.

- Start PTCs.
- Wait for PTCs having finished.

Additionally the MTC may host the upper tester but this is left open to implementation.

For maintenance reasons it shall be possible to generate the top level test case definitions defined for the MTC automatically by an appropriate tool. To achieve this, the name of a function to be started on particular PTC need derived from the test case name:

e.g. the function for PTC_A in test case TC_XX_YY_ZZ shall be f_TC_XX_YY_ZZ_A.

Cells are created in an off-state in the preambles of the corresponding PTCs while UE is in the switched off-state.

B.4.3 Inter Component Communication

Communication between PTCs or PTCs and the MTC can be done by messages or by build-in mechanisms as *done* and *kill*. For maintenance reasons and extendibility the inter component communication shall be encapsulated by TTCN-3 implementation.

B.4.4 Encoding Information

For UE conformance tests several encoding rules need to be applied by the TTCN-3 codec. Even though the codec is out of scope of the present document there are aspects with impact on TTCN-3 implementation depending on different type definitions.

Table B.4.4-1

Type definitions	Encoding
ASN.1 types used for RRC signalling	ASN.1 PER
ASN.1 types used by NAS protocols	ASN.1 BER
NAS types	Tabular notated (see note)
SMS Types	Tabular notated (see note)
DRB types	Tabular notated (see note)
DHCPv4 types	Tabular notated (see note)
ICMPv6 types	Tabular notated (see note)
DNS types	Tabular notated (see note)
GERAN types	Tabular notated (see note)
GPRS Padding	see TS 34.123-3 [7], clause 6.10.2.9.1
GSM Spare Padding	see TS 34.123-3 [7], clause 6.10.2.9.2
LowHigh Rule	see TS 34.123-3 [7], clause 6.10.2.9.3
SACCHSysInfo Spare Padding	see TS 34.123-3 [7], clause 6.10.2.9.5
TTCN-3 types not used at the air interface: <ul style="list-style-type: none"> - Configuration of system simulator - Coordination between components - Types used internally in TTCN-3 	(no specific encoding required)
NOTE: Tabular notated is performed by concatenation of all the present fields in the TTCN-3 template.	

Encoding information may be provided and supported in TTCN-3 by grouping of type definitions and using the *encode* attribute.

B.4.5 Verdict Assignment

In general the following rules shall be applied.

Table B.4.5-1: Rules for verdict assignment

Verdict	Rule
Pass	shall be assigned for each step defined in the prose of the test case
Fail	shall be assigned when there is a non-conformant signalling by the UE within the test body
Inconc	shall be assigned outside the test body and when it is not unequivocal whether a misbehaviour is caused by non-conformity of the UE signalling
Error	In case of obvious programming or parameterisation errors (e.g. missing case in a <i>select</i> statement)

B.4.5.1 PASS verdict assignment

The PASS verdicts are assigned by test cases or test case specific functions.

For generic test procedures as specified in 36.508 cl. 6.4.2, the preliminary pass is assigned directly after the procedure if all described in the procedure UL messages have been successfully received; this allows re-usage of these procedures for other purposes.

B.4.5.2 FAIL or INCONC verdict assignment

The verdict FAIL or INCONC can be assigned in test cases, in the test case-specific function, in the common functions and in the default behaviour.

Test case or test case-specific function:

In normal cases the common function `f_EUTRA_SetVerdictFailOrInconc` or `f_UTRAN_SetVerdictFailOrInconc` shall be used to assign FAIL or INCONC depending on whether it is in the test body or outside of the body.

An exception is made in the NITZ test cases: TC 9.1.5.1 in 3GPP TS 36.523-1 [1], TC 9.4.10, TC 12.2.1.13, TC 12.2.1.14, TC 12.2.1.15 in 3GPP TS 34.123-1 [2], in the UE capability test cases: TC 8.4.5.1 in 3GPP TS 36.523-1 [1] and TC 8.1.5.7 in 3GPP TS 34.123-1 [2]: the function `f_SetVerdict` is used in the test body to assign a FAIL verdict without stopping the execution of the test case.

If in test cases a verdict FAIL shall be assigned for watchdog timer timeouts this needs to be done explicitly.

Common Functions:

The majority of the common functions have no verdict assignment. If a verdicts assignment is required in some common functions, the common function `f_EUTRA_SetVerdictFailOrInconc` or `f_UTRAN_SetVerdictFailOrInconc` shall be used to assign FAIL or INCONC.

As an exception in the altstep `a_EUTRA_RacingCond_AwaitRrcMessage` an INCONC is assigned when the RRC message and the L1/MAC indication are in the wrong order.

B.4.5.3 Verdict assignment in default behaviour

The default behaviour handles all events not being handled in test cases or functions. Whether the verdict FAIL or INCONC to be assigned in the default behaviour it depends very much on the port where the event occurs.

Table B.4.5.3-1: Verdict assignment in default behaviour upon test ports

Test port	Message	Comment	Verdict
SYS	SYSTEM_CTRL_CNF	unexpected confirmation	INCONC
SYSIND	SYSTEM_IND: Error indication	unspecific error at SS	INCONC
	SYSTEM_IND: MAC indication	(see note 1)	FAIL in the test body INCONC outside the test body
	SYSTEM_IND: L1 indication	RachPreamble, SchedReq, UL_HARQ may be repeated by the UE in case of transmission errors (see note 1)	INCONC
SRB	SRB_COMMON_IND	Any unexpected L3 signalling (see note 3)	FAIL in the test body INCONC outside the test body
NASCTRL	NAS_CTRL_CNF	unexpected confirmation	INCONC
DRB	DRB_COMMON_IND	L2 and combined tests (see note 2)	FAIL in the test body INCONC outside the test body
		pure signalling tests (see note 2)	INCONC
UT	UT_COMMON_CNF	unexpected confirmation	INCONC
NOTE 1: L1/MAC indications need to be enabled by the test case therefore they occur only when being relevant for the test case.			
NOTE 2: L2 and combined tests can be distinguished from pure signalling tests by additional global information controlled by f_EUTRA_TestBody_Set.			
NOTE 3: Layer 3 signalling by definition covers NAS and RRC signalling i.e. in general unexpected RRC messages will cause a FAIL in the body of any NAS test case as well as unexpected NAS messages will cause a FAIL in the body of any RRC test case.			

Table B.4.5.3-2: Verdict assignment in default behaviour when time-out

Timeout	Comment	Verdict
any timer	unspecific timeout (see note)	INCONC
NOTE: Local timers of test cases or functions cannot be distinguished in the default behaviour.		

B.4.6 Default Behaviour

As experience from UMTS conformance tests there shall be one standard default behaviour for each component.

The following rules shall be applied:

- The standard default behaviour is activated during initialisation of the respective component. In normal cases a TTCN writer does not need to care about the default.
- In general there is only one default behaviour activated (i.e. the standard default behaviour).
- The standard default behaviour shall cover all ports and timers of the component.
- Whenever possible deviations from the standard default behaviour shall be implemented locally rather than by introducing a new default behaviour.

If for exceptional cases the standard default behaviour needs to be replaced by another default behaviour or another default behaviour needs to be activated on top, the TTCN writer is responsible:

- to avoid side effects;
- to restore the standard behaviour.

B.4.7 Templates for Sending and Receiving

Templates used for sending and receiving shall be separated in general:

- A template shall be either for sending or for receiving; this shall be reflected in the prefix of the identifier.
- Send templates shall use no receive templates and vice versa.
- All parameters of a send template shall be restricted to:
 - values;
 - template (value);
 - template (omit).
- Parameters of receive templates may allow wildcards. They can be:
 - values;
 - unrestricted template parameters;
 - template parameters restricted to be present.
- The only exception to the above rule is for "quasi-constant" definitions, as described in note 5 of table B.3.1. Otherwise, even when the same data is expected for sending and receiving templates, there shall be different templates and the following rule shall be applied.
- The receive template is assigned the send template e.g.:
 - template My_Type cr_Template := cs_Template
- This results in separate definitions for sending and receiving and improves maintainability.

NOTE 1: For maintenance reasons, a send template shall never be derived from a receive template; and also a receive template shall never be assigned to a send template.

NOTE 2: When a send template is assigned to a receive template, the formal parameters of the receive template must follow the rules of send templates (i.e. it shall only contain 'template (value)', 'template (omit)' or values only).

B.4.8 Logging

In general no explicit log statements shall be used. As an exception log may be used to report unexpected situations in TTCN-3 like fatal programming error.

B.4.8.1 Prose Step Numbers

Informative comments containing the prose steps defined in 36.523-1 should be implemented according to the following guidelines:

- They relate to the Expected Sequence steps in the prose
- They should not be placed in common functions
- They should only be placed in functions containing the test case body
- They should always start with `//@siclog`
- They should always finish with `siclog@`
- For single steps they should be in the form `//@siclog "Step 1" siclog@`
- For multiple steps (where several steps are completed in a common function), they should be in the form `//@siclog "Steps 1 - 3" siclog@` - i.e. Steps, space, first number, space, dash, space, second number

- They should be placed as close as possible, but always BEFORE, the line send/receive/function call
- The step number should also be included in any pass/fail verdict specified in the test case body
- If the step is listed as Void (or a group of steps) in the expected sequence, include the word Void in the comment.

Therefore the format of the comment should be:

```
//@siclog "Step[s] X [- Y] [Void]" siclog@
```

B.4.9 Top level comments

No restriction is specified for the top level comments.

B.4.10 Mapping of DRBs

LTE DRBs are mapped in TTCN according to the following rules:

- DRB1 is exclusively reserved for the default DRB and hence is always AM
- additional DRBs (AM or UM) may be assigned from DRB2 onward in any order
- there shall be no reconfiguration of a DRB from AM to UM or vice versa (unless a test case explicitly requires this); this especially means that DRB1 is never reconfigured to UM
- in general at the SS all DRBs needed by a test case may be configured at the beginning of the test case.

B.5 Modularisation

Even though there are no specific rules how to apply modularisation in general some principles can be defined:

- Maintainability and extendibility:
 - Maintainability and extendibility are essential for definition of the modular structure.
- Granularity of modules:
 - Cyclic imports are forbidden in TTCN-3; this has impact on the extendibility:
 - The granularity of modules shall not be too small.
 - Too big modules are hard to handle and may cause increase of compilation time:
 - The granularity of modules shall not be too rough.

NOTE: These are only vague principles since there is no way to define what small or huge modules are.

- General module structure:
 - The following modularisation can be applied independent from the internal structure:
 - Type definitions: TTCN-3, ASN.1.
 - Component definitions.
 - Common Templates: component dependent, component independent.
 - Common behaviour: MTC, PTCs.
 - Test case specific templates.
 - Test case specific behaviour.

- Whether or how these module groups can further be sub-divided is implementation dependent and therefore out of scope of the present document.

Annex C (informative): Design Principles

C.1 ASP Design

All ASPs consist of a common part (defined as a TTCN-3 type) and a specific part.

All ASPs sent by the SS include timing information (SFN, subframe number) in the common part.

Only one ASP is defined per direction per port, but this ASP may contain a union of several sub-ASPs in the specific part.

In general a small number of common ASPs cover all functionality, although other ASPs may be introduced to simplify TTCN-3 implementation and improve readability. Recurrent SS changes, such as power level changes, security activation and MAC scheduling are handled in dedicated ASPs. In addition, special purpose ASPs are used to control special behaviour, for example in L2 tests.

Configuration ASPs re-use ASN.1 definitions defined in the core specs.

No encoding rules are specified for the configuration ASPs; how they are encoded is left up to the SS implementation.

Configuration ASPs are 'procedure-based', rather than 'protocol layer-based' and reflect the state transitions of the SS. The same ASPs are used for reconfiguration and for initial configuration. In the case of reconfiguration the semantics of omit is to keep the configuration as it is; therefore when an IE in a configuration may be left out this is done e.g. by setting the respective field to a special value "None".

Data ASPs for sending/receiving peer-to-peer PDUs and user data all have different ASPs for the different SAPs.

The common part includes (at least):

- Timing Info:
 - SFN.
 - Subframe number (optional).
 - Which timing to use will depend on the test procedure and ASP purpose.
- Control Info:
 - Confirmation Flag.

The RRC ASN.1 IEs used in the specific part of the configuration ASPs:

- are imported using the granularity at the channel structure level or below;
- allow the ASP to be organised according to SS requirements;
- have a name that relates to SS configuration.

The SS specific IEs used in the specific part of the configuration ASPs (i.e. those elements not imported from the RRC ASN.1):

- use a naming convention such that they are easily distinguishable from the RRC ASN.1 IEs;
- are defined in TTCN-3 (i.e. not in ASN.1).

C.2 SS State Model

Figure C.2 shows the basic SS state model. It is basic in the sense that internally the SS may have more states; however, (re)configuration actions (state transitions in the model) should cause the SS to transit between the states defined below.

The following assumptions have been made about this state model:

- It presents a model of states in scope of a single cell. Hence, all configuration activities shall be performed in scope of a single cell.
- It depicts only SS states and SS (re)configuration actions between these states:
 - It does not show events which may trigger state transitions, e.g. L3 messages or procedures - i.e. it is test case and L3 procedure agnostic.
 - It does not show any peer-to-peer (i.e. between SS and UE) messages.
- Triggers for state transitions are always SS configuration messages (ASPs) coming from the test suite:
 - L2 messages coming from the UE can only trigger internal SS sub-state transitions and semi-autonomous procedures.
- L1 and L2 procedures (e.g. random access procedure, scheduling, security activation steps) are semi-autonomously handled by the SS and after being pre-configured do not require interaction with the test case:
 - The majority of test cases do not need to worry about e.g. RA procedure and letting the SS handle it would greatly simplify test case definition and implementation.
 - There may be stringent time requirements in case of some procedures that can be hard to meet in a generic way in the test suite.
 - Semi-autonomous procedures should be flexibly configurable and should have a "manual" mode in which they are handled by the test suite in order to enable testing them. What is the desired level and way of control is FFS.

Most states are stationary states, i.e. the SS can stay in them for a long time or, after performing some procedures, returns to these states. However, there is one state (indicated by dashed lines) which is part of the AS security activation procedure and is transitional, i.e. the SS can only stay in it for a short time until a transition to the next stationary state is triggered.

To make the diagram more readable, a separate state called *ANY_STATE* has been introduced, together with some transitions. It shows which transitions are allowed at any point of time in any state.

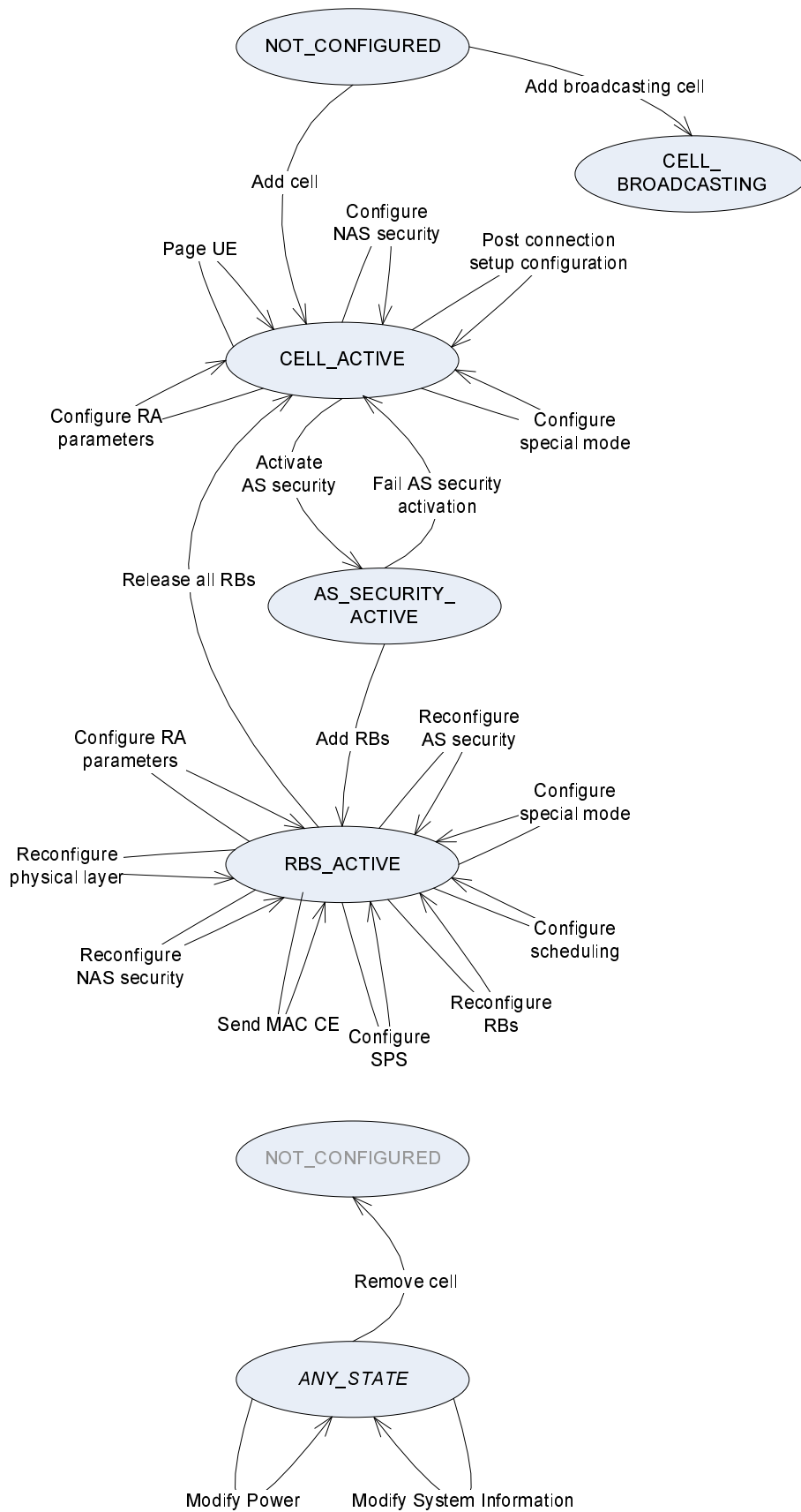

Figure C.2-1: Basic SS state model

Description of states.

Table C.2-1: Description of states

State	Description
NOT_CONFIGURED	The cell does not exist (is not configured) in the SS
CELL_BROADCASTING	Physical DL channels and signals configured Initial cell configuration done: freq, BW, antennas, MIMO mode, power, etc. Transport and logical channels configured for SI broadcast Cell is broadcasting SI and downlink signals NOTE 1: This type of cell is needed only to serve as a neighbouring cell for measurement purposes, where full cell configuration does not need to be specified. There is no need to be able to promote a broadcasting cell to a full cell. NOTE 2: It is currently open whether a separate cell type with limited PRACH/RACH Rx capability is needed - this depends on whether a justified use case is defined for such a cell type.
CELL_ACTIVE	Cell configured to send and receive data from UE (fully functional) SRB0 defined (default configuration specified in TS 36.508 [3]) SRB1 defined (default configuration specified in TS 36.508 [3])
AS_SECURITY_ACTIVE	The SS has AS security (integrity protection and ciphering) active NOTE 3: The SS needs to autonomously take care of a temporary state in which integrity protection is applied to an outgoing SMC message, but ciphering is not.
RBS_ACTIVE	SRB2 and/or DRBs are configured for the UE (in addition to SRB0 and SRB1)
ANY_STATE	Represents any of the above states (except NOT_CONFIGURED)

Annex D (informative)

TTCN-3 Definitions

D.1 EUTRA_ASP_TypeDefs

Type definitions for configuration of the system simulator;

Common design principles:

Semantics of OMIT: for all TTCN-3 type definitions used in ASPs omit means "keep as it is" =>

- on initial configuration in general all fields shall be provided
- no default values for fields are foreseen
- if necessary non-existence of information shall be explicitly configured (e.g. with a union of "no configuration" and "configuration parameters")
- fields within structures imported from the core spec are excepted from this rule

D.1.1 ASN1_Container

Definitions containing ASN.1 types for backward compatibility;

NOTE 1: PCCH_Message and BCCH_DL_SCH_Message already have a critical extension mechanism by RRC type definition

NOTE 2: BCCH_BCH_Message contains the MIB and therefore is considered to be not extendable

NOTE 3: "simple types" are not considered: C_RNTI, PhysCellId, CellIdentity, ARFCN_ValueEUTRA

AntennaInfoDedicated_R8andLater_Type

TTCN-3 Record Type			
Name	AntennaInfoDedicated_R8andLater_Type		
Comment			
antennaInfo	AntennaInfoDedicated		
antennaInfo_v920	AntennaInfoDedicated_v920	opt	

AntennaInfoDedicated_R10andLater_Type

TTCN-3 Record Type			
Name	AntennaInfoDedicated_R10andLater_Type		
Comment			
antennaInfo	AntennaInfoDedicated_r10		
antennaInfoUL	AntennaInfoUL_r10	opt	
antennaInfoDedicated_v1250	AntennaInfoDedicated_v1250	opt	

CQI_ReportConfig_R8andLater_Type

TTCN-3 Record Type			
Name	CQI_ReportConfig_R8andLater_Type		
Comment			
cqi_ReportConfig	CQI_ReportConfig		
cqi_ReportConfig_v920	CQI_ReportConfig_v920	opt	

CQI_ReportConfig_R10andLater_Type

TTCN-3 Record Type			
Name	CQI_ReportConfig_R10andLater_Type		
Comment			
cqi_ReportConfig_r10	CQI_ReportConfig_r10		NOTE: field 'csi-SubframePatternConfig-r10' is not relevant as long as a cell is configured as SCell
cqi_ReportConfig_v1130	CQI_ReportConfig_v1130	opt	
cqi_ReportConfig_v1250	CQI_ReportConfig_v1250	opt	

PUCCH_ConfigDedicated_R8andLater_Type

TTCN-3 Record Type			
Name	PUCCH_ConfigDedicated_R8andLater_Type		
Comment			
pucch_ConfigDedicated	PUCCH_ConfigDedicated		
pucch_ConfigDedicated_v1020	PUCCH_ConfigDedicated_v1020	opt	
pucch_ConfigDedicated_v1130	PUCCH_ConfigDedicated_v1130	opt	
pucch_ConfigDedicated_v1250	PUCCH_ConfigDedicated_v1250	opt	

PUSCH_ConfigDedicated_R8andLater_Type

TTCN-3 Record Type			
Name	PUSCH_ConfigDedicated_R8andLater_Type		
Comment			
pusch_ConfigDedicated	PUSCH_ConfigDedicated		in case of CA beta offset shall be the same for the PCell and the associated SCells
pusch_ConfigDedicated_v1020	PUSCH_ConfigDedicated_v1020	opt	optionally present for Rel 10 cells (normal or CA); in case of CA beta offset shall be the same for the PCell and the associated SCells
pusch_ConfigDedicated_v1130	PUSCH_ConfigDedicated_v1130	opt	
pusch_ConfigDedicated_v1250	PUSCH_ConfigDedicated_v1250	opt	

UplinkPowerControlCommon_R8andLater_Type

TTCN-3 Record Type			
Name	UplinkPowerControlCommon_R8andLater_Type		
Comment			
uplinkPowerControlCommon	UplinkPowerControlCommon		
uplinkPowerControlCommon_v1020	UplinkPowerControlCommon_v1020	opt	optionally present for Rel 10 cells (normal or CA); NOTE: 'p0-NominalPUCCH', 'deltaFList-PUCCH', 'deltaPreambleMsg3' and 'UplinkPowerControlCommon-v1020' are not relevant as long as a cell is configured as SCell
uplinkPowerControlCommonSCell_v1130	UplinkPowerControlCommonSCell_v1130	opt	only present when cell is configured as Rel 11 or later SCell
uplinkPowerControlCommonPSCell_r12	UplinkPowerControlCommonPSCell_r12	opt	

UplinkPowerControlDedicated_R8andLater_Type

TTCN-3 Record Type			
Name	UplinkPowerControlDedicated_R8andLater_Type		
Comment			
uplinkPowerControlDedicated	UplinkPowerControlDedicated		
uplinkPowerControlDedicated_v1020	UplinkPowerControlDedicated_v1020	opt	optionally present for Rel 10 cells (normal or CA); NOTE: field 'p0-UE-PUCCH' is not relevant as long as a cell is configured as SCell
pathlossReferenceLinking	SCellPathlossReferenceLinking_Type	opt	NOTE: relevant only as long as a cell is configured as SCell
uplinkPowerControlDedicated_v1130	UplinkPowerControlDedicated_v1130	opt	
uplinkPowerControlDedicated_v1250	UplinkPowerControlDedicated_v1250	opt	

SoundingRS_UL_ConfigDedicated_R8andLater_Type

TTCN-3 Record Type			
Name	SoundingRS_UL_ConfigDedicated_R8andLater_Type		
Comment			
soundingRS_UL_ConfigDedicated	SoundingRS_UL_ConfigDedicated	opt	
soundingRS_UL_ConfigDedicated_v1020	SoundingRS_UL_ConfigDedicated_v1020	opt	
soundingRS_UL_ConfigDedicatedAperiodic_r10	SoundingRS_UL_ConfigDedicatedAperiodic_r10	opt	

SchedulingRequestConfig_R8andLater_Type

TTCN-3 Record Type			
Name	SchedulingRequestConfig_R8andLater_Type		
Comment			
schedulingRequestConfig	SchedulingRequestConfig		
schedulingRequestConfig_v1020	SchedulingRequestConfig_v1020	opt	

TDD_Config_R8andLater_Type

TTCN-3 Record Type			
Name	TDD_Config_R8andLater_Type		
Comment			
R8	TDD_Config		
tdd_Config_v1130	TDD_Config_v1130	opt	

RACH_ConfigCommon_R8andLater_Type

TTCN-3 Record Type			
Name	RACH_ConfigCommon_R8andLater_Type		
Comment			
rach_ConfigCommon	RACH_ConfigCommon		All parameters in RACH_ConfigCommonScell_r11 are covered by RACH_ConfigCommon; RACH_ConfigCommon will be used in Scell also for a complete set of RACH parameters both when configured as a Scell or normal RACH procedure when it ceases to exist as Scell; when cell is configured as Scell, additional parameters shall be ignored by SS
rach_ConfigCommon_v1250	RACH_ConfigCommon_v1250	opt	

TDD_Config_Type

TTCN-3 Union Type			
Name	TDD_Config_Type		
Comment			
R8andLater	TDD_Config_R8andLater_Type		

AntennaInfoCommon_Type

TTCN-3 Union Type			
Name	AntennaInfoCommon_Type		
Comment			
R8	AntennaInfoCommon		

AntennaInfoDedicated_Type

TTCN-3 Union Type			
Name	AntennaInfoDedicated_Type		
Comment	NOTE: acc. to Cond AI-r8/AI-r10 of PhysicalConfigDedicated 'antennaInfo'/antennaInfo-v920' and 'antennaInfo-r10' are mutual exclusive		
R8andLater	AntennaInfoDedicated_R8andLater_Type		
R10andLater	AntennaInfoDedicated_R10andLater_Type		

PHICH_Config_Type

TTCN-3 Union Type	
Name	PHICH_Config_Type
Comment	
R8	PHICH_Config

PRACH_Config_Type

TTCN-3 Union Type	
Name	PRACH_Config_Type
Comment	
R8andLater	PRACH_Config_R8andLater_Type

PRACH_Config_R8andLater_Type

TTCN-3 Record Type	
Name	PRACH_Config_R8andLater_Type
Comment	
prach_Config	PRACH_Config
prach_Config_v1310	PRACH_Config_v1310 opt

PUCCH_ConfigCommon_Type

TTCN-3 Union Type	
Name	PUCCH_ConfigCommon_Type
Comment	
R8andLater	PUCCH_ConfigCommon_R8andLater_Type

PUCCH_ConfigCommon_R8andLater_Type

TTCN-3 Record Type	
Name	PUCCH_ConfigCommon_R8andLater_Type
Comment	
pucch_ConfigCommon	PUCCH_ConfigCommon
pucch_ConfigCommon_v1310	PUCCH_ConfigCommon_v1310 opt

PUCCH_ConfigDedicated_Type

TTCN-3 Union Type	
Name	PUCCH_ConfigDedicated_Type
Comment	
R8andLater	PUCCH_ConfigDedicated_R8andLater_Type
R13andLater	PUCCH_ConfigDedicated_R13andLater_Type

PUCCH_ConfigDedicated_R13andLater_Type

TTCN-3 Record Type			
Name	PUCCH_ConfigDedicated_R13andLater_Type		
Comment			
pucch_ConfigDedicated_r13	PUCCH_ConfigDedicated_r13		E-UTRAN configures pucch-ConfigDedicated-r13 only if pucch-ConfigDedicated is not configured

PUSCH_ConfigCommon_Type

TTCN-3 Union Type			
Name	PUSCH_ConfigCommon_Type		
Comment			
R8andLater	PUSCH_ConfigCommon_R8andLater_Type		

PUSCH_ConfigCommon_R8andLater_Type

TTCN-3 Record Type			
Name	PUSCH_ConfigCommon_R8andLater_Type		
Comment			
pusch_ConfigCommon	PUSCH_ConfigCommon		
pusch_ConfigCommon_v1270	PUSCH_ConfigCommon_v1270	opt	
pusch_ConfigCommon_v1310	PUSCH_ConfigCommon_v1310	opt	

PUSCH_ConfigDedicated_Type

TTCN-3 Union Type			
Name	PUSCH_ConfigDedicated_Type		
Comment			
R8andLater	PUSCH_ConfigDedicated_R8andLater_Type		
R13andLater	PUSCH_ConfigDedicated_R13andLater_Type		

PUSCH_ConfigDedicated_R13andLater_Type

TTCN-3 Record Type			
Name	PUSCH_ConfigDedicated_R13andLater_Type		
Comment			
pusch_ConfigDedicated_r13	PUSCH_ConfigDedicated_r13		E-UTRAN configures pusch-ConfigDedicated-r13 only if pusch-ConfigDedicated is not configured

SoundingRS_UL_ConfigCommon_Type

TTCN-3 Union Type			
Name	SoundingRS_UL_ConfigCommon_Type		
Comment			
R8	SoundingRS_UL_ConfigCommon		

SoundingRS_UL_ConfigDedicated_Type

TTCN-3 Union Type	
Name	SoundingRS_UL_ConfigDedicated_Type
Comment	
R8andLater	SoundingRS_UL_ConfigDedicated_R8andLater_Type

SchedulingRequestConfig_Type

TTCN-3 Union Type	
Name	SchedulingRequestConfig_Type
Comment	
R8andLater	SchedulingRequestConfig_R8andLater_Type

CQI_ReportConfig_Type

TTCN-3 Union Type	
Name	CQI_ReportConfig_Type
Comment	NOTE: acc. to Cond CQI-r8/CQI-r10 of PhysicalConfigDedicated 'cqi-ReportConfig'/cqi-ReportConfig-v920' and 'cqi-ReportConfig-r10' are mutual exclusive
R8andLater	CQI_ReportConfig_R8andLater_Type
R10andLater	CQI_ReportConfig_R10andLater_Type

RACH_ConfigCommon_Type

TTCN-3 Union Type	
Name	RACH_ConfigCommon_Type
Comment	
R8andLater	RACH_ConfigCommon_R8andLater_Type

RACH_ConfigDedicated_Type

TTCN-3 Union Type	
Name	RACH_ConfigDedicated_Type
Comment	
R8	RACH_ConfigDedicated

MeasGapConfig_Type

TTCN-3 Union Type	
Name	MeasGapConfig_Type
Comment	
R8	MeasGapConfig

PDCP_Config_Type

TTCN-3 Union Type	
Name	PDCP_Config_Type
Comment	
R8	PDCP_Config

UL_AM_RLC_Type

TTCN-3 Union Type		
Name	UL_AM_RLC_Type	
Comment		
R8	UL_AM_RLC	

DL_AM_RLC_Type

TTCN-3 Union Type		
Name	DL_AM_RLC_Type	
Comment		
R8	DL_AM_RLC	

UL_UM_RLC_Type

TTCN-3 Union Type		
Name	UL_UM_RLC_Type	
Comment		
R8	UL_UM_RLC	

DL_UM_RLC_Type

TTCN-3 Union Type		
Name	DL_UM_RLC_Type	
Comment		
R8	DL_UM_RLC	

TTI_BundlingConfig_R8andLater_Type

TTCN-3 Record Type			
Name	TTI_BundlingConfig_R8andLater_Type		
Comment			
TTI_BundlingEnabled	TTI_Bundling_Type		
E_HARQ_Pattern	E_HARQ_Pattern_r12_Type	opt	

TTI_BundlingConfig_Type

TTCN-3 Union Type		
Name	TTI_BundlingConfig_Type	
Comment		
R8	boolean	
R8andLater	TTI_BundlingConfig_R8andLater_Type	

DRX_Config_R8andLater_Type

TTCN-3 Record Type			
Name	DRX_Config_R8andLater_Type		
Comment			
R8	DRX_Config	opt	
R13	DRX_Config_r13_Type	opt	
EDRX_CycleStartOffset_r13	EDRX_CycleStartOffset_r13_Type	opt	

DRX_Config_Type

TTCN-3 Union Type	
Name	DRX_Config_Type
Comment	
R8andLater	DRX_Config_R8andLater_Type

SpsConfigurationDL_Type

TTCN-3 Union Type	
Name	SpsConfigurationDL_Type
Comment	
R8	SPS_ConfigDL.setup

SpsConfigurationUL_Type

TTCN-3 Union Type	
Name	SpsConfigurationUL_Type
Comment	
R8	SPS_ConfigUL.setup

UplinkPowerControlCommon_Type

TTCN-3 Union Type	
Name	UplinkPowerControlCommon_Type
Comment	
R8andLater	UplinkPowerControlCommon_R8andLater_Type

UplinkPowerControlDedicated_Type

TTCN-3 Union Type	
Name	UplinkPowerControlDedicated_Type
Comment	
R8andLater	UplinkPowerControlDedicated_R8andLater_Type

CSI_RS_Config_Type

TTCN-3 Record Type			
Name	CSI_RS_Config_Type		
Comment			
CSI_RS_Config	CSI_RS_Config_r10	opt	The IE is used for TM1-9
CSI_RS_ConfigNZPTToAddModList	CSI_RS_ConfigNZPTToAddModList_r11	opt	The IE is to configure the non-zero power CSI-RS resource configuration
CSI_RS_ConfigNZPToreleaseModList	CSI_RS_ConfigNZPToreleaseList_r11	opt	The IE is to release the non-zero power CSI-RS resource configuration
CSI_RS_ConfigZPTToAddModList	CSI_RS_ConfigZPTToAddModList_r11	opt	The IE is to configure the zero power CSI-RS resource configuration
CSI_RS_ConfigZPToreleaseModList	CSI_RS_ConfigZPToreleaseList_r11	opt	The IE is to release the zero power CSI-RS resource configuration
RelativeTxPower	ToRS_EPRES_Ratios_Type	opt	power ratio for CSI-RS resource elements relative to the CRS

DS_RS_Config_Type

TTCN-3 Record Type			
Name	DS_RS_Config_Type		
Comment	These IE's are to simulate the discovery of partial off cell as per 36.300 clause 16.1.10. The SS shall transmit discovery signals only in the timing enabled by the IE's DMTC_PeriodOffset and DS_OccasionDuration. The SS shall stop transmitting discovery signal in other periods in the cell. Other signals and scheduled transmissions (like SysInfo) are not restricted.		
DMTC_PeriodOffset	DMTC_PeriodOffset_r12_Type	opt	Indicates the discovery signals measurement timing configuration (DMTC) periodicity (dmtc-Periodicity) and offset (dmtc-Offset)
DS_OccasionDuration_r12	DS_OccasionDuration_r12_Type	opt	Indicates the duration of discovery signal occasion

LAA_SubframeConfiguration_Type

TTCN-3 Record Type			
Name	LAA_SubframeConfiguration_Type		
Comment			
SubframeConfiguration	B4_Type		as per 36.213 Table 13A-1

D.1.2 System_Configuration

Formal ASP Definitions for system configuration

SystemRequest_Type

TTCN-3 Union Type		
Name	SystemRequest_Type	
Comment		
Cell	CellConfigRequest_Type	configure/release a cell
CellAttenuation List	CellAttenuationList_Type	power attenuation for one or several cells; all cells included in the list shall be changed at the same time; all cells in the list shall reach the new cell power within a maximum of 100ms (10 frames) acc. to the tolerances given in TS 36.508 NOTE: In the common ASP part the CellId shall be set - to the cell the timing information refers to if activation time shall be applied - to extra_Cell_NonSpecific when there is no activation time
RadioBearerList	RadioBearerList_Type	configure/release one or several SRBs and/or DRBs NOTE: RBs are not configured in an SCell
EnquireTiming	Null_Type	get SFN and sub-frame number for this cell
AS_Security	AS_Security_Type	StartRestart/Release of AS security
Sps	SpsConfig_Type	to configure/activate or release semi-persistent scheduling
Paging	PagingTrigger_Type	to trigger SS to send paging at the given paging occasion (as calculated in TTCN)
L1MacIndCtrl	L1Mac_IndicationControl_Type	to configure SS to generate indications for L1/MAC events
RlcIndCtrl	Rlc_IndicationControl_Type	to configure SS to generate indications for RLC events
PdcpCount	PDCP_CountReq_Type	to set or enquire PDCP COUNT for one ore more RBs
PdcpHandover Control	PDCP_HandoverControlReq_Type	to inform the target cell about the handover
L1_TestMode	L1_TestMode_Type	To Set L1/MAC in special Test modes e.g. DL CRC, PHICH etc
PdchOrder	RA_PDCCH_Order_Type	to configure SS to transmit a PDCCH order with configured C-RNTI to the UE to trigger RA procedure; result in DCI Format 1A transmission as in TS 36.212, clause 5.3.3.1.3
ActivateScell	ActivateScell_Type	to configure SS to transmit a MAC control Element to activate an SCell
MbmsConfig	MBMS_Config_Type	Configuration of PMCH/MCCH/MTCH for eMBMS
PDCCH_MCC H_ChangeNotification	PDCCH_MCCH_ChangeNotification_Type	To trigger SS to send MCCH change notification at the given SFN/subframe (as calculated in TTCN)
MSI_Config	MSI_Config_Type	Configuration of MSI in MBMS normal mode to be included by the SS in the first subframe allocated to the MCH within the MCH scheduling period; uses MRB_ID option in routing info and logical channel ID is omitted
UE_Cat_Info	UE_CategoryInfo_Type	provides UE category info to SS; to be used e.g. for determination of Nsoft bits for rate matching To be configured in SS after preamble in MAC TBS test cases
OCNG_Config	OCNG_Config_Type	Provides SS Mode for Activating/Releasing OCNG configuration in the cell
PdchTddConfigOrder	PDCCH_TDD_ConfigOrder_Type	To trigger SS to send DCI 1C message(s) from a given SFN/subframe (as calculated in TTCN) over PDCCH with CRC scrambled by the eIMTA-RNTI, to indicate the eIMTA-UL/DL-configuration. The SS shall set the DCI 1C content according to eimta_UL_DL_ConfigIndex_r12 provided in EIMTA_Config
DirectIndication Info	DirectIndicationInfoTrigger_Type	To Trigger SS to transmit a Direct Indication information using DCI command 6_2 and including the 8 bits in the DCI command
LAA_Subframe Configuration	LAA_SubframeConfiguration_Type	to trigger transmission of DCI format 1C transmitted for CC-RNTI to configure subframe configuration for frame structure type 3

SystemConfirm_Type

TTCN-3 Union Type		
Name	SystemConfirm_Type	
Comment	confirmations for system configuration; in general to be sent after the configuration has been done	
Cell	Null_Type	(no further parameters from SS)
CellAttenuationList	Null_Type	(no further parameters from SS) NOTE 1: the confirmation shall be sent when all cells have changed power levels NOTE 2: for the CellId in the common ASP part the same rules are applied as for the SYSTEM REQ
RadioBearerList	Null_Type	(no further parameters from SS)
EnquireTiming	Null_Type	SFN and sub-frame number are included in the TimingInfo
AS_Security	Null_Type	(no further parameters from SS)
Sps	Null_Type	(no further parameters from SS)
Paging	Null_Type	normally not needed but defined for completeness
L1MacIndCtrl	Null_Type	(no further parameters from SS)
RlcIndCtrl	Null_Type	(no further parameters from SS)
PdcpCount	PDCP_CountCnf_Type	as response to 'Get' a list is returned containing COUNT information for the requested RBs
PdcpHandoverControl	Null_Type	confirmation for PDCP handover control
L1_TestMode	Null_Type	confirmation for L1 test mode
PdchOrder	Null_Type	confirmation for PDCCH Order
ActivateScell	Null_Type	confirmation for ActivateScell
MbmsConfig	Null_Type	confirmation for MbmsConfig
PDCCH_MCC H_ChangeNotification	Null_Type	normally not needed but defined for completeness
MSI_Config	Null_Type	confirmation for explicit MSI Configuration
UE_Cat_Info	Null_Type	confirmation for UE CAT info
OCNG_Config	Null_Type	Confirmation of OCNG configuration
DirectIndicationInfo	Null_Type	Confirmation of DirectIndicationInfo

SystemIndication_Type

TTCN-3 Union Type		
Name	SystemIndication_Type	
Comment		
Error	charstring	indicates an error situation in SS; is not explicitly handled in TTCN but causes an INCONC due to default behaviour; an additional error code can be signalled in the common part of the ASP; SS shall raise an error in case of - Invalid TimingInfo for TDD - Contradiction of periodic UL grants and TDD configuration - Data scheduled for the same TTI does not fit into an available transport block (NOTE: additional cases may occur)
RachPreamble	RachPreamble_Type	RACH preamble being sent by the UE In case of Preamble repetition (BL/CE UE under test) the SS sends one indication after reception of all preamble repetitions of a preamble attempt based on the CE level of UE.
SchedReq	Null_Type	indication for scheduling request sent by the UE
BSR	BSR_Type	to report the Buffer/Extended Buffer status report being received
UL_HARQ	HARQ_Type	to report the UL HARQ as received on PUCCH[TTI] for corresponding DL transmission in TTI-x, where x is normally 4
C_RNTI	C_RNTI	indicates C-RNTI being contained in a MAC PDU sent by the UE
PHR	PHR_Type	to report the Power headroom report received
HarqError	HarqError_Type	indicates detection of HARQ error: 1. HARQ CRC error for UL data 2. HARQ NACK from the UE unless SS is configured to report HARQ ACK/NACK
RlcDiscardInd	RlcDiscardInd_Type	indicates e.g. discarded PDUs
PeriodicRI	RI_Type	indicates periodic Rank Indicator (RI) reported by the UE on PUCCH or PUSCH; periodic CQI/PMI/RI Reporting is semi-statically configured at the UE by higher layers (see TS 36.213 clause 7.2.2); aperiodic reporting acc. to TS 36.213 clause 7.2.1 shall not be indicated NOTE: Acc. to TS 36.213 clause 7.2 aperiodic reporting has higher precedence than periodic reporting; => as working assumption the CQI request field in DCI format 0 is expected to be 0 for UL grants assigned by the SS i.e. aperiodic reporting acc. to TS 213 clause 7.2.1 does not happen
EPHR	MAC_CTRL_ExtPowerHeadRoom_Type	indicates Extended Power headroom report reported by the UE
CqiInd	Null_Type	indicates periodic CQI reported by the UE - NOTE: Report CQI value is currently not required
SrsInd	SRSInd_Type	Indicates start or stop of Type 0 SRS reception on configured periodic SRS resources
DC_PHR	MAC_CTRL_DC PowerHeadRoom_Type	indicates Dual Connectivity Power headroom report reported by the UE

D.1.3 Cell_Configuration

Specific Info for Cell Configuration Primitive

D.1.3.1 Cell_Configuration_Common

Cell_Configuration_Common: Basic Type Definitions

TTCN-3 Basic Types		
EUTRA_FDD_Info_Type	Null_Type	no further parameters defined for FDD
CfiValue_Type	integer (1..3)	

CellConfigRequest_Type

TTCN-3 Union Type		
Name	CellConfigRequest_Type	
Comment		
AddOrReconfigure	CellConfigInfo_Type	for cell configuration: CellId : identifier of the cell to be configured RoutingInfo : None TimingInfo : Now (for initial configuration and for reconfiguration in general) ControlInfo : CnfFlag:=true; FollowOnFlag:=false (in general)
Release	Null_Type	to remove a cell completely - CellId : identifier of the cell to be released; eutra_Cell_NonSpecific, in case all cells shall be released RoutingInfo : None TimingInfo : Now ControlInfo : CnfFlag:=true; FollowOnFlag:=false (in general)

CellConfigInfo_Type

TTCN-3 Record Type			
Name	CellConfigInfo_Type		
Comment	common information for initial cell configuration or reconfiguration; in case of reconfiguration OMIT means 'keep configuration as it is'		
Basic	BasicCellConfig_Type	opt	basic information for a cell (e.g. broadcasting)
Active	ActiveCellConfig_Type	opt	add. configuration for active cell (i.e. cell being capable to receive RACH preamble)

CellConfigCapability_Type

TTCN-3 Enumerated Type	
Name	CellConfigCapability_Type
Comment	capabilities of a cell acc. to the initial condition of a test case
broadcastOnlyCell	no detection of RACH preables required; cell is only broadcasting
minimumUplinkCell	detection of RACH preables required but not any further RX capability
fullCell	full TX and RX capabilities

CA_CellInitialConfig_Type

TTCN-3 Enumerated Type	
Name	CA_CellInitialConfig_Type
Comment	
PCell	The cell when added as a CC in CA scenario for first time will be configured as an PCell
Scell_Active	The cell when added as a CC in CA scenario for first time will be configured as an SCell, and when configured as Scell, it may be activated, 36.508 clause 6.3.4
Scell_Inactive	The cell when added as a CC in CA scenario for first time will be configured as an SCell, and when configured as Scell, it will never be activated, 36.508 clause 6.3.4
PScell	The cell when added as a CC in CA-Dual connectivity scenario for first time will be configured as a PScell. PScell is always active like PCell

BasicCellConfig_Type

TTCN-3 Record Type			
Name	BasicCellConfig_Type		
Comment			
ConfigCapability	CellConfigCapability_Type	opt	mandatory for the initial configuration; to be omitted afterwards
StaticCellInfo	StaticCellInfo_Type	opt	Common information which does not change during a test
PhysicalLayerConfigDL	PhysicalLayerConfigDL_Type	opt	default settings regarding physical control channels: PCFICH, PHICH, PDCCH
InitialCellPower	InitialCellPower_Type	opt	reference cell power for the RS of each antenna in DL NOTE 1: the power of the RS of an antenna may be reduced by antenna specific configuration NOTE 2: in general the power may be adjusted on a per resource element basis => all physical channel/signal power settings shall be adjusted relatively to the RS; if there are more than one TX antennas each one may have its own attenuation; independently from those relative power settings the cell power can easily be adjusted by just changing the reference power
BcchConfig	BcchConfig_Type	opt	configuration of BCCH/BCH; SS is triggered to configure RLC/MAC regardingly; BCCH data on the PDSCH is distinguished by the SI-RNTI PBCH: MIB; PDSCH: scheduling and resource allocation; SIBs
PcchConfig	PcchConfig_Type	opt	configuration of PCCH/PCH; SS is triggered to configure RLC/MAC regardingly; PCCH data on the PDSCH is distinguished by the P-RNTI (needed even to modify SI => shall be configured for CELL_BROADCASTING)
CA_CellInitialConfig	CA_CellInitialConfig_Type	opt	capability of a cell when added as a CC in CA scenario. 1. Provided at the initial configuration of a cell in CA test cases; to be omitted afterwards; 2. Always omit for a cell which remains normal non CA cell
BRBcchConfig	Bcch_BRConfig_Type	opt	configuration of BCCH_BR/BCH; SS is triggered to configure RLC/MAC regardingly; BCCH_BR data on the PDSCH is follows fixed schedule hence no SI-RNTI DCI sent PBCH: MIB; PDSCH: scheduling and resource allocation; SIBs
LAA_SCellConfiguration	LAA_SCellConfiguration_r13	opt	LAA specific information provided if the cell is being configured as SCell with frame structure 3 i.e. in Unlicensed band

ActiveCellConfig_Type

TTCN-3 Record Type			
Name	ActiveCellConfig_Type		
Comment			
C_RNTI	C_RNTI	opt	(pre-)configured C-RNTI; affects scrambling of PDSCH/PUSCH and CRC of PDCCH(s); shall be used implicitly in RACH procedure (i.e. as CE in RAR)
PhysicalLayerConfigUL	PhysicalLayerConfigUL_Type	opt	parameters for PRACH, PUCCH, PUSCH Omitted when no UL frequency is applied to the band
RachProcedureConfig	RachProcedureConfig_Type	opt	to configure the SS's behaviour for the RACH procedure Omitted when no UL frequency is applied to the band
CcchDcchDtchConfig	CcchDcchDtchConfig_Type	opt	Parameters related to CCCH/DCCH/DTCH in UL and DL
ServingCellConfig	ServingCellConfig_Type	opt	not present as long as the cell is 'normal' cell (i.e. does not act as a carrier component in CA); present to configure cell for CA (Pcell or SCell); in general at initial configuration 'ServingCellInfo' is omit; after sending/scheduling the RRCConnectionReconfiguration adding 1 or more cells for CA 'ServingCellInfo' is provided for the cell which gets Pcell and for the cell which gets SCell
SciSchedulingConfig	SciSchedulingConfig_Type	opt	Parameters related to Sidelink scheduling SCI format 0
EIMTA_Config	EIMTA_Config_Type	opt	Parameters related to eIMTA in UL and DL
CE_Mode	CE_Mode_r13_Type	opt	Indicates the CE mode as specified in TS 36.213 It is FFS if this can be ignored by SS

StaticCellInfo_Type

TTCN-3 Record Type			
Name	StaticCellInfo_Type		
Comment	Common information which (normally) does not change during a test; therefore all fields are mandatory		
Common	CommonStaticCellInfo_Type		
Downlink	DownlinkStaticCellInfo_Type		
Uplink	UplinkStaticCellInfo_Type	opt	NOTE: for TDD UL and DL are using the same parameters Omitted when no UL frequency is applied to the band

CommonStaticCellInfo_Type

TTCN-3 Record Type			
Name	CommonStaticCellInfo_Type		
Comment	information common for UL and DL; all fields are mandatory		
RAT	EUTRA_RAT_Type		FDD or TDD; FDD/TDD specific parameters
PhysicalCellId	PhysCellId		N(cell, ID): imported from core spec; -> cell specific reference signals (non-MBSFN) -> scrambling of all DL physical channels: PBCH, PCFICH, PDCCH, PHICH and PDSCH (together with nRNTI)
eNB_CellId	CellIdentity	opt	Placeholder for Cell identity (28 bits): eNB (20bits) and cell identity (8bits). The use of that field is for future usage and omit for the time being
EutraBand	integer		NOTE: in 3G there are overlapping bands therefore the band needs to be provided; in EUTRA it is provided as well to be extendable in the future
CellTimingInfo	CellTimingInfo_Type		

EUTRA_TDD_Info_Type

TTCN-3 Record Type	
Name	EUTRA_TDD_Info_Type
Comment	
Configuration	TDD_Config_Type TDD_Config acc. to RRC ASN.1 (acc. TS 36.331, clause 6.3.2)

EUTRA_HalfDuplexFDD_Info_Type

TTCN-3 Record Type	
Name	EUTRA_HalfDuplexFDD_Info_Type
Comment	NOTE: No specific elements required When UE is FDD Type B Half-Duplex SS shall restrict non-explicitly scheduled UL data transmission in subframe 2 and DL transmission in subframe 8. This results in UL HARQ feedback in subframe 2, DL HARQ feedback in subframe 6, UL grant allocation in subframe 8. SS shall obey explicit scheduling.

EUTRA_RAT_Type

TTCN-3 Union Type	
Name	EUTRA_RAT_Type
Comment	specifies RAT type and frame structure (TS 36.211, clause 4)
FDD	EUTRA_FDD_Info_Type
TDD	EUTRA_TDD_Info_Type
HalfDuplexFDD	EUTRA_HalfDuplexFDD_Info_Type

DownlinkStaticCellInfo_Type

TTCN-3 Record Type	
Name	DownlinkStaticCellInfo_Type
Comment	DL Static Info
Earfcn	integer DL-EARFCN as defined in TS 36.101
Bandwidth	DL_Bandwidth_Type N(DL, RB) = 6..110 (6, 15, 25, 50, 75, 100)
RBSize	EUTRA_RBSize_Type may be skipped assuming normal sub-carrier spacing => N(RB, SC) = 12
CyclicPrefix	EUTRA_CyclicPrefix_Type

UplinkStaticCellInfo_Type

TTCN-3 Record Type	
Name	UplinkStaticCellInfo_Type
Comment	UL Static Info
Earfcn	integer UL-EARFCN as defined in TS 36.101
Bandwidth	UI_Bandwidth_Type N(DL, RB) = 6..110 (6, 15, 25, 50, 75, 100)
CyclicPrefix	EUTRA_CyclicPrefix_Type

EUTRA_RBSize_Type

TTCN-3 Enumerated Type	
Name	EUTRA_RBSize_Type
Comment	Resource Block Size in freq domain; N(RB,SC) is 12 for normal sub-carrier spacing
n_RB_SC_12	
n_RB_SC_24	

EUTRA_CyclicPrefix_Type

TTCN-3 Enumerated Type	
Name	EUTRA_CyclicPrefix_Type
Comment	NOTE: in DL extended cyclic prefix depends on sub-carrier spacing
normal	
extended	

Modulation_Type

TTCN-3 Enumerated Type	
Name	Modulation_Type
Comment	'unused' e.g. for 2nd codeword when there is no spatial multiplexing
unused	
qpsk	
qam16	
qam64	

ToRS_EPRES_Ratios_Type

TTCN-3 Record Type			
Name	ToRS_EPRES_Ratios_Type		
Comment	RA and RB ratios according to see TS 36.213, clause 5.2		
RA	ToRS_EPRES_Ratio_Type	opt	
RB	ToRS_EPRES_Ratio_Type	opt	

UE_CategoryInfo_Type

TTCN-3 Record Type			
Name	UE_CategoryInfo_Type		
Comment			
ue_Category	UE_Category_Type		
ue_Category_V1020	UE_Category_v1020_Type	opt	
ue_Category_v1170	UE_Category_v1170_Type	opt	
ue_Category_v11a0	UE_Category_v11a0_Type	opt	
ue_Category_v1250	UE_Category_v1250_Type	opt	If UE category is 0 then 1. SS shall forward UL CCCH SDU only when indicated with LCHID '01011'B. 2. SS shall restrict DL UE-dedicated MAC TBS to 1000.
ue_CategoryDL_r12	UE_CategoryDL_r12_Type	opt	
ue_CategoryDL_v1260	UE_CategoryDL_v1260_Type	opt	
ue_CategoryDL_v1310	UE_CategoryDL_v1310_Type	opt	

D.1.3.2 Downlink_Physical_Layer_Configuration

Downlink physical layer configuration:

- DL antenna configuration
- control region (PCFICH, PHICH, PDCCH)
- primary/secondary sync signals
- power control for physical channels and signals

D.1.3.2.1 Antenna_Configuration

Antenna_Configuration: Basic Type Definitions

TTCN-3 Basic Types		
AntennaPortId_Type	integer (0, 1, 2, 3, 4, 5, 6, 7, 8)	Antenna port 0..3: Cell specific reference signals Antenna port 4: MBSFN reference signals Antenna port 5: UE specific reference signals Antenna port 6: Positioning reference signals Antenna port 7: UE specific reference signals for dual layer beamforming Antenna port 8: UE specific reference signals for dual layer beamforming (Antenna ports in DL acc. to 36.211 cl. 6.2.1)

AntennaPortInfo_Type

TTCN-3 Record Type		
Name	AntennaPortInfo_Type	
Comment	NOTE: for conformance tests it may not be necessary to consider propagation pathes for different antennas; => fields of AntennaPortInfo_Type are used as place holders for future usage and are of 'Dummy_Type' for the time being	
PowerAttenuation	Dummy_Type	even though eNb shall send with the same power on all antennas at the UE there may be different signal strength => RS will have reduced power NOTE: the EPRE ratios (e.g. PDSCH-to-RS ratio) are assumed to be equal for all antennas
PropagationDelay	Dummy_Type	signal from different antennas may have different propagation delay

AntennaPortConfig_Type

TTCN-3 Union Type		
Name	AntennaPortConfig_Type	
Comment		
AddOrReconfigure	AntennaPortInfo_Type	add / re-configure antenna port
Release	Null_Type	release antenna port

AntennaPort_Type

TTCN-3 Record Type		
Name	AntennaPort_Type	
Comment		
Id	AntennaPortId_Type	
Config	AntennaPortConfig_Type	

DownlinkAntennaGroupConfig_Type

TTCN-3 Record Type			
Name	DownlinkAntennaGroupConfig_Type		
Comment			
AntennaInfoCommon	AntennaInfoCommon_Type		acc. to TS 36.331, clause 6.3.2; contains antennaPortsCount = an1, an2, an4; static parameter; will (normally) not be modified whilst a test; NOTE: information is redundant since number of antenna ports may implicitly be determined by the number of ports being configured
AntennaPort	record length (1..4) of AntennaPort_Type		1, 2 or 4 antennas; from the UE's point of view each antenna may have a different power level and a different propagation delay

D.1.3.2.2 Physical_Channels

PbchConfig_Type

TTCN-3 Record Type			
Name	PbchConfig_Type		
Comment			
RelativeTxPower	ToRS_EPRES_Ratios_Type	opt	power ratio for PBCH's resource elements relative to the RS

PcfichConfig_Type

TTCN-3 Record Type			
Name	PcfichConfig_Type		
Comment			
CfiValue	CfiValue_Type	opt	control format indicator signalled on PCFICH
RelativeTxPower	ToRS_EPRES_Ratios_Type	opt	power ratio for PCFICH's resource elements relative to the RS

PhichConfig_Type

TTCN-3 Record Type			
Name	PhichConfig_Type		
Comment			
PhichConfig	PHICH_Config_Type	opt	parameters acc. TS 36.331, clause 6.3.2: phich-Duration, phich-Resource; may have impact on Cfi
RelativeTxPower	ToRS_EPRES_Ratios_Type	opt	power ratio for PHICH's resource elements relative to the RS

CCE_StartIndex_DL_UL_Type

TTCN-3 Record Type			
Name	CCE_StartIndex_DL_UL_Type		
Comment	CCE_St_Ind' or CCE_St_Ind" acc. to table 7.1.1-1 in TS 36.523-3		
CCE_StartIndex_DL	integer		
CCE_StartIndex_UL	integer		

CCE_StartIndexList_Type

TTCN-3 Record of Type	
Name	CCE_StartIndexList_Type
Comment	describes PDCCH candidates for all sub-frames
record length(10) of CCE_StartIndex_DL_UL_Type	

PdcchCandidate_Type

TTCN-3 Record Type		
Name	PdcchCandidate_Type	
Comment	CCE start indeces for a given RNTI value acc. to table 7.1.1-1 in TS 36.523-3	
RNTI	C_RNTI	RNTI value as per table 7.1.1-1
CCE_StartIndexList	CCE_StartIndexList_Type	CCE Start Indices corresponding to the RNTI

PdcchCandidateList_Type

TTCN-3 Record of Type	
Name	PdcchCandidateList_Type
Comment	list of RNTIs and their corresponding CCE Start Indices
record of PdcchCandidate_Type	

PdcchConfig_Type

TTCN-3 Record Type			
Name	PdcchConfig_Type		
Comment	UE performs blind detection for common and UE specific search spaces for different aggregation levels (PDCCH formats acc. TS 36.211, clause 6.8.1) content of the PDCCHs (DCI formats acc. TS 36.212, clause 5.3.3) shall be controlled together with scheduling and resource allocation		
CommonSearchSpaceFormat	integer (2, 3)	opt	PDCCH format for common search space; acc. to TS 36.213, clause 9.1.1 only aggregation level 4 and 8 are allowed (i.e. PDCCH format 2 and 3)
UeSpecificSearchSpaceFormat	integer (0, 1, 2, 3)	opt	UE specific search space: corresponding aggregation levels 1, 2, 4, 8
PdcchCandidateList	PdcchCandidateList_Type	opt	PDCCH candidate list acc. to table 7.1.1-1 in TS 36.523-3
RelativeTxPower	ToRS_EPRES Ratios_Type	opt	power ratio for PDCCH's resource elements relative to the RS

PdschRelativeTxPower_Type

TTCN-3 Record Type			
Name	PdschRelativeTxPower_Type		
Comment	NOTE 1: the power control for the PDSCH is assumed to be (semi-)static for signalling conformance tests acc. to TS 36.323; nevertheless for different channels and purposes with the PDSCH there may be different power settings; NOTE 2: acc. to TS 36.213, clause 5.2 the EPRE ratio is different in time domain for OFDM symbols containing or not containing reference signals; this needs to be considered by SS		
RachResponse	ToRS EPRE Ratios_Type	opt	
BcchOnPdsch	ToRS EPRE Ratios_Type	opt	
PcchOnPdsch	ToRS EPRE Ratios_Type	opt	
CcchOnPdsch	ToRS EPRE Ratios_Type	opt	
DcchDtchOnPdsch	ToRS EPRE Ratios_Type	opt	
OcngOnPdsch	ToRS EPRE Ratios_Type	opt	the power offset used for modeling allocations to virtual UE's (different from the UE under test)

PdschConfig_Type

TTCN-3 Record Type			
Name	PdschConfig_Type		
Comment			
RelativeTxPower	PdschRelativeTxPower_Type	opt	
PDSCH_ConfigCommon	PDSCH_ConfigCommon_v1310	opt	

EpdccchConfig_Type

TTCN-3 Record Type			
Name	EpdccchConfig_Type		
Comment			
RelativeTxPower	ToRS EPRE Ratios_Type	opt	power ratio for ePDCCH's/MPDCCH(if configured) resource elements relative to the RS
ePdcchCandidateList	PdcchCandidateList_Type	opt	ePDCCH candidate list acc. to tables in TS 36.523-3 clause 7.1.2
EPDCCH_Config	EPDCCH_Config_r11	opt	If present with choice 'setup' SS starts using ePDCCH in subframes reserved for ePDCCH for UL/DL grant transmission on C-RNTI/SPS-RNTI and PDCCH in non reserved sub frames or MPDCCH (if present) in all sub frames when using DCI formats 6-xx If present with choice 'release' SS releases ePDCCH/MPDCCH configuration and uses PDCCH for UL/DL grant transmission in all sub frames 'omit' is no change from previous configuration

D.1.3.2.3 Physical_Signals

PrimarySyncSignal_Type

TTCN-3 Record Type			
Name	PrimarySyncSignal_Type		
Comment			
RelativeTxPower	ToRS EPRE Ratios_Type	opt	power ratio for PSS's resource elements relative to the RS

SecondarySyncSignal_Type

TTCN-3 Record Type			
Name	SecondarySyncSignal_Type		
Comment			
RelativeTxPower	ToRS_EPRES_Ratios_Type	opt	power ratio for SSS's resource elements relative to the RS

SRS_UL_Config_Type

TTCN-3 Record Type			
Name	SRS_UL_Config_Type		
Comment			
Common	SoundingRS_UL_ConfigCommon_Type		
Dedicated	SoundingRS_UL_ConfigDedicated_Type		

PhysicalLayerConfigDL_Type

TTCN-3 Record Type			
Name	PhysicalLayerConfigDL_Type		
Comment	all fields are declared as optional to allow single reconfigurations; in this case omit means "keep as it is"		
AntennaGroup	DownlinkAntennaGroupConfig_Type	opt	
Pbch	PbchConfig_Type	opt	
Pcfich	PcfichConfig_Type	opt	
Phich	PhichConfig_Type	opt	
Pdcch	PdcchConfig_Type	opt	
Pdsch	PdschConfig_Type	opt	
Pss	PrimarySyncSignal_Type	opt	
Sss	SecondarySyncSignal_Type	opt	
CSI_RS_Config	CSI_RS_Config_Type	opt	
Pmch	PmchConfig_Type	opt	Same power offset for all PMCH carrying MCCH or MTCH
Epdccch	EpdccchConfig_Type	opt	
DS_RS_Config	DS_RS_Config_Type	opt	

D.1.3.3 Uplink_Physical_Layer_Configuration

Uplink physical channel configuration: PRACH, PUCCH, PUSCH and UL RS

PUCCH_Configuration_Type

TTCN-3 Record Type			
Name	PUCCH_Configuration_Type		
Comment			
Common	PUCCH_ConfigCommon_Type	opt	
Dedicated	PUCCH_ConfigDedicated_Type	opt	

PUSCH_Configuration_Type

TTCN-3 Record Type			
Name	PUSCH_Configuration_Type		
Comment			
Common	PUSCH_ConfigCommon_Type	opt	
Dedicated	PUSCH_ConfigDedicated_Type	opt	

PhysicalLayerConfigUL_Type

TTCN-3 Record Type			
Name	PhysicalLayerConfigUL_Type		
Comment	NOTE: For the time being there is no requirement to configure the SS with TPC-PDCCH-Config; In general SS is required to keep the UE's UL power constant		
Prach	PRACH_Config_Type	opt	parameters acc. TS 36.331, clause 6.3.2; in general depending on FDD/TDD (see TS 36.211, clause 5.7)
Pucch	PUCCH_Configuration_Type	opt	parameters acc. TS 36.331, clause 6.3.2
Pusch	PUSCH_Configuration_Type	opt	parameters acc. TS 36.331, clause 6.3.2 (including configuration of RS)
TimingAdvance	SS_TimingAdvanceConfig_Type	opt	to adjust timing advance; normally timing advance is configured as 0 at the beginning and never changed during the test case; in some MAC test cases timing advance may be configured to a non-zero (11 bit value) at the beginning and modified by (6 bit) timing advance commands during the test
SRS_UL_Config	SRS_UL_Config_Type	opt	sounding reference symbol (SRS); -> TS 36.213, clause 8.2, TS 36.211, clause 5.5.3
SR_Config	SchedulingRequestConfig_Type	opt	PUCCH resources for scheduling requests acc. to TS 36.213 table 10.15; as signalled to the UE acc. to TS 36.331, clause 6.3.2
CQI_ReportConfig	CQI_ReportConfig_Type	opt	
UplinkPowerControlCommon	UplinkPowerControlCommon_Type	opt	
UplinkPowerControlDedicated	UplinkPowerControlDedicated_Type	opt	

D.1.3.4 Common_MAC_Configuration

Transport channel and MAC related procedures and configuration

Common_MAC_Configuration: Basic Type Definitions

TTCN-3 Basic Types		
ImcsValue_Type	integer (0..31)	Modulation and coding scheme index coding
RepetitionNumber_Type	integer (0..7)	DCI Format 6-0A, value 0..3 as per 36.213 table 8.2b DCI Format 6-0B, value 0..7 as per 36.213 table 8.2c DCI Format 6-1A, value 0..3 as per 36.213 table 7.1.11-1 DCI Format 6-1B, 6_2, value 0..7 as per 36.213 table 7.1.11-2
DCISubframeRepetitionNumber_Type	integer (0..3)	36.213 clause as defined in section 9.1.5

RedundancyVersionListDL_Type

TTCN-3 Record of Type	
Name	RedundancyVersionListDL_Type
Comment	NOTE: in general the list shall contain maxHARQ-Tx elements; if there are not enough elements specified SS shall raise an error; per default the list is configured to 0,2,3,1,0 (TS 36.321, clause 5.4.2.2)
record length (1..28) of RedundancyVersion_Type	

UL_TransRetransmission_Type

TTCN-3 Union Type		
Name	UL_TransRetransmission_Type	
Comment		
NewTransmission	Null_Type	new transmission of data with redundancy version RV=0 (acc. to TS 36.321 clause 5.4.2.2); NDI is toggled
RetransmissionAdaptive	RedundancyVersion_Type	SS assigns grant to requests retransmission of data with given redundancy version; NDI is not toggled
RetransmissionNonAdaptive	Null_Type	place holder for non-adaptive retransmissions; SS does not send any grant
RetransmissionAsynchronous	RetransmissionAsynchronous_Type	Used to schedule time controlled asynchronous UL grant for BL/CE UEs

RetransmissionAsynchronous_Type

TTCN-3 Record Type			
Name	RetransmissionAsynchronous_Type		
Comment			
RedundancyVersion	RedundancyVersion_Type		SS assigns grant to requests retransmission of data with given redundancy version; NDI is not toggled
SubframeOffset	integer		the subframe offset since previous grant in the list, shall include all repetitions
RepetitionNumber	RepetitionNumber_Type		
DCISubframeRepetitionNumber	DCISubframeRepetitionNumber_Type		

UL_TransRetransmissionList_Type

TTCN-3 Record of Type	
Name	UL_TransRetransmissionList_Type
Comment	list of transmission and subsequent retransmissions: in UL retransmissions are synchronous (every 8 TTIs for FDD); independent from the HARQ_ModelList SS shall send grants for every adaptive retransmissions; in case of non-adaptive retransmissions SS simply does not sent a grant (i.e. RetransmissionNonAdaptive elements are used to adjust timing of the adaptive retransmissions only)
record length (1..28) of UL_TransRetransmission_Type	

Imcs_Type

TTCN-3 Union Type		
Name	Imcs_Type	
Comment		
Value	ImcsValue_Type	
NotUsed	Null_Type	

ULGrant_Period_Type

TTCN-3 Union Type		
Name	ULGrant_Period_Type	
Comment		
OnlyOnce	Null_Type	grant is sent out only once; no period
Duration	integer (1..infinity)	duration of the grant period (TTI=1ms); for TDD the starting time and periodicity need to be chosen in TTCN so that the grants are assigned at valid subframes only; otherwise SS shall raise an error

FreqDomainSchedulCommon_Type

TTCN-3 Record Type		
Name	FreqDomainSchedulCommon_Type	
Comment	<p>common type to specify restrictions for frequency domain scheduling by a start index and a maximum range of RBs; in general the resource allocation refers to virtual resource blocks:</p> <ul style="list-style-type: none"> - format 1A (localised): FirstRbIndex refers to the first physical RB; the RBs are subsequent (upto MaxRbCnt RBs); may be applied for all kind of channels - format 1C (distributed): FirstRbIndex refers to the first virtual RB; the virtual RBs are subsequent (upto MaxRbCnt RBs) but mapped (distributed) to physical resource; typically applied on BCCH, PCCH and RAR - format 1 (localised): FirstRbIndex refers to the first physical RB; RBs are not consecutive; SS needs to provided bitmap of RBs (see TS 36.523-3) to cope with mapping of virtual resource allocation (format 1C) applied on other channels; typically there are either <ul style="list-style-type: none"> - all channels having format 1A (localised) - BCCH, PCCH and RAR having format 1C (distributed) + DTCH/DCCH having format 1 	
FirstRbIndex	integer	<p>index of the first (vital) resource block in frequency domain; 0 .. N(UL/DL, RB) - 1; NOTE: DCI format 1C refers to a virtual RB allocation i.e. the resource block index; differs from the physical resource allocation where the RBs are distributed over the whole frequency bandwidth (TS 36.213, clause 7.1.6.3)</p>
MaxRbCnt	integer	<p>max. number of resource blocks to be assigned; FirstRbIndex + MaxRbCnt <= N(UL/DL, RB); SS shall not assigned more than the given resource blocks to the respective channel (i.e. MaxRbCnt is the upper bound); if the the configuration for a channel exceeds the total bandwidth this is a TTCN error (=> SS shall raise an error)</p>

FreqDomainSchedulExplicit_Type

TTCN-3 Record Type		
Name	FreqDomainSchedulExplicit_Type	
Comment	type used for explicit DL scheduling; Nprb is the exact number of RBs whereas in FreqDomainSchedulCommon_Type MaxRbCnt is the upper bound	
FirstRbIndex	integer	index of the first resource block in frequency domain; 0 .. N(UL/DL, RB) - 1
Nprb	integer	number of resource blocks to be assigned;

PdcchDciFormat_Type

TTCN-3 Enumerated Type	
Name	PdcchDciFormat_Type
Comment	DCI format acc. to TS 36.212, clause 5.3.3.1; SS shall apply physical parameters accordingly as specified in TS 36.508, clause 4.3.6
dci_0	physical layer parameters acc. TS 36.508 Table 4.3.6.1.1-1
dci_1	physical layer parameters acc. TS 36.508 Table 4.3.6.1.2-1
dci_1A	physical layer parameters acc. TS 36.508 Table 4.3.6.1.3-1
dci_1B	
dci_1C	physical layer parameters acc. TS 36.508 Table 4.3.6.1.4-1
dci_1D	
dci_2	physical layer parameters acc. TS 36.508 Table 4.3.6.1.5-1
dci_2A	physical layer parameters acc. TS 36.508 Table 4.3.6.1.6-1
dci_2B	
dci_2C	
dci_2D	
dci_3	
dci_3A	
dci_4	
dci_6_0A	DCI format 6-0A is used for the scheduling of PUSCH in one UL cell
dci_6_0B	DCI format 6-0B is used for the scheduling of PUSCH in one UL cell
dci_6_1A	DCI format 6-1A is used for the compact scheduling of one PDSCH codeword in one cell and random access procedure initiated by a PDCCH order. The DCI corresponding to a PDCCH order can be carried by MPDCCH
dci_6_1B	DCI format 6-1B is used for the scheduling of one PDSCH codeword in one cell
dci_6_2	DCI format 6-2 is used for for paging and direct indication

PdcchResourceAllocation_Type

TTCN-3 Enumerated Type	
Name	PdcchResourceAllocation_Type
Comment	Resource allocation acc. TS 36.213, clause 7.1.6
ra_0	
ra_1	
ra_2_Localised	=> physical and virtual RB index are identical
ra_2_Distributed	=> virtual resource allocation
ra_Unspecified	=> None of above resource allocations and as specified by DCI format in 36.211. For example used for DCI 6_1B

MIMO_PrecodingBits_Type

TTCN-3 Union Type		
Name	MIMO_PrecodingBits_Type	
Comment	Number of bits for precoding information acc. TS 36.212, table 5.3.3.1.5-3 and 5.3.3.1.5A-1	
None	Null_Type	DCI 2A: 2 antenna ports at eNodeB (table 5.3.3.1.5A-1)
Bit2	B2_Type	DCI 2A: 4 antenna ports at eNodeB (table 5.3.3.1.5A-1)
Bit3	B3_Type	DCI 2: 2 antenna ports at eNodeB (table 5.3.3.1.5-3)
Bit6	B6_Type	DCI 2: 4 antenna ports at eNodeB (table 5.3.3.1.5-3)

MIMO_DciDlInfo_Type

TTCN-3 Record Type			
Name	MIMO_DciDlInfo_Type		
Comment	additional information for DL DCI in case of MIMO (i.e. when a 2nd CW is specified)		
RedundancyVersionList_2ndCW	RedundancyVersionListDL_Type	opt	list of Redundancy version for 2nd code word; shall have the same length as RedundancyVersionList_1stCW; if omit, for the 2nd CW the same RedundancyVersionList shall be applied as for the 1st CW
CodeWordSwapFlag	B1_Type		transport block to codeword mapping acc. to TS 36.212 Table 5.3.3.1.5-1
PrecodingBits	MIMO_PrecodingBits_Type		precoding information acc. TS 36.212, table 5.3.3.1.5-3 and 5.3.3.1.5A-1

DciDlInfoCommon_Type

TTCN-3 Record Type			
Name	DciDlInfoCommon_Type		
Comment	used for normal DL scheduling acc. to TS 36.523-3, clause 7.3		
Format	PdcchDciFormat_Type		BCCH, PCCH and RACH Response: 1A or 1C (TS 36.213, clause 7.1) CCCH: 1A since transmission mode is not (may not be) configured at the UE yet (TS 36.213, clause 7.1) DTCH/DCCH: depending on transmission mode
ResourceAllocationType	PdcchResourceAllocation_Type		depends on DCI format, e.g. ra_2_Localised or ra_2_Distributed for DCI format 1A
Modulation_1stCW	Modulation_Type		max. modulation scheme for the 1st code word; depending on the amount of data a lower modulation scheme may be by SS but not a higher one; BCCH, PCCH and RACH Response: QPSK only
Modulation_2ndCW	Modulation_Type		modulation scheme for 2nd code word in case of spatial multiplexing; can be different than 1st code word (see TS 36.211, clause 6.3.2; TS 36.212, clause 5.3.3.1.5); 'unused' when there is no spatial multiplexing; NOTE: Acc. to 36.523-3 cl. 7.3.3.4 in normal mode MIMO shall not be used => for the time being Modulation_2ndCW is always "unused"
FreqDomainScheduling	FreqDomainSchedulingComm_Type		index of 1st RB; max. number of RBs per TTI; NOTE: in case of DCI format 1C the first RB index has no meaning since distributed virtual resource blocks assigned in this case (TS 36.213, clause 7.1.6.3) NOTE: For DCI formats used for BL/CE UEs i.e DCIs 6_X, this IE identifies the Narrow band of 6 PRBs
RedundancyVersionList	RedundancyVersionListDL_Type		list of Redundancy version to be used in case of retransmission; the number of elements in the list provides the maxHARQ-Tx
RepetitionNumber	RepetitionNumber_Type	opt	used only for DCI format 6_X for BL/CE UEs
DCISubframeRepetitionNumber	DCISubframeRepetitionNumber_Type	opt	used only for DCI format 6_X for BL/CE UEs

DciDlInfoExplicit_Type

TTCN-3 Record Type			
Name	DciDlInfoExplicit_Type		
Comment	used for explicit DL scheduling acc. to TS 36.523-3, clause 7.3		
Imcs_1stCW	Imcs_Type		MCS index of table 7.1.7.1-1 of TS 36.213
Imcs_2ndCW	Imcs_Type		MCS index for the 2nd code word in case of MIMO; 'NotUsed' when MIMO is not used
Format	PdcchDciFormat_Type		
ResourceAlloc Type	PdcchResourceAllocation_Type		
FreqDomainSchedul	FreqDomainSchedulExplicit_Type		For DCI formats used for BL/CE UEs i.e DCIs 6_X, this IE identifies the resources in Narrow band of 6 PRBs
RedundancyVersionList	RedundancyVersionListDL_Type		list of Redundancy version to be used in case of retransmission the number of elements in the list provides the maxHARQ-Tx
MimoInfo	MIMO DciDlInfo_Type	opt	shall be present when Imcs_2ndCW specifies a 2nd CW to be used; shall be omit when Imcs_2ndCW is 'NotUsed'
RepetitionNumber	RepetitionNumber_Type	opt	used only for DCI format 6_X for BL/CE UEs
DCISubframeRepetitionNumber	DCISubframeRepetitionNumber_Type	opt	used only for DCI format 6_X for BL/CE UEs

DciDlInfo_Type

TTCN-3 Union Type		
Name	DciDlInfo_Type	
Comment		
Auto	DciDlInfoCommon_Type	SS shall chose the appropriate TBS up to the maximim number of resource blocks
Explicit	DciDlInfoExplicit_Type	used in MAC or RAB tests where exact TBS needs to be specified

DciUlInfo_Type

TTCN-3 Record Type			
Name	DciUlInfo_Type		
Comment			
Imcs	Imcs_Type		MCS index of table 8.6.1-1 of TS 36.213
TransRetransmissionList	UL_TransRetransmissionList_Type		list of possible retransmissions and their redundancy versions (depending on being adaptive or non-adaptive); the list shall <ul style="list-style-type: none"> - start with <ul style="list-style-type: none"> - "New Transmission" (normal case) or - "Adaptive Retransmission" (e.g. to request a retransmission even when the data has been acknowledged with a HARQ ACK) - end with "Adaptive Retransmission" (if there are retransmissions) NOTE1: TTCN implementation shall ensure that a reconfiguration is done not before the previous list has been fully processed NOTE2: for normal operation the list contains only one NewTransmission element (i.e. possible retransmissions are non-adaptive)
FreqDomainScheduling	FreqDomainSchedulingExplicit_Type		For DCI formats used for BL/CE UEs i.e DCIs 6_0X, this IE identifies the resources in Narrow band of 6 PRBs
Format	PdcchDciFormat_Type	opt	If omit, default DCI format 0 will be applied; for BL/CE UEs 6_0X shall be specified
HarqProcessId	integer	opt	Can be present in DCI format is not 6_0X; If present SS Uses the specified HARQ process for all UL transmissions/retransmissions;
RepetitionNumber	RepetitionNumber_Type	opt	used only for DCI format 6_X for BL/CE UEs
DCISubframeRepetitionNumber	DCISubframeRepetitionNumber_Type	opt	used only for DCI format 6_X for BL/CE UEs

PeriodicGrant_Type

TTCN-3 Record Type			
Name	PeriodicGrant_Type		
Comment			
Period	ULGrant_Period_Type		time period after which UL Grant need to be automatically transmitted or 'OnlyOnce'
NoOfRepetitions	TransmissionRepetition_Type		number of UL Grant repetitions to be automatically transmitted or continuous repetition

UL_GrantConfig_Type

TTCN-3 Union Type			
Name	UL_GrantConfig_Type		
Comment			
OnSR_Reception	Null_Type		SS transmits UL Grant as configured by CommonDciInfoUL_Type at every reception of SR; to be used in non L2 Test
Periodic	PeriodicGrant_Type		SS transmits UL Grant as configured by CommonDciInfoUL_Type periodically; to be used in L2 tests; MAC tests testing Grants might set the period as infinite and num grant as 1
PeriodicOnSR_Reception	PeriodicGrant_Type		SS transmits UL Grant as configured by CommonDciInfoUL_Type periodically; the periodic grant transmission is started/restarted on reception of a SR from UE to be used in non L2 Test to enable large UL data transmission for lower category UEs (Cat<=1)
None	Null_Type		disable any grant transmission

D.1.3.5 Random_Access_Procedure

UplinkGrant_Type

TTCN-3 Record Type	
Name	UplinkGrant_Type
Comment	TS 36.213, clause 6.2
HoppingFlag	B1_Type Hopping flag
RB_Allocation	B10_Type Fixed size resource block assignment
ModAndCodScheme	B4_Type Truncated modulation and coding scheme
TPC_Command	B3_Type TPC command for scheduled PUSCH
UL_Delay	B1_Type UL delay
CQI_Req	B1_Type CQI request

CRNTI_ContentionResolutionCtrl_Type

TTCN-3 Union Type	
Name	CRNTI_ContentionResolutionCtrl_Type
Comment	configuration for Random Access Procedure in RRC_CONNECTED (see TS 36.300, clause 10.1.5.1); when SS receives C-RNTI MAC element sent by the UE after Random Access Response, SS shall deal with the C-RNTI as specified in this structure
AutomaticGrant	DciUlInfo_Type before expiry of the contention resolution timer SS shall automatically address PDCCH using C-RNTI as sent by the UE; the UL grant is specified acc. to DciUlInfo_Type
None	Null_Type Used in case of dedicated preamble transmission or to simulate failure cases; SS shall not address PDCCH using C-RNTI => expiry of contention resolution timer on UE side

ContentionResolutionCtrl_Type

TTCN-3 Union Type	
Name	ContentionResolutionCtrl_Type
Comment	NOTE: SS only needs to consider one kind of contention resolution at one time; in the initial configuration of a cell TCRNTI_Based shall be configured and the common assumption is that in RRC_CONNECTED normally there are no RACH procedures (i.e. no CRNTI_Based configuration needed) whereas e.g. in case of handover scenarios CRNTI_Based shall be configured
TCRNTI_Based	TCRNTI_ContentionResolutionCtrl_Type TCRNTI based contention resolution (e.g. initial access), hence involves inclusion contention resolution identity in DL message 4 of RACH procedure
CRNTI_Based	CRNTI_ContentionResolutionCtrl_Type CRNTI based contention resolution (e.g. in case UE is being in RRC_CONNECTED): hence uplink message in step 3 (of RACH procedure) is followed by PDCCH transmission with UE C-RNTI to end procedure

RandomAccessResponseParameters_Type

TTCN-3 Record Type		
Name	RandomAccessResponseParameters_Type	
Comment	parameters to control content of RAR sent to the UE	
RapId	RapIdCtrl_Type	to control Random Access Preamble Id to be sent back to the UE; used in RAR MAC sub-header
InitialGrant	UplinkGrant_Type	initial UL grantgrant ; May be ignored if UplinkGrantCE_Mode_Type is configured
TimingAdvance	RACH_TimingAdvance_Type	timing advance: granularity of 0.52 micro sec (16*Ts); see TS 36.300, clause 5.2.7.3, TS 36.321, clause 6.1.3.5; NOTE: timing advance has impact not only on the RA procedure; SS in general needs to adjust its timing accordingly
TempC_RNTI	TempC_RNTI_Type	NOTE: For initial Random Access Procedure at network (SS) side there is no temporary C-RNTI: network assigns the C-RNTI which is used by any UE as being temporary; the UE which 'wins' the contention resolution keeps the (temporary) C-RNTI; other UEs need to repeat the RACH procedure; => at the SS the TempC_RNTI shall be 'SameAsC_RNTI' For Random Access Procedure in RRC_CONNECTED state the NW assigns a temporary C-RNTI which is replaced by the one stored at the UE; => TempC_RNTI may be 'SameAsC_RNTI' (in this case temp. C-RNTI and C-RNTI are equal what is not likely in a real network), or there is an explicit temp. C-RNTI what is used during RA procedure only (as in a real network)
InitialGrantCE_Mode	UplinkGrantCE_Mode_Type	opt used by SS based on PRACH coverage enhancement levels

RarList_Type

TTCN-3 Record of Type	
Name	RarList_Type
Comment	in general MAC PDU may contain one or several RARs; normally only one RAR is contained
record of RandomAccessResponseParameters_Type	

UplinkGrantCE_ModeA_Type

TTCN-3 Record Type		
Name	UplinkGrantCE_ModeA_Type	
Comment	TS 36.213, clause 6.2 table 6-2	
Msg3_PUSCH_NB_Index	B4_Type	Msg3 PUSCH narrowband index
Msg3_PUSCH_ResAllocation	B4_Type	Msg3 PUSCH Resource allocation
Msg3_PUSCH_Repetitions	B2_Type	Number of Repetitions for Msg3 PUSCH
MCS	B3_Type	
TPC_Command	B3_Type	TPC command for scheduled PUSCH
CSI_Req	B1_Type	CSI request
UL_Delay	B1_Type	UL delay
Msg3_4_MPDCCH_NB_Index	B2_Type	Msg3/4 MPDCCH narrowband index

UplinkGrantCE_ModeB_Type

TTCN-3 Record Type		
Name	UplinkGrantCE_ModeB_Type	
Comment	TS 36.213, clause 6.2 table 6-2	
Msg3_PUSCH_NB_Index	B2_Type	Msg3 PUSCH narrowband index
Msg3_PUSCH_ResAllocation	B3_Type	Msg3 PUSCH Resource allocation
Msg3_PUSCH_Repetitions	B3_Type	Number of Repetitions for Msg3 PUSCH
TBS	B2_Type	TBS
Msg3_4_MPDCCCH_NB_Index	B2_Type	Msg3/4 MPDCCH narrowband index

UplinkGrantCE_Mode_Type

TTCN-3 Record Type		
Name	UplinkGrantCE_Mode_Type	
Comment		
CE_ModeA	UplinkGrantCE_ModeA_Type	If the most recent PRACH coverage enhancement level for the UE is 0 or 1, the contents of the Random Access Response Grant are interpreted according to CEModeA.
CE_ModeB	UplinkGrantCE_ModeB_Type	If the most recent PRACH coverage enhancement level for the UE is 2 or 3, the contents of the Random Access Response Grant are interpreted according to CEModeB

RandomAccessResponse_Type

TTCN-3 Union Type		
Name	RandomAccessResponse_Type	
Comment		
None	Null_Type	used for unsuccessful RA procedure
List	RarList_Type	normally one RAR to be sent to the UE; in general there can be more than one RAR

RandomAccessResponseCtrl_Type

TTCN-3 Record Type		
Name	RandomAccessResponseCtrl_Type	
Comment	configuration for Random Access Response mapped to DL-SCH mapped to PDSCH TransmissionMode: single antenna mode when there is only one antenna configured, transmit diversity else; RNTI: RA-RNTI (TS 36.321, clause 7.1); if both RAR msg and backoff indicator are 'None' SS shall not respond on random access preamble	
DciInfo	DciDlInfoCommon_Type	DCI format: 1A or 1C (TS 36.213, clause 7.1) ResourceAllocType: 2 (acc. to DCI format) Modulation: QPSK Frequency domain schedule: index of 1st RB; max. number of RBs per TTI
Rar	RandomAccessResponse_Type	RAR to be sent to the UE
BackoffInd	RandomAccessBackoffIndicator_Type	possible backoff indicator; 'None' for normal cases

RandomAccessResponseConfig_Type

TTCN-3 Union Type		
Name	RandomAccessResponseConfig_Type	
Comment		
Ctrl	RandomAccessResponseCtrl_Type	contains information to control sending of RAR
Ctrl_CRC_Error	RandomAccessResponseCtrl_Type	same as Ctrl (see above), but MAC PDU transmitted will contain CRC bits (0-3) being toggled; no retransmissions shall be made as UE shall not send a NACK
None	Null_Type	to be used when there is no RAR to be sent at all

RachProcedure_Type

TTCN-3 Record Type		
Name	RachProcedure_Type	
Comment		
RAResponse	RandomAccessResponseConfig_Type	control of how the SS shall react on RA preamble; this may be - the RAP id as expected by the UE - a RAP id not matching to the UE's RAP - a backoff indicator - nothing at all
ContentionResolutionCtrl	ContentionResolutionCtrl_Type	

RachProcedureList_Type

TTCN-3 Record of Type	
Name	RachProcedureList_Type
Comment	<p>to simulate RACH procedure with one or more than one attempt by the UE: There is one RachProcedure_Type in the list per PRACH Preamble attempt. When PRACH preamble is repeated within a Preamble attempt (BL/CE UE), the SS shall wait for all PRACH preamble repetitions before acting as per configured RAR. The discrete set of RAPIDS to be used by UE in each CE level is provided in RACH_ConfigCommon->RACH_CE_LevellInfoList_r13 and the repetitions of preamble based on CE level is provided in PRACH_Config_v1310-> prach_ParametersListCE_r13. If UE is not repeating preambles as per its detected CE level the SS shall raises an error. The same applies to contention resolution, one per RACH procedure Msg 3 transmission plus its repetitions.</p> <p>1. Normal cases: one single RandomAccessResponse is sent to the UE matching the UE's RACH preamble; contention resolution is successful immediately => list contains only one element which is used for any RA procedure (Even if a RACH procedure is repeated by the UE for any reason this element shall be used; e.g. it needs not to be handled as error when the UE sends another RACH preamble instead of the RRC connection request message)</p> <p>2. Special cases: there are upto tsc_RandomAccessResponseListSize preambles sent by the UE => there are upto tsc_RandomAccessResponseListSize responses to be configured as elements of the list; SS shall start with the first element in the list and use the RAR as specified in this element; if the RAR matches at the UE side the UE will send UL data and contention resolution is performed as configured for this element; if the RAR does not match the UE sends another RAP and SS continues with the next element in the list; in this case the contention resolution of the respective element is not used; if the end of the list is reached and further RACH preambles are sent by the UE SS shall repeatedly apply the last element of the list (this is necessary because there might be not enough time to reconfigure SS after the end of the list has been reached and there shall be well-defined behaviour after the list has been processed);</p> <p>to change from a special mode to normal mode the RachProcedureList is reconfigured by TTCN to achieve transparency and readability of the code;</p> <p>NOTE: when there are RACH_ConfigDedicated configured (see below) and the RA preamble matches with one the configured ones the contention resolution ctrl is obsolete (non contention based random access procedure)</p>
record length(1.. tsc_RandomAccessResponseListSize) of RachProcedure_Type	

RachProcedureConfig_Type

TTCN-3 Record Type			
Name	RachProcedureConfig_Type		
Comment	parameters to control the random access procedure; TS 36.321, clause 5.1		
RACH_ConfigCommon	RACH_ConfigCommon_Type	opt	acc. TS 36.331, clause 6.3.2; may not be necessary for SS; omit: "keep as it is"
RACH_ConfigDedicated	RACH_ConfigDedicated_Type	opt	acc. TS 36.331, clause 6.3.2; when random access preamble sent by the UE matches with the configured one, SS shall assume the random access procedure being non-contention based; initial configuration: no RACH_ConfigDedicated are configured; omit means "keep as it is"
RachProcedureList	RachProcedureList_Type	opt	in normal cases there is one element which is used for any RA procedure; special cases are used in MAC test cases; omit means "keep as it is" If the cell is an Active Scell, the RACH procedure configuration in the Active Scell controls the RAR transmission in the associated Pcell, for received PRACH preamble in Scell

D.1.3.6 System_Information_Control

Primitive to configuration BCCH/BCH

System_Information_Control: Basic Type Definitions

TTCN-3 Basic Types		
BcchToPbchConfig_Type	Null_Type	place holder for BCCH mapped to BCH mapped to PBCH: MIB using fixed scheduling (periodicity: 40ms); transmission mode: single antenna port configuration (layer mapping acc. TS 36.211, clause 6.3.3.1) or transmit diversity (layer mapping acc. TS 36.211, clause 6.3.3.3) depending on antenna configuration

Sib1Schedul_Type

TTCN-3 Record Type			
Name	Sib1Schedul_Type		
Comment	SIB1: fixed scheduling in time domain acc. TS 36.331, clause 5.2.1.2 (periodicity: 80ms; repetitions every 20ms)		
DciInfo	DciDlInfoCommon_Type	opt	DCI format: 1A or 1C (TS 36.213, clause 7.1) ResourceAllocType: 2 (acc. to DCI format) Modulation: QPSK Frequency domain schedule: index of 1st RB; max. number of RBs per TTI

SingleSiSchedul_Type

TTCN-3 Record Type			
Name	SingleSiSchedul_Type		
Comment	specifies scheduling for a single SI in freq and time domain		
DciInfo	DciDlInfoCommon_Type	opt	DCI format: 1A or 1C (TS 36.213, clause 7.1) ResourceAllocType: 2 (acc. to DCI format) Modulation: QPSK Frequency domain schedule: index of 1st RB; max. number of RBs per TTI
SubframeOffset	integer	opt	offset within the SI-window; NOTE: SI-window may span more than one frame

SiSchedul_Type

TTCN-3 Record Type			
Name	SiSchedul_Type		
Comment	specifies for a specific SI scheduling and repetitions within as SI window		
Periodicity	SiPeriodicity_Type	opt	
Window	record of SingleSiSchedul_Type	opt	NOTE: acc. to TS 36.331, clause 5.2.1.2 the same SI may occur more than once in an SI-window; to allow this there is a "record of" even though acc. to TS 36.508, clause 4.4.3.3 all SIs are sent only once within the window

SiSchedulList_Type

TTCN-3 Record of Type	
Name	SiSchedulList_Type
Comment	
record length(1..maxSI_Message) of SiSchedul_Type	

AllSiSchedul_Type

TTCN-3 Record Type			
Name	AllSiSchedul_Type		
Comment			
WindowLength	SiWindowLength_Type	opt	to calculate start of each SI window acc. TS 36.331, clause 5.2.3
SiList	SiSchedulList_Type	opt	list of scheduling info for the SIs containing one ore more SIBs
SegmentedSiList	SiSchedulList_Type	opt	list of scheduling info for segmented SIs (e.g. SI containing SIB11); corresponds to SegmentedSIs in BcchInfo_Type: SS shall subsequently schedule the elements of the corresponding SegmentedSIs (BcchInfo_Type); e.g. SegmentedSiList[i] provided scheduling info for BcchInfo_Type's SegmentedSIs[i] and the kth element of SegmentedSIs[i] is sent at $T_0 + ((K * N) + k) * \text{periodicity}$ with K: number for segments k = 0 .. K-1 N = 0, 1, 2, ... T0, periodicity: scheduling info as given by SegmentedSiList[i]

BcchToPdschConfig_Type

TTCN-3 Record Type			
Name	BcchToPdschConfig_Type		
Comment	configuration for BCCH mapped to DL-SCH mapped to PDSCH TransmissionMode: single antenna mode when there is only one antenna configured, transmit diversity else; RNTI: SI-RNTI (TS 36.321, clause 7.1)		
Sib1Schedul	Sib1Schedul_Type	opt	scheduling of SIB1 in frequency domain
SiSchedul	AllSiSchedul_Type	opt	scheduling of SIs in frequency and time domain

SI_List_Type

TTCN-3 Record of Type	
Name	SI_List_Type
Comment	TS 36.331, clause 6.2.1 BCCH-DL-SCH-Message and clause 6.2.2 SystemInformation
record of BCCH_DL_SCH_Message	

SegmentedSI_List_Type

TTCN-3 Record of Type	
Name	SegmentedSI_List_Type
Comment	Each element is a list of segments; used for SIB11/12 segmentation
record of SI_List_Type	

BcchInfo_Type

TTCN-3 Record Type			
Name	BcchInfo_Type		
Comment	all fields are declared as optional to allow modification of single field; acc. to TS 36.331, clause 9.1.1.1 "RRC will perform padding, if required due to the granularity of the TF signalling, as defined in 8.5."; therefore this needs to be done by the system simulator		
MIB	BCCH_BCH_Message	opt	TS 36.331, clause 6.2.1 BCCH-BCH-Message and clause 6.2.2 MasterInformationBlock; NOTE: the sequence number included in MIB needs to be handled and maintained by the system simulator; that means that the sequence number being setup by TTCN will be overwritten by SS
SIB1	BCCH_DL_SCH_Message	opt	TS 36.331, clause 6.2.1 BCCH-DL-SCH-Message and clause 6.2.2 SystemInformationBlockType1
SIs	SI_List_Type	opt	list of SIs corresponding to SiList of AllSiSchedul_Type (i.e. element i of AllSiSchedul_Type's SiList specifies the scheduling for SIs[i])
SegmentedSIs	SegmentedSI_List_Type	opt	list of SIs containing segmented SIBs; corresponds to SegmentedSiList in AllSiSchedul_Type

BcchConfig_Type

TTCN-3 Record Type			
Name	BcchConfig_Type		
Comment	all fields are optional to allow single modifications; activation time may be applied in the common part of the ASP; NOTE 1: acc. to TS 36.331, clause 9.1.1.1 there is no PDCP and RLC/MAC are in TM NOTE 2: mapping/scheduling and contents of the System Information in general is done in one go (i.e. there are no separate ports for SIB data and configuration)		
Pbch	BcchToPbchConfig_Type	opt	
Pdsch	BcchToPdschConfig_Type	opt	
BcchInfo	BcchInfo_Type	opt	
StopSib1Transmission	Null_Type	opt	if omitted: SS transmits SIB1 last provided in BcchInfo and associated DCI. if set: SS shall stop transmission of SIB1 and associated DCI. To resume SIB1 transmission, this flag shall be omitted and SIB1 shall be provided in BcchInfo.

Bcch_BRConfig_Type

TTCN-3 Record Type			
Name	Bcch_BRConfig_Type		
Comment	all fields are optional to allow single modifications; activation time may be applied in the common part of the ASP; NOTE 1: acc. to TS 36.331, clause 9.1.1.8 there is no PDCP and RLC/MAC are in TM NOTE 2: mapping/scheduling and contents of the System Information in general is done in one go (i.e. there are no separate ports for SIB data and configuration)		
Pbch	Bcch_BRToPbchConfig_Type	opt	
Pdsch	Bcch_BRToPdschConfig_Type	opt	
BcchInfo	Bcch_BRInfo_Type	opt	
StopSib1Transmission	Null_Type	opt	if omitted: SS transmits SIB1 last provided in BcchInfo and associated DCI. if set: SS shall stop transmission of SIB1 and associated DCI. To resume SIB1 transmission, this flag shall be omitted and SIB1 shall be provided in BcchInfo.

Bcch_BRToPbchConfig_Type

TTCN-3 Record Type			
Name	Bcch_BRToPbchConfig_Type		
Comment	BCCH_BL mapped to BCH mapped to PBCH: MIB using fixed scheduling (periodicity: 40ms); transmission mode: single antenna port configuration (layer mapping acc. TS 36.211, clause 6.3.3.1) or transmit diversity (layer mapping acc. TS 36.211, clause 6.3.3.3) depending on antenna configuration		
EnableMIB_Repetition	boolean		If true MIB transmission shall be repeated in subframe#9 of the previous radio frame for FDD and subframe #5 of the same radio frame for TDD

SI_SubframeOffsetList_Type

TTCN-3 Record of Type	
Name	SI_SubframeOffsetList_Type
Comment	
record of integer	

Bcch_BRToPdschConfig_Type

TTCN-3 Record Type			
Name	Bcch_BRToPdschConfig_Type		
Comment	Configuration for BCCH_BR mapped to DL-SCH mapped to PDSCH TransmissionMode: single antenna mode when there is only one antenna configured, transmit diversity else; RNTI: No RNTI as BR SIs are sent without DCI info and scheduling for SIB-1 is provided in MIB and for other SIBs in SIB 1		
Sib1_BRScheduled	Sib1_BRScheduled_Type	opt	scheduling of SIB1 in frequency & time domain
SiSchedul	BandwidthReducedAccessRelatedInfo_Type	opt	scheduling of SIs in frequency and time domain. SS shall ignore si-ValidityTime-r13 and systemInfoValueTagList-r13 and TTCN shall omit them. SS shall restrict all non-explicitly scheduled DL transmissions (TimingInfo = now) respecting subframe restriction configured by IE fdd-DownlinkOrTddSubframeBitmapBR-r13. SS shall allocate autonomous UL grants (not explicitly scheduled, eg. On SR reception) for UL transmission respecting subframe restriction configured by IEs fdd-DownlinkOrTddSubframeBitmapBR-r13 & fdd-UplinkSubframeBitmapBR-r13.
SubframeOffsetList	SI_SubframeOffsetList_Type	opt	offset within the SI-window; NOTE: SI-window may span more than one frame. There shall be 1 to 1 mapping with BandwidthReducedAccessRelatedInfo_Type.schedulingInfoList_BR_r13 elements

Sib1_BRScheduled_Type

TTCN-3 Record Type			
Name	Sib1_BRScheduled_Type		
Comment	SIB1: fixed scheduling in time domain acc. TS 36.331, clause 5.2.1.2 (periodicity: 80ms) For a BL/CE UE, the resource allocation for PDSCH carrying SystemInformationBlockType1-BR and SI messages is a set of six contiguously allocated localized virtual resource blocks within a narrowband . the Narrow band index used for a transmission is as per 36.211 clause 6.4.1		
SchedulingInfoSIB1_BR_r13	SchedulingInfoSIB1_BR_r13_Type		TBS for SystemInformationBlockType1-BR and the repetitions made within 80ms as indicated in MIB

BR_SI_List_Type

TTCN-3 Record of Type	
Name	BR_SI_List_Type
Comment	TS 36.331, clause 6.2.1 BCCH-DL-SCH-Message-BR and clause 6.2.2 SystemInformation
record of BCCH_DL_SCH_Message_BR	

BR_SegmentedSI_List_Type

TTCN-3 Record of Type	
Name	BR_SegmentedSI_List_Type
Comment	Each element is a list of segments; used for SIB11/12 segmentation
record of BR_SI_List_Type	

Bcch_BRInfo_Type

TTCN-3 Record Type			
Name	Bcch_BRInfo_Type		
Comment	all fields are declared as optional to allow modification of single field; acc. to TS 36.331, clause 9.1.1.1 "RRC will perform padding, if required due to the granularity of the TF signalling, as defined in 8.5."; therefore this needs to be done by the system simulator		
MIB	BCCH_BCH_Message	opt	The MIB shall not be present if transmission of MIB is configured by BcchInfo_Type. TS 36.331, clause 6.2.1 BCCH-BCH-Message and clause 6.2.2 MasterInformationBlock; NOTE: the sequence number included in MIB needs to be handled and maintained by the system simulator; that means that the sequence number being setup by TTCN will be overwritten by SS
SIB1	BCCH_DL_SCH_Message_BR	opt	TS 36.331, clause 6.2.1 BCCH-DL-SCH-Message-BR and clause 6.2.2 SystemInformationBlockType1
SIs	BR_SI_List_Type	opt	list of SIs corresponding to SiList of AllSiSchedul_Type (i.e. element i of AllSiSchedul_Type's SiList specifies the scheduling for SIs[i])
SegmentedSIs	BR_SegmentedSI_List_Type	opt	list of SIs containing segmented SIBs; corresponds to SegmentedSiList in AllSiSchedul_Type

D.1.3.7 Paging_Control

Primitive to configuration PCCH/PCH

PcchConfig_Type

TTCN-3 Record Type			
Name	PcchConfig_Type		
Comment	configuration for PCCH mapped to PCH mapped to PDSCH TransmissionMode: single antenna mode when there is only one antenna configured, transmit diversity else; RNTI: P-RNTI (TS 36.321, clause 7.1) NOTE: acc. to TS 36.331, clause 9.1.1.3 there is no PDCP and RLC/MAC are in TM		
DciInfo	DciDlInfoCommon_Type	opt	DCI format: 1A or 1C (TS 36.213, clause 7.1) ResourceAllocType: 2 (acc. to DCI format) Modulation: QPSK Frequency domain schedule: index of 1st RB; max. number of RBs per TTI
PCCH_Config_v13	PCCH_Config_v1310	opt	provides MPDCCH repetition for PCCH etc

D.1.3.8 UE_Specific_Channel_Configuration**D.1.3.8.1 UE_Specific_Channel_Configuration_DL**

Scheduling and other information for CCCH/DCCH/DTCH mapped to DL-SCH mapped to PDSCH

HarqProcessConfigDL_Type

TTCN-3 Union Type		
Name	HarqProcessConfigDL_Type	
Comment	HARQ processes to be used automatically for DL assignments	
AllProcesses	Null_Type	all HARQ processes shall be used for automatic assignment; this is the normal case
SpecificSubset	HarqProcessList_Type	only the HARQ processes of this list shall be used automatically, other processes are excluded from automatic assignments; nevertheless all HARQ processes may be addressed explicitly by DRB_DataPerSubframe_DL_Type.HarqProcess

CcchDcchDtchConfigDL_Type

TTCN-3 Record Type		
Name	CcchDcchDtchConfigDL_Type	
Comment	configuration for CCCH/DCCH/DTCH mapped to DL-SCH mapped to PDSCH TransmissionMode: as signalled to the UE (AntennaInfoDedicated in RRCConnectionSetup); RNTI: C-RNTI (TS 36.321, clause 7.1); all fields optional (omit = "keep as it is") since DCI format and modulation may be changed during a test; for initial configuration all fields are mandatory	
DciInfo	DciDlInfo_Type	opt DCI format: 1A per default since for CCCH mimo cannot be applied in general ResourceAllocType: (depending on DCI format) Modulation: QPSK for signalling Frequency domain schedule: index of 1st RB; max. number of RBs per TTI; in case of spatial multiplexing if there are 2 code words FreqDomainSchedule shall be applied to both
AntennaInfo	AntennaInfoDedicated_Type	opt as signalled to the UE (TS 36.331, clause 6.3.2): transmissionMode, codebookSubsetRestriction
HarqProcessConfig	HarqProcessConfigDL_Type	opt HARQ processes automatically used by the SS in DL

D.1.3.8.2 UE_Specific_Channel_Configuration_UL

Scheduling information for CCCH/DCCH/DTCH mapped to UL-SCH mapped to PUSCH

PucchHoppingBits_Type

TTCN-3 Union Type		
Name	PucchHoppingBits_Type	
Comment	Number of hopping bits acc. to TS 36.213 table 8.4-2	
OneBit	B1_Type	N(UL, RB) = 6..49 i.e. default system bandwidth this less than 10 MHz (does not include 10 MHz)
TwoBits	B2_Type	N(UL, RB) = 50..110 i.e. default system bandwidth is 10 MHz or above

UplinkHoppingResourceParameters_Type

TTCN-3 Record Type		
Name	UplinkHoppingResourceParameters_Type	
Comment		
PucchHopping	PucchHoppingBits_Type	to control hopping resource allocation as signalled in DCI format 0 (TS 36.212, clause 5.3.3.1.1)

UplinkHoppingControl_Type

TTCN-3 Union Type	
Name	UplinkHoppingControl_Type
Comment	shall be considered by SS to fill in the information needed for DCI format 0 (TS 36.213, clause 7.1)
Deactivated	Null_Type
Activated	UplinkHoppingResourceParameters_Type

CcchDcchDtchConfigUL_Type

TTCN-3 Record Type	
Name	CcchDcchDtchConfigUL_Type
Comment	scheduling for CCCH/DCCH/DTCH mapped to UL-SCH mapped to PUSCH NOTE 1: for definition of the possible UL grants the location of the PUCCH (TS 36.211, clause 5.4.3) and the PRACH (TS 36.211, clause 5.7.3) need to be taken into account; NOTE 2: In contrast to the DL where the scheduling can be done (with consideration of some restrictions) by SS on a per need basis in the UL the scheduling depends on information provided by the UE: e.g. BSR (buffer status report), SR (scheduling request) see TS 36.523-3 clause 7.2 for further information.
DciInfo	DciUlInfo_Type opt DCI format: 0 (TS 36.213, clause 7.1) ResourceAllocType: 2 (acc. to DCI format) Modulation: QPSK per default Frequency domain schedule: index of 1st RB; max. number of RBs per TTI (upper bound up to which SS may assign grants to the UE)
Hopping	UplinkHoppingControl_Type opt when Hopping = 'Activated' SS shall set hopping flag in DCI format 0
PUCCH_Synch	UplinkTimeAlignment_Synch_Type opt parameters to control automatic control of timing advance
UL_GrantConfig	UL_GrantConfig_Type opt UL grant allocation to be applied

UE_Specific_Channel_Configuration: Basic Type Definitions

TTCN-3 Basic Types	
N_PSCCH_Type	B6_Type
ltp_Type	integer (0..127)

DrxCtrl_Type

TTCN-3 Union Type	
Name	DrxCtrl_Type
Comment	DRX configuration for connected mode (TS 36.321, clause 5.7)
None	Null_Type DRX not configured
Config	DRX_Config_Type DRX is configured as signalled to the UE; NOTE: the release branch of DRX-Config in general is not used for configuration of the SS

MeasGapCtrl_Type

TTCN-3 Union Type	
Name	MeasGapCtrl_Type
Comment	support of measurement gap configuration
None	Null_Type no measurement gap configuration
Config	MeasGapConfig_Type measurement gap configuration acc. to TS 36.331, clause 6.3.5 and gap pattern acc. TS 36.133 Table 8.1.2.1-1; NOTE: the release branch of MeasGapConfig in general is not used for configuration of the SS

CcchDcchDtchConfig_Type

TTCN-3 Record Type			
Name	CcchDcchDtchConfig_Type		
Comment			
MeasGapCtrl	MeasGapCtrl_Type	opt	to tell the SS when no assignments/grants shall be assigned to the UE
DL	CcchDcchDtchConfigDL_Type	opt	Scheduling, parameters related to CCCH, DCCH and DTCH in DL
UL	CcchDcchDtchConfigUL_Type	opt	Scheduling, parameters related to CCCH, DCCH and DTCH in UL
DrxCtrl	DrxCtrl_Type	opt	DRX configuration as sent to the UE (or 'None' when the UE does not support connected mode DRX)
TtiBundling	TTI_BundlingConfig_Type	opt	TTI bundling as configured at the UE
CifPresence	boolean	opt	corresponds to PhysicalConfigDedicated.cif_Presence_r10: The CIF field is applied for dedicated search space scheduling i.e. DCCH/DTCH. Not present for common search space scheduling. CIF indicator as true may be configured even in non CA cell, to facilitate the future false: no serving cell is cross scheduled by this cell true: carrier indicator field is present when the PDCCH CRC is scrambled by C-RNTI or SPS C-RNTI omit means "keep as it is"

SciSchedulingConfig_Type

TTCN-3 Record Type			
Name	SciSchedulingConfig_Type		
Comment	Scheduling for STCH mapped to SL-SCH mapped to PSSCH DPCCH DCI format 5 (TS 36.213, clause 14.2) UL grant allocation to be applied: On SL-BSR Reception For the time being there is no requirement to configure the SS with TPC-PDCCH-Config; In general SS is required to keep the UE's UL power constant		
SL_RNTI_r12	C_RNTI	opt	
N_PSCCH	N_PSCCH_Type	opt	Resource for PSCCH - 6 bits
SL_Scheduling	SL_SciConfig_Type	opt	SCI format 0 configuration

SL_SciConfig_Type

TTCN-3 Record Type			
Name	SL_SciConfig_Type		
Comment	SCI format 0 (TS 36.213 clause 14.2 TS 36.212 clause 5.3.3.1.9) ResourceAllocType: 0 (36.213 cl 14.1.1.2.1 and 8.1.1) Frequency domain schedule: index of 1st RB; max. number of RBs per TTI (upper bound up to which SS may assign grants to the UE)		
Hopping	UplinkHoppingControl_Type		Frequency hopping flag - bit
FreqDomainSchedul	FreqDomainSchedulExplicit_Type		Resource block assignment
litrp	litrp_Type		Time resource pattern of 14.1.1.1.1 of TS 36.213

D.1.3.9 Carrier_Aggregation

ActivateScell_Type

TTCN-3 Record Type			
Name	ActivateScell_Type		
Comment			
ScellActivation	ScellBitMap_Type		36.321 clause 6.1.3.8; B0=C7, B1=C6 .. B6=C1, B7 is reserved. B0 to B6, 1 means Activate associated Scell
SendMCE	boolean		If true the SS sends a MAC Control Element to the UE

Scell_Capability_Type

TTCN-3 Enumerated Type	
Name	Scell_Capability_Type
Comment	
DIOnly	the CC is configured in DL only, no aggregation in this cell in UL
UL_DL	the aggregation is configured in both UL and DL

ScellDeactivationTimer_Type

TTCN-3 Union Type		
Name	ScellDeactivationTimer_Type	
Comment	NOTE: this type is a union to allow semantic of "keep as it is" for optional fields of this type	
NumberOfRadioFrames	MAC_MainConfig_ScellDeactivationTimer_Type	Scell deactivation timer acc. to TS 36.321
Infinity	Null_Type	infinity as when 'sCellDeactivationTimer' is omitted in 'MAC-MainConfig' sent to the UE

SCellIndexList_List

TTCN-3 Record of Type	
Name	SCellIndexList_List
Comment	
record length (1..7) of SCellIndex_r10	

CrossCarrierScheduledCellsList_Type

TTCN-3 Union Type		
Name	CrossCarrierScheduledCellsList_Type	
Comment		
None	Null_Type	No Cells Cross Scheduled by this Cell; CIF can still be true.
CrossScheduledCells	SCellIndexList_List	List of Scells Scheduled by this Scell; CIF field shall be true; Pcell cannot be cross scheduled

SchedulingCarrierConfig_Type

TTCN-3 Union Type		
Name	SchedulingCarrierConfig_Type	
Comment		
Own	CrossCarrierScheduledCellsList_Type	Cell is scheduled by itself and possible cross schedules other Scells
CrossScheduled	CrossSchedulingCarrierInfo_Type	Cell is cross Scheduled by other carrier; the CIF field shall be configured in the serving cell scheduling this scell

CrossCarrierSchedulingConfig_Type

TTCN-3 Union Type		
Name	CrossCarrierSchedulingConfig_Type	
Comment		
Config	SchedulingCarrierConfig_Type	When cross carrier scheduling is enabled then the CIF field shall be configured in the serving cell scheduling this scell
None	Null_Type	

PrimaryCellInfo_Type

TTCN-3 Record Type			
Name	PrimaryCellInfo_Type		
Comment			
AssociatedScellList	EUTRA_CellIdList_Type		List of Scells associated with the Pcell/PScells (needs to be consistent with AssociatedPcellId in Scell/PScell)
MeasSubframePatternPCell	MeasSubframePatternPCell_r10	opt	
CrossCarrierScheduledCellsList	CrossCarrierScheduledCellsList_Type	opt	Information of possible Cells Cross Scheduled by this cell

Pcell_Mode_Type

TTCN-3 Union Type		
Name	Pcell_Mode_Type	
Comment		
FDD	Null_Type	
TDD	TDD_SubframeAssignment_Type	

SecondaryCellInfo_Type

TTCN-3 Record Type			
Name	SecondaryCellInfo_Type		
Comment			
AssociatedPcellId	EUTRA_CellId_Type		cell ID of associated Pcell/PSCell (eutra_Cell_NonSpecific is not allowed)
SCellIndex	SCellIndex_r10		
Scell_Capability	Scell_Capability_Type	opt	if DL only or both UL and DL (omit means "keep as it is")
ScellDeactivationTimer	ScellDeactivationTimer_Type	opt	SCell deactivation timer; omit means "keep as it is"; when there is more than one SCell associated to the same PCell this field shall be set to the same value for each SCell
CrossCarrierSchedulingConfig	CrossCarrierSchedulingConfig_Type	opt	omit means "keep as it is"
STAG_Id	STAG_Id_r11	opt	if IE is never configured then scell is part of PTAG. Uses the STAG_ID or PTAG in Auto PUCCH synchronization when transmitting periodically Timing Advance MCE
Pcell_Mode	Pcell_Mode_Type	opt	omit means Pcell/PScell and Scell mode are same. To be provide for FDD-TDD mixed mode CA/Dual connectivity configurations

ServingCellConfig_Type

TTCN-3 Union Type		
Name	ServingCellConfig_Type	
Comment		
PCell	PrimaryCellInfo_Type	cell shall become PCell
SCell	SecondaryCellInfo_Type	cell shall become SCell
PSCell	PSCellInfo_Type	cell shall become PSCell
Release	Null_Type	cell is changed back to normal non CA cell

PSCellInfo_Type

TTCN-3 Record Type		
Name	PSCellInfo_Type	
Comment		
AssociatedPcellId	EUTRA_CellId_Type	cell ID of associated Pcell (eutra_Cell_NonSpecific is not allowed)
SCellIndex	SCellIndex_r10	
AssociatedScellList	EUTRA_CellIdList_Type	List of Scells associated with the PSCell (needs to be consistent with AssociatedPcellId in Scell)
CrossCarrierSchedulingConfig	CrossCarrierSchedulingConfig_Type	opt omit means "keep as it is"
Pcell_Mode	Pcell_Mode_Type	opt omit means PCell and PSCell mode are same. To be provide for FDD-TDD mixed mode Dual connectivity configurations

D.1.3.10 OCNG_Config

OCNG_Config_Type

TTCN-3 Union Type		
Name	OCNG_Config_Type	
Comment		
Activate	OCNG_ActivateInfo_Type	CellId : identifier of the cell where the OCNG needs to be activated RoutingInfo : None TimingInfo : activation time from when the SS starts transmission of uncorrelated pseudo random MAC TB's addressed to Virtual UE's in non ABS subframes. ControllInfo : CnfFlag:=false; FollowOnFlag:=false
Deactivate	Null_Type	CellId : identifier of the cell where the OCNG needs to be deactivated RoutingInfo : None TimingInfo : activation time from when the SS stops transmission of MAC TB's addressed to Virtual UE's in non ABS subframes. ControllInfo : CnfFlag:=false; FollowOnFlag:=false

OCNG_ActivateInfo_Type

TTCN-3 Record Type		
Name	OCNG_ActivateInfo_Type	
Comment	OFDMA Channel Noise Generator (OCNG): SS for transmitting uncorrelated pseudo random data in MAC TB's addressed to Virtual UE's, will not do any retransmissions due to no HARQ ACK/NACK reception being considered as NACK.	
MeasSubframePattern	MeasSubframePattern_r10	provides the bit string for x (size of bit string divided by 10) frames to be repeated continuously from provided timing info; 1 represents ABS subframe hence no pseudo random MAC TB is scheduled 0 represent non-ABS subframe and SS automatically transmits MAC TB's consisting of pseudo random data in each non-ABS subframe

D.1.3.11 EIMTA_Config

EIMTA_Config_Type

TTCN-3 Record Type			
Name	EIMTA_Config_Type		
Comment			
EIMTA_MainConfig_r12	EIMTA_MainConfig_r12		The IE EIMTA-MainConfig is used to specify the eIMTA-RNTI used for eIMTA and the subframes used for PDCCH monitoring by the UE with eIMTA-RNTI
EIMTA_MainConfigServCell_r12	EIMTA_MainConfigServCell_r12		The IE EIMTA-MainConfigServCell is used to specify the eIMTA related parameters applicable for the cell

PeriodicTransmission_Type

TTCN-3 Record Type			
Name	PeriodicTransmission_Type		
Comment			
Period	integer (1..infinity)		DCI 1C transmission period (TTI=1ms); the starting time, Period and NumRepetitions need to be chosen in TTCN so that the DCI 1C transmissions are assigned at valid subframes according to EIMTA_MainConfig_r12 settings; otherwise SS shall raise an error
NumRepetitions	TransmissionRepetition Type		number of DCI 1C repetitions to be automatically transmitted or 'Continuous'

PDCCH_TDD_ConfigOrder_Type

TTCN-3 Union Type			
Name	PDCCH_TDD_ConfigOrder_Type		
Comment			
OnlyOnce	Null_Type		DCI 1C is sent out on PDCCH with CRC scrambled by eIMTA-RNTI only once; no period
Periodic	PeriodicTransmission_Type		SS transmits DCI 1C periodically as configured by EIMTA_MainConfig_Type
None	Null_Type		stop DCI 1C transmission

D.1.4 Cell_Power_Attenuation

CellAttenuationConfig_Type

TTCN-3 Record Type			
Name	CellAttenuationConfig_Type		
Comment			
CellId	EUTRA_CellId_Type		
Attenuation	Attenuation_Type		
TimingInfo	TimingInfo_Type	opt	

CellAttenuationList_Type

TTCN-3 Record of Type			
Name	CellAttenuationList_Type		
Comment			
record length	(1.. tsc_EUTRA_MaxNumberOfCells) of CellAttenuationConfig_Type		

D.1.5 Radio_Bearer_Configuration

Radio Bearer Configuration: SRBs/DRBs

D.1.5.1 PDCP_Configuration

PDCP_SNLength_Type

TTCN-3 Enumerated Type	
Name	PDCP_SNLength_Type
Comment	PDCP Sequence Number
PDCP_SNLength5	TS 36.323 clause 6.2.2
PDCP_SNLength7	TS 36.323 clause 6.2.3
PDCP_SNLength12	TS 36.323 clause 6.2.4
PDCP_SNLength16	TS 36.323 clause 6.2.10

PDCP_ROHC_Mode_Type

TTCN-3 Record Type	
Name	PDCP_ROHC_Mode_Type
Comment	
SN_Size	PDCP_SNLength_Type

PDCP_NonROHC_Mode_Type

TTCN-3 Record Type	
Name	PDCP_NonROHC_Mode_Type
Comment	
SN_Size	PDCP_SNLength_Type

PDCP_TestModelInfo_Type

TTCN-3 Union Type		
Name	PDCP_TestModelInfo_Type	
Comment		
PDCP_ROHC_Mode	PDCP_ROHC_Mode_Type	ROHC test mode acc. to TS 36.523-3, clause 4.2.1.3.1; requires PDCP to be configured for this RB => <ul style="list-style-type: none"> - SS applies ciphering in UL and DL - SS maintains PDCP sequence numbers and state variables Furthermore in this mode <ul style="list-style-type: none"> - SS does not add/remove PDCP headers (in UL the PDCP PDUs are decoded depending on SN_Size) - SS applies ROHC in DL only
PDCP_NonROHC_Mode	PDCP_NonROHC_Mode_Type	PDCP test mode acc. to TS 36.523-3, clause 4.2.1.3.2 (non-ROHC test mode); requires PDCP to be configured as transparent => <ul style="list-style-type: none"> - SS does not apply ciphering in UL and DL - SS does not interpret, insert or remove PDCP headers (in UL PDCP PDUs are decoded depending on SN_Size) - SS does not maintain PDCP sequence numbers and state variables

PDCP_TestModeConfig_Type

TTCN-3 Union Type	
Name	PDCP_TestModeConfig_Type
Comment	
None	Null_Type
Info	PDCP_TestModelInfo_Type

PDCP_RbConfig_Type

TTCN-3 Union Type		
Name	PDCP_RbConfig_Type	
Comment		
Srb	Null_Type	for SRB1/2 there are no PDCP_Parameters; SN is always 5 bits
Drb	PDCP_Config_Type	PDCP-Configuration acc. to TS 36.331, clause 6.3.2; among others for UM here pdcp-SN-Size is configured to be either len7bits or len12bits; for AM it always is 12bit
Transparent	Null_Type	used for PDCP tests (TS 36.523-3, clause 4.2.1.3.2): the SS does not apply ciphering and does not maintain PDCP sequence numbers and state variables; in UL the PDCP PDUs are decoded acc. to the TestMode; Note: a reconfiguration of a RB from transparent mode to 'normal' mode is not foreseen (i.e. there is no mechanism to restore Ciphering, PDCP sequence numbers and state variables at the SS)

PDCP_ConfigInfo_Type

TTCN-3 Record Type			
Name	PDCP_ConfigInfo_Type		
Comment			
Rb	PDCP_RbConfig_Type	opt	mandatory for initial configuration; omit means "keep as it is"
TestMode	PDCP_TestModeConfig_Type	opt	mandatory for initial configuration; omit means "keep as it is"

PDCP_Configuration_Type

TTCN-3 Union Type		
Name	PDCP_Configuration_Type	
Comment		
None	Null_Type	for SRB0 no PDCP is configured; furthermore the PDCP may not be configured e.g. for DRBs tested in MAC test cases
Config	PDCP_ConfigInfo_Type	

D.1.5.2 RLC_Configuration

RLC configuration: radio bearer specific

RLC_Configuration: Basic Type Definitions

TTCN-3 Basic Types		
RLC_AM_SequenceNumber_Type	integer (0..1023)	RLC AM sequence number
SS_RLC_TM_Type	Null_Type	TM to configure SRB0; no parameters to be defined

RLC_ACK_Prohibit_Type

TTCN-3 Enumerated Type	
Name	RLC_ACK_Prohibit_Type
Comment	
Prohibit	cause SS RLC layer to stop any ACK transmission for UL PDU's received from UE
Continue	bring back the SS RLC in normal mode, where ACK/NACK are transmitted at polling

RLC_NotACK_NextRLC_PDU_Type

TTCN-3 Enumerated Type	
Name	RLC_NotACK_NextRLC_PDU_Type
Comment	
Start	cause SS RLC layer not to ACK the next received RLC PDU; this is done regardless of whether the poll bit is set or not; Example [from UMTS]: when the UE gets new security information in a SECURITY MODE COMMAND the response (SECURITY MODE COMPLETE) sent by the UE is not acknowledged at the RLC level; this causes the UE to continue using the "old" security information

RLC_TestModelInfo_Type

TTCN-3 Union Type		
Name	RLC_TestModelInfo_Type	
Comment		
AckProhibit	RLC_ACK_Prohibit_Type	valid only when the RLC is configured in AM
NotACK_NextRLC_PDU	RLC_NotACK_NextRLC_PDU_Type	valid only when the RLC is configured in AM
ModifyVTS	RLC_AM_SequenceNumber_Type	to modify the VT(S) at SS: VT(S) at the SS side is set to this (absolute) value; valid only when the RLC is configured in AM
TransparentMode_UMDwith5BitSN	Null_Type	shall be set when TTCN expects RLC PDUs as UMD in UL with an SN of 5 bits; valid only when the RLC is configured in TM
TransparentMode_UMDwith10BitSN	Null_Type	shall be set when TTCN expects RLC PDUs as UMD in UL with an SN of 10 bits; valid only when the RLC is configured in TM
TransparentMode_AMD	Null_Type	shall be set when TTCN expects RLC PDUs as AMD in UL; valid only when the RLC is configured in TM

RLC_TestModeConfig_Type

TTCN-3 Union Type		
Name	RLC_TestModeConfig_Type	
Comment		
None	Null_Type	
Info	RLC_TestModelInfo_Type	

SS_RLC_AM_Type

TTCN-3 Record Type			
Name	SS_RLC_AM_Type		
Comment			
Tx	UL_AM_RLC_Type	opt	the UE's UL setting to be used in SS's tx direction
Rx	DL_AM_RLC_Type	opt	the UE's DL setting to be used in SS's rx direction
ExtendedLI	RLC_Config_v1250	opt	Indicates the RLC LI field size. Value TRUE means that 15 bit LI length shall be used, otherwise 11 bit LI length shall be used

SS_RLC_UM_Bi_Directional_Type

TTCN-3 Record Type			
Name	SS_RLC_UM_Bi_Directional_Type		
Comment			
Tx	UL_UM_RLC_Type	opt	the UE's UL setting to be used in SS's tx direction
Rx	DL_UM_RLC_Type	opt	the UE's DL setting to be used in SS's rx direction

SS_RLC_UM_Uni_Directional_UL_Type

TTCN-3 Record Type			
Name	SS_RLC_UM_Uni_Directional_UL_Type		
Comment			
Rx	DL_UM_RLC_Type	opt	the UE's DL setting to be used in SS's rx direction

SS_RLC_UM_Uni_Directional_DL_Type

TTCN-3 Record Type			
Name	SS_RLC_UM_Uni_Directional_DL_Type		
Comment			
Tx	UL_UM_RLC_Type	opt	the UE's UL setting to be used in SS's tx direction

RLC_RbConfig_Type

TTCN-3 Union Type			
Name	RLC_RbConfig_Type		
Comment			
AM	SS_RLC_AM_Type		
UM	SS_RLC_UM_Bi_Directional_Type		
UM_OnlyUL	SS_RLC_UM_Uni_Directional_UL_Type		
UM_OnlyDL	SS_RLC_UM_Uni_Directional_DL_Type		
TM	SS_RLC_TM_Type		normally SRB0 only; may be used for test purposes also

RLC_Configuration_Type

TTCN-3 Record Type			
Name	RLC_Configuration_Type		
Comment			
Rb	RLC_RbConfig_Type	opt	mandatory for initial configuration; omit means "keep as it is"
TestMode	RLC_TestModeConfig_Type	opt	mandatory for initial configuration; omit means "keep as it is"

D.1.5.3 MAC_Configuration

MAC configuration: radio bearer specific configuration

EUTRA_ASP_TypeDefs: Constant Definitions

TTCN-3 Basic Types			
tsc_MaxHarqRetransmission	integer	28	maximum value for maxHARQ-Msg3Tx as being signalled to the UE

MAC_Test_DLLogChID_Type

TTCN-3 Union Type		
Name	MAC_Test_DLLogChID_Type	
Comment		
LogChId	TestLogicalChannelId_Type	Specifies to over write the logical channel ID in MAC header in all the DL messages sent on the configured logical channel
ConfigLchId	Null_Type	Specifies that the normal mode of correct logical channel ID to be used in DL Mac header. This will be the default mode, when SS is initially configured.

MAC_Test_DL_SCH_CRC_Mode_Type

TTCN-3 Enumerated Type	
Name	MAC_Test_DL_SCH_CRC_Mode_Type
Comment	
Normal	default mode, the CRC generation is correct
Erroneous	SS shall generate CRC error by toggling CRC bits; the CRC error shall be applied for all PDUs of the given RNTI and their retransmission until SS is configured back to 'normal' operation
Error1AndNormal	the SS generates wrong CRC for first transmission and correct CRC on first retransmission. Later SS operates in normal mode. The retransmission is automatically triggered by reception of HARQ NACK

MAC_Test_SCH_NoHeaderManipulation_Type

TTCN-3 Enumerated Type	
Name	MAC_Test_SCH_NoHeaderManipulation_Type
Comment	
NormalMode	MAC header is fully controlled by the SS
DL_SCH_Only	TTCN can submit a final MAC PDU including header and payloads; SS does not do anything with this MAC PDU i.e. no header is added for the DL SCH transport channel. It is possible that data belonging to multiple DRBs is sent in one MAC PDU and from one special RB configured. NOTE: SRBs shall work as in normal mode and data can be sent/received on SRBs but sending on SRBs shall be in different TTIs than sending data PDUs.
DL_UL_SCH	In UL and DL the SS' MAC layer is transparent i.e. SS does not add or remove any MAC header

HARQ_ModeList_Type

TTCN-3 Record of Type	
Name	HARQ_ModeList_Type
Comment	
record length (1.. tsc_MaxHargRetransmission) of HARQ_Type	

PhichTestMode_Type

TTCN-3 Union Type		
Name	PhichTestMode_Type	
Comment		
NormalMode	Null_Type	PHICH is configured to operate in normal mode
ExplicitMode	HARQ_ModeList_Type	the number of elements in explicit list shall match the number of retransmissions being expected

MAC_TestModelInfo_Type

TTCN-3 Record Type			
Name	MAC_TestModelInfo_Type		
Comment	Parameters/Configuration for MAC tests		
DiffLogChId	MAC_Test_DLLogChID_Type		to be used in test cases 7.1.1.1 and 7.1.1.2 for using a different logical channel ID in MAC-header on DL-SCH channel
No_HeaderManipulation	MAC_Test_SCH_NoHeaderManipulation_Type		to configure mode for no header manipulation in SS MAC layer for DL/UL SCH

MAC_TestModeConfig_Type

TTCN-3 Union Type		
Name	MAC_TestModeConfig_Type	
Comment		
None	Null_Type	
Info	MAC_TestModeInfo_Type	

MAC_LogicalChannelConfig_Type

TTCN-3 Record Type		
Name	MAC_LogicalChannelConfig_Type	
Comment		
Priority	integer	logical channel priority for the DL as described in TS 36.321, clause 5.4.3.1 for the UL
PrioritizedBitRate	PrioritizedBitRate_Type	PBR as described for the UL; probably not needed at SS

MAC_Configuration_Type

TTCN-3 Record Type		
Name	MAC_Configuration_Type	
Comment		
LogicalChannel	MAC_LogicalChannelConfig_Type	opt mandatory for initial configuration; omit means "keep as it is"
TestMode	MAC_TestModeConfig_Type	opt mandatory for initial configuration; omit means "keep as it is"; for none MAC tests "TestMode.None:=true"

Radio_Bearer_Configuration: Basic Type Definitions

TTCN-3 Basic Types		
TestLogicalChannelId_Type	integer (0..31)	To be used in MAC test mode for reserved values of Logical channels;

RadioBearerConfigInfo_Type

TTCN-3 Record Type		
Name	RadioBearerConfigInfo_Type	
Comment	semantics of omit: "keep as it is"	
Pdcp	PDPCP_Configuration_Type	opt for SRB0: "Pdcp.None:=true" mandatory for initial configuration; omit means "keep as it is"
Rlc	RLC_Configuration_Type	opt mandatory for initial configuration; omit means "keep as it is"
LogicalChannelId	LogicalChannelId_Type	opt DRBs: DTCH-LogicalChannelIdentity as for rb-MappingInfo in DRB-ToAddModifyList; SRBs: for SRBs specified configurations acc. to TS 36.331, clause 9.1.2 shall be applied: SRB1: ul-LogicalChannel-Identity = dl-LogicalChannel-Identity = 1 SRB2: ul-LogicalChannel-Identity = dl-LogicalChannel-Identity = 2 for SRB0 being mapped to CCCH the LCID is '00000'B acc. to TS 36.321, clause 6.2.1; mandatory for initial configuration; omit means "keep as it is"
Mac	MAC_Configuration_Type	opt
DiscardULData	boolean	opt if omitted: initial configuration: data is handed over to TTCN as usual re-configuration: "keep as it is" if set: true - SS shall discard any data in UL for this radio bearer false - (re)configuration back to normal mode NOTE: typically applicable for UM DRBs only

RadioBearerConfig_Type

TTCN-3 Union Type		
Name	RadioBearerConfig_Type	
Comment		
AddOrReconfigure	RadioBearerConfigInfo_Type	add / re-configure RB - CellId : identifier of the cell being configured RoutingInfo : None TimingInfo : 'Now' in common cases ControlInfo : CnfFlag:=true; FollowOnFlag:=false (in general)
Release	Null_Type	release RB - CellId : identifier of the cell being configured RoutingInfo : None TimingInfo : 'Now' in common cases ControlInfo : CnfFlag:=true; FollowOnFlag:=false (in general)

RadioBearer_Type

TTCN-3 Record Type		
Name	RadioBearer_Type	
Comment		
Id	RadioBearerId_Type	either for SRB or DRB
Config	RadioBearerConfig_Type	

RadioBearerList_Type

TTCN-3 Record of Type	
Name	RadioBearerList_Type
Comment	array of SRBs and/or DRBs (DRBs + 3 SRBs)
record length (1.. tsc_MaxRB) of RadioBearer_Type	

D.1.6 AS_Security

Primitive for control of AS security

PdcpSQN_Type

TTCN-3 Record Type		
Name	PdcpSQN_Type	
Comment		
Format	PdcpCountFormat_Type	5 bit, 7 bit or 12 bit SQN
Value	integer	SQN value (5 bit, 7 bit or 12 bit SQN) NOTE: in TTCN the test case writer is responsible to deal with potential overflows (e.g. there shall be a "mod 32", "mod 128" or "mod 4096" according to the format)

PDCP_ActTime_Type

TTCN-3 Union Type		
Name	PDCP_ActTime_Type	
Comment	The sequence number in UL and DL for SRB1 should be one more than the present SQN, as Cipherring starts in UL and DL soon after SMC and SMComp; For other SRB/DRB it should be the present SQN.	
None	Null_Type	No Activation time; to be used if Cipherring is not applied
SQN	PdcpSQN_Type	PDCP sequence number

SecurityActTime_Type

TTCN-3 Record Type			
Name	SecurityActTime_Type		
Comment			
RadioBearerId	RadioBearerId_Type		
UL	PDCP_ActTime_Type		
DL	PDCP_ActTime_Type		

SecurityActTimeList_Type

TTCN-3 Record of Type			
Name	SecurityActTimeList_Type		
Comment			
record length (1.. tsc_MaxRB) of SecurityActTime_Type			

AS_IntegrityInfo_Type

TTCN-3 Record Type			
Name	AS_IntegrityInfo_Type		
Comment	for initial configuration activation time is not needed for integrity protection as all messages in DL after security activation are integrity protected; this means this ASP is invoked before transmission of Security mode command; if there is a integrity violation in UL SS shall set the IndicationStatus in the common ASP part to flag the integrity error (IndicationStatus.Error.Integrity.Pdcp := true); integrity to be provided for each SRB as per core spec		
Algorithm	IntegrityProtAlgorithm_Type		IntegrityProtAlgorithm_Type being defined in RRC ASN.1
KRRRCint	B128_Key_Type		
ActTimeList	SecurityActTimeList_Type	opt	omit for initial configuration (i.e. all SRBs to be integrity protected immediately); in HO scenarios activation time may be needed e.g. for SRB1

AS_CipheringInfo_Type

TTCN-3 Record Type			
Name	AS_CipheringInfo_Type		
Comment			
Algorithm	CipheringAlgorithm_r12		CipheringAlgorithm_Type being defined in RRC ASN.1
KRRRCenc	B128_Key_Type		
KUPenc	B128_Key_Type		KUPenc is mandatory; and SS uses it when DRB are configured
ActTimeList	SecurityActTimeList_Type		

AS_SecStartRestart_Type

TTCN-3 Record Type			
Name	AS_SecStartRestart_Type		
Comment			
Integrity	AS_IntegrityInfo_Type	opt	optional to allow separated activation of integrity and ciphering; omit: keep as it is
Ciphering	AS_CipheringInfo_Type	opt	optional to allow separated activation of integrity and ciphering; omit: keep as it is

AS_Security_Type

TTCN-3 Union Type		
Name	AS_Security_Type	
Comment	Security mode command procedure (TS 36.331, clause 5.3.4): both SMC and SMComp are integrity protected (nevertheless SS shall be able to cope with unprotected SM reject); ciphering is started just after SMComp (acc. to TS 36.331, clause 5.3.4.3 and 5.3.1.1)	
StartRestart	AS_SecStartRestart_Type	information to start/restart AS security protection in the PDCP
Release	Null_Type	to release AS security protection in the PDCP

D.1.7 Semi_Persistent_Scheduling

Semi-persistent scheduling (SPS)

NOTE 1:

configuration of SPS cannot be done completely in advance but needs to be activated by PDCCH signalling
=> SPS is configured/activated in an own primitive which may be sent to SS during RBs are being configured

NOTE 2:

semi-persistent (configured) scheduling is per UE (as well as 'normal' scheduling; see e.g. TS 36.300, clause 11.1)

SpsAssignmentUL_Type

TTCN-3 Record Type			
Name	SpsAssignmentUL_Type		
Comment	information to assign semi-persistent scheduls in UL		
DciInfo	DciUlInfo_Type	opt	to apply a grant
SchedulInterval	SpsConfigurationUL_Type	opt	as in TS 36.331, clause 6.3.2 SPS-ConfigUL
SetNDI_1	Null_Type	opt	if present then NDI is set as 1 indicating a retransmission; If absent then NDI is set as 0 indicating a new transmission

SpsAssignmentDL_Type

TTCN-3 Record Type			
Name	SpsAssignmentDL_Type		
Comment	information to assign semi-persistent scheduls in DL		
DciInfo	DciDlInfo_Type	opt	to apply a assignment
SchedulInterval	SpsConfigurationDL_Type	opt	as in TS 36.331, clause 6.3.2 SPS-ConfigDL
SetNDI_1	Null_Type	opt	if present then NDI is set as 1 indicating a retransmission; If absent then NDI is set as 0 indicating a new transmission

SpsActivateInfo_Type

TTCN-3 Record Type			
Name	SpsActivateInfo_Type		
Comment	<p>Semi-persistent scheduling (SPS): Even though SPS is pre-configured at the UE (e.g. RRCConnectionSetup->RadioResourceConfiguration->MAC_MainConfig) it needs to be activated by L1 signalling => SS shall 'activate' SPS by sending appropriate assignments/grants to the UE; this shall be done with an activation time. If SPS is already configured and new Activate command is received, at the activation time SS locally deactivates old SPS configuration, sends UE an PDCCH assignment for new SPS assignment and locally activates new SPS configuration. In DL, in addition to SS SPS assignment configuration with activation time 'T', TTCN writer shall also schedule a DL MAC PDU with same activation time 'T' and at every SPS ScheduleInterval (NOTE: in general it is an error when TTCN does not provide data for a ScheduleInterval; SS shall send no data in this case). Special fields of PDCCH assignment are filled as per table 9.2-1 of 36.213</p>		
SPS_C_RNTI	C_RNTI		SPS C-RNTI as signalled to UE
UplinkGrant	SpsAssignmentUL_Type	opt	
DownlinkAssignment	SpsAssignmentDL_Type	opt	

SpsPdcchRelease_Type

TTCN-3 Record Type			
Name	SpsPdcchRelease_Type		
Comment	<p>On reception of this information SS shall send an SPS release indicated by PDCCH transmission with indicated DCI format (0 or 1A) at the activation time. Special fields of PDCCH assignment are filled as per table 9.2-1A of 36.213</p>		
SPS_C_RNTI	C_RNTI		
DCI_Format	PdcchDciFormat_Type		only formats 0 (UL release) and 1A (DL release) are applicable. It is a TTCN error if any other formats are used.

SpsDeactivateInfo_Type

TTCN-3 Union Type			
Name	SpsDeactivateInfo_Type		
Comment			
LocalRelease	Null_Type		SPS configuration shall be released at the SS, that means as well that the SS shall not address SPS_C_RNTI anymore from the given TimingInfo onward; NOTE: there is no SPS release to be signalled on PDCCH (this is done with PdcchExplicitRelease - see below)
PdcchExplicitRelease	SpsPdcchRelease_Type		SS transmits PDCCH content indicating SPS release but holds the local SPS configuration until it is locally released

SpsConfig_Type

TTCN-3 Union Type			
Name	SpsConfig_Type		
Comment			
Activate	SpsActivateInfo_Type		CellId : identifier of the cell where the UE is active RoutingInfo : None TimingInfo : activation time for SPS assignment/grant transmission; NOTE: the first SPS DL data packet shall be sent with the same timing information ControllInfo : CnfFlag:=false; FollowOnFlag:=false
Deactivate	SpsDeactivateInfo_Type		CellId : identifier of the cell where the UE is active RoutingInfo : None TimingInfo : activation time for SPS release indicated by PDCCH transmission or SS local deactivation ControllInfo : CnfFlag:=false; FollowOnFlag:=false

D.1.8 Paging_Trigger

SubframeOffsetList_Type

TTCN-3 Record of Type	
Name	SubframeOffsetList_Type
Comment	
record length (1..infinity) of integer	

PagingTrigger_Type

TTCN-3 Record Type			
Name	PagingTrigger_Type		
Comment	CellId : identifier of the cell where the UE is active RoutingInfo : None TimingInfo : Calculated paging occasion ControllInfo : CnfFlag:=false; FollowOnFlag:=false primitive to trigger transmission of a paging on the PCCH at a calculated paging occasion (TS 36.304, clause 7); the paging occasion is calculated by TTCN and activation time is applied; as for BCCH Infor acc. to TS 36.331, clause 9.1.1.3 "RRC will perform padding, if required due to the granularity of the TF signalling, as defined in 8.5."; therefore this needs to be done by the system simulator		
Paging	PCCH_Message		paging to be send out at paging occasion and being announced on PDCCH using P-RNTI
SubframeOffset List	SubframeOffsetList_Type	opt	list of subframe offsets relative to the absolute timing information given in the common part of the ASP; if present, multiple pagings are sent out at all occasions given by the list; if omitted only a single paging is sent at the occasion given timing information given in the common part of the ASP

D.1.9 L1_MAC_Indication_Control

Primitive for control of L1/MAC indication for special purposes

L1Mac_IndicationControl_Type

TTCN-3 Record Type			
Name	L1Mac_IndicationControl_Type		
Comment	NOTE: Initially all indications are disabled in SS (i.e. it shall not be necessary in 'normal' test cases to use this primitive but only if a specific indication is needed); omit means indication mode is not changed		
RachPreamble	IndicationAndControlMode_Type	opt	To enable/disable reporting of PRACH preamble received.
SchedReq	IndicationAndControlMode_Type	opt	To enable/disable reporting of reception of Scheduling Request on PUCCH.
BSR	IndicationAndControlMode_Type	opt	To enable/disable reporting of Buffer/Extended Buffer Status Report. NOTE: this is applicable only when MAC is configured in normal mode in UL; MAC configured in test mode, results in over writing the report.
UL_HARQ	IndicationAndControlMode_Type	opt	To enable/disable reporting of reception of HARQ ACK/NACK.
C_RNTI	IndicationAndControlMode_Type	opt	To enable/disable reporting of C-RNTI sent by the UE within MAC PDU
PHR	IndicationAndControlMode_Type	opt	To enable/disable reporting of Power Headroom Report. NOTE: this is applicable only when MAC is configured in normal mode in UL; MAC configured in test mode, results in over writing the report.
HarqError	IndicationAndControlMode_Type	opt	To enable/disable reporting of HARQ errors
PeriodicRI	IndicationAndControlMode_Type	opt	To enable/disable reporting of reception of periodic Rank Indicators
EPHR	IndicationAndControlMode_Type	opt	To enable/disable reporting of Extended Power Headroom Report. NOTE: this is applicable only when MAC is configured in normal mode for UL; MAC configured in test mode, results in overwriting the report.
PeriodicCQI	IndicationAndControlMode_Type	opt	To enable/disable reporting of reception of periodic CQI
SRS	IndicationAndControlMode_Type	opt	To enable/disable reporting of start and stop of reception of Type 0 (Configured by Higher Layer) SRS in frames meant for periodic SRS transmission by UE. SS reports an indication every time when SRS reception from UE has toggled in the frames configured for periodic SRS reception i.e. 'No periodic SRS' reception -> 'periodic SRS' reception or 'periodic SRS' reception -> 'No periodic' SRS reception.
DC_PHR	IndicationAndControlMode_Type	opt	To enable/disable reporting of Dual Connectivity Power Headroom Report. NOTE: this is applicable only when MAC is configured in normal mode for UL; MAC configured in test mode, results in overwriting the report.

D.1.10 Rlc_Indication_Control

Primitive for control of RLC indication for special purposes

Rlc_IndicationMode_Type

TTCN-3 Enumerated Type	
Name	Rlc_IndicationMode_Type
Comment	
enable	
disable	

Rlc_IndicationControl_Type

TTCN-3 Record Type			
Name	Rlc_IndicationControl_Type		
Comment			
Discard	Rlc_IndicationMode_Type	opt	To enable/disable reporting of discarded RLC PDUs

D.1.11 PDCP_Count

Primitives to enquire PDCP COUNT

PdcpCountFormat_Type

TTCN-3 Enumerated Type	
Name	PdcpCountFormat_Type
Comment	
PdcpCount_Srb	27 bit HFN; 5 bit SQF
PdcpCount_DrbLong SQN	20 bit HFN; 12 bit SQF
PdcpCount_DrbShort SQN	25 bit HFN; 7 bit SQF

PdcpCount_Type

TTCN-3 Record Type			
Name	PdcpCount_Type		
Comment			
Format	PdcpCountFormat_Type		
Value	PdcpCountValue_Type		

PdcpCountInfo_Type

TTCN-3 Record Type			
Name	PdcpCountInfo_Type		
Comment			
RadioBearerId	RadioBearerId_Type		
UL	PdcpCount_Type	opt	omit: keep as it is
DL	PdcpCount_Type	opt	omit: keep as it is

PdcpCountInfoList_Type

TTCN-3 Record of Type	
Name	PdcpCountInfoList_Type
Comment	
record length (1.. tsc_MaxRB) of PdcpCountInfo_Type	

PdcpCountGetReq_Type

TTCN-3 Union Type		
Name	PdcpCountGetReq_Type	
Comment		
AllRBs	Null_Type	return COUNT values for all RBs being configured
SingleRB	RadioBearerId_Type	

PDCP_CountReq_Type

TTCN-3 Union Type		
Name	PDCP_CountReq_Type	
Comment		
Get	Pdcpcountgetreq_Type	Request PDCP count for one or all RBs being configured at the PDCP
Set	Pdcpcountinfolist_Type	Set PDCP count for one or all RBs being configured at the PDCP; list for RBs which's COUNT shall be manipulated

PDCP_CountCnf_Type

TTCN-3 Union Type		
Name	PDCP_CountCnf_Type	
Comment		
Get	Pdcpcountinfolist_Type	RBs in ascending order; SRBs first
Set	Null_Type	

D.1.12 PDCP_Handover

Primitives to control PDCP regarding handover

PDCP_HandoverInit_Type

TTCN-3 Record Type		
Name	PDCP_HandoverInit_Type	
Comment		
SourceCellId	EUTRA_CellId_Type	

PDCP_HandoverControlReq_Type

TTCN-3 Union Type		
Name	PDCP_HandoverControlReq_Type	
Comment		
HandoverInit	PDCP_HandoverInit_Type	to inform SS that a handover will follow: in the common ASP part the CellId shall be set to the id of the target cell
HandoverComplete	Null_Type	to inform SS that the handover has successfully been performed by the UE; this shall trigger the SS to sent a PDCP Status Report to the UE; in the common ASP part the CellId shall be set to the id of the target cell

D.1.13 L1_MAC_Test_Mode

Primitive for control of L1/MAC Test Modes

L1_TestMode_Type

TTCN-3 Record Type		
Name	L1_TestMode_Type	
Comment	L1 test mode; in general RACH is handled separately	
DL_SCH_CRC	DL_SCH_CRC_Type	Manipulation of CRC bit generation for DL-SCH
Phich	PhichTestMode_Type	HARQ feedback mode on the PHICH

DL_SCH_CRC_Type

TTCN-3 Union Type		
Name	DL_SCH_CRC_Type	
Comment	NOTE: CRC error mode for RA_RNTI is not addressed as it will be configured in RACHProcedureConfig	
C_RNTI	MAC_Test_DL_SCH_CRC_Mode_Type	to configure mode for CRC bit for all MAC PDU's for which C-RNTI is used in PDCCH transmission
SI_RNTI	MAC_Test_DL_SCH_CRC_Mode_Type	to configure mode for CRC bit for all MAC PDU's for which SI-RNTI is used in PDCCH transmission
SPS_RNTI	MAC_Test_DL_SCH_CRC_Mode_Type	to configure mode for CRC bit for all MAC PDU's for which SPS-RNTI is used in PDCCH transmission

D.1.14 PDCCH_Order

Primitive to trigger SS to send PDCCH order to initiate RA procedure (TS 36.321, clause 5.1.1)

PDCCH_Order: Basic Type Definitions

TTCN-3 Basic Types		
PrachPreambleIndex_Type	Ra_PreambleIndex_Type	
PrachMaskIndex_Type	integer (0..15)	TS 36.321, clause 7.3

RA_PDCCH_Order_Type

TTCN-3 Record Type		
Name	RA_PDCCH_Order_Type	
Comment	see also TS 36.212, clause 5.3.3.1.3	
PreambleIndex	PrachPreambleIndex_Type	naming acc. TS 36.212, clause 5.3.3.1.3
PrachMaskIndex	PrachMaskIndex_Type	naming acc. TS 36.212, clause 5.3.3.1.3

D.1.15 System_Indications

Primitives for System indications

System_Indications: Basic Type Definitions

TTCN-3 Basic Types		
PRTPower_Type	Dummy_Type	needs to define appropriately the power level report of PREAMBLE_RECEIVED_TARGET_POWER; NOTE: for the time being this is just a place holder for enhancements in the future.
LogicalChannelGroup_Type	integer (0..3)	
BSR_Value_Type	integer (0..63)	
PHR_Type	integer (0..63)	
RI_Type	integer (1..4)	Rank indicator reported acc. to TS 36.212 Table 5.2.2.6-6

HarqProcessInfo_Type

TTCN-3 Record Type			
Name	HarqProcessInfo_Type		
Comment			
Id	HarqProcessId_Type		
CURRENT_TX_NB	integer		acc. to TS 36.321 clause 5.4.2.2

HarqError_Type

TTCN-3 Union Type			
Name	HarqError_Type		
Comment			
UL	HarqProcessInfo_Type		indicates HARQ error detected at the SS side (error at UL transmission)
DL	HarqProcessInfo_Type		indicates HARQ NACK sent by the UE (error at DL transmission)

RachPreamble_Type

TTCN-3 Record Type			
Name	RachPreamble_Type		
Comment			
RAPID	PrachPreambleIndex_Type		indicates the RAPID of the preamble used (integer (0..63))
PRTPower	PRTPower_Type		represents the PREAMBLE_RECEIVED_TARGET_POWER
RepetitionsPerPreambleAttempt	integer	opt	Applicable when numRepetitionPerPreambleAttempt-r13 is configured

Short_BSR_Type

TTCN-3 Record Type			
Name	Short_BSR_Type		
Comment			
LCG	LogicalChannelGroup_Type		Logical channel Group
Value	BSR_Value_Type		BSR or Extended BSR value

Long_BSR_Type

TTCN-3 Record Type			
Name	Long_BSR_Type		
Comment			
Value_LCG1	BSR_Value_Type		BSR or Extended BSR value for LCG 1
Value_LCG2	BSR_Value_Type		BSR or Extended BSR value for LCG 2
Value_LCG3	BSR_Value_Type		BSR or Extended BSR value for LCG 3
Value_LCG4	BSR_Value_Type		BSR or Extended BSR value for LCG 4

BSR_Type

TTCN-3 Union Type			
Name	BSR_Type		
Comment			
Short	Short_BSR_Type		
Truncated	Short_BSR_Type		
Long	Long_BSR_Type		

RlcDiscardInd_Type

TTCN-3 Record Type	
Name	RlcDiscardInd_Type
Comment	SS shall send this indication if it discards a received RLC AMD PDU as specified in TS 36.322 cl. 5.1.3.2.2.
SequenceNumber	integer
ber	sequence number of the PDU being discarded

SRSInd_Type

TTCN-3 Enumerated Type	
Name	SRSInd_Type
Comment	
SRS_Start	SS was not receiving SRS in the frames configured for periodic SRS, and SS has started reception of higher layer configured SRS in frame meant for periodic SRS transmission
SRS_Stop	SS was receiving SRS in the frames configured for periodic SRS, and SS has stopped reception of higher layer configured SRS in frame meant for periodic SRS transmission

D.1.16 System_Interface

SYSTEM_CTRL_REQ

TTCN-3 Record Type		
Name	SYSTEM_CTRL_REQ	
Comment		
Common	ReqAspCommonPart_Type	TimingInfo depends on respective primitive:
Request	SystemRequest_Type	<ul style="list-style-type: none"> - Cell TimingInfo: 'now' (in general) - CellAttenuationList TimingInfo: 'now' (in general, but activation time may be used also) - RadioBearerList TimingInfo: 'now' in general; activation time may be used in special case for release and/or reconfiguration of one or several RBs; the following rules shall be considered: <ul style="list-style-type: none"> - release/Reconfiguration of an RB shall not be scheduled earlier than 5ms after a previous data transmission on this RB - subsequent release and reconfiguration(s) shall be scheduled with an interval of at least 5ms - a subsequent data transmission on an RB shall not be scheduled earlier than 5ms after the last reconfiguration of the RB the configuration shall be performed exactly at the given time - EnquireTiming TimingInfo: 'now' - AS_Security TimingInfo: 'now'; NOTE: "activation time" may be specified in the primitive based on PDCP SQN - Sps TimingInfo: activation time for SPS assignment transmission - Paging TimingInfo: Calculated paging occasion - L1MacIndCtrl TimingInfo: 'now' (in general) - Pdcpcount TimingInfo: 'now' (in general) activation time may be used in case of CA inter cell handover to set the Pdcpcount - L1_TestMode TimingInfo: depends on the test mode; activation time is used e.g. for manipulation of the CRC - PdcchOrder TimingInfo: 'now' (in general)

SYSTEM_CTRL_CNF

TTCN-3 Record Type		
Name	SYSTEM_CTRL_CNF	
Comment		
Common	CnfAspCommonPart_Type	TimingInfo is ignored by TTCN (apart from EnquireTiming) => SS may set TimingInfo to "None"
Confirm	SystemConfirm_Type	

SYSTEM_IND

TTCN-3 Record Type			
Name	SYSTEM_IND		
Comment			
Common	IndAspCommonPart_Type		The SS shall provide TimingInfo (HSFN + SFN + subframe number) depending on the respective indication:
Indication	SystemIndication_Type		<ul style="list-style-type: none"> - Error/HarqError TimingInfo: related to the error (if available) - RachPreamble TimingInfo: shall indicate start of the RACH preamble. In case of Preamble repetition (BL/CE UE under test), indicates the timing of the first Preamble transmission. - SchedReq TimingInfo: subframe containing the SR - BSR TimingInfo: subframe in which the MAC PDU contains the BSR - UL_HARQ TimingInfo: subframe containing the UL HARQ - C_RNTI TimingInfo: subframe in which the MAC PDU contains the C_RNTI - PHR TimingInfo: subframe in which the MAC PDU contains the PHR

EUTRA_SYSTEM_PORT

TTCN-3 Port Type			
Name	EUTRA_SYSTEM_PORT		
Comment	EUTRA PTC: Port for system configuration		
out	SYSTEM_CTRL_REQ		
in	SYSTEM_CTRL_CNF		

EUTRA_SYSIND_PORT

TTCN-3 Port Type			
Name	EUTRA_SYSIND_PORT		
Comment	EUTRA PTC: Port for system indications		
in	SYSTEM_IND		

D.1.17 MBMS_Configuration

EUTRA_ASP_TypeDefs: Constant Definitions

TTCN-3 Basic Types			
tsc_MaxMRB	integer	32	maximum MRB used in test cases - Value arbitrarily set to 32 (5bits) Theoretically the maximum value is maxPMCH-PerMBSFN * maxSessionPerPMCH i.e. 15*29

MBMS_Config_Type

TTCN-3 Record Type			
Name	MBMS_Config_Type		
Comment	all fields are optional to allow single modifications; activation time is applied in the common part of the ASP		
Mbsfn_SubframeConfigList	MBSFN_SubframeConfigList	opt	Configure subframes reserved for MBSFN
MbsfnAreaList	MbsfnAreaList_Type	opt	Configure all MBSFN areas
SctpmConfig	SCPTM_Config_Type	opt	If this IE is present, MBMS services are provided via SC-PTM

MbsfnAreaList_Type

TTCN-3 Record of Type	
Name	MbsfnAreaList_Type
Comment	
record length(1..maxMBSFN_Area) of MbsfnArea_Type	

MbsfnArea_Type

TTCN-3 Record Type			
Name	MbsfnArea_Type		
Comment			
Mbsfn_ArealInfo	MBSFN_ArealInfo_r9	opt	Configure MCCH scheduling acc. to TS 36. 331 cl 9.1.1.4 there is no PDCP and MCCH use the RLC-UM mode configuration/scheduling and contents of the MCCH Information is done in one go (i.e. there are no separate ports for MCCH data and configuration)
MchData	MCCH_Data_Type	opt	MCCH information to be broadcasted
MbsfnAreaConfiguration	MBSFNAreaConfiguration_r9	opt	Configuration parameters for CommonCSA/PMCH/MTCH
MRB_List	MRB_List_Type	opt	Configure/release MTCH MRBs

MCCH_Data_Type

TTCN-3 Record Type			
Name	MCCH_Data_Type		
Comment			
Mbsfn_ArealInfo	MBSFN_ArealInfo_r12	opt	Used only for modification of MCCH info. Omitted if Mbsfn_ArealInfo is present and mandatory present otherwise
MsgList	MCCH_MessageList_Type		

MCCH_MessageList_Type

TTCN-3 Record of Type	
Name	MCCH_MessageList_Type
Comment	Includes mbsfnAreaConfiguration-r9 and optionally mbmsCountingRequest-r10.
record length(1..2) of MCCH_Message	

MRB_List_Type

TTCN-3 Record of Type	
Name	MRB_List_Type
Comment	
record length(1.. tsc MaxMRB) of MRB_Type	

MRB_Type

TTCN-3 Record Type			
Name	MRB_Type		
Comment			
PmchLogicalChannel	PmchLogicalChannel_Type		
Config	MTCH_Config_Type	opt	present for MRB_COMMON_REQ for MTCH data scheduling; not present for SystemRequest_Type MSI_Conf

MSI_Config_Type

TTCN-3 Union Type		
Name	MSI_Config_Type	
Comment		
None	Null_Type	no MSI MCE included
Auto	MSI_MCE_Type	SS automatically includes configured MSI in the first subframes allocated to the MCH within the MCH scheduling period

MSI_Type

TTCN-3 Record Type			
Name	MSI_Type		
Comment	36.321 clause 6.1.3.7		
LchID	integer (0..31)		MRB Logical Channel ID
StopMTCH	integer (0..2047)		Stop MTCH

MSI_MCE_Type

TTCN-3 Record of Type	
Name	MSI_MCE_Type
Comment	
record of MSI_Type	

MTCH_Config_Type

TTCN-3 Union Type		
Name	MTCH_Config_Type	
Comment		
AddOrReconfigure	MTCH_ConfigInfo_Type	Add/re-configure RB - CellId : identifier of the cell being configured RoutingInfo : none TimingInfo : 'Now' in common cases ControlInfo : CnfFlag:=true; FollowOnFlag:=false (in general)
Release	Null_Type	release RB - CellId : identifier of the cell being configured RoutingInfo : none TimingInfo : 'Now' in common cases ControlInfo : CnfFlag:=true; FollowOnFlag:=false (in general)

MTCH_ConfigInfo_Type

TTCN-3 Record Type			
Name	MTCH_ConfigInfo_Type		
Comment	Acc. to TS 36.331 cl 9.1.1.4 there is no PDCP and MTCH use the RLC-UM mode		
Rlc	RLC_Configuration_Type	opt	Mandatory for initial configuration; omit means "keep as it is" Note RLC DL only UM mode with SN 5 bits is only valid
Mac	MAC_MCH_TestModeConfig_Type	opt	

MAC_MCH_TestModeConfig_Type

TTCN-3 Union Type		
Name	MAC_MCH_TestModeConfig_Type	
Comment		
None	Null_Type	MAC operation in normal mode for MCH
Config	Null_Type	MAC is configured in no header manipulation in DL [MTCH is DL only channel]

PDCCH_MCCH_ChangeNotification_Type

TTCN-3 Record Type			
Name	PDCCH_MCCH_ChangeNotification_Type		
Comment			
NotificationIndicator_r9	NotificationIndicator_r9_Type	opt	MCCH change notification: shall be present, PDCCH shall be scrambled with M-RNTI SC-MCCH change notification: shall be omitted. PDCCH shall be scrambled with SC-N-RNTI
SubframeOffsetList	SubframeOffsetList_Type	opt	list of subframe offsets relative to the absolute timing information given in the common part of the ASP, this IE is MCCH-relevant and may be present only if NotificationIndicator_r9 is present; if present, multiple MCCH Change Notifications are sent out at all occasions given by the list; if omitted only a single MCCH Change Notifications is sent at the occasion given timing information given in the common part of the ASP

PmchConfig_Type

TTCN-3 Record Type			
Name	PmchConfig_Type		
Comment			
RelativeTxPower	ToRS_EPRES_Ratios_Type	opt	power ratio for MBSFN-RS and PMCH's resource elements relative to the CRS

D.1.18 SCPTM_Configuration**EUTRA_ASP_TypeDefs: Constant Definitions**

TTCN-3 Basic Types			
tsc_MaxSC_MRB	integer	1023	maximum SC-MRBs used in test cases arbitrarily set to 32 (5bits), but can set to max number of SC-MTCHs in one cell that is 1023(10bits)

SCPTM_Config_Type

TTCN-3 Record Type			
Name	SCPTM_Config_Type		
Comment	all fields are optional to allow single modifications; if IE is set to "omit" - no change from previous configuration activation time is applied in the common part of the ASP		
ScMcchScheduling	SC_MCCH_Scheduling_Type	opt	SC-MCCH scheduling configuration on PDCCH as per SystemInformationBlockType20 acc. to TS 36. 331 cl 9.1.1.4 there is no PDCP and SC-MCCH uses the RLC-UM mode configuration/scheduling and contents of the SC-MCCH Information is done in one go (i.e. there are no separate ports for SC-MCCH data and configuration)
ScptmConfiguration	SCPTMConfiguration_r13	opt	Message containing SC-MTCH configuration to be broadcasted on SC-MCCH
ScMrbList	SC_MRB_List_Type	opt	Configure/release SC-MTCH SC-MRB

SC_MCCH_Scheduling_Type

TTCN-3 Record Type			
Name	SC_MCCH_Scheduling_Type		
Comment			
ScMcchRepetitionPeriod	SC_MCCH_RepetitionPeriod_Type		
ScMcchOffset	SC_MCCH_Offset_Type		
ScMcchFirstSubframe	SC_MCCH_FirstSubframe_Type		
ScMcchDuration	SC_MCCH_Duration_Type	opt	
ScMcchModificationPeriod	SC_MCCH_ModificationPeriod_Type		

SC_MRB_List_Type

TTCN-3 Record of Type	
Name	SC_MRB_List_Type
Comment	
record length(1.. tsc MaxSC MRB) of SC_MRB_Type	

SC_MRB_Type

TTCN-3 Record Type			
Name	SC_MRB_Type		
Comment			
ScMrbId	SC_MRB_Identity_Type		
Config	SC_MTCH_Config_Type		

SC_MTCH_Config_Type

TTCN-3 Record Type			
Name	SC_MTCH_Config_Type		
Comment			
GRnti	B16_Type		
ScMtchConfig	MTCH_Config_Type		
ScMtchSchedulingInfo	SC_MTCH_SchedulingInfo_r13	opt	

D.1.19 DirectIndicationInfo_Trigger

DirectIndicationInfoTrigger_Type

TTCN-3 Record Type			
Name	DirectIndicationInfoTrigger_Type		
Comment	CellId : identifier of the cell where the UE is active RoutingInfo : None TimingInfo : Calculated paging occasion ControllInfo : CnfFlag:=false; FollowOnFlag:=false primitive to trigger transmission of a Direct Indication Information on MPDCCH at a calculated paging occasion (TS 36.304, clause 7) using DCI command 6_2 with Flag=0 and including the 8 bits in the DCI command (TS 36.212 clause 5.3.3.1.14); the paging occasion is calculated by TTCN and activation time is applied;		
DirectIndicationInfo	B8_Type		Direct Indication Information
SubframeOffsetList	SubframeOffsetList_Type	opt	list of subframe offsets relative to the absolute timing information given in the common part of the ASP; if present, multiple direct indications are sent out at all occasions given by the list; if omitted only a single direct indication is sent at the occasion given timing information given in the common part of the ASP

D.2 EUTRA_ASP_DrbDefs

ASP interface for DRBs

D.2.1 MBMS_MRB_Primitive_Definitions

EUTRA_MRB_PORT

TTCN-3 Port Type			
Name	EUTRA_MRB_PORT		
Comment			
out	MRB_COMMON_REQ		

MRB_COMMON_REQ

TTCN-3 Record Type			
Name	MRB_COMMON_REQ		
Comment	common ASP to send PDUs to MRBs		
Common	ReqAspCommonPart_Type		CellId : identifier of the cell RoutingInfo : set to Mrb TimingInfo : starting point when to start sending sequence of data PDUs e.g. SFN = X, subframe number = x; U_Plane.SubframeDataList[i].SubframeOffset := offset_i; => U_Plane.SubframeDataList[i].PduSduList shall be sent out at SFN = X + ((x + offset_i) / 10); subframe number = (x + offset_i) % 10 ControllInfo : CnfFlag:=false; FollowOnFlag:=false
U_Plane	L2Data_Request_Type		

D.2.2 System_Interface

DRB_COMMON_REQ

TTCN-3 Record Type			
Name	DRB_COMMON_REQ		
Comment	common ASP to send PDUs to DRBs		
Common	ReqAspCommonPart_Type		CellId : identifier of the cell RoutingInfo : DRB id TimingInfo : starting point when to start sending sequence of data PDUs e.g. SFN = X, subframe number = x; U_Plane.SubframeDataList[j].SubframeOffset := offset_i; => U_Plane.SubframeDataList[j].PduSduList shall be sent out at at SFN = X + ((x + offset_i) / 10); subframe number = (x + offset_i) % 10 ControllInfo : CnfFlag:=false; FollowOnFlag:=false
U_Plane	L2Data_Request_Type		
SuppressPdcch ForC_RNTI	Null_Type	opt	By default all DRB_COMMON_REQ scheduled DL PDU's are associated with an appropriate explicit configured or SS selected DL assignment allocation on PDCCH. For SuppressPdcch:=true in the sub frame in which DL PDU's are transmitted, there is no associated DL assignment allocation for configured C-RNTI. This will be used for SPS assignment based transmission or in any error scenarios; NOTE: this flag has no impact on PDCCH messages required for SPS activation

DRB_COMMON_IND

TTCN-3 Record Type			
Name	DRB_COMMON_IND		
Comment	common ASP to receive PDUs from DRBs		
Common	IndAspCommonPart_Type		CellId : identifier of the cell RoutingInfo : DRB id TimingInfo : time when message has been received NOTE 1: For MAC and RCL PDUs per definition L2Data_Indication_Type correspond to exactly one subframe => TimingInfo refers to this subframe NOTE 2: For PDCP a single PDU or SDU may take more than one TTI => TimingInfo refers to the end of the PDU/SDU and the length is given by NoOfTTIs in L2Data_Indication_Type (the end of the PDU/SDU is the last RLC PDU being received; in case of retransmissions this is not necessarily the RLC PDU with the last SN)
U_Plane	L2Data_Indication_Type		

EUTRA_DRB_PORT

TTCN-3 Port Type			
Name	EUTRA_DRB_PORT		
Comment			
out	DRB_COMMON_REQ		
in	DRB_COMMON_IND		

D.3 EUTRA_NB_ASP_L2DataDefs

ASP interface for DRBs

D.3.1 PDU_TypeDefs

D.3.1.1 MAC_PDU

MAC_PDU: Basic Type Definitions

TTCN-3 Basic Types		
MAC_CTRL_C_RNTI_Type	C_RNTI	TS 36.321, clause 6.1.3.2
MAC_CTRL_ContentionResolutionId_Type	ContentionResolutionId_Type	TS 36.321, clause 6.1.3.4 fix 48-bit size; consists of a single field defined UE Contention Resolution Identity (first 48 bits of the uplink CCCH SDU transmitted by MAC)
MAC_CTRL_TimingAdvance_Type	B8_Type	TS 36.321, clause 6.1.3.5 indicates the amount of timing adjustment in 0.5 ms that the UE has to apply; the length of the field is 8 bits
MAC_SDU_Type	octetstring	

MAC_PDU_Length_Type

TTCN-3 Record Type		
Name	MAC_PDU_Length_Type	
Comment	NOTE: since F and L field are either both present or both omitted they are put into this record; to allow homogeneous (direct) encoding the PDU length is not defined as union; TTCN-3 does allow length restrictions to one length or a range of length but not to two specific lengths; further restriction may be achieved by appropriate templates (parameter either 7 or 15 bit)	
Format	B1_Type	F: The Format field indicates the size of the Length field as indicated in table 6.2.1-3. There is one F field per MAC PDU subheader except for the last subheader and sub-headers corresponding to fixed-sized MAC control elements. The size of the F field is 1 bit. If the size of the MAC SDU or MAC control element is less than 128 bytes, the UE shall set the value of the F field to 0, otherwise the UE shall set it to 1
Value	B7_15_Type	L: The Length field indicates the length of the corresponding MAC SDU or MAC control element in bytes. There is one L field per MAC PDU subheader except for the last subheader and sub-headers corresponding to fixed-sized MAC control elements. The size of the L field is indicated by the F field

MAC_PDU_SubHeader_Type

TTCN-3 Record Type			
Name	MAC_PDU_SubHeader_Type		
Comment			
Reserved	B2_Type		Reserved bits
Extension	B1_Type		E: The Extension field is a flag indicating if more fields are present in the MAC header or not. The E field is set to "1" to indicate another set of at least R/R/E/LCID fields. The E field is set to "0" to indicate that either a MAC SDU, a MAC control element or padding starts at the next byte
LCID	B5_Type		LCID: The Logical Channel ID field identifies the logical channel instance of the corresponding MAC SDU or the type of the corresponding MAC control element or padding as described in tables 6.2.1-1 and 6.2.1-2 for the DL and UL-SCH respectively. There is one LCID field for each MAC SDU, MAC control element or padding included in the MAC PDU. The LCID field size is 5 bits; NOTE: In case of DRX command the sub-header corresponds to a control element of length zero (i.e. there is no control element)
Length	MAC_PDU_Length_Type	opt	

MAC_Header_Type

TTCN-3 Record of Type	
Name	MAC_Header_Type
Comment	
record of MAC_PDU_SubHeader_Type	

MAC_CTRL_ShortBSR_Type

TTCN-3 Record Type			
Name	MAC_CTRL_ShortBSR_Type		
Comment	TS 36.321, clause 6.1.3.1		
LCG	B2_Type		
Value	B6_Type		

MAC_CTRL_LongBSR_Type

TTCN-3 Record Type			
Name	MAC_CTRL_LongBSR_Type		
Comment	TS 36.321, clause 6.1.3.1		
Value_LCG1	B6_Type		
Value_LCG2	B6_Type		
Value_LCG3	B6_Type		
Value_LCG4	B6_Type		

MAC_CTRL_PowerHeadRoom_Type

TTCN-3 Record Type			
Name	MAC_CTRL_PowerHeadRoom_Type		
Comment	TS 36.321, clause 6.1.3.6		
Reserved	B2_Type		
Value	B6_Type		

MAC_CTRL_ElementList_Type

TTCN-3 Set Type			
Name	MAC_CTRL_ElementList_Type		
Comment	NOTE 1: for simplification UL and DL are not distinguished even though the control elements are either UL or DL NOTE 2: type is defined as set: the ordering is not significant; nevertheless the ordering is well-defined by the sub-headers; for codec implementations it is in any case necessary to evaluate the sub-header information in order to encode/decode the payload		
ShortBSR	MAC_CTRL_ShortBSR_Type	opt	UL only
LongBSR	MAC_CTRL_LongBSR_Type	opt	UL only
C_RNTI	MAC_CTRL_C_RNTI_Type	opt	UL only
ContentionResolutionID	MAC_CTRL_ContentionResolutionId_Type	opt	DL only
TimingAdvance	MAC_CTRL_TimingAdvance_Type	opt	DL only
PowerHeadRoom	MAC_CTRL_PowerHeadRoom_Type	opt	UL only
ScellActDeact	MAC_CTRL_ScellActDeact_Type	opt	DL only
ExtPowerHeadRoom	MAC_CTRL_ExtPowerHeadRoom_Type	opt	UL only. Only one among PowerHeadroom, ExtPowerHeadroom and DC_PowerHeadRoom may be present
DC_PowerHeadRoom	MAC_CTRL_DC_PowerHeadRoom_Type	opt	UL only. Only one among PowerHeadroom, ExtPowerHeadroom and DC_PowerHeadRoom may be present

MAC_SDUList_Type

TTCN-3 Record of Type	
Name	MAC_SDUList_Type
Comment	record of MAC_SDU_Type

MAC_PDU_Type

TTCN-3 Record Type			
Name	MAC_PDU_Type		
Comment			
Header	MAC_Header_Type		list of MAC PDU SubHeaders corresponding to MAC control elements and MAC SDUs
CtrlElementList	MAC_CTRL_ElementList_Type	opt	Mac control elements; acc. to TS 36.321, clause 6.1.2 "MAC control elements, are always placed before any MAC SDU."
SduList	MAC_SDUList_Type	opt	MAC SDUs, which can typically be RLC PDUs
Padding	octetstring	opt	Octet aligned Padding if more than or equal to 2 bytes

MAC_PDUList_Type

TTCN-3 Record of Type	
Name	MAC_PDUList_Type
Comment	record of MAC_PDU_Type

D.3.1.2 RLC_PDU

D.3.1.2.1 Common

RLC PDU definition: common AM/UM field definitions

Common: Basic Type Definitions

TTCN-3 Basic Types		
RLC_FramingInfo_Type	B2_Type	00 - First byte of the Data field corresponds to the first byte of a RLC SDU. Last byte of the Data field corresponds to the last byte of a RLC SDU. 01 - First byte of the Data field corresponds to the first byte of a RLC SDU. Last byte of the Data field does not correspond to the last byte of a RLC SDU. 10 - First byte of the Data field does not correspond to the first byte of a RLC SDU. Last byte of the Data field corresponds to the last byte of a RLC SDU. 11 - First byte of the Data field does not correspond to the first byte of a RLC SDU. Last byte of the Data field does not correspond to the last byte of a RLC SDU.

RLC_LengthIndicator_LI11_Type

TTCN-3 Record Type			
Name	RLC_LengthIndicator_LI11_Type		
Comment			
Extension	B1_Type		0 - Data field follows from the octet following the LI field following this E field 1 - A set of E field and LI field follows from the bit following the LI field following this E field
LengthIndicator	B11_Type		Length Indicator

RLC_LengthIndicator_LI15_Type

TTCN-3 Record Type			
Name	RLC_LengthIndicator_LI15_Type		
Comment			
Extension	B1_Type		0 - Data field follows from the octet following the LI field following this E field 1 - A set of E field and LI field follows from the bit following the LI field following this E field
LengthIndicator	B15_Type		15 bit Length Indicator

RLC_LI11_List_Type

TTCN-3 Record of Type	
Name	RLC_LI11_List_Type
Comment	record of RLC_LengthIndicator_LI11_Type

RLC_LI15_List_Type

TTCN-3 Record of Type	
Name	RLC_LI15_List_Type
Comment	
record of RLC_LengthIndicator_LI15_Type	

RLC_LI_List_Type

TTCN-3 Union Type	
Name	RLC_LI_List_Type
Comment	
LI11	RLC_LI11_List_Type
LI15	RLC_LI15_List_Type

RLC_PDU_Header_FlexPart_Type

TTCN-3 Record Type		
Name	RLC_PDU_Header_FlexPart_Type	
Comment	Flexible part of the header with a number of K LIs	
LengthIndicator	RLC_LI_List_Type	List of E, LI fields
Padding	B4_Type	opt optional 4 bit padding present in case of odd number of LI's

D.3.1.2.2 TM_Data

RLC PDU definition: UM (TS 36.322, clause 6.2.1.2)

TM_Data: Basic Type Definitions

TTCN-3 Basic Types		
RLC_TMD_PDU_Type	octetstring	TS 36.322, clause 6.2.1.2

D.3.1.2.3 UM_Data

RLC PDU definition: UM (TS 36.322, clause 6.2.1.3)

NOTE:

To allow direct encoding the definition for RLC UM Data PDU is split into data PDU with 5/10 bit sequence number

UM_Data: Basic Type Definitions

TTCN-3 Basic Types		
RLC_DataField_Type	octetstring	restrictions imposed from LI size of 11 bits is not applicable when the LI's are not present

RLC_UMD_Header_FixPartShortSN_Type

TTCN-3 Record Type		
Name	RLC_UMD_Header_FixPartShortSN_Type	
Comment	TS 36.322, clause 6.2.1.3 Figure 6.2.1.3-1, 6.2.1.3-3 and 6.2.1.3-4); one octet	
FramingInfo	RLC_FramingInfo_Type	2 bits FI
Extension	B1_Type	1 bit E
SequenceNumber	B5_Type	5 bits SN

RLC_UMD_Header_FixPartLongSN_Type

TTCN-3 Record Type			
Name	RLC_UMD_Header_FixPartLongSN_Type		
Comment	TS 36.322, clause 6.2.1.3 Figure 6.2.1.3-2, 6.2.1.3-5 and 6.2.1.3-6); two octets		
Reserved	B3_Type		3 bits reserved
FramingInfo	RLC_FramingInfo_Type		2 bits FI
Extension	B1_Type		1 bit E
SequenceNumber	B10_Type		10 bits SN

RLC_UMD_HeaderShortSN_Type

TTCN-3 Record Type			
Name	RLC_UMD_HeaderShortSN_Type		
Comment			
FixPart	RLC_UMD_Header_FixPartShortSN_Type		
FlexPart	RLC_PDU_Header_FlexPart_Type	opt	

RLC_UMD_HeaderLongSN_Type

TTCN-3 Record Type			
Name	RLC_UMD_HeaderLongSN_Type		
Comment			
FixPart	RLC_UMD_Header_FixPartLongSN_Type		
FlexPart	RLC_PDU_Header_FlexPart_Type	opt	

RLC_DataFieldList_Type

TTCN-3 Record of Type			
Name	RLC_DataFieldList_Type		
Comment	One to one correspondence with sub headers (LengthIndicatorList_Type) record of RLC_DataField_Type		

RLC_UMD_PDU_ShortSN_Type

TTCN-3 Record Type			
Name	RLC_UMD_PDU_ShortSN_Type		
Comment			
Header	RLC_UMD_HeaderShortSN_Type		
Data	RLC_DataFieldList_Type		

RLC_UMD_PDU_LongSN_Type

TTCN-3 Record Type			
Name	RLC_UMD_PDU_LongSN_Type		
Comment			
Header	RLC_UMD_HeaderLongSN_Type		
Data	RLC_DataFieldList_Type		

RLC_UMD_PDU_Type

TTCN-3 Union Type		
Name	RLC_UMD_PDU_Type	
Comment		
ShortSN	RLC_UMD_PDU_ShortSN_Type	
LongSN	RLC_UMD_PDU_LongSN_Type	

D.3.1.2.4 AM_Data

RLC PDU definition: AM (TS 36.322, clause 6.2.1.4 and 6.2.1.5)

RLC_AMD_Header_FixPart_Type

TTCN-3 Record Type		
Name	RLC_AMD_Header_FixPart_Type	
Comment	TS 36.322, clause 6.2.1.4 Figure 6.2.1.4-1, 6.2.1.4-2 and 6.2.1.4-3); 2 or 4 octets (AMD PDU or AMD PDU segment)	
D_C	B1_Type	0 - Control PDU 1 - Data PDU
ReSeg	B1_Type	0 - AMD PDU 1 - AMD PDU segment
Poll	B1_Type	0 - Status report not requested 1 - Status report is requested
FramingInfo	RLC_FramingInfo_Type	2 bit FI
Extension	B1_Type	1 bit E
SN	B10_Type	Sequence number

RLC_AMD_Header_FixPartExt_Type

TTCN-3 Record Type		
Name	RLC_AMD_Header_FixPartExt_Type	
Comment	TS 36.322, clause 6.2.1.4 Figure 6.2.1.4-1a, 6.2.1.4-2a and 6.2.1.4-3a); 3 octets	
D_C	B1_Type	0 - Control PDU 1 - Data PDU
ReSeg	B1_Type	0 - AMD PDU 1 - AMD PDU segment
Poll	B1_Type	0 - Status report not requested 1 - Status report is requested
FramingInfo	RLC_FramingInfo_Type	2 bit FI
Extension	B1_Type	1 bit E
Reserved	B2_Type	2 reserved bits
SN_Ext	B16_Type	Sequence number

RLC_AMD_Header_FixPartSegExt_Type

TTCN-3 Record Type			
Name	RLC_AMD_Header_FixPartSegExt_Type		
Comment	TS 36.322, clause 6.2.1.5 Figure 6.2.1.5-1a); 5 octets		
D_C	B1_Type		0 - Control PDU 1 - Data PDU
ReSeg	B1_Type		0 - AMD PDU 1 - AMD PDU segment
Poll	B1_Type		0 - Status report not requested 1 - Status report is requested
FramingInfo	RLC_FramingInfo_Type		2 bit FI
Extension	B1_Type		1 bit E
LastSegmentFlag	B1_Type		0 - Last byte of the AMD PDU segment does not correspond to the last byte of an AMD PDU 1 - Last byte of the AMD PDU segment corresponds to the last byte of an AMD PDU
Reserved	B1_Type		1 reserved bit
SN_Ext	B16_Type		Sequence number

RLC_AMD_Header_SegmentPart_Type

TTCN-3 Record Type			
Name	RLC_AMD_Header_SegmentPart_Type		
Comment	AMD PDU segment related info in PDU header acc. TS 36.322, clause 6.2.1.5		
LastSegmentFlag	B1_Type		0 - Last byte of the AMD PDU segment does not correspond to the last byte of an AMD PDU 1 - Last byte of the AMD PDU segment corresponds to the last byte of an AMD PDU
SegOffset	B15_Type		The SO field indicates the position of the AMD PDU segment in bytes within the original AMD PDU. Specifically, the SO field indicates the position within the Data field of the original AMD PDU to which the first byte of the Data field of the AMD PDU segment corresponds to.

RLC_AMD_Header_SegmentPartExt_Type

TTCN-3 Record Type			
Name	RLC_AMD_Header_SegmentPartExt_Type		
Comment	AMD PDU segment related info in PDU header acc. TS 36.322, clause 6.2.1.5		
SegOffset	B16_Type		The SO field indicates the position of the AMD PDU segment in bytes within the original AMD PDU. Specifically, the SO field indicates the position within the Data field of the original AMD PDU to which the first byte of the Data field of the AMD PDU segment corresponds to.

RLC_AMD_Header_Type

TTCN-3 Record Type			
Name	RLC_AMD_Header_Type		
Comment			
FixPart	RLC_AMD_Header_FixPart_Type		
SegmentPart	RLC_AMD_Header_SegmentPart_Type	opt	present in case of AMD Seg PDU only
FlexPart	RLC_PDU_Header_FlexPart_Type	opt	

RLC_AMD_HeaderExt_Type

TTCN-3 Record Type			
Name	RLC_AMD_HeaderExt_Type		
Comment			
FixPartExt	RLC_AMD_Header_FixPart_Ext_Type		
FlexPart	RLC_PDU_Header_FlexPart_Type	opt	

RLC_AMD_HeaderSegExt_Type

TTCN-3 Record Type			
Name	RLC_AMD_HeaderSegExt_Type		
Comment			
FixPartSegExt	RLC_AMD_Header_FixPart_SegExt_Type		
SegmentPart	RLC_AMD_Header_SegmentPartExt_Type	opt	present in case of AMD Seg PDU only
FlexPart	RLC_PDU_Header_FlexPart_Type	opt	

RLC_AMD_PDU_Type

TTCN-3 Record Type			
Name	RLC_AMD_PDU_Type		
Comment			
Header	RLC_AMD_Header_Type		
Data	RLC_DataFieldList_Type		

RLC_AMD_PDU_Ext_Type

TTCN-3 Record Type			
Name	RLC_AMD_PDU_Ext_Type		
Comment			
HeaderExt	RLC_AMD_HeaderExt_Type		
Data	RLC_DataFieldList_Type		

RLC_AMD_PDU_SegExt_Type

TTCN-3 Record Type			
Name	RLC_AMD_PDU_SegExt_Type		
Comment			
HeaderSegExt	RLC_AMD_HeaderSegExt_Type		
Data	RLC_DataFieldList_Type		

D.3.1.2.5 AM_Status

AM Status PDU (TS 36.322, clause 6.2.1.6)

AM_Status: Basic Type Definitions

TTCN-3 Basic Types		
RLC_Status_Padding_Type	bitstring length (1..7)	NOTE: in TTCN-3 length restriction cannot be done inline in record definition => explicit type definition necessary

RLC_Status_ACK_Type

TTCN-3 Record Type		
Name	RLC_Status_ACK_Type	
Comment		
ACK_SN	B10_Type	Acknowledgement SN (TS 36.322, clause 6.2.2.14)
Extn1	B1_Type	0 - a set of NACK_SN, E1 and E2 does not follow. 1 - a set of NACK_SN, E1 and E2 follows.

RLC_Status_ACK_Ext_Type

TTCN-3 Record Type		
Name	RLC_Status_ACK_Ext_Type	
Comment		
ACK_SN_Ext	B16_Type	Acknowledgement SN (TS 36.322, clause 6.2.2.14)
Extn1	B1_Type	0 - a set of NACK_SN, E1 and E2 does not follow. 1 - a set of NACK_SN, E1 and E2 follows.

RLC_Status_SegOffset_Type

TTCN-3 Record Type		
Name	RLC_Status_SegOffset_Type	
Comment		
Start	B15_Type	SOstart field indicates the position of the first byte of the portion of the AMD PDU in bytes within the Data field of the AMD PDU
End	B15_Type	SOend field indicates the position of the last byte of the portion of the AMD PDU in bytes within the Data field of the AMD PDU. The special SOend value '1111111111111111'B is used to indicate that the missing portion of the AMD PDU includes all bytes to the last byte of the AMD PDU

RLC_Status_SegOffset_Ext_Type

TTCN-3 Record Type		
Name	RLC_Status_SegOffset_Ext_Type	
Comment		
Start	B16_Type	SOstart field indicates the position of the first byte of the portion of the AMD PDU in bytes within the Data field of the AMD PDU
End	B16_Type	SOend field indicates the position of the last byte of the portion of the AMD PDU in bytes within the Data field of the AMD PDU. The special SOend value '1111111111111111'B is used to indicate that the missing portion of the AMD PDU includes all bytes to the last byte of the AMD PDU

RLC_Status_NACK_Type

TTCN-3 Record Type			
Name	RLC_Status_NACK_Type		
Comment			
NACK_SN	B10_Type		
Extn1	B1_Type		0 - A set of NACK_SN, E1 and E2 does not follow. 1 - A set of NACK_SN, E1 and E2 follows.
Extn2	B1_Type		0 - A set of SOstart and SOend does not follow for this NACK_SN. 1 - A set of SOstart and SOend follows for this NACK_SN.
SO	RLC_Status_SegOffset_Type	opt	

RLC_Status_NACK_List_Type

TTCN-3 Record of Type	
Name	RLC_Status_NACK_List_Type
Comment	
record of RLC_Status_NACK_Type	

RLC_Status_NACK_Ext_Type

TTCN-3 Record Type			
Name	RLC_Status_NACK_Ext_Type		
Comment			
NACK_SN_Ext	B16_Type		
Extn1	B1_Type		0 - A set of NACK_SN, E1 and E2 does not follow. 1 - A set of NACK_SN, E1 and E2 follows.
Extn2	B1_Type		0 - A set of SOstart and SOend does not follow for this NACK_SN. 1 - A set of SOstart and SOend follows for this NACK_SN.
SO	RLC_Status_SegOffset_Ext_Type	opt	

RLC_Status_NACK_Ext_List_Type

TTCN-3 Record of Type	
Name	RLC_Status_NACK_Ext_List_Type
Comment	
record of RLC_Status_NACK_Ext_Type	

RLC_AM_StatusPDU_Type

TTCN-3 Record Type			
Name	RLC_AM_StatusPDU_Type		
Comment	RLC STATUS PDU (TS 36.322, clause 6.2.1.6)		
D_C	B1_Type		0 - Control PDU 1 - Data PDU
CP_Type	B3_Type		000 - STATUS PDU 001..111 - Reserved (=> PDU to be discarded by the receiving entity for this release of the protocol)
Ack	RLC_Status_ACK_Type		ACK_SN and E1 bit
NackList	RLC_Status_NACK_List_Type	opt	presence depends on Extn1 bit of Ack filed (RLC_Status_ACK_Type)
Padding	RLC_Status_Padding_Type	opt	1..7 bit padding if needed for octet alignment

RLC_AM_StatusPDU_Ext_Type

TTCN-3 Record Type			
Name	RLC_AM_StatusPDU_Ext_Type		
Comment	RLC STATUS PDU (TS 36.322, clause 6.2.1.6)		
D_C	B1_Type		0 - Control PDU 1 - Data PDU
CP_Type	B3_Type		000 - STATUS PDU 001..111 - Reserved (=> PDU to be discarded by the receiving entity for this release of the protocol)
Ack_Ext	RLC_Status_ACK_Ext_Type		ACK_SN and E1 bit
Nack_Ext_List	RLC_Status_NACK_Ext_List_Type	opt	presence depends on Extn1 bit of Ack field (RLC_Status_ACK_Type)
Padding	RLC_Status_Padding_Type	opt	1..7 bit padding if needed for octet alignment

RLC_PDU: Basic Type Definitions

TTCN-3 Basic Types		
RLC_SDU_Type	octetstring	

RLC_PDU_Type

TTCN-3 Union Type		
Name	RLC_PDU_Type	
Comment		
TMD	RLC_TMD_PDU_Type	
UMD	RLC_UMD_PDU_Type	
AMD	RLC_AMD_PDU_Type	
AMD_Ext	RLC_AMD_PDU_Ext_Type	
AMD_SegExt	RLC_AMD_PDU_SegExt_Type	
Status	RLC_AM_StatusPDU_Type	
Status_Ext	RLC_AM_StatusPDU_Ext_Type	

RLC_PDUList_Type

TTCN-3 Record of Type	
Name	RLC_PDUList_Type
Comment	
record of RLC_PDU_Type	

RLC_SDUList_Type

TTCN-3 Record of Type	
Name	RLC_SDUList_Type
Comment	
record of RLC_SDU_Type	

D.3.1.3 PDCP

PDCP user plane SDU and PDU definitions

NOTE:

To allow direct encoding the definition for PDCP Data PDU is split into data PDU with long/short sequence number

PDCP: Basic Type Definitions

TTCN-3 Basic Types		
PDCP_SDU_Type	octetstring	

PDCP_SDUList_Type

TTCN-3 Record of Type	
Name	PDCP_SDUList_Type
Comment	record of PDCP_SDU_Type

PDCP_DataPdu_LongSN_Type

TTCN-3 Record Type		
Name	PDCP_DataPdu_LongSN_Type	
Comment	User plane PDCP Data PDU with long sequence number (TS 36.323, clause 6.2.3)	
D_C	B1_Type	0 - Control PDU 1 - Data PDU
Reserved	B3_Type	3 reserved bits
SequenceNumber	B12_Type	12 bit sequence number
SDU	PDCP_SDU_Type	content (octetstring)

PDCP_DataPdu_ShortSN_Type

TTCN-3 Record Type		
Name	PDCP_DataPdu_ShortSN_Type	
Comment	User plane PDCP Data PDU with short sequence number (TS 36.323, clause 6.2.4)	
D_C	B1_Type	0 - Control PDU 1 - Data PDU
SequenceNumber	B7_Type	7 bit sequence number
SDU	PDCP_SDU_Type	content (octetstring)

PDCP_DataPdu_ExtSN_Type

TTCN-3 Record Type		
Name	PDCP_DataPdu_ExtSN_Type	
Comment	User plane PDCP Data PDU with extended sequence number (TS 36.323, clause 6.2.9)	
D_C	B1_Type	0 - Control PDU 1 - Data PDU
SequenceNumber	B15_Type	15 bit sequence number
SDU	PDCP_SDU_Type	content (octetstring)

PDCP_DataPdu_18bitSN_Type

TTCN-3 Record Type		
Name	PDCP_DataPdu_18bitSN_Type	
Comment	User plane PDCP Data PDU with 18 bit sequence number (TS 36.323, clause 6.2.11)	
D_C	B1_Type	0 - Control PDU 1 - Data PDU
PollingBit	B1_Type	1 - when eNB triggers a PDCP status report or LWA status report
Reserved	B4_Type	4 reserved bits
SequenceNumber	B18_Type	18 bit sequence number
SDU	PDCP_SDU_Type	content (octetstring)

PDCP_DataPdu_SLRB_Type

TTCN-3 Record Type			
Name	PDCP_DataPdu_SLRB_Type		
Comment	User plane PDCP Data PDU for SLRB (TS 36.323, clause 6.2.10.1)		
SDU_Type	B3_Type		000 - IP 001 - ARP 010 - PC5 Signaling 011 - 111 reserved
PGK_Index	B5_Type		5 LSBs of PGK Identity (TS 33.303, clause 6.2.3)
PTK_Identity	B16_Type		PTK Identity (TS 33.303, clause 6.2.3)
SequenceNumber	B16_Type		16 bit sequence number
SDU	PDCP_SDU_Type		content (octetstring)

PDCP_DataPdu_SLRB_1to1_Type

TTCN-3 Record Type			
Name	PDCP_DataPdu_SLRB_1to1_Type		
Comment	User plane PDCP Data PDU for SLRB (TS 36.323, clause 6.2.10.2)		
SDU_Type	B3_Type		000 - IP 001 - ARP 010 - PC5 Signaling 011 - 111 reserved
Reserved	B5_Type		5 reserved bits
KD_sess_ID	B16_Type		KD_sess Identity (TS 33.303, clause 6.5.3.1)
SequenceNumber	B16_Type		16 bit sequence number
SDU	PDCP_SDU_Type		content (octetstring)
MAC_I	O4_Type		MAC-I

PDCP_Ctrl_ROHC_FB_PDU_Type

TTCN-3 Record Type			
Name	PDCP_Ctrl_ROHC_FB_PDU_Type		
Comment	PDCP Control PDU for interspersed ROHC feedback packet (TS 36.323, clause 6.2.5)		
D_C	B1_Type		0 - Control PDU 1 - Data PDU
PDU_Type	B3_Type		000 - PDCP status report 001 - Header Compression Feedback Information 010 - LWA status report 011..111 - reserved
Reserved	B4_Type		
ROHC_FB	octetstring		Contains one ROHC packet with only feedback, i.e. a ROHC packet that is not associated with a PDCP

PDCP_Ctrl_StatusReport_Type

TTCN-3 Record Type			
Name	PDCP_Ctrl_StatusReport_Type		
Comment	PDCP Control PDU for PDCP status report (TS 36.323, clause 6.2.6)		
D_C	B1_Type		0 - Control PDU 1 - Data PDU
PDU_Type	B3_Type		000 - PDCP status report 001 - Header Compression Feedback Information 010 - LWA status report 011..111 - reserved
FMS	B12_Type		PDCP SN of the first missing PDCP SDU.
Bitmap	octetstring	opt	The MSB of the first octet of the type "Bitmap" indicates whether or not the PDCP SDU with the SN (FMS + 1) modulo 4096 has been received and, optionally decompressed correctly. 0 - PDCP SDU with PDCP SN = (FMS + bit position) modulo 4096 is missing in the receiver. The bit position of Nth bit in the Bitmap is N, i.e. the bit position of the first bit in the Bitmap is 1. 1 - PDCP SDU with PDCP SN = (FMS + bit position) modulo 4096 does not need to be retransmitted. The bit position of Nth bit in the Bitmap is N, i.e. the bit position of the first bit in the Bitmap is 1.

PDCP_Ctrl_StatusReportExt_Type

TTCN-3 Record Type			
Name	PDCP_Ctrl_StatusReportExt_Type		
Comment	PDCP Control PDU for PDCP status report using a 15 bit SN (TS 36.323, clause 6.2.6)		
D_C	B1_Type		0 - Control PDU 1 - Data PDU
PDU_Type	B3_Type		000 - PDCP status report 001 - Header Compression Feedback Information 010 - LWA status report 011..111 - reserved
Reserved	B5_Type		5 reserved bits
FMS_Ext	B15_Type		PDCP SN of the first missing PDCP SDU.
Bitmap	octetstring	opt	The MSB of the first octet of the type "Bitmap" indicates whether or not the PDCP SDU with the SN (FMS + 1) modulo (Maximum_PDCP_SN + 1) has been received and, optionally decompressed correctly. 0 - PDCP SDU with PDCP SN = (FMS + bit position) modulo (Maximum_PDCP_SN + 1) is missing in the receiver. The bit position of Nth bit in the Bitmap is N, i.e. the bit position of the first bit in the Bitmap is 1. 1 - PDCP SDU with PDCP SN = (FMS + bit position) modulo (Maximum_PDCP_SN + 1) does not need to be retransmitted. The bit position of Nth bit in the Bitmap is N, i.e. the bit position of the first bit in the Bitmap is 1.

PDCP_Ctrl_StatusReport_18bitSN_Type

TTCN-3 Record Type			
Name	PDCP_Ctrl_StatusReport_18bitSN_Type		
Comment	PDCP Control PDU for PDCP status report using a 18 bit SN (TS 36.323, clause 6.2.6)		
D_C	B1_Type		0 - Control PDU 1 - Data PDU
PDU_Type	B3_Type		000 - PDCP status report 001 - Header Compression Feedback Information 010 - LWA status report 011..111 - reserved
Reserved	B2_Type		2 reserved bits
FMS_18bitSN	B18_Type		PDCP SN of the first missing PDCP SDU.
Bitmap	octetstring	opt	The MSB of the first octet of the type "Bitmap" indicates whether or not the PDCP SDU with the SN (FMS + 1) modulo (Maximum_PDCP_SN + 1) has been received and, optionally decompressed correctly. 0 - PDCP SDU with PDCP SN = (FMS + bit position) modulo (Maximum_PDCP_SN + 1) is missing in the receiver. The bit position of Nth bit in the Bitmap is N, i.e. the bit position of the first bit in the Bitmap is 1. 1 - PDCP SDU with PDCP SN = (FMS + bit position) modulo (Maximum_PDCP_SN + 1) does not need to be retransmitted. The bit position of Nth bit in the Bitmap is N, i.e. the bit position of the first bit in the Bitmap is 1.

PDCP_Ctrl_LWA_StatusReport_Type

TTCN-3 Record Type			
Name	PDCP_Ctrl_LWA_StatusReport_Type		
Comment	PDCP Control PDU for LWA status report (TS 36.323, clause 6.2.12)		
D_C	B1_Type		0 - Control PDU 1 - Data PDU
PDU_Type	B3_Type		000 - PDCP status report 001 - Header Compression Feedback Information 010 - LWA status report 011..111 - reserved
FMS	B12_Type		PDCP SN of the first missing PDCP SDU.
HRW	B12_Type		PDCP SN of the PDCP SDU received on WLAN with highest associated PDCP COUNT value.
NMP	B12_Type		Number of Missing PDCP PDUs with PDCP SNs below HRW starting from and including FMS.

PDCP_Ctrl_LWA_StatusReportExt_Type

TTCN-3 Record Type		
Name	PDCP_Ctrl_LWA_StatusReportExt_Type	
Comment	PDCP Control PDU for LWA status report (TS 36.323, clause 6.2.12)	
D_C	B1_Type	0 - Control PDU 1 - Data PDU
PDU_Type	B3_Type	000 - PDCP status report 001 - Header Compression Feedback Information 010 - LWA status report 011..111 - reserved
Reserved	B5_Type	5 reserved bits
FMS_Ext	B15_Type	PDCP SN of the first missing PDCP SDU.
Reserved2	B1_Type	1 reserved bit
HRW_Ext	B15_Type	PDCP SN of the PDCP SDU received on WLAN with highest associated PDCP COUNT value.
Reserved3	B1_Type	1 reserved bit
NMP_Ext	B15_Type	Number of Missing PDCP PDUs with PDCP SNs below HRW starting from and including FMS.

PDCP_Ctrl_LWA_StatusReport_18bitSN_Type

TTCN-3 Record Type		
Name	PDCP_Ctrl_LWA_StatusReport_18bitSN_Type	
Comment	PDCP Control PDU for LWA status report (TS 36.323, clause 6.2.12)	
D_C	B1_Type	0 - Control PDU 1 - Data PDU
PDU_Type	B3_Type	000 - PDCP status report 001 - Header Compression Feedback Information 010 - LWA status report 011..111 - reserved
Reserved	B2_Type	2 reserved bits
FMS_18bitSN	B18_Type	PDCP SN of the first missing PDCP SDU.
HRW_18bitSN	B18_Type	PDCP SN of the PDCP SDU received on WLAN with highest associated PDCP COUNT value.
Reserved2	B4_Type	4 reserved bits
NMP_18bitSN	B18_Type	Number of Missing PDCP PDUs with PDCP SNs below HRW starting from and including FMS.

PDCP_PDU_Type

TTCN-3 Union Type		
Name	PDCP_PDU_Type	
Comment		
DataLongSN	PDCP_DataPdu_LongSN_Type	user plane PDCP data PDU with 12 Bit Seq Number
DataShortSN	PDCP_DataPdu_ShortSN_Type	user plane PDCP data PDU with 7 Bit Seq Number
DataExtSN	PDCP_DataPdu_ExtSN_Type	user plane PDCP data PDU with 15 Bit Seq Number
Data_18bitSN	PDCP_DataPdu_18bitSN_Type	user plane PDCP data PDU with 18 Bit Seq Number
RohcFeedback	PDCP_Ctrl_ROHC_FB_PDU_Type	PDCP Control PDU for interspersed ROHC feedback packet
StatusReport	PDCP_Ctrl_StatusReport_Type	PDCP Control PDU for PDCP status report
StatusReportExt	PDCP_Ctrl_StatusReportExt_Type	PDCP Control PDU for PDCP status report using a 15 bit SN
StatusReport_18bitSN	PDCP_Ctrl_StatusReport_18bitSN_Type	PDCP Control PDU for PDCP status report using a 18 bit SN
LWA_StatusReport	PDCP_Ctrl_LWA_StatusReport_Type	PDCP Control PDU for LWA status report
LWA_StatusReportExt	PDCP_Ctrl_LWA_StatusReportExt_Type	PDCP Control PDU for LWA status report using a 15 bit SN
LWA_StatusReport_18bitSN	PDCP_Ctrl_LWA_StatusReport_18bitSN_Type	PDCP Control PDU for LWA status report using a 18 bit SN
DataSLRB	PDCP_DataPdu_SLRB_Type	user plane PDCP Data PDU for SLRB
DataSLRB_1to1	PDCP_DataPdu_SLRB_1to1_Type	user plane PDCP Data PDU for SLRB one to one communication

PDCP_PDUList_Type

TTCN-3 Record of Type	
Name	PDCP_PDUList_Type
Comment	
record of PDCP_PDU_Type	

D.3.2 DRB_Primitive_Definitions

Primitive definitions to send/receive data PDUs over DRB's

D.3.2.1 DRB_Common**L2DataList_Type**

TTCN-3 Union Type		
Name	L2DataList_Type	
Comment	<p>MAC: acc. to rel-8 protocols there is not more than one MAC PDU per TTI; any MAC PDU is completely included in one subframe</p> <p>RLC: one or more RLC PDUs per TTI (e.g. RLC Data + Status PDU on a logical channel; more than one RLC Data PDU in one MAC PDU is valid too) any RLC PDU is completely included in one subframe</p> <p>PDCP: one or more PDUs per TTI; one PDCP PDU may be included in more than one subframe</p>	
MacPdu	MAC_PDUList_Type	SS configuration: RLC TM mode, MAC no header removal (PDCP is not configured)
RlcPdu	RLC_PDUList_Type	SS configuration: RLC TM mode, MAC header removal (PDCP is not configured)
PdcpPdu	PDCP_PDUList_Type	SS configuration: RLC AM/UM mode, PDCP no header removal
PdcpSdu	PDCP_SDUList_Type	SS configuration: RLC AM/UM mode, PDCP header removal
RlcSdu	RLC_SDUList_Type	SS configuration: RLC UM mode with no PDCP, for example MRB

HarqProcessAssignment_Type

TTCN-3 Union Type		
Name	HarqProcessAssignment_Type	
Comment	in DL the HARQ process id may be specified by the test case or automatically assigned by SS	
Id	HarqProcessId_Type	HARQ process as specified by the test case NOTE1: the scope of this type is only for data being sent in one TTI; if data needs more than one TTI the HarqProcessId is undefined for the 2nd TTI onward what shall be handled as an error at the SS; SS may send a SYSTEM_IND indicating an error in this case; NOTE2: The initial value of the NDI shall be the same for all HARQ processes and cells
Automatic	Null_Type	HARQ process id automatically assigned by SS

D.3.2.2 Downlink**DRB_DataPerSubframe_DL_Type**

TTCN-3 Record Type		
Name	DRB_DataPerSubframe_DL_Type	
Comment	common definition for one or several PDUs/SDUs; in EUTRA the DL data is sent in the subframe given by the subframe offset; in NB-IOT the DL transmission is scheduled in the search space candidate given by "SubframeOffset" for NB-IOT it specifies the NOTE 1: For MAC and RLC PDUs a single PDU is always sent in one subframe; SS shall raise an error indication (using SYSTEM_IND) when that is not possible NOTE 2: For PDCP the data may be spread over more than one subframe (segmented by the RLC); the TTCN implementation is responsible to calculate appropriate offsets accordingly; the exact timing depends on (and is exactly specified by) configuration of the DL scheduling; SS shall raise an error when there is any conflict	
SubframeOffset	integer	EUTRA: Subframe offset relative to the absolute timing information given in the common part of the ASP; NB-IOT: Offset of the search space candidate relative to the (default) search space candidate as configured for the NPDCCH UE specific search space; the search space candidate is in the next search space starting at or after the point in time given by the timing information of the common part of the ASP NOTE 1: Notes: Acc. to TS 36.523-3, clause 7.3.3 in case of TDD or half-duplex configuration only subframes available for DL are taken into consideration NOTE 2: if a PDCP PDU or SDU takes more than one subframe, SubframeOffset specifies the first TTI
HarqProcess	HarqProcessAssignment_Type	opt HARQ process to be used: specific value (0..7) or automatically assigned by SS; in automatic mode SS chooses HARQ process out of the set configured by CcchDcchDtchConfigDL_Type.HarqProcessConfig NOTE 1: for PDCP SDUs or PDUs automatic mode shall be used; otherwise SS shall raise an error NOTE 2: for NB-IoT the HarqProcess shall be omitted by TTCN and ignored by the SS
PduSduList	L2DataList_Type	list of PDUs/SDUs to be sent in one TTI

DRB_DataPerSubframeList_DL_Type

TTCN-3 Record of Type	
Name	DRB_DataPerSubframeList_DL_Type
Comment	list of user plane data to be sent in sub-frames given by the SubframeOffset in the single elements of the list; Timing: the start time for the whole sequence is given by the timing info of the ASP (common information); the timing for the respective data pdus is given by the SubframeOffset relative to the common timing info; design consideration: repetitions of this sequence are not foreseen (in which case the subframe offset could not be related to the timing info of the ASP)
record of DRB_DataPerSubframe_DL_Type	

L2Data_Request_Type

TTCN-3 Record Type	
Name	L2Data_Request_Type
Comment	NOTE: formal type definition to allow later enhancements; L2Data_Request_Type defines a sequence of subframes in which data shall be sent
SubframeDataList	DRB_DataPerSubframeList_DL_Type

D.3.2.3 Uplink

DRB_DataPerSubframe_UL_Type

TTCN-3 Record Type	
Name	DRB_DataPerSubframe_UL_Type
Comment	common definition for one or several PDUs/SDUs being received in one subframe or to receive one PDCP PDU or SDU being spread over more than one TTI; NOTE: There is a fix relation between HARQ process id and subframe in UL => it is not necessary to include HARQ process id for UL data
PduSduList	L2DataList_Type list of PDUs/SDUs being received in one TTI; elements of the list appear in the same order as the PDUs/SDUs in the MAC PDU; for PDCP when a PDU or SDU takes more than one TTI the list only contains this PDU or SDU
NoOfTTIs	integer in case of PDCP: number of TTIs the SDU or PDU has taken NOTE 1: for the time being the NoOfTTIs is not checked by TTCN-3 and may be set to 1 by SS; NOTE 2: the timing info in common part of the ASP refers to the last TTI NOTE 3: when NoOfTTIs > 1 => PduSduList shall only contain one PDCP PDU or SDU in case of MAC or RLC PDUs: NoOfTTIs shall always be 1 (acc. to TS 36.321 MAC is not doing segmentation of RLC PDUs and acc. to TS 36.322, clause 6.2.2.2 the maximum RLC data is calculated to fit into a MAC PDU and RLC does segmentation accordingly)

L2Data_Indication_Type

TTCN-3 Record Type	
Name	L2Data_Indication_Type
Comment	NOTE: formal type definition to allow later enhancements; L2Data_Indication_Type defines data being received in a single subframe i.e. PDUs of subsequent TTIs are indicated in separated ASPs
SubframeData	DRB_DataPerSubframe_UL_Type

D.4 EUTRA_ASP_SrbDefs**D.4.1 SRB_DATA_ASPs**

ASP Definitions to send/receive peer-to-peer messages on SRBs

C_Plane_Request_Type

TTCN-3 Record Type				
Name	C_Plane_Request_Type			
Comment	RRC and/or NAS PDU to be send to the UE; Note: it may be necessary to allow more than one NAS PDU (-> "record of")			
Rrc	<table border="1"> <tr> <td>RRC_MSG_Request_Type</td> <td>opt</td> <td>omit: NAS message shall be present; NAS message shall be sent in DLInformationTransfer present: if NAS message is present also, (piggybacked) NAS PDU shall be security protected (if necessary) and inserted in RRC PDU's DedicatedInfoNAS</td> </tr> </table>	RRC_MSG_Request_Type	opt	omit: NAS message shall be present; NAS message shall be sent in DLInformationTransfer present: if NAS message is present also, (piggybacked) NAS PDU shall be security protected (if necessary) and inserted in RRC PDU's DedicatedInfoNAS
RRC_MSG_Request_Type	opt	omit: NAS message shall be present; NAS message shall be sent in DLInformationTransfer present: if NAS message is present also, (piggybacked) NAS PDU shall be security protected (if necessary) and inserted in RRC PDU's DedicatedInfoNAS		
Nas	<table border="1"> <tr> <td>NAS_MSG_RequestList_Type</td> <td>opt</td> <td>omit: RRC message shall be present; RRC message does not contain (piggybacked) NAS PDU present: if RRC message is omitted => NAS message shall be sent embedded in DLInformationTransfer if RRC message is present => NAS message is piggybacked in RRC message in case of RRC message is sent on CCCH, NAS message shall be omitted NOTE: acc. DEC 08 ASN.1 RRCConnectionReconfiguration may contain DedicatedInfoNAS several times</td> </tr> </table>	NAS_MSG_RequestList_Type	opt	omit: RRC message shall be present; RRC message does not contain (piggybacked) NAS PDU present: if RRC message is omitted => NAS message shall be sent embedded in DLInformationTransfer if RRC message is present => NAS message is piggybacked in RRC message in case of RRC message is sent on CCCH, NAS message shall be omitted NOTE: acc. DEC 08 ASN.1 RRCConnectionReconfiguration may contain DedicatedInfoNAS several times
NAS_MSG_RequestList_Type	opt	omit: RRC message shall be present; RRC message does not contain (piggybacked) NAS PDU present: if RRC message is omitted => NAS message shall be sent embedded in DLInformationTransfer if RRC message is present => NAS message is piggybacked in RRC message in case of RRC message is sent on CCCH, NAS message shall be omitted NOTE: acc. DEC 08 ASN.1 RRCConnectionReconfiguration may contain DedicatedInfoNAS several times		

C_Plane_Indication_Type

TTCN-3 Record Type			
Name	C_Plane_Indication_Type		
Comment	RRC and/or NAS PDU to be received from the UE; Note: it may be necessary to allow more than one NAS PDU (-> "record of")		
Rrc	RRC_MSG_Indication_Type	opt	omit: NAS message shall be present; NAS message is received in ULInformationTransfer present: if NAS message is present also, DedicatedInfoNAS contains unstructured and ciphered NAS message and the NAS message is the deciphered message in structured format
Nas	NAS_MSG_IndicationList_Type	opt	omit: RRC message shall be present; RRC message does not contain (piggybacked) NAS PDU present: if RRC message is omitted => NAS message has been received in ULInformationTransfer if RRC message is present => NAS message has been piggybacked in RRC message NOTE: even though currently (DEC 08 ASN.1) there is no RRC PDU in UL containing more than one DedicatedInfoNAS we provide a list to allow extendability

SRB_COMMON_REQ

TTCN-3 Record Type			
Name	SRB_COMMON_REQ		
Comment	common ASP to send PDUs to SRB0, SRB1 or SRB2		
Common	ReqAspCommonPart_Type		CellId identifier of the cell RoutingInfo SRB0, SRB1, SRB2 TimingInfo Now in normal cases; For latency tests TimingInfo can be set to the SFN/subframe in which the RRC messages shall be sent out (in this case and if the RRC PDU is too long to be sent in one TTI the TimingInfo corresponds to the first TTI) ControllInfo CnfFlag:=false; FollowOnFlag true: Indicates that the message(s) to be sent on the same TTI will follow NOTE 1: When FollowOnFlag is true, TimingInfo shall always be "Now". Otherwise SS shall produce an error NOTE 2: the follow on flag applies only for messages of the same SRB false: Indicates that no more message(s) will follow
Signalling	C_Plane_Request_Type		

SRB_COMMON_IND

TTCN-3 Record Type			
Name	SRB_COMMON_IND		
Comment	common ASP to receive PDUs from SRB0, SRB1 or SRB2		
Common	IndAspCommonPart_Type		CellId identifier of the cell RoutingInfo SRB0, SRB1, SRB2 TimingInfo time when message has been received (as received from the SS by the NAS emulator)
Signalling	C_Plane_Indication_Type		

D.4.2 Port_Definitions

EUTRA_SRB_PORT

TTCN-3 Port Type	
Name	EUTRA_SRB_PORT
Comment	EUTRA PTC: Port for Sending/Receiving data on SRBs
out	SRB_COMMON_REQ
in	SRB_COMMON_IND

NASEMU_EUTRA_SRB_PORT

TTCN-3 Port Type	
Name	NASEMU_EUTRA_SRB_PORT
Comment	NASEMU PTC: Port for Sending/Receiving data on SRBs (interface to EUTRA PTC)
out	SRB_COMMON_IND
in	SRB_COMMON_REQ

D.5 IP_ASP_TypeDefs

General Notes:

NOTE 1:

In general the handling of IP data shall be independent from the RAT being used on lower layers.

NOTE 2:

It shall be possible for SS implementation to reuse existing IP stack implementations in the system adaptor; therefore the well-known concept of socket programming shall be supported (regardless of whether those are used in the system adaptor implementation or not)

NOTE 3:

Since in general at the network side there are several different IP addresses the SS needs to simulate more than one IP address;

that can be based on a concept of multiple virtual network adaptors

NOTE 4:

There is no easy way to control the routing of IP data for an IP connection from above the IP stack

i.e. there are no parameters at the socket interface to determine e.g. cell id and DRB id

=> another independent logical entity (DRB-MUX) is needed below the IP stack which is responsible to control the routing of IP packets from/to DRBs in different cells of different RATs

Reference:

An introduction to socket programming can be found in

UNIX Network Programming Volume 1, Third Edition: The Sockets Networking API

by W. Richard Stevens, Bill Fenner, Andrew M. Rudoff

D.5.1 IP_Common

IP_Common: Basic Type Definitions

TTCN-3 Basic Types	
PortNumber_Type	UInt16_Type

IPv4_AddrInfo_Type

TTCN-3 Record Type			
Name	IPv4_AddrInfo_Type		
Comment	IPv4 specific info of the socket addr (AF_INET)		
Addr	charstring		IP Address as string (IP v4 dot notation) to be converted to 32-bit unsigned integer

IPv6_AddrInfo_Type

TTCN-3 Record Type			
Name	IPv6_AddrInfo_Type		
Comment	IPv6 specific info of the socket addr (AF_INET6); NOTE: sin6_flowinfo can be ignored and set to 0		
Addr	charstring		to be converted to sin6_addr
Scopeld	UInt32_Type	opt	sin6_scope_id in general an IPv6 address is like "fe80::1%eth0" with eth0 being the network adaptor mapped to a scope id (Unix) assumption: for UE conformance testing it is not necessary to distinguish different scopes and the scope id in general can be determined by the system adaptor => omit

IP_AddrInfo_Type

TTCN-3 Union Type			
Name	IP_AddrInfo_Type		
Comment			
V4	IPv4_AddrInfo_Type		
V6	IPv6_AddrInfo_Type		

IP_Socket_Type

TTCN-3 Record Type			
Name	IP_Socket_Type		
Comment	Socket		
IpAddr	IP_AddrInfo_Type	opt	IP address
Port	PortNumber_Type	opt	port number

InternetProtocol_Type

TTCN-3 Enumerated Type	
Name	InternetProtocol_Type
Comment	
udp	
tcp	
icmp	
icmpv6	

IP_Connection_Type

TTCN-3 Record Type			
Name	IP_Connection_Type		
Comment	A connection between peer-to-peer entities is unambiguously defined by the protocol (udp/tcp/icmp/icmpv4), the local socket and the remote socket		
Protocol	InternetProtocol_Type		
Local	IP_Socket_Type	opt	
Remote	IP_Socket_Type	opt	

D.5.2 IP_Config

Configuration of the routing table managed by the system adaptor's DRB-MUX:
for each IP connection it is specified which

- RAT
- Cell
- DRB

to be used.

The IP connection does not need to be fully specified depending on the role SS plays (e.g. in case of a server role the port number of the remote side is not known in advance).

The configurations of DRBs within the same cell shall be mutual exclusive.

With the configuration of the IP routing the DRB is configured either in IP or in raw mode:

either there are entries for the DRB in the routing table (IP mode) or not (raw mode)

=> It is not necessary to reconfigure this for the respective RAT.

Behaviour of the DRB-MUX in UL:

- SS gets data packet from the lower layers (e.g. PDCP SDU)
- SS checks whether there is any IP connection configured for this DRB (identified by {RAT, CellId, DrbId})
 - if YES => packet is routed to the IP stack (IP mode)
 - if NO => packet is handed over to the DRB port (raw mode)

NOTE 1:

If there is any entry for a DRB in the routing table this DRB is considered as being in IP mode and all UL IP packets are sent to the IP stack regardless of whether their addresses match the DRB's routing entries or not (in general 'unknown' packets are discarded by the IP stack)

=> a DRB can be either in IP or in raw mode

NOTE 2:

=> The SS does not need to evaluate any IP headers to decide whether data shall be routed to the DRB port or to the IP stack (i.e. there is no conflict with unstructured loopback data)

Behaviour of the DRB-MUX in DL:

- SS gets IP packets from the IP stack for an IP connection
- SS compares the IP connection (protocol, local/remote IP Addr) against the IP routing table and checks whether the corresponding protocol stack is configured at the lower layers =>

1. no match:

no entry in the routing table fits to the address in the IP packet
or the corresponding RB is not configured

=> SS shall raise an error (DRBMUX_COMMON_IND_CNF.Error)

2. one match:

There is exactly one possibility to route the IP packet

=> SS shall send the packet to this RB

3. several matches:

There are more than one DRBs, cells or RATs to which the packet may be routed

=> SS shall raise an error if there is more than one DRB in one cell matching;

if the DRBs belong to different cells or RATs SS shall send the data to all of them
(whether this may occur in test cases is FFS)

General notes:

NOTE 1:

SS may use the information of the routing table to determine which network adaptors it needs to simulate (implementation dependent);

in general there will be more than one IP address at the network side.

NOTE 2:

In general the routing table is a simplified DL TFT implementation

NOTE 3:

When the routing table is empty all DRBs are in raw mode; this shall be the initial condition at the DRB-MUX;

=> for L2 testing in general (and apart from the preamble) there is no need to use/configure the IP_PTC; the configuration of the RAT specific U-plane stacks is not affected

IP_DataMode_Type

TTCN-3 Enumerated Type	
Name	IP_DataMode_Type
Comment	
discard	
loopbackRTP	
loopbackRTCP	
IPsecTunnel	

IP_RoutingInfo_Type

TTCN-3 Record Type			
Name	IP_RoutingInfo_Type		
Comment			
IpInfo	IP_Connection_Type		<p>IP connection tuple: protocol, local socket, remote socket depending on the role the SS plays the following information may be provided (informative; even less information can be sufficient):</p> <ol style="list-style-type: none"> TCP/UDP server <ul style="list-style-type: none"> - local IP addr -- provided - local port -- provided - remote IP addr -- omit - remote port -- omit TCP/UDP client <ul style="list-style-type: none"> - local IP addr -- provided (to inform SS about the local IP addr for this service) - local port -- omit; for UDP a well-defined port may be defined (protocol dependent, e.g. DHCP) - remote IP addr -- provided - remote port -- provided ICMP (in general ICMP may be mapped only to a single DRB) <ul style="list-style-type: none"> - local IP addr -- provided (to inform SS about the local IP addr for this service) - local port -- n/a (shall be set to omit) - remote IP addr -- omit - remote port -- n/a (shall be set to omit) <p>NOTE: In case of broadcasts in UL the broadcast address shall match any local IP address; in DL for broadcast services typically no remote IP address is specified in the routing table</p>
DRB	IP_DrbInfo_Type		
DataMode	IP_DataMode_Type	opt	present when IP packets matching this entry shall be discarded or be looped back to the UE as defined for RTP or RTCP

IP_RoutingTable_Type

TTCN-3 Record of Type	
Name	IP_RoutingTable_Type
Comment	NOTE: configurations of DRBs within the same cell shall be mutual exclusive
record of	IP_RoutingInfo_Type

D.5.3 IPsec_Config

IP_ASP_TypeDefs: Constant Definitions

TTCN-3 Basic Types			
tsc_IPsec_SPI_Max	integer	4294967295	

IPsec_Config: Basic Type Definitions

TTCN-3 Basic Types		
IPsec_SPI_Type	integer (0.. tsc IPsec SPI Max)	security parameter index for IPsec; According to RFC 2406, SPI values from 0 to 255 are reserved

IPsec_IntegrityAlgorithm_Type

TTCN-3 Enumerated Type	
Name	IPsec_IntegrityAlgorithm_Type
Comment	
hmac_md5_96	
hmac_sha_1_96	

IPsec_CipheringAlgorithm_Type

TTCN-3 Enumerated Type	
Name	IPsec_CipheringAlgorithm_Type
Comment	
des_ed3_cbc	
aes_cbc	
nociph	no ciphering

IPsec_SecurityKeys_Type

TTCN-3 Record Type			
Name	IPsec_SecurityKeys_Type		
Comment	to install the security keys		
MD5_96Key	bitstring length (128)		
SHA_1_96Key	bitstring length (160)		
DES_EDE3_C BCKey	bitstring length (192)		
AES_CBCKey	bitstring length (128)		

IPsec_SecurityAssociation_Type

TTCN-3 Record Type			
Name	IPsec_SecurityAssociation_Type		
Comment	single security association (SA); for configuration of an SA at the SS all fields are mandatory; to release an SA the optional information is omitted		
SPI	IPsec_SPI_Type		
SrcAddress	charstring		
DestAddress	charstring		
SrcPort	UInt16_Type		
DestPort	UInt16_Type		
IntegrityAlgorith m	IPsec_IntegrityAlgorithm_T ype	opt	mandatory to set-up an SA
CipheringAlgori thm	IPsec_CipheringAlgorithm_ Type	opt	mandatory to set-up an SA

IPsec_SecurityAssociationList_Type

TTCN-3 Record of Type	
Name	IPsec_SecurityAssociationList_Type
Comment	
record of IPsec_SecurityAssociation_Type	

IPsec_Configure_Type

TTCN-3 Record Type	
Name	IPsec_Configure_Type
Comment	add new security associations; existing SAs are not affected
SA_List	IPsec_SecurityAssociationList_Type
SecurityKeys	IPsec_SecurityKeys_Type

IPsec_Release_Type

TTCN-3 Record Type	
Name	IPsec_Release_Type
Comment	release security associations; NOTE: in context with multiple PDNs it cannot be ensured that all SPIs are unique; e.g. the UE may use the same SPI values in different PDNs in which case uniqueness cannot be achieved furthermore it depends on the system implementation how entries in the IPsec SAD and SPD are administrated => to release SAs the SS gets the same information as for configuration but without the security algorithms
SA_List	IPsec_SecurityAssociationList_Type

D.5.4 IP_SocketHandling

Handling of IP data and IP connections

NOTE 1:

In general IP connections are distinguished by the tuple {protocol, local socket, remote socket}; this information is used at the interface between TTCN and the system adaptor.

It is up to the system adaptor implementation to associate the IP connection with the internal socket (file descriptor; implementation dependent)

NOTE 2:

In general the association of the IP connections to (internal) sockets and the routing table for the DRB mapping (as configured with IP_RoutingTable_Type) are independent from each other

D.5.4.1 Socket_Common

IP_SockOpt_Type

TTCN-3 Union Type	
Name	IP_SockOpt_Type
Comment	socket options acc. to the setsockopt system call (i.e. for level=SOL_SOCKET in case of Berkeley socket API); NOTE: only options being relevant for a specific applications (upon a socket) are configured by TTCN other options (e.g. SO_REUSEADDR) are out of TTCN and therefore a matter of system adaptor implementation
SO_BROADCAST	boolean set to true when IP broadcast messages shall be allowed for a port; this is required e.g. in case of DHCP
IP_MTU_SIZE	integer MTU size to be used for IP data; NOTES: - Even though the MTU size is defined as socket option it shall be the same for all sockets of a given interface (i.e. at least within one PDN the MTU size shall be the same) - in general a PIXIT is used as constant value for all sockets

IP_SockOptList_Type

TTCN-3 Record of Type	
Name	IP_SockOptList_Type
Comment	
record of IP_SockOpt_Type	

IP_SocketError_Type

TTCN-3 Union Type	
Name	IP_SocketError_Type
Comment	used to indicate errors related to sockets; the IP_Connection shall contain as much address information as available at the system adaptor
InvalidAddress	Null_Type TTCN error: e.g. invalid or incomplete address information
System	integer system error caused by system call; the integer value may be used for validation but shall not be evaluated by TTCN

D.5.4.2 Socket_Datagram

Socket_Datagram: Basic Type Definitions

TTCN-3 Basic Types		
Datagram_Content_Type	octetstring	data as sent/received with sendto()/recvfrom() on UDP or ICMP socket; NOTE: For ICMP the data may depend on the socket options; in general it does not include the IP header and the checksum of the ICMP packet needs to be calculated/checked in TTCN

Datagram_DL_Type

TTCN-3 Record Type	
Name	Datagram_DL_Type
Comment	datagram to be sent at a UDP or ICMP socket
Buffer	Datagram_Content_Type content of the IP packet

Datagram_UL_Type

TTCN-3 Record Type	
Name	Datagram_UL_Type
Comment	datagram as received on a UDP or ICMP socket
Buffer	Datagram_Content_Type content of the IP packet
DrbInfo	IP_DrbInfo_Type opt "interface id" where the data comes from in case of broadcast or multicast packets: for the LTE test model this is the DRB on which the IP packet has been received; the information is necessary when the SS cannot resolve an IP address being assigned to that DRB. => when the SS provides a broadcast or multicast address as local address in the ConnectionId of the ASP, the SS shall provide the DRB information in this field When the ConnectionId of the ASP is fully specified and unique (unicast address at least for local address) the DrbId is ignored by TTCN

D.5.4.3 TCP_Socket

TCP primitives used on the IP port

TCP_Socket: Basic Type Definitions

TTCN-3 Basic Types		
TCP_Data_Type	octetstring	data as sent/received with send()/recv() on a TCP socket

InternetApplication_Type

TTCN-3 Enumerated Type	
Name	InternetApplication_Type
Comment	as TCP is stream oriented SS may need information about which criteria to be applied to get start/end of an application message
ims	
http	

TLS_CIPHER_Type

TTCN-3 Enumerated Type	
Name	TLS_CIPHER_Type
Comment	Cipher suite to be used for TLS
TLS_PSK_WITH_RC4_128_SHA	RFC 4279
TLS_PSK_WITH_3DES_EDE_CBC_SHA	RFC 4279
TLS_PSK_WITH_AES_128_CBC_SHA	RFC 4279
TLS_PSK_WITH_AES_256_CBC_SHA	RFC 4279
TLS_PSK_WITH_AES_128_CBC_SHA256	RFC 5487

PSK_BootstrappingInfo_Type

TTCN-3 Record Type			
Name	PSK_BootstrappingInfo_Type		
Comment	bootstrapping information as defined in 24.109		
BTid	charstring		
Ks_NAF	bitstring		

TLS_PSK_Info_Type

TTCN-3 Record Type			
Name	TLS_PSK_Info_Type		
Comment	configuration information for PSK TLS		
IdentityHint	charstring		
BootstrappingInfo	PSK_BootstrappingInfo_Type		

TLS_CipherSuiteInfo_Type

TTCN-3 Union Type	
Name	TLS_CipherSuiteInfo_Type
Comment	
psk	TLS_PSK_Info_Type

TLSInfo_Type

TTCN-3 Record Type	
Name	TLSInfo_Type
Comment	
cipherSuite	TLS_CIPHER_Type Cipher suite to be used
cipherSuiteInfo	TLS_CipherSuiteInfo_Type parameters for the respective cipher suite

TCP_ConnectRequest_Type

TTCN-3 Record Type	
Name	TCP_ConnectRequest_Type
Comment	TCP client: -> 'connect' system call
SockOptList	IP_SockOptList_Type when there are no options to configure the list is empty
Application	InternetApplication_Type to specify start/end criteria for application messages

TCP_Listen_Type

TTCN-3 Record Type	
Name	TCP_Listen_Type
Comment	TCP server: -> 'listen' system call
SockOptList	IP_SockOptList_Type when there are no options to configure the list is empty
Application	InternetApplication_Type to specify start/end criteria for application messages
TLSInfo	TLSInfo_Type opt to support TLS for HTTP server implementation

TCP_CtrlRequest_Type

TTCN-3 Union Type		
Name	TCP_CtrlRequest_Type	
Comment		
ConnectReq	TCP_ConnectRequest_Type	<p>request a 'connect' to a remote server</p> <p>system calls (informative) socket -- get file descriptor (setsockopt) -- normally not needed bind -- assign local IP addr (to cope with multiple IP addresses) and dedicated port number (if local port is given) connect -- connect to the client</p> <p>IP_Connection: protocol -- tcp local IP addr -- mandatory to distinguish different network adaptors local port -- omit (ephemeral port will be assigned by the system) or specific port to be used for this connection (e.g. to bind a given port number to the IMS client) remote IP addr -- mandatory remote port -- mandatory</p>
Listen	TCP_Listen_Type	<p>establish a server at the local (SS) side</p> <p>system calls (informative) socket -- get file descriptor (setsockopt) -- if needed bind -- assign local IP addr and port listen -- await incoming connection</p> <p>IP_Connection: protocol -- tcp local IP addr -- mandatory to distinguish different network adaptors local port -- mandatory remote IP addr -- omit remote port -- omit</p>
Close	Null_Type	<p>close a connection</p> <p>system calls (informative): close</p> <p>IP_Connection: protocol -- tcp local IP addr -- mandatory local port -- mandatory remote IP addr -- mandatory for TCP connections, omit for TCP server remote port -- mandatory for TCP connections, omit for TCP server</p>

TCP_DataRequest_Type

TTCN-3 Union Type		
Name	TCP_DataRequest_Type	
Comment		
Send	TCP_Data_Type	<p>send data</p> <p>system calls (informative): send or write</p> <p>IP_Connection: protocol -- tcp local IP addr -- mandatory local port -- mandatory remote IP addr -- mandatory remote port -- mandatory</p>

TCP_CtrlIndication_Type

TTCN-3 Union Type		
Name	TCP_CtrlIndication_Type	
Comment		
ConnectCnf	Null_Type	<p>confirm a 'connect' to a remote server</p> <p>system calls (informative): getsockname -- get local port (ephemeral port assigned by the system)</p> <p>IP_Connection: protocol -- tcp local IP addr -- mandatory (as in corresponding TCP_ConnectRequest) local port -- mandatory (if there is more than one connection to the same server the local port is necessary to distinguish the connections) remote IP addr -- mandatory (as in corresponding TCP_ConnectRequest) remote port -- mandatory (as in corresponding TCP_ConnectRequest)</p>
Accept	Null_Type	<p>sent by the SS when it 'accepts' an incoming connection</p> <p>system calls (informative): accept</p> <p>IP_Connection: protocol -- tcp local IP addr -- mandatory (as in corresponding TCP_ListenRequest) local port -- mandatory (as in corresponding TCP_ListenRequest) remote IP addr -- mandatory (as gotten from 'accept') remote port -- mandatory (as gotten from 'accept')</p>
Close	Null_Type	<p>indicate 'close' by the remote side</p> <p>system calls (informative): indicated by recv or read</p> <p>IP_Connection: protocol -- tcp local IP addr -- mandatory local port -- mandatory remote IP addr -- mandatory remote port -- mandatory</p>
CloseCnf	Null_Type	<p>Confirmation for 'close' request; necessary since for TCP there are IP packets to release the connection</p> <p>system calls (informative): close</p> <p>IP_Connection: protocol -- tcp local IP addr -- mandatory local port -- mandatory remote IP addr -- mandatory for TCP connections, omit for TCP server remote port -- mandatory for TCP connections, omit for TCP server</p>

TCP_DataIndication_Type

TTCN-3 Union Type		
Name	TCP_DataIndication_Type	
Comment		
Recv	TCP_Data_Type	receive data system calls (informative): recv or read IP_Connection: protocol -- tcp local IP addr -- mandatory local port -- mandatory remote IP addr -- mandatory remote port -- mandatory

D.5.4.4 UDP_Socket

UDP primitives used on the IP port

NOTE:

In principle a UDP socket may communicate with different remote entities;
 therefore the system adaptor may associate the socket handle with the local socket only
 (local IP address and local port)

UDP_SocketReq_Type

TTCN-3 Record Type		
Name	UDP_SocketReq_Type	
Comment	to establish a UDP server or to bind local port number	
SockOptList	IP_SockOptList_Type	e.g. to allow broadcast messages; when there are no options to configure the list is empty

UDP_CtrlRequest_Type

TTCN-3 Union Type		
Name	UDP_CtrlRequest_Type	
Comment		
SocketReq	UDP_SocketReq_Type	<p>request the system adaptor to bind a socket to a local address; this is needed in general when the system adaptor acts as</p> <ol style="list-style-type: none"> 1. UDP server 2. UDP client when it uses a well-known port rather than an ephemeral port (this is e.g. for DHCP) 3. UDP client when a local address needs to be bond (e.g. when there are several local addresses) <p>system calls (informative): socket -- get file descriptor (setsockopt) -- needed e.g. to allow broad cast message bind -- assign local IP address (to cope with multiple IP addresses) and local port (in case of well-known local port)</p> <p>IP_Connection: protocol -- udp local IP addr -- mandatory (to distinguish multiple IP addresses) local port -- optional (mandatory in case of a UDP server) remote IP addr -- omit remote port -- omit</p>
Close	Null_Type	<p>release local socket</p> <p>system calls (informative): close</p> <p>IP_Connection: protocol -- udp local IP addr -- mandatory (to identify local socket) local port -- mandatory (to identify local socket) remote IP addr -- omit remote port -- omit</p>

UDP_DataRequest_Type

TTCN-3 Union Type		
Name	UDP_DataRequest_Type	
Comment		
SendTo	Datagram_DL_Type	<p>send data to (any) remote socket; NOTE: To simplify implementation of the system adaptor the local socket shall be bond in any case (using 'SocketReq') to specify the local IP address before sending data; (in general the sendto system call can be used without explicitly binding the socket before; in this case the port gets implicitly bond to an ephemeral port and the default IP address is used)</p> <p>system calls (informative): sendto</p> <p>IP_Connection: protocol -- udp local IP addr -- mandatory (to identify local socket) local port -- mandatory (to identify local socket) remote IP addr -- mandatory (to address remote socket) remote port -- mandatory (to address remote socket)</p>

UDP_CtrlIndication_Type

TTCN-3 Union Type		
Name	UDP_CtrlIndication_Type	
Comment		
SocketCnf	Null_Type	<p>confirm 'SocketReq' and tell TTCN about assignment of ephemeral port;</p> <p>system calls (informative): getsockname -- get local port (ephemeral port assigned by the system; not needed if local port is well-known)</p> <p>IP_Connection: protocol -- udp local IP addr -- mandatory local port -- mandatory (well-known or ephemeral port assigned by the system) remote IP addr -- omit remote port -- omit</p>

UDP_DataIndication_Type

TTCN-3 Union Type		
Name	UDP_DataIndication_Type	
Comment		
RecvFrom	Datagram_UL_Type	<p>receive data;</p> <p>system calls (informative): recvfrom -- get data and src addr</p> <p>IP_Connection: protocol -- udp local IP addr -- mandatory (see note) local port -- mandatory remote IP addr -- mandatory (as gotten from recvfrom) remote port -- mandatory (as gotten from recvfrom)</p> <p>NOTE: The UE may send a UDP packet as broadcast (IP Addr 255.255.255.255 - e.g. in case of DHCP) or multicast (e.g. ICMPv6) SS shall consider a broadcast address as matching every IP for UL and DL; the SS shall not replace the broadcast/multicast address by the local unicast address, but shall provide DRB information in RecvFrom; example: - SS gets DHCPDISCOVER with DEST_Addr=255.255.255.255 DEST_Port=67, SRC_Addr=0.0.0.0 SRC_Port=68 - TTCN gets DHCPDISCOVER with local Addr=(255.255.255.255 Port=67), remote Addr=(0.0.0.0 Port=68), DrbId=(LTE, cell1, DRB1) - TTCN sends DHCPOFFER with local Addr=(local IP Addr Port=67), remote Addr=(255.255.255.255 Port=68)</p>

D.5.4.5 ICMP_Socket

ICMP primitives used on the IP port

NOTE:

the local side is identified by the protocol and in general by the local IP address

ICMP_SocketReq_Type

TTCN-3 Record Type	
Name	ICMP_SocketReq_Type
Comment	to establish a raw socket to send/receive ICMP packets
SockOptList	IP_SockOptList_Type e.g. to set the IP_HDRINCL socket option (to include the IP header in the data buffer) when there are no options to configure the list is empty

ICMP_CtrlRequest_Type

TTCN-3 Union Type	
Name	ICMP_CtrlRequest_Type
Comment	
SocketReq	ICMP_SocketReq_Type request the system adaptor to open a raw socket (IPv4 or IPv6) system calls (informative): socket -- get file descriptor (IPPROTO_ICMP or IPPROTO_IPV6); (setsockopt) -- optional; to set socket options bind -- assign local IP address (to cope with multiple IP addresses) IP_Connection: protocol -- icmp or icmpv6 local IP addr -- mandatory (to distinguish multiple IP addresses) local port -- omit (not applicable for ICMP) remote IP addr -- omit remote port -- omit (not applicable for ICMP)
Close	Null_Type release local socket system calls (informative): close IP_Connection: protocol -- icmp or icmpv6 local IP addr -- mandatory (to identify local socket) local port -- omit remote IP addr -- omit remote port -- omit

ICMP_DataRequest_Type

TTCN-3 Union Type	
Name	ICMP_DataRequest_Type
Comment	
SendTo	Datagram_DL_Type send datagram system calls (informative): sendto IP_Connection: protocol -- icmp or icmpv6 local IP addr -- mandatory (to identify local socket) local port -- omit remote IP addr -- mandatory remote port -- omit

ICMP_CtrlIndication_Type

TTCN-3 Union Type		
Name	ICMP_CtrlIndication_Type	
Comment		
SocketCnf	Null_Type	confirm 'SocketReq' system calls (informative): (SocketCnf is sent when all system calls for SocketReq have been successful) IP_Connection: protocol -- icmp or icmpv6 local IP addr -- mandatory local port -- omit remote IP addr -- omit remote port -- omit

ICMP_DataIndication_Type

TTCN-3 Union Type		
Name	ICMP_DataIndication_Type	
Comment		
RecvFrom	Datagram_UL_Type	receive datagram system calls (informative): recvfrom -- get data and src addr IP_Connection: protocol -- icmp or icmpv6 local IP addr -- mandatory (see note) local port -- omit remote IP addr -- mandatory (as gotten from recvfrom) remote port -- omit NOTE: As for UDP there may be multicast/broadcast packets. In this case - as for UDP - the SS shall provide the DRB information in RecvFrom.

D.5.4.6 Socket_Primitives

IP_CtrlRequest_Type

TTCN-3 Union Type		
Name	IP_CtrlRequest_Type	
Comment		
TCP	TCP_CtrlRequest_Type	
UDP	UDP_CtrlRequest_Type	
ICMP	ICMP_CtrlRequest_Type	

IP_DataRequest_Type

TTCN-3 Union Type		
Name	IP_DataRequest_Type	
Comment		
TCP	TCP_DataRequest_Type	
UDP	UDP_DataRequest_Type	
ICMP	ICMP_DataRequest_Type	

IP_CtrlIndication_Type

TTCN-3 Union Type	
Name	IP_CtrlIndication_Type
Comment	
TCP	TCP_CtrlIndication_Type
UDP	UDP_CtrlIndication_Type
ICMP	ICMP_CtrlIndication_Type
Error	IP_SocketError_Type

IP_DataIndication_Type

TTCN-3 Union Type	
Name	IP_DataIndication_Type
Comment	
TCP	TCP_DataIndication_Type
UDP	UDP_DataIndication_Type
ICMP	ICMP_DataIndication_Type

D.5.5 System_Interface

DRBMUX_CONFIG_REQ

TTCN-3 Union Type	
Name	DRBMUX_CONFIG_REQ
Comment	<p>NOTE 1: There is just one primitive to configure the whole routing table. It is not foreseen to add, remove or manipulate single entries but the table is managed in TTCN and completely configured on any change; (otherwise it might get complicated to identify single entries)</p> <p>NOTE 2: the SS's routing table shall be empty at the beginning and can be cleared by an empty record (DRBMUX_CONFIG_REQ.RoutingInfo = {})</p> <p>NOTE 3: In general a reconfiguration of the routing table during a test case would be necessary only if an ephemeral port is needed to distinguish different routing (e.g. when there are several TCP connections of the same service routed to different DRBs)</p>
RoutingInfo	IP_RoutingTable_Type

DRBMUX_COMMON_IND_CNF

TTCN-3 Union Type	
Name	DRBMUX_COMMON_IND_CNF
Comment	
Confirm	Null_Type confirm DRBMUX_CONFIG_REQ
Error	Null_Type indication of errors at the DRB-MUX: An Error shall be raised by the DRB-MUX e.g. in the following cases: - in DL when there are IP packets which cannot be routed to any DRB i.e. the IP packet does not match to any entry in the routing table or the corresponding RB is not configured - in DL when there are several DRBs possible for routing in the same cell

IPSEC_CONFIG_REQ

TTCN-3 Union Type		
Name	IPSEC_CONFIG_REQ	
Comment		
Configure	IPsec_Configure_Type	
Release	IPsec_Release_Type	

IPSEC_CONFIG_CNF

TTCN-3 Union Type		
Name	IPSEC_CONFIG_CNF	
Comment		
Confirm	Null_Type	confirm IPSEC_CONFIG_REQ
Error	Null_Type	to indicate invalid configuration of IPsec

IP_SOCKET_CTRL_REQ

TTCN-3 Record Type		
Name	IP_SOCKET_CTRL_REQ	
Comment		
ConnectionId	IP_Connection_Type	
Req	IP_CtrlRequest_Type	

IP_SOCKET_DATA_REQ

TTCN-3 Record Type		
Name	IP_SOCKET_DATA_REQ	
Comment		
ConnectionId	IP_Connection_Type	
Req	IP_DataRequest_Type	

IP_SOCKET_CTRL_IND

TTCN-3 Record Type		
Name	IP_SOCKET_CTRL_IND	
Comment		
ConnectionId	IP_Connection_Type	
Ind	IP_CtrlIndication_Type	

IP_SOCKET_DATA_IND

TTCN-3 Record Type		
Name	IP_SOCKET_DATA_IND	
Comment		
ConnectionId	IP_Connection_Type	
Ind	IP_DataIndication_Type	

IP_SOCKET_REQ

TTCN-3 Union Type		
Name	IP_SOCKET_REQ	
Comment		
CTRL	IP_SOCKET_CTRL_REQ	
DATA	IP_SOCKET_DATA_REQ	

IP_SOCKET_IND

TTCN-3 Union Type		
Name	IP_SOCKET_IND	
Comment		
CTRL	IP_SOCKET_CTRL_IND	
DATA	IP_SOCKET_DATA_IND	

IP_CONTROL_PORT

TTCN-3 Port Type		
Name	IP_CONTROL_PORT	
Comment		
out	DRBMUX_CONFIG_REQ	
in	DRBMUX_COMMON_IND_CNF	

IPSEC_CONTROL_PORT

TTCN-3 Port Type		
Name	IPSEC_CONTROL_PORT	
Comment		
out	IPSEC_CONFIG_REQ	
in	IPSEC_CONFIG_CNF	

IP_SOCKET_PORT

TTCN-3 Port Type		
Name	IP_SOCKET_PORT	
Comment		
out	IP_SOCKET_REQ	
in	IP_SOCKET_IND	

D.6 NasEmu_AspTypes_EUTRA

System interface between NAS emulation and system adaptor

D.6.1 System_Interface

EUTRA_RRC_PDU_REQ

TTCN-3 Record Type	
Name	EUTRA_RRC_PDU_REQ
Comment	
Common	<p>ReqAspCommonPart_Type</p> <p>CellId : identifier of the cell RoutingInfo : SRB0, SRB1, SRB2 TimingInfo : Now in normal cases; For latency tests TimingInfo can be set to the SFN/subframe in which the RRC messages shall be sent out NOTE 1: if the RRC PDU is too long to be sent in one TTI the TimingInfo corresponds to the first TTI NOTE 2: the TimingInfo is not changed by the NAS Emu (i.e. the timing info as coming from the test case (SRB_COMMON_REQ) is handed through by the NAS Emu) ControllInfo CnfFlag:=false; FollowOnFlag true: Indicates that the message(s) to be sent on the same TTI will follow NOTE 1: If the TimingInfo is not the same for messages to be sent on the same TTI, the SS shall produce an error NOTE 2: the follow on flag applies only for messages of the same SRB false: Indicates that no more message(s) will follow</p>
RrcPdu	RRC MSG Request_Type

EUTRA_RRC_PDU_IND

TTCN-3 Record Type	
Name	EUTRA_RRC_PDU_IND
Comment	common ASP to receive PDUs from SRB0, SRB1 or SRB2
Common	<p>IndAspCommonPart_Type</p> <p>CellId : identifier of the cell RoutingInfo : SRB0, SRB1, SRB2 TimingInfo : time when message has been received (frame and sub-frame number); this is handed through to the test case by the NAS emulation NOTE: normally an RRC PDU is expected in one TTI; nevertheless if it is spread over more than one TTIs TimingInfo shall refer to the end of the PDU i.e. to the last RLC PDU being received; Status : OK or RRC integrity error</p>
RrcPdu	RRC MSG Indication_Type

NASEMU_EUTRA_SYSTEM_PORT

TTCN-3 Port Type	
Name	NASEMU_EUTRA_SYSTEM_PORT
Comment	NASEMU PTC: Port for Sending/Receiving data to/from the SYSTEM Interface
out	EUTRA_RRC_PDU_REQ
in	EUTRA_RRC_PDU_IND

D.7 EUTRA_CommonDefs

D.7.1 Common_Types

Common_Types: Basic Type Definitions

TTCN-3 Basic Types		
RedundancyVersion_Type	integer (0..3)	used in EUTRA_ASP_DrbDefs and EUTRA_ASP_Typedefs

HarqProcessList_Type

TTCN-3 Record of Type	
Name	HarqProcessList_Type
Comment	list of HARQ processes: each element shall be unique
record length(0..14) of HarqProcessId_Type	

RRC_MSG_Request_Type

TTCN-3 Union Type	
Name	RRC_MSG_Request_Type
Comment	DL RRC PDU on CCCH or DCCH
Ccch	DL_CCCH_Message
Dcch	DL_DCCH_Message

RRC_MSG_Indication_Type

TTCN-3 Union Type	
Name	RRC_MSG_Indication_Type
Comment	UL RRC PDU on CCCH or DCCH
Ccch	UL_CCCH_Message
Dcch	UL_DCCH_Message

D.7.2 Common_Constants

EUTRA_CommonDefs: Constant Definitions

TTCN-3 Basic Types			
tsc_EUTRA_MaxNumberOfCells	integer	20	Maximum number of cells; in TS 36.508 in, clause 4.4.2 and 6.3.2.2 there are tables for cells being used in non-NAS and NAS test cases; in both cases less than 20 cells are listed

D.7.3 RRC_Nested_Types

RRC_Nested_Types: Basic Type Definitions

TTCN-3 Basic Types		
SchedulingInfoSIB1_BR_r13_Type	MasterInformationBlock.schedulingInfoSIB1_BR_r13	
SiWindowLength_Type	SystemInformationBlockType1.si_WindowLength	
BandwidthReducedAccessRelatedInfo_Type	SystemInformationBlockType1_v1310_IES.bandwidthReducedAccessRelatedInfo_r13	
SiPeriodicity_Type	SchedulingInfoList[0].si_Periodicity	
PrioritizedBitRate_Type	LogicalChannelConfig.ul_SpecificParameters.prioritisedBitRate	
DL_Bandwidth_Type	CarrierBandwidthEUTRA.dl_Bandwidth	
UL_Bandwidth_Type	CarrierBandwidthEUTRA.ul_Bandwidth	
Ra_PreambleIndex_Type	RACH_ConfigDedicated.ra_PreambleIndex	
EDRX_CycleStartOffset_r13_Type	MAC_MainConfig.eDRX_Config_CycleStartOffset_r13	
UE_Category_Type	UE_EUTRA_Capability.ue_Category	
DRX_Config_r13_Type	MAC_MainConfig.drx_Config_r13	
TDD_SubframeAssignment_Type	TDD_Config.subframeAssignment	
SCellPathlossReferenceLinking_Type	UplinkPowerControlDedicatedSCell_r10.pathlossReferenceLinking_r10	
MAC_MainConfig_ScellDeactivationTimer_Type	MAC_MainConfig.mac_MainConfig_v1020.sCellDeactivationTimer_r10	
CrossSchedulingCarrierInfo_Type	CrossCarrierSchedulingConfig_r10.schedulingCellInfo_r10.other_r10	
NotificationIndicator_r9_Type	MBSFN_AreaInfo_r9.notificationIndicator_r9	
LogicalChannelIdentity_r9_Type	MBMS_SessionInfo_r9.logicalChannelIdentity_r9	
UE_Category_v1020_Type	UE_EUTRA_Capability_v1020_IES.ue_Category_v1020	
UE_Category_v1170_Type	UE_EUTRA_Capability_v1170_IES.ue_Category_v1170	
UE_Category_v11a0_Type	UE_EUTRA_Capability_v11a0_IES.ue_Category_v11a0	
UE_CategoryDL_v1310_Type	UE_EUTRA_Capability_v1310_IES.ue_CategoryDL_v1310	
UE_Category_v1250_Type	UE_RadioPagingInfo_r12.ue_Category_v1250	
UE_CategoryDL_r12_Type	UE_EUTRA_Capability_v1250_IES.ue_CategoryDL_r12	
UE_CategoryDL_v1260_Type	UE_EUTRA_Capability_v1260_IES.ue_CategoryDL_v1260	
E_HARQ_Pattern_r12_Type	MAC_MainConfig.e_HARQ_Pattern_r12	
TTI_Bundling_Type	MAC_MainConfig.ul_SCH_Config.ttiBundling	
CE_Mode_r13_Type	PhysicalConfigDedicated.ce_Mode_r13	
SC_MCCH_Duration_Type	SystemInformationBlockType20_r13.sc_mcch_duration_r13	
SC_MCCH_FirstSubframe_Type	SystemInformationBlockType20_r13.sc_mcch_FirstSubframe_r13	
SC_MCCH_ModificationPeriod_Type	SystemInformationBlockType20_r13.sc_mcch_ModificationPeriod_r13	
SC_MCCH_Offset_Type	SystemInformationBlockType20_r13.sc_mcch_Offset_r13	
SC_MCCH_RepetitionPeriod_Type	SystemInformationBlockType20_r13.sc_mcch_RepetitionPeriod_r13	
DMTC_PeriodOffset_r12_Type	MeasDS_Config_r12.setup.dmtc_PeriodOffset_r12	

DS_OccasionDuration_r12_Type	MeasDS_Config_r12.setup.ds_OccasionDuration_r12	
-------------------------------------	---	--

D.7.4 ASP_CommonPart

Definition of ASP common parts for REQ-, CNF- and IND-ASPs

D.7.4.1 ASP_CommonPart_Definitions

D.7.4.1.1 Routing_Info

EUTRA_CommonDefs: Constant Definitions

TTCN-3 Basic Types			
tsc_MaxRB	integer	maxDRB + 3	DRBs + 3 SRBs
tsc_SRB2	integer	2	

Routing_Info: Basic Type Definitions

TTCN-3 Basic Types		
SRB_Identity_Type	integer (tsc_SRB0 , tsc_SRB1 , tsc_SRB2)	SRB0 to be covered as well
CarrierAggregationInfo_Type	Null_Type	place holder for additional routing information for carrier aggregation

SC_MRB_Identity_Type

TTCN-3 Record Type			
Name	SC_MRB_Identity_Type		
Comment			
MbmsSessionInfo	MBMSSessionInfo_r13		

RadioBearerId_Type

TTCN-3 Union Type		
Name	RadioBearerId_Type	
Comment		
Srb	SRB_Identity_Type	
Drb	DRB_Identity	
Mrb	MRB_Identity_Type	
ScMrb	SC_MRB_Identity_Type	

RoutingInfo_Type

TTCN-3 Union Type		
Name	RoutingInfo_Type	
Comment		
None	Null_Type	
RadioBearerId	RadioBearerId_Type	

D.7.4.2 REQ_ASP_CommonPart

ReqAspCommonPart_Type

TTCN-3 Record Type			
Name	ReqAspCommonPart_Type		
Comment			
CellId	EUTRA_CellId_Type		
RoutingInfo	RoutingInfo_Type		
TimingInfo	TimingInfo_Type		
ControllInfo	ReqAspControllInfo_Type		
CA_Info	CarrierAggregationInfo_Type	opt	place holder for additional routing information for carrier aggregation

D.7.4.3 CNF_ASP_CommonPart

CnfAspCommonPart_Type

TTCN-3 Record Type			
Name	CnfAspCommonPart_Type		
Comment			
CellId	EUTRA_CellId_Type		
RoutingInfo	RoutingInfo_Type		
TimingInfo	TimingInfo_Type		
Result	ConfirmationResult_Type		

D.7.4.4 IND_ASP_CommonPart

IndAspCommonPart_Type

TTCN-3 Record Type			
Name	IndAspCommonPart_Type		
Comment			
CellId	EUTRA_CellId_Type		
RoutingInfo	RoutingInfo_Type		
TimingInfo	TimingInfo_Type		
Status	IndicationStatus_Type		
CA_Info	CarrierAggregationInfo_Type	opt	place holder for additional routing information for carrier aggregation

D.7.5 MBMS_CommonDefs

Common definitions for MBMS needed for configuration of the SS

MBMS_CommonDefs: Basic Type Definitions

TTCN-3 Basic Types		
Pmch_InfoIndex_Type	integer (0..maxPMCH_PerMBSFN)	

MRB_Identity_Type

TTCN-3 Record Type			
Name	MRB_Identity_Type		
Comment	MTCH is uniquely identified by: - the logicalChannelIdentity in the mbms-SessionInfoList-r9 - the MBSFN area identity, - the MCH index in the pmch-InfoList-r9		
Mbsfn_Areald	MBSFN_Areald_r12		
PmchLogicalChannel	PmchLogicalChannel_Type		

PmchLogicalChannel_Type

TTCN-3 Record Type			
Name	PmchLogicalChannel_Type		
Comment			
Pmch_InfoIndex	Pmch_InfoIndex_Type		
LogicalChannelIdentity	LogicalChannelIdentity_r9_Type		

D.8 CDMA2000_ASP_TypeDefs

D.8.1 CDMA2000_Common

Common definitions for CDMA2000 and CDMA2000 ASPs

D.8.1.1 CDMA2000_SystemContants

CDMA2000_ASP_TypeDefs: Constant Definitions

TTCN-3 Basic Types			
tsc_CDMA2000_MaxNumberOfCells	integer	8	Maximum number of CDMA2000 cells; in TS 36.508 in, clause 6.3.1.5 and 6.3.1.6 define 4 cells each for HRPD and 1XRTT; hence total is 8

D.8.1.2 CDMA2000_Routing

CDMA2000_Routing: Basic Type Definitions

TTCN-3 Basic Types		
RLP_FlowId_Type	integer (0..30)	As per S.0024, clause 4.8.2.10 both MaxNumRLPFlowsFwd and MaxNumRLPFlowsRvs need to be in the range of 0x06(6) to 0x1F(31) As per x.s007 clause 10, the PDN ID and Flow ID identify a flow

RLP_FlowIdList_Type

TTCN-3 Record of Type	
Name	RLP_FlowIdList_Type
Comment	
record of RLP_FlowId_Type	

CDMA2000_RoutingInfo_Type

TTCN-3 Union Type	
Name	CDMA2000_RoutingInfo_Type
Comment	
None	Null_Type
RLP_FlowId	RLP_FlowId_Type

D.8.1.3 CDMA2000_TimingInfo

CDMA2000_TimingInfo: Basic Type Definitions

TTCN-3 Basic Types		
HRPD_FrameNumber_Type	integer	CDMA system time specified in units of 16 slots i.e. 26.66 ms.
SubFrameNumber_Type	integer (0..3)	A sub-frame is a group of four contiguous slots. The start of a sub-frame is specified by $(T - \text{FrameOffset}) \bmod 4 = 0$, where T is the CDMA System Time in slots
RTT1X_FrameNumber_Type	integer	CDMA System Time, in integer multiples of 20 ms

HRPD_SubFrameInfo_Type

TTCN-3 Union Type	
Name	HRPD_SubFrameInfo_Type
Comment	
Number	SubFrameNumber_Type
Any	Null_Type no specific sub-frame (valid for REQ ASPs only)

HRPD_Frame_Type

TTCN-3 Union Type	
Name	HRPD_Frame_Type
Comment	
Number	HRPD_FrameNumber_Type
Any	Null_Type no specific TimeStamp (valid for REQ ASPs only)

RTT1X_Frame_Type

TTCN-3 Union Type	
Name	RTT1X_Frame_Type
Comment	
Number	RTT1X_FrameNumber_Type
Any	Null_Type no specific TimeStamp (valid for REQ ASPs only)

HRPD_SubFrameTiming_Type

TTCN-3 Record Type			
Name	HRPD_SubFrameTiming_Type		
Comment			
Frame	HRPD_Frame_Type		
Subframe	HRPD_SubFrameInfo_Type		

CDMA2000_SubFrameTiming_Type

TTCN-3 Union Type			
Name	CDMA2000_SubFrameTiming_Type		
Comment			
HRPD	HRPD_SubFrameTiming_Type		HRPD Timing
RTT1X	RTT1X_Frame_Type		RTT1X Timing specified in terms of Frames only

CDMA2000_TimingInfo_Type

TTCN-3 Union Type			
Name	CDMA2000_TimingInfo_Type		
Comment			
SubFrame	CDMA2000_SubFrameTiming_Type		
Now	Null_Type		to be used in REQ ASPs when there is no 'activation time'
None	Null_Type		only to be used in SYSTEM_CTRL_CNF but not for EnquireTiming

D.8.1.4 CDMA2000_ReqAspCommonPart

CDMA2000_ReqAspControllInfo_Type

TTCN-3 Record Type			
Name	CDMA2000_ReqAspControllInfo_Type		
Comment			
CnfFlag	boolean		<p>true => SS shall send CNF: when the REQ is with no timing information (no activation time), SS shall send the confirmation when the configuration is done, i.e. when the test case may continue.</p> <p>Example: when there is a configuration follow by a send event it shall not be necessary to have a wait timer in between but the CNF triggers the send event or system Command. If there are other triggers e.g. like the UE sending a message, CnfFlag shall be set to false by the test case to avoid racing conditions with the CNF and the signalling message. When there is an activation time SS shall send the CNF after the configuration has been scheduled; that means SS shall not wait until the activation time has been expired.</p>
FollowOnFlag	boolean		<p>false => no further (related) information true: further related information will be sent to SS ; Currently this value is not foreseen to be used.</p>

CDMA2000_ReqAspCommonPart_Type

TTCN-3 Record Type			
Name	CDMA2000_ReqAspCommonPart_Type		
Comment			
CellId	CDMA2000_CellId_Type		
RoutingInfo	CDMA2000_RoutingInfo_Type		
TimingInfo	CDMA2000_TimingInfo_Type		
ControllInfo	CDMA2000_ReqAspControllInfo_Type		

D.8.1.5 CDMA2000_IndAspCommonPart

CDMA2000_ErrorIndication_Type

TTCN-3 Record Type			
Name	CDMA2000_ErrorIndication_Type		
Comment			
System	integer		any other error: may be SS specific error code; this will not be evaluated by TTCN; e.g. an error shall be raised when the UE requests retransmission of an RLC PDU

CDMA2000_IndicationStatus_Type

TTCN-3 Union Type			
Name	CDMA2000_IndicationStatus_Type		
Comment			
Ok	Null_Type		
Error	CDMA2000_ErrorIndication_Type		

CDMA2000_IndAspCommonPart_Type

TTCN-3 Record Type			
Name	CDMA2000_IndAspCommonPart_Type		
Comment			
CellId	CDMA2000_CellId_Type		
RoutingInfo	CDMA2000_RoutingInfo_Type		
TimingInfo	CDMA2000_TimingInfo_Type		
Status	CDMA2000_IndicationStatus_Type		

D.8.1.6 CDMA2000_CnfAspCommonPart

CDMA2000_ConfirmationResult_Type

TTCN-3 Union Type			
Name	CDMA2000_ConfirmationResult_Type		
Comment			
Success	Null_Type		
Error	integer		may contain SS specific error code; this will not be evaluated by TTCN

CDMA2000_CnfAspCommonPart_Type

TTCN-3 Record Type			
Name	CDMA2000_CnfAspCommonPart_Type		
Comment			
CellId	CDMA2000_CellId_Type		
RoutingInfo	CDMA2000_RoutingInfo_Type		
TimingInfo	CDMA2000_TimingInfo_Type		
Result	CDMA2000_ConfirmationResult_Type		Similar definition as EUTRA

D.8.2 CDMA2000_PowerLevel

CDMA2000_ASP_TypeDefs: Constant Definitions

TTCN-3 Basic Types			
tsc_CDMA2000_Attenuation_Off	CDMA2000_Attenuation_Type	{Off:=true}	

CDMA2000_PowerLevel: Basic Type Definitions

TTCN-3 Basic Types		
CDMA2000_InitialAttenuation_Type	CDMA2000_Attenuation_Type (tsc_CDMA2000_Attenuation_Off)	Attenuation restricted to 'Off'

CDMA2000_Attenuation_Type

TTCN-3 Union Type		
Name	CDMA2000_Attenuation_Type	
Comment	attenuation of the reference power	
Value	Attenuation_Type	cell power reference power reduced by the given attenuation (value is in dB)
Off	Null_Type	for non suitable off cell we specify an explicit "Off" value here

CDMA2000_CellAttenuation_Type

TTCN-3 Record Type			
Name	CDMA2000_CellAttenuation_Type		
Comment			
CellId	CDMA2000_CellId_Type		
Attenuation	CDMA2000_Attenuation_Type		

CDMA2000_CellAttenuationList_Type

TTCN-3 Record of Type	
Name	CDMA2000_CellAttenuationList_Type
Comment	
record length(1.. tsc_CDMA2000_MaxNumberOfCells) of CDMA2000_CellAttenuation_Type	

CDMA2000_AbsoluteCellPower_Type

TTCN-3 Record Type			
Name	CDMA2000_AbsoluteCellPower_Type		
Comment			
Powerloc	Powerloc_Type		TTCN writer Shall set same vale in all cells; SS shall have only one AWGN channel for all configured cells per frequency SS shall create a AWGN channel in first cell per frequency and ignore this in later cell creations on the same frequency; i.e. this channel is created along once for Cell 15 or 16 and one each per 17 and 19 similary for RTT1X once for 19 or 20 and one each per 21 and 22
Powerlor	Powerlor_Type		Total Transmit power in cell before attenuation
PilotOffset	PilotOffset_Type		Default -7

CDMA2000_InitialCellPower_Type

TTCN-3 Record Type			
Name	CDMA2000_InitialCellPower_Type		
Comment			
MaxReference Power	CDMA2000_AbsoluteCellPower_Type		maximum value of cell reference power corresponding to Max lor/loc in power level table; a cell is initialised with this reference power; its value is the upper bound of the cell power during the test case
Attenuation	CDMA2000_InitialAttenuation_Type		initial attenuation Cell is off

D.8.3 CDMA2000_Data

Data primitives sent/received at CDMA2000_RLP_FLOW_PORT

CDMA2000_Data: Basic Type Definitions

TTCN-3 Basic Types		
RLP_SDU_Type	octetstring	

RLP_SDUList_Type

TTCN-3 Record of Type	
Name	RLP_SDUList_Type
Comment	
record of RLP_SDU_Type	

CDMA2000_U_PlaneData_Type

TTCN-3 Union Type		
Name	CDMA2000_U_PlaneData_Type	
Comment	Union structure is provided for future possible enhancements	
RLP_Sdu	RLP_SDUList_Type	RLP SDU's

RLPFlow_DataPerSubframe_DL_Type

TTCN-3 Record Type	
Name	RLPFlow_DataPerSubframe_DL_Type
Comment	common definition for one or several SDUs to be sent in the subframe given by the subframe offset; SS shall raise an error indication (using SYSTEM_IND) when that is not possible NOTE 1: For RLP the data may be spread over more than one subframe ; the TTCN implementation is responsible to calculate appropriate offsets accordingly
SubframeOffset	integer subframe offset relative to the absolute timing information given in the common part of the ASP; NOTE : if a RLP SDU takes more than one subframe, SubframeOffset specifies the first TTI
SduList	CDMA2000_U_PlaneData_Type list of PDUs/SDUs to be sent in one subframe

RLPFlow_DataPerSubframeList_DL_Type

TTCN-3 Record of Type	
Name	RLPFlow_DataPerSubframeList_DL_Type
Comment	list of user plane data to be sent in sub-frames given by the SubframeOffset in the single elements of the list; Timing: the start time for the whole sequence is given by the timing info of the ASP (common information); the timing for the respective data pdus is given by the SubframeOffset relative to the common timing info; design consideration: repetitions of this sequence are not foreseen (in which case the subframe offset could not be related to the timing info of the ASP)
record of RLPFlow_DataPerSubframe_DL_Type	

CDMA2000_U_Plane_Request_Type

TTCN-3 Record Type	
Name	CDMA2000_U_Plane_Request_Type
Comment	NOTE: formal type definition to allow later enhancements; CDMA2000_U_Plane_Request_Type defines a sequence of subframes in which data shall be sent
SubframeDataList	RLPFlow_DataPerSubframeList_DL_Type

D.8.4 CDMA2000_CellConfiguration

HRPD_CellParameters_Type

TTCN-3 Record Type			
Name	HRPD_CellParameters_Type		
Comment	Parameters specific to HRPD		
SystemType	SystemType_Type		Specifies the system type of Channel As per Table 13.1-1 of C.S0024 0, 1, 2 are defined values and 3 to 255 are reserved
SubNetMask	B8_Type		7.11.6.2.2 of C.S0024 Sector Subnet identifier set this field to the number of consecutive 1s in the subnet mask of the subnet to which this sector belongs
ColorCode	ColorCode_Type		7.11.6.2.1 of C.S0024 set to the color code corresponding to this sector part of QuickConfig Over head message
CountryCode	MCC_Type		7.11.6.2.2 of C.S0024 three-digit BCD (binary coded decimal) encoded representation of the Mobile Country Code associated with this sector
OpenLoopAdjust	OpenLoopAdjust_Type		9.4.6.2.6 of C.S0024; The negative of the nominal power to be used by access terminals in the open loop power estimate, expressed as an unsigned value in units of 1 dB. The value used by the access terminal is -1 times the value of this field
ReverseRateLimit	ReverseRateLimit_Type		Table 9.9.6.3-2 of C.S0024; set to the highest data rate that the access terminal is allowed to use on the Reverse Traffic Channel
MACIndex	ReverseLinkMACIndex_Type		C.S0024 clause 12.4.1.3.2.2 Forward channel MAC is derived from this based on table 12.4.1.3.2.2-1
PacketApp	PacketApplication_Type		Multi Flow Packet Application to be used Enhanced Multi-Flow Packet Application subtype(0x0009) defined in C.S0087 or as per C.S0087, clause 2.3 the UE Shall not propose AEMPA during stream protocol negotiation (0xFFFE) in C.R1001
ControlChannelRate	ControlChannelRate_Type		MAC index to be used for the Control Channel
PDN_Id	PDN_Id_Type		PDN_ID of the bearer
PDN_Address	PDN_Address_Type		the PDN Address to be provided to the UE in VSNCP ConfigAck
UATI	UATI_Type		UATI to be Assigned to the UE

RTT1X_CellParameters_Type

TTCN-3 Record Type		
Name	RTT1X_CellParameters_Type	
Comment	Parameters specific to 1XRTT	
Reg_Zone	B12_Type	C.S005 clause 3.7.2.3.2.1 and 2.6.5.1.5 Registration Zone of the base station Reg_Zone, SID and NID shall be unique for each base station
Base_Class	B4_Type	C.S0005 clause 3.7.2.3.2.1 Base station class. The base station shall set this field as follows: For Band Class 1 and 4, the base station shall set this field to '0001'; otherwise, the base station shall set this field to '0000'
MCC	B10_Type	3.7.2.3.2.13 and 2.3.1.1 of C.S0005 encoding is int2bit (100*D1+10*D2+D3 -111,10) with digit 0 being mapped to 10 binary representation of the Mobile Country Code associated with this sector
IMSI_11_12	B7_Type	3.7.2.3.2.13 and 2.3.1.2 of C.S0005 encoding is int2bit (10*D2+D3 -11,7) with digit 0 being mapped to 10 binary representation of the Mobile Network Code associated with this sector
TMSI	TMSI_Type	the TMSI to be assigned to the MS
ProtRev	ProtRev_Type	Protocol Revision
Min_ProtRev	ProtRev_Type	the minimum protocol revision supported by Base station
Sig_Encryption Mode	EncryptionMode_Type	Encryption mode for Common and dedicated signalling
USerInfo_EncryptionMode	EncryptionMode_Type	User information Encryption mode

ModeSpecificCellParams_Type

TTCN-3 Union Type		
Name	ModeSpecificCellParams_Type	
Comment		
RTT1X	RTT1X_CellParameters_Type	
HRPD	HRPD_CellParameters_Type	

CDMA2000_CellParameters_Type

TTCN-3 Record Type		
Name	CDMA2000_CellParameters_Type	
Comment		
Type	CDMA2K_Type	Gives if cell is EHRPD or RTT1X
CarrierFreq	CarrierFreqCDMA2000_Type	Contains bandclass (5 bit) and arfcn i.e. 11 bit channel number
PhysCellId	PhysCellIdCDMA2000_Type	PN offset of pilot 0..511
CellGlobalId	CellGlobalIdCDMA2000_Type	Contains the 128 bit cell ID for HRPD and 47 bit cell ID for 1XRTT
SearchWindow	SearchWindowSizeRecord_Type	contains the SearchWindow for Active, Neighbor & Remaining cells

CDMA2000_CellConfigInfo_Type

TTCN-3 Record Type		
Name	CDMA2000_CellConfigInfo_Type	
Comment		
CellParameters	CDMA2000_CellParameters_Type	Parameters common to HRPD and RTT1X
InitialCellPower	CDMA2000_InitialCellPower_Type	Power level parameters
ModeSpecificCellParams	ModeSpecificCellParams_Type	Parameters specific to RTT1X or HRPD

CDMA2000_CellConfigRequest_Type

TTCN-3 Union Type		
Name	CDMA2000_CellConfigRequest_Type	
Comment		
AddOrReconfigure	CDMA2000_CellConfigInfo_Type	for cell configuration: CellId : identifier of the cell to be configured RoutingInfo : None TimingInfo : Now (for initial configuration and for reconfiguration in general) ControlInfo : CnfFlag:=true; FollowOnFlag:=false (in general)
Release	Null_Type	to remove a cell completely - CellId : identifier of the cell to be released; extra_Cell_NonSpecific, in case all cells shall be released RoutingInfo : None TimingInfo : Now ControlInfo : CnfFlag:=true; FollowOnFlag:=false (in general)

D.8.5 CDMA2000_HRPD

D.8.5.1 CDMA2000_PDN_Defs

CDMA2000_PDN_Defs: Basic Type Definitions

TTCN-3 Basic Types		
CDMA2000_AttachType	O3_Type	Defined values: 1: Initial Attach to a PDN, 3: Handover attach to a PDN. Rest undefined and not used
IPv4_Address_Type	O4_Type	represents the IPv4 address as per 24.301 clause 9.9.4.9
IPv6_Address_Type	O8_Type	represents the IPv6 interface identifier as per 24.301 clause 9.9.4.9
PDN_Id_Type	B4_Type	indicates the PDN Id associated with the bearer PDN Identifier of the PDN for which the user data is sent. it is the low order 4 bits of, containing the PDN-ID identifies the PDN (i.e. one per default bearer) Reference x.s0057 clause 10.1.5; gives only low order 4 bits, and high order 4 bits are added as all zero's
Flow_Id_Type	B4_Type	the lower 4 bits of the Flow Identifier, as defined in Table 15 of x.s0057 identify each reservation that is requested to be added or deleted the complete 8 bit flow Identifier is formed by PDN-ID and Flow-Id

IPv4v6_Address_Type

TTCN-3 Record Type			
Name	IPv4v6_Address_Type		
Comment			
IPv4	IPv4_Address_Type		IP v4 address to be allocated
IPv6	IPv6_Address_Type		IP v6 interface identifier to be allocated

PDN_Address_Type

TTCN-3 Union Type			
Name	PDN_Address_Type		
Comment	based on 24.301 cl. 9.9.4.9		
IPv4	IPv4_Address_Type		only IP v4 address to be allocated
IPv6	IPv6_Address_Type		only IP v6 interface identifier to be allocated
IPv4v6	IPv4v6_Address_Type		both IP v4 address and IP v6 interface identifier to be allocated

Flow_IdList_Type

TTCN-3 Record of Type	
Name	Flow_IdList_Type
Comment	
record of Flow_Id_Type	

D.8.5.2 CDMA2000_SubProtocols

LCP_DetachInit_Type

TTCN-3 Enumerated Type	
Name	LCP_DetachInit_Type
Comment	
networkInitiated	x.s0057 clause 11.2
UEInitiated	x.s0057 clause 11.1.2

DHCP_Ind_Type

TTCN-3 Record Type			
Name	DHCP_Ind_Type		
Comment			
RapidCommit	boolean		indicates if Rapid Comit option of DHCP is used

UATI104_Type

TTCN-3 Union Type			
Name	UATI104_Type		
Comment			
Value	O13_Type		
None	Null_Type		

UATI_Type

TTCN-3 Record Type			
Name	UATI_Type		
Comment			
UATI24	O3_Type		Represents UATI (0:23), as per clause 6.3.7.2.2 of C.S0024
UATI104	UATI104_Type		Represents UATI (127:24), as per clause 6.3.7.2.2 of C.S0024 if has to be assigned

D.8.5.3 HRPD_Indications

RegAndDefBearerEstInd_Type

TTCN-3 Record Type			
Name	RegAndDefBearerEstInd_Type		
Comment			
UATI_Assignm entCmpl	Null_Type		UATIAssignment is received UATIComplete is received
InitialChAssign Cmpl	Null_Type		Initial Traffic/Extended Channel/AlternateLink(Pre-registration) Assignment procedure started UE has sent ConnectionRequest/AlternateLinkOpen message Traffic/Extended Channel /AlternateLink(Pre-registration) assignment is completed UE has sent TrafficChannelComplete(Route update protocol)/ AlternateLinkOpenComplete. In the registration and Default bearer establishment procedure, UE initiated Channel/Alternate Link can be released and configured, only first assignment is reported.
SCP_ConfigC mpl	Null_Type		SCP (Session Configuration Protocol)ConfigurationRequest message is received SCP (Session Configuration Protocol)ConfigurationResponse message is transmitted
Stream_Config Cmpl	Null_Type		Stream Protocol Configuration ConfigurationRequest message is received Stream Protocol Configuration ConfigurationResponse message is transmitted
EMPA_MMPA_ ConfigCmpl	Null_Type		Enhanced Multi flow/Multi flow Packet application ConfigurationRequest message is received Enhanced Multi flow/Multi flow Packet application ConfigurationComplete message is received EMPA ConfigurationResponse message or MMPA ConfigurationResponse is received corresponding to steps 30A TO 30C of table 4.5.2B.3-2
SessionNegotia tionCmpl	Null_Type	opt	SS initiated Session Negotiation has started; Session Negotiation has completed
DeviceAuthCm pl	Null_Type	opt	Device level authentication has started; Device level authentication has completed
LocationUpdate Cmpl	Null_Type	opt	Location Update started; Location Update completed
EAP_AKA_Cm pl	Null_Type		Improved Extensible Authentication protocol for Authentication and Key agreement started RFC 5448 * Message flow in x.s0057 clause 5.2.5.1 Authentication and Key agreement Completed optionally After entering PPP LCP Open State, PPP Version Capability Indicaiton and/or Max PPP Inactivity Timer negotiation are completed
VSNCP_Config Cmpl	Null_Type		PDN connection establishment started and UE has sent PPP Vendor Specific Network Control Protocol Configuration Request PDN Connection and default bearer establishment is completed with possible IPV4 address (optional) and or IPV6 interface ID (Mandatory) provided Attach type shall be Handover Attach
DHCP_ConfigC mpl	DHCP_Ind_Type	opt	UE and SS decided for IPV4 address allocation by DHCP IPV4 address allocation completed by UE and SS Completion of IP Address through DHCP
ICMPv6_Config Cmpl	Null_Type	opt	UE optionally sent IPV6 stateless autoconfiguration Router solitation message and SS has responded with IPV6 Router Advertisement message

HRPD_ZoneRegistrationInd_Type

TTCN-3 Record Type			
Name	HRPD_ZoneRegistrationInd_Type		
Comment			
UATI_Assignm entCmpl	Null_Type		UATIAssignment is received UATIComplete is received
EAP_AKA_Cm pl	Null_Type		Improved Extensible Authentication protocol for Authentication and Key agreement started RFC 5448 Message flow in x.s0057 clause 5.2.5.1 Authentication and Key agreement Completed optionally After entering PPP LCP Open State, PPP Version Capability Indicaiton and/or Max PPP Inactivity Timer negotiation are completed
VSNCP_Config Cmpl	Null_Type		PDN connection establishment started and UE has sent PPP Vendor Specific Network Control Protocol Configuration Request PDN Connection and default bearer establishment is completed with possible IPV4 address (optional) and or IPV6 interface ID (Mandatory) provided Attach type shall be Handover Attach
DHCP_ConfigC mpl	DHCP_Ind_Type	opt	UE and SS decided for IPv4 address allocation by DHCP IPv4 address allocation completed by UE and SS Completion of IP Address through DHCP
ICMPv6_Config Cmpl	Null_Type	opt	UE optionally sent ICMPv6 Router solitation message and SS has responded with IPv6 Router Advertisement message

DedicatedBearerRelInd_Type

TTCN-3 Record Type			
Name	DedicatedBearerRelInd_Type		
Comment			
VSNP_Termina teCmpl	Null_Type		Dedicated bearers are deactivated/ released
SCP_ReleaseC mpl	Null_Type	opt	Session Configuration Protocol to relase the reservations exclusively associated with the deleted bearer Reservation deletion completed

DefaultBearerRelDetachInd_Type

TTCN-3 Record Type			
Name	DefaultBearerRelDetachInd_Type		
Comment			
VSNCP_Termi nateCmpl	Null_Type	opt	To Released configured default bearer and hense associated Dedicated bearer x.s0057 clause 11.3 and 11.1.1 To indicate the default bearer is released
LCP_Terminate Cmpl	Null_Type		To detach the UE x.s0057 clause 11.2 Detach completed

MobilityFromEUTRACmpl_Type

TTCN-3 Record Type			
Name	MobilityFromEUTRACmpl_Type		
Comment			
ConnectionReq Rcvd	Null_Type		Received Tunneled HRPD Connection Request Message
RouteUpdateIn d	Null_Type		Received Tunneled HRPD Route Update Message
TrafficChCmpl Rcvd	Null_Type		Received HRPD Traffic Channel Complete in HRPD RAT, after transmission of tunneled Traffic Channel Assignment, HRPD Silence Parameters and HRPD Open Loop Parameters

AdditionalDefBearerEstInd_Type

TTCN-3 Record Type			
Name	AdditionalDefBearerEstInd_Type		
Comment			
VSNCp_ConfigCmpl	Null_Type		PDN connection establishment started and UE has sent PPP Vendor Specific Network Control Protocol Configuration Request PDN Connection and default bearer establishment is completed with possible IPV4 address (optional) and or IPV6 interface ID (Mandatory) provided Attach type shall be Handover Attach(pre-registration) or Initial Attach (if normal registration in HRPD cell)
DHCP_ConfigCmpl	DHCP_Ind_Type	opt	UE and SS decided for IPV4 address allocation by DHCP IPv4 address allocation completed by UE and SS Completion of IP Address through DHCP
ICMPv6_ConfigCmpl	Null_Type	opt	UE optionally sent ICMPv6 Router solitation message and SS has responded with IPV6 Router Advertisement message

HRPD_SystemIndication_Type

TTCN-3 Union Type			
Name	HRPD_SystemIndication_Type		
Comment			
Error	Null_Type		Used by SS to indicate any error; the Actual Error types reported in ASP common part in CDMA2000_IndicationStatus_Type
InitialAccessProbeRcvd	Null_Type		Initial Access probe is received;
RegAndDefBearerEstInd	RegAndDefBearerEstInd_Type		UE has successfully performed registration and default bearer establishment
DedicatedBearerEstInd	Null_Type		Vendor specific network protocol (RFC 3772) procedures to re-establish Dedicated bearer as defined in S.0057 clause 5.5.3.1 (BCM is MS/NW) or clause 5.5.4.1.1 (BCM = MS-Only) Bearer Configuration Mode Dedicated bearers are (re) established
DedicatedBearerRelInd	DedicatedBearerRelInd_Type		To indicate the Dedicated bearer is released
DefaultBearerRelDetachInd	DefaultBearerRelDetachInd_Type		To Release configured default bearer and hence associated Dedicated bearer x.s0057 clause 11.3 and 11.1.1 Dedicated bearers are deactivated/released To detach the UE x.s0057 clause 11.2 Detach completed
MovedToDormantMode	Null_Type		The channels are released and UE is moved to PPP dormant mode/Air interface Idle.
MobilityFromEUTRACmpl	MobilityFromEUTRACmpl_Type		To confirm that Handover from EUTRAN is completed by receiving Traffic Channel Complete and the MessageSequence is same as in Traffic Channel Assignment
AdditionalDefBearerEstInd	AdditionalDefBearerEstInd_Type		UE has successfully performed additional default bearer establishment (additional PDN)
HRPD_ZoneRegistrationInd	HRPD_ZoneRegistrationInd_Type		Initially pre-registered UE detects change in HRPD Zone ID in SIB and hence updates registration

D.8.5.4 HRPD_Commands

HRPD_UE_InitStateType

TTCN-3 Enumerated Type	
Name	HRPD_UE_InitStateType
Comment	HRPD UE states as defined in C.S0057 clause 3.1
idle_Null	In the Inactive/Null State, 1. there is no physical traffic channel between the UE and the eAN, and no connection exists between the eAN and the ePCF 2. no PPP link between the UE and the HSGW . 3. The UE may have a Universal Access Terminal Identifier (UATI) that has been assigned by an eHRPD eAN
dormant	In the Dormant State, 1. no physical traffic channel exists between the UE and the eAN and no connection exists between the eAN and the ePCF. 2. PPP link between the UE and the HSGW 3. eHRPD DORMANT state equates to the "idle" state referred to in TS 23.402
active_Connected	In the Active/Connected State, 1. a physical traffic channel exists between the UE and the eAN over which data may be sent. A connection exists between the eAN and the ePCF, and between the ePCF and the HSGW, 2. there is a PPP link between the UE and the HSGW
preregister	The UE is performing pre-register though a different Access network

RegAndDefBearerEst_Type

TTCN-3 Record Type	
Name	RegAndDefBearerEst_Type
Comment	
InitState	HRPD_UE_InitStateType
RLP_FlowId	RLP_FlowId_Type Associated RLP Flow ID
AttachType	CDMA2000_AttachType The Attach Type to be expected in VSNCP procedure

DefaultBearerRelDetach_Type

TTCN-3 Record Type	
Name	DefaultBearerRelDetach_Type
Comment	
InitState	HRPD_UE_InitStateType
PDN_Id	PDN_Id_Type PDN_ID of the bearer
RLP_FlowId	RLP_FlowId_Type Associated RLP Flow ID
UE_NW_Initiated	LCP_DetachInit_Type If initiated by UE or Network

DedicatedBearerEstRel_Type

TTCN-3 Record Type	
Name	DedicatedBearerEstRel_Type
Comment	
InitState	HRPD_UE_InitStateType PPP and Air Interface state of UE when the procedure is being executed
AssociatedDefaultBearer	PDN_Id_Type the PDN ID of the associated default bearer; Gives the APN with which additional Dedicated Bearer needs to be established
Flow_Ids	Flow_IdList_Type Flow_ID's of the multiple dedicated bearers to be Activated/Deactivated
RLP_FlowIds	RLP_FlowIdList_Type Associated RLP Flow ID; There is one to one association between elements in Flow_IdList_Type and RLP_FlowIdList_Type ; ITs a TTCN programming error otherwise

AdditionalDefBearerEst_Type

TTCN-3 Record Type			
Name	AdditionalDefBearerEst_Type		
Comment	used for multiple PDN connections		
InitState	HRPD_UE_InitStateType		
RLP_FlowId	RLP_FlowId_Type		Associated RLP Flow ID

HRPD_SystemCommand_Type

TTCN-3 Union Type		
Name	HRPD_SystemCommand_Type	
Comment		
ReportInitialAccessProbe	Null_Type	SS is expected to report any possible Access probes received on HRPD Cell; will be used in situations where UE is not expected to camp on a HRPD Cell
RegAndDefBearerEst	RegAndDefBearerEst_Type	To complete registration and establish Default bearer; Initial UE State is Idle_Null State Indications upto VSNCP protocol and possible IP signalling over DHCPv4 and/or ICMPv6 is performed At the end of procedure, UE is still in Active/Connected state (not pre-registration); SS is expected to send InitialAccessProbeRcvd (only if initial state is not Active and not pre-registration) and RegAndDefBearerEstInd as an indication for successful completion of procedure
DedicatedBearerEst	DedicatedBearerEstRel_Type	Dedicated bearers are established/Activated by VSNP/EMPA protocol; PDN ID and RLP flow ID pairs are provided for each Dedicated bearer At the end of procedure, UE is still in Active/Connected state SS is expected to send InitialAccessProbeRcvd (only if initial state is not Active) and DedicatedBearerEstInd as an indication for successful completion of procedure
MoveToDormantState	Null_Type	UE is Active_Connected state and is moved to Dormant state SS is expected to send MovedToDormantMode
MoveToActiveState	RLP_FlowIdList_Type	UE is initially Dormant state; UE is made to Move to Active_Connected State List of RLP flow Id's (associated with default + dedicated bearer), need to be established are provided SS is expected to send InitialAccessProbeRcvd
DedicatedBearerRel	DedicatedBearerEstRel_Type	Dedicated bearers are released/De-Activated by VSNP terminate and SCP release protocol; At the end of procedure, UE is still in Active/Connected state (not pre-registration) SS is expected to send InitialAccessProbeRcvd (only if initial state is not Active and not pre-registration) and DedicatedBearerRelInd as an indication for successful completion of procedure
DefaultBearerRelDetach	DefaultBearerRelDetach_Type	Default bearer is released by VSNCP terminate and SCP release protocol UE is made to detach by LCP protocol and Possible Channels are released At the end of procedure, UE is in Idle_Null state Notes: When Detach is network initiated the sequence is 1. Default bearer (and hence all associated Dedicated bearers) released by VSNCP terminate 2. UE is detached by LCP terminate procedure When Detach is UE initiated, UE may only perform LCP terminate procedure SS is expected to send InitialAccessProbeRcvd (only if initial state is not Active) and DefaultBearerRelDetachInd as an indication for successful completion of procedure
MobilityFromEUTRA	Null_Type	Prepare CDMA SS for receiving tunneled HRPD Connection Request and Route Update tunneled in ULHandoverPreparationTransfer Respond with GCSNA encapsulated HRPD Silence Parameters and HRPD Open Loop Parameters, HRPD Traffic Channel Assignment to be sent tunneled in MobilityFromEUTRACommand Receive Traffic Channel Complete in the HRPD Cell; After Receiving Traffic Channel Assignment, HRPD Silence Parameters and HRPD Open Loop Parameters embedded in EUTRA message MobilityFromEUTRACommand, UE has

		Tuned to HRPD Radio and transmitted Traffic Channel Complete in the HRPD Cell SS is expected to send MobilityFromEUTRACmpl as an indication for succesful completion of procedure
AdditionalDefBearerEst	AdditionalDefBearerEst_Type	To establish an additional PDN connection Initial UE State is Idle_Null State or procedure performed through pre-registration Indications upto VSNCp protocol and possible IP signalling over DHCPv4 and/or ICMPv6 is performed At the end of procedure, UE is still in Active/Connected state(not pre-registration); SS is expected to send InitialAccessProbeRcvd (only if initial state is not Active and not pre-registration) and AdditionalDefBearerEstInd as an indication for successful completion of procedure
HRPDZoneRegister	RegAndDefBearerEst_Type	To update registration by a UE already registered and established Default bearer; Initial UE State is Idle_Null State Indications upto VSNCp protocol and possible IP signalling over DHCPv4 and/or ICMPv6 is performed At the end of procedure, UE is still in Active/Connected state (not pre-registration); SS is expected to send InitialAccessProbeRcvd(only if initial state is not Active and not pre-registration) and RegAndDefBearerEstInd as an indication for succesful completion of procedure

D.8.6 CDMA2000_RTT1X

D.8.6.1 RTT1X_Indications

RTT1X call flows in RTT1x cell

Expected Sequence for Attach (Power Up Attach)

1. Initial AccessProbeRcvd
2. CS_RegistrationStart (Powerup)
3. CS_RegistrationCmpl

Expected Sequence for Detach (Power Down Attach)

1. Initial AccessProbeRcvd
2. CS_RegistrationStart (PowerDown)
3. CS_RegistrationCmpl

Expected Sequence for CSFB Call Establishment

1. Initial AccessProbeRcvd
2. CS_CallEstStart (Origination/ PageResponse)
3. ChAssignCmpl (Extended Channel Assignment is sent)
4. CS_CallEstCompleted (Acknowledgement Order Sent, Service Connect sent, Service Connect Completion received, Alert Sent/Received and ConnectOrder is received)

Expected Sequence for SRVCC call handover

1. HandoffCmpl

RTT1X_CS_CallType

TTCN-3 Enumerated Type	
Name	RTT1X_CS_CallType
Comment	
mo	Call is UE originated
mt	Call is UE Terminated
mo_Emergency	UE originated Emergency Call

RTT1XAttachType

TTCN-3 Enumerated Type	
Name	RTT1XAttachType
Comment	Ref C.S005 Table 2.7.1.3.2.1-1
powerUpAttach	UE is doing Power up attach REG_Type = '0001'B; it was not previously attached
powerDownAttach	UE is doing power down attach REG_Type = '0011'B; it was previously attached
zoneBasedAttach	UE is doing Zone based attach REG_Type = '0010'B
orderedAttach	UE is doing Ordered attach REG_Type = '0101'B
OtherAttach	Any other Attach REG_Type does not equal above values

CS_RegCmplInd_Type

TTCN-3 Record Type	
Name	CS_RegCmplInd_Type
Comment	
CS_Registratio nCmpl	RTT1XAttachType CS power up/down registration is completed UE Sent Registration message and received an L2 Acknowledgement Optionally SS can perform Authentication and and has sent Registration Accepted order

CS_Reg_CallCmplInd_Type

TTCN-3 Record Type	
Name	CS_Reg_CallCmplInd_Type
Comment	
CS_Registratio nCmpl	RTT1XAttachType opt CS power up/down registration is completed; This is omit if implicit registration is done UE Sent Registration message and received an L2 Acknowledgement Optionally SS can perform Authentication and and has sent Registration Accepted order UE can also do a implicit registration; i.e. reception of Origination/reconnect/CallRecovery/Page message by Base station is treated as implicit registration
CS_CallEstStar ted	RTT1X_CS_CallType Received Origination message for MO and Page Response for MT
ChAssignCmpl	Null_Type (Extended) Channel Assignment procedure started UE has sent ConnectionRequestTraffic Extended Channel assignment is completedUE has sent TrafficChannelComplete
CS_CallEstCo mpleted	Null_Type SS received Service Connect Completion (Mo) or ConnectOrder(MT) (i.e User Accepted call)

CS_CallCmplInd_Type

TTCN-3 Record Type	
Name	CS_CallCmplInd_Type
Comment	
CS_CallEstStar ted	RTT1X_CS_CallType Received Origination message for MO and Page Response for MT
ChAssignCmpl	Null_Type (Extended) Channel Assignment procedure started completed
CS_CallEstCo mpleted	Null_Type SS received Service Connect Completion (MO) or ConnectOrder (MT) (i.e User Accepted call)
IsEmergencyC all	boolean True indicates the established call is emergency call, false indicates a normal voice has been established

ECSFB_CallCmplInd_Type

TTCN-3 Record Type			
Name	ECSFB_CallCmplInd_Type		
Comment			
CS_CallEstStarted	RTT1X_CS_CallType		Received Tunneled GCSNA encapsulated Origination message for MO and Page Response for MT call
HandoffCmpl	Null_Type		indicates SS has received HandoffComplete message and the call is established
CS_CallEstCompleted	Null_Type		SS received Service Connect Completion (MO) or ConnectOrder (MT) (i.e User Accepted call)
IsEmergencyCall	boolean		True indicates the established call is emergency call, false indicates a normal voice has been established

ECAM_CS_CallCmplInd_Type

TTCN-3 Record Type			
Name	ECAM_CS_CallCmplInd_Type		
Comment			
CS_TunneledCallEstStarted	RTT1X_CS_CallType		Received Tunneled GCSNA encapsulated Origination message for MO and Page Response for MT call
CS_CallEstStarted	RTT1X_CS_CallType		Received Origination message for MO and Page Response for MT
ChAssignCmpl	Null_Type		Extended Channel Assignment procedure started completed
CS_CallEstCompleted	Null_Type		SS received Service Connect[MO] or ConnectOrder[MT] (i.e User Accepted call)
IsEmergencyCall	boolean		True indicates the established call is emergency call, false indicates a normal voice has been established

ECSFB_CallRejInd_Type

TTCN-3 Record Type			
Name	ECSFB_CallRejInd_Type		
Comment			
CS_CallEstRejected	RTT1X_CS_CallType		SS Received tunneled 1xRTT Origination (MO)/Page Response (MT) message Respond with 1xRTT Release Order message
IsEmergencyCall	boolean		True indicates the established call is emergency call, false indicates a normal voice has been established

RTT1X_SystemIndication_Type

TTCN-3 Union Type		
Name	RTT1X_SystemIndication_Type	
Comment		
Error	Null_Type	Used by SS to indicate any error; the Actual Error types reported in ASP common part in CDMA2000_IndicationStatus_Type
InitialAccessProbeRcvd	Null_Type	Initial Access probe is received
CS_Registratio nCmpl	CS_RegCmplInd_Type	CS power up/down registration is completed As registration message, and possible Authentication Registration accepted order are all sent received on f/r-csch UE at end is in Idle state
CS_Reg_CallC mplInd	CS_Reg_CallCmplInd_Type	CS Registration /implicit registration and Call Indication MO or MT UE is in connected state with f/r dtch configured
CS_CallCmplIn d	CS_CallCmplInd_Type	CS Call Indication MO or MT UE is in connected state with f/r dtch configured
HandoffCmpl	Null_Type	needed for SRVCC handover of an IMS voice call on LTE to 1XRTT indicates SS has received HandoffComplete message and the call is established
MovedToIdleSt ate	Null_Type	The channels are released and UE is moved to Idle state. CS Call is released by exchange of Release order in both directions C.S0005 figure B3 and B4
ECSFB_CallC mplInd	ECSFB_CallCmplInd_Type	eCSFB Call Indication MO or MT UE is in connected state with f/r dtch configured
ECSFB_ECAM _CallCmplInd	ECAM_CS_CallCmplInd_Type	eCSFB ECAM based Call Indication MO or MT UE is in connected state with f/r dtch configured
ECSFB_CallRe jInd	ECSFB_CallRejInd_Type	eCSFB Call Rejected MO or MT UE is not camping in 1xRTT

D.8.6.2 RTT1X_Commands

CS_Registration_Type

TTCN-3 Record Type		
Name	CS_Registration_Type	
Comment		
AttachType	RTT1XAttachType	
IsPreRegistrati on	boolean	Indicates if it is done as pre registration Value is ignored if Attach Type is Power down (Assumption detach happens only in 1XRTT cell)
RAND	B32_Type	opt RAND [From eNB] to be included in CSFBParametersResponseCDMA2000, HandoverFromEUTRAPreparationRequest Value not present for power down registration

RTT1X_SystemCommand_Type

TTCN-3 Union Type		
Name	RTT1X_SystemCommand_Type	
Comment		
ReportInitialAccessProbe	Null_Type	SS is expected to report any possible Access probes received on 1XRTT Cell; will be used in situations where UE is not expected to camp on a 1XRTT Cell
CS_Registratio n	CS_Registration_Type	Power up attach/ power down attach in 1xRTT cell or Pre registration (Power up attach) tunelled through a different RAT in case of pre-registration attach, the CDMA SS starts by sending mobilityParameters to be tunelled in CSFBParametersRequestCDMA2000 SS is expected to send InitialAccessProbeRcvd (only if initial state is not pre-registration) and CS_RegistrationCmpl as an indication for succesful completion of procedure
CSFB_Call	RTT1X_CS_CallType	CSFB by a (pre-)registered UE If the call Type is mt, CDMA SS sends 1x RTT GCSNA encapsulated General Page to be tunelled in DLInformation Transfer SS is expected to send InitialAccessProbeRcvd and CS_CallCmplInd as an indication for succesful completion of procedure
CS_Reg_CSFB _Call	RTT1X_CS_CallType	UE not previously pre-registered hence performs registration (Power up attach) and CSFB call Registration can be implicit registration SS is expected to send InitialAccessProbeRcvd and CS_Reg_CallCmplInd as an indication for succesful completion of procedure
MobilityFromE UTRA_1XRTT	Null_Type	Prepare SS for Mobility from Eutra CDMA SS sends mobilityParameters to be tunelled in HandoverFromEUTRAPreparationRequest Receive tunelled 1xRTT GCSNA Encapsulated Origination message and MEID in ULHandoverPreparationTransfer Respond with GCSNA encapsulated 1xRTT Handoff Direction message to be sent tunelled in MobilityFromEUTRACommand Receive HandoffCmpl in the 1xRTT Cell; SS is expected to send HandoffCmpl as an indication for succesful completion of procedure
CS_OrderedRe gistration	CS_Registration_Type	ordered registration on (already registered) 1xRTT cell or Pre registration Power up attach) through a different RAT. SS triggers the procedure by sending Registration Request order (GCSNA encapsulated in case of pre-registration) and sends mobilityParameters to be tunelled in CSFBParametersRequestCDMA2000 SS is expected to send InitialAccessProbeRcvd (only if initial state is not pre-registration) and CS_RegistrationCmpl as an indication for succesful completion of procedure
E_CSFB_Call	RTT1X_CS_CallType	Prepare SS for Enhanced CSFB call If the call Type is mt, CDMA SS sends 1x RTT GCSNA encapsulated General Page to be tunelled in DLInformation Transfer CDMA SS sends mobilityParameters to be tunelled in HandoverFromEUTRAPreparationRequest Receive tunelled 1xRTT GCSNA Encapsulated Origination (MO)/Page Response (MT) message and MEID in ULHandoverPreparationTransfer Respond with GCSNA encapsulated 1xRTT Handoff Direction message to be sent tunelled in MobilityFromEUTRACommand Receive HandoffCmpl in the 1xRTT Cell; SS responds with Alert With Information (MT)/Sevice connect (MO) in the 1xRTT cell. SS receives Connect order (MT)/Service Connect Completion (MO)

		SS is expected to send ECSFB_CallCmplInd as an indication for succesful completion of procedure
E_CSFB_Call_ECAM	RTT1X_CS_CallType	Prepare SS for Enhanced CSFB call with Extended channel assignment If the call Type is mt, CDMA SS sends 1x RTT GCSNA encapsulated General Page to be tunneled in DLInformation Transfer CDMA SS sends mobilityParameters to be tunneled in HandoverFromEUTRAPreparationRequest Receive tunneled 1xRTT GCSNA Encapsulated Origination (MO)/Page Response (MT) message and MEID in ULHandoverPreparationTransfer Respond with GCSNA Encapsulated ECAM message to be sent tunneled in MobilityFromEUTRACommand Receive Origination in the 1xRTT Cell; After extended channel assignment, SS receives Connect order (MT)/Service Connect Completion (MO) SS is expected to send ECSFB_ECAM_CallCmplInd as an indication for succesful completion of procedure
E_CSFB_Call_Reject	RTT1X_CS_CallType	Prepare SS for Enhanced CSFB call, which needs to be rejected If the call Type is mt, CDMA SS sends 1x RTT GCSNA encapsulated General Page to be tunneled in DLInformation Transfer CDMA SS sends mobilityParameters to be tunneled in HandoverFromEUTRAPreparationRequest Receive tunneled 1xRTT GCSNA Encapsulated Origination (MO)/Page Response (MT) message and MEID in ULHandoverPreparationTransfer Respond with GCSNA encapsulated 1xRTT Release Order message to be sent tunneled in DLInformation Transfer SS is expected to send ECSFB_CallRejInd as an indication for succesful completion of procedure

D.8.7 System_Interface

CDMA2000_SystemRequest_Type

TTCN-3 Union Type		
Name	CDMA2000_SystemRequest_Type	
Comment		
Cell	CDMA2000_CellConfigRequest_Type	configure/release a cell
CellAttenuation List	CDMA2000_CellAttenuationList_Type	

CDMA2000_SystemConfirm_Type

TTCN-3 Union Type		
Name	CDMA2000_SystemConfirm_Type	
Comment	confirmations for system configuration; in general to be sent after the configuration has been done	
Cell	Null_Type	(no further parameters from SS)
CellAttenuation List	Null_Type	(no further parameters from SS) NOTE 1: the confirmation shall be sent when all cells have changed power levels NOTE 2: for the CellId in the common ASP part the same rules are applied as for the CDMA2000 SYSTEM REQ

CDMA2000_SYSTEM_CTRL_REQ

TTCN-3 Record Type			
Name	CDMA2000_SYSTEM_CTRL_REQ		
Comment			
Common	CDMA2000_ReqAspComm onPart_Type		TimingInfo depends on respective primitive:
Request	CDMA2000_SystemReque st_Type		- Cell TimingInfo: 'now' (in general) - CellAttenuationList TimingInfo: 'now' (in general, but activation time may be used also)

CDMA2000_SYSTEM_CTRL_CNF

TTCN-3 Record Type			
Name	CDMA2000_SYSTEM_CTRL_CNF		
Comment			
Common	CDMA2000_CnfAspComm onPart_Type		TimingInfo is ignored by TTCN => SS may set TimingInfo to "None"
Confirm	CDMA2000_SystemConfir m_Type		

CDMA2000_SystemCommand_Type

TTCN-3 Union Type		
Name	CDMA2000_SystemCommand_Type	
Comment		
HRPD	HRPD_SystemCommand_Type	HRPD Specific System commands
RTT1X	RTT1X_SystemCommand_Type	1XRTT specific System commands

CDMA2000_SYSTEM_CMD

TTCN-3 Record Type			
Name	CDMA2000_SYSTEM_CMD		
Comment			
Common	CDMA2000_ReqAspComm onPart_Type		Routing info will be none generally; TimingInfo is generally now but activation time may be used also for all System commands Cnf and Follow on flags are both false
Command	CDMA2000_SystemComm and_Type		HRPD or 1XRTT System commands

CDMA2000_SystemIndication_Type

TTCN-3 Union Type		
Name	CDMA2000_SystemIndication_Type	
Comment		
HRPD	HRPD_SystemIndication_Type	
RTT1X	RTT1X_SystemIndication_Type	

CDMA2000_SYSTEM_IND

TTCN-3 Record Type			
Name	CDMA2000_SYSTEM_IND		
Comment			
Common	CDMA2000_IndAspCommonPart_Type		The SS shall provide TimingInfo depending on the respective indication:
Indication	CDMA2000_SystemIndication_Type		- Error TimingInfo: related to the error (if available) - HRPD/RTT1X Procedure completion The timing info corresponding to logical completion of the complete procedure includes completion of all sub protocols

CDMA2000_RLP_FLOW_COMMON_IND

TTCN-3 Record Type			
Name	CDMA2000_RLP_FLOW_COMMON_IND		
Comment	ASP to receive PDUs from RLP Packet Flows		
Common	CDMA2000_IndAspCommonPart_Type		CellId : identifier of the cell RoutingInfo : RLP Flow id TimingInfo : time when RLP SDU's has been completely received
Data	CDMA2000_U_PlaneData_Type		

CDMA2000_RLP_FLOW_COMMON_REQ

TTCN-3 Record Type			
Name	CDMA2000_RLP_FLOW_COMMON_REQ		
Comment	ASP to send PDUs to RLP Packet flows		
Common	CDMA2000_ReqAspCommonPart_Type		CellId : identifier of the cell RoutingInfo : RLP Flow id TimingInfo : starting point when to start sending sequence of data PDUs e.g. TimeStampLong_Type = X, subframe number = x; U_Plane.SubframeDataList (i).SubframeOffset := offset_i; => U_Plane.SubframeDataList(i).PduSduList shall be sent out at TimeStampLong_Type = X + ((x + offset_i) / 4); subframe number = (x + offset_i) mod 4 ControlInfo : CnfFlag:=false; FollowOnFlag:=false
U_Plane	CDMA2000_U_Plane_Req_Type		

CDMA2000_SYSTEM_PORT

TTCN-3 Port Type			
Name	CDMA2000_SYSTEM_PORT		
Comment	CDMA2000 PTC: Port for system configuration		
out	CDMA2000_SYSTEM_CTRL_REQ		
in	CDMA2000_SYSTEM_CTRL_CONF		

CDMA2000_SYSCMD_IND_PORT

TTCN-3 Port Type	
Name	CDMA2000_SYSCMD_IND_PORT
Comment	CDMA2000 PTC: Port for system indications/Commands
out	CDMA2000_SYSTEM_CMD
in	CDMA2000_SYSTEM_IND

CDMA2000_RLP_FLOW_PORT

TTCN-3 Port Type	
Name	CDMA2000_RLP_FLOW_PORT
Comment	CDMA2000 PTC: Port for RLP SDU's to be sent on RLP packet data streams
out	CDMA2000_RLP_FLOW_COMM ON_REQ
in	CDMA2000_RLP_FLOW_COMM ON_IND

D.9 CDMA2000_CommonDefs

type definitions used by CDMA2000 and EUTRA

CDMA2000_CommonDefs: Basic Type Definitions

TTCN-3 Basic Types		
SearchWindowSize_Type	integer (0..15)	Search Window as in 36.331 ASN.1 definition for SystemInformationBlockType8.searchWindowSize
BandclassCDMA2000_Type	integer (0..31)	Band class defined as in 36.331 ASN.1 definition for BandclassCDMA2000
ARFCN_ValueCDMA2000_Type	integer (0..2047)	ARFCN for CDMA2000 cell as in 36.331 ASN.1 definition for ARFCN_ValueCDMA2000
PhysCellIdCDMA2000_Type	integer (0..511)	PN offset for CDMA2000 cell as in 36.331 ASN.1 definition for PhysCellIdCDMA2000
ProtRev_Type	integer (0..255)	protocol revision
OpenLoopAdjust_Type	integer (0..255)	9.4.6.2.6 of C.S0024
BCD_Digit_Type	integer (0..9)	To represent BCD digit of MCC
TMSI_Code_Type	O4_Type	
EncryptionMode_Type	integer (0..7)	C.S0005 table 3.7.4.5-1 & 3.7.5.7-3 0 ... Encryption disabled 1 ... Encryption with ORYX algorithm for User Info and Enhanced Cellular Msg Encryption Algorithm for Signalling 2 ... Encryption with Rijndael algorithm 3-7 ... reserved
TMSI_ZoneLen_Type	integer (1..8)	TMSI Zone Length; On encoding this is encoded to B4_Type
SectorID_HRPD_Type	B128_Type	Sector ID for HRPD as in 36.331 ASN.1 definition for CellGlobalIdCDMA2000.cellGlobalIdHRPD
PilotOffset_Type	integer (-31..0)	Represents the offset i.e. Pilot Channel power to total cell power(dB); By default shall be set to -7 127 selected Max value by 7 bits
Powerlor_Type	integer (-127..0)	Represents the cell total Tx power lor (dBm/1.23 MHz)
Powerloc_Type	integer (-127..0)	Represents the cell total AWGN power loc (dBm/1.23 MHz) which is independent of cell
Attenuation_Type	integer (0..127)	
SystemType_Type	integer (0..255)	0 to 2 are allowed and 3 to 255 are reserved 13.1 of C.S0024
ColorCode_Type	integer (0..255)	7.11.6.2.1 of C.S0024
ReverseLinkMACIndex_Type	integer (0..383)	C.S0024 clause 12.4.1.3.2.2

MCC_Type

TTCN-3 Record of Type	
Name	MCC_Type
Comment	Represents Mobile Country Code
record length (3) of BCD_Digit_Type	

TMSI_Zone_Type

TTCN-3 Record of Type	
Name	TMSI_Zone_Type
Comment	TMSI Zone 1 to 8 octets
record length (1..8) of B8_Type	

TMSI_Type

TTCN-3 Record Type			
Name	TMSI_Type		
Comment	Globally unique TMSI as defined in C.s0005 clause 3.7.2.3.2.19		
TMSI_ZoneLen	TMSI_ZoneLen_Type		Length of TMSI_Zone 1..8
TMSI_Zone	TMSI_Zone_Type		TMSI_ZoneLen octets of TMSI_Zone
TMSI_Code	TMSI_Code_Type		TMSI code

SectorID_RTT1X_Type

TTCN-3 Record Type			
Name	SectorID_RTT1X_Type		
Comment	Sector ID for 1XR TT acc. to C.S0005 clause 3.7.2.3.2.1 and as in 36.331 ASN.1 clause 6.3.4, definition of CellGlobalIdCDMA2000.cellGlobalId1XR TT		
BaselId	B16_Type		Base station identification. The base station shall set this field to its identification number
NID	B16_Type		Network identification This field serves as a sub-identifier of a system as defined by the owner of the SID. The base station shall set this field to the network identification number for this network
SID	B15_Type		System identification. set to the system identification number for this system

CarrierFreqCDMA2000_Type

TTCN-3 Record Type			
Name	CarrierFreqCDMA2000_Type		
Comment	Carrier Frequency for CDMA2000 cell as in 36.331 ASN.1 definition for CarrierFreqCDMA2000; contains Band class 5 bit and Channel number 11 bit part of Sector Channel over head message contained in 24 bit Channel IE		
BandClass	BandclassCDMA2000_Type		
ARFCN	ARFCN_ValueCDMA2000_Type		

CDMA2K_Type

TTCN-3 Enumerated Type			
Name	CDMA2K_Type		
Comment	CDMA 2000 Type for CDMA2000 cell as in 36.331 ASN.1 definition for CDMA2000-Type		
type1XR TT			
typeHRPD			

CellGlobalIdCDMA2000_Type

TTCN-3 Union Type			
Name	CellGlobalIdCDMA2000_Type		
Comment	CDMA 2000 Type Sector ID of the Cell as in 36.331 ASN.1 definition CellGlobalIdCDMA2000		
RTT1X	SectorID_RTT1X_Type		
HRPD	SectorID_HRPD_Type		

ReverseRateLimit_Type

TTCN-3 Enumerated Type	
Name	ReverseRateLimit_Type
Comment	Table 9.9.6.3-2 of C.S0024; set to the highest data rate that the access terminal is allowed to use on the Reverse Traffic Channel; 10 Reserved values
kbps0	
kbps9_6	
kbps19_2	
kbps38_4	
kbps76_8	
kbps153_6	
resrv1	
resrv2	
resrv3	
resrv4	
resrv5	
resrv6	
resrv7	
resrv8	
resrv9	
resrv10	

PacketApplication_Type

TTCN-3 Enumerated Type	
Name	PacketApplication_Type
Comment	Type of Packet Application to be used in Stream protocol
enhMultiFlowPacketApp	

ControlChannelRate_Type

TTCN-3 Enumerated Type	
Name	ControlChannelRate_Type
Comment	Determines the MAC configuration for Control Channel
macIndex2	
macIndex3	

CDMA2000_CellId_Type

TTCN-3 Enumerated Type	
Name	CDMA2000_CellId_Type
Comment	
cdma2000_Cell_Non Specific	
cdma2000_Cell15	HRDP Cell
cdma2000_Cell16	HRDP Cell
cdma2000_Cell17	HRDP Cell
cdma2000_Cell18	HRDP Cell
cdma2000_Cell19	RTT1X Cell
cdma2000_Cell20	RTT1X Cell
cdma2000_Cell21	RTT1X Cell
cdma2000_Cell22	RTT1X Cell

SearchWindowSizeRecord_Type

TTCN-3 Record Type			
Name	SearchWindowSizeRecord_Type		
Comment			
SearchWindow_Active	SearchWindowSize_Type		Search Window for Active Cells
SearchWindow_Neighbor	SearchWindowSize_Type		Search Window for Neighbor Cells
SearchWindow_Remaining	SearchWindowSize_Type		Search Window for Rest Cells

D.10 EUTRA_ASP_CDMA2000TunnellingDefs

ASP definitions for tunnelling of CDMA2000 messages e.g. during CDMA2000 pre-registration

EUTRA_ASP_CDMA2000TunnellingDefs: Basic Type Definitions

TTCN-3 Basic Types		
TunneledInfoCDMA2000	octetstring	
MEID_Type	ULHandoverPreparationTransfer_r8_IEs.meid	
CDMA2000_MSG_REQ	CDMA2000_UL_Container_Type	
CDMA2000_MSG_IND	CDMA2000_DL_Container_Type	

UL_TunneledInfoCDMA2000

TTCN-3 Record Type			
Name	UL_TunneledInfoCDMA2000		
Comment			
Msg	TunneledInfoCDMA2000		OCTET STRING
Meid	MEID_Type	opt	ASN.1 type: BIT STRING (SIZE (56)) used to tunnel meid received from UE in ULHandoverPreparationTransfer for 1xRTT, not present other wise

CDMA2000_UL_Container_Type

TTCN-3 Record Type			
Name	CDMA2000_UL_Container_Type		
Comment			
CDMA2000Type	CDMA2000_Type		ASN.1 type: type1XRTT, typeHRPD
UL_Msg	UL_TunneledInfoCDMA2000		

DL_TunneledInfoCDMA2000

TTCN-3 Record Type			
Name	DL_TunneledInfoCDMA2000		
Comment			
Msg	TunneledInfoCDMA2000		OCTET STRING

CDMA2000_DL_Container_Type

TTCN-3 Record Type			
Name	CDMA2000_DL_Container_Type		
Comment			
CDMA2000Type	CDMA2000_Type		ASN.1 type: type1XRTT, typeHRPD
DL_Msg	DL_TunneledInfoCDMA2000		OCTET STRING

CDMA2000_TUNNELLING_PORT

TTCN-3 Port Type			
Name	CDMA2000_TUNNELLING_PORT		
Comment	EUTRA PTC: Port to deal with tunnelling of CDMA2000 messages		
out	CDMA2000_MSG_REQ		
in	CDMA2000_MSG_IND		

D.11 EUTRA_ASP_VirtualNoiseDefs

ASP definitions for virtual noise generation in EUTRA cells.

The noise is configured for an already existing EUTRA cell.

For UEs with 2 antenna connectors the AWGN (Additive white Gaussian noise) signals applied to each receiver antenna connector shall be uncorrelated.

EUTRA_ASP_VirtualNoiseDefs: Basic Type Definitions

TTCN-3 Basic Types		
EUTRA_VngConfigConfirm_Type	Null_Type	

EUTRA_VngConfigInfo_Type

TTCN-3 Record Type			
Name	EUTRA_VngConfigInfo_Type		
Comment			
Bandwidth	DL_Bandwidth_Type		Bandwidth to be used for the noise (in general the same bandwidth as for the associated EUTRA cell)
NocLevel	integer		Noc level; calculation is according to 36.523-3 cl 7.22

EUTRA_VngConfigRequest_Type

TTCN-3 Union Type			
Name	EUTRA_VngConfigRequest_Type		
Comment	configure/activate noise for a given cell; NOTE: it is assumed the the associated EUTRA cell has been created beforehand		
Configure	EUTRA_VngConfigInfo_Type		configuration of the virtual noise generator; regardless of the power level the noise generator is off before it gets activated for this cell; in case the configuration needs to be changed during a test, the noise generator shall be deactivated for this cell
Activate	Null_Type		noise is activated (switched on) for the given cell acc. to the previous configuration; while being active the configuration shall not be modified
Deactivate	Null_Type		deactivate noise for given cell

EUTRA_VNG_CTRL_REQ

TTCN-3 Record Type			
Name	EUTRA_VNG_CTRL_REQ		
Comment			
Common	ReqAspCommonPart_Type		CellId : as for the associated EUTRA cell RoutingInfo : None TimingInfo : Now ControlInfo : CnfFlag:=true; FollowOnFlag:=false
Request	EUTRA_VngConfigRequest_Type		

EUTRA_VNG_CTRL_CNF

TTCN-3 Record Type			
Name	EUTRA_VNG_CTRL_CNF		
Comment			
Common	CnfAspCommonPart_Type		TimingInfo is ignored by TTCN (apart from EnquireTiming) => SS may set TimingInfo to "None"
Confirm	EUTRA_VngConfigConfirm_Type		

EUTRA_VNG_PORT

TTCN-3 Port Type			
Name	EUTRA_VNG_PORT		
Comment	EUTRA PTC: Port for virtual noise generator		
out	EUTRA_VNG_CTRL_REQ		
in	EUTRA_VNG_CTRL_CNF		

D.12 UTRAN_ASP_VirtualNoiseDefs

ASP definitions for virtual noise generation in UTRAN cells.

The noise is configured for an already existing UTRAN cell.

NOTE: For the time being VNG is applicable for UTRAN FDD only as acc. to TS 36.304 clause 5.2.4.5 there is no quality based measurement for UTRAN TDD, GERAN or CDMA2000

UTRAN_ASP_VirtualNoiseDefs: Basic Type Definitions

TTCN-3 Basic Types			
UTRAN_VngConfigConfirm_Type	Null_Type		

UTRAN_VngConfigInfo_Type

TTCN-3 Record Type			
Name	UTRAN_VngConfigInfo_Type		
Comment			
locLevel	integer		loc level; calculation is testcase specific

UTRAN_VngConfigRequest_Type

TTCN-3 Union Type		
Name	UTRAN_VngConfigRequest_Type	
Comment	configure/activate noise for a given cell; NOTE: it is assumed the the associated UTRAN cell has been created beforehand	
Configure	UTRAN_VngConfigInfo_Type	configuration of the virtual noise generator; regardless of the power level the noise generator is off before it gets activated for this cell; in case the configuration needs to be changed during a test, the noise generator shall be deactivated for this cell
Activate	Null_Type	noise is activated (switched on) for the given cell acc. to the previous configuration; while being active the configuration shall not be modified
Deactivate	Null_Type	deactivate noise for given cell

UTRAN_VNG_CTRL_REQ

TTCN-3 Record Type			
Name	UTRAN_VNG_CTRL_REQ		
Comment			
CellId	integer		id of associated UTRAN cell
Request	UTRAN_VngConfigRequest_Type		

UTRAN_VNG_CTRL_CNF

TTCN-3 Record Type			
Name	UTRAN_VNG_CTRL_CNF		
Comment			
CellId	integer		id of associated UTRAN cell
Confirm	UTRAN_VngConfigConfirm_Type		

UTRAN_VNG_PORT

TTCN-3 Port Type		
Name	UTRAN_VNG_PORT	
Comment	UTRAN PTC: Port for virtual noise generator	
out	UTRAN_VNG_CTRL_REQ	
in	UTRAN_VNG_CTRL_CNF	

D.13 WLAN_ASP_TypeDefs

WLAN_ASP_TypeDefs: Constant Definitions

TTCN-3 Basic Types			
tsc_WLAN_MaxNumberOfCells	integer	3	Only one cell is foreseen to be used. defined 3 just for completeness.

WLAN_ASP_TypeDefs: Basic Type Definitions

TTCN-3 Basic Types		
WLAN_ChannelNumber_Type	integer (1..2047)	Channel Number of WLAN Channel 1 to 14 belong to 2.4 Ghz ISM band 131-138 belong to 3.6 Ghz ISM band 36,40,44,48,52,56,60,64,100,104,108,112,116 ,120,124,128,132,136,140,149,153,157,161&1 65 belong to 5Ghz ISM band Other channel numbers may be defined in future for other bands and are reserved until defined Channel number uniquely identifies the frequency
WLAN_BeaconRSSI_Type	integer (0..255)	WLAN Beacon RSSI is defined in IEEE 802.11-2012, Part 11 table 6.7 as integer - 100..40 but defined in 36.331/25.331 as integer(0..255) so actual beacon RSSI = value -100, and values 141..255 are not used or spares
WLAN_ChannelUtilization_Type	integer (0..255)	As defined in in IEEE 802.11-2012, Part 11 clause 8.4.2.20 used in BSS load element
WLAN_AttenuationValue_Type	integer (0..127)	
WLAN_TimeStamp_Type	O8_Type	TimeStamp field (TSF) timer in microseconds as defined in IEEE 802.11-2012 clause 8.4.1.10

WLAN_Band_Type

TTCN-3 Enumerated Type	
Name	WLAN_Band_Type
Comment	
Band2_4Ghz	Band2_4Ghz = 2.4 Ghz ISM band
Band5Ghz	Band5Ghz = 5Ghz ISM band
Band3_6Ghz	Band3_6Ghz = 3.6 Ghz ISM band

WLAN_CellId_Type

TTCN-3 Enumerated Type	
Name	WLAN_CellId_Type
Comment	
wlan_Cell_NonSpecifi c	
wlan_Cell27	WLAN AP in EUTRA environment
wlan_Cell39	WLAN AP in UTRA environment

WLAN_RoutingInfo_Type

TTCN-3 Union Type		
Name	WLAN_RoutingInfo_Type	
Comment		
None	Null_Type	place holder for any possible extensions, currently only none defined

WLAN_TimingInfo_Type

TTCN-3 Union Type		
Name	WLAN_TimingInfo_Type	
Comment		
TimeStamp	WLAN_TimeStamp_Type	
Now	Null_Type	to be used in REQ ASPs when there is no 'activation time'
None	Null_Type	only to be used in WLAN_AP_SYSTEM_CTRL_CNF

WLAN_ReqAspControllInfo_Type

TTCN-3 Record Type		
Name	WLAN_ReqAspControllInfo_Type	
Comment		
CnfFlag	boolean	<p>true => SS shall send CNF: when the REQ is with no timing information (no activation time), SS shall send the confirmation when the configuration is done, i.e. when the test case may continue. Example: when there is a configuration follow by a send event it shall not be necessary to have a wait timer in between but the CNF triggers the send event or system Command. If there are other triggers e.g. like the UE sending a message, CnfFlag shall be set to false by the test case to avoid racing conditions with the CNF and the signalling message. When there is an activation time SS shall send the CNF after the configuration has been scheduled; that means SS shall not wait until the activation time has been expired.</p>
FollowOnFlag	boolean	<p>false => no further (related) information true: further related information will be sent to SS; currently this value is not foreseen to be used.</p>

WLAN_ReqAspCommonPart_Type

TTCN-3 Record Type		
Name	WLAN_ReqAspCommonPart_Type	
Comment		
CellId	WLAN_CellId_Type	
RoutingInfo	WLAN_RoutingInfo_Type	
TimingInfo	WLAN_TimingInfo_Type	
ControllInfo	WLAN_ReqAspControllInfo_Type	

WLAN_ErrorIndication_Type

TTCN-3 Record Type		
Name	WLAN_ErrorIndication_Type	
Comment		
System	integer	<p>any other error: may be SS specific error code; this will not be evaluated by TTCN; e.g. an error shall be raised when the UE performs an out of sequence signalling</p>

WLAN_IndicationStatus_Type

TTCN-3 Union Type		
Name	WLAN_IndicationStatus_Type	
Comment		
Ok	Null_Type	
Error	WLAN_ErrorIndication_Type	

WLAN_IndAspCommonPart_Type

TTCN-3 Record Type		
Name	WLAN_IndAspCommonPart_Type	
Comment		
CellId	WLAN_CellId_Type	
RoutingInfo	WLAN_RoutingInfo_Type	
TimingInfo	WLAN_TimingInfo_Type	
Status	WLAN_IndicationStatus_Type	

WLAN_ConfirmationResult_Type

TTCN-3 Union Type		
Name	WLAN_ConfirmationResult_Type	
Comment		
Success	Null_Type	
Error	integer	may contain SS specific error code; this will not be evaluated by TTCN

WLAN_CnfAspCommonPart_Type

TTCN-3 Record Type		
Name	WLAN_CnfAspCommonPart_Type	
Comment		
CellId	WLAN_CellId_Type	
RoutingInfo	WLAN_RoutingInfo_Type	
TimingInfo	WLAN_TimingInfo_Type	
Result	WLAN_ConfirmationResult_Type	Similar definition as EUTRA

WLAN_Attenuation_Type

TTCN-3 Union Type		
Name	WLAN_Attenuation_Type	
Comment	attenuation of the reference power	
Value	WLAN_AttenuationValue_Type	cell power reference power reduced by the given attenuation (value is in dB)
Off	Null_Type	for non suitable off cell we specify an explicit "Off" value here

WLAN_CellAttenuation_Type

TTCN-3 Record Type		
Name	WLAN_CellAttenuation_Type	
Comment		
CellId	WLAN_CellId_Type	
Attenuation	WLAN_Attenuation_Type	

WLAN_CellAttenuationList_Type

TTCN-3 Record of Type	
Name	WLAN_CellAttenuationList_Type
Comment	
record length(1.. tsc WLAN_MaxNumberOfCells) of WLAN_CellAttenuation_Type	

WLAN_InitialCellPower_Type

TTCN-3 Record Type	
Name	WLAN_InitialCellPower_Type
Comment	
BeaconRSSI	WLAN_BeaconRSSI_Type maximum value of beacon RSSI a cell is initialised with this Beacon RSSI; its value is the upper bound of the Beacon RSSI during the test case
Attenuation	WLAN_Attenuation_Type initial attenuation Cell is off

WLAN_Revision_Type

TTCN-3 Enumerated Type	
Name	WLAN_Revision_Type
Comment	
Rev_2012	802.11-2012, specified to be used in corespecs
Rev_n	802.11n

WLAN_ChannelBandwidth_Type

TTCN-3 Enumerated Type	
Name	WLAN_ChannelBandwidth_Type
Comment	
bw5	5 Mhz
bw10	10 Mhz
bw20	20 Mhz
bw40	40 Mhz
bw80	80 Mhz

WLAN_Identifiers_Type

TTCN-3 Record Type	
Name	WLAN_Identifiers_Type
Comment	
SSID	octetstring length (1..32) opt
BSSID	O6_Type opt
HESSID	O6_Type opt

WLAN_Hotspot_Version_Type

TTCN-3 Enumerated Type	
Name	WLAN_Hotspot_Version_Type
Comment	
None	no hotspot certification
Rev_2	Referred in core spec; Hotspot Revision 2.0 release 2
Rev_1	Hotspot Revision 1.0

WLAN_AP_Parameters_Type

TTCN-3 Record Type			
Name	WLAN_AP_Parameters_Type		
Comment	Parameters specific to WLAN AP		
WLAN_Band	WLAN_Band_Type		
ChannelNumber	WLAN_ChannelNumber_Type		WLAN band and channel number identify the frequency
ChannelBandwidth	WLAN_ChannelBandwidth_Type		Channel Bandwidth of 802.11
WLAN_Identifiers	WLAN_Identifiers_Type		defined in 36.331, need to figure out how to import or define an equivalent
WLAN_Revision	WLAN_Revision_Type		Version of WLAN AP, core specs specify it to be 802.11-2012
WLAN_Hotspot_Version	WLAN_Hotspot_Version_Type		Hotspot certification version, Core spec specify it is Hotspot 2.0

WLAN_PDN_AddressInfo_Type

TTCN-3 Record Type			
Name	WLAN_PDN_AddressInfo_Type		
Comment			
UE_IPAddressIPv4	charstring		PDN IP Address of the UE in the 3GPP network
UE_IPAddressIPv6	charstring		PDN IP Address of the UE in the 3GPP network
ePDG_IPAddressIPv4	charstring		IP address of the ePDG in the non-3GPP network
ePDG_IPAddressIPv6	charstring		IP address of the ePDG in the non-3GPP network
PCSCF_IPAddressIPv4	charstring		IP address of the P-CSCF (3GPP network)
PCSCF_IPAddressIPv6	charstring		IP address of the P-CSCF (3GPP network)

WLAN_EAP_AKA_Cntrl_Type

TTCN-3 Record Type			
Name	WLAN_EAP_AKA_Cntrl_Type		
Comment	configurable parameters for EAP AKA		
IMSI	hexstring		IMSI/USIM of UE
RAND	B128_Type		RAND to be used in initial key derivation
AuthK	B128_Type		Authentication secret key shared between AAA-server and USIM

IPsec_ePDG_Cntrl_Type

TTCN-3 Record Type			
Name	IPsec_ePDG_Cntrl_Type		
Comment	Parameters to be used for all IPsec security associations between UE and ePDG		
IntegrityAlgorithm	IPsec_IntegrityAlgorithm_Type		
CipheringAlgorithm	IPsec_CipheringAlgorithm_Type		

WLAN_AP_CellConfigInfo_Type

TTCN-3 Record Type			
Name	WLAN_AP_CellConfigInfo_Type		
Comment			
WLAN_AP_Parameters	WLAN_AP_Parameters_Type		Parameters for WLAN AP
InitialCellPower	WLAN_InitialCellPower_Type		Power level parameters

WLAN_ePDG_ConfigInfo_Type

TTCN-3 Record Type			
Name	WLAN_ePDG_ConfigInfo_Type		
Comment			
PDN_AddressInfo	WLAN_PDN_AddressInfo_Type		Various IP Addresses to be used
IPsec_SA	IPsec_ePDG_Cntrl_Type		Parameters for ePDG secure tunnels
EAP_AKA_Cntrl	WLAN_EAP_AKA_Cntrl_Type		Parameters for EAP AKA control

WLAN_AP_CellConfigRequest_Type

TTCN-3 Union Type			
Name	WLAN_AP_CellConfigRequest_Type		
Comment			
AddOrReconfigure	WLAN_AP_CellConfigInfo_Type		for cell configuration: CellId : identifier of the cell to be configured RoutingInfo : None TimingInfo : Now (for initial configuration and for reconfiguration in general) ControlInfo : CnfFlag:=true; FollowOnFlag:=false (in general)
Release	Null_Type		to remove a cell completely - CellId : identifier of the cell to be released; Cell_NonSpecific, in case all cells shall be released RoutingInfo : None TimingInfo : Now ControlInfo : CnfFlag:=true; FollowOnFlag:=false (in general)

WLAN_ePDG_ConfigRequest_Type

TTCN-3 Union Type			
Name	WLAN_ePDG_ConfigRequest_Type		
Comment	Configuration of ePDG and AAA-server emulation		
AddOrReconfigure	WLAN_ePDG_ConfigInfo_Type		to setup configuration of ePDG and AAA-server emulation
Release	Null_Type		to release the ePDG/AAA-server emulation

WLAN_OffloadSpecificParams_Type

TTCN-3 Record Type			
Name	WLAN_OffloadSpecificParams_Type		
Comment	parameters that are used for offload to/from WLAN and controlled by Hotspot 2.0 version 2		
ChannelUtilisation	WLAN_ChannelUtilizationType	opt	omit means unchanged, if present AP transmits this parameter in BSS Load element IEEE 802.11-2012 clause 8.4.2.30
BackHaulDLBandwidth	O4_Type	opt	Omit means unchanged, DL WAN bandwidth in kbps If present AP hotspot uses this value in WAN Metrics element Hotspot 2.0 release 2 clause 4.4
BackHaulULBandwidth	O4_Type	opt	Omit means unchanged, UL WAN bandwidth in kbps If present AP hotspot uses this value in WAN Metrics element Hotspot 2.0 release 2 clause 4.4

WLAN_AP_SystemRequest_Type

TTCN-3 Union Type		
Name	WLAN_AP_SystemRequest_Type	
Comment		
Cell	WLAN_AP_CellConfigRequest_Type	configure/release a cell
CellAttenuationList	WLAN_CellAttenuationList_Type	power attenuation for one or several cells, WLAN AP; all cells included in the list shall be changed at the same time; all cells in the list shall reach the new cell power within a maximum of 100ms (10 frames)
OffloadSpecificParams	WLAN_OffloadSpecificParams_Type	parameter used in offload decisions

WLAN_AP_SystemConfirm_Type

TTCN-3 Union Type		
Name	WLAN_AP_SystemConfirm_Type	
Comment	confirmations for system configuration; in general to be sent after the configuration has been done	
Cell	Null_Type	(no further parameters from SS)
CellAttenuationList	Null_Type	(no further parameters from SS) NOTE 1: the confirmation shall be sent when all cells have changed power levels NOTE 2: for the CellId in the common ASP part the same rules are applied as for the WLAN SYSTEM REQ
OffloadSpecificParams	Null_Type	(no further parameters from SS)

WLAN_ePDG_SystemRequest_Type

TTCN-3 Union Type		
Name	WLAN_ePDG_SystemRequest_Type	
Comment		
ePDG	WLAN_ePDG_ConfigRequest_Type	setup/release configuration of ePDG and AAA-server emulation

WLAN_ePDG_SystemConfirm_Type

TTCN-3 Union Type		
Name	WLAN_ePDG_SystemConfirm_Type	
Comment	confirmations for system configuration; in general to be sent after the configuration has been done	
ePDG	Null_Type	(no further parameters from SS)

WLAN_AP_SYSTEM_CTRL_REQ

TTCN-3 Record Type			
Name	WLAN_AP_SYSTEM_CTRL_REQ		
Comment			
Common	WLAN_ReqAspCommonPart_Type		TimingInfo depends on respective primitive:
Request	WLAN_AP_SystemRequest_Type		- Cell TimingInfo: 'now' (in general) - CellAttenuationList TimingInfo: 'now' (in general, but activation time may be used also)

WLAN_ePDG_SYSTEM_CTRL_CNF

TTCN-3 Record Type			
Name	WLAN_ePDG_SYSTEM_CTRL_CNF		
Comment			
Common	WLAN_CnfAspCommonPart_Type		CellId, RoutingInfo and TimingInfo are ignored by TTCN
Confirm	WLAN_ePDG_SystemConfirm_Type		

WLAN_ePDG_SYSTEM_CTRL_REQ

TTCN-3 Record Type			
Name	WLAN_ePDG_SYSTEM_CTRL_REQ		
Comment			
Common	WLAN_ReqAspCommonPart_Type		CellId : wlan_Cell_NonSpecific RoutingInfo : None TimingInfo : Now ControllInfo : CnfFlag:=true; FollowOnFlag:=false (in general)
Request	WLAN_ePDG_SystemRequest_Type		

WLAN_AP_SYSTEM_CTRL_CNF

TTCN-3 Record Type			
Name	WLAN_AP_SYSTEM_CTRL_CNF		
Comment			
Common	WLAN_CnfAspCommonPart_Type		TimingInfo is ignored by TTCN => SS may set TimingInfo to "None"
Confirm	WLAN_AP_SystemConfirm_Type		

WLAN_ePDG_SystemCommand_Type

TTCN-3 Union Type			
Name	WLAN_ePDG_SystemCommand_Type		
Comment			
IpsecTunnelDisccCmd	Null_Type		To trigger SS for ePDG initiated tunnel disconnection procedure acc. to 24.234 clause 8.3.1.2 and 8.3.2.1 (e.g. step 11 of Table 6.4.3.11-1 in 36.508)

WLAN_AP_SystemCommand_Type

TTCN-3 Union Type		
Name	WLAN_AP_SystemCommand_Type	
Comment		
AssociateWLANAP	Null_Type	To prepare SS to expect WLAN association by the UE: SS shall indicate when the UE has already associated or if not already associated, indicate when the UE associates
DisassociateWLANAP	Null_Type	To prepare SS to expect WLAN disassociation by the UE: SS shall indicate when the UE has already disassociated or if not already disassociated, indicate when the UE disassociates

WLAN_AP_SYSTEM_CMD

TTCN-3 Record Type		
Name	WLAN_AP_SYSTEM_CMD	
Comment		
Common	WLAN_ReqAspCommonPart_Type	Routing info will be none generally; TimingInfo is generally now but activation time may be used also for all System commands Cnf and Follow on flags are both false
Command	WLAN_AP_SystemCommand_Type	WLAN AP System commands

WLAN_ePDG_SYSTEM_CMD

TTCN-3 Record Type		
Name	WLAN_ePDG_SYSTEM_CMD	
Comment		
Common	WLAN_ReqAspCommonPart_Type	CellId : wlan_Cell_NonSpecific RoutingInfo : None TimingInfo : Now ControlInfo : CnfFlag:=false; FollowOnFlag:=false
Command	WLAN_ePDG_SystemCommand_Type	WLAN ePDG System commands

WLAN_AP_SystemIndication_Type

TTCN-3 Union Type		
Name	WLAN_AP_SystemIndication_Type	
Comment		
Error	Null_Type	Used by SS to indicate any error; the Actual Error types reported in ASP common part in WLAN_IndicationStatus_Type
AssociateWLANAP_Ind	Null_Type	UE has associated to WLAN as per IEEE 802.11-2012 clause 4.5.3.3
DisassociateWLANAP_Ind	Null_Type	UE has disassociated from WLAN as per IEEE 802.11-2012 clause 4.5.3.5

WLAN_ePDG_SystemIndication_Type

TTCN-3 Union Type		
Name	WLAN_ePDG_SystemIndication_Type	
Comment		
Error	Null_Type	Used by SS to indicate any error; the Actual Error types reported in ASP common part in WLAN_IndicationStatus_Type
IPsecTunnelEstablnd	IPsecTunnelEstablnd_Type	To indicate progress for IPsec tunnel establishment
IPsecTunnelDisclnd	IPsecTunnelDisclnd_Type	To indicate progress for release of the IPsec tunnel

IPsecTunnelDisclnd_Type

TTCN-3 Union Type		
Name	IPsecTunnelDisclnd_Type	
Comment		
IPSecTunnelReICmpl	Null_Type	Indication raised by the SS when the UE has sent INFORMATIONAL response according to 24.234 clause 8.3.1.2 (ePDG initiated tunnel disconnection as specified for step 11 of Table 6.4.3.11-1 in 36.508) or SS has sent INFORMATIONAL response according to 24.234 clause 8.3.2.2 (WLAN UE initiated tunnel disconnection)

EAP_AKA_Cmpl_Status_Type

TTCN-3 Enumerated Type	
Name	EAP_AKA_Cmpl_Status_Type
Comment	
success	
failure	

EAP_AKA_Cmpl_Type

TTCN-3 Record Type			
Name	EAP_AKA_Cmpl_Type		
Comment			
EAP_AKA_Status	EAP_AKA_Cmpl_Status_Type		
XRES_Length	integer	opt	provide XRES_Length for success status

IPsecTunnelEstabInd_Type

TTCN-3 Union Type		
Name	IPsecTunnelEstabInd_Type	
Comment		
IKE_SA_INIT_Ind	Null_Type	indication by the SS that the UE has started the attempt to establish an IPsec tunnel to the ePDG by sending an initial IKEv2 IKE_SA_INIT (step 1 of Figure 8.2.2-1 in 33.402) NOTE: the major purpose of this primitive is to get an early indication when the UE shall not attempt to establish the IPsec tunnel
EAP_AKA_Cmpl	EAP_AKA_Cmpl_Type	indication by the SS that the UE has provided all necessary parameters for EAP-AKA and the SS has sent an EAP Success/Failure message to UE according to step 11 of Figure 8.2.2-1 in 33.402
IPSecTunnelEstabCmpl	Null_Type	indication by the SS that IPsec tunnel is established: SS shall indicate this immediately after it has sent out the final IKE_AUTH response (containing the CFG_REPLY) at step 15 of Figure 8.2.2-1 in 33.402 NOTE: Typically the UE gets all relevant IP addresses of the 3GPP network in the configuration payload (CFG_REPLY)

WLAN_AP_SYSTEM_IND

TTCN-3 Record Type		
Name	WLAN_AP_SYSTEM_IND	
Comment		
Common	WLAN_IndAspCommonPart_Type	The SS shall provide TimingInfo depending on the respective indication:
Indication	WLAN_AP_SystemIndication_Type	- Error TimingInfo: related to the error (if available) - WLAN offload Procedure completion The timing info corresponding to logical completion of the complete procedure includes completion of all sub protocols

WLAN_ePDG_SYSTEM_IND

TTCN-3 Record Type		
Name	WLAN_ePDG_SYSTEM_IND	
Comment		
Common	WLAN_IndAspCommonPart_Type	CellId, RoutingInfo and TimingInfo are ignored by TTCN
Indication	WLAN_ePDG_SystemIndication_Type	

WLAN_AP_SYSTEM_PORT

TTCN-3 Port Type		
Name	WLAN_AP_SYSTEM_PORT	
Comment	WLAN PTC: Port for WLAN AP system configuration	
out	WLAN_AP_SYSTEM_CTRL_REQ	
in	WLAN_AP_SYSTEM_CTRL_CNF	

WLAN_AP_SYSCMD_IND_PORT

TTCN-3 Port Type	
Name	WLAN_AP_SYSCMD_IND_PORT
Comment	WLAN PTC: Port for WLAN AP system indications/Commands
out	WLAN_AP_SYSTEM_CMD
in	WLAN_AP_SYSTEM_IND

WLAN_ePDG_SYSTEM_PORT

TTCN-3 Port Type	
Name	WLAN_ePDG_SYSTEM_PORT
Comment	WLAN PTC: Port for WLAN ePDG/AAA-Server system configuration
out	WLAN_ePDG_SYSTEM_CTRL_REQ
in	WLAN_ePDG_SYSTEM_CTRL_CNF

WLAN_ePDG_SYSCMD_IND_PORT

TTCN-3 Port Type	
Name	WLAN_ePDG_SYSCMD_IND_PORT
Comment	WLAN PTC: Port for WLAN ePDG/AAA-Server emulation system indications/Commands
out	WLAN_ePDG_SYSTEM_CMD
in	WLAN_ePDG_SYSTEM_IND

D.14 SideLinkUE_ASP_TypeDefs

D.14.1 SideLinkUE_Data

SL_DATA_REQ

TTCN-3 Record Type	
Name	SL_DATA_REQ
Comment	Common ASP to send PDUs on PC5 channels SL-DCH or SLRB
Common	SL_RegAspCommonPart_Type SS_UE_Id : identifier of the SL UE * RoutingInfo : SL-DCH or SLRB identity * TimingInfo : For Direct Discovery see description in DiscPeriodResourceList_Type; For communication: SFN/Subframe or DFN/DirectSubframe to use to start sending data PDUs. * ControllInfo : CnfFlag:=false; FollowOnFlag:=false
U_Plane	SL_U_PlaneTx_Type

SL_DATA_IND

TTCN-3 Record Type	
Name	SL_DATA_IND
Comment	Common ASP to receive PDUs from PC5 channels SL-DCH or SLRB
Common	SL_IndAspCommonPart_Type SS_UE_Id : identifier of the SL UE RoutingInfo : SL-DCH or SLRB identity TimingInfo : SFN/Subframe or DFN/DirectSubframe when message has been received
U_Plane	SL_U_PlaneRx_Type

SL_U_PlaneTx_Type

TTCN-3 Record Type			
Name	SL_U_PlaneTx_Type		
Comment			
U_Plane	SL_U_Plane_Type		
SL_DataScheduling	SL_DataScheduling_Type	opt	Applied on SL-DCH and PSCCH/PSSCH

SL_U_PlaneRx_Type

TTCN-3 Record Type			
Name	SL_U_PlaneRx_Type		
Comment			
U_Plane	SL_U_Plane_Type		
FreqDomainScheduling	FreqDomainSchedulingExplicit_Type	opt	Applied on SL-RB and SL-DCH

SL_U_Plane_Type

TTCN-3 Union Type		
Name	SL_U_Plane_Type	
Comment		
Discovery	SL_DCH_Message_Type	SL-DCH message
PdcpPdu	PDCP_PDUList_Type	SS configuration: PDCP no header removal - In Rx only one PDCP PDU is expected
PdcpSdu	PDCP_SDUList_Type	SS configuration: PDCP header removal - In Rx only one PDCP SDU is expected

SL_DCH_Message_Type

TTCN-3 Union Type		
Name	SL_DCH_Message_Type	
Comment	SL-DCH message	
pC5_DISCOVERY	PC5_DISCOVERY	

SL_DataScheduling_Type

TTCN-3 Union Type		
Name	SL_DataScheduling_Type	
Comment		
DiscPeriodResource	DiscPeriodResourceList_Type	Applied for SS-UE transmission on SL-DCH/PSDCH
CommPeriodResource	CommPeriodResourceList_Type	Applied for SS-UE transmission on PSCCH

DiscPeriodResourceList_Type

TTCN-3 Record Type	
Name	DiscPeriodResourceList_Type
Comment	Parameters for transmission of the PC5_DISCOVERY message during NumberOfTransmissionPeriod discovery Periods TimingInfo in Common indicates the SFN/subframe of the first discovery period
NumberOfTransmissionPeriod	integer Number of consecutive discovery period
N_PDSCH	integer Resource number in the range 0..(Nt*Nf-1) (see TS 36.213 cl 14.3.1) Multiple PC5_DISCOVERY messages can be transmitted within a discovery period, different SL_DATA_REQ and N_PDSCH values will be provided

CommPeriodResourceList_Type

TTCN-3 Record of Type	
Name	CommPeriodResourceList_Type
Comment	One entry in the list per STCH packets provided in the U_Plane field One entry per communication period
record of CommPeriodResource_Type	

CommPeriodResource_Type

TTCN-3 Record Type	
Name	CommPeriodResource_Type
Comment	Parameters for transmission of the STCH packets TimingInfo in Common indicates the SFN/subframe of the first communication period
N_PSCCH	integer PSCCH Resource number (see TS 36.213 cl 14.2.1.1) Multiple STCH packets can be transmitted within a communication period, different SL_DATA_REQ and N_PSCCH values will be provided

SL_DATA_PORT

TTCN-3 Port Type	
Name	SL_DATA_PORT
Comment	
out	SL_DATA_REQ
in	SL_DATA_IND

D.14.2 SideLinkUE_Configuration**D.14.2.1 SL_Routing_Timing****SL_Routing_Timing: Basic Type Definitions**

TTCN-3 Basic Types	
DirectFrameNumber_Type	MasterInformationBlock_SL.directFrameNumber_r12
DirectSubframeNumber_Type	MasterInformationBlock_SL.directSubframeNumber_r12
SLRB_Identity_Type	integer

SS_UE_Id_Type

TTCN-3 Enumerated Type	
Name	SS_UE_Id_Type
Comment	Simulated UE-ID
ss_UE_NonSpecific	Represents all Simulated UEs
ss_UE_Id1	
ss_UE_Id2	
ss_UE_Id3	

SL_RoutingInfo_Type

TTCN-3 Union Type	
Name	SL_RoutingInfo_Type
Comment	
None	Null_Type
ChannelRadioB earerId	SL_ChannelRadioBearerId_Type

SL_ChannelRadioBearerId_Type

TTCN-3 Union Type	
Name	SL_ChannelRadioBearerId_Type
Comment	
SLDCH	Null_Type Discovery SL-DCH
SLRB	SLRB_Identity_Type Communication SL-RB

SL_TimingInfo_Type

TTCN-3 Union Type	
Name	SL_TimingInfo_Type
Comment	
InCoverageTim ing	TimingInfo_Type SFN/subframe
OutOfCoverage Timing	SL_OoC_TimingInfo_Type DFN/DirectSubframe

SL_OoC_TimingInfo_Type

TTCN-3 Union Type	
Name	SL_OoC_TimingInfo_Type
Comment	Out of coverage timing info
DirectSubFram e	DirectSubFrameTiming_Type
Now	Null_Type to be used in REQ ASPs when there is no 'activation time'
None	Null_Type to be used in CNF ASPs but not for EnquireTiming

DirectSubFrameTiming_Type

TTCN-3 Record Type	
Name	DirectSubFrameTiming_Type
Comment	
DFN	DirectFrameNumber_Type
DSubframe	DirectSubframeNumber_Ty pe

D.14.2.2 SL_SystemRequestAsp

D.14.2.2.1 SL_RequestAspCommon_Part

SL_RequestAspCommon_Part: Basic Type Definitions

TTCN-3 Basic Types		
SL_Bandwidth_Type	MasterInformationBlock_SL.sl_Bandwidth_r12	

SL_ReqAspCommonPart_Type

TTCN-3 Record Type			
Name	SL_ReqAspCommonPart_Type		
Comment			
SS_UE_Id	SS_UE_Id_Type		SS-UE ID
RoutingInfo	SL_RoutingInfo_Type		Channel or RB Id
TimingInfo	SL_TimingInfo_Type		In coverage or Out of coverage timing
ControllInfo	ReqAspControllInfo_Type		

SL_SystemRequest_Type

TTCN-3 Union Type		
Name	SL_SystemRequest_Type	
Comment		
SS_UE_Config	SS_UE_ConfigRequest_Type	Configure/release a SS-UE
EnquireTiming	Null_Type	Get SFN/subframe number or DFN/Direct subframe time for this SS-UE
L1MacIndCtrl	SL_L1Mac_IndicationControl_Type	To configure SS_UE to generate indications for L1/MAC events
SL_Security	SL_Security_Type	StartRestart/Release of SLRB security

SL_L1Mac_IndicationControl_Type

TTCN-3 Record Type			
Name	SL_L1Mac_IndicationControl_Type		
Comment	NOTE: Initially all indications are disabled in SS (i.e. it shall not be necessary in 'normal' test cases to use this primitive but only if a specific indication is needed); omit means indication mode is not changed		
DiscSync	IndicationAndControlMode_Type	opt	To enable/disable reporting of start and stop of reception of Discovery SLSS as configured. NOTE: this is applicable when SS_UE is configured with RxDiscSyncRef SS reports an indication every time when SLSS reception from UE has toggled in the subframes configured for SLSS reception
CommSLSS_MIBSL	IndicationAndControlMode_Type	opt	To enable/disable reporting of start and stop of reception of communication SLSS and MIB-SL as configured. NOTE: this is applicable when SS_UE is configured with CommRxSyncRef SS reports an indication every time when SLSS/MIB-SL reception from UE has toggled in the subframes configured for SLSS/MIB-SL reception

SS_UE_ConfigRequest_Type

TTCN-3 Union Type		
Name	SS_UE_ConfigRequest_Type	
Comment		
AddOrReconfigure	SS_UE_ConfigInfo_Type	For one SS-UE configuration: SS_UE_Id : identifier of the SS-UE to be configured RoutingInfo : None TimingInfo : Now (for initial configuration) ControllInfo : Cnfflag:=true; FollowOnFlag:=false (in general)
Release	Null_Type	To remove all SS-UEs completely SS_UE_Id : ss_UE_NonSpecific RoutingInfo : None TimingInfo : Now ControllInfo : Cnfflag:=true; FollowOnFlag:=false (in general)

SS_UE_ConfigInfo_Type

TTCN-3 Record Type			
Name	SS_UE_ConfigInfo_Type		
Comment			
SS_UE_ProSeCoverage	SS_UE_ProSeCoverage_Type	opt	Mandatory in the first configuration - omit means no change InCoverage for discovery
Power	SS_UE_Power_Type	opt	Reference power for the RS of each antenna in Tx Initially configured as switched ON
DiscConfig	DiscConfig_Type	opt	
CommConfig	CommConfig_Type	opt	

SS_UE_Power_Type

TTCN-3 Record Type			
Name	SS_UE_Power_Type		
Comment			
MaxReferencePower	AbsoluteCellPower_Type	opt	Maximum value of SS-UE reference power (in dBm/15kHz as per TS 36.508, clause 4.3.4.1); SS-UE is initialised with this reference power; its value can't be reconfigured during test execution, attenuation is used to change SS-UE power level its value is the upper bound of the SS-UE power during the test case
Attenuation	Attenuation_Type		Initial attenuation: ON

InCoverageConfig_Type

TTCN-3 Record Type			
Name	InCoverageConfig_Type		
Comment			
UL_CarrierFreq	ARFCN_ValueEUTRA_r9		
UL_bandwidth	UI_Bandwidth_Type		
TDD_Config	TDD_Config	opt	omitted for FDD
CellTimingInfo	CellTimingInfo_Type		

OutOfCoverageConfig_Type

TTCN-3 Record Type			
Name	OutOfCoverageConfig_Type		
Comment			
CarrierFreq_r12	ARFCN_ValueEUTRA_r9		
SL_bandwidth_r12	SL_Bandwidth_Type		
TDD_ConfigSL_r12	TDD_ConfigSL_r12		
SS_UE_TimingInfo	SS_UE_TimingInfo_Type		

SS_UE_TimingInfo_Type

TTCN-3 Record Type			
Name	SS_UE_TimingInfo_Type		
Comment	SS_UE Timing		
DSubframeOffset	integer (0..307199)		frame duration $T_f = 307200 * T_s = 10\text{ms}$; System Time Unit $T_s = 1/(15000 * 2048)$
DfnOffset	integer (0..1023)		(assuming 10 bit DFN)

SS_UE_ProSeCoverage_Type

TTCN-3 Union Type			
Name	SS_UE_ProSeCoverage_Type		
Comment	For Discovery only InCoverage is applied		
InCoverage	InCoverageConfig_Type		In coverage SS-UE shall use Band/Bandwidth/UL frequency/Cell timing/TDD Frame structure/CP of the associated EUTRA cell
OutOfCoverage	OutOfCoverageConfig_Type		

PrimarySideLinkSyncSignal_Type

TTCN-3 Record Type			
Name	PrimarySideLinkSyncSignal_Type		
Comment			
RelativeTxPower	SideLinkChannelPower_Type	opt	Power for PSSS relative to the SS-UE power level - value in dB

SecondarySideLinkSyncSignal_Type

TTCN-3 Record Type			
Name	SecondarySideLinkSyncSignal_Type		
Comment			
RelativeTxPower	SideLinkChannelPower_Type	opt	Power for SSSS relative to the SS-UE power level - value in dB

D.14.2.2.2 Discovery_Specific

Discovery_Specific: Basic Type Definitions

TTCN-3 Basic Types		
DiscPeriod_r12_Type	SL_DiscResourcePool_r12.discPeriod_r12	
DiscNumRetx_r12_Type	SL_DiscResourcePool_r12.numRetx_r12	
DiscNumRepetition_r12_Type	SL_DiscResourcePool_r12.numRepetition_r12	
SideLinkChannelPower_Type	integer	see TS 36.213, clause 14

DiscConfig_Type

TTCN-3 Record Type			
Name	DiscConfig_Type		
Comment	Acc. to 36.321: HARQ configured with fixed TBS=232 - MAC configured in TM PC5_DISCOVERY msg = 232 bits, transmitted in one MAC TM PDU. The PSDCH is transmitted on two contiguous physical resource blocks per slot. The SideLink process is configured with a maximum number of HARQ retransmissions by RRC: numRetx.		
SL_DCH_Tx	SL_DCH_TxConfig_Type	opt	Corresponding to UE Rx resource pool
SL_DCH_Rx	SL_DCH_RxConfig_Type	opt	Corresponding to UE Tx resource allocation

SL_DCH_TxConfig_Type

TTCN-3 Union Type		
Name	SL_DCH_TxConfig_Type	
Comment		
AddOrReconfigure	SL_DCH_TxConfigInfo_Type	
Release	Null_Type	

SL_DCH_TxConfigInfo_Type

TTCN-3 Record Type			
Name	SL_DCH_TxConfigInfo_Type		
Comment			
SS_UE_Tx	DiscResourcePool_Type	opt	
DiscTxSyncRef	DiscTxSyncRefConfig_Type	opt	Configure SS_UE to transmit Sync SLSS with PC5_DISCOVERY Tx No prose yet - See 36.331 clause 5.10.5 Note 4
Psdch	PsdchConfig_Type	opt	

SL_DCH_RxConfig_Type

TTCN-3 Union Type		
Name	SL_DCH_RxConfig_Type	
Comment		
AddOrReconfigure	SL_DCH_RxConfigInfo_Type	
Release	Null_Type	

SL_DCH_RxConfigInfo_Type

TTCN-3 Record Type			
Name	SL_DCH_RxConfigInfo_Type		
Comment			
SS_UE_Rx	DiscResourcePoolList_Type	opt	
DiscRxSyncRef	DiscRxSyncRefConfig_Type	opt	For SS_UE to detect SLSS transmitted by UE under test It is assumed that only a single Rx resource pool will be specified for the receipt of SLSS by SS-UE

DiscResourcePool_Type

TTCN-3 Record Type			
Name	DiscResourcePool_Type		
Comment	All fields are mandatory for initial configuration; omit means "keep as it is"		
cp_Len_r12	SL_CP_Len_r12	opt	
discPeriod_r12	DiscPeriod_r12_Type	opt	
numRetx_r12	DiscNumRetx_r12_Type	opt	
numRepetition_r12	DiscNumRepetition_r12_Type	opt	
tf_ResourceConfig_r12	SL_TF_ResourceConfig_r12	opt	
discTF_IndexList_r12b	SL_TF_IndexPairList_r12b	opt	Applied in SL-DCH Rx when UE is configured in transmission mode 2B To ensure SS-UE and UE are timing aligned, the indexes are provided to SS-UE using the same activation as the one used to send the signalling reconfiguration message to UE

DiscResourcePoolList_Type

TTCN-3 Record of Type	
Name	DiscResourcePoolList_Type
Comment	
record length(1..maxSL_TxPool_r12) of DiscResourcePool_Type	

DiscTxSyncRefConfig_Type

TTCN-3 Union Type	
Name	DiscTxSyncRefConfig_Type
Comment	To start/reconfigure or stop transmitting SLSS (irrespective of any measurement)
AddOrReconfigure	DiscTxSyncRefConfigInfo_Type
Release	Null_Type

DiscRxSyncRefConfig_Type

TTCN-3 Union Type	
Name	DiscRxSyncRefConfig_Type
Comment	
AddOrReconfigure	DiscSyncConfigParam_Type
Release	Null_Type

DiscTxSyncRefConfigInfo_Type

TTCN-3 Record Type			
Name	DiscTxSyncRefConfigInfo_Type		
Comment	All fields are mandatory for initial configuration; omit means "keep as it is"		
SyncConfig	DiscSyncConfigParam_Type	opt	
Psss	PrimarySideLinkSyncSignal_Type	opt	
Ssss	SecondarySideLinkSyncSignal_Type	opt	

DiscSyncConfigParam_Type

TTCN-3 Record Type			
Name	DiscSyncConfigParam_Type		
Comment	All fields are mandatory for initial configuration; omit means "keep as it is"		
syncCP_Len_r12	SL_CP_Len_r12	opt	
syncOffsetIndicator_r12	SL_OffsetIndicatorSync_r12	opt	
slssid_r12	SLSSID_r12	opt	

PsdchConfig_Type

TTCN-3 Record Type			
Name	PsdchConfig_Type		
Comment			
RelativeTxPower	SideLinkChannelPower_Type	opt	Power for PSDCH relative to the SS-UE power level - value in dB

D.14.2.2.3 Communication_Specific

SideLinkUE_ASP_TypeDefs: Constant Definitions

TTCN-3 Basic Types			
tsc_MaxNumberSL_STCH	integer	1	Acc to 36.508 cl 4.2.2.3.1.1

Communication_Specific: Basic Type Definitions

TTCN-3 Basic Types		
SLSSID_Type	integer (0..335)	Covering values for In and Out of coverage
Mcs_Type	SL_CommConfig_r12.commTxResources_r12.setup.scheduled_r12.mcs_r12	
SL_Rohc_Profiles_Type	SL_PreconfigGeneral_r12.rohc_Profiles_r12	

CommConfig_Type

TTCN-3 Record Type			
Name	CommConfig_Type		
Comment			
CommSyncRef	CommSyncConfig_Type	opt	
CommRxConfig	CommRxConfig_Type	opt	
CommTxConfig	CommTxConfig_Type	opt	

CommSyncConfig_Type

TTCN-3 Record Type			
Name	CommSyncConfig_Type		
Comment			
CommTxSyncRef	CommTxSyncRefConfig_Type	opt	
CommRxSyncRef	CommRxSyncRefConfig_Type	opt	
SynchronisationSource	SL_SyncRef_Type	opt	Applied when OoC - When In coverage: omit ueSyncRef UE under test is SyncRef UE SS_UE shall synchronise from received SLSS/MIB-SL configured in CommRxSyncRef UE shall be transmitting SL-SS when SS_UE is switched on sS_UE_SyncRef SS_UE is SyncRef UE SS_UE shall initiate DFN/DirectSubframe and transmit SLSS/MIB-SL acc to CommTxSyncRef

CommTxSyncRefConfig_Type

TTCN-3 Union Type		
Name	CommTxSyncRefConfig_Type	
Comment	To start/reconfigure or stop transmitting SLSS/MIB-SL (irrespective of any measurement)	
AddOrReconfigure	CommTxSyncRef_Type	Add/re-configure SLSS or SBCCH
Release	Null_Type	Stop SLSS and SBCCH transmission

CommRxSyncRefConfig_Type

TTCN-3 Union Type		
Name	CommRxSyncRefConfig_Type	
Comment		
AddOrReconfigure	CommRxSyncRef_Type	Add/re-configure reception of SLSS or SBCCH
Release	Null_Type	Release/stop reception of SLSS and SBCCH transmission

CommRxSyncRef_Type

TTCN-3 Record Type			
Name	CommRxSyncRef_Type		
Comment			
SyncCP_Len_r12	SL_CP_Len_r12		
Slssid_r12	SLSSID_Type	opt	Omit means any value is expected
SyncOffsetIndicator1_r12	SL_OffsetIndicatorSync_r12		
SyncOffsetIndicator2_r12	SL_OffsetIndicatorSync_r12	opt	When present both SyncOffsetIndicator1_r12 and SyncOffsetIndicator2_r12 shall be monitored

CommTxSyncRef_Type

TTCN-3 Record Type			
Name	CommTxSyncRef_Type		
Comment	SBCCH - RLC TM - MAC TM SS will perform padding, if required due to the granularity of the TF signalling, as defined in 36.331 cl 8.5.		
TxSyncConfig	CommTxSyncRefParam_Type	opt	
MIB_SL	MasterInformationBlock_SL	opt	DFN and Direct subframe set to a dummy value - to be set by SS-UE
Psss	PrimarySideLinkSyncSignal_Type	opt	
Ssss	SecondarySideLinkSyncSignal_Type	opt	
Psbch	PsbchConfig_Type	opt	The transmit power of PSBCH is same as the transmit power of primary sidelink synchronisation signal

CommTxSyncRefParam_Type

TTCN-3 Record Type			
Name	CommTxSyncRefParam_Type		
Comment			
SyncCP_Len_r12	SL_CP_Len_r12		
Slsid_r12	SLSSID_Type	opt	
SyncOffsetIndicator1_r12	SL_OffsetIndicatorSync_r12		

SL_SyncRef_Type

TTCN-3 Enumerated Type	
Name	SL_SyncRef_Type
Comment	
sS_UE_SyncRef	
ueSyncRef	

CommRxConfig_Type

TTCN-3 Union Type		
Name	CommRxConfig_Type	
Comment	SS-UE ID : identifier of the simulated UE being configured RoutingInfo : none TimingInfo : 'Now' in common cases ControllInfo : CnfFlag:=true; FollowOnFlag:=false (in general)	
AddOrReconfigure	CommRx_ConfigInfo_Type	Add/re-configure SideLink PSCCH/PSSCH/SL-SCH/STCH/RLC/PDCP
Release	Null_Type	Release SideLink PSCCH/PSSCH/SL-SCH/STCH/RLC/PDCP

CommTxConfig_Type

TTCN-3 Union Type		
Name	CommTxConfig_Type	
Comment	SS-UE ID : identifier of the simulated UE being configured RoutingInfo : none TimingInfo : 'Now' in common cases ControllInfo : CnfFlag:=true; FollowOnFlag:=false (in general)	
AddOrReconfigure	CommTx_ConfigInfo_Type	Add/re-configure SideLink PSCCH/PSSCH/SL-SCH/STCH/RLC/PDCP
Release	Null_Type	Release SideLink PSCCH/PSSCH/SL-SCH/STCH/RLC/PDCP

CommRx_ConfigInfo_Type

TTCN-3 Record Type			
Name	CommRx_ConfigInfo_Type		
Comment	It is assume that one SSUE layer 2 ID/one SLRB needs to be handled		
ResourcePoolList	CommResourcePoolList_Type	opt	Configure subframes reserved for PSSCH and PSCCH Present for first configuration omit means no change
SL_SCH_Config	SL_SCH_Config_Type	opt	SL-SCH/MAC configuration Present for first configuration omit means no change
STCH_ConfigList	STCH_ConfigList_Type	opt	

CommResourcePoolList_Type

TTCN-3 Record of Type	
Name	CommResourcePoolList_Type
Comment	record length(1..maxSL_TxPool_r12) of CommResourcePool_Type

CommResourcePool_Type

TTCN-3 Record Type			
Name	CommResourcePool_Type		
Comment			
sc_CP_Len_r12	SL_CP_Len_r12	opt	
sc_Period_r12	SL_PeriodComm_r12	opt	
sc_TF_ResourceConfig_r12	SL_TF_ResourceConfig_r12	opt	
data_CP_Len_r12	SL_CP_Len_r12	opt	
dataHoppingConfig_r12	SL_HoppingConfigComm_r12	opt	
data_TF_ResourceConfig_r12	SL_TF_ResourceConfig_r12	opt	
trpt_Subset_r12	SL_TRPT_Subset_r12	opt	

CommTx_ConfigInfo_Type

TTCN-3 Record Type			
Name	CommTx_ConfigInfo_Type		
Comment	All fields are optional; present for first configuration omit means no change		
ResourcePoolList	CommResourcePoolList_Type	opt	Configure pool of resources for PSSCH and PSCCH
Mcs_r12	Mcs_Type	opt	Indicates the Modulation and Coding Scheme as defined in TS 36.212 [23, 14.2.1]
SL_SCH_Config	SL_SCH_Config_Type	opt	SL-SCH/MAC configuration
STCH_ConfigList	STCH_ConfigList_Type	opt	RLC PDCP
SL_Scheduling	SSUE_SciConfig_Type	opt	SCI fixed grant used
PscchConfig	PscchConfig_Type	opt	
PsschConfig	PsschConfig_Type	opt	

SSUE_SciConfig_Type

TTCN-3 Record Type			
Name	SSUE_SciConfig_Type		
Comment			
Imcs	ImcsValue_Type		Modulation and coding scheme - 5 bits as defined in section 14.1.1 of [3]
SL_Scheduling	SL_SciConfig_Type		SCI fixed grant used

SL_SCH_Config_Type

TTCN-3 Record Type			
Name	SL_SCH_Config_Type		
Comment	All fields are mandatory for initial configuration; omit means "keep as it is"		
Mac	MAC_SLDCH_TestModeConfig_Type	opt	
SS_UE_Layer2Id	B24_Type	opt	

MAC_SLDCH_TestModeConfig_Type

TTCN-3 Union Type			
Name	MAC_SLDCH_TestModeConfig_Type		
Comment			
None	Null_Type		MAC operation in normal mode for SL-DCH
Config	Null_Type		

STCH_ConfigList_Type

TTCN-3 Record of Type			
Name	STCH_ConfigList_Type		
Comment			
record length(1.. tsc_MaxNumberSL_STCH) of STCH_Config_Type			

STCH_Config_Type

TTCN-3 Record Type			
Name	STCH_Config_Type		
Comment	All fields are mandatory for initial configuration; omit means "keep as it is"		
SLRB	SLRB_Identity_Type	opt	
SL_RBIDConfig	SLRB_Config_Type	opt	

SLRB_Config_Type

TTCN-3 Union Type		
Name	SLRB_Config_Type	
Comment		
AddOrReconfigure	SLRB_ConfigInfo_Type	Add/re-configure SideLink RB
Release	Null_Type	Release SideLink RB

SLRB_ConfigInfo_Type

TTCN-3 Record Type			
Name	SLRB_ConfigInfo_Type		
Comment	All fields are mandatory for initial configuration; omit means "keep as it is"		
Rlc	STCH_RLC_Type	opt	
Pdcp	SL_PDCP_Configuration_Type	opt	

STCH_RLC_Type

TTCN-3 Record Type			
Name	STCH_RLC_Type		
Comment	One RLC entity per Tx peer UE Uni-directional UM RLC sn-fieldLength = 5 LCG = 3 SN is set to the first received UMD PDU in Rx UM_Window size = 0		
Layer2Id	B24_Type	opt	Layer-2 Id of RLC entity: SourceLayer2-Id in Rx - DestinationLayer2Id in Tx
LCID	B5_Type	opt	Applied in Tx, in Rx SS shall use the value received in the first STCH data PDU

SL_PDCP_Configuration_Type

TTCN-3 Union Type		
Name	SL_PDCP_Configuration_Type	
Comment		
None	Null_Type	no PDCP is configured; e.g. for SLRBs tested in MAC test cases
Config	SL_PDCP_ConfigInfo_Type	

SL_PDCP_ConfigInfo_Type

TTCN-3 Record Type			
Name	SL_PDCP_ConfigInfo_Type		
Comment			
SIRb	PDCP_SLRB_Type	opt	mandatory for initial configuration; omit means "keep as it is"
TestMode	PDCP_TestModeConfig_Type	opt	mandatory for initial configuration; omit means "keep as it is"

PDCP_SLRB_Type

TTCN-3 Record Type			
Name	PDCP_SLRB_Type		
Comment	PDCP SN length = 16b discard timer = undefined maxCID=15		
headerCompression	SL_Rohc_Profiles_Type	opt	mandatory for initial configuration; omit means "keep as it is"

PsbchConfig_Type

TTCN-3 Record Type			
Name	PsbchConfig_Type		
Comment			
RelativeTxPower	SideLinkChannelPower_Type	opt	Power for PSBCH relative to the SS-UE power level - value in dB

PsschConfig_Type

TTCN-3 Record Type			
Name	PsschConfig_Type		
Comment			
RelativeTxPower	SideLinkChannelPower_Type	opt	Power for PSSCH relative to the SS-UE power level - value in dB

PscchConfig_Type

TTCN-3 Record Type			
Name	PscchConfig_Type		
Comment			
RelativeTxPower	SideLinkChannelPower_Type	opt	Power for PSCCH relative to the SS-UE power level - value in dB

D.14.2.2.4 SL_Security

SL_Security_Type

TTCN-3 Union Type		
Name	SL_Security_Type	
Comment	When not configured ciphering is considered as off	
StartRestart	SL_CipheringStartRestart_Type	Information to start/restart SL security protection in the PDCP SLRB
Release	Null_Type	To release SL security protection in the PDCP

SL_CipheringStartRestart_Type

TTCN-3 Record Type		
Name	SL_CipheringStartRestart_Type	
Comment	Acc to 33.303 NOTE: Group Member Id (i.e. the Layer 2 source address of the sending UE) and Group Id (i.e. the destination Layer 2 identity of the group) are configured in MAC and RLC (SL_SCH_Config_Type and STCH_RLC_Type). Expiry time to be handled by TTCN	
GroupId	B24_Type	ProSe Layer-2 Group Id
AlgorithmInfo	B3_Type	Security algorithm acc to 33.303 Table E.5.2.2.7-1
PGK	B256_Type	
PGK_Id	B64_Type	PGK identity
PTK_Id	B16_Type	For SS_UE Tx - For PTK derivation at SS-UE side. The value may be different from UE PTK-Id
Counter	B16_Type	For SS_UE Tx - For PTK derivation

D.14.2.3 SL_SystemConfirmAsp

SL_CnfAspCommonPart_Type

TTCN-3 Record Type			
Name	SL_CnfAspCommonPart_Type		
Comment			
SS_UE_Id	SS_UE_Id_Type		
RoutingInfo	SL_RoutingInfo_Type		
TimingInfo	SL_TimingInfo_Type		
Result	ConfirmationResult_Type		

SL_SystemConfirm_Type

TTCN-3 Union Type		
Name	SL_SystemConfirm_Type	
Comment	Confirmations for SL system configuration; in general to be sent after the configuration has been done	
SS_UE_Config	Null_Type	Confirmation for SS-UE configuration
EnquireTiming	Null_Type	Confirmation for EnquireTiming
L1MacIndCtrl	Null_Type	Confirmation for L1MacIndCtrl
SL_Security	Null_Type	(no further parameters from SS)

D.14.2.4 SL_SystemIndicationAsp

SL_IndAspCommonPart_Type

TTCN-3 Record Type			
Name	SL_IndAspCommonPart_Type		
Comment			
SS_UE_Id	SS_UE_Id_Type		Simulated SS-UE ID
RoutingInfo	SL_RoutingInfo_Type		Channel ID or RB Id for STCH
TimingInfo	SL_TimingInfo_Type		In coverage or Out of coverage timing
Status	IndicationStatus_Type		

SL_SystemIndication_Type

TTCN-3 Union Type		
Name	SL_SystemIndication_Type	
Comment		
Error	charstring	Indicates an error situation in SS-UE; is not explicitly handled in TTCN but causes an INCONC due to default behaviour; an additional error code can be signalled in the common part of the ASP; SS shall raise an error in case of - Invalid TimingInfo - Data scheduled does not fit into an available resource in a resource pool (NOTE: additional cases may occur)
DiscSync	DiscSLSS_Ind_Type	Indication for Discovery SLSS sent by UE
CommSLSS_MIBSL	CommSLSS_MIBSL_Ind_Type	Indication for Communication SLSSID and MIB-SL sent by UE

DiscSLSS_Ind_Type

TTCN-3 Enumerated Type	
Name	DiscSLSS_Ind_Type
Comment	<p>When transmitted SLSS is associated with a PC5_DISCOVERY message according to RxDiscSyncRef.</p> <p>Start is triggered in SS_UE when</p> <ul style="list-style-type: none"> - the first SLSS associated with a PC5_Discovery message is received by SS-UE since enabling of SLSS reporting - the previous SLSS indication was 'stop' or 'spurious' and an SLSS associated with a PC5_Discovery message is received by SS-UE <p>Stop is triggered in SS_UE when</p> <ul style="list-style-type: none"> - the first PC5_DISCOVERY message is received without SLSS - the previous SLSS indication was 'start' or 'spurious' and PC5_DISCOVERY message is received without SLSS <p>Spurious is triggered in SS_UE when</p> <ul style="list-style-type: none"> - the first SLSS is received without PC5_DISCOVERY message since enabling of SLSS reporting - the previous SLSS indication was 'start' or 'stop' and SLSS is received without associated PC5_DISCOVERY message
DiscSLSS_Start	
DiscSLSS_Stop	
DiscSLSS_Spurious	

CommSLSS_MIBSL_Ind_Type

TTCN-3 Union Type	
Name	CommSLSS_MIBSL_Ind_Type
Comment	<p>Start is triggered in SS_UE when</p> <ul style="list-style-type: none"> - the first SLSS associated with a MIB-SL is received in the same subframe by SS-UE since enabling of reporting - the previous indication was 'stop' or 'spurious' and an SLSS associated with a MIB-SL is received by SS-UE <p>Stop is triggered in SS_UE when</p> <ul style="list-style-type: none"> - no SLSS/MIB-SL is transmitted in the period - the previous indication was 'start' or 'spurious' and no SLSS/MIB-SL is transmitted in the period <p>Spurious is triggered in SS_UE when</p> <ul style="list-style-type: none"> - the first SLSS is received without MIB-SL or MIB-SL is received without SLSS since enabling of SLSS reporting - the previous indication was 'start' or 'stop' and SLSS is received without MIB-SL or MIB-SL is received without SLSS
CommSLSS_Start	CommSyncParamInd_Type
CommSLSS_Stop	Null_Type
CommSLSS_Spurious	Null_Type

CommSyncParamInd_Type

TTCN-3 Record Type	
Name	CommSyncParamInd_Type
Comment	
SLSSID	SLSSID_Type
MIB_SL	MasterInformationBlock_SL

D.14.2.5 SL_System_Interface

SL_SYSTEM_CTRL_REQ

TTCN-3 Record Type			
Name	SL_SYSTEM_CTRL_REQ		
Comment	ASP to request/control SideLink system configuration		
Common	SL_ReqAspCommonPart_Type		TimingInfo depends on respective primitive:
Request	SL_SystemRequest_Type		<ul style="list-style-type: none"> - SS_UE_Config TimingInfo: depends on the request - EnquireTiming TimingInfo: 'now' - L1MacIndCtrl TimingInfo: 'now' - SL_Security RoutingInfo: SLRB TimingInfo: 'now'

SL_SYSTEM_CTRL_CNF

TTCN-3 Record Type			
Name	SL_SYSTEM_CTRL_CNF		
Comment	ASP to confirm a SideLink system configuration request		
Common	SL_CnfAspCommonPart_Type		TimingInfo is ignored by TTCN (apart from EnquireTiming): SS may set TimingInfo to "None"
Confirm	SL_SystemConfirm_Type		<ul style="list-style-type: none"> - EnquireTiming TimingInfo InCoverage: SFN/Subframe

SL_SYSTEM_IND

TTCN-3 Record Type			
Name	SL_SYSTEM_IND		
Comment	ASP to report errors or system indications		
Common	SL_IndAspCommonPart_Type		The SS shall provide TimingInfo (SFN + subframe number) depending on the respective indication:
Indication	SL_SystemIndication_Type		<ul style="list-style-type: none"> - Error TimingInfo: related to the error (if available) - DiscSync TimingInfo: SFN/Subframe related to the SLSS - CommSLSS TimingInfo: SFN/Subframe or DFN/DirectSubframe related to the SLSS - CommMIB_SL TimingInfo: SFN/Subframe or DFN/DirectSubframe related to the MIB-SL

SL_SYSTEM_PORT

TTCN-3 Port Type			
Name	SL_SYSTEM_PORT		
Comment	SideLink UE PTC: Port for system configuration		
out	SL_SYSTEM_CTRL_REQ		
in	SL_SYSTEM_CTRL_CNF		

SL_SYSIND_PORT

TTCN-3 Port Type	
Name	SL_SYSIND_PORT
Comment	SideLink UE PTC: Port for system indications
in	SL_SYSTEM_IND

D.15 CommonDefs

CommonDefs: Constant Definitions

TTCN-3 Basic Types			
tsc_UInt16Max	integer	65535	
tsc_UInt32Max	integer	4294967295	

CommonDefs: Basic Type Definitions

TTCN-3 Basic Types		
B1_Type	bitstring length(1)	
B2_Type	bitstring length(2)	
B3_Type	bitstring length(3)	
B4_Type	bitstring length(4)	
B5_Type	bitstring length(5)	
B6_Type	bitstring length(6)	
B7_Type	bitstring length(7)	
B7_15_Type	bitstring length(7..15)	NOTE: length restriction can only be a range but not two distinct lengths
B8_Type	bitstring length(8)	
B10_Type	bitstring length(10)	
B11_Type	bitstring length(11)	
B12_Type	bitstring length(12)	
B15_Type	bitstring length(15)	
B16_Type	bitstring length(16)	
B18_Type	bitstring length(18)	
B24_Type	bitstring length(24)	
B32_Type	bitstring length(32)	
B64_Type	bitstring length(64)	
B128_Type	bitstring length(128)	
B256_Type	bitstring length(256)	
B128_Key_Type	B128_Type	128 bit security key
O3_Type	octetstring length(3)	
O4_Type	octetstring length(4)	
O6_Type	octetstring length(6)	
O8_Type	octetstring length(8)	
O13_Type	octetstring length(13)	
Null_Type	boolean (true)	dummy type for 'typeless' fields in unions
Dummy_Type	boolean (true)	dummy type for temporary purposes only
UInt16_Type	integer (0 .. tsc UInt16Max)	
UInt32_Type	integer (0 .. tsc UInt32Max)	
IP_Drbld_Type	integer	DRB identity type common for all RATs: - for EUTRA it corresponds to the ASN.1 type DRB-Identity - for UTRAN it corresponds to the ASN.1 type RB-Identity and values are as defined in TS 34.123-3 Table 8.2.4.1 - for GERAN the NSAPI value (type record NSAPI) may be used NOTE: this is introduced to simplify the dependencies (i.e. to keep IP_ASP_TypeDefs independent from any RAT specific type definitions)
PdcpCountValue_Type	B32_Type	

IndicationAndControlMode_Type

TTCN-3 Enumerated Type	
Name	IndicationAndControlMode_Type
Comment	
enable	
disable	

EUTRA_CellId_Type

TTCN-3 Enumerated Type	
Name	EUTRA_CellId_Type
Comment	
eutra_Cell_NonSpecific	
eutra_Cell1	
eutra_Cell2	
eutra_Cell3	
eutra_Cell4	
eutra_Cell6	
eutra_Cell10	
eutra_Cell11	
eutra_Cell12	
eutra_Cell13	
eutra_Cell14	
eutra_Cell23	
eutra_Cell28	
eutra_Cell29	
eutra_Cell30	
eutra_Cell31	
eutra_CellA	
eutra_CellB	
eutra_CellC	
eutra_CellD	
eutra_CellE	
eutra_CellG	
eutra_CellH	
eutra_CellI	
eutra_CellJ	
eutra_CellK	
eutra_CellL	
eutra_CellM	

EUTRA_CellIdList_Type

TTCN-3 Record of Type	
Name	EUTRA_CellIdList_Type
Comment	
record length (0..9) of EUTRA_CellId_Type	

IP_EUTRA_DrbInfo_Type

TTCN-3 Record Type			
Name	IP_EUTRA_DrbInfo_Type		
Comment			
CellId	EUTRA_CellId_Type		data is routed to a specific cell regardless of whether the same DRB is configured in any other cell
DrbId	IP_DrbId_Type	opt	mandatory at the system interface

IP_UTRAN_GERAN_DrbInfo_Type

TTCN-3 Record Type			
Name	IP_UTRAN_GERAN_DrbInfo_Type		
Comment			
CellId	integer		
DrbId	IP_DrbId_Type	opt	mandatory at the system interface

IP_WLAN_DrblInfo_Type

TTCN-3 Record Type	
Name	IP_WLAN_DrblInfo_Type
Comment	
CellId	integer

IP_DrblInfo_Type

TTCN-3 Union Type	
Name	IP_DrblInfo_Type
Comment	
Eutra	IP_EUTRA_DrblInfo_Type
Utran	IP_UTRAN_GERAN_DrblInfo_Type
Geran	IP_UTRAN_GERAN_DrblInfo_Type
Wlan	IP_WLAN_DrblInfo_Type
IPsecTunnel	Null_Type
FBBA	Null_Type

D.16 EUTRA_NB_ASP_TypeDefs

Type definitions for configuration of the system simulator;

Common design principles:

Semantics of OMIT: for all TTCN-3 type definitions used in ASPs omit means "keep as it is" =>

- on initial configuration in general all fields shall be provided
- no default values for fields are foreseen
- if necessary non-existence of information shall be explicitly configured (e.g. with a union of "no configuration" and "configuration parameters")
- fields within structures imported from the core spec are excepted from this rule

D.16.1 Cell_Configuration

Specific Info for Cell Configuration Primitive

D.16.1.1 Cell_Configuration_Common

EUTRA_NB_ASP_TypeDefs: Constant Definitions

TTCN-3 Basic Types	
tsc_CellAttenuation_Off	Attenuation_Type {Off:=true}

Cell_Configuration_Common: Basic Type Definitions

TTCN-3 Basic Types	
InitialAttenuation_Type	Attenuation_Type (tsc_CellAttenuation_Off) Attenuation restricted to 'Off'
ToRS_EPRES_Ratio_Type	integer (-35..0) any-resource-element to RS ratio in dB (e.g. PDSCH-to-RS ratio; see TS 36.213, clause 5.2)

CellTimingInfo_Type

TTCN-3 Record Type			
Name	CellTimingInfo_Type		
Comment	Cell Timing		
Tcell	integer (0..307199)		frame duration $T_f = 307200 * T_s = 10\text{ms}$; System Time Unit $T_s = 1/(15000 * 2048)$
SfnOffset	integer (0..1023)		
HsfnOffset	integer (0..1023)		

Attenuation_Type

TTCN-3 Union Type			
Name	Attenuation_Type		
Comment	attenuation of the reference power		
Value	integer (0..149)		cell power reference power reduced by the given attenuation (value is in dB)
Off	Null_Type		even though in TS 36.508 -145dBm for LTE and -150dBm for NB-IoT is given for a non suitable cell we specify an explicit "Off" value here

InitialCellPower_Type

TTCN-3 Record Type			
Name	InitialCellPower_Type		
Comment			
MaxReference Power	AbsoluteCellPower_Type		maximum value of cell reference power (RS EPRE in dBm/15kHz as per TS 36.508, clause 4.3.4.1); a cell is initialised with this reference power; its value is the upper bound of the cell power during the test case
Attenuation	InitialAttenuation_Type		initial attenuation

D.16.1.2 Uplink_Physical_Layer_Configuration**SS_TimingAdvanceConfig_Type**

TTCN-3 Union Type			
Name	SS_TimingAdvanceConfig_Type		
Comment			
InitialValue	RACH_TimingAdvance_Type		initial value corresponding to what is sent to the UE in RACH response (range acc. 11 bit value; 0 in normal cases)
Relative	TimingAdvanceIndex_Type		timing advance command to adjust changes of timing advance acc. to TS 36.213, clause 4.2.3; (range acc. 6 bit value: -31..32)

D.16.1.3 Common_MAC_Configuration

Transport channel and MAC related procedures and configuration

Common_MAC_Configuration: Basic Type Definitions

TTCN-3 Basic Types		
TimingAdvanceIndex_Type	integer (0..63)	acc. to TS 36.321, clause 6.1.3.5 "Timing Advance Command MAC Control Element" and TS 36.213, clause 4.2.3 "Transmission timing adjustments"
TimingAdvance_Period_Type	integer (400, 600, 1020, 1530, 2040, 4090, 8190)	the values correspond to 80 % of TimeAlignmentTimer (acc. to TS 36.523-3, clause 7.2) (TS 36.331, clause 6.3.2: sf500, sf750, sf1280, sf1920, sf2560, sf5120, sf10240) rounded to nearest multiple of 10

UplinkTimeAlignment_AutoSynch_Type

TTCN-3 Record Type		
Name	UplinkTimeAlignment_AutoSynch_Type	
Comment		
TimingAdvance	TimingAdvanceIndex_Type	
TA_Period	TimingAdvance_Period_Type	time period after which TA MAC control elements need to be automatically transmitted
TA_Repetition	TransmissionRepetition_Type	number of TA MAC control element repetitions to be automatically transmitted or 'Continuous'

UplinkTimeAlignment_Synch_Type

TTCN-3 Union Type		
Name	UplinkTimeAlignment_Synch_Type	
Comment		
None	Null_Type	no PUCCH Synchronisation applied
Auto	UplinkTimeAlignment_AutoSynch_Type	SS automatically maintains PUCCH synchronization at UE If the cell is a - Rel 10 or earlier cell - or Rel 11 or later Pcell - or the Rel-11 or later scell with no STAG-ID configured, the TAG-ID is set to '00' i.e. P-TAG in Timing advance MCE If the cell is Rel 11 scell with STAG-ID configured, the configured stag-ID is used as TAG-ID in Timing advance MCE

TransmissionRepetition_Type

TTCN-3 Union Type		
Name	TransmissionRepetition_Type	
Comment		
Continuous	Null_Type	
NumOfCycles	integer (1..infinity)	

D.16.1.4 Random_Access_Procedure

EUTRA_NB_ASP_TypeDefs: Constant Definitions

TTCN-3 Basic Types			
tsc_RandomAccessResponseListSize	integer	10	arbitrary value (needs to be extended, if necessary); in case of RACH in idle, UE will keep on making RACH attempts until t300 expires => number of PRACH preambles maybe even greater than maximum value of PREAMBLE_TRANS_MAX

Random_Access_Procedure: Basic Type Definitions

TTCN-3 Basic Types		
RACH_TimingAdvance_Type	integer (0..2047)	11 bit timing advance as used in RACH response (absolute value)

ContentionResolution_ContainedRlcPdu_Type

TTCN-3 Union Type		
Name	ContentionResolution_ContainedRlcPdu_Type	
Comment		
RlcPdu	octetstring	octetstring of an RLC PDU containing e.g. the RRC Connection Setup; to be sent in the same MAC PDU as the MAC Contention Resolution Control Element
None	Null_Type	MAC PDU containing the MAC Contention Resolution Control Element does not contain an RLC PDU (i.e. RRC Connection Setup is sent in another PDU)

ContentionResolution_ContainedId_Type

TTCN-3 Union Type		
Name	ContentionResolution_ContainedId_Type	
Comment		
XorMask	ContentionResolutionId_Type	When SS receives Contention Resolution ID from the UE, SS shall XOR it with the given mask and use this as Contention Resolution ID; this allows to get an unmatching Contention Resolution ID; in normal cases mask shall be set to tsc_ContentionResolutionId_Unchanged (i.e. the Contention Resolution ID remains unchanged)
None	Null_Type	MAC Contention Resolution Control Element is not contained in the MAC PDU sent out as response on Msg3

TCRNTI_ContentionResolutionMacPdu_Type

TTCN-3 Record Type	
Name	TCRNTI_ContentionResolutionMacPdu_Type
Comment	NOTE: Either ContainedId or ContainedRlcPdu (or both) shall not be 'none'; (if no Contention Resolution Mac Pdu shall be sent, TCRNTI_ContentionResolutionCtrl_Type.NoContResolID shall be used instead)
ContainedId	ContentionResolution_ContainedId_Type Either the Contention Resolution ID as received from the UE or a modified Contention Resolution ID (XorMask != tsc_ContentionResolutionId_Unchanged) or no Contention Resolution ID at all
ContainedRlcPdu	ContentionResolution_ContainedRlcPdu_Type the MAC PDU containing the MAC Contention Resolution Control Element may contain the RRC Connection Setup; in this case the RRC PDU shall be completely encoded been contained in an RLC PDU

TCRNTI_ContentionResolutionCtrl_Type

TTCN-3 Union Type	
Name	TCRNTI_ContentionResolutionCtrl_Type
Comment	when the UE responds on a Random Access Response with a RRC Connection Request on CCCH and not with a C-RNTI SS shall assume initial Random Access Procedure (TS 36.300, clause 10.1.5.1), i.e. sends a ContentionResolutionId back to the UE
MacPdu	TCRNTI_ContentionResolutionMacPdu_Type MAC PDU containing the Contention Resolution ID and optionally an RRC PDU (RRC Connection Setup)
MacPdu_CRC_Error	TCRNTI_ContentionResolutionMacPdu_Type same as MacPdu (see above), but SS shall generate CRC error by toggling CRC bits; no retransmissions shall be made as UE shall not send a NACK
NoContResolID	Null_Type SS shall not include contention resolution ID (i.e. no MAC PDU shall be sent); used for contention resolution fail case

RapidCtrl_Type

TTCN-3 Union Type	
Name	RapidCtrl_Type
Comment	
Automatic	Null_Type SS shall automatically use same RAPID as received from the UE
Unmatched	Null_Type SS shall use RAPID being different from preamble sent by the UE; SS shall calculate this RAPID acc. to $RAPID := (RAPID + 3..63) \bmod 64$ if single RAR is transmitted in a MAC PDU then only 3 is added if multiple RAR's are transmitted in MAC PDU, then for first unmatched RAR 3 is added, second unmatched 4 is added, third unmatched 5 is added and so on

TempC_RNTI_Type

TTCN-3 Union Type		
Name	TempC_RNTI_Type	
Comment		
SameAsC_RNTI	Null_Type	in the RA response SS shall use the same C-RNTI as configured in ActiveCellConfig_Type; this is useful for initial random access
Explicit	C_RNTI	in the RA response SS shall use different value as configured in ActiveCellConfig_Type; this can be used when the UE already is in RRC_CONNECTED to have a temporary C-RNTI different from the one used by the UE; NOTE: when the UE is not in RRC_CONNECTED there shall be no explicit temp. C-RNTI since then the UE would assume this value as C-RNTI

RandomAccessBackoffIndicator_Type

TTCN-3 Union Type		
Name	RandomAccessBackoffIndicator_Type	
Comment		
None	Null_Type	normal case, no back off indicator included
Index	integer (0..15)	Backoff Parameter values acc. TS 36.321, clause 7.2; values 0..12 are defined, 13..15 may be used in error case

D.16.2 System_Indications

HARQ_Type

TTCN-3 Enumerated Type	
Name	HARQ_Type
Comment	ack represents HARQ ACK; nack represents HARQ NACK
ack	
nack	

D.17 EUTRA_NB_CommonDefs

D.17.1 Common_Types

Common_Types: Basic Type Definitions

TTCN-3 Basic Types		
LogicalChannelId_Type	integer (0..10)	acc. TS 36.331, clause 6.3.2 and clause 6.7.3.2 for DRBs DTCH- LogicalChannelIdentity is INTEGER (3..10); additionally we have 0..2 for the SRBs
HarqProcessId_Type	integer (0..14)	The values 0..7 represent the ID of HARQ process ID; value range 0..14 is for TDD
ContentionResolutionId_Type	bitstring length(48)	used in EUTRA_ASP_DrbDefs and EUTRA_ASP_Typedefs
AbsoluteCellPower_Type	integer (-150..0)	absolute cell power (dBm)

D.17.2 RRC_Nested_Types

RRC_Nested_Types: Basic Type Definitions

TTCN-3 Basic Types		
IntegrityProtAlgorithm_Type	SecurityAlgorithmConfig.integrityProtAlgorithm	

D.17.3 ASP_CommonPart

Definition of ASP common parts for REQ-, CNF- and IND-ASPs

D.17.3.1 ASP_CommonPart_Definitions

D.17.3.1.1 Routing_Info

EUTRA_NB_CommonDefs: Constant Definitions

TTCN-3 Basic Types			
tsc_SRB0	integer	0	
tsc_SRB1	integer	1	

D.17.3.1.2 Timing_Info

Timing_Info: Basic Type Definitions

TTCN-3 Basic Types		
SystemFrameNumber_Type	integer (0..1023)	
SubFrameNumber_Type	integer (0..9)	
HyperSystemFrameNumberInfo_Type	SystemFrameNumberInfo_Type	

SubFrameInfo_Type

TTCN-3 Union Type		
Name	SubFrameInfo_Type	
Comment		
Number	SubFrameNumber_Type	
Any	Null_Type	no specific sub-frame (valid for REQ ASPs only)

SystemFrameNumberInfo_Type

TTCN-3 Union Type		
Name	SystemFrameNumberInfo_Type	
Comment		
Number	SystemFrameNumber_Type	
Any	Null_Type	no specific frame number (valid for REQ ASPs only)

SubFrameTiming_Type

TTCN-3 Record Type			
Name	SubFrameTiming_Type		
Comment			
SFN	SystemFrameNumberInfo_Type		
Subframe	SubFrameInfo_Type		
HSFN	HyperSystemFrameNumberInfo_Type		

TimingInfo_Type

TTCN-3 Union Type			
Name	TimingInfo_Type		
Comment			
SubFrame	SubFrameTiming_Type		
Now	Null_Type		to be used in REQ ASPs when there is no 'activation time'
None	Null_Type		only to be used in SYSTEM_CTRL_CNF but not for EnquireTiming

D.17.3.2 REQ_ASP_CommonPart

ReqAspControllInfo_Type

TTCN-3 Record Type			
Name	ReqAspControllInfo_Type		
Comment			
CnfFlag	boolean		<p>true => SS shall send CNF: when the REQ is with no timing information (no activation time), SS shall send the confirmation when the configuration is done, i.e. when the test case may continue. Example: when there is a configuration follow by a send event it shall not be necessary to have a wait timer in between but the CNF triggers the send event. If there are other triggers e.g. like the UE sending a message, CnfFlag shall be set to false by the test case to avoid racing conditions with the CNF and the signalling message. When there is an activation time SS shall send the CNF after the configuration has been scheduled; that means SS shall not wait until the activation time has been expired.</p>
FollowOnFlag	boolean		<p>false => no further (related) information true: further related information will be sent to SS (semantics depending on respective ASP)</p>

D.17.3.3 CNF_ASP_CommonPart

ConfirmationResult_Type

TTCN-3 Union Type			
Name	ConfirmationResult_Type		
Comment			
Success	Null_Type		
Error	integer		may contain SS specific error code; this will not be evaluated by TTCN

D.17.3.4 IND_ASP_CommonPart

IntegrityErrorIndication_Type

TTCN-3 Record Type			
Name	IntegrityErrorIndication_Type		
Comment			
Nas	boolean		NAS Integrity: set to true when received MAC does not match calculated MAC
Pdcp	boolean		PDCP Integrity: set to true when received MAC does not match calculated MAC

ErrorIndication_Type

TTCN-3 Record Type			
Name	ErrorIndication_Type		
Comment			
Integrity	IntegrityErrorIndication_Type		Integrity error: received MAC does not match calculated MAC
System	integer		any other error: may be SS specific error code; this will not be evaluated by TTCN; e.g. an error shall be raised when the UE requests retransmission of an RLC PDU

IndicationStatus_Type

TTCN-3 Union Type			
Name	IndicationStatus_Type		
Comment			
Ok	Null_Type		
Error	ErrorIndication_Type		

D.17.4 L2Data_CommonDefs

Common definitions of L2 control elements used in L2 messages (EUTRA_NB_ASP_L2DataDefs) as well as for SS configuration (EUTRA_ASP_TypeDefs)

L2Data_CommonDefs: Basic Type Definitions

TTCN-3 Basic Types		
MAC_CTRL_ScellActDeact_Type	ScellBitMap_Type	36.321 clause 6.1.3.8

ScellBitMap_Type

TTCN-3 Record Type			
Name	ScellBitMap_Type		
Comment			
Value	B7_Type		7 MSB bits the C Fields C7 to C1. 1 => the corresponding Scell is Active 0 => Inactive
Reserved	B1_Type		LSBit Reserved. Shall be set to 0

PH_Record_Type

TTCN-3 Record Type			
Name	PH_Record_Type		
Comment	36.321 clause 6.1.3.6a		
P_Bit	B1_Type		P bit: 1 indicates the UE applies power backoff due to power management
V_Bit	B1_Type		V bit: Indicates if the PH value is based on a real transmission or a reference format. For Type 1 PH, V=0 indicates real transmission on PUSCH and V=1 indicates that a PUSCH reference format is used
Valve	B6_Type		The power headroom level. Ph Type 2 (if configured) for Pcell and Type 1 for Pcell and Scell
Reserved	B2_Type	opt	2 reservid bits. Present if V=1
PCMaxc	B6_Type	opt	Present if V=1

PH_RecordList_Type

TTCN-3 Record of Type	
Name	PH_RecordList_Type
Comment	If simultaneousPUCCH-PUSCH is not configured at least oneType 1 PH record for Pcell is present. Additional one record per Scell for which respective 'C' bit is set as 1. If simultaneousPUCCH-PUSCH is configured then one PH Type 2 record for P cell followed by PH Type 1 record for P cell is present. Additional one record per Scell for which respective 'C' bit is set as 1
record length(1..9) of PH_Record_Type	

MAC_CTRL_ExtPowerHeadRoom_Type

TTCN-3 Record Type			
Name	MAC_CTRL_ExtPowerHeadRoom_Type		
Comment			
EPH_Octet1	ScellBitMap_Type		
PH_RecordList	PH_RecordList_Type		At least one record for Pcell is present. Additional one record per Scell for which respective 'C' bit is set as 1

DC_PH_RecordList_Type

TTCN-3 Record of Type	
Name	DC_PH_RecordList_Type
Comment	If simultaneousPUCCH-PUSCH is not configured at least oneType 1 PH record for Pcell is present. Additional one record per PScell/Scell for which respective 'C' bit is set as 1. If simultaneousPUCCH-PUSCH is configured then one PH Type 2 record for Pcell followed one PH Type 2 record for PScell followed by PH Type 1 record for Pcell is present. Additional one record per PScell/Scell for which respective 'C' bit is set as 1
record length(1..10) of PH_Record_Type	

MAC_CTRL_DC_PowerHeadRoom_Type

TTCN-3 Record Type			
Name	MAC_CTRL_DC_PowerHeadRoom_Type		
Comment			
DC_PH_Octet1	ScellBitMap_Type		
DC_PH_RecordList	DC_PH_RecordList_Type		At least one record for Pcell is present. Additional one record per PScell/Scell for which respective 'C' bit is set as 1

D.18 References to TTCN-3

References to TTCN-3		
EUTRA_ASP_TypeDefs	EUTRA_Defs/EUTRA_ASP_TypeDefs.ttcn	Rev 18686
EUTRA_ASP_DrbDefs	EUTRA_Defs/EUTRA_ASP_DrbDefs.ttcn	Rev 17253
EUTRA_NB_ASP_L2DataDefs	Common_EUTRA_NB/EUTRA_NB_ASP_L2DataDefs.ttcn	Rev 17857
EUTRA_ASP_SrbDefs	EUTRA_Defs/EUTRA_ASP_SrbDefs.ttcn	Rev 17118
IP_ASP_TypeDefs	IP_PTC/IP_ASP_TypeDefs.ttcn	Rev 16676
NasEmu_AspTypes_EUTRA	NasEmulation/NasEmu_AspTypes_EUTRA.ttcn	Rev 17118
EUTRA_CommonDefs	EUTRA_Defs/EUTRA_CommonDefs.ttcn	Rev 18682
CDMA2000_ASP_TypeDefs	C2K/CDMA2000_ASP_TypeDefs.ttcn	Rev 12722
CDMA2000_CommonDefs	C2K/CDMA2000_CommonDefs.ttcn	Rev 9022
EUTRA_ASP_CDMA2000TunnellingDefs	EUTRA_Defs/EUTRA_ASP_CDMA2000TunnellingDefs.ttcn	Rev 8820
EUTRA_ASP_VirtualNoiseDefs	EUTRA_Defs/EUTRA_ASP_VirtualNoiseDefs.ttcn	Rev 17199
UTRAN_ASP_VirtualNoiseDefs	UTRAN/UTRAN_ASP_VirtualNoiseDefs.ttcn	Rev 15724
WLAN_ASP_TypeDefs	WLAN/WLAN_ASP_TypeDefs.ttcn	Rev 17351
SideLinkUE_ASP_TypeDefs	D2D_SideLink/SideLinkUE_ASP_TypeDefs.ttcn	Rev 17253
CommonDefs	Common/CommonDefs.ttcn	Rev 18638
EUTRA_NB_ASP_TypeDefs	Common_EUTRA_NB/EUTRA_NB_ASP_TypeDefs.ttcn	Rev 17662
EUTRA_NB_CommonDefs	Common_EUTRA_NB/EUTRA_NB_CommonDefs.ttcn	Rev 18679

Annex E (informative): Upper Tester Scenarios

Depending on whether automatic operation is used, or is replaced by the SS by manual intervention, the following scenarios may occur.

E.1 No confirmation

There is no confirmation required in TTCN e.g. because the UE starts signalling triggered by the UT command.

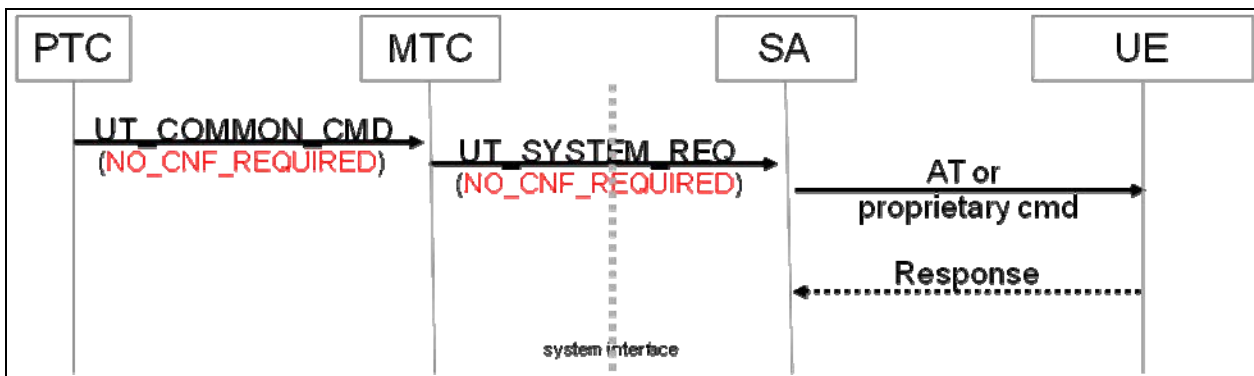

Figure E.1-1: No confirmation (automatic operation)

NOTE: The SS discards any response from the UE.

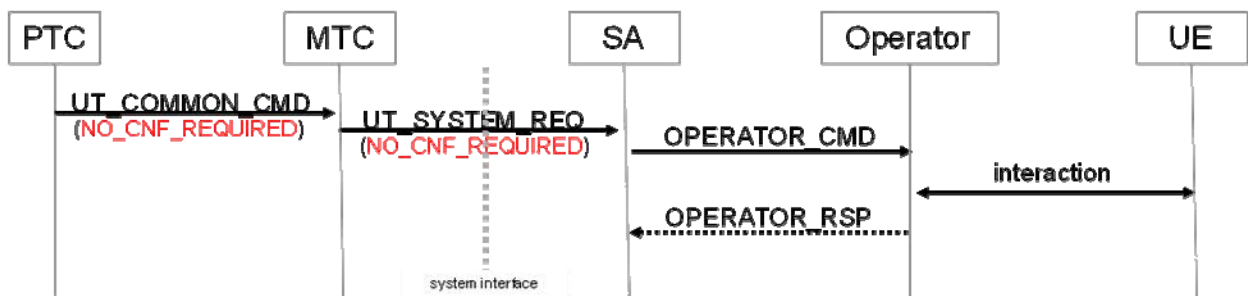

Figure E.1-2: No confirmation (manual intervention)

E.2 Immediate confirmation

TTCN needs an immediate response as a trigger to continue e.g. with DL signalling or starting a timer. In general there is no signalling in between UT_COMMON_CMD and UT_COMMON_CNF.

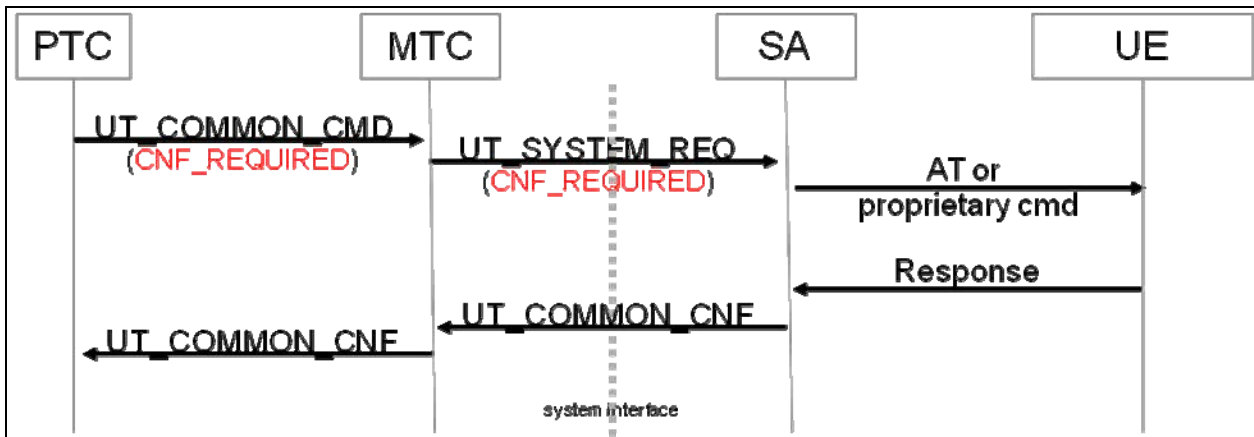

Figure E.2-1: Immediate confirmation (automatic operation, normal case)

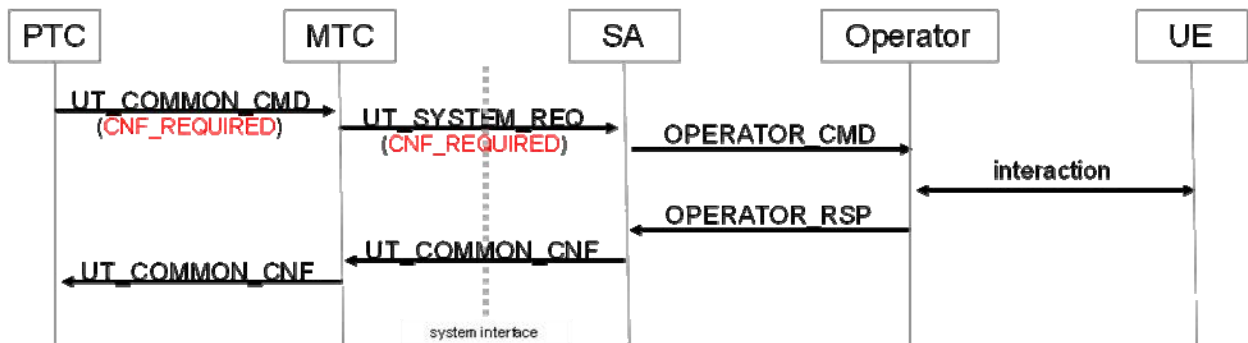

Figure E.2-2: Immediate confirmation (manual intervention, normal case)

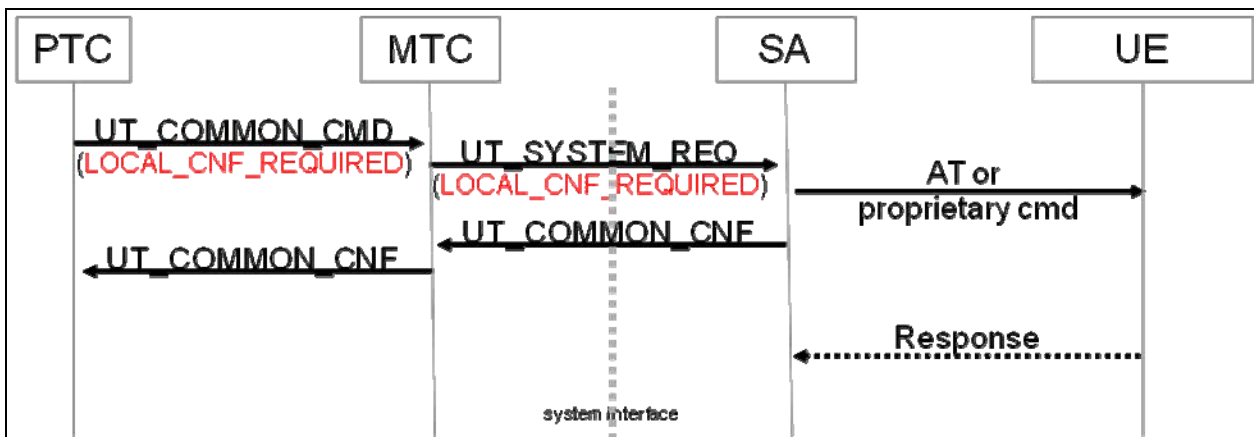

Figure E.2-3: Immediate confirmation (automatic operation, local confirmation)

NOTE: When local confirmation is required in automatic operation mode the SS discards any late response from the UE.

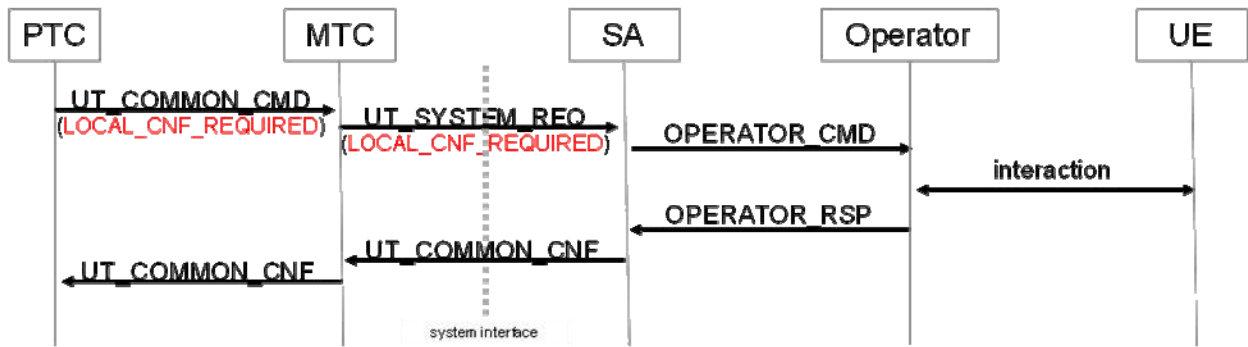

Figure E.2-4: Immediate confirmation (manual intervention, local confirmation)

E.3 Late response

TTCN needs to get the response which is provided by the UE after some signalling related to the UT command. To achieve a common implementation for automatic operation and manual intervention, the TTCN provides a DUMMY command to trigger a 2nd interaction between the operator and the UE. Whether or not this DUMMY is used for automatic operation is up to SS implementation. Nevertheless the DUMMY is sent just before the final DL message which triggers the UE to generate the response, i.e. the SS may use the DUMMY to trigger reception of the response (NOTE: in this case it is up to SS implementation to be fast enough). When replacing the AT command with manual intervention, the SS is responsible to ensure that 2nd interaction does not happen before the final DL message has been received and processed by the UE.

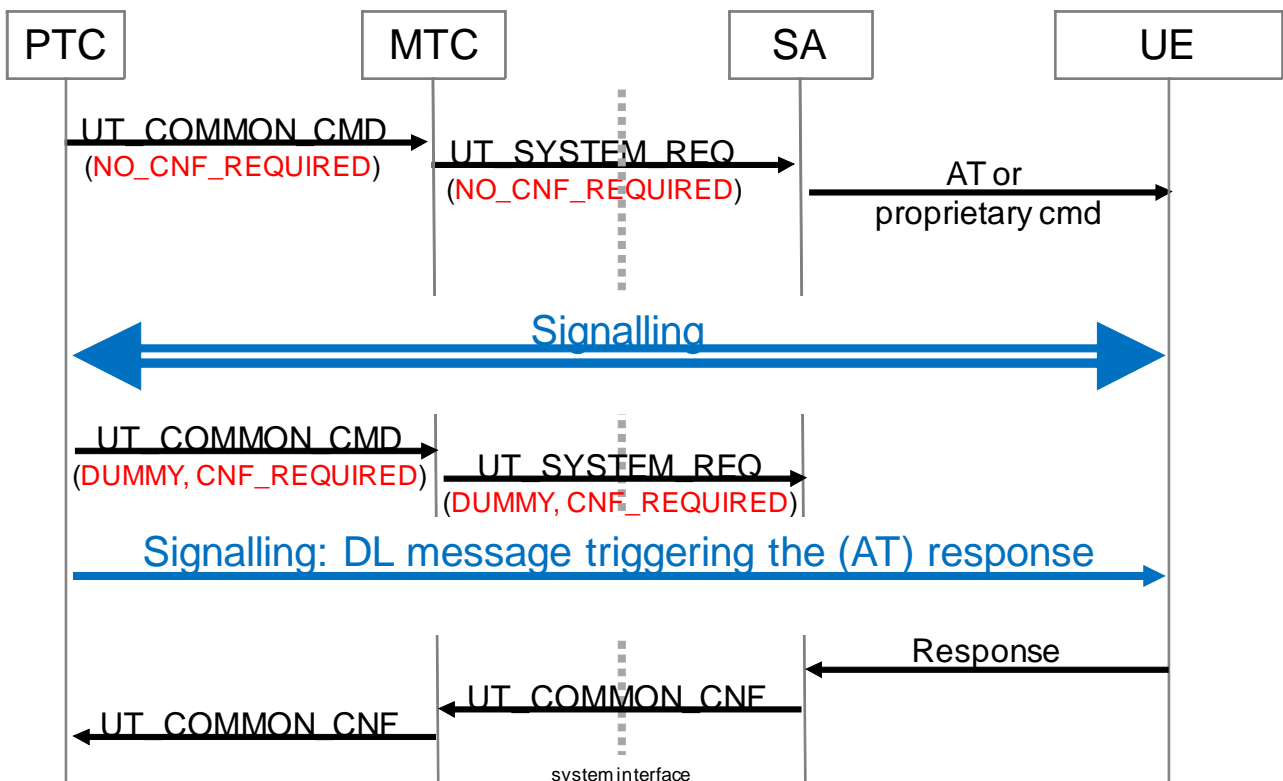

Figure E.3-1: Late response (automatic operation)

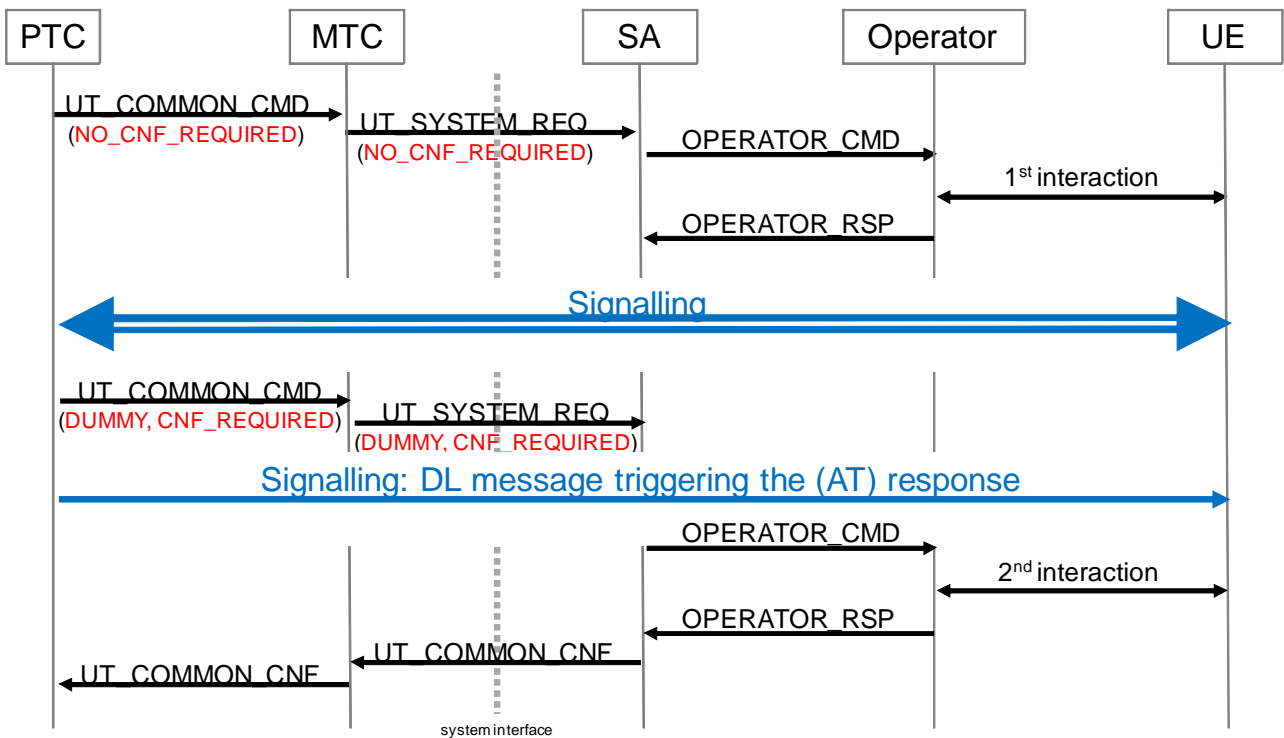

Figure E.3-2: Late response (manual intervention)

E.4 Multiple responses

In principle the message flow for multiple responses is the same as for a single late response but for more than one response (⇒ The same requirements as for late response are applicable).

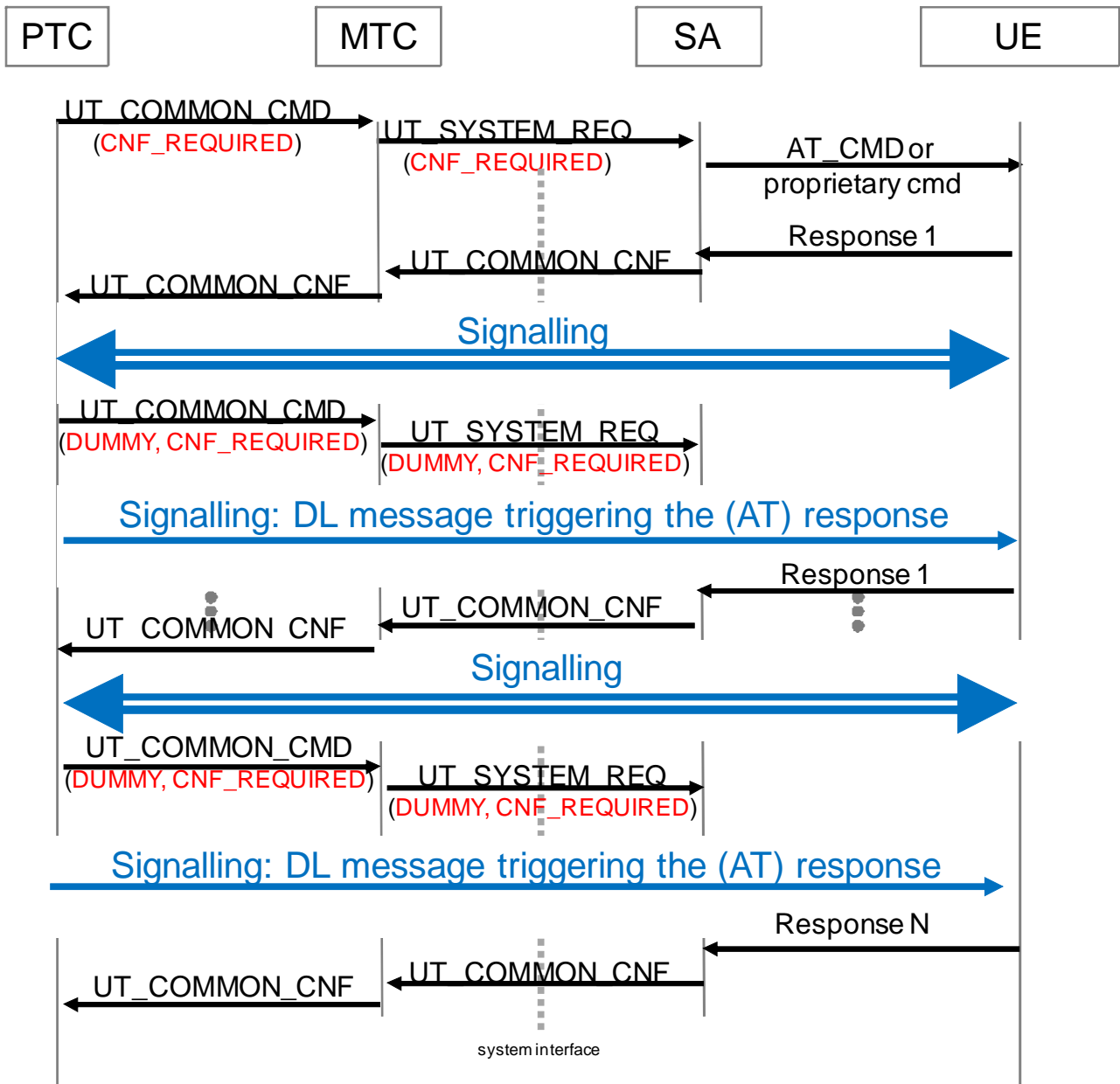

Figure E.4-1: Multiple responses (automatic operation)

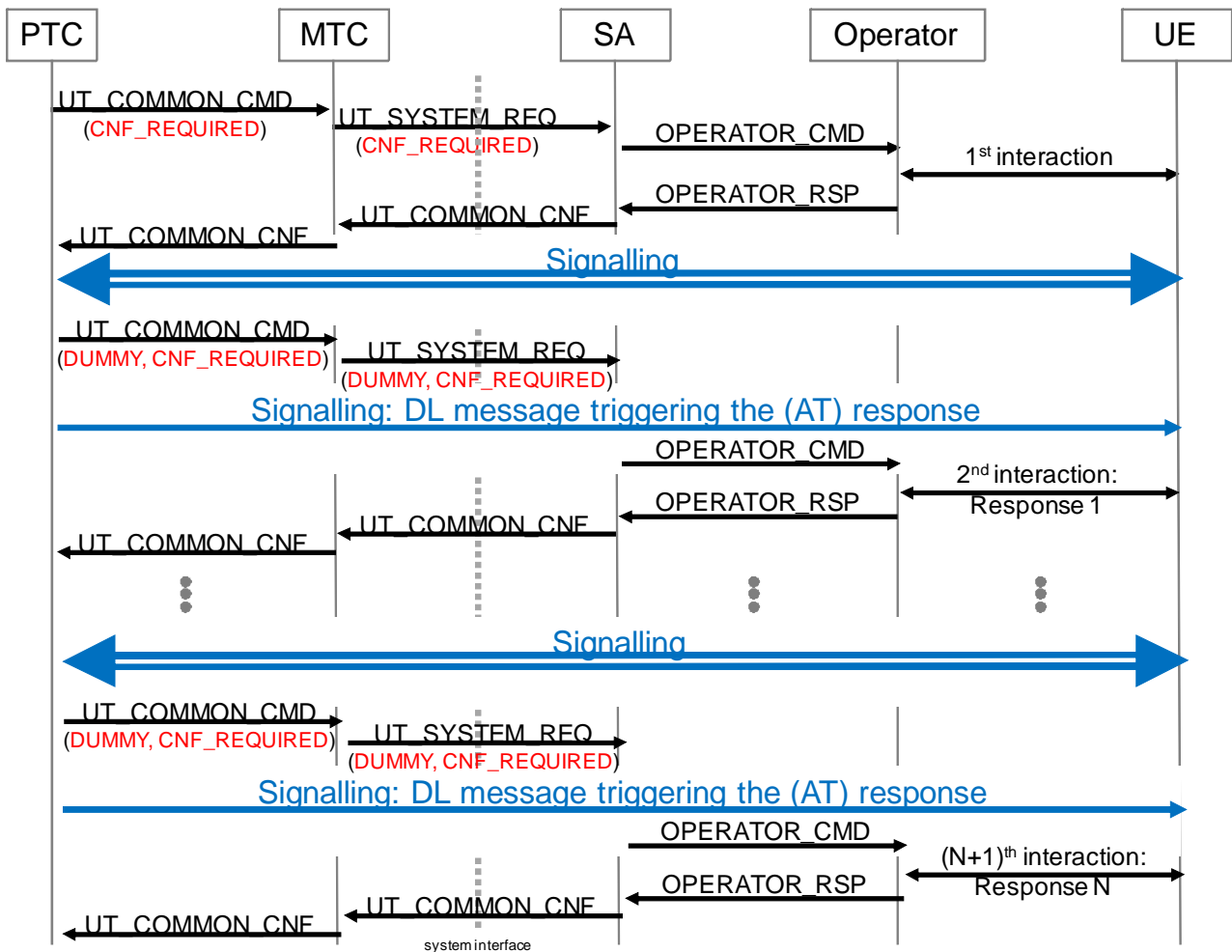

Figure E.4-2: Multiple responses (manual intervention)

Annex F (informative)

TTCN-3 Definitions

F.1 NBIOT_ASP_TypeDefs

Type definitions for configuration of the system simulator;

Common design principles:

Semantics of OMIT: for all TTCN-3 type definitions used in ASPs omit means "keep as it is" =>

- on initial configuration in general all fields shall be provided
- no default values for fields are foreseen
- if necessary non-existence of information shall be explicitly configured (e.g. with a union of "no configuration" and "configuration parameters")
- fields within structures imported from the core spec are excepted from this rule

F.1.1 ASN1_Container

Definitions containing ASN.1 types for backward compatibility;

NOTE 1: PCCH_Message and BCCH_DL_SCH_Message already have a critical extension mechanism by RRC type definition

NOTE 2: BCCH_BCH_Message contains the MIB and therefore is considered to be not extendable

NOTE 3: "simple types" are not considered: C_RNTI, PhysCellId, CellIdentity, ARFCN_ValueEUTRA

NPUSCH_ConfigDedicated_Type

TTCN-3 Record Type			
Name	NPUSCH_ConfigDedicated_Type		
Comment			
R13	NPUSCH_ConfigDedicated_NB_r13		

NPRACH_Config_Type

TTCN-3 Record Type			
Name	NPRACH_Config_Type		
Comment			
R13	NPRACH_ConfigSIB_NB_r13		

NB_RACH_ConfigCommon_Type

TTCN-3 Record Type			
Name	NB_RACH_ConfigCommon_Type		
Comment			
R13	RACH_ConfigCommon_NB_r13		

NB_PDCP_Config_Type

TTCN-3 Union Type			
Name	NB_PDCP_Config_Type		
Comment			
R13	PDCP_Config_NB_r13		

NB_UL_AM_RLC_Type

TTCN-3 Record Type			
Name	NB_UL_AM_RLC_Type		
Comment			
R13	UL_AM_RLC_NB_r13		

NB_DL_AM_RLC_Type

TTCN-3 Record Type			
Name	NB_DL_AM_RLC_Type		
Comment			
R13	DL_AM_RLC_NB_r13		

NPUSCH_ConfigCommon_Type

TTCN-3 Record Type			
Name	NPUSCH_ConfigCommon_Type		
Comment			
R13	NPUSCH_ConfigCommon_NB_r13		

NB_DRX_Config_Type

TTCN-3 Record Type			
Name	NB_DRX_Config_Type		
Comment			
R13	DRX_Config_NB_r13		

CarrierConfigDedicated_Type

TTCN-3 Record Type			
Name	CarrierConfigDedicated_Type		
Comment			
R13	CarrierConfigDedicated_NB_r13		

DL_GapConfig_Type

TTCN-3 Record Type			
Name	DL_GapConfig_Type		
Comment			
R13	DL_GapConfig_NB_r13		

DL_Bitmap_Type

TTCN-3 Record Type			
Name	DL_Bitmap_Type		
Comment			
R13	DL_Bitmap_NB_r13		

F.1.2 System_Configuration

Formal ASP Definitions for system configuration

System_Configuration: Basic Type Definitions

TTCN-3 Basic Types		
NB_DPR_DataVolumnIndex_Type	integer (0..15)	
NB_DPR_PowerHeadroomLevel_Type	integer (0..3)	

NB_SystemRequest_Type

TTCN-3 Union Type		
Name	NB_SystemRequest_Type	
Comment		
Cell	NB_CellConfigRequest_Type	configure/release a cell
CellAttenuationList	NB_CellAttenuationList_Type	power attenuation for one or several cells; all cells included in the list shall be changed at the same time; all cells in the list shall reach the new cell power within a maximum of 100ms (10 frames) acc. to the tolerances given in TS 36.508 NOTE: In the common ASP part the CellId shall be set - to the cell the timing information refers to if activation time shall be applied - to nbiot_Cell_NonSpecific when there is no activation time
RadioBearerList	NB_RadioBearerList_Type	configure/release one or several SRBs and/or DRBs
EnquireTiming	Null_Type	get HSFN, SFN and sub-frame number for this cell
AS_Security	NB_AS_Security_Type	StartRestart/Release of AS security
Paging	NB_PagingTrigger_Type	to trigger SS to send paging at the given paging occasion (as calculated in TTCN) or a Direct Indication
L1MacIndCtrl	NB_L1Mac_IndicationControl_Type	to configure SS to generate indications for L1/MAC events
PdcpCount	NB_PDCP_CountReq_Type	to set or enquire PDCP COUNT for one or more RBs
RlcCounts	NB_RLC_CountsReq_Type	to set or enquire RLC Counts VTS and VRR
NpdccOrder	NB_RA_NPDCCH_Order_Type	to configure SS to transmit a NPDCCH order with configured C-RNTI to the UE to trigger RA procedure; result in DCI Format N1 transmission as in TS 36.212, clause 6.4.3.2; the SS shall schedule the NPDCCH order in the same way as DCI for DL transmissions

NB_SystemConfirm_Type

TTCN-3 Union Type		
Name	NB_SystemConfirm_Type	
Comment	confirmations for system configuration; in general to be sent after the configuration has been done	
Cell	Null_Type	(no further parameters from SS)
CellAttenuationList	Null_Type	(no further parameters from SS) NOTE 1: the confirmation shall be sent when all cells have changed power levels NOTE 2: for the CellId in the common ASP part the same rules are applied as for the SYSTEM REQ
RadioBearerList	Null_Type	(no further parameters from SS)
EnquireTiming	Null_Type	SFN and sub-frame number are included in the TimingInfo
AS_Security	Null_Type	(no further parameters from SS)
Paging	Null_Type	normally not needed but defined for completeness
L1MacIndCtrl	Null_Type	(no further parameters from SS)
PdcpCount	NB_PDCP_CountCnf_Type	as response to 'Get' a list is returned containing COUNT information for the requested RBs
RlcCounts	NB_RLC_CountsCnf_Type	as response to 'Get' a list is returned containing RLC Counts VTS and VRR
NpdccOrder	Null_Type	confirmation for NPDCCH Order

NB_HarqError_Type

TTCN-3 Union Type		
Name	NB_HarqError_Type	
Comment		
UL	Null_Type	there is just one HARQ process for NB-IoT and uplink HARQ operation is asynchronous (see TS 36.321 clause 5.4.2)
DL	Null_Type	

NB_RachPreamble_Type

TTCN-3 Record Type			
Name	NB_RachPreamble_Type		
Comment			
RAPID	integer		indicates the RAPID of the preamble used (integer (0..63)); according to 36.321 clause 6.2.2 "For NB-IoT, the Random Access Preamble Identifier field corresponds to the start subcarrier index"
RepetitionsPerPreambleAttempt	integer		number of preambles the SS has detected for the preamble attempt

NB_DPR_Type

TTCN-3 Record Type			
Name	NB_DPR_Type		
Comment			
DataVolumnIndex	NB_DPR_DataVolumnIndex_Type		
PowerHeadroomLevel	NB_DPR_PowerHeadroomLevel_Type		

NB_SystemIndication_Type

TTCN-3 Union Type		
Name	NB_SystemIndication_Type	
Comment		
Error	charstring	indicates an error situation in SS; is not explicitly handled in TTCN but causes an INCONC due to default behaviour; an additional error code can be signalled in the common part of the ASP;
RachPreamble	NB_RachPreamble_Type	RACH preamble being sent by the UE NOTE 1: for NB-IoT there can be more than one repetition per preamble attempt (numRepetitionsPerPreambleAttempt-r13 in NPRACH-ConfigSIB-NB-DEFAULT in SystemInformationBlockType2-NB); nevertheless the SS shall raise only one indication per preamble attempt and indicate the number of attempts in the 'RepetitionsPerPreambleAttempt' field of the indication NOTE 2: The SS shall provide start of the attempt's first preamble as timing information of the primitive (in a lab environment in general this is the start time of the NPRACH preamble transmission according to clause 10.1.6.1 of TS 36.211 - depending on nprach-Periodicity and nprach-StartTime)
DPR	NB_DPR_Type	indicates MAC DPR control element (TS 36.321 clause 6.1.3.10) being contained in MAC PDU
HarqError	NB_HarqError_Type	indicates detection of HARQ error: 1. HARQ CRC error for UL data 2. HARQ NACK from the UE unless SS is configured to report HARQ ACK/NACK
UL_HARQ	HARQ_Type	to report the UL HARQ ACK/NACK

F.1.3 Cell_Configuration

Specific Info for Cell Configuration Primitive

F.1.3.1 Cell_Configuration_Common

Cell_Configuration_Common: Basic Type Definitions

TTCN-3 Basic Types		
NB_ToRS_EPRES_Ratio_Type	integer (-35..0)	any-resource-element to NRS ratio in dB (e.g. NPDSCH-to-NRS ratio; see TS 36.213, clause 16.2.2)

NB_CellConfigRequest_Type

TTCN-3 Union Type		
Name	NB_CellConfigRequest_Type	
Comment		
AddOrReconfigure	NB_CellConfigInfo_Type	for cell configuration: CellId : identifier of the cell to be configured RoutingInfo : None TimingInfo : Now (for initial configuration and for reconfiguration in general) ControlInfo : CnfFlag:=true; FollowOnFlag:=false (in general)
Release	Null_Type	to remove a cell completely - CellId : identifier of the cell to be released; nbiot_Cell_NonSpecific, in case all cells shall be released RoutingInfo : None TimingInfo : Now ControlInfo : CnfFlag:=true; FollowOnFlag:=false (in general)

NB_CellConfigInfo_Type

TTCN-3 Record Type			
Name	NB_CellConfigInfo_Type		
Comment	common information for initial cell configuration or reconfiguration; in case of reconfiguration OMIT means 'keep configuration as it is'		
Basic	NB_BasicCellConfig_Type	opt	basic information for a cell (e.g. broadcasting)
Active	NB_ActiveCellConfig_Type	opt	add. configuration for active cell (i.e. cell being capable to receive RACH preamble)

NB_BasicCellConfig_Type

TTCN-3 Record Type			
Name	NB_BasicCellConfig_Type		
Comment			
StaticCellInfo	NB_StaticCellInfo_Type	opt	Common information which does not change during a test
PhysicalLayerConfigDL	NB_PhysicalLayerConfigDL_Type	opt	default settings regarding DL physical control channels
InitialCellPower	InitialCellPower_Type	opt	reference cell power for the NRS of each antenna in DL NOTE 1: the power of the RS of an antenna may be reduced by antenna specific configuration NOTE 2: in general the power may be adjusted on a per resource element basis => all physical channel/signal power settings shall be adjusted relatively to the NRS; if there are more than one TX antennas each one may have its own attenuation; independently from those relative power settings the cell power can easily be adjusted by just changing the reference power
DownlinkBitmapConfig	NB_DownlinkBitmapConfig_Type	opt	Usage of bitmap or no bitmap to define valid NB-IoT DL subframes; omit means "keep as it is"
BcchConfig	NB_BcchConfig_Type	opt	configuration of BCCH/BCH; SS is triggered to configure RLC/MAC regardingly; BCCH data on the NPDSCH NPBCH: MIB; NPDSCH: scheduling and resource allocation; SIBs
PcchConfig	NB_PcchConfig_Type	opt	configuration of PCCH/PCH; SS is triggered to configure RLC/MAC regardingly; PCCH data on the NPDSCH is distinguished by the P-RNTI (needed even to modify SI => shall be configured for CELL_BROADCASTING)

NB_ActiveCellConfig_Type

TTCN-3 Record Type			
Name	NB_ActiveCellConfig_Type		
Comment			
C_RNTI	EUTRA ASN1 C_RNTI_Type	opt	(pre-)configured C-RNTI; affects scrambling of NPDSCH/NPUSCH and CRC of NPDCCH(s); shall be used implicitly in RACH procedure (i.e. as CE in RAR)
PhysicalLayerConfigUL	NB_PhysicalLayerConfigUL_Type	opt	parameters for NPRACH, NPUSCH Omitted when no UL frequency is applied to the band
RachProcedureConfig	NB_RachProcedureConfig_Type	opt	to configure the SS's behaviour for the RACH procedure Omitted when no UL frequency is applied to the band
CcchDcchDtchConfig	NB_CcchDcchDtchConfig_Type	opt	Parameters related to CCCH/DCCH/DTCH in UL and DL
NonAnchorCarrier	NB_NonAnchorCarrier_Type	opt	configuration for non-Anchor Carrier ("None" if there is no non-Anchor Carrier)

NB_StaticCellInfo_Type

TTCN-3 Record Type			
Name	NB_StaticCellInfo_Type		
Comment	Common information which (normally) does not change during a test; therefore all fields are mandatory		
Common	NB_CommonStaticCellInfo_Type		information common for UL and DL
Earfcn	NB_CarrierFreq_Type		DL or UL EARFCN as defined in TS 36.101

NB_CommonStaticCellInfo_Type

TTCN-3 Record Type			
Name	NB_CommonStaticCellInfo_Type		
Comment	information common for UL and DL; all fields are mandatory		
PhysicalCellId	EUTRA_ASN1_PhysCellId_Type		N(Ncell, ID): imported from core spec; -> narrowband reference signals -> scrambling of all DL physical channels: NPBCH, NPDCCH, and NPDSCH (together with nRNTI)
NB_Band	integer		
CellTimingInfo	CellTimingInfo_Type		
OperationModeInfo	NB_OperationModeInfo_Type		
eutraControlRegionSize	NB_EutraControlRegionSize_Type	opt	Only used for the in-band operation mode, omitted otherwise. Indicates the control region size of the E-UTRA cell.

F.1.3.2 Downlink_Physical_Layer_Configuration

Downlink physical layer configuration:

- DL antenna configuration
- control region (NPDCCH)
- primary/secondary sync signals
- power control for physical channels and signals

F.1.3.2.1 Physical_Channels**Physical_Channels: Basic Type Definitions**

TTCN-3 Basic Types		
NPdcchSearchSpaceCandidateIndex_Type	integer (0..7)	Index of the search space candidate to be used for UL grant or DL assignment (corresponds to "u" in the calculations of clause 16.6 in TS 36.213)

NPbchConfig_Type

TTCN-3 Record Type			
Name	NPbchConfig_Type		
Comment			
RelativeTxPower	NB_ToRS_EPRES_Ratio_Type	opt	power ratio for NPBCH's resource elements relative to the NRS

NPdcchFormat_Type

TTCN-3 Enumerated Type	
Name	NPdcchFormat_Type
Comment	NPDCCH format according to 36.211 clauses 10.2.5.1 => aggregation level according to 36.213 clause 16.6
npdcchFormat0	
npdcchFormat1	

NPdcchUESpecificSearchSpace_Type

TTCN-3 Record Type	
Name	NPdcchUESpecificSearchSpace_Type
Comment	parameters for UE specific search space (UESS, TS 36.213 clause 16.6); In addition the SS needs to consider the "DCISubFrameRepetitionNumber" in the DCI UL/DL configuration to determine the value of R (actual number of NPDCCH repetitions for the DCI)
NPdcchFormat	NPdcchFormat_Type Aggregation level: According to tables 16.6-1, 16.6-2, 16.6-3 in TS 36.213 for typical search space configuration as per TS 36.508 NPDCCH format 1 is used i.e. there is just one search space candidate per NPDCCH transmission. Use cases for NPDCCH format 0 are FFS
NumRepetitions	NPDCCH_NumRepetitions_UESS_Type Rmax for UE specific search space; TS 36.213 clause 16.6
StartSF	NPDCCH_StartSF_UESS_Type G for UE specific search space; TS 36.213 clause 16.6
Offset	NPDCCH_Offset_UESS_Type offset for UE specific search space; TS 36.213 clause 16.6
SearchSpaceCandidateForDL	NPdcchSearchSpaceCandidateIndex_Type index of the search space candidate to be used for DL assignment
SearchSpaceCandidateForUL	NPdcchSearchSpaceCandidateIndex_Type index of the search space candidate to be used for UL grant

NPdcchType1CommonSearchSpace_Type

TTCN-3 Record Type	
Name	NPdcchType1CommonSearchSpace_Type
Comment	parameters for Type1 common search space for paging (Type1CSS, TS 36.213 clause 16.6); In addition the SS needs to consider the "DCISubFrameRepetitionNumber" in the DCI DL configuration to determine the value of R (actual number of NPDCCH repetitions for the DCI)
NumRepetitions	NPDCCH_NumRepetitions_Type1CSS_Type Rmax for Type1 common search space; TS 36.213 clause 16.6

NPdcchType2CommonSearchSpace_Type

TTCN-3 Record Type			
Name	NPdcchType2CommonSearchSpace_Type		
Comment	parameters for Type2 common search space for RACH procedure (Type2CSS, TS 36.213 clause 16.6); In addition the SS needs to consider the "DCISubFrameRepetitionNumber" in the DCI DL configuration to determine the value of R (actual number of NPDCCH repetitions for the DCI); NOTE: NumRepetitions, StartSF and Offset are also included in each entry of the nprach-ParametersList of NPRACH_Config_Type (NB_PhysicalLayerConfigUL_Type); nevertheless NPRACH_Config_Type contains a list of NPRACH resources whereas the SS needs to consider only one search space corresponding to the NPRACH resource the UE shall select		
NumRepetitions	NPDCCH_NumRepetitions_Type2CSS_Type		Rmax for Type2 common search space; TS 36.213 clause 16.6
StartSF	NPDCCH_StartSF_Type2CSS_Type		G for Type2 common search space; TS 36.213 clause 16.6
Offset	NPDCCH_Offset_Type2CSS_Type		offset for Type2 common search space; TS 36.213 clause 16.6
SearchSpaceCandidateForRAR	NPdcchSearchSpaceCandidateIndex_Type		index of the search space candidate to be used for random access response
SearchSpaceCandidateForMsg4	NPdcchSearchSpaceCandidateIndex_Type		index of the search space candidate to be used for Msg4 scheduling; this can be an DL transmission (contention resolution id based) or an UL transmission (C-RNTI based)

NPdcchConfig_Type

TTCN-3 Record Type			
Name	NPdcchConfig_Type		
Comment			
UESS	NPdcchUESpecificSearchSpace_Type	opt	parameters for UE specific search space
Type1CSS	NPdcchType1CommonSearchSpace_Type	opt	parameters for Type1 common search space
Type2CSS	NPdcchType2CommonSearchSpace_Type	opt	parameters for Type2 common search space
RelativeTxPower	NB_ToRS_EPRES_Ratio_Type	opt	power ratio for NPDCCH's resource elements relative to the NRS

NPdschRelativeTxPower_Type

TTCN-3 Record Type			
Name	NPdschRelativeTxPower_Type		
Comment	FFS		
RachResponse	NB_ToRS_EPRES_Ratio_Type	opt	
BcchOnNPdsc h	NB_ToRS_EPRES_Ratio_Type	opt	
PcchOnNPdsc h	NB_ToRS_EPRES_Ratio_Type	opt	
CcchOnNPdsc h	NB_ToRS_EPRES_Ratio_Type	opt	
DcchDtchOnNPdsc h	NB_ToRS_EPRES_Ratio_Type	opt	

NPdschConfig_Type

TTCN-3 Record Type			
Name	NPdschConfig_Type		
Comment			
RelativeTxPower	NPdschRelativeTxPower_Type	opt	

F.1.3.2.2 Physical_Signals

NB_PrimarySyncSignal_Type

TTCN-3 Record Type			
Name	NB_PrimarySyncSignal_Type		
Comment			
RelativeTxPower	NB_ToRS_EPRES_Ratio_Type	opt	power ratio for NPSS's resource elements relative to the NRS (NOTE: applicable even though NRS is not in the same subframe)

NB_SecondarySyncSignal_Type

TTCN-3 Record Type			
Name	NB_SecondarySyncSignal_Type		
Comment			
RelativeTxPower	NB_ToRS_EPRES_Ratio_Type	opt	power ratio for NPSS's resource elements relative to the NRS (NOTE: applicable even though NRS is not in the same subframe)

NB_LTE_CellSpecificReferenceSignal_Type

TTCN-3 Record Type			
Name	NB_LTE_CellSpecificReferenceSignal_Type		
Comment			
RelativeTxPower	NB_ToRS_EPRES_Ratio_Type	opt	power ratio for the LTE CRS in case of In-band transmission with same PCI

AntennaConfig_Type

TTCN-3 Enumerated Type	
Name	AntennaConfig_Type
Comment	This type specifies how many Tx antennas shall be used by the SS
AN1	single Tx antenna shall be used by the SS
AN2	two Tx antennas shall be used by the SS

NB_PhysicalLayerConfigDL_Type

TTCN-3 Record Type			
Name	NB_PhysicalLayerConfigDL_Type		
Comment	all fields are declared as optional to allow single reconfigurations; in this case omit means "keep as it is"		
Antenna	AntennaConfig_Type	opt	
NPbch	NPbchConfig_Type	opt	
NPdch	NPdchConfig_Type	opt	
NPdsch	NPdschConfig_Type	opt	
NPss	NB_PrimarySyncSignal_Type	opt	
NSss	NB_SecondarySyncSignal_Type	opt	
LteCrsc	NB_LTE_CellSpecificReferenceSignal_Type	opt	if omitted in initial configuration the CRS shall be considered as being not present, i.e. shall not be transmitted by the SS

NB_DownlinkBitmapConfig_Type

TTCN-3 Union Type		
Name	NB_DownlinkBitmapConfig_Type	
Comment	to specify valid NB-IoT DL subframes according to TS 36.213 clause 16.4	
Bitmap	DL_Bitmap_Type	valid NB-IoT DL subframe specified by bitmap and does not contain NPSS/NSSS/NPBCH/NB-SIB1 transmission
None	Null_Type	valid NB-IoT DL subframe does not contain NPSS/NSSS/NPBCH/NB-SIB1 transmission

NB_NonAnchorCarrier_Type

TTCN-3 Union Type		
Name	NB_NonAnchorCarrier_Type	
Comment		
Config	CarrierConfigDedicated_Type	
None	Null_Type	

F.1.3.3 Uplink_Physical_Layer_Configuration

Uplink physical channel configuration: NPRACH, NPUSCH and UL RS

NB_SubCarrierSpacingUL_Type

TTCN-3 Enumerated Type	
Name	NB_SubCarrierSpacingUL_Type
Comment	
subCarrierSpacing_1 5kHz	
subCarrierSpacing_3 _75kHz	

NPUSCH_Configuration_Type

TTCN-3 Record Type			
Name	NPUSCH_Configuration_Type		
Comment			
Common	NPUSCH_ConfigCommon_Type	opt	
Dedicated	NPUSCH_ConfigDedicated_Type	opt	

NB_PhysicalLayerConfigUL_Type

TTCN-3 Record Type			
Name	NB_PhysicalLayerConfigUL_Type		
Comment	NOTE: In general SS is required to keep the UE's UL power constant		
NPrach	NPRACH_Config_Type	opt	parameters acc. TS 36.331, clause 6.7.3.2
NPusch	NPUSCH_Configuration_Type	opt	parameters acc. TS 36.331, clause 6.7.3.2 (including configuration of RS)
TimingAdvance	SS_TimingAdvanceConfig_Type	opt	to adjust timing advance; at cell initialization absolute timing advance is configured as 0; absolute timing advance may be modified as part of the Random Access procedure configuration; in some MAC test cases timing advance may be configured to a non-zero (11 bit value) at the beginning and modified by (6 bit) timing advance commands during the test
SubCarrierSpacingUL	NB_SubCarrierSpacingUL_Type	opt	15kHz or 3.75kHz UL carrier spacing; cyclic prefix as per 36.211 Table 10.1.5-1 accordingly

F.1.3.4 Common_MAC_Configuration

Transport channel and MAC related procedures and configuration

Common_MAC_Configuration: Basic Type Definitions

TTCN-3 Basic Types		
NPDSCH_ImcsValue_Type	integer (0..12)	Modulation and coding scheme index coding; TS 36.213 Table 16.4.1.5.1-1
NPUSCH_ImcsValue_Type	integer (0..12)	Modulation and coding scheme index coding; TS 36.213 Table 16.5.1.2-2

NB_PdcchDciFormat_Type

TTCN-3 Enumerated Type	
Name	NB_PdcchDciFormat_Type
Comment	
dci_N0	physical layer parameters acc. TS 36.508 Table 8.1.3.6.1.1-1 (for NPUSCH)
dci_N1	physical layer parameters acc. TS 36.508 Table 8.1.3.6.1.1-3 (for NPDSCH)
dci_N2	physical layer parameters acc. TS 36.508 Table 8.1.3.6.1.1-3 (for Paging)

NB_CRC_ErrorMode_Type

TTCN-3 Enumerated Type	
Name	NB_CRC_ErrorMode_Type
Comment	
noError	SS shall not generate any CRC error
crcErrorWithRetransmission	SS shall generate CRC error for DL transmissions and schedule retransmissions for each HARQ NACK
crcErrorWithoutRetransmission	SS shall generate CRC error for DL transmissions but not do any retransmissions

NB_DciDIInfoCommon_Type

TTCN-3 Record Type			
Name	NB_DciDIInfoCommon_Type		
Comment	Downlink control information according to 36.212 clause 6.4.3		
Format	NB_PdcchDciFormat_Type		NPDSCH: N1; Paging: N2
RepetitionNumber	integer		Defined in TS 36.213, clause 16.4.1.3
DCISubFrameRepetitionNumber	integer		Defined in TS 36.213, clause 16.6
SchedulingDelay	integer	opt	Defined in TS 36.213, clause 16.4.1 Present for N1; not present for N2 (Paging)
HARQ_ACKResource	integer	opt	Defined in TS 36.213, clause 16.4.2 present for N1; not present for N2 (Paging)
CRC_ErrorMode	NB_CRC_ErrorMode_Type		no CRC error, CRC error with or without subsequent retransmission by the SS

NB_DciDIInfoExplicit_Type

TTCN-3 Record Type			
Name	NB_DciDIInfoExplicit_Type		
Comment	Downlink control information according to 36.212 clause 6.4.3		
Format	NB_PdcchDciFormat_Type		NPDSCH: N1; Paging: N2
Imcs	NPDSCH_ImcsValue_Type		MCS index of TS 36.213 Table 16.4.1.5.1-1
ResourceAssignment	integer		Defined in TS 36.213, clause 16.4.1.3: to determine the number of subframes
RepetitionNumber	integer		Defined in TS 36.213, clause 16.4.1.3
DCISubFrameRepetitionNumber	integer		Defined in TS 36.213, clause 16.6
SchedulingDelay	integer	opt	Defined in TS 36.213, clause 16.4.1 Present for N1; not present for N2 (Paging)
HARQ_ACKResource	integer	opt	Defined in clause 16.4.2 present for N1; not present for N2 (Paging)
CRC_ErrorMode	NB_CRC_ErrorMode_Type		no CRC error, CRC error with or without subsequent retransmission by the SS

NB_DciDIInfo_Type

TTCN-3 Union Type		
Name	NB_DciDIInfo_Type	
Comment		
Auto	NB_DciDIInfoCommon_Type	SS shall choose the appropriate TBS
Explicit	NB_DciDIInfoExplicit_Type	used in MAC or RAB tests where exact TBS needs to be specified

NB_AdaptiveHarqNack_Type

TTCN-3 Record Type			
Name	NB_AdaptiveHarqNack_Type		
Comment			
RedundancyVersion	integer		to be used in DCI for HARQ NACK to request UL retransmission

NB_UL_TransRetransmission_Type

TTCN-3 Union Type		
Name	NB_UL_TransRetransmission_Type	
Comment		
NewTransmission	Null_Type	new transmission of data with redundancy version RV=0 (acc. to TS 36.321 clause 5.4.2.2); NDI is toggled
RetransmissionAdaptive	NB_AdaptiveHargNack_Type	DCI requesting retransmission (NDI not toggled)

NB_UL_TransRetransmissionList_Type

TTCN-3 Record of Type	
Name	NB_UL_TransRetransmissionList_Type
Comment	to allow multiple retransmissions
record length (1..infinity) of NB_UL_TransRetransmission_Type	

NB_DciUInfo_Type

TTCN-3 Record Type			
Name	NB_DciUInfo_Type		
Comment	Downlink control information according to 36.212 clause 6.4.3		
SubCarrierIndication	integer		Defined in TS 36.213, clause 16.5.1.1
ResourceAssignment	integer		Defined in TS 36.213, clause 16.5.1.2
SchedulingDelay	integer		Defined in TS 36.213, clause 16.5.1
Imcs	NPUSCH_ImcsValue_Type		Defined in TS 36.213, clause 16.5.1.2
RedundancyVersion	integer		Defined in TS 36.213, clause 16.5.1.2
RepetitionNumber	integer		Defined in TS 36.213, clause 16.5.1.1
DCISubFrameRepetitionNumber	integer		Defined in TS 36.213, clause 16.6
TransRetransmissionList	NB_UL_TransRetransmissionList_Type		for possible adaptive retransmissions: when there is more than one entry in the list the SS shall send DCIs for the subsequent entries as ACK/NACK response according to TS 36.213 clause 16.5.2

NB_PeriodicGrant_Type

TTCN-3 Record Type			
Name	NB_PeriodicGrant_Type		
Comment	configuration of UL grants to be assigned periodically acc. to configuration of the UE specific search space; DL assignments have higher priority than UL grant schedules: when there is a DL transmission to be scheduled for some search space the UL grant shall be scheduled in the next search space which is not used for DL assignment		
DciInfo	NB_DciUInfo_Type		DCI format: N0 (TS 36.212, clause 6.4.3.1)
NoOfRepetitions	TransmissionRepetition_Type		number of UL Grants to be automatically transmitted or continuous repetition
Periodicity	integer	opt	1 => every search space, 2 => every 2nd search space, 3 => every 3rd search space, etc. may be omitted if only one UL grant shall be assigned and shall be ignored by the SS in this case; the periodicity is related to beginning of the UL grant scheduling, i.e. independent from whether or single grant is postponed due to pending DL assignment

NB_UESS_GrantScheduling_Type

TTCN-3 Union Type		
Name	NB_UESS_GrantScheduling_Type	
Comment	Configuration of (periodic) UL grants for the UE specific search space; NOTE: UL grants for Type2 common search space during RACH procedure are configured as part of the RACH procedure configuration	
None	Null_Type	no UL grant configured => UE needs to trigger RACH procedure to get UL resources; to used also to stop periodic UL grant scheduling when the UE goes back to IDLE
Periodic	NB_PeriodicGrant_Type	configuration of one or several grants
PeriodicAfterRachContResolution	NB_PeriodicGrant_Type	The SS shall schedule UL grants periodically after sending the DCI for contention resolution: a) contention resolution id based contention resolution: DCI is DL assignment of Msg4 sent to the UE b) C-RNTI based contention resolution: DCI is grant for UL transmission The periodicity starts from the search space of DCI used for contention resolution NOTE: for now it is not foreseen that the SS needs to evaluate BSRs for (automatic) UL grant assignments; FFS

F.1.3.5 Random_Access_Procedure**NB_RAR_UplinkGrant_Type**

TTCN-3 Record Type		
Name	NB_RAR_UplinkGrant_Type	
Comment	TS 36.213, clause 16.3.3 First bit for subcarrier spacing shall be set according to SubCarrierSpacingUL in NB_PhysicalLayerConfigUL_Type	
SubCarrierIndication	B6_Type	Defined in TS 36.213 clause 16.5.1.1
SchedulingDelay	B2_Type	Defined in TS 36.213 clause 16.5.1 where NB-IoT DL subframe n is the last subframe in which the NPDSCH associated with the NB random access response grant is transmitted
Msg3RepetitionNumber	B3_Type	Defined in TS 36.213 clause 16.5.1.1
MCSIndex	B3_Type	Indicating TBS, modulation and number of RUs for Msg3 according to TS 36.213 table 16.3.3-1

NB_CRNTI_ContentionResolutionCtrl_Type

TTCN-3 Union Type		
Name	NB_CRNTI_ContentionResolutionCtrl_Type	
Comment	configuration for Random Access Procedure in RRC_CONNECTED (see TS 36.300, clause 10.1.5.1); when SS receives C-RNTI MAC element sent by the UE after Random Access Response, SS shall deal with the C-RNTI as specified in this structure	
AutomaticGrant	NB_DciUllInfo_Type	before expiry of the contention resolution timer SS shall automatically send an UL grant to the UE by addressing NPDCCH using C-RNTI as sent by the UE in Msg3 but scheduled according to Type2 common search space; the UL grant is explicitly specified by NB_DciUllInfo_Type
None	Null_Type	Used in case of dedicated preamble transmission or to simulate failure cases; SS shall not address PDCCH using C-RNTI => expiry of contention resolution timer on UE side

NB_ContentionResolutionCtrl_Type

TTCN-3 Union Type		
Name	NB_ContentionResolutionCtrl_Type	
Comment	NOTE: SS only needs to consider one kind of contention resolution at one time; in the initial configuration of a cell TCRNTI_Based shall be configured; whether or not a UE triggers RACH procedures in RRC_CONNECTED depends on RRC signalling (logicalChannelSR-Prohibit, logicalChannelSR-ProhibitTimer); when the UE is supposed to trigger RACH procedures in RRC_CONNECTED the SS needs to be configured for C-RNTI based contention resolution after the temporary C-RNTI based contention resolution has been done at RRC connection establishment	
TCRNTI_Based	TCRNTI_ContentionResolutionCtrl_Type	TCRNTI based contention resolution (e.g. initial access), hence involves inclusion contention resolution identity in DL message 4 of RACH procedure
CRNTI_Based	NB_CRNTI_ContentionResolutionCtrl_Type	CRNTI based contention resolution (e.g. in case UE is being in RRC_CONNECTED): hence uplink message in step 3 (of RACH procedure) is followed by PDCCH transmission with UE C-RNTI to end procedure

NB_RandomAccessResponseParameters_Type

TTCN-3 Record Type		
Name	NB_RandomAccessResponseParameters_Type	
Comment	parameters to control content of RAR sent to the UE	
RapId	RapIdCtrl_Type	to control Random Access Preamble Id to be sent back to the UE; used in RAR MAC sub-header
InitialGrant	NB_RAR_UplinkGrant_Type	initial UL grant
TimingAdvance	RACH_TimingAdvance_Type	timing advance: granularity of 0.52 micro sec (16*Ts); see TS 36.300, clause 5.2.7.3, TS 36.321, clause 6.1.3.5; NOTE: timing advance has impact not only on the RA procedure; SS in general needs to adjust its timing accordingly
TempC_RNTI	TempC_RNTI_Type	NOTE: For initial Random Access Procedure at network (SS) side there is no temporary C-RNTI: network assigns the C-RNTI which is used by any UE as being temporary; the UE which 'wins' the contention resolution keeps the (temporary) C-RNTI; other UEs need to repeat the RACH procedure; => at the SS the TempC_RNTI shall be 'SameAsC_RNTI' For Random Access Procedure in RRC_CONNECTED state the NW assigns a temporary C-RNTI which is replaced by the one stored at the UE; => TempC_RNTI may be 'SameAsC_RNTI' (in this case temp. C-RNTI and C-RNTI are equal what is not likely in a real network), or there is an explicit temp. C-RNTI what is used during RA procedure only (as in a real network)

NB_RarList_Type

TTCN-3 Record of Type	
Name	NB_RarList_Type
Comment	in general MAC PDU may contain one or several RARs; normally only one RAR is contained
record of NB_RandomAccessResponseParameters_Type	

NB_RandomAccessResponse_Type

TTCN-3 Union Type		
Name	NB_RandomAccessResponse_Type	
Comment		
None	Null_Type	used for unsuccessful RA procedure
List	NB_RarList_Type	normally one RAR to be sent to the UE; in general there can be more than one RAR

NB_RandomAccessResponseCtrl_Type

TTCN-3 Record Type		
Name	NB_RandomAccessResponseCtrl_Type	
Comment	configuration for Random Access Response mapped to DL-SCH mapped to NPDSCH TransmissionMode: single antenna mode when there is only one antenna configured, transmit diversity else; RNTI: RA-RNTI (TS 36.321, clause 7.1); if both RAR msg and backoff indicator are 'None' SS shall not respond on random access preamble	
DciInfo	NB_DciDlInfoCommon_Type	DCI format N1 addressed by RA-RNTI
Rar	NB_RandomAccessResponse_Type	RAR to be sent to the UE
BackoffInd	RandomAccessBackoffIndicator_Type	possible backoff indicator; 'None' for normal cases

NB_RandomAccessResponseConfig_Type

TTCN-3 Union Type		
Name	NB_RandomAccessResponseConfig_Type	
Comment		
Ctrl	NB_RandomAccessResponseCtrl_Type	contains information to control sending of RAR
None	Null_Type	to be used when there is no RAR to be sent at all

NB_RachProcedure_Type

TTCN-3 Record Type		
Name	NB_RachProcedure_Type	
Comment		
RAResponse	NB_RandomAccessResponseConfig_Type	control of how the SS shall react on RA preamble; this may be - the RAP id as expected by the UE - a RAP id not matching to the UE's RAP - a backoff indicator - nothing at all
ContentionResolutionCtrl	NB_ContentionResolutionCtrl_Type	

NB_RachProcedureList_Type

TTCN-3 Record of Type	
Name	NB_RachProcedureList_Type
Comment	<p>to simulate RACH procedure with one or more than one attempt by the UE:</p> <p>1. Normal cases: one single RandomAccessResponse is sent to the UE matching the UE's RACH preamble; contention resolution is successful immediately => list contains only one element which is used for any RA procedure (Even if a RACH procedure is repeated by the UE for any reason this element shall be used; e.g. it needs not to be handled as error when the UE sends another RACH preamble instead of the RRC connection request message)</p> <p>2. Special cases: SS shall start with the first element in the list and use the RAR as specified in this element; if the RAR matches at the UE side the UE will send UL data and contention resolution is performed as configured for this element; if the RAR does not match the UE sends another RAP and SS continues with the next element in the list; in this case the contention resolution of the respective element is not used; if the end of the list is reached and further RACH preambles are sent by the UE SS shall repeatedly apply the last element of the list (this is necessary because there might be not enough time to reconfigure SS after the end of the list has been reached and there shall be well-defined behaviour after the list has been processed);</p> <p>to change from a special mode to normal mode the RachProcedureList is reconfigured by TTCN to achieve transparency and readability of the code;</p> <p>NOTE: for NB-IoT there can be more than one repetition per preamble attempt (numRepetitionsPerPreambleAttempt-r13 in NPRACH-ConfigSIB-NB-DEFAULT in SystemInformationBlockType2-NB); the SS gets configured with the nprach-ParametersList (NPRACH_Config_Type in NB_PhysicalLayerConfigUL_Type) and it is up to SS implementation how to get out how many preamble repetitions an attempt has; => NB_PhysicalLayerConfigUL_Type contains one entry per attempt and the SS shall report the number of preambles per attempt in a RachPreamble indication (if configured)</p>
record of NB_RachProcedure_Type	

NB_RachProcedureConfig_Type

TTCN-3 Record Type			
Name	NB_RachProcedureConfig_Type		
Comment	parameters to control the random access procedure; TS 36.321, clause 5.1		
RACH_ConfigCommon	NB_RACH_ConfigCommon_Type	opt	acc. TS 36.331, clause 6.7.3.2; may not be necessary for SS; omit: "keep as it is"
RachProcedureList	NB_RachProcedureList_Type	opt	in normal cases there is one element which is used for any RA procedure; special cases are used in MAC test cases; omit means "keep as it is"

NB_RA_NPDCCH_Order_Type

TTCN-3 Record Type			
Name	NB_RA_NPDCCH_Order_Type		
Comment	TS 36.212, clause 5.3.3.1.3		
NprachRepetitions	integer		TS 36.213, Table 16.3.2-1: 0, 1, 3
SubcarrierIndex	integer		

F.1.3.6 System_Information_Control

Primitive to configuration BCCH/BCH

NB_SiSchedul_Type

TTCN-3 Record Type			
Name	NB_SiSchedul_Type		
Comment	for specific SI scheduling and repetitions		
Periodicity	NB_SiPeriodicity_Type	opt	
RepetitionPattern	NB_SiRepetitionPattern_Type	opt	Indicates the starting radio frames within the SI window used for SI message transmission
SchedulingInfoSI	NB_SiTransportBlockSize_Type	opt	This field indicates the transport block size in number of bits used to broadcast the SI message

NB_SiSchedulList_Type

TTCN-3 Record of Type	
Name	NB_SiSchedulList_Type
Comment	
record length(1..maxSI_Message_NB_r13) of NB_SiSchedul_Type	

NB_AllSiSchedul_Type

TTCN-3 Record Type			
Name	NB_AllSiSchedul_Type		
Comment	SI-message scheduling according to TS 36.331, clause 5.1.2.1a and clause 5.2.3a		
WindowLength	NB_SiWindowLength_Type	opt	Common window size for all SIs to calculate start of each SI window acc. TS 36.331, clause 5.2.3a
RadioFrameOffset	integer	opt	Integer (0..15); Frame offset for scheduling of SI-messages (see TS 36.331, clause 5.2.3a)
SiList	NB_SiSchedulList_Type	opt	List of scheduling info for the SIs containing one or more SIBs

SIScheduleConfig_Type

TTCN-3 Record Type			
Name	SIScheduleConfig_Type		
Comment	configuration for BCCH mapped to DL-SCH mapped to NPDSCH SIB1-NB: fixed scheduling in time domain according to TS 36.331 clause 5.2.1.2a (subframe 4, periodicity 2560ms, repetitions in every other frame in 160ms)		
SchedulingInfoSIB1_NB	NB_SchedulingInfoSIB1_Type	opt	Integer (0..15) TBSize and Repetition number refer to TS 36.213 table 16.4.1.5.2-1
SiSchedul	NB_AllSiSchedul_Type	opt	scheduling of SIs and TBSize in time domain

NB_SI_List_Type

TTCN-3 Record of Type	
Name	NB_SI_List_Type
Comment	TS 36.331, clause 6.7.1 BCCH-DL-SCH-Message-NB and clause 6.7.2 SystemInformation-NB
record of BCCH_DL_SCH_Message_NB	

NB_BcchInfo_Type

TTCN-3 Record Type			
Name	NB_BcchInfo_Type		
Comment	all fields are declared as optional to allow modification of single field; acc. to TS 36.331, clause 9.1.1.1 "RRC will perform padding, if required due to the granularity of the TF signalling, as defined in 8.5."; therefore this needs to be done by the system simulator		
MIB_NB	BCCH_BCH_Message_NB	opt	TS 36.331, clause 6.7.1 BCCH-BCH-Message_NB and clause 6.7.2 MasterInformationBlock-NB; NOTE: the sequence numbers included in MIB-NB need to be handled and maintained by the system simulator; that means that the sequence numbers being setup by TTCN will be overwritten by SS
SIB1_NB	BCCH_DL_SCH_Message_NB	opt	TS 36.331, clause 6.7.1 BCCH-DL-SCH-Message-NB and clause 6.7.2 SystemInformationBlockType1-NB
SIs	NB_Si_List_Type	opt	list of SIs corresponding to SiList of AllSiSchedul_Type (i.e. element i of AllSiSchedul_Type's SiList specifies the scheduling for SIs[i])

NB_BcchConfig_Type

TTCN-3 Record Type			
Name	NB_BcchConfig_Type		
Comment	all fields are optional to allow single modifications; activation time may be applied in the common part of the ASP; NOTE 1: mapping/scheduling and contents of the System Information in general is done in one go (i.e. there are no separate ports for SIB data and configuration)		
SIConfig	SIScheduleConfig_Type	opt	
BcchInfo	NB_BcchInfo_Type	opt	

F.1.3.7 Paging_Control

Primitive to configuration PCCH/PCH

NB_PcchConfig_Type

TTCN-3 Record Type			
Name	NB_PcchConfig_Type		
Comment	configuration for PCCH mapped to NPCH TransmissionMode: single antenna mode when there is only one antenna configured, transmit diversity else; RNTI: P-RNTI (TS 36.321, clause 7.1) NOTE: acc. to TS 36.331, clause 9.1.1.3 there is no PDCP and RLC/MAC are in TM		
DciInfoPaging	NB_DciDlInfoCommon_Type	opt	DCI format: N2, Paging (TS 36.212, clause 6.4.3.3)
NoOfDciRepetitionsForDirectIndication	integer	opt	Absolute number of NPDCCH repetitions (R) for direct indication

F.1.3.8 UE_Specific_Channel_Configuration**F.1.3.8.1 UE_Specific_Channel_Configuration_DL**

Scheduling and other information for CCCH/DCCH/DTCH mapped to DL-SCH mapped to NPDSCH

NB_DownlinkGapConfig_Type

TTCN-3 Union Type		
Name	NB_DownlinkGapConfig_Type	
Comment	to specify DL gaps for NPDSCH according to TS 36.211 clause 10.2.3.4	
DownlinkGapConfig	DL_GapConfig_Type	DL gaps shall be used according to the DL gap configuration (TS 36.331 clause 6.7.3.2)
None	Null_Type	there are no gaps in DL

NB_CcchDcchDtchConfigDL_Type

TTCN-3 Record Type		
Name	NB_CcchDcchDtchConfigDL_Type	
Comment	configuration for CCCH/DCCH/DTCH mapped to DL-SCH mapped to NPDSCH RNTI: C-RNTI (TS 36.321, clause 7.1); all fields optional (omit = "keep as it is") since DCI format and modulation may be changed during a test; for initial configuration all fields are mandatory	
DciInfo	NB_DciDInfo_Type	opt
GapConfig	NB_DownlinkGapConfig_Type	opt to specify the DL gap configuration for NPDSCH

F.1.3.8.2 UE_Specific_Channel_Configuration_UL

Scheduling information for CCCH/DCCH/DTCH mapped to UL-SCH mapped to NPUSCH

NB_CcchDcchDtchConfigUL_Type

TTCN-3 Record Type		
Name	NB_CcchDcchDtchConfigUL_Type	
Comment	scheduling for CCCH/DCCH/DTCH mapped to UL-SCH mapped to NPUSCH NOTE 1: for definition of the possible UL grants the location of the NPUSCH (TS 36.211, clause 10.1.3) and the NPRACH (TS 36.211, clause 10.1.6) need to be taken into account; NOTE 2: In contrast to the DL where the scheduling can be done (with consideration of some restrictions) by SS on a per need basis in the UL the scheduling depends on information provided by the UE: e.g. BSR (buffer status report) see TS 36.523-3 clause 7.2 for further information.	
UplinkTimeAlignment_Synch	UplinkTimeAlignment_Synch_Type	opt parameters to control automatic control of timing advance
UESS_GrantScheduling	NB_UESS_GrantScheduling_Type	opt UL grant allocation to be applied

NB_DrxCtrl_Type

TTCN-3 Union Type		
Name	NB_DrxCtrl_Type	
Comment	DRX configuration for connected mode (TS 36.321, clause 5.7)	
None	Null_Type	DRX not configured
Config	NB_DRX_Config_Type	DRX is configured as signalled to the UE; NOTE: the release branch of DRX-Config in general is not used for configuration of the SS

NB_CcchDcchDtchConfig_Type

TTCN-3 Record Type			
Name	NB_CcchDcchDtchConfig_Type		
Comment			
DL	NB_CcchDcchDtchConfigDL_Type	opt	Scheduling, parameters related to CCCH, DCCH and DTCH in DL
UL	NB_CcchDcchDtchConfigUL_Type	opt	Scheduling, parameters related to CCCH, DCCH and DTCH in UL
DrxCtrl	NB_DrxCtrl_Type	opt	DRX configuration as sent to the UE (or 'None' when the UE does not support connected mode DRX)

F.1.4 Cell_Power_Attenuation

NB_CellAttenuationConfig_Type

TTCN-3 Record Type			
Name	NB_CellAttenuationConfig_Type		
Comment			
CellId	NBIOT_CellId_Type		
Attenuation	Attenuation_Type		
TimingInfo	TimingInfo_Type	opt	

NB_CellAttenuationList_Type

TTCN-3 Record of Type	
Name	NB_CellAttenuationList_Type
Comment	
record of NB_CellAttenuationConfig_Type	

F.1.5 Radio_Bearer_Configuration

Radio Bearer Configuration: SRBs/DRBs

F.1.5.1 RLC_Configuration

RLC configuration: radio bearer specific

RLC_Configuration: Basic Type Definitions

TTCN-3 Basic Types		
NB_SS_RLC_TM_Type	Null_Type	TM to configure SRB0; no parameters to be defined

NB_RLC_TestModeConfig_Type

TTCN-3 Union Type	
Name	NB_RLC_TestModeConfig_Type
Comment	
None	Null_Type

NB_SS_RLC_AM_Type

TTCN-3 Record Type			
Name	NB_SS_RLC_AM_Type		
Comment			
Tx	NB_UL_AM_RLC_Type	opt	the UE's UL setting to be used in SS's tx direction
Rx	NB_DL_AM_RLC_Type	opt	the UE's DL setting to be used in SS's rx direction

NB_RLC_RbConfig_Type

TTCN-3 Union Type			
Name	NB_RLC_RbConfig_Type		
Comment			
AM	NB_SS_RLC_AM_Type		
TM	NB_SS_RLC_TM_Type		normally SRB0 only; may be used for test purposes also

NB_RLC_Configuration_Type

TTCN-3 Record Type			
Name	NB_RLC_Configuration_Type		
Comment			
Rb	NB_RLC_RbConfig_Type	opt	mandatory for initial configuration; omit means "keep as it is"
TestMode	NB_RLC_TestModeConfig_Type	opt	mandatory for initial configuration; omit means "keep as it is"

F.1.5.2 MAC_Configuration

MAC configuration: radio bearer specific configuration

NB_MAC_TestModeConfig_Type

TTCN-3 Union Type			
Name	NB_MAC_TestModeConfig_Type		
Comment			
None	Null_Type		
Transparent	Null_Type		In UL and DL the SS' MAC layer is transparent i.e. SS does not add or remove any MAC header

NB_MAC_LogicalChannelConfig_Type

TTCN-3 Record Type			
Name	NB_MAC_LogicalChannelConfig_Type		
Comment			
Priority	integer		logical channel priority for the DL as described in TS 36.321, clause 5.4.3.1 for the UL

NB_MAC_Configuration_Type

TTCN-3 Record Type			
Name	NB_MAC_Configuration_Type		
Comment			
LogicalChannel	NB_MAC_LogicalChannelConfig_Type	opt	mandatory for initial configuration; omit means "keep as it is"
TestMode	NB_MAC_TestModeConfig_Type	opt	mandatory for initial configuration; omit means "keep as it is"; for none MAC tests "TestMode.None:=true"

NB_PDCP_TestModelInfo_Type

TTCN-3 Union Type		
Name	NB_PDCP_TestModelInfo_Type	
Comment		
PDCP_NonROHC_Mode	Null_Type	requires PDCP to be configured as transparent => - SS does not apply ciphering in UL and DL - SS does not interpret, insert or remove PDCP headers - SS does not maintain PDCP sequence numbers and state variables
PDCP_ROHC_Mode	Null_Type	requires PDCP to be configured as transparent (see above) but ROHC is maintained by the SS

NB_PDCP_TestModeConfig_Type

TTCN-3 Union Type		
Name	NB_PDCP_TestModeConfig_Type	
Comment		
None	Null_Type	
Info	NB_PDCP_TestModelInfo_Type	

NB_PDCP_RbConfig_Type

TTCN-3 Union Type		
Name	NB_PDCP_RbConfig_Type	
Comment		
Srb	Null_Type	
Drb	NB_PDCP_Config_Type	PDCP-Configuration acc. to TS 36.331, clause 6.7.3.2

NB_PDCP_ConfigInfo_Type

TTCN-3 Record Type			
Name	NB_PDCP_ConfigInfo_Type		
Comment			
Rb	NB_PDCP_RbConfig_Type	opt	mandatory for initial configuration; omit means "keep as it is"
TestMode	NB_PDCP_TestModeConfig_Type	opt	mandatory for initial configuration; omit means "keep as it is"

NB_PDCP_Configuration_Type

TTCN-3 Union Type		
Name	NB_PDCP_Configuration_Type	
Comment		
None	Null_Type	for SRB0 & SRB1bis no PDCP is configured;
Config	NB_PDCP_ConfigInfo_Type	

NB_RadioBearerConfigInfo_Type

TTCN-3 Record Type			
Name	NB_RadioBearerConfigInfo_Type		
Comment	semantics of omit: "keep as it is"		
Pdcp	NB_PDCP_Configuration_Type	opt	for SRB0 & SRB1bis: "Pdcp.None:=true" mandatory for initial configuration; omit means "keep as it is"
Rlc	NB_RLC_Configuration_Type	opt	mandatory for initial configuration; omit means "keep as it is"
LogicalChannelId	LogicalChannelId_Type	opt	DRBs: DTCH-LogicalChannelIdentity as for rb-MappingInfo in DRB-ToAddModifyList (according to 36.331 a value of 3 shall not be used in DRB-ToAddModifyList); SRBs: for SRBs specified configurations acc. to TS 36.331, clause 9.1.2 shall be applied: SRB1: ul-LogicalChannel-Identity = dl-LogicalChannel-Identity = 1 SRB1bis: ul-LogicalChannel-Identity = dl-LogicalChannel-Identity = 3 for SRB0 being mapped to CCCH the LCID is '00000'B acc. to TS 36.321, clause 6.2.1; mandatory for initial configuration; omit means "keep as it is"
Mac	NB_MAC_Configuration_Type	opt	

NB_RadioBearerConfig_Type

TTCN-3 Union Type		
Name	NB_RadioBearerConfig_Type	
Comment		
AddOrReconfigure	NB_RadioBearerConfigInfo_Type	add / re-configure RB - CellId : identifier of the cell being configured RoutingInfo : None TimingInfo : 'Now' in common cases ControlInfo : CnfFlag:=true; FollowOnFlag:=false (in general)
Release	Null_Type	release RB - CellId : identifier of the cell being configured RoutingInfo : None TimingInfo : 'Now' in common cases ControlInfo : CnfFlag:=true; FollowOnFlag:=false (in general)

NB_RadioBearer_Type

TTCN-3 Record Type			
Name	NB_RadioBearer_Type		
Comment			
Id	NB_RadioBearerId_Type		either for SRB or DRB
L2TestMode	IndicationAndControlMode_Type	opt	to enable/disable L2 testmode: omit : "keep as it is"; "omit" in initial configuration means that L2 testmode is disabled enable : SS shall route uplink data to N_L2DATA port instead of N_SRB port disable : SS shall route uplink data to N_SRB port as usual
Config	NB_RadioBearerConfig_Type		

NB_RadioBearerList_Type

TTCN-3 Record of Type	
Name	NB_RadioBearerList_Type
Comment	array of SRBs and/or DRBs
record length (1.. tsc NB_MaxRB) of NB_RadioBearer_Type	

F.1.6 AS_Security

Primitive for control of AS security

NB_PdcpSQN_Type

TTCN-3 Record Type			
Name	NB_PdcpSQN_Type		
Comment			
Format	NB_PdcpCountFormat_Type		5 bit, 7 bit or 12 bit SQN
Value	integer		SQN value (5 bit, 7 bit or 12 bit SQN) NOTE: in TTCN the test case writer is responsible to deal with potential overflows (e.g. there shall be a "mod 32", "mod 128" or "mod 4096" according to the format)

NB_PDCP_ActTime_Type

TTCN-3 Union Type			
Name	NB_PDCP_ActTime_Type		
Comment	The sequence number in UL and DL for SRB1 should be one more than the present SQN, as Ciphering starts in UL and DL soon after SMC and SMComp; For DRBs it should be the present SQN		
None	Null_Type		No Activation time; to be used if Ciphering is not applied
SQN	NB_PdcpSQN_Type		PDCP sequence number

NB_SecurityActTime_Type

TTCN-3 Record Type			
Name	NB_SecurityActTime_Type		
Comment			
RadioBearerId	NB_RadioBearerId_Type		
UL	NB_PDCP_ActTime_Type		
DL	NB_PDCP_ActTime_Type		

NB_SecurityActTimeList_Type

TTCN-3 Record of Type	
Name	NB_SecurityActTimeList_Type
Comment	
record length (1..tsc NB_MaxRB) of NB_SecurityActTime_Type	

NB_AS_IntegrityInfo_Type

TTCN-3 Record Type			
Name	NB_AS_IntegrityInfo_Type		
Comment	for initial configuration activation time is not needed for integrity protection as all messages in DL after security activation are integrity protected; this means this ASP is invoked before transmission of Security mode command; if there is a integrity violation in UL SS shall set the IndicationStatus in the common ASP part to flag the integrity error (IndicationStatus.Error.Integrity.Pdcp := true); integrity to be provided for each SRB as per core spec		
Algorithm	IntegrityProtAlgorithm_Type		IntegrityProtAlgorithm_Type being defined in RRC ASN.1
KRRCint	B128_Key_Type		
ActTimeList	NB_SecurityActTimeList_Type	opt	omit for initial configuration (i.e. all SRBs to be integrity protected immediately)

NB_AS_CipheringInfo_Type

TTCN-3 Record Type			
Name	NB_AS_CipheringInfo_Type		
Comment			
Algorithm	EUTRA ASN1 CipheringAlgorithm_r12_Type		CipheringAlgorithm_Type being defined in RRC ASN.1
KRRCenc	B128_Key_Type		
KUPenc	B128_Key_Type		KUPenc is used by SS when DRBs are configured
ActTimeList	NB_SecurityActTimeList_Type		

NB_AS_SecStartRestart_Type

TTCN-3 Record Type			
Name	NB_AS_SecStartRestart_Type		
Comment			
Integrity	NB_AS_IntegrityInfo_Type	opt	optional to allow separated activation of integrity and ciphering; omit: keep as it is
Ciphering	NB_AS_CipheringInfo_Type	opt	optional to allow separated activation of integrity and ciphering; omit: keep as it is

NB_AS_Security_Type

TTCN-3 Union Type			
Name	NB_AS_Security_Type		
Comment	Security mode command procedure (TS 36.331, clause 5.3.4): both SMC and SMComp are integrity protected (nevertheless SS shall be able to cope with unprotected SM reject); ciphering is started just after SMComp (acc. to TS 36.331, clause 5.3.4.3 and 5.3.1.1)		
StartRestart	NB_AS_SecStartRestart_Type		information to start/restart AS security protection in the PDCP
Release	Null_Type		to release AS security protection in the PDCP

F.1.7 Paging_Trigger**NB_PagingMessage_Type**

TTCN-3 Union Type			
Name	NB_PagingMessage_Type		
Comment			
Paging	PCCH_Message_NB		
DirectIndication	B8_Type		

NB_PagingTrigger_Type

TTCN-3 Record Type			
Name	NB_PagingTrigger_Type		
Comment	CellId : identifier of the cell where the UE is active RoutingInfo : None TimingInfo : Calculated paging occasion ControllInfo : Cnfflag:=false; FollowOnFlag:=false primitive to trigger transmission of a paging on the NPCCH at a calculated paging occasion (TS 36.304, clause 7); the paging occasion is calculated by TTCN and activation time is applied; as for BCCH Info acc. to TS 36.331, clause 9.1.1.3 "RRC will perform padding, if required due to the granularity of the TF signalling, as defined in 8.5."; therefore this needs to be done by the system simulator		
Paging	NB_PagingMessage_Type		paging to be scheduled in the Type1 common search space beginning from the time given in the timing information of the common part of the ASP; the DCI is transmitted on the NPDCCH using P-RNTI

F.1.8 RLC_Counts

Primitives to enquire RLC Counts AM_VTS and AM_VRR

NB_RLC_CountsInfoList_Type

TTCN-3 Record Type			
Name	NB_RLC_CountsInfoList_Type		
Comment			
AM_VTS	integer		sequence number for DL
AM_VRR	integer		sequence number for UL

NB_RLC_CountsReq_Type

TTCN-3 Union Type			
Name	NB_RLC_CountsReq_Type		
Comment			
Get	Null_Type		Request RLC Counts
Set	NB_RLC_CountsInfoList_Type		Set RLC Counts

NB_RLC_CountsCnf_Type

TTCN-3 Union Type			
Name	NB_RLC_CountsCnf_Type		
Comment			
Get	NB_RLC_CountsInfoList_Type		VTS and VRR
Set	Null_Type		

F.1.9 PDCP_Count

Primitives to enquire PDCP COUNT

NB_PdcCountFormat_Type

TTCN-3 Enumerated Type	
Name	NB_PdcCountFormat_Type
Comment	
PdcCount_Srb	27 bit HFN; 5 bit SQF
PdcCount_DrbShort SQN	25 bit HFN; 7 bit SQF

NB_PdcCount_Type

TTCN-3 Record Type	
Name	NB_PdcCount_Type
Comment	
Format	NB_PdcCountFormat_Type
Value	PdcCountValue_Type

NB_PdcCountInfo_Type

TTCN-3 Record Type	
Name	NB_PdcCountInfo_Type
Comment	
RadioBearerId	NB_RadioBearerId_Type
UL	NB_PdcCount_Type opt omit: keep as it is
DL	NB_PdcCount_Type opt omit: keep as it is

NB_PdcCountInfoList_Type

TTCN-3 Record of Type	
Name	NB_PdcCountInfoList_Type
Comment	
record length (1.. tsc_NB_MaxRB) of NB_PdcCountInfo_Type	

NB_PdcCountGetReq_Type

TTCN-3 Union Type	
Name	NB_PdcCountGetReq_Type
Comment	
AllRBs	Null_Type return COUNT values for all RBs being configured
SingleRB	NB_RadioBearerId_Type

NB_PDCP_CountReq_Type

TTCN-3 Union Type	
Name	NB_PDCP_CountReq_Type
Comment	
Get	NB_PdcCountGetReq_Type Request PDCP count for one or all RBs being configured at the PDCP
Set	NB_PdcCountInfoList_Type Set PDCP count for one or all RBs being configured at the PDCP; list for RBs which's COUNT shall be manipulated

NB_PDCP_CountCnf_Type

TTCN-3 Union Type		
Name	NB_PDCP_CountCnf_Type	
Comment		
Get	NB_PdcpCountInfoList_Type	RBs in ascending order; SRBs first
Set	Null_Type	

F.1.10 L1_MAC_Test_Mode

Primitive for control of L1/MAC Test Modes

NB_L1Mac_IndicationControl_Type

TTCN-3 Record Type			
Name	NB_L1Mac_IndicationControl_Type		
Comment			
RachPreamble	IndicationAndControlMode_Type	opt	To enable/disable reporting of NPRACH preamble received
DPR	IndicationAndControlMode_Type	opt	To enable/disable reporting of MAC DPR control elements
HarqError	IndicationAndControlMode_Type	opt	To enable/disable reporting of HARQ errors
UL_HARQ	IndicationAndControlMode_Type	opt	To enable/disable reporting of HARQ ACK/NACK

F.1.11 System_Interface**NB_SYSTEM_CTRL_REQ**

TTCN-3 Record Type			
Name	NB_SYSTEM_CTRL_REQ		
Comment			
Common	NB_ReqAspCommonPart_Type		TimingInfo depends on respective primitive:
Request	NB_SystemRequest_Type		<ul style="list-style-type: none"> - Cell TimingInfo: 'now' (in general) - CellAttenuationList TimingInfo: 'now' (in general, but activation time may be used also) - RadioBearerList TimingInfo: 'now' in general; activation time may be used in special case for release and/or reconfiguration of one or several RBs;

NB_SYSTEM_CTRL_CNF

TTCN-3 Record Type			
Name	NB_SYSTEM_CTRL_CNF		
Comment			
Common	NB_CnfAspCommonPart_Type		TimingInfo is ignored by TTCN (apart from EnquireTiming) => SS may set TimingInfo to "None"
Confirm	NB_SystemConfirm_Type		

NB_SYSTEM_IND

TTCN-3 Record Type			
Name	NB_SYSTEM_IND		
Comment			
Common	NB_IndAspCommonPart_Type		The SS shall provide TimingInfo (HSFN + SFN + subframe number) depending on the respective indication:
Indication	NB_SystemIndication_Type		

NBIOT_SYSTEM_PORT

TTCN-3 Port Type			
Name	NBIOT_SYSTEM_PORT		
Comment	NBIOT PTC: Port for system configuration		
out	NB_SYSTEM_CTRL_REQ		
in	NB_SYSTEM_CTRL_CNF		

NBIOT_SYSIND_PORT

TTCN-3 Port Type			
Name	NBIOT_SYSIND_PORT		
Comment	NBIOT PTC: Port for system indications		
in	NB_SYSTEM_IND		

F.2 NBIOT_ASP_SrbDefs

F.2.1 SRB_DATA_ASPs

ASP Definitions to send/receive peer-to-peer messages on SRBs

NB_C_Plane_Request_Type

TTCN-3 Record Type			
Name	NB_C_Plane_Request_Type		
Comment	RRC and/or NAS PDU to be send to the UE; Note: it may be necessary to allow more than one NAS PDU (-> "record of")		
Rrc	NB_RRC_MSG_Request_Type	opt	omit: NAS message shall be present; NAS message shall be sent in DLInformationTransfer present: if NAS message is present also, (piggybacked) NAS PDU shall be security protected (if necessary) and inserted in RRC PDU's DedicatedInfoNAS
Nas	NAS_MSG_RequestList_Type	opt	omit: RRC message shall be present; RRC message does not contain (piggybacked) NAS PDU present: if RRC message is omitted => NAS message shall be sent embedded in DLInformationTransfer if RRC message is present => NAS message is piggybacked in RRC message in case of RRC message is sent on CCCH, NAS message shall be omitted

NB_C_Plane_Indication_Type

TTCN-3 Record Type			
Name	NB_C_Plane_Indication_Type		
Comment	RRC and/or NAS PDU to be received from the UE; Note: it may be necessary to allow more than one NAS PDU (-> "record of")		
Rrc	NB_RRC_MSG_Indication_Type	opt	omit: NAS message shall be present; NAS message is received in ULInformationTransfer present: if NAS message is present also, DedicatedInfoNAS contains unstructured and ciphered NAS message and the NAS message is the deciphered message in structured format
Nas	NAS_MSG_IndicationList_Type	opt	omit: RRC message shall be present; RRC message does not contain (piggybacked) NAS PDU present: if RRC message is omitted => NAS message has been received in ULInformationTransfer if RRC message is present => NAS message has been piggybacked in RRC message

NB_SRB_COMMON_REQ

TTCN-3 Record Type			
Name	NB_SRB_COMMON_REQ		
Comment	common ASP to send PDUs to SRB0, SRB1 or SRB1bis		
Common	NB_ReqAspCommonPart_Type		CellId identifier of the cell RoutingInfo SRB0, SRB1, SRB1bis TimingInfo Now in normal cases; For latency tests TimingInfo can be set to the SFN/subframe in which the RRC messages shall be sent out (in this case and if the RRC PDU is too long to be sent in one TTI the TimingInfo corresponds to the first TTI) ControllInfo Cnfflag:=false; FollowOnFlag true: Indicates that the message(s) to be sent on the same TTI will follow NOTE 1: When FollowOnFlag is true, TimingInfo shall always be "Now". Otherwise SS shall produce an error NOTE 2: the follow on flag applies only for messages of the same SRB false: Indicates that no more message(s) will follow
Signalling	NB_C_Plane_Request_Type		

NB_SRB_COMMON_IND

TTCN-3 Record Type			
Name	NB_SRB_COMMON_IND		
Comment	common ASP to receive PDUs from SRB0, SRB1 or SRB1bis		
Common	NB_IndAspCommonPart_Type		CellId identifier of the cell RoutingInfo SRB0, SRB1, SRB1bis TimingInfo time when message has been received (as received from the SS by the NAS emulator)
Signalling	NB_C_Plane_Indication_Type		

F.2.2 Port_Definitions

NBIOT_SRB_PORT

TTCN-3 Port Type	
Name	NBIOT_SRB_PORT
Comment	NBIOT PTC: Port for Sending/Receiving data on SRBs
out	NB_SRB_COMMON_REQ
in	NB_SRB_COMMON_IND

NASEMU_NBIOT_SRB_PORT

TTCN-3 Port Type	
Name	NASEMU_NBIOT_SRB_PORT
Comment	NASEMU PTC: Port for Sending/Receiving data on SRBs (interface to NBIOT PTC)
out	NB_SRB_COMMON_IND
in	NB_SRB_COMMON_REQ

F.3 NBIOT_ASP_L2DataDefs

F.3.1 System_Interface

NB_L2_DATA_REQ

TTCN-3 Record Type	
Name	NB_L2_DATA_REQ
Comment	common ASP to send L2 data
Common	NB_ReqAspCommonPart_Type CellId : identifier of the cell RoutingInfo : SRB/DRB id TimingInfo : starting point when to start sending sequence of data PDUs e.g. SFN = X, subframe number = x; L2Data.SubframeDataList[i].SubframeOffset := offset_i; => L2Data.SubframeDataList[i].PduSduList shall be scheduled in the next search space after SFN = X + ((x + offset_i) / 10); subframe number = (x + offset_i) % 10 ControllInfo : CnfFlag:=false; FollowOnFlag:=false
L2Data	L2Data_Request_Type

NB_L2_DATA_IND

TTCN-3 Record Type	
Name	NB_L2_DATA_IND
Comment	common ASP to receive L2 data
Common	NB_IndAspCommonPart_Type CellId : identifier of the cell RoutingInfo : SRB/DRB id TimingInfo : time when message has been received according to clause 7A.6 of TS 36.523-3
L2Data	L2Data_Indication_Type

NBIOT_L2DATA_PORT

TTCN-3 Port Type	
Name	NBIOT_L2DATA_PORT
Comment	
out	NB_L2_DATA_REQ
in	NB_L2_DATA_IND

F.4 EUTRA_NB_ASP_L2DataDefs

ASP interface for DRBs

F.4.1 PDU_TypeDefs

F.4.1.1 MAC_PDU

MAC_PDU: Basic Type Definitions

TTCN-3 Basic Types		
MAC_CTRL_C_RNTI_Type	C_RNTI	TS 36.321, clause 6.1.3.2
MAC_CTRL_ContentionResolutionId_Type	ContentionResolutionId_Type	TS 36.321, clause 6.1.3.4 fix 48-bit size; consists of a single field defined UE Contention Resolution Identity (first 48 bits of the uplink CCCH SDU transmitted by MAC)
MAC_CTRL_TimingAdvance_Type	B8_Type	TS 36.321, clause 6.1.3.5 indicates the amount of timing adjustment in 0.5 ms that the UE has to apply; the length of the field is 8 bits
MAC_SDU_Type	octetstring	

MAC_PDU_Length_Type

TTCN-3 Record Type	
Name	MAC_PDU_Length_Type
Comment	NOTE: since F and L field are either both present or both omitted they are put into this record; to allow homogeneous (direct) encoding the PDU length is not defined as union; TTCN-3 does allow length restrictions to one length or a range of length but not to two specific lengths; further restriction may be achieved by appropriate templates (parameter either 7 or 15 bit)
Format	B1_Type F: The Format field indicates the size of the Length field as indicated in table 6.2.1-3. There is one F field per MAC PDU subheader except for the last subheader and sub-headers corresponding to fixed-sized MAC control elements. The size of the F field is 1 bit. If the size of the MAC SDU or MAC control element is less than 128 bytes, the UE shall set the value of the F field to 0, otherwise the UE shall set it to 1
Value	B7_15_Type L: The Length field indicates the length of the corresponding MAC SDU or MAC control element in bytes. There is one L field per MAC PDU subheader except for the last subheader and sub-headers corresponding to fixed-sized MAC control elements. The size of the L field is indicated by the F field

MAC_PDU_SubHeader_Type

TTCN-3 Record Type			
Name	MAC_PDU_SubHeader_Type		
Comment			
Reserved	B2_Type		Reserved bits
Extension	B1_Type		E: The Extension field is a flag indicating if more fields are present in the MAC header or not. The E field is set to "1" to indicate another set of at least R/R/E/LCID fields. The E field is set to "0" to indicate that either a MAC SDU, a MAC control element or padding starts at the next byte
LCID	B5_Type		LCID: The Logical Channel ID field identifies the logical channel instance of the corresponding MAC SDU or the type of the corresponding MAC control element or padding as described in tables 6.2.1-1 and 6.2.1-2 for the DL and UL-SCH respectively. There is one LCID field for each MAC SDU, MAC control element or padding included in the MAC PDU. The LCID field size is 5 bits; NOTE: In case of DRX command the sub-header corresponds to a control element of length zero (i.e. there is no control element)
Length	MAC_PDU_Length_Type	opt	

MAC_Header_Type

TTCN-3 Record of Type	
Name	MAC_Header_Type
Comment	
record of MAC_PDU_SubHeader_Type	

MAC_CTRL_ShortBSR_Type

TTCN-3 Record Type			
Name	MAC_CTRL_ShortBSR_Type		
Comment	TS 36.321, clause 6.1.3.1		
LCG	B2_Type		
Value	B6_Type		

MAC_CTRL_LongBSR_Type

TTCN-3 Record Type			
Name	MAC_CTRL_LongBSR_Type		
Comment	TS 36.321, clause 6.1.3.1		
Value_LCG1	B6_Type		
Value_LCG2	B6_Type		
Value_LCG3	B6_Type		
Value_LCG4	B6_Type		

MAC_CTRL_PowerHeadRoom_Type

TTCN-3 Record Type			
Name	MAC_CTRL_PowerHeadRoom_Type		
Comment	TS 36.321, clause 6.1.3.6		
Reserved	B2_Type		
Value	B6_Type		

MAC_CTRL_ElementList_Type

TTCN-3 Set Type			
Name	MAC_CTRL_ElementList_Type		
Comment	NOTE 1: for simplification UL and DL are not distinguished even though the control elements are either UL or DL NOTE 2: type is defined as set: the ordering is not significant; nevertheless the ordering is well-defined by the sub-headers; for codec implementations it is in any case necessary to evaluate the sub-header information in order to encode/decode the payload		
ShortBSR	MAC_CTRL_ShortBSR_Type	opt	UL only
LongBSR	MAC_CTRL_LongBSR_Type	opt	UL only
C_RNTI	MAC_CTRL_C_RNTI_Type	opt	UL only
ContentionResolutionID	MAC_CTRL_ContentionResolutionId_Type	opt	DL only
TimingAdvance	MAC_CTRL_TimingAdvance_Type	opt	DL only
PowerHeadRoom	MAC_CTRL_PowerHeadRoom_Type	opt	UL only
ScellActDeact	MAC_CTRL_ScellActDeact_Type	opt	DL only
ExtPowerHeadRoom	MAC_CTRL_ExtPowerHeadRoom_Type	opt	UL only. Only one among PowerHeadroom, ExtPowerHeadroom and DC_PowerHeadRoom may be present
DC_PowerHeadRoom	MAC_CTRL_DC_PowerHeadRoom_Type	opt	UL only. Only one among PowerHeadroom, ExtPowerHeadroom and DC_PowerHeadRoom may be present

MAC_SDUList_Type

TTCN-3 Record of Type	
Name	MAC_SDUList_Type
Comment	record of MAC_SDU_Type

MAC_PDU_Type

TTCN-3 Record Type			
Name	MAC_PDU_Type		
Comment			
Header	MAC_Header_Type		list of MAC PDU SubHeaders corresponding to MAC control elements and MAC SDUs
CtrlElementList	MAC_CTRL_ElementList_Type	opt	Mac control elements; acc. to TS 36.321, clause 6.1.2 "MAC control elements, are always placed before any MAC SDU."
SduList	MAC_SDUList_Type	opt	MAC SDUs, which can typically be RLC PDUs
Padding	octetstring	opt	Octet aligned Padding if more than or equal to 2 bytes

MAC_PDUList_Type

TTCN-3 Record of Type	
Name	MAC_PDUList_Type
Comment	record of MAC_PDU_Type

F.4.1.2 RLC_PDU

F.4.1.2.1 Common

RLC PDU definition: common AM/UM field definitions

Common: Basic Type Definitions

TTCN-3 Basic Types		
RLC_FramingInfo_Type	B2_Type	00 - First byte of the Data field corresponds to the first byte of a RLC SDU. Last byte of the Data field corresponds to the last byte of a RLC SDU. 01 - First byte of the Data field corresponds to the first byte of a RLC SDU. Last byte of the Data field does not correspond to the last byte of a RLC SDU. 10 - First byte of the Data field does not correspond to the first byte of a RLC SDU. Last byte of the Data field corresponds to the last byte of a RLC SDU. 11 - First byte of the Data field does not correspond to the first byte of a RLC SDU. Last byte of the Data field does not correspond to the last byte of a RLC SDU.

RLC_LengthIndicator_LI11_Type

TTCN-3 Record Type			
Name	RLC_LengthIndicator_LI11_Type		
Comment			
Extension	B1_Type		0 - Data field follows from the octet following the LI field following this E field 1 - A set of E field and LI field follows from the bit following the LI field following this E field
LengthIndicator	B11_Type		Length Indicator

RLC_LengthIndicator_LI15_Type

TTCN-3 Record Type			
Name	RLC_LengthIndicator_LI15_Type		
Comment			
Extension	B1_Type		0 - Data field follows from the octet following the LI field following this E field 1 - A set of E field and LI field follows from the bit following the LI field following this E field
LengthIndicator	B15_Type		15 bit Length Indicator

RLC_LI11_List_Type

TTCN-3 Record of Type	
Name	RLC_LI11_List_Type
Comment	record of RLC_LengthIndicator_LI11_Type

RLC_LI15_List_Type

TTCN-3 Record of Type	
Name	RLC_LI15_List_Type
Comment	
record of RLC_LengthIndicator_LI15_Type	

RLC_LI_List_Type

TTCN-3 Union Type	
Name	RLC_LI_List_Type
Comment	
LI11	RLC_LI11_List_Type
LI15	RLC_LI15_List_Type

RLC_PDU_Header_FlexPart_Type

TTCN-3 Record Type		
Name	RLC_PDU_Header_FlexPart_Type	
Comment	Flexible part of the header with a number of K LIs	
LengthIndicator	RLC_LI_List_Type	List of E, LI fields
Padding	B4_Type	opt optional 4 bit padding present in case of odd number of LI's

F.4.1.2.2 TM_Data

RLC PDU definition: UM (TS 36.322, clause 6.2.1.2)

TM_Data: Basic Type Definitions

TTCN-3 Basic Types		
RLC_TMD_PDU_Type	octetstring	TS 36.322, clause 6.2.1.2

F.4.1.2.3 UM_Data

RLC PDU definition: UM (TS 36.322, clause 6.2.1.3)

NOTE:

To allow direct encoding the definition for RLC UM Data PDU is split into data PDU with 5/10 bit sequence number

UM_Data: Basic Type Definitions

TTCN-3 Basic Types		
RLC_DataField_Type	octetstring	restrictions imposed from LI size of 11 bits is not applicable when the LI's are not present

RLC_UMD_Header_FixPartShortSN_Type

TTCN-3 Record Type		
Name	RLC_UMD_Header_FixPartShortSN_Type	
Comment	TS 36.322, clause 6.2.1.3 Figure 6.2.1.3-1, 6.2.1.3-3 and 6.2.1.3-4); one octet	
FramingInfo	RLC_FramingInfo_Type	2 bits FI
Extension	B1_Type	1 bit E
SequenceNumber	B5_Type	5 bits SN

RLC_UMD_Header_FixPartLongSN_Type

TTCN-3 Record Type			
Name	RLC_UMD_Header_FixPartLongSN_Type		
Comment	TS 36.322, clause 6.2.1.3 Figure 6.2.1.3-2, 6.2.1.3-5 and 6.2.1.3-6); two octets		
Reserved	B3_Type		3 bits reserved
FramingInfo	RLC_FramingInfo_Type		2 bits FI
Extension	B1_Type		1 bit E
SequenceNumber	B10_Type		10 bits SN

RLC_UMD_HeaderShortSN_Type

TTCN-3 Record Type			
Name	RLC_UMD_HeaderShortSN_Type		
Comment			
FixPart	RLC_UMD_Header_FixPartShortSN_Type		
FlexPart	RLC_PDU_Header_FlexPart_Type	opt	

RLC_UMD_HeaderLongSN_Type

TTCN-3 Record Type			
Name	RLC_UMD_HeaderLongSN_Type		
Comment			
FixPart	RLC_UMD_Header_FixPartLongSN_Type		
FlexPart	RLC_PDU_Header_FlexPart_Type	opt	

RLC_DataFieldList_Type

TTCN-3 Record of Type			
Name	RLC_DataFieldList_Type		
Comment	One to one correspondence with sub headers (LengthIndicatorList_Type) record of RLC_DataField_Type		

RLC_UMD_PDU_ShortSN_Type

TTCN-3 Record Type			
Name	RLC_UMD_PDU_ShortSN_Type		
Comment			
Header	RLC_UMD_HeaderShortSN_Type		
Data	RLC_DataFieldList_Type		

RLC_UMD_PDU_LongSN_Type

TTCN-3 Record Type			
Name	RLC_UMD_PDU_LongSN_Type		
Comment			
Header	RLC_UMD_HeaderLongSN_Type		
Data	RLC_DataFieldList_Type		

RLC_UMD_PDU_Type

TTCN-3 Union Type		
Name	RLC_UMD_PDU_Type	
Comment		
ShortSN	RLC_UMD_PDU_ShortSN_Type	
LongSN	RLC_UMD_PDU_LongSN_Type	

F.4.1.2.4 AM_Data

RLC PDU definition: AM (TS 36.322, clause 6.2.1.4 and 6.2.1.5)

RLC_AMD_Header_FixPart_Type

TTCN-3 Record Type		
Name	RLC_AMD_Header_FixPart_Type	
Comment	TS 36.322, clause 6.2.1.4 Figure 6.2.1.4-1, 6.2.1.4-2 and 6.2.1.4-3); 2 or 4 octets (AMD PDU or AMD PDU segment)	
D_C	B1_Type	0 - Control PDU 1 - Data PDU
ReSeg	B1_Type	0 - AMD PDU 1 - AMD PDU segment
Poll	B1_Type	0 - Status report not requested 1 - Status report is requested
FramingInfo	RLC_FramingInfo_Type	2 bit FI
Extension	B1_Type	1 bit E
SN	B10_Type	Sequence number

RLC_AMD_Header_FixPartExt_Type

TTCN-3 Record Type		
Name	RLC_AMD_Header_FixPartExt_Type	
Comment	TS 36.322, clause 6.2.1.4 Figure 6.2.1.4-1a, 6.2.1.4-2a and 6.2.1.4-3a); 3 octets	
D_C	B1_Type	0 - Control PDU 1 - Data PDU
ReSeg	B1_Type	0 - AMD PDU 1 - AMD PDU segment
Poll	B1_Type	0 - Status report not requested 1 - Status report is requested
FramingInfo	RLC_FramingInfo_Type	2 bit FI
Extension	B1_Type	1 bit E
Reserved	B2_Type	2 reserved bits
SN_Ext	B16_Type	Sequence number

RLC_AMD_Header_FixPartSegExt_Type

TTCN-3 Record Type			
Name	RLC_AMD_Header_FixPartSegExt_Type		
Comment	TS 36.322, clause 6.2.1.5 Figure 6.2.1.5-1a); 5 octets		
D_C	B1_Type		0 - Control PDU 1 - Data PDU
ReSeg	B1_Type		0 - AMD PDU 1 - AMD PDU segment
Poll	B1_Type		0 - Status report not requested 1 - Status report is requested
FramingInfo	RLC_FramingInfo_Type		2 bit FI
Extension	B1_Type		1 bit E
LastSegmentFlag	B1_Type		0 - Last byte of the AMD PDU segment does not correspond to the last byte of an AMD PDU 1 - Last byte of the AMD PDU segment corresponds to the last byte of an AMD PDU
Reserved	B1_Type		1 reserved bit
SN_Ext	B16_Type		Sequence number

RLC_AMD_Header_SegmentPart_Type

TTCN-3 Record Type			
Name	RLC_AMD_Header_SegmentPart_Type		
Comment	AMD PDU segment related info in PDU header acc. TS 36.322, clause 6.2.1.5		
LastSegmentFlag	B1_Type		0 - Last byte of the AMD PDU segment does not correspond to the last byte of an AMD PDU 1 - Last byte of the AMD PDU segment corresponds to the last byte of an AMD PDU
SegOffset	B15_Type		The SO field indicates the position of the AMD PDU segment in bytes within the original AMD PDU. Specifically, the SO field indicates the position within the Data field of the original AMD PDU to which the first byte of the Data field of the AMD PDU segment corresponds to.

RLC_AMD_Header_SegmentPartExt_Type

TTCN-3 Record Type			
Name	RLC_AMD_Header_SegmentPartExt_Type		
Comment	AMD PDU segment related info in PDU header acc. TS 36.322, clause 6.2.1.5		
SegOffset	B16_Type		The SO field indicates the position of the AMD PDU segment in bytes within the original AMD PDU. Specifically, the SO field indicates the position within the Data field of the original AMD PDU to which the first byte of the Data field of the AMD PDU segment corresponds to.

RLC_AMD_Header_Type

TTCN-3 Record Type			
Name	RLC_AMD_Header_Type		
Comment			
FixPart	RLC_AMD_Header_FixPart_Type		
SegmentPart	RLC_AMD_Header_SegmentPart_Type	opt	present in case of AMD Seg PDU only
FlexPart	RLC_PDU_Header_FlexPart_Type	opt	

RLC_AMD_HeaderExt_Type

TTCN-3 Record Type			
Name	RLC_AMD_HeaderExt_Type		
Comment			
FixPartExt	RLC_AMD_Header_FixPart_Ext_Type		
FlexPart	RLC_PDU_Header_FlexPart_Type	opt	

RLC_AMD_HeaderSegExt_Type

TTCN-3 Record Type			
Name	RLC_AMD_HeaderSegExt_Type		
Comment			
FixPartSegExt	RLC_AMD_Header_FixPart_SegExt_Type		
SegmentPart	RLC_AMD_Header_SegmentPartExt_Type	opt	present in case of AMD Seg PDU only
FlexPart	RLC_PDU_Header_FlexPart_Type	opt	

RLC_AMD_PDU_Type

TTCN-3 Record Type			
Name	RLC_AMD_PDU_Type		
Comment			
Header	RLC_AMD_Header_Type		
Data	RLC_DataFieldList_Type		

RLC_AMD_PDU_Ext_Type

TTCN-3 Record Type			
Name	RLC_AMD_PDU_Ext_Type		
Comment			
HeaderExt	RLC_AMD_HeaderExt_Type		
Data	RLC_DataFieldList_Type		

RLC_AMD_PDU_SegExt_Type

TTCN-3 Record Type			
Name	RLC_AMD_PDU_SegExt_Type		
Comment			
HeaderSegExt	RLC_AMD_HeaderSegExt_Type		
Data	RLC_DataFieldList_Type		

F.4.1.2.5 AM_Status

AM Status PDU (TS 36.322, clause 6.2.1.6)

AM_Status: Basic Type Definitions

TTCN-3 Basic Types		
RLC_Status_Padding_Type	bitstring length (1..7)	NOTE: in TTCN-3 length restriction cannot be done inline in record definition => explicit type definition necessary

RLC_Status_ACK_Type

TTCN-3 Record Type		
Name	RLC_Status_ACK_Type	
Comment		
ACK_SN	B10_Type	Acknowledgement SN (TS 36.322, clause 6.2.2.14)
Extn1	B1_Type	0 - a set of NACK_SN, E1 and E2 does not follow. 1 - a set of NACK_SN, E1 and E2 follows.

RLC_Status_ACK_Ext_Type

TTCN-3 Record Type		
Name	RLC_Status_ACK_Ext_Type	
Comment		
ACK_SN_Ext	B16_Type	Acknowledgement SN (TS 36.322, clause 6.2.2.14)
Extn1	B1_Type	0 - a set of NACK_SN, E1 and E2 does not follow. 1 - a set of NACK_SN, E1 and E2 follows.

RLC_Status_SegOffset_Type

TTCN-3 Record Type		
Name	RLC_Status_SegOffset_Type	
Comment		
Start	B15_Type	SOstart field indicates the position of the first byte of the portion of the AMD PDU in bytes within the Data field of the AMD PDU
End	B15_Type	SOend field indicates the position of the last byte of the portion of the AMD PDU in bytes within the Data field of the AMD PDU. The special SOend value '1111111111111111'B is used to indicate that the missing portion of the AMD PDU includes all bytes to the last byte of the AMD PDU

RLC_Status_SegOffset_Ext_Type

TTCN-3 Record Type		
Name	RLC_Status_SegOffset_Ext_Type	
Comment		
Start	B16_Type	SOstart field indicates the position of the first byte of the portion of the AMD PDU in bytes within the Data field of the AMD PDU
End	B16_Type	SOend field indicates the position of the last byte of the portion of the AMD PDU in bytes within the Data field of the AMD PDU. The special SOend value '1111111111111111'B is used to indicate that the missing portion of the AMD PDU includes all bytes to the last byte of the AMD PDU

RLC_Status_NACK_Type

TTCN-3 Record Type			
Name	RLC_Status_NACK_Type		
Comment			
NACK_SN	B10_Type		
Extn1	B1_Type		0 - A set of NACK_SN, E1 and E2 does not follow. 1 - A set of NACK_SN, E1 and E2 follows.
Extn2	B1_Type		0 - A set of SOstart and SOend does not follow for this NACK_SN. 1 - A set of SOstart and SOend follows for this NACK_SN.
SO	RLC_Status_SegOffset_Type	opt	

RLC_Status_NACK_List_Type

TTCN-3 Record of Type	
Name	RLC_Status_NACK_List_Type
Comment	
record of RLC_Status_NACK_Type	

RLC_Status_NACK_Ext_Type

TTCN-3 Record Type			
Name	RLC_Status_NACK_Ext_Type		
Comment			
NACK_SN_Ext	B16_Type		
Extn1	B1_Type		0 - A set of NACK_SN, E1 and E2 does not follow. 1 - A set of NACK_SN, E1 and E2 follows.
Extn2	B1_Type		0 - A set of SOstart and SOend does not follow for this NACK_SN. 1 - A set of SOstart and SOend follows for this NACK_SN.
SO	RLC_Status_SegOffset_Ext_Type	opt	

RLC_Status_NACK_Ext_List_Type

TTCN-3 Record of Type	
Name	RLC_Status_NACK_Ext_List_Type
Comment	
record of RLC_Status_NACK_Ext_Type	

RLC_AM_StatusPDU_Type

TTCN-3 Record Type			
Name	RLC_AM_StatusPDU_Type		
Comment	RLC STATUS PDU (TS 36.322, clause 6.2.1.6)		
D_C	B1_Type		0 - Control PDU 1 - Data PDU
CP_Type	B3_Type		000 - STATUS PDU 001..111 - Reserved (=> PDU to be discarded by the receiving entity for this release of the protocol)
Ack	RLC_Status_ACK_Type		ACK_SN and E1 bit
NackList	RLC_Status_NACK_List_Type	opt	presence depends on Extn1 bit of Ack filed (RLC_Status_ACK_Type)
Padding	RLC_Status_Padding_Type	opt	1..7 bit padding if needed for octet alignment

RLC_AM_StatusPDU_Ext_Type

TTCN-3 Record Type			
Name	RLC_AM_StatusPDU_Ext_Type		
Comment	RLC STATUS PDU (TS 36.322, clause 6.2.1.6)		
D_C	B1_Type		0 - Control PDU 1 - Data PDU
CP_Type	B3_Type		000 - STATUS PDU 001..111 - Reserved (=> PDU to be discarded by the receiving entity for this release of the protocol)
Ack_Ext	RLC_Status_ACK_Ext_Type		ACK_SN and E1 bit
Nack_Ext_List	RLC_Status_NACK_Ext_List_Type	opt	presence depends on Extn1 bit of Ack field (RLC_Status_ACK_Type)
Padding	RLC_Status_Padding_Type	opt	1..7 bit padding if needed for octet alignment

RLC_PDU: Basic Type Definitions

TTCN-3 Basic Types		
RLC_SDU_Type	octetstring	

RLC_PDU_Type

TTCN-3 Union Type		
Name	RLC_PDU_Type	
Comment		
TMD	RLC_TMD_PDU_Type	
UMD	RLC_UMD_PDU_Type	
AMD	RLC_AMD_PDU_Type	
AMD_Ext	RLC_AMD_PDU_Ext_Type	
AMD_SegExt	RLC_AMD_PDU_SegExt_Type	
Status	RLC_AM_StatusPDU_Type	
Status_Ext	RLC_AM_StatusPDU_Ext_Type	

RLC_PDUList_Type

TTCN-3 Record of Type	
Name	RLC_PDUList_Type
Comment	
record of RLC_PDU_Type	

RLC_SDUList_Type

TTCN-3 Record of Type	
Name	RLC_SDUList_Type
Comment	
record of RLC_SDU_Type	

F.4.1.3 PDCP

PDCP user plane SDU and PDU definitions

NOTE:

To allow direct encoding the definition for PDCP Data PDU is split into data PDU with long/short sequence number

PDCP: Basic Type Definitions

TTCN-3 Basic Types		
PDCP_SDU_Type	octetstring	

PDCP_SDUList_Type

TTCN-3 Record of Type	
Name	PDCP_SDUList_Type
Comment	record of PDCP_SDU_Type

PDCP_DataPdu_LongSN_Type

TTCN-3 Record Type		
Name	PDCP_DataPdu_LongSN_Type	
Comment	User plane PDCP Data PDU with long sequence number (TS 36.323, clause 6.2.3)	
D_C	B1_Type	0 - Control PDU 1 - Data PDU
Reserved	B3_Type	3 reserved bits
SequenceNumber	B12_Type	12 bit sequence number
SDU	PDCP_SDU_Type	content (octetstring)

PDCP_DataPdu_ShortSN_Type

TTCN-3 Record Type		
Name	PDCP_DataPdu_ShortSN_Type	
Comment	User plane PDCP Data PDU with short sequence number (TS 36.323, clause 6.2.4)	
D_C	B1_Type	0 - Control PDU 1 - Data PDU
SequenceNumber	B7_Type	7 bit sequence number
SDU	PDCP_SDU_Type	content (octetstring)

PDCP_DataPdu_ExtSN_Type

TTCN-3 Record Type		
Name	PDCP_DataPdu_ExtSN_Type	
Comment	User plane PDCP Data PDU with extended sequence number (TS 36.323, clause 6.2.9)	
D_C	B1_Type	0 - Control PDU 1 - Data PDU
SequenceNumber	B15_Type	15 bit sequence number
SDU	PDCP_SDU_Type	content (octetstring)

PDCP_DataPdu_18bitSN_Type

TTCN-3 Record Type		
Name	PDCP_DataPdu_18bitSN_Type	
Comment	User plane PDCP Data PDU with 18 bit sequence number (TS 36.323, clause 6.2.11)	
D_C	B1_Type	0 - Control PDU 1 - Data PDU
PollingBit	B1_Type	1 - when eNB triggers a PDCP status report or LWA status report
Reserved	B4_Type	4 reserved bits
SequenceNumber	B18_Type	18 bit sequence number
SDU	PDCP_SDU_Type	content (octetstring)

PDCP_DataPdu_SLRB_Type

TTCN-3 Record Type			
Name	PDCP_DataPdu_SLRB_Type		
Comment	User plane PDCP Data PDU for SLRB (TS 36.323, clause 6.2.10.1)		
SDU_Type	B3_Type		000 - IP 001 - ARP 010 - PC5 Signaling 011 - 111 reserved
PGK_Index	B5_Type		5 LSBs of PGK Identity (TS 33.303, clause 6.2.3)
PTK_Identity	B16_Type		PTK Identity (TS 33.303, clause 6.2.3)
SequenceNumber	B16_Type		16 bit sequence number
SDU	PDCP_SDU_Type		content (octetstring)

PDCP_DataPdu_SLRB_1to1_Type

TTCN-3 Record Type			
Name	PDCP_DataPdu_SLRB_1to1_Type		
Comment	User plane PDCP Data PDU for SLRB (TS 36.323, clause 6.2.10.2)		
SDU_Type	B3_Type		000 - IP 001 - ARP 010 - PC5 Signaling 011 - 111 reserved
Reserved	B5_Type		5 reserved bits
KD_sess_ID	B16_Type		KD_sess Identity (TS 33.303, clause 6.5.3.1)
SequenceNumber	B16_Type		16 bit sequence number
SDU	PDCP_SDU_Type		content (octetstring)
MAC_I	O4_Type		MAC-I

PDCP_Ctrl_ROHC_FB_PDU_Type

TTCN-3 Record Type			
Name	PDCP_Ctrl_ROHC_FB_PDU_Type		
Comment	PDCP Control PDU for interspersed ROHC feedback packet (TS 36.323, clause 6.2.5)		
D_C	B1_Type		0 - Control PDU 1 - Data PDU
PDU_Type	B3_Type		000 - PDCP status report 001 - Header Compression Feedback Information 010 - LWA status report 011..111 - reserved
Reserved	B4_Type		
ROHC_FB	octetstring		Contains one ROHC packet with only feedback, i.e. a ROHC packet that is not associated with a PDCP

PDCP_Ctrl_StatusReport_Type

TTCN-3 Record Type			
Name	PDCP_Ctrl_StatusReport_Type		
Comment	PDCP Control PDU for PDCP status report (TS 36.323, clause 6.2.6)		
D_C	B1_Type		0 - Control PDU 1 - Data PDU
PDU_Type	B3_Type		000 - PDCP status report 001 - Header Compression Feedback Information 010 - LWA status report 011..111 - reserved
FMS	B12_Type		PDCP SN of the first missing PDCP SDU.
Bitmap	octetstring	opt	The MSB of the first octet of the type "Bitmap" indicates whether or not the PDCP SDU with the SN (FMS + 1) modulo 4096 has been received and, optionally decompressed correctly. 0 - PDCP SDU with PDCP SN = (FMS + bit position) modulo 4096 is missing in the receiver. The bit position of Nth bit in the Bitmap is N, i.e. the bit position of the first bit in the Bitmap is 1. 1 - PDCP SDU with PDCP SN = (FMS + bit position) modulo 4096 does not need to be retransmitted. The bit position of Nth bit in the Bitmap is N, i.e. the bit position of the first bit in the Bitmap is 1.

PDCP_Ctrl_StatusReportExt_Type

TTCN-3 Record Type			
Name	PDCP_Ctrl_StatusReportExt_Type		
Comment	PDCP Control PDU for PDCP status report using a 15 bit SN (TS 36.323, clause 6.2.6)		
D_C	B1_Type		0 - Control PDU 1 - Data PDU
PDU_Type	B3_Type		000 - PDCP status report 001 - Header Compression Feedback Information 010 - LWA status report 011..111 - reserved
Reserved	B5_Type		5 reserved bits
FMS_Ext	B15_Type		PDCP SN of the first missing PDCP SDU.
Bitmap	octetstring	opt	The MSB of the first octet of the type "Bitmap" indicates whether or not the PDCP SDU with the SN (FMS + 1) modulo (Maximum_PDCP_SN + 1) has been received and, optionally decompressed correctly. 0 - PDCP SDU with PDCP SN = (FMS + bit position) modulo (Maximum_PDCP_SN + 1) is missing in the receiver. The bit position of Nth bit in the Bitmap is N, i.e. the bit position of the first bit in the Bitmap is 1. 1 - PDCP SDU with PDCP SN = (FMS + bit position) modulo (Maximum_PDCP_SN + 1) does not need to be retransmitted. The bit position of Nth bit in the Bitmap is N, i.e. the bit position of the first bit in the Bitmap is 1.

PDCP_Ctrl_StatusReport_18bitSN_Type

TTCN-3 Record Type			
Name	PDCP_Ctrl_StatusReport_18bitSN_Type		
Comment	PDCP Control PDU for PDCP status report using a 18 bit SN (TS 36.323, clause 6.2.6)		
D_C	B1_Type		0 - Control PDU 1 - Data PDU
PDU_Type	B3_Type		000 - PDCP status report 001 - Header Compression Feedback Information 010 - LWA status report 011..111 - reserved
Reserved	B2_Type		2 reserved bits
FMS_18bitSN	B18_Type		PDCP SN of the first missing PDCP SDU.
Bitmap	octetstring	opt	The MSB of the first octet of the type "Bitmap" indicates whether or not the PDCP SDU with the SN (FMS + 1) modulo (Maximum_PDCP_SN + 1) has been received and, optionally decompressed correctly. 0 - PDCP SDU with PDCP SN = (FMS + bit position) modulo (Maximum_PDCP_SN + 1) is missing in the receiver. The bit position of Nth bit in the Bitmap is N, i.e. the bit position of the first bit in the Bitmap is 1. 1 - PDCP SDU with PDCP SN = (FMS + bit position) modulo (Maximum_PDCP_SN + 1) does not need to be retransmitted. The bit position of Nth bit in the Bitmap is N, i.e. the bit position of the first bit in the Bitmap is 1.

PDCP_Ctrl_LWA_StatusReport_Type

TTCN-3 Record Type			
Name	PDCP_Ctrl_LWA_StatusReport_Type		
Comment	PDCP Control PDU for LWA status report (TS 36.323, clause 6.2.12)		
D_C	B1_Type		0 - Control PDU 1 - Data PDU
PDU_Type	B3_Type		000 - PDCP status report 001 - Header Compression Feedback Information 010 - LWA status report 011..111 - reserved
FMS	B12_Type		PDCP SN of the first missing PDCP SDU.
HRW	B12_Type		PDCP SN of the PDCP SDU received on WLAN with highest associated PDCP COUNT value.
NMP	B12_Type		Number of Missing PDCP PDUs with PDCP SNs below HRW starting from and including FMS.

PDCP_Ctrl_LWA_StatusReportExt_Type

TTCN-3 Record Type		
Name	PDCP_Ctrl_LWA_StatusReportExt_Type	
Comment	PDCP Control PDU for LWA status report (TS 36.323, clause 6.2.12)	
D_C	B1_Type	0 - Control PDU 1 - Data PDU
PDU_Type	B3_Type	000 - PDCP status report 001 - Header Compression Feedback Information 010 - LWA status report 011..111 - reserved
Reserved	B5_Type	5 reserved bits
FMS_Ext	B15_Type	PDCP SN of the first missing PDCP SDU.
Reserved2	B1_Type	1 reserved bit
HRW_Ext	B15_Type	PDCP SN of the PDCP SDU received on WLAN with highest associated PDCP COUNT value.
Reserved3	B1_Type	1 reserved bit
NMP_Ext	B15_Type	Number of Missing PDCP PDUs with PDCP SNs below HRW starting from and including FMS.

PDCP_Ctrl_LWA_StatusReport_18bitSN_Type

TTCN-3 Record Type		
Name	PDCP_Ctrl_LWA_StatusReport_18bitSN_Type	
Comment	PDCP Control PDU for LWA status report (TS 36.323, clause 6.2.12)	
D_C	B1_Type	0 - Control PDU 1 - Data PDU
PDU_Type	B3_Type	000 - PDCP status report 001 - Header Compression Feedback Information 010 - LWA status report 011..111 - reserved
Reserved	B2_Type	2 reserved bits
FMS_18bitSN	B18_Type	PDCP SN of the first missing PDCP SDU.
HRW_18bitSN	B18_Type	PDCP SN of the PDCP SDU received on WLAN with highest associated PDCP COUNT value.
Reserved2	B4_Type	4 reserved bits
NMP_18bitSN	B18_Type	Number of Missing PDCP PDUs with PDCP SNs below HRW starting from and including FMS.

PDCP_PDU_Type

TTCN-3 Union Type		
Name	PDCP_PDU_Type	
Comment		
DataLongSN	PDCP_DataPdu_LongSN_Type	user plane PDCP data PDU with 12 Bit Seq Number
DataShortSN	PDCP_DataPdu_ShortSN_Type	user plane PDCP data PDU with 7 Bit Seq Number
DataExtSN	PDCP_DataPdu_ExtSN_Type	user plane PDCP data PDU with 15 Bit Seq Number
Data_18bitSN	PDCP_DataPdu_18bitSN_Type	user plane PDCP data PDU with 18 Bit Seq Number
RohcFeedback	PDCP_Ctrl_ROHC_FB_PDU_Type	PDCP Control PDU for interspersed ROHC feedback packet
StatusReport	PDCP_Ctrl_StatusReport_Type	PDCP Control PDU for PDCP status report
StatusReportExt	PDCP_Ctrl_StatusReportExt_Type	PDCP Control PDU for PDCP status report using a 15 bit SN
StatusReport_18bitSN	PDCP_Ctrl_StatusReport_18bitSN_Type	PDCP Control PDU for PDCP status report using a 18 bit SN
LWA_StatusReport	PDCP_Ctrl_LWA_StatusReport_Type	PDCP Control PDU for LWA status report
LWA_StatusReportExt	PDCP_Ctrl_LWA_StatusReportExt_Type	PDCP Control PDU for LWA status report using a 15 bit SN
LWA_StatusReport_18bitSN	PDCP_Ctrl_LWA_StatusReport_18bitSN_Type	PDCP Control PDU for LWA status report using a 18 bit SN
DataSLRB	PDCP_DataPdu_SLRB_Type	user plane PDCP Data PDU for SLRB
DataSLRB_1to1	PDCP_DataPdu_SLRB_1to1_Type	user plane PDCP Data PDU for SLRB one to one communication

PDCP_PDUList_Type

TTCN-3 Record of Type	
Name	PDCP_PDUList_Type
Comment	
record of PDCP_PDU_Type	

F.4.2 DRB_Primitive_Definitions

Primitive definitions to send/receive data PDUs over DRB's

F.4.2.1 DRB_Common**L2DataList_Type**

TTCN-3 Union Type		
Name	L2DataList_Type	
Comment	<p>MAC: acc. to rel-8 protocols there is not more than one MAC PDU per TTI; any MAC PDU is completely included in one subframe</p> <p>RLC: one or more RLC PDUs per TTI (e.g. RLC Data + Status PDU on a logical channel; more than one RLC Data PDU in one MAC PDU is valid too) any RLC PDU is completely included in one subframe</p> <p>PDCP: one or more PDUs per TTI; one PDCP PDU may be included in more than one subframe</p>	
MacPdu	MAC_PDUList_Type	SS configuration: RLC TM mode, MAC no header removal (PDCP is not configured)
RlcPdu	RLC_PDUList_Type	SS configuration: RLC TM mode, MAC header removal (PDCP is not configured)
PdcpPdu	PDCP_PDUList_Type	SS configuration: RLC AM/UM mode, PDCP no header removal
PdcpSdu	PDCP_SDUList_Type	SS configuration: RLC AM/UM mode, PDCP header removal
RlcSdu	RLC_SDUList_Type	SS configuration: RLC UM mode with no PDCP, for example MRB

HarqProcessAssignment_Type

TTCN-3 Union Type		
Name	HarqProcessAssignment_Type	
Comment	in DL the HARQ process id may be specified by the test case or automatically assigned by SS	
Id	HarqProcessId_Type	HARQ process as specified by the test case NOTE1: the scope of this type is only for data being sent in one TTI; if data needs more than one TTI the HarqProcessId is undefined for the 2nd TTI onward what shall be handled as an error at the SS; SS may send a SYSTEM_IND indicating an error in this case; NOTE2: The initial value of the NDI shall be the same for all HARQ processes and cells
Automatic	Null_Type	HARQ process id automatically assigned by SS

F.4.2.2 Downlink

DRB_DataPerSubframe_DL_Type

TTCN-3 Record Type		
Name	DRB_DataPerSubframe_DL_Type	
Comment	common definition for one or several PDUs/SDUs; in EUTRA the DL data is sent in the subframe given by the subframe offset; in NB-IoT the DL transmission is scheduled in the search space candidate given by "SubframeOffset" for NB-IoT it specifies the NOTE 1: For MAC and RLC PDUs a single PDU is always sent in one subframe; SS shall raise an error indication (using SYSTEM_IND) when that is not possible NOTE 2: For PDCP the data may be spread over more than one subframe (segmented by the RLC); the TTCN implementation is responsible to calculate appropriate offsets accordingly; the exact timing depends on (and is exactly specified by) configuration of the DL scheduling; SS shall raise an error when there is any conflict	
SubframeOffset	integer	EUTRA: Subframe offset relative to the absolute timing information given in the common part of the ASP; NB-IoT: Offset of the search space candidate relative to the (default) search space candidate as configured for the NPDCCH UE specific search space; the search space candidate is in the next search space starting at or after the point in time given by the timing information of the common part of the ASP NOTE 1: Notes: Acc. to TS 36.523-3, clause 7.3.3 in case of TDD or half-duplex configuration only subframes available for DL are taken into consideration NOTE 2: if a PDCP PDU or SDU takes more than one subframe, SubframeOffset specifies the first TTI
HarqProcess	HarqProcessAssignment_Type	opt HARQ process to be used: specific value (0..7) or automatically assigned by SS; in automatic mode SS chooses HARQ process out of the set configured by CcchDcchDtchConfigDL_Type.HarqProcessConfig NOTE 1: for PDCP SDUs or PDUs automatic mode shall be used; otherwise SS shall raise an error NOTE 2: for NB-IoT the HarqProcess shall be omitted by TTCN and ignored by the SS
PduSduList	L2DataList_Type	list of PDUs/SDUs to be sent in one TTI

DRB_DataPerSubframeList_DL_Type

TTCN-3 Record of Type	
Name	DRB_DataPerSubframeList_DL_Type
Comment	list of user plane data to be sent in sub-frames given by the SubframeOffset in the single elements of the list; Timing: the start time for the whole sequence is given by the timing info of the ASP (common information); the timing for the respective data pdus is given by the SubframeOffset relative to the common timing info; design consideration: repetitions of this sequence are not foreseen (in which case the subframe offset could not be related to the timing info of the ASP)
record of DRB_DataPerSubframe_DL_Type	

L2Data_Request_Type

TTCN-3 Record Type	
Name	L2Data_Request_Type
Comment	NOTE: formal type definition to allow later enhancements; L2Data_Request_Type defines a sequence of subframes in which data shall be sent
SubframeDataList	DRB_DataPerSubframeList_DL_Type

F.4.2.3 Uplink

DRB_DataPerSubframe_UL_Type

TTCN-3 Record Type	
Name	DRB_DataPerSubframe_UL_Type
Comment	common definition for one or several PDUs/SDUs being received in one subframe or to receive one PDCP PDU or SDU being spread over more than one TTI; NOTE: There is a fix relation between HARQ process id and subframe in UL => it is not necessary to include HARQ process id for UL data
PduSduList	L2DataList_Type list of PDUs/SDUs being received in one TTI; elements of the list appear in the same order as the PDUs/SDUs in the MAC PDU; for PDCP when a PDU or SDU takes more than one TTI the list only contains this PDU or SDU
NoOfTTIs	integer in case of PDCP: number of TTIs the SDU or PDU has taken NOTE 1: for the time being the NoOfTTIs is not checked by TTCN-3 and may be set to 1 by SS; NOTE 2: the timing info in common part of the ASP refers to the last TTI NOTE 3: when NoOfTTIs > 1 => PduSduList shall only contain one PDCP PDU or SDU in case of MAC or RLC PDUs: NoOfTTIs shall always be 1 (acc. to TS 36.321 MAC is not doing segmentation of RLC PDUs and acc. to TS 36.322, clause 6.2.2.2 the maximum RLC data is calculated to fit into a MAC PDU and RLC does segmentation accordingly)

L2Data_Indication_Type

TTCN-3 Record Type	
Name	L2Data_Indication_Type
Comment	NOTE: formal type definition to allow later enhancements; L2Data_Indication_Type defines data being received in a single subframe i.e. PDUs of subsequent TTIs are indicated in separated ASPs
SubframeData	DRB_DataPerSubframe_U_L_Type

F.5 NasEmu_AspTypes_NBIOT

System interface between NAS emulation and system adaptor

F.5.1 System_Interface

NBIOT_RRC_PDU_REQ

TTCN-3 Record Type	
Name	NBIOT_RRC_PDU_REQ
Comment	
Common	<p>NB_ReqAspCommonPart_Type</p> <p>CellId : identifier of the cell RoutingInfo : SRB0, SRB1, SRB1bis TimingInfo : Now in normal cases; For latency tests TimingInfo can be set to the SFN/subframe in which the RRC messages shall be sent out NOTE 1: if the RRC PDU is too long to be sent in one TTI the TimingInfo corresponds to the first TTI NOTE 2: the TimingInfo is not changed by the NAS Emu (i.e. the timing info as coming from the test case (SRB_COMMON_REQ) is handed through by the NAS Emu) ControllInfo CnfFlag:=false; FollowOnFlag true: Indicates that the message(s) to be sent on the same TTI will follow NOTE 1: If the TimingInfo is not the same for messages to be sent on the same TTI, the SS shall produce an error NOTE 2: the follow on flag applies only for messages of the same SRB false: Indicates that no more message(s) will follow</p>
RrcPdu	NB_RRC_MSG_Request_Type

NBIOT_RRC_PDU_IND

TTCN-3 Record Type		
Name	NBIOT_RRC_PDU_IND	
Comment	common ASP to receive PDUs from SRB0, SRB1, SRB1bis	
Common	NB_IndAspCommonPart_Type	<p>CellId : identifier of the cell RoutingInfo : SRB0, SRB1, SRB1bis TimingInfo : time when message has been received (frame and sub-frame number); this is handed through to the test case by the NAS emulation</p> <p>NOTE: normally an RRC PDU is expected in one TTI; nevertheless if it is spread over more than one TTIs TimingInfo shall refer to the end of the PDU i.e. to the last RLC PDU being received; Status : OK or RRC integrity error</p>
RrcPdu	NB_RRC_MSG_Indication_Type	

NASEMU_NBIOT_SYSTEM_PORT

TTCN-3 Port Type		
Name	NASEMU_NBIOT_SYSTEM_PORT	
Comment	NASEMU PTC: Port for Sending/Receiving data to/from the SYSTEM Interface	
out	NBIOT_RRC_PDU_REQ	
in	NBIOT_RRC_PDU_IND	

F.6 NBIOT_CommonDefs

F.6.1 NBIOT_Common_Types

NBIOT_CellId_Type

TTCN-3 Enumerated Type	
Name	NBIOT_CellId_Type
Comment	
nbiot_Cell_NonSpecific	
nbiot_Cell1	
nbiot_Cell2	
nbiot_Cell3	
nbiot_Cell4	
nbiot_Cell6	
nbiot_Cell10	
nbiot_Cell11	
nbiot_Cell12	
nbiot_Cell13	
nbiot_Cell14	
nbiot_Cell23	
nbiot_Cell50	
nbiot_Cell51	
nbiot_Cell52	
nbiot_Cell53	
nbiot_Cell54	
nbiot_Cell55	
nbiot_Cell56	
nbiot_Cell57	
nbiot_Cell58	
nbiot_Cell59	
nbiot_Cell60	
nbiot_Cell61	
nbiot_Cell62	
nbiot_Cell63	

NB_CarrierFreq_Type

TTCN-3 Record Type	
Name	NB_CarrierFreq_Type
Comment	
DL	CarrierFreq_NB_r13
UL	CarrierFreq_NB_r13

NB_RRC_MSG_Request_Type

TTCN-3 Union Type	
Name	NB_RRC_MSG_Request_Type
Comment	DL RRC PDU on CCCH or DCCH
Ccch	DL_CCCH_Message_NB
Dcch	DL_DCCH_Message_NB

NB_RRC_MSG_Indication_Type

TTCN-3 Union Type		
Name	NB_RRC_MSG_Indication_Type	
Comment	UL RRC PDU on CCCH or DCCH	
Ccch	UL_CCCH_Message_NB	
Dcch	UL_DCCH_Message_NB	

F.6.2 NBIOT_RRC_Nested_Types

NBIOT_RRC_Nested_Types: Basic Type Definitions

TTCN-3 Basic Types		
NB_OperationModelInfo_Type	MasterInformationBlock_NB.operationModelInfo_r13	
NB_SchedulingInfoSIB1_Type	MasterInformationBlock_NB.schedulingInfoSIB1_r13	
NB_SiWindowLength_Type	SystemInformationBlockType1_NB.siWindowLength_r13	
NB_EutraControlRegionSize_Type	SystemInformationBlockType1_NB.eutraControlRegionSize_r13	
NB_SiPeriodicity_Type	SchedulingInfoList_NB_r13[0].si_Periodicity_r13	
NB_SiRepetitionPattern_Type	SchedulingInfoList_NB_r13[0].si_RepetitionPattern_r13	
NB_SiTransportBlockSize_Type	SchedulingInfoList_NB_r13[0].si_TB_r13	
NPDCCH_NumRepetitions_UESS_Type	NPDCCH_ConfigDedicated_NB_r13.npdccch_NumRepetitions_r13	
NPDCCH_StartSF_UESS_Type	NPDCCH_ConfigDedicated_NB_r13.npdccch_StartSF_USS_r13	
NPDCCH_Offset_UESS_Type	NPDCCH_ConfigDedicated_NB_r13.npdccch_Offset_USS_r13	
NPDCCH_NumRepetitions_Type1CSS_Type	PCCH_Config_NB_r13.npdccch_NumRepetitionPaging_r13	
NPDCCH_NumRepetitions_Type2CSS_Type	NPRACH_Parameters_NB_r13.npdccch_NumRepetitions_RA_r13	
NPDCCH_StartSF_Type2CSS_Type	NPRACH_Parameters_NB_r13.npdccch_StartSF_CSS_RA_r13	
NPDCCH_Offset_Type2CSS_Type	NPRACH_Parameters_NB_r13.npdccch_Offset_RA_r13	

F.6.3 NBIOT_ASP_CommonPart

Definition of ASP common parts for REQ-, CNF- and IND-ASPs

F.6.3.1 NBIOT_ASP_CommonPart_Definitions

F.6.3.1.1 NBIOT_Routing_Info

NBIOT_CommonDefs: Constant Definitions

TTCN-3 Basic Types			
tsc_NB_MaxRB	integer	2 + 2	2 DRBs + 2 SRBs
tsc_SRB1bis	integer	3	

NBIOT_Routing_Info: Basic Type Definitions

TTCN-3 Basic Types	
NB_SRB_Identity_Type	integer (tsc_SRB0 , tsc_SRB1 , tsc_SRB1bis)

NB_RadioBearerId_Type

TTCN-3 Union Type	
Name	NB_RadioBearerId_Type
Comment	
Srb	NB_SRB_Identity_Type
Drb	EUTRA ASN1 DRB Identity Type

NB_RoutingInfo_Type

TTCN-3 Union Type	
Name	NB_RoutingInfo_Type
Comment	
None	Null_Type
L2Test	Null_Type
RadioBearerId	NB_RadioBearerId_Type
	to be used to let the NAS emulator route back encoded an RRC message back to the test case instead of forwarding it to the SS

F.6.3.2 REQ_ASP_CommonPart

NB_ReqAspCommonPart_Type

TTCN-3 Record Type	
Name	NB_ReqAspCommonPart_Type
Comment	
CellId	NBIOT_CellId_Type
RoutingInfo	NB_RoutingInfo_Type
TimingInfo	TimingInfo_Type
ControllInfo	ReqAspControllInfo_Type

F.6.3.3 NBIOT_CNF_ASP_CommonPart

NB_CnfAspCommonPart_Type

TTCN-3 Record Type	
Name	NB_CnfAspCommonPart_Type
Comment	
CellId	NBIOT_CellId_Type
RoutingInfo	NB_RoutingInfo_Type
TimingInfo	TimingInfo_Type
Result	ConfirmationResult_Type

F.6.3.4 NBIOT_IND_ASP_CommonPart

NB_IndAspCommonPart_Type

TTCN-3 Record Type			
Name	NB_IndAspCommonPart_Type		
Comment			
CellId	NBIOT_CellId_Type		
RoutingInfo	NB_RoutingInfo_Type		
TimingInfo	TimingInfo_Type		
Status	IndicationStatus_Type		

F.7 NBIOT_Imported_EUTRA_ASN1_Types

NBIOT_Imported_EUTRA_ASN1_Types: Basic Type Definitions

TTCN-3 Basic Types		
EUTRA_ASN1_DRB_Identity_Type	DRB_Identity	
EUTRA_ASN1_PhysCellId_Type	PhysCellId	
EUTRA_ASN1_C_RNTI_Type	C_RNTI	
EUTRA_ASN1_CipheringAlgorithm_r12_Type	CipheringAlgorithm_r12	

F.8 NBIOT_ASP_VirtualNoiseDefs

ASP definitions for virtual noise generation in NBIOT cells.

The noise is configured for an already existing NBIOT cell.

For UEs with 2 antenna connectors the AWGN (Additive white Gaussian noise) signals applied to each receiver antenna connector shall be uncorrelated.

NBIOT_ASP_VirtualNoiseDefs: Basic Type Definitions

TTCN-3 Basic Types		
NBIOT_VngConfigConfirm_Type	Null_Type	

NBIOT_VngConfigInfo_Type

TTCN-3 Record Type			
Name	NBIOT_VngConfigInfo_Type		
Comment			
NocLevel	integer		Noc level; calculation is according to 36.523-3 cl 7.22

NBIOT_VngConfigRequest_Type

TTCN-3 Union Type		
Name	NBIOT_VngConfigRequest_Type	
Comment	configure/activate noise for a given cell; NOTE: it is assumed the the associated NBIOT cell has been created beforehand	
Configure	NBIOT_VngConfigInfo_Type	configuration of the virtual noise generator; regardless of the power level the noise generator is off before it gets activated for this cell; in case the configuration needs to be changed during a test, the noise generator shall be deactivated for this cell
Activate	Null_Type	noise is activated (switched on) for the given cell acc. to the previous configuration; while being active the configuration shall not be modified
Deactivate	Null_Type	deactivate noise for given cell

NBIOT_VNG_CTRL_REQ

TTCN-3 Record Type		
Name	NBIOT_VNG_CTRL_REQ	
Comment		
Common	NB_ReqAspCommonPart_Type	CellId : as for the associated NBIOT cell RoutingInfo : None TimingInfo : Now ControlInfo : CnfFlag:=true; FollowOnFlag:=false
Request	NBIOT_VngConfigRequest_Type	

NBIOT_VNG_CTRL_CNF

TTCN-3 Record Type		
Name	NBIOT_VNG_CTRL_CNF	
Comment		
Common	NB_CnfAspCommonPart_Type	TimingInfo is ignored by TTCN (apart from EnquireTiming) => SS may set TimingInfo to "None"
Confirm	NBIOT_VngConfigConfirm_Type	

NBIOT_VNG_PORT

TTCN-3 Port Type		
Name	NBIOT_VNG_PORT	
Comment	NBIOT PTC: Port for virtual noise generator	
out	NBIOT_VNG_CTRL_REQ	
in	NBIOT_VNG_CTRL_CNF	

F.9 CommonDefs

CommonDefs: Basic Type Definitions

TTCN-3 Basic Types		
B1_Type	bitstring length(1)	
B2_Type	bitstring length(2)	
B3_Type	bitstring length(3)	
B4_Type	bitstring length(4)	
B5_Type	bitstring length(5)	
B6_Type	bitstring length(6)	
B7_Type	bitstring length(7)	
B7_15_Type	bitstring length(7..15)	NOTE: length restriction can only be a range but not two distinct lengths
B8_Type	bitstring length(8)	
B10_Type	bitstring length(10)	
B11_Type	bitstring length(11)	
B12_Type	bitstring length(12)	
B15_Type	bitstring length(15)	
B16_Type	bitstring length(16)	
B18_Type	bitstring length(18)	
B32_Type	bitstring length(32)	
B128_Type	bitstring length(128)	
B128_Key_Type	B128_Type	128 bit security key
O4_Type	octetstring length(4)	
Null_Type	boolean (true)	dummy type for 'typeless' fields in unions
PdcpCountValue_Type	B32_Type	

IndicationAndControlMode_Type

TTCN-3 Enumerated Type	
Name	IndicationAndControlMode_Type
Comment	
enable	
disable	

F.10 EUTRA_NB_ASP_TypeDefs

Type definitions for configuration of the system simulator;

Common design principles:

Semantics of OMIT: for all TTCN-3 type definitions used in ASPs omit means "keep as it is" =>

- on initial configuration in general all fields shall be provided
- no default values for fields are foreseen
- if necessary non-existence of information shall be explicitly configured (e.g. with a union of "no configuration" and "configuration parameters")
- fields within structures imported from the core spec are excepted from this rule

F.10.1 Cell_Configuration

Specific Info for Cell Configuration Primitive

F.10.1.1 Cell_Configuration_Common

EUTRA_NB_ASP_TypeDefs: Constant Definitions

TTCN-3 Basic Types			
tsc_CellAttenuation_Off	Attenuation_Type	{Off:=true}	

Cell_Configuration_Common: Basic Type Definitions

TTCN-3 Basic Types		
InitialAttenuation_Type	Attenuation_Type (tsc_CellAttenuation_Off)	Attenuation restricted to 'Off'

CellTimingInfo_Type

TTCN-3 Record Type			
Name	CellTimingInfo_Type		
Comment	Cell Timing		
Tcell	integer (0..307199)		frame duration $T_f = 307200 * T_s = 10\text{ms}$; System Time Unit $T_s = 1/(15000 * 2048)$
SfnOffset	integer (0..1023)		
HsfnOffset	integer (0..1023)		

Attenuation_Type

TTCN-3 Union Type		
Name	Attenuation_Type	
Comment	attenuation of the reference power	
Value	integer (0..149)	cell power reference power reduced by the given attenuation (value is in dB)
Off	Null_Type	even though in TS 36.508 -145dBm for LTE and -150dBm for NB-IoT is given for a non suitable cell we specify an explicit "Off" value here

InitialCellPower_Type

TTCN-3 Record Type			
Name	InitialCellPower_Type		
Comment			
MaxReferencePower	AbsoluteCellPower_Type		maximum value of cell reference power (RS EPRE in dBm/15kHz as per TS 36.508, clause 4.3.4.1); a cell is initialised with this reference power; its value is the upper bound of the cell power during the test case
Attenuation	InitialAttenuation_Type		initial attenuation

F.10.1.2 Uplink_Physical_Layer_Configuration

SS_TimingAdvanceConfig_Type

TTCN-3 Union Type		
Name	SS_TimingAdvanceConfig_Type	
Comment		
InitialValue	RACH_TimingAdvance_Type	initial value corresponding to what is sent to the UE in RACH response (range acc. 11 bit value; 0 in normal cases)
Relative	TimingAdvanceIndex_Type	timing advance command to adjust changes of timing advance acc. to TS 36.213, clause 4.2.3; (range acc. 6 bit value: -31..32)

F.10.1.3 Common_MAC_Configuration

Transport channel and MAC related procedures and configuration

Common_MAC_Configuration: Basic Type Definitions

TTCN-3 Basic Types		
TimingAdvanceIndex_Type	integer (0..63)	acc. to TS 36.321, clause 6.1.3.5 "Timing Advance Command MAC Control Element" and TS 36.213, clause 4.2.3 "Transmission timing adjustments"
TimingAdvance_Period_Type	integer (400, 600, 1020, 1530, 2040, 4090, 8190)	the values correspond to 80 % of TimeAlignmentTimer (acc. to TS 36.523-3, clause 7.2) (TS 36.331, clause 6.3.2: sf500, sf750, sf1280, sf1920, sf2560, sf5120, sf10240) rounded to nearest multiple of 10

UplinkTimeAlignment_AutoSynch_Type

TTCN-3 Record Type		
Name	UplinkTimeAlignment_AutoSynch_Type	
Comment		
TimingAdvance	TimingAdvanceIndex_Type	
TA_Period	TimingAdvance_Period_Type	time period after which TA MAC control elements need to be automatically transmitted
TA_Repetition	TransmissionRepetition_Type	number of TA MAC control element repetitions to be automatically transmitted or 'Continuous'

UplinkTimeAlignment_Synch_Type

TTCN-3 Union Type		
Name	UplinkTimeAlignment_Synch_Type	
Comment		
None	Null_Type	no PUCCH Synchronisation applied
Auto	UplinkTimeAlignment_AutoSynch_Type	SS automatically maintains PUCCH synchronization at UE If the cell is a - Rel 10 or earlier cell - or Rel 11 or later Pcell - or the Rel-11 or later scell with no STAG-ID configured, the TAG-ID is set to '00' i.e. P-TAG in Timing advance MCE If the cell is Rel 11 scell with STAG-ID configured, the configured stag-ID is used as TAG-ID in Timing advance MCE

TransmissionRepetition_Type

TTCN-3 Union Type	
Name	TransmissionRepetition_Type
Comment	
Continuous	Null_Type
NumOfCycles	integer (1..infinity)

F.10.1.4 Random_Access_Procedure

Random_Access_Procedure: Basic Type Definitions

TTCN-3 Basic Types		
RACH_TimingAdvance_Type	integer (0..2047)	11 bit timing advance as used in RACH response (absolute value)

ContentionResolution_ContainedRlcPdu_Type

TTCN-3 Union Type		
Name	ContentionResolution_ContainedRlcPdu_Type	
Comment		
RlcPdu	octetstring	octetstring of an RLC PDU containing e.g. the RRC Connection Setup; to be sent in the same MAC PDU as the MAC Contention Resolution Control Element
None	Null_Type	MAC PDU containing the MAC Contention Resolution Control Element does not contain an RLC PDU (i.e. RRC Connection Setup is sent in another PDU)

ContentionResolution_ContainedId_Type

TTCN-3 Union Type		
Name	ContentionResolution_ContainedId_Type	
Comment		
XorMask	ContentionResolutionId_Type	When SS receives Contention Resolution ID from the UE, SS shall XOR it with the given mask and use this as Contention Resolution ID; this allows to get an unmatching Contention Resolution ID; in normal cases mask shall be set to tsc_ContentionResolutionId_Unchanged (i.e. the Contention Resolution ID remains unchanged)
None	Null_Type	MAC Contention Resolution Control Element is not contained in the MAC PDU sent out as response on Msg3

TCRNTI_ContentionResolutionMacPdu_Type

TTCN-3 Record Type		
Name	TCRNTI_ContentionResolutionMacPdu_Type	
Comment	NOTE: Either ContainedId or ContainedRlcPdu (or both) shall not be 'none'; (if no Contention Resolution Mac Pdu shall be sent, TCRNTI_ContentionResolutionCtrl_Type.NoContResolID shall be used instead)	
ContainedId	ContentionResolution_ContainedId_Type	Either the Contention Resolution ID as received from the UE or a modified Contention Resolution ID (XorMask != tsc_ContentionResolutionId_Unchanged) or no Contention Resolution ID at all
ContainedRlcPdu	ContentionResolution_ContainedRlcPdu_Type	the MAC PDU containing the MAC Contention Resolution Control Element may contain the RRC Connection Setup; in this case the RRC PDU shall be completely encoded been contained in an RLC PDU

TCRNTI_ContentionResolutionCtrl_Type

TTCN-3 Union Type		
Name	TCRNTI_ContentionResolutionCtrl_Type	
Comment	when the UE responds on a Random Access Response with a RRC Connection Request on CCCH and not with a C-RNTI SS shall assume initial Random Access Procedure (TS 36.300, clause 10.1.5.1), i.e. sends a ContentionResolutionId back to the UE	
MacPdu	TCRNTI_ContentionResolutionMacPdu_Type	MAC PDU containing the Contention Resolution ID and optionally an RRC PDU (RRC Connection Setup)
MacPdu_CRC_Error	TCRNTI_ContentionResolutionMacPdu_Type	same as MacPdu (see above), but SS shall generate CRC error by toggling CRC bits; no retransmissions shall be made as UE shall not send a NACK
NoContResolID	Null_Type	SS shall not include contention resolution ID (i.e. no MAC PDU shall be sent); used for contention resolution fail case

RapIdCtrl_Type

TTCN-3 Union Type		
Name	RapIdCtrl_Type	
Comment		
Automatic	Null_Type	SS shall automatically use same RAPID as received from the UE
Unmatched	Null_Type	SS shall use RAPID being different from preamble sent by the UE; SS shall calculate this RAPID acc. to $RAPID := (RAPID + 3..63) \bmod 64$ if single RAR is transmitted in a MAC PDU then only 3 is added if multiple RAR's are transmitted in MAC PDU, then for first unmatched RAR 3 is added, second unmatched 4 is added, third unmatched 5 is added and so on

TempC_RNTI_Type

TTCN-3 Union Type		
Name	TempC_RNTI_Type	
Comment		
SameAsC_RNTI	Null_Type	in the RA response SS shall use the same C-RNTI as configured in ActiveCellConfig_Type; this is useful for initial random access
Explicit	C_RNTI	in the RA response SS shall use different value as configured in ActiveCellConfig_Type; this can be used when the UE already is in RRC_CONNECTED to have a temporary C-RNTI different from the one used by the UE; NOTE: when the UE is not in RRC_CONNECTED there shall be no explicit temp. C-RNTI since then the UE would assume this value as C-RNTI

RandomAccessBackoffIndicator_Type

TTCN-3 Union Type		
Name	RandomAccessBackoffIndicator_Type	
Comment		
None	Null_Type	normal case, no back off indicator included
Index	integer (0..15)	Backoff Parameter values acc. TS 36.321, clause 7.2; values 0..12 are defined, 13..15 may be used in error case

F.10.2 System_Indications

HARQ_Type

TTCN-3 Enumerated Type	
Name	HARQ_Type
Comment	ack represents HARQ ACK; nack represents HARQ NACK
ack	
nack	

F.11 EUTRA_NB_CommonDefs

F.11.1 Common_Types

Common_Types: Basic Type Definitions

TTCN-3 Basic Types		
LogicalChannelId_Type	integer (0..10)	acc. TS 36.331, clause 6.3.2 and clause 6.7.3.2 for DRBs DTCH-LogicalChannelIdentity is INTEGER (3..10); additionally we have 0..2 for the SRBs
HarqProcessId_Type	integer (0..14)	The values 0..7 represent the ID of HARQ process ID; value range 0..14 is for TDD
ContentionResolutionId_Type	bitstring length(48)	used in EUTRA_ASP_DrbDefs and EUTRA_ASP_Typedefs
AbsoluteCellPower_Type	integer (-150..0)	absolute cell power (dBm)

F.11.2 RRC_Nested_Types

RRC_Nested_Types: Basic Type Definitions

TTCN-3 Basic Types		
IntegrityProtAlgorithm_Type	SecurityAlgorithmConfig.integrityProtAlgorithm	

F.11.3 ASP_CommonPart

Definition of ASP common parts for REQ-, CNF- and IND-ASPs

F.11.3.1 ASP_CommonPart_Definitions

F.11.3.1.1 Routing_Info

EUTRA_NB_CommonDefs: Constant Definitions

TTCN-3 Basic Types			
tsc_SRB0	integer	0	
tsc_SRB1	integer	1	

F.11.3.1.2 Timing_Info

Timing_Info: Basic Type Definitions

TTCN-3 Basic Types		
SystemFrameNumber_Type	integer (0..1023)	
SubFrameNumber_Type	integer (0..9)	
HyperSystemFrameNumberInfo_Type	SystemFrameNumberInfo_Type	

SubFrameInfo_Type

TTCN-3 Union Type		
Name	SubFrameInfo_Type	
Comment		
Number	SubFrameNumber_Type	
Any	Null_Type	no specific sub-frame (valid for REQ ASPs only)

SystemFrameNumberInfo_Type

TTCN-3 Union Type		
Name	SystemFrameNumberInfo_Type	
Comment		
Number	SystemFrameNumber_Type	
Any	Null_Type	no specific frame number (valid for REQ ASPs only)

SubFrameTiming_Type

TTCN-3 Record Type			
Name	SubFrameTiming_Type		
Comment			
SFN	SystemFrameNumberInfo_Type		
Subframe	SubFrameInfo_Type		
HSFN	HyperSystemFrameNumberInfo_Type		

TimingInfo_Type

TTCN-3 Union Type		
Name	TimingInfo_Type	
Comment		
SubFrame	SubFrameTiming_Type	
Now	Null_Type	to be used in REQ ASPs when there is no 'activation time'
None	Null_Type	only to be used in SYSTEM_CTRL_CNF but not for EnquireTiming

F.11.3.2 REQ_ASP_CommonPart

ReqAspControllInfo_Type

TTCN-3 Record Type		
Name	ReqAspControllInfo_Type	
Comment		
CnfFlag	boolean	<p>true => SS shall send CNF: when the REQ is with no timing information (no activation time), SS shall send the confirmation when the configuration is done, i.e. when the test case may continue. Example: when there is a configuration follow by a send event it shall not be necessary to have a wait timer in between but the CNF triggers the send event. If there are other triggers e.g. like the UE sending a message, CnfFlag shall be set to false by the test case to avoid racing conditions with the CNF and the signalling message. When there is an activation time SS shall send the CNF after the configuration has been scheduled; that means SS shall not wait until the activation time has been expired.</p>
FollowOnFlag	boolean	<p>false => no further (related) information true: further related information will be sent to SS (semantics depending on respective ASP)</p>

F.11.3.3 CNF_ASP_CommonPart

ConfirmationResult_Type

TTCN-3 Union Type		
Name	ConfirmationResult_Type	
Comment		
Success	Null_Type	
Error	integer	may contain SS specific error code; this will not be evaluated by TTCN

F.11.3.4 IND_ASP_CommonPart

IntegrityErrorIndication_Type

TTCN-3 Record Type		
Name	IntegrityErrorIndication_Type	
Comment		
Nas	boolean	NAS Integrity: set to true when received MAC does not match calculated MAC
Pdcp	boolean	PDCCP Integrity: set to true when received MAC does not match calculated MAC

ErrorIndication_Type

TTCN-3 Record Type			
Name	ErrorIndication_Type		
Comment			
Integrity	IntegrityErrorIndication_Type		Integrity error: received MAC does not match calculated MAC
System	integer		any other error: may be SS specific error code; this will not be evaluated by TTCN; e.g. an error shall be raised when the UE requests retransmission of an RLC PDU

IndicationStatus_Type

TTCN-3 Union Type			
Name	IndicationStatus_Type		
Comment			
Ok	Null_Type		
Error	ErrorIndication_Type		

F.11.4 L2Data_CommonDefs

Common definitions of L2 control elements used in L2 messages (EUTRA_NB_ASP_L2DataDefs) as well as for SS configuration (EUTRA_ASP_TypeDefs)

L2Data_CommonDefs: Basic Type Definitions

TTCN-3 Basic Types		
MAC_CTRL_ScellActDeact_Type	ScellBitMap_Type	36.321 clause 6.1.3.8

ScellBitMap_Type

TTCN-3 Record Type			
Name	ScellBitMap_Type		
Comment			
Value	B7_Type		7 MSB bits the C Fields C7 to C1. 1 => the corresponding Scell is Active 0 => Inactive
Reserved	B1_Type		LSBit Reserved. Shall be set to 0

PH_Record_Type

TTCN-3 Record Type			
Name	PH_Record_Type		
Comment	36.321 clause 6.1.3.6a		
P_Bit	B1_Type		P bit: 1 indicates the UE applies power backoff due to power management
V_Bit	B1_Type		V bit: Indicates if the PH value is based on a real transmission or a reference format. For Type 1 PH, V=0 indicates real transmission on PUSCH and V=1 indicates that a PUSCH reference format is used
Valve	B6_Type		The power headroom level. Ph Type 2 (if configured) for Pcell and Type 1 for Pcell and Scell
Reserved	B2_Type	opt	2 reservid bits. Present if V=1
PCMaxc	B6_Type	opt	Present if V=1

PH_RecordList_Type

TTCN-3 Record of Type	
Name	PH_RecordList_Type
Comment	<p>If simultaneousPUCCH-PUSCH is not configured at least oneType 1 PH record for Pcell is present. Additional one record per Scell for which respective 'C' bit is set as 1. If simultaneousPUCCH-PUSCH is configured then one PH Type 2 record for P cell followed by PH Type 1 record for P cell is present. Additional one record per Scell for which respective 'C' bit is set as 1</p>
record length(1..9) of PH_Record_Type	

MAC_CTRL_ExtPowerHeadRoom_Type

TTCN-3 Record Type	
Name	MAC_CTRL_ExtPowerHeadRoom_Type
Comment	
EPH_Octet1	ScellBitMap_Type
PH_RecordList	PH_RecordList_Type <p>At least one record for Pcell is present. Additional one record per Scell for which respective 'C' bit is set as 1</p>

DC_PH_RecordList_Type

TTCN-3 Record of Type	
Name	DC_PH_RecordList_Type
Comment	<p>If simultaneousPUCCH-PUSCH is not configured at least oneType 1 PH record for Pcell is present. Additional one record per PScell/Scell for which respective 'C' bit is set as 1. If simultaneousPUCCH-PUSCH is configured then one PH Type 2 record for Pcell followed one PH Type 2 record for PScell followed by PH Type 1 record for Pcell is present. Additional one record per PScell/Scell for which respective 'C' bit is set as 1</p>
record length(1..10) of PH_Record_Type	

MAC_CTRL_DC_PowerHeadRoom_Type

TTCN-3 Record Type	
Name	MAC_CTRL_DC_PowerHeadRoom_Type
Comment	
DC_PH_Octet1	ScellBitMap_Type
DC_PH_RecordList	DC_PH_RecordList_Type <p>At least one record for Pcell is present. Additional one record per PScell/Scell for which respective 'C' bit is set as 1</p>

F.12 References to TTCN-3

References to TTCN-3		
NBIOT_ASP_TypeDefs	NBIOT/NBIOT_ASP_TypeDefs.ttcn	Rev 18566
NBIOT_ASP_SrbDefs	NBIOT/NBIOT_ASP_SrbDefs.ttcn	Rev 17118
NBIOT_ASP_L2DataDefs	NBIOT/NBIOT_ASP_L2DataDefs.ttcn	Rev 17446
EUTRA_NB_ASP_L2DataDefs	Common_EUTRA_NB/EUTRA_NB_ASP_L2DataDefs.ttcn	Rev 17857
NasEmu_AspTypes_NBIOT	NasEmulation/NasEmu_AspTypes_NBIOT.ttcn	Rev 17143
NBIOT_CommonDefs	NBIOT/NBIOT_CommonDefs.ttcn	Rev 18309
NBIOT_Imported_EUTRA_ASN1_Types	NBIOT/NBIOT_Imported_EUTRA_ASN1_Types.ttcn	Rev 16620
NBIOT_ASP_VirtualNoiseDefs	NBIOT/NBIOT_ASP_VirtualNoiseDefs.ttcn	Rev 17199
CommonDefs	Common/CommonDefs.ttcn	Rev 18638
EUTRA_NB_ASP_TypeDefs	Common_EUTRA_NB/EUTRA_NB_ASP_TypeDefs.ttcn	Rev 17662
EUTRA_NB_CommonDefs	Common_EUTRA_NB/EUTRA_NB_CommonDefs.ttcn	Rev 18679

Annex G (informative): Change history

Date	TSG #	TSG Doc.	CR	Rev	Subject/Comment	Old	New
2008-05					Creation of draft TS		0.0.2
2008-08					Add test models	0.0.2	0.1.0
2008-10					Add ASPs and state model	0.1.1	0.3.0
2008-12					Add details of UL/DL scheduling and cell configurations	0.4.0	0.5.0
2009-02					Change naming conventions, add more design considerations	0.5.0	1.0.0
2009-03	RAN#43	RP-090271			Presentation for Information	1.0.0	1.0.2
2009-03					Add Upper tester interface	1.0.2	1.1.0
2009-04					Improved DL scheduling	1.1.0	1.2.0
2009-06					Add normative annex D for ASP definitions	1.2.0	1.3.0
2009-08					General update	1.3.0	1.4.0
2009-09					Style /format check from ETSI EditHelp	1.4.0	1.4.1
2009-09	RAN#45	RP-090753			Presentation of v2.0.0 for approval	1.4.1	2.0.0
2009-09					Updated to 8.0.0 with no change	2.0.0	8.0.0
2009-12	RAN#46	RP-091122	0001	-	LTE ASP clarifications and update	8.0.0	8.1.0
2009-12	RAN#46	RP-091119	0002	-	CR to 36.523-3: Add new e-mail agreed LTE TTCN test cases in the TC list of Annex A and update Annex D	8.0.0	8.1.0
2009-12	RAN#46	R5s090180	0003	-	Resubmission of GCF WI 81 LTE RRC test case 8.1.2.1 on wk42 TTCN	8.0.0	8.1.0
2009-12	RAN#46	R5s090139	0004	-	Addition of GCF WI 81 LTE RRC test case 8.1.1.1	8.0.0	8.1.0
2009-12	RAN#46	R5s090144	0005	-	Addition of GCF WI 81 LTE RRC test case 8.1.3.1	8.0.0	8.1.0
2009-12	RAN#46	R5s090163	0006	-	Addition of GCF WI 82 EUTRA NAS test case 9.2.1.1.2	8.0.0	8.1.0
2009-12	RAN#46	R5s090141	0007	-	Addition of GCF WI 81 LTE MAC test case 7.1.1.1	8.0.0	8.1.0
2009-12	RAN#46	R5s090160	0008	-	Addition of GCF WI 81 EUTRA RLC test case 7.2.3.1	8.0.0	8.1.0
2009-12	RAN#46	R5s090156	0009	-	Addition of GCF WI 81 EUTRA RLC test case 7.2.3.2	8.0.0	8.1.0
2009-12	RAN#46	R5s090154	0010	-	Addition of GCF WI 82 EPC test case 9.2.2.1	8.0.0	8.1.0
2009-12	RAN#46	R5s090165	0011	-	Addition of GCF WI 81 EUTRA RLC test case 7.2.3.3	8.0.0	8.1.0
2009-12	RAN#46	R5s090171	0012	-	Addition of GCF WI 81 EUTRA MAC test case 7.1.3.3	8.0.0	8.1.0
2009-12	RAN#46	R5s090176	0013	-	Addition of GCF WI 82 EPC test case 9.3.2.1	8.0.0	8.1.0
2009-12	RAN#46	R5s090174	0014	-	Addition of GCF WI 81 EUTRA MAC test case 7.1.3.7	8.0.0	8.1.0
2009-12	RAN#46	R5s090178	0015	-	Addition of GCF WI 81 EUTRA MAC test case 7.1.3.6	8.0.0	8.1.0
2009-12	RAN#46	R5s090198	0016	-	Addition of GCF WI 81 EUTRA PDCP test case 7.3.3.1	8.0.0	8.1.0
2009-12	RAN#46	R5s090204	0017	-	Addition of GCF WI 81 EUTRA PDCP test case 7.3.3.4	8.0.0	8.1.0
2009-12	RAN#46	R5s090202	0018	-	Addition of GCF WI 81 EUTRA PDCP test case 7.3.3.3	8.0.0	8.1.0
2009-12	RAN#46	R5s090200	0019	-	Addition of GCF WI 81 EUTRA PDCP test case 7.3.3.2	8.0.0	8.1.0
2009-12	RAN#46	R5s090196	0020	-	Addition of GCF WI 81 EUTRA PDCP test case 7.3.4.2	8.0.0	8.1.0
2009-12	RAN#46	R5s090194	0021	-	Addition of GCF WI 81 EUTRA PDCP test case 7.3.4.1	8.0.0	8.1.0
2010-03	RAN#47	R5-100103	0090	-	An additional option for IP address allocation in test cases using UE test mode	8.1.0	8.2.0
2010-03	RAN#47	R5-101049	0081	-	Add a new clause for postamble in a UTRA/GERAN cell	8.1.0	8.2.0
2010-03	RAN#47	R5-101050	0082	2	Routine maintenance of TS 36.523-3	8.1.0	8.2.0
2010-03	RAN#47	RP-100147	0022	1	CR to 36.523-3: Add new verified and e-mail agreed TTCN test cases in the TC lists in 36.523-3 (prose), Annex A	8.1.0	8.2.0
2010-03	RAN#47	R5s090209	0076	-	Addition of GCF WI 81 LTE Idle Mode test case 6.1.2.2 on wk42 TTCN	8.1.0	8.2.0
2010-03	RAN#47	R5s090210	0075	-	Addition of GCF WI 82 EPC test case 9.1.3.1	8.1.0	8.2.0
2010-03	RAN#47	R5s090212	0078	-	Addition of GCF WI 82 EPC test case 9.2.3.1.5	8.1.0	8.2.0
2010-03	RAN#47	R5s090214	0077	-	Addition of GCF WI 81 EUTRA MAC test case 7.1.4.15	8.1.0	8.2.0
2010-03	RAN#47	R5s090217	0072	-	Addition of GCF WI 81 EUTRA RLC test case 7.2.3.5	8.1.0	8.2.0
2010-03	RAN#47	R5s090219	0073	-	Addition of GCF WI 81 EUTRA RLC test case 7.2.3.17	8.1.0	8.2.0
2010-03	RAN#47	R5s090222	0074	-	Addition of GCF WI 81 EUTRA RLC test case 7.2.3.20	8.1.0	8.2.0
2010-03	RAN#47	R5s090306	0045	-	Addition of GCF WI 81 LTE RRC test case 8.5.4.1	8.1.0	8.2.0
2010-03	RAN#47	R5s090310	0038	-	Addition of GCF WI-82 EPC test case 9.1.2.1	8.1.0	8.2.0

Date	TSG #	TSG Doc.	CR	Rev	Subject/Comment	Old	New
2010-03	RAN#47	R5s090314	0030	-	Addition of GCF WI 81 EUTRA RLC test case 7.2.2.1	8.1.0	8.2.0
2010-03	RAN#47	R5s090316	0049	-	Addition of GCF WI 81 EUTRA RLC test case 7.2.2.2	8.1.0	8.2.0
2010-03	RAN#47	R5s090318	0042	-	Addition of GCF WI 81 EUTRA RLC test case 7.2.2.3	8.1.0	8.2.0
2010-03	RAN#47	R5s090320	0041	-	Addition of GCF WI 81 EUTRA RLC test case 7.2.2.4	8.1.0	8.2.0
2010-03	RAN#47	R5s090322	0028	-	Correction to test step f_GetPDNAddress	8.1.0	8.2.0
2010-03	RAN#47	R5s090331	0024	-	Resubmission of GCF WI-81 LTE RRC test case 8.2.2.1 on ATS_wk47	8.1.0	8.2.0
2010-03	RAN#47	R5s090333	0025	-	Resubmission of GCF WI-81 LTE RRC test case 8.2.2.2 on ATS_wk47	8.1.0	8.2.0
2010-03	RAN#47	R5s090335	0023	-	Resubmission of GCF WI-81 LTE RRC test case 8.2.3.1 on ATS_wk47	8.1.0	8.2.0
2010-03	RAN#47	R5s090337	0027	-	Correction to EUTRA MAC test cases 7.1.3.3 and 7.1.3.7	8.1.0	8.2.0
2010-03	RAN#47	R5s090340	0040	-	Addition of GCF WI 81 EUTRA RLC test case 7.2.2.5.1	8.1.0	8.2.0
2010-03	RAN#47	R5s090342	0039	-	Addition of GCF WI 81 EUTRA RLC test case 7.2.2.5.2	8.1.0	8.2.0
2010-03	RAN#47	R5s090345	0043	-	Addition of GCF WI 81 EUTRA MAC test case 7.1.1.2	8.1.0	8.2.0
2010-03	RAN#47	R5s090347	0048	-	Addition of GCF WI 81 EUTRA MAC test case 7.1.2.2	8.1.0	8.2.0
2010-03	RAN#47	R5s090349	0033	-	Addition of GCF WI 81 EUTRA MAC test case 7.1.2.3	8.1.0	8.2.0
2010-03	RAN#47	R5s090351	0034	-	Addition of GCF WI 81 EUTRA MAC test case 7.1.2.4	8.1.0	8.2.0
2010-03	RAN#47	R5s090353	0035	-	Addition of GCF WI 81 EUTRA MAC test case 7.1.2.5	8.1.0	8.2.0
2010-03	RAN#47	R5s090355	0047	-	Addition of GCF WI 81 EUTRA MAC test case 7.1.2.7	8.1.0	8.2.0
2010-03	RAN#47	R5s090357	0032	-	Addition of GCF WI 81 EUTRA MAC test case 7.1.2.9	8.1.0	8.2.0
2010-03	RAN#47	R5s090359	0050	-	Addition of GCF WI 81 EUTRA MAC test case 7.1.4.4	8.1.0	8.2.0
2010-03	RAN#47	R5s090361	0026	-	Correction of GCF WI 81 EUTRA RLC test case 7.2.3.2	8.1.0	8.2.0
2010-03	RAN#47	R5s090362	0031	-	Addition of GCF WI 81 EUTRA MAC test case 7.1.4.13	8.1.0	8.2.0
2010-03	RAN#47	R5s090364	0054	-	Addition of GCF WI 81 EUTRA MAC test case 7.1.3.1	8.1.0	8.2.0
2010-03	RAN#47	R5s090366	0046	-	Addition of GCF WI 82 EPC test case 9.3.1.1	8.1.0	8.2.0
2010-03	RAN#47	R5s090368	0029	-	Addition of GCF WI 81 EUTRA MAC test case 7.1.4.5	8.1.0	8.2.0
2010-03	RAN#47	R5s090373	0037	-	TTCN corrections from LTE ATS_wk51 regression testing	8.1.0	8.2.0
2010-03	RAN#47	R5s090375	0056	-	Addition of GCF WI 81 EUTRA RLC test case 7.2.3.8	8.1.0	8.2.0
2010-03	RAN#47	R5s090377	0055	-	Addition of GCF WI 81 EUTRA MAC test case 7.1.4.6	8.1.0	8.2.0
2010-03	RAN#47	R5s090379	0036	-	Correction to EPC test case 9.2.3.1.5	8.1.0	8.2.0
2010-03	RAN#47	R5s100001	0044	-	Correction to EUTRA RLC test case 7.2.3.17	8.1.0	8.2.0
2010-03	RAN#47	R5s100002	0052	-	Addition of GCF WI 81 EUTRA RLC test case 7.2.3.14	8.1.0	8.2.0
2010-03	RAN#47	R5s100004	0059	-	Addition of GCF WI 81 EUTRA RLC test case 7.2.2.6	8.1.0	8.2.0
2010-03	RAN#47	R5s100006	0050	-	Addition of GCF WI 81 EUTRA RLC test case 7.2.2.7	8.1.0	8.2.0
2010-03	RAN#47	R5s100008	0056	-	Addition of GCF WI 82 LTE NAS test case 9.2.1.1.1	8.1.0	8.2.0
2010-03	RAN#47	R5s100012	0053	-	Addition of GCF WI 81 EUTRA PDCP test case 7.3.1.1	8.1.0	8.2.0
2010-03	RAN#47	R5s100014	0051	-	Addition of GCF WI 81 EUTRA RLC test case 7.2.2.9	8.1.0	8.2.0

Date	TSG #	TSG Doc.	CR	Rev	Subject/Comment	Old	New
2010-03	RAN#47	R5s100016	0058	-	Addition of GCF WI 81 EUTRA RLC test case 7.1.4.1	8.1.0	8.2.0
2010-03	RAN#47	R5s100018	0053	-	Addition of GCF WI 81 EUTRA RLC test case 7.2.3.4	8.1.0	8.2.0
2010-03	RAN#47	R5s100020	0052	-	Summary of regression errors in wk51 LTE ATS	8.1.0	8.2.0
2010-03	RAN#47	R5s100021	0051	-	Addition of GCF WI 81 EUTRA MAC test case 7.1.3.4	8.1.0	8.2.0
2010-03	RAN#47	R5s100024	0054	-	Addition of GCF WI-082 EPC test case 13.1.1	8.1.0	8.2.0
2010-03	RAN#47	R5s100029	0057	-	Addition of GCF WI 81 EUTRA Idle Mode test case 6.1.2.4	8.1.0	8.2.0
2010-03	RAN#47	R5s100031	0058	-	Addition of GCF WI 81 EUTRA RLC test case 7.2.3.10	8.1.0	8.2.0
2010-03	RAN#47	R5s100039	0055	-	Addition of GCF WI 81 EUTRA RLC test case 7.2.3.18	8.1.0	8.2.0
2010-03	RAN#47	R5s100041	0057	-	Addition of GCF WI 81 EUTRA MAC test case 7.1.4.7	8.1.0	8.2.0
2010-03	RAN#47	R5s100043	0070	-	Addition of GCF WI 81 LTE MAC test case 7.1.4.10	8.1.0	8.2.0
2010-03	RAN#47	R5s100047	0071	-	Corrections of GCF WI 81 EUTRA RLC test cases 7.2.3.1, 7.2.3.4, and 7.2.3.5.	8.1.0	8.2.0
2010-03	RAN#47	R5s100049	0059	-	Regression CR for LTE wk03 ATS	8.1.0	8.2.0
2010-03	RAN#47	R5s100053	0079	-	Correction of GCF WI 81 EUTRA RLC test case 7.2.3.8	8.1.0	8.2.0
2010-03	RAN#47	R5s100054	0080	-	Addition of GCF WI 81 EUTRA RLC test case 7.2.3.15	8.1.0	8.2.0
2010-06	RAN#48	RP-100515	0084	-	CR to 36.523-3: Add new verified and e-mail agreed TTCN test cases in the TC lists in 36.523-3 (prose), Annex A	8.2.0	8.3.0
2010-06	RAN#48	R5-103845	0141	-	Specification of default UL grant type and exception TC list	8.2.0	8.3.0
2010-06	RAN#48	R5-103846	0142	-	Routine maintenance of TS 36.523-3	8.2.0	8.3.0
2010-06	RAN#48	R5-103847	0143	-	Align the postambles with the new specified UTRA test end states and UE attach implementation capabilities	8.2.0	8.3.0
2010-06	RAN#48	R5s100057	0085	-	Addition of GCF WI-081 RRC test case 8.2.1.1	8.2.0	8.3.0
2010-06	RAN#48	R5s100065	0086	-	Correction of GCF WI 81 EUTRA RLC test case 7.2.2.5.2	8.2.0	8.3.0
2010-06	RAN#48	R5s100068	0092	-	Regression CR for LTE wk07 ATS	8.2.0	8.3.0
2010-06	RAN#48	R5s100072	0091	-	Correction to EPC test case 9.2.2.2.1	8.2.0	8.3.0
2010-06	RAN#48	R5s100073	0090	-	Correction to LTE MAC test case 7.1.2.3 and 7.1.4.5	8.2.0	8.3.0
2010-06	RAN#48	R5s100074	0087	-	Addition of GCF WI 81 EUTRA MAC test case 7.1.3.5	8.2.0	8.3.0
2010-06	RAN#48	R5s100076	0089	-	Corrections to GCF WI-81 EUTRA RLC test cases 7.2.2.1, 7.2.2.3 and 7.2.2.5.1.	8.2.0	8.3.0
2010-06	RAN#48	R5s100077	0088	-	Correction to 'EUTRA_NASSteps.tcn' module (here: APN IE)	8.2.0	8.3.0
2010-06	RAN#48	R5s100078	0113	-	Addition of GCF WI 81 EUTRA RLC test case 7.2.2.8	8.2.0	8.3.0
2010-06	RAN#48	R5s100080	0112	-	Addition of GCF WI 81 EUTRA NAS test case 7.2.3.16	8.2.0	8.3.0
2010-06	RAN#48	R5s100082	0109	-	Addition of GCF WI 81 EUTRA PDCP test case 7.3.1.2	8.2.0	8.3.0
2010-06	RAN#48	R5s100086	0108	-	Addition of GCF WI 82 EPC test case 9.1.2.4	8.2.0	8.3.0
2010-06	RAN#48	R5s100088	0107	-	Addition of GCF WI 82 EPC test case 9.1.2.5	8.2.0	8.3.0
2010-06	RAN#48	R5s100090	0106	-	Addition of GCF WI 82 EPC test case 9.2.3.1.8	8.2.0	8.3.0
2010-06	RAN#48	R5s100092	0110	-	Addition of GCF WI 82 EPC test case 9.1.4.2	8.2.0	8.3.0
2010-06	RAN#48	R5s100094	0105	-	Addition of GCF WI 82 EPC test case 9.3.1.7a	8.2.0	8.3.0
2010-06	RAN#48	R5s100096	0104	-	Addition of GCF WI 82 EPC test case 9.3.1.7	8.2.0	8.3.0

Date	TSG #	TSG Doc.	CR	Rev	Subject/Comment	Old	New
2010-06	RAN#48	R5s100098	0111	-	Addition of GCF WI 82 EPC test case 9.1.3.2	8.2.0	8.3.0
2010-06	RAN#48	R5s100100	0093	-	Addition of GCF WI 81 EUTRA RAB test case 12.2.1	8.2.0	8.3.0
2010-06	RAN#48	R5s100102	0103	-	Addition of GCF WI 81 EUTRA MAC test case 7.1.4.16	8.2.0	8.3.0
2010-06	RAN#48	R5s100104	0099	-	Addition of GCF WI 81 EUTRA RLC test case 7.2.2.10	8.2.0	8.3.0
2010-06	RAN#48	R5s100106	0102	-	Addition of GCF WI -081 test case 8.2.1.3	8.2.0	8.3.0
2010-06	RAN#48	R5s100109	0131	-	Addition of GCF WI-082 EUTRA EPS test case 9.4.1	8.2.0	8.3.0
2010-06	RAN#48	R5s100111	0101	-	Addition of GCF WI 82 EPC NAS test case 9.4.3	8.2.0	8.3.0
2010-06	RAN#48	R5s100113	0100	-	Addition of GCF WI 82 EPC test case 9.4.4	8.2.0	8.3.0
2010-06	RAN#48	R5s100116	0094	-	Regression CR for LTE wk11 ATS	8.2.0	8.3.0
2010-06	RAN#48	R5s100117	0098	-	Addition of GCF WI 82 EPC test case 9.4.2	8.2.0	8.3.0
2010-06	RAN#48	R5s100127	0097	-	Resubmission of GCF WI 82 EPC test case 9.1.2.3	8.2.0	8.3.0
2010-06	RAN#48	R5s100130	0095	-	Resubmission of GCF WI 81 EUTRA MAC test case 7.1.4.8	8.2.0	8.3.0
2010-06	RAN#48	R5s100132	0096	-	Addition of GCF WI 82 EPC test case 9.2.2.1.6	8.2.0	8.3.0
2010-06	RAN#48	R5s100135	0136	-	Baseline upgrade to December-09 Rel-8	8.2.0	8.3.0
2010-06	RAN#48	R5s100136	0130	-	Correction to the test step f_TestcasesL2Testcase	8.2.0	8.3.0
2010-06	RAN#48	R5s100137	0129	-	Correction to PDCCH candidate selection based on channel bandwidth under test	8.2.0	8.3.0
2010-06	RAN#48	R5s100138	0127	-	Addition of GCF WI-081 MAC test case 7.1.2.1	8.2.0	8.3.0
2010-06	RAN#48	R5s100140	0128	-	Regression CR for LTE/SAE ATS_10wk11	8.2.0	8.3.0
2010-06	RAN#48	R5s100141	0125	-	Correction to GCF WI 81 EUTRA MAC test case 7.1.3.5	8.2.0	8.3.0
2010-06	RAN#48	R5s100142	0126	-	Correction to EUTRA RLC test case 7.2.3.10	8.2.0	8.3.0
2010-06	RAN#48	R5s100143	0118	-	Addition of GCF WI 81 EUTRA RLC test case 7.2.3.9	8.2.0	8.3.0
2010-06	RAN#48	R5s100145	0119	-	Addition of GCF WI 81 EUTRA RLC test case 7.2.3.13	8.2.0	8.3.0
2010-06	RAN#48	R5s100147	0122	-	Addition of GCF WI 81 EUTRA PDCP test case 7.3.6.1	8.2.0	8.3.0
2010-06	RAN#48	R5s100149	0120	-	Addition of GCF WI 81 EUTRA RRC test case 8.3.1.1	8.2.0	8.3.0
2010-06	RAN#48	R5s100151	0121	-	Addition of GCF WI 81 EUTRA RRC test case 8.5.1.5	8.2.0	8.3.0
2010-06	RAN#48	R5s100153	0123	-	Addition of GCF WI 82 EPC EMM test case 9.2.2.1.1	8.2.0	8.3.0
2010-06	RAN#48	R5s100155	0117	-	Addition of GCF WI 81 EUTRA MAC test case 7.1.7.1.1	8.2.0	8.3.0
2010-06	RAN#48	R5s100157	0116	-	Addition of GCF WI 81 EUTRA MAC test case 7.1.7.1.2	8.2.0	8.3.0
2010-06	RAN#48	R5s100159	0114	-	Addition of GCF WI 81 EUTRA MAC test case 7.1.7.1.3	8.2.0	8.3.0
2010-06	RAN#48	R5s100161	0115	-	Addition of GCF WI 81 EUTRA MAC test case 7.1.7.1.4	8.2.0	8.3.0
2010-06	RAN#48	R5s100163	0124	-	Correction to MME Group ID to set MSB to 1	8.2.0	8.3.0
2010-06	RAN#48	R5s100169	0132	-	Correction of GCF WI-082 EPC test cases 9.1.2.3, 9.1.2.4 and 9.1.2.5	8.2.0	8.3.0
2010-06	RAN#48	R5s100172	0133	-	Further regression CR for LTE/SAE 10wk11 ATS	8.2.0	8.3.0
2010-06	RAN#48	R5s100176	0135	-	Addition of GCF WI 81 EUTRA RRC test case 8.3.1.2	8.2.0	8.3.0
2010-06	RAN#48	R5s100178	0137	-	Addition of GCF WI 81 EUTRA RRC test case 8.2.4.3	8.2.0	8.3.0
2010-06	RAN#48	R5s100180	0138	-	Addition of GCF WI 81 EUTRA RLC test case 7.2.2.11	8.2.0	8.3.0

Date	TSG #	TSG Doc.	CR	Rev	Subject/Comment	Old	New
2010-06	RAN#48	R5s100182	0139	-	Regression CR for LTE wk11 ATS	8.2.0	8.3.0
2010-06	RAN#48	R5s100183	0134	-	Corrections to EUTRA RLC and PDCP test cases	8.2.0	8.3.0
2010-09	RAN#49	R5-104796	0145	-	Routine maintenance of TS 36.523-3	8.3.0	8.4.0
2010-09	RAN#49	R5-104197	0144	-	Addition of MMI command 'DISABLE EPS CAPABILITY'	8.3.0	8.4.0
2010-09	RAN#49	RP-100826	0146	-	CR to 36.523-3: Add new verified and e-mail agreed TTCN test cases in the TC lists in 36.523-3 (prose), Annex A	8.3.0	8.4.0
2010-09	-	-	-	-	Updated the lists of approved test cases for FDD and LCR TDD in Annex A to align with TTCN.	8.3.0	8.4.0
2010-09	RAN#49	R5s100198	0175	-	LTE_TDD : Addition of GCF WI 91 EUTRA RRC test case 8.2.3.1	8.3.0	8.4.0
2010-09	RAN#49	R5s100302	0200	-	Regression CR for LTE/SAE iwd_10wk22 ATS	8.3.0	8.4.0
2010-09	RAN#49	R5s100268	0281	-	Addition of GCF WI 81 EUTRA MAC test case 7.1.6.1	8.3.0	8.4.0
2010-09	RAN#49	R5s100298	0206	-	Addition of GCF WI 81 EUTRA PDCP test case 7.3.5.3	8.3.0	8.4.0
2010-09	RAN#49	R5s100260	0187	-	LTE_TDD : Addition of GCF WI 91 EUTRA MAC test case 7.1.1.2	8.3.0	8.4.0
2010-09	RAN#49	R5s100300	0205	-	Correction to EPC test case 9.3.1.1	8.3.0	8.4.0
2010-09	RAN#49	R5s100226	0194	-	LTE_TDD: Addition of GCF WI 91 EUTRA RLC test case 7.2.3.5	8.3.0	8.4.0
2010-09	RAN#49	R5s100274	0155	-	Regression CR for LTE wk17 ATS	8.3.0	8.4.0
2010-09	RAN#49	R5s100249	0191	-	LTE_TDD: Addition of GCF WI 91 EUTRA RLC test case 7.2.2.1	8.3.0	8.4.0
2010-09	RAN#49	R5s100228	0163	-	LTE_TDD : Addition of GCF WI 91 EUTRA RLC test case 7.2.3.17	8.3.0	8.4.0
2010-09	RAN#49	R5s100293	0279	-	Addition of GCF WI 81 EUTRA DRB test case 12.2.2	8.3.0	8.4.0
2010-09	RAN#49	R5s100224	0195	-	LTE_TDD: Addition of GCF WI 81 EUTRA RLC test case 7.2.3.4	8.3.0	8.4.0
2010-09	RAN#49	R5s100270	0280	-	Addition of GCF WI 81 EUTRA MAC test case 7.1.6.2	8.3.0	8.4.0
2010-09	RAN#49	R5s100266	0152	-	Addition of GCF WI 81 EUTRA RLC test case 7.2.3.7	8.3.0	8.4.0
2010-09	RAN#49	R5s100295	0207	-	Addition of GCF WI 82 ESM test case 10.2.1	8.3.0	8.4.0
2010-09	RAN#49	R5s100210	0170	-	LTE_TDD : Addition of GCF WI 91 EUTRA MAC test case 7.1.2.7	8.3.0	8.4.0
2010-09	RAN#49	R5s100287	0182	-	Correction to TFT filter identifier and precedence values	8.3.0	8.4.0
2010-09	RAN#49	R5s100222	0164	-	LTE_TDD : Addition of GCF WI 91 EUTRA RLC test case 7.2.3.3	8.3.0	8.4.0
2010-09	RAN#49	R5s100214	0168	-	LTE_TDD : Addition of GCF WI 91 EUTRA RLC test case 7.2.2.3	8.3.0	8.4.0
2010-09	RAN#49	R5s100189	0150	-	Regression CR for LTE wk17 ATS	8.3.0	8.4.0
2010-09	RAN#49	R5s100220	0165	-	LTE_TDD : Addition of GCF WI 91 EUTRA RLC test case 7.2.3.2	8.3.0	8.4.0
2010-09	RAN#49	R5s100272	0157	-	Corrections to EUTRA MAC test case.	8.3.0	8.4.0
2010-09	RAN#49	R5s100187	0149	-	Addition of GCF WI 81 EUTRA RRC test case 8.3.1.5	8.3.0	8.4.0
2010-09	RAN#49	R5s100273	0156	-	Corrections to EUTRA RLC test case 7.2.2.6 and 7.2.2.10	8.3.0	8.4.0
2010-09	RAN#49	R5s100279	0181	-	Regression CR for LTE wk22 ATS	8.3.0	8.4.0
2010-09	RAN#49	R5s100208	0171	-	LTE_TDD : Addition of GCF WI 91 EUTRA MAC test case 7.1.2.5	8.3.0	8.4.0
2010-09	RAN#49	R5s100256	0154	-	Addition of GCF WI 81 EUTRA RLC test case 7.2.3.21	8.3.0	8.4.0
2010-09	RAN#49	R5s100283	0184	-	Addition of GCF WI 81 EUTRA PDCP test case 7.3.1.3	8.3.0	8.4.0
2010-09	RAN#49	R5s100291	0180	-	Addition of GCF WI 81 EUTRA MAC test case 7.1.2.6	8.3.0	8.4.0
2010-09	RAN#49	R5s100301	0204	-	Correction to EUTRA test case 7.1.4.6	8.3.0	8.4.0

Date	TSG #	TSG Doc.	CR	Rev	Subject/Comment	Old	New
2010-09	RAN#49	R5s100196	0176	-	LTE_TDD: Addition of GCF WI 91 EUTRA RRC test case 8.2.2.2	8.3.0	8.4.0
2010-09	RAN#49	R5s100258	0188	-	LTE_TDD: Addition of GCF WI 91 EUTRA RLC test case 7.2.3.1	8.3.0	8.4.0
2010-09	RAN#49	R5s100234	0160	-	LTE_TDD : Addition of GCF WI 91 EUTRA PDCP test case 7.3.3.3	8.3.0	8.4.0
2010-09	RAN#49	R5s100303	0217	-	Addition of GCF WI 81 EUTRA MAC test case 7.1.7.2.1	8.3.0	8.4.0
2010-09	RAN#49	R5s100285	0220	-	LTE_TDD : Addition of GCF WI 92 EUTRA Multi layer test case 13.1.1	8.3.0	8.4.0
2010-09	RAN#49	R5s100247	0192	-	LTE_TDD: Addition of GCF WI 81 EUTRA PDCP test case 7.3.3.4	8.3.0	8.4.0
2010-09	RAN#49	R5s100238	0158	-	LTE_TDD : Addition of GCF WI 91 EUTRA PDCP test case 7.3.4.2	8.3.0	8.4.0
2010-09	RAN#49	R5s100240	0148	-	Addition of GCF WI 81 EUTRA RRC test case 8.2.4.2	8.3.0	8.4.0
2010-09	RAN#49	R5s100236	0159	-	LTE_TDD : Addition of GCF WI 91 EUTRA PDCP test case 7.3.4.1	8.3.0	8.4.0
2010-09	RAN#49	R5s100262	0186	-	LTE_TDD : Addition of GCF WI 91 EUTRA MAC test case 7.1.3.5	8.3.0	8.4.0
2010-09	RAN#49	R5s100305	0203	-	Addition of GCF WI 81 EUTRA PDCP test case 7.3.5.2	8.3.0	8.4.0
2010-09	RAN#49	R5s100216	0167	-	LTE_TDD : Addition of GCF WI 91 EUTRA RLC test case 7.2.2.4	8.3.0	8.4.0
2010-09	RAN#49	R5s100218	0166	-	LTE_TDD : Addition of GCF WI 91 EUTRA RLC test case 7.2.2.9	8.3.0	8.4.0
2010-09	RAN#49	R5s100264	0153	-	Addition of GCF WI 81 EUTRA RLC test case 7.2.3.6	8.3.0	8.4.0
2010-09	RAN#49	R5s100281	0185	-	Addition of GCF WI 81 EUTRA Idle Mode test case 6.1.2.3	8.3.0	8.4.0
2010-09	RAN#49	R5s100194	0177	-	LTE_TDD: Addition of GCF WI 91 EUTRA RRC test case 8.2.2.1	8.3.0	8.4.0
2010-09	RAN#49	R5s100190	0179	-	LTE_TDD : Addition of GCF WI 91 EUTRA RRC test case 8.1.1.1	8.3.0	8.4.0
2010-09	RAN#49	R5s100202	0173	-	LTE_TDD : Addition of GCF WI 91 EUTRA MAC test case 7.1.1.1	8.3.0	8.4.0
2010-09	RAN#49	R5s100204	0172	-	LTE_TDD : Addition of GCF WI 91 EUTRA MAC test case 7.1.2.2	8.3.0	8.4.0
2010-09	RAN#49	R5s100253	0189	-	LTE_TDD: Addition of GCF WI 91 EUTRA RRC test case 8.1.3.1	8.3.0	8.4.0
2010-09	RAN#49	R5s100251	0190	-	LTE_TDD: Addition of GCF WI 91 EUTRA RLC test case 7.2.2.2	8.3.0	8.4.0
2010-09	RAN#49	R5s100245	0193	-	LTE_TDD: Addition of GCF WI 91 EUTRA PDCP test case 7.3.3.2	8.3.0	8.4.0
2010-09	RAN#49	R5s100200	0174	-	LTE_TDD : Addition of GCF WI 81 EUTRA RRC test case 8.5.4.1	8.3.0	8.4.0
2010-09	RAN#49	R5s100288	0183	-	Addition of GCF WI 82 EPC Multi-layer test case 13.2.1	8.3.0	8.4.0
2010-09	RAN#49	R5s100192	0178	-	LTE_TDD : Addition of GCF WI 91 EUTRA RRC test case 8.1.2.1	8.3.0	8.4.0
2010-09	RAN#49	R5s100230	0162	-	LTE_TDD : Addition of GCF WI 91 EUTRA RLC test case 7.2.3.20	8.3.0	8.4.0
2010-09	RAN#49	R5s100242	0147	-	Addition of GCF WI 81 EUTRA RRC test case 8.2.4.5	8.3.0	8.4.0
2010-09	RAN#49	R5s100307	0202	-	Addition of GCF WI 81 EUTRA PDCP test case 7.3.5.4	8.3.0	8.4.0
2010-09	RAN#49	R5s100309	0201	-	Addition of GCF WI 81 EUTRA PDCP test case 7.3.5.5	8.3.0	8.4.0
2010-09	RAN#49	R5s100311	0197	-	Addition of GCF WI-081 EUTRA RRC test case 8.1.2.5	8.3.0	8.4.0
2010-09	RAN#49	R5s100313	0199	-	Addition of GCF WI 82 ESM test case 10.5.1	8.3.0	8.4.0
2010-09	RAN#49	R5s100317	0198	-	Addition of GCF WI 81 EUTRA RRC test case 8.1.2.7	8.3.0	8.4.0
2010-09	RAN#49	R5s100319	0196	-	Addition of GCF WI 81 EUTRA RRC test case 8.5.1.3	8.3.0	8.4.0
2010-09	RAN#49	R5s100321	0219	-	Correction to EUTRA MAC 7.1.7.1.x test cases	8.3.0	8.4.0
2010-09	RAN#49	R5s100322	0218	-	Addition of GCF WI 82 EPC test case 9.2.1.1.20	8.3.0	8.4.0
2010-09	RAN#49	R5s100324	0216	-	Addition of GCF WI 81 EUTRA RRC test case 8.5.1.1	8.3.0	8.4.0
2010-09	RAN#49	R5s100326	0215	-	Addition of GCF WI 82 EPC test case 10.6.1	8.3.0	8.4.0

Date	TSG #	TSG Doc.	CR	Rev	Subject/Comment	Old	New
2010-09	RAN#49	R5s100329	0211	-	LTE_TDD: Addition of GCF WI 91 EUTRA MAC test case 7.1.2.3	8.3.0	8.4.0
2010-09	RAN#49	R5s100331	0210	-	LTE_TDD: Addition of GCF WI 91 EUTRA MAC test case 7.1.2.9	8.3.0	8.4.0
2010-09	RAN#49	R5s100333	0209	-	LTE_TDD: Addition of GCF WI 91 EUTRA MAC test case 7.1.4.1	8.3.0	8.4.0
2010-09	RAN#49	R5s100335	0244	-	LTE_TDD: Addition of GCF WI 91 EUTRA MAC test case 7.1.7.1.2	8.3.0	8.4.0
2010-09	RAN#49	R5s100337	0243	-	LTE_TDD: Addition of GCF WI 91 EUTRA MAC test case 7.1.7.1.4	8.3.0	8.4.0
2010-09	RAN#49	R5s100339	0208	-	LTE_TDD: Addition of GCF WI 91 EUTRA RLC-UM test case 7.2.2.5.1	8.3.0	8.4.0
2010-09	RAN#49	R5s100341	0212	-	LTE_TDD: Addition of GCF WI 91 EUTRA RLC-UM test case 7.2.2.6	8.3.0	8.4.0
2010-09	RAN#49	R5s100343	0213	-	LTE_TDD: Addition of GCF WI 91 EUTRA RLC test case 7.2.2.7	8.3.0	8.4.0
2010-09	RAN#49	R5s100345	0242	-	LTE_TDD: Addition of GCF WI 91 EUTRA DRB test case 12.2.1	8.3.0	8.4.0
2010-09	RAN#49	R5s100347	0214	-	Correction of GCF WI-081 E-UTRA PDCP test case 7.3.6.1	8.3.0	8.4.0
2010-09	RAN#49	R5s100348	0221	-	Addition of GCF WI-081 E-UTRA RRC test case 8.1.3.4	8.3.0	8.4.0
2010-09	RAN#49	R5s100350	0264	-	Addition of GCF WI-082 EMM test case 9.2.1.1.9	8.3.0	8.4.0
2010-09	RAN#49	R5s100184	0151	-	TTCN Correction to 36.523-3 LTE/SAE NAS definition of LAIList	8.3.0	8.4.0
2010-09	RAN#49	R5s100232	0161	-	LTE_TDD : Addition of GCF WI 91 EUTRA PDCP test case 7.3.3.1	8.3.0	8.4.0
2010-09	RAN#49	R5s100352	0263	-	Addition of GCF WI-082 EMM test case 9.2.1.1.10	8.3.0	8.4.0
2010-09	RAN#49	R5s100354	0233	-	Corrections to EUTRA MAC test case 7.1.3.1	8.3.0	8.4.0
2010-09	RAN#49	R5s100356	0232	-	Corrections to EUTRA Idle Mode Testcases 6.1.2.3	8.3.0	8.4.0
2010-09	RAN#49	R5s100358	0241	-	Addition of GCF WI 82 EPC test case 9.2.1.1.14	8.3.0	8.4.0
2010-09	RAN#49	R5s100360	0286	-	Addition of GCF WI 82 ESM test case 10.3.1	8.3.0	8.4.0
2010-09	RAN#49	R5s100362	0285	-	Addition of GCF WI 82 ESM test case 10.7.1	8.3.0	8.4.0
2010-09	RAN#49	R5s100364	0293	-	Addition of GCF WI 82 ESM test case 10.7.2	8.3.0	8.4.0
2010-09	RAN#49	R5s100366	0240	-	LTE_TDD: Addition of GCF WI 91 EUTRA MAC test case 7.1.3.1	8.3.0	8.4.0
2010-09	RAN#49	R5s100368	0239	-	LTE_TDD: Addition of GCF WI 91 EUTRA MAC test case 7.1.3.3	8.3.0	8.4.0
2010-09	RAN#49	R5s100370	0238	-	LTE_TDD: Addition of GCF WI 91 EUTRA MAC test case 7.1.3.4	8.3.0	8.4.0
2010-09	RAN#49	R5s100372	0237	-	LTE_TDD: Addition of GCF WI 91 EUTRA MAC test case 7.1.3.6	8.3.0	8.4.0
2010-09	RAN#49	R5s100374	0236	-	LTE_TDD: Addition of GCF WI 91 EUTRA MAC test case 7.1.3.7	8.3.0	8.4.0
2010-09	RAN#49	R5s100376	0235	-	LTE_TDD: Addition of GCF WI 91 EUTRA MAC test case 7.1.4.4	8.3.0	8.4.0
2010-09	RAN#49	R5s100378	0234	-	LTE_TDD: Addition of GCF WI 91 EUTRA MAC test case 7.1.4.13	8.3.0	8.4.0
2010-09	RAN#49	R5s100380	0231	-	Corrections to EUTRA EMM Testcases 9.2.1.1.20	8.3.0	8.4.0
2010-09	RAN#49	R5s100381	0227	-	LTE_TDD: Addition of GCF WI 91 EUTRA MAC test case 7.1.2.6	8.3.0	8.4.0
2010-09	RAN#49	R5s100383	0226	-	LTE_TDD: Addition of GCF WI 91 EUTRA RLC test case 7.2.3.18	8.3.0	8.4.0
2010-09	RAN#49	R5s100385	0230	-	Correction to EUTRA DRB test cases 12.2.1, 12.2.2, 12.2.3, 12.2.4	8.3.0	8.4.0
2010-09	RAN#49	R5s100386	0229	-	Correction to GCF WI-081 EUTRA RLC Testcase 7.2.3.10	8.3.0	8.4.0
2010-09	RAN#49	R5s100387	0228	-	Correction to GCF WI-081 EUTRA RLC Testcase 7.2.3.16	8.3.0	8.4.0
2010-09	RAN#49	R5s100388	0224	-	LTE_TDD: Addition of GCF WI 91 EUTRA RLC test case 7.2.2.5.2	8.3.0	8.4.0
2010-09	RAN#49	R5s100390	0223	-	LTE_TDD: Addition of GCF WI 91 EUTRA RRC test case 8.2.1.1	8.3.0	8.4.0
2010-09	RAN#49	R5s100392	0225	-	Correction to the function fl_EUTRA_InitPhysicalCellId	8.3.0	8.4.0

Date	TSG #	TSG Doc.	CR	Rev	Subject/Comment	Old	New
2010-09	RAN#49	R5s100394	0222	-	Addition of GCF WI 82 EPC test case 9.2.3.1.2	8.3.0	8.4.0
2010-09	RAN#49	R5s100398	0262	-	Regression CR for LTE wk26 ATS	8.3.0	8.4.0
2010-09	RAN#49	R5s100400	0300	-	LTE_TDD: Addition of GCF WI 91 EUTRA Idle Mode test case 6.1.2.2	8.3.0	8.4.0
2010-09	RAN#49	R5s100402	0299	-	LTE_TDD: Addition of GCF WI 91 EUTRA PDCP test case 7.3.1.1	8.3.0	8.4.0
2010-09	RAN#49	R5s100405	0253	-	LTE_TDD:Corrections to EUTRA RLC test cases regarding subframe offset calculation for TDD	8.3.0	8.4.0
2010-09	RAN#49	R5s100406	0261	-	LTE_TDD: Addition of GCF WI 91 EUTRA RLC AM test case 7.2.3.6	8.3.0	8.4.0
2010-09	RAN#49	R5s100212	0169	-	LTE_TDD : Addition of GCF WI 91 EUTRA MAC test case 7.1.4.15	8.3.0	8.4.0
2010-09	RAN#49	R5s100408	0260	-	LTE_TDD: Addition of GCF WI 91 EUTRA RLC AM test case 7.2.3.7	8.3.0	8.4.0
2010-09	RAN#49	R5s100412	0259	-	LTE_TDD: Addition of GCF WI 91 EUTRA RLC AM test case 7.2.3.8	8.3.0	8.4.0
2010-09	RAN#49	R5s100414	0258	-	LTE_TDD: Addition of GCF WI 91 EUTRA RLC AM test case 7.2.3.9	8.3.0	8.4.0
2010-09	RAN#49	R5s100416	0257	-	LTE_TDD: Addition of GCF WI 91 EUTRA RLC AM test case 7.2.3.14	8.3.0	8.4.0
2010-09	RAN#49	R5s100418	0256	-	LTE_TDD: Addition of GCF WI 91 EUTRA RLC AM test case 7.2.3.15	8.3.0	8.4.0
2010-09	RAN#49	R5s100420	0278	-	LTE_TDD: Addition of GCF WI 91 EUTRA MAC test case 7.1.4.8	8.3.0	8.4.0
2010-09	RAN#49	R5s100422	0277	-	LTE_TDD: Addition of GCF WI 91 EUTRA MAC test case 7.1.7.1.1	8.3.0	8.4.0
2010-09	RAN#49	R5s100424	0275	-	LTE_TDD: Addition of GCF WI 91 EUTRA RLC UM test case 7.2.2.8	8.3.0	8.4.0
2010-09	RAN#49	R5s100426	0274	-	LTE_TDD: Addition of GCF WI 91 EUTRA RLC AM test case 7.2.3.13	8.3.0	8.4.0
2010-09	RAN#49	R5s100430	0289	-	LTE_TDD: Addition of GCF WI 91 EUTRA RLC AM test case 7.2.3.21	8.3.0	8.4.0
2010-09	RAN#49	R5s100432	0273	-	LTE_TDD: Addition of GCF WI 91 EUTRA PDCP test case 7.3.1.2	8.3.0	8.4.0
2010-09	RAN#49	R5s100434	0272	-	LTE_TDD: Addition of GCF WI 91 EUTRA PDCP test case 7.3.6.1	8.3.0	8.4.0
2010-09	RAN#49	R5s100436	0271	-	LTE_TDD: Addition of GCF WI 91 EUTRA RRC test case 8.2.1.3	8.3.0	8.4.0
2010-09	RAN#49	R5s100438	0270	-	LTE_TDD: Addition of GCF WI 91 EUTRA RRC test case 8.3.1.1	8.3.0	8.4.0
2010-09	RAN#49	R5s100440	0269	-	LTE_TDD: Addition of GCF WI 91 EUTRA RRC test case 8.3.1.2	8.3.0	8.4.0
2010-09	RAN#49	R5s100442	0268	-	LTE_TDD: Addition of GCF WI 91 EUTRA RRC test case 8.5.1.5	8.3.0	8.4.0
2010-09	RAN#49	R5s100444	0267	-	LTE_TDD: Addition of GCF WI 91 EUTRA DRB test case 12.2.2	8.3.0	8.4.0
2010-09	RAN#49	R5s100446	0276	-	LTE_TDD: Addition of GCF WI 91 EUTRA MAC test case 7.1.7.2.1	8.3.0	8.4.0
2010-09	RAN#49	R5s100457	0255	-	Correction of GCF WI-081 E-UTRA MAC test case 7.1.2.4	8.3.0	8.4.0
2010-09	RAN#49	R5s100458	0254	-	Correction of GCF WI-081 E-UTRA MAC test case 7.1.2.7	8.3.0	8.4.0
2010-09	RAN#49	R5s100459	0250	-	Corrections to GCF WI-081EUTRA RRC Testcase 8.5.1.1	8.3.0	8.4.0
2010-09	RAN#49	R5s100461	0249	-	Corrections to GCF WI-082 EUTRA ESM Testcase 10.6.1	8.3.0	8.4.0
2010-09	RAN#49	R5s100462	0252	-	Correction of GCF WI-081 E-UTRA MAC test case 7.1.3.1	8.3.0	8.4.0
2010-09	RAN#49	R5s100463	0251	-	Correction of GCF WI-081 E-UTRA MAC test case 7.1.3.4	8.3.0	8.4.0
2010-09	RAN#49	R5s100464	0288	-	Addition of GCF WI 82 ESM test case 10.4.1	8.3.0	8.4.0
2010-09	RAN#49	R5s100466	0247	-	Regression CR for LTE wk26 ATS	8.3.0	8.4.0
2010-09	RAN#49	R5s100468	0248	-	Corrections to GCF WI-081EUTRA RLC Testcase 7.2.3.4	8.3.0	8.4.0
2010-09	RAN#49	R5s100469	0265	-	Corrections to GCF WI-081EUTRA DRB Testcase 12.2.1 and 12.2.2	8.3.0	8.4.0
2010-09	RAN#49	R5s100472	0287	-	LTE_TDD: Addition of GCF WI 91 EUTRA RLC test case 7.2.2.11	8.3.0	8.4.0
2010-09	RAN#49	R5s100475	0266	-	Addition of GCF WI 81 EUTRA Idle Mode test case 6.1.2.6	8.3.0	8.4.0

Date	TSG #	TSG Doc.	CR	Rev	Subject/Comment	Old	New
2010-09	RAN#49	R5s100477	0298	-	Addition of GCF WI-081 E-UTRA RRC test case 8.2.4.6	8.3.0	8.4.0
2010-09	RAN#49	R5s100479	0246	-	Corrections to GCF WI-082 EUTRA ESM Testcase 10.6.1	8.3.0	8.4.0
2010-09	RAN#49	R5s100485	0245	-	Regression CR for LTE/SAE 10wk26 ATS [Revision of R5s100485]	8.3.0	8.4.0
2010-09	RAN#49	R5s100487	0284	-	Addition of GCF WI 82 EMM test case 9.2.3.1.1	8.3.0	8.4.0
2010-09	RAN#49	R5s100489	0283	-	LTE_TDD: Addition of GCF WI 91 EUTRA PDCP test case 7.3.1.3	8.3.0	8.4.0
2010-09	RAN#49	R5s100491	0282	-	Addition of GCF WI-081 E-UTRA RRC test case 8.3.1.8	8.3.0	8.4.0
2010-09	RAN#49	R5s100495	0290	-	Addition of GCF WI-081 E-UTRA RRC test case 8.3.1.3	8.3.0	8.4.0
2010-09	RAN#49	R5s100496	0292	-	Addition of GCF WI 81 EUTRA RRC test case 8.2.4.1	8.3.0	8.4.0
2010-09	RAN#49	R5s100498	0291	-	Addition of GCF WI 81 EUTRA RRC test case 8.2.4.7	8.3.0	8.4.0
2010-09	RAN#49	R5s100500	0297	-	Addition of GCF WI 81 EUTRA IDLE MODE test case 6.1.2.8	8.3.0	8.4.0
2010-09	RAN#49	R5s100503	0295	-	Addition of GCF WI-081 E-UTRA Idle Mode test case 6.1.2.11	8.3.0	8.4.0
2010-09	RAN#49	R5s100505	0294	-	Addition of GCF WI-081 E-UTRA Idle Mode test case 6.1.2.15	8.3.0	8.4.0
2010-09	RAN#49	R5s100507	0296	-	Addition of GCF WI 81 EUTRA IDLE MODE test case 6.1.2.9	8.3.0	8.4.0
2010-12	RAN#50	R5-106578	0301	-	Clarification on cell power change time	8.4.0	8.5.0
2010-12	RAN#50	R5-106675	0302	-	LTE test model updates	8.4.0	8.5.0
2010-12	RAN#50	RP-101151	0303	-	CR to 36.523-3: Add new verified and e-mail agreed TTCN test cases in the TC lists in 36.523-3 (prose), Annex A	8.4.0	8.5.0
2010-12	RAN#50	R5s100399	0307	-	Corrections to EUTRA RLC test case 7.2.3.2, 7.2.3.5, 7.2.3.18, 7.2.3.10	8.4.0	8.5.0
2010-12	RAN#50	R5s100448	0381	-	LTE_TDD: Addition of GCF WI 91 EUTRA Idle Mode test case 6.1.2.4	8.4.0	8.5.0
2010-12	RAN#50	R5s100450	0380	-	LTE_TDD: Addition of GCF WI 91 EUTRA MAC test case 7.1.2.1	8.4.0	8.5.0
2010-12	RAN#50	R5s100454	0379	-	LTE_TDD: Addition of GCF WI 92 EUTRA Multi-layer test case 13.2.1	8.4.0	8.5.0
2010-12	RAN#50	R5s100470	0305	-	Addition of GCF WI 82 ESM test case 10.8.1	8.4.0	8.5.0
2010-12	RAN#50	R5s100473	0309	-	Addition of GCF WI 81 EUTRA MAC test case 7.1.4.3	8.4.0	8.5.0
2010-12	RAN#50	R5s100493	0306	-	Addition of GCF WI-081 E-UTRA RRC test case 8.3.1.9	8.4.0	8.5.0
2010-12	RAN#50	R5s100513	0304	-	LTE_TDD: Correction to f_EUTRA_SS_ConfigureActiveCell to configure Tcell and sfn offset	8.4.0	8.5.0
2010-12	RAN#50	R5s100515	0320	-	Correction to GCF WI-081 E-UTRA RRC test case 8.2.4.5	8.4.0	8.5.0
2010-12	RAN#50	R5s100516	0319	-	Addition of GCF WI 81 EUTRA RRC test case 8.3.1.10	8.4.0	8.5.0
2010-12	RAN#50	R5s100520	0318	-	Regression CR for LTE wk33 ATS	8.4.0	8.5.0
2010-12	RAN#50	R5s100522	0308	-	Addition of GCF WI 81 EUTRA MAC test case 7.1.4.11	8.4.0	8.5.0
2010-12	RAN#50	R5s100524	0316	-	Correction to GCF WI-081 E-UTRA RRC test cases 8.2.4.x	8.4.0	8.5.0
2010-12	RAN#50	R5s100525	0317	-	Addition of GCF WI 81 EUTRA MAC test case 7.1.2.8	8.4.0	8.5.0
2010-12	RAN#50	R5s100527	0315	-	Addition of GCF WI 81 EUTRA Idle Mode test case 6.1.2.7	8.4.0	8.5.0
2010-12	RAN#50	R5s100529	0314	-	Addition of GCF WI 81 EUTRA MAC test case 7.1.4.12	8.4.0	8.5.0
2010-12	RAN#50	R5s100531	0310	-	Correction of GCF WI-081 E-UTRA RLC test case 7.2.3.9	8.4.0	8.5.0
2010-12	RAN#50	R5s100532	0325	-	Corrections to GCF WI-081 EUTRA MAC Testcase 7.1.1.1	8.4.0	8.5.0
2010-12	RAN#50	R5s100533	0313	-	Corrections to GCF WI-081 EUTRA MAC Testcase 7.1.4.10	8.4.0	8.5.0
2010-12	RAN#50	R5s100535	0312	-	Corrections to Usage of Float Values in LTE TTCN ATS	8.4.0	8.5.0
2010-12	RAN#50	R5s100536	0311	-	Correction to GCF WI-082 E-UTRA EMM test case 9.2.3.1.5	8.4.0	8.5.0

Date	TSG #	TSG Doc.	CR	Rev	Subject/Comment	Old	New
2010-12	RAN#50	R5s100538	0321	-	Regression CR for LTE wk37 ATS	8.4.0	8.5.0
2010-12	RAN#50	R5s100539	0324	-	Correction to GCF WI-081 E-UTRA RRC test cases 8.1.2.7	8.4.0	8.5.0
2010-12	RAN#50	R5s100541	0323	-	Addition of GCF WI 81 EUTRA RRC test case 8.1.3.5	8.4.0	8.5.0
2010-12	RAN#50	R5s100545	0322	-	Addition of GCF WI 82 EMM test case 9.2.1.1.1a	8.4.0	8.5.0
2010-12	RAN#50	R5s100548	0328	-	Correction of GCF WI-081 EUTRA RRC test case 8.2.4.6	8.4.0	8.5.0
2010-12	RAN#50	R5s100549	0327	-	Correction of GCF WI-082 EPC test case 10.7.2	8.4.0	8.5.0
2010-12	RAN#50	R5s100550	0326	-	Correction of GCF WI-082 EPC test case 10.3.1	8.4.0	8.5.0
2010-12	RAN#50	R5s100555	0338	-	Correction to GCF WI-082 EMM test case 9.2.3.1.8	8.4.0	8.5.0
2010-12	RAN#50	R5s100556	0329	-	Regression TTCN CR for IWD D10_wk37 ATS	8.4.0	8.5.0
2010-12	RAN#50	R5s100557	0337	-	Correction to AT commands used in LTE ATS	8.4.0	8.5.0
2010-12	RAN#50	R5s100558	0336	-	Correction of GCF WI-081 EUTRA MAC test case 7.1.4.16	8.4.0	8.5.0
2010-12	RAN#50	R5s100559	0335	-	Correction to L2 test cases to allow HARQ retransmissions	8.4.0	8.5.0
2010-12	RAN#50	R5s100560	0334	-	Correction to GCF WI-081 EUTRA PDCP test cases 7.3.5.x	8.4.0	8.5.0
2010-12	RAN#50	R5s100561	0333	-	Correction to GCF WI-081 EUTRA RRC test case 8.2.4.5	8.4.0	8.5.0
2010-12	RAN#50	R5s100562	0332	-	Correction to GCF WI-081 EUTRA PDCP test case 7.3.5.4	8.4.0	8.5.0
2010-12	RAN#50	R5s100563	0330	-	Correction to GCF WI-081 EUTRA MAC test case 7.1.3.7	8.4.0	8.5.0
2010-12	RAN#50	R5s100564	0331	-	Correction to GCF WI-081 EUTRA RRC test case 8.5.1.1	8.4.0	8.5.0
2010-12	RAN#50	R5s100566	0341	-	Correction to GCF WI-081 EUTRA RLC test case 7.2.3.14	8.4.0	8.5.0
2010-12	RAN#50	R5s100571	0386	-	Correction of GCF WI-081 E-UTRA MAC test case 7.1.4.5	8.4.0	8.5.0
2010-12	RAN#50	R5s100572	0340	-	Correction of GCF WI-081 E-UTRA MAC test case 7.1.2.3	8.4.0	8.5.0
2010-12	RAN#50	R5s100573	0347	-	Correction to GCF WI-081 EUTRA RRC Testcase 8.2.4.3	8.4.0	8.5.0
2010-12	RAN#50	R5s100576	0339	-	Correction to GCF WI-081 EUTRA RRC Testcase 8.2.4.1	8.4.0	8.5.0
2010-12	RAN#50	R5s100579	0343	-	Correction to GCF WI-081 EUTRA PDCP test case 7.3.5.5	8.4.0	8.5.0
2010-12	RAN#50	R5s100580	0342	-	Correction to GCF WI-081 EUTRA RRC Testcase 8.3.1.10	8.4.0	8.5.0
2010-12	RAN#50	R5s100582	0352	-	Addition of GCF WI 82 EMM test case 9.2.1.1.15	8.4.0	8.5.0
2010-12	RAN#50	R5s100584	0351	-	Addition of GCF WI 82 EMM test case 9.2.1.1.17	8.4.0	8.5.0
2010-12	RAN#50	R5s100586	0385	-	Addition of GCF WI 82 EMM SMS test case 11.1.1	8.4.0	8.5.0
2010-12	RAN#50	R5s100588	0384	-	Addition of GCF WI 82 EMM SMS test case 11.1.2	8.4.0	8.5.0
2010-12	RAN#50	R5s100590	0350	-	Addition of GCF WI 81 EUTRA test case 6.1.2.5	8.4.0	8.5.0
2010-12	RAN#50	R5s100592	0349	-	Correction to GCF WI-081 EUTRA MAC Testcase 7.1.3.6	8.4.0	8.5.0
2010-12	RAN#50	R5s100593	0348	-	Correction to GCF WI-081 EUTRA MAC Testcase 7.1.4.13	8.4.0	8.5.0
2010-12	RAN#50	R5s100595	0346	-	Correction to GCF WI-081 EUTRA RLC Testcase 7.2.2.11	8.4.0	8.5.0
2010-12	RAN#50	R5s100597	0345	-	Addition of GCF WI 81 EUTRA RRC test case 9.2.1.1.13	8.4.0	8.5.0
2010-12	RAN#50	R5s100604	0383	-	Addition of GCF WI 82 EMM SMS test case 11.1.3	8.4.0	8.5.0
2010-12	RAN#50	R5s100606	0382	-	Addition of GCF WI 82 EMM SMS test case 11.1.4	8.4.0	8.5.0
2010-12	RAN#50	R5s100608	0344	-	Correction of GCF WI-081 E-UTRA TAU	8.4.0	8.5.0
2010-12	RAN#50	R5s100610	0367	-	Addition of GCF WI 82 EMM test case 9.2.1.1.7	8.4.0	8.5.0

Date	TSG #	TSG Doc.	CR	Rev	Subject/Comment	Old	New
2010-12	RAN#50	R5s100614	0364	-	LTE_TDD: Addition of GCF WI 91 EUTRA Idle Mode test case 6.1.2.3	8.4.0	8.5.0
2010-12	RAN#50	R5s100616	0363	-	LTE_TDD: Addition of GCF WI 91 EUTRA MAC test case 7.1.2.8	8.4.0	8.5.0
2010-12	RAN#50	R5s100618	0362	-	LTE_TDD: Addition of GCF WI 91 EUTRA MAC test case 7.1.4.5	8.4.0	8.5.0
2010-12	RAN#50	R5s100620	0361	-	LTE_TDD: Addition of GCF WI 91 EUTRA MAC test case 7.1.4.6	8.4.0	8.5.0
2010-12	RAN#50	R5s100622	0360	-	LTE_TDD: Addition of GCF WI 91 EUTRA MAC test case 7.1.4.7	8.4.0	8.5.0
2010-12	RAN#50	R5s100624	0366	-	Addition of GCF WI 82 EMM test case 9.2.3.1.4	8.4.0	8.5.0
2010-12	RAN#50	R5s100626	0359	-	LTE_TDD: Addition of GCF WI 91 EUTRA MAC test case 7.1.4.10	8.4.0	8.5.0
2010-12	RAN#50	R5s100628	0358	-	LTE_TDD: Addition of GCF WI 91 EUTRA MAC test case 7.1.4.16	8.4.0	8.5.0
2010-12	RAN#50	R5s100632	0357	-	LTE_TDD: Addition of GCF WI 91 EUTRA RLC test case 7.2.3.10	8.4.0	8.5.0
2010-12	RAN#50	R5s100634	0356	-	LTE_TDD: Addition of GCF WI 91 EUTRA RLC test case 7.2.3.16	8.4.0	8.5.0
2010-12	RAN#50	R5s100636	0355	-	LTE_TDD: Addition of GCF WI 91 EUTRA RRC test case 8.2.4.3	8.4.0	8.5.0
2010-12	RAN#50	R5s100638	0354	-	LTE_TDD: Addition of GCF WI 91 EUTRA RRC test case 8.5.1.1	8.4.0	8.5.0
2010-12	RAN#50	R5s100640	0365	-	Addition of GCF WI 82 EMM test case 9.2.1.2.4	8.4.0	8.5.0
2010-12	RAN#50	R5s100642	0353	-	LTE_TDD: Addition of GCF WI 91 EUTRA MAC test case 7.1.7.1.3	8.4.0	8.5.0
2010-12	RAN#50	R5s100644	0378	-	LTE_TDD: Addition of GCF WI 91 EUTRA Idle Mode test case 6.1.2.6	8.4.0	8.5.0
2010-12	RAN#50	R5s100646	0377	-	LTE_TDD: Addition of GCF WI 91 EUTRA RRC test case 8.1.2.5	8.4.0	8.5.0
2010-12	RAN#50	R5s100648	0376	-	LTE_TDD: Addition of GCF WI 91 EUTRA RRC test case 8.2.4.2	8.4.0	8.5.0
2010-12	RAN#50	R5s100650	0375	-	LTE_TDD: Addition of GCF WI 91 EUTRA RRC test case 8.2.4.5	8.4.0	8.5.0
2010-12	RAN#50	R5s100652	0374	-	LTE_TDD: Addition of GCF WI 91 EUTRA RRC test case 8.3.1.5	8.4.0	8.5.0
2010-12	RAN#50	R5s100654	0373	-	LTE_TDD: Addition of GCF WI 91 EUTRA RRC test case 8.3.1.8	8.4.0	8.5.0
2010-12	RAN#50	R5s100656	0372	-	LTE_TDD: Addition of GCF WI 91 EUTRA RRC test case 8.5.1.3	8.4.0	8.5.0
2010-12	RAN#50	R5s100658	0368	-	LTE_TDD: Addition of GCF WI 91 EUTRA MAC test case 7.1.4.11	8.4.0	8.5.0
2010-12	RAN#50	R5s100660	0371	-	Addition of GCF WI 82 EMM test case 9.2.2.2.2	8.4.0	8.5.0
2010-12	RAN#50	R5s100662	0370	-	Addition of GCF WI 82 EMM test case 9.2.1.2.1	8.4.0	8.5.0
2010-12	RAN#50	R5s100664	0369	-	Addition of GCF WI 82 EMM test case 9.2.3.2.1	8.4.0	8.5.0
2010-12	RAN#50	R5s100669	0390	-	LTE_TDD: Addition of GCF WI 91 EUTRA PDCP test case 7.3.5.4	8.4.0	8.5.0
2010-12	RAN#50	R5s100671	0389	-	LTE_TDD: Addition of GCF WI 91 EUTRA RRC test case 8.2.4.1	8.4.0	8.5.0
2010-12	RAN#50	R5s100673	0388	-	LTE_TDD: Addition of GCF WI 91 EUTRA RRC test case 8.3.1.9	8.4.0	8.5.0
2010-12	RAN#50	R5s100675	0398	-	Addition of GCF WI 81 EUTRA IDLE MODE test case 6.1.1.1	8.4.0	8.5.0
2010-12	RAN#50	R5s100678	0401	-	Addition of GCF WI 81 RRC test case 8.3.1.7	8.4.0	8.5.0
2010-12	RAN#50	R5s100680	0400	-	Addition of GCF WI 81 EUTRA RRC test case 8.1.2.3	8.4.0	8.5.0
2010-12	RAN#50	R5s100682	0399	-	Addition of GCF WI 81 EUTRA RRC test case 8.1.1.2	8.4.0	8.5.0
2010-12	RAN#50	R5s100688	0397	-	Addition of GCF WI 82 EMM test case 9.2.1.1.21	8.4.0	8.5.0
2010-12	RAN#50	R5s100690	0396	-	Addition of GCF WI 84 EMM test case 9.2.1.1.22	8.4.0	8.5.0
2010-12	RAN#50	R5s100692	0402	-	Regression CR for LTE wk42 ATS	8.4.0	8.5.0
2010-12	RAN#50	R5s100693	0393	-	Addition of GCF WI 82 ESM test case 10.8.2	8.4.0	8.5.0
2010-12	RAN#50	R5s100695	0392	-	Addition of GCF WI 82 ESM test case 10.8.3	8.4.0	8.5.0

Date	TSG #	TSG Doc.	CR	Rev	Subject/Comment	Old	New
2010-12	RAN#50	R5s100697	0391	-	Addition of GCF WI 82 EMM test case 9.3.1.17	8.4.0	8.5.0
2010-12	RAN#50	R5s100699	0395	-	Addition of GCF WI 82 EUTRA DRB test case 12.2.3	8.4.0	8.5.0
2010-12	RAN#50	R5s100701	0394	-	Addition of GCF WI 82 EMM test case 9.2.1.1.19	8.4.0	8.5.0
2010-12	RAN#50	R5s100703	0387	-	Addition of GCF WI 81 EUTRA RRC test case 8.1.1.6	8.4.0	8.5.0
2010-12	RAN#50	R5s100705	0408	-	Addition of GCF Priority 3 E-UTRA RRC test case 8.2.1.7	8.4.0	8.5.0
2010-12	RAN#50	R5s100707	0407	-	Addition of GCF Priority 3 E-UTRA RRC test case 8.5.1.2	8.4.0	8.5.0
2010-12	RAN#50	R5s100709	0406	-	Correction of GCF WI-081 Test Case 7.1.4.5	8.4.0	8.5.0
2010-12	RAN#50	R5s100712	0405	-	Addition of GCF WI 82 ESM test case 10.7.3	8.4.0	8.5.0
2010-12	RAN#50	R5s100714	0404	-	Addition of GCF WI 81 EUTRA RRC test case 8.2.4.4	8.4.0	8.5.0
2010-12	RAN#50	R5s100720	0403	-	Addition of GCF WI 82 Multilayer test case 13.3.1.1	8.4.0	8.5.0
2010-12	RAN#50	R5s100722	0409	-	Addition of GCF WI 82 EMM test case 9.2.1.1.23	8.4.0	8.5.0
2010-12	RAN#50	R5s100724	0414	-	Correction to IP address allocation and ESM cause for condition IPv4viaNAS_TestMode	8.4.0	8.5.0
2010-12	RAN#50	R5s100725	0413	-	Correction of the q-RxLevMin value in the sib5 interFreqCarrierFreqList	8.4.0	8.5.0
2010-12	RAN#50	R5s100726	0411	-	LTE_TDD: Resubmission of GCF WI 91 EUTRA RLC test case 7.2.2.10	8.4.0	8.5.0
2010-12	RAN#50	R5s100728	0412	-	Addition of GCF WI 82 EMM test case 9.3.1.16	8.4.0	8.5.0
2010-12	RAN#50	R5s100730	0410	-	Addition of GCF WI 82 EMM test case 9.2.2.1.2	8.4.0	8.5.0
2010-12	RAN#50	R5s100732	0422	-	LTE_TDD: Addition of GCF WI 91 EUTRA Idle mode test case 6.1.2.11	8.4.0	8.5.0
2010-12	RAN#50	R5s100734	0421	-	LTE_TDD: Addition of GCF WI 91 EUTRA Idle mode test case 6.1.2.8	8.4.0	8.5.0
2010-12	RAN#50	R5s100738	0419	-	LTE_TDD: Addition of GCF WI 91 EUTRA RRC test case 8.3.1.3	8.4.0	8.5.0
2010-12	RAN#50	R5s100740	0418	-	LTE_TDD: Addition of GCF WI 93 EUTRA RRC test case 8.3.1.7	8.4.0	8.5.0
2010-12	RAN#50	R5s100742	0417	-	LTE_TDD: Addition of GCF WI 91 EUTRA PDCP test case 7.3.5.5	8.4.0	8.5.0
2010-12	RAN#50	R5s100744	0416	-	Addition of GCF WI 82 Multilayer test case 13.3.1.2	8.4.0	8.5.0
2010-12	RAN#50	R5s100746	0415	-	Addition of GCF WI 82 ESM test case 10.7.4	8.4.0	8.5.0
2010-12	RAN#50	R5s100748	0423	-	Addition of GCF P3 E-UTRA ESM test case 10.5.3	8.4.0	8.5.0
2010-12	RAN#50	R5s100750	0424	-	Addition of GCF P3 E-UTRA EMM test case 9.2.3.1.13	8.4.0	8.5.0
2010-12	RAN#50	R5s100754	0425	-	Correction of GCF WI-081 EPC test case 9.1.2.5	8.4.0	8.5.0
2010-12	RAN#50	R5s100755	0426	-	Correction of GCF WI-081 EMM test case 9.2.3.1.5 and 9.2.3.1.8	8.4.0	8.5.0
2010-12	RAN#50	R5s100758	0434	-	Addition of GCF WI-82 P3 E-UTRA EMM test case 9.2.3.1.14	8.4.0	8.5.0
2010-12	RAN#50	R5s100760	0432	-	Correction of GCF WI-081 EPC test case 12.2.1 and 12.2.2	8.4.0	8.5.0
2010-12	RAN#50	R5s100761	0433	-	Correction of GCF WI-081 ESM test case 10.6.1, 10.4.1, 10.5.1, 10.5.3	8.4.0	8.5.0
2010-12	RAN#50	R5s100766	0431	-	Correction to GCF WI 81 EUTRA IDLE MODE test case 6.1.2.9	8.4.0	8.5.0
2010-12	RAN#50	R5s100767	0430	-	Correction to GCF WI 81 EUTRA MAC test case 7.1.4.1	8.4.0	8.5.0
2010-12	RAN#50	R5s100768	0429	-	Correction to GCF WI 82 EPC SMS test cases 11.1.3 and 11.1.4	8.4.0	8.5.0
2010-12	RAN#50	R5s100769	0428	-	Correction to GCF WI 81 EUTRA MAC test case 7.1.2.8	8.4.0	8.5.0
2010-12	RAN#50	R5s100784	0427	-	Addition of GCF WI 82 EMM test case 9.2.1.1.16	8.4.0	8.5.0
2010-12	RAN#50	R5s100787	0420	-	LTE_TDD: Addition of GCF WI 91 EUTRA RRC test case 8.1.1.6	8.4.0	8.5.0
2011-03	RAN#51	RP-110170	0436	-	CR to 36.523-3: Add new verified and e-mail agreed TTCN test cases in the TC lists in 36.523-3 (prose), Annex A	8.5.0	8.6.0

Date	TSG #	TSG Doc.	CR	Rev	Subject/Comment	Old	New
2011-03	RAN#51	R5-110803	0435	-	Routine maintenance of LTE test model and postambles	8.5.0	8.6.0
2011-03	RAN#51	R5s100751	0470	-	Addition of GCF WI-081 EUTRA RRC InterRAT test case 8.3.2.3	8.5.0	8.6.0
2011-03	RAN#51	R5s100772	0456	-	Correction to GCF WI 81 EUTRA MAC test case 7.1.4.12	8.5.0	8.6.0
2011-03	RAN#51	R5s100773	0455	-	Correction to GCF WI 82 EPC SMS test cases 11.1.1, 11.1.2, 11.1.3, 11.1.4	8.5.0	8.6.0
2011-03	RAN#51	R5s100774	0513	-	LTE_TDD: Addition of GCF WI 91 EUTRA Idle mode test case 6.1.2.15	8.5.0	8.6.0
2011-03	RAN#51	R5s100776	0512	-	LTE_TDD: Addition of GCF WI 91 EUTRA MAC test case 7.1.4.3	8.5.0	8.6.0
2011-03	RAN#51	R5s100778	0511	-	LTE_TDD: Addition of GCF WI 91 EUTRA PDCP test case 7.3.5.3	8.5.0	8.6.0
2011-03	RAN#51	R5s100780	0485	-	Addition of GCF WI 82 EMM test case 9.2.2.2.14	8.5.0	8.6.0
2011-03	RAN#51	R5s100782	0510	-	LTE_TDD: Addition of GCF WI 91 EUTRA RRC test case 8.2.1.7	8.5.0	8.6.0
2011-03	RAN#51	R5s100789	0509	-	Addition of GCF P3 E-UTRA EMM test case 9.1.2.6	8.5.0	8.6.0
2011-03	RAN#51	R5s100792	0508	-	Correction to EMM test cases 9.2.1.1.14, 9.2.3.1.2 and 10.4.1	8.5.0	8.6.0
2011-03	RAN#51	R5s100793	0507	-	Addition of GCF P3 E-UTRA EMM test case 9.2.2.1.7	8.5.0	8.6.0
2011-03	RAN#51	R5s100795	0506	-	Addition of GCF P3 E-UTRA EMM test case 9.2.3.1.9a	8.5.0	8.6.0
2011-03	RAN#51	R5s100799	0505	-	Correction of GCF WI 82 ESM test case 10.4.1	8.5.0	8.6.0
2011-03	RAN#51	R5s100800	0517	-	Correction to GCF WI-082 ESM test case 10.4.1	8.5.0	8.6.0
2011-03	RAN#51	R5s100801	0469	-	Correction to GCF WI-081 PDCP / RRC intra-LTE intercell HO test cases	8.5.0	8.6.0
2011-03	RAN#51	R5s100802	0516	-	Correction to GCF WI-081 EUTRA PDCP test case 7.3.1.3	8.5.0	8.6.0
2011-03	RAN#51	R5s100803	0502	-	Regression CR for LTE WK42 ATS	8.5.0	8.6.0
2011-03	RAN#51	R5s100811	0515	-	Addition of GCF P3 E-UTRA EMM test case 9.2.1.1.25	8.5.0	8.6.0
2011-03	RAN#51	R5s100812	0468	-	Correction to GCF WI 82 EMM test case 9.2.1.2.1	8.5.0	8.6.0
2011-03	RAN#51	R5s100813	0467	-	Correction to GCF WI 82 EMM test case 9.2.2.2.2	8.5.0	8.6.0
2011-03	RAN#51	R5s100815	0514	-	Addition of GCF P3 E-UTRA EMM test case 9.2.1.1.26	8.5.0	8.6.0
2011-03	RAN#51	R5s100817	0466	-	Addition of GCF WI 82 EMM test case 9.2.3.1.28	8.5.0	8.6.0
2011-03	RAN#51	R5s100819	0465	-	Addition of GCF WI-082 EMM test case 9.2.3.1.27	8.5.0	8.6.0
2011-03	RAN#51	R5s100821	0464	-	LTE_TDD: Addition of GCF WI 91 EUTRA MAC test case 7.1.2.4	8.5.0	8.6.0
2011-03	RAN#51	R5s100825	0463	-	LTE_TDD: Addition of GCF WI 91 EUTRA Idle mode test case 6.1.2.7	8.5.0	8.6.0
2011-03	RAN#51	R5s100827	0458	-	Addition of GCF WI 81 EUTRA RRC test case 8.1.2.2	8.5.0	8.6.0
2011-03	RAN#51	R5s100829	0457	-	LTE_TDD: Addition of GCF WI 91 EUTRA Idle Mode test case 6.1.2.9	8.5.0	8.6.0
2011-03	RAN#51	R5s100831	0462	-	LTE_TDD: Addition of GCF WI 91 EUTRA RRC test case 8.1.3.4	8.5.0	8.6.0
2011-03	RAN#51	R5s100833	0461	-	LTE_TDD: Addition of GCF WI 91 EUTRA RRC test case 8.1.3.5	8.5.0	8.6.0
2011-03	RAN#51	R5s100835	0454	-	LTE_TDD: Addition of GCF WI 91 EUTRA Idle Mode test case 6.1.1.1	8.5.0	8.6.0
2011-03	RAN#51	R5s100837	0460	-	LTE_TDD: Addition of GCF WI 91 EUTRA RRC test case 8.2.4.6	8.5.0	8.6.0
2011-03	RAN#51	R5s100839	0459	-	LTE_TDD: Addition of GCF WI 91 EUTRA DRB test case 12.2.3	8.5.0	8.6.0
2011-03	RAN#51	R5s100848	0484	-	Addition of GCF WI 81 LTE-C2K test case 8.3.2.7	8.5.0	8.6.0
2011-03	RAN#51	R5s100850	0478	-	Addition of GCF WI 81 RRC test case 8.3.3.1	8.5.0	8.6.0
2011-03	RAN#51	R5s100852	0453	-	Addition of GCF WI 81 EUTRA MAC test case 7.1.3.9	8.5.0	8.6.0
2011-03	RAN#51	R5s100854	0452	-	Addition of GCF WI 82 Multilayer test case 13.4.1.2	8.5.0	8.6.0

Date	TSG #	TSG Doc.	CR	Rev	Subject/Comment	Old	New
2011-03	RAN#51	R5s100856	0437	-	Addition of GCF WI-82 EMM test case 9.2.3.1.23	8.5.0	8.6.0
2011-03	RAN#51	R5s100858	0451	-	Addition of GCF WI-82 EMM test case 9.2.3.1.19	8.5.0	8.6.0
2011-03	RAN#51	R5s100860	0450	-	Correction to GCF WI 82 EMM test cases 9.2.1.1.21 and 9.2.1.1.22	8.5.0	8.6.0
2011-03	RAN#51	R5s100863	0449	-	LTE_TDD: Addition of GCF WI 91 EUTRA MAC test case 7.1.4.12	8.5.0	8.6.0
2011-03	RAN#51	R5s100865	0448	-	LTE_TDD: Addition of GCF WI 91 EUTRA RRC test case 8.1.2.2	8.5.0	8.6.0
2011-03	RAN#51	R5s100867	0447	-	LTE_TDD: Addition of GCF WI 92 Multilayer test case 13.3.1.1	8.5.0	8.6.0
2011-03	RAN#51	R5s100869	0446	-	LTE_TDD: Addition of GCF WI 92 Multilayer test case 13.4.1.2	8.5.0	8.6.0
2011-03	RAN#51	R5s100871	0473	-	Addition of GCF WI 81 EUTRA RRC test case 8.1.3.6	8.5.0	8.6.0
2011-03	RAN#51	R5s100873	0474	-	Addition of GCF WI 81 EUTRA Idlemode test case 6.2.3.5	8.5.0	8.6.0
2011-03	RAN#51	R5s100876	0445	-	Correction to GCF WI 82 EMM test case 9.2.3.1.14	8.5.0	8.6.0
2011-03	RAN#51	R5s100877	0444	-	Addition of GCF WI 82 EMM test case 9.2.2.1.8	8.5.0	8.6.0
2011-03	RAN#51	R5s100879	0477	-	Addition of GCF WI 81 EUTRA test case 8.3.1.11	8.5.0	8.6.0
2011-03	RAN#51	R5s100881	0443	-	LTE_TDD: Addition of GCF WI 91 EUTRA MAC test case 7.1.3.9	8.5.0	8.6.0
2011-03	RAN#51	R5s100883	0476	-	Addition of GCF WI 82 EMM test case 9.2.2.1.9	8.5.0	8.6.0
2011-03	RAN#51	R5s110001	0442	-	Correction to GCF WI 81 EUTRA RRC test case 8.1.2.3	8.5.0	8.6.0
2011-03	RAN#51	R5s110002	0440	-	Correction to GCF WI 82 ESM test case 10.8.2	8.5.0	8.6.0
2011-03	RAN#51	R5s110003	0441	-	LTE_TDD: Addition of GCF WI 91 EUTRA RRC test case 8.1.2.3	8.5.0	8.6.0
2011-03	RAN#51	R5s110005	0439	-	Correction to GCF WI 81 EUTRA RRC test case 8.3.1.7	8.5.0	8.6.0
2011-03	RAN#51	R5s110006	0438	-	Correction to GCF WI 82 EMM test case 9.1.2.6	8.5.0	8.6.0
2011-03	RAN#51	R5s110007	0475	-	Correction to EMM test cases	8.5.0	8.6.0
2011-03	RAN#51	R5s110008	0472	-	Regression CR for iwd-EUTRA-B2009-12_D10wk49 ATS	8.5.0	8.6.0
2011-03	RAN#51	R5s110009	0471	-	LTE_TDD: Addition of GCF WI 91 EUTRA RRC test case 8.5.1.2	8.5.0	8.6.0
2011-03	RAN#51	R5s110011	0483	-	Correction to GCF WI-082 ESM test cases 10.4.1 and 10.5.1 ((IP address assignment for second PDN)	8.5.0	8.6.0
2011-03	RAN#51	R5s110012	0482	-	Correction to GCF WI-081 MAC test case 7.2.3.10	8.5.0	8.6.0
2011-03	RAN#51	R5s110013	0481	-	Correction to GCF WI-081 EUTRA MAC test cases 7.1.7.x	8.5.0	8.6.0
2011-03	RAN#51	R5s110014	0480	-	Addition of GCF WI-081 EUTRA Idle Mode test case 6.2.2.1	8.5.0	8.6.0
2011-03	RAN#51	R5s110016	0479	-	Correction of RV values used in Dci1C scheduling for SI (BCCH)	8.5.0	8.6.0
2011-03	RAN#51	R5s110019	0492	-	Regression CR for LTE WK49 ATS	8.5.0	8.6.0
2011-03	RAN#51	R5s110020	0493	-	Addition of GCF WI 81 EUTRA test case 8.3.1.4	8.5.0	8.6.0
2011-03	RAN#51	R5s110024	0490	-	Addition of GCF WI 82 EMM test case 9.2.3.1.16	8.5.0	8.6.0
2011-03	RAN#51	R5s110026	0491	-	Addition of GCF WI 82 EMM test case 9.2.1.1.24	8.5.0	8.6.0
2011-03	RAN#51	R5s110028	0489	-	Addition of GCF WI 82 EMM test case 9.2.3.1.25	8.5.0	8.6.0
2011-03	RAN#51	R5s110030	0488	-	Correction to GCF WI 81 EUTRA RLC test case 7.2.3.21	8.5.0	8.6.0
2011-03	RAN#51	R5s110031	0501	-	Addition of GCF WI 81 EUTRA Idle Mode test case 6.2.3.3	8.5.0	8.6.0
2011-03	RAN#51	R5s110033	0487	-	Correction to GCF WI 81 EUTRA PDCP test case 7.3.5.2	8.5.0	8.6.0
2011-03	RAN#51	R5s110034	0486	-	Correction to use of DCI combination 1 (5 MHz) with 9 PRBs	8.5.0	8.6.0
2011-03	RAN#51	R5s110035	0499	-	Correction of NAS type definition in TS 36.523-3	8.5.0	8.6.0

Date	TSG #	TSG Doc.	CR	Rev	Subject/Comment	Old	New
2011-03	RAN#51	R5s110036	0498	-	Correction to GCF WI 81 EUTRA MAC test case 7.1.4.6	8.5.0	8.6.0
2011-03	RAN#51	R5s110037	0497	-	Correction to GCF WI 81 EUTRA RRC test case 8.3.2.3	8.5.0	8.6.0
2011-03	RAN#51	R5s110038	0496	-	Addition of GCF WI 82 EMM test case 9.3.2.2	8.5.0	8.6.0
2011-03	RAN#51	R5s110040	0495	-	Addition of GCF WI 82 EMM test case 9.3.2.2a	8.5.0	8.6.0
2011-03	RAN#51	R5s110042	0494	-	Addition of GCF WI 81 EUTRA IDLE MODE test case 6.1.2.13	8.5.0	8.6.0
2011-03	RAN#51	R5s110046	0500	-	Correction of TTCN for EMM inter-RAT / inter-frequency test cases	8.5.0	8.6.0
2011-03	RAN#51	R5s110051	0504	-	Correction to GCF WI-082 E-UTRA test case 13.3.1.1	8.5.0	8.6.0
2011-03	RAN#51	R5s110052	0520	-	Correction to GCF WI-082 E-UTRA test case 9.2.3.1.8	8.5.0	8.6.0
2011-03	RAN#51	R5s110054	0519	-	Correction to GCF WI-082 E-UTRA ESM test cases 10.8.1 and 10.8.3	8.5.0	8.6.0
2011-03	RAN#51	R5s110055	0518	-	Correction to GCF WI-082 E-UTRA ESM test case 10.4.1	8.5.0	8.6.0
2011-03	RAN#51	R5s110057	0503	-	Correction to GCF WI-081 MAC test case 7.1.2.6	8.5.0	8.6.0
2011-03	RAN#51	R5s110060	0523	-	Correction to GCF WI-081 E-UTRA MAC Testcase 7.1.2.9	8.5.0	8.6.0
2011-03	RAN#51	R5s110061	0521	-	Correction to GCF WI 81 EUTRA Idle Mode test case 6.2.3.3	8.5.0	8.6.0
2011-03	RAN#51	R5s110062	0522	-	Correction to GCF WI 81 EUTRA Idle Mode test case 6.2.3.5	8.5.0	8.6.0
2011-03	RAN#51	R5s110064	0525	-	Correction to GCF WI 82 SMS test cases	8.5.0	8.6.0
2011-03	RAN#51	R5s110068	0529	-	Addition of GCF WI 82 EMM test case 9.2.3.1.26	8.5.0	8.6.0
2011-03	RAN#51	R5s110070	0528	-	Correction to GCF WI 82 EMM test case 9.2.1.1.24	8.5.0	8.6.0
2011-03	RAN#51	R5s110073	0527	-	Addition of GCF WI 81 RRC test case 8.2.4.9	8.5.0	8.6.0
2011-03	RAN#51	R5s110075	0526	-	Addition of GCF WI 82 EMM test case 9.2.2.1.3	8.5.0	8.6.0
2011-03	RAN#51	R5s110077	0524	-	Correction to GCF WI-081 MAC test case 7.1.4.4	8.5.0	8.6.0
2011-03	RAN#51	R5s110078	0533	-	Correction to GCF WI-082 NAS common module	8.5.0	8.6.0
2011-03	RAN#51	R5s110084	0531	-	Correction to GCF WI-082 E-UTRA EMM Testcase 9.2.2.1.9	8.5.0	8.6.0
2011-03	RAN#51	R5s110085	0530	-	Correction to GCF WI-081 E-UTRA MAC Testcase 7.1.4.13	8.5.0	8.6.0
2011-03	RAN#51	R5s110086	0532	-	Correction to GCF WI 82 ESM test case 10.4.1	8.5.0	8.6.0
2011-06	RAN#52	RP-110656	0536	-	CR to 36.523-3: Add new verified and e-mail agreed TTCN test cases in the TC lists in 36.523-3 (prose), Annex A	8.6.0	9.0.0
2011-06	RAN#52	R5-112665	0535	-	Routine maintenance of LTE test model and postambles	8.6.0	9.0.0
2011-06	RAN#52	R5s110081	0564	-	Addition of GCF WI-081 EUTRA RRC InterRAT test case 8.1.3.8	8.6.0	9.0.0
2011-06	RAN#52	R5s110087	0582	-	Addition of GCF WI 81 EUTRA idle mode test case 6.2.2.2	8.6.0	9.0.0
2011-06	RAN#52	R5s110089	0545	-	Addition of GCF WI 81 RRC test case 8.1.1.4	8.6.0	9.0.0
2011-06	RAN#52	R5s110091	0544	-	Correction to GCF WI-082 test case 11.1.3 and 11.1.4	8.6.0	9.0.0
2011-06	RAN#52	R5s110092	0543	-	Correction to GCF WI-081 EUTRA PDCP test cases 7.3.4.1 and 7.3.4.2	8.6.0	9.0.0
2011-06	RAN#52	R5s110094	0542	-	Resubmission of GCF WI 82 EMM test case 9.2.1.2.10	8.6.0	9.0.0
2011-06	RAN#52	R5s110096	0541	-	Correction to EUTRA MAC test case 7.1.4.3	8.6.0	9.0.0
2011-06	RAN#52	R5s110097	0540	-	Correction to EUTRA MAC test case 7.1.2.6	8.6.0	9.0.0
2011-06	RAN#52	R5s110098	0539	-	Correction to EUTRA RRC test case 8.2.4.7	8.6.0	9.0.0
2011-06	RAN#52	R5s110099	0538	-	Addition of GCF WI 82 EUTRA EMM test case 9.3.1.15	8.6.0	9.0.0
2011-06	RAN#52	R5s110101	0537	-	Correction to GCF WI 82 ESM test cases 10.7.2 & 10.8.1	8.6.0	9.0.0

Date	TSG #	TSG Doc.	CR	Rev	Subject/Comment	Old	New
2011-06	RAN#52	R5s110109	0563	-	Addition of GCF WI 82 EUTRA EMM test case 9.3.1.3	8.6.0	9.0.0
2011-06	RAN#52	R5s110112	0562	-	Correction to GCF WI-081 EUTRA <> UTRAN test cases 8.3.2.3, 8.1.3.6, 6.2.3.3, 6.2.3.5.	8.6.0	9.0.0
2011-06	RAN#52	R5s110114	0561	-	Correction to GCF WI-082 EMM test case 9.2.3.1.23	8.6.0	9.0.0
2011-06	RAN#52	R5s110115	0560	-	Correction to GCF WI-081 E-UTRA MAC test case 7.1.2.9	8.6.0	9.0.0
2011-06	RAN#52	R5s110116	0559	-	Correction to GCF WI-082 E-UTRA EMM test case 9.2.1.1.24	8.6.0	9.0.0
2011-06	RAN#52	R5s110117	0558	-	Correction to GCF WI-081 PDCP test cases 7.3.4.1 and 7.3.4.2	8.6.0	9.0.0
2011-06	RAN#52	R5s110118	0557	-	Correction to EMM test cases 9.2.1.1.1 and 9.2.1.1.20	8.6.0	9.0.0
2011-06	RAN#52	R5s110120	0555	-	Correction to GCF WI-081 EUTRA MAC test case 7.1.4.11	8.6.0	9.0.0
2011-06	RAN#52	R5s110121	0556	-	Correction to GCF WI-081 EUTRA PDCP test case 7.3.5.2	8.6.0	9.0.0
2011-06	RAN#52	R5s110122	0554	-	Correction to previously accepted R5s110034 ((DCI combi 1 / 5 MHz / with 9 PRBs)	8.6.0	9.0.0
2011-06	RAN#52	R5s110123	0586	-	Addition of GCF WI 81 EUTRA RRC test case 8.5.2.1	8.6.0	9.0.0
2011-06	RAN#52	R5s110125	0553	-	Correction EUTRA and EMM test cases	8.6.0	9.0.0
2011-06	RAN#52	R5s110127	0552	-	Addition of GCF WI 81 EUTRA idle mode test case 6.2.3.6	8.6.0	9.0.0
2011-06	RAN#52	R5s110129	0551	-	Addition of GCF WI 82 EMM test case 9.2.1.2.2	8.6.0	9.0.0
2011-06	RAN#52	R5s110131	0550	-	Addition of GCF WI 82 EMM test case 9.2.1.2.11	8.6.0	9.0.0
2011-06	RAN#52	R5s110133	0548	-	Addition of GCF WI 82 EMM test case 9.2.3.1.10	8.6.0	9.0.0
2011-06	RAN#52	R5s110135	0547	-	Addition of GCF WI 82 EMM test case 9.2.3.1.11	8.6.0	9.0.0
2011-06	RAN#52	R5s110137	0546	-	Addition of GCF WI 82 EMM test case 9.2.3.1.12	8.6.0	9.0.0
2011-06	RAN#52	R5s110139	0549	-	Correction to EMM test cases	8.6.0	9.0.0
2011-06	RAN#52	R5s110140	0579	-	Addition of GCF WI 82 EMM test case 9.2.3.1.15	8.6.0	9.0.0
2011-06	RAN#52	R5s110142	0581	-	Correction to GCF WI-082 EMM test case 9.1.3.1	8.6.0	9.0.0
2011-06	RAN#52	R5s110143	0578	-	Addition of GCF WI 82 EUTRA EMM test case 9.2.1.2.3	8.6.0	9.0.0
2011-06	RAN#52	R5s110145	0577	-	Addition of GCF WI 82 EUTRA EMM test case 9.2.3.2.3	8.6.0	9.0.0
2011-06	RAN#52	R5s110147	0580	-	Correction to GCF WI-081 EUTRA MAC test case 7.1.4.4	8.6.0	9.0.0
2011-06	RAN#52	R5s110149	0575	-	Correction to EUTRA SS security configuration steps	8.6.0	9.0.0
2011-06	RAN#52	R5s110150	0576	-	Correction to EMM test case 9.2.3.1.14	8.6.0	9.0.0
2011-06	RAN#52	R5s110151	0574	-	Addition of GCF WI 82 EMM test case 9.2.1.1.12	8.6.0	9.0.0
2011-06	RAN#52	R5s110153	0573	-	Correction to GCF WI-081 IDLE MODE test case 6.1.1.1	8.6.0	9.0.0
2011-06	RAN#52	R5s110154	0571	-	Correction to EUTRA_AspCommon_Templates.ttcn	8.6.0	9.0.0
2011-06	RAN#52	R5s110155	0572	-	Addition of GCF WI 82 EMM test case 9.2.3.3.6	8.6.0	9.0.0
2011-06	RAN#52	R5s110157	0570	-	Correction to EMM test case 9.2.1.1.26	8.6.0	9.0.0
2011-06	RAN#52	R5s110158	0569	-	Addition of GCF WI 82 EMM test case 9.2.1.2.13	8.6.0	9.0.0
2011-06	RAN#52	R5s110160	0568	-	LTE_TDD: Addition of GCF WI 91 EUTRA Idle mode test case 6.1.2.13	8.6.0	9.0.0
2011-06	RAN#52	R5s110162	0567	-	LTE_TDD: Addition of GCF WI 91 EUTRA RRC test case 8.3.1.10	8.6.0	9.0.0
2011-06	RAN#52	R5s110164	0566	-	LTE_TDD: Addition of GCF WI 92 EUTRA Multi-Layer test case 13.3.1.2	8.6.0	9.0.0
2011-06	RAN#52	R5s110166	0565	-	Addition of GCF WI 81 EUTRA Idle mode test case 6.3.6	8.6.0	9.0.0
2011-06	RAN#52	R5s110168	0620	-	Regression CR for LTE wk11 ATS	8.6.0	9.0.0

Date	TSG #	TSG Doc.	CR	Rev	Subject/Comment	Old	New
2011-06	RAN#52	R5s110170	0585	-	Correction to EMM test case 9.2.3.1.4	8.6.0	9.0.0
2011-06	RAN#52	R5s110171	0618	-	Regression CR for LTE wk11 ATS	8.6.0	9.0.0
2011-06	RAN#52	R5s110172	0584	-	Correction to EMM test case 9.2.3.1.5	8.6.0	9.0.0
2011-06	RAN#52	R5s110173	0619	-	Correction to EUTRA MAC test cases 7.1.6.1 and 7.1.6.2	8.6.0	9.0.0
2011-06	RAN#52	R5s110174	0583	-	Correction to the use of Grant Allocation Type 2 in LTE wk11 ATS	8.6.0	9.0.0
2011-06	RAN#52	R5s110176	0615	-	Baseline upgrade of E-UTRA ATS to March-11 in Rel-9	8.6.0	9.0.0
2011-06	RAN#52	R5s110177	0608	-	Addition of GCF WI 82 EMM test case 9.3.1.4	8.6.0	9.0.0
2011-06	RAN#52	R5s110179	0607	-	Addition of GCF WI 82 EMM test case 9.3.1.5	8.6.0	9.0.0
2011-06	RAN#52	R5s110181	0606	-	LTE_TDD: Addition of GCF WI 91 EUTRA PDCP test case 7.3.5.2	8.6.0	9.0.0
2011-06	RAN#52	R5s110183	0605	-	LTE_TDD: Addition of GCF WI 91 EUTRA RRC test case 8.1.2.7	8.6.0	9.0.0
2011-06	RAN#52	R5s110185	0604	-	LTE_TDD: Addition of GCF WI 91 EUTRA RRC test case 8.2.4.7	8.6.0	9.0.0
2011-06	RAN#52	R5s110187	0603	-	Addition of GCF WI 82 EMM test case 9.2.1.2.5	8.6.0	9.0.0
2011-06	RAN#52	R5s110189	0602	-	Addition of GCF WI 82 EMM test case 9.2.1.2.7	8.6.0	9.0.0
2011-06	RAN#52	R5s110192	0601	-	Addition of GCF WI 82 EMM test case 9.2.1.2.6	8.6.0	9.0.0
2011-06	RAN#52	R5s110194	0598	-	Addition of GCF WI 82 EMM test case 9.2.1.2.8	8.6.0	9.0.0
2011-06	RAN#52	R5s110196	0600	-	Correction to EUTRA RRC test case 8.2.4.7	8.6.0	9.0.0
2011-06	RAN#52	R5s110197	0599	-	LTE_TDD: Addition of GCF WI 91 EUTRA RRC test case 8.1.1.2	8.6.0	9.0.0
2011-06	RAN#52	R5s110199	0626	-	Addition of GCF WI 82 EMM test case 9.2.1.2.15	8.6.0	9.0.0
2011-06	RAN#52	R5s110201	0596	-	Correction to EUTRA test cases 7.1.3.9, 7.2.3.6, 7.2.3.18	8.6.0	9.0.0
2011-06	RAN#52	R5s110202	0597	-	Addition of GCF WI 82 EMM test case 9.2.3.2.9	8.6.0	9.0.0
2011-06	RAN#52	R5s110204	0595	-	Addition of GCF WI 82 EMM test case 9.2.1.2.9	8.6.0	9.0.0
2011-06	RAN#52	R5s110206	0594	-	Correction to EMM SMS test cases 11.1.3 and 11.1.4	8.6.0	9.0.0
2011-06	RAN#52	R5s110207	0593	-	Correction of GCF WI 81 RLC test case 7.2.2.11	8.6.0	9.0.0
2011-06	RAN#52	R5s110208	0591	-	Correction to ESM test case 10.7.3	8.6.0	9.0.0
2011-06	RAN#52	R5s110209	0590	-	Correction to EMM test cases 9.2.1.2.1 and 9.2.2.2	8.6.0	9.0.0
2011-06	RAN#52	R5s110210	0592	-	Addition of GCF WI 81 EUTRA Idle Mode test case 6.2.3.4	8.6.0	9.0.0
2011-06	RAN#52	R5s110212	0589	-	Correction to EMM test case 9.1.2.6	8.6.0	9.0.0
2011-06	RAN#52	R5s110213	0588	-	Correction to TFT templates	8.6.0	9.0.0
2011-06	RAN#52	R5s110214	0587	-	Correction to EMM test case 9.2.1.1.1a	8.6.0	9.0.0
2011-06	RAN#52	R5s110215	0611	-	Corrections to LTE / WCDMA InterRAT test cases	8.6.0	9.0.0
2011-06	RAN#52	R5s110216	0624	-	Addition of GCF WI-081 EUTRA RRC test case 8.4.1.2	8.6.0	9.0.0
2011-06	RAN#52	R5s110218	0610	-	Correction to GCF WI-082 EMM test case 9.1.3.2	8.6.0	9.0.0
2011-06	RAN#52	R5s110219	0609	-	Correction to EUTRA and EMM test cases	8.6.0	9.0.0
2011-06	RAN#52	R5s110222	0617	-	Corrections to GCF WI-081 RLC test case 7.2.3.6	8.6.0	9.0.0
2011-06	RAN#52	R5s110223	0616	-	Correction of GCF WI81 MAC test case 7.1.2.9	8.6.0	9.0.0
2011-06	RAN#52	R5s110226	0614	-	Correction to EUTRA MAC test case 7.1.4.3	8.6.0	9.0.0
2011-06	RAN#52	R5s110227	0613	-	Correction to EMM test case 9.2.2.1.2	8.6.0	9.0.0

Date	TSG #	TSG Doc.	CR	Rev	Subject/Comment	Old	New
2011-06	RAN#52	R5s110228	0612	-	Correction to EMM test cases 9.4.1, 9.4.2, 9.4.3, 9.4.4	8.6.0	9.0.0
2011-06	RAN#52	R5s110230	0623	-	Correction to GCF WI-082 EMM test cases 9.3.1.7 and 9.3.1.7a	8.6.0	9.0.0
2011-06	RAN#52	R5s110232	0622	-	Correction to EMM MRAT test cases	8.6.0	9.0.0
2011-06	RAN#52	R5s110233	0621	-	Correction of type record VoiceDomainPref	8.6.0	9.0.0
2011-06	RAN#52	R5s110234	0625	-	Correction to EMM test case 9.2.1.1.19	8.6.0	9.0.0
2011-06	RAN#52	R5s110235	0630	-	Correction of UL EARFCN for FDD Band 19	8.6.0	9.0.0
2011-06	RAN#52	R5s110236	0629	-	Addition of GCF WI 81 EUTRA MAC test case 7.1.5.2	8.6.0	9.0.0
2011-06	RAN#52	R5s110238	0628	-	Addition of GCF WI 81 EUTRA MAC test case 7.1.5.4	8.6.0	9.0.0
2011-06	RAN#52	R5s110242	0627	-	Correction to LTE ATS	8.6.0	9.0.0
2011-06	RAN#52	R5s110243	0631	-	Correction to GCF WI-081 MAC test case 7.2.3.10	8.6.0	9.0.0
2011-06	RAN#52	R5s110244	0632	-	Correction to EUTRA/EMM test cases	8.6.0	9.0.0
2011-06	-	-	-	-	Correction in history table: removal of R5-112253.	9.0.0	9.0.1
2011-09	RAN#53	RP-111161	0634	-	CR to 36.523-3: Add new verified and e-mail agreed TTCN test cases in the TC lists in 36.523-3 (prose), Annex A	9.0.1	9.1.0
2011-09	RAN#53	R5-113734	0633	-	Routine maintenance and updates	9.0.1	9.1.0
2011-09	RAN#53	R5s110245	0642	-	Addition of GCF WI 81 EUTRA RRC test case 8.1.2.8	9.0.1	9.1.0
2011-09	RAN#53	R5s110247	0643	-	Addition of GCF WI 81 EUTRA RRC test case 8.1.2.6	9.0.1	9.1.0
2011-09	RAN#53	R5s110249	0644	-	Addition of GCF WI 81 EUTRA RRC test case 8.5.1.4	9.0.1	9.1.0
2011-09	RAN#53	R5s110251	0646	-	Addition of GCF WI 82 EMM test case 9.2.3.2.15	9.0.1	9.1.0
2011-09	RAN#53	R5s110253	0650	-	Addition of GCF WI 82 EMM test case 9.2.3.2.5	9.0.1	9.1.0
2011-09	RAN#53	R5s110255	0649	-	Addition of GCF WI 82 EMM test case 9.2.3.2.6	9.0.1	9.1.0
2011-09	RAN#53	R5s110257	0648	-	Addition of GCF WI 82 EMM test case 9.2.3.2.7	9.0.1	9.1.0
2011-09	RAN#53	R5s110259	0645	-	Addition of GCF WI 82 EMM test case 9.2.3.2.10	9.0.1	9.1.0
2011-09	RAN#53	R5s110261	0647	-	Addition of GCF WI 82 EMM test case 9.2.3.2.12	9.0.1	9.1.0
2011-09	RAN#53	R5s110263	0640	-	Addition of GCF WI 81 EUTRA RRC test case 8.1.1.3	9.0.1	9.1.0
2011-09	RAN#53	R5s110265	0641	-	Addition of GCF WI 82 EMM test case 9.2.3.2.8	9.0.1	9.1.0
2011-09	RAN#53	R5s110267	0672	-	Addition of GCF WI 82 EMM test case 9.2.3.2.4	9.0.1	9.1.0
2011-09	RAN#53	R5s110269	0639	-	Addition of GCF WI 86 EUTRA EMM test case 9.2.3.2.11	9.0.1	9.1.0
2011-09	RAN#53	R5s110271	0671	-	Addition of GCF WI 82 EMM test case 9.2.3.2.2	9.0.1	9.1.0
2011-09	RAN#53	R5s110273	0638	-	Addition of GCF WI 81 EUTRA RRC test case 8.2.4.8	9.0.1	9.1.0
2011-09	RAN#53	R5s110275	0637	-	Correction to the ESM test case 10.4.1	9.0.1	9.1.0
2011-09	RAN#53	R5s110276	0636	-	Addition of GCF WI 81 EUTRA Idle mode test case 6.2.2.6	9.0.1	9.1.0
2011-09	RAN#53	R5s110278	0670	-	Miscellaneous corrections to inter-RAT LTE-UTRAN ATS	9.0.1	9.1.0
2011-09	RAN#53	R5s110279	0669	-	Regression CR for LTE wk15 ATS	9.0.1	9.1.0
2011-09	RAN#53	R5s110282	0635	-	Correction of GCF WI 81 EUTRA EMM test case 9.2.3.1.25	9.0.1	9.1.0
2011-09	RAN#53	R5s110285	0668	-	Addition of GCF WI 81 EUTRA RRC test case 8.1.2.13	9.0.1	9.1.0
2011-09	RAN#53	R5s110287	0667	-	Addition of GCF WI 81 EUTRA RRC test case 8.1.2.9	9.0.1	9.1.0
2011-09	RAN#53	R5s110289	0666	-	Addition of GCF WI 82 ESM test case 10.8.5	9.0.1	9.1.0

Date	TSG #	TSG Doc.	CR	Rev	Subject/Comment	Old	New
2011-09	RAN#53	R5s110291	0665	-	Addition of GCF WI-081 E-UTRA Idle Mode test case 6.1.2.10	9.0.1	9.1.0
2011-09	RAN#53	R5s110293	0664	-	Addition of GCF WI-082 E-UTRA ESM testcase 10.7.5	9.0.1	9.1.0
2011-09	RAN#53	R5s110295	0658	-	Correction to EUTRA_ConfigurationSteps	9.0.1	9.1.0
2011-09	RAN#53	R5s110296	0657	-	Correction to EUTRA_Timing	9.0.1	9.1.0
2011-09	RAN#53	R5s110297	0656	-	Correction to EUTRA MAC test cases 7.1.6.x	9.0.1	9.1.0
2011-09	RAN#53	R5s110298	0663	-	LTE_TDD: Addition of GCF WI 91 EUTRA RRC test case 8.1.2.6	9.0.1	9.1.0
2011-09	RAN#53	R5s110300	0662	-	LTE_TDD: Addition of GCF WI 91 EUTRA RRC test case 8.1.2.13	9.0.1	9.1.0
2011-09	RAN#53	R5s110302	0661	-	LTE_TDD :Addition of GCF WI 91 EUTRA RRC test case 8.5.1.4	9.0.1	9.1.0
2011-09	RAN#53	R5s110303	0655	-	Correction to EUTRA PDCP test case 7.3.5.3	9.0.1	9.1.0
2011-09	RAN#53	R5s110306	0660	-	Correction to EUTRA Paging procedure	9.0.1	9.1.0
2011-09	RAN#53	R5s110307	0654	-	Correction to EMM test cases 9.2.1.1.1a, 9.2.2.1.1, 9.2.2.1.8, 9.2.3.2.11 and 9.3.1.16	9.0.1	9.1.0
2011-09	RAN#53	R5s110308	0653	-	Correction to EMM test cases 9.2.3.1.15 and 9.2.3.1.18	9.0.1	9.1.0
2011-09	RAN#53	R5s110309	0652	-	Improving LTE/SAE test cases by indicating the need for special Test USIM settings	9.0.1	9.1.0
2011-09	RAN#53	R5s110310	0678	-	Correction to EUTRA RRC test case 8.5.1.2	9.0.1	9.1.0
2011-09	RAN#53	R5s110311	0659	-	Addition of GCF WI-082 E-UTRA ESM testcase 10.8.6	9.0.1	9.1.0
2011-09	RAN#53	R5s110313	0651	-	Correction to GCF WI-082 ESM test cases 10.2.1. and 10.4.1	9.0.1	9.1.0
2011-09	RAN#53	R5s110314	0676	-	Modification of f_EUTRA_CellInfo_GetAntennaInfoCommon	9.0.1	9.1.0
2011-09	RAN#53	R5s110315	0677	-	Correction to EUTRA Idle Mode test case 6.2.3.4	9.0.1	9.1.0
2011-09	RAN#53	R5s110317	0675	-	Correction to EMM test case 9.2.3.1.16	9.0.1	9.1.0
2011-09	RAN#53	R5s110318	0681	-	Regression CR for LTE wk23 ATS	9.0.1	9.1.0
2011-09	RAN#53	R5s110319	0674	-	Correction to EUTRA test case 6.1.2.6	9.0.1	9.1.0
2011-09	RAN#53	R5s110320	0673	-	Addition of GCF WI 81 EUTRA DRB test case 12.3.1	9.0.1	9.1.0
2011-09	RAN#53	R5s110322	0692	-	Correction to GCF WI 86 RRC test case 8.1.3.6	9.0.1	9.1.0
2011-09	RAN#53	R5s110323	0691	-	Addition of GCF WI-081 E-UTRA IDLE MODE testcase 6.1.2.12	9.0.1	9.1.0
2011-09	RAN#53	R5s110325	0690	-	Addition of GCF WI-081 E-UTRA IDLE MODE testcase 6.1.2.14	9.0.1	9.1.0
2011-09	RAN#53	R5s110327	0689	-	Addition of GCF WI 81 EUTRA DRB test case 12.2.4	9.0.1	9.1.0
2011-09	RAN#53	R5s110329	0687	-	Correction to GCF WI 81 EUTRA RRC test case 8.3.1.7	9.0.1	9.1.0
2011-09	RAN#53	R5s110330	0688	-	Addition of GCF WI 81 EUTRA DRB test case 12.3.4	9.0.1	9.1.0
2011-09	RAN#53	R5s110336	0686	-	Addition of GCF WI 81 EUTRA DRB test case 12.3.2	9.0.1	9.1.0
2011-09	RAN#53	R5s110338	0685	-	Addition of GCF WI 81 EUTRA DRB test case 12.3.3	9.0.1	9.1.0
2011-09	RAN#53	R5s110340	0716	-	Regression CR for LTE wk23 ATS	9.0.1	9.1.0
2011-09	RAN#53	R5s110341	0684	-	Correction to configuration of EUTRA SIB scheduling	9.0.1	9.1.0
2011-09	RAN#53	R5s110342	0682	-	Correction to f_EUTRA_SS_SetupSchedulingInfo and f_EUTRA_IdleUpdated_Step5_14	9.0.1	9.1.0
2011-09	RAN#53	R5s110346	0683	-	Addition of GCF WI 82 EMM test case 9.2.3.2.17	9.0.1	9.1.0
2011-09	RAN#53	R5s110348	0715	-	Correction to EUTRA NAS cells initialization	9.0.1	9.1.0
2011-09	RAN#53	R5s110350	0680	-	Correction to GCF WI-081 RRC test case 8.5.4.1	9.0.1	9.1.0
2011-09	RAN#53	R5s110351	0679	-	Regression CR for LTE wk23 MRAT Testcases	9.0.1	9.1.0

Date	TSG #	TSG Doc.	CR	Rev	Subject/Comment	Old	New
2011-09	RAN#53	R5s110352	0711	-	Correction to GCF WI 81 EUTRA RRC test case 8.3.3.1	9.0.1	9.1.0
2011-09	RAN#53	R5s110353	0710	-	Correction of frequencies used for LTE Band 6, 14, 17 and 38	9.0.1	9.1.0
2011-09	RAN#53	R5s110354	0709	-	Addition of GCF WI 81 EUTRA RRC test case 8.3.1.6	9.0.1	9.1.0
2011-09	RAN#53	R5s110356	0708	-	Correction to EUTRA RRC test cases 8.2.4.1, 8.2.4.4 and 8.2.4.7	9.0.1	9.1.0
2011-09	RAN#53	R5s110357	0707	-	LTE_TDD: Addition of GCF WI 91 EUTRA RRC test case 8.3.1.6	9.0.1	9.1.0
2011-09	RAN#53	R5s110359	0706	-	Addition of GCF WI 82 EMM test case 9.2.3.1.18	9.0.1	9.1.0
2011-09	RAN#53	R5s110361	0705	-	LTE_TDD: Addition of GCF WI 91 EUTRA RRC test case 8.2.4.8	9.0.1	9.1.0
2011-09	RAN#53	R5s110363	0704	-	Correction to GCF WI 86 EMM test cases 9.2.3.2.5, 9.2.3.2.6 and 9.2.3.2.7	9.0.1	9.1.0
2011-09	RAN#53	R5s110364	0703	-	Correction of GCF WI 82 EMM test cases 9.2.1.2.5, TC 9.2.1.2.6 and TC 9.2.1.2.7	9.0.1	9.1.0
2011-09	RAN#53	R5s110365	0702	-	Correction to GCF WI-082 ESM test cases 10.2.1 and 10.4.1	9.0.1	9.1.0
2011-09	RAN#53	R5s110368	0701	-	Correction to EMM test case 9.2.1.2.11	9.0.1	9.1.0
2011-09	RAN#53	R5s110369	0700	-	Addition of GCF WI 82 EMM test case 9.2.1.1.11	9.0.1	9.1.0
2011-09	RAN#53	R5s110371	0699	-	Addition of GCF WI 81 Idle Mode test case 6.2.1.2	9.0.1	9.1.0
2011-09	RAN#53	R5s110373	0698	-	Addition of GCF WI-082 E-UTRA ESM testcase 10.8.7	9.0.1	9.1.0
2011-09	RAN#53	R5s110375	0697	-	Addition of GCF WI-082 E-UTRA ESM testcase 10.8.4	9.0.1	9.1.0
2011-09	RAN#53	R5s110377	0696	-	Addition of GCF WI-087 EUTRA Idle mode InterRAT test case 6.2.2.7	9.0.1	9.1.0
2011-09	RAN#53	R5s110382	0695	-	Correction to EUTRA RRC test case 8.4.1.2	9.0.1	9.1.0
2011-09	RAN#53	R5s110383	0694	-	Correction of EUTRA RLC test case 7.2.3.9	9.0.1	9.1.0
2011-09	RAN#53	R5s110384	0693	-	Addition of GCF WI 82 EMM test case 9.2.3.1.17	9.0.1	9.1.0
2011-09	RAN#53	R5s110386	0714	-	Correction to UTRAN common modules in LTE ATS	9.0.1	9.1.0
2011-09	RAN#53	R5s110389	0713	-	Correction to GCF WI81 RLC test case 7.2.3.17	9.0.1	9.1.0
2011-09	RAN#53	R5s110394	0712	-	Correction of RLC and MAC test cases for TDD scheduling	9.0.1	9.1.0
2011-09	RAN#53	R5s110395	0732	-	Correction to EMM test cases	9.0.1	9.1.0
2011-09	RAN#53	R5s110396	0719	-	Correction to EUTRA RRC test case 8.5.1.2	9.0.1	9.1.0
2011-09	RAN#53	R5s110397	0726	-	LTE_TDD: Addition of GCF WI 81 EUTRA test case 6.1.2.12	9.0.1	9.1.0
2011-09	RAN#53	R5s110399	0725	-	LTE_TDD: Addition of GCF WI 81 EUTRA test case 6.1.2.14	9.0.1	9.1.0
2011-09	RAN#53	R5s110401	0724	-	LTE_TDD: Addition of GCF WI 81 EUTRA RRC test case 8.1.1.3	9.0.1	9.1.0
2011-09	RAN#53	R5s110403	0723	-	LTE_TDD: Addition of GCF WI 81 EUTRA RRC test case 8.1.1.4	9.0.1	9.1.0
2011-09	RAN#53	R5s110405	0722	-	LTE_TDD: Addition of GCF WI 81 EUTRA RRC test case 8.3.1.4	9.0.1	9.1.0
2011-09	RAN#53	R5s110407	0721	-	LTE_TDD: Addition of GCF WI 81 EUTRA RRC test case 8.1.2.8	9.0.1	9.1.0
2011-09	RAN#53	R5s110409	0720	-	LTE_TDD: Addition of GCF WI 81 E-UTRA DRB test case 12.2.4	9.0.1	9.1.0
2011-09	RAN#53	R5s110411	0717	-	Correction of MAC test cases 7.1.4.15 and 7.1.4.16 for TDD scheduling	9.0.1	9.1.0
2011-09	RAN#53	R5s110412	0718	-	LTE_TDD: Addition of GCF WI-091 E-UTRA RRC testcase 8.2.4.4	9.0.1	9.1.0
2011-09	RAN#53	R5s110414	0738	-	LTE_TDD: Addition of GCF WI 91 EUTRA MAC test case 7.1.5.2	9.0.1	9.1.0
2011-09	RAN#53	R5s110416	0737	-	LTE_TDD: Addition of GCF WI 91 EUTRA MAC test case 7.1.5.4	9.0.1	9.1.0
2011-09	RAN#53	R5s110418	0794	-	Correction to GCF WI-081 EUTRA PDCP test cases 7.3.4.1 and 7.3.4.2	9.0.1	9.1.0
2011-09	RAN#53	R5s110421	0736	-	Correction to GCF WI-086 /-087 EMM test case 9.2.1.2.15	9.0.1	9.1.0

Date	TSG #	TSG Doc.	CR	Rev	Subject/Comment	Old	New
2011-09	RAN#53	R5s110422	0735	-	Correction to GCF WI-081 EUTRA MAC test case 7.1.5.x	9.0.1	9.1.0
2011-09	RAN#53	R5s110423	0734	-	Correction to GCF WI-082 EMM test case 9.2.1.2.2	9.0.1	9.1.0
2011-09	RAN#53	R5s110424	0733	-	Correction to GCF WI-082 EMM test case 9.2.3.1.26	9.0.1	9.1.0
2011-09	RAN#53	R5s110425	0731	-	Corrections required for IPv6	9.0.1	9.1.0
2011-09	RAN#53	R5s110426	0730	-	Correction to GCF WI 82 EMM test cases 9.2.3.1.9a and 9.2.3.1.23	9.0.1	9.1.0
2011-09	RAN#53	R5s110427	0729	-	Correction to EUTRA EMM test cases 9.4.1, 9.4.2, 9.4.3, 9.4.4, 9.1.3.2 and 9.2.1.1.1a	9.0.1	9.1.0
2011-09	RAN#53	R5s110428	0728	-	LTE_TDD: Addition of GCF WI 081 EUTRA Idle Mode test case 6.3.6	9.0.1	9.1.0
2011-09	RAN#53	R5s110430	0727	-	Correction to Multilayer test case 13.3.1.2	9.0.1	9.1.0
2011-09	RAN#53	R5s110431	0772	-	Correction to UTRAN Default Handling in LTE/SAE ATS	9.0.1	9.1.0
2011-09	RAN#53	R5s110432	0771	-	Correction to ESM testcase 10.7.5	9.0.1	9.1.0
2011-09	RAN#53	R5s110433	0770	-	Correction to LTE<->GERAN Testcases	9.0.1	9.1.0
2011-09	RAN#53	R5s110435	0788	-	Addition of GCF WI-086 E-UTRA RRC testcase 8.3.2.4	9.0.1	9.1.0
2011-09	RAN#53	R5s110437	0768	-	LTE_TDD: Addition of GCF WI-091 E-UTRA RRC testcase 8.3.1.11	9.0.1	9.1.0
2011-09	RAN#53	R5s110439	0769	-	Addition of GCF WI 82 EMM test case 9.1.5.1	9.0.1	9.1.0
2011-09	RAN#53	R5s110441	0762	-	Correction to GCF WI-081 EUTRA RRC test case 8.2.4.7	9.0.1	9.1.0
2011-09	RAN#53	R5s110443	0767	-	Correction to GCF WI 82 EMM test cases 9.3.1.4 and 9.3.1.5	9.0.1	9.1.0
2011-09	RAN#53	R5s110445	0760	-	Correction to GCF WI-085 Interband Testcase 6.1.2.5	9.0.1	9.1.0
2011-09	RAN#53	R5s110446	0765	-	Correction to GCF WI-082 EMM Testcase 9.2.3.1.4	9.0.1	9.1.0
2011-09	RAN#53	R5s110447	0764	-	Correction to GCF WI-081 RRC Testcase 8.1.3.5	9.0.1	9.1.0
2011-09	RAN#53	R5s110448	0783	-	Correction to GCF WI-082 EMM Testcases 9.2.1.2.10 and 9.2.3.1.26	9.0.1	9.1.0
2011-09	RAN#53	R5s110449	0763	-	Corrections required to support IPv6	9.0.1	9.1.0
2011-09	RAN#53	R5s110456	0766	-	Correction to GCF WI-081 EUTRA MAC test cases 7.1.3.9 and 7.1.4.12	9.0.1	9.1.0
2011-09	RAN#53	R5s110461	0761	-	Correction to constant tsc_EUTRA_DelayForCellSelection	9.0.1	9.1.0
2011-09	RAN#53	R5s110462	0759	-	Addition of GCF WI-082 EMM test case 9.2.3.3.5	9.0.1	9.1.0
2011-09	RAN#53	R5s110464	0758	-	Addition of GCF WI-081 EUTRA MAC test case 7.1.5.5	9.0.1	9.1.0
2011-09	RAN#53	R5s110465	0747	-	Correction to UTRAN PS RB Establishment	9.0.1	9.1.0
2011-09	RAN#53	R5s110466	0749	-	Corrections to UTRAN GMM Service Request	9.0.1	9.1.0
2011-09	RAN#53	R5s110468	0756	-	Correction to the Idle Mode test case 6.1.2.10	9.0.1	9.1.0
2011-09	RAN#53	R5s110469	0757	-	Addition of GCF WI-081 EUTRA RRC test case 8.2.1.6	9.0.1	9.1.0
2011-09	RAN#53	R5s110472	0755	-	Correction of EMM test cases 9.2.3.2.11, 9.2.1.1.13	9.0.1	9.1.0
2011-09	RAN#53	R5s110473	0754	-	Correction to EUTRA MAC test case 7.1.3.5	9.0.1	9.1.0
2011-09	RAN#53	R5s110474	0752	-	Correction to GCF WI-091 EUTRA RLC test cases	9.0.1	9.1.0
2011-09	RAN#53	R5s110475	0751	-	Improvement to EUTRA IRAT preamble	9.0.1	9.1.0
2011-09	RAN#53	R5s110476	0753	-	Correction to EMM test case 9.3.1.17	9.0.1	9.1.0
2011-09	RAN#53	R5s110478	0750	-	Correction to EMM test case 9.2.3.1.5	9.0.1	9.1.0
2011-09	RAN#53	R5s110481	0746	-	LTE_TDD: Addition of GCF WI 91 EUTRA DRB test case 12.3.1	9.0.1	9.1.0
2011-09	RAN#53	R5s110483	0745	-	LTE_TDD: Addition of GCF WI 91 EUTRA DRB test case 12.3.2	9.0.1	9.1.0

Date	TSG #	TSG Doc.	CR	Rev	Subject/Comment	Old	New
2011-09	RAN#53	R5s110485	0744	-	LTE_TDD: Addition of GCF WI 91 EUTRA DRB test case 12.3.3	9.0.1	9.1.0
2011-09	RAN#53	R5s110487	0743	-	LTE_TDD: Addition of GCF WI 91 EUTRA DRB test case 12.3.4	9.0.1	9.1.0
2011-09	RAN#53	R5s110489	0748	-	Correction to AT command to initiate CS speech call	9.0.1	9.1.0
2011-09	RAN#53	R5s110491	0742	-	Correction of EUTRA Idle Mode test cases 6.1.2.10	9.0.1	9.1.0
2011-09	RAN#53	R5s110492	0793	-	Addition of GCF WI-088 EUTRA –HRPD InterRAT test case 8.1.3.9	9.0.1	9.1.0
2011-09	RAN#53	R5s110494	0792	-	Addition of GCF WI-088 EUTRA –HRPD InterRAT test case 6.2.2.3	9.0.1	9.1.0
2011-09	RAN#53	R5s110496	0791	-	Addition of GCF WI-088 EUTRA –HRPD InterRAT test case 6.2.3.8	9.0.1	9.1.0
2011-09	RAN#53	R5s110498	0775	-	Correction to GCF-WI-082 EMM test case 9.2.1.1.7	9.0.1	9.1.0
2011-09	RAN#53	R5s110499	0739	-	Correction to GCF WI-082 EUTRA Multi-Layer test case 13.3.1.2	9.0.1	9.1.0
2011-09	RAN#53	R5s110500	0741	-	Correction of GCF WI 82 ESM test cases 10.7.3 and 10.8.3	9.0.1	9.1.0
2011-09	RAN#53	R5s110505	0740	-	Addition of GCF WI 81 EUTRA RRC test case 8.2.4.12	9.0.1	9.1.0
2011-09	RAN#53	R5s110509	0786	-	Addition of GCF WI 81 EUTRA test case 6.1.1.2	9.0.1	9.1.0
2011-09	RAN#53	R5s110511	0785	-	Addition of GCF WI 81 EUTRA test case 6.1.1.4	9.0.1	9.1.0
2011-09	RAN#53	R5s110513	0782	-	Addition of GCF WI-081 E-UTRA MAC testcase 7.1.5.1	9.0.1	9.1.0
2011-09	RAN#53	R5s110515	0784	-	Correction to WI-086 EUTRA Idle Mode Testcase 6.2.3.4	9.0.1	9.1.0
2011-09	RAN#53	R5s110516	0781	-	Regression TTCN CR for IWD_wk27 ATS	9.0.1	9.1.0
2011-09	RAN#53	R5s110517	0780	-	Correction to GCF WI-082 'SMS over SGs' test cases 11.1.x	9.0.1	9.1.0
2011-09	RAN#53	R5s110518	0779	-	Correction to GCF WI-082 EMM test case 9.2.3.1.17	9.0.1	9.1.0
2011-09	RAN#53	R5s110519	0789	-	Addition of GCF WI-086 E-UTRA Idle Mode testcase 6.2.3.13	9.0.1	9.1.0
2011-09	RAN#53	R5s110521	0774	-	Correction to GCF WI-082 EMM test case 9.2.1.2.1	9.0.1	9.1.0
2011-09	RAN#53	R5s110526	0778	-	Correction to EUTRA RLC test case 7.2.3.16	9.0.1	9.1.0
2011-09	RAN#53	R5s110527	0773	-	Correction to GCF WI-082 EMM test case 9.2.1.1.1a	9.0.1	9.1.0
2011-09	RAN#53	R5s110528	0790	-	Addition of GCF WI 81 EUTRA Test Case 6.1.1.3	9.0.1	9.1.0
2011-09	RAN#53	R5s110530	0776	-	Addition of GCF WI-081 E-UTRA RRC testcase 8.2.1.5	9.0.1	9.1.0
2011-09	RAN#53	R5s110532	0777	-	LTE_TDD: Addition of GCF WI 91 EUTRA RRC test case 8.2.4.12	9.0.1	9.1.0
2011-09	RAN#53	R5s110534	0787	-	LTE_TDD: Addition of GCF WI 91 EUTRA RRC test case 8.2.1.6	9.0.1	9.1.0
2011-09	RAN#53	R5s110546	0795	-	Correction to GCF WI-082 EMM test case 9.2.1.1.24	9.0.1	9.1.0
2011-09	RAN#53	R5s110551	0796	-	Correction to EMM test case 9.2.1.2.3	9.0.1	9.1.0
2011-09	RAN#53	R5s110552	0798	-	Correction to EUTRA MAC test case 7.1.6.1 and 7.1.6.2	9.0.1	9.1.0
2011-09	RAN#53	R5s110553	0797	-	LTE_TDD: Addition of GCF WI-091 EUTRA MAC testcase 7.1.5.1	9.0.1	9.1.0
2011-12	RAN#54	R5-115770	0799	-	Routine maintenance and updates for EUTRA test model	9.1.0	9.2.0
2011-12	RAN#54	RP-111588	0800	-	CR to 36.523-3: Add new verified and e-mail agreed TTCN test cases in the TC lists in 36.523-3 (prose), Annex A	9.1.0	9.2.0
2011-12	RAN#54	R5s110549	0801	-	Addition of GCF WI 82 EMM test case 9.3.1.6	9.1.0	9.2.0
2011-12	RAN#54	R5s110547	0802	-	Addition of GCF WI 86 EUTRA Idle Mode test case 6.2.2.5	9.1.0	9.2.0
2011-12	RAN#54	R5s110575	0803	-	Correction to GCF WI-087 Idle Mode Testcases 6.2.2.6	9.1.0	9.2.0
2011-12	RAN#54	R5s110573	0804	-	Addition of GCF WI-081 E-UTRA MAC testcase 7.1.5.3	9.1.0	9.2.0
2011-12	RAN#54	R5s110571	0805	-	Correction to EUTRA MAC test case 7.1.5.4	9.1.0	9.2.0

Date	TSG #	TSG Doc.	CR	Rev	Subject/Comment	Old	New
2011-12	RAN#54	R5s110570	0806	-	Correction to AT commands	9.1.0	9.2.0
2011-12	RAN#54	R5s110569	0807	-	Correction to GCF WI-086 EMM Testcases 9.2.1.2.11	9.1.0	9.2.0
2011-12	RAN#54	R5s110568	0808	-	Correction to GCF WI-082 EMM Testcases 9.2.3.1.17	9.1.0	9.2.0
2011-12	RAN#54	R5s110566	0809	-	Addition of GCF WI82 EMM test case 9.2.3.1.22	9.1.0	9.2.0
2011-12	RAN#54	R5s110565	0810	-	Correction to GCF WI-081 RRC test case 8.5.4.1	9.1.0	9.2.0
2011-12	RAN#54	R5s110444	0811	-	Correction to GCF WI-081 EUTRA RRC Testcase 8.2.4.7	9.1.0	9.2.0
2011-12	RAN#54	R5s110563	0812	-	Correction to GCF WI-086 EUTRA RRC Testcase 8.4.1.2	9.1.0	9.2.0
2011-12	RAN#54	R5s110561	0813	-	Addition of GCF WI 82 EMM Test Case 9.2.1.2.12	9.1.0	9.2.0
2011-12	RAN#54	R5s110560	0814	-	Correction to GCF WI-081 EUTRA RRC test case 8.2.4.7	9.1.0	9.2.0
2011-12	RAN#54	R5s110558	0815	-	Correction to GCF WI-091 EUTRA MAC test cases 7.1.4.15 + 7.1.4.16 and RLC test case 7.2.3.15	9.1.0	9.2.0
2011-12	RAN#54	R5s110556	0816	-	Addition of GCF WI 81 EUTRA Test Case 6.1.1.6	9.1.0	9.2.0
2011-12	RAN#54	R5s110559	0817	-	Correction to GCF WI-081 EUTRA RRC Testcase 8.2.4.12	9.1.0	9.2.0
2011-12	RAN#54	R5s110555	0818	-	Correction of GCF WI 91 RLC test case 7.2.3.17	9.1.0	9.2.0
2011-12	RAN#54	R5s110587	0819	-	Correction to EMM test case 9.2.1.1.20	9.1.0	9.2.0
2011-12	RAN#54	R5s110580	0820	-	Addition of GCF WI 86 Multilayer Test Case 13.1.2	9.1.0	9.2.0
2011-12	RAN#54	R5s110588	0821	-	Correction to GCF WI-086 Idle Mode Testcases 6.2.3.13	9.1.0	9.2.0
2011-12	RAN#54	R5s110584	0822	-	Correction to EMM test case 9.1.5.1	9.1.0	9.2.0
2011-12	RAN#54	R5s110585	0823	-	Addition of GCF WI-081 E-UTRA MAC testcase 7.1.7.1.6	9.1.0	9.2.0
2011-12	RAN#54	R5s110582	0824	-	Addition of GCF WI-081 E-UTRA MAC testcase 7.1.7.1.5	9.1.0	9.2.0
2011-12	RAN#54	R5s110572	0825	-	Correction of DRB test cases 12.3.1,12.3.2,12.3.3,12.3.4	9.1.0	9.2.0
2011-12	RAN#54	R5s110576	0826	-	Correction to GCF WI-081 EUTRA MAC test case 7.1.3.9	9.1.0	9.2.0
2011-12	RAN#54	R5s110598	0827	-	Addition of GCF WI-086 EUTRA RRC test case 8.3.3.2	9.1.0	9.2.0
2011-12	RAN#54	R5s110603	0828	-	Corrections to the IP component	9.1.0	9.2.0
2011-12	RAN#54	R5s110593	0829	-	Regression CR for LTE wk37 ATS	9.1.0	9.2.0
2011-12	RAN#54	R5s110604	0830	-	Addition of GCF WI-082 ESM test case 10.9.1	9.1.0	9.2.0
2011-12	RAN#54	R5s110634	0831	-	Correction to GCF WI 82 ESM test case 10.3.1	9.1.0	9.2.0
2011-12	RAN#54	R5s110633	0832	-	Correction to function f_UT_ManualPLMN_Select	9.1.0	9.2.0
2011-12	RAN#54	R5s110632	0833	-	Correction to EMM test cases	9.1.0	9.2.0
2011-12	RAN#54	R5s110631	0834	-	Correction to GCF WI-082 Idle Mode Testcases 9.3.2.2 and 9.3.2.2a	9.1.0	9.2.0
2011-12	RAN#54	R5s110623	0835	-	Correction to GCF WI-081 E-UTRA MIMO DRB Test Case Testcases 12.3.1, 12.3.2, 12.3.3 and 12.3.4	9.1.0	9.2.0
2011-12	RAN#54	R5s110610	0836	-	LTE_TDD: Addition of GCF WI-095 EUTRA RRC test case 8.2.4.9	9.1.0	9.2.0
2011-12	RAN#54	R5s110608	0837	-	LTE_TDD: Addition of GCF WI-095 EUTRA Idle Mode test case 6.1.2.5	9.1.0	9.2.0
2011-12	RAN#54	R5s110621	0838	-	LTE_TDD: Addition of GCF WI-091 EUTRA MAC testcase 7.1.5.5	9.1.0	9.2.0
2011-12	RAN#54	R5s110619	0839	-	LTE_TDD: Addition of GCF WI-091 EUTRA MAC testcase 7.1.5.3	9.1.0	9.2.0
2011-12	RAN#54	R5s110607	0840	-	Correction to GCF WI-86 EMM test case 9.2.3.3.5	9.1.0	9.2.0
2011-12	RAN#54	R5s110618	0841	-	Correction to LTE wk37 ATS	9.1.0	9.2.0
2011-12	RAN#54	R5s110616	0842	-	LTE_TDD: Addition of GCF WI-091 EUTRA Idle mode testcase 6.1.2.10	9.1.0	9.2.0

Date	TSG #	TSG Doc.	CR	Rev	Subject/Comment	Old	New
2011-12	RAN#54	R5s110614	0843	-	LTE_TDD: Addition of GCF WI-091 EUTRA MAC testcase 7.1.7.1.6	9.1.0	9.2.0
2011-12	RAN#54	R5s110612	0844	-	LTE_TDD: Addition of GCF WI-091 EUTRA MAC testcase 7.1.7.1.5	9.1.0	9.2.0
2011-12	RAN#54	R5s110596	0845	-	Regression CR for LTE IWD_wk37	9.1.0	9.2.0
2011-12	RAN#54	R5s110594	0846	-	Addition of GCF WI-082 E-UTRA EMM testcase 9.2.3.2.1a	9.1.0	9.2.0
2011-12	RAN#54	R5s110591	0847	-	LTE_TDD: Addition of GCF WI 97 EUTRA Idle mode test case 6.2.2.7	9.1.0	9.2.0
2011-12	RAN#54	R5s110589	0848	-	LTE_TDD: Addition of GCF WI 97 EUTRA RRC test case 8.1.3.8	9.1.0	9.2.0
2011-12	RAN#54	R5s110577	0849	-	Correction to EMM test case 9.2.3.2.3	9.1.0	9.2.0
2011-12	RAN#54	R5s110643	0850	-	Addition of GCF WI 82 EMM test case 9.2.2.1.4	9.1.0	9.2.0
2011-12	RAN#54	R5s110641	0851	-	Correction to EMM test case 9.2.3.1.17	9.1.0	9.2.0
2011-12	RAN#54	R5s110639	0852	-	Addition of GCF WI 81 EUTRA MAC test case 7.1.4.14	9.1.0	9.2.0
2011-12	RAN#54	R5s110637	0853	-	Addition of GCF WI 82 EMM test case 9.3.1.12a	9.1.0	9.2.0
2011-12	RAN#54	R5s110636	0854	-	Correction of GCF WI81 EUTRA Idle Mode in test case 6.1.1.3	9.1.0	9.2.0
2011-12	RAN#54	R5s110600	0855	-	Addition of GCF WI-088 EUTRA –1xRTT InterRAT test case 6.2.2.4	9.1.0	9.2.0
2011-12	RAN#54	R5s110658	0856	-	Correction to Timing Issues in Case of Big RRC + NAS Messages in EUTRA Testcases	9.1.0	9.2.0
2011-12	RAN#54	R5s110657	0857	-	Correction of GERAN Common Functions and Type Definitions in LTE / SAE ATS	9.1.0	9.2.0
2011-12	RAN#54	R5s110655	0858	-	Addition of GCF WI-086 EUTRA-UTRA Idle Mode test case 6.2.3.32	9.1.0	9.2.0
2011-12	RAN#54	R5s110653	0859	-	Addition of GCF WI-086 EUTRA-UTRA Idle Mode test case 6.2.3.31	9.1.0	9.2.0
2011-12	RAN#54	R5s110651	0860	-	Addition of GCF WI-086 EUTRA-UTRA Idle Mode test case 6.2.2.8	9.1.0	9.2.0
2011-12	RAN#54	R5s110649	0861	-	Addition of GCF WI-086 E-UTRA EMM testcase 9.2.3.2.14	9.1.0	9.2.0
2011-12	RAN#54	R5s110647	0862	-	Addition of GCF WI-086 E-UTRA EMM testcase 9.2.2.1.10	9.1.0	9.2.0
2011-12	RAN#54	R5s110666	0863	-	Correction to GCF WI-081 EUTRA MAC Testcase 7.1.4.14	9.1.0	9.2.0
2011-12	RAN#54	R5s110602	0864	-	Removal of SRB0 from SS SRB / DRB handling functions	9.1.0	9.2.0
2011-12	RAN#54	R5s110659	0865	-	Correction to GCF WI-081 EUTRA RAB test cases 12.3.x	9.1.0	9.2.0
2011-12	RAN#54	R5s110682	0866	-	Correction to Type Def. in LTE/SAE ATS	9.1.0	9.2.0
2011-12	RAN#54	R5s110680	0867	-	LTE_TDD: Addition of GCF WI-091 EUTRA Idle mode testcase 6.1.1.3	9.1.0	9.2.0
2011-12	RAN#54	R5s110678	0868	-	LTE_TDD: Addition of GCF WI-091 EUTRA Idle mode testcase 6.1.1.4	9.1.0	9.2.0
2011-12	RAN#54	R5s110676	0869	-	LTE_TDD: Addition of GCF WI-091 EUTRA Idle mode testcase 6.1.1.2	9.1.0	9.2.0
2011-12	RAN#54	R5s110675	0870	-	Corrections to GCF WI82 ESM test case 10.5.3	9.1.0	9.2.0
2011-12	RAN#54	R5s110674	0871	-	Correction to GCF WI-081 EUTRA RRC Testcase 8.1.2.13	9.1.0	9.2.0
2011-12	RAN#54	R5s110673	0872	-	Corrections to GCF WI82 ESM test case 10.3.1	9.1.0	9.2.0
2011-12	RAN#54	R5s110645	0873	-	Corrections to GCF WI82 ESM test case 10.9.1	9.1.0	9.2.0
2011-12	RAN#54	R5s110646	0874	-	Correction to GCF WI81 Idle Mode test case 6.1.2.14	9.1.0	9.2.0
2011-12	RAN#54	R5s110688	0875	-	Correction to EMM test case 9.2.3.1.1	9.1.0	9.2.0
2011-12	RAN#54	R5s110685	0876	-	Correction required to EMM test case 9.2.3.2.1a	9.1.0	9.2.0
2011-12	RAN#54	R5s110695	0877	-	Correction to Multi-Layer test case 13.1.2	9.1.0	9.2.0
2011-12	RAN#54	R5s110697	0878	-	Correction to EUTRA MAC test case 7.1.7.1.5 and 7.1.7.1.6	9.1.0	9.2.0
2011-12	RAN#54	R5s110694	0879	-	Correction to EMM test case 9.2.2.1.3	9.1.0	9.2.0

Date	TSG #	TSG Doc.	CR	Rev	Subject/Comment	Old	New
2011-12	RAN#54	R5s110687	0880	-	Correction to GCF WI-081 EUTRA MAC test case 7.1.3.9	9.1.0	9.2.0
2011-12	RAN#54	R5s110690	0881	-	Addition of GCF WI-086 EUTRA-UTRA Idle Mode test case 6.2.1.3	9.1.0	9.2.0
2011-12	RAN#54	R5s110696	0882	-	Correction to Idle mode test case 6.2.2.6	9.1.0	9.2.0
2011-12	RAN#54	R5s110699	0883	-	Addition of GCF WI-087 EUTRA RRC test case 8.3.3.3	9.1.0	9.2.0
2011-12	RAN#54	R5s110702	0884	-	Correction to EMM test case 9.3.1.6	9.1.0	9.2.0
2011-12	RAN#54	R5s110701	0885	-	Correction to EMM test case 9.3.1.17	9.1.0	9.2.0
2011-12	RAN#54	R5s110698	0886	-	Correction to EUTRA MAC test cases 7.1.6.1 and 7.1.6.2	9.1.0	9.2.0
2011-12	RAN#54	R5s110705	0887	-	Correction to EMM test case 9.2.3.2.14	9.1.0	9.2.0
2011-12	RAN#54	R5s110683	0888	-	Addition of GCF WI-086 EUTRA-UTRA (HSPA) RRC test case 8.4.1.4	9.1.0	9.2.0
2011-12	RAN#54	R5s110710	0889	-	Correction to EMM test case 9.2.1.1.24	9.1.0	9.2.0
2011-12	RAN#54	R5s110709	0890	-	Correction to EUTRA MAC test cases 7.1.7.1.1, 7.1.7.1.2, 7.1.7.1.3, 7.1.7.1.4, 7.1.7.1.5, 7.1.7.1.6 and 7.1.7.2.1 for LTE band 25	9.1.0	9.2.0
2011-12	RAN#54	R5s110708	0891	-	Correction to EUTRA RRC test case 8.1.2.8	9.1.0	9.2.0
2011-12	RAN#54	R5s110707	0892	-	Correction to RRC test case 8.2.4.8	9.1.0	9.2.0
2011-12	RAN#54	R5s110706	0893	-	Correction to MAC test case 7.1.2.3	9.1.0	9.2.0
2011-12	RAN#54	R5s110692	0894	-	Correction to EMM test cases 9.2.1.1.20 and 9.2.1.1.26	9.1.0	9.2.0
2011-12	RAN#54	R5s110693	0895	-	Correction to MAC test case 7.1.4.5	9.1.0	9.2.0
2011-12	RAN#54	R5s110718	0896	-	Addition of GCF WI-086 E-UTRA EMM testcase 9.2.3.2.13	9.1.0	9.2.0
2011-12	RAN#54	R5s110724	0898	-	Addition of GCF WI 88 EUTRA test case 8.3.2.6	9.1.0	9.2.0
2011-12	RAN#54	R5s110721	0899	-	Addition of GCF WI 87 EUTRA test case 8.3.2.1	9.1.0	9.2.0
2011-12	RAN#54	R5s110720	0900	-	Correction of LTE GERAN test cases	9.1.0	9.2.0
2012-03	RAN#55	R5-120721	0901	-	Routine maintenance and updates for EUTRA test model	9.2.0	9.3.0
2012-03	RAN#55	R5s110667	0971	-	Addition of GCF WI-081 E-UTRA ETWS testcase 14.1	9.2.0	9.3.0
2012-03	RAN#55	R5s110726	0970	-	Addition of GCF WI 86 EMM Test Case 9.2.3.3.1	9.2.0	9.3.0
2012-03	RAN#55	R5s110731	0960	-	Correction to GCF WI-082 EMM test case 9.2.2.1.6	9.2.0	9.3.0
2012-03	RAN#55	R5s110737	0968	-	Correction to EMM test case 9.2.2.1.6	9.2.0	9.3.0
2012-03	RAN#55	R5s110738	0969	-	Correction to EUTRA RRC test case 8.3.3.2	9.2.0	9.3.0
2012-03	RAN#55	R5s110739	0967	-	Correction to EUTRA MAC TBS test cases	9.2.0	9.3.0
2012-03	RAN#55	R5s110740	0966	-	Correction to EUTRA MAC test cases	9.2.0	9.3.0
2012-03	RAN#55	R5s110741	0965	-	Correction to GCF WI-088 Inter-RAT cell selection test cases 6.2.2.3 & 6.2.2.4	9.2.0	9.3.0
2012-03	RAN#55	R5s110742	0978	-	Types mismatch in f_UTRAN_CellInfo_GetNMO	9.2.0	9.3.0
2012-03	RAN#55	R5s110743	0974	-	Correction to EUTRA test cases to configure measurement gaps	9.2.0	9.3.0
2012-03	RAN#55	R5s110744	0964	-	Correction to EMM test cases	9.2.0	9.3.0
2012-03	RAN#55	R5s110746	0963	-	Correction to EUTRA RRC test cases 8.2.1.5 and 8.2.1.6	9.2.0	9.3.0
2012-03	RAN#55	R5s110747	0962	-	Addition of GCF WI 86,87 EUTRA test case 9.2.1.2.1b	9.2.0	9.3.0
2012-03	RAN#55	R5s110749	0977	-	Modification of template cas_RL_Modify_DPCHInfo_FDD	9.2.0	9.3.0
2012-03	RAN#55	R5s110750	0973	-	Correction to SMS over SG test cases 11.1.1 and 11.1.2	9.2.0	9.3.0

Date	TSG #	TSG Doc.	CR	Rev	Subject/Comment	Old	New
2012-03	RAN#55	R5s110751	0972	-	Correction to SMS over SG test cases 11.1.3 and 11.1.4	9.2.0	9.3.0
2012-03	RAN#55	R5s110752	0976	-	Correction to f_UTRAN_RB_SetUp	9.2.0	9.3.0
2012-03	RAN#55	R5s110753	0913	-	Correction to calls to f_EUTRA_SetSIB6_InterFreqCarrierFreqList_F8	9.2.0	9.3.0
2012-03	RAN#55	R5s110754	0975	-	Correction to GCF WI-086 Inter-RAT Handover testcases 8.4.1.2 & 8.4.1.4	9.2.0	9.3.0
2012-03	RAN#55	R5s110757	0914	-	Correction to f_EUTRA_TAU_Check	9.2.0	9.3.0
2012-03	RAN#55	R5s110759	0912	-	Addition of GCF WI 81 EUTRA test case 14.2	9.2.0	9.3.0
2012-03	RAN#55	R5s110761	0961	-	Addition of GCF WI 81 EUTRA test case 14.1	9.2.0	9.3.0
2012-03	RAN#55	R5s110763	0911	-	Addition of GCF WI87 EUTRA Idle Mode test case 6.2.3.1	9.2.0	9.3.0
2012-03	RAN#55	R5s110765	0910	-	Addition of EUTRA test case 8.3.1.9a	9.2.0	9.3.0
2012-03	RAN#55	R5s110767	0909	-	Addition of EUTRA test case 8.3.1.11a	9.2.0	9.3.0
2012-03	RAN#55	R5s110771	0908	-	Correction to UTRA RRC establishment cause and check of UTRA QoS params	9.2.0	9.3.0
2012-03	RAN#55	R5s110773	0907	-	Corrections to IPv6	9.2.0	9.3.0
2012-03	RAN#55	R5s110776	0924	-	Correction to LTE wk49 ATS	9.2.0	9.3.0
2012-03	RAN#55	R5s110777	0905	-	Regression CR for EUTRA EMM Testcases for D11wk49 ATS	9.2.0	9.3.0
2012-03	RAN#55	R5s110778	0906	-	Correction to GCF WI-082 EUTRA ESM Testcases 10.8.5, 10.8.6, 10.9.1	9.2.0	9.3.0
2012-03	RAN#55	R5s110779	0904	-	Correction to GCF WI-086 EUTRA Idle Mode Testcases 6.2.3.31	9.2.0	9.3.0
2012-03	RAN#55	R5s110782	0934	-	Correction to UTRAN SIB segmentation	9.2.0	9.3.0
2012-03	RAN#55	R5s110783	0933	-	Correction to GCF WI-081 EUTRA Idle Mode Testcase 6.1.2.13	9.2.0	9.3.0
2012-03	RAN#55	R5s110785	0903	-	Correction to GCF WI-081 RLC test cases 7.2.3.10 and 7.2.3.13	9.2.0	9.3.0
2012-03	RAN#55	R5s110787	0932	-	Correction to GCF WI-086 EUTRA Multi Layer Testcase 13.1.2	9.2.0	9.3.0
2012-03	RAN#55	R5s110788	0931	-	Correction to GCF WI-086 EUTRA RRC Testcase 8.4.1.4 and 8.4.12	9.2.0	9.3.0
2012-03	RAN#55	R5s110789	0930	-	Correction to GCF WI-082 EUTRA EMM Testcase 9.2.3.1.26	9.2.0	9.3.0
2012-03	RAN#55	R5s110790	0929	-	Correction to GCF WI-081 EUTRA RRC Testcase 8.3.1.7	9.2.0	9.3.0
2012-03	RAN#55	R5s110791	0928	-	Addition of GCF WI-086 E-UTRA EMM testcase 9.2.3.1.6	9.2.0	9.3.0
2012-03	RAN#55	R5s110801	0927	-	Addition of GCF WI-086 E-UTRA EMM testcase 9.2.3.3.4	9.2.0	9.3.0
2012-03	RAN#55	R5s120002	0926	-	Correction to function fl_RequestPDPContext	9.2.0	9.3.0
2012-03	RAN#55	R5s120003	0925	-	Correction to GCF WI-081 testcase 8.3.1.7	9.2.0	9.3.0
2012-03	RAN#55	R5s120006	0923	-	Correction to GCF WI-086 EUTRA RRC Testcase 8.3.3.2	9.2.0	9.3.0
2012-03	RAN#55	R5s120007	0948	-	LTE_TDD: Addition of GCF WI-091 EUTRA RRC testcase 8.2.1.5	9.2.0	9.3.0
2012-03	RAN#55	R5s120009	0947	-	Addition of GCF WI 81 EUTRA MAC test case 7.1.4.7a	9.2.0	9.3.0
2012-03	RAN#55	R5s120011	0946	-	LTE_TDD: Addition of GCF WI-091 EUTRA MAC testcase 7.1.4.7a	9.2.0	9.3.0
2012-03	RAN#55	R5s120013	0945	-	Addition of GCF WI 82 EMM Test Case 9.2.1.1.18	9.2.0	9.3.0
2012-03	RAN#55	R5s120016	0922	-	Addition of GCF WI87 EUTRA Idle Mode test case 6.2.3.14	9.2.0	9.3.0
2012-03	RAN#55	R5s120019	0921	-	Correction to EUTRA Idle Mode test case 6.2.1.3	9.2.0	9.3.0
2012-03	RAN#55	R5s120020	0920	-	Correction to EUTRA Idle Mode test case 6.1.2.13	9.2.0	9.3.0
2012-03	RAN#55	R5s120021	0919	-	Correction to EUTRA RRC test case 8.3.2.6	9.2.0	9.3.0
2012-03	RAN#55	R5s120022	0918	-	Correction to EMM test cases 9.2.2.2.2 and 9.3.2.2a	9.2.0	9.3.0

Date	TSG #	TSG Doc.	CR	Rev	Subject/Comment	Old	New
2012-03	RAN#55	R5s120023	0917	-	Correction to MAC test case 7.1.4.12	9.2.0	9.3.0
2012-03	RAN#55	R5s120024	0915	-	Correction to EUTRA RRC test cases 8.2.1.5	9.2.0	9.3.0
2012-03	RAN#55	R5s120025	0916	-	Addition of GCF WI-087 E-UTRA PLMN Selection testcase 6.2.1.4	9.2.0	9.3.0
2012-03	RAN#55	R5s120027	0944	-	Addition of GCF WI87 EUTRA Idle Mode test case 6.2.1.6	9.2.0	9.3.0
2012-03	RAN#55	R5s120029	0943	-	Addition of GCF WI-088 EUTRA-1xRTT test case 6.2.3.10	9.2.0	9.3.0
2012-03	RAN#55	R5s120033	0942	-	Correction to EUTRA RRC test cases 8.3.1.11	9.2.0	9.3.0
2012-03	RAN#55	R5s120034	0941	-	Correction to EMM test case 9.2.3.1.4	9.2.0	9.3.0
2012-03	RAN#55	R5s120035	0940	-	Correction to RLC test case 7.2.3.8 and MAC test case 7.1.7.2.1	9.2.0	9.3.0
2012-03	RAN#55	R5s120036	0939	-	Correction to GCF WI-081 EUTRA RRC Testcase 8.2.4.4	9.2.0	9.3.0
2012-03	RAN#55	R5s120037	0982	-	Addition of GCF WI-081 EUTRA MAC test case 7.1.8.1	9.2.0	9.3.0
2012-03	RAN#55	R5s120039	0938	-	Correction to EUTRA test cases 8.3.1.9 and 8.3.1.10	9.2.0	9.3.0
2012-03	RAN#55	R5s120040	0937	-	Correction to EUTRA MAC test cases 7.1.7.2.1, 7.1.6.1 and 7.1.6.2	9.2.0	9.3.0
2012-03	RAN#55	R5s120048	0936	-	Correction to EUTRA RRC test cases 8.3.3.2 and 8.3.3.3	9.2.0	9.3.0
2012-03	RAN#55	R5s120049	0935	-	Correction to GCF WI-086 Multi-Layer test case 13.1.2	9.2.0	9.3.0
2012-03	RAN#55	R5s120050	0953	-	Correction to GERAN modules in LTE ATS_wk49	9.2.0	9.3.0
2012-03	RAN#55	R5s120051	0952	-	Correction to GCF WI-088 EUTRA-HRPD test case 6.2.2.3	9.2.0	9.3.0
2012-03	RAN#55	R5s120052	0951	-	Correction to EUTRA_Measurement_Specific_Templates in LTE ATS wk49	9.2.0	9.3.0
2012-03	RAN#55	R5s120053	0954	-	Correction to GCF WI-081 EUTRA RRC Testcase 9.2.3.1.16	9.2.0	9.3.0
2012-03	RAN#55	R5s120054	0955	-	Addition of GCF WI 81 EUTRA MAC test case 7.1.3.2	9.2.0	9.3.0
2012-03	RAN#55	R5s120056	0950	-	Correction to TLLI deletion at GPRS detach	9.2.0	9.3.0
2012-03	RAN#55	R5s120057	0949	-	Correction to GCF WI-085 Interband test case 6.1.2.5 and 8.2.4.9	9.2.0	9.3.0
2012-03	RAN#55	R5s120059	0981	-	LTE_TDD Addition of GCF WI-091 EUTRA MAC test case 7.1.8.1	9.2.0	9.3.0
2012-03	RAN#55	R5s120061	0958	-	Correction to GCF WI-082 EUTRA NAS test case 9.2.1.1.7	9.2.0	9.3.0
2012-03	RAN#55	R5s120062	0957	-	Correction to GCF WI-081 EUTRA RRC test cases 8.5.1.2 and 8.5.1.4	9.2.0	9.3.0
2012-03	RAN#55	R5s120065	0956	-	Correction to EUTRA Idle Mode test cases 6.1.1.3, 6.1.2.7	9.2.0	9.3.0
2012-03	RAN#55	R5s120067	0959	-	Correction to EMM testcase 9.2.3.3.4	9.2.0	9.3.0
2012-03	RAN#55	R5s120068	0990	-	Addition of GCF WI-086 UTRAN-EUTRA RRC test case 8.1.3.7	9.2.0	9.3.0
2012-03	RAN#55	R5s120070	0989	-	Addition of GCF WI-086 UTRAN-EUTRA Multi-Layer test case 13.1.4	9.2.0	9.3.0
2012-03	RAN#55	R5s120072	0979	-	Correction to EMM testcase 9.2.1.2.1b	9.2.0	9.3.0
2012-03	RAN#55	R5s120073	0980	-	Correction to EutraBand_Type	9.2.0	9.3.0
2012-03	RAN#55	R5s120074	0983	-	Addition of GCF WI-088 EUTRA-1xRTT RRC test case 8.1.3.10	9.2.0	9.3.0
2012-03	RAN#55	R5s120076	0987	-	Correction to ICMPv6 template in LTE/SAE ATS_12wk05	9.2.0	9.3.0
2012-03	RAN#55	R5s120077	0984	-	Correction to EMM testcases 9.2.3.1.17 and 9.2.3.1.19	9.2.0	9.3.0
2012-03	RAN#55	R5s120078	0988	-	Correction to EUTRA Idle Mode test case 6.1.1.2	9.2.0	9.3.0
2012-03	RAN#55	R5s120079	0986	-	Correction to GCF WI-082 EMM test case 9.2.1.2.3	9.2.0	9.3.0
2012-03	RAN#55	R5s120080	0985	-	Correction to GCF WI-082 ESM test case 10.8.7	9.2.0	9.3.0
2012-03	RAN#55	RP-120188	0902	-	CR to 36.523-3: Add new verified and e-mail agreed TTCN test cases in the TC lists in 36.523-3 (prose), Annex A	9.2.0	9.3.0

Date	TSG #	TSG Doc.	CR	Rev	Subject/Comment	Old	New
2012-06	RAN#56	R5-121777	0991	-	Update of Timing parameters of E-UTRAN TDD cells	9.3.0	9.4.0
2012-06	RAN#56	R5s120082	1156	-	Correction to EUTRA RRC test case 8.3.2.6	9.3.0	9.4.0
2012-06	RAN#56	R5s120083	1155	-	Correction to EUTRA MAC testcase 7.1.4.14	9.3.0	9.4.0
2012-06	RAN#56	R5s120084	1154	-	Correction to EMM testcase 9.2.1.1.25	9.3.0	9.4.0
2012-06	RAN#56	R5s120086	1153	-	Addition of GCF WI 86 Multilayer test case 13.1.15	9.3.0	9.4.0
2012-06	RAN#56	R5s120088	1152	-	Correction to EUTRA MAC test cases 7.1.4.7a	9.3.0	9.4.0
2012-06	RAN#56	R5s120089	1150	-	Correction to EMM testcase 9.2.3.1.23	9.3.0	9.4.0
2012-06	RAN#56	R5s120090	1149	-	Correction to EUTRA Idle mode test case 6.2.3.14	9.3.0	9.4.0
2012-06	RAN#56	R5s120091	1151	-	Correction to EUTRA Idle mode test case 6.2.3.1	9.3.0	9.4.0
2012-06	RAN#56	R5s120095	1148	-	Correction to EUTRA testcases	9.3.0	9.4.0
2012-06	RAN#56	R5s120096	1147	-	Correction to EMM test case 9.2.3.2.17	9.3.0	9.4.0
2012-06	RAN#56	R5s120097	1146	-	Correction to LTE IRAT test cases	9.3.0	9.4.0
2012-06	RAN#56	R5s120098	1145	-	Correction to UTRAN Component in LTE ATS_12wk05	9.3.0	9.4.0
2012-06	RAN#56	R5s120099	1142	-	Correction to EUTRA Test Case 8.2.1.5 and 8.2.1.6	9.3.0	9.4.0
2012-06	RAN#56	R5s120100	1143	-	Correction to EUTRA EMM test case 9.2.1.2.11	9.3.0	9.4.0
2012-06	RAN#56	R5s120101	1144	-	Correction to DCI2 configuration	9.3.0	9.4.0
2012-06	RAN#56	R5s120102	1141	-	Addition of GCF WI-081 EUTRA Idle Mode test case 6.3.1	9.3.0	9.4.0
2012-06	RAN#56	R5s120104	1139	-	Correction to GCF WI-082 EMM test case 9.2.3.1.17	9.3.0	9.4.0
2012-06	RAN#56	R5s120106	1140	-	Correction to GERAN paging group calculation in LTE ATS_12wk05	9.3.0	9.4.0
2012-06	RAN#56	R5s120109	1138	-	Addition of GCF WI-082 EMM test case 9.2.3.1.9	9.3.0	9.4.0
2012-06	RAN#56	R5s120111	1136	-	Addition of GCF WI-086 EUTRA –UTRAN test case 13.1.16	9.3.0	9.4.0
2012-06	RAN#56	R5s120113	1137	-	Addition of GCF WI-086 EUTRA <->UTRA testcase 13.4.2.1	9.3.0	9.4.0
2012-06	RAN#56	R5s120115	1134	-	Addition of EUTRA Hybrid CSG Cell test case 6.4.1	9.3.0	9.4.0
2012-06	RAN#56	R5s120117	1135	-	Addition of GCF WI-086 EUTRA <->UTRA testcase 13.1.5	9.3.0	9.4.0
2012-06	RAN#56	R5s120119	1108	-	Regression CR for LTE wk09 ATS	9.3.0	9.4.0
2012-06	RAN#56	R5s120121	1133	-	Correction to TA transmission in wk09 TTCN	9.3.0	9.4.0
2012-06	RAN#56	R5s120122	1131	-	Correction to GCF WI-086 UTRAN-EUTRA test case 6.2.2.8	9.3.0	9.4.0
2012-06	RAN#56	R5s120124	1132	-	Correction to EUTRA RRC test case 8.1.1.3	9.3.0	9.4.0
2012-06	RAN#56	R5s120125	1130	-	Correction to EMM testcase 9.2.1.1.23, 9.2.3.2.4, 9.2.3.2.14, 9.2.3.2.2, 9.2.3.2.17	9.3.0	9.4.0
2012-06	RAN#56	R5s120127	1126	-	Correction to GCF WI-086 EUTRA-UTRAN test case 9.2.3.3.4	9.3.0	9.4.0
2012-06	RAN#56	R5s120129	1128	-	Correction to the implementation of SI 2 quarter message	9.3.0	9.4.0
2012-06	RAN#56	R5s120130	1129	-	Correction to WI-081 EUTRA Idle Mode Testcase 6.1.2.13	9.3.0	9.4.0
2012-06	RAN#56	R5s120132	1127	-	Correction to WI-086 EUTRA EMM Testcase 9.2.1.1.11	9.3.0	9.4.0
2012-06	RAN#56	R5s120133	1124	-	Correction to GCF WI-086 EUTRA EMM Testcase 9.2.1.2.11	9.3.0	9.4.0
2012-06	RAN#56	R5s120134	1125	-	Correction to EUTRA Auxiliary Functions in LTE/SAE ATS_12wk09	9.3.0	9.4.0
2012-06	RAN#56	R5s120135	1123	-	Correction to GCF WI-081 EUTRA MAC test cases 7.1.7.x	9.3.0	9.4.0
2012-06	RAN#56	R5s120136	1120	-	Correction to EUTRA Idle Updated Teststep	9.3.0	9.4.0

Date	TSG #	TSG Doc.	CR	Rev	Subject/Comment	Old	New
2012-06	RAN#56	R5s120137	1122	-	Correction to GCF WI-086 EUTRA EMM Testcase 9.2.3.3.1	9.3.0	9.4.0
2012-06	RAN#56	R5s120138	1121	-	Correction to GCF WI-86 EUTRA RRC Testcase 8.4.1.2 and 8.4.1.4	9.3.0	9.4.0
2012-06	RAN#56	R5s120139	1109	-	Addition of GCF WI-086 EUTRA <->UTRA testcase 13.3.2.1	9.3.0	9.4.0
2012-06	RAN#56	R5s120141	1119	-	Correction to UTRAN function f_UTRAN_GMM_RAU	9.3.0	9.4.0
2012-06	RAN#56	R5s120142	1118	-	Correction to f_EUTRA_IdleUpdated_Step14_15	9.3.0	9.4.0
2012-06	RAN#56	R5s120143	1117	-	Correction to GCF WI-086 EUTRA-UTRAN test case 9.2.3.2.9	9.3.0	9.4.0
2012-06	RAN#56	R5s120144	1116	-	LTE_TDD: Addition of GCF WI-091 EUTRA MAC testcase 7.1.4.14	9.3.0	9.4.0
2012-06	RAN#56	R5s120146	1115	-	Addition of EUTRA Idle Mode testcase 6.1.2.7a	9.3.0	9.4.0
2012-06	RAN#56	R5s120148	1112	-	Addition of EUTRA Idle Mode testcase 6.1.2.8a	9.3.0	9.4.0
2012-06	RAN#56	R5s120150	1111	-	Addition of GCF WI-091 EUTRA Idle Mode testcase 6.1.2.9a	9.3.0	9.4.0
2012-06	RAN#56	R5s120152	1114	-	Addition of EUTRA Idle Mode testcase 6.1.1.2a	9.3.0	9.4.0
2012-06	RAN#56	R5s120154	1113	-	Addition of EUTRA Idle Mode testcase 6.1.1.3b	9.3.0	9.4.0
2012-06	RAN#56	R5s120156	1110	-	Addition of EMM EUTRA <->UTRA testcase 9.2.1.2.1d	9.3.0	9.4.0
2012-06	RAN#56	R5s120158	1106	-	Addition of EUTRA Idle Mode testcase 6.1.1.6a	9.3.0	9.4.0
2012-06	RAN#56	R5s120160	1107	-	Addition of EUTRA Idle Mode testcase 6.1.1.1b	9.3.0	9.4.0
2012-06	RAN#56	R5s120162	1105	-	Correction to EMM test case 9.2.1.2.15	9.3.0	9.4.0
2012-06	RAN#56	R5s120165	1102	-	LTE_TDD: Addition of GCF WI-097 EUTRA Idle mode test case 6.2.1.4	9.3.0	9.4.0
2012-06	RAN#56	R5s120167	1103	-	LTE_TDD: Addition of GCF WI-097 EUTRA Idle mode test case 6.2.2.6	9.3.0	9.4.0
2012-06	RAN#56	R5s120169	1104	-	LTE_TDD: Addition of GCF WI-097 EUTRA Idle mode test case 6.2.3.14	9.3.0	9.4.0
2012-06	RAN#56	R5s120173	1101	-	LTE_TDD: Addition of EUTRA Idle mode test case 6.1.1.3b	9.3.0	9.4.0
2012-06	RAN#56	R5s120175	1100	-	LTE_TDD: Addition of EUTRA Idle mode test case 6.1.2.7a	9.3.0	9.4.0
2012-06	RAN#56	R5s120178	1032	-	Baseline upgrade of LTE ATS to March-12 in Rel-10	9.3.0	9.4.0
2012-06	RAN#56	R5s120179	1099	-	LTE_TDD: Addition of GCF WI-097 EUTRA Idle mode test case 6.2.1.6	9.3.0	9.4.0
2012-06	RAN#56	R5s120181	1097	-	LTE_TDD: Addition of GCF WI-097 EUTRA Idle mode test case 6.2.2.2	9.3.0	9.4.0
2012-06	RAN#56	R5s120183	1098	-	LTE_TDD: Addition of GCF WI-097 EUTRA Idle mode test case 6.2.3.1	9.3.0	9.4.0
2012-06	RAN#56	R5s120185	1093	-	LTE_TDD: Addition of GCF WI-092 EMM test case 9.2.1.1.12	9.3.0	9.4.0
2012-06	RAN#56	R5s120187	1094	-	LTE_TDD: Addition of GCF WI-092 EMM test case 9.2.3.1.10	9.3.0	9.4.0
2012-06	RAN#56	R5s120189	1095	-	LTE_TDD: Addition of GCF WI-092 EMM test case 9.2.3.1.11	9.3.0	9.4.0
2012-06	RAN#56	R5s120191	1096	-	LTE_TDD: Addition of GCF WI-092 EMM test case 9.2.3.1.12	9.3.0	9.4.0
2012-06	RAN#56	R5s120193	1091	-	LTE_TDD: Addition of GCF WI-092 EMM test case 9.3.1.4	9.3.0	9.4.0
2012-06	RAN#56	R5s120195	1092	-	LTE_TDD: Addition of GCF WI-092 EMM test case 9.3.1.5	9.3.0	9.4.0
2012-06	RAN#56	R5s120197	1090	-	Correction to EUTRA test case 7.1.4.12	9.3.0	9.4.0
2012-06	RAN#56	R5s120198	1089	-	Addition of GCF WI 81 EUTRA MAC test case 7.1.4.2	9.3.0	9.4.0
2012-06	RAN#56	R5s120200	1088	-	Correction to EUTRA test case 7.1.3.2	9.3.0	9.4.0
2012-06	RAN#56	R5s120201	1087	-	Correction to GCF WI-081 EUTRA RRC test case 8.2.1.5	9.3.0	9.4.0
2012-06	RAN#56	R5s120202	1085	-	LTE_TDD: Addition of GCF WI-092 EMM test case 9.2.1.1.11	9.3.0	9.4.0
2012-06	RAN#56	R5s120204	1086	-	LTE_TDD: Addition of GCF WI-092 EMM test case 9.2.3.1.18	9.3.0	9.4.0

Date	TSG #	TSG Doc.	CR	Rev	Subject/Comment	Old	New
2012-06	RAN#56	R5s120206	1084	-	Update of default bandwidth for signalling conformance tests in E-UTRA band 11 + 18	9.3.0	9.4.0
2012-06	RAN#56	R5s120207	1083	-	Correction to GCF WI-081 RLC test case 7.2.3.21	9.3.0	9.4.0
2012-06	RAN#56	R5s120208	1082	-	Correction to EUTRA test case 8.1.3.8	9.3.0	9.4.0
2012-06	RAN#56	R5s120209	1081	-	Correction to GCF WI-085 Interband test case 8.2.4.9	9.3.0	9.4.0
2012-06	RAN#56	R5s120210	1080	-	Correction to EMM testcase 9.2.3.3.5	9.3.0	9.4.0
2012-06	RAN#56	R5s120211	1079	-	Correction to GCF WI-082 EMM test case 9.2.3.1.26	9.3.0	9.4.0
2012-06	RAN#56	R5s120212	1078	-	Correction to EMM testcase 9.2.3.2.1a	9.3.0	9.4.0
2012-06	RAN#56	R5s120213	1077	-	Correction to EMM test case 9.2.2.1.8	9.3.0	9.4.0
2012-06	RAN#56	R5s120214	1076	-	LTE_TDD: Addition of GCF WI-091 EUTRA MAC testcase 7.1.3.2	9.3.0	9.4.0
2012-06	RAN#56	R5s120216	1075	-	Correction to GCF WI-082 EMM test case 9.2.3.1.16	9.3.0	9.4.0
2012-06	RAN#56	R5s120218	1074	-	Addition of GCF WI-087 EMM testcase 9.2.3.4.1	9.3.0	9.4.0
2012-06	RAN#56	R5s120220	1073	-	Correction to the template cs_508_UplinkPowerControlDedicated_Default	9.3.0	9.4.0
2012-06	RAN#56	R5s120221	1070	-	Addition of GCF WI-087 EUTRA - GERAN test case 6.2.3.15	9.3.0	9.4.0
2012-06	RAN#56	R5s120223	1072	-	Correction to default Packet Application type	9.3.0	9.4.0
2012-06	RAN#56	R5s120224	1071	-	Correction to GCF WI-082 EMM test case 9.2.3.1.9	9.3.0	9.4.0
2012-06	RAN#56	R5s120227	1069	-	Correction to EUTRA test case 6.1.1.4	9.3.0	9.4.0
2012-06	RAN#56	R5s120228	1068	-	Addition of EMM EUTRA <>UTRA testcase 9.2.3.2.1c	9.3.0	9.4.0
2012-06	RAN#56	R5s120230	1067	-	Addition of GCF WI-082 EMM test case 9.2.3.1.20	9.3.0	9.4.0
2012-06	RAN#56	R5s120232	1066	-	Addition of GCF WI-082 EMM test case 9.2.3.2.16	9.3.0	9.4.0
2012-06	RAN#56	R5s120234	1064	-	LTE_TDD: Addition of GCF WI-097 EMM test case 9.2.1.2.5	9.3.0	9.4.0
2012-06	RAN#56	R5s120236	1063	-	LTE_TDD: Addition of GCF WI-097 EMM test case 9.2.1.2.6	9.3.0	9.4.0
2012-06	RAN#56	R5s120238	1062	-	LTE_TDD: Addition of GCF WI-097 EMM test case 9.2.1.2.7	9.3.0	9.4.0
2012-06	RAN#56	R5s120240	1061	-	LTE_TDD: Addition of GCF WI-097 EMM test case 9.2.1.2.15	9.3.0	9.4.0
2012-06	RAN#56	R5s120243	1065	-	Correction to EUTRA-HRPD test case 6.2.3.8	9.3.0	9.4.0
2012-06	RAN#56	R5s120244	1060	-	Addition of GCF WI-087 EUTRA RRC testcase 8.3.2.2	9.3.0	9.4.0
2012-06	RAN#56	R5s120246	1059	-	LTE_TDD: Addition of GCF WI-097 EUTRA RRC testcase 8.3.2.2	9.3.0	9.4.0
2012-06	RAN#56	R5s120248	1058	-	LTE_TDD: Addition of GCF WI-097 EUTRA RRC testcase 8.3.2.1	9.3.0	9.4.0
2012-06	RAN#56	R5s120250	1047	-	Correction to GCF WI-081 EUTRA test case 8.5.4.1	9.3.0	9.4.0
2012-06	RAN#56	R5s120251	1057	-	LTE_TDD: Addition of GCF WI-097 EMM test case 9.2.3.2.5	9.3.0	9.4.0
2012-06	RAN#56	R5s120253	1055	-	LTE_TDD: Addition of GCF WI-097 EMM test case 9.2.3.2.6	9.3.0	9.4.0
2012-06	RAN#56	R5s120255	1056	-	LTE_TDD: Addition of GCF WI-097 EMM test case 9.2.3.2.7	9.3.0	9.4.0
2012-06	RAN#56	R5s120257	1054	-	LTE_TDD: Addition of GCF WI-097 EMM test case 9.2.1.2.9	9.3.0	9.4.0
2012-06	RAN#56	R5s120259	1053	-	LTE_TDD: Addition of GCF WI-097 EMM test case 9.2.1.2.11	9.3.0	9.4.0
2012-06	RAN#56	R5s120261	1052	-	Correction to EMM testcase 9.2.3.2.17	9.3.0	9.4.0
2012-06	RAN#56	R5s120262	1051	-	Correction to EMM testcase 9.2.1.1.18	9.3.0	9.4.0
2012-06	RAN#56	R5s120263	1049	-	Correction to EMM testcase 9.2.2.1.10	9.3.0	9.4.0
2012-06	RAN#56	R5s120264	1050	-	Correction to EMM testcase 9.2.3.1.25, 9.2.3.1.26, 9.2.1.1.23, 9.3.1.4, 9.3.1.5 and 9.3.1.6	9.3.0	9.4.0

Date	TSG #	TSG Doc.	CR	Rev	Subject/Comment	Old	New
2012-06	RAN#56	R5s120265	1048	-	Correction to EMM test cases 9.2.3.1.9, 9.2.1.2.1b, 9.2.2.1.4 and 9.2.3.2.1b	9.3.0	9.4.0
2012-06	RAN#56	R5s120266	1045	-	Correction of GCF WI 86 Multilayer test case 13.1.2	9.3.0	9.4.0
2012-06	RAN#56	R5s120271	1046	-	Correction to GCF WI-086 EUTRA EMM Testcase 9.2.3.3.5	9.3.0	9.4.0
2012-06	RAN#56	R5s120274	1044	-	Correction to EMM Test Cases	9.3.0	9.4.0
2012-06	RAN#56	R5s120275	1043	-	LTE_TDD: Addition of EUTRA Idle mode test case 6.1.1.1b	9.3.0	9.4.0
2012-06	RAN#56	R5s120277	1042	-	LTE_TDD: Addition of EUTRA Idle mode test case 6.1.2.8a	9.3.0	9.4.0
2012-06	RAN#56	R5s120279	1041	-	LTE_TDD: Addition of EUTRA Idle mode test case 6.1.2.9a	9.3.0	9.4.0
2012-06	RAN#56	R5s120281	1039	-	LTE_TDD: Addition of EUTRA Idle mode test case 6.1.1.2a	9.3.0	9.4.0
2012-06	RAN#56	R5s120283	1040	-	LTE_TDD: Addition of EUTRA Idle mode test case 6.1.1.6a	9.3.0	9.4.0
2012-06	RAN#56	R5s120287	1038	-	Addition of GCF WI-087 EUTRA - GERAN test case 6.2.3.16	9.3.0	9.4.0
2012-06	RAN#56	R5s120289	1037	-	Correction to Timing Calculation on EUTRA Cells	9.3.0	9.4.0
2012-06	RAN#56	R5s120290	1036	-	Correction for SIB 7 default contents	9.3.0	9.4.0
2012-06	RAN#56	R5s120291	1035	-	Correction to GCF WI-082 EMM test case 9.2.3.1.16	9.3.0	9.4.0
2012-06	RAN#56	R5s120292	1034	-	LTE_TDD: Addition of EUTRA RRC test case 8.1.2.9	9.3.0	9.4.0
2012-06	RAN#56	R5s120294	1033	-	Correction to template cdr_RRC_ConnReqWith_v860ext	9.3.0	9.4.0
2012-06	RAN#56	R5s120295	1031	-	LTE_TDD: Addition of GCF WI-092 EMM test case 9.2.3.1.17	9.3.0	9.4.0
2012-06	RAN#56	R5s120297	1030	-	Correction to EUTRA MAC test case 7.1.4.10	9.3.0	9.4.0
2012-06	RAN#56	R5s120298	1029	-	Correction to GCF WI-082 EUTRA CSG Testcase 9.2.3.1.9	9.3.0	9.4.0
2012-06	RAN#56	R5s120301	1028	-	Addition of GCF WI 86 Multilayer test case 13.1.3	9.3.0	9.4.0
2012-06	RAN#56	R5s120303	1027	-	Correction for GERAN message definitions	9.3.0	9.4.0
2012-06	RAN#56	R5s120304	1026	-	Correction to GCF WI-081 EUTRA MAC testcase 7.1.8.1	9.3.0	9.4.0
2012-06	RAN#56	R5s120305	1025	-	Correction for EMM testcase 9.2.3.1.22	9.3.0	9.4.0
2012-06	RAN#56	R5s120306	1024	-	LTE_TDD: Addition of GCF WI-097 EUTRA - GERAN test case 6.2.3.15	9.3.0	9.4.0
2012-06	RAN#56	R5s120308	1023	-	Addition of GCF WI 86 Multilayer test case 13.4.2.4	9.3.0	9.4.0
2012-06	RAN#56	R5s120310	1022	-	Correction to EUTRA test case 8.3.2.2	9.3.0	9.4.0
2012-06	RAN#56	R5s120312	1021	-	Correction to GCF WI-086 EUTRA Multilayer Testcase 13.4.2.1	9.3.0	9.4.0
2012-06	RAN#56	R5s120313	1017	-	Correction to GCF WI-081 EUTRA MAC Testcase 7.1.4.12	9.3.0	9.4.0
2012-06	RAN#56	R5s120314	1018	-	Correction to GCF WI-081 EUTRA EPC testcase 9.2.1.1.2 and 9.2.2.1.8	9.3.0	9.4.0
2012-06	RAN#56	R5s120315	1019	-	Correction to GCF WI-089 EUTRA RRCTestcase 8.3.2.6	9.3.0	9.4.0
2012-06	RAN#56	R5s120316	1020	-	Correction to GCF WI-081 EUTRA MAC SPS testcase 7.1.4.2	9.3.0	9.4.0
2012-06	RAN#56	R5s120317	1015	-	Correction to GCF WI-086 EUTRA Multilayer Testcase 13.4.2.1	9.3.0	9.4.0
2012-06	RAN#56	R5s120318	1016	-	Correction to EUTRA Idle Mode Testcase 6.1.2.8a and 6.1.2.9a	9.3.0	9.4.0
2012-06	RAN#56	R5s120320	1014	-	Correction to EMM test case 9.2.3.3.1	9.3.0	9.4.0
2012-06	RAN#56	R5s120321	1013	-	Correction to UTRA SIB19 for IE "qRxLevMinEUTRA"	9.3.0	9.4.0
2012-06	RAN#56	R5s120322	1012	-	Correction of EUTRA Idle Mode Testcase 6.1.1.1b	9.3.0	9.4.0
2012-06	RAN#56	R5s120323	1011	-	Correction for GERAN SI2Quarter message content	9.3.0	9.4.0
2012-06	RAN#56	R5s120325	1010	-	Correction to GCF WI-087 EUTRA EMM Testcase 9.2.1.2.9	9.3.0	9.4.0

Date	TSG #	TSG Doc.	CR	Rev	Subject/Comment	Old	New
2012-06	RAN#56	R5s120326	1009	-	Correction to GCF WI-082 EUTRA CSG Testcase 9.2.1.1.18	9.3.0	9.4.0
2012-06	RAN#56	R5s120327	1007	-	Correction of GCF WI-082 EUTRA EMM Testcase 9.2.3.2.4	9.3.0	9.4.0
2012-06	RAN#56	R5s120328	1008	-	Correction of GCF WI-086 EUTRA EMM Testcase 9.2.3.3.5	9.3.0	9.4.0
2012-06	RAN#56	R5s120329	1006	-	Addition of GCF WI-082 EUTRA CSG Testcase 9.3.1.18	9.3.0	9.4.0
2012-06	RAN#56	R5s120334	1005	-	Correction to the Band applicability of single frequency operation test cases	9.3.0	9.4.0
2012-06	RAN#56	R5s120335	1004	-	LTE_TDD: Addition of GCF WI-097 Idle mode test case 6.2.3.16	9.3.0	9.4.0
2012-06	RAN#56	R5s120338	1003	-	Correction to GCF WI-082 EUTRA CSG Testcase 9.2.1.1.18	9.3.0	9.4.0
2012-06	RAN#56	R5s120339	1001	-	Correction to GCF WI-087 EUTRA EMM Testcase 9.2.1.2.8	9.3.0	9.4.0
2012-06	RAN#56	R5s120340	1002	-	LTE_TDD: Addition of GCF WI-092 EMM test case 9.2.3.1.15	9.3.0	9.4.0
2012-06	RAN#56	R5s120342	1000	-	Correction to GCF WI-086 EUTRA Multilayer Testcase 13.1.5	9.3.0	9.4.0
2012-06	RAN#56	R5s120344	0999	-	Correction to GCF WI-081 EUTRA MAC SPS testcase 7.1.4.14	9.3.0	9.4.0
2012-06	RAN#56	R5s120345	0998	-	Correction to GCF WI-091 EUTRA RLC test cases 7.2.3.10 and 7.2.3.13	9.3.0	9.4.0
2012-06	RAN#56	R5s120346	0997	-	Correction to EMM test case 9.2.1.2.1d	9.3.0	9.4.0
2012-06	RAN#56	R5s120347	0996	-	Correction to EMM test case 9.2.1.1.7	9.3.0	9.4.0
2012-06	RAN#56	RP-120653	0995	-	CR to 36.523-3: Add new verified and e-mail agreed TTCN test cases in the TC lists in 36.523-3 (prose), Annex A	9.3.0	9.4.0
2012-06	RAN#56	R5-121779	0992	-	36523-3 routine maintenance and updates	9.4.0	10.0.0
2012-06	RAN#56	R5-121850	0993	-	Correction to Postamble Procedure for E-UTRAN to GERAN tests	9.4.0	10.0.0
2012-06	RAN#56	R5-122121	0994	-	Add new guidelines for TC executions	9.4.0	10.0.0
2012-09	RAN#57	R5-123081	1157	-	Update the guidelines for TC executions	10.0.0	10.1.0
2012-09	RAN#57	R5-123245	1158	-	Correction to postamble procedure of EUTRAN-GERAN test cases	10.0.0	10.1.0
2012-09	RAN#57	R5-123310	1159	-	Removal of technical content in 36.523-3 v9.4.0 and substitution with pointer to the next Release	10.0.0	10.1.0
2012-09	RAN#57	R5-123740	1160	-	36523-3: Routine maintenance and updates	10.0.0	10.1.0
2012-09	RAN#57	R5s120348	1161	-	Addition of Rel-9 EUTRA RRC test case 8.1.2.14	10.0.0	10.1.0
2012-09	RAN#57	R5s120350	1162	-	Addition of GCF WI-087 EUTRA-GERAN test case 6.2.3.21	10.0.0	10.1.0
2012-09	RAN#57	R5s120352	1163	-	LTE_TDD : Addition of GCF WI-091 EUTRA MAC Testcase 7.1.6.1	10.0.0	10.1.0
2012-09	RAN#57	R5s120354	1164	-	LTE_TDD : Addition of GCF WI-091 EUTRA MAC Testcase 7.1.6.2	10.0.0	10.1.0
2012-09	RAN#57	R5s120356	1165	-	Correction to EMM test case 9.2.3.4.1	10.0.0	10.1.0
2012-09	RAN#57	R5s120357	1166	-	Correction to GERAN paging group calculation	10.0.0	10.1.0
2012-09	RAN#57	R5s120358	1167	-	Addition of GCF WI 86 EMM test case 9.2.3.3.5a	10.0.0	10.1.0
2012-09	RAN#57	R5s120360	1168	-	Enhanced decoding of GERAN Types in LTE/SAE ATS	10.0.0	10.1.0
2012-09	RAN#57	R5s120361	1169	-	Correction to Manual PLMN Selection after Switch On in LTE/SAE ATS	10.0.0	10.1.0
2012-09	RAN#57	R5s120366	1170	-	Correction to template "cds_DL_CommonInformation_CompressedMode_FDD" in LTE/SAE ATS	10.0.0	10.1.0
2012-09	RAN#57	R5s120367	1171	-	Addition of GCF WI-082 EMM CSG test case 9.2.1.2.14	10.0.0	10.1.0
2012-09	RAN#57	R5s120369	1172	-	Correction to EUTRA MAC test case 7.1.1.2	10.0.0	10.1.0
2012-09	RAN#57	R5s120370	1173	-	Correction to EUTRA MAC test case 7.1.4.7a	10.0.0	10.1.0
2012-09	RAN#57	R5s120371	1174	-	Correction to DRX parameter in the Tracking Area Update Request message	10.0.0	10.1.0

Date	TSG #	TSG Doc.	CR	Rev	Subject/Comment	Old	New
2012-09	RAN#57	R5s120372	1175	-	Addition of GCF WI-087 EUTRA testcase 8.4.3.2	10.0.0	10.1.0
2012-09	RAN#57	R5s120374	1176	-	Addition of GCF WI-087 EUTRA testcase 8.4.3.3	10.0.0	10.1.0
2012-09	RAN#57	R5s120377	1177	-	Correction to EUTRA SIB 6 content for combination C10	10.0.0	10.1.0
2012-09	RAN#57	R5s120378	1178	-	Addition of GCF WI-086 EUTRA -UTRAN test case 9.2.3.3.2	10.0.0	10.1.0
2012-09	RAN#57	R5s120380	1179	-	Correction to EMM test case 9.3.1.18	10.0.0	10.1.0
2012-09	RAN#57	R5s120381	1180	-	Addition of GCF WI 86 LTE<->UTRAN test case 9.2.3.3.3	10.0.0	10.1.0
2012-09	RAN#57	R5s120383	1181	-	Correction to Uplink F4 Frequency for EUTRA Band 5	10.0.0	10.1.0
2012-09	RAN#57	R5s120386	1182	-	LTE_TDD : Addition of GCF WI-097 EUTRA EMM Testcase 9.2.1.2.8	10.0.0	10.1.0
2012-09	RAN#57	R5s120390	1183	-	LTE_TDD : Addition of GCF WI-097 EUTRA EMM Testcase 9.2.3.2.9	10.0.0	10.1.0
2012-09	RAN#57	R5s120393	1184	-	Addition of Rel9 EUTRA RRC Testcase 8.2.1.8	10.0.0	10.1.0
2012-09	RAN#57	R5s120395	1185	-	LTE_TDD : Addition of Rel9 EUTRA RRC Testcase 8.1.2.14	10.0.0	10.1.0
2012-09	RAN#57	R5s120397	1186	-	Addition of GCF WI-086 EUTRA<->UTRA HSPA Handover Testcase 8.4.1.5	10.0.0	10.1.0
2012-09	RAN#57	R5s120399	1187	-	LTE_TDD: Addition of Rel9 EUTRA RRC Testcase 8.2.1.8	10.0.0	10.1.0
2012-09	RAN#57	R5s120401	1188	-	LTE_TDD: Addition of GCF WI-097 EUTRA test case 6.2.3.21	10.0.0	10.1.0
2012-09	RAN#57	R5s120403	1189	-	Addition of GCF WI-088 EUTRA Idle Mode Testcase 6.2.3.7	10.0.0	10.1.0
2012-09	RAN#57	R5s120405	1190	-	LTE_TDD: Addition of GCF WI-096 EUTRA test case 8.3.2.3	10.0.0	10.1.0
2012-09	RAN#57	R5s120407	1191	-	Addition of GCF WI-088 EUTRA<->CDMA200 1XRTT Testcase 6.2.3.9	10.0.0	10.1.0
2012-09	RAN#57	R5s120409	1192	-	Addition of EMM testcase 9.2.1.1.1b	10.0.0	10.1.0
2012-09	RAN#57	R5s120411	1193	-	Addition of EMM testcase 9.2.1.1.13a	10.0.0	10.1.0
2012-09	RAN#57	R5s120413	1194	-	Addition of EMM testcase 9.2.1.1.15a	10.0.0	10.1.0
2012-09	RAN#57	R5s120415	1195	-	Addition of EMM testcase 9.2.1.1.16a	10.0.0	10.1.0
2012-09	RAN#57	R5s120417	1196	-	Addition of EMM testcase 9.2.3.1.18a	10.0.0	10.1.0
2012-09	RAN#57	R5s120419	1197	-	Addition of EMM testcase 9.2.1.1.7a	10.0.0	10.1.0
2012-09	RAN#57	R5s120421	1198	-	Addition of EMM testcase 9.2.3.1.15a	10.0.0	10.1.0
2012-09	RAN#57	R5s120423	1199	-	Addition of GCF WI-087 EUTRA - GERAN test case 6.2.3.17	10.0.0	10.1.0
2012-09	RAN#57	R5s120425	1200	-	Addition of GCF WI-087 EUTRA - GERAN test case 6.2.3.18	10.0.0	10.1.0
2012-09	RAN#57	R5s120427	1201	-	Correction to GCF WI-086 EUTRA EMM Testcase 9.2.1.2.1b	10.0.0	10.1.0
2012-09	RAN#57	R5s120431	1202	-	Addition of Rel 9 EUTRA RRC Interband Testcase 8.2.4.13	10.0.0	10.1.0
2012-09	RAN#57	R5s120433	1203	-	Addition of Rel9 EUTRA RRC Interband Testcase 8.1.3.11	10.0.0	10.1.0
2012-09	RAN#57	R5s120436	1204	-	Addition of Rel-9 EUTRA-HRPD Idle Mode test case 6.2.3.7a	10.0.0	10.1.0
2012-09	RAN#57	R5s120440	1205	-	Correction to GCF WI-086 EMM test case 9.2.3.3.4	10.0.0	10.1.0
2012-09	RAN#57	R5s120442	1206	-	LTE_TDD: Addition of GCF WI-097 EMM test case 9.2.1.2.13	10.0.0	10.1.0
2012-09	RAN#57	R5s120446	1207	-	LTE_TDD: Addition of Rel9 EUTRA RRC Interband Testcase 8.1.3.11	10.0.0	10.1.0
2012-09	RAN#57	R5s120448	1208	-	LTE_TDD: Addition of Rel 9 EUTRA RRC Interband Testcase 8.2.4.13	10.0.0	10.1.0
2012-09	RAN#57	R5s120450	1209	-	Addition of Rel9 EUTRA RRC Interband Testcase 8.1.3.12	10.0.0	10.1.0
2012-09	RAN#57	R5s120452	1210	-	LTE_TDD: Addition of GCF WI-097 EMM test case 9.2.3.2.8	10.0.0	10.1.0
2012-09	RAN#57	R5s120455	1211	-	Correction to GCF WI-086 EUTRA-UTRAN Multi-layer test case 13.1.4	10.0.0	10.1.0

Date	TSG #	TSG Doc.	CR	Rev	Subject/Comment	Old	New
2012-09	RAN#57	R5s120456	1212	-	Addition of Rel9 EUTRA RRC Interband Testcase 8.2.4.15	10.0.0	10.1.0
2012-09	RAN#57	R5s120458	1213	-	Addition of GCF WI-086 EUTRA EMM Testcase 9.2.1.2.1c	10.0.0	10.1.0
2012-09	RAN#57	R5s120461	1214	-	Correction to EMM test case 9.2.1.2.1d	10.0.0	10.1.0
2012-09	RAN#57	R5s120462	1215	-	Correction to f_UTRAN_PhyChReconf_InterRatCompressedModeActivate	10.0.0	10.1.0
2012-09	RAN#57	R5s120463	1216	-	Correction to EMM test case 9.2.3.1.4	10.0.0	10.1.0
2012-09	RAN#57	R5s120464	1217	-	Correction to EMM test case 9.2.1.1.24	10.0.0	10.1.0
2012-09	RAN#57	R5s120465	1218	-	Addition of GCF WI-088 EUTRA<->CDMA200 1XRTT RRC Testcase 8.3.2.9	10.0.0	10.1.0
2012-09	RAN#57	R5s120469	1219	-	Correction to function f_EUTRA_Capability in LTE/SAE ATS	10.0.0	10.1.0
2012-09	RAN#57	R5s120470	1220	-	Correction to usage of IP packets in EUTRA Test Mode B for IPv6-only UEs	10.0.0	10.1.0
2012-09	RAN#57	R5s120473	1221	-	Addition of Rel 9 EUTRA RRC Interband Testcase 8.2.4.14	10.0.0	10.1.0
2012-09	RAN#57	R5s120475	1222	-	Correction to GCF WI-081 EUTRA MAC DRX testcase 7.1.6.1	10.0.0	10.1.0
2012-09	RAN#57	R5s120476	1223	-	Correction for GERAN SI2Quater message content	10.0.0	10.1.0
2012-09	RAN#57	R5s120477	1224	-	Correction to EUTRA Idle mode test case 6.2.2.2	10.0.0	10.1.0
2012-09	RAN#57	R5s120478	1225	-	Correction to GCF WI-086 EMM Testcase 9.2.3.3.5	10.0.0	10.1.0
2012-09	RAN#57	R5s120479	1226	-	Correction to ESM testcases 10.8.5 and 10.8.6	10.0.0	10.1.0
2012-09	RAN#57	R5s120480	1227	-	Correction to function f_EUTRA_RmvFbdnPLMN and CSG test cases	10.0.0	10.1.0
2012-09	RAN#57	R5s120481	1228	-	Correction to Multilayer test case 13.4.2.4	10.0.0	10.1.0
2012-09	RAN#57	R5s120482	1229	-	Correction to EMM test case 9.2.3.3.2	10.0.0	10.1.0
2012-09	RAN#57	R5s120483	1230	-	Correction GCF WI-082 EUTRA EMM Testcase 9.2.3.1.23	10.0.0	10.1.0
2012-09	RAN#57	R5s120484	1231	-	Correction GCF WI-086 EUTRA EMM Testcase 9.2.3.2.9	10.0.0	10.1.0
2012-09	RAN#57	R5s120485	1232	-	Correction GCF WI-086 EUTRA Multilayer Testcase 13.1.3	10.0.0	10.1.0
2012-09	RAN#57	R5s120486	1233	-	Correction GCF WI-086 EUTRA EMM Testcase 9.2.3.2.1c	10.0.0	10.1.0
2012-09	RAN#57	R5s120487	1234	-	Correction GCF WI-081 EUTRA MAC Testcase 7.1.4.12	10.0.0	10.1.0
2012-09	RAN#57	R5s120488	1235	-	Correction to EUTRA RRC test case 8.5.4.1	10.0.0	10.1.0
2012-09	RAN#57	R5s120489	1236	-	Correction GCF WI-086 EUTRA Idle Mode Testcase 6.2.1.2	10.0.0	10.1.0
2012-09	RAN#57	R5s120490	1237	-	Addition of GCF WI-086 EUTRA-UTRAN test case 8.4.2.2	10.0.0	10.1.0
2012-09	RAN#57	R5s120492	1238	-	LTE_TDD: Addition of Rel 9 EUTRA RRC Interband Testcase 8.2.4.14	10.0.0	10.1.0
2012-09	RAN#57	R5s120494	1239	-	Correction for GERAN Packet Uplink Assignment template	10.0.0	10.1.0
2012-09	RAN#57	R5s120497	1240	-	Correction to EUTRA RRC test case 8.1.3.7	10.0.0	10.1.0
2012-09	RAN#57	R5s120498	1241	-	Addition of GCF WI-087 Multi-layer test case 13.1.7	10.0.0	10.1.0
2012-09	RAN#57	R5s120500	1242	-	Addition of EUTRA Multi-layer test case 13.1.8	10.0.0	10.1.0
2012-09	RAN#57	R5s120502	1243	-	Addition of GCF WI-087 EUTRA - GERAN test case 6.2.3.19	10.0.0	10.1.0
2012-09	RAN#57	R5s120504	1244	-	Addition of GCF WI-087 Multi-layer test case 13.1.9	10.0.0	10.1.0
2012-09	RAN#57	R5s120506	1245	-	Correction to Rel9 EUTRA RRC testcase 8.2.1.8	10.0.0	10.1.0
2012-09	RAN#57	R5s120507	1246	-	Correction to EMM test case 9.2.1.2.13	10.0.0	10.1.0
2012-09	RAN#57	R5s120508	1247	-	Correction to EMM test case 9.1.5.1	10.0.0	10.1.0
2012-09	RAN#57	R5s120509	1248	-	Addition of GCF WI-087 Multi-layer test case 13.1.10	10.0.0	10.1.0

Date	TSG #	TSG Doc.	CR	Rev	Subject/Comment	Old	New
2012-09	RAN#57	R5s120511	1249	-	Correction to f_UT_ConfigureCombinedAttach and f_UT_ConfigureEPSAttach	10.0.0	10.1.0
2012-09	RAN#57	R5s120515	1250	-	Addition of GCF WI-087 Multi-layer test case 6.2.3.20	10.0.0	10.1.0
2012-09	RAN#57	R5s120517	1251	-	Addition of Rel9 EUTRA<->CDMA2000 1xRTT Testcase 6.2.3.9a	10.0.0	10.1.0
2012-09	RAN#57	R5s120519	1252	-	Correction to GERAN Type Defs in LTE/SAE ATS	10.0.0	10.1.0
2012-09	RAN#57	R5s120520	1253	-	Correction to initial 'Power Off' MMI command in LTE/SAE ATS	10.0.0	10.1.0
2012-09	RAN#57	R5s120521	1254	-	Addition of GCF WI-087 EUTRA - GERAN test case 6.2.3.24	10.0.0	10.1.0
2012-09	RAN#57	R5s120523	1255	-	Correction to function f_SelectionExpr	10.0.0	10.1.0
2012-09	RAN#57	R5s120524	1256	-	Addition of Rel9 EUTRA<->CDMA2000 1xRTT Testcase 6.2.3.10a	10.0.0	10.1.0
2012-09	RAN#57	R5s120527	1257	-	Correction to GCF WI-087 testcase 6.2.3.16	10.0.0	10.1.0
2012-09	RAN#57	R5s120528	1258	-	Correction to Selection Expression for EMM test case 9.2.3.2.4 and 9.2.1.2.4	10.0.0	10.1.0
2012-09	RAN#57	R5s120529	1259	-	Correction of GCF WI-086 EMM testcase 9.2.3.2.1a	10.0.0	10.1.0
2012-09	RAN#57	R5s120531	1260	-	Correction to multiLayer test case 13.1.3	10.0.0	10.1.0
2012-09	RAN#57	R5s120532	1261	-	Correction to EMM test case 9.2.3.3.5a	10.0.0	10.1.0
2012-09	RAN#57	R5s120533	1262	-	Correction to WI-086 EUTRA-UTRAN EMM Testcase 9.2.3.2.14	10.0.0	10.1.0
2012-09	RAN#57	R5s120534	1263	-	Correction to function fl_EUTRA_CheckNoAttach_Common	10.0.0	10.1.0
2012-09	RAN#57	R5s120535	1264	-	Addition of GCF WI-086 UTRA<->EUTRA HSPA Handover Testcase 8.4.2.4	10.0.0	10.1.0
2012-09	RAN#57	R5s120551	1265	-	Correction to GCF WI-086 RRC test case 8.4.1.5	10.0.0	10.1.0
2012-09	RAN#57	R5s120552	1266	-	Addition of GCF WI-089 EUTRA test case 8.3.2.5	10.0.0	10.1.0
2012-09	RAN#57	R5s120554	1267	-	Addition of Rel-9 EUTRA-HRPD Idle Mode test case 6.2.3.8a	10.0.0	10.1.0
2012-09	RAN#57	R5s120556	1268	-	LTE_TDD: Addition of GCF WI-097 EUTRA Idle Mode testcase 6.2.3.17	10.0.0	10.1.0
2012-09	RAN#57	R5s120558	1269	-	LTE_TDD: Addition of GCF WI-097 EUTRA Idle Mode testcase 6.2.3.18	10.0.0	10.1.0
2012-09	RAN#57	R5s120560	1270	-	LTE_TDD: Addition of GCF WI-097 EMM test case 9.2.3.2.11	10.0.0	10.1.0
2012-09	RAN#57	R5s120562	1271	-	LTE_TDD: Addition of GCF WI-097 EMM test case 9.2.3.4.1	10.0.0	10.1.0
2012-09	RAN#57	R5s120564	1272	-	Correction to GCF WI-086 EUTRA-UTRAN test case 9.2.2.1.10	10.0.0	10.1.0
2012-09	RAN#57	R5s120565	1273	-	Correction to EUTRA RRC test case 8.1.3.7	10.0.0	10.1.0
2012-09	RAN#57	R5s120566	1274	-	Correction to applicability for test case 6.1.2.15	10.0.0	10.1.0
2012-09	RAN#57	R5s120567	1275	-	Correction to EMM test case 9.2.3.4.1	10.0.0	10.1.0
2012-09	RAN#57	R5s120568	1276	-	Addition of GCF WI-089 EUTRA test case 6.2.1.1	10.0.0	10.1.0
2012-09	RAN#57	R5s120570	1277	-	Addition of GCF WI-087 LTE<->GERAN Multilayer Testcase 13.3.2.2	10.0.0	10.1.0
2012-09	RAN#57	R5s120572	1278	-	Correction EUTRA<->GERAN Testcases using Multiple GERAN Cell	10.0.0	10.1.0
2012-09	RAN#57	R5s120573	1279	-	Correction to EUTRA<->UTRA Band IX Testcases	10.0.0	10.1.0
2012-09	RAN#57	R5s120574	1280	-	Correction to GCF WI-087 EUTRA EMM testcase 9.2.3.2.13	10.0.0	10.1.0
2012-09	RAN#57	R5s120575	1281	-	Correction to EMM test cases 9.3.1.4, 9.3.1.5, 9.3.1.6	10.0.0	10.1.0
2012-09	RAN#57	R5s120576	1282	-	Correction for function fl_ConvertPLMN	10.0.0	10.1.0
2012-09	RAN#57	R5s120579	1283	-	Correction to GCF WI-087 EUTRA EMM testcase 9.2.3.2.8	10.0.0	10.1.0
2012-09	RAN#57	R5s120580	1284	-	LTE_TDD: Addition of EUTRA test case 8.1.3.12	10.0.0	10.1.0
2012-09	RAN#57	R5s120582	1285	-	LTE_TDD: Addition of EUTRA test case 8.2.4.15	10.0.0	10.1.0

Date	TSG #	TSG Doc.	CR	Rev	Subject/Comment	Old	New
2012-09	RAN#57	R5s120584	1286	-	Correction to EUTRA EMM testcase 9.2.3.3.5a	10.0.0	10.1.0
2012-09	RAN#57	R5s120585	1287	-	Correction to GCF WI-082 EMM testcases 9.2.3.1.10, 9.2.3.1.11, 9.2.3.1.12 and 9.2.3.1.16	10.0.0	10.1.0
2012-09	RAN#57	R5s120586	1288	-	Correction to Common IRAT NAS templates in LTE/SAE ATS	10.0.0	10.1.0
2012-09	RAN#57	R5s120587	1289	-	Correction to LTE<->GERAN test cases	10.0.0	10.1.0
2012-09	RAN#57	R5s120588	1290	-	LTE_TDD: Addition of GCF WI-097 EUTRA test case 6.2.3.19	10.0.0	10.1.0
2012-09	RAN#57	R5s120590	1291	-	LTE_TDD: Addition of GCF WI-097 EUTRA test case 6.2.3.20	10.0.0	10.1.0
2012-09	RAN#57	R5s120592	1292	-	LTE_TDD: Addition of GCF WI-097 Multilayer test case 13.1.7	10.0.0	10.1.0
2012-09	RAN#57	R5s120594	1293	-	LTE_TDD: Addition of GCF WI-097 Multilayer test case 13.1.8	10.0.0	10.1.0
2012-09	RAN#57	R5s120600	1294	-	Correction to GCF WI-087 EUTRA Multilayer testcase 13.1.9	10.0.0	10.1.0
2012-09	RAN#57	R5s120602	1295	-	Correction for GERAN cell selection parameters	10.0.0	10.1.0
2012-09	RAN#57	R5s120604	1296	-	Correction to GCF WI-086 EMM test case 9.2.3.3.3	10.0.0	10.1.0
2012-09	RAN#57	RP-121107	1297	-	CR to 36.523-3: Add new verified and e-mail agreed TTCN test cases in the TC lists in 36.523-3 (prose), Annex A	10.0.0	10.1.0
2012-12	RAN#58	R5-125091	1298	-	Correction to system information scheduling in section 7.7.2	10.1.0	10.2.0
2012-12	RAN#58	R5-125093	1299	-	Correction to delay after RRC CONN REL in section 7.18	10.1.0	10.2.0
2012-12	RAN#58	R5-125127	1300	-	Update guidelines for TC executions	10.1.0	10.2.0
2012-12	RAN#58	R5-125133	1301	-	New PIXIT to minimize loopback delay	10.1.0	10.2.0
2012-12	RAN#58	R5-125278	1302	-	Change of default value for px_RRC_CipheringAlgorithm	10.1.0	10.2.0
2012-12	RAN#58	R5-125755	1303	-	36523-3: Routine maintenance and updates	10.1.0	10.2.0
2012-12	RAN#58	R5s120597	1304	-	Correction to UT function for "UE Switch On" in LTE/SAE ATS	10.1.0	10.2.0
2012-12	RAN#58	R5s120611	1305	-	LTE_TDD: Addition of GCF WI-091 EUTRA Idle mode testcase 6.1.1.6	10.1.0	10.2.0
2012-12	RAN#58	R5s120613	1306	-	LTE_TDD: Addition of GCF WI-091 EUTRA RRC test case 8.3.3.1	10.1.0	10.2.0
2012-12	RAN#58	R5s120615	1307	-	Correction for GERAN initialisation functions	10.1.0	10.2.0
2012-12	RAN#58	R5s120617	1308	-	Addition of GCF WI-081 EUTRA Manual CSG Testcase 6.3.5	10.1.0	10.2.0
2012-12	RAN#58	R5s120619	1309	-	LTE_TDD: Addition of GCF WI-097 EMM testcase 9.2.3.2.13	10.1.0	10.2.0
2012-12	RAN#58	R5s120623	1310	-	Correction to EUTRA RRC test case 8.5.4.1	10.1.0	10.2.0
2012-12	RAN#58	R5s120628	1311	-	Correction to EMM test case 9.2.3.1.17	10.1.0	10.2.0
2012-12	RAN#58	R5s120629	1312	-	Correction to EUTRA MAC test case 7.1.3.9	10.1.0	10.2.0
2012-12	RAN#58	R5s120632	1313	-	LTE_TDD: Addition of GCF WI-092 EMM testcase 9.3.1.6	10.1.0	10.2.0
2012-12	RAN#58	R5s120634	1314	-	Correction to EUTRA MAC test case 7.1.6.1	10.1.0	10.2.0
2012-12	RAN#58	R5s120637	1315	-	Correction to EUTRA-GERAN Multi-Layer test cases 13.1.7, 13.1.8, 13.1.9 and 13.1.10	10.1.0	10.2.0
2012-12	RAN#58	R5s120638	1316	-	Correction to EUTRA-GERAN Idle Mode test case 6.2.3.17	10.1.0	10.2.0
2012-12	RAN#58	R5s120639	1317	-	Correction to EMM test case 9.2.3.3.5a	10.1.0	10.2.0
2012-12	RAN#58	R5s120641	1318	-	Correction to EUTRA test cases	10.1.0	10.2.0
2012-12	RAN#58	R5s120642	1319	-	Correction to function f_IPv4IPv6_lcmpEchoReply	10.1.0	10.2.0
2012-12	RAN#58	R5s120643	1320	-	LTE_TDD: Addition of GCF WI-097 EMM testcase 9.2.3.2.14	10.1.0	10.2.0
2012-12	RAN#58	R5s120647	1321	-	Addition of EUTRA test case 6.1.2.15b	10.1.0	10.2.0
2012-12	RAN#58	R5s120649	1322	-	Addition of GCF WI-086 EMM test case 9.2.3.2.1b	10.1.0	10.2.0

Date	TSG #	TSG Doc.	CR	Rev	Subject/Comment	Old	New
2012-12	RAN#58	R5s120651	1323	-	Addition of GCF WI-151 LTE FDD-TDD Inter-mode test case 6.1.1.3a	10.1.0	10.2.0
2012-12	RAN#58	R5s120653	1324	-	Addition of GCF WI-151 LTE FDD-TDD Inter-mode test case 8.1.3.11a	10.1.0	10.2.0
2012-12	RAN#58	R5s120655	1325	-	Addition of GCF WI-151 LTE FDD-TDD Inter-mode test case 8.2.4.10	10.1.0	10.2.0
2012-12	RAN#58	R5s120657	1326	-	Correction for GERAN PTC initialisation	10.1.0	10.2.0
2012-12	RAN#58	R5s120658	1327	-	Correction to EUTRA MAC test case 7.1.6.2	10.1.0	10.2.0
2012-12	RAN#58	R5s120659	1328	-	Correction to EUTRA InterRAT test function	10.1.0	10.2.0
2012-12	RAN#58	R5s120660	1329	-	Correction to EUTRA InterRAT Testcases	10.1.0	10.2.0
2012-12	RAN#58	R5s120661	1330	-	Addition of GCF WI-151 LTE FDD-TDD Inter-mode test case 6.1.1.1a	10.1.0	10.2.0
2012-12	RAN#58	R5s120663	1331	-	Addition of GCF WI-151 LTE FDD-TDD Inter-mode test case 13.4.1.3	10.1.0	10.2.0
2012-12	RAN#58	R5s120666	1332	-	Correction to Selection Expressions in LTE/SAE ATS	10.1.0	10.2.0
2012-12	RAN#58	R5s120667	1333	-	Correction to EUTRA MAC Testcase 7.1.3.9	10.1.0	10.2.0
2012-12	RAN#58	R5s120668	1334	-	Correction to EUTRA GCF WI-086 Multilayer Testcase 13.1.3	10.1.0	10.2.0
2012-12	RAN#58	R5s120669	1335	-	Correction to EUTRA GCF WI-086 EMM Testcase 9.2.1.2.1b	10.1.0	10.2.0
2012-12	RAN#58	R5s120670	1336	-	Correction to EUTRA Idle Mode test case 6.2.3.15	10.1.0	10.2.0
2012-12	RAN#58	R5s120671	1337	-	Correction to EUTRA GCF WI-086 RRC Testcase 8.4.1.5	10.1.0	10.2.0
2012-12	RAN#58	R5s120672	1338	-	Correction to Multilayer test case 13.4.2.4	10.1.0	10.2.0
2012-12	RAN#58	R5s120673	1339	-	Correction to f_UTRAN_CS_Fallback_WithHandover function	10.1.0	10.2.0
2012-12	RAN#58	R5s120675	1340	-	Addition of Rel 9 EUTRA RRC Interband Testcase 8.3.1.12	10.1.0	10.2.0
2012-12	RAN#58	R5s120677	1341	-	Addition of Rel 9 EUTRA RRC Interband Testcase 8.3.1.14	10.1.0	10.2.0
2012-12	RAN#58	R5s120679	1342	-	Addition of Rel 9 EUTRA RRC Interband Testcase 13.4.1.4	10.1.0	10.2.0
2012-12	RAN#58	R5s120681	1343	-	Addition of Rel 9 EUTRA RRC Interband Testcase 8.3.1.15	10.1.0	10.2.0
2012-12	RAN#58	R5s120683	1344	-	Correction to EUTRA EMM Testcase 9.2.3.1.23 and 9.2.3.2.3	10.1.0	10.2.0
2012-12	RAN#58	R5s120684	1345	-	Correction to GCF WI-081 EUTRA CSG Testcase 6.3.5	10.1.0	10.2.0
2012-12	RAN#58	R5s120685	1346	-	Correction to Idle ModeTest Cases 6.1.1.3, 6.1.1.3b and 6.2.1.4.	10.1.0	10.2.0
2012-12	RAN#58	R5s120686	1347	-	Correction to GCF WI-086 UTRA<->EUTRA RRC Testcases 8.4.2.2 & 8.4.2.4	10.1.0	10.2.0
2012-12	RAN#58	R5s120688	1348	-	Correction to GCF WI-086 EUTRA EMM Testcase 9.2.3.3.2	10.1.0	10.2.0
2012-12	RAN#58	R5s120689	1349	-	LTE_TDD: Addition of GCF WI-097 EUTRA RRC Testcase 8.4.3.2	10.1.0	10.2.0
2012-12	RAN#58	R5s120693	1350	-	Addition of GCF WI-151 LTE FDD-TDD Inter-mode test case 8.2.4.13a	10.1.0	10.2.0
2012-12	RAN#58	R5s120695	1351	-	Corrections to Eutra EMM Test case 9.2.3.4.1	10.1.0	10.2.0
2012-12	RAN#58	R5s120696	1352	-	Corrections to EUTRA EMM Test case 9.2.3.1.16	10.1.0	10.2.0
2012-12	RAN#58	R5s120697	1353	-	Correction to GCF WI-086 EMM test case 9.2.3.3.3	10.1.0	10.2.0
2012-12	RAN#58	R5s120698	1354	-	Corrections to EMM test case 9.2.1.1.7a	10.1.0	10.2.0
2012-12	RAN#58	R5s120699	1355	-	Corrections to Multi-layer test case 13.1.9	10.1.0	10.2.0
2012-12	RAN#58	R5s120700	1356	-	Addition of Rel-9 LTE Multi-layer Procedures test case 13.3.1.3	10.1.0	10.2.0
2012-12	RAN#58	R5s120702	1357	-	Correction to EUTRA EMM Testcase 9.2.3.2.3	10.1.0	10.2.0
2012-12	RAN#58	R5s120703	1358	-	Corrections to EMM test case 9.2.3.3..4	10.1.0	10.2.0
2012-12	RAN#58	R5s120704	1359	-	Addition of Rel 9 EUTRA RRC Interband Testcase 8.3.1.13	10.1.0	10.2.0

Date	TSG #	TSG Doc.	CR	Rev	Subject/Comment	Old	New
2012-12	RAN#58	R5s120706	1360	-	Corrections to EUTRA RRC test case 8.5.4.1	10.1.0	10.2.0
2012-12	RAN#58	R5s120707	1361	-	Corrections to EUTRA EMM test case 9.2.3.3.1	10.1.0	10.2.0
2012-12	RAN#58	R5s120708	1362	-	Corrections to EUTRA Idle Mode Test case 6.2.3.19	10.1.0	10.2.0
2012-12	RAN#58	R5s120709	1363	-	Addition of Rel-9 LTE Multi-layer Procedures test case 13.4.1.5	10.1.0	10.2.0
2012-12	RAN#58	R5s120711	1364	-	Correction to GCF WI-086 EUTRA EMM Testcase 9.2.3.3.4.	10.1.0	10.2.0
2012-12	RAN#58	R5s120713	1365	-	Addition of GCF WI-151 EUTRA FDD-TDD Testcase 8.3.1.12a	10.1.0	10.2.0
2012-12	RAN#58	R5s120715	1366	-	Corrections to EMM test case 9.2.3.3.5a	10.1.0	10.2.0
2012-12	RAN#58	R5s120719	1367	-	Correction to UTRAN functions	10.1.0	10.2.0
2012-12	RAN#58	R5s120720	1368	-	Corrections to function f_EUTRA_RmvFbdnPLMN function	10.1.0	10.2.0
2012-12	RAN#58	R5s120721	1369	-	Corrections to EMM test case 9.2.2.1.3	10.1.0	10.2.0
2012-12	RAN#58	R5s120722	1370	-	Addition of GCF WI-151 LTE FDD-TDD Inter-mode test case 8.3.1.14a	10.1.0	10.2.0
2012-12	RAN#58	R5s120724	1371	-	Correction to EMM test case 9.2.1.2.15	10.1.0	10.2.0
2012-12	RAN#58	R5s120725	1372	-	Addition of GCF WI-151 LTE FDD-TDD Inter-mode test case 8.3.1.13a	10.1.0	10.2.0
2012-12	RAN#58	R5s120727	1373	-	Corrections to IMS procedures in LTE test suite	10.1.0	10.2.0
2012-12	RAN#58	R5s120728	1374	-	Correction to EUTRA EMM test case 9.2.3.3.5	10.1.0	10.2.0
2012-12	RAN#58	R5s120738	1375	-	LTE_TDD: Addition of GCF WI-096 Idle Mode test case 6.2.1.2	10.1.0	10.2.0
2012-12	RAN#58	R5s120740	1376	-	LTE_TDD: Addition of GCF WI-096 Idle Mode test case 6.2.2.1	10.1.0	10.2.0
2012-12	RAN#58	R5s120742	1377	-	LTE_TDD: Addition of GCF WI-096 Idle Mode test case 6.2.2.8	10.1.0	10.2.0
2012-12	RAN#58	R5s120744	1378	-	LTE_TDD: Addition of GCF WI-096 Idle Mode test case 6.2.3.3	10.1.0	10.2.0
2012-12	RAN#58	R5s120746	1379	-	LTE_TDD: Addition of GCF WI-096 Idle Mode test case 6.2.3.5	10.1.0	10.2.0
2012-12	RAN#58	R5s120748	1380	-	LTE_TDD: Addition of GCF WI-096 Idle Mode test case 6.2.3.6	10.1.0	10.2.0
2012-12	RAN#58	R5s120750	1381	-	LTE_TDD: Addition of GCF WI-096 Idle Mode test case 6.2.3.13	10.1.0	10.2.0
2012-12	RAN#58	R5s120752	1382	-	LTE_TDD: Addition of GCF WI-096 Idle Mode test case 6.2.3.31	10.1.0	10.2.0
2012-12	RAN#58	R5s120754	1383	-	LTE_TDD: Addition of GCF WI-096 Idle Mode test case 6.2.3.32	10.1.0	10.2.0
2012-12	RAN#58	R5s120756	1384	-	LTE_TDD: Addition of GCF WI-096 RRC test case 8.1.3.6	10.1.0	10.2.0
2012-12	RAN#58	R5s120758	1385	-	LTE_TDD: Addition of GCF WI-096 RRC test case 8.5.2.1	10.1.0	10.2.0
2012-12	RAN#58	R5s120760	1386	-	LTE_TDD: Addition of GCF WI-096 EMM test case 9.2.1.2.1b	10.1.0	10.2.0
2012-12	RAN#58	R5s120762	1387	-	LTE_TDD: Addition of GCF WI-096 EMM test case 9.2.2.1.10	10.1.0	10.2.0
2012-12	RAN#58	R5s120764	1388	-	LTE_TDD: Addition of GCF WI-096 EMM test case 9.2.3.3.3	10.1.0	10.2.0
2012-12	RAN#58	R5s120768	1389	-	Corrections to Multi-layer test cases 13.1.7,13.1.8,13.1.9,13.1.10	10.1.0	10.2.0
2012-12	RAN#58	R5s120769	1390	-	Correction to fl_EUTRA_RRC_Procedure_Latency function	10.1.0	10.2.0
2012-12	RAN#58	R5s120770	1391	-	Correction to GCF WI-086 EUTRA<->UTRA Testcases 6.2.1.3 and 8.3.3.2	10.1.0	10.2.0
2012-12	RAN#58	R5s120771	1392	-	Correction to GCF WI-082 EUTRA Multilayer Testcase 13.3.1.2	10.1.0	10.2.0
2012-12	RAN#58	R5s120772	1393	-	Addition of Rel 9 GCF WI-151 EUTRA RRC Testcase 6.1.2.16	10.1.0	10.2.0
2012-12	RAN#58	R5s120774	1394	-	Addition of GCF WI-087 Multi layer test case 13.4.2.5	10.1.0	10.2.0
2012-12	RAN#58	R5s120776	1395	-	Addition of Rel-9 EUTRA-UTRAN RRC test case 8.1.3.6a	10.1.0	10.2.0
2012-12	RAN#58	R5s120778	1396	-	Correction to GCF WI-086 E-UTRA to UTRAN RRC test case 8.4.1.5	10.1.0	10.2.0

Date	TSG #	TSG Doc.	CR	Rev	Subject/Comment	Old	New
2012-12	RAN#58	R5s120779	1397	-	LTE_TDD : Addition of Rel9 EUTRA Multilayer Testcase 13.3.1.3	10.1.0	10.2.0
2012-12	RAN#58	R5s120781	1398	-	LTE_TDD : Addition of Rel9 EUTRA Multilayer Testcase 13.4.1.5	10.1.0	10.2.0
2012-12	RAN#58	R5s120783	1399	-	Addition of Rel 9 RSRQ Idle Mode Testcase 6.1.2.2a	10.1.0	10.2.0
2012-12	RAN#58	R5s120785	1400	-	Addition of GCF WI-151 EUTRA FDD-TDD Inter-mode Testcase 6.1.2.15a	10.1.0	10.2.0
2012-12	RAN#58	R5s120787	1401	-	Correction to EMM Test Case 9.2.1.2.1d	10.1.0	10.2.0
2012-12	RAN#58	R5s120788	1402	-	Correction to GCF WI-086 EUTRA EMM Testcase 9.2.1.2.1d	10.1.0	10.2.0
2012-12	RAN#58	R5s120789	1403	-	Correction to EUTRA Idle Mode Testcase 6.1.2.9a	10.1.0	10.2.0
2012-12	RAN#58	R5s120790	1404	-	Correction to GCF WI-086 EMM test case 9.2.3.3.2	10.1.0	10.2.0
2012-12	RAN#58	R5s120791	1405	-	Corrections to EUTRA Idle Mode Test Cases	10.1.0	10.2.0
2012-12	RAN#58	R5s120793	1406	-	Correction to GCF WI-087 LTE<->GERAN Testcase 6.2.3.24	10.1.0	10.2.0
2012-12	RAN#58	R5s120797	1407	-	LTE_TDD: Addition of GCF WI-096 Idle Mode test case 6.2.3.6	10.1.0	10.2.0
2012-12	RAN#58	R5s120799	1408	-	Correction to f_UTRAN_LocationUpdate_WithoutLAUReq function	10.1.0	10.2.0
2012-12	RAN#58	R5s120800	1409	-	Correction to ESM test cases 10.8.5 and 10.8.6	10.1.0	10.2.0
2012-12	RAN#58	R5s120801	1410	-	Correction to Idle Mode test case 6.2.2.2	10.1.0	10.2.0
2012-12	RAN#58	R5s120802	1411	-	Correction to GERAN XID procedure	10.1.0	10.2.0
2012-12	RAN#58	R5s120808	1412	-	Addition of Rel9 EUTRA RRC test case 8.5.1.6	10.1.0	10.2.0
2012-12	RAN#58	R5s120810	1413	-	Corrections to EUTRA RRC test case 8.5.4.1	10.1.0	10.2.0
2012-12	RAN#58	R5s120811	1414	-	Correction to Idle Mode test case 6.2.1.1	10.1.0	10.2.0
2012-12	RAN#58	R5s120812	1415	-	Addition of GCF WI-151 EUTRA FDD-TDD Inter-mode test case 8.2.4.14a.	10.1.0	10.2.0
2012-12	RAN#58	R5s120815	1416	-	Correction to EUTRA Idle Mode Test Case 6.2.1.4	10.1.0	10.2.0
2012-12	RAN#58	R5s120817	1417	-	Addition of GCF WI-151 EUTRA FDD-TDD Inter-mode test case 8.2.4.15a.	10.1.0	10.2.0
2012-12	RAN#58	R5s120819	1418	-	Correction to f_UTRAN_CS_Fallback_WithHandover function	10.1.0	10.2.0
2012-12	RAN#58	R5s120820	1419	-	Correction to EUTRA Multi Layer test case 13.3.2.2	10.1.0	10.2.0
2012-12	RAN#58	R5s120821	1420	-	Correction to f_GetTestcaseAttrib_Eutra_Release function	10.1.0	10.2.0
2012-12	RAN#58	R5s120822	1421	-	Correction to GCF WI-081 MAC test cases 7.1.7.1.x and 7.1.7.2.1 for Band 18.	10.1.0	10.2.0
2012-12	RAN#58	R5s120823	1422	-	Correction to GCF WI-086 EUTRA RRC Testcase 8.4.1.5	10.1.0	10.2.0
2012-12	RAN#58	R5s120824	1423	-	Correction to GCF WI-087 EUTRA RRC Testcase 9.2.1.2.1b	10.1.0	10.2.0
2012-12	RAN#58	R5s120825	1424	-	Correction to GCF WI-086 EUTRA EMM Testcase 9.2.3.2.1b	10.1.0	10.2.0
2012-12	RAN#58	R5s120826	1425	-	Correction to Rel9 EUTRA Multilayer Testcase 13.3.1.3	10.1.0	10.2.0
2012-12	RAN#58	R5s120827	1426	-	Addition of Rel9 EUTRA RRC Interband Testcase 8.3.1.16.	10.1.0	10.2.0
2012-12	RAN#58	R5s120829	1427	-	Correction to GCF WI-086 EUTRA EMM Testcase 9.2.1.2.1c	10.1.0	10.2.0
2012-12	RAN#58	R5s120831	1428	-	Correction to GCF WI-086 EUTRA EMM Testcase 9.2.3.2.1c	10.1.0	10.2.0
2012-12	RAN#58	R5s120832	1429	-	Correction to GCF WI-082 EUTRA CSG Testcase 6.3.5	10.1.0	10.2.0
2012-12	RAN#58	R5s120833	1430	-	Correction to GCF WI-087 EUTRA EMM Testcase 9.2.1.2.13	10.1.0	10.2.0
2012-12	RAN#58	R5s120834	1431	-	Correction to GCF WI-086 EUTRA EMM Testcase 9.2.3.2.1b	10.1.0	10.2.0
2012-12	RAN#58	R5s120835	1432	-	Correction to GCF WI-087 EUTRA EMM Testcases 9.2.3.2.3, 9.2.1.2.1b, 9.2.3.2.1b	10.1.0	10.2.0
2012-12	RAN#58	R5s120836	1433	-	Correction to Rel 9 GCF WI-151 EUTRA RRC Testcase 6.1.2.15a	10.1.0	10.2.0

Date	TSG #	TSG Doc.	CR	Rev	Subject/Comment	Old	New
2012-12	RAN#58	R5s120837	1434	-	Correction to GCF WI-087 EUTRA EMM Testcase 9.2.3.4.1	10.1.0	10.2.0
2012-12	RAN#58	R5s120838	1435	-	Correction to GCF WI-087 EUTRA EMM Testcase 9.2.3.1.6	10.1.0	10.2.0
2012-12	RAN#58	R5s120839	1436	-	Correction to Rel9 EUTRA Hybrid Cell Testcase 6.4.1	10.1.0	10.2.0
2012-12	RAN#58	R5s120841	1437	-	Correction to Rel 9 GCF WI-151 EUTRA RRC Testcase 6.1.1.3a	10.1.0	10.2.0
2012-12	RAN#58	R5s120842	1438	-	Correction to Testcase Release Applicability of Rel9 EUTRA Testcases.	10.1.0	10.2.0
2012-12	RAN#58	R5s120843	1439	-	LTE_TDD : Addition of Rel9 GCF WI-150 EUTRA RSRQ Idle Mode Testcase 6.1.2.2a	10.1.0	10.2.0
2012-12	RAN#58	RP-121670	1440	-	CR to 36.523-3: Add new verified and e-mail agreed TTCN test cases in the TC lists in 36.523-3 (prose), Annex A	10.1.0	10.2.0
2013-03	RAN#59	R5-130670	1441	-	36523-3: Routine maintenance and updates	10.2.0	10.3.0
2013-03	RAN#59	R5-130693	1442	-	36523-3: Introduce CA test model and ASP	10.2.0	10.3.0
2013-03	RAN#59	R5s120830	1443	-	Correction to GCF WI-087 EUTRA EMM testcase 9.2.3.3.5	10.2.0	10.3.0
2013-03	RAN#59	R5s120849	1444	-	Correction to f_UTRAN_CellInfo_SetMultiplePLMNIdentities	10.2.0	10.3.0
2013-03	RAN#59	R5s120852	1445	-	Corrections to Redirection Test Cases	10.2.0	10.3.0
2013-03	RAN#59	R5s120853	1446	-	Correction to EUTRA Idle Mode Test Case 6.2.3.13	10.2.0	10.3.0
2013-03	RAN#59	R5s120854	1447	-	LTE_TDD : Addition of Rel9 EUTRA Interband Testcase 8.3.1.12	10.2.0	10.3.0
2013-03	RAN#59	R5s120856	1448	-	LTE_TDD : Addition of Rel9 EUTRA Interband Testcase 8.3.1.14	10.2.0	10.3.0
2013-03	RAN#59	R5s120860	1449	-	Corrections to Rel9 EUTRA RRC Test case 8.3.1.16	10.2.0	10.3.0
2013-03	RAN#59	R5s120861	1450	-	Correction to GCF WI-87 EUTRA Multilayer Testcase 13.3.2.2	10.2.0	10.3.0
2013-03	RAN#59	R5s120862	1451	-	LTE_TDD : Addition of Rel9 EUTRA Interband Testcase 8.3.1.15	10.2.0	10.3.0
2013-03	RAN#59	R5s120864	1452	-	LTE_TDD : Addition of Rel9 EUTRA RRC Testcase 8.5.1.6	10.2.0	10.3.0
2013-03	RAN#59	R5s120866	1453	-	Correction to GCF WI-87 EUTRA EMM Testcase 9.2.3.3.5a	10.2.0	10.3.0
2013-03	RAN#59	R5s120867	1454	-	Corrections to EUTRA EMM Test cases	10.2.0	10.3.0
2013-03	RAN#59	R5s120868	1455	-	Correction to EUTRA WI-086 Multilayer Testcase 13.1.3	10.2.0	10.3.0
2013-03	RAN#59	R5s120869	1456	-	Correction to EUTRA RRC Test Case 8.3.1.11a	10.2.0	10.3.0
2013-03	RAN#59	R5s120870	1457	-	Correction to EUTRA RRC Test Cases 8.2.4.15 and 8.2.4.15a	10.2.0	10.3.0
2013-03	RAN#59	R5s120871	1458	-	LTE_TDD: Correction to UTRA-TDD RRC RAB Template	10.2.0	10.3.0
2013-03	RAN#59	R5s120872	1459	-	LTE_TDD: Correction to GCF WI-086 EUTRA EMM Testcase 9.2.1.2.5,9.2.1.2.6 and 9.2.1.2.7	10.2.0	10.3.0
2013-03	RAN#59	R5s120873	1460	-	LTE_TDD: Correction to GCF WI-096 EUTRA EMM Testcase 9.2.1.2.15	10.2.0	10.3.0
2013-03	RAN#59	R5s120876	1461	-	Correction to EUTRA Idle Mode Test Case 6.1.1.3a	10.2.0	10.3.0
2013-03	RAN#59	R5s120878	1462	-	Correction to EMM test case 9.2.3.2.3	10.2.0	10.3.0
2013-03	RAN#59	R5s120879	1463	-	Addition of GCF WI-150 Rel-9 EUTRA RSRQ test case 6.1.2.3a	10.2.0	10.3.0
2013-03	RAN#59	R5s120883	1464	-	Addition of GCF WI-150 Rel9 RSRQ Idle Mode Testcase 6.1.2.17	10.2.0	10.3.0
2013-03	RAN#59	R5s120885	1465	-	Correction to GCF WI-82 EUTRA EMM Testcase 9.2.1.1.23	10.2.0	10.3.0
2013-03	RAN#59	R5s120886	1466	-	Correction to GCF WI-82 EUTRA EMM Testcase 9.2.2.1.6	10.2.0	10.3.0
2013-03	RAN#59	R5s120888	1467	-	Correction to GCF WI-82 EUTRA EMM Testcase 9.2.1.1.24	10.2.0	10.3.0
2013-03	RAN#59	R5s120889	1468	-	Correction to GCF WI-87 EUTRA EMM Testcase 9.2.1.2.15	10.2.0	10.3.0
2013-03	RAN#59	R5s120890	1469	-	Correction to declarations based on XSD types in LTE Test Suite.	10.2.0	10.3.0
2013-03	RAN#59	R5s120891	1470	-	Addition of GCF WI-159 Rel-9 LTE Pre-registration at 1xRTT test case 13.4.4.1	10.2.0	10.3.0

Date	TSG #	TSG Doc.	CR	Rev	Subject/Comment	Old	New
2013-03	RAN#59	R5s120893	1471	-	Correction to EMM Test Cases 9.2.1.1.12, 9.2.3.1.12 and 9.2.3.1.18	10.2.0	10.3.0
2013-03	RAN#59	R5s120894	1472	-	Correction to GCF WI-87 EUTRA EMM Testcase 9.2.3.1.6	10.2.0	10.3.0
2013-03	RAN#59	R5s120895	1473	-	Correction to GCF WI-81 EUTRA Idle Mode Testcase 6.1.2.9a	10.2.0	10.3.0
2013-03	RAN#59	R5s120896	1474	-	Correction to GCF WI-82 EUTRA EMM Testcase 9.2.3.1.27	10.2.0	10.3.0
2013-03	RAN#59	R5s120897	1475	-	Correction to GCF WI-86 EUTRA EMM Testcase 9.2.3.2.1c	10.2.0	10.3.0
2013-03	RAN#59	R5s120898	1476	-	Addition of GCF WI-159 Rel-9 LTE Pre-registration at 1xRTT test case 13.4.4.5	10.2.0	10.3.0
2013-03	RAN#59	R5s120900	1477	-	Correction to GCF WI-86 EUTRA EMM Testcase 9.2.3.2.1a	10.2.0	10.3.0
2013-03	RAN#59	R5s120901	1478	-	Correction to GCF WI-82 EUTRA EMM Testcase 9.2.1.2.3	10.2.0	10.3.0
2013-03	RAN#59	R5s120902	1479	-	Correction to EMM test case 9.2.2.1.3	10.2.0	10.3.0
2013-03	RAN#59	R5s120903	1480	-	Correction to SMDCP Ports in LTE<>GERAN	10.2.0	10.3.0
2013-03	RAN#59	R5s120904	1481	-	Correction to EUTRA<> UTRA Testcases	10.2.0	10.3.0
2013-03	RAN#59	R5s120905	1482	-	Addition of GCF WI-150 Rel-9 EUTRA RSRQ test case 6.1.2.18	10.2.0	10.3.0
2013-03	RAN#59	R5s120908	1483	-	Correction to EUTRA RRC test cases 8.4.3.2 and 8.4.3.3	10.2.0	10.3.0
2013-03	RAN#59	R5s120909	1484	-	Correction to EUTRA Idle Mode test case 6.2.3.31	10.2.0	10.3.0
2013-03	RAN#59	R5s120910	1485	-	Correction to GCF WI-081 EUTRA MAC Testcase 7.1.2.3	10.2.0	10.3.0
2013-03	RAN#59	R5s120911	1486	-	Correction to GCF WI-081 EUTRA RRC Testcase 8.1.2.6	10.2.0	10.3.0
2013-03	RAN#59	R5s120912	1487	-	Correction to GCF WI-156 EUTRA Interband Testcase 8.2.4.14	10.2.0	10.3.0
2013-03	RAN#59	R5s120913	1488	-	Addition of GCF WI-088 LTE-1xRTT test case 8.3.2.10	10.2.0	10.3.0
2013-03	RAN#59	R5s120915	1489	-	Addition of GCF WI-088 LTE-HRPD test case 8.3.2.8	10.2.0	10.3.0
2013-03	RAN#59	R5s120917	1490	-	Correction to EUTRA EMM Test case 9.2.3.2.12	10.2.0	10.3.0
2013-03	RAN#59	R5s120918	1491	-	Correction to GCF WI-87 EUTRA EMM Testcase 9.2.3.3.5	10.2.0	10.3.0
2013-03	RAN#59	R5s120919	1492	-	Correction to GCF WI-87 EUTRA Multilayer testcase 13.3.2.2	10.2.0	10.3.0
2013-03	RAN#59	R5s120920	1493	-	Correction to GCF WI-087 LTE<>GERAN Testcase 13.4.2.5	10.2.0	10.3.0
2013-03	RAN#59	R5s120921	1494	-	Correction to EUTRA RRC Test Case 8.2.4.15a	10.2.0	10.3.0
2013-03	RAN#59	R5s120922	1495	-	Correction to EMM test case 9.2.3.3.2	10.2.0	10.3.0
2013-03	RAN#59	R5s120923	1496	-	Correction to EMM test case 9.2.1.2.1c	10.2.0	10.3.0
2013-03	RAN#59	R5s120925	1497	-	Addition of GCF WI-150 Rel-9 EUTRA RSRQ test case 8.3.1.3a	10.2.0	10.3.0
2013-03	RAN#59	R5s120933	1498	-	Correction to EMM Test Case 9.2.3.1.17	10.2.0	10.3.0
2013-03	RAN#59	R5s120935	1499	-	Correction to GCF WI-086 UTRA<>EUTRA RRC Testcases 8.4.2.2 and 8.4.2.4	10.2.0	10.3.0
2013-03	RAN#59	R5s120937	1500	-	Correction to EUTRA RRC test case 8.1.3.7	10.2.0	10.3.0
2013-03	RAN#59	R5s120938	1501	-	Correction to EUTRA Idle Mode test case 6.2.3.3	10.2.0	10.3.0
2013-03	RAN#59	R5s120939	1502	-	Addition of GCF WI-087 EUTRA Idle Mode test case 6.2.3.23	10.2.0	10.3.0
2013-03	RAN#59	R5s120941	1503	-	Correction to EUTRA RRC test cases 8.4.2.2 and 8.4.2.4	10.2.0	10.3.0
2013-03	RAN#59	R5s120942	1504	-	Correction to GCF WI-086 EUTRA EMM testcase 9.2.3.2.13	10.2.0	10.3.0
2013-03	RAN#59	R5s120943	1505	-	Correction to function f_EUTRA_TrackingAreaUpdateFromAnotherRAT_WithoutRRConnReq	10.2.0	10.3.0
2013-03	RAN#59	R5s120944	1506	-	Correction to function f_EUTRA_TrackingAreaUpdateFromAnotherRAT_WithoutRRConnReq	10.2.0	10.3.0

Date	TSG #	TSG Doc.	CR	Rev	Subject/Comment	Old	New
2013-03	RAN#59	R5s120951	1507	-	LTE_TDD: Correction to RAU procedure of UTRA	10.2.0	10.3.0
2013-03	RAN#59	R5s120952	1508	-	LTE_TDD : Correction to GCF WI-096 EUTRA Idle Mode Test Case 6.2.3.4	10.2.0	10.3.0
2013-03	RAN#59	R5s120953	1509	-	LTE_TDD: Correction to RLC CONFIG in CS12.2K Scenario of UTRA	10.2.0	10.3.0
2013-03	RAN#59	R5s120954	1510	-	LTE_TDD: Corrections to DL Common Information in RB SETUP message of UTRA	10.2.0	10.3.0
2013-03	RAN#59	R5s120955	1511	-	LTE_TDD: Corrections to Physical Channel Parameters used in PS64K Scenario of UTRA	10.2.0	10.3.0
2013-03	RAN#59	R5s120956	1512	-	LTE_TDD: Corrections to Physical Channel Parameters used in CS12.2K Scenario of UTRA	10.2.0	10.3.0
2013-03	RAN#59	R5s120958	1513	-	LTE_TDD: Addition of EUTRA Multi-layer Test case 13.1.9	10.2.0	10.3.0
2013-03	RAN#59	R5s120960	1514	-	LTE_TDD: Addition of EUTRA Multi-layer Test case 13.1.10	10.2.0	10.3.0
2013-03	RAN#59	R5s120963	1515	-	Correction to EUTRA EMM Testcases 9.2.1.2.11 and 9.2.1.2.12	10.2.0	10.3.0
2013-03	RAN#59	R5s120964	1516	-	Addition of EUTRA Idle mode Test case 6.2.3.5a	10.2.0	10.3.0
2013-03	RAN#59	R5s120967	1517	-	Corrections to EUTRA-GERAN test cases 6.2.3.1 and 9.2.3.4.1	10.2.0	10.3.0
2013-03	RAN#59	R5s120968	1518	-	Correction to EMM test case 9.2.3.2.3 in Voice-Centric Mode in EUTRA-UTRAN path	10.2.0	10.3.0
2013-03	RAN#59	R5s130000	1519	-	Correction to EMM test case 9.2.2.1.10	10.2.0	10.3.0
2013-03	RAN#59	R5s130002	1520	-	LTE_TDD: Addition of EUTRA Idle Mode Test Case 6.2.3.4	10.2.0	10.3.0
2013-03	RAN#59	R5s130004	1521	-	LTE_TDD: Addition of EMM Test Case 9.2.3.2.1a	10.2.0	10.3.0
2013-03	RAN#59	R5s130006	1522	-	LTE_TDD: Addition of EMM Test Case 9.2.3.3.6	10.2.0	10.3.0
2013-03	RAN#59	R5s130008	1523	-	Correction to SIB5 definition for UTRAN-TDD (1.28 Mcps)	10.2.0	10.3.0
2013-03	RAN#59	R5s130009	1524	-	Correction to template cds_RadioBearerSetup_r9_IEs_64k_PS_TDD	10.2.0	10.3.0
2013-03	RAN#59	R5s130010	1525	-	Correction to EUTRA RRC Test Case 8.4.2.2	10.2.0	10.3.0
2013-03	RAN#59	R5s130013	1526	-	LTE_TDD: Addition of GCF WI-097 EMM test case 9.2.3.2.1b	10.2.0	10.3.0
2013-03	RAN#59	R5s130017	1527	-	LTE_TDD: Addition of GCF WI-150 Rel-9 EUTRA RSRQ test case 6.1.2.18	10.2.0	10.3.0
2013-03	RAN#59	R5s130019	1528	-	Correction to EUTRA RRC Test Case 8.4.3.3	10.2.0	10.3.0
2013-03	RAN#59	R5s130020	1529	-	Addition of Rel9 RSRQ Idle Mode Testcase 6.2.3.4a	10.2.0	10.3.0
2013-03	RAN#59	R5s130022	1530	-	LTE_TDD: Addition of GCF WI-150 Rel-9 EUTRA RSRQ test case 6.1.2.17	10.2.0	10.3.0
2013-03	RAN#59	R5s130024	1531	-	LTE_TDD : Addition of Rel9 EUTRA RSRQ Testcase 8.3.1.3a	10.2.0	10.3.0
2013-03	RAN#59	R5s130026	1532	-	LTE_TDD: Addition of GCF WI-150 Rel-9 EUTRA RSRQ test case 6.1.2.3a	10.2.0	10.3.0
2013-03	RAN#59	R5s130034	1533	-	Correction to EMM Test Case 9.2.3.2.9	10.2.0	10.3.0
2013-03	RAN#59	R5s130037	1534	-	Correction to EUTRA RRC test case 8.2.4.14a	10.2.0	10.3.0
2013-03	RAN#59	R5s130038	1535	-	Correction to f_RoutingTable_ChangeEutraCell function	10.2.0	10.3.0
2013-03	RAN#59	R5s130040	1536	-	Correction to EUTRA EMM Testcases 9.2.1.1.15, 9.2.1.1.15a, 9.2.1.1.16, 9.2.1.1.16a in Ipv6	10.2.0	10.3.0
2013-03	RAN#59	R5s130043	1537	-	LTE_TDD: Addition of GCF WI-097 EMM test case 9.2.3.2.3	10.2.0	10.3.0
2013-03	RAN#59	R5s130045	1538	-	Correction to EUTRA ICMP Echo Reply function	10.2.0	10.3.0
2013-03	RAN#59	R5s130046	1539	-	Correction to EMM test case 9.2.1.1.24	10.2.0	10.3.0
2013-03	RAN#59	R5s130050	1540	-	Correction to EUTRA-GERAN test cases 6.2.3.1 and 9.2.3.4.1	10.2.0	10.3.0
2013-03	RAN#59	R5s130051	1541	-	Correction to EUTRA RRC test case 8.3.2.9	10.2.0	10.3.0
2013-03	RAN#59	R5s130052	1542	-	Correction to Test case 8.1.3.7	10.2.0	10.3.0
2013-03	RAN#59	R5s130055	1543	-	Addition of GCF WI-151 LTE FDD-TDD Inter-mode test case 8.3.1.15a	10.2.0	10.3.0

Date	TSG #	TSG Doc.	CR	Rev	Subject/Comment	Old	New
2013-03	RAN#59	R5s130057	1544	-	Addition of GCF WI-088 LTE-1xRTT Inter-RAT test case 8.4.7.4	10.2.0	10.3.0
2013-03	RAN#59	R5s130060	1545	-	Correction to EUTRA-GERAN test case 6.2.3.1	10.2.0	10.3.0
2013-03	RAN#59	R5s130061	1546	-	Addition of Rel9 RSRQ Idle Mode Testcase 6.2.3.3a	10.2.0	10.3.0
2013-03	RAN#59	R5s130064	1547	-	Correction to f_EUTRA_Capability function	10.2.0	10.3.0
2013-03	RAN#59	R5s130067	1548	-	Correction to EMM test case 9.1.5.1	10.2.0	10.3.0
2013-03	RAN#59	R5s130068	1549	-	Correction to LTE FDD-TDD Intermode test case 8.2.4.14a	10.2.0	10.3.0
2013-03	RAN#59	R5s130069	1550	-	Correction to EUTRA Idle Mode test case 6.1.1.1	10.2.0	10.3.0
2013-03	RAN#59	R5s130076	1551	-	Correction to EUTRA Idle Mode Test Case 6.1.2.13	10.2.0	10.3.0
2013-03	RAN#59	R5s130077	1552	-	Correction to ESM Test Case 10.4.1	10.2.0	10.3.0
2013-03	RAN#59	R5s130083	1553	-	Correction to Test case 9.2.1.2.1c	10.2.0	10.3.0
2013-03	RAN#59	R5s130084	1554	-	Addition of Rel9 EUTRA<->UTRA RSRQ RRC Testcase 8.3.2.3a	10.2.0	10.3.0
2013-03	RAN#59	R5s130088	1555	-	Correction to EUTRA RRC Test Case 8.5.4.1	10.2.0	10.3.0
2013-03	RAN#59	RP-130151	1556	-	CR to 36.523-3: Add new verified and e-mail agreed TTCN test cases in the TC lists in 36.523-3 (prose), Annex A	10.2.0	10.3.0
2013-06	RAN#60	R5-131868	1561	-	Addition of IMS de-registration procedures to postamble sequences for E-UTRA test cases	10.3.0	10.4.0
2013-06	RAN#60	RP-130618	1678	-	CR to 36.523-3: Add new verified and e-mail agreed TTCN test cases in the TC lists in 36.523-3 (prose), Annex A	10.3.0	10.4.0
2013-06	RAN#60	R5s130050	1563	-	Correction to EUTRA-GERAN test cases 6.2.3.1 and 9.2.3.4.1	10.3.0	10.4.0
2013-06	RAN#60	R5s130065	1564	-	Addition of GCF WI-151 LTE FDD-TDD Inter-mode test case 8.3.1.16a	10.3.0	10.4.0
2013-06	RAN#60	R5s130078	1565	-	Addition of Rel 9 EUTRA PWS Test cases 18.1.2	10.3.0	10.4.0
2013-06	RAN#60	R5s130081	1566	-	Addition of Rel-9 EUTRA PWS test case 18.1.1	10.3.0	10.4.0
2013-06	RAN#60	R5s130086	1567	-	LTE_TDD: Addition of GCF WI-099 Multi-RAT test case 6.2.1.1	10.3.0	10.4.0
2013-06	RAN#60	R5s130089	1568	-	Correction to EUTRA Multi-Layer Test Cases 13.1.x	10.3.0	10.4.0
2013-06	RAN#60	R5s130090	1569	-	Addition of GCF WI-159 LTE-1xRTT CSFB Handover test case 8.4.7.9	10.3.0	10.4.0
2013-06	RAN#60	R5s130092	1570	-	Correction to EMM Test Case 9.2.1.1.20	10.3.0	10.4.0
2013-06	RAN#60	R5s130094	1571	-	LTE_TDD: Addition of EMM Test Case 9.2.3.1.6	10.3.0	10.4.0
2013-06	RAN#60	R5s130097	1572	-	Addition of GCF WI-088 LTE-1xRTT CSFB Emergency Call test case 13.1.17	10.3.0	10.4.0
2013-06	RAN#60	R5s130100	1573	-	Correction to E-UTRA EMM testcases 9.2.1.1.7a, 9.2.3.1.16, 9.2.3.1.18 , 9.2.3.1.18a, 9.2.3.2.10 and 9.2.3.2.2	10.3.0	10.4.0
2013-06	RAN#60	R5s130103	1574	-	Addition of Rel 9 EUTRA PWS(CMAS) Test cases 18.1.3	10.3.0	10.4.0
2013-06	RAN#60	R5s130105	1575	-	Addition of GCF WI-088 LTE-1xRTT CSFB test case 8.4.7.3	10.3.0	10.4.0
2013-06	RAN#60	R5s130107	1576	-	Correction to handling of security capabilities in EUTRA Testcases	10.3.0	10.4.0
2013-06	RAN#60	R5s130110	1577	-	LTE_TDD: Addition of GCF WI-099 Multi-RAT test case 8.3.2.6	10.3.0	10.4.0
2013-06	RAN#60	R5s130112	1578	-	Correction to EUTRA Idle Mode Test Case 6.1.1.3a	10.3.0	10.4.0
2013-06	RAN#60	R5s130113	1579	-	Correction to 36.523 IMS preamble part with IPsec enabled	10.3.0	10.4.0
2013-06	RAN#60	R5s130116	1580	-	Correction to Security Procedure for EUTRA TDD<->TDSDMA Testcases	10.3.0	10.4.0
2013-06	RAN#60	R5s130117	1581	-	Correction to EUTRA EMM Test Case 9.2.1.2.3	10.3.0	10.4.0
2013-06	RAN#60	R5s130122	1582	-	Corrections to ESM test cases 10.3.1 and 10.9.1	10.3.0	10.4.0
2013-06	RAN#60	R5s130127	1583	-	Addition of GCF WI-151 LTE FDD-TDD Inter-mode test case 6.1.1.4a	10.3.0	10.4.0
2013-06	RAN#60	R5s130129	1584	-	Correction to EUTRA RRC Test Case 8.3.2.2	10.3.0	10.4.0

Date	TSG #	TSG Doc.	CR	Rev	Subject/Comment	Old	New
2013-06	RAN#60	R5s130131	1585	-	Correction to EMM Test Case 9.2.3.1.19	10.3.0	10.4.0
2013-06	RAN#60	R5s130132	1586	-	Correction to px_CipherAlg PIXIT type	10.3.0	10.4.0
2013-06	RAN#60	R5s130135	1587	-	Clarification for modifies of 'record of' record in TTCN3 core language	10.3.0	10.4.0
2013-06	RAN#60	R5s130137	1588	-	Correction to GCF WI-086 EUTRA Multilayer Testcase 13.1.5	10.3.0	10.4.0
2013-06	RAN#60	R5s130138	1589	-	Correction to Idle Mode Test Case 6.1.2.17	10.3.0	10.4.0
2013-06	RAN#60	R5s130140	1590	-	Correction to EUTRA RRC Test Case 8.2.4.14a	10.3.0	10.4.0
2013-06	RAN#60	R5s130141	1591	-	Correction to EUTRA RRC Test Case 8.3.1.16a	10.3.0	10.4.0
2013-06	RAN#60	R5s130142	1592	-	Correction to EUTRA RRC Test Case 8.4.2.2	10.3.0	10.4.0
2013-06	RAN#60	R5s130143	1593	-	Correction to GCF WI-082 testcase 9.3.1.6 (LTE-UTRA)	10.3.0	10.4.0
2013-06	RAN#60	R5s130144	1594	-	Correction to GCF WI-086 testcase 8.4.1.5	10.3.0	10.4.0
2013-06	RAN#60	R5s130161	1595	-	LTE_TDD: Addition of GCF WI-096 RRC test case 8.1.3.7	10.3.0	10.4.0
2013-06	RAN#60	R5s130163	1596	-	LTE_TDD: Addition of GCF WI-096 TD-LTE<>TDSMA Testcase 13.4.2.4	10.3.0	10.4.0
2013-06	RAN#60	R5s130165	1597	-	Correction to Support of UTRAN band 19	10.3.0	10.4.0
2013-06	RAN#60	R5s130166	1598	-	Correction to EMM Test Case 9.2.3.3.2	10.3.0	10.4.0
2013-06	RAN#60	R5s130169	1599	-	Addition of Rel 9 EUTRA Multiple MO-SMS over SGs/Idle mode Test case 11.1.5	10.3.0	10.4.0
2013-06	RAN#60	R5s130171	1600	-	Addition of Rel 9 Multiple MO-SMS over SGs / Active mode Test cases 11.1.6.	10.3.0	10.4.0
2013-06	RAN#60	R5s130173	1601	-	Correction to GCF WI-086 EUTRA EMM Test case 9.2.3.3.2	10.3.0	10.4.0
2013-06	RAN#60	R5s130174	1602	-	Correction to GCF WI-086 EUTRA EMM Test case 9.2.3.2.1a	10.3.0	10.4.0
2013-06	RAN#60	R5s130175	1603	-	Correction to EMM Test Case 9.2.3.2.3	10.3.0	10.4.0
2013-06	RAN#60	R5s130179	1604	-	Correction to EUTRA EMM Test Cases	10.3.0	10.4.0
2013-06	RAN#60	R5s130180	1605	-	Correction to EMM Test Case 9.2.3.3.5a	10.3.0	10.4.0
2013-06	RAN#60	R5s130185	1606	-	Correction to check of establishment cause in EUTRA-UTRA Idle lrat test cases	10.3.0	10.4.0
2013-06	RAN#60	R5s130189	1607	-	Correction to EUTRA RRC Test Case 8.3.2.6	10.3.0	10.4.0
2013-06	RAN#60	R5s130190	1608	-	Addition of EUTRA Idle Mode Test Case 6.2.3.23	10.3.0	10.4.0
2013-06	RAN#60	R5s130192	1609	-	Correction for GCF WI-086 EUTRA EMM test cases 9.2.3.2.9	10.3.0	10.4.0
2013-06	RAN#60	R5s130195	1610	-	Baseline upgrade of TTCN-3 ATSS to March-13 in Rel-11	10.3.0	10.4.0
2013-06	RAN#60	R5s130201	1611	-	Addition of Rel-9 EMM test case 9.1.3.3	10.3.0	10.4.0
2013-06	RAN#60	R5s130206	1612	-	Corrections to EUTRA RRC test cases 8.2.4.14, 8.2.4.14a and 8.3.1.16a	10.3.0	10.4.0
2013-06	RAN#60	R5s130207	1613	-	Correction to EUTRA Idle Mode Test Case 6.2.3.15	10.3.0	10.4.0
2013-06	RAN#60	R5s130208	1614	-	Addition of EUTRA Idle Mode Test Case 6.2.3.1a	10.3.0	10.4.0
2013-06	RAN#60	R5s130210	1615	-	LTE_TDD: Correction of RV value for SI3, SI4 and SI5 in EUTRA TDD mode	10.3.0	10.4.0
2013-06	RAN#60	R5s130211	1616	-	LTE_TDD: Addition of GCF WI-096 test case 6.2.1.3	10.3.0	10.4.0
2013-06	RAN#60	R5s130215	1617	-	LTE_TDD: Addition of GCF WI-096 test cases 8.4.1.2	10.3.0	10.4.0
2013-06	RAN#60	R5s130217	1618	-	LTE_TDD: Addition of GCF WI-096 test cases 8.4.1.4	10.3.0	10.4.0
2013-06	RAN#60	R5s130219	1619	-	LTE_TDD: Addition of GCF WI-096 test cases 8.4.2.2	10.3.0	10.4.0
2013-06	RAN#60	R5s130221	1620	-	LTE_TDD: Addition of GCF WI-096 test cases 8.4.2.4	10.3.0	10.4.0
2013-06	RAN#60	R5s130225	1621	-	LTE_TDD: Addition of GCF WI-096 test case 9.2.3.3.1	10.3.0	10.4.0

Date	TSG #	TSG Doc.	CR	Rev	Subject/Comment	Old	New
2013-06	RAN#60	R5s130227	1622	-	LTE_TDD: Addition of GCF WI-096 test case 9.2.3.3.2	10.3.0	10.4.0
2013-06	RAN#60	R5s130229	1623	-	LTE_TDD: Addition of GCF WI-096 test case 9.2.3.3.5	10.3.0	10.4.0
2013-06	RAN#60	R5s130237	1624	-	Correction to EUTRA RRC Test Case 8.5.4.1	10.3.0	10.4.0
2013-06	RAN#60	R5s130238	1625	-	Correction to EUTRA Multi Layer Test Case 13.4.2.5	10.3.0	10.4.0
2013-06	RAN#60	R5s130239	1626	-	Correction to EUTRA-GERAN Idle mode test case 6.2.3.1	10.3.0	10.4.0
2013-06	RAN#60	R5s130240	1627	-	Correction to EUTRA EMM test case 9.2.2.1.8	10.3.0	10.4.0
2013-06	RAN#60	R5s130241	1628	-	Additional corrections to EUTRA-GERAN Idle Mode test case 6.2.3.23 on top of R5s130190	10.3.0	10.4.0
2013-06	RAN#60	R5s130243	1629	-	LTE_TDD: Addition of GCF WI-096 test case 9.2.1.2.1d	10.3.0	10.4.0
2013-06	RAN#60	R5s130245	1630	-	LTE_TDD: Addition of GCF WI-096 test case 13.1.2	10.3.0	10.4.0
2013-06	RAN#60	R5s130250	1631	-	Correction of GCF WI-088 Inter-RAT Measurements test case 8.3.2.8	10.3.0	10.4.0
2013-06	RAN#60	R5s130251	1632	-	Correction of GCF WI-088 EUTRA-1XRTT test case 8.3.2.10	10.3.0	10.4.0
2013-06	RAN#60	R5s130252	1633	-	Renaming Condition Types in Selection Expressions	10.3.0	10.4.0
2013-06	RAN#60	R5s130253	1634	-	LTE_TDD: Addition of GCF WI-097 test case 13.3.2.2	10.3.0	10.4.0
2013-06	RAN#60	R5s130255	1635	-	Correction to EUTRA EMM Test Case 9.2.3.2.9	10.3.0	10.4.0
2013-06	RAN#60	R5s130257	1636	-	Correction to template car_G_LLC_XID_IndAny	10.3.0	10.4.0
2013-06	RAN#60	R5s130258	1637	-	Correction to GCF WI-087 EUTRA-GERAN test case 8.4.3.3	10.3.0	10.4.0
2013-06	RAN#60	R5s130259	1638	-	Correction to GCF WI 086 testcase 9.2.3.2.1b	10.3.0	10.4.0
2013-06	RAN#60	R5s130260	1639	-	Corrections to functions f_GERAN_EnterU10_MT and f_GERAN_EnterU10_MO_WithoutRRConnEst	10.3.0	10.4.0
2013-06	RAN#60	R5s130268	1640	-	Correction to EUTRA RRC Test Case 8.3.2.3	10.3.0	10.4.0
2013-06	RAN#60	R5s130269	1641	-	Correction to EUTRA RRC Test Case 8.5.4.1	10.3.0	10.4.0
2013-06	RAN#60	R5s130270	1642	-	Addition of GCF WI-151 LTE FDD-TDD Inter-mode test case 8.1.3.12a	10.3.0	10.4.0
2013-06	RAN#60	R5s130273	1643	-	Correction to EUTRA EMM Test Case 9.2.2.1.3	10.3.0	10.4.0
2013-06	RAN#60	R5s130275	1644	-	Correction to function f_EUTRA_TrackingAreaUpdateFromAnotherRAT_WithoutRRConnReq	10.3.0	10.4.0
2013-06	RAN#60	R5s130276	1645	-	Correction to EUTRA Idle Mode Test Case 6.2.3.3a	10.3.0	10.4.0
2013-06	RAN#60	R5s130286	1646	-	LTE_TDD: Correction to f_UTRAN_CellInfo_Init_TDD function	10.3.0	10.4.0
2013-06	RAN#60	R5s130287	1647	-	Correction to EUTRA EMM Test Case 9.2.1.2.1c	10.3.0	10.4.0
2013-06	RAN#60	R5s130292	1648	-	LTE_TDD: Addition of Rel-9 EUTRA Multi-Layer test case 13.4.1.4	10.3.0	10.4.0
2013-06	RAN#60	R5s130300	1649	-	LTE_TDD: Addition of GCF WI-096 TD-LTE<->TDSMA Testcase 8.3.2.4	10.3.0	10.4.0
2013-06	RAN#60	R5s130302	1650	-	Addition of GCF WI-088 EUTRA<->HRPD Inter-RAT test case 8.3.3.4	10.3.0	10.4.0
2013-06	RAN#60	R5s130305	1651	-	Correction to GCF WI-081 EUTRA MAC test case 7.1.1.2	10.3.0	10.4.0
2013-06	RAN#60	R5s130307	1652	-	Correction to PDU Type Definition PAGINGRESPONSE message	10.3.0	10.4.0
2013-06	RAN#60	R5s130308	1653	-	Correction to EUTRA RRC Test Case 8.4.1.5	10.3.0	10.4.0
2013-06	RAN#60	R5s130310	1654	-	Correction to UTRAN Capability information Procedure in EUTRA Testcases	10.3.0	10.4.0
2013-06	RAN#60	R5s130312	1655	-	Correction to EUTRA Multi-layer Test Case 13.3.1.3	10.3.0	10.4.0
2013-06	RAN#60	R5s130313	1656	-	Correction to GCF WI-082 E-UTRA EMM test case 9.1.2.6	10.3.0	10.4.0
2013-06	RAN#60	R5s130314	1657	-	Correction to GCF WI-151 LTE FDD-TDD Inter-mode test case 8.1.3.12a	10.3.0	10.4.0

Date	TSG #	TSG Doc.	CR	Rev	Subject/Comment	Old	New
2013-06	RAN#60	R5s130316	1658	-	LTE_TDD: Addition of GCF WI-096 TD-LTE<>TDS DMA Testcase 13.3.2.1	10.3.0	10.4.0
2013-06	RAN#60	R5s130318	1659	-	LTE_TDD: Addition of GCF WI-096 TD-LTE<>TDS DMA Testcase 9.2.1.2.1c	10.3.0	10.4.0
2013-06	RAN#60	R5s130320	1660	-	Correction to function f_DeriveSuppEutraBandsFromPics	10.3.0	10.4.0
2013-06	RAN#60	R5s130321	1661	-	Correction to EMM TC 9.2.1.1.24	10.3.0	10.4.0
2013-06	RAN#60	R5s130322	1662	-	LTE_TDD: Addition of Rel9 TD-LTE<>TDS DMA Testcase 6.2.3.33	10.3.0	10.4.0
2013-06	RAN#60	R5s130324	1663	-	Correction to GCF WI-086 E-UTRA EMM testcase 9.2.1.2.8	10.3.0	10.4.0
2013-06	RAN#60	R5s130325	1664	-	Correction to the EMM Test Case 9.2.3.3.5a	10.3.0	10.4.0
2013-06	RAN#60	R5s130326	1665	-	Correction to Eutra Idle Mode TC 6.2.3.1a	10.3.0	10.4.0
2013-06	RAN#60	R5s130327	1666	-	Correction to manual PLMN selection test cases 6.1.1.3, 6.1.1.3a, 6.1.1.3b, 6.2.1.4, 9.2.1.1.13 and 9.2.1.1.13a	10.3.0	10.4.0
2013-06	RAN#60	R5s130329	1667	-	Correction to IXIT px_MaxNumberROHC_ContextSessions in module EUTRA_Parameters in LTE TTCN suite.	10.3.0	10.4.0
2013-06	RAN#60	R5s130330	1668	-	Correction to EUTRA RRC test case 8.1.2.8	10.3.0	10.4.0
2013-06	RAN#60	R5s130331	1669	-	Correction for EUTRA RRC test case 8.1.3.7	10.3.0	10.4.0
2013-06	RAN#60	R5s130337	1670	-	Correction of RRC test case 8.5.4.1	10.3.0	10.4.0
2013-06	RAN#60	R5s130338	1671	-	LTE_TDD: Addition of GCF WI-096 EMM test case 9.2.3.3.4	10.3.0	10.4.0
2013-06	RAN#60	R5s130340	1672	-	Correction to GCF WI-086 testcase 9.2.2.2.2	10.3.0	10.4.0
2013-06	RAN#60	R5s130341	1673	-	Correction in LLC XID negotiation	10.3.0	10.4.0
2013-06	RAN#60	R5s130342	1674	-	LTE_TDD: Correction of GCF WI-096 test cases 8.4.2.2 and 8.4.2.4	10.3.0	10.4.0
2013-06	RAN#60	R5s130344	1675	-	Corrections to GCF WI-088 EUTRA<>HRPD and 1xRTT Test cases 8.3.2.8 and 8.3.2.10	10.3.0	10.4.0
2013-06	RAN#60	R5s130345	1676	-	LTE_TDD: Correction to GCF WI-096 EUTRA test case 13.1.2	10.3.0	10.4.0
2013-06	RAN#60	R5s130347	1677	-	Local guard timer for common preamble functions	10.3.0	10.4.0
2013-06	RAN#60	R5-131068	1557	-	Update of CDMA2000 specification references: Clause 2 of TS 36.523-3	10.4.0	11.0.0
2013-06	RAN#60	R5-131070	1558	-	Update of CDMA2000 specification references: PIXIT for TS 36.523-3	10.4.0	11.0.0
2013-06	RAN#60	R5-131125	1559	-	Clarification of CA test model	10.4.0	11.0.0
2013-06	RAN#60	R5-131129	1560	-	36523-3: Routine maintenance and updates	10.4.0	11.0.0
2013-06	RAN#60	R5-131870	1562	-	Update of CDMA2000 specification references: Annex D of TS 36.523-3	10.4.0	11.0.0
2013-09	RAN#61	R5-133612	1680	-	36523-3: Routine maintenance and updates	11.0.0	11.1.0
2013-09	RAN#61	R5s130352	1681	-	LTE_TDD: Addition of GCF WI-096 test case 13.1.4	11.0.0	11.1.0
2013-09	RAN#61	R5s130356	1682	-	LTE_TDD: Addition of GCF WI-096 test case 13.1.16	11.0.0	11.1.0
2013-09	RAN#61	R5s130376	1698	-	Improved guidance of the test operator during ETWS and CMAS test case execution	11.0.0	11.1.0
2013-09	RAN#61	R5s130378	1699	-	Correction to Generic IMS Registration procedure	11.0.0	11.1.0
2013-09	RAN#61	R5s130379	1700	-	Addition of GCF WI-167 EUTRA-UTRAN Idle Mode test case 6.2.3.33	11.0.0	11.1.0
2013-09	RAN#61	R5s130382	1701	-	Corrections to EPS Attach Procedure to enable IMS Registration via NAS signalling in 36.523 Suite	11.0.0	11.1.0
2013-09	RAN#61	R5s130384	1702	-	Correction to Idle mode test cases 6.2.3.4	11.0.0	11.1.0
2013-09	RAN#61	R5s130385	1703	-	Correction to Idle mode test cases 6.2.3.4a	11.0.0	11.1.0
2013-09	RAN#61	R5s130388	1704	-	Addition of GCF WI-162 LTE-A Carrier Aggregation RRC inter-band test case 8.5.1.7.2	11.0.0	11.1.0
2013-09	RAN#61	R5s130389	1705	-	Re-verification of EMM Test Case 9.2.3.3.4	11.0.0	11.1.0
2013-09	RAN#61	R5s130395	1706	-	Addition of LTE-A (Rel-10) Carrier Aggregation MAC test case 7.1.4.18	11.0.0	11.1.0

Date	TSG #	TSG Doc.	CR	Rev	Subject/Comment	Old	New
2013-09	RAN#61	R5s130397	1707	-	Addition of LTE-A (Rel-10) Carrier Aggregation RRC test case 8.3.1.18.2	11.0.0	11.1.0
2013-09	RAN#61	R5s130400	1708	-	Addition of LTE-A (Rel-10) Carrier Aggregation RRC test case 8.3.1.17.2	11.0.0	11.1.0
2013-09	RAN#61	R5s130402	1709	-	Addition of LTE-A (Rel-10) Carrier Aggregation RRC test case 8.3.1.22.2	11.0.0	11.1.0
2013-09	RAN#61	R5s130404	1710	-	Addition of LTE-A (Rel-10) Carrier Aggregation RRC test case 8.2.2.3.2	11.0.0	11.1.0
2013-09	RAN#61	R5s130406	1711	-	Addition of LTE-A Carrier Aggregation RRC inter-band test case 8.2.2.4.2	11.0.0	11.1.0
2013-09	RAN#61	R5s130408	1712	-	Addition of LTE-A Carrier Aggregation RRC inter-band test case 8.2.2.5.2	11.0.0	11.1.0
2013-09	RAN#61	R5s130413	1713	-	Re-verification of EMM Test Case 9.2.3.4.1	11.0.0	11.1.0
2013-09	RAN#61	R5s130417	1714	-	Correction to template cr_SingleAccessCapAny in LTE ATS	11.0.0	11.1.0
2013-09	RAN#61	R5s130418	1683	-	LTE_TDD : Correction to EUTRA RRC TC 8.3.1.16	11.0.0	11.1.0
2013-09	RAN#61	R5s130419	1715	-	LTE/SAE ATS cleanup (... moving "modulepar" PICS to 'parameters.ttcn')	11.0.0	11.1.0
2013-09	RAN#61	R5s130420	1716	-	Correction to Eutra RRC TC 8.5.1.2	11.0.0	11.1.0
2013-09	RAN#61	R5s130422	1717	-	Addition of GCF WI-162 LTE-A Carrier Aggregation RRC handover test case 8.2.4.18.2	11.0.0	11.1.0
2013-09	RAN#61	R5s130426	1718	-	Correction to EUTRA multi layer Test Case 13.3.1.3	11.0.0	11.1.0
2013-09	RAN#61	R5s130428	1719	-	Correction to EUTRA EMM TC 9.2.2.1.3	11.0.0	11.1.0
2013-09	RAN#61	R5s130429	1720	-	Correction to EMM test case 9.2.2.2.2	11.0.0	11.1.0
2013-09	RAN#61	R5s130431	1721	-	Correction to function f_EUTRA_ActivateAdditionalPDNOnDef()	11.0.0	11.1.0
2013-09	RAN#61	R5s130432	1722	-	Correction to RLC Explicit size for FACH configuration in UTRA TDD	11.0.0	11.1.0
2013-09	RAN#61	R5s130433	1723	-	Correction to function f_UTRAN_Init	11.0.0	11.1.0
2013-09	RAN#61	R5s130434	1724	-	Correction to testcase 9.2.3.2.3 & 9.2.3.2.1b	11.0.0	11.1.0
2013-09	RAN#61	R5s130436	1725	-	Correction to EUTRA Multi-Layer Test Case 13.1.9	11.0.0	11.1.0
2013-09	RAN#61	R5s130438	1726	-	Correction to GCF WI-082 EUTRA EMM Testcase 9.1.4.2	11.0.0	11.1.0
2013-09	RAN#61	R5s130440	1727	-	Correction to GCF WI-151 EUTRA FDD-TDD Testcase 8.3.1.13a	11.0.0	11.1.0
2013-09	RAN#61	R5s130441	1728	-	Correction to GCF WI-151 EUTRA FDD-TDD Testcase 8.3.1.16a	11.0.0	11.1.0
2013-09	RAN#61	R5s130442	1729	-	Correction to EUTRA RRC Test Case 8.2.4.14	11.0.0	11.1.0
2013-09	RAN#61	R5s130443	1730	-	Correction to GCF WI-151 EUTRA FDD-TDD Testcase 8.3.1.15a	11.0.0	11.1.0
2013-09	RAN#61	R5s130444	1731	-	Correction to EMM Test Case 9.2.3.1.6	11.0.0	11.1.0
2013-09	RAN#61	R5s130447	1684	-	LTE_TDD: Addition to GCF WI-096 EUTRA EMM test case 9.2.3.2.1c	11.0.0	11.1.0
2013-09	RAN#61	R5s130451	1732	-	Correction to GCF WI-086 EUTRA EMM Testcase 9.2.3.2.3	11.0.0	11.1.0
2013-09	RAN#61	R5s130452	1733	-	Correction to the naming convention of ASN.1 type controlChannelDRXInfoTDD128 for TD LTE<->TDSMA testcases	11.0.0	11.1.0
2013-09	RAN#61	R5s130453	1734	-	Correction to Generic IMS Registration procedure	11.0.0	11.1.0
2013-09	RAN#61	R5s130455	1735	-	Correction to functions in f_EUTRA_Preamble_EmptyCSG_AllowedList()	11.0.0	11.1.0
2013-09	RAN#61	R5s130456	1736	-	Correction to EMM Test Cases 9.2.3.2.1b and 9.2.1.2.1b	11.0.0	11.1.0
2013-09	RAN#61	R5s130471	1737	-	GCF Priority 1 - Corrections to EUTRA RRC Test Case 8.2.4.13a	11.0.0	11.1.0
2013-09	RAN#61	R5s130479	1738	-	Correction to EMM TC 9.2.3.2.1b	11.0.0	11.1.0
2013-09	RAN#61	R5s130481	1739	-	Correction to EUTRA Idle Mode TC 6.4.1	11.0.0	11.1.0
2013-09	RAN#61	R5s130482	1740	-	Correction to EMM test cases 9.2.3.3.5 and 9.2.3.2.3	11.0.0	11.1.0
2013-09	RAN#61	R5s130483	1685	-	LTE_TDD: Addition of GCF WI-162 LTE-A Carrier Aggregation RRC intra-band test case 8.5.1.7.1	11.0.0	11.1.0

Date	TSG #	TSG Doc.	CR	Rev	Subject/Comment	Old	New
2013-09	RAN#61	R5s130485	1686	-	LTE_TDD: Addition of GCF WI-162 LTE-A Carrier Aggregation RRC intra-band test case 8.2.2.4.1	11.0.0	11.1.0
2013-09	RAN#61	R5s130487	1687	-	LTE_TDD: Addition of GCF WI-162 LTE-A Carrier Aggregation RRC intra-band test case 8.2.2.5.1	11.0.0	11.1.0
2013-09	RAN#61	R5s130489	1741	-	Addition of GCF WI-162 LTE-A Carrier Aggregation RRC intra-band test case 8.5.1.7.1	11.0.0	11.1.0
2013-09	RAN#61	R5s130493	1742	-	Addition of GCF WI-162 LTE-A Carrier Aggregation RRC intra-band test case 8.2.2.5.1	11.0.0	11.1.0
2013-09	RAN#61	R5s130495	1743	-	Addition of GCF WI-154/ee1 EUTRA IMS Emergency Call test case 8.1.2.11	11.0.0	11.1.0
2013-09	RAN#61	R5s130498	1744	-	Corrections to PLMN values for UTRAN band VI	11.0.0	11.1.0
2013-09	RAN#61	R5s130501	1745	-	Correction to AddressInfo in PktDataProtoAddr	11.0.0	11.1.0
2013-09	RAN#61	R5s130502	1746	-	Correction to Test Case Selection Expressions for TC 6.2.2.5	11.0.0	11.1.0
2013-09	RAN#61	R5s130503	1747	-	Correction to f_EUTRA_508RRC_AddModRel_Scell_Common function	11.0.0	11.1.0
2013-09	RAN#61	R5s130505	1748	-	TTCN Correction in Test case 8.5.4.1 for optional IE checking in UE Capability Information	11.0.0	11.1.0
2013-09	RAN#61	R5s130506	1749	-	Correction to GCF WI-086 EUTRA Multilayer Testcase 13.4.2.1	11.0.0	11.1.0
2013-09	RAN#61	R5s130507	1750	-	Correction to Selection Expressions for SMS over SGs test cases.	11.0.0	11.1.0
2013-09	RAN#61	R5s130512	1751	-	Correction to IP Handing for EUTRA<->UTRA Testcases	11.0.0	11.1.0
2013-09	RAN#61	R5s130513	1752	-	Correction to the System Information for EUTRA Testcases	11.0.0	11.1.0
2013-09	RAN#61	R5s130520	1753	-	Correction to EUTRA Idle Mode TC 6.2.2.5	11.0.0	11.1.0
2013-09	RAN#61	R5s130521	1688	-	LTE_TDD: Addition of GCF WI-096 test case 6.2.2.5	11.0.0	11.1.0
2013-09	RAN#61	R5s130523	1689	-	LTE_TDD: Addition to GCF WI-096 EUTRA Multilayer test case 13.4.2.1	11.0.0	11.1.0
2013-09	RAN#61	R5s130527	1754	-	Addition of LTE-A ZUC test case 7.3.3.5 for FDD	11.0.0	11.1.0
2013-09	RAN#61	R5s130529	1755	-	Addition of LTE-A ZUC test case 7.3.3.6 for FDD	11.0.0	11.1.0
2013-09	RAN#61	R5s130531	1756	-	Addition of LTE-A ZUC test case 7.3.4.3 for FDD	11.0.0	11.1.0
2013-09	RAN#61	R5s130533	1757	-	Addition of LTE-A ZUC test case 9.4.5 for FDD	11.0.0	11.1.0
2013-09	RAN#61	R5s130535	1758	-	Addition of LTE-A ZUC test case 9.4.6 for FDD	11.0.0	11.1.0
2013-09	RAN#61	R5s130537	1759	-	Correction to f_UT_CheckETWS_CMAS_NoAlert	11.0.0	11.1.0
2013-09	RAN#61	R5s130538	1690	-	LTE_TDD: Addition of GCF WI-169 test case 8.1.3.6a	11.0.0	11.1.0
2013-09	RAN#61	R5s130540	1760	-	Correction to GCF WI-081 EUTRA MAC Testcase 7.1.5.1	11.0.0	11.1.0
2013-09	RAN#61	R5s130545	1761	-	Correction to LTE-GERAN test case 13.4.2.5	11.0.0	11.1.0
2013-09	RAN#61	R5s130546	1762	-	Correction to LTE-GERAN Idle Mode testcase 6.2.3.1	11.0.0	11.1.0
2013-09	RAN#61	R5s130547	1763	-	Correction to GCF WI-096 EUTRA EMM Testcase 9.2.3.2.1b	11.0.0	11.1.0
2013-09	RAN#61	R5s130548	1691	-	LTE_TDD : Addition of LTE-A ZUC test case 7.3.3.5	11.0.0	11.1.0
2013-09	RAN#61	R5s130550	1692	-	LTE_TDD : Addition of LTE-A ZUC test case 7.3.3.6	11.0.0	11.1.0
2013-09	RAN#61	R5s130552	1693	-	LTE_TDD : Addition of LTE-A ZUC test case 7.3.4.3	11.0.0	11.1.0
2013-09	RAN#61	R5s130554	1694	-	LTE_TDD : Addition of LTE-A ZUC test case 9.4.6	11.0.0	11.1.0
2013-09	RAN#61	R5s130556	1695	-	LTE_TDD : Addition of LTE-A ZUC test case 9.4.5	11.0.0	11.1.0
2013-09	RAN#61	R5s130558	1764	-	Correction to Ciphering configuration for UTRA TDD	11.0.0	11.1.0
2013-09	RAN#61	R5s130559	1765	-	Correction to DL RB0 configuration and BCCH configuration for UTRA TDD	11.0.0	11.1.0
2013-09	RAN#61	R5s130577	1696	-	LTE_TDD: Addition of GCF WI-169 test case 6.2.3.4a	11.0.0	11.1.0
2013-09	RAN#61	R5s130587	1766	-	Addition of HeNB test case 6.3.9	11.0.0	11.1.0

Date	TSG #	TSG Doc.	CR	Rev	Subject/Comment	Old	New
2013-09	RAN#61	R5s130589	1767	-	Correction to EMM Testcase 9.2.1.2.11	11.0.0	11.1.0
2013-09	RAN#61	RP-131108	1697	-	CR to 36.523-3: Add new verified and e-mail agreed TTCN test cases in the TC lists in 36.523-3 (prose), Annex A	11.0.0	11.1.0
2013-12	RAN#62	R5-135000	1768	-	36523-3: Routine maintenance and updates	11.1.0	11.2.0
2013-12	RAN#62	R5s130491	1769	-	Addition of GCF WI-162 LTE-A Carrier Aggregation RRC intra-band test case 8.2.2.4.1	11.1.0	11.2.0
2013-12	RAN#62	R5s130525	1770	-	Addition of LTE-A Minimization of Drive Tests (MDT) test case 8.6.2.1	11.1.0	11.2.0
2013-12	RAN#62	R5s130561	1771	-	Addition of GCF WI-086 Multi-Layer SRVCC test case 13.4.3.1	11.1.0	11.2.0
2013-12	RAN#62	R5s130563	1772	-	Addition of MDT test case 8.6.4.1	11.1.0	11.2.0
2013-12	RAN#62	R5s130566	1773	-	Addition of LTE-A Minimization of Drive Tests (MDT) test case 8.6.2.6	11.1.0	11.2.0
2013-12	RAN#62	R5s130568	1774	-	Addition of LTE-A Minimization of Drive Tests (MDT) test case 8.6.2.7	11.1.0	11.2.0
2013-12	RAN#62	R5s130577	1775	-	LTE_TDD: Addition of GCF WI-169 test case 6.2.3.4a	11.1.0	11.2.0
2013-12	RAN#62	R5s130582	1776	-	Addition of LTE MDT test case 8.6.2.4	11.1.0	11.2.0
2013-12	RAN#62	R5s130584	1777	-	Addition of LTE MDT test case 8.6.2.2	11.1.0	11.2.0
2013-12	RAN#62	R5s130589	1778	-	Correction to EMM Testcase 9.2.1.2.11	11.1.0	11.2.0
2013-12	RAN#62	R5s130591	1779	-	Addition of LTE-A Minimization of Drive Tests (MDT) test case 8.6.2.5	11.1.0	11.2.0
2013-12	RAN#62	R5s130593	1780	-	Addition of LTE MDT test case 8.6.4.2	11.1.0	11.2.0
2013-12	RAN#62	R5s130600	1781	-	Addition of GCF WI-159 EUTRA-1xRTT eCSFB test case 8.4.7.6	11.1.0	11.2.0
2013-12	RAN#62	R5s130602	1782	-	Addition of GCF WI-159 EUTRA-1xRTT eCSFB test case 8.4.7.7	11.1.0	11.2.0
2013-12	RAN#62	R5s130604	1783	-	LTE_TDD : Correction to RRC Testcase 8.4.1.4	11.1.0	11.2.0
2013-12	RAN#62	R5s130605	1784	-	LTE_TDD : Correction in f_SS_DL_DPCH_ModifySRB_to_HS_DSCH function	11.1.0	11.2.0
2013-12	RAN#62	R5s130606	1785	-	LTE_TDD: Addition to GCF WI-096 EUTRA Multilayer test case 13.1.3	11.1.0	11.2.0
2013-12	RAN#62	R5s130608	1786	-	Correction to LTE-A Carrier Aggregation test cases 8.2.2.3.x	11.1.0	11.2.0
2013-12	RAN#62	R5s130610	1787	-	Correction to EMM Test Case 9.3.1.4 and 9.3.1.5	11.1.0	11.2.0
2013-12	RAN#62	R5s130615	1788	-	Addition of LTE-A Minimization of Drive Tests (MDT) test case 8.6.4.6	11.1.0	11.2.0
2013-12	RAN#62	R5s130617	1789	-	Correction to EUTRA Idle Mode Test Case 6.2.3.1a	11.1.0	11.2.0
2013-12	RAN#62	R5s130622	1790	-	TTCN Correction in EMM test case 9.2.3.1.17	11.1.0	11.2.0
2013-12	RAN#62	R5s130623	1791	-	LTE_TDD: Addition of GCF WI-156 EUTRA RRC measurement test case 8.3.1.16	11.1.0	11.2.0
2013-12	RAN#62	R5s130629	1792	-	Correction in Test case applicability for CA test cases	11.1.0	11.2.0
2013-12	RAN#62	R5s130631	1793	-	Addition of GCF WI-162 LTE-A Carrier Aggregation MAC test case 7.1.4.21	11.1.0	11.2.0
2013-12	RAN#62	R5s130633	1794	-	Correction of test case 7.1.5.1	11.1.0	11.2.0
2013-12	RAN#62	R5s130634	1795	-	Correction of test case 9.2.3.2.10 and 9.3.1.7a	11.1.0	11.2.0
2013-12	RAN#62	R5s130636	1796	-	Addition of Multilayer test case 13.1.2a	11.1.0	11.2.0
2013-12	RAN#62	R5s130639	1797	-	Addition of LTE-A Minimization of Drive Tests (MDT) test case 8.6.4.3	11.1.0	11.2.0
2013-12	RAN#62	R5s130641	1798	-	Correction to idle mode test case 6.2.3.1	11.1.0	11.2.0
2013-12	RAN#62	R5s130642	1799	-	Correction to RLC test case 7.2.2.3	11.1.0	11.2.0
2013-12	RAN#62	R5s130643	1800	-	Addition of (Rel-9) EUTRA RRC Measurement test case 8.3.1.23	11.1.0	11.2.0
2013-12	RAN#62	R5s130645	1801	-	Addition of (Rel-9) EUTRA RRC Measurement test case 8.3.1.25	11.1.0	11.2.0
2013-12	RAN#62	R5s130647	1802	-	Correction to Ciphering configuration for EUTRA<->UTRA Testcases	11.1.0	11.2.0

Date	TSG #	TSG Doc.	CR	Rev	Subject/Comment	Old	New
2013-12	RAN#62	R5s130648	1803	-	Correction to GCF WI-082 EUTRA ESM Testcase 10.6.1	11.1.0	11.2.0
2013-12	RAN#62	R5s130649	1804	-	Correction to GCF WI-151 EUTRA FDD<>TDD Testcase 8.2.4.13a	11.1.0	11.2.0
2013-12	RAN#62	R5s130650	1805	-	Correction to GCF WI-151 EUTRA FDD<>TDD Testcase 8.3.1.15a	11.1.0	11.2.0
2013-12	RAN#62	R5s130651	1806	-	Correction to GCF WI-154 IMS Emergency Call over EPS / EUTRA Testcase 8.1.2.11	11.1.0	11.2.0
2013-12	RAN#62	R5s130652	1807	-	LTE_TDD: Addition of (Rel-9) EUTRA RRC Measurement test case 8.3.1.23	11.1.0	11.2.0
2013-12	RAN#62	R5s130654	1808	-	LTE_TDD: Addition of (Rel-9) EUTRA RRC Measurement test case 8.3.1.24	11.1.0	11.2.0
2013-12	RAN#62	R5s130656	1809	-	LTE_TDD: Addition of EMM test case 9.2.3.3.5a	11.1.0	11.2.0
2013-12	RAN#62	R5s130658	1810	-	LTE_TDD : Addition of Multi-layer test case 13.1.2a	11.1.0	11.2.0
2013-12	RAN#62	R5s130660	1811	-	Correction required to IMS Registration procedure	11.1.0	11.2.0
2013-12	RAN#62	R5s130661	1812	-	LTE_TDD: Correction to GCF WI-096 TD_LTE<>TDSDMA Testcase 8.4.1.4	11.1.0	11.2.0
2013-12	RAN#62	R5s130662	1813	-	LTE_TDD: Correction to GCF WI-096 TD_LTE<>TDSDMA Testcase 13.1.4	11.1.0	11.2.0
2013-12	RAN#62	R5s130663	1814	-	LTE_TDD: Addition of (Rel-9) EUTRA RRC Measurement test case 8.3.1.25	11.1.0	11.2.0
2013-12	RAN#62	R5s130665	1815	-	LTE_TDD: Addition of (Rel-9) EUTRA RRC Measurement test case 8.3.1.26	11.1.0	11.2.0
2013-12	RAN#62	R5s130667	1816	-	LTE_TDD: Addition of (Rel-9) EUTRA RRC Measurement test case 8.3.1.27	11.1.0	11.2.0
2013-12	RAN#62	R5s130669	1817	-	Addition of (Rel-9) EUTRA RRC Measurement test case 8.3.1.24	11.1.0	11.2.0
2013-12	RAN#62	R5s130671	1818	-	Addition of (Rel-9) EUTRA RRC Measurement test case 8.3.1.26	11.1.0	11.2.0
2013-12	RAN#62	R5s130676	1819	-	LTE_TDD : Addition of EMM test case 9.2.2.1.3	11.1.0	11.2.0
2013-12	RAN#62	R5s130678	1820	-	Correction in function f_UTRAN_CS_Fallback_WithHandover()	11.1.0	11.2.0
2013-12	RAN#62	R5s130680	1821	-	Correction in function f_EUTRA_SendAuthParameters() and related functions	11.1.0	11.2.0
2013-12	RAN#62	R5s130682	1822	-	Correction for applicability for SMS test cases 11.1.5 and 11.1.6	11.1.0	11.2.0
2013-12	RAN#62	R5s130683	1823	-	Correction for EUTRA Idle Mode test case 6.1.2.17	11.1.0	11.2.0
2013-12	RAN#62	R5s130688	1824	-	LTE_TDD: Addition of LTE-A Carrier Aggregation MAC test case 7.1.4.18	11.1.0	11.2.0
2013-12	RAN#62	R5s130690	1825	-	Correction to LTE-A Carrier Aggregation RRC test cases 8.3.1.18.x	11.1.0	11.2.0
2013-12	RAN#62	R5s130693	1826	-	Correction for EMM Test Case 9.2.3.4.1	11.1.0	11.2.0
2013-12	RAN#62	R5s130695	1827	-	Correction to RRC TC 8.3.1.13	11.1.0	11.2.0
2013-12	RAN#62	R5s130696	1828	-	LTE_TDD: Addition of GCF WI-162 LTE-A Carrier Aggregation MAC test case 7.1.4.21	11.1.0	11.2.0
2013-12	RAN#62	R5s130699	1829	-	Correction of GCF WI-086 E-UTRA EMM Test case 9.2.3.3.4	11.1.0	11.2.0
2013-12	RAN#62	R5s130700	1830	-	Correction to MDT test case 8.6.2.4	11.1.0	11.2.0
2013-12	RAN#62	R5s130703	1831	-	Correction for RRC test case 8.5.1.3	11.1.0	11.2.0
2013-12	RAN#62	R5s130704	1832	-	LTE_TDD : Correction in cs_TrChInfoTrCHListDL_336_148_TDD template	11.1.0	11.2.0
2013-12	RAN#62	R5s130705	1833	-	Correction to function cs_TrLogMappingPCH_FACH_PS_TDD	11.1.0	11.2.0
2013-12	RAN#62	R5s130707	1834	-	Correction to test case 9.2.1.2.1b and 9.2.1.2.1c	11.1.0	11.2.0
2013-12	RAN#62	R5s130708	1835	-	Correction to MDT test case 8.6.2.6 .	11.1.0	11.2.0
2013-12	RAN#62	R5s130709	1836	-	Correction to test case 9.2.3.2.3	11.1.0	11.2.0
2013-12	RAN#62	R5s130711	1837	-	LTE_TDD: Addition of EUTRA Multi-layer test case 13.1.5	11.1.0	11.2.0
2013-12	RAN#62	R5s130713	1838	-	Correction to test case LTE-UTRA test case 6.2.3.33	11.1.0	11.2.0
2013-12	RAN#62	R5s130717	1839	-	Correction to GCF WI-151 EUTRA FDD-TDD test case 8.3.1.13a	11.1.0	11.2.0

Date	TSG #	TSG Doc.	CR	Rev	Subject/Comment	Old	New
2013-12	RAN#62	R5s130718	1840	-	Correction to GCF WI-151 EUTRA FDD-TDD test case 8.3.1.16a	11.1.0	11.2.0
2013-12	RAN#62	R5s130720	1841	-	Correction of (Rel-9) EUTRA RRC Measurement test case 8.3.1.25	11.1.0	11.2.0
2013-12	RAN#62	R5s130721	1842	-	Correction to EUTRA EMM test case 9.2.3.2.1b	11.1.0	11.2.0
2013-12	RAN#62	R5s130722	1843	-	Correction to EUTRA EMM test case 9.2.3.2.3	11.1.0	11.2.0
2013-12	RAN#62	R5s130723	1844	-	LTE_TDD: Addition of GCF WI-169 test case 8.3.2.11	11.1.0	11.2.0
2013-12	RAN#62	R5s130725	1845	-	LTE_TDD: Addition of GCF WI-169 test case 8.3.2.3a	11.1.0	11.2.0
2013-12	RAN#62	R5s130727	1846	-	Correction of (Rel-9) EUTRA RRC Measurement test case 8.3.1.26	11.1.0	11.2.0
2013-12	RAN#62	R5s130730	1847	-	Correction to PLMN MCC conversion functions	11.1.0	11.2.0
2013-12	RAN#62	R5s130731	1848	-	Addition of LTE-A Carrier Aggregation RRC test case 8.2.4.21.2	11.1.0	11.2.0
2013-12	RAN#62	R5s130733	1849	-	Addition of (Rel-9) EUTRA RRC Measurement test case 8.3.1.27	11.1.0	11.2.0
2013-12	RAN#62	R5s130735	1850	-	Corrections to EUTRA Idle Mode Test case 6.2.1.1	11.1.0	11.2.0
2013-12	RAN#62	R5s130736	1851	-	Correction to EUTRA RRC Test case 8.1.1.6	11.1.0	11.2.0
2013-12	RAN#62	R5s130741	1852	-	Correction of Rel-9 EUTRA RRC Measurement test case 8.3.1.26	11.1.0	11.2.0
2013-12	RAN#62	R5s130744	1853	-	LTE_TDD : Addition of RRC test case 8.3.2.5	11.1.0	11.2.0
2013-12	RAN#62	R5s130745	1854	-	Correction to MDT test case 8.6.2.6	11.1.0	11.2.0
2013-12	RAN#62	R5s130748	1855	-	Addition of GCF WI-154/ee1 IMS Emergency Call over EPS test case 11.2.1	11.1.0	11.2.0
2013-12	RAN#62	R5s130752	1856	-	LTE_TDD : Addition of LTE-A CA RRC test case 8.2.2.3.1	11.1.0	11.2.0
2013-12	RAN#62	R5s130762	1857	-	Correction to GCF WI-086 EUTRA EMM Test case 9.2.3.3.5	11.1.0	11.2.0
2013-12	RAN#62	R5s130763	1858	-	Correction to GCF WI-088 EUTRA<->HRPD Inter-RAT test case 8.3.3.4	11.1.0	11.2.0
2013-12	RAN#62	R5s130772	1859	-	Correction to test case 9.2.3.2.1a	11.1.0	11.2.0
2013-12	RAN#62	R5s130773	1860	-	correction to f_UTRAN_CS_Fallback_WithRedirection_WithoutRRCConnEst	11.1.0	11.2.0
2013-12	RAN#62	R5s130774	1861	-	Correction to test case 9.2.1.2.8 and 9.2.3.2.8	11.1.0	11.2.0
2013-12	RAN#62	R5s130775	1862	-	Correction to test case 13.4.2.4	11.1.0	11.2.0
2013-12	RAN#62	R5s130777	1863	-	Correction to LTE-GERAN test cases on SNDTCP and IP config	11.1.0	11.2.0
2013-12	RAN#62	R5s130778	1864	-	Correction to GCF WI-086 EUTRA Testcases 6.2.3.31 and 9.2.3.3.1	11.1.0	11.2.0
2013-12	RAN#62	R5s130782	1865	-	Addition of LTE-A Carrier Aggregation RRC Handover test cases 8.2.4.17.2	11.1.0	11.2.0
2013-12	RAN#62	R5s130784	1866	-	Addition of LTE-A Carrier Aggregation RRC Handover test cases 8.2.4.20.2	11.1.0	11.2.0
2013-12	RAN#62	R5s130786	1867	-	LTE_TDD: Addition of GCF WI-091 EUTRA Idle Mode CSG test case 6.3.1	11.1.0	11.2.0
2013-12	RAN#62	R5s130788	1868	-	Addition of LTE-A Carrier Aggregation RRC Handover test cases 8.2.4.19.2	11.1.0	11.2.0
2013-12	RAN#62	R5s130797	1869	-	Correction to common function of UTRAN_CS_Fallback_WithHandover	11.1.0	11.2.0
2013-12	RAN#62	R5s130807	1870	-	Correction to SRVCC test case 13.4.3.1	11.1.0	11.2.0
2013-12	RAN#62	R5s130812	1871	-	Re-verification of HeNB test case 6.3.9	11.1.0	11.2.0
2013-12	RAN#62	R5s130814	1872	-	Correction to EMM test cases 9.2.1.2.1d and 9.2.3.2.1c	11.1.0	11.2.0
2013-12	RAN#62	R5s130817	1873	-	Correction to ESM test case 10.8.7	11.1.0	11.2.0
2013-12	RAN#62	R5s130819	1874	-	LTE_TDD: Addition of EUTRA Idle Mode CSG test case 6.4.1	11.1.0	11.2.0
2013-12	RAN#62	R5s130825	1875	-	Addition of Rel-9 EUTRA RRC test case 8.3.2.11	11.1.0	11.2.0
2013-12	RAN#62	R5s130828	1876	-	Correction to RRC test case 8.5.4.1	11.1.0	11.2.0

Date	TSG #	TSG Doc.	CR	Rev	Subject/Comment	Old	New
2013-12	RAN#62	R5s130829	1877	-	Addition of Rel-9 EUTRA Idle Mode MFBI test case 6.1.2.19	11.1.0	11.2.0
2013-12	RAN#62	R5s130831	1878	-	Addition of Rel-9 EUTRA Idle Mode MFBI test case 6.1.2.20	11.1.0	11.2.0
2013-12	RAN#62	R5s130833	1879	-	LTE_TDD : Addition of Multi-layer test case 13.1.15	11.1.0	11.2.0
2013-12	RAN#62	R5s130837	1880	-	Addition of GCF WI-156 EUTRA Idle Mode MFBI test case 6.1.2.21	11.1.0	11.2.0
2013-12	RAN#62	R5s130839	1881	-	LTE_TDD : Addition of HeNB test case 6.3.9	11.1.0	11.2.0
2013-12	RAN#62	R5s130841	1882	-	Addition of Rel-9 EUTRA RRC MFBI test case 8.2.4.22	11.1.0	11.2.0
2013-12	RAN#62	R5s130845	1883	-	Correction to LTE-A CA test case 8.2.4.17.2	11.1.0	11.2.0
2013-12	RAN#62	R5s130851	1884	-	Correction to common function f_UTRAN_InterRAT_InitialiseAuthParams_Common()	11.1.0	11.2.0
2013-12	RAN#62	R5s130852	1885	-	LTE_TDD: Addition of GCF WI-162 LTE-A Carrier Aggregation test case 8.3.1.17.1	11.1.0	11.2.0
2013-12	RAN#62	R5s130856	1886	-	Correction to MultiLayer test case 13.1.2a	11.1.0	11.2.0
2013-12	RAN#62	R5s130857	1887	-	Correction to EMM test case 9.2.3.2.3	11.1.0	11.2.0
2013-12	RAN#62	R5s130858	1888	-	Addition of EUTRA<->UTRA Hybrid CSG Cell test case 6.4.5	11.1.0	11.2.0
2013-12	RAN#62	R5s130860	1889	-	Corrections to EUTRA FDD-TDD test case 8.3.1.16a	11.1.0	11.2.0
2013-12	RAN#62	R5s130863	1890	-	Correction to EUTRA RRC Test case 8.5.4.1	11.1.0	11.2.0
2013-12	RAN#62	R5s130864	1891	-	LTE_TDD : Addition of LTE-A CA RRC test case 8.3.1.22.1	11.1.0	11.2.0
2013-12	RAN#62	R5s130866	1892	-	Addition of LTE-A CA RRC test case 8.3.1.22.1	11.1.0	11.2.0
2013-12	RAN#62	RP-131869	1893	-	CR to 36.523-3: Add new verified and e-mail agreed TTCN test cases in the TC lists in 36.523-3 (prose), Annex A	11.1.0	11.2.0
2014-03	RAN#63	R5-140787	1894	-	Addition to test execution guidelines for EUTRA CA inter-band test cases for band combination with 29A	11.2.0	11.3.0
2014-03	RAN#63	R5-140788	1895	-	CA Enhancements: Test Model	11.2.0	11.3.0
2014-03	RAN#63	R5-141113	1896	-	Routine maintenance and updates	11.2.0	11.3.0
2014-03	RAN#63	R5s130876	1897	-	LTE_TDD : Addition of LTE-A CA RRC test case 8.3.1.18.1	11.2.0	11.3.0
2014-03	RAN#63	R5s130879	1898	-	Correction of GCF WI-087 Multilayer Testcases TC 13.1.8, 13.1.9	11.2.0	11.3.0
2014-03	RAN#63	R5s130880	1899	-	Correction to GCF WI-082 EUTRA ESM Testcase 10.6.1	11.2.0	11.3.0
2014-03	RAN#63	R5s130883	1900	-	Correction to LTE-GERAN test cases on SNDCP and IP config	11.2.0	11.3.0
2014-03	RAN#63	R5s130886	1901	-	LTE_TDD : Addition of GCF WI-082 EMM test case 9.2.3.1.15a	11.2.0	11.3.0
2014-03	RAN#63	R5s130888	1902	-	LTE_TDD : Addition of GCF WI-082 EMM test case 9.2.3.1.18a	11.2.0	11.3.0
2014-03	RAN#63	R5s130890	1903	-	Addition of RRC MDT test case 8.6.6.1	11.2.0	11.3.0
2014-03	RAN#63	R5s130895	1904	-	LTE_TDD: Addition of Rel-9 EUTRA RRC Measurement test case 8.3.1.13	11.2.0	11.3.0
2014-03	RAN#63	R5s130898	1905	-	Correction to Test Frequencies for CA Band Combinations CA_1A_18A and CA_11A_18A .	11.2.0	11.3.0
2014-03	RAN#63	R5s130899	1906	-	Correction to GCF WI-154 IMS Emergency Call over EPS test case 8.1.2.11	11.2.0	11.3.0
2014-03	RAN#63	R5s130902	1907	-	Correction of the setting of Location services indicators in all POS TCs	11.2.0	11.3.0
2014-03	RAN#63	R5s130903	1908	-	Correction to GCF WI-081 EUTRA RRC Test Case 8.2.1.5	11.2.0	11.3.0
2014-03	RAN#63	R5s130904	1909	-	Correction to GCF WI-081 Multilayer SRVCC Test Case 13.4.3.1	11.2.0	11.3.0
2014-03	RAN#63	R5s130915	1910	-	Correction to Idle Mode Testcase 6.2.3.15	11.2.0	11.3.0
2014-03	RAN#63	R5s130917	1911	-	13wk43 regression CRs related to IMS Emergency Call test cases	11.2.0	11.3.0
2014-03	RAN#63	R5s130918	1912	-	Addition of EUTRA Hybrid CSG Cell test case 6.4.2	11.2.0	11.3.0
2014-03	RAN#63	R5s130920	1913	-	LTE_TDD: Addition of EUTRA Hybrid CSG Cell test case 6.4.2	11.2.0	11.3.0

Date	TSG #	TSG Doc.	CR	Rev	Subject/Comment	Old	New
2014-03	RAN#63	R5s130922	1914	-	Addition of GCF WI-086 EUTRA <->UTRA CSG test case 6.3.3	11.2.0	11.3.0
2014-03	RAN#63	R5s130929	1915	-	Correction to GCF WI-086 EUTRA Idle Mode Testcase 6.2.3.31	11.2.0	11.3.0
2014-03	RAN#63	R5s130933	1916	-	LTE_TDD : Addition of EUTRA Idle Mode test case 6.1.2.15b	11.2.0	11.3.0
2014-03	RAN#63	R5s130935	1917	-	LTE_TDD : Addition of EUTRA Idle Mode MFBI test case 6.1.2.19	11.2.0	11.3.0
2014-03	RAN#63	R5s130937	1918	-	LTE_TDD : Addition of EUTRA Idle Mode MFBI test case 6.1.2.20	11.2.0	11.3.0
2014-03	RAN#63	R5s130939	1919	-	LTE_TDD : Addition of EUTRA RRC test case 8.3.1.9a	11.2.0	11.3.0
2014-03	RAN#63	R5s130941	1920	-	LTE_TDD : Addition of EUTRA RRC test case 8.3.1.11a	11.2.0	11.3.0
2014-03	RAN#63	R5s130943	1921	-	LTE_TDD : Addition of EUTRA Idle mode test case 6.2.3.1a	11.2.0	11.3.0
2014-03	RAN#63	R5s130946	1922	-	LTE_TDD: Addition of GCF WI-162 LTE-A Carrier Aggregation RRC test case 8.2.4.17.1	11.2.0	11.3.0
2014-03	RAN#63	R5s130949	1923	-	Correction for GCF WI-081 EUTRA MAC test case 7.1.3.6	11.2.0	11.3.0
2014-03	RAN#63	R5s130951	1924	-	Correction to GCF WI-81 EUTRA RRC latency test cases 8.2.1.5 and 8.2.1.6	11.2.0	11.3.0
2014-03	RAN#63	R5s130960	1925	-	Correction to GCF WI-162 LTE-A CA test case 8.3.1.18.2	11.2.0	11.3.0
2014-03	RAN#63	R5s130961	1926	-	LTE_TDD : Addition of EUTRA RRC MFBI test case 8.2.4.22	11.2.0	11.3.0
2014-03	RAN#63	R5s130964	1927	-	Corrections to LTE-A CA test case 8.2.4.19.2	11.2.0	11.3.0
2014-03	RAN#63	R5s130965	1928	-	Correction to QuantityConfig in Measurement Configuration of EUTRA Testcases	11.2.0	11.3.0
2014-03	RAN#63	R5s130967	1929	-	Addition of EUTRA RRC test case 8.1.3.12b	11.2.0	11.3.0
2014-03	RAN#63	R5s130969	1930	-	Correction of Rel-9 EUTRA Idle Mode MFBI test case 6.1.2.20	11.2.0	11.3.0
2014-03	RAN#63	R5s130970	1931	-	Correction to GCF WI-086 E-UTRA EMM testcase 9.2.1.2.8	11.2.0	11.3.0
2014-03	RAN#63	R5s130971	1932	-	Corrections for LTE-A week49 TTCN delivery	11.2.0	11.3.0
2014-03	RAN#63	R5s130975	1933	-	Addition of EUTRA RRC MDT test case 8.6.6.2	11.2.0	11.3.0
2014-03	RAN#63	R5s130977	1934	-	Correction to f_EUTRA_IdleUpdated_Step14_15 and test case 8.1.2.11	11.2.0	11.3.0
2014-03	RAN#63	R5s130979	1935	-	Addition of GCF WI-162 LTE-A Carrier Aggregation test case 8.4.2.7.2	11.2.0	11.3.0
2014-03	RAN#63	R5s130982	1936	-	Correction of test cases 8.2.4.14a, 8.3.1.15a and 8.3.1.16a	11.2.0	11.3.0
2014-03	RAN#63	R5s130984	1937	-	LTE_TDD: Correction of default UE_TXPWR_MAX_RACH	11.2.0	11.3.0
2014-03	RAN#63	R5s130986	1938	-	Correction of EUTRA Rel-9 Home eNB Enh test case 6.4.2	11.2.0	11.3.0
2014-03	RAN#63	R5s130987	1939	-	Correction of GCF WI-154 EUTRA Emergency Call Test Case 11.2.1	11.2.0	11.3.0
2014-03	RAN#63	R5s130988	1940	-	Addition of GCF WI-154 IMS Emergency Call over EPS test case 11.2.2	11.2.0	11.3.0
2014-03	RAN#63	R5s130989	1941	-	Addition of GCF WI-154 IMS Emergency Call over EPS test case 11.2.4	11.2.0	11.3.0
2014-03	RAN#63	R5s130991	1942	-	Correction to CA test case 8.3.1.22	11.2.0	11.3.0
2014-03	RAN#63	R5s130992	1943	-	Addition of EMM testcase 9.2.1.1.7b	11.2.0	11.3.0
2014-03	RAN#63	R5s130994	1944	-	Correction to GERAN ASP G_CLLC_XID_REQ	11.2.0	11.3.0
2014-03	RAN#63	R5s130995	1945	-	LTE_TDD : Addition of EUTRA Idle mode test case 6.3.3	11.2.0	11.3.0
2014-03	RAN#63	R5s130997	1946	-	LTE_TDD : Addition of EUTRA Idle Mode HeNB test case 6.4.5	11.2.0	11.3.0
2014-03	RAN#63	R5s131000	1947	-	Addition of GCF WI-103 Rel-8 test case 9.2.1.1.28	11.2.0	11.3.0
2014-03	RAN#63	R5s131002	1948	-	Correction of GCF WI-151 EUTRA FDD-TDD Testcase 8.3.1.12a	11.2.0	11.3.0
2014-03	RAN#63	R5s131003	1949	-	Correction of GCF WI-082 EUTRA CSG Testcase 9.2.3.2.16	11.2.0	11.3.0
2014-03	RAN#63	R5s131013	1950	-	Correction to functions f_UTRAN_ConfigureCipherringBeforeHO and f_UTRAN_ConfigureCipherringBeforeHO_SRVCC	11.2.0	11.3.0

Date	TSG #	TSG Doc.	CR	Rev	Subject/Comment	Old	New
2014-03	RAN#63	R5s131014	1951	-	LTE_TDD: Addition of GCF WI-162 LTE-A Carrier Aggregation RRC test case 8.2.4.18.1	11.2.0	11.3.0
2014-03	RAN#63	R5s131016	1952	-	LTE_TDD: Addition of GCF WI-162 LTE-A Carrier Aggregation RRC test case 8.2.4.19.1	11.2.0	11.3.0
2014-03	RAN#63	R5s131018	1953	-	LTE_TDD: Addition of GCF WI-162 LTE-A Carrier Aggregation RRC test case 8.2.4.20.1	11.2.0	11.3.0
2014-03	RAN#63	R5s131020	1954	-	LTE_TDD: Addition of GCF WI-162 LTE-A Carrier Aggregation RRC test case 8.2.4.21.1	11.2.0	11.3.0
2014-03	RAN#63	R5s131022	1955	-	Addition of GCF WI-162 LTE-A Carrier Aggregation RRC test case 8.2.4.18.1	11.2.0	11.3.0
2014-03	RAN#63	R5s131024	1956	-	Addition of GCF WI-162 LTE-A Carrier Aggregation RRC test case 8.2.4.17.1	11.2.0	11.3.0
2014-03	RAN#63	R5s131026	1957	-	Addition of GCF WI-162 LTE-A Carrier Aggregation RRC test case 8.2.4.21.1	11.2.0	11.3.0
2014-03	RAN#63	R5s131032	1958	-	Addition of GCF WI-162 LTE-A Carrier Aggregation RRC test case 8.2.4.19.1	11.2.0	11.3.0
2014-03	RAN#63	R5s131034	1959	-	Correction to GCF WI-081 Multilayer SRVCC Test Case 13.4.3.1	11.2.0	11.3.0
2014-03	RAN#63	R5s131035	1960	-	Addition of LTE-A Minimization of Drive Tests (MDT) Testcase 8.6.2.8	11.2.0	11.3.0
2014-03	RAN#63	R5s131037	1961	-	Addition of LTE-A Minimization of Drive Tests (MDT) Testcase 8.6.6.3	11.2.0	11.3.0
2014-03	RAN#63	R5s131039	1962	-	Correction of GCF WI-162 CA test cases 8.3.1.22.1/2, 8.2.4.18.1/2 and 8.2.4.19.1/2	11.2.0	11.3.0
2014-03	RAN#63	R5s131041	1963	-	Corrections required for LTE-A Band 29.	11.2.0	11.3.0
2014-03	RAN#63	R5s131042	1964	-	Correction to EUTRA RRC Test Case 8.3.1.16a	11.2.0	11.3.0
2014-03	RAN#63	R5s140002	1965	-	Correction of test cases 13.1.7 and 13.1.9	11.2.0	11.3.0
2014-03	RAN#63	R5s140007	1966	-	LTE_TDD: Correction of Midamble Configuration	11.2.0	11.3.0
2014-03	RAN#63	R5s140009	1967	-	Correction to LTE-A Carrier-Aggregation RRC test case 8.3.1.18.x	11.2.0	11.3.0
2014-03	RAN#63	R5s140010	1968	-	Correction to LTE-A Carrier-Aggregation RRC test case 8.2.2.3.x	11.2.0	11.3.0
2014-03	RAN#63	R5s140011	1969	-	Addition of LTE-A NIMTC test case 9.2.1.1.27	11.2.0	11.3.0
2014-03	RAN#63	R5s140031	1970	-	Addition of GCF WI-154 IMS Emergency Call over EPS test case 8.1.2.12	11.2.0	11.3.0
2014-03	RAN#63	R5s140032	1971	-	Correction of GCF WI-86 EUTRA<->UTRA SRVCC test cases 13.4.3.1	11.2.0	11.3.0
2014-03	RAN#63	R5s140041	1972	-	Addition of LTE-A NIMTC test case 9.2.1.1.2a	11.2.0	11.3.0
2014-03	RAN#63	R5s140045	1973	-	Correction to GCF WI-087 EMM Test Case 9.2.3.4.1	11.2.0	11.3.0
2014-03	RAN#63	R5s140046	1974	-	Correction of test frequencies for UTRAN band VI in EUTRAN test cases	11.2.0	11.3.0
2014-03	RAN#63	R5s140072	1975	-	Correction to EUTRA EMM test cases 9.2.1.2.1b, 9.2.1.2.1c and 9.2.3.2.1b	11.2.0	11.3.0
2014-03	RAN#63	R5s140074	1976	-	Correction to common template cdr_ATTACH_REQUEST_SRVCC	11.2.0	11.3.0
2014-03	RAN#63	R5s140075	1977	-	Addition of LTE-A NIMTC test case 9.2.3.1.5a	11.2.0	11.3.0
2014-03	RAN#63	R5s140078	1978	-	Correction to EUTRA RRC Inter-RAT Measurements test case 8.3.2.2	11.2.0	11.3.0
2014-03	RAN#63	R5s140084	1979	-	Correction to GCF WI-154 IMS Emergency Call over EPS test case 11.2.4	11.2.0	11.3.0
2014-03	RAN#63	RP-140314	1980	-	CR to 36.523-3: Add new verified and e-mail agreed TTCN test cases in the TC lists in 36.523-3 (prose), Annex A	11.2.0	11.3.0
2014-06	RAN#64	R5-142272	1981	-	feICIC: Test Method	11.3.0	11.4.0
2014-06	RAN#64	R5-142917	1982	-	Addition of operating restrictions for EUTRA MFBI test cases	11.3.0	11.4.0
2014-06	RAN#64	R5-142919	1984	-	Correction to Postambles for E-UTRA to UTRA test for IMS de-registration procedures	11.3.0	11.4.0
2014-06	RAN#64	R5-142985	1985	-	Routine maintenance and updates	11.3.0	11.4.0
2014-06	RAN#64	R5-142987	1986	-	Addition of MFBI Band IXIT	11.3.0	11.4.0
2014-06	RAN#64	R5s130983	1987	-	Correction of test case TC_9_2_1_2_1c	11.3.0	11.4.0

Date	TSG #	TSG Doc.	CR	Rev	Subject/Comment	Old	New
2014-06	RAN#64	R5s140020	1988	-	Addition of Rel-9 MultiLayer SRVCC test case 13.4.3.6	11.3.0	11.4.0
2014-06	RAN#64	R5s140022	1989	-	Addition of MultiLayer SRVCC test case 13.4.3.4	11.3.0	11.4.0
2014-06	RAN#64	R5s140027	1990	-	Addition of GCF WI-154 IMS Emergency Call over EPS test case 11.2.5	11.3.0	11.4.0
2014-06	RAN#64	R5s140043	1991	-	Addition of Rel-9 MultiLayer SRVCC test case 13.4.3.5	11.3.0	11.4.0
2014-06	RAN#64	R5s140049	1992	-	LTE_TDD: Addition of Rel-10 MDT test case 8.6.2.1	11.3.0	11.4.0
2014-06	RAN#64	R5s140051	1993	-	LTE_TDD: Addition of Rel-10 MDT test case 8.6.2.2	11.3.0	11.4.0
2014-06	RAN#64	R5s140053	1994	-	LTE_TDD: Addition of Rel-10 MDT test case 8.6.2.4	11.3.0	11.4.0
2014-06	RAN#64	R5s140055	1995	-	LTE_TDD: Addition of Rel-10 MDT test case 8.6.2.5	11.3.0	11.4.0
2014-06	RAN#64	R5s140057	1996	-	LTE_TDD: Addition of Rel-10 MDT test case 8.6.2.7	11.3.0	11.4.0
2014-06	RAN#64	R5s140059	1997	-	LTE_TDD: Addition of Rel-10 MDT test case 8.6.4.1	11.3.0	11.4.0
2014-06	RAN#64	R5s140061	1998	-	LTE_TDD: Addition of Rel-10 MDT test case 8.6.4.2	11.3.0	11.4.0
2014-06	RAN#64	R5s140063	1999	-	LTE_TDD: Addition of Rel-10 MDT test case 8.6.4.6	11.3.0	11.4.0
2014-06	RAN#64	R5s140065	2000	-	LTE_TDD: Addition of Rel-10 MDT test case 8.6.2.8	11.3.0	11.4.0
2014-06	RAN#64	R5s140067	2001	-	Addition of LTE-A Minimization of Drive Tests (MDT) Testcase 8.6.4.5	11.3.0	11.4.0
2014-06	RAN#64	R5s140069	2002	-	LTE_TDD: Addition of LTE-A Minimization of Drive Tests (MDT) Testcase 8.6.4.5	11.3.0	11.4.0
2014-06	RAN#64	R5s140073	2003	-	Correction Correction to GCF WI-150 multilayer test case 13.4.1.5	11.3.0	11.4.0
2014-06	RAN#64	R5s140083	2004	-	Corrections of GCF WI-162 LTE-A CA inter-band test cases for band combination with Band 29A	11.3.0	11.4.0
2014-06	RAN#64	R5s140094	2005	-	Addition of GCF WI-086 EUTRA<>UTRA CSG test case 6.3.4	11.3.0	11.4.0
2014-06	RAN#64	R5s140096	2006	-	Addition of GCF WI-086 MultiLayer SRVCC test case 13.4.3.2	11.3.0	11.4.0
2014-06	RAN#64	R5s140101	2007	-	LTE_TDD: Addition of GCF WI-097 EUTRA<>GERAN test case 8.3.3.3	11.3.0	11.4.0
2014-06	RAN#64	R5s140102	2008	-	LTE_TDD: Addition of GCF WI-097 Multi-layer test case 13.4.2.5	11.3.0	11.4.0
2014-06	RAN#64	R5s140104	2009	-	Correction to EMM test case 9.3.1.18	11.3.0	11.4.0
2014-06	RAN#64	R5s140107	2010	-	Correction to GCF WI-081 RLC test case 7.2.2.4	11.3.0	11.4.0
2014-06	RAN#64	R5s140108	2011	-	Correction to LTE-GERAN Multi-layer test case 13.3.2.2	11.3.0	11.4.0
2014-06	RAN#64	R5s140109	2012	-	Correction to EMM test case 9.2.3.1.12	11.3.0	11.4.0
2014-06	RAN#64	R5s140110	2013	-	Addition of LTE-A Minimization of Drive Tests (MDT) Test case 8.6.2.3	11.3.0	11.4.0
2014-06	RAN#64	R5s140112	2014	-	LTE_TDD: Addition of LTE-A Minimization of Drive Tests (MDT) Test case 8.6.2.3	11.3.0	11.4.0
2014-06	RAN#64	R5s140118	2015	-	Correction to EUTRA EMM Test Case 9.2.1.2.1b/ 9.2.1.2.1c	11.3.0	11.4.0
2014-06	RAN#64	R5s140119	2016	-	Correction of Test Case 9.2.3.4.1	11.3.0	11.4.0
2014-06	RAN#64	R5s140120	2017	-	LTE_TDD: Correction of Test Case 8.1.3.7	11.3.0	11.4.0
2014-06	RAN#64	R5s140129	2018	-	Addition of Rel-9 Home eNB test case 8.3.4.2	11.3.0	11.4.0
2014-06	RAN#64	R5s140131	2019	-	Addition of Rel-9 Home eNB test case 8.3.4.3	11.3.0	11.4.0
2014-06	RAN#64	R5s140138	2020	-	Correction to WI-151 RRC FDD<>TDD Test Case 8.2.4.15a	11.3.0	11.4.0
2014-06	RAN#64	R5s140139	2021	-	Addition of GCF WI-164 LTE eMBMS Test case 17.1.1	11.3.0	11.4.0
2014-06	RAN#64	R5s140144	2022	-	Correction to GCF WI-086 EMM Test Case 9.2.3.3.1	11.3.0	11.4.0
2014-06	RAN#64	R5s140145	2023	-	Correction to GCF WI-087 Idle Mode test case 6.2.3.16	11.3.0	11.4.0
2014-06	RAN#64	R5s140146	2024	-	Correction to Selection Expressions C130 and C63	11.3.0	11.4.0

Date	TSG #	TSG Doc.	CR	Rev	Subject/Comment	Old	New
2014-06	RAN#64	R5s140147	2025	-	Addition of LTE-A Minimization of Drive Tests (MDT) Test case 8.6.4.4	11.3.0	11.4.0
2014-06	RAN#64	R5s140149	2026	-	Correction to GCF WI-086 EUTRA RRC Inter-RAT Handover Test Case 8.4.2.2 and 8.4.2.4	11.3.0	11.4.0
2014-06	RAN#64	R5s140150	2027	-	Addition of GCF WI-177 EUTRA Rel10 Inter-RAT test Case 8.6.7.1	11.3.0	11.4.0
2014-06	RAN#64	R5s140152	2028	-	LTE_TDD: Addition of Synchronisation Parameters of SYNC_UL	11.3.0	11.4.0
2014-06	RAN#64	R5s140153	2029	-	Addition of LTE-A NIMTC test case 10.5.4	11.3.0	11.4.0
2014-06	RAN#64	R5s140155	2030	-	Correction to EMM test cases 9.2.1.1.18 and 9.2.1.2.14	11.3.0	11.4.0
2014-06	RAN#64	R5s140158	2031	-	Addition of Multi-Layer SRVCC test case 13.4.3.3	11.3.0	11.4.0
2014-06	RAN#64	R5s140160	2032	-	Correction for IMS emergency call test cases	11.3.0	11.4.0
2014-06	RAN#64	R5s140161	2033	-	Corrections to Multi-Layer SRVCC test cases 13.4.3.x	11.3.0	11.4.0
2014-06	RAN#64	R5s140162	2034	-	Correction to GCF WI-082 EMM test case 9.2.1.1.7a	11.3.0	11.4.0
2014-06	RAN#64	R5s140167	2035	-	Correction to EUTRA MDT test Case 8.6.6.2	11.3.0	11.4.0
2014-06	RAN#64	R5s140169	2036	-	Correction to GCF WI-154 IMS Emergency Call over EPS test case 11.2.1	11.3.0	11.4.0
2014-06	RAN#64	R5s140170	2037	-	Correction to GCF WI-154 IMS Emergency Call over EPS test case 11.2.2	11.3.0	11.4.0
2014-06	RAN#64	R5s140179	2038	-	TTCN Correction for EUTRA EMM Test case 9.2.3.1.6	11.3.0	11.4.0
2014-06	RAN#64	R5s140181	2039	-	Correction to GCF WI-082 EMM Test Case 9.2.3.3.4	11.3.0	11.4.0
2014-06	RAN#64	R5s140182	2040	-	Correction to GCF WI-167 EUTRA Inter-RAT test case 6.2.3.3a	11.3.0	11.4.0
2014-06	RAN#64	R5s140183	2041	-	Correction to EUTRA Test Case 6.1.1.4a	11.3.0	11.4.0
2014-06	RAN#64	R5s140184	2042	-	Correction to QuantityConfig in Measurement Configuration of EUTRA Testcases	11.3.0	11.4.0
2014-06	RAN#64	R5s140188	2043	-	Correction to GCF WI-086 Multilyer SRVCC test Case 13.4.3.2	11.3.0	11.4.0
2014-06	RAN#64	R5s140189	2044	-	Correction to EUTRA Testcases	11.3.0	11.4.0
2014-06	RAN#64	R5s140190	2045	-	Addition of GCF WI-164 LTE eMBMS Test case 17.1.2	11.3.0	11.4.0
2014-06	RAN#64	R5s140192	2046	-	Addition of GCF WI-164 LTE eMBMS Test case 17.1.3	11.3.0	11.4.0
2014-06	RAN#64	R5s140195	2047	-	Addition of LTE-A NIMTC test case 6.1.1.7	11.3.0	11.4.0
2014-06	RAN#64	R5s140198	2048	-	Addition of GCF WI-162 LTE-A Carrier Aggregation test case 8.4.2.7.1	11.3.0	11.4.0
2014-06	RAN#64	R5s140200	2049	-	Addition of GCF WI-164 LTE eMBMS Test case 17.1.4	11.3.0	11.4.0
2014-06	RAN#64	R5s140202	2050	-	Correction to test frequencies for LTE FDD band 28	11.3.0	11.4.0
2014-06	RAN#64	R5s140205	2051	-	Correction to GCF WI-162 LTE-A CA Testcase 8.2.2.3.2	11.3.0	11.4.0
2014-06	RAN#64	R5s140206	2052	-	Addition of GCF WI-164 LTE eMBMS Test case 17.2.1	11.3.0	11.4.0
2014-06	RAN#64	R5s140208	2053	-	Addition of GCF WI-164 LTE eMBMS Test case 17.2.2	11.3.0	11.4.0
2014-06	RAN#64	R5s140210	2054	-	Addition of GCF WI-164 LTE eMBMS Test case 17.2.3	11.3.0	11.4.0
2014-06	RAN#64	R5s140212	2055	-	LTE_TDD: Addition of Rel-9 EUTRA RRC Interband test case 8.1.3.12b	11.3.0	11.4.0
2014-06	RAN#64	R5s140214	2056	-	Correction of GCF WI-151 EUTRA FDD-TDD Inter-mode test case 8.2.4.15a	11.3.0	11.4.0
2014-06	RAN#64	R5s140215	2057	-	Correction to GCF WI-082 EMM test case 9.3.1.18	11.3.0	11.4.0
2014-06	RAN#64	R5s140216	2058	-	Correction to GCF WI-177 EUTRA testcase 8.6.4.4	11.3.0	11.4.0
2014-06	RAN#64	R5s140217	2059	-	Correction to GCF WI-88 EUTRA<>C2K testcase 8.3.2.8	11.3.0	11.4.0
2014-06	RAN#64	R5s140218	2060	-	Correction to GCF WI-88 EUTRA<>C2K testcase 8.3.2.10	11.3.0	11.4.0
2014-06	RAN#64	R5s140222	2061	-	Correction to GCF WI-082 EMM Test Case 9.2.3.1.16	11.3.0	11.4.0

Date	TSG #	TSG Doc.	CR	Rev	Subject/Comment	Old	New
2014-06	RAN#64	R5s140223	2062	-	LTE_TDD : Addition of GCF WI-087 EUTRAN RRC test case 8.4.3.3	11.3.0	11.4.0
2014-06	RAN#64	R5s140225	2063	-	Correction to GCF WI-150 Multi-layer Test Case 13.4.1.5	11.3.0	11.4.0
2014-06	RAN#64	R5s140226	2064	-	Correction to GCF WI-086 EUTRA EMM Test Case 9.2.3.3.5a	11.3.0	11.4.0
2014-06	RAN#64	R5s140230	2065	-	LTE_TDD: Addition of LTE-A Minimization of Drive Tests (MDT) Testcase 8.6.4.4	11.3.0	11.4.0
2014-06	RAN#64	R5s140233	2066	-	Correction to RACH TFS CCCH Configuration (LTE-TDSCDMA)	11.3.0	11.4.0
2014-06	RAN#64	R5s140234	2067	-	Correction to implementation of 34.229-1 Annex C.31 procedure for SRVCC test case 13.4.3.6	11.3.0	11.4.0
2014-06	RAN#64	R5s140235	2068	-	Correction to GCF WI-167 EUTRA Rel9 SRVCC test Case 13.4.3.6	11.3.0	11.4.0
2014-06	RAN#64	R5s140240	2069	-	Correction to GCF WI-086 EUTRA EMM Test Case 9.2.1.2.1c and 9.2.1.2.1b	11.3.0	11.4.0
2014-06	RAN#64	R5s140241	2070	-	Correction to add CA band combination CA_1A-26A	11.3.0	11.4.0
2014-06	RAN#64	R5s140244	2071	-	LTE_TDD: Addition of LTE-A Minimization of Drive Tests (MDT) Testcase 8.6.2.6	11.3.0	11.4.0
2014-06	RAN#64	R5s140246	2072	-	LTE_TDD: Addition of LTE-A Minimization of Drive Tests (MDT) Testcase 8.6.6.1	11.3.0	11.4.0
2014-06	RAN#64	R5s140248	2073	-	LTE_TDD: Addition of LTE-A Minimization of Drive Tests (MDT) Testcase 8.6.6.2	11.3.0	11.4.0
2014-06	RAN#64	R5s140250	2074	-	LTE_TDD: Addition of LTE-A Minimization of Drive Tests (MDT) Testcase 8.6.6.3	11.3.0	11.4.0
2014-06	RAN#64	R5s140252	2075	-	Correction to EMM test case 9.2.1.2.14	11.3.0	11.4.0
2014-06	RAN#64	R5s140258	2076	-	Correction to LTE-A Carrier Aggregation test case 8.2.4.20.x	11.3.0	11.4.0
2014-06	RAN#64	R5s140259	2077	-	Correction to GCF WI-086 Multi-Layer SRVCC test case 13.4.3.2	11.3.0	11.4.0
2014-06	RAN#64	R5s140260	2078	-	Correction to GCF WI-087 EMM test case 9.2.3.3.5	11.3.0	11.4.0
2014-06	RAN#64	R5s140263	2079	-	Corrections for multilayer SRVCC test cases	11.3.0	11.4.0
2014-06	RAN#64	R5s140267	2080	-	Correction to GCF WI-86 EUTRA RRC test case 8.3.3.2	11.3.0	11.4.0
2014-06	RAN#64	R5s140268	2081	-	Correction of GCF WI-082 EUTRA EMM test case 9.1.5.1	11.3.0	11.4.0
2014-06	RAN#64	R5s140273	2082	-	Correction to f_UTRAN_RB_SetUp_PS_RAB	11.3.0	11.4.0
2014-06	RAN#64	R5s140274	2083	-	Correction to f_GetTestcaseAttrib_DICcchMsgInSeparateMacPdu	11.3.0	11.4.0
2014-06	RAN#64	R5s140277	2084	-	Addition of GCF WI-165 LTE eMBMS Test case 17.3.2	11.3.0	11.4.0
2014-06	RAN#64	R5s140279	2085	-	Correction to CSG related EMM test cases	11.3.0	11.4.0
2014-06	RAN#64	R5s140280	2086	-	Addition of GCF WI-164 LTE eMBMS Test case 17.1.5	11.3.0	11.4.0
2014-06	RAN#64	R5s140282	2087	-	Addition of GCF WI-165 LTE eMBMS Test case 17.3.1	11.3.0	11.4.0
2014-06	RAN#64	R5s140286	2088	-	Corrections for LTE<->GERAN test cases 6.2.3.1, 6.2.3.1a and 9.2.3.4.1	11.3.0	11.4.0
2014-06	RAN#64	R5s140287	2089	-	Corrections for emergency call test cases 11.2.2 and 11.2.4	11.3.0	11.4.0
2014-06	RAN#64	R5s140289	2090	-	LTE_TDD: Addition of Rel-9 Home eNB test case 8.3.4.1	11.3.0	11.4.0
2014-06	RAN#64	R5s140291	2091	-	LTE_TDD: Addition of Rel-9 Home eNB test case 8.3.4.2	11.3.0	11.4.0
2014-06	RAN#64	R5s140298	2092	-	Addition of Rel-9 EUTRA Home eNB test case 8.3.4.5	11.3.0	11.4.0
2014-06	RAN#64	R5s140300	2093	-	Correction of GCF WI-87 Testcase 6.2.3.21 for Ipv6 Over GERAN	11.3.0	11.4.0
2014-06	RAN#64	R5s140301	2094	-	Addition of GCF WI-87 LTE GERAN Test case 6.2.3.28	11.3.0	11.4.0
2014-06	RAN#64	R5s140305	2095	-	Addition of Rel-10 EPS Enhancements EPS FDD <->UTRAN test Case 8.6.5.1	11.3.0	11.4.0
2014-06	RAN#64	R5s140309	2096	-	Correction to GCF WI-086 EUTRA RRC test cases 8.4.1.2 and 8.4.1.4	11.3.0	11.4.0
2014-06	RAN#64	R5s140310	2097	-	LTE_TDD : Addition of GCF WI-164 LTE eMBMS test case 17.1.1	11.3.0	11.4.0
2014-06	RAN#64	R5s140312	2098	-	LTE_TDD : Addition of GCF WI-164 LTE eMBMS test case 17.1.2	11.3.0	11.4.0

Date	TSG #	TSG Doc.	CR	Rev	Subject/Comment	Old	New
2014-06	RAN#64	R5s140314	2099	-	LTE_TDD : Addition of GCF WI-164 LTE eMBMS test case 17.1.3	11.3.0	11.4.0
2014-06	RAN#64	R5s140322	2100	-	Addition of GCF WI-177 Rel-10 LTE Enhancements test case 9.2.3.1.20a	11.3.0	11.4.0
2014-06	RAN#64	R5s140326	2101	-	Correction for GCF WI-086 E-UTRA EMM testcase 9.2.3.2.14	11.3.0	11.4.0
2014-06	RAN#64	R5s140332	2102	-	Correction to GCF WI-159 Pre-registration at 1xRTT testcase 13.4.4.1	11.3.0	11.4.0
2014-06	RAN#64	R5s140335	2103	-	Correction to function f_UTRAN_ConfigureIntegrityAfterHO()	11.3.0	11.4.0
2014-06	RAN#64	R5s140336	2104	-	Addition of Rel-9 EUTRA Home eNB test case 8.3.4.4	11.3.0	11.4.0
2014-06	RAN#64	R5s140340	2105	-	Correction to GCF WI-096 EUTRA TDD<>TDSMA test case 8.1.3.7	11.3.0	11.4.0
2014-06	RAN#64	R5s140341	2106	-	Correction to GCF WI-087 EUTRA EMM testcase 9.2.3.3.5	11.3.0	11.4.0
2014-06	RAN#64	R5s140344	2107	-	Correction of GCF WI-086 EUTRA RRC test case 8.3.3.2	11.3.0	11.4.0
2014-06	RAN#64	R5s140346	2108	-	Correction to WI-103 IMS MTSI Testcase 9.2.1.1.28	11.3.0	11.4.0
2014-06	RAN#64	R5s140348	2109	-	Corrections to GCF WI-150 rel-9 multilayer test case 13.4.1.5	11.3.0	11.4.0
2014-06	RAN#64	R5s140349	2110	-	Correction to GCF WI-87 E-UTRA RRC test case 8.4.3.3	11.3.0	11.4.0
2014-06	RAN#64	R5s140352	2111	-	LTE_TDD: Addition of LTE-WCDMA RRC Measurement test case 8.3.3.2	11.3.0	11.4.0
2014-06	RAN#64	R5s140354	2112	-	LTE_TDD: Addition of LTE-HSPA RRC Handover test case 8.4.1.5	11.3.0	11.4.0
2014-06	RAN#64	R5s140361	2113	-	Correction to LTE-A NIMTC test case 6.1.1.7	11.3.0	11.4.0
2014-06	RAN#64	R5s140362	2114	-	Addition of GCF WI-182 LTE-A Rel10 Enhancement EUTRA FDD<>GERAN test case 8.6.7.2	11.3.0	11.4.0
2014-06	RAN#64	R5s140364	2115	-	LTE_TDD: Addition of GCF WI-184 LTE-A Rel10 Enhancement EUTRA TDD<>GERAN test case 8.6.7.2	11.3.0	11.4.0
2014-06	RAN#64	R5s140366	2116	-	Correction to GCF WI-181 Rel-10 EPS Enhancements EPS FDD <>UTRAN test Case 8.6.5.1	11.3.0	11.4.0
2014-06	RAN#64	R5s140367	2117	-	Correction of 8.3.1.13a	11.3.0	11.4.0
2014-06	RAN#64	R5s140369	2118	-	Correction to test case 9.1.5.1, Table 9.1.5.1.3.3-1: EMM INFORMATION (step 1, Table 9.1.5.1.3.2-1)	11.3.0	11.4.0
2014-06	RAN#64	R5s140370	2119	-	Addition of GCF WI-172 EUTRA<>UTRA aSRVCC Testcase 13.4.3.9	11.3.0	11.4.0
2014-06	RAN#64	R5s140372	2120	-	Addition of GCF WI-086 EUTRA-UTRAN CSG test case 6.3.7	11.3.0	11.4.0
2014-06	RAN#64	R5s140374	2121	-	Addition of EUTRA-UTRAN Rel-9 Home eNB test case 6.4.3	11.3.0	11.4.0
2014-06	RAN#64	R5s140376	2122	-	Corrections to function f_EUTRA_508RRC_AddModRel_Scell_Common	11.3.0	11.4.0
2014-06	RAN#64	R5s140377	2123	-	Addition of WI-162 LTE-A Carrier Aggregation test case 8.2.2.3.1	11.3.0	11.4.0
2014-06	RAN#64	R5s140379	2124	-	Addition of WI-162 LTE-A Carrier Aggregation test case 8.2.4.20.1	11.3.0	11.4.0
2014-06	RAN#64	R5s140381	2125	-	Addition of WI-162 LTE-A Carrier Aggregation test case 8.3.1.17.1	11.3.0	11.4.0
2014-06	RAN#64	R5s140383	2126	-	Addition of WI-162 LTE-A Carrier Aggregation test case 8.3.1.18.1	11.3.0	11.4.0
2014-06	RAN#64	R5s140385	2127	-	Addition of GCF WI-172 EUTRA<>UTRA aSRVCC Testcase 13.4.3.11	11.3.0	11.4.0
2014-06	RAN#64	R5s140392	2128	-	LTE_TDD : Addition of WI-162 LTE-A Carrier Aggregation test case 8.4.2.7.1	11.3.0	11.4.0
2014-06	RAN#64	R5s140394	2129	-	Correction to GCF WI-081 EUTRA Idle mode test case 6.3.1	11.3.0	11.4.0
2014-06	RAN#64	R5s140396	2130	-	Correction to GCF WI-087 EMM test case 9.2.3.3.5	11.3.0	11.4.0
2014-06	RAN#64	R5s140397	2131	-	Addition of LTE-A Inter-RAT MDT test case 8.6.3.1	11.3.0	11.4.0
2014-06	RAN#64	R5s140402	2132	-	Correction to GCF WI-156 EUTRA RRC test case 8.2.4.14	11.3.0	11.4.0
2014-06	RAN#64	R5s140403	2133	-	Correction of EUTRA MDT test Cases 8.6.2.3, 8.6.2.6, 8.6.2.7 and 8.6.2.8.	11.3.0	11.4.0
2014-06	RAN#64	R5s140404	2134	-	Addition of GCF WI-172 EUTRA<>UTRA aSRVCC Testcase 13.4.3.10	11.3.0	11.4.0
2014-06	RAN#64	R5s140406	2135	-	Addition of GCF WI-172 EUTRA<>UTRA aSRVCC Testcase 13.4.3.7	11.3.0	11.4.0

Date	TSG #	TSG Doc.	CR	Rev	Subject/Comment	Old	New
2014-06	RAN#64	R5s140411	2136	-	Correction to applicability condition C81 for Multi-layer test case 13.1.4 & 13.1.5	11.3.0	11.4.0
2014-06	RAN#64	R5s140414	2137	-	Correction to GCF WI-082 EMM Test Case 9.2.3.1.12	11.3.0	11.4.0
2014-06	RAN#64	R5s140421	2138	-	Addition of GCF WI-172 EUTRA<->UTRA aSRVCC Testcase 13.4.3.14	11.3.0	11.4.0
2014-06	RAN#64	R5s140423	2139	-	Correction to GCF WI-156 EUTRA RRC test case 8.2.4.15a	11.3.0	11.4.0
2014-06	RAN#64	R5s140424	2140	-	Addition of Rel-10 MDT test case 8.6.2.9	11.3.0	11.4.0
2014-06	RAN#64	R5s140431	2141	-	Addition of GCF WI-172 EUTRA<->UTRA aSRVCC Testcase 13.4.3.16	11.3.0	11.4.0
2014-06	RAN#64	R5s140440	2142	-	LTE_TDD: Addition of LTE eMBMS Testcase 17.1.4	11.3.0	11.4.0
2014-06	RAN#64	R5s140442	2143	-	LTE_TDD: Addition of LTE eMBMS Testcase 17.2.1	11.3.0	11.4.0
2014-06	RAN#64	RP-140823	2144	-	CR to 36.523-3: Add new verified and e-mail agreed TTCN test cases in the TC lists in 36.523-3 (prose), Annex A	11.3.0	11.4.0
2014-09	RAN#65	R5-144219	2145	-	Routine maintenance and updates	11.4.0	11.5.0
2014-09	RAN#65	R5-144399	2146	-	Correction to the guideline of EUTRA CA test execution on Band 29	11.4.0	11.5.0
2014-09	RAN#65	R5-144678	2147	-	Correction to the calculation in Test method for RRC signalling latency	11.4.0	11.5.0
2014-09	RAN#65	RP-141582	2301	-	CR to 36.523-3: Add new verified and e-mail agreed TTCN test cases in the TC lists in 36.523-3 (prose), Annex A	11.4.0	11.5.0
2014-09	RAN#65	R5s140127	2148	-	Addition of Rel-9 Home eNB test case 8.3.4.1	11.4.0	11.5.0
2014-09	RAN#65	R5s140331	2149	-	Correction to SRVCC test case 13.4.3.2	11.4.0	11.5.0
2014-09	RAN#65	R5s140333	2150	-	Correction to GCF WI-159 Pre-registration at 1xRTT testcase 13.4.4.5	11.4.0	11.5.0
2014-09	RAN#65	R5s140412	2151	-	Addition of LTE-A Minimization of Drive Tests (MDT) Testcase 8.6.11.1	11.4.0	11.5.0
2014-09	RAN#65	R5s140427	2152	-	Correction to SRVCC testcases 13.4.3.4 and 13.4.3.5	11.4.0	11.5.0
2014-09	RAN#65	R5s140429	2153	-	Addition of GCF WI-164 eMBMS test case 17.2.4	11.4.0	11.5.0
2014-09	RAN#65	R5s140444	2154	-	Correction to GCF WI-081 EUTRA Idle mode Test Case 6.1.2.8a	11.4.0	11.5.0
2014-09	RAN#65	R5s140447	2155	-	Correction to common function in NAS Authentication module	11.4.0	11.5.0
2014-09	RAN#65	R5s140448	2156	-	LTE_TDD : Addition of GCF WI-086 EUTRA-UTRAN CSG test case 6.3.7	11.4.0	11.5.0
2014-09	RAN#65	R5s140450	2157	-	LTE_TDD : Addition of EUTRA-UTRAN Rel-9 Home eNB test case 6.4.3	11.4.0	11.5.0
2014-09	RAN#65	R5s140455	2158	-	LTE_TDD: Addition of LTE eMBMS Testcase 17.2.2	11.4.0	11.5.0
2014-09	RAN#65	R5s140457	2159	-	LTE_TDD: Addition of LTE eMBMS Testcase 17.2.3	11.4.0	11.5.0
2014-09	RAN#65	R5s140459	2160	-	Addition of GCF WI-172 EUTRA<->UTRA aSRVCC Testcase 13.4.3.13	11.4.0	11.5.0
2014-09	RAN#65	R5s140461	2161	-	Correction of GCF WI-167 EUTRA RRC test case 8.3.2.11	11.4.0	11.5.0
2014-09	RAN#65	R5s140465	2162	-	LTE_TDD: Addition of Rel-9 Home eNB test case 8.3.4.4	11.4.0	11.5.0
2014-09	RAN#65	R5s140467	2163	-	Correction of GCF WI-167 EUTRA Inter-RAT test cases 6.2.3.4a and 6.2.3.5a	11.4.0	11.5.0
2014-09	RAN#65	R5s140468	2164	-	Correction to f_UTRAN_RB_SetUp_PS_RAB	11.4.0	11.5.0
2014-09	RAN#65	R5s140470	2165	-	Addition of Rel-10 MDT test case 8.6.1.1	11.4.0	11.5.0
2014-09	RAN#65	R5s140472	2166	-	Correction to definition of O13_Type	11.4.0	11.5.0
2014-09	RAN#65	R5s140473	2167	-	Correction of GCF WI-086 EUTRA<->UTRAN CSG test case 6.3.7	11.4.0	11.5.0
2014-09	RAN#65	R5s140474	2168	-	Correction of EUTRA-UTRAN HomeENB test case 6.4.3	11.4.0	11.5.0
2014-09	RAN#65	R5s140475	2169	-	Correction to function f_UTRAN_CS_Fallback_WithRedirection_WithoutRRCConnEst.	11.4.0	11.5.0
2014-09	RAN#65	R5s140476	2170	-	Correction to function f_SS_Config_64kPS_DCH4_RAB for TD_LTE<->TDSMA	11.4.0	11.5.0
2014-09	RAN#65	R5s140477	2171	-	Correction to GCF WI-086 EUTRA EMM Test Case 9.2.1.2.1c	11.4.0	11.5.0

Date	TSG #	TSG Doc.	CR	Rev	Subject/Comment	Old	New
2014-09	RAN#65	R5s140478	2172	-	Addition of GCF WI-172 EUTRA<->UTRA aSRVCC Testcase 13.4.3.15	11.4.0	11.5.0
2014-09	RAN#65	R5s140480	2173	-	Correction to IMS Emergency Call test case 11.2.5	11.4.0	11.5.0
2014-09	RAN#65	R5s140481	2174	-	Correction to GCF WI-086 UTRA<->EUTRA HSPA Handover Testcase 8.4.2.4	11.4.0	11.5.0
2014-09	RAN#65	R5s140482	2175	-	Correction for SI 2 quater message for EUTRA<->UTRA<->GERAN test case 8.3.2.6	11.4.0	11.5.0
2014-09	RAN#65	R5s140483	2176	-	Correction to GCF WI-156 EUTRA RRC test case 8.2.4.15a	11.4.0	11.5.0
2014-09	RAN#65	R5s140484	2177	-	LTE_TDD: Addition of LTE eMBMS Testcase 17.1.5	11.4.0	11.5.0
2014-09	RAN#65	R5s140488	2178	-	LTE_TDD: Addition of LTE eMBMS Testcase 17.3.2	11.4.0	11.5.0
2014-09	RAN#65	R5s140492	2179	-	Correction of test cases 8.3.1.12a, 8.3.1.15, 8.3.1.16 and 8.6.4.4	11.4.0	11.5.0
2014-09	RAN#65	R5s140493	2180	-	Correction to template cr_G_AttachReq_EUTRANCap	11.4.0	11.5.0
2014-09	RAN#65	R5s140496	2181	-	Correction to Rel-9 EUTRA Home eNB test case 8.3.4.5	11.4.0	11.5.0
2014-09	RAN#65	R5s140497	2182	-	Correction to GCF WI-081 EUTRA RRC Test Case 8.2.1.5	11.4.0	11.5.0
2014-09	RAN#65	R5s140498	2183	-	Addition of WI-162 LTE-A Carrier Aggregation MAC test case 7.1.3.11.2	11.4.0	11.5.0
2014-09	RAN#65	R5s140501	2184	-	Correction for EUTRA RRC MDT re-establishment test cases	11.4.0	11.5.0
2014-09	RAN#65	R5s140503	2185	-	Correction to GCF WI-086 EUTRA RRC handover test cases 8.4.2.2 and 8.4.2.4	11.4.0	11.5.0
2014-09	RAN#65	R5s140505	2186	-	Correction to eMBMS common functions	11.4.0	11.5.0
2014-09	RAN#65	R5s140506	2187	-	Correction to SIB 6 contents for EUTRA<->UTRA test cases using UTRA Band VI	11.4.0	11.5.0
2014-09	RAN#65	R5s140507	2188	-	Addition of WI-162 LTE-A Carrier Aggregation MAC test case 7.1.3.11.1	11.4.0	11.5.0
2014-09	RAN#65	R5s140509	2189	-	Extension of EUTRA common functions for MAC test cases	11.4.0	11.5.0
2014-09	RAN#65	R5s140513	2190	-	Correction to GCF WI-087 EMM Test Case 9.2.3.4.1	11.4.0	11.5.0
2014-09	RAN#65	R5s140514	2191	-	Addition of Rel-10 eICIC test case 8.3.1.21	11.4.0	11.5.0
2014-09	RAN#65	R5s140520	2192	-	Correction of test cases 8.4.2.4	11.4.0	11.5.0
2014-09	RAN#65	R5s140526	2193	-	Correction of LTE-A Minimization of Drive Tests (MDT) Testcase 8.6.3.1	11.4.0	11.5.0
2014-09	RAN#65	R5s140527	2194	-	Correction of GCF WI-162 LTE-A CA inter-band test cases for band combination with Band 29A	11.4.0	11.5.0
2014-09	RAN#65	R5s140528	2195	-	Correction to test case applicability conditions	11.4.0	11.5.0
2014-09	RAN#65	R5s140529	2196	-	Correction to GCF WI-086 EUTRA Idle mode test case 6.2.3.31	11.4.0	11.5.0
2014-09	RAN#65	R5s140530	2197	-	Correction to LTE-IRAT test cases 8.4.2.2 and 8.4.2.4	11.4.0	11.5.0
2014-09	RAN#65	R5s140531	2198	-	Correction to GCF WI-162 LTE-A Carrier Aggregation MAC test case 7.1.3.11.1/7.1.3.11.2	11.4.0	11.5.0
2014-09	RAN#65	R5s140533	2199	-	Correction to EUTRA MDT test Case 8.6.2.3	11.4.0	11.5.0
2014-09	RAN#65	R5s140534	2200	-	Correction of LTE-A Minimization of Drive Tests (MDT) Test case 8.6.2.8	11.4.0	11.5.0
2014-09	RAN#65	R5s140535	2201	-	Correction to GCF WI-181 EUTRA EPS FDD <->UTRAN test Case 8.6.5.1	11.4.0	11.5.0
2014-09	RAN#65	R5s140537	2202	-	Correction of GCF WI-182 EUTRA FDD<->GERAN test case 8.6.7.2	11.4.0	11.5.0
2014-09	RAN#65	R5s140539	2203	-	Correction to EUTRA eMBMS function f_EUTRA_SetSysinfoCombination_MBMS	11.4.0	11.5.0
2014-09	RAN#65	R5s140540	2204	-	Correction to UE Test Loop Mode C for EUTRA eMBMS Testcases	11.4.0	11.5.0
2014-09	RAN#65	R5s140541	2205	-	Corrections of GCF WI-162 LTE-A CA Testcase 8.2.2.3.x for Band 29A	11.4.0	11.5.0
2014-09	RAN#65	R5s140543	2206	-	Correction of EUTRA RRC Measurement test case 8.3.1.27	11.4.0	11.5.0
2014-09	RAN#65	R5s140544	2207	-	Correction to EUTRA RRC Measurement test case 8.3.3.3	11.4.0	11.5.0
2014-09	RAN#65	R5s140545	2208	-	Correction to GCF WI-082 EUTRA RRC handover test cases 8.4.1.2 and 8.4.1.4	11.4.0	11.5.0

Date	TSG #	TSG Doc.	CR	Rev	Subject/Comment	Old	New
2014-09	RAN#65	R5s140546	2209	-	LTE_TDD : Correction in RRC test case 8.4.1.5 in LTE_TDD<->TDSCDMA path	11.4.0	11.5.0
2014-09	RAN#65	R5s140547	2210	-	Correction to GCF WI-081 EUTRA Idle mode test Case 6.1.1.3	11.4.0	11.5.0
2014-09	RAN#65	R5s140548	2211	-	Correction of test cases 7.1.4.5	11.4.0	11.5.0
2014-09	RAN#65	R5s140549	2212	-	Correction to GCF WI-086 EMM test case 9.2.3.3.2	11.4.0	11.5.0
2014-09	RAN#65	R5s140550	2213	-	Correction to EUTRA Idle Mode HeNB test case 6.4.3	11.4.0	11.5.0
2014-09	RAN#65	R5s140552	2214	-	Correction to UTRAN postamble function f_UTRAN_Postamble	11.4.0	11.5.0
2014-09	RAN#65	R5s140554	2215	-	Correction for GCF WI-086 EUTRA EMM Test case 9.2.3.1.6	11.4.0	11.5.0
2014-09	RAN#65	R5s140555	2216	-	Correction in common function f_GERAN_GPRSAttach()	11.4.0	11.5.0
2014-09	RAN#65	R5s140556	2217	-	Correction of GCF WI-086 EUTRA<->UTRAN CSG test case 6.3.7	11.4.0	11.5.0
2014-09	RAN#65	R5s140557	2218	-	Correction to EUTRA Idle Mode MFBI test Case 6.1.2.21	11.4.0	11.5.0
2014-09	RAN#65	R5s140560	2219	-	Correction to EMM test case 9.2.1.1.28	11.4.0	11.5.0
2014-09	RAN#65	R5s140562	2220	-	Correction to EUTRA RRC HeNB test case 8.3.4.1	11.4.0	11.5.0
2014-09	RAN#65	R5s140563	2221	-	Correction to EUTRA RRC HeNB test case 8.3.4.4	11.4.0	11.5.0
2014-09	RAN#65	R5s140564	2222	-	Correction to EUTRA-UTRAN Multi-Layer SRVCC test case 13.4.3.2	11.4.0	11.5.0
2014-09	RAN#65	R5s140568	2223	-	Correction to EMM test case 9.2.3.1.20a	11.4.0	11.5.0
2014-09	RAN#65	R5s140570	2224	-	Correction to IMS Emergency Call over EPS test case 11.2.2	11.4.0	11.5.0
2014-09	RAN#65	R5s140572	2225	-	Correction for GCF WI-172 EUTRA<->UTRA aSRVCC Testcase 13.4.3.14	11.4.0	11.5.0
2014-09	RAN#65	R5s140573	2226	-	Correction for GCF WI-086 EUTRA<->UTRA SRVCC Testcase 13.4.3.2	11.4.0	11.5.0
2014-09	RAN#65	R5s140574	2227	-	Correction to Multi-layer test case 13.1.3	11.4.0	11.5.0
2014-09	RAN#65	R5s140575	2228	-	LTE_TDD: Addition of WI-162 LTE-A Carrier Aggregation MAC test case 7.1.3.11.1	11.4.0	11.5.0
2014-09	RAN#65	R5s140578	2229	-	Correction for GCF WI-172 EUTRA<->UTRA aSRVCC Testcase 13.4.3.16	11.4.0	11.5.0
2014-09	RAN#65	R5s140579	2230	-	Correction for GCF WI-086 EUTRA<->UTRA SRVCC Testcase 13.4.3.4	11.4.0	11.5.0
2014-09	RAN#65	R5s140582	2231	-	Correction for GCF WI-087 EUTRA<->GERAN SRVCC Testcase 13.4.3.5	11.4.0	11.5.0
2014-09	RAN#65	R5s140583	2232	-	Correction for GCF WI-167 EUTRA<->UTRA SRVCC Testcase 13.4.3.6	11.4.0	11.5.0
2014-09	RAN#65	R5s140584	2233	-	Correction of GERAN Common function fl_GERAN_TLLI_Update	11.4.0	11.5.0
2014-09	RAN#65	R5s140585	2234	-	Correction to EUTRA eMBMS test case 17.2.4	11.4.0	11.5.0
2014-09	RAN#65	R5s140586	2235	-	Correction to EUTRA Idle Mode MFBI test Case 6.1.2.20	11.4.0	11.5.0
2014-09	RAN#65	R5s140587	2236	-	Correction for aSRVCC test cases	11.4.0	11.5.0
2014-09	RAN#65	R5s140588	2237	-	Addition of GCF WI-154 IMS Emergency Call over EPS test case 11.2.8	11.4.0	11.5.0
2014-09	RAN#65	R5s140589	2238	-	Correction for GCF WI-172 EUTRA<->UTRA aSRVCC Testcase 13.4.3.7	11.4.0	11.5.0
2014-09	RAN#65	R5s140590	2239	-	Correction for GCF WI-172 EUTRA<->UTRA aSRVCC Testcase 13.4.3.9	11.4.0	11.5.0
2014-09	RAN#65	R5s140591	2240	-	Correction for GCF WI-172 EUTRA<->UTRA aSRVCC Testcase 13.4.3.10	11.4.0	11.5.0
2014-09	RAN#65	R5s140592	2241	-	Correction for GCF WI-172 EUTRA<->UTRA aSRVCC Testcase 13.4.3.11	11.4.0	11.5.0
2014-09	RAN#65	R5s140593	2242	-	Correction to EUTRA RRC MDT test case 8.6.6.2	11.4.0	11.5.0
2014-09	RAN#65	R5s140594	2243	-	Correction to EUTRA RRC HeNB test case 8.3.4.1	11.4.0	11.5.0
2014-09	RAN#65	R5s140595	2244	-	Correction for GCF WI-172 EUTRA<->UTRA aSRVCC Testcase 13.4.3.13	11.4.0	11.5.0
2014-09	RAN#65	R5s140596	2245	-	Correction to EMM test case 9.2.1.1.28	11.4.0	11.5.0

Date	TSG #	TSG Doc.	CR	Rev	Subject/Comment	Old	New
2014-09	RAN#65	R5s140601	2246	-	Correction to EUTRA RRC test cases 8.2.4.14 and 8.2.4.14a	11.4.0	11.5.0
2014-09	RAN#65	R5s140604	2247	-	Correction for GCF WI-172 EUTRA<->UTRA aSRVCC Testcase 13.4.3.15	11.4.0	11.5.0
2014-09	RAN#65	R5s140607	2248	-	LTE_TDD : Correction to EUTRAN TDD eMBMS TC 17.1.4	11.4.0	11.5.0
2014-09	RAN#65	R5s140608	2249	-	LTE_TDD : Correction in SIB13 notificationSF-Index-r9 for eMBMS test cases	11.4.0	11.5.0
2014-09	RAN#65	R5s140609	2250	-	Correction to EUTRAN eMBMS TC 17.3.2	11.4.0	11.5.0
2014-09	RAN#65	R5s140610	2251	-	Correction to EUTRA eMBMS function f_EUTRA_SetSysinfoCombination_MBMS	11.4.0	11.5.0
2014-09	RAN#65	R5s140617	2252	-	Correction to EUTRA Idle mode test case 6.2.3.23	11.4.0	11.5.0
2014-09	RAN#65	R5s140618	2253	-	Corrections for SS configuration in IMS voice call test cases	11.4.0	11.5.0
2014-09	RAN#65	R5s140619	2254	-	Correction to EUTRA RRC MDT test case 8.6.7.1	11.4.0	11.5.0
2014-09	RAN#65	R5s140620	2255	-	Corrections for multilayer EUTRA->GERAN SRVCC test case 13.4.3.3	11.4.0	11.5.0
2014-09	RAN#65	R5s140624	2256	-	Correction to LTE-A Carrier Aggregation MAC test cases 7.1.3.11.1/7.1.3.11.2	11.4.0	11.5.0
2014-09	RAN#65	R5s140625	2257	-	Correction to GCF WI-088 EUTRA<->1xRTT Test case 8.3.2.10	11.4.0	11.5.0
2014-09	RAN#65	R5s140626	2258	-	Correction to LTE-A Minimization of Drive Tests (MDT) test case 8.6.4.6	11.4.0	11.5.0
2014-09	RAN#65	R5s140627	2259	-	Correction to GCF WI-082 EUTRA RRC handover test case 8.4.1.5	11.4.0	11.5.0
2014-09	RAN#65	R5s140635	2260	-	Correction to multilayer aSRVCC test 13.4.3.15	11.4.0	11.5.0
2014-09	RAN#65	R5s140636	2261	-	Correction to GCF WI-151 EUTRA RRC test cases 8.2.4.14a and 8.3.1.16a	11.4.0	11.5.0
2014-09	RAN#65	R5s140643	2262	-	Correction to GCF WI-081 EUTRA RRC Test Case 8.5.4.1	11.4.0	11.5.0
2014-09	RAN#65	R5s140648	2263	-	Correction to GCF WI-087 EUTRA Idle mode Test Case 6.2.3.28	11.4.0	11.5.0
2014-09	RAN#65	R5s140649	2264	-	Corrections to GCF WI-154 IMS Emergency Call test case 11.2.4	11.4.0	11.5.0
2014-09	RAN#65	R5s140650	2265	-	Correction to GCF WI-086 EUTRA EMM Testcase 9.2.3.2.1b	11.4.0	11.5.0
2014-09	RAN#65	R5s140651	2266	-	Correction of GCF WI-082 EUTRA EMM Testcase 9.1.5.1	11.4.0	11.5.0
2014-09	RAN#65	R5s140657	2267	-	Correction to GCF WI-154 IMS Emergency Call test case 11.2.5	11.4.0	11.5.0
2014-09	RAN#65	R5s140658	2268	-	Correction to WI-086 EUTRA EMM Testcase 9.2.3.3.4	11.4.0	11.5.0
2014-09	RAN#65	R5s140659	2269	-	Correction to GCF WI-086 EUTRA Multilayer Test case 13.4.2.1	11.4.0	11.5.0
2014-09	RAN#65	R5s140660	2270	-	Correction to WI-086 EUTRA EMM Testcase 9.2.3.3.1	11.4.0	11.5.0
2014-09	RAN#65	R5s140664	2271	-	Correction to EUTRA RRC test cases 8.2.4.14a, 8.2.4.15, 8.3.1.16a	11.4.0	11.5.0
2014-09	RAN#65	R5s140670	2272	-	Correction to EUTRA RRC HeNB Testcase 8.3.4.1	11.4.0	11.5.0
2014-09	RAN#65	R5s140671	2273	-	Correction to LTE-A Carrier Aggregation Handover test cases 8.2.4.21.x	11.4.0	11.5.0
2014-09	RAN#65	R5s140674	2274	-	Correction to GCF WI-87 Multi-Layer SRVCC test cases 13.4.3.3 and 13.4.3.5	11.4.0	11.5.0
2014-09	RAN#65	R5s140675	2275	-	Corrections to GCF WI-154 IMS Emergency Call test cases 11.2.2 and 11.2.4	11.4.0	11.5.0
2014-09	RAN#65	R5s140677	2276	-	Corrections to GCF WI-087 EUTRA<->GERAN SRVCC test case 13.4.3.3	11.4.0	11.5.0
2014-09	RAN#65	R5s140679	2277	-	Correction to GCF WI-81 EUTRA MIMO test cases 7.1.7.1.5 and 7.1.7.1.6 for CAT-6 and higher categories	11.4.0	11.5.0
2014-09	RAN#65	R5s140680	2278	-	Correction to GCF WI-81 EUTRA MIMO Testcase 7.1.7.2.1 for CAT-6 and higher categories	11.4.0	11.5.0
2014-09	RAN#65	R5s140682	2279	-	LTE TDD : Addition of MAC test case 7.1.4.2	11.4.0	11.5.0
2014-09	RAN#65	R5s140684	2280	-	LTE_TDD : Addition of Idle mode test case 6.3.5	11.4.0	11.5.0
2014-09	RAN#65	R5s140686	2281	-	Addition of GCF WI-172 multilayer aSRVCC test case 13.4.3.8	11.4.0	11.5.0
2014-09	RAN#65	R5s140688	2282	-	LTE_TDD: Correction to RRC Testcase 8.1.3.7 in LTE_TDD<->TDSCDMA path	11.4.0	11.5.0

Date	TSG #	TSG Doc.	CR	Rev	Subject/Comment	Old	New
2014-09	RAN#65	R5s140689	2283	-	LTE_TDD : Addition of EUTRA RRC HeNB test case 8.3.4.3	11.4.0	11.5.0
2014-09	RAN#65	R5s140691	2284	-	Addition of GCF WI-162 LTE-A Carrier Aggregation MAC test case 7.1.9.1.1	11.4.0	11.5.0
2014-09	RAN#65	R5s140693	2285	-	Addition of GCF WI-162 LTE-A Carrier Aggregation MAC test case 7.1.9.1.2	11.4.0	11.5.0
2014-09	RAN#65	R5s140697	2286	-	Addition of multilayer aSRVCC test case 13.4.3.24	11.4.0	11.5.0
2014-09	RAN#65	R5s140699	2287	-	Addition of multilayer aSRVCC test case 13.4.3.26	11.4.0	11.5.0
2014-09	RAN#65	R5s140701	2288	-	Corrections to EMM test case 9.2.3.1.6 on EUTRA<->GERAN path	11.4.0	11.5.0
2014-09	RAN#65	R5s140702	2289	-	Correction to EUTRA RRC InterRAT measurement on HRPD test case 8.3.2.8	11.4.0	11.5.0
2014-09	RAN#65	R5s140703	2290	-	Addition of multilayer aSRVCC test case 13.4.3.27	11.4.0	11.5.0
2014-09	RAN#65	R5s140705	2291	-	Addition of multilayer aSRVCC test case 13.4.3.28	11.4.0	11.5.0
2014-09	RAN#65	R5s140707	2292	-	Correction to function f_ConfigureULGrant_MaxTBSupported	11.4.0	11.5.0
2014-09	RAN#65	R5s140710	2293	-	Correction to SRVCC test case 13.4.3.2	11.4.0	11.5.0
2014-09	RAN#65	R5s140711	2294	-	Addition of multilayer aSRVCC test case 13.4.3.25	11.4.0	11.5.0
2014-09	RAN#65	R5s140714	2295	-	Addition of multilayer aSRVCC test case 13.4.3.30	11.4.0	11.5.0
2014-09	RAN#65	R5s140716	2296	-	Addition of Rel-9 EUTRA<->UTRA Idle Mode HeNB test case 6.4.6	11.4.0	11.5.0
2014-09	RAN#65	R5s140720	2297	-	Corrections to EUTRA PDCP test case 7.3.4.1,7.3.4.2 and 7.3.4.3	11.4.0	11.5.0
2014-09	RAN#65	R5s140721	2298	-	Addition of Rel-10 EUTRA RRC eICIC test case 8.3.1.19	11.4.0	11.5.0
2014-09	RAN#65	R5s140723	2299	-	LTE_TDD: Addition of GCF WI-162 LTE-A Carrier Aggregation MAC test case 7.1.9.1.1	11.4.0	11.5.0
2014-09	RAN#65	R5s140725	2300	-	Addition of GCF WI-086 EUTRA Idle Mode HeNB test case 6.3.4	11.4.0	11.5.0
2014-12	RAN#66	R5-145713	2302	-	Harmonization of CA terminology (36.523-3)	11.5.0	11.6.0
2014-12	RAN#66	R5-145754	2304	-	Routine maintenance and updates	11.5.0	11.6.0
2014-12	RAN#66	R5s140672	2305	-	Correction to SRS config dedicated for EUTRA Testcases	11.5.0	11.6.0
2014-12	RAN#66	R5s140708	2306	-	Addition of GCF WI-154 IMS Emergency Call over EPS test case 11.2.11	11.5.0	11.6.0
2014-12	RAN#66	R5s140728	2307	-	Correction to fl_EUTRA_RRC_Procedure_Latency	11.5.0	11.6.0
2014-12	RAN#66	R5s140729	2308	-	Correction to EUTRA Idle Mode HeNB test case 6.4.5	11.5.0	11.6.0
2014-12	RAN#66	R5s140730	2309	-	Corrections to EUTRA->GERAN SRVCC test cases	11.5.0	11.6.0
2014-12	RAN#66	R5s140731	2310	-	Addition of IMS emergency call test case 11.2.10	11.5.0	11.6.0
2014-12	RAN#66	R5s140733	2311	-	Addition of LTE Advanced bSRVCC test case 13.4.3.18	11.5.0	11.6.0
2014-12	RAN#66	R5s140735	2312	-	Addition of LTE Advanced bSRVCC test case 13.4.3.20	11.5.0	11.6.0
2014-12	RAN#66	R5s140737	2313	-	Addition of LTE Advanced bSRVCC test case 13.4.3.23	11.5.0	11.6.0
2014-12	RAN#66	R5s140741	2314	-	Addition of Rel-10 MDT test case 8.6.4.7	11.5.0	11.6.0
2014-12	RAN#66	R5s140743	2315	-	Addition of Rel-10 MDT test case 8.6.6.4	11.5.0	11.6.0
2014-12	RAN#66	R5s140745	2316	-	Addition of EUTRA-UTRAN Rel-9 Home eNB test case 6.4.4	11.5.0	11.6.0
2014-12	RAN#66	R5s140747	2317	-	Addition of LTE Advanced bSRVCC test case 13.4.3.21	11.5.0	11.6.0
2014-12	RAN#66	R5s140749	2318	-	Correction to GCF WI-086 EUTRA RRC Testcase 8.3.2.4	11.5.0	11.6.0
2014-12	RAN#66	R5s140750	2319	-	Addition of multilayer bSRVCC test case 13.4.3.19	11.5.0	11.6.0
2014-12	RAN#66	R5s140752	2320	-	Addition of multilayer bSRVCC test case 13.4.3.22	11.5.0	11.6.0
2014-12	RAN#66	R5s140754	2321	-	Correction to EUTRA Idle Mode test case 6.1.1.3a	11.5.0	11.6.0

Date	TSG #	TSG Doc.	CR	Rev	Subject/Comment	Old	New
2014-12	RAN#66	R5s140757	2322	-	Addition of GCF WI-178 LTE Advanced eMBMS-SC test case 17.4.1	11.5.0	11.6.0
2014-12	RAN#66	R5s140759	2323	-	Addition of GCF WI-178 LTE Advanced eMBMS-SC test case 17.4.1a	11.5.0	11.6.0
2014-12	RAN#66	R5s140761	2324	-	Addition of GCF WI-178 LTE Advanced eMBMS-SC test case 17.4.5	11.5.0	11.6.0
2014-12	RAN#66	R5s140763	2325	-	LTE_TDD: Addition of Rel-10 MDT test case 8.6.3.1	11.5.0	11.6.0
2014-12	RAN#66	R5s140765	2326	-	LTE_TDD: Addition of Rel-10 MDT test case 8.6.4.3	11.5.0	11.6.0
2014-12	RAN#66	R5s140767	2327	-	LTE_TDD: Addition of GCF WI-183 Rel-10 MDT test case 8.6.5.1	11.5.0	11.6.0
2014-12	RAN#66	R5s140771	2328	-	Correction to EUTRA RSRQ testcases 6.1.2.17, 6.1.2.18, 6.1.2.2a, 6.1.2.3a, 8.3.1.25, 8.3.1.27 and 8.3.1.3a	11.5.0	11.6.0
2014-12	RAN#66	R5s140772	2329	-	Correction to GCF WI-150 MFBI test case 6.1.2.20	11.5.0	11.6.0
2014-12	RAN#66	R5s140774	2330	-	Correction to comments tag in f_TC_8_1_3_12a_EUTRA()	11.5.0	11.6.0
2014-12	RAN#66	R5s140775	2331	-	Correction of GCF WI-162 LTE-A Carrier Aggregation test case 8.4.2.7.1 and 8.4.2.7.2 in Band29	11.5.0	11.6.0
2014-12	RAN#66	R5s140776	2332	-	Correction to EUTRA HomeNB testcase 6.4.3	11.5.0	11.6.0
2014-12	RAN#66	R5s140778	2333	-	Correction to IE "TMSI Based NRI Container"	11.5.0	11.6.0
2014-12	RAN#66	R5s140781	2334	-	Correction to EUTRA-UTRAN Idle Mode HeNB test case 6.4.6	11.5.0	11.6.0
2014-12	RAN#66	R5s140787	2335	-	Correction to GCF WI-156 EUTRA RRC testcase 8.1.3.11	11.5.0	11.6.0
2014-12	RAN#66	R5s140790	2336	-	Corrections to EUTRA RRC test case 8.1.2.12	11.5.0	11.6.0
2014-12	RAN#66	R5s140792	2337	-	Corrections to IMS Emergency Call test case 11.2.4	11.5.0	11.6.0
2014-12	RAN#66	R5s140793	2338	-	Correction to GCF WI-086 RRC Test Case 8.3.2.4	11.5.0	11.6.0
2014-12	RAN#66	R5s140794	2339	-	LTE_TDD : Addition of Rel-10 eICIC test case 8.3.1.19	11.5.0	11.6.0
2014-12	RAN#66	R5s140798	2340	-	Correction to GCF WI-154 IMS Emergency call Testcase 8.1.2.11	11.5.0	11.6.0
2014-12	RAN#66	R5s140799	2341	-	Correction to EUTRA Idle Mode HeNB test case 6.4.2	11.5.0	11.6.0
2014-12	RAN#66	R5s140804	2342	-	Addition of GCF WI-159 Pre-registration at 1xRTT testcase 13.4.4.2	11.5.0	11.6.0
2014-12	RAN#66	R5s140806	2343	-	Addition of GCF WI-159 EUTRA<->1xRTT Testcase 8.4.7.5	11.5.0	11.6.0
2014-12	RAN#66	R5s140808	2344	-	Addition of GCF WI-159 EUTRA<->1xRTT Testcase 8.4.7.8	11.5.0	11.6.0
2014-12	RAN#66	R5s140810	2345	-	Addition of GCF WI-159 EUTRA<->1xRTT Testcase 8.4.7.10	11.5.0	11.6.0
2014-12	RAN#66	R5s140812	2346	-	Correction to EMM test case 9.2.1.1.28	11.5.0	11.6.0
2014-12	RAN#66	R5s140814	2347	-	LTE_TDD : Addition of Rel-10 eICIC test case 8.3.1.21	11.5.0	11.6.0
2014-12	RAN#66	R5s140816	2348	-	Addition of GCF WI-178 LTE Advanced eMBMS-SC test case 17.4.4	11.5.0	11.6.0
2014-12	RAN#66	R5s140818	2349	-	LTE_TDD: Addition of LTE-A additional special subframe configuration test case 7.1.3.12	11.5.0	11.6.0
2014-12	RAN#66	R5s140821	2350	-	Addition of GCF WI-178 LTE Advanced eMBMS-SC test case 17.4.3	11.5.0	11.6.0
2014-12	RAN#66	R5s140823	2351	-	Addition of GCF WI-178 LTE Advanced eMBMS-SC test case 17.4.3a	11.5.0	11.6.0
2014-12	RAN#66	R5s140825	2352	-	LTE_TDD : Addition of EUTRA Idle mode test case 6.2.3.23	11.5.0	11.6.0
2014-12	RAN#66	R5s140827	2353	-	LTE_TDD : Addition of Idle mode test case 6.2.3.24	11.5.0	11.6.0
2014-12	RAN#66	R5s140829	2354	-	Correction to EUTRA RRC test case 8.2.4.15a	11.5.0	11.6.0
2014-12	RAN#66	R5s140830	2355	-	LTE_TDD : Addition of EUTRA<->UTRAN Rel-9 HeNB test case 6.4.4	11.5.0	11.6.0
2014-12	RAN#66	R5s140832	2356	-	Correction to GCF WI-086 EMM Test Case 9.2.3.3.4	11.5.0	11.6.0
2014-12	RAN#66	R5s140833	2357	-	Correction to GCF WI-162 EUTRA RRC test case 8.2.4.20.X	11.5.0	11.6.0
2014-12	RAN#66	R5s140834	2358	-	Correction to function f_EUTRA_InitSystemInformation5	11.5.0	11.6.0

Date	TSG #	TSG Doc.	CR	Rev	Subject/Comment	Old	New
2014-12	RAN#66	R5s140835	2359	-	Correction to GCF WI-172 EUTRA<>UTRA aSRVCC Testcases 13.4.3.9, 13.4.3.11, 13.4.3.16 and 13.4.3.14	11.5.0	11.6.0
2014-12	RAN#66	R5s140836	2360	-	Addition of GCF WI-178 LTE Advanced eMBMS-SC test case 17.4.8	11.5.0	11.6.0
2014-12	RAN#66	R5s140838	2361	-	Addition of GCF WI-178 LTE Advanced eMBMS-SC test case 17.4.6	11.5.0	11.6.0
2014-12	RAN#66	R5s140840	2362	-	Addition of GCF WI-178 LTE Advanced eMBMS-SC test case 17.4.2	11.5.0	11.6.0
2014-12	RAN#66	R5s140842	2363	-	Addition of GCF WI-178 LTE Advanced eMBMS-SC test case 17.4.2a	11.5.0	11.6.0
2014-12	RAN#66	R5s140845	2364	-	Correction to GCF WI-086 EUTRA RRC test case 8.3.2.4	11.5.0	11.6.0
2014-12	RAN#66	R5s140846	2365	-	Correction to GCF WI-154 IMS emergency call test case 11.2.10	11.5.0	11.6.0
2014-12	RAN#66	R5s140847	2366	-	Correction to GCF WI-154 IMS Emergency Call over EPS test case 11.2.8	11.5.0	11.6.0
2014-12	RAN#66	R5s140848	2367	-	Correction to GCF WI-081 EUTRA RRC test case 8.1.1.2	11.5.0	11.6.0
2014-12	RAN#66	R5s140849	2368	-	Correction to CA / RRC connection reconfiguration tests 8.4.2.7.X	11.5.0	11.6.0
2014-12	RAN#66	R5s140851	2369	-	LTE_TDD : Addition of EUTRA eMBMS test case 17.2.4	11.5.0	11.6.0
2014-12	RAN#66	R5s140853	2370	-	Correction to GCF WI-086 EUTRA EMM test cases 9.2.1.2.1b and 9.2.1.2.1c	11.5.0	11.6.0
2014-12	RAN#66	R5s140854	2371	-	Correction to GCF WI-154 IMS Emergency Call test case 11.2.5	11.5.0	11.6.0
2014-12	RAN#66	R5s140857	2372	-	Correction to EUTRA RRC handover Test Cases 8.4.1.2, 8.4.1.4, 8.4.1.5	11.5.0	11.6.0
2014-12	RAN#66	R5s140858	2373	-	Correction of f_EUTRA_508Check_TrackingAreaUpdating_AfterHO and f_UTRAN_GMM_RAU functions.	11.5.0	11.6.0
2014-12	RAN#66	R5s140860	2374	-	LTE_TDD: Addition of Rel-11 LTE-A eMBMS-SC test case 17.4.4	11.5.0	11.6.0
2014-12	RAN#66	R5s140862	2375	-	LTE_TDD : Addition of LTE-A eMBMS-SC test case 17.4.6	11.5.0	11.6.0
2014-12	RAN#66	R5s140864	2376	-	LTE_TDD: Addition of GCF WI-178 LTE Advanced eMBMS-SC test case 17.4.5	11.5.0	11.6.0
2014-12	RAN#66	R5s140866	2377	-	LTE_TDD : Addition of LTE-A eMBMS-SC test case 17.4.8	11.5.0	11.6.0
2014-12	RAN#66	R5s140868	2378	-	LTE_TDD: Addition of GCF WI-178 LTE Advanced eMBMS-SC test case 17.4.3	11.5.0	11.6.0
2014-12	RAN#66	R5s140870	2379	-	LTE_TDD: Addition of GCF WI-178 LTE Advanced eMBMS-SC test case 17.4.3a	11.5.0	11.6.0
2014-12	RAN#66	R5s140873	2380	-	Correction to GCF WI-154 IMS Emergency Call test case 11.2.1 and 11.2.2	11.5.0	11.6.0
2014-12	RAN#66	R5s140874	2381	-	Correction to GCF WI-154 IMS Emergency Call test case 8.1.2.12	11.5.0	11.6.0
2014-12	RAN#66	R5s140875	2382	-	Correction to GCF WI-082 EUTRA RRC handover test cases 8.4.1.2, 8.4.1.4, 8.4.1.5	11.5.0	11.6.0
2014-12	RAN#66	R5s140876	2383	-	Correction to common function f_GERAN_508CheckCampOnNewGeranCell()	11.5.0	11.6.0
2014-12	RAN#66	R5s140892	2384	-	Corrections to GCF WI-086 EMM Test cases 9.2.3.3.2 and 9.2.3.3.3	11.5.0	11.6.0
2014-12	RAN#66	R5s140893	2385	-	Correction to GCF WI-162 EUTRA MAC CA Test cases 7.1.9.1.x	11.5.0	11.6.0
2014-12	RAN#66	R5s140894	2386	-	Correction to common function f_AuthenticationInit()	11.5.0	11.6.0
2014-12	RAN#66	R5s140898	2387	-	Correction for GCF WI-087 multilayer SRVCC test case 13.4.3.3	11.5.0	11.6.0
2014-12	RAN#66	R5s140899	2388	-	Correction for GCF WI-087 multilayer SRVCC test case 13.4.3.5	11.5.0	11.6.0
2014-12	RAN#66	R5s140900	2389	-	Correction for template cr_AUTHENTICATION_FAIL_Any	11.5.0	11.6.0
2014-12	RAN#66	R5s140901	2390	-	Correction to GCF WI-086 EUTRA<>UTRA SRVCC testcases 13.4.3.4 and 13.4.3.5	11.5.0	11.6.0
2014-12	RAN#66	R5s140902	2391	-	Correction to GCF WI-172 EUTRA<>UTRA aSRVCC testcases 13.4.3.9 and 13.4.3.11	11.5.0	11.6.0
2014-12	RAN#66	R5s140903	2392	-	Correction to EUTRA bSRVCC testcases 13.4.3.20 and 13.4.3.23	11.5.0	11.6.0
2014-12	RAN#66	R5s140904	2393	-	Correction to GCF WI-172 EUTRA<>GERAN aSRVCC testcases 13.4.3.26 and 13.4.3.28	11.5.0	11.6.0
2014-12	RAN#66	R5s140906	2394	-	Correction to GCF WI-159 Pre-registration at 1xRTT testcase 13.4.4.1	11.5.0	11.6.0

Date	TSG #	TSG Doc.	CR	Rev	Subject/Comment	Old	New
2014-12	RAN#66	R5s140907	2395	-	Addition of LTE test case 9.1.2.7	11.5.0	11.6.0
2014-12	RAN#66	R5s140910	2396	-	Correction to template cr_MeasResultNeighCells_measResultListUTRA_2Entries_FDD	11.5.0	11.6.0
2014-12	RAN#66	R5s140913	2397	-	Correction to GCF WI-082 EMM test case 9.1.5.1	11.5.0	11.6.0
2014-12	RAN#66	R5s140915	2398	-	Correction to eMBMS Rel-9 test case 17.1.3	11.5.0	11.6.0
2014-12	RAN#66	R5s140917	2399	-	Correction to GCF WI-172 EUTRA<>GERAN aSRVCC testcases 13.4.3.26	11.5.0	11.6.0
2014-12	RAN#66	R5s140918	2400	-	Correction to GCF WI-172 EUTRA<>GERAN aSRVCC testcases 13.4.3.28	11.5.0	11.6.0
2014-12	RAN#66	R5s140921	2401	-	Correction to WI-086 EUTRA Multi-layer test case 13.1.3	11.5.0	11.6.0
2014-12	RAN#66	R5s140922	2402	-	LTE_TDD: Addition of GCF WI-162 LTE-A Interband CA test case 8.2.2.4.2	11.5.0	11.6.0
2014-12	RAN#66	R5s140924	2403	-	LTE_TDD: Addition of GCF WI-162 LTE-A Interband CA test case 8.2.2.5.2	11.5.0	11.6.0
2014-12	RAN#66	R5s140926	2404	-	LTE_TDD: Addition of GCF WI-162 LTE-A Interband CA test case 8.2.4.18.2	11.5.0	11.6.0
2014-12	RAN#66	R5s140928	2405	-	LTE_TDD: Addition of GCF WI-162 LTE-A Interband CA test case 8.2.4.21.2	11.5.0	11.6.0
2014-12	RAN#66	R5s140930	2406	-	LTE_TDD: Addition of GCF WI-162 LTE-A Interband CA test case 8.3.1.22.2	11.5.0	11.6.0
2014-12	RAN#66	R5s140932	2407	-	LTE_TDD: Addition of GCF WI-162 LTE-A Interband CA test case 8.5.1.7.2	11.5.0	11.6.0
2014-12	RAN#66	R5s140936	2408	-	Correction to the function f_GERAN_LLC_XIDReset()	11.5.0	11.6.0
2014-12	RAN#66	R5s140937	2409	-	LTE_TDD: Addition of GCF WI-162 LTE-A Interband CA test case 8.2.2.3.2	11.5.0	11.6.0
2014-12	RAN#66	R5s140939	2410	-	LTE_TDD: Addition of GCF WI-162 LTE-A Interband CA test case 8.2.4.17.2	11.5.0	11.6.0
2014-12	RAN#66	R5s140941	2411	-	LTE_TDD: Addition of GCF WI-162 LTE-A Interband CA test case 8.2.4.19.2	11.5.0	11.6.0
2014-12	RAN#66	R5s140943	2412	-	LTE_TDD: Addition of GCF WI-162 LTE-A Interband CA test case 8.2.4.20.2	11.5.0	11.6.0
2014-12	RAN#66	R5s140945	2413	-	LTE_TDD: Addition of GCF WI-162 LTE-A Interband CA test case 8.3.1.17.2	11.5.0	11.6.0
2014-12	RAN#66	R5s140947	2414	-	LTE_TDD: Addition of GCF WI-162 LTE-A Interband CA test case 8.3.1.18.2	11.5.0	11.6.0
2014-12	RAN#66	R5s140949	2415	-	Corrections for GCF WI-154 IMS Emergency Call test case 11.2.11	11.5.0	11.6.0
2014-12	RAN#66	R5s140950	2416	-	Correction to aSRVCC test cases 13.4.3.x	11.5.0	11.6.0
2014-12	RAN#66	R5s140951	2417	-	Corrections for GCF WI-154 IMS Emergency Call test case 11.2.8	11.5.0	11.6.0
2014-12	RAN#66	R5s140952	2418	-	LTE_TDD : Addition of bSRVCC EUTRA<>GERAN testcase 13.4.3.22	11.5.0	11.6.0
2014-12	RAN#66	R5s140954	2419	-	LTE_TDD : Addition of aSRVCC EUTRA<>GERAN testcase 13.4.3.24	11.5.0	11.6.0
2014-12	RAN#66	R5s140956	2420	-	LTE_TDD : Addition of aSRVCC EUTRA<>GERAN testcase 13.4.3.27	11.5.0	11.6.0
2014-12	RAN#66	R5s140961	2421	-	Corrections for GCF WI-154 IMS Emergency Call test case 11.2.10	11.5.0	11.6.0
2014-12	RAN#66	R5s140962	2422	-	Correction for multilayer bSRVCC test cases	11.5.0	11.6.0
2014-12	RAN#66	R5s140964	2423	-	Correction in common function f_GERAN_GPRSAttach()	11.5.0	11.6.0
2014-12	RAN#66	R5s140965	2424	-	Correction for GCF WI-154 IMS Emergency Call test case 11.2.5	11.5.0	11.6.0
2014-12	RAN#66	R5s140978	2425	-	LTE_TDD: Addition of GCF WI-162 LTE-A Interband CA Inter-RAT test case 8.4.2.7.2	11.5.0	11.6.0
2014-12	RAN#66	R5s140985	2426	-	LTE_TDD : Addition of EUTRA<>GERAN aSRVCC testcase 13.4.3.25 in TDD	11.5.0	11.6.0
2014-12	RAN#66	R5s140987	2427	-	LTE_TDD: Addition of GCF WI-172 LTE-GERAN aSRVCC test case 13.4.3.30	11.5.0	11.6.0
2014-12	RAN#66	R5s140995	2428	-	Addition of EMM test case 9.2.1.1.30	11.5.0	11.6.0
2014-12	RAN#66	R5s140998	2429	-	LTE_TDD : Addition of Rel-10 MDT test case 8.6.1.1	11.5.0	11.6.0
2014-12	RAN#66	R5s141000	2430	-	LTE_TDD : Addition of Rel-10 MDT test case 8.6.2.9	11.5.0	11.6.0

Date	TSG #	TSG Doc.	CR	Rev	Subject/Comment	Old	New
2014-12	RAN#66	R5s141002	2431	-	LTE_TDD : Addition of Rel-10 MDT test case 8.6.4.7	11.5.0	11.6.0
2014-12	RAN#66	R5s141004	2432	-	LTE_TDD : Addition of Rel-10 MDT test case 8.6.6.4	11.5.0	11.6.0
2014-12	RAN#66	R5s141006	2433	-	Corrections for GCF WI-086 EUTRA<->GERAN SRVCC test cases 13.4.3.5	11.5.0	11.6.0
2014-12	RAN#66	R5s141007	2434	-	Corrections to multilayer SRVCC test case 13.4.3.22	11.5.0	11.6.0
2014-12	RAN#66	R5s141008	2435	-	Correction to EUTRA<->GERAN bSRVCC test cases 13.4.3.23	11.5.0	11.6.0
2014-12	RAN#66	R5s141009	2436	-	Correction to GCF WI-172 EUTRA<->GERAN aSRVCC test cases 13.4.3.26	11.5.0	11.6.0
2014-12	RAN#66	R5s141010	2437	-	Correction to GCF WI-172 EUTRA<->GERAN aSRVCC test cases 13.4.3.28	11.5.0	11.6.0
2014-12	RAN#66	R5s141014	2438	-	Addition of LTE-A Rel-11 felCIC test case 8.2.2.8	11.5.0	11.6.0
2014-12	RAN#66	R5s141016	2439	-	Correction to GCF WI-081 EUTRA RRC Testcase 8.5.4.1	11.5.0	11.6.0
2014-12	RAN#66	R5s141018	2440	-	Addition of GCF WI-178 LTE-A eMBMS-SC test case 17.4.7	11.5.0	11.6.0
2014-12	RAN#66	R5s141021	2441	-	Correction to GCF WI-154 IMS Emergency Call test case 11.2.11	11.5.0	11.6.0
2014-12	RAN#66	R5s141022	2442	-	Correction to EUTRA bSRVCC testcase 13.4.3.23	11.5.0	11.6.0
2014-12	RAN#66	R5s141023	2443	-	Correction to GCF WI-172 EUTRA<->GERAN aSRVCC testcase 13.4.3.26 and 13.4.3.28	11.5.0	11.6.0
2014-12	RAN#66	R5s141024	2444	-	LTE_TDD: Addition of GCF WI-87 LTE-GERAN SRVCC test case 13.4.3.3	11.5.0	11.6.0
2014-12	RAN#66	R5s141026	2445	-	LTE_TDD: Addition of GCF WI-87 LTE-GERAN SRVCC test case 13.4.3.5	11.5.0	11.6.0
2014-12	RAN#66	R5s141028	2446	-	LTE_TDD: Addition of GCF WI-167 LTE-UTRAN SRVCC test case 13.4.3.6	11.5.0	11.6.0
2014-12	RAN#66	R5s141030	2447	-	LTE_TDD: Addition of GCF WI-172 LTE-UTRAN aSRVCC test case 13.4.3.9	11.5.0	11.6.0
2014-12	RAN#66	R5s141032	2448	-	LTE_TDD: Addition of GCF WI-172 LTE-UTRAN aSRVCC test case 13.4.3.11	11.5.0	11.6.0
2014-12	RAN#66	R5s141034	2449	-	LTE_TDD: Addition of GCF WI-172 LTE-UTRAN aSRVCC test case 13.4.3.13	11.5.0	11.6.0
2014-12	RAN#66	R5s141036	2450	-	LTE_TDD: Addition of GCF WI-172 LTE-UTRAN aSRVCC test case 13.4.3.15	11.5.0	11.6.0
2014-12	RAN#66	R5s141038	2451	-	LTE_TDD: Addition of LTE-UTRAN bSRVCC test case 13.4.3.19	11.5.0	11.6.0
2014-12	RAN#66	R5s141040	2452	-	LTE_TDD: Addition of LTE-UTRAN bSRVCC test case 13.4.3.20	11.5.0	11.6.0
2014-12	RAN#66	R5s141043	2453	-	LTE_TDD : Addition of Rel-11 LTE-A eMBMS-SC test case 17.4.7	11.5.0	11.6.0
2014-12	RAN#66	R5s141045	2454	-	Correction to eMBMS test cases 17.1.3	11.5.0	11.6.0
2014-12	RAN#66	R5s141046	2455	-	LTE_TDD : Addition of LTE Advanced Rel-11 eMBMS-SC test case 17.4.2	11.5.0	11.6.0
2014-12	RAN#66	R5s141048	2456	-	LTE_TDD : Addition of LTE Advanced Rel-11 eMBMS-SC test case 17.4.2a	11.5.0	11.6.0
2014-12	RAN#66	R5s141057	2457	-	LTE_TDD : Addition of EUTRA<->GERAN bSRVCC testcase 13.4.3.23	11.5.0	11.6.0
2014-12	RAN#66	R5s141060	2458	-	LTE_TDD: Addition of LTE-GERAN bSRVCC test case 13.4.3.21	11.5.0	11.6.0
2014-12	RAN#66	R5s141099	2459	-	LTE TDD/UTRA FDD:Addition of EUTRA<->UTRA aSRVCC testcase 13.4.3.7	11.5.0	11.6.0
2014-12	RAN#66	R5s141101	2460	-	LTE TDD/UTRA FDD:Addition of EUTRA<->UTRA aSRVCC testcase 13.4.3.8	11.5.0	11.6.0
2014-12	RAN#66	R5s141103	2461	-	LTE TDD/UTRA FDD:Addition of EUTRA<->UTRA aSRVCC testcase 13.4.3.10	11.5.0	11.6.0
2014-12	RAN#66	R5s141105	2462	-	LTE TDD/UTRA FDD:Addition of EUTRA<->UTRA aSRVCC testcase 13.4.3.14	11.5.0	11.6.0
2014-12	RAN#66	R5s141107	2463	-	LTE TDD/UTRA FDD:Addition of EUTRA<->UTRA aSRVCC testcase 13.4.3.16	11.5.0	11.6.0
2014-12	RAN#66	R5s141109	2464	-	LTE_TDD: Addition of GCF WI-178 LTE Advanced eMBMS-SC test case 17.4.1	11.5.0	11.6.0
2014-12	RAN#66	R5s141111	2465	-	LTE_TDD : Addition of LTE-A eMBMS-SC test case 17.4.1a	11.5.0	11.6.0
2014-12	RAN#66	R5s141132	2466	-	Correction of GCF WI-162 LTE-A Carrier Aggregation test case 8.4.2.7.1 and 8.4.2.7.2 in Band29	11.5.0	11.6.0

Date	TSG #	TSG Doc.	CR	Rev	Subject/Comment	Old	New
2014-12	RAN#66	R5s141137	2467	-	Correction to GCF WI-087 EUTRA EMM testcase 9.2.3.3.5	11.5.0	11.6.0
2014-12	RAN#66	R5s141145	2468	-	Corrections for 2nd PDN handling in 36.523-3 test model	11.5.0	11.6.0
2014-12	RAN#66	R5s141146	2469	-	Corrections to GCF WI-172 EUTRA aSRVCC<->GERAN test case 13.4.3.30	11.5.0	11.6.0
2014-12	RAN#66	R5s141149	2470	-	Correction to the Multiple PDN handling during initial registration	11.5.0	11.6.0
2014-12	RAN#66	R5s141157	2471	-	Correction of GCF WI-086 EUTRA<->UTRA SRVCC test case 13.4.3.2	11.5.0	11.6.0
2014-12	RAN#66	R5s141158	2472	-	Correction to GERAN postamble function f_GERAN_SwitchPowerOff()	11.5.0	11.6.0
2014-12	RAN#66	R5s141160	2473	-	Correction to Rel-11 eMBMS-SC test cases 17.4.1 + 17.4.1a	11.5.0	11.6.0
2014-12	RAN#66	R5s141161	2474	-	Correction to GCF WI-179 EUTRA NIMTC test case 10.5.4	11.5.0	11.6.0
2014-12	RAN#66	R5s141164	2475	-	Correction to f_UTRAN_CellInfo_SetPLMNIdentity for Band VI	11.5.0	11.6.0
2014-12	RAN#66	R5s141165	2476	-	LTE_TDD: Addition of Rel-11 LTE-A feCIC test case 8.2.2.8	11.5.0	11.6.0
2014-12	RAN#66	R5s141167	2477	-	Addition of Rel-11 LTE-A eMDT test case 8.6.8.1	11.5.0	11.6.0
2014-12	RAN#66	R5s141169	2478	-	LTE_TDD : Addition of Rel-11 LTE-A eMDT test case 8.6.8.1	11.5.0	11.6.0
2014-12	RAN#66	R5s141171	2479	-	Addition of Rel-11 LTE-A eMDT test case 8.6.8.2	11.5.0	11.6.0
2014-12	RAN#66	R5s141173	2480	-	LTE_TDD: Addition of Rel-11 LTE-A eMDT test case 8.6.8.2	11.5.0	11.6.0
2014-12	RAN#66	R5s141175	2481	-	Addition of Rel-11 LTE-A eMDT test case 8.6.8.3	11.5.0	11.6.0
2014-12	RAN#66	R5s141177	2482	-	LTE_TDD: Addition of Rel-11 LTE-A eMDT test case 8.6.8.3	11.5.0	11.6.0
2014-12	RAN#66	R5s141179	2483	-	Addition of Rel-11 LTE-A eMDT test case 8.6.2.3a	11.5.0	11.6.0
2014-12	RAN#66	R5s141182	2484	-	LTE_TDD: Addition of Rel-11 LTE-A eMDT test case 8.6.2.3a	11.5.0	11.6.0
2014-12	RAN#66	R5s141189	2485	-	Addition of Rel-11 LTE-A eMDT test case 8.6.6.7	11.5.0	11.6.0
2014-12	RAN#66	R5s141191	2486	-	LTE_TDD: Addition of Rel-11 LTE-A eMDT test case 8.6.6.7	11.5.0	11.6.0
2014-12	RAN#66	R5s141193	2487	-	Addition of Rel-11 LTE-A eMDT test case 8.6.6.5	11.5.0	11.6.0
2014-12	RAN#66	R5s141195	2488	-	LTE_TDD: Addition of Rel-11 LTE-A eMDT test case 8.6.6.5	11.5.0	11.6.0
2014-12	RAN#66	R5s141203	2489	-	Correction to function fl_CheckTimingInfoOneTTI	11.5.0	11.6.0
2014-12	RAN#66	R5s141204	2490	-	Correction to the template cs_UE_CapabilityEnqAll	11.5.0	11.6.0
2014-12	RAN#66	R5s141205	2491	-	Correction to EUTRA SRVCC Testcases 13.4.3.4 and 13.4.3.5	11.5.0	11.6.0
2014-12	RAN#66	R5s141206	2492	-	Correction to GCF WI-154 IMS Emergency TCs 8.1.2.11	11.5.0	11.6.0
2014-12	RAN#66	R5s141211	2493	-	Correction to GCF WI-082 EMM test case 9.2.1.1.7	11.5.0	11.6.0
2014-12	RAN#66	R5s141213	2494	-	LTE_TDD: Correction to WI-091 testcase 8.2.1.5 and 8.2.1.6	11.5.0	11.6.0
2014-12	RAN#66	R5s141214	2495	-	Addition of GCF WI-179 EUTRA NIMTC Testcase 6.1.1.7a	11.5.0	11.6.0
2014-12	RAN#66	R5s141218	2496	-	Correction to SRVCC and aSRVCC failure test cases	11.5.0	11.6.0
2014-12	RAN#66	R5s141220	2497	-	Correction to f_UTRAN_UE_CapabilityInformation() function	11.5.0	11.6.0
2014-12	RAN#66	R5-145714	2303	-	Band 30: Guidance on test execution	11.6.0	12.0.0
2014-12	RAN#66	RP-142065	2498	-	CR to 36.523-3: Add new verified and e-mail agreed TTCN test cases in the TC lists in 36.523-3 (prose), Annex A	11.6.0	12.0.0
2015-03	RAN#67	R5-150123	2499	-	Routine maintenance for TS 36.523-3	12.0.0	12.1.0
2015-03	RAN#67	R5-150356	2500	-	rSRVCC Test Model	12.0.0	12.1.0
2015-03	RAN#67	RP-150334	2625	-	CR to 36.523-3: Add new verified and e-mail agreed TTCN test cases in the TC lists in 36.523-3 (prose), Annex A	12.0.0	12.1.0
2015-03	RAN#67	R5s140966	2501	-	Correction to GCF WI-177 EUTRA MDT Test cases 8.6.4.5	12.0.0	12.1.0

Date	TSG #	TSG Doc.	CR	Rev	Subject/Comment	Old	New
2015-03	RAN#67	R5s141159	2502	-	Correction to test case 9.1.5.1, function fl_TC_9_1_5_1_Body() in NAS_EMMInformation.ttcn	12.0.0	12.1.0
2015-03	RAN#67	R5s141198	2503	-	Addition of Rel-11 LTE-A eMDT test case 8.6.4.8	12.0.0	12.1.0
2015-03	RAN#67	R5s141200	2504	-	LTE_TDD: Addition of Rel-11 LTE-A eMDT test case 8.6.4.8	12.0.0	12.1.0
2015-03	RAN#67	R5s141219	2505	-	Corrrection to function f_GERAN_CreatePhyCombinedCellControlCh	12.0.0	12.1.0
2015-03	RAN#67	R5s141228	2506	-	Addition of Rel-11 EUTRA RRC eMDT test case 8.6.2.10	12.0.0	12.1.0
2015-03	RAN#67	R5s141230	2507	-	LTE_TDD: Addition of Rel-11 EUTRA RRC eMDT test case 8.6.2.10	12.0.0	12.1.0
2015-03	RAN#67	R5s141233	2508	-	Addition of GCF WI-162 EUTRA RRC Carrier Aggregation test case 8.2.4.16.1	12.0.0	12.1.0
2015-03	RAN#67	R5s141235	2509	-	Addition of GCF WI-162 LTE-A Carrier Aggregation RRC test case 8.2.4.16.2	12.0.0	12.1.0
2015-03	RAN#67	R5s141239	2510	-	LTE_TDD: Addition of GCF WI-191 LTE-A additional special subframe configuration test case 7.1.3.13	12.0.0	12.1.0
2015-03	RAN#67	R5s141241	2511	-	Correction to common function f_GetTestcaseAttrib_DICcchMsgInSeparateMacPdu() for eMDT test cases	12.0.0	12.1.0
2015-03	RAN#67	R5s141245	2512	-	Addition of LTE-A Carrier Aggregation test case 8.2.4.23.2	12.0.0	12.1.0
2015-03	RAN#67	R5s141247	2513	-	Addition of LTE-A (Rel-11) Carrier Aggregation test case 8.2.2.5.3	12.0.0	12.1.0
2015-03	RAN#67	R5s141249	2514	-	Addition of LTE-A (Rel-11) Carrier Aggregation test case 8.2.4.17.3	12.0.0	12.1.0
2015-03	RAN#67	R5s141251	2515	-	Addition of LTE-A (Rel-11) Carrier Aggregation test case 8.2.4.21.3	12.0.0	12.1.0
2015-03	RAN#67	R5s141253	2516	-	Addition of LTE-A (Rel-11) Carrier Aggregation test case 8.3.1.17.3	12.0.0	12.1.0
2015-03	RAN#67	R5s141255	2517	-	Addition of LTE-A (Rel-11) Carrier Aggregation test case 8.3.1.18.3	12.0.0	12.1.0
2015-03	RAN#67	R5s141257	2518	-	Addition of LTE-A (Rel-11) Carrier Aggregation test case 8.3.1.22.3	12.0.0	12.1.0
2015-03	RAN#67	R5s141259	2519	-	Addition of LTE-A (Rel-11) Carrier Aggregation test case 8.5.1.7.3	12.0.0	12.1.0
2015-03	RAN#67	R5s141261	2520	-	Addition of LTE-A (Rel-11) Carrier Aggregation test case 8.2.2.3.3	12.0.0	12.1.0
2015-03	RAN#67	R5s141263	2521	-	Addition of LTE-A (Rel-11) Carrier Aggregation test case 8.2.2.4.3	12.0.0	12.1.0
2015-03	RAN#67	R5s141265	2522	-	Addition of LTE-A (Rel-11) Carrier Aggregation test case 8.2.4.23.3	12.0.0	12.1.0
2015-03	RAN#67	R5s141267	2523	-	LTE_TDD: Addition of GCF WI-156 MFBI Idle Mode test case 6.1.2.21	12.0.0	12.1.0
2015-03	RAN#67	R5s141269	2524	-	LTE_TDD: Addition of LTE-A Enhanced Minimization of Drive Tests (eMDT) Testcase 8.6.11.1	12.0.0	12.1.0
2015-03	RAN#67	R5s141271	2525	-	LTE_TDD: Addition of GCF WI-177 EUTRA RRC test Case 8.6.7.1	12.0.0	12.1.0
2015-03	RAN#67	R5s141275	2526	-	Addition of LTE-A Carrier Aggregation test case 8.2.4.23.1	12.0.0	12.1.0
2015-03	RAN#67	R5s141277	2527	-	LTE_TDD : Correction to GCF WI-086 EUTRA RRC test case 8.1.3.7	12.0.0	12.1.0
2015-03	RAN#67	R5s141278	2528	-	Addition of Rel-11 LTE-A Carrier Aggregation MAC test case 7.1.9.1.3	12.0.0	12.1.0
2015-03	RAN#67	R5s141280	2529	-	Addition of Rel-11 LTE-A Carrier Aggregation RRC test case 8.2.4.16.3	12.0.0	12.1.0
2015-03	RAN#67	R5s141282	2530	-	Addition of Rel-11 LTE-A Carrier Aggregation test case 8.2.4.18.3	12.0.0	12.1.0
2015-03	RAN#67	R5s141284	2531	-	Addition of Rel-11 LTE-A Carrier Aggregation test case 8.2.4.20.3	12.0.0	12.1.0
2015-03	RAN#67	R5s141288	2532	-	Addition of LTE-A (Rel-11) CA Handover from UTRAN test case 8.4.2.7.3	12.0.0	12.1.0
2015-03	RAN#67	R5s141292	2533	-	Addition of Rel-11 LTE-A eMDT test case 8.6.2.12	12.0.0	12.1.0
2015-03	RAN#67	R5s141294	2534	-	LTE_TDD: Addition of Rel-11 LTE-A eMDT test case 8.6.2.12	12.0.0	12.1.0
2015-03	RAN#67	R5s141297	2535	-	Addition of Rel-11 LTE-A eMDT test case 8.6.4.9	12.0.0	12.1.0
2015-03	RAN#67	R5s141299	2536	-	LTE_TDD: Addition of Rel-11 LTE-A eMDT test case 8.6.4.9	12.0.0	12.1.0
2015-03	RAN#67	R5s141301	2537	-	Addition of Rel-11 LTE-A eMDT test case 8.6.6.6	12.0.0	12.1.0

Date	TSG #	TSG Doc.	CR	Rev	Subject/Comment	Old	New
2015-03	RAN#67	R5s141303	2538	-	LTE_TDD: Addition of Rel-11 LTE-A eMDT test case 8.6.6.6	12.0.0	12.1.0
2015-03	RAN#67	R5s141305	2539	-	Addition of Rel-11 LTE-A eMDT test case 8.6.8.5	12.0.0	12.1.0
2015-03	RAN#67	R5s141307	2540	-	Addition of Rel-11 LTE-A eMDT test case 8.6.8.6	12.0.0	12.1.0
2015-03	RAN#67	R5s141309	2541	-	LTE_TDD: Addition of Rel-11 LTE-A eMDT test case 8.6.8.6	12.0.0	12.1.0
2015-03	RAN#67	R5s141311	2542	-	Addition of Rel-11 LTE-A eMDT test case 8.6.2.11	12.0.0	12.1.0
2015-03	RAN#67	R5s141313	2543	-	LTE_TDD: Addition of Rel-11 LTE-A eMDT test case 8.6.2.11	12.0.0	12.1.0
2015-03	RAN#67	R5s141317	2544	-	Correction to GCF WI-081 EUTRA RRC test case 8.5.1.4 and WI-082 EMM test case 9.2.3.1.9a	12.0.0	12.1.0
2015-03	RAN#67	R5s141319	2545	-	Addition of LTE-A Carrier Aggregation test case 8.2.4.23.1	12.0.0	12.1.0
2015-03	RAN#67	R5s141324	2546	-	Correction to function fl_IP_AddrServers_Stop	12.0.0	12.1.0
2015-03	RAN#67	R5s141325	2547	-	Correction to Importing of Parameters in UTRAN_RAB_Functions for LTE, POS and IMS test suites	12.0.0	12.1.0
2015-03	RAN#67	R5s141327	2548	-	Correction to GCF WI-082 EUTRA ESM Test cases 10.4.1	12.0.0	12.1.0
2015-03	RAN#67	R5s141331	2549	-	LTE_TDD : Correction to EUTRA MAC TDD-SSC test cases 7.1.3.12, 7.1.3.12a, 7.1.3.13, 7.1.3.13a	12.0.0	12.1.0
2015-03	RAN#67	R5s141332	2550	-	Correction to common function f_GERAN_SwitchPowerOff()	12.0.0	12.1.0
2015-03	RAN#67	R5s141334	2551	-	Correction to WI-086 EUTRA Multi-layer test cases 13.1.2, 13.1.2a, 13.1.3, 13.1.15	12.0.0	12.1.0
2015-03	RAN#67	R5s141338	2552	-	Correction of LTE-A Carrier Aggregation test cases 8.3.1.18.x	12.0.0	12.1.0
2015-03	RAN#67	R5s141339	2553	-	Addition of GCF WI-154 IMS Emergency Call test case 11.2.3	12.0.0	12.1.0
2015-03	RAN#67	R5s141345	2554	-	Correction of GCF WI-154 IMS Emergency Call over EPS test case 11.2.1	12.0.0	12.1.0
2015-03	RAN#67	R5s141349	2555	-	Correction to f_EUTRA_CA_InitFrequenciesInterBand() function for CA_3A-7A_Rev band combination	12.0.0	12.1.0
2015-03	RAN#67	R5s141352	2556	-	Correction of GCF WI-178 LTE-A eMBMS-SC test case 17.4.3	12.0.0	12.1.0
2015-03	RAN#67	R5s141354	2557	-	Correction of GCF WI-178 LTE-A eMBMS-SC test case 17.4.7	12.0.0	12.1.0
2015-03	RAN#67	R5s141358	2558	-	Correction of GCF WI-178 LTE-A eMBMS-SC test case 17.4.1	12.0.0	12.1.0
2015-03	RAN#67	R5s141361	2559	-	Correction to EUTRA multilayer aSRVCC test case 13.4.3.28	12.0.0	12.1.0
2015-03	RAN#67	R5s141362	2560	-	Correction to EUTRA bSRVCC testcases 13.4.3.19	12.0.0	12.1.0
2015-03	RAN#67	R5s141363	2561	-	Correction to function f_SS_HS_DSCH_PDSCH_Cfg_DPCH_Modify_TDD	12.0.0	12.1.0
2015-03	RAN#67	R5s141364	2562	-	Correction of GCF WI-178 LTE-A eMBMS-SC test case 17.4.2	12.0.0	12.1.0
2015-03	RAN#67	R5s141365	2563	-	LTE_TDD : Correction to Multilayer test case 13.4.2.4	12.0.0	12.1.0
2015-03	RAN#67	R5s141366	2564	-	Correction of GCF WI-150 MFBI Testcase 6.1.2.20	12.0.0	12.1.0
2015-03	RAN#67	R5s141367	2565	-	Correction of QCI value in EPS bearer context no.2	12.0.0	12.1.0
2015-03	RAN#67	R5s141368	2566	-	Addition of Rel-8 EUTRA Idle Mode LTE<->GERAN test case 6.2.3.29	12.0.0	12.1.0
2015-03	RAN#67	R5s141371	2567	-	Correction to LTE-A CA test cases 8.2.4.16.x, 8.2.4.18.3 and 8.2.4.20.3	12.0.0	12.1.0
2015-03	RAN#67	R5s141372	2568	-	Correction to EUTRA<->UTRA bSRVCC testcase 13.4.3.20	12.0.0	12.1.0
2015-03	RAN#67	R5s141373	2569	-	Correction to LTE-A CA test case 7.1.9.1.3	12.0.0	12.1.0
2015-03	RAN#67	R5s141374	2570	-	Correction to GCF WI-164 eMBMS test case 17.1.3	12.0.0	12.1.0
2015-03	RAN#67	R5s141375	2571	-	Addition of GCF WI-103 ESM test case 10.4.2	12.0.0	12.1.0
2015-03	RAN#67	R5s141384	2572	-	Correction to LTE-GERAN aSRVCC test cases 13.4.3.26 & 13.4.3.28	12.0.0	12.1.0
2015-03	RAN#67	R5s141385	2573	-	LTE_TDD : Addition of GCF WI-172 LTE-GERAN aSRVCC test case 13.4.3.26	12.0.0	12.1.0
2015-03	RAN#67	R5s141387	2574	-	LTE_TDD : Addition of GCF WI-172 LTE-GERAN aSRVCC test case 13.4.3.28	12.0.0	12.1.0

Date	TSG #	TSG Doc.	CR	Rev	Subject/Comment	Old	New
2015-03	RAN#67	R5s141389	2575	-	Corrections to coordinate XID and IPv6 procedures	12.0.0	12.1.0
2015-03	RAN#67	R5s141393	2576	-	Correction to multilayer bSRVCC test case 13.4.3.21	12.0.0	12.1.0
2015-03	RAN#67	R5s141394	2577	-	Correction to EUTRA RRC Inter-mode test case 8.2.4.15a	12.0.0	12.1.0
2015-03	RAN#67	R5s141395	2578	-	Addition of Rel-11 LTE-A CA MAC test case 7.1.3.11.3	12.0.0	12.1.0
2015-03	RAN#67	R5s141397	2579	-	LTE_TDD: Addition of Rel-11 LTE-A eMDT test case 8.6.8.5	12.0.0	12.1.0
2015-03	RAN#67	R5s141399	2580	-	Corrections to IMS emergency call test case 11.2.5	12.0.0	12.1.0
2015-03	RAN#67	R5s141400	2581	-	Correction to GCF WI-082 SMS over SGs test cases 11.1.3, 11.1.4, 11.1.5, 11.1.6	12.0.0	12.1.0
2015-03	RAN#67	R5s150001	2582	-	Updates to multi-PDNs implementation for CDMA2000-related procedures	12.0.0	12.1.0
2015-03	RAN#67	R5s150003	2583	-	Addition of Rel-8 EUTRA Idle Mode LTE<->GERAN test case 6.2.3.26	12.0.0	12.1.0
2015-03	RAN#67	R5s150005	2584	-	Addition of EMM test case 9.2.1.1.29	12.0.0	12.1.0
2015-03	RAN#67	R5s150007	2585	-	LTE_TDD: Addition of LTE-A Carrier Aggregation MAC test case 7.1.9.1.2	12.0.0	12.1.0
2015-03	RAN#67	R5s150009	2586	-	Correction to GCF WI-086 EMM test case 9.2.3.3.1	12.0.0	12.1.0
2015-03	RAN#67	R5s150010	2587	-	Correction to GCF WI-081 Idle mode test cases 6.1.1.4, 6.1.1.6 and 6.1.1.6a.	12.0.0	12.1.0
2015-03	RAN#67	R5s150019	2588	-	Correction to LTE-GERAN test case 6.2.3.1a	12.0.0	12.1.0
2015-03	RAN#67	R5s150026	2589	-	Correction of GCF WI-178 LTE-A eMBMS-SC test case 17.4.1, 17.4.1a, 17.4.3, 17.4.3a 17.4.4	12.0.0	12.1.0
2015-03	RAN#67	R5s150031	2590	-	Corrections for LTE test case execution with IMS-enabled device	12.0.0	12.1.0
2015-03	RAN#67	R5s150034	2591	-	Correction to EUTRA test cases 8.2.4.14a and 8.2.4.15	12.0.0	12.1.0
2015-03	RAN#67	R5s150036	2592	-	Corrections for eMDT test case 8.6.2.3a and 8.6.2.10	12.0.0	12.1.0
2015-03	RAN#67	R5s150037	2593	-	Correction to LTE-A Carrier Aggregation Enhancement test cases	12.0.0	12.1.0
2015-03	RAN#67	R5s150038	2594	-	Implementation of Prose CR R5-145793	12.0.0	12.1.0
2015-03	RAN#67	R5s150053	2595	-	Corrections to IMS emergency call test case 11.2.3	12.0.0	12.1.0
2015-03	RAN#67	R5s150057	2596	-	Corrections to EUTRA Testcases with IMS enabled UE	12.0.0	12.1.0
2015-03	RAN#67	R5s150062	2597	-	Addition of EUTRA DRX Testcase 7.1.6.3	12.0.0	12.1.0
2015-03	RAN#67	R5s150066	2598	-	LTE_TDD:Addition of EUTRA DRX Testcase 7.1.6.3	12.0.0	12.1.0
2015-03	RAN#67	R5s150070	2599	-	Correction to GCF WI-162 LTE-A CA test cases 7.1.9.1.x	12.0.0	12.1.0
2015-03	RAN#67	R5s150071	2600	-	Correction to GCF WI-087 EUTRA EMM test case 9.2.1.2.1b	12.0.0	12.1.0
2015-03	RAN#67	R5s150074	2601	-	Correction for IP_PTC for IMS-enabled UEs	12.0.0	12.1.0
2015-03	RAN#67	R5s150076	2602	-	Addition of Rel-11 LTE-A eMDT test case 8.6.4.10	12.0.0	12.1.0
2015-03	RAN#67	R5s150078	2603	-	LTE_TDD: Addition of Rel-11 LTE-A eMDT test case 8.6.4.10	12.0.0	12.1.0
2015-03	RAN#67	R5s150081	2604	-	Correction to GCF WI-159 LTE<-> 1xRTT testcase 13.4.4.1	12.0.0	12.1.0
2015-03	RAN#67	R5s150082	2605	-	Multi-PDN related correction to EUTRA RRC test case 8.1.2.8	12.0.0	12.1.0
2015-03	RAN#67	R5s150089	2606	-	Correction of GCF WI-178 LTE Advanced eMBMS-SC test case 17.4.2 & 17.4.2a	12.0.0	12.1.0
2015-03	RAN#67	R5s150090	2607	-	Correction of GCF WI-178 LTE Advanced eMBMS-SC test case 17.4.7	12.0.0	12.1.0
2015-03	RAN#67	R5s150092	2608	-	Addition of RFT-117 EUTRA MFBI Testcase 6.2.3.35	12.0.0	12.1.0
2015-03	RAN#67	R5s150096	2609	-	LTE_TDD: Addition of LTE-A Carrier Aggregation test case 8.2.2.4.3	12.0.0	12.1.0
2015-03	RAN#67	R5s150098	2610	-	LTE_TDD: Addition of LTE-A Carrier Aggregation test case 8.2.2.5.3	12.0.0	12.1.0
2015-03	RAN#67	R5s150100	2611	-	LTE_TDD:Addition of LTE-A Carrier Aggregation test case 8.2.4.18.3	12.0.0	12.1.0

Date	TSG #	TSG Doc.	CR	Rev	Subject/Comment	Old	New
2015-03	RAN#67	R5s150102	2612	-	LTE_TDD: Addition of LTE-A Carrier Aggregation test case 8.3.1.17.3	12.0.0	12.1.0
2015-03	RAN#67	R5s150104	2613	-	LTE_TDD: Addition of LTE-A Carrier Aggregation test case 8.3.1.18.3	12.0.0	12.1.0
2015-03	RAN#67	R5s150106	2614	-	LTE_TDD: Addition of LTE-A Carrier Aggregation test case 8.3.1.22.3	12.0.0	12.1.0
2015-03	RAN#67	R5s150108	2615	-	LTE_TDD: Addition of LTE-A Carrier Aggregation test case 8.5.1.7.3	12.0.0	12.1.0
2015-03	RAN#67	R5s150113	2616	-	LTE_TDD: Addition of LTE-A Carrier Aggregation MAC test case 7.1.9.1.3	12.0.0	12.1.0
2015-03	RAN#67	R5s150118	2617	-	Further correction for LTE TC execution with IMS-enabled devices	12.0.0	12.1.0
2015-03	RAN#67	R5s150119	2618	-	LTE_TDD: Addition of Rel-11 LTE_CA_enh test case 8.4.2.7.3	12.0.0	12.1.0
2015-03	RAN#67	R5s150121	2619	-	Addition of GEA4 and A5/4 ciphering algorithms	12.0.0	12.1.0
2015-03	RAN#67	R5s150122	2620	-	Correction of GCF WI-87 EUTRA<>GERAN Testcase 6.2.3.28	12.0.0	12.1.0
2015-03	RAN#67	R5s150123	2621	-	Correction of GCF WI-87 EUTRA<>GERAN Testcase 6.2.3.29	12.0.0	12.1.0
2015-03	RAN#67	R5s150133	2622	-	LTE_TDD: Addition of GCF WI-172 TD_LTE<>TDSCDMA Testcase 13.4.3.9	12.0.0	12.1.0
2015-03	RAN#67	R5s150135	2623	-	LTE_TDD: Addition of GCF WI-172 TD_LTE<>TDSCDMA Testcase 13.4.3.11	12.0.0	12.1.0
2015-03	RAN#67	R5s150137	2624	-	LTE_TDD: Addition of GCF WI-172 TD_LTE<>TDSCDMA Testcase 13.4.3.13	12.0.0	12.1.0
2015-06	RAN#68	R5-151103	2627	-	Band 32 - Guidance on LTE test execution	12.1.0	12.2.0
2015-06	RAN#68	R5-151150	2628	-	Update execution guidelines for MFBI test case 6.1.2.20	12.1.0	12.2.0
2015-06	RAN#68	R5-151677	2629	-	Update execution guidelines for CA test case 8.2.4.21.2	12.1.0	12.2.0
2015-06	RAN#68	R5-151792	2626	1	Routine maintenance for TS 36.523-3	12.1.0	12.2.0
2015-06	RAN#68	-	2631	-	CR to 36.523-3: Add new verified and e-mail agreed TTCN test cases in the TC lists in 36.523-3 (prose), Annex A	12.1.0	12.2.0
2015-06	RAN#68	R5s150064	2632	-	Addition of EUTRA DRX Testcase 7.1.6.4	12.1.0	12.2.0
2015-06	RAN#68	R5s150068	2633	-	LTE_TDD: Addition of EUTRA DRX Testcase 7.1.6.4	12.1.0	12.2.0
2015-06	RAN#68	R5s150072	2634	-	Addition of PTCRB RFT-119 EUTRA Idle Mode test case 6.1.1.8	12.1.0	12.2.0
2015-06	RAN#68	R5s150075	2635	-	Corrections for eMBMS_SC test case 17.4.7	12.1.0	12.2.0
2015-06	RAN#68	R5s150094	2636	-	Addition of PTCRB RFT-119 EUTRA Idle Mode test case 6.1.1.9	12.1.0	12.2.0
2015-06	RAN#68	R5s150124	2637	-	LTE_TDD: Addition of Rel-11 LTE_CA_enh test case 8.2.4.21.3	12.1.0	12.2.0
2015-06	RAN#68	R5s150124	2637	-	LTE_TDD: Addition of Rel-11 LTE_CA_enh test case 8.2.4.21.3	12.1.0	12.2.0
2015-06	RAN#68	R5s150126	2638	-	LTE_TDD: Addition of Rel-11 LTE_CA_enh test case 8.2.4.23.3	12.1.0	12.2.0
2015-06	RAN#68	R5s150126	2638	-	LTE_TDD: Addition of Rel-11 LTE_CA_enh test case 8.2.4.23.3	12.1.0	12.2.0
2015-06	RAN#68	R5s150128	2639	-	LTE_TDD: Addition of LTE-A Carrier Aggregation test case 8.2.2.3.3	12.1.0	12.2.0
2015-06	RAN#68	R5s150128	2639	-	LTE_TDD: Addition of LTE-A Carrier Aggregation test case 8.2.2.3.3	12.1.0	12.2.0
2015-06	RAN#68	R5s150130	2640	-	LTE_TDD: Addition of EUTRA PLMN Selection Testcase 6.1.1.8	12.1.0	12.2.0
2015-06	RAN#68	R5s150130	2640	-	LTE_TDD: Addition of EUTRA PLMN Selection Testcase 6.1.1.8	12.1.0	12.2.0
2015-06	RAN#68	R5s150139	2641	-	Correction of Rel-8 EUTRA Idle Mode LTE<>GERAN test cases 6.2.3.26, 6.2.3.28 and 6.2.3.29	12.1.0	12.2.0
2015-06	RAN#68	R5s150140	2642	-	LTE_TDD : Addition of GCF WI-097 LTE-GERAN test case 6.2.3.26	12.1.0	12.2.0
2015-06	RAN#68	R5s150142	2643	-	Correction to IMS Emergency Call test cases 11.2.2, 11.2.3 and 8.1.2.12	12.1.0	12.2.0
2015-06	RAN#68	R5s150143	2644	-	LTE_TDD : Addition of GCF WI-097 LTE-GERAN test case 6.2.3.28	12.1.0	12.2.0
2015-06	RAN#68	R5s150145	2645	-	LTE_TDD : Addition of GCF WI-097 LTE-GERAN test case 6.2.3.29	12.1.0	12.2.0
2015-06	RAN#68	R5s150149	2646	-	LTE_TDD: Addition of EUTRA RRC Connection Establishment of	12.1.0	12.2.0

Date	TSG #	TSG Doc.	CR	Rev	Subject/Comment	Old	New
					Emergency Call test case 8.1.2.11		
2015-06	RAN#68	R5s150151	2647	-	LTE_TDD: Addition of EUTRA RRC Connection Establishment of Emergency Call test case 8.1.2.12	12.1.0	12.2.0
2015-06	RAN#68	R5s150159	2648	-	Correction to WI 082 EUTRA Testcase 9.1.2.4 and 9.1.2.5 with IMS enabled	12.1.0	12.2.0
2015-06	RAN#68	R5s150162	2649	-	Correction for GCF WI-086 EMM test cases 9.2.3.3.1 and 9.2.3.3.4	12.1.0	12.2.0
2015-06	RAN#68	R5s150164	2650	-	Correction of function f_UT_GetEmergencyNumbers	12.1.0	12.2.0
2015-06	RAN#68	R5s150166	2651	-	Correction to EUTRA EMM Testcases with IMS enabled	12.1.0	12.2.0
2015-06	RAN#68	R5s150169	2652	-	Correction to GCF WI-086 EUTRA EPC Testcase 9.2.1.2.1c with Ipv6	12.1.0	12.2.0
2015-06	RAN#68	R5s150170	2653	-	Correction of GCF WI-086 EUTRA EMM Testcase 9.2.1.2.1b with Ipv6	12.1.0	12.2.0
2015-06	RAN#68	R5s150171	2654	-	Correction of LTE-A EUTRA eMDT Testcases 8.6.4.10	12.1.0	12.2.0
2015-06	RAN#68	R5s150172	2655	-	Correction of GCF WI-103 EUTRA EMM test case 10.4.2	12.1.0	12.2.0
2015-06	RAN#68	R5s150173	2656	-	Addition of Rel-11 LTE_CA_enh test case 8.2.4.19.3	12.1.0	12.2.0
2015-06	RAN#68	R5s150176	2657	-	Correction for GCF WI-082 EMM test case 9.3.1.6	12.1.0	12.2.0
2015-06	RAN#68	R5s150177	2658	-	Addition of GCF WI-154 IMS Emergency Call test case 11.2.6	12.1.0	12.2.0
2015-06	RAN#68	R5s150182	2659	-	LTE_TDD: Addition of EUTRA Idle Mode RPLMN Selection Testcase 6.1.1.9	12.1.0	12.2.0
2015-06	RAN#68	R5s150185	2660	-	Corrections to GCF WI-164 eMBMS test case 17.2.4	12.1.0	12.2.0
2015-06	RAN#68	R5s150186	2661	-	Correction to GCF WI-091 EUTRA MAC Testcase 7.1.3.2	12.1.0	12.2.0
2015-06	RAN#68	R5s150187	2662	-	Correction to GCF WI-092 EUTRA MAC Testcase 7.1.4.2	12.1.0	12.2.0
2015-06	RAN#68	R5s150188	2663	-	Correction of LTE-A Carrier Aggregation test cases 8.2.4.23.x	12.1.0	12.2.0
2015-06	RAN#68	R5s150189	2664	-	Correction to GCF WI-082 EUTRA EMM test case 9.2.3.1.9a	12.1.0	12.2.0
2015-06	RAN#68	R5s150190	2665	-	Correction to GCF WI-082 EUTRA EMM test case 9.2.2.1.1	12.1.0	12.2.0
2015-06	RAN#68	R5s150191	2666	-	Correction to RFT-119 EUTRA Idle Mode test case 6.1.1.8	12.1.0	12.2.0
2015-06	RAN#68	R5s150192	2667	-	Correction to EUTRA Idle Mode test case 6.1.1.9	12.1.0	12.2.0
2015-06	RAN#68	R5s150194	2668	-	Correction to GCF WI-081 EUTRA RRC Testcase 8.5.4.1	12.1.0	12.2.0
2015-06	RAN#68	R5s150198	2669	-	Addition of Rel-11 LTE-A eMDT test case 8.6.9.2	12.1.0	12.2.0
2015-06	RAN#68	R5s150200	2670	-	LTE_TDD: Addition of Rel-11 LTE-A eMDT test case 8.6.9.2	12.1.0	12.2.0
2015-06	RAN#68	R5s150204	2671	-	Correction for multilayer GCF WI-087 SRVCC test cases 13.4.3.4, 13.4.3.5 and 13.4.3.6	12.1.0	12.2.0
2015-06	RAN#68	R5s150206	2672	-	Correction of GCF WI-87 EUTRA<>GERAN Testcase 6.2.3.24	12.1.0	12.2.0
2015-06	RAN#68	R5s150207	2673	-	Correction of GCF WI-87 EUTRA<>GERAN Testcase 6.2.3.29	12.1.0	12.2.0
2015-06	RAN#68	R5s150209	2674	-	Correction for GCF WI-086 EMM test case 9.2.1.2.9	12.1.0	12.2.0
2015-06	RAN#68	R5s150210	2675	-	Correction for GCF WI-086 Multi-layer test case 13.1.3	12.1.0	12.2.0
2015-06	RAN#68	R5s150211	2676	-	Correction for GCF WI-086 EMM test case 9.2.3.2.11	12.1.0	12.2.0
2015-06	RAN#68	R5s150212	2677	-	Correction for GCF WI-082 EMM test case 9.2.3.1.15	12.1.0	12.2.0
2015-06	RAN#68	R5s150214	2678	-	Correction for multilayer Rel-12 bSRVCC test case 13.4.3.20	12.1.0	12.2.0
2015-06	RAN#68	R5s150215	2679	-	Correction of LTE-A Carrier Aggregation test case 8.2.4.18.3	12.1.0	12.2.0
2015-06	RAN#68	R5s150216	2680	-	Correction to EUTRA EMM Testcases with IMS enabled	12.1.0	12.2.0
2015-06	RAN#68	R5s150217	2681	-	Correction to GCF WI-081 EUTRA UE Capability Audit Testcase 8.5.4.1	12.1.0	12.2.0
2015-06	RAN#68	R5s150219	2682	-	Correction in selection expression for test case 8.3.4.1, 8.3.4.2 and 8.3.4.3	12.1.0	12.2.0

Date	TSG #	TSG Doc.	CR	Rev	Subject/Comment	Old	New
2015-06	RAN#68	R5s150220	2683	-	Correction to IMS Emergency Call test case 11.2.8	12.1.0	12.2.0
2015-06	RAN#68	R5s150221	2684	-	Correction for GCF WI-087 LTE IRAT PLMN selection test case 6.2.1.4	12.1.0	12.2.0
2015-06	RAN#68	R5s150223	2685	-	Addition of LTE-GERAN SRVCC test case 13.4.3.41	12.1.0	12.2.0
2015-06	RAN#68	R5s150225	2686	-	LTE-TDD : Addition of LTE-GERAN SRVCC test case 13.4.3.41	12.1.0	12.2.0
2015-06	RAN#68	R5s150227	2687	-	Correction to function f_ESM_EvaluateAPN	12.1.0	12.2.0
2015-06	RAN#68	R5s150229	2688	-	Correction of f_EUTRA_508RRC_AddModRel_Scell_Common	12.1.0	12.2.0
2015-06	RAN#68	R5s150230	2689	-	Correction to GCF WI-178 LTE-A eMBMS-SC test case 17.4.3a	12.1.0	12.2.0
2015-06	RAN#68	R5s150231	2690	-	Correction to EUTRA EMM Testcases 9.2.1.1.25, 9.2.1.2.2 with IMS enabled	12.1.0	12.2.0
2015-06	RAN#68	R5s150232	2691	-	Correction to MDT test case 8.6.6.4	12.1.0	12.2.0
2015-06	RAN#68	R5s150233	2692	-	Correction to the test execution guidelines for Rel-10 LTE-A CA test case 8.2.4.19.2	12.1.0	12.2.0
2015-06	RAN#68	R5s150234	2693	-	Corrections for Rel-11 eMDT test cases	12.1.0	12.2.0
2015-06	RAN#68	R5s150235	2694	-	Corrections for Rel-11 eMDT test case 8.6.6.6	12.1.0	12.2.0
2015-06	RAN#68	R5s150238	2695	-	Correction to IMS Emergency call test case 11.2.6	12.1.0	12.2.0
2015-06	RAN#68	R5s150239	2696	-	Correction to IMS Emergency call test case 11.2.3	12.1.0	12.2.0
2015-06	RAN#68	R5s150249	2697	-	Correction for LTE<->GERAN SRVCC test cases 13.4.3.3, 13.4.3.21, 13.4.3.24, 13.4.3.25 and 13.4.3.27	12.1.0	12.2.0
2015-06	RAN#68	R5s150251	2698	-	Correction to cs_108_UE_CapabilityEnq_TDD	12.1.0	12.2.0
2015-06	RAN#68	R5s150252	2699	-	LTE_TDD: Addition of GCF WI-191 LTE-A SSC-TDD test case 7.1.3.12a	12.1.0	12.2.0
2015-06	RAN#68	R5s150254	2700	-	LTE_TDD: Addition of GCF WI-191 LTE-A SSC-TDD test case 7.1.3.13a	12.1.0	12.2.0
2015-06	RAN#68	R5s150256	2701	-	Correction to EUTRA EMM Testcases 9.3.1.1.12a, 9.2.3.1.13, 9.2.3.1.14, 9.2.3.2.10, 9.3.1.7 and 9.3.1.7a with IMS enabled	12.1.0	12.2.0
2015-06	RAN#68	R5s150257	2702	-	Correction to ESM test case 10.4.2	12.1.0	12.2.0
2015-06	RAN#68	R5s150261	2703	-	Correction to GCF WI-81 EUTRA RRC test case 8.5.4.1	12.1.0	12.2.0
2015-06	RAN#68	R5s150262	2704	-	Corrections to EUTRAN<->GERAN Idle Mode test case 6.2.3.28	12.1.0	12.2.0
2015-06	RAN#68	R5s150263	2705	-	Correction for LTE-A CA test cases 8.2.4.16.x	12.1.0	12.2.0
2015-06	RAN#68	R5s150268	2706	-	Corrections for GCF WI-154 IMS Emergency Call test case 11.2.4	12.1.0	12.2.0
2015-06	RAN#68	R5s150272	2707	-	Correction for GCF WI-087 EMM test case 9.2.3.1.6 in EUTRA<->GERAN path	12.1.0	12.2.0
2015-06	RAN#68	R5s150277	2708	-	Correction to IMS Emergency Call test case 11.2.5	12.1.0	12.2.0
2015-06	RAN#68	R5s150278	2709	-	Correction to EUTRA RRC test case 8.5.4.1	12.1.0	12.2.0
2015-06	RAN#68	R5s150285	2710	-	Addition of LTE-A eMBMS-SC-CA test case 17.4.10.1	12.1.0	12.2.0
2015-06	RAN#68	R5s150287	2711	-	Addition of LTE-A eMBMS-SC-CA test case 17.4.10.2	12.1.0	12.2.0
2015-06	RAN#68	R5s150291	2712	-	LTE_TDD: Addition of LTE-A Carrier Aggregation test case 8.2.4.20.3	12.1.0	12.2.0
2015-06	RAN#68	R5s150293	2713	-	Correction to GCF WI-151 LTE Interband test cases against IMS UE	12.1.0	12.2.0
2015-06	RAN#68	R5s150294	2714	-	Correction to GCF WI-154 LTE Emergency call test case 11.2.5	12.1.0	12.2.0
2015-06	RAN#68	R5s150297	2715	-	LTE_TDD: Addition of Rel-11 LTE_CA_enh test case 8.2.4.17.3	12.1.0	12.2.0
2015-06	RAN#68	R5s150300	2716	-	Addition of GCF WI-209 LTE-UTRA FE-FACH test case 6.2.4.1	12.1.0	12.2.0
2015-06	RAN#68	R5s150302	2717	-	Addition of GCF WI-209 LTE-UTRA FE-FACH test case 6.2.4.2	12.1.0	12.2.0
2015-06	RAN#68	R5s150304	2718	-	Addition of GCF WI-209 LTE-UTRA FE-FACH test case 6.2.4.3	12.1.0	12.2.0
2015-06	RAN#68	R5s150306	2719	-	Addition of GCF WI-209 LTE-UTRA FE-FACH test case 6.2.4.4	12.1.0	12.2.0

Date	TSG #	TSG Doc.	CR	Rev	Subject/Comment	Old	New
2015-06	RAN#68	R5s150310	2720	-	LTE_TDD: Addition of Rel-10 CA test case 7.1.3.11.2	12.1.0	12.2.0
2015-06	RAN#68	R5s150312	2721	-	LTE_TDD: Addition of Rel-11 CA test case 8.2.4.19.3	12.1.0	12.2.0
2015-06	RAN#68	R5s150314	2722	-	Addition of Rel-11 eMBMS_SC_CA test case 17.4.9.2	12.1.0	12.2.0
2015-06	RAN#68	R5s150315	2723	-	LTE_TDD: Addition of Rel-10 CA test case 8.2.4.23.2	12.1.0	12.2.0
2015-06	RAN#68	R5s150319	2724	-	Addition of Rel-11 eMBMS_SC_CA test case 17.4.9.1	12.1.0	12.2.0
2015-06	RAN#68	R5s150320	2725	-	Corrections to Switch-Off/Detach procedures in context of IMS-enabled UE	12.1.0	12.2.0
2015-06	RAN#68	R5s150322	2726	-	Correction to EUTRA test case 7.1.4.6	12.1.0	12.2.0
2015-06	RAN#68	R5s150324	2727	-	Addition of GCF WI-180 EUTRA<>C2K Inter-RAT test Case 8.6.7.3	12.1.0	12.2.0
2015-06	RAN#68	R5s150326	2728	-	Correction of GCF WI-87 EUTRA<>GERAN Testcase 6.2.3.26	12.1.0	12.2.0
2015-06	RAN#68	R5s150329	2729	-	Rel-12 baseline upgrade for LTE Test Suites	12.1.0	12.2.0
2015-06	RAN#68	R5s150332	2730	-	Addition of GCF WI-209 LTE-UTRA FE-FACH test case 6.2.4.6	12.1.0	12.2.0
2015-06	RAN#68	R5s150334	2731	-	Addition of GCF WI-209 LTE-UTRA FE-FACH test case 6.2.4.5	12.1.0	12.2.0
2015-06	RAN#68	R5s150338	2732	-	Dynamic DRB configuration at the SS	12.1.0	12.2.0
2015-06	RAN#68	R5s150340	2733	-	Correction of GCF WI-154 IMS Emergency call Testcase 11.2.4	12.1.0	12.2.0
2015-06	RAN#68	R5s150347	2734	-	Addition of LTE-A eMBMS-SC-CA test case 17.4.11.1	12.1.0	12.2.0
2015-06	RAN#68	R5s150349	2735	-	Addition of LTE-A eMBMS-SC-CA test case 17.4.11.2	12.1.0	12.2.0
2015-06	RAN#68	R5s150351	2736	-	Correction of GCF WI-177 Test Case 8.6.6.1	12.1.0	12.2.0
2015-06	RAN#68	R5s150354	2737	-	Correction of Test Cases 8.2.2.3.X	12.1.0	12.2.0
2015-06	RAN#68	R5s150355	2738	-	Correction of Test Cases 7.1.3.11.X	12.1.0	12.2.0
2015-06	RAN#68	R5s150356	2739	-	Correction of Test Cases 8.2.4.17.x	12.1.0	12.2.0
2015-06	RAN#68	R5s150362	2740	-	Addition of LTE-A (Rel-11) CoMP test case 7.1.10.1	12.1.0	12.2.0
2015-06	RAN#68	R5s150364	2741	-	Addition of LTE-A (Rel-11) CoMP test case 7.1.10.2	12.1.0	12.2.0
2015-06	RAN#68	R5s150369	2742	-	Correction to GCF WI-086 EUTRA Idle mode test case 6.3.7	12.1.0	12.2.0
2015-06	RAN#68	R5s150370	2743	-	Correction to GCF WI-082 EMM test case 9.3.1.18	12.1.0	12.2.0
2015-06	RAN#68	R5s150375	2744	-	Correction to DRB configuration handling in ATS_15wk18	12.1.0	12.2.0
2015-06	RAN#68	R5s150377	2745	-	LTE_TDD : Addition of GCF WI-183 LTE-UTRA MDT test case 8.6.5.1	12.1.0	12.2.0
2015-06	RAN#68	R5s150381	2746	-	Correction of GCF WI-162 EUTRA CA Testcase 7.1.3.11.x	12.1.0	12.2.0
2015-06	RAN#68	R5s150384	2747	-	Correction to GCF WI-159 Pre-registration at 1xRTT testcase 13.4.4.2	12.1.0	12.2.0
2015-06	RAN#68	R5s150385	2748	-	LTE_TDD: Addition of LTE-TDD / UTRA-FDD FE-FACH test case 6.2.4.1	12.1.0	12.2.0
2015-06	RAN#68	R5s150387	2749	-	LTE_TDD: Addition of LTE-TDD / UTRA-FDD FE-FACH test case 6.2.4.2	12.1.0	12.2.0
2015-06	RAN#68	R5s150389	2750	-	LTE_TDD: Addition of LTE-TDD / UTRA-FDD FE-FACH test case 6.2.4.3	12.1.0	12.2.0
2015-06	RAN#68	R5s150391	2751	-	LTE_TDD: Addition of LTE-TDD / UTRA-FDD FE-FACH test case 6.2.4.4	12.1.0	12.2.0
2015-06	RAN#68	R5s150393	2752	-	LTE_TDD: Addition of LTE-TDD / UTRA-FDD FE-FACH test case 6.2.4.5	12.1.0	12.2.0
2015-06	RAN#68	R5s150395	2753	-	LTE_TDD: Addition of LTE-TDD / UTRA-FDD FE-FACH test case 6.2.4.6	12.1.0	12.2.0
2015-06	RAN#68	R5s150397	2754	-	Correction to EUTRA MAC test case 7.1.2.6	12.1.0	12.2.0
2015-06	RAN#68	R5s150398	2755	-	Correction to GCF WI-081 RRC test case 8.5.4.1	12.1.0	12.2.0
2015-06	RAN#68	R5s150399	2756	-	Update Guard timer for EMM Test cases 9.2.1.2.9, 9.2.3.2.11, 9.2.3.1.15 and 9.2.3.1.15a	12.1.0	12.2.0

Date	TSG #	TSG Doc.	CR	Rev	Subject/Comment	Old	New
2015-06	RAN#68	R5s150400	2757	-	Correction to EUTRA EMM test case 9.1.3.3	12.1.0	12.2.0
2015-06	RAN#68	R5s150401	2758	-	Correction to GCF WI-082 EUTRA ESM Test cases 10.4.1	12.1.0	12.2.0
2015-06	RAN#68	R5s150402	2759	-	Correction to GCF WI-082 EUTRA EMM test case 9.2.1.1.21	12.1.0	12.2.0
2015-06	RAN#68	R5s150403	2760	-	Correction to GCF Wi-082 EUTRA EMM test case 9.2.1.1.22	12.1.0	12.2.0
2015-06	RAN#68	R5s150406	2761	-	Correction to LTE-A CA test cases 8.2.4.16.x	12.1.0	12.2.0
2015-06	RAN#68	R5s150407	2762	-	Correction of GCF WI 81 EUTRA MAC test case 7.1.2.8	12.1.0	12.2.0
2015-06	RAN#68	R5s150408	2763	-	Correction to GCF WI-086 EUTRA EMM Test Case 9.2.3.3.5a	12.1.0	12.2.0
2015-06	RAN#68	R5s150409	2764	-	Correction to GCF WI-082 Test cases 9.2.1.1.1a and 9.2.1.1.1b	12.1.0	12.2.0
2015-06	RAN#68	R5s150410	2765	-	Correction to GCF WI-154 EUTRA Emergency testcase 8.1.2.11	12.1.0	12.2.0
2015-06	RAN#68	R5s150411	2766	-	Correction to LTE with Pre-registration on 1xRTT test cases 13.4.4.1 and 13.4.4.2	12.1.0	12.2.0
2015-06	RAN#68	R5s150413	2767	-	Correction of GCF WI 81 EUTRA MAC test case 7.1.3.9	12.1.0	12.2.0
2015-06	RAN#68	R5s150415	2768	-	Correction of GCF WI-87 EUTRA<->GERAN Testcases 6.2.3.23, 6.2.3.24, 6.2.3.27,6.2.3.29	12.1.0	12.2.0
2015-06	RAN#68	R5s150416	2769	-	Correction of GCF WI-172 EUTRA<->GERAN aSRVCC test case 13.4.3.30	12.1.0	12.2.0
2015-06	RAN#68	R5s150417	2770	-	Correction to GCF WI-082 EUTRA Testcase 9.1.5.1	12.1.0	12.2.0
2015-06	RAN#68	R5s150422	2771	-	Correction of EUTRA-GERAN GCF WI-087 test cases 13.1.7, 13.1.10, 6.2.3.19	12.1.0	12.2.0
2015-06	RAN#68	R5s150423	2772	-	LTE_TDD: Addition of LTE-A (Rel-11) CoMP test case 7.1.10.1	12.1.0	12.2.0
2015-06	RAN#68	R5s150425	2773	-	LTE_TDD: Addition of LTE-A (Rel-11) CoMP test case 7.1.10.2	12.1.0	12.2.0
2015-06	RAN#68	R5s150427	2774	-	Correction of GCF WI-082 EUTRA EMM test case 9.3.1.16	12.1.0	12.2.0
2015-06	RAN#68	R5s150429	2775	-	Correction of EUTRA test cases 9.2.1.1.20, 9.2.3.2.17, 9.2.3.1.25	12.1.0	12.2.0
2015-06	RAN#68	R5s150430	2776	-	Correction to Multiple PDN for handling non-IMS APN	12.1.0	12.2.0
2015-06	RAN#68	R5s150431	2777	-	LTE_TDD: Addition of LTE-A eMBMS-SC-CA test case 17.4.11.1	12.1.0	12.2.0
2015-06	RAN#68	R5s150433	2778	-	LTE_TDD: Addition of LTE-A eMBMS-SC-CA test case 17.4.11.2	12.1.0	12.2.0
2015-06	RAN#68	R5s150436	2779	-	Correction to GCF WI-082 EMM test cases 9.2.1.1.20, 9.2.3.1.25 and 9.2.3.2.17	12.1.0	12.2.0
2015-06	RAN#68	R5s150438	2780	-	Correction to Bandwidth initialisation of CA Testcases	12.1.0	12.2.0
2015-06	RAN#68	R5s150442	2781	-	LTE_TDD: Addition of LTE-A eMBMS-SC-CA test case 17.4.10.1	12.1.0	12.2.0
2015-06	RAN#68	R5s150444	2782	-	LTE_TDD: Addition of LTE-A eMBMS-SC-CA test case 17.4.10.2	12.1.0	12.2.0
2015-09	RAN#69	R5-153142	2784	-	Low-cost MTC: Introduction of Test Model	12.2.0	12.3.0
2015-09	RAN#69	R5-153143	2785	-	FDD-TDD CA: Introduction of Test Model	12.2.0	12.3.0
2015-09	RAN#69	R5-153746	2783	1	Routine maintenance for TS 36.523-3	12.2.0	12.3.0
2015-09	RAN#69	RP-151418	2786	-	CR to 36.523-3: Add new verified and e-mail agreed TTCN test cases in the TC lists in 36.523-3 (prose), Annex A	12.2.0	12.3.0
2015-09	RAN#69	R5s150179	2788	-	Correction to ESM test case 10.2.1	12.2.0	12.3.0
2015-09	RAN#69	R5s150352	2789	-	Correction to GCF WI-087 EUTRA EMM Testcase 9.2.2.1.3	12.2.0	12.3.0
2015-09	RAN#69	R5s150440	2790	-	Correction to function f_UTRAN_SRVCC_WithHandover	12.2.0	12.3.0
2015-09	RAN#69	R5s150447	2791	-	Correction to LTE-A CA Handover Testcases for Rel11 UEs	12.2.0	12.3.0
2015-09	RAN#69	R5s150448	2792	-	Addition of Rel-11 LTE-A eMDT test case 8.6.9.1	12.2.0	12.3.0
2015-09	RAN#69	R5s150450	2865	-	LTE_TDD: Addition of Rel-11 LTE-A eMDT test case 8.6.9.1	12.2.0	12.3.0
2015-09	RAN#69	R5s150452	2793	-	Addition of Rel-11 LTE-A eMDT test case 8.6.9.3	12.2.0	12.3.0

Date	TSG #	TSG Doc.	CR	Rev	Subject/Comment	Old	New
2015-09	RAN#69	R5s150454	2866	-	LTE_TDD: Addition of Rel-11 LTE-A eMDT test case 8.6.9.3	12.2.0	12.3.0
2015-09	RAN#69	R5s150456	2867	-	LTE_TDD: Addition of GCF WI-223 EUTRA-HRPD test case 6.2.2.3	12.2.0	12.3.0
2015-09	RAN#69	R5s150458	2868	-	LTE_TDD: Addition of GCF WI-223 EUTRA-HRPD test case 6.2.3.7	12.2.0	12.3.0
2015-09	RAN#69	R5s150460	2869	-	LTE_TDD: Addition of GCF WI-224 EUTRA-HRPD test case 6.2.3.7a	12.2.0	12.3.0
2015-09	RAN#69	R5s150462	2870	-	LTE_TDD: Addition of GCF WI-223 EUTRA-HRPD test case 6.2.3.8	12.2.0	12.3.0
2015-09	RAN#69	R5s150464	2871	-	LTE_TDD: Addition of GCF WI-224 EUTRA-HRPD test case 6.2.3.8a	12.2.0	12.3.0
2015-09	RAN#69	R5s150466	2872	-	LTE_TDD: Addition of GCF WI-223 EUTRA-HRPD test case 8.1.3.9	12.2.0	12.3.0
2015-09	RAN#69	R5s150468	2873	-	LTE_TDD: Addition of GCF WI-223 EUTRA-HRPD test case 8.3.2.7	12.2.0	12.3.0
2015-09	RAN#69	R5s150470	2874	-	LTE_TDD: Addition of GCF WI-223 EUTRA-HRPD test case 8.3.2.8	12.2.0	12.3.0
2015-09	RAN#69	R5s150472	2875	-	LTE_TDD: Addition of GCF WI-223 EUTRA-HRPD test case 8.3.3.4	12.2.0	12.3.0
2015-09	RAN#69	R5s150474	2876	-	LTE_TDD: Addition of EUTRA-1xRTT test case 6.2.2.4	12.2.0	12.3.0
2015-09	RAN#69	R5s150476	2877	-	LTE_TDD: Addition of EUTRA-1xRTT test case 6.2.3.9	12.2.0	12.3.0
2015-09	RAN#69	R5s150478	2878	-	LTE_TDD: Addition of EUTRA-1xRTT test case 6.2.3.9a	12.2.0	12.3.0
2015-09	RAN#69	R5s150480	2879	-	LTE_TDD: Addition of EUTRA-1xRTT test case 6.2.3.10	12.2.0	12.3.0
2015-09	RAN#69	R5s150482	2880	-	LTE_TDD: Addition of EUTRA-1xRTT test case 6.2.3.10a	12.2.0	12.3.0
2015-09	RAN#69	R5s150484	2881	-	LTE_TDD: Addition of EUTRA-1xRTT test case 8.1.3.10	12.2.0	12.3.0
2015-09	RAN#69	R5s150486	2882	-	LTE_TDD: Addition of EUTRA-1xRTT test case 8.3.2.9	12.2.0	12.3.0
2015-09	RAN#69	R5s150488	2883	-	LTE_TDD: Addition of EUTRA-1xRTT test case 8.3.2.10	12.2.0	12.3.0
2015-09	RAN#69	R5s150490	2884	-	LTE_TDD: Addition of EUTRA-1xRTT test case 8.4.7.3	12.2.0	12.3.0
2015-09	RAN#69	R5s150492	2794	-	Correction to EUTRA MDT test case 8.6.4.4	12.2.0	12.3.0
2015-09	RAN#69	R5s150493	2795	-	Correction to CA NonContiguous band combination 3A-3A	12.2.0	12.3.0
2015-09	RAN#69	R5s150494	2796	-	Correction to LTE-A CA Testcases 8.2.2.3.x and 8.3.1.17.x	12.2.0	12.3.0
2015-09	RAN#69	R5s150495	2797	-	Correction to Geran MO call procedure for LTE<->GERAN Testcases	12.2.0	12.3.0
2015-09	RAN#69	R5s150496	2798	-	Correction to GCF WI-086 EMM test cases 9.2.3.3.2	12.2.0	12.3.0
2015-09	RAN#69	R5s150497	2799	-	Correction to common function f_IMS_SIP_DecodeMatchAndCheckSDP()	12.2.0	12.3.0
2015-09	RAN#69	R5s150498	2885	-	LTE_TDD: Addition of EUTRA-1xRTT test case 8.4.7.4	12.2.0	12.3.0
2015-09	RAN#69	R5s150500	2886	-	LTE_TDD: Addition of EUTRA-1xRTT test case 8.4.7.6	12.2.0	12.3.0
2015-09	RAN#69	R5s150502	2887	-	LTE_TDD: Addition of EUTRA-1xRTT test case 8.4.7.9	12.2.0	12.3.0
2015-09	RAN#69	R5s150504	2888	-	LTE_TDD: Addition of EUTRA-1xRTT test case 13.4.4.1	12.2.0	12.3.0
2015-09	RAN#69	R5s150506	2889	-	LTE_TDD: Addition of EUTRA-1xRTT test case 13.4.4.5	12.2.0	12.3.0
2015-09	RAN#69	R5s150508	2890	-	LTE_TDD: Addition of EUTRA-1xRTT test case 13.1.17	12.2.0	12.3.0
2015-09	RAN#69	R5s150510	2800	-	Correction to GCF WI-154 IMS Emergency call test case 11.2.4	12.2.0	12.3.0
2015-09	RAN#69	R5s150511	2801	-	Addition of GCF WI-227 EUTRA eMDT test case 8.6.1.2	12.2.0	12.3.0
2015-09	RAN#69	R5s150513	2802	-	Addition of Rel-11 LTE-A eMDT test case 8.6.3.4	12.2.0	12.3.0
2015-09	RAN#69	R5s150515	2891	-	LTE_TDD: Addition of Rel-11 LTE-A eMDT test case 8.6.3.4	12.2.0	12.3.0
2015-09	RAN#69	R5s150517	2803	-	Addition of Rel-11 LTE-A eMDT test case 8.6.5.1a	12.2.0	12.3.0
2015-09	RAN#69	R5s150519	2892	-	LTE_TDD: Addition of Rel-11 LTE-A eMDT test case 8.6.5.1a	12.2.0	12.3.0

Date	TSG #	TSG Doc.	CR	Rev	Subject/Comment	Old	New
2015-09	RAN#69	R5s150521	2804	-	Correction to GCF WI-081 EUTRA RRC Test Case 8.5.4.1	12.2.0	12.3.0
2015-09	RAN#69	R5s150523	2805	-	Correction of GCF WI-082 EUTRA IdleMode test case 6.1.2.6	12.2.0	12.3.0
2015-09	RAN#69	R5s150524	2806	-	Correction of GCF WI-151 EUTRA FDD-TDD Testcase 8.3.1.13a	12.2.0	12.3.0
2015-09	RAN#69	R5s150525	2807	-	Correction to GCF WI-154 IMS Emergency Call Testcase 11.2.8	12.2.0	12.3.0
2015-09	RAN#69	R5s150526	2808	-	Correction to GCF WI-081 EUTRA RRC Test Case 8.5.4.1	12.2.0	12.3.0
2015-09	RAN#69	R5s150527	2809	-	Correction to test cases 13.4.3.1, 13.4.3.6, 13.4.3.14, 13.4.3.16	12.2.0	12.3.0
2015-09	RAN#69	R5s150528	2810	-	Correction to DRB release in multi-PDN test cases	12.2.0	12.3.0
2015-09	RAN#69	R5s150529	2811	-	Correction of LTE-A EUTRA eMDT Testcase 8.6.11.1	12.2.0	12.3.0
2015-09	RAN#69	R5s150536	2812	-	Correction of Postamble procedure for LTE<->1xRTT Pre-registration TCs	12.2.0	12.3.0
2015-09	RAN#69	R5s150588	2813	-	Correction of Rel-11 LTE-A eMDT test case 8.6.2.11	12.2.0	12.3.0
2015-09	RAN#69	R5s150619	2893	-	LTE_TDD: Addition of GCF WI-162 Rel-10 LTE-A CA test case 8.2.4.16.1	12.2.0	12.3.0
2015-09	RAN#69	R5s150623	2814	-	Addition of GCF WI-159 LTE<->1xRTT testcase 13.1.18	12.2.0	12.3.0
2015-09	RAN#69	R5s150627	2815	-	Correction to IMS Emergency Call test case 11.2.3	12.2.0	12.3.0
2015-09	RAN#69	R5s150632	2816	-	Correction of CF WI-082 EUTRA Idle Mode test case 6.1.2.6	12.2.0	12.3.0
2015-09	RAN#69	R5s150634	2817	-	Correction to EUTRA Idle Mode test case 6.1.1.8 and 6.1.1.9	12.2.0	12.3.0
2015-09	RAN#69	R5s150635	2818	-	Correction to EUTRA MFBI test case 6.2.3.35	12.2.0	12.3.0
2015-09	RAN#69	R5s150636	2819	-	Correction of GCF WI-209 EUTRA FE-FACH test case 6.2.4.3	12.2.0	12.3.0
2015-09	RAN#69	R5s150637	2820	-	Correction to function fl_EUTRA_CheckRel10_FGIs()	12.2.0	12.3.0
2015-09	RAN#69	R5s150638	2821	-	Correction to EUTRA MDT test case 8.6.4.4	12.2.0	12.3.0
2015-09	RAN#69	R5s150639	2822	-	Correction to EUTRA CA test cases 8.2.4.17.x	12.2.0	12.3.0
2015-09	RAN#69	R5s150640	2894	-	LTE_TDD: Addition of EUTRA-1xRTT test case 8.4.7.7	12.2.0	12.3.0
2015-09	RAN#69	R5s150642	2895	-	LTE_TDD: Addition of EUTRA-1xRTT test case 8.4.7.8	12.2.0	12.3.0
2015-09	RAN#69	R5s150644	2896	-	LTE_TDD: Addition of EUTRA-1xRTT test case 8.4.7.10	12.2.0	12.3.0
2015-09	RAN#69	R5s150648	2823	-	PDN handling at IP PTC	12.2.0	12.3.0
2015-09	RAN#69	R5s150650	2824	-	Correction to WI-162 Inter-RAT handover UTRA to EUTRA test 8.4.2.7.x	12.2.0	12.3.0
2015-09	RAN#69	R5s150651	2825	-	Correction for GCF WI-103 EMM test case 9.2.1.1.28	12.2.0	12.3.0
2015-09	RAN#69	R5s150652	2826	-	Correction to EUTRA eMDT test case 8.6.3.4	12.2.0	12.3.0
2015-09	RAN#69	R5s150653	2827	-	Correction of GCF WI-091 EUTRA RLC test case 7.2.2.10	12.2.0	12.3.0
2015-09	RAN#69	R5s150654	2828	-	Addition of GCF WI-209 LTE-UTRA FE-FACH test case 6.2.4.7	12.2.0	12.3.0
2015-09	RAN#69	R5s150656	2897	-	LTE_TDD: Addition of GCF WI-209 LTE-UTRA FE-FACH test case 6.2.4.7	12.2.0	12.3.0
2015-09	RAN#69	R5s150658	2829	-	Re-verification of GCF WI-200 LTE-A eCIC test case 8.3.1.21 (new test model with OCN simulation in non-ABS subframes)	12.2.0	12.3.0
2015-09	RAN#69	R5s150660	2830	-	Correction to EUTRA eMBMS_SC_CA test cases 17.4.11.1 and 17.4.11.2	12.2.0	12.3.0
2015-09	RAN#69	R5s150661	2831	-	Correction for LTE-A CA test case 8.2.4.20.2	12.2.0	12.3.0
2015-09	RAN#69	R5s150662	2832	-	Correction of LTE_A MDT/eMDT test cases 8.6.4.5, 8.6.4.9, 8.6.5.1 and 8.6.2.12	12.2.0	12.3.0
2015-09	RAN#69	R5s150663	2833	-	Correction to common function f_EUTRA_CA_SetDIUIBandwidth()	12.2.0	12.3.0
2015-09	RAN#69	R5s150664	2834	-	Correction of LTE_A MDT/eMDT test cases	12.2.0	12.3.0
2015-09	RAN#69	R5s150669	2835	-	Addition of Rel-10 LTE-CA Inter band test case 8.2.2.3.2 in FDD+TDD band combination	12.2.0	12.3.0

Date	TSG #	TSG Doc.	CR	Rev	Subject/Comment	Old	New
2015-09	RAN#69	R5s150671	2836	-	Addition of Rel-10 LTE-CA Inter band test case 8.5.1.7.2 in FDD+TDD band combination	12.2.0	12.3.0
2015-09	RAN#69	R5s150673	2837	-	Correction to APN name for IMS PDN in MultiPDN testing	12.2.0	12.3.0
2015-09	RAN#69	R5s150689	2838	-	Correction to UTRAN postamble function for IMS emergency call test cases	12.2.0	12.3.0
2015-09	RAN#69	R5s150696	2839	-	Addition of GCF WI-200 LTE-A eCIC test case 8.3.1.28 (new test model with OCNG simulation in non-ABS subframes)	12.2.0	12.3.0
2015-09	RAN#69	R5s150698	2898	-	LTE_TDD: Addition of GCF WI-201 LTE-A eCIC test case 8.3.1.28 (new test model with OCNG simulation in non-ABS subframes)	12.2.0	12.3.0
2015-09	RAN#69	R5s150701	2840	-	Correction to test case 10.3.1 and 10.9.1	12.2.0	12.3.0
2015-09	RAN#69	R5s150703	2841	-	Correction to GCF WI-151 Measurement configuration control and reporting test 8.3.1.16a	12.2.0	12.3.0
2015-09	RAN#69	R5s150719	2899	-	LTE_TDD: Addition of Rel-10 LTE-A CA test case 8.2.4.16.2	12.2.0	12.3.0
2015-09	RAN#69	R5s150722	2842	-	Correction to GCF WI-156 Measurement configuration control and reporting test 8.3.1.16	12.2.0	12.3.0
2015-09	RAN#69	R5s150723	2843	-	Correction to eMBMS test cases 17.3.x	12.2.0	12.3.0
2015-09	RAN#69	R5s150724	2844	-	Correction to eMBMS test case 17.1.3	12.2.0	12.3.0
2015-09	RAN#69	R5s150727	2900	-	LTE_TDD: Addition of LTE<>1xRTT testcase 13.1.18	12.2.0	12.3.0
2015-09	RAN#69	R5s150729	2845	-	Corrections of GCF WI-087 and WI-097 test cases 13.1.9 and 13.1.10	12.2.0	12.3.0
2015-09	RAN#69	R5s150730	2846	-	Addition of GCF WI-227 Inter-RAT eMDT test case 8.6.10.1	12.2.0	12.3.0
2015-09	RAN#69	R5s150732	2901	-	LTE_TDD: Addition of GCF WI-227 Inter-RAT eMDT test case 8.6.10.1	12.2.0	12.3.0
2015-09	RAN#69	R5s150734	2847	-	Correction to GCF WI-81 RRC test cases 8.2.1.5 and 8.2.1.6	12.2.0	12.3.0
2015-09	RAN#69	R5s150736	2848	-	Correction to LTE<>IRAT Testcases with IMS enabled	12.2.0	12.3.0
2015-09	RAN#69	R5s150737	2849	-	Correction of test case 13.3.2.2	12.2.0	12.3.0
2015-09	RAN#69	R5s150738	2850	-	Correction to bandwidth initialization of LTE-A CA test cases	12.2.0	12.3.0
2015-09	RAN#69	R5s150740	2851	-	Correction to GCF WI-103 ESM test case 10.4.2	12.2.0	12.3.0
2015-09	RAN#69	R5s150742	2852	-	Correction to IMS emergency call test cases	12.2.0	12.3.0
2015-09	RAN#69	R5s150743	2853	-	Addition of Rel-11 LTE-A SIMTC test case 9.2.1.1.27a	12.2.0	12.3.0
2015-09	RAN#69	R5s150745	2854	-	Addition of Rel-11 LTE-A SIMTC test case 10.5.1a	12.2.0	12.3.0
2015-09	RAN#69	R5s150747	2855	-	Addition of GCF WI-210 LTE-A SIMTC test case 9.2.1.2.4a	12.2.0	12.3.0
2015-09	RAN#69	R5s150749	2856	-	Addition of GCF WI-210 LTE-A SIMTC test case 9.2.3.2.4a	12.2.0	12.3.0
2015-09	RAN#69	R5s150753	2857	-	Addition of TC 8.7.1 - Inter-RAT / UTRAN ANR measurement, logging and reporting / E-UTRAN cell.	12.2.0	12.3.0
2015-09	RAN#69	R5s150756	2858	-	Addition of Rel-11 LTE-A SIMTC test case 8.1.1.7	12.2.0	12.3.0
2015-09	RAN#69	R5s150759	2902	-	LTE_TDD: Addition of Rel-11 LTE-A SIMTC test case 8.1.1.7	12.2.0	12.3.0
2015-09	RAN#69	R5s150761	2859	-	Addition of EUTRA-GERAN IMS Emergency Call test case 11.2.12	12.2.0	12.3.0
2015-09	RAN#69	R5s150763	2860	-	Correction to GCF WI-081 Idle mode test cases 6.1.1.4, 6.1.1.6, 6.1.1.6a	12.2.0	12.3.0
2015-09	RAN#69	R5s150764	2861	-	Correction to GCF WI-178 Rel-11 eMBMS test case 17.4.5	12.2.0	12.3.0
2015-09	RAN#69	R5s150765	2862	-	Correction to LTE-A MAC CA test cases 7.1.3.11.1,7.1.3.11.2 and 7.1.3.11.3	12.2.0	12.3.0
2015-09	RAN#69	R5s150766	2863	-	Addition of LTE-A Rel-11 Carrier Aggregation test case 8.2.2.7.1	12.2.0	12.3.0
2015-09	RAN#69	R5s150768	2903	-	LTE_TDD: Addition of LTE-A Rel-11 Carrier Aggregation test case 8.2.2.7.1	12.2.0	12.3.0
2015-09	RAN#69	R5s150770	2864	-	Correction to GCF WI-082 EMM test cases 9.3.1.7, 9.3.1.7a, 9.2.3.2.10, 9.2.3.1.13, 9.2.3.1.14.	12.2.0	12.3.0
2015-09	RAN#69	-	-	-	update of the "non-specific references" in section 2 according to the approved R5-153582 and an action point on ETSI MCC	12.2.0	12.3.0
2015-12	RAN#70	R5-155055	2906	-	Low-cost MTC: Test Model enhancement for half-duplex FDD Cat.0 UEs	12.3.0	12.4.0

Date	TSG #	TSG Doc.	CR	Rev	Subject/Comment	Old	New
2015-12	RAN#70	R5-155057	2907	-	3GPP / WLAN Radio Interworking: Introduction of Test Model	12.3.0	12.4.0
2015-12	RAN#70	R5-155058	2908	-	D2D ProSe: Introduction of Test Model	12.3.0	12.4.0
2015-12	RAN#70	R5-155909	2909	1	Editorial update of Guidelines of EUTRA MFBI test cases	12.3.0	12.4.0
2015-12	RAN#70	R5-156151	2911	1	Routine maintenance for TS 36.523-3	12.3.0	12.4.0
2015-12	RAN#70	R5s150694	2912	-	LTE_TDD: Addition of GCF WI-201 LTE-A eCIC test case 8.3.1.21 (... new test model with OCN simulation in non-ABS subframes)	12.3.0	12.4.0
2015-12	RAN#70	R5s150704	2913	-	Addition of Rel-11 EUTRA<->UTRA rSRVCC test case 13.4.3.32	12.3.0	12.4.0
2015-12	RAN#70	R5s150741	2914	-	Correction to IMS SIP De-registration procedure for xSRVCC test cases	12.3.0	12.4.0
2015-12	RAN#70	R5s150751	2915	-	Addition of Rel-11 EUTRA<->UTRA rSRVCC test case 13.4.3.34	12.3.0	12.4.0
2015-12	RAN#70	R5s150771	2916	-	Correction of Cell reselection test case 6.1.2.3	12.3.0	12.4.0
2015-12	RAN#70	R5s150772	2917	-	Correction of Intra E-UTRAN measurement test case 8.3.1.4	12.3.0	12.4.0
2015-12	RAN#70	R5s150774	2918	-	Correction to GCF WI-0150 EUTRA RRC test case 8.5.1.6	12.3.0	12.4.0
2015-12	RAN#70	R5s150777	2919	-	Correction to GCF WI-082 SMS over SGs test cases 11.1.3, 11.1.4, 11.1.5, 11.1.6	12.3.0	12.4.0
2015-12	RAN#70	R5s150778	2920	-	Addition of Rel-11 LTE-A SIMTC test case 10.5.1b	12.3.0	12.4.0
2015-12	RAN#70	R5s150782	2921	-	Addition of LTE-A 2x UL Carrier Aggregation test case 8.2.2.7.2	12.3.0	12.4.0
2015-12	RAN#70	R5s150784	2922	-	LTE_TDD: Addition of LTE-A 2x UL Carrier Aggregation test case 8.2.2.7.2	12.3.0	12.4.0
2015-12	RAN#70	R5s150787	2923	-	Addition of LTE-A 2UL Carrier Aggregation MAC test case 7.1.4.19.2	12.3.0	12.4.0
2015-12	RAN#70	R5s150789	2924	-	LTE_TDD: Addition of LTE-A 2UL Carrier Aggregation MAC test case 7.1.4.19.2	12.3.0	12.4.0
2015-12	RAN#70	R5s150790	2925	-	LTE_TDD: Addition of LTE-A 2x UL Carrier Aggregation test case 8.2.2.7.3	12.3.0	12.4.0
2015-12	RAN#70	R5s150793	2926	-	Correction to LTE-A RRC CA test cases 8.3.1.18.1, 8.3.1.18.2 and 8.3.1.18.3	12.3.0	12.4.0
2015-12	RAN#70	R5s150794	2927	-	Correction to GCF WI-082 EMM test case 9.2.1.2.4	12.3.0	12.4.0
2015-12	RAN#70	R5s150796	2928	-	Correction to GEA4 and A5/4 Ciphering Algorithm Implementation	12.3.0	12.4.0
2015-12	RAN#70	R5s150797	2929	-	Addition of LTE-A 2UL Carrier Aggregation RACH on SCell test case 7.1.2.10.2	12.3.0	12.4.0
2015-12	RAN#70	R5s150799	2930	-	Correction to GCF WI-172 aSRVCC test case 13.4.3.8	12.3.0	12.4.0
2015-12	RAN#70	R5s150801	2931	-	Correction to EUTRA Idle-mode test case 6.1.2.3a	12.3.0	12.4.0
2015-12	RAN#70	R5s150802	2932	-	Correction to GCF WI-081 EUTRA Idle Mode test case 6.1.1.1b	12.3.0	12.4.0
2015-12	RAN#70	R5s150803	2933	-	Correction to LTE UTRA CSG test case 6.3.3	12.3.0	12.4.0
2015-12	RAN#70	R5s150804	2934	-	Correction to LTE-UTRA CSG test case 6.3.4	12.3.0	12.4.0
2015-12	RAN#70	R5s150806	2935	-	Correction to GCF WI-082 ESM test case 10.2.1	12.3.0	12.4.0
2015-12	RAN#70	R5s150807	2936	-	Correction to LTE-A (Rel-11) rSRVCC test case 13.4.3.34	12.3.0	12.4.0
2015-12	RAN#70	R5s150808	2937	-	Correction of 7.1.7.1.x and 7.1.7.2.1 test cases	12.3.0	12.4.0
2015-12	RAN#70	R5s150810	2938	-	Addition of Rel-11 LTE-A SIMTC test case 9.2.3.1.8a	12.3.0	12.4.0
2015-12	RAN#70	R5s150812	2939	-	Correction to GCF WI-087 EUTRA RRC Test case 8.4.3.3	12.3.0	12.4.0
2015-12	RAN#70	R5s150815	2940	-	Correction to GCF WI-087 EUTRA Idle mode Testcases 6.2.3.28, 6.2.3.30	12.3.0	12.4.0
2015-12	RAN#70	R5s150816	2941	-	Correction to GCF WI-179 LTE-NIMTC testcase 9.2.1.1.2a	12.3.0	12.4.0
2015-12	RAN#70	R5s150819	2942	-	Correction to LTE-A MAC test case 7.1.3.11.x	12.3.0	12.4.0
2015-12	RAN#70	R5s150820	2943	-	Correction to LTE-A RRC CA test cases 8.2.4.16.1, 8.2.4.16.2 and 8.2.4.16.3	12.3.0	12.4.0
2015-12	RAN#70	R5s150821	2944	-	Addition of Rel-11 LTE-A SIMTC test case 9.2.3.1.8b	12.3.0	12.4.0

Date	TSG #	TSG Doc.	CR	Rev	Subject/Comment	Old	New
2015-12	RAN#70	R5s150824	2945	-	Correction to GCF WI-087 Multi-layer testcase 13.3.2.2	12.3.0	12.4.0
2015-12	RAN#70	R5s150828	2946	-	Correction to GCF WI-162 CA IRAT test case 8.4.2.7.1, 8.4.2.7.2 and 8.4.2.7.3	12.3.0	12.4.0
2015-12	RAN#70	R5s150833	2947	-	Addition of GCF WI-227 Inter-RAT eMDT test case 8.6.7.4	12.3.0	12.4.0
2015-12	RAN#70	R5s150836	2948	-	Correction to TestCases 6.2.2.2, 6.2.3.1, 6.2.3.1a	12.3.0	12.4.0
2015-12	RAN#70	R5s150837	2949	-	Correction to configuration of DRX	12.3.0	12.4.0
2015-12	RAN#70	R5s150838	2950	-	Correction to UTRAN function f_UTRAN_GMM_ServReq	12.3.0	12.4.0
2015-12	RAN#70	R5s150839	2951	-	Correction of GCF WI-081 Testcases 12.2.x and 12.3.x	12.3.0	12.4.0
2015-12	RAN#70	R5s150840	2952	-	Correction of GCF WI-082 EPC test case 9.3.2.1	12.3.0	12.4.0
2015-12	RAN#70	R5s150842	2953	-	Correction of GCF WI 82 EPC test case 9.1.2.3	12.3.0	12.4.0
2015-12	RAN#70	R5s150844	2954	-	Correction to Rel-9 eMBMS test case 17.2.4	12.3.0	12.4.0
2015-12	RAN#70	R5s150845	2955	-	Correction to SS configuration for UTRAN	12.3.0	12.4.0
2015-12	RAN#70	R5s150847	2956	-	Correction to GCF WI-162 CA testcases 8.4.2.7.x	12.3.0	12.4.0
2015-12	RAN#70	R5s150848	2957	-	Correction to GCF WI-162 TestCase 7.1.3.11.2	12.3.0	12.4.0
2015-12	RAN#70	R5s150849	2958	-	Correction to IMSs emergency call TestCases 11.2.1, 11.2.2 and 11.2.5	12.3.0	12.4.0
2015-12	RAN#70	R5s150852	2959	-	Correction of GCF WI-162-Inter test cases 8.2.2.3.x	12.3.0	12.4.0
2015-12	RAN#70	R5s150853	2960	-	Correction to GCF WI-086 SRVCC Testcases 13.4.3.x	12.3.0	12.4.0
2015-12	RAN#70	R5s150855	2961	-	Correction to IMS emergency call TestCases 11.2.6	12.3.0	12.4.0
2015-12	RAN#70	R5s150856	2962	-	Correction to Rel-11 rSRVCC test case 13.4.3.32	12.3.0	12.4.0
2015-12	RAN#70	R5s150857	2963	-	Correction of function f_EUTRA_508Check_TrackingAreaUpdating_AfterHO_Steps7to8	12.3.0	12.4.0
2015-12	RAN#70	R5s150858	2964	-	Correction to GCF WI-087 EUTRA EMM testcase 9.2.3.3.5	12.3.0	12.4.0
2015-12	RAN#70	R5s150859	2965	-	Correction to GCF WI-081 testcase 7.2.3.5	12.3.0	12.4.0
2015-12	RAN#70	R5s150860	2966	-	Correction to GCF WI-082 EUTRA EMM test case 9.2.1.1.22	12.3.0	12.4.0
2015-12	RAN#70	R5s150861	2967	-	Correction to eMBMS-SC test cases 17.4.x	12.3.0	12.4.0
2015-12	RAN#70	R5s150862	2968	-	Correction to Bandwidth in MIB in initialisation of CA Testcases	12.3.0	12.4.0
2015-12	RAN#70	R5s150863	2969	-	Correction to EMM test case 9.2.2.1.3	12.3.0	12.4.0
2015-12	RAN#70	R5s150867	2970	-	Correction to Rel-8 LTE<->GERAN test cases	12.3.0	12.4.0
2015-12	RAN#70	R5s150869	2971	-	Correction to ESM test case 10.2.1	12.3.0	12.4.0
2015-12	RAN#70	R5s150870	2972	-	Correction to Rel-10 MDT test case 8.6.4.4	12.3.0	12.4.0
2015-12	RAN#70	R5s150871	2973	-	Addition of LTE-A Rel-11 test case 8.5.4.2	12.3.0	12.4.0
2015-12	RAN#70	R5s150874	2974	-	Correction to Rel-11 SIMTC test case 10.5.1b	12.3.0	12.4.0
2015-12	RAN#70	R5s150875	2975	-	Correction of GCF WI-227-Handover failure logging test case 8.6.6.6	12.3.0	12.4.0
2015-12	RAN#70	R5s150876	2976	-	Correction of GCF WI-227 RLF logging test case 8.6.4.9	12.3.0	12.4.0
2015-12	RAN#70	R5s150877	2977	-	Correction to EMM test case 9.2.1.1.30	12.3.0	12.4.0
2015-12	RAN#70	R5s150882	2978	-	LTE_TDD: Addition of LTE-A Rel-11 test case 8.5.4.2	12.3.0	12.4.0
2015-12	RAN#70	R5s150884	2979	-	Correction of Postamble procedure for LTE<->1xRTT Pre-registration TCs	12.3.0	12.4.0
2015-12	RAN#70	R5s150887	2980	-	Correction to IMS Emergency Call test case 11.2.10	12.3.0	12.4.0
2015-12	RAN#70	R5s150899	2981	-	Correction to UTRAN postamble function for IMS emergency call test cases	12.3.0	12.4.0

Date	TSG #	TSG Doc.	CR	Rev	Subject/Comment	Old	New
2015-12	RAN#70	R5s150901	2982	-	Correction to GCF WI-172 EUTRA<>GERAN aSRVCC testcases 13.4.3.26 and 13.4.3.28	12.3.0	12.4.0
2015-12	RAN#70	R5s150902	2983	-	Correction to test case 9.2.3.2.12 with IMS enabled	12.3.0	12.4.0
2015-12	RAN#70	R5s150903	2984	-	Correction to GCF WI-179 NiMTC test case 6.1.1.7	12.3.0	12.4.0
2015-12	RAN#70	R5s150904	2985	-	Correction to MAC layer CA test cases 7.1.4.19.x	12.3.0	12.4.0
2015-12	RAN#70	R5s150905	2986	-	Correction to LTE<>GERAN test cases 6.2.3.23, 6.2.3.24, 6.2.3.29	12.3.0	12.4.0
2015-12	RAN#70	R5s150906	2987	-	LTE_TDD: Addition of Rel-10 LTE-A NIMTC test case 6.1.1.7	12.3.0	12.4.0
2015-12	RAN#70	R5s150912	2988	-	Correction to EUTRA eMDT test case 8.6.11.1	12.3.0	12.4.0
2015-12	RAN#70	R5s150913	2989	-	Correction to TestCases 6.2.2.2, 6.2.3.1, 6.2.3.1a with IMS enabled	12.3.0	12.4.0
2015-12	RAN#70	R5s150914	2990	-	Correction to UL EARFCN for CA_4A-30A	12.3.0	12.4.0
2015-12	RAN#70	R5s150917	2991	-	Correction to SS configuration for UTRAN	12.3.0	12.4.0
2015-12	RAN#70	R5s150920	2992	-	LTE_TDD: Addition of Rel-10 LTE-A NIMTC test case 6.1.1.7a	12.3.0	12.4.0
2015-12	RAN#70	R5s150922	2993	-	Correction to LTE MAC test cases ((IMS enabled UE / Multi-PDN)	12.3.0	12.4.0
2015-12	RAN#70	R5s150923	2994	-	Correction to MDT test cases 8.6.6.1,8.6.6.2 and 8.6.6.4	12.3.0	12.4.0
2015-12	RAN#70	R5s150924	2995	-	Addition of EUTRA eMDT test case 8.6.8.4	12.3.0	12.4.0
2015-12	RAN#70	R5s150926	2996	-	LTE-TDD : Addition of EUTRA eMDT test case 8.6.8.4	12.3.0	12.4.0
2015-12	RAN#70	R5s150928	2997	-	Addition of SSAC test case 13.5.1	12.3.0	12.4.0
2015-12	RAN#70	R5s150930	2998	-	Addition of SSAC test case 13.5.2	12.3.0	12.4.0
2015-12	RAN#70	R5s150932	2999	-	Addition of SSAC test case 13.5.3	12.3.0	12.4.0
2015-12	RAN#70	R5s150935	3000	-	LTE_TDD : Addition of SSAC test case 13.5.1	12.3.0	12.4.0
2015-12	RAN#70	R5s150937	3001	-	LTE_TDD : Addition of SSAC test case 13.5.2	12.3.0	12.4.0
2015-12	RAN#70	R5s150939	3002	-	LTE_TDD : Addition of SSAC test case 13.5.3	12.3.0	12.4.0
2015-12	RAN#70	R5s150941	3003	-	Addition of 6.2.3.27 - InterRAT GCF WI-87 EUTRA<>GERAN Test case	12.3.0	12.4.0
2015-12	RAN#70	R5s150943	3004	-	Correction to LTE-IRAT CSG and Home eNB testcases with UTRAN Bands 4,9 and 10	12.3.0	12.4.0
2015-12	RAN#70	R5s150944	3005	-	Correction to test case 9.2.3.2.2 with IMS enabled	12.3.0	12.4.0
2015-12	RAN#70	R5s150947	3006	-	Correction for LTE test cases requiring IMS registration	12.3.0	12.4.0
2015-12	RAN#70	R5s150948	3007	-	Correction to eMBMS_SC_CA test cases 17.4.11.1 and 17.4.11.2	12.3.0	12.4.0
2015-12	RAN#70	R5s150954	3008	-	Addition of EUTRA Rel-11 eDDA test case 8.2.2.6.1	12.3.0	12.4.0
2015-12	RAN#70	R5s150957	3009	-	LTE-TDD : Addition of EUTRA Rel-11 eDDA test case 8.2.2.6.1	12.3.0	12.4.0
2015-12	RAN#70	R5s150960	3010	-	Correction to EUTRA RRC test case 8.2.4.1 ((IMS enabled UE / Multi-PDN)	12.3.0	12.4.0
2015-12	RAN#70	R5s150961	3011	-	Correction to EMM test case 9.2.2.2.1 ((IMS enabled UE / Multi-PDN)	12.3.0	12.4.0
2015-12	RAN#70	R5s150963	3012	-	Correction to EMM test cases for IMS-enabled UEs	12.3.0	12.4.0
2015-12	RAN#70	R5s150964	3013	-	Correction of f_EUTRA_508_IMSEmergencyCallLimitedService_Steps5a1_15	12.3.0	12.4.0
2015-12	RAN#70	R5s150966	3014	-	Correction to function f_TC_8_4_2_7_Common_UTRAN	12.3.0	12.4.0
2015-12	RAN#70	R5s150969	3015	-	Correction to GCF WI-082 EMM test case 9.3.1.18	12.3.0	12.4.0
2015-12	RAN#70	R5s150971	3016	-	Correction to function f_IMS_InviteRequest_MessageHeaderRX() for SRVCC test cases	12.3.0	12.4.0
2015-12	RAN#70	RP-151694	3017	-	CR to 36.523-3: Add new verified and e-mail agreed TTCN test cases in the TC lists in 36.523-3 (prose), Annex A	12.3.0	12.4.0
2016-03	RAN#71	R5-160083	3076	-	WLAN/3GPP Radio Interworking: Test Model updates	12.4.0	12.5.0

Date	TSG #	TSG Doc.	CR	Rev	Subject/Comment	Old	New
2016-03	RAN#71	R5-160637	3098	-	IXIT parameters required for ProSe TCs	12.4.0	12.5.0
2016-03	RAN#71	R5-160764	3097	1	Guideline update for 6.2.3.34	12.4.0	12.5.0
2016-03	RAN#71	R5-160779	3077	1	D2D ProSe: Test Model updates	12.4.0	12.5.0
2016-03	RAN#71	R5-160961	3088	1	Dual Connectivity: Introduction of Test Model	12.4.0	12.5.0
2016-03	RAN#71	R5-160981	3075	1	Routine maintenance for TS 36.523-3	12.4.0	12.5.0
2016-03	RAN#71	R5s150866	3122	-	Correction of GCF WI-082 test case 9.1.5.1	12.4.0	12.5.0
2016-03	RAN#71	R5s150962	3123	-	Correction to LTE-InterRAT ANR test case 8.7.1	12.4.0	12.5.0
2016-03	RAN#71	R5s150973	3124	-	LTE_TDD: Addition of EUTRA eMBMS test case 17.3.1	12.4.0	12.5.0
2016-03	RAN#71	R5s150977	3125	-	E-UTRA RRC asn.1 baseline upgrade to Rel-12 Sep-2015	12.4.0	12.5.0
2016-03	RAN#71	R5s150978	3126	-	Addition of GCF WI-103 EUTRA EMM test case 9.2.1.1.28a	12.4.0	12.5.0
2016-03	RAN#71	R5s150982	3127	-	Correction to LTE-IRAT CSG testcase 6.3.7	12.4.0	12.5.0
2016-03	RAN#71	R5s150983	3128	-	Correction to LTE CSG testcase 6.3.1	12.4.0	12.5.0
2016-03	RAN#71	R5s150984	3129	-	Correction to LTE testcase 6.3.5	12.4.0	12.5.0
2016-03	RAN#71	R5s150985	3130	-	Correction to LTE CSG testcase 6.4.1	12.4.0	12.5.0
2016-03	RAN#71	R5s150986	3131	-	Correction to LTE CSG testcase 6.4.2	12.4.0	12.5.0
2016-03	RAN#71	R5s150987	3132	-	Correction to LTE-IRAT CSG testcase 6.4.3	12.4.0	12.5.0
2016-03	RAN#71	R5s150988	3133	-	Correction to LTE-IRAT CSG testcase 6.4.4	12.4.0	12.5.0
2016-03	RAN#71	R5s150989	3134	-	Correction to LTE-IRAT CSG testcase 6.4.5	12.4.0	12.5.0
2016-03	RAN#71	R5s150990	3135	-	Correction to LTE CSG testcase 6.4.6	12.4.0	12.5.0
2016-03	RAN#71	R5s150991	3136	-	Correction to LTE CSG testcase 8.3.4.1	12.4.0	12.5.0
2016-03	RAN#71	R5s150992	3137	-	Correction to LTE CSG testcase 8.3.4.2	12.4.0	12.5.0
2016-03	RAN#71	R5s150993	3138	-	Correction to LTE CSG testcase 8.3.4.3	12.4.0	12.5.0
2016-03	RAN#71	R5s150994	3139	-	Correction to LTE CSG testcase 9.2.1.1.18	12.4.0	12.5.0
2016-03	RAN#71	R5s150995	3140	-	Correction to LTE CSG testcase 9.2.1.2.14	12.4.0	12.5.0
2016-03	RAN#71	R5s150996	3141	-	Correction to LTE CSG testcase 9.2.3.1.9	12.4.0	12.5.0
2016-03	RAN#71	R5s150997	3142	-	Correction to LTE CSG testcase 9.2.3.1.20	12.4.0	12.5.0
2016-03	RAN#71	R5s150998	3143	-	Correction to LTE CSG testcase 9.2.3.2.16	12.4.0	12.5.0
2016-03	RAN#71	R5s150999	3144	-	Correction to LTE CSG testcase 9.3.1.18	12.4.0	12.5.0
2016-03	RAN#71	R5s151000	3145	-	Correction to GCF WI-081 TestCase 7.1.4.4	12.4.0	12.5.0
2016-03	RAN#71	R5s151002	3146	-	Correction to LTE CSG testcase 8.3.4.4	12.4.0	12.5.0
2016-03	RAN#71	R5s151007	3147	-	Correction to EUTRA RRC MDT test case 8.6.6.2	12.4.0	12.5.0
2016-03	RAN#71	R5s151008	3148	-	Correction to EUTRA SSAC Emergency call testcase 13.5.3	12.4.0	12.5.0
2016-03	RAN#71	R5s151011	3149	-	Correction to IMS Emergency Call Limited Service Functionality	12.4.0	12.5.0
2016-03	RAN#71	R5s151012	3150	-	TTCN-3 Test Suites re-structuring	12.4.0	12.5.0
2016-03	RAN#71	R5s151013	3151	-	Correction to common function in ATS_15wk38	12.4.0	12.5.0
2016-03	RAN#71	R5s151015	3152	-	Correction to GCF WI-178 test case 9.2.3.4.1	12.4.0	12.5.0
2016-03	RAN#71	R5s151017	3153	-	Correction to SRVCC/aSRVCC/bSRVCC test cases	12.4.0	12.5.0

Date	TSG #	TSG Doc.	CR	Rev	Subject/Comment	Old	New
2016-03	RAN#71	R5s151018	3154	-	LTE_TDD: Addition of Rel-11 LTE-A CA test case 8.2.4.16.3	12.4.0	12.5.0
2016-03	RAN#71	R5s151020	3155	-	Addition of EUTRA Rel-11 eDDA test case 8.2.2.6.3	12.4.0	12.5.0
2016-03	RAN#71	R5s151022	3156	-	LTE-TDD : Addition of EUTRA Rel-11 eDDA test case 8.2.2.6.3	12.4.0	12.5.0
2016-03	RAN#71	R5s151032	3157	-	Correction to TestCase 6.1.2.17	12.4.0	12.5.0
2016-03	RAN#71	R5s151033	3158	-	Correction to TestCase 9.2.3.2.2	12.4.0	12.5.0
2016-03	RAN#71	R5s151035	3159	-	Correction to TestCase 9.3.1.16	12.4.0	12.5.0
2016-03	RAN#71	R5s151036	3160	-	Correction to MBMS Test cases	12.4.0	12.5.0
2016-03	RAN#71	R5s151037	3161	-	Correction to SS configuration for UTRAN	12.4.0	12.5.0
2016-03	RAN#71	R5s151039	3162	-	Correction to Inter-Band EUTRAN Handover TCs 8.2.4.13a, 8.2.4.15a, 8.3.1.12a, 8.3.1.13a, 8.3.1.14a, 8.3.1.15a	12.4.0	12.5.0
2016-03	RAN#71	R5s151040	3163	-	Correction to GCF WI-82 TC 9.2.2.1.9	12.4.0	12.5.0
2016-03	RAN#71	R5s151041	3164	-	Correction to GCF WI-082 EUTRA EMM test case 9.2.1.1.22	12.4.0	12.5.0
2016-03	RAN#71	R5s151042	3165	-	Correction to TestCases 8.2.4.15a	12.4.0	12.5.0
2016-03	RAN#71	R5s151043	3166	-	Correction to TestCase 7.2.3.15	12.4.0	12.5.0
2016-03	RAN#71	R5s151044	3167	-	Correction to ESM test case 10.4.2	12.4.0	12.5.0
2016-03	RAN#71	R5s151045	3168	-	Correction to LTE-A CA test cases 8.2.4.18.x	12.4.0	12.5.0
2016-03	RAN#71	R5s151046	3169	-	Correction to EUTRA Inter-mode measurement test case 8.3.1.14a	12.4.0	12.5.0
2016-03	RAN#71	R5s160001	3018	-	Correction to GCF WI-086 EUTRA RRC test case 8.5.2.1	12.4.0	12.5.0
2016-03	RAN#71	R5s160002	3019	-	Correction to function f_CalculateStartValue_ConnectedMode	12.4.0	12.5.0
2016-03	RAN#71	R5s160003	3020	-	Addition of EUTRA MFBI test case 6.1.2.22	12.4.0	12.5.0
2016-03	RAN#71	R5s160005	3021	-	Correction of GCF WI-082 test case 9.1.5.1	12.4.0	12.5.0
2016-03	RAN#71	R5s160007	3022	-	Correction to f_EUTRA_SendUE_LocationInformation	12.4.0	12.5.0
2016-03	RAN#71	R5s160008	3023	-	Correction to LTE CSG testcase 6.3.1	12.4.0	12.5.0
2016-03	RAN#71	R5s160009	3024	-	Correction to LTE CSG testcase 8.3.4.4	12.4.0	12.5.0
2016-03	RAN#71	R5s160010	3025	-	Correction of GCF WI-227 eMDT test cases 8.6.8.x and 8.6.9.x	12.4.0	12.5.0
2016-03	RAN#71	R5s160012	3026	-	Corrections to EMM test case 9.2.1.1.28a	12.4.0	12.5.0
2016-03	RAN#71	R5s160016	3027	-	Correction to postamble of LTE test case 9.2.1.1.28a	12.4.0	12.5.0
2016-03	RAN#71	R5s160017	3028	-	Correction to ESM test case 10.5.3	12.4.0	12.5.0
2016-03	RAN#71	R5s160020	3029	-	Correction to EUTRA RRC Test case 8.1.1.3	12.4.0	12.5.0
2016-03	RAN#71	R5s160021	3030	-	Addition of LTE Inter-RAT IMS Emergency Call test case 13.1.19	12.4.0	12.5.0
2016-03	RAN#71	R5s160023	3031	-	Addition of LTE Inter-RAT IMS Emergency Call test case 13.1.20	12.4.0	12.5.0
2016-03	RAN#71	R5s160025	3032	-	LTE_TDD: Addition of LTE Inter-RAT IMS Emergency Call test case 13.1.19	12.4.0	12.5.0
2016-03	RAN#71	R5s160027	3033	-	LTE_TDD: Addition of LTE Inter-RAT IMS Emergency Call test case 13.1.20	12.4.0	12.5.0
2016-03	RAN#71	R5s160033	3034	-	Corrections to LTE Emergency Call Limited Service Functionality	12.4.0	12.5.0
2016-03	RAN#71	R5s160034	3035	-	Correction to LTE CSG testcase 6.4.5	12.4.0	12.5.0
2016-03	RAN#71	R5s160035	3036	-	Correction to EUTRA RRC CA test cases 8.2.2.3.1 & 8.2.2.3.2	12.4.0	12.5.0
2016-03	RAN#71	R5s160037	3037	-	Addition of EUTRA Rel-11 eDDA test case 8.2.2.6.2	12.4.0	12.5.0
2016-03	RAN#71	R5s160039	3038	-	LTE-TDD : Addition of EUTRA Rel-11 eDDA test case 8.2.2.6.2	12.4.0	12.5.0

Date	TSG #	TSG Doc.	CR	Rev	Subject/Comment	Old	New
2016-03	RAN#71	R5s160042	3040	-	Correction to UL CA inter-band test cases	12.4.0	12.5.0
2016-03	RAN#71	R5s160044	3041	-	Corrections to ESM test case 10.4.2	12.4.0	12.5.0
2016-03	RAN#71	R5s160047	3042	-	Correction to EUTRA MAC test case 7.1.4.4	12.4.0	12.5.0
2016-03	RAN#71	R5s160048	3043	-	Corrections to XID/ IPv6 handling in LTE-GERAN test cases	12.4.0	12.5.0
2016-03	RAN#71	R5s160049	3044	-	Correction to EUTRA EMM test case 9.2.3.1.6	12.4.0	12.5.0
2016-03	RAN#71	R5s160050	3045	-	Correction to EUTRA RRC test case 8.5.4.1 for multi-PDN operation	12.4.0	12.5.0
2016-03	RAN#71	R5s160051	3046	-	Correction to EUTRA RRC test case 8.5.4.1 for IMS enabled UE (Multi PDN support)	12.4.0	12.5.0
2016-03	RAN#71	R5s160053	3048	-	Correction to LTE SSAC test case 13.5.3	12.4.0	12.5.0
2016-03	RAN#71	R5s160056	3050	-	Correction to EUTRA RRC InterRAT measurement on 1xRTT test case 8.3.2.10	12.4.0	12.5.0
2016-03	RAN#71	R5s160057	3051	-	Correction to test case 9.3.1.16	12.4.0	12.5.0
2016-03	RAN#71	R5s160059	3052	-	Correction to TestCase 7.1.4.7a	12.4.0	12.5.0
2016-03	RAN#71	R5s160063	3054	-	Correction to EMM test case 9.3.1.17 for IMS-enabled UEs	12.4.0	12.5.0
2016-03	RAN#71	R5s160064	3055	-	Corrections to eMBMS_SC test case 17.4.10.1 and 17.4.10.2	12.4.0	12.5.0
2016-03	RAN#71	R5s160065	3056	-	Correction to IMS emergency test cases 13.1.19 and 13.1.20	12.4.0	12.5.0
2016-03	RAN#71	R5s160066	3057	-	Correction to EUTRA Idle Mode CSG test case 6.3.4	12.4.0	12.5.0
2016-03	RAN#71	R5s160067	3058	-	Correction to EUTRA Idle mode HeNB test case 6.4.6	12.4.0	12.5.0
2016-03	RAN#71	R5s160068	3059	-	Correction for EMM test case 9.2.2.1.3	12.4.0	12.5.0
2016-03	RAN#71	R5s160079	3062	-	Correction to test case 9.2.3.1.16 with IMS enabled	12.4.0	12.5.0
2016-03	RAN#71	R5s160080	3063	-	Correction to test case 9.2.3.1.18 with IMS enabled	12.4.0	12.5.0
2016-03	RAN#71	R5s160081	3064	-	Correction to test case 9.2.3.1.18a with IMS enabled	12.4.0	12.5.0
2016-03	RAN#71	R5s160083	3066	-	LTE_TDD: Addition of LTE-A Carrier Aggregation test case 7.1.4.19.1	12.4.0	12.5.0
2016-03	RAN#71	R5s160084	3067	-	Addition of LTE-A Carrier Aggregation test case 7.1.4.19.1	12.4.0	12.5.0
2016-03	RAN#71	R5s160091	3068	-	Correction to LTE IRAT testcase 6.3.3	12.4.0	12.5.0
2016-03	RAN#71	R5s160093	3070	-	Addition of LTE-CA Inter band test case 8.5.1.7.2 in Rel-12 FDD+TDD band combination	12.4.0	12.5.0
2016-03	RAN#71	R5s160094	3071	-	Correction to LTE IRAT testcase 6.3.4	12.4.0	12.5.0
2016-03	RAN#71	R5s160095	3072	-	Correction to LTE IRAT testcase 6.4.6	12.4.0	12.5.0
2016-03	RAN#71	R5s160097	3073	-	Correction to EUTRA EMM test cases 9.4.x on multi-PDN UE	12.4.0	12.5.0
2016-03	RAN#71	R5s160098	3074	-	Correction to EUTRA band 25 – CDMA BC 1 band combination	12.4.0	12.5.0
2016-03	RAN#71	R5s160103	3079	-	Addition of Rel-12 SSAC test case 13.5.1a	12.4.0	12.5.0
2016-03	RAN#71	R5s160104	3080	-	LTE_TDD : Addition of Rel-12 SSAC test case 13.5.1a	12.4.0	12.5.0
2016-03	RAN#71	R5s160110	3082	-	Addition of Rel-12 SSAC test case 13.5.2a	12.4.0	12.5.0
2016-03	RAN#71	R5s160112	3083	-	LTE_TDD : Addition of Rel-12 SSAC test case 13.5.2a	12.4.0	12.5.0
2016-03	RAN#71	R5s160118	3086	-	Addition of Rel-12 SSAC test case 13.5.3a	12.4.0	12.5.0
2016-03	RAN#71	R5s160120	3087	-	LTE_TDD : Addition of Rel-12 SSAC test case 13.5.3a	12.4.0	12.5.0
2016-03	RAN#71	R5s160123	3089	-	Correction to LTE IRAT MFBI test case 6.2.3.35	12.4.0	12.5.0
2016-03	RAN#71	R5s160124	3090	-	Correction to EUTRA RRC Handover test cases 8.2.4.13a, 8.3.1.12a and 8.3.1.13a	12.4.0	12.5.0
2016-03	RAN#71	R5s160126	3091	-	Correction to Cell-FACH RB setup procedure.	12.4.0	12.5.0

Date	TSG #	TSG Doc.	CR	Rev	Subject/Comment	Old	New
2016-03	RAN#71	R5s160133	3093	-	Facilitating support for IMS registration over UTRAN for Inter-RAT test cases starting in UTRAN	12.4.0	12.5.0
2016-03	RAN#71	R5s160134	3094	-	Addition of LTE-CA Inter band test case 8.2.4.19.2 in Rel-12 FDD+TDD band combination	12.4.0	12.5.0
2016-03	RAN#71	R5s160137	3095	-	Correction to RPLMN test case 6.1.1.8	12.4.0	12.5.0
2016-03	RAN#71	R5s160138	3096	-	Correction to RPLMN test case 6.1.1.9.	12.4.0	12.5.0
2016-03	RAN#71	R5s160140	3099	-	Correction to eDDA Testcase 8.2.2.6.3	12.4.0	12.5.0
2016-03	RAN#71	R5s160141	3100	-	Correction to eMDT Testcase 8.6.7.4	12.4.0	12.5.0
2016-03	RAN#71	R5s160142	3101	-	Correction to eMDT testcase 8.6.7.1	12.4.0	12.5.0
2016-03	RAN#71	R5s160144	3102	-	Correction to function f_IMS_MessageRequest_MessageHeaderRX_RSRVCC	12.4.0	12.5.0
2016-03	RAN#71	R5s160145	3103	-	Correction to LTE-A eMBMS-SC-CA test case 17.4.9.1 and 17.4.9.2	12.4.0	12.5.0
2016-03	RAN#71	R5s160146	3104	-	Correction to encoding of IMS APN name (IMS enabled UE / Multi-PDN)	12.4.0	12.5.0
2016-03	RAN#71	R5s160147	3105	-	Correction to test case 8.2.4.14a, function f_TC_8_2_4_14a_EUTRA() in RRC_Handover.ttcn	12.4.0	12.5.0
2016-03	RAN#71	R5s160154	3106	-	Correction to LTE IRAT test case 9.2.3.3.1	12.4.0	12.5.0
2016-03	RAN#71	R5s160155	3107	-	Addition of GCF WI-227 Inter-RAT eMDT test case 8.6.5.4	12.4.0	12.5.0
2016-03	RAN#71	R5s160159	3109	-	LTE_TDD - Addition of 6.2.3.27 - InterRAT GCF WI-97 EUTRA<>GERAN Test case	12.4.0	12.5.0
2016-03	RAN#71	R5s160160	3110	-	Correction for SysInfo Configuration c14	12.4.0	12.5.0
2016-03	RAN#71	R5s160163	3113	-	LTE_TDD : Addition of EUTRA Rel-11 eMDT test case 8.6.5.4	12.4.0	12.5.0
2016-03	RAN#71	R5s160172	3117	-	Correction to applicability for EUTRA MFBI test case 6.1.2.22	12.4.0	12.5.0
2016-03	RAN#71	R5s160253	3174	-	Corrections to IMS emergency call test cases	12.4.0	12.5.0
2016-03	RAN#71	RP-160124	3121	-	CR to 36.523-3: Add new verified and e-mail agreed TTCN test cases in the TC lists in 36.523-3 (prose), Annex A	12.4.0	12.5.0
2016-06	RAN#72	R5-162026	3249	-	D2D ProSe: Test Model updates	12.5.0	12.6.0
2016-06	RAN#72	R5-163035	3281	1	Dual Connectivity: Test Model updates	12.5.0	12.6.0
2016-06	RAN#72	R5-163084	3288	1	Addition of PIXIT parameter required for MFBI ehancement test case	12.5.0	12.6.0
2016-06	RAN#72	R5-163085	3248	1	Routine maintenance for TS 36.523-3	12.5.0	12.6.0
2016-06	RAN#72	R5s160296	3201	-	Correction to IMS Emergency Call test case 11.2.6	12.5.0	12.6.0
2016-06	RAN#72	R5s160298	3202	-	Addition of Rel-11 EUTRA MAC test case 7.1.2.10.1	12.5.0	12.6.0
2016-06	RAN#72	R5s160301	3204	-	Addition of Rel-11 EUTRA MAC test case 7.1.2.10.3	12.5.0	12.6.0
2016-06	RAN#72	R5s160303	3205	-	Addition of LTE-CA Inter band test case 8.2.2.3.2 in Rel-12 FDD+TDD band combination	12.5.0	12.6.0
2016-06	RAN#72	R5s160305	3206	-	Correction to Rel-10 EUTRA MAC test cases 7.1.4.18 and 7.1.4.21	12.5.0	12.6.0
2016-06	RAN#72	R5s160306	3207	-	Correction to EMM test case 9.1.3.1 for IMS-enabled UE	12.5.0	12.6.0
2016-06	RAN#72	R5s160308	3209	-	Correction to EMM test case 9.1.2.5 (Multi-PDN / IMS enabled UE)	12.5.0	12.6.0
2016-06	RAN#72	R5s160309	3210	-	Correction to EMM test case 9.1.2.7 (Multi-PDN / IMS enabled UE)	12.5.0	12.6.0
2016-06	RAN#72	R5s160315	3213	-	Addition of LTE-A CA 2UL test case 7.1.2.11.2	12.5.0	12.6.0
2016-06	RAN#72	R5s160317	3214	-	LTE_TDD: Addition of LTE-A CA 2UL test case 7.1.2.11.2	12.5.0	12.6.0
2016-06	RAN#72	R5s160319	3215	-	Correction to function f_Get_508_EPSBearerTI	12.5.0	12.6.0
2016-06	RAN#72	R5s160320	3216	-	Correction to EUTRA RRC test case 8.5.4.1	12.5.0	12.6.0
2016-06	RAN#72	R5s160321	3217	-	Correction to EMM test case 9.2.3.1.25	12.5.0	12.6.0
2016-06	RAN#72	R5s160322	3218	-	Addition of Rel-11 LTE-A CA test case 8.2.2.7.3	12.5.0	12.6.0

Date	TSG #	TSG Doc.	CR	Rev	Subject/Comment	Old	New
2016-06	RAN#72	R5s160326	3219	-	Correction to testcase 7.3.5.5	12.5.0	12.6.0
2016-06	RAN#72	R5s160327	3220	-	Correction to IMS Emergency Call test case 11.2.6	12.5.0	12.6.0
2016-06	RAN#72	R5s160329	3222	-	Correction to Cell-FACH RB setup procedure	12.5.0	12.6.0
2016-06	RAN#72	R5s160330	3223	-	Correction to (x)SRVCC test cases 13.4.3.2, 13.4.3.15 and 13.4.3.18	12.5.0	12.6.0
2016-06	RAN#72	R5s160331	3224	-	Corrections to EMM test case 9.2.1.1.29	12.5.0	12.6.0
2016-06	RAN#72	R5s160333	3226	-	Correction to test case 9.2.3.2.14 with IMS enabled	12.5.0	12.6.0
2016-06	RAN#72	R5s160334	3227	-	Corrections to EMM test cases 9.2.1.1.1a and 9.2.1.1.1b for Multi-PDN UEs	12.5.0	12.6.0
2016-06	RAN#72	R5s160335	3228	-	Correction to EMM test case 9.2.3.1.16 for IMS-enabled UE	12.5.0	12.6.0
2016-06	RAN#72	R5s160336	3229	-	Corrections to Rel-12 SSAC test cases	12.5.0	12.6.0
2016-06	RAN#72	R5s160337	3230	-	Correction to EUTRA LTE-A<>IRAT TestCase 8.6.5.4	12.5.0	12.6.0
2016-06	RAN#72	R5s160340	3231	-	Correction to EMM test case 9.2.2.2.14 (IMS enabled UE / Multi-PDN)	12.5.0	12.6.0
2016-06	RAN#72	R5s160341	3232	-	Correction to usage of function f_EUTRA_RRC_ActivateSecurity	12.5.0	12.6.0
2016-06	RAN#72	R5s160342	3233	-	Correction to function f_EUTRA_MobileInfo_GetUECapability_UECategoryExtn	12.5.0	12.6.0
2016-06	RAN#72	R5s160343	3234	-	Corrections to GCF WI-086 CSG test case 6.3.4	12.5.0	12.6.0
2016-06	RAN#72	R5s160344	3235	-	Corrections to CSG test case 6.4.6	12.5.0	12.6.0
2016-06	RAN#72	R5s160346	3237	-	Correction to function f_EUTRA_508RRC_IntraLTE_HO_InterCell_Common_Steps1_12	12.5.0	12.6.0
2016-06	RAN#72	R5s160347	3238	-	Correction to Emergency Call test case 11.2.3	12.5.0	12.6.0
2016-06	RAN#72	R5s160348	3239	-	Correction to GCF WI-082 test case 9.2.3.1.18 with IMS enabled	12.5.0	12.6.0
2016-06	RAN#72	R5s160350	3241	-	Correction of GCF WI-082 EMM test case 9.1.5.1	12.5.0	12.6.0
2016-06	RAN#72	R5s160351	3242	-	Correction to LTE-A eMBMS-SC-CA test case 17.4.9.1 and 17.4.9.2.	12.5.0	12.6.0
2016-06	RAN#72	R5s160354	3244	-	Addition of LTE-A UL CA test case 7.1.4.20.3	12.5.0	12.6.0
2016-06	RAN#72	R5s160359	3245	-	Corrections to EMM test case 9.2.1.2.1 for Multi-PDN UE	12.5.0	12.6.0
2016-06	RAN#72	R5s160360	3246	-	Corrections to EMM test case 9.2.1.1.19 for Multi-PDN UE	12.5.0	12.6.0
2016-06	RAN#72	R5s160361	3247	-	Corrections to EMM test case 9.2.1.1.24 for Multi-PDN UE	12.5.0	12.6.0
2016-06	RAN#72	R5s160362	3250	-	Corrections to EMM test case 9.2.1.1.1 for Multi-PDN UE	12.5.0	12.6.0
2016-06	RAN#72	R5s160363	3251	-	Corrections to EMM test case 9.2.1.2.1d for Multi-PDN UE	12.5.0	12.6.0
2016-06	RAN#72	R5s160365	3253	-	Correction to EUTRA LTE<>IRAT TestCase 6.2.1.2 and 6.2.1.3	12.5.0	12.6.0
2016-06	RAN#72	R5s160367	3254	-	Correction to IMS MO video call SSAC test case 13.5.2a	12.5.0	12.6.0
2016-06	RAN#72	R5s160368	3255	-	Corrections to EMM test case 9.2.1.1.18 for Multi-PDN UE	12.5.0	12.6.0
2016-06	RAN#72	R5s160369	3256	-	Corrections to EMM test case 9.2.1.2.4a for Multi-PDN UE	12.5.0	12.6.0
2016-06	RAN#72	R5s160370	3257	-	Corrections to EMM test case 9.2.1.1.26 for Multi-PDN UE	12.5.0	12.6.0
2016-06	RAN#72	R5s160376	3259	-	Corrections to EUTRA Idle Mode test case 6.1.1.4 for Multi-PDN UE	12.5.0	12.6.0
2016-06	RAN#72	R5s160383	3260	-	Corrections to EUTRA MAC test cases 7.1.2.8 and 7.1.3.9	12.5.0	12.6.0
2016-06	RAN#72	R5s160384	3261	-	LTE_TDD: Correction to EUTRA eMDT test case 8.6.8.5	12.5.0	12.6.0
2016-06	RAN#72	R5s160385	3262	-	Correction to UTRAN Registration procedure with IMS enabled for LTE-IRAT test cases	12.5.0	12.6.0
2016-06	RAN#72	R5s160386	3263	-	Corrections to EMM test case 9.2.1.1.2 for IMS-enabled UE	12.5.0	12.6.0
2016-06	RAN#72	R5s160387	3264	-	Corrections to EMM test case 9.2.2.1.2 for IMS-enabled UE	12.5.0	12.6.0

Date	TSG #	TSG Doc.	CR	Rev	Subject/Comment	Old	New
2016-06	RAN#72	R5s160388	3265	-	Correction to IMS Emergency Call test case 11.2.3 for Multi-PDN UEs	12.5.0	12.6.0
2016-06	RAN#72	R5s160391	3266	-	Correction to GERAN ciphering setup for InterRAT test cases with IMS relation	12.5.0	12.6.0
2016-06	RAN#72	R5s160393	3267	-	Correction to test cases 9.2.3.1.15, 9.2.3.1.15a and 9.2.3.1.18a with MultiPDN configuration	12.5.0	12.6.0
2016-06	RAN#72	R5s160394	3268	-	Correction to LTE-IRAT test cases 6.2.3.13 & 6.2.3.4 for IMS over UTRA enabled UEs	12.5.0	12.6.0
2016-06	RAN#72	R5s160395	3269	-	Correction to LTE-A eMBMS-SC-CA test case 17.4.9.1 and 17.4.9.2	12.5.0	12.6.0
2016-06	RAN#72	R5s160396	3270	-	Correction to CA / RRC connection reconfiguration test cases 8.2.4.17.x	12.5.0	12.6.0
2016-06	RAN#72	R5s160397	3271	-	Correction to f_EUTRA_508RRC_IntraLTE_CA_HO_InterCell	12.5.0	12.6.0
2016-06	RAN#72	R5s160398	3272	-	Correction to test case 7.1.4.12	12.5.0	12.6.0
2016-06	RAN#72	R5s160399	3273	-	Corrections to EMM test case 9.2.1.2.2 for IMS-enabled UE	12.5.0	12.6.0
2016-06	RAN#72	R5s160400	3274	-	Addition of PTCRB RFT-111 EUTRA Hybrid Cell TestCase 6.4.7	12.5.0	12.6.0
2016-06	RAN#72	R5s160402	3276	-	Corrections to EMM test case 9.2.1.2.3 for IMS-enabled UE	12.5.0	12.6.0
2016-06	RAN#72	R5s160404	3278	-	Corrections to EMM test case 9.2.1.2.4 for Multi-PDN UE	12.5.0	12.6.0
2016-06	RAN#72	R5s160405	3279	-	Corrections to testcase 11.2.8	12.5.0	12.6.0
2016-06	RAN#72	R5s160407	3280	-	Correction to NIMTC test case 10.5.4	12.5.0	12.6.0
2016-06	RAN#72	R5s160408	3282	-	Corrections to EMM test case 9.2.3.2.11 for IMS-enabled UE	12.5.0	12.6.0
2016-06	RAN#72	R5s160412	3284	-	Correction to GCF WI-227 Inter-RAT eMDT test case 8.6.7.4	12.5.0	12.6.0
2016-06	RAN#72	R5s160414	3287	-	Corrections to EMM test case 9.2.2.2.1 for Multi-PDN UE	12.5.0	12.6.0
2016-06	RAN#72	R5s160415	3289	-	Corrections to EMM test case 9.2.3.1.5 for Multi-PDN UE	12.5.0	12.6.0
2016-06	RAN#72	R5s160416	3290	-	Corrections to EMM test case 9.2.3.2.2 for IMS-enabled UE	12.5.0	12.6.0
2016-06	RAN#72	R5s160417	3291	-	Correction to EMM test case 9.2.1.1.30	12.5.0	12.6.0
2016-06	RAN#72	R5s160418	3292	-	Correction to CMAS test case 18.1.3 for IMS enabled UE with Multi-PDN configuration	12.5.0	12.6.0
2016-06	RAN#72	R5s160422	3294	-	Correction to LTE-A eMBMS-SC-CA test cases	12.5.0	12.6.0
2016-06	RAN#72	R5s160423	3295	-	Corrections to testcases 13.1.19 and 13.1.20	12.5.0	12.6.0
2016-06	RAN#72	R5s160424	3296	-	LTE_TDD: Addition of Rel-11 LTE-A CA Enhancements test case 7.1.2.10.1	12.5.0	12.6.0
2016-06	RAN#72	R5s160426	3297	-	Correction to EMM test case 9.2.2.1.8 for IMS enabled UEs	12.5.0	12.6.0
2016-06	RAN#72	R5s160429	3298	-	Corrections to EMM test cases 9.2.2.1.6 and 9.2.2.1.7	12.5.0	12.6.0
2016-06	RAN#72	R5s160430	3299	-	Corrections for EMM test cases 9.2.1.1.13 and 9.2.1.2.12	12.5.0	12.6.0
2016-06	RAN#72	R5s160434	3300	-	Correction to LTE-IRAT test case 6.2.2.8 for "IMS over UTRA" enabled UEs	12.5.0	12.6.0
2016-06	RAN#72	R5s160437	3303	-	Correction to LTE-IRAT test case 6.2.3.31 for "IMS over UTRA" enabled UEs	12.5.0	12.6.0
2016-06	RAN#72	R5s160449	3312	-	Correction for EPS transaction Identifier IE	12.5.0	12.6.0
2016-06	RAN#72	R5s160452	3314	-	Correction to EMM test case 9.2.3.1.5 for Multi-PDN UEs	12.5.0	12.6.0
2016-06	RAN#72	RP-160852	3316	-	Add new verified and e-mail agreed TTCN test cases in the TC lists in 36.523-3 (prose), Annex A	12.5.0	12.6.0
2016-06	RAN#72	R5s160459	3060	1	Correction to EUTRA Idle Mode PLMN Selection test case 6.1.1.9	12.5.0	12.6.0
2016-06	RAN#72	R5s160464	3111	1	Correction to WI-82 EMM Information procedure Testcase 9.1.5.1	12.5.0	12.6.0
2016-06	RAN#72	R5s160465	3112	1	Addition of LTE-A UL CA test case 7.1.4.20.1	12.5.0	12.6.0
2016-06	RAN#72	R5s160466	3114	1	LTE_TDD: Addition of LTE-A UL CA test case 7.1.4.20.1	12.5.0	12.6.0
2016-06	RAN#72	R5s160467	3115	1	Addition of LTE-A CA 2UL test case 7.1.4.20.2	12.5.0	12.6.0

Date	TSG #	TSG Doc.	CR	Rev	Subject/Comment	Old	New
2016-06	RAN#72	R5s160468	3116	1	LTE_TDD: Addition of LTE-A CA 2UL test case 7.1.4.20.2	12.5.0	12.6.0
2016-06	RAN#72	R5s160469	3118	1	Correction to test condition C179	12.5.0	12.6.0
2016-06	RAN#72	R5s160470	3119	1	Corrections for Inter-RAT PLMN selection test case 6.2.1.2 and 6.2.1.3	12.5.0	12.6.0
2016-06	RAN#72	R5s160471	3170	1	Correction to eMDT Testcase 8.6.9.1	12.5.0	12.6.0
2016-06	RAN#72	R5s160473	3171	1	Correction to testcase 8.2.4.14	12.5.0	12.6.0
2016-06	RAN#72	R5s160474	3172	1	Correction to template cr_RRCConnectionsetupComplete_r11	12.5.0	12.6.0
2016-06	RAN#72	R5s160476	3173	1	Correction to EMM test case 9.2.1.1.30	12.5.0	12.6.0
2016-06	RAN#72	R5s160477	3175	1	Correction to RRC CA test cases 8.2.4.16.x	12.5.0	12.6.0
2016-06	RAN#72	R5s160481	3176	1	Correction to eMDT Testcase 8.6.5.1a	12.5.0	12.6.0
2016-06	RAN#72	R5s160482	3177	1	Improved handling of system interface	12.5.0	12.6.0
2016-06	RAN#72	R5s160483	3178	1	Corrections for EMM test cases 9.2.2.1.6 and 9.2.2.1.7 on IMS-enabled UEs	12.5.0	12.6.0
2016-06	RAN#72	R5s160484	3179	1	Corrections to UTRAN cell initialization functions	12.5.0	12.6.0
2016-06	RAN#72	R5s160485	3180	1	Corrections to Delay for IMS signalling	12.5.0	12.6.0
2016-06	RAN#72	R5s160486	3181	1	Correction to EMM testcase 9.1.3.1	12.5.0	12.6.0
2016-06	RAN#72	R5s160487	3182	1	Correction to EMM testcase 9.1.3.2	12.5.0	12.6.0
2016-06	RAN#72	R5s160488	3183	1	Correction to function f_EUTRA_ConnectedMode_TAU	12.5.0	12.6.0
2016-06	RAN#72	R5s160489	3184	1	Corrections to testcases 9.2.1.1.1a and 9.2.1.1.1b	12.5.0	12.6.0
2016-06	RAN#72	R5s160491	3185	1	Correction to testcase 9.2.3.2.12	12.5.0	12.6.0
2016-06	RAN#72	R5s160493	3186	1	Correction to testcase 9.2.1.2.4	12.5.0	12.6.0
2016-06	RAN#72	R5s160494	3187	1	Corrections to testcases 9.2.1.1.7 and 9.2.1.1.7a	12.5.0	12.6.0
2016-06	RAN#72	R5s160495	3188	1	Correction to GCF WI-177 TC 8.6.4.3	12.5.0	12.6.0
2016-06	RAN#72	R5s160496	3189	1	Correction to GCF WI-081 TC 8.5.1.2	12.5.0	12.6.0
2016-06	RAN#72	R5s160497	3190	1	Correction to testcase 7.1.4.7a	12.5.0	12.6.0
2016-06	RAN#72	R5s160498	3191	1	Correction to testcases 8.2.4.16.x	12.5.0	12.6.0
2016-06	RAN#72	R5s160499	3192	1	Correction to testcase 9.2.1.1.20	12.5.0	12.6.0
2016-06	RAN#72	R5s160500	3193	1	Correction to testcase 9.2.3.1.16	12.5.0	12.6.0
2016-06	RAN#72	R5s160501	3194	1	Correction to testcase 9.2.3.1.18	12.5.0	12.6.0
2016-06	RAN#72	R5s160504	3196	1	Correction to GCF WI-178 eMBMS-SC TC 17.4.5	12.5.0	12.6.0
2016-06	RAN#72	R5s160505	3197	1	Correction to GCF WI-178 eMBMS-SC TC 17.4.6	12.5.0	12.6.0
2016-06	RAN#72	R5s160506	3198	1	Correction to SSAC test case 13.5.3	12.5.0	12.6.0
2016-06	RAN#72	R5s160508	3199	1	Correction to GCF WI-227 eMDT test case 8.6.7.4	12.5.0	12.6.0
2016-06	RAN#72	R5s160509	3200	1	Correction to UE Location information procedure	12.5.0	12.6.0
2016-06	RAN#72	R5s160517	3195	1	Correction to testcase 13.5.3a	12.5.0	12.6.0
2016-09	RAN#73	R5-165260	3419	-	D2D ProSe: Test Model updates	12.6.0	12.7.0
2016-09	RAN#73	R5-165263	3420	-	eIMTA: Introduction of Test Model	12.6.0	12.7.0
2016-09	RAN#73	R5-166330	3418	2	Routine maintenance for TS 36.523-3	12.6.0	12.7.0
2016-09	RAN#73	R5s160617	3370	-	Corrections to EMM test case 9.2.1.1.19 for Multi-PDN UE	12.6.0	12.7.0

Date	TSG #	TSG Doc.	CR	Rev	Subject/Comment	Old	New
2016-09	RAN#73	R5s160619	3372	-	Corrections to LTE-UTRA testcase 6.3.3 (IMS over UTRA enabled devices)	12.6.0	12.7.0
2016-09	RAN#73	R5s160620	3373	-	Corrections to LTE-UTRA testcase 6.3.4 (IMS over UTRA enabled devices)	12.6.0	12.7.0
2016-09	RAN#73	R5s160621	3374	-	Corrections to LTE-UTRA testcase 6.4.5 (IMS over UTRA enabled devices)	12.6.0	12.7.0
2016-09	RAN#73	R5s160622	3375	-	Corrections to LTE-UTRA testcase 6.4.6 (IMS over UTRA enabled devices)	12.6.0	12.7.0
2016-09	RAN#73	R5s160623	3376	-	Correction to EUTRA RRC test case 8.5.4.1	12.6.0	12.7.0
2016-09	RAN#73	R5s160624	3377	-	Correction to EMM test case 9.1.5.1	12.6.0	12.7.0
2016-09	RAN#73	R5s160625	3378	-	Correction to EMM test case 9.2.2.2.1 for Multi-PDN UE	12.6.0	12.7.0
2016-09	RAN#73	R5s160626	3379	-	Further corrections of test frequencies for LTE-A CA intra-band test cases	12.6.0	12.7.0
2016-09	RAN#73	R5s160627	3380	-	Correction to Rel-11 eMDT test case 8.6.9.2	12.6.0	12.7.0
2016-09	RAN#73	R5s160631	3382	-	Correction to IMS emergency call test case 11.2.12	12.6.0	12.7.0
2016-09	RAN#73	R5s160633	3384	-	Correction to EMM test cases 9.2.1.2.2 and 9.2.1.2.4	12.6.0	12.7.0
2016-09	RAN#73	R5s160635	3386	-	LTE_TDD: Addition of LTE-A Rel-12 DL-256 QAM test case 7.1.7.1.8	12.6.0	12.7.0
2016-09	RAN#73	R5s160638	3387	-	Correction to EUTRA RRC MDT test case 8.6.4.5	12.6.0	12.7.0
2016-09	RAN#73	R5s160639	3388	-	Correction to Rel-11 eMDT test case 8.6.3.4	12.6.0	12.7.0
2016-09	RAN#73	R5s160640	3389	-	Correction to the applicability of Rel-11 eMBMS_CA test case 17.4.11.2	12.6.0	12.7.0
2016-09	RAN#73	R5s160641	3390	-	Correction to EUTRA MAC test cases 7.1.6.3 and 7.1.6.4	12.6.0	12.7.0
2016-09	RAN#73	R5s160643	3391	-	Correction to Security for IMS over UTRAN functionality	12.6.0	12.7.0
2016-09	RAN#73	R5s160646	3283	1	Correction to EUTRA Idle Mode PLMN Selection test case 6.1.1.8	12.6.0	12.7.0
2016-09	RAN#73	R5s160647	3286	1	Correction to EUTRA Idle Mode PLMN Selection test case 6.1.1.9	12.6.0	12.7.0
2016-09	RAN#73	R5s160648	3293	1	Addition of Rel-12 LTE-A CA FDD-TDD test case 7.1.3.11.4	12.6.0	12.7.0
2016-09	RAN#73	R5s160649	3301	1	Correction to Handover Failure logging / Reporting of GERAN Inter-RAT measurements 8.6.7.2	12.6.0	12.7.0
2016-09	RAN#73	R5s160650	3307	1	Correction to f_EUTRA_508RRC_AddMod_1Scell	12.6.0	12.7.0
2016-09	RAN#73	R5s160651	3309	1	Addition of Rel-12 LTE-A CA FDD-TDD test case 7.1.3.11.5	12.6.0	12.7.0
2016-09	RAN#73	R5s160652	3310	1	Correction to EUTRA eMDT test case 8.6.8.2	12.6.0	12.7.0
2016-09	RAN#73	R5s160653	3311	1	Correction to EUTRA Idle mode test case 6.1.1.4	12.6.0	12.7.0
2016-09	RAN#73	R5s160657	3315	1	Correction for EMM test case 9.2.3.3.5a for IMS-enabled UE	12.6.0	12.7.0
2016-09	RAN#73	R5s160663	3335	1	Correction to test case 8.2.2.8	12.6.0	12.7.0
2016-09	RAN#73	R5s160664	3338	1	Addition of GCF WI-087 EUTRA CSG TestCase 6.3.2	12.6.0	12.7.0
2016-09	RAN#73	R5s160666	3392	-	Correction to GCF WI-081 EUTRA RRC test case 8.5.4.1	12.6.0	12.7.0
2016-09	RAN#73	R5s160667	3340	1	Corrections to Delay for IMS signalling	12.6.0	12.7.0
2016-09	RAN#73	R5s160668	3342	1	Correction to GCF WI-202 Test case 8.2.2.8	12.6.0	12.7.0
2016-09	RAN#73	R5s160670	3346	1	Correction to EUTRA<->UTRA multilayer test case 13.4.3.4	12.6.0	12.7.0
2016-09	RAN#73	R5s160671	3347	1	Corrections to f_GetSystemSpecificCapability	12.6.0	12.7.0
2016-09	RAN#73	R5s160672	3349	1	Correction to EMM test case 9.2.3.1.15	12.6.0	12.7.0
2016-09	RAN#73	R5s160673	3350	1	Correction to EMM test case 9.2.1.1.28 for Multi-PDN UEs	12.6.0	12.7.0
2016-09	RAN#73	R5s160675	3354	1	Correction to EMM test case 9.2.3.1.25	12.6.0	12.7.0
2016-09	RAN#73	R5s160680	3393	-	Corrections to LTE-UTRA testcase 8.1.3.7 (IMS over UTRA enabled devices)	12.6.0	12.7.0

Date	TSG #	TSG Doc.	CR	Rev	Subject/Comment	Old	New
2016-09	RAN#73	R5s160681	3394	-	Corrections to LTE-UTRA testcase 9.2.2.1.10 (IMS over UTRA enabled devices)	12.6.0	12.7.0
2016-09	RAN#73	R5s160682	3395	-	Corrections to LTE-UTRA testcase 9.2.3.1.6 (IMS over UTRA enabled devices)	12.6.0	12.7.0
2016-09	RAN#73	R5s160683	3396	-	Corrections to LTE-UTRA testcase 9.2.3.3.1 (IMS over UTRA enabled devices)	12.6.0	12.7.0
2016-09	RAN#73	R5s160685	3398	-	Correction to MDT test case 8.6.4.4	12.6.0	12.7.0
2016-09	RAN#73	R5s160689	3400	-	Corrections to f_EUTRA_UE_DetachMO (IMS over UTRA enabled devices)	12.6.0	12.7.0
2016-09	RAN#73	R5s160690	3401	-	Corrections to LTE-UTRA testcase 8.5.2.1 (IMS over UTRA enabled devices)	12.6.0	12.7.0
2016-09	RAN#73	R5s160691	3402	-	Addition of LTE-A Rel-12 DL-256 QAM test case 7.1.7.1.11	12.6.0	12.7.0
2016-09	RAN#73	R5s160693	3403	-	Addition of LTE-A Rel-12 DL-256 QAM test case 7.1.7.1.12	12.6.0	12.7.0
2016-09	RAN#73	R5s160695	3404	-	Correction to GCF WI-150 EUTRA Idle Mode Testcase 6.1.2.18	12.6.0	12.7.0
2016-09	RAN#73	R5s160702	3408	-	LTE_TDD: Addition of LTE-A Rel-12 DL-256 QAM test case 7.1.7.1.12	12.6.0	12.7.0
2016-09	RAN#73	R5s160704	3409	-	Correction to EMM test case 9.3.1.6 for Multi-PDN UEs	12.6.0	12.7.0
2016-09	RAN#73	R5s160705	3410	-	Correction to LTE-A Carrier Aggregation MAC test cases 7.1.4.20.x	12.6.0	12.7.0
2016-09	RAN#73	R5s160707	3411	-	Correction to PCell configuration in common CA functions	12.6.0	12.7.0
2016-09	RAN#73	R5s160708	3412	-	Corrections to EMM test cases 9.2.1.2.2 and 9.2.1.2.4	12.6.0	12.7.0
2016-09	RAN#73	R5s160716	3416	-	Correction to applicability of eMBMS TCs with IMS enabled devices.	12.6.0	12.7.0
2016-09	RAN#73	R5s160719	3417	-	Correction to applicability of LTE-A CA test case 8.3.1.22.3	12.6.0	12.7.0
2016-09	RAN#73	R5s160720	3422	-	Correction to GCF WI-081 EUTRA PDCP Testcase 7.3.5.2	12.6.0	12.7.0
2016-09	RAN#73	R5s160730	3425	-	Correction to common function f_EUTRA_Calculate_PF_PO()	12.6.0	12.7.0
2016-09	RAN#73	R5s160731	3426	-	LTE_TDD: Addition of Rel-11 eMDT test case 8.6.1.2	12.6.0	12.7.0
2016-09	RAN#73	R5s160733	3427	-	LTE_TDD: Addition of Rel-11 eMDT test case 8.6.7.4	12.6.0	12.7.0
2016-09	RAN#73	R5s160738	3428	-	Correction to EUTRA MAC test cases 7.1.3.2 and 7.1.3.6	12.6.0	12.7.0
2016-09	RAN#73	R5s160739	3429	-	Correction to ESM test cases 10.8.1 and 10.8.2 for IMS-enabled device	12.6.0	12.7.0
2016-09	RAN#73	R5s160740	3430	-	Correction for IMS Registration for LTE<->UTRA Testcases	12.6.0	12.7.0
2016-09	RAN#73	R5s160741	3431	-	Addition of LTE-A Rel-12 Coverage Enhancement test case 7.1.4.23	12.6.0	12.7.0
2016-09	RAN#73	R5s160746	3432	-	Correction to EUTRA MAC test cases 7.1.4.14	12.6.0	12.7.0
2016-09	RAN#73	R5s160748	3434	-	Correction to EUTRA ETWS and PWS test cases	12.6.0	12.7.0
2016-09	RAN#73	R5s160749	3435	-	Correction to EUTRA RLC test cases 7.2.2.10	12.6.0	12.7.0
2016-09	RAN#73	R5s160750	3436	-	Correction to Inter-RAT Idle mode CSG test cases 6.3.3 and 6.3.4	12.6.0	12.7.0
2016-09	RAN#73	R5s160751	3437	-	Correction to EMM test case 9.2.1.2.2	12.6.0	12.7.0
2016-09	RAN#73	R5s160752	3438	-	Correction to EMM test cases 9.2.1.1.7, 9.2.1.1.7a, 9.2.1.1.7b, 9.2.1.1.7c	12.6.0	12.7.0
2016-09	RAN#73	R5s160753	3439	-	Correction to EMM test cases 9.3.1.4, 9.3.1.5 and 9.3.1.6 for IMS-enabled UEs	12.6.0	12.7.0
2016-09	RAN#73	R5s160756	3441	-	Correction to HSFN handling in TTCN	12.6.0	12.7.0
2016-09	RAN#73	R5s160757	3442	-	Correction to LTE<->UTRAN EMM test case 9.2.1.2.15 for IMS-enabled device	12.6.0	12.7.0
2016-09	RAN#73	R5s160758	3443	-	Corrections required for EPS_NAS_TypeDefs and NAS_24008TypeDefs	12.6.0	12.7.0
2016-09	RAN#73	R5s160762	3304	1	Correction to LTE-IRAT test case 6.3.3 for "IMS over UTRA" enabled UEs	12.6.0	12.7.0
2016-09	RAN#73	R5s160763	3305	1	Corrections to testcase 8.6.4.3	12.6.0	12.7.0
2016-09	RAN#73	R5s160764	3308	1	Corrections to IMS Emergency Call test case 11.2.3	12.6.0	12.7.0

Date	TSG #	TSG Doc.	CR	Rev	Subject/Comment	Old	New
2016-09	RAN#73	R5s160765	3317	1	Correction to applicability of Rel-11 SI-MTC test case 9.2.1.1.27a	12.6.0	12.7.0
2016-09	RAN#73	R5s160766	3319	1	Correction of test frequencies for LTE-A CA intra-band test cases	12.6.0	12.7.0
2016-09	RAN#73	R5s160767	3320	1	Addition of LTE-A Rel-12 LC-MTC test case 8.5.4.4	12.6.0	12.7.0
2016-09	RAN#73	R5s160768	3322	1	Addition of LTE-A Rel-12 LC-MTC test case 7.1.1.1a	12.6.0	12.7.0
2016-09	RAN#73	R5s160769	3323	1	Addition of LTE-A Rel-12 LC-MTC test case 7.1.3.3a	12.6.0	12.7.0
2016-09	RAN#73	R5s160770	3324	1	Addition of IMS Emergency Call test case 11.2.7	12.6.0	12.7.0
2016-09	RAN#73	R5s160771	3329	1	Correction to LTE-IRAT test case 6.3.4 for "IMS over UTRA" enabled UEs	12.6.0	12.7.0
2016-09	RAN#73	R5s160772	3330	1	Correction to LTE-IRAT test case 8.1.3.7 for "IMS over UTRA" enabled UEs	12.6.0	12.7.0
2016-09	RAN#73	R5s160775	3332	1	Correction to EUTRA MAC test case 7.1.8.1	12.6.0	12.7.0
2016-09	RAN#73	R5s160776	3336	1	Correction to test cases 7.1.3.11.x	12.6.0	12.7.0
2016-09	RAN#73	R5s160777	3337	1	Correction to EUTRA RRC InterRAT measurement on 1xRTT test case 8.3.2.10	12.6.0	12.7.0
2016-09	RAN#73	R5s160778	3351	1	Addition of LTE-A Rel-12 DL-256 QAM test case 7.1.7.1.7	12.6.0	12.7.0
2016-09	RAN#73	R5s160779	3352	1	LTE_TDD: Addition of LTE-A Rel-12 DL-256 QAM test case 7.1.7.1.7	12.6.0	12.7.0
2016-09	RAN#73	R5s160780	3353	1	Addition of LTE-A Rel-12 DL-256 QAM test case 7.1.7.1.8	12.6.0	12.7.0
2016-09	RAN#73	R5s160781	3355	1	Addition of LTE-A Rel-12 LC-MTC test case 8.5.4.4 in Half Duplex Mode	12.6.0	12.7.0
2016-09	RAN#73	R5s160782	3356	1	Addition of LTE-A Rel-12 LC-MTC test case 7.1.1.1a in Half Duplex mode	12.6.0	12.7.0
2016-09	RAN#73	R5s160783	3357	1	Addition of LTE-A Rel-12 LC-MTC test case 7.1.3.3a in Half Duplex mode	12.6.0	12.7.0
2016-09	RAN#73	R5s160784	3358	1	Correction to function f_EUTRA_CA_InitFrequenciesInterBand	12.6.0	12.7.0
2016-09	RAN#73	R5s160785	3359	1	Correction to function fl_DNS_AddressResolutionTable()	12.6.0	12.7.0
2016-09	RAN#73	R5s160786	3360	1	Correction to RRC connection management procedures test case 8.1.1.3	12.6.0	12.7.0
2016-09	RAN#73	R5s160787	3361	1	Correction to IMS emergency call test case 11.2.6	12.6.0	12.7.0
2016-09	RAN#73	R5s160793	3362	1	Corrections to LTE-UTRA testcases (IMS over UTRA enabled devices)	12.6.0	12.7.0
2016-09	RAN#73	R5s160795	3363	1	Correction to EMM test case 9.2.1.1.30	12.6.0	12.7.0
2016-09	RAN#73	R5s160796	3364	1	Correction to multilayer test case 13.1.9	12.6.0	12.7.0
2016-09	RAN#73	R5s160797	3365	1	Correction to R12 SSAC test cases 13.5.1a and 13.5.2a	12.6.0	12.7.0
2016-09	RAN#73	R5s160798	3366	1	Addition of LTE-A Rel-12 LC-MTC test case 6.1.2.2b (FDD Full Duplex)	12.6.0	12.7.0
2016-09	RAN#73	R5s160799	3367	1	Correction to GCF WI-171 SSAC TC 13.5.3	12.6.0	12.7.0
2016-09	RAN#73	R5s160800	3368	1	Correction to EMM test case 9.2.1.2.4	12.6.0	12.7.0
2016-09	RAN#73	R5s160801	3369	1	Correction to GCF WI-226 SSAC TC 13.5.3a	12.6.0	12.7.0
2016-09	RAN#73	R5s160810	3344	1	LTE_TDD: Addition of LTE-A CA 2UL test case 7.1.2.10.2	12.6.0	12.7.0
2016-09	RAN#73	R5s160811	3348	1	Correction to function f_EUTRA_ConfigureBigULGrant	12.6.0	12.7.0
2016-09	RAN#73	R5-166273	3421	1	eDRX: Introduction of Test Model	12.7.0	13.0.0
2016-09	RAN#73	R5-165329	3423	-	eMTC: Introduction of Test Model	12.7.0	13.0.0
2016-09	RAN#73	R5s160711	3414	-	Rel-13 baseline upgrade for LTE Test Suites	12.7.0	13.0.0
2016-09	RAN#73	RP-161433	3444	-	Add new verified and e-mail agreed TTCN test cases in the TC lists in 36.523-3 (prose), Annex A	12.7.0	13.0.0
2016-12	RAN#74	R5-168069	3488	-	D2D ProSe: Test Model updates	13.0.0	13.1.0
2016-12	RAN#74	R5-168084	3491	-	eDRX: Test Model updates	13.0.0	13.1.0

Date	TSG #	TSG Doc.	CR	Rev	Subject/Comment	Old	New
2016-12	RAN#74	R5-168098	3492	-	SC-PTM: Introduction of Test Model	13.0.0	13.1.0
2016-12	RAN#74	R5-168426	3496	-	Correction to UTRAN postamble sequence	13.0.0	13.1.0
2016-12	RAN#74	R5-169113	3490	-	eMTC: Test Model updates	13.0.0	13.1.0
2016-12	RAN#74	R5-169120	3487	-	Routine maintenance for TS 36.523-3	13.0.0	13.1.0
2016-12	RAN#74	R5-169149	3489	-	NB-IoT: Introduction of Test Model	13.0.0	13.1.0
2016-12	RAN#74	R5s160843	3461	-	Correction to EUTRA test cases for FDD half-duplex operation	13.0.0	13.1.0
2016-12	RAN#74	R5s160844	3462	-	Additional corrections to SCE_PHY test cases 7.1.7.1.x for DL 256QAM	13.0.0	13.1.0
2016-12	RAN#74	R5s160845	3463	-	Correction to EMM test case 9.2.3.3.4	13.0.0	13.1.0
2016-12	RAN#74	R5s160846	3464	-	Correction to EUTRA RRC MDT test case 8.6.6.2	13.0.0	13.1.0
2016-12	RAN#74	R5s160847	3465	-	Correction to Rel-10 EMM test case 9.2.1.1.7b	13.0.0	13.1.0
2016-12	RAN#74	R5s160849	3466	-	Corrections for EUTRA radio bearer test cases	13.0.0	13.1.0
2016-12	RAN#74	R5s160850	3467	-	Correction for EUTRA MAC test cases 7.1.4.10 and 7.1.4.18	13.0.0	13.1.0
2016-12	RAN#74	R5s160851	3468	-	Corrections to Inter-RAT Idle mode HeNB test case 6.4.6	13.0.0	13.1.0
2016-12	RAN#74	R5s160857	3471	-	Correction to EUTRA band 2 and band 25 <-> CDMA BC 1 for LTE<->1xRTT test cases	13.0.0	13.1.0
2016-12	RAN#74	R5s160858	3472	-	Correction to function f_EUTRA_SS_ConfigureActiveCell()	13.0.0	13.1.0
2016-12	RAN#74	R5s160866	3473	-	Correction to IMS emergency vcall test case test case 11.2.8	13.0.0	13.1.0
2016-12	RAN#74	R5s160870	3474	-	Addition of Rel-12 LTE UEPCOP test case 9.2.1.1.7c	13.0.0	13.1.0
2016-12	RAN#74	R5s160872	3475	-	Addition of Rel-12 LTE UEPCOP test case 9.2.3.1.1a	13.0.0	13.1.0
2016-12	RAN#74	R5s160875	3477	-	Addition of LTE-A Rel-12 Coverage Enhancement test case 7.1.4.24	13.0.0	13.1.0
2016-12	RAN#74	R5s160877	3478	-	Correction to LTE-A Rel-12 DL-256QAM test cases 7.1.7.1.11 and 7.1.7.1.12	13.0.0	13.1.0
2016-12	RAN#74	R5s160880	3480	-	Addition of Rel-12 LTE-A SCM test case 13.5.4	13.0.0	13.1.0
2016-12	RAN#74	R5s160882	3481	-	Addition of Rel-12 LTE UEPCOP test case 9.2.3.1.5b	13.0.0	13.1.0
2016-12	RAN#74	R5s160884	3482	-	LTE_TDD: Addition of Rel-12 LTE-A SCM test case 13.5.4	13.0.0	13.1.0
2016-12	RAN#74	R5s160886	3483	-	Addition of testcase 13.5.5- MTSI MO video call / SCM / 0% access probability skip for MTSI MO video call	13.0.0	13.1.0
2016-12	RAN#74	R5s160890	3485	-	Correction to handling of IMSoGERAN procedures	13.0.0	13.1.0
2016-12	RAN#74	R5s160891	3486	-	Correction to LTE-GERAN TC 6.2.2.2	13.0.0	13.1.0
2016-12	RAN#74	R5s160896	3494	-	Correction to NIMTC test case 10.5.4	13.0.0	13.1.0
2016-12	RAN#74	R5s160897	3495	-	Correction to EUTRA Idle Mode CSG test case 6.3.4	13.0.0	13.1.0
2016-12	RAN#74	R5s160902	3499	-	Correction to Idle Mode Test cases 6.1.1.8 and 6.1.1.9	13.0.0	13.1.0
2016-12	RAN#74	R5s160904	3500	-	LTE_TDD: Addition of LTE-A Rel-12 Coverage Enhancement test case 7.1.4.24	13.0.0	13.1.0
2016-12	RAN#74	R5s160906	3501	-	Correction to test case 9.2.3.2.1b	13.0.0	13.1.0
2016-12	RAN#74	R5s160907	3502	-	Correction to EMM Inter-RAT test case 9.2.3.4.1 for IMS-enabled UEs	13.0.0	13.1.0
2016-12	RAN#74	R5s160909	3504	-	Correction to common function f_GERAN_LLC_XID()	13.0.0	13.1.0
2016-12	RAN#74	R5s160914	3415	1	Correction to IMS Emergency Call test case 11.2.6	13.0.0	13.1.0
2016-12	RAN#74	R5s160915	3445	1	Correction to EUTRA CA Testcases 8.2.4.18.x and 8.2.4.21.x	13.0.0	13.1.0
2016-12	RAN#74	R5s160917	3446	1	Correction to function f_EUTRA_SetSystemInformationBlockType1_FreqBandIndicatorExt()	13.0.0	13.1.0

Date	TSG #	TSG Doc.	CR	Rev	Subject/Comment	Old	New
2016-12	RAN#74	R5s160918	3447	1	Correction to GCF WI-081 EUTRA Idle Mode test case 6.1.2.15	13.0.0	13.1.0
2016-12	RAN#74	R5s160919	3448	1	Correction to GCF WI-086 EUTRA RRC test cases 8.1.3.7 and 8.5.2.1	13.0.0	13.1.0
2016-12	RAN#74	R5s160920	3449	1	Correction to LTE<->U/G test cases with pre-preamble in UTRA	13.0.0	13.1.0
2016-12	RAN#74	R5s160921	3451	1	Correction to MultiPDN handling in EUTRA Testcases	13.0.0	13.1.0
2016-12	RAN#74	R5s160922	3452	1	Enhancement to MFBI pixit px_OverlappingSupportedFrequencyBand_MFBI	13.0.0	13.1.0
2016-12	RAN#74	R5s160924	3453	1	Correction to GCF WI-167 MultiLayer test case 13.1.2a	13.0.0	13.1.0
2016-12	RAN#74	R5s160926	3455	1	Correction to Rel-10 EUTRA MDT test case 8.6.3.1	13.0.0	13.1.0
2016-12	RAN#74	R5s160928	3456	1	Correction to eMBMS-SC CA TCs 17.4.9.X, 17.4.10.X, 17.4.11.X	13.0.0	13.1.0
2016-12	RAN#74	R5s160929	3458	1	Correction to GCF WI-081 EUTRA MAC test cases TCs 7.1.7.1.x	13.0.0	13.1.0
2016-12	RAN#74	R5s160930	3459	1	Correction to measCycleSCell_r10 for EUTRA CA Testcases	13.0.0	13.1.0
2016-12	RAN#74	R5s160959	3440	2	Correction to IMS emergency call test case 11.2.10	13.0.0	13.1.0
2016-12	RAN#74	R5s160960	3450	1	Correction to GCF WI-151 EUTRA RRC testcases 8.3.1.14a and 8.2.4.15a	13.0.0	13.1.0
2016-12	RAN#74	R5s160961	3454	1	Correction to function f_CheckUE_SupportedEUTRA_Bands_Chunk()	13.0.0	13.1.0
2016-12	RAN#74	R5s160963	3457	1	Correction to EUTRA Band2 – CDMA BC 1 band combination	13.0.0	13.1.0
2017-03	RAN#75	R5-170552	3566	-	Routine maintenance for TS 36.523-3	13.1.0	13.2.0
2017-03	RAN#75	R5-171366	-	-	LAA: Introduction of Test Model	13.1.0	13.2.0
2017-03	RAN#75	R5-171566	3568	1	eMTC: Test Model updates	13.1.0	13.2.0
2017-03	RAN#75	R5-171586	3567	1	NB-IoT: Test Model updates	13.1.0	13.2.0
2017-03	RAN#75	R5s170040	3549	-	Correction to LTE-A Rel-12 UEPCOP test case 9.2.3.1.5b	13.1.0	13.2.0
2017-03	RAN#75	R5s170042	3550	-	Correction to Rel-11 eDDA test cases Test case 8.2.2.6.2	13.1.0	13.2.0
2017-03	RAN#75	R5s170043	3551	-	Correction to common IP function fl_TCP_Close()	13.1.0	13.2.0
2017-03	RAN#75	R5s170048	3552	-	Correction to LTE-IRAT IMS Emergency Call Testcases 13.1.19 and 13.1.20	13.1.0	13.2.0
2017-03	RAN#75	R5s170049	3553	-	Correction to IMS Emergency Call test case 11.2.7	13.1.0	13.2.0
2017-03	RAN#75	R5s170051	3554	-	Corrections to EMM test case 9.2.1.2.1b for Multi-PDN UE	13.1.0	13.2.0
2017-03	RAN#75	R5s170053	3555	-	Correction to IMS Emergency Call test case 11.2.7	13.1.0	13.2.0
2017-03	RAN#75	R5s170057	3556	-	LTE_TDD: Addition of Rel-12 LTE-A SCM test case 13.5.5	13.1.0	13.2.0
2017-03	RAN#75	R5s170059	3557	-	Correction to test case 11.2.7	13.1.0	13.2.0
2017-03	RAN#75	R5s170060	3558	-	Addition of GCF WI-257 NB-IoT test case 22.4.6	13.1.0	13.2.0
2017-03	RAN#75	R5s170064	3560	-	Correction to EUTRA CA test cases	13.1.0	13.2.0
2017-03	RAN#75	R5s170068	3561	-	Addition of Test case 6.1.2.23 : Inter-Band cell reselection / MFBI frequency band priority adjustment/inter-band CA	13.1.0	13.2.0
2017-03	RAN#75	R5s170070	3562	-	Correction to function f_EUTRA_ModifySysinfo_ValueTag	13.1.0	13.2.0
2017-03	RAN#75	R5s170080	3563	-	Updates of L2 definitions to allow re-use for NB-IoT	13.1.0	13.2.0
2017-03	RAN#75	R5s170081	3564	-	Addition of GCF WI-257 NB-IoT test case 22.4.11	13.1.0	13.2.0
2017-03	RAN#75	R5s170083	3565	-	Correction to EUTRA RRC MDT test case 8.6.6.2	13.1.0	13.2.0
2017-03	RAN#75	R5s170088	3573	-	Correction to CTZE Dummy command	13.1.0	13.2.0
2017-03	RAN#75	R5s170089	3574	-	Correction to LTE-IRAT testcase 6.4.3	13.1.0	13.2.0
2017-03	RAN#75	R5s170092	3576	-	Correction to selection expression for Rel-10 MDT test case 8.6.5.1	13.1.0	13.2.0

Date	TSG #	TSG Doc.	CR	Rev	Subject/Comment	Old	New
2017-03	RAN#75	R5s170093	3577	-	Correction to GCF WI-081 TCs 7.1.7.1.1, 7.1.7.1.2 to 7.1.7.1.6	13.1.0	13.2.0
2017-03	RAN#75	R5s170094	3578	-	Correction to altstep a_UTRAN_DeactivatePDPCContext_MO	13.1.0	13.2.0
2017-03	RAN#75	R5s170104	3476	1	Corrections for EUTRA PDCP test case 7.3.5.3	13.1.0	13.2.0
2017-03	RAN#75	R5s170105	3484	1	Addition of testcase 13.5.6 : MTSI MO SMS / SCM / 0% access probability skip for MTSI MO SMS over IP	13.1.0	13.2.0
2017-03	RAN#75	R5s170107	3498	1	Correction to IMS Emergency Call test case 11.2.7	13.1.0	13.2.0
2017-03	RAN#75	R5s170109	3505	1	Correction to LTE-A Rel-11 eMDT test cases 8.6.3.4, 8.6.7.4 and 8.6.9.1	13.1.0	13.2.0
2017-03	RAN#75	R5s170111	3506	1	Correction to EMM test case 9.2.3.1.25 for Multi-PDN UE	13.1.0	13.2.0
2017-03	RAN#75	R5s170119	3510	1	Correction to IMS Emergency test case 11.2.10	13.1.0	13.2.0
2017-03	RAN#75	R5s170120	3511	1	Correction to test case 8.1.1.2	13.1.0	13.2.0
2017-03	RAN#75	R5s170121	3512	1	Correction to EMM test cases for IMS enabled UEs with IMS as second PDN	13.1.0	13.2.0
2017-03	RAN#75	R5s170123	3513	1	Correction to GCF WI-227 testcases 8.6.3.4, 8.6.8.2, 8.6.6.6	13.1.0	13.2.0
2017-03	RAN#75	R5s170125	3514	1	LTE_TDD: Addition of LTE-A InterRAT CA test case 8.4.2.7.2	13.1.0	13.2.0
2017-03	RAN#75	R5s170126	3516	1	Correction to test case 8.3.1.25	13.1.0	13.2.0
2017-03	RAN#75	R5s170132	3520	1	Correction to LTE IRAT testcase 6.4.6	13.1.0	13.2.0
2017-03	RAN#75	R5s170133	3521	1	Corrections for common TTCN functions for REL-13 UEs	13.1.0	13.2.0
2017-03	RAN#75	R5s170134	3523	1	Correction for EUTRA RRC test case 8.5.4.1	13.1.0	13.2.0
2017-03	RAN#75	R5s170141	3524	1	Addition of LTE-A Rel-11 CA test case 8.5.4.3	13.1.0	13.2.0
2017-03	RAN#75	R5s170142	3525	1	LTE_TDD: Addition of LTE-A Rel-11 CA test case 8.5.4.3	13.1.0	13.2.0
2017-03	RAN#75	R5s170144	3526	1	Correction to SRVCC test case 13.4.3.2	13.1.0	13.2.0
2017-03	RAN#75	R5s170145	3529	1	Correction for mutli-layer test case 13.1.2a	13.1.0	13.2.0
2017-03	RAN#75	R5s170146	3530	1	Correction for EUTRA PDCP test case 7.3.5.3	13.1.0	13.2.0
2017-03	RAN#75	R5s170147	3531	1	Correction to selection expression conditions in function f_SelectionExpr()	13.1.0	13.2.0
2017-03	RAN#75	R5s170149	3533	1	Correction to DL and UL categories in 7.1.7.1.1 upto .6	13.1.0	13.2.0
2017-03	RAN#75	R5s170150	3535	1	Correction for EMM test case 9.2.3.3.5a	13.1.0	13.2.0
2017-03	RAN#75	R5s170151	3536	1	Correction for EUTRA RRC test case 8.4.1.5	13.1.0	13.2.0
2017-03	RAN#75	R5s170152	3537	1	Correction for EMM test case 9.2.1.2.1b	13.1.0	13.2.0
2017-03	RAN#75	R5s170153	3541	1	Correction to Idle Mode test case 6.1.1.9	13.1.0	13.2.0
2017-03	RAN#75	R5s170154	3542	1	Correction to SRVCC test cases 13.4.3.2, 13.4.3.14 and 13.4.3.16	13.1.0	13.2.0
2017-03	RAN#75	R5s170155	3543	1	Correction to LTE-A eMDT test case 8.6.6.7	13.1.0	13.2.0
2017-03	RAN#75	R5s170156	3544	1	Addition of GCF WI-257 NB-IoT test case 22.4.13	13.1.0	13.2.0
2017-03	RAN#75	R5s170157	3545	1	Addition of GCF WI-257 NB-IoT test case 22.4.2	13.1.0	13.2.0
2017-03	RAN#75	R5s170158	3546	1	Addition of GCF WI-257 NB-IoT test case 22.5.10	13.1.0	13.2.0
2017-03	RAN#75	R5s170159	3547	1	Addition of GCF WI-257 NB-IoT test case 22.5.11	13.1.0	13.2.0
2017-03	RAN#75	R5s170160	3548	1	Addition of GCF WI-257 NB-IoT test case 22.5.12	13.1.0	13.2.0
2017-03	RAN#75	R5s170161	3469	1	Correction to EMM test case 9.2.1.2.1b	13.1.0	13.2.0
2017-03	RAN#75	R5s170162	3503	1	Correction LTE<->GERAN inter-RAT test cases for IMS_enabled UEs	13.1.0	13.2.0
2017-03	RAN#75	R5s170163	3507	1	LTE_TDD: Addition of Rel-12 LTE-A SCM test case 13.5.6	13.1.0	13.2.0

Date	TSG #	TSG Doc.	CR	Rev	Subject/Comment	Old	New
2017-03	RAN#75	R5s170165	3532	1	Correction for EUTRA RRC test case 8.5.4.1	13.1.0	13.2.0
2017-03	RAN#75	R5s170168	3534	1	Correction for EMM test case 9.2.3.3.3	13.1.0	13.2.0
2017-03	RAN#75	R5s170171	3539	1	Correction to LTE-A Rel-11 eDDA test cases Test case 8.2.2.6.3	13.1.0	13.2.0
2017-03	RAN#75	R5s170175	3508	1	Correction to EMM test case 9.2.3.2.1b for IMS-enabled device	13.1.0	13.2.0
2017-03	RAN#75	R5s170185	3594	-	Add new verified and e-mail agreed TTCN test cases in the TC lists in 36.523-3 (prose), Annex A	13.1.0	13.2.0
2017-06	RAN#76	R5-172046	3680	-	Routine maintenance for TS 36.523-3	13.2.0	13.3.0
2017-06	RAN#76	R5-172058	3681	-	NB-IoT: Test Model updates	13.2.0	13.3.0
2017-06	RAN#76	R5-172924	3692	1	Addition of MFBI band combinations for Band 66	13.2.0	13.3.0
2017-06	RAN#76	R5-173005	3682	1	eMTC: Test Model updates	13.2.0	13.3.0
2017-06	RAN#76	R5s170217	3609		Correction to function f_EUTRA_NB_Authentication_S13	13.2.0	13.3.0
2017-06	RAN#76	R5s170218	3610		Correction to EMM test case 9.2.1.2.11	13.2.0	13.3.0
2017-06	RAN#76	R5s170219	3611		Correction to EMM test cases 9.2.1.1.7 and 9.2.1.1.7a	13.2.0	13.3.0
2017-06	RAN#76	R5s170220	3612		Corrections to generic modules in ATS_17wk10 for Cat.M1 UEs	13.2.0	13.3.0
2017-06	RAN#76	R5s170221	3613		Correction to function f_EUTRA_508RRC_AddMod_1Scell for LTE-A CA test cases	13.2.0	13.3.0
2017-06	RAN#76	R5s170222	3614		Correction GCF WI-156 LTE test case 8.1.3.11	13.2.0	13.3.0
2017-06	RAN#76	R5s170223	3615		Correction to GCF WI-81 LTE test case 8.2.4.6	13.2.0	13.3.0
2017-06	RAN#76	R5s170224	3616		Correction to GCF WI-156 LTE test cases 8.3.1.13, 8.3.1.14 and 8.3.1.16	13.2.0	13.3.0
2017-06	RAN#76	R5s170225	3617		Correction to EUTRA RRC test case 8.1.2.7	13.2.0	13.3.0
2017-06	RAN#76	R5s170226	3618		Correction to GCF WI-081 Rel-8 LTE test case 8.3.1.7	13.2.0	13.3.0
2017-06	RAN#76	R5s170227	3619		Correction to Rel-11 GCF WI-178 eMBMS CA testcases 17.4.11.1 and 17.4.11.2	13.2.0	13.3.0
2017-06	RAN#76	R5s170229	3620		Corrections to EUTRA Idle Mode test case 6.1.2.3a for CAT-M1 device	13.2.0	13.3.0
2017-06	RAN#76	R5s170230	3621		Corrections for EUTRA MAC test cases with CAT-M1 devices	13.2.0	13.3.0
2017-06	RAN#76	R5s170233	3622		Corrections to generic functions for NB-IoT	13.2.0	13.3.0
2017-06	RAN#76	R5s170234	3623		Corrections to MAC common part in ATS_17wk10 for Cat.NB1 UEs	13.2.0	13.3.0
2017-06	RAN#76	R5s170235	3624		Corrections to RLC common part in ATS_17wk10 for Cat.NB1 UEs	13.2.0	13.3.0
2017-06	RAN#76	R5s170236	3625		Addition of GCF WI-257 NB-IoT test case 22.3.1.3	13.2.0	13.3.0
2017-06	RAN#76	R5s170238	3626		Addition of GCF WI-257 NB-IoT test case 22.3.1.4	13.2.0	13.3.0
2017-06	RAN#76	R5s170240	3627		Addition of GCF WI-257 NB-IoT test case 22.3.1.6	13.2.0	13.3.0
2017-06	RAN#76	R5s170242	3628		Addition of GCF WI-257 NB-IoT test case 22.3.2.1	13.2.0	13.3.0
2017-06	RAN#76	R5s170244	3629		Addition of GCF WI-257 NB-IoT test case 22.3.2.2	13.2.0	13.3.0
2017-06	RAN#76	R5s170246	3630		Correction for EUTRA RRC test case 8.5.4.1	13.2.0	13.3.0
2017-06	RAN#76	R5s170247	3631		Updates to SI-BR and SI scheduling in the eMTC Test Environment	13.2.0	13.3.0
2017-06	RAN#76	R5s170248	3632		Addition of GCF WI-257 NB-IoT test case 22.3.2.3	13.2.0	13.3.0
2017-06	RAN#76	R5s170250	3633		Addition of GCF WI-257 NB-IoT test case 22.3.3.1	13.2.0	13.3.0
2017-06	RAN#76	R5s170252	3634		Addition of GCF WI-257 NB-IoT test case 22.4.21	13.2.0	13.3.0
2017-06	RAN#76	R5s170254	3635		Addition of GCF WI-257 NB-IoT test case 22.5.3	13.2.0	13.3.0
2017-06	RAN#76	R5s170256	3636		Addition of GCF WI-257 NB-IoT test case 22.5.4	13.2.0	13.3.0

Date	TSG #	TSG Doc.	CR	Rev	Subject/Comment	Old	New
2017-06	RAN#76	R5s170258	3637		Addition of GCF WI-257 NB-IoT test case 22.3.3.2	13.2.0	13.3.0
2017-06	RAN#76	R5s170260	3638		Addition of GCF WI-257 NB-IoT test case 22.3.3.3	13.2.0	13.3.0
2017-06	RAN#76	R5s170263	3639		Correction to function f_NBIOT_RRC_ConnectionRelease	13.2.0	13.3.0
2017-06	RAN#76	R5s170264	3640		Correction to EMM test case 9.2.3.1.23 for Multi-PDN UE	13.2.0	13.3.0
2017-06	RAN#76	R5s170265	3641		Correction to Inter-RAT idle mode test case 6.2.3.4a for IMS enabled UE	13.2.0	13.3.0
2017-06	RAN#76	R5s170266	3642		Correction to R12 MFBI test case 6.1.2.23	13.2.0	13.3.0
2017-06	RAN#76	R5s170267	3643		Correction to GCF WI-150 Rel-9 LTE test case 13.4.1.5 for Band > 64	13.2.0	13.3.0
2017-06	RAN#76	R5s170268	3644		Correction to function f_EUTRA_CellInfo_SetSysInfo_NCEinSIB1	13.2.0	13.3.0
2017-06	RAN#76	R5s170270	3645		Correction to CSG ID selection test case 6.3.5	13.2.0	13.3.0
2017-06	RAN#76	R5s170272	3647		Correction to eMBMS test cases 17.4.x in band >64	13.2.0	13.3.0
2017-06	RAN#76	R5s170273	3648		Correction to GCF WI-081 Rel-8 LTE test cases 7.2.2.1, 7.2.2.2, 7.2.2.3, 7.2.2.4 and 7.2.2.5.1 for CAT-M1	13.2.0	13.3.0
2017-06	RAN#76	R5s170274	3649		Correction to GCF WI-081 test case 7.1.2.1 (band>64)	13.2.0	13.3.0
2017-06	RAN#76	R5s170275	3650		Correction to GCF WI-162 Rel-10 CA test case 8.3.1.22.2	13.2.0	13.3.0
2017-06	RAN#76	R5s170276	3651		Correction to inter-RAT MFBI test case 6.2.3.34	13.2.0	13.3.0
2017-06	RAN#76	R5s170277	3652		Correction to Explicit UL Grant Assignment functions for Cat-M1 UEs	13.2.0	13.3.0
2017-06	RAN#76	R5s170278	3653		Correction to postamble of EUTRA CSG test cases	13.2.0	13.3.0
2017-06	RAN#76	R5s170279	3654		Correction to EUTRA MAC CA test cases 7.1.2.11.x	13.2.0	13.3.0
2017-06	RAN#76	R5s170280	3655		Addition of Rel-13 eDRX test case 9.2.4.1.1	13.2.0	13.3.0
2017-06	RAN#76	R5s170282	3656		Correction to EUTRA Idle Mode test case 6.2.1.3 for Multi-PDN UE	13.2.0	13.3.0
2017-06	RAN#76	R5s170284	3657		Addition of GCF WI-257 NB-IoT test case 22.2.8	13.2.0	13.3.0
2017-06	RAN#76	R5s170286	3658		Correction to function f_IPv6Packet_Create	13.2.0	13.3.0
2017-06	RAN#76	R5s170287	3659		Correction to NB-IoT test case 22.4.2	13.2.0	13.3.0
2017-06	RAN#76	R5s170288	3660		Correction to template cr_ESM_DATA_TRANSPORT	13.2.0	13.3.0
2017-06	RAN#76	R5s170289	3661		Correction to NB-IoT test case 22.5.2	13.2.0	13.3.0
2017-06	RAN#76	R5s170290	3662		Correction to function fl_NBIOT_CheckSupportedBands	13.2.0	13.3.0
2017-06	RAN#76	R5s170295	3663		Correction to template cs_508_LogicalChannelConfig_DRB_UM	13.2.0	13.3.0
2017-06	RAN#76	R5s170296	3664		Correction to GCF WI-081 testcases 7.1.5.1 and 7.1.5.2 with Cat-M1	13.2.0	13.3.0
2017-06	RAN#76	R5s170298	3665		Correction for EUTRA capability check test case 8.5.4.1	13.2.0	13.3.0
2017-06	RAN#76	R5s170300	3666		Correction to GCF WI-081 Rel-8 LTE test case 7.1.4.4	13.2.0	13.3.0
2017-06	RAN#76	R5s170301	3667		Correction to GCF WI-081 Rel-8 LTE test cases 7.2.2.5.2, 7.2.2.9 for CAT-M1	13.2.0	13.3.0
2017-06	RAN#76	R5s170303	3669		Correction to handling UE category	13.2.0	13.3.0
2017-06	RAN#76	R5s170306	3671		Correction to function f_EUTRA_CA_InitFrequenciesIntraBand	13.2.0	13.3.0
2017-06	RAN#76	R5s170307	3672		Correction to EMM test case 10.3.1 for Multi-PDN UE	13.2.0	13.3.0
2017-06	RAN#76	R5s170308	3673		Correction to EUTRA<->UTRAN test cases with IMS-enabled UE	13.2.0	13.3.0
2017-06	RAN#76	R5s170309	3674		Correction to EMM test case 9.2.3.1.23 with Multi-PDN UE	13.2.0	13.3.0
2017-06	RAN#76	R5s170325	3678		Addition of Rel-13 eDRX test case 9.2.4.1.2	13.2.0	13.3.0
2017-06	RAN#76	R5s170334	3683		Correction to eMTC Idle Mode test case 6.1.2.6a	13.2.0	13.3.0

Date	TSG #	TSG Doc.	CR	Rev	Subject/Comment	Old	New
2017-06	RAN#76	R5s170337	3685		Correction to EMM test case 9.2.3.1.5a for Multi-PDN UEs	13.2.0	13.3.0
2017-06	RAN#76	R5s170338	3686		Correction to MDT test case 8.6.9.2	13.2.0	13.3.0
2017-06	RAN#76	R5s170339	3687		Addition of GCF WI-257 NB-IoT test case 22.4.12	13.2.0	13.3.0
2017-06	RAN#76	R5s170342	3689		Correction to EMM test case 9.2.3.1.27 for CAT-M1 UEs	13.2.0	13.3.0
2017-06	RAN#76	R5s170343	3690		Correction to GCF WI-081 TC 7.1.4.13 for Cat-M1 UE	13.2.0	13.3.0
2017-06	RAN#76	R5s170351	3697		Correction to GCF WI-257 NB-IoT test case 22.4.11	13.2.0	13.3.0
2017-06	RAN#76	R5s170352	3698		Correction to RRC test case 8.1.1.3 for CAT-M1 UEs	13.2.0	13.3.0
2017-06	RAN#76	R5s170353	3699		Correction to function fl_DciDllInfo_Init for CAT-M1 UEs	13.2.0	13.3.0
2017-06	RAN#76	R5s170355	3701		Correction to GCF WI-081 TC 7.2.2.7, 7.2.2.8, 7.2.3.14 for Cat-M1 UE	13.2.0	13.3.0
2017-06	RAN#76	R5s170356	3702		Correction to function f_ExecutionGuideline_InterBand	13.2.0	13.3.0
2017-06	RAN#76	R5s170361	3703		Correction to PSM test case 9.2.1.1.7c	13.2.0	13.3.0
2017-06	RAN#76	R5s170362	3704		Correction to GCF WI-151 test case 8.1.3.12a	13.2.0	13.3.0
2017-06	RAN#76	R5s170366	3706		Correction to f_NBIOT_RRC_ConnectionRelease_Common	13.2.0	13.3.0
2017-06	RAN#76	R5s170367	3707		Correction to GCF WI-254 Rel-13 LTE test case 8.1.1.1a	13.2.0	13.3.0
2017-06	RAN#76	R5s170369	3709		Correction to GCF WI-086 SRVCC TC 13.4.3.2	13.2.0	13.3.0
2017-06	RAN#76	R5s170370	3710		Correction to GCF WI-082 Test Case 9.2.1.1.1a	13.2.0	13.3.0
2017-06	RAN#76	R5s170371	3571	1	Addition of GCF WI-257 NB-IoT test case 22.5.1	13.2.0	13.3.0
2017-06	RAN#76	R5s170372	3575	1	Addition of LTE-A PRO (Rel-13) eMTC Idle Mode test case 6.1.2.2c	13.2.0	13.3.0
2017-06	RAN#76	R5s170373	3579	1	Correction to EUTRA PDCP handover test case 7.3.5.3	13.2.0	13.3.0
2017-06	RAN#76	R5s170374	3580	1	Addition of Rel-9 LTE<>UTRA MBFI test case Test case 6.2.3.34	13.2.0	13.3.0
2017-06	RAN#76	R5s170375	3583	1	Addition of LTE-A PRO (Rel-13) eMTC Layer 2 test case 7.1.7.1.13	13.2.0	13.3.0
2017-06	RAN#76	R5s170376	3585	1	Correction to EMM test case 9.4.6	13.2.0	13.3.0
2017-06	RAN#76	R5s170379	3587	1	Correction to function f_EUTRA_UE_CategoryInfo_Init	13.2.0	13.3.0
2017-06	RAN#76	R5s170380	3588	1	Addition of GCF WI-257 NB-IoT test case 22.5.2	13.2.0	13.3.0
2017-06	RAN#76	R5s170381	3589	1	Correction to EMM test case 9.2.3.3.5a for Multi-PDN UE	13.2.0	13.3.0
2017-06	RAN#76	R5s170382	3590	1	Correction to Inter-RAT cell reselection test case 6.2.3.4a for IMS enabled UE	13.2.0	13.3.0
2017-06	RAN#76	R5s170384	3592	1	Addition of LTE-A PRO (Rel-13) eMTC RRC test case 8.1.1.1a.	13.2.0	13.3.0
2017-06	RAN#76	R5s170385	3593	1	Correction to function fl_NBIOT_InitCellIdentities_NAS	13.2.0	13.3.0
2017-06	RAN#76	R5s170386	3595	1	Correction to function f_CheckUE_SupportedEUTRA_BandsExt	13.2.0	13.3.0
2017-06	RAN#76	R5s170389	3597	1	Correction to EMM test case 9.2.1.2.1b	13.2.0	13.3.0
2017-06	RAN#76	R5s170392	3602	1	Correction to Rel-11 eDDA testcase 8.2.2.6.3	13.2.0	13.3.0
2017-06	RAN#76	R5s170393	3603	1	Correction to GCF WI-082 NAS test cases 9.4.x	13.2.0	13.3.0
2017-06	RAN#76	R5s170394	3604	1	Correction to function f_EUTRA_ARFCN_Value_v9e0	13.2.0	13.3.0
2017-06	RAN#76	R5s170395	3605	1	Correction to eMDT Test Cases 8.6.2.3a, 8.6.2.10, 8.6.2.11 and 8.6.2.12	13.2.0	13.3.0
2017-06	RAN#76	R5s170396	3606	1	Correction to Rel-10 ANR test cases test case 8.7.1	13.2.0	13.3.0
2017-06	RAN#76	R5s170397	3607	1	Correction to LTE-A CA Test Cases 8.4.2.7.1, 8.4.2.7.2 and 8.4.2.7.3	13.2.0	13.3.0
2017-06	RAN#76	R5s170398	3608	1	Correction to EMM test case 9.2.3.1.5a for Multi-PDN UE	13.2.0	13.3.0

Date	TSG #	TSG Doc.	CR	Rev	Subject/Comment	Old	New
2017-06	RAN#76	R5s170407	3584	1	Addition of LTE-A PRO (Rel-13) eMTC Idle Mode test case 6.1.2.6a	13.2.0	13.3.0
2017-06	RAN#76	R5s170408	3591	1	Addition of LTE-A PRO (Rel-13) eMTC Layer 2 test case 7.1.7.2.2	13.2.0	13.3.0
2017-06	RAN#76	R5s170409	3596	1	Addition of GCF WI-254-A Rel-13 eMTC Idle Mode test case 6.1.2.2d	13.2.0	13.3.0
2017-06	RAN#76	R5s170410	3598	1	Correction for selection expression for Rel-12 EUTRA MFBI test case 6.1.2.23	13.2.0	13.3.0
2017-06	RAN#76	R5s170411	3599	1	Correction to xSRVCC TCs 13.4.3.2, 13.4.3.14, 13.4.3.16 and 13.4.3.18	13.2.0	13.3.0
2017-06	RAN#76	R5s170412	3601	1	Addition of Rel-11 SIMTC test case 10.8.8	13.2.0	13.3.0
2017-06	RAN#76	R5s170414	3718		Add new verified and e-mail agreed TTCN test cases in the TC lists in 36.523-3 (prose), Annex A	13.3.0	14.0.0
2017-06	RAN#76	R5s170422	3679	1	Addition of TDD Band 41 power class 2 operation / High-Power UE test case 6.1.2.5a	13.3.0	14.0.0

History

Document history		
V14.0.0	August 2017	Publication