



**Digital cellular telecommunications system (Phase 2+) (GSM);
Universal Mobile Telecommunications System (UMTS);
LTE;
5G;
NR, E-UTRA, UTRA and GSM/EDGE;
Multi-Standard Radio (MSR) Base Station (BS)
conformance testing
(3GPP TS 37.141 version 15.15.0 Release 15)**



ReferenceRTS/TSGR-0437141vff0

Keywords5G,GSM,LTE,UMTS

ETSI

650 Route des Lucioles
F-06921 Sophia Antipolis Cedex - FRANCE

Tel.: +33 4 92 94 42 00 Fax: +33 4 93 65 47 16

Siret N° 348 623 562 00017 - NAF 742 C
Association à but non lucratif enregistrée à la
Sous-Préfecture de Grasse (06) N° 7803/88

Important notice

The present document can be downloaded from:

<http://www.etsi.org/standards-search>

The present document may be made available in electronic versions and/or in print. The content of any electronic and/or print versions of the present document shall not be modified without the prior written authorization of ETSI. In case of any existing or perceived difference in contents between such versions and/or in print, the prevailing version of an ETSI deliverable is the one made publicly available in PDF format at www.etsi.org/deliver.

Users of the present document should be aware that the document may be subject to revision or change of status.

Information on the current status of this and other ETSI documents is available at

<https://portal.etsi.org/TB/ETSIDeliverableStatus.aspx>

If you find errors in the present document, please send your comment to one of the following services:

<https://portal.etsi.org/People/CommiteeSupportStaff.aspx>

Copyright Notification

No part may be reproduced or utilized in any form or by any means, electronic or mechanical, including photocopying and microfilm except as authorized by written permission of ETSI.

The content of the PDF version shall not be modified without the written authorization of ETSI.

The copyright and the foregoing restriction extend to reproduction in all media.

© ETSI 2021.

All rights reserved.

DECT™, **PLUGTESTS™**, **UMTS™** and the ETSI logo are trademarks of ETSI registered for the benefit of its Members.

3GPP™ and **LTE™** are trademarks of ETSI registered for the benefit of its Members and of the 3GPP Organizational Partners.

oneM2M™ logo is a trademark of ETSI registered for the benefit of its Members and of the oneM2M Partners.

GSM® and the GSM logo are trademarks registered and owned by the GSM Association.

Intellectual Property Rights

Essential patents

IPRs essential or potentially essential to normative deliverables may have been declared to ETSI. The information pertaining to these essential IPRs, if any, is publicly available for **ETSI members and non-members**, and can be found in ETSI SR 000 314: "*Intellectual Property Rights (IPRs); Essential, or potentially Essential, IPRs notified to ETSI in respect of ETSI standards*", which is available from the ETSI Secretariat. Latest updates are available on the ETSI Web server (<https://ipr.etsi.org/>).

Pursuant to the ETSI IPR Policy, no investigation, including IPR searches, has been carried out by ETSI. No guarantee can be given as to the existence of other IPRs not referenced in ETSI SR 000 314 (or the updates on the ETSI Web server) which are, or may be, or may become, essential to the present document.

Trademarks

The present document may include trademarks and/or tradenames which are asserted and/or registered by their owners. ETSI claims no ownership of these except for any which are indicated as being the property of ETSI, and conveys no right to use or reproduce any trademark and/or tradename. Mention of those trademarks in the present document does not constitute an endorsement by ETSI of products, services or organizations associated with those trademarks.

Legal Notice

This Technical Specification (TS) has been produced by ETSI 3rd Generation Partnership Project (3GPP).

The present document may refer to technical specifications or reports using their 3GPP identities. These shall be interpreted as being references to the corresponding ETSI deliverables.

The cross reference between 3GPP and ETSI identities can be found under <http://webapp.etsi.org/key/queryform.asp>.

Modal verbs terminology

In the present document "**shall**", "**shall not**", "**should**", "**should not**", "**may**", "**need not**", "**will**", "**will not**", "**can**" and "**cannot**" are to be interpreted as described in clause 3.2 of the [ETSI Drafting Rules](#) (Verbal forms for the expression of provisions).

"**must**" and "**must not**" are **NOT** allowed in ETSI deliverables except when used in direct citation.

Contents

Intellectual Property Rights	2
Legal Notice	2
Modal verbs terminology.....	2
Foreword.....	11
1 Scope	12
2 References	12
3 Definitions, symbols and abbreviations	13
3.1 Definitions	13
3.2 Symbols.....	16
3.3 Abbreviations	19
4 General test conditions and declarations	20
4.1 Measurement uncertainties and test requirements	20
4.1.1 General.....	20
4.1.2 Acceptable uncertainty of Test System.....	21
4.1.2.1 Measurement of transmitter	22
4.1.2.2 Measurement of receiver	23
4.1.3 Interpretation of measurement results	25
4.2 Base Station classes.....	26
4.3 Regional requirements.....	26
4.4 Operating bands and band categories	28
4.4.1 Band category 1 aspects (BC1).....	32
4.4.2 Band category 2 aspects (BC2).....	33
4.4.3 Band category 3 aspects (BC3).....	33
4.5 Channel arrangement.....	33
4.5.1 Channel spacing.....	33
4.5.1A CA Channel spacing	34
4.5.2 Channel raster	35
4.5.3 Carrier frequencies and numbering.....	35
4.6 Manufacturer's declarations of regional and optional requirements	35
4.6.1 Operating band and frequency range	35
4.6.2 Spurious emissions category.....	36
4.6.3 Additional operating band unwanted emissions	36
4.6.4 Co-existence with other systems.....	36
4.6.5 Co-location with other Base Stations.....	37
4.6.6 NB-IoT sub-carrier spacing	37
4.6.7 NB-IoT power dynamic range	37
4.7 Capability set definition and manufacturer's declarations of supported RF configurations	37
4.7.1 Definition of Capability Sets (CS).....	37
4.7.2 Manufacturer's declarations of supported RF configurations	40
4.8 MSR test configurations	44
4.8.1 TC1: UTRA multicarrier operation	44
4.8.1.1 TC1a generation.....	44
4.8.1.2 TC1b generation.....	44
4.8.1.3 TC1 power allocation.....	44
4.8.1a NTC1: UTRA multicarrier non-contiguous operation	44
4.8.1a.1 NTC1a generation.....	45
4.8.1a.2 NTC1 power allocation	45
4.8.2 TC2: E-UTRA multicarrier operation.....	45
4.8.2.1 TC2 generation.....	45
4.8.2.2 TC2 power allocation.....	45
4.8.2a NTC2: E-UTRA multicarrier non-contiguous operation	45
4.8.2a.1 NTC2 generation.....	46
4.8.2a.2 NTC2 power allocation.....	46
4.8.3 TC3: UTRA and E-UTRA multi RAT operation.....	46

4.8.3.1	TC3a generation.....	46
4.8.3.2	TC3b generation.....	47
4.8.3.3	TC3 power allocation.....	47
4.8.3a	NTC3: UTRA and E-UTRA multi RAT non-contiguous operation.....	47
4.8.3a.1	NTC3a generation.....	47
4.8.3a.2	NTC3 power allocation.....	48
4.8.4	TC4: BC2 transmitter operation.....	48
4.8.4.1	TC4a generation.....	48
4.8.4.2	TC4b generation.....	48
4.8.4.3	TC4c generation.....	49
4.8.4.4	TC4d generation.....	49
4.8.4.5	TC4e generation.....	49
4.8.4.6	TC4 power allocation.....	50
4.8.4a	NTC4: Non-contiguous multi RAT operations with GSM for the transmitter.....	50
4.8.4a.1	NTC4a generation.....	50
4.8.4a.2	NTC4b generation.....	51
4.8.4a.3	NTC4c generation.....	51
4.8.4a.4	NTC4 power allocation.....	52
4.8.5	TC5: BC2 receiver operation.....	52
4.8.5.1	TC5a generation.....	52
4.8.5.2	TC5b generation.....	53
4.8.5a	NTC5: Non-contiguous multi RAT operations with GSM for the receiver.....	53
4.8.5a.1	NTC5a generation.....	53
4.8.5a.2	NTC5b generation.....	53
4.8.5a.3	NTC5c generation.....	53
4.8.6	TC6: Single carrier for receiver tests.....	54
4.8.6.1	TC6a generation.....	54
4.8.6.2	TC6b generation.....	54
4.8.6.3	TC6c generation.....	54
4.8.7	Generation of MB-MSR test configurations.....	54
4.8.7.1	TC7a: MB-MSR test configuration for full carrier allocation.....	54
4.8.7.1.1	TC7a generation.....	54
4.8.7.1.2	TC7a power allocation.....	55
4.8.7.2	TC7b: MB-MSR test configuration with high PSD per carrier.....	55
4.8.7.2.1	TC7b generation.....	55
4.8.7.2.2	TC7b power allocation.....	56
4.8.7.3	TC7c: MB-MSR test configuration with GSM/EDGE single RAT operation in one band.....	56
4.8.7.3.1	TC7c generation.....	56
4.8.7.3.2	TC7c power allocation.....	57
4.8.8	TC8: NB-IoT standalone multi-carrier operation.....	57
4.8.8.1	TC8 generation.....	57
4.8.8.2	TC8 power allocation.....	57
4.8.9	TC9: GSM and NB-IoT standalone multi-carrier operation.....	57
4.8.9.1	TC9 generation.....	58
4.8.9.2	TC9 power allocation.....	58
4.8.10	TC10: UTRA and NB-IoT standalone multi-carrier operation.....	58
4.8.10.1	TC10 generation.....	58
4.8.10.2	TC10 power allocation.....	58
4.8.11	TC11: E-UTRA and NB-IoT standalone multi-carrier operation.....	58
4.8.11.1	TC11 generation.....	59
4.8.11.2	TC11 power allocation.....	59
4.8.12	TC12: GSM and UTRA and NB-IoT standalone multi-carrier operation.....	59
4.8.12.1	TC12 generation.....	59
4.8.12.2	TC12 power allocation.....	60
4.8.13	TC13: GSM and E-UTRA and NB-IoT standalone multi-carrier operation.....	60
4.8.13.1	TC13 generation.....	60
4.8.13.2	TC13 power allocation.....	60
4.8.14	TC14: UTRA and E-UTRA and NB-IoT standalone multi-carrier operation.....	60
4.8.14.1	TC14 generation.....	60
4.8.14.2	TC14 power allocation.....	61
4.8.15	TC15: GSM and E-UTRA with NB-IoT in-band multi-carrier operation.....	61
4.8.15.1	TC15 generation.....	61

4.8.15.2	TC15 power allocation	61
4.8.16	TC16: UTRA and E-UTRA with NB-IoT in-band multi-carrier operation	61
4.8.16.1	TC16 generation.....	61
4.8.16.2	TC16 power allocation.....	62
4.8.17	TC17: E-UTRA and E-UTRA with NB-IoT in-band multi-carrier operation	62
4.8.17.1	TC17 generation.....	62
4.8.17.2	TC17 power allocation.....	62
4.8.18	TC18: GSM and E-UTRA with NB-IoT guard-band multi-carrier operation	62
4.8.18.1	TC18 generation.....	62
4.8.18.2	TC18 power allocation.....	63
4.8.19	TC19: UTRA and E-UTRA with NB-IoT guard-band multi-carrier operation	63
4.8.19.1	TC19 generation.....	63
4.8.19.2	TC19 power allocation.....	63
4.8.20	TC20: E-UTRA and E-UTRA with NB-IoT guard-band multi-carrier operation	63
4.8.20.1	TC20 generation.....	63
4.8.20.2	TC20 power allocation.....	64
4.8.21	TC21: Contiguous operation in CS16.....	64
4.8.21.1	TC21 generation.....	64
4.8.21.2	TC21 power allocation.....	64
4.8.22	NTC21: Non-contiguous operation in CS16.....	65
4.8.22.1	NTC21 generation.....	65
4.8.22.2	NTC21 power allocation	65
4.8.23	TC22: Contiguous operation in CS17	65
4.8.23.1	TC22 generation.....	65
4.8.23.2	TC22 power allocation.....	66
4.9	RF channels and test models	66
4.9.1	RF channels	66
4.9.2	Test models	67
4.10	BS configurations	68
4.10.1	Transmit configurations	68
4.10.1.1	Transmission with multiple transmitter antenna connectors	68
4.10.2	Receive configurations	68
4.10.2.1	Reception with multiple receiver antenna connectors, receiver diversity	69
4.10.3	Duplexers.....	69
4.10.4	Power supply options.....	69
4.10.5	Ancillary RF amplifiers	69
4.10.6	BS with integrated Iuant BS modem	70
4.10.7	BS using antenna arrays.....	70
4.10.7.1	Receiver tests	70
4.10.7.2	Transmitter tests.....	71
4.11	Format and interpretation of tests	71
4.12	Requirements for BS capable of multi-band operation	72
4.13	Tests for BS capable of multi-band operation with three or more bands	73
5	Applicability of requirements and test configurations	73
5.1	Multi-RAT capable Base Stations	75
5.2	Single-RAT Multi-carrier capable Base Stations	99
5.3	Multi-band capable Base Stations	111
6	Transmitter characteristics	114
6.1	General	114
6.2	Base Station output power.....	114
6.2.1	Base Station maximum output power	114
6.2.1.1	Definition and applicability.....	114
6.2.1.2	Minimum requirement	115
6.2.1.2A	Additional requirement (regional).....	115
6.2.1.3	Test purpose	115
6.2.1.4	Method of test	115
6.2.1.4.1	Initial conditions.....	115
6.2.1.4.2	Procedure.....	115
6.2.1.5	Test requirements.....	115
6.2.2	E-UTRA DL RS power.....	116

6.2.2.1	Definition and applicability.....	116
6.2.2.2	Minimum requirement	116
6.2.2.3	Test purpose	116
6.2.2.4	Method of test	116
6.2.2.5	Test requirements.....	116
6.2.3	UTRA FDD primary CPICH power	116
6.2.3.1	Definition and applicability.....	116
6.2.3.2	Minimum requirement	116
6.2.3.3	Test purpose	117
6.2.3.4	Method of test	117
6.2.3.5	Test requirements.....	117
6.2.3A	UTRA FDD secondary CPICH power.....	117
6.2.3A.1	Definition and applicability.....	117
6.2.3A.2	Minimum requirement	117
6.2.3A.3	Test purpose	117
6.2.3A.4	Method of test	117
6.2.3A.5	Test requirements.....	117
6.2.4	UTRA TDD primary CCPCH power.....	118
6.2.4.1	Definition and applicability.....	118
6.2.4.2	Minimum requirement	118
6.2.4.3	Test purpose	118
6.2.4.4	Method of test	118
6.2.4.5	Test requirements.....	118
6.2.5	NB-IoT DL NRS power.....	118
6.2.5.1	Definition and applicability.....	118
6.2.5.2	Minimum requirement	118
6.2.5.3	Test purpose	118
6.2.5.4	Method of test	119
6.2.5.5	Test requirements.....	119
6.3	Output power dynamics.....	119
6.3.1	Definition and applicability	119
6.3.2	Minimum Requirement.....	119
6.3.3	Test purpose.....	119
6.3.4	Method of test.....	119
6.3.4.1	Initial conditions for GSM/EDGE output power dynamics for CS7.....	119
6.3.4.2	Procedure for GSM/EDGE output power dynamics	120
6.3.5	Test Requirement.....	120
6.4	Transmit ON/OFF power	120
6.4.1	Definition and applicability	120
6.4.2	Minimum Requirement.....	121
6.4.3	Test purpose.....	121
6.4.4	Method of test.....	122
6.4.4.1	Initial conditions	122
6.4.4.2	Procedure	122
6.4.5	Test requirement	122
6.5	Transmitted signal quality	122
6.5.1	Modulation quality.....	122
6.5.1.1	Definition and applicability.....	122
6.5.1.2	Minimum Requirement	122
6.5.1.3	Test purpose	123
6.5.1.4	Method of test	123
6.5.1.4.1	Initial conditions.....	123
6.5.1.4.2	Procedure.....	123
6.5.1.5	Test Requirements.....	123
6.5.1.5.1	E-UTRA test requirement.....	123
6.5.1.5.2	UTRA FDD test requirement	123
6.5.1.5.3	UTRA TDD test requirement	124
6.5.1.5.4	GSM/EDGE test requirement.....	124
6.5.1.5.5	NB-IoT test requirement.....	124
6.5.1.5.6	NR test requirement.....	124
6.5.2	Frequency error.....	124
6.5.2.1	Definition and applicability.....	124

6.5.2.2	Minimum Requirement	124
6.5.2.3	Test purpose	124
6.5.2.4	Method of test	124
6.5.2.5	Test Requirements.....	124
6.5.2.5.1	E-UTRA test requirement.....	124
6.5.2.5.2	UTRA FDD test requirement	124
6.5.2.5.3	UTRA TDD test requirement	124
6.5.2.5.4	GSM/EDGE test requirement.....	124
6.5.2.5.5	NB-IoT test requirement.....	125
6.5.2.5.6	NR test requirement.....	125
6.5.3	Time alignment error	125
6.5.3.1	Definition and applicability.....	125
6.5.3.2	Minimum requirement	125
6.5.3.3	Test purpose	125
6.5.3.4	Method of test	125
6.5.3.5	Test requirement	126
6.6	Unwanted emissions.....	126
6.6.1	Transmitter spurious emissions.....	126
6.6.1.1	Definition and applicability.....	126
6.6.1.2	Minimum requirement	126
6.6.1.3	Test purpose	127
6.6.1.4	Method of test	127
6.6.1.4.1	Initial conditions	127
6.6.1.4.2	Procedure.....	127
6.6.1.5	Test requirements	127
6.6.1.5.1	Spurious emissions (Category A)	128
6.6.1.5.2	Spurious emissions (Category B)	128
6.6.1.5.3	Additional test requirement for BC2 (category B)	128
6.6.1.5.4	Protection of the BS receiver of own or different BS	129
6.6.1.5.5	Additional spurious emission requirements.....	129
6.6.1.5.6	Co-location with other Base Stations	138
6.6.2	Operating band unwanted emissions	144
6.6.2.1	Definition and applicability.....	144
6.6.2.2	Minimum requirement	144
6.6.2.3	Test purpose	144
6.6.2.4	Method of test	144
6.6.2.4.1	Initial conditions	145
6.6.2.4.2	Procedure.....	145
6.6.2.5	Test requirement	146
6.6.2.5.1	Test requirements for Band Categories 1 and 3.....	146
6.6.2.5.2	Test requirements for Band Category 2.....	157
6.6.2.5.3	Test requirements for GSM/EDGE single-RAT requirements.....	165
6.6.2.5.4	Test requirements for additional requirements	165
6.6.2.5.4.1	Limits in FCC Title 47.....	165
6.6.2.5.4.2	Unsynchronized operation for BC3	165
6.6.2.5.4.3	Protection of DTT.....	165
6.6.2.5.4.4	Void	166
6.6.2.5.4.7	Additional requirements for band 48	167
6.6.3	Occupied bandwidth	168
6.6.3.1	Definition and applicability.....	168
6.6.3.2	Minimum requirements	168
6.6.3.3	Test purpose	168
6.6.3.4	Method of test	168
6.6.3.5	Test requirement	168
6.6.4	Adjacent Channel Leakage Power Ratio (ACLR)	169
6.6.4.1	Definition and applicability.....	169
6.6.4.2	Minimum requirement	169
6.6.4.3	Test purpose	169
6.6.4.4	Method of test	169
6.6.4.4.1	Initial conditions	169
6.6.4.4.2	Procedure.....	169
6.6.4.5	Test requirements.....	170

6.6.4.5.1	E-UTRA test requirement.....	170
6.6.4.5.2	UTRA FDD test requirement	172
6.6.4.5.3	UTRA TDD test requirement	172
6.6.4.5.4	Cumulative ACLR requirement in non-contiguous spectrum	172
6.6.4.5.5	NB-IoT test requirement.....	173
6.6.4.5.6	NR test requirement.....	174
6.7	Transmitter intermodulation.....	175
6.7.1	Definition and applicability	175
6.7.2	Minimum requirement	176
6.7.2A	Additional requirement for Band 41	176
6.7.3	Test purpose.....	176
6.7.4	Method of test.....	176
6.7.4.1	Initial conditions	176
6.7.4.2	Procedure	176
6.7.4.2.1	General minimum requirement test procedure	176
6.7.4.2.2	Additional minimum requirement (BC1 and BC2) test procedure	177
6.7.4.2.3	Additional minimum requirement (BC3) test procedure	178
6.7.5	Test requirements.....	178
6.7.5.1	General test requirement	178
6.7.5.2	Additional test requirement (BC1 and BC2).....	179
6.7.5.3	Additional test requirement (BC3).....	179
6.7.5.4	Additional test requirement for Band 41	179
7	Receiver characteristics.....	179
7.1	General	179
7.2	Reference sensitivity level.....	180
7.2.1	Definition and applicability	180
7.2.2	Minimum requirement	180
7.2.3	Test purpose.....	180
7.2.4	Method of test.....	180
7.2.4.1	Initial conditions for GSM/EDGE reference sensitivity level for CS7 and CS15.....	180
7.2.4.2	Procedure for GSM/EDGE reference sensitivity level for CS7 and CS15.....	181
7.2.5	Test requirements.....	181
7.3	Dynamic range	181
7.3.1	Definition and applicability	181
7.3.2	Minimum requirement	181
7.3.3	Test purpose.....	181
7.3.4	Method of test.....	181
7.3.4.1	Initial conditions for GSM/EDGE dynamic range for CS7 and CS15	182
7.3.4.2	Procedure for GSM/EDGE dynamic range for CS7 and CS15	182
7.3.5	Test requirements.....	182
7.4	In-band selectivity and blocking	183
7.4.1	Definition and applicability	183
7.4.2	Minimum requirement	183
7.4.3	Test purpose.....	183
7.4.4	Method of test.....	183
7.4.4.1	Initial conditions	183
7.4.4.2	Procedure for general blocking	184
7.4.4.3	Procedure for narrowband blocking.....	184
7.4.4.4	Procedure for additional narrowband blocking for GSM/EDGE	184
7.4.4.4.1	Initial conditions for additional narrowband blocking for GSM/EDGE for CS7 and CS15.....	184
7.4.4.4.2	Procedure for additional narrowband blocking for GSM/EDGE for CS7 and CS15.....	185
7.4.4.5	Procedure for GSM/EDGE AM suppression	185
7.4.4.5.1	Initial conditions for GSM/EDGE AM suppression for CS7 and CS15.....	185
7.4.4.5.2	Procedure for GSM/EDGE AM suppression for CS7 and CS15.....	185
7.4.4.6	Procedure for additional BC3 blocking requirement.....	186
7.4.5	Test requirements.....	186
7.4.5.1	General blocking test requirement	186
7.4.5.2	General narrowband blocking test requirement	187
7.4.5.3	Additional narrowband blocking test requirement for GSM/EDGE	189
7.4.5.4	GSM/EDGE test requirements for AM suppression	189
7.4.5.5	Additional BC3 blocking test requirement.....	189

7.5	Out-of-band blocking	189
7.5.1	Definition and applicability	189
7.5.2	Minimum requirement	190
7.5.3	Test purpose.....	190
7.5.4	Method of test	190
7.5.4.1	Initial conditions	190
7.5.4.2	Procedure	190
7.5.5	Test requirements.....	191
7.5.5.1	General out-of-band blocking test requirements	191
7.5.5.2	Co-location test requirements.....	191
7.6	Receiver spurious emissions.....	196
7.6.1	Definition and applicability	196
7.6.2	Minimum requirements.....	197
7.6.3	Test purpose.....	197
7.6.4	Method of test	197
7.6.4.1	Initial conditions	197
7.6.4.2	Procedure	197
7.6.5	Test requirements.....	197
7.6.5.1	General test requirements.....	197
7.6.5.2	Additional test requirement for BC2 (Category B)	198
7.7	Receiver intermodulation	198
7.7.1	Definition and applicability	198
7.7.2	Minimum requirement	198
7.7.3	Test purpose.....	199
7.7.4	Method of test	199
7.7.4.1	Initial conditions	199
7.7.4.2	Procedure for general and narrowband intermodulation	199
7.7.4.3	Procedure for additional narrowband intermodulation for GSM/EDGE.....	199
7.7.4.3.1	Initial conditions for additional narrowband intermodulation for GSM/EDGE for CS7 and CS15	200
7.7.4.3.2	Procedure for additional narrowband intermodulation for GSM/EDGE for CS7 and CS15	200
7.7.5	Test requirements.....	200
7.7.5.1	General intermodulation test requirement	200
7.7.5.2	General narrowband intermodulation test requirement	204
7.7.5.3	Additional narrowband intermodulation test requirement for GSM/EDGE.....	208
7.8	In-channel selectivity	208
7.8.1	Definition and applicability	208
7.8.2	Minimum requirement	208
7.8.3	Test purpose.....	208
7.8.4	Method of testing	208
7.8.5	Test requirements.....	209
8	Performance requirements.....	209
Annex A (normative): Characteristics of interfering signals		210
A.1	UTRA FDD interfering signal.....	210
A.2	UTRA TDD interfering signal	210
A.3	E-UTRA interfering signal.....	210
Annex B (normative): Environmental requirements for the BS equipment		211
B.1	General	211
B.2	Normal test environment.....	211
B.3	Extreme test environment.....	211
B.3.1	Extreme temperature	211
B.4	Vibration.....	212
B.5	Power supply	212
B.6	Measurement of test environments.....	212

Annex C (informative):	Test Tolerances and Derivation of test requirements.....	213
C.1	Measurement of transmitter.....	214
C.2	Measurement of receiver.....	218
Annex D (informative):	Measurement system set-up.....	221
D.1	Transmitter.....	221
D.1.1	Base station output power, transmitter ON/OFF power, modulation quality, transmitter spurious emissions and operating band unwanted emissions.....	221
D.1.2	Transmitter intermodulation.....	221
D.2	Receiver.....	222
D.2.1	Blocking characteristics.....	222
D.2.2	Receiver spurious emissions.....	222
D.2.3	Receiver intermodulation.....	222
Annex E (normative):	E-UTRA Test model for BC3 CS3 BS.....	223
E.0	BC3 CS3 Test model description.....	223
E.0A	BC3 CS16/17 Test model description.....	224
E.1	E-UTRA Test Model 1.1 (E-TM1.1_BC3CS3).....	224
E.1A	NR FR1 Test Model 1.1 (NR-FR1-TM1.1_BC3CS16/17).....	224
E.2	E-UTRA Test Model 1.2 (E-TM1.2_BC3CS3).....	225
E.2A	NR FR1 Test Model 1.2 (NR-FR1-TM1.2_BC3CS16/17).....	225
E.3	E-UTRA Test Model 2 (E-TM2_BC3CS3).....	225
E.3A	NR FR1 Test Model 2 (NR-FR1-TM2_BC3CS16/17).....	225
E.3B	NR FR1 Test Model 2a (NR-FR1-TM2a_BC3CS16/17).....	225
E.3C	E-UTRA Test Model 2a (E-TM2a_BC3CS3).....	225
E.3D	E-UTRA Test Model 2b (E-TM2b_BC3CS3).....	225
E.4	E-UTRA Test Model 3.1 (E-TM3.1_BC3CS3).....	225
E.4Y	E-UTRA Test Model 3.1a (E-TM3.1a_BC3CS3).....	226
E.4Z	E-UTRA Test Model 3.1b (E-TM3.1b_BC3CS3).....	226
E.4ZA	NR Test Model 3.1a (NR-FR1-TM3.1a_BC3CS16/17).....	226
E.4A	NR FR1 Test Model 3.1 (NR-FR1-TM3.1_BC3CS16/17).....	226
E.5	E-UTRA Test Model 3.2 (E-TM3.2_BC3CS3).....	226
E.5A	NR FR1 Test Model 3.2 (NR-FR1-TM3.2_BC3CS16/17).....	226
E.6	E-UTRA Test Model 3.3 (E-TM3.3_BC3CS3).....	226
E.6A	NR FR1 Test Model 3.3 (NR-FR1-TM3.3_BC3CS16/17).....	226
Annex F (informative):	Change history.....	227
History	236

Foreword

This Technical Specification has been produced by the 3rd Generation Partnership Project (3GPP).

The contents of the present document are subject to continuing work within the TSG and may change following formal TSG approval. Should the TSG modify the contents of the present document, it will be re-released by the TSG with an identifying change of release date and an increase in version number as follows:

Version x.y.z

where:

- x the first digit:
 - 1 presented to TSG for information;
 - 2 presented to TSG for approval;
 - 3 or greater indicates TSG approved document under change control.
- y the second digit is incremented for all changes of substance, i.e. technical enhancements, corrections, updates, etc.
- z the third digit is incremented when editorial only changes have been incorporated in the document.

1 Scope

The present document specifies the Radio Frequency (RF) test methods and conformance requirements for NR, E-UTRA, UTRA, GSM/EDGE and NB-IoT Multi-Standard Radio (MSR) Base Station (BS). These have been derived from, and are consistent with the NR, E-UTRA, UTRA, GSM/EDGE and NB-IoT MSR BS specification defined in [2].

2 References

The following documents contain provisions which, through reference in this text, constitute provisions of the present document.

- References are either specific (identified by date of publication, edition number, version number, etc.) or non-specific.
- For a specific reference, subsequent revisions do not apply.
- For a non-specific reference, the latest version applies. In the case of a reference to a 3GPP document (including a GSM document), a non-specific reference implicitly refers to the latest version of that document *in the same Release as the present document*.

- [1] 3GPP TR 21.905: "Vocabulary for 3GPP Specifications".
- [2] 3GPP TS 37.104: "E-UTRA, UTRA and GSM/EDGE; Multi-Standard Radio (MSR) Base Station (BS) radio transmission and reception".
- [3] 3GPP TS 25.104: "Base Station (BS) radio transmission and reception (FDD) ".
- [4] 3GPP TS 25.105: "Base Station (BS) radio transmission and reception (TDD) ".
- [5] 3GPP TS 36.104: "Evolved Universal Terrestrial Radio Access (E-UTRA); Base Station (BS) radio transmission and reception".
- [6] 3GPP TS 45.005: "Radio transmission and reception".
- [7] ITU-R Recommendation M.1545, "Measurement uncertainty as it applies to test limits for the terrestrial component of International Mobile Telecommunications-2000".
- [8] "Title 47 of the Code of Federal Regulations (CFR)", Federal Communications Commission.
- [9] 3GPP TS 36.141: "Evolved Universal Terrestrial Radio Access (E-UTRA); Base Station (BS) conformance testing".
- [10] 3GPP TS 25.141: "Base Station (BS) conformance testing (FDD) ".
- [11] 3GPP TS 51.021: "Base Station System (BSS) equipment specification; Radio aspects".
- [12] 3GPP TS 25.142: "Base Station (BS) conformance testing (TDD) ".
- [13] Recommendation ITU-R SM.329-10, "Unwanted emissions in the spurious domain".
- [14] 3GPP TR 25.942: "Radio Frequency (RF) system scenarios".
- [15] ITU-R recommendation SM.328: "Spectra and bandwidth of emissions".
- [16] IEC 60721: "Classification of environmental conditions".
- [17] IEC 60721-3-3: "Classification of environmental conditions - Part 3-3: Classification of groups of environmental parameters and their severities - Stationary use at weather protected locations".
- [18] IEC 60721-3-4: "Classification of environmental conditions - Part 3: Classification of groups of environmental parameters and their severities - Section 4: Stationary use at non-weather protected locations".

- [19] ETSI EN 300 019-1-3, *European Standard (Telecommunications series)*, “Environmental Engineering (EE); Environmental conditions and environmental tests for telecommunications equipment; Part 1-3: Classification of environmental conditions; Stationary use at weather protected locations”
- [20] ETSI EN 300 019-1-4, *European Standard (Telecommunications series)*, “Environmental Engineering (EE); Environmental conditions and environmental tests for telecommunications equipment; Part 1-4: Classification of environmental conditions; Stationary use at non-weather protected locations”.
- [21] IEC 60068-2-1 (2007): "Environmental testing - Part 2: Tests. Tests A: Cold".
- [22] IEC 60068-2-2 (2007): "Environmental testing - Part 2: Tests. Tests B: Dry heat".
- [23] IEC 60068-2-6 (2007): "Environmental testing - Part 2: Tests - Test Fc: Vibration (sinusoidal)".
- [24] CEPT ECC Decision (13)03, "The harmonised use of the frequency band 1452-1492 MHz for Mobile/Fixed Communications Networks Supplemental Downlink (MFCN SDL)".
- [25] CEPT ECC Decision (17)06, “The harmonised use of the frequency bands 1427-1452 MHz and 1492-1518 MHz for Mobile/Fixed Communications Networks Supplemental Downlink (MFCN SDL)”.
- [26] 3GPP TS 38.141-1: "NR; Base Station (BS) conformance testing Part 1: Conducted conformance testing".
- [27] 3GPP TS 38.104: "NR; Base Station (BS) radio transmission and reception".
- [28] Void.
- [29] 3GPP TS 38.101-1: "NR; User Equipment (UE) radio transmission and reception; Part 1: Range 1 Standalone"

3 Definitions, symbols and abbreviations

3.1 Definitions

For the purposes of the present document, the terms and definitions given in TR 21.905 [1] and the following apply. A term defined in the present document takes precedence over the definition of the same term, if any, in TR 21.905 [1].

Band category: group of operating bands for which the same MSR scenarios apply.

Base Station RF Bandwidth: RF bandwidth in which a base station transmits and/or receives single or multiple carrier(s) and/or RATs simultaneously within a supported operating band.

NOTE: In single carrier operation, the Base Station RF Bandwidth is equal to the channel bandwidth.

Base Station RF Bandwidth edge: frequency of one of the edges of the Base Station RF Bandwidth.

Carrier: modulated waveform conveying the NR, E-UTRA, UTRA or GSM/EDGE physical channels.

Carrier aggregation: aggregation of two or more NR or E-UTRA component carriers in order to support wider transmission bandwidths.

Carrier aggregation band: set of one or more operating bands across which multiple NR or E-UTRA carriers are aggregated with a specific set of technical requirements.

NOTE: Carrier aggregation band(s) for an E-UTRA BS is declared by the manufacturer according to the designations in Tables 5.5-2 to 5.5-4 of TS 36.104 [5].

Channel bandwidth: RF bandwidth supporting a single NR, E-UTRA, UTRA or GSM/EDGE RF carrier with the transmission bandwidth configured in the uplink or downlink of a cell.

NOTE: The channel bandwidth is measured in MHz and is used as a reference for transmitter and receiver RF requirements.

NOTE: The term channel bandwidth is referred to as BS channel bandwidth in the NR specifications, since for NR the BS and UE may operate with differing bandwidths.

Contiguous carriers: set of two or more carriers configured in a spectrum block where there are no RF requirements based on co-existence for un-coordinated operation within the spectrum block.

Carrier power: power at the antenna connector in the channel bandwidth of the carrier averaged over at least one subframe for NR or E-UTRA, at least one slot for UTRA and the useful part of the burst for GSM/EDGE.

Contiguous spectrum: spectrum consisting of a contiguous block of spectrum with no sub-block gap(s).

Downlink operating band: part of the operating band designated for downlink.

Highest Carrier: carrier with the highest carrier centre frequency transmitted/received in the specified operating band(s).

Inter RF Bandwidth gap: frequency gap between two consecutive Base Station RF Bandwidths that are placed within two supported operating bands.

Inter-band carrier aggregation: carrier aggregation of NR or E-UTRA component carriers in different operating bands.

NOTE: Carriers aggregated in each band can be contiguous or non-contiguous.

Inter-band gap: The frequency gap between two supported consecutive operating bands.

Intra-band contiguous carrier aggregation: contiguous NR or E-UTRA carriers aggregated in the same operating band.

Intra-band non-contiguous carrier aggregation: non-contiguous NR or E-UTRA carriers aggregated in the same operating band.

Lowest Carrier: carrier with the lowest carrier centre frequency transmitted/received in the specified operating band(s).

Lower Base Station RF Bandwidth edge: frequency of the lower Base Station RF Bandwidth edge, used as a frequency reference point for transmitter and receiver requirements.

Lower sub-block edge: frequency at the lower edge of one sub-block.

NOTE: It is used as a frequency reference point for both transmitter and receiver requirements.

Maximum Base Station RF Bandwidth: maximum RF bandwidth supported by a BS within each supported operating band.

NOTE: The maximum Base Station RF Bandwidth for BS configured for contiguous and non-contiguous operation within each supported operating band is declared separately.

Maximum carrier output power: carrier power available at the antenna connector for a specified reference condition.

Maximum Radio Bandwidth: maximum frequency difference between the upper edge of the highest used carrier and the lower edge of the lowest used carrier.

Maximum RAT output power: sum of the power of all carriers of the same RAT available at the antenna connector for a specified reference condition.

Maximum throughput: maximum achievable throughput for a reference measurement channel.

Maximum total output power: sum of the power of all carriers available at the antenna connector for a specified reference condition.

MB-MSR Base Station: MSR base station characterized by the ability of its transmitter and/or receiver to process two or more carriers in common active RF components simultaneously, where at least one carrier is configured at a different operating band (which is not a sub-band or superseding-band of another supported operating band) than the other carrier(s).

Mean power: power measured in the bandwidth and period of measurement applicable for each RAT

NOTE: Mean power for an E-UTRA carrier is defined in TS 36.141 [9] and mean power for a UTRA carrier is defined in TS 25.141 [10]. In case of multiple carriers, the mean power is the sum of the mean power of all carriers.

Measurement bandwidth: RF bandwidth in which an emission level is specified.

MSR Base Station: base station characterized by the ability of its receiver and transmitter to process two or more carriers in common active RF components simultaneously in a declared Base Station RF Bandwidth, where at least one carrier is of a different RAT than the other carrier(s).

Multi-band connector: *antenna* connector of the *BS type 1-C* associated with a transmitter or receiver that is characterized by the ability to process two or more carriers in common active RF components simultaneously, where at least one carrier is configured at a different *operating band* than the other carrier(s) and where this different *operating band* is not a sub-band or superseding-band of another supported operating band.

Multi-band transmitter: transmitter characterized by the ability to process two or more carriers in common active RF components simultaneously, where at least one carrier is configured at a different operating band (which is not a sub-band or superseding-band of another supported operating band) than the other carrier(s).

Multi-band receiver: receiver characterized by the ability to process two or more carriers in common active RF components simultaneously, where at least one carrier is configured at a different operating band (which is not a sub-band or superseding-band of another supported operating band) than the other carrier(s).

Non-contiguous spectrum: spectrum consisting of two or more sub-blocks separated by sub-block gap(s).

NB-IoT In-band operation: NB-IoT is operating in-band when it utilizes the resource block(s) within a normal E-UTRA carrier.

NB-IoT guard band operation: NB-IoT is operating in guard band when it utilizes the unused resource block(s) within a E-UTRA carrier's guard-band.

NB-IoT standalone operation: NB-IoT is operating standalone when it utilizes its own spectrum, for example the spectrum currently being used by GERAN systems as a replacement of one or more GSM carriers, as well as scattered spectrum for potential IoT deployment.

Occupied bandwidth: width of a frequency band such that, below the lower and above the upper frequency limits, the mean powers emitted are each equal to a specified percentage $\beta/2$ of the total mean power of a given emission.

Operating band: A frequency range in which NR, E-UTRA, UTRA or GSM/EDGE operates (paired or unpaired), that is defined with a specific set of technical requirements.

NOTE: The operating band(s) for a base station is declared by the manufacturer.

Sub-band: A sub-band of an operating band contains a part of the uplink and downlink frequency range of the operating band.

Sub-block: one contiguous allocated block of spectrum for use by the same base station.

NOTE: There may be multiple instances of sub-blocks within an RF bandwidth.

Sub-block bandwidth: RF bandwidth of one sub-block.

Sub-block gap: frequency gap between two consecutive sub-blocks within an Base Station RF Bandwidth, where the RF requirements in the gap are based on co-existence for un-coordinated operation.

Superseding-band: A superseding-band of an operating band includes the whole of the uplink and downlink frequency range of the operating band.

Single-RAT operation: operation of a base station in an operating band with only one RAT configured in that operating band.

Synchronized operation: operation of TDD in two different systems, where no simultaneous uplink and downlink occur.

RAT power: sum of all carrier powers for all carriers of the same type.

Rated carrier output power: mean power level per carrier that the manufacturer has declared to be available at the antenna connector.

Rated RAT output power: mean power level per RAT that the manufacturer has declared to be available at the antenna connector.

Rated total output power: total mean power level that the manufacturer has declared to be available at the antenna connector.

RRC filtered mean power: mean power of a UTRA carrier as measured through a root raised cosine filter with roll-off factor α and a bandwidth equal to the chip rate of the radio access mode.

NOTE: The RRC filtered mean power of a perfectly modulated UTRA signal is 0.246 dB lower than the mean power of the same signal.

Throughput: number of payload bits successfully received per second for a reference measurement channel in a specified reference condition.

Total output power: sum of all carrier powers for all carriers transmitted by the BS.

Total RF Bandwidth: maximum sum of Base Station RF Bandwidths in all supported operating bands.

Transmission bandwidth: bandwidth of an instantaneous NR or E-UTRA transmission from a UE or BS, measured in resource block units.

Transmission bandwidth configuration: highest NR or E-UTRA transmission bandwidth allowed for uplink or downlink in a given channel bandwidth, measured in resource block units.

Transmitter ON period: time period during which the base station transmitter is transmitting data and/or reference symbols.

Transmitter OFF period: time period during which the base station transmitter is not allowed to transmit.

Transmitter transient period: time period during which the transmitter is changing from the OFF period to the ON period or vice versa.

Unsynchronized operation: operation of TDD in two different systems, where the conditions for synchronized operation are not met.

Uplink operating band: part of the operating band designated for uplink.

Upper Base Station RF Bandwidth edge: frequency of the upper Base Station RF Bandwidth edge, used as a frequency reference point for transmitter and receiver requirements.

Upper sub-block edge: frequency at the upper edge of one sub-block.

NOTE: It is used as a frequency reference point for both transmitter and receiver requirements.

3.2 Symbols

For the purposes of the present document, the following symbols apply:

α	Roll-off factor
β	Percentage of the mean transmitted power emitted outside the occupied bandwidth on the assigned channel
BW_{Channel}	Channel bandwidth (for E-UTRA and NR)
BW_{Config}	Transmission bandwidth configuration (for E-UTRA), expressed in MHz, where $BW_{\text{Config}} = N_{\text{RB}} \times 180$ kHz in the uplink and $BW_{\text{Config}} = 15$ kHz + $N_{\text{RB}} \times 180$ kHz in the downlink. Transmission bandwidth configuration (for NR), where $BW_{\text{Config}} = N_{\text{RB}} \times \text{SCS} \times 12$.
BW_{RF}	Base Station RF Bandwidth, where $BW_{\text{RF}} = F_{\text{BW RF,high}} - F_{\text{BW RF,low}}$
$BW_{\text{RF,max}}$	Maximum Base Station RF Bandwidth
CA_X	CA for band X where X is the applicable E-UTRA operating band
CA_X-Y	CA for band X and Band Y where X and Y are the applicable E-UTRA operating band

DwPTS	Downlink part of the special subframe (for E-UTRA TDD operation)
f	Frequency
Δf	Separation between the Base Station RF Bandwidth edge frequency and the nominal -3dB point of the measuring filter closest to the carrier frequency
Δf_{\max}	The largest value of Δf used for defining the requirement
Δf_{OBUE}	Maximum offset of the <i>operating band</i> unwanted emissions mask from the downlink <i>operating band edge</i>
Δf_{OOB}	Maximum offset of the out-of-band boundary from the uplink <i>operating band edge</i>
F_C	Carrier centre frequency
F_{filter}	Filter centre frequency
f_{offset}	Separation between the Base Station RF Bandwidth edge frequency and the centre of the measuring filter
$f_{\text{offset}_{\max}}$	The maximum value of f_{offset} used for defining the requirement
$F_{\text{block,high}}$	Upper sub-block edge, where $F_{\text{block,high}} = F_{C,\text{block,high}} + F_{\text{offset, RAT}}$
$F_{\text{block,low}}$	Lower sub-block edge, where $F_{\text{block,low}} = F_{C,\text{block,low}} - F_{\text{offset, RAT}}$
$F_{\text{BW RF,high}}$	Upper Base Station RF Bandwidth edge, where $F_{\text{BW RF,high}} = F_{C,\text{high}} + F_{\text{offset, RAT}}$
$F_{\text{BW RF,low}}$	Lower Base Station RF Bandwidth edge, where $F_{\text{BW RF,low}} = F_{C,\text{low}} - F_{\text{offset, RAT}}$
$F_{C \text{ band, high}}$	Center frequency of the highest transmitted/received carrier in a band.
$F_{C \text{ band, low}}$	Center frequency of the lowest transmitted/received carrier in a band.
$F_{C,\text{block, high}}$	Centre frequency of the highest transmitted/received carrier in a sub-block.
$F_{C,\text{block, low}}$	Centre frequency of the lowest transmitted/received carrier in a sub-block.
$F_{C,\text{high}}$	Centre frequency of the highest transmitted/received carrier.
$F_{C,\text{low}}$	Centre frequency of the lowest transmitted/received carrier.
$F_{\text{offset, RAT}}$	Frequency offset from the centre frequency of the <i>highest</i> transmitted/received carrier to the <i>upper</i> Base Station RF Bandwidth edge, sub-block edge or Inter RF Bandwidth edge, or from the centre frequency of the <i>lowest</i> transmitted/received carrier to the <i>lower</i> Base Station RF Bandwidth edge, sub-block edge or Inter RF Bandwidth edge for a specific RAT.
$F_{\text{DL,low}}$	The lowest frequency of the downlink operating band
$F_{\text{DL,high}}$	The highest frequency of the downlink operating band
$F_{\text{UL,low}}$	The lowest frequency of the uplink operating band
$F_{\text{UL,high}}$	The highest frequency of the uplink operating band
N_{RB}	Transmission bandwidth configuration, expressed in units of resource blocks (for E-UTRA)
$P_{\text{EM,B32,B75,B76,ind}}$	Declared emission level in Band 32, Band 75 and Band 76, ind=a, b, c
$P_{\text{EM,B32,ind}}$	Declared emission level in Band 32, ind= d, e
$P_{\text{EM,B50,B74,B75,ind}}$	Declared emission level for Band 50, Band 74 and Band 75, ind=a,b
P_{max}	Maximum total output power
$P_{\text{max,c}}$	Maximum carrier output power
$P_{\text{max,RAT}}$	Maximum RAT output power
$P_{\text{Rated,c}}$	Rated carrier output power
P_{REFSENS}	Reference Sensitivity power level
W_{gap}	Sub-block gap size or Inter RF Bandwidth gap size

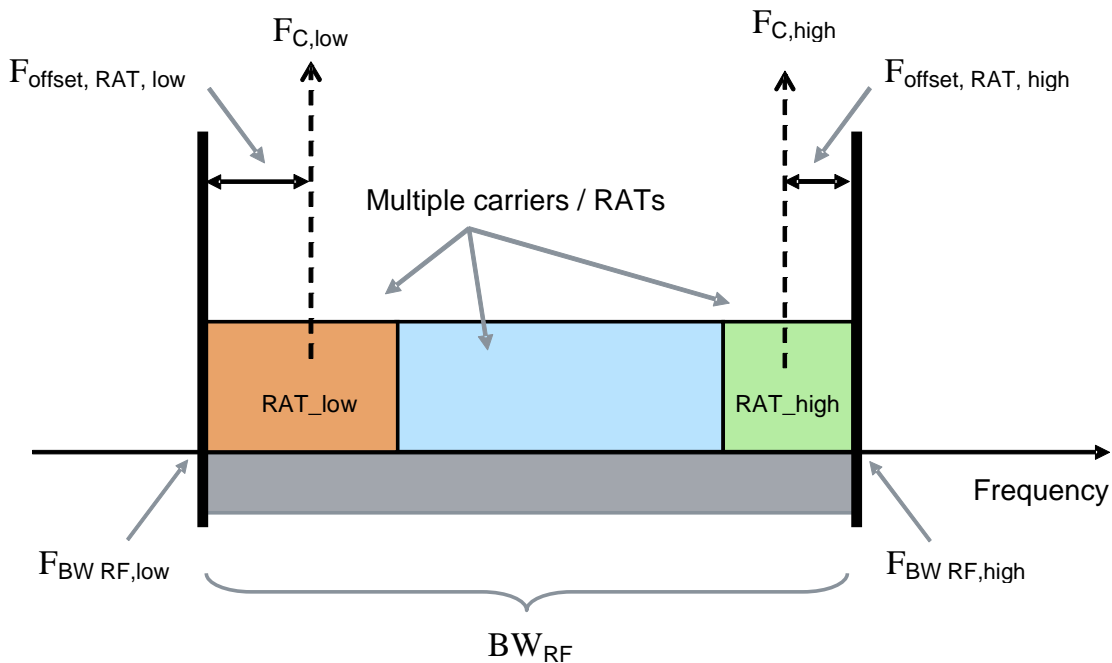

Figure 3.2-1: Illustration of Base Station RF Bandwidth related symbols and definitions for Multi-Standard Radio

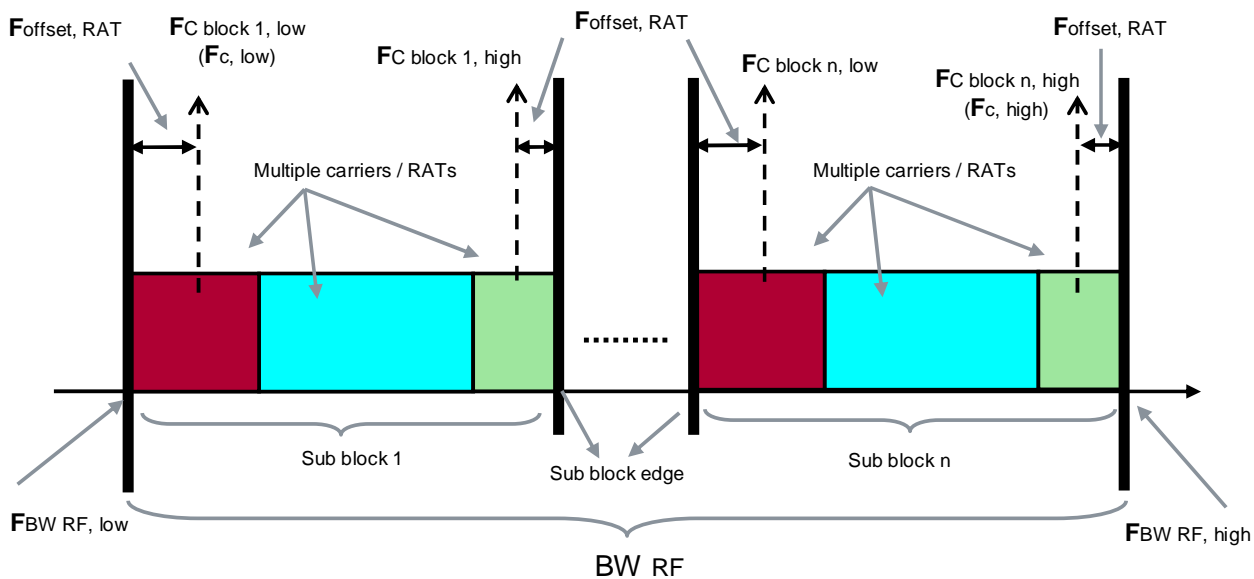

Figure 3.2-2: Illustration of Base Station RF Bandwidth related symbols and definitions for non-contiguous Multi-Standard Radio

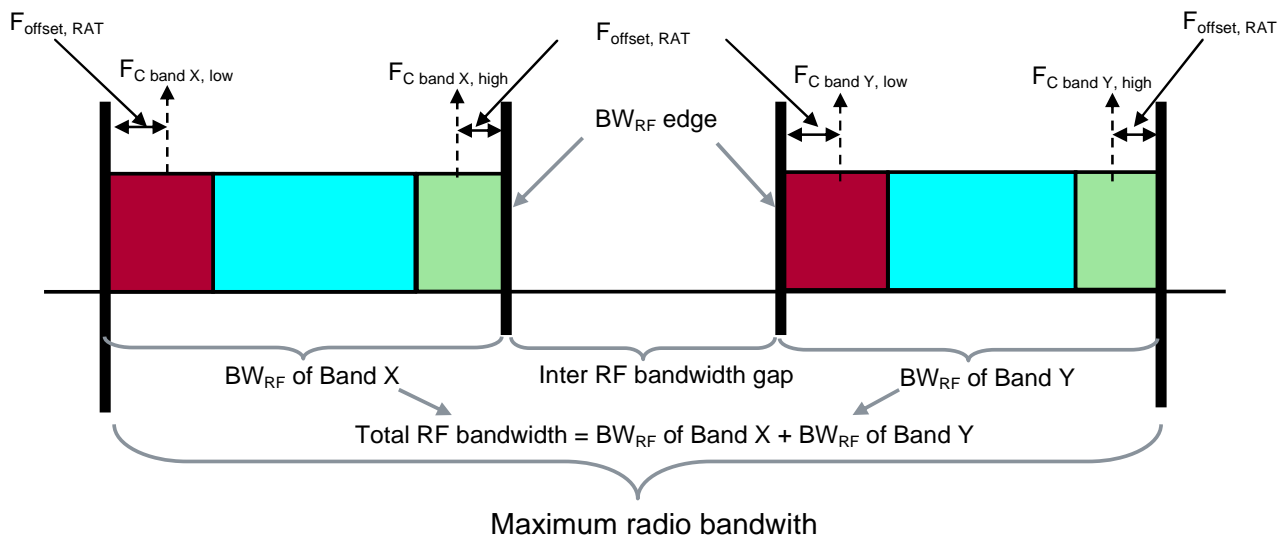

Figure 3.2-3: Illustration of Maximum Radio Bandwidth and Total RF Bandwidth for Multi-band Multi-standard Radio

3.3 Abbreviations

For the purposes of the present document, the abbreviations given in TR 21.905 [1] and the following apply. An abbreviation defined in the present document takes precedence over the definition of the same abbreviation, if any, in TR 21.905 [1].

ACIR	Adjacent Channel Interference Ratio
ACLR	Adjacent Channel Leakage Ratio
ACK	Acknowledgement (in HARQ protocols)
ACS	Adjacent Channel Selectivity
ARFCN	Absolute Radio Frequency Channel Number
AWGN	Additive White Gaussian Noise
BC	Band Category
BER	Bit Error Ratio
BS	Base Station
BTS	Base Transceiver Station
BW	Bandwidth
CA	Carrier Aggregation
CACLR	Cumulative Adjacent Channel Leakage Ratio
CP	Cyclic prefix
CRC	Cyclic Redundancy Check
CW	Continuous Wave
DC	Direct Current
DC-HSDPA	Dual Cell HSDPA
DTX	Discontinuous Transmission
EARFCN	E-UTRA Absolute Radio Frequency Channel Number
EDGE	Enhanced Data rates for GSM Evolution
EIRP	Effective Isotropic Radiated Power
E-UTRA	Evolved UTRA
EVM	Error Vector Magnitude
FCC	Federal Communications Commission
FDD	Frequency Division Duplex
FR	Frequency Range
FRC	Fixed Reference Channel
GP	Guard Period (for E-UTRA TDD operation)
GSM	Global System for Mobile Communications
HSDPA	High Speed Downlink Packet Access

ICS	In-Channel Selectivity
ITU-R	Radiocommunication Sector of the ITU
LA	Local Area
LNA	Low Noise Amplifier
MCL	Minimum Coupling Loss
MCS	Modulation and Coding Scheme
MIMO	Multiple Input Multiple Output
MB-MSR	Multi-Band Multi-Standard Radio
MBT	Multi-Band Testing
MFCN	Mobile/Fixed Communications Network
MR	Medium Range
MS	Mobile Station
MSR	Multi-Standard Radio
NB-IoT	Narrowband-Internet of Things
NR	New Radio
NR-ARFCN	NR Absolute Radio Frequency Channel Number
NRS	Narrowband Reference Signal
OBUE	Operating Band Unwanted Emissions
OFDM	Orthogonal Frequency Division Multiplex
OOB	Out-Of-band
PA	Power Amplifier
PHS	Personal Handyphone System
QAM	Quadrature Amplitude Modulation
QPSK	Quadrature Phase-Shift Keying
RAT	Radio Access Technology
RB	Resource Block
REFSENS	Reference Sensitivity
RF	Radio Frequency
RMS	Root Mean Square (value)
RS	Reference Symbol
RX	Receiver
RRC	Root Raised Cosine
SCS	Sub-Carrier Spacing
SBT	Single Band Testing
SNR	Signal-to-Noise Ratio
TAE	Time Alignment Error
TDD	Time Division Duplex
TT	Test Tolerance
TX	Transmitter
UARFCN	UTRA Absolute Radio Frequency Channel Number
UE	User Equipment
UEM	operating band Unwanted Emissions Mask
WA	Wide Area

4 General test conditions and declarations

4.1 Measurement uncertainties and test requirements

4.1.1 General

The requirements of this clause apply to all applicable tests in this specification.

The minimum requirements are given in TS 37.104 [2] and the references therein. Test requirements are given in this specification or are included by reference to TS 25.141 [10], TS 25.142 [12], TS 36.141 [9], TS 38.141-1 [26] or TS 51.021 [11]. Test Tolerances for the test requirements explicitly stated in the present specification are defined in

Annex C of this specification. Test Tolerances for test requirements included by reference are defined in the respective referred test specification.

Test Tolerances are individually calculated for each test. The Test Tolerances are used to relax the minimum requirements to create test requirements.

When a test requirement differs from the corresponding minimum requirement, then the Test Tolerance applied for the test is non-zero. The Test Tolerance for the test and the explanation of how the minimum requirement has been relaxed by the Test Tolerance are given in Annex C.

4.1.2 Acceptable uncertainty of Test System

The maximum acceptable uncertainty of the Test System is specified below for each test defined explicitly in the present specification, where appropriate. The maximum acceptable uncertainty of the Test System for test requirements included by reference is defined in the respective referred test specification.

The Test System shall enable the stimulus signals in the test case to be adjusted to within the specified tolerance and the equipment under test to be measured with an uncertainty not exceeding the specified values. All tolerances and uncertainties are absolute values, and are valid for a confidence level of 95 %, unless otherwise stated.

A confidence level of 95% is the measurement uncertainty tolerance interval for a specific measurement that contains 95% of the performance of a population of test equipment.

For RF tests, it should be noted that the uncertainties in clause 4.1.2 apply to the Test System operating into a nominal 50 ohm load and do not include system effects due to mismatch between the DUT and the Test System.

Unless otherwise stated, the uncertainties in clause 4.1.2 apply to the Test System for testing NR, E-UTRA, UTRA, GSM/EDGE and NB-IoT MSR BS.

4.1.2.1 Measurement of transmitter

Table 4.1.2-1: Maximum Test System uncertainty for transmitter tests

Clause	Maximum Test System Uncertainty	Derivation of Test System Uncertainty
6.2.1 Base Station maximum output power	± 0.7 dB for UTRA, E-UTRA and NR, $f \leq 3.0$ GHz ± 1.0 dB, 3.0 GHz $< f \leq 4.2$ GHz for UTRA, E-UTRA and NR ± 1.0 dB for GSM/EDGE or standalone NB-IoT	
6.4 Transmit ON/OFF power	± 2.0 dB, $f \leq 3.0$ GHz ± 2.5 dB, 3.0 GHz $< f \leq 4.2$ GHz	
6.6.1.5.1 Transmitter spurious emissions, Mandatory Requirements	9 kHz $< f \leq 4$ GHz: ± 2.0 dB 4 GHz $< f \leq 19$ GHz: ± 4.0 dB	
6.6.1.5.2 Transmitter spurious emissions, Mandatory Requirements	9 kHz $< f \leq 4$ GHz: ± 2.0 dB 4 GHz $< f \leq 19$ GHz: ± 4.0 dB	
6.6.1.5.3 Transmitter spurious emissions, Additional BC2 Requirement	9 kHz $< f \leq 4$ GHz: ± 2.0 dB 4 GHz $< f \leq 12.75$ GHz: ± 4.0 dB	
6.6.1.5.4 Transmitter spurious emissions, Protection of BS receiver	± 3.0 dB	
6.6.1.5.5 Transmitter spurious emissions, Additional spurious emission requirements	± 2.0 dB for > -60 dBm, $f \leq 3.0$ GHz ± 2.5 dB, 3.0 GHz $< f \leq 4.2$ GHz ± 3.0 dB for ≤ -60 dBm, $f \leq 3.0$ GHz ± 3.5 dB, 3.0 GHz $< f \leq 4.2$ GHz	
6.6.1.5.6 Transmitter spurious emissions, Co-location	± 3.0 dB	
6.6.2 Operating band unwanted emissions	± 1.5 dB, $f \leq 3.0$ GHz ± 1.8 dB, 3.0 GHz $< f \leq 4.2$ GHz	
6.6.3 Occupied bandwidth	For NR: 5 MHz, 10 MHz BS Channel BW: ± 100 kHz 15 MHz, 20 MHz, 25 MHz, 30 MHz, 40 MHz, 50 MHz BS Channel BW: ± 300 kHz 60 MHz, 70 MHz, 80 MHz, 90 MHz, 100 MHz BS Channel BW: ± 600 kHz For E-UTRA: 1.4 MHz, 3 MHz Channel BW: ± 30 kHz 5 MHz, 10 MHz Channel BW: ± 100 kHz 15 MHz, 20 MHz: Channel BW: ± 300 kHz For UTRA: ± 100 kHz	
6.6.4 Adjacent Channel Leakage Power Ratio (ACLR)	ACLR $BW \leq 20$ MHz: ± 0.8 dB $BW > 20$ MHz: ± 1.2 dB Absolute power ± 2.0 dB, $f \leq 3.0$ GHz Absolute power ± 2.5 dB, 3.0 GHz $< f \leq 4.2$ GHz CACLR $BW \leq 20$ MHz: ± 0.8 dB $BW > 20$ MHz: ± 1.2 dB CACLR absolute power ± 2.0 dB, $f \leq 3.0$ GHz CACLR absolute power ± 2.5 dB, 3.0 GHz $< f \leq 4.2$ GHz	
6.7 Transmitter intermodulation (interferer requirements) This tolerance applies to the stimulus and not the measurements defined in 6.6.1, 6.6.2 and 6.6.4	The value below applies only to the interfering signal and is unrelated to the measurement uncertainty of the tests (6.6.1, 6.6.2 and 6.6.4) which have to be carried out in the presence of the interferer. ± 1.0 dB	The uncertainty of interferer has double the effect on the result due to the frequency offset

4.1.2.2 Measurement of receiver

Table 4.1.2-2: Maximum Test System Uncertainty for receiver tests

Clause	Maximum Test System Uncertainty	Derivation of Test System Uncertainty
7.4 In-band selectivity and blocking (General blocking requirements)	± 1.4 dB, $f \leq 3.0$ GHz ± 1.8 dB, 3.0 GHz $< f \leq 4.2$ GHz	<p>Overall system uncertainty comprises three quantities:</p> <ol style="list-style-type: none"> 1. Wanted signal level error 2. Interferer signal level error 3. Additional impact of interferer leakage <p>Items 1 and 2 are assumed to be uncorrelated so can be root sum squared to provide the ratio error of the two signals. The interferer leakage effect is systematic and is added arithmetically.</p> <p>Test System uncertainty = [SQRT (wanted_level_error² + interferer_level_error²)] + leakage effect.</p> <p>$f \leq 3.0$ GHz Wanted signal level ± 0.7 dB Interferer signal level ± 0.7 dB 3.0 GHz $< f \leq 4.2$ GHz Wanted signal level ± 1.0 dB Interferer signal level ± 1.0 dB</p> <p>$f \leq 4.2$ GHz Impact of interferer leakage 0.4 dB.</p>
7.4 In-band selectivity and blocking (Narrowband blocking requirements)	± 1.4 dB, $f \leq 3.0$ GHz ± 1.8 dB, 3.0 GHz $< f \leq 4.2$ GHz	Same as In-band selectivity and blocking (General blocking requirements).
7.4 In-band selectivity and blocking (BC3 blocking requirements)	± 1.4 dB, $f \leq 3.0$ GHz ± 1.8 dB, 3.0 GHz $< f \leq 4.2$ GHz	Same as In-band selectivity and blocking (General blocking requirements).
7.5 Out-of-band blocking	1 MHz $\leq f_{\text{interferer}} \leq 3$ GHz: ± 1.3 dB 3 GHz $< f_{\text{interferer}} \leq 12.75$ GHz: ± 3.2 dB	<p>Overall system uncertainty comprises three quantities:</p> <ol style="list-style-type: none"> 1. Wanted signal level error 2. Interferer signal level error 3. Interferer broadband noise <p>Items 1 and 2 are assumed to be uncorrelated so can be root sum squared to provide the ratio error of the two signals. The Interferer Broadband noise effect is systematic and is added arithmetically.</p> <p>Test System uncertainty = [SQRT (wanted_level_error² + interferer_level_error²)] + Broadband noise effect.</p> <p>Out of band blocking, using CW interferer: Wanted signal level: ± 0.7 dB up to 3 GHz ± 1.0 dB up to 4.2 GHz Interferer signal level: ± 1.0 dB up to 3 GHz ± 3.0 dB up to 12.75 GHz Impact of interferer Broadband noise 0.1 dB</p>
7.6 Receiver spurious emissions	30 MHz $\leq f \leq 4$ GHz: ± 2.0 dB 4 GHz $< f \leq 19$ GHz: ± 4.0 dB	

<p>7.7.5 Receiver intermodulation (General requirements)</p>	<p>± 1.8 dB, $f \leq 3.0$ GHz ± 2.4 dB, 3.0 GHz $< f \leq 4.2$ GHz</p>	<p>Overall system uncertainty comprises four quantities:</p> <ol style="list-style-type: none"> 1. Wanted signal level error 2. CW Interferer level error 3. Modulated Interferer level error 4. Impact of interferer ACLR <p>The effect of the closer CW signal has twice the effect.</p> <p>Items 1, 2 and 3 are assumed to be uncorrelated so can be root sum squared to provide the combined effect of the three signals. The interferer ACLR effect is systematic and is added arithmetically.</p> <p>Test System uncertainty = $\text{SQRT} [(2 \times \text{CW_level_error})^2 + (\text{mod interferer_level_error})^2 + (\text{wanted signal_level_error})^2] + \text{ACLR effect.}$</p> <p>$f \leq 3.0$ GHz Wanted signal level ± 0.7dB CW interferer level ± 0.5 dB Mod interferer level ± 0.7 dB 3.0 GHz $< f \leq 4.2$ GHz Wanted signal level ± 1.0 dB CW Interferer level ± 0.7 dB Mod Interferer level ± 1.0 dB</p> <p>$f \leq 4.2$ GHz Impact of interferer ACLR 0.4 dB</p>
<p>7.7.5 Receiver intermodulation (Narrowband requirements)</p>	<p>± 1.8 dB, $f \leq 3.0$ GHz ± 2.4 dB, 3.0 GHz $< f \leq 4.2$ GHz</p>	<p>Same as Receiver intermodulation (General requirements).</p>
<p>NOTE 1: Unless otherwise noted, only the Test System stimulus error is considered here. The effect of errors in the throughput measurements or the BER/FER due to finite test duration is not considered.</p>		

4.1.3 Interpretation of measurement results

The measurement results returned by the Test System are compared - without any modification - against the test requirements as defined by the Shared Risk principle.

The Shared Risk principle is defined in ITU-R M.1545 [7].

The actual measurement uncertainty of the Test System for the measurement of each parameter shall be included in the test report.

The recorded value for the Test System uncertainty shall be, for each measurement, equal to or lower than the appropriate figure in clause 4.1.2 of this specification.

If the Test System for a test is known to have a measurement uncertainty greater than that specified in clause 4.1.2, it is still permitted to use this apparatus provided that an adjustment is made as follows.

Any additional uncertainty in the Test System over and above that specified in clause 4.1.2 shall be used to tighten the test requirement, making the test harder to pass. (For some tests e.g. receiver tests, this may require modification of stimulus signals). This procedure (defined in Annex C) will ensure that a Test System not compliant with clause 4.1.2 does not increase the chance of passing a device under test where that device would otherwise have failed the test if a Test System compliant with clause 4.1.2 had been used.

4.2 Base Station classes

The requirements in this specification apply to Wide Area Base Stations, Medium Range Base Stations and Local Area Base Stations unless otherwise stated.

Wide Area Base Stations are characterised by requirements derived from Macro Cell scenarios with a BS to UE minimum coupling loss equal to 70 dB. The Wide Area Base Station class has the same requirements as the base station for General Purpose application in Release 9 and 10.

Medium Range Base Stations are characterised by requirements derived from Micro Cell scenarios with a BS to UE minimum coupling loss equals to 53 dB.

Local Area Base Stations are characterised by requirements derived from Pico Cell scenarios with a BS to UE minimum coupling loss equal to 45 dB.

For GSM/EDGE operation of an MSR BS, the requirements according to the applicable multicarrier BTS class apply. The Wide Area BS, Medium Range BS and Local Area BS in the present specification correspond to the Wide Area multicarrier BTS, Medium Range multicarrier BTS and Local Area multicarrier BTS respectively in the GSM/EDGE specifications. MSR requirements for multi-RAT operation only apply for the highest GSM/EDGE static power step.

The manufacturer shall declare the intended class of the BS under test.

4.3 Regional requirements

Some requirements in the present document may only apply in certain regions either as optional requirements, or set by local and regional regulation as mandatory requirements. It is normally not stated in the 3GPP specifications under what exact circumstances that the requirements apply, since this is defined by local or regional regulation.

Table 4.3-1 lists all requirements in the present specification that may be applied differently in different regions. There are additional single-RAT regional requirements that may apply. These are referenced from the present specification, but listed in the specification for the RATs concerned [3][4][5][6][27].

Table 4.3-1: List of regional requirements

Clause number	Requirement	Comments
4.5	Operating bands and Band Categories	Some bands may be applied regionally.
6.2.1.2A	Base station output power	Additional requirements may apply as defined in TS 37.104 [2] clause 6.2.2.
6.6.1.5.1	Spurious emissions (Category A)	Category A limits are mandatory for regions where Category A limits for spurious emissions, as defined in ITU-R Recommendation SM.329 [13] apply.
6.6.1.5.2	Spurious emissions (Category B)	Category B limits are mandatory for regions where Category B limits for spurious emissions, as defined in ITU-R Recommendation SM.329 [13] apply.
6.6.1.5.3	Additional requirement for BC2 (Category B)	Category B limits are mandatory for regions where Category B limits for spurious emissions, as defined in ITU-R Recommendation SM.329 [13] apply.
6.6.1.5.5	Additional spurious emissions requirements	These requirements may be applied for the protection of system operating in frequency ranges other than the MSR BS operating band. In addition to the requirements in clauses 6.6.1.5.1, 6.6.1.5.2, 6.6.1.5.3, 6.6.1.5.4 and 6.6.1.5.5, the BS may have to comply with the applicable emission limits established by FCC Title 47 [8], when deployed in regions where those limits are applied, and under the conditions declared by the manufacturer.
6.6.1.5.6	Co-location (spurious emissions)	These requirements may be applied for the protection of other BS receivers when a BS operating in another frequency band is co-located with any BS.
6.6.2.5.4.1	Additional requirements (Operating band unwanted emissions)	In addition to the requirements in clauses 6.6.2.5.1 and 6.6.2.5.2, the BS may have to comply with the applicable emission limits established by FCC Title 47 [8], when deployed in regions where those limits are applied and under the conditions declared by the manufacturer.
6.6.2.5.4.2	Unsynchronized operation for BC3 (Operating band unwanted emissions)	The requirements for unsynchronized TDD co-existence may apply regionally.
6.6.2.5.4.3	Protection of DTT (Operating band unwanted emissions)	The requirements for protection of DTT may apply regionally.
6.6.2.5.4.4	Co-existence with services in adjacent frequency bands (Operating band unwanted emissions)	This regional requirement may be applied for the protection of systems operating in frequency bands adjacent to band 1 as defined in clause 4.5, in geographic areas in which both an adjacent band service and UTRA and/or E-UTRA are deployed.
6.6.2.5.4.6	Additional band 32 unwanted emissions	These requirements may apply in certain regions
6.6.3.5	Occupied bandwidth	The requirement may be applied regionally. There may also be regional requirements to declare the Occupied bandwidth according to the definition.
6.6.4.5.6	Adjacent Channel Leakage Power Ratio (ACLR)	For Band 41 operation in Japan, absolute ACLR limits shall be applied to the sum of the absolute ACLR power over all <i>antenna connectors</i> .
6.7.2A	Additional requirements for Band 41	These requirements may apply in certain regions for Band 41
6.7.5.4	Additional test requirements for Band 41	These requirements may apply in certain regions for Band 41
7.5.2.5	Co-location requirement (blocking)	These requirements may be applied for the protection of the BS receiver when a BS operating in another frequency band is co-located with any BS.

4.4 Operating bands and band categories

MSR requirements are applicable for band definitions and band numbering as defined in the specifications TS 45.005 [6], TS25.104 [3], TS 25.105 [4], TS 36.104 [5] and TS 38.104 [27]. For the purpose of defining the BS requirements, the operating bands are divided into three band categories as follows:

- Band Category 1 (BC1): Bands for NR FDD, E-UTRA FDD and/or UTRA FDD operation. Bands in this category are also used for NB-IoT operation (all modes).
- Band Category 2 (BC2): Bands for NR FDD, E-UTRA FDD, UTRA FDD and/or GSM/EDGE operation. Bands in this category are also used for NB-IoT operation (all modes).
- Band Category 3 (BC3): Bands for NR TDD, E-UTRA TDD and/or UTRA TDD operation. Bands in this category are also used for NB-IoT operation (all modes).

NOTE: For UTRA TDD, requirements in the present document cover the 1.28 Mcps UTRA TDD option.

The paired and unpaired bands for the three Band Categories are shown in Table 4.4-1 and 4.4-2, together with the corresponding NR, E-UTRA, UTRA and GSM/EDGE band designations. In the present specification, the operating band of an MSR Base Stations is designated using the E-UTRA band number according to the tables.

Table 4.4-1: Paired bands in NR, E-UTRA, UTRA and GSM/EDGE

MSR and E-UTRA Band number	NR Band number	UTRA Band number	GSM/EDGE Band designation	Uplink (UL) BS receive UE transmit	Downlink (DL) BS transmit UE receive	Band category
1	n1	I	-	1920 MHz – 1980 MHz	2110 MHz – 2170 MHz	1
2	n2	II	PCS 1900	1850 MHz – 1910 MHz	1930 MHz – 1990 MHz	2
3	n3	III	DCS 1800	1710 MHz – 1785 MHz	1805 MHz – 1880 MHz	2
4		IV	-	1710 MHz – 1755 MHz	2110 MHz – 2155 MHz	1
5	n5	V	GSM 850	824 MHz – 849 MHz	869 MHz – 894 MHz	2
6		VI	-	830 MHz – 840 MHz	875 MHz – 885 MHz	1 (NOTE 1)
7	n7	VII	-	2500 MHz – 2570 MHz	2620 MHz – 2690 MHz	1 (NOTE 3)
8	n8	VIII	E-GSM	880 MHz – 915 MHz	925 MHz – 960 MHz	2
9		IX	-	1749.9 MHz – 1784.9 MHz	1844.9 MHz – 1879.9 MHz	1 (NOTE 12)
10		X	-	1710 MHz – 1770 MHz	2110 MHz – 2170 MHz	1 (NOTE 12)
11		XI	-	1427.9 MHz – 1447.9 MHz	1475.9 MHz – 1495.9 MHz	1
12	n12	XII	-	699 MHz – 716 MHz	729 MHz – 746 MHz	1
13		XIII	-	777 MHz – 787 MHz	746 MHz – 756 MHz	1
14		XIV	-	788 MHz – 798 MHz	758 MHz – 768 MHz	1
15		XV	-	Reserved	Reserved	
16		XVI	-	Reserved	Reserved	
17		-	-	704 MHz – 716 MHz	734 MHz – 746 MHz	1 (NOTE 13)
18		-	-	815 MHz – 830 MHz	860 MHz – 875 MHz	1 (NOTE 13)
19		XIX	-	830 MHz – 845 MHz	875 MHz – 890 MHz	1
20	n20	XX	-	832 MHz – 862 MHz	791 MHz – 821 MHz	1
21		XXI	-	1447.9 MHz – 1462.9 MHz	1495.9 MHz – 1510.9 MHz	1
22		XXII	-	3410 MHz – 3490 MHz	3510 MHz – 3590 MHz	1 (NOTE 12)
23 ⁸		-	-	2000 MHz – 2020 MHz	2180 MHz – 2200 MHz	1 (NOTE 11)
24 ¹⁰		-	-	1626.5 MHz – 1660.5 MHz	1525 MHz – 1559 MHz	1 (NOTE 11)
25	n25	XXV	-	1850 MHz – 1915 MHz	1930 MHz – 1995 MHz	1
26		XXVI	-	814 MHz – 849 MHz	859 MHz – 894 MHz	1
27		-	-	807 MHz – 824 MHz	852 MHz – 869 MHz	1 (NOTE 11)
28	n28	-	-	703 MHz – 748 MHz	758 MHz – 803 MHz	1 (NOTE 4)
29		-	-	N/A	717 MHz – 728 MHz	1 (NOTE 11, NOTE 5)
30		-	-	2305 MHz – 2315 MHz	2350 MHz – 2360 MHz	1 (NOTE 11)
31		-	-	452.5 MHz – 457.5 MHz	462.5 MHz – 467.5 MHz	1 (NOTE 13)

32		XXXII (NOTE 6)	-	N/A	1452 MHz – 1496 MHz	1 (NOTE 12, NOTE 5)
64		-	-	Reserved		
65		-	-	1920 MHz – 2010 MHz	2110 MHz – 2200 MHz	1 (NOTE 11)
66	n66	-	-	1710 MHz – 1780 MHz	2110 MHz – 2200 MHz	1 (NOTE 4, NOTE 7)
67		-	-	N/A	738 MHz – 758 MHz	1 (NOTE 11, NOTE 5)
68		-	-	698 MHz – 728 MHz	753 MHz – 783 MHz	1 (NOTE 11)
69		-	-	N/A	2570 MHz – 2620 MHz	1 (NOTE 11, NOTE 5)
70	n70	-	-	1695 MHz – 1710 MHz	1995 MHz – 2020 MHz	1 (NOTE 4, NOTE 9)
71	n71	-	-	663 MHz – 698 MHz	617 MHz – 652 MHz	1 (NOTE 4)
72		-	-	451 MHz – 456 MHz	461 MHz – 466 MHz	1 (NOTE 13)
73		-	-	450 MHz – 455 MHz	460 MHz – 465 MHz	1 (NOTE 13)
74	n74	-	-	1427 MHz – 1470 MHz	1475 MHz – 1518 MHz	1 (NOTE 4)
75	n75	-	-	N/A	1432 MHz – 1517 MHz	1 (NOTE 2, NOTE 5)
76	n76	-	-	N/A	1427 MHz – 1432 MHz	1 (NOTE 2, NOTE 5)
85		-	-	698 MHz – 716 MHz	728 MHz – 746 MHz	1 (NOTE 13)

NOTE 1: The band is for UTRA only.

NOTE 2: The band is for E-UTRA and/or NR only.

NOTE 3: The band is for NR, E-UTRA and/or UTRA only.

NOTE 4: The band is for NR, E-UTRA and/or NB-IoT only.

NOTE 5: Restricted to NR and/or E-UTRA operation when carrier aggregation is configured. The downlink operating band is paired with the uplink operating band (external) of the carrier aggregation configuration that is supporting the configured Pcell.

NOTE 6: Restricted to UTRA operation when dual band is configured (e.g., DB-DC-HSDPA or dual band 4C-HSDPA). The down link frequency(ies) of this band are paired with the uplink frequenc(ies) of the other FDD band (external) of the dual band configuration.

NOTE 7: In E-UTRA operation, the range 2180-2200 MHz of the DL operating band is restricted to operation when carrier aggregation is configured.

NOTE 8: Band 23 is not applicable.

NOTE 9: In E-UTRA operation, the range 2010-2020 MHz of the DL operating band is restricted to operation when carrier aggregation is configured and TX-RX separation is 300 MHz. In E-UTRA operation, the range 2005-2020 MHz of the DL operating band is restricted to operation when carrier aggregation is configured and TX-RX separation is 295 MHz.

NOTE 10: DL operation is restricted to 1526-1536 MHz frequency range. UL operation is restricted to 1627.5 – 1637.5 MHz and 1646.5 – 1656.5 MHz per FCC Order DA 20-48.

NOTE 11: The band is for E-UTRA only.

NOTE 12: The band is for E-UTRA and/or UTRA only.

NOTE 13: The band is for E-UTRA and/or NB-IoT only

NOTE: For BS capable of multi-band operation, the supported operating bands may belong to different Band Categories.

Table 4.4-2: Unpaired bands in NR, E-UTRA and UTRA

MSR and E-UTRA Band number	NR Band number	UTRA Band number	Uplink (UL) BS receive UE transmit	Downlink (DL) BS transmit UE receive	Band category
33		a)	1900 MHz – 1920 MHz	1900 MHz – 1920 MHz	3
34	n34	a)	2010 MHz – 2025 MHz	2010 MHz – 2025 MHz	3
35		b)	1850 MHz – 1910 MHz	1850 MHz – 1910 MHz	3
36		b)	1930 MHz – 1990 MHz	1930 MHz – 1990 MHz	3
37		c)	1910 MHz – 1930 MHz	1910 MHz – 1930 MHz	3
38	n38	d)	2570 MHz – 2620 MHz	2570 MHz – 2620 MHz	3
39	n39	f)	1880 MHz – 1920 MHz	1880 MHz – 1920 MHz	3
40	n40	e)	2300 MHz – 2400 MHz	2300 MHz – 2400 MHz	3
41	n41	-	2496 MHz – 2690 MHz	2496 MHz – 2690 MHz	3 (NOTE 1)
42		-	3400 MHz – 3600 MHz	3400 MHz – 3600 MHz	3
43		-	3600 MHz – 3800 MHz	3600 MHz – 3800 MHz	3
44		-	703 MHz – 803 MHz	703 MHz – 803 MHz	3
45		-	1447 MHz – 1467 MHz	1447 MHz – 1467 MHz	3
48		-	3550 MHz – 3700 MHz	3550 MHz – 3700 MHz	3
50	n50	-	1432 MHz – 1517 MHz	1432 MHz – 1517 MHz	3
51	n51	-	1427 MHz – 1432 MHz	1427 MHz – 1432 MHz	3
52		-	3300 MHz – 3400 MHz	3300 MHz – 3400 MHz	3
77	n77	-	3300 MHz - 4200 MHz	3300 MHz - 4200 MHz	3 (NOTE 2)
78	n78	-	3300 MHz - 3800 MHz	3300 MHz - 3800 MHz	3 (NOTE 2)

NOTE 1: The band supports NB-IoT (in certain regions).
NOTE 2: The band is for NR only.

Table 4.4-3. Void

Table 4.4-4. Void

E-UTRA is designed to operate for the carrier aggregation bands defined in Tables 5.5-2, 5.5-3 and 5.5-4 of TS 36.104 [5]. The E-UTRA channel bandwidth BW_{Channel} for a single carrier and the Aggregated Channel Bandwidth $BW_{\text{Channel_CA}}$ for E-UTRA carrier aggregation are specified in clause 5.6 of TS 36.104 [5].

The NB-IoT channel bandwidth BW_{Channel} is specified in clause 5.6 of TS 36.104 [5].

The NR BS channel bandwidth and PRB utilization is specified in clause 5.3 of TS 38.104 [27].

4.4.1 Band category 1 aspects (BC1)

For each BC1 band, BC1 requirements for receiver and transmitter shall apply with a frequency offset $F_{\text{offset, RAT}}$ from the lowest and highest carriers to the Base Station RF Bandwidth edges and sub-block edges (if any) as defined in Table 4.4.1-1.

Table 4.4.1-1: $F_{\text{offset, RAT}}$ for band category 1

RAT	$F_{\text{offset, RAT}}$
1.4, 3 MHz E-UTRA	$BW_{\text{Channel}}/2 + 200 \text{ kHz}$
5, 10, 15, 20 MHz E-UTRA and NR	$BW_{\text{Channel}}/2$
UTRA FDD	2.5 MHz
Standalone NB-IoT	200 kHz

4.4.2 Band category 2 aspects (BC2)

For each BC2 band, BC2 requirements for receiver and transmitter shall apply with a frequency offset $F_{\text{offset, RAT}}$ from the lowest and highest carriers to the Base Station RF Bandwidth edges and sub-block edges (if any) as defined in Table 4.4.2-1.

Table 4.4.2-1: $F_{\text{offset, RAT}}$ for band category 2

RAT	$F_{\text{offset, RAT}}$
E-UTRA and NR	$BW_{\text{Channel}}/2$
UTRA FDD	2.5 MHz
GSM/EDGE	200 kHz
Standalone NB-IoT	200 kHz

4.4.3 Band category 3 aspects (BC3)

For each BC3 band, BC3 requirements for receiver and transmitter shall apply with a frequency offset $F_{\text{offset, RAT}}$ from the lowest and highest carriers to the Base Station RF Bandwidth edges and sub-block edges (if any) as defined in Table 4.4.3-1.

Table 4.4.3-1: $F_{\text{offset, RAT}}$ for band category 3

RAT	$F_{\text{offset, RAT}}$
1.4, 3 MHz E-UTRA	$BW_{\text{Channel}}/2 + 200 \text{ kHz}$
5, 10, 15, 20 MHz E-UTRA and NR	$BW_{\text{Channel}}/2$
1.28 Mcps UTRA TDD	1 MHz
Standalone NB-IoT	200 kHz

4.5 Channel arrangement

4.5.1 Channel spacing

The GSM/EDGE carrier spacing is 200 kHz [6].

The nominal UTRA FDD channel spacing is 5 MHz. The nominal channel spacing is 1.6 MHz for the 1.28 Mcps UTRA TDD Option. These can be adjusted to optimise performance in a particular deployment scenario [3,4].

In E-UTRA the spacing between carriers will depend on the deployment scenario, the size of the frequency block available and the channel bandwidths. The nominal channel spacing between two adjacent E-UTRA carriers is defined as following:

$$\text{Nominal Channel spacing} = (BW_{\text{Channel}(1)} + BW_{\text{Channel}(2)})/2$$

where $BW_{\text{Channel}(1)}$ and $BW_{\text{Channel}(2)}$ are the channel bandwidths of the two respective E-UTRA carriers. The channel spacing can be adjusted to optimize performance in a particular deployment scenario [5].

The standalone NB-IoT carrier spacing is 200 kHz.

In NR the spacing between carriers will depend on the deployment scenario, the size of the frequency block available and the *BS channel bandwidths*. The nominal channel spacing between two adjacent NR carriers is defined as following:

- For NR FR1 operating bands with 100 kHz channel raster,

$$\text{Nominal Channel spacing} = (BW_{\text{Channel}(1)} + BW_{\text{Channel}(2)})/2$$

- For NR FR1 operating bands with 15 kHz channel raster,

- Nominal Channel spacing = $(BW_{\text{Channel}(1)} + BW_{\text{Channel}(2)})/2 + \{-5 \text{ kHz}, 0 \text{ kHz}, 5 \text{ kHz}\}$ for ΔF_{Raster} equals to 15 kHz

- Nominal Channel spacing = $(BW_{\text{Channel}(1)} + BW_{\text{Channel}(2)})/2 + \{-10 \text{ kHz}, 0 \text{ kHz}, 10 \text{ kHz}\}$ for ΔF_{Raster} equals to 30 kHz

where $BW_{\text{Channel}(1)}$ and $BW_{\text{Channel}(2)}$ are the *BS channel bandwidths* of the two respective NR carriers. The channel spacing can be adjusted depending on the channel raster to optimize performance in a particular deployment scenario [27].

The spacing between E-UTRA and NR carriers will depend on the deployment scenario, the size of the frequency block available and the channel bandwidths. The nominal channel spacing between and E-UTRA carrier and an adjacent NR carrier is defined as following:

- For NR operating bands with 100 kHz channel raster,

$$\text{Nominal Channel spacing} = (BW_{\text{E-UTRA_Channel}} + BW_{\text{NR_Channel}})/2$$

- For NR operating bands with 15 kHz channel raster,

Nominal Channel spacing = $(BW_{\text{E-UTRA_Channel}} + BW_{\text{NR_Channel}})/2 + \{-5\text{kHz}, 0\text{kHz}, 5\text{kHz}\}$ for ΔF_{Raster} equals to 15 kHz

Nominal Channel spacing = $(BW_{\text{E-UTRA_Channel}} + BW_{\text{NR_Channel}})/2 + \{-10 \text{ kHz}, 0 \text{ kHz}, 10 \text{ kHz}\}$ for ΔF_{Raster} equals to 30 kHz

where $BW_{\text{E-UTRA_Channel}}$ and $BW_{\text{NR_Channel}}$ are the channel bandwidths of the E-UTRA and NR carriers, ΔF_{Raster} is the band dependent channel raster granularity defined in TS38.101-1[29]. The channel spacing can be adjusted depending on the channel raster to optimize performance in a particular deployment scenario.

4.5.1A CA Channel spacing

In E-UTRA, for intra-band contiguously aggregated carriers the channel spacing between adjacent component carriers shall be multiple of 300 kHz.

The nominal channel spacing between two adjacent aggregated E-UTRA carriers is defined as follows:

$$\text{Nominal channel spacing} = \left\lfloor \frac{BW_{\text{Channel}(1)} + BW_{\text{Channel}(2)} - 0.1 |BW_{\text{Channel}(1)} - BW_{\text{Channel}(2)}|}{0.6} \right\rfloor 0.3$$

where $BW_{\text{Channel}(1)}$ and $BW_{\text{Channel}(2)}$ are the channel bandwidths of the two respective E-UTRA component carriers according to Table 5.6-1 with values in MHz. The channel spacing for intra-band contiguous carrier aggregation can be adjusted to any multiple of 300 kHz less than the nominal channel spacing to optimize performance in a particular deployment scenario.

In NR for intra-band contiguously aggregated carriers, the channel spacing between adjacent component carriers shall be multiple of least common multiple of channel raster and sub-carrier spacing.

The nominal channel spacing between two adjacent aggregated NR carriers is defined as follows:

For NR operating bands with 100 kHz channel raster:

$$\text{Nominal channel spacing} = \left\lfloor \frac{BW_{\text{Channel}(1)} + BW_{\text{Channel}(2)} - 2 |G B_{\text{Channel}(1)} - G B_{\text{Channel}(2)}|}{0.6} \right\rfloor 0.3 \text{ [MHz]}$$

For NR operating bands with 15 kHz channel raster:

$$\text{Nominal channel spacing} = \left\lfloor \frac{BW_{\text{Channel}(1)} + BW_{\text{Channel}(2)} - 2 |G B_{\text{Channel}(1)} - G B_{\text{Channel}(2)}|}{0.015 * 2^{n+1}} \right\rfloor 0.015 * 2^n \text{ [MHz]}$$

with

$$n = \mu_0$$

where $BW_{\text{Channel}(1)}$ and $BW_{\text{Channel}(2)}$ are the *BS channel bandwidths* of the two respective NR component carriers according to Table 5.3.3-1 and 5.3.3-2 in TS 38.104 [17] with values in MHz, μ_0 the largest μ value among the subcarrier spacing configurations supported in the operating band for both of the channel bandwidths according to

Table 5.3.5-1 and Table 5.3.5-2 in TS 38.104 [17] and $GB_{Channel(i)}$ the minimum guard band for channel bandwidth i according to Table 5.3.3-1 and Table 5.3.3-2 in TS 38.104 [17] for the said μ value, with μ as defined in TS 38.211. In case there is no common μ value for both of the channel bandwidths, $\mu_0=1$ is selected for NR *operating bands* with 15 kHz channel raster and $GB_{Channel(i)}$ is the minimum guard band for channel bandwidth i according to Table 5.3.3-1 in TS 38.104 [17] for $\mu=1$ with μ as defined in TS 38.211.

In NR the channel spacing for intra-band contiguous carrier aggregation can be adjusted to any multiple of least common multiple of channel raster and sub-carrier spacing less than the nominal channel spacing to optimize performance in a particular deployment scenario.

4.5.2 Channel raster

The GSM/EDGE channel raster is 200 kHz for all bands [6].

The UTRA FDD and TDD channel raster is 200 kHz for all bands, which means that the centre frequency must be an integer multiple of 200 kHz. In addition a number of additional centre frequencies are specified for UTRA FDD according to [3], which means that the centre frequencies for UTRA FDD channels are shifted 100 kHz relative to the general raster.

The E-UTRA channel raster is 100 kHz for all bands, which means that the carrier centre frequency must be an integer multiple of 100 kHz [5].

NB-IoT channel raster is 100 kHz for all bands [5].

NR channel raster is specified in clause 5.4.2 of TS 38.104 [27].

4.5.3 Carrier frequencies and numbering

The carrier frequencies and corresponding numbering is defined for each RAT in the respective specifications TS 38.104 [27], TS 36.104 [5] TS 25.104 [3], TS 25.105 [4] and TS 45.005 [6]. In the context of MSR, the frequency numbering scheme for each RAT will remain.

- The E-UTRA carrier frequency numbering (EARFCN) is defined in clause 5.7 of TS 36.104 [5].
- The UTRA FDD carrier frequency numbering (UARFCN) is defined in clause 5.4 of TS 25.104 [3].
- The UTRA TDD carrier frequency numbering (UARFCN) is defined in clause 5.4 of TS 25.105 [4].
- The GSM/EDGE carrier frequency numbering (ARFCN) is defined clause 2 of TS 45.005 [6].
- The NB-IoT carrier frequency numbering is defined in clause 5.7 of TS 36.104 [5].
- The NR carrier frequency numbering (NR-ARFCN) is defined in clause 5.4.2.3 of TS 38.104 [27].

NOTE: The numbering schemes for UTRA FDD and TDD are not coordinated, while both are called UARFCN.

4.6 Manufacturer's declarations of regional and optional requirements

4.6.1 Operating band and frequency range

The manufacturer shall declare which operating band(s) specified in clause 4.4 that is supported by the BS under test and if applicable, which frequency ranges within the operating band(s) that the Base Station can operate in. Requirements for other operating bands and frequency ranges need not be tested.

The manufacturer shall declare which operating band(s) specified in clause 4.4 are supported by the BS under test for carrier aggregation.

The manufacturer shall declare which NB-IoT operating mode (standalone, in-band and/or guard band) the BS supports for the declared supported band.

For standalone NB-IoT operating mode, the manufacturer shall declare the number of supported NB-IoT carriers.

For each supported E-UTRA channel bandwidth, the manufacturer shall declare if BS supports NB-IoT in-band and/or guard band operation and the number of supported NB-IoT PRBs.

4.6.2 Spurious emissions category

The manufacturer shall declare one of the following:

- a) The BS is tested against Category A limits for spurious emissions, as defined in ITU-R Recommendation SM.329 [13]. In this case
 - conformance with the spurious emissions requirements in clause 6.6.1.5.1 is mandatory, and the requirements specified in clause 6.6.1.5.2 and 6.6.1.5.3 need not be demonstrated.
- b) The BS is tested against Category B limits for spurious emissions, as defined in ITU-R Recommendation SM.329 [13]. In this case,
 - conformance with the spurious emissions requirements in clause 6.6.1.5.2 and 6.6.1.5.3 (for BC2) are mandatory, and the requirements specified in clause 6.6.1.5.1 need not be demonstrated.

4.6.3 Additional operating band unwanted emissions

The manufacturer shall declare whether the BS under test is intended to operate in geographic areas where the additional operating band unwanted emission limits defined in clause 6.6.2.4 of TS 37.104 [2] apply. If this is the case, conformance with the applicable emission limits shall be demonstrated.

NOTE: For the emission limits established by FCC Title 47 [8], there is no test method or requirement defined in the present specification.

For a BS declared to support Band 20 and to operate in geographic areas within the CEPT in which frequencies are allocated to broadcasting (DTT) service, the manufacturer shall additionally declare the following quantities associated with the applicable test conditions of Table 6.6.2.5.4.4-1 and information in annex G of TS 36.104 [5] :

$P_{EM,N}$ Declared emission level for channel N

P_{10MHz} Maximum output Power in 10 MHz

Conformance with the declared emission level $P_{EM,N}$ shall be demonstrated.

For a BS declared to support Band 32, 75 or 76 and to operate in geographic areas within the CEPT, the manufacturer shall additionally declare the following quantities associated with the applicable test conditions of Table 6.6.2.5.4.6-1 and Table 6.6.2.5.4.6-2:

$P_{EM,B32,B75,B76,ind}$ Declared emission level in Band 32, Band 75 and Band 76, ind=a, b, c

$P_{EM,B32,ind}$ Declared emission level in Band 32, ind= d, e

Conformance with the declared emission level $P_{EM,B32,B75,B76,ind}$ and $P_{EM,B32,ind}$ shall be demonstrated.

For a BS declared to support Band 50, 74 or 75 and to operate in geographic areas where the additional unwanted emission limit defined in Table 6.6.2.5.4.6-3 applies, the manufacturer shall additionally declare the following quantity associated with the applicable test conditions of Table 6.6.2.5.4.6-3:

$P_{EM,B50,B74,B75,ind}$ Declared emission level for Band 50, Band 74 and Band 75, ind=a,b

Conformance with the declared emission level $P_{EM,B50,B74,B75,ind}$ shall be demonstrated.

4.6.4 Co-existence with other systems

The manufacturer shall declare whether the BS under test is intended to operate in geographic areas where one or more of the systems GSM850, GSM900, DCS1800, PCS1900, UTRA FDD, UTRA TDD, E-UTRA, NR and/or PHS operating in another band are deployed. If this is the case, conformance with the applicable test requirement for spurious emissions specified in clause 6.6.1.5.5 shall be demonstrated.

4.6.5 Co-location with other Base Stations

The manufacturer shall declare whether the BS under test is intended to operate co-located with Base Stations of one or more of the systems GSM850, GSM900, DCS1800, PCS1900, UTRA FDD, UTRA TDD, E-UTRA and/or NR operating in another band. If this is the case,

- Conformance with the applicable test requirement for spurious emissions specified in clause 6.6.1.5.6 shall be demonstrated.
- Conformance with the applicable test requirement for receiver blocking specified in clause 7.5.5.2 shall be demonstrated.

4.6.6 NB-IoT sub-carrier spacing

If the BS supports NB-IoT, manufacturer shall declare if it supports 15 kHz sub-carrier spacing, 3.75 kHz sub-carrier spacing, or both for NPUSCH.

4.6.7 NB-IoT power dynamic range

If the BS supports E-UTRA with NB-IoT operating in-band and/or in guard band, manufacturer shall declare the maximum power dynamic range it could support with a minimum of +6dB as mentioned in TS 36.104 [5] clause 6.3.3.

If the BS supports 5 MHz E-UTRA with NB-IoT operating in guard band, manufacturer shall also declare the maximum power that could be allocated to this NB-IoT PRB.

4.7 Capability set definition and manufacturer's declarations of supported RF configurations

4.7.1 Definition of Capability Sets (CS)

Capability set is defined as the BS capability to support certain RAT combinations in an operating band.

The manufacturer shall declare the supported capability set(s) according to Table 4.7.1-1 and Table 4.7.1-2 for each supported operating band.

Table 4.7.1-1 Capability sets

Capability Set supported by the BS	CS1	CS2	CS3	CS4	CS5	CS6	CS7	CS16
Supported RATs	UTRA (MC)	E-UTRA (MC) ³	UTRA, E-UTRA ³	GSM, UTRA	GSM, E-UTRA ³	GSM, UTRA, E-UTRA	GSM, UTRA, E-UTRA ³	NR, E-UTRA ³
Supported configurations	SR UTRA (SC, MC)	SR E-UTRA ³ (SC, MC, CA)	MR UTRA + E-UTRA ³ SR UTRA (SC, MC) SR E-UTRA ³ (SC, MC, CA)	MR GSM + UTRA SR GSM (MCBTS) SR UTRA (SC, MC)	MR GSM + E-UTRA ³ SR GSM (MCBTS) SR E-UTRA ³ (SC, MC, CA)	MR GSM + UTRA + E-UTRA MR GSM + UTRA MR GSM + E-UTRA MR UTRA + E-UTRA SR GSM (MCBTS) SR UTRA (SC, MC) SR E-UTRA (SC, MC, CA)	MR GSM + UTRA ² MR GSM + E-UTRA ³ MR E-UTRA ³ + UTRA ² SR UTRA (SC, MC) ² SR E-UTRA ³ (SC, MC)	MR E-UTRA ³ + NR SR NR (SC, MC, CA) SR E-UTRA ³ (SC, MC, CA)
Applicable BC	BC1, BC2 or BC3	BC1, BC2 or BC3	BC1, BC2 or BC3	BC2	BC2	BC2	BC2	BC1, BC2 or BC3
<p>NOTE 1: MC denotes multi-carrier in single RAT; SC denotes single carrier; MR denotes multi-RAT; SR denotes single-RAT.</p> <p>NOTE 2: For this configuration related to BC2 bands, the support of UTRA in band 3 is declared by the manufacturer.</p> <p>NOTE 3: Includes optional (declared by the manufacturer) support of NB-IoT in-band and/or NB-IoT guard band operation within E-UTRA carrier(s).</p> <p>NOTE 4: Void</p> <p>NOTE 5: Void</p>								

Table 4.7.1-2 Capability sets with NB-IoT standalone operation

Capability Set supported by the BS	CS8	CS9	CS10	CS11	CS12	CS13	CS14	CS15	CS17
Supported RATs	NB-IoT standalone	GSM, NB-IoT standalone	UTRA, NB-IoT standalone	E-UTRA, NB-IoT standalone	GSM, UTRA, NB-IoT standalone	GSM, E-UTRA, NB-IoT standalone	UTRA, E-UTRA, NB-IoT standalone	GSM, UTRA, E-UTRA, NB-IoT standalone	NR, E-UTRA ³ , NB-IoT standalone
Supported configurations	SR NB-IoT standalone (SC, MC)	MR GSM + NB-IoT standalone SR GSM (MCBTS) SR NB-IoT standalone (SC, MC)	MR UTRA + NB-IoT standalone SR UTRA (SC, MC) SR NB-IoT standalone (SC, MC)	MR E-UTRA + NB-IoT standalone SR E-UTRA (SC, MC, CA) SR NB-IoT standalone (SC, MC)	MR GSM + UTRA + NB-IoT standalone SR GSM (MCBTS) SR UTRA (SC, MC) SR NB-IoT standalone (SC, MC) MR GSM + NB-IoT standalone MR UTRA + NB-IoT standalone MR GSM + UTRA	MR GSM + E-UTRA + NB-IoT standalone SR GSM (MCBTS) SR UTRA (SC, MC) SR E-UTRA (SC, MC, CA) SR NB-IoT standalone (SC, MC) MR GSM + NB-IoT standalone MR E-UTRA + NB-IoT standalone MR GSM + E-UTRA	MR UTRA + E-UTRA + NB-IoT standalone SR UTRA (SC, MC) SR E-UTRA (SC, MC, CA) SR NB-IoT standalone (SC, MC) MR UTRA + NB-IoT standalone MR E-UTRA + NB-IoT standalone MR UTRA + E-UTRA	MR GSM + UTRA ² + NB-IoT standalone MR GSM + E-UTRA + NB-IoT standalone MR UTRA ² + E-UTRA + NB-IoT standalone MR GSM + NB-IoT standalone MR UTRA ² + NB-IoT standalone MR E-UTRA + NB-IoT standalone MR GSM + UTRA ² MR GSM + E-UTRA MR E-UTRA + UTRA ² SR UTRA (SC, MC) ² SR E-UTRA (SC, MC) SR NB-IoT standalone (SC, MC)	MR E-UTRA ³ + NR SR NR (SC, MC, CA) SR E-UTRA ³ (SC, MC, CA) SR NB-IoT standalone (SC, MC) MR E-UTRA ³ + NB-IoT standalone MR NR + NB-IoT standalone MR NR + E-UTRA ³ + NB-IoT standalone
Applicable BC	BC1, BC2 or BC3	BC2	BC1, BC2 or BC3	BC1, BC2 or BC3	BC2	BC2	BC1, BC2 or BC3	BC2	BC1, BC2 or BC3

NOTE 1: MC denotes multi-carrier in single RAT;
 SC denotes single carrier;
 MR denotes multi-RAT;
 SR denotes single-RAT.

NOTE 2: For this configuration related to BC2 bands, the support of UTRA in band 3 is declared by the manufacturer.

NOTE 3: Includes optional (declared by the manufacturer) support of NB-IoT in-band and/or NB-IoT guard band operation within E-UTRA carrier(s).

NOTE 4: Void

NOTE 5: Void

The applicable test configurations for each RF requirement are defined in clause 5.1 and 5.2 for the declared capability set(s). For a BS declared to be capable of multi-band operation, the applicable test configurations for each RF requirement are defined in clause 5.3 for the declared capability set(s).

NOTE: Not every supported configuration within a CS is tested, but the tables in clause 5.1, 5.2 and 5.3 provide a judicious choice among the supported configurations and test configurations to ensure proper test coverage.

4.7.2 Manufacturer's declarations of supported RF configurations

The manufacturer shall declare which operational configurations the BS supports by declaring the following parameters:

a) General Parameters:

- Support of the BS in non-contiguous spectrum operation. If the BS does not support non-contiguous spectrum operation the parameters for non-contiguous spectrum operation below shall not be declared.
- The supported operating bands defined in clause 4.4.
- The frequency range within the above frequency band(s) supported by the BS.
- Supported capability set(s) in each supported operating band
- The maximum Base Station RF Bandwidth supported by a MSR BS within an operating band when the BS is configured with carriers of different RATs.
 - for contiguous spectrum operation.
 - for non-contiguous spectrum operation
- The rated total output power as a sum over all RATs
 - for contiguous spectrum operation.
 - for non-contiguous spectrum operation

NOTE 1: If a BS is capable of 256QAM DL operation then two rated output power declarations may be made. One declaration is applicable when configured for 256QAM transmissions and the other declaration is applicable when not configured for 256QAM transmissions.

NOTE 2: If a BS is capable of 1024QAM DL operation then up to three rated output power declarations may be made. One declaration is applicable when configured for 1024QAM transmissions, a different declaration is applicable when configured for 256QAM transmissions and the other declaration is applicable when configured neither for 256 nor 1024QAM transmissions.

- Maximum supported power difference between carriers
- Total number of supported carriers

For MSR BS supporting CS7, the rated total output power as a sum over all RATs, total number of supported carriers and the maximum Base Station RF Bandwidth is declared in e).

If the rated total output power and total number of supported carriers are not simultaneously supported in Multi-RAT operations, the manufacturer shall declare the following additional parameters:

- The reduced number of supported carriers at the rated total output power in Multi-RAT operations (i.e. < total number of supported carriers)
- The reduced total output power at the total number of supported carriers in Multi-RAT operations (i.e. < rated total output power)

NOTE 1: If a BS is capable of 256QAM DL operation then two rated output power declarations may be made. One declaration is applicable when configured for 256QAM transmissions and the other declaration is applicable when not configured for 256QAM transmissions.

NOTE 2: If a BS is capable of 1024QAM DL operation then up to three rated output power declarations may be made. One declaration is applicable when configured for 1024QAM transmissions, a different declaration is applicable when configured for 256QAM transmissions and the other declaration is applicable when configured neither for 256 nor 1024QAM transmissions.

b) Parameters related to operation of GSM:

- The maximum number of supported GSM carriers
- The maximum Base Station RF Bandwidth supported by the MSR BS when configured with GSM carriers only
 - for contiguous spectrum operation
 - for non-contiguous spectrum operation
- The rated carrier output power for GSM for each supported number of GSM carriers up to the maximum, for the case that all carriers are operated at the same nominal output power.
 - for contiguous spectrum operation
 - for non-contiguous spectrum operation

The declaration shall be given for each supported modulation.

c) Parameters related to operation of UTRA:

- The maximum number of supported UTRA carriers
- The maximum Base Station RF Bandwidth supported by the MSR BS when configured with UTRA carriers only
 - for contiguous spectrum operation
 - for non-contiguous spectrum operation
- The rated RAT output power for UTRA as a sum of all UTRA carriers
 - for contiguous spectrum operation
 - for non-contiguous spectrum operation
- The rated carrier output power for UTRA
 - for contiguous spectrum operation
 - for non-contiguous spectrum operation

d) Parameters related to operation of E-UTRA:

- Which of the E-UTRA channel bandwidths specified in TS 36.104 [5] clause 5.6 are supported
- The maximum number of supported E-UTRA carriers
- The maximum Base Station RF Bandwidth supported by the MSR BS when configured with E-UTRA carriers only
 - for contiguous spectrum operation
 - for non-contiguous spectrum operation

The rated RAT output power for E-UTRA as a sum of all E-UTRA carriers

- for contiguous spectrum operation
- for non-contiguous spectrum operation

NOTE 1: If a BS is capable of 256QAM DL operation then two rated output power declarations may be made. One declaration is applicable when configured for 256QAM transmissions and the other declaration is applicable when not configured for 256QAM transmissions.

NOTE 2: If a BS is capable of 1024QAM DL operation then up to three rated output power declarations may be made. One declaration is applicable when configured for 1024QAM transmissions, a different declaration is applicable when configured for 256QAM transmissions and the other declaration is applicable when configured neither for 256 nor 1024QAM transmissions.

- The rated carrier output power for E-UTRA
 - for contiguous spectrum operation
 - for non-contiguous spectrum operation

NOTE 1: If a BS is capable of 256QAM DL operation then two rated output power declarations may be made. One declaration is applicable when configured for 256QAM transmissions and the other declaration is applicable when not configured for 256QAM transmissions.

NOTE 2: If a BS is capable of 1024QAM DL operation then up to three rated output power declarations may be made. One declaration is applicable when configured for 1024QAM transmissions, a different declaration is applicable when configured for 256QAM transmissions and the other declaration is applicable when configured neither for 256 nor 1024QAM transmissions.

- The supported component carrier combinations at nominal channel spacing within each operating band.

e) Parameters related to CS7:

- The RAT combinations can be categorized into two sub-groups, where all RAT combinations of both sub-groups are mandatory.
 - Sub-group 1:
 - MR UTRA+E-UTRA
 - SR UTRA
 - SR E-UTRA
 - Sub-group 2:
 - MR GSM+UTRA
 - MR GSM+E-UTRA
- For above CS7 configurations including UTRA and related to BC2 bands, the manufacturer shall declare support of UTRA in Band 3.
- Total number of supported carriers
 - for Sub-group 1
 - for Sub-group 2
- The manufacturer shall declare the rated total output power as a sum over all RATs and the maximum Base Station RF Bandwidth supported by the MSR BS for Sub-group 1
 - for contiguous spectrum operation
 - for non-contiguous spectrum operation
- The manufacturer shall declare the rated total output power as a sum over all RATs and the maximum Base Station RF Bandwidth supported by the MSR BS for Sub-group 2
 - for contiguous spectrum operation
 - for non-contiguous spectrum operation

f) Parameters related to operation of NR:

- Which of the NR channel bandwidths and SCS specified in TS 38.104 [27] clause 5.3 are supported
- The maximum number of supported NR carriers
- The maximum Base Station RF Bandwidth supported by the MSR BS when configured with NR carriers only
 - for contiguous spectrum operation
 - for non-contiguous spectrum operation

The rated RAT output power for NR as a sum of all NR carriers

- for contiguous spectrum operation
- for non-contiguous spectrum operation

NOTE: If a BS is capable of 256QAM DL operation then two rated output power declarations may be made. One declaration is applicable when configured for 256QAM transmissions and the other declaration is applicable when not configured for 256QAM transmissions.

- The rated carrier output power for NR
 - for contiguous spectrum operation
 - for non-contiguous spectrum operation

NOTE: If a BS is capable of 256QAM DL operation then two rated output power declarations may be made. One declaration is applicable when configured for 256QAM transmissions and the other declaration is applicable when not configured for 256QAM transmissions.

- The supported component carrier combinations at nominal channel spacing within each operating band.

For BS capable of multi-band operation, the parameters in a) to e) shall be declared for each supported operating band, in which declarations of supported capability set, the maximum Base Station RF Bandwidth, total number of supported carriers, the rated carrier output power and rated total output power are applied for single-band operation only. In addition the manufacturer shall declare the following additional parameters for BS capable of multi-band operation:

- Supported operating band combinations of the BS
- Supported operating band(s) of each antenna connector
- Supported capability set in each supported operating band in multi-band operation
- Support of multi-band transmitter and/or multi-band receiver, including mapping to antenna connector(s)
- Total number of supported carriers for the declared band combinations of the BS
- Maximum number of supported carriers per band in multi-band operation
- Total RF Bandwidth of transmitter and receiver for the declared band combinations of the BS
- Maximum Base Station RF Bandwidth of each supported operating band in multi-band operation
- Maximum Radio Bandwidth in transmit and receive direction for the declared band combinations of the BS
- Any other limitations under simultaneous operation in the declared band combinations of the BS which have any impact on the test configuration generation
- Rated total output power as a sum over all supported operating bands in the declared band combinations of the BS
- Maximum supported power difference between any two carriers in any two different supported operating bands
- The rated carrier output power in multi-band operation
- Rated total output power of each supported operating band in multi-band operation

NOTE: Certain parameter combinations may result in test configurations that are not possible to use for testing. The manufacturer shall ensure that the declared parameters generate test configurations possible to use for test.

4.8 MSR test configurations

The test configurations shall be constructed using the methods defined below subject to the parameters declared by the manufacturer as listed in clause 4.7.

For test contiguous operation configurations used in receiver tests only the outermost carriers need to be generated by the test equipment. For non-contiguous operation test configurations used in receiver tests, outermost carriers for each sub-block need to be generated by the test equipment.

The applicable test models for generation of the carrier transmit test signal are defined in clause 4.9.2.

NOTE: In case carriers are shifted to align with the channel raster Foffset, RAT as defined in clauses 4.4.1 and 4.4.2 may be different.

4.8.1 TC1: UTRA multicarrier operation

The purpose of TC1 is to test UTRA multi-carrier aspects.

4.8.1.1 TC1a generation

TC1a is constructed using the following method:

- The Base Station RF Bandwidth shall be the declared maximum Base Station RF Bandwidth.
- Place two UTRA FDD carriers adjacent to the upper and lower Base Station RF Bandwidth edges. The specified $F_{\text{Offset-RAT}}$ shall apply.
- For transmitter tests, alternately place a UTRA FDD carrier adjacent to the already placed carriers at the lower and upper Base Station RF Bandwidth edges until there is no more space to fit a carrier or the BS does not support more carriers. The nominal carrier spacing defined in clause 4.5.1 shall apply.
- The carrier(s) may be shifted maximum 100 kHz towards lower frequencies for B_{RFBW} and M_{RFBW} and towards higher frequencies for T_{RFBW} to align with the channel raster.

4.8.1.2 TC1b generation

TC1b is constructed using the following method:

- The Base Station RF Bandwidth shall be the declared maximum Base Station RF Bandwidth.
- Place two UTRA TDD carriers adjacent to the upper and lower Base Station RF Bandwidth edges. The specified $F_{\text{Offset-RAT}}$ shall apply.
- For transmitter tests, alternately place a UTRA TDD carrier adjacent to the already placed carriers at the lower and upper Base Station RF Bandwidth edges until there is no more space to fit a carrier or the BS does not support more carriers. The nominal carrier spacing defined in clause 4.5.1 shall apply.

4.8.1.3 TC1 power allocation

Set the power of each carrier to the same power so that the sum of the carrier powers equals the rated RAT output power for UTRA according to the manufacturer's declaration in clause 4.7.2 c).

4.8.1a NTC1: UTRA multicarrier non-contiguous operation

The purpose of NTC1 is to test UTRA multicarrier non-contiguous aspects.

4.8.1a.1 NTC1a generation

The purpose of NTC1a is to test UTRA multicarrier non-contiguous aspects. NTC1a is constructed using the following method:

- The Base Station RF Bandwidth shall be the maximum Base Station RF Bandwidth for non-contiguous operation. The Base Station RF Bandwidth consists of one sub-block gap and two sub-blocks located at the edges of the declared maximum Base Station RF Bandwidth.
- For transmitter tests, place one UTRA carrier adjacent to the upper Base Station RF Bandwidth edge and one UTRA carrier adjacent to the lower Base Station RF Bandwidth edge. The specified $F_{\text{Offset-RAT}}$ shall apply.
- For receiver tests, place one UTRA carrier adjacent to the upper Base Station RF Bandwidth edge and one UTRA carrier adjacent to the lower Base Station RF Bandwidth edge.
- For single-band operation receiver tests, if the maximum Base Station RF Bandwidth is at least 35 MHz and the BS supports at least 4 UTRA FDD carriers, place a UTRA FDD carrier adjacent to each already placed carrier for each sub-block. The nominal carrier spacing defined in clause 4.5.1 shall apply.
- The sub-block edges adjacent to the sub-block gap shall be determined using the specified $F_{\text{Offset-RAT}}$ for the carrier adjacent to the sub-block gap.
- The UTRA FDD carrier in the lower sub-block may be shifted maximum 100 kHz towards lower frequencies and the UTRA FDD carrier in the upper sub-block may be shifted maximum 100 kHz towards higher frequencies to align with the channel raster.

4.8.1a.2 NTC1 power allocation

Set the power of each carrier to the same power so that the sum of the carrier powers equals the rated RAT output power according to the manufacturer's declaration in clause 4.7.2 c).

4.8.2 TC2: E-UTRA multicarrier operation

The purpose of the TC2 is to test E-UTRA multi-carrier aspects.

4.8.2.1 TC2 generation

TC2 is constructed using the following method:

- The Base Station RF Bandwidth shall be the declared maximum Base Station RF Bandwidth.
- Select the narrowest supported E-UTRA carrier and place it adjacent to the lower Base Station RF Bandwidth edge. Place a 5 MHz E-UTRA carrier adjacent to the upper Base Station RF Bandwidth edge. The specified $F_{\text{Offset-RAT}}$ shall apply.
- For transmitter tests, select as many 5 MHz E-UTRA carriers that the BS supports and that fit in the rest of the Base Station RF Bandwidth. Place the carriers adjacent to each other starting from the high Base Station RF Bandwidth edge. The nominal carrier spacing defined in clause 4.5 shall apply. The specified $F_{\text{Offset-RAT}}$ shall apply.
- If 5 MHz E-UTRA carriers are not supported by the BS the narrowest supported channel BW shall be selected instead.

4.8.2.2 TC2 power allocation

Set the power of each carrier to the same power so that the sum of the carrier powers equals the rated RAT output power for E-UTRA according to the manufacturer's declaration in sub clause 4.7.2 d).

4.8.2a NTC2: E-UTRA multicarrier non-contiguous operation

The purpose of NTC2 is to test E-UTRA multicarrier non-contiguous aspects.

4.8.2a.1 NTC2 generation

The purpose of NTC2 is to test E-UTRA multicarrier non-contiguous aspects. NTC2 is constructed using the following method:

- The Base Station RF Bandwidth shall be the maximum Base Station RF Bandwidth for non-contiguous operation. The Base Station RF Bandwidth consists of one sub-block gap and two sub-blocks located at the edges of the declared maximum Base Station RF Bandwidth.
- For transmitter tests, place a 5MHz E-UTRA carrier adjacent to the upper Base Station RF Bandwidth edge and a 5MHz E-UTRA carrier adjacent to the lower Base Station RF Bandwidth edge. The specified $F_{\text{Offset-RAT}}$ shall apply. If 5 MHz E-UTRA carriers are not supported by the BS, the narrowest supported channel BW shall be selected instead.
- For receiver tests, place a 5MHz E-UTRA carrier adjacent to the upper Base Station RF Bandwidth edge and a 5MHz E-UTRA carrier adjacent to the lower Base Station RF Bandwidth edge. If 5 MHz E-UTRA carriers are not supported by the BS, the narrowest supported channel BW shall be selected instead.
- For single-band operation receiver tests, if the remaining gap is at least 15 MHz plus two times the channel BW used in the previous step and the BS supports at least 4 E-UTRA carriers, place a E-UTRA carrier of this BW adjacent to each already placed carrier for each sub-block. The nominal carrier spacing defined in clause 4.5.1 shall apply.
- The sub-block edges adjacent to the sub-block gap shall be determined using the specified $F_{\text{Offset-RAT}}$ for the carrier adjacent to the sub-block gap.

4.8.2a.2 NTC2 power allocation

Set the power of each carrier to the same power so that the sum of the carrier powers equals the rated RAT output power according to the manufacturer's declaration in clause 4.7.2 d).

4.8.3 TC3: UTRA and E-UTRA multi RAT operation

The purpose of TC3 is to test UTRA and E-UTRA multi-RAT aspects.

If the rated total output power and total number of supported carriers are not simultaneously supported in Multi-RAT operations, two instances of TC3 shall be generated using the following values for rated total output power and the total number of supported carriers:

- 1) The rated total output power and the reduced number of supported carriers at the rated total output power in Multi-RAT operations
- 2) The reduced total output power at the total number of supported carriers in Multi-RAT operations and the total number of supported carriers.

Tests that use TC3 shall be performed using both instances 1) and 2) of TC3.

4.8.3.1 TC3a generation

TC3a is constructed using the following method:

- The Base Station RF Bandwidth shall be the declared maximum Base Station RF Bandwidth.
- Select an FDD UTRA carrier to be placed at the lower Base Station RF Bandwidth edge. The specified $F_{\text{Offset-RAT}}$ shall apply. The UTRA FDD may be shifted maximum 100 kHz towards lower frequencies to align with the channel raster.
- Place a 5 MHz E-UTRA carrier at the upper Base Station RF Bandwidth edge. If that is not possible use the narrowest E-UTRA carrier supported by the BS. The specified $F_{\text{Offset-RAT}}$ shall apply.
- For transmitter tests, alternately add FDD UTRA carriers at the low end and 5 MHz E-UTRA carriers at the high end adjacent to the already placed carriers until the Base Station RF Bandwidth is filled or the total number of supported carriers is reached. The nominal carrier spacing defined in clause 4.5.1 shall apply.

4.8.3.2 TC3b generation

TC3b is constructed using the following method:

- The Base Station RF Bandwidth shall be the declared maximum Base Station RF Bandwidth.
- Select a UTRA TDD carrier to be placed at the lower Base Station RF Bandwidth edge. The specified $F_{\text{Offset-RAT}}$ shall apply.
- Place a 5 MHz E-UTRA carrier at the upper Base Station RF Bandwidth edge. If that is not possible use the narrowest E-UTRA carrier supported by the BS. The specified $F_{\text{Offset-RAT}}$ shall apply.
- For transmitter tests, alternately add UTRA TDD carriers at the low end and 5 MHz E-UTRA carriers at the high end adjacent to the already placed carriers until the Base Station RF Bandwidth is filled or the total number of supported carriers is reached. The nominal carrier spacing defined in clause 4.5.1 shall apply.

4.8.3.3 TC3 power allocation

Set the power of each carrier to the same power so that the sum of the carrier powers equals the rated total output power according to the manufacturer's declaration in clause 4.7.2 c) and d).

4.8.3a NTC3: UTRA and E-UTRA multi RAT non-contiguous operation

The purpose of NTC3 is to test UTRA and E-UTRA multi RAT non-contiguous aspects.

If the rated total output power and total number of supported carriers are not simultaneously supported in Multi-RAT operations, two instances of NTC3 shall be generated using the following values for rated total output power and the total number of supported carriers:

- 1) The rated total output power and the reduced number of supported carriers at the rated total output power in Multi-RAT operations
- 2) The reduced total output power at the total number of supported carriers in Multi-RAT operations and the total number of supported carriers.

If the reduced number of supported carriers is 4 or more, only instance 1) of NTC3 shall be used in the tests, otherwise both instances 1) and 2) of NTC3 shall be used in the tests.

4.8.3a.1 NTC3a generation

The purpose of NTC3a is to test UTRA and E-UTRA multi RAT non-contiguous aspects. NTC3a is constructed using the following method:

- The Base Station RF Bandwidth shall be the declared maximum Base Station RF Bandwidth for non-contiguous operation. The Base Station RF Bandwidth consists of one sub-block gap and two sub-blocks located at the edges of the declared maximum Base Station RF Bandwidth.
- For transmitter tests, place an UTRA carrier at the lower RF Bandwidth edge and a 5 MHz E-UTRA carrier at the upper Base Station RF Bandwidth edge. The specified $F_{\text{Offset-RAT}}$ shall apply. If 5 MHz E-UTRA carriers are not supported by the BS, the narrowest supported channel BW shall be selected instead. The UTRA FDD carrier may be shifted maximum 100 kHz towards lower frequencies to align with the channel raster.
- For receiver tests, place an UTRA carrier at the lower RF Bandwidth edge and a 5 MHz E-UTRA carrier at the upper Base Station RF Bandwidth edge. The specified $F_{\text{Offset-RAT}}$ shall apply. If 5 MHz E-UTRA carriers are not supported by the BS, the narrowest supported channel BW shall be selected instead. The UTRA FDD carrier may be shifted maximum 100 kHz towards lower frequencies to align with the channel raster.
- For single-band operation receiver tests, if the remaining gap is at least 20 MHz plus the channel BW of the E-UTRA carrier used in the previous step and the BS supports at least 2 UTRA and 2 E-UTRA carriers, place a E-UTRA carrier of this BW adjacent to the carrier at the lower Base Station RF Bandwidth edge and UTRA carrier adjacent to the carrier at the upper Base Station RF Bandwidth edge. The nominal carrier spacing defined in clause 4.5.1 shall apply. The UTRA FDD carrier may be shifted maximum 100 kHz towards higher frequencies to align with the channel raster.

- The sub-block edges adjacent to the sub-block gap shall be determined using the specified $F_{\text{Offset-RAT}}$ for the carrier adjacent to the sub-block gap.

4.8.3a.2 NTC3 power allocation

Set the power of each carrier to the same power so that the sum of the carrier powers equals the rated total output power according to the manufacturer's declaration in clause 4.7.2 c) and d).

4.8.4 TC4: BC2 transmitter operation

The purpose of TC4 is to test multi-RAT operations with GSM for the transmitter.

If the rated total output power and total number of supported carriers are not simultaneously supported in Multi-RAT operations, two instances of TC4 shall be generated using the following values for rated total output power and the total number of supported carriers:

- 1) The rated total output power and the reduced number of supported carriers at the rated total output power in Multi-RAT operations
- 2) The reduced rated total output power at the total number of supported carriers in Multi-RAT operations and the total number of supported carriers.

If the rated total output power and total number of supported carriers are not simultaneously supported in Multi-RAT operations, tests that use TC4 shall be performed using both instances 1) and 2) of TC4, except tests for modulation accuracy in which only TC4 according to 2) shall be used.

4.8.4.1 TC4a generation

TC4a is only applicable for a BS that supports UTRA and GSM. TC4a is constructed using the following method:

- The Base Station RF Bandwidth shall be the declared maximum Base Station RF Bandwidth.
- In the case of a BS supporting only one GSM carrier and one UTRA carrier, place a GSM carrier at the lower edge and a UTRA carrier at the upper Base Station RF Bandwidth edge. The specified $F_{\text{Offset-RAT}}$ shall apply
- Place a GSM carrier at the upper edge and a GSM carrier at the lower Base Station RF Bandwidth edge. The specified $F_{\text{Offset-RAT}}$ shall apply.
- Place two UTRA FDD carriers in the middle of the Base Station RF Bandwidth. If two UTRA FDD carriers do not fit, place only one carrier in the middle of the Base Station RF Bandwidth. The UTRA FDD carrier(s) may be shifted maximum 100 kHz towards lower frequencies for B_{RFBW} and M_{RFBW} and towards higher frequencies for T_{RFBW} to align with the channel raster.
- Add GSM carriers at the edges using 600 kHz spacing until no more GSM carriers are supported or no more GSM carriers fit.
- Add additional UTRA FDD carriers in the middle if possible.

4.8.4.2 TC4b generation

TC4b is only applicable for a BS that supports E-UTRA and GSM. TC4b is constructed using the following method:

- The Base Station RF Bandwidth shall be the declared maximum Base Station RF Bandwidth.
- In the case of a BS supporting only one GSM carrier and one E-UTRA carrier, place a GSM carrier at the lower edge and a E-UTRA carrier at the upper Base Station RF Bandwidth edge. The specified $F_{\text{Offset-RAT}}$ shall apply.
- Place a GSM carrier at the upper edge and a GSM carrier at the lower Base Station RF Bandwidth edge. The specified $F_{\text{Offset-RAT}}$ shall apply.
- Place two 5 MHz E-UTRA carriers in the middle of the Base Station RF Bandwidth. If the BS does not support 5 MHz channel BW use the narrowest supported BW, if two carriers do not fit place only one carrier.

- Add GSM carriers at the edges using 600 kHz spacing until no more GSM carriers are supported or no more GSM carriers fit.
- Add additional E-UTRA carriers of the same bandwidth as the already allocated E-UTRA carriers in the middle if possible.

4.8.4.3 TC4c generation

TC4c is only applicable for a BS that supports UTRA, E-UTRA and GSM. TC4c is constructed using the following method:

- The Base Station RF Bandwidth shall be the declared maximum Base Station RF Bandwidth.
- Place a GSM carrier at the upper edge and a GSM carrier at the lower Base Station RF Bandwidth edge. The specified $F_{\text{Offset-RAT}}$ shall apply.
- In the case of a BS supporting only one GSM carrier and one E-UTRA or UTRA carrier, place a GSM carrier at the lower edge and a E-UTRA carrier at the upper Base Station RF Bandwidth edge. The specified $F_{\text{Offset-RAT}}$ shall apply.
- Place one 5 MHz E-UTRA carrier and one UTRA carrier in the middle of the Base Station RF Bandwidth. If the BS does not support 5 MHz E-UTRA channel BW use the narrowest supported BW. The carrier(s) may be shifted maximum 100 kHz towards lower frequencies for B_{RFBW} and M_{RFBW} and towards higher frequencies for T_{RFBW} to align with the channel raster.
- Add GSM carriers at the edges using 600 kHz spacing until no more GSM carriers are supported or no more GSM carriers fit.
- Add additional UTRA and E-UTRA carriers in the middle if possible. For E-UTRA the same bandwidth as the already allocated E-UTRA carriers shall be used.

4.8.4.4 TC4d generation

TC4d is only applicable for a BS that supports UTRA and GSM. TC4d is only applicable when any of the following conditions is satisfied:

- 1) The declared Base Station RF Bandwidth for GSM single-RAT operation is not equal to the declared Base Station RF Bandwidth for multi-RAT operations and the frequency range supported by the BS is a subset of the operating band.
- 2) The maximum Base Station RF Bandwidth covers the entire operating band.

TC4d is constructed using the following method:

- The Base Station RF Bandwidth shall be 600 kHz less than the declared maximum Base Station RF Bandwidth.
- The Base Station RF Bandwidth shall be adjacent to the high end of the frequency range supported by the BS.
- Place a GSM carrier at the lower Base Station RF Bandwidth edge. Add one GSM carrier, if the BS supports more than one GSM carrier, at the lower edge using 600 kHz spacing. The specified $F_{\text{Offset-RAT}}$ shall apply.
- Place one UTRA carrier adjacent to the upper Base Station RF Bandwidth edge. The specified $F_{\text{Offset-RAT}}$ shall apply. The carrier may be shifted maximum 100 kHz towards higher frequencies to align with the channel raster.

4.8.4.5 TC4e generation

TC4e is only applicable for a BS that supports E-UTRA and GSM. TC4e is only applicable when any of the following conditions is satisfied:

- 1) The declared Base Station RF Bandwidth for GSM single-RAT operation is not equal to the declared Base Station RF Bandwidth for multi-RAT operations and the frequency range supported by the BS is a subset of the operating band.
- 2) The maximum Base Station RF Bandwidth covers the entire operating band.

TC4e is constructed using the following method:

- The Base Station RF Bandwidth shall be 600 kHz less than the declared maximum Base Station RF Bandwidth.
- The Base Station RF Bandwidth shall be adjacent to the upper edge of the frequency range supported by the BS.
- Place a GSM carrier at the lower Base Station RF Bandwidth edge. Add one GSM carrier, if the BS supports more than one GSM carrier, at the lower edge using 600 kHz spacing. The specified $F_{\text{Offset-RAT}}$ shall apply.
- Place one 5 MHz E-UTRA carrier adjacent to the upper Base Station RF Bandwidth edge. If the BS does not support 5 MHz channel BW use the narrowest supported BW. The specified $F_{\text{Offset-RAT}}$ shall apply.

4.8.4.6 TC4 power allocation

- a) Unless otherwise stated, set each carrier to the same power so that the sum of the carrier powers equals the rated total output power according to manufacturer's declarations in clause 4.7.2 a)
- b) In case that TC4 is configured for testing modulation quality, the power allocated per carrier for the RAT on which modulation quality is measured shall be the highest possible for the given modulation configuration according to the manufacturer's declarations in clause 4.7.2, unless that power is higher than the level defined by case a). The power of the remaining carriers from other RAT(s) shall be set to the same level as in case a).

If in the case of b) the power of one RAT needs to be reduced in order to meet the manufacture's declaration, the power in the other RAT(s) does not need to be increased.

4.8.4a NTC4: Non-contiguous multi RAT operations with GSM for the transmitter

The purpose of NTC4 is to test non-contiguous multi RAT operations with GSM for the transmitter.

If the rated total output power and total number of supported carriers are not simultaneously supported in Multi-RAT operations, two instances of NTC4 shall be generated using the following values for rated total output power and the total number of supported carriers:

- 1) The rated total output power and the reduced number of supported carriers at the rated total output power in Multi-RAT operations
- 2) The reduced rated total output power at the total number of supported carriers in Multi-RAT operations and the total number of supported carriers.

If the rated total output power and total number of supported carriers are not simultaneously supported in Multi-RAT operations, tests that use NTC4 shall be performed using both instances 1) and 2) of NTC4, except:

- 1) Tests for modulation accuracy in which only NTC4 according to 2) shall be used.
- 2) If the reduced number of supported carriers is 6 or more, only instance 1) of NTC4 shall be used.

4.8.4a.1 NTC4a generation

NTC4a is only applicable for a BS that supports UTRA and GSM. NTC4a is constructed using the following method:

- The Base Station RF Bandwidth shall be the declared maximum Base Station RF Bandwidth for non-contiguous operation. The Base Station RF Bandwidth consists of one sub-block gap and two sub-blocks located at the edges of the declared maximum Base Station RF Bandwidth. The sub-block bandwidth shall be equal to 6MHz.
- If the BS supports up to 3 carriers, place one GSM carrier adjacent to the lower sub-block edge and one GSM carrier adjacent to the upper sub-block edge of the lower sub-block. Place a UTRA FDD carrier adjacent to the upper Base Station RF Bandwidth edge. The upper sub-block edge adjacent to the sub-block gap shall be determined using the specified $F_{\text{Offset-RAT}}$ for the UTRA carrier in the upper sub-block. The UTRA FDD carrier may be shifted maximum 100 kHz towards higher frequencies to align with the channel raster.
- If the BS supports up to 4 carriers, place one GSM carrier adjacent to the lower Base Station RF Bandwidth edge and one GSM carrier adjacent to the upper Base Station RF Bandwidth edge. Place one UTRA FDD carrier

adjacent to the upper sub-block edge of the lower sub-block and one UTRA FDD carrier adjacent to the lower sub-block edge of the upper sub-block. The specified $F_{\text{Offset-RAT}}$ shall apply. The UTRA FDD carrier in the lower sub-block may be shifted maximum 100 kHz towards higher frequencies and the UTRA FDD carrier in the upper sub-block may be shifted maximum 100 kHz towards lower frequencies to align with the channel raster.

- If the BS supports up to 5 carriers, place one GSM carrier adjacent to the lower Base Station RF Bandwidth edge and one GSM carrier adjacent to the upper Base Station RF Bandwidth edge. Place one GSM carrier adjacent to the upper sub-block edge of the lower sub-block, one UTRA FDD carrier adjacent to the lower sub-block edge of the upper sub-block and one UTRA FDD carrier in the middle of the lower sub-block bandwidth. The specified $F_{\text{Offset-RAT}}$ shall apply. The UTRA FDD carrier in the upper sub-block may be shifted maximum 100 kHz towards lower frequencies to align with the channel raster.
- If the BS supports at least 6 carriers, place one GSM carrier adjacent to the lower Base Station RF Bandwidth edge and one GSM carrier adjacent to the upper Base Station RF Bandwidth edge. Place one GSM carrier adjacent to the upper sub-block edge of the lower sub-block and one GSM carrier adjacent to the lower sub-block edge of the upper sub-block. Place one UTRA FDD carrier in the middle of each sub-block bandwidth. The specified $F_{\text{Offset-RAT}}$ shall apply.

4.8.4a.2 NTC4b generation

NTC4b is only applicable for a BS that supports E-UTRA and GSM. NTC4b is constructed using the following method:

- The Base Station RF Bandwidth shall be the declared maximum Base Station RF Bandwidth for non-contiguous operation. The Base Station RF Bandwidth consists of one sub-block gap and two sub-blocks located at the edges of the declared maximum Base Station RF Bandwidth.
- If the BS supports up to 3 carriers, place one GSM carrier adjacent to the lower sub-block edge and one GSM carrier adjacent to the upper sub-block edge of the lower sub-block. Place a 5MHz E-UTRA carrier adjacent to the upper Base Station RF Bandwidth edge. If 5 MHz E-UTRA carriers are not supported by the BS, the narrowest supported channel BW shall be selected instead. The lower sub-block bandwidth shall be equal to 6MHz. The upper sub-block edge adjacent to the sub-block gap shall be determined using the specified $F_{\text{Offset-RAT}}$ for the carrier in the upper sub-block.
- If the BS supports up to 4 carriers, place one GSM carrier adjacent to the lower Base Station RF Bandwidth edge and one GSM carrier adjacent to the upper Base Station RF Bandwidth edge. Place one E-UTRA FDD carrier adjacent to the upper sub-block edge of the lower sub-block and one 5MHz E-UTRA carrier adjacent to the lower sub-block edge of the upper sub-block. If 5 MHz E-UTRA carriers are not supported by the BS, the narrowest supported channel BW shall be selected instead. The sub-block bandwidth shall be equal to the bandwidth of the allocated non-GSM carrier in that sub-block plus 1MHz. The specified $F_{\text{Offset-RAT}}$ shall apply.
- If the BS supports up to 5 carriers, place one GSM carrier adjacent to the lower Base Station RF Bandwidth edge and one GSM carrier adjacent to the upper Base Station RF Bandwidth edge. Place one GSM carrier adjacent to the upper sub-block edge of the lower sub-block, Place one 5 MHz E-UTRA carrier adjacent to the lower sub-block edge of the upper sub-block and one 5MHz E-UTRA carrier in the middle of the lower sub-block bandwidth. If 5 MHz E-UTRA carriers are not supported by the BS, the narrowest supported channel BW shall be selected instead. The sub-block bandwidth shall be equal to the bandwidth of the allocated non-GSM carrier in that sub-block plus 1MHz. The specified $F_{\text{Offset-RAT}}$ shall apply.
- If the BS supports at least 6 carriers, place one GSM carrier adjacent to the lower Base Station RF Bandwidth edge and one GSM carrier adjacent to the upper Base Station RF Bandwidth edge. Place one GSM carrier adjacent to the upper sub-block edge of the lower sub-block and one GSM carrier adjacent to the lower sub-block edge of the upper sub-block. Place one 5MHz E-UTRA carrier in the middle of the lower sub-block bandwidth and one 5MHz E-UTRA carrier in the middle of the upper sub-block bandwidth. If 5 MHz E-UTRA carriers are not supported by the BS, the narrowest supported channel BW shall be selected instead. The sub-block bandwidth shall be equal to the bandwidth of the allocated non-GSM carrier in that sub-block plus 1MHz. The specified $F_{\text{Offset-RAT}}$ shall apply.

4.8.4a.3 NTC4c generation

NTC4c is only applicable for a BS that supports UTRA, E-UTRA and GSM. NTC4c is constructed using the following method:

- The Base Station RF Bandwidth shall be the declared maximum Base Station RF Bandwidth for non-contiguous operation. The Base Station RF Bandwidth consists of one sub-block gap and two sub-blocks located at the edges of the declared maximum Base Station RF Bandwidth.
- If the BS supports up to 3 carriers, place one GSM carrier adjacent to the lower sub-block edge and one UTRA FDD carrier adjacent to the upper sub-block edge of the lower sub-block. Place a 5MHz E-UTRA carrier adjacent to the upper Base Station RF Bandwidth edge. If 5 MHz E-UTRA carriers are not supported by the BS, the narrowest supported channel BW shall be selected instead. The lower sub-block bandwidth shall be equal to 6MHz. The upper sub-block edge adjacent to the sub-block gap shall be determined using the specified $F_{\text{Offset-RAT}}$ for the carrier in the upper sub-block. The UTRA FDD carrier may be shifted maximum 100 kHz towards higher frequencies to align with the channel raster.
- If the BS supports up to 4 carriers, place one GSM carrier adjacent to the lower Base Station RF Bandwidth edge and one GSM carrier adjacent to the upper Base Station RF Bandwidth edge. Place one UTRA FDD carrier adjacent to the upper sub-block edge of the lower sub-block and one 5MHz E-UTRA carrier adjacent to the lower sub-block edge of the upper sub-block. If 5 MHz E-UTRA carriers are not supported by the BS, the narrowest supported channel BW shall be selected instead. The sub-block bandwidth shall be equal to the bandwidth of the allocated non-GSM carrier in that sub-block plus 1MHz. The specified $F_{\text{Offset-RAT}}$ shall apply. The UTRA FDD carrier may be shifted maximum 100 kHz towards higher frequencies to align with the channel raster.
- If the BS supports up to 5 carriers, place one GSM carrier adjacent to the lower Base Station RF Bandwidth edge and one GSM carrier adjacent to the upper Base Station RF Bandwidth edge. Place one GSM carrier adjacent to the upper sub-block edge of the lower sub-block. Place one 5MHz E-UTRA carrier adjacent to the lower sub-block edge of the upper sub-block and one UTRA FDD carrier in the middle of the lower sub-block bandwidth. If 5 MHz E-UTRA carriers are not supported by the BS, the narrowest supported channel BW shall be selected instead. The sub-block bandwidth shall be equal to the bandwidth of the allocated non-GSM carrier in that sub-block plus 1MHz. The specified $F_{\text{Offset-RAT}}$ shall apply.
- If the BS supports at least 6 carriers, place one GSM carrier adjacent to the lower Base Station RF Bandwidth edge and one GSM carrier adjacent to the upper Base Station RF Bandwidth edge. Place one GSM carrier adjacent to the upper sub-block edge of the lower sub-block and one GSM carrier adjacent to the lower sub-block edge of the upper sub-block. Place one UTRA FDD carrier in the middle of the lower sub-block bandwidth and one 5MHz E-UTRA carrier in the middle of the upper sub-block bandwidth. If 5 MHz E-UTRA carriers are not supported by the BS, the narrowest supported channel BW shall be selected instead. The sub-block bandwidth shall be equal to the bandwidth of the allocated non-GSM carrier in that sub-block plus 1MHz. The specified $F_{\text{Offset-RAT}}$ shall apply.

4.8.4a.4 NTC4 power allocation

- a) Unless otherwise stated, set each carrier to the same power so that the sum of the carrier powers equals the rated total output power according to manufacturer's declarations in clause 4.7.2 a)
- b) In case that NTC4 is configured for testing modulation quality, the power allocated per carrier for the RAT on which modulation quality is measured shall be the highest possible for the given modulation configuration according to the manufacturer's declarations in clause 4.7.2, unless that power is higher than the level defined by case a). The power of the remaining carriers from other RAT(s) shall be set to the same level as in case a).

If in the case of b) the power of one RAT needs to be reduced in order to meet the manufacture's declaration the power in the other RAT(s) does not need to be increased.

4.8.5 TC5: BC2 receiver operation

4.8.5.1 TC5a generation

TC5a is constructed using the following method:

- The Base Station RF Bandwidth shall be the declared maximum Base Station RF Bandwidth.
- Place a GSM carrier at the lower Base Station RF Bandwidth edge. The specified $F_{\text{Offset-RAT}}$ shall apply.

- Place a UTRA FDD carrier at the upper Base Station RF Bandwidth edge. The specified $F_{\text{Offset-RAT}}$ shall apply. The UTRA FDD carrier may be shifted maximum 100 kHz towards higher frequencies to align with the channel raster.

4.8.5.2 TC5b generation

TC5b is constructed using the following method:

- The Base Station RF Bandwidth shall be the declared maximum Base Station RF Bandwidth.
- Place a GSM carrier at the lower Base Station RF Bandwidth edge. The specified $F_{\text{Offset-RAT}}$ shall apply.
- Place a 5MHz E-UTRA carrier at the upper Base Station RF Bandwidth edge. If the BS does not support 5 MHz channel BW select the narrowest supported channel BW. The specified $F_{\text{Offset-RAT}}$ shall apply.

4.8.5a NTC5: Non-contiguous multi RAT operations with GSM for the receiver

The purpose of NTC5 is to test non-contiguous multi RAT operations with GSM for the receiver.

4.8.5a.1 NTC5a generation

NTC5a is only applicable for a BS that supports UTRA and GSM. NTC5a is constructed using the following method:

- The Base Station RF Bandwidth shall be the declared maximum Base Station RF Bandwidth for non-contiguous operation. The Base Station RF Bandwidth consists of one sub-block gap and two sub-blocks located at the edges of the declared maximum Base Station RF Bandwidth. The sub-block bandwidth shall be equal to 6MHz.
- If the BS supports up to 3 carriers use the method to generate NTC4a for up to 3 carriers.
- If the BS supports at least 4 carriers use the method to generate NTC4a for up to 4 carriers.

4.8.5a.2 NTC5b generation

NTC5b is only applicable for a BS that supports E-UTRA and GSM. NTC5b is constructed using the following method:

- The Base Station RF Bandwidth shall be the declared maximum Base Station RF Bandwidth for non-contiguous operation. The Base Station RF Bandwidth consists of one sub-block gap and two sub-blocks located at the edges of the declared maximum Base Station RF Bandwidth.
- If the BS supports up to 3 carriers use the method to generate NTC4b for up to 3 carriers.
- If the BS supports at least 4 carriers use the method to generate NTC4b for up to 4 carriers.

4.8.5a.3 NTC5c generation

NTC5c is only applicable for a BS that supports UTRA, E-UTRA and GSM. NTC5c is constructed using the following method:

- The Base Station RF Bandwidth shall be the declared maximum Base Station RF Bandwidth for non-contiguous operation. The Base Station RF Bandwidth consists of one sub-block gap and two sub-blocks located at the edges of the declared maximum Base Station RF Bandwidth.
- If the BS supports up to 3 carriers use the method to generate NTC4c for up to 3 carriers.
- If the BS supports at least 4 carriers use the method to generate NTC4c for up to 4 carriers.

4.8.6 TC6: Single carrier for receiver tests

4.8.6.1 TC6a generation

TC6a is constructed using the following method:

- Place a single UTRA carrier in the middle of the maximum Base Station RF Bandwidth. The carrier may be shifted maximum 100 kHz towards lower frequencies for B_{RFBW} and M_{RFBW} and towards higher frequencies for T_{RFBW} to align with the channel raster.

4.8.6.2 TC6b generation

TC6b is constructed using the following method:

- Place the narrowest supported E-UTRA carrier in the middle of the maximum Base Station RF Bandwidth.

4.8.6.3 TC6c generation

TC6c is constructed using the following method:

- Place a single UTRA TDD carrier in the middle of the maximum Base Station RF Bandwidth.

4.8.7 Generation of MB-MSR test configurations

4.8.7.1 TC7a: MB-MSR test configuration for full carrier allocation

The purpose of TC7a is to test multi-band operation aspects considering maximum supported number of carriers.

4.8.7.1.1 TC7a generation

TC7a is based on re-using the existing test configurations applicable per band involved in multi-band operation. TC7a is constructed using the following method:

- The Base Station RF Bandwidth of each supported operating band shall be the declared maximum Base Station RF Bandwidth in multi-band operation.
- The number of carriers of each supported operating band shall be the declared maximum number of supported carriers in multi-band operation. Carriers shall first be placed at the outermost edges of the declared Maximum Radio Bandwidth for outermost bands and the Base Station RF Bandwidths edges for middle band(s) if any. Additional carriers shall next be placed at the Base Station RF Bandwidth edges, if possible.
- The allocated Base Station RF Bandwidth of the outermost bands shall be located at the outermost edges of the declared Maximum Radio Bandwidth.
- Each concerned band shall be considered as an independent band and the carrier placement in each band shall be according to the test configuration referenced in Table 4.8.7.1.1-1, where the declared parameters for multi-band operation shall apply. The mirror image of the single band test configuration shall be used in each alternate band(s) and in the highest band being tested for the BS.
- If only one carrier can be placed for the concerned band(s), the carrier(s) shall be placed at the outermost edges of the declared maximum radio bandwidth for outermost band(s) and at one of the outermost edges of the supported frequency range within the Base Station RF Bandwidths for middle band(s) if any.
- If the sum of the maximum Base Station RF Bandwidth of each supported operating bands is larger than the declared Total RF Bandwidth of transmitter and receiver for the declared band combinations of the BS, repeat the steps above for test configurations where the Base Station RF Bandwidth of one of the operating band shall be reduced so that the Total RF Bandwidth of transmitter and receiver is not exceeded and vice versa.
- If the sum of the maximum number of supported carrier of each supported operating bands in multi-band operation is larger than the declared total number of supported carriers for the declared band combinations of the BS, repeat the steps above for test configurations where in each test configuration the number of carriers of one

of the operating band shall be reduced so that the total number of supported carriers is not be exceeded and vice versa.

Table 4.8.7.1.1-1: The applicability of test configuration for carrier placement in each band

BC	CS 1	CS 2	CS 3	CS 4	CS 5	CS 6	CS 7	CS16
BC1	TC1a	TC2	TC3a	N/A	N/A	N/A	N/A	TC21
BC2	TC1a	TC2	TC3a	TC4a	TC4b	TC4c	TC4a and TC4b	TC21
BC3	TC1b	TC2	TC3b	N/A	N/A	N/A	N/A	TC21

4.8.7.1.2 TC7a power allocation

Unless otherwise stated, set the power of each carrier in all supported operating bands to the same power so that the sum of the carrier powers equals the rated total output power according to the manufacturer's declaration.

If the allocated power of a supported operating band(s) exceeds the declared rated total output power of the operating band(s) in multi-band operation, the exceeded part shall, if possible, be reallocated into the other band(s). If the power allocated for a carrier exceeds the rated carrier output power declared for that carrier, the exceeded power shall, if possible, be reallocated into the other carriers.

4.8.7.2 TC7b: MB-MSR test configuration with high PSD per carrier

The purpose of TC7b is to test multi-band operation aspects considering higher PSD cases with reduced number of carriers and non-contiguous operation (if supported) in multi-band mode.

4.8.7.2.1 TC7b generation

TC7b is based on re-using the existing test configurations applicable per band involved in multi-band operation. TC7b is constructed using the following method:

- The Base Station RF Bandwidth of each supported operating band shall be the declared maximum Base Station RF Bandwidth in multi-band operation.
- The allocated Base Station RF Bandwidth of the outermost bands shall be located at the outermost edges of the declared Maximum Radio Bandwidth.
- The maximum number of carriers for a BC2 band is limited to three per band for transmitter tests when the BS supports CS4, CS5, CS6 or CS7. For other transmitter tests and for all receiver tests, the maximum number of carriers is limited to two per band. Carriers shall first be placed at the outermost edges of the declared Maximum Base Station Radio Bandwidth, for outermost bands and the Base Station RF Bandwidths edges for middle band(s) if any. Additional carriers shall next be placed at the Base Station RF Bandwidth edges.
- For BS supporting CS1, CS2, CS3 or CS16 in the band, each concerned band shall be considered as an independent band and the carrier placement in each band shall be according to the test configuration referenced in Table 4.8.7.2.1-1, where the declared parameters for multi-band operation shall apply. Narrowest supported E-UTRA channel bandwidth shall be used in the test configuration. The mirror image of the single band test configuration shall be used in each alternate band(s) and in the highest band being tested for the BS.
- If the maximum supported number of carriers is two for a BC2 band when the BS supports CS4, CS5, CS6 or CS7, place the UTRA/E-UTRA carrier at the Base Station RF Bandwidth edge adjacent to the Inter RF Bandwidth gap and place the GSM/EDGE carrier at the edge of the declared Maximum Base Station Radio Bandwidth. Narrowest supported E-UTRA channel bandwidth shall be used in the test configuration.
- If the maximum supported number of carriers is three or more for a BC2 band when the BS supports CS4, CS5, CS6 or CS7, place one GSM/EDGE carrier at the Base Station RF Bandwidth edge adjacent to the Inter RF Bandwidth gap, place the second GSM/EDGE carrier at the edge of the declared Maximum Base Station Radio Bandwidth and place the UTRA/E-UTRA carrier adjacent to the GSM/EDGE carrier at the inter RF bandwidth gap. Narrowest supported E-UTRA channel bandwidth shall be used in the test configuration. The adjacent UTRA/E-UTRA carrier shall be placed with its channel BW edge aligned with the channel BW edge of the GSM/EDGE carrier by applying $F_{\text{offset,RAT}}$ in clause 4.4.2.

- If the sum of the maximum Base Station RF Bandwidth of each supported operating bands is larger than the declared Total RF Bandwidth of transmitter and receiver for the declared band combinations of the BS, repeat the steps above for test configurations where the Base Station RF Bandwidth of one of the operating band shall be reduced so that the Total RF Bandwidth of transmitter and receiver is not exceeded and vice versa.

Table 4.8.7.2.1-1: The applicability of test configuration for carrier placement in each band

BC	CS 1	CS 2	CS 3	CS16
BC1	NTC1a	NTC2	NTC3a	NTC21
BC2	NTC1a	NTC2	NTC3a	NTC21
BC3	TC1b	NTC2	NTC3a	NTC21

4.8.7.2.2 TC7b power allocation

Unless otherwise stated, set the power of each carrier in all supported operating bands to the same power so that the sum of the carrier powers equals the rated total output power according to the manufacturer's declaration.

If the allocated power of a supported operating band(s) exceeds the declared rated total output power of the operating band(s) in multi-band operation, the exceeded part shall, if possible, be reallocated into the other band(s). If the power allocated for a carrier exceeds the rated carrier output power declared for that carrier, the exceeded power shall, if possible, be reallocated into the other carriers.

4.8.7.3 TC7c: MB-MSR test configuration with GSM/EDGE single RAT operation in one band

The purpose of TC7c is to test single-RAT GSM/EDGE UEM requirement for multi-band base station supporting GSM/EDGE single-RAT operation in BC2 band.

4.8.7.3.1 TC7c generation

TC7c is constructed using the following method:

- The Base Station RF Bandwidth of each supported operating band shall be the declared maximum Base Station RF Bandwidth in multi-band operation.
- The allocated Base Station RF Bandwidth of the outermost bands shall be located at the outermost edges of the declared Maximum Radio Bandwidth.
- If the BS supports one BC1 band and one BC2 band, the maximum number of carriers in a test configuration for BC1 band is limited to two. A UTRA/E-UTRA carrier from BC1 shall first be placed at the outermost edge of the declared Maximum Radio Bandwidth. If two or more carriers are supported in BC1 band, additional UTRA/E-UTRA carrier shall next be placed at the BC1 Base Station RF Bandwidth edge adjacent to the Inter RF Bandwidth gap. For BC2 band, where GSM/EDGE single-RAT operation is supported, one GSM/EDGE carrier shall first be placed at the other outermost edge of the declared Maximum Radio Bandwidth and additional GSM/EDGE carriers shall be placed within the declared maximum Base Station RF Bandwidth for the GSM/EDGE single-RAT BC2 band according to test case b) in TS 51.021 clause 6.12.2.
- If the BS supports two BC2 bands, the maximum number of carriers in a test configuration is two for a BC2 band where CS1, CS2 or CS3 is supported.

One UTRA/E-UTRA carrier from the BC2 band, where CS1, CS2 or CS3 is supported, shall first be placed at the outermost edge of the declared Maximum Radio Bandwidth. If two or more carriers are supported in this BC2 band, additional UTRA/E-UTRA carrier shall next be placed at the Base Station RF Bandwidth edge adjacent to the Inter RF Bandwidth gap. For BC2 band, where GSM/EDGE single-RAT operation is supported, place GSM/EDGE carrier at the other outermost edge of the declared Maximum Radio Bandwidth, additional GSM/EDGE carriers shall be placed within the declared maximum Base Station RF Bandwidth for the GSM/EDGE single-RAT BC2 band according to test case b) in TS 51.021 clause 6.12.2.

- If the BS supports two BC2 bands with GSM/EDGE operation (CS4, CS5, CS6 or CS7) and in at least one band CS4, CS5 or CS6 is supported, the maximum number of carriers for one BC2 band configured to multi-RAT operation is limited to three.
 - For the GSM/EDGE single-RAT BC2 band, one GSM/EDGE carrier shall first be placed at the outermost edge of the declared Maximum Radio Bandwidth, additional GSM/EDGE carriers for the BC2 band shall be placed within the declared maximum Base Station RF Bandwidth for the GSM/EDGE single-RAT BC2 band according to test case b) in TS 51.021 clause 6.12.2.
 - For the multi-RAT BC2 band, if the maximum supported number of carriers is two, place the UTRA/E-UTRA carrier at the Base Station RF Bandwidth edge adjacent to the Inter RF Bandwidth gap, then place the GSM/EDGE carrier at the other edge of the declared Maximum Radio Bandwidth.
 - For the multi-RAT BC2 band, if the maximum supported number of carriers is three or more, place one GSM/EDGE carrier at the Base Station RF Bandwidth edge adjacent to the Inter RF Bandwidth gap, then place the second GSM/EDGE carrier at the other edge of the declared Maximum Radio Bandwidth, then place the UTRA/E-UTRA carrier in the middle of the Base Station RF Bandwidth.

If both BC2 bands are declared as CS4, CS5 or CS6, repeat the steps above with the allocated carriers swapped between the two BC2 bands so that each BC2 band is tested once according to test case b) in TS 51.021 clause 6.12.2.

- The narrowest supported E-UTRA channel bandwidth shall be used in the test configuration.
- If the sum of the maximum Base Station RF Bandwidth of each supported operating bands is larger than the declared total bandwidth of transmitter and receiver for the declared band combinations of the BS, repeat the steps above for test configurations where the Base Station RF Bandwidth of one of the operating band shall be reduced so that the Total RF Bandwidth of transmitter and receiver is not exceeded and vice versa.

4.8.7.3.2 TC7c power allocation

Unless otherwise stated, set the power of each carrier in all supported operating bands to the same power so that the sum of the carrier powers equals the rated total output power according to the manufacturer's declaration.

If the allocated power of a supported operating band(s) exceeds the declared rated total output power of the operating band(s) in multi-band operation, the exceeded part shall, if possible, be reallocated into the other band(s). If the power allocated for a carrier exceeds the rated carrier output power declared for that carrier, the exceeded power shall, if possible, be reallocated into the other carriers.

4.8.8 TC8: NB-IoT standalone multi-carrier operation

The purpose of the TC8 is to test NB-IoT standalone multi-carrier aspects.

4.8.8.1 TC8 generation

TC8 is constructed using the following method:

- The Base Station RF Bandwidth shall be the declared maximum Base Station RF Bandwidth.
- Place a NB-IoT carrier at the upper edge and a NB-IoT carrier at the lower Base Station RF Bandwidth edge. The specified $F_{\text{Offset-RAT}}$ shall apply.
- For transmitter tests, add NB-IoT carriers at the edges using 600 kHz spacing until no more NB-IoT carriers are supported or no more NB-IoT carriers fit.

4.8.8.2 TC8 power allocation

Set the power of each carrier to the same power so that the sum of the carrier powers equals the rated total output power according to the manufacturer's declaration in clause 4.7.2.

4.8.9 TC9: GSM and NB-IoT standalone multi-carrier operation

The purpose of the TC9 is to test GSM and NB-IoT standalone multi-carrier aspects.

4.8.9.1 TC9 generation

TC9 is constructed using the following method:

- The Base Station RF Bandwidth shall be the declared maximum Base Station RF Bandwidth.
- Place a NB-IoT carrier at the upper edge and a GSM carrier at the lower Base Station RF Bandwidth edge. The specified $F_{\text{Offset-RAT}}$ shall apply.
- For transmitter tests, alternately add NB-IoT carriers at the upper edge and GSM carriers at the lower edge using 600 kHz spacing until the Base Station RF Bandwidth is filled or the total number of supported carriers is reached.

4.8.9.2 TC9 power allocation

Set the power of each carrier to the same power so that the sum of the carrier powers equals the rated total output power according to the manufacturer's declaration in clause 4.7.2.

4.8.10 TC10: UTRA and NB-IoT standalone multi-carrier operation

The purpose of the TC10 is to test UTRA and NB-IoT standalone multi-carrier aspects.

4.8.10.1 TC10 generation

TC10 is constructed using the following method:

- The Base Station RF Bandwidth shall be the declared maximum Base Station RF Bandwidth.
- For receiver tests, place a NB-IoT carrier at the lower edge and a UTRA FDD carrier at the upper Base Station RF Bandwidth edge. The specified $F_{\text{Offset-RAT}}$ shall apply.
- For transmitter tests and in the case of a BS supporting only one NB-IoT carrier, place a NB-IoT carrier at the lower edge and a UTRA FDD carrier at the upper Base Station RF Bandwidth edge. The specified $F_{\text{Offset-RAT}}$ shall apply. Add additional UTRA FDD carriers in the middle if possible. The UTRA FDD carrier(s) may be shifted maximum 100 kHz towards lower frequencies for B_{RFBW} and M_{RFBW} and towards higher frequencies for T_{RFBW} to align with the channel raster.
- For transmitter tests and in the case of a BS supporting more than one NB-IoT carrier, carry out the following steps.
 - Place a NB-IoT carrier at the upper edge and a NB-IoT carrier at the lower Base Station RF Bandwidth edge. The specified $F_{\text{Offset-RAT}}$ shall apply.
 - Place two UTRA FDD carriers in the middle of the Base Station RF Bandwidth. If only one UTRA FDD carrier is supported or two UTRA FDD carriers do not fit, place only one carrier in the middle of the Base Station RF Bandwidth. The UTRA FDD carrier(s) may be shifted maximum 100 kHz towards lower frequencies for B_{RFBW} and M_{RFBW} and towards higher frequencies for T_{RFBW} to align with the channel raster.
 - Add NB-IoT carriers at the edges using 600 kHz spacing until no more NB-IoT carriers are supported or no more NB-IoT carriers fit.
 - Add additional UTRA FDD carriers in the middle if possible.

4.8.10.2 TC10 power allocation

Set the power of each carrier to the same power so that the sum of the carrier powers equals the rated total output power according to the manufacturer's declaration in clause 4.7.2.

4.8.11 TC11: E-UTRA and NB-IoT standalone multi-carrier operation

The purpose of the TC11 is to test E-UTRA and NB-IoT standalone multi-carrier aspects.

4.8.11.1 TC11 generation

TC11 is constructed using the following method:

- The Base Station RF Bandwidth shall be the declared maximum Base Station RF Bandwidth.
- For receiver tests, place a NB-IoT carrier at the lower edge and a 5MHz E-UTRA carrier at the upper Base Station RF Bandwidth edge. If the BS does not support 5 MHz channel BW use the narrowest supported BW. The specified $F_{\text{Offset-RAT}}$ shall apply.
- For transmitter tests and in the case of a BS supporting only one NB-IoT carrier, place a NB-IoT carrier at the lower edge and a 5MHz E-UTRA carrier at the upper Base Station RF Bandwidth edge. If the BS does not support 5 MHz channel BW use the narrowest supported BW. The specified $F_{\text{Offset-RAT}}$ shall apply. Add additional E-UTRA carriers of the same bandwidth as the already allocated E-UTRA carriers in the middle if possible.
- For transmitter tests and in the case of a BS supporting more than one NB-IoT carrier, carry out the following steps.
 - Place a NB-IoT carrier at the upper edge and a NB-IoT carrier at the lower Base Station RF Bandwidth edge. The specified $F_{\text{Offset-RAT}}$ shall apply.
 - Place two 5 MHz E-UTRA carriers in the middle of the Base Station RF Bandwidth. If the BS does not support 5 MHz channel BW use the narrowest supported BW, if only one carrier is supported or two carriers do not fit place only one carrier.
 - Add NB-IoT carriers at the edges using 600 kHz spacing until no more NB-IoT carriers are supported or no more NB-IoT carriers fit.
 - Add additional E-UTRA carriers of the same bandwidth as the already allocated E-UTRA carriers in the middle if possible.

4.8.11.2 TC11 power allocation

Set the power of each carrier to the same power so that the sum of the carrier powers equals the rated total output power according to the manufacturer's declaration in clause 4.7.2.

4.8.12 TC12: GSM and UTRA and NB-IoT standalone multi-carrier operation

The purpose of the TC12 is to test GSM and UTRA and NB-IoT standalone multi-carrier aspects.

4.8.12.1 TC12 generation

TC12 is constructed using the following method:

- The Base Station RF Bandwidth shall be the declared maximum Base Station RF Bandwidth.
- Place a NB-IoT carrier at the upper edge and a GSM carrier at the lower Base Station RF Bandwidth edge. The specified $F_{\text{Offset-RAT}}$ shall apply.
- Place two UTRA FDD carriers in the middle of the Base Station RF Bandwidth. If only one UTRA FDD carrier is supported or two UTRA FDD carriers do not fit, place only one carrier in the middle of the Base Station RF Bandwidth. The UTRA FDD carrier(s) may be shifted maximum 100 kHz towards lower frequencies for B_{RFBW} and M_{RFBW} and towards higher frequencies for T_{RFBW} to align with the channel raster.
- For transmitter tests, alternately add NB-IoT carriers at the upper edge and GSM carriers at the lower edge using 600 kHz spacing until the Base Station RF Bandwidth is filled or the total number of supported carriers is reached.
- For transmitter tests, add additional UTRA FDD carriers in the middle if possible.

4.8.12.2 TC12 power allocation

Set the power of each carrier to the same power so that the sum of the carrier powers equals the rated total output power according to the manufacturer's declaration in clause 4.7.2.

4.8.13 TC13: GSM and E-UTRA and NB-IoT standalone multi-carrier operation

The purpose of the TC13 is to test GSM and E-UTRA and NB-IoT standalone multi-carrier aspects.

4.8.13.1 TC13 generation

TC13 is constructed using the following method:

- The Base Station RF Bandwidth shall be the declared maximum Base Station RF Bandwidth.
- Place a NB-IoT carrier at the upper edge and a GSM carrier at the lower Base Station RF Bandwidth edge. The specified $F_{\text{Offset-RAT}}$ shall apply.
- Place two 5 MHz E-UTRA carriers in the middle of the Base Station RF Bandwidth. If the BS does not support 5 MHz channel BW use the narrowest supported BW, if only one carrier is supported or two carriers do not fit place only one carrier.
- For transmitter tests, alternately add NB-IoT carriers at the upper edge and GSM carriers at the lower edge using 600 kHz spacing until the Base Station RF Bandwidth is filled or the total number of supported carriers is reached.
- For transmitter tests, add additional E-UTRA carriers of the same bandwidth as the already allocated E-UTRA carriers in the middle if possible.

4.8.13.2 TC13 power allocation

Set the power of each carrier to the same power so that the sum of the carrier powers equals the rated total output power according to the manufacturer's declaration in clause 4.7.2.

4.8.14 TC14: UTRA and E-UTRA and NB-IoT standalone multi-carrier operation

The purpose of the TC14 is to test UTRA and E-UTRA and NB-IoT standalone multi-carrier aspects.

4.8.14.1 TC14 generation

TC14 is constructed using the following method:

- The Base Station RF Bandwidth shall be the declared maximum Base Station RF Bandwidth.
- For receiver tests, place a NB-IoT carrier at the lower edge and a 5MHz E-UTRA carrier at the upper Base Station RF Bandwidth edge. If the BS does not support 5 MHz channel BW use the narrowest supported BW. The specified $F_{\text{Offset-RAT}}$ shall apply. Place a UTRA FDD carrier in the middle of the Base Station RF Bandwidth. The UTRA FDD carrier may be shifted maximum 100 kHz towards lower frequencies for B_{RFBW} and M_{RFBW} and towards higher frequencies for T_{RFBW} to align with the channel raster.
- For transmitter tests and in the case of a BS supporting only one NB-IoT carrier, place a NB-IoT carrier at the lower edge and a 5MHz E-UTRA carrier at the upper Base Station RF Bandwidth edge. If the BS does not support 5 MHz channel BW use the narrowest supported BW. The specified $F_{\text{Offset-RAT}}$ shall apply. Place a UTRA FDD carrier in the middle of the Base Station RF Bandwidth. The UTRA FDD carrier may be shifted maximum 100 kHz towards lower frequencies for B_{RFBW} and M_{RFBW} and towards higher frequencies for T_{RFBW} to align with the channel raster. Add additional UTRA and E-UTRA carriers in the middle if possible. For E-UTRA the same bandwidth as the already allocated E-UTRA carriers shall be used.

- For transmitter tests and in the case of a BS supporting more than one NB-IoT carrier, carry out the following steps.
 - Place a NB-IoT carrier at the upper edge and a NB-IoT carrier at the lower Base Station RF Bandwidth edge. The specified $F_{\text{Offset-RAT}}$ shall apply.
 - Place one 5 MHz E-UTRA carrier and one UTRA FDD carrier in the middle of the Base Station RF Bandwidth. If the BS does not support 5 MHz E-UTRA channel BW use the narrowest supported BW. The carrier(s) may be shifted maximum 100 kHz towards lower frequencies for B_{RFBW} and M_{RFBW} and towards higher frequencies for T_{RFBW} to align with the channel raster.
 - Add NB-IoT carriers at the edges using 600 kHz spacing until no more NB-IoT carriers are supported or no more NB-IoT carriers fit.
 - Add additional UTRA and E-UTRA carriers in the middle if possible. For E-UTRA the same bandwidth as the already allocated E-UTRA carriers shall be used.

4.8.14.2 TC14 power allocation

Set the power of each carrier to the same power so that the sum of the carrier powers equals the rated total output power according to the manufacturer's declaration in clause 4.7.2.

4.8.15 TC15: GSM and E-UTRA with NB-IoT in-band multi-carrier operation

The purpose of the TC15 is to test GSM and NB-IoT in-band multi-carrier aspects.

4.8.15.1 TC15 generation

TC15 is constructed using the following method:

- The Base Station RF Bandwidth shall be the declared maximum Base Station RF Bandwidth.
- Place a GSM carrier at the lower Base Station RF Bandwidth edge. Place a 5 MHz E-UTRA carrier adjacent to the upper Base Station RF Bandwidth edge. Place the power boosted NB-IoT PRB at the outermost in-band position eligible for NB-IoT PRB (according to clause 4.5.3) at the upper Base Station RF Bandwidth edge. The specified $F_{\text{Offset-RAT}}$ shall apply.
- For transmitter tests, add GSM carriers at the edges using 600 kHz spacing until no more GSM carriers are supported or no more GSM carriers fit, then select as many 5 MHz E-UTRA carriers that the BS supports and that fit in the rest of the Base Station RF Bandwidth. Place the carriers adjacent to each other starting from the high Base Station RF Bandwidth edge. The nominal carrier spacing defined in clause 4.5.1 shall apply.
- If 5 MHz E-UTRA carriers are not supported by the BS the narrowest supported channel BW shall be selected instead.

4.8.15.2 TC15 power allocation

Set the power of each carrier to the same power so that the sum of the carrier powers equals the rated total output power according to the manufacturer's declaration in clause 4.7.2.

4.8.16 TC16: UTRA and E-UTRA with NB-IoT in-band multi-carrier operation

The purpose of the TC16 is to test UTRA and NB-IoT in-band multi-carrier aspects.

4.8.16.1 TC16 generation

TC16 is constructed using the following method:

- The Base Station RF Bandwidth shall be the declared maximum Base Station RF Bandwidth.

- Place an UTRA FDD carrier at the lower Base Station RF Bandwidth edge. The UTRA FDD may be shifted maximum 100 kHz towards lower frequencies to align with the channel raster. Place a 5 MHz E-UTRA carrier adjacent to the upper Base Station RF Bandwidth edge. Place the power boosted NB-IoT PRB at the outermost in-band position eligible for NB-IoT PRB (according to clause 4.5.3) at the upper Base Station RF Bandwidth edge. The specified $F_{\text{Offset-RAT}}$ shall apply.
- For transmitter tests, select as many 5 MHz E-UTRA carriers that the BS supports and that fit in the rest of the Base Station RF Bandwidth. Place the carriers adjacent to each other starting from the high Base Station RF Bandwidth edge. The nominal carrier spacing defined in clause 4.5.1 shall apply.
- If 5 MHz E-UTRA carriers are not supported by the BS the narrowest supported channel BW shall be selected instead.

4.8.16.2 TC16 power allocation

Set the power of each carrier to the same power so that the sum of the carrier powers equals the rated total output power according to the manufacturer's declaration in clause 4.7.2.

4.8.17 TC17: E-UTRA and E-UTRA with NB-IoT in-band multi-carrier operation

The purpose of the TC17 is to test E-UTRA and NB-IoT in-band multi-carrier aspects.

4.8.17.1 TC17 generation

TC17 is constructed using the following method:

- The Base Station RF Bandwidth shall be the declared maximum Base Station RF Bandwidth.
- Place a 5 MHz E-UTRA carrier adjacent to the lower Base Station RF Bandwidth edge. Place the power boosted NB-IoT PRB at the outermost in-band position eligible for NB-IoT PRB (according to clause 4.5.3) at the lower Base Station RF Bandwidth edge. Place a 5 MHz E-UTRA carrier adjacent to the upper Base Station RF Bandwidth edge. In the case of a BS supporting more than one NB-IoT in-band carrier, place the power boosted NB-IoT PRB at the outermost in-band position eligible for NB-IoT PRB (according to clause 4.5.3) at the upper Base Station RF Bandwidth edge. The specified $F_{\text{Offset-RAT}}$ shall apply.
- For transmitter tests, select as many 5 MHz E-UTRA carriers that the BS supports and that fit in the rest of the Base Station RF Bandwidth. Place the carriers adjacent to each other starting from the high Base Station RF Bandwidth edge. The nominal carrier spacing defined in clause 4.5.1 shall apply.
- If 5 MHz E-UTRA carriers are not supported by the BS the narrowest supported channel BW shall be selected instead.

4.8.17.2 TC17 power allocation

Set the power of each carrier to the same power so that the sum of the carrier powers equals the rated total output power according to the manufacturer's declaration in clause 4.7.2.

4.8.18 TC18: GSM and E-UTRA with NB-IoT guard-band multi-carrier operation

The purpose of the TC18 is to test GSM and NB-IoT guard-band multi-carrier aspects.

4.8.18.1 TC18 generation

TC18 is constructed using the following method:

- The Base Station RF Bandwidth shall be the declared maximum Base Station RF Bandwidth.

- Place a GSM carrier at the lower Base Station RF Bandwidth edge. Place a 10 MHz E-UTRA carrier adjacent to the upper Base Station RF Bandwidth edge. Place the power boosted NB-IoT PRB at the outermost guard-band position eligible for NB-IoT PRB (according to clause 4.5.3) at the upper Base Station RF Bandwidth edge and adjacent to the E-UTRA PRB edge as close as possible (i.e., away from the upper Base Station RF Bandwidth edge). The specified $F_{\text{Offset-RAT}}$ shall apply.
- For transmitter tests, add GSM carriers at the edge using 600 kHz spacing until no more GSM carriers are supported or no more GSM carriers fit, then select as many 10 MHz E-UTRA carriers that the BS supports and that fit in the rest of the Base Station RF Bandwidth. Place the carriers adjacent to each other starting from the high Base Station RF Bandwidth edge. The nominal carrier spacing defined in clause 4.5.1 shall apply.
- If 10 MHz E-UTRA carriers are not supported by the BS the narrowest supported channel BW shall be selected instead.

4.8.18.2 TC18 power allocation

Set the power of each carrier to the same power so that the sum of the carrier powers equals the rated total output power according to the manufacturer's declaration in clause 4.7.2.

4.8.19 TC19: UTRA and E-UTRA with NB-IoT guard-band multi-carrier operation

The purpose of the TC19 is to test UTRA and NB-IoT guard-band multi-carrier aspects.

4.8.19.1 TC19 generation

TC19 is constructed using the following method:

- The Base Station RF Bandwidth shall be the declared maximum Base Station RF Bandwidth.
- Place an UTRA FDD carrier at the lower Base Station RF Bandwidth edge. The UTRA FDD may be shifted maximum 100 kHz towards lower frequencies to align with the channel raster. Place a 10 MHz E-UTRA carrier adjacent to the upper Base Station RF Bandwidth edge. Place the power boosted NB-IoT PRB at the outermost guard-band position eligible for NB-IoT PRB (according to clause 4.5.3) at the upper Base Station RF Bandwidth edge and adjacent to the E-UTRA PRB edge as close as possible (i.e., away from the upper Base Station RF Bandwidth edge). The specified $F_{\text{Offset-RAT}}$ shall apply.
- For transmitter tests, select as many UTRA FDD carriers that the BS supports and that fit in the rest of the Base Station RF Bandwidth. Place the carriers adjacent to each other starting from the high Base Station RF Bandwidth edge. The carrier(s) may be shifted maximum 100 kHz towards lower frequencies for B_{RFBW} and M_{RFBW} and towards higher frequencies for T_{RFBW} to align with the channel raster. The nominal carrier spacing defined in clause 4.5.1 shall apply.

4.8.19.2 TC19 power allocation

Set the power of each carrier to the same power so that the sum of the carrier powers equals the rated total output power according to the manufacturer's declaration in clause 4.7.2.

4.8.20 TC20: E-UTRA and E-UTRA with NB-IoT guard-band multi-carrier operation

The purpose of the TC20 is to test E-UTRA and NB-IoT guard-band multi-carrier aspects.

4.8.20.1 TC20 generation

TC20 is constructed using the following method:

- The Base Station RF Bandwidth shall be the declared maximum Base Station RF Bandwidth.

- Place a 10 MHz E-UTRA carrier adjacent to the lower Base Station RF Bandwidth edge. Place the power boosted NB-IoT PRB at the outermost guard-band position eligible for NB-IoT PRB (according to clause 4.5.3) at the lower Base Station RF Bandwidth edge and adjacent to the E-UTRA PRB edge as close as possible (i.e., away from the lower Base Station RF Bandwidth edge). Place a 10 MHz E-UTRA carrier adjacent to the upper Base Station RF Bandwidth edge. In the case of a BS supporting more than one NB-IoT guard-band carrier, place the power boosted NB-IoT PRB at the outermost guard-band position eligible for NB-IoT PRB (according to clause 4.5.3) at the upper Base Station RF Bandwidth edge and adjacent to the E-UTRA PRB edge as close as possible (i.e., away from the upper Base Station RF Bandwidth edge). The specified $F_{\text{Offset-RAT}}$ shall apply.
- For transmitter tests, select as many 10 MHz E-UTRA carriers that the BS supports and that fit in the rest of the Base Station RF Bandwidth. Place the carriers adjacent to each other starting from the high Base Station RF Bandwidth edge. The nominal carrier spacing defined in clause 4.5.1 shall apply.
- If 10 MHz E-UTRA carriers are not supported by the BS, the narrowest supported channel BW > 10 MHz shall be selected instead.

4.8.20.2 TC20 power allocation

Set the power of each carrier to the same power so that the sum of the carrier powers equals the rated total output power according to the manufacturer's declaration in clause 4.7.2.

4.8.21 TC21: Contiguous operation in CS16

4.8.21.1 TC21 generation

TC21 is constructed using the following method:

- The Base Station RF Bandwidth shall be the declared maximum Base Station RF Bandwidth.
- Place a 5MHz/15kHz SCS NR carrier at the lower Base Station RF Bandwidth edge and:
 - If NB-IoT guard band operation is supported, place a 10 MHz E-UTRA carrier adjacent to the upper Base Station RF Bandwidth edge. Place the power boosted NB-IoT PRB at the outermost guard-band position eligible for NB-IoT PRB (according to clause 4.5.3) at the upper Base Station RF Bandwidth edge and adjacent to the E-UTRA PRB edge as close as possible (i.e., away from the upper Base Station RF Bandwidth edge). The specified $F_{\text{Offset-RAT}}$ shall apply.
 - If NB-IoT guard-band operation is not supported and NB-IoT in-band operation is supported, place a 5 MHz E-UTRA carrier adjacent to the upper Base Station RF Bandwidth edge. Place the power boosted NB-IoT PRB at the outermost in-band position eligible for NB-IoT PRB (according to clause 4.5.3) at the upper Base Station RF Bandwidth edge. The specified $F_{\text{Offset-RAT}}$ shall apply.
 - If neither NB-IoT guard-band nor NB-IoT in-band operation is supported, place a 5 MHz E-UTRA carrier adjacent to the upper Base Station RF Bandwidth edge. The specified $F_{\text{Offset-RAT}}$ shall apply.
- For transmitter tests, alternately add 5MHz/15kHz SCS NR carriers at the low end and 5 MHz E-UTRA carriers at the high end adjacent to the already placed carriers until the Base Station RF Bandwidth is filled or the total number of supported carriers is reached. The nominal carrier spacing defined in clause 4.5.1 shall apply.
- If NR 5MHz and/or E-UTRA 5/10 MHz channel bandwidth is not supported, the narrowest carrier shall be selected. If 15kHz SCS is not supported for particular NR operating band, the smallest supported SCS declared per operating band shall be selected.

4.8.21.2 TC21 power allocation

Set the power of each carrier to the same power so that the sum of the carrier powers equals the rated total output power according to the manufacturer's declaration in clause 4.7.2.

4.8.22 NTC21: Non-contiguous operation in CS16

4.8.22.1 NTC21 generation

NTC21 is constructed using the following method:

- The Base Station RF Bandwidth shall be the declared maximum Base Station RF Bandwidth for non-contiguous operation. The Base Station RF Bandwidth consists of one sub-block gap and two sub-blocks located at the edges of the declared maximum Base Station RF Bandwidth.
- Place a 5MHz/15kHz SCS NR carrier at the lower RF Bandwidth edge and:
 - If NB-IoT guard band operation is supported, place a 10 MHz E-UTRA carrier adjacent to the upper Base Station RF Bandwidth edge. Place the power boosted NB-IoT PRB at the outermost guard-band position eligible for NB-IoT PRB (according to clause 4.5.3) at the upper Base Station RF Bandwidth edge and adjacent to the E-UTRA PRB edge as close as possible (i.e., away from the upper Base Station RF Bandwidth edge). The specified $F_{\text{Offset-RAT}}$ shall apply.
 - If NB-IoT guard-band operation is not supported and NB-IoT in-band operation is supported, place a 5 MHz E-UTRA carrier adjacent to the upper Base Station RF Bandwidth edge. Place the power boosted NB-IoT PRB at the outermost in-band position eligible for NB-IoT PRB (according to clause 4.5.3) at the upper Base Station RF Bandwidth edge. The specified $F_{\text{Offset-RAT}}$ shall apply.
 - If neither NB-IoT guard-band nor NB-IoT in-band operation is supported, place a 5 MHz E-UTRA carrier adjacent to the upper Base Station RF Bandwidth edge. The specified $F_{\text{Offset-RAT}}$ shall apply.
- The sub-block edges adjacent to the sub-block gap shall be determined using the specified $F_{\text{Offset-RAT}}$ for the carrier adjacent to the sub-block gap.
- If NR 5MHz and/or E-UTRA 5/10 MHz channel bandwidth is not supported, the narrowest carrier shall be selected. If 15kHz SCS is not supported for particular NR operating band, the smallest supported SCS declared per operating band shall be selected.

4.8.22.2 NTC21 power allocation

Set the power of each carrier to the same power so that the sum of the carrier powers equals the rated total output power according to the manufacturer's declaration in clause 4.7.2.

4.8.23 TC22: Contiguous operation in CS17

4.8.23.1 TC22 generation

TC22 is constructed using the following method:

- The Base Station RF Bandwidth shall be the declared maximum Base Station RF Bandwidth.
- Place a standalone NB-IoT carrier at the upper Base Station RF Bandwidth edge.
 - If NB-IoT guard band operation is supported, place a 10 MHz E-UTRA carrier adjacent to the lower Base Station RF Bandwidth edge. Place the NB-IoT PRB at the outermost guard-band position eligible for NB-IoT PRB (according to clause 4.5.3) at the lower Base Station RF Bandwidth edge and adjacent to the E-UTRA PRB edge as close as possible (i.e., away from the lower Base Station RF Bandwidth edge). The specified $F_{\text{Offset-RAT}}$ shall apply. Place a 5MHz / 15kHz SCS NR carrier adjacent to the 10 MHz E-UTRA carrier.
 - If NB-IoT guard-band operation is not supported and NB-IoT in-band operation is supported, place a 5 MHz E-UTRA carrier adjacent to the lower Base Station RF Bandwidth edge. Place the NB-IoT PRB at the outermost in-band position eligible for NB-IoT PRB (according to clause 4.5.3) at the lower Base Station RF Bandwidth edge. The specified $F_{\text{Offset-RAT}}$ shall apply. Place a 5MHz / 15kHz SCS NR carrier adjacent to the 5 MHz E-UTRA carrier.

- If neither NB-IoT guard-band nor NB-IoT in-band operation is supported, place a 5MHz/15kHz SCS NR carrier adjacent to the lower Base Station RF Bandwidth edge. The specified $F_{\text{Offset-RAT}}$ shall apply. Place a 5 MHz E-UTRA carrier adjacent to the 5MHz / 15kHz SCS NR carrier.
- For transmitter tests, alternately add 5MHz E-UTRA carriers at the low end and NB-IoT standalone carriers at the high end adjacent to the already placed carriers until the Base Station RF Bandwidth is filled or the total number of supported carriers is reached. The nominal carrier spacing defined in clause 4.5.1 shall apply.
- If NR 5MHz and/or E-UTRA 5/10 MHz channel bandwidth is not supported, the narrowest carrier shall be selected. If 15kHz SCS is not supported for particular NR operating band, the smallest supported SCS declared per operating band shall be selected.

4.8.23.2 TC22 power allocation

Set the power of each carrier to the same power so that the sum of the carrier powers equals the rated total output power according to the manufacturer's declaration in clause 4.7.2.

4.9 RF channels and test models

4.9.1 RF channels

Many tests in this TS are performed with the maximum Base Station RF Bandwidth located at the bottom, middle and top of the supported frequency range in the operating band. These are denoted as B_{RFBW} (bottom), M_{RFBW} (middle) and T_{RFBW} (top).

Unless otherwise stated, the test shall be performed at B_{RFBW} , M_{RFBW} and T_{RFBW} defined as following:

B_{RFBW} : maximum Base Station RF Bandwidth located at the bottom of the supported frequency range in the operating band.

M_{RFBW} : maximum Base Station RF Bandwidth located in the middle of the supported frequency range in the operating band. M_{RFBW} may be shifted maximum 100 kHz towards lower frequencies to align carriers with the channel raster.

T_{RFBW} : maximum Base Station RF Bandwidth located at the top of the supported frequency range in the operating band.

For the test of certain RF requirements the present specification refers to test procedures defined in the single-RAT specifications. In this case, the interpretation of the RF channels to be tested shall be according to the definitions in the corresponding single-RAT specifications.

For BS capable of multi-band operation, unless otherwise stated, the test shall be performed at $B_{\text{RFBW}}'T_{\text{RFBW}}$ and $B_{\text{RFBW}}'T_{\text{RFBW}}$ defined as following:

- $B_{\text{RFBW}}'T_{\text{RFBW}}$: the Base Station RF Bandwidths located at the bottom of the supported frequency range in the lowest operating band and at the highest possible simultaneous frequency position, within the Maximum Radio Bandwidth, in the highest operating band. The Base Station RF Bandwidth(s) are located at the bottom of the supported frequency range(s) in the middle band(s).
- $B_{\text{RFBW}}'T_{\text{RFBW}}$: the Base Station RF Bandwidths located at the top of the supported frequency range in the highest operating band and at the lowest possible simultaneous frequency position, within the Maximum Radio Bandwidth, in the lowest operating band. The Base Station RF Bandwidth(s) are located at the top of the supported frequency range(s) in the middle band(s).

NOTE: $B_{\text{RFBW}}'T_{\text{RFBW}} = B_{\text{RFBW}}'T_{\text{RFBW}} = B_{\text{RFBW}}'T_{\text{RFBW}}$ when the declared Maximum Radio Bandwidth spans all operating bands. $B_{\text{RFBW}}'T_{\text{RFBW}}$ means the Base Station RF Bandwidths are located at the bottom of the supported frequency range in the lowest operating band and at the top of the supported frequency range in the highest operating band, and the Base Station RF Bandwidth(s) are located at the bottom of the supported frequency range(s) in the middle band(s) in the first test and then at the top of the supported frequency range(s) in the middle band(s) in the second test.

When a test is performed by a test laboratory, the position of B_{RFBW} , M_{RFBW} and T_{RFBW} in each supported operating band, the position of $B_{\text{RFBW}}T_{\text{RFBW}}$ and $B'_{\text{RFBW}}T_{\text{RFBW}}$ in the supported operating band combinations shall be specified by the laboratory. The laboratory may consult with operators, the manufacturer or other bodies.

4.9.2 Test models

a) Unless otherwise stated, carriers within MSR test configurations used for transmitter tests shall be configured as follows:

- UTRA FDD carriers shall be configured according to TM1 as defined in TS 25.141 [10] clause 6.1.1.1.
- UTRA TDD carriers shall be configured according to Table 6.1A as defined in TS 25.142 [12] clause 6.2.4.1.2.
- E-UTRA carriers shall be configured according to E-TM1.1 as defined in clause 6.1.1.1 of TS 36.141 [9], and data content of physical channels and signals as defined in clause 6.1.2 of TS 36.141 [9].

For BC3 CS3, BC3 CS16 and BC3 CS17 BS testing, E-UTRA carriers shall be configured according to E-TM1.1_BC3CS3 defined in Annex E.

For BC3 CS2 BS testing with NB-IoT inband and/or guard band, E-UTRA carriers shall be configured according to E-TM1.1_BC3CS3 defined in Annex E.

- GSM carriers shall use GMSK modulation as defined in TS 51.021 [11] clause 6.2.2.
- NB-IoT carriers shall be configured according to N-TM as defined in TS 36.141 [9] clauses 6.1.3, 6.1.4, 6.1.5 and 6.1.6.
- NR carriers shall be configured according to NR-FR1-TM1.1 as defined in clause 4.9.2 of TS 38.141-1 [26], and data content of physical channels and signals as defined in clause 4.9.2.3 of TS 38.141-1 [26].

b) The configuration of the carriers in test configurations used for testing modulation quality and frequency error shall be as follows:

- For the case that modulation accuracy is measured for UTRA FDD, the UTRA FDD carriers shall be configured according to the supported TM1, TM4 and if HS-PDSCH transmission using 16QAM is supported also TM5 as defined in TS 25.141 [10] clause 6.1.1.1, 6.1.1.4 and 6.1.1.4A whilst any remaining carriers from other RAT(s) shall be configured according to a).
- For the case that modulation accuracy is measured for UTRA TDD, the UTRA TDD carriers shall be configured according to the supported modulation in Table 6.2A, Table 6.39A, Table 6.39B, Table 6.39C, Table 6.39D, Table 6.40A, Table 6.40B, Table 6.41A, Table 6.41B as defined in TS 25.142 [12] clause 6.3.4, 6.8.1, 6.8.2 and 6.8.3 whilst any remaining carriers from other RAT(s) shall be configured according to a).
- For the case that modulation accuracy is measured for E-UTRA, the E-UTRA carriers shall be configured according to the supported E-TM3.1, E-TM3.1a, E-TM3.1b, E-TM3.2, E-TM3.3 and E-TM2 as defined in clauses 6.1.1.4, 6.1.1.5, 6.1.1.6 and 6.1.1.3 of TS 36.141 [9], and data content of physical channels and signals as defined in clause 6.1.2 of TS 36.141 [9], whilst any remaining carriers from other RAT(s) shall be configured according to a).

For BC3 CS3, BC3 CS16 and BC3 CS17 BS testing, E-UTRA carriers shall be configured according to E-TM3.1_BC3CS3, E-TM3.1a_BC3CS3, E-TM3.1b_BC3CS3, E-TM3.2_BC3CS3, E-TM3.3_BC3CS3, E-TM2_BC3CS3, E-TM2a_BC3CS3 and E-TM2b_BC3CS3 defined in Annex E.

- For the case that modulation accuracy is measured for GSM, the GSM carriers shall be configured for the supported modulation according to TS 51.021 [11] clause 6.2.2 whilst any remaining carriers from other RAT(s) shall be configured according to a).
- For the case that modulation accuracy is measured for NR, the NR carriers shall be configured according to the supported NR-FR1-TM2, NR-FR1-TM2a, NR-FR1-TM3.1, NR-FR1-TM3.1a, NR-FR1-TM3.2 and NR-FR1-TM3.3, as defined in clauses 4.9.2.2.3, 4.9.2.2.4, 4.9.2.2.5, 4.9.2.2.6, 4.9.2.2.7 and 4.9.2.2.8 of TS 38.141-1 [26], and data content of physical channels and signals as defined in clause 4.9.2.3 of TS 38.141-1 [26], whilst any remaining carriers from other RAT(s) shall be configured according to a).

For the test of certain RF requirements clause 5 refers to the test configurations as defined in the single-RAT specifications. In this case, the transmitter test signals and test models as defined within the referred test specification for the RF requirement shall be used.

4.10 BS configurations

4.10.1 Transmit configurations

Unless otherwise stated, the transmitter characteristics in clause 6 are specified at the BS antenna connector (test port A) with a full complement of transceivers for the configuration in normal operating conditions. If any external apparatus such as a TX amplifier, a filter or the combination of such devices is used, requirements apply at the far end antenna connector (test port B).

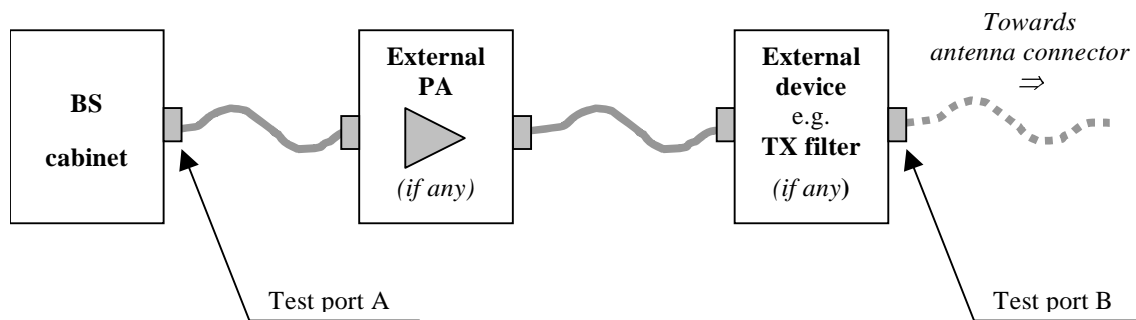

Figure 4.10.1-1: Transmitter test ports

4.10.1.1 Transmission with multiple transmitter antenna connectors

Unless otherwise stated, for the tests in clause 6 of the present document, the requirement applies for each transmitter antenna connector in the case of transmission with multiple transmitter antenna connectors.

Transmitter requirements are tested at the antenna connector, with the remaining antenna connector(s) being terminated. If the manufacturer has declared the transmitter paths to be equivalent, it is sufficient to measure the signal at any one of the transmitter antenna connectors.

4.10.2 Receive configurations

Unless otherwise stated, the receiver characteristics in clause 7 are specified at the BS antenna connector (test port A) with a full complement of transceivers for the configuration in normal operating conditions. If any external apparatus such as a RX amplifier, a filter or the combination of such devices is used, requirements apply at the far end antenna connector (test port B).

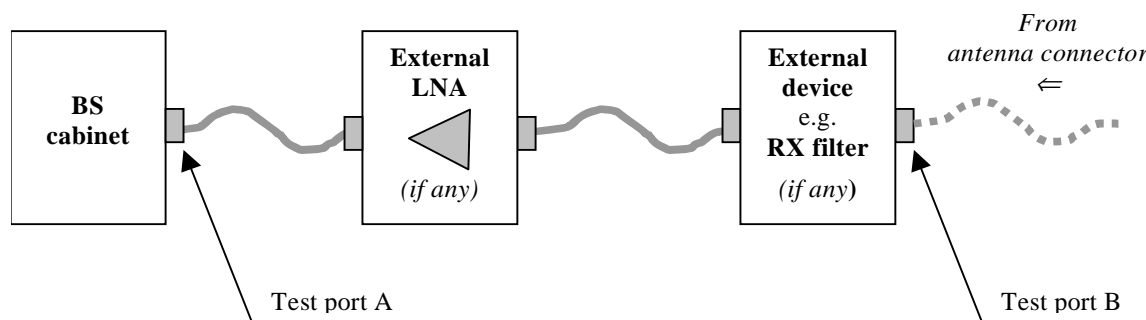

Figure 4.10.2-1: Receiver test ports

4.10.2.1 Reception with multiple receiver antenna connectors, receiver diversity

For the tests in clause 7 of the present document, the requirement applies at each receiver antenna connector for receivers with antenna diversity or in the case of multi-carrier reception with multiple receiver antenna connectors.

Receiver requirements are tested at the antenna connector, with the remaining receiver(s) disabled or their antenna connector (s) being terminated. If the manufacturer has declared the receiver paths to be equivalent, it is sufficient to apply the specified test signal at any one of the receiver antenna connectors.

For a multi-band BS, multi-band tests for blocking and intermodulation are performed with the interferer(s) applied to each antenna connector mapped to the receiver for the wanted signal(s), however only to one antenna at a time. Antenna connectors to which no signals are applied are terminated.

4.10.3 Duplexers

The requirements of the present document shall be met with a duplexer fitted, if a duplexer is supplied as part of the BS.

NOTE: The present release of this specification does not contain test requirements for the case that the duplexer is supplied as an option by the manufacturer. This is left for future releases.

4.10.4 Power supply options

If the BS is supplied with a number of different power supply configurations, it may not be necessary to test RF parameters for each of the power supply options, provided that it can be demonstrated that the range of conditions over which the equipment is tested is at least as great as the range of conditions due to any of the power supply configurations.

This applies particularly if a BS contains a DC rail which can be supplied either externally or from an internal mains power supply. In this case, the conditions of extreme power supply for the mains power supply options can be tested by testing only the external DC supply option. The range of DC input voltages for the test should be sufficient to verify the performance with any of the power supplies, over its range of operating conditions within the BS, including variation of mains input voltage, temperature and output current.

4.10.5 Ancillary RF amplifiers

The requirements of the present document shall be met with the ancillary RF amplifier fitted. At tests according to clauses 6 and 7 for TX and RX respectively, the ancillary amplifier is connected to the BS by a connecting network (including any cable(s), attenuator(s), etc.) with applicable loss to make sure the appropriate operating conditions of the ancillary amplifier and the BS. The applicable connecting network loss range is declared by the manufacturer. Other characteristics and the temperature dependence of the attenuation of the connecting network are neglected. The actual attenuation value of the connecting network is chosen for each test as one of the applicable extreme values. The lowest value is used unless otherwise stated.

Sufficient tests should be repeated with the ancillary amplifier fitted and, if it is optional, without the ancillary RF amplifier to verify that the BS meets the requirements of the present document in both cases.

When testing, the following tests shall be repeated with the optional ancillary amplifier fitted according to Table 4.10.5-1, where x denotes that the test is applicable:

Table 4.10.5-1: Tests applicable to ancillary RF Amplifiers

Receiver Tests	Clause	TX amplifier only	RX amplifier only	TX/RX amplifiers combined (Note)
	7.2		X	X
	7.4		X	X
	7.5		X	X
	7.6		X	X
	7.7		X	
Transmitter Tests	6.2	X		X
	6.6.1	X		X
	6.6.2	X		X
	6.6.3	X		X
	6.6.4	X		X
	6.7	X		X

NOTE: Combining can be by duplex filters or any other network. The amplifiers can either be in RX or TX branch or in both. Either one of these amplifiers could be a passive network.

In test according to clauses 6.2 and 7.2 highest applicable attenuation value is applied.

4.10.6 BS with integrated Iuant BS modem

Unless otherwise stated, for the tests in the present document, the integrated Iuant BS modem shall be switched off. Spurious emissions according to clauses 6.6.4 and 7.7 shall be measured only for frequencies above 20MHz with the integrated Iuant BS modem switched on.

4.10.7 BS using antenna arrays

A BS may be configured with a multiple antenna port connection for some or all of its transceivers or with an antenna array related to one cell (not one array per transceiver). This clause applies to a BS which meets at least one of the following conditions:

- the transmitter output signals from one or more transceiver appear at more than one antenna port; or
- there is more than one receiver antenna port for a transceiver or per cell and an input signal is required at more than one port for the correct operation of the receiver thus the outputs from the transmitters as well as the inputs to the receivers are directly connected to several antennas (known as "aircombining"); or
- transmitters and receivers are connected via duplexers to more than one antenna.

In case of diversity or spatial multiplexing, multiple antennas are not considered as an antenna array.

If a BS is used, in normal operation, in conjunction with an antenna system which contains filters or active elements which are necessary to meet the BS requirements, the conformance tests may be performed on a system comprising the BS together with these elements, supplied separately for the purposes of testing. In this case, it must be demonstrated that the performance of the configuration under test is representative of the system in normal operation, and the conformance assessment is only applicable when the BS is used with the antenna system.

For conformance testing of such a BS, the following procedure may be used.

4.10.7.1 Receiver tests

For each test, the test signals applied to the receiver antenna connectors shall be such that the sum of the powers of the signals applied equals the power of the test signal(s) specified in the test.

An example of a suitable test configuration is shown in figure 4.10.7.1-1.

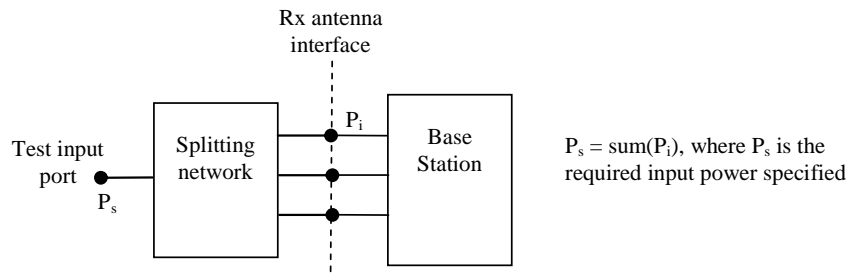

Figure 4.10.7.1-1: Receiver test set-up

For spurious emissions from the receiver antenna connector, the test may be performed separately for each receiver antenna connector.

4.10.7.2 Transmitter tests

For each test, the test signals applied to the transmitter antenna connectors (P_i) shall be such that the sum of the powers of the signals applied equals the power of the test signal(s) (P_s) specified in the test. This may be assessed by separately measuring the signals emitted by each antenna connector and summing the results, or by combining the signals and performing a single measurement. The characteristics (e.g. amplitude and phase) of the combining network should be such that the power of the combined signal is maximised.

An example of a suitable test configuration is shown in figure 4.10.7.2-1.

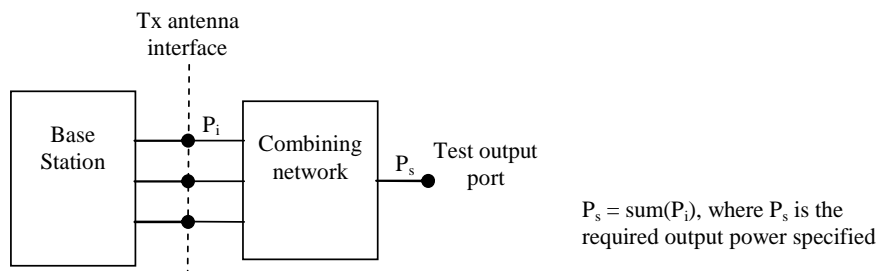

Figure 4.10.7.2-1: Transmitter test set-up

For Intermodulation attenuation, the test may be performed separately for each transmitter antenna connector.

4.11 Format and interpretation of tests

Each test in the following clauses has a standard format:

X Title

All tests are applicable to all equipment within the scope of the present document, unless otherwise stated.

X.1 Definition and applicability

This clause gives the general definition of the parameter under consideration and specifies whether the test is applicable to all equipment or only to a certain subset. Required manufacturer declarations may be included here.

X.2 Minimum requirement

This clause contains the reference to the clause to the 3GPP reference (or core) specification which defines the minimum requirement.

X.3 Test purpose

This clause defines the purpose of the test.

X.4 Method of test

X.4.1 Initial conditions

This clause defines the initial conditions for each test, including the test environment, the RF channels to be tested and the basic measurement set-up. For the test of certain RF requirements the present specification refers to the test method of the single-RAT specifications. In this case, the initial conditions as defined within the referred test specification for the RF requirement shall be used.

X.4.2 Procedure

This clause describes the steps necessary to perform the test and provides further details of the test definition like point of access (e.g. test port), domain (e.g. frequency-span), range, weighting (e.g. bandwidth), and algorithms (e.g. averaging). For the test of certain RF requirements the present specification refers to the test method of the single-RAT specifications. In this case, the test procedure as defined within the referred test specification for the RF requirement shall be used.

X.5 Test requirement

This clause defines the pass/fail criteria for the equipment under test. See clause 4.1.3 Interpretation of measurement results. For the test of certain RF requirements the present specification refers to the requirements of the single-RAT specifications. In this case, the test requirement as defined within the referred test specification for the RF requirement shall be used.

4.12 Requirements for BS capable of multi-band operation

For BS capable of multi-band operation (for NR this refers to BS type 1-C with a multi-band connector), the RF requirements in clause 6 and 7 apply for each supported operating band unless otherwise stated. For some requirements it is explicitly stated that specific additions or exclusions to the requirement apply for BS capable of multi-band operation. In the case of multiband operation of a BS, single-RAT operation and the corresponding applicability of the requirements for each operating band is determined based on the RAT configuration within only that operating band, unless otherwise stated.

For BS capable of multi-band operation, various structures in terms of combinations of different transmitter and receiver implementations (multi-band or single band) with mapping of transceivers to one or more antenna port(s) in different ways are possible. In the case where multiple bands are mapped on an antenna connector, the exclusions or provisions for multi-band capable BS are applicable to this antenna connector. In the case where a single band is mapped on an antenna connector, the following applies:

- Single-band transmitter spurious emissions, operating band unwanted emissions, ACLR, transmitter intermodulation and receiver spurious emissions requirements apply to this antenna connector that is mapped to single-band.
- If the BS is configured for single-band operation, single-band requirements shall apply to this antenna connector configured for single-band operation and no exclusions or provisions for multi-band capable BS are applicable. Single-band requirements are tested separately at the antenna connector configured for single-band operation, with all other antenna connectors terminated.

For a band supported by a Base Station where the transmitted carriers are not processed in active RF components together with carriers in any other band, single-band transmitter requirements shall apply. For a band supported by a Base Station where the received carriers are not processed in active RF components together with carriers in any other band, single-band receiver requirements shall apply.

For a BS capable of multi-band operation supporting BC3 bands for TDD, the RF requirements in the present specification assume synchronized operation, where no simultaneous uplink and downlink occur between the bands.

The RF requirements in the present specification are FFS for multi-band operation supporting bands for both FDD and TDD.

4.13 Tests for BS capable of multi-band operation with three or more bands

For BS supports multiple multi-band combinations, the test(s) shall be applied using the following principles:

- 1) The supported multi-band combination covering the widest radio bandwidth should be tested.
- 2) Among the remaining supported multi-band combinations, the following ones should also be tested:
 - Those with a larger rated total output power (per band or per band combination).
 - Those with a larger total number of supported carriers (per band or per band combination).
 - Those with a larger Maximum Base Station RF Bandwidth (per band).

5 Applicability of requirements and test configurations

The present clause defines for each RF test requirement the set of mandatory test configurations which shall be used for demonstrating conformance. This is specified in the Table 5.2-1 and Table 5.2-1a for single-RAT Multi-carrier, Table 5.1-1, Table 5.1-1a, Table 5.1-1b and Table 5.1-1c for multi-RAT Base Stations and Table 5.3-1 for multi-band capable Base Station.

Requirements apply according to the declared RAT Capability Set (CS) within each supported operating band of the MSR Base Station and the Band Category of the declared operating band (BC1, BC2 or BC3), as listed in the heading of each table. Some RF requirements listed in the tables may not be mandatory or they may apply only regionally. This is further specified for each requirement in clause 6 and 7, and in Table 4.3-1.

For a declared RAT Capability Set (CS) in Table 5.1-1, 5.1-1a, 5.1-1b, 5.1-1c and 5.2-1, only the requirements listed in the column for that CS apply. Requirements listed under CS other than the declared CS(s) need not be tested.

For a BS declared to be capable of contiguous operation only, the test configuration(s) in Tables 5.1-1, 5.1-1c and 5.2-1 denoted by a "C" and entries that refer to single-RAT specifications shall be used for testing.

For a BS declared to be capable of contiguous and non-contiguous operation and where the parameters in the manufacture's declaration according to clause 4.7.2 are identical for contiguous and non-contiguous operation (within subgroup in case of CS7), the test configuration(s) in Table 5.1-1, 5.1-1c and 5.2-1 denoted by "CNC" and entries that refer to single-RAT specifications shall be used.

For a BS declared to be capable of contiguous and non-contiguous operation and where the parameters in the manufacture's declaration according to clause 4.7.2 are not identical for contiguous and non-contiguous operation (within subgroup in case of CS7), the test configuration(s) in Table 5.1-1, 5.1-1c and 5.2-1 denoted by "C/NC" and entries that refer to single-RAT specifications shall be used for testing.

For a BS declared to support NB-IoT operating in-band, the test configuration(s) in Table 5.1-1 and 5.2-1 denoted by "NI" and entries that refer to single-RAT specifications shall be used for testing. For a BS declared to support NB-IoT operating in-band, the test configuration(s) in Table 5.1-1c denoted by "NI" for BS capable of contiguous operation only, by "NCNI" for BS capable of contiguous and non-contiguous operation with same declared parameters, by "C/NCNI" for BS capable of contiguous and non-contiguous operation with different declared parameters and entries that refer to single-RAT specifications shall be used for testing.

For a BS declared to support NB-IoT operating in guard band, the test configuration(s) in Table 5.1-1 and 5.2-1 denoted by "NG" and entries that refer to single-RAT specifications shall be used for testing. For a BS declared to support NB-IoT operating in guard band, the test configuration(s) in Table 5.1-1c denoted by "NG" for BS capable of contiguous operation only, by "NCNG" for BS capable of contiguous and non-contiguous operation with same declared parameters, by "C/NCNG" for BS capable of contiguous and non-contiguous operation with different declared parameters and entries that refer to single-RAT specifications shall be used for testing.

For a BS declared to support NB-IoT operating in guard band and in-band, the test configuration(s) in Table 5.1-1, 5.1-1c and 5.2-1 denoted by "NG" or/and "NI" and entries that refer to single-RAT specifications shall be used for testing.

For a BS declared to support NB-IoT standalone, the test configuration(s) in Table 5.1-1a, 5.1-1b, 5.1-1c and 5.2-1 and entries that refer to single-RAT specifications shall be used for testing.

For some of the RF test requirements entries within Tables 5.1-1 and 5.2-1 refer to the single-RAT specifications; this is denoted by "(TS 25.141)", "(TS 25.142)", "(TS 36.141)", "(TS 51.021)" or "(TS 38.141-1)". In this case the following shall apply:

- transmitter test signals and test models as defined within the referred test specification shall be used, see clause 4.9.2. For some RF requirements this comprises a mandatory test case in addition to a test case using the MSR test configurations defined in clause 4.8.
- for some RF requirements the initial conditions and test procedure as defined within the referred single-RAT test specification for the RF requirement shall be used. This is specified in further detail in clauses 6, 7 and 8 of the present document.
- for some RF requirements the test requirement as defined within the referred single-RAT test specification for the RF requirement shall be used. This is specified in further detail in clauses 6, 7 and 8 of the present document. In this case (see clause 4.1):
 - The maximum acceptable uncertainty of the Test System for test requirements are defined in the respective referred test specification
 - Test Tolerances are defined in the respective referred test specification.
 - If the parameters in the manufacturer's declarations according to clause 4.7.2 are not identical for contiguous and non-contiguous operation, the parameters for contiguous operation shall be used for the test in the single RAT test specification.

For a BS declared to be capable of multi-band operation, the applicability of the requirement for each operating band is determined by the RAT configuration within that operating band as identified in Tables 5.1-1, 5.1-1c and 5.2-1, unless otherwise stated. The testing of multi-band capable BS shall be according to Table 5.3-1 as follows:

- For requirements test denoted by SBT (Single Band Test), the test configuration (s) in Table 5.1-1, 5.1-1c and 5.2-1 shall be used for each operating band depending on the RAT configuration within that band.
- For requirements test denoted by MBT (Multi-Band Test), the test configuration (s) in Table 5.3-1 shall be used depending on the Band Category of the declared operating band combination.

5.1 Multi-RAT capable Base Stations

Table 5.1-1: Test configurations for capability sets (CS 3-7) for Multi-RAT capable BS

Capability Set	UTRA + E-UTRA NB-IoT in-band***, NB-IoT guard band**** (CS 3)			GSM+ UTRA (CS 4)	GSM + E-UTRA, NB-IoT in- band***, NB-IoT guard band**** (CS 5)	GSM + UTRA + E-UTRA (CS 6)	GSM+UTRA/ E-UTRA, UTRA+ E-UTRA, NB-IoT in- band***, NB-IoT guard band**** (CS7)
	BS test case	BC1	BC2				
6.2 Base Station output power	-	-	-	-	-	-	-
Base Station maximum output power	C: TC3a CNC: TC3a C/NC: TC3a, NTC3a NI: TC16 NG: TC19	C: TC3a CNC: TC3a C/NC: TC3a, NTC3a NI: TC16 NG: TC19	C: TC3b NI: TC16 NG: TC19	C: TC4a CNC: TC4a C/NC: TC4a, NTC4a	C: TC4b CNC: TC4b C/NC: TC4b, NTC4b NI: TC15 NG: TC18	C: TC4c CNC: TC4c C/NC: TC4c, NTC4c	C: TC4a*, TC4b, TC3a* CNC: TC4a*, TC4b, TC3a* C/NC: TC4a*, NTC4a*, TC4b, NTC4b, TC3a*, NTC3a* NI: TC15,TC16* NG: TC18,TC19*
Additional regional requirement (only for band 34)	N/A	N/A	Compliance stated by manufacturer declaration	N/A	N/A	N/A	N/A
E-UTRA for DL RS power	(TS 36.141)	(TS 36.141)	(TS 36.141)	N/A	(TS 36.141)	(TS 36.141)	(TS 36.141)
NB-IoT for DL RS power	(TS 36.141)	(TS 36.141)	N/A	N/A	(TS 36.141)	N/A	(TS 36.141)
UTRA FDD primary CPICH power	(TS 25.141)	(TS 25.141)	N/A	(TS 25.141)	N/A	(TS 25.141)	(TS 25.141)*
UTRA FDD secondary CPICH power	(TS 25.141)	(TS 25.141)	N/A	(TS 25.141)	N/A	(TS 25.141)	(TS 25.141)*
UTRA TDD primary CCPCCH power	N/A	N/A	(TS 25.142)	N/A	N/A	N/A	N/A
6.3 Output power dynamics	-	-	-	-	-	-	-
E-UTRA	(TS 36.141)	(TS 36.141)	(TS 36.141)	N/A	(TS 36.141)	(TS 36.141)	(TS 36.141)
UTRA FDD	(TS 25.141)	(TS 25.141)	N/A	(TS 25.141)	N/A	(TS 25.141)	(TS 25.141)*
UTRA TDD	N/A	N/A	(TS 25.142)	N/A	N/A	N/A	N/A
GSM/EDGE	N/A	N/A	N/A	(TS 51.021)	(TS 51.021)	(TS 51.021)	TC4b
NB-IoT	(TS 36.141)	(TS 36.141)	N/A	N/A	(TS 36.141)	N/A	(TS 36.141)
6.4 Transmit ON/OFF power	-	-	-	-	-	-	-
Transmitter OFF power	N/A	N/A	C: TC3b	N/A	N/A	N/A	N/A
Transmitter transient period	N/A	N/A	C: TC3b	N/A	N/A	N/A	N/A
6.5 Transmitted signal quality	-	-	-	-	-	-	-
6.5.1 Modulation quality	-	-	-	-	-	-	-

Capability Set	UTRA + E-UTRA NB-IoT in-band***, NB-IoT guard band**** (CS 3)			GSM+ UTRA (CS 4)	GSM + E-UTRA, NB-IoT in- band***, NB-IoT guard band**** (CS 5)	GSM + UTRA + E-UTRA (CS 6)	GSM+UTRA/ E-UTRA, UTRA+ E-UTRA, NB-IoT in- band***, NB-IoT guard band**** (CS7)
	BS test case	BC1	BC2				
E-UTRA	C: TC3a CNC: TC3a C/NC: TC3a, NTC3a NI/NG : (Note2)	C: TC3a CNC: TC3a C/NC: TC3a, NTC3a NI/NG : (Note2)	C: TC3b NI/NG : (Note2)	N/A	C: TC4b CNC: TC4b C/NC: TC4b, NTC4b NI/NG: (Note2)	C: TC4c CNC: TC4c C/NC: TC4c, NTC4c	C: TC4b CNC: TC4b C/NC: TC4b, NTC4b NI/NG: (Note2)
UTRA FDD	C: TC3a CNC: TC3a C/NC: TC3a, NTC3a	C: TC3a CNC: TC3a C/NC: TC3a, NTC3a	N/A	C: TC4a CNC: TC4a C/NC: TC4a, NTC4a	N/A	C: TC4c CNC: TC4c C/NC: TC4c, NTC4c	C: TC4a* CNC: TC4a* C/NC: TC4a* NTC4a*
UTRA TDD	N/A	N/A	C: TC3b	N/A	N/A	N/A	N/A
GSM/EDGE	N/A	N/A	N/A	C: TC4a CNC: TC4a C/NC: TC4a, NTC4a	C: TC4b CNC: TC4b C/NC: TC4b, NTC4b	C: TC4c CNC: TC4c C/NC: TC4c, NTC4c	C: TC4b CNC: TC4b C/NC: TC4b, NTC4b
NB-IoT	N/A : (Note2)	N/A : (Note2)	N/A: (Note 2)	N/A	N/A: (Note2)	N/A	N/A: (Note2)
6.5.2 Frequency error	-	-	-	-	-	-	-
E-UTRA	Same TC as used in 6.5.1 NI/NG: (Note2)	Same TC as used in 6.5.1 NI/NG: (Note2)	Same TC as used in 6.5.1 NI/NG: (Note2)	N/A	Same TC as used in 6.5.1 NI/NG: (Note2)	Same TC as used in 6.5.1	Same TC as used in 6.5.1 NI/NG: (Note2)
UTRA FDD	Same TC as used in 6.5.1	Same TC as used in 6.5.1	N/A	Same TC as used in 6.5.1	N/A	Same TC as used in 6.5.1	Same TC as used in 6.5.1
UTRA TDD	N/A	N/A	Same TC as used in 6.5.1	N/A	N/A	N/A	N/A
GSM/EDGE	N/A	N/A	N/A	Same TC as used in 6.5.1	Same TC as used in 6.5.1	Same TC as used in 6.5.1	Same TC as used in 6.5.1
NB-IoT	N/A: (Note2)	N/A: (Note2)	N/A: (Note2)	N/A	N/A: (Note2)	N/A	N/A: (Note2)
6.5.3 Time alignment error	-	-	-	-	-	-	-
E-UTRA	(TS 36.141) NI/NG: (Note2)	(TS 36.141) NI/NG: (Note2)	(TS 36.141) NI/NG: (Note2)	N/A	(TS 36.141) NI/NG: (Note2)	(TS 36.141)	(TS 36.141) NI/NG: (Note2)
UTRA FDD	(TS 25.141)	(TS 25.141)	N/A	(TS 25.141)	N/A	(TS 25.141)	(TS 25.141)*
UTRA TDD	N/A	N/A	(TS 25.142)	N/A	N/A	N/A	N/A
NB-IoT	N/A: (Note2)	N/A: (Note2)	N/A: (Note2)	N/A	N/A: (Note2)	N/A	N/A: (Note2)
6.6 Unwanted emissions	-	-	-	-	-	-	-
6.6.1 Transmitter spurious emissions	-	-	-	-	-	-	-

Capability Set	UTRA + E-UTRA NB-IoT in-band***, NB-IoT guard band**** (CS 3)			GSM+ UTRA (CS 4)	GSM + E-UTRA, NB-IoT in- band***, NB-IoT guard band**** (CS 5)	GSM + UTRA + E-UTRA (CS 6)	GSM+UTRA/ E-UTRA, UTRA+ E-UTRA, NB-IoT in- band***, NB-IoT guard band**** (CS7)
BS test case	BC1	BC2	BC3	BC2	BC2	BC2	BC2
(Category A)	C: TC3a CNC: NTC3a C/NC: TC3a, NTC3a NI: TC16 NG: TC19	C: TC3a CNC: NTC3a C/NC: TC3a, NTC3a NI: TC16 NG: TC19	C: TC3b NI: TC16 NG: TC19	C: TC4a CNC: NTC4a C/NC: TC4a, NTC4a	C: TC4b CNC: NTC4b C/NC: TC4b, NTC4b NI: TC15 NG: TC18	C: TC4c CNC: NTC4c C/NC: TC4c, NTC4c	C: (TC4a, TC3a)*, TC4b CNC: (NTC4a, NTC3a)*, NTC4b C/NC: (TC4a, NTC4a, TC3a, NTC3a)*, TC4b, NTC4b NI: TC15, (TC16)* NG: TC18, (TC19)*
(Category B)	C: TC3a CNC: NTC3a C/NC: TC3a, NTC3a NI: TC16 NG: TC19	C: TC3a CNC: NTC3a C/NC: TC3a, NTC3a NI: TC16 NG: TC19	C: TC3b NI: TC16 NG: TC19	C: TC4a CNC: NTC4a C/NC: TC4a, NTC4a	C: TC4b CNC: NTC4b C/NC: TC4b, NTC4b NI: TC15 NG: TC18	C: TC4c CNC: NTC4c C/NC: TC4c, NTC4c	C: (TC4a, TC3a)*, TC4b CNC: (NTC4a, NTC3a)*, NTC4b C/NC: (TC4a, NTC4a, TC3a, NTC3a)*, TC4b, NTC4b NI: TC15, (TC16)* NG: TC18, (TC19)*
Additional requirement for BC2 (Category B)	N/A	N/A	N/A	C: TC4a CNC: NTC4a C/NC: TC4a, NTC4a	C: TC4b CNC: NTC4b C/NC: TC4b, NTC4b NI: TC15 NG: TC18	C: TC4c CNC: NTC4c C/NC: TC4c, NTC4c	C: TC4a*, TC4b CNC: NTC4a*, NTC4b C/NC: (TC4a, NTC4a)*, TC4b, NTC4b NI: TC15 NG: TC18

Capability Set	UTRA + E-UTRA NB-IoT in-band***, NB-IoT guard band**** (CS 3)			GSM+ UTRA (CS 4)	GSM + E-UTRA, NB-IoT in- band***, NB-IoT guard band**** (CS 5)	GSM + UTRA + E-UTRA (CS 6)	GSM+UTRA/ E-UTRA, UTRA+ E-UTRA, NB-IoT in- band***, NB-IoT guard band**** (CS7)
	BS test case	BC1	BC2				
Protection of the BS receiver of own or different BS	C: TC3a CNC: NTC3a C/NC: TC3a, NTC3a NI: TC16 NG: TC19	C: TC3a CNC: NTC3a C/NC: TC3a, NTC3a NI: TC16 NG: TC19	C: TC3b NI: TC16 NG: TC19	C: TC4a CNC: NTC4a C/NC: TC4a, NTC4a	C: TC4b CNC: NTC4b C/NC: TC4b, NTC4b NI: TC15 NG: TC18	C: TC4c CNC: NTC4c C/NC: TC4c, NTC4c	C: (TC4a, TC3a)*, TC4b CNC: (NTC4a, NTC3a)*, NTC4b C/NC: (TC4a, NTC4a, TC3a, NTC3a)*, TC4b, NTC4b NI: TC15,(TC16)* NG: TC18,(TC19)*
Additional spurious emissions requirements	C: TC3a CNC: NTC3a C/NC: TC3a, NTC3a NI: TC16 NG: TC19	C: TC3a CNC: NTC3a C/NC: TC3a, NTC3a NI: TC16 NG: TC19	C: TC3b NI: TC16 NG: TC19	C: TC4a CNC: NTC4a C/NC: TC4a, NTC4a	C: TC4b CNC: NTC4b C/NC: TC4b, NTC4b NI: TC15 NG: TC18	C: TC4c CNC: NTC4c C/NC: TC4c, NTC4c	C: (TC4a, TC3a)*, TC4b CNC: (NTC4a, NTC3a)*, NTC4b C/NC: (TC4a, NTC4a, TC3a, NTC3a)*, TC4b, NTC4b NI: TC15,(TC16)* NG: TC18,(TC19)*
Co-location with other Base Stations	C: TC3a CNC: NTC3a C/NC: TC3a, NTC3a NI: TC16 NG: TC19	C: TC3a CNC: NTC3a C/NC: TC3a, NTC3a NI: TC16 NG: TC19	C: TC3b NI: TC16 NG: TC19	C: TC4a CNC: NTC4a C/NC: TC4a, NTC4a	C: TC4b CNC: NTC4b C/NC: TC4b, NTC4b NI: TC15 NG: TC18	C: TC4c CNC: NTC4c C/NC: TC4c, NTC4c	C: (TC4a, TC3a)*, TC4b CNC: (NTC4a, NTC3a)*, NTC4b C/NC: (TC4a, NTC4a, TC3a, NTC3a)*, TC4b, NTC4b NI: TC15,(TC16)* NG: TC18,(TC19)*
6.6.2 Operating band unwanted emissions	-	-	-	-	-	-	-

Capability Set	UTRA + E-UTRA NB-IoT in-band***, NB-IoT guard band**** (CS 3)			GSM + UTRA (CS 4)	GSM + E-UTRA, NB-IoT in- band***, NB-IoT guard band**** (CS 5)	GSM + UTRA + E-UTRA (CS 6)	GSM+UTRA/ E-UTRA, UTRA+ E-UTRA, NB-IoT in- band***, NB-IoT guard band**** (CS7)
BS test case	BC1	BC2	BC3	BC2	BC2	BC2	BC2
General requirement for Band Categories 1 and 3	(TS 25.141) (TS 36.141) C: TC3a CNC: TC3a, NTC3a C/NC: TC3a, NTC3a NI: TC16 NG: TC19	N/A	(TS 25.142) (TS 36.141) C: TC3b NI: TC16 NG: TC19	N/A	N/A	N/A	N/A
General requirement for Band Category 2	N/A	(TS 25.141) (TS 36.141) C: TC3a CNC: TC3a, NTC3a C/NC: TC3a, NTC3a NI: TC16 NG: TC19	N/A	(TS 25.141) C: TC4a, TC4d (note1) CNC:TC4a, TC4d(note1), NTC4a C/NC: TC4a, TC4d(note1), NTC4a	(TS 36.141) C: TC4b, TC4e (note1) CNC:TC4b, TC4e(note1), NTC4b C/NC: TC4b, TC4e(note1), NTC4b NI: TC15 NG: TC18	(TS 25.141) (TS 36.141) C: TC4c, TC4e (note1) CNC: TC4c, TC4e (note1), NTC4c C/NC: TC4c, TC4e (note1), NTC4c	(TS 36.141) (TS 25.141)* C: TC4b, TC3a* CNC:TC4b, NTC4b, TC3a*, NTC3a* C/NC: TC4b, NTC4b, TC3a*, NTC3a* NI: TC15 NG: TC18
GSM/EDGE single-RAT requirement	N/A	N/A	N/A	(TS 51.021)	(TS 51.021)	(TS 51.021)	N/A
Additional requirements	Compliance stated by manufacturer declaration	Compliance stated by manufacturer declaration	Compliance stated by manufacturer declaration	Compliance stated by manufacturer declaration	Compliance stated by manufacturer declaration	Compliance stated by manufacturer declaration	Compliance stated by manufacturer declaration
6.6.3 Occupied bandwidth	-	-	-	-	-	-	-
Minimum requirement	(TS 25.141) (TS 36.141)	(TS 25.141) (TS 36.141)	(TS 25.142) (TS 36.141)	(TS 25.141)	(TS 36.141)	(TS 25.141) (TS 36.141)	(TS 25.141)* (TS 36.141)
6.6.4 Adjacent Channel Leakage power Ratio (ACLR)	-	-	-	-	-	-	-
E- UTRA	C: TC2 CNC: NTC2 C/NC:TC2, NTC2	C: TC2 CNC: NTC2 C/NC:TC2, NTC2	C: TC2 CNC: NTC2 C/NC:TC2, NTC2	N/A	C: TC2 CNC: NTC2 C/NC:TC2, NTC2	C: TC2 CNC: NTC2 C/NC:TC2, NTC2	C: TC2 CNC: NTC2 C/NC:TC2, NTC2
UTRA FDD	(TS 25.141)	(TS 25.141)	N/A	(TS 25.141)	N/A	N/A	(TS 25.141)*
UTRA TDD	N/A	N/A	(TS 25.142)	N/A	N/A	N/A	N/A
NB-IoT	NI: TC16 NG: TC19	NI: TC16 NG: TC19	NI: TC16 NG: TC19	N/A	NI: TC15 NG: TC18	N/A	NI: TC15,(TC16)* NG: TC18,(TC19)*
Cumulative ACLR	CNC: NTC3a C/NC: NTC3a	CNC: NTC3a C/NC: NTC3a		CNC: NTC1a C/NC: NTC1a	CNC: NTC2 C/NC: NTC2	CNC: NTC3a C/NC: NTC3a	CNC: NTC3a*, NTC2** C/NC: NTC3a*, NTC2**
6.7 Transmitter intermodulation	-	-	-	-	-	-	-
General requirement	Same TC as used in 6.6	Same TC as used in 6.6	Same TC as used in 6.6	Same TC as used in 6.6	Same TC as used in 6.6	Same TC as used in 6.6	Same TC as used in 6.6
Additional requirement (BC1 and BC2)	CNC: NTC3a C/NC: NTC3a	Same TC as used in 6.6	N/A	Same TC as used in 6.6	Same TC as used in 6.6	Same TC as used in 6.6	Same TC as used in 6.6

Capability Set	UTRA + E-UTRA NB-IoT in-band***, NB-IoT guard band**** (CS 3)			GSM+ UTRA (CS 4)	GSM + E-UTRA, NB-IoT in- band***, NB-IoT guard band**** (CS 5)	GSM + UTRA + E-UTRA (CS 6)	GSM+UTRA/ E-UTRA, UTRA+ E-UTRA, NB-IoT in- band***, NB-IoT guard band**** (CS7)
	BS test case	BC1	BC2				
Additional requirement (BC3)	N/A	N/A	Same TC as used in 6.6	N/A	N/A	N/A	N/A
7.2 Reference sensitivity level	-	-	-	-	-	-	-
E-UTRA	(TS 36.141)	(TS 36.141)	(TS 36.141)	N/A	(TS 36.141)	(TS 36.141)	(TS 36.141)
UTRA FDD	(TS 25.141)	(TS 25.141)	N/A	(TS 25.141)	N/A	(TS 25.141)	(TS 25.141)*
UTRA TDD	N/A	N/A	(TS 25.142)	N/A	N/A	N/A	N/A
GSM/EDGE	N/A	N/A	N/A	(TS 51.021)	(TS 51.021)	(TS 51.021)	TC5b
NB-IoT	(TS 36.141)	(TS 36.141)	(TS 36.141)	N/A	(TS 36.141)	N/A	(TS 36.141)
7.3 Dynamic range	-	-	-	-	-	-	-
E-UTRA	(TS 36.141)	(TS 36.141)	(TS 36.141)	N/A	(TS 36.141)	(TS 36.141)	(TS 36.141)
UTRA FDD	(TS 25.141)	(TS 25.141)	N/A	(TS 25.141)	N/A	(TS 25.141)	(TS 25.141)*
UTRA TDD	N/A	N/A	(TS 25.142)	N/A	N/A	N/A	N/A
GSM/EDGE	N/A	N/A	N/A	(TS 51.021)	(TS 51.021)	(TS 51.021)	TC5b
NB-IoT	(TS 36.141)	(TS 36.141)	(TS 36.141)	N/A	(TS 36.141)	N/A	(TS 36.141)
7.4 In-band selectivity and blocking	-	-	-	-	-	-	-
General blocking requirement	C: TC3a CNC: NTC3a C/NC: TC3a, NTC3a NI: TC16 NG: TC19	C: TC3a CNC: NTC3a C/NC: TC3a, NTC3a NI: TC16 NG: TC19	C: TC3b NI: TC16 NG: TC19	C: TC5a CNC: NTC5a C/NC: TC5a, NTC5a	C: TC5b CNC: NTC5b C/NC: TC5b, NTC5b NI: TC15 NG: TC18	C: TC5b CNC: NTC5c C/NC: TC5b, NTC5c	C: TC5b CNC: NTC5b C/NC: TC5b, NTC5b NI: TC15 NG: TC18
General narrowband blocking requirement	C: TC3a, TC6b CNC: NTC3a, TC6b C/NC: TC3a, NTC3a, TC6b NI: TC16 NG: TC19	C: TC3a, TC6b CNC: NTC3a, TC6b C/NC: TC3a, NTC3a, TC6b NI: TC16 NG: TC19	C: TC3b, TC6b NI: TC16 NG: TC19	C: TC5a, TC6a CNC: NTC5a, TC6a C/NC: TC5a, NTC5a, TC6a	C:TC5b, TC6b CNC: NTC5b, TC6b C/NC: TC5b, NTC5b, TC6b NI: TC15 NG: TC18	C: TC5b, TC6a CNC: NTC5c, TC6a C/NC: TC5b, NTC5c, TC6a	C: TC5b, TC6a* CNC: NTC5b, TC6a* C/NC: TC5b, NTC5b, TC6a* NI: TC15 NG: TC18
Additional narrowband blocking requirement for GSM/EDGE	N/A	N/A	N/A	(TS 51.021)	(TS 51.021)	(TS 51.021)	TC5b
GSM/EDGE requirements for AM suppression	N/A	N/A	N/A	(TS 51.021)	(TS 51.021)	(TS 51.021)	TC5b
Additional BC3 blocking requirement	N/A	N/A	C: TC3b	N/A	N/A	N/A	N/A
7.5 Out-of-band blocking	-	-	-	-	-	-	-
General requirement	C: TC3a CNC: NTC3a C/NC: TC3a, NTC3a NI: TC16 NG: TC19	C: TC3a CNC: NTC3a C/NC: TC3a, NTC3a NI: TC16 NG: TC19	C: TC3b NI: TC16 NG: TC19	C: TC5a CNC: NTC5a C/NC: TC5a, NTC5a	C: TC5b CNC: NTC5b C/NC: TC5b, NTC5b NI: TC15 NG: TC18	C: TC5b CNC: NTC5c, C/NC: TC5b, NTC5c	C: TC5b CNC: NTC5b C/NC: TC5b, NTC5b NI: TC15 NG: TC18

Capability Set	UTRA + E-UTRA NB-IoT in-band***, NB-IoT guard band**** (CS 3)			GSM+ UTRA (CS 4)	GSM + E-UTRA, NB-IoT in- band***, NB-IoT guard band**** (CS 5)	GSM + UTRA + E-UTRA (CS 6)	GSM+UTRA/ E-UTRA, UTRA+ E-UTRA, NB-IoT in- band***, NB-IoT guard band**** (CS7)
BS test case	BC1	BC2	BC3	BC2	BC2	BC2	BC2
Co-location requirement	C: TC3a CNC: NTC3a C/NC: TC3a, NTC3a NI: TC16 NG: TC19	C: TC3a CNC: NTC3a C/NC: TC3a, NTC3a NI: TC16 NG: TC19	C: TC3b NI: TC16 NG: TC19	C: TC5a CNC: NTC5a C/NC: TC5a, NTC5a	C: TC5b CNC: NTC5b C/NC: TC5b, NTC5b NI: TC15 NG: TC18	C: TC5b CNC: NTC5c C/NC: TC5b, NTC5c	C: TC5b CNC: NTC5b C/NC: TC5b, NTC5b NI: TC15 NG: TC18
7.6 Receiver spurious emissions	-	-	-	-	-	-	-
General requirement	C: TC3a CNC: NTC3a C/NC: TC3a, NTC3a NI: TC16 NG: TC19	C: TC3a CNC: NTC3a C/NC: TC3a, NTC3a NI: TC16 NG: TC19	C: TC3b NI: TC16 NG: TC19	C: TC4a CNC: NTC4a C/NC: TC4a, NTC4a	C: TC4b CNC: NTC4b C/NC: TC4b, NTC4b NI: TC15 NG: TC18	C: TC4c CNC: NTC4c C/NC: TC4c, NTC4c	C: (TC4a, TC3a)*, TC4b CNC: (NTC4a, NTC3a)*, NTC4b C/NC: (TC4a, NTC4a, TC3a, NTC3a)* , TC4b, NTC4b NI: TC15,(TC16)* NG: TC18,(TC19)*
Additional requirement for BC2 (Category B)	N/A	N/A	N/A	C: TC4a CNC: NTC4a C/NC: TC4a, NTC4a	C: TC4b CNC: NTC4b C/NC: TC4b, NTC4b NI: TC15 NG: TC18	C: TC4c CNC: NTC4c C/NC: TC4c, NTC4c	C: TC4a*, TC4b CNC: NTC4a*, NTC4b C/NC: (TC4a, NTC4a)*, TC4b, NTC4b NI: TC15 NG: TC18
7.7 Receiver intermodulation	-	-	-	-	-	-	-
General intermodulation requirement	C: TC3a CNC: NTC3a C/NC: TC3a, NTC3a NI: TC16 NG: TC19	C: TC3a CNC: NTC3a C/NC: TC3a, NTC3a NI: TC16 NG: TC19	C: TC3b NI: TC16 NG: TC19	C: TC5a CNC: NTC5a C/NC: TC5a, NTC5a	C: TC5b CNC: NTC5b C/NC: TC5b, NTC5b NI: TC15 NG: TC18	C: TC5b CNC: NTC5c C/NC: TC5b, NTC5c	C: TC5b CNC: NTC5b C/NC: TC5b, NTC5b NI: TC15 NG: TC18
General narrowband intermodulation requirement	C: TC3a, TC6b CNC: NTC3a, TC6b C/NC: TC3a, NTC3a, TC6b NI: TC16 NG: TC19	C: TC3a TC6b CNC: NTC3a, TC6b C/NC: TC3a, NTC3a; TC6b NI: TC16 NG: TC19	C: TC3b, TC6b NI: TC16 NG: TC19	C: TC5a, TC6a CNC: NTC5a, TC6a C/NC: TC5a NTC5a, TC6a	C: TC5b, TC6b CNC: NTC5b, TC6b C/NC: TC5b, NTC5b, TC6b NI: TC15 NG: TC18	C: TC5b, TC6a CNC: NTC5c, TC6a C/NC: TC5b, NTC5c, TC6a	C: TC5b, TC6a* CNC: NTC5b, TC6a* C/NC: TC5b NTC5b, TC6a* NI: TC15,(TC16)* NG: TC18,(TC19)*

Capability Set	UTRA + E-UTRA NB-IoT in-band***, NB-IoT guard band**** (CS 3)			GSM+ UTRA (CS 4)	GSM + E-UTRA, NB-IoT in- band***, NB-IoT guard band**** (CS 5)	GSM + UTRA + E-UTRA (CS 6)	GSM+UTRA/ E-UTRA, UTRA+ E-UTRA, NB-IoT in- band***, NB-IoT guard band**** (CS7)
BS test case	BC1	BC2	BC3	BC2	BC2	BC2	BC2
Additional narrowband intermodulation requirement for GSM/EDGE	N/A	N/A	N/A	(TS 51.021)	(TS 51.021)	(TS 51.021)	TC5b
7.8 In-channel selectivity	-	-	-	-	-	-	-
E-UTRA requirement	(TS 36.141)	(TS 36.141)	(TS 36.141)	N/A	(TS 36.141)	(TS 36.141)	(TS 36.141)
NB-IoT requirement	(TS 36.141)	(TS 36.141)	(TS 36.141)	N/A	(TS 36.141)	N/A	(TS 36.141)
<p>NOTE 1: The TC shall be used for performing tests when the declared Base Station RF Bandwidth for GSM single-RAT operation is not equal to the declared Base Station RF Bandwidth for multi-RAT operations and the frequency range supported by the BS is a subset of the operating band, or when the maximum Base Station RF Bandwidth covers the entire operating band.</p> <p>NOTE 2: There is no specific test with NB-IoT for those requirements, tests could be performed using E-UTRA signal only, without NB-IoT.</p> <p>NOTE *: For Band 3, the test configuration is only applicable if UTRA is declared to be supported in Band 3. For other BC2 bands, the test configurations are always applicable.</p> <p>NOTE **: For Band 3 only, the test configuration is only applicable if UTRA is not declared to be supported in Band 3.</p> <p>NOTE ***: The support of NB-IoT in-band operation is optional and declared by the manufacturer. If not supported, the test configurations denoted by "NI" shall not be used for testing.</p> <p>NOTE****: The support of NB-IoT guard band operation is optional and declared by the manufacturer. If not supported, the test configurations denoted by "NG" shall not be used for testing.</p>							

Table 5.1-1a: Test configurations for capability sets (CS8-13) for Multi-RAT capable BS

Capability Set	GSM+NB-IoT standalone (CS 9)	UTRA + NB-IoT standalone (CS 10)		E-UTRA + NB-IoT standalone (CS 11)			GSM+UTRA+NB-IoT standalone (CS 12)	GSM+ E-UTRA+NB-IoT standalone (CS 13)
		BC1	BC2	BC1	BC2	BC3		
BS test case	BC2	BC1	BC2	BC1	BC2	BC3	BC1	BC2
6.2 Base Station output power	-	-	-	-	-	-	-	-
Base Station maximum output power	TC9	TC10	TC10	TC11	TC11	TC11	TC12	TC13
Additional regional requirement (only for band 34)	N/A	N/A	N/A	N/A	N/A	N/A	N/A	N/A
E-UTRA for DL RS power	N/A	N/A	N/A	(TS 36.141)	(TS 36.141)	(TS 36.141)	N/A	(TS 36.141)
NB-IoT for DL RS power	(TS 36.141)	(TS 36.141)	(TS 36.141)	(TS 36.141)	(TS 36.141)	(TS 36.141)	(TS 36.141)	(TS 36.141)
UTRA FDD primary CPICH power	N/A	(TS 25.141)	(TS 25.141)	N/A	N/A	N/A	(TS 25.141)	N/A
UTRA FDD secondary CPICH power	N/A	(TS 25.141)	(TS 25.141)	N/A	N/A	N/A	(TS 25.141)	N/A
UTRA TDD primary CCPCH power	N/A	N/A	N/A	N/A	N/A	N/A	N/A	N/A
6.3 Output power dynamics	-	-	-	-	-	-	-	-
E-UTRA	N/A	N/A	N/A	(TS 36.141)	(TS 36.141)	(TS 36.141)	N/A	(TS 36.141)
UTRA FDD	N/A	(TS 25.141)	(TS 25.141)	N/A	N/A	N/A	(TS 25.141)	N/A
UTRA TDD	N/A	N/A	N/A	N/A	N/A	N/A		N/A
GSM/EDGE	(TS 51.021)	N/A	N/A	N/A	N/A	N/A	(TS 51.021)	(TS 51.021)
NB-IoT	(TS 36.141)	(TS 36.141)	(TS 36.141)	(TS 36.141)	(TS 36.141)	(TS 36.141)	(TS 36.141)	(TS 36.141)
6.4 Transmit ON/OFF power	-	-	-	-	-	-	-	-
Transmitter OFF power	N/A	N/A	N/A	N/A	N/A	TC11	N/A	N/A
Transmitter transient period	N/A	N/A	N/A	N/A	N/A	TC11	N/A	N/A
6.5 Transmitted signal quality	-	-	-	-	-	-	-	-
6.5.1 Modulation quality	-	-	-	-	-	-	-	-
E-UTRA	N/A	N/A	N/A	TC11	TC11	TC11	N/A	TC13
UTRA FDD	N/A	TC10	TC10	N/A	N/A	N/A	TC12	N/A
UTRA TDD	N/A	N/A	N/A	N/A	N/A	N/A	N/A	N/A
GSM/EDGE	TC9	N/A	N/A	N/A	N/A	N/A	TC12	TC13
NB-IoT	TC9	TC10	TC10	TC11	TC11	TC11	TC12	TC13

6.5.2 Frequency error	-	-	-	-	-	-	-	-
E-UTRA	N/A	N/A	N/A	Same TC as used in 6.5.1	Same TC as used in 6.5.1	Same TC as used in 6.5.1	N/A	Same TC as used in 6.5.1
UTRA FDD	N/A	Same TC as used in 6.5.1	Same TC as used in 6.5.1	N/A	N/A	N/A	Same TC as used in 6.5.1	N/A
UTRA TDD	N/A	N/A	N/A	N/A	N/A	N/A	N/A	N/A
GSM/EDGE	Same TC as used in 6.5.1	N/A	N/A	N/A	N/A	N/A	Same TC as used in 6.5.1	Same TC as used in 6.5.1
NB-IoT	Same TC as used in 6.5.1	Same TC as used in 6.5.1	Same TC as used in 6.5.1	Same TC as used in 6.5.1	Same TC as used in 6.5.1	Same TC as used in 6.5.1	Same TC as used in 6.5.1	Same TC as used in 6.5.1
6.5.3 Time alignment error	-	-	-	-	-	-	-	-
E-UTRA	N/A	N/A	N/A	(TS 36.141)	(TS 36.141)	(TS 36.141)	N/A	(TS 36.141)
UTRA FDD	N/A	(TS 25.141)	(TS 25.141)	N/A	N/A	N/A	(TS 25.141)	N/A
UTRA TDD	N/A	N/A	N/A	N/A	N/A	N/A	N/A	N/A
NB-IoT	(TS 36.141)	(TS 36.141)	(TS 36.141)	(TS 36.141)	(TS 36.141)	(TS 36.141)	(TS 36.141)	(TS 36.141)
6.6 Unwanted emissions	-	-	-	-	-	-	-	-
6.6.1 Transmitter spurious emissions	-	-	-	-	-	-	-	-
(Category A)	TC9	TC10	TC10	TC11	TC11	TC11	TC12	TC13
(Category B)	TC9	TC10	TC10	TC11	TC11	TC11	TC12	TC13
Additional requirement for BC2 (Category B)	TC9	TC10	TC10	TC11	TC11	N/A	TC12	TC13
Protection of the BS receiver of own or different BS	TC9	TC10	TC10	TC11	TC11	TC11	TC12	TC13
Additional spurious emissions requirements	TC9	TC10	TC10	TC11	TC11	TC11	TC12	TC13
Co-location with other Base Stations	TC9	TC10	TC10	TC11	TC11	TC11	TC12	TC13
6.6.2 Operating band unwanted emissions	-	-	-	-	-	-	-	-
General requirement for Band Categories 1 and 3	N/A	(TS 36.141) (TS 25.141) TC10	N/A	(TS 36.141) TC11	N/A	(TS 36.141) TC11	N/A	N/A

General requirement for Band Category 2	(TS 36.141) TC9	N/A	(TS 36.141) (TS 25.141) TC10	N/A	(TS 36.141) TC11	N/A	(TS 36.141) (TS 25.141) TC12	(TS 36.141) TC13
GSM/EDGE single-RAT requirement	(TS 51.021)	N/A	N/A	N/A	N/A	N/A	(TS 51.021)	(TS 51.021)
Additional requirements	Compliance stated by manufacturer declaration	Compliance stated by manufacturer declaration	Compliance stated by manufacturer declaration	Compliance stated by manufacturer declaration	Compliance stated by manufacturer declaration	Compliance stated by manufacturer declaration	Compliance stated by manufacturer declaration	Compliance stated by manufacturer declaration
6.6.3 Occupied bandwidth	-	-	-	-	-	-	-	-
Minimum requirement	(TS 36.141)	(TS 25.141) (TS 36.141)	(TS 25.141) (TS 36.141)	(TS 36.141)	(TS 36.141)	(TS 36.141)	(TS 25.141) (TS 36.141)	(TS 36.141)
6.6.4 Adjacent Channel Leakage Power Ratio (ACLR)	-	-	-	-	-	-	-	-
E-UTRA	N/A	N/A	N/A	TC11	TC11	TC11	N/A	TC13
UTRA FDD	N/A	TC10	TC10	N/A	N/A	N/A	TC12	N/A
UTRA TDD	N/A	N/A	N/A	N/A	N/A	N/A	N/A	N/A
NB-IoT	TC9	TC10	TC10	TC11	TC11	TC11	TC12	TC13
Cumulative ACLR	N/A	N/A	N/A	N/A	N/A	N/A	N/A	N/A
6.7 Transmitter intermodulation		-		-				
General requirement	Same TC as used in 6.6	Same TC as used in 6.6	Same TC as used in 6.6	Same TC as used in 6.6	Same TC as used in 6.6	Same TC as used in 6.6	Same TC as used in 6.6	Same TC as used in 6.6
Additional requirement (BC1 and BC2)	Same TC as used in 6.6	Same TC as used in 6.6	Same TC as used in 6.6	Same TC as used in 6.6	Same TC as used in 6.6	N/A	Same TC as used in 6.6	Same TC as used in 6.6
Additional requirement (BC3)	N/A	N/A	N/A	N/A	N/A	Same TC as used in 6.6	N/A	N/A
7.2 Reference sensitivity level	-	-	-	-	-	-	-	-
E-UTRA	N/A	N/A	N/A	(TS 36.141)	(TS 36.141)	(TS 36.141)	N/A	(TS 36.141)
UTRA FDD	N/A	(TS 25.141)	(TS 25.141)	N/A	N/A	N/A	(TS 25.141)	N/A
UTRA TDD	N/A	N/A	N/A	N/A	N/A	N/A	N/A	N/A
GSM/EDGE	(TS 51.021)	N/A	N/A	N/A	N/A	N/A	(TS 51.021)	(TS 51.021)
NB-IoT	(TS 36.141)	(TS 36.141)	(TS 36.141)	(TS 36.141)	(TS 36.141)	(TS 36.141)	(TS 36.141)	(TS 36.141)
7.3 Dynamic range	-	-	-	-	-	-	-	-
E-UTRA	N/A	N/A	N/A	(TS 36.141)	(TS 36.141)	(TS 36.141)	N/A	(TS 36.141)

UTRA FDD	N/A	(TS 25.141)	(TS 25.141)	N/A	N/A	N/A	(TS 25.141)	N/A
UTRA TDD	N/A	N/A	N/A	N/A	N/A	N/A	N/A	N/A
GSM/EDGE	(TS 51.021)	(TS 51.021)	N/A	N/A	N/A	N/A	(TS 51.021)	(TS 51.021)
NB-IoT	(TS 36.141)	(TS 36.141)	(TS 36.141)	(TS 36.141)	(TS 36.141)	(TS 36.141)	(TS 36.141)	(TS 36.141)
7.4 In-band selectivity and blocking	-	-	-	-	-	-	-	-
General blocking requirement	TC9	TC10	TC10	TC11	TC11	TC11	TC12	TC13
General narrowband blocking requirement	TC9	TC10	TC10	TC11	TC11	TC11	TC12	TC13
Additional narrowband blocking requirement for GSM/EDGE	(TS 51.021)	N/A	N/A	N/A	N/A	N/A	(TS 51.021)	(TS 51.021)
GSM/EDGE requirements for AM suppression	(TS 51.021)	N/A	N/A	N/A	N/A	N/A	(TS 51.021)	(TS 51.021)
Additional BC3 blocking requirement	N/A	N/A	N/A	N/A	N/A	TC11	N/A	N/A
7.5 Out-of-band blocking	-	-	-	-	-	-	-	-
General requirement	TC9	TC10	TC10	TC11	TC11	TC11	TC12	TC13
Co-location requirement	TC9	TC10	TC10	TC11	TC11	TC11	TC12	TC13
7.6 Receiver spurious emissions	-	-	-	-	-	-	-	-
General requirement	TC9	TC10	TC10	TC11	TC11	TC11	TC12	TC13
Additional requirement for BC2 (Category B)	TC9	N/A	TC10	N/A	TC11	TC11	TC12	TC13
7.7 Receiver intermodulation	-	-	-	-	-	-	-	-
General intermodulation requirement	TC9	TC10	TC10	TC11	TC11	TC11	TC12	TC13
General narrowband intermodulation requirement	TC9	TC10	TC10	TC11	TC11	TC11	TC12	TC13
Additional narrowband intermodulation requirement for GSM/EDGE	(TS 51.021)	N/A	N/A	N/A	N/A	N/A	(TS 51.021)	(TS 51.021)

7.8 In-channel selectivity	-	-	-	-	-	-	-	-
E-UTRA requirement	N/A	N/A	N/A	(TS 36.141)	(TS 36.141)	(TS 36.141)	N/A	(TS 36.141)
NB-IoT	N/A	N/A	N/A	N/A	N/A	N/A	N/A	N/A

Table 5.1-1b: Test configurations for capability sets (CS14-15) for Multi-RAT capable BS

Capability Set	UTRA + E-UTRA + NB-IoT standalone (CS 14)			GSM + UTRA + E-UTRA + NB-IoT standalone (CS 15)	
	BS test case	BC1	BC2	BC3	BC2
6.2 Base Station output power	-	-	-	-	-
Base Station maximum output power	TC14	TC14	TC14	TC14	TC13, TC12*
Additional regional requirement (only for band 34)	N/A	N/A	N/A	N/A	N/A
E-UTRA for DL RS power	(TS 36.141)	(TS 36.141)	(TS 36.141)	(TS 36.141)	(TS 36.141)
NB-IoT for DL RS power	(TS 36.141)	(TS 36.141)	(TS 36.141)	(TS 36.141)	(TS 36.141)
UTRA FDD primary CPICH power	(TS 25.141)	(TS 25.141)	(TS 25.141)	(TS 25.141)	(TS 25.141)*
UTRA FDD secondary CPICH power	(TS 25.141)	(TS 25.141)	(TS 25.141)	(TS 25.141)	(TS 25.141)*
UTRA TDD primary CCPCH power	N/A	N/A	N/A	N/A	N/A
6.3 Output power dynamics	-	-	-	-	-
E-UTRA	(TS 36.141)	(TS 36.141)	(TS 36.141)	(TS 36.141)	(TS 36.141)
UTRA FDD	(TS 25.141)	(TS 25.141)	(TS 25.141)	(TS 25.141)	(TS 25.141)*
UTRA TDD	N/A	N/A	N/A	N/A	N/A
GSM/EDGE	N/A	N/A	N/A	N/A	TC13
NB-IoT	(TS 36.141)	(TS 36.141)	(TS 36.141)	(TS 36.141)	(TS 36.141)
6.4 Transmit ON/OFF power	-	-	-	-	-
Transmitter OFF power	N/A	N/A	TC14	TC14	N/A
Transmitter transient period	N/A	N/A	TC14	TC14	N/A
6.5 Transmitted signal quality	-	-	-	-	-
6.5.1 Modulation quality	-	-	-	-	-
E-UTRA	TC14	TC14	TC14	TC14	TC13
UTRA FDD	TC14	TC14	TC14	TC14	TC12*
UTRA TDD	N/A	N/A	N/A	N/A	N/A
GSM/EDGE	N/A	N/A	N/A	N/A	TC13
NB-IoT	TC14	TC14	TC14	TC14	TC13
6.5.2 Frequency error	-	-	-	-	-
E-UTRA	Same TC as used in 6.5.1	Same TC as used in 6.5.1	Same TC as used in 6.5.1	Same TC as used in 6.5.1	Same TC as used in 6.5.1
UTRA FDD	Same TC as used in 6.5.1	Same TC as used in 6.5.1	Same TC as used in 6.5.1	Same TC as used in 6.5.1	Same TC as used in 6.5.1
UTRA TDD	N/A	N/A	N/A	N/A	N/A
GSM/EDGE	N/A	N/A	N/A	N/A	Same TC as used in 6.5.1
NB-IoT	Same TC as used in 6.5.1	Same TC as used in 6.5.1	Same TC as used in 6.5.1	Same TC as used in 6.5.1	Same TC as used in 6.5.1
6.5.3 Time alignment error	-	-	-	-	-
E-UTRA	(TS 36.141)	(TS 36.141)	(TS 36.141)	(TS 36.141)	(TS 36.141)
UTRA FDD	(TS 25.141)	(TS 25.141)	(TS 25.141)	(TS 25.141)	(TS 25.141)*
UTRA TDD	N/A	N/A	N/A	N/A	N/A
NB-IoT	(TS 36.141)	(TS 36.141)	(TS 36.141)	(TS 36.141)	(TS 36.141)
6.6 Unwanted emissions	-	-	-	-	-
6.6.1 Transmitter spurious emissions	-	-	-	-	-
(Category A)	TC14	TC14	TC14	TC14	TC13, (TC12, TC13)*
(Category B)	TC14	TC14	TC14	TC14	TC13, (TC12, TC13)*
Additional requirement for BC2 (Category B)	N/A	TC14	N/A	N/A	TC13, (TC12, TC13)*

Capability Set	UTRA + E-UTRA + NB-IoT standalone (CS 14)			GSM + UTRA + E-UTRA + NB-IoT standalone (CS 15)
	BS test case	BC1	BC2	BC3
Protection of the BS receiver of own or different BS	TC14	TC14	TC14	TC13, (TC12, TC13)*
Additional spurious emissions requirements	TC14	TC14	TC14	TC13, (TC12, TC13)*
Co-location with other Base Stations	TC14	TC14	TC14	TC13, (TC12, TC13)*
6.6.2 Operating band unwanted emissions	-	-	-	-
General requirement for Band Categories 1 and 3	(TS 36.141) (TS 25.141) TC14	N/A	(TS 36.141) (TS 25.141) TC14	N/A
General requirement for Band Category 2	N/A	(TS 36.141) (TS 25.141) TC14	N/A	(TS 36.141) (TS 25.141)* TC14, TC12*
GSM/EDGE single-RAT requirement	N/A	N/A	N/A	N/A
Additional requirements	Compliance stated by manufacturer declaration	Compliance stated by manufacturer declaration	Compliance stated by manufacturer declaration	Compliance stated by manufacturer declaration
6.6.3 Occupied bandwidth	-	-	-	-
Minimum requirement	(TS 25.141) (TS 36.141)	(TS 25.141) (TS 36.141)	(TS 25.141) (TS 36.141)	(TS 25.141)* (TS 36.141)
6.6.4 Adjacent Channel Leakage Power Ratio (ACLR)	-	-	-	-
E-UTRA	TC14	TC14	TC14	TC13
UTRA FDD	(TS 25.141)	(TS 25.141)	(TS 25.141)	(TS 25.141)*
UTRA TDD	N/A	N/A	N/A	N/A
NB-IoT	TC14	TC14	TC14	TC13
Cumulative ACLR	N/A	N/A	N/A	N/A
6.7 Transmitter intermodulation	-	-	-	-
General requirement	Same TC as used in 6.6	Same TC as used in 6.6	Same TC as used in 6.6	Same TC as used in 6.6
Additional requirement (BC1 and BC2)	Same TC as used in 6.6	Same TC as used in 6.6	N/A	Same TC as used in 6.6
Additional requirement (BC3)	N/A	N/A	Same TC as used in 6.6	N/A
7.2 Reference sensitivity level	-	-	-	-
E-UTRA	(TS 36.141)	(TS 36.141)	(TS 36.141)	(TS 36.141)
UTRA FDD	(TS 25.141)	(TS 25.141)	(TS 25.141)	(TS 25.141)*
UTRA TDD	N/A	N/A	N/A	N/A
GSM/EDGE	N/A	N/A	N/A	TC13
NB-IoT	(TS 36.141)	(TS 36.141)	(TS 36.141)	(TS 36.141)
7.3 Dynamic range	-	-	-	-
E-UTRA	(TS 36.141)	(TS 36.141)	(TS 36.141)	(TS 36.141)
UTRA FDD	(TS 25.141)	(TS 25.141)	(TS 25.141)	(TS 25.141)*
UTRA TDD	N/A	N/A	N/A	
GSM/EDGE	N/A	N/A	N/A	TC13
NB-IoT	(TS 36.141)	(TS 36.141)	(TS 36.141)	(TS 36.141)
7.4 In-band selectivity and blocking	-	-	-	-
General blocking requirement	TC14	TC14	TC14	TC13
General narrowband blocking requirement	TC14	TC14	TC14	TC13

Capability Set	UTRA + E-UTRA + NB-IoT standalone (CS 14)			GSM + UTRA + E-UTRA + NB-IoT standalone (CS 15)	
	BS test case	BC1	BC2	BC3	BC2
Additional narrowband blocking requirement for GSM/EDGE	N/A	N/A	N/A	N/A	TC13
GSM/EDGE requirements for AM suppression	N/A	N/A	N/A	N/A	TC13
Additional BC3 blocking requirement	N/A	N/A	TC14	TC14	N/A
7.5 Out-of-band blocking	-	-	-	-	-
General requirement	TC14	TC14	TC14	TC14	TC13
Co-location requirement	TC14	TC14	TC14	TC14	TC13
7.6 Receiver spurious emissions	-	-	-	-	-
General requirement	TC14	TC14	TC14	TC14	TC13
Additional requirement for BC2 (Category B)	TC14	TC14	TC14	TC14	TC13
7.7 Receiver intermodulation	-	-	-	-	-
General intermodulation requirement	TC14	TC14	TC14	TC14	TC13
General narrowband intermodulation requirement	TC14	TC14	TC14	TC14	TC13
Additional narrowband intermodulation requirement for GSM/EDGE	N/A	N/A	N/A	N/A	TC13
7.8 In-channel selectivity	-	-	-	-	-
E-UTRA requirement	(TS 36.141)	(TS 36.141)	(TS 36.141)	(TS 36.141)	(TS 36.141)
NB-IoT	N/A	N/A	N/A	N/A	N/A

Table 5.1-1c: Test configurations for capability sets (CS16-17) for Multi-RAT capable BS

Capability Set	NR + E-UTRA NB-IoT in-band (Note 1) NB-IoT guard band (Note 2) (CS 16)		NR + NB-IoT standalone + E-UTRA NB-IoT in-band (Note 1) NB-IoT guard band (Note 2) (CS 17)		
	BS test case	BC1 and BC2	BC3	BC1 and BC2	BC3
6.2 Base Station output power	-	-	-	-	-
Base Station maximum output power	C, NI, NG: TC21 CNC, NCNI, NCNG: NTC21 C/NC, C/NCNI, C/NCNG: NTC21, TC21	C, NI, NG: TC21 CNC, NCNI, NCNG: NTC21 C/NC, C/NCNI, C/NCNG: NTC21, TC21	C: TC22 NI: TC22 NG:TC22	C: TC22 NI: TC22 NG:TC22	
E-UTRA for DL RS power	(TS 36.141)	(TS 36.141)	(TS 36.141)	(TS 36.141)	(TS 36.141)
NB-IoT for DL RS power	(TS 36.141)	(TS 36.141)	(TS 36.141)	(TS 36.141)	(TS 36.141)
6.3 Output power dynamics	-	-	-	-	-
E-UTRA	(TS 36.141)	(TS 36.141)	(TS 36.141)	(TS 36.141)	(TS 36.141)
NB-IoT	(TS 36.141)	(TS 36.141)	(TS 36.141)	(TS 36.141)	(TS 36.141)
NR	(TS 38.141-1)	(TS 38.141-1)	(TS 38.141-1)	(TS 38.141-1)	(TS 38.141-1)
6.4 Transmit ON/OFF power	-	-	-	-	-
Transmitter OFF power	N/A	C: TC21 CNC: NTC21	N/A	C: TC22	
Transmitter transient period	N/A	C: TC21 CNC: NTC21	N/A	C: TC22	
6.5 Transmitted signal quality	-	-	-	-	-
6.5.1 Modulation quality	-	-	-	-	-
E-UTRA	C: TC21 NI, NG: (Note 4) CNC: TC21 NCNI, NCNG: (Note 4) C/NC: NTC21, TC21 C/NCNI, C/NCNG: (Note 4)	C: TC21 NI, NG: (Note 4) CNC: TC21 NCNI, NCNG: (Note 4) C/NC: NTC21, TC21 C/NCNI, C/NCNG: (Note 4)	C: TC22 NI, NG: (Note 4)	C: TC22 NI, NG: (Note 4)	
NB-IoT	N/A (Note 4)	N/A (Note 4)	Standalone: C: TC22 NI, NG: (Note 4)	Standalone C: TC22 NI, NG: (Note 4)	
NR	C: TC21 CNC: TC21 C/NC: NTC21, TC21	C: TC21 CNC: TC21 C/NC: NTC21, TC21	C: TC22	C: TC22	
6.5.2 Frequency error	-	-	-	-	-
E-UTRA	Same TC as 6.5.1	Same TC as 6.5.1	Same TC as 6.5.1	Same TC as 6.5.1	Same TC as 6.5.1
NB-IoT	N/A (Note 4)	N/A (Note 4)	Same TC as 6.5.1	Same TC as 6.5.1	Same TC as 6.5.1
NR	Same TC as 6.5.1	Same TC as 6.5.1	Same TC as 6.5.1	Same TC as 6.5.1	Same TC as 6.5.1
6.5.3 Time alignment error	-	-	-	-	-
E-UTRA	(TS 36.141) NI, NG: (Note 4) NCNI, NCNG: (Note 4) C/NCNI, C/NCNG: (Note 4)	(TS 36.141) NI, NG: (Note 4) NCNI, NCNG: (Note 4) C/NCNI, C/NCNG: (Note 4)	(TS 36.141) NI, NG: (Note 4)	(TS 36.141) NI, NG: (Note 4)	
NB-IoT	N/A (Note 4)	N/A (Note 4)	Standalone: (TS 36.141) NI, NG: (Note 4)	Standalone: (TS 36.141) NI, NG: (Note 4)	
NR	(TS 38.141-1)	(TS 38.141-1)	(TS 38.141-1)	(TS 38.141-1)	
6.6 Unwanted emissions	-	-	-	-	-
6.6.1 Transmitter spurious emissions	-	-	-	-	-

Capability Set	NR + E-UTRA NB-IoT in-band (Note 1) NB-IoT guard band (Note 2) (CS 16)		NR + NB-IoT standalone + E-UTRA NB-IoT in-band (Note 1) NB-IoT guard band (Note 2) (CS 17)	
BS test case	BC1 and BC2	BC3	BC1 and BC2	BC3
(Category A)	C, NI, NG: TC21 CNC, NCNI, NCNG: NTC21 C/NC, C/NCNI, C/NCNG: NTC21, TC21	C, NI, NG: TC21 CNC, NCNI, NCNG: NTC21 C/NC, C/NCNI, C/NCNG: NTC21, TC21	C: TC22 NI: TC22 NG: TC22	C: TC22 NI: TC22 NG: TC22
(Category B)	C, NI, NG: TC21 CNC, NCNI, NCNG: NTC21 C/NC, C/NCNI, C/NCNG: NTC21, TC21	C, NI, NG: TC21 CNC, NCNI, NCNG: NTC21 C/NC, C/NCNI, C/NCNG: NTC21, TC21	C: TC22 NI: TC22 NG: TC22	C: TC22 NI: TC22 NG: TC22
Protection of the BS receiver of own or different BS	C, NI, NG: TC21 CNC, NCNI, NCNG: NTC21 C/NC, C/NCNI, C/NCNG: NTC21, TC21	C, NI, NG: TC21 CNC, NCNI, NCNG: NTC21 C/NC, C/NCNI, C/NCNG: NTC21, TC21	C: TC22 NI: TC22 NG: TC22	C: TC22 NI: TC22 NG: TC22
Additional spurious emissions requirements	C, NI, NG: TC21 CNC, NCNI, NCNG: NTC21 C/NC, C/NCNI, C/NCNG: NTC21, TC21	C, NI, NG: TC21 CNC, NCNI, NCNG: NTC21 C/NC, C/NCNI, C/NCNG: NTC21, TC21	C: TC22 NI: TC22 NG: TC22	C: TC22 NI: TC22 NG: TC22
Co-location with other Base Stations	C, NI, NG: TC21 CNC, NCNI, NCNG: NTC21 C/NC, C/NCNI, C/NCNG: NTC21, TC21	C, NI, NG: TC21 CNC, NCNI, NCNG: NTC21 C/NC, C/NCNI, C/NCNG: NTC21, TC21	C: TC22 NI: TC22 NG: TC22	C: TC22 NI: TC22 NG: TC22
6.6.2 Operating band unwanted emissions	-	-	-	-
General requirement for Band Categories 1 and 3	C, NI, NG: TC21 CNC, NCNI, NCNG: NTC21 C/NC, C/NCNI, C/NCNG: NTC21, TC21 SC: (Note 3)	C, NI, NG: TC21 CNC, NCNI, NCNG: NTC21 C/NC, C/NCNI, C/NCNG: NTC21, TC21 SC: (Note 3)	C: TC22 NI: TC22 NG: TC22 SC: (Note 3)	C: TC22 NI: TC22 NG: TC22 SC: (Note 3)
General requirement for Band Category 2	C, NI, NG: TC21 CNC, NCNI, NCNG: NTC21 C/NC, C/NCNI, C/NCNG: NTC21, TC21 SC: (Note 3)	N/A	C: TC22 NI: TC22 NG: TC22 SC: (Note 3)	N/A

Capability Set	NR + E-UTRA NB-IoT in-band (Note 1) NB-IoT guard band (Note 2) (CS 16)		NR + NB-IoT standalone + E-UTRA NB-IoT in-band (Note 1) NB-IoT guard band (Note 2) (CS 17)	
BS test case	BC1 and BC2	BC3	BC1 and BC2	BC3
Additional requirements	Compliance stated by manufacturer declaration	Compliance stated by manufacturer declaration	Compliance stated by manufacturer declaration	Compliance stated by manufacturer declaration
6.6.3 Occupied bandwidth	-	-	-	-
Minimum requirement	(TS 36.141) (TS 38.141-1)	(TS 36.141) (TS 38.141-1)	(TS 36.141) (TS 38.141-1)	(TS 36.141) (TS 38.141-1)
6.6.4 Adjacent Channel Leakage power Ratio (ACLR)	-	-	-	-
E-UTRA	C: TC21 CNC: NTC21 C/NC: NTC21, TC21	C: TC21 CNC: NTC21 C/NC: NTC21, TC21	C: TC21	C: TC21
NB-IoT	NI: TC21 NG: TC21 NCNI: NTC21 NCNG: NTC21 C/NCNI, C/NCNG: NTC21, TC21	NI: TC21 NG: TC21 NCNI: NTC21 NCNG: NTC21 C/NCNI, C/NCNG: NTC21, TC21	TC22	TC22
NR	C: TC21 CNC: NTC21 C/NC: NTC21, TC21	C: TC21 CNC: NTC21 C/NC: NTC21, TC21	C: TC21	C: TC21
Cumulative ACLR	CNC: NTC21 C/NC: NTC21	CNC: NTC21 C/NC: NTC21	N/A	N/A
6.7 Transmitter intermodulation	-	-	-	-
General requirement	Same TC as used in 6.6	Same TC as used in 6.6	Same TC as used in 6.6	Same TC as used in 6.6
Additional requirement (BC1 and BC2)	CNC: NTC21 C/NC: NTC21	N/A	Same TC as used in 6.6	
Additional requirement (BC3)		N/A		N/A
7.2 Reference sensitivity level	-	-	-	-
E-UTRA	(TS 36.141)	(TS 36.141)	(TS 36.141)	(TS 36.141)
NB-IoT	(TS 36.141)	(TS 36.141)	(TS 36.141)	(TS 36.141)
NR	(TS 38.141-1)	(TS 38.141-1)	(TS 38.141-1)	(TS 38.141-1)
7.3 Dynamic range				
E-UTRA	(TS 36.141)	(TS 36.141)	(TS 36.141)	(TS 36.141)
NB-IoT	(TS 36.141)	(TS 36.141)	(TS 36.141)	(TS 36.141)
NR	(TS 38.141-1)	(TS 38.141-1)	(TS 38.141-1)	(TS 38.141-1)
7.4 In-band selectivity and blocking	-	-	-	-
General blocking requirement	C, NI, NG: TC21 CNC, NCNI, NCNG: NTC21 C/NC, C/NCNI, C/NCNG: NTC21, TC21	C, NI, NG: TC21 CNC, NCNI, NCNG: NTC21 C/NC, C/NCNI, C/NCNG: NTC21, TC21	C: TC22 NI: TC22 NG: TC22	C: TC22 NI: TC22 NG: TC22
General narrowband blocking requirement	C, NI, NG: TC21 CNC, NCNI, NCNG: NTC21 C/NC, C/NCNI, C/NCNG: NTC21, TC21	C, NI, NG: TC21 CNC, NCNI, NCNG: NTC21 C/NC, C/NCNI, C/NCNG: NTC21, TC21	C: TC22 NI: TC22 NG: TC22	C: TC22 NI: TC22 NG: TC22
Additional BC3 blocking requirement	N/A	N/A	N/A	N/A
7.5 Out-of-band blocking	-	-	-	-

Capability Set	NR + E-UTRA NB-IoT in-band (Note 1) NB-IoT guard band (Note 2) (CS 16)		NR + NB-IoT standalone + E-UTRA NB-IoT in-band (Note 1) NB-IoT guard band (Note 2) (CS 17)	
	BS test case	BC1 and BC2	BC3	BC1 and BC2
General requirement	C, NI, NG: TC21 CNC, NCNI, NCNG: NTC21 C/NC, C/NCNI, C/NCNG: NTC21, TC21	C, NI, NG: TC21 CNC, NCNI, NCNG: NTC21 C/NC, C/NCNI, C/NCNG: NTC21, TC21	C: TC22 NI: TC22 NG: TC22	C: TC22 NI: TC22 NG: TC22
Co-location requirement	C, NI, NG: TC21 CNC, NCNI, NCNG: NTC21 C/NC, C/NCNI, C/NCNG: NTC21, TC21	C, NI, NG: TC21 CNC, NCNI, NCNG: NTC21 C/NC, C/NCNI, C/NCNG: NTC21, TC21	C: TC22 NI: TC22 NG: TC22	C: TC22 NI: TC22 NG: TC22
7.6 Receiver spurious emissions	-	-	-	-
General requirement	C, NI, NG: TC21 CNC, NCNI, NCNG: NTC21 C/NC, C/NCNI, C/NCNG: NTC21, TC21	C, NI, NG: TC21 CNC, NCNI, NCNG: NTC21 C/NC, C/NCNI, C/NCNG: NTC21, TC21	C: TC22 NI: TC22 NG: TC22	C: TC22 NI: TC22 NG: TC22
Additional requirement for BC2 (Category B)	N/A	N/A	C: TC22 NI: TC22 NG: TC22	N/A
7.7 Receiver intermodulation	-	-	-	-
General intermodulation requirement	C, NI, NG: TC21 CNC, NCNI, NCNG: NTC21 C/NC, C/NCNI, C/NCNG: NTC21, TC21	C, NI, NG: TC21 CNC, NCNI, NCNG: NTC21 C/NC, C/NCNI, C/NCNG: NTC21, TC21	C: TC22 NI: TC22 NG: TC22	C: TC22 NI: TC22 NG: TC22
General narrowband intermodulation requirement	C, NI, NG: TC21 CNC, NCNI, NCNG: NTC21 C/NC, C/NCNI, C/NCNG: NTC21, TC21	C, NI, NG: TC21 CNC, NCNI, NCNG: NTC21 C/NC, C/NCNI, C/NCNG: NTC21, TC21	C: TC22 NI: TC22 NG: TC22	C: TC22 NI: TC22 NG: TC22
7.8 In-channel selectivity	-	-	-	-
E-UTRA requirement	(TS 36.141)	(TS 36.141)	(TS 36.141)	(TS 36.141)
NB-IoT	(TS 36.141)	(TS 36.141)	(TS 36.141)	(TS 36.141)
NR	(TS 38.141-1)	(TS 38.141-1)	(TS 38.141-1)	(TS 38.141-1)

NOTE 1: The support of NB-IoT in-band operation is optional and declared by the manufacturer. If not supported, the test configurations denoted by "NI" shall not be used for testing.

NOTE 2: The support of NB-IoT guard band operation is optional and declared by the manufacturer. If not supported, the test configurations denoted by "NG" shall not be used for testing.

NOTE 3: For Operating band unwanted emissions, NR shall also be tested with SC with widest supported channel bandwidth and highest supported sub-carrier spacing.

NOTE 4: There is no specific test with NB-IoT for those requirements, tests could be performed using E-UTRA signal only, without NB-IoT.

5.2 Single-RAT Multi-carrier capable Base Stations

This clause includes E-UTRA MC BS with one E-UTRA carrier supporting NB-IoT in-band and/or guard band.

Table 5.2-1: Test configurations for capability sets for Single-RAT capable BS

Capability Set	UTRA (MC) capable BS (CS1)			E-UTRA (MC) capable BS NB-IoT in-band*, NB-IoT guard band** (CS2)		
	BC1	BC2	BC3	BC1	BC2	BC3
6.2 Base Station output power	-	-	-	-	-	-
Base Station maximum output power	C: TC1a CNC: TC1a C/NC: TC1a, NTC1a	C: TC1a CNC: TC1a C/NC: TC1a, NTC1a	C: TC1b	C: TC2 CNC: TC2 C/NC: TC2, NTC2 NI: TC17 NG: TC20	C: TC2 CNC: TC2 C/NC: TC2, NTC2 NI: TC17 NG: TC20	C: TC2 CNC: TC2 C/NC: TC2, NTC2 NI: TC17 NG: TC20
Additional regional requirement (only for band 34)	N/A	N/A	N/A	N/A	N/A	Compliance stated by manufacturer declaration
E-UTRA DL RS power	N/A	N/A	N/A	(TS 36.141)	(TS 36.141)	(TS 36.141)
NB-IoT for DL RS power	N/A	N/A	N/A	(TS 36.141)	(TS 36.141)	(TS 36.141)
UTRA FDD primary CPICH power	(TS 25.141)	(TS 25.141)	N/A	N/A	N/A	N/A
UTRA FDD secondary CPICH power	(TS 25.141)	(TS 25.141)	N/A	N/A	N/A	N/A
UTRA TDD primary CCPCH power	N/A	N/A	(TS 25.142)	N/A	N/A	N/A
6.3 Output power dynamics	-	-	-	-	-	-
E-UTRA	N/A	N/A	N/A	(TS 36.141)	(TS 36.141)	(TS 36.141)
UTRA FDD	(TS 25.141)	(TS 25.141)	N/A	N/A	N/A	N/A
UTRA TDD	N/A	N/A	(TS 25.142)	N/A	N/A	N/A
GSM/EDGE	N/A	N/A	N/A	N/A	N/A	N/A
NB-IoT	N/A	N/A	N/A	(TS 36.141)	(TS 36.141)	(TS 36.141)
6.4 Transmit ON/OFF power	-	-	-	-	-	-
Transmitter OFF power	N/A	N/A	C: TC1b	N/A	N/A	C: TC2 CNC: TC2 C/NC: TC2, NTC2 NI: TC17 NG: TC20
Transmitter transient period	N/A	N/A	C: TC1b	N/A	N/A	C: TC2 CNC: TC2 C/NC: TC2, NTC2 NI: TC17 NG: TC20
6.5 Transmitted signal quality	-	-	-	-	-	-
6.5.1 Modulation quality	-	-	-	-	-	-
E-UTRA	N/A	N/A	N/A	C: TC2 CNC: TC2 C/NC: TC2, NTC2 NI/NG: (Note 1)	C: TC2 CNC: TC2 C/NC: TC2, NTC2 NI/NG: (Note 1)	C: TC2 CNC: TC2 C/NC: TC2, NTC2 NI/NG: (Note 1)

Capability Set	UTRA (MC) capable BS (CS1)			E-UTRA (MC) capable BS NB-IoT in-band*, NB-IoT guard band** (CS2)		
	BC1	BC2	BC3	BC1	BC2	BC3
BS test case						
UTRA FDD	C: TC1a CNC: TC1a C/NC: TC1a, NTC1a	C: TC1a CNC: TC1a C/NC: TC1a, NTC1a	N/A	N/A	N/A	N/A
UTRA TDD	N/A	N/A	C: TC1b	N/A	N/A	N/A
GSM/EDGE	N/A	N/A	N/A	N/A	N/A	N/A
NB-IoT	N/A	N/A	N/A	N/A: (Note 1)	N/A: (Note 1)	N/A: (Note 1)
6.5.2 Frequency error	-	-	-	-	-	-
E-UTRA	N/A	N/A	N/A	Same TC as used in 6.5.1 NI/NG: (Note 1)	Same TC as used in 6.5.1 NI/NG: (Note 1)	Same TC as used in 6.5.1 NI/NG: (Note 1)
UTRA FDD	Same TC as used in 6.5.1	Same TC as used in 6.5.1	N/A	N/A	N/A	N/A
UTRA TDD	N/A	N/A	Same TC as used in 6.5.1	N/A	N/A	N/A
GSM/EDGE	N/A	N/A	N/A	N/A	N/A	N/A
NB-IoT	N/A	N/A	N/A	N/A: (Note 1)	N/A: (Note 1)	N/A: (Note 1)
6.5.3 Time alignment error	-	-	-	-	-	-
E-UTRA	N/A	N/A	N/A	(TS 36.141) NI/NG: (Note 1)	(TS 36.141) NI/NG: (Note 1)	(TS 36.141) NI/NG: (Note 1)
UTRA FDD	(TS 25.141)	(TS 25.141)	N/A	N/A	N/A	N/A
UTRA TDD	N/A	N/A	(TS 25.142)	N/A	N/A	N/A
NB-IoT	N/A	N/A	N/A	N/A: (Note 1)	N/A: (Note 1)	N/A: (Note 1)
6.6 Unwanted emissions	-	-	-	-	-	-
6.6.1 Transmitter spurious emissions	-	-	-	-	-	-
(Category A)	C: TC1a CNC: NTC1a C/NC: TC1a, NTC1a	C: TC1a CNC: NTC1a C/NC: TC1a, NTC1a	C: TC1b	C: TC2 CNC: NTC2 C/NC: TC2, NTC2 NI: TC17 NG: TC20	C: TC2 CNC: NTC2 C/NC: TC2, NTC2 NI: TC17 NG: TC20	C: TC2 CNC: NTC2 C/NC: TC2, NTC2 NI: TC17 NG: TC20
(Category B)	C: TC1a CNC: NTC1a C/NC: TC1a, NTC1a	C: TC1a CNC: NTC1a C/NC: TC1a, NTC1a	C: TC1b	C: TC2 CNC: NTC2 C/NC: TC2, NTC2 NI: TC17 NG: TC20	C: TC2 CNC: NTC2 C/NC: TC2, NTC2 NI: TC17 NG: TC20	C: TC2 CNC: NTC2 C/NC: TC2, NTC2 NI: TC17 NG: TC20
Additional requirement for BC2 (Category B)	N/A	N/A	N/A	N/A	N/A	N/A
Protection of the BS receiver of own or different BS	C: TC1a CNC: NTC1a C/NC: TC1a, NTC1a	C: TC1a CNC: NTC1a C/NC: TC1a, NTC1a	C: TC1b	C: TC2 CNC: NTC2 C/NC: TC2, NTC2 NI: TC17 NG: TC20	C: TC2 CNC: NTC2 C/NC: TC2, NTC2 NI: TC17 NG: TC20	C: TC2 CNC: NTC2 C/NC: TC2, NTC2 NI: TC17 NG: TC20
Additional spurious emissions requirements	C: TC1a CNC: NTC1a C/NC: TC1a, NTC1a	C: TC1a CNC: NTC1a C/NC: TC1a, NTC1a	C: TC1b	C: TC2 CNC: NTC2 C/NC: TC2, NTC2 NI: TC17 NG: TC20	C: TC2 CNC: NTC2 C/NC: TC2, NTC2 NI: TC17 NG: TC20	C: TC2 CNC: NTC2 C/NC: TC2, NTC2 NI: TC17 NG: TC20

Capability Set	UTRA (MC) capable BS (CS1)			E-UTRA (MC) capable BS NB-IoT in-band*, NB-IoT guard band** (CS2)		
BS test case	BC1	BC2	BC3	BC1	BC2	BC3
Co-location with other Base Stations	C: TC1a CNC: NTC1a C/NC: TC1a, NTC1a	C: TC1a CNC: NTC1a C/NC: TC1a, NTC1a	C: TC1b	C: TC2 CNC: NTC2 C/NC: TC2, NTC2 NI: TC17 NG: TC20	C: TC2 CNC: NTC2 C/NC: TC2, NTC2 NI: TC17 NG: TC20	C: TC2 CNC: NTC2 C/NC: TC2, NTC2 NI: TC17 NG: TC20
6.6.2 Operating band unwanted emissions	-	-	-	-	-	-
General requirement for Band Categories 1 and 3	(TS 25.141) C: TC1a CNC: TC1a, NTC1a C/NC: TC1a, NTC1a	N/A	(TS 25.142) C: TC1b	(TS 36.141) C: TC2 CNC: TC2, NTC2 C/NC: TC2, NTC2 NI: TC17 NG: TC20	N/A	(TS 36.141) C: TC2 CNC: TC2, NTC2 C/NC: TC2, NTC2 NI: TC17 NG: TC20
General requirement for Band Category 2	N/A	(TS 25.141) C: TC1a CNC: TC1a, NTC1a C/NC: TC1a, NTC1a	N/A	N/A	(TS 36.141) C: TC2 CNC: TC2, NTC2 C/NC: TC2, NTC2 NI: TC17 NG: TC20	N/A
GSM/EDGE single-RAT requirements	N/A	N/A	N/A	N/A	N/A	N/A
Additional requirements	Compliance stated by manufacturer declaration	Compliance stated by manufacturer declaration	Compliance stated by manufacturer declaration	Compliance stated by manufacturer declaration	Compliance stated by manufacturer declaration	Compliance stated by manufacturer declaration
6.6.3 Occupied bandwidth	-	-	-	-	-	-
Minimum requirement	(TS 25.141)	(TS 25.141)	(TS 25.142)	(TS 36.141)	(TS 36.141)	(TS 36.141)
6.6.4 Adjacent Channel Leakage Power Ratio (ACLR)						
E-UTRA	N/A	N/A	N/A	C: TC2 CNC: NTC2 C/NC: TC2, NTC2 NI: TC17 NG: TC20	C: TC2 CNC: NTC2 C/NC: TC2, NTC2 NI: TC17 NG: TC20	C: TC2 CNC: NTC2 C/NC: TC2, NTC2 NI: TC17 NG: TC20
UTRA FDD	(TS 25.141)	(TS 25.141)	N/A	N/A	N/A	N/A
UTRA TDD	N/A	N/A	(TS 25.142)	N/A	N/A	N/A
NB-IoT	N/A	N/A	N/A	NI: TC17 NG: TC20	NI: TC17 NG: TC20	NI: TC17 NG: TC20
Cumulative ACLR	CNC: NTC1a C/NC: NTC1a	CNC: NTC1a C/NC: NTC1a	-	CNC: NTC2 C/NC: NTC2	CNC: NTC2 C/NC: NTC2	CNC: NTC2 C/NC: NTC2
6.7 Transmitter intermodulation	-	-	-	-	-	-
General requirement	Same TC as used in 6.6	Same TC as used in 6.6	Same TC as used in 6.6	Same TC as used in 6.6	Same TC as used in 6.6	Same TC as used in 6.6
Additional requirement (BC1 and BC2)	CNC: NTC1a C/NC: NTC1a	Same TC as used in 6.6	N/A	CNC: NTC2 C/NC: NTC2 NI: TC17 NG: TC20	Same TC as used in 6.6	N/A
Additional requirement (BC3)	N/A	N/A	Same TC as used in 6.6	N/A	N/A	Same TC as used in 6.6

Capability Set	UTRA (MC) capable BS (CS1)			E-UTRA (MC) capable BS NB-IoT in-band*, NB-IoT guard band** (CS2)		
	BC1	BC2	BC3	BC1	BC2	BC3
7.2 Reference sensitivity level	-	-	-	-	-	-
E-UTRA requirement	N/A	N/A	N/A	(TS 36.141)	(TS 36.141)	(TS 36.141)
UTRA FDD requirement	(TS 25.141)	(TS 25.141)	N/A	N/A	N/A	N/A
UTRA TDD requirement	N/A	N/A	(TS 25.142)	N/A	N/A	N/A
GSM/EDGE requirement	N/A	N/A	N/A	N/A	N/A	N/A
NB-IoT requirement	N/A	N/A	N/A	(TS 36.141)	(TS 36.141)	(TS 36.141)
7.3 Dynamic range	-	-	-	-	-	-
E-UTRA	N/A	N/A	N/A	(TS 36.141)	(TS 36.141)	(TS 36.141)
UTRA FDD	(TS 25.141)	(TS 25.141)	N/A	N/A	N/A	N/A
UTRA TDD	N/A	N/A	(TS 25.142)	N/A	N/A	N/A
GSM/EDGE	N/A	N/A	N/A	N/A	N/A	N/A
NB-IoT	N/A	N/A	N/A	(TS 36.141)	(TS 36.141)	(TS 36.141)
7.4 In-band selectivity and blocking	-	-	-	-	-	-
General blocking requirement	C: TC1a CNC: NTC1a C/NC: TC1a, NTC1a	C: TC1a CNC: NTC1a C/NC: TC1a, NTC1a	C: TC1b	C: TC2 CNC: NTC2 C/NC: TC2, NTC2 NI: TC17 NG: TC20	C: TC2 CNC: NTC2 C/NC: TC2, NTC2 NI: TC17 NG: TC20	C: TC2 CNC: NTC2 C/NC: TC2, NTC2 NI: TC17 NG: TC20
General narrowband blocking requirement	C: TC1a, TC6a CNC: NTC1a, TC6a C/NC: TC1a, NTC1a, TC6a	C: TC1a, TC6a CNC: NTC1a, TC6a C/NC: TC1a, NTC1a, TC6a	C: TC1b TC6c	C: TC2, TC6b CNC: NTC2, TC6b C/NC: TC2, NTC2, TC6b NI: TC17 NG: TC20	C: TC2, TC6b CNC: NTC2, TC6b C/NC: TC2, NTC2, TC6b NI: TC17 NG: TC20	C: TC2, TC6b CNC: NTC2, TC6b C/NC: TC2, NTC2, TC6b NI: TC17 NG: TC20
Additional narrowband blocking requirement for GSM/EDGE	N/A	N/A	N/A	N/A	N/A	N/A
GSM/EDGE requirements for AM suppression	N/A	N/A	N/A	N/A	N/A	N/A
Additional BC3 blocking minimum requirement	N/A	N/A	C: TC1b	N/A	N/A	C: TC2 CNC: NTC2 C/NC: TC2, NTC2 NI: TC17 NG: TC20
7.5 Out-of-band blocking	-	-	-	-	-	-
General requirement	C: TC1a CNC: NTC1a C/NC: TC1a, NTC1a	C: TC1a CNC: NTC1a C/NC: TC1a, NTC1a	C: TC1b	C: TC2 CNC: NTC2 C/NC: TC2, NTC2 NI: TC17 NG: TC20	C: TC2 CNC: NTC2 C/NC: TC2, NTC2 NI: TC17 NG: TC20	C: TC2 CNC: NTC2 C/NC: TC2, NTC2 NI: TC17 NG: TC20

Capability Set	UTRA (MC) capable BS (CS1)			E-UTRA (MC) capable BS NB-IoT in-band*, NB-IoT guard band** (CS2)		
	BC1	BC2	BC3	BC1	BC2	BC3
BS test case						
Co-location requirement	C: TC1a CNC: NTC1a C/NC: TC1a, NTC1a	C: TC1a CNC: NTC1a C/NC: TC1a, NTC1a	C: TC1b	C: TC2 CNC: NTC2 C/NC: TC2, NTC2 NI: TC17 NG: TC20	C: TC2 CNC: NTC2 C/NC: TC2, NTC2 NI: TC17 NG: TC20	C: TC2 CNC: NTC2 C/NC: TC2, NTC2 NI: TC17 NG: TC20
7.6 Receiver spurious emissions	-	-	-	-	-	-
General requirement	C: TC1a CNC: NTC1a C/NC: TC1a, NTC1a	C: TC1a CNC: NTC1a C/NC: TC1a, NTC1a	C: TC1b	C: TC2 CNC: NTC2 C/NC: TC2, NTC2 NI: TC17 NG: TC20	C: TC2 CNC: NTC2 C/NC: TC2, NTC2 NI: TC17 NG: TC20	C: TC2 CNC: NTC2 C/NC: TC2, NTC2 NI: TC17 NG: TC20
Additional requirement for BC2 (Category B)	N/A	N/A	N/A	N/A	N/A	N/A
7.7 Receiver intermodulation	-	-	-	-	-	-
General intermodulation requirement	C: TC1a CNC: NTC1a C/NC: TC1a, NTC1a	C: TC1a CNC: NTC1a C/NC: TC1a, NTC1a	C: TC1b	C: TC2 CNC: NTC2 C/NC: TC2, NTC2 NI: TC17 NG: TC20	C: TC2 CNC: NTC2 C/NC: TC2, NTC2 NI: TC17 NG: TC20	C: TC2 CNC: NTC2 C/NC: TC2, NTC2 NI: TC17 NG: TC20
General narrowband intermodulation requirement	C: TC1a, TC6a CNC: NTC1a, TC6a C/NC: TC1a, NTC1a, TC6a	C: TC1a, TC6a CNC: NTC1a, TC6a C/NC: TC1a, NTC1a, TC6a	C: TC1b, TC6c	C: TC2, TC6b CNC: NTC2, TC6b C/NC: TC2, NTC2, TC6b NI: TC17 NG: TC20	C: TC2, TC6b CNC: NTC2, TC6b C/NC: TC2, NTC2, TC6b NI: TC17 NG: TC20	C: TC2, TC6b CNC: NTC2, TC6b C/NC: TC2, NTC2, TC6b NI: TC17 NG: TC20
Additional narrowband intermodulation requirement for GSM/EDGE	N/A	N/A	N/A	N/A	N/A	N/A
7.8 In-channel selectivity	-	-	-	-	-	-
E-UTRA requirement	N/A	N/A	N/A	(TS 36.141)	(TS 36.141)	(TS 36.141)
NB-IoT requirement	N/A	N/A	N/A	(NI: TS 36.141)	(NI: TS 36.141)	(NI: TS 36.141)

Table 5.2-1a: Test configurations for capability sets for Single-RAT capable BS

Capability Set	NB-IoT (MC) capable (CS 8)		
BS test case	BC1	BC2	BC3
6.2 Base Station output power	-	-	-
Base Station maximum output power	TC8	TC8	TC8
Additional regional requirement (only for band 34)	N/A	N/A	N/A
E-UTRA DL RS power	N/A	N/A	N/A
NB-IoT for DL RS power	(TS 36.141)	(TS 36.141)	(TS 36.141)
UTRA FDD primary CPICH power	N/A	N/A	N/A
UTRA FDD secondary CPICH power	N/A	N/A	N/A
UTRA TDD primary CCPCH power	N/A	N/A	N/A
6.3 Output power dynamics	-	-	-
E-UTRA	N/A	N/A	N/A
UTRA FDD	N/A	N/A	N/A
UTRA TDD	N/A	N/A	N/A
GSM/EDGE	N/A	N/A	N/A
NB-IoT	(TS 36.141)	(TS 36.141)	(TS 36.141)
6.4 Transmit ON/OFF power	-	-	-
Transmitter OFF power	N/A	N/A	TC8
Transmitter transient period	N/A	N/A	TC8
6.5 Transmitted signal quality	-	-	-
6.5.1 Modulation quality	-	-	-
E-UTRA	N/A	N/A	N/A
UTRA FDD	N/A	N/A	N/A
UTRA TDD	N/A	N/A	N/A
GSM/EDGE	N/A	N/A	N/A
NB-IoT	TC8	TC8	TC8
6.5.2 Frequency error	-	-	-
E-UTRA	N/A	N/A	N/A
UTRA FDD	N/A	N/A	N/A
UTRA TDD	N/A	N/A	N/A
GSM/EDGE	N/A	N/A	N/A
NB-IoT	Same TC as used in 6.5.1	Same TC as used in 6.5.1	Same TC as used in 6.5.1
6.5.3 Time alignment error	-	-	-
E-UTRA	N/A	N/A	N/A
UTRA FDD	N/A	N/A	N/A
UTRA TDD	N/A	N/A	N/A

Capability Set	NB-IoT (MC) capable (CS 8)		
	BC1	BC2	BC3
BS test case	BC1	BC2	BC3
NB-IoT	(TS 36.141)	(TS 36.141)	(TS 36.141)
6.6 Unwanted emissions	-	-	-
6.6.1 Transmitter spurious emissions	-	-	-
(Category A)	TC8	TC8	TC8
(Category B)	TC8	TC8	TC8
Additional requirement for BC2 (Category B)	N/A	N/A	N/A
Protection of the BS receiver of own or different BS	TC8	TC8	TC8
Additional spurious emissions requirements	TC8	TC8	TC8
Co-location with other Base Stations	TC8	TC8	TC8
6.6.2 Operating band unwanted emissions	-	-	-
General requirement for Band Categories 1 and 3	(TS 36.141) TC8	N/A	(TS 36.141) TC8
General requirement for Band Category 2	N/A	(TS 36.141) TC8	N/A
GSM/EDGE single-RAT requirements	N/A	N/A	N/A
Additional requirements	Compliance stated by manufacturer declaration	Compliance stated by manufacturer declaration	Compliance stated by manufacturer declaration
6.6.3 Occupied bandwidth	-	-	-
Minimum requirement	(TS 36.141)	(TS 36.141)	(TS 36.141)
6.6.4 Adjacent Channel Leakage Power Ratio (ACLR)	-	-	-
E-UTRA	N/A	N/A	N/A
UTRA FDD	N/A	N/A	N/A
UTRA TDD	N/A	N/A	N/A
NB-IoT	TC8	TC8	TC8
Cumulative ACLR	N/A	N/A	N/A
6.7 Transmitter intermodulation	-	-	-
General requirement	Same TC as used in 6.6	Same TC as used in 6.6	Same TC as used in 6.6
Additional requirement (BC1 and BC2)	Same TC as used in 6.6	Same TC as used in 6.6	N/A

Capability Set	NB-IoT (MC) capable (CS 8)		
BS test case	BC1	BC2	BC3
Additional requirement (BC3)	N/A	N/A	Same TC as used in 6.6
7.2 Reference sensitivity level	-	-	-
E-UTRA requirement	N/A	N/A	N/A
UTRA FDD requirement	N/A	N/A	N/A
UTRA TDD requirement	N/A	N/A	N/A
GSM/EDGE requirement	N/A	N/A	N/A
NB-IoT requirement	(TS 36.141)	(TS 36.141)	(TS 36.141)
7.3 Dynamic range	-	-	-
E-UTRA	N/A	N/A	N/A
UTRA FDD	N/A	N/A	N/A
UTRA TDD	N/A	N/A	N/A
GSM/EDGE	N/A	N/A	N/A
NB-IoT	(TS 36.141)	(TS 36.141)	(TS 36.141)
7.4 In-band selectivity and blocking	-	-	-
General blocking requirement	TC8	TC8	TC8
General narrowband blocking requirement	TC8	TC8	TC8
Additional narrowband blocking requirement for GSM/EDGE	N/A	N/A	N/A
GSM/EDGE requirements for AM suppression	N/A	N/A	N/A
Additional BC3 blocking minimum requirement	N/A	N/A	TC8
7.5 Out-of-band blocking	-	-	-
General requirement	TC8	TC8	TC8
Co-location requirement	TC8	TC8	TC8
7.6 Receiver spurious emissions	-	-	-
General requirement	TC8	TC8	TC8
Additional requirement for BC2 (Category B)	N/A	N/A	N/A
7.7 Receiver intermodulation	-	-	-

Capability Set	NB-IoT (MC) capable (CS 8)		
BS test case	BC1	BC2	BC3
General intermodulation requirement	TC8	TC8	TC8
General narrowband intermodulation requirement	TC8	TC8	TC8
Additional narrowband intermodulation requirement for GSM/EDGE	N/A	N/A	N/A
7.8 In-channel selectivity	-	-	-
E-UTRA requirement	N/A	N/A	N/A
NB-IoT requirement	N/A	N/A	N/A

5.3 Multi-band capable Base Stations

Table 5.3-1: Test configurations for Multi-Band capable BS (CS1-CS7 and CS16)

BS test case	Test for Multi-Band capable BS		Test configuration for MBT	
	Common antenna connector	Separate antenna connector	BC1/BC2	BC3
6.2 Base Station output power	-	-	-	-
Base Station maximum output power	SBT, MBT	SBT, MBT	TC7a	TC7a
Additional regional requirement (only for band 34)	N/A	N/A	N/A	-
E-UTRA for DL RS power	SBT	SBT	-	-
UTRA FDD primary CPICH power	SBT	SBT	-	-
UTRA TDD primary CCPCH power	SBT	SBT	-	-
NB-IoT for DL RS power	SBT	SBT	-	-
6.3 Output power dynamics	-	-	-	-
E-UTRA	SBT	SBT	-	-
UTRA FDD	SBT	SBT	-	-
UTRA TDD	SBT	SBT	-	-
GSM/EDGE	SBT	SBT	-	-
NB-IoT	SBT	SBT	-	-
NR	SBT	SBT	-	-
6.4 Transmit ON/OFF power			-	-
Transmitter OFF power	MBT, SBT ⁷	MBT, SBT ⁷	N/A	TC7a
Transmitter transient period	MBT, SBT ⁷	MBT, SBT ⁷	N/A	TC7a
6.5 Transmitted signal quality				
6.5.1 Modulation quality				
E-UTRA	SBT, MBT	SBT, MBT	TC7a	TC7a
UTRA FDD	SBT, MBT	SBT, MBT	TC7a	N/A
UTRA TDD	SBT, MBT	SBT, MBT	N/A	TC7a
GSM/EDGE	SBT, MBT	SBT, MBT	TC7a	N/A
NB-IoT	N/A (Note 8)	N/A (Note 8)	-	-
NR	SBT, MBT	SBT, MBT	TC7a	TC7a
6.5.2 Frequency error				
E-UTRA	SBT, MBT	SBT, MBT	TC7a	TC7a
UTRA FDD	SBT, MBT	SBT, MBT	TC7a	N/A
UTRA TDD	SBT, MBT	SBT, MBT	N/A	TC7a
GSM/EDGE	SBT, MBT	SBT, MBT	TC7a	N/A
NB-IoT	N/A (Note 8)	N/A (Note 8)	-	-
NR	SBT, MBT	SBT, MBT	TC7a	TC7a
6.5.3 Time alignment between transmitter branches				
E-UTRA	SBT, MBT ¹	SBT, MBT ¹	TC7b	TC7b
UTRA FDD	SBT, MBT ¹	SBT, MBT ¹	TC7b	N/A
UTRA TDD	SBT	SBT	N/A	-
NB-IoT	N/A (Note 8)	N/A (Note 8)	-	-
NR	SBT, MBT ¹	SBT, MBT ¹	TC7b	TC7b
6.6 Unwanted emissions				
6.6.1 Transmitter spurious emissions				
(Category A)	SBT, MBT	SBT ² , MBT ²	TC7b	TC7b
(Category B)	SBT, MBT	SBT ² , MBT ²	TC7b	TC7b
Additional requirement for BC2 (Category B)	SBT, MBT ³	SBT ² , MBT ^{2,3}	TC7b	N/A
Protection of the BS receiver of own or different BS	SBT, MBT	SBT ² , MBT ²	TC7b	TC7b
Additional spurious emissions requirements	SBT, MBT	SBT ² , MBT ²	TC7b	TC7b
Co-location with other Base Stations	SBT, MBT	SBT ² , MBT ²	TC7b	TC7b
6.6.2 Operating band unwanted emissions				
General requirement for Band Categories 1 and 3	SBT, MBT	SBT ² , MBT ²	TC7b	TC7b

General requirement for Band Category 2	SBT, MBT	SBT ² , MBT ²	TC7b	N/A
GSM/EDGE single-RAT requirement	SBT, MBT ⁶	SBT ² , MBT ^{2,6}	TC7c	N/A
Additional requirements	SBT, MBT	SBT ² , MBT ²	-	-
6.6.3 Occupied bandwidth				
Minimum requirement	SBT	SBT	-	-
6.6.4 Adjacent Channel Leakage Power Ratio (ACLR)				
E- UTRA	SBT, MBT ⁴	SBT ² , MBT ^{2, 4}	TC7b	TC7b
UTRA FDD	SBT, MBT ⁴	SBT ² , MBT ^{2, 4}	TC7b	N/A
UTRA TDD	SBT, MBT ⁴	SBT ² , MBT ^{2, 4}	N/A	TC7b
Cumulative ACLR	SBT, MBT ⁴	SBT ²	TC7b	TC7b
NB-IoT	SBT, MBT ⁴	SBT ² , MBT ^{2, 4}	TC7b	TC7b
NR	SBT, MBT ⁴	SBT ² , MBT ^{2, 4}	TC7b	TC7b
6.7 Transmitter intermodulation				
General requirement	SBT	SBT ²	-	-
Additional requirement (BC1 and BC2)	SBT	SBT ²	-	N/A
Additional requirement (BC3)	SBT	SBT ²	N/A	-
7.2 Reference sensitivity level				
E-UTRA	SBT	SBT	-	-
UTRA FDD	SBT	SBT	-	-
UTRA TDD	SBT	SBT	-	-
GSM/EDGE	SBT	SBT	-	-
NB-IoT	SBT	SBT	-	-
NR	SBT	SBT	-	-
7.3 Dynamic range				
E-UTRA	SBT	SBT	-	-
UTRA FDD	SBT	SBT	-	-
UTRA TDD	SBT	SBT	-	-
GSM/EDGE	SBT	SBT	-	-
NB-IoT	SBT	SBT	-	-
NR	SBT	SBT	-	-
7.4 In- band selectivity and blocking				
General blocking requirement	MBT, SBT ⁷	SBT, MBT ⁵	TC7b	TC7b
General narrowband blocking requirement	MBT, SBT ⁷	SBT, MBT ⁵	TC7b	TC7b
Additional narrowband blocking requirement for GSM/EDGE	SBT	SBT	-	
GSM/EDGE requirements for AM suppression	SBT	SBT	-	
Additional BC3 blocking requirement	MBT, SBT ⁷	SBT, MBT ⁵	N/A	TC7b
7.5 Out-of-band blocking				
General requirement	MBT, SBT ⁷	SBT, MBT ⁵	TC7b	TC7b
Co-location requirement	MBT, SBT ⁷	SBT, MBT ⁵	TC7b	TC7b
7.6 Receiver spurious emissions				
General requirement	SBT, MBT	SBT ² MBT ²	TC7b	TC7b
Additional requirement for BC2 (Category B)	SBT, MBT ³	SBT ² , MBT ^{2, 3}	TC7b	N/A
7.7 Receiver intermodulation				
General intermodulation requirement	MBT, SBT ⁷	SBT, MBT ⁵	TC7b	TC7b
General narrowband intermodulation requirement	MBT, SBT ⁷	SBT, MBT ⁵	TC7b	TC7b
Additional narrowband intermodulation requirement for GSM/EDGE	SBT	SBT	-	N/A
7.8 In-channel selectivity				
E-UTRA requirement	SBT	SBT	-	-
NB-IoT	SBT	SBT	-	-
NR	SBT	SBT	-	-

NOTE 1: MBT is only applicable when DB-DC-HSDPA / inter-band CA is supported.

NOTE 2: Single-band requirement apply to each antenna connector for both multi-band operation test and single-band operation test. For single-band operation test, other antenna connector(s) is (are) terminated.

NOTE 3: For multi-band operation, this additional requirement for BC2 is applicable only when all supported operating bands belong to BC2 and GSM/EDGE is configured in all operating bands.

NOTE 4: For ACLR, MBT shall be applied for the Inter RF Bandwidth gap only. In case of a BS capable of CS4, CS5, CS6 or CS7, the referenced test configuration shall be the corresponding one for CS1, CS2 or CS3 respectively, i.e. without GSM/EDGE carriers.

NOTE 5: MBT is only applied for multi-band receiver.

NOTE 6: MBT is only applicable for multi-band BS supporting CS4, CS5 or CS6 in at least one band.

NOTE 7: SBT is only applicable if different Capability Sets are declared for single-band and multi-band operation.

NOTE 8: There is no specific test with NB-IoT for those requirements, tests could be performed using E-UTRA signal only, without NB-IoT.

6 Transmitter characteristics

6.1 General

General test conditions for transmitter tests are given in clause 4, including interpretation of measurement results and configurations for testing. BS configurations for the tests are defined in clause 4.10.

Unless otherwise stated, a BS declared to be capable of E-UTRA with NB-IoT in-band or guard band operations (or any combination with GSM and/or UTRA or NR) is only required to pass the transmitter tests for E-UTRA with NB-IoT in-band or guard band (or any combination with GSM and/or UTRA or NR); it is not required to perform the transmitter tests again for E-UTRA only (or any combination with GSM and/or UTRA or NR).

Unless otherwise stated, a BS declared to be capable of E-UTRA with NB-IoT in-band and guard band operations (or any combination with GSM and/or UTRA or NR) needs only to pass the transmitter tests for E-UTRA with guard band operation (or any combination with GSM and/or UTRA or NR).

6.2 Base Station output power

6.2.1 Base Station maximum output power

6.2.1.1 Definition and applicability

Output power of the Base Station is the mean power delivered to a load with resistance equal to the nominal load impedance of the transmitter.

The maximum total output power, P_{\max} , of the Base Station is the mean power level measured at the antenna connector during the transmitter ON period in a specified reference condition.

The maximum RAT output power, $P_{\max,RAT}$, of the Base Station is the mean power level measured at the antenna connector during the transmitter ON period for a specific RAT in a specified reference condition.

The maximum carrier output power, $P_{\max,c}$ of the Base Station is the mean power level measured at the antenna connector during the transmitter ON period for a specific carrier in a specified reference condition.

The rated carrier output power, $P_{\text{Rated},c}$, of the base station is the mean power level for a specific carrier that the manufacturer has declared to be available at the antenna connector during the transmitter ON period.

In certain regions, the minimum requirement for normal conditions may apply also for some conditions outside the ranges defined for the Normal test environment in Annex B.

The rated carrier output power of the BS shall be as specified in Table 6.2-1.

Table 6.2-1: Base Station rated carrier output power

BS class	$P_{\text{Rated,c}}$ (note)
Wide Area BS	$\leq +38$ dBm
Medium Range BS	$\leq +24$ dBm
Local Area BS	$\leq +24$ dBm
NOTE: There is no upper limit for the rated carrier output power of the Wide Area Base Station.	

In addition, for Band 85 NB-IoT standalone operation, the BS rated output power limit of 43 dBm applies over the NB-IoT carriers in the range 728-729 MHz of the DL operating band. The BS output power limit of 43 dBm shall be considered as shared among all NB-IoT carriers in the 728-729 MHz frequency range or as the maximum value per NB-IoT carrier in the case where only one NB-IoT carrier is deployed in 728-729 MHz frequency range.

6.2.1.2 Minimum requirement

The minimum requirement is in TS 37.104 [2] clause 6.2.1.

6.2.1.2A Additional requirement (regional)

The additional requirement is in TS 37.104 [2] clause 6.2.2.

6.2.1.3 Test purpose

The test purpose is to verify the accuracy of the maximum carrier output power across the frequency range and under normal and extreme conditions for all transmitters in the BS.

6.2.1.4 Method of test

6.2.1.4.1 Initial conditions

Test environment: normal; see Annex B.2.

Base Station RF Bandwidth positions to be tested: B_{RFBW} , M_{RFBW} and T_{RFBW} in single-band operation, see clause 4.9.1; $B_{\text{RFBW}}T_{\text{RFBW}}$ and $B'_{\text{RFBW}}T_{\text{RFBW}}$ in multi-band operation, see clause 4.9.1.

In addition, a single test shall be performed under extreme power supply conditions as defined in Annex B.5. In this case, it is sufficient to test on a single combination of one ARFCN, UARFCN, E-ARFCN or NR-ARFCN, one Base Station RF Bandwidth position and with only one applicable test configuration defined in clause 5.

NOTE: Tests under extreme power supply also test extreme temperature.

Connect the power measuring equipment to the MSR Base Station antenna connector as shown in Annex D.1.1.

6.2.1.4.2 Procedure

- 1) Set the Base Station to transmit at maximum power according to the applicable test configuration in clause 5 using the corresponding test models or set of physical channels in clause 4.9.2.
- 2) Measure the mean power for each carrier at the Base Station antenna connector.

In addition, for a multi-band capable BS, the following step shall apply:

- 3) For multi-band capable BS and single band tests, repeat the steps above per involved band where single band test configurations and test models shall apply with no carrier activated in the other band. For multi-band capable BS with separate antenna connector, the antenna connector not being under test in case of SBT or MBT shall be terminated.

6.2.1.5 Test requirements

In normal conditions, the measurement result in step 2 of clause 6.2.1.4.2 shall for UTRA, E-UTRA and NR remain:

within +2.7 dB and –2.7 dB of the manufacturer's rated carrier output power for carrier frequency $f \leq 3.0$ GHz,
within +3.0 dB and –3.0 dB of the manufacturer's rated output power for carrier frequency $3.0 \text{ GHz} < f \leq 4.2 \text{ GHz}$,
and for GSM/EDGE and NB-IoT remain within +3.0 dB and –3.0 dB of the manufacturer's rated carrier output power.

In extreme conditions, measurement result in step 2 of clause 6.2.1.4.2 shall for UTRA, E-UTRA and NR remain:

within +3.2 dB and –3.2 dB of the manufacturer's rated carrier output power for carrier frequency $f \leq 3.0$ GHz,
within +3.5 dB and –3.5 dB of the manufacturer's rated output power for carrier frequency $3.0 \text{ GHz} < f \leq 4.2 \text{ GHz}$,
and for GSM/EDGE and NB-IoT remain within +3.5 dB and –3.5 dB of the manufacturer's rated carrier output power.

6.2.2 E-UTRA DL RS power

6.2.2.1 Definition and applicability

E-UTRA DL RS power is the resource element power of Downlink Reference Symbol.

The absolute DL RS power is indicated on the DL-SCH. The absolute accuracy is defined as the maximum deviation between the DL RS power indicated on the DL-SCH and the DL RS power at the BS antenna connector.

6.2.2.2 Minimum requirement

The minimum requirement is in TS 37.104 [2] clause 6.2.3.

6.2.2.3 Test purpose

The test purpose is to verify that the E-UTRA DL RS power is within the limits specified by the minimum requirement.

6.2.2.4 Method of test

For this requirement Tables 5.1-1 and 5.2-1 refer to single-RAT specifications; see clause 5. The following shall apply:

- For references to TS 36.141 [9], the method of test is specified in TS 36.141 [9], clause 6.5.4.4.

In addition, for a multi-band capable BS, the following step shall apply:

- For multi-band capable BS and single band tests, repeat the tests per involved band where single carrier test models shall apply with no carrier activated in the other band. For multi-band capable BS with separate antenna connector, the antenna connector not being under test shall be terminated.

6.2.2.5 Test requirements

The test requirement for DL RS power is specified in TS 36.141 [9], clause 6.5.4.5.

6.2.3 UTRA FDD primary CPICH power

6.2.3.1 Definition and applicability

UTRA FDD primary CPICH power is the code domain power of the Common Pilot Channel. Primary CPICH power is indicated on the BCH. CPICH power accuracy is defined as the maximum deviation between the Primary CPICH code domain power indicated on the BCH and the Primary CPICH code domain power measured at the TX antenna interface.

6.2.3.2 Minimum requirement

The minimum requirement is in TS 37.104 [2] clause 6.2.4.

6.2.3.3 Test purpose

The test purpose is to verify that the UTRA FDD primary CPICH power is within the limits specified by the minimum requirement.

6.2.3.4 Method of test

For this requirement Tables 5.1-1 and 5.2-1 refer to single-RAT specifications; see clause 5. The following shall apply:

- For references to TS 25.141 [10], the method of test is specified in TS 25.141 [10], clause 6.2.2.4.

In addition, for a multi-band capable BS, the following step shall apply:

- For multi-band capable BS and single band tests, repeat the tests per involved band where single band test configurations and test models shall apply with no carrier activated in the other band. For multi-band capable BS with separate antenna connector, the antenna connector not being under test shall be terminated.

6.2.3.5 Test requirements

For UTRA FDD the test requirement for CPICH power is specified in TS 25.141 [10], clause 6.2.2.5.

6.2.3A UTRA FDD secondary CPICH power

6.2.3A.1 Definition and applicability

UTRA FDD secondary CPICH power is the code domain power of the Secondary Common Pilot Channel. Secondary CPICH power is equal to the sum of the Primary CPICH power and the power offset, which are signalled to the UE. Secondary CPICH power accuracy is defined as the maximum deviation of the relevant IE between the Primary CPICH power transmitted at the first antenna connector and the Secondary CPICH power transmitted at the second antenna connector.

6.2.3A.2 Minimum requirement

The minimum requirement is in TS 37.104 [2] clause 6.2.4A.

6.2.3A.3 Test purpose

The test purpose is to verify that the UTRA FDD secondary CPICH power is within the limits specified by the minimum requirement.

6.2.3A.4 Method of test

For this requirement Tables 5.1-1 and 5.2-1 refer to single-RAT specifications; see clause 5. The following shall apply:

- For references to TS 25.141 [10], the method of test is specified in TS 25.141 [10], clause 6.2.3.4.

In addition, for a multi-band capable BS, the following step shall apply:

- For multi-band capable BS and single band tests, repeat the tests per involved band where single band test configurations and test models shall apply with no carrier activated in the other band. For multi-band capable BS with separate antenna connector, the antenna connector not being under test shall be terminated.

6.2.3A.5 Test requirements

For UTRA FDD the test requirement for CPICH power is specified in TS 25.141 [10], clause 6.2.3.5.

6.2.4 UTRA TDD primary CCPCH power

6.2.4.1 Definition and applicability

UTRA TDD primary CCPCH power is the code domain power of the Primary Common Control Physical Channel averaged over the transmit timeslot. Primary CCPCH power is signalled on the BCH.

UTRA TDD differential accuracy of the Primary CCPCH power is the relative transmitted power accuracy of PCCPCH in consecutive frames when the nominal PCCPCH power is not changed.

6.2.4.2 Minimum requirement

The minimum requirement is in TS 37.104 [2] clause 6.2.5.

6.2.4.3 Test purpose

The test purpose is to verify that the UTRA TDD primary CCPCH power and differential accuracy of Primary CCPCH power are within the limits specified by the minimum requirement.

6.2.4.4 Method of test

For this requirement Tables 5.1-1 and 5.2-1 refer to single-RAT specifications; see clause 5. The following shall apply:

- For references to TS 25.142, the methods of test are specified in TS 25.142 [12], clause 6.4.5.4 and 6.4.6.4 respectively.

In addition, for a multi-band capable BS, the following step shall apply:

- For multi-band capable BS and single band tests, repeat the tests per involved band where single band test configurations and test models shall apply with no carrier activated in the other band. For multi-band capable BS with separate antenna connector, the antenna connector not being under test shall be terminated.

6.2.4.5 Test requirements

For UTRA TDD, the test requirement for primary CCPCH power and the differential accuracy of Primary CCPCH power are specified in TS 25.142 [12], clause 6.4.5.5 and 6.4.6.5, respectively.

6.2.5 NB-IoT DL NRS power

6.2.5.1 Definition and applicability

For NB-IoT, DL NRS power is the resource element power of the Downlink Narrow-band Reference Signal.

The absolute DL NRS power is indicated on the DL-SCH. The absolute accuracy is defined as the maximum deviation between the DL NRS power indicated on the DL-SCH and the DL NRS power of each NB-IoT carrier at the BS antenna connector.

6.2.5.2 Minimum requirement

The minimum requirement is in TS 37.104 [2] clause 6.2.6.

6.2.5.3 Test purpose

The test purpose is to verify that the NB-IoT DL NRS power is within the limits specified by the minimum requirement.

6.2.5.4 Method of test

For this requirement Tables 5.1-1 and 5.2-1 refer to single-RAT specifications; see clause 5. The following shall apply:

- For references to TS 36.141 [9], the method of test is specified in TS 36.141 [9], clause 6.5.4.4.

6.2.5.5 Test requirements

The test requirement for DL RS power is specified in TS 36.141 [9], clause 6.5.4.5.

6.3 Output power dynamics

6.3.1 Definition and applicability

Output power dynamics is defined by the MSR BS transmitter's ability to operate at varying output power levels.

6.3.2 Minimum Requirement

The minimum requirement is in TS 37.104 [2] clause 6.3.

6.3.3 Test purpose

The test purpose is to verify that the output power dynamics are met as specified by the minimum requirement.

6.3.4 Method of test

For this requirement Tables 5.1-1 and 5.2-1 refer to single-RAT specifications; see clause 5, for a BS declared to support CS1 to CS6, CS8 to CS14 and CS16 to CS17. The following shall apply for a BS declared to support CS1 to CS6, CS8 to CS14 and CS16 to CS17:

- For references to TS 38.141-1 [26], the method of test is specified in TS 38.141-1 [26], clause 6.3.4.4.
- For references to TS 36.141 [9], the method of test is specified in TS 36.141 [9], clause 6.3.2.4 and 6.3.3.4.
- For references to TS 25.141 [10], the method of test is specified in TS 25.141 [10], clause 6.4.2.4, 6.4.3.4, 6.4.4.4 and 6.4.5.4.
- For references to TS 25.142 [12], the method of test is specified in TS 25.142 [12], clause 6.4.2.4, 6.4.3.4, 6.4.4.4, 6.4.5.4 and 6.4.6.4.
- For references to TS 51.021 [11], the method of test is specified in TS 51.021 [11], clause 6.3 and 6.4.

If a BS is declared to support CS7 and CS15, the following shall apply:

- For references to TS 36.141 [9], the method of test is specified in TS 36.141 [9], clause 6.3.2.4 and 6.3.3.4.
- For references to TS 25.141 [10], the method of test is specified in TS 25.141 [10], clause 6.4.2.4, 6.4.3.4, 6.4.4.4 and 6.4.5.4.
- For testing GSM/EDGE output power dynamics, steps in clause 6.3.4.1 and 6.3.4.2 shall apply.

6.3.4.1 Initial conditions for GSM/EDGE output power dynamics for CS7

Base Station RF Bandwidth positions to be tested: M_{RFBW} in single-band operation, see clause 4.9.1,

- 1) Set up the equipment as shown in Annex D.1.1.

6.3.4.2 Procedure for GSM/EDGE output power dynamics

- 1) Set the BS to transmit according to the applicable test configuration in clause 5 using the corresponding test models or set of physical channels in clause 4.9.2. The highest possible power shall be allocated to GSM carriers taking into account declared rated total output power for Sub-group 2 and maximum supported power difference between carriers.
- 2) Perform the measurement on a GSM/EDGE carrier as follows: For every measured GSM/EDGE carrier, the requirement and the method of test is specified in TS 51.021 [11], applicable parts of clause 6.3 and 6.4.

In addition, for a multi-band capable BS, the following step shall apply:

- For multi-band capable BS and single band tests, repeat the tests per involved band where single carrier test models shall apply with no carrier activated in the other band. For multi-band capable BS with separate antenna connector, the antenna connector not being under test shall be terminated.

6.3.5 Test Requirement

For E-UTRA, the test requirement is specified in TS 36.141 [9], clause 6.3.2.5.

For UTRA FDD, the test requirement is specified in TS 25.141 [10], clause 6.4.2.5, 6.4.3.5, 6.4.4.5 and 6.4.5.5.

For UTRA TDD, the test requirement is specified in TS 25.142 [12], clause 6.4.2.5, 6.4.3.5, 6.4.4.5, 6.4.5.5 and 6.4.6.5.

For GSM/EDGE, the test requirement is specified in TS 51.021 [11], clause 6.3.4 and 6.4.4.

For NB-IoT, the test requirement is specified in TS 36.141 [9], clause 6.3.3.5.

For NR, the test requirement is specified in TS 38.141-1 [26], clause 6.3.4.5.

6.4 Transmit ON/OFF power

The requirements in clause 6.4 are only applied for BC3 BS.

6.4.1 Definition and applicability

For UTRA and E-UTRA, transmitter OFF power is defined as the mean power measured over 70 us filtered with a square filter of bandwidth equal to the Base Station RF Bandwidth(s) of the BS centred on the central frequency of the Base Station RF Bandwidth(s) during the transmitter OFF period.

For NR, transmitter OFF power is defined as the mean power measured over $70/N$ us filtered with a square filter of bandwidth equal to the transmission bandwidth configuration of the BS (BW_{Config}) centred on the central frequency of the Base Station RF Bandwidth(s) during the transmitter OFF period. $N = \text{SCS}/15$, where SCS is Sub Carrier Spacing in kHz.

For BS supporting intra-band contiguous CA, the transmitter OFF power is defined as the mean power measured over $70/N$ us filtered with a square filter of bandwidth equal to the *Aggregated BS Channel Bandwidth* $BW_{\text{Channel_CA}}$ centred on $(F_{\text{edge,high}} + F_{\text{edge,low}})/2$ during the *transmitter OFF period*. N is equal to 1 if there are any UTRA or E-UTRA carriers, or for NR $N = \text{SCS}/15$, where SCS is the smallest supported Sub Carrier Spacing in kHz in the *Aggregated BS Channel Bandwidth*.

The transmitter transient period is the time period during which the transmitter is changing from the OFF period to the ON period or vice versa. The transmitter transient period is illustrated in Figure 6.4.1-1 and Figure 6.4.1-2.

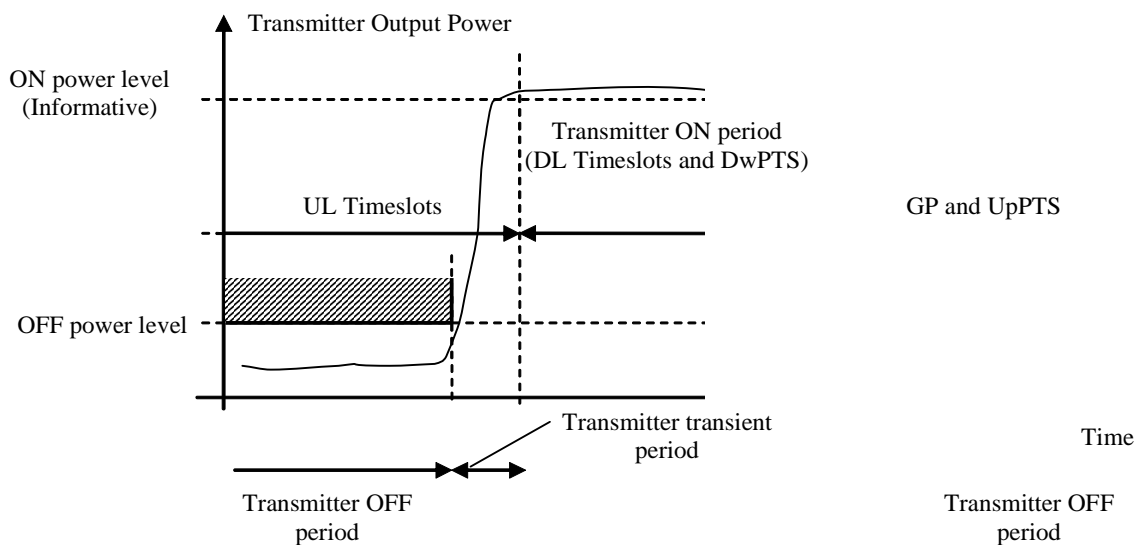

Figure 6.4.1-1: Illustration of the relations of transmitter ON period, transmitter OFF period and transmitter transient period (for E-UTRA/UTRA)

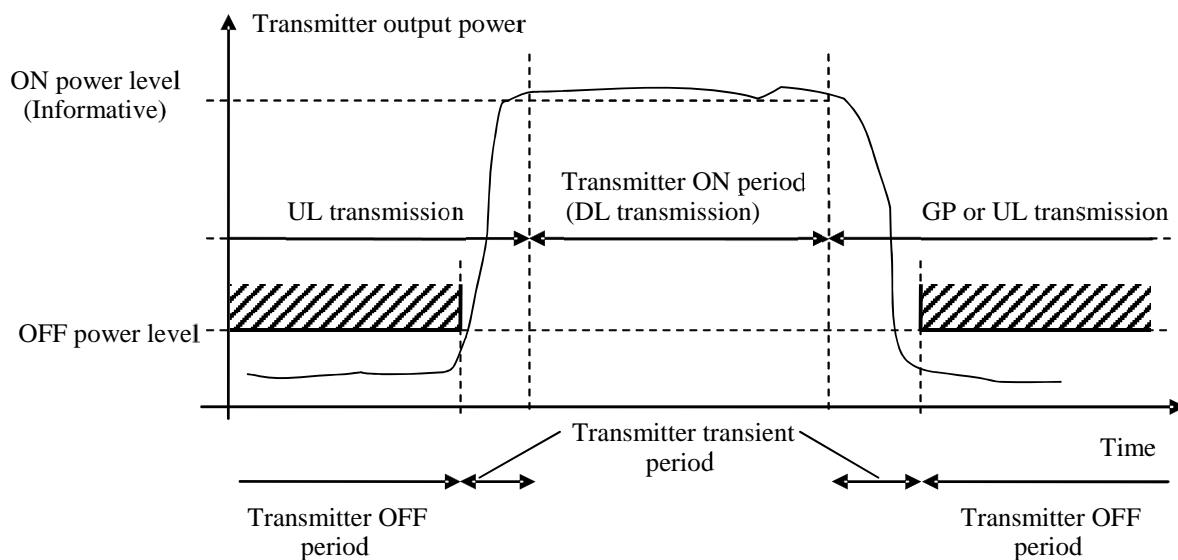

Figure 6.4.1-2: Illustration of the relations of transmitter ON period, transmitter OFF period and transmitter transient period (for NR)

6.4.2 Minimum Requirement

The minimum requirement is in TS 37.104 [2] clause 6.4.1.1 and clause 6.4.2.1.

6.4.3 Test purpose

The purpose of this test is to verify the BC3 BS transmitter OFF power and transient periods are within the limits of the minimum requirements.

6.4.4 Method of test

6.4.4.1 Initial conditions

Test environment: normal; see Annex B.2.

Base Station RF Bandwidth positions to be tested: M_{RFBW} in single band operation, see clause 4.9.1; $B_{\text{RFBW}}T_{\text{RFBW}}$ and $B'_{\text{RFBW}}T_{\text{RFBW}}$ in multi-band operation; see clause 4.9.1.

Connect the signal analyzer to the MSR BS antenna connector as shown in Annex D.1.1.

6.4.4.2 Procedure

- 1) Set the BS to transmit a signal according to the applicable test configuration in clause 5 using the corresponding test models or set of physical channels in clause 4.9.2.
- 2) For UTRA and E-UTRA, measure the mean power spectral density measured over $70\mu\text{s}$ filtered with a square filter of bandwidth equal to the Base Station RF Bandwidth centred on the central frequency of the Base Station RF Bandwidth. $70\mu\text{s}$ average window centre is set from $35\mu\text{s}$ after end of one transmitter ON period + $17\mu\text{s}$ to $35\mu\text{s}$ before start of next transmitter ON period – $6.25\mu\text{s}$.

For NR, measure the mean power spectral density over $70/N \mu\text{s}$ filtered with a square filter of bandwidth equal to the RF bandwidth of the *antenna connector* centred on the central frequency of the RF bandwidth. $70/N \mu\text{s}$ average window centre is set from $35/N \mu\text{s}$ after end of one transmitter ON period + $10 \mu\text{s}$ to $35/N \mu\text{s}$ before start of next transmitter ON period – $10 \mu\text{s}$. $N = \text{SCS}/15$, where SCS is Sub Carrier Spacing in kHz.

For multi-band capable BS with separate antenna connector, the antenna connector not being under test shall be terminated.

6.4.5 Test requirement

The transmitter OFF power spectral density shall be less than -83 dBm/MHz .

For BS capable of multi-band operation, the requirement is only applicable during the transmitter OFF period in all supported operating bands.

The measured mean power spectral density according to clause 6.4.4.2 shall be less than -83 dBm/MHz for carrier frequency $f \leq 3.0 \text{ GHz}$.

The measured mean power spectral density shall be less than -82.5 dBm/MHz for carrier frequency $3.0 \text{ GHz} < f \leq 4.2 \text{ GHz}$.

NOTE: If the above Test Requirement differs from the Minimum Requirement then the Test Tolerance applied for this test is non-zero. The Test Tolerance for this test and the explanation of how the Minimum Requirement has been relaxed by the Test Tolerance are given in Annex C.

6.5 Transmitted signal quality

6.5.1 Modulation quality

6.5.1.1 Definition and applicability

Modulation quality is defined by the difference between the measured carrier signal and a reference signal. Modulation quality can e.g. be expressed as Error Vector Magnitude (EVM), Peak Code Domain Error (PCDE) or Relative Code Domain Error (RCDE).

6.5.1.2 Minimum Requirement

The minimum requirement is in TS 37.104 [2] clause 6.5.1.

6.5.1.3 Test purpose

The test purpose is to verify that modulation quality is within the limit specified by the minimum requirement.

6.5.1.4 Method of test

6.5.1.4.1 Initial conditions

Test environment: normal; see Annex B.2.

Base Station RF Bandwidth position to be tested: B_{RFBW} , M_{RFBW} and T_{RFBW} single-band operation, see clause 4.9.1 single-band operation.

- 1) Connect measurement device to the base station antenna connector as shown in Annex D.1.1.

6.5.1.4.2 Procedure

- 1) Set the BS to transmit according to the applicable test configuration in clause 5 using the corresponding test models or set of physical channels in clause 4.9.2.
- 2) Perform the modulation quality measurement on each carrier as outlined in respective measurement procedures in RAT-specific specifications, with the test configurations, test models or corresponding set of physical channels as defined in step 1:
 - For EVM measurement on a NR carrier, see TS 38.141-1 [26] clause 6.5.3.4.2.
 - For EVM measurement on an E-UTRA carrier, see TS 36.141 [9] clause 6.5.2.4.2.
 - For EVM measurement on a UTRA FDD carrier, see TS 25.141 [10] clause 6.7.1.4.2.
 - For PCDE measurement on a UTRA FDD carrier, see TS 25.141 [10] clause 6.7.2.4.2.
 - For RCDE measurement on a UTRA FDD carrier, see TS 25.141 [10] clause 6.7.4.4.2.
 - For EVM measurement on a UTRA TDD carrier, see TS 25.142 [12] clause 6.8.1.4.2.2.
 - For PCDE measurement on a UTRA TDD carrier, see TS 25.142 [12] clause 6.8.2.4.1.2.
 - For RCDE measurement on a UTRA TDD carrier, see TS 25.142 [12] clause 6.8.3.4.1.1.
 - For EVM measurement on a GSM/EDGE carrier, see TS 51.021 [11] clause 6.2.2.
 - For EVM measurement on an NB-IoT carrier, see TS 36.141 [9] clause 6.5.2.4.2.

In addition, for a multi-band capable BS, the following step shall apply:

- 3) For multi-band capable BS and single band tests, repeat the steps above per involved band where single band test configurations and test models shall apply with no carrier activated in the other band. For multi-band capable BS with separate antenna connector, the antenna connector not being under test in case of SBT or MBT shall be terminated.

6.5.1.5 Test Requirements

6.5.1.5.1 E-UTRA test requirement

For every measured E-UTRA carrier, the test requirement is specified in TS 36.141 [9] clause 6.5.2.5.

6.5.1.5.2 UTRA FDD test requirement

For every measured UTRA FDD carrier, the test requirement is specified in TS 25.141 [10] clause 6.7.1.5, 6.7.2.5 and 6.7.4.5.

6.5.1.5.3 UTRA TDD test requirement

For every measured UTRA TDD carrier, the test requirement is specified in TS 25.142 [12] clause 6.8.1.5, 6.8.2.5 and 6.8.3.5.

6.5.1.5.4 GSM/EDGE test requirement

For every measured GSM/EDGE carrier, the test requirement is specified in TS 51.021 [11] clause 6.2.3.

6.5.1.5.5 NB-IoT test requirement

For every measured NB-IoT carrier, the test requirement is specified in TS 36.141 [9] clause 6.5.2.5.

6.5.1.5.6 NR test requirement

For every measured NR carrier, the test requirement is specified in TS 38.141-1 [26] clause 6.5.3.5.

6.5.2 Frequency error

6.5.2.1 Definition and applicability

Frequency error is the measure of the difference between the actual BS transmit frequency and the assigned frequency. The same source shall be used for RF frequency and data clock generation.

It is not possible to verify by testing that the data clock is derived from the same frequency source as used for RF generation. This may be confirmed by the manufacturer's declaration.

6.5.2.2 Minimum Requirement

The minimum requirement is in TS 37.104 [2] clause 6.5.2.

6.5.2.3 Test purpose

The test purpose is to verify that frequency error is within the limit specified by the minimum requirement.

6.5.2.4 Method of test

Requirement is tested together with Error Vector Magnitude test, as described in clause 6.5.1.

6.5.2.5 Test Requirements

6.5.2.5.1 E-UTRA test requirement

For every measured E-UTRA carrier, the test requirement is specified in TS 36.141 [9] clause 6.5.1.5.

6.5.2.5.2 UTRA FDD test requirement

For every measured UTRA FDD carrier, the test requirement is specified in TS 25.141 [10] clause 6.3.5.

6.5.2.5.3 UTRA TDD test requirement

For every measured UTRA TDD carrier, the test requirement is specified in TS 25.142 [12] clause 6.3.5.

6.5.2.5.4 GSM/EDGE test requirement

For every measured GSM/EDGE carrier, the test requirement is specified in TS 51.021 [11] clause 6.2.3.

6.5.2.5.5 NB-IoT test requirement

For every measured NB-IoT carrier, the test requirement is specified in TS 36.141 [9] clause 6.5.1.5.

6.5.2.5.6 NR test requirement

For every measured NR carrier, the test requirement is specified in TS 38.141-1 [26] clause 6.5.2.5.

6.5.3 Time alignment error

6.5.3.1 Definition and applicability

This requirement applies to frame timing in:

- UTRA single/multi-carrier transmissions, and their combinations with MIMO or TX diversity.
- E-UTRA single/multi-carrier transmissions, and their combinations with MIMO or TX diversity.
- NR single/multi-carrier transmissions, and their combinations with MIMO.
- E-UTRA Carrier Aggregation, with or without MIMO or TX diversity.
- NR Carrier Aggregation, with or without MIMO.
- NB-IoT transmissions with TX diversity.

Frames of the WCDMA/LTE/NR/NB-IoT signals present at the BS transmitter antenna connector(s) are not perfectly aligned in time. In relation to each other, the RF signals present at the BS transmitter antenna connector(s) experience certain timing differences.

For a specific set of signals/transmitter configuration/transmission mode, Time Alignment Error (TAE) is defined as the largest timing difference between any two signals.

6.5.3.2 Minimum requirement

The minimum requirement is in TS 37.104 [2] clause 6.5.3.

6.5.3.3 Test purpose

To verify that the time alignment error is within the limit specified by the minimum requirement.

6.5.3.4 Method of test

For this requirement Tables 5.1-1 and 5.2-1 refer to single-RAT specifications; see clause 5. The following shall apply:

- For references to TS 25.141 [10], the method of test is specified in TS 25.141 [10], clause 6.7.3.4.
- For references to TS 25.142 [12], the method of test is specified in TS 25.142 [12], clause 6.8.4.4.
- For references to TS 36.141 [9], the method of test is specified in TS 36.141 [9], clause 6.5.3.4.
- For references to TS 38.141-1 [26], the method of test is specified in TS 38.141-1 [26], clause 6.5.4.4.

In addition, for a multi-band capable BS, the following step shall apply:

- For multi-band capable BS and single band tests, repeat the tests per involved band where single band test configurations and test models shall apply with no carrier activated in the other band. For multi-band capable BS with separate antenna connector, the antenna connector not being under test in case of SBT or MBT shall be terminated.

6.5.3.5 Test requirement

For E-UTRA, the test requirement for time alignment error is specified in TS 36.141 [9], clause 6.5.3.5.

For UTRA FDD, the test requirement for time alignment error is specified in TS 25.141 [10], clause 6.7.3.5.

For UTRA TDD, the test requirement for time alignment error is specified in TS 25.142 [12], clause 6.8.4.5.

For NB-IoT, the test requirement for time alignment error is specified in TS 36.141 [9], clause 6.5.3.5.

For NR, the test requirement for time alignment error is specified in TS 38.141-1 [26], clause 6.5.4.5.

6.6 Unwanted emissions

Unwanted emissions consist of out-of-band emissions and spurious emissions [13]. Out of band emissions are unwanted emissions immediately outside the channel bandwidth resulting from the modulation process and non-linearity in the transmitter but excluding spurious emissions. Spurious emissions are emissions which are caused by unwanted transmitter effects such as harmonics emission, parasitic emission, intermodulation products and frequency conversion products, but exclude out of band emissions.

The out-of-band emissions requirement for the BS transmitter is specified in terms of an Operating band unwanted emissions requirement that defines limits for emissions in each supported downlink operating band plus the frequency ranges Δf_{OBUE} above and Δf_{OBUE} below each band. Emissions outside of this frequency range are limited by a spurious emissions requirement. The values of Δf_{OBUE} are defined in table 6.6-1. For a BS with multi-RAT operation where the individual RATs are in different RAT specific bands that partially or fully overlap; Δf_{OBUE} is according to the combined frequency range occupied by the overlapping bands.

Table 6.6-1: Maximum offset of OBUE outside the downlink operating band

Operating band characteristics	Δf_{OBUE} [MHz]
$F_{\text{DL_high}} - F_{\text{DL_low}} \leq 200$ MHz	10
$200 \text{ MHz} < F_{\text{DL_high}} - F_{\text{DL_low}} \leq 900$ MHz	40

There is in addition a requirement for occupied bandwidth and an ACLR requirement applicable for some RATs.

6.6.1 Transmitter spurious emissions

6.6.1.1 Definition and applicability

The transmitter spurious emission limits apply from 9 kHz to 12.75 GHz, excluding the frequency range from Δf_{OBUE} below the lowest frequency of the downlink operating band up to Δf_{OBUE} above the highest frequency of the downlink operating band. For BS capable of multi-band operation where multiple bands are mapped on the same antenna connector, this exclusion applies for each supported operating band. For BS capable of multi-band operation where multiple bands are mapped on separate antenna connectors, the single-band requirements apply and the multi-band exclusions and provisions are not applicable.

Exceptions are the requirement in Table 6.6.1.3.1-2 in TS 37.104 [2], and specifically stated exceptions in Table 6.6.1.5.5-1 that apply also closer than Δf_{OBUE} from the downlink operating band. For some operating bands the upper frequency limit is higher than 12.75 GHz.

The requirements shall apply whatever the type of transmitter considered. It applies for all transmission modes foreseen by the manufacturer's specification. Unless otherwise stated, all requirements are measured as mean power (RMS).

6.6.1.2 Minimum requirement

The minimum requirement is in TS 37.104 [2] clause 6.6.1.

6.6.1.3 Test purpose

This test measures conducted spurious emission from the MSR BS transmitter antenna connector, while the transmitter is in operation.

6.6.1.4 Method of test

6.6.1.4.1 Initial conditions

Test environment: normal; see Annex B.2.

Base Station RF Bandwidth positions to be tested: B_{RFBW} , M_{RFBW} and T_{RFBW} single-band operation, see clause 4.9.1; $B_{\text{RFBW}}T_{\text{RFBW}}$ and $B'_{\text{RFBW}}T_{\text{RFBW}}$ in multi-band operation, see clause 4.9.1.

- 1) Connect the BS antenna connector to a measurement receiver according to Annex D.1.1 using an attenuator or a directional coupler if necessary
- 2) Measurements shall use a measurement bandwidth in accordance to the conditions in TS 37.104 [2] clause 6.6.1.
- 3) Detection mode: True RMS.

6.6.1.4.2 Procedure

- 1) Set the Base Station to transmit at maximum power according to the applicable test configuration in clause 5 using the corresponding test models or set of physical channels in clause 4.9.2.
- 2) Measure the emission at the specified frequencies with specified measurement bandwidth and note that the measured value does not exceed the specified value.

In addition, for a multi-band capable BS, the following step shall apply:

- 4) For multi-band capable BS and single band tests, repeat the steps above per involved band where single band test configurations and test models shall apply with no carrier activated in the other band. For multi-band capable BS with separate antenna connector, the antenna connector not being under test in case of SBT or MBT shall be terminated.

6.6.1.5 Test requirements

The measurement result in step 2 of 6.6.1.4.2 shall not exceed the maximum level specified in Table 6.6.1.5.1-1 to Table 6.6.1.5.6-1 if applicable for the BS under test.

The test requirements of either clause 6.6.1.5.1 (Category A limits) or clause 6.6.1.5.2 (Category B limits) shall apply. In addition for a BS operating in Band Category 2, the test requirements of 6.6.1.5.3 shall apply in case of Category B limits.

6.6.1.5.1 Spurious emissions (Category A)

The power of any spurious emission shall not exceed the limits in Table 6.6.1.5.1-1

Table 6.6.1.5.1-1: BS Spurious emission limits, Category A

Frequency range	Maximum level	Measurement Bandwidth	Note
9kHz - 150kHz	-13 dBm	1 kHz	Note 1
150kHz - 30MHz		10 kHz	Note 1
30MHz - 1GHz		100 kHz	Note 1
1GHz - 12.75 GHz		1 MHz	Note 2
12.75 GHz – 5 th harmonic of the upper frequency edge of the DL operating band in GHz		1 MHz	Note 2, Note 3
NOTE 1: Bandwidth as in ITU-R SM.329 [13], s4.1			
NOTE 2: Bandwidth as in ITU-R SM.329 [13], s4.1. Upper frequency as in ITU-R SM.329 [13], s2.5 table 1			
NOTE 3: This spurious frequency range applies only for <i>operating bands</i> for which the 5 th harmonic of the upper frequency edge of the DL <i>operating band</i> is reaching beyond 12.75 GHz.			

6.6.1.5.2 Spurious emissions (Category B)

The power of any spurious emission shall not exceed the limits in Table 6.6.1.5.2-1

Table 6.6.1.5.2-1: BS Spurious emissions limits, Category B

Frequency range	Maximum Level	Measurement Bandwidth	Note
9 kHz ↔ 150 kHz	-36 dBm	1 kHz	Note 1
150 kHz ↔ 30 MHz	-36 dBm	10 kHz	Note 1
30 MHz ↔ 1 GHz	-36 dBm	100 kHz	Note 1
1 GHz ↔ 12.75 GHz	-30 dBm	1 MHz	Note 2
12.75 GHz ↔ 5 th harmonic of the upper frequency edge of the DL operating band in GHz	-30 dBm	1 MHz	Note 2, Note 3
NOTE 1: Bandwidth as in ITU-R SM.329 [13], s4.1			
NOTE 2: Bandwidth as in ITU-R SM.329 [13], s4.1. Upper frequency as in ITU-R SM.329 [13], s2.5 table 1			
NOTE 3: This spurious frequency range applies only for <i>operating bands</i> for which the 5 th harmonic of the upper frequency edge of the DL <i>operating band</i> is reaching beyond 12.75 GHz.			

6.6.1.5.3 Additional test requirement for BC2 (category B)

For a BS operating in Band Category 2 when GSM/EDGE is configured, the power of any spurious emission shall not exceed the limits in Table 6.6.1.5.3-1.

For BS capable of multi-band operation, the limits in Table 6.6.1.5.3-1 are only applicable when all supported operating bands belong to BC2 and GSM/EDGE is configured in all bands.

Table 6.6.1.5.3-1: Additional BS Spurious emissions limits for BC2, Category B

Frequency range	Frequency offset from transmitter operating band edge (Note1)	Maximum Level	Measurement Bandwidth
500 MHz ↔ 1 GHz	10 – 20 MHz	-36 dBm	300 kHz
	20 – 30 MHz	-36 dBm	1 MHz
	≥ 30 MHz	-36 dBm	3 MHz
1 GHz ↔ 12.75 GHz	≥ 30 MHz	-30 dBm	3 MHz
NOTE 1: For BS capable of multi-band operation, the frequency offset is relative to the closest operating band.			

6.6.1.5.4 Protection of the BS receiver of own or different BS

This requirement shall be applied for FDD operation in order to prevent the receivers of Base Stations being desensitised by emissions from the BS transmitter. It is measured at the transmit antenna port for any type of BS which has common or separate Tx/Rx antenna ports.

The power of any spurious emission shall not exceed the limits in Table 6.6.1.5.4-1, depending on the declared Base Station class and Band Category.

Table 6.6.1.5.4-1: BS Spurious emissions limits for protection of the BS receiver

BS Class	Band category	Frequency range	Maximum Level	Measurement Bandwidth	Note
Wide Area BS	BC1	$F_{UL_low} - F_{UL_high}$	-96 dBm	100 kHz	
Wide Area BS	BC2	$F_{UL_low} - F_{UL_high}$	-98 dBm	100 kHz	
Medium Range BS	BC1,BC2	$F_{UL_low} - F_{UL_high}$	-91 dBm	100 kHz	
Local Area BS	BC1,BC2	$F_{UL_low} - F_{UL_high}$	-88 dBm	100 kHz	
Note 1: For E-UTRA Band 28 BS operating in regions where Band 28 is only partially allocated for E-UTRA operations, this requirement only applies in the UL frequency range of the partial allocation.					

6.6.1.5.5 Additional spurious emission requirements

These requirements may be applied for the protection of system operating in frequency ranges other than the BS downlink operating band. The limits may apply as an optional protection of such systems that are deployed in the same geographical area as the BS, or they may be set by local or regional regulation as a mandatory requirement for an operating band. It is in some cases not stated in the present document whether a requirement is mandatory or under what exact circumstances that a limit applies, since this is set by local or regional regulation. An overview of regional requirements in the present document is given in clause 4.4.

Some requirements may apply for the protection of specific equipment (UE, MS and/or BS) or equipment operating in specific systems (GSM/EDGE, CDMA, UTRA, E-UTRA, NR, etc.) as listed below. The power of any spurious emission shall not exceed the limits of Table 6.6.1.5.5-1 for a BS where requirements for co-existence with the system listed in the first column apply. For BS capable of multi-band operation, the exclusions and conditions in the Note column of Table 6.6.1.5.5-1 apply for each supported operating band. For BS capable of multi-band operation where multiple bands are mapped on separate antenna connectors, the exclusions and conditions in the Note column of Table 6.6.1.5.5-1 apply for the operating band supported at that antenna connector.

Table 6.6.1.5.5-1: BS Spurious emissions limits for co-existence with systems operating in other frequency bands

System type to co-exist with	Frequency range for co-existence requirement	Maximum Level	Measurement Bandwidth	Note
GSM900	921 - 960 MHz	-57 dBm	100 kHz	This requirement does not apply to BS operating in band 8
	876 - 915 MHz	-61 dBm	100 kHz	For the frequency range 880-915 MHz, this requirement does not apply to BS operating in band 8, since it is already covered by the requirement in clause 6.6.1.5.4.
DCS1800 (Note 3)	1805 - 1880 MHz	-47 dBm	100 kHz	This requirement does not apply to BS operating in band 3.
	1710 - 1785 MHz	-61 dBm	100 kHz	This requirement does not apply to BS operating in band 3, since it is already covered by the requirement in clause 6.6.1.5.4.
PCS1900	1930 - 1990 MHz	-47 dBm	100 kHz	This requirement does not apply to BS operating in band 2, 25, band 36 or band 70.
	1850 - 1910 MHz	-61 dBm	100 kHz	This requirement does not apply to BS operating in band 2 or 25, since it is already covered by the requirement in clause 6.6.1.5.4. This requirement does not apply to BS operating in band 35.
GSM850 or CDMA850	869 - 894 MHz	-57 dBm	100 kHz	This requirement does not apply to BS operating in band 5 or 26. This requirement applies to E-UTRA BS operating in Band 27 for the frequency range 879-894 MHz.
	824 - 849 MHz	-61 dBm	100 kHz	This requirement does not apply to BS operating in band 5 or 26, since it is already covered by the requirement in clause 6.6.1.5.4. For BS operating in Band 27, it applies 3 MHz below the Band 27 downlink operating band.
UTRA FDD Band I or E-UTRA Band 1 or NR Band n1	2110 - 2170 MHz	-52 dBm	1 MHz	This requirement does not apply to BS operating in band 1 or 65 .
	1920 - 1980 MHz	-49 dBm	1 MHz	This requirement does not apply to BS operating in band 1 or 65, since it is already covered by the requirement in clause 6.6.1.5.4.
UTRA FDD Band II or E-UTRA Band 2 or NR Band n2	1930 - 1990 MHz	-52 dBm	1 MHz	This requirement does not apply to BS operating in band 2, 25 or 70.
	1850 - 1910 MHz	-49 dBm	1 MHz	This requirement does not apply to BS operating in band 2 or 25, since it is already covered by the requirement in clause 6.6.1.5.4
UTRA FDD Band III or E-UTRA Band 3 or NR Band n3 (Note 3)	1805 - 1880 MHz	-52 dBm	1 MHz	This requirement does not apply to BS operating in band 3 or 9.
	1710 - 1785 MHz	-49 dBm	1 MHz	This requirement does not apply to BS operating in band 3, since it is already covered by the requirement in clause 6.6.1.5.4. For BS operating in band 9, it applies for 1710 MHz to 1749.9 MHz and 1784.9 MHz to 1785 MHz, while the rest is covered in clause 6.6.1.5.4.
UTRA FDD Band IV or E-UTRA Band 4	2110 - 2155 MHz	-52 dBm	1 MHz	This requirement does not apply to BS operating in band 4, 10 or 66.
	1710 - 1755 MHz	-49 dBm	1 MHz	This requirement does not apply to BS operating in band 4, 10 or 66, since it is already covered by the requirement in clause 6.6.1.5.4.
UTRA FDD Band V or E-UTRA Band 5 or NR Band n5	869 - 894 MHz	-52 dBm	1 MHz	This requirement does not apply to BS operating in band 5 or 26. This requirement applies to E-UTRA BS operating in Band 27 for the frequency range 879-894 MHz.
	824 - 849 MHz	-49 dBm	1 MHz	This requirement does not apply to BS operating in band 5 or 26, since it is already covered by the requirement in clause 6.6.1.5.4. For BS operating in Band 27, it applies 3 MHz below the Band 27 downlink operating band.
UTRA FDD Band VI, XIX or E-UTRA Band 6, 18, 19	860 - 890 MHz	-52 dBm	1 MHz	This requirement does not apply to BS operating in band 6, 18, 19
	815 - 830 MHz	-49 dBm	1 MHz	This requirement does not apply to BS operating in band 18 since it is already covered by the requirement in clause 6.6.1.5.4.

	830 - 845 MHz	-49 dBm	1 MHz	This requirement does not apply to BS operating in band 6, 19, since it is already covered by the requirement in clause 6.6.1.5.4.
UTRA FDD Band VII or E-UTRA Band 7 or NR Band n7	2620 - 2690 MHz	-52 dBm	1 MHz	This requirement does not apply to BS operating in band 7.
	2500 - 2570 MHz	-49 dBm	1 MHz	This requirement does not apply to BS operating in band 7, since it is already covered by the requirement in clause 6.6.1.5.4.
UTRA FDD Band VIII or E-UTRA Band 8 or NR Band n8	925 - 960 MHz	-52 dBm	1 MHz	This requirement does not apply to BS operating in band 8.
	880 - 915 MHz	-49 dBm	1 MHz	This requirement does not apply to BS operating in band 8, since it is already covered by the requirement in clause 6.6.1.5.4.
UTRA FDD Band IX or E-UTRA Band 9	1844.9 - 1879.9 MHz	-52 dBm	1 MHz	This requirement does not apply to BS operating in band 3 or 9.
	1749.9 - 1784.9 MHz	-49 dBm	1 MHz	This requirement does not apply to BS operating in band 3 or 9, since it is already covered by the requirement in clause 6.6.1.5.4.
UTRA FDD Band X or E-UTRA Band 10	2110 - 2170 MHz	-52 dBm	1 MHz	This requirement does not apply to BS operating in band 4, 10 or 66.
	1710 - 1770 MHz	-49 dBm	1 MHz	This requirement does not apply to BS operating in band 10 or 66, since it is already covered by the requirement in clause 6.6.1.5.4. For BS operating in band 4, it applies for 1755 MHz to 1770 MHz, while the rest is covered in clause 6.6.1.5.4.
UTRA FDD Band XI or XXI or E-UTRA Band 11 or 21	1475.9 - 1510.9 MHz	-52 dBm	1 MHz	This requirement does not apply to BS operating in band 11, 21, 32, 50, 74 or 75.
	1427.9 - 1447.9 MHz	-49 dBm	1 MHz	This requirement does not apply to BS operating in band 11 or 74, since it is already covered by the requirement in clause 6.6.1.5.4. This requirement does not apply to BS operating in band 32, 50, 51, 75 or 76.
	1447.9 - 1462.9 MHz	-49 dBm	1 MHz	This requirement does not apply to BS operating in band 21 or 74, since it is already covered by the requirement in clause 6.6.1.5.4. This requirement does not apply to BS operating in band 32, 50 or 75.
UTRA FDD Band XII or E-UTRA Band 12 or NR Band n12	729 - 746 MHz	-52 dBm	1 MHz	This requirement does not apply to BS operating in band 12 or 85.
	699 - 716 MHz	-49 dBm	1 MHz	This requirement does not apply to BS operating in band 12 or 85, since it is already covered by the requirement in clause 6.6.1.5.4. For BS operating in Band 29, it applies 1 MHz below the Band 29 downlink operating band (Note 7).
UTRA FDD Band XIII or E-UTRA Band 13	746 - 756 MHz	-52 dBm	1 MHz	This requirement does not apply to BS operating in band 13.
	777 - 787 MHz	-49 dBm	1 MHz	This requirement does not apply to BS operating in band 13, since it is already covered by the requirement in clause 6.6.1.5.4.
UTRA FDD Band XIV or E-UTRA Band 14	758 - 768 MHz	-52 dBm	1 MHz	This requirement does not apply to BS operating in band 14.
	788 - 798 MHz	-49 dBm	1 MHz	This requirement does not apply to BS operating in band 14, since it is already covered by the requirement in clause 6.6.1.5.4.
E-UTRA Band 17	734 - 746 MHz	-52 dBm	1 MHz	This requirement does not apply to BS operating in band 17.
	704 - 716 MHz	-49 dBm	1 MHz	This requirement does not apply to BS operating in band 17, since it is already covered by the requirement in clause 6.6.1.5.4. For BS operating in Band 29, it applies 1 MHz below the Band 29 downlink operating band (Note 7).
UTRA FDD Band XX or E-UTRA Band 20 or NR Band n20	791 - 821 MHz	-52 dBm	1 MHz	This requirement does not apply to BS operating in band 20 or 28.
	832 - 862 MHz	-49 dBm	1 MHz	This requirement does not apply to BS operating in band 20, since it is already covered by the requirement in clause 6.6.1.5.4.
UTRA FDD Band XXII or	3510 - 3590 MHz	-52 dBm	1 MHz	This requirement does not apply to BS operating in band 22, 42, 48, 49, 77 or 78.

E-UTRA Band 22	3410 – 3490 MHz	-49 dBm	1 MHz	This requirement does not apply to BS operating in band 22, since it is already covered by the requirement in clause 6.6.1.5.4. This requirement does not apply to Band 42
E-UTRA Band 24	1525 – 1559 MHz	-52 dBm	1 MHz	This requirement does not apply to BS operating in band 24.
	1626.5 – 1660.5 MHz	-49 dBm	1 MHz	This requirement does not apply to BS operating in band 24, since it is already covered by the requirement in clause 6.6.1.5.4.
UTRA FDD Band XXV or E-UTRA Band 25 or NR Band n25	1930 - 1995 MHz	-52 dBm	1 MHz	This requirement does not apply to BS operating in band 2, 25 or 70.
	1850 - 1915 MHz	-49 dBm	1 MHz	This requirement does not apply to BS operating in band 25, since it is already covered by the requirement in clause 6.6.1.5.4. For BS operating in band 2, it applies for 1910 MHz to 1915 MHz, while the rest is covered in clause 6.6.1.5.4.
UTRA FDD Band XXVI or E-UTRA Band 26	859 - 894 MHz	-52 dBm	1 MHz	This requirement does not apply to BS operating in band 5 or 26. This requirement applies to E-UTRA BS operating in Band 27 for the frequency range 879-894 MHz.
	814 - 849 MHz	-49 dBm	1 MHz	This requirement does not apply to BS operating in band 26, since it is already covered by the requirement in clause 6.6.1.5.4. For BS operating in band 5, it applies for 814 MHz to 824 MHz, while the rest is covered in clause 6.6.1.5.4. For BS operating in Band 27, it applies 3 MHz below the Band 27 downlink operating band.
E-UTRA Band 27	852 – 869 MHz	-52 dBm	1 MHz	This requirement does not apply to BS operating in band 5, 26 or 27.
	807 – 824 MHz	-49 dBm	1 MHz	This requirement does not apply to BS operating in band 27, since it is already covered by the requirement in clause 6.6.1.5.4. For BS operating in Band 26, it applies for 807 MHz to 814 MHz, while the rest is covered in clause 6.6.1.5.4. This requirement also applies to BS operating in Band 28, starting 4 MHz above the Band 28 downlink operating band (Note 6).
E-UTRA Band 28 or NR Band n28	758 - 803 MHz	-52 dBm	1 MHz	This requirement does not apply to BS operating in band 20, 28, 44 or 67.
	703 - 748 MHz	-49 dBm	1 MHz	This requirement does not apply to BS operating in band 28, since it is already covered by the requirement in clause 6.6.1.5.4. This requirement does not apply to BS operating in Band 44. For BS operating in Band 67, it applies for 703-736MHz. For E-UTRA BS operating in Band 68, it applies for 728MHz to 733MHz.
E-UTRA Band 29	717 – 728 MHz	-52 dBm	1 MHz	This requirement does not apply to BS operating in Band 29 or 85.
E-UTRA Band 30	2350 - 2360 MHz	-52 dBm	1 MHz	This requirement does not apply to BS operating in band 30 or 40.
	2305 - 2315 MHz	-49 dBm	1 MHz	This requirement does not apply to BS operating in band 30, since it is already covered by the requirement in clause 6.6.1.5.4. This requirement does not apply to BS operating in Band 40.
E-UTRA Band 31	462.5 – 467.5 MHz	-52 dBm	1 MHz	This requirement does not apply to BS operating in band 31, 72 or 73.
	452.5 – 457.5 MHz	-49 dBm	1 MHz	This requirement does not apply to BS operating in band 31, since it is already covered by the requirement in clause 6.6.1.5.4. This requirement does not apply to BS operating in band 72 or 73.
UTRA FDD Band XXXII or E-UTRA Band 32	1452 - 1496 MHz	-52 dBm	1 MHz	This requirement does not apply to BS operating in band 11, 21, 32, 50, 74 or 75.

UTRA TDD Band a) or E-UTRA Band 33	1900 - 1920 MHz	-52 dBm	1 MHz	This requirement does not apply to BS operating in Band 33
UTRA TDD Band a) or E-UTRA Band 34 or NR Band n34	2010 - 2025 MHz	-52 dBm	1 MHz	This requirement does not apply to BS operating in Band 34
UTRA TDD Band b) or E-UTRA Band 35	1850 – 1910 MHz	-52 dBm	1 MHz	This requirement does not apply to BS operating in Band 35
UTRA TDD Band b) or E-UTRA Band 36	1930 - 1990 MHz	-52 dBm	1 MHz	This requirement does not apply to BS operating in Band 2, 25 or 36
UTRA TDD in Band c) or E-UTRA Band 37	1910 - 1930 MHz	-52 dBm	1 MHz	This is not applicable to BS operating in Band 37. This unpaired band is defined in ITU-R M.1036, but is pending any future deployment.
UTRA TDD Band d) or E-UTRA Band 38 or NR Band n38	2570 – 2620 MHz	-52 dBm	1 MHz	This requirement does not apply to BS operating in Band 38 or 69.
UTRA TDD Band f) or E-UTRA Band 39 or NR Band n39	1880 – 1920MHz	-52 dBm	1 MHz	This is not applicable to BS operating in Band 39
UTRA TDD Band e) or E-UTRA Band 40 or NR Band n40	2300 – 2400MHz	-52 dBm	1 MHz	This is not applicable to BS operating in Band 30 or 40
E-UTRA Band 41 or NR Band n41	2496 – 2690MHz	-52 dBm	1 MHz	This is not applicable to BS operating in Band 41
E-UTRA Band 42	3400 – 3600 MHz	-52 dBm	1 MHz	This is not applicable to BS operating in Band 22, 42, 43, 48, 49, 52, 77 or 78.
E-UTRA Band 43	3600 – 3800 MHz	-52 dBm	1 MHz	This is not applicable to BS operating in Band 42, 43, 48, 49, 77 or 78.
E-UTRA Band 44	703 - 803 MHz	-52 dBm	1 MHz	This is not applicable to BS operating in Band 28 or 44
E-UTRA Band 45	1447 - 1467 MHz	-52 dBm	1 MHz	This is not applicable to BS operating in Band 45
E-UTRA Band 46	5150 - 5925 MHz	-52 dBm	1 MHz	This is not applicable to BS operating in Band 46
E-UTRA Band 47	5855 - 5925 MHz	-52 dBm	1 MHz	
E-UTRA Band 48	3550 – 3700 MHz	-52 dBm	1 MHz	This is not applicable to BS operating in Band 22, 42, 43, 48, 49, 77 or 78
E-UTRA Band 49	3550 – 3700 MHz	-52 dBm	1 MHz	This is not applicable to BS operating in Band 22, 42, 43, 48, 49, 77 or 78
E-UTRA Band 50 or NR Band n50	1432 - 1517 MHz	-52 dBm	1 MHz	This requirement does not apply to E-UTRA BS operating in Band 11, 21, 32, 45, 50, 51, 74, 75 or 76.
E-UTRA Band 51 or NR Band n51	1427 - 1432 MHz	-52 dBm	1 MHz	This requirement does not apply to E-UTRA BS operating in Band 50, 51, 75 or 76.
E-UTRA Band 52	3300 – 3400 MHz	-52 dBm	1 MHz	This is not applicable to BS operating in Band 42 or 52.
E-UTRA Band 65	2110 - 2200 MHz	-52 dBm	1 MHz	This requirement does not apply to BS operating in band 1 or 65,
	1920 - 2010 MHz	-49 dBm	1 MHz	This requirement does not apply to BS operating in band 65, since it is already covered by the requirement in clause 6.6.1.5.4. For BS operating in Band 1, it applies for 1980 MHz to 2010 MHz, while the rest is covered in clause 6.6.1.5.4.

E-UTRA Band 66 or NR Band n66	2110 - 2200 MHz	-52 dBm	1 MHz	This requirement does not apply to BS operating in band 4, 10, 23 or 66.
	1710 - 1780 MHz	-49 dBm	1 MHz	This requirement does not apply to BS operating in band 66, since it is already covered by the requirement in clause 6.6.1.5.4. For BS operating in Band 4, it applies for 1755 MHz to 1780 MHz, while the rest is covered in clause 6.6.1.5.4. For BS operating in Band 10, it applies for 1770 MHz to 1780 MHz, while the rest is covered in clause 6.6.1.5.4.
E-UTRA Band 67	738 – 758 MHz	-52 dBm	1 MHz	This requirement does not apply to BS operating in band 28 or 67.
E-UTRA Band 68	753 -783 MHz	-52 dBm	1 MHz	This requirement does not apply to BS operating in band 28 or 68.
	698-728 MHz	-49 dBm	1 MHz	This requirement does not apply to BS operating in band 68, since it is already covered by the requirement in clause 6.6.1.5.4. For BS operating in Band 28, it applies between 698 MHz and 703 MHz, while the rest is covered in clause 6.6.1.5.4.
E-UTRA Band 69	2570 - 2620 MHz	-52 dBm	1 MHz	This requirement does not apply to BS operating in Band 38 or 69.
E-UTRA Band 70 or NR Band n70	1995 - 2020 MHz	-52 dBm	1 MHz	This requirement does not apply to BS operating in band 2, 25 or 70
	1695 – 1710 MHz	-49 dBm	1 MHz	This requirement does not apply to BS operating in band 70, since it is already covered by the requirement in clause 6.6.1.5.4.
E-UTRA Band 71 or NR Band n71	617 - 652 MHz	-52 dBm	1 MHz	This requirement does not apply to BS operating in band 71.
	663 – 698 MHz	-49 dBm	1 MHz	This requirement does not apply to BS operating in band 71, since it is already covered by the requirement in clause 6.6.1.5.4.
E-UTRA Band 72	461 - 466 MHz	-52 dBm	1 MHz	This requirement does not apply to BS operating in band 31, 72 or 73.
	451 - 456 MHz	-49 dBm	1 MHz	This requirement does not apply to BS operating in band 72, since it is already covered by the requirement in clause 6.6.1.5.4. This requirement does not apply to BS operating in band 73.
E-UTRA Band 73	460 - 465 MHz	-52 dBm	1 MHz	This requirement does not apply to BS operating in band 31, 72 or 73.
	450 - 455 MHz	-49 dBm	1 MHz	This requirement does not apply to BS operating in band 73, since it is already covered by the requirement in clause 6.6.1.5.4.
E-UTRA Band 74 or NR Band n74	1475 – 1518 MHz	-52 dBm	1 MHz	This requirement does not apply to BS operating in band 11, 21, 32, 50, 74 or 75.
	1427 – 1470 MHz	-49 dBm	1MHz	This requirement does not apply to BS operating in Band 74, since it is already covered by the requirement in clause 6.6.1.5.4. This requirement does not apply to BS operating in band 32, 45, 50, 51, 75 or 76.
E-UTRA Band 75 or NR Band n75	1432 - 1517 MHz	-52 dBm	1 MHz	This requirement does not apply to BS operating in Band 11, 21, 32, 45, 50, 51, 74, 75 or 76.
E-UTRA Band 76 or NR Band n76	1427 - 1432 MHz	-52 dBm	1 MHz	This requirement does not apply to BS operating in Band 50, 51, 75 or 76.
NR Band n77	3300 MHz – 4200 MHz	-52 dBm	1 MHz	This is not applicable to BS operating in Band 22, 42, 43, 48, 49, 52, 77 or 78
NR Band n78	3300 MHz – 3800 MHz	-52 dBm	1 MHz	This is not applicable to BS operating in Band 22, 42, 43, 48, 49, 52, 77 or 78
NR Band n80	1710 - 1785 MHz	-49 dBm	1 MHz	This requirement does not apply to BS operating in band 3, since it is already covered by the requirement in clause 6.6.1.5.4. For BS operating in band 9, it applies for 1710 MHz to 1749.9 MHz and 1784.9 MHz to 1785 MHz, while the rest is covered in clause 6.6.1.5.4.

NR Band n81	880 - 915 MHz	-49 dBm	1 MHz	This requirement does not apply to BS operating in band 8, since it is already covered by the requirement in clause 6.6.1.5.4.
NR Band n82	832 - 862 MHz	-49 dBm	1 MHz	This requirement does not apply to BS operating in band 20, since it is already covered by the requirement in clause 6.6.1.5.4.
NR Band n83	703 - 748 MHz	-49 dBm	1 MHz	This requirement does not apply to BS operating in band 28, since it is already covered by the requirement in clause 6.6.1.5.4. This requirement does not apply to BS operating in Band 44. For BS operating in Band 67, it applies for 703-736MHz. For BS operating in Band 68, it applies for 728MHz to 733MHz.
NR Band n84	1920 - 1980 MHz	-49 dBm	1 MHz	This requirement does not apply to BS operating in band 1 or 65, since it is already covered by the requirement in clause 6.6.1.5.4.
E-UTRA Band 85	728 - 746 MHz	-52 dBm	1 MHz	This requirement does not apply to BS operating in band 12, 29 or 85.
	698 - 716 MHz	-49 dBm	1 MHz	This requirement does not apply to BS operating in band 85, since it is already covered by the requirement in clause 6.6.1.5.4. For BS operating in Band 29, it applies 1 MHz below the Band 29 downlink operating band (Note 7).
NR Band n86	1710 - 1780 MHz	-49 dBm	1 MHz	This requirement does not apply to BS operating in band 66, since it is already covered by the requirement in clause 6.6.1.5.4. For BS operating in Band 4, it applies for 1755 MHz to 1780 MHz, while the rest is covered in clause 6.6.1.5.4. For BS operating in Band 10, it applies for 1770 MHz to 1780 MHz, while the rest is covered in clause 6.6.1.5.4.
NOTE 5: Void				

NOTE 1: As defined in the scope for spurious emissions in this clause, except for the cases where the noted requirements apply to a BS operating in Band 25, Band 27, Band 28 or Band 29, the co-existence requirements in Table 6.6.1.5.5-1 do not apply for the 10 MHz frequency range immediately outside the downlink operating band (see Tables 4.4-1 and 4.4-2). Emission limits for this excluded frequency range may be covered by local or regional requirements.

NOTE 2: Table 6.6.1.5.5-1 assumes that two operating bands, where the frequency ranges in Table 4.4-1 or Table 4.4-2 would be overlapping, are not deployed in the same geographical area. For such a case of operation with overlapping frequency arrangements in the same geographical area, special co-existence requirements may apply that are not covered by the 3GPP specifications.

NOTE 3: For the protection of DCS1800, UTRA Band III, E-UTRA Band 3 or NR Band n3 in China, the frequency ranges of the downlink and uplink protection requirements are 1805 – 1850 MHz and 1710 – 1755 MHz respectively.

NOTE 4: TDD base stations deployed in the same geographical area, that are synchronized and use the same or adjacent operating bands can transmit without additional co-existence requirements. For unsynchronized base stations(except in Band 46), special co-existence requirements may apply that are not covered by the 3GPP specifications.

NOTE 6: For Band 28 BS, specific solutions may be required to fulfil the spurious emissions limits for BS for co-existence with Band 27 UL operating band.

NOTE 7: For Band 29 BS, specific solutions may be required to fulfil the spurious emissions limits for BS for co-existence with UTRA Band XII or E-UTRA Band 12 UL operating band or E-UTRA Band 17 UL operating band or E-UTRA Band 85 UL operating band.

The following requirement may be applied for the protection of PHS. This requirement is also applicable at specified frequencies falling between Δf_{OBUE} below the lowest BS transmitter frequency of the downlink operating band and Δf_{OBUE} above the highest BS transmitter frequency of the downlink operating band.

The power of any spurious emission shall not exceed:

Table 6.6.1.5.5-2: BS Spurious emissions limits for BS for co-existence with PHS

Frequency range	Maximum Level	Measurement Bandwidth	Note
1884.5 - 1915.7 MHz	-41 dBm	300 kHz	Applicable for co-existence with PHS system operating in 1884.5-1915.7MHz
NOTE: The requirement is not applicable in China.			

The following requirement may apply to operating in Band 41 in certain regions. This requirement is also applicable at the frequency range from Δf_{OBUE} below the lowest frequency of the BS downlink operating band up to Δf_{OBUE} above the highest frequency of the BS downlink operating band.

For Band 41 NR operation, the additional BS spurious emissions limits shall be applied to the sum of the emission power over all *antenna connectors*.

The power of any spurious emission shall not exceed:

Table 6.6.1.5.5-3: Additional BS Spurious emissions limits for BS operating in Band 41

Frequency range	Maximum Level	Measurement Bandwidth	Note
2505MHz – 2535MHz	-42dBm	1 MHz	
NOTE: This requirement applies for carriers allocated within 2545-2645 MHz.			

In addition to the requirements in clauses 6.6.1.5.1 to 6.6.1.5.4 and above in the present clause, the BS may have to comply with the applicable emission limits established by FCC Title 47 [8], when deployed in regions where those limits are applied, and under the conditions declared by the manufacturer.

The following requirement may apply to BS operating in Band 30 in certain regions. This requirement is also applicable at the frequency range from 10 MHz below the lowest frequency of the BS downlink operating band up to 10 MHz above the highest frequency of the BS downlink operating band.

The power of any spurious emission shall not exceed:

Table 6.6.1.5.5-4: Additional BS Spurious emissions limits for Band 30

Frequency range	Maximum Level	Measurement Bandwidth	Note
2200MHz – 2345MHz	-45dBm	1 MHz	
2362.5MHz – 2365MHz	-25dBm	1 MHz	
2365MHz – 2367.5MHz	-40dBm	1 MHz	
2367.5MHz – 2370MHz	-42dBm	1 MHz	
2370MHz – 2395MHz	-45dBm	1 MHz	

In certain regions the following requirement may apply to E-UTRA BS operating in Band 45. Emissions shall not exceed the maximum levels specified in Table 6.6.1.5.5-5.

Table 6.6.1.5.5-5: Emissions limits for protection of adjacent band services

Operating Band	Filter centre frequency, F_{filter}	Maximum Level [dBm]	Measurement Bandwidth
45	$F_{\text{filter}} = 1467.5$	-20	1 MHz
	$F_{\text{filter}} = 1468.5$	-23	1 MHz
	$F_{\text{filter}} = 1469.5$	-26	1 MHz
	$F_{\text{filter}} = 1470.5$	-33	1 MHz
	$F_{\text{filter}} = 1471.5$	-40	1 MHz
	$1472.5 \text{ MHz} \leq F_{\text{filter}} \leq 1491.5 \text{ MHz}$	-47	1 MHz

The following requirement may apply to E-UTRA BS operating in Band 48 in certain regions. The power of any spurious emission shall not exceed:

Table 6.6.1.5.5-6: Additional BS Spurious emissions limits for Band 48

Frequency range	Maximum Level	Measurement Bandwidth	Note
3530MHz – 3720MHz	-25dBm	1 MHz	Applicable 10MHz from the assigned channel edge
3100MHz – 3530MHz 3720MHz – 4200MHz	-40dBm	1 MHz	

6.6.1.5.6 Co-location with other Base Stations

These requirements may be applied for the protection of other BS receivers when GSM900, DCS1800, PCS1900, GSM850, CDMA850, UTRA FDD, UTRA TDD, E-UTRA and/or NR BS are co-located with a BS.

The requirements assume a 30 dB coupling loss between transmitter and receiver and are based on co-location with base stations of the same class.

The power of any spurious emission shall not exceed the limits of Table 6.6.1.5.6-1 for a BS where requirements for co-location with a BS type listed in the first column apply, depending on the declared Base Station class. For BS capable of multi-band operation, the exclusions and conditions in the Note column of Table 6.6.1.5.6-1 apply for each supported operating band. For BS capable of multi-band operation where multiple bands are mapped on separate antenna

connectors, the exclusions and conditions in the Note column of Table 6.6.1.5.6-1 apply for the operating band supported at that antenna connector.

Table 6.6.1.5.6-1: BS Spurious emissions limits for BS co-located with another BS

Type of co-located BS	Frequency range for co-location requirement	Maximum Level (WA BS)	Maximum Level (MR BS)	Maximum Level (LA BS)	Measurement Bandwidth	Note
GSM900	876-915 MHz	-98 dBm	-91 dBm	-88 dBm	100 kHz	
DCS1800	1710 - 1785 MHz	-98 dBm	-91 dBm	-88 dBm	100 kHz	
PCS1900	1850 - 1910 MHz	-98 dBm	-91 dBm	-88 dBm	100 kHz	
GSM850 or CDMA850	824 - 849 MHz	-98 dBm	-91 dBm	-88 dBm	100 kHz	
UTRA FDD Band I or E-UTRA Band 1 or NR Band n1	1920 - 1980 MHz	-96 dBm	-91 dBm	-88 dBm	100 kHz	
UTRA FDD Band II or E-UTRA Band 2 or NR Band n2	1850 - 1910 MHz	-96 dBm	-91 dBm	-88 dBm	100 kHz	
UTRA FDD Band III or E-UTRA Band 3 or NR Band n3	1710 - 1785 MHz	-96 dBm	-91 dBm	-88 dBm	100 kHz	
UTRA FDD Band IV or E-UTRA Band 4	1710 - 1755 MHz	-96 dBm	-91 dBm	-88 dBm	100 kHz	
UTRA FDD Band V or E-UTRA Band 5 or NR Band n5	824 - 849 MHz	-96 dBm	-91 dBm	-88 dBm	100 kHz	
UTRA FDD Band VI, XIX or E-UTRA Band 6, 19	830 - 845 MHz	-96 dBm	-91 dBm	-88 dBm	100 kHz	
UTRA FDD Band VII or E-UTRA Band 7 or NR Band n7	2500 - 2570 MHz	-96 dBm	-91 dBm	-88 dBm	100 kHz	
UTRA FDD Band VIII or E-UTRA Band 8 or NR Band n8	880 - 915 MHz	-96 dBm	-91 dBm	-88 dBm	100 kHz	
UTRA FDD Band IX or E-UTRA Band 9	1749.9 - 1784.9 MHz	-96 dBm	-91 dBm	-88 dBm	100 kHz	
UTRA FDD Band X or E-UTRA Band 10	1710 - 1770 MHz	-96 dBm	-91 dBm	-88 dBm	100 kHz	
UTRA FDD Band XI or E-UTRA Band 11	1427.9 - 1447.9 MHz	-96 dBm	-91 dBm	-88 dBm	100 kHz	This is not applicable to BS operating in Band 50, 51, 75 or 76
UTRA FDD Band XII or E-UTRA Band 12 or NR Band n12	699 - 716 MHz	-96 dBm	-91 dBm	-88 dBm	100 kHz	
UTRA FDD Band XIII or E-UTRA Band 13	777 - 787 MHz	-96 dBm	-91 dBm	-88 dBm	100 kHz	
UTRA FDD Band XIV or E-UTRA Band 14	788 - 798 MHz	-96 dBm	-91 dBm	-88 dBm	100 kHz	
E-UTRA Band 17	704 - 716 MHz	-96 dBm	-91 dBm	-88 dBm	100 kHz	
E-UTRA Band 18	815 - 830 MHz	-96 dBm	-91 dBm	-88 dBm	100 kHz	
UTRA FDD Band XX or E-UTRA Band 20 or NR Band n20	832 - 862 MHz	-96 dBm	-91 dBm	-88 dBm	100 kHz	
UTRA FDD Band XXI or E-UTRA Band 21	1447.9 – 1462.9 MHz	-96 dBm	-91 dBm	-88 dBm	100 kHz	This is not applicable to BS operating in Band 32, 50 or 75

UTRA FDD Band XXII or E-UTRA Band 22	3410 – 3490 MHz	-96 dBm	-91 dBm	-88 dBm	100 kHz	This is not applicable to BS operating in Band 42, 77 or 78
E-UTRA Band 23	2000 - 2020 MHz	-96 dBm	-91 dBm	-88 dBm	100 kHz	
E-UTRA Band 24	1626.5 – 1660.5 MHz	-96 dBm	-91 dBm	-88 dBm	100 kHz	
UTRA FDD Band XXV or E-UTRA Band 25 or NR Band n25	1850 - 1915 MHz	-96 dBm	-91 dBm	-88 dBm	100 kHz	
UTRA FDD Band XXVI or E-UTRA Band 26	814 - 849 MHz	-96 dBm	-91 dBm	-88 dBm	100 kHz	
E-UTRA Band 27	807 - 824 MHz	-96 dBm	-91 dBm	-88 dBm	100 kHz	
E-UTRA Band 28 or NR Band n28	703 – 748 MHz	-96 dBm	-91 dBm	-88 dBm	100 kHz	This is not applicable to BS operating in Band 44
E-UTRA Band 30	2305 - 2315 MHz	-96 dBm	-91 dBm	-88 dBm	100 kHz	This is not applicable to BS operating in Band 40
E-UTRA Band 31	452.5 – 457.5 MHz	-96 dBm	-91 dBm	-88 dBm	100 kHz	
UTRA TDD Band a) or E-UTRA Band 33	1900 - 1920 MHz	-96 dBm	-91 dBm	-88 dBm	100 kHz	This is not applicable to BS operating in Band 33
UTRA TDD Band a) or E-UTRA Band 34 or NR Band n34	2010 - 2025 MHz	-96 dBm	-91 dBm	-88 dBm	100 kHz	This is not applicable to BS operating in Band 34
UTRA TDD Band b) or E-UTRA Band 35	1850 – 1910 MHz	-96 dBm	-91 dBm	-88 dBm	100 kHz	This is not applicable to BS operating in Band 35
UTRA TDD Band b) or E-UTRA Band 36	1930 - 1990 MHz	-96 dBm	-91 dBm	-88 dBm	100 kHz	This is not applicable to BS operating in Band 2 and 36
UTRA TDD Band c) or E-UTRA Band 37	1910 - 1930 MHz	-96 dBm	-91 dBm	-88 dBm	100 kHz	This is not applicable to BS operating in Band 37. This unpaired band is defined in ITU-R M.1036, but is pending any future deployment.
UTRA TDD Band d) or E-UTRA Band 38 or NR Band n38	2570 – 2620 MHz	-96 dBm	-91 dBm	-88 dBm	100 kHz	This is not applicable to BS operating in Band 38.

UTRA TDD Band f) or E-UTRA Band 39 or NR Band n39	1880 – 1920MHz	-96 dBm	-91 dBm	-88 dBm	100 kHz	This is not applicable to BS operating in Band 33 and 39
UTRA TDD Band e) or E-UTRA Band 40 or NR Band n40	2300 – 2400MHz	-96 dBm	-91 dBm	-88 dBm	100 kHz	This is not applicable to BS operating in Band 30 or 40
E-UTRA Band 41 or NR Band n41	2496 – 2690MHz	-96 dBm	-91 dBm	-88 dBm	100 kHz	This is not applicable to BS operating in Band 41
E-UTRA Band 42	3400 – 3600 MHz	-96 dBm	-91 dBm	-88 dBm	100 kHz	This is not applicable to BS operating in Band 22, 42, 43, 48, 49, 52 77 or 78.
E-UTRA Band 43	3600 – 3800 MHz	-96 dBm	-91 dBm	-88 dBm	100 kHz	This is not applicable to BS operating in Band 42, 43, 48, 49 77 or 78.
E-UTRA Band 44	703 – 803 MHz	-96 dBm	-91 dBm	-88 dBm	100 kHz	This is not applicable to BS operating in Band 28 or 44
E-UTRA Band 45	1447 – 1467 MHz	-96 dBm	-91 dBm	-88 dBm	100 kHz	This is not applicable to BS operating in Band 45
E-UTRA Band 46	5150 – 5925 MHz	N/A	-91 dBm	-88 dBm	100 kHz	This is not applicable to BS operating in Band 46
E-UTRA Band 48	3550 – 3700 MHz	-96 dBm	-91 dBm	-88 dBm	100 kHz	This is not applicable to BS operating in Band 42, 43, 48, 49, 77 or 78
E-UTRA Band 49	3550 – 3700 MHz	N/A	N/A	-88 dBm	100 kHz	This is not applicable to BS operating in Band 42, 43, 48, 49, 77 or 78

E-UTRA Band 50 or NR Band n50	1432 – 1517 MHz	-96 dBm	-91 dBm	-88 dBm	100 kHz	This is not applicable to BS operating in Band 11, 21, 32, 51, 74, 75 or 76
E-UTRA Band 51 or NR Band n51	1427 – 1432 MHz	N/A	N/A	-88 dBm	100 kHz	This is not applicable to E-UTRA BS operating in Band 50, 75 or 76
E-UTRA Band 52	3300 – 3400 MHz	-96 dBm	-91 dBm	-88 dBm	100 kHz	This is not applicable to BS operating in Band 42 or 52.
E-UTRA Band 65	1920 - 2010 MHz	-96 dBm	-91 dBm	-88 dBm	100 kHz	
E-UTRA Band 66 or NR Band n66	1710 – 1780 MHz	-96 dBm	-91 dBm	-88 dBm	100 kHz	
E-UTRA Band 68	698 – 728 MHz	-96 dBm	-91 dBm	-88 dBm	100 kHz	
E-UTRA Band 70 or NR Band n70	1695 – 1710 MHz	-96 dBm	-91 dBm	-88 dBm	100 kHz	
E-UTRA Band 71 or NR Band 71	663 – 698 MHz	-96 dBm	-91 dBm	-88 dBm	100 kHz	
E-UTRA Band 72	451 – 456 MHz	-96 dBm	-91 dBm	-88 dBm	100 kHz	
E-UTRA Band 73	450 – 455 MHz	-96 dBm	-91 dBm	-88 dBm	100 kHz	
E-UTRA Band 74 or NR Band n74	1427 – 1470 MHz	-96 dBm	-91 dBm	-88 dBm	100 kHz	This is not applicable to BS operating in Band 50 or 51
NR Band n77	3300 MHz – 4200 MHz	-96 dBm	-91 dBm	-88 dBm	100 kHz	This is not applicable to BS operating in Band 22, 42, 43, 48, 49, 52, 77 or 78
NR Band n78	3300 MHz – 3800 MHz	-96 dBm	-91 dBm	-88 dBm	100 kHz	This is not applicable to BS operating in Band 22, 42, 43, 48, 49, 52, 77 or 78
NR Band n80	1710 – 1785 MHz	-96 dBm	-91 dBm	-88 dBm	100 kHz	
NR Band n81	880 – 915 MHz	-96 dBm	-91 dBm	-88 dBm	100 kHz	
NR Band n82	832 – 862 MHz	-96 dBm	-91 dBm	-88 dBm	100 kHz	
NR Band n83	703 – 748 MHz	-96 dBm	-91 dBm	-88 dBm	100 kHz	This is not applicable to BS operating in Band 44
NR Band n84	1920 – 1980 MHz	-96 dBm	-91 dBm	-88 dBm	100 kHz	
E-UTRA Band 85	698 - 716 MHz	-96 dBm	-91 dBm	-88 dBm	100 kHz	
NR Band n86	1710 – 1780 MHz	-96 dBm	-91 dBm	-88 dBm	100 kHz	

NOTE 1: As defined in the scope for spurious emissions in this clause, the co-location requirements in Table 6.6.1.5.6-1 do not apply for the Δf_{OBUE} frequency range immediately outside the BS transmit frequency range of a downlink operating band (see Tables 4.4-1 and 4.4-2). The current state-of-the-art technology does not allow a single generic solution for co-location with other system on adjacent frequencies for 30 dB BS-BS minimum coupling loss. However, there are certain site-engineering solutions that can be used. These techniques are addressed in TR 25.942 [14].

NOTE 2: Table 6.6.1.5.6-1 assumes that two operating bands, where the corresponding BS transmit and receive frequency ranges in Table 4.4-1 or Table 4.4-2 would be overlapping, are not deployed in the same geographical area. For such a case of operation with overlapping frequency arrangements in the same geographical area, special co-location requirements may apply that are not covered by the 3GPP specifications.

NOTE 3: Co-located TDD Base Stations that are synchronized and using the same or adjacent operating band can transmit without special co-locations requirements. For unsynchronized Base Stations, special co-location requirements may apply that are not covered by the 3GPP specifications.

6.6.2 Operating band unwanted emissions

6.6.2.1 Definition and applicability

The Operating band unwanted emission limits are defined from Δf_{OBUE} below the lowest frequency of each supported downlink operating band to the lower Base Station RF Bandwidth edge located at $F_{\text{BW RF,low}}$ and from the upper Base Station RF Bandwidth edge located at $F_{\text{BW RF,high}}$ up to Δf_{OBUE} above the highest frequency of each supported downlink operating band. In addition, for a BS operating in non-contiguous spectrum, it applies inside any sub-block gap. In addition, for a BS operating in multiple bands, it applies inside any Inter RF Bandwidth gap. The values of Δf_{OBUE} are defined in table 6.6-1.

The requirements shall apply whatever the type of transmitter considered and for all transmission modes foreseen by the manufacturer's specification, except for any operating band with GSM/EDGE single RAT operation. The requirements in TS 45.005 [6] as defined in clause 6.6.2.3 apply to an MSR Base Station for any operating band with GSM/EDGE single RAT operation in Band Category 2.

For BS capable of multi-band operation where multiple bands are mapped on separate antenna connectors, the single-band requirements apply and the cumulative evaluation of the emission limit in the Inter RF Bandwidth gap are not applicable.

6.6.2.2 Minimum requirement

The minimum requirement is in TS 37.104 [2] clause 6.6.2.1, 6.6.2.2, 6.6.2.3 and 6.6.2.4.

6.6.2.3 Test purpose

This test measures the emissions of the MSR BS, close to the assigned channel bandwidth of the wanted signal, while the transmitter is in operation.

6.6.2.4 Method of test

For some of the test cases Tables 5.1-1 and 5.2-1 refer to single-RAT specifications; see clause 5. In this case the following shall apply:

- For references to TS 25.141 [10], the method of test is specified in TS 25.141 [10], clause 6.5.2.1.4.
- For references to TS 25.142 [12], the method of test is specified in TS 25.142 [12], clause 6.6.2.1.4.
- For references to TS 36.141 [9], the method of test is specified in TS 36.141 [9], clause 6.6.3.4.
- For references to TS 38.141-1 [26], the method of test is specified in TS 38.141-1 [26], clause 6.6.4.4.

NOTE: In this case the test requirements of the present document defined in clause 6.6.2.5 apply.

For GSM/EDGE single-RAT requirements, the method of test is specified in TS 51.021 [11], applicable parts of clause 6.5.1, 6.5.2, 6.6.2 and 6.12.

For test requirements of operating band unwanted emissions using the MSR test configurations defined in clause 4.8, the method of test described in clauses 6.6.2.4.1 and 6.6.2.4.2 applies.

6.6.2.4.1 Initial conditions

Test environment: normal; see Annex B.2.

Base Station RF Bandwidth positions to be tested: B_{RFBW} , M_{RFBW} and T_{RFBW} in single-band operation, see clause 4.9.1; $B_{\text{RFBW}}T_{\text{RFBW}}$ and $B'_{\text{RFBW}}T_{\text{RFBW}}$ in multi-band operation, see clause 4.9.1.

- 1) Connect the signal analyzer to the Base Station antenna connector as shown in Annex D.1.1.

As a general rule, the resolution bandwidth of the measuring equipment should be equal to the measurement bandwidth. However, to improve measurement accuracy, sensitivity, efficiency and to avoid e.g. carrier leakage, the resolution bandwidth may be smaller than the measurement bandwidth. When the resolution bandwidth is smaller than the measurement bandwidth, the result should be integrated over the measurement bandwidth in order to obtain the equivalent noise bandwidth of the measurement bandwidth.

- 2) Detection mode: True RMS.

6.6.2.4.2 Procedure

- 1) Set the Base Station to transmit at maximum power according to the applicable test configuration in clause 5 using the corresponding test models or set of physical channels in clause 4.9.2.
- 2) Step the centre frequency of the measurement filter in contiguous steps and measure the emission within the specified frequency ranges with the specified measurement bandwidth. For BS operating in multiple bands or non-contiguous spectrum, the emission within the Inter RF Bandwidth or sub-block gap shall be measured using the specified measurement bandwidth from the closest RF Bandwidth or sub block edge.
- 3) Repeat the test for the remaining test cases with channel set-up according to clause 5 and clause 4.9.2.

In addition, for a multi-band capable BS, the following step shall apply:

- 4) For multi-band capable BS and single band tests, repeat the steps above per involved band where single band test configurations and test models shall apply with no carrier activated in the other band. For multi-band capable BS with separate antenna connector, the antenna connector not being under test in case of SBT or MBT shall be terminated.

6.6.2.5 Test requirement

6.6.2.5.1 Test requirements for Band Categories 1 and 3

For a Wide Area BS operating in Band Category 1 or Band Category 3, the requirement applies outside the Base Station RF Bandwidth edges. In addition, for a Wide Area BS operating in non-contiguous spectrum, it applies inside any sub-block gap. In addition, for a Wide Area BS operating in multiple bands, it applies inside any Inter RF Bandwidth gap.

For a Medium Range BS operating in Band Category 1 the requirement applies outside the Base Station RF Bandwidth edges. In addition, for a Medium Range BS operating in non-contiguous spectrum, it applies inside any sub-block gap. In addition, for a Medium Range BS operating in multiple bands, it applies inside any Inter RF Bandwidth gap.

For a Local Area BS operating in Band Category 1 the requirement applies outside the Base Station RF Bandwidth edges. In addition, for a Local Area BS operating in non-contiguous spectrum, it applies inside any sub-block gap. In addition, for a Local Area BS operating in multiple bands, it applies inside any Inter RF Bandwidth gap.

Outside the Base Station RF Bandwidth edges, emissions shall not exceed the maximum levels specified in Tables 6.6.2.5.1-1 to 6.6.2.5.1-4 below, where:

- Δf is the separation between the Base Station RF Bandwidth edge frequency and the nominal -3 dB point of the measuring filter closest to the carrier frequency.
- f_{offset} is the separation between the Base Station RF Bandwidth edge frequency and the centre of the measuring filter.
- $f_{\text{offset}_{\text{max}}}$ is the offset to the frequency Δf_{OBUE} outside the downlink operating band.
- Δf_{max} is equal to $f_{\text{offset}_{\text{max}}}$ minus half of the bandwidth of the measuring filter.

For a BS operating in multiple bands, inside any Inter RF Bandwidth gaps with $W_{\text{gap}} < 2 * \Delta f_{\text{OBUE}}$, emissions shall not exceed the cumulative sum of the test requirements specified at the Base Station RF Bandwidth edges on each side of the Inter RF Bandwidth gap. The test requirement for Base Station RF Bandwidth edge is specified in Table 6.6.2.5.1-1 to 6.6.2.5.1-4 below, where in this case:

- Δf is the separation between the Base Station RF Bandwidth edge frequency and the nominal -3 dB point of the measuring filter closest to the carrier frequency.
- f_{offset} is the separation between the Base Station RF Bandwidth edge frequency and the centre of the measuring filter.
- $f_{\text{offset}_{\text{max}}}$ is equal to the Inter RF Bandwidth gap minus half of the bandwidth of the measuring filter.
- Δf_{max} is equal to $f_{\text{offset}_{\text{max}}}$ minus half of the bandwidth of the measuring filter.

For BS capable of multi-band operation where multiple bands are mapped on the same antenna connector, the operating band unwanted emission limits apply also in a supported operating band without any carriers transmitted, in the case where there are carriers transmitted in other supported operating band(s). In this case where there is no carrier transmitted in an operating band the operating band unwanted emission limit, as defined in the tables of the present clause for the largest frequency offset (Δf_{max}), of a band where there are no carriers transmitted shall apply from Δf_{OBUE} below the lowest frequency, up to Δf_{OBUE} above the highest frequency of the supported downlink operating band without any carrier transmitted. And no cumulative limits are applied in the inter-band gap between a supported downlink band with carrier(s) transmitted and a downlink band without any carrier transmitted.

Inside any sub-block gap for a BS operating in non-contiguous spectrum, emissions shall not exceed the cumulative sum of the test requirements specified for the adjacent sub blocks on each side of the sub block gap. The test requirement for each sub block is specified in Tables 6.6.2.5.1-1 to 6.6.2.5.1-4 below, where in this case:

- Δf is the separation between the sub block edge frequency and the nominal -3 dB point of the measuring filter closest to the sub block edge frequency.
- f_{offset} is the separation between the sub block edge frequency and the centre of the measuring filter.
- $f_{\text{offset}_{\text{max}}}$ is equal to the sub block gap bandwidth minus half of the bandwidth of the measuring filter.
- Δf_{max} is equal to $f_{\text{offset}_{\text{max}}}$ minus half of the bandwidth of the measuring filter.

For Band 41 NR operation in Japan, the operating band unwanted emissions limits shall be applied to the sum of the emission power over all *antenna connectors*.

Applicability of Wide Area operating band unwanted emission requirements in Tables 6.6.2.5.1-1/1a, 6.6.2.5.1-1c and 6.6.2.5.1-1d/1e is specified in Table 6.6.2.5.1-0.

Table 6.6.2.5.1-0: Applicability of operating band unwanted emission requirements for BC1 and BC3 Wide Area BS

NR Band operation	Standalone NB-IoT carrier adjacent to the BS RF bandwidth edge	UTRA supported (Note 1)	Applicable requirement table
None	Y/N	Y/N	6.6.2.5.1-1/1a
In certain regions (NOTE 2), bands 1, 7, 38	N	N	6.6.2.5.1-1/1a
Any	Y	N	6.6.2.5.1-1/1a
Any below 1GHz	N	N	6.6.2.1-1c
Any above 1GHz except for, in certain regions (NOTE 2), bands 1, 7, 38	N	N	6.6.2.1-1d/1e
NOTE 1: NR operation with UTRA is not supported in this specification.			
NOTE 2: Applicable only for operation in regions where Category B limits as defined in ITU-R Recommendation SM.329 [13] are used for which category B option 2 operating band unwanted emissions requirements as defined in TS 36.104 [5] and TS 38.104 [27] are applied.			

Table 6.6.2.5.1-1: WA BS OBUE in BC1 and BC3 bands ≤ 3 GHz applicable for: BS not supporting NR; BS operating NR in Band 1, 7 and/or 38 in Europe; or BS with standalone NB-IoT at the BS RF bandwidth edge (irrespective of NR support)

Frequency offset of measurement filter -3dB point, Δf	Frequency offset of measurement filter centre frequency, f_{offset}	Test requirement (Note 1, 2)	Measurement bandwidth (Note 6)
$0 \text{ MHz} \leq \Delta f < 0.2 \text{ MHz}$	$0.015 \text{ MHz} \leq f_{\text{offset}} < 0.215 \text{ MHz}$	-12.5 dBm	30 kHz
$0.2 \text{ MHz} \leq \Delta f < 1 \text{ MHz}$	$0.215 \text{ MHz} \leq f_{\text{offset}} < 1.015 \text{ MHz}$	$-12.5 \text{ dBm} - 15 \cdot \left(\frac{f_{\text{offset}}}{\text{MHz}} - 0.215 \right) \text{ dB}$ (Note 4)	30 kHz
(Note 5)	$1.015 \text{ MHz} \leq f_{\text{offset}} < 1.5 \text{ MHz}$	-24.5 dBm (Note 4)	30 kHz
$1 \text{ MHz} \leq \Delta f \leq \min(\Delta f_{\text{max}}, 10 \text{ MHz})$	$1.5 \text{ MHz} \leq f_{\text{offset}} < \min(f_{\text{offset}_{\text{max}}}, 10.5 \text{ MHz})$	-11.5 dBm (Note 4)	1 MHz
$10 \text{ MHz} \leq \Delta f \leq \Delta f_{\text{max}}$	$10.5 \text{ MHz} \leq f_{\text{offset}} < f_{\text{offset}_{\text{max}}}$	-15 dBm (Note 4, 7)	1 MHz
<p>NOTE 1: For MSR BS supporting non-contiguous spectrum operation within any operating band the test requirement within sub-block gaps is calculated as a cumulative sum of contributions from adjacent sub blocks on each side of the sub block gap, where the contribution from the far-end sub-block shall be scaled according to the measurement bandwidth of the near-end sub-block. Exception is $\Delta f \geq 10 \text{ MHz}$ from both adjacent sub blocks on each side of the sub-block gap, where the test requirement within sub-block gaps shall be -15dBm/MHz (for MSR BS supporting multi-band operation, either this limit or -16dBm/100kHz with correspondingly adjusted f_{offset} shall apply for this frequency offset range for operating bands <1GHz).</p> <p>NOTE2: For MSR BS supporting multi-band operation with Inter RF Bandwidth gap $< 2 \times \Delta f_{\text{OBUE}}$ the test requirement within the Inter RF Bandwidth gaps is calculated as a cumulative sum of contributions from adjacent sub-blocks or RF Bandwidth on each side of the Inter RF Bandwidth gap, where the contribution from the far-end sub-block or RF Bandwidth shall be scaled according to the measurement bandwidth of the near-end sub-block or RF Bandwidth.</p> <p>NOTE 3: For operation with a standalone NB-IoT carrier adjacent to the Base Station RF Bandwidth edge, the limits in Table 6.6.2.5.1-1b apply for $0 \text{ MHz} \leq \Delta f < 0.15 \text{ MHz}$.</p> <p>NOTE 4: For MSR BS supporting multi-band operation, either this limit or -16dBm/100kHz with correspondingly adjusted f_{offset} shall apply for this frequency offset range for operating bands <1GHz.</p>			

Table 6.6.2.5.1-1a: WA BS OBUE in BC1 and BC3 bands > 3 GHz applicable for: BS not supporting NR; BS with standalone NB-IoT at the BS RF bandwidth edge (irrespective of NR support)

Frequency offset of measurement filter -3dB point, Δf	Frequency offset of measurement filter centre frequency, f_{offset}	Test requirement (Note 1, 2)	Measurement bandwidth (Note 4)
$0 \text{ MHz} \leq \Delta f < 0.2 \text{ MHz}$	$0.015 \text{ MHz} \leq f_{\text{offset}} < 0.215 \text{ MHz}$	-12.2 dBm	30 kHz
$0.2 \text{ MHz} \leq \Delta f < 1 \text{ MHz}$	$0.215 \text{ MHz} \leq f_{\text{offset}} < 1.015 \text{ MHz}$	$-12.2 \text{ dBm} - 15 \cdot \left(\frac{f_{\text{offset}}}{\text{MHz}} - 0.215 \right) \text{ dB}$	30 kHz
(Note 3)	$1.015 \text{ MHz} \leq f_{\text{offset}} < 1.5 \text{ MHz}$	-24.2 dBm	30 kHz
$1 \text{ MHz} \leq \Delta f \leq \min(\Delta f_{\text{max}}, 10 \text{ MHz})$	$1.5 \text{ MHz} \leq f_{\text{offset}} < \min(f_{\text{offset}_{\text{max}}}, 10.5 \text{ MHz})$	-11.2 dBm	1 MHz
$10 \text{ MHz} \leq \Delta f \leq \Delta f_{\text{max}}$	$10.5 \text{ MHz} \leq f_{\text{offset}} < f_{\text{offset}_{\text{max}}}$	-15 dBm (Note 7)	1 MHz
<p>NOTE 1: For MSR BS supporting non-contiguous spectrum operation within any operating band the test requirement within sub-block gaps is calculated as a cumulative sum of contributions from adjacent sub blocks on each side of the sub block gap, where the contribution from the far-end sub-block shall be scaled according to the measurement bandwidth of the near-end sub-block. Exception is $\Delta f \geq 10 \text{ MHz}$ from both adjacent sub blocks on each side of the sub-block gap, where the test requirement within sub-block gaps shall be -15dBm/MHz.</p> <p>NOTE2: For MSR BS supporting multi-band operation with Inter RF Bandwidth gap $< 2 \times \Delta f_{\text{OBUE}}$ the test requirement within the Inter RF Bandwidth gaps is calculated as a cumulative sum of contributions from adjacent sub-blocks or RF Bandwidth on each side of the Inter RF Bandwidth gap, where the contribution from the far-end sub-block or RF Bandwidth shall be scaled according to the measurement bandwidth of the near-end sub-block or RF Bandwidth.</p>			

Table 6.6.2.5.1-1b: WA BS OBUE in BC1 and BC3 bands ≤ 3 GHz applicable for: BS with standalone NB-IoT carrier adjacent to the Base Station RF Bandwidth edge

Frequency offset of measurement filter -3dB point, Δf	Frequency offset of measurement filter centre frequency, f_{offset}	Minimum requirement (Note 1, 2, 3, 4)	Measurement bandwidth (Note 6)
$0 \text{ MHz} \leq \Delta f < 0.05 \text{ MHz}$	$0.015 \text{ MHz} \leq f_{\text{offset}} < 0.065 \text{ MHz}$	$Max(6.5 \text{ dBm} - 60 \cdot \left(\frac{f_{\text{offset}}}{\text{MHz}} - 0.015 \right) \text{ dB} + X \text{ dB}, -12.5 \text{ dBm})$	30 kHz
$0.05 \text{ MHz} \leq \Delta f < 0.15 \text{ MHz}$	$0.065 \text{ MHz} \leq f_{\text{offset}} < 0.165 \text{ MHz}$	$Max(3.5 \text{ dBm} - 160 \cdot \left(\frac{f_{\text{offset}}}{\text{MHz}} - 0.065 \right) \text{ dB} + X \text{ dB}, -12.5 \text{ dBm})$	30 kHz

NOTE 1: The limits in this table only apply for operation with a standalone NB-IoT carrier adjacent to the Base Station RF Bandwidth edge.

NOTE 2: For MSR BS supporting non-contiguous spectrum operation within any operating band the minimum requirement within sub-block gaps is calculated as a cumulative sum of contributions from adjacent sub blocks on each side of the sub block gap.

NOTE 3: For MSR BS supporting multi-band operation with Inter RF Bandwidth gap $< 2 \times \Delta f_{\text{OBUE}}$ the minimum requirement within the Inter RF Bandwidth gaps is calculated as a cumulative sum of contributions from adjacent sub-blocks or RF Bandwidth on each side of the Inter RF Bandwidth gap.

NOTE 4: In case the carrier adjacent to the RF bandwidth edge is a standalone NB-IoT carrier, the value of $X = \text{PNB-IoTcarrier} - 43$, where PNB-IoTcarrier is the power level of the standalone NB-IoT carrier adjacent to the RF bandwidth edge. In other cases, $X = 0$.

Table 6.6.2.5.1-1c: WA BS OBUE in BC1 and BC3 bands ≤ 1 GHz applicable for: BS supporting NR, not supporting UTRA, and with no standalone NB-IoT carrier at the BS RF bandwidth edge

Frequency offset of measurement filter -3dB point, Δf	Frequency offset of measurement filter centre frequency, f_{offset}	Minimum requirement (Note 1, 2)	Measurement bandwidth (Note 6)
$0 \text{ MHz} \leq \Delta f < 5 \text{ MHz}$	$0.05 \text{ MHz} \leq f_{\text{offset}} < 5.05 \text{ MHz}$	$-5.5 \text{ dBm} - 7/5(f_{\text{offset}}/\text{MHz} - 0.05) \text{ dB}$	100 kHz
$5 \text{ MHz} \leq \Delta f < \min(10 \text{ MHz}, \Delta f_{\text{max}})$	$5.05 \text{ MHz} \leq f_{\text{offset}} < \min(10.05 \text{ MHz}, f_{\text{offset}_{\text{max}}})$	-12.5 dBm	100 kHz
$10 \text{ MHz} \leq \Delta f \leq \Delta f_{\text{max}}$	$10.05 \text{ MHz} \leq f_{\text{offset}} < f_{\text{offset}_{\text{max}}}$	-16 dBm (Note 7)	100 kHz

NOTE 1: For MSR BS supporting non-contiguous spectrum operation within any operating band, the minimum requirement within sub-block gaps is calculated as a cumulative sum of contributions from adjacent sub blocks on each side of the sub block gap, where the contribution from the far-end sub-block or RF Bandwidth shall be scaled according to the measurement bandwidth of the near-end sub-block or RF Bandwidth. Exception is $\Delta f \geq 10 \text{ MHz}$ from both adjacent sub blocks on each side of the sub-block gap, where the minimum requirement within sub-block gaps shall be -16dBm/100kHz.

NOTE 2: For MSR BS supporting multi-band operation with Inter RF Bandwidth gap $< 2 \times \Delta f_{\text{OBUE}}$ the minimum requirement within the Inter RF Bandwidth gaps is calculated as a cumulative sum of contributions from adjacent sub-blocks or RF Bandwidth on each side of the Inter RF Bandwidth gap, where the contribution from the far-end sub-block or RF Bandwidth shall be scaled according to the measurement bandwidth of the near-end sub-block or RF Bandwidth.

Table 6.6.2.5.1-1d: WA BS OBUE in BC1 and BC3 bands > 1 GHz and ≤ 3 GHz for: BS supporting NR, not operating NR in Band 1, 7 and/or 38 in Europe, not supporting UTRA, and with no standalone NB-IoT carrier at the BS RF bandwidth edge

Frequency offset of measurement filter -3dB point, Δf	Frequency offset of measurement filter centre frequency, f_{offset}	Minimum requirement (Note 1, 2)	Measurement bandwidth (Note 6)
$0 \text{ MHz} \leq \Delta f < 5 \text{ MHz}$	$0.05 \text{ MHz} \leq f_{\text{offset}} < 5.05 \text{ MHz}$	$-5.5 \text{ dBm} - 7/5(f_{\text{offset}}/\text{MHz} - 0.05) \text{ dB}$	100 kHz
$5 \text{ MHz} \leq \Delta f < \min(10 \text{ MHz}, \Delta f_{\text{max}})$	$5.05 \text{ MHz} \leq f_{\text{offset}} < \min(10.05 \text{ MHz}, f_{\text{offset}_{\text{max}}})$	-12.5 dBm	100 kHz
$10 \text{ MHz} \leq \Delta f \leq \Delta f_{\text{max}}$	$10.5 \text{ MHz} \leq f_{\text{offset}} < f_{\text{offset}_{\text{max}}}$	-15 dBm (Note 7)	1MHz
<p>NOTE 1: For MSR BS supporting non-contiguous spectrum operation within any operating band, the minimum requirement within sub-block gaps is calculated as a cumulative sum of contributions from adjacent sub blocks on each side of the sub block gap, where the contribution from the far-end sub-block shall be scaled according to the measurement bandwidth of the near-end sub-block. Exception is $\Delta f \geq 10 \text{ MHz}$ from both adjacent sub blocks on each side of the sub-block gap, where the minimum requirement within sub-block gaps shall be -15dBm/1MHz.</p> <p>NOTE 2: For MSR BS supporting multi-band operation with Inter RF Bandwidth gap $< 2 \times \Delta f_{\text{OBUE}}$ the minimum requirement within the Inter RF Bandwidth gaps is calculated as a cumulative sum of contributions from adjacent sub-blocks or RF Bandwidth on each side of the Inter RF Bandwidth gap, where the contribution from the far-end sub-block or RF Bandwidth shall be scaled according to the measurement bandwidth of the near-end sub-block or RF Bandwidth.</p>			

Table 6.6.2.5.1-1e: WA BS OBUE in BC1 and BC3 bands above 3 GHz for: BS supporting NR, not supporting UTRA, and with no standalone NB-IoT carrier at the BS RF bandwidth edge

Frequency offset of measurement filter -3dB point, Δf	Frequency offset of measurement filter centre frequency, f_{offset}	Minimum requirement (Note 1, 2)	Measurement bandwidth (Note 6)
$0 \text{ MHz} \leq \Delta f < 5 \text{ MHz}$	$0.05 \text{ MHz} \leq f_{\text{offset}} < 5.05 \text{ MHz}$	$-5.2 \text{ dBm} - 7/5(f_{\text{offset}}/\text{MHz} - 0.05) \text{ dB}$	100 kHz
$5 \text{ MHz} \leq \Delta f < \min(10 \text{ MHz}, \Delta f_{\text{max}})$	$5.05 \text{ MHz} \leq f_{\text{offset}} < \min(10.05 \text{ MHz}, f_{\text{offset}_{\text{max}}})$	-12.2 dBm	100 kHz
$10 \text{ MHz} \leq \Delta f \leq \Delta f_{\text{max}}$	$10.5 \text{ MHz} \leq f_{\text{offset}} < f_{\text{offset}_{\text{max}}}$	-15 dBm (Note 7)	1MHz
<p>NOTE 1: For MSR BS supporting non-contiguous spectrum operation within any operating band, the minimum requirement within sub-block gaps is calculated as a cumulative sum of contributions from adjacent sub blocks on each side of the sub block gap, where the contribution from the far-end sub-block shall be scaled according to the measurement bandwidth of the near-end sub-block. Exception is $\Delta f \geq 10 \text{ MHz}$ from both adjacent sub blocks on each side of the sub-block gap, where the minimum requirement within sub-block gaps shall be -15dBm/1MHz.</p> <p>NOTE 2: For MSR BS supporting multi-band operation with Inter RF Bandwidth gap $< 2 \times \Delta f_{\text{OBUE}}$ the minimum requirement within the Inter RF Bandwidth gaps is calculated as a cumulative sum of contributions from adjacent sub-blocks or RF Bandwidth on each side of the Inter RF Bandwidth gap, where the contribution from the far-end sub-block or RF Bandwidth shall be scaled according to the measurement bandwidth of the near-end sub-block or RF Bandwidth.</p>			

Table 6.6.2.5.1-2: MR BS OBUE in BC1 bands ≤ 3 GHz applicable for: BS with maximum output power $31 < P_{\text{Rated,c}} \leq 38$ dBm and not supporting NR

Frequency offset of measurement filter -3dB point, Δf	Frequency offset of measurement filter centre frequency, f_{offset}	Test requirement (Note 1, 2)	Measurement bandwidth (Note 6)
$0 \text{ MHz} \leq \Delta f < 0.6 \text{ MHz}$	$0.015 \text{ MHz} \leq f_{\text{offset}} < 0.615 \text{ MHz}$	$P_{\text{Rated,c}} - 56.5 \text{ dB} - 7/5(f_{\text{offset}}/\text{MHz} - 0.015) \text{ dB}$	30 kHz
$0.6 \text{ MHz} \leq \Delta f < 1 \text{ MHz}$	$0.615 \text{ MHz} \leq f_{\text{offset}} < 1.015 \text{ MHz}$	$P_{\text{Rated,c}} - 51.5 \text{ dB} - 15(f_{\text{offset}}/\text{MHz} - 0.215) \text{ dB}$	30 kHz
(Note 5)	$1.015 \text{ MHz} \leq f_{\text{offset}} < 1.5 \text{ MHz}$	$P_{\text{Rated,c}} - 63.5 \text{ dB}$	30 kHz
$1 \text{ MHz} \leq \Delta f \leq 2.6 \text{ MHz}$	$1.5 \text{ MHz} \leq f_{\text{offset}} < 3.1 \text{ MHz}$	$P_{\text{Rated,c}} - 50.5 \text{ dB}$	1 MHz
$2.6 \text{ MHz} \leq \Delta f \leq 5 \text{ MHz}$	$3.1 \text{ MHz} \leq f_{\text{offset}} < 5.5 \text{ MHz}$	$\min(P_{\text{Rated,c}} - 50.5 \text{ dB}, -13.5 \text{ dBm})$	1 MHz
$5 \text{ MHz} \leq \Delta f \leq \min(\Delta f_{\text{max}}, 10 \text{ MHz})$	$5.5 \text{ MHz} \leq f_{\text{offset}} < \min(f_{\text{offset}_{\text{max}}}, 10.5 \text{ MHz})$	$P_{\text{Rated,c}} - 54.5 \text{ dB}$	1 MHz
$10 \text{ MHz} \leq \Delta f \leq \Delta f_{\text{max}}$	$10.5 \text{ MHz} \leq f_{\text{offset}} < f_{\text{offset}_{\text{max}}}$	$P_{\text{Rated,c}} - 56 \text{ dB}$ (Note 7)	1 MHz
<p>NOTE 1: For MSR BS supporting non-contiguous spectrum operation within any operating band the test requirement within sub-block gaps is calculated as a cumulative sum of contributions from adjacent sub blocks on each side of the sub block gap, where the contribution from the far-end sub-block shall be scaled according to the measurement bandwidth of the near-end sub-block. Exception is $\Delta f \geq 10 \text{ MHz}$ from both adjacent sub blocks on each side of the sub-block gap, where the test requirement within sub-block gaps shall be $(P_{\text{Rated,c}} - 56 \text{ dB})/\text{MHz}$.</p> <p>NOTE2: For MSR BS supporting multi-band operation with Inter RF Bandwidth gap $< 2 \times \Delta f_{\text{OBUE}}$ the test requirement within the Inter RF Bandwidth gaps is calculated as a cumulative sum of contributions from adjacent sub-blocks or RF Bandwidth on each side of the Inter RF Bandwidth gap, where the contribution from the far-end sub-block or RF Bandwidth shall be scaled according to the measurement bandwidth of the near-end sub-block or RF Bandwidth.</p> <p>NOTE 3: For operation with a standalone NB-IoT carrier adjacent to the Base Station RF Bandwidth edge, the limits in Table 6.6.2.5.1-2b apply for $0 \text{ MHz} \leq \Delta f < 0.15 \text{ MHz}$.</p>			

Table 6.6.2.5.1-2a: MR BS OBUE in BC1 bands > 3 GHz applicable for: BS with maximum output power $31 < P_{\text{Rated,c}} \leq 38$ dBm and not supporting NR

Frequency offset of measurement filter -3dB point, Δf	Frequency offset of measurement filter centre frequency, f_{offset}	Test requirement (Note 1, 2)	Measurement bandwidth (Note 6)
$0 \text{ MHz} \leq \Delta f < 0.6 \text{ MHz}$	$0.015 \text{ MHz} \leq f_{\text{offset}} < 0.615 \text{ MHz}$	$P_{\text{Rated,c}} - 56.2 \text{ dB} - 7/5(f_{\text{offset}}/\text{MHz} - 0.015) \text{ dB}$	30 kHz
$0.6 \text{ MHz} \leq \Delta f < 1 \text{ MHz}$	$0.615 \text{ MHz} \leq f_{\text{offset}} < 1.015 \text{ MHz}$	$P_{\text{Rated,c}} - 51.2 \text{ dB} - 15(f_{\text{offset}}/\text{MHz} - 0.215) \text{ dB}$	30 kHz
(Note 5)	$1.015 \text{ MHz} \leq f_{\text{offset}} < 1.5 \text{ MHz}$	$P_{\text{Rated,c}} - 63.2 \text{ dB}$	30 kHz
$1 \text{ MHz} \leq \Delta f \leq 2.6 \text{ MHz}$	$1.5 \text{ MHz} \leq f_{\text{offset}} < 3.1 \text{ MHz}$	$P_{\text{Rated,c}} - 50.2 \text{ dB}$	1 MHz
$2.6 \text{ MHz} \leq \Delta f \leq 5 \text{ MHz}$	$3.1 \text{ MHz} \leq f_{\text{offset}} < 5.5 \text{ MHz}$	$\min(P_{\text{Rated,c}} - 50.2 \text{ dB}, -13.2 \text{ dBm})$	1 MHz
$5 \text{ MHz} \leq \Delta f \leq \min(\Delta f_{\text{max}}, 10 \text{ MHz})$	$5.5 \text{ MHz} \leq f_{\text{offset}} < \min(f_{\text{offset}_{\text{max}}}, 10.5 \text{ MHz})$	$P_{\text{Rated,c}} - 54.2 \text{ dB}$	1 MHz
$10 \text{ MHz} \leq \Delta f \leq \Delta f_{\text{max}}$	$10.5 \text{ MHz} \leq f_{\text{offset}} < f_{\text{offset}_{\text{max}}}$	$P_{\text{Rated,c}} - 56 \text{ dB}$ (Note 7)	1 MHz
<p>NOTE 1: For MSR BS supporting non-contiguous spectrum operation within any operating band the test requirement within sub-block gaps is calculated as a cumulative sum of contributions from adjacent sub blocks on each side of the sub block gap, where the contribution from the far-end sub-block shall be scaled according to the measurement bandwidth of the near-end sub-block. Exception is $\Delta f \geq 10 \text{ MHz}$ from both adjacent sub blocks on each side of the sub-block gap, where the test requirement within sub-block gaps shall be $(P_{\text{Rated,c}} - 56 \text{ dB})/\text{MHz}$.</p> <p>NOTE2: For MSR BS supporting multi-band operation with Inter RF Bandwidth gap $< 2 \times \Delta f_{\text{OBUE}}$ the test requirement within the Inter RF Bandwidth gaps is calculated as a cumulative sum of contributions from adjacent sub-blocks or RF Bandwidth on each side of the Inter RF Bandwidth gap, where the contribution from the far-end sub-block or RF Bandwidth shall be scaled according to the measurement bandwidth of the near-end sub-block or RF Bandwidth.</p>			

Table 6.6.2.5.1-2b: MR BS OBUE in BC1 bands ≤ 3 GHz applicable for: BS with maximum output power $31 < P_{\text{Rated}} \leq 38$ dBm and with standalone NB-IoT carrier adjacent to the Base Station RF Bandwidth edge

Frequency offset of measurement filter -3dB point, Δf	Frequency offset of measurement filter centre frequency, f_{offset}	Minimum requirement (Note 1, 2, 3)	Measurement bandwidth (Note 7)
$0 \text{ MHz} \leq \Delta f < 0.05 \text{ MHz}$ (Note 1)	$0.015 \text{ MHz} \leq f_{\text{offset}} < 0.065 \text{ MHz}$	$P_{\text{Rated,c}} - 36.5\text{dB} - 60(f_{\text{offset}}/\text{MHz} - 0.015)\text{dB}$	30 kHz
$0.05 \text{ MHz} \leq \Delta f < 0.15 \text{ MHz}$	$0.065 \text{ MHz} \leq f_{\text{offset}} < 0.165 \text{ MHz}$	$P_{\text{Rated,c}} - 39.5\text{dB} - 160(f_{\text{offset}}/\text{MHz} - 0.065)\text{dB}$	30 kHz
NOTE 1: The limits in this table only apply for operation with a standalone NB-IoT carrier adjacent to the Base Station RF Bandwidth edge.			
NOTE 2: For MSR BS supporting non-contiguous spectrum operation within any operating band the minimum requirement within sub-block gaps is calculated as a cumulative sum of contributions from adjacent sub blocks on each side of the sub block gap.			
NOTE 3: For MSR BS supporting multi-band operation with Inter RF Bandwidth gap $< 2 \times \Delta f_{\text{OBUE}}$ the minimum requirement within the Inter RF Bandwidth gaps is calculated as a cumulative sum of contributions from adjacent sub-blocks or RF Bandwidth on each side of the Inter RF Bandwidth gap.			

Table 6.6.2.5.1-2c: MR BS OBUE in BC1 bands ≤ 3 GHz applicable for: BS with maximum output power $31 < P_{\text{Rated,c}} \leq 38$ dBm, supporting NR and not supporting UTRA

Frequency offset of measurement filter -3dB point, Δf	Frequency offset of measurement filter centre frequency, f_{offset}	Minimum requirement (Note 1, 2)	Measurement bandwidth (Note 6)
$0 \text{ MHz} \leq \Delta f < 5 \text{ MHz}$	$0.05 \text{ MHz} \leq f_{\text{offset}} < 5.05 \text{ MHz}$	$P_{\text{Rated,c}} - 51.5\text{dB} - 7/5(f_{\text{offset}}/\text{MHz} - 0.05)\text{dB}$	100 kHz
$5 \text{ MHz} \leq \Delta f < \min(10 \text{ MHz}, \Delta f_{\text{max}})$	$5.05 \text{ MHz} \leq f_{\text{offset}} < \min(10.05 \text{ MHz}, f_{\text{offset}_{\text{max}}})$	$P_{\text{Rated,c}} - 58.5\text{dB}$	100 kHz
$10 \text{ MHz} \leq \Delta f \leq \Delta f_{\text{max}}$	$10.05 \text{ MHz} \leq f_{\text{offset}} < f_{\text{offset}_{\text{max}}}$	$\text{Min}(P_{\text{Rated,c}} - 60\text{dB}, -25\text{dBm})$ (Note 7)	100 kHz
NOTE 1: For MSR BS supporting non-contiguous spectrum operation within any operating band the minimum requirement within sub-block gaps is calculated as a cumulative sum of contributions from adjacent sub blocks on each side of the sub block gap, where the contribution from the far-end sub-block shall be scaled according to the measurement bandwidth of the near-end sub-block. Exception is $\Delta f \geq 10\text{MHz}$ from both adjacent sub blocks on each side of the sub-block gap, where the minimum requirement within sub-block gaps shall be $\text{Min}(P_{\text{Rated,c}} - 60\text{dB}, -25\text{dBm})/100\text{kHz}$.			
NOTE 2: For MSR BS supporting multi-band operation with Inter RF Bandwidth gap $< 2 \times \Delta f_{\text{OBUE}}$ the minimum requirement within the Inter RF Bandwidth gaps is calculated as a cumulative sum of contributions from adjacent sub-blocks or RF Bandwidth on each side of the Inter RF Bandwidth gap, where the contribution from the far-end sub-block shall be scaled according to the measurement bandwidth of the near-end sub-block.			
NOTE 3: For operation with a standalone NB-IoT carrier adjacent to the Base Station RF Bandwidth edge, the limits in Table 6.6.2.5.1-2b apply for $0 \text{ MHz} \leq \Delta f < 0.15 \text{ MHz}$.			

Table 6.6.2.5.1-2d: MR BS OBUE in BC1 bands >3 GHz applicable for: BS with maximum output power $31 < P_{\text{Rated,c}} \leq 38$ dBm, supporting NR and not supporting UTRA

Frequency offset of measurement filter -3dB point, Δf	Frequency offset of measurement filter centre frequency, f_{offset}	Minimum requirement (Note 1, 2)	Measurement bandwidth (Note 6)
$0 \text{ MHz} \leq \Delta f < 5 \text{ MHz}$	$0.05 \text{ MHz} \leq f_{\text{offset}} < 5.05 \text{ MHz}$	$P_{\text{Rated,c}} - 51.2\text{dB} - 7/5(f_{\text{offset}}/\text{MHz} - 0.05)\text{dB}$	100 kHz
$5 \text{ MHz} \leq \Delta f < \min(10 \text{ MHz}, \Delta f_{\text{max}})$	$5.05 \text{ MHz} \leq f_{\text{offset}} < \min(10.05 \text{ MHz}, f_{\text{offset,max}})$	$P_{\text{Rated,c}} - 58.2\text{dB}$	100 kHz
$10 \text{ MHz} \leq \Delta f \leq \Delta f_{\text{max}}$	$10.05 \text{ MHz} \leq f_{\text{offset}} < f_{\text{offset,max}}$	$\text{Min}(P_{\text{Rated,c}} - 60\text{dB}, -25\text{dBm})$ (Note 7)	100 kHz
<p>NOTE 1: For MSR BS supporting non-contiguous spectrum operation within any operating band the minimum requirement within sub-block gaps is calculated as a cumulative sum of contributions from adjacent sub blocks on each side of the sub block gap, where the contribution from the far-end sub-block shall be scaled according to the measurement bandwidth of the near-end sub-block. Exception is $\Delta f \geq 10\text{MHz}$ from both adjacent sub blocks on each side of the sub-block gap, where the minimum requirement within sub-block gaps shall be $\text{Min}(P_{\text{Rated,c}} - 60\text{dB}, -25\text{dBm})/100\text{kHz}$.</p> <p>NOTE 2: For MSR BS supporting multi-band operation with Inter RF Bandwidth gap $< 2 \times \Delta f_{\text{OBUE}}$ the minimum requirement within the Inter RF Bandwidth gaps is calculated as a cumulative sum of contributions from adjacent sub-blocks or RF Bandwidth on each side of the Inter RF Bandwidth gap, where the contribution from the far-end sub-block shall be scaled according to the measurement bandwidth of the near-end sub-block.</p>			

Table 6.6.2.5.1-3: MR BS OBUE in BC1 bands ≤ 3 GHz applicable for: BS with maximum output power $P_{\text{Rated,c}} \leq 31$ dBm and not supporting NR

Frequency offset of measurement filter -3dB point, Δf	Frequency offset of measurement filter centre frequency, f_{offset}	Test requirement (Note 1, 2)	Measurement bandwidth (Note 6)
$0 \text{ MHz} \leq \Delta f < 0.6 \text{ MHz}$	$0.015\text{MHz} \leq f_{\text{offset}} < 0.615\text{MHz}$	$-25.5\text{dBm} - \frac{7}{5} \left(\frac{f_{\text{offset}}}{\text{MHz}} - 0.015 \right) \text{dB}$	30 kHz
$0.6 \text{ MHz} \leq \Delta f < 1 \text{ MHz}$	$0.615\text{MHz} \leq f_{\text{offset}} < 1.015\text{MHz}$	$-20.5\text{dBm} - 15 \cdot \left(\frac{f_{\text{offset}}}{\text{MHz}} - 0.215 \right) \text{dB}$	30 kHz
(Note 5)	$1.015\text{MHz} \leq f_{\text{offset}} < 1.5 \text{ MHz}$	-32.5 dBm	30 kHz
$1 \text{ MHz} \leq \Delta f \leq 5 \text{ MHz}$	$1.5 \text{ MHz} \leq f_{\text{offset}} < 5.5 \text{ MHz}$	-19.5 dBm	1 MHz
$5 \text{ MHz} \leq \Delta f \leq \min(\Delta f_{\text{max}}, 10\text{MHz})$	$5.5 \text{ MHz} \leq f_{\text{offset}} < \min(f_{\text{offset,max}}, 10.5\text{MHz})$	-23.5 dBm	1 MHz
$10 \text{ MHz} \leq \Delta f \leq \Delta f_{\text{max}}$	$10.5 \text{ MHz} \leq f_{\text{offset}} < f_{\text{offset,max}}$	-25 dBm (Note 7)	1MHz
<p>NOTE 1: For MSR BS supporting non-contiguous spectrum operation within any operating band the test requirement within sub-block gaps is calculated as a cumulative sum of contributions from adjacent sub blocks on each side of the sub block gap, where the contribution from the far-end sub-block shall be scaled according to the measurement bandwidth of the near-end sub-block. Exception is $\Delta f \geq 10\text{MHz}$ from both adjacent sub blocks on each side of the sub-block gap, where the test requirement within sub-block gaps shall be $-25\text{dBm}/\text{MHz}$.</p> <p>NOTE2: For MSR BS supporting multi-band operation with Inter RF Bandwidth gap $< 2 \times \Delta f_{\text{OBUE}}$ the test requirement within the Inter RF Bandwidth gaps is calculated as a cumulative sum of contributions from adjacent sub-blocks or RF Bandwidth on each side of the Inter RF Bandwidth gap, where the contribution from the far-end sub-block or RF Bandwidth shall be scaled according to the measurement bandwidth of the near-end sub-block or RF Bandwidth.</p> <p>NOTE 3: For operation with a standalone NB-IoT carrier adjacent to the Base Station RF Bandwidth edge, the limits in Table 6.6.2.5.1-3b apply for $0 \text{ MHz} \leq \Delta f < 0.15 \text{ MHz}$.</p>			

Table 6.6.2.5.1-3a: MR BS OBUE in BC1 bands > 3 GHz applicable for: BS with maximum output power $P_{\text{Rated,c}} \leq 31$ dBm and not supporting NR

Frequency offset of measurement filter -3dB point, Δf	Frequency offset of measurement filter centre frequency, f_{offset}	Test requirement (Note 1, 2)	Measurement bandwidth (Note 6)
$0 \text{ MHz} \leq \Delta f < 0.6 \text{ MHz}$	$0.015 \text{ MHz} \leq f_{\text{offset}} < 0.615 \text{ MHz}$	$-25.2 \text{ dBm} - \frac{7}{5} \left(\frac{f_{\text{offset}}}{\text{MHz}} - 0.015 \right) \text{ dB}$	30 kHz
$0.6 \text{ MHz} \leq \Delta f < 1 \text{ MHz}$	$0.615 \text{ MHz} \leq f_{\text{offset}} < 1.015 \text{ MHz}$	$-20.2 \text{ dBm} - 15 \cdot \left(\frac{f_{\text{offset}}}{\text{MHz}} - 0.215 \right) \text{ dB}$	30 kHz
(Note 5)	$1.015 \text{ MHz} \leq f_{\text{offset}} < 1.5 \text{ MHz}$	-32.2 dBm	30 kHz
$1 \text{ MHz} \leq \Delta f \leq 5 \text{ MHz}$	$1.5 \text{ MHz} \leq f_{\text{offset}} < 5.5 \text{ MHz}$	-19.2 dBm	1 MHz
$5 \text{ MHz} \leq \Delta f \leq \min(\Delta f_{\text{max}}, 10 \text{ MHz})$	$5.5 \text{ MHz} \leq f_{\text{offset}} < \min(f_{\text{offset}_{\text{max}}}, 10.5 \text{ MHz})$	-23.2 dBm	1 MHz
$10 \text{ MHz} \leq \Delta f \leq \Delta f_{\text{max}}$	$10.5 \text{ MHz} \leq f_{\text{offset}} < f_{\text{offset}_{\text{max}}}$	-25 dBm (Note 7)	1 MHz
<p>NOTE 1: For MSR BS supporting non-contiguous spectrum operation within any operating band the test requirement within sub-block gaps is calculated as a cumulative sum of contributions from adjacent sub blocks on each side of the sub block gap, where the contribution from the far-end sub-block shall be scaled according to the measurement bandwidth of the near-end sub-block. Exception is $\Delta f \geq 10 \text{ MHz}$ from both adjacent sub blocks on each side of the sub-block gap, where the test requirement within sub-block gaps shall be -25dBm/MHz.</p> <p>NOTE2: For MSR BS supporting multi-band operation with Inter RF Bandwidth gap $< 2 \times \Delta f_{\text{OBUE}}$ the test requirement within the Inter RF Bandwidth gaps is calculated as a cumulative sum of contributions from adjacent sub-blocks or RF Bandwidth on each side of the Inter RF Bandwidth gap, where the contribution from the far-end sub-block or RF Bandwidth shall be scaled according to the measurement bandwidth of the near-end sub-block or RF Bandwidth.</p>			

Table 6.6.2.5.1-3b: MR BS OBUE in BC1 bands ≤ 3 GHz applicable for: BS with maximum output power $P_{\text{Rated,c}} \leq 31$ dBm BS and standalone NB-IoT carrier adjacent to the Base Station RF Bandwidth edge

Frequency offset of measurement filter -3dB point, Δf	Frequency offset of measurement filter centre frequency, f_{offset}	Minimum requirement (Note 1, 2, 3, 4)	Measurement bandwidth (Note 7)
$0 \text{ MHz} \leq \Delta f < 0.05 \text{ MHz}$ (Note 1)	$0.015 \text{ MHz} \leq f_{\text{offset}} < 0.065 \text{ MHz}$	$\text{Max} \left(-5.5 \text{ dBm} - 60 \cdot \left(\frac{f_{\text{offset}}}{\text{MHz}} - 0.015 \right) \text{ dB} + X \text{ dB}, -25.5 \text{ dBm} \right)$	30 kHz
$0.05 \text{ MHz} \leq \Delta f < 0.15 \text{ MHz}$	$0.065 \text{ MHz} \leq f_{\text{offset}} < 0.165 \text{ MHz}$	$\text{Max} \left(-8.5 \text{ dBm} - 160 \cdot \left(\frac{f_{\text{offset}}}{\text{MHz}} - 0.065 \right) \text{ dB} + X \text{ dB}, -25.5 \text{ dBm} \right)$	30 kHz
<p>NOTE 1: The limits in this table only apply for operation with a standalone NB-IoT carrier adjacent to the Base Station RF Bandwidth edge.</p> <p>NOTE 2: For MSR BS supporting non-contiguous spectrum operation within any operating band the minimum requirement within sub-block gaps is calculated as a cumulative sum of contributions from adjacent sub blocks on each side of the sub block gap.</p> <p>NOTE 3: For MSR BS supporting multi-band operation with Inter RF Bandwidth gap $< 2 \times \Delta f_{\text{OBUE}}$ the minimum requirement within the Inter RF Bandwidth gaps is calculated as a cumulative sum of contributions from adjacent sub-blocks or RF Bandwidth on each side of the Inter RF Bandwidth gap.</p> <p>NOTE 4: In case the carrier adjacent to the RF bandwidth edge is a standalone NB-IoT carrier, the value of $X = P_{\text{NB-IoT carrier}} - 31$, where $P_{\text{NB-IoT carrier}}$ is the power level of the standalone NB-IoT carrier adjacent to the RF bandwidth edge. In other cases, $X = 0$.</p>			

Table 6.6.2.5.1-3c: MR BS OBUE in BC1 bands ≤ 3 GHz applicable for: BS with maximum output power $P_{\text{Rated,c}} \leq 31$ dBm, supporting NR and not supporting UTRA

Frequency offset of measurement filter -3dB point, Δf	Frequency offset of measurement filter centre frequency, f_{offset}	Minimum requirement (Note 1, 2)	Measurement bandwidth (Note 6)
$0 \text{ MHz} \leq \Delta f < 5 \text{ MHz}$	$0.05 \text{ MHz} \leq f_{\text{offset}} < 5.05 \text{ MHz}$	$-20.5 \text{ dBm} - 7/5(f_{\text{offset}}/\text{MHz} - 0.05) \text{ dB}$	100 kHz
$5 \text{ MHz} \leq \Delta f < \min(10 \text{ MHz}, \Delta f_{\text{max}})$	$5.05 \text{ MHz} \leq f_{\text{offset}} < \min(10.05 \text{ MHz}, f_{\text{offset}_{\text{max}}})$	-27.5 dBm	100 kHz
$10 \text{ MHz} \leq \Delta f \leq \Delta f_{\text{max}}$	$10.05 \text{ MHz} \leq f_{\text{offset}} < f_{\text{offset}_{\text{max}}}$	-29 dBm (Note 7)	100 kHz
<p>NOTE 1: For MSR BS supporting non-contiguous spectrum operation within any operating band the minimum requirement within sub-block gaps is calculated as a cumulative sum of contributions from adjacent sub blocks on each side of the sub block gap, where the contribution from the far-end sub-block shall be scaled according to the measurement bandwidth of the near-end sub-block. Exception is $\Delta f \geq 10 \text{ MHz}$ from both adjacent sub blocks on each side of the sub-block gap, where the minimum requirement within sub-block gaps shall be -29dBm/100kHz.</p> <p>NOTE 2: For MSR BS supporting multi-band operation with Inter RF Bandwidth gap $< 2 \times \Delta f_{\text{OBUE}}$ the minimum requirement within the Inter RF Bandwidth gaps is calculated as a cumulative sum of contributions from adjacent sub-blocks or RF Bandwidth on each side of the Inter RF Bandwidth gap, where the contribution from the far-end sub-block shall be scaled according to the measurement bandwidth of the near-end sub-block.</p> <p>NOTE 3: For operation with a standalone NB-IoT carrier adjacent to the Base Station RF Bandwidth edge, the limits in Table 6.6.2.5.1-3b apply for $0 \text{ MHz} \leq \Delta f < 0.15 \text{ MHz}$.</p>			

Table 6.6.2.5.1-3d: MR BS OBUE in BC1 bands >3 GHz applicable for: BS with maximum output power $P_{\text{Rated,c}} \leq 31$ dBm, supporting NR and not supporting UTRA

Frequency offset of measurement filter -3dB point, Δf	Frequency offset of measurement filter centre frequency, f_{offset}	Minimum requirement (Note 1, 2)	Measurement bandwidth (Note 6)
$0 \text{ MHz} \leq \Delta f < 5 \text{ MHz}$	$0.05 \text{ MHz} \leq f_{\text{offset}} < 5.05 \text{ MHz}$	$-20.2 \text{ dBm} - 7/5(f_{\text{offset}}/\text{MHz} - 0.05) \text{ dB}$	100 kHz
$5 \text{ MHz} \leq \Delta f < \min(10 \text{ MHz}, \Delta f_{\text{max}})$	$5.05 \text{ MHz} \leq f_{\text{offset}} < \min(10.05 \text{ MHz}, f_{\text{offset}_{\text{max}}})$	-27.2 dBm	100 kHz
$10 \text{ MHz} \leq \Delta f \leq \Delta f_{\text{max}}$	$10.05 \text{ MHz} \leq f_{\text{offset}} < f_{\text{offset}_{\text{max}}}$	-29 dBm (Note 7)	100 kHz
<p>NOTE 1: For MSR BS supporting non-contiguous spectrum operation within any operating band the minimum requirement within sub-block gaps is calculated as a cumulative sum of contributions from adjacent sub blocks on each side of the sub block gap, where the contribution from the far-end sub-block shall be scaled according to the measurement bandwidth of the near-end sub-block. Exception is $\Delta f \geq 10 \text{ MHz}$ from both adjacent sub blocks on each side of the sub-block gap, where the minimum requirement within sub-block gaps shall be -29dBm/100kHz.</p> <p>NOTE 2: For MSR BS supporting multi-band operation with Inter RF Bandwidth gap $< 2 \times \Delta f_{\text{OBUE}}$ the minimum requirement within the Inter RF Bandwidth gaps is calculated as a cumulative sum of contributions from adjacent sub-blocks or RF Bandwidth on each side of the Inter RF Bandwidth gap, where the contribution from the far-end sub-block shall be scaled according to the measurement bandwidth of the near-end sub-block.</p>			

Table 6.6.2.5.1-4: LA BS OBUE in BC1 bands ≤ 3 GHz

Frequency offset of measurement filter -3dB point, Δf	Frequency offset of measurement filter centre frequency, f_{offset}	Test requirement (Note 1, 2)	Measurement bandwidth (Note 6)
$0 \text{ MHz} \leq \Delta f < 5 \text{ MHz}$	$0.05 \text{ MHz} \leq f_{\text{offset}} < 5.05 \text{ MHz}$	$-28.5 \text{ dBm} - \frac{7}{5} \left(\frac{f_{\text{offset}}}{\text{MHz}} - 0.05 \right) \text{ dB}$	100 kHz
$5 \text{ MHz} \leq \Delta f < \min(10 \text{ MHz}, \Delta f_{\text{max}})$	$5.05 \text{ MHz} \leq f_{\text{offset}} < \min(10.05 \text{ MHz}, f_{\text{offset}_{\text{max}}})$	-35.5 dBm	100 kHz
$10 \text{ MHz} \leq \Delta f \leq \Delta f_{\text{max}}$	$10.05 \text{ MHz} \leq f_{\text{offset}} < f_{\text{offset}_{\text{max}}}$	-37 dBm (Note 7)	100 kHz
<p>NOTE 1: For MSR BS supporting non-contiguous spectrum operation within any operating band the test requirement within sub-block gaps is calculated as a cumulative sum of contributions from adjacent sub blocks on each side of the sub block gap. Exception is $\Delta f \geq 10 \text{ MHz}$ from both adjacent sub blocks on each side of the sub-block gap, where the test requirement within sub-block gaps shall be -37dBm/100 kHz.</p> <p>NOTE2: For MSR BS supporting multi-band operation with Inter RF Bandwidth gap $< 2 \times \Delta f_{\text{OBUE}}$ the test requirement within the Inter RF Bandwidth gaps is calculated as a cumulative sum of contributions from adjacent sub-blocks or RF Bandwidth on each side of the Inter RF Bandwidth gap.</p> <p>NOTE 3: For operation with a standalone NB-IoT carrier adjacent to the Base Station RF Bandwidth edge, the limits in Table 6.6.2.5.1-4b apply for $0 \text{ MHz} \leq \Delta f < 0.15 \text{ MHz}$.</p>			

Table 6.6.2.5.1-4a: LA BS OBUE in BC1 bands > 3 GHz

Frequency offset of measurement filter -3dB point, Δf	Frequency offset of measurement filter centre frequency, f_{offset}	Test requirement (Note 1, 2)	Measurement bandwidth (Note 6)
$0 \text{ MHz} \leq \Delta f < 5 \text{ MHz}$	$0.05 \text{ MHz} \leq f_{\text{offset}} < 5.05 \text{ MHz}$	$-28.2 \text{ dBm} - \frac{7}{5} \left(\frac{f_{\text{offset}}}{\text{MHz}} - 0.05 \right) \text{ dB}$	100 kHz
$5 \text{ MHz} \leq \Delta f < \min(10 \text{ MHz}, \Delta f_{\text{max}})$	$5.05 \text{ MHz} \leq f_{\text{offset}} < \min(10.05 \text{ MHz}, f_{\text{offset}_{\text{max}}})$	-35.2 dBm	100 kHz
$10 \text{ MHz} \leq \Delta f \leq \Delta f_{\text{max}}$	$10.05 \text{ MHz} \leq f_{\text{offset}} < f_{\text{offset}_{\text{max}}}$	-37 dBm (Note 7)	100 kHz
<p>NOTE 1: For MSR BS supporting non-contiguous spectrum operation within any operating band the test requirement within sub-block gaps is calculated as a cumulative sum of contributions from adjacent sub blocks on each side of the sub block gap. Exception is $\Delta f \geq 10 \text{ MHz}$ from both adjacent sub blocks on each side of the sub-block gap, where the test requirement within sub-block gaps shall be -37dBm/100 kHz.</p> <p>NOTE2: For MSR BS supporting multi-band operation with Inter RF Bandwidth gap $< 2 \times \Delta f_{\text{OBUE}}$ the test requirement within the Inter RF Bandwidth gaps is calculated as a cumulative sum of contributions from adjacent sub-blocks or RF Bandwidth on each side of the Inter RF Bandwidth gap.</p>			

Table 6.6.2.5.1-4b: LA MR BS OBUE in BC1 bands ≤ 3 GHz applicable for: BS with standalone NB-IoT carrier adjacent to the Base Station RF Bandwidth edge

Frequency offset of measurement filter -3dB point, Δf	Frequency offset of measurement filter centre frequency, f_{offset}	Minimum requirement (Note 1, 2, 3, 4)	Measurement bandwidth (Note 7)
$0 \text{ MHz} \leq \Delta f < 0.05 \text{ MHz}$ (Note 1)	$0.015 \text{ MHz} \leq f_{\text{offset}} < 0.065 \text{ MHz}$	$\text{Max}(-12.5\text{dBm} - 60 \cdot \left(\frac{f_{\text{offset}} - 0.015}{\text{MHz}}\right) \text{dB} + X\text{dB}, -33.5\text{dBm})$	30 kHz
$0.05 \text{ MHz} \leq \Delta f < 0.16 \text{ MHz}$	$0.065 \text{ MHz} \leq f_{\text{offset}} < 0.175 \text{ MHz}$	$\text{Max}(-15.5\text{dBm} - 160 \cdot \left(\frac{f_{\text{offset}} - 0.065}{\text{MHz}}\right) \text{dB} + X\text{dB}, -33.5\text{dBm})$	30 kHz

NOTE 1: The limits in this table only apply for operation with a standalone NB-IoT carrier adjacent to the Base Station RF Bandwidth edge.

NOTE 2: For MSR BS supporting non-contiguous spectrum operation within any operating band the minimum requirement within sub-block gaps is calculated as a cumulative sum of contributions from adjacent sub blocks on each side of the sub block gap.

NOTE 3: For MSR BS supporting multi-band operation with Inter RF Bandwidth gap $< 2 \times \Delta f_{\text{OBUE}}$ the minimum requirement within the Inter RF Bandwidth gaps is calculated as a cumulative sum of contributions from adjacent sub-blocks or RF Bandwidth on each side of the Inter RF Bandwidth gap.

NOTE 4: In case the carrier adjacent to the RF bandwidth edge is a standalone NB-IoT carrier, the value of $X = P_{\text{NB-IoT carrier}} - 24$, where $P_{\text{NB-IoT carrier}}$ is the power level of the standalone NB-IoT carrier adjacent to the RF bandwidth edge. In other cases, $X = 0$.

NOTE 5: This frequency range ensures that the range of values of f_{offset} is continuous.

NOTE 6: As a general rule for the requirements in the present clause, the resolution bandwidth of the measuring equipment should be equal to the measurement bandwidth. However, to improve measurement accuracy, sensitivity and efficiency, the resolution bandwidth may be smaller than the measurement bandwidth. When the resolution bandwidth is smaller than the measurement bandwidth, the result should be integrated over the measurement bandwidth in order to obtain the equivalent noise bandwidth of the measurement bandwidth.

NOTE 7: The requirement is not applicable when $\Delta f_{\text{max}} < \Delta f_{\text{OBUE}}$.

6.6.2.5.2 Test requirements for Band Category 2

For a BS operating in Band Category 2 the requirement applies outside the Base Station RF Bandwidth edges. In addition, for a BS operating in non-contiguous spectrum, it applies inside any sub-block gap.

Outside the Base Station RF Bandwidth edges, emissions shall not exceed the maximum levels specified in Table 6.6.2.5.2-1 to 6.6.2.5.2-8 below, where:

- Δf is the separation between the Base Station RF Bandwidth edge frequency and the nominal -3dB point of the measuring filter closest to the carrier frequency.
- f_{offset} is the separation between the Base Station RF Bandwidth edge frequency and the centre of the measuring filter.
- $f_{\text{offset}_{\text{max}}}$ is the offset to the frequency Δf_{OBUE} outside the downlink operating band.
- Δf_{max} is equal to $f_{\text{offset}_{\text{max}}}$ minus half of the bandwidth of the measuring filter.

For a BS operating in multiple bands, inside any Inter RF Bandwidth gaps with $W_{\text{gap}} < 2 * \Delta f_{\text{OBUE}}$, emissions shall not exceed the cumulative sum of the test requirements specified at the Base Station RF Bandwidth edges on each side of the Inter RF Bandwidth gap. The test requirement for Base Station RF Bandwidth edge is specified in Table 6.6.2.5.2-1 to 6.6.2.5.2-8 below, where in this case:

- Δf is the separation between the Base Station RF Bandwidth edge frequency and the nominal -3 dB point of the measuring filter closest to the carrier frequency.

- f_{offset} is the separation between the Base Station RF Bandwidth edge frequency and the centre of the measuring filter.
- $f_{\text{offset}_{\text{max}}}$ is equal to the Inter RF Bandwidth gap minus half of the bandwidth of the measuring filter.
- Δf_{max} is equal to $f_{\text{offset}_{\text{max}}}$ minus half of the bandwidth of the measuring filter.

For a BS capable of multi-band operation where multiple bands are mapped on the same antenna connector and where there is no carrier transmitted in an operating band, the operating band unwanted emission limit, as defined in the tables of the present clause for the largest frequency offset (Δf_{max}), of a band where there are no carriers transmitted shall apply from Δf_{OBUE} below the lowest frequency, up to Δf_{OBUE} above the highest frequency of the supported downlink operating band without any carrier transmitted. And no cumulative limits are applied in the inter-band gap between a supported downlink band with carrier(s) transmitted and a supported downlink band without any carrier transmitted.

Inside any sub-block gap for a BS operating in non-contiguous spectrum, emissions shall not exceed the cumulative sum of the test requirement specified for the adjacent sub blocks on each side of the sub block gap. The test requirement for each sub block is specified in Tables 6.6.2.5.2-1 to 6.6.2.5.2-8 below, where in this case:

- Δf is the separation between the sub block edge frequency and the nominal -3 dB point of the measuring filter closest to the sub block edge.
- f_{offset} is the separation between the sub block edge frequency and the centre of the measuring filter.
- $f_{\text{offset}_{\text{max}}}$ is equal to the sub block gap bandwidth minus half of the bandwidth of the measuring filter.
- Δf_{max} is equal to $f_{\text{offset}_{\text{max}}}$ minus half of the bandwidth of the measuring filter.

Applicability of Wide Area operating band unwanted emission requirements in Tables 6.6.2.5.2-1, 6.6.2.5.2-2a and 6.6.2.5.2-2b is specified in Table 6.6.2.5.2-0.

Table 6.6.2.5.2-0: Applicability of operating band unwanted emission requirements for BC2 Wide Area BS

NR Band operation	Standalone NB-IoT carrier adjacent to the BS RF bandwidth edge	UTRA or GSM supported (Note 1)	Applicable requirement table
None	Y/N	Y/N	6.6.2.5.2-1
In certain regions (NOTE 2), bands 3, 8	N	N	6.6.2.5.2-1
Any	Y	N	6.6.2.5.2-1
Any below 1GHz except for, in certain regions (NOTE 2), band 8	N	N	6.6.2.5.2-2a
Any above 1GHz except for, in certain regions (NOTE 2), bands 3	N	N	6.6.2.5.2-2b
NOTE 1: NR operation with UTRA or GSM is not supported in this specification.			
NOTE 2: Applicable only for operation in regions where Category B limits as defined in ITU-R Recommendation SM.329 [13] are used for which category B option 2 operating band unwanted emissions requirements as defined in TS 36.104 [5] and TS 38.104 [27] are applied.			

Table 6.6.2.5.2-1: WA BS OBUE in BC2 bands applicable for: BS not supporting NR; BS operating NR in Band 3 or 8 in Europe; or BS with standalone NB-IoT at the BS RF bandwidth edge (irrespective of NR support)

Frequency offset of measurement filter -3dB point, Δf	Frequency offset of measurement filter centre frequency, f_{offset}	Test requirement (Note 2, 3)	Measurement bandwidth (Note 9)
$0 \text{ MHz} \leq \Delta f < 0.2 \text{ MHz}$ (Note 1)	$0.015 \text{ MHz} \leq f_{\text{offset}} < 0.215 \text{ MHz}$	-12.5 dBm	30 kHz
$0.2 \text{ MHz} \leq \Delta f < 1 \text{ MHz}$	$0.215 \text{ MHz} \leq f_{\text{offset}} < 1.015 \text{ MHz}$	$-12.5 \text{ dBm} - 15 \cdot \left(\frac{f_{\text{offset}}}{\text{MHz}} - 0.215 \right) \text{ dB}$ (Note 4)	30 kHz
(Note 8)	$1.015 \text{ MHz} \leq f_{\text{offset}} < 1.5 \text{ MHz}$	-24.5 dBm (Note 4)	30 kHz
$1 \text{ MHz} \leq \Delta f \leq \min(\Delta f_{\text{max}}, 10 \text{ MHz})$	$1.5 \text{ MHz} \leq f_{\text{offset}} < \min(f_{\text{offset}_{\text{max}}}, 10.5 \text{ MHz})$	-11.5 dBm (Note 4)	1 MHz
$10 \text{ MHz} \leq \Delta f \leq \Delta f_{\text{max}}$	$10.5 \text{ MHz} \leq f_{\text{offset}} < f_{\text{offset}_{\text{max}}}$	-15 dBm (Note 4, 10)	1 MHz
NOTE 1: For operation with a GSM/EDGE or standalone NB-IoT or an E-UTRA 1.4 or 3 MHz carrier adjacent to the Base Station RF Bandwidth edge, the limits in Table 6.6.2.5-2 apply for $0 \text{ MHz} \leq \Delta f < 0.15 \text{ MHz}$.			
NOTE 2: For MSR BS supporting non-contiguous spectrum operation within any operating band the test requirement within sub-block gaps is calculated as a cumulative sum of contributions from adjacent sub blocks on each side of the sub block gap, where the contribution from the far-end sub-block shall be scaled according to the measurement bandwidth of the near-end sub-block. Exception is $\Delta f \geq 10 \text{ MHz}$ from both adjacent sub blocks on each side of the sub-block gap, where the test requirement within sub-block gaps shall be -15dBm/MHz (for MSR BS supporting multi-band operation, either this limit or -16dBm/100kHz with correspondingly adjusted f_{offset} shall apply for this frequency offset range for operating bands <1GHz).			
NOTE3: For MSR BS supporting multi-band operation with Inter RF Bandwidth gap $< 2 \times \Delta f_{\text{OBUE}}$ operation the test requirement within the Inter RF Bandwidth gaps is calculated as a cumulative sum of contributions from adjacent sub-blocks or RF Bandwidth on each side of the Inter RF Bandwidth gap, where the contribution from the far-end sub-block or RF Bandwidth shall be scaled according to the measurement bandwidth of the near-end sub-block or RF Bandwidth.			
NOTE 4: For MSR BS supporting multi-band operation, either this limit or -16dBm/100kHz with correspondingly adjusted f_{offset} shall apply for this frequency offset range for operating bands <1GHz.			

Table 6.6.2.5.2-2: WA BS OBUE in BC2 bands applicable for: BS with GSM/EDGE or standalone NB-IoT or E-UTRA 1.4 or 3 MHz carriers adjacent to the Base Station RF Bandwidth edge

Frequency offset of measurement filter -3dB point, Δf	Frequency offset of measurement filter centre frequency, f_{offset}	Test requirement (Note 5, 6, 7, 8)	Measurement bandwidth (Note 9)
$0 \text{ MHz} \leq \Delta f < 0.05 \text{ MHz}$	$0.015 \text{ MHz} \leq f_{\text{offset}} < 0.065 \text{ MHz}$	$\text{Max}(6.5 \text{ dBm} - 60 \cdot \left(\frac{f_{\text{offset}}}{\text{MHz}} - 0.015 \right) \text{ dB} +$ $-12.5 \text{ dBm})$	30 kHz
$0.05 \text{ MHz} \leq \Delta f < 0.15 \text{ MHz}$	$0.065 \text{ MHz} \leq f_{\text{offset}} < 0.165 \text{ MHz}$	$\text{Max}(3.5 \text{ dBm} - 160 \cdot \left(\frac{f_{\text{offset}}}{\text{MHz}} - 0.065 \right) \text{ dB} +$ $-12.5 \text{ dBm})$	30 kHz
NOTE 4: The limits in this table only apply for operation with a GSM/EDGE or standalone NB-IoT or an E-UTRA 1.4 or 3 MHz carrier adjacent to the Base Station RF Bandwidth edge.			
NOTE 5: For MSR BS supporting non-contiguous spectrum operation within any operating band the test requirement within sub-block gaps is calculated as a cumulative sum of contributions from adjacent sub blocks on each side of the sub block gap.			
NOTE 6: For MSR BS supporting multi-band operation with Inter RF Bandwidth gap $< 2 \times \Delta f_{\text{OBUE}}$ the test requirement within the Inter RF Bandwidth gaps is calculated as a cumulative sum of contributions from adjacent sub-blocks or RF Bandwidth on each side of the Inter RF Bandwidth gap.			
NOTE 7: In case the carrier adjacent to the Base Station RF Bandwidth edge is a GSM/EDGE carrier, the value of $X = P_{\text{GSMcarrier}} - 43$, where $P_{\text{GSMcarrier}}$ is the power level of the GSM/EDGE carrier adjacent to the Base Station RF Bandwidth edge. In other cases, $X = 0$.			
NOTE 8: In case the carrier adjacent to the RF bandwidth edge is a NB-IoT carrier, the value of $X = P_{\text{NB-IoTcarrier}} - 43$, where $P_{\text{NB-IoTcarrier}}$ is the power level of the NB-IoT carrier adjacent to the RF bandwidth edge. In other cases, $X = 0$.			

Table 6.6.2.5.2-2a: WA BS OBUE in BC2 bands ≤ 1 GHz applicable for: BS supporting NR, not operating NR in Band 8 in Europe, not supporting UTRA, not supporting GSM, and with no standalone NB-IoT carrier at the BS RF bandwidth edge

Frequency offset of measurement filter -3dB point, Δf	Frequency offset of measurement filter centre frequency, f_{offset}	Minimum requirement (Note 1, 2)	Measurement bandwidth (Note 9)
$0 \text{ MHz} \leq \Delta f < 5 \text{ MHz}$	$0.05 \text{ MHz} \leq f_{\text{offset}} < 5.05 \text{ MHz}$	$-5.5 \text{ dBm} - 7/5(f_{\text{offset}}/\text{MHz} - 0.05) \text{ dB}$	100 kHz
$5 \text{ MHz} \leq \Delta f < \min(10 \text{ MHz}, \Delta f_{\text{max}})$	$5.05 \text{ MHz} \leq f_{\text{offset}} < \min(10.05 \text{ MHz}, f_{\text{offset}_{\text{max}}})$	-12.5 dBm	100 kHz
$10 \text{ MHz} \leq \Delta f \leq \Delta f_{\text{max}}$	$10.05 \text{ MHz} \leq f_{\text{offset}} < f_{\text{offset}_{\text{max}}}$	-16 dBm (Note 10)	100 kHz
<p>NOTE 1: For MSR BS supporting non-contiguous spectrum operation within any operating band, the minimum requirement within sub-block gaps is calculated as a cumulative sum of contributions from adjacent sub blocks on each side of the sub block gap, where the contribution from the far-end sub-block or RF Bandwidth shall be scaled according to the measurement bandwidth of the near-end sub-block or RF Bandwidth. Exception is $\Delta f \geq 10 \text{ MHz}$ from both adjacent sub blocks on each side of the sub-block gap, where the minimum requirement within sub-block gaps shall be -16dBm/100kHz.</p> <p>NOTE 2: For MSR BS supporting multi-band operation with Inter RF Bandwidth gap $< 2 \times \Delta f_{\text{OBUE}}$ the minimum requirement within the Inter RF Bandwidth gaps is calculated as a cumulative sum of contributions from adjacent sub-blocks or RF Bandwidth on each side of the Inter RF Bandwidth gap, where the contribution from the far-end sub-block or RF Bandwidth shall be scaled according to the measurement bandwidth of the near-end sub-block or RF Bandwidth.</p> <p>NOTE 3: For operation with an E-UTRA 1.4 or 3MHz carrier adjacent to the Base Station RF Bandwidth edge, the limits in Table 6.6.2.5.2-2 apply for $0 \text{ MHz} \leq \Delta f < 0.15 \text{ MHz}$.</p>			

Table 6.6.2.5.2-2b: WA BS OBUE in BC2 bands > 1 GHz applicable for: BS supporting NR, not operating NR in Band 3 in Europe, not supporting UTRA, not supporting GSM, and with no standalone NB-IoT carrier at the BS RF bandwidth edge

Frequency offset of measurement filter -3dB point, Δf	Frequency offset of measurement filter centre frequency, f_{offset}	Minimum requirement (Note 1, 2)	Measurement bandwidth (Note 9)
$0 \text{ MHz} \leq \Delta f < 5 \text{ MHz}$	$0.05 \text{ MHz} \leq f_{\text{offset}} < 5.05 \text{ MHz}$	$-5.5 \text{ dBm} - 7/5(f_{\text{offset}}/\text{MHz} - 0.05) \text{ dB}$	100 kHz
$5 \text{ MHz} \leq \Delta f < \min(10 \text{ MHz}, \Delta f_{\text{max}})$	$5.05 \text{ MHz} \leq f_{\text{offset}} < \min(10.05 \text{ MHz}, f_{\text{offset}_{\text{max}}})$	-12.5 dBm	100 kHz
$10 \text{ MHz} \leq \Delta f \leq \Delta f_{\text{max}}$	$10.5 \text{ MHz} \leq f_{\text{offset}} < f_{\text{offset}_{\text{max}}}$	-15 dBm (Note 10)	1MHz
<p>NOTE 1: For MSR BS supporting non-contiguous spectrum operation within any operating band, the minimum requirement within sub-block gaps is calculated as a cumulative sum of contributions from adjacent sub blocks on each side of the sub block gap, where the contribution from the far-end sub-block shall be scaled according to the measurement bandwidth of the near-end sub-block. Exception is $\Delta f \geq 10 \text{ MHz}$ from both adjacent sub blocks on each side of the sub-block gap, where the minimum requirement within sub-block gaps shall be -15dBm/1MHz.</p> <p>NOTE 2: For MSR BS supporting multi-band operation with Inter RF Bandwidth gap $< 2 \times \Delta f_{\text{OBUE}}$ the minimum requirement within the Inter RF Bandwidth gaps is calculated as a cumulative sum of contributions from adjacent sub-blocks or RF Bandwidth on each side of the Inter RF Bandwidth gap, where the contribution from the far-end sub-block or RF Bandwidth shall be scaled according to the measurement bandwidth of the near-end sub-block or RF Bandwidth.</p> <p>NOTE 3: For operation with an E-UTRA 1.4 or 3MHz carrier adjacent to the Base Station RF Bandwidth edge, the limits in Table 6.6.2.5.2-2 apply for $0 \text{ MHz} \leq \Delta f < 0.15 \text{ MHz}$.</p>			

Table 6.6.2.5.2-3: MR BS OBUE in BC2 bands applicable for: BS with maximum output power 31 < $P_{\text{Rated,c}} \leq 38$ dBm and not supporting NR

Frequency offset of measurement filter -3dB point, Δf	Frequency offset of measurement filter centre frequency, f_{offset}	Test requirement (Note 2, 3)	Measurement bandwidth (Note 9)
$0 \text{ MHz} \leq \Delta f < 0.6 \text{ MHz}$ (Note 1)	$0.015 \text{ MHz} \leq f_{\text{offset}} < 0.615 \text{ MHz}$	$P_{\text{Rated,c}} - 56.5 \text{ dB} - 7/5(f_{\text{offset}}/\text{MHz} - 0.015) \text{ dB}$	30 kHz
$0.6 \text{ MHz} \leq \Delta f < 1 \text{ MHz}$ (Note 8)	$0.615 \text{ MHz} \leq f_{\text{offset}} < 1.015 \text{ MHz}$ $1.015 \text{ MHz} \leq f_{\text{offset}} < 1.5 \text{ MHz}$	$P_{\text{Rated,c}} - 51.5 \text{ dB} - 15(f_{\text{offset}}/\text{MHz} - 0.215) \text{ dB}$ $P_{\text{Rated,c}} - 63.5 \text{ dB}$	30 kHz
$1 \text{ MHz} \leq \Delta f \leq 2.8 \text{ MHz}$	$1.5 \text{ MHz} \leq f_{\text{offset}} < 3.3 \text{ MHz}$	$P_{\text{Rated,c}} - 50.5 \text{ dB}$	1 MHz
$2.8 \text{ MHz} \leq \Delta f \leq 5 \text{ MHz}$	$3.3 \text{ MHz} \leq f_{\text{offset}} < 5.5 \text{ MHz}$	$\min(P_{\text{Rated,c}} - 50.5 \text{ dB}, -13.5 \text{ dBm})$	1 MHz
$5 \text{ MHz} \leq \Delta f \leq \min(\Delta f_{\text{max}}, 10 \text{ MHz})$	$5.5 \text{ MHz} \leq f_{\text{offset}} < \min(f_{\text{offset}_{\text{max}}}, 10.5 \text{ MHz})$	$P_{\text{Rated,c}} - 54.5 \text{ dB}$	1 MHz
$10 \text{ MHz} \leq \Delta f \leq \Delta f_{\text{max}}$	$10.5 \text{ MHz} \leq f_{\text{offset}} < f_{\text{offset}_{\text{max}}}$	$P_{\text{Rated,c}} - 56 \text{ dB}$ (Note 10)	1 MHz
NOTE 1: For operation with a GSM/EDGE or standalone NB-IoT or an E-UTRA 1.4 or 3 MHz carrier adjacent to the Base Station RF Bandwidth edge, the limits in Table 6.6.2.5.2-5 apply for $0 \text{ MHz} \leq \Delta f < 0.15 \text{ MHz}$.			
NOTE 2: For MSR BS supporting non-contiguous spectrum operation within any operating band the test requirement within sub-block gaps is calculated as a cumulative sum of contributions from adjacent sub blocks on each side of the sub block gap, where the contribution from the far-end sub-block shall be scaled according to the measurement bandwidth of the near-end sub-block. Exception is $\Delta f \geq 10 \text{ MHz}$ from both adjacent sub blocks on each side of the sub-block gap, where the test requirement within sub-block gaps shall be $(P_{\text{Rated,c}} - 56 \text{ dB})/\text{MHz}$.			
NOTE 3: For MSR BS supporting multi-band operation with Inter RF Bandwidth gap $< 2 \times \Delta f_{\text{OBUE}}$ the test requirement within the Inter RF Bandwidth gaps is calculated as a cumulative sum of contributions from adjacent sub-blocks or RF Bandwidth on each side of the Inter RF Bandwidth gap, where the contribution from the far-end sub-block or RF Bandwidth shall be scaled according to the measurement bandwidth of the near-end sub-block or RF Bandwidth.			

Table 6.6.2.5.2-3a: MR BS OBUE in BC2 bands applicable for: BS with maximum output power 31 < $P_{\text{Rated,c}} \leq 38$ dBm, supporting NR, not supporting UTRA, and not supporting GSM

Frequency offset of measurement filter -3dB point, Δf	Frequency offset of measurement filter centre frequency, f_{offset}	Minimum requirement (Note 1, 2)	Measurement bandwidth (Note 9)
$0 \text{ MHz} \leq \Delta f < 5 \text{ MHz}$	$0.05 \text{ MHz} \leq f_{\text{offset}} < 5.05 \text{ MHz}$	$P_{\text{Rated,c}} - 51.5 \text{ dB} - 7/5(f_{\text{offset}}/\text{MHz} - 0.05) \text{ dB}$	100 kHz
$5 \text{ MHz} \leq \Delta f < \min(10 \text{ MHz}, \Delta f_{\text{max}})$	$5.05 \text{ MHz} \leq f_{\text{offset}} < \min(10.05 \text{ MHz}, f_{\text{offset}_{\text{max}}})$	$P_{\text{Rated,c}} - 58.5 \text{ dB}$	100 kHz
$10 \text{ MHz} \leq \Delta f \leq \Delta f_{\text{max}}$	$10.05 \text{ MHz} \leq f_{\text{offset}} < f_{\text{offset}_{\text{max}}}$	$\min(P_{\text{Rated,c}} - 60 \text{ dB}, -25 \text{ dBm})$ (Note 10)	100 kHz
NOTE 1: For MSR BS supporting non-contiguous spectrum operation within any operating band the minimum requirement within sub-block gaps is calculated as a cumulative sum of contributions from adjacent sub blocks on each side of the sub block gap, where the contribution from the far-end sub-block shall be scaled according to the measurement bandwidth of the near-end sub-block. Exception is $\Delta f \geq 10 \text{ MHz}$ from both adjacent sub blocks on each side of the sub-block gap, where the minimum requirement within sub-block gaps shall be $\min(P_{\text{Rated,c}} - 60 \text{ dB}, -25 \text{ dBm})/100 \text{ kHz}$.			
NOTE 2: For MSR BS supporting multi-band operation with Inter RF Bandwidth gap $< 2 \times \Delta f_{\text{OBUE}}$ the minimum requirement within the Inter RF Bandwidth gaps is calculated as a cumulative sum of contributions from adjacent sub-blocks or RF Bandwidth on each side of the Inter RF Bandwidth gap, where the contribution from the far-end sub-block shall be scaled according to the measurement bandwidth of the near-end sub-block.			
NOTE 3: For operation with a standalone NB-IoT or an E-UTRA 1.4 or 3 MHz carrier adjacent to the Base Station RF Bandwidth edge, the limits in Table 6.6.2.5.2-5 apply for $0 \text{ MHz} \leq \Delta f < 0.15 \text{ MHz}$.			

Table 6.6.2.5.2-4: MR BS OBUE in in BC2 bands applicable for: BS with maximum output power $P_{Rated,c} \leq 31$ dBm and not supporting NR

Frequency offset of measurement filter -3dB point, Δf	Frequency offset of measurement filter centre frequency, f_{offset}	Test requirement (Note 2, 3)	Measurement bandwidth (Note 9)
$0 \text{ MHz} \leq \Delta f < 0.6 \text{ MHz}$ (Note 1)	$0.015 \text{ MHz} \leq f_{offset} < 0.615 \text{ MHz}$	$-25.5 \text{ dBm} - \frac{7}{5} \left(\frac{f_{offset}}{\text{MHz}} - 0.015 \right) \text{ dB}$	30 kHz
$0.6 \text{ MHz} \leq \Delta f < 1 \text{ MHz}$	$0.615 \text{ MHz} \leq f_{offset} < 1.015 \text{ MHz}$	$-20.5 \text{ dBm} - 15 \cdot \left(\frac{f_{offset}}{\text{MHz}} - 0.215 \right) \text{ dB}$	30 kHz
(Note 8)	$1.015 \text{ MHz} \leq f_{offset} < 1.5 \text{ MHz}$	-32.5 dBm	30 kHz
$1 \text{ MHz} \leq \Delta f \leq 5 \text{ MHz}$	$1.5 \text{ MHz} \leq f_{offset} < 5.5 \text{ MHz}$	-19.5 dBm	1 MHz
$5 \text{ MHz} \leq \Delta f \leq \min(\Delta f_{max}, 10 \text{ MHz})$	$5.5 \text{ MHz} \leq f_{offset} < \min(f_{offset_{max}}, 10.5 \text{ MHz})$	-23.5 dBm	1 MHz
$10 \text{ MHz} \leq \Delta f \leq \Delta f_{max}$	$10.5 \text{ MHz} \leq f_{offset} < f_{offset_{max}}$	-25 dBm (Note 10)	1 MHz
NOTE 1: For operation with a GSM/EDGE or standalone NB-IoT or an E-UTRA 1.4 or 3 MHz carrier adjacent to the Base Station RF Bandwidth edge, the limits in Table 6.6.2.5.2-6 apply for $0 \text{ MHz} \leq \Delta f < 0.15 \text{ MHz}$.			
NOTE 2: For MSR BS supporting non-contiguous spectrum operation within any operating band the test requirement within sub-block gaps is calculated as a cumulative sum of contributions from adjacent sub blocks on each side of the sub block gap, where the contribution from the far-end sub-block shall be scaled according to the measurement bandwidth of the near-end sub-block. Exception is $\Delta f \geq 10 \text{ MHz}$ from both adjacent sub blocks on each side of the sub-block gap, where the test requirement within sub-block gaps shall be -25dBm/MHz.			
NOTE 3: For MSR BS supporting multi-band operation with Inter RF Bandwidth gap $< 2 \times \Delta f_{OBUE}$ the test requirement within the Inter RF Bandwidth gaps is calculated as a cumulative sum of contributions from adjacent sub-blocks or RF Bandwidth on each side of the Inter RF Bandwidth gap, where the contribution from the far-end sub-block or RF Bandwidth shall be scaled according to the measurement bandwidth of the near-end sub-block or RF Bandwidth.			

Table 6.6.2.5.2-4a: MR BS OBUE in BC2 bands applicable for: BS with maximum output power $P_{Rated,c} \leq 31$ dBm BS, supporting NR, not supporting UTRA, and not supporting GSM

Frequency offset of measurement filter -3dB point, Δf	Frequency offset of measurement filter centre frequency, f_{offset}	Minimum requirement (Note 1, 2)	Measurement bandwidth (Note 9)
$0 \text{ MHz} \leq \Delta f < 5 \text{ MHz}$	$0.05 \text{ MHz} \leq f_{offset} < 5.05 \text{ MHz}$	$-20.5 \text{ dBm} - 7/5(f_{offset}/\text{MHz} - 0.05) \text{ dB}$	100 kHz
$5 \text{ MHz} \leq \Delta f < \min(10 \text{ MHz}, \Delta f_{max})$	$5.05 \text{ MHz} \leq f_{offset} < \min(10.05 \text{ MHz}, f_{offset_{max}})$	-27.5 dBm	100 kHz
$10 \text{ MHz} \leq \Delta f \leq \Delta f_{max}$	$10.05 \text{ MHz} \leq f_{offset} < f_{offset_{max}}$	-29 dBm (Note 10)	100 kHz
NOTE 1: For MSR BS supporting non-contiguous spectrum operation within any operating band the minimum requirement within sub-block gaps is calculated as a cumulative sum of contributions from adjacent sub blocks on each side of the sub block gap, where the contribution from the far-end sub-block shall be scaled according to the measurement bandwidth of the near-end sub-block. Exception is $\Delta f \geq 10 \text{ MHz}$ from both adjacent sub blocks on each side of the sub-block gap, where the minimum requirement within sub-block gaps shall be -29dBm/100kHz.			
NOTE 2: For MSR BS supporting multi-band operation with Inter RF Bandwidth gap $< 2 \times \Delta f_{OBUE}$ the minimum requirement within the Inter RF Bandwidth gaps is calculated as a cumulative sum of contributions from adjacent sub-blocks or RF Bandwidth on each side of the Inter RF Bandwidth gap, where the contribution from the far-end sub-block shall be scaled according to the measurement bandwidth of the near-end sub-block.			
NOTE 3: For operation with a standalone NB-IoT or an E-UTRA 1.4 or 3MHz carrier adjacent to the Base Station RF Bandwidth edge, the limits in Table 6.6.2.5.2-6 apply for $0 \text{ MHz} \leq \Delta f < 0.15 \text{ MHz}$.			

Table 6.6.2.5.2-5: MR BS OBUE in BC2 bands applicable for: BS with maximum output power 31 $P_{\text{Rated,c}} \leq 38 \text{ dBm}$ and with GSM/EDGE or E-UTRA 1.4 or 3 MHz carriers or standalone NB-IoT adjacent to the Base Station RF Bandwidth edge

Frequency offset of measurement filter -3dB point, Δf	Frequency offset of measurement filter centre frequency, f_{offset}	Test requirement (Note 5, 6)	Measurement bandwidth (Note 9)
$0 \text{ MHz} \leq \Delta f < 0.05 \text{ MHz}$	$0.015 \text{ MHz} \leq f_{\text{offset}} < 0.065 \text{ MHz}$	$P_{\text{Rated,c}} - 36.5\text{dB} - 60(f_{\text{offset}}/\text{MHz} - 0.015)\text{dB}$	30 kHz
$0.05 \text{ MHz} \leq \Delta f < 0.15 \text{ MHz}$	$0.065 \text{ MHz} \leq f_{\text{offset}} < 0.165 \text{ MHz}$	$P_{\text{Rated,c}} - 39.5\text{dB} - 160(f_{\text{offset}}/\text{MHz} - 0.065)\text{dB}$	30 kHz

NOTE 4: The limits in this table only apply for operation with a GSM/EDGE or an E-UTRA 1.4 or 3 MHz carrier adjacent to the Base Station RF Bandwidth edge.

NOTE 5: For MSR BS supporting non-contiguous spectrum operation within any operating band the test requirement within sub-block gaps is calculated as a cumulative sum of contributions from adjacent sub blocks on each side of the sub block gap.

NOTE 6: For MSR BS supporting multi-band operation with Inter RF Bandwidth gap $< 2 \times \Delta f_{\text{OBUE}}$ the test requirement within the Inter RF Bandwidth gaps is calculated as a cumulative sum of contributions from adjacent sub-blocks or RF Bandwidth on each side of the Inter RF Bandwidth gap.

Table 6.6.2.5.2-6: MR BS OBUE in BC2 bands applicable for: BS with maximum output power $P_{\text{Rated,c}} \leq 31 \text{ dBm}$ and with GSM/EDGE or E-UTRA 1.4 or 3 MHz carriers or standalone NB-IoT adjacent to the Base Station RF Bandwidth edge

Frequency offset of measurement filter -3dB point, Δf	Frequency offset of measurement filter centre frequency, f_{offset}	Test requirement (Note 5, 6, 7)	Measurement bandwidth (Note 9)
$0 \text{ MHz} \leq \Delta f < 0.05 \text{ MHz}$	$0.015 \text{ MHz} \leq f_{\text{offset}} < 0.065 \text{ MHz}$	$\text{Max}(-5.5\text{dBm} - 60 \cdot \left(\frac{f_{\text{offset}}}{\text{MHz}} - 0.015\right) + X\text{dB}, -25.5\text{dBm})$	30 kHz
$0.05 \text{ MHz} \leq \Delta f < 0.15 \text{ MHz}$	$0.065 \text{ MHz} \leq f_{\text{offset}} < 0.165 \text{ MHz}$	$\text{Max}(-8.5\text{dBm} - 160 \cdot \left(\frac{f_{\text{offset}}}{\text{MHz}} - 0.065\right) + X\text{dB}, -25.5\text{dBm})$	30 kHz

NOTE 4: The limits in this table only apply for operation with a GSM/EDGE or an E-UTRA 1.4 or 3 MHz carrier adjacent to the Base Station RF Bandwidth edge.

NOTE 5: For MSR BS supporting non-contiguous spectrum operation within any operating band the test requirement within sub-block gaps is calculated as a cumulative sum of contributions from adjacent sub blocks on each side of the sub block gap.

NOTE 6: For MSR BS supporting multi-band operation with Inter RF Bandwidth gap $< 2 \times \Delta f_{\text{OBUE}}$ the test requirement within the Inter RF Bandwidth gaps is calculated as a cumulative sum of contributions from adjacent sub-blocks or RF Bandwidth on each side of the Inter RF Bandwidth gap.

NOTE 7: In case the carrier adjacent to the Base Station RF Bandwidth edge is a GSM/EDGE carrier, the value of $X = P_{\text{GSMcarrier}} - 31$, where $P_{\text{GSMcarrier}}$ is the power level of the GSM/EDGE carrier adjacent to the Base Station RF Bandwidth edge. In other cases, $X = 0$.

NOTE 8: In case the carrier adjacent to the RF bandwidth edge is a NB-IoT carrier, the value of $X = P_{\text{NB-IoTcarrier}} - 31$, where $P_{\text{NB-IoTcarrier}}$ is the power level of the NB-IoT carrier adjacent to the RF bandwidth edge. In other cases, $X = 0$.

Table 6.6.2.5.2-7: LA BS OBUE in BC2 bands

Frequency offset of measurement filter -3dB point, Δf	Frequency offset of measurement filter centre frequency, f_{offset}	Test requirement (Note 2, 3)	Measurement bandwidth (Note 9)
$0 \text{ MHz} \leq \Delta f < 5 \text{ MHz}$ (Note 1)	$0.05 \text{ MHz} \leq f_{\text{offset}} < 5.05 \text{ MHz}$	$-28.5 \text{ dBm} - \frac{7}{5} \left(\frac{f_{\text{offset}}}{\text{MHz}} - 0.05 \right) \text{ dB}$	100 kHz
$5 \text{ MHz} \leq \Delta f < \min(10 \text{ MHz}, \Delta f_{\text{max}})$	$5.05 \text{ MHz} \leq f_{\text{offset}} < \min(10.05 \text{ MHz}, f_{\text{offset}_{\text{max}}})$	-35.5 dBm	100 kHz
$10 \text{ MHz} \leq \Delta f \leq \Delta f_{\text{max}}$	$10.05 \text{ MHz} \leq f_{\text{offset}} < f_{\text{offset}_{\text{max}}}$	-37 dBm (Note 7)	100 kHz

NOTE 1: For operation with a GSM/EDGE or standalone NB-IoT or an E-UTRA 1.4 or 3 MHz carrier adjacent to the Base Station RF Bandwidth edge, the limits in Table 6.6.2.5.2-8 apply for $0 \text{ MHz} \leq \Delta f < 0.16 \text{ MHz}$.

NOTE 2: For MSR BS supporting non-contiguous spectrum operation within any operating band the test requirement within sub-block gaps is calculated as a cumulative sum of contributions from adjacent sub blocks on each side of the sub block gap. Exception is $\Delta f \geq 10 \text{ MHz}$ from both adjacent sub blocks on each side of the sub-block gap, where the test requirement within sub-block gaps shall be -37dBm/100 kHz.

NOTE 3: For MSR BS supporting multi-band operation with Inter RF Bandwidth gap $< 2 \times \Delta f_{\text{OBUE}}$ the test requirement within the Inter RF Bandwidth gaps is calculated as a cumulative sum of contributions from adjacent sub-blocks or RF Bandwidth on each side of the Inter RF Bandwidth gap.

Table 6.6.2.5.2-8: LA BS OBUE in BC2 bands applicable for: BS with GSM/EDGE or E-UTRA 1.4 or 3 MHz carriers or standalone NB-IoT adjacent to the Base Station RF Bandwidth edge

Frequency offset of measurement filter -3dB point, Δf	Frequency offset of measurement filter centre frequency, f_{offset}	Test requirement (Note 5, 6, 7)	Measurement bandwidth (Note 9)
$0 \text{ MHz} \leq \Delta f < 0.05 \text{ MHz}$	$0.015 \text{ MHz} \leq f_{\text{offset}} < 0.065 \text{ MHz}$	$\text{Max}(-12.5 \text{ dBm} - 60 \cdot \left(\frac{f_{\text{offset}}}{\text{MHz}} - 0.01 \right) + X \text{ dB}, -33.5 \text{ dBm})$	30 kHz
$0.05 \text{ MHz} \leq \Delta f < 0.16 \text{ MHz}$	$0.065 \text{ MHz} \leq f_{\text{offset}} < 0.175 \text{ MHz}$	$\text{Max}(-15.5 \text{ dBm} - 160 \cdot \left(\frac{f_{\text{offset}}}{\text{MHz}} - 0.0 \right) + X \text{ dB}, -33.5 \text{ dBm})$	30 kHz

NOTE 4: The limits in this table only apply for operation with a GSM/EDGE or an E-UTRA 1.4 or 3 MHz carrier adjacent to the Base Station RF Bandwidth edge.

NOTE 5: For MSR BS supporting non-contiguous spectrum operation within any operating band the test requirement within sub-block gaps is calculated as a cumulative sum of contributions from adjacent sub blocks on each side of the sub block gap.

NOTE 6: For MSR BS supporting multi-band operation with Inter RF Bandwidth gap $< 2 \times \Delta f_{\text{OBUE}}$ the test requirement within the Inter RF Bandwidth gaps is calculated as a cumulative sum of contributions from adjacent sub-blocks or RF Bandwidth on each side of the Inter RF Bandwidth gap.

NOTE 7: In case the carrier adjacent to the Base Station RF Bandwidth edge is a GSM/EDGE carrier, the value of $X = P_{\text{GSMcarrier}} - 24$, where $P_{\text{GSMcarrier}}$ is the power level of the GSM/EDGE carrier adjacent to the Base Station RF Bandwidth edge. In other cases, $X = 0$.

NOTE 8: In case the carrier adjacent to the RF bandwidth edge is a NB-IoT carrier, the value of $X = P_{\text{NB-IoTcarrier}} - 24$, where $P_{\text{NB-IoTcarrier}}$ is the power level of the NB-IoT carrier adjacent to the RF bandwidth edge. In other cases, $X = 0$.

NOTE 8: This frequency range ensures that the range of values of f_{offset} is continuous.

NOTE 9: As a general rule for the requirements in the present clause, the resolution bandwidth of the measuring equipment should be equal to the measurement bandwidth. However, to improve measurement accuracy, sensitivity and efficiency, the resolution bandwidth may be smaller than the measurement bandwidth. When the resolution bandwidth is smaller than the measurement bandwidth, the result should be integrated over the measurement bandwidth in order to obtain the equivalent noise bandwidth of the measurement bandwidth.

NOTE 10: The requirement is not applicable when $\Delta f_{\text{max}} < \Delta f_{\text{OBUE}}$.

6.6.2.5.3 Test requirements for GSM/EDGE single-RAT requirements

The following test requirements and the corresponding test method specified in TS 51.021 [11] apply to an MSR Base Station for any operating band with GSM/EDGE single RAT operation in Band Category 2:

- Spectrum due to the modulation and wide band noise, applicable parts of clause 6.5.1.
- Spectrum due to switching transients, applicable parts of clause 6.5.2.
- Emission requirement for frequency offsets of between 2 and 10 MHz outside relevant transmit band, applicable parts of clause 6.6.2.
- Intra BTS Intermodulation, applicable parts of clause 6.12.

6.6.2.5.4 Test requirements for additional requirements

6.6.2.5.4.1 Limits in FCC Title 47

In addition to the requirements in clauses 6.6.2.5.1 and 6.6.2.5.2, the BS may have to comply with the applicable emission limits established by FCC Title 47 [8], when deployed in regions where those limits are applied, and under the conditions declared by the manufacturer.

6.6.2.5.4.2 Unsynchronized operation for BC3

In certain regions, the following requirements may apply to a TDD BS operating in BC3 in the same geographic area and in the same operating band as another TDD system without synchronisation. For this case the emissions shall not exceed -52 dBm/MHz in each supported downlink operating band except in:

- The frequency range from 10 MHz below the lower Base Station RF Bandwidth edge to the frequency 10 MHz above the upper Base Station RF Bandwidth edge of each supported band.

NOTE 1: Local or regional regulations may specify another excluded frequency range, which may include frequencies where synchronised TDD systems operate.

NOTE 2: TDD Base Stations that are synchronized and operating in BC3 can transmit without these additional co-existence requirements.

NOTE 3: Unsynchronized operation for BC3 BS with any NR configuration is FFS.

6.6.2.5.4.3 Protection of DTT

In certain regions the following requirement may apply for protection of DTT. For a BS operating in Band 20, the level of emissions in the band 470-790 MHz, measured in an 8 MHz filter bandwidth on centre frequencies F_{filter} according to Table 6.6.2.5.4.3-1, shall not exceed the maximum emission level $P_{\text{EM},N}$ declared by the manufacturer. This requirement applies in the frequency range 470-790 MHz even though part of the range falls in the spurious domain.

Table 6.6.2.5.4.3-1: Declared emissions levels for protection of DTT

Filter centre frequency, F_{filter}	Measurement bandwidth	Declared emission level [dBm]
$F_{\text{filter}} = 8 \cdot N + 306$ (MHz); $21 \leq N \leq 60$	8 MHz	$P_{\text{EM},N}$

NOTE: The regional requirement is defined in terms of EIRP (effective isotropic radiated power), which is dependent on both the BS emissions at the antenna connector and the deployment (including antenna gain and feeder loss). The requirement defined above provides the characteristics of the Base Station needed to verify compliance with the regional requirement. Compliance with the regional requirement can be determined using the method outlined in Annex G of TS 36.104 [5].

6.6.2.5.4.4 Void

Table 6.6.2.5.4.4-1: Void

6.6.2.5.4.5 Void

Table 6.6.2.5.4.5-1: Void

6.6.2.5.4.6 Additional band 32, 50, 51, 74, 75 and 76 unwanted emissions

In certain regions, the following requirements may apply to BS operating in Band 32 within 1452-1492 MHz, in Band 75 within 1432-1517 MHz and in Band 76 within 1427-1432 MHz. The level of operating band unwanted emissions, measured on centre frequencies f_{offset} with filter bandwidth, according to Table 6.6.2.5.4.6-1, shall neither exceed the maximum emission level $P_{EM,B32,B75,B76,a}$, $P_{EM,B32,B75,B76,b}$ nor $P_{EM,B32,B75,B76,c}$ declared by the manufacturer.

For Band 32, this requirement applies in the frequency range 1452-1492 MHz when non-Mobile/Fixed Communications Network (MFCN) services are deployed in adjacent frequency ranges, while it applies also within 1427-1452 MHz and/or 1492-1517 MHz when MFCN services are deployed in such frequency ranges, even though part of the ranges falls in the spurious domain. For Band 75, this requirement applies in the frequency range 1427-1517 MHz. For Band 76, this requirement applies in the frequency range 1432-1517 MHz even though part of the range falls in the spurious domain.

Table 6.6.2.5.4.6-1: Declared operating band 32, 75 and 76 unwanted emission within 1427-1517 MHz

Frequency offset of measurement filter centre frequency, f_{offset}	Declared emission level [dBm]	Measurement bandwidth
2.5 MHz	$P_{EM,B32,B75,B76,a}$	5 MHz
7.5 MHz	$P_{EM,B32,B75,B76,b}$	5 MHz
$12.5 \text{ MHz} \leq f_{\text{offset}} \leq f_{\text{offset}_{\text{max}}}$	$P_{EM,B32,B75,B76,c}$	5 MHz
NOTE: For Band 32, when non-MFCN services are deployed in the adjacent bands, $f_{\text{offset}_{\text{max}}}$ denotes the frequency difference between the lower Base Station RF Bandwidth edge and 1454.5 MHz, and the frequency difference between the upper Base Station RF Bandwidth edge and 1489.5 MHz for the set channel position. For Band 32, when MFCN services are deployed in the adjacent frequencies, Band 75 and Band 76, $f_{\text{offset}_{\text{max}}}$ denotes the frequency difference between the lower Base Station RF Bandwidth edge and 1429.5 MHz, and the frequency difference between the upper Base Station RF Bandwidth edge and 1514.5 MHz for the set channel position		

NOTE: The regional requirement, included in [25], is defined in terms of EIRP per antenna, which is dependent on both the BS emissions at the antenna connector and the deployment (including antenna gain and feeder loss). The requirement defined above provides the characteristics of the base station needed to verify compliance with the regional requirement. The assessment of the EIRP level is described in Annex H of TS 36.104 [5].

In certain regions, the following requirement may apply to BS operating in Band 32 within 1452-1492MHz for the protection of non-MFCN services in spectrum adjacent to the frequency range 1452-1492 MHz. The level of emissions, measured on centre frequencies F_{filter} with filter bandwidth according to Table 6.6.2.5.4.6-2, shall neither exceed the maximum emission level $P_{EM,B32,d}$ nor $P_{EM,B32,e}$ declared by the manufacturer. This requirement applies in the frequency range 1429-1518MHz even though part of the range falls in the spurious domain.

Table 6.6.2.5.4.6-2: Operating band 32 declared emission outside 1452-1492 MHz

Filter centre frequency, F_{filter}	Declared emission level [dBm]	Measurement bandwidth
$1429.5 \text{ MHz} \leq F_{\text{filter}} \leq 1448.5 \text{ MHz}$	$P_{\text{EM},\text{B32},\text{d}}$	1 MHz
$F_{\text{filter}} = 1450.5 \text{ MHz}$	$P_{\text{EM},\text{B32},\text{e}}$	3 MHz
$F_{\text{filter}} = 1493.5 \text{ MHz}$	$P_{\text{EM},\text{B32},\text{e}}$	3 MHz
$1495.5 \text{ MHz} \leq F_{\text{filter}} \leq 1517.5 \text{ MHz}$	$P_{\text{EM},\text{B32},\text{d}}$	1 MHz

NOTE: The regional requirement, included in [24], is defined in terms of EIRP, which is dependent on both the BS emissions at the antenna connector and the deployment (including antenna gain and feeder loss). The requirement defined above provides the characteristics of the base station needed to verify compliance with the regional requirement. The assessment of the EIRP level is described in Annex H of TS 36.104 [5].

In certain regions, the following requirement may apply to BS operating in Band 50 and Band 75 within 1492-1517 MHz and in Band 74 within 1492-1518 MHz. The level of emissions, measured on centre frequencies F_{filter} with filter bandwidth according to Table 6.6.2.5.4.6-3, shall neither exceed the maximum emission level $P_{\text{EM},\text{B50},\text{B74},\text{B75},\text{a}}$ nor $P_{\text{EM},\text{B50},\text{B74},\text{B75},\text{b}}$ declared by the manufacturer.

Table 6.6.2.5.4.6-3: Operating band 50, 74 and 75 declared emission above 1518 MHz

Filter centre frequency, F_{filter}	Declared emission level [dBm]	Measurement bandwidth
$1518.5 \text{ MHz} \leq F_{\text{filter}} \leq 1519.5 \text{ MHz}$	$P_{\text{EM},\text{B50},\text{B74},\text{B75},\text{a}}$	1 MHz
$1520.5 \text{ MHz} \leq F_{\text{filter}} \leq 1558.5 \text{ MHz}$	$P_{\text{EM},\text{B50},\text{B74},\text{B75},\text{b}}$	1 MHz

NOTE: The regional requirement, included in [25], is defined in terms of EIRP, which is dependent on both the BS emissions at the antenna connector and the deployment (including antenna gain and feeder loss). The requirement defined above provides the characteristics of the base station needed to verify compliance with the regional requirement. The assessment of the EIRP level is described in Annex H.

In certain regions, the following requirement may apply to E-UTRA or NR BS operating in Band 50 and Band 75 within 1432-1452 MHz, and in Band 51 and Band 76. Emissions shall not exceed the maximum levels specified in Table 6.6.2.5.4.6-4.

Table 6.6.2.5.4.6-4: Additional operating band unwanted emission limits for BS operating in Band 50 and 75 within 1432-1452 MHz, and in Band 51 and 76

Filter centre frequency, F_{filter}	Maximum Level [dBm]	Measurement Bandwidth
$F_{\text{filter}} = 1413.5 \text{ MHz}$	-42	27 MHz

6.6.2.5.4.7 Additional requirements for band 48

The following requirement may apply to BS operating in Band 48 in certain regions. Emissions shall not exceed the maximum levels specified in Table 6.6.2.4.9-1.

Table 6.6.2.5.4.7-1: Additional operating band unwanted emission limits for Band 48

Channel bandwidth	Frequency offset of measurement filter -3dB point, Δf	Frequency offset of measurement filter centre frequency, f_{offset}	Minimum requirement	Measurement bandwidth
All	$0 \text{ MHz} \leq \Delta f < 10 \text{ MHz}$	$0.5 \text{ MHz} \leq f_{\text{offset}} < 9.5 \text{ MHz}$	-13 dBm	1 MHz

6.6.3 Occupied bandwidth

6.6.3.1 Definition and applicability

The occupied bandwidth is the width of a frequency band such that, below the lower and above the upper frequency limits, the mean powers emitted are each equal to a specified percentage $\beta/2$ of the total mean transmitted power. See also ITU-R Recommendation SM.328 [15].

The value of $\beta/2$ shall be taken as 0.5%.

6.6.3.2 Minimum requirements

The minimum requirement is in TS 37.104 [2] clause 6.6.3.

6.6.3.3 Test purpose

The occupied bandwidth, defined in the Radio Regulations of the International Telecommunication Union ITU, is a useful concept for specifying the spectral properties of a given emission in the simplest possible manner; see also ITU-R Recommendation SM.328 [15]. The test purpose is to verify that the emission of the BS does not occupy an excessive bandwidth for the service to be provided and is, therefore, not likely to create interference to other users of the spectrum beyond undue limits.

6.6.3.4 Method of test

For this requirement Tables 5.1-1 and 5.2-1 refer to single-RAT specifications; see clause 5. The following shall apply:

- For references to TS 25.141 [10], the method of test is specified in TS 25.141 [10], clause 6.5.1.4.
- For references to TS 25.142 [12], the method of test is specified in TS 25.142 [12], clause 6.6.1.4.
- For references to TS 36.141 [9], the method of test is specified in TS 36.141 [9], clause 6.6.1.4.
- For references to TS 38.141-1 [26], the method of test is specified in TS 38.141-1 [26], clause 6.6.2.4.

In addition, for a multi-band capable BS, the following steps shall apply:

- For multi-band capable BS and single band tests, repeat the tests per involved band where single carrier test models shall apply, with no carrier activated in the other band. In addition, when contiguous CA is supported, single band test configurations and test models shall apply with no carrier activated in the other band.

For multi-band capable BS with separate antenna connector, the antenna connector not being under test shall be terminated.

6.6.3.5 Test requirement

The occupied bandwidth of a single carrier shall be less than the values listed in Table 6.6.3.5-1. For E-UTRA intra-band contiguous carrier aggregation, test requirement in clause 6.6.1.5 of TS 36.141 [9] applies for the E-UTRA component carriers that are aggregated. For NR intra-band contiguous carrier aggregation, test requirement in clause 6.6.2.5 of TS 38.141-1 [26] applies for the NR component carriers that are aggregated.

Table 6.6.3.5-1: Occupied bandwidth

RAT	Occupied bandwidth limit
E-UTRA and NR	BW_{Channel}
UTRA FDD	5 MHz
1.28 Mcps UTRA TDD	1.6 MHz
NB-IoT	200 kHz

6.6.4 Adjacent Channel Leakage Power Ratio (ACLR)

6.6.4.1 Definition and applicability

Adjacent Channel Leakage Power Ratio (ACLR) is the ratio of the filtered mean power centred on the assigned channel frequency to the filtered mean power centred on an adjacent channel frequency.

6.6.4.2 Minimum requirement

The minimum requirement is in TS 37.104 [2] clause 6.6.4.

6.6.4.3 Test purpose

To verify that the adjacent channel leakage power ratio requirement shall be met as specified by the minimum requirement.

6.6.4.4 Method of test

For this requirement Tables 5.1-1 and 5.2-1 also refer to single-RAT specifications for UTRA; see clause 5. The following shall apply for references to UTRA single-RAT specifications:

- For references to TS 25.141 [10], the method of test is specified in TS 25.141 [10], clause 6.5.2.2.4.
- For references to TS 25.142 [12], the method of test is specified in TS 25.142 [12], clause 6.6.2.2.4.

For NR and E-UTRA ACLR requirement outside the Base Station RF Bandwidth edges and the ACLR requirement applied inside sub-block gap, in addition, for non-contiguous spectrum operation or Inter RF Bandwidth gap for multi-band operation using, the test configurations defined in clause 4.8, the method of test described in clauses 6.6.4.4.1 and 6.6.4.4.2 applies.

6.6.4.4.1 Initial conditions

Test environment: normal; see Annex B.2.

Base Station RF Bandwidth positions to be tested: B_{RFBW} , M_{RFBW} and T_{RFBW} in single-band operation; see clause 4.9.1; $B'_{\text{RFBW}}T_{\text{RFBW}}$ and $B_{\text{RFBW}}T'_{\text{RFBW}}$ in multi-band operation, see clause 4.9.1.

- 1) Connect the signal analyzer to the Base Station antenna connector as shown in Annex D.1.1.
- 2) The measurement device characteristics shall be:
 - measurement filter bandwidth: defined in clause 6.6.4.5;
 - detection mode: true RMS voltage or true average power.

6.6.4.4.2 Procedure

- 1) Set the Base Station to transmit at maximum power according to the applicable test configuration in clause 5 using the corresponding test models or set of physical channels in clause 4.9.2.
- 2) For E-UTRA with NB-IoT (in-band and/or guard band operation), measure ACLR outside the Base Station RF Bandwidth edges and ACLR inside sub-block gap or Inter RF Bandwidth gap, in addition, for non-contiguous spectrum operation as specified in clause 6.6.4.5.1. For NB-IoT stand-alone operation, measure ACLR as specified in clause 6.6.4.5.5. For NR, measure ACLR outside the Base Station RF Bandwidth edges and ACLR inside sub-block gap or Inter RF Bandwidth gap, in addition, for non-contiguous spectrum operation as specified in clause 6.6.4.5.6.
- 3) For UTRA FDD, measure ACLR inside sub-block gap or Inter RF Bandwidth gap as specified in clause 6.6.4.5.2.
- 4) Measure Cumulative Adjacent Channel Leakage Power Ratio (CACLR) inside sub-block gap or the Inter RF Bandwidth gap as specified in clause 6.6.4.5.4.

In addition, for a multi-band capable BS, the following step shall apply:

- 5) For multi-band capable BS and single band tests, repeat the steps above per involved band where single band test configurations and test models shall apply with no carrier activated in the other band. For multi-band capable BS with separate antenna connector, the antenna connector not being under test in case of SBT or MBT shall be terminated.

6.6.4.5 Test requirements

6.6.4.5.1 E-UTRA test requirement

For E-UTRA, the test requirement is specified in Tables 6.6.4.5.1-1 and 6.6.4.5.1-2, and applies outside the Base Station RF Bandwidth or Maximum Radio Bandwidth.

For a BS operating in non-contiguous spectrum, the ACLR also applies for the first adjacent channel inside any sub-blockgap with a gap size $W_{\text{gap}} \geq 15\text{MHz}$. The ACLR requirement for the second adjacent channel applies inside any sub-block gap with a gap size $W_{\text{gap}} \geq 20\text{MHz}$. The CA CLR test requirement in clause 6.6.4.5.4 applies in sub block gaps for the frequency ranges defined in Table 6.6.4.5.4-1.

For a BS operating in multiple bands, where multiple bands are mapped onto the same antenna connector, the ACLR also applies for the first adjacent channel inside any Inter RF Bandwidth gap with a gap size $W_{\text{gap}} \geq 15\text{MHz}$. The ACLR requirement for the second adjacent channel applies inside any Inter RF Bandwidth gap with a gap size $W_{\text{gap}} \geq 20\text{MHz}$. The CA CLR requirement in clause 6.6.4.5.4 applies in Inter RF Bandwidth gaps for the frequency ranges defined in Table 6.6.4.5.4-1.

The requirement applies during the transmitter on period.

The ACLR is defined with a square filter of bandwidth equal to the transmission bandwidth configuration of the transmitted signal (BW_{Config}) centred on the assigned channel frequency and a filter centered on the adjacent channel frequency according to the tables below.

For Category A Wide Area BS, either the ACLR limits in the tables below or the absolute limit of -13dBm/MHz shall apply, whichever is less stringent.

For Category B Wide Area BS, either the ACLR limits in the tables below or the absolute limit of -15 dBm/MHz shall apply, whichever is less stringent.

For Medium Range BS, either the ACLR limits in the tables below or the absolute limit of -25 dBm/MHz shall apply, whichever is less stringent.

For Local Area BS, either the ACLR limits in the tables below or the absolute limit of -32dBm/MHz shall apply, whichever is less stringent.

For operation in paired spectrum, the ACLR shall be higher than the value specified in Table 6.6.4.5.1-1.

Table 6.6.4.5.1-1: Base Station ACLR in paired spectrum

Channel bandwidth of E-UTRA Lowest/Highest Carrier transmitted BW_{Channel} [MHz]	BS adjacent channel centre frequency offset below the lower or above the upper Base Station RF Bandwidth edge	Assumed adjacent channel carrier	Filter on the adjacent channel frequency and corresponding filter bandwidth	ACLR limit
1.4, 3.0, 5, 10, 15, 20	$0.5 \times BW_{\text{Channel}}$	E-UTRA of same BW	Square (BW_{Config})	44.2 dB
	$1.5 \times BW_{\text{Channel}}$	E-UTRA of same BW	Square (BW_{Config})	44.2 dB
	2.5 MHz	3.84 Mcps UTRA	RRC (3.84 Mcps)	44.2 dB
	7.5 MHz	3.84 Mcps UTRA	RRC (3.84 Mcps)	44.2 dB
NOTE 1: BW_{Channel} and BW_{Config} are the channel bandwidth and transmission bandwidth configuration of the E-UTRA Lowest/Highest Carrier transmitted on the assigned channel frequency.				
NOTE 2: The RRC filter shall be equivalent to the transmit pulse shape filter defined in TS 25.104 [3], with a chip rate as defined in this table.				

For operation in unpaired spectrum, the ACLR shall be higher than the value specified in Table 6.6.4.5.1-2.

Table 6.6.4.5.1-2: Base Station ACLR in unpaired spectrum with synchronized operation

Channel bandwidth of E-UTRA Lowest/Highest Carrier transmitted BW_{Channel} [MHz]	BS adjacent channel centre frequency offset below the lower or above the upper Base Station RF Bandwidth edge	Assumed adjacent channel carrier	Filter on the adjacent channel frequency and corresponding filter bandwidth	ACLR limit
1.4, 3	$0.5 \times BW_{\text{Channel}}$	E-UTRA of same BW	Square (BW_{Config})	44.2 dB
	$1.5 \times BW_{\text{Channel}}$	E-UTRA of same BW	Square (BW_{Config})	44.2 dB
	0.8 MHz	1.28 Mcps UTRA	RRC (1.28 Mcps)	44.2 dB
	2.4 MHz	1.28 Mcps UTRA	RRC (1.28 Mcps)	44.2 dB
5, 10, 15, 20	$0.5 \times BW_{\text{Channel}}$	E-UTRA of same BW	Square (BW_{Config})	44.2 dB
	$1.5 \times BW_{\text{Channel}}$	E-UTRA of same BW	Square (BW_{Config})	44.2 dB
	0.8 MHz	1.28 Mcps UTRA	RRC (1.28 Mcps)	44.2 dB
	2.4 MHz	1.28 Mcps UTRA	RRC (1.28 Mcps)	44.2 dB
	2.5 MHz	3.84 Mcps UTRA	RRC (3.84 Mcps)	44.2 dB
	7.5 MHz	3.84 Mcps UTRA	RRC (3.84 Mcps)	44.2 dB
	5 MHz	7.68 Mcps UTRA	RRC (7.68 Mcps)	44.2 dB
	15 MHz	7.68 Mcps UTRA	RRC (7.68 Mcps)	44.2 dB
NOTE 1: BW_{Channel} and BW_{Config} are the channel bandwidth and transmission bandwidth configuration of the E-UTRA Lowest/Highest Carrier transmitted on the assigned channel frequency.				
NOTE 2: The RRC filter shall be equivalent to the transmit pulse shape filter defined in TS 25.105 [4], with a chip rate as defined in this table.				

For operation in non-contiguous paired spectrum, the ACLR shall be higher than the value specified in Table 6.6.4.5.1-3.

Table 6.6.4.5.1-3: Base Station ACLR in non-contiguous paired spectrum

Sub-block gap size (W_{gap}) where the limit applies	BS adjacent channel centre frequency offset below or above the sub-block edge (inside the gap)	Assumed adjacent channel carrier	Filter on the adjacent channel frequency and corresponding filter bandwidth	ACLR limit
$W_{\text{gap}} \geq 15$ MHz	2.5 MHz	3.84 Mcps UTRA	RRC (3.84 Mcps)	44.2 dB
$W_{\text{gap}} \geq 20$ MHz	7.5 MHz	3.84 Mcps UTRA	RRC (3.84 Mcps)	44.2 dB
NOTE: The RRC filter shall be equivalent to the transmit pulse shape filter defined in TS 25.104 [3], with a chip rate as defined in this table.				

For operation in non-contiguous unpaired spectrum, the ACLR shall be higher than the value specified in Table 6.6.4.5.1-4.

Table 6.6.4.5.1-4: Base Station ACLR in non-contiguous unpaired spectrum

Sub-block gap size (W_{gap}) where the limit applies	BS adjacent channel centre frequency offset below or above the sub-block edge (inside the gap)	Assumed adjacent channel carrier	Filter on the adjacent channel frequency and corresponding filter bandwidth	ACLR limit
$W_{\text{gap}} \geq 15$ MHz	2.5 MHz	5MHz E-UTRA	Square (BW_{Config})	44.2 dB
$W_{\text{gap}} \geq 20$ MHz	7.5 MHz	5MHz E-UTRA	Square (BW_{Config})	44.2 dB

6.6.4.5.2 UTRA FDD test requirement

For UTRA FDD, the test requirement is specified in TS 25.141 [10] clause 6.5.2.2.5, and applies outside the Base Station RF Bandwidth or Maximum Radio Bandwidth.

For a BS operating in non-contiguous spectrum, ACLR requirement also applies for the first adjacent channel, inside any sub-block gap with a gap size $W_{\text{gap}} \geq 15$ MHz. The ACLR requirement for the second adjacent channel applies inside any sub-block gap with a gap size $W_{\text{gap}} \geq 20$ MHz. The CACLR test requirement in clause 6.6.4.5.4 applies in sub block gaps for the frequency ranges defined in Table 6.6.4.5.4-1.

For a BS operating in multiple bands, where multiple bands are mapped onto the same antenna connector, ACLR requirement also applies for the first adjacent channel, inside any Inter RF Bandwidth gap with a gap size $W_{\text{gap}} \geq 15$ MHz. The ACLR requirement for the second adjacent channel applies inside any Inter RF Bandwidth gap with a gap size $W_{\text{gap}} \geq 20$ MHz. The CACLR requirement in clause 6.6.4.5.4 applies in Inter RF Bandwidth gaps for the frequency ranges defined in Table 6.6.4.5.4-1.

6.6.4.5.3 UTRA TDD test requirement

For UTRA TDD, the test requirement is specified in TS 25.142 [12] clause 6.6.2.2.5, and applies outside the Base Station RF Bandwidth or Maximum Radio Bandwidth.

6.6.4.5.4 Cumulative ACLR requirement in non-contiguous spectrum

The following test requirement applies for sub-block or Inter RF Bandwidth gap sizes listed in Table 6.6.4.5.4-1,

- Inside a sub-block gap within an operating band for a BS operating in non-contiguous spectrum.
- Inside an Inter RF Bandwidth gap for a BS operating in multiple bands, where multiple bands are mapped on the same antenna connector.

The Cumulative Adjacent Channel Leakage Power Ratio (CACLR) in a sub-block gap or the Inter RF Bandwidth gap is the ratio of

- a) the sum of the filtered mean power centred on the assigned channel frequencies for the two carriers adjacent to each side of the sub-block gap or the Inter RF Bandwidth gap, and
- b) the filtered mean power centred on a frequency channel adjacent to one of the respective sub-block edges or Base Station RF Bandwidth edges.

The requirement applies to adjacent channels of NR, E-UTRA or UTRA carriers allocated adjacent to each side of the sub-block gap or the Inter RF Bandwidth gap. The assumed filter for the adjacent channel frequency is defined in Table 6.6.4.5.4-1 and the filters on the assigned channels are defined in Table 6.6.4.5.4-2.

NOTE: If the RAT on the assigned channel frequencies is different, the filters used are also different.

For Wide Area Category A BS, either the CACLR limits in Table 6.6.4.5.4-1 or the absolute limit of -13dBm/MHz shall apply, whichever is less stringent.

For Wide Area Category B BS, either the CACLR limits in Table 6.6.4.5.4-1 or the absolute limit of -15dBm/MHz shall apply, whichever is less stringent.

For Medium Range BS, either the CACLR limits in Table 6.6.4.4-1 or the absolute limit of -25 dBm/MHz shall apply, whichever is less stringent.

For Local Area BS, either the CA CLR limits in Table 6.6.4.4-1 or the absolute limit of -32 dBm/MHz shall apply, whichever is less stringent.

The CA CLR for E-UTRA and UTRA carriers located on either side of the sub-block gap or the Inter RF Bandwidth gap shall be higher than the value specified in Table 6.6.4.5.4-1.

Table 6.6.4.5.4-1: Base Station CA CLR in non-contiguous spectrum or multiple bands

Band Category	Sub-block or Inter RF Bandwidth gap size (W_{gap}) where the limit applies (MHz)	BS adjacent channel centre frequency offset below or above the sub-block edge or the Base Station RF Bandwidth edge (inside the gap)	Assumed adjacent channel carrier (informative)	Filter on the adjacent channel frequency and corresponding filter bandwidth	CA CLR limit
BC1, BC2	$5 \leq W_{\text{gap}} < 15$ (Note 3)	2.5 MHz	3.84 Mcps UTRA	RRC (3.84 Mcps)	44.2 dB
BC1, BC2	$10 \leq W_{\text{gap}} < 20$ (Note 3)	7.5 MHz	3.84 Mcps UTRA	RRC (3.84 Mcps)	44.2 dB
BC3	$5 \leq W_{\text{gap}} < 15$ (Note 3)	2.5 MHz	5MHz E-UTRA	Square (BW_{Config})	44.2 dB
BC3	$10 < W_{\text{gap}} < 20$ (Note 3)	7.5 MHz	5MHz E-UTRA	Square (BW_{Config})	44.2 dB
BC1, BC2, BC3	$5 \leq W_{\text{gap}} < 45$ (Note 4)	2.5 MHz	5 MHz NR (Note 2)	Square (BW_{Config})	44.2 dB
BC1, BC2, BC3	$10 \leq W_{\text{gap}} < 50$ (Note 4)	7.5 MHz	5 MHz NR (Note 2)	Square (BW_{Config})	44.2 dB
BC1, BC2, BC3	$20 \leq W_{\text{gap}} < 30$ (Note 3, 5)	10 MHz	20 MHz NR (Note 2)	Square (BW_{Config})	44.2 dB
BC1, BC2, BC3	$20 \leq W_{\text{gap}} < 60$ (Note 4)	10 MHz	20 MHz NR (Note 2)	Square (BW_{Config})	44.2 dB
BC1, BC2, BC3	$40 \leq W_{\text{gap}} < 50$ (Note 3, 5)	30 MHz	20 MHz NR (Note 2)	Square (BW_{Config})	44.2 dB
BC1, BC2, BC3	$40 \leq W_{\text{gap}} < 80$ (Note 4)	30 MHz	20 MHz NR (Note 2)	Square (BW_{Config})	44.2 dB

NOTE 1: For BC1 and BC2 the RRC filter shall be equivalent to the transmit pulse shape filter defined in TS 25.104 [3], with a chip rate as defined in this table.
NOTE 2: With SCS that provides largest transmission bandwidth configuration (BW_{Config}).
NOTE 3: Applicable in case the *channel bandwidth* of the carrier transmitted at the other edge of the gap is 5, 10, 15, 20 MHz.
NOTE 4: Applicable in case the *channel bandwidth* of the NR carrier transmitted at the other edge of the gap is 25, 30, 40, 50, 60, 70, 80, 90, 100 MHz.
NOTE 5: Applicable in case the *channel bandwidth* of the lowest/highest NR carrier transmitted is 25, 30, 40, 50, 60, 70, 80, 90, 100 MHz.

Table 6.6.4.5.4-2: Filter parameters for the assigned channel

RAT of the carrier adjacent to the sub-block or Inter RF Bandwidth gap	Filter on the assigned channel frequency and corresponding filter bandwidth
E-UTRA	E-UTRA of same BW
UTRA FDD	RRC (3.84 Mcps)
NR	NR of same BW with SCS that provides largest transmission bandwidth configuration

NOTE: The RRC filter shall be equivalent to the transmit pulse shape filter defined in TS 25.104 [3], with a chip rate as defined in this table.

6.6.4.5.5 NB-IoT test requirement

For NB-IoT in-band and guard band operation, the E-UTRA minimum requirement specified in clause 6.6.4.5.1 shall apply.

For NB-IoT standalone operation, the ACLR shall be higher than the value specified in Table 6.6.4.5.5-1.

Table 6.6.4.5.5-1: Base Station ACLR for NB-IoT standalone operation

Channel bandwidth of standalone NB-IoT lowest/highest carrier transmitted BW_{Channel}	BS adjacent channel centre frequency offset below the lowest or above the highest carrier centre frequency transmitted	Assumed adjacent channel carrier (informative)	Filter on the adjacent channel frequency and corresponding filter bandwidth	ACLR limit
200 kHz	300 kHz	Standalone NB-IoT	Square (BW_{Config})	39.2 dB
	500 kHz	Standalone NB-IoT	Square (BW_{Config})	49.2 dB
NOTE 1: BW_{Config} is the transmission bandwidth configuration of the E-UTRA Lowest/Highest Carrier transmitted on the assigned channel frequency.				

6.6.4.5.6 NR test requirement

For NR, the requirements shall apply outside the Base Station RF Bandwidth or Radio Bandwidth whatever the type of transmitter considered (single carrier or multi-carrier) and for all transmission modes foreseen by the manufacturer's specification.

For a BS operating in non-contiguous spectrum, the ACLR requirement shall apply in *sub-block gaps* for the frequency ranges defined in table 6.6.4.5.6-2a, while the CACLR requirement shall apply in *sub-block gaps* for the frequency ranges defined in table 6.6.4.5.4-1.

For BS operating in multiple bands, where multiple bands are mapped onto the same *antenna connector*, the ACLR requirement shall apply in *Inter RF Bandwidth gaps* for the frequency ranges defined in table 6.6.4.5.6-2a, while the CACLR requirement in clause 6.6.4.5.4 shall apply in *Inter RF Bandwidth gaps* for the frequency ranges defined in table 6.6.4.5.4-1.

The requirement shall apply during the *transmitter ON period*. The ACLR is defined with a square filter of bandwidth equal to the transmission bandwidth configuration of the transmitted signal (BW_{Config}) centred on the assigned channel frequency and a filter centred on the adjacent channel frequency according to the tables below.

The ACLR absolute *limit* in table 6.6.4.5.6-2 or the ACLR (CACLR) *limit* in table 6.6.4.5.6-1, 6.6.4.5.6-2a or 6.6.4.5.4-1, whichever is less stringent, shall apply for each *antenna connector*.

For Band 41 operation in Japan, absolute ACLR limits shall be applied to the sum of the absolute ACLR power over all *antenna connectors*.

For operation in paired and unpaired spectrum, the ACLR shall be higher than the value specified in table 6.6.4.5.6-1.

Table 6.6.4.5.6-1: Base station ACLR limit

Channel bandwidth of lowest/highest NR carrier transmitted BW_{Channel} [MHz]	BS adjacent channel centre frequency offset below the lowest or above the highest carrier centre frequency transmitted	Assumed adjacent channel carrier (informative)	Filter on the adjacent channel frequency and corresponding filter bandwidth	ACLR limit
5, 10, 15, 20, 25, 30, 40, 50, 60, 70, 80, 90, 100	BW_{Channel}	NR of same BW (Note 2)	Square (BW_{Config})	44.2 dB
	$2 \times BW_{\text{Channel}}$	NR of same BW (Note 2)	Square (BW_{Config})	44.2 dB
	$BW_{\text{Channel}}/2 + 2.5 \text{ MHz}$	5 MHz E-UTRA	Square (4.5 MHz)	44.2 dB (Note 3)
	$BW_{\text{Channel}}/2 + 7.5 \text{ MHz}$	5 MHz E-UTRA	Square (4.5 MHz)	44.2 dB (Note 3)
NOTE 1: BW_{Channel} and BW_{Config} are the <i>channel bandwidth</i> and transmission bandwidth configuration of the lowest/highest NR carrier transmitted on the assigned channel frequency.				
NOTE 2: With SCS that provides largest transmission bandwidth configuration (BW_{Config}).				
NOTE 3: The requirements are applicable when the band is also defined for E-UTRA or UTRA.				

The ACLR absolute limit is specified in table 6.6.4.5.6-2.

Table 6.6.4.5.6-2: Base station ACLR absolute limit

BS category / BS class	ACLR absolute limit
Category A Wide Area BS	-13 dBm/MHz
Category B Wide Area BS	-15 dBm/MHz
Medium Range BS	-25 dBm/MHz
Local Area BS	-32 dBm/MHz

For operation in non-contiguous spectrum or multiple bands, the ACLR shall be higher than the value specified in Table 6.6.4.5.6-2a.

Table 6.6.4.5.6-2a: Base Station ACLR limit in non-contiguous spectrum or multiple bands

Channel bandwidth of lowest/highest NR carrier transmitted BW_{Channel} [MHz]	Sub-block or Inter RF Bandwidth gap size (W_{gap}) where the limit applies [MHz]	BS adjacent channel centre frequency offset below or above the sub-block or Base Station RF Bandwidth edge (inside the gap)	Assumed adjacent channel carrier	Filter on the adjacent channel frequency and corresponding filter bandwidth	ACLR limit
5, 10, 15, 20	$W_{\text{gap}} \geq 15$ (Note 3) $W_{\text{gap}} \geq 45$ (Note 4)	2.5 MHz	5 MHz NR (Note 2)	Square (BW_{Config})	44.2 dB
	$W_{\text{gap}} \geq 20$ (Note 3) $W_{\text{gap}} \geq 50$ (Note 4)	7.5 MHz	5 MHz NR (Note 2)	Square (BW_{Config})	44.2 dB
25, 30, 40, 50, 60, 70, 80, 90, 100	$W_{\text{gap}} \geq 60$ (Note 4) $W_{\text{gap}} \geq 30$ (Note 3)	10 MHz	20 MHz NR (Note 2)	Square (BW_{Config})	44.2 dB
	$W_{\text{gap}} \geq 80$ (Note 4) $W_{\text{gap}} \geq 50$ (Note 3)	30 MHz	20 MHz NR (Note 2)	Square (BW_{Config})	44.2 dB
NOTE 1: BW_{Config} is the transmission bandwidth configuration of the assumed adjacent channel carrier. NOTE 2: With SCS that provides largest transmission bandwidth configuration (BW_{Config}). NOTE 3: Applicable in case the <i>channel bandwidth</i> of the carrier transmitted at the other edge of the gap is 5, 10, 15, 20 MHz. NOTE 4: Applicable in case the <i>channel bandwidth</i> of the NR carrier transmitted at the other edge of the gap is 25, 30, 40, 50, 60, 70, 80, 90, 100 MHz.					

6.7 Transmitter intermodulation

6.7.1 Definition and applicability

The transmitter intermodulation requirement is a measure of the capability of the transmitter to inhibit the generation of signals in its nonlinear elements caused by presence of the wanted signal and an interfering signal reaching the transmitter via the antenna. The requirement applies during the transmitter ON period and the transmitter transient period. The transmitter intermodulation level is the power of the intermodulation products when an interfering signal is injected into the antenna connector.

For BS capable of multi-band operation where multiple bands are mapped on separate antenna connectors, the single-band requirements apply regardless of the interfering signals position relative to the Inter RF Bandwidth gap.

In case the test signal in clause 5 refer to single-RAT specifications following shall apply:

- For references to TS 25.141 [10], the method of test is specified in TS 25.141 [10], clause 6.6.4.
- For references to TS 25.142 [12], the method of test is specified in TS 25.142 [12], clause 6.7.4.

- For references to TS 36.141 [9], the method of test is specified in TS 36.141 [9], clause 6.7.4.
- For references to TS 38.141-1 [26], the method of test is specified in TS 38.141-1 [26], clause 6.7.4.

NOTE: In this case the test requirements of the present document defined in clauses 6.6.2.5 and 6.6.4.5 apply.

- For GSM/EDGE single-RAT requirements, the method of test is specified in TS 51.021 [11], applicable parts of clauses 6.7 and 6.11.

NOTE: In this case the test requirements of 51.021 [11] defined in the applicable clauses 6.7.3, 6.7.4, 6.11.3 and 6.11.4 apply.

6.7.2 Minimum requirement

The minimum requirement is in TS 37.104 [2] clause 6.7.1, 6.7.2 and 6.7.3.

6.7.2A Additional requirement for Band 41

The additional requirement for Band 41 in certain regions is in TS 37.104 [2] clause 6.7.4.

6.7.3 Test purpose

The test purpose is to verify the ability of the MSR BS transmitter to restrict the generation of intermodulation products in its nonlinear elements caused by presence of the wanted signal and an interfering signal reaching the transmitter via the antenna to below specified levels.

6.7.4 Method of test

6.7.4.1 Initial conditions

Test environment: normal; see Annex B.2.

Base Station RF Bandwidth position to be tested: according to the initial conditions specified in clauses 6.6.1, 6.6.2 and 6.6.4.

Connect the signal analyzer to the Base Station antenna connector as shown in Annex D.1.2.

6.7.4.2 Procedure

6.7.4.2.1 General minimum requirement test procedure

- 1) Set the BS to transmit the test signal according to clause 5 at maximum output power according to the applicable test configuration.
- 2) Generate the interfering signal using E-TM1.1 as defined in TS 36.141 [9] clause 6.1.1.1, with 5 MHz channel bandwidth, at a centre frequency offset according to the conditions in Table 6.7.1-1 in TS 37.104 [2], but exclude interfering frequencies that are outside of the allocated downlink operating band or interfering frequencies that are not completely within the sub-block gap or within the Inter RF Bandwidth gap.
- 3) Adjust ATT1 so that level of the E-UTRA interfering signal is as defined in Table 6.7.1-1 in TS 37.104 [2].
- 4) If the test signal is applicable according to clause 5, perform the Out-of-band emission tests as specified in clauses 6.6.2 and 6.6.4, for all third and fifth order intermodulation products which appear in the frequency ranges defined in clauses 6.6.2 and 6.6.4. The width of the intermodulation products shall be taken into account.
- 5) If the test signal is applicable according to clause 5, perform the Transmitter spurious emissions test as specified in clause 6.6.1, for all third and fifth order intermodulation products which appear in the frequency ranges defined in clause 6.6.1. The width of the intermodulation products shall be taken into account.
- 6) Verify that the emission level does not exceed the required level with the exception of interfering signal frequencies.

- 7) Repeat the test for the remaining interfering signal centre frequency offsets according to the conditions of Table 6.7.1-1 in TS 37.104 [2].
- 8) Repeat the test for the remaining test signals defined in clause 5 for requirements 6.6.1, 6.6.2 and 6.6.4.

In addition, for a multi-band capable BS, the following step shall apply:

- 9) For multi-band capable BS and single band tests, repeat the steps above per involved band where single band test configurations and test models shall apply with no carrier activated in the other band. For multi-band capable BS with separate antenna connector, the antenna connector not being under test shall be terminated.

NOTE: The third order intermodulation products are centred at $2F1 \pm F2$ and $2F2 \pm F1$. The fifth order intermodulation products are centred at $3F1 \pm 2F2$, $3F2 \pm 2F1$, $4F1 \pm F2$, and $4F2 \pm F1$ where $F1$ represents the test signal centre frequency or centre frequency of each sub-block and $F2$ represents the interfering signal centre frequency. The widths of intermodulation products are

- $(n \cdot BW_{F1} + m \cdot 5\text{MHz})$ for the $nF1 \pm mF2$ products
- $(n \cdot 5\text{MHz} + m \cdot BW_{F1})$ for the $nF2 \pm mF1$ products

where BW_{F1} represents the test signal RF bandwidth, or channel bandwidth in case of single carrier, or sub-block bandwidth.

6.7.4.2.2 Additional minimum requirement (BC1 and BC2) test procedure

- 1) Set the BS to transmit the test signal according to clause 5 at maximum output power according to the applicable test configuration.
- 2) Generate a CW signal as the interfering signal with a centre frequency offset of 0.8 MHz, but exclude interfering frequencies that are outside of the allocated downlink operating band or interfering frequencies in a sub-block gap or in the Inter RF Bandwidth gap, in case the gap is smaller than two times the interfering signal centre frequency offset.
- 3) Adjust ATT1 so that level of the interfering signal is as defined in Table 6.7.2-1 in TS 37.104 [2].
- 4) If the test signal is applicable according to clause 5, perform the Out-of-band emission tests as specified in clauses 6.6.2 and 6.6.4, for all third and fifth order intermodulation products which appear in the frequency ranges defined in clauses 6.6.2 and 6.6.4.
- 5) If the test signal is applicable according to clause 5, perform the Transmitter spurious emissions test as specified in clause 6.6.1, for all third and fifth order intermodulation products which appear in the frequency ranges defined in clause 6.6.1.
- 6) Verify that the emission level does not exceed the required level with the exception of interfering signal frequencies.
- 7) Repeat the test for interfering signal centre frequency offsets of 2.0MHz, 3.2MHz and 6.2MHz.
- 8) Repeat the test for the remaining test signals defined in clause 5 for requirements 6.6.1, 6.6.2 and 6.6.4.

In addition, for a multi-band capable BS, the following step shall apply:

- 9) For multi-band capable BS and single band tests, repeat the steps above per involved band where single band test configurations and test models shall apply with no carrier activated in the other band. For multi-band capable BS with separate antenna connector, the antenna connector not being under test shall be terminated.

NOTE: The third order intermodulation products are centred at $2F1 \pm F2$ and $2F2 \pm F1$. The fifth order intermodulation products are centred at $3F1 \pm 2F2$, $3F2 \pm 2F1$, $4F1 \pm F2$, and $4F2 \pm F1$ where $F1$ represents the test signal centre frequency or centre frequency of each sub-block and $F2$ represents the interfering signal centre frequency. The widths of intermodulation products are

- $(n \cdot BW_{F1})$ for the $nF1 \pm mF2$ products
- $(m \cdot BW_{F1})$ for the $nF2 \pm mF1$ products

where BW_{F1} represents the test signal RF bandwidth, or channel bandwidth in case of single carrier, or sub-block bandwidth.

6.7.4.2.3 Additional minimum requirement (BC3) test procedure

- 1) Set the BS to transmit the test signal according to clause 5 at maximum output power according to the applicable test configuration.
- 2) Generate the interfering signal according to Table 6.38A in TS 25.142 [12] at a centre frequency offset according to the conditions in Table 6.7.3-1 in TS 37.104 [2], but exclude interfering frequencies that are outside of the allocated downlink operating band.
- 3) Adjust ATT1 so that level of the interfering signal is as defined in Table 6.7.3-1 in TS 37.104 [2].
- 4) If the test signal is applicable according to clause 5, perform the Out-of-band emission tests as specified in clauses 6.6.2 and 6.6.4, for all third and fifth order intermodulation products which appear in the frequency ranges defined in clauses 6.6.2 and 6.6.4. The width of the intermodulation products shall be taken into account.
- 5) If the test signal is applicable according to clause 5, perform the Transmitter spurious emissions test as specified in clause 6.6.1, for all third and fifth order intermodulation products which appear in the frequency ranges defined in clause 6.6.1. The width of the intermodulation products shall be taken into account.
- 6) Verify that the emission level does not exceed the required level with the exception of interfering signal frequencies.
- 7) Repeat the test for the remaining interfering signal centre frequency offsets according to the conditions of Table 6.7.3-1 in TS 37.104 [2].
- 8) Repeat the test for the remaining test signals and physical channels in Table 4.9.2-1.

In addition, for a multi-band capable BS, the following step shall apply:

- 9) For multi-band capable BS and single band tests, repeat the steps above per involved band where single band test configurations and test models shall apply with no carrier activated in the other band. For multi-band capable BS with separate antenna connector, the antenna connector not being under test shall be terminated.

NOTE: The third order intermodulation products are centred at $2F1 \pm F2$ and $2F2 \pm F1$. The fifth order intermodulation products are centred at $3F1 \pm 2F2$, $3F2 \pm 2F1$, $4F1 \pm F2$, and $4F2 \pm F1$ where $F1$ represents the test signal centre frequency or centre frequency of each sub-block and $F2$ represents the interfering signal centre frequency. The widths of intermodulation products are

- $(n \cdot BW_{F1} + m \cdot 1.6\text{MHz})$ for the $nF1 \pm mF2$ products
- $(n \cdot 1.6\text{MHz} + m \cdot BW_{F1})$ for the $nF2 \pm mF1$ products

where BW_{F1} represents the test signal RF bandwidth or channel bandwidth in case of single carrier, or sub-block bandwidth.

6.7.5 Test requirements

6.7.5.1 General test requirement

In the frequency range relevant for this test, the transmitter intermodulation level shall not exceed the unwanted emission limits in clause 6.6.1, 6.6.2 and 6.6.4 in the presence of a wanted signal and an interfering signal according to Table 6.7.1-1 in TS 37.104 [2] for BS operation in BC1, BC2 and BC3. The measurement may be limited to frequencies on which third and fifth order intermodulation products appear, considering the width of these products and excluding the bandwidths of the wanted and interfering signals.

The requirement is applicable outside the Base Station RF Bandwidth or Maximum Radio Bandwidth. The interfering signal offset is defined relative to the Base Station RF Bandwidth edges or Maximum Radio Bandwidth edges.

For BS operating in non-contiguous spectrum, the requirement is also applicable inside a sub-block gap for interfering signal offsets where the interfering signal falls completely within the sub-block gap. The interfering signal offset is defined relative to the sub-block edges.

For BS capable of multi-band operation, the requirement applies relative to the Base Station RF Bandwidth edges of each operating band. In case the Inter RF Bandwidth gap is less than 15 MHz, the requirement in the gap applies only for interfering signal offsets where the interfering signal falls completely within the Inter RF Bandwidth gap.

6.7.5.2 Additional test requirement (BC1 and BC2)

In the frequency range relevant for this test, the transmitter intermodulation level shall not exceed the unwanted emission limits in clause 6.6.1, 6.6.2 and 6.6.4 in the presence of a wanted signal and an interfering signal according to Table 6.7.2-1 in TS 37.104 [2] for BS operation in BC2. The measurement may be limited to frequencies on which third and fifth order intermodulation products appear, considering the width of these products and excluding the bandwidths of the wanted and interfering signals.

The requirement is applicable outside the Base Station RF Bandwidth or Maximum Radio Bandwidth for BC2. The interfering signal offset is defined relative to the Base Station RF Bandwidth edges or Maximum Radio Bandwidth edges.

For BS operating in non-contiguous spectrum in BC1 or BC2, the requirement is also applicable inside a sub-block gap larger than or equal to two times the interfering signal centre frequency offset. For BS operating in non-contiguous spectrum in BC1, the requirement is not applicable inside a sub-block gap with a gap size equal or larger than 5MHz. The interfering signal offset is defined relative to the sub-block edges.

For BS capable of multi-band operation, the requirement applies relative to the Base Station RF Bandwidth edges of a BC2 operating band. The requirement is also applicable for BC1 and BC2 inside an Inter RF Bandwidth gap equal to or larger than two times the interfering signal centre frequency offset. For BS capable of multi-band operation, the requirement is not applicable for BC1 band inside an Inter RF Bandwidth gap with a gap size equal to or larger than 5MHz.

6.7.5.3 Additional test requirement (BC3)

In the frequency range relevant for this test, the transmitter intermodulation level shall not exceed the unwanted emission limits in clause 6.6.1, 6.6.2 and 6.6.4 in the presence of a wanted signal and an interfering signal according to Table 6.7.3-1 in TS 37.104 [2] for BS operation in BC3. The measurement may be limited to frequencies on which third and fifth order intermodulation products appear, considering the width of these products and excluding the bandwidths of the wanted and interfering signals.

For BS capable of multi-band operation, the requirement applies relative to the Base Station RF Bandwidth edges of each operating band. In case the Inter RF Bandwidth gap is less than 3.2 MHz, the requirement in the gap applies only for interfering signal offsets where the interfering signal falls completely within the Inter RF Bandwidth gap.

6.7.5.4 Additional test requirement for Band 41

In the frequency range relevant for this test, the transmitter intermodulation level shall not exceed the maximum levels according to Table 6.6.1.5.5-3 and Table 6.6.4.5.1-2 with a square filter in the first adjacent channel, in the presence of a wanted signal and an interfering signal according to Table 6.7.4-1 in TS 37.104 [2] for a BS E-UTRA single-RAT operating in Band 41. The measurement may be limited to frequencies on which third and fifth order intermodulation products appear, considering the width of these products and excluding the bandwidths of the wanted and interfering signals.

7 Receiver characteristics

7.1 General

General test conditions for receiver tests are given in clause 4, including interpretation of measurement results and configurations for testing. BS configurations for the tests are defined in clause 4.10.

Unless otherwise stated the requirements in clause 7 apply during the Base Station receive period.

Unless otherwise stated, a BS declared to be capable of E-UTRA with NB-IoT in-band or guard band operations (or any combination with GSM and/or UTRA and/or NR) is only required to pass the receiver tests for E-UTRA with NB-IoT in-band or guard band (or any combination with GSM and/or UTRA and/or NR); it is not required to perform the receiver tests again for E-UTRA only (or any combination with GSM and/or UTRA and/or NR).

For a BS declared to be capable of E-UTRA (and where applicable NR) with NB-IoT in-band operations, it is not required to perform the receiver test for subPRB allocation

7.2 Reference sensitivity level

7.2.1 Definition and applicability

The reference sensitivity power level PREFSENS is the minimum mean power received at the antenna connector at which a reference performance requirement shall be met for a specified reference measurement channel.

Additional details are in TS 38.141-1 [26] clause 7.2, TS 36.141 [9] clause 7.2, TS 25.141 [10] clause 7.2, TS 25.142 [12] clause 7.2, and TS 51.021 [11] clauses 7.3 and 7.4.

7.2.2 Minimum requirement

The minimum requirement is in TS 37.104 [2] clauses 7.2.1, 7.2.2, 7.2.3, 7.2.4, 7.2.5 and 7.2.6.

7.2.3 Test purpose

To verify that at the BS Reference sensitivity level the performance requirements shall be met for a specified reference measurement channel.

7.2.4 Method of test

For this requirement Tables 5.1-1, 5.1-1a, 5.1-1b and 5.2-1 refer to single-RAT specifications; see clause 5, for a BS declared to support CS1 to CS6, CS8 to CS14 or CS16 to CS17. The following shall apply, for a BS declared to support CS1 to CS6 or CS16 to CS17:

- For references to TS 51.021 [11], the method of test is specified in TS 51.021 [11], clauses 7.3 and 7.4.
- For references to TS 25.141 [10], the method of test is specified in TS 25.141 [10], clause 7.2.4.
- For references to TS 25.142 [12], the method of test is specified in TS 25.142 [12], clause 7.2.4.
- For references to TS 36.141 [9], the method of test is specified in TS 36.141 [9], clause 7.2.4.
- For references to TS 38.141-1 [26], the method of test is specified in TS 38.141-1 [26], clause 7.2.4.

If a BS is declared to support CS7 or CS15, the following shall apply:

- For references to TS 25.141 [10], the method of test is specified in TS 25.141 [10], clause 7.2.4.
- For references to TS 36.141 [9], the method of test is specified in TS 36.141 [9], clause 7.2.4.
- For testing GSM/EDGE reference sensitivity, steps in clause 7.2.4.1 and 7.2.4.2 shall apply.

7.2.4.1 Initial conditions for GSM/EDGE reference sensitivity level for CS7 and CS15

Test environment: Normal; see Annex B.2.

Base Station RF Bandwidth positions to be tested: M_{RFBW} in single-band operation, see clause 4.9.1,

- 1) Set up the equipment as shown in Annex I.2.1 TS 36.141[9].

- 2) Generate the wanted signal according to the applicable test configuration (see clause 5) using applicable reference measurement channel to the BS under test as follows:
 - For GSM see clauses 7.3 and 7.4 in TS 51.021 [11] and Annex P in TS 45.005 [6] for reference channels to test.

7.2.4.2 Procedure for GSM/EDGE reference sensitivity level for CS7 and CS15

- 1) Set the BS according to the applicable test configuration(s) (see clause 5).
- 2) Adjust the GSM/EDGE signal generator to the wanted signal levels as specified in TS 51.021, applicable parts of clauses 7.3 and 7.4.
- 3) Measure the performance of the GSM/EDGE wanted signal at the BS receiver, as defined in TS 51.021, applicable parts of clauses 7.3 and 7.4.

In addition, for a multi-band capable BS, the following step shall apply:

- For multi-band capable BS and single band tests, repeat the tests per involved band where single carrier test models shall apply with no carrier activated in the other band. For multi-band capable BS with separate antenna connector, the antenna connector not being under test shall be terminated.

7.2.5 Test requirements

For E-UTRA the test requirement is in TS 36.141 [9] clause 7.2.5.

For UTRA-FDD the test requirement is in TS 25.141 [10] clause 7.2.5.

For UTRA-TDD the test requirement is in TS 25.142 [12] clause 7.2.5.

For GSM-EDGE the test requirement is in TS 51.021 [11] clauses 7.3 and 7.4.

For NB-IoT the test requirement is in TS 36.141 [9] clause 7.2.5.

For NR the test requirement is in TS 38.141-1 [26] clause 7.2.5.

7.3 Dynamic range

7.3.1 Definition and applicability

The dynamic range is a measure of the capability of the receiver to receive a wanted signal in the presence of an interfering signal inside the received channel bandwidth or the capability of receiving high level of the wanted signal.

7.3.2 Minimum requirement

The minimum requirement is in TS 37.104 [2] clauses 7.3.1, 7.3.2, 7.3.3, 7.3.4, 7.3.5 and 7.3.6.

7.3.3 Test purpose

To verify that at the BS receiver dynamic range, the receiver performance shall fulfil the specified limit.

7.3.4 Method of test

For this requirement Tables 5.1-1, 5.1-1a, 5.1-1b and 5.2-1 refer to single-RAT specifications; see clause 5, for a BS declared to support CS1 to CS6, CS8 to CS14 or CS16 to CS17. The following shall apply, for a BS declared to support CS1 to CS6, CS8 to CS14 or CS16 to CS17:

- For references to TS 51.021 [11], the method of test is specified in TS 51.021 [11], clause 7.1.
- For references to TS 25.141 [10], the method of test is specified in TS 25.141 [10], clause 7.3.4.

- For references to TS 25.142 [12], the method of test is specified in TS 25.142 [12], clause 7.3.4.
- For references to TS 36.141 [9], the method of test is specified in TS 36.141 [9], clause 7.3.4.
- For references to TS 38.141-1 [26], the method of test is specified in TS 38.141-1 [26], clause 7.3.4.

If a BS is declared to support CS7 and CS15, the following shall apply:

- For references to TS 25.141 [10], the method of test is specified in TS 25.141 [10], clause 7.3.4.
- For references to TS 36.141 [9], the method of test is specified in TS 36.141 [9], clause 7.3.4.
- For testing GSM/EDGE dynamic range, steps in clause 7.3.4.1 and 7.3.4.2 shall apply.

7.3.4.1 Initial conditions for GSM/EDGE dynamic range for CS7 and CS15

Test environment: Normal; see Annex B.2.

Base Station RF Bandwidth positions to be tested: M_{RFBW} in single-band operation, see clause 4.9.1,

- 1) Set up the equipment as shown in Annex I.2.1 TS 36.141[9].
- 2) Generate the wanted signal according to the applicable test configuration (see clause 5) using applicable reference measurement channel to the BS under test as follows:
 - For GSM see clause 7.1 in TS 51.021 [11] for reference channels to test.

7.3.4.2 Procedure for GSM/EDGE dynamic range for CS7 and CS15

- 1) Set the BS according to the applicable test configuration(s) (see clause 5).
- 2) Adjust the GSM/EDGE signal generator to the wanted signal levels as specified in TS 51.021, applicable parts of clauses 7.1
- 3) Measure the performance of the GSM/EDGE wanted signal at the BS receiver, as defined in TS 51.021, applicable parts of clause 7.1.

In addition, for a multi-band capable BS, the following step shall apply:

- For multi-band capable BS and single band tests, repeat the tests per involved band with no carrier activated in the other band. For multi-band capable BS with separate antenna connector, the antenna connector not being under test shall be terminated.

7.3.5 Test requirements

For E-UTRA the test requirement is in TS 36.141 [9] clause 7.3.5.

For UTRA-FDD the test requirement is in TS 25.141 [10] clause 7.3.5.

For UTRA-TDD the test requirement is in TS 25.142 [12] clause 7.3.5.

For GSM-EDGE the test requirement is in TS 51.021 [11] clause 7.1.

For NB-IoT the test requirement is in TS 36.141 [9] clause 7.3.5.

For NR the test requirement is in TS 38.141-1 [26] clause 7.3.5.

7.4 In-band selectivity and blocking

7.4.1 Definition and applicability

The in-band selectivity and blocking characteristics are measures of the receiver ability to receive a wanted signal at its assigned channel in the presence of an unwanted interferer inside the operating band and are defined by a wideband and a narrowband blocking requirement.

The in-band blocking requirement applies from $F_{UL_low} - \Delta f_{OOB}$ to $F_{UL_high} + \Delta f_{OOB}$, excluding the downlink frequency range of the FDD *operating band*. The values of Δf_{OOB} are defined in table 7.4.1-1. For a BS with multi-RAT operation where the individual RATs are in different RAT specific bands that partially or fully overlap; Δf_{OOB} is according to the combined frequency range occupied by the overlapping bands.

Table 7.4.1-1: Maximum Δf_{OOB} offset outside the uplink operating band

Operating band characteristics	Δf_{OOB} [MHz]
$200 \text{ MHz} \geq F_{UL_high} - F_{UL_low}$	20
$200 \text{ MHz} < F_{UL_high} - F_{UL_low} \leq 900 \text{ MHz}$	60

Unless otherwise stated, a BS declared to be capable of E-UTRA with NB-IoT in-band and guard band operations (or any combination with GSM and/or UTRA) is only required to pass the in-band selectivity and blocking receiver tests for E-UTRA with guard band operation (or any combination with GSM and/or UTRA). It's not required to perform the in-band selectivity and blocking receiver tests again for E-UTRA with in-band operation (or any combination with GSM and/or UTRA).

7.4.2 Minimum requirement

The minimum requirement is in TS 37.104 [2] clauses 7.4.1, 7.4.2, 7.4.3, 7.4.4, and 7.4.5.

7.4.3 Test purpose

The test stresses the ability of the BS receiver to withstand high-level interference from unwanted signals at specified frequency offsets without undue degradation of its sensitivity.

7.4.4 Method of test

7.4.4.1 Initial conditions

Test environment: Normal; see Annex B.2.

Base Station RF Bandwidth positions to be tested: M_{RFBW} in single-band operation, see clause 4.9.1, $B_{RFBW_T'_{RFBW}}$ and $B'_{RFBW_T_{RFBW}}$ in multi-band operation, see clause 4.9.1.

- 1) Set up the equipment as shown in Annex D.2.1.
- 2) Generate the wanted signal according to the applicable test configuration (see clause 5) using applicable reference measurement channel to the BS under test as follows:
 - For E-UTRA see Annex A.1 in TS 36.141 [9].
 - For UTRA FDD see Annex A.2 in TS 25.141 [10].
 - For UTRA TDD see Annex A.2.1 in TS 25.142 [12].
 - For GSM see clause 7.6.2 in TS 51.021 [11] and Annex P in TS 45.005 [6] for reference channels to test.
 - For NB-IoT see Annex A.14 in TS 36.141 [9].
 - For NR see Annex A.1 in TS 38.141-1 [26].

7.4.4.2 Procedure for general blocking

- 1) Set the BS to transmit with the carrier set-up and power allocation according to the applicable test configuration(s) (see clause 5).
- 2) Adjust the signal generators to the type of interfering signal, levels and the frequency offsets as specified in Table 7.4.5.1-1.
- 3) The interfering signal shall be swept with a step size of 1 MHz starting from the minimum offset to the channel edges of the wanted signals as specified in Table 7.4.5.1-1
- 4) Measure the performance of the wanted signal at the BS receiver, as defined in clause 7.4.5, for the relevant carriers specified by the test configuration in clause 4.8.

In addition, for a multi-band capable BS with separate antenna connectors, the following steps shall apply:

- 5) For single band tests, repeat the steps above per involved band where single band test configurations and test models shall apply with no carrier activated in the other band.
- 6) For multi-band tests, the interfering signal shall first be applied on the same port as the wanted signal. The test shall be repeated with the interfering signal applied on the other port (if any) mapped to the same receiver as wanted signal. Any antenna connector with no signal applied shall be terminated.
- 7) Repeat step 6 with the wanted signal for the other band(s) applied on the respective port(s).

7.4.4.3 Procedure for narrowband blocking

- 1) Set the BS to transmit with the carrier set-up and power allocation according to the applicable test configuration(s) (see clause 5).
- 2) Adjust the signal generators to the type of interfering signal, levels and the frequency offsets as specified in Tables 7.4.5.2-1 and 7.4.5.2-2.
- 3) Set-up and sweep the interfering RB centre frequency offset to the channel edge of the wanted signal according to Tables 7.4.5.2-1 and 7.4.5.2-2.
- 4) Measure the performance of the wanted signal at the BS receiver, as defined in clause 7.4.5, for the relevant carriers specified by the test configuration in clause 4.8.

In addition, for a multi-band capable BS with separate antenna connectors, the following steps shall apply:

- 5) For single band tests, repeat the steps above per involved band where single band test configurations and test models shall apply with no carrier activated in the other band.
- 6) For multi-band tests, the interfering signal shall first be applied on the same port as the wanted signal. The test shall be repeated with the interfering signal applied on the other port (if any) mapped to the same receiver as the wanted signal. Any antenna connector with no signal applied shall be terminated.
- 7) Repeat step 6 with the wanted signal for the other band(s) applied on the respective port(s).

7.4.4.4 Procedure for additional narrowband blocking for GSM/EDGE

For a BS declared to support CS1 to CS6 or CS9 to CS13, the GSM/EDGE in-band blocking method of test is stated in TS 51.021 [11], applicable parts of clause 7.6.

The conditions specified in TS 45.005 [6], Annex P.2.1 apply for GSM/EDGE in-band narrowband blocking.

If a BS is declared to support CS7 or CS15, the steps in clause 7.4.4.4.1 and 7.4.4.4.2 for testing additional narrowband blocking for GSM/EDGE shall apply:

7.4.4.4.1 Initial conditions for additional narrowband blocking for GSM/EDGE for CS7 and CS15

Test environment: Normal; see Annex B.2.

Base Station RF Bandwidth positions to be tested: M_{RFBW} in single-band operation, see clause 4.9.1,

- 1) Set up the equipment as shown in Annex D.2.1.
- 2) Generate the wanted signal according to the applicable test configuration (see clause 5) using applicable reference measurement channel to the BS under test as follows:
 - For GSM see clause 7.6.2 in TS 51.021 [11] and Annex P.2.1 in TS 45.005 [6] for reference channels to test.

7.4.4.4.2 Procedure for additional narrowband blocking for GSM/EDGE for CS7 and CS15

- 1) Set the BS according to the applicable test configuration(s) (see clause 5).
- 2) Adjust the GSM/EDGE signal generator to the wanted signal levels as specified in TS 51.021, applicable parts of clauses 7.6.
- 3) Set-up the interfering signal as specified in TS 51.021, applicable parts of clauses 7.6.
- 4) Measure the performance of the GSM/EDGE wanted signal at the BS receiver, as defined in TS 51.021, applicable parts of clause 7.6.

In addition, for multi-band capable BS and single band tests, repeat the procedure above per involved band where single band test configurations and test models shall apply with no carrier activated in the other band. Any antenna connector with no signal applied shall be terminated.

7.4.4.5 Procedure for GSM/EDGE AM suppression

For a BS declared to support CS1 to CS6, the GSM/EDGE in-band blocking method of test is stated in TS 51.021 [11], applicable parts of clause 7.8.

The conditions specified in TS 45.005 [6], Annex P.2.3 apply for GSM/EDGE AM suppression.

If a BS is declared to support CS7, the steps in clause 7.4.4.5.1 and 7.4.4.5.2 for testing additional narrowband blocking for GSM/EDGE shall apply:

7.4.4.5.1 Initial conditions for GSM/EDGE AM suppression for CS7 and CS15

Test environment: Normal; see Annex B.2.

Base Station RF Bandwidth positions to be tested: M_{RFBW} in single-band operation, see clause 4.9.1.

- 1) Set up the equipment as shown in Annex D.2.1.
- 2) Generate the wanted signal according to the applicable test configuration (see clause 5) using applicable reference measurement channel to the BS under test as follows:
 - For GSM see clause 7.8 in TS 51.021 [11] and Annex P.2.3 in TS 45.005 [6] for reference channels to test.

7.4.4.5.2 Procedure for GSM/EDGE AM suppression for CS7 and CS15

- 1) Set the BS according to the applicable test configuration(s) (see clause 5).
- 2) Adjust the GSM/EDGE signal generator to the wanted signal levels as specified in TS 51.021, applicable parts of clauses 7.8.
- 3) Set-up the interfering signal as specified in TS 51.021, applicable parts of clauses 7.8.
- 4) Measure the performance of the GSM/EDGE wanted signal at the BS receiver, as defined in TS 51.021, applicable parts of clause 7.8.

In addition, for multi-band capable BS and single band tests, repeat the procedure above per involved band where single band test configurations and test models shall apply with no carrier activated in the other band. Any antenna connector with no signal applied shall be terminated.

7.4.4.6 Procedure for additional BC3 blocking requirement

- 1) Adjust the signal generators to the type of interfering signal, levels and the frequency offsets as specified in Table 7.4.5.5-1
- 2) Measure the performance of the wanted signal at the BS receiver, as defined in clause 7.4.5, for the relevant carriers specified by the test configuration in clause 4.8.

7.4.5 Test requirements

7.4.5.1 General blocking test requirement

For the general blocking requirement, the interfering signal shall be a UTRA FDD signal as specified in Annex A.1 for a UTRA, E-UTRA, NB-IOT, GSM/EDGE or NR (≤ 20 MHz) wanted signal. The interfering signal shall be a 20 MHz E-UTRA signal for NR wanted signal channel bandwidth greater than 20MHz.

The requirement is applicable outside the Base Station RF Bandwidth or Maximum Radio Bandwidth. The interfering signal offset is defined relative to the Base Station RF Bandwidth edges or Maximum Radio Bandwidth edges.

For BS operating in non-contiguous spectrum, the requirement applies in addition inside any sub-block gap, in case the sub-block gap size is at least 15MHz. The interfering signal offset is defined relative to the sub-block edges inside the sub-block gap.

For BS capable of multi-band operation, the requirement applies in addition inside any Inter RF Bandwidth gap, in case the gap size is at least 15MHz. The interfering signal offset is defined relative to the Base Station RF Bandwidth edges inside the Inter RF Bandwidth gap.

For the wanted and interfering signal coupled to the Base Station antenna input, using the parameters in Table 7.4.5.1-1, the following requirements shall be met:

- For any measured E-UTRA carrier, the throughput shall be $\geq 95\%$ of the maximum throughput of the reference measurement channel defined in TS 36.104 [5], clause 7.2.
- For any measured UTRA FDD carrier, the BER shall not exceed 0.001 for the reference measurement channel defined in TS 25.104 [3], clause 7.2.
- For any measured UTRA TDD carrier, the BER shall not exceed 0.001 for the reference measurement channel defined in TS 25.105 [4], clause 7.2.
- For any measured GSM/EDGE carrier, the conditions are specified in TS 45.005 [6], Annex P.2.1.
- For any measured NB-IoT carrier, the throughput shall be $\geq 95\%$ of the maximum throughput of the reference measurement channel defined in TS 36.104 [5], clause 7.2.
- For any measured NR carrier, the throughput shall be $\geq 95\%$ of the maximum throughput of the reference measurement channel defined in TS 38.104 [27], clause 7.2.

For BS capable of multi-band operation, the requirement applies according to Table 7.4.5.1-1 for the in-band blocking frequency ranges of each supported operating band.

Table 7.4.5.1-1: General blocking requirement

Base Station Type	Mean power of interfering signal [dBm]	Wanted Signal mean power [dBm] (Note 1)	Centre Frequency of Interfering Signal	Interfering signal centre frequency minimum frequency offset from the Base Station RF Bandwidth edge or sub-block edge inside a gap [MHz]
Wide Area BS	-40+y (Note 7)	$P_{\text{REFSENS}} + x$ dB (Note 2, 6)	$F_{\text{UL_low}} - \Delta f_{\text{OOB}}$ to $F_{\text{UL_high}} + \Delta f_{\text{OOB}}$ (Note 8)	$\pm(7.5 + z)$ (Note 9)
Medium Range BS	-35+y (Note 7)	$P_{\text{REFSENS}} + x$ dB (Note 3, 6)		
Local Area BS	-30+y (Note 7)	$P_{\text{REFSENS}} + x$ dB (Note 4, 6)		
<p>NOTE 1: P_{REFSENS} depends on the RAT, the BS class and on the channel bandwidth, see clause 7.2 in TS 37.104.</p> <p>NOTE 2: For WA BS not supporting NR, "x" is equal to 6 in case of E-UTRA or UTRA or NB-IoT wanted signals and equal to 3 in case of GSM/EDGE wanted signal.</p> <p>NOTE 3: For MR BS not supporting NR, "x" is equal to 6 in case of UTRA wanted signals, 9 in case of E-UTRA or NB-IoT wanted signal and 3 in case of GSM/EDGE wanted signal.</p> <p>NOTE 4: For LA BS not supporting NR, "x" is equal to 11 in case of E-UTRA or NB-IoT wanted signal, 6 in case of UTRA wanted signal and equal to 3 in case of GSM/EDGE wanted signal.</p> <p>NOTE 5: For a BS capable of multi-band operation, "x" in Note 2, 3, 4, 6 applies in case of interfering signals that are in the in-band blocking frequency range of the operating band where the wanted signal is present or in the in-band blocking frequency range of an adjacent or overlapping operating band. For other in-band blocking frequency ranges of the interfering signal for the supported operating bands, "x" is equal to 1.4 dB.</p> <p>NOTE 6: For a BS supporting NR and not supporting UTRA nor GSM, x is equal to 6.</p> <p>NOTE 7: For a BS not supporting NR, "y" is equal to zero for all BS classes. For a BS supporting NR and not supporting UTRA nor GSM, "y" is equal to -3 for the WA and MR BS class and -5 for the LA BS class.</p> <p>NOTE 8: The downlink frequency range of an FDD operating band is excluded from the general blocking requirement.</p> <p>NOTE 9: For NR wanted signal channel bandwidth greater than 20 MHz, $z = 22.5$. For all other cases, $z = 0$.</p>				

Table 7.4.5.1-2: Void

NOTE: The requirement in Table 7.4.5.1-1 assumes that two operating bands, where the downlink operating band (see Table 4.4-1 and Table 4.4-2) of one band would be within the in-band blocking region of the other band, are not deployed in the same geographical area.

7.4.5.2 General narrowband blocking test requirement

For the narrowband blocking requirement, the interfering signal shall be an E-UTRA 1RB signal as specified in Annex A.3.

The requirement is applicable outside the Base Station RF Bandwidth or Maximum Radio Bandwidth. The interfering signal offset is defined relative to the Base Station RF Bandwidth edges or Maximum Radio Bandwidth edges.

For BS operating in non-contiguous spectrum, the requirement applies in addition inside any sub-block gap, in case the sub-block gap size is at least 3MHz. The interfering signal offset is defined relative to the sub-block edges inside the sub-block gap.

For BS capable of multi-band operation, the requirement applies in addition inside any Inter RF Bandwidth gap in case the gap size is at least 3MHz. The interfering signal offset is defined relative to the Base Station RF Bandwidth edges inside the Inter RF Bandwidth gap.

For the wanted and interfering signal coupled to the Base Station antenna input, using the parameters in Table 7.4.5.2-1 the following requirements shall be met:

- For any measured E-UTRA carrier, the throughput shall be $\geq 95\%$ of the maximum throughput of the reference measurement channel defined in TS 36.104 [5], clause 7.2.

- For any measured UTRA FDD carrier, the BER shall not exceed 0.001 for the reference measurement channel defined in TS 25.104 [3], clause 7.2.
- For any measured UTRA TDD carrier, the BER shall not exceed 0.001 for the reference measurement channel defined in TS 25.105 [4], clause 7.2.
- For any measured GSM/EDGE carrier, the conditions are specified in TS 45.005 [6], Annex P.2.1.
- For any measured NB-IoT carrier, the throughput shall be $\geq 95\%$ of the maximum throughput of the reference measurement channel defined in TS 36.104 [5], clause 7.2.
- For any measured NR carrier, the throughput shall be $\geq 95\%$ of the maximum throughput of the reference measurement channel defined in TS 38.104 [27], clause 7.2.

Table 7.4.5.2-1: Narrowband blocking requirement

Base Station Type	RAT of the carrier	Wanted signal mean power [dBm] (Note 1, 2, 6)	Interfering signal mean power [dBm]	Interfering RB (Note 3) centre frequency offset from the Base Station RF Bandwidth edge or sub-block edge inside a gap [kHz]
Wide Area BS	NR, E-UTRA, NB-IoT (Note 4), E UTRA and GSM/EDG	$P_{\text{REFSENS}} + x$ dB	-49	$\pm(240 + m \cdot 180)$, $m=0, 1, 2, 3, 4, 9, 14$ (Note 5) $\pm(550 + m \cdot 180)$, $m=0, 1, 2, 3, 4, 29, 54, 79, 99$ (Note 6)
Medium Range BS			-44	
Local Area BS			-41	
<p>NOTE 1: P_{REFSENS} depends on the RAT, the BS class and on the channel bandwidth, see clause 7.2 in TS 37.104.</p> <p>NOTE 2: "x" is equal to 6 in case of NR, E-UTRA or UTRA wanted signals and equal to 3 in case of GSM/EDGE wanted signal. "x" is specified in Table 7.4.2-2 for NB-IoT.</p> <p>NOTE 3: Interfering signal (E-UTRA 3MHz) consisting of one resource block positioned at the stated offset, the channel bandwidth of the interfering signal is located adjacently to the Base Station RF Bandwidth edge.</p> <p>NOTE 4: For NB-IoT, the mentioned desensitized values consider only one NB-IoT PRB in the guard band, which is placed adjacent to the E-UTRA PRB edge as close as possible (i.e., away from edge of channel bandwidth).</p> <p>NOTE 5: Applicable for <i>channel bandwidths</i> equal to or below 20 MHz.</p> <p>NOTE 6: Applicable for <i>channel bandwidths</i> above 20 MHz.</p> <p>NOTE 6: 7.5 kHz shift is not applied to the wanted signal of NR.</p> <p>NOTE 7: Void</p>				

Table 7.4.5.2-2: "x" for NB-IoT wanted signals

Operation mode	LTE channel bandwidth for in-band/guard band operation	x
Standalone	-	12
In Band	3 MHz	11
	5 MHz	9
	10 MHz	6
	15 MHz	6
	20 MHz	6
Guard band	5 MHz	13
	10 MHz	6
	15 MHz	6
	20 MHz	6

7.4.5.3 Additional narrowband blocking test requirement for GSM/EDGE

The GSM/EDGE in-band blocking test requirements are stated in TS 51.021 [11], applicable parts of clause 7.6.

The conditions specified in TS 45.005 [6], Annex P.2.1 apply for GSM/EDGE in-band narrowband blocking.

7.4.5.4 GSM/EDGE test requirements for AM suppression

The GSM/EDGE in-band blocking test requirements are stated in TS 51.021 [11], applicable parts of clause 7.8.

The conditions specified in TS 45.005 [6], Annex P.2.3 apply for GSM/EDGE AM suppression.

7.4.5.5 Additional BC3 blocking test requirement

The interfering signal is a 1.28Mcps UTRA TDD modulated signal as specified in Annex A.2.

The requirement is applicable outside the Base Station RF Bandwidth or Maximum Radio Bandwidth. The interfering signal offset is defined relative to the Base Station RF Bandwidth edges or Maximum Radio Bandwidth edges.

For BS capable of multi-band operation, the requirement applies in addition inside any Inter RF Bandwidth gap, in case the gap size is at least 4.8MHz. The interfering signal offset is defined relative to the Base Station RF Bandwidth edges inside the Inter RF Bandwidth gap.

For the wanted and interfering signal coupled to the Base Station antenna input, using the parameters in Table 7.4.5.5-1, the following requirements shall be met:

- For any measured E-UTRA TDD carrier, the throughput shall be $\geq 95\%$ of the maximum throughput of the reference measurement channel defined in TS 36.104 [5], clause 7.2.
- For any measured UTRA TDD carrier, the BER shall not exceed 0.001 for the reference measurement channel defined in TS 25.105 [4], clause 7.2.

Table 7.4.5.5-1: Additional blocking requirement for Band Category 3

Operating Band	Centre Frequency of Interfering Signal [MHz]	Interfering Signal mean power [dBm]	Wanted Signal mean power [dBm]	Interfering signal centre frequency minimum frequency offset from the Base Station RF Bandwidth edge [MHz]
33 - 40	(F _{UL_low} - 20) to (F _{UL_high} + 20)	-40,	P _{PREFSENS} + 6 dB*	±2.4
NOTE*: P _{PREFSENS} depends on the RAT and on the channel bandwidth, see clause 7.2.				

7.5 Out-of-band blocking

7.5.1 Definition and applicability

The Out-of-band blocking characteristic is a measure of the receiver ability to receive a wanted signal at its assigned channel in the presence of an unwanted interferer outside the uplink operating band.

The blocking performance requirement applies as specified in the Table 7.5.5.1-1 and Table 7.5.5.2-1.

Unless otherwise stated, a BS declared to be capable of E-UTRA with NB-IoT in-band and guard band operations (or any combination with GSM and/or UTRA) is only required to pass the out-of-band blocking tests for E-UTRA with guard band operation (or any combination with GSM and/or UTRA). It's not required to perform the out-of-band blocking receiver tests again for E-UTRA with in-band operation (or any combination with GSM and/or UTRA).

7.5.2 Minimum requirement

The general minimum requirement is in TS 37.104 [2] clause 7.5.1. The co-location minimum requirement is in TS 37.104 [2] clause 7.5.2.

7.5.3 Test purpose

The test stresses the ability of the BS receiver to withstand high-level interference from unwanted signals at specified frequency bands, without undue degradation of its sensitivity.

7.5.4 Method of test

7.5.4.1 Initial conditions

Test environment: normal; see Annex B.2.

Base Station RF Bandwidth positions to be tested: M_{RFBW} in single-band operation, see clause 4.9.1, $B_{\text{RFBW}}T_{\text{RFBW}}$ and $B'_{\text{RFBW}}T_{\text{RFBW}}$ in multi-band operation, see clause 4.9.1.

In addition, in multi-band operation:

- For $B_{\text{RFBW}}T_{\text{RFBW}}$, out-of-band blocking testing above the highest operating band may be omitted
 - For $B'_{\text{RFBW}}T_{\text{RFBW}}$, out-of-band blocking testing below the lowest operating band may be omitted
- 1) Set up the equipment as shown in Annex D.2.1.
 - 2) Generate the wanted signal according to the applicable test configuration (see clause 5) using reference measurement channel to the BS under test as follows:
 - For E-UTRA see Annex A.1 in TS 36.141 [9].
 - For UTRA FDD see Annex A.2 in TS 25.141 [10].
 - For UTRA TDD see Annex A.2.1 in TS 25.142 [12].
 - For GSM see clause 7.6.2 in TS 51.021 [11] and Annex P in TS 45.005 [6] for reference channels to test.
 - For NB-IoT see Annex A.14 in TS 36.141 [9].
 - For NR see Annex A.1 in TS 38.141-1 [26].

7.5.4.2 Procedure

- 1) Set the BS to transmit with the carrier set-up and power allocation according to the applicable test configuration(s) (see clause 5).

The transmitter may be turned off for the out-of-band blocker tests when the frequency of the blocker is such that no IM2 or IM3 products fall inside the bandwidth of the wanted signal.

- 2) Adjust the signal generators to the type of interfering signals, levels and the frequency offsets as specified for general test requirements in Table 7.5.5.1-1 and, when applicable, for co-location test requirements in Table 7.5.5.2-1.
- 3) The CW interfering signal shall be swept with a step size of 1 MHz within the specified range.
- 4) Measure the performance of the wanted signal at the BS receiver, as defined in the clause 7.5.5, for the relevant carriers specified by the test configuration in clause 4.8.

In addition, for a multi-band capable BS with separate antenna connectors, the following steps shall apply:

- 5) For single band tests, repeat the steps above per involved band where single band test configurations and test models shall apply with no carrier activated in the other band.

- 6) For multi-band tests, the interfering signal shall first be applied on the same port as the wanted signal. The test shall be repeated with the interfering signal applied on the other port (if any) mapped to the same receiver as the wanted signal. Any antenna connector with no signal applied shall be terminated.
- 7) Repeat step 6 with the wanted signal for the other band(s) applied on the respective port(s).

7.5.5 Test requirements

7.5.5.1 General out-of-band blocking test requirements

For a wanted and an interfering signal coupled to BS antenna input using the parameters in Table 7.5.5.1-1, the following requirements shall be met:

- For any measured E-UTRA carrier, the throughput shall be $\geq 95\%$ of the maximum throughput of the reference measurement channel defined in TS 36.104 [5], clause 7.2.
- For any measured UTRA FDD carrier, the BER shall not exceed 0.001 for the reference measurement channel defined in TS 25.104 [3], clause 7.2.
- For any measured UTRA TDD carrier, the BER shall not exceed 0.001 for the reference measurement channel defined in TS 25.105 [4], clause 7.2.
- For any measured GSM/EDGE carrier, the conditions are specified in TS 45.005 [6], Annex P.2.1.
- For any measured NB-IoT carrier, the throughput shall be $\geq 95\%$ of the maximum throughput of the reference measurement channel defined in TS 36.104 [5], clause 7.2.
- For any measured NR carrier, the throughput shall be $\geq 95\%$ of the maximum throughput of the reference measurement channel defined in TS 38.104 [27], clause 7.2.

For BS capable of multi-band operation, the requirement applies for each supported operating band. The in-band blocking frequency ranges of all supported operating bands according to Table 7.4.5.1-1 shall be excluded from the requirement.

The out-of-band blocking requirement applies from 1 MHz to $F_{UL_low} - \Delta f_{OOB}$ and from $F_{UL_high} + \Delta f_{OOB}$ up to 12750 MHz, including the downlink frequency range of the FDD *operating band* for BS supporting FDD. Δf_{OOB} is defined in table 7.4.1-1.

Table 7.5.5.1-1: Out-of-band blocking performance requirement

Interfering Signal mean power [dBm]	Wanted Signal mean power [dBm]	Type of Interfering Signal
-15 (NOTE2)	$P_{REFSENS} + xdB$ (NOTE1)	CW carrier
<p>NOTE1: $P_{REFSENS}$ depends on the RAT, the BS class and the channel bandwidth, see clause 7.2. "x" is equal to 6 in case of NR, E-UTRA, UTRA or NB-IoT wanted signals and equal to 3 in case of GSM/EDGE wanted signal.</p> <p>NOTE2: For NB-IoT, up to 24 exceptions are allowed for spurious response frequencies in each wanted signal frequency when measured using a 1MHz step size. For these exceptions the above throughput requirement shall be met when the blocking signal is set to a level of -40 dBm for 15 kHz subcarrier spacing and -46 dBm for 3.75 kHz subcarrier spacing. In addition, each group of exceptions shall not exceed three contiguous measurements using a 1MHz step size.</p>		

7.5.5.2 Co-location test requirements

This additional blocking requirement may be applied for the protection of BS receivers when NR, E-UTRA, UTRA, CDMA or GSM/EDGE BS operating in a different frequency band are co-located with a BS.

The requirements in this clause assume a 30 dB coupling loss between the interfering transmitter and the BS receiver and are based on co-location with base stations of the same class.

For a wanted and an interfering signal coupled to BS antenna input using the parameters in Table 7.5.5.2-1, the following requirements shall be met:

- For any measured E-UTRA carrier, the throughput shall be $\geq 95\%$ of the maximum throughput of the reference measurement channel defined in TS 36.104 [5], clause 7.2.
- For any measured UTRA FDD carrier, the BER shall not exceed 0.001 for the reference measurement channel defined in TS 25.104 [3], clause 7.2.
- For any measured UTRA TDD carrier, the BER shall not exceed 0.001 for the reference measurement channel defined in TS 25.105 [4], clause 7.2.
- For any measured GSM/EDGE carrier, the conditions are specified in TS 45.005 [6], Annex P.2.1.
- For any measured NB-IoT carrier, the throughput shall be $\geq 95\%$ of the maximum throughput of the reference measurement channel defined in TS 36.104 [5], clause 7.2.
- For any measured NR carrier, the throughput shall be $\geq 95\%$ of the maximum throughput of the reference measurement channel defined in TS 38.104 [27], clause 7.2.

Table 7.5.5.2-1: Blocking requirement for co-location with BS in other frequency bands

Type of co-located BS	Centre Frequency of Interfering Signal (MHz)	Interfering Signal mean power for WA BS (dBm)	Interfering Signal mean power for MR BS (dBm)	Interfering Signal mean power for LA BS (dBm)	Wanted Signal mean power (dBm)	Type of Interfering Signal
GSM850 or CDMA850	869 – 894	+16**	+8**	-6**	$P_{\text{REFSENS}} + x \text{ dB}^*$	CW carrier
GSM900	921 – 960	+16**	+8**	-6**	$P_{\text{REFSENS}} + x \text{ dB}^*$	CW carrier
DCS1800	1805 – 1880 (Note 4)	+16**	+8**	-6**	$P_{\text{REFSENS}} + x \text{ dB}^*$	CW carrier
PCS1900	1930 – 1990	+16**	+8**	-6**	$P_{\text{REFSENS}} + x \text{ dB}^*$	CW carrier
UTRA FDD Band I or E-UTRA Band 1 or NR Band n1	2110 – 2170	+16**	+8**	-6**	$P_{\text{REFSENS}} + x \text{ dB}^*$	CW carrier
UTRA FDD Band II or E-UTRA Band 2 or NR Band n2	1930 – 1990	+16**	+8**	-6**	$P_{\text{REFSENS}} + x \text{ dB}^*$	CW carrier
UTRA FDD Band III or E-UTRA Band 3 or NR Band n3	1805 – 1880 (Note 4)	+16**	+8**	-6**	$P_{\text{REFSENS}} + x \text{ dB}^*$	CW carrier
UTRA FDD Band IV or E-UTRA Band 4	2110 – 2155	+16**	+8**	-6**	$P_{\text{REFSENS}} + x \text{ dB}^*$	CW carrier
UTRA FDD Band V or E-UTRA Band 5 or NR Band n5	869 – 894	+16**	+8**	-6**	$P_{\text{REFSENS}} + x \text{ dB}^*$	CW carrier
UTRA FDD Band VI or E-UTRA Band 6	875 – 885	+16**	+8**	-6**	$P_{\text{REFSENS}} + x \text{ dB}^*$	CW carrier
UTRA FDD Band VII or E-UTRA Band 7 or NR Band n7	2620 – 2690	+16**	+8**	-6**	$P_{\text{REFSENS}} + x \text{ dB}^*$	CW carrier
UTRA FDD Band VIII or E-UTRA Band 8 or NR Band n8	925 – 960	+16**	+8**	-6**	$P_{\text{REFSENS}} + x \text{ dB}^*$	CW carrier
UTRA FDD Band IX or E-UTRA Band 9	1844.9 – 1879.9	+16**	+8**	-6**	$P_{\text{REFSENS}} + x \text{ dB}^*$	CW carrier
UTRA FDD Band X or E-UTRA Band 10	2110 – 2170	+16**	+8**	-6**	$P_{\text{REFSENS}} + x \text{ dB}^*$	CW carrier
UTRA FDD Band XI or E-UTRA Band 11	1475.9 - 1495.9	+16**	+8**	-6**	$P_{\text{REFSENS}} + x \text{ dB}^*$	CW carrier
UTRA FDD Band XII or E-UTRA Band 12 or NR Band n12	729 - 746	+16**	+8**	-6**	$P_{\text{REFSENS}} + x \text{ dB}^*$	CW carrier
UTRA FDD Band XIII or E-UTRA Band 13	746 - 756	+16**	+8**	-6**	$P_{\text{REFSENS}} + x \text{ dB}^*$	CW carrier
UTRA FDD Band XIV or E-UTRA Band 14	758 - 768	+16**	+8**	-6**	$P_{\text{REFSENS}} + x \text{ dB}^*$	CW carrier
E-UTRA Band 17	734 - 746	+16**	+8**	-6**	$P_{\text{REFSENS}} + x \text{ dB}^*$	CW carrier
E-UTRA Band 18	860 - 875	+16**	+8**	-6**	$P_{\text{REFSENS}} + x \text{ dB}^*$	CW carrier
UTRA FDD Band XIX or E-UTRA Band 19	875 - 890	+16**	+8**	-6**	$P_{\text{REFSENS}} + x \text{ dB}^*$	CW carrier

UTRA FDD Band XX or E-UTRA Band 20 or NR Band n20	791 - 821	+16**	+8**	-6**	$P_{\text{REFSENS}} + x \text{ dB}^*$	CW carrier
UTRA FDD Band XXI or E-UTRA Band 21	1495.9 – 1510.9	+16**	+8**	-6**	$P_{\text{REFSENS}} + x \text{ dB}^*$	CW carrier
UTRA FDD Band XXII or E-UTRA Band 22	3510 – 3590	+16**	+8**	-6**	$P_{\text{REFSENS}} + x \text{ dB}^*$	CW carrier
E-UTRA Band 23	2180 - 2200	+16**	+8**	-6**	$P_{\text{REFSENS}} + x \text{ dB}^*$	CW carrier
E-UTRA Band 24	1525 – 1559	+16**	+8**	-6**	$P_{\text{REFSENS}} + x \text{ dB}^*$	CW carrier
UTRA FDD Band XXV or E-UTRA Band 25 or NR Band n25	1930 – 1995	+16**	+8**	-6**	$P_{\text{REFSENS}} + x \text{ dB}^*$	CW carrier
UTRA FDD Band XXVI or E-UTRA Band 26	859 – 894	+16**	+8**	-6**	$P_{\text{REFSENS}} + x \text{ dB}^*$	CW carrier
E-UTRA Band 27	852 - 869	+16**	+8**	-6**	$P_{\text{REFSENS}} + x \text{ dB}^*$	CW carrier
E-UTRA Band 28 or NR Band n28	758 – 803	+16**	+8**	-6**	$P_{\text{REFSENS}} + x \text{ dB}^*$	CW carrier
E-UTRA Band 29	717-728	+16**	+8**	-6**	$P_{\text{REFSENS}} + 6\text{dB}^*$	CW carrier
E-UTRA Band 30	2350-2360	+16**	+8**	-6**	$P_{\text{REFSENS}} + x \text{ dB}^*$	CW carrier
E-UTRA Band 31	462.5–467.5	+16**	+8**	-6**	$P_{\text{REFSENS}} + 6\text{dB}^*$	CW carrier
UTRA FDD Band XXXII or E-UTRA Band 32	1452 – 1496 (NOTE 5)	+16**	+8**	-6**	$P_{\text{REFSENS}} + 6\text{dB}^*$	CW carrier
UTRA TDD Band a) or E-UTRA Band 33	1900-1920	+16**	+8**	-6**	$P_{\text{REFSENS}} + x \text{ dB}^*$	CW carrier
UTRA TDD Band a) or E-UTRA Band 34 or NR Band n34	2010-2025	+16**	+8**	-6**	$P_{\text{REFSENS}} + x \text{ dB}^*$	CW carrier
UTRA TDD Band b) or E-UTRA Band 35	1850-1910	+16**	+8**	-6**	$P_{\text{REFSENS}} + x \text{ dB}^*$	CW carrier
UTRA TDD Band b) or E-UTRA Band 36	1930-1990	+16**	+8**	-6**	$P_{\text{REFSENS}} + x \text{ dB}^*$	CW carrier
UTRA TDD Band c) or E-UTRA Band 37	1910-1930	+16**	+8**	-6**	$P_{\text{REFSENS}} + x \text{ dB}^*$	CW carrier
UTRA TDD Band d) or E-UTRA Band 38 or NR Band n38	2570-2620	+16**	+8**	-6**	$P_{\text{REFSENS}} + x \text{ dB}^*$	CW carrier
UTRA TDD Band f) or E-UTRA Band 39 or NR Band n39	1880-1920	+16**	+8**	-6**	$P_{\text{REFSENS}} + x \text{ dB}^*$	CW carrier
UTRA TDD Band e) or E-UTRA Band 40 or NR Band n40	2300-2400	+16**	+8**	-6**	$P_{\text{REFSENS}} + x \text{ dB}^*$	CW carrier
E-UTRA Band 41 or NR Band n41	2496 - 2690	+16**	+8**	-6**	$P_{\text{REFSENS}} + x \text{ dB}^*$	CW carrier
E-UTRA Band 42	3400 – 3600	+16**	+8**	-6**	$P_{\text{REFSENS}} + x \text{ dB}^*$	CW carrier
E-UTRA Band 43	3600 – 3800	+16**	+8**	-6**	$P_{\text{REFSENS}} + x \text{ dB}^*$	CW carrier
E-UTRA Band 44	703 - 803	+16**	+8**	-6**	$P_{\text{REFSENS}} + x \text{ dB}^*$	CW carrier
E-UTRA Band 45	1447 - 1467	+16**	+8**	-6**	$P_{\text{REFSENS}} + x \text{ dB}^*$	CW carrier
E-UTRA Band 46	5150 - 5925	N/A	+8**	-6**	$P_{\text{REFSENS}} + x \text{ dB}^*$	CW carrier
E-UTRA Band 48	3550 - 3700	+16**	+8**	-6**	$P_{\text{REFSENS}} + x \text{ dB}^*$	CW carrier
E-UTRA Band 49	3550 - 3700	N/A	N/A	-6**	$P_{\text{REFSENS}} + x \text{ dB}^*$	CW carrier
E-UTRA Band 50 or NR Band n50	1432 - 1517	+16	+8**	-6**	$P_{\text{REFSENS}} + x \text{ dB}^*$	CW carrier

E-UTRA Band 51 or NR Band n51	1427 - 1432	N/A	N/A	-6**	$P_{\text{REFSENS}} + x \text{ dB}^*$	CW carrier
E-UTRA Band 52	3300 – 3400	+16**	+8	-6	$P_{\text{REFSENS}} + x \text{ dB}^*$	CW carrier
E-UTRA Band 65	2110 – 2200	+16**	+8**	-6**	$P_{\text{REFSENS}} + x \text{ dB}^*$	CW carrier
E-UTRA Band 66 or NR Band n66	2110 – 2200	+16**	+8**	-6**	$P_{\text{REFSENS}} + x \text{ dB}^*$	CW carrier
E-UTRA Band 67	738 – 758	+16**	+8**	-6**	$P_{\text{REFSENS}} + x \text{ dB}^*$	CW carrier
E-UTRA Band 68	753 – 783	+16**	+8**	-6**	$P_{\text{REFSENS}} + x \text{ dB}^*$	CW carrier
E-UTRA Band 69	2570-2620	+16**	+8**	-6**	$P_{\text{REFSENS}} + x \text{ dB}^*$	CW carrier
E-UTRA Band 70 or NR Band n70	1995 - 2020	+16**	+8**	-6**	$P_{\text{REFSENS}} + x \text{ dB}^*$	CW carrier
E-UTRA Band 71 or NR Band n71	617 - 652	+16**	+8**	-6**	$P_{\text{REFSENS}} + x \text{ dB}^*$	CW carrier
E-UTRA Band 72	461 - 466	+16**	+8**	-6**	$P_{\text{REFSENS}} + x \text{ dB}^*$	CW carrier
E-UTRA Band 73	460 - 465	+16**	+8**	-6**	$P_{\text{REFSENS}} + x \text{ dB}^*$	CW carrier
E-UTRA Band 74 or NR Band n74	1475 - 1518	+16**	+8**	-6**	$P_{\text{REFSENS}} + x \text{ dB}^*$	CW carrier
E-UTRA Band 75 or NR Band n75	1432 - 1517	+16**	+8**	-6**	$P_{\text{REFSENS}} + x \text{ dB}^*$	CW carrier
E-UTRA Band 76 or NR Band n76	1427 - 1432	N/A	N/A	-6**	$P_{\text{REFSENS}} + x \text{ dB}^*$	CW carrier
NR Band n77	3300 - 4200	+16**	+8	-6	$P_{\text{REFSENS}} + x \text{ dB}^*$	CW carrier
NR Band n78	3300 - 3800	+16**	+8	-6	$P_{\text{REFSENS}} + x \text{ dB}^*$	CW carrier
E-UTRA Band 85	728 - 746	+16**	+8	-6	$P_{\text{REFSENS}} + x \text{ dB}^*$	CW carrier

NOTE 1 (*): P_{REFSENS} depends on the RAT, the BS class and the channel bandwidth, see clause 7.2.
"x" is equal to 3 in case of GSM/EDGE wanted signal and equal to 6 in case of NR, UTRA or E-UTRA wanted signals.

NOTE 2: Except for a BS operating in Band 13, these requirements do not apply when the interfering signal falls within any of the supported uplink operating band or in the Δf_{OOB} immediately outside any of the supported uplink operating band.
For a BS operating in band 13 the requirements do not apply when the interfering signal falls within the frequency range 768-797MHz.

NOTE 3: Some combinations of bands may not be possible to co-site based on the requirements above. The current state-of-the-art technology does not allow a single generic solution for co-location of UTRA TDD or E-UTRA TDD or NR TDD with E-UTRA FDD or NR FDD on adjacent frequencies for 30dB BS-BS minimum coupling loss. However, there are certain site-engineering solutions that can be used. These techniques are addressed in TR 25.942 [14].

NOTE 4: In China, the blocking requirement for co-location with DCS1800 and Band III BS is only applicable in the frequency range 1805-1850MHz.

NOTE 5: For a BS operating in band 11, 21 or 74, the requirement for co-location with Band 32 applies for interfering signal within the frequency range 1475.9-1495.9 MHz.

NOTE 6: Co-located TDD base stations that are synchronized and using the same or adjacent operating band can receive without special co-location requirements. For unsynchronized base stations, special co-location requirements may apply that are not covered by the 3GPP specifications.

NOTE 7 (**): For NB-IoT, up to 24 exceptions are allowed for spurious response frequencies in each wanted signal frequency when measured using a 1MHz step size. For these exceptions the above throughput requirement shall be met when the blocking signal is set to a level of -40 dBm for 15 kHz subcarrier spacing and -46 dBm for 3.75 kHz subcarrier spacing. In addition, each group of exceptions shall not exceed three contiguous measurements using a 1MHz step size.

7.6 Receiver spurious emissions

7.6.1 Definition and applicability

The receiver spurious emissions power is the power of emissions generated or amplified in a receiver that appear at the BS receiver antenna connector. The requirements apply to all BS with separate RX and TX antenna ports. In this case for FDD BS the test shall be performed when both TX and RX are on, with the TX port terminated.

For TDD BS with common RX and TX antenna port the requirement applies during the Transmitter OFF period. For FDD BS with common RX and TX antenna port the transmitter spurious emission limits as specified in clause 6.6.1 are valid.

For BS capable of multi-band operation where multiple bands are mapped on separate antenna connectors, the single-band requirements apply and the excluded frequency range is only applicable for the operating band supported on each antenna connector.

Unless otherwise stated, a BS declared to be capable of E-UTRA with NB-IoT in-band and guard band operations (or any combination with GSM and/or UTRA) is only required to pass the receiver spurious emissions tests for E-UTRA with guard band operation (or any combination with GSM and/or UTRA). It's not required to perform the receiver spurious emissions tests again for E-UTRA with in-band operation (or any combination with GSM and/or UTRA).

7.6.2 Minimum requirements

The minimum requirement is in TS 37.104 [2] clause 7.6.1.

7.6.3 Test purpose

The test purpose is to verify the ability of the BS to limit the interference caused by receiver spurious emissions to other systems.

7.6.4 Method of test

7.6.4.1 Initial conditions

Test environment: Normal; see Annex B.2.

Base Station RF Bandwidth positions to be tested: M_{RFBW} in single-band operation, see clause 4.9.1, $B_{\text{RFBW}}T_{\text{RFBW}}$ and $B'_{\text{RFBW}}T_{\text{RFBW}}$ in multi-band operation, see clause 4.9.1.

- 1) Set up the equipment as shown in Annex D.2.1.

7.6.4.2 Procedure

- 1) Set the measurement equipment parameters as specified in Table 7.6.5.1-1. For BC2, the parameters in Table 7.6.5.2-1 apply in addition.
- 2) Set the BS to transmit with the carrier set-up and power allocation according to the applicable test configuration(s) (see clause 5).
- 3) Measure the spurious emissions over each frequency range described in clause 7.6.5.

In addition, for a multi-band capable BS, the following step shall apply:

- 4) For multi-band capable BS and single band tests, repeat the steps above per involved band where single band test configurations and test models shall apply with no carrier activated in the other band. For multi-band capable BS with separate antenna connector, the antenna connector not being under test in case of SBT or MBT shall be terminated.

7.6.5 Test requirements

7.6.5.1 General test requirements

The power of any spurious emission shall not exceed the levels in Table 7.6.5.1-1.

Table 7.6.5.1-1: General spurious emission test requirement

Frequency range	Maximum level	Measurement Bandwidth	Note
30 MHz - 1 GHz	-57 dBm	100 kHz	
1 GHz - 12.75 GHz	-47 dBm	1 MHz	
12.75 GHz - 5 th harmonic of the upper frequency edge of the UL operating band in GHz	-47 dBm	1 MHz	This spurious frequency range applies only for <i>operating bands</i> for which the 5 th harmonic of the upper frequency edge of the UL <i>operating band</i> is reaching beyond 12.75 GHz.
NOTE: The frequency range from $F_{BW,RF,DL,low} - \Delta f_{OBUe}$ to $F_{BW,RF,DL,high} + \Delta f_{OBUe}$ may be excluded from the requirement. For BS capable of multi-band operation, the exclusion applies for all supported operating bands. For BS capable of multi-band operation where multiple bands are mapped on separate antenna connectors, the single-band requirements apply and the excluded frequency range is only applicable for the operating band supported on each antenna connector.			

In addition to the requirements in Table 7.6.5.1-1, the power of any spurious emission shall not exceed the additional spurious emissions requirements in clause 6.6.1.5.5 and in case of FDD BS (for BC1 and BC2) emission shall not exceed the levels specified for protection of the BS receivers of own or different BS in clause 6.6.1.5.4. In addition, the requirements for co-location with other Base Stations specified in clause 6.6.1.5.6 may also be applied.

7.6.5.2 Additional test requirement for BC2 (Category B)

For a BS operating in Band Category 2 when GSM/EDGE is configured and where Category B spurious emissions apply, the power of any spurious emissions shall not exceed the limits in Table 7.6.5.2-1.

For BS capable of multi-band operation, the limits in Table 7.6.5.2-1 are only applicable when all supported operating bands belong to BC2 and GSM/EDGE is configured in all bands.

Table 7.6.5.2-1: Additional BS spurious emissions limits for BC2, Category B

Frequency range	Frequency offset from transmitter operating band edge (Note 1)	Maximum level	Measurement Bandwidth
500 MHz – 1 GHz	10 – 20 MHz	-57 dBm	300 kHz
	20 – 30 MHz	-57 dBm	1 MHz
	≥ 30 MHz	-57 dBm	3 MHz
1 GHz – 12.75 GHz	≥ 30 MHz	-47 dBm	3 MHz
NOTE 1: For BS capable of multi-band operation, the frequency offset is relative to the closest supported operating band.			

7.7 Receiver intermodulation

7.7.1 Definition and applicability

Third and higher order mixing of the two interfering RF signals can produce an interfering signal in the band of the desired channel. Intermodulation response rejection is a measure of the capability of the receiver to receive a wanted signal on its assigned channel frequency in the presence of two interfering signals which have a specific frequency relationship to the wanted signal.

Unless otherwise stated, a BS declared to be capable of E-UTRA with NB-IoT in-band and guard band operations (or any combination with GSM and/or UTRA) is only required to pass the receiver intermodulation tests for E-UTRA with guard band operation (or any combination with GSM and/or UTRA). It's not required to perform the receiver intermodulation tests again for E-UTRA with in-band operation (or any combination with GSM and/or UTRA).

7.7.2 Minimum requirement

The minimum requirement is in TS 37.104 [2], clauses 7.7.1, 7.7.2 and 7.7.3.

7.7.3 Test purpose

The test purpose is to verify the ability of the BS receiver to inhibit the generation of intermodulation products in its non-linear elements caused by the presence of two high-level interfering signals at frequencies with a specific relationship to the frequency of the wanted signal.

7.7.4 Method of test

7.7.4.1 Initial conditions

Test environment: Normal; see Annex B.2.

Base Station RF Bandwidth positions to be tested: In single-band operation: M_{RFBW} if TC6 is applicable; B_{RFBW} and T_{RFBW} for other TC, see clause 4.9.1, Table 5.1-1 and Table 5.2-1. In multi-band operation: $B_{\text{RFBW}}T_{\text{RFBW}}$ and $B'_{\text{RFBW}}T_{\text{RFBW}}$, see clause 4.9.1.

- 1) Set-up the measurement system as shown in Annex D.2.3.
- 2) Generate the wanted signal according to the applicable test configuration (see clause 5) using reference measurement channel to the BS under test as follows:
 - For E-UTRA see Annex A.1 in TS 36.141 [9].
 - For UTRA FDD see Annex A.2 in TS 25.141 [10].
 - For UTRA TDD see Annex A.2.1 in TS 25.142 [12].
 - For GSM see clause 7.7.2 in TS 51.021 [11] and Annex P in TS 45.005 [6] for reference channels to test.
 - For NB-IoT see Annex A.14 in TS 36.141 [9].
 - For NR see Annex A.1 in TS 38.141-1 [26].

7.7.4.2 Procedure for general and narrowband intermodulation

- 1) Adjust the signal generators to the type of interfering signals, levels and the frequency offsets as specified in Table 7.7.5.1-1 and Table 7.7.5.1-2 for general intermodulation requirement, and Table 7.7.5.2-1 and Table 7.7.5.2-2 for narrowband intermodulation requirement.
- 2) Measure the performance of the wanted signal at the BS receiver, as defined in clause 7.7.5.1 and 7.7.5.2, for the relevant carriers specified by the test configuration in clause 4.8.

In addition, for a multi-band capable BS with separate antenna connectors, the following steps shall apply:

- 3) For single band tests, repeat the steps above per involved band where single band test configurations shall apply with no carrier activated in the other band.
- 4) For multi-band tests, the interfering signal shall first be applied on the same port as the wanted signal. The test shall be repeated with the interfering signal applied on the other port (if any) mapped to the same receiver as the wanted signal. Any antenna connector with no signal applied shall be terminated.
- 5) Repeat step 6 with the wanted signal for the other band(s) applied on the respective port(s).

7.7.4.3 Procedure for additional narrowband intermodulation for GSM/EDGE

For a BS declared to support CS1 to CS6 or CS9 to CS13, the GSM/EDGE MC-BTS receiver intermodulation method of test is stated in TS 51.021 [11], applicable parts of clause 7.7, shall apply for GSM/EDGE carriers.

The conditions specified in TS 45.005 [6], Annex P.2.2 apply for the GSM/EDGE intermodulation requirement.

If a BS is declared to support CS7 or CS15, the steps in clause 7.7.4.3.1 and 7.7.4.3.2 for testing additional narrowband blocking for GSM/EDGE shall apply:

7.7.4.3.1 Initial conditions for additional narrowband intermodulation for GSM/EDGE for CS7 and CS15

Test environment: Normal; see Annex B.2.

Base Station RF Bandwidth positions to be tested: M_{RFBW} in single-band operation, see clause 4.9.1,

- 1) Set up the equipment as shown in Annex D.2.3.
- 2) Generate the wanted signal according to the applicable test configuration (see clause 5) using applicable reference measurement channel to the BS under test as follows:
 - For GSM see clause 7.7 in TS 51.021 [11] and Annex P.2.2 in TS 45.005 [6] for reference channels to test.

7.7.4.3.2 Procedure for additional narrowband intermodulation for GSM/EDGE for CS7 and CS15

- 1) Set the BS according to the applicable test configuration(s) (see clause 5).
- 2) Adjust the GSM/EDGE signal generator to the wanted signal levels as specified in TS 51.021, applicable parts of clauses 7.7.
- 3) Set-up the interfering signal as specified in TS 51.021, applicable parts of clauses 7.7.
- 4) Measure the performance of the GSM/EDGE wanted signal at the BS receiver, as defined in TS 51.021, applicable parts of clause 7.7.

In addition, for multi-band capable BS and single band tests, repeat the procedure above per involved band where single band test configurations and test models shall apply with no carrier activated in the other band. Any antenna connector with no signal applied shall be terminated.

7.7.5 Test requirements

7.7.5.1 General intermodulation test requirement

Interfering signals shall be a CW signal and an E-UTRA or UTRA signal, as specified in Annex A.

The requirement is applicable outside the Base Station RF Bandwidth or Maximum Radio Bandwidth. The interfering signal offset is defined relative to the Base Station RF Bandwidth edges or Maximum Radio Bandwidth edges.

For BS capable of multi-band operation, the requirement applies in addition inside any Inter RF Bandwidth gap, in case the gap size is at least twice as wide as the UTRA/E-UTRA interfering signal centre frequency offset from the Base Station RF Bandwidth edge. The interfering signal offset is defined relative to the Base Station RF Bandwidth edges inside the Inter RF Bandwidth gap.

For the wanted signal at the assigned channel frequency and two interfering signals coupled to the Base Station antenna input, using the parameters in Table 7.7.5.1-1 and 7.7.5.1-2, the following requirements shall be met:

- For any measured E-UTRA carrier, the throughput shall be $\geq 95\%$ of the maximum throughput of the reference measurement channel defined in TS 36.104 [5], clause 7.2.
- For any measured UTRA FDD carrier, the BER shall not exceed 0.001 for the reference measurement channel defined in TS 25.104 [3], clause 7.2.
- For any measured UTRA TDD carrier, the BER shall not exceed 0.001 for the reference measurement channel defined in TS 25.105 [4], clause 7.2.
- For any measured GSM/EDGE carrier, the conditions are specified in TS 45.005 [6], Annex P.2.2.
- For any measured NB-IoT carrier, the throughput shall be $\geq 95\%$ of the maximum throughput of the reference measurement channel defined in TS 36.104 [5], clause 7.2.
- For any measured NR carrier, the throughput shall be $\geq 95\%$ of the maximum throughput of the reference measurement channel defined in TS 38.104 [27], clause 7.2.

Table 7.7.5.1-1: General intermodulation requirement

Base Station Type	Mean power of interfering signals [dBm]	Wanted Signal mean power [dBm]	Type of interfering signal
Wide Area BS	-48+y (Note 6)	$P_{\text{PREFSENS}} + x$ dB (Note 2, 5)	See Table 7.7.5.1-2
Medium Range BS	-44+y (Note 6)	$P_{\text{PREFSENS}} + x$ dB (Note 3, 5)	
Local Area BS	-38+y (Note 6)	$P_{\text{PREFSENS}} + x$ dB (Note 4, 5)	
<p>NOTE 1: P_{PREFSENS} depends on the RAT, the BS class and on the channel bandwidth, see clause 7.2 in TS 37.104 [2]. For E-UTRA channel bandwidths 10, 15 and 20 MHz this requirement shall apply only for a FRC A1-3 mapped to the frequency range at the channel edge adjacent to the interfering signals.</p> <p>NOTE 2: For WA BS not supporting NR, "x" is equal to 6 in case of E-UTRA or UTRA or NB-IoT wanted signals and equal to 3 in case of GSM/EDGE wanted signal.</p> <p>NOTE 3: For MR BS not supporting NR, "x" is equal to 6 in case of UTRA wanted signals, 9 in case of E-UTRA or NB-IoT wanted signal and equal to 3 in case of GSM/EDGE wanted signal.</p> <p>NOTE 4: For LA BS not supporting NR, "x" is equal to 12 in case of E-UTRA or NB-IoT wanted signals, 6 in case of UTRA wanted signal and equal to 3 in case of GSM/EDGE wanted signal.</p> <p>NOTE 5: For a BS that transmits NR in some configurations and does not transmit UTRA or GSM in any configuration, x is equal to 6.</p> <p>NOTE 6: For a BS not supporting NR, "y" is equal to zero for all BS classes. For a BS supporting NR and not supporting UTRA nor GSM; "y" is equal to -4 for the WA BS class, -3 for the MR BS class and -6 for the LA BS class.</p>			

Table 7.7.5.1-2: Interfering signals for intermodulation requirement

RAT of the carrier adjacent to the upper/lower Base Station RF Bandwidth edge	Interfering signal centre frequency offset from the Base Station RF Bandwidth edge [MHz]	Type of interfering signal
E-UTRA 1.4 MHz	± 2.0 (BC1 and BC3) / ± 2.1 (BC2)	CW
	± 4.9	1.4MHz E-UTRA signal
E-UTRA 3 MHz or E-UTRA with NB-IoT in-band	± 4.4 (BC1 and BC3) / ± 4.5 (BC2)	CW
	± 10.5	3MHz E-UTRA signal
UTRA FDD and E-UTRA or E-UTRA with NB-IoT in-band/guard band 5 MHz	± 7.5	CW
	± 17.5	5MHz E-UTRA signal
E-UTRA or E-UTRA with NB-IoT in-band/guard band 10 MHz	± 7.375	CW
	± 17.5	5MHz E-UTRA signal
E-UTRA or E-UTRA with NB-IoT in-band/guard band 15 MHz	± 7.25	CW
	± 17.5	5MHz E-UTRA signal
E-UTRA or E-UTRA with NB-IoT in-band/guard band 20 MHz	± 7.125	CW
	± 17.5	5MHz E-UTRA signal
GSM/EDGE	± 7.575	CW
	± 17.5	5MHz E-UTRA signal
NB-IoT standalone	± 7.575	CW
	± 17.5	5MHz E-UTRA signal
1.28 Mcps UTRA TDD	± 2.3 (BC3)	CW
	± 5.6 (BC3)	1.28Mcps UTRA TDD signal
NR 5 MHz	± 7.5	CW
	± 17.5	5MHz E-UTRA signal
NR 10 MHz	± 7.465	CW
	± 17.5	5MHz E-UTRA signal
NR 15 MHz	± 7.43	CW
	± 17.5	5MHz E-UTRA signal
NR 20 MHz	± 7.395	CW
	± 17.5	5MHz E-UTRA signal
NR 25 MHz	± 7.465	CW
	± 25	20MHz E-UTRA signal
NR 30 MHz	± 7.43	CW
	± 25	20MHz E-UTRA signal
NR 40 MHz	± 7.45	CW
	± 25	20MHz E-UTRA signal
NR 50 MHz	± 7.35	CW
	± 25	20MHz E-UTRA signal
NR 60 MHz	± 7.49	CW
	± 25	20MHz E-UTRA signal
NR 70 MHz	± 7.42	CW
	± 25	20MHz E-UTRA signal
NR 80 MHz	± 7.44	CW
	± 25	20MHz E-UTRA signal
NR 90 MHz	± 7.46	CW
	± 25	20MHz E-UTRA signal
NR 100 MHz	± 7.48	CW

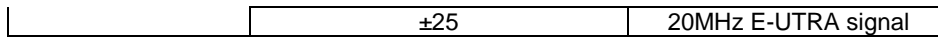

7.7.5.2 General narrowband intermodulation test requirement

Interfering signals shall be a CW signal and an E-UTRA 1RB signal, as specified in Annex A.

The requirement is applicable outside the Base Station RF Bandwidth or Maximum Radio Bandwidth. The interfering signal offset is defined relative to the Base Station RF Bandwidth edges or Maximum Radio Bandwidth edges.

For BS operating in non-contiguous spectrum within each supported operating band, the requirement applies in addition inside any sub-block gap in case the sub-block gap is at least as wide as the channel bandwidth of the E-UTRA interfering signal in Table 7.7.5.2-2. The interfering signal offset is defined relative to the sub-block edges inside the gap.

For BS capable of multi-band operation, the requirement applies in addition inside any Inter RF Bandwidth gap in case the gap size is at least as wide as the E-UTRA interfering signal in Table 7.7.5.2-2. The interfering signal offset is defined relative to the Base Station RF Bandwidth edges inside the Inter RF Bandwidth gap.

For the wanted signal at the assigned channel frequency and two interfering signals coupled to the Base Station antenna input, using the parameters in Table 7.7.5.2-1 and 7.7.5.2-2, the following requirements shall be met:

- For any measured E-UTRA carrier, the throughput shall be $\geq 95\%$ of the maximum throughput of the reference measurement channel defined in TS 36.104 [5], clause 7.2.
- For any measured UTRA FDD carrier, the BER shall not exceed 0.001 for the reference measurement channel defined in TS 25.104 [3], clause 7.2.
- For any measured UTRA TDD carrier, the BER shall not exceed 0.001 for the reference measurement channel defined in TS 25.105 [4], clause 7.2.
- For any measured GSM/EDGE carrier, the conditions are specified in TS 45.005 [6], Annex P.2.2.
- For any measured NB-IoT carrier, the throughput shall be $\geq 95\%$ of the maximum throughput of the reference measurement channel defined in TS 36.104 [5], clause 7.2.
- For any measured NR carrier, the throughput shall be $\geq 95\%$ of the maximum throughput of the reference measurement channel defined in TS 38.104 [27], clause 7.2.

Table 7.7.5.2-1: General narrowband intermodulation requirement

Base Station Type	Mean power of interfering signals [dBm]	Wanted Signal mean power [dBm]	Type of interfering signal
Wide Area BS	-52	$P_{\text{REFSENS}} + x \text{ dB}$ (NOTE 1)	See Table 7.7.5.2-2
Medium Range BS	-47		
Local Area BS	-44		
NOTE 1: P_{REFSENS} depends on the RAT, the BS class and on the channel bandwidth, see clause 7.2 in TS 37.104. "x" is equal to 6 in case of NR, E-UTRA or UTRA wanted signals and equal to 3 in case of GSM/EDGE wanted signal. "x" is specified in Table 7.7.5.2-1a for NB-IoT			

Table 7.7.5.2-1a: “x” for NB-IoT wanted signals

Operation mode	LTE channel bandwidth for in-band/guard band operation	X
Standalone	-	6
In Band	3 MHz	6
	5 MHz	6
	10 MHz	6
	15 MHz	6
	20 MHz	6
Guard band	5 MHz	6
	10 MHz	6
	15 MHz	6
	20 MHz	6

Table 7.7.5.2-2: Interfering signals for narrowband intermodulation requirement

RAT of the carrier adjacent to the upper/lower Base Station RF Bandwidth edge or sub-block edge	Interfering signal centre frequency offset from the Base Station RF Bandwidth edge or sub-block edge inside a gap [kHz]	Type of interfering signal
E-UTRA 1.4 MHz	± 260 (BC1 and BC3) / ± 270 (BC2)	CW
	± 970 (BC1 and BC3) / ± 790 (BC2)	1.4 MHz E-UTRA signal, 1 RB (NOTE 1)
E-UTRA or E-UTRA with NB-IoT in-band 3 MHz	± 260 (BC1 and BC3) / ± 270 (BC2)	CW
	± 960 (BC1 and BC3) / ± 780 (BC2)	3.0 MHz E-UTRA signal, 1 RB (NOTE 1)
E-UTRA or E-UTRA with NB-IoT in-band/guard band 5 MHz	± 360 (NOTE 3)	CW
	± 1060	5 MHz E-UTRA signal, 1 RB (NOTE 1)
E-UTRA or E-UTRA with NB-IoT in-band/guard band 10 MHz (NOTE 2)	± 325 (NOTE 3)	CW
	± 1240	5 MHz E-UTRA signal, 1 RB (NOTE 1)
E-UTRA or E-UTRA with NB-IoT in-band/guard band 15 MHz (NOTE 2)	± 380 (NOTE 3)	CW
	± 1600	5MHz E-UTRA signal, 1 RB (NOTE 1)
E-UTRA or E-UTRA with NB-IoT in-band/guard band 20 MHz (NOTE 2)	± 345 (NOTE 3)	CW
	± 1780	5MHz E-UTRA signal, 1 RB (NOTE 1)
UTRA FDD	± 345 (BC1 and BC2)	CW
	± 1780 (BC1 and BC2)	5MHz E-UTRA signal, 1 RB (NOTE 1)
GSM/EDGE	± 340	CW
	± 880	5MHz E-UTRA signal, 1 RB (NOTE 1)
NB-IoT standalone	± 340	CW
	± 880	5MHz E-UTRA signal, 1 RB (NOTE 1)
1.28Mcps UTRA TDD	± 190 (BC3)	CW
	± 970 (BC3)	1.4 MHz E-UTRA signal, 1 RB (NOTE 1)
NR 5 MHz	± 360	CW
	± 1420	E-UTRA signal, 1 RB (NOTE 1)
NR 10 MHz	± 370	CW
	± 1960	E-UTRA signal, 1 RB (NOTE 1)
NR 15 MHz (Note 2)	± 380	CW
	± 1960	E-UTRA signal, 1 RB (NOTE 1)
NR 20 MHz (Note 2)	± 390	CW
	± 2320	E-UTRA signal, 1 RB (NOTE 1)
NR 25 MHz (Note 2)	± 325	CW
	± 2350	E-UTRA signal, 1 RB (NOTE 1)
NR 30 MHz (Note 2)	± 335	CW
	± 2350	E-UTRA signal, 1 RB (NOTE 1)
NR 40 MHz (Note 2)	± 355	CW
	± 2710	E-UTRA signal, 1 RB (NOTE 1)
NR 50 MHz (Note 2)	± 375	CW
	± 2710	E-UTRA signal, 1 RB (NOTE 1)
NR 60 MHz (Note 2)	± 395	CW
	± 2710	E-UTRA signal, 1 RB (NOTE 1)
NR 70 MHz (Note 2)	± 415	CW
	± 2710	E-UTRA signal, 1 RB (NOTE 1)

NR 80 MHz (Note 2)	± 435	CW
	± 2710	E-UTRA signal, 1 RB (NOTE 1)
NR 90 MHz (Note 2)	± 365	CW
	± 2530	E-UTRA signal, 1 RB (NOTE 1)
NR 100 MHz (Note 2)	± 385	CW
	± 2530	E-UTRA signal, 1 RB (NOTE 1)
<p>NOTE 1: Interfering signal consisting of one resource block positioned at the stated offset, the channel bandwidth of the interfering signal is located adjacently to the Base Station RF Bandwidth edge or sub-block edge inside a gap.</p> <p>NOTE 2: This requirement shall apply only for an E-UTRA FRC A1-3 or NR G-FRC mapped to the frequency range at the channel edge adjacent to the interfering signals.</p> <p>NOTE 3: The frequency offset shall be adjusted to accommodate the IMD product to fall in the NB-IoT RB for NB-IoT in-band/guard band operation.</p> <p>NOTE 4: The frequency offset shall be adjusted to accommodate the IMD product to fall in the NB-IoT RB for NB-IoT in-band/guard band operation.</p> <p>NOTE 5: If a BS RF receiver fails the test of the requirement, the test shall be performed with the CW interfering signal frequency shifted away from the wanted signal by 180 kHz and the E-UTRA interfering signal frequency shifted away from the wanted signal by 360 kHz. If the BS RF receiver still fails the test after the frequency shift, then the BS RF receiver shall be deemed to fail the requirement.</p>		

7.7.5.3 Additional narrowband intermodulation test requirement for GSM/EDGE

The GSM/EDGE MC-BTS receiver intermodulation test requirements are stated in TS 51.021 [11], applicable parts of clause 7.7, shall apply for GSM/EDGE carriers.

The conditions specified in TS 45.005 [6], Annex P.2.2 apply for the GSM/EDGE intermodulation requirement.

7.8 In-channel selectivity

7.8.1 Definition and applicability

In-channel selectivity (ICS) is a measure of the receiver ability to receive a wanted signal at its assigned resource block locations in the presence of an interfering signal received at a larger power spectral density. In this condition a throughput requirement shall be met for a specified reference measurement channel. This requirement is applicable for NR, E-UTRA carriers and NB-IoT in-band operation carrier.

7.8.2 Minimum requirement

The minimum requirement is in TS 37.104 [2] clause 7.8.1.

7.8.3 Test purpose

The purpose of this test is to verify the BS receiver ability to suppress the IQ leakage.

7.8.4 Method of testing

For this requirement Tables 5.1-1 and 5.2-1 refer to single-RAT specifications; see clause 5. The following shall apply:

- For references to TS 36.141 [9], the method of test is specified in TS 36.141 [9], clause 7.4.4.
- For references to TS 38.141-1 [26], the method of test is specified in TS 38.141-1 [26], clause 7.8.4.

In addition, for a multi-band capable BS, the following step shall apply:

- For multi-band capable BS and single band tests, repeat the tests per involved band with no carrier activated in the other band. For multi-band capable BS with separate antenna connector, the antenna connector not being under test shall be terminated.

7.8.5 Test requirements

The test requirements are in TS 36.141 [9], clause 7.4.5 and in TS 38.141-1 [26], clause 7.8.5.

8 Performance requirements

Void

Annex A (normative): Characteristics of interfering signals

A.1 UTRA FDD interfering signal

The UTRA FDD interfering signal shall be a DPCH containing the DPCCH and one DPDCH. The data content for each channelization code shall be uncorrelated with each other and to the wanted signal and spread and modulated according to clause 4 of TS 25.213. Further characteristics of DPDCH and DPCCH are specified in Table A.1-1.

Table A.1-1: Characteristics of UTRA FDD interfering signal

Channel	Bit Rate	Spreading Factor	Channelization Code	Relative Power
DPDCH	240 kbps	16	4	0 dB
DPCCH	15 kbps	256	0	-5.46 dB
NOTE: The DPDCH and DPCCH settings are chosen to simulate a signal with realistic Peak to Average Ratio.				

A.2 UTRA TDD interfering signal

The UTRA TDD interfering signal shall be 1.28 Mcps UTRA TDD signal with one code. The data content shall be uncorrelated to the wanted signal. They are specified in Table A.2-1.

Table A.2-1: Characteristics of UTRA TDD interfering signal

UTRA TDD option	Type of Interfering Signal
1.28 Mcps UTRA TDD	1,28 Mcps UTRA TDD signal with one code*
* NOTE: The channelisation code ID and Midamble shift shall be different with the wanted signal's.	

A.3 E-UTRA interfering signal

The E-UTRA interfering signal shall be a PUSCH containing data and reference symbols. Normal CP is used. The data content shall be uncorrelated to the wanted signal and modulated according to clause 5 of TS 36.211. Mapping of PUSCH modulation to receiver requirement are specified in Table A.3-1.

Table A.3-1: Modulation of the E-UTRA interfering signal

Receiver requirement	Modulation
Narrowband blocking	QPSK
Receiver intermodulation	QPSK

Annex B (normative): Environmental requirements for the BS equipment

B.1 General

For each test in the present document, the environmental conditions under which the BS is to be tested are defined. The environmental conditions and class shall be from the relevant IEC specifications or the corresponding ETSI specifications.

B.2 Normal test environment

When a normal test environment is specified for a test, the test should be performed within the minimum and maximum limits of the conditions stated in Table B.1.

Table B.1: Limits of conditions for Normal Test Environment

Condition	Minimum	Maximum
Barometric pressure	86 kPa	106 kPa
Temperature	15°C	30°C
Relative Humidity	20 %	85 %
Power supply	Nominal, as declared by the manufacturer	
Vibration	Negligible	

The ranges of barometric pressure, temperature and humidity represent the maximum variation expected in the uncontrolled environment of a test laboratory. If it is not possible to maintain these parameters within the specified limits, the actual values shall be recorded in the test report.

B.3 Extreme test environment

The manufacturer shall declare one of the following:

- 1) The equipment class for the equipment under test, as defined in the IEC 60721-3-3 [17] or ETSI EN 300 019-1-3 [19] ("Stationary use at weather protected locations");
- 2) The equipment class for the equipment under test, as defined in the IEC 60721-3-4 [18] or ETSI EN 300 019-1-4 [20] ("Stationary use at non weather protected locations");
- 3) The equipment that does not comply to the mentioned classes, the relevant classes from IEC 60721 [16] documentation for Temperature, Humidity and Vibration shall be declared.

NOTE: Reduced functionality for conditions that fall out side of the standard operational conditions are not tested in the present document. These may be stated and tested separately.

B.3.1 Extreme temperature

When an extreme temperature test environment is specified for a test, the test shall be performed at the standard minimum and maximum operating temperatures defined by the manufacturer's declaration for the equipment under test.

Minimum temperature:

The test shall be performed with the environment test equipment and methods including the required environmental phenomena into the equipment, conforming to the test procedure of IEC 60068-2-1 [21].

Maximum temperature:

The test shall be performed with the environmental test equipment and methods including the required environmental phenomena into the equipment, conforming to the test procedure of IEC 60068-2-2 [22].

NOTE: It is recommended that the equipment is made fully operational prior to the equipment being taken to its lower operating temperature.

B.4 Vibration

When vibration conditions are specified for a test, the test shall be performed while the equipment is subjected to a vibration sequence as defined by the manufacturer's declaration for the equipment under test. This shall use the environmental test equipment and methods of inducing the required environmental phenomena in to the equipment, conforming to the test procedure of IEC 60068-2-6 [23]. Other environmental conditions shall be within the ranges specified in clause B.2.

NOTE: The higher levels of vibration may induce undue physical stress in to equipment after a prolonged series of tests. The testing body should only vibrate the equipment during the RF measurement process.

B.5 Power supply

When extreme power supply conditions are specified for a test, the test shall be performed at the standard upper and lower limits of operating voltage defined by manufacturer's declaration for the equipment under test.

Upper voltage limit:

The equipment shall be supplied with a voltage equal to the upper limit declared by the manufacturer (as measured at the input terminals to the equipment). The tests shall be carried out at the steady state minimum and maximum temperature limits declared by the manufacturer for the equipment, to the methods described in IEC 60068-2-1 [21] Test Ab/Ad and IEC 60068-2-2 [22] Test Bb/Bd: Dry Heat.

Lower voltage limit:

The equipment shall be supplied with a voltage equal to the lower limit declared by the manufacturer (as measured at the input terminals to the equipment). The tests shall be carried out at the steady state minimum and maximum temperature limits declared by the manufacturer for the equipment, to the methods described in IEC 60068-2-1 [21] Test Ab/Ad and IEC 60068-2-2 [22] Test Bb/Bd: Dry Heat.

B.6 Measurement of test environments

The measurement accuracy of the BS test environments shall be.

Pressure:	±5 kPa.
Temperature:	±2 degrees.
Relative Humidity:	±5 %.
DC Voltage:	±1,0 %.
AC Voltage:	±1,5 %.
Vibration:	10 %.
Vibration frequency:	0,1 Hz.

The above values shall apply unless the test environment is otherwise controlled and the specification for the control of the test environment specifies the uncertainty for the parameter.

Annex C (informative): Test Tolerances and Derivation of test requirements

The test requirements explicitly defined in this specification have been calculated by relaxing the minimum requirements of the core specification using the Test Tolerances defined here. When the Test Tolerance is zero, the test requirement will be the same as the minimum requirement. When the Test Tolerance is non-zero, the test requirements will differ from the minimum requirements, and the formula used for this relaxation is given in the following tables.

Test requirements which are included by reference to TS 25.141 [10], TS 25.142[12], TS 36.141[9] or TS 51.021[11] have been calculated within the referred test specification using the Test Tolerances defined therein.

The Test Tolerances are derived from Test System uncertainties, regulatory requirements and criticality to system performance. As a result, the Test Tolerances may sometimes be set to zero.

The test tolerances should not be modified for any reason e.g. to take account of commonly known test system errors (such as mismatch, cable loss, etc.).

Note that a formula for applying Test Tolerances is provided for all tests, even those with a test tolerance of zero. This is necessary in the case where the Test System uncertainty is greater than that allowed in clause 4.1.2. In this event, the excess error shall be subtracted from the defined test tolerance in order to generate the correct tightened test requirements as defined in this Annex.

Unless otherwise stated, the uncertainties in clause 4.1.2 apply to the Test System for testing E-UTRA, UTRA, GSM/EDGE and NB-IoT MSR BS.

C.1 Measurement of transmitter

Table C.1-1: Derivation of test requirements (Transmitter tests)

Test	Minimum requirement in TS 37.104	Test Tolerance (TT)	Test requirement
6.2.1 Base Station maximum output power	<p>UTRA, E-UTRA and NR In normal conditions: within ± 2 dB of manufacturer's rated output power</p> <p>In extreme conditions: within ± 2.5 dB of manufacturer's rated output power</p> <p>GSM/EDGE or standalone NB-IoT In normal conditions: within ± 2 dB of manufacturer's rated output power</p> <p>In extreme conditions: within ± 2.5 dB of manufacturer's rated output power</p>	<p>0.7 dB, $f \leq 3.0$ GHz</p> <p>1.0 dB, 3.0 GHz $< f \leq 4.2$ GHz</p> <p>0.7 dB, $f \leq 3.0$ GHz</p> <p>1.0 dB, 3.0 GHz $< f \leq 4.2$ GHz</p> <p>1.0 dB</p> <p>1.0 dB</p>	<p>Formula: Upper limit + TT, Lower limit - TT</p> <p>In normal conditions: within +2.7 dB and -2.7 dB of the manufacturer's rated output power, $f \leq 3.0$ GHz; within +3 dB and -3 dB of the manufacturer's rated output power, 3.0 GHz $< f \leq 4.2$ GHz</p> <p>In extreme conditions: within +3.2 dB and -3.2 dB of the manufacturer's rated output power, $f \leq 3.0$ GHz; within +3.5 dB and -3.5 dB of the manufacturer's rated output power, 3.0 GHz $< f \leq 4.2$ GHz</p> <p>In normal conditions: within +3.0 dB and -3.0 dB of the manufacturer's rated output power</p> <p>In extreme conditions: within +3.5 dB and -3.5 dB of the manufacturer's rated output power</p>
6.4 Transmit ON/OFF power	-85 dBm/MHz.	<p>2 dB, $f \leq 3.0$GHz</p> <p>2.5 dB, 3.0GHz $< f \leq 4.2$GHz</p>	Formula: Minimum Requirement + TT
6.6.1.5.1 Transmitter spurious emissions, Mandatory Requirements	Maximum level defined in Table 6.6.1.1.1-1 of TS 37.104 [2].	0 dB	Formula: Minimum Requirement + TT
6.6.1.5.2 Transmitter spurious emissions, Mandatory Requirements	Maximum level defined in Table 6.6.1.1.2-1 of TS 37.104 [2].	0 dB	Formula: Minimum Requirement + TT
6.6.1.5.3 Transmitter spurious emissions, Additional BC2 Requirement	Maximum level defined in Table 6.6.1.1.3-1 of TS 37.104 [2].	0 dB	Formula: Minimum Requirement + TT
6.6.1.5.4 Transmitter spurious emissions, Protection of BS receiver	Maximum level defined in Table 6.6.1.2.1-1 of TS 37.104 [2].	0 dB	Formula: Minimum Requirement + TT
6.6.1.5.5 Transmitter spurious emissions, Additional spurious emission requirements	Maximum level defined in Tables 6.6.1.3.1-1 and 6.6.1.3.1-2 of TS 37.104 [2].	0 dB	Formula: Minimum Requirement + TT
6.6.1.5.6 Transmitter spurious emissions, Co-location	Maximum level defined in Table 6.6.1.4.1-1 of TS 37.104 [2].	0 dB	Formula: Minimum Requirement + TT

<p>6.6.2 Operating band unwanted emissions</p>	<p><u>For BC1 and BC2:</u></p> <p>Offset < 1 MHz -14dBm/30kHz to -26dBm/30kHz</p> <p>1 MHz ≤ Offset <10 MHz -13 dBm/1 MHz</p> <p>10 MHz ≤ Offsets -15 dBm/1 MHz</p> <p><u>For BC1 with adjacent standalone NB-IoT carriers:</u></p> <p>Offset < 0.05 MHz 2 dBm/30kHz to 5 dBm/30 kHz</p> <p>0.05 MHz ≤ Offset -14 dBm/30kHz to 2 dBm/30 kHz</p> <p><u>For BC2 with adjacent GSM/EDGE or standalone NB-IoT or E-UTRA 1.4 and 3 MHz carriers:</u></p> <p>Offset < 0.05 MHz 2 dBm/30kHz to 5 dBm/30 kHz</p> <p>0.05 MHz ≤ Offset -14 dBm/30kHz to 2 dBm/30 kHz</p>	<p>1.5 dB, f ≤ 3.0 GHz 1.8 dB, 3.0 GHz < f ≤ 4.2 GHz</p> <p>1.5 dB, f ≤ 3.0 GHz 1.8 dB, 3.0 GHz < f ≤ 4.2 GHz</p> <p>0 dB</p> <p>1.5 dB</p> <p>1.5 dB</p> <p>1.5 dB</p> <p>1.5 dB</p>	<p>Formula: Minimum requirement + TT</p> <p>-12.5 dBm/30kHz to -24.5 dBm/30kHz, f ≤ 3.0 GHz; -12.2 dBm/30kHz to -24.2 dBm/30kHz, 3.0 GHz < f ≤ 4.2 GHz</p> <p>-11.5 dBm/1 MHz, f ≤ 3.0 GHz; -11.2 dBm/1 MHz, 3.0 GHz < f ≤ 4.2 GHz</p> <p>-15 dBm/1 MHz</p> <p>3.5 dBm/30kHz to 6.5 dBm/30 kHz</p> <p>-12.5 dBm/30kHz to 3.5 dBm/30 kHz</p> <p>3.5 dBm/30kHz to 6.5 dBm/30 kHz</p> <p>-12.5 dBm/30kHz to 3.5 dBm/30 kHz</p>
<p>6.6.3 Occupied bandwidth</p>	<p>BW_{Channel} for E-UTRA and NR 5 MHz for UTRA FDD 1.6 MHz for UTRA TDD 200 kHz for standalone NB-IoT</p>	<p>0 kHz</p>	<p>Formula: Minimum Requirement + TT</p>
<p>6.6.4 Adjacent Channel Leakage Power Ratio (ACLR)</p>	<p>Paired spectrum ACLR: 45 dB for E-UTRA</p> <p>Standalone NB-IoT: 40 dB (ACLR1) 50 dB (ACLR2)</p> <p>Unpaired spectrum ACLR: 45 dB for E-UTRA and NR</p> <p>CACLR: 45 dB for E-UTRA and NR 45 dB for UTRA</p> <p>Absolute limit -13 dBm/MHz Absolute limit -15 dBm/MHz</p>	<p>0.8 dB</p> <p>0.8 dB 0.8 dB</p> <p>0.8 dB</p> <p>0.8 dB 0.8 dB</p> <p>0 dB 0 dB</p>	<p>Formula: ACLR Minimum Requirement - TT Absolute limit +TT</p> <p>Paired spectrum ACLR: 44.2 dB</p> <p>Standalone NB-IoT: 39.2 dB (ACLR1) 49.2 dB (ACLR2) Unpaired spectrum ACLR: 44.2 dB</p> <p>CACLR Minimum Requirement - TT 44.2 dB 44.2 dB</p> <p>Absolute limit -13 dBm/MHz Absolute limit -15 dBm/MHz</p>

6.7 Transmitter intermodulation (interferer requirements) This tolerance applies to the stimulus and not the measurements defined in 6.6.1, 6.6.2 and 6.6.4.	Wanted signal level - interferer level = 30 dB	0 dB	Formula: Ratio + TT Wanted signal level - interferer level = 30 + 0 dB
---	--	------	---

C.2 Measurement of receiver

Table C.2-1: Derivation of test requirements (Receiver tests)

Test	Minimum Requirement in TS 37.104	Test Tolerance (TT)	Test Requirement
7.4.5.1 In-band selectivity and blocking, General blocking requirement	<p>Wanted Signal mean power = $P_{\text{PREFSENS}} + x$ dB, where x is equal to 6 in case of E-UTRA or UTRA or NB-IoT or NR and equal to 3 in case of GSM/EDGE.</p> <p>Interferer signal mean power: -40 dBm.</p>	0 dB	<p>Formula: Wanted signal power + TT.</p> <p>Interferer signal power unchanged.</p>
7.4.5.2 In-band selectivity and blocking, General narrowband blocking requirement	<p>Wanted Signal mean power = $P_{\text{PREFSENS}} + x$ dB, where x is equal to 6 in case of NR or E-UTRA or UTRA and equal to 3 in case of GSM/EDGE, and equal to the following in case of NB-IoT.</p> <p>For in-band NB-IoT, 1.4 MHz and 3 MHz BW: $X = 11$ For in-band NB-IoT, 5 MHz BW: $X = 9$ For in-band NB-IoT, 10MHz, 15MHz and 20MHz BW: $X = 6$ For guard-band NB-IoT, 5 MHz BW: $X = 13$ For guard-band NB-IoT, 10MHz, 15MHz and 20MHz BW: $X = 6$ For standalone NB-IoT, 200 kHz BW: $X = 12$</p> <p>Interferer signal mean power: -49 dBm.</p>	0 dB	<p>Formula: Wanted signal power + TT.</p> <p>Interferer signal power unchanged.</p>
7.4.5.5 In-band selectivity and blocking, Additional BC3 requirement	<p>Wanted Signal mean power = $P_{\text{PREFSENS}} + x$ dB, where x is equal to 6 in case of NR or E-UTRA or UTRA [or NB-IoT].</p> <p>Interferer signal mean power: -40 dBm.</p>	0 dB	<p>Formula: Wanted signal power + TT.</p> <p>Interferer signal power unchanged.</p>
7.5.5.1 Out-of-band blocking, General requirement	<p>Wanted Signal mean power = $P_{\text{PREFSENS}} + x$ dB, where x is equal to 6 in case of NR or E-UTRA or UTRA or NB-IoT and equal to 3 in case of GSM/EDGE.</p> <p>Interferer signal mean power: -15 dBm.</p>	0 dB	<p>Formula: Wanted signal power + TT.</p> <p>Interferer signal power unchanged.</p>
7.5.5.2 Out-of-band blocking, Co-location	<p>Wanted Signal mean power = $P_{\text{PREFSENS}} + x$ dB, where x is equal to 6 in case of NR or E-UTRA or UTRA or NB-IoT and equal to 3 in case of GSM/EDGE.</p> <p>Interferer signal mean power: +16 dBm.</p>	0 dB	<p>Formula: Wanted signal power + TT.</p> <p>Interferer signal power unchanged.</p>

7.6.5 Receiver spurious emissions	Maximum level defined in Tables 7.6.5.1-1 and 7.6.5.2-1 of TS 37.104 [2].	0 dB	Formula: Maximum level + TT
7.7.5.1 Receiver intermodulation, General requirement	Wanted Signal mean power = $P_{\text{REFSENS}} + x$ dB, where x is equal to 6 in case of NR or E-UTRA or UTRA or NB-IoT and equal to 3 in case of GSM/EDGE. Interferer signal mean power: -48 dBm.	0 dB	Formula: Wanted signal mean power + TT. CW interferer signal power unchanged. Modulated interferer signal power unchanged.
7.7.5.2 Receiver intermodulation, General narrowband requirement	Wanted Signal mean power = $P_{\text{REFSENS}} + x$ dB, where x is equal to 6 in case of NR or E-UTRA or UTRA or NB-IoT and equal to 3 in case of GSM/EDGE. Interferer signal mean power: -52 dBm.	0 dB	Formula: Wanted signal mean power + TT. CW interferer signal power unchanged. Modulated interferer signal power unchanged.

Annex D (informative): Measurement system set-up

Example of measurement system set-ups are attached below as an informative annex.

D.1 Transmitter

D.1.1 Base station output power, transmitter ON/OFF power, modulation quality, transmitter spurious emissions and operating band unwanted emissions

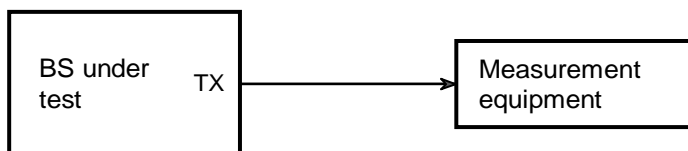

Figure D.1-1: Measuring system set-up for base station output power, transmitter ON/OFF power, modulation quality, transmitter spurious emissions and operating band unwanted emissions

D.1.2 Transmitter intermodulation

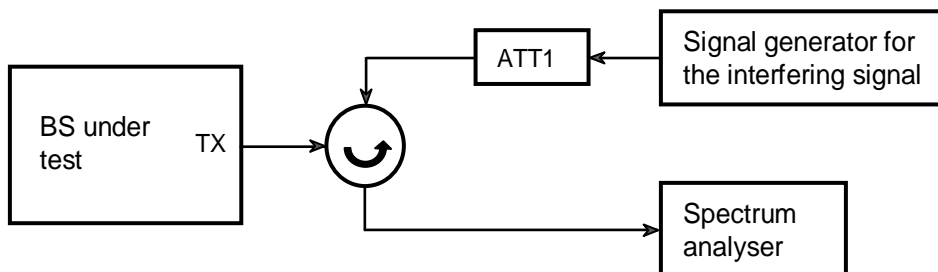

Figure D.1-2: Measuring system set-up for transmitter intermodulation

D.2 Receiver

D.2.1 Blocking characteristics

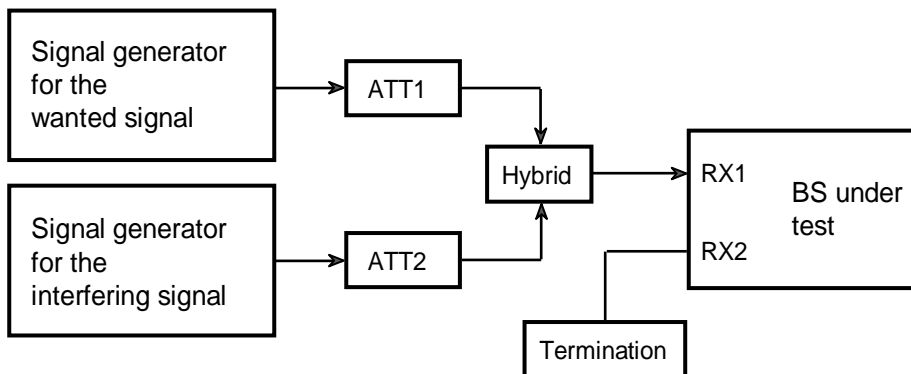

Figure D.2-1: Measuring system set-up for blocking characteristics

D.2.2 Receiver spurious emissions

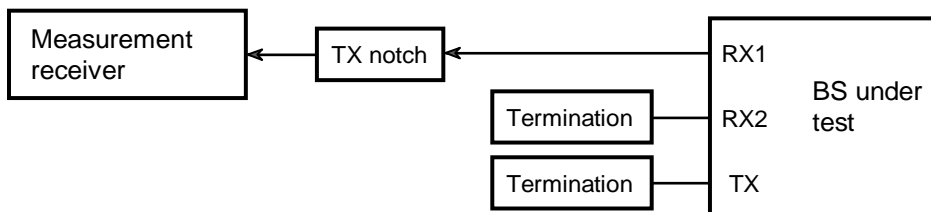

Figure D.2-2: Measuring system set-up for receiver spurious emissions

D.2.3 Receiver intermodulation

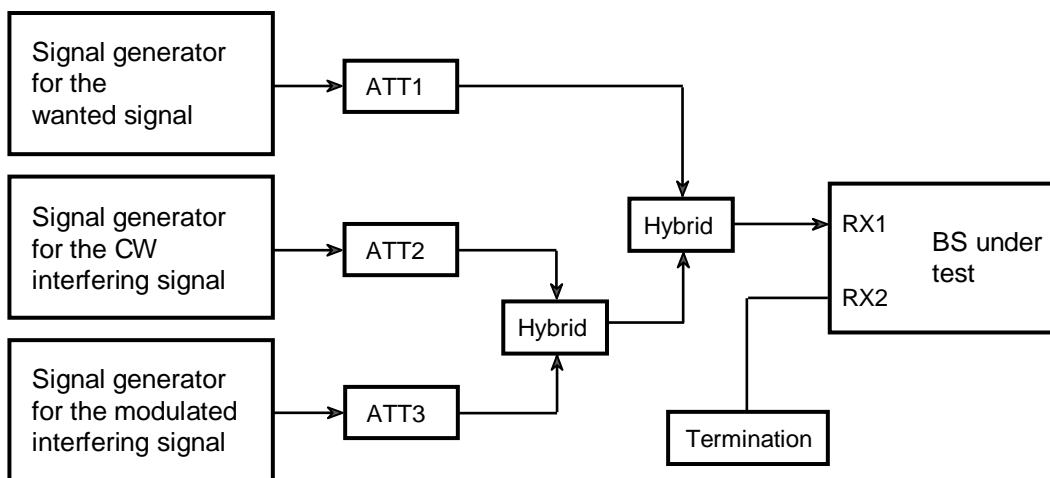

Figure D.2-3: Measuring system set-up for receiver intermodulation

Annex E (normative): E-UTRA Test model for BC3 CS3 BS

E.0 BC3 CS3 Test model description

The set-up of physical channels for E-UTRA TDD in part of BC3 CS3, BC3 CS16 and BC3 CS17 (and CS2 when NB-IoT in-band and/or guard band is supported) BS transmitter tests shall be according to the applicable test models shown below. A detailed reference to the applicable test model is made in clause 4.9.2.

The parameters in 36.141 clause 6.1.1 shall be reused by the test models in E.1 to E.6 (E.2 shall not be used for BC3 CS2 BS testing when NB-IoT in-band and/or guard band is supported) with the following exceptions,

- Duration is 30 subframes (30ms), e.g. number of frames for the test model is 3.
- Uplink/downlink configuration 1 and special subframe configuration 7 shall be used as shown in table E-1.

Table E-1: Configurations

Downlink-to-Uplink Switch-point periodicity	Number of UL/DL subframes per half frame (10 ms)		DwPTS	GP	UpPTS
	DL	UL			
a) 5ms	a) 2	a) 2	a) $21952 \cdot T_s$	$4384 \cdot T_s$	$4384 \cdot T_s$

The test models in E.1 to E.6 shall be constructed based on the corresponding test model in 36.141 along with the principles on data mapping between the test models in E.1 to E.6 and the test models in 36.141 Clause 6.1.1.1 to 6.1.1.6 as shown in Table E-2.

Table E-2: Numbers (n_{PRB}) of the boosted PRBs

Frame1	Subframe 0	Subframe 1	Subframe 4	Subframe 5	Subframe 6	Subframe 9
Note	NOTE 1	NOTE 1	NOTE 2	NOTE 1	NOTE 3	NOTE 1

Frame2	Subframe 0	Subframe 1	Subframe 4	Subframe 5	Subframe 6	Subframe 9
Note	NOTE 1	NOTE 1	NOTE 4	NOTE 1	NOTE 3	NOTE 1

Frame3	Subframe 0	Subframe 1	Subframe 4	Subframe 5	Subframe 6	Subframe 9
Note	NOTE 5	NOTE 3	NOTE 6	NOTE 7	NOTE 3	NOTE 8

NOTE 1: The data in this subframe shall re-use the same data as specified in the corresponding subframe of the corresponding test models in 36.141 clause 6.1.1.

NOTE 2: The data in this subframe shall re-use the same data as specified in subframe 7 of Frame 1 in the corresponding test model in 36.141 clause 6.1.1.

NOTE 3: The data in this subframe shall re-use the same data as specified in subframe 1 of Frame 1 in the corresponding test model in 36.141 clause 6.1.1.

NOTE 4: The data in this subframe shall re-use the same data as specified in subframe 8 of Frame 1 in the corresponding test model in 36.141 clause 6.1.1.

NOTE 5: The data in this subframe shall re-use the same data as specified in subframe 7 of Frame 2 in the corresponding test model in 36.141 clause 6.1.1.

NOTE 6: The data in this subframe shall re-use the same data as specified in subframe 8 of Frame 2 in the corresponding test model in 36.141 clause 6.1.1.

NOTE 7: The data in this subframe shall re-use the same data as specified in subframe 6 of Frame 1 in the corresponding test model in 36.141 clause 6.1.1.

NOTE 8: The data in this subframe shall re-use the same data as specified in subframe 6 of Frame 2 in the corresponding test model in 36.141 clause 6.1.1.

E.0A BC3 CS16/17 Test model description

The set-up of physical channels for NR TDD in part of BC3 CS16/17 BS transmitter tests shall be according to the applicable test models shown below. A detailed reference to the applicable test model is made in clause 4.9.2.

The parameters in TS 38.141-1 [26] clause 4.9.2.2 shall be reused by the test models in E.1A to E.6A with the following exceptions:

- Duration is 3 radio frames (30ms).

Table E.0A-1: Configurations

Field name	15 kHz SCS	30 kHz SCS	60 kHz SCS
<i>Tdd-UL-DL-Configuration</i>			
<i>referenceSubcarrierSpacing</i>	15	30	60
Periodicity (ms) for <i>dl-UL-TransmissionPeriodicity</i>	5	5	5
<i>nrofDownlinkSlots</i>	1	2	4
<i>nrofDownlinkSymbols</i>	0	0	0
<i>nrofUplinkSlots</i>	0	0	0
<i>nrofUplinkSymbols</i>	0	0	0
<i>Tdd-UL-DL-ConfigDedicated</i>			
<i>nrofDownlinkSymbols</i>	For Slot#1: 10	For Slot#3: 6	For Slot#6:12 For Slot#7:0
<i>nrofUplinkSymbols</i>	For Slot#1: 2	For Slot#3: 4	For Slot#6:0 For Slot#7:8
<i>slotIndex</i>	1	3	6,7
<i>nrofDownlinkSymbols</i>	10	6	12,0
<i>nrofUplinkSymbols</i>	2	4	0,8
<i>slotIndex</i>	2,3	4,5,6,7	8,9,10,11,12, 13,14,15
<i>symbols</i>	allUplink	allUplink	allUplink
<i>slotIndex</i>	4	2,8,9	4,5,16,17,18, 19
<i>symbols</i>	allDownlink	allDownlink	allDownlink

The test models in E.1a to E.6a shall be constructed based on the corresponding test model in TS 38.141-1 [26].

E.1 E-UTRA Test Model 1.1 (E-TM1.1_BC3CS3)

This test model shall be constructed based on E-TM1.1 in TS 36.141 [9] clause 6.1.1.1 according to the data mapping principals elaborated in Table E-2.

E.1A NR FR1 Test Model 1.1 (NR-FR1-TM1.1_BC3CS16/17)

This test model shall be constructed based on NR-FR1-TM1.1 in TS 38.141-1 [26] clause 4.9.2.2.1.

E.2 E-UTRA Test Model 1.2 (E-TM1.2_BC3CS3)

This test model shall be constructed based on E-TM1.2 in TS 36.141 [9] clause 6.1.1.2 according to the data mapping principles elaborated in Table E-2.

This Test Model shall not be used when testing for BC3 CS2 BS and when NB-IoT in-band and/or guard band is supported.

E.2A NR FR1 Test Model 1.2 (NR-FR1-TM1.2_BC3CS16/17)

This test model shall be constructed based on NR-FR1-TM1.2 in TS 38.141-1 [26] clause 4.9.2.2.2.

E.3 E-UTRA Test Model 2 (E-TM2_BC3CS3)

This test model shall be constructed based on E-TM2 in TS 36.141 [9] clause 6.1.1.3 according to the data mapping principles elaborated in Table E-2.

E.3A NR FR1 Test Model 2 (NR-FR1-TM2_BC3CS16/17)

This test model shall be constructed based on NR-FR1-TM2 in TS 38.141-1 [26] clause 4.9.2.2.3.

E.3B NR FR1 Test Model 2a (NR-FR1-TM2a_BC3CS16/17)

This test model shall be constructed based on NR-FR1-TM2a in TS 38.141-1 [26] clause 4.9.2.2.4.

E.3C E-UTRA Test Model 2a (E-TM2a_BC3CS3)

This test model shall be constructed based on E-TM2a in TS 36.141 [9] clause 6.1.1.3a according to the data mapping principles elaborated in Table E-2.

E.3D E-UTRA Test Model 2b (E-TM2b_BC3CS3)

This test model shall be constructed based on E-TM2b in TS 36.141 [9] clause 6.1.1.3b according to the data mapping principles elaborated in Table E-2.

E.4 E-UTRA Test Model 3.1 (E-TM3.1_BC3CS3)

This test model shall be constructed based on E-TM 3.1 in TS 36.141 [9] clause 6.1.1.4 according to the data mapping principles elaborated in Table E-2.

E.4Y E-UTRA Test Model 3.1a (E-TM3.1a_BC3CS3)

This test model shall be constructed based on E-TM3.1a in TS 36.141 [9] clause 6.1.1.4a according to the data mapping principles elaborated in Table E-2.

E.4Z E-UTRA Test Model 3.1b (E-TM3.1b_BC3CS3)

This test model shall be constructed based on E-TM3.1b in TS 36.141 [9] clause 6.1.1.4b according to the data mapping principles elaborated in Table E-2.

E.4ZA NR Test Model 3.1a (NR-FR1-TM3.1a_BC3CS16/17)

This test model shall be constructed based on NR-FR1-TM3.1a in TS 38.141-1 [26] clause 4.9.2.2.6.

E.4A NR FR1 Test Model 3.1 (NR-FR1-TM3.1_BC3CS16/17)

This test model shall be constructed based on NR-FR1-TM3.1 in TS 38.141-1 [26] clause 4.9.2.2.5.

E.5 E-UTRA Test Model 3.2 (E-TM3.2_BC3CS3)

This test model shall be constructed based on E-TM3.2 in TS 36.141 [9] clause 6.1.1.5 according to the data mapping principles elaborated in Table E-2.

E.5A NR FR1 Test Model 3.2 (NR-FR1-TM3.2_BC3CS16/17)

This test model shall be constructed based on NR-FR1-TM3.2 in TS 38.141-1 [26] clause 4.9.2.2.7.

E.6 E-UTRA Test Model 3.3 (E-TM3.3_BC3CS3)

This test model shall be constructed based on E-TM3.3 in TS 36.141 [9] clause 6.1.1.6 according to the data mapping principles elaborated in Table E-2.

E.6A NR FR1 Test Model 3.3 (NR-FR1-TM3.3_BC3CS16/17)

This test model shall be constructed based on NR-FR1-TM3.3 in TS 38.141-1 [26] clause 4.9.2.2.8.

Annex F (informative): Change history

Change history							
Date	Meeting	TDoc	CR	Rev	Cat	Subject/Comment	New version
2009-10	R4#52bis	R4-093772				Specification skeleton created from 3GPP TS template	0.0.1
2009-11	R4#53	R4-094778				Agreed Text Proposals in RAN4#53: R4-094507 , "TP for TS 37.141 clause 2 and 3." R4-094805 , "TP for TS 37.141 clause 4.11; BS Configurations. " R4-094871 , "TP for TS 37.141 clause 4.1, 4.2, 4.3, 4.4 and 4.5." R4-094872 , "TP for TS 37.141 Annex C; Test Tolerances and derivation of test requirements. "	0.1.0
2010-02	R4#54	R4-100579				Agreed Text Proposals in RAN4 AH#1: R4-100026 , "TP for TS37.141: Format and interpretation of tests" R4-100028 , "TP for TS37.141: Selection of configurations for testing" R4-100241 , "TP for TS 37.141 clause 2, 3 and 4."	0.2.0
2010-02	R4#54	R4-100975				Agreed Text Proposals in RAN4#54: R4-100405 , "TP for TS37.141: Manufacturers declarations of regional and optional requirements" R4-100863 , "TP Manufacturers declaration of supported RF configurations for clause 4.7" R4-100986 , "TP for TS 37.141 clause 6.6.1; Transmitter spurious emissions" R4-101036 , "TP MSR test configurations for clause 4.8"	0.3.0
2010-04	R4#55	R4-101576				Agreed Text Proposals in RAN4 AH#2 and E-mail approved Text Proposals after RAN4 AH#2: R4-101186 , "TP for TS 37.141 clause 6.6.4; Adjacent Channel Leakage power Ratio (ACLR)" R4-101207 , "TP for manufacturers declaration, clause 4.7.2" R4-101208 , "TP TDD test configurations, clause 4.8" R4-101510 , "TP for requirements and test configuration applicability, clause 5.1" R4-101511 , "TP for requirements and test configuration applicability, clause 5.2" R4-101512 , "TP for capability set, clause 4.7.1" R4-101514 , "TP for update of Transmitter spurious emissions test in TS 37.141" R4-101515 , "TP for TS 37.141 clause 6.7; Transmitter intermodulation" R4-101520 , "Text proposal for 37.141 on B, M and T channels definition" R4-101521 , "TP for TS 37.141, clause 7.2 MSR Receiver reference sensitivity level" R4-101522 , "TP for TS 37.141 clause 7.3; Dynamic range" R4-101523 , "TP for TS 37.141 clause 6.6.2; Operating band unwanted emissions" R4-101524 , "TP for TS 37.141, clause 7.4 MSR Receiver in-band selectivity and blocking" R4-101525 , "TP for TS 37.141, clause 7.5 MSR Receiver out-of-band-blocking" R4-101526 , "TP for TS 37.141, clause 7.6 MSR Receiver spurious emissions" R4-101527 , "TP for TS 37.141, clause 7.7 MSR Receiver intermodulation" R4-101528 , "TP for TS 37.141, clause 7.8 MSR Receiver in-channel selectivity" R4-101542 , "TP for TS 37.141 clause 6.6.3: Occupied bandwidth"	0.4.0

2010-05	R4#55	R4-102216				Agreed Text Proposals in RAN4#54: R4-101882 , "TP for TS 37.141; Transmitter Test uncertainties" R4-101884 , "TP for TS 37.141; clause 4.4 Operating band update" R4-101885 , "TP for TS 37.141; Adding missing text in clause 4.11.5 and 4.11.7" R4-102058 , "Corrections for clause 4.1" R4-102059 , "Corrections for Annex C" R4-102060 , "Corrections for clauses 4.9, 4.10" R4-102061 , "Corrections for clauses 4.11, 4.12" R4-102062 , "Corrections for clause 5" R4-102086 , "Corrections to clause 7.1" R4-102087 , "Corrections to clause 7.2" R4-102088 , "Corrections to clause 7.3" R4-102093 , "Corrections to clause 7.8" R4-102096 , "TS 37.141: TP for Co-existence with services in adjacent frequency bands" R4-102129 , "Spurious emissions limits and blocking requirements for coexistence with CDMA850" R4-102173 , "TP for TS 37.141; clause 4.3 Regional Requirements" R4-102245 , "TP for TS 37.141 clause 6.5.3; Time alignment between transmitter branches" R4-102249 , "Corrections to clause 7.4" R4-102250 , "Corrections to clause 7.5" R4-102251 , "Corrections to clause 7.6" R4-102252 , "Corrections to clause 7.7" R4-102273 , "TP for TS 37.141; Clause 6.2 BS output power" R4-102274 , "TP for Clause 4.9.2" R4-102275 , "Corrections for clause 6.6.1" R4-102276 , "Corrections for clause 6.6.2" R4-102277 , "Corrections for clause 6.6.3" R4-102278 , "Corrections for clause 6.6.4" R4-102282 , "Corrections for clause 4.8" R4-102279 , "TP for TS 37.141; Clause 6.7 Tx IM clarification"	0.5.0
2010-06	RP#48	RP-100580				Presentation to TSG RAN plenary.	1.0.0
2010-06	RP#48	RP-100580				Approved by TSG RAN plenary.	9.0.0
2010-09	RP-49	RP-100923	002	1		Clarifications on Base Station transmit and receive configurations	9.1.0
2010-09	RP-49	RP-100923	003	2		Annex B: Environmental conditions	9.1.0
2010-09	RP-49	RP-100923	006			Adding transmitter test tolerances	9.1.0
2010-09	RP-49	RP-100923	008			Adding test System Uncertainty for transmitter spurious emission tests	9.1.0
2010-09	RP-49	RP-100923	009	1		Correction of the Ancillary RF Amplifiers references and references to Annex A, B and D	9.1.0
2010-09	RP-49	RP-100923	010			Update of the Transmitter characteristics General clause	9.1.0
2010-09	RP-49	RP-100923	013	1		Adding Modulation quality and Frequency error test cases	9.1.0
2010-09	RP-49	RP-100923	014			Correction of the NOTES in the transmitter intermodulation procedure	9.1.0
2010-09	RP-49	RP-100923	015			Characteristics of interfering signals	9.1.0
2010-09	RP-49	RP-100923	021	1		Test configuration and power allocation completion	9.1.0
2010-09	RP-49	RP-100923	023			TS 37.141 Clause 6.3; Output power dynamics	9.1.0
2010-09	RP-49	RP-100923	024			General corrections for the MSR test specification	9.1.0
2010-09	RP-49	RP-100923	025			Maximum Test system Uncertainty for Occupied bandwidth and Transmitter intermodulation	9.1.0
2010-09	RP-49	RP-100923	026	1		Adding test tolerances and test system uncertainty for receiver spurious emissions tests	9.1.0
2010-09	RP-49	RP-100923	027	1		Measurement set-ups for transmitter and receiver tests	9.1.0

2010-09	RP-49	RP-100923	028			Modification on testing of time mask of BC3 base station	9.1.0
2010-09	RP-49	RP-100928	022			CR LTE_TDD_2600_US spectrum band definition additions to TS 37.141	10.0.0
2010-12	RP-50	RP-101345	036			Band XII/12 frequency range	10.1.0
2010-12	RP-50	RP-101346	032			Adding missing Test System Uncertainty for the receiver tests	10.1.0
2010-12	RP-50	RP-101346	034			TS 37.141 Clause 7.7; Receiver intermodulation	10.1.0
2010-12	RP-50	RP-101356	029	4		Band 42 and 43 parameters for UMTS/LTE 3500 (TDD) for TS 37.141	10.1.0
2010-12	RP-50	RP-101361	030			Protection of E-UTRA Band 24	10.1.0
2011-04	RP-51	RP-110344	039	1		Receiver intermodulation reference correction	10.2.0
2011-04	RP-51	RP-110352	043	1		Correction of the test port description for TS 37.141 Rel-10	10.2.0
2011-04	RP-51	RP-110357	044	-		Band 42 and 43 co-existence for UMTS/LTE 3500 (TDD) for TS 37.141	10.2.0
2011-06	RP-52	RP-110814	051			Fixing Band 24 inclusion in TS 37.141	10.3.0
2011-06	RP-52	RP-110794	053			Modifications to Band 3 to allow LTE Band 3 operation in Japan (Rel-10 TS37.141 CR)	10.3.0
2011-06	RP-52	RP-110804	054			Add Expanded 1900MHz band in 37.141	10.3.0
2011-06	RP-52	RP-110794	058			Correction of RX spurious emissions for non-GSM/EDGE configurations	10.3.0
2011-06	RP-52	RP-110802	063			Co-existence/co-location between Band 42 and 43 in TS 37.141	10.3.0
2011-06	RP-52	RP-110794	073	1		Correction for TS 37.141	10.3.0
2011-06	RP-52	RP-110794	060	1		General corrections for TS 37.141	10.3.0
2011-06	RP-52	RP-110813	056	1		Add 2GHz S-Band (Band 23) in 37.141	10.3.0
2011-06	RP-52	RP-110794	071	2		Correction on Modulation Quality Testing in TS 37.141	10.3.0
2011-06	RP-52	RP-110794	065	2		Revision of Time Alignment Error definition	10.3.0
2011-06	RP-52	RP-110794	068	1		Correction on MSR Test Configuration (Rel-10)	10.3.0
2011-09	RP-53	RP-111252	076			Correction of receiver conformance testing	10.4.0
2011-09	RP-53	RP-111252	083			Correction on TR 37.141 clause 6.6.2.5	10.4.0
2011-09	RP-53	RP-111255	081			Add Band 22/XXII for LTE/UMTS 3500 (FDD) to TS 37.141	10.4.0
2011-09	RP-53	RP-111256	085			Introduction of test requirements for MSR-NC in 37.141	10.4.0
2011-09	RP-53	RP-111262	078			Co-existence and co-location corrections in 37.141	10.4.0
2011-09	RP-53	RP-111265	066	2		Introduction of Carrier Aggregation for LTE in TS 37.141	10.4.0
2011-09	RP-53	RP-111267	084	1		Two carrier test case for MSR	10.4.0
2011-12	RP-54	RP-111735	086			Definition of multi-carrier configuration	10.5.0
2011-12	RP-54	RP-111734	087			Clarification of general blocking requirements for co-existence in TS 37.141	10.5.0
2011-12	RP-54	RP-111735	088			CR to TS37.141 Adding the OBW requirements for carrier aggregation	10.5.0
2011-12	RP-54	RP-111690	092	1		update to improve readability of tables in section 4.4 of 37.141	10.5.0
2011-12	RP-54	RP-111735	093			Correction of MSR NC requirements	10.5.0
2011-12	RP-54	RP-111683	096	1		Alignment of TC carrier position with channel raster in TS 37.141 (Rel-10)	10.5.0
2011-12	RP-54	RP-111735	097			Clarification of multi-carrier transmission and reception with multiple antenna connectors	10.5.0
2011-12	RP-54	RP-111687	098	2		TX ON or OFF CR 37.141	10.5.0
2011-12	RP-54	RP-111733	099			Correction of frequency range for spurious emission requirements	10.5.0
2012-03	RP-55	RP-120303	106			Correction on BS Spurious emissions limits for co-existence with Band 25 uplink	10.6.0
2012-03	RP-55	RP-120303	107			Absolute limit for CA CLR: Removal of brackets	10.6.0
2012-03	RP-55	RP-120304	109	1		Definition of synchronized operation	10.6.0
2012-03	RP-55	RP-120303	110	1		Introduction of NC operation for TDD in 37.141	10.6.0
2012-03	RP-55	RP-120305	105			Add Extending 850 MHz Upper Band (814 - 849 MHz) to TS37.141	11.0.0

2012-06	RP-56	RP-120770	114			Correct maximum test system uncertainty for transmit ON/OFF power	11.1.0
2012-06	RP-56	RP-120778	118			Correcting a test configuration in TS 37.141	11.1.0
2012-06	RP-56	RP-120779	121			Correction on ACLR procedure and test requirement	11.1.0
2012-06	RP-56	RP-120771	124			Transmitter intermodulation applicability clarification for single-RAT specifications	11.1.0
2012-06	RP-56	RP-120793	125			Introduction of APAC700(FDD) into TS 37.141	11.1.0
2012-06	RP-56	RP-120778	127			Correction of the manufacturer's declaration	11.1.0
2012-06	RP-56	RP-120778	129	1		Correction of test case for transmitter intermodulation requirement of BC1	11.1.0
2012-06	RP-56	RP-120779	131			Corrections for MSR and MSR-NC	11.1.0
2012-06	RP-56	RP-120777	135			Additional BC3 blocking	11.1.0
2012-06	RP-56	RP-120793	136	1		Introduction of Band 44	11.1.0
2012-06	RP-56	RP-120792	137	2		Introduction of e850_LB (Band 27) to TS 37.141	11.1.0
2012-09	RP-57	RP-121310	139	-		Correct the f_offsetmax definition for TS 37.141	11.2.0
2012-09	RP-57	RP-121308	140	2		Reusing band 41 requirements for the Japan 2.5G TDD band	11.2.0
2012-09	RP-57	RP-121310	142	1		Intra-band non-contiguous receiver requirements	11.2.0
2012-09	RP-57	RP-121310	144	-		Deleting additional BC3 transmitter intermodulation requirement for NC MSR	11.2.0
2012-09	RP-57	RP-121300	147	-		Modifications of frequency ranges on spurious emission requirements for Band 6, 18, 19	11.2.0
2012-09	RP-57	RP-121311	149	-		Clarification of non-contiguous BC1 transmitter intermodulation requirements	11.2.0
2012-09	RP-57	RP-121311	151	1		Clean-up of ACLR wording for MSR-NC	11.2.0
2012-09	RP-57	RP-121312	153	-		BS test uncertainties above 3 GHz	11.2.0
2012-09	RP-57	RP-121340	155	-		Modification to increase GSM Carrier Power in MSR BS for Band Category 2	11.2.0
2012-09	RP-57					Editorial correction in Table 6.6.2.5.2-2	11.2.1
2012-12	RP-58	RP-121857	158	-		Correction to additional BS spurious emissions limits for BC2	11.3.0
2012-12	RP-58	RP-121859	161	-		Correction of PHS protection requirement	11.3.0
2012-12	RP-58	RP-121867	165	-		Clean up of specification R11	11.3.0
2012-12	RP-58	RP-121907	166	-		Introduction of new BS classes to MSR specification (general parts)	11.3.0
2012-12	RP-58	RP-121867	167	-		Correction to test requirements of operating band unwanted emissions	11.3.0
2012-12	RP-58	RP-121907	169	-		Introduction of new BS classes to TS37.141 (Transmitter part)	11.3.0
2012-12	RP-58	RP-121864	171	-		Transmitter IM correction for MSR-NC	11.3.0
2012-12	RP-58	RP-121907	172	-		Introduction of new BS classes to MSR test specification (receiver part)	11.3.0
2012-12	RP-58	RP-121867	175	-		Removal of conflicts in ACLR requirement	11.3.0
2012-12	RP-58	RP-121861	178	-		Change to CA combination list from table to reference	11.3.0
2012-12	RP-58	RP-121867	180	-		Clarification of BS output power test under extreme power supply conditions	11.3.0
2012-12	RP-58	RP-121902	181	-		Introduction of Band 29	11.3.0
2012-12	RP-58	RP-121857	182			Modification to increase GSM Carrier Power in MSR BS for Band Category 2	11.3.0
2013-03	RP-59	RP-130274	187			Correction to MSR BS classes conformance test requirements	11.4.0
2013-03	RP-59	RP-130287	188			Band 41 requirements for operation in Japan	11.4.0
2013-06	RP-60	RP-130763	189			Correcting Time alignment between transmitter branches title in section 5 in TS37.141	11.5.0
2013-06	RP-60	RP-130764	193			Corrections to transmitter intermodulation test requirement	11.5.0
2013-06	RP-60	RP-130764	198			Correction on UTRA and E-UTRA multi RAT non-contiguous test configuration	11.5.0
2013-06	RP-60	RP-130763	201			channel raster	11.5.0
2013-06	RP-60	RP-130792	202	1		Introduction of Band 30	12.0.0
2013-06	RP-60	RP-130790	203			Introduction of LTE 450 into TS 37.141	12.0.0
2013-09	RP-61	RP-131280	207			Correction on reference number	12.1.0

2013-09	RP-61	RP-131280	212			UEM requirement in BC2 for lower BS output power	12.1.0
2013-12	RP-62	RP-131927	215			Clarification of Tx IM requirement for BC1 band supporting non-contiguous operation	12.2.0
2013-12	RP-62	RP-131934	217			Introduction of receiver test requirements for multi-band BS	12.2.0
2013-12	RP-62	RP-131934	219			Introduction of multi-band operation to TS 37.141 (Clause 6) Partially Implemented: changes to section 6.6.4.5.4 are not implemented as are not based on the latest version of the spec	12.2.0
2013-12	RP-62	RP-131925	223			Correction on capability of test configurations for BC3	12.2.0
2013-12	RP-62	RP-131934	225			Introduction of Multi-band operation in TS37.141(clause 1~3)	12.2.0
2013-12	RP-62	RP-131960	233			Changes to TS 37.141 for LTE_CA_C_B27	12.2.0
2013-12	RP-62	RP-131934	235			Introduction of MB-MSR Manufacturer's declaration to TS 37.141	12.2.0
2013-12	RP-62	RP-131926	242			Introduction of secondary CPICH requirement	12.2.0
2013-12	RP-62	RP-131934	244			Introduction of multi-band BS testing to TS 37.141 (Clauses 4.8 4.11)	12.2.0
2013-12	RP-62	RP-131934	246			Update of TS 37.141 for MB-MSR	12.2.0
2013-12	RP-62	RP-131934	251			Applicability of requirements and test configurations for MB-MSR	12.2.0
2013-12	RP-62	RP-131967	252	1		Band 41 deployment in Japan	12.2.0
03-2014	RP-63	RP-140372	259			Correction on manufacturer's declaration in TS37.141	12.3.0
03-2014	RP-63	RP-140372	261			Some corrections for MB-MSR in TS 37.141	12.3.0
03-2014	RP-63	RP-140368	265			Correction on RF channels	12.3.0
03-2014	RP-63	RP-140367	269			Test models for BC3 BS	12.3.0
03-2014	RP-63	RP-140367	273			Differential accuracy of Primary CCPCH power	12.3.0
03-2014	RP-63	RP-140368	281			Clarification of interfering signals for receiver intermodulation requirement in MSR	12.3.0
03-2014	RP-63	RP-140372	282			Multi-band corrections in 37.141 chapter 6	12.3.0
03-2014	RP-63	RP-140372	284			Multi-band corrections in 37.141 chapter 7	12.3.0
06-2014	RP-64	RP-140910	291			Clarification of power allocation for RX test cases in TS 37.141 (Rel-12)	12.4.0
06-2014	RP-64	RP-140913	303			Clarification on definitions and ACLR requirement in TS37.141	12.4.0
06-2014	RP-64	RP-140913	286			Multi-band corrections in 37.141 chapter 6	12.4.0
06-2014	RP-64	RP-140913	288	1		Multi-band corrections in 37.141 chapter 7	12.4.0
06-2014	RP-64	RP-140913	312			Correction of UEM for Medium Range and Local Area BS	12.4.0
06-2014	RP-64	RP-140914	299			Band 29 correction	12.4.0
06-2014	RP-64	RP-140918	321			Clarification of Foffset-RAT in relation to radio bandwidth in TS 37.141 (Rel-12)	12.4.0
06-2014	RP-64	RP-140918	309			BS output power definitions and testing	12.4.0
06-2014	RP-64	RP-140926	307	1		Introduction of Band 32/XXXII	12.4.0
09-2014	RP-65	RP-141526	324	1		Removal of FFS for TC4	12.5.0
09-2014	RP-65	RP-141528	336	-		Correction on UEM related to multi-band operation in TS37.141	12.5.0
09-2014	RP-65	RP-141562	337	2		Update of definitions to support supplemental DL in TS37.141	12.5.0
12-2014	RP-66	RP-142143	351			Correction of procedure for general and narrowband intermodulation	12.6.0
12-2014	RP-66	RP-142143	341	1		Modification on BC3 MSR BS test model	12.6.0
12-2014	RP-66	RP-142146	357			Tx intermodulation corrections	12.6.0
12-2014	RP-66	RP-142146	359			Multi-band test configurations corrections	12.6.0
12-2014	RP-66	RP-142143	367			Clarification of Capability Set per band	12.6.0
03-2015	RP-67	RP-150382	375			Co-location between Band 42 and Band 43 in TS 37.141	12.7.0
03-2015	RP-67	RP-150388	382			MB and TDD+FDD	12.7.0
07-2015	RP-68	RP-150955	392			Clarification of parameter P for emission requirements	12.8.0
07-2015	RP-68	RP-150953	393			The applicability of TC4d and TC4e	12.8.0
07-2015	RP-68	RP-150955	402			Some corrections related to RF bandwidth edge	12.8.0
07-2015	RP-68	RP-150953	400	1		New capability set for excluding GSM/EDGE single-RAT operation	13.0.0
12-2015	RP-70	RP-152157	0422	1		Introduction of Band 67 to 37.141	13.1.0

12-2015	RP-70	RP-152172	0427	-		Introduction of Band 66	13.1.0
12-2015	RP-70	RP-152171	0428	-		Introduction of Band 65	13.1.0
12-2015	RP-70	RP-152173	0429	-		Introduction of 1447-1467MHz Band into 37.141	13.1.0
12-2015	RP-70	RP-152132	0432	-		BS Spec improvements: TS 37.141 Corrections	13.1.0
12-2015	RP-70	RP-152132	0435	-		Multi-band test configuration clarification	13.1.0
12-2015	RP-70	RP-152132	0438	-		Corrections on definition of f_offsetmax for BS operating in multiple bands or non-contiguous spectrum	13.1.0
12-2015	RP-70	RP-152132	0444	-		Clarification on the transmitter intermodulation requirement in TS37.141	13.1.0
12-2015	RP-70	RP-152132	0447	-		Correction of Unwanted Emission Mask (UEM) for MSR BS capable of multiband operation	13.1.0
03/2016	RP-71	RP-160483	0448	2	B	Introduction of Band 68 into 37.141	13.2.0
03/2016	RP-71	RP-160488	0453		A	Band 20 and Band 28 BS co-existence	13.2.0
03/2016	RP-71	RP-160490	0450		F	Correction on spurious emissions for co-existence	13.2.0
06/2016	RP-72	RP-161140	455	1	F	Clarification in MB test configuration TC7b	13.3.0
06/2016	RP-72	RP-161141	456	1	A	Corrections to BS spurious emissions requirements in TS37.141 (Rel-13)	13.3.0
06/2016	RP-72	RP-161140	461	1	F	Corrections on definition of multi-band definition and blocking	13.3.0
06/2016	RP-72	RP-161134	462	1	B	Introduction of Band 46 in TS 37.141	13.3.0
06/2016	RP-72	RP-161125	460	-	B	Introduction of Band 70 to 37.141	14.0.0
06/2016	RP-72	RP-161124	463	-	B	Introduction of Band 69 to 37.141	14.0.0
09/2016	RP-73	RP-161631	0467	-	A	Minor clarifications in MSR NTC1a and NTC3a	14.1.0
09/2016	RP-73	RP-161784	0470	-	A	TS 37.141 Corrections	14.1.0
09/2016	RP-73	RP-161633	0474	-	A	TC7b correction	14.1.0
12/2016	RP-74	RP-162395	0475	1	B	CR for TS 37.141: Multi-band testing with 3 or more bands.	14.2.0
12/2016	RP-74	RP-162379	0477	-	A	CR to TS 37.141 introducing NB-IoT	14.2.0
12/2016	RP-74	RP-162405	0478	1	B	Introduction of Band 48	14.2.0
03/2017	RP-75	RP-170600	0483	-	A	Corrections on NB-IoT narrowband intermodulation performance requirement	14.3.0
03/2017	RP-75	RP-170600	0485	-	A	Corrections on NB-IoT Test Configurations	14.3.0
06/2017	RP-76	RP-171282	0493	1	F	CR on BS for protection of V2X UE in TS 37.141	14.4.0
06/2017	RP-76	RP-171297	0498	1	A	TS 37.141: Correction of reference	14.4.0
06/2017	RP-76	RP-171255	0775	1	B	CR on eLAA BS for TS 37.141	14.4.0
06/2017	RP-76	RP-171302	0777		A	Remove NB-IoT inband support for 1.4 MHz - Tests	14.4.0
06/2017	RP-76	RP-171279	0778	1	B	Add NB-IoT support to Band 21	14.4.0
06/2017	RP-76	RP-171300	0781		A	Narrowband blocking requirement for NB-IoT guard band operation (TS 37.141)	14.4.0
06/2017	RP-76	RP-171303	0783		A	Intermodulation performance requirement for NB-IoT operation (TS 37.141)	14.4.0
06/2017	RP-76	RP-171302	0785	1	A	Testing for BS supporting NB-IoT operation (TS 37.141)	14.4.0
09/2017	RP-77	RP-171966	0787		A	Operating band unwanted emissions for MB MSR BS (TS 37.141)	14.5.0
09/2017	RP-77	RP-171943	0790		F	CR to 37.141: NB-IoT inconsistency with 37.104	14.5.0
09/2017	RP-77	RP-171948	0788	2	B	Introduction of the FDD L-band (Band 74) into TS 37.141	15.0.0
09/2017	RP-77	RP-171946	0789		B	CR to 37.141: Introduction of Band 72	15.0.0
09/2017	RP-77	RP-171952	0791		B	CR to 37.141: Introduction of Band 71	15.0.0
09/2017	RP-77	RP-171950	0793	1	B	CR to 37.141: Introduction of B75 and B76	15.0.0
09/2017	RP-77	RP-171949	0794	1	B	Introduction of TDD L-band into TS 37.141	15.0.0
09/2017	RP-77	RP-172051	0795		B	CR to 37.141: Support of NB-IoT for Bands 4, 14 and 71	15.0.0
2017-12	RAN#78	RP-172593	0796	1	B	Introduction of Band 73 into TS 37.141	15.1.0
2017-12	RAN#78	RP-172613	0799		A	CR to 37.141: BS Spurious emissions limits for protection of the BS receiver for B28 in Europe	15.1.0
2017-12	RAN#78	RP-172605	0802	1	A	Corrections for MB MSR BS supporting non-contiguous spectrum operation (TS 37.141)	15.1.0
2017-12	RAN#78	RP-172584	0804		A	CR to 37.141: Corrections to co-location tables for B48	15.1.0
2017-12	RAN#78	RP-172594	0805	1	B	CR to 37.141: Introduction of Band 49	15.1.0
2017-12	RAN#78	RP-172588	0806		B	Introduction of Microcell and Picocell NB-IoT BS into 37.141	15.1.0
2018-03	RAN#79	RP-180279	0807		B	CR to 37.141: Introduction of Band 85	15.2.0
2018-03	RAN#79	RP-180287	0810		A	Correction to GSM/EDGE output power dynamics	15.2.0
2018-03	RAN#79	RP-180267	0811		F	CR NB-IoT small cells: co-location requirements fix	15.2.0
2018-03	RAN#79	RP-180281	0812	1	B	CR to 37.141: Introduction of new additional unwanted emission limit for L-Band	15.2.0
2018-03	RAN#79	RP-180278	0813	1	B	Introduction of TDD 3.3-3.4GHz band into TS 37.141	15.2.0
2018-06	RAN#80	RP-181100	0814		F	CR to 37.141: Medium Range BS UEM corrections	15.3.0
2018-09	RAN#81	RP-181900	0815	2	B	Introduction of NB-IoT TDD support	15.4.0
2018-09	RAN#81	RP-181899	0816	1	B	CR of test on BS REFSSENS for subPRB feature	15.4.0

2018-12	RAN#82	RP-182381	0828		A	CR to TS 37.141: Clarification on NB-IoT test models	15.5.0
2018-12	RAN#82	RP-182362	0831	1	B	Introduction of NR operation in MSR specification 37.141	15.5.0
2019-03	RAN#83	R4-1900401	0833		A	CR for TS 37.141 Rel-15: Correction of UTRA operation in CS7	15.6.0
2019-03	RAN#83	RP-190420	0836	1	F	Correction to 256QAM and 1024QAM test models and declarations	15.6.0
2019-03	RAN#83	RP-190402	0838	1	F	Correction to TDD OFF power requirement	15.6.0
2019-03	RAN#83	RP-190402	0842		F	CR to TS 37.141: Corrections on transmitter co-existence and co-location	15.6.0
2019-03	RAN#83	RP-190421	0844		F	CR to 37.141: clean up for LTE-M related text	15.6.0
2019-03	RAN#83	RP-190401	0846	1	F	CR to 37.141 on Corrections for NR	15.6.0
2019-03	RAN#83	RP-190402	0848	1	F	CR to TS 37.141 – Blocking requirement for MSR	15.6.0
2019-06	RAN#84	RP-191236	0850	1	F	Correction to unwanted emissions mask for bands 7 and 38	15.7.0
2019-06	RAN#84	RP-191267	0852		F	CR to 37.141: Correcton on Definition of Capability Sets (CS)	15.7.0
2019-06	RAN#84	RP-191236	0856		F	Correction to 256QAM and 1024QAM test models and declarations for NR and E-UTRA	15.7.0
2019-06	RAN#84	RP-191236	0862		F	Correction to n66 and n70 band information	15.7.0
2019-06	RAN#84	RP-191259	0868	1	F	CR to 37.141: Simplification of capability sets definition	15.7.0
2019-09	RAN#85	RP-192020	0872		F	CR to TS 37.141 some clarification as blocking test range	15.8.0
2019-09	RAN#85	RP-192020	0874	1	F	CR to TS 37.141 TX&RX spurious emission range clause 6.6.1.5.1&7.6.5.1	15.8.0
2019-09	RAN#85	RP-192020	0876	1	F	CR to TS37.141: removal of Tx diversity for NR (section 6.5.3)	15.8.0
2019-09	RAN#85	RP-192020	0878	1	F	CR to TS37.141 Corrections on NBB requirement (section 7.4)	15.8.0
2019-09	RAN#85	RP-192020	0880	1	F	CR to TS 37.141: CA channel spacing	15.8.0
2019-09	RAN#85	RP-192020	0883		F	CR to TS 37.141 with addition of reference to data content for test models	15.8.0
2019-09	RAN#85	RP-192020	0888		F	Correction of NTC21	15.8.0
2019-12	RAN#86	RP-193002	0894	1	F	CR to 37.141 on Reciever Intermodulation signal offset correction	15.9.0
2019-12	RAN#86	RP-193045	0898		A	CR to TS 37.141: Correction of references for NB-IoT testing	15.9.0
2019-12	RAN#86	RP-193002	0902	2	F	CR to 37.141: Update of procedure in Modulation quality test	15.9.0
2019-12	RAN#86	RP-193002	0904		F	CR to TS 37.141 - CS14-TC22 inconsistency fix	15.9.0
2019-12	RAN#86	RP-193002	0906		F	Introduction of channel spacing between E-UTRA and NR carriers	15.9.0
2019-12	RAN#86	RP-193002	0908	1	F	Narrowband blocking corrections	15.9.0
2019-12	RAN#86	RP-193045	0914		F	NB-IoT corrections	15.9.0
2020-03	RAN#87	RP-200393	0920		F	CR to TS 37.141: Update on Tx transient period definition	15.10.0
2020-03	RAN#87	RP-200393	0925	1	F	CR to TS 37.141 channel spacing R15	15.10.0
2020-06	RAN#88	RP-200984	0929		F	TS 37.141: Corrections related to Foffset Note: CR0929 is based on something else than the latest version of the specification and hence it isnot implemented.	15.11.0
2020-06	RAN#88	RP-200984	0933		F	CR to TS 37.141 Rel-15 - Issues with TC applicabilities CS17	15.11.0
2020-06	RAN#88	RP-200984	0935		F	[R15]CR to TS 37.141 on channel spacing correction	15.11.0
2020-06	RAN#88	RP-200984	0939		F	CR to 37.141: Rel-15 corrections	15.11.0
2020-06	RAN#88	RP-200984	0937	1	F	CR to TS37.141[R15]_Correction on the CA nominal channel spacing	15.11.0
2020-09	RAN#89	RP-201512	0945		A	CR to TS 37.141: Clarification on manufacturer's declaration of the number of supported NB-IoT carriers	15.12.0
2020-09	RAN#89	RP-201512	0947		F	CR to 37.141: Correction to applicability of additional BC3 requirement (Rel-15)	15.12.0
2020-12	RAN#90	RP-202489	0953		F	CR to 37.141: Correction to ACLR limit in non-contiguous spectrum (Rel-15)	15.13.0
2020-12	RAN#90	RP-202510	0955		F	CR to 37.141 on Removal of additional limit for Band 1	15.13.0
2020-12	RAN#90	RP-202510	0957		F	CR to 37.141 on MSR Blocking correction	15.13.0
2021-03	RAN#91e	RP-210116	0961		F	CR to 37.141: Correction to ACLR limit in non-contiguous spectrum (Rel-15)	15.14.0
2021-03	RAN#91e	RP-210111	0970		A	CR to 37.141: Correction to Band 24 requirements (Rel-15)	15.14.0
2021-03	RAN#91e	RP-210121	0973	1	F	CR to 37.141 on OBUE table headings and applicability	15.14.0
2021-06	RAN#92	RP-211082	0976	1	F	CR to TS 37.141: Regional requirements for band 41 and n41 in Japan, Rel-15	15.15.0

2021-06	RAN#92	RP-211091	0984		F	CR to 37.141: Correction of NR bands for MSR BS	15.15.0
2021-06	RAN#92	RP-211083	0987	1	F	CR to 37.141: In-band blocking for multi-band Base Stations	15.15.0

History

Document history		
V15.3.0	July 2018	Publication
V15.4.0	October 2018	Publication
V15.5.0	April 2019	Publication
V15.6.0	May 2019	Publication
V15.7.0	July 2019	Publication
V15.8.0	October 2019	Publication
V15.9.0	January 2020	Publication
V15.10.0	April 2020	Publication
V15.11.0	September 2020	Publication
V15.12.0	November 2020	Publication
V15.13.0	January 2021	Publication
V15.14.0	April 2021	Publication
V15.15.0	September 2021	Publication