

ETSI TS 137 145-2 V15.4.0 (2019-07)



**Universal Mobile Telecommunications System (UMTS);
LTE;
Active Antenna System (AAS) Base Station (BS)
conformance testing;
Part 2: radiated conformance testing
(3GPP TS 37.145-2 version 15.4.0 Release 15)**



Reference

RTS/TSGR-0437145-2v40

Keywords

LTE,UMTS

ETSI

650 Route des Lucioles
F-06921 Sophia Antipolis Cedex - FRANCE

Tel.: +33 4 92 94 42 00 Fax: +33 4 93 65 47 16

Siret N° 348 623 562 00017 - NAF 742 C
Association à but non lucratif enregistrée à la
Sous-Préfecture de Grasse (06) N° 7803/88

Important notice

The present document can be downloaded from:

<http://www.etsi.org/standards-search>

The present document may be made available in electronic versions and/or in print. The content of any electronic and/or print versions of the present document shall not be modified without the prior written authorization of ETSI. In case of any existing or perceived difference in contents between such versions and/or in print, the prevailing version of an ETSI deliverable is the one made publicly available in PDF format at www.etsi.org/deliver.

Users of the present document should be aware that the document may be subject to revision or change of status.

Information on the current status of this and other ETSI documents is available at

<https://portal.etsi.org/TB/ETSIDeliverableStatus.aspx>

If you find errors in the present document, please send your comment to one of the following services:

<https://portal.etsi.org/People/CommiteeSupportStaff.aspx>

Copyright Notification

No part may be reproduced or utilized in any form or by any means, electronic or mechanical, including photocopying and microfilm except as authorized by written permission of ETSI.

The content of the PDF version shall not be modified without the written authorization of ETSI.

The copyright and the foregoing restriction extend to reproduction in all media.

© ETSI 2019.

All rights reserved.

DECT™, **PLUGTESTS™**, **UMTS™** and the ETSI logo are trademarks of ETSI registered for the benefit of its Members.

3GPP™ and **LTE™** are trademarks of ETSI registered for the benefit of its Members and of the 3GPP Organizational Partners.

oneM2M™ logo is a trademark of ETSI registered for the benefit of its Members and of the oneM2M Partners.

GSM® and the GSM logo are trademarks registered and owned by the GSM Association.

Intellectual Property Rights

Essential patents

IPRs essential or potentially essential to normative deliverables may have been declared to ETSI. The information pertaining to these essential IPRs, if any, is publicly available for **ETSI members and non-members**, and can be found in ETSI SR 000 314: *"Intellectual Property Rights (IPRs); Essential, or potentially Essential, IPRs notified to ETSI in respect of ETSI standards"*, which is available from the ETSI Secretariat. Latest updates are available on the ETSI Web server (<https://ipr.etsi.org/>).

Pursuant to the ETSI IPR Policy, no investigation, including IPR searches, has been carried out by ETSI. No guarantee can be given as to the existence of other IPRs not referenced in ETSI SR 000 314 (or the updates on the ETSI Web server) which are, or may be, or may become, essential to the present document.

Trademarks

The present document may include trademarks and/or tradenames which are asserted and/or registered by their owners. ETSI claims no ownership of these except for any which are indicated as being the property of ETSI, and conveys no right to use or reproduce any trademark and/or tradename. Mention of those trademarks in the present document does not constitute an endorsement by ETSI of products, services or organizations associated with those trademarks.

Legal Notice

This Technical Specification (TS) has been produced by ETSI 3rd Generation Partnership Project (3GPP).

The present document may refer to technical specifications or reports using their 3GPP identities. These shall be interpreted as being references to the corresponding ETSI deliverables.

The cross reference between 3GPP and ETSI identities can be found under <http://webapp.etsi.org/key/queryform.asp>.

Modal verbs terminology

In the present document "**shall**", "**shall not**", "**should**", "**should not**", "**may**", "**need not**", "**will**", "**will not**", "**can**" and "**cannot**" are to be interpreted as described in clause 3.2 of the [ETSI Drafting Rules](#) (Verbal forms for the expression of provisions).

"**must**" and "**must not**" are **NOT** allowed in ETSI deliverables except when used in direct citation.

Contents

Intellectual Property Rights	2
Legal Notice	2
Modal verbs terminology.....	2
Foreword.....	14
1 Scope	15
2 References	15
3 Definitions, symbols and abbreviations	17
3.1 Definitions	17
3.2 Symbols.....	21
3.3 Abbreviations	23
4 General test conditions and declarations	24
4.1 Measurement uncertainties and test requirements	24
4.1.1 General.....	24
4.1.2 Acceptable uncertainty of Test System.....	26
4.1.2.1 General	26
4.1.2.2 Measurement of transmitter	27
4.1.2.3 Measurement of receiver	30
4.1.2.4 Measurement of performance requirement	32
4.1.3 Interpretation of measurement results	32
4.2 Conducted and radiated requirement reference points	32
4.3 Base station classes for AAS BS	33
4.4 Regional requirements.....	33
4.5 Operating bands and band categories	35
4.6 Channel arrangements	35
4.7 Requirements for AAS BS capable of multi-band operation	35
4.8 AAS BS configurations	35
4.8.1 Transmit configurations	35
4.8.2 Receive configurations	36
4.8.3 Power supply options.....	37
4.8.4 BS with integrated Iuant BS modem	37
4.9 Capability sets	37
4.10 Manufacturer declarations	38
4.11 Test signal configurations for testing	45
4.11.1 General.....	45
4.11.1A NR Test signal used to build Test Configurations	45
4.11.2 Test signal configurations.....	45
4.11.2.1 ATCR1: UTRA multicarrier operation	45
4.11.2.1.1 General	45
4.11.2.1.2 ATCR1a generation.....	45
4.11.2.1.3 ATCR1b generation.....	45
4.11.2.1.4 ATCR1 power allocation.....	46
4.11.2.2 ANTCR1: UTRA FDD multicarrier non-contiguous operation.....	46
4.11.2.2.1 General	46
4.11.2.2.2 ANTCR1 generation.....	46
4.11.2.2.3 ANTCR1 power allocation.....	46
4.11.2.3 ATCR2: E-UTRA multicarrier operation.....	47
4.11.2.3.1 General	47
4.11.2.3.2 ATCR2a generation.....	47
4.11.2.3.3 ATCR2b generation.....	47
4.11.2.3.4 ATCR2 power allocation.....	48
4.11.2.4 ANTCR2: E-UTRA multicarrier non-contiguous operation	48
4.11.2.4.1 General	48
4.11.2.4.2 ANTCR2 generation.....	48
4.11.2.4.3 ANTCR2 power allocation.....	48

4.11.2.5	ATCR3: UTRA and E-UTRA multi RAT operation	49
4.11.2.5.1	General	49
4.11.2.5.2	ATCR3a generation.....	49
4.11.2.5.3	ATCR3b generation.....	49
4.11.2.5.4	ATCR3 power allocation.....	49
4.11.2.6	ANTCR3: UTRA and E-UTRA multi RAT non-contiguous operation.....	50
4.11.2.6.1	General	50
4.11.2.6.2	ANTCR3a generation.....	50
4.11.2.6.3	ANTCR3 power allocation.....	50
4.11.2.7	ATCR4: Single carrier for receiver tests.....	51
4.11.2.7.1	ATCR4a generation.....	51
4.11.2.7.2	ATCR4b generation.....	51
4.11.2.7.3	ATCR4c generation.....	51
4.11.2.7.3A	ATCR4d generation.....	51
11.2.7.4	ATCR4 power allocation.....	51
4.11.2.8	Generation of MB-MSR test configurations	51
4.11.2.8.1	ATCR5a: MB-MSR test configuration for full carrier allocation.....	51
4.11.2.8.1.1	General.....	51
4.11.2.8.1.2	ATCR5a generation	51
4.11.2.8.1.3	ATCR5a power allocation	52
4.11.2.8.2	ATCR5b: MB-MSR test configuration with high PSD per carrier.....	52
4.11.2.8.2.1	General.....	52
4.11.2.8.2.2	ATCR5b generation.....	52
4.11.2.8.2.3	ATCR5b power allocation	53
4.11.2.9	ATCR6: Single carrier for Transmitter tests	53
4.11.2.9.1	ATCR6a generation.....	53
4.11.2.9.2	ATCR6b generation.....	53
4.11.2.9.3	Void.....	54
4.11.2.9.3A	ATCR6d generation.....	54
4.11.2.9.4	ATCR6 power allocation.....	54
4.11.2.10	ATCR7: E-UTRA and NR multi RAT operation.....	54
4.11.2.10.1	General	54
4.11.2.10.2	ATCR7 generation.....	54
4.11.2.10.3	ATCR7 power allocation.....	54
4.11.2.11	ANTCR7: E-UTRA and NR multi RAT non-contiguous operation	55
4.11.2.11.1	General	55
4.11.2.11.2	ANTCR7 generation.....	55
4.11.2.11.3	ANTCR7 power allocation.....	55
4.11.12.3	ATCR8: NR multicarrier operation.....	55
4.11.2.12.1	General	55
4.11.2.12.2	ATCR8a generation.....	56
4.11.2.3.3	ATCR8b generation.....	56
4.11.2.12.4	ATCR8 power allocation.....	56
4.11.2.13	ANTCR8: NR multicarrier non-contiguous operation	57
4.11.2.13.1	General	57
4.11.2.13.2	ANTCR8 generation.....	57
4.11.2.13.3	ANTCR8 power allocation.....	57
4.12	RF channels and test models	57
4.12.1	RF channels	57
4.12.2	Test models	58
4.13	Format and interpretation of tests.....	59
4.14	Reference coordinate system.....	60
4.15	Co-location requirements	61
4.15.1	General.....	61
4.15.2.2	Co-location test antenna characteristics	61
5	Applicability of Requirements	63
5.1	General	63
5.2	Test configurations for AAS BS for operating bands where MSR with more than 1 RAT is supported	65
5.3	Test configurations for multi-carrier capable AAS BS in operating bands where one RAT capability sets are supported	72
5.3.1	General.....	72

5.3.2	AAS BS supporting one RAT only MSR in the operating band.....	73
5.3.3	AAS BS supporting Single-RAT UTRA in the operating band.....	77
5.3.4	AAS BS supporting Single-RAT E-UTRA in the operating band.....	78
5.4	Test configurations for AAS BS operating bands with multi-band dependencies.....	80
5.4.1	AAS BS operating bands with multi-band dependencies supporting MSR operation.....	80
5.4.2	AAS BS operating bands with multi-band dependencies supporting Single-RAT only.....	81
6	Radiated transmitter characteristics.....	83
6.1	General.....	83
6.2	Radiated Transmit Power.....	83
6.2.1	Definition and applicability.....	83
6.2.2	Minimum Requirement.....	84
6.2.3	Test purpose.....	84
6.2.4	Method of test.....	84
6.2.4.1	Initial conditions.....	84
6.2.4.2	Procedure.....	85
6.2.5	Test Requirement.....	85
6.3	OTA Base Station output power.....	85
6.3.1	General.....	85
6.3.2	OTA Maximum output power.....	86
6.3.2.1	Definition and applicability.....	86
6.3.2.2	Minimum Requirement.....	86
6.3.2.3	Test purpose.....	86
6.3.2.4	Method of test.....	86
6.3.2.4.1	Initial conditions.....	86
6.3.2.4.2	Procedure.....	86
6.3.2.5	Test Requirement.....	87
6.3.3	OTA E-UTRA DL RS power.....	87
6.3.3.1	Definition and applicability.....	87
6.3.3.2	Minimum Requirement.....	87
6.3.3.3	Test purpose.....	87
6.3.3.4	Method of test.....	88
6.3.3.4.1	Initial conditions.....	88
6.3.3.4.2	Procedure.....	88
6.3.3.5	Test Requirement.....	88
6.4	OTA Output power dynamics.....	88
6.4.1	General.....	88
6.4.2	OTA UTRA Inner loop power control in the downlink.....	89
6.4.2.1	Definition and applicability.....	89
6.4.2.2	Minimum requirement.....	89
6.4.2.3	Test purpose.....	89
6.4.2.4	Method of test.....	89
6.4.2.4.1	Initial conditions.....	89
6.4.2.4.2	Procedure.....	89
6.4.2.5	Test Requirement.....	90
6.4.3	OTA Power control dynamic range.....	91
6.4.3.1	Definition and applicability.....	91
6.4.3.2	Minimum Requirement.....	91
6.4.3.3	Test purpose.....	91
6.4.3.4	Method of test.....	91
6.4.3.4.1	Initial conditions.....	91
6.4.3.4.2	Procedure.....	91
6.4.3.5	Test Requirement.....	92
6.4.4	OTA total power dynamic range.....	92
6.4.4.1	Definition and applicability.....	92
6.4.4.2	Minimum Requirement.....	92
6.4.4.3	Test purpose.....	93
6.4.4.4	Method of test.....	93
6.4.4.4.1	Initial conditions.....	93
6.4.4.4.2	Procedure.....	93
6.4.4.4.2.1	General procedure.....	93
6.4.4.4.2.2	UTRA FDD.....	93

6.4.4.4.2.3	E-UTRA.....	93
6.4.4.4.2.4	NR.....	94
6.4.4.5	Test Requirement	95
6.4.4.5.1	UTRA FDD	95
6.4.4.5.2	E-UTRA	95
6.4.4.5.3	NR	95
6.4.5	OTA IPDL time mask.....	96
6.4.5.1	Definition and applicability.....	96
6.4.5.2	Minimum Requirement	96
6.4.5.3	Test purpose	96
6.4.5.4	Method of test	96
6.4.5.4.1	Initial conditions.....	96
6.4.5.4.2	Procedure.....	96
6.4.5.5	Test Requirement	97
6.4.6	OTA RE Power control dynamic range	97
6.4.6.1	Definition and applicability.....	97
6.4.6.2	Minimum Requirement	97
6.4.6.3	Method of test	98
6.5	OTA Transmit ON/OFF power	98
6.5.1	General.....	98
6.5.2	OTA Transmitter OFF power	98
6.5.2.1	Definition and applicability.....	98
6.5.2.2	Minimum Requirement	98
6.5.2.3	Test purpose	98
6.5.2.4	Method of test	98
6.5.2.4.1	Initial conditions.....	98
6.5.2.4.2	Procedure.....	99
6.5.2.5	Test Requirement	99
6.5.3	OTA Transmitter transient period.....	99
6.5.3.1	Definition and applicability.....	99
6.5.3.2	Minimum Requirement	100
6.5.3.3	Test purpose	100
6.5.3.4	Method of test	100
6.5.3.4.1	Initial conditions.....	100
6.5.3.4.2	Procedure.....	100
6.5.3.5	Test Requirement	101
6.6	OTA Transmitted signal quality	101
6.6.1	General.....	101
6.6.2	OTA Frequency Error.....	101
6.6.2.1	Definition and applicability.....	101
6.6.2.2	Minimum Requirement	102
6.6.2.3	Test purpose	102
6.6.2.4	Method of test	102
6.6.2.5	Test Requirement	102
6.6.2.5.1	UTRA FDD test requirement	102
6.6.2.5.2	E-UTRA and NR test requirement	102
6.6.3	OTA Time alignment error	102
6.6.3.1	Definition and applicability.....	102
6.6.3.2	Minimum Requirement	103
6.6.3.3	Test purpose	103
6.6.3.4	Method of test	103
6.6.3.4.1	Initial conditions.....	103
6.6.3.4.1.1	General test conditions.....	103
6.6.3.4.1.2	UTRA FDD.....	103
6.6.3.4.1.3	E-UTRA and NR	103
6.6.3.4.2	Procedure.....	104
6.6.3.4.2.1	General Procedure.....	104
6.6.3.4.2.2	UTRA FDD Procedure	104
6.6.3.4.2.3	E-UTRA and NR Procedure	104
6.6.3.5	Test Requirement	105
6.6.3.5.1	UTRA FDD test requirement	105
6.6.3.5.2	E-UTRA test requirement.....	105

6.6.3.5.3	NR test requirement.....	105
6.6.4	OTA modulation quality	105
6.6.4.1	Definition and applicability.....	105
6.6.4.2	Minimum Requirement	105
6.6.4.3	Test purpose	106
6.6.4.4	Method of test	106
6.6.4.4.1	UTRA method of test	106
6.6.4.4.1.1	Initial conditions	106
6.6.4.4.1.2	Procedure	106
6.6.4.4.1.2.1	General procedure	106
6.6.4.4.1.2.3	PCDE procedure.....	107
6.6.4.4.1.2.4	RCDE procedure.....	107
6.6.4.4.2	E-UTRA and NR method of test	107
6.6.4.4.2.1	Initial conditions	107
6.6.4.4.2.2	Procedure	107
6.6.4.5	Test Requirement	108
6.6.4.5.1	UTRA test requirement	108
6.6.4.5.2	E-UTRA and NR test requirement	109
6.7	OTA Unwanted Emissions	109
6.7.1	General.....	109
6.7.2	OTA occupied bandwidth.....	110
6.7.2.1	Definition and applicability.....	110
6.7.2.2	Minimum Requirement	110
6.7.2.3	Test purpose	110
6.7.2.4	Method of test	110
6.7.2.4.1	Initial conditions	110
6.7.2.4.1.1	General test conditions.....	110
6.7.2.4.1.2	UTRA FDD.....	111
6.7.2.4.1.3	E-UTRA and NR	111
6.7.2.4.2	Procedure.....	111
6.7.2.5	Test Requirement	112
6.7.2.5.1	MSR	112
6.7.2.5.2	UTRA FDD	112
6.7.2.5.3	E-UTRA	113
6.7.3	OTA Adjacent Channel Leakage power Ratio.....	113
6.7.3.1	Definition and applicability.....	113
6.7.3.2	Minimum Requirement	113
6.7.3.3	Test purpose	113
6.7.3.4	Method of test	113
6.7.3.4.1	Initial conditions	113
6.7.3.4.1.1	General test conditions.....	113
6.7.3.4.1.2	MSR.....	113
6.7.3.4.1.3	UTRA FDD.....	113
6.7.3.4.1.4	E-UTRA.....	114
6.7.3.4.1.5	NR.....	114
6.7.3.4.2	Procedure.....	114
6.7.3.4.2.1	General.....	114
6.7.3.4.2.2	MSR.....	114
6.7.3.4.2.3	UTRA FDD.....	115
6.7.3.4.2.4	E-UTRA.....	115
6.7.3.5	Test Requirement	115
6.7.3.5.1	MSR	115
6.7.3.5.1.1	MSR E-UTRA test requirement	115
6.7.3.5.1.2	MSR UTRA FDD test requirement	118
6.7.3.5.1.3	OTA Cumulative ACLR test requirement in non-contiguous spectrum.....	119
6.7.3.5.1.4	NR test requirement	121
6.7.3.5.2	UTRA FDD	122
6.7.3.5.2.1	OTA ACLR.....	122
6.7.3.5.2.2	OTA Cumulative ACLR test requirement in non-contiguous spectrum or multiple bands	123
6.7.3.5.3	E-UTRA	124
6.7.3.5.3.1	OTA ACLR.....	124
6.7.3.5.3.2	OTA Cumulative ACLR test requirement in non-contiguous spectrum	126

6.7.4	OTA Spectrum emission mask	127
6.7.4.1	Definition and applicability.....	127
6.7.4.2	Minimum requirement	127
6.7.4.3	Test purpose	127
6.7.4.4	Method of test	127
6.7.4.4.1	Initial conditions.....	127
6.7.4.4.1.1	General test conditions.....	127
6.7.4.4.1.2	UTRA FDD.....	128
6.7.4.4.2	Procedure.....	128
6.7.4.5	Test Requirement	129
6.7.4.5.1	UTRA FDD	129
6.7.5	OTA Operating band unwanted emission.....	139
6.7.5.1	Definition and applicability.....	139
6.7.5.2	Minimum Requirement	139
6.7.5.3	Test purpose	140
6.7.5.4	Method of test	140
6.7.5.4.1	Initial conditions.....	140
6.7.5.4.2	Procedure.....	140
6.7.5.5	Test Requirement	141
6.7.5.5.1	General	141
6.7.5.5.2	MSR Band categories 1 and 3	141
6.7.5.5.3	MSR Band Category 2.....	149
6.7.5.5.4	MSR Additional requirements.....	156
6.7.5.5.4.1	Limits in FCC Title 47.....	156
6.7.5.5.4.2	Unsynchronized operation for BC3	156
6.7.5.5.4.3	Protection of DTT.....	157
6.7.5.5.5	E-UTRA	157
6.7.5.5.5.1	General.....	157
6.7.5.5.5.2	Wide Area BS (Category A).....	158
6.7.5.5.5.3	Wide Area BS Category B (Option1)	163
6.7.5.5.5.4	Wide Area BS Category B (Option 2)	167
6.7.5.5.5.5	Local Area BS (Category A and B)	169
6.7.5.5.5.6	Medium Range BS (Category A and B)	171
6.7.5.5.5.7	Additional requirements.....	176
6.7.6	OTA Spurious emission.....	178
6.7.6.1	General.....	178
6.7.6.2	Mandatory Requirements	178
6.7.6.2.1	Definition and applicability.....	178
6.7.6.2.2	Minimum Requirement	178
6.7.6.2.3	Test purpose	178
6.7.6.2.4	Method of test.....	179
6.7.6.2.4.1	Initial conditions	179
6.7.6.2.4.2	Procedure	179
6.7.6.2.5	Test Requirement.....	180
6.7.6.2.5.1	MSR operation.....	180
6.7.6.2.5.2	Single RAT UTRA operation	181
6.7.6.2.5.3	Single RAT E-UTRA operation.....	182
6.7.6.3	Protection of the BS receiver of own or different BS	182
6.7.6.3.1	Definition and applicability	182
6.7.6.3.2	Minimum Requirement	182
6.7.6.3.3	Test purpose	183
6.7.6.3.4	Method of test.....	183
6.7.6.3.4.1	Initial conditions	183
6.7.6.3.4.2	Procedure	183
6.7.6.3.5	Test Requirement.....	184
6.7.6.3.5.1	MSR operation.....	184
6.7.6.3.5.2	Single RAT UTRA operation	185
6.7.6.3.5.3	Single RAT E-UTRA operation.....	185
6.7.6.4	Additional spurious emissions requirements.....	185
6.7.6.4.1	Definition and applicability	185
6.7.6.4.2	Minimum Requirement	185
6.7.6.4.3	Test purpose	186

6.7.6.4.4	Method of test.....	186
6.7.6.4.4.1	Initial conditions	186
6.7.6.4.4.2	Procedure	186
6.7.6.4.5	Test Requirement.....	187
6.7.6.4.5.1	MSR operation.....	187
6.7.6.4.5.1.1	E-UTRA and NR MSR operation	187
6.7.6.4.5.2	Single RAT UTRA operation	196
6.7.6.4.5.3	Single RAT E-UTRA operation.....	203
6.7.6.5	Co-location with other base stations	214
6.7.6.5.1	Definition and applicability	214
6.7.6.5.2	Minimum Requirement	214
6.7.6.5.3	Test purpose	214
6.7.6.5.4	Method of test.....	214
6.7.6.5.4.1	Initial conditions	214
6.7.6.5.4.2	Procedure	214
6.7.6.5.5	Test Requirement.....	214
6.8	OTA Transmitter intermodulation.....	232
6.8.1	Definition and applicability	232
6.8.2	Minimum Requirement	232
6.8.3	Test purpose.....	232
6.8.4	Method of test.....	232
6.8.4.1	Initial conditions	232
6.8.4.2	Procedure	233
6.8.5	Test Requirement.....	235
7	Radiated receiver characteristics	239
7.1	General	239
7.2	OTA sensitivity	240
7.2.1	Definition and applicability	240
7.2.2	Minimum Requirement.....	241
7.2.3	Test Purpose.....	241
7.2.4	Method of test.....	241
7.2.4.1	Initial conditions	241
7.2.4.2	Procedure	241
7.2.5	Test Requirements	242
7.2.5.1	General	242
7.2.5.2	UTRA FDD Test Requirements.....	242
7.2.5.3	UTRA TDD 1,28Mcp option Test Requirements	242
7.2.5.4	E-UTRA Test Requirements	243
7.2.5.5	NR Test Requirements	243
7.3	OTA Reference sensitivity level	243
7.3.1	Definition and applicability	243
7.3.2	Minimum Requirement.....	244
7.3.3	Test purpose.....	244
7.3.4	Method of test.....	244
7.3.4.1	Initial conditions	244
7.3.4.2	Procedure	244
7.3.5	Test Requirement.....	245
7.3.5.1	General	245
7.3.5.2	UTRA FDD Test Requirements.....	245
7.3.5.3	E-UTRA Test Requirements	245
7.3.5.4	NR Test Requirements	246
7.4	OTA Dynamic range	247
7.4.1	Definition and applicability	247
7.4.2	Minimum Requirement.....	247
7.4.3	Test purpose.....	247
7.4.4	Method of test.....	247
7.4.4.1	Initial conditions	247
7.4.4.2	Procedure	248
7.4.5	Test Requirement.....	248
7.4.5.1	UTRA FDD operation.....	248
7.4.5.2	E-UTRA operation.....	249

7.4.5.3	NR operation	250
7.5	OTA Adjacent channel selectivity, general blocking, and narrowband blocking	254
7.5.1	Definition and applicability	254
7.5.2	Minimum Requirement	254
7.5.3	Test purpose	255
7.5.4	Method of test	255
7.5.4.1	Initial conditions	255
7.5.4.2	Procedure	255
7.5.4.2.1	General procedure	255
7.5.4.2.2	MSR operation	255
7.5.4.2.2.1	Procedure for general blocking	255
7.5.4.2.2.2	Procedure for narrowband blocking	256
7.5.4.2.2.3	Procedure for additional BC3 blocking requirement	256
7.5.4.2.3	Single RAT UTRA FDD operation	256
7.5.4.2.4	Single RAT E-UTRA operation	257
7.5.4.2.4.1	Procedure for adjacent channel selectivity	257
7.5.4.2.4.2	Procedure for narrow-band blocking	257
7.5.5	Test Requirement	257
7.5.5.1	MSR operation	257
7.5.5.1.1	General blocking test requirement	257
7.5.5.1.2	General narrowband blocking test requirement	259
7.5.5.1.3	Additional BC3 blocking test requirement	260
7.5.5.2	Single RAT UTRA FDD operation	261
7.5.5.3	Single RAT E-UTRA operation	261
7.6	OTA Blocking	264
7.6.1	General	264
7.6.2	General Requirement	265
7.6.2.1	Definition and applicability	265
7.6.2.2	Minimum Requirement	265
7.6.2.3	Test purpose	265
7.6.2.4	Method of test	265
7.6.2.4.1	Initial conditions	265
7.6.2.4.2	Procedure	265
7.6.2.4.2.1	General procedure	265
7.6.2.5	Test Requirement	267
7.6.2.5.1	MSR operation	267
7.6.3	Co-location Requirement	270
7.6.3.1	Definition and applicability	270
7.6.3.2	Minimum Requirement	271
7.6.3.3	Test purpose	271
7.6.3.4	Method of test	271
7.6.3.4.1	Initial conditions	271
7.6.3.4.2	Procedure	271
7.6.3.5	Test Requirement	271
7.7	OTA Receiver spurious emissions	286
7.7.1	Definition and applicability	286
7.7.2	Minimum Requirement	287
7.7.3	Test purpose	287
7.7.4	Method of test	287
7.7.4.1	Initial conditions	287
7.7.4.2	Procedure	287
7.7.5	Test Requirement	288
7.8	OTA Receiver intermodulation	288
7.8.1	Definition and applicability	288
7.8.2	Minimum Requirement	289
7.8.3	Test purpose	289
7.8.4	Method of test	289
7.8.4.1	Initial conditions	289
7.8.4.2	Procedure	289
7.8.4.2.1	General procedure	289
7.8.4.2.2	MSR operation	290
7.8.4.2.3	Single RAT UTRA FDD operation	290

7.8.4.2.4	Single RAT E-UTRA operation	290
7.8.5	Test Requirement	291
7.8.5.1	MSR operation	291
7.8.5.1.1	General intermodulation test requirement	291
7.8.5.1.2	General narrowband intermodulation test requirement	293
7.8.5.2	Single RAT UTRA operation.....	296
7.8.5.3	Single RAT E- UTRA operation	297
7.9	OTA In-channel selectivity	301
7.9.1	Definition and applicability	301
7.9.2	Minimum Requirement	301
7.9.3	Test purpose.....	302
7.9.4	Method of test	302
7.9.4.1	Initial conditions	302
7.9.4.2	Procedure	302
7.9.5	Test Requirement.....	303
7.9.5.1	E-UTRA test requirement	303
7.9.5.2	NR test requirement	304
8	Radiated performance requirements.....	307
8.1	General	307
8.1.1	OTA demodulation branches	307
8.2	Radiated performance requirements for MSR.....	308
8.3	Radiated performance requirements for UTRA FDD.....	308
8.3.1	General.....	308
8.3.2	Definitions and applicability.....	309
8.3.3	Minimum requirements.....	309
8.3.4	Test purposes	310
8.3.5	Method of test	310
8.3.5.1	Initial conditions	310
8.3.5.2	Procedure	310
8.3.6	Test requirements.....	311
8.4	Radiated performance requirements for E-UTRA.....	311
8.4.1	General.....	311
8.4.2	Definitions and applicability.....	312
8.4.3	Minimum requirements.....	313
8.4.4	Test purposes	313
8.4.5	Method of test	313
8.4.5.1	Initial conditions	313
8.4.5.2	Procedure	314
8.4.6	Test requirements.....	315
8.5	Radiated performance requirements for NR.....	315
8.5.1	General.....	315
8.5.2	Definitions and applicability.....	316
8.5.3	Minimum requirements.....	316
8.5.4	Test purposes	316
8.5.5	Method of test	316
8.5.5.1	Initial conditions	316
8.5.5.2	Procedure	317
8.5.6	Test requirements.....	317
Annex A (normative):	Test system characterization.....	318
Annex B (normative):	Calibration.....	319
Annex C (informative):	Test tolerances and derivation of test requirements.....	320
C.1	General	320
C.2	Measurement of transmitter (OTA).....	321
C.3	Measurement of receiver (OTA)	323
Annex D (informative):	Test system set-up	324

D.1	Transmitter	324
D.1.1	Radiated Transmit Power, OTA E-UTRA DL RS power, output power dynamics and Transmitter signal quality	324
D.1.2	OTA Base Station output power, ACLR, OTA spectrum emissions mask, OTA operating band unwanted emissions	325
D.1.3	OTA spurious emissions	325
D.1.4	OTA Co-location emissions, TX OFF power	326
D.1.5	OTA Transmitter Intermodulation	326
D.2	Receiver	327
D.2.1	OTA sensitivity and OTA Reference sensitivity	327
D.2.2	OTA Dynamic range	327
D.2.3	OTA Adjacent channel selectivity, general blocking, and narrowband blocking	328
D.2.4	OTA Blocking	329
D.2.5	OTA Receiver spurious emissions	330
D.2.6	OTA Receiver intermodulation	330
D.2.7	OTA In-channel selectivity	331
D.3	Performance requirements	332
Annex E (normative): Estimation of Measurement Uncertainty		333
E.1	General	333
E.2	Measurement methodology descriptions	333
E.3	Measurement uncertainty budget format	333
E.4	Measurement uncertainty budgets	333
E.5	Measurement error contribution descriptions	333
Annex F (normative): TRP measurement grids		334
F.1	General	334
F.2	Spherical equal angle grid	334
F.2.1	General	334
F.2.2	Reference angular step criteria	334
F.3	Spherical equal area grid	336
F.4	Spherical Fibonacci grid	336
F.5	Orthogonal cut grid	337
F.6	Wave vector space grid	338
F.7	Orthogonal 2 cuts with pattern multiplication	338
F.8	Orthogonal 2 or 3 cut with dense sampling	339
F.8.1	Operating band unwanted emissions	339
F.8.2	Spurious unwanted emissions	339
F.9	Full sphere with sparse sampling	339
F.10	Beam-based directions	340
F.11	Peak method	340
F.12	Equal sector with peak average	340
F.13	Pre-scan	341
Annex G (normative): Environmental requirements for the BS equipment		342
G.1	General	342
G.2	Normal test environment	342
G.3	Extreme test environment	342

G.3.1	General	342
G.3.2	Extreme temperature	342
G.4	Vibration.....	343
G.5	Power supply	343
G.6	Measurement of test environments.....	343
G.7	OTA extreme test methods.....	344
G.7.1	Direct far field method	344
G.7.2	Relative method.....	344
Annex H (informative):	Measuring noise close to noise-floor.....	346
Annex I (informative):	Change history	347
History		349

Foreword

This Technical Specification has been produced by the 3rd Generation Partnership Project (3GPP).

The contents of the present document are subject to continuing work within the TSG and may change following formal TSG approval. Should the TSG modify the contents of the present document, it will be re-released by the TSG with an identifying change of release date and an increase in version number as follows:

Version x.y.z

where:

- x the first digit:
 - 1 presented to TSG for information;
 - 2 presented to TSG for approval;
 - 3 or greater indicates TSG approved document under change control.
- y the second digit is incremented for all changes of substance, i.e. technical enhancements, corrections, updates, etc.
- z the third digit is incremented when editorial only changes have been incorporated in the document.

1 Scope

The present document specifies radiated test methods and conformance requirements for 2 types of AAS BS; *hybrid requirements set* which specify requirements for a *hybrid AAS BS* with both a conducted and a radiated interface and *OTA requirements set* which specify requirements for an *OTA AAS BS* which has a radiated interface only.

The *hybrid AAS BS* requirements are specified for E-UTRA AAS Base Station (BS), the FDD mode of UTRA AAS Base Station (BS), the 1,28 Mcps TDD mode of UTRA AAS Base Station (BS) in single RAT and any MSR AAS Base Station (BS) implementation of these RATs including NR operation.

The *OTA AAS BS* requirements are specified for E-UTRA AAS Base Station (BS), the FDD mode of UTRA AAS Base Station (BS), in single RAT and any MSR AAS Base Station (BS) implementation of these RATs and/or NR.

The requirements have been derived from, and are consistent with non-AAS BS specifications in 3GPP TS 25.104 [2], 3GPP TS 25.105 [3], 3GPP TS 36.104 [4] or 3GPP TS 37.104 [5] and where applicable with the NR specification 38.104 [33]. The technical specification 3GPP TS 37.145 is in 2 parts, part 3GPP TS 37.145-1 [9] covers conducted requirements and part 3GPP TS 37.145-2 (the present document) covers radiated requirements.

The present document does not establish radiated test methods and conformance requirements for Band 46 operation as it is not supported by AAS BS. Conducted Band 46 test requirements are still applicable for AAS BS for protection of and against Band 46 operation, as specified in 3GPP TS 37.145-1 [9].

The present document does not establish minimum RF characteristics or minimum performance requirements for Narrow-Band Internet of Things (NB-IoT) in band, NB-IoT guard band, or standalone NB-IoT operation, for AAS BS in *single RAT E-UTRA operation* or in *MSR operation* using E-UTRA.

2 References

The following documents contain provisions which, through reference in this text, constitute provisions of the present document.

- References are either specific (identified by date of publication, edition number, version number, etc.) or non-specific.
- For a specific reference, subsequent revisions do not apply.
- For a non-specific reference, the latest version applies. In the case of a reference to a 3GPP document (including a GSM document), a non-specific reference implicitly refers to the latest version of that document *in the same Release as the present document*.

- [1] 3GPP TR 21.905: "Vocabulary for 3GPP Specifications".
- [2] 3GPP TS 25.104: "Base Station (BS) radio transmission and reception (FDD)".
- [3] 3GPP TS 25.105: "Base Station (BS) radio transmission and reception (TDD)".
- [4] 3GPP TS 36.104: "Evolved Universal Terrestrial Radio Access (E-UTRA); Base Station (BS) radio transmission and reception".
- [5] 3GPP TS 37.104: "NR, E-UTRA, UTRA and GSM/EDGE; Multi-Standard Radio (MSR) Base Station (BS) radio transmission and reception".
- [6] 3GPP TS 37.105: "Active Antenna System (AAS) Base Station (BS) transmission and reception".
- [7] 3GPP TR 37.842: "E-UTRA and UTRA; Radio Frequency (RF) requirement background for Active Antenna System (AAS) Base Station (BS)".
- [8] Recommendation ITU-R M.1545: "Measurement uncertainty as it applies to test limits for the terrestrial component of International Mobile Telecommunications-2000".
- [9] 3GPP TS 37.145-1: "Active Antenna System (AAS) Base Station (BS) conformance testing; Part 1: Conducted conformance testing".

- [10] 3GPP TS 25.141: "Base Station (BS) conformance testing (FDD)".
- [11] 3GPP TS 25.142: "Base Station (BS) conformance testing (TDD)".
- [12] 3GPP TS 36.141: "Evolved Universal Terrestrial Radio Access (E-UTRA); Base Station (BS) conformance testing".
- [13] 3GPP TS 37.141: "NR, E-UTRA, UTRA and GSM/EDGE; Multi-Standard Radio (MSR) Base Station (BS) conformance testing".
- [14] Recommendation ITU-R M.328: "Spectra and bandwidth of emissions".
- [15] 3GPP TS 25.331 (V14.3.0): "Radio Resource Control (RRC); Protocol specification (Release 14)".
- [16] Recommendation ITU-R SM.329-10: "Unwanted emissions in the spurious domain".
- [17] FCC publication number 662911: "Emissions Testing of Transmitters with Multiple Outputs in the Same Band"
- [18] "Title 47 of the Code of Federal Regulations (CFR)", Federal Communications Commission
- [19] CEPT ECC Decision (13)03, "The harmonised use of the frequency band 1452-1492 MHz for Mobile/Fixed Communications Networks Supplemental Downlink (MFCN SDL)".
- [20] IEC 60721: "Classification of environmental conditions"
- [21] IEC 60721-3-3: "Classification of environmental conditions - Part 3-3: Classification of groups of environmental parameters and their severities - Stationary use at weather protected locations"
- [22] IEC 60721-3-4: "Classification of environmental conditions - Part 3: Classification of groups of environmental parameters and their severities - Section 4: Stationary use at non-weather protected locations"
- [23] ETSI EN 300 019-1-3: "Environmental Engineering (EE); Environmental conditions and environmental tests for telecommunications equipment; Part 1-3: Classification of environmental conditions; Stationary use at weatherprotected locations"
- [24] ETSI EN 300 019-1-4: "Environmental Engineering (EE); Environmental conditions and environmental tests for telecommunications equipment; Part 1-4: Classification of environmental conditions; Stationary use at non-weatherprotected locations"
- [25] IEC 60068-2-1 (2007): "Environmental testing - Part 2: Tests. Tests A: Cold"
- [26] IEC 60068-2-2 (2007): "Environmental testing - Part 2: Tests. Tests B: Dry heat"
- [27] IEC 60068-2-6 (2007): "Environmental testing - Part 2: Tests - Test Fc: Vibration (sinusoidal)"
- [28] 3GPP TS 36.211: "Evolved Universal Terrestrial Radio Access (E-UTRA); Physical channels and modulation"
- [29] 3GPP TR 37.843: "Radio Frequency (RF) requirement background for Active Antenna System (AAS) Base Station (BS) radiated requirements"
- [30] Recommendation ITU-T O.153: "Basic parameters for the measurement of error performance at bit rates below the primary rate"
- [31] 3GPP TR 25.942: "Radio Frequency (RF) system scenarios".
- [32] 3GPP TS 45.004: "Digital cellular telecommunications system (Phase 2+); Modulation".
- [33] 3GPP TS 38.104: "NR Base Station (BS) radio transmission and reception".
- [34] 3GPP TS 38.141-2: "Base Station (BS) conformance testing Part 2: Radiated conformance testing".
- [35] 3GPP TS 38.141-1: "NR;Base Station (BS) conformance testing; Part 1: Conducted conformance testing".

[36] 3GPP TS 38.211: "NR; Physical channels and modulation".

3 Definitions, symbols and abbreviations

3.1 Definitions

For the purposes of the present document, the terms and definitions given in 3GPP TR 21.905 [1] and the following apply. A term defined in the present document takes precedence over the definition of the same term, if any, in 3GPP TR 21.905 [1].

AAS BS receiver: composite receiver function of an AAS BS receiving in an operating band

active antenna system base station: base station system which combines an Antenna Array with an Active transceiver unit array and a *Radio Distribution Network*

band category: group of operating bands for which the same MSR scenarios apply

Base Station RF Bandwidth: bandwidth in which a base station transmits and/or receives single or multiple carrier(s) and/or RATs simultaneously within a supported operating band

NOTE: In single carrier operation, the *Base Station RF Bandwidth* is equal to the channel bandwidth.

Base Station RF Bandwidth edge: frequency of one of the edges of the *Base Station RF Bandwidth*

beam: main lobe of a radiation pattern from an AAS BS

NOTE: For certain AAS antenna array, there may be more than one beam.

beam centre direction: direction equal to the geometric centre of the -3 dB EIRP contour of the beam

beam direction pair: data set consisting of the *beam centre direction* and the related *beam peak direction*

beam peak direction: direction where the maximum EIRP is supposed to be found

beamwidth: angles describing the major and minor axes of an ellipsoid closest fit to an essentially elliptic half-power contour of a beam

carrier: modulated waveform conveying the physical channels

carrier aggregation: aggregation of two or more NR or E-UTRA component carriers in order to support wider *transmission bandwidths*

channel bandwidth: RF bandwidth supporting a single RF carrier with the *transmission bandwidth* configured in the uplink or downlink of a cell

NOTE 1: The *channel bandwidth* is measured in MHz and is used as a reference for transmitter and receiver RF requirements.

NOTE 2: For UTRA FDD, the *channel bandwidth* is the nominal channel spacing specified in 3GPP TS 25.104 [2]. For UTRA TDD 1,28 Mcps, the *channel bandwidth* is the nominal channel spacing specified in 3GPP TS 25.105 [3].

NOTE 3: For E-UTRA, the *channel bandwidths* are specified in 3GPP TS 36.104 [4].

NOTE 4: In TS 38.104 [33] for NR, *channel bandwidths* are referred to as BS channel bandwidths, since for NR BS and UE channel bandwidths may differ.

channel edge: lowest or highest frequency of the NR carrier, separated by the *BS channel bandwidth*

contiguous spectrum: spectrum consisting of a contiguous block of spectrum with no *sub-block gap(s)*

demodulation branch: single input of the *AAS BS receiver* to the demodulation algorithms

NOTE 1: For UTRA FDD, *non-AAS BS a demodulation branch* is referred to as a receive diversity branch or an UL MIMO branch. For E-UTRA *non-AAS BS a demodulation branch* is referred to as an RX antenna in the performance requirement tables.

NOTE 2: The term "RX antenna" in clause 8 (i.e. Performance requirements) of the E-UTRA specification 3GPP TS 36.104 [4] does not refer to physical receiver antennas.

co-location reference antenna: a passive antenna used as reference for base station to base station co-location requirements

contiguous spectrum: spectrum consisting of a contiguous block of spectrum with no *sub-block gap(s)*

downlink operating band: part of the (FDD) operating band designated for downlink

equivalent isotropic radiated power: equivalent power radiated from an isotropic directivity device producing the same field intensity at a point of observation as the field intensity radiated in the direction of the same point of observation by the discussed device

NOTE: Isotropic directivity is equal in all directions (0 dBi).

equivalent isotropic sensitivity: sensitivity for an isotropic directivity device equivalent to the sensitivity of the discussed device exposed to an incoming wave from a defined AoA

NOTE 1: The sensitivity is the minimum received power level at which a RAT specific requirement is met.

NOTE 2: Isotropic directivity is equal in all directions (0 dBi).

fractional bandwidth: fractional bandwidth FBW is defined as $FBW = 200 \cdot \frac{F_{FBWhigh} - F_{FBWlow}}{F_{FBWhigh} + F_{FBWlow}} \%$

highest carrier: the carrier with the highest carrier frequency transmitted/received in a specified frequency band

hybrid AAS BS: AAS BS which has both a conducted RF interface and a radiated RF interface in the far field and conforms to a *hybrid requirements set*

NOTE: For NR operation, a *hybrid AAS BS* corresponds to NR *type 1-H* in [34].

hybrid requirements set: complete set of requirements applied to a *hybrid AAS BS* with both conducted and radiated requirements

inter-band carrier aggregation: carrier aggregation of component carriers in different operating bands

NOTE: Carriers aggregated in each band can be contiguous or non-contiguous.

intra-band contiguous carrier aggregation: *contiguous carriers* aggregated in the same operating band

intra-band non-contiguous carrier aggregation: non-contiguous carriers aggregated in the same operating band

Inter RF Bandwidth gap: frequency gap between two consecutive *Base Station RF Bandwidths* that are placed within two supported operating bands

maximum carrier TRP: mean power level measured per RIB during the *transmitter ON period* for a specific carrier in a specified reference condition and corresponding to the declared *rated carrier TRP* ($P_{rated,c,TRP}$)

maximum transmitter TRP: mean power level measured per RIB during the *transmitter ON period* in a specified reference condition and corresponding to the declared *rated transmitter TRP* ($P_{rated,t,TRP}$)

minSENS: the lowest declared EIS value for the OSDD's declared for OTA sensitivity requirement.

minSENS RoAoA: the *reference RoAoA* associated with the OSDD with the lowest declared EIS value.

MSR operation: operation of AAS BS declared to be MSR in particular *operating band(s)*

multi-band RIB: *operating band* specific RIB which is paired with one or more additional *operating band* specific RIBs where the multiple bands are supported through common active electronic component(s)

non-AAS BS: BS conforming to one of the RF requirement specifications 3GPP TS 25.104 [2], 3GPP TS 25.105 [3], 3GPP TS 36.104 [4] or 3GPP TS 37.104 [5]

non-contiguous spectrum: spectrum consisting of two or more *sub-blocks* separated by *sub-block gap(s)*

operating band: frequency range in which the AAS BS operates (paired or unpaired), that is defined with a specific set of technical requirements

OTA AAS BS: AAS BS which has ≥ 8 *transceiver units* for E-UTRA or MSR and ≥ 4 *transceiver units* for UTRA per cell and has a radiated RF interface only and conforms to the *OTA requirements set*.

NOTE: For NR operation, an *OTA AAS BS* corresponds to an NR *type 1-O* BS in [34].

OTA coverage range: a common range of directions within which TX OTA requirements that are neither specified in the *OTA peak directions sets* nor as *TRP requirement* are intended to be met

OTA coverage range: a common range of directions within which TX OTA requirements that are neither specified in the *OTA peak directions sets* nor as TRP requirement are intended to be met

OTA peak directions set: set(s) of *beam peak directions* within which certain TX OTA requirements are intended to be met, where all *OTA peak directions set(s)* are subsets of the *OTA coverage range*

NOTE 1: The *beam peak directions* are related to a corresponding contiguous range or discrete list of *beam centre directions* by the *beam direction pairs* included in the set.

NOTE 2: *OTA peak directions set* definition (applicable to multiple *directional requirements*) is replacing the Rel-13/14 *EIRP accuracy directions set* definition (which was applicable to EIRP requirement only).

OTA REFSENS RoAoA: Is the RoAoA determined by the contour defined by the points at which the achieved EIS is 3dB higher than the achieved EIS in the reference direction assuming that for any AoA, the receiver gain is optimized for that AoA.

NOTE: This contour will be related to the average element/sub-array radiation pattern 3dB beam width.

OTA requirements set: complete set of OTA requirements applied to an *OTA AAS BS*.

OTA sensitivity directions declaration: set of manufacturer declarations comprising one or more EIS values (with related RAT and *channel bandwidth*), and the directions where it (they) applies

NOTE: All the directions apply to all the EIS values in an OSDD.

polarization match: condition that exists when a plane wave, incident upon an antenna from a given direction, has a polarization that is the same as the receiving polarization of the antenna in that direction

radiated interface boundary: *operating band* specific radiated requirements reference where the radiated requirements apply.

NOTE: For requirements based on EIRP/EIS, the radiated interface boundary is associated to the far-field region.

Radio Bandwidth: frequency difference between the upper edge of the highest used carrier and the lower edge of the lowest used carrier.

radio distribution network: passive network which distributes radio signals generated by the transceiver unit array to the antenna array, and/or distributes the radio signals collected by the antenna array to the transceiver unit array

NOTE: In the case when the active transceiver units are physically integrated with the array elements of the antenna array, the radio distribution network is a one-to-one mapping.

rated beam EIRP: EIRP that is declared as being achieved in the *beam peak direction* associated with a particular *beam direction pair*

rated carrier TRP: mean power level declared by the manufacturer per carrier, for BS operating in single carrier, multi-carrier, or carrier aggregation configurations that the manufacturer has declared to be available at the RIB during the *transmitter ON period*

rated transmitter TRP: mean power level declared by the manufacturer to be available at the RIB during the *transmitter ON period*

receiver target: angles of arrival in which reception is performed

receiver target redirection range: union of all the *sensitivity RoAoA* achievable through redirecting the *receiver target* related to the OSDD

receiver target reference direction: direction inside the *receiver target redirection range* declared by the manufacturer for conformance testing.

NOTE For an OSDD without *receiver target redirection range*, this is a direction inside the *sensitivity RoAoA*.

reference beam direction: declared *beam direction pair*, including reference *beam centre direction* and reference *beam peak direction* where the reference *beam peak direction* is the direction for the intended maximum EIRP within the EIRP accuracy compliance directions set

reference beam direction pair: declared *beam direction pair*, including reference *beam centre direction* and reference *beam peak direction* where the reference *beam peak direction* is the direction for the intended maximum EIRP within the *OTA peak directions set*

reference RoAoA: the *sensitivity RoAoA* associated with the *receiver target reference direction* for each OSDD.

sensitivity RoAoA: RoAoA within which the declared EIS(s) of an OSDD is intended to be achieved at any instance of time for a specific AAS BS direction setting

single-band RIB: *operating band* specific RIB without any common active electronic component(s) shared with other *operating bands*

single RAT E-UTRA operation: operation of AAS BS declared to be single RAT E-UTRA in the *operating band*

NOTE: *Single RAT E-UTRA operation* does not cover in-band NB-IoT, nor guardband NB-IoT operation.

single RAT UTRA operation: operation of AAS BS declared to be single RAT UTRA in the *operating band*

sTTI: A transmission time interval (TTI) of either one slot or one subslot as defined in TS 36.211 [38] on either uplink or downlink.

sub-block: one contiguous allocated block of spectrum for use by the same Base Station

NOTE There may be multiple instances of *sub-blocks* within a *Base Station RF Bandwidth*.

sub-block gap: frequency gap between two consecutive *sub-blocks* within an *Base Station RF Bandwidth*, where the RF requirements in the gap are based on co-existence for un-coordinated operation

TAB connector: transceiver array boundary connector

throughput: number of payload bits successfully received per second for a reference measurement channel in a specified reference condition

total radiated power: is the total power radiated by the antenna.

NOTE 1: The *total radiated power* is the power radiating in all direction for two orthogonal polarizations.

NOTE 2: *total radiated power* is defined in both the near-field region and the far-field region.

total RF bandwidth: maximum sum of Base Station RF Bandwidths in all supported *operating bands*

transceiver array boundary: conducted interface between the transceiver unit array and the composite antenna

transmission bandwidth: bandwidth of an instantaneous E-UTRA transmission from a UE or BS, measured in Resource Block units

uplink operating band: part of the (FDD) operating band designated for uplink

3.2 Symbols

For the purposes of the present document, the following symbols apply:

β	Percentage of the mean transmitted power emitted outside the occupied bandwidth on the assigned channel
BeW_{θ}	The Beam width in θ
BeW_{ϕ}	The Beam width in ϕ
$BeW_{\theta,REFSENS}$	The beamwidth equivalent to the OTA REFSENS RoAoA in the θ -axis in degrees.
$BeW_{\phi,REFSENS}$	The beamwidth equivalent to the OTA REFSENS RoAoA in the ϕ -axis in degrees.
$BW_{Channel}$	Channel bandwidth (for E-UTRA or NR)
$BW_{Channel_CA}$	Aggregated channel bandwidth, expressed in MHz. $BW_{Channel_CA} = F_{edge_high} - F_{edge_low}$.
BW_{Config}	Transmission bandwidth configuration (for E-UTRA), expressed in MHz, where $BW_{Config} = N_{RB} \times 180$ kHz in the uplink and $BW_{Config} = 15$ kHz + $N_{RB} \times 180$ kHz in the downlink.
BW_{tot}	Total RF bandwidth
$DwPTS$	Downlink part of the special subframe (for E-UTRA TDD) operation
E_b	Average energy per information bit (for UTRA)
f	Frequency
Δf	Separation between the Base Station RF bandwidth edge frequency and the nominal -3dB point of the measuring filter closest to the carrier frequency
Δf_{max}	The largest value of Δf used for defining the requirement
Δf_{OBUE}	Maximum offset of the <i>operating band</i> unwanted emissions mask from the downlink <i>operating band</i> edge
Δf_{OOB}	Maximum offset of the out-of-band boundary from the uplink <i>operating band</i> edge
$\Delta f_{minSENS}$	Difference between conducted reference sensitivity and $EIS_{minsens}$
$\Delta f_{OTAREFSENS}$	Difference between conducted reference sensitivity and OTA REFSENS
Δf_{sample}	The difference between the nominal and extreme power measurements dueing extreme EIRP testing, $P_{max,sample,nom} - P_{max,sample,ex}$
$EIS_{minsens}$	The EIS declared for the <i>minSENS RoAoA</i>
F_C	Carrier centre frequency
F_{filter}	Filter centre frequency
f_{offset}	Separation between the Base Station RF bandwidth edge frequency and the centre of the measuring filter
$f_{offset_{max}}$	The maximum value of f_{offset} used for defining the requirement
$F_{BW\ RF,high}$	Upper RF bandwidth edge, where $F_{BW\ RF,high} = F_{C,high} + F_{offset, RAT}$
$F_{BW\ RF,low}$	Lower RF bandwidth edge, where $F_{BW\ RF,low} = F_{C,low} - F_{offset, RAT}$
F_C	<i>RF reference frequency</i> on the channel raster
$F_{C,high}$	Centre frequency of the highest transmitted/received carrier.
$F_{C,low}$	Centre frequency of the lowest transmitted/received carrier.
F_{DL_low}	The lowest frequency of the downlink <i>operating band</i>
F_{DL_high}	The highest frequency of the downlink <i>operating band</i>
F_{edge_low}	The lower edge of aggregated channel bandwidth, expressed in MHz. $F_{edge_low} = F_{C,low} - F_{offset}$.
F_{edge_high}	The upper edge of aggregated channel bandwidth, expressed in MHz. $F_{edge_high} = F_{C,high} + F_{offset}$.
	$F_{offset, RAT}$ Frequency offset from the centre frequency of the <i>highest</i> transmitted/received carrier to the <i>upper</i> RF bandwidth edge, sub-block edge or inter-RF bandwidth edge, or from the centre frequency of the <i>lowest</i> transmitted/received carrier to the <i>lower</i> RF bandwidth edge, sub-block edge or inter-RF bandwidth edge for a specific RAT.
$F_{FBWhigh}$	Highest supported frequency within supported operating band, for which <i>fractional bandwidth</i> support was declared
F_{FBWlow}	Lowest supported frequency within supported operating band, for which <i>fractional bandwidth</i> support was declared
F_{UL_low}	The lowest frequency of the <i>uplink operating band</i>
F_{UL_high}	The highest frequency of the <i>uplink operating band</i>
F_{uw}	Frequency offset of unwanted signal
N_{cells}	The declared number corresponding to the minimum number of cells that can be transmitted by an AAS BS in a particular band with transmission on all transceiver units supporting the operating band
N_0	Total one-sided noise power spectral density due to all noise sources (for UTRA)
$N_{RXU,active}$	The number of active receiver units. The same as the number of <i>demodulation branches</i> to which compliance is declared for chapter 8 performance requirements

N_{RB}	Transmission bandwidth configuration, expressed in units of resource blocks (for E-UTRA)
$P_{max,c,EIRP}$	The maximum carrier EIRP when the AAS BS is configured at the rated carrier TRP ($P_{Rated,c,TRP}$)
$P_{max,c,EIRP,extreme}$	The maximum carrier EIRP when the AAS BS is configured at the rated carrier TRP ($P_{Rated,c,TRP}$) under extreme conditions, either measured directly or calculated.
$P_{max,c,TRP}$	The maximum carrier TRP per cell
$P_{max,sample,nom}$	The measured sample power in extreme conditionals chamber when the AAS BS is configured at the rated carrier TRP ($P_{rated,c,TRP}$), under nominal conditions.
$P_{max,sample,ext}$	The measured sample power in extreme conditionals chamber when the AAS BS is configured at the rated carrier TRP ($P_{rated,c,TRP}$), under extreme conditions. $P_{max,t,TRP}$ the maximum total output power per cell
$P_{rated,c,EIRP}$	The rated carrier EIRP when the AAS BS is configured at the rated carrier TRP ($P_{rated,c,TRP}$)
$P_{rated,c,FBHigh}$	The rated carrier EIRP for the higher supported frequency range within supported <i>operating band</i> , for which <i>fractional bandwidth</i> support was declared
$P_{rated,c,FBLow}$	The rated carrier EIRP for the lower supported frequency range within supported <i>operating band</i> , for which <i>fractional bandwidth</i> support was declared
$P_{rated,c,TRP}$	The rated carrier TRP
$P_{rated,t,TRP}$	Rated transmitter TRP declared per RIB
W_{gap}	<i>Sub-block gap size</i> or <i>Inter RF Bandwidth gap size</i>
θ	The angle in the reference coordinate system between the projection of the x/y plane and the radiation vector defined between -90° and 90° . 0° represents the direction perpendicular to the y/z plane. The angle is aligned with the down-tilt angle.
ϕ	The angle in the reference coordinate system between the x-axis and the projection of the radiation vector onto the x/y plane defined between -180° and 180° .
$P_{REFSENS}$	Conducted reference Sensitivity power level
$TRP_{Estimate}$	Numerically approximated TRP

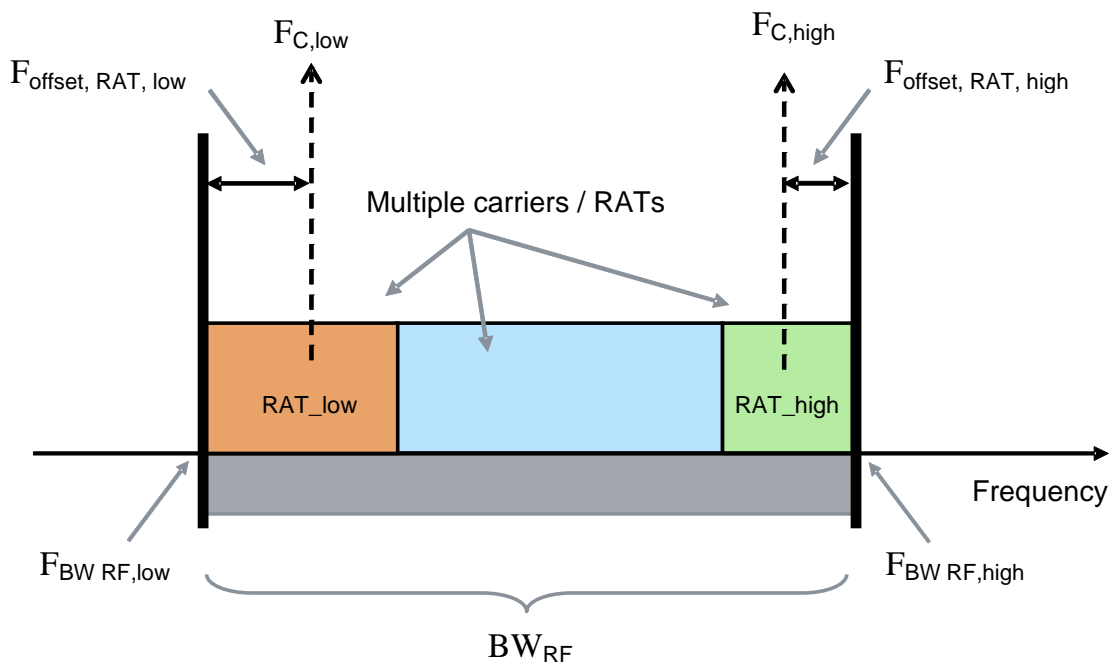

Figure 3.2-1: Illustration of RF bandwidth related symbols and definitions for Multi-standard Radio

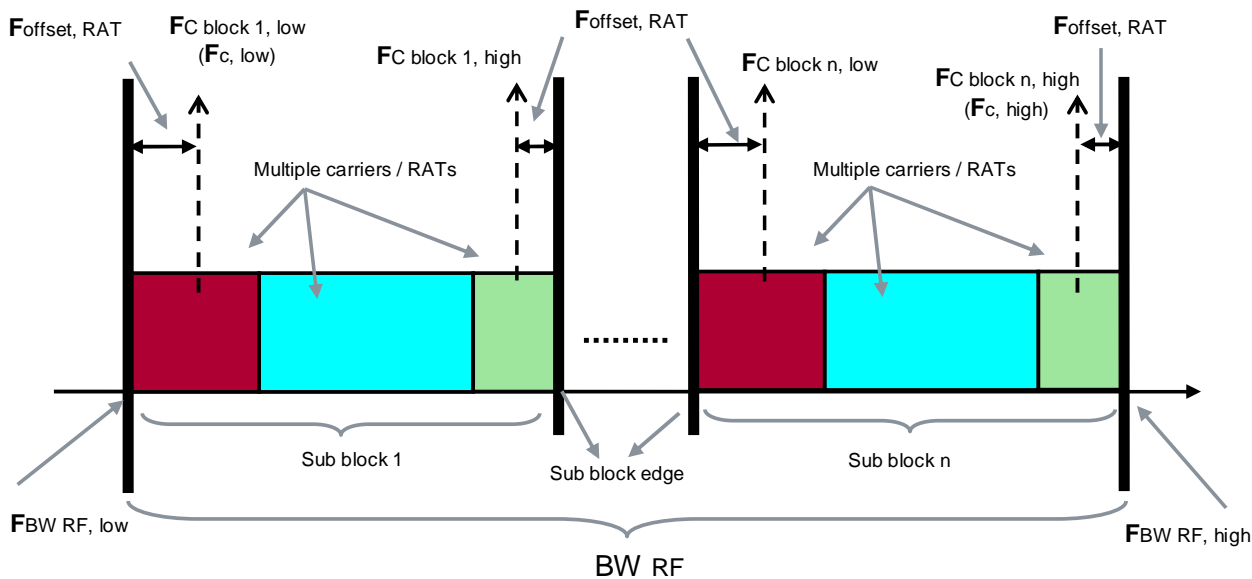

Figure 3.2-2: Illustration of RF bandwidth related symbols and definitions for non-contiguous Multi-standard Radio

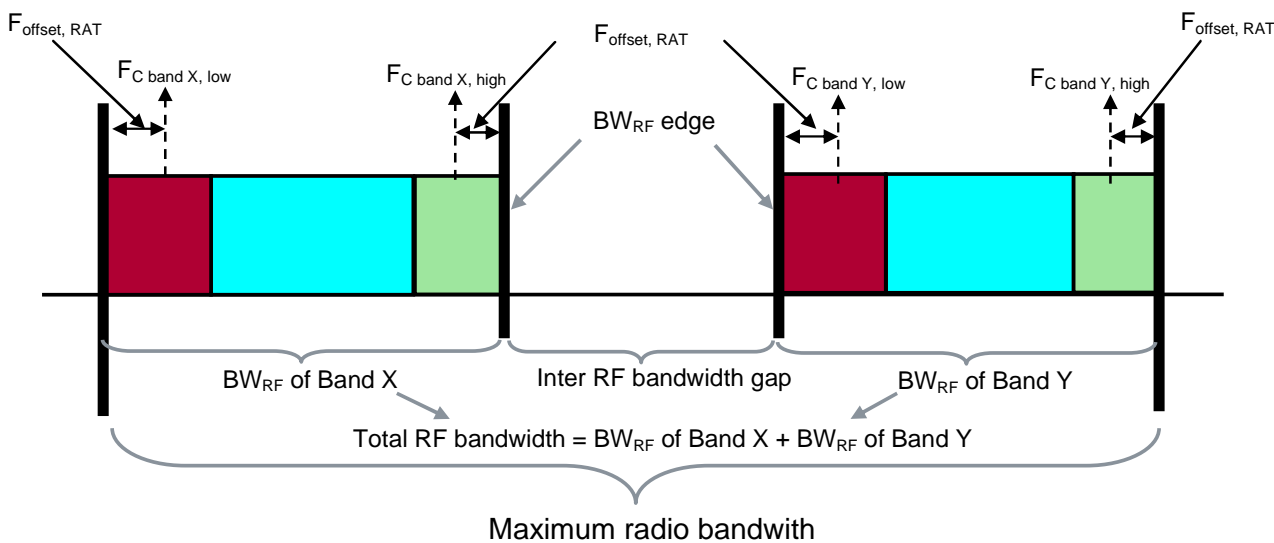

Figure 3.2-3: Illustration of maximum radio bandwidth and Total RF bandwidth for Multi-band Multi-standard Radio

3.3 Abbreviations

For the purposes of the present document, the abbreviations given in 3GPP TR 21.905 [1] and the following apply. An abbreviation defined in the present document takes precedence over the definition of the same abbreviation, if any, in 3GPP TR 21.905 [1].

AAS BS	Active Antenna System Base Station
ACLR	Adjacent Channel Leakage Ratio
ACS	Adjacent Channel Selectivity
AoA	Angle of Arrival
BC	Band Category
BER	Bit Error Rate
BLER	Block Error Rate

CA	Carrier Aggregation
CACLR	Cumulative ACLR
CLTA	Co-Location Test Antenna
DTT	Digital Terrestrial Television
DUT	Device Under Test
DIP	Dominant Interferer Proportion
EIRP	Equivalent Isotropic Radiated Power
EIS	Equivalent Isotropic Sensitivity
FBW	Fractional Bandwidth
FDD	Frequency Division Duplex
FRC	Fixed Reference Channel
ICS	In-Channel Selectivity
ITU	International Telecommunication Union
ITU-R	Radio communication Sector of the ITU
MB-MSR	Multi-Band Multi-Standard Radio
MBT	Multi-Band Testing
MC	Multi-Carrier in a Single RAT
NR	New Radio
OBW	Occupied Band Width
OSDD	OTA Sensitivity Directions Declaration
OTA	Over The Air
RAT	Radio Access Technology
RB	Resource Block (for E-UTRA)
RDN	Radio Distribution Network
REFSENS	Reference Sensitivity
RIB	Radiated Interface Boundary
RF	Radio Frequency
RoAoA	Range of Angles of Arrival
SBT	Single Band Testing
SC	Single-Carrier
sPDSCH	shortened Physical Downlink Shared Channel
TAB	Transceiver Array Boundary
TAE	Time Alignment Error
TDD	Time Division Duplex
TRP	Total Radiated Power
TT	Test Tolerance
UE	User Equipment

4 General test conditions and declarations

4.1 Measurement uncertainties and test requirements

4.1.1 General

The requirements of this clause apply to all applicable tests in part 2 of this specification, i.e. to all AAS BS radiated tests.

The minimum requirements for AAS BS radiated requirements are given in 3GPP TS 37.105 [14] subclause 9 and 10 for the radiated transmitter and radiated receiver characteristics, respectively. Test Tolerances for the radiated test requirements explicitly stated in part 2 of the present specification are given in annex C of this specification.

Test Tolerances are individually calculated for each test. The Test Tolerances are used to relax the minimum requirements to create test requirements.

When a test requirement differs from the corresponding minimum requirement, then the Test Tolerance applied for the test is non-zero. The Test Tolerance for the test and the explanation of how the minimum requirement has been relaxed by the Test Tolerance are given in annex C.

Table 4.1.1-1: Overview of radiated Tx requirements

AAS BS requirement		OTA requirement type	Coverage range	Notes
Base station output power	Output power accuracy for EIRP	Directional	OTA peak directions set	Output power accuracy for EIRP requirement is already included as a core requirement in TS 37.105 [].
	Output power accuracy for TRP	TRP	N/A	
E-UTRA DL RS power		Directional	OTA peak directions set	Conformance testing is carried out in the reference direction
Output power dynamics		Directional	OTA peak directions set	Conformance testing is carried out in the reference direction.
Transmitter OFF power		Co-location	N/A	
Frequency Error		Directional	OTA coverage range	Conformance testing is carried out in the reference direction.
Time Alignment Error		Directional	OTA coverage range	Conformance testing is carried out in the reference direction.
Modulation Quality (EVM)		Directional	OTA coverage range	Conformance testing is carried out in the reference direction and the maximum directions of the OTA coverage range on each axis.
Unwanted emissions	Occupied Bandwidth	Directional	OTA coverage range	Conformance testing is carried out in the reference direction.
	Adjacent Channel Leakage Ratio (ACLR)	TRP	N/A	
	Spectrum emission mask	TRP	N/A	
Spurious emissions	Mandatory Requirements	TRP	N/A	
	Protection of the BS receiver of own or different BS	Co-location	N/A	
	Additional spurious emissions requirements	TRP	N/A	Includes co-existence in same geographical area
	Co-location with other base stations	Co-location	N/A	
Transmitter intermodulation		Co-location	N/A	The interferer is applied as a co-location requirements, the radiated emissions requirements are specified in the appropriated referenced sub-clause, generally TRP
NOTE: Directional does not imply one compliance direction only. The requirement applies to a single direction at a time.				

Table 4.1.1-2: Overview of radiated Rx requirements

AAS BS requirement	OTA requirement type	Applicability levels	Coverage range	Number of conformance directions
OTA sensitivity	Directional	N/A	<i>Receiver redirection target range (D10.8)</i>	5
OTA reference sensitivity	Directional	OTA REFSSENS	<i>OTA REFSSENS RoAoA</i>	5

Dynamic range		Directional	OTA REFSENS	<i>OTA REFSENS RoAoA</i>	1
In-band selectivity and blocking		Directional	OTA REFSENS and minSENS	<i>OTA REFSENS RoAoA and minSENS RoAoA</i>	5
ACS and narrowband blocking		Directional	OTA REFSENS (NB blocking only) and minSENS	<i>OTA REFSENS RoAoA (NB blocking only) minSENS RoAoA (NB blocking and ACS)</i>	5 (blocking) 1 (ACS)
Out-of-band blocking	Mandatory	Directional	<i>minSENS</i>	<i>minSENS RoAoA</i>	1
	Co-location with other base stations	Co-location	N/A	N/A	
Receiver spurious emissions		TRP	N/A	N/A	-
Receiver intermodulation		Directional	OTA REFSENS and minSENS	<i>OTA REFSENS RoAoA and minSENS RoAoA</i>	1
In-channel selectivity		Directional	<i>minSENS</i>	<i>minSENS RoAoA</i>	1
NOTE: Directional does not imply one compliance direction only. The requirement applies to a single direction at a time.					

4.1.2 Acceptable uncertainty of Test System

4.1.2.1 General

The maximum acceptable uncertainty of the Test System is specified below for each test defined explicitly in the present specification, where appropriate.

The Test System shall enable the stimulus signals in the test case to be adjusted to within the specified tolerance and the equipment under test to be measured with an uncertainty not exceeding the specified values. All tolerances and uncertainties are absolute values, and are valid for a confidence level of 95 %, unless otherwise stated.

A confidence level of 95 % is the measurement uncertainty tolerance interval for a specific measurement that contains 95 % of the performance of a population of test equipment.

For details on measurement uncertainty budget calculation, OTA measurement methodology description (including calibration and measurement stage for each test range), MU budget format and its contributions, refer to TR 37.843 [29].

4.1.2.2 Measurement of transmitter

Table 4.1.2.2-1: Maximum Test System uncertainty for transmitter tests

Subclause	Maximum Test System Uncertainty	Derivation of Test System Uncertainty
6.2 Radiated transmit power (Normal conditions)	± 1.1 dB, $f \leq 3.0$ GHz ± 1.3 dB, 3.0 GHz $< f \leq 4.2$ GHz	See 3GPP TR 37.842 [7], subclause 10.3.2.2. Uncertainty budget contributors as well as uncertainty budget assessment described in annex E.
6.2 Radiated transmit power (extreme conditions)	± 2.5 dB, $f \leq 3.0$ GHz ± 2.6 dB, 3.0 GHz $< f \leq 4.2$	See 3GPP TR 37.843 [28], subclause 10.2.8. Uncertainty budget contributors as well as uncertainty budget assessment described in annex C.
6.3.2 OTA Maximum output power	± 1.4 dB, $f \leq 3.0$ GHz ± 1.5 dB, 3.0 GHz $< f \leq 4.2$ GHz	See 3GPP TR 37.843 [28], subclause 10.4.1. Uncertainty budget contributors as well as uncertainty budget assessment described in annex C.
6.3.3 OTA E-UTRA DL RS power	1.3 dB, $f \leq 3.0$ GHz 1.5 dB, 3.0 GHz $< f \leq 4.2$ GHz	See 3GPP TR 37.843 [28], subclause 10.2.2. Uncertainty budget contributors as well as uncertainty budget assessment described in annex C.
6.4.2 OTA UTRA Inner loop power control in the downlink	0.1 dB	See 3GPP TR 37.843 [28], subclause 10.2.3. Uncertainty budget contributors as well as uncertainty budget assessment described in annex C.
6.4.3 OTA Power control dynamic range	1.1 dB	See 3GPP TR 37.843 [28], subclause 10.2.3. Uncertainty budget contributors as well as uncertainty budget assessment described in annex C.
6.4.4 OTA Total power dynamic range	0.3 dB UTRA 0.4 dB E-UTRA & NR	See 3GPP TR 37.843 [28], subclause 10.2.3. Uncertainty budget contributors as well as uncertainty budget assessment described in annex C.
6.4.5 OTA IPDL time mask	0.7 dB	See 3GPP TR 37.843 [28], subclause 10.2.3. Uncertainty budget contributors as well as uncertainty budget assessment described in annex C.
6.5 OTA Transmit ON/OFF power	± 3.4 dB, $f \leq 3.0$ GHz ± 3.6 dB, 3.0 GHz $< f \leq 4.2$ GHz (NOTE 1)	See 3GPP TR 37.843 [28], subclause 10.6.2. Uncertainty budget contributors as well as uncertainty budget assessment described in annex C.
6.6.2 OTA Frequency Error	12 Hz	See 3GPP TR 37.843 [28], subclause 10.2.4. Uncertainty budget contributors as well as uncertainty budget assessment described in annex C.
6.6.3 OTA Time Alignment Error	25 ns	See 3GPP TR 37.843 [28], subclause 10.2.6. Uncertainty budget contributors as well as uncertainty budget assessment described in annex C.
6.6.4 OTA Modulation Quality	1 %	See 3GPP TR 37.843 [28], subclause 10.2.5. Uncertainty budget contributors as well as uncertainty budget assessment described in annex C.
6.7.2 OTA occupied bandwidth	30 kHz: BW_{Channel} 1.4 MHz, 3 MHz 100 kHz: BW_{Channel} 5 MHz, 10 MHz 300 kHz: BW_{Channel} 15 MHz, 20 MHz 25 MHz, 30 MHz, 40 MHz, 50 MHz 600 kHz: BW_{Channel} 60 MHz, 70 MHz, 80 MHz, 90 MHz, 100 MHz	See 3GPP TR 37.843 [28], subclause 10.2.7. Uncertainty budget contributors as well as uncertainty budget assessment described in annex C.
6.7.3 OTA ACLR/CACLR	± 1.0 dB, $f \leq 3.0$ GHz ± 1.2 dB, 3.0 GHz $< f \leq 4.2$ Absolute limit ± 2.2 dB, $f \leq 3.0$ GHz ± 2.7 dB, 3.0 GHz $< f \leq 4.2$ GHz	See 3GPP TR 37.843 [28], subclause 10.4.2. Uncertainty budget contributors as well as uncertainty budget assessment described in annex C.
6.7.4 OTA Spectrum emission mask	± 1.8 dB, $f \leq 3.0$ GHz ± 2.0 dB, 3.0 GHz $< f \leq 4.2$ GHz	See 3GPP TR 37.843 [28], subclause 10.4.4. Uncertainty budget contributors as well as uncertainty budget assessment described in annex C.
6.7.5 OTA Operating band unwanted emissions	± 1.8 dB, $f \leq 3.0$ GHz ± 2.0 dB, 3.0 GHz $< f \leq 4.2$ GHz	See 3GPP TR 37.843 [28], subclause 10.4.3. Uncertainty budget contributors as well as uncertainty budget assessment described in annex C.
6.7.6.2 OTA Transmitter spurious emissions, Mandatory Requirements	± 2.3 dB, 30 MHz $< f \leq 6$ GHz ± 4.2 dB, 6 GHz $< f \leq 19$ GHz	See 3GPP TR 37.843 [28], subclause 10.5. Uncertainty budget contributors as well as uncertainty budget assessment described in annex C.
6.7.6.3 Transmitter spurious emissions, Protection of BS receiver	± 3.1 dB, $f \leq 3.0$ GHz ± 3.3 dB, 3.0 GHz $< f \leq 4.2$ GHz (NOTE 1)	See 3GPP TR 37.843 [28], subclause 10.6.3. Uncertainty budget contributors as well as uncertainty budget assessment described in annex C.

6.7.6.4 Transmitter spurious emissions, Additional spurious emission requirements	±2.6 dB, $f \leq 3.0\text{GHz}$ ±3.0 dB, $3.0\text{GHz} < f \leq 4.2\text{GHz}$	See 3GPP TR 37.843 [28], subclause 10.5. Uncertainty budget contributors as well as uncertainty budget assessment described in annex C.
6.7.6.5 Transmitter spurious emissions, Co-location	±3.1 dB, $f \leq 3.0\text{GHz}$ ±3.3 dB, $3.0\text{GHz} < f \leq 4.2\text{GHz}$ (NOTE 1)	See 3GPP TR 37.843 [28], subclause 10.6.3. Uncertainty budget contributors as well as uncertainty budget assessment described in annex C.
6.8 OTA Transmitter intermodulation (interferer requirements) This tolerance applies to the stimulus and not the measurements defined in 6.8	The value below applies only to the interfering signal and is unrelated to the measurement uncertainty of the tests (6.6.1, 6.6.2 and 6.6.4) which have to be carried out in the presence of the interferer. ±3.2 dB, $f \leq 3.0\text{GHz}$ ±3.4 dB, $3.0\text{GHz} < f \leq 4.2\text{GHz}$ (NOTE 1)	See 3GPP TR 37.843 [28], subclause 10.6.4. Uncertainty budget contributors as well as uncertainty budget assessment described in annex C.
NOTE 1: Fulfilling the criteria for CLTA selection and placement in subclause 4.15 is deemed sufficient for the test purposes. When these criteria are met, the measurement uncertainty related to the selection of the co-location test antenna and its alignment as specified in the appropriate measurement uncertainty budget in TR 37.843 [28], subclause 10.6 shall be used for evaluating the test system uncertainty.		

4.1.2.3 Measurement of receiver

Table 4.1.2.3-1: Maximum Test System Uncertainty for receiver tests

Subclause	Maximum Test System Uncertainty	Derivation of Test System Uncertainty
7.2 OTA Sensitivity	± 1.3 dB, $f \leq 3.0$ GHz ± 1.4 dB, 3.0 GHz $< f \leq 4.2$ GHz	See 3GPP TR 37.842 [7], subclause 10.3.2.2. Uncertainty budget contributors as well as uncertainty budget assessment described in annex E.
7.3 OTA Reference Sensitivity	± 1.3 dB, $f \leq 3.0$ GHz ± 1.4 dB, 3.0 GHz $< f \leq 4.2$ GHz	See 3GPP TR 37.842 [7], subclause 10.3.2.2. Uncertainty budget contributors as well as uncertainty budget assessment described in annex E.
7.4 OTA Dynamic range	± 0.3 dB	See 3GPP TR 37.843 [28], subclause 10.3.4. Uncertainty budget contributors as well as uncertainty budget assessment described in annex C.
7.5 OTA Adjacent channel selectivity, general blocking, and narrowband blocking	± 1.7 dB, $f \leq 3.0$ GHz ± 2.1 dB, 3.0 GHz $< f \leq 4.2$ GHz	See 3GPP TR 37.843 [28], subclause 10.3.5. Uncertainty budget contributors as well as uncertainty budget assessment described in annex C.
7.5 OTA In-band general blocking,	± 1.9 dB, $f \leq 3.0$ GHz ± 2.2 dB, 3.0 GHz $< f \leq 4.2$ GHz	See 3GPP TR 37.843 [28], subclause 10.3.5. Uncertainty budget contributors as well as uncertainty budget assessment described in annex C.
7.6.2 OTA Blocking	$f_{\text{wanted}} \leq 3$ GHz 1 MHz $< f_{\text{interferer}} \leq 3$ GHz: ± 2.0 dB 3 GHz $< f_{\text{interferer}} \leq 6$ GHz: ± 2.1 dB 6 GHz $< f_{\text{interferer}} \leq 12.75$ GHz: ± 3.5 dB 3 GHz $< f_{\text{wanted}} \leq 4.2$ GHz: 1 MHz $< f_{\text{interferer}} \leq 3$ GHz: ± 2.0 dB 3 GHz $< f_{\text{interferer}} \leq 6$ GHz: ± 2.1 dB 6 GHz $< f_{\text{interferer}} \leq 12.75$ GHz: ± 3.6 dB	See 3GPP TR 37.843 [28], subclause 10.8. Uncertainty budget contributors as well as uncertainty budget assessment described in annex C.
7.6.3 Co-location blocking	$f_{\text{wanted}} \leq 3.0$ GHz: ± 3.4 dB, $f_{\text{interferer}} \leq 3.0$ GHz ± 3.5 dB, 3.0 GHz $< f_{\text{interferer}} \leq 4.2$ GHz 3 GHz $< f_{\text{wanted}} \leq 4.2$ GHz: ± 3.5 dB, $f_{\text{interferer}} \leq 3.0$ GHz ± 3.6 dB, 3.0 GHz $< f_{\text{interferer}} \leq 4.2$ GHz (NOTE 2)	See 3GPP TR 37.843 [28], subclause 10.6.5. Uncertainty budget contributors as well as uncertainty budget assessment described in annex
7.7 Receiver spurious emissions	± 2.5 dB, 30 MHz $< f \leq 6$ GHz: dB ± 4.2 dB, 6 GHz $< f \leq 19$ GHz	See 3GPP TR 37.843 [28], subclause 10.5. Uncertainty budget contributors as well as uncertainty budget assessment described in annex C.
7.8 OTA Receiver intermodulation (General requirements)	± 2.0 dB, $f \leq 3.0$ GHz ± 2.6 dB, 3.0 GHz $< f \leq 4.2$ GHz	See 3GPP TR 37.843 [28], subclause 10.3.6. Uncertainty budget contributors as well as uncertainty budget assessment described in annex C.
7.8 OTA Receiver intermodulation (Narrowband requirements)	± 2.0 dB, $f \leq 3.0$ GHz ± 2.6 dB, 3.0 GHz $< f \leq 4.2$ GHz	See 3GPP TR 37.843 [28], subclause 10.3.6. Uncertainty budget contributors as well as uncertainty budget assessment described in annex C.
7.9 OTA In-channel selectivity	± 1.7 dB, $f \leq 3.0$ GHz ± 2.1 dB, 3.0 GHz $< f \leq 4.2$ GHz	See 3GPP TR 37.843 [28], subclause 10.3.7. Uncertainty budget contributors as well as uncertainty budget assessment described in annex
NOTE 1: Unless otherwise noted, only the Test System stimulus error is considered here. The effect of errors in the throughput measurements or the BER/FER due to finite test duration is not considered.		
NOTE 2: Fulfilling the criteria for CLTA selection and placement in subclause 4.15 is deemed sufficient for the test purposes. When these criteria are met, the measurement uncertainty related to the selection of the co-location test antenna and its alignment as specified in the appropriate measurement uncertainty budget in TR 37.843 [28], subclause 10.6 shall be used for evaluating the test system uncertainty.		

4.1.2.4 Measurement of performance requirement

The measurement uncertainties for the performance requirements are the same as those quoted in TS 36.141 [12] subclause 4.2.1.3 and TS 25.141 [10] subclause 4.1.4.

4.1.3 Interpretation of measurement results

The measurement results returned by the Test System are compared - without any modification - against the test requirements as defined by the Shared Risk principle.

The Shared Risk principle is defined in Recommendation ITU-R M.1545 [8].

The actual measurement uncertainty of the Test System for the measurement of each parameter shall be included in the test report.

The recorded value for the Test System uncertainty shall be, for each measurement, equal to or lower than the appropriate figure in subclause 4.1.2 of the present document.

If the Test System for a test is known to have a measurement uncertainty greater than that specified in subclause 4.1.2, it is still permitted to use this apparatus provided that an adjustment is made as follows.

Any additional uncertainty in the Test System over and above that specified in subclause 4.1.2 shall be used to tighten the test requirement, making the test harder to pass. (For some tests e.g. receiver tests, this may require modification of stimulus signals). This procedure (defined in annex C) will ensure that a Test System not compliant with subclause 4.1.2 does not increase the chance of passing a device under test where that device would otherwise have failed the test if a Test System compliant with subclause 4.1.2 had been used.

4.2 Conducted and radiated requirement reference points

AAS BS requirements are defined for two points of reference, signified by radiated requirements (RIB) and conducted requirements (TAB).

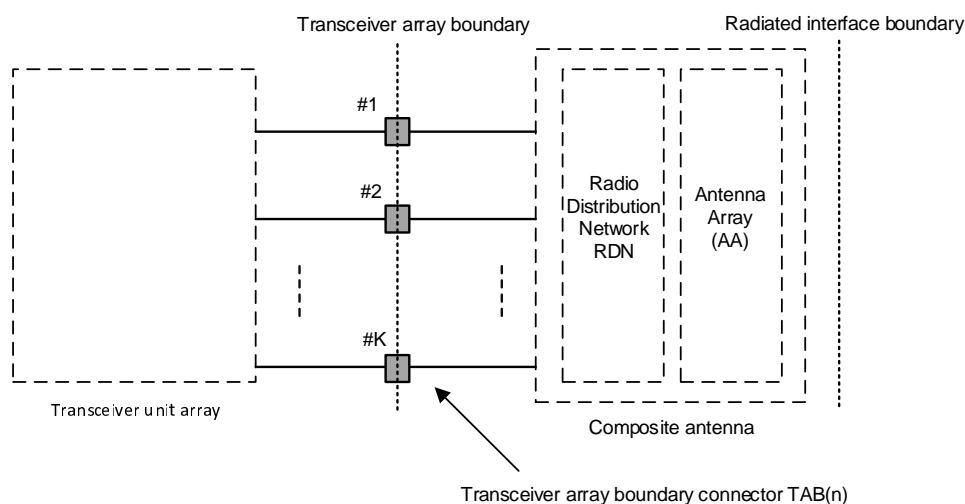

Figure 4.2-1: Radiated and conducted points of reference of hybrid AAS BS

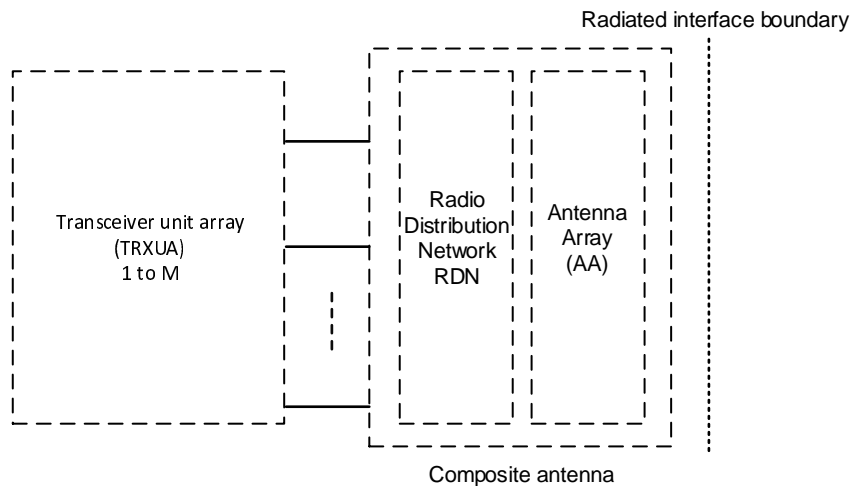

Figure 4.3-2: Radiated points of reference of OTA AAS BS

Radiated characteristics are defined over the air (OTA) at the *radiated interface boundary* (RIB). Radiated requirements are also referred to as OTA requirements. The (spatial) directions in which the OTA requirements apply are detailed for each requirement.

Some OTA requirements are specified as co-location requirements where the requirements are specified at the conducted interface of the *co-location reference antenna*, co-location requirements are further defined in subclause 4.15

Conducted characteristics are defined at individual or groups of *TAB connectors* at the *transceiver array boundary*, which is the conducted interface between the transceiver unit array and the composite antenna.

The transceiver unit array is part of the composite transceiver functionality generating modulated transmit signal structures and performing receiver combining and demodulation.

The transceiver unit array contains an implementation specific number of transmitter units and an implementation specific number of receiver units. Transmitter units and receiver units may be combined into transceiver units. The transmitter/receiver units have the ability to receive/send parallel independent modulated symbol streams.

The composite antenna contains a *radio distribution network* (RDN) and an antenna array. The RDN is a linear passive network that distributes the RF power between the *transceiver array boundary* and the antenna array, in an implementation specific way.

How a conducted requirement is applied to the *transceiver array boundary* is detailed in the respective requirement subclause.

The present document details the test requirements of the radiated requirements only and hence only requires the radiated reference points.

4.3 Base station classes for AAS BS

The requirements in this specification apply to AAS BS of Wide Area BS, Medium Range BS and Local Area BS classes unless otherwise stated.

The base station classes are defined in 3GPP TS 37.105 [6].

4.4 Regional requirements

Some requirements in the present document may only apply in certain regions either as optional requirements, or set by local and regional regulation as mandatory requirements. It is normally not stated in the 3GPP specifications under what exact circumstances that the requirements apply, since this is defined by local or regional regulation.

Table 4.4-1 lists all requirements in the present specification that may be applied differently in different regions. Non-AAS requirements are applicable as defined in the present document. In many cases, such requirements include regional

requirements that are implicitly referenced from the present specification, and listed in the specification for the specifications concerned [2] [5].

Table 4.4-1: List of regional requirements

Clause number	Requirement	Comments
4.6	Operating bands and Band Categories	Some bands may be applied regionally.
6.3	OTA Base Station output power	These requirements apply in Japan for an E-UTRA BS operating in band 34 and Band 41.
6.7.2	OTA Occupied bandwidth	The requirement may be applied regionally. There may also be regional requirements to declare the Occupied bandwidth according to the definition.
6.7.4	OTA Spectrum emission mask	The mask specified may be mandatory in certain regions. In other regions this mask may not be applied. Additional spectrum protection requirements may apply regionally.
6.7.5	OTA Operating band unwanted emissions	The BS may have to comply with the applicable emission limits established by FCC Title 47 [18], when deployed in regions where those limits are applied and under the conditions declared by the manufacturer.
6.7.5	OTA Operating band unwanted emissions	The requirements for unsynchronized TDD co-existence may apply regionally.
6.7.5	OTA Operating band unwanted emissions	The requirements for protection of DTT may apply regionally.
6.7.5	OTA Operating band unwanted emissions	Regional requirement as defined in 3GPP TS 37.104, subclause 6.6.2.4.4 [5] may be applied for the protection of systems operating in frequency bands adjacent to band 1 as defined in 3GPP TS 37.104, subclause 4.5, [5] in geographic areas in which both an adjacent band service and UTRA and/or E-UTRA are deployed.
6.7.5	OTA Operating band unwanted emissions	Additional requirements for band 41 may apply in certain regions as additional operating band unwanted emission limits.
6.7.5	OTA Operating band unwanted emissions	Additional band 32 unwanted emissions requirements may apply in certain regions
6.7.6	OTA Spurious emissions	Category A limits are mandatory for regions where Category A limits for spurious emissions, as defined in Recommendation ITU-R SM.329 [16] apply. Category B limits are mandatory for regions where Category B limits for spurious emissions, as defined in Recommendation ITU-R SM.329 [16] apply.
6.7.6	OTA Spurious emissions	Additional spurious emissions requirements may be applied for the protection of system operating in frequency ranges other than the AAS BS operating band as described in 3GPP TS 37.104 [5] subclause 6.6.1.3 (NOTE).
6.7.6	OTA Spurious emissions	In addition to 3GPP requirements, the BS may have to comply with the applicable emission limits established by FCC Title 47 [18], when deployed in regions where those limits are applied, and under the conditions declared by the manufacturer.
6.7.6	OTA Spurious emissions	Co-location spurious emissions requirements may be applied for the protection of other BS receivers when an MSR BS operating in another frequency band is co-located with an AAS BS.
6.7.6	OTA Spurious emissions	The emission limits specified as the <i>basic limit</i> + X (dB) are applicable, unless stated differently in regional regulation.
6.8	OTA Transmitter intermodulation	Additional requirements may apply in certain regions.
7.6	OTA Blocking	Co-location blocking requirements may be applied for the protection of the BS receiver when a BS operating in another frequency band is co-located with an AAS BS.
7.6	OTA Blocking	For the Public Safety LTE BS in Korea from 718 to 728 MHz in Band 28, regional blocking requirement is specified in TS 36.104 [4], subclause 7.6.3.
7.7	OTA Rx spurious emissions	The emission limits specified as the <i>basic limit</i> + X (dB) are applicable, unless stated differently in regional regulation.
NOTE:	AAS BS does not support Band 46 operation, but additional spurious emissions requirements for Band 46 as described in 3GPP TS 37.104 [5] subclause 6.6.1.3, are still applicable for AAS BS for protection of Band 46 operation.	

4.5 Operating bands and band categories

The operating bands and band categories for AAS BS are the same as for *non-AAS BS*, as described in 3GPP TS 37.104 [6].

NOTE 1: AAS BS does not support GSM, but BC2 is still applicable for protection of/against GSM operation in BC2 operating bands.

NOTE 2: AAS BS does not support Band 46 (and all its sub-bands defined in 3GPP TS 36.104 [4]) operation. Conducted Band 46 test requirements are still applicable for AAS BS for protection of and against Band 46 operation, as specified in 3GPP TS 37.145-1 [9].

4.6 Channel arrangements

The channel arrangements for AAS BS are the same as those for UTRA *non-AAS BS* and E-UTRA *non-AAS BS* as described in 3GPP TS 37.104 [5].

4.7 Requirements for AAS BS capable of multi-band operation

For AAS BS capable of operation in multiple operating bands, the RF requirements in clause 6 and 7 apply separately to each supported operating band unless otherwise stated.

4.8 AAS BS configurations

4.8.1 Transmit configurations

Unless otherwise stated, the radiated transmitter characteristics in clause 6 are specified at the *radiated interface boundary* (RIB). The AAS BS shall have a full complement of transceiver units for the configuration in normal operating conditions.

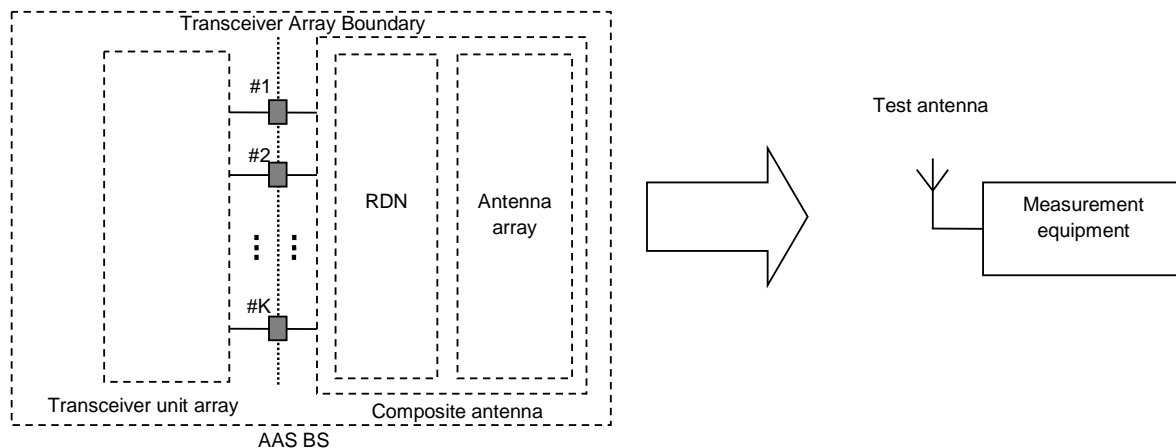

Figure 4.8.1-1: Transmitter test interfaces

Top view

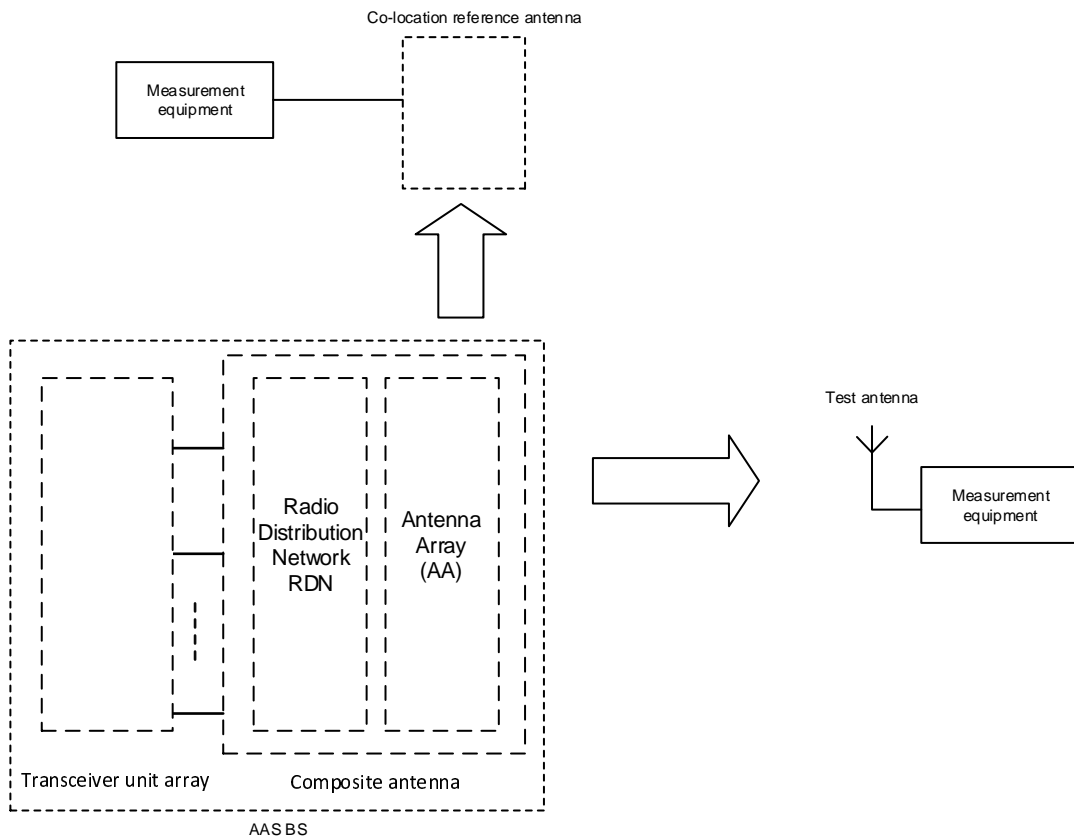

Figure 4.8.1-2: Transmitter test interfaces for co-location concept

4.8.2 Receive configurations

Unless otherwise stated, the radiated receiver characteristics in clause 7 are specified at the *radiated interface boundary* (RIB). The AAS BS shall have a full complement of transceiver units for the configuration in normal operating conditions.

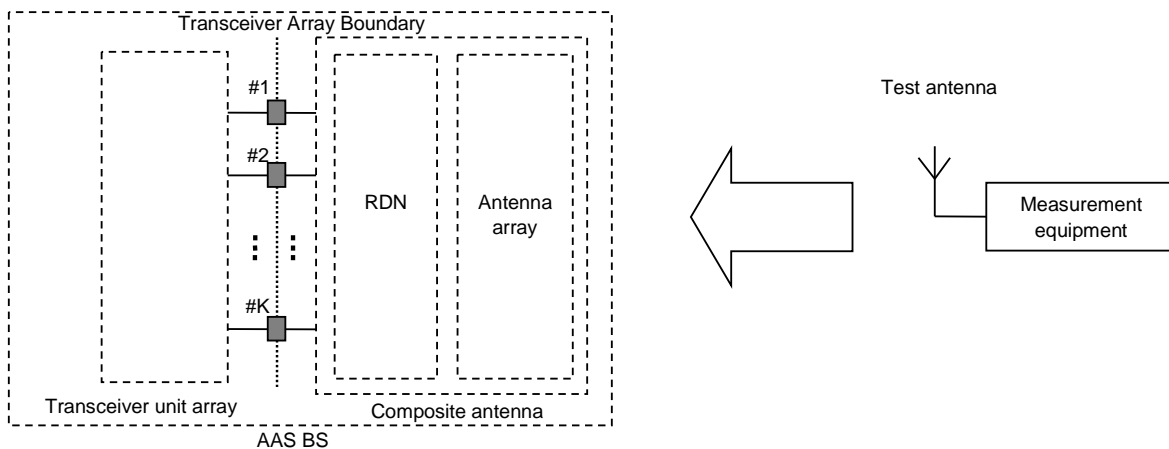

Figure 4.8.2-1: Receiver test interfaces

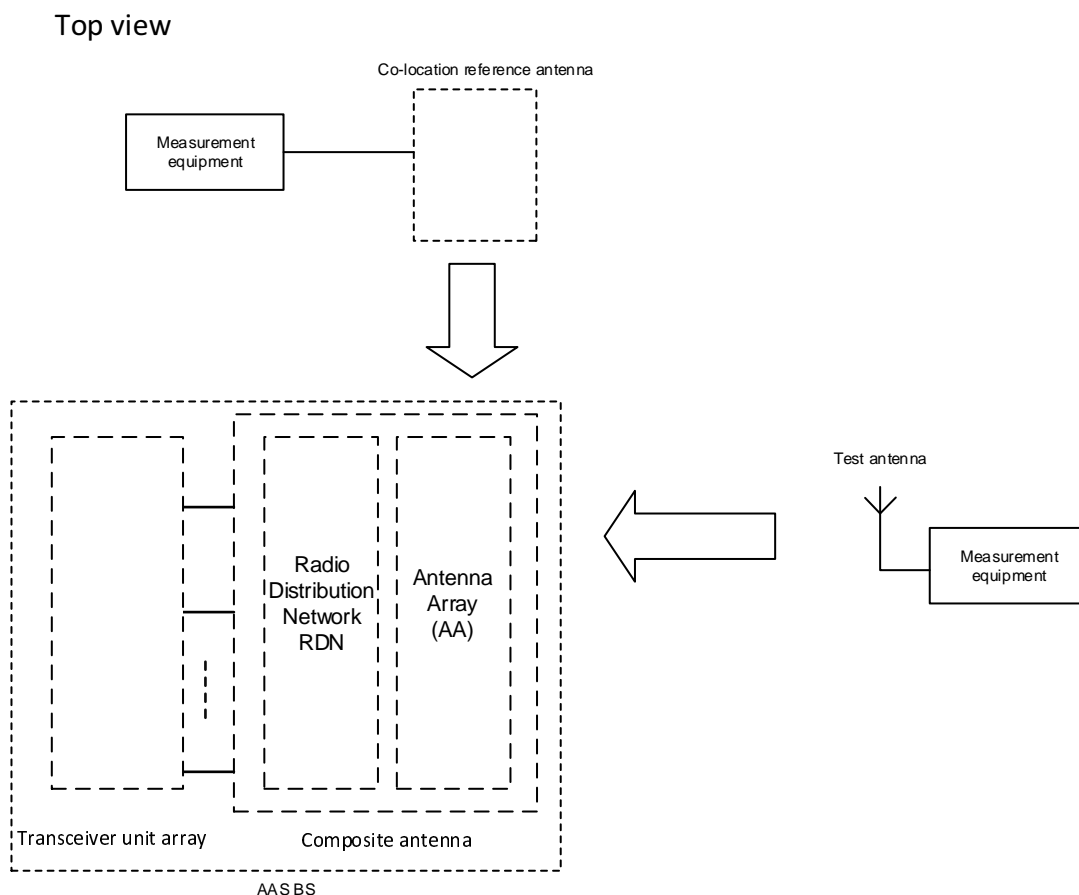

Figure 4.8.2-2: Receiver test interfaces for co-location concept

4.8.3 Power supply options

If the AAS BS is supplied with a number of different power supply configurations, it may not be necessary to test RF parameters for each of the power supply options, provided that it can be demonstrated that the range of conditions over which the equipment is tested is at least as great as the range of conditions due to any of the power supply configurations.

4.8.4 BS with integrated Iuant BS modem

Unless otherwise stated, for the tests in the present document, the integrated Iuant BS modem shall be switched OFF.

4.9 Capability sets

A radiated capability set is defined as the AAS BS capability to support certain RAT combinations in an operating band.

The manufacturer shall declare (D9.25) the supported radiated capability set(s) according to table 4.9-1 for each supported operating band.

Table 4.9-1 Radiated capability sets

Radiated capability Set supported by the AAS BS	RCSA1	RCSA2	RCSA3	RCSA3A	RCSA4	RCSA5
Supported RATs	AAS BS supports MSR operation of UTRA only in the band	AAS BS supports MSR operation of E-UTRA only in the band	AAS BS supports MSR E-UTRA and UTRA in the band	AAS BS supports NR and E-UTRA MSR in the band	AAS BS supports single-RAT UTRA in the band	AAS BS supports single-RAT E-UTRA in the band
Supported configurations	SR UTRA (SC, MC)	SR E-UTRA (SC, MC, CA)	MR UTRA + E-UTRA SR UTRA (SC, MC) SR E-UTRA (SC, MC, CA)	MR E-UTRA + NR SR NR (SC, MC, CA) SR E-UTRA (SC, MC, CA)	SR UTRA (SC, MC)	SR E-UTRA (SC, MC, CA)
Applicable BC	BC1, BC2 or BC3	BC1, BC2 or BC3	BC1, BC2 or BC3	BC1, BC2 or BC3	BC1, BC2 or BC3	BC1, BC2 or BC3

The applicable test configurations for each RF requirement are defined in subclause 5.1, 5.2 and 5.3 for the declared radiated capability set(s). For beams with multi-band beam dependencies the applicable test configurations for each RF requirement are defined in subclause 5.4 for the declared radiated capability set(s).

NOTE: Not every supported configuration within a capability set is tested, but the tables in subclauses 5.2, 5.3 and 5.4 provide a judicious choice among the supported configurations and test configurations to ensure proper test coverage.

4.10 Manufacturer declarations

The AAS BS declarations categories D9.x and D10.x listed in table 4.10-1 are required to be provided by the manufacturer for the radiated requirements testing of the *hybrid AAS BS* or the OTA AAS BS.

For the *hybrid AAS BS* declarations required for the conducted requirements testing, refer to 3GPP TS 37.145-1 [9], subclause 4.10.

NOTE 1: D9.x declarations are related to the radiated Tx requirements, while D10.x declarations are related to the radiated Rx requirements.

NOTE 2: From Rel-15 onwards, additional D11.x declarations are introduced in table 4.10-2 for OTA AAS BS, in order to easily distinguish from the Rel-13/14 OTA declarations which are also applicable for *hybrid AAS BS*. Declarations in table 4.10-2 are applicable to OTA AAS BS only.

Table 4.10-1: Hybrid AAS BS and OTA AAS BS manufacturer declarations for radiated test requirements

Declaration identifier	Declaration	Description
D9.1	Coordinate system reference point	Location of coordinated system reference point in reference to an identifiable physical feature of the AAS BS enclosure.
D9.2	Coordinate system orientation	Orientation of the coordinate system in reference to an identifiable physical feature of the AAS BS enclosure.
D9.3	Beam identifier	A unique title to identify a beam, e.g. a, b, c or 1, 2, 3. The vendor may declare any number of beam with unique identifiers. The minimum set to declare, for conformance, correspond to the beams at the reference beam direction, with the highest intended EIRP, and covering the properties listed below: <ol style="list-style-type: none"> 1) A beam with the narrowest intended BeW_{θ}, and narrowest intended BeW_{ϕ} possible when narrowest intended BeW_{θ} is used. 2) A beam with the narrowest intended BeW_{ϕ} and narrowest intended BeW_{θ} possible when narrowest intended BeW_{ϕ} is used.

Declaration identifier	Declaration	Description
		<p>3) A beam with the widest intended BeW_{θ} and widest intended BeW_{ϕ} possible when widest intended BeW_{θ} is used.</p> <p>4) A beam with the widest intended BeW_{ϕ} and widest intended BeW_{θ} possible when widest intended BeW_{ϕ} is used.</p> <p>5) A beam which provides the highest intended EIRP of all possible beams.</p> <p>NOTE 1: Depending on the capability of the system some of these beams may be the same.</p> <p>When selecting the above five beam widths for declaration, all beams that the AAS BS is intended to produce shall be considered, including beams that during operation may be identified by any kind of cell or UE specific reference signals, with the exception of any type of beam that is created from a group of transmitters that are not all phase synchronised.</p>
D9.4	Operating bands and frequency ranges	<p>List of UTRA or E-UTRA operating band(s) supported by BS and if applicable, frequency range(s) within the <i>operating band(s)</i> that the BS can operate in.</p> <p>Supported bands declared for every beam (D9.3).</p> <p>NOTE 2: these operating bands are related to their respective single-band RIBs.</p> <p>NOTE 3: this declaration indirectly provide information on the RAT's supported by the AAS BS.</p>
D9.5	Beam RAT support	RAT(s) supported by each beam for each supported operating band, declared for every beam identified in D9.3.
D9.6	E-UTRA channel band width support	E-UTRA channel bandwidth supported. Declared for each beam (D9.3) and each E-UTRA operating band (D9.4).
D9.7	<i>Reference beam direction pair</i>	The beam direction pair, describing the reference beam peak direction and the reference beam centre direction. Declared for every beam
D9.8	<i>OTA peak directions set</i>	<p>The <i>OTA peak directions set</i> for each beam. Declared for every beam identified in D9.3.</p> <p>NOTE 4: In Rel-13/14 version of this specification, this declaration was called <i>EIRP accuracy directions set</i>.</p>
D9.9	Maximum steering direction(s)	<p>The <i>beam direction pair(s)</i> corresponding to the following points:</p> <ol style="list-style-type: none"> 1) The <i>beam peak direction</i> corresponding to the maximum steering from the <i>reference beam centre direction</i> in the positive Φ direction, while the θ value being the closest possible to the <i>reference beam centre direction</i>. 2) The beam peak direction corresponding to the maximum steering from the reference beam centre direction in the negative Φ direction, while the θ value being the closest possible to the reference beam centre direction. 3) The beam peak direction corresponding to the maximum steering from the reference beam centre direction in the positive θ direction, while the Φ value being the closest possible to the reference beam centre direction. 4) The beam peak direction corresponding to the maximum steering from the reference beam centre direction in the negative θ direction, while the Φ value being the closest possible to the reference beam centre direction. <p>The maximum steering direction(s) may coincide with the <i>reference beam centre direction</i>.</p> <p>Declared for every beam identified in D9.3.</p>
D9.10	Rated beam EIRP	The rated EIRP level per carrier ($P_{Rated,c,EIRP}$) at the <i>beam peak direction</i> associated with a particular <i>beam direction pair</i> for each of the declared maximum steering directions (D9.9), as well as the <i>reference beam direction pair</i> (D9.7). Declared for every beam identified in D9.3. (Note 1, Note 2)
D9.11	Beamwidth	The <i>beamwidth</i> for the <i>reference beam direction pair</i> and the four maximum steering directions. Declared for every beam identified in D9.3.
D9.12	Equivalent beams	<p>List of beams which are declared to be equivalent.</p> <p>Equivalent beams imply that the beams are expected to have identical <i>OTA peak directions sets</i> and intended to have identical spatial properties at all steering directions within the <i>OTA peak directions set</i> when presented with identical signals. All declarations</p>

Declaration identifier	Declaration	Description
		(D9.4-D9.11) made for the beams are identical and the transmitter unit, RDN and antenna array responsible for generating the beam are of identical design.
D9.13	Parallel beams	List of beams which have been declared equivalent (D9.12) and can be generated in parallel using independent RF power resources. Independent power resources mean that the beams are transmitted from mutually exclusive transmitter units.
D9.14	Number of carriers at maximum TRP	The number of carriers per operating band the AAS BS is capable of generating at maximum TRP declared each RAT (and multi-RAT) for every beam identified in D9.3.
D9.15	Multi-band transceiver units	Declared if an operating band is generated using transceiver units supporting operation in multiple operating bands through common active RF components.
D9.16	Operating bands with multi-band dependencies	List operating bands which are generated by multi-band transceiver units. Declared for each operating band for which multi-band transceiver units (D9.15) have been declared,
D9.15	Maximum radiated Base Station RF Bandwidth	Maximum Base Station RF Bandwidth in the operating band, declared for each supported operating band identified in D9.4.
D9.18	Maximum radiated Base Station RF Bandwidth for contiguous operation.	Largest Base Station RF Bandwidth for contiguous spectrum operation, declared for each supported operating band (D9.4).
D9.19	Maximum radiated Base Station RF Bandwidth for non-contiguous operation.	Maximum Base Station RF Bandwidth for non-contiguous spectrum operation, declared for each supported operating band (D9.4).
D9.20	Inter-band CA bands	Declared inter-band CA bands supported per operating band (D9.4).
D9.21	CA only operation	Declared per operating band identified in D9.4.
D9.22	Multi-carrier HSPA only operation	Declared per each supported UTRA operating band (D9.4).
D9.23	Reduced number of supported carriers at maximum TRP in multi-RAT operations	Declared for each supported operating (D9.4).
D9.24	Reduced maximum TRP at the total number of supported carriers in multi-RAT operations	Declared for each supported operating band (D9.4). (Note 1, Note 2)
D9.25	Radiated capability set (RCSA)	The manufacturer shall declare the supported radiated capability set(s) according to table 4.9-1 for each supported operating band (D9.4). NOTE: in case of <i>hybrid AAS BS</i> , set of <i>operating band</i> specific RCSA declarations shall be aligned with the set of CSA's declared by D6.12 in TS 37.145-1 [9] for the conducted testing for the <i>operating band</i> in question.
D9.26	Maximum <i>Radio Bandwidth</i> of the operating band with multi-band dependencies	Largest <i>Radio Bandwidth</i> that can be supported by the operating bands with multi-band dependencies. Declared for each supported operating band which has multi-band dependencies (D9.16)
D9.27	Total number of supported carriers for operating bands with multi-band dependencies	Total number of supported carriers for operating bands declared to have multi-band dependencies (D9.16).
D9.28	Contiguous or non-contiguous spectrum support	Ability of AAS BS to support contiguous or non-contiguous (or both) frequency distribution of carriers when operating multi-carrier in an operating band.
D9.29	Non-contiguous parameters	If non-contiguous operation is supported in <i>operating band</i> () and parameters (e.g. frequency range, maximum Base Station RF Bandwidth, rated transmitter TRP, etc.) differ from the contiguous spectrum operation, then this declaration provided parameters for the non-contiguous operation. Otherwise, parameters for contiguous or non-contiguous spectrum operation in the operating band are assumed to be the same.
D9.30	DL RS EIRP for conformance test	The DL RS EIRP transmitted during the DL RS power conformance test derived from the power broadcast on the DL-SCH and the AAS BS directivity in the direction to be tested.
D9.31	NR BS channel band width and SCS support	NR BS channel bandwidth and SCS supported. Declared for each beam () and each operating band ().
D9.32	Total RF bandwidth (BW _{tot})	Total RF bandwidth BW _{tot} of transmitter and receiver, declared per the band combinations ().

Declaration identifier	Declaration	Description
D9.33	Inter-band CA bands	Declared inter-band CA bands supported by the beam. Declared per beam (D.3).
D9.34	CA only operation	Declared of CA-only but not multiple carriers operation, declared per <i>operating band</i> (D.4) and per beam (D.3).
D10.1	OSDD identifier	A unique identifier for the OSDD.
D10.2	OSDD operating band support	Operating band supported by the OSDD, declared for every OSDD identified in D10.1. NOTE 2: As each identified OSDD has a declared minimum EIS value (D10.6), multiple operating band can be only be declared if they have the same minimum EIS declaration.
D10.3	OSDD RAT support	RAT(s) supported by the OSDD for each supported operating band, declared for every OSDD identified in D10.1. NOTE 3: If the OSDD supports multiple RAT's with different minimum EIS value (D10.6) if all other parameters are the same then different EIS values for different RATs and signal BW's may be declared for an OSDD.
D10.4	OTA sensitivity E-UTRA supported channel bandwidths	The E-UTRA channel bandwidths supported by each OSDD.
D10.5	Redirection of receiver target support	Ability to redirect the receiver target related to the OSDD
D10.6	Minimum EIS	The minimum EIS requirement (i.e. maximum allowable EIS value) applicable to all sensitivity RoAoA per OSDD. Declared for per RAT and E-UTRA supported channel BW for the OSDD (10.4). The lowest EIS value for all the declared OSDD's is called <i>minSENS</i> , while its related range of angles of arrival is called <i>minSENS RoAoA</i> . NOTE 4: If the AAS BS is not capable of redirecting the receiver target related to the OSDD then there is only one RoAoA applicable to the OSDD.
D10.7	Receiver target reference direction Sensitivity Range of Angle of Arrival	The sensitivity RoAoA associated with the receiver target reference direction (D10.9) for each OSDD.
D10.8	Receiver target redirection range	For each OSDD the associated union of all the sensitivity RoAoA achievable through redirecting the receiver target related to the OSDD
D10.9	Receiver target reference direction	For each OSDD an associated direction inside the receiver target redirection range (D10.8). NOTE 5: For an OSDD without receiver target redirection range, this is a direction inside the sensitivity RoAoA.
D10.10	Conformance test directions sensitivity RoAoA	For each OSDD that includes a receiver target redirection range, four sensitivity RoAoA comprising the conformance test directions (D10.11).
D10.11	Conformance test directions	For each OSDD four conformance test directions. If the OSDD includes a receiver target redirection range the following four directions shall be declared: <ol style="list-style-type: none"> 1) The direction determined by the maximum φ value achievable inside the receiver target redirection range, while θ value being the closest possible to the receiver target reference direction. 2) The direction determined by the minimum φ value achievable inside the receiver target redirection range, while θ value being the closest possible to the receiver target reference direction. 3) The direction determined by the maximum θ value achievable inside the receiver target redirection range, while φ value being the closest possible to the receiver target reference direction. 4) The direction determined by the minimum θ value achievable inside the receiver target redirection range, while φ value being the closest possible to the receiver target reference direction. If an OSDD does not include a receiver target redirection range the following 4 directions shall be declared: <ol style="list-style-type: none"> 1) The direction determined by the maximum φ value achievable inside the sensitivity RoAoA, while θ value being the closest possible to the receiver target reference direction.

Declaration identifier	Declaration	Description
		2) The direction determined by the minimum φ value achievable inside the sensitivity RoAoA, while θ value being the closest possible to the receiver target reference direction. 3) The direction determined by the maximum θ value achievable inside the sensitivity RoAoA, while φ value being the closest possible to the receiver target reference direction. 4) The direction determined by the minimum θ value achievable inside the sensitivity RoAoA, while φ value being the closest possible to the receiver target reference direction.
D10.12	OTA sensitivity supported NR BS channel bandwidth and SCS	The NR BS channel bandwidths and SCS supported by each OSDD.
NOTE 1: If a BS is capable of 256QAM DL operation (and not 1024QAM DL operation) then two rated output power declarations may be made. One declaration is applicable when configured for 256QAM transmissions and the other declaration is applicable when not configured for 256QAM transmissions. NOTE 2: If a BS is capable of 1024QAM DL operation then up to three rated output power declarations may be made. One declaration is applicable when configured for 1024QAM transmissions, a different declaration is applicable when configured for 256QAM transmissions and the other declaration is applicable when configured neither for 256 QAM nor 1024QAM transmissions.		

Table 4.10-2: OTA AAS BS manufacturers declarations for radiated test requirements

Declaration identifier	Declaration	Description
D11.1	AAS BS requirements set	Declaration of either <i>hybrid AAS BS</i> architecture conforming to the <i>hybrid requirement set</i> , or OTA AAS BS architecture conforming to the <i>OTA requirement set</i> .
D11.2	BS class	BS Class of the AAS BS, declared as Wide Area BS, Medium Range BS, or Local Area BS.
D11.3	OTA coverage range	Declared as a single range within which selected TX OTA requirements are intended to be met. NOTE 1: <i>OTA coverage range</i> is used for conformance testing of such TX OTA requirements as occupied bandwidth, frequency error, TAE or EVM.
D11.4	OTA coverage range reference direction	The direction describing the reference direction of the <i>OTA converge range</i> (D11.2). NOTE 2: The <i>OTA coverage reference</i> direction may be the same as the <i>Reference beam direction pair</i> (D9.7) but does not have to be.
D11.5	OTA coverage range maximum directions	The directions corresponding to the following points: 1) The direction determined by the maximum φ value achievable inside the <i>OTA coverage range</i> , while θ value being the closest possible to the <i>OTA coverage range</i> reference direction. 2) The direction determined by the minimum φ value achievable inside the <i>OTA coverage range</i> , while θ value being the closest possible to the <i>OTA coverage range</i> reference direction. 3) The direction determined by the maximum θ value achievable inside the <i>OTA coverage range</i> , while φ value being the closest possible to the <i>OTA coverage range</i> reference direction. 4) The direction determined by the minimum θ value achievable inside the <i>OTA coverage range</i> , while φ value being the closest possible to the <i>OTA coverage range</i> reference direction.
D11.6	The rated carrier OTA BS power, $P_{\max,c,TRP}$	$P_{\max,c,TRP}$ is declared as TRP OTA power per carrier, declared per supported operating band, per supported RAT. (Note 1, Note 2)
D11.7	Worst-case side of the AAS BS on which the co-location test antenna is placed	Declare the worst-case side of the AAS BS on which the co-location test antenna is placed and test will be done only on the declared side.
D11.8	Spurious emission category	Declare the OTA AAS BS spurious emission category as either category A or B with respect to the limits for spurious emissions, as defined in Recommendation ITU-R SM.329 [16].

Declaration identifier	Declaration	Description
D11.9	Geographic area support	The manufacturer shall declare the regions the OTA AAS BS may operate in. e.g. CEPT.
D11.10	Band 20 or Band XX support, operating in geographical areas allocated to broadcasting (DTT)	If the OTA AAS BS supports Band 20/XX or Band 32/XXXII, the manufacturer shall declare if the OTA AAS BS may operate in geographical areas allocated to broadcasting (DTT).
D11.11	Band 20 or Band XX support, emission level for channel N ($P_{EM,N}$)	If the OTA AAS BS supports Band 20 or Band XX and has been declared to operate in geographical areas allocated to broadcasting (DTT; declaration D11.7), the emission level for channel N (as defined in annex G of 3GPP TS 36.104 [4]) shall be declared.
D11.12	Band 20 or Band XX support, Maximum output power in 10 MHz (P_{10MHz})	If the OTA AAS BS supports Band 20 or Band XX and has been declared to operate in geographical areas allocated to broadcasting (DTT; declaration D11.7), the maximum output power in 10 MHz (annex G of 3GPP TS 36.104 [4]) shall be declared.
D11.13	Band 32 or Band XXXII support, Declared emission level in Band 32/XXXII ($P_{EM,B32,ind}$)	If the OTA AAS BS supports Band 32 or Band XXXII and has been declared to operate in geographical areas allocated to broadcasting (DTT; declaration D11.7), the emission level in Band 32/XXXII ($P_{EM,B32,ind}$, ind = a, b, c, d, e) shall be declared.
D11.14	Co-existence with other systems	The manufacturer shall declare whether the OTA AAS BS under test is intended to operate in geographic areas where one or more of the systems GSM850, GSM900, DCS1800, PCS1900, UTRA FDD, UTRA TDD, E-UTRA and/or PHS operating in another operating band are deployed.
D11.15	Co-location with other base stations	The manufacturer shall declare whether the OTA AAS BS under test is intended to operate co-located with Base Stations of one or more of the systems GSM850, GSM900, DCS1800, PCS1900, UTRA FDD, UTRA TDD and/or E-UTRA operating in another operating band.
D11.16	<i>Single-band RIB or multi-band RIB</i>	List of <i>single-band RIB and/or multi-band RIB</i> resulting from the supported operating bands (D9.4), and operating bands with multi-band dependencies (D9.16).
D11.17	Single or multiple carrier	OTA AAS BS capability to operate with a single carrier (only) or multiple carriers. Declared per supported operating band, per RAT, per RIB.
D11.18	Maximum number of supported carriers per band	Maximum number of supported carriers. Declared per supported operating band, per RAT, per RIB.
D11.19	Total maximum number of supported carriers	Maximum number of supported carriers for all supported operating bands. Declared per RIB.
D11.20	Other band combination multi-band restrictions	Declare any other limitation under simultaneous operation in the declared band combinations (D9.16), which have any impact on the test configuration generation.
D11.21	N_{cells}	Number corresponding to the minimum number of cells that can be transmitted by an OTA AAS BS in a particular operating band. Declared per RIB (D11.13).
D11.22	Maximum supported power difference between carriers	Maximum supported TRP difference between carriers in each supported operating band. Declared per RIB.
D11.23	Maximum supported power difference between carriers is different operating bands	Maximum supported power difference between any two carriers in any two different supported operating bands. Declared per operating bands combination (D9.16, D11.16).
D11.24	UTRA FDD MIMO support	Number of 'antennas' supported by the UTRA FDD MIMO mode (i.e. 2 or 4). Declared per supported UTRA FDD operating band (D9.4). NOTE 3: The concept of "antenna 2", "antenna 3" and "antenna 4" is described in 3GPP TS 25.104 [2].

Declaration identifier	Declaration	Description
D11.25	UTRA Inner loop power control dynamic range	Power control dynamic range for UTRA inner loop power control. Declared per supported UTRA FDD operating band, per RIB.
D11.26	Inter-band CA or inter-band HSDPA	Declaration of operating band combinations supporting inter-band CA or multi-band HSDPA. Declared per operating band combination (D9.16, D11.16).
D11.27	Intra-band contiguous CA or intra-band contiguous HSDPA	Declaration of operating band(s) supporting intra-band contiguous CA, or intra-band contiguous HSDPA. Declared per operating band with CA support.
D11.28	Intra-band non-contiguous CA or intra-band contiguous HSDPA	Declaration of operating band(s) supporting intra-band non-contiguous CA, or intra-band non-contiguous HSDPA. Declared per operating band with CA support.
D11.29	OTA REFSENS RoAoA	The REFSENS RoAoA associated with the receiver target reference direction (D11.30).
D11.30	OTA REFSENS receiver target reference direction	An associated direction inside the OTA REFSENS RoAoA (D11.29).
D11.31	OTA REFSENS conformance test directions	Four conformance test directions for the OTA REFSENS: <ol style="list-style-type: none"> 1) The direction determined by the maximum φ value achievable inside the OTA REFSENS RoAoA, while θ value being the closest possible to the receiver target reference direction. 2) The direction determined by the minimum φ value achievable inside the OTA REFSENS RoAoA, while θ value being the closest possible to the receiver target reference direction. 3) The direction determined by the maximum θ value achievable inside the OTA REFSENS RoAoA, while φ value being the closest possible to the receiver target reference direction. 4) The direction determined by the minimum θ value achievable inside the OTA REFSENS RoAoA, while φ value being the closest possible to the receiver target reference direction.
D11.32	Supported frequency range of the NR <i>operating band</i>	List of supported frequency ranges representing <i>fractional bandwidths</i> (FBW) of <i>operating bands</i> with FBW larger than 6%.
D11.33	Rated beam EIRP at lower frequency range of the <i>fractional bandwidth</i> ($P_{\text{rated,c,FBWlow}}$)	The rated EIRP level per carrier at lower frequency range of the <i>fractional bandwidth</i> ($P_{\text{rated,c,FBWlow}}$), at the <i>beam peak direction</i> associated with a particular <i>beam direction pair</i> for each of the declared maximum steering directions (D9.9), as well as the reference <i>beam direction pair</i> (D9.7). (Note 1, Note 2) Declared per beam for all supported frequency ranges (D11.32). NOTE 13: if D11.33 is declared for certain frequency range (D11.32), there shall be no "Rated beam EIRP" declaration (D9.10) for the <i>operating band</i> containing that particular frequency range.
D11.34	Rated beam EIRP at higher frequency range of the <i>fractional bandwidth</i> ($P_{\text{rated,c,FBWhigh}}$)	The rated EIRP level per carrier at higher frequency range of the <i>fractional bandwidth</i> ($P_{\text{rated,c,FBWhigh}}$), at the <i>beam peak direction</i> associated with a particular <i>beam direction pair</i> for each of the declared maximum steering directions (D9.9), as well as the reference <i>beam direction pair</i> (D9.7). (Note 1, Note 2) Declared per beam for all supported frequency ranges in (D11.32). NOTE 14: if D11.34 is declared for certain frequency range (D11.32), there shall be no "Rated beam EIRP" declaration (D9.10) for the <i>operating band</i> containing that particular frequency range.
NOTE 1: If a BS is capable of 256QAM DL operation (and not 1024QAM DL operation) then two rated output power declarations may be made. One declaration is applicable when configured for 256QAM transmissions and the other declaration is applicable when not configured for 256QAM transmissions.		
NOTE 2: If a BS is capable of 1024QAM DL operation then up to three rated output power declarations may be made. One declaration is applicable when configured for 1024QAM transmissions, a different declaration is applicable when configured for 256QAM transmissions and the other declaration is applicable when configured neither for 256 QAM nor 1024QAM transmissions.		

4.11 Test signal configurations for testing

4.11.1 General

The test configurations shall be constructed using the methods defined below subject to the parameters declared by the manufacturer as listed in subclause 4.10.

For test contiguous spectrum operation configurations used in receiver tests only the carriers in the outermost frequency positions in the *Base Station RF Bandwidth* need to be generated by the test equipment. For non-contiguous spectrum operation test configurations used in receiver tests, outermost carriers for each sub-block need to be generated by the test equipment.

The applicable test models for generation of the carrier transmit test signal are defined in subclause 4.12.2.

NOTE: In case carriers are shifted to align with the channel raster Foffset.

4.11.1A NR Test signal used to build Test Configurations

The signal's Channel Bandwidth and Subcarrier spacing used to build NR Test Configurations shall be selected according to table 4.11.1A-1.

Table 4.11.1A-1: Signal to be used to build NR TCs

Operating Band characteristics		$F_{DL_high} - F_{DL_low} < 100 \text{ MHz}$	$F_{DL_high} - F_{DL_low} \geq 100 \text{ MHz}$
TC signal characteristics	$BW_{channel}$	5 MHz (Note 1)	20 MHz (Note 1)
	Subcarrier spacing	Smallest supported subcarrier spacing	
Note 1: If this channel bandwidth is not supported, the narrowest supported channel bandwidth shall be used.			

4.11.2 Test signal configurations

4.11.2.1 ATCR1: UTRA multicarrier operation

4.11.2.1.1 General

The purpose of ATCR1 is to test UTRA OTA multi-carrier aspects.

4.11.2.1.2 ATCR1a generation

ATCR1a should be constructed using the following method:

- The *Base Station RF Bandwidth* shall be the declared maximum radiated *Base Station RF Bandwidth* for contiguous operation (see table 4.10-1, D9.18).
- Place one UTRA FDD carrier adjacent to the upper *Base Station RF Bandwidth edge* and one UTRA FDD carrier adjacent to the lower *Base Station RF Bandwidth edge*. The specified F_{Offset} shall apply.
- For transmitter tests, alternately place a UTRA FDD carrier adjacent to the already placed carriers at the low and high *Base Station RF Bandwidth edges* until there is no more space to fit a carrier or the beam does not support more carriers. The nominal carrier spacing defined in subclause 4.6 shall apply.
- The carrier(s) may be shifted maximum 100 kHz towards lower frequencies for B_{RFBW} and M_{RFBW} and towards higher frequencies for T_{RFBW} to align with the channel raster.

4.11.2.1.3 ATCR1b generation

ATCR1b is constructed using the following method:

- The *Base Station RF Bandwidth* shall be the declared maximum radiated *Base Station RF Bandwidth* for contiguous operation (see table 4.10-1, D6.20).
- Place one UTRA TDD carrier adjacent to the upper *Base Station RF Bandwidth edge* and one UTRA TDD carrier adjacent to the lower *Base Station RF Bandwidth edge*. The specified F_{Offset} shall apply.
- For transmitter tests, alternately place a UTRA TDD carrier adjacent to the already placed carriers at the low and high *Base Station RF Bandwidth edges* until there is no more space to fit a carrier or the beam does not support more carriers. The nominal carrier spacing defined in subclause 4.6 shall apply.

4.11.2.1.4 ATCR1 power allocation

Set the number of carriers to the number of carriers at maximum TRP (see table 4.10-1, D9.14).

For EIRP accuracy requirements set each beam to maximum EIRP (see table 4.10-1, D9.10) for the tested *beam direction pair*.

For all other requirements ensure the total radiated power is $P_{\text{Rated,c,TRP}}$ (see table 4.10-2, D11.6).

4.11.2.2 ANTCR1: UTRA FDD multicarrier non-contiguous operation

4.11.2.2.1 General

The purpose of ANTCR1 is to test UTRA FDD multicarrier non-contiguous aspects.

4.11.2.2.2 ANTCR1 generation

ANTCR1 is constructed as NTC1a in 3GPP TS 37.141 [13], subclause 4.8.1a.1

ANTCR1 is constructed using the following method:

- The *Base Station RF Bandwidth* of each supported operating band shall be the declared maximum radiated *Base Station RF Bandwidth* for non-contiguous operation (see table 4.10-1, D6.21). The *Base Station RF Bandwidth* consists of one sub-block gap and two sub-blocks located at the edges of the declared maximum *Base Station RF Bandwidth* for non-contiguous operation.
- For transmitter tests, place one UTRA carrier adjacent to the upper *Base Station RF Bandwidth edge* and one UTRA carrier adjacent to the lower *Base Station RF Bandwidth edge*. The specified $F_{\text{Offset-RAT}}$ shall apply.
- For receiver tests, place one UTRA carrier adjacent to the upper *Base Station RF Bandwidth edge* and one UTRA carrier adjacent to the lower *Base Station RF Bandwidth edge*. For single-band operation, if the maximum *Base Station RF Bandwidth* for non-contiguous operation is at least 35 MHz and the beam supports at least 4 UTRA FDD carriers, place a UTRA FDD carrier adjacent to each already placed carrier for each sub-block. The nominal carrier spacing defined in subclause 4.6 shall apply.
- The sub-block edges adjacent to the sub-block gap shall be determined using the specified $F_{\text{Offset-RAT}}$ for the carrier adjacent to the sub-block gap.
- The UTRA FDD carrier in the lower sub-block may be shifted maximum 100 kHz towards lower frequencies and the UTRA FDD carrier in the upper sub-block may be shifted maximum 100 kHz towards higher frequencies to align with the channel raster.

4.11.2.2.3 ANTCR1 power allocation

Set the number of carriers to the number of carriers at maximum TRP (see table 4.10-1, D9.14).

For EIRP accuracy requirements set each beam to maximum EIRP (see table 4.10-1, D9.10) for the tested *beam direction pair*.

For all other requirements ensure the total radiated power is $P_{\text{Rated,c,TRP}}$ (see table 4.10-2, D11.6).

4.11.2.3 ATCR2: E-UTRA multicarrier operation

4.11.2.3.1 General

The purpose of ATCR2a is to test E-UTRA multi-carrier aspects excluding CA occupied bandwidth.

The purpose of ATCR2b is to test E-UTRA Contiguous CA occupied bandwidth.

4.11.2.3.2 ATCR2a generation

ATCR2a is constructed using the following method:

- The *Base Station RF Bandwidth* of each supported operating band shall be the declared maximum radiated *Base Station RF Bandwidth* for contiguous operation (see table 4.10-1, D9.18).
- Select the narrowest supported E-UTRA carrier and place it adjacent to the low *Base Station RF Bandwidth edge*. Place a 5 MHz E-UTRA carrier adjacent to the high *Base Station RF Bandwidth edge*. The specified $F_{\text{Offset-RAT}}$ shall apply.
- For transmitter tests, select as many 5 MHz E-UTRA carriers that the beam supports and that fit in the rest of the *Base Station RF Bandwidth*. Place the carriers adjacent to each other starting from the high *Base Station RF Bandwidth edge*. The nominal carrier spacing defined in subclause 4.6 shall apply. The specified $F_{\text{Offset-RAT}}$ shall apply.
- If 5 MHz E-UTRA carriers are not supported by the beam the narrowest supported *channel bandwidth* (see table 4.10-1, D9.6) shall be selected instead.

The test configuration should be constructed on a per band basis for all component carriers of the inter-band CA bands declared to be supported by the beam (see table 4.10-1, D9.20). All configured component carriers are transmitted simultaneously in the tests where the transmitter should be on.

4.11.2.3.3 ATCR2b generation

ATCR2b is constructed on a per band basis using the following method:

- All component carrier combinations supported by the beam, which have different sum of *channel bandwidth* of component carrier, shall be tested. For all component carrier combinations which have the same sum of *channel bandwidth* of component carriers, only one of the component carrier combinations shall be tested.
- Of all component carrier combinations which have same sum of *channel bandwidth* of component carrier, select those with the narrowest carrier at the lower *Base Station RF Bandwidth edge*.
- Of the combinations selected in the previous step, select one with the narrowest carrier at the upper *Base Station RF Bandwidth edge*.
- If there are multiple combinations fulfilling previous steps, select the one with the smallest number of component carrier.
- If there are multiple combinations fulfilling previous steps, select the one with the widest carrier being adjacent to the lowest carrier.
- If there are multiple combinations fulfilling previous steps, select the one with the widest carrier being adjacent to the highest carrier.
- If there are multiple combinations fulfilling previous steps, select the one with the widest carrier being adjacent to the carrier which has been selected in the previous step.
- If there are multiple combinations fulfilling previous steps, repeat the previous step until there is only one combination left.
- The nominal carrier spacing defined in subclause 4.6 shall apply.

4.11.2.3.4 ATCR2 power allocation

Set the number of carriers to the number of carriers at maximum TRP (see table 4.10-1, D9.14).

For EIRP accuracy requirements set each beam to maximum EIRP (see table 4.10-1, D9.10) for the tested *beam direction pair*.

For all other requirements ensure the total radiated power is $P_{\text{Rated,c,TRP}}$ (see table 4.10-2, D11.6).

For a beam declared to support only CA operation (see table 4.10-1, D6.23), set the power spectral density of of each carrier to the same level so that the sum of the carrier power equals the same value as above.

4.11.2.4 ANTCR2: E-UTRA multicarrier non-contiguous operation

4.11.2.4.1 General

The purpose of ANTCR2 is to test E-UTRA multicarrier non-contiguous aspects.

4.11.2.4.2 ANTCR2 generation

ANTCR2 is constructed as NTC2 in 3GPP TS 37.141 [13], subclause 4.8.2a.1

ANTCR2 is constructed using the following method:

- The *Base Station RF Bandwidth* of each supported operating band shall be the declared maximum radiated *Base Station RF Bandwidth* for non-contiguous operation (see table 4.10-1, D9.19). The *Base Station RF Bandwidth* consists of one sub-block gap and two sub-blocks located at the edges of the declared maximum radiated *Base Station RF Bandwidth* (see table 4.10-1, D9.17).
- For transmitter tests, place a 5MHz E-UTRA carrier adjacent to the upper *Base Station RF Bandwidth edge* and a 5MHz E-UTRA carrier adjacent to the lower *Base Station RF Bandwidth edge*. The specified $F_{\text{Offset-RAT}}$ shall apply. If 5 MHz E-UTRA carriers are not supported by the beam, the narrowest supported *channel bandwidth* shall be selected instead.
- For receiver tests, place a 5MHz E-UTRA carrier adjacent to the upper *Base Station RF Bandwidth edge* and a 5MHz E-UTRA carrier adjacent to the lower *Base Station RF Bandwidth edge*. If 5 MHz E-UTRA carriers are not supported by the beam, the narrowest supported *channel bandwidth* shall be selected instead.
- For single-band operation receiver tests, if the remaining gap is at least 15 MHz plus two times the *channel bandwidth* used in the previous step and the beam supports at least 4 E-UTRA carriers, place a E-UTRA carrier of this *channel bandwidth* adjacent to each already placed carrier for each sub-block. The nominal carrier spacing defined in subclause 4.5 shall apply.
- The sub-block edges adjacent to the sub-block gap shall be determined using the specified $F_{\text{Offset-RAT}}$ for the carrier adjacent to the sub-block gap.

4.11.2.4.3 ANTCR2 power allocation

Set the number of carriers to the number of carriers at maximum EIRP (see table 4.10-1, D9.14).

For EIRP accuracy requirements set each beam to maximum EIRP (see table 4.10-1, D9.10) for the tested *beam direction pair*.

For all other requirements ensure the total radiated power is $P_{\text{Rated,c,TRP}}$ (see table 4.10-2, D11.6).

4.11.2.5 ATCR3: UTRA and E-UTRA multi RAT operation

4.11.2.5.1 General

The purpose of ATCR3 is to test UTRA and E-UTRA multi-RAT aspects.

If the maximum EIRP and total number of supported carriers at maximum EIRP are not simultaneously supported in Multi-RAT operations, two instances of ATCR3 shall be generated using the following values for rated transmitter TRP and the total number of supported carriers:

- 1) The maximum EIRP and the reduced number of supported carriers at the maximum EIRP in Multi-RAT operations.
- 2) The reduced maximum EIRP at the total number of supported carriers in Multi-RAT operations and the total number of supported carriers.

Tests that use ATCR3 shall be performed using both instances 1) and 2) of ATCR3.

4.11.2.5.2 ATCR3a generation

ATCR3a is constructed using the following method:

- The *Base Station RF Bandwidth* of each supported operating band shall be the declared maximum radiated *Base Station RF Bandwidth* (see table 4.10-1 D9.17).
- Select an FDD UTRA carrier to be placed at the lower *Base Station RF Bandwidth edge*. The specified $F_{\text{Offset-RAT}}$ shall apply. The UTRA FDD may be shifted maximum 100 kHz towards lower frequencies to align with the channel raster.
- Place a 5 MHz E-UTRA carrier at the upper *Base Station RF Bandwidth edge*. If that is not possible use the narrowest E-UTRA carrier supported by the beam. The specified $F_{\text{Offset-RAT}}$ shall apply.
- For transmitter tests, alternately add FDD UTRA carriers at the low end and 5 MHz E-UTRA carriers at the high end adjacent to the already placed carriers until the *Base Station RF Bandwidth* is filled or the total number of supported carriers (see table 4.10-1, D9.14) is reached. The nominal carrier spacing defined in subclause 4.6 shall apply.

4.11.2.5.3 ATCR3b generation

ATCR3b is constructed using the following method:

- The *Base Station RF Bandwidth* of each supported operating band shall be the declared maximum radiated *Base Station RF Bandwidth* (see table 4.10-1 D9.17).
- Select a UTRA TDD carrier to be placed at the lower *Base Station RF Bandwidth edge*. The specified $F_{\text{Offset-RAT}}$ shall apply.
- Place a 5 MHz E-UTRA carrier at the upper *Base Station RF Bandwidth edge*. If that is not possible use the narrowest E-UTRA carrier supported by the beam. The specified $F_{\text{Offset-RAT}}$ shall apply.
- For transmitter tests, alternately add UTRA TDD carriers at the low end and 5 MHz E-UTRA carriers at the high end adjacent to the already placed carriers until the *Base Station RF Bandwidth* is filled or the total number of supported carriers is reached. The nominal carrier spacing defined in clause 4.6 shall apply.

4.11.2.5.4 ATCR3 power allocation

For ATCR3a set the number of carriers to the reduced number of carriers at maximum TRP in multi-RAT operations (see table 4.10-1, D9.23) and set each carrier to maximum EIRP (see table 4.10-1, D9.11).

For EIRP accuracy requirements set each beam to maximum EIRP (see table 4.10-1, D9.10) for the tested *beam direction pair*.

For all other requirements ensure the total radiated power is $P_{\text{Rated,c,TRP}}$ (see table 4.10-2, D11.6).

4.11.2.6 ANTCR3: UTRA and E-UTRA multi RAT non-contiguous operation

4.11.2.6.1 General

The purpose of ANTCR3 is to test UTRA and E-UTRA multi RAT non-contiguous aspects.

If the maximum EIRP and total number of supported carriers at maximum EIRP are not simultaneously supported in Multi-RAT operations, two instances of ANTCR3 shall be generated using the following values for rated transmitter TRP and the total number of supported carriers:

- 1) The maximum EIRP and the reduced number of supported carriers at the maximum EIRP in Multi-RAT operations.
- 2) The reduced maximum EIRP at the total number of supported carriers in Multi-RAT operations and the total number of supported carriers.

If the reduced number of supported carriers is 4 or more, only instance 1) of ANTCR3 shall be used in the tests, otherwise both instances 1) and 2) of ANTCR3 shall be used in the tests.

4.11.2.6.2 ANTCR3a generation

ANTCR3a is constructed using the following method:

- The *Base Station RF Bandwidth* of each supported operating band shall be the declared maximum radiated *Base Station RF Bandwidth* for non-contiguous operation (see table 4.10-1, D6.21). The *Base Station RF Bandwidth* consists of one sub-block gap and two sub-blocks located at the edges of the declared maximum *Base Station RF Bandwidth* for non-contiguous operation.
- For transmitter tests, place an UTRA carrier at the lower *Base Station RF Bandwidth edge* and a 5 MHz E-UTRA carrier at the upper *Base Station RF Bandwidth edge*. The specified $F_{\text{Offset-RAT}}$ shall apply. If 5 MHz E-UTRA carriers are not supported by the beam, the narrowest supported *channel bandwidth* shall be selected instead. The UTRA FDD may be shifted maximum 100 kHz towards lower frequencies to align with the channel raster.
- For receiver tests, place an UTRA carrier at the lower *Base Station RF Bandwidth edge* and a 5 MHz E-UTRA carrier at the upper *Base Station RF Bandwidth edge*. The specified $F_{\text{Offset-RAT}}$ shall apply. If 5 MHz E-UTRA carriers are not supported by the beam, the narrowest supported *channel bandwidth* shall be selected instead. The UTRA FDD may be shifted maximum 100 kHz towards lower frequencies to align with the channel raster.
- For single-band operation receiver tests, if the remaining gap is at least 20 MHz plus the *channel bandwidth* of the E-UTRA carrier used in the previous step and the beam supports at least 2 UTRA and 2 E-UTRA carriers, place a E-UTRA carrier of this *channel bandwidth* adjacent to the carrier at the lower *Base Station RF Bandwidth edge* and UTRA carrier adjacent to the carrier at the upper *Base Station RF Bandwidth edge*. The nominal carrier spacing defined in subclause 4.6 shall apply. The UTRA FDD may be shifted maximum 100 kHz towards higher frequencies to align with the channel raster.
- The sub-block edges adjacent to the sub-block gap shall be determined using the specified $F_{\text{Offset-RAT}}$ for the carrier adjacent to the sub-block gap.

4.11.2.6.3 ANTCR3 power allocation

For case (1) in subclause 4.11.2.6.1 set the number of carriers to the reduced number of carriers at maximum TRP in multi-RAT operations (see table 4.10-1, D9.23).

For EIRP accuracy requirements set each beam to maximum EIRP (see table 4.10-1, D9.10) for the tested *beam direction pair*.

For all other requirements ensure the total radiated power is $P_{\text{Rated,c,TRP}}$ (see table 4.10-2, D11.6).

For case (2) in subclause 4.11.2.6.1 set the number of carriers to the reduced number of carriers at maximum TRP (see table 4.10-1, D9.14) and set each carrier to the reduced maximum TRP at the total number of supported carriers in Multi-RAT operations (see table 4.10-1, D9.24) for the tested *beam direction pair*.

4.11.2.7 ATCR4: Single carrier for receiver tests

4.11.2.7.1 ATCR4a generation

ATCR4a is constructed using the following method:

- Place a single (UTRA FDD) carrier in the middle of the maximum radiated *Base Station RF Bandwidth*. The carrier may be shifted maximum 100 kHz towards lower frequencies for B_{RFBW} and M_{RFBW} and towards higher frequencies for T_{RFBW} to align with the channel raster.

4.11.2.7.2 ATCR4b generation

ATCR4b is constructed using the following method:

- Place the narrowest supported E-UTRA carrier in the middle of the maximum radiated *Base Station RF Bandwidth*.

4.11.2.7.3 ATCR4c generation

ATCR4c is constructed using the following method:

- Place a single UTRA TDD carrier in the middle of the maximum radiated *Base Station RF Bandwidth*.

4.11.2.7.3A ATCR4d generation

ATCR4d is constructed using the following method:

- Place a single NR carrier as specified in subclause 4.11.1A in the middle of the maximum radiated *Base Station RF Bandwidth*.

11.2.7.4 ATCR4 power allocation

Set the beam EIRP on the carrier such that it's EIRP level is equal to the sum of *rated beam EIRPs* (see table 4.10-1, D9.12) when transmitting the maximum supported carriers at the *beam peak direction* (see table 4.10-1, D9.16).

4.11.2.8 Generation of MB-MSR test configurations

4.11.2.8.1 ATCR5a: MB-MSR test configuration for full carrier allocation

4.11.2.8.1.1 General

The purpose of ATCR5a is to test beams which have been generated using transceiver units supporting operation in multiple operating bands through common active electronic components(s), considering maximum supported number of carriers.

4.11.2.8.1.2 ATCR5a generation

ATCR5a is based on re-using the existing test configurations applicable per band on beams generated using Multi-band transceiver units and hence have declared multi-band dependencies (see table 4.10-1, D9.16). ATCR5a is constructed using the following method:

- The *Base Station RF Bandwidth* of each supported operating band shall be the declared maximum radiated *Base Station RF Bandwidth* (see table 4.10-1, D9.17).
- The number of carriers of each supported operating band shall be the declared maximum number of supported carriers by the multi-band dependencies in each band (see table 4.10-1, D9.16). Carriers shall first be placed at

the outermost edges of the declared maximum radiated *Radio Bandwidth* (see table 4.10-1, D9.17). Additional carriers shall next be placed at the edges of the *Base Station RF Bandwidths*, if possible.

- The allocated *Base Station RF Bandwidth* of the outermost bands shall be located at the outermost edges of the declared maximum radiated *Radio Bandwidth* (see table 4.10-1, D9.17).
- Each concerned band shall be considered as an independent band and the corresponding test configuration shall be generated in each band. The mirror image of the single band test configuration shall be used in the highest band being tested for the beam.
- Band category and declared per band capability set (see table 4.10-1, D9.25) shall be used to generate per band RAT/carrier allocation according to table 4.11.2.8.1.2-1 for each band category and radiated capability set. If an operating band with multi-band dependencies supports three carriers only, two carriers shall be placed in one band according to the relevant test configuration while the remaining carrier shall be placed at the edge of the maximum *Radio Bandwidth* (DUID9) in the other band.
- If the sum of the maximum *Base Station RF bandwidths* of each of the supported operating bands is greater than the declared *Total RF Bandwidth* BW_{tot} (D9.32) of transmitter and receiver for the declared band combinations of the BS, then repeat the steps above for test configurations where the *Base Station RF Bandwidth* of one of the operating band shall be reduced so that the declared *Total RF Bandwidth* is not exceeded and vice versa.
- If the sum of the maximum number of supported carrier of each supported operating bands with multi-band dependencies (see table 4.10-1, D9.16) is larger than the declared *t* Total number of supported carriers for operating bands with multi-band dependencies (see table 4.10-1, D9.27), repeat the steps above for test configurations where in each test configuration the number of carriers of one of the operating band shall be reduced so that the total number of supported carriers is not be exceeded and vice versa.

Table 4.11.2.8.1.2-1: The applicability of test configuration in each band

BC	RCSA 1	RCSA 2	RCSA 3	RCSA 3A	RCSA 4	RCSA 5
BC1	ATCR1a	ATCR2a	ATCR3a	ATCR7	ATCR1a	ATCR2a
BC2	ATCR1a	ATCR2a	ATCR3a	ATCR7	ATCR1a	ATCR2a
BC3	ATCR1b	ATCR2a	ATCR3b	ATCR7	ATCR1b	ATCR2a

4.11.2.8.1.3 ATCR5a power allocation

Set the number of carriers to the total number of supported carriers for the declared multi-band dependencies (see table 4.10-1, D9.27).

For EIRP accuracy requirements set each beam to maximum EIRP (see table 4.10-1, D9.10) for the tested *beam direction pair*.

For all other requirements ensure the total radiated power is $P_{Rated,c,TRP}$ (see table 4.10-2, D11.6).

If the allocated number of carriers in an operating band exceeds the declared number of carriers at maximum TRP in an operating band (see table 4.10-1, D9.14) the carriers should if possible be allocated to a different operating band.

4.11.2.8.2 ATCR5b: MB-MSR test configuration with high PSD per carrier

4.11.2.8.2.1 General

The purpose of ATCR5b is to test multi-band operation aspects considering higher PSD cases with reduced number of carriers and non-contiguous operation (if supported) in multi-band mode.

4.11.2.8.2.2 ATCR5b generation

ATCR5b is based on re-using the existing test configurations applicable for operating bands using multi-band transceiver units and hence have declared multi-band dependencies (see table 4.10-1, D9.16). ATCR5b is constructed using the following method:

- The *Base Station RF Bandwidth* of each supported operating band shall be the declared maximum radiated *Base Station RF Bandwidth* (see table 4.10-1, D9.17).

- The allocated *Radio Bandwidth* of the outermost bands shall be located at the outermost edges of the declared maximum *Radio Bandwidth* of the operating band with multi-band dependencies (see table 4.10-1, D9.26).
- The maximum number of carriers is limited to two per band. Carriers shall be placed at the outermost edges of the declared maximum *Radio Bandwidth* of the operating band with multi-band dependencies (see table 4.10-1, D9.26).
- Each concerned band shall be considered as an independent band and the corresponding test configuration for non-contiguous operation shall be generated in each band according to table 4.11.2.8.2.2-1. Narrowest supported E-UTRA *channel bandwidth* shall be used in the test configuration. The mirror image of the single band test configuration shall be used in the highest band being tested.
- For AAS BS supporting CSA4 in the band and supports three carriers only, two carriers shall be placed in one band according to AUTC2 while the remaining carrier shall be placed at the edge of the Maximum *Base Station RF Bandwidth* in the other band.
- If the sum of the maximum *Base Station RF bandwidths* of each of the supported operating bands is greater than the declared *Total RF Bandwidth* BW_{tot} (D9.32) of transmitter and receiver for the declared band combinations of the BS, then repeat the steps above for test configurations where the *Base Station RF Bandwidth* of one of the operating band shall be reduced so that the declared *Total RF Bandwidth* of the operating band with multi-band dependencies (see table 4.10-1, D9.26) is not exceeded and vice versa.

Table 4.11.2.8.2.2-1: The applicability of test configuration in each band

BC	RCSA 1	RCSA 2	RCSA 3	RCSA 3A	RCSA 4	RCSA 5
BC1	ANTCR1a	ANTCR2	ANTCR3a	ANTCR7	ANTCR1	ANTCR2
BC2	ANTCR1a	ANTCR2	ANTCR3a	ANTCR7	ANTCR1	ANTCR2
BC3	ATCR1b	ANTCR2	ANTCR3a	ANTCR7	N/A	ANTCR2

4.11.2.8.2.3 ATCR5b power allocation

Set the number of carriers to the total number of supported carriers for the declared multi-band dependencies (see table 4.10-1, D9.27).

For EIRP accuracy requirements set each beam to maximum EIRP (see table 4.10-1, D9.10) for the tested *beam direction pair*.

For all other requirements ensure the total radiated power is $P_{Rated,c,TRP}$ (see table 4.10-2, D11.6).

If the sum of the TRP for all carriers in an operating band(s) exceeds the sum of the maximum TRP per carrier (see table 4.10-1, D9.14) for the number of carriers transmitted in multi-band operation, the exceeded part shall, if possible, be reallocated into the other band(s). If the TRP allocated for a carrier exceeds the declared maximum TRP, the exceeded power shall, if possible, be reallocated into the other carriers.

4.11.2.9 ATCR6: Single carrier for Transmitter tests

4.11.2.9.1 ATCR6a generation

ATCR6a is constructed using the following method:

- Place a single UTRA carrier at the RF channel to be tested.

4.11.2.9.2 ATCR6b generation

ATCR6b is constructed using the following method:

- Place a 5 MHz E-UTRA carrier i at the RF channel to be tested. If 5 MHz carriers are not supported by the beam the narrowest supported channel BW shall be selected instead.

4.11.2.9.3 Void

4.11.2.9.3A ATCR6d generation

ATCR6d is constructed using the following method:

- Place a single NR carrier as specified in subclause 4.11.1A at the RF channel to be tested.

4.11.2.9.4 ATCR6 power allocation

Set the number of carriers to 1. Set the beam parameters to those appropriate for the beam identifier of the beam under test and to the direction to be tested from the beam declarations (see table 4.10-1, D9.3 - 13).

4.11.2.10 ATCR7: E-UTRA and NR multi RAT operation

4.11.2.10.1 General

The purpose of ATCR7 is to test E-UTRA and NR multi-RAT aspects.

If the maximum EIRP and total number of supported carriers at maximum EIRP are not simultaneously supported in Multi-RAT operations, two instances of ATCR7 shall be generated using the following values for rated transmitter TRP and the total number of supported carriers:

- 1) The maximum EIRP and the reduced number of supported carriers at the maximum EIRP in Multi-RAT operations.
- 2) The reduced maximum EIRP at the total number of supported carriers in Multi-RAT operations and the total number of supported carriers.

Tests that use ATCR7 shall be performed using both instances 1) and 2) of ATCR7.

4.11.2.10.2 ATCR7 generation

ATCR7 is constructed using the following method:

- The *Base Station RF Bandwidth* of each supported operating band shall be the declared maximum radiated *Base Station RF Bandwidth* (see table 4.10-1 D9.17).
- Select a NR carrier as specified in subclause 4.11.1A to be placed at the lower *Base Station RF Bandwidth edge*. The specified $F_{\text{Offset-RAT}}$ shall apply.
- Place a 5 MHz E-UTRA carrier at the upper *Base Station RF Bandwidth edge*. If that is not possible use the narrowest E-UTRA carrier supported by the beam. The specified $F_{\text{Offset-RAT}}$ shall apply.
- For transmitter tests, alternately add NR carriers as specified in subclause 4.11.1A at the low end and 5 MHz E-UTRA carriers at the high end adjacent to the already placed carriers until the *Base Station RF Bandwidth* is filled or the total number of supported carriers (see table 4.10-1, D9.14) is reached. The nominal carrier spacing defined in subclause 4.6 shall apply.

4.11.2.10.3 ATCR7 power allocation

Set the number of carriers to the reduced number of carriers at maximum TRP in multi-RAT operations (see table 4.10-1, D9.23) and set each carrier to maximum EIRP (see table 4.10-1, D9.11).

For EIRP accuracy requirements set each beam to maximum EIRP (see table 4.10-1, D9.10) for the tested *beam direction pair*.

For all other requirements ensure the total radiated power is $P_{\text{Rated,c,TRP}}$ (see table 4.10-2, D11.6).

4.11.2.11 ANTCR7: E-UTRA and NR multi RAT non-contiguous operation

4.11.2.11.1 General

The purpose of ANTCR7 is to test E-UTRA and NR multi RAT non-contiguous aspects.

If the maximum EIRP and total number of supported carriers at maximum EIRP are not simultaneously supported in Multi-RAT operations, two instances of ANTCR7 shall be generated using the following values for rated transmitter TRP and the total number of supported carriers:

- 1) The maximum EIRP and the reduced number of supported carriers at the maximum EIRP in Multi-RAT operations.
- 2) The reduced maximum EIRP at the total number of supported carriers in Multi-RAT operations and the total number of supported carriers.

If the reduced number of supported carriers is 4 or more, only instance 1) of ANTCR7 shall be used in the tests, otherwise both instances 1) and 2) of ANTCR7 shall be used in the tests.

4.11.2.11.2 ANTCR7 generation

ANTRC7 is constructed using the following method:

- The *Base Station RF Bandwidth* of each supported operating band shall be the declared maximum radiated *Base Station RF Bandwidth* for non-contiguous operation (see table 4.10-1, D6.21). The *Base Station RF Bandwidth* consists of one sub-block gap and two sub-blocks located at the edges of the declared maximum *Base Station RF Bandwidth* for non-contiguous operation.
- For transmitter tests, place an NR carrier as specified in subclause 4.11.1A at the lower *Base Station RF Bandwidth edge* and a 5 MHz E-UTRA carrier at the upper *Base Station RF Bandwidth edge*. The specified $F_{\text{Offset-RAT}}$ shall apply. If 5 MHz E-UTRA carriers are not supported by the beam, the narrowest supported *channel bandwidth* shall be selected instead.
- For receiver tests, place a NR carrier as specified in subclause 4.11.1A at the lower *Base Station RF Bandwidth edge* and a 5 MHz E-UTRA carrier at the upper *Base Station RF Bandwidth edge*. The specified $F_{\text{Offset-RAT}}$ shall apply. If 5 MHz E-UTRA carriers are not supported by the beam, the narrowest supported *channel bandwidth* shall be selected instead.
- The sub-block edges adjacent to the sub-block gap shall be determined using the specified $F_{\text{Offset-RAT}}$ for the carrier adjacent to the sub-block gap.

4.11.2.11.3 ANTCR7 power allocation

For case (1) in subclause 4.11.2.6.1 set the number of carriers to the reduced number of carriers at maximum TRP in multi-RAT operations (see table 4.10-1, D9.23).

For EIRP accuracy requirements set each beam to maximum EIRP (see table 4.10-1, D9.10) for the tested *beam direction pair*.

For all other requirements ensure the total radiated power is $P_{\text{Rated,c,TRP}}$ (see table 4.10-2, D11.6).

For case (2) in subclause 4.11.2.6.1 set the number of carriers to the reduced number of carriers at maximum TRP (see table 4.10-1, D9.14) and set each carrier to the reduced maximum TRP at the total number of supported carriers in Multi-RAT operations (see table 4.10-1, D9.24) for the tested *beam direction pair*.

4.11.12.3 ATCR8: NR multicarrier operation

4.11.2.12.1 General

The purpose of ATCR8a is to test NR multi-carrier aspects excluding CA occupied bandwidth.

The purpose of ATCR8b is to test NR Contiguous CA occupied bandwidth.

4.11.2.12.2 ATCR8a generation

ATCR8 is constructed using the following method:

- The *Base Station RF Bandwidth* of each supported operating band shall be the declared radiated *Base Station RF Bandwidth* for contiguous operation (see table 4.10-1, D9.18).
- Select the NR carrier as specified in subclause 4.11.1A and place it adjacent to the low *Base Station RF Bandwidth edge*. Place a similar NR carrier adjacent to the high *Base Station RF Bandwidth edge*. The specified $F_{\text{Offset-RAT}}$ shall apply.
- For transmitter tests, select as many similar NR carriers that the beam supports and that fit in the rest of the *Base Station RF Bandwidth*. Place the carriers adjacent to each other starting from the high *Base Station RF Bandwidth edge*. The nominal carrier spacing defined in subclause 4.6 shall apply. The specified $F_{\text{Offset-RAT}}$ shall apply.

The test configuration should be constructed on a per band basis for all component carriers of the inter-band CA bands declared to be supported by the beam (see table 4.10-1, D9.20). All configured component carriers are transmitted simultaneously in the tests where the transmitter should be on.

4.11.2.3.3 ATCR8b generation

ATCR8b is constructed on a per band basis using the following method:

- All component carrier combinations supported by the beam, which have different sum of *channel bandwidth* of component carrier, shall be tested. For all component carrier combinations which have the same sum of *channel bandwidth* of component carriers, only one of the component carrier combinations shall be tested.
- Of all component carrier combinations which have same sum of *channel bandwidth* of component carrier, select those with the narrowest carrier at the lower *Base Station RF Bandwidth edge*.
- Of the combinations selected in the previous step, select one with the narrowest carrier at the upper *Base Station RF Bandwidth edge*.
- If there are multiple combinations fulfilling previous steps, select the one with the smallest number of component carrier.
- If there are multiple combinations fulfilling previous steps, select the one with the widest carrier being adjacent to the lowest carrier.
- If there are multiple combinations fulfilling previous steps, select the one with the widest carrier being adjacent to the highest carrier
- If there are multiple combinations fulfilling previous steps, select the one with the widest carrier being adjacent to the carrier which has been selected in the previous step.
- If there are multiple combinations fulfilling previous steps, repeat the previous step until there is only one combination left.
- The nominal carrier spacing defined in subclause 4.6 shall apply.

4.11.2.12.4 ATCR8 power allocation

Set the number of carriers to the number of carriers at maximum TRP (see table 4.10-1, D9.14).

For EIRP accuracy requirements set each beam to maximum EIRP (see table 4.10-1, D9.10) for the tested *beam direction pair*.

For all other requirements ensure the total radiated power is $P_{\text{Rated,c,TRP}}$ (see table 4.10-2, D11.6).

For a beam declared to support only CA operation (see table 4.10-1, D6.23), set the power spectral density of of each carrier to the same level so that the sum of the carrier power equals the same value as above.

4.11.2.13 ANTCR8: NR multicarrier non-contiguous operation

4.11.2.13.1 General

The purpose of ANTCR8 is to test NR multicarrier non-contiguous aspects.

4.11.2.13.2 ANTCR8 generation

ANTCR8 is constructed using the following method:

- The *Base Station RF Bandwidth* of each supported operating band shall be the declared maximum radiated *Base Station RF Bandwidth* for non-contiguous operation (see table 4.10-1, D9.19). The *Base Station RF Bandwidth* consists of one sub-block gap and two sub-blocks located at the edges of the declared maximum radiated *Base Station RF Bandwidth* (see table 4.10-1, D9.17).
- For transmitter tests, place a NR carrier as specified in subclause 4.11.1A adjacent to the upper *Base Station RF Bandwidth edge* and a similar NR carrier adjacent to the lower *Base Station RF Bandwidth edge*. The specified $F_{\text{Offset-RAT}}$ shall apply.
- For receiver tests, place a NR carrier as specified in subclause 4.11.1A adjacent to the upper *Base Station RF Bandwidth edge* and a similar NR carrier adjacent to the lower *Base Station RF Bandwidth edge*. - The sub-block edges adjacent to the *sub-block gap* shall be determined using the specified $F_{\text{Offset-RAT}}$ for the carrier adjacent to the *sub-block gap*.

4.11.2.13.3 ANTCR8 power allocation

Set the number of carriers to the number of carriers at maximum EIRP (see table 4.10-1, D9.14).

For EIRP accuracy requirements set each beam to maximum EIRP (see table 4.10-1, D9.10) for the tested *beam direction pair*.

For all other requirements ensure the total radiated power is $P_{\text{Rated,c,TRP}}$ (see table 4.10-2, D11.6).

4.12 RF channels and test models

4.12.1 RF channels

For single carrier tests unless otherwise stated the tests shall be performed with a single carrier at each of the RF channels B, M and T.

Many tests in this TS are performed with the maximum radiated *Base Station RF Bandwidth* located at the bottom, middle and top of the supported frequency range in the operating band. These are denoted as B_{RFBW} (bottom), M_{RFBW} (middle) and T_{RFBW} (top).

- Unless otherwise stated, the test shall be performed at B_{RFBW} , M_{RFBW} and T_{RFBW} defined as following:
- B_{RFBW} : maximum *Base Station RF Bandwidth* located at the bottom of the supported frequency range in the operating band.
- M_{RFBW} : maximum *Base Station RF Bandwidth* located in the middle of the supported frequency range in the operating band. M_{RFBW} may be shifted maximum 100 kHz towards lower frequencies to align carriers with the channel raster.
- T_{RFBW} : maximum *Base Station RF Bandwidth* located at the top of the supported frequency range in the operating band.

For the test of certain RF requirements the present specification refers to test procedures defined in the single-RAT specifications [2], [3], [4], [5]. In this case, the interpretation of the RF channels to be tested shall be according to the definitions in the corresponding single-RAT specifications [2], [3], [4], [5].

For an operating band which has multi-band beam dependencies capable of dual-band operation, unless otherwise stated, the test shall be performed at B_{RFBW_T} and B'_{RFBW_T} defined as following:

- $B_{\text{RFBW_T'RFBW}}$: the *Base Station RF Bandwidths* located at the bottom of the supported frequency range in the lower operating band and at the highest possible simultaneous frequency position, within the maximum *Radio Bandwidth*, in the upper operating band.
- $B'_{\text{RFBW_T'RFBW}}$: the *Base Station RF Bandwidths* located at the top of the supported frequency range in the upper operating band and at the lowest possible simultaneous frequency position, within the maximum *Radio Bandwidth*, in the lower operating band.

NOTE: $B_{\text{RFBW_T'RFBW}} = B'_{\text{RFBW_T'RFBW}} = B_{\text{RFBW_T'RFBW}}$ when the declared maximum radiated *Radio Bandwidth* (see table 4.10-1, D9.17) spans both operating bands. $B_{\text{RFBW_T'RFBW}}$ means the *Base Station RF Bandwidths* are located at the bottom of the supported frequency range in the lower operating band and at the top of the supported frequency range in the upper operating band.

When a test is performed by a test laboratory, the position of B_{RFBW} , M_{RFBW} and T_{RFBW} in each supported operating band, the position of $B_{\text{RFBW_T'RFBW}}$ and $B'_{\text{RFBW_T'RFBW}}$ in the supported operating band combinations shall be specified by the laboratory. The laboratory may consult with operators, the manufacturer or other bodies.

4.12.2 Test models

a) Unless otherwise stated, carriers used for transmitter tests shall be configured as follows:

- UTRA FDD carriers shall be configured according to TM1 as defined in TS 25.141 [10], subclause 6.1.1.1.
- UTRA TDD carriers shall be configured according to table 6.1A as defined in TS 25.142 [11], subclause 6.2.4.1.2.
- E-UTRA carriers shall be configured according to E-TM1.1 as defined in TS 36.141 [12], subclause 6.1.1.1.

For BC3 RCS3 BS testing, E-UTRA carriers shall be configured according to E-TM1_BC3CS3 defined in annex E of TS 37.141 [13].

- NR carriers shall be configured according to NR-FR1-TM1 as defined in TS 38.141-2 [34], subclause 4.9.2.2.

For BC3 BS testing, NR carriers shall be configured according to NR-FR1-TM1_CS3 defined in annex E of TS 37.141 [13].

b) The configuration of the carriers in test configurations used for testing modulation quality and frequency error shall be as follows:

- For the case that modulation accuracy is measured for UTRA FDD, the UTRA FDD carriers shall be configured according to the supported TM1 and TM4, as defined in TS 25.141 [10], subclause 6.1.1, whilst any remaining carriers from other RAT(s) shall be configured according to bullet a) above.

If HS-PDSCH transmission using 16QAM is supported, the UTRA FDD carriers shall be configured according to TM4 and TM5, as defined in TS 25.141 [10], subclause 6.1.1.

- For the case that modulation accuracy is measured for E-UTRA, the E-UTRA carriers shall be configured according to the supported E-TM3.1, E-TM3.2, E-TM3.3 and E-TM2 as defined in TS 36.141 [12] subclause 6.1.1. whilst any remaining carriers from other RAT(s) shall be configured according to bullet a) above.

- If transmission using 256QAM is supported, the E-UTRA carriers shall be configured according to E-TM 2a and E-TM3.1a as defined in TS 36.141 [17] subclause 6.1.1.

- If transmission using 1024QAM is supported, the E-UTRA carriers shall be configured according to E-TM2b and E-TM3.1b as defined in TS 36.141 [17] subclause 6.1.1.

For BC3 CS3 BS testing, E-UTRA carriers shall be configured according to E-TM3.1_BC3CS3, E-TM3.2_BC3CS3, E-TM3.3_BC3CS3 and E-TM2_BC3CS3 defined in annex E of TS 37.141 [13].

- For the case that modulation accuracy is measured for E-UTRA with sTTI, the E-UTRA carriers shall be configured according to the supported sE-TM3.1-1 and sE-TM2-1 (for subslot TTI), or sE-TM3.1-2 and sE-TM2-2 (for slot TTI) as defined in TS 36.141 [12] subclause 6.1.1, whilst any remaining carriers from other RAT(s) shall be configured according to bullet a) above.- For the case that modulation accuracy is measured for NR, the NR carriers shall be configured according to the supported NR-FR1-TM3.1, NR-FR1-TM3.2, NR-FR1-TM3.3 and NR-

FR1-TM2 as defined in TS 38.141-2 [34] subclause 4.9.2.2, whilst any remaining carriers from other RAT(s) shall be configured according to bullet a) above.

- If transmission using 256QAM is supported, the NR carriers shall be configured according to E-TM2a and E-TM3.1a as defined in TS 38.141-1 [34] subclause 4.9.2.2.

For BC3 BS testing, NR carriers shall be configured according to NR-FR1-TM3.1_BC3, NR-FR1-TM3.1a_BC3, NR-FR1-TM3.2_BC3, NR-FR1-TM3.3_BC3, NR-FR1-TM2_BC3 and NR-FR1-TM2a_BC3 defined in annex E of TS 37.141 [13].

c) Unless otherwise stated, transmitter carriers used for receiver tests shall be configured as follows:

- UTRA FDD carriers shall be configured according to TM1 as defined in TS 25.141 [10], subclause 6.1.1.1.
- UTRA TDD carriers shall be configured according to table 6.1A as defined in TS 25.142 [11], subclause 6.2.4.1.2.
- E-UTRA carriers shall be configured according to E-TM1.1 as defined in TS 36.141 [12], subclause 6.1.1.1. For BC3 CS3 BS testing, E-UTRA carriers shall be configured according to E-TM1_BC3CS3 defined in annex E of TS 37.141 [13].
- NR carriers shall be configured according to NR-FR1-TM1 as defined in TS 38.141-1 [37], subclause 4.9.2.2. For BC3 BS testing, NR carriers shall be configured according to NR-FR1-TM1_CS3 defined in annex E of TS 37.141 [16].

For the test of certain RF requirements clause 5 refers to the test configurations as defined in the single-RAT specifications. In this case, the transmitter test signals and test models as defined within the referred test specification for the RF requirement shall be used.

4.13 Format and interpretation of tests

Each test in the following clauses has a standard format:

X Title

All tests are applicable to all equipment within the scope of the present document, unless otherwise stated.

X.1 Definition and applicability

This subclause gives the general definition of the parameter under consideration and specifies whether the test is applicable to all equipment or only to a certain subset. Required manufacturer declarations may be included here.

X.2 Minimum requirement

This subclause contains the reference to the subclause to the 3GPP reference (or core) specification which defines the minimum requirement. For each requirement, there are separate references for MSR and single RAT, where applicable in the core requirement. If the requirement does not apply to a particular RAT, this is explicitly stated here (rather than through a reference).

X.3 Test purpose

This subclause defines the purpose of the test.

X.4 Method of test

X.4.1 General

In some cases there are alternative test procedures or initial conditions. In such cases, guidance for which initial conditions and test procedures can be applied are stated here. In the case only one test procedure is applicable, that is stated here.

X.4.2y First test method

X.4.2y.1 Initial conditions

This subclause defines the initial conditions for each test, including the test environment, the RF channels to be tested and the basic measurement set-up. The test system is assumed to be correctly calibrated as part of the initial conditions. Calibration is not explicitly mentioned.

X.4.2y.2 Procedure

This subclause describes the steps necessary to perform the test and provides further details of the test definition like point of access (e.g. test port), domain (e.g. frequency-span), range, weighting (e.g. bandwidth), and algorithms (e.g. averaging). The procedure may comprise data processing of the measurement result before comparison with the test requirement (e.g. average result from several measurement positions).

X.4.3y Alternative test method (if any)

If there are alternative test methods, each is described with its initial conditions and procedures.

X.5 Test requirement

This subclause defines the pass/fail criteria for the equipment under test, see subclause 4.1.3 Interpretation of measurement results. Test requirements for every minimum requirement referred in subclause X.2 are listed here. Cases where minimum requirements do not apply need not be mentioned.

The test requirements may be different depending on the test method applied. A test requirement for each test method applicable to the respective MSR/Single RAT requirement is given in separate subclauses where applicable.

4.14 Reference coordinate system

Radiated requirements are stated in terms of electromagnetic characteristics (e.g. EIRP and EIS) at certain angles with respect to the base station. To be able to declare radiated characteristics part of radiated requirements a reference coordinate system is required. The reference coordinate system is should be associated to an identifiable physical feature on the base station enclosure.. The location of the origin and the orientation of the reference coordinate system are for the base station manufacturer to declare.

The reference coordinate system is created of a Cartesian coordinate system with rectangular axis (x, y, z) and spherical angles (θ , ϕ) as showed in figure 4.14-1.

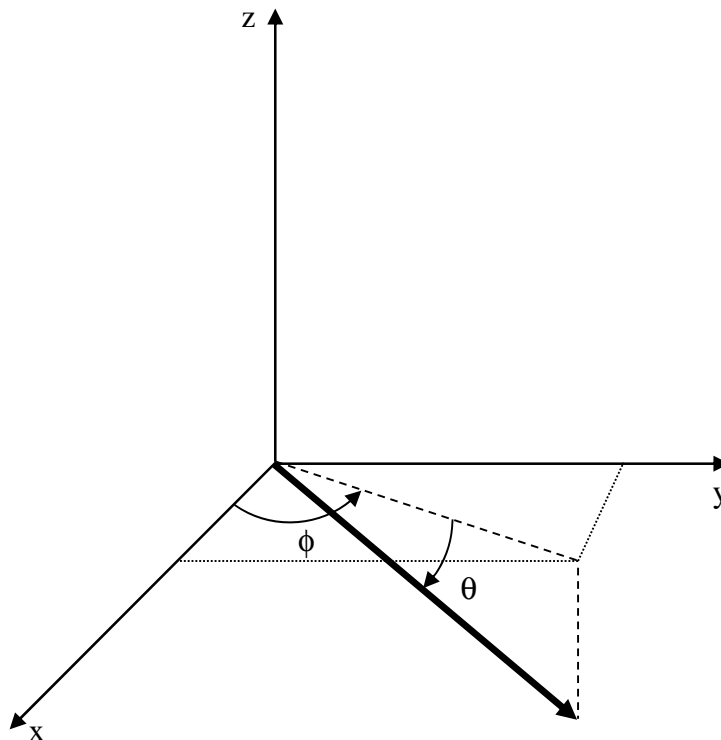

Figure 4.14-1: Reference coordinate system

ϕ is the angle in the x/y plane, between the x-axis and the projection of the radiating vector onto the x/y plane and is defined between -180° and $+180^\circ$, inclusive. θ is the angle between the projection of the vector in the x/y plane and the radiating vector and is defined between -90° and $+90^\circ$, inclusive. Note that θ is defined as positive along the down-tilt angle.

4.15 Co-location requirements

4.15.1 General

Co-location requirements are requirements which are based on assuming the AAS BS is co-located with another BS of the same base station class. They ensure that both co-located systems can operate with minimal degradation to each other.

The co-location requirements in Table 4.15-1-1 rely on a *co-location reference antenna* used to mimic a base station to base station co-location scenario.

Table 4.15-1-1: Co-location requirements

Clause number	Requirement	Co-location reference antenna operation	Type
6.5	OTA Transmit ON/OFF power	Measure emission	Mandatory
6.7.6.3 6.7.6.5	OTA Spurious emission	Measure emission	Optional based on declaration
6.8	OTA Transmitter intermodulation	Inject the interferer signal	Mandatory
7.6.3	OTA Blocking	Inject the interferer signal	Optional based on declaration

The OTA Transmit ON/OFF power requirement and OTA Transmitter intermodulation requirement are mandatory requirements where the test requirement is derived using the *co-location reference antenna*, which represents the worst-case scenario.

The *co-location reference antenna* is defined in 3GPP TS 37.105[6].

4.15.2 Co-location test antenna

4.15.2.1 General

Co-location requirements are specified as power levels into or out of the conducted interface of the *co-location reference antenna*. For conformance testing the requirements are translated to the input or output of a *co-location test antenna* (CLTA).

A CLTA is a practical antenna which can be used to test conformance to the co-location requirements.

4.15.2.2 Co-location test antenna characteristics

A co-location test antenna is a practical passive antenna that is used for conformance testing of the co-location requirements and is based on the definition of the *co-location reference antenna*. A CLTA shall comply to the requirements specified in Table 4.15.2.2-1. Translation of the requirements to other test antennas is not precluded but suitable translations between the *co-location reference antenna* and test antennas must be provided to demonstrate that the method is within the specified MU.

The currently defined CLTAs are suitable for testing AAS BSs implemented with a planar antenna array. The method for testing AAS BS with other antenna array implementations is FFS.

Table 4.15.2.2-1: CLTA characteristics

Parameter	in-band CLTA	out-of-band CLTAs
Vertical radiating dimension (h)	Test object vertical radiating length $\pm 30\%$	N/A
Horizontal beam width	$65^\circ \pm 10^\circ$	$65^\circ \pm 10^\circ$
Vertical beam width	N/A	The half-power vertical beam width of the CLTA equals the narrowest declared vertical <i>beamwidth</i> $\pm 3^\circ$
Polarization	Match	Match to in-band
Conducted interface return loss	$> 10\text{dB}$	$> 10\text{dB}$
NOTE 1: If a multi-column or multi-band antenna is used the column closest to the AAS BS shall be selected while other columns are terminated during testing.		

4.15.2.3 Co-location test antenna alignment

The alignment between the AAS BS under test and the *co-location test antenna* is specified in Table 4.15.2.3-1 and Figure 4.15.2.3-1.

Table 4.15.2.3-1: CLTA alignment tolerances

Parameter	in-band	out-of-band
Edge-to-edge separation between the AAS BS and the CLTA, d	$0.1\text{ m} \pm 0.01\text{ m}$	$0.1\text{ m} \pm 0.01\text{ m}$
Vertical alignment	Centre $\pm 0.01\text{ m}$	Centre $\pm 0.01\text{ m}$
Front alignment	Radome front $\pm 0.01\text{ m}$	Radome front $\pm 0.01\text{ m}$

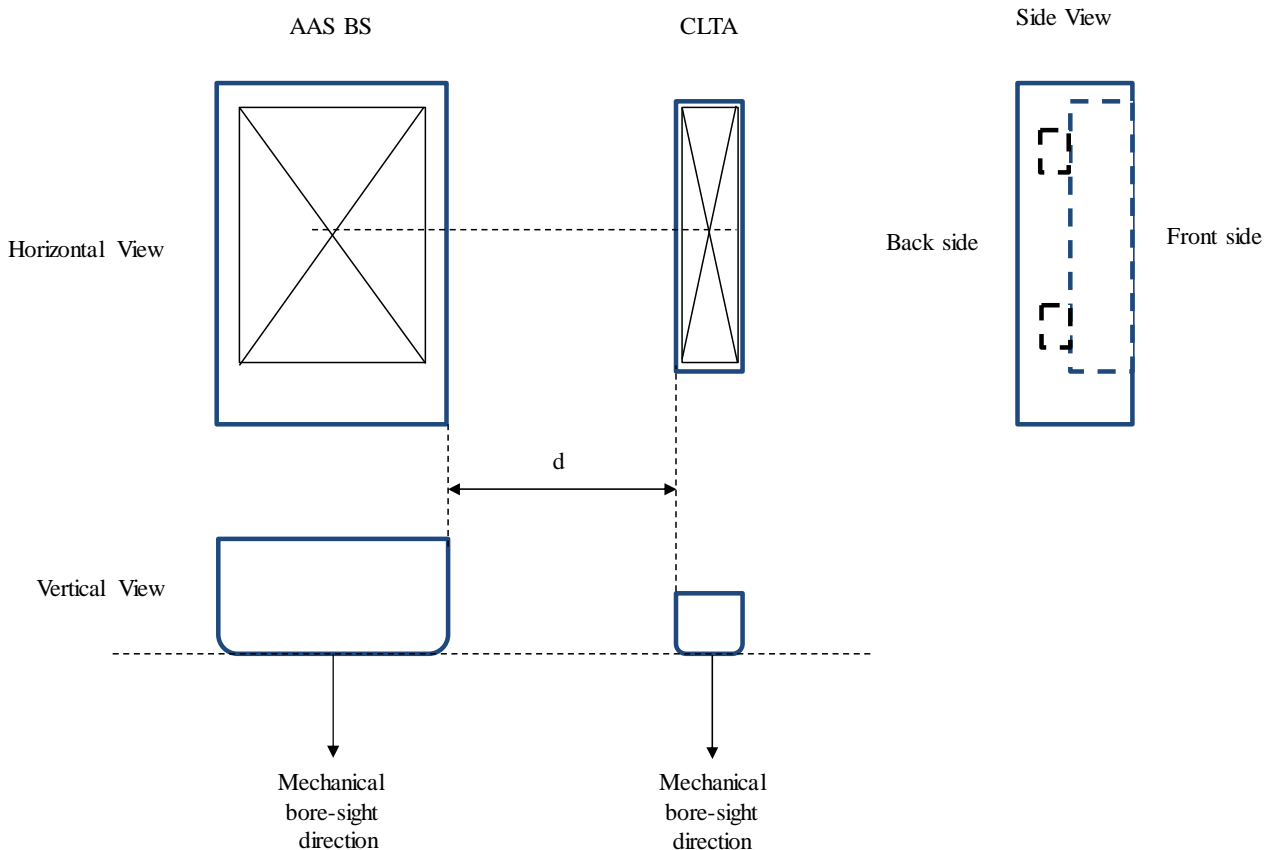

Figure 4.15.2.3-1 Alignment of AAS BS and CLTA

5 Applicability of Requirements

5.1 General

The present clause defines for each radiated test requirement the set of mandatory test configurations which shall be used for demonstrating conformance for radiated requirement.

Test configurations for beams supporting multiple RAT in the tested operating band are specified in subclause 5.1.

Test configurations for radiated requirements where the operating band has been declared to support single RAT requirements (see table 4.10-1, D9.5) by either MSR requirements for UTRA only or E-UTRA only or with a single-RAT UTRA requirements or single RAT E-UTRA requirements are specified in subclause 5.2.

Test configurations for an AAS BS with operating bands which have multi-band dependencies are specified in subclause 5.3.

Requirements apply to AAS BS according to the declared RAT radiated Capability Set (see table 4.10-1, D9.25) within each supported operating band the Band Category of the declared operating band (see table 4.10-1, D9.4), as listed in the heading of each table. Some RF requirements listed in the tables may not be mandatory or they may apply only regionally. This is further specified for each requirement in clauses 6 and 7, and in table 4.4-1.

For a declared RAT radiated Capability Set (see table 4.10-1, D9.25) in tables 5.2-1, 5.3.2-1, 5.3.3-1, 5.3.4-1, 5.4.1-1 or 5.4.2-1 only the requirements listed in the column for that radiated Capability Set apply. Requirements listed under RCSA other than the declared RCSA(s) need not be tested.

An AAS BS where the operating band is declared: to support multiple RATs (MSR) and to be capable of contiguous spectrum operation only, the test configuration(s) in tables 5.2-1 and 5.3.2-1 denoted by a "C" and entries that refer to single-RAT specifications shall be used for testing.

An AAS BS where the operating band is declared: to support multiple RATs (MSR), to be capable of contiguous and non-contiguous spectrum operation (see table 4.10-1, D9.28), where the parameters according to subclause 4.10 are identical for contiguous and non-contiguous operation (see table 4.10-1, D9.29). Shall use for each declared operating band the test configuration(s) in tables 5.2-1 and 5.3.2-1 denoted by "CNC" and entries that refer to single-RAT specifications shall be used.

An AAS BS where the operating band is declared: to support multiple RATs (MSR), to be capable of contiguous and non-contiguous spectrum operation (see table 4.10-1, D9.28), where the parameters according to subclause 4.10 are not identical for contiguous and non-contiguous operation (see table 4.10-1, D9.29). Shall use for each declared operating band the test configuration(s) in tables 5.2-1 and 5.3.2-1 denoted by "C/NC" and entries that refer to single-RAT specifications shall be used.

For an AAS BS operating bands which have multi-band dependencies which is MSR capable the applicability of the requirement for each operating band is determined by the RAT configuration within that operating band as identified in tables 5.2-1 and 5.3.2-1, unless otherwise stated. The testing of an AAS BS in operating bands with multi-band dependencies which are MSR capable shall be according to table 5.4.1-1 as follows:

- For requirements test denoted by SBT (Single Band Test), the test configuration (s) in tables 5.2-1 and 5.3.2-1 shall be used for each operating band depending on the RAT configuration within that band.
- For requirements test denoted by MBT (Multi-Band Test), the test configuration (s) in table 5.4.1-1 shall be used depending on the Band Category of the declared operating band combination.

For a single-RAT UTRA only operating bands subclause 5.3.3 defines for each radiated test requirement the set of mandatory test configurations which shall be used for demonstrating conformance. The applicable test configurations are specified in table 5.3.3-1 for each supported RF configuration, which shall be declared according to subclause 4.10. The generation and EIRP allocation for each test configuration is defined in subclause 4.11.2.

For a single-RAT E-UTRA only operating bands subclause 5.3.4 defines for each radiated test requirement the set of mandatory test configurations which shall be used for demonstrating conformance. The applicable test configurations

are specified in table 5.3.4-1 for each supported RF configuration, which shall be declared according to subclause 4.10. The generation and EIRP allocation for each test configuration is defined in subclause 4.11.3.

For an AAS BS operating band declared to be capable of single carrier operation only (see table 4.10-1, D9.4), a single carrier (SC) shall be used for testing.

5.2 Test configurations for AAS BS for operating bands where MSR with more than 1 RAT is supported

Table 5.2-1: Test configuration applicability to requirements and capability sets for AAS BS supporting MSR operation

Test case	UTRA + E-UTRA (RCSA 3)			E-UTRA + NR (RCSA 3A)		
	BC1	BC2	BC3	BC1	BC2	BC3
6.2 Radiated transmit power	C: ATCR3a CNC: ATCR3a C/NC: ATCR3a, ANTCR3a	C: ATCR3a CNC: ATCR3a C/NC: ATCR3a, ANTCR3a	C: ATCR3b	C: ATCR7 CNC: ATCR7 C/NC: ATCR7, ANTCR7	C: ATCR7 CNC: ATCR7 C/NC: ATCR7, ANTCR7	C: ATCR7 CNC: ATCR7 C/NC: ATCR7, ANTCR 7
6.3 OTA Base Station output power	-	-	-	-	-	-
6.3 OTA Maximum output power .2	C: ATCR3a CNC: ATCR3a C/NC: ATCR3a, ANTCR3a	C: ATCR3a CNC: ATCR3a C/NC: ATCR3a, ANTCR3a	N/A	C: ATCR7 CNC: ATCR7 C/NC: ATCR7, ANTCR7	C: ATCR7 CNC: ATCR7 C/NC: ATCR7, ANTCR7	C: ATCR7 CNC: ATCR7 C/NC: ATCR7, ANTCR 7
6.3 OTA E-UTRA DL RS power .3	Subclause 5.3.4	Subclause 5.3.4	Subclau se 5.3.4	Subclause 5.3.4	Subclause 5.3.4	Subclau se 5.3.4
6.4 OTA Output power dynamics	-	-	-	-	-	-
E-UTRA	Subclause 5.3.4	Subclause 5.3.4	Subclau se 5.3.4	Subclause 5.3.4	Subclause 5.3.4	Subclau se 5.3.4
UTRA FDD	Subclause 5.3.3	Subclause 5.3.3	N/A	N/A	N/A	N/A
NR – RE power control dynamic range	N/A	N/A	N/A	Tested with Error Vector Magnitude	Tested with Error Vector Magnitude	Tested with Error Vector Magnitu de
NR – total power dynamic range	N/A	N/A	N/A	SC	SC	SC
6.5 OTA Transmit ON/OFF power	-	-	-	-	-	-
6.5 OTA Transmitter OFF power .1	N/A	N/A	N/A	N/A	N/A	C: ATCR7 CNC: ATCR7 C/NC: ATCR7, ANTCR 7
6.5 OTA Transmitter transient period .2	N/A	N/A	N/A	N/A	N/A	C: ATCR7 CNC: ATCR7 C/NC: ATCR7, ANTCR 7
6.6 Transmitted signal quality	-	-	-	-	-	-
6.6 OTA Frequency error .2	-	-	-	-	-	-
E-UTRA	Same TC as used in subclause 6.6.4	Same TC as used in subclause 6.6.4	Same TC as used in subclaus e 6.6.4	Same TC as used in subclause 6.6.4	Same TC as used in subclause 6.6.4	Same TC as used in subclaus e 6.6.4
UTRA FDD	Same TC as used in subclause 6. 6.4	Same TC as used in subclause 6. 6.4	N/A	N/A	N/A	N/A

Test case	UTRA + E-UTRA (RCSA 3)			E-UTRA + NR (RCSA 3A)		
	BC1	BC2	BC3	BC1	BC2	BC3
NR NR	N/A	N/A		Same TC as used in subclause 6.6.4	Same TC as used in subclause 6.6.4	Same TC as used in subclause 6.6.4
6.6.3 OTA Time alignment error	-	-	-	-	-	-
E-UTRA	Subclause 5.3.4	Subclause 5.3.4	Subclause 5.3.4	Subclause 5.3.4	Subclause 5.3.4	Subclause 5.3.4
UTRA FDD	Subclause 5.3.3	Subclause 5.3.3	N/A	N/A	N/A	N/A
NR	N/A	N/A	N/A	C: ATCR8 CNC: ATCR8 C/NC: ATCR8, ANTCR8	C: ATCR8 CNC: ATCR8 C/NC: ATCR8, ANTCR8	C: ATCR8 CNC: ATCR8 C/NC: ATCR8, ANTCR8
6.6.4 OTA Modulation quality - EVM	-	-	-	-	-	-
E-UTRA	C: ATCR3a CNC: ATCR3a C/NC: ATCR3a, ANTCR3a	C: ATCR3a CNC: ATCR3a C/NC: ATCR3a, ANTCR3a	N/A	C: ATCR7 CNC: ATCR7 C/NC: ATCR7, ANTCR7	C: ATCR7 CNC: ATCR7 C/NC: ATCR7, ANTCR7	C: ATCR7 CNC: ATCR7 C/NC: ATCR7, ANTCR7
UTRA FDD	C: ATCR3a CNC: ATCR3a C/NC: ATCR3a, ANTCR3a	C: ATCR3a CNC: ATCR3a C/NC: ATCR3a, ANTCR3a	N/A	N/A	N/A	N/A
	NR	N/A	N/A	N/A	C: ATCR7 CNC: ATCR7 C/NC: ATCR7, ANTCR7	C: ATCR7 CNC: ATCR7 C/NC: ATCR7, ANTCR7
6.7 OTA Unwanted Emissions	-	-	-	-	-	-
6.7.2 OTA Occupied bandwidth	-	-	-	-	-	-
Minimum requirement	Subclause 5.3.3 Subclause 5.3.4	Subclause 5.3.3 Subclause 5.3.4	Subclause 5.3.3 Subclause 5.3.4	Subclause 5.3.4 SC, ATCR8b (Note)	Subclause 5.3.4 SC, ATCR8b (Note)	Subclause 5.3.4 SC, ATCR8b (Note)
6.7.3 OTA Adjacent Channel Leakage power Ratio	-	-	-	-	-	-

Test case	UTRA + E-UTRA (RCSA 3)			E-UTRA + NR (RCSA 3A)		
	BC1	BC2	BC3	BC1	BC2	BC3
E-UTRA	C: ATCR2a CNC: ANTCR2 C/NC:ATC R2a, ANTCR2	C: ATCR2a CNC: ANTCR2 C/NC:ATCR2 a, ANTCR2	C: ATCR2a CNC: ANTCR 2 C/NC:A TCR2a, ANTCR 2	C: ATCR2a CNC: ANTCR2 C/NC:ATC R2a, ANTCR2	C: ATCR2a CNC: ANTCR2 C/NC:ATCR2 a, ANTCR2	C: ATCR2a CNC: ANTCR 2 C/NC:A TCR2a, ANTCR 2
UTRA FDD	Subclause 5.3.3	Subclause 5.3.3	N/A	N/A	N/A	N/A

Test case	UTRA + E-UTRA (RCSA 3)			E-UTRA + NR (RCSA 3A)		
	BC1	BC2	BC3	BC1	BC2	BC3
NR	N/A	N/A	N/A	C: ATCR8a CNC: ANTCR8 C/NC: ATCR8a, ANTCR8	C: ATCR8a CNC: ANTCR8 C/NC: ATCR8a, ANTCR8	C: ATCR8a CNC: ANTCR 8 C/NC: ATCR8a , ANTCR 8
Cumulative ACLR	CNC: ANTCR3a C/NC:ANT CR3a	CNC: ANTCR3a C/NC:ANTCR 3a		CNC: ANTCR7 C/NC:ANT CR7	CNC: ANTCR7 C/NC:ANTCR 7	CNC: ANTCR 7 C/NC:A NCR7
6.6.5 OTA Operating band unwanted emission	-	-	-	-	-	-
General requirement for Band Categories 1 and 3	Subclause 5.3.3 Subclause 5.3.4 C: ATCR3a CNC: ATCR3a, ANTCR3a C/NC: ATCR3a, ANTCR3a	N/A	Subclau se 5.3.3 Subclau se 5.3.4	Subclause 5.3.4 C: ATCR7 CNC: ATCR7, ANTCR7 C/NC: ATCR7, ANTCR7	N/A	Subclau se 5.3.4 C: ATCR7 CNC: ATCR7, ANTCR 7 C/NC: ATCR7, ANTCR 7
General requirement for Band Category 2	N/A	Subclause 5.3.3 Subclause 5.3.4 C: ATCR3a CNC: ATCR3a, ANTCR3a C/NC: ATCR3a, ANTCR3a	N/A	N/A	Subclause 5.3.4 C: ATCR7 CNC: ATCR7, ANTCR7 C/NC: ATCR7, ANTCR7	N/A
Additional requirements	(note)	(note)	(note)	(note)	(note)	(note)
6.7.6 OTA Spurious emission	-	-	-	-	-	-
(Category A)	C: ATCR3a CNC: ANTCR3a C/NC: ATCR3a, ANTCR3a	C: ATCR3a CNC: ANTCR3a C/NC: ATCR3a, ANTCR3a	N/A	C: ATCR7 CNC: ANTCR7 C/NC: ATCR7, ANTCR7	C: ATCR7 CNC: ANTCR7 C/NC: ATCR7, ANTCR7	C: ATCR7 CNC: ANTCR 7 C/NC: ATCR7, ANTCR 7
(Category B)	C: ATCR3a CNC: ANTCR3a C/NC: ATCR3a, ANTCR3a	C: ATCR3a CNC: ANTCR3a C/NC: ATCR3a, ANTCR3a	N/A	C: ATCR7 CNC: ANTCR7 C/NC: ATCR7, ANTCR7	C: ATCR7 CNC: ANTCR7 C/NC: ATCR7, ANTCR7	C: ATCR7 CNC: ANTCR 7 C/NC: ATCR7, ANTCR 7

Test case	UTRA + E-UTRA (RCSA 3)			E-UTRA + NR (RCSA 3A)		
	BC1	BC2	BC3	BC1	BC2	BC3
Protection of the BS receiver of own or different BS	C: ATCR3a CNC: ANTCR3a C/NC: ATCR3a, ANTCR3a	C: ATCR3a CNC: ANTCR3a C/NC: ATCR3a, ANTCR3a	N/A	C: ATCR7 CNC: ANTCR7 C/NC: ATCR7, ANTCR7	C: ATCR7 CNC: ANTCR7 C/NC: ATCR7, ANTCR7	C: ATCR7 CNC: ANTCR 7 C/NC: ATCR7, ANTCR 7
Additional spurious emissions requirements	C: ATCR3a, CNC: ANTCR3a, C/NC: ATCR3a, ATCR3a	C: ATCR3a CNC: ANTCR3a C/NC: ATCR3a, ANTCR3a	N/A	C: ATCR7, CNC: ANTCR7, C/NC: ATCR7, ANTCR7	C: ATCR7 CNC: ANTCR7 C/NC: ATCR7, ANTCR7	C: ATCR7 CNC: ANTCR 7 C/NC: ATCR7, ANTCR 7
Co-location with other Base Stations	C: ATCR3a CNC: ANTCR3a C/NC: ATCR3a, ANTCR3a	C: ATCR3a CNC: ANTCR3a C/NC: ATCR3a, ANTCR3a	N/A	C: ATCR7 CNC: ANTCR7 C/NC: ATCR7, ANTCR7	C: ATCR7 CNC: ANTCR7 C/NC: ATCR7, ANTCR7	C: ATCR7 CNC: ANTCR 7 C/NC: ATCR7, ANTCR 7
6.8 OTA Transmitter intermodulation	-	-	-	-	-	-
General requirement	Same TC as used in subclause 6.7	Same TC as used in subclause 6.7	Same TC as used in subclause 6.7	Same TC as used in subclause 6.7	Same TC as used in subclause 6.7	Same TC as used in subclause 6.7
Additional requirement (BC1 and BC2)	CNC: ANTCR3a C/NC:ANTCR3a	Same TC as used in subclause 6.7	N/A	CNC: ANTCR7 C/NC:ANTCR7a	Same TC as used in subclause 6.7	N/A
Additional requirement (BC3)	N/A	N/A	Same TC as used in subclause 6.7	N/A	N/A	Same TC as used in subclause 6.7
7.2 OTA sensitivity	-	-	-	-	-	-
E-UTRA requirement	subclause 5.3.4	subclause 5.3.4	subclause 5.3.4	subclause 5.3.4	subclause 5.3.4	subclause 5.3.4
UTRA FDD requirement	subclause 5.3.3	subclause 5.3.3	N/A	N/A	N/A	N/A
UTRA TDD requirement	N/A	N/A	subclause 5.3.3	N/A	N/A	N/A
NR requirement	N/A	N/A	N/A	ATCR4d	ATCR4d	ATCR4d
7.3 OTA reference sensitivity level	-	-	-	-	-	-
E-UTRA requirement	subclause 5.3.4	subclause 5.3.4	subclause 5.3.4	subclause 5.3.4	subclause 5.3.4	subclause 5.3.4
UTRA FDD requirement	subclause 5.3.3	subclause 5.3.3	N/A	N/A	N/A	N/A
NR requirement	N/A	N/A	N/A	ATCR4d	ATCR4d	ATCR4d
7.4 OTA Dynamic range	-	-	-	-	-	-
E-UTRA	Subclause 5.3.4	Subclause 5.3.4	Subclause 5.3.4	Subclause 5.3.4	Subclause 5.3.4	Subclause 5.3.4
UTRA FDD	Subclause 5.3.3	Subclause 5.3.3	N/A	N/A	N/A	N/A
NR	N/A	N/A	N/A	ATCR4d	ATCR4d	ATCR4d
7.5 OTA Adjacent channel selectivity and narrowband blocking	-	-	-	-	-	-

Test case	UTRA + E-UTRA (RCSA 3)			E-UTRA + NR (RCSA 3A)		
	BC1	BC2	BC3	BC1	BC2	BC3
General blocking requirement	C: ATCR3a CNC: ANTCR3a C/NC: ATCR3a, ANTCR3a	C: ATCR3a CNC: ANTCR3a C/NC: ATCR3a, ANTCR3a	N/A	C: ATCR7 CNC: ANTCR7 C/NC: ATCR7, ANTCR7	C: ATCR7 CNC: ANTCR7 C/NC: ATCR7, ANTCR7	C: ATCR7 CNC: ANTCR 7 C/NC: ATCR7, ANTCR 7
General narrowband blocking requirement	C: ATCR3a, ATCR4b CNC:ANT CR3a, ATCR4b C/NC: ATCR3a, ANTCR3a, ATCR4b	C: ATCR3a, ATCR4b CNC:ANTCR3 a, ATCR4b C/NC: ATCR3a, ANTCR3a,AT CR4b	C: ATCR4b	C: ATCR7, ATCR4b, ATCR4d CNC:ANT CR7, ATCR4b, ATCR4d C/NC: ATCR7, ANTCR7, ATCR4b, ATCR4d	C: ATCR7, ATCR4b, ATCR4d CNC:ANTCR 7, ATCR4b, ATCR4d C/NC: ATCR7, ANTCR7,ATC R4b, ATCR4d	C: ATCR7, ATCR4b , ATCR4d CNC: ANTCR 7, ATCR4b , ATCR4d C/NC: ATCR7, ANTCR 7, ATCR4b , ATCR4d
Additional BC3 blocking minimum requirement	N/A	N/A	N/A	N/A	N/A	C: ATCR7 CNC: ANTCR 7 C/NC: ATCR7, ANTCR 7
7.6 OTA Blocking	-	-	-	-	-	-
General requirement	C: ATCR3a CNC: ANTCR3a C/NC: ATCR3a, ANTCR3a	C: ATCR3a CNC: ANTCR3a C/NC: ATCR3a, ANTCR3a	N/A	C: ATCR7 CNC: ANTCR7 C/NC: ATCR7, ANTCR7	C: ATCR7 CNC: ANTCR7 C/NC: ATCR7, ANTCR7	C: ATCR7 CNC: ANTCR 7 C/NC: ATCR7, ANTCR 7
Co-location requirement	C: ATCR3a CNC: ANTCR3a C/NC: ATCR3a, ANTCR3a	C: ATCR3a CNC: ANTCR3a C/NC: ATCR3a, ANTCR3a	N/A	C: ATCR7 CNC: ANTCR7 C/NC: ATCR7, ANTCR7	C: ATCR7 CNC: ANTCR7 C/NC: ATCR7, ANTCR7	C: ATCR7 CNC: ANTCR 7 C/NC: ATCR7, ANTCR 7

Test case	UTRA + E-UTRA (RCSA 3)			E-UTRA + NR (RCSA 3A)		
	BC1	BC2	BC3	BC1	BC2	BC3
7.7 OTA Receiver spurious emissions	-	-	-	-	-	-
General requirement	C: ATCR3a CNC: ANTCR3a C/NC: ATCR3a, ANTCR3a	C: ATCR3a CNC: ANTCR3a C/NC: ATCR3a, ANTCR3a	N/A	C: ATCR7 CNC: ANTCR7 C/NC: ATCR7, ANTCR7	C: ATCR7 CNC: ANTCR7 C/NC: ATCR7, ANTCR7	C: ATCR7 CNC: ANTCR 7 C/NC: ATCR7, ANTCR 7
Additional requirement for BC2 (Category B)	N/A	N/A	N/A	N/A	N/A	N/A
7.8 OTA Receiver intermodulation	-	-	-	-	-	-
General intermodulation requirement	C: ATCR3a CNC: ANTCR3a C/NC: ATCR3a, ANTCR3a	C: ATCR3a CNC: ANTCR3a C/NC: ATCR3a, ANTCR3a	N/A	C: ATCR7 CNC: ANTCR7 C/NC: ATCR7, ANTCR7	C: ATCR7 CNC: ANTCR7 C/NC: ATCR7, ANTCR7	C: ATCR7 CNC: ANTCR 7 C/NC: ATCR7, ANTCR 7
General narrowband intermodulation requirement	C: ATCR3a, ATCR4b CNC:ANT CR3a, ATCR4b C/NC: ATCR3a, ANTCR3a, ATCR4b	C: ATCR3a ATCR4b CNC:ANTCR3 a,ATCR4b C/NC: ATCR3a, ANTCR3a; ATCR4b	C: ATCR4b	C: ATCR7, ATCR4b, ATCR4d CNC:ANT CR7, ATCR4b, ATCR4d C/NC: ATCR7, ANTCR7, ATCR4b, ATCR4d	C: ATCR7 ATCR4b, ATCR4d CNC:ANTCR 7,ATCR4b, ATCR4d C/NC: ATCR7, ANTCR7; ATCR4b, ATCR4d	C: ATCR7, ATCR4b , ATCR4d CNC: ANTCR 7, ATCR4b , ATCR4d C/NC: ATCR7, ANTCR 7, ATCR4b , ATCR4d
7.9 OTA In-channel selectivity	-	-	-	-	-	-
E-UTRA requirement	Subclause 5.3.4	Subclause 5.3.4	Subclau se 5.3.4	Subclause 5.3.4	Subclause 5.3.4	Subclau se 5.3.4
NR requirement	N/A	N/A	N/A	ATCR4d	ATCR4d	ATCR4d

NOTE: ATCR8b is only applicable when contiguous CA is supported.

5.3 Test configurations for multi-carrier capable AAS BS in operating bands where one RAT capability sets are supported

5.3.1 General

An AAS BS may support only one RAT operation in an operating band by fulfilling different sets of requirements. Both UTRA and E-UTRA have two complete sets of requirements that may be fulfilled depending on whether the beam is declared to be MSR or single RAT in the operating band. MSR and single RAT requirements are addressed separately by separate test requirements (and corresponding core requirements). They are also identified by different capability sets as described in subclauses 4.11 and 5.2.

5.3.2 AAS BS supporting one RAT only MSR in the operating band

This subclause contains test configuration applicability to requirements and capability sets for AAS BS supporting one RAT only MSR operation operating with multiple carriers (MC).

Table 5.3.2-1: Test configuration applicability to requirements and capability sets for operating bands supporting one RAT only MSR operation

Capability Set		UTRA (MC) capable BS (RCSA1)			E-UTRA (MC) capable BS (RCSA2)		
Test case		BC1	BC2	BC3	BC1	BC2	BC3
6.2	Radiated transmit power	C: ATCR1a CNC: ATCR1a C/NC: ATCR1a, ANTCR1a	C: ATCR1a CNC: ATCR1a C/NC: ATCR1a, ANTCR1a	C: ATCR1b	C: ATCR2a CNC: ATCR2a C/NC: ATCR2a, ANTCR2	C: ATCR2a CNC: ATCR2a C/NC: ATCR2a, ANTCR2	C: ATCR2a CNC: ATCR2a C/NC: ATCR2a, ANTCR2
6.3	OTA Base Station output power	-	-	-	-	-	-
6.3.2	OTA maximum output power	C: ATCR1a CNC: ATCR1a C/NC: ATCR1a, ANTCR1a	C: ATCR1a CNC: ATCR1a C/NC: ATCR1a, ANTCR1a	N/A	C: ATCR2a CNC: ATCR2a C/NC: ATCR2a, ANTCR2	C: ATCR2a CNC: ATCR2a C/NC: ATCR2a, ANTCR2	C: ATCR2a CNC: ATCR2a C/NC: ATCR2a, ANTCR2
6.3.3	OTA E-UTRA DL RS power	N/A	N/A	N/A	Subclause 5.3.4	Subclause 5.3.4	Subclause 5.3.4
6.4	OTA Output power dynamics	-	-	-	-	-	-
6.4.2	OTA UTRA Inner loop power control in the downlink	N/A	N/A	N/A	Subclause 5.3.4	Subclause 5.3.4	Subclause 5.3.4
6.4.3	OTA Power control dynamic range	Subclause 5.3.3	Subclause 5.3.3	N/A	N/A	N/A	N/A
6.4.4	OTA Total power dynamic range	N/A	N/A	Subclause 5.3.3	N/A	N/A	N/A
6.4.5	OTA IPDL time mask	Subclause 5.3.3	Subclause 5.3.3	N/A			
6.4.6	OTA RE Power control dynamic range	N/A	N/A	N/A	Subclause 5.3.4	Subclause 5.3.4	Subclause 5.3.4
6.5	OTA Transmit ON/OFF power	-	-	-	-	-	-
6.5.1	OTA Transmitter OFF power	N/A	N/A	N/A	N/A	N/A	C: ATCR2a CNC: ATCR2a C/NC: ATCR2a, ANTCR2
6.5.2	OTA Transmitter transient period	N/A	N/A	N/A	N/A	N/A	C: ATCR2a CNC: ATCR2a C/NC: ATCR2a, ANTCR2
6.6	OTA signal quality	-	-	-	-	-	-
6.6.2	OTA Frequency error	-	-	-	-	-	-
	E-UTRA	N/A	N/A	N/A	Same TC as used in subclause 6.5.4	Same TC as used in subclause 6.5.4	Same TC as used in subclause 6.5.4
	UTRA FDD	Same TC as used in subclause 6.5.4	Same TC as used in subclause 6.5.4	N/A	N/A	N/A	N/A
6.6.3	OTA Time alignment error	-	-	-	-	-	-

Capability Set		UTRA (MC) capable BS (RCSA1)			E-UTRA (MC) capable BS (RCSA2)		
		BC1	BC2	BC3	BC1	BC2	BC3
Test case							
E-UTRA		N/A	N/A	N/A	Subclause 5.3.4	Subclause 5.3.4	Subclause 5.3.4
UTRA FDD		Subclause 5.3.3	Subclause 5.3.3	N/A	N/A	N/A	N/A
6.6.4	OTA Modulation quality - EVM	-	-	-	-	-	-
E-UTRA		N/A	N/A	N/A	C: ATCR2a CNC: ATCR2a C/NC: ATCR2a, ANTCR2	C: ATCR2a CNC: ATCR2a C/NC: ATCR2a, ANTCR2	C: ATCR2a CNC: ATCR2aC/ NC: ATCR2a, ANTCR2
UTRA FDD		C: ATCR1a CNC: ATCR1a C/NC: ATCR1a, ANTCR1a	C: ATCR1a CNC: ATCR1a C/NC: ATCR1a, ANTCR1a	N/A	N/A	N/A	N/A
6.7	OTA Unwanted Emissions	-	-	-	-	-	-
6.7.2	OTA Occupied bandwidth	-	-	-	-	-	-
Minimum requirement		Subclause 5.3.3	Subclause 5.3.3	Subclause 5.3.3	Subclause 5.3.4	Subclause 5.3.4	Subclause 5.3.4
6.7.3	OTA Adjacent Channel Leakage power Ratio		-	-	-	-	-
E-UTRA		N/A	N/A	N/A	C: ATCR2a CNC: ANTCR2 C/NC: ATCR2a, ANTCR2	C: ATCR2a CNC: ANTCR2 C/NC: ATCR2a, ANTCR2	C: ATCR2a CNC: ANTCR2 C/NC: ATCR2a, ANTCR2
UTRA FDD		Subclause 5.3.3	Subclause 5.3.3	N/A	N/A	N/A	N/A
Cumulative ACLR		CNC: ANTCR1a C/NC: ANTCR1a	CNC: ANTCR1a C/NC: ANTCR1a	-	CNC: ANTCR2 C/NC: ANTCR2	CNC: ANTCR2 C/NC: ANTCR2	CNC: ANTCR2 C/NC: ANTCR2
6.7.4	OTA Spectrum emission mask						
6.7.5	OTA Operating band unwanted emission	-	-	-	-	-	-
General requirement for Band Categories 1 and 3		Subclause 5.3.3 C: ATCR1a CNC: ATCR1a, ANTCR1a C/NC: ATCR1a, ANTCR1a	N/A	Subclause 5.3.3	Subclause 5.3.4 C: ATCR2a CNC: ATCR2a, ANTCR2 C/NC: ATCR2a, ANTCR2	N/A	Subclause 5.3.4 C: ATCR2a CNC: ATCR2a, ANTCR2 C/NC: ATCR2a, ANTCR2
General requirement for Band Category 2		N/A	Subclause 5.3.3 C: ATCR1a CNC: ATCR1a, ANTCR1a C/NC: ATCR1a, ANTCR1a	N/A	N/A	Subclause 5.3.4 C: ATCR2a CNC: ATCR2a, ANTCR2 C/NC: ATCR2a, ANTCR2	N/A
Additional requirements		(note)	(note)	(note)	(note)	(note)	(note)
6.7.6	OTA Spurious emission (Category A)	-	-	-	-	-	-
		C: ATCR1a CNC:	C: ATCR1a CNC:	N/A	C: ATCR2a CNC:	C: ATCR2a CNC:	C: ATCR2a CNC:

Capability Set		UTRA (MC) capable BS (RCSA1)			E-UTRA (MC) capable BS (RCSA2)		
Test case		BC1	BC2	BC3	BC1	BC2	BC3
		ANTCR1a C/NC: ATCR1a, ANTCR1a	ANTCR1a C/NC: ATCR1a, ANTCR1a		ANTCR2 C/NC: ATCR2a, ANTCR2	ANTCR2 C/NC: ATCR2a, ANTCR2	ANTCR2 C/NC: ATCR2a, ANTCR2
	(Category B)	C: ATCR1a CNC: ANTCR1a C/NC: ATCR1a, ANTCR1a	C: ATCR1a CNC: ANTCR1a C/NC: ATCR1a, ANTCR1a	N/A	C: ATCR2a CNC: ANTCR2 C/NC: ATCR2a, ANTCR2	C: ATCR2a CNC: ANTCR2 C/NC: ATCR2a, ANTCR2	C: ATCR2a CNC: ANTCR2 C/NC: ATCR2a, ANTCR2
	Protection of the BS receiver of own or different BS	C: ATCR1a CNC: ANTCR1a C/NC: ATCR1a, ANTCR1a	C: ATCR1a CNC: ANTCR1a C/NC: ATCR1a, ANTCR1a	N/A	C: ATCR2a CNC: ANTCR2 C/NC: ATCR2a, ANTCR2	C: ATCR2a CNC: ANTCR2 C/NC: ATCR2a, ANTCR2	C: ATCR2a CNC: ANTCR2 C/NC: ATCR2a, ANTCR2
	Additional spurious emissions requirements	C: ATCR1a CNC: ANTCR1a C/NC: ATCR1a, ANTCR1a	C: ATCR1a CNC: ANTCR1a C/NC: ATCR1a, ANTCR1a	N/A	C: ATCR2a CNC: ANTCR2 C/NC: ATCR2a, ANTCR2	C: ATCR2a CNC: ANTCR2 C/NC: ATCR2a, ANTCR2	C: ATCR2a CNC: ANTCR2 C/NC: ATCR2a, ANTCR2
	Co-location with other Base Stations	C: ATCR1a CNC: ANTCR1a C/NC: ATCR1a, ANTCR1a	C: ATCR1a CNC: ANTCR1a C/NC: ATCR1a, ANTCR1a	N/A	C: ATCR2a CNC: ANTCR2 C/NC: ATCR2a, ANTCR2	C: ATCR2a CNC: ANTCR2 C/NC: ATCR2a, ANTCR2	C: ATCR2a CNC: ANTCR2C/ NC: ATCR2a, ANTCR2
6.8	OTA Transmitter intermodulation	-	-	-	-	-	-
	General requirement	Same TC as used in subclause 6.6	Same TC as used in subclause 6.6	Same TC as used in subclause 6.6	Same TC as used in subclause 6.6	Same TC as used in subclause 6.6	Same TC as used in subclause 6.6
	Additional requirement (BC1 and BC2)	CNC: ANTCR1a C/NC:ANTC R1a	Same TC as used in 6.6	N/A	CNC: ANTCR2 C/NC: ANTCR2	Same TC as used in 6.6	N/A
	Additional requirement (BC3)	N/A	N/A	Same TC as used in subclause 6.6	N/A	N/A	Same TC as used in 6.6
7.2	OTA sensitivity	-	-	-	-	-	-
	E-UTRA requirement	N/A	N/A	N/A	subclause 5.3.4	subclause 5.3.4	subclause 5.3.4
	UTRA FDD requirement	subclause 5.3.3	subclause 5.3.3	N/A	N/A	N/A	N/A
	UTRA TDD requirement	N/A	N/A	subclause 5.3.3	N/A	N/A	N/A
7.3	OTA Reference sensitivity level	-	-	-	-	-	-
	E-UTRA requirement	N/A	N/A	N/A	Subclause 5.3.4	Subclause 5.3.4	Subclause 5.3.4
	UTRA FDD requirement	Subclause 5.3.3	Subclause 5.3.3	N/A	N/A	N/A	N/A
7.4	OTA Dynamic range	-	-	-	-	-	-
	E-UTRA	N/A	N/A	N/A	Subclause 5.3.4	Subclause 5.3.4	Subclause 5.3.4
	UTRA FDD	Subclause 5.3.3	Subclause 5.3.3	N/A	N/A	N/A	N/A
7.5	OTA Adjacent channel selectivity and narrowband blocking	-	-	-	-	-	-

Capability Set	UTRA (MC) capable BS (RCSA1)			E-UTRA (MC) capable BS (RCSA2)		
	BC1	BC2	BC3	BC1	BC2	BC3
General blocking requirement	C: ATCR1a CNC: ANTCR1a C/NC: ATCR1a , ANTCR1a	C: ATCR1a, NC: ANTCR1a C/NC: ATCR1a , ANTCR1a	N/A	C: ATCR2a CNC: ANTCR2 C/NC: ATCR2a, ANTCR2	C: ATCR2a CNC: ANTCR2 C/NC: ATCR2a, ANTCR2	C: ATCR2a CNC: ANTCR2 C/NC: ATCR2a, ANTCR2
General narrowband blocking requirement	C: ATCR1a, ATCR4a CNC: ANTCR1a, ATCR4a C/NC: ATCR1a, ANTCR1a, ATCR4a	C: ATCR1a, ATCR4a CNC:ANTC R1a, ATCR4a C/NC: ATCR1a, ANTCR1a, ATCR4a	N/A	C: ATCR2a, ATCR4b CNC:ANTC R2, ATCR4b C/NC: ATCR2a, ANTCR2	C: ATCR2a, ATCR4b CNC: ANTCR2, ATCR4b C/NC: ATCR2a, ANTCR2, ATCR4b	C: ATCR2a, ATCR4b CNC: ANTCR2, ATCR4b C/NC: ATCR2a, ANTCR2, ATCR4b
Additional BC3 blocking minimum requirement	N/A	N/A	N/A	N/A	N/A	C: ATCR2a CNC: ANTCR2 C/NC: ATCR2a, ANTCR2
7.6 OTA Blocking	-	-	-	-	-	-
General requirement	C: ATCR1a CNC: ANTCR1a C/NC: ATCR1a, ANTCR1a	C: ATCR1a CNC: ANTCR1a C/NC: ATCR1a, ANTCR1a	N/A	C: ATCR2a CNC: ANTCR2 C/NC: ATCR2a, ANTCR2	C: ATCR2a CNC: ANTCR2 C/NC: ATCR2a, ANTCR2	C: ATCR2a CNC: ANTCR2 C/NC: ATCR2a, ANTCR2
Co-location requirement	C: ATCR1a CNC: ANTCR1a C/NC: ATCR1a, ANTCR1a	C: ATCR1a CNC: ANTCR1a C/NC: ATCR1a, ANTCR1a	N/A	C: ATCR2a CNC: ANTCR2 C/NC: ATCR2a, ANTCR2	C: ATCR2a CNC: ANTCR2 C/NC: ATCR2a, ANTCR2	C: ATCR2a CNC: ANTCR2 C/NC: ATCR2a, ANTCR2
7.7 OTA Receiver spurious emissions	-	-	-	-	-	-
General requirement	C: ATCR1a CNC: ANTCR1a C/NC: ATCR1a, ANTCR1a	C: ATCR1a CNC: ANTCR1a C/NC: ATCR1a, ANTCR1a	N/A	C: ATCR2a CNC: ANTCR2 C/NC: ATCR2a, ANTCR2	C: ATCR2a CNC: ANTCR2 C/NC: ATCR2a, ANTCR2	C: ATCR2a CNC: ANTCR2 C/NC: ATCR2a, ANTCR2
7.8 OTA Receiver intermodulation	-	-	-	-	-	-
General intermodulation requirement	C: ATCR1a CNC: ANTCR1a C/NC: ATCR1a , ANTCR1a	C: ATCR1a CNC: ANTCR1a C/NC: ATCR1a , ANTCR1a	N/A	C: ATCR2a CNC: ANTCR2 C/NC: ATCR2a, ANTCR2	C: ATCR2a CNC: ANTCR2 C/NC: ATCR2a, ANTCR2	C: ATCR2a CNC: ANTCR2 C/NC: ATCR2a, ANTCR2
General narrowband intermodulation requirement	C: ATCR1a, ATCR4a CNC:ANTCR 1a, ATCR4a C/NC: ATCR1a, ANTCR1a, ATCR4a	C: ATCR1a, ATCR4a CNC:ANTC R1a, ATCR4a C/NC: ATCR1a, ANTCR1a, ATCR4a	N/A	C: ATCR2a, ATCR4b CNC: ANTCR2, ATCR4b C/NC: ATCR2a, ANTCR2, ATCR4b	C: ATCR2a, ATCR4b CNC: ANTCR2, ATCR4b C/NC: ATCR2a, ANTCR2, ATCR4b	C: ATCR2a, ATCR4b CNC: ANTCR2, ATCR4b C/NC: ATCR2a, ANTCR2, ATCR4b
7.9 OTA In-channel selectivity	-	-	-	-	-	-

Capability Set	UTRA (MC) capable BS (RCSA1)			E-UTRA (MC) capable BS (RCSA2)		
	BC1	BC2	BC3	BC1	BC2	BC3
Test case						
E-UTRA requirement	N/A	N/A	N/A	Subclause 5.3.4	Subclause 5.3.4	Subclause 5.3.4

5.3.3 AAS BS supporting Single-RAT UTRA in the operating band

This subclause contains the test configurations for AAS BS supporting single-RAT UTRA in the operating band. The test configurations apply to beams operating with multiple carriers (MC).

For an AAS BS declared to support multi-carrier operation in contiguous spectrum operation in single band only, the test configurations in the second column of table 5.3.3-1 for FDD, and in the fifth column of table 5.3.3-1 for TDD, shall be used for testing.

NOTE: The applicability of test configurations for TDD in this subclause is only applicable to UTRA TDD 1,28 Mcps option.

For FDD an AAS BS declared to support multi-carrier operation in contiguous and non-contiguous spectrum in single band and where the parameters in the manufacture's declaration according to subclause 4.10 are identical for contiguous (C) and non-contiguous (NC) spectrum operation, the test configurations in the third column of table 5.3.3-1 shall be used for testing.

For FDD an AAS BS declared to support multi-carrier operation in contiguous and non-contiguous spectrum in single band and where the parameters in the manufacture's declaration according to subclause 4.10 are not identical for contiguous and non-contiguous spectrum operation, the test configurations in the fourth column of table 5.3.3-1 shall be used for testing.

Table 5.3.3-1: Test configurations for a AAS BS supporting single-RAT UTRA operation

test case		Single-RAT UTRA FDD MC capable AAS BS operating band (RCSA4) C capable only	Single-RAT UTRA FDD MC capable AAS BS operating band (RCSA4) C and NC capable with identical parameters	Single-RAT UTRA FDD MC capable AAS BS operating band (RCSA4) C and NC capable with different parameters	Single-RAT UTRA TDD MC AAS BS operating band (RCSA4) C capable only
6.2	Radiated Transmit Power	ATCR1a	ATCR1a	ATCR1a, ANTCR1	ATCR1b
6.3	OTA Base Station output power	-	-	-	N/A
6.3.2	Base Station maximum output power	ATC1a	ATC1a	ATC1a, ANTC1	N/A
6.4	OTA Output power dynamics	-	-	-	N/A
6.4.2	OTA UTRA Inner loop power control in the downlink	SC	SC	SC	N/A
6.4.3	OTA Power control dynamic range	SC	SC	SC	N/A
6.4.4	OTA Total power dynamic range	SC or ATC1a	SC or ATC1a	SC or ATC1a	N/A
6.4.5	OTA IPDL time mask	SC	SC	SC	N/A
6.6	OTA Transmitted signal quality	-	-	-	N/A
6.6.2	OTA Frequency error	ATC1a	ATC1a	ATC1a, ANTC1	N/A
6.6.3	OTA Time alignment error	ATC1a	ATC1a	ATC1a, ANTC1	N/A
6.6.4	OTA Modulation quality - EVM	ATC1a	ATC1a	ATC1a, ANTC1	N/A
6.6.4	OTA Modulation quality - PCDE	ATC1a	ATC1a	ATC1a, ANTC1	N/A
6.6.4	OTA Modulation quality - RCDE	ATC1a	ATC1a	ATC1a	N/A
6.7	OTA Unwanted Emissions	-	-	-	N/A
6.7.2	OTA Occupied bandwidth	SC	SC	SC	N/A
6.7.3	OTA Adjacent Channel Leakage power Ratio	ATC1a	ANTC1	ATC1a, ANTC1	N/A
	Cumulative ACLR	-	ANTC1	ANTC1	N/A
6.7.4	OTA Spectrum emission mask	ATC1a	ATC1a, ANTC1	ATC1a, ANTC1	N/A
6.7.6	OTA Spurious emission	ATC1a	ANTC1	ATC1a, ANTC1	N/A

test case		Single-RAT UTRA FDD MC capable AAS BS operating band (RCSA4) C capable only	Single-RAT UTRA FDD MC capable AAS BS operating band (RCSA4) C and NC capable with identical parameters	Single-RAT UTRA FDD MC capable AAS BS operating band (RCSA4) C and NC capable with different parameters	Single-RAT UTRA TDD MC AAS BS operating band (RCSA4) C capable only
6.8	OTA Transmitter intermodulation	ATC1a	ATC1a, ANTC1	ATC1a, ANTC1	N/A
7.2	OTA sensitivity	ATCR4a	ATCR4a	ATCR4a	ATCR4c
7.3	OTA Reference sensitivity level	ATCR4a	ATCR4a	ATCR4a	N/A
7.4	OTA Dynamic range	ATCR4a	ATCR4a	ATCR4a	N/A
7.5	OTA Adjacent channel selectivity and narrowband blocking	ATCR1a	ANTCR1	ATCR1a, ANTCR1	N/A
7.6	OTA Blocking	ATCR1a	ANTCR1	ATCR1a, ANTCR1	N/A
7.7	OTA Receiver spurious emissions	ATCR1a	ANTCR1	ATCR1a, ANTCR1	N/A
7.8	OTA Receiver intermodulation	ATCR1a	ANTCR1	ATCR1a, ANTCR1	N/A

5.3.4 AAS BS supporting Single-RAT E-UTRA in the operating band

This subclause contains the test configurations for AAS BS supporting single-RAT E-UTRA in the operating band. The test configurations apply to AAS BS operating bands operating with multiple carriers (MC).

For an AAS BS declared to support multi-carrier and/or CA operation in contiguous spectrum operation in single band only, the test configurations in the second column of table 5.3.4-1 shall be used for testing.

For an AAS BS declared to support multi-carrier and/or CA operation in contiguous and non-contiguous spectrum in single band and where the parameters in the manufacture's declaration according to subclause 4.10 are identical for contiguous (C) and non-contiguous (NC) spectrum operation, the test configurations in the third column of table 5.3.4-1 shall be used for testing.

For an AAS BS declared to support multi-carrier and/or CA in contiguous and non-contiguous spectrum in single band and where the parameters in the manufacture's declaration according to subclause 4.10 are not identical for contiguous and non-contiguous spectrum operation, the test configurations in the fourth column of table 5.3.4-1 shall be used for testing.

Table 5.3.4-1: Test configurations for a AAS BS supporting single-RAT E-UTRA operation capable of both contiguous and non-contiguous spectrum in multi-carrier and/or CA operation in single band

test case		Single-RAT E-UTRA MC capable AAS BS operating band (RCSA5) C capable only	Single-RAT E-UTRA MC capable AAS BS operating band (RCSA5) C and NC capable BS with identical parameters	Single-RAT E-UTRA MC capable AAS BS operating band (RCSA5) C and NC capable BS with different parameters
6.2	Radiated Transmit Power	ATCR2a	ATCR2a	ATCR2a, ANTCR2
6.3	OTA Base Station output power	-	-	-
6.3.2	OTA Base Station maximum output power	ATCR2a	ATCR2a	ATCR2a, ANTCR2
6.3.3	OTA E-UTRA DL RS power	SC	SC	SC
6.4	OTA Output power dynamics	-	-	-
6.4.4	OTA Total power dynamic range	SC	SC	SC
6.4.6	OTA RE Power control dynamic range	Tested with Error Vector Magnitude	Tested with Error Vector Magnitude	Tested with Error Vector Magnitude

test case		Single-RAT E-UTRA MC capable AAS BS operating band (RCSA5) C capable only	Single-RAT E-UTRA MC capable AAS BS operating band (RCSA5) C and NC capable BS with identical parameters	Single-RAT E-UTRA MC capable AAS BS operating band (RCSA5) C and NC capable BS with different parameters
6.5	OTA Transmit ON/OFF power	ATCR2a	ATCR2a	ATCR2a, ANTCR2
6.6	OTA Transmitted signal quality	-	-	-
6.6.2	OTA Frequency error	Tested with Error Vector Magnitude	Tested with Error Vector Magnitude	Tested with Error Vector Magnitude
6.6.3	OTA Time alignment error	ATCR2a	ATCR2a	ATCR2a, ANTCR2
6.6.4	OTA Modulation quality - EVM	ATCR2a	ATCR2a	ATCR2a, ANTCR2
6.7	OTA Unwanted Emissions	-	-	-
6.7.2	OTA Occupied bandwidth	SC, ATCR2b (Note)	SC, ATCR2b (Note)	SC, ATCR2b (Note)
6.7.3	OTA Adjacent Channel Leakage power Ratio	ATCR2a	ATCR2a, ANTCR2	ATCR2a, ANTCR2
6.7.3	OTA Cumulative ACLR	-	ANTCR2	ANTCR2
6.7.5	OTA Operating band unwanted emission	ATCR2a	ATCR2a, ANTCR2	ATCR2a, ANTCR2
6.7.6	OTA Spurious emission	ATCR2a	ANTCR2	ATCR2a, ANTCR2
6.8	OTA Transmitter intermodulation	ATCR2a	Same TC as used in 6.6	Same TC as used in 6.6
7.2	OTA sensitivity	ATCR4b	ATCR4b	ATCR4b
7.3	OTA Reference sensitivity level	ATCR4b	ATCR4b	ATCR4b
7.4	OTA Dynamic range	ATCR4b	ATCR4b	ATCR4b
7.5	OTA Adjacent channel selectivity and narrowband blocking	ATCR2a	ANTCR2	ATCR1, ANTCR2
7.6	OTA Blocking	ATCR2a	ANTCR2	ATCR2a, ANTCR2
7.7	OTA Receiver spurious emissions	ATCR2a	ANTCR2	ATCR2a, ANTCR2
7.8	OTA Receiver intermodulation	ATCR2a	ANTCR2	ATCR2a, ANTCR2
7.9	OTA In-channel selectivity	ATCR4b	ATCR4b	ATCR4b
NOTE: ATCR2b is only applicable when contiguous CA is supported.				

5.4 Test configurations for AAS BS operating bands with multi-band dependencies

5.4.1 AAS BS operating bands with multi-band dependencies supporting MSR operation

Table 5.4.1-1: Test configuration for AAS BS operating bands containing beams with multi-band dependencies supporting MSR operation

test case	Test for AAS BS operating bands with multi-band dependencies RCSA1,RCSA2, RCSA3, RCSA3A	Test configuration for MBT	
		BC1/BC2	BC3
6.2 Radiated Transmit Power	SBT, MBT	ATCR5a	ATCR5a
6.3 OTA Base Station output power	-	-	-
6.3.2 OTA Base Station maximum output power	SBT, MBT	ATCR5a	ATCR5a
6.3.3 OTA E-UTRA DL RS power	E-UTRA for DL RS power	SBT	-
6.4 OTA Output power dynamics	-	-	-
6.4.2 OTA UTRA Inner loop power control in the downlink	SBT	-	-
6.4.3 OTA Power control dynamic range	SBT	-	-
6.4.4 OTA Total power dynamic range	SBT	-	N/A
6.4.5 OTA IPDL time mask	SBT	-	N/A
6.4.6 OTA RE Power control dynamic range	SBT	-	N/A
6.5 OTA Transmit ON/OFF power	-	-	-
6.5.1 OTA Transmitter OFF power	MBT, SBT (note 3)	N/A	ATCR5a
6.5.2 OTA Transmitter transient period	MBT, SBT (note 3)	N/A	ATCR5a
6.6 OTA Transmitted signal quality	-	-	-
6.6.2 OTA Frequency error	-	-	-
E-UTRA	SBT, MBT	ATCR5a	ATCR5a
UTRA FDD	SBT, MBT	ATCR5a	N/A
NR	SBT, MBT	ATCR5a	ATCR5a
6.6.3 OTA Time alignment error	-	-	-
E-UTRA	SBT, MBT (note 1)	ATCR5b	ATCR5b
UTRA FDD	SBT, MBT (note 1)	ATCR5b	N/A
NR	SBT, MBT (note 1)	ATCR5b	ATCR5b
6.6.4 OTA Modulation quality - EVM	-	-	-
E-UTRA	SBT, MBT	ATCR5a	ATCR5a
UTRA FDD	SBT, MBT	ATCR5a	N/A
NR	SBT, MBT	ATCR5a	ATCR5a
6.7 OTA Unwanted Emissions	-	-	-
6.6.2 OTA Occupied bandwidth	-	-	-
Minimum requirement	SBT	-	-
6.7.3 OTA Adjacent Channel Leakage power Ratio	-	-	-
E-UTRA	SBT, MBT (note 2)	ATCR5b	ATCR5b
UTRA FDD	SBT, MBT (note 2)	ATCR5b	N/A
NR	SBT, MBT (note 2)	ATCR5b	ATCR5b

test case	Test for AAS BS operating bands with multi-band dependencies RCSA1,RCSA2, RCSA3, RCSA3A	Test configuration for MBT	
		BC1/BC2	BC3
Cumulative ACLR	SBT, MBT (note 2)	ATCR5b	ATCR5b
6.7.4 OTA Spectrum emission mask	-	-	-
6.7.5 OTA Operating band unwanted emission	-	-	-
General requirement for Band Categories 1 and 3	SBT, MBT	ATCR5b	ATCR5b
General requirement for Band Category 2	SBT, MBT	ATCR5b	N/A
Additional requirements	SBT, MBT	-	-
6.7.6 OTA Spurious emission	-	-	-
(Category A)	SBT, MBT	ATCR5b	ATCR5b
(Category B)	SBT, MBT	ATCR5b	ATCR5b
Protection of the BS receiver of own or different BS	SBT, MBT	ATCR5b	ATCR5b
Additional spurious emissions requirements	SBT, MBT	ATCR5b	ATCR5b
Co-location with other Base Stations	-	-	-
6.8 OTA Transmitter intermodulation	-	-	-
General requirement	SBT	-	-
Additional requirement (BC1 and BC2)	SBT	-	N/A
Additional requirement (BC3)	SBT	N/A	-
7.2 OTA sensitivity	SBT	ATCR4a,ATCR4b	None
7.3 OTA Reference sensitivity level	-	-	-
E-UTRA requirement	SBT	-	-
UTRA FDD requirement	SBT	-	-
NR requirement	SBT	-	-
7.4 OTA Dynamic range	-	-	-
E-UTRA	SBT	-	-
UTRA FDD	SBT	-	-
NR	SBT	-	-
7.5 OTA Adjacent channel selectivity and narrowband blocking	-	-	-
General blocking requirement	MBT, SBT (note 3)	ATCR5b	ATCR5b
General narrowband blocking requirement	MBT, SBT (note 3)	ATCR5b	ATCR5b
7.6 OTA Blocking	-	-	-
General requirement	MBT, SBT(note 3)	ATCR5b	ATCR5b
Co-location requirement	MBT, SBT(note 3)	ATCR5b	ATCR5b
7.7 OTA Receiver spurious emissions	-	-	-
General requirement	SBT, MBT	ATCR5b	ATCR5b
7.8 OTA Receiver intermodulation	-	-	-
General intermodulation requirement	MBT, SBT(note 3)	ATCR5b	ATCR5b
General narrowband intermodulation requirement	MBT, SBT(note 3)	ATCR5b	ATCR5b
7.9 OTA In-channel selectivity	-	-	-
E-UTRA requirement	SBT	-	-
NR requirement	SBT	-	-

NOTE 1: MBT is only applicable when DB-DC-HSDPA or inter-band CA is supported.

NOTE 2: For ACLR, MBT shall be applied for the Inter RF bandwidth gap only.

NOTE 3: SBT is only applicable if different Capability Sets are declared for single-band and multi-band operation.

5.4.2 AAS BS operating bands with multi-band dependencies supporting Single-RAT only

For an AAS BS operating bands with multi-band dependencies supporting single-RAT only in the operational band, the test configurations in table 5.4.2-1, shall be used for testing.

Table 5.4.2-1: Test configuration for AAS BS operating bands with multi-band dependencies supporting Single-RAT only

test case	UTRA FDD RCSA4	UTRA TDD RCSA4	E-UTRA Test RCSA5
6.2 Radiated Transmit Power	ATCR1a/ANTCR1 (Note 1) ATCR5a	ATCR1b (Note 3), ATCR5a	ATCR2a/ANTCR 2 (Note 5), ATCR5a
6.3 OTA Base Station output power	-	-	-
6.3.2 OTA Base Station maximum output power	ATCR1a/ANTCR1 (note 1) ATCR5a	N/A	ATCR2a/ANTCR 2 (note 6), ATCR5a
6.3.3 OTA E-UTRA DL RS power	N/A	N/A	SC
6.4 OTA Output power dynamics	-	-	-
6.4.2 OTA UTRA Inner loop power control in the downlink	SC	N/A	N/A
6.4.3 OTA Power control dynamic range	SC	N/A	SC
6.4.4 OTA Total power dynamic range	SC or ATCR1a	N/A	SC
6.4.5 OTA IPDL time mask	SC	N/A	N/A
6.4.6 OTA RE Power control dynamic range	N/A	N/A	Tested with Error Vector Magnitude
6.5 OTA Transmit ON/OFF power	-	-	-
6.5.1 OTA Transmitter OFF power	N/A	N/A	ATCR5a (only applied for E-UTRA TDD BS)
6.5.2 OTA Transmitter transient period	N/A	N/A	SC
6.6 OTA Transmitted signal quality	-	-	-
6.6.2 OTA Frequency error	Tested with EVM	N/A	Tested with Error Vector Magnitude
6.6.3 OTA Time alignment error	ATCR1a/ANTCR1 (note 1) ATCR5b	N/A	ATCR2a/ANTCR 2 (note 6), ATCR5b (note 7)
6.6.4 OTA Modulation quality - EVM	ATCR1a/ANTCR1 (note 1), ATCR5a	N/A	ATCR2a/ANTCR 2 (note 6), ATCR5a
6.6.4 OTA Modulation quality - PCDE	ATCR1a/ANTCR1 (note 1)	N/A	N/A
6.6.4 OTA Modulation quality - RCDE	ATCR1	N/A	N/A
6.7 OTA Unwanted Emissions	-	-	-
6.7.2 OTA Occupied bandwidth	SC	N/A	SC, ATCR2b (note 8)
6.7.3 OTA Adjacent Channel Leakage power Ratio	ATCR1a/ANTCR1 (note 1) ATCR5b (note 2)	N/A	ATCR2a/ANTCR 2 (note 6), ATCR5b (note 9)
6.7.4 OTA Spectrum emission mask	ATCR1a/ANTCR1 (note 1) ATCR5b	N/A	N/A
6.7.5 OTA Operating band unwanted emission	N/A	N/A	ATCR2a/ANTCR 2 (note 6), ATCR5b
6.7.6 OTA Spurious emission	ATCR1a/ANTCR1 (note 1) ATCR5b	N/A	ATCR2a/ANTCR 2 (note 6), ATCR5b
6.8 OTA Transmitter intermodulation	ATCR1a/ANTCR1 (note 1)	N/A	ATCR2a/ANTCR 2 (note 6)
7.2 Reference sensitivity level	ATCR4a	ATCR4c	ATCR4b
7.3 OTA Reference sensitivity level	ATCR4a	N/A	ATCR4a
7.4 OTA Dynamic range	ATCR4a	N/A	ATCR4a
7.5 OTA Adjacent channel selectivity and narrowband blocking	ATCR5b	N/A	ATCR5b
7.6 OTA Blocking	ATCR5b	N/A	ATCR5b

test case	UTRA FDD RCSA4	UTRA TDD RCSA4	E-UTRA Test RCSA5
7.7 OTA Receiver spurious emissions	ATCR1a/ANTC1 (note 1) ATCR5b	N/A	ATCR2a/ANTC2 (note 6), ATCR5b
7.8 OTA Receiver intermodulation	ATCR5b	N/A	ATCR5b
7.9 OTA In-channel selectivity	N/A	N/A	ATCR4a
NOTE 1: ATCR1a and/or ANTCR1 shall be applied in each supported operating band according to table 5.3.3-1. NOTE 2: ATCR5b may be applied for Inter RF Bandwidth gap only. NOTE 3: ATCR1b shall be applied in each supported operating band according to table 5.3.3-1. NOTE 4: Void NOTE 5: ATCR5a may be applied for Inter RF bandwidth gap only. NOTE 6: ATCR2 and/or ANTCR2 shall be applied in each supported operating band according to table 5.3.4-1. NOTE 7: ATCR5b is only applicable when inter-band CA is supported. NOTE 8: ATCR2b is only applicable when contiguous CA is supported. NOTE 9: ATCR5b may be applied for Inter RF bandwidth gap only.			

6 Radiated transmitter characteristics

6.1 General

General test conditions for transmitter tests are given in clause 4, including interpretation of measurement results and configuration for testing. AAS BS configurations for the tests are defined in subclause 4.8.

If beams have been declared equivalent and parallel (see table 4.10-1, D9.12, D9.13), only a representative beam is necessary to demonstrate conformance. The manufacturer shall declare the minimum number of supported geographical cells (i.e. geographical areas). The minimum number of supported geographical cells (N_{cells}) relates to the AAS BS setting with the minimum amount of cell splitting supported.

OTA AAS BS transmitter requirements apply per geographical cell.

Any radiated transmitter test requirement specified in 3GPP TS 37.105 [6] is not applicable for AAS BS operation in Band 46.

For OTA base station output power (sub-clause 6.3), OTA transmit ON/OFF power (sub-clause 6.5), OTA unwanted emissions requirements (sub-clause 6.7) and OTA receiver spurious emissions (sub-clause 7.7), TRP is defined in spherical coordinates as:

$$TRP = \int \int_{4\pi} P_D(r, \theta, \varphi) r^2 |\sin(\theta)| d\theta d\varphi$$

, where $P_D(r, \theta, \varphi)$ is the power density in W/m^2 of two orthogonal polarizations at a distance r (meters).

NOTE: General TRP expression that is obtained by integrating the Poynting vector over a spherical surface.

6.2 Radiated Transmit Power

6.2.1 Definition and applicability

An AAS BS is declared to support one or more beams. Radiated transmit power is defined as the EIRP level for a declared beam at a specific *beam peak direction*.

For each beam, the requirement is based on declarations (see table 4.10-1) of a beam identifier (D9.3), *reference beam direction pair* (D9.7), *rated beam EIRP* (D9.10) at the *reference beam direction pair*, *OTA peak directions set* (D9.8), the *beam direction pairs* at the maximum steering directions (D9.9) and their associated *rated beam EIRP* and *beamwidth(s)* (D9.11) for *reference beam direction pair* and maximum steering directions.

For a declared beam identifier and *beam direction pair*, the *rated beam EIRP* level is the maximum power that the base station is declared to radiate at the associated *beam peak direction* during the *transmitter ON period*.

For each *beam peak direction* associated with a *beam direction pair* within the *OTA peak directions set*, a specific *rated beam EIRP* level may be claimed. Any claimed value shall be met within the accuracy requirement as described below. *Rated beam EIRP* is only required to be declared for the *beam direction pairs* subject to conformance testing as detailed in subclause 6.2.4.1.

NOTE 1: The *OTA peak directions set* for a beam is the complete continuous or discrete set of all *beam direction* for which the EIRP accuracy is intended to be achieved for the beam.

NOTE 2: A *beam direction pair* consists of a *beam centre direction* and an associated *beam peak direction*.

NOTE 3: A declared EIRP value is a value provided by the manufacturer for verification according to the conformance specification declaration requirements, whereas a claimed EIRP value is provided by the manufacturer to the equipment user for normal operation of the equipment and is not subject to formal conformance testing.

For *operating bands* where the supported *fractional bandwidth* (FBW) is larger than 6%, two rated carrier EIRP may be declared by manufacturer:

- $P_{\text{rated,c,FBWlow}}$ for lower supported frequency range, and
- $P_{\text{rated,c,FBWhigh}}$ for higher supported frequency range.

For frequencies in between F_{FBWlow} and F_{FBWhigh} the rated carrier EIRP is:

- $P_{\text{rated,c,FBWlow}}$, for the carrier whose carrier frequency is within frequency range $F_{\text{FBWlow}} \leq f < (F_{\text{FBWlow}} + F_{\text{FBWhigh}}) / 2$,
- $P_{\text{rated,c,FBWhigh}}$, for the carrier whose carrier frequency is within frequency range $(F_{\text{FBWlow}} + F_{\text{FBWhigh}}) / 2 \leq f \leq F_{\text{FBWhigh}}$.

6.2.2 Minimum Requirement

For AAS BS in *MSR operation* the minimum requirement is defined in TS 37.105 [6], subclause 9.2.2.

For AAS BS in *single RAT UTRA operation* the minimum requirement is defined in TS 37.105 [6], subclause 9.2.3.

For AAS BS in *single RAT E-UTRA operation* the minimum requirement is defined in TS 37.105 [6], subclause 9.2.4.

6.2.3 Test purpose

The test purpose is to verify the ability to accurately generate and direct radiated power per beam, across the frequency range and under normal conditions, for all declared beams of the AAS BS.

6.2.4 Method of test

6.2.4.1 Initial conditions

Test environment: Normal; see annex G.2.

RF bandwidth positions to be tested: B_{RFBW} , M_{RFBW} and T_{RFBW} in single-band operation, see subclause 4.12.1.

$B_{\text{RFBW}}T_{\text{RFBW}}$ and $B'_{\text{RFBW}}T_{\text{RFBW}}$ in multi-band operation, see subclause 4.12.1.

Directions to be tested: The *reference beam direction pair* (see table 4.10-1, D9.7) and the maximum steering directions (see table 4.10-1, D9.9).

In addition for a OTA AAS BS, a single test case shall be performed under extreme test environment as defined in annex clause G.3 In this case, it is sufficient to test on a single combination of one ARFCN, UARFCN or EARFCN, one RF bandwidth position and with only one applicable test configuration defined in clause 5.

NOTE: Tests under extreme power supply also test extreme temperature.

6.2.4.2 Procedure

- 1) Place the AAS BS at the positioner.
- 2) Align the manufacturer declared coordinate system orientation (see table 4.10-1, D9.2) of the AAS BS with the test system.
- 3) Move the AAS BS on the positioner in order that the direction to be tested aligns with the test antenna
- 4) Configure the beam peak direction of the AAS BS according to the declared beam direction pair.
- 5) Set the base station to transmit according to the applicable test configuration in clause 5 using the corresponding test model(s) in subclause 4.12.2.

In addition, for an AAS BS declared to be capable of multi-carrier and/or CA operation use the applicable test signal configuration and corresponding power setting specified in subclause 4.11.

- 6) Measure EIRP by either a) or b) below:
 - a) If the test facility only supports single polarization, then measure EIRP with the test facility's test antenna/probe polarization matched to the AAS BS.
 - b) If the test facility supports dual polarization then measure total EIRP for two orthogonal polarizations (denoted p1 and p2) and calculate total radiated transmit power for particular *beam direction pair* as $EIRP = EIRP_{p1} + EIRP_{p2}$.
- 7) Test steps 3 to 6 are repeated for all declared beams (see table 4.10-1, D9.3) and their reference beam direction pairs and *maximum steering directions* (see table 4.10-1, D9.7 and D9.11).

For multi-band capable AAS BS and single band tests, repeat the steps above per involved band where single band test configurations and test models shall apply with no carriers activated in the other band.

- 8) For extreme conditions tests the methods in annex G may be used where a representative power measurement is taken at both nominal conditions ($P_{\max, \text{sample}, \text{nom}}$) and extreme conditions ($P_{\max, \text{sample}, \text{ext}}$) and the delta (Δ_{sample}) is added to the nominal measurement from step 6 such that $P_{\max, \text{c}, \text{EIRP}, \text{extreme}} = P_{\max, \text{c}, \text{EIRP}} + \Delta_{\text{sample}}$.

6.2.5 Test Requirement

For each declared conformance beam direction pair, in normal conditions, the EIRP measurement result in step 6 of subclause 6.2.4.2 shall for UTRA, E-UTRA and NR remain:

- within +3.3 dB and –3.3 dB of the manufacturer's declared rated beam EIRP value for carrier frequency $f \leq 3.0$ GHz;
- within +3.5 dB and –3.5 dB of the manufacturer's declared rated beam EIRP value for carrier frequency 3.0 GHz $< f \leq 4.2$ GHz.

For a OTA AAS BS in extreme conditions, the result in step 8 ($P_{\max, \text{c}, \text{EIRP}, \text{extreme}}$) of subclause 6.2.4.2 shall be:

- within +5.2 dB and –5.2 dB of the manufacturer's declared rated beam EIRP value for carrier frequency $f \leq 3.0$ GHz;
- within +5.3 dB and –5.3 dB of the manufacturer's declared rated beam EIRP value for carrier frequency 3.0 GHz $< f \leq 4.2$ GHz.

6.3 OTA Base Station output power

6.3.1 General

The *OTA AAS BS* base station output power is declared as TRP.

6.3.2 OTA Maximum output power

6.3.2.1 Definition and applicability

The rated carrier TRP shall be as specified for UTRA in table 6.3.2.1-1, and for E-UTRA and NR in table 6.3.2.1-2

Table 6.3.2.1-1: UTRA OTA AAS Base Station rated output power limits for BS classes

OTA AAS BS class	$P_{\text{Rated,c,TRP}}$
Wide Area BS	(NOTE)
Medium Range BS	≤ 44 dBm
Local Area BS	≤ 30 dBm
NOTE: There is no upper limit for the $P_{\text{Rated,c,TRP}}$ of the Wide Area Base Station.	

Table 6.3.2.1-2: E-UTRA and NR OTA AAS Base Station rated output power limits for BS classes

OTA AAS BS class	$P_{\text{Rated,c,TRP}}$
Wide Area BS	(NOTE)
Medium Range BS	≤ 47 dBm
Local Area BS	≤ 33 dBm
NOTE: There is no upper limit for the $P_{\text{Rated,c,TRP}}$ of the Wide Area Base Station.	

6.3.2.2 Minimum Requirement

For AAS BS in *MSR operation* the minimum requirement is defined in TS 37.105 [6], subclause 9.3.2.2.

For AAS BS in *single RAT UTRA operation* the minimum requirement is defined in TS 37.105 [6], subclause 9.3.2.3.

For AAS BS in *single RAT E-UTRA operation* the minimum requirement is defined in TS 37.105 [6], subclause 9.3.2.4.

6.3.2.3 Test purpose

The test purpose is to verify the accuracy of the *maximum carrier TRP* ($P_{\text{max,c,TRP}}$) across the frequency range for all *RIBs* in the AAS BS.

6.3.2.4 Method of test

6.3.2.4.1 Initial conditions

Test environment: Normal; see annex G.2.

RF bandwidth positions to be tested: B_{RFBW} , M_{RFBW} and T_{RFBW} in single-band operation, see subclause 4.12.1.

$B_{\text{RFBW}}T_{\text{RFBW}}$ and $B'_{\text{RFBW}}T_{\text{RFBW}}$ in multi-band operation, see subclause 4.12.1.

As the requirement is TRP the beam pattern(s) may be set up to optimise the TRP measurement procedure (see annex F) as long as the required TRP level is achieved.

6.3.2.4.2 Procedure

- 1) Place the AAS BS at the positioner.
- 2) Align the manufacturer declared coordinate system orientation (see table 4.10-1, D9.2) of the AAS BS with the test system.
- 3) Configure the AAS BS such that the beam peak direction(s) applied during the power measurement step 6 are consistent with the grid and measurement approach for the TRP test.

- 4) Set the AAS BS to transmit according to the applicable test configuration in clause 5 using the corresponding test model(s) in subclause 4.12.2.

In addition, for an AAS BS declared to be capable of multi-carrier and/or CA operation use the applicable test signal configuration and corresponding power setting specified in subclause 4.11.

- 5) Align the BS and the test antenna such that measurements to determine TRP can be performed.(see annex F)
- 6) Measure power by either a) or b) below:
 - a) If the test facility only supports single polarization, then measure power with the test facility's test antenna/probe polarization matched to the AAS BS.
 - b) If the test facility supports dual polarization then measure total power for two orthogonal polarizations (denoted p1 and p2) and calculate total radiated transmit power for particular *beam direction pair* as $\text{power} = \text{power}_{p1} + \text{power}_{p2}$.
- 7) Repeat step 5-6 for all directions in the appropriated TRP measurement grid needed for full TRP estimation (see annex F).
- 8) Calculate TRP using the power measurements.

For multi-band capable AAS BS and single band tests, repeat the steps above per involved band where single band test configurations and test models shall apply with no carriers activated in the other band.

6.3.2.5 Test Requirement

The TRP measurement result in step 9 of subclause 6.3.2.4.2 shall for UTRA, E-UTRA and NR remain:

- within +3.4 dB and -3.4dB of the manufacturer's declared rated TRP value for carrier frequency $f \leq 3.0$ GHz;
- within +3.5 dB and -3.5 dB of the manufacturer's declared rated TRP value for carrier frequency $3.0 \text{ GHz} < f \leq 4.2$ GHz.

6.3.3 OTA E-UTRA DL RS power

6.3.3.1 Definition and applicability

This requirement applies to the RIB(s) transmitting primary DL RS.

The DL RS power is the resource element power of the Downlink Reference Symbol at the RIB transmitting the DL RS for a cell.

The absolute DL RS power is indicated on the DL-SCH. The absolute accuracy is defined as the maximum deviation between the DL RS power indicated on the DL-SCH and the DL RS power of each E-UTRA carrier.

6.3.3.2 Minimum Requirement

For AAS BS in *MSR operation* the minimum requirement is defined in TS 37.105 [6], subclause 9.3.3.2.

There is no DL RS power requirement for *single RAT UTRA operation*.

For AAS BS in *single RAT E-UTRA operation* the minimum requirement is defined in TS 37.105 [6], subclause 9.3.3.4.

6.3.3.3 Test purpose

The test purpose is to verify that the E-UTRA FDD DL RS power is within the limits specified by the minimum requirement.

6.3.3.4 Method of test

6.3.3.4.1 Initial conditions

Test environment: normal: see annex G.2.

RF channels to be tested: B, M and T; see subclause 4.12.1.

Beams to be tested: The narrowest declared beam (see table 4.10-1, D9.3, D9.11).

Directions to be tested: The *reference beam direction pair* (see table 4.10-1, D9.7).

6.3.3.4.2 Procedure

- 1) Place the AAS BS at the positioner.
- 2) Align the manufacturer declared coordinate system orientation (see table 4.10-1, D9.2) of the AAS BS with the test system.
- 3) Move the AAS BS on the positioner in order that the direction to be tested aligns with the test antenna.
- 4) Configure the beam peak direction of the AAS BS according to the declared beam direction pair
- 5) Set the AAS BS to transmit using E-TM 1.1, in 36.141 [12]3GPP TS 36.141 [12] subclause 6.1.1.1 at manufacturers declared *rated carrier EIRP* ($P_{\text{Rated,c,EIRP}}$).
- 6) Measure DL RS power EIRP by either a) or b) below:
 - a) If the test facility only supports single polarization, then measure EIRP with the test facility's test antenna/probe polarization matched to the AAS BS. Sum the EIRP measured on both polarizations.
 - b) If the test facility supports dual polarization then measure total EIRP for two orthogonal polarizations (denoted p1 and p2) and calculate total radiated transmit power for particular *beam direction pair* as $\text{EIRP} = \text{EIRP}_{\text{p1}} + \text{EIRP}_{\text{p2}}$.

The DL RS power is measured according to annex F in 36.141 [12]3GPP TS 36.141 [12].

In addition, for *multi-band RIB(s)*, the following steps shall apply:

- 7) For *multi-band RIBs* and single band tests, repeat the steps above per involved band where single band test configurations and test models shall apply with no carrier activated in the other band.

6.3.3.5 Test Requirement

The DL RS EIRP of each E-UTRA carrier shall be:

within $\pm 3,4$ dB of the declared DL RS EIRP (see table 4.10-1, D9.30) for carrier frequency $f \leq 3.0\text{GHz}$.

within $\pm 3,6$ dB of the declared DL RS EIRP (see table 4.10-1, D9.30) for carrier frequency $3.0\text{GHz} < f \leq 4.2\text{GHz}$.

6.4 OTA Output power dynamics

6.4.1 General

The requirements in TS 37.105 [6] subclause 9.4 apply during the *transmitter ON period*. Transmit signal quality (as specified in subclause 9.6 of the TS 37.105 [6]) shall be maintained for the output power dynamics requirements. Power control is used to limit the interference level. The TA output power requirements are *directional requirements* and apply to the *beam peak directions* associated with the *beam direction pairs* over the *OTA peak directions set*.

6.4.2 OTA UTRA Inner loop power control in the downlink

6.4.2.1 Definition and applicability

Inner loop power control in the downlink is the ability of the AAS BS transmitter to adjust the transmitter output power of a code channel in accordance with the corresponding TPC symbols received in the uplink.

6.4.2.2 Minimum requirement

For AAS BS in *MSR operation* the minimum requirement is defined in TS 37.105 [6], subclause 9.4.2.2.

For AAS BS in *single RAT UTRA operation* the minimum requirement is defined in TS 37.105 [6], subclause 9.4.2.3.

This requirement does not apply to single RAT E-UTRA or NR operation.

6.4.2.3 Test purpose

The test purpose is to verify that the Inner loop power control in the downlink is within the limits specified by the minimum requirement.

6.4.2.4 Method of test

6.4.2.4.1 Initial conditions

Test environment: normal; see annex G.2.

RF channels to be tested: M; see subclause 4.12.1.

Beams to be tested: The narrowest declared beam (see table 4.10-1, D9.3, D9.11).

Directions to be tested: The *reference beam direction pair* (see table 4.10-1, D9.7).

Disable closed loop power control.

The DPCH intended for power control is on channel 120 starting at -3 dB.

Establish downlink power control with parameters as specified in table 6.4.2.4.1-1.

Table 6.4.2.4.1-1: DL power control parameters

Parameter	Level/status	Unit
UL signal mean power	$P_{\text{REFSENS}} + 10 \text{ dB}$	dBm
Data sequence	PN9	

6.4.2.4.2 Procedure

- 1) Place the AAS BS at the positioner.
- 2) Align the manufacturer declared coordinate system orientation (see table 4.10-1, D9.2) of the AAS BS with the test system.
- 3) Move the AAS BS on the positioner in order that the direction to be tested aligns with the test antenna
- 4) Configure the beam peak direction of the AAS BS according to the declared beam direction pair
- 5) Set the AAS BS to transmit using TM2, in 3GPP TS 25.141 [10], subclause 6.1.1.2 at the manufacturers declared *rated carrier EIRP* ($P_{\text{Rated,c,EIRP}}$).
- 6) Set and send alternating TPC bits from the UE simulator or UL signal generator.
- 7) Measure mean power level of the code under the test each time TPC command is transmitted by either a) or b) below:

- a) If the test facility only supports single polarization, then measure EIRP with the test facility's test antenna/probe polarization matched to the AAS BS. Sum the EIRP measured on both polarizations.
- b) If the test facility supports dual polarization then measure total EIRP for two orthogonal polarizations (denoted p1 and p2) and calculate total radiated transmit power for particular *beam direction pair* as $EIRP = EIRP_{p1} + EIRP_{p2}$.

All steps within power control dynamic range declared by manufacturer (see table 4.10-1, D6.57) shall be measured. Use the code domain power measurement method defined in annex E in 3GPP TS 25.141 [10].

- 8) Measure the 10 highest and the 10 lowest power step levels within the power control dynamic range declared by manufacturer by either a) or b) below:
- a) If the test facility only supports single polarization, then measure EIRP with the test facility's test antenna/probe polarization matched to the AAS BS. Sum the EIRP measured on both polarizations.
- b) If the test facility supports dual polarization then measure total EIRP for two orthogonal polarizations (denoted p1 and p2) and calculate total radiated transmit power for particular *beam direction pair* as $EIRP = EIRP_{p1} + EIRP_{p2}$.

Measure by sending 10 consecutive equal commands as described in 3GPP TS 37.105 [6], subclause 6.3.2. Table 6.3.2.3-2

In addition, for *multi-band RIB(s)*, the following steps shall apply:

- 9) For *multi-band RIBs* and single band tests, repeat the steps above per involved band where single band test configurations and test models shall apply with no carrier activated in the other band.

6.4.2.5 Test Requirement

For UTRA FDD the test requirement Inner loop power control is:

- a) AAS BS shall fulfil step size requirement shown in table 6.4.2.5-1 for all power control steps declared by manufacture in subclause 4.10.
- b) For all measured Up/Down cycles, the difference of code domain power between before and after 10 equal commands (Up and Down), derived in step (3), shall not exceed the prescribed tolerance in table 6.4.2.5.1-2.

Table 6.4.2.5-1: UTRA FDD power control step tolerance

Power control commands in the down link	Transmitter power control step tolerance							
	2 dB step size		1,5 dB step size		1 dB step size		0,5 dB step size	
	Lower	Upper	Lower	Upper	Lower	Upper	Lower	Upper
Up (TPC command "1")	+0.9 dB	+3.1 dB	+0.65 dB	+2.35 dB	+0.4 dB	+1.6 dB	+0.15 dB	+0.85 dB
Down (TPC command "0")	-0.9 dB	-3.1 dB	-0.65 dB	-2.35 dB	-0.4 dB	-1.6 dB	-0.15 dB	-0.85 dB

Table 6.4.2.5-2: UTRA FDD aggregated power control step range

Power control commands in the down link	Transmitter aggregated power control step change after 10 consecutive equal commands (up or down)							
	2 dB step size		1,5 dB step size		1 dB step size		0,5 dB step size	
	Lower	Upper	Lower	Upper	Lower	Upper	Lower	Upper
Up (TPC command "1")	+15.9 dB	+24.1 dB	+11.9 dB	+18.1 dB	+7.9 dB	+12.1 dB	+3.9 dB	+6.1 dB
Down (TPC command "0")	-15.9 dB	-24.1 dB	-11.9 dB	-18.1 dB	-7.9 dB	-12.1 dB	-3.9 dB	-6.1 dB

NOTE: If the above Test Requirement differs from the Minimum Requirement then the Test Tolerance applied for this test is non-zero. The Test Tolerance for this test is defined in subclause 4.1.2 and the explanation of how the Minimum Requirement has been relaxed by the Test Tolerance is given in annex C.

6.4.3 OTA Power control dynamic range

6.4.3.1 Definition and applicability

The power control dynamic range is the difference between the maximum and the minimum *code domain power* of a code channel for a specified reference condition.

This requirement applies at each RIB supporting transmission in the operating band.

This requirement applies to UTRA operation only.

6.4.3.2 Minimum Requirement

For AAS BS in *MSR operation* the minimum requirement is defined in TS 37.105 [6], subclause 9.4.3.2.

For AAS BS in *single RAT UTRA operation* the minimum requirement is defined in TS 37.105 [6], subclause 9.4.3.3.

This requirement does not apply to single RAT E-UTRA or NR operation.

6.4.3.3 Test purpose

The test purpose is to verify that the power control dynamic range is within the limits specified by the minimum requirement.

6.4.3.4 Method of test

6.4.3.4.1 Initial conditions

Test environment: normal; see annex G.2.

RF channels to be tested: B, M and T; see subclause 4.12.1.

Beams to be tested: The narrowest declared beam (see table 4.10-1, D9.3, D9.11).

Directions to be tested: The *reference beam direction pair* (see table 4.10-1, D9.7).

6.4.3.4.2 Procedure

- 1) Place the AAS BS at the positioner.
- 2) Align the manufacturer declared coordinate system orientation (see table 4.10-1, D9.2) of the AAS BS with the test system.
- 3) Move the AAS BS on the positioner in order that the direction to be tested aligns with the test antenna
- 4) Configure the beam peak direction of the AAS BS according to the declared beam direction pair.
- 5) Set the AAS BS to transmit using TM2, in 3GPP TS 25.141 [10], subclause 6.1.1.2 at the manufacturers declared *rated carrier EIRP* ($P_{\text{Rated,c,EIRP}}$).
- 6) Using TM2, set the code domain EIRP of the DPCH under test to $P_{\text{max,c,EIRP}} - 3$ dB. Power levels for other code channels may be adjusted if necessary.
- 7) Measure the code domain EIRP of the code channel under test by either a) or b) below:
 - a) If the test facility only supports single polarization, then measure EIRP with the test facility's test antenna/probe polarization matched to the AAS BS. Sum the EIRP measured on both polarizations.
 - b) If the test facility supports dual polarization then measure total EIRP for two orthogonal polarizations (denoted p1 and p2) and calculate total radiated transmit power for particular *beam direction pair* as $\text{EIRP} = \text{EIRP}_{\text{p1}} + \text{EIRP}_{\text{p2}}$.

Use the code domain power measurement method defined in annex E in 3GPP TS 25.141 [10].

- 8) Set the code domain EIRP of the DPCH under test to $P_{\max,c,EIRP} - 28$ dB by means determined by the manufacturer. The power levels for the other code channels used in step 2 shall remain unchanged (the overall output power will drop by approximately 3 dB).
- 9) Measure the code domain EIRP of the code channel under test by either a) or b) below:
 - a) If the test facility only supports single polarization, then measure EIRP with the test facility's test antenna/probe polarization matched to the AAS BS. Sum the EIRP measured on both polarizations.
 - b) If the test facility supports dual polarization then measure total EIRP for two orthogonal polarizations (denoted p_1 and p_2) and calculate total radiated transmit power for particular *beam direction pair* as $EIRP = EIRP_{p_1} + EIRP_{p_2}$.

In addition, for *multi-band RIB(s)*, the following steps shall apply:

- 10) For *multi-band RIBs* and single band tests, repeat the steps above per involved band where single band test configurations and test models shall apply with no carrier activated in the other band.

6.4.3.5 Test Requirement

For UTRA FDD the test requirement Inner loop power control is:

Downlink (DL) power control dynamic range:

- maximum code domain power: maximum EIRP ($P_{\max,c,EIRP}$) -4.1 dB or greater;
- minimum code domain power: maximum EIRP ($P_{\max,c,EIRP}$) -26.9 dB or less.

NOTE: If the above Test Requirement differs from the Minimum Requirement then the Test Tolerance applied for this test is non-zero. The Test Tolerance for this test is defined in subclause 4.1.2 and the explanation of how the Minimum Requirement has been relaxed by the Test Tolerance is given in annex C.

6.4.4 OTA total power dynamic range

6.4.4.1 Definition and applicability

The total power dynamic range is the difference between the maximum and the minimum output power for a specified reference condition.

This requirement applies at each RIB supporting transmission in the operating band.

NOTE 1: The upper limit of the dynamic range is the BS maximum carrier EIRP ($P_{\max,c,EIRP}$). The lower limit of the dynamic range is the lowest minimum power from the AAS BS when no traffic channels are activated in the same direction using the same beam.

Particularly for E-UTRA, the total power dynamic range is the difference between the maximum and the minimum transmit power of an OFDM symbol for a specified reference condition.

NOTE 2: The upper limit of the dynamic range at a RIB is the OFDM symbol power at maximum carrier EIRP ($P_{\max,c,EIRP}$) when transmitting on all RBs. The lower limit of the dynamic range at a RIB is the OFDM symbol power when one resource block is transmitted. The OFDM symbol carries PDSCH or sPDSCH (for sTTI) and not contain RS, PBCH or synchronization signals in the same direction using the same beam.

6.4.4.2 Minimum Requirement

For AAS BS in *MSR operation* the minimum requirement is defined in TS 37.105 [6], subclause 9.4.4.2.

For AAS BS in *single RAT UTRA operation* the minimum requirement is defined in TS 37.105 [6], subclause 9.4.4.3.

For AAS BS in *single RAT E-UTRA operation* the minimum requirement is defined in TS 37.105 [6], subclause 9.4.4.4.

The minimum requirement for NR operation is in TS 38.104 [33], subclause 6.3.3.2.

6.4.4.3 Test purpose

The test purpose is to verify that the total power dynamic range is within the limits specified by the minimum requirement.

6.4.4.4 Method of test

6.4.4.4.1 Initial conditions

Test environment: normal; see annex G.2.

RF channels to be tested: B, M and T; see subclause 4.12.1.

Base Station RF Bandwidth positions to be tested for multi-carrier: B_{RFBW} , M_{RFBW} and T_{RFBW} in single band operation; see subclause 4.12.1.

Beams to be tested: The narrowest declared beam (see table 4.10-1, D9.3, D9.11).

Directions to be tested: The *reference beam direction pair* (see table 4.10-1, D9.7).

6.4.4.4.2 Procedure

6.4.4.4.2.1 General procedure

- 1) Place the AAS BS at the positioner.
- 2) Align the manufacturer declared coordinate system orientation (see table 4.10-1, D9.2) of the AAS BS with the test system.
- 3) Move the AAS BS on the positioner in order that the direction to be tested aligns with the test antenna.
- 4) Configure the beam peak direction of the AAS BS according to the declared beam direction pair.

6.4.4.4.2.2 UTRA FDD

- 5) Set the AAS BS to transmit using TM2, in 3GPP TS 25.141 [10], subclause 6.1.1.2 at the manufacturers declared *rated carrier EIRP* ($P_{Rated,c,EIRP}$).

The downlink total dynamic range is computed as the difference of the maximum EIRP, measured as defined in step 6 in subclause 6.2.4.2 and the EIRP measured at step 3 of the Error Vector Magnitude test, as described in subclause 6.6.4.4.2.1.

In addition, for *multi-band RIB(s)*, the following steps shall apply:

- 6) For *multi-band RIBs* and single band tests, repeat the steps above per involved band where single band test configurations and test models shall apply with no carrier activated in the other band.

6.4.4.4.2.3 E-UTRA

- 5) Set the AAS BS to transmit using E-TM 3.1 (or sE-TM3.1-1 for subslot TTI, or sE-TM3.1-2 for slot TTI), as defined in TS 36.141 [12] subclause 6.1.1 at the manufacturers declared *rated carrier EIRP* ($P_{Rated,c,EIRP}$).
- 6) Measure the average OFDM symbol EIRP as defined in annex F in TS 36.141 [12] by either a) or b) below:
 - a) If the test facility only supports single polarization, then measure EIRP with the test facility's test antenna/probe polarization matched to the AAS BS. Sum the EIRP measured on both polarizations.
 - b) If the test facility supports dual polarization then measure total EIRP for two orthogonal polarizations (denoted p1 and p2) and calculate total radiated transmit power for particular beam direction pair as $EIRP = EIRP_{p1} + EIRP_{p2}$.
- 7) Set the AAS BS to transmit using E-TM2 (or sE-TM2-1 for subslot TTI, or sE-TM2-2 for slot TTI, with the same selection as in step 5), as defined in TS 36.141 [12] subclause 6.1.1.

- 8) Measure the average OFDM symbol power as defined in annex F of TS 36.141 [12] by either a) or b) below:
- If the test facility only supports single polarization, then measure EIRP with the test facility's test antenna/probe polarization matched to the AAS BS. Sum the EIRP measured on both polarizations.
 - If the test facility supports dual polarization then measure total EIRP for two orthogonal polarizations (denoted p_1 and p_2) and calculate total radiated transmit power for particular *beam direction pair* as $EIRP = EIRP_{p_1} + EIRP_{p_2}$.

The measured OFDM symbols shall not contain RS, PBCH or synchronisation signals.

- 9) If BS supports 256QAM, set the channel set-up of the transmitted signal according to E-TM3.1a (or sE-TM3.1a-1 for subslot TTI, or sE-TM3.1a-2 for slot TTI).and repeat step 6. Set to transmit a signal according to E-TM 2a (or sE-TM2a-1 for subslot TTI, or sE-TM2a-2 for slot TTI) and repeat step 8.
- 10)If BS supports 1024QAM, set the channel set-up of the *TAB connector* transmitted signal according to E-TM3.1b and repeat step 6. Set the *TAB connector* to transmit a signal according to E-TM2b and repeat step 8.

In addition, for *multi-band RIB(s)*, the following steps shall apply:

- 11)For *multi-band RIBs* and single band tests, repeat the steps above per involved band where single band test configurations and test models shall apply with no carrier activated in the other band.

6.4.4.4.2.4 NR

- 5) Set the BS to transmit a signal according to:
- NR-FR1-TM3.1a as defined in TS 38.141-1 [35] subclause 4.9.2.2.6 if 256QAM is supported by BS without power back off, or
 - NR-FR1-TM3.1 as defined in TS 38.141-1 [35] subclause 4.9.2.2.5 if 256QAM is not supported by BS, or
 - NR-FR1-TM3.1 as defined in TS 38.141-1 [35] subclause 4.9.2.2.5 if 256QAM is supported by BS with power back off.
- 6) Measure the average OFDM symbol power as defined by either a) or b) below:
- If the test facility only supports single polarization, then measure EIRP with the test facility's test antenna/probe polarization matched to the BS. Sum the EIRP measured on both polarizations.
 - If the test facility supports dual polarization then measure total EIRP for two orthogonal polarizations (denoted p_1 and p_2) and calculate total radiated transmit power for particular *beam direction pair* as $EIRP = EIRP_{p_1} + EIRP_{p_2}$.
- 7) Set the BS to transmit a signal according to:
- NR-FR1-TM2a as defined in TS 38.141-1 [35] subclause 4.9.2.2.4 if 256QAM is supported by BS, or
 - NR-FR1-TM2 as defined in TS 38.141-1 [35] subclause 4.9.2.2.3 if 256QAM is not supported by BS.
- 8) Measure the average OFDM symbol power as defined by either a) or b) below:
- If the test facility only supports single polarization, then measure EIRP with the test facility's test antenna/probe polarization matched to the BS. Sum the EIRP measured on both polarizations.
 - If the test facility supports dual polarization then measure total EIRP for two orthogonal polarizations (denoted p_1 and p_2) and calculate total radiated transmit power for particular *beam direction pair* as $EIRP = EIRP_{p_1} + EIRP_{p_2}$.

The measured OFDM symbols shall not contain RS or SSB.

In addition, for *multi-band RIB(s)*, the following steps shall apply:

- 9) For *multi-band RIBs* and single band tests, repeat the steps above per involved band where single band test configurations and test models shall apply with no carrier activated in the other band.

6.4.4.5 Test Requirement

6.4.4.5.1 UTRA FDD

For UTRA FDD the downlink total power dynamic range shall be 17.7 dB or greater.

NOTE: If the above Test Requirement differs from the Minimum Requirement then the Test Tolerance applied for this test is non-zero. The Test Tolerance for this test is defined in subclause 4.1.2 and the explanation of how the Minimum Requirement has been relaxed by the Test Tolerance is given in annex C.

6.4.4.5.2 E-UTRA

The downlink (DL) total power dynamic range for each E-UTRA carrier shall be larger than or equal to the level in table 6.4.4.5.1-1.

Table 6.4.4.5.2-1 E-UTRA total power dynamic range, paired spectrum

E-UTRA channel bandwidth (MHz)	Total power dynamic range (dB)
1.4	7.3
3	11.3
5	13.5
10	16.5
15	18.3
20	19.6

NOTE 1: If the above Test Requirement differs from the Minimum Requirement then the Test Tolerance applied for this test is non-zero. The Test Tolerance for this test is defined in subclause 4.1.2 and the explanation of how the Minimum Requirement has been relaxed by the Test Tolerance is given in annex C.

NOTE 2: Additional test requirements for the Error Vector Magnitude (EVM) at the lower limit of the dynamic range are defined in subclause 6.6.4.5.

6.4.4.5.3 NR

The downlink (DL) total power dynamic range for each NR carrier shall be larger than or equal to the level in table 6.4.4.5.3-1.

Table 6.4.4.5.3-1: Total power dynamic range

BS channel bandwidth (MHz)	Total power dynamic range (dB)		
	15 kHz SCS	30 kHz SCS	60 kHz SCS
5	13.5	10	N/A
10	16.7	13.4	10
15	18.5	15.3	12.1
20	19.8	16.6	13.4
25	20.8	17.7	14.5
30	21.6	18.5	15.3
40	22.9	19.8	16.6
50	23.9	20.8	17.7
60	N/A	21.6	18.5
70	N/A	22.3	19.2
80	N/A	22.9	19.8
90	N/A	23.4	20.4
100	N/A	23.9	20.9

NOTE 1: If the above Test Requirement differs from the Minimum Requirement then the Test Tolerance applied for this test is non-zero. The Test Tolerance for this test is defined in subclause 4.1.2 and the explanation of how the Minimum Requirement has been relaxed by the Test Tolerance is given in annex C.

NOTE 2: Additional test requirements for the Error Vector Magnitude (EVM) at the lower limit of the dynamic range are defined in subclause 6.6.4.5.

6.4.5 OTA IPDL time mask

6.4.5.1 Definition and applicability

To support IPDL location method in UTRA FDD operation, the AAS BS shall interrupt all transmitted signals in the downlink (i.e. common and dedicated channels). The IPDL time mask specifies the limits at the RIB output power during these idle periods.

This requirement applies only to AAS BS supporting IPDL. The requirement applies at each RIB supporting transmission in the operating band.

6.4.5.2 Minimum Requirement

For AAS BS in *MSR operation* the minimum requirement is defined in TS 37.105 [6], subclause 9.4.5.2.

For AAS BS in *single RAT UTRA operation* the minimum requirement is defined in TS 37.105 [6], subclause 9.4.5.3.

This requirement does not apply to single RAT E-UTRA or MSR E-UTRA/NR operation.

6.4.5.3 Test purpose

The test purpose is to verify the ability of the AAS BS to temporarily reduce its output power below a specified value to improve time difference measurements made by UE for location services.

6.4.5.4 Method of test

6.4.5.4.1 Initial conditions

Test environment: normal; see annex G.2.

RF channels to be tested: B, M and T; see subclause 4.12.1.

Beams to be tested: The narrowest declared beam (see table 4.10-1, D9.3, D9.11).

Directions to be tested: The *reference beam direction pair* (see table 4.10-1, D9.7).

Configure the AAS BS to produce idle periods in continuous mode. The IPDL parameters as defined in 3GPP TS 25.214 [23] shall have the following values:

- IP_Spacing = 5
- IP_Length = 10 CPICH symbols
- Seed = 0

6.4.5.4.2 Procedure

- 1) Place the AAS BS at the positioner.
- 2) Align the manufacturer declared coordinate system orientation (see table 4.10-1, D9.2) of the AAS BS with the test system.
- 3) Move the AAS BS on the positioner in order that the direction to be tested aligns with the test antenna.
- 4) Configure the beam peak direction of the AAS BS according to the declared beam direction pair.
- 5) Set the AAS BS to transmit using TM1, in 3GPP TS 25.141 [10], subclause 6.1.1.2 at the manufacturers declared *rated carrier EIRP* ($P_{\text{Rated,c,EIRP}}$).

- 6) Measure the mean EIRP over a period starting 27 chips after the beginning of the IPDL period and ending 27 chips before the expiration of the IPDL period by either a) or b) below:
- If the test facility only supports single polarization, then measure EIRP with the test facility's test antenna/probe polarization matched to the AAS BS. Sum the EIRP measured on both polarizations.
 - If the test facility supports dual polarization then measure total EIRP for two orthogonal polarizations (denoted p1 and p2) and calculate total radiated transmit power for particular *beam direction pair* as $EIRP = EIRP_{p1} + EIRP_{p2}$.

In addition, for *multi-band RIB(s)*, the following steps shall apply:

- For *multi-band RIBs* and single band tests, repeat the steps above per involved band where single band test configurations and test models shall apply with no carrier activated in the other band.

6.4.5.5 Test Requirement

The mean EIRP measured according to step (3) in clause 6.4.5.4.2 shall be equal to or less than

$$\text{maximum EIRP } (P_{\max,c,EIRP}) - 34.3 \text{ dB.}$$

See also figure 6.4.5.5-1.

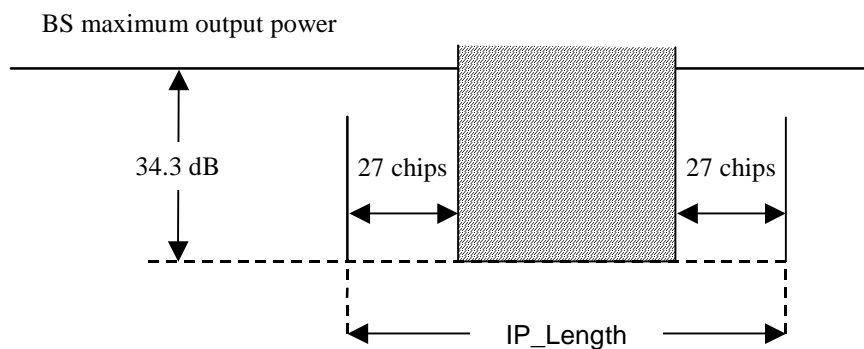

Figure 6.4.5.5-1: IPDL Time Mask

NOTE: If the above Test Requirement differs from the Minimum Requirement then the Test Tolerance applied for this test is non-zero. The Test Tolerance for this test is defined in subclause 4.1.2 and the explanation of how the Minimum Requirement has been relaxed by the Test Tolerance is given in annex C.

6.4.6 OTA RE Power control dynamic range

6.4.6.1 Definition and applicability

The RE power control dynamic range is the difference between the power of an RE and the average RE power for an AAS BS at maximum output power ($P_{\text{Rated,c,TRP}}$) for a specified reference condition.

This requirement applies at each RIB supporting transmission in the operating band.

6.4.6.2 Minimum Requirement

For AAS BS in *MSR operation* the minimum requirement is defined in TS 37.105 [6], subclause 9.4.6.2.

This requirement does not apply to *single RAT UTRA operation*.

For AAS BS *single RAT E-UTRA operation* the minimum requirement is defined in TS 37.105 [6], subclause 9.4.6.4.

6.4.6.3 Method of test

No specific test or test requirements are defined for RE Power control dynamic range. The Error Vector Magnitude test, as described in subclause 6.6.4 provides sufficient test coverage for this requirement.

6.5 OTA Transmit ON/OFF power

6.5.1 General

OTA transmitter ON/OFF power requirements apply only to TDD operation of E-UTRA and NR.

The OTA Transmit ON/OFF power requirements are co-location requirements and specified as the power sum of the supported polarization(s) at the *co-location reference* antenna conducted output(s), see subclause 4.15.

6.5.2 OTA Transmitter OFF power

6.5.2.1 Definition and applicability

OTA transmitter OFF power is defined as the mean power measured over $70/N$ μ s filtered with a square filter of bandwidth equal to the *Base Station RF Bandwidth*(s) centred on the central frequency of the *Base Station RF Bandwidth* (s) during the *transmitter OFF period*. For UTRA and E-UTRA, $N=1$. For NR, $N = \text{SCS}/15$, where SCS is Sub Carrier Spacing in kHz.

For *multi-band RIBs and single band RIBs supporting transmission in multiple bands*, the requirement is only applicable during the *transmitter OFF period* in all supported operating bands.

For AAS BS supporting intra-band contiguous CA, the transmitter OFF power is defined as the mean power measured over $70/N$ μ s filtered with a square filter of bandwidth equal to the *Aggregated BS Channel Bandwidth* $BW_{\text{Channel_CA}}$ centred on $(F_{\text{edge,high}}+F_{\text{edge,low}})/2$ during the *transmitter OFF period*. N is equal to 1 if there are any UTRA or E-UTRA carriers, or for NR $N = \text{SCS}/15$, where SCS is the smallest supported Sub Carrier Spacing in kHz in the *Aggregated BS Channel Bandwidth*.

6.5.2.2 Minimum Requirement

For AAS BS in *MSR operation* the minimum requirement is defined in TS 37.105 [6], subclause 9.5.2.2.

For AAS BS in *single RAT UTRA operation* the minimum requirement is defined in TS 37.105 [6], subclause 9.5.2.3.

For AAS BS in *single RAT E-UTRA operation* the minimum requirement is defined in TS 37.105 [6], subclause 9.5.2.4.

6.5.2.3 Test purpose

The purpose of this test is to verify the OTA transmitter OFF power is within the limits of the minimum requirements.

6.5.2.4 Method of test

6.5.2.4.1 Initial conditions

Test environment:

- normal; see annex G.2.

RF channels to be tested:

- M; see subclause 4.12.1.

Base Station RF Bandwidth positions to be tested:

- M_{RFBW} in single band operation, see subclause 4.12.1; $B_{\text{RFBW_T'RFBW}}$ and $B'_{\text{RFBW_T'RFBW}}$ in multi-band operation; see subclause 4.12.1.

6.5.2.4.2 Procedure

- 1) Place the AAS BS at the positioner.
- 2) Align the manufacturer declared coordinate system orientation (see table 4.10-1, D9.2) of the AAS BS with the test system.
- 3) Set the AAS BS in the direction of the declared beam peak direction of the beam direction pair, for the beam to be tested.
- 4) Place the *co-location test antenna* as specified in subclause 4.15.
- 5) Configure the beam peak direction of the AAS BS according to the declared beam direction pair.
- 6) Set the AAS BS to output according to the applicable test configuration in clause 5 using the corresponding test models or set of physical channels in subclause 4.12.2. For single carrier set the AAS BS to transmit at manufacturers declared *rated carrier TRP* ($P_{\text{Rated,c,TRP}}$).
- 7) For E-UTRA and UTRA, measure the mean power spectral density at the output(s) of co-location test antenna as power sum over all supported polarizations over $70\mu\text{s}$ filtered with a square filter of bandwidth equal to the RF bandwidth of the AAS BS centred on the central frequency of the RF bandwidth. $70\mu\text{s}$ average window centre is set from $35\mu\text{s}$ after end of one transmitter ON period + $17\mu\text{s}$ to $35\mu\text{s}$ before start of next transmitter ON period - $17\mu\text{s}$.

For NR, measure the mean power spectral density over $70/N \mu\text{s}$ filtered with a square filter of bandwidth equal to the RF bandwidth of the *TAB connector* centred on the central frequency of the RF bandwidth. $70/N \mu\text{s}$ average window centre is set from $35/N \mu\text{s}$ after end of one transmitter ON period + $10 \mu\text{s}$ to $35/N \mu\text{s}$ before start of next transmitter ON period - $10 \mu\text{s}$. $N = \text{SCS}/15$, where SCS is Sub Carrier Spacing in kHz.

- 8) For an AAS BS supporting contiguous CA, measure the mean power spectral density at the output(s) of co-location test antenna as power sum over all supported polarizations over $70 \mu\text{s}$ filtered with a square filter of bandwidth equal to the Aggregated Channel Bandwidth $\text{BW}_{\text{Channel_CA}}$ centred on $(F_{\text{edge_high}} + F_{\text{edge_low}})/2$. $70 \mu\text{s}$ average window centre is set from $35 \mu\text{s}$ after end of one transmitter ON period + $17 \mu\text{s}$ to $35\mu\text{s}$ before start of next transmitter ON period - $17 \mu\text{s}$.

In addition, for a multi-band RIB, the following steps shall apply:

- 9) For a multi-band RIB and single band tests, repeat the steps above per involved band where single band test configurations and test models shall apply with no carrier activated in the other band.

6.5.2.5 Test Requirement

The mean power spectral density measured according to subclause 6.5.2.4.2 shall be less than -102.6 dBm/MHz for carrier frequency $f \leq 3.0 \text{ GHz}$.

The mean power spectral density measured according to subclause 6.5.2.4.2 shall be less than -102.4 dBm/MHz for carrier frequency $3.0 \text{ GHz} < f \leq 4.2 \text{ GHz}$.

For a multi-band RIB, the requirement is only applicable during the transmitter OFF period in all supported operating bands.

NOTE: If the above Test Requirement differs from the Minimum Requirement then the Test Tolerance applied for this test is non-zero. The Test Tolerance for this test is defined in subclause 4.1.2 and the explanation of how the Minimum Requirement has been relaxed by the Test Tolerance given in annex C.

6.5.3 OTA Transmitter transient period

6.5.3.1 Definition and applicability

The OTA *transmitter transient period* is the time period during which the transmitter unit is changing from the OFF period to the ON period or vice versa. The OTA *transmitter transient period* is illustrated in figure 6.5.3.1-1.

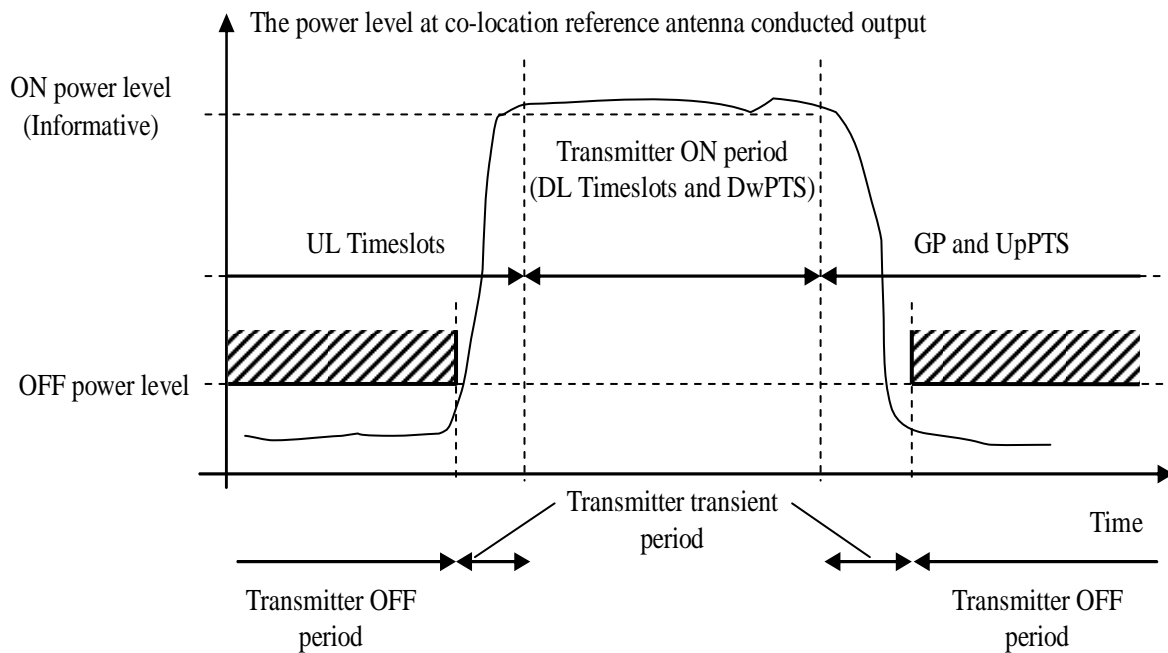

Figure 6.5.3.1-1: Illustration of the relations of transmitter ON period, transmitter OFF period and transmitter transient period

This requirement applies at *RIB* supporting reception in the operating band and is measured at the *co-location reference antenna conducted* outputs.

6.5.3.2 Minimum Requirement

This requirement does not apply to *single RAT UTRA* operation.

For AAS BS in *single RAT E-UTRA* and NR operation, the minimum requirement is defined in TS 37.105 [6], subclause 9.5.3.2.

6.5.3.3 Test purpose

The purpose of this test is to verify that the OTA transmitter transient periods are within the limits of the minimum requirements.

6.5.3.4 Method of test

6.5.3.4.1 Initial conditions

Test environment:

- normal; see annex G.2.

RF channels to be tested for single carrier:

- M; see subclause 4.12.1.

RF bandwidth positions to be tested for multi-carrier and/or CA:

- M_{RFBW} in single-band operation, see subclause 4.12.1; $B'_{\text{RFBW}}T'_{\text{RFBW}}$ and $B'_{\text{RFBW}}T_{\text{RFBW}}$ in multi-band operation, see subclause 4.12.1.

6.5.3.4.2 Procedure

- 1) Place the AAS BS at the positioner.

- 2) Align the manufacturer declared coordinate system orientation (see table 4.10-1, D9.2) of the AAS BS with the test system.
- 3) Set the AAS BS in the direction of the declared *beam peak direction* of the *beam direction pair*, for the beam to be tested.
- 4) Place the *co-location test antenna* as specified in subclause 4.15.
- 5) Configure the beam peak direction of the AAS BS according to the declared beam direction pair.
- 6) Set the AAS BS to output according to the applicable test configuration in clause 5 using the corresponding test models or set of physical channels in subclause 4.12.2. For single carrier set the AAS BS to transmit at manufacturers declared *rated carrier TRP* ($P_{\text{Rated,c,TRP}}$).
- 7) Measure the mean power spectral density at the output(s) of co-location test antenna as power sum over all supported polarizations over $70\mu\text{s}$ filtered with a square filter of bandwidth equal to the RF bandwidth of the AAS BS centred on the central frequency of the RF bandwidth. $70\mu\text{s}$ average window centre is set from $35\mu\text{s}$ after end of one transmitter ON period + $17\mu\text{s}$ to $35\mu\text{s}$ before start of next transmitter ON period - $17\mu\text{s}$.
- 8) For an AAS BS supporting contiguous CA, measure the mean power spectral density at the output(s) of co-location test antenna as power sum over all supported polarizations over $70\mu\text{s}$ filtered with a square filter of bandwidth equal to the Aggregated Channel Bandwidth $BW_{\text{Channel,CA}}$ centred on $(F_{\text{edge_high}}+F_{\text{edge_low}})/2$. $70\mu\text{s}$ average window centre is set from $35\mu\text{s}$ after end of one transmitter ON period + $17\mu\text{s}$ to $35\mu\text{s}$ before start of next transmitter ON period - $17\mu\text{s}$.

In addition, for a multi-band RIB, the following steps shall apply:

- 9) For a multi-band RIB and single band tests, repeat the steps above per involved band where single band test configurations and test models shall apply with no carrier activated in the other band.

6.5.3.5 Test Requirement

The mean power spectral density measured according to subclause 6.5.3.4.2 shall be less than -102.6 dBm/MHz for carrier frequency $f \leq 3.0\text{ GHz}$.

The mean power spectral density measured according to subclause 6.5.3.4.2 shall be less than -102.4 dBm/MHz for carrier frequency $3.0\text{ GHz} < f \leq 4.2\text{ GHz}$.

For a multi-band RIB, the requirement is only applicable during the transmitter OFF period in all supported operating bands.

NOTE: If the above Test Requirement differs from the Minimum Requirement then the Test Tolerance applied for this test is non-zero. The Test Tolerance for this test is defined in subclause 4.1.2 and the explanation of how the Minimum Requirement has been relaxed by the Test Tolerance is given in annex C.

6.6 OTA Transmitted signal quality

6.6.1 General

Unless otherwise stated, the requirements in clause 6.6 apply during the *transmitter ON period*.

6.6.2 OTA Frequency Error

6.6.2.1 Definition and applicability

OTA frequency error is the measure of the difference between the actual AAS BS transmit frequency and the assigned frequency. The same source shall be used for RF frequency and data clock generation.

The OTA frequency error requirement is defined as a directional requirement at the RIB and shall be met within the *OTA coverage range*.

6.6.2.2 Minimum Requirement

For AAS BS in *MSR operation* the minimum requirement is defined in TS 37.105 [6], subclause 9.6.2.2.

For AAS BS in *single RAT UTRA operation* the minimum requirement is defined in TS 37.105 [6], subclause 9.6.2.3.

For AAS BS in *single RAT E-UTRA operation* the minimum requirement is defined in TS 37.105 [6], subclause 9.6.2.4.

6.6.2.3 Test purpose

The test purpose is to verify that OTA frequency error is within the limit specified by the minimum requirement.

6.6.2.4 Method of test

Requirement is tested together with OTA modulation quality test, as described in subclause 6.6.4.

NOTE: Measurement only in the OTA coverage range reference direction (see table 4.10-1, D11.4) is enough for OTA frequency error measurement.

6.6.2.5 Test Requirement

6.6.2.5.1 UTRA FDD test requirement

The OTA frequency error for every measured slot shall be between the minimum and maximum value specified in table 6.6.2.5.1-1.

Table 6.6.2.5.1-1: OTA frequency error test requirement

BS class	Accuracy
Wide Area BS	$\pm(0.05 \text{ ppm} + 12 \text{ Hz})$
Medium Range BS	$\pm(0.1 \text{ ppm} + 12 \text{ Hz})$
Local Area BS	$\pm(0.1 \text{ ppm} + 12 \text{ Hz})$

NOTE: If the above Test Requirement differs from the Minimum Requirement then the Test Tolerance applied for this test is non-zero. The Test Tolerance for this test is defined in subclause 4.1.2 and the explanation of how the Minimum Requirement has been relaxed by the Test Tolerance is given in annex C.

6.6.2.5.2 E-UTRA and NR test requirement

The modulated carrier frequency of each E-UTRA and NR carrier configured by the AAS BS shall be accurate to within the accuracy range given in table 6.6.2.5.2-1 observed over a period of one subframe (1 ms).

Table 6.6.2.5.2-1: OTA frequency error test requirement

BS class	Accuracy
Wide Area BS	$\pm(0.05 \text{ ppm} + 12 \text{ Hz})$
Medium Range BS	$\pm(0.1 \text{ ppm} + 12 \text{ Hz})$
Local Area BS	$\pm(0.1 \text{ ppm} + 12 \text{ Hz})$

NOTE: If the above Test Requirement differs from the Minimum Requirement then the Test Tolerance applied for this test is non-zero. The Test Tolerance for this test is defined in subclause 4.1.2 and the explanation of how the Minimum Requirement has been relaxed by the Test Tolerance is given in annex C.

6.6.3 OTA Time alignment error

6.6.3.1 Definition and applicability

This requirement applies to frame timing in:

- UTRA single/multi-carrier transmissions and their combinations with MIMO or TX diversity.
- E-UTRA and/or NR single/multi-carrier transmissions and their combinations with MIMO or TX diversity.
- E-UTRA and /or NR *carrier aggregation*, with or without MIMO or TX diversity (except NR).

Frames of the UTRA/E-UTRA/NR signals present in the radiated domain are not perfectly aligned in time. In relation to each other, the RF signals present in the radiated domain may experience certain timing differences.

For a specific set of signals/transmitter configuration/transmission mode, the OTA Time Alignment Error (OTA TAE) is defined as the largest timing difference between any two different E-UTRA signals or any two different UTRA or any two different NR signals belonging to different *reference symbols* (e.g. *CRS0 or CRS1 for E-UTRA, DMRS ports 1000 and 1001 for NR*) in the radiated domain. The OTA time alignment error requirement is defined as a *directional requirement* at the RIB and shall be met within the *OTA coverage range*.

6.6.3.2 Minimum Requirement

For AAS BS in *MSR operation* the minimum requirement is defined in TS 37.105 [6], subclause 9.6.3.2.

For AAS BS in *single RAT UTRA operation* the minimum requirement is defined in TS 37.105 [6], subclause 9.6.3.3.

For AAS BS in *single RAT E-UTRA operation* the minimum requirement is defined in TS 37.105 [6], subclause 9.6.3.4.

6.6.3.3 Test purpose

The test purpose is to verify that the OTA time alignment error is within the limit specified by the minimum requirement.

6.6.3.4 Method of test

6.6.3.4.1 Initial conditions

6.6.3.4.1.1 General test conditions

Test environment:

- normal; see annex G.2.

RF channels to be tested for single carrier:

- M; see subclause 4.12.1.

Directions to be tested: The OTA coverage range reference direction (see table 4.10-1, D11.4).

For dual polarized systems the requirement shall be tested and met considering both polarisations. If the measurement antenna does not support dual polarization, time alignment error shall be measured under the condition that measurement antenna is aligned between the AAS BS polarisations such that it receives half the power from each polarisation.

6.6.3.4.1.2 UTRA FDD

Base Station RF Bandwidth positions to be tested for multi-carrier:

- B_{RFBW} , M_{RFBW} and T_{RFBW} in single-band operation; $B_{\text{RFBW}}T_{\text{RFBW}}$ and $B'_{\text{RFBW}}T_{\text{RFBW}}$ in multi-band operation, see subclause 4.12.1.

Refer to subclause D.1.3 for a functional block diagram of the test set-up.

6.6.3.4.1.3 E-UTRA and NR

Base Station RF Bandwidth positions to be tested for multi-carrier and/or CA:

- M_{RFBW} in single-band operation, see subclause 4.12.1; $B_{RFBW_T_{RFBW}}$ and $B'_{RFBW_T_{RFBW}}$ in multi-band operation, see subclause 4.12.1.

6.6.3.4.2 Procedure

6.6.3.4.2.1 General Procedure

- 1) Place the AAS BS at the positioner.
- 2) Align the manufacturer declared coordinate system orientation (see table 4.10-1, D9.2) of the AAS BS with the test system.
- 3) Move the AAS BS on the positioner in order that the direction to be tested aligns with the test antenna.
- 4) Configure the beamforming settings of the AAS BS according to the direction to be tested.

6.6.3.4.2.2 UTRA FDD Procedure

- 5) If the AAS BS supports TX diversity or MIMO, set the AAS BS to transmit TM1, subclause 4.12.2, at manufacturer's declared rated carrier TRP, $P_{Rated,c,TRP}$ using TX diversity or MIMO.
- 6) Measure the time alignment error between the signals using different P-CPICH and CPICH signals on different beams.
- 7) If the AAS BS supports DC-HSDPA, 4C-HSDPA, NC-4C-HSDPA or 8C-HSDPA set the AAS BS to transmit according to TM1, without using TX diversity or MIMO, on all carriers configured using the applicable test configuration and corresponding power setting specified in subclause 4.11.
- 8) Measure the time alignment error between the signals using the P-CPICH and CPICH signals on another beam.
- 9) If the AAS BS supports DB-DC-HSDPA or any of the multi-band 4C-HSDPA or 8C-HSDPA configurations set the AAS BS to transmit TM1 on two carriers belonging to different frequency bands, without using TX diversity or MIMO on any of the carriers.
- 10) Measure the time alignment error between the signals using different P-CPICH and CPICH signals on different beams.

In addition, for a multi-band RIB, the following steps shall apply:

- 11) For a multi-band RIB and single band tests, repeat the steps above per involved band where single band test configurations and test models shall apply with no carrier activated in the other band.

6.6.3.4.2.3 E-UTRA and NR Procedure

- 5) Set the AAS BS to transmit E-TM1.1 or NR-FR1-TM1.1 or any DL signal using TX diversity (except NR), MIMO transmission or carrier aggregation, using the configuration with the minimum number of cells and reference signals.

NOTE 1: For TX diversity and MIMO transmissions, different ports may be configured in E-TM (using $p = 0$ and 1).

NOTE 2: For MIMO transmission, different ports may be configured in NR-FR1-TM (using ports 1000 and 1001).

For an AAS BS declared to be capable of single carrier operation only, set the AAS BS to transmit according to manufacturer's declared rated carrier TRP, $P_{Rated,c,TRP}$.

If the AAS BS supports intra band contiguous or non-contiguous Carrier Aggregation set the AAS BS to transmit using the applicable test configuration and corresponding power setting specified in subclauses 4.11.

If the AAS BS supports inter band carrier aggregation set the AAS BS to transmit, for each band, a single carrier or all carriers, using the applicable test configuration and corresponding power setting specified in subclauses 4.11.

- 6) Measure the time alignment error between the different reference symbols on different beams on the carrier(s).

In addition, for a multi-band RIB, the following steps shall apply:

- 7) For a multi-band RIB and single band tests, repeat the steps above per involved band where single band test configurations and test models shall apply with no carrier activated in the other band.

6.6.3.5 Test Requirement

6.6.3.5.1 UTRA FDD test requirement

For Tx diversity and MIMO transmission, in the tested cell, TAE shall not exceed $0.35 T_c$.

For transmission of multiple cells within a frequency band TAE shall not exceed $0.6 T_c$.

For transmission of multiple cells in different frequency bands TAE shall not exceed $5.1 T_c$.

NOTE: If the above Test Requirement differs from the Minimum Requirement then the Test Tolerance applied for this test is non-zero. The Test Tolerance for this test is defined in subclause 4.1.2 and the explanation of how the Minimum Requirement has been relaxed by the Test Tolerance is given in annex C.

6.6.3.5.2 E-UTRA test requirement

For MIMO or TX diversity transmissions, at each carrier frequency, TAE shall not exceed 90 ns.

For intra-band carrier aggregation, with or without MIMO or TX diversity, TAE shall not exceed 155 ns.

For intra-band non-contiguous carrier aggregation, with or without MIMO or TX diversity, TAE shall not exceed 285 ns.

For inter-band carrier aggregation, with or without MIMO or TX diversity, TAE shall not exceed 285 ns.

NOTE: If the above Test Requirement differs from the Minimum Requirement then the Test Tolerance applied for this test is non-zero. The Test Tolerance for this test is defined in subclause 4.1.2 and the explanation of how the Minimum Requirement has been relaxed by the Test Tolerance is given in annex C.

6.6.3.5.3 NR test requirement

For MIMO transmission, at each carrier frequency, OTA TAE shall not exceed 90 ns.

For intra-band contiguous carrier aggregation, with or without MIMO, OTA TAE shall not exceed 285 ns.

For intra-band non-contiguous carrier aggregation, with or without MIMO, OTA TAE shall not exceed $3.025 \mu\text{s}$.

For inter-band carrier aggregation, with or without MIMO, OTA TAE shall not exceed $3.025 \mu\text{s}$.

NOTE: If the above Test Requirement differs from the Minimum Requirement then the Test Tolerance applied for this test is non-zero. The Test Tolerance for this test is defined in subclause 4.1.2 and the explanation of how the Minimum Requirement has been relaxed by the Test Tolerance is given in annex C.

6.6.4 OTA modulation quality

6.6.4.1 Definition and applicability

OTA modulation quality is defined by the difference between the measured carrier signal and a reference signal. Modulation quality can be expressed e.g. as Peak Code Domain Error (PCDE) or Relative Code Domain Error (RCDE) or Error Vector Magnitude (EVM) for UTRA and Error Vector Magnitude (EVM) for E-UTRA.

The OTA modulation quality requirement is defined as a *directional requirement* at the RIB and shall be met within the *OTA coverage range*.

6.6.4.2 Minimum Requirement

For AAS BS the in *MSR operation* minimum requirement is defined in TS 37.105 [6], subclause 9.6.4.2.

For AAS BS in *single RAT UTRA operation* the minimum requirement is defined in TS 37.105 [6], subclause 9.6.4.3.

For AAS BS in *single RAT E-UTRA operation* the minimum requirement is defined in TS 37.105 [6], subclause 9.6.4.4.

6.6.4.3 Test purpose

The test purpose is to verify that OTA modulation quality is within the limit specified by the minimum requirement.

6.6.4.4 Method of test

6.6.4.4.1 UTRA method of test

6.6.4.4.1.1 Initial conditions

Test environment: normal; see annex G.2.

RF channels to be tested for single carrier: B, M and T; see subclause 4.12.1.

Base Station RF Bandwidth position to be tested:

- B_{RFBW} , M_{RFBW} and T_{RFBW} in single-band operation, see subclause 4.12.1;
- $B'_{\text{RFBW}}T_{\text{RFBW}}$ and $B'_{\text{RFBW}}T_{\text{RFBW}}$ in multi-band operation, see subclause 4.12.1.

Directions to be tested:

- The OTA coverage range reference direction (see table 4.10-2, D11.4) and the OTA coverage range maximum directions (see table 4.10-2, D11.5).
- The EVM test is performed once using the narrowest beamwidth supported by the AAS BS

For dual polarised systems the requirement shall be tested and met for each of the supported polarisations.

6.6.4.4.1.2 Procedure

6.6.4.4.1.2.1 General procedure

- 1) Place the AAS BS at the positioner.
- 2) Align the manufacturer declared coordinate system orientation (see table 4.10-1, D9.2) of the AAS BS with the test system.
- 3) Move the AAS BS on the positioner in order that the direction to be tested aligns with the test antenna.
- 4) Configure the beamforming settings of the AAS BS according to the direction to be tested.

6.6.4.4.1.2.2 EVM procedure

- 5) Set the AAS BS to output according to the applicable test configuration in clause 5 using the corresponding test models or set of physical channels in subclause 4.12.2. For single carrier set the AAS BS to transmit at manufacturers declared rated carrier EIRP ($P_{\text{Rated,c,EIRP}}$).
- 6) For each carrier, measure the Error Vector Magnitude and frequency error as defined in annex D.1.1 and the mean EIRP (in the conformance direction) of the signal. The measurement shall be performed on all 15 slots of the frame defined by the Test Model.
- 7) Using the same setting as in step 5), set the AAS BS to transmit a signal according to TM4, subclause 4.12.2, with X value equal to 18, and repeat step 6). If the requirement in subclause 6.6.4.5 is not fulfilled, decrease the total output power by setting the base station to transmit a signal according to TM4 with X greater than 18, and repeat step 6).

The following test shall be additionally performed if the base station supports HS-PDSCH transmission using 16QAM:

- 8) Using the same setting as in step 5), set the base station to transmit according to TM5, subclause 4.12.2.
- 9) Repeat step 6).

In addition, for a multi-band RIB, the following steps shall apply:

- 10) For multi-band RIB and single band tests, repeat the steps above per involved band where single band test configurations and test models shall apply with no carrier activated in the other band.

6.6.4.4.1.2.3 PCDE procedure

- 5) Set the AAS BS to output according to the applicable test configuration in clause 5 using the corresponding test models or set of physical channels in subclause 4.12.2. For single carrier set the AAS BS to transmit at manufacturers declared rated carrier EIRP ($P_{\text{Rated,c,EIRP}}$).
- 6) Measure Peak code domain error according to annex D.1.1. The measurement shall be performed on all 15 slots of the frame defined by TM3. For an AAS BS declared to be capable of multi-carrier operation the measurement is performed on one of the carriers under test.

In addition, for a multi-band RIB, the following steps shall apply:

- 7) For multi-band RIB and single band tests, repeat the steps above per involved band where single band test configurations and test models shall apply with no carrier activated in the other band.

6.6.4.4.1.2.4 RCDE procedure

- 5) Set the AAS BS to output according to the applicable test configuration in clause 5 using the corresponding test models or set of physical channels in subclause 4.12.2. For single carrier set the AAS BS to transmit at manufacturers declared rated carrier EIRP ($P_{\text{Rated,c,EIRP}}$).
- 6) Measure average Relative code domain error according to annex E. The measurement shall be performed over one frame defined by TM6 and averaged as specified in 3GPP TS 25.141 [10] subclause 6.7.4.4.2. For an AAS BS declared to be capable of multi-carrier operation the measurement is performed on one of the carriers under test.

In addition, for a multi-band RIB, the following steps shall apply:

- 7) For multi-band RIB and single band tests, repeat the steps above per involved band where single band test configurations and test models shall apply with no carrier activated in the other band.

6.6.4.4.2 E-UTRA and NR method of test

6.6.4.4.2.1 Initial conditions

Test environment: normal; see annex G.2.

RF channels to be tested for single carrier: B and T; see subclause 4.12.1.

RF bandwidth positions to be tested for multi-carrier and/or CA:

- B_{RFBW} and T_{RFBW} in single-band operation, see subclause 4.12.1;
- $B_{\text{RFBW}}'T_{\text{RFBW}}$ and $B_{\text{RFBW}}'T_{\text{RFBW}}$ in multi-band operation, see subclause 4.12.1.

Directions to be tested:

- OTA coverage range reference direction (see table 4.10-2, D11.4)
- OTA coverage range maximum directions (see table 4.10-2, D11.5).

For dual polarised systems the requirement shall be [tested and met for both polarisations.

6.6.4.4.2.2 Procedure

- 1) Place the AAS BS at the positioner.

- 2) Align the manufacturer declared coordinate system orientation (see table 4.10-1, D9.2) of the AAS BS with the test system.
- 3) Move the AAS BS on the positioner in order that the direction to be tested aligns with the test antenna
- 4) Configure the beamforming settings of the AAS BS according to the direction to be tested.
- 5) Set the AAS BS to output according to the applicable test configuration in clause 5 using the corresponding test models or set of physical channels in subclause 4.12.2. For single carrier operation only, set the AAS BS to transmit signal according to E-TM3.1 for E-UTRA (or sE-TM3.1-1 for subslot TTI, or sE-TM3.1-2 for slot TTI) or NR-FR1-TM3.1 (for NR), at manufacturers declared rated carrier EIRP ($P_{\text{Rated,c.EIRP}}$).
- 6) Measure the EVM and frequency error as defined in annex D.
- 7) Repeat steps 5 and 6 for the following test models:
 - For E-UTRA: repeat steps 5 and 6 for E-TM 3.2, E-TM 3.3 and E-TM2,
 - For E-UTRA with subslot TTI: repeat steps 5 and 6 for sE-TM3.2-1, sE-TM3.3-1 and sE-TM2-1,
 - For E-UTRA with slot TTI: repeat steps 5 and 6 for sE-TM3.2-2, sE-TM3.3-2 and sE-TM2-2.
 - For NR: repeat steps 5 and 6 for NR-FR1-TM3.2, NR-FR1-TM3.3 and NR-FR1-TM2,

If 256QAM is supported by BS:

- For E-UTRA: repeat steps 5 and 6 for E-TM3.1a and E-TM2a,
- For E-UTRA with subslot TTI: repeat steps 5 and 6 for sE-TM3.1a-1 and sE-TM2a-1,
- For E-UTRA with slot TTI: repeat steps 5 and 6 for sE-TM3.1a-2 and sE-TM2a-2.
- For NR: repeat steps 5 and 6 for NR-FR1-TM3.1a and NR-FR1-TM2a,

For E-UTRA test model E-TM2 and E-TM2a the OFDM symbol power shall be at the lower limit of the OTA dynamic range according to the test procedure in subclause 6.4.4.2 and test requirements in subclause 6.4.4.5.2.

For subslot TTI test model sE-TM2-1 and sE-TM2a-1 (or for sE-TM2-2 and sE-TM2a-2 for slot TTI) the OFDM symbol power shall be at the lower limit of the OTA dynamic range according to the test procedure in subclause 6.4.4.2 and test requirements in subclause 6.4.4.5.2.

In addition, for multi-band RIB, the following steps shall apply:

- 8) For multi-band RIB and single band tests, repeat the steps above per involved band where single band test configurations and test models shall apply with no carrier activated in the other band.

6.6.4.5 Test Requirement

6.6.4.5.1 UTRA test requirement

The Error Vector Magnitude for each UTRA carrier and every measured slot shall be less than 18.5 % when the AAS BS is transmitting a composite signal using only QPSK modulation and shall be less than 13.5 % when the AAS BS is transmitting a composite signal that includes 16QAM modulation.

The peak code domain error for every measured slot shall not exceed 32 dB at spreading factor 256.

The average Relative Code Domain Error for 64QAM modulated codes shall not exceed 20 dB at spreading factor 16.

NOTE: If the above Test Requirement differs from the Minimum Requirement then the Test Tolerance applied for this test is non-zero. The Test Tolerance for this test is defined in subclause 4.1.2 and the explanation of how the Minimum Requirement has been relaxed by the Test Tolerance is given in annex C.

6.6.4.5.2 E-UTRA and NR test requirement

The EVM of each E-UTRA carrier for different modulation schemes on PDSCH or sPDSCH shall be less than the limits in table 6.6.4.5.2-1.

The EVM of each NR carrier for different modulation schemes on PDSCH shall be less than the limits in table 6.6.4.5.2-1a.

Table 6.6.4.5.2-1: EVM requirements for E-UTRA

Modulation scheme for PDSCH or sPDSCH	Required EVM (%)
QPSK	18.5
16QAM	13.5
64QAM	9
256QAM	4.5
1024QAM	3.5

Table 6.6.4.5.2-1a: EVM requirements for NR

Modulation scheme for PDSCH	Required EVM (%)
QPSK	18.5
16QAM	13.5
64QAM	9
256QAM	4.5

NOTE: If the above Test Requirement differs from the Minimum Requirement then the Test Tolerance applied for this test is non-zero. The Test Tolerance for this test is defined in subclause 4.1.2 and the explanation of how the Minimum Requirement has been relaxed by the Test Tolerance is given in annex C.

The EVM requirement shall be applicable within a time period around the centre of the CP therefore the EVM requirement is tested against the maximum of the RMS average of 10 subframes at the two window W extremities.

For E-UTRA, the EVM window length (W) for normal CP and extended CP is specified in TS 36.104 [4], annex E.5.1.

Table 6.6.4.5.2-2: Void

For NR, the EVM window length (W) for normal CP and extended CP is specified in TS 38.104 [36], annex B.5.2.

6.7 OTA Unwanted Emissions

6.7.1 General

Unwanted emissions consist of so-called out-of-band emissions and spurious emissions according to ITU definitions 3GPP TS 25.331 [15]. In ITU terminology, out of band emissions are unwanted emissions immediately outside the *channel bandwidth* resulting from the modulation process and non-linearity in the transmitter but excluding spurious emissions. Spurious emissions are emissions which are caused by unwanted transmitter effects such as harmonics emission, parasitic emission, intermodulation products and frequency conversion products, but exclude out of band emissions.

OTA unwanted emissions for *OTA AAS BS in single RAT E-UTRA operation* and *MSR operation* using E-UTRA consist of an OTA operating band unwanted emissions requirement and OTA spurious emissions requirement. OTA operating band unwanted emissions requirement defines limits for emissions in each supported *downlink operating band* plus the frequency ranges Δf_{OBUE} above and Δf_{OBUE} below each band, where Δf_{OBUE} is the maximum offset of the operating band unwanted emission mask from the operating band edge. Emissions outside of this frequency range are limited by OTA spurious emissions requirement.

The values of Δf_{OBUE} are defined for OTA AAS BS for E-UTRA, NR and UTRA FDD operating bands in Table 6.7.1-1.

Table 6.7.1-1: Maximum offset of OBUE outside the downlink *operating band*

BS type	Operating band characteristics	Δf_{OBUE} [MHz]
OTA AAS BS	$F_{\text{DL_high}} - F_{\text{DL_low}} < 100$ MHz	10
	$100 \text{ MHz} \leq F_{\text{DL_high}} - F_{\text{DL_low}} \leq 900$ MHz	40

OTA unwanted emissions for *OTA AAS BS* in *single UTRA operation* and *MSR operation* using UTRA consist of OTA spectrum emission mask requirement and OTA spurious emissions requirement.

NOTE: for definitions of conducted unwanted emissions requirements refer to clause 6.6 in TS 37.145-1 [9].

The unwanted emission requirements are applied per cell for all the configurations supported by *OTA AAS BS*. Requirements for OTA unwanted emissions are captured using TRP, *directional requirements* or co-location requirements as described per requirement.

There is in addition a requirement for occupied bandwidth and an ACLR requirement.

6.7.2 OTA occupied bandwidth

6.7.2.1 Definition and applicability

The OTA occupied bandwidth is the width of a frequency band such that, below the lower and above the upper frequency limits, the mean powers emitted are each equal to a specified percentage $\beta/2$ of the total mean transmitted power. See also recommendation ITU-R SM.328 [14].

The value of $\beta/2$ shall be taken as 0.5%.

The OTA occupied bandwidth requirement applies during the *transmitter ON period* for a single transmitted carrier. The minimum requirement below may be applied regionally. There may also be regional requirements to declare the OTA occupied bandwidth according to the definition in the present clause.

The OTA occupied bandwidth is defined as a *directional requirement* and shall be met in the manufacturer's declared *OTA coverage range* at the RIB.

6.7.2.2 Minimum Requirement

For AAS BS in *MSR operation* the minimum requirement is defined in TS 37.105 [6], subclause 9.7.2.2.

For AAS BS in *single RAT UTRA operation* the minimum requirement is defined in TS 37.105 [6], subclause 9.7.2.3.

For AAS BS in *single RAT E-UTRA operation* the minimum requirement is defined in TS 37.105 [6], subclause 9.7.2.4.

6.7.2.3 Test purpose

The test purpose is to verify that the emission at the *RIB* does not occupy an excessive bandwidth for the service to be provided and is, therefore, not likely to create interference to other users of the spectrum beyond undue limits.

6.7.2.4 Method of test

6.7.2.4.1 Initial conditions

6.7.2.4.1.1 General test conditions

Test environment:

- normal; see annex G.2.

RF channels to be tested:

- M; see subclause 4.12.1.

Aggregated Channel Bandwidth positions to be tested for contiguous carrier aggregation: $M_{\text{BW Channel CA}}$

Directions to be tested:

- The *reference beam direction pair* (see table 4.10-1, D9.7).

6.7.2.4.1.2 UTRA FDD

- Set the AAS BS to transmit a signal in accordance to TM1 in subclause 4.12.2 at manufacturers declared *rated carrier EIRP* ($P_{\text{Rated,c,EIRP}}$).

6.7.2.4.1.3 E-UTRA and NR

- Aggregated Channel Bandwidth positions to be tested for contiguous carrier aggregation:
- $B_{\text{BW Channel CA}}$, $M_{\text{BW Channel CA}}$ and $T_{\text{BW Channel CA}}$.
- For a AAS BS declared to be capable of single carrier operation, start transmission according to E-TM1.1 or N-TM1.1, subclause 4.12.2 at manufacturers declared *rated carrier EIRP* ($P_{\text{Rated,c,EIRP}}$).
- For a AAS BS declared to be capable of contiguous carrier aggregation operation, set the base station to transmit according to E-TM1.1 or N-TM1.1, on all carriers configured using the applicable test configuration and corresponding power setting specified in clause 5
- For an AAS BS declared to be capable of multi-carrier and/or CA operation use the applicable test signal configuration and corresponding power setting specified in subclause 4.1.1.

6.7.2.4.2 Procedure

- 1) Place the AAS BS at the positioner.
- 2) Align the manufacturer declared coordinate system orientation (see table 4.10-1, D9.2) of the AAS BS with the test system.
- 3) Set the AAS BS so that the direction of the declared *beam peak direction* of the *beam direction pair*, for the beam to be tested is toward the test antenna.
- 4) Configure the beam peak direction of the AAS BS according to the declared beam direction pair.
- 5) Set the AAS BS to transmit signal.
- 6) For UTRA FDD, measure the spectrum of the transmitted signal across a span of 10 MHz, based on an occupied bandwidth requirement of 5 MHz. The selected resolution bandwidth (RBW) filter of the analyser shall be 30 kHz or less. The spectrum shall be measured at 400 or more points across the measurement span.

For E-UTRA and NR measure the spectrum emission of the transmitted signal using at least the number of measurement points, and across a span, as listed in table 6.7.2.4.2-1. The selected resolution bandwidth (RBW) filter of the analyser shall be 30 kHz or less.

NOTE: The detection mode of the spectrum analyzer will not have any effect on the result if the statistical properties of the out-of-OBW power are the same as those of the inside-OBW power. Both are expected to have the Rayleigh distribution of the amplitude of Gaussian noise. In any case where the statistics are not the same, though, the detection mode is power responding. There are at least two ways to be power responding. The spectrum analyser can be set to "sample" detection, with its video bandwidth setting at least three times its RBW setting. Or the analyser may be set to respond to the average of the power (root-mean-square of the voltage) across the measurement cell.

Table 6.7.2.4.2-1: Span and number of measurement points for OBW measurements for E-UTRA/NR

Bandwidth	Channel bandwidth BW _{Channel} (MHz)						Aggregated channel bandwidth BW _{Channel_CA} (MHz)
	1.4	3	5	10	15	> 20	> 20
Span (MHz)	10	10	10	20	30	$2 \times BW_{Channel}$	$2 \times BW_{Channel_CA}$
Minimum number of measurement points	1429	667	400	400	400	$\frac{2 \times BW_{Channel}}{100}$	$\left\lceil \frac{2 \times BW_{Channel_CA}}{100kHz} \right\rceil$

- 7) Compute the total of the EIRP, P0, (in power units, not decibel units) of all the measurement cells in the measurement span. Compute P1, the EIRP outside the occupied bandwidth on each side. P1 is half of the total EIRP outside the bandwidth. P1 is half of (100 % - (occupied percentage)) of P0. For the occupied percentage of 99 %, P1 is 0.005 times P0. The EIRP calculation depends on whether the test facility supports dual polarization:
 - a) If the test facility only supports single polarization, then measure EIRP with the test facility's test antenna/probe polarization matched to the AAS BS. Measure and sum the EIRP on both polarizations to obtain P0 or P1.
 - b) If the test facility supports dual polarization then measure total EIRP for two orthogonal polarizations (denoted p1 and p2) and calculate total radiated transmit power as the sum over both polarizations to obtain P0 or P1
- 8) Determine the lowest frequency, f1, for which the sum of all EIRP in the measurement cells from the beginning of the span to f1 exceeds P1.
- 9) Determine the highest frequency, f2, for which the sum of all EIRP in the measurement cells from the end of the span to f2 exceeds P1.
- 10) Compute the OTA occupied bandwidth as f2 - f1.

In addition, for *multi-band RIB(s)*, the following steps shall apply:

- 11) For *multi-band RIBs* and single band tests, repeat the steps 6) - 10) above per involved band where single band test configurations and test models shall apply with no carriers activated in the other band.

6.7.2.5 Test Requirement

6.7.2.5.1 MSR

The OTA occupied bandwidth of a single carrier shall be less than the values listed in table 6.7.2.5.1-1. In addition, for E-UTRA/NR intra-band contiguous carrier aggregation, test requirement in clause 6.6.1.5 of 3GPP TS 36.141 [12] applies for the E-UTRA/NR component carriers that are aggregated.

Table 6.7.2.5.1-1: OTA Occupied bandwidth

RAT	OTA Occupied bandwidth limit
E-UTRA/NR	BW _{Channel}
UTRA FDD	5 MHz

6.7.2.5.2 UTRA FDD

The OTA occupied bandwidth shall be less than 5 MHz based on a chip rate of 3,84 Mcps.

NOTE: If the above Test Requirement differs from the Minimum Requirement then the Test Tolerance applied for this test is non-zero. The Test Tolerance for this test is defined in subclause 4.1.2 and the explanation of how the Minimum Requirement has been relaxed by the Test Tolerance is given in annex C.

6.7.2.5.3 E-UTRA

The OTA occupied bandwidth for each E-UTRA carrier shall be less than the channel bandwidth. For contiguous CA, the occupied bandwidth shall be less than or equal to the Aggregated Channel Bandwidth as defined in 3GPP TS 36.141 [12] subclause 5.6.

NOTE: If the above Test Requirement differs from the Minimum Requirement then the Test Tolerance applied for this test is non-zero. The Test Tolerance for this test is defined in subclause 4.1.2 and the explanation of how the Minimum Requirement has been relaxed by the Test Tolerance is given in annex C.

6.7.3 OTA Adjacent Channel Leakage power Ratio

6.7.3.1 Definition and applicability

OTA Adjacent Channel Leakage power Ratio (ACLR) is the ratio of the filtered mean power centred on the assigned channel frequency to the filtered mean power centred on an adjacent channel frequency. The measured power is TRP.

6.7.3.2 Minimum Requirement

For AAS BS in *MSR operation* the minimum requirement is defined in TS 37.105 [6], subclause 9.7.3.2.

For AAS BS in *single RAT UTRA operation* the minimum requirement is defined in TS 37.105 [6], subclause 9.7.3.3.

For AAS BS in *single RAT E-UTRA operation* the minimum requirement is defined in TS 37.105 [6], subclause 9.7.3.4.

6.7.3.3 Test purpose

To verify that the adjacent channel leakage power ratio requirement shall be met as specified by the minimum requirement.

6.7.3.4 Method of test

6.7.3.4.1 Initial conditions

6.7.3.4.1.1 General test conditions

Test environment:

- normal; see annex G.2.

RF channels to be tested for single carrier:

- B and T; see subclause 4.12.1.

Base Station RF Bandwidth positions to be tested for multi-carrier:

- B_{RFBW} and T_{RFBW} in single-band operation; see subclause 4.12.1; $B_{\text{RFBW}}T_{\text{RFBW}}$ and $B'_{\text{RFBW}}T_{\text{RFBW}}$ in multi-band operation, see subclause 4.12.1.

6.7.3.4.1.2 MSR

For E-UTRA ACLR requirement outside the *Base Station RF Bandwidth edges* and the ACLR requirement applied inside sub-block gap, in addition, for non-contiguous spectrum operation or *Inter RF Bandwidth gap* for multi-band operation using, the test configurations defined in subclause 4.8, the method of test described in subclause 6.7.3.4.2 applies.

6.7.3.4.1.3 UTRA FDD

Set the AAS BS to transmit a signal modulated in accordance to TM1, in subclause 4.12.2.

For an AAS BS declared to be capable of multi-carrier operation, set the base station to transmit according to TM1 on all carriers configured.

6.7.3.4.1.4 E-UTRA

For an AAS BS declared to be capable of single carrier operation only set to transmit a signal according to E-TM1.1 in subclause 4.12.2.

For an AAS BS declared to be capable of multi-carrier and/or CA operation, set to transmit according to E-TM1.1 on all carriers configured.

6.7.3.4.1.5 NR

For an AAS BS declared to be capable of single carrier operation only set to transmit a signal according to NR-FR1-TM1.1 in subclause 4.12.2.

For an AAS BS declared to be capable of multi-carrier and/or CA operation, set to transmit according to NR-FR1-TM1.1 on all carriers configured.

6.7.3.4.2 Procedure

6.7.3.4.2.1 General Procedure

- 1) Place the AAS BS at the positioner.
- 2) Align the manufacturer declared coordinate system orientation (see table 4.10-1, D9.2) of the AAS BS with the test system.
- 3) Configure the AAS BS such that the beam peak direction(s) applied during the power measurement step 6 are consistent with the grid and measurement approach for the TRP test.

The measurement devices characteristics shall be:

- measurement filter bandwidth: defined in subclause 6.7.3.5.
- detection mode: true RMS voltage or true power averaging.

- 4) For single carrier operation, set the AAS BS to transmit according to the applicable test configuration in clause 5 using the corresponding test model(s) in subclause 4.12.2 at manufacturers declared *rated carrier TRP* ($P_{\text{Rated,c,TRP}}$).

For an AAS BS declared to be capable of multi-carrier and/or CA operation use the applicable test signal configuration and corresponding power setting specified in subclause 4.11.

- 5) Align the BS and the test antenna such that measurements to determine TRP can be performed (see Annex F)
- 6) Measure the absolute total power of the assigned channel frequency and the (adjacent channel frequency)
- 7) Repeat step 6-7 for all directions in the appropriated TRP measurement grid needed for $\text{TRP}_{\text{Estimate}}$ for each of the assigned channel frequency and the adjacent channel frequency (see Annex F).
- 8) Calculate $\text{TRP}_{\text{Estimate}}$ for the absolute total radiated power of the wanted channel and the adjacent channel and the ACLR estimate using the measurements made in Step 7.

NOTE: ACLR is calculated by the ratio of the absolute TRP of the assigned channel frequency and the absolute TRP of the adjacent frequency channel.

6.7.3.4.2.2 MSR

- 1) For E-UTRA and NR, measure OTA ACLR:
 - outside the Base Station RF Bandwidth edges;
 - inside sub-block gap for non-contiguous spectrum operation as specified in subclause 6.7.3.5.1.1;

- inside Inter RF Bandwidth gap for multi-band operation.
- 2) For UTRA FDD, measure ACLR inside sub-block gap or Inter RF Bandwidth gap as specified in subclause 6.7.3.5.1.2.
- 3) Measure Cumulative Adjacent Channel Leakage power Ratio (CACLR) inside sub-block gap or the *Inter RF Bandwidth gap* as specified in subclause 6.7.3.5.1.3.

In addition, for *multi-band RIB*, the following steps shall apply:

- 4) For *multi-band RIB* and single band tests, repeat the steps above per involved band where single band test configurations and test models shall apply with no carrier activated in the other band.

6.7.3.4.2.3 UTRA FDD

- 1) Measure OTA ACLR for 5 MHz and 10 MHz offsets both side of channel frequency. In multiple carrier case only offset frequencies below the lowest and above the highest carrier frequency used shall be measured.
- 2) For the OTA ACLR requirement applied inside sub-block gap for non-contiguous spectrum operation or inside *Inter RF Bandwidth gap* for multi-band operation:
 - a) Measure OTA ACLR inside sub-block gap or *Inter RF Bandwidth gap* as specified in clause 6.7.3.5.2.1, if applicable.
 - b) Measure OTA CACLR inside sub-block gap or *Inter RF Bandwidth gap* as specified in clause 6.7.3.5.2.2, if applicable.

In addition, for *multi-band RIB*, the following steps shall apply:

- 3) For *multi-band RIB* and single band tests, repeat the steps above per involved band where single band test configurations and test models shall apply with no carrier activated in the other band.

6.7.3.4.2.4 E-UTRA

- 1) Measure OTA ACLR for the frequency offsets both side of channel frequency as specified in table 6.7.3.5.3.1-1 (Paired spectrum case) or Table 6.7.3.5.3.1-2 (Unpaired spectrum case) respectively. In multiple carrier case only offset frequencies below the lowest and above the highest carrier frequency used shall be measured.
- 2) For the OTA ACLR requirement applied inside sub-block gap for non-contiguous spectrum operation: or inside *Inter RF Bandwidth gap* for multi-band operation:
 - a) Measure OTA ACLR inside sub-block gap or *Inter RF Bandwidth gap* as specified in subclause 6.7.3.5.3.1, if applicable.
 - b) Measure OTA CACLR inside sub-block gap or *Inter RF Bandwidth gap* as specified in subclause 6.7.3.5.3.2, if applicable.
- 3) Repeat the test with the channel set-up according to E- TM1.2 in subclause 4.12.2.

In addition, for *multi-band TAB connector(s)*, the following steps shall apply:

- 4) For *multi-band TAB connectors* and single band tests, repeat the steps above per involved band where single band test configurations and test models shall apply with no carrier activated in the other band.

6.7.3.5 Test Requirement

6.7.3.5.1 MSR

6.7.3.5.1.1 MSR E-UTRA test requirement

For E-UTRA, the test requirement is specified in tables 6.7.3.5.1.1-1 and 6.7.3.5.1.1-2, and applies outside the *Base Station RF Bandwidth* or *Maximum Radio Bandwidth*.

For an AAS BS operating in non-contiguous spectrum, the OTA ACLR also applies for the first adjacent channel inside any sub-block gap with a gap size $W_{\text{gap}} \geq 15$ MHz. The OTA ACLR requirement for the second adjacent channel applies inside any sub-block gap with a gap size $W_{\text{gap}} \geq 20$ MHz. The CA ACLR test requirement in subclause 6.6.3.5.6.2 applies in sub-block gaps for the frequency ranges defined in table 6.6.3.5.6.2-1.

For a *multi-band RIB*, the ACLR also applies for the first adjacent channel inside any *Inter RF Bandwidth gap* with a gap size $W_{\text{gap}} \geq 15$ MHz. The ACLR requirement for the second adjacent channel applies inside any *Inter RF Bandwidth gap* with a gap size $W_{\text{gap}} \geq 20$ MHz. The OTA CA ACLR requirement in subclause 6.7.3.5.3.2 applies in *Inter RF Bandwidth gaps* for the frequency ranges defined in Table 6.7.3.5.3.2-1.

The requirement applies during the transmitter on period.

The OTA ACLR is defined with a square filter of bandwidth equal to the transmission bandwidth configuration of the transmitted signal (BW_{Config}) centred on the assigned channel frequency and a filter centred on the adjacent channel frequency according to the tables below.

For operation in paired spectrum, the measurement result shall not be less than the OTA ACLR limit specified in Table 6.7.3.5.1.1-1.

Table 6.7.3.5.1.1-1: OTA ACLR in paired spectrum

Channel bandwidth of E-UTRA Lowest/Highest Carrier transmitted BW_{Channel} (MHz)	BS adjacent channel centre frequency offset below the lower or above the upper <i>Base Station RF Bandwidth edge</i>	Assumed adjacent channel carrier	Filter on the adjacent channel frequency and corresponding filter bandwidth	OTA ACLR limit for bands below 3GHz	OTA ACLR limit for bands between 3 and 4.2GHz
1.4, 3.0, 5, 10, 15, 20	0.5 x BW_{Channel}	E-UTRA of same BW	Square (BW_{Config})	44 dB	43.8dB
	1.5 x BW_{Channel}	E-UTRA of same BW	Square (BW_{Config})	44 dB	43.8dB
	2.5 MHz	3.84 Mcps UTRA	RRC (3.84 Mcps)	44 dB	43.8dB
	7.5 MHz	3.84 Mcps UTRA	RRC (3.84 Mcps)	44 dB	43.8dB
NOTE 1: BW_{Channel} and BW_{Config} are the channel bandwidth and transmission bandwidth configuration of the E-UTRA Lowest/Highest Carrier transmitted on the assigned channel frequency.					
NOTE 2: The RRC filter shall be equivalent to the transmit pulse shape filter defined in 3GPP TS 25.104 [2], with a chip rate as defined in this table.					

For operation in unpaired spectrum, the measurement result shall not be less than the OTA ACLR limit specified in Table 6.7.3.5.1.1-2.

Table 6.7.3.5.1.1-2: OTA ACLR in unpaired spectrum with synchronized operation

Channel bandwidth of E-UTRA Lowest/Highest Carrier transmitted BW_{Channel} (MHz)	BS adjacent channel centre frequency offset below the lower or above the upper Base Station RF Bandwidth edge	Assumed adjacent channel carrier	Filter on the adjacent channel frequency and corresponding filter bandwidth	OTA ACLR limit for bands below 3GHz	OTA ACLR limit for bands between 3 and 4.2GHz
1.4, 3	0.5 x BW_{Channel}	E-UTRA of same BW	Square (BW_{Config})	44 dB	43.8dB
	1.5 x BW_{Channel}	E-UTRA of same BW	Square (BW_{Config})	44 dB	43.8dB
	0.8 MHz	1.28 Mcps UTRA	RRC (1.28 Mcps)	44 dB	43.8dB
	2.4 MHz	1.28 Mcps UTRA	RRC (1.28 Mcps)	44 dB	43.8dB
5, 10, 15, 20	0.5 x BW_{Channel}	E-UTRA of same BW	Square (BW_{Config})	44 dB	43.8dB
	1.5 x BW_{Channel}	E-UTRA of same BW	Square (BW_{Config})	44 dB	43.8dB
	0.8 MHz	1.28 Mcps UTRA	RRC (1.28 Mcps)	44 dB	43.8dB
	2.4 MHz	1.28 Mcps UTRA	RRC (1.28 Mcps)	44 dB	43.8dB
	2.5 MHz	3.84 Mcps UTRA	RRC (3.84 Mcps)	44 dB	43.8dB
	7.5 MHz	3.84 Mcps UTRA	RRC (3.84 Mcps)	44 dB	43.8dB
	5 MHz	7.68 Mcps UTRA	RRC (7.68 Mcps)	44 dB	43.8dB
	15 MHz	7.68 Mcps UTRA	RRC (7.68 Mcps)	44 dB	43.8dB

NOTE 1: BW_{Channel} and BW_{Config} are the channel bandwidth and transmission bandwidth configuration of the E-UTRA Lowest/Highest Carrier transmitted on the assigned channel frequency.

NOTE 2: The RRC filter shall be equivalent to the transmit pulse shape filter defined in 3GPP TS 25.105 [3], with a chip rate as defined in this table.

For operation in non-contiguous paired spectrum, the measurement results shall not be less than the OTA ACLR limit specified in Table 6.7.3.5.1.1-3.

Table 6.7.3.5.1.1-3: OTA ACLR in non-contiguous paired spectrum

Sub-block gap size (W_{gap}) where the limit applies	BS adjacent channel centre frequency offset below or above the sub-block edge (inside the gap)	Assumed adjacent channel carrier	Filter on the adjacent channel frequency and corresponding filter bandwidth	OTA ACLR limit for bands below 3GHz	OTA ACLR limit for bands between 3 and 4.2GHz
$W_{\text{gap}} \geq 15$ MHz	2.5 MHz	3.84 Mcps UTRA	RRC (3.84 Mcps)	44 dB	43.8dB
$W_{\text{gap}} \geq 20$ MHz	7.5 MHz	3.84 Mcps UTRA	RRC (3.84 Mcps)	44 dB	43.8dB

NOTE: The RRC filter shall be equivalent to the transmit pulse shape filter defined in 3GPP TS 25.104 [2], with a chip rate as defined in this table.

For operation in non-contiguous unpaired spectrum, the measurement result shall not be less than the OTA ACLR limit specified in Table 6.7.3.5.1.1-4.

Table 6.7.3.5.1.1-4: OTA ACLR in non-contiguous unpaired spectrum

Sub-block gap size (W_{gap}) where the limit applies	BS adjacent channel centre frequency offset below or above the sub-block edge (inside the gap)	Assumed adjacent channel carrier	Filter on the adjacent channel frequency and corresponding filter bandwidth	OTA ACLR limit for bands below 3GHz	OTA ACLR limit for bands between 3 and 4.2GHz
$W_{\text{gap}} \geq 15$ MHz	2.5 MHz	5 MHz E-UTRA	Square (BW_{Config})	44 dB	43.8dB
$W_{\text{gap}} \geq 20$ MHz	7.5 MHz	5 MHz E-UTRA	Square (BW_{Config})	44 dB	43.8dB

For Category A, an E-UTRA AAS BS of Wide Area BS class, either the OTA ACLR limits in Tables 6.7.3.5.1.1-1/2/3/4 or OTA ACLR absolute limit of -4 dBm/MHz shall apply, whichever is less stringent.

For Category B, an E-UTRA AAS BS of Wide Area BS class, either the OTA ACLR limits in Tables 6.7.3.5.1.1-1/2/3/4 or OTA ACLR absolute limit of -6 dBm/MHz shall apply, whichever is less stringent.

For an E-UTRA AAS BS of Medium Range BS class, either the OTA ACLR limits in Tables 6.7.3.5.1.1-1/2/3/4 or OTA ACLR absolute limit of -16 dBm/MHz shall apply, whichever is less stringent.

For an E-UTRA AAS BS of Local Area BS class, either the OTA ACLR limits in Tables 6.7.3.5.1.1-1/2/3/4 or OTA ACLR absolute limit of -23 dBm/MHz shall apply, whichever is less stringent.

6.7.3.5.1.2 MSR UTRA FDD test requirement

For UTRA FDD, the test requirement is specified in Tables 6.7.3.5.1.2-1 and 6.7.3.5.1.2-2, and applies outside the *Base Station RF Bandwidth* or Maximum Radio Bandwidth.

The measurement result shall not be less than the OTA ACLR limit specified in Table 6.7.3.5.1.2-1.

Table 6.7.3.5.1.2-1: OTA ACLR

BS channel offset below the first or above the last carrier frequency used	OTA ACLR limit for bands below 3GHz	OTA ACLR limit for bands between 3 and 4.2GHz
5 MHz	44 dB	43.8dB
10 MHz	44 dB	43.8dB
Note 1: In certain regions, the adjacent channel power (the RRC filtered mean power centered on an adjacent channel frequency) shall be less than or equal to -7.2 dBm/3.84 MHz (for Band I, III, IX, XI and XXI) or +2.8 dBm/3.84MHz (for Band VI, VIII and XIX) or as specified by the ACLR limit, whichever is the higher. This note is not applicable for Home BS. Note 2: For Home BS, the adjacent channel power (the RRC filtered mean power centered on an adjacent channel frequency) shall be less than or equal to -42.7 dBm/3.84MHz $f \leq 3.0$ GHz and -42.4 dBm/3.84MHz for 3.0 GHz $< f \leq 4.2$ GHz or as specified by the ACLR limit, whichever is the higher.		

NOTE: If the above Test Requirement differs from the Minimum Requirement then the Test Tolerance applied for this test is non-zero. The Test Tolerance for this test is defined in clause 4.2 and the explanation of how the Minimum Requirement has been relaxed by the Test Tolerance is given in Annex F.

The measurement result shall not be less than the OTA ACLR limit specified in Table 6.7.3.5.1.2-2.

Table 6.7.3.5.1.2-2: OTA ACLR in non-contiguous spectrum or multiple bands

Sub-block or Inter RF Bandwidth gap size (W_{gap}) where the limit applies	BS adjacent channel centre frequency offset below or above the sub-block edge or the Base Station RF Bandwidth edge (inside the gap)	Assumed adjacent channel carrier (informative)	Filter on the adjacent channel frequency and corresponding filter bandwidth	OTA ACLR limit for bands below 3GHz	OTA ACLR limit for bands between 3 and 4.2GHz
$W_{\text{gap}} \geq 15$ MHz	2.5 MHz	3.84 Mcps UTRA	RRC (3.84 Mcps)	44 dB	43.8dB
$W_{\text{gap}} \geq 20$ MHz	7.5 MHz	3.84 Mcps UTRA	RRC (3.84 Mcps)	44 dB	43.8dB
NOTE: The RRC filter shall be equivalent to the transmit pulse shape filter defined in TS 25.104, with a chip rate as defined in this table.					

For an AAS BS operating in non-contiguous spectrum, OTA ACLR requirement also applies for the first adjacent channel, inside any sub-block gap with a gap size $W_{\text{gap}} \geq 15$ MHz. The OTA ACLR requirement for the second adjacent channel applies inside any sub-block gap with a gap size $W_{\text{gap}} \geq 20$ MHz. The OTA ACLR test requirement in subclause 6.7.3.5.3.2 applies in sub block gaps for the frequency ranges defined in Table 6.7.3.5.3.2-1.

For a multi-band capable AAS BS OTA ACLR requirement also applies for the first adjacent channel, inside any *Inter RF Bandwidth gap* with a gap size $W_{\text{gap}} \geq 15$ MHz. The OTA ACLR requirement for the second adjacent channel applies inside any *Inter RF Bandwidth gap* with a gap size $W_{\text{gap}} \geq 20$ MHz. The OTA ACLR requirement in subclause 6.7.3.5.3.2 applies in *Inter RF Bandwidth gaps* for the frequency ranges defined in Table 6.7.3.5.3.2-1.

For Category A, a UTRA AAS BS of Wide Area BS class, either the OTA ACLR limits in the Tables 6.7.3.5.1.2-1/2 or the absolute limit of -7 dBm/MHz shall apply, whichever is less stringent.

For Category B, a UTRA AAS BS of Wide Area BS class, either the OTA ACLR limits in the Tables 6.7.3.5.1.2-1/2 or the absolute limit of -9 dBm/MHz shall apply, whichever is less stringent.

For a UTRA AAS BS of Medium Range BS class, either the OTA ACLR limits in the Tables 6.7.3.5.1.2-1/2 or the absolute limit of -19 dBm/MHz shall apply, whichever is less stringent.

For a UTRA AAS BS of Local Area BS class, either the OTA ACLR limits in the Tables 6.7.3.5.1.2-1/2 or the absolute limit of -26 dBm/MHz shall apply, whichever is less stringent.

6.7.3.5.1.3 OTA Cumulative ACLR test requirement in non-contiguous spectrum

The following test requirement applies for sub-block or *Inter RF Bandwidth gap* sizes listed in Table 6.7.3.5.1.3-1:

- Inside a sub-block gap within an operating band for a BS operating in non-contiguous spectrum.
- Inside an *Inter RF Bandwidth gap* for a BS operating in multiple bands, where multiple bands are mapped on the same antenna connector.

The Cumulative Adjacent Channel Leakage power Ratio (CACLR) in a sub-block gap or the *Inter RF Bandwidth gap* is the ratio of:

- a) the sum of the filtered mean power centred on the assigned channel frequencies for the two carriers adjacent to each side of the sub-block gap or the *Inter RF Bandwidth gap*; and
- b) the filtered mean power centred on a frequency channel adjacent to one of the respective sub-block edges or *Base Station RF Bandwidth edges*.

The requirement applies to adjacent channels of E-UTRA or UTRA carriers allocated adjacent to each side of the sub-block gap or the *Inter RF Bandwidth gap*. The assumed filter for the adjacent channel frequency is defined in Table 6.7.3.5.1.3-1 and the filters on the assigned channels are defined in Table 6.7.3.5.1.3-2.

NOTE: If the RAT on the assigned channel frequencies is different, the filters used are also different.

The CACLR for E-UTRA and UTRA carriers located on either side of the sub-block gap or the *Inter RF Bandwidth gap* shall not be less than the value specified in Table 6.7.3.5.1.3-1.

Table 6.7.3.5.1.3-1: OTA CACLR in non-contiguous spectrum or multiple bands

Band Category	Sub-block or Inter RF Bandwidth gap size (W_{gap}) where the limit applies [MHz]	BS adjacent channel centre frequency offset below or above the sub-block edge or the Base Station RF Bandwidth edge (inside the gap)	Assumed adjacent channel carrier (informative)	Filter on the adjacent channel frequency and corresponding filter bandwidth	OTA CACLR limit for bands below 3GHz	OTA CACLR limit for bands between 3 and 4.2GHz
BC1, BC2	$5 \leq W_{\text{gap}} < 15$ (Note 3)	2.5 MHz	3.84 Mcps UTRA	RRC (3.84 Mcps)	44 dB	43.8dB
BC1, BC2	$10 < W_{\text{gap}} < 20$ (Note 3)	7.5 MHz	3.84 Mcps UTRA	RRC (3.84 Mcps)	44 dB	43.8dB
BC3	$5 \leq W_{\text{gap}} < 15$ (Note 3)	2.5 MHz	5MHz E-UTRA	Square (BWConfig)	44 dB	43.8dB
BC3	$10 < W_{\text{gap}} < 20$ (Note 3)	7.5 MHz	5MHz E-UTRA	Square (BWConfig)	44 dB	43.8dB
BC1, BC2, BC3	$5 \leq W_{\text{gap}} < 45$ (Note 4)	2.5 MHz	5 MHz NR (Note 2)	Square (BWConfig)	44 dB	43.8dB
BC1, BC2, BC3	$10 \leq W_{\text{gap}} < 50$ (Note 4)	7.5 MHz	5 MHz NR (Note 2)	Square (BWConfig)	44 dB	43.8dB
BC1, BC2, BC3	$20 \leq W_{\text{gap}} < 30$ (Note 3, 5)	10 MHz	20 MHz NR (Note 2)	Square (BWConfig)	44 dB	43.8dB
BC1, BC2, BC3	$20 \leq W_{\text{gap}} < 60$ (Note 4)	10 MHz	20 MHz NR (Note 2)	Square (BWConfig)	45 dB	43.8dB
BC1, BC2, BC3	$40 \leq W_{\text{gap}} < 50$ (Note 3, 5)	30 MHz	20 MHz NR (Note 2)	Square (BWConfig)	44 dB	43.8dB
BC1, BC2, BC3	$40 \leq W_{\text{gap}} < 80$ (Note 4)	30 MHz	20 MHz NR (Note 2)	Square (BWConfig)	44 dB	43.8dB

NOTE 1: The RRC filter shall be equivalent to the transmit pulse shape filter defined in TS 25.104 [2], with a chip rate as defined in this table.

NOTE 2: With SCS that provides largest transmission bandwidth configuration (BW_{Config}).

NOTE 3: Applicable in case the *channel bandwidth* of the carrier transmitted at the other edge of the gap is 5, 10, 15, 20 MHz.

NOTE 4: Applicable in case the *channel bandwidth* of the NR carrier transmitted at the other edge of the gap is 25, 30, 40, 50, 60, 70, 80, 90, 100 MHz.

NOTE 5: Applicable in case the *channel bandwidth* of the lowest/highest NR carrier transmitted is 25, 30, 40, 50, 60, 70, 80, 90, 100 MHz.

Table 6.7.3.5.1.3-2: Filter parameters for the assigned channel

RAT of the carrier adjacent to the sub-block or Inter RF Bandwidth gap	Filter on the assigned channel frequency and corresponding filter bandwidth
E-UTRA	E-UTRA of same BW
NR	NR of same BW with SCS that provides largest transmission bandwidth configuration
UTRA FDD	RRC (3.84 Mcps)

NOTE: The RRC filter shall be equivalent to the transmit pulse shape filter defined in 3GPP TS 25.104 [2], with a chip rate as defined in this table.

For Category A, an E-UTRA or NR AAS BS of Wide Area BS class, either the OTA CACLR limits in Table 6.7.3.5.1.3-1 or OTA ACLR absolute limit of -4 dBm/MHz shall apply, whichever is less stringent.

For Category B, an E-UTRA or NR AAS BS of Wide Area BS class, either the OTA CACLR limits in Table 6.7.3.5.1.3-1 or OTA ACLR absolute limit of -6 dBm/MHz shall apply, whichever is less stringent.

For an E-UTRA or NR AAS BS of Medium Range BS class, either the OTA CACLR limits in Table 6.7.3.5.1.3-1 or OTA ACLR absolute limit of -16 dBm/MHz shall apply, whichever is less stringent.

For an E-UTRA or NR AAS BS of Local Area BS class, either the OTA CACLR limits in Table 6.7.3.5.1.3-1 or OTA ACLR absolute limit of -23 dBm/MHz shall apply, whichever is less stringent.

For Category A, a UTRA AAS BS of Wide Area BS class, either the OTA CACLR limits in Table 6.7.3.5.1.3-1 or OTA ACLR absolute limit of -7 dBm/MHz shall apply, whichever is less stringent.

For Category B, a UTRA AAS BS of Wide Area BS class, either the OTA ACLR limits in Table 6.7.3.5.1.3-1 or OTA ACLR absolute limit of -9 dBm/MHz shall apply, whichever is less stringent.

For a UTRA AAS BS of Medium Range BS class, either the OTA ACLR limits in Table 6.7.3.5.1.3-1 or OTA ACLR absolute limit of -19 dBm/MHz shall apply, whichever is less stringent.

For a UTRA AAS BS of Local Area BS class, either the OTA ACLR limits in Table 6.7.3.5.1.3-1 or OTA ACLR absolute limit of -26 dBm/MHz shall apply, whichever is less stringent.

6.7.3.5.1.4 NR test requirement

For the NR OTA ACLR requirement either the OTA ACLR limits in tables 6.7.3.5.1.4-1/2a or the OTA ACLR absolute limits in tables 6.7.3.5.1.4-2 shall apply, whichever is less stringent. The OTA ACLR limits in subclause 6.7.3.5.1.3 shall also apply.

For a RIB operating in non-contiguous spectrum, the OTA ACLR requirement applies inside sub block gaps for the frequency ranges defined in table 6.7.3.5.1.4-2a, while the ACLR requirement applies inside sub block gaps for the frequency ranges defined in table 6.7.3.5.1.3-1.

For a *multi-band RIB*, the OTA ACLR test requirement applies inside Inter RF Bandwidth gaps for the frequency ranges defined in table 6.7.3.5.1.4-2a, while the OTA ACLR requirement applies inside Inter RF Bandwidth gaps for the frequency ranges defined in table 6.7.3.5.1.3-1.

For operation in paired and unpaired spectrum, the OTA ACLR measurement result shall not be less than the OTA ACLR limit specified in table 6.7.3.5.1.4-1.

Table 6.7.3.5.1.4-1: NR ACLR limit

BS channel bandwidth of lowest/highest NR carrier transmitted BW_{Channel} [MHz]	BS adjacent channel centre frequency offset below the lowest or above the highest carrier centre frequency transmitted	Assumed adjacent channel carrier (informative)	Filter on the adjacent channel frequency and corresponding filter bandwidth	OTA ACLR limit (0 – 3 GHz)	OTA ACLR limit (3 – 6 GHz)
5, 10, 15, 20, 25, 30, 40, 50, 60, 70, 80, 90,100	BW _{Channel}	NR of same BW (Note 2)	Square (BW _{Config})	44 dB	43.8 dB
	2 x BW _{Channel}	NR of same BW (Note 2)	Square (BW _{Config})	44 dB	43.8 dB
	BW _{Channel} /2 + 2.5 MHz	5 MHz E-UTRA	Square (4.5 MHz)	44 dB (Note 3)	43.8 dB (Note 3)
	BW _{Channel} /2 + 7.5 MHz	5 MHz E-UTRA	Square (4.5 MHz)	44 dB (Note 3)	43.8 dB (Note 3)
NOTE 1: BW _{Channel} and BW _{Config} are the <i>BS channel bandwidth</i> and transmission bandwidth configuration of the lowest/highest NR carrier transmitted on the assigned channel frequency.					
NOTE 2: With SCS that provides largest transmission bandwidth configuration (BW _{Config}).					
NOTE 3: The requirements are applicable when the band is also defined for E-UTRA or UTRA.					

The absolute total power measurement shall not exceed the OTA ACLR absolute limit specified in table 6.7.3.5.1.4-2.

Table 6.7.3.5.1.4-2: NR ACLR absolute limit

BS category / BS class	OTA ACLR absolute limit
Category A Wide Area BS	-4 dBm/MHz
Category B Wide Area BS	-6 dBm/MHz
Medium Range BS	-16 dBm/MHz
Local Area BS	-23 dBm/MHz

For operation in non-contiguous spectrum or multiple bands, the OTA ACLR measurement result shall not be less than the OTA ACLR limit specified in table 6.7.3.5.1.4-2a.

Table 6.7.3.5.1.4-2a: NR ACLR limit in non-contiguous spectrum or multiple bands

BS channel bandwidth of lowest/highest NR carrier transmitted BW_{Channel} [MHz]	Sub-block or Inter RF Bandwidth gap size (W_{gap}) where the limit applies [MHz]	BS adjacent channel centre frequency offset below or above the sub-block or Base Station RF Bandwidth edge (inside the gap)	Assumed adjacent channel carrier	Filter on the adjacent channel frequency and corresponding filter bandwidth	OTA ACLR limit (0-3GHz)	OTA ACLR limit (3-6GHz)
5, 10, 15, 20	$W_{\text{gap}} \geq 15$ (Note 3) $W_{\text{gap}} \geq 45$ (Note 4)	2.5 MHz	5 MHz NR (Note 2)	Square (BW_{Config})	44 dB	43.8 dB
	$W_{\text{gap}} \geq 20$ (Note 3) $W_{\text{gap}} \geq 50$ (Note 4)	7.5 MHz	5 MHz NR (Note 2)	Square (BW_{Config})	44 dB	43.8 dB
25, 30, 40, 50, 60, 70, 80, 90, 100	$W_{\text{gap}} \geq 60$ (Note 4) $W_{\text{gap}} \geq 30$ (Note 3)	10 MHz	20 MHz NR (Note 2)	Square (BW_{Config})	44 dB	43.8 dB
	$W_{\text{gap}} \geq 80$ (Note 4) $W_{\text{gap}} \geq 50$ (Note 3)	30 MHz	20 MHz NR (Note 2)	Square (BW_{Config})	44 dB	43.8 dB

NOTE 1: BW_{Config} is the transmission bandwidth configuration of the assumed adjacent channel carrier.
NOTE 2: With SCS that provides largest transmission bandwidth configuration (BW_{Config}).
NOTE 3: Applicable in case the BS channel bandwidth of the NR carrier transmitted at the other edge of the gap is 5, 10, 15, 20 MHz.
NOTE 4: Applicable in case the BS channel bandwidth of the NR carrier transmitted at the other edge of the gap is 25, 30, 40, 50, 60, 70, 80, 90, 100 MHz.

The OTA CACLR measurement result shall not less than the OTA CACLR limit specified in table 6.7.3.5.1.4-1.

6.7.3.5.2 UTRA FDD

6.7.3.5.2.1 OTA ACLR

The measurement result shall not be less than the OTA ACLR limit specified in Table 6.7.3.5.2.1-1.

Table 6.7.3.5.2.1-1: OTA BS ACLR

BS channel offset below the first or above the last carrier frequency used	OTA ACLR limit for bands below 3GHz	OTA ACLR limit for bands between 3 and 4.2GHz
5 MHz	44 dB	43.8dB
10 MHz	44 dB	43.8dB

NOTE 1: In certain regions, the adjacent channel power (the RRC filtered mean power centred on an adjacent channel frequency) shall be less than or equal to -7.2 dBm/3.84 MHz (for Band I, III, IX, XI and XXI) or +2.8 dBm/3.84 MHz (for Band VI, VIII and XIX) or as specified by the ACLR limit, whichever is the higher. This note is not applicable for Home BS.
NOTE 2: For Home BS, the adjacent channel power (the RRC filtered mean power centred on an adjacent channel frequency) shall be less than or equal to -42.7 dBm/3.84 MHz $f \leq 3.0$ GHz and -42.4 dBm/3.84 MHz for 3.0 GHz $< f \leq 4.2$ GHz or as specified by the ACLR limit, whichever is the higher.

NOTE: If the above Test Requirement differs from the Minimum Requirement then the Test Tolerance applied for this test is non-zero. The Test Tolerance for this test is defined in subclause 4.1.2 and the explanation of how the Minimum Requirement has been relaxed by the Test Tolerance is given in annex C.

The measurement result shall not be less than the OTA ACLR limit specified in Table 6.7.3.5.2.1-2.

Table 6.7.3.5.2.1-2: OTA ACLR in non-contiguous spectrum or multiple bands

Sub-block or <i>Inter RF Bandwidth gap</i> size (W_{gap}) where the limit applies	BS adjacent channel centre frequency offset below or above the sub-block edge or the <i>Base Station RF Bandwidth edge</i> (inside the gap)	Assumed adjacent channel carrier (informative)	Filter on the adjacent channel frequency and corresponding filter bandwidth	OTA ACLR limit for bands below 3GHz	OTA ACLR limit for bands between 3 and 4.2GHz
$W_{\text{gap}} \geq 15$ MHz	2.5 MHz	3.84 Mcps UTRA	RRC (3.84 Mcps)	44 dB	43.8dB
$W_{\text{gap}} \geq 20$ MHz	7.5 MHz	3.84 Mcps UTRA	RRC (3.84 Mcps)	44 dB	43.8dB

NOTE: The RRC filter shall be equivalent to the transmit pulse shape filter defined in 3GPP TS 25.104 [2], with a chip rate as defined in this table.

For Category A, a UTRA AAS BS of Wide Area BS class, either the OTA ACLR limits in Tables 6.7.3.5.2.1-1/2 or OTA ACLR absolute limit of -7 dBm/MHz shall apply, whichever is less stringent.

For Category B, a UTRA AAS BS of Wide Area BS class, either the OTA ACLR limits in Tables 6.7.3.5.2.1-1/2 or OTA ACLR absolute limit of -9 dBm/MHz shall apply, whichever is less stringent.

For a UTRA AAS BS of Medium Range BS class, either the OTA ACLR limits in Tables 6.7.3.5.2.1-1/2 or OTA ACLR absolute limit of -19 dBm/MHz shall apply, whichever is less stringent.

For a UTRA AAS BS of Local Area BS class, either the OTA ACLR limits in Tables 6.7.3.5.2.1-1/2 or OTA ACLR absolute limit of -26 dBm/MHz shall apply, whichever is less stringent.

6.7.3.5.2.2 OTA Cumulative ACLR test requirement in non-contiguous spectrum or multiple bands

The following test requirement applies for an AAS BS operating in non-contiguous spectrum or multiple bands.

The following requirement applies for the gap sizes listed in Table 6.7.3.5.2.2-1:

- inside a sub-block gap within an operating band for an AAS BS operating in non-contiguous spectrum;
- inside an *Inter RF Bandwidth gap* for a multi-band capable AAS BS.

The Cumulative Adjacent Channel Leakage power Ratio (CACLR) in a sub-block gap or *Inter RF Bandwidth gap* is the ratio of:

- a) the sum of the filtered mean power centred on the assigned channel frequencies for the two carriers adjacent to each side of the sub-block gap or *Inter RF Bandwidth gap*; and
- b) the filtered mean power centred on a frequency channel adjacent to one of the respective sub-block edges or *Base Station RF Bandwidth edges*.

The assumed filter for the adjacent channel frequency is defined in Table 6.7.3.5.2.2-1 and the filters on the assigned channels are defined in Table 6.7.3.5.2.2-2.

The CACLR for UTRA carriers located on either side of the sub-block gap or *Inter RF Bandwidth gap* shall not be less than the value specified in Table 6.7.3.5.2.2-1.

Table 6.7.3.5.2.2-1: OTA CACLR in non-contiguous spectrum or multiple bands

Sub-block or <i>Inter RF Bandwidth gap</i> size (W_{gap}) where the limit applies	BS adjacent channel centre frequency offset below or above the sub-block edge or the <i>Base Station RF Bandwidth edge</i> (inside the gap)	Assumed adjacent channel carrier (informative)	Filter on the adjacent channel frequency and corresponding filter bandwidth	OTA CACLR limit for bands below 3GHz	OTA CACLR limit for bands between 3 and 4.2GHz
$5 \text{ MHz} \leq W_{\text{gap}} < 15 \text{ MHz}$	2.5 MHz	3.84 Mcps UTRA	RRC (3.84 Mcps)	44 dB	43.8dB
$10 \text{ MHz} < W_{\text{gap}} < 20 \text{ MHz}$	7.5 MHz	3.84 Mcps UTRA	RRC (3.84 Mcps)	44 dB	43.8dB

NOTE: The RRC filter shall be equivalent to the transmit pulse shape filter defined in 3GPP TS 25.104 [2], with a chip rate as defined in this table.

Table 6.7.3.5.2.2-2: Filter parameters for the assigned channel

RAT of the carrier adjacent to the sub-block or <i>Inter RF Bandwidth gap</i>	Filter on the assigned channel frequency and corresponding filter bandwidth
UTRA FDD	RRC (3.84 Mcps)

NOTE: The RRC filter shall be equivalent to the transmit pulse shape filter defined in 3GPP TS 25.104 [2], with a chip rate as defined in this table.

For Category A, a UTRA AAS BS of Wide Area BS class, either the OTA CACLR limits in Table 6.7.3.5.2.2-1 or OTA ACLR absolute limit of -7 dBm/MHz shall apply, whichever is less stringent.

For Category B, a UTRA AAS BS of Wide Area BS class, either the OTA CACLR limits in Table 6.7.3.5.2.2-1 or OTA ACLR absolute limit of -9 dBm/MHz shall apply, whichever is less stringent.

For a UTRA AAS BS of Medium Range BS class, either the OTA CACLR limits in Table 6.7.3.5.2.2-1 or OTA ACLR absolute limit of -19 dBm/MHz shall apply, whichever is less stringent.

For a UTRA AAS BS of Local Area BS class, either the OTA CACLR limits in Table 6.7.3.5.2.2-1 or OTA ACLR absolute limit of -26 dBm/MHz shall apply, whichever is less stringent.

6.7.3.5.3 E-UTRA

6.7.3.5.3.1 OTA ACLR

For operation in paired spectrum, the OTA ACLR shall be higher than the value specified in Table 6.7.3.5.3.1-1.

Table 6.7.3.5.3.1-1: OTA ACLR in paired spectrum

Channel bandwidth of E-UTRA lowest/highest carrier transmitted BW_{Channel} (MHz)	BS adjacent channel centre frequency offset below the lowest or above the highest carrier centre frequency transmitted	Assumed adjacent channel carrier (informative)	Filter on the adjacent channel frequency and corresponding filter bandwidth	OTA ACLR limit for bands below 3GHz	OTA ACLR limit for bands between 3 and 4.2GHz
1.4, 3.0, 5, 10, 15, 20	BW_{Channel}	E-UTRA of same BW	Square (BW_{Config})	44 dB	43.8dB
	$2 \times BW_{\text{Channel}}$	E-UTRA of same BW	Square (BW_{Config})	44 dB	43.8dB
	$BW_{\text{Channel}}/2 + 2.5 \text{ MHz}$	3.84 Mcps UTRA	RRC (3.84 Mcps)	44 dB	43.8dB
	$BW_{\text{Channel}}/2 + 7.5 \text{ MHz}$	3.84 Mcps UTRA	RRC (3.84 Mcps)	44 dB	43.8dB

NOTE 1: BW_{Channel} and BW_{Config} are the channel bandwidth and transmission bandwidth configuration of the E-UTRA lowest/highest/ carrier transmitted on the assigned channel frequency.

NOTE 2: The RRC filter shall be equivalent to the transmit pulse shape filter defined in 3GPP TS 25.014 [3] with a chip rate as defined in this table.

For operation in unpaired spectrum, the measurement result shall not be less than the OTA ACLR limit specified in Table 6.7.3.5.3.1-2.

Table 6.7.3.5.3.1-2: OTA ACLR in unpaired spectrum with synchronized operation

Channel bandwidth of E-UTRA lowest/highest carrier transmitted BW_{Channel} (MHz)	BS adjacent channel centre frequency offset below the lowest or above the highest carrier centre frequency transmitted	Assumed adjacent channel carrier (informative)	Filter on the adjacent channel frequency and corresponding filter bandwidth	OTA ACLR limit for bands below 3GHz	OTA ACLR limit for bands between 3 and 4.2GHz
1.4, 3.0	BW_{Channel}	E-UTRA of same BW	Square (BW_{Config})	44 dB	43.8dB
	$2 \times BW_{\text{Channel}}$	E-UTRA of same BW	Square (BW_{Config})	44 dB	43.8dB
	$BW_{\text{Channel}}/2 + 0.8$ MHz	1.28 Mcps UTRA	RRC (1.28 Mcps)	44 dB	43.8dB
	$BW_{\text{Channel}}/2 + 2.4$ MHz	1.28 Mcps UTRA	RRC (1.28 Mcps)	44 dB	43.8dB
5, 10, 15, 20	BW_{Channel}	E-UTRA of same BW	Square (BW_{Config})	44 dB	43.8dB
	$2 \times BW_{\text{Channel}}$	E-UTRA of same BW	Square (BW_{Config})	44 dB	43.8dB
	$BW_{\text{Channel}}/2 + 0.8$ MHz	1.28 Mcps UTRA	RRC (1.28 Mcps)	44 dB	43.8dB
	$BW_{\text{Channel}}/2 + 2.4$ MHz	1.28 Mcps UTRA	RRC (1.28 Mcps)	44 dB	43.8dB
	$BW_{\text{Channel}}/2 + 2.5$ MHz	3.84 Mcps UTRA	RRC (3.84 Mcps)	44 dB	43.8dB
	$BW_{\text{Channel}}/2 + 7.5$ MHz	3.84 Mcps UTRA	RRC (3.84 Mcps)	44 dB	43.8dB
	$BW_{\text{Channel}}/2 + 5$ MHz	7.68 Mcps UTRA	RRC (7.68 Mcps)	44 dB	43.8dB
	$BW_{\text{Channel}}/2 + 15$ MHz	7.68 Mcps UTRA	RRC (7.68 Mcps)	44 dB	43.8dB

NOTE 1: BW_{Channel} and BW_{Config} are the channel bandwidth and transmission bandwidth configuration of the E-UTRA lowest/highest carrier transmitted on the assigned channel frequency.

NOTE 2: The RRC filter shall be equivalent to the transmit pulse shape filter defined in 3GPP TS 25.014 [3] with a chip rate as defined in this table.

For operation in non-contiguous paired spectrum or multiple bands, the measurement result shall not be less than the OTA ACLR limit specified in Table 6.7.3.5.3.1-3.

Table 6.7.3.5.3.1-3: OTA ACLR in non-contiguous paired spectrum or multiple bands

Sub-block or Inter RF Bandwidth gap size (W_{gap}) where the limit applies	BS adjacent channel centre frequency offset below or above the sub-block edge or the Base Station RF Bandwidth edge (inside the gap)	Assumed adjacent channel carrier (informative)	Filter on the adjacent channel frequency and corresponding filter bandwidth	OTA ACLR limit for bands below 3GHz	OTA ACLR limit for bands between 3 and 4.2GHz
$W_{\text{gap}} \geq 15$ MHz	2.5 MHz	3.84 Mcps UTRA	RRC (3.84 Mcps)	44 dB	43.8dB
$W_{\text{gap}} \geq 20$ MHz	7.5 MHz	3.84 Mcps UTRA	RRC (3.84 Mcps)	44 dB	43.8dB

NOTE: The RRC filter shall be equivalent to the transmit pulse shape filter defined in 3GPP TS 25.104 [2], with a chip rate as defined in this table.

For operation in non-contiguous unpaired spectrum or multiple bands, the measurement result shall not be less than the OTA ACLR limit specified in Table 6.7.3.5.3.1-4.

Table 6.7.3.5.3.1-4: OTA ACLR in non-contiguous unpaired spectrum or multiple bands

Sub-block or Inter RF Bandwidth gap size (W_{gap}) where the limit applies	BS adjacent channel centre frequency offset below or above the sub-block edge or the Base Station RF Bandwidth edge (inside the gap)	Assumed adjacent channel carrier (informative)	Filter on the adjacent channel frequency and corresponding filter bandwidth	OTA ACLR limit for bands below 3GHz	OTA ACLR limit for bands between 3 and 4.2GHz
$W_{\text{gap}} \geq 15$ MHz	2.5 MHz	5 MHz E-UTRA	Square (BW_{Config})	44 dB	43.8dB
$W_{\text{gap}} \geq 20$ MHz	7.5 MHz	5 MHz E-UTRA	Square (BW_{Config})	44 dB	43.8dB

For Category A, an E-UTRA AAS BS of Wide Area BS class, either the OTA ACLR limits in Tables 6.7.3.5.3.1-1/2/3/4 or OTA ACLR absolute limit of -4 dBm/MHz shall apply, whichever is less stringent.

For Category B, an E-UTRA AAS BS of Wide Area BS class, either the OTA ACLR limits in Tables 6.7.3.5.3.1-1/2/3/4 or OTA ACLR absolute limit of -6 dBm/MHz shall apply, whichever is less stringent.

For an E-UTRA AAS BS of Medium Range BS class, either the OTA ACLR limits in Tables 6.7.3.5.3.1-1/2/3/4 or OTA ACLR absolute limit of -16 dBm/MHz shall apply, whichever is less stringent.

For an E-UTRA AAS BS of Local Area BS class, either the OTA ACLR limits in Tables 6.7.3.5.3.1-1/2/3/4 or OTA ACLR absolute limit of -23 dBm/MHz shall apply, whichever is less stringent.

6.7.3.5.3.2 OTA Cumulative ACLR test requirement in non-contiguous spectrum

The following test requirement applies for the sub-block or *Inter RF Bandwidth gap* sizes listed in Table 6.7.3.5.3.2-1,

- Inside a sub-block gap within an operating band for a BS operating in non-contiguous spectrum.
- Inside an *Inter RF Bandwidth gap* for a multi-band capable AAS BS.

The Cumulative Adjacent Channel Leakage power Ratio (CACLR) in a sub-block gap or *Inter RF Bandwidth gap* is the ratio of:

- a) the sum of the filtered mean power centred on the assigned channel frequencies for the two carriers adjacent to each side of the sub-block gap or *Inter RF Bandwidth gap*; and
- b) the filtered mean power centred on a frequency channel adjacent to one of the respective sub-block edges or *Base Station RF Bandwidth edges*.

The assumed filter for the adjacent channel frequency is defined in Tables 6.7.3.5.3.2-1 and 6.7.3.5.3.2-2. Filters on the assigned channels are defined in Table 6.7.3.5.3.2-3.

For operation in non-contiguous spectrum or multiple bands, the CACLR for E-UTRA carriers located on either side of the sub-block gap or *Inter RF Bandwidth gap* shall not be less than the value specified in Tables 6.7.3.5.3.2-1 and 6.7.3.5.3.2-2.

Table 6.7.3.5.3.2-1: OTA CACLR in non-contiguous paired spectrum or multiple bands

Sub-block or <i>Inter RF Bandwidth gap</i> size (W_{gap}) where the limit applies	BS adjacent channel centre frequency offset below or above the sub-block edge or the <i>Base Station RF Bandwidth edge</i> (inside the gap)	Assumed adjacent channel carrier (informative)	Filter on the adjacent channel frequency and corresponding filter bandwidth	OTA CACLR limit for bands below 3GHz	OTA CACLR limit for bands between 3 and 4.2GHz
$5 \text{ MHz} \leq W_{\text{gap}} < 15 \text{ MHz}$	2.5 MHz	3.84 Mcps UTRA	RRC (3.84 Mcps)	44 dB	43.8dB
$10 \text{ MHz} < W_{\text{gap}} < 20 \text{ MHz}$	7.5 MHz	3.84 Mcps UTRA	RRC (3.84 Mcps)	44 dB	43.8dB

NOTE: The RRC filter shall be equivalent to the transmit pulse shape filter defined in 3GPP TS 25.104 [2], with a chip rate as defined in this table.

Table 6.7.3.5.3.2-2: OTA CACLR in non-contiguous unpaired spectrum or multiple bands

Sub-block or <i>Inter RF Bandwidth gap</i> size (W_{gap}) where the limit applies	BS adjacent channel centre frequency offset below or above the sub-block edge or the <i>Base Station RF Bandwidth edge</i> (inside the gap)	Assumed adjacent channel carrier (informative)	Filter on the adjacent channel frequency and corresponding filter bandwidth	OTA CACLR limit for bands below 3GHz	OTA CACLR limit for bands between 3 and 4.2GHz
$5 \text{ MHz} \leq W_{\text{gap}} < 15 \text{ MHz}$	2.5 MHz	5 MHz E-UTRA carrier	Square (BW_{Config})	44 dB	43.8dB
$10 \text{ MHz} < W_{\text{gap}} < 20 \text{ MHz}$	7.5 MHz	5 MHz E-UTRA carrier	Square (BW_{Config})	44 dB	43.8dB

Table 6.7.3.5.3.2-3: Filter parameters for the assigned channel

RAT of the carrier adjacent to the sub-block or <i>Inter RF Bandwidth gap</i>	Filter on the assigned channel frequency and corresponding filter bandwidth
E-UTRA	E-UTRA of same BW

NOTE: If the above Test Requirement differs from the Minimum Requirement then the Test Tolerance applied for this test is non-zero. The Test Tolerance for this test is defined in subclause 4.1.2 and the explanation of how the Minimum Requirement has been relaxed by the Test Tolerance is given in annex C.

For Category A, an E-UTRA AAS BS of Wide Area BS class, either the OTA CACLR limits in Tables 6.7.3.5.3.2-1/2 or OTA ACLR absolute limit of -4 dBm/MHz shall apply, whichever is less stringent.

For Category B, an E-UTRA AAS BS of Wide Area BS class, either the OTA CACLR limits in Tables 6.7.3.5.3.2-1/2 or OTA ACLR absolute limit of -6 dBm/MHz shall apply, whichever is less stringent.

For an E-UTRA AAS BS of Medium Range BS class, either the OTA CACLR limits in Tables 6.7.3.5.3.2-1/2 or OTA ACLR absolute limit of -16 dBm/MHz shall apply, whichever is less stringent.

For an E-UTRA AAS BS of Local Area BS class, either the OTA CACLR limits in Tables 6.7.3.5.3.2-1/2 or OTA ACLR absolute limit of -23 dBm/MHz shall apply, whichever is less stringent.

6.7.4 OTA Spectrum emission mask

6.7.4.1 Definition and applicability

This requirement is applicable for AAS BS in *single RAT UTRA operation* only.

The spectrum emission mask minimum requirements are quoted as TRP unless otherwise stated.

6.7.4.2 Minimum requirement

For AAS BS in *single RAT UTRA operation* the minimum requirement is defined in TS 37.105 [6], subclause 9.7.4.3.

This requirement does not apply to *single RAT E-UTRA operation* or *MSR operation*.

6.7.4.3 Test purpose

This test measures the emissions of the AAS BS, close to the assigned channel bandwidth of the wanted signal, while the AAS BS is in operation.

6.7.4.4 Method of test

6.7.4.4.1 Initial conditions

6.7.4.4.1.1 General test conditions

Test environment:

- normal; see annex G.2.

RF channels to be tested for single carrier:

- B, M and T; see subclause 4.12.1.

Base Station RF Bandwidth positions to be tested for multi-carrier:

- B_{RFBW} , M_{RFBW} and T_{RFBW} in single-band operation; see subclause 4.12.1; $B_{RFBW_T_{RFBW}}$ and $B'_{RFBW_T_{RFBW}}$ in multi-band operation, see subclause 4.12.1.

6.7.4.4.1.2 UTRA FDD

For an AAS BS declared to be capable of single carrier operation only, set to transmit a signal according to TM1, in subclause 4.12.2.

For a multi-carrier capable AAS BS, set to transmit according to TM1 on all carriers configured using the applicable test configuration.

6.7.4.4.2 Procedure

- 1) Place the AAS BS at the positioner.
- 2) Align the manufacturer declared coordinate system orientation (see table 4.10-1, D9.2) of the AAS BS with the test system.
- 3) Configure the AAS BS such that the beam peak direction(s) applied during the power measurement step 6 are consistent with the grid and measurement approach for the TRP test.

The measurement devices characteristics shall be:

- a 30 kHz measurement bandwidth.
- Measurements with an offset from the carrier centre frequency between 2,515 MHz and 4.0 MHz shall use Measurements with an offset from the carrier centre frequency between 4.0 MHz and ($f_{\text{offset}_{\text{max}}} - 500$ kHz) shall use a 1 MHz measurement bandwidth.
- detection mode: true RMS voltage or true power averaging.

As a general rule, the resolution bandwidth of the measuring equipment should be equal to the measurement bandwidth. However, to improve measurement accuracy, sensitivity, efficiency and avoiding e.g. carrier leakage, the resolution bandwidth may be smaller than the measurement bandwidth. When the resolution bandwidth is smaller than the measurement bandwidth, the result should be integrated over the measurement bandwidth in order to obtain the equivalent noise bandwidth of the measurement bandwidth.

- 4) For single carrier operation, set the AAS BS to transmit according to the applicable test configuration in clause 5 using the corresponding test model(s) in subclause 4.12.2 at manufacturers declared *rated carrier TRP* ($P_{\text{Rated,c,TRP}}$).

For an AAS BS declared to be capable of multi-carrier and/or CA operation use the applicable test signal configuration and corresponding power setting specified in subclause 4.11.

- 5) For UTRA FDD *multi-band RIB* or *RIB* operating in non-contiguous spectrum, the emission within the Inter RF Bandwidth or sub-block gap shall be measured using the specified measurement bandwidth from the closest *Base Station RF Bandwidth* or sub block edge.

In addition, for *multi-band RIB*, the following steps shall apply:

- 6) For *multi-band RIB* and single band tests, repeat the steps above per involved band where single band test configurations and test models shall apply with no carrier activated in the other band.
- 7) Align the BS and the test antenna such that measurements to determine TRP can be performed (see Annex xx)
- 8) Sweep the centre frequency of the measurement filter in contiguous steps and measure emission power within the specified frequency ranges with the specified measurement bandwidth.
- 9) Repeat step 8-9 for all directions in the appropriated TRP measurement grid needed for $\text{TRP}_{\text{Estimate}}$ (see Annex F).
- 10) Calculate $\text{TRP}_{\text{Estimate}}$ using the measurements made in Step 7.

6.7.4.5 Test Requirement

6.7.4.5.1 UTRA FDD

The measurement result shall not exceed the test requirements specified in Tables 6.7.4.5.1-1 to 6.7.4.5.1-11 for the appropriate $P_{\text{rated,c,TRP}}$, where

- Δf is the separation between the carrier frequency and the nominal -3 dB point of the measuring filter closest to the carrier frequency.
- f_{offset} is the separation between the carrier frequency and the centre of the measurement filter;
- $f_{\text{offset,max}}$ is either 12.5 MHz or the offset to the UMTS Tx band edge as defined in clause 3.4.1, whichever is the greater.
- Δf_{max} is equal to $f_{\text{offset,max}}$ minus half of the bandwidth of the measuring filter.

Inside any *Inter RF Bandwidth gaps* with $W_{\text{gap}} < 2 \times \Delta f_{\text{OBUE}}$ for a *multi-band RIB*, emissions shall not exceed the cumulative sum of the *minimum requirements* specified at the *Base Station RF Bandwidth edges* on each side of the *Inter RF Bandwidth gap*. The *minimum requirements* for *Base Station RF Bandwidth edge* is specified in tables 9.7.3.4.2-1 to 9.7.3.4.2-10 below, where in this case:

- Δf is equal to 2.5MHz plus the separation between the *Base Station RF Bandwidth edge* frequency and the nominal -3dB point of the measuring filter closest to the *Base Station RF Bandwidth edge*.
- f_{offset} is equal to 2.5MHz plus the separation between the *Base Station RF Bandwidth edge* frequency and the centre of the measuring filter.
- $f_{\text{offset,max}}$ is either 12.5 MHz or the offset to the UMTS Tx band edge as defined in section 5.2, whichever is the greater.
- Δf_{max} is equal to $f_{\text{offset,max}}$ minus half of the bandwidth of the measuring filter.

For a *multi-band RIB*, the operating band unwanted emission minimum requirements apply also in a supported operating band without any carrier transmitted, in the case where there are carrier(s) transmitted in another supported operating band. In this case, no cumulative limit is applied in the *inter-band gap* between a supported *downlink operating band* with carrier(s) transmitted and a supported *downlink operating band* without any carrier transmitted and

- In case the *inter-band gap* between a downlink band with carrier(s) transmitted and a downlink band without any carrier transmitted is less than $2 \times \Delta f_{\text{OBUE}}$, $f_{\text{offset,max}}$ shall be the offset to the frequency Δf_{OBUE} outside the outermost edges of the two *downlink operating bands* and the operating band unwanted emission limit of the band where there are carriers transmitted, as defined in the tables of the present subclause, shall apply across both downlink bands.
- In other cases, the operating band unwanted emission limit of the band where there are carriers transmitted, as defined in the tables of the present subclause for the largest frequency offset (Δf_{max}), shall apply from Δf_{OBUE} below the lowest frequency, up to Δf_{OBUE} above the highest frequency of the *downlink operating band* without any carrier transmitted.

Inside any *sub-block gap* for a RIB operating in *non-contiguous spectrum*, emissions shall not exceed the cumulative sum of the *minimum requirements* specified for the adjacent sub blocks on each side of the *sub-block gap*. The *minimum requirement* for each sub block is specified in Tables 6.7.4.5.1-1 to 6.7.4.5.1-11 below, where in this case:

- Δf is equal to 2.5MHz plus the separation between the sub block edge frequency and the nominal -3 dB point of the measuring filter closest to the sub block edge.
- f_{offset} is equal to 2.5MHz plus the separation between the sub block edge frequency and the centre of the measuring filter.
- $f_{\text{offset,max}}$ is equal to the *sub-block gap* bandwidth minus half of the bandwidth of the measuring filter plus 2.5MHz.
- Δf_{max} is equal to $f_{\text{offset,max}}$ minus half of the bandwidth of the measuring filter.

Table 6.7.4.5.1-1: Spectrum emission mask values, $P_{\max,c,TRP} \geq 49$ dBm for UTRA FDD bands ≤ 3 GHz

Frequency offset of measurement filter - 3 dB point, Δf	Frequency offset of measurement filter centre frequency, f_{offset}	Test requirement (notes 1 and 2)	Measurement bandwidth (Note 5)
$2.5 \text{ MHz} \leq \Delta f < 2.7 \text{ MHz}$	$2.515 \text{ MHz} \leq f_{\text{offset}} < 2.715 \text{ MHz}$	-6.2 dBm	30 kHz
$2.7 \text{ MHz} \leq \Delta f < 3.5 \text{ MHz}$	$2.715 \text{ MHz} \leq f_{\text{offset}} < 3.515 \text{ MHz}$	$-6.2 + 15 \cdot (f_{\text{offset}}/\text{MHz} - 2.715) \text{ dBm}$	30 kHz
(Note 4)	$3.515 \text{ MHz} \leq f_{\text{offset}} < 4.0 \text{ MHz}$	-18.2 dBm	30 kHz
$3.5 \text{ MHz} \leq \Delta f < 7.5 \text{ MHz}$	$4.0 \text{ MHz} \leq f_{\text{offset}} < 8.0 \text{ MHz}$	-5.2 dBm	1 MHz
$7.5 \text{ MHz} \leq \Delta f \leq \Delta f_{\max}$	$8.0 \text{ MHz} \leq f_{\text{offset}} < f_{\text{offset}_{\max}}$	-5.2 dBm	1 MHz
<p>NOTE 1: For a <i>RIB</i> supporting non-contiguous spectrum operation the test requirement within sub-block gaps within any operating band is calculated as a cumulative sum of contributions from adjacent sub blocks on each side of the sub block gap, where the contribution from the far-end sub-block shall be scaled according to the measurement bandwidth of the near-end sub-block. Exception is $\Delta f \geq 12.5$ MHz from both adjacent sub blocks on each side of the sub-block gap, where the spurious emission <i>test requirement</i> in subclauses 6.7.6 shall be met.</p> <p>NOTE 2: For a <i>multi-band RIB</i> with <i>Inter RF Bandwidth gap</i> $< 2 \times \Delta f_{\text{OBUE}}$ the test requirement within the <i>Inter RF Bandwidth gaps</i> is calculated as a cumulative sum of contributions from adjacent sub-blocks or RF Bandwidth on each side of the <i>Inter RF Bandwidth gap</i>, where the contribution from the far-end sub-block or <i>Base Station RF Bandwidth</i> shall be scaled according to the measurement bandwidth of the near-end sub-block or <i>Base Station RF Bandwidth</i>.</p> <p>NOTE 4: This frequency range ensures that the range of values of f_{offset} is continuous.</p> <p>NOTE 5: As a general rule, the resolution bandwidth of the measuring equipment should be equal to the measurement bandwidth. However, to improve measurement accuracy, sensitivity and efficiency, the resolution bandwidth can be smaller than the measurement bandwidth. When the resolution bandwidth is smaller than the measurement bandwidth, the result should be integrated over the measurement bandwidth in order to obtain the equivalent noise bandwidth of the measurement bandwidth.</p>			

Table 6.7.4.5.1-2: Spectrum emission mask values, $P_{\max,c,TRP} \geq 49$ dBm for UTRA FDD bands > 3 GHz

Frequency offset of measurement filter -3 dB point, Δf	Frequency offset of measurement filter centre frequency, f_{offset}	Test requirement (notes 1 and 2)	Measurement bandwidth (Note 5)
$2.5 \text{ MHz} \leq \Delta f < 2.7 \text{ MHz}$	$2.515 \text{ MHz} \leq f_{\text{offset}} < 2.715 \text{ MHz}$	-6 dBm	30 kHz
$2.7 \text{ MHz} \leq \Delta f < 3.5 \text{ MHz}$	$2.715 \text{ MHz} \leq f_{\text{offset}} < 3.515 \text{ MHz}$	$-6 + 15 \cdot (f_{\text{offset}}/\text{MHz} - 2.715) \text{ dBm}$	30 kHz
(Note 4)	$3.515 \text{ MHz} \leq f_{\text{offset}} < 4.0 \text{ MHz}$	-18 dBm	30 kHz
$3.5 \text{ MHz} \leq \Delta f < 7.5 \text{ MHz}$	$4.0 \text{ MHz} \leq f_{\text{offset}} < 8.0 \text{ MHz}$	-5 dBm	1 MHz
$7.5 \text{ MHz} \leq \Delta f \leq \Delta f_{\max}$	$8.0 \text{ MHz} \leq f_{\text{offset}} < f_{\text{offset}_{\max}}$	-5 dBm	1 MHz

NOTE 1: For a *RIB* supporting non-contiguous spectrum operation the test requirement within sub-block gaps within any operating band is calculated as a cumulative sum of contributions from adjacent sub blocks on each side of the sub block gap, where the contribution from the far-end sub-block shall be scaled according to the measurement bandwidth of the near-end sub-block. Exception is $\Delta f \geq 12.5$ MHz from both adjacent sub blocks on each side of the sub-block gap, where the spurious emission *test requirement* in clause 6.7.6 shall be met.

NOTE 2: For a *multi-band RIB* with *Inter RF Bandwidth gap* $< 2 \times \Delta f_{\text{OBUE}}$ the test requirement within the *Inter RF Bandwidth gaps* is calculated as a cumulative sum of contributions from adjacent sub-blocks or *Base Station RF Bandwidth* on each side of the *Inter RF Bandwidth gap*, where the contribution from the far-end sub-block or *Base Station RF Bandwidth* shall be scaled according to the measurement bandwidth of the near-end sub-block or *Base Station RF Bandwidth*.

NOTE 4: This frequency range ensures that the range of values of f_{offset} is continuous.

NOTE 5: As a general rule, the resolution bandwidth of the measuring equipment should be equal to the measurement bandwidth. However, to improve measurement accuracy, sensitivity and efficiency, the resolution bandwidth can be smaller than the measurement bandwidth. When the resolution bandwidth is smaller than the measurement bandwidth, the result should be integrated over the measurement bandwidth in order to obtain the equivalent noise bandwidth of the measurement bandwidth.

Table 6.7.4.5.1-3: Spectrum emission mask values, $45 \text{ dBm} \leq P_{\text{rated,c,TRP}} < 49 \text{ dBm}$ for UTRA FDD bands $\leq 3 \text{ GHz}$

Frequency offset of measurement filter -3 dB point, Δf	Frequency offset of measurement filter centre frequency, f_{offset}	Test requirement (notes 1 and 2)	Measurement bandwidth (Note 5)
$2.5 \text{ MHz} \leq \Delta f < 2.7 \text{ MHz}$	$2.515 \text{ MHz} \leq f_{\text{offset}} < 2.715 \text{ MHz}$	-6.2 dBm	30 kHz
$2.7 \text{ MHz} \leq \Delta f < 3.5 \text{ MHz}$	$2.715 \text{ MHz} \leq f_{\text{offset}} < 3.515 \text{ MHz}$	$-6.2 + 15(f_{\text{offset}}/\text{MHz} - 2.715) \text{ dBm}$	30 kHz
(Note 4)	$3.515 \text{ MHz} \leq f_{\text{offset}} < 4.0 \text{ MHz}$	-18.2 dBm	30 kHz
$3.5 \text{ MHz} \leq \Delta f < 7.5 \text{ MHz}$	$4.0 \text{ MHz} \leq f_{\text{offset}} < 8.0 \text{ MHz}$	-5.2 dBm	1 MHz
$7.5 \text{ MHz} \leq \Delta f \leq \Delta f_{\text{max}}$	$8.0 \text{ MHz} \leq f_{\text{offset}} < f_{\text{offset}_{\text{max}}}$	$P_{\text{rated,c,TRP}} - 54.2 \text{ dB}$	1 MHz

NOTE 1: For a *RIB* supporting non-contiguous spectrum operation the *test requirement* within sub-block gaps within any operating band is calculated as a cumulative sum of contributions from adjacent sub blocks on each side of the sub block gap, where the contribution from the far-end sub-block shall be scaled according to the measurement bandwidth of the near-end sub-block. Exception is $\Delta f \geq 12.5 \text{ MHz}$ from both adjacent sub blocks on each side of the sub-block gap, where the spurious emission *test requirement* in subclauses 6.7.6 shall be met.

NOTE 2: For a *multi-band RIB* with *Inter RF Bandwidth gap* $< 2 \times \Delta f_{\text{OBUE}}$ the test requirement within the *Inter RF Bandwidth gaps* is calculated as a cumulative sum of contributions from adjacent sub-blocks or *Base Station RF Bandwidth* on each side of the *Inter RF Bandwidth gap*, where the contribution from the far-end sub-block or *Base Station RF Bandwidth* shall be scaled according to the measurement bandwidth of the near-end sub-block or *Base Station RF Bandwidth*.

NOTE 4: This frequency range ensures that the range of values of f_{offset} is continuous.

NOTE 5: As a general rule, the resolution bandwidth of the measuring equipment should be equal to the measurement bandwidth. However, to improve measurement accuracy, sensitivity and efficiency, the resolution bandwidth can be smaller than the measurement bandwidth. When the resolution bandwidth is smaller than the measurement bandwidth, the result should be integrated over the measurement bandwidth in order to obtain the equivalent noise bandwidth of the measurement bandwidth.

Table 6.7.4.5.1-4: Spectrum emission mask values, $45 \text{ dBm} \leq P_{\text{rated,c,TRP}} < 49 \text{ dBm}$ for UTRA FDD bands $> 3 \text{ GHz}$

Frequency offset of measurement filter -3 dB point, Δf	Frequency offset of measurement filter centre frequency, f_{offset}	Test requirement (notes 1 and 2)	Measurement bandwidth (Note 5)
$2.5 \text{ MHz} \leq \Delta f < 2.7 \text{ MHz}$	$2.515 \text{ MHz} \leq f_{\text{offset}} < 2.715 \text{ MHz}$	-6 dBm	30 kHz
$2.7 \text{ MHz} \leq \Delta f < 3.5 \text{ MHz}$	$2.715 \text{ MHz} \leq f_{\text{offset}} < 3.515 \text{ MHz}$	$-6 + 15(f_{\text{offset}}/\text{MHz} - 2.715) \text{ dBm}$	30 kHz
(Note 4)	$3.515 \text{ MHz} \leq f_{\text{offset}} < 4.0 \text{ MHz}$	-18 dBm	30 kHz
$3.5 \text{ MHz} \leq \Delta f < 7.5 \text{ MHz}$	$4.0 \text{ MHz} \leq f_{\text{offset}} < 8.0 \text{ MHz}$	-5 dBm	1 MHz
$7.5 \text{ MHz} \leq \Delta f \leq \Delta f_{\text{max}}$	$8.0 \text{ MHz} \leq f_{\text{offset}} < f_{\text{offset}_{\text{max}}}$	$P_{\text{rated,c,TRP}} - 54 \text{ dB}$	1 MHz
<p>NOTE 1: For a <i>RIB</i> supporting non-contiguous spectrum operation the <i>test requirement</i> within sub-block gaps within any operating band is calculated as a cumulative sum of contributions from adjacent sub blocks on each side of the sub block gap, where the contribution from the far-end sub-block shall be scaled according to the measurement bandwidth of the near-end sub-block. Exception is $\Delta f \geq 12.5 \text{ MHz}$ from both adjacent sub blocks on each side of the sub-block gap, where the spurious emission <i>test requirement</i> in clause 6.7.6 shall be met.</p> <p>NOTE 2: For a <i>multi-band RIB</i> with <i>Inter RF Bandwidth gap</i> $< 2 \times \Delta f_{\text{OBUE}}$ the <i>test requirement</i> within the <i>Inter RF Bandwidth gaps</i> is calculated as a cumulative sum of contributions from adjacent sub-blocks or <i>Base Station RF Bandwidth</i> on each side of the <i>Inter RF Bandwidth gap</i>, where the contribution from the far-end sub-block or <i>Base Station RF Bandwidth</i> shall be scaled according to the measurement bandwidth of the near-end sub-block or <i>Base Station RF Bandwidth</i>.</p> <p>NOTE 4: This frequency range ensures that the range of values of f_{offset} is continuous.</p> <p>NOTE 5: As a general rule, the resolution bandwidth of the measuring equipment should be equal to the measurement bandwidth. However, to improve measurement accuracy, sensitivity and efficiency, the resolution bandwidth can be smaller than the measurement bandwidth. When the resolution bandwidth is smaller than the measurement bandwidth, the result should be integrated over the measurement bandwidth in order to obtain the equivalent noise bandwidth of the measurement bandwidth.</p>			

Table 6.7.4.5.1-5: Spectrum emission mask values, $37 \text{ dBm} \leq P_{\text{rated,c,TRP}} < 45 \text{ dBm}$ for UTRA FDD bands $\leq 3 \text{ GHz}$

Frequency offset of measurement filter - 3 dB point, Δf	Frequency offset of measurement filter centre frequency, f_{offset}	Test requirement (notes 1 and 2)	Measurement bandwidth (Note 5)
$2.5 \text{ MHz} \leq \Delta f < 2.7 \text{ MHz}$	$2.515 \text{ MHz} \leq f_{\text{offset}} < 2.715 \text{ MHz}$	$P_{\text{rated,c,TRP}} - 51.2 \text{ dB}$	30 kHz
$2.7 \text{ MHz} \leq \Delta f < 3.5 \text{ MHz}$	$2.715 \text{ MHz} \leq f_{\text{offset}} < 3.515 \text{ MHz}$	$P_{\text{rated,c,TRP}} - 51.2 - 15(f_{\text{offset}}/\text{MHz} - 2.715) \text{ dB}$	30 kHz
(Note 4)	$3.515 \text{ MHz} \leq f_{\text{offset}} < 4.0 \text{ MHz}$	$P_{\text{rated,c,TRP}} - 63.2 \text{ dB}$	30 kHz
$3.5 \text{ MHz} \leq \Delta f < 7.5 \text{ MHz}$	$4.0 \text{ MHz} \leq f_{\text{offset}} < 8.0 \text{ MHz}$	$P_{\text{rated,c,TRP}} - 50.2 \text{ dB}$	1 MHz
$7.5 \text{ MHz} \leq \Delta f \leq \Delta f_{\text{max}}$	$8.0 \text{ MHz} \leq f_{\text{offset}} < f_{\text{offset}_{\text{max}}}$	$P_{\text{rated,c,TRP}} - 54.2 \text{ dB}$	1 MHz
<p>NOTE 1: For a <i>RIB</i> supporting non-contiguous spectrum operation the <i>test requirement</i> within sub-block gaps within any operating band is calculated as a cumulative sum of contributions from adjacent sub blocks on each side of the sub block gap, where the contribution from the far-end sub-block shall be scaled according to the measurement bandwidth of the near-end sub-block. Exception is $\Delta f \geq 12.5 \text{ MHz}$ from both adjacent sub blocks on each side of the sub-block gap, where the spurious emission <i>test requirement</i> in subclauses 6.7.6 shall be met.</p> <p>NOTE 2: For a <i>multi-band RIB</i> with <i>Inter RF Bandwidth gap</i> $< 2 \times \Delta f_{\text{OBUE}}$ the test requirement within the <i>Inter RF Bandwidth gaps</i> is calculated as a cumulative sum of contributions from adjacent sub-blocks or <i>Base Station RF Bandwidth</i> on each side of the <i>Inter RF Bandwidth gap</i>, where the contribution from the far-end sub-block or <i>Base Station RF Bandwidth</i> shall be scaled according to the measurement bandwidth of the near-end sub-block or <i>Base Station RF Bandwidth</i>.</p> <p>NOTE 4: This frequency range ensures that the range of values of f_{offset} is continuous.</p> <p>NOTE 5: As a general rule, the resolution bandwidth of the measuring equipment should be equal to the measurement bandwidth. However, to improve measurement accuracy, sensitivity and efficiency, the resolution bandwidth can be smaller than the measurement bandwidth. When the resolution bandwidth is smaller than the measurement bandwidth, the result should be integrated over the measurement bandwidth in order to obtain the equivalent noise bandwidth of the measurement bandwidth.</p>			

Table 6.7.4.5.1-6: Spectrum emission mask values, $37 \text{ dBm} \leq P_{\text{rated,c,TRP}} < 45 \text{ dBm}$ for UTRA FDD bands $> 3 \text{ GHz}$

Frequency offset of measurement filter - 3 dB point, Δf	Frequency offset of measurement filter centre frequency, f_{offset}	Test requirement (notes 1 and 2)	Measurement bandwidth (Note 5)
$2.5 \text{ MHz} \leq \Delta f < 2.7 \text{ MHz}$	$2.515 \text{ MHz} \leq f_{\text{offset}} < 2.715 \text{ MHz}$	$P_{\text{rated,c,TRP}} - 51 \text{ dB}$	30 kHz
$2.7 \text{ MHz} \leq \Delta f < 3.5 \text{ MHz}$	$2.715 \text{ MHz} \leq f_{\text{offset}} < 3.515 \text{ MHz}$	$P_{\text{rated,c,TRP}} - 51 - 15(f_{\text{offset}}/\text{MHz} - 2.715) \text{ dB}$	30 kHz
(Note 4)	$3.515 \text{ MHz} \leq f_{\text{offset}} < 4.0 \text{ MHz}$	$P_{\text{rated,c,TRP}} - 63 \text{ dB}$	30 kHz
$3.5 \text{ MHz} \leq \Delta f < 7.5 \text{ MHz}$	$4.0 \text{ MHz} \leq f_{\text{offset}} < 8.0 \text{ MHz}$	$P_{\text{rated,c,TRP}} - 50 \text{ dB}$	1 MHz
$7.5 \text{ MHz} \leq \Delta f \leq \Delta f_{\text{max}}$	$8.0 \text{ MHz} \leq f_{\text{offset}} < f_{\text{offset}_{\text{max}}}$	$P_{\text{rated,c,TRP}} - 54 \text{ dB}$	1 MHz
<p>NOTE 1: For a <i>RIB</i> supporting non-contiguous spectrum operation the <i>test requirement</i> within sub-block gaps within any operating band is calculated as a cumulative sum of contributions from adjacent sub blocks on each side of the sub block gap, where the contribution from the far-end sub-block shall be scaled according to the measurement bandwidth of the near-end sub-block. Exception is $\Delta f \geq 12.5 \text{ MHz}$ from both adjacent sub blocks on each side of the sub-block gap, where the spurious emission <i>test requirement</i> in subclauses 6.7.6 shall be met.</p> <p>NOTE 2: For a <i>multi-band RIB</i> with <i>Inter RF Bandwidth gap</i> $< 2 \times \Delta f_{\text{OBUE}}$ the test requirement within the <i>Inter RF Bandwidth gaps</i> is calculated as a cumulative sum of contributions from adjacent sub-blocks or <i>Base Station RF Bandwidth</i> on each side of the <i>Inter RF Bandwidth gap</i>, where the contribution from the far-end sub-block or <i>Base Station RF Bandwidth</i> shall be scaled according to the measurement bandwidth of the near-end sub-block or <i>Base Station RF Bandwidth</i>.</p> <p>NOTE 4: This frequency range ensures that the range of values of f_{offset} is continuous.</p> <p>NOTE 5: As a general rule, the resolution bandwidth of the measuring equipment should be equal to the measurement bandwidth. However, to improve measurement accuracy, sensitivity and efficiency, the resolution bandwidth can be smaller than the measurement bandwidth. When the resolution bandwidth is smaller than the measurement bandwidth, the result should be integrated over the measurement bandwidth in order to obtain the equivalent noise bandwidth of the measurement bandwidth.</p>			

Table 6.7.4.5.1-7: Spectrum emission mask values, $P_{\text{rated,c,TRP}} < 37$ dBm for UTRA FDD bands ≤ 3 GHz

Frequency offset of measurement filter - 3 dB point, Δf	Frequency offset of measurement filter centre frequency, f_{offset}	Test requirement (Notes 1 and 2)	Measurement bandwidth (Note 5)
$2.5 \text{ MHz} \leq \Delta f < 2.7 \text{ MHz}$	$2.515 \text{ MHz} \leq f_{\text{offset}} < 2.715 \text{ MHz}$	-14.2 dBm	30 kHz
$2.7 \leq \Delta f < 3.5 \text{ MHz}$	$2.715 \text{ MHz} \leq f_{\text{offset}} < 3.515 \text{ MHz}$	$-14.2 \text{ dBm} - 15(f_{\text{offset}}/\text{MHz} - 2.715)\text{dB}$	30 kHz
(Note 4)	$3.515 \text{ MHz} \leq f_{\text{offset}} < 4.0 \text{ MHz}$	-26.2 dBm	30 kHz
$3.5 \text{ MHz} \leq \Delta f < 7.5 \text{ MHz}$	$4.0 \text{ MHz} \leq f_{\text{offset}} < 8.0 \text{ MHz}$	-13.2 dBm	1 MHz
$7.5 \text{ MHz} \leq \Delta f \leq \Delta f_{\text{max}}$	$8.0 \text{ MHz} \leq f_{\text{offset}} < f_{\text{offset}_{\text{max}}}$	-17.2 dBm	1 MHz

NOTE 1: For RIB supporting non-contiguous spectrum operation the *test requirement* within sub-block gaps within any operating band is calculated as a cumulative sum of contributions from adjacent sub blocks on each side of the sub block gap, where the contribution from the far-end sub-block shall be scaled according to the measurement bandwidth of the near-end sub-block. Exception is $\Delta f \geq 12.5$ MHz from both adjacent sub blocks on each side of the sub-block gap, where the spurious emission *test requirement* in subclauses 6.7.6 shall be met.

NOTE 2: For a *multi-band RIB* with *Inter RF Bandwidth gap* $< 2 \times \Delta f_{\text{OBUE}}$ the test requirement within the *Inter RF Bandwidth gaps* is calculated as a cumulative sum of contributions from adjacent sub-blocks or *Base Station RF Bandwidth* on each side of the *Inter RF Bandwidth gap*, where the contribution from the far-end sub-block or *Base Station RF Bandwidth* shall be scaled according to the measurement bandwidth of the near-end sub-block or *Base Station RF Bandwidth*.

NOTE 4: This frequency range ensures that the range of values of f_{offset} is continuous.

NOTE 5: As a general rule, the resolution bandwidth of the measuring equipment should be equal to the measurement bandwidth. However, to improve measurement accuracy, sensitivity and efficiency, the resolution bandwidth can be smaller than the measurement bandwidth. When the resolution bandwidth is smaller than the measurement bandwidth, the result should be integrated over the measurement bandwidth in order to obtain the equivalent noise bandwidth of the measurement bandwidth.

Table 6.7.4.5.1-8: Spectrum emission mask values, $P_{\text{rated,c,TRP}} < 37$ dBm for UTRA FDD bands > 3 GHz

Frequency offset of measurement filter - 3 dB point, Δf	Frequency offset of measurement filter centre frequency, f_{offset}	Test requirement (notes 1 and 2)	Measurement bandwidth (Note 5)
$2.5 \text{ MHz} \leq \Delta f < 2.7 \text{ MHz}$	$2.515 \text{ MHz} \leq f_{\text{offset}} < 2.715 \text{ MHz}$	-14 dBm	30 kHz
$2.7 \leq \Delta f < 3.5 \text{ MHz}$	$2.715 \text{ MHz} \leq f_{\text{offset}} < 3.515 \text{ MHz}$	$-14 \text{ dBm} - 15(f_{\text{offset}}/\text{MHz} - 2.715)\text{dB}$	30 kHz
(Note 4)	$3.515 \text{ MHz} \leq f_{\text{offset}} < 4.0 \text{ MHz}$	-26 dBm	30 kHz
$3.5 \text{ MHz} \leq \Delta f < 7.5 \text{ MHz}$	$4.0 \text{ MHz} \leq f_{\text{offset}} < 8.0 \text{ MHz}$	-13 dBm	1 MHz
$7.5 \text{ MHz} \leq \Delta f \leq \Delta f_{\text{max}}$	$8.0 \text{ MHz} \leq f_{\text{offset}} < f_{\text{offset}_{\text{max}}}$	-17 dBm	1 MHz

NOTE 1: For a *RIB* supporting non-contiguous spectrum operation the test *requirement* within sub-block gaps within any operating band is calculated as a cumulative sum of contributions from adjacent sub blocks on each side of the sub block gap, where the contribution from the far-end sub-block shall be scaled according to the measurement bandwidth of the near-end sub-block. Exception is $\Delta f \geq 12.5$ MHz from both adjacent sub blocks on each side of the sub-block gap, where the spurious emission *test requirement* in subclauses 6.7.6 shall be met.

NOTE 2: For a *multi-band RIB* with *Inter RF Bandwidth gap* $< 2 \times \Delta f_{\text{OBUe}}$ the test requirement within the *Inter RF Bandwidth gaps* is calculated as a cumulative sum of contributions from adjacent sub-blocks or *Base Station RF Bandwidth* on each side of the *Inter RF Bandwidth gap*, where the contribution from the far-end sub-block or *Base Station RF Bandwidth* shall be scaled according to the measurement bandwidth of the near-end sub-block or *Base Station RF Bandwidth*.

NOTE 4: This frequency range ensures that the range of values of f_{offset} is continuous.

NOTE 5: As a general rule, the resolution bandwidth of the measuring equipment should be equal to the measurement bandwidth. However, to improve measurement accuracy, sensitivity and efficiency, the resolution bandwidth can be smaller than the measurement bandwidth. When the resolution bandwidth is smaller than the measurement bandwidth, the result should be integrated over the measurement bandwidth in order to obtain the equivalent noise bandwidth of the measurement bandwidth.

For operation in band II, IV, V, X, XII, XIII, XIV, XXV and XXVI, the applicable additional requirement in tables 6.7.4.5.1-9 to 6.7.4.5.1-11 apply in addition to the test requirements in tables 6.7.4.5.1-1 to 6.7.4.5.1-8.

Table 6.7.4.5.1-9: Additional spectrum emission limits for Bands II, IV, X, XXV

Frequency offset of measurement filter -3dB point, Δf	Frequency offset of measurement filter centre frequency, f_{offset}	Additional requirement	Measurement bandwidth (Note 5)
$2.5 \text{ MHz} \leq \Delta f < 3.5 \text{ MHz}$	$2.515 \text{ MHz} \leq f_{\text{offset}} < 3.515 \text{ MHz}$	-7.2 dBm	30 kHz
$3.5 \text{ MHz} \leq \Delta f \leq \Delta f_{\text{max}}$	$4.0 \text{ MHz} \leq f_{\text{offset}} < f_{\text{offset}_{\text{max}}}$	-5.2 dBm	1 MHz

NOTE 5: As a general rule, the resolution bandwidth of the measuring equipment should be equal to the measurement bandwidth. However, to improve measurement accuracy, sensitivity and efficiency, the resolution bandwidth can be smaller than the measurement bandwidth. When the resolution bandwidth is smaller than the measurement bandwidth, the result should be integrated over the measurement bandwidth in order to obtain the equivalent noise bandwidth of the measurement bandwidth.

Table 6.7.4.5.1-10: Additional spectrum emission limits for Bands V, XXVI

Frequency offset of measurement filter -3dB point, Δf	Frequency offset of measurement filter centre frequency, f_{offset}	Additional requirement	Measurement bandwidth (Note 5)
$2.5 \text{ MHz} \leq \Delta f < 3.5 \text{ MHz}$	$2.515 \text{ MHz} \leq f_{\text{offset}} < 3.515 \text{ MHz}$	-7.2 dBm	30 kHz
$3.5 \text{ MHz} \leq \Delta f \leq \Delta f_{\text{max}}$	$3.55 \text{ MHz} \leq f_{\text{offset}} < f_{\text{offset}_{\text{max}}}$	-5.2 dBm	100 kHz

NOTE 5: As a general rule, the resolution bandwidth of the measuring equipment should be equal to the measurement bandwidth. However, to improve measurement accuracy, sensitivity and efficiency, the resolution bandwidth can be smaller than the measurement bandwidth. When the resolution bandwidth is smaller than the measurement bandwidth, the result should be integrated over the measurement bandwidth in order to obtain the equivalent noise bandwidth of the measurement bandwidth.

Table 6.7.4.5.1-11: Additional spectrum emission limits for Bands XII, XIII, XIV

Frequency offset of measurement filter -3dB point, Δf	Frequency offset of measurement filter centre frequency, f_{offset}	Additional requirement	Measurement bandwidth (Note 5)
$2.5 \text{ MHz} \leq \Delta f < 2.6 \text{ MHz}$	$2.515 \text{ MHz} \leq f_{\text{offset}} < 2.615 \text{ MHz}$	-5.2 dBm	30 kHz
$2.6 \text{ MHz} \leq \Delta f \leq \Delta f_{\text{max}}$	$2.65 \text{ MHz} \leq f_{\text{offset}} < f_{\text{offset}_{\text{max}}}$	-5.2 dBm	100 kHz

NOTE 5: As a general rule, the resolution bandwidth of the measuring equipment should be equal to the measurement bandwidth. However, to improve measurement accuracy, sensitivity and efficiency, the resolution bandwidth can be smaller than the measurement bandwidth. When the resolution bandwidth is smaller than the measurement bandwidth, the result should be integrated over the measurement bandwidth in order to obtain the equivalent noise bandwidth of the measurement bandwidth.

In certain regions the following test requirement may apply for protection of DTT. For a *RIB* operating in Band XX, the level of emissions in the band 470-790 MHz, measured in an 8MHz filter bandwidth on centre frequencies F_{filter} according to Table 6.7.4.5.1-12, shall not exceed the maximum emission level TRP in Table 6.7.4.5.1-12.

Table 6.7.4.5.1-12: Emissions levels for protection of DTT

Case	Measurement filter centre frequency	Condition on BS maximum aggregate EIRP / 10 MHz, $P_{\text{EIRP}_{10\text{MHz}}}$ (NOTE)	Maximum Level $P_{\text{EIRP},N,\text{MAX}}$	Measurement Bandwidth
A: for DTT frequencies where broadcasting is protected	$N*8 + 306 \text{ MHz}$, $21 \leq N \leq 60$	$P_{\text{EIRP}_{10\text{MHz}}} \geq 59 \text{ dBm}$	1.8 dBm	8 MHz
	$N*8 + 306 \text{ MHz}$, $21 \leq N \leq 60$	$36 \leq P_{\text{EIRP}_{10\text{MHz}}} < 59 \text{ dBm}$	$P_{\text{EIRP}_{10\text{MHz}}} - 57.2 \text{ dBm}$	8 MHz
	$N*8 + 306 \text{ MHz}$, $21 \leq N \leq 60$	$P_{\text{EIRP}_{10\text{MHz}}} < 36 \text{ dBm}$	-21.2 dBm	8 MHz
B: for DTT frequencies where broadcasting is subject to an intermediate level of protection	$N*8 + 306 \text{ MHz}$, $21 \leq N \leq 60$	$P_{\text{EIRP}_{10\text{MHz}}} \geq 59 \text{ dBm}$	11.8 dBm	8 MHz
	$N*8 + 306 \text{ MHz}$, $21 \leq N \leq 60$	$36 \leq P_{\text{EIRP}_{10\text{MHz}}} < 59 \text{ dBm}$	$P_{\text{EIRP}_{10\text{MHz}}} - 47.2 \text{ dBm}$	8 MHz
	$N*8 + 306 \text{ MHz}$, $21 \leq N \leq 60$	$P_{\text{EIRP}_{10\text{MHz}}} < 36 \text{ dBm}$	-11.2 dBm	8 MHz
C: for DTT frequencies where broadcasting is not protected	$N*8 + 306 \text{ MHz}$, $21 \leq N \leq 60$	N.A.	23.8 dBm	8 MHz

NOTE: $P_{\text{EIRP}_{10\text{MHz}}}$ (dBm) is defined by the expression $P_{\text{EIRP}_{10\text{MHz}}} = P_{10\text{MHz}} + G_{\text{ant}} + 6\text{dB}$ for UTRA and $P_{\text{EIRP}_{10\text{MHz}}} = P_{10\text{MHz}} + G_{\text{ant}} + 9\text{dB}$ for E-UTRA, where G_{ant} is [17] dBi

NOTE 1: The regional requirement is defined in terms of EIRP (effective isotropic radiated power), which is dependent on both the BS emissions at the antenna connector and the deployment (including antenna gain and feeder loss). The method outlined in annex B1, TS 37.105 [6] indicates how the limit in Table 6.7.4.5.1-12 demonstrates compliance to the regional requirement

In certain regions, the following test requirements may apply to a *RIB* operating in Band XXXII within 1452-1492 MHz. The level of unwanted emissions, measured on centre frequencies f_{offset} with filter bandwidth, according to Table 6.7.4.5.1-13, shall not exceed the maximum TRP limits indicated in the table.

Table 6.7.4.5.1-13: Declared frequency band XXXII unwanted emission within 1452-1492 MHz

Frequency offset of measurement filter centre frequency, f_{offset}	Maximum level (dBm)	Measurement bandwidth
5 MHz	$P_{\text{EIRP}} - 17 \text{ dBi} + 7.8 \text{ dB}$	5 MHz
10 MHz	$P_{\text{EIRP}} - 17 \text{ dBi} + 7.8 \text{ dB}$	5 MHz
$15 \text{ MHz} \leq f_{\text{offset}} \leq f_{\text{offset}_{\text{max, B32}}}$	$P_{\text{EIRP}} - 17 \text{ dBi} + 7.8 \text{ dB}$	5 MHz
NOTE: $f_{\text{offset}_{\text{max, B32}}}$ denotes the frequency difference between the lower channel carrier frequency and 1454.5 MHz, and the frequency difference between the upper channel carrier frequency and 1489.5 MHz for the set channel position.		

NOTE 2: The regional requirement, included in CEPT ECC Decision (13)03 [xx], is defined in terms of EIRP per antenna, which is dependent on both the BS emissions at the antenna connector and the deployment (including antenna gain and feeder loss). The method outlined in annex B, TS 37.105 [6] indicates how the limit in Table 6.7.4.5.1-13 demonstrates compliance to the regional requirement.

In certain regions, the following test requirement may apply to *RIB* operating in Band XXXII within 1452-1492MHz for the protection of services in spectrum adjacent to the frequency range 1452-1492 MHz. The level of emissions, measured on centre frequencies F_{filter} with filter bandwidth according to Table 6.7.4.5.1-14, shall not exceed the maximum emission TRP limits in the table. This requirement applies in the frequency range 1429-1518MHz even though part of the range falls in the spurious domain.

Table 6.7.4.5.1-14: Frequency band XXXII declared emission outside 1452-1492 MHz

Filter centre frequency, F_{filter}	Declared emission level (dBm)	Measurement bandwidth
$1429.5 \text{ MHz} \leq F_{\text{filter}} \leq 1448.5 \text{ MHz}$	$P_{\text{EIRP}} - 17 \text{ dBi} + 7.8 \text{ dB}$	1 MHz
$F_{\text{filter}} = 1450.5 \text{ MHz}$	$P_{\text{EIRP}} - 17 \text{ dBi} + 7.8 \text{ dB}$	3 MHz
$F_{\text{filter}} = 1493.5 \text{ MHz}$	$P_{\text{EIRP}} - 17 \text{ dBi} + 7.8 \text{ dB}$	3 MHz
$1495.5 \text{ MHz} \leq F_{\text{filter}} \leq 1517.5 \text{ MHz}$	$P_{\text{EIRP}} - 17 \text{ dBi} + 7.8 \text{ dB}$	1 MHz

NOTE 3: The regional requirement, included in CEPT ECC Decision (13)03 [19], is defined in terms of EIRP, which is dependent on both the BS emissions at the antenna connector and the deployment (including antenna gain and feeder loss). The method outlined in annex B, TS 37.105 indicates how the limit in Table 6.7.4.5.1-14 demonstrates compliance to the regional requirement.

6.7.5 OTA Operating band unwanted emission

6.7.5.1 Definition and applicability

Unless otherwise stated, for E-UTRA single band and MSR the operating band unwanted emission limits are defined from Δf_{OBUE} below the lowest frequency of each supported *downlink operating band* to the lower *Base Station RF Bandwidth edge* located at $F_{\text{BW RF,low}}$ and from the upper *Base Station RF Bandwidth edge* located at $F_{\text{BW RF,high}}$ up to Δf_{OBUE} above the highest frequency of each supported *downlink operating band*.

The requirements shall apply whatever the type of transmitter considered and for all transmission modes foreseen by the manufacturer's specification.

6.7.5.2 Minimum Requirement

For AAS BS in *MSR operation* the minimum requirement is defined in TS 37.105 [6], subclause 9.7.5.2

For AAS BS in *single RAT E-UTRA operation* the minimum requirement is defined in TS 37.105 [6], subclause 9.7.5.4.

This requirement does not apply to *single RAT UTRA operation*.

6.7.5.3 Test purpose

This test measures the emissions of the AAS BS, close to the assigned channel bandwidth of the wanted signal, while the AAS BS is in operation.

6.7.5.4 Method of test

6.7.5.4.1 Initial conditions

Test environment:

- normal; annex G.2.

RF channels to be tested for single carrier:

- B, M and T; see subclause 4.12.1.

Base Station RF Bandwidth positions to be tested for multi-carrier:

- B_{RFBW} , M_{RFBW} and T_{RFBW} in single-band operation; see subclause 4.12.1; B'_{RFBW} , T'_{RFBW} and B'_{RFBW} , T'_{RFBW} in multi-band operation, see subclause 4.12.1

6.7.5.4.2 Procedure

- 1) Place the AAS BS at the positioner.
- 2) Align the manufacturer declared coordinate system orientation (see table 4.10-1, D9.2) of the AAS BS with the test system.
- 3) Configure the AAS BS such that the beam peak direction(s) applied during the power measurement step 6 are consistent with the grid and measurement approach for the TRP test.

The measurement devices characteristics shall be:

- detection mode: true RMS voltage or true power averaging.

- 4) Set the AAS BS to transmit:

a) For MSR:

- Set the AAS BS to transmit maximum power according to the applicable test configuration in clause 5 using the corresponding test models or set of physical channels in subclause 4.12.

b) For E-UTRA:

- AAS BS declared to be capable of single carrier operation only, set the AAS BS to transmit a signal according to E-TM1.1 (subclause 4.12.2) at manufacturer's declared *rated carrier TRP* ($P_{\text{Rated,c,TRP}}$).
- For an AAS BS declared to be capable of multi-carrier and/or CA operation, set the set the AAS BS to transmit according to E-TM1.1 on all carriers configured using the applicable test configuration and corresponding power setting specified in subclause 4.11.

- 5) Align the BS and the test antenna such that measurements to determine TRP can be performed (see Annex xx)
- 6) Sweep the centre frequency of the measurement filter in contiguous steps and measure emission power within the specified frequency ranges with the specified measurement bandwidth.
- 7) Repeat step 6-7 for all directions in the appropriated TRP measurement grid needed for $\text{TRP}_{\text{Estimate}}$ (see annex F).
- 8) Calculate $\text{TRP}_{\text{Estimate}}$ using the measurements made in Step 7.
- 9) Repeat the test for the remaining test cases:
 - a) For MSR with channel set-up according to clause 5 and subclause 4.12.2.
 - b) For E-UTRA with the channel set-up according to E-TM 1.2

In addition, for *multi-band RIB*, the following steps shall apply:

- 10) For *multi-band RIB* and single band tests, repeat the steps above per involved band where single band test configurations and test models shall apply with no carrier activated in the other band.

6.7.5.5 Test Requirement

6.7.5.5.1 General

As a general rule, the resolution bandwidth of the measuring equipment should be equal to the measurement bandwidth. However, to improve measurement accuracy, sensitivity and efficiency, the resolution bandwidth can be smaller than the measurement bandwidth. When the resolution bandwidth is smaller than the measurement bandwidth, the result should be integrated over the measurement bandwidth in order to obtain the equivalent noise bandwidth of the measurement bandwidth.

6.7.5.5.2 MSR Band categories 1 and 3

For an AAS BS of Wide Area BS class operating in Band Category 1 or Band Category 3, the requirement applies outside the *Base Station RF Bandwidth edges*. In addition, for a Wide Area BS operating in non-contiguous spectrum, it applies inside any sub-block gap. In addition, for an AAS BS of Wide Area BS class operating in multiple bands, it applies inside any *Inter RF Bandwidth gap*.

For an AAS BS of Medium Range BS class operating in Band Category 1 the requirement applies outside the *Base Station RF Bandwidth edges*. In addition, for a Medium Range BS operating in non-contiguous spectrum, it applies inside any sub-block gap. In addition, for an AAS BS of Medium Range BS class operating in multiple bands, it applies inside any *Inter RF Bandwidth gap*.

For an AAS BS of Local Area BS class operating in Band Category 1 the requirement applies outside the *Base Station RF Bandwidth edges*. In addition, for a Local Area BS operating in non-contiguous spectrum, it applies inside any sub-block gap. In addition, for an AAS BS of Local Area BS class operating in multiple bands, it applies inside any *Inter RF Bandwidth gap*.

Outside the *Base Station RF Bandwidth edges*, emissions shall not exceed the maximum levels specified in Tables 6.7.5.5.2-1 to 6.7.5.5.2-8 below, where:

- Δf is the separation between the *Base Station RF Bandwidth edge* frequency and the nominal -3 dB point of the measuring filter closest to the carrier frequency.
- f_{offset} is the separation between the *Base Station RF Bandwidth edge* frequency and the centre of the measuring filter.
- $f_{\text{offset}_{\text{max}}}$ is the offset to the frequency Δf_{OBUe} MHz outside the downlink operating band.
- Δf_{max} is equal to $f_{\text{offset}_{\text{max}}}$ minus half of the bandwidth of the measuring filter.

For a *multi-band TAB RIB*, inside any *Inter RF Bandwidth gaps* with $W_{\text{gap}} < 2 \times \Delta f_{\text{OBUe}}$ MHz, emissions shall not exceed the cumulative sum of the test requirements specified at the *Base Station RF Bandwidth edges* on each side of the *Inter RF Bandwidth gap*. The minimum requirement for *Base Station RF Bandwidth edge* is specified in Tables 6.7.5.5.2-1 to 6.7.5.5.2-8, where in this case:

- Δf is the separation between the *Base Station RF Bandwidth edge* frequency and the nominal -3 dB point of the measuring filter closest to the carrier frequency.
- f_{offset} is the separation between the *Base Station RF Bandwidth edge* frequency and the centre of the measuring filter.
- $f_{\text{offset}_{\text{max}}}$ is equal to the *Inter RF Bandwidth gap* divided by two.
- Δf_{max} is equal to $f_{\text{offset}_{\text{max}}}$ minus half of the bandwidth of the measuring filter.

For a *multi-band RIB*, the operating band unwanted emission limits apply also in a supported operating band without any carriers transmitted, in the case where there are carriers transmitted in another operating band. In this case where there is no carrier transmitted in an operating band, no cumulative limits are applied in the *inter-band gap* between a supported downlink band with carrier(s) transmitted and a supported downlink band without any carrier transmitted and

- In case the *Inter RF Bandwidth gap* between a supported downlink band with carrier(s) transmitted and a supported downlink band without any carrier transmitted is less than $2 \times \Delta f_{\text{OBUE}}$ MHz, $f_{\text{offset}_{\text{max}}}$ shall be the offset to the frequency Δf_{OBUE} MHz outside the outermost edges of the two supported downlink operating bands and the operating band unwanted emission limit of the band where there are carriers transmitted, as defined in the tables of the present subclause, shall apply across both supported downlink bands.
- In other cases, the operating band unwanted emission limit of the band where there are carriers transmitted, as defined in the tables of the present subclause for the largest frequency offset (Δf_{max}), shall apply from Δf_{OBUE} MHz below the lowest frequency, up to Δf_{OBUE} MHz above the highest frequency of the supported downlink operating band without any carrier transmitted.

Inside any sub-block gap for a *RIB* operating in non-contiguous spectrum, emissions shall not exceed the cumulative sum of the test requirements specified for the adjacent sub blocks on each side of the sub block gap. The minimum requirement for each sub block is specified in Tables 6.7.5.5.2-1 to 6.7.5.5.2-8, where in this case:

- Δf is the separation between the sub block edge frequency and the nominal -3 dB point of the measuring filter closest to the sub block edge frequency.
- f_{offset} is the separation between the sub block edge frequency and the centre of the measuring filter.
- $f_{\text{offset}_{\text{max}}}$ is equal to the sub block gap bandwidth divided by two.
- Δf_{max} is equal to $f_{\text{offset}_{\text{max}}}$ minus half of the bandwidth of the measuring filter.

Table 6.7.5.5.2-1: Wide Area operating band unwanted emission mask (UEM) for BC1 and BC3 bands ≤ 3 GHz for BS not supporting NR (except for BS operating in Band n1)

Frequency offset of measurement filter -3dB point, Δf	Frequency offset of measurement filter centre frequency, f_{offset}	Test requirement (Notes 1 and 2)	Measurement bandwidth
$0 \text{ MHz} \leq \Delta f < 0.2 \text{ MHz}$	$0.015 \text{ MHz} \leq f_{\text{offset}} < 0.215 \text{ MHz}$	-3.2 dBm	30 kHz
$0.2 \text{ MHz} \leq \Delta f < 1 \text{ MHz}$	$0.215 \text{ MHz} \leq f_{\text{offset}} < 1.015 \text{ MHz}$	$-3.2-15(f_{\text{offset}}/\text{MHz}-0.215)\text{dBm}$	30 kHz
(Note 3)	$1.015 \text{ MHz} \leq f_{\text{offset}} < 1.5 \text{ MHz}$	-15.2 dBm	30 kHz
$1 \text{ MHz} \leq \Delta f \leq \min(\Delta f_{\text{max}}, 10 \text{ MHz})$	$1.5 \text{ MHz} \leq f_{\text{offset}} < \min(f_{\text{offset}_{\text{max}}}, 10.5 \text{ MHz})$	-2.2 dBm	1 MHz
$10 \text{ MHz} \leq \Delta f \leq \Delta f_{\text{max}}$	$10.5 \text{ MHz} \leq f_{\text{offset}} < f_{\text{offset}_{\text{max}}}$	-6 dBm (NOTE 5)	1 MHz
NOTE 1: For MSR RIB supporting non-contiguous spectrum operation within any operating band the test requirement within sub-block gaps is calculated as a cumulative sum of contributions from adjacent sub blocks on each side of the sub block gap. Exception is $\Delta f \geq 10$ MHz from both adjacent sub blocks on each side of the sub-block gap, where the test requirement within sub-block gaps shall be -6 dBm/MHz.			
NOTE 2: For MSR <i>multi-band RIB</i> with <i>Inter RF Bandwidth gap</i> $< 2 \times \Delta f_{\text{OBUE}}$ MHz the test requirement within the <i>Inter RF Bandwidth gaps</i> is calculated as a cumulative sum of contributions from adjacent sub-blocks on each side of the <i>Inter RF Bandwidth gap</i> .			
NOTE 3: This frequency range ensures that the range of values of f_{offset} is continuous.			
NOTE 5: The requirement is not applicable when $\Delta f_{\text{max}} < 10$ MHz.			

Table 6.7.5.2-2: Wide Area operating band unwanted emission mask (UEM) for BC1 and BC3 bands > 3GHz for BS not supporting NR (except for BS operating in Band n1)

Frequency offset of measurement filter -3dB point, Δf	Frequency offset of measurement filter centre frequency, f_{offset}	Test requirement (Notes 1 and 2)	Measurement bandwidth
$0 \text{ MHz} \leq \Delta f < 0.2 \text{ MHz}$	$0.015 \text{ MHz} \leq f_{\text{offset}} < 0.215 \text{ MHz}$	-3 dBm	30 kHz
$0.2 \text{ MHz} \leq \Delta f < 1 \text{ MHz}$	$0.215 \text{ MHz} \leq f_{\text{offset}} < 1.015 \text{ MHz}$	$-3-15(f_{\text{offset}}/\text{MHz}-0.215)\text{dBm}$	30 kHz
(Note 3)	$1.015 \text{ MHz} \leq f_{\text{offset}} < 1.5 \text{ MHz}$	-15 dBm	30 kHz
$1 \text{ MHz} \leq \Delta f \leq \min(\Delta f_{\text{max}}, 10 \text{ MHz})$	$1.5 \text{ MHz} \leq f_{\text{offset}} < \min(f_{\text{offset}_{\text{max}}}, 10.5 \text{ MHz})$	-2 dBm	1 MHz
$10 \text{ MHz} \leq \Delta f \leq \Delta f_{\text{max}}$	$10.5 \text{ MHz} \leq f_{\text{offset}} < f_{\text{offset}_{\text{max}}}$	-6 dBm (NOTE 5)	1 MHz

NOTE 1: For MSR RIB supporting non-contiguous spectrum operation within any operating band the *test requirement* within sub-block gaps is calculated as a cumulative sum of contributions from adjacent sub blocks on each side of the sub block gap. Exception is $\Delta f \geq 10 \text{ MHz}$ from both adjacent sub blocks on each side of the sub-block gap, where the *test requirement* within sub-block gaps shall be -6dBm/MHz.

NOTE 2: For MSR *multi-band RIB* with *Inter RF Bandwidth gap* < $2 \times \Delta f_{\text{OBUE}}$ MHz the *test requirement* within the *Inter RF Bandwidth gaps* is calculated as a cumulative sum of contributions from adjacent sub-blocks on each side of the *Inter RF Bandwidth gap*.

NOTE 3: This frequency range ensures that the range of values of f_{offset} is continuous.

NOTE 5: The requirement is not applicable when $\Delta f_{\text{max}} < 10 \text{ MHz}$.

Table 6.7.5.2-2a: Wide Area operating band unwanted emission mask (UEM) for BS supporting NR and not supporting UTRA in BC1 and BC3 bands below 1GHz

Frequency offset of measurement filter -3dB point, Δf	Frequency offset of measurement filter centre frequency, f_{offset}	Minimum requirement (Note 1, 2)	Measurement bandwidth (Note 7)
$0 \text{ MHz} \leq \Delta f < 5 \text{ MHz}$	$0.05 \text{ MHz} \leq f_{\text{offset}} < 5.05 \text{ MHz}$	$3.8 \text{ dBm} - 7/5(f_{\text{offset}}/\text{MHz}-0.05)\text{dB}$	100 kHz
$5 \text{ MHz} \leq \Delta f < \min(10 \text{ MHz}, \Delta f_{\text{max}})$	$5.05 \text{ MHz} \leq f_{\text{offset}} < \min(10.05 \text{ MHz}, f_{\text{offset}_{\text{max}}})$	-3.2 dBm	100 kHz
$10 \text{ MHz} \leq \Delta f \leq \Delta f_{\text{max}}$	$10.05 \text{ MHz} \leq f_{\text{offset}} < f_{\text{offset}_{\text{max}}}$	-7 dBm (Note 5)	100 kHz

NOTE 1: For AAS BS supporting non-contiguous spectrum operation within any operating band, the minimum requirement within sub-block gaps is calculated as a cumulative sum of contributions from adjacent sub blocks on each side of the sub block gap, where the contribution from the far-end sub-block or RF Bandwidth shall be scaled according to the measurement bandwidth of the near-end sub-block or RF Bandwidth. Exception is $\Delta f \geq 10\text{MHz}$ from both adjacent sub blocks on each side of the sub-block gap, where the minimum requirement within sub-block gaps shall be -7dBm/100kHz.

NOTE 2: For AAS BS supporting multi-band operation with *Inter RF Bandwidth gap* < $2 \times \Delta f_{\text{OBUE}}$ the minimum requirement within the *Inter RF Bandwidth gaps* is calculated as a cumulative sum of contributions from adjacent sub-blocks or RF Bandwidth on each side of the *Inter RF Bandwidth gap*, where the contribution from the far-end sub-block or RF Bandwidth shall be scaled according to the measurement bandwidth of the near-end sub-block or RF Bandwidth.

Table 6.7.5.2-2b: Wide Area operating band unwanted emission mask (UEM) for BS supporting NR (except operation in Band n1) and not supporting UTRA in BC1 and BC3 bands > 3GHz

Frequency offset of measurement filter -3dB point, Δf	Frequency offset of measurement filter centre frequency, f_{offset}	Minimum requirement (Note 1, 2)	Measurement bandwidth (Note 7)
$0 \text{ MHz} \leq \Delta f < 5 \text{ MHz}$	$0.05 \text{ MHz} \leq f_{\text{offset}} < 5.05 \text{ MHz}$	$-4 \text{ dBm} - 7/5(f_{\text{offset}}/\text{MHz}-0.05)\text{dB}$	100 kHz
$5 \text{ MHz} \leq \Delta f < \min(10 \text{ MHz}, \Delta f_{\text{max}})$	$5.05 \text{ MHz} \leq f_{\text{offset}} < \min(10.05 \text{ MHz}, f_{\text{offset}_{\text{max}}})$	-3 dBm	100 kHz
$10 \text{ MHz} \leq \Delta f \leq \Delta f_{\text{max}}$	$10.5 \text{ MHz} \leq f_{\text{offset}} < f_{\text{offset}_{\text{max}}}$	-6 dBm (Note 5)	1MHz
<p>NOTE 1: For AAS BS supporting non-contiguous spectrum operation within any operating band, the minimum requirement within sub-block gaps is calculated as a cumulative sum of contributions from adjacent sub blocks on each side of the sub block gap, where the contribution from the far-end sub-block shall be scaled according to the measurement bandwidth of the near-end sub-block. Exception is $\Delta f \geq 10\text{MHz}$ from both adjacent sub blocks on each side of the sub-block gap, where the minimum requirement within sub-block gaps shall be -6dBm/1MHz.</p> <p>NOTE 2: For AAS BS supporting multi-band operation with Inter RF Bandwidth gap $< 2 \times \Delta f_{\text{OBUE}}$ the minimum requirement within the Inter RF Bandwidth gaps is calculated as a cumulative sum of contributions from adjacent sub-blocks or RF Bandwidth on each side of the Inter RF Bandwidth gap, where the contribution from the far-end sub-block or RF Bandwidth shall be scaled according to the measurement bandwidth of the near-end sub-block or RF Bandwidth.</p>			

Table 6.7.5.2-3: Medium Range BS operating band unwanted emission mask (UEM) for BC1 for bands $\leq 3 \text{ GHz}$, $40 < P_{\text{rated,c,TRP}} \leq 47 \text{ dBm}$ for BS not supporting NR

Frequency offset of measurement filter -3dB point, Δf	Frequency offset of measurement filter centre frequency, f_{offset}	Test requirement (Notes 1 and 2)	Measurement bandwidth
$0 \text{ MHz} \leq \Delta f < 0.6 \text{ MHz}$	$0.015 \text{ MHz} \leq f_{\text{offset}} < 0.615 \text{ MHz}$	$P_{\text{rated,c,TRP}} - 56.2\text{dB} - (7/5) \cdot (f_{\text{offset}} - 0.015)\text{dB}$	30 kHz
$0.6 \text{ MHz} \leq \Delta f < 1 \text{ MHz}$	$0.615 \text{ MHz} \leq f_{\text{offset}} < 1.015 \text{ MHz}$	$P_{\text{rated,c,TRP}} - 51.2\text{dB} - (7/5) \cdot (f_{\text{offset}} - 0.615)\text{dB}$	30 kHz
(Note 3)	$1.015 \text{ MHz} \leq f_{\text{offset}} < 1.5 \text{ MHz}$	$P_{\text{rated,c,TRP}} - 63.2 \text{ dB}$	30 kHz
$1 \text{ MHz} \leq \Delta f \leq 2.6 \text{ MHz}$	$1.5 \text{ MHz} \leq f_{\text{offset}} < 3.1 \text{ MHz}$	$P_{\text{rated,c,TRP}} - 50.2 \text{ dB}$	1 MHz
$2.6 \text{ MHz} \leq \Delta f \leq 5 \text{ MHz}$	$3.1 \text{ MHz} \leq f_{\text{offset}} < 5.5 \text{ MHz}$	$\min(P_{\text{rated,c,TRP}} - 50.2 \text{ dB}, -4.2\text{dBm})$	1 MHz
$5 \text{ MHz} \leq \Delta f \leq \min(\Delta f_{\text{max}}, 10 \text{ MHz})$	$5.5 \text{ MHz} \leq f_{\text{offset}} < \min(f_{\text{offset}_{\text{max}}}, 10.5 \text{ MHz})$	$P_{\text{rated,c,TRP}} - 54.2 \text{ dB}$	1 MHz
$10 \text{ MHz} \leq \Delta f \leq \Delta f_{\text{max}}$	$10.5 \text{ MHz} \leq f_{\text{offset}} < f_{\text{offset}_{\text{max}}}$	$P_{\text{rated,c,TRP}} - 56 \text{ dB}$	1 MHz
<p>NOTE 1: For MSR RIB supporting non-contiguous spectrum operation within any operating band the <i>test requirement</i> within sub-block gaps is calculated as a cumulative sum of contributions from adjacent sub blocks on each side of the sub block gap. Exception is $\Delta f \geq 10 \text{ MHz}$ from both adjacent sub blocks on each side of the sub-block gap, where the <i>test requirement</i> within sub-block gaps shall be $(P_{\text{rated,c,TRP}} - 56 \text{ dB})/\text{MHz}$.</p> <p>NOTE 2: For MSR <i>multi-band RIB</i> with <i>Inter RF Bandwidth gap</i> $< 2 \times \Delta f_{\text{OBUE}}$ MHz the <i>test requirement</i> within the <i>Inter RF Bandwidth gaps</i> is calculated as a cumulative sum of contributions from adjacent sub-blocks on each side of the <i>Inter RF Bandwidth gap</i>.</p> <p>NOTE 3: This frequency range ensures that the range of values of f_{offset} is continuous.</p> <p>NOTE 5: The requirement is not applicable when $\Delta f_{\text{max}} < 10 \text{ MHz}$.</p>			

Table 6.7.5.5.2-3a: Medium Range BS operating band unwanted emission mask (UEM) for BS supporting NR and not supporting UTRA in BC1 bands ≤ 3 GHz, BS maximum output power $40 < P_{\text{rated,c,TRP}} \leq 47$ dBm

Frequency offset of measurement filter -3dB point, Δf	Frequency offset of measurement filter centre frequency, f_{offset}	Minimum requirement (Note 1, 2)	Measurement bandwidth (Note 7)
$0 \text{ MHz} \leq \Delta f < 5 \text{ MHz}$	$0.05 \text{ MHz} \leq f_{\text{offset}} < 5.05 \text{ MHz}$	$P_{\text{rated,c,TRP}} - 51.2 \text{ dB} - (7/5) * (f_{\text{offset}} - 0.05) \text{ dB}$	100 kHz
$5 \text{ MHz} \leq \Delta f < \min(10 \text{ MHz}, \Delta f_{\text{max}})$	$5.05 \text{ MHz} \leq f_{\text{offset}} < \min(10.05 \text{ MHz}, f_{\text{offset}_{\text{max}}})$	$P_{\text{rated,c,TRP}} - 58.2 \text{ dB}$	100 kHz
$10 \text{ MHz} \leq \Delta f \leq \Delta f_{\text{max}}$	$10.05 \text{ MHz} \leq f_{\text{offset}} < f_{\text{offset}_{\text{max}}}$	$\text{Min}(P_{\text{rated,c,TRP}} - 60 \text{ dB}, -16 \text{ dBm})$ (Note 5)	100 kHz
<p>NOTE 1: For AAS BS supporting non-contiguous spectrum operation within any operating band the minimum requirement within sub-block gaps is calculated as a cumulative sum of contributions from adjacent sub blocks on each side of the sub block gap, where the contribution from the far-end sub-block shall be scaled according to the measurement bandwidth of the near-end sub-block. Exception is $\Delta f \geq 10$ MHz from both adjacent sub blocks on each side of the sub-block gap, where the minimum requirement within sub-block gaps shall be $\text{Min}(P_{\text{rated,c,TRP}} - 60 \text{ dB}, -16 \text{ dBm}) / 100 \text{ kHz}$.</p> <p>NOTE 2: For AAS BS supporting multi-band operation with Inter RF Bandwidth gap $< 2 * \Delta f_{\text{OBUE}}$ the minimum requirement within the Inter RF Bandwidth gaps is calculated as a cumulative sum of contributions from adjacent sub-blocks or RF Bandwidth on each side of the Inter RF Bandwidth gap, where the contribution from the far-end sub-block shall be scaled according to the measurement bandwidth of the near-end sub-block.</p>			

Table 6.7.5.5.2-4: Medium Range BS operating band unwanted emission mask (UEM) for BC1 for bands > 3 GHz, $40 < P_{\text{rated,c,TRP}} \leq 47$ dBm for BS not supporting NR

Frequency offset of measurement filter -3dB point, Δf	Frequency offset of measurement filter centre frequency, f_{offset}	Test requirement (Notes 1 and 2)	Measurement bandwidth
$0 \text{ MHz} \leq \Delta f < 0.6 \text{ MHz}$	$0.015 \text{ MHz} \leq f_{\text{offset}} < 0.615 \text{ MHz}$	$P_{\text{rated,c,TRP}} - 56 \text{ dB} - (7/5) * (f_{\text{offset}} - 0.015) \text{ dB}$	30 kHz
$0.6 \text{ MHz} \leq \Delta f < 1 \text{ MHz}$	$0.615 \text{ MHz} \leq f_{\text{offset}} < 1.015 \text{ MHz}$	$P_{\text{rated,c,TRP}} - 51 \text{ dB} - (7/5) * (f_{\text{offset}} - 0.015) \text{ dB}$	30 kHz
(Note 3)	$1.015 \text{ MHz} \leq f_{\text{offset}} < 1.5 \text{ MHz}$	$P_{\text{rated,c,TRP}} - 63 \text{ dB}$	30 kHz
$1 \text{ MHz} \leq \Delta f \leq 2.6 \text{ MHz}$	$1.5 \text{ MHz} \leq f_{\text{offset}} < 3.1 \text{ MHz}$	$P_{\text{rated,c,TRP}} - 50 \text{ dB}$	1 MHz
$2.6 \text{ MHz} \leq \Delta f \leq 5 \text{ MHz}$	$3.1 \text{ MHz} \leq f_{\text{offset}} < 5.5 \text{ MHz}$	$\text{min}(P_{\text{rated,c,TRP}} - 50 \text{ dB}, -4 \text{ dBm})$	1 MHz
$5 \text{ MHz} \leq \Delta f \leq \min(\Delta f_{\text{max}}, 10 \text{ MHz})$	$5.5 \text{ MHz} \leq f_{\text{offset}} < \min(f_{\text{offset}_{\text{max}}}, 10.5 \text{ MHz})$	$P_{\text{rated,c,TRP}} - 54 \text{ dB}$	1 MHz
$10 \text{ MHz} \leq \Delta f \leq \Delta f_{\text{max}}$	$10.5 \text{ MHz} \leq f_{\text{offset}} < f_{\text{offset}_{\text{max}}}$	$P_{\text{rated,c,TRP}} - 56 \text{ dB}$	1 MHz
<p>NOTE 1: For MSR RIB supporting non-contiguous spectrum operation within any operating band the <i>test requirement</i> within sub-block gaps is calculated as a cumulative sum of contributions from adjacent sub blocks on each side of the sub block gap. Exception is $\Delta f \geq 10$ MHz from both adjacent sub blocks on each side of the sub-block gap, where the <i>test requirement</i> within sub-block gaps shall be $(P_{\text{rated,c,TRP}} - 56 \text{ dB}) / \text{MHz}$.</p> <p>NOTE 2: For MSR multi-band RIB with <i>Inter RF Bandwidth gap</i> $< 2 * \Delta f_{\text{OBUE}}$ MHz the <i>test requirement</i> within the <i>Inter RF Bandwidth gaps</i> is calculated as a cumulative sum of contributions from adjacent sub-blocks on each side of the <i>Inter RF Bandwidth gap</i>.</p> <p>NOTE 3: This frequency range ensures that the range of values of f_{offset} is continuous.</p> <p>NOTE 5: The requirement is not applicable when $\Delta f_{\text{max}} < 10$ MHz.</p>			

Table 6.7.5.5.2-4a: Medium Range BS operating band unwanted emission mask (UEM) for BS supporting NR and not supporting UTRA in BC1 bands > 3GHz, BS maximum output power 40 < $P_{\text{rated,c,TRP}} \leq 47$ dBm

Frequency offset of measurement filter -3dB point, Δf	Frequency offset of measurement filter centre frequency, f_{offset}	Minimum requirement (Note 1, 2)	Measurement bandwidth (Note 7)
$0 \text{ MHz} \leq \Delta f < 5 \text{ MHz}$	$0.05 \text{ MHz} \leq f_{\text{offset}} < 5.05 \text{ MHz}$	$P_{\text{rated,c,TRP}} - 51 \text{ dB} - 7/5(f_{\text{offset}}/\text{MHz} - 0.05) \text{ dB}$	100 kHz
$5 \text{ MHz} \leq \Delta f < \min(10 \text{ MHz}, \Delta f_{\text{max}})$	$5.05 \text{ MHz} \leq f_{\text{offset}} < \min(10.05 \text{ MHz}, f_{\text{offset}_{\text{max}}})$	$P_{\text{rated,c,TRP}} - 58 \text{ dB}$	100 kHz
$10 \text{ MHz} \leq \Delta f \leq \Delta f_{\text{max}}$	$10.05 \text{ MHz} \leq f_{\text{offset}} < f_{\text{offset}_{\text{max}}}$	$\text{Min}(P_{\text{rated,c,TRP}} - 60 \text{ dB}, -16 \text{ dBm})$ (Note 5)	100 kHz
<p>NOTE 1: For AAS BS supporting non-contiguous spectrum operation within any operating band the minimum requirement within sub-block gaps is calculated as a cumulative sum of contributions from adjacent sub blocks on each side of the sub block gap, where the contribution from the far-end sub-block shall be scaled according to the measurement bandwidth of the near-end sub-block. Exception is $\Delta f \geq 10 \text{ MHz}$ from both adjacent sub blocks on each side of the sub-block gap, where the minimum requirement within sub-block gaps shall be $\text{Min}(P_{\text{rated,c,TRP}} - 60 \text{ dB}, -16 \text{ dBm})/100 \text{ kHz}$.</p> <p>NOTE 2: For AAS BS supporting multi-band operation with Inter RF Bandwidth gap < $2 \times \Delta f_{\text{OBUE}}$ the minimum requirement within the Inter RF Bandwidth gaps is calculated as a cumulative sum of contributions from adjacent sub-blocks or RF Bandwidth on each side of the Inter RF Bandwidth gap, where the contribution from the far-end sub-block shall be scaled according to the measurement bandwidth of the near-end sub-block.</p>			

Table 6.7.5.5.2-5: Medium Range BS operating band unwanted emission mask (UEM) for BC1 for bands ≤ 3 GHz, $P_{\text{rated,c,TRP}} \leq 40$ dBm for BS not supporting NR

Frequency offset of measurement filter -3dB point, Δf	Frequency offset of measurement filter centre frequency, f_{offset}	Test requirement (Notes 1 and 2)	Measurement bandwidth
$0 \text{ MHz} \leq \Delta f < 0.6 \text{ MHz}$	$0.015 \text{ MHz} \leq f_{\text{offset}} < 0.615 \text{ MHz}$	$-7.2 - 5/3(f_{\text{offset}}/\text{MHz} - 0.015) \text{ dBm}$	30 kHz
$0.6 \text{ MHz} \leq \Delta f < 1 \text{ MHz}$	$0.615 \text{ MHz} \leq f_{\text{offset}} < 1.015 \text{ MHz}$	$-2.2 - 15(f_{\text{offset}}/\text{MHz} - 0.015) \text{ dBm}$	30 kHz
(Note 3)	$1.015 \text{ MHz} \leq f_{\text{offset}} < 1.5 \text{ MHz}$	-23.2 dBm	30 kHz
$1 \text{ MHz} \leq \Delta f \leq 5 \text{ MHz}$	$1.5 \text{ MHz} \leq f_{\text{offset}} < 5.5 \text{ MHz}$	-10.2 dBm	1 MHz
$5 \text{ MHz} \leq \Delta f \leq \min(\Delta f_{\text{max}}, 10 \text{ MHz})$	$5.5 \text{ MHz} \leq f_{\text{offset}} < \min(f_{\text{offset}_{\text{max}}}, 10.5 \text{ MHz})$	-14.2 dBm	1 MHz
$10 \text{ MHz} \leq \Delta f \leq \Delta f_{\text{max}}$	$10.5 \text{ MHz} \leq f_{\text{offset}} < f_{\text{offset}_{\text{max}}}$	-16 dBm (Note 5)	1 MHz
<p>NOTE 1: For MSR RIB supporting non-contiguous spectrum operation within any operating band the <i>test requirement</i> within sub-block gaps is calculated as a cumulative sum of contributions from adjacent sub blocks on each side of the sub block gap. Exception is $\Delta f \geq 10 \text{ MHz}$ from both adjacent sub blocks on each side of the sub-block gap, where the <i>test requirement</i> within sub-block gaps shall be -16 dBm/MHz.</p> <p>NOTE 2: For MSR <i>multi-band RIB</i> with <i>Inter RF Bandwidth gap</i> < $2 \times \Delta f_{\text{OBUE}}$ MHz the <i>test requirement</i> within the <i>Inter RF Bandwidth gaps</i> is calculated as a cumulative sum of contributions from adjacent sub-blocks on each side of the <i>Inter RF Bandwidth gap</i>.</p> <p>NOTE 3: This frequency range ensures that the range of values of f_{offset} is continuous.</p> <p>NOTE 5: The requirement is not applicable when $\Delta f_{\text{max}} < 10 \text{ MHz}$.</p>			

Table 6.7.5.5.2-5a: Medium Range BS operating band unwanted emission mask (UEM) for BS supporting NR and not supporting UTRA in BC1 bands ≤ 3 GHz, BS maximum output power $P_{\text{rated,c,TRP}} \leq 40$ dBm

Frequency offset of measurement filter -3dB point, Δf	Frequency offset of measurement filter centre frequency, f_{offset}	Minimum requirement (Note 1, 2)	Measurement bandwidth (Note 7)
$0 \text{ MHz} \leq \Delta f < 5 \text{ MHz}$	$0.05 \text{ MHz} \leq f_{\text{offset}} < 5.05 \text{ MHz}$	$-11.2 \text{ dBm} - 7/5(f_{\text{offset}}/\text{MHz}-0.05)\text{dB}$	100 kHz
$5 \text{ MHz} \leq \Delta f < \min(10 \text{ MHz}, \Delta f_{\text{max}})$	$5.05 \text{ MHz} \leq f_{\text{offset}} < \min(10.05 \text{ MHz}, f_{\text{offset}_{\text{max}}})$	-18.2 dBm	100 kHz
$10 \text{ MHz} \leq \Delta f \leq \Delta f_{\text{max}}$	$10.05 \text{ MHz} \leq f_{\text{offset}} < f_{\text{offset}_{\text{max}}}$	-20 dBm (Note 8)	100 kHz
<p>NOTE 1: For AAS BS supporting non-contiguous spectrum operation within any operating band the minimum requirement within sub-block gaps is calculated as a cumulative sum of contributions from adjacent sub blocks on each side of the sub block gap, where the contribution from the far-end sub-block shall be scaled according to the measurement bandwidth of the near-end sub-block. Exception is $\Delta f \geq 10$MHz from both adjacent sub blocks on each side of the sub-block gap, where the minimum requirement within sub-block gaps shall be -20dBm/100kHz.</p> <p>NOTE 2: For AAS BS supporting multi-band operation with Inter RF Bandwidth gap $< 2 \times \Delta f_{\text{OBUE}}$ the minimum requirement within the Inter RF Bandwidth gaps is calculated as a cumulative sum of contributions from adjacent sub-blocks or RF Bandwidth on each side of the Inter RF Bandwidth gap, where the contribution from the far-end sub-block shall be scaled according to the measurement bandwidth of the near-end sub-block.</p>			

Table 6.7.5.5.2-6: Medium Range BS operating band unwanted emission mask (UEM) for BC1 for bands > 3 GHz, $P_{\text{rated,c,TRP}} \leq 40$ dBm for BS not supporting NR

Frequency offset of measurement filter -3dB point, Δf	Frequency offset of measurement filter centre frequency, f_{offset}	Test requirement (Notes 1 and 2)	Measurement bandwidth
$0 \text{ MHz} \leq \Delta f < 0.6 \text{ MHz}$	$0.015 \text{ MHz} \leq f_{\text{offset}} < 0.615 \text{ MHz}$	$-7-5/3(f_{\text{offset}}/\text{MHz}-0.015)\text{dBm}$	30 kHz
$0.6 \text{ MHz} \leq \Delta f < 1 \text{ MHz}$	$0.615 \text{ MHz} \leq f_{\text{offset}} < 1.015 \text{ MHz}$	$-2-15(f_{\text{offset}}/\text{MHz}-0.015)\text{dBm}$	30 kHz
(Note 3)	$1.015 \text{ MHz} \leq f_{\text{offset}} < 1.5 \text{ MHz}$	-23 dBm	30 kHz
$1 \text{ MHz} \leq \Delta f \leq 5 \text{ MHz}$	$1.5 \text{ MHz} \leq f_{\text{offset}} < 5.5 \text{ MHz}$	-10 dBm	1 MHz
$5 \text{ MHz} \leq \Delta f \leq \min(\Delta f_{\text{max}}, 10 \text{ MHz})$	$5.5 \text{ MHz} \leq f_{\text{offset}} < \min(f_{\text{offset}_{\text{max}}}, 10.5 \text{ MHz})$	-14 dBm	1 MHz
$10 \text{ MHz} \leq \Delta f \leq \Delta f_{\text{max}}$	$10.5 \text{ MHz} \leq f_{\text{offset}} < f_{\text{offset}_{\text{max}}}$	-16dBm (Note 5)	1 MHz
<p>NOTE 1: For MSR RIB supporting non-contiguous spectrum operation within any operating band the <i>test requirement</i> within sub-block gaps is calculated as a cumulative sum of contributions from adjacent sub blocks on each side of the sub block gap. Exception is $\Delta f \geq 10$ MHz from both adjacent sub blocks on each side of the sub-block gap, where the <i>test requirement</i> within sub-block gaps shall be -16 dBm/MHz.</p> <p>NOTE 2: For MSR <i>multi-band RIB</i> with <i>Inter RF Bandwidth gap</i> $< 2 \times \Delta f_{\text{OBUE}}$ MHz the <i>test requirement</i> within the <i>Inter RF Bandwidth gaps</i> is calculated as a cumulative sum of contributions from adjacent sub-blocks on each side of the <i>Inter RF Bandwidth gap</i>.</p> <p>NOTE 3: This frequency range ensures that the range of values of f_{offset} is continuous.</p> <p>NOTE 5: The requirement is not applicable when $\Delta f_{\text{max}} < 10$ MHz.</p>			

Table 6.7.5.5.2-6a: Medium Range BS operating band unwanted emission mask (UEM) for BS supporting NR and not supporting UTRA in BC1 bands > 3GHz, BS maximum output power $P_{\text{rated,c,TRP}} \leq 40$ dBm

Frequency offset of measurement filter -3dB point, Δf	Frequency offset of measurement filter centre frequency, f_{offset}	Minimum requirement (Note 1, 2)	Measurement bandwidth (Note 7)
$0 \text{ MHz} \leq \Delta f < 5 \text{ MHz}$	$0.05 \text{ MHz} \leq f_{\text{offset}} < 5.05 \text{ MHz}$	$-11 \text{ dBm} - 7/5(f_{\text{offset}}/\text{MHz} - 0.05)\text{dB}$	100 kHz
$5 \text{ MHz} \leq \Delta f < \min(10 \text{ MHz}, \Delta f_{\text{max}})$	$5.05 \text{ MHz} \leq f_{\text{offset}} < \min(10.05 \text{ MHz}, f_{\text{offset}_{\text{max}}})$	-18 dBm	100 kHz
$10 \text{ MHz} \leq \Delta f \leq \Delta f_{\text{max}}$	$10.05 \text{ MHz} \leq f_{\text{offset}} < f_{\text{offset}_{\text{max}}}$	-20 dBm (Note 5)	100 kHz
<p>NOTE 1: For AAS BS supporting non-contiguous spectrum operation within any operating band the minimum requirement within sub-block gaps is calculated as a cumulative sum of contributions from adjacent sub blocks on each side of the sub block gap, where the contribution from the far-end sub-block shall be scaled according to the measurement bandwidth of the near-end sub-block. Exception is $\Delta f \geq 10\text{MHz}$ from both adjacent sub blocks on each side of the sub-block gap, where the minimum requirement within sub-block gaps shall be -20dBm/100kHz.</p> <p>NOTE 2: For AAS BS supporting multi-band operation with Inter RF Bandwidth gap $< 2 \times \Delta f_{\text{OBUE}}$ the minimum requirement within the Inter RF Bandwidth gaps is calculated as a cumulative sum of contributions from adjacent sub-blocks or RF Bandwidth on each side of the Inter RF Bandwidth gap, where the contribution from the far-end sub-block shall be scaled according to the measurement bandwidth of the near-end sub-block.</p>			

Table 6.7.5.5.2-7: Local Area operating band unwanted emission mask (UEM) for BC1 for bands ≤ 3 GHz

Frequency offset of measurement filter -3dB point, Δf	Frequency offset of measurement filter centre frequency, f_{offset}	Test requirement (Notes 1 and 2)	Measurement bandwidth
$0 \text{ MHz} \leq \Delta f < 5 \text{ MHz}$	$0.05 \text{ MHz} \leq f_{\text{offset}} < 5.05 \text{ MHz}$	$-19.2 \text{ dBm} - 7/5(f_{\text{offset}}/\text{MHz} - 0.05) \text{ dB}$	100 kHz
$5 \text{ MHz} \leq \Delta f < \min(10 \text{ MHz}, \Delta f_{\text{max}})$	$5.05 \text{ MHz} \leq f_{\text{offset}} < \min(10.05 \text{ MHz}, f_{\text{offset}_{\text{max}}})$	-26.2 dBm	100 kHz
$10 \text{ MHz} \leq \Delta f \leq \Delta f_{\text{max}}$	$10.05 \text{ MHz} \leq f_{\text{offset}} < f_{\text{offset}_{\text{max}}}$	-28 dBm (Note 5)	100 kHz
<p>NOTE 1: For MSR RIB supporting non-contiguous spectrum operation within any operating band the <i>test requirement</i> within sub-block gaps is calculated as a cumulative sum of contributions from adjacent sub blocks on each side of the sub block gap. Exception is $\Delta f \geq 10$ MHz from both adjacent sub blocks on each side of the sub-block gap, where the <i>test requirement</i> within sub-block gaps shall be -28 dBm/100 kHz.</p> <p>NOTE 2: For MSR <i>multi-band RIB</i> with <i>Inter RF Bandwidth gap</i> $< 2 \times \Delta f_{\text{OBUE}}$ MHz the <i>test requirement</i> within the <i>Inter RF Bandwidth gaps</i> is calculated as a cumulative sum of contributions from adjacent sub-blocks on each side of the <i>Inter RF Bandwidth gap</i>.</p> <p>NOTE 3: This frequency range ensures that the range of values of f_{offset} is continuous.</p> <p>NOTE 5: The requirement is not applicable when $\Delta f_{\text{max}} < 10$ MHz.</p>			

Table 6.7.5.5.2-8: Local Area operating band unwanted emission mask (UEM) for BC1 for bands > 3 GHz

Frequency offset of measurement filter -3dB point, Δf	Frequency offset of measurement filter centre frequency, f_{offset}	Test requirement (Note 1, 2)	Measurement bandwidth
$0 \text{ MHz} \leq \Delta f < 5 \text{ MHz}$	$0.05 \text{ MHz} \leq f_{\text{offset}} < 5.05 \text{ MHz}$	$-19 \text{ dBm} - 7/5(f_{\text{offset}}/\text{MHz} - 0.05) \text{ dB}$	100 kHz
$5 \text{ MHz} \leq \Delta f < \min(10 \text{ MHz}, \Delta f_{\text{max}})$	$5.05 \text{ MHz} \leq f_{\text{offset}} < \min(10.05 \text{ MHz}, f_{\text{offset}_{\text{max}}})$	-26 dBm	100 kHz
$10 \text{ MHz} \leq \Delta f \leq \Delta f_{\text{max}}$	$10.05 \text{ MHz} \leq f_{\text{offset}} < f_{\text{offset}_{\text{max}}}$	-28 dBm (Note 5)	100 kHz
<p>NOTE 1: For MSR RIB supporting non-contiguous spectrum operation within any operating band the <i>test requirement</i> within sub-block gaps is calculated as a cumulative sum of contributions from adjacent sub blocks on each side of the sub block gap. Exception is $\Delta f \geq 10 \text{ MHz}$ from both adjacent sub blocks on each side of the sub-block gap, where the <i>test requirement</i> within sub-block gaps shall be -28 dBm/100 kHz.</p> <p>NOTE 2: For MSR <i>multi-band RIB</i> with <i>Inter RF Bandwidth gap</i> $< 2 \times \Delta f_{\text{OBUE}}$ MHz the <i>test requirement</i> within the <i>Inter RF Bandwidth gaps</i> is calculated as a cumulative sum of contributions from adjacent sub-blocks on each side of the <i>Inter RF Bandwidth gap</i>.</p> <p>NOTE 3: This frequency range ensures that the range of values of f_{offset} is continuous.</p> <p>NOTE 5: The requirement is not applicable when $\Delta f_{\text{max}} < 10 \text{ MHz}$.</p>			

6.7.5.5.3 MSR Band Category 2

For a *RIB* operating in Band Category 2 the requirement applies outside the *Base Station RF Bandwidth edges*. In addition, for a *RIB* operating in non-contiguous spectrum, it applies inside any sub-block gap.

Outside the *Base Station RF Bandwidth edges*, emissions shall not exceed the maximum levels specified in Tables 6.7.5.5.3-1 to 6.7.5.5.3-8, where:

- Δf is the separation between the *Base Station RF Bandwidth edge* frequency and the nominal -3dB point of the measuring filter closest to the carrier frequency.
- f_{offset} is the separation between the *Base Station RF Bandwidth edge* frequency and the centre of the measuring filter.
- $f_{\text{offset}_{\text{max}}}$ is the offset to the frequency Δf_{OBUE} MHz outside the downlink operating band.
- Δf_{max} is equal to $f_{\text{offset}_{\text{max}}}$ minus half of the bandwidth of the measuring filter.

For a *multi-band RIB*, inside any *Inter RF Bandwidth gaps* with $W_{\text{gap}} < 2 \times \Delta f_{\text{OBUE}}$ MHz, emissions shall not exceed the cumulative sum of the test requirements specified at the *Base Station RF Bandwidth edges* on each side of the *Inter RF Bandwidth gap*. The *minimum requirement* for *Base Station RF Bandwidth edge* is specified in Tables 6.7.5.5.3-1 to 6.7.5.5.3-8, where in this case:

- Δf is the separation between the *Base Station RF Bandwidth edge* frequency and the nominal -3 dB point of the measuring filter closest to the carrier frequency.
- f_{offset} is the separation between the *Base Station RF Bandwidth edge* frequency and the centre of the measuring filter.
- $f_{\text{offset}_{\text{max}}}$ is equal to the *Inter RF Bandwidth gap* divided by two.
- Δf_{max} is equal to $f_{\text{offset}_{\text{max}}}$ minus half of the bandwidth of the measuring filter.

For a *multi-band RIB* and where there is no carrier transmitted in an operating band, no cumulative limits are applied in the *inter-band gap* between a supported downlink band with carrier(s) transmitted and a supported downlink band without any carrier transmitted and

- In case the *inter-band gap* between a supported downlink band with carrier(s) transmitted and a supported downlink band without any carrier transmitted less than is $2 \times \Delta f_{\text{OBUE}}$ MHz, $f_{\text{offset}_{\text{max}}}$ shall be the offset to the frequency Δf_{OBUE} MHz outside the outermost edges of the two supported downlink operating bands and the operating band unwanted emission limit of the band where there are carriers transmitted, as defined in the tables of the present subclause, shall apply across both supported downlink bands.

- In other cases, the operating band unwanted emission limit of the band where there are carriers transmitted, as defined in the tables of the present subclause for the largest frequency offset (Δf_{\max}), shall apply from Δf_{OBUE} MHz below the lowest frequency, up to Δf_{OBUE} MHz above the highest frequency of the supported downlink operating band without any carrier transmitted.

Inside any sub-block gap for a *RIB* operating in non-contiguous spectrum, emissions shall not exceed the cumulative sum of the test requirement specified for the adjacent sub blocks on each side of the sub block gap. The *minimum requirement* for each sub block is specified in Tables 6.7.5.5.3-1 to 6.7.5.5.3-8, where in this case:

- Δf is the separation between the sub block edge frequency and the nominal -3 dB point of the measuring filter closest to the sub block edge.
- f_{offset} is the separation between the sub block edge frequency and the centre of the measuring filter.
- $f_{\text{offset}_{\max}}$ is equal to the sub block gap bandwidth divided by two.
- Δf_{\max} is equal to $f_{\text{offset}_{\max}}$ minus half of the bandwidth of the measuring filter.

Table 6.7.5.5.3-1: Wide Area operating band unwanted emission mask (UEM) for BC2 for BS not supporting NR (except for BS operating in Band n3 or n8) Wide

Frequency offset of measurement filter -3dB point, Δf	Frequency offset of measurement filter centre frequency, f_{offset}	Test requirement (Notes 2 and 3)	Measurement bandwidth
$0 \text{ MHz} \leq \Delta f < 0.2 \text{ MHz}$ (Note 1)	$0.015 \text{ MHz} \leq f_{\text{offset}} < 0.215 \text{ MHz}$	-3.2 dBm	30 kHz
$0.2 \text{ MHz} \leq \Delta f < 1 \text{ MHz}$	$0.215 \text{ MHz} \leq f_{\text{offset}} < 1.015 \text{ MHz}$	$-3.2-15(f_{\text{offset}}/\text{MHz}-0.215) \text{ dBm}$	30 kHz
(Note 8)	$1.015 \text{ MHz} \leq f_{\text{offset}} < 1.5 \text{ MHz}$	-15.2 dBm	30 kHz
$1 \text{ MHz} \leq \Delta f \leq \min(\Delta f_{\max}, 10 \text{ MHz})$	$1.5 \text{ MHz} \leq f_{\text{offset}} < \min(f_{\text{offset}_{\max}}, 10.5 \text{ MHz})$	-2.2 dBm	1 MHz
$10 \text{ MHz} \leq \Delta f \leq \Delta f_{\max}$	$10.5 \text{ MHz} \leq f_{\text{offset}} < f_{\text{offset}_{\max}}$	-6 dBm (Note 10)	1 MHz
NOTE 1: For operation with a GSM/EDGE or an E-UTRA 1.4 or 3 MHz carrier adjacent to the <i>Base Station RF Bandwidth edge</i> , the limits in table 6.7.5.5.3-2 apply for $0 \text{ MHz} \leq \Delta f < 0.15 \text{ MHz}$.			
NOTE 2: For MSR RIB supporting non-contiguous spectrum operation within any operating band the <i>test requirement</i> within sub-block gaps is calculated as a cumulative sum of contributions from adjacent sub blocks on each side of the sub block gap. Exception is $\Delta f \geq 10 \text{ MHz}$ from both adjacent sub blocks on each side of the sub-block gap, where the <i>minimum requirement</i> within sub-block gaps shall be -6 dBm/MHz.			
NOTE 3: For MSR <i>multi-band RIB</i> with <i>Inter RF Bandwidth gap</i> $< 2 \times \Delta f_{\text{OBUE}}$ MHz operation the <i>test requirement</i> within the <i>Inter RF Bandwidth gaps</i> is calculated as a cumulative sum of contributions from adjacent sub-blocks on each side of the <i>Inter RF Bandwidth gap</i> .			
NOTE 8: This frequency range ensures that the range of values of f_{offset} is continuous.			
NOTE 10: The requirement is not applicable when $\Delta f_{\max} < 10 \text{ MHz}$			

Table 6.7.5.3-2: Wide Area BS operating band unwanted emission limits for operation in BC2 with GSM/EDGE or E-UTRA 1.4 or 3 MHz carriers adjacent to the *Base Station RF Bandwidth edge*

Frequency offset of measurement filter -3dB point, Δf	Frequency offset of measurement filter centre frequency, f_{offset}	Test requirement (Note 2, 3 and 4)	Measurement bandwidth
$0 \text{ MHz} \leq \Delta f < 0.05 \text{ MHz}$	$0.015 \text{ MHz} \leq f_{\text{offset}} < 0.065 \text{ MHz}$	$\text{Max}(15.8\text{dBm}-60(f_{\text{offset}}/\text{MHz}-0.015)+X\text{dB}, -3.2 \text{ dBm})$	30 kHz
$0.05 \text{ MHz} \leq \Delta f < 0.15 \text{ MHz}$	$0.065 \text{ MHz} \leq f_{\text{offset}} < 0.165 \text{ MHz}$	$\text{Max}(12.8\text{dBm}-160(f_{\text{offset}}/\text{MHz}-0.065)+X\text{dB}, -3.2 \text{ dBm})$	30 kHz

NOTE 1: The limits in this table only apply for operation with a GSM/EDGE or an E-UTRA 1.4 or 3 MHz carrier adjacent to the *Base Station RF Bandwidth edge*.

NOTE 2: For MSR RIB supporting non-contiguous spectrum operation within any operating band the *test requirement* within sub-block gaps is calculated as a cumulative sum of contributions from adjacent sub blocks on each side of the sub block gap.

NOTE 3: For MSR *multi-band RIB* with *Inter RF Bandwidth gap* $< 2 \times \Delta f_{\text{OBUE}}$ MHz the *test requirement* within the *Inter RF Bandwidth gaps* is calculated as a cumulative sum of contributions from adjacent sub-blocks on each side of the *Inter RF Bandwidth gap*.

NOTE 4: In case the carrier adjacent to the *Base Station RF Bandwidth edge* is a GSM/EDGE carrier, the value of $X = P_{\text{GSMcarrier}} - 43$, where $P_{\text{GSMcarrier}}$ is the power level of the GSM/EDGE carrier adjacent to the *Base Station RF Bandwidth edge*. In other cases, $X = 0$.

NOTE 8: This frequency range ensures that the range of values of f_{offset} is continuous.

NOTE 10: The requirement is not applicable when $\Delta f_{\text{max}} < 10 \text{ MHz}$

Table 6.7.5.3-2a: Wide Area operating band unwanted emission mask (UEM) for BS supporting NR (except operation in Band n8) and not supporting UTRA in BC2 bands below 1GHz

Frequency offset of measurement filter -3dB point, Δf	Frequency offset of measurement filter centre frequency, f_{offset}	Minimum requirement (Note 1, 2)	Measurement bandwidth (Note 7)
$0 \text{ MHz} \leq \Delta f < 5 \text{ MHz}$	$0.05 \text{ MHz} \leq f_{\text{offset}} < 5.05 \text{ MHz}$	$3.8 \text{ dBm} - 7/5(f_{\text{offset}}/\text{MHz} - 0.05)\text{dB}$	100 kHz
$5 \text{ MHz} \leq \Delta f < \min(10 \text{ MHz}, \Delta f_{\text{max}})$	$5.05 \text{ MHz} \leq f_{\text{offset}} < \min(10.05 \text{ MHz}, f_{\text{offsetmax}})$	-3.2 dBm	100 kHz
$10 \text{ MHz} \leq \Delta f \leq \Delta f_{\text{max}}$	$10.05 \text{ MHz} \leq f_{\text{offset}} < f_{\text{offsetmax}}$	-7 dBm (Note 10)	100 kHz

NOTE 1: For AAS BS supporting non-contiguous spectrum operation within any operating band, the minimum requirement within sub-block gaps is calculated as a cumulative sum of contributions from adjacent sub blocks on each side of the sub block gap, where the contribution from the far-end sub-block or RF Bandwidth shall be scaled according to the measurement bandwidth of the near-end sub-block or RF Bandwidth. Exception is $\Delta f \geq 10\text{MHz}$ from both adjacent sub blocks on each side of the sub-block gap, where the minimum requirement within sub-block gaps shall be -7dBm/100kHz.

NOTE 2: For AAS BS supporting multi-band operation with *Inter RF Bandwidth gap* $< 2 \times \Delta f_{\text{OBUE}}$ the minimum requirement within the *Inter RF Bandwidth gaps* is calculated as a cumulative sum of contributions from adjacent sub-blocks or RF Bandwidth on each side of the *Inter RF Bandwidth gap*, where the contribution from the far-end sub-block or RF Bandwidth shall be scaled according to the measurement bandwidth of the near-end sub-block or RF Bandwidth.

NOTE 3: For operation with an E-UTRA 1.4 or 3MHz carrier adjacent to the *Base Station RF Bandwidth edge*, the limits in Table 6.7.5.3-2 apply for $0 \text{ MHz} \leq \Delta f < 0.15 \text{ MHz}$.

NOTE 4: This frequency range ensures that the range of values of f_{offset} is continuous.

NOTE 5: The requirement is not applicable when $\Delta f_{\text{max}} < 10 \text{ MHz}$.

Table 6.7.5.5.3-2b: Wide Area operating band unwanted emission mask (UEM) for BS supporting NR (except operation in Band n3) and not supporting UTRA in BC2 bands above 1GHz

Frequency offset of measurement filter -3dB point, Δf	Frequency offset of measurement filter centre frequency, f_{offset}	Minimum requirement (Note 1, 2)	Measurement bandwidth (Note 7)
$0 \text{ MHz} \leq \Delta f < 5 \text{ MHz}$	$0.05 \text{ MHz} \leq f_{\text{offset}} < 5.05 \text{ MHz}$	$3.8 \text{ dBm} - 7/5(f_{\text{offset}}/\text{MHz} - 0.05)\text{dB}$	100 kHz
$5 \text{ MHz} \leq \Delta f < \min(10 \text{ MHz}, \Delta f_{\text{max}})$	$5.05 \text{ MHz} \leq f_{\text{offset}} < \min(10.05 \text{ MHz}, f_{\text{offset}_{\text{max}}})$	-3.2 dBm	100 kHz
$10 \text{ MHz} \leq \Delta f \leq \Delta f_{\text{max}}$	$10.5 \text{ MHz} \leq f_{\text{offset}} < f_{\text{offset}_{\text{max}}}$	-7 dBm (Note 5)	1MHz
<p>NOTE 1: For AAS BS supporting non-contiguous spectrum operation within any operating band, the minimum requirement within sub-block gaps is calculated as a cumulative sum of contributions from adjacent sub blocks on each side of the sub block gap, where the contribution from the far-end sub-block shall be scaled according to the measurement bandwidth of the near-end sub-block. Exception is $\Delta f \geq 10\text{MHz}$ from both adjacent sub blocks on each side of the sub-block gap, where the minimum requirement within sub-block gaps shall be -6dBm/1MHz.</p> <p>NOTE 2: For AAS BS supporting multi-band operation with Inter RF Bandwidth gap $< 2 \times \Delta f_{\text{OBUe}}$ the minimum requirement within the Inter RF Bandwidth gaps is calculated as a cumulative sum of contributions from adjacent sub-blocks or RF Bandwidth on each side of the Inter RF Bandwidth gap, where the contribution from the far-end sub-block or RF Bandwidth shall be scaled according to the measurement bandwidth of the near-end sub-block or RF Bandwidth.</p> <p>NOTE 3: For operation with an E-UTRA 1.4 or 3MHz carrier adjacent to the Base Station RF Bandwidth edge, the limits in Table 6.7.5.5.3-2 apply for $0 \text{ MHz} \leq \Delta f < 0.15 \text{ MHz}$.</p> <p>NOTE 4: This frequency range ensures that the range of values of f_{offset} is continuous.</p> <p>NOTE 5: The requirement is not applicable when $\Delta f_{\text{max}} < 10 \text{ MHz}$.</p>			

Table 6.7.5.5.3-3: Medium Range BS operating band unwanted emission mask (UEM) for BC2, $40 < P_{\text{rated,c,TRP}} \leq 47 \text{ dBm}$ for BS not supporting NR

Frequency offset of measurement filter -3dB point, Δf	Frequency offset of measurement filter centre frequency, f_{offset}	Test requirement (Notes 2 and 3)	Measurement bandwidth
$0 \text{ MHz} \leq \Delta f < 0.6 \text{ MHz}$ (Note 1)	$0.015 \text{ MHz} \leq f_{\text{offset}} < 0.615 \text{ MHz}$	$P_{\text{rated,c,TRP}} - 56.2\text{dB} - (5/3) * (f_{\text{offset}} - 0.015)\text{dB}$	30 kHz
$0.6 \text{ MHz} \leq \Delta f < 1 \text{ MHz}$ (Note 8)	$0.615 \text{ MHz} \leq f_{\text{offset}} < 1.015 \text{ MHz}$	$P_{\text{rated,c,TRP}} - 51.2\text{dB} - 15 * (f_{\text{offset}} - 0.615)\text{dB}$	30 kHz
	$1.015 \text{ MHz} \leq f_{\text{offset}} < 1.5 \text{ MHz}$	$P_{\text{rated,c,TRP}} - 63.2 \text{ dB}$	30 kHz
$1 \text{ MHz} \leq \Delta f \leq 2.8 \text{ MHz}$	$1.5 \text{ MHz} \leq f_{\text{offset}} < 3.3 \text{ MHz}$	$P_{\text{rated,c,TRP}} - 50.2 \text{ dB}$	1 MHz
$2.8 \text{ MHz} \leq \Delta f \leq 5 \text{ MHz}$	$3.3 \text{ MHz} \leq f_{\text{offset}} < 5.5 \text{ MHz}$	$\min(P_{\text{rated,c,TRP}} - 50.2 \text{ dB}, -4.2\text{dBm})$	1 MHz
$5 \text{ MHz} \leq \Delta f \leq \min(\Delta f_{\text{max}}, 10 \text{ MHz})$	$5.5 \text{ MHz} \leq f_{\text{offset}} < \min(f_{\text{offset}_{\text{max}}}, 10.5 \text{ MHz})$	$P_{\text{rated,c,TRP}} - 54.2 \text{ dB}$	1 MHz
$10 \text{ MHz} \leq \Delta f \leq \Delta f_{\text{max}}$	$10.5 \text{ MHz} \leq f_{\text{offset}} < f_{\text{offset}_{\text{max}}}$	$P_{\text{rated,c,TRP}} - 56 \text{ dB}$ (Note 10)	1 MHz
<p>NOTE 1: For operation with a GSM/EDGE or an E-UTRA 1.4 or 3 MHz carrier adjacent to the <i>Base Station RF Bandwidth edge</i>, the limits in Table 6.7.5.5.3-5 apply for $0 \text{ MHz} \leq \Delta f < 0.15 \text{ MHz}$.</p> <p>NOTE 2: For MSR RIB supporting non-contiguous spectrum operation within any operating band the <i>test requirement</i> within sub-block gaps is calculated as a cumulative sum of contributions from adjacent sub blocks on each side of the sub block gap. Exception is $\Delta f \geq 10 \text{ MHz}$ from both adjacent sub blocks on each side of the sub-block gap, where the <i>test requirement</i> within sub-block gaps shall be $(P_{\text{rated,c,TRP}} - 56 \text{ dB})/\text{MHz}$.</p> <p>NOTE 3: For MSR <i>multi-band RIB</i> with <i>Inter RF Bandwidth gap</i> $< 2 \times \Delta f_{\text{OBUe}}$ MHz the <i>test requirement</i> within the <i>Inter RF Bandwidth gaps</i> is calculated as a cumulative sum of contributions from adjacent sub-blocks on each side of the <i>Inter RF Bandwidth gap</i>.</p> <p>NOTE 8: This frequency range ensures that the range of values of f_{offset} is continuous.</p> <p>NOTE 10: The requirement is not applicable when $\Delta f_{\text{max}} < 10 \text{ MHz}$</p>			

Table 6.7.5.5.3-3a: Medium Range BS operating band unwanted emission mask (UEM) for BS supporting NR and not supporting UTRA in BC2 bands, BS maximum output power $40 < P_{\text{rated,c,TRP}} \leq 47$ dBm

Frequency offset of measurement filter -3dB point, Δf	Frequency offset of measurement filter centre frequency, f_{offset}	Minimum requirement (Note 1, 2)	Measurement bandwidth (Note 7)
$0 \text{ MHz} \leq \Delta f < 5 \text{ MHz}$	$0.05 \text{ MHz} \leq f_{\text{offset}} < 5.05 \text{ MHz}$	$P_{\text{rated,c,TRP}} - 51.2\text{dB} - 7/5(f_{\text{offset}}/\text{MHz} - 0.05)\text{dB}$	100 kHz
$5 \text{ MHz} \leq \Delta f < \min(10 \text{ MHz}, \Delta f_{\text{max}})$	$5.05 \text{ MHz} \leq f_{\text{offset}} < \min(10.05 \text{ MHz}, f_{\text{offset}_{\text{max}}})$	$P_{\text{rated,c,TRP}} - 58.2\text{dB}$	100 kHz
$10 \text{ MHz} \leq \Delta f \leq \Delta f_{\text{max}}$	$10.05 \text{ MHz} \leq f_{\text{offset}} < f_{\text{offset}_{\text{max}}}$	$\text{Min}(P_{\text{rated,c,TRP}} - 60\text{dB}, -16\text{dBm})$ (Note 5)	100 kHz
<p>NOTE 1: For AAS BS supporting non-contiguous spectrum operation within any operating band the minimum requirement within sub-block gaps is calculated as a cumulative sum of contributions from adjacent sub blocks on each side of the sub block gap, where the contribution from the far-end sub-block shall be scaled according to the measurement bandwidth of the near-end sub-block. Exception is $\Delta f \geq 10\text{MHz}$ from both adjacent sub blocks on each side of the sub-block gap, where the minimum requirement within sub-block gaps shall be $\text{Min}(P_{\text{rated,c,TRP}} - 60\text{dB}, -16\text{dBm})/100\text{kHz}$.</p> <p>NOTE 2: For AAS BS supporting multi-band operation with Inter RF Bandwidth gap $< 2 \times \Delta f_{\text{OBUE}}$ the minimum requirement within the Inter RF Bandwidth gaps is calculated as a cumulative sum of contributions from adjacent sub-blocks or RF Bandwidth on each side of the Inter RF Bandwidth gap, where the contribution from the far-end sub-block shall be scaled according to the measurement bandwidth of the near-end sub-block.</p> <p>NOTE 3: For operation with an E-UTRA 1.4 or 3MHz carrier adjacent to the Base Station RF Bandwidth edge, the limits in Table 6.7.5.5.3-5 apply for $0 \text{ MHz} \leq \Delta f < 0.15 \text{ MHz}$.</p> <p>NOTE 4: This frequency range ensures that the range of values of f_{offset} is continuous.</p> <p>NOTE 5: The requirement is not applicable when $\Delta f_{\text{max}} < 10 \text{ MHz}$.</p>			

Table 6.7.5.5.3-4: Medium Range BS operating band unwanted emission mask (UEM) for BC2, $P_{\text{rated,c,TRP}} \leq 40$ dBm

Frequency offset of measurement filter -3dB point, Δf	Frequency offset of measurement filter centre frequency, f_{offset}	Test requirement (Notes 2 and 3)	Measurement bandwidth
$0 \text{ MHz} \leq \Delta f < 0.6 \text{ MHz}$ (Note 1)	$0.015 \text{ MHz} \leq f_{\text{offset}} < 0.615 \text{ MHz}$	$-16.2\text{dBm} - 5/3(f_{\text{offset}}/\text{MHz} - 0.015)\text{dB}$	30 kHz
$0.6 \text{ MHz} \leq \Delta f < 1 \text{ MHz}$	$0.615 \text{ MHz} \leq f_{\text{offset}} < 1.015 \text{ MHz}$	$-11.2\text{dBm} - 15(f_{\text{offset}}/\text{MHz} - 0.215)\text{dB}$	30 kHz
(Note 8)	$1.015 \text{ MHz} \leq f_{\text{offset}} < 1.5 \text{ MHz}$	-23.2 dBm	30 kHz
$1 \text{ MHz} \leq \Delta f \leq 5 \text{ MHz}$	$1.5 \text{ MHz} \leq f_{\text{offset}} < 5.5 \text{ MHz}$	-10.2 dBm	1 MHz
$5 \text{ MHz} \leq \Delta f \leq \min(\Delta f_{\text{max}}, 10 \text{ MHz})$	$5.5 \text{ MHz} \leq f_{\text{offset}} < \min(f_{\text{offset}_{\text{max}}}, 10.5 \text{ MHz})$	-14.2 dBm	1 MHz
$10 \text{ MHz} \leq \Delta f \leq \Delta f_{\text{max}}$	$10.5 \text{ MHz} \leq f_{\text{offset}} < f_{\text{offset}_{\text{max}}}$	-16 dBm (Note 10)	1 MHz
<p>NOTE 1: For operation with a GSM/EDGE or an E-UTRA 1.4 or 3 MHz carrier adjacent to the <i>Base Station RF Bandwidth edge</i>, the limits in table 6.7.5.5.3-6 apply for $0 \text{ MHz} \leq \Delta f < 0.15 \text{ MHz}$.</p> <p>NOTE 2: For MSR RIB supporting non-contiguous spectrum operation within any operating band the <i>test requirement</i> within sub-block gaps is calculated as a cumulative sum of contributions from adjacent sub blocks on each side of the sub block gap. Exception is $\Delta f \geq 10 \text{ MHz}$ from both adjacent sub blocks on each side of the sub-block gap, where the <i>test requirement</i> within sub-block gaps shall be $-16 \text{ dBm}/\text{MHz}$.</p> <p>NOTE 3: For MSR <i>multi-band RIB</i> with <i>Inter RF Bandwidth gap</i> $< 2 \times \Delta f_{\text{OBUE}}$ MHz the <i>test requirement</i> within the <i>Inter RF Bandwidth gaps</i> is calculated as a cumulative sum of contributions from adjacent sub-blocks on each side of the <i>Inter RF Bandwidth gap</i>.</p> <p>NOTE 8: This frequency range ensures that the range of values of f_{offset} is continuous.</p> <p>NOTE 10: The requirement is not applicable when $\Delta f_{\text{max}} < 10 \text{ MHz}$</p>			

Table 6.7.5.5.3-4a: Medium Range BS operating band unwanted emission mask (UEM) for BS supporting NR and not supporting UTRA in BC2 bands, BS maximum output power $P_{rated,c,TRP} \leq 40$ dBm

Frequency offset of measurement filter -3dB point, Δf	Frequency offset of measurement filter centre frequency, f_{offset}	Minimum requirement (Note 1, 2)	Measurement bandwidth (Note 7)
$0 \text{ MHz} \leq \Delta f < 5 \text{ MHz}$	$0.05 \text{ MHz} \leq f_{offset} < 5.05 \text{ MHz}$	$-11.2 \text{ dBm} - 7/5(f_{offset}/\text{MHz} - 0.05) \text{ dB}$	100 kHz
$5 \text{ MHz} \leq \Delta f < \min(10 \text{ MHz}, \Delta f_{max})$	$5.05 \text{ MHz} \leq f_{offset} < \min(10.05 \text{ MHz}, f_{offset_{max}})$	-18.2 dBm	100 kHz
$10 \text{ MHz} \leq \Delta f \leq \Delta f_{max}$	$10.05 \text{ MHz} \leq f_{offset} < f_{offset_{max}}$	-20 dBm (Note 5)	100 kHz

NOTE 1: For AAS BS supporting non-contiguous spectrum operation within any operating band the minimum requirement within sub-block gaps is calculated as a cumulative sum of contributions from adjacent sub blocks on each side of the sub block gap, where the contribution from the far-end sub-block shall be scaled according to the measurement bandwidth of the near-end sub-block. Exception is $\Delta f \geq 10\text{MHz}$ from both adjacent sub blocks on each side of the sub-block gap, where the minimum requirement within sub-block gaps shall be -20dBm/100kHz.

NOTE 2: For AAS BS supporting multi-band operation with Inter RF Bandwidth gap $< 2 \times \Delta f_{OBUE}$ the minimum requirement within the Inter RF Bandwidth gaps is calculated as a cumulative sum of contributions from adjacent sub-blocks or RF Bandwidth on each side of the Inter RF Bandwidth gap, where the contribution from the far-end sub-block shall be scaled according to the measurement bandwidth of the near-end sub-block.

NOTE 3: For operation with an E-UTRA 1.4 or 3MHz carrier adjacent to the Base Station RF Bandwidth edge, the limits in Table 6.7.5.5.3-6 apply for $0 \text{ MHz} \leq \Delta f < 0.15 \text{ MHz}$.

NOTE 4: This frequency range ensures that the range of values of f_{offset} is continuous.

NOTE 5: The requirement is not applicable when $\Delta f_{max} < 10 \text{ MHz}$.

Table 6.7.5.5.3-5: Medium Range operating band unwanted emission limits for operation in BC2 with GSM/EDGE or E-UTRA 1.4 or 3 MHz carriers adjacent to the Base Station RF Bandwidth edge, $40 < P_{rated,c,TRP} \leq 47$ dBm

Frequency offset of measurement filter -3dB point, Δf	Frequency offset of measurement filter centre frequency, f_{offset}	Test requirement (Notes 2 and 3)	Measurement bandwidth
$0 \text{ MHz} \leq \Delta f < 0.05 \text{ MHz}$	$0.015 \text{ MHz} \leq f_{offset} < 0.065 \text{ MHz}$	$P_{rated,c,TRP} - 36.2 - 60(f_{offset} - 0.015)$	30 kHz
$0.05 \text{ MHz} \leq \Delta f < 0.15 \text{ MHz}$	$0.065 \text{ MHz} \leq f_{offset} < 0.165 \text{ MHz}$	$P_{rated,c,TRP} - 39.2 - 160(f_{offset} - 0.065)$	30 kHz

NOTE 1: The limits in this table only apply for operation with a GSM/EDGE or an E-UTRA 1.4 or 3 MHz carrier adjacent to the Base Station RF Bandwidth edge.

NOTE 2: For MSR RIB supporting non-contiguous spectrum operation within any operating band the *test requirement* within sub-block gaps is calculated as a cumulative sum of contributions from adjacent sub blocks on each side of the sub block gap.

NOTE 3: For MSR *multi-band RIB* with *Inter RF Bandwidth gap* $< 2 \times \Delta f_{OBUE}$ MHz the *test requirement* within the *Inter RF Bandwidth gaps* is calculated as a cumulative sum of contributions from adjacent sub-blocks on each side of the *Inter RF Bandwidth gap*.

NOTE 8: This frequency range ensures that the range of values of f_{offset} is continuous.

NOTE 10: The requirement is not applicable when $\Delta f_{max} < 10 \text{ MHz}$.

Table 6.7.5.5.3-6: Medium Range operating band unwanted emission limits for operation in BC2 with GSM/EDGE or E-UTRA 1.4 or 3 MHz carriers adjacent to the *Base Station RF Bandwidth edge*, $P_{\text{rated,c,TRP}} \leq 40$ dBm

Frequency offset of measurement filter -3dB point, Δf	Frequency offset of measurement filter centre frequency, f_{offset}	Test requirement (Notes 2, 3 and 4)	Measurement bandwidth
$0 \text{ MHz} \leq \Delta f < 0.05 \text{ MHz}$	$0.015 \text{ MHz} \leq f_{\text{offset}} < 0.065$	$\text{Max}(3.8-60(f_{\text{offset}}/\text{MHz}-0.015)+X, -16.2) \text{ dBm}$	30 kHz
$0.05 \text{ MHz} \leq \Delta f < 0.15 \text{ MHz}$	$0.065 \text{ MHz} \leq f_{\text{offset}} < 0.165 \text{ MHz}$	$\text{Max}(0.8-160(f_{\text{offset}}/\text{MHz}-0.065)+X, -16.2) \text{ dBm}$	30 kHz

NOTE 1: The limits in this table only apply for operation with a GSM/EDGE or an E-UTRA 1.4 or 3 MHz carrier adjacent to the *Base Station RF Bandwidth edge*.

NOTE 2: For MSR RIB supporting non-contiguous spectrum operation within any operating band the *test requirement* within sub-block gaps is calculated as a cumulative sum of contributions from adjacent sub blocks on each side of the sub block gap.

NOTE 3: For *multi-band RIB* with *Inter RF Bandwidth gap* $< 2 \times \Delta f_{\text{OBUE}}$ MHz the *test requirement* within the *Inter RF Bandwidth gaps* is calculated as a cumulative sum of contributions from adjacent sub-blocks on each side of the *Inter RF Bandwidth gap*.

NOTE 4: In case the carrier adjacent to the *Base Station RF Bandwidth edge* is a GSM/EDGE carrier, the value of $X = P_{\text{GSMcarrier}} - 31$, where $P_{\text{GSMcarrier}}$ is the power level of the GSM/EDGE carrier adjacent to the *Base Station RF Bandwidth edge*. In other cases, $X = 0$.

NOTE 8: This frequency range ensures that the range of values of f_{offset} is continuous.

NOTE 10: The requirement is not applicable when $\Delta f_{\text{max}} < 10$ MHz

Table 6.7.5.5.3-7: Local Area operating band unwanted emission mask (UEM) for BC2

Frequency offset of measurement filter -3dB point, Δf	Frequency offset of measurement filter centre frequency, f_{offset}	Test requirement (Notes 2 and 3)	Measurement bandwidth
$0 \text{ MHz} \leq \Delta f < 5 \text{ MHz}$ (Note 1)	$0.05 \text{ MHz} \leq f_{\text{offset}} < 5.05 \text{ MHz}$	$-19.2-7/5(f_{\text{offset}}/\text{MHz}-0.05) \text{ dBm}$	100 kHz
$5 \text{ MHz} \leq \Delta f < \min(10 \text{ MHz}, \Delta f_{\text{max}})$	$5.05 \text{ MHz} \leq f_{\text{offset}} < \min(10.05 \text{ MHz}, f_{\text{offsetmax}})$	-26.2 dBm	100 kHz
$10 \text{ MHz} \leq \Delta f \leq \Delta f_{\text{max}}$	$10.05 \text{ MHz} \leq f_{\text{offset}} < f_{\text{offsetmax}}$	-28 dBm (Note 10)	100 kHz

NOTE 1: For operation with a GSM/EDGE or an E-UTRA 1.4 or 3 MHz carrier adjacent to the *Base Station RF Bandwidth edge*, the limits in table 6.6.5.5.3-8 apply for $0 \text{ MHz} \leq \Delta f < 0.16 \text{ MHz}$.

NOTE 2: For MSR RIB supporting non-contiguous spectrum operation within any operating band the *test requirement* within sub-block gaps is calculated as a cumulative sum of contributions from adjacent sub blocks on each side of the sub block gap. Exception is $\Delta f \geq 10$ MHz from both adjacent sub blocks on each side of the sub-block gap, where the *test requirement* within sub-block gaps shall be -28 dBm/100 kHz.

NOTE 3: For MSR *multi-band RIB* with *Inter RF Bandwidth gap* $< 2 \times \Delta f_{\text{OBUE}}$ MHz the *test requirement* within the *Inter RF Bandwidth gaps* is calculated as a cumulative sum of contributions from adjacent sub-blocks on each side of the *Inter RF Bandwidth gap*.

NOTE 8: This frequency range ensures that the range of values of f_{offset} is continuous.

NOTE 10: The requirement is not applicable when $\Delta f_{\text{max}} < 10$ MHz

Table 6.7.5.5.3-8: Local Area operating band unwanted emission limits for operation in BC2 with GSM/EDGE or E-UTRA 1.4 or 3 MHz carriers adjacent to the *Base Station RF Bandwidth edge*

Frequency offset of measurement filter -3dB point, Δf	Frequency offset of measurement filter centre frequency, f_{offset}	Test requirement (Notes 2, 3 and 4)	Measurement bandwidth
$0 \text{ MHz} \leq \Delta f < 0.05 \text{ MHz}$	$0.015 \text{ MHz} \leq f_{\text{offset}} < 0.065 \text{ MHz}$	$\text{Max}(-3.2\text{dBm}-60(f_{\text{offset}}/\text{MHz}-0.015)\text{dB} + X \text{ dB}, -24.2\text{dBm})$	30 kHz
$0.05 \text{ MHz} \leq \Delta f < 0.16 \text{ MHz}$	$0.065 \text{ MHz} \leq f_{\text{offset}} < 0.175 \text{ MHz}$	$\text{max}(-6.2\text{dBm}-160(f_{\text{offset}}/\text{MHz}-0.065)\text{dB} + X \text{ dB}, -24.2 \text{ dBm})$	30 kHz

NOTE 1: The limits in this table only apply for operation with a GSM/EDGE or an E-UTRA 1.4 or 3 MHz carrier adjacent to the *Base Station RF Bandwidth edge*.

NOTE 2: For MSR *RIB* supporting non-contiguous spectrum operation within any operating band the *test requirement* within sub-block gaps is calculated as a cumulative sum of contributions from adjacent sub blocks on each side of the sub block gap.

NOTE 3: For MSR *multi-band RIB* with *Inter RF Bandwidth gap* $< 2 \times \Delta f_{\text{OBUe}}$ MHz the *test requirement* within the *Inter RF Bandwidth gaps* is calculated as a cumulative sum of contributions from adjacent sub-blocks on each side of the *Inter RF Bandwidth gap*.

NOTE 4: In case the carrier adjacent to the *Base Station RF Bandwidth edge* is a GSM/EDGE carrier, the value of $X = P_{\text{GSMcarrier}} - 24$, where $P_{\text{GSMcarrier}}$ is the power level of the GSM/EDGE carrier adjacent to the *Base Station RF Bandwidth edge*. In other cases, $X = 0$.

NOTE 8: This frequency range ensures that the range of values of f_{offset} is continuous.

NOTE 10: The requirement is not applicable when $\Delta f_{\text{max}} < 10 \text{ MHz}$

NOTE 9: As a general rule for the requirements in the present subclause, the resolution bandwidth of the measuring equipment should be equal to the measurement bandwidth. However, to improve measurement accuracy, sensitivity and efficiency, the resolution bandwidth may be smaller than the measurement bandwidth. When the resolution bandwidth is smaller than the measurement bandwidth, the result should be integrated over the measurement bandwidth in order to obtain the equivalent noise bandwidth of the measurement bandwidth.

6.7.5.5.4 MSR Additional requirements

6.7.5.5.4.1 Limits in FCC Title 47

In addition to the requirements in subclauses 6.7.5.5.2 and 6.7.5.5.3, the AAS BSW may have to comply with the applicable emission limits established by FCC Title 47 [18], when deployed in regions where those limits are applied, and under the conditions declared by the manufacturer.

6.7.5.5.4.2 Unsynchronized operation for BC3

In certain regions, the following requirements may apply to a TDD AAS BS operating in BC3 in the same geographic area and in the same operating band as another TDD system without synchronisation. For this case the emissions shall not exceed -52 dBm/MHz in each supported downlink operating band except in:

- The frequency range from 10 MHz below the lower *Base Station RF Bandwidth edge* to the frequency 10 MHz above the upper *Base Station RF Bandwidth edge* of each supported band.

NOTE 1: Local or regional regulations may specify another excluded frequency range, which may include frequencies where synchronised TDD systems operate.

NOTE 2: TDD Base Stations that are synchronized and operating in BC3 can transmit without these additional co-existence requirements.

6.7.5.5.4.3 Protection of DTT

In certain regions the following requirement may apply for protection of DTT. For an AAS BS operating in Band 20/n20, the level of emissions in the band 470-790 MHz, measured in an 8 MHz filter bandwidth on centre frequencies F_{filter} according to table 6.7.5.5.4.3-1, shall not exceed the maximum emission level TRP level shown in the table. This requirement applies in the frequency range 470-790 MHz even though part of the range falls in the spurious domain.

Table 6.7.5.5.4.3-1: Declared emissions levels for protection of DTT

Case	Measurement filter centre frequency	Condition on BS maximum aggregate TRP / 10 MHz, $P_{\text{TRP_10MHz}}$ (NOTE)	Maximum Level $P_{\text{TRP,N,MAX}}$	Measurement Bandwidth
A: for DTT frequencies where broadcasting is protected	$N*8 + 306$ MHz, $21 \leq N \leq 60$	$P_{\text{TRP_10MHz}} \geq 59$ dBm	1.8dBm	8 MHz
	$N*8 + 306$ MHz, $21 \leq N \leq 60$	$36 \leq P_{\text{TRP_10MHz}} < 59$ dBm	$P_{\text{TRP_10MHz}} - 57.2$ dBm	8 MHz
	$N*8 + 306$ MHz, $21 \leq N \leq 60$	$P_{\text{TRP_10MHz}} < 36$ dBm	-21.2dBm	8 MHz
B: for DTT frequencies where broadcasting is subject to an intermediate level of protection	$N*8 + 306$ MHz, $21 \leq N \leq 60$	$P_{\text{TRP_10MHz}} \geq 59$ dBm	11.8 dBm	8 MHz
	$N*8 + 306$ MHz, $21 \leq N \leq 60$	$36 \leq P_{\text{TRP_10MHz}} < 59$ dBm	$P_{\text{TRP_10MHz}} - 47.2$ dBm	8 MHz
	$N*8 + 306$ MHz, $21 \leq N \leq 60$	$P_{\text{TRP_10MHz}} < 36$ dBm	-11.2dBm	8 MHz
C: for DTT frequencies where broadcasting is not protected	$N*8 + 306$ MHz, $21 \leq N \leq 60$	N.A.	23.8 dBm	8 MHz
NOTE: $P_{\text{TRP_10MHz}}$ (dBm) is defined by the expression $P_{\text{TRP_10MHz}} = P_{10\text{MHz}} + G_{\text{ant}} + 6\text{dB}$ for UTRA and $P_{\text{TRP_10MHz}} = P_{10\text{MHz}} + G_{\text{ant}} + 9\text{dB}$ for E-UTRA, where G_{ant} is 17 dBi				

NOTE: The regional requirement is defined in terms of EIRP (effective isotropic radiated power), which is dependent on both the BS emissions and the deployment (including antenna gain and feeder loss). The method outlined in annex B1, 3GPP TS 37.105 [6] indicates how the limit in Table 6.7.5.5.4.3-1 demonstrates compliance to the regional requirement.

6.7.5.5.5 E-UTRA

6.7.5.5.5.1 General

The measurement results in subclause 6.7.5.4 shall not exceed the maximum levels specified in the tables below, where:

- Δf is the separation between the channel edge frequency and the nominal -3dB point of the measuring filter closest to the carrier frequency.
- f_{offset} is the separation between the channel edge frequency and the centre of the measuring filter.
- $f_{\text{offset}_{\text{max}}}$ is the offset to the frequency Δf_{OBUE} MHz outside the downlink operating band.
- Δf_{max} is equal to $f_{\text{offset}_{\text{max}}}$ minus half of the bandwidth of the measuring filter.

For a *multi-band RIB*, inside any *Inter RF Bandwidth gaps* with $W_{\text{gap}} < 2 \times \Delta f_{\text{OBUE}}$ MHz, emissions shall not exceed the cumulative sum of the test requirements specified at the *Base Station RF Bandwidth edges* on each side of the *Inter RF Bandwidth gap*. The test requirement for *Base Station RF Bandwidth edge* is specified in Tables 6.7.5.5.5.2-1 to 6.7.5.5.5.2-9, where in this case:

- Δf is the separation between the *Base Station RF Bandwidth edge* frequency and the nominal -3 dB point of the measuring filter closest to the *Base Station RF Bandwidth edge*.
- f_{offset} is the separation between the *Base Station RF Bandwidth edge* frequency and the centre of the measuring filter.

- $f_{\text{offset_max}}$ is equal to the *Inter RF Bandwidth gap* minus half of the bandwidth of the measuring filter.
- Δf_{max} is equal to $f_{\text{offset_max}}$ minus half of the bandwidth of the measuring filter.

For *multi-band RIB*, the operating band unwanted emission limits apply also in a supported operating band without any carrier transmitted, in the case where there are carrier(s) transmitted in another supported operating band. In this case, no cumulative limit is applied in the *inter-band gap* between a supported downlink operating band with carrier(s) transmitted and a supported downlink operating band without any carrier transmitted and:

- In case the *inter-band gap* between a supported downlink operating band with carrier(s) transmitted and a supported downlink operating band without any carrier transmitted is less than $2 \times \Delta f_{\text{OBUE}}$ MHz, $f_{\text{offset_max}}$ shall be the offset to the frequency Δf_{OBUE} MHz outside the outermost edges of the two supported downlink operating bands and the operating band unwanted emission limit of the band where there are carriers transmitted, as defined in the tables of the present subclause, shall apply across both downlink bands.
- In other cases, the operating band unwanted emission limit of the band where there are carriers transmitted, as defined in the tables of the present subclause for the largest frequency offset (Δf_{max}), shall apply from Δf_{OBUE} MHz below the lowest frequency, up to Δf_{OBUE} MHz above the highest frequency of the supported downlink operating band without any carrier transmitted.

For a multicarrier E-UTRA TAB connector or a RIB configured for intra-band contiguous or non-contiguous carrier aggregation the definitions above apply to the lower edge of the carrier transmitted at the lowest carrier frequency and the upper edge of the carrier transmitted at the highest carrier frequency within a specified frequency band.

In addition inside any sub-block gap for a RIB operating in non-contiguous spectrum, measurement results shall not exceed the cumulative sum of the test requirements specified for the adjacent sub blocks on each side of the sub block gap. The minimum requirement for each sub block is specified in Tables 6.7.5.5.2-1 to 6.7.5.5.2-9, where in this case:

- Δf is the separation between the sub block edge frequency and the nominal -3 dB point of the measuring filter closest to the sub block edge.
- f_{offset} is the separation between the sub block edge frequency and the centre of the measuring filter.
- $f_{\text{offset_max}}$ is equal to the sub block gap bandwidth minus half of the bandwidth of the measuring filter.
- Δf_{max} is equal to $f_{\text{offset_max}}$ minus half of the bandwidth of the measuring filter.

6.7.5.5.2 Wide Area BS (Category A)

For E-UTRA RIB operating in Bands 5, 6, 8, 12, 13, 14, 17, 18, 19, 26, 27, 28, 29, 31, 44, 68, 71, 72, 73, 85 emissions shall not exceed the maximum levels specified in Tables 6.7.5.5.2-1 to 6.7.5.5.2-3.

Table 6.7.5.5.2-1: Wide Area BS operating band unwanted emission limits for 1.4 MHz channel bandwidth (E-UTRA bands < 1 GHz) for Category A

Frequency offset of measurement filter -3dB point, Δf	Frequency offset of measurement filter centre frequency, f_{offset}	Test requirement (Notes 1 and 2)	Measurement bandwidth
$0 \text{ MHz} \leq \Delta f < 1.4 \text{ MHz}$	$0.05 \text{ MHz} \leq f_{\text{offset}} < 1.45 \text{ MHz}$	9.8 dBm - $10/1.4(f_{\text{offset}}/\text{MHz}-0.05)$ dB	100 kHz
$1.4 \text{ MHz} \leq \Delta f < 2.8 \text{ MHz}$	$1.45 \text{ MHz} \leq f_{\text{offset}} < 2.85 \text{ MHz}$	-0.2 dBm	100 kHz
$2.8 \text{ MHz} \leq \Delta f \leq \min(10 \text{ MHz}, \Delta f_{\text{max}})$	$2.85 \text{ MHz} \leq f_{\text{offset}} < \min(10.05 \text{ MHz}, f_{\text{offset_max}})$	-2.2 dBm	100 kHz
$10 \text{ MHz} \leq \Delta f \leq \Delta f_{\text{max}}$	$10.05 \text{ MHz} \leq f_{\text{offset}} < f_{\text{offset_max}}$	-4 dBm (Note 8)	100 kHz
NOTE 1: For a RIB supporting non-contiguous spectrum operation within any operating band the test requirement within sub-block gaps is calculated as a cumulative sum of contributions from adjacent sub blocks on each side of the sub block gap. Exception is $\Delta f \geq 10$ MHz from both adjacent sub blocks on each side of the sub-block gap, where the test requirement within sub-block gaps shall be -4 dBm/100 kHz.			
NOTE 2: For a <i>multi-band RIB</i> with <i>Inter RF Bandwidth gap</i> < $2 \times \Delta f_{\text{OBUE}}$ MHz the test requirement within the <i>Inter RF Bandwidth gaps</i> is calculated as a cumulative sum of contributions from adjacent sub-blocks or <i>Base Station RF Bandwidth</i> on each side of the <i>Inter RF Bandwidth gap</i> .			
NOTE 8: The requirement is not applicable when $\Delta f_{\text{max}} < 10$ MHz.			

Table 6.7.5.5.2-2: Wide Area BS operating band unwanted emission limits for 3 MHz channel bandwidth (E-UTRA bands < 1 GHz) for Category A

Frequency offset of measurement filter -3dB point, Δf	Frequency offset of measurement filter centre frequency, f_{offset}	Test requirement (Notes 1 and 2)	Measurement bandwidth
$0 \text{ MHz} \leq \Delta f < 3 \text{ MHz}$	$0.05 \text{ MHz} \leq f_{\text{offset}} < 3.05 \text{ MHz}$	$5.8 \text{ dBm} - 10/3(f_{\text{offset}}/\text{MHz} - 0.05) \text{ dB}$	100 kHz
$3 \text{ MHz} \leq \Delta f < 6 \text{ MHz}$	$3.05 \text{ MHz} \leq f_{\text{offset}} < 6.05 \text{ MHz}$	-4.2 dBm	100 kHz
$6 \text{ MHz} \leq \Delta f \leq \min(10 \text{ MHz}, \Delta f_{\text{max}})$	$6.05 \text{ MHz} \leq f_{\text{offset}} < \min(10.05 \text{ MHz}, f_{\text{offset}_{\text{max}}})$	-2.2 dBm (Note 8)	100 kHz
$10 \text{ MHz} \leq \Delta f \leq \Delta f_{\text{max}}$	$10.05 \text{ MHz} \leq f_{\text{offset}} < f_{\text{offset}_{\text{max}}}$	-4 dBm (Note 8)	100 kHz
<p>NOTE 1: For a RIB supporting non-contiguous spectrum operation within any operating band the test requirement within sub-block gaps is calculated as a cumulative sum of contributions from adjacent sub blocks on each side of the sub block gap. Exception is $\Delta f \geq 10 \text{ MHz}$ from both adjacent sub blocks on each side of the sub-block gap, where the test requirement within sub-block gaps shall be -4 dBm/100 kHz.</p> <p>NOTE 2: For a <i>multi-band RIB</i> with <i>Inter RF Bandwidth gap</i> $< 2 \times \Delta f_{\text{OBUE}}$ MHz the test requirement within the <i>Inter RF Bandwidth gaps</i> is calculated as a cumulative sum of contributions from adjacent sub-blocks or <i>Base Station RF Bandwidth</i> on each side of the <i>Inter RF Bandwidth gap</i>.</p> <p>NOTE 8: The requirement is not applicable when $\Delta f_{\text{max}} < 10 \text{ MHz}$.</p>			

Table 6.7.5.5.2-3: Wide Area BS operating band unwanted emission limits for 5, 10, 15 and 20 MHz channel bandwidth (E-UTRA bands < 1 GHz) for Category A

Frequency offset of measurement filter -3dB point, Δf	Frequency offset of measurement filter centre frequency, f_{offset}	Test requirement (Notes 1 and 2)	Measurement bandwidth
$0 \text{ MHz} \leq \Delta f < 5 \text{ MHz}$	$0.05 \text{ MHz} \leq f_{\text{offset}} < 5.05 \text{ MHz}$	$3.8 \text{ dBm} - 7/5(f_{\text{offset}}/\text{MHz} - 0.05) \text{ dB}$	100 kHz
$5 \text{ MHz} \leq \Delta f < \min(10 \text{ MHz}, \Delta f_{\text{max}})$	$5.05 \text{ MHz} \leq f_{\text{offset}} < \min(10.05 \text{ MHz}, f_{\text{offset}_{\text{max}}})$	-3.2 dBm	100 kHz
$10 \text{ MHz} \leq \Delta f \leq \Delta f_{\text{max}}$	$10.05 \text{ MHz} \leq f_{\text{offset}} < f_{\text{offset}_{\text{max}}}$	-4 dBm (NOTE 8)	100 kHz
<p>NOTE 1: For a RIB supporting non-contiguous spectrum operation within any operating band the test requirement within sub-block gaps is calculated as a cumulative sum of contributions from adjacent sub blocks on each side of the sub block gap. Exception is $\Delta f \geq 10 \text{ MHz}$ from both adjacent sub blocks on each side of the sub-block gap, where the test requirement within sub-block gaps shall be -4 dBm/100 kHz.</p> <p>NOTE 2: For a <i>multi-band RIB</i> with <i>Inter RF Bandwidth gap</i> $< 2 \times \Delta f_{\text{OBUE}}$ MHz the test requirement within the <i>Inter RF Bandwidth gaps</i> is calculated as a cumulative sum of contributions from adjacent sub-blocks or <i>Base Station RF Bandwidth</i> on each side of the <i>Inter RF Bandwidth gap</i>.</p> <p>NOTE 8: The requirement is not applicable when $\Delta f_{\text{max}} < 10 \text{ MHz}$.</p>			

For E-UTRA *RIB* operating in Bands 1, 2, 3, 4, 7, 9, 10, 11, 21, 23, 24, 25, 30, 32, 33, 34, 35, 36, 37, 38, 39, 40, 41, 45, 48, 65, 66, 69, 70, emissions shall not exceed the maximum levels specified in tables 6.6.5.5.2-4, 6.6.5.5.2-6 and 6.6.5.5.2-8.

For E-UTRA *RIB* operating in Bands 22, 42, 43, 52 emissions shall not exceed the maximum levels specified in tables 6.6.5.5.2-5, 6.6.5.5.2-7 and 6.6.5.5.2-9.

Table 6.7.5.5.2-4: Wide Area BS operating band unwanted emission limits for 1.4 MHz channel bandwidth (1GHz < E-UTRA bands ≤ 3 GHz) for Category A

Frequency offset of measurement filter -3dB point, Δf	Frequency offset of measurement filter centre frequency, f_{offset}	Test requirement (Notes 1 and 2)	Measurement bandwidth
$0 \text{ MHz} \leq \Delta f < 1.4 \text{ MHz}$	$0.05 \text{ MHz} \leq f_{\text{offset}} < 1.45 \text{ MHz}$	$9.8 \text{ dBm} - 10/1.4(f_{\text{offset}}/\text{MHz}-0.05) \text{ dB}$	100 kHz
$1.4 \text{ MHz} \leq \Delta f < 2.8 \text{ MHz}$	$1.45 \text{ MHz} \leq f_{\text{offset}} < 2.85 \text{ MHz}$	-0.2 dBm	100 kHz
$2.8 \text{ MHz} \leq \Delta f < \min(10 \text{ MHz}, \Delta f_{\text{max}})$	$3.3 \text{ MHz} \leq f_{\text{offset}} < \min(10.5 \text{ MHz}, f_{\text{offset}_{\text{max}}})$	-2.2 (Note 8) dBm	1 MHz
$10 \text{ MHz} \leq \Delta f \leq \Delta f_{\text{max}}$	$10.5 \text{ MHz} \leq f_{\text{offset}} < f_{\text{offset}_{\text{max}}}$	-4 dBm (NOTE 8)	1MHz
NOTE 1: For a RIB supporting non-contiguous spectrum operation within any operating band the test requirement within sub-block gaps is calculated as a cumulative sum of contributions from adjacent sub blocks on each side of the sub block gap, where the contribution from the far-end sub-block shall be scaled according to the measurement bandwidth of the near-end sub-block. Exception is $\Delta f \geq 10 \text{ MHz}$ from both adjacent sub blocks on each side of the sub-block gap, where the test requirement within sub-block gaps shall be -4 dBm/1 MHz.			
NOTE 2: For a <i>multi-band RIB</i> with <i>Inter RF Bandwidth gap</i> < $2 \times \Delta f_{\text{OBUE}}$ MHz the test requirement within the <i>Inter RF Bandwidth gaps</i> is calculated as a cumulative sum of contributions from adjacent sub-blocks or <i>Base Station RF Bandwidth</i> on each side of the <i>Inter RF Bandwidth gap</i> , where the contribution from the far-end sub-block or <i>Base Station RF Bandwidth</i> shall be scaled according to the measurement bandwidth of the near-end sub-block or <i>Base Station RF Bandwidth</i> .			
NOTE 8: The requirement is not applicable when $\Delta f_{\text{max}} < 10 \text{ MHz}$.			

Table 6.7.5.5.2-5: Wide Area BS operating band unwanted emission limits for 1.4 MHz channel bandwidth (E-UTRA bands > 3 GHz) for Category A

Frequency offset of measurement filter -3dB point, Δf	Frequency offset of measurement filter centre frequency, f_{offset}	Test requirement (Notes 1 and 2)	Measurement bandwidth
$0 \text{ MHz} \leq \Delta f < 1.4 \text{ MHz}$	$0.05 \text{ MHz} \leq f_{\text{offset}} < 1.45 \text{ MHz}$	$10 \text{ dBm} - 10/1.4(f_{\text{offset}}/\text{MHz}-0.05) \text{ dB}$	100 kHz
$1.4 \text{ MHz} \leq \Delta f < 2.8 \text{ MHz}$	$1.45 \text{ MHz} \leq f_{\text{offset}} < 2.85 \text{ MHz}$	0 dBm	100 kHz
$2.8 \text{ MHz} \leq \Delta f < \min(10 \text{ MHz}, \Delta f_{\text{max}})$	$3.3 \text{ MHz} \leq f_{\text{offset}} < \min(10.5 \text{ MHz}, f_{\text{offset}_{\text{max}}})$	-2 (Note 8) dBm	1 MHz
$10 \text{ MHz} \leq \Delta f \leq \Delta f_{\text{max}}$	$10.5 \text{ MHz} \leq f_{\text{offset}} < f_{\text{offset}_{\text{max}}}$	-4 dBm (NOTE 8)	1 MHz
NOTE 1: For a RIB supporting non-contiguous spectrum operation within any operating band the test requirement within sub-block gaps is calculated as a cumulative sum of contributions from adjacent sub blocks on each side of the sub block gap, where the contribution from the far-end sub-block shall be scaled according to the measurement bandwidth of the near-end sub-block. Exception is $\Delta f \geq 10 \text{ MHz}$ from both adjacent sub blocks on each side of the sub-block gap, where the test requirement within sub-block gaps shall be -4 dBm/1 MHz.			
NOTE 2: For a <i>multi-band RIB</i> with <i>Inter RF Bandwidth gap</i> < $2 \times \Delta f_{\text{OBUE}}$ MHz the test requirement within the <i>Inter RF Bandwidth gaps</i> is calculated as a cumulative sum of contributions from adjacent sub-blocks or <i>Base Station RF Bandwidth</i> on each side of the <i>Inter RF Bandwidth gap</i> , where the contribution from the far-end sub-block or <i>Base Station RF Bandwidth</i> shall be scaled according to the measurement bandwidth of the near-end sub-block or <i>Base Station RF Bandwidth</i> .			
NOTE 8: The requirement is not applicable when $\Delta f_{\text{max}} < 10 \text{ MHz}$.			

Table 6.7.5.5.2-6: Wide Area BS operating band unwanted emission limits for 3 MHz channel bandwidth (1GHz < E-UTRA bands ≤ 3 GHz) for Category A

Frequency offset of measurement filter -3dB point, Δf	Frequency offset of measurement filter centre frequency, f_{offset}	Test requirement (Notes 1 and 2)	Measurement bandwidth
$0 \text{ MHz} \leq \Delta f < 3 \text{ MHz}$	$0.05 \text{ MHz} \leq f_{\text{offset}} < 3.05 \text{ MHz}$	5.8 dBm - 10/3(f_{offset} /MHz-0.05) dB	100 kHz
$3 \text{ MHz} \leq \Delta f < 6 \text{ MHz}$	$3.05 \text{ MHz} \leq f_{\text{offset}} < 6.05 \text{ MHz}$	-4.2 dBm	100 kHz
$6 \text{ MHz} \leq \Delta f < \min(10 \text{ MHz}, \Delta f_{\text{max}})$	$6.5 \text{ MHz} \leq f_{\text{offset}} < \min(10.5 \text{ MHz}, f_{\text{offset}_{\text{max}}})$	-2.2 dBm (Note 8)	1 MHz
$10 \text{ MHz} \leq \Delta f \leq \Delta f_{\text{max}}$	$10.5 \text{ MHz} \leq f_{\text{offset}} < f_{\text{offset}_{\text{max}}}$	-4 dBm (Note 8)	1 MHz
NOTE 1: For a RIB supporting non-contiguous spectrum operation within any operating band the test requirement within sub-block gaps is calculated as a cumulative sum of contributions from adjacent sub blocks on each side of the sub block gap, where the contribution from the far-end sub-block shall be scaled according to the measurement bandwidth of the near-end sub-block. Exception is $\Delta f \geq 10$ MHz from both adjacent sub blocks on each side of the sub-block gap, where the test requirement within sub-block gaps shall be -4 dBm/1 MHz.			
NOTE 2: For a <i>multi-band RIB</i> with <i>Inter RF Bandwidth gap</i> < $2 \times \Delta f_{\text{OBUE}}$ MHz the test requirement within the <i>Inter RF Bandwidth gaps</i> is calculated as a cumulative sum of contributions from adjacent sub-blocks or <i>Base Station RF Bandwidth</i> on each side of the <i>Inter RF Bandwidth gap</i> , where the contribution from the far-end sub-block or <i>Base Station RF Bandwidth</i> shall be scaled according to the measurement bandwidth of the near-end sub-block or <i>Base Station RF Bandwidth</i> .			
NOTE 8: The requirement is not applicable when $\Delta f_{\text{max}} < 10$ MHz.			

Table 6.7.5.5.2-7: Wide Area BS operating band unwanted emission limits for 3 MHz channel bandwidth (E-UTRA bands > 3 GHz) for Category A

Frequency offset of measurement filter -3dB point, Δf	Frequency offset of measurement filter centre frequency, f_{offset}	Test requirement (Notes 1 and 2)	Measurement bandwidth
$0 \text{ MHz} \leq \Delta f < 3 \text{ MHz}$	$0.05 \text{ MHz} \leq f_{\text{offset}} < 3.05 \text{ MHz}$	6 dBm - 10/3(f_{offset} /MHz-0.05) dB	100 kHz
$3 \text{ MHz} \leq \Delta f < 6 \text{ MHz}$	$3.05 \text{ MHz} \leq f_{\text{offset}} < 6.05 \text{ MHz}$	-4.0 dBm	100 kHz
$6 \text{ MHz} \leq \Delta f < \min(10 \text{ MHz}, \Delta f_{\text{max}})$	$6.5 \text{ MHz} \leq f_{\text{offset}} < \min(10.5 \text{ MHz}, f_{\text{offset}_{\text{max}}})$	-2.0 dBm (Note 8)	1 MHz
$10 \text{ MHz} \leq \Delta f \leq \Delta f_{\text{max}}$	$10.5 \text{ MHz} \leq f_{\text{offset}} < f_{\text{offset}_{\text{max}}}$	-4 dBm (Note 8)	1 MHz
NOTE 1: For a RIB supporting non-contiguous spectrum operation within any operating band the test requirement within sub-block gaps is calculated as a cumulative sum of contributions from adjacent sub blocks on each side of the sub block gap, where the contribution from the far-end sub-block shall be scaled according to the measurement bandwidth of the near-end sub-block. Exception is $\Delta f \geq 10$ MHz from both adjacent sub blocks on each side of the sub-block gap, where the test requirement within sub-block gaps shall be -4 dBm/1 MHz.			
NOTE 2: For a <i>multi-band RIB</i> with <i>Inter RF Bandwidth gap</i> < $2 \times \Delta f_{\text{OBUE}}$ MHz the test requirement within the <i>Inter RF Bandwidth gaps</i> is calculated as a cumulative sum of contributions from adjacent sub-blocks or <i>Base Station RF Bandwidth</i> on each side of the <i>Inter RF Bandwidth gap</i> , where the contribution from the far-end sub-block or <i>Base Station RF Bandwidth</i> shall be scaled according to the measurement bandwidth of the near-end sub-block or <i>Base Station RF Bandwidth</i> .			
NOTE 8: The requirement is not applicable when $\Delta f_{\text{max}} < 10$ MHz.			

Table 6.7.5.5.2-8: Wide Area BS operating band unwanted emission limits for 5, 10, 15 and 20 MHz channel bandwidth (1GHz < E-UTRA bands ≤ 3 GHz) for Category A

Frequency offset of measurement filter -3dB point, Δf	Frequency offset of measurement filter centre frequency, f_{offset}	Test requirement (Notes 1 and 2)	Measurement bandwidth
$0 \text{ MHz} \leq \Delta f < 5 \text{ MHz}$	$0.05 \text{ MHz} \leq f_{\text{offset}} < 5.05 \text{ MHz}$	$3.8 \text{ dBm} - 7/5(f_{\text{offset}}/\text{MHz} - 0.05) \text{ dB}$	100 kHz
$5 \text{ MHz} \leq \Delta f < \min(10 \text{ MHz}, \Delta f_{\text{max}})$	$5.05 \text{ MHz} \leq f_{\text{offset}} < \min(10.05 \text{ MHz}, f_{\text{offset}_{\text{max}}})$	-3.2 dBm	100 kHz
$10 \text{ MHz} \leq \Delta f \leq \Delta f_{\text{max}}$	$10.5 \text{ MHz} \leq f_{\text{offset}} < f_{\text{offset}_{\text{max}}}$	-4 dBm (NOTE 8)	1 MHz
NOTE 1: For a RIB supporting non-contiguous spectrum operation within any operating band the test requirement within sub-block gaps is calculated as a cumulative sum of contributions from adjacent sub blocks on each side of the sub block gap, where the contribution from the far-end sub-block shall be scaled according to the measurement bandwidth of the near-end sub-block. Exception is $\Delta f \geq 10 \text{ MHz}$ from both adjacent sub blocks on each side of the sub-block gap, where the test requirement within sub-block gaps shall be -4 dBm/1 MHz.			
NOTE 2: For a multi-band RIB with Inter RF Bandwidth gap < $2 \times \Delta f_{\text{OBUE}}$ MHz the test requirement within the Inter RF Bandwidth gaps is calculated as a cumulative sum of contributions from adjacent sub-blocks or Base Station RF Bandwidth on each side of the Inter RF Bandwidth gap, where the contribution from the far-end sub-block or Base Station RF Bandwidth shall be scaled according to the measurement bandwidth of the near-end sub-block or Base Station RF Bandwidth.			
NOTE 8: The requirement is not applicable when $\Delta f_{\text{max}} < 10 \text{ MHz}$.			

Table 6.7.5.5.2-9: Wide Area BS operating band unwanted emission limits for 5, 10, 15 and 20 MHz channel bandwidth (E-UTRA bands > 3 GHz) for Category A

Frequency offset of measurement filter -3dB point, Δf	Frequency offset of measurement filter centre frequency, f_{offset}	Test requirement (Notes 1 and 2)	Measurement bandwidth
$0 \text{ MHz} \leq \Delta f < 5 \text{ MHz}$	$0.05 \text{ MHz} \leq f_{\text{offset}} < 5.05 \text{ MHz}$	$4 \text{ dBm} - 7/5(f_{\text{offset}}/\text{MHz} - 0.05) \text{ dB}$	100 kHz
$5 \text{ MHz} \leq \Delta f < \min(10 \text{ MHz}, \Delta f_{\text{max}})$	$5.05 \text{ MHz} \leq f_{\text{offset}} < \min(10.05 \text{ MHz}, f_{\text{offset}_{\text{max}}})$	-3 dBm	100 kHz
$10 \text{ MHz} \leq \Delta f \leq \Delta f_{\text{max}}$	$10.5 \text{ MHz} \leq f_{\text{offset}} < f_{\text{offset}_{\text{max}}}$	-4 dBm (NOTE 8)	1 MHz
NOTE 1: For a RIB supporting non-contiguous spectrum operation within any operating band the test requirement within sub-block gaps is calculated as a cumulative sum of contributions from adjacent sub blocks on each side of the sub block gap, where the contribution from the far-end sub-block shall be scaled according to the measurement bandwidth of the near-end sub-block. Exception is $\Delta f \geq 10 \text{ MHz}$ from both adjacent sub blocks on each side of the sub-block gap, where the test requirement within sub-block gaps shall be -4 dBm/1 MHz.			
NOTE 2: For a multi-band RIB with Inter RF Bandwidth gap < $2 \times \Delta f_{\text{OBUE}}$ MHz the test requirement within the Inter RF Bandwidth gaps is calculated as a cumulative sum of contributions from adjacent sub-blocks or Base Station RF Bandwidth on each side of the Inter RF Bandwidth gap, where the contribution from the far-end sub-block or Base Station RF Bandwidth shall be scaled according to the measurement bandwidth of the near-end sub-block or Base Station RF Bandwidth.			
NOTE 8: The requirement is not applicable when $\Delta f_{\text{max}} < 10 \text{ MHz}$.			

6.7.5.5.3 Wide Area BS Category B (Option1)

For Category B Operating band unwanted emissions, there are two options for the limits that may be applied regionally, option 1 is as follows. For E-UTRA AAS BS operating in Bands 5, 8, 12, 13, 14, 17, 20, 26, 27, 28, 29, 31, 44, 67, 68, 71, 72, 73, 85 emissions shall not exceed the maximum levels specified in Tables 6.7.5.5.3-1 to 6.7.5.5.3-3.

Table 6.7.5.5.3-1: Wide Area BS operating band unwanted emission limits for 1.4 MHz channel bandwidth (E-UTRA bands < 1 GHz) for Category B

Frequency offset of measurement filter -3dB point, Δf	Frequency offset of measurement filter centre frequency, f_{offset}	Test requirement (Notes 1 and 2)	Measurement bandwidth
$0 \text{ MHz} \leq \Delta f < 1.4 \text{ MHz}$	$0.05 \text{ MHz} \leq f_{\text{offset}} < 1.45 \text{ MHz}$	$9.8 \text{ dBm} - 10/1.4(f_{\text{offset}}/\text{MHz}-0.05) \text{ dB}$	100 kHz
$1.4 \text{ MHz} \leq \Delta f < 2.8 \text{ MHz}$	$1.45 \text{ MHz} \leq f_{\text{offset}} < 2.85 \text{ MHz}$	-0.2 dBm	100 kHz
$2.8 \text{ MHz} \leq \Delta f \leq \min(10 \text{ MHz}, \Delta f_{\text{max}})$	$2.85 \text{ MHz} \leq f_{\text{offset}} < \min(10.05 \text{ MHz}, f_{\text{offsetmax}})$	-5.2 dBm	100 kHz
$10 \text{ MHz} \leq \Delta f \leq \Delta f_{\text{max}}$	$10.05 \text{ MHz} \leq f_{\text{offset}} < f_{\text{offsetmax}}$	-7 dBm (Note 8)	100 kHz
NOTE 1: For a RIB supporting non-contiguous spectrum operation within any operating band the test requirement within sub-block gaps is calculated as a cumulative sum of contributions from adjacent sub blocks on each side of the sub block gap. Exception is $\Delta f \geq 10 \text{ MHz}$ from both adjacent sub blocks on each side of the sub-block gap, where the test requirement within sub-block gaps shall be -7 dBm/100 kHz.			
NOTE 2: For a <i>multi-band RIB</i> with <i>Inter RF Bandwidth gap</i> < $2 \times \Delta f_{\text{OBUE}}$ MHz the test requirement within the <i>Inter RF Bandwidth gaps</i> is calculated as a cumulative sum of contributions from adjacent sub-blocks or <i>Base Station RF Bandwidth</i> on each side of the <i>Inter RF Bandwidth gap</i> .			
NOTE 8: The requirement is not applicable when $\Delta f_{\text{max}} < 10 \text{ MHz}$.			

Table 6.7.5.5.3-2: Wide Area BS operating band unwanted emission limits for 3 MHz channel bandwidth (E-UTRA bands < 1 GHz) for Category B

Frequency offset of measurement filter -3dB point, Δf	Frequency offset of measurement filter centre frequency, f_{offset}	Test requirement (Notes 1 and 2)	Measurement bandwidth
$0 \text{ MHz} \leq \Delta f < 3 \text{ MHz}$	$0.05 \text{ MHz} \leq f_{\text{offset}} < 3.05 \text{ MHz}$	$5.8 \text{ dBm} - 10/3(f_{\text{offset}}/\text{MHz}-0.05) \text{ dB}$	100 kHz
$3 \text{ MHz} \leq \Delta f < 6 \text{ MHz}$	$3.05 \text{ MHz} \leq f_{\text{offset}} < 6.05 \text{ MHz}$	-4.2 dBm	100 kHz
$6 \text{ MHz} \leq \Delta f \leq \min(10 \text{ MHz}, \Delta f_{\text{max}})$	$6.05 \text{ MHz} \leq f_{\text{offset}} < \min(10.05 \text{ MHz}, f_{\text{offsetmax}})$	-5.2 dBm (Note 8)	100 kHz
$10 \text{ MHz} \leq \Delta f \leq \Delta f_{\text{max}}$	$10.05 \text{ MHz} \leq f_{\text{offset}} < f_{\text{offsetmax}}$	-7 dBm (Note 8)	100kHz
NOTE 1: For a RIB supporting non-contiguous spectrum operation within any operating band the test requirement within sub-block gaps is calculated as a cumulative sum of contributions from adjacent sub blocks on each side of the sub block gap. Exception is $\Delta f \geq 10 \text{ MHz}$ from both adjacent sub blocks on each side of the sub-block gap, where the test requirement within sub-block gaps shall be -7 dBm/100 kHz.			
NOTE 2: For a <i>multi-band RIB</i> with <i>Inter RF Bandwidth gap</i> < $2 \times \Delta f_{\text{OBUE}}$ MHz the test requirement within the <i>Inter RF Bandwidth gaps</i> is calculated as a cumulative sum of contributions from adjacent sub-blocks or <i>Base Station RF Bandwidth</i> on each side of the <i>Inter RF Bandwidth gap</i> .			
NOTE 8: The requirement is not applicable when $\Delta f_{\text{max}} < 10 \text{ MHz}$.			

Table 6.7.5.5.3-3: Wide Area BS operating band unwanted emission limits for 5, 10, 15 and 20 MHz channel bandwidth (E-UTRA bands < 1 GHz) for Category B

Frequency offset of measurement filter -3dB point, Δf	Frequency offset of measurement filter centre frequency, f_{offset}	Test requirement (Notes 1 and 2)	Measurement bandwidth
$0 \text{ MHz} \leq \Delta f < 5 \text{ MHz}$	$0.05 \text{ MHz} \leq f_{\text{offset}} < 5.05 \text{ MHz}$	$3.8 \text{ dBm} - 7/5(f_{\text{offset}}/\text{MHz} - 0.05) \text{ dB}$	100 kHz
$5 \text{ MHz} \leq \Delta f < \min(10 \text{ MHz}, \Delta f_{\text{max}})$	$5.05 \text{ MHz} \leq f_{\text{offset}} < \min(10.05 \text{ MHz}, f_{\text{offset}_{\text{max}}})$	-3.2 dBm	100 kHz
$10 \text{ MHz} \leq \Delta f \leq \Delta f_{\text{max}}$	$10.05 \text{ MHz} \leq f_{\text{offset}} < f_{\text{offset}_{\text{max}}}$	-7 dBm (NOTE 8)	100 kHz
NOTE 1: For a RIB supporting non-contiguous spectrum operation within any operating band the test requirement within sub-block gaps is calculated as a cumulative sum of contributions from adjacent sub blocks on each side of the sub block gap. Exception is $\Delta f \geq 10 \text{ MHz}$ from both adjacent sub blocks on each side of the sub-block gap, where the test requirement within sub-block gaps shall be -7 dBm/100 kHz.			
NOTE 2: For a <i>multi-band RIB</i> with <i>Inter RF Bandwidth gap</i> < $2 \times \Delta f_{\text{OBUE}}$ MHz the requirement within the <i>Inter RF Bandwidth gaps</i> is calculated as a cumulative sum of contributions from adjacent sub-blocks or <i>Base Station RF Bandwidth</i> on each side of the <i>Inter RF Bandwidth gap</i> .			
NOTE 8: The requirement is not applicable when $\Delta f_{\text{max}} < 10 \text{ MHz}$.			

For E-UTRA *RIB* operating in Bands 1, 2, 3, 4, 7, 10, 25, 30, 33, 34, 35, 36, 37, 38, 39, 40, 41, 45, 48, 65, 66, 69, 70, emissions shall not exceed the maximum levels specified in tables 6.6.5.5.3-4, 6.6.5.5.3-6 and 6.6.5.5.3-8.

For E-UTRA *RIB* operating in Bands 22, 42, 43, 52 emissions shall not exceed the maximum levels specified in tables 6.6.5.5.3-5, 6.6.5.5.3-7 and 6.6.5.5.3-9.

Table 6.7.5.5.3-4: Wide Area BS operating band unwanted emission limits for 1.4 MHz channel bandwidth (1GHz < E-UTRA bands \leq 3 GHz) for Category B

Frequency offset of measurement filter -3dB point, Δf	Frequency offset of measurement filter centre frequency, f_{offset}	Test requirement (Notes 1 and 2)	Measurement bandwidth
$0 \text{ MHz} \leq \Delta f < 1.4 \text{ MHz}$	$0.05 \text{ MHz} \leq f_{\text{offset}} < 1.45 \text{ MHz}$	$9.8 \text{ dBm} - 10/1.4(f_{\text{offset}}/\text{MHz} - 0.05) \text{ dB}$	100 kHz
$1.4 \text{ MHz} \leq \Delta f < 2.8 \text{ MHz}$	$1.45 \text{ MHz} \leq f_{\text{offset}} < 2.85 \text{ MHz}$	-0.2 dBm	100 kHz
$2.8 \text{ MHz} \leq \Delta f < \min(10 \text{ MHz}, \Delta f_{\text{max}})$	$3.3 \text{ MHz} \leq f_{\text{offset}} < \min(10.5 \text{ MHz}, f_{\text{offset}_{\text{max}}})$	-4.2 dBm (Note 8)	1 MHz
$10 \text{ MHz} \leq \Delta f \leq \Delta f_{\text{max}}$	$10.5 \text{ MHz} \leq f_{\text{offset}} < f_{\text{offset}_{\text{max}}}$	-6 dBm (Note 8)	1MHz
NOTE 1: For a RIB supporting non-contiguous spectrum operation within any operating band the test requirement within sub-block gaps is calculated as a cumulative sum of contributions from adjacent sub blocks on each side of the sub block gap, where the contribution from the far-end sub-block shall be scaled according to the measurement bandwidth of the near-end sub-block. Exception is $\Delta f \geq 10 \text{ MHz}$ from both adjacent sub blocks on each side of the sub-block gap, where the test requirement within sub-block gaps shall be -6 dBm/1 MHz.			
NOTE 2: For a <i>multi-band RIB</i> with <i>Inter RF Bandwidth gap</i> < $2 \times \Delta f_{\text{OBUE}}$ MHz the test requirement within the <i>Inter RF Bandwidth gaps</i> is calculated as a cumulative sum of contributions from adjacent sub-blocks or <i>Base Station RF Bandwidth</i> on each side of the <i>Inter RF Bandwidth gap</i> , where the contribution from the far-end sub-block or <i>Base Station RF Bandwidth</i> shall be scaled according to the measurement bandwidth of the near-end sub-block or <i>Base Station RF Bandwidth</i> .			
NOTE 8: The requirement is not applicable when $\Delta f_{\text{max}} < 10 \text{ MHz}$.			

Table 6.7.5.5.3-5: Wide Area BS operating band unwanted emission limits for 1.4 MHz channel bandwidth (E-UTRA bands > 3 GHz) for Category B

Frequency offset of measurement filter -3dB point, Δf	Frequency offset of measurement filter centre frequency, f_{offset}	Test requirement (Notes 1 and 2)	Measurement bandwidth
$0 \text{ MHz} \leq \Delta f < 1.4 \text{ MHz}$	$0.05 \text{ MHz} \leq f_{\text{offset}} < 1.45 \text{ MHz}$	$10\text{dBm} - 10/1.4(f_{\text{offset}}/\text{MHz}-0,05) \text{ dB}$	100 kHz
$1.4 \text{ MHz} \leq \Delta f < 2.8 \text{ MHz}$	$1.45 \text{ MHz} \leq f_{\text{offset}} < 2.85 \text{ MHz}$	0 dBm	100 kHz
$2.8 \text{ MHz} \leq \Delta f < \min(10 \text{ MHz}, \Delta f_{\text{max}})$	$3.3 \text{ MHz} \leq f_{\text{offset}} < \min(10.5 \text{ MHz}, f_{\text{offset}_{\text{max}}})$	-4 dBm (Note 8)	1 MHz
$10 \text{ MHz} \leq \Delta f \leq \Delta f_{\text{max}}$	$10.5 \text{ MHz} \leq f_{\text{offset}} < f_{\text{offset}_{\text{max}}}$	-6 dBm (Note 8)	1MHz
NOTE 1: For a <i>RIB</i> supporting non-contiguous spectrum operation within any operating band the test requirement within sub-block gaps is calculated as a cumulative sum of contributions from adjacent sub blocks on each side of the sub block gap, where the contribution from the far-end sub-block shall be scaled according to the measurement bandwidth of the near-end sub-block. Exception is $\Delta f \geq 10 \text{ MHz}$ from both adjacent sub blocks on each side of the sub-block gap, where the test requirement within sub-block gaps shall be -6 dBm/1 MHz.			
NOTE 2: For a <i>multi-band RIB</i> with <i>Inter RF Bandwidth gap</i> $< 2 \times \Delta f_{\text{OBUE}}$ MHz the test requirement within the <i>Inter RF Bandwidth gaps</i> is calculated as a cumulative sum of contributions from adjacent sub-blocks or <i>Base Station RF Bandwidth</i> on each side of the <i>Inter RF Bandwidth gap</i> , where the contribution from the far-end sub-block or <i>Base Station RF Bandwidth</i> shall be scaled according to the measurement bandwidth of the near-end sub-block or <i>Base Station RF Bandwidth</i> .			
NOTE 8: The requirement is not applicable when $\Delta f_{\text{max}} < 10 \text{ MHz}$.			

Table 6.7.5.5.3-6: Wide Area BS operating band unwanted emission limits for 3 MHz channel bandwidth (1GHz < E-UTRA bands \leq 3 GHz) for Category B

Frequency offset of measurement filter -3dB point, Δf	Frequency offset of measurement filter centre frequency, f_{offset}	Test requirement (Notes 1 and 2)	Measurement bandwidth
$0 \text{ MHz} \leq \Delta f < 3 \text{ MHz}$	$0.05 \text{ MHz} \leq f_{\text{offset}} < 3.05 \text{ MHz}$	$5.8 \text{ dBm} - 10/3(f_{\text{offset}}/\text{MHz}-0,05) \text{ dB}$	100 kHz
$3 \text{ MHz} \leq \Delta f < 6 \text{ MHz}$	$3.05 \text{ MHz} \leq f_{\text{offset}} < 6.05 \text{ MHz}$	-4.2 dBm	100 kHz
$6 \text{ MHz} \leq \Delta f < \min(10 \text{ MHz}, \Delta f_{\text{max}})$	$6.5 \text{ MHz} \leq f_{\text{offset}} < \min(10.5 \text{ MHz}, f_{\text{offset}_{\text{max}}})$	-4.2 dBm (Note 8)	1 MHz
$10 \text{ MHz} \leq \Delta f \leq \Delta f_{\text{max}}$	$10.5 \text{ MHz} \leq f_{\text{offset}} < f_{\text{offset}_{\text{max}}}$	-6 dBm (Note 8)	1MHz
NOTE 1: For a <i>RIB</i> supporting non-contiguous spectrum operation within any operating band the test requirement within sub-block gaps is calculated as a cumulative sum of contributions from adjacent sub blocks on each side of the sub block gap, where the contribution from the far-end sub-block shall be scaled according to the measurement bandwidth of the near-end sub-block. Exception is $\Delta f \geq 10 \text{ MHz}$ from both adjacent sub blocks on each side of the sub-block gap, where the test requirement within sub-block gaps shall be -6 dBm/1 MHz.			
NOTE 2: For a <i>multi-band RIB</i> with <i>Inter RF Bandwidth gap</i> $< 2 \times \Delta f_{\text{OBUE}}$ MHz the test requirement within the <i>Inter RF Bandwidth gaps</i> is calculated as a cumulative sum of contributions from adjacent sub-blocks or <i>Base Station RF Bandwidth</i> on each side of the <i>Inter RF Bandwidth gap</i> , where the contribution from the far-end sub-block or <i>Base Station RF Bandwidth</i> shall be scaled according to the measurement bandwidth of the near-end sub-block or <i>Base Station RF Bandwidth</i> .			
NOTE 8: The requirement is not applicable when $\Delta f_{\text{max}} < 10 \text{ MHz}$.			

Table 6.7.5.5.3-7: Wide Area BS operating band unwanted emission limits for 3 MHz channel bandwidth (E-UTRA bands > 3 GHz) for Category B

Frequency offset of measurement filter -3dB point, Δf	Frequency offset of measurement filter centre frequency, f_{offset}	Test requirement (Notes 1 and 2)	Measurement bandwidth
$0 \text{ MHz} \leq \Delta f < 3 \text{ MHz}$	$0.05 \text{ MHz} \leq f_{\text{offset}} < 3.05 \text{ MHz}$	6 dBm - $10/3(f_{\text{offset}}/\text{MHz}-0.05)$ dB	100 kHz
$3 \text{ MHz} \leq \Delta f < 6 \text{ MHz}$	$3.05 \text{ MHz} \leq f_{\text{offset}} < 6.05 \text{ MHz}$	-4 dBm	100 kHz
$6 \text{ MHz} \leq \Delta f < \min(10 \text{ MHz}, \Delta f_{\text{max}})$	$6.5 \text{ MHz} \leq f_{\text{offset}} < \min(10.5 \text{ MHz}, f_{\text{offset}_{\text{max}}})$	-4 dBm (Note 8)	1 MHz
$10 \text{ MHz} \leq \Delta f \leq \Delta f_{\text{max}}$	$10.5 \text{ MHz} \leq f_{\text{offset}} < f_{\text{offset}_{\text{max}}}$	-6 dBm (Note 8)	1 MHz
<p>NOTE 1: For a <i>RIB</i> supporting non-contiguous spectrum operation within any operating band the test requirement within sub-block gaps is calculated as a cumulative sum of contributions from adjacent sub blocks on each side of the sub block gap, where the contribution from the far-end sub-block shall be scaled according to the measurement bandwidth of the near-end sub-block. Exception is $\Delta f \geq 10$ MHz from both adjacent sub blocks on each side of the sub-block gap, where the test requirement within sub-block gaps shall be -6 dBm/1 MHz.</p> <p>NOTE 2: For a <i>multi-band RIB</i> with <i>Inter RF Bandwidth gap</i> < $2 \times \Delta f_{\text{OBUE}}$ MHz the test requirement within the <i>Inter RF Bandwidth gaps</i> is calculated as a cumulative sum of contributions from adjacent sub-blocks or <i>Base Station RF Bandwidth</i> on each side of the <i>Inter RF Bandwidth gap</i>, where the contribution from the far-end sub-block or <i>Base Station RF Bandwidth</i> shall be scaled according to the measurement bandwidth of the near-end sub-block or <i>Base Station RF Bandwidth</i>.</p> <p>NOTE 8: The requirement is not applicable when $\Delta f_{\text{max}} < 10$ MHz.</p>			

Table 6.7.5.5.3-8: Wide Area BS operating band unwanted emission limits for 5, 10, 15 and 20 MHz channel bandwidth (1GHz < E-UTRA bands \leq 3 GHz) for Category B

Frequency offset of measurement filter -3dB point, Δf	Frequency offset of measurement filter centre frequency, f_{offset}	Test requirement (Notes 1 and 2)	Measurement bandwidth
$0 \text{ MHz} \leq \Delta f < 5 \text{ MHz}$	$0.05 \text{ MHz} \leq f_{\text{offset}} < 5.05 \text{ MHz}$	3.8 dBm - $7/5(f_{\text{offset}}/\text{MHz}-0.05)$ dB	100 kHz
$5 \text{ MHz} \leq \Delta f < \min(10 \text{ MHz}, \Delta f_{\text{max}})$	$5.05 \text{ MHz} \leq f_{\text{offset}} < \min(10.05 \text{ MHz}, f_{\text{offset}_{\text{max}}})$	-3.2 dBm	100 kHz
$10 \text{ MHz} \leq \Delta f \leq \Delta f_{\text{max}}$	$10.5 \text{ MHz} \leq f_{\text{offset}} < f_{\text{offset}_{\text{max}}}$	-6 dBm (NOTE 8)	1 MHz
<p>NOTE 1: For a <i>RIB</i> supporting non-contiguous spectrum operation within any operating band the test requirement within sub-block gaps is calculated as a cumulative sum of contributions from adjacent sub blocks on each side of the sub block gap, where the contribution from the far-end sub-block shall be scaled according to the measurement bandwidth of the near-end sub-block. Exception is $\Delta f \geq 10$ MHz from both adjacent sub blocks on each side of the sub-block gap, where the test requirement within sub-block gaps shall be -6 dBm/1 MHz.</p> <p>NOTE 2: For a <i>multi-band RIB</i> with <i>Inter RF Bandwidth gap</i> < $2 \times \Delta f_{\text{OBUE}}$ MHz the test requirement within the <i>Inter RF Bandwidth gaps</i> is calculated as a cumulative sum of contributions from adjacent sub-blocks or <i>Base Station RF Bandwidth</i> on each side of the <i>Inter RF Bandwidth gap</i>, where the contribution from the far-end sub-block or <i>Base Station RF Bandwidth</i> shall be scaled according to the measurement bandwidth of the near-end sub-block or <i>Base Station RF Bandwidth</i>.</p> <p>NOTE 8: The requirement is not applicable when $\Delta f_{\text{max}} < 10$ MHz.</p>			

Table 6.7.5.5.3-9: Wide Area BS operating band unwanted emission limits for 5, 10, 15 and 20 MHz channel bandwidth (E-UTRA bands > 3 GHz) for Category B

Frequency offset of measurement filter -3dB point, Δf	Frequency offset of measurement filter centre frequency, f_{offset}	Test requirement (Notes 1 and 2)	Measurement bandwidth
$0 \text{ MHz} \leq \Delta f < 5 \text{ MHz}$	$0.05 \text{ MHz} \leq f_{\text{offset}} < 5.05 \text{ MHz}$	4 dBm - 7/5(f_{offset} /MHz-0.05) dB	100 kHz
$5 \text{ MHz} \leq \Delta f < \min(10 \text{ MHz}, \Delta f_{\text{max}})$	$5.05 \text{ MHz} \leq f_{\text{offset}} < \min(10.05 \text{ MHz}, f_{\text{offsetmax}})$	-3 dBm	100 kHz
$10 \text{ MHz} \leq \Delta f \leq \Delta f_{\text{max}}$	$10.5 \text{ MHz} \leq f_{\text{offset}} < f_{\text{offsetmax}}$	-6 dBm (NOTE 8)	1 MHz
NOTE 1: For a <i>RIB</i> supporting non-contiguous spectrum operation within any operating band the test requirement within sub-block gaps is calculated as a cumulative sum of contributions from adjacent sub blocks on each side of the sub block gap, where the contribution from the far-end sub-block shall be scaled according to the measurement bandwidth of the near-end sub-block. Exception is $\Delta f \geq 10$ MHz from both adjacent sub blocks on each side of the sub-block gap, where the test requirement within sub-block gaps shall be -6 dBm/1 MHz.			
NOTE 2: For a <i>multi-band RIB</i> with <i>Inter RF Bandwidth gap</i> < $2 \times \Delta f_{\text{OBUE}}$ MHz the test requirement within the <i>Inter RF Bandwidth gaps</i> is calculated as a cumulative sum of contributions from adjacent sub-blocks or <i>Base Station RF Bandwidth</i> on each side of the <i>Inter RF Bandwidth gap</i> , where the contribution from the far-end sub-block or <i>Base Station RF Bandwidth</i> shall be scaled according to the measurement bandwidth of the near-end sub-block or <i>Base Station RF Bandwidth</i> .			
NOTE 8: The requirement is not applicable when $\Delta f_{\text{max}} < 10$ MHz.			

6.7.5.5.4 Wide Area BS Category B (Option 2)

For Category B Operating band unwanted emissions, there are two options for the limits that may be applied regionally, option 2 is as follows.

The limits in this subclause are intended for Europe and may be applied regionally for a *RIB* operating in band 1, 3, 8, 32, 33, 34 or 65.

For a *RIB* operating in band 1, 3, 8, 32, 33, 34 or 65, emissions shall not exceed the maximum levels specified in table 6.6.5.5.4-1 below for 5, 10, 15 and 20 MHz channel bandwidth.

Table 6.7.5.5.4-1: Regional Wide Area BS operating band unwanted emission limits in band 1, 3, 8, 32, 33, 34 or 65 for 5, 10, 15 and 20 MHz channel bandwidth for Category B

Frequency offset of measurement filter -3dB point, Δf	Frequency offset of measurement filter centre frequency, f_{offset}	Test requirement (Notes 1 and 2)	Measurement bandwidth
$0 \text{ MHz} \leq \Delta f < 0.2 \text{ MHz}$	$0.015 \text{ MHz} \leq f_{\text{offset}} < 0.215 \text{ MHz}$	-3.2 dBm	30 kHz
$0.2 \text{ MHz} \leq \Delta f < 1 \text{ MHz}$	$0.215 \text{ MHz} \leq f_{\text{offset}} < 1.015 \text{ MHz}$	-3.2 dBm - 15(f_{offset} /MHz-0.215) dB	30 kHz
(Note 7)	$1.015 \text{ MHz} \leq f_{\text{offset}} < 1.5 \text{ MHz}$	-15.2 dBm	30 kHz
$1 \text{ MHz} \leq \Delta f \leq \min(10 \text{ MHz}, \Delta f_{\text{max}})$	$1.5 \text{ MHz} \leq f_{\text{offset}} < \min(10.5 \text{ MHz}, f_{\text{offsetmax}})$	-2.2 dBm	1 MHz
$10 \text{ MHz} \leq \Delta f \leq \Delta f_{\text{max}}$	$10.5 \text{ MHz} \leq f_{\text{offset}} < f_{\text{offsetmax}}$	-6 dBm (NOTE 8)	1 MHz
NOTE 1: For a <i>RIB</i> supporting non-contiguous spectrum operation within any operating band the test requirement within sub-block gaps is calculated as a cumulative sum of contributions from adjacent sub blocks on each side of the sub block gap, where the contribution from the far-end sub-block shall be scaled according to the measurement bandwidth of the near-end sub-block. Exception is $\Delta f \geq 10$ MHz from both adjacent sub blocks on each side of the sub-block gap, where the test requirement within sub-block gaps shall be -6 dBm/1 MHz.			
NOTE 2: For a <i>multi-band RIB</i> with <i>Inter RF Bandwidth gap</i> < $2 \times \Delta f_{\text{OBUE}}$ MHz the test requirement within the <i>Inter RF Bandwidth gaps</i> is calculated as a cumulative sum of contributions from adjacent sub-blocks or <i>Base Station RF Bandwidth</i> on each side of the <i>Inter RF Bandwidth gap</i> , where the contribution from the far-end sub-block or <i>Base Station RF Bandwidth</i> shall be scaled according to the measurement bandwidth of the near-end sub-block or <i>Base Station RF Bandwidth</i> .			
NOTE 7: This frequency range ensures that the range of values of f_{offset} is continuous.			
NOTE 8: The requirement is not applicable when $\Delta f_{\text{max}} < 10$ MHz.			

For a *RIB* operating in band 3, 8 or 65, emissions shall not exceed the maximum levels specified in table 6.7.5.5.4-2 for 3 MHz channel bandwidth.

Table 6.7.5.5.4-2: Regional Wide Area BS operating band unwanted emission limits in band 3, 8 or 65 for 3 MHz channel bandwidth for Category B

Frequency offset of measurement filter -3dB point, Δf	Frequency offset of measurement filter centre frequency, f_{offset}	Test requirement (Notes 1 and 2)	Measurement bandwidth
$0 \text{ MHz} \leq \Delta f < 0.05 \text{ MHz}$	$0.015 \text{ MHz} \leq f_{\text{offset}} < 0.065 \text{ MHz}$	15.8 dBm - 60($f_{\text{offset_MHz}} - 0.015$) dB	30 kHz
$0.05 \text{ MHz} \leq \Delta f < 0.15 \text{ MHz}$	$0.065 \text{ MHz} \leq f_{\text{offset}} < 0.165 \text{ MHz}$	12.8dBm-160($f_{\text{offset}}/\text{MHz} - 0.065$) dB	30 kHz
$0.15 \text{ MHz} \leq \Delta f < 0.2 \text{ MHz}$	$0.165 \text{ MHz} \leq f_{\text{offset}} < 0.215 \text{ MHz}$	-3.2 dBm	30 kHz
$0.2 \text{ MHz} \leq \Delta f < 1 \text{ MHz}$	$0.215 \text{ MHz} \leq f_{\text{offset}} < 1.015 \text{ MHz}$	-3.2 dBm-15($f_{\text{offset}}/\text{MHz}-0.215$) dB	30 kHz
(Note 7)	$1.015 \text{ MHz} \leq f_{\text{offset}} < 1.5 \text{ MHz}$	-15.2 dBm	30 kHz
$1 \text{ MHz} \leq \Delta f \leq 6 \text{ MHz}$	$1.5 \text{ MHz} \leq f_{\text{offset}} < 6.5 \text{ MHz}$,	-2.2 dBm	1 MHz
$6 \text{ MHz} \leq \Delta f < \min(10 \text{ MHz}, \Delta f_{\text{max}})$	$6.5 \text{ MHz} \leq f_{\text{offset}} < \min(10.5 \text{ MHz}, f_{\text{offset_max}})$	-4.2 dBm	1 MHz
$10 \text{ MHz} \leq \Delta f \leq \Delta f_{\text{max}}$	$10.5 \text{ MHz} \leq f_{\text{offset}} < f_{\text{offset_max}}$	-6 dBm (Note 8)	

NOTE 1: For a *RIB* supporting non-contiguous spectrum operation within any operating band the test requirement within sub-block gaps is calculated as a cumulative sum of contributions from adjacent sub blocks on each side of the sub block gap, where the contribution from the far-end sub-block shall be scaled according to the measurement bandwidth of the near-end sub-block. Exception is $\Delta f \geq 10$ MHz from both adjacent sub blocks on each side of the sub-block gap, where the test requirement within sub-block gaps shall be -6dBm/1 MHz.

NOTE 2: For a *multi-band RIB* with *Inter RF Bandwidth gap* $< 2 \times \Delta f_{\text{OBUE}}$ MHz the test requirement within the *Inter RF Bandwidth gaps* is calculated as a cumulative sum of contributions from adjacent sub-blocks or *Base Station RF Bandwidth* on each side of the *Inter RF Bandwidth gap*, where the contribution from the far-end sub-block or *Base Station RF Bandwidth* shall be scaled according to the measurement bandwidth of the near-end sub-block or *Base Station RF Bandwidth*.

NOTE 7: This frequency range ensures that the range of values of f_{offset} is continuous.

NOTE 8: The requirement is not applicable when $\Delta f_{\text{max}} < 10$ MHz.

For a BS operating in band 3, 8 or 65, emissions shall not exceed the maximum levels specified in table 6.7.5.5.4-3 for 1.4 MHz channel bandwidth.

Table 6.7.5.5.4-3: Regional Wide Area BS operating band unwanted emission limits in band 3, 8 or 65 for 1.4 MHz channel bandwidth for Category B

Frequency offset of measurement filter -3dB point, Δf	Frequency offset of measurement filter centre frequency, f_{offset}	Test requirement (Notes 1 and 2)	Measurement bandwidth
$0 \text{ MHz} \leq \Delta f < 0.05 \text{ MHz}$	$0.015 \text{ MHz} \leq f_{\text{offset}} < 0.065 \text{ MHz}$	15.8 dBm - $60(f_{\text{offset}}/\text{MHz} - 0.015) \text{ dB}$	30 kHz
$0.05 \text{ MHz} \leq \Delta f < 0.15 \text{ MHz}$	$0.065 \text{ MHz} \leq f_{\text{offset}} < 0.165 \text{ MHz}$	12.8 dBm - $160(f_{\text{offset}}/\text{MHz} - 0.065) \text{ dB}$	30 kHz
$0.15 \text{ MHz} \leq \Delta f < 0.2 \text{ MHz}$	$0.165 \text{ MHz} \leq f_{\text{offset}} < 0.215 \text{ MHz}$	-3.2 dBm	30 kHz
$0.2 \text{ MHz} \leq \Delta f < 1 \text{ MHz}$	$0.215 \text{ MHz} \leq f_{\text{offset}} < 1.015 \text{ MHz}$	$-3.2 - 15(f_{\text{offset}}/\text{MHz} - 0.215) \text{ dB}$	30 kHz
(Note 7)	$1.015 \text{ MHz} \leq f_{\text{offset}} < 1.5 \text{ MHz}$	-15.2 dBm	30 kHz
$1 \text{ MHz} \leq \Delta f \leq 2.8 \text{ MHz}$	$1.5 \text{ MHz} \leq f_{\text{offset}} < 3.3 \text{ MHz}$	-2.2 dBm	1 MHz
$2.8 \text{ MHz} \leq \Delta f < \min(10 \text{ MHz}, \Delta f_{\text{max}})$	$3.3 \text{ MHz} \leq f_{\text{offset}} < \min(10.5 \text{ MHz}, f_{\text{offset}_{\text{max}}})$	-4.2 dBm (Note 8)	1 MHz
$10 \text{ MHz} \leq \Delta f \leq \Delta f_{\text{max}}$	$10.5 \text{ MHz} \leq f_{\text{offset}} < f_{\text{offset}_{\text{max}}}$	-6 dBm (Note 8)	1 MHz

NOTE 1: For a *RIB* supporting non-contiguous spectrum operation within any operating band the test requirement within sub-block gaps is calculated as a cumulative sum of contributions from adjacent sub blocks on each side of the sub block gap, where the contribution from the far-end sub-block shall be scaled according to the measurement bandwidth of the near-end sub-block. Exception is $\Delta f \geq 10 \text{ MHz}$ from both adjacent sub blocks on each side of the sub-block gap, where the test requirement within sub-block gaps shall be -6 dBm/1 MHz.

NOTE 2: For a *multi-band RIB* with *Inter RF Bandwidth gap* $< 2 \times \Delta f_{\text{OBUE}}$ MHz the test requirement within the *Inter RF Bandwidth gaps* is calculated as a cumulative sum of contributions from adjacent sub-blocks or *Base Station RF Bandwidth* on each side of the *Inter RF Bandwidth gap*, where the contribution from the far-end sub-block or *Base Station RF Bandwidth* shall be scaled according to the measurement bandwidth of the near-end sub-block or *Base Station RF Bandwidth*.

NOTE 7: This frequency range ensures that the range of values of f_{offset} is continuous.

NOTE 8: The requirement is not applicable when $\Delta f_{\text{max}} < 10 \text{ MHz}$.

6.7.5.5.5.5 Local Area BS (Category A and B)

For an AAS BS of Local Area BS class in E-UTRA bands $\leq 3 \text{ GHz}$, emissions shall not exceed the maximum levels specified in Tables 6.7.5.5.5.5-1, 6.7.5.5.5.5-3 and 6.7.5.5.5.5-5.

For an AAS BS of Local Area BS class in E-UTRA bands $> 3 \text{ GHz}$, emissions shall not exceed the maximum levels specified in tables 6.7.5.5.5.5-2, 6.7.5.5.5.5-4 and 6.7.5.5.5.5-6.

Table 6.7.5.5.5-1: Local Area BS operating band unwanted emission limits for 1.4 MHz channel bandwidth (E-UTRA bands $\leq 3 \text{ GHz}$)

Frequency offset of measurement filter -3dB point, Δf	Frequency offset of measurement filter centre frequency, f_{offset}	Test requirement (Notes 1 and 2)	Measurement bandwidth
$0 \text{ MHz} \leq \Delta f < 1.4 \text{ MHz}$	$0.05 \text{ MHz} \leq f_{\text{offset}} < 1.45 \text{ MHz}$	$-10.2 \text{ dBm} - 10/1.4(f_{\text{offset}}/\text{MHz} - 0.05) \text{ dB}$	100 kHz
$1.4 \text{ MHz} \leq \Delta f < 2.8 \text{ MHz}$	$1.45 \text{ MHz} \leq f_{\text{offset}} < 2.85 \text{ MHz}$	-20.2 dBm	100 kHz
$2.8 \text{ MHz} \leq \Delta f < \min(10 \text{ MHz}, \Delta f_{\text{max}})$	$2.85 \text{ MHz} \leq f_{\text{offset}} < \min(10.05 \text{ MHz}, f_{\text{offset}_{\text{max}}})$	-20.2 dBm (Note 8)	100 kHz
$10 \text{ MHz} \leq \Delta f \leq \Delta f_{\text{max}}$	$10.05 \text{ MHz} \leq f_{\text{offset}} < f_{\text{offset}_{\text{max}}}$	-22 dBm (Note 8)	100 kHz

NOTE 1: For a *RIB* supporting non-contiguous spectrum operation within any operating band the test requirement within sub-block gaps is calculated as a cumulative sum of contributions from adjacent sub blocks on each side of the sub block gap. Exception is $\Delta f \geq 10 \text{ MHz}$ from both adjacent sub blocks on each side of the sub-block gap, where the test requirement within sub-block gaps shall be -22 dBm/100 kHz.

NOTE 2: For a *multi-band RIB* with *Inter RF Bandwidth gap* $< 2 \times \Delta f_{\text{OBUE}}$ MHz the test requirement within the *Inter RF Bandwidth gaps* is calculated as a cumulative sum of contributions from adjacent sub-blocks or *Base Station RF Bandwidth* on each side of the *Inter RF Bandwidth gap*.

NOTE 8: The requirement is not applicable when $\Delta f_{\text{max}} < 10 \text{ MHz}$.

Table 6.7.5.5.5-2: Local Area BS operating band unwanted emission limits for 1.4 MHz channel bandwidth (E-UTRA bands > 3 GHz)

Frequency offset of measurement filter -3dB point, Δf	Frequency offset of measurement filter centre frequency, f_{offset}	Test requirement (Notes 1 and 2)	Measurement bandwidth
$0 \text{ MHz} \leq \Delta f < 1.4 \text{ MHz}$	$0.05 \text{ MHz} \leq f_{\text{offset}} < 1.45 \text{ MHz}$	$-10 \text{ dBm} - 10/1.4(f_{\text{offset}}/\text{MHz} - 0.05) \text{ dB}$	100 kHz
$1.4 \text{ MHz} \leq \Delta f < 2.8 \text{ MHz}$	$1.45 \text{ MHz} \leq f_{\text{offset}} < 2.85 \text{ MHz}$	-20 dBm	100 kHz
$2.8 \text{ MHz} \leq \Delta f < \min(10 \text{ MHz}, \Delta f_{\text{max}})$	$2.85 \text{ MHz} \leq f_{\text{offset}} < \min(10.05 \text{ MHz}, f_{\text{offset}_{\text{max}}})$	-20 dBm (Note 8)	100 kHz
$10 \text{ MHz} \leq \Delta f \leq \Delta f_{\text{max}}$	$10.05 \text{ MHz} \leq f_{\text{offset}} < f_{\text{offset}_{\text{max}}}$	-22 dBm (Note 8)	100 kHz
NOTE 1: For a <i>RIB</i> supporting non-contiguous spectrum operation within any operating band the test requirement within sub-block gaps is calculated as a cumulative sum of contributions from adjacent sub blocks on each side of the sub block gap. Exception is $\Delta f \geq 10 \text{ MHz}$ from both adjacent sub blocks on each side of the sub-block gap, where the test requirement within sub-block gaps shall be -22 dBm/100 kHz.			
NOTE 2: For a <i>multi-band RIB</i> with <i>Inter RF Bandwidth gap</i> $< 2 \times \Delta f_{\text{OBUE}}$ MHz the test requirement within the <i>Inter RF Bandwidth gaps</i> is calculated as a cumulative sum of contributions from adjacent sub-blocks or <i>Base Station RF Bandwidth</i> on each side of the <i>Inter RF Bandwidth gap</i> .			
NOTE 8: The requirement is not applicable when $\Delta f_{\text{max}} < 10 \text{ MHz}$.			

Table 6.7.5.5.5-3: Local Area BS operating band unwanted emission limits for 3 MHz channel bandwidth (E-UTRA bands $\leq 3 \text{ GHz}$)

Frequency offset of measurement filter -3dB point, Δf	Frequency offset of measurement filter centre frequency, f_{offset}	Test requirement (Notes 1 and 2)	Measurement bandwidth
$0 \text{ MHz} \leq \Delta f < 3 \text{ MHz}$	$0.05 \text{ MHz} \leq f_{\text{offset}} < 3.05 \text{ MHz}$	$-14.2 \text{ dBm} - 10/3(f_{\text{offset}}/\text{MHz} - 0.05) \text{ dB}$	100 kHz
$3 \text{ MHz} \leq \Delta f < 6 \text{ MHz}$	$3.05 \text{ MHz} \leq f_{\text{offset}} < 6.05 \text{ MHz}$	-24.2 dBm	100 kHz
$6 \text{ MHz} \leq \Delta f < \min(10 \text{ MHz}, \Delta f_{\text{max}})$	$6.05 \text{ MHz} \leq f_{\text{offset}} < \min(10.05 \text{ MHz}, f_{\text{offset}_{\text{max}}})$	-24.2 dBm (Note 8)	100 kHz
$10 \text{ MHz} \leq \Delta f \leq \Delta f_{\text{max}}$	$10.05 \text{ MHz} \leq f_{\text{offset}} < f_{\text{offset}_{\text{max}}}$	-26 dBm (Note 8)	100 kHz
NOTE 1: For a <i>RIB</i> supporting non-contiguous spectrum operation within any operating band the test requirement within sub-block gaps is calculated as a cumulative sum of contributions from adjacent sub blocks on each side of the sub block gap. Exception is $\Delta f \geq 10 \text{ MHz}$ from both adjacent sub blocks on each side of the sub-block gap, where the test requirement within sub-block gaps shall be -26 dBm/100 kHz.			
NOTE 2: For a <i>multi-band RIB</i> with <i>Inter RF Bandwidth gap</i> $< 2 \times \Delta f_{\text{OBUE}}$ MHz the test requirement within the <i>Inter RF Bandwidth gaps</i> is calculated as a cumulative sum of contributions from adjacent sub-blocks or <i>Base Station RF Bandwidth</i> on each side of the <i>Inter RF Bandwidth gap</i> .			
NOTE 8: The requirement is not applicable when $\Delta f_{\text{max}} < 10 \text{ MHz}$.			

Table 6.7.5.5.5-4: Local Area BS operating band unwanted emission limits for 3 MHz channel bandwidth (E-UTRA bands > 3 GHz)

Frequency offset of measurement filter -3dB point, Δf	Frequency offset of measurement filter centre frequency, f_{offset}	Test requirement (Notes 1 and 2)	Measurement bandwidth
$0 \text{ MHz} \leq \Delta f < 3 \text{ MHz}$	$0.05 \text{ MHz} \leq f_{\text{offset}} < 3.05 \text{ MHz}$	$-14 \text{ dBm} - 10/3(f_{\text{offset}}/\text{MHz} - 0.05) \text{ dB}$	100 kHz
$3 \text{ MHz} \leq \Delta f < 6 \text{ MHz}$	$3.05 \text{ MHz} \leq f_{\text{offset}} < 6.05 \text{ MHz}$	-24 dBm	100 kHz
$6 \text{ MHz} \leq \Delta f < \min(10 \text{ MHz}, \Delta f_{\text{max}})$	$6.05 \text{ MHz} \leq f_{\text{offset}} < \min(10.05 \text{ MHz}, f_{\text{offset}_{\text{max}}})$	-24 dBm (Note 8)	100 kHz
$10 \text{ MHz} \leq \Delta f \leq \Delta f_{\text{max}}$	$10.05 \text{ MHz} \leq f_{\text{offset}} < f_{\text{offset}_{\text{max}}}$	-26 dBm (Note 8)	100 kHz
NOTE 1: For a <i>RIB</i> supporting non-contiguous spectrum operation within any operating band the test requirement within sub-block gaps is calculated as a cumulative sum of contributions from adjacent sub blocks on each side of the sub block gap. Exception is $\Delta f \geq 10 \text{ MHz}$ from both adjacent sub blocks on each side of the sub-block gap, where the test requirement within sub-block gaps shall be -26 dBm/100 kHz.			
NOTE 2: For a <i>multi-band RIB</i> with <i>Inter RF Bandwidth gap</i> $< 2 \times \Delta f_{\text{OBUE}}$ MHz the test requirement within the <i>Inter RF Bandwidth gaps</i> is calculated as a cumulative sum of contributions from adjacent sub-blocks or <i>Base Station RF Bandwidth</i> on each side of the <i>Inter RF Bandwidth gap</i> .			
NOTE 8: The requirement is not applicable when $\Delta f_{\text{max}} < 10 \text{ MHz}$.			

Table 6.7.5.5.5-5: Local Area BS operating band unwanted emission limits for 5, 10, 15 and 20 MHz channel bandwidth (E-UTRA bands ≤ 3 GHz)

Frequency offset of measurement filter -3dB point, Δf	Frequency offset of measurement filter centre frequency, f_{offset}	Test requirement (Notes 1 and 2)	Measurement bandwidth
$0 \text{ MHz} \leq \Delta f < 5 \text{ MHz}$	$0.05 \text{ MHz} \leq f_{\text{offset}} < 5.05 \text{ MHz}$	$-19.2 \text{ dBm} - 7/5(f_{\text{offset}}/\text{MHz} - 0.05) \text{ dB}$	100 kHz
$5 \text{ MHz} \leq \Delta f < \min(10 \text{ MHz}, \Delta f_{\text{max}})$	$5.05 \text{ MHz} \leq f_{\text{offset}} < \min(10.05 \text{ MHz}, f_{\text{offset}_{\text{max}}})$	-26.2 dBm	100 kHz
$10 \text{ MHz} \leq \Delta f \leq \Delta f_{\text{max}}$	$10.05 \text{ MHz} \leq f_{\text{offset}} < f_{\text{offset}_{\text{max}}}$	-28 dBm (NOTE 8)	100 kHz
NOTE 1: For a <i>RIB</i> supporting non-contiguous spectrum operation within any operating band the test requirement within sub-block gaps is calculated as a cumulative sum of contributions from adjacent sub blocks on each side of the sub block gap. Exception is $\Delta f \geq 10$ MHz from both adjacent sub blocks on each side of the sub-block gap, where the test requirement within sub-block gaps shall be -28 dBm/100 kHz.			
NOTE 2: For a <i>multi-band RIB</i> with <i>Inter RF Bandwidth gap</i> $< 2 \times \Delta f_{\text{OBUE}}$ MHz the test requirement within the <i>Inter RF Bandwidth gaps</i> is calculated as a cumulative sum of contributions from adjacent sub-blocks or <i>Base Station RF Bandwidth</i> on each side of the <i>Inter RF Bandwidth gap</i> .			
NOTE 8: The requirement is not applicable when $\Delta f_{\text{max}} < 10$ MHz.			

Table 6.7.5.5.5-6: Local Area BS operating band unwanted emission limits for 5, 10, 15 and 20 MHz channel bandwidth (E-UTRA bands > 3 GHz)

Frequency offset of measurement filter -3dB point, Δf	Frequency offset of measurement filter centre frequency, f_{offset}	Test requirement (Notes 1 and 2)	Measurement bandwidth
$0 \text{ MHz} \leq \Delta f < 5 \text{ MHz}$	$0.05 \text{ MHz} \leq f_{\text{offset}} < 5.05 \text{ MHz}$	$-19 \text{ dBm} - 7/5(f_{\text{offset}}/\text{MHz} - 0.05) \text{ dB}$	100 kHz
$5 \text{ MHz} \leq \Delta f < \min(10 \text{ MHz}, \Delta f_{\text{max}})$	$5.05 \text{ MHz} \leq f_{\text{offset}} < \min(10.05 \text{ MHz}, f_{\text{offset}_{\text{max}}})$	-26 dBm	100 kHz
$10 \text{ MHz} \leq \Delta f \leq \Delta f_{\text{max}}$	$10.05 \text{ MHz} \leq f_{\text{offset}} < f_{\text{offset}_{\text{max}}}$	-28 dBm (NOTE 8)	100 kHz
NOTE 1: For a <i>RIB</i> supporting non-contiguous spectrum operation within any operating band the test requirement within sub-block gaps is calculated as a cumulative sum of contributions from adjacent sub blocks on each side of the sub block gap. Exception is $\Delta f \geq 10$ MHz from both adjacent sub blocks on each side of the sub-block gap, where the test requirement within sub-block gaps shall be -28 dBm/100 kHz.			
NOTE 2: For BS a <i>multi-band RIB</i> with <i>Inter RF Bandwidth gap</i> $< 2 \times \Delta f_{\text{OBUE}}$ MHz the test requirement within the <i>Inter RF Bandwidth gaps</i> is calculated as a cumulative sum of contributions from adjacent sub-blocks or <i>Base Station RF Bandwidth</i> on each side of the <i>Inter RF Bandwidth gap</i> .			
NOTE 8: The requirement is not applicable when $\Delta f_{\text{max}} < 10$ MHz.			

6.7.5.5.5.6 Medium Range BS (Category A and B)

For an AAS BS of Medium Range BS class in E-UTRA bands ≤ 3 GHz, emissions shall not exceed the maximum levels specified in Tables 6.7.5.5.5.6-1, 6.7.5.5.5.6-3, 6.7.5.5.5.6-5, 6.7.5.5.5.6-7, 6.7.5.5.5.6-9 and 6.7.5.5.5.6-11.

For an AAS BS of Medium Range BS class in E-UTRA bands > 3 GHz, emissions shall not exceed the maximum levels specified in Tables 6.7.5.5.5.6-2, 6.7.5.5.5.6-4, 6.7.5.5.5.6-6, 6.7.5.5.5.6-8, 6.7.5.5.5.6-10 and 6.7.5.5.5.6-12.

Table 6.7.5.5.6-1: Medium Range BS operating band unwanted emission limits for 1.4 MHz channel bandwidth, $40 < P_{\text{rated,c,TRP}} \leq 47$ dBm (E-UTRA bands ≤ 3 GHz)

Frequency offset of measurement filter -3dB point, Δf	Frequency offset of measurement filter centre frequency, f_{offset}	Test requirement (Notes 1 and 2)	Measurement bandwidth
$0 \text{ MHz} \leq \Delta f < 1.4 \text{ MHz}$	$0.05 \text{ MHz} \leq f_{\text{offset}} < 1.45 \text{ MHz}$	$P_{\text{rated,c,TRP}} - 43.2 \text{ dB} - (10/1.4) \cdot (f_{\text{offset}} - 0.05) \text{ dB}$	100 kHz
$1.4 \text{ MHz} \leq \Delta f < 2.8 \text{ MHz}$	$1.45 \text{ MHz} \leq f_{\text{offset}} < 2.85 \text{ MHz}$	$P_{\text{rated,c,TRP}} - 53.2 \text{ dB}$	100 kHz
$2.8 \text{ MHz} \leq \Delta f < \min(10 \text{ MHz}, \Delta f_{\text{max}})$	$2.85 \text{ MHz} \leq f_{\text{offset}} < \min(10.05 \text{ MHz}, f_{\text{offset}_{\text{max}}})$	-14.2 dBm (Note 8)	100 kHz
$10 \text{ MHz} \leq \Delta f \leq \Delta f_{\text{max}}$	$10.05 \text{ MHz} \leq f_{\text{offset}} < f_{\text{offset}_{\text{max}}}$	-16 dBm (Note 8)	100 kHz

NOTE 1: For a *RIB* supporting non-contiguous spectrum operation within any operating band the test requirement within sub-block gaps is calculated as a cumulative sum of contributions from adjacent sub blocks on each side of the sub block gap. Exception is $\Delta f \geq 10$ MHz from both adjacent sub blocks on each side of the sub-block gap, where the test requirement within sub-block gaps shall be -16 dBm/100 kHz.

NOTE 2: For a *multi-band RIB* with *Inter RF Bandwidth gap* $< 2 \times \Delta f_{\text{OBUE}}$ MHz the test requirement within the *Inter RF Bandwidth gaps* is calculated as a cumulative sum of contributions from adjacent sub-blocks or *Base Station RF Bandwidth* on each side of the *Inter RF Bandwidth gap*.

NOTE 8: The requirement is not applicable when $\Delta f_{\text{max}} < 10$ MHz.

Table 6.7.5.5.6-2: Medium Range BS operating band unwanted emission limits for 1.4 MHz channel bandwidth, $40 < P_{\text{rated,c,TRP}} \leq 47$ dBm (E-UTRA bands > 3 GHz)

Frequency offset of measurement filter -3dB point, Δf	Frequency offset of measurement filter centre frequency, f_{offset}	Test requirement (Notes 1 and 2)	Measurement bandwidth
$0 \text{ MHz} \leq \Delta f < 1.4 \text{ MHz}$	$0.05 \text{ MHz} \leq f_{\text{offset}} < 1.45 \text{ MHz}$	$P_{\text{rated,c,TRP}} - 43 \text{ dB} - (10/1.4) \cdot (f_{\text{offset}} - 0.05) \text{ dB}$	100 kHz
$1.4 \text{ MHz} \leq \Delta f < 2.8 \text{ MHz}$	$1.45 \text{ MHz} \leq f_{\text{offset}} < 2.85 \text{ MHz}$	$P_{\text{rated,c,TRP}} - 53 \text{ dB}$	100 kHz
$2.8 \text{ MHz} \leq \Delta f < \min(10 \text{ MHz}, \Delta f_{\text{max}})$	$2.85 \text{ MHz} \leq f_{\text{offset}} < \min(10.05 \text{ MHz}, f_{\text{offset}_{\text{max}}})$	-14 dBm (Note 8)	100 kHz
$10 \text{ MHz} \leq \Delta f \leq \Delta f_{\text{max}}$	$10.05 \text{ MHz} \leq f_{\text{offset}} < f_{\text{offset}_{\text{max}}}$	-16 dBm (Note 8)	100 kHz

NOTE 1: For a *RIB* supporting non-contiguous spectrum operation within any operating band the test requirement within sub-block gaps is calculated as a cumulative sum of contributions from adjacent sub blocks on each side of the sub block gap. Exception is $\Delta f \geq 10$ MHz from both adjacent sub blocks on each side of the sub-block gap, where the test requirement within sub-block gaps shall be -25 dBm/100 kHz.

NOTE 2: For a *multi-band RIB* with *Inter RF Bandwidth gap* $< 2 \times \Delta f_{\text{OBUE}}$ MHz the test requirement within the *Inter RF Bandwidth gaps* is calculated as a cumulative sum of contributions from adjacent sub-blocks or *Base Station RF Bandwidth* on each side of the *Inter RF Bandwidth gap*.

NOTE 8: The requirement is not applicable when $\Delta f_{\text{max}} < 10$ MHz.

Table 6.7.5.5.6-3: Medium Range BS operating band unwanted emission limits for 1.4 MHz channel bandwidth, $P_{\text{rated,c,TRP}} \leq 40$ dBm (E-UTRA bands ≤ 3 GHz)

Frequency offset of measurement filter -3dB point, Δf	Frequency offset of measurement filter centre frequency, f_{offset}	Test requirement (Notes 1 and 2)	Measurement bandwidth
$0 \text{ MHz} \leq \Delta f < 1.4 \text{ MHz}$	$0.05 \text{ MHz} \leq f_{\text{offset}} < 1.45 \text{ MHz}$	$-3.2 \text{ dBm} - 10/1.4(f_{\text{offset}}/\text{MHz}-0.05) \text{ dB}$	100 kHz
$1.4 \text{ MHz} \leq \Delta f < 2.8 \text{ MHz}$	$1.45 \text{ MHz} \leq f_{\text{offset}} < 2.85 \text{ MHz}$	-13.2 dBm	100 kHz
$2.8 \text{ MHz} \leq \Delta f < \min(10 \text{ MHz}, \Delta f_{\text{max}})$	$2.85 \text{ MHz} \leq f_{\text{offset}} < \min(10.05 \text{ MHz}, f_{\text{offset}_{\text{max}}})$	-14.2dBm (Note 8)	100 kHz
$10 \text{ MHz} \leq \Delta f \leq \Delta f_{\text{max}}$	$10.05 \text{ MHz} \leq f_{\text{offset}} < f_{\text{offset}_{\text{max}}}$	-16 dBm (Note 8)	100 kHz
NOTE 1: For a <i>RIB</i> supporting non-contiguous spectrum operation within any operating band the test requirement within sub-block gaps is calculated as a cumulative sum of contributions from adjacent sub blocks on each side of the sub block gap. Exception is $\Delta f \geq 10$ MHz from both adjacent sub blocks on each side of the sub-block gap, where the test requirement within sub-block gaps shall be -16 dBm/100 kHz.			
NOTE 2: For BS a <i>multi-band RIB</i> with <i>Inter RF Bandwidth gap</i> $< 2 \times \Delta f_{\text{OBUE}}$ MHz the test requirement within the <i>Inter RF Bandwidth gaps</i> is calculated as a cumulative sum of contributions from adjacent sub-blocks or <i>Base Station RF Bandwidth</i> on each side of the <i>Inter RF Bandwidth gap</i> .			
NOTE 8: The requirement is not applicable when $\Delta f_{\text{max}} < 10$ MHz.			

Table 6.7.5.5.6-4: Medium Range BS operating band unwanted emission limits for 1.4 MHz channel bandwidth, $P_{\text{rated,c,TRP}} \leq 40$ dBm (E-UTRA bands > 3 GHz)

Frequency offset of measurement filter -3dB point, Δf	Frequency offset of measurement filter centre frequency, f_{offset}	Test requirement (Notes 1 and 2)	Measurement bandwidth
$0 \text{ MHz} \leq \Delta f < 1.4 \text{ MHz}$	$0.05 \text{ MHz} \leq f_{\text{offset}} < 1.45 \text{ MHz}$	$-3 \text{ dBm} - 10/1.4(f_{\text{offset}}/\text{MHz}-0.05) \text{ dB}$	100 kHz
$1.4 \text{ MHz} \leq \Delta f < 2.8 \text{ MHz}$	$1.45 \text{ MHz} \leq f_{\text{offset}} < 2.85 \text{ MHz}$	-13 dBm	100 kHz
$2.8 \text{ MHz} \leq \Delta f < \min(10 \text{ MHz}, \Delta f_{\text{max}})$	$2.85 \text{ MHz} \leq f_{\text{offset}} < \min(10.05 \text{ MHz}, f_{\text{offset}_{\text{max}}})$	-14dBm (Note 8)	100 kHz
$10 \text{ MHz} \leq \Delta f \leq \Delta f_{\text{max}}$	$10.05 \text{ MHz} \leq f_{\text{offset}} < f_{\text{offset}_{\text{max}}}$	-16 dBm (Note 8)	100 kHz
NOTE 1: For a <i>RIB</i> supporting non-contiguous spectrum operation within any operating band the test requirement within sub-block gaps is calculated as a cumulative sum of contributions from adjacent sub blocks on each side of the sub block gap. Exception is $\Delta f \geq 10$ MHz from both adjacent sub blocks on each side of the sub-block gap, where the test requirement within sub-block gaps shall be -16 dBm/100 kHz.			
NOTE 2: For a <i>multi-band RIB</i> with <i>Inter RF Bandwidth gap</i> $< 2 \times \Delta f_{\text{OBUE}}$ MHz the test requirement within the <i>Inter RF Bandwidth gaps</i> is calculated as a cumulative sum of contributions from adjacent sub-blocks or <i>Base Station RF Bandwidth</i> on each side of the <i>Inter RF Bandwidth gap</i> .			
NOTE 8: The requirement is not applicable when $\Delta f_{\text{max}} < 10$ MHz.			

Table 6.7.5.5.6-5: Medium Range BS operating band unwanted emission limits for 3 MHz channel bandwidth, $40 < P_{\text{rated,c,TRP}} \leq 47$ dBm (E-UTRA bands ≤ 3 GHz)

Frequency offset of measurement filter -3dB point, Δf	Frequency offset of measurement filter centre frequency, f_{offset}	Test requirement (Notes 1 and 2)	Measurement bandwidth
$0 \text{ MHz} \leq \Delta f < 3 \text{ MHz}$	$0.05 \text{ MHz} \leq f_{\text{offset}} < 3.05 \text{ MHz}$	$P_{\text{rated,c,TRP}} - 47.2 \text{ dB} - (10/3) \cdot (f_{\text{offset}} - 0.05) \text{ dB}$	100 kHz
$3 \text{ MHz} \leq \Delta f < 6 \text{ MHz}$	$3.05 \text{ MHz} \leq f_{\text{offset}} < 6.05 \text{ MHz}$	$P_{\text{rated,c,TRP}} - 57.2 \text{ dB}$	100 kHz
$6 \text{ MHz} \leq \Delta f < \min(10 \text{ MHz}, \Delta f_{\text{max}})$	$6.05 \text{ MHz} \leq f_{\text{offset}} < \min(10.05 \text{ MHz}, f_{\text{offset}_{\text{max}}})$	$\text{Min}(P_{\text{rated,c,TRP}} - 57.2 \text{ dB}, -14.2 \text{ dBm})$ (Note 8)	100 kHz
$10 \text{ MHz} \leq \Delta f \leq \Delta f_{\text{max}}$	$10.05 \text{ MHz} \leq f_{\text{offset}} < f_{\text{offset}_{\text{max}}}$	$\text{Min}(P_{\text{rated,c,TRP}} - 59 \text{ dB}, -16 \text{ dBm})$ (Note 8)	100 kHz
NOTE 1: For a <i>RIB</i> supporting non-contiguous spectrum operation within any operating band the test requirement within sub-block gaps is calculated as a cumulative sum of contributions from adjacent sub blocks on each side of the sub block gap. Exception is $\Delta f \geq 10$ MHz from both adjacent sub blocks on each side of the sub-block gap, where the test requirement within sub-block gaps shall be $\text{Min}(P_{\text{rated,c,TRP}} - 59 \text{ dB}, -16 \text{ dBm})/100$ kHz.			
NOTE 2: For a <i>multi-band RIB</i> with <i>Inter RF Bandwidth gap</i> $< 2 \times \Delta f_{\text{OBUE}}$ MHz the test requirement within the <i>Inter RF Bandwidth gaps</i> is calculated as a cumulative sum of contributions from adjacent sub-blocks or <i>Base Station RF Bandwidth</i> on each side of the <i>Inter RF Bandwidth gap</i> .			
NOTE 8: The requirement is not applicable when $\Delta f_{\text{max}} < 10$ MHz.			

Table 6.7.5.5.6-6: Medium Range BS operating band unwanted emission limits for 3 MHz channel bandwidth, $40 < P_{\text{rated,c,TRP}} \leq 47$ dBm (E-UTRA bands > 3 GHz)

Frequency offset of measurement filter -3dB point, Δf	Frequency offset of measurement filter centre frequency, f_{offset}	Test requirement (Notes 1 and 2)	Measurement bandwidth
$0 \text{ MHz} \leq \Delta f < 3 \text{ MHz}$	$0.05 \text{ MHz} \leq f_{\text{offset}} < 3.05 \text{ MHz}$	$P_{\text{rated,c,TRP}} - 47 \text{ dB} - (10/3) \cdot (f_{\text{offset}} - 0.05) \text{ dB}$	100 kHz
$3 \text{ MHz} \leq \Delta f < 6 \text{ MHz}$	$3.05 \text{ MHz} \leq f_{\text{offset}} < 6.05 \text{ MHz}$	$P_{\text{rated,c,TRP}} - 57 \text{ dB}$	100 kHz
$6 \text{ MHz} \leq \Delta f < \min(10 \text{ MHz}, \Delta f_{\text{max}})$	$6.05 \text{ MHz} \leq f_{\text{offset}} < \min(10.05 \text{ MHz}, f_{\text{offset,max}})$	$\text{Min}(P_{\text{rated,c,TRP}} - 57 \text{ dB}, -14 \text{ dBm})$ (Note 8)	100 kHz
$10 \text{ MHz} \leq \Delta f \leq \Delta f_{\text{max}}$	$10.05 \text{ MHz} \leq f_{\text{offset}} < f_{\text{offset,max}}$	$\text{Min}(P_{\text{rated,c,TRP}} - 59 \text{ dB}, -16 \text{ dBm})$ (Note 8)	100 kHz

NOTE 1: For a *RIB* supporting non-contiguous spectrum operation within any operating band the test requirement within sub-block gaps is calculated as a cumulative sum of contributions from adjacent sub blocks on each side of the sub block gap. Exception is $\Delta f \geq 10$ MHz from both adjacent sub blocks on each side of the sub-block gap, where the test requirement within sub-block gaps shall be $\text{Min}(P_{\text{rated,c,TRP}} - 59 \text{ dB}, -16 \text{ dBm})/100$ kHz.

NOTE 2: For a *multi-band RIB* with *Inter RF Bandwidth gap* $< 2 \times \Delta f_{\text{OBUE}}$ MHz the test requirement within the *Inter RF Bandwidth gaps* is calculated as a cumulative sum of contributions from adjacent sub-blocks or *Base Station RF Bandwidth* on each side of the *Inter RF Bandwidth gap*.

NOTE 8: The requirement is not applicable when $\Delta f_{\text{max}} < 10$ MHz.

Table 6.7.5.5.6-7: Medium Range BS operating band unwanted emission limits for 3 MHz channel bandwidth, $P_{\text{rated,c,TRP}} \leq 40$ dBm (E-UTRA bands ≤ 3 GHz)

Frequency offset of measurement filter -3dB point, Δf	Frequency offset of measurement filter centre frequency, f_{offset}	Test requirement (Notes 1 and 2)	Measurement bandwidth
$0 \text{ MHz} \leq \Delta f < 3 \text{ MHz}$	$0.05 \text{ MHz} \leq f_{\text{offset}} < 3.05 \text{ MHz}$	$-7.2 \text{ dBm} - 10/3(f_{\text{offset}}/\text{MHz} - 0.05) \text{ dB}$	100 kHz
$3 \text{ MHz} \leq \Delta f < 6 \text{ MHz}$	$3.05 \text{ MHz} \leq f_{\text{offset}} < 6.05 \text{ MHz}$	-17.2 dBm	100 kHz
$6 \text{ MHz} \leq \Delta f < \min(10 \text{ MHz}, \Delta f_{\text{max}})$	$6.05 \text{ MHz} \leq f_{\text{offset}} < \min(10.05 \text{ MHz}, f_{\text{offset,max}})$	-17.2 dBm (Note 8)	100 kHz
$10 \text{ MHz} \leq \Delta f \leq \Delta f_{\text{max}}$	$10.05 \text{ MHz} \leq f_{\text{offset}} < f_{\text{offset,max}}$	-19 dBm (Note 8)	100 kHz

NOTE 1: For a *RIB* supporting non-contiguous spectrum operation within any operating band the test requirement within sub-block gaps is calculated as a cumulative sum of contributions from adjacent sub blocks on each side of the sub block gap. Exception is $\Delta f \geq 10$ MHz from both adjacent sub blocks on each side of the sub-block gap, where the test requirement within sub-block gaps shall be -19 dBm/100 kHz.

NOTE 2: For a *multi-band RIB* with *Inter RF Bandwidth gap* $< 2 \times \Delta f_{\text{OBUE}}$ MHz the test requirement within the *Inter RF Bandwidth gaps* is calculated as a cumulative sum of contributions from adjacent sub-blocks or *Base Station RF Bandwidth* on each side of the *Inter RF Bandwidth gap*.

NOTE 8: The requirement is not applicable when $\Delta f_{\text{max}} < 10$ MHz.

Table 6.7.5.5.6-8: Medium Range BS operating band unwanted emission limits for 3 MHz channel bandwidth, $P_{\text{rated,c,TRP}} \leq 40$ dBm (E-UTRA bands > 3 GHz)

Frequency offset of measurement filter -3dB point, Δf	Frequency offset of measurement filter centre frequency, f_{offset}	Test requirement (Notes 1 and 2)	Measurement bandwidth
$0 \text{ MHz} \leq \Delta f < 3 \text{ MHz}$	$0.05 \text{ MHz} \leq f_{\text{offset}} < 3.05 \text{ MHz}$	$-7 \text{ dBm} - 10/3(f_{\text{offset}}/\text{MHz} - 0.05) \text{ dB}$	100 kHz
$3 \text{ MHz} \leq \Delta f < 6 \text{ MHz}$	$3.05 \text{ MHz} \leq f_{\text{offset}} < 6.05 \text{ MHz}$	-17 dBm	100 kHz
$6 \text{ MHz} \leq \Delta f < \min(10 \text{ MHz}, \Delta f_{\text{max}})$	$6.05 \text{ MHz} \leq f_{\text{offset}} < \min(10.05 \text{ MHz}, f_{\text{offset,max}})$	-17 dBm (Note 8)	100 kHz
$10 \text{ MHz} \leq \Delta f \leq \Delta f_{\text{max}}$	$10.05 \text{ MHz} \leq f_{\text{offset}} < f_{\text{offset,max}}$	-19 dBm (Note 8)	100 kHz

NOTE 1: For a *RIB* supporting non-contiguous spectrum operation within any operating band the test requirement within sub-block gaps is calculated as a cumulative sum of contributions from adjacent sub blocks on each side of the sub block gap. Exception is $\Delta f \geq 10$ MHz from both adjacent sub blocks on each side of the sub-block gap, where the test requirement within sub-block gaps shall be -19 dBm/100 kHz.

NOTE 2: For a *multi-band RIB* with *Inter RF Bandwidth gap* $< 2 \times \Delta f_{\text{OBUE}}$ MHz the test requirement within the *Inter RF Bandwidth gaps* is calculated as a cumulative sum of contributions from adjacent sub-blocks or *Base Station RF Bandwidth* on each side of the *Inter RF Bandwidth gap*.

NOTE 8: The requirement is not applicable when $\Delta f_{\text{max}} < 10$ MHz.

Table 6.7.5.5.6-9: Medium Range BS operating band unwanted emission limits for 5, 10, 15 and 20 MHz channel bandwidth, $40 < P_{\text{rated,c,TRP}} \leq 47$ dBm (E-UTRA bands ≤ 3 GHz)

Frequency offset of measurement filter -3dB point, Δf	Frequency offset of measurement filter centre frequency, f_{offset}	Test requirement (Notes 1 and 2)	Measurement bandwidth
$0 \text{ MHz} \leq \Delta f < 5 \text{ MHz}$	$0.05 \text{ MHz} \leq f_{\text{offset}} < 5.05 \text{ MHz}$	$P_{\text{rated,c,TRP}} - 51.2 \text{ dB} - (7/5) \cdot (f_{\text{offset}} - 0.05) \text{ dB}$	100 kHz
$5 \text{ MHz} \leq \Delta f < \min(10 \text{ MHz}, \Delta f_{\text{max}})$	$5.05 \text{ MHz} \leq f_{\text{offset}} < \min(10.05 \text{ MHz}, f_{\text{offset,max}})$	$P_{\text{rated,c,TRP}} - 58.2 \text{ dB}$	100 kHz
$10 \text{ MHz} \leq \Delta f \leq \Delta f_{\text{max}}$	$10.05 \text{ MHz} \leq f_{\text{offset}} < f_{\text{offset,max}}$	$\text{Min}(P_{\text{rated,c,TRP}} - 60 \text{ dB}, -16 \text{ dBm})$ (NOTE 8)	100 kHz

NOTE 1: For a *RIB* supporting non-contiguous spectrum operation within any operating band the test requirement within sub-block gaps is calculated as a cumulative sum of contributions from adjacent sub blocks on each side of the sub block gap. Exception is $\Delta f \geq 10$ MHz from both adjacent sub blocks on each side of the sub-block gap, where the test requirement within sub-block gaps shall be $\text{Min}(P_{\text{rated,c,TRP}} - 60 \text{ dB}, -16 \text{ dBm})/100$ kHz.

NOTE 2: For a *multi-band RIB* with *Inter RF Bandwidth gap* $< 2 \cdot \Delta f_{\text{OBUE}}$ MHz the test requirement within the *Inter RF Bandwidth gaps* is calculated as a cumulative sum of contributions from adjacent sub-blocks or *Base Station RF Bandwidth* on each side of the *Inter RF Bandwidth gap*.

NOTE 8: The requirement is not applicable when $\Delta f_{\text{max}} < 10$ MHz.

Table 6.7.5.5.6-10: Medium Range BS operating band unwanted emission limits for 5, 10, 15 and 20 MHz channel bandwidth, $40 < P_{\text{rated,c,TRP}} \leq 47$ dBm (E-UTRA bands > 3 GHz)

Frequency offset of measurement filter -3dB point, Δf	Frequency offset of measurement filter centre frequency, f_{offset}	Test requirement (Notes 1 and 2)	Measurement bandwidth
$0 \text{ MHz} \leq \Delta f < 5 \text{ MHz}$	$0.05 \text{ MHz} \leq f_{\text{offset}} < 5.05 \text{ MHz}$	$P_{\text{rated,c,TRP}} - 51 \text{ dB} - (7/5) \cdot (f_{\text{offset}} - 0.05) \text{ dB}$	100 kHz
$5 \text{ MHz} \leq \Delta f < \min(10 \text{ MHz}, \Delta f_{\text{max}})$	$5.05 \text{ MHz} \leq f_{\text{offset}} < \min(10.05 \text{ MHz}, f_{\text{offset,max}})$	$P_{\text{rated,c,TRP}} - 58 \text{ dB}$	100 kHz
$10 \text{ MHz} \leq \Delta f \leq \Delta f_{\text{max}}$	$10.05 \text{ MHz} \leq f_{\text{offset}} < f_{\text{offset,max}}$	$\text{Min}(P_{\text{rated,c,TRP}} - 60 \text{ dB}, -16 \text{ dBm})$ (NOTE 8)	100 kHz

NOTE 1: For a *RIB* supporting non-contiguous spectrum operation within any operating band the test requirement within sub-block gaps is calculated as a cumulative sum of contributions from adjacent sub blocks on each side of the sub block gap. Exception is $\Delta f \geq 10$ MHz from both adjacent sub blocks on each side of the sub-block gap, where the test requirement within sub-block gaps shall be $\text{Min}(P_{\text{rated,c,TRP}} - 60 \text{ dB}, -16 \text{ dBm})/100$ kHz.

NOTE 2: For a *multi-band RIB* with *Inter RF Bandwidth gap* $< 2 \cdot \Delta f_{\text{OBUE}}$ MHz the test requirement within the *Inter RF Bandwidth gaps* is calculated as a cumulative sum of contributions from adjacent sub-blocks or *Base Station RF Bandwidth* on each side of the *Inter RF Bandwidth gap*.

NOTE 8: The requirement is not applicable when $\Delta f_{\text{max}} < 10$ MHz.

Table 6.7.5.5.6-11: Medium Range BS operating band unwanted emission limits for 5, 10, 15 and 20 MHz channel bandwidth, $P_{\text{rated,c,TRP}} \leq 40$ dBm (E-UTRA bands ≤ 3 GHz)

Frequency offset of measurement filter -3dB point, Δf	Frequency offset of measurement filter centre frequency, f_{offset}	Test requirement (Notes 1 and 2)	Measurement bandwidth
$0 \text{ MHz} \leq \Delta f < 5 \text{ MHz}$	$0.05 \text{ MHz} \leq f_{\text{offset}} < 5.05 \text{ MHz}$	$P_{\text{rated,c,TRP}} - 11.2 \text{ dB} - (7/5) \cdot (f_{\text{offset}} - 0.05) \text{ dB}$	100 kHz
$5 \text{ MHz} \leq \Delta f < \min(10 \text{ MHz}, \Delta f_{\text{max}})$	$5.05 \text{ MHz} \leq f_{\text{offset}} < \min(10.05 \text{ MHz}, f_{\text{offset,max}})$	-18.2 dBm	100 kHz
$10 \text{ MHz} \leq \Delta f \leq \Delta f_{\text{max}}$	$10.05 \text{ MHz} \leq f_{\text{offset}} < f_{\text{offset,max}}$	-20 dBm (NOTE 8)	100 kHz

NOTE 1: For a *RIB* supporting non-contiguous spectrum operation within any operating band the test requirement within sub-block gaps is calculated as a cumulative sum of contributions from adjacent sub blocks on each side of the sub block gap. Exception is $\Delta f \geq 10$ MHz from both adjacent sub blocks on each side of the sub-block gap, where the test requirement within sub-block gaps shall be -20dBm/100 kHz.

NOTE 2: For a *multi-band RIB* with *Inter RF Bandwidth gap* $< 2 \cdot \Delta f_{\text{OBUE}}$ MHz the test requirement within the *Inter RF Bandwidth gaps* is calculated as a cumulative sum of contributions from adjacent sub-blocks or *Base Station RF Bandwidth* on each side of the *Inter RF Bandwidth gap*.

NOTE 8: The requirement is not applicable when $\Delta f_{\text{max}} < 10$ MHz.

Table 6.7.5.5.6-12: Medium Range BS operating band unwanted emission limits for 5, 10, 15 and 20 MHz channel bandwidth, $P_{\text{rated,c,TRP}} \leq 40$ dBm (E-UTRA bands > 3 GHz)

Frequency offset of measurement filter -3dB point, Δf	Frequency offset of measurement filter centre frequency, f_{offset}	Test requirement (Notes 1 and 2)	Measurement bandwidth
$0 \text{ MHz} \leq \Delta f < 5 \text{ MHz}$	$0.05 \text{ MHz} \leq f_{\text{offset}} < 5.05 \text{ MHz}$	$P_{\text{rated,c,TRP}} - 11 \text{ dB} - (7/5) * (f_{\text{offset}} - 0.05) \text{ dB}$	100 kHz
$5 \text{ MHz} \leq \Delta f < \min(10 \text{ MHz}, \Delta f_{\text{max}})$	$5.05 \text{ MHz} \leq f_{\text{offset}} < \min(10.05 \text{ MHz}, f_{\text{offset,max}})$	-18 dBm	100 kHz
$10 \text{ MHz} \leq \Delta f \leq \Delta f_{\text{max}}$	$10.05 \text{ MHz} \leq f_{\text{offset}} < f_{\text{offset,max}}$	-20 dBm (NOTE 8)	100 kHz

NOTE 1: For a *RIB* supporting non-contiguous spectrum operation within any operating band the test requirement within sub-block gaps is calculated as a cumulative sum of contributions from adjacent sub blocks on each side of the sub block gap. Exception is $\Delta f \geq 10$ MHz from both adjacent sub blocks on each side of the sub-block gap, where the test requirement within sub-block gaps shall be -20 dBm/100 kHz.

NOTE 2: For a *multi-band RIB* with *Inter RF Bandwidth gap* < $2 * \Delta f_{\text{OBUe}}$ MHz the test requirement within the *Inter RF Bandwidth gaps* is calculated as a cumulative sum of contributions from adjacent sub-blocks or *Base Station RF Bandwidth* on each side of the *Inter RF Bandwidth gap*.

NOTE 8: The requirement is not applicable when $\Delta f_{\text{max}} < 10$ MHz.

6.7.5.5.7 Additional requirements

In certain regions the following test requirement may apply. For E-UTRA *RIB* operating in Bands 5, 26, 27 or 28, emissions shall not exceed the maximum levels specified in Table 6.7.5.5.7-1.

Table 6.7.5.5.7-1: Additional operating band unwanted emission limits for E-UTRA bands < 1 GHz

Channel bandwidth	Frequency offset of measurement filter -3dB point, Δf	Frequency offset of measurement filter centre frequency, f_{offset}	Test requirement	Measurement bandwidth
1.4 MHz	$0 \text{ MHz} \leq \Delta f < 1 \text{ MHz}$	$0.005 \text{ MHz} \leq f_{\text{offset}} < 0.995 \text{ MHz}$	-12.2 dBm	10 kHz
3 MHz	$0 \text{ MHz} \leq \Delta f < 1 \text{ MHz}$	$0.015 \text{ MHz} \leq f_{\text{offset}} < 0.985 \text{ MHz}$	-11.2 dBm	30 kHz
5 MHz	$0 \text{ MHz} \leq \Delta f < 1 \text{ MHz}$	$0.015 \text{ MHz} \leq f_{\text{offset}} < 0.985 \text{ MHz}$	-13.2 dBm	30 kHz
10 MHz	$0 \text{ MHz} \leq \Delta f < 1 \text{ MHz}$	$0.05 \text{ MHz} \leq f_{\text{offset}} < 0.95 \text{ MHz}$	-11.2 dBm	100 kHz
15 MHz	$0 \text{ MHz} \leq \Delta f < 1 \text{ MHz}$	$0.05 \text{ MHz} \leq f_{\text{offset}} < 0.95 \text{ MHz}$	-11.2 dBm	100 kHz
20 MHz	$0 \text{ MHz} \leq \Delta f < 1 \text{ MHz}$	$0.05 \text{ MHz} \leq f_{\text{offset}} < 0.95 \text{ MHz}$	-11.2 dBm	100 kHz
All	$1 \text{ MHz} \leq \Delta f < \min(10 \text{ MHz}, \Delta f_{\text{max}})$	$1.05 \text{ MHz} \leq f_{\text{offset}} < \min(10.05 \text{ MHz}, f_{\text{offset,max}})$	-11.2 dBm (Note 8)	100 kHz
All	$10 \text{ MHz} \leq \Delta f \leq \Delta f_{\text{max}}$	$10.05 \text{ MHz} \leq f_{\text{offset}} < f_{\text{offset,max}}$	-13 dBm (Note 8)	100 kHz

NOTE 8: The requirement is not applicable when $\Delta f_{\text{max}} < 10$ MHz.

In certain regions the following test requirement may apply. For E-UTRA a *RIB* operating in Bands 2, 4, 10, 23, 25, 30, 35, 36, 41, 66, emissions shall not exceed the maximum levels specified in Table 6.7.5.5.7-2.

Table 6.7.5.5.7-2: Additional operating band unwanted emission limits for E-UTRA bands > 1GHz

Channel bandwidth	Frequency offset of measurement filter -3dB point, Δf	Frequency offset of measurement filter centre frequency, f_{offset}	Test requirement	Measurement bandwidth
1.4 MHz	$0 \text{ MHz} \leq \Delta f < 1 \text{ MHz}$	$0.005 \text{ MHz} \leq f_{\text{offset}} < 0.995 \text{ MHz}$	-12.2 dBm	10 kHz
3 MHz	$0 \text{ MHz} \leq \Delta f < 1 \text{ MHz}$	$0.015 \text{ MHz} \leq f_{\text{offset}} < 0.985 \text{ MHz}$	-11.2 dBm	30 kHz
5 MHz	$0 \text{ MHz} \leq \Delta f < 1 \text{ MHz}$	$0.015 \text{ MHz} \leq f_{\text{offset}} < 0.985 \text{ MHz}$	-13.2 dBm	30 kHz
10 MHz	$0 \text{ MHz} \leq \Delta f < 1 \text{ MHz}$	$0.05 \text{ MHz} \leq f_{\text{offset}} < 0.95 \text{ MHz}$	-11.2 dBm	100 kHz
15 MHz	$0 \text{ MHz} \leq \Delta f < 1 \text{ MHz}$	$0.05 \text{ MHz} \leq f_{\text{offset}} < 0.95 \text{ MHz}$	-13.2 dBm	100 kHz
20 MHz	$0 \text{ MHz} \leq \Delta f < 1 \text{ MHz}$	$0.05 \text{ MHz} \leq f_{\text{offset}} < 0.95 \text{ MHz}$	-14.2 dBm	100 kHz
All	$1 \text{ MHz} \leq \Delta f < \min(10 \text{ MHz}, \Delta f_{\text{max}})$	$1.5 \text{ MHz} \leq f_{\text{offset}} < \min(10.5 \text{ MHz}, f_{\text{offset,max}})$	-11.2 dBm (Note 8)	1 MHz
All	$10 \text{ MHz} \leq \Delta f \leq \Delta f_{\text{max}}$	$10.5 \text{ MHz} \leq f_{\text{offset}} < f_{\text{offset,max}}$	-13 dBm (Note 8)	1 MHz

NOTE 8: The requirement is not applicable when $\Delta f_{\text{max}} < 10$ MHz.

In certain regions the following test requirement may apply. For E-UTRA a *RIB* operating in Bands 12, 13, 14, 17, 29, 85 emissions shall not exceed the maximum levels specified in Table 6.7.5.5.7-3.

Table 6.7.5.5.7-3: Additional operating band unwanted emission limits for E-UTRA (bands 12, 13, 14, 17, 29, 85)

Channel bandwidth	Frequency offset of measurement filter -3dB point, Δf	Frequency offset of measurement filter centre frequency, f_{offset}	Test requirement	Measurement bandwidth
All	$0 \text{ MHz} \leq \Delta f < 100 \text{ kHz}$	$0.015 \text{ MHz} \leq f_{\text{offset}} < 0.085 \text{ MHz}$	-11.2 dBm	30 kHz
All	$100 \text{ kHz} \leq \Delta f < \min(10 \text{ MHz}, \Delta f_{\text{max}})$	$150 \text{ kHz} \leq f_{\text{offset}} < \min(10.05 \text{ MHz}, f_{\text{offset}_{\text{max}}})$	-11.2 dBm (Note 8)	100 kHz
All	$10 \text{ MHz} \leq \Delta f \leq \Delta f_{\text{max}}$	$10.05 \text{ MHz} \leq f_{\text{offset}} < f_{\text{offset}_{\text{max}}}$	-13 dBm (Note 8)	100 kHz

NOTE 8: The requirement is not applicable when $\Delta f_{\text{max}} < 10 \text{ MHz}$.

In certain regions, the following test requirements may apply to an E-UTRA TDD *RIB* operating in the same geographic area and in the same operating band as another E-UTRA TDD system without synchronisation. For this case the emissions shall not exceed -52 dBm/MHz in each supported downlink operating band, except in:

- The frequency range from Δf_{OBUE} MHz below the lower channel edge to the frequency Δf_{OBUE} MHz above the upper channel edge of each supported band.

In certain regions the following test requirement may apply for protection of DTT. For E-UTRA a *RIB* operating in Band 20, the level of emissions in the band 470-790 MHz, measured in an 8MHz filter bandwidth on centre frequencies F_{filter} according to Table 6.7.5.5.7-4, shall not exceed the maximum emission TRP level shown in the table. This test requirement applies in the frequency range 470-790 MHz even though part of the range falls in the spurious domain.

Table 6.7.5.5.7-4: Declared emissions levels for protection of DTT

Case	Measurement filter centre frequency	Condition on BS maximum aggregate EIRP / 10 MHz, $P_{\text{EIRP}_{10\text{MHz}}}$ (NOTE)	Maximum Level $P_{\text{EIRP},N,\text{MAX}}$	Measurement Bandwidth
A: for DTT frequencies where broadcasting is protected	$N*8 + 306 \text{ MHz}, 21 \leq N \leq 60$	$P_{\text{EIRP}_{10\text{MHz}}} \geq 59 \text{ dBm}$	1.8dBm	8 MHz
	$N*8 + 306 \text{ MHz}, 21 \leq N \leq 60$	$36 \leq P_{\text{EIRP}_{10\text{MHz}}} < 59 \text{ dBm}$	$P_{\text{EIRP}_{10\text{MHz}}} - 57.2 \text{ dBm}$	8 MHz
	$N*8 + 306 \text{ MHz}, 21 \leq N \leq 60$	$P_{\text{EIRP}_{10\text{MHz}}} < 36 \text{ dBm}$	-21.2dBm	8 MHz
B: for DTT frequencies where broadcasting is subject to an intermediate level of protection	$N*8 + 306 \text{ MHz}, 21 \leq N \leq 60$	$P_{\text{EIRP}_{10\text{MHz}}} \geq 59 \text{ dBm}$	11.8dBm	8 MHz
	$N*8 + 306 \text{ MHz}, 21 \leq N \leq 60$	$36 \leq P_{\text{EIRP}_{10\text{MHz}}} < 59 \text{ dBm}$	$P_{\text{EIRP}_{10\text{MHz}}} - 47.2 \text{ dBm}$	8 MHz
	$N*8 + 306 \text{ MHz}, 21 \leq N \leq 60$	$P_{\text{EIRP}_{10\text{MHz}}} < 36 \text{ dBm}$	-11,2dBm	8 MHz
C: for DTT frequencies where broadcasting is not protected	$N*8 + 306 \text{ MHz}, 21 \leq N \leq 60$	N.A.	23.8dBm	8 MHz

NOTE: $P_{\text{EIRP}_{10\text{MHz}}}$ (dBm) is defined by the expression $P_{\text{EIRP}_{10\text{MHz}}} = P_{10\text{MHz}} + G_{\text{ant}} + 6\text{dB}$ for UTRA and $P_{\text{EIRP}_{10\text{MHz}}} = P_{10\text{MHz}} + G_{\text{ant}} + 9\text{dB}$ for E-UTRA, where G_{ant} is 17 dBi

NOTE 1: The regional requirement is defined in terms of EIRP (effective isotropic radiated power), which is dependent on both the BS emissions and the deployment (including antenna gain and feeder loss). The method outlined in annex B1, 3GPP TS 37.105 [6] indicates how the limit in Table 6.7.5.5.7-4 demonstrates compliance to the regional requirement.

6.7.6 OTA Spurious emission

6.7.6.1 General

The OTA spurious emissions limits are specified as TRP per cell unless otherwise specified.

The OTA transmitter spurious emission limits apply from 30 MHz to 12.75 GHz, excluding the following RAT-specific frequency ranges:

- UTRA FDD BS as specified in TS 25.104 [2]: from 12.5MHz below the lowest carrier frequency used up to 12.5MHz above the highest carrier frequency used.
- E-UTRA BS as specified in TS 36.104 [4]: from Δf_{OBUE} below the lowest frequency of the *downlink operating band* up to Δf_{OBUE} above the highest frequency of the *downlink operating band*, where Δf_{OBUE} is defined in subclause 6.7.1.
- MSR BS as specified in TS 37.104 [5]: from Δf_{OBUE} below the lowest frequency of the *downlink operating band* up to Δf_{OBUE} above the highest frequency of the *downlink operating band*, where Δf_{OBUE} is defined in subclause 6.7.1. For some operating bands the upper frequency limit is higher than 12.75 GHz in order to comply with the 5th harmonic limit of the *downlink operating band*, as specified in ITU-R recommendation SM.329 [16]. In some exceptional cases, requirements apply also closer than 10 MHz from the *downlink operating band*; these cases are highlighted in the requirement tables in respective referenced UTRA, E-UTRA, NR or MSR specifications. For operating bands supported by *multi-band RIB* each supported band including the Δf_{OBUE} around the band are excluded from the spurious emissions requirements.

The requirements apply for both *single band RIBs* and *multi-band RIBs* (except for frequencies at which exclusion bands or other multi-band provisions apply) and for all transmission modes foreseen by the manufacturer's specification. Unless otherwise stated, all requirements are measured as mean power.

For operation in Region 2, where the FCC guidance for MIMO systems in [17] is applicable, the emissions limits are the same regardless of the number of transceiver units so the limits are equivalent to those for a single transceiver unit as specified in the as the corresponding applicable *non-AAS BS* per transmitter requirement specified in 3GPP TS 25.104 [2], 3GPP TS 25.105 [3], 3GPP TS 36.104 [4], 3GPP TS 37.104 [5] or 3GPP TS 38.104 [33]. For E-UTRA and NR the limits will be 9dB lower and for UTRA FDD the limits will be 6dB lower, unless stated differently in regional regulation.

The AAS BS requirements for spurious emissions limits which are specified for Band 46 in 3GPP TS 37.104 [5], are applicable for AAS BS.

6.7.6.2 Mandatory Requirements

6.7.6.2.1 Definition and applicability

The OTA spurious emissions mandatory requirements include the CAT A, CAT B and additional minimum requirements for BC2, limits are specified as TRP per cell unless otherwise specified.

6.7.6.2.2 Minimum Requirement

For AAS BS in *MSR operation* the minimum requirement is defined in TS 37.105 [6], subclause 9.7.6.2.1.

For AAS BS in *single RAT UTRA operation* the minimum requirement is defined in TS 37.105 [6], subclause 9.7.6.3.1.

For AAS BS in *single RAT E-UTRA operation* the minimum requirement is defined in TS 37.105 [6], subclause 9.7.6.4.1.

6.7.6.2.3 Test purpose

The test purpose is to verify the radiated spurious emissions from the AAS BS at the RIB are within the specified minimum requirements.

6.7.6.2.4 Method of test

6.7.6.2.4.1 Initial conditions

Test environment: normal, see annex G.2.

RF channels to be tested for single carrier:

B when testing from 30 MHz to $F_{DL_low} - \Delta f_{OBUE}$

T when testing from $F_{DL_high} + \Delta f_{OBUE}$ to 12.75GHz (or to 5th harmonic)

RF bandwidth positions to be tested: [FFS] in single-band operation, see subclause 4.12.1.

B_{RFBW} when testing from 30 MHz to $F_{DL_low} - \Delta f_{OBUE}$

T_{RFBW} when testing from $F_{DL_high} + \Delta f_{OBUE}$ to 12.75GHz (or 5th harmonic)

RF bandwidth positions to be tested in multi-band operation, see subclause 4.12.1.

$B_{RFBW_T'_{RFBW}}$ when testing from 30 MHz to $F_{DL_Blow_low} - \Delta f_{OBUE}$

$B'_{RFBW_T_{RFBW}}$ when testing from $F_{DL_Bhigh_high} + \Delta f_{OBUE}$ to 12.75GHz (or to 5th harmonic)

$B_{RFBW_T'_{RFBW}}$ and $B'_{RFBW_T_{RFBW}}$ when testing from $F_{DL_Blow_high} + \Delta f_{OBUE}$ to $F_{DL_Bhigh_low} - \Delta f_{OBUE}$

Directions to be tested

As the requirement is TRP the beam pattern(s) may be set up to optimise the TRP measurement procedure (see annex F) as long as the required TRP level is achieved.

6.7.6.2.4.2 Procedure

- 1) Place the AAS BS at the positioner.
- 2) Align the manufacturer declared coordinate system orientation (see table 4.10-1, D9.2) of the AAS BS with the test system.
- 3) Measurements shall use a measurement bandwidth in accordance to the conditions in subclause 6.7.6.
- 4) The measurement device characteristics shall be:
 - Detection mode: True RMS.
- 5) Set the AAS BS to transmit
 - a) For MSR:
 - Set the RIB to transmit maximum power according to the applicable test configuration in clause 5 using the corresponding test models or set of physical channels in subclause 4.11.
 - b) For UTRA:
 - For a RIB declared to be capable of single carrier operation only, set the RIB to transmit a signal according to TM1, subclause 4.12.2, at the manufacturer's declared rated carrier TRP, $P_{rated,c,TRP}$.
 - For a RIB declared to be capable of multi-carrier operation, set the set the RIB to transmit according to TM1 on all carriers configured using the applicable test configuration and corresponding power setting specified in subclause 4.11.
 - c) For E-UTRA:
 - RIB declared to be capable of single carrier operation only, set the RIB to transmit a signal according to E-TM1.1 in subclause 4.12.2, at manufacturer's declared rated carrier TRP, $P_{rated,c,TRP}$.

- For a RIB declared to be capable of multi-carrier and/or CA operation, set the set the RIB to transmit according to E-TM1.1 on all carriers configured using the applicable test configuration and corresponding power setting specified in subclause 4.11.

6) Align the BS and the test antenna such that measurements to determine TRP can be performed (see annex F)

7) Measure the emission at the specified frequencies with specified measurement bandwidth

8) Repeat step 6-7 for all directions in the appropriated TRP measurement grid needed for full TRP estimation (see annex F).

Note 1: the TRP measurement grid may not be the same for all measurement frequencies.

Note 2: the frequency sweep or the TRP measurement grid sweep may be done in any order

9) Calculate TRP at each specified frequency using the directional measurements.

In addition, for *multi-band RIB(s)*, the following steps shall apply:

10) For *multi-band RIBs* and single band tests, repeat the steps above per involved band where single band test configurations and test models shall apply with no carrier activated in the other band.

NOTE: As an alternative, TRP can be measured in a reverberation chamber following step 1, 3, 4, 5, 7 and 10.

6.7.6.2.5 Test Requirement

6.7.6.2.5.1 MSR operation

Category A requirements

For an AAS BS meeting category A the TRP of any spurious emission shall not exceed the limits in table 6.7.6.2.5.1-1

Table 6.7.6.2.5.1-1: AAS BS OTA Spurious emission limits, Category A

Frequency range	Maximum level	Measurement Bandwidth	NOTE
30MHz - 1GHz	-13 + X dBm	100 kHz	NOTE 1
1GHz - 12.75 GHz		1 MHz	NOTE 2
12.75 GHz – 5 th harmonic of the upper frequency edge of the DL operating band in GHz		1 MHz	NOTE 2, NOTE 3
NOTE 1: Bandwidth as in ITU-R SM.329 [16], s4.1			
NOTE 2: Bandwidth as in ITU-R SM.329 [16], s4.1. Upper frequency as in ITU-R SM.329 [16] , s2.5 table 1			
NOTE 3: Applies only for Bands 22, 42, 43, 48.			
NOTE 4: X = 9 dB for E-UTRA, X = 6 dB for UTRA, unless stated differently in regional regulation.			

Category B requirements

For UTRA, the minimum requirement is specified in subclause 6.7.6.2.5.2

For E-UTRA and NR, the minimum requirement is specified in subclause 6.7.6.2.5.3

Additional requirements for BC2 (category B)

For AAS BS operating in Band Category 2 when GSM/EDGE is configured, the power of any spurious emission shall not exceed the limits in table 6.7.6.2.5.1-2.

For *multi-band RIBs* the limits in table 6.7.6.2.5.1-2 are only applicable when all supported operating bands belong to BC2 and GSM/EDGE is configured in all bands.

Table 6.7.6.2.5.1-2: Additional AAS BS OTA Spurious emissions limits for BC2, Category B

Frequency range	Frequency offset from <i>downlink operating band edge</i> (NOTE)	Maximum Level	Measurement Bandwidth
500 MHz ↔ 1 GHz	10 – 20 MHz	-25 dBm	300 kHz
	20 – 30 MHz	-25 dBm	1 MHz
	≥ 30 MHz	-25 dBm	3 MHz
1 GHz ↔ 12.75 GHz	≥ 30 MHz	-22 dBm	3 MHz

NOTE: For *multi-band RIBs*, the frequency offset is relative to the closest operating band.

6.7.6.2.5.2 Single RAT UTRA operation

Category A requirements

For an AAS BS meeting category A the TRP of any spurious emission shall not exceed the limits in table 6.7.6.2.5.1-1

Category B requirements

The following limits shall be met in cases where Category B limits for spurious emissions, as defined in ITU-R Recommendation SM.329 [17], are applied.

The TRP of any spurious emission shall not exceed the limits in tables 6.7.6.2.5.2-1 and 6.7.6.2.5.2-2

Table 6.7.6.2.5.2-1: OTA AAS BS Mandatory spurious emissions limits, operating band I, II, III, IV, VII, X, XXII, XXV, XXXII (Category B)

Band	Maximum Level (Note 5)	Measurement Bandwidth	Notes
30 MHz ↔ 1 GHz	-36 + X dBm	100 kHz	NOTE 1
1 GHz ↔ $F_{low} - 10$ MHz	-30 + X dBm	1 MHz	NOTE 1
$F_{low} - 10$ MHz ↔ $F_{high} + 10$ MHz	-15 + X dBm	1 MHz	NOTE 2
$F_{high} + 10$ MHz ↔ 12.75 GHz	-30 + X dBm	1 MHz	NOTE 3
12.75 GHz - 5 th harmonic of the upper frequency edge of the DL operating band in GHz	-30 + X dBm	1 MHz	NOTE 3, NOTE 4

NOTE 1: Bandwidth as in ITU-R Recommendation SM.329 [16], s4.1
NOTE 2: Limit based on ITU-R Recommendation SM.329 [16], s4.3 and Annex 7
NOTE 3: Bandwidth as in ITU-R Recommendation SM.329 [16], s4.1. Upper frequency as in ITU-R SM.329 [16], s2.5 table 1
NOTE 4: Applies only for Band XXII
NOTE 5: X = 6 dB, unless stated differently in regional regulation.

Key:
 F_{low} : The lowest downlink frequency of the operating band as defined in subclause 4.7
 F_{high} : The highest downlink frequency of the operating band as defined in subclause 4.7

Table 6.7.6.2.5.2-2: BS Mandatory spurious emissions limits, operating band V, VIII, XII, XIII, XIV, XX, XXVI (Category B)

Band	Maximum Level (Note 4)	Measurement Bandwidth	Notes
30 MHz \leftrightarrow $F_{low} - 10$ MHz	-36 + X dBm	100 kHz	NOTE 1
$F_{low} - 10$ MHz \leftrightarrow $F_{high} + 10$ MHz	-16 + X dBm	100 kHz	NOTE 2
$F_{high} + 10$ MHz \leftrightarrow 1 GHz	-36 + X dBm	100 kHz	NOTE 1
1GHz \leftrightarrow 12.75GHz	-30 + X dBm	1 MHz	NOTE 3
NOTE 1: Bandwidth as in ITU-R Recommendation SM.329 [17], s4.1			
NOTE 2: Limit based on ITU-R Recommendation SM.329 [17], s4.3 and Annex 7			
NOTE 3: Bandwidth as in ITU-R Recommendation SM.329 [17], s4.1. Upper frequency as in ITU-R SM.329 [17], s2.5 table 1			
NOTE 4: X = 6 dB, unless stated differently in regional regulation.			
Key:			
F_{low} :	The lowest downlink frequency of the operating band as defined in subclause 4.7		
F_{high} :	The highest downlink frequency of the operating band as defined in subclause 4.7		

6.7.6.2.5.3 Single RAT E-UTRA operation

Category A requirements

For an AAS BS meeting category A the TRP of any spurious emission shall not exceed the limits in table 6.7.6.2.5.1-1

Category B requirements

The TRP of any spurious emission shall not exceed the limits in table 6.7.6.2.5.3-1

Table 6.7.6.2.5.3-1: AAS BS OTA Spurious emissions limits, Category B

Frequency range	Maximum Level (Note 4)	Measurement Bandwidth	Notes
30 MHz \leftrightarrow 1 GHz	-36 + X dBm	100 kHz	NOTE 1
1 GHz \leftrightarrow 12.75 GHz	-30 + X dBm	1 MHz	NOTE 2
12.75 GHz \leftrightarrow 5 th harmonic of the upper frequency edge of the DL operating band in GHz	-36 + X dBm	1 MHz	NOTE 2, NOTE 3
NOTE 1: Bandwidth as in ITU-R SM.329 [16], s4.1			
NOTE 2: Bandwidth as in ITU-R SM.329 [16], s4.1. Upper frequency as in ITU-R SM.329 [16], s2.5 table 1			
NOTE 3: Applies only for Bands 22, 42, 43, 48.			
NOTE 4: X = 9 dB, unless stated differently in regional regulation.			

6.7.6.3 Protection of the BS receiver of own or different BS

6.7.6.3.1 Definition and applicability

This requirement shall be applied for FDD operation in order to prevent the receivers of own or a different BS of the same band being desensitised by emissions from a *OTA AAS BS*.

The requirement is a co-location requirement, the power levels specified at the CLTA output(s).

6.7.6.3.2 Minimum Requirement

The minimum requirement for AAS BS in *MSR operation* is defined in TS 37.105 [6], subclause 9.7.6.2.

The minimum requirement for AAS BS in *single RAT UTRA operation* is defined in TS 37.105 [6], subclause 9.7.6.3.

The minimum requirement for AAS BS in *single RAT E-UTRA operation* is defined in TS 37.105 [6], subclause 9.7.6.4.

6.7.6.3.3 Test purpose

The test purpose of OTA spurious emission is to verify the radiated spurious emissions from the AAS BS at the *RIB* are within specified requirements.

For OTA co-locate spurious emission, the test purpose is to verify that the emission is within the specified requirement limits at the CLTA conducted output(s).

6.7.6.3.4 Method of test

6.7.6.3.4.1 Initial conditions

Test environment:

- normal; see annex G.2.

RF channels to be tested for single carrier (SC):

- M; see subclause 4.12.1.

Base Station RF Bandwidth positions to be tested for multi-carrier (MC):

- M_{RFBW} for *single-band RIB*, see subclause 4.12.1; $B'_{\text{RFBW}}T_{\text{RFBW}}$ and $B'_{\text{RFBW}}T_{\text{RFBW}}$ for *multi-band RIB*, see subclause 4.12.1.

In addition, for *multi-band RIB*:

- For $B'_{\text{RFBW}}T_{\text{RFBW}}$, co-location spurious emission testing above the highest operating band may be omitted.
- For $B'_{\text{RFBW}}T_{\text{RFBW}}$, co-location spurious emission testing below the lowest operating band may be omitted.

Directions to be tested:

- As the general spurious emission requirement is defined on TRP the beam pattern(s) may be set up to optimise the TRP measurement procedure (see annex F) as long as the required TRP level is achieved.

6.7.6.3.4.2 Procedure

- 1) Select a CLTA according to parameters given in Table 4.15.2.2-1 and place the CLTA according to parameters given in Table 4.15.2.3-1.
- 2) Several CLTAs are required to cover the whole co-location spurious emission frequency ranges.
- 3) The test antenna shall be dual (or single) polarized with the same frequency range as the AAS BS for co-location spurious emission test case.
- 4) Connect test antenna and CLTA to the measurement equipment as depicted in Annex D1.4.
- 5) OTA co-location spurious emission is measured at the CLTA conducted output(s).
- 6) The measurement device (signal analyzer) characteristics shall be:
 - Detection mode: True RMS.
- 7) Set the AAS BS to transmit:
 - a) For MSR:
 - Set the AAS BS to transmit maximum power, according to the applicable test configuration in clause 5 using the corresponding test models or set of physical channels in subclause 4.11.
 - b) For UTRA FDD:
 - For a AAS BS declared to be capable of single carrier operation only, set the AAS BS to transmit full maximum power according to TM1, subclause 4.12.2, at the manufacturer's declared rated carrier TRP, $P_{\text{Rated,c,TRP}}$.

- For a *AAS BS* declared to be capable of multi-carrier operation, set the *AAS BS* to transmit maximum power according to TM1 on all carriers configured using the applicable test configuration and corresponding power setting specified in subclause 4.11.

c) For E-UTRA:

- For *AAS BS* declared to be capable of single carrier operation only, set the *AAS BS* to transmit maximum power according to E-TM1.1 in subclause 4.12.2, at manufacturer's declared rated carrier TRP, $P_{Rated,c,TRP}$.
- For a *AAS BS* declared to be capable of multi-carrier and/or CA operation, set the *AAS BS* to transmit maximum power according to E-TM1.1 on all carriers configured using the applicable test configuration and corresponding power setting specified in subclause 4.11.

8) Measure the emission at the specified frequencies with specified measurement bandwidth and note that the measured value does not exceed the test requirement in subclause 6.7.6.5.

NOTE: An alternative measurement method to be used for measuring the OTA emission is described in Annex H.

In addition, for *multi-band RIB*, the following steps shall apply:

- 9) For *multi-band RIB* and single band tests, repeat the steps above per involved band where single band test configurations and test models shall apply with no carrier activated in the other band.

6.7.6.3.5 Test Requirement

6.7.6.3.5.1 MSR operation

The total power from both polarizations of the CLTA connector output(s) of any spurious emission shall not exceed the limits in table 6.7.6.3.5.1-1 depending on the declared Base Station class and Band Category.

Table 6.7.6.3.5.1-1: BS Spurious emissions limits for protection of the BS receiver

BS-class	Band category	Frequency range	Maximum Level for bands below 3GHz	Maximum Level for bands between 3 and 4.2GHz	Measurement bandwidth
Wide Area BS	BC1	$F_{UL_low} - F_{UL_high}$	-113.9 dBm	-113.7 dBm	100 kHz
Wide Area BS	BC2	$F_{UL_low} - F_{UL_high}$	-115.9 dBm	-115.7 dBm	100 kHz
Medium Range BS	BC1,BC2	$F_{UL_low} - F_{UL_high}$	-108.9 dBm	-108.7 dBm	100 kHz
Local Area BS	BC1,BC2	$F_{UL_low} - F_{UL_high}$	-105.9 dBm	-105.7 dBm	100 kHz
Note:	For E-UTRA Band 28 BS operating in regions where Band 28 is only partially allocated for E-UTRA operations, this requirement only applies in the UL frequency range of the partial allocation.				

6.7.6.3.5.2 Single RAT UTRA operation

The total power of any spurious emission from both polarizations of the CLTA connector output(s) shall not exceed the limits in table 6.7.6.3.5.2-1.

Table 6.7.6.3.5.2-1: BS Spurious emissions limits for protection of the BS receiver

	Frequency range	Maximum Level for bands below 3GHz	Maximum Level for bands between 3 and 4.2GHz	Measurement Bandwidth	Notes
Wide Area BS	$F_{UL_low} - F_{UL_high}$	- 116.9 dBm	- 116.7 dBm	100 kHz	
Medium Range BS	$F_{UL_low} - F_{UL_high}$	- 106.9 dBm	- 106.7 dBm	100 kHz	
Local Area BS	$F_{UL_low} - F_{UL_high}$	- 102.9 dBm	- 102.7 dBm	100 kHz	

6.7.6.3.5.3 Single RAT E-UTRA operation

The total power of any spurious emission from both polarizations of the CLTA connector output(s) shall not exceed the limits in table 6.7.6.3.5.3-1.

Table 6.7.6.3.5.3-1: BS Spurious emissions limits for protection of the BS receiver

	Frequency range	Maximum Level for bands below 3GHz	Maximum Level for bands between 3 and 4.2GHz	Measurement bandwidth
Wide Area BS	$F_{UL_low} - F_{UL_high}$	-113.9 dBm	-113.7 dBm	100 kHz
Medium Range BS	$F_{UL_low} - F_{UL_high}$	-108.9 dBm	-108.7 dBm	100 kHz
Local Area BS	$F_{UL_low} - F_{UL_high}$	-105.9 dBm	-105.7 dBm	100 kHz
Note:	For E-UTRA Band 28 BS operating in regions where Band 28 is only partially allocated for E-UTRA operations, this requirement only applies in the UL frequency range of the partial allocation.			

6.7.6.4 Additional spurious emissions requirements

6.7.6.4.1 Definition and applicability

These requirements may be applied for the protection of system operating in frequency ranges other than the BS *downlink operating band*. The limits may apply as an optional protection of such systems that are deployed in the same geographical area as the BS, or they may be set by local or regional regulation as a mandatory requirement for an operating band. It is in some cases not stated in the present document whether a requirement is mandatory or under what exact circumstances that a limit applies, since this is set by local or regional regulation. An overview of regional requirements in the present document is given in subclause 4.5.

Some requirements may apply for the protection of specific equipment (UE, MS and/or BS) or equipment operating in specific systems (GSM/EDGE, CDMA, UTRA, E-UTRA, NR etc.) as listed below.

All additional spurious requirements are TRP unless otherwise stated.

6.7.6.4.2 Minimum Requirement

For AAS BS in *MSR operation* the minimum requirement is defined in TS 37.105 [6], subclause 9.7.6.2.3.

For AAS BS in *single RAT UTRA operation* the minimum requirement is defined in TS 37.105 [6], subclause 9.7.6.3.3.

For AAS BS in *single RAT E-UTRA operation* the minimum requirement is defined in TS 37.105 [6], subclause 9.7.6.4.3.

6.7.6.4.3 Test purpose

The test purpose is to verify the radiated spurious emissions from the AAS BS at the RIB are within the specified additional spurious emissions requirements.

6.7.6.4.4 Method of test

6.7.6.4.4.1 Initial conditions

Test environment: normal, see annex G.2.

RF channels to be tested for single carrier:

B when testing from 30 MHz to $F_{DL_low} - \Delta f_{OBUE}$

T when testing from $F_{DL_high} + \Delta f_{OBUE}$ to 12.75GHz (or to 5th harmonic)

RF bandwidth positions to be tested: in single-band operation, see subclause 4.12.1.

B_{RFBW} when testing from 30 MHz to $F_{DL_low} - \Delta f_{OBUE}$

T_{RFBW} when testing from $F_{DL_high} + \Delta f_{OBUE}$ to 12.75GHz (or to 5th harmonic)

RF bandwidth positions to be tested in multi-band operation, see subclause 4.12.1.

$B_{RFBW_T'_{RFBW}}$ when testing from 30 MHz to $F_{DL_Blow_low} - \Delta f_{OBUE}$

$B'_{RFBW_T_{RFBW}}$ when testing from $F_{DL_Bhigh_high} + \Delta f_{OBUE}$ to 12.75GHz (or to 5th harmonic)

$B_{RFBW_T'_{RFBW}}$ and $B'_{RFBW_T_{RFBW}}$ when testing from $F_{DL_Blow_high} + \Delta f_{OBUE}$ to $F_{DL_Bhigh_low} - \Delta f_{OBUE}$

Directions to be tested:

As the requirement is TRP the beam pattern(s) may be set up to optimise the TRP measurement procedure (see annex F) as long as the required TRP level is achieved.

6.7.6.4.4.2 Procedure

- 1) Place the AAS BS at the positioner.
- 2) Align the manufacturer declared coordinate system orientation (see table 4.10-1, D9.2) of the AAS BS with the test system.
- 3) Measurements shall use a measurement bandwidth in accordance to the conditions in 3GPP TS 37.104 [5] subclause 6.6.1.
- 4) The measurement device characteristics shall be:
 - Detection mode: True RMS.
- 5) Set the AAS BS to transmit
 - a) For MSR:
 - Set the RIB to transmit maximum power according to the applicable test configuration in clause 5 using the corresponding test models or set of physical channels in subclause 4.11.
 - b) For UTRA:
 - For a RIB declared to be capable of single carrier operation only, set the RIB to transmit a signal according to TM1, subclause 4.12.2, at the manufacturer's declared rated carrier TRP, $P_{rated,c,TRP}$.
 - For a RIB declared to be capable of multi-carrier operation, set the set the RIB to transmit according to TM1 on all carriers configured using the applicable test configuration and corresponding power setting specified in subclause 4.11.

c) For E-UTRA:

- RIB declared to be capable of single carrier operation only, set the RIB to transmit a signal according to E-TM1.1 in subclause 4.12.2, at manufacturer's declared rated carrier TRP $P_{\text{rated,c,TRP}}$.
- For a RIB declared to be capable of multi-carrier and/or CA operation, set the set the RIB to transmit according to E-TM1.1 on all carriers configured using the applicable test configuration and corresponding power setting specified in subclause 4.11.

6) Align the BS and the test antenna such that measurement in the direction of the appropriate TRP measurement grid point can be performed. (see annex F)

7) Measure the emission at the specified frequencies with specified measurement bandwidth

8) Repeat step 6-7 for all directions in the appropriated TRP measurement grid needed for full TRP estimation (see annex F).

Note 1: the TRP measurement grid may not be the same for all measurement frequencies.

Note 2: the frequency sweep or the TRP measurement grid sweep may be done in any order

9) Calculate TRP at each specified frequency using the directional measurements.

In addition, for *multi-band RIB(s)*, the following steps shall apply:

10) For *multi-band RIBs* and single band tests, repeat the steps above per involved band where single band test configurations and test models shall apply with no carrier activated in the other band.

NOTE: As an alternative, TRP can be measured in a reverberation chamber following step 1, 3, 4, 5, 7 and 10.

6.7.6.4.5 Test Requirement

6.7.6.4.5.1 MSR operation

For UTRA, the minimum requirement is specified in subclause 6.7.6.4.5.2

For E-UTRA, the minimum requirement is specified in subclause 6.7.6.4.5.3.

6.7.6.4.5.1.1 E-UTRA and NR MSR operation

The TRP of any spurious emission shall not exceed the limits of table 6.7.6.4.5.1.1-1 for an AAS BS where requirements for co-existence with the system listed in the first column apply. For a *multi-band RIB*, the exclusions and conditions in the notes column of table 6.7.6.4.5.1.1-1 apply for each supported operating band.

Table 6.7.6.4.5.1.1-1: AAS BS OTA Spurious emissions limits for co-existence with systems operating in other frequency bands

System type to co-exist with	Frequency range for co-existence requirement	Maximum Level	Measurement Bandwidth	Note
GSM900	921 - 960 MHz	-45.4 dBm	100 kHz	This requirement does not apply to BS operating in band 8/n8
	876 - 915 MHz	-49.4 dBm	100 kHz	For the frequency range 880-915 MHz, this requirement does not apply to BS operating in band 8/n8, since it is already covered by the requirement in sub-clause 6.7.6.3.5.1
DCS1800 (Note 3)	1805 - 1880 MHz	-35.4 dBm	100 kHz	This requirement does not apply to BS operating in band 3/n3.
	1710 - 1785 MHz	-49.4 dBm	100 kHz	This requirement does not apply to BS operating in band 3/n3, since it is already covered by the requirement in sub-clause 6.7.6.3.5.1

PCS1900	1930 - 1990 MHz	-35.4 dBm	100 kHz	This requirement does not apply to BS operating in band 2/n2, 25/n25, band 36 or band 70/n70.
	1850 - 1910 MHz	-49.4 dBm	100 kHz	This requirement does not apply to BS operating in band 2/n2 or 25/n25, since it is already covered by the requirement in sub-clause 6.7.6.3.5.1 This requirement does not apply to BS operating in band 35.
GSM850 or CDMA850	869 - 894 MHz	-45.4 dBm	100 kHz	This requirement does not apply to BS operating in band 5/n5 or 26. This requirement applies to E-UTRA BS operating in Band 27 for the frequency range 879-894 MHz.
	824 - 849 MHz	-49.4 dBm	100 kHz	This requirement does not apply to BS operating in band 5/n5 or 26, since it is already covered by the requirement in sub-clause 6.7.6.3.5.1 For BS operating in Band 27, it applies 3 MHz below the Band 27 downlink operating band.
UTRA FDD Band I or E-UTRA Band 1 or NR Band n1	2110 - 2170 MHz	-40.4 dBm	1 MHz	This requirement does not apply to BS operating in band 1/n1 or 65 .
	1920 - 1980 MHz	-37.4 dBm	1 MHz	This requirement does not apply to BS operating in band 1/n1 or 65, since it is already covered by the requirement in sub-clause 6.7.6.3.5.1
UTRA FDD Band II or E-UTRA Band 2 or NR Band n2	1930 - 1990 MHz	-40.4 dBm	1 MHz	This requirement does not apply to BS operating in band 2/n2, 25/n25 or 70/n70.
	1850 - 1910 MHz	-37.4 dBm	1 MHz	This requirement does not apply to BS operating in band 2/n2 or 25/n25, since it is already covered by the requirement in sub-clause 6.6.6.5.2.4
UTRA FDD Band III or E-UTRA Band 3 or NR Band n3 (Note 3)	1805 - 1880 MHz	-40.4 dBm	1 MHz	This requirement does not apply to BS operating in band 3/n3 or 9.
	1710 - 1785 MHz	-37.4 dBm	1 MHz	This requirement does not apply to BS operating in band 3/n3, since it is already covered by the requirement in sub-clause 6.7.6.3.5.1 For BS operating in band 9, it applies for 1710 MHz to 1749.9 MHz and 1784.9 MHz to 1785 MHz, while the rest is covered in sub-clause 6.7.6.3.5.1
UTRA FDD Band IV or E-UTRA Band 4	2110 - 2155 MHz	-40.4 dBm	1 MHz	This requirement does not apply to BS operating in band 4, 10 or 66.
	1710 - 1755 MHz	-37.4 dBm	1 MHz	This requirement does not apply to BS operating in band 4, 10 or 66, since it is already covered by the requirement in sub-clause 6.7.6.3.5.1
UTRA FDD Band V or E-UTRA Band 5 or NR Band n5	869 - 894 MHz	-40.4 dBm	1 MHz	This requirement does not apply to BS operating in band 5/n5 or 26. This requirement applies to E-UTRA BS operating in Band 27 for the frequency range 879-894 MHz.
	824 - 849 MHz	-37.4 dBm	1 MHz	This requirement does not apply to BS operating in band 5/n5 or 26, since it is already covered by the requirement in sub-clause 6.7.6.3.5.1 For BS operating in Band 27, it applies 3 MHz below the Band 27 downlink operating band.
UTRA FDD Band VI, XIX or E-UTRA Band 6, 18, 19	860 - 890 MHz	-40.4 dBm	1 MHz	This requirement does not apply to BS operating in band 6, 18, 19
	815 - 830 MHz	-37.4 dBm	1 MHz	This requirement does not apply to BS operating in band 18 since it is already covered by the requirement in sub-clause 6.7.6.3.5.1
	830 - 845 MHz	-37.4 dBm	1 MHz	This requirement does not apply to BS operating in band 6, 19, since it is already covered by the requirement in sub-clause 6.7.6.3.5.1
UTRA FDD Band VII or E-UTRA Band 7 or NR Band n7	2620 - 2690 MHz	-40.4 dBm	1 MHz	This requirement does not apply to BS operating in band 7/n7.
	2500 - 2570 MHz	-37.4 dBm	1 MHz	This requirement does not apply to BS operating in band 7/n7, since it is already covered by the requirement in sub-clause 6.7.6.3.5.1
UTRA FDD Band VIII or E-UTRA Band 8 or NR Band n8	925 - 960 MHz	-40.4 dBm	1 MHz	This requirement does not apply to BS operating in band 8/n8.
	880 - 915 MHz	-37.4 dBm	1 MHz	This requirement does not apply to BS operating in band 8/n8, since it is already covered by the requirement in sub-clause 6.7.6.3.5.1

UTRA FDD Band IX or E-UTRA Band 9	1844.9 - 1879.9 MHz	-40.4 dBm	1 MHz	This requirement does not apply to BS operating in band 3/n3 or 9.
	1749.9 - 1784.9 MHz	-37.4 dBm	1 MHz	This requirement does not apply to BS operating in band 3/n3 or 9, since it is already covered by the requirement in sub-clause 6.7.6.3.5.1
UTRA FDD Band X or E-UTRA Band 10	2110 - 2170 MHz	-40.4 dBm	1 MHz	This requirement does not apply to BS operating in band 4, 10 or 66/n66.
	1710 - 1770 MHz	-37.4 dBm	1 MHz	This requirement does not apply to BS operating in band 10 or 66/n66, since it is already covered by the requirement in sub-clause 6.7.6.3.5.1 For BS operating in band 4, it applies for 1755 MHz to 1770 MHz, while the rest is covered in sub-clause 6.7.6.3.5.1
UTRA FDD Band XI or XXI or E-UTRA Band 11 or 21	1475.9 - 1510.9 MHz	-40.4 dBm	1 MHz	This requirement does not apply to BS operating in band 11, 21, 32, 50/n50, 74 or 75/n75.
	1427.9 - 1447.9 MHz	-37.4 dBm	1 MHz	This requirement does not apply to BS operating in band 11 or 74, since it is already covered by the requirement in sub-clause 6.7.6.3.5.1 This requirement does not apply to BS operating in band 32, 50/n50, 51/n51, 75/n75 or 76/n76.
	1447.9 - 1462.9 MHz	-37.4 dBm	1 MHz	This requirement does not apply to BS operating in band 21 or 74, since it is already covered by the requirement in sub-clause 6.7.6.3.5.1 This requirement does not apply to BS operating in band 32, 50/n50 or 75/n75.
UTRA FDD Band XII or E-UTRA Band 12 or NR Band n12	729 - 746 MHz	-40.4 dBm	1 MHz	This requirement does not apply to BS operating in band 12/n12 or 85.
	699 - 716 MHz	-37.4 dBm	1 MHz	This requirement does not apply to BS operating in band 12/n12 or 85, since it is already covered by the requirement in sub-clause 6.7.6.3.5.1 For BS operating in Band 29, it applies 1 MHz below the Band 29 downlink operating band (Note 7).
UTRA FDD Band XIII or E-UTRA Band 13	746 - 756 MHz	-40.4 dBm	1 MHz	This requirement does not apply to BS operating in band 13.
	777 - 787 MHz	-37.4 dBm	1 MHz	This requirement does not apply to BS operating in band 13, since it is already covered by the requirement in sub-clause 6.7.6.3.5.1
UTRA FDD Band XIV or E-UTRA Band 14	758 - 768 MHz	-40.4 dBm	1 MHz	This requirement does not apply to BS operating in band 14.
	788 - 798 MHz	-37.4 dBm	1 MHz	This requirement does not apply to BS operating in band 14, since it is already covered by the requirement in sub-clause 6.7.6.3.5.1
E-UTRA Band 17	734 - 746 MHz	-40.4 dBm	1 MHz	This requirement does not apply to BS operating in band 17.
	704 - 716 MHz	-37.4 dBm	1 MHz	This requirement does not apply to BS operating in band 17, since it is already covered by the requirement in subclause 6.7.6.3.5.1 For BS operating in Band 29, it applies 1 MHz below the Band 29 downlink operating band (Note 7).
UTRA FDD Band XX or E-UTRA Band 20 or NR Band n20	791 - 821 MHz	-40.4 dBm	1 MHz	This requirement does not apply to BS operating in band 20/n20 or 28/n28.
	832 - 862 MHz	-37.4 dBm	1 MHz	This requirement does not apply to BS operating in band 20/n20, since it is already covered by the requirement in subclause 6.7.6.3.5.1
UTRA FDD Band XXII or E-UTRA Band 22	3510 - 3590 MHz	-40.0 dBm	1 MHz	This requirement does not apply to BS operating in band 22, 42, 48, n77 or n78.
	3410 - 3490 MHz	-37.0 dBm	1 MHz	This requirement does not apply to BS operating in band 22, since it is already covered by the requirement in subclause 6.7.6.3.5.1 This requirement does not apply to Band 42

E-UTRA Band 24	1525 – 1559 MHz	-40.4 dBm	1 MHz	This requirement does not apply to BS operating in band 24.
	1626.5 – 1660.5 MHz	-37.4 dBm	1 MHz	This requirement does not apply to BS operating in band 24, since it is already covered by the requirement in subclause 6.7.6.3.5.1
UTRA FDD Band XXV or E-UTRA Band 25 or NR Band n25	1930 - 1995 MHz	-40.4 dBm	1 MHz	This requirement does not apply to BS operating in band 2/n2, 25/n25 or 70/n70.
	1850 - 1915 MHz	-37.4 dBm	1 MHz	This requirement does not apply to BS operating in band 25/n25, since it is already covered by the requirement in sub-clause 6.7.6.3.5.1 For BS operating in band 2/n2, it applies for 1910 MHz to 1915 MHz, while the rest is covered in sub-clause 6.7.6.3.5.1
UTRA FDD Band XXVI or E-UTRA Band 26	859 - 894 MHz	-40.4 dBm	1 MHz	This requirement does not apply to BS operating in band 5/n5 or 26. This requirement applies to E-UTRA BS operating in Band 27 for the frequency range 879-894 MHz.
	814 - 849 MHz	-37.4 dBm	1 MHz	This requirement does not apply to BS operating in band 26, since it is already covered by the requirement in sub-clause 6.7.6.3.5.1 For BS operating in band 5/n5, it applies for 814 MHz to 824 MHz, while the rest is covered in sub-clause 6.7.6.3.5.1 For BS operating in Band 27, it applies 3 MHz below the Band 27 downlink operating band.
E-UTRA Band 27	852 – 869 MHz	-40.4 dBm	1 MHz	This requirement does not apply to BS operating in band 5/n5, 26 or 27.
	807 – 824 MHz	-37.4 dBm	1 MHz	This requirement does not apply to BS operating in band 27, since it is already covered by the requirement in subclause 6.7.6.3.5.1 For BS operating in Band 26, it applies for 807 MHz to 814 MHz, while the rest is covered in sub-clause 6.7.6.3.5.1 This requirement also applies to BS operating in Band 28/n28, starting 4 MHz above the Band 28/n28 downlink operating band (Note 6).
E-UTRA Band 28 or NR Band n28	758 - 803 MHz	-40.4 dBm	1 MHz	This requirement does not apply to BS operating in band 20/n20, 28/n28, 44 or 67.
	703 - 748 MHz	-37.4 dBm	1 MHz	This requirement does not apply to BS operating in band 28/n28, since it is already covered by the requirement in sub-clause 6.7.6.3.5.1 This requirement does not apply to BS operating in Band 44. For BS operating in Band 67, it applies for 703-736MHz. For E-UTRA BS operating in Band 68, it applies for 728MHz to 733MHz.
E-UTRA Band 29	717 – 728 MHz	-40.4 dBm	1 MHz	This requirement does not apply to BS operating in Band 29 or 85.
E-UTRA Band 30	2350 - 2360 MHz	-40.4 dBm	1 MHz	This requirement does not apply to BS operating in band 30 or 40/n40.
	2305 - 2315 MHz	-37.4 dBm	1 MHz	This requirement does not apply to BS operating in band 30, since it is already covered by the requirement in sub-clause 6.7.6.3.5.1 This requirement does not apply to BS operating in Band 40.
E-UTRA Band 31	462.5 – 467.5 MHz	-40.4 dBm	1 MHz	This requirement does not apply to BS operating in band 31, 72 or 73.
	452.5 – 457.5 MHz	-37.4 dBm	1 MHz	This requirement does not apply to BS operating in band 31, since it is already covered by the requirement in sub-clause 6.7.6.3.5.1 This requirement does not apply to BS operating in band 72 or 73.
UTRA FDD Band XXXII or E-UTRA Band 32	1452 - 1496 MHz	-40.4 dBm	1 MHz	This requirement does not apply to BS operating in band 11, 21, 32, 50/n50, 74 or 75/n75.
UTRA TDD Band a) or E-UTRA Band 33	1900 - 1920 MHz	-40.4 dBm	1 MHz	This requirement does not apply to BS operating in Band 33

UTRA TDD Band a) or E-UTRA Band 34 or NR Band n34	2010 - 2025 MHz	-40.4 dBm	1 MHz	This requirement does not apply to BS operating in Band 34/n34
UTRA TDD Band b) or E-UTRA Band 35	1850 – 1910 MHz	-40.4 dBm	1 MHz	This requirement does not apply to BS operating in Band 35
UTRA TDD Band b) or E-UTRA Band 36	1930 - 1990 MHz	-40.4 dBm	1 MHz	This requirement does not apply to BS operating in Band 2/n2, 25/n25 or 36
UTRA TDD in Band c) or E-UTRA Band 37	1910 - 1930 MHz	-40.4 dBm	1 MHz	This is not applicable to BS operating in Band 37. This unpaired band is defined in ITU-R M.1036, but is pending any future deployment.
UTRA TDD Band d) or E-UTRA Band 38 or NR Band n38	2570 – 2620 MHz	-40.4 dBm	1 MHz	This requirement does not apply to BS operating in Band 38/n38 or 69.
UTRA TDD Band f) or E-UTRA Band 39 or NR Band n39	1880 – 1920MHz	-40.4 dBm	1 MHz	This is not applicable to BS operating in Band 39/n39
UTRA TDD Band e) or E-UTRA Band 40 or NR Band n40	2300 – 2400MHz	-40.4 dBm	1 MHz	This is not applicable to BS operating in Band 30 or 40/n40
E-UTRA Band 41 or NR Band n41	2496 – 2690MHz	-40.4 dBm	1 MHz	This is not applicable to BS operating in Band 41/n41
E-UTRA Band 42	3400 – 3600 MHz	-40.0 dBm	1 MHz	This is not applicable to BS operating in Band 22, 42, 43, 48, 52, n77 or n78.
E-UTRA Band 43	3600 – 3800 MHz	-40.0 dBm	1 MHz	This is not applicable to BS operating in Band 42, 43, 48, n77 or n78.
E-UTRA Band 44	703 - 803 MHz	-40.4 dBm	1 MHz	This is not applicable to BS operating in Band 28/n28 or 44
E-UTRA Band 45	1447 - 1467 MHz	-40.4 dBm	1 MHz	This is not applicable to BS operating in Band 45
E-UTRA Band 46	5150 - 5925 MHz	-39.5 dBm	1 MHz	This is not applicable to BS operating in Band 46
E-UTRA Band 47	5855 - 5925 MHz	-39.5 dBm	1 MHz	
E-UTRA Band 48	3550 – 3700 MHz	-40.0 dBm	1 MHz	This is not applicable to BS operating in Band 22, 42, 43, 48, n77 or n78
E-UTRA Band 49	3550 – 3700 MHz	-40.0 dBm	1 MHz	This is not applicable to BS operating in Band 22, 42, 43, 48, n77 or n78
E-UTRA Band 50 or NR Band n50	1432 - 1517 MHz	-40.4 dBm	1 MHz	This requirement does not apply to BS operating in Band 11, 21, 32, 45, 50/n50, 51/n51, 74, 75/n75 or 76/n76.
E-UTRA Band 51 or NR Band n51	1427 - 1432 MHz	-40.4 dBm	1 MHz	This requirement does not apply to BS operating in Band 50/n50, 51/n51, 75/n75 or 76/n76.
E-UTRA Band 52	3300 – 3400 MHz	-40.4 dBm	1 MHz	This is not applicable to BS operating in Band 42 or 52.
E-UTRA Band 65	2110 - 2200 MHz	-40.4 dBm	1 MHz	This requirement does not apply to BS operating in band 1/n1 or 65,
	1920 - 2010 MHz	-37.4 dBm	1 MHz	This requirement does not apply to BS operating in band 65, since it is already covered by the requirement in sub-clause 6.7.6.3.5.1 For BS operating in Band 1, it applies for 1980 MHz to 2010 MHz, while the rest is covered in sub-clause 6.7.6.3.5.1
	2110 - 2200 MHz	-40.4 dBm	1 MHz	This requirement does not apply to BS operating in band 4, 10, 23 or 66/n66.

E-UTRA Band 66 or NR Band n66	1710 - 1780 MHz	-37.4 dBm	1 MHz	This requirement does not apply to BS operating in band 66/n66, since it is already covered by the requirement in clause 6.7.6.3.5.1 For BS operating in Band 4, it applies for 1755 MHz to 1780 MHz, while the rest is covered in clause 6.7.6.3.5.1 For BS operating in Band 10, it applies for 1770 MHz to 1780 MHz, while the rest is covered in clause 6.7.6.3.5.1
E-UTRA Band 67	738 – 758 MHz	-40.4 dBm	1 MHz	This requirement does not apply to BS operating in band 28/n28 or 67.
E-UTRA Band 68	753 -783 MHz	-40.4 dBm	1 MHz	This requirement does not apply to BS operating in band 28/n28 or 68.
	698-728 MHz	-37.4 dBm	1 MHz	This requirement does not apply to BS operating in band 68, since it is already covered by the requirement in sub-clause 6.7.6.3.5.1 For BS operating in Band 28/n28, it applies between 698 MHz and 703 MHz, while the rest is covered in sub-clause 6.7.6.3.5.1
E-UTRA Band 69	2570 - 2620 MHz	-40.4 dBm	1 MHz	This requirement does not apply to BS operating in Band 38 or 69.
E-UTRA Band 70 or NR Band n70	1995 - 2020 MHz	-40.4 dBm	1 MHz	This requirement does not apply to BS operating in band 2/n2, 25/n25 or 70/n70
	1695 – 1710 MHz	-37.4 dBm	1 MHz	This requirement does not apply to BS operating in band 70/n70, since it is already covered by the requirement in sub-clause 6.7.6.3.5.1
E-UTRA Band 71 or NR Band n71	617 - 652 MHz	-40.4 dBm	1 MHz	This requirement does not apply to BS operating in band 71/n71.
	663 – 698 MHz	-37.4 dBm	1 MHz	This requirement does not apply to BS operating in band 71/n71, since it is already covered by the requirement in sub-clause 6.7.6.3.5.1
E-UTRA Band 72	461 - 466 MHz	-40.4 dBm	1 MHz	This requirement does not apply to BS operating in band 31, 72 or 73.
	451 - 456 MHz	-37.4 dBm	1 MHz	This requirement does not apply to BS operating in band 72, since it is already covered by the requirement in sub-clause 6.7.6.3.5.1 This requirement does not apply to BS operating in band 73.
E-UTRA Band 73	460 - 465 MHz	-40.4 dBm	1 MHz	This requirement does not apply to BS operating in band 31, 72 or 73.
	450 - 455 MHz	-37.4 dBm	1 MHz	This requirement does not apply to BS operating in band 73, since it is already covered by the requirement in sub-clause 6.7.6.3.5.1
E-UTRA Band 74 or NR Band n74	1475 – 1518 MHz	-40.4 dBm	1 MHz	This requirement does not apply to BS operating in band 11, 21, 32, 50/n50, 74 or 75/n75.
	1427 – 1470 MHz	-37.4 dBm	1MHz	This requirement does not apply to BS operating in Band 74, since it is already covered by the requirement in sub-clause 6.7.6.3.5.1 This requirement does not apply to BS operating in band 32, 45, 50/n50, 51/n51, 75/n75 or 76/n76.
E-UTRA Band 75 or NR Band n75	1432 - 1517 MHz	-40.4 dBm	1 MHz	This requirement does not apply to BS operating in Band 11, 21, 32, 45, 50/n50, 51/n51, 74, 75/n75 or 76/n76.
E-UTRA Band 76 or NR Band n76	1427 - 1432 MHz	-40.4 dBm	1 MHz	This requirement does not apply to BS operating in Band 50/n50, 51/n51, 75/n75 or 76/n76.
NR Band n77	3300 – 4200 MHz	-40.0 dBm	1 MHz	This is not applicable to BS operating in Band 22, 42, 43, 48, 52, n77 or n78
NR Band n78	3300 – 3800 MHz	-40.0 dBm	1 MHz	This is not applicable to BS operating in Band 22, 42, 43, 48, 52, n77 or n78
NR Band n79	4400 – 5000 MHz	-39.5 dBm	1 MHz	This requirement does not apply to BS operating in Band n79
NR Band n80	1710 - 1785 MHz	-37.4 dBm	1 MHz	This requirement does not apply to BS operating in band 3/n3, since it is already covered by the requirement in sub-clause 6.7.6.3.5.1 For BS operating in band 9, it applies for 1710 MHz to 1749.9 MHz and 1784.9 MHz to 1785 MHz, while the rest is covered in sub-clause 6.7.6.3.5.1

NR Band n81	880 - 915 MHz	-37.4 dBm	1 MHz	This requirement does not apply to BS operating in band 8/n8, since it is already covered by the requirement in sub-clause 6.7.6.3.5.1
NR Band n82	832 - 862 MHz	-37.4 dBm	1 MHz	This requirement does not apply to BS operating in band 20/n20, since it is already covered by the requirement in subclause 6.7.6.3.5.1
NR Band n83	703 - 748 MHz	-37.4 dBm	1 MHz	This requirement does not apply to BS operating in band 28/n28, since it is already covered by the requirement in sub-clause 6.7.6.3.5.1 This requirement does not apply to BS operating in Band 44. For BS operating in Band 67, it applies for 703-736MHz. For BS operating in Band 68, it applies for 728MHz to 733MHz.
NR Band n84	1920 - 1980 MHz	-37.4 dBm	1 MHz	This requirement does not apply to BS operating in band 1/n1 or 65, since it is already covered by the requirement in sub-clause 6.7.6.3.5.1
E-UTRA Band 85	728 - 746 MHz	-40.4 dBm	1 MHz	This requirement does not apply to BS operating in band 12/n12, 29 or 85.
	698 - 716 MHz	-37.4 dBm	1 MHz	This requirement does not apply to BS operating in band 12/n12 or 85, since it is already covered by the requirement in subclause 6.7.6.3.5.1 For BS operating in Band 29, it applies 1 MHz below the Band 29 downlink operating band (Note 7).
NR Band n86	1710 - 1780 MHz	-37.4 dBm	1 MHz	This requirement does not apply to BS operating in band 66/n66, since it is already covered by the requirement in subclause 6.7.6.3.5.1 For BS operating in Band 4, it applies for 1755 MHz to 1780 MHz, while the rest is covered in sub-clause 6.7.6.3.5.1 For BS operating in Band 10, it applies for 1770 MHz to 1780 MHz, while the rest is covered in sub-clause 6.7.6.3.5.1

NOTE 1: As defined in the scope for spurious emissions in this subclause, except for the cases where the noted requirements apply to a BS operating in Band 25/n25, Band 27, Band 28/n28 or Band 29, the co-existence requirements in table 6.7.6.4.5.1.1-1 do not apply for the Δf_{OBUE} frequency range immediately outside the *downlink operating band* (see subclause 6.7.1). Emission limits for this excluded frequency range may be covered by local or regional requirements.

NOTE 2: Table 6.7.6.4.5.1.1-1 assumes that two operating bands, where the frequency ranges in subclause 4.7 would be overlapping, are not deployed in the same geographical area. For such a case of operation with overlapping frequency arrangements in the same geographical area, special co-existence requirements may apply that are not covered by the 3GPP specifications.

NOTE 3: For the protection of DCS1800, UTRA Band III or E-UTRA Band 3 or NR band n3 in China, the frequency ranges of the downlink and uplink protection requirements are 1805 – 1850 MHz and 1710 – 1755 MHz respectively.

NOTE 4: TDD base stations deployed in the same geographical area, that are synchronized and use the same or adjacent operating bands can transmit without additional co-existence requirements. For unsynchronized base stations (except in Band 46), special co-existence requirements may apply that are not covered by the 3GPP specifications.

NOTE 6: For Band 28/n28 BS, specific solutions may be required to fulfil the spurious emissions limits for BS for co-existence with Band 27 UL operating band.

NOTE 7: For Band 29 BS, specific solutions may be required to fulfil the spurious emissions limits for BS for co-existence with UTRA Band XII or E-UTRA Band 12 UL operating band, E-UTRA Band 17 UL operating band or E-UTRA Band 85 UL operating band.

The following requirement may be applied for the protection of PHS. This requirement is also applicable at specified frequencies falling between Δf_{OBUE} below the lowest BS transmitter frequency of the *downlink operating band* and Δf_{OBUE} above the highest BS transmitter frequency of the *downlink operating band*.

The TRP of any spurious emission shall not exceed:

Table 6.7.6.4.5.1.1-2: AAS BS OTA Spurious emissions limits for BS for co-existence with PHS

Frequency range	Maximum Level	Measurement Bandwidth	Notes
1884.5 - 1915.7 MHz	-32 dBm	300 kHz	Applicable for co-existence with PHS system operating in 1884.5-1915.7MHz
NOTE: The requirement is not applicable in China.			

The following requirement shall be applied to AAS BS operating in Bands 13 and 14 to ensure that appropriate interference protection is provided to 700 MHz public safety operations. This requirement is also applicable at the frequency range from Δf_{OBUE} below the lowest frequency of the BS *downlink operating band* up to Δf_{OBUE} above the highest frequency of the BS *downlink operating band*.

The TRP of any spurious emission shall not exceed:

Table 6.7.6.4.5.1.1-3: AAS BS OTA Spurious emissions limits for protection of 700 MHz public safety operations

Operating Band	Frequency range	Maximum Level	Measurement Bandwidth	Notes
13	763 - 775 MHz	-37 dBm	6.25 kHz	
13	793 - 805 MHz	-37 dBm	6.25 kHz	
14	769 - 775 MHz	-37 dBm	6.25 kHz	
14	799 - 805 MHz	-37 dBm	6.25 kHz	

The following requirement shall be applied to AAS BS operating in Band 26 to ensure that appropriate interference protection is provided to 800 MHz public safety operations. This requirement is also applicable at the frequency range from Δf_{OBUE} below the lowest frequency of the BS *downlink operating band* up to Δf_{OBUE} above the highest frequency of the BS *downlink operating band*.

The TRP of any spurious emission shall not exceed:

Table 6.7.6.4.5.1.1-4: AAS BS OTA Spurious emissions limits for protection of 800 MHz public safety operations

Operating Band	Frequency range	Maximum Level	Measurement Bandwidth	Notes
26	851 - 859 MHz	-4 dBm	100 kHz	Applicable for offsets > 37.5kHz from the channel edge

The following requirement may apply to E-UTRA AAS BS operating in Band 41 in certain regions. This requirement is also applicable at the frequency range from Δf_{OBUE} below the lowest frequency of the BS *downlink operating band* up to Δf_{OBUE} above the highest frequency of the BS *downlink operating band*.

The TRP of any spurious emission shall not exceed:

Table 6.7.6.4.5.1.1-5: Additional AAS BS OTA Spurious emissions limits for Band 41

Frequency range	Maximum Level	Measurement Bandwidth	Notes
2505MHz – 2535MHz	-30.4 dBm	1 MHz	
2535MHz – 2655MHz	-10.4 dBm	1 MHz	Applicable at offsets \geq 250% of <i>channel bandwidth</i> from carrier frequency
NOTE: This requirement applies for 10 or 20 MHz E-UTRA carriers allocated within 2545-2575MHz or 2595-2645MHz.			

The following requirement may apply to AAS BS operating in Band 30 in certain regions. This requirement is also applicable at the frequency range from Δf_{OBUE} below the lowest frequency of the BS *downlink operating band* up to Δf_{OBUE} above the highest frequency of the BS *downlink operating band*.

The TRP of any spurious emission shall not exceed:

Table 6.7.6.4.5.1.1-6: Additional AAS BS OTA Spurious emissions limits for Band 30

Frequency range	Maximum Level	Measurement Bandwidth	Notes
2200MHz – 2345MHz	-33.4 dBm	1 MHz	
2362.5MHz – 2365MHz	-13.4 dBm	1 MHz	
2365MHz – 2367.5MHz	-28.4 dBm	1 MHz	
2367.5MHz – 2370MHz	-30.4 dBm	1 MHz	
2370MHz – 2395MHz	-33.4 dBm	1 MHz	

The following requirement may apply to AAS BS operating in Band 48 in certain regions. The TRP of any spurious emission shall not exceed:

Table 6.7.6.4.5.1.1-7: Additional AAS BS OTA Spurious emissions limits for Band 48

Frequency range	Maximum Level	Measurement Bandwidth	Notes
3530MHz – 3720MHz	-13 dBm	1 MHz	Applicable 10MHz from the assigned channel edge
3100MHz – 3530MHz 3720MHz – 4200MHz	-28.0 dBm	1 MHz	

In addition to the requirements in subclauses in the present subclause, the AAS BS may have to comply with the applicable emission limits established by FCC Title 47 [18], when deployed in regions where those limits are applied, and under the conditions declared by the manufacturer.

The following requirement shall be applied to AAS BS operating in Bands 13 and 14 to ensure that appropriate interference protection is provided to 700 MHz public safety operations. This requirement is also applicable at the frequency range from 10 MHz below the lowest frequency of the BS *downlink operating band* up to 10 MHz above the highest frequency of the BS *downlink operating band*.

Table 6.7.6.4.5.1.1-8: AAS BS OTA Spurious emissions limits for protection of 700 MHz public safety operations

Operating Band	Frequency range	Maximum Level	Measurement Bandwidth	Notes
13	763 - 775 MHz	-37 dBm	6.25 kHz	
13	793 - 805 MHz	-37 dBm	6.25 kHz	
14	769 - 775 MHz	-37 dBm	6.25 kHz	
14	799 - 805 MHz	-37 dBm	6.25 kHz	

The following requirement shall be applied to AAS BS operating in Band 26 to ensure that appropriate interference protection is provided to 800 MHz public safety operations. This requirement is also applicable at the frequency range from Δf_{OBUE} below the lowest frequency of the BS *downlink operating band* up to Δf_{OBUE} above the highest frequency of the BS *downlink operating band*.

The TRP of any spurious emission shall not exceed:

Table 6.7.6.4.5.1.1-9: AAS BS OTA Spurious emissions limits for protection of 800 MHz public safety operations

Operating Band	Frequency range	Maximum Level	Measurement Bandwidth	Notes
26	851 - 859 MHz	-13 dBm	100 kHz	Applicable for offsets > 37.5kHz from the channel edge

6.7.6.4.5.2 Single RAT UTRA operation

The TRP of any spurious emission shall not exceed the limits of table 6.7.6.4.5.2-1 for a AAS BS where requirements for co-existence with the system listed in the first column apply. For a *multi-band RIB*, the exclusions and conditions in the notes column of table 6.7.6.4.5.2-1 apply for each supported operating band.

Table 6.7.6.4.5.2-1 *OTA AAS BS* Spurious emissions limits for UTRA FDD BS in geographic coverage area of systems operating in other frequency bands

System type operating in the same geographical area	Band for co-existence requirement	Maximum Level	Measurement Bandwidth	Notes
GSM900	921 - 960 MHz	-48.4 dBm	100 kHz	This requirement does not apply to UTRA FDD operating in band VIII
	876 - 915 MHz	-52.4 dBm	100 kHz	For the frequency range 880-915 MHz, this requirement does not apply to UTRA FDD operating in band VIII, since it is already covered by the requirement in subclause 6.7.6.5.1.4.
DCS1800	1805 - 1880 MHz	-38.4 dBm	100 kHz	This requirement does not apply to UTRA FDD operating in band III
	1710 - 1785 MHz	-52.4 dBm	100 kHz	This requirement does not apply to UTRA FDD operating in band III, since it is already covered by the requirement in subclause 6.7.6.5.1.4.
PCS1900	1930 - 1990 MHz	-38.4 dBm	100 kHz	This requirement does not apply to UTRA FDD BS operating in frequency band II or band XXV
	1850 - 1910 MHz	-52.4 dBm	100 kHz	This requirement does not apply to UTRA FDD BS operating in frequency band II or band XXV, since it is already covered by the requirement in subclause 6.7.6.5.1.4.
GSM850 or CDMA850	869 - 894 MHz	-48.4 dBm	100 kHz	This requirement does not apply to UTRA FDD BS operating in frequency band V or XXVI
	824 - 849 MHz	-52.4 dBm	100 kHz	This requirement does not apply to UTRA FDD BS operating in frequency band V or XXVI, since it is already covered by the requirement in subclause 6.7.6.5.1.4.
UTRA FDD Band I or E-UTRA Band 1 or NR band n1	2110 - 2170 MHz	-43.4 dBm	1 MHz	This requirement does not apply to UTRA FDD BS operating in band I,
	1920 - 1980 MHz	-40.4 dBm	1 MHz	This requirement does not apply to UTRA FDD BS operating in band I, since it is already covered by the requirement in subclause 6.7.6.5.1.4.
UTRA FDD Band II or E-UTRA Band 2 or NR band n2	1930 - 1990 MHz	-43.4 dBm	1 MHz	This requirement does not apply to UTRA FDD BS operating in band II or band XXV
	1850 - 1910 MHz	-40.4 dBm	1 MHz	This requirement does not apply to UTRA FDD BS operating in band II or band XXV, since it is already covered by the requirement in subclause 6.7.6.5.1.4.
UTRA FDD Band III or E-UTRA Band 3 or NR band n3	1805 - 1880 MHz	-43.4 dBm	1 MHz	This requirement does not apply to UTRA FDD BS operating in band III or band IX
	1710 - 1785 MHz	-40.4 dBm	1 MHz	This requirement does not apply to UTRA FDD BS operating in band III, since it is already covered by the requirement in subclause 6.7.6.5.1.4. For UTRA BS operating in band IX, it applies for 1710 MHz to 1749.9 MHz and 1784.9 MHz to 1785 MHz, while the rest is covered in subclause 6.7.6.5.1.4.
UTRA FDD Band IV or E-UTRA Band 4	2110 - 2155 MHz	-43.4 dBm	1 MHz	This requirement does not apply to UTRA FDD BS operating in band IV or band X
	1710 - 1755 MHz	-40.4 dBm	1 MHz	This requirement does not apply to UTRA FDD BS operating in band IV or band X, since it is already covered by the requirement in subclause 6.7.6.5.1.4.
UTRA FDD Band V or E-UTRA Band 5 or NR band n5	869 - 894 MHz	-43.4 dBm	1 MHz	This requirement does not apply to UTRA FDD BS operating in band V or XXVI
	824 - 849 MHz	-40.4 dBm	1 MHz	This requirement does not apply to UTRA FDD BS operating in band V or XXVI, since it is already covered by the requirement in subclause 6.7.6.5.1.4.
UTRA FDD Band VI or XIX, E-UTRA Band 6, 18 or 19	860 - 890 MHz	-43.4 dBm	1 MHz	This requirement does not apply to UTRA FDD BS operating in band VI or XIX
	815 - 845 MHz	-40.4 dBm	1 MHz	This requirement does not apply to UTRA FDD BS operating in band VI or XIX, since it is already covered by the requirement in subclause 6.7.6.5.1.4.
UTRA FDD Band VII or E-UTRA Band 7 or NR band n7	2620 - 2690 MHz	-43.4 dBm	1 MHz	This requirement does not apply to UTRA FDD BS operating in band VII,
	2500 - 2570 MHz	-40.4 dBm	1 MHz	This requirement does not apply to UTRA FDD BS operating in band VII, since it is already covered by the requirement in subclause 6.7.6.5.1.4.

UTRA FDD Band VIII or E-UTRA Band 8 or NR band n8	925 - 960 MHz	-43.4 dBm	1 MHz	This requirement does not apply to UTRA FDD BS operating in band VIII.
	880 - 915 MHz	-40.4 dBm	1 MHz	This requirement does not apply to UTRA FDD BS operating in band VIII, since it is already covered by the requirement in subclause 6.7.6.5.1.4.
UTRA FDD Band IX or E-UTRA Band 9	1844.9 - 1879.9 MHz	-43.4 dBm	1 MHz	This requirement does not apply to UTRA FDD BS operating in band III or band IX
	1749.9 - 1784.9 MHz	-40.4 dBm	1 MHz	This requirement does not apply to UTRA FDD BS operating in band III or band IX, since it is already covered by the requirement in subclause 6.7.6.5.1.4.
UTRA FDD Band X or E-UTRA Band 10	2110 - 2170 MHz	-43.4 dBm	1 MHz	This requirement does not apply to UTRA FDD BS operating in band IV or band X.
	1710 - 1770 MHz	-40.4 dBm	1 MHz	This requirement does not apply to UTRA FDD BS operating in band X, since it is already covered by the requirement in subclause 6.7.6.5.1.4. For UTRA FDD BS operating in Band IV, it applies for 1755 MHz to 1770 MHz, while the rest is covered in subclause 6.7.6.5.1.4.
UTRA FDD Band XI or XXI or E-UTRA Band 11 or 21	1475.9 - 1510.9 MHz	-43.4 dBm	1 MHz	This requirement does not apply to UTRA FDD BS operating in band XI , XXI or XXXII.
	1427.9 - 1447.9 MHz	-40.4 dBm	1 MHz	This requirement does not apply to UTRA FDD BS operating in band XI, since it is already covered by the requirement in subclause 6.7.6.5.1.4. For UTRA BS operating in band XXXII, this requirement applies for carriers allocated within 1475.9MHz and 1495.9MHz.
	1447.9 - 1462.9 MHz	-40.4 dBm	1 MHz	This requirement does not apply to UTRA FDD BS operating in band XXI, since it is already covered by the requirement in subclause 6.7.6.5.1.4. For UTRA BS operating in band XXXII, this requirement applies for carriers allocated within 1475.9MHz and 1495.9MHz.
UTRA FDD Band XII or E-UTRA Band 12 or NR band n12	729 - 746 MHz	-43.4 dBm	1 MHz	This requirement does not apply to UTRA FDD BS operating in band XII
	699 - 716 MHz	-40.4 dBm	1 MHz	This requirement does not apply to UTRA FDD BS operating in band XII, since it is already covered by the requirement in subclause 6.7.6.5.1.4.
UTRA FDD Band XIII or E-UTRA Band 13	746 - 756 MHz	-43.4 dBm	1 MHz	This requirement does not apply to UTRA FDD BS operating in band XIII
	777 - 787 MHz	-40.4 dBm	1 MHz	This requirement does not apply to UTRA FDD BS operating in band XIII, since it is already covered by the requirement in sub-clause 6.7.6.5.1.4.
UTRA FDD Band XIV or E-UTRA Band 14	758 - 768 MHz	-43.4 dBm	1 MHz	This requirement does not apply to UTRA FDD BS operating in band XIV
	788 - 798 MHz	-40.4 dBm	1 MHz	This requirement does not apply to UTRA FDD BS operating in band XIV, since it is already covered by the requirement in subclause 6.7.6.5.1.4.
E-UTRA Band 17	734 - 746 MHz	-43.4 dBm	1 MHz	This requirement does not apply to UTRA FDD BS operating in band XII
	704 - 716 MHz	-40.4 dBm	1 MHz	This requirement does not apply to UTRA FDD BS operating in band XII, since it is already covered by the requirement in subclause 6.7.6.5.1.4.
UTRA FDD Band XX or E-UTRA Band 20 or NR band n20	791 - 821 MHz	-43.4 dBm	1 MHz	This requirement does not apply to UTRA FDD BS operating in band XX
	832 - 862 MHz	-40.4 dBm	1 MHz	This requirement does not apply to UTRA FDD BS operating in band XX, since it is already covered by the requirement in subclause 6.7.6.5.1.4.
UTRA FDD Band XXII or E-UTRA Band 22	3510 -3590 MHz	-43.0 dBm	1 MHz	This requirement does not apply to UTRA FDD BS operating in band XXII.
	3410 -3490 MHz	-40.0 dBm	1 MHz	This requirement does not apply to UTRA FDD BS operating in band XXII, since it is already covered by the requirement in subclause 6.7.6.5.1.4.
	2010 – 2020 MHz	-40.4 dBm	1 MHz	
E-UTRA Band 24	1525 – 1559 MHz	-43.4 dBm	1 MHz	
	1626.5 – 1660.5 MHz	-40.4 dBm	1 MHz	
	1930 - 1995 MHz	-43.4 dBm	1 MHz	This requirement does not apply to UTRA FDD BS operating in band II or band XXV

UTRA FDD Band XXV or E-UTRA Band 25 or NR band n25	1850 - 1915 MHz	-40.4 dBm	1 MHz	This requirement does not apply to UTRA FDD BS operating in band XXV, since it is already covered by the requirement in subclause 6.7.6.5.1.4. For UTRA FDD BS operating in Band II, it applies for 1910 MHz to 1915 MHz, while the rest is covered in sub-clause 6.7.6.5.1.4.
UTRA FDD Band XXVI or E-UTRA Band 26	859-894 MHz	-43.4 dBm	1 MHz	This requirement does not apply to UTRA FDD BS operating in band V or band XXVI
	814-849 MHz	-40.4 dBm	1 MHz	This requirement does not apply to UTRA FDD BS operating in band XXVI, since it is already covered by the requirements in subclause 6.7.6.5.1.4 For UTRA FDD BS operating in band V, it applies for 814MHz to 824MHz, while the rest is covered in subclause 6.7.6.5.1.4
E-UTRA Band 27	852 – 869 MHz	-43.4 dBm	1 MHz	This requirement does not apply to UTRA BS operating in Band V or XXVI.
	807 – 824 MHz	-40.4 dBm	1 MHz	For UTRA BS operating in Band XXVI, it applies for 807 MHz to 814 MHz, while the rest is covered in subclause 6.7.6.5.1.4.
E-UTRA Band 28 or NR band n28	758 – 803 MHz	-43.4 dBm	1 MHz	
	703 – 748 MHz	-40.4 dBm	1 MHz	
E-UTRA Band 29	717 – 728 MHz	-43.4 dBm	1 MHz	
E-UTRA Band 30	2350 - 2360 MHz	-43.4 dBm	1 MHz	
	2305 - 2315 MHz	-40.4 dBm	1 MHz	
E-UTRA Band 31	462.5 -467.5 MHz	-43.4 dBm	1 MHz	
	452.5 -457.5 MHz	-40.4 dBm	1 MHz	
UTRA FDD Band XXXII or E-UTRA Band 32	1452 – 1496 MHz	-43.4 dBm	1 MHz	This requirement does not apply to UTRA BS operating in Band XI, XXI, or XXXII
UTRA TDD Band a) or E-UTRA Band 33	1900 – 1920 MHz	-43.4 dBm	1 MHz	
UTRA TDD Band a) or E-UTRA Band 34 or NR band n34	2010 – 2025 MHz	-43.4 dBm	1 MHz	
UTRA TDD Band b) or E-UTRA Band 35	1850 – 1910 MHz	-43.4 dBm	1 MHz	
UTRA TDD Band b) or E-UTRA Band 36	1930 – 1990 MHz	-43.4 dBm	1 MHz	
UTRA TDD Band c) or E-UTRA Band 37	1910 – 1930 MHz	-43.4 dBm	1 MHz	
UTRA TDD Band d) or E-UTRA Band 38 or NR band n38	2570 – 2620 MHz	-43.4 dBm	1 MHz	
UTRA TDD Band f) or E-UTRA Band 39 or NR band n39	1880 – 1920 MHz	-43.4 dBm	1 MHz	Applicable in China
UTRA TDD in Band e) or E-UTRA Band 40 or NR band n40	2300 – 2400 MHz	-43.4 dBm	1 MHz	
E-UTRA Band 41 or NR band n41	2496 - 2690 MHz	-43.4 dBm	1 MHz	
E-UTRA Band 42	3400 – 3600 MHz	-43.0 dBm	1 MHz	
E-UTRA Band 43	3600 – 3800 MHz	-43.0 dBm	1 MHz	
E-UTRA Band 44	703 - 803 MHz	-43.4 dBm	1 MHz	

E-UTRA Band 45	1447 - 1467 MHz	-43.4 dBm	1 MHz	
E-UTRA Band 46	5150 - 5925 MHz	-42.5 dBm	1 MHz	
E-UTRA Band 47	5855 - 5925 MHz	-42.5 dBm	1 MHz	
E-UTRA Band 48	3550 – 3700 MHz	-43.0 dBm	1 MHz	
E-UTRA Band 49	3550 – 3700 MHz	-43.0 dBm	1 MHz	
E-UTRA Band 50 or NR Band n50	1432 - 1517 MHz	-43.4 dBm	1 MHz	This requirement does not apply to UTRA BS operating in Band XI
E-UTRA Band 51 or NR Band n51	1427 - 1432 MHz	-43.4 dBm	1 MHz	
E-UTRA Band 52	3300 – 3400 MHz	-43.0 dBm	1 MHz	
E-UTRA Band 65	2110 - 2200 MHz	-43.4 dBm	1 MHz	This requirement does not apply to UTRA BS operating in band I.
	1920 - 2010 MHz	-40.4 dBm	1 MHz	For UTRA BS operating in Band I, it applies for 1980 MHz to 2010 MHz, while the rest is covered in subclause 6.7.6.5.1.4
E-UTRA Band 66 or NR band n66	2110 - 2200 MHz	-43.4 dBm	1 MHz	This requirement does not apply to UTRA BS operating in band IV or X.
	1710 - 1780 MHz	-40.4 dBm	1 MHz	For UTRA BS operating in Band IV, this requirement applies for 1755 MHz to 1780 MHz, while the rest is covered in subclause 6.7.6.5.1.4. For UTRA BS operating in Band X, this requirement applies for 1770 MHz to 1780 MHz, while the rest is covered in subclause 6.7.6.5.1.4.
E-UTRA Band 67	738 - 758 MHz	-43.4 dBm	1 MHz	
E-UTRA Band 68	753 -783 MHz	-43.4 dBm	1 MHz	
	698-728 MHz	-40.4 dBm	1 MHz	
E-UTRA Band 69	2570 - 2620 MHz	-43.4 dBm	1 MHz	
E-UTRA Band 70 or NR band n70	1995 – 2020 MHz	-43.4 dBm	1 MHz	This requirement does not apply to UTRA BS operating in band II or XXV.
	1695 – 1710 MHz	-40.4 dBm	1 MHz	
E-UTRA Band 71 or NR Band n71	617 - 652 MHz	-40.4 dBm	1 MHz	
	663 – 698 MHz	-37.4 dBm	1 MHz	
E-UTRA Band 72	461 - 466 MHz	-40.4 dBm	1 MHz	
	451 - 456 MHz	-37.4 dBm	1 MHz	
E-UTRA Band 73	460 - 465 MHz	-40.4 dBm	1 MHz	
	450 - 455 MHz	-37.4 dBm	1 MHz	
E-UTRA Band 74 or NR band n74	1475 – 1518 MHz	-43.4 dBm	1 MHz	This requirement does not apply to UTRA FDD BS operating in band XI.
	1427 – 1470 MHz	-40.4 dBm	1MHz	
E-UTRA Band 75 or NR Band n75	1432 - 1517 MHz	-43.4 dBm	1 MHz	This requirement does not apply to UTRA FDD BS operating in band XI.
E-UTRA Band 76 or NR Band n76	1427 - 1432 MHz	-43.4 dBm	1 MHz	
NR Band n77	3300 – 4200 MHz	-43.0 dBm	1 MHz	
NR Band n78	3300 – 3800 MHz	-43.0 dBm	1 MHz	
NR Band n79	4400 – 5000 MHz	-42.5 dBm	1 MHz	
NR Band n80	1710 - 1785 MHz	-40.4 dBm	1 MHz	For BS operating in band IX.
NR Band n81	880 - 915 MHz	-40.4 dBm	1 MHz	This requirement does not apply to BS operating in band IIX
NR Band n82	832 - 862 MHz	-40.4 dBm	1 MHz	
NR Band n83	703 - 748 MHz	-40.4 dBm	1 MHz	
NR Band n84	1920 - 1980 MHz	-40.4 dBm	1 MHz	This requirement does not apply to BS operating in band I

E-UTRA Band 85	728 - 746 MHz	-43.4 dBm	1 MHz	This requirement does not apply to BS operating in band XII
	698 - 716 MHz	-40.4 dBm	1 MHz	
NR Band n86	1710 - 1780 MHz	-40.4 dBm	1 MHz	For BS operating in Band IV, it applies for 1755 MHz to 1780 MHz, while the rest is covered in sub-clause 6.7.6.5.1.4 For BS operating in Band X, it applies for 1770 MHz to 1780 MHz, while the rest is covered in sub-clause 6.7.6.5.1.4

NOTE 1: The co-existence requirements do not apply for the 10 MHz frequency range immediately outside the *downlink operating band* (see subclause 6.7.1). Emission limits for this excluded frequency range may be covered by local or regional requirements.

NOTE 2: The table above assumes that two operating bands, where the frequency ranges would be overlapping, are not deployed in the same geographical area. For such a case of operation with overlapping frequency arrangements in the same geographical area, special co-existence requirements may apply that are not covered by the 3GPP specifications.

The following requirement may be applied for the protection of PHS in geographic areas in which both PHS and UTRA FDD are deployed. This requirement is also applicable at specified frequencies falling between 12.5MHz below the first carrier frequency used and 12.5MHz above the last carrier frequency used.

The TRP of any spurious emission shall not exceed:

Table 6.7.6.4.5.2-2: AAS BS OTA Spurious emissions limits for BS in geographic coverage area of PHS

Band	Maximum Level	Measurement Bandwidth	Notes
1884.5 - 1915.7 MHz	-35 dBm	300 kHz	

The following requirement may be applied for the protection in bands adjacent to bands I or VII as defined in subclause 4.4, in geographic areas in which both an adjacent band service and UTRA FDD are deployed.

The TRP of any spurious emission shall not exceed:

Table 6.7.6.4.5.2-3: AAS BS OTA Spurious emissions limits for protection of adjacent band services

Operating Band	Band	Maximum Level	Measurement Bandwidth	Notes
I	2100-2105 MHz	$-24 + 6.0 \cdot (f - 2100 \text{ MHz}) \text{ dBm}$	1 MHz	
	2175-2180 MHz	$-24 + 6.0 \cdot (2180 \text{ MHz} - f) \text{ dBm}$	1 MHz	
VII	2610-2615 MHz	$-24 + 6.0 \cdot (f - 2610 \text{ MHz}) \text{ dBm}$	1 MHz	
	2695-2700 MHz	$-24 + 6.0 \cdot (2700 \text{ MHz} - f) \text{ dBm}$	1 MHz	

NOTE: This requirement for the frequency range 2610-2615 MHz may be applied to geographic areas in which both UTRA-TDD and UTRA-FDD are deployed.

The following requirement shall be applied to AAS BS operating in Bands XIII and XIV to ensure that appropriate interference protection is provided to 700 MHz public safety operations. This requirement is also applicable at specified frequencies falling between 12.5 MHz below the first carrier frequency used and 12.5 MHz above the last carrier frequency used.

The TRP of any spurious emission shall not exceed:

Table 6.7.6.4.5.2-4: AAS BS OTA Spurious emissions limits

Operating Band	Band	Maximum Level	Measurement Bandwidth	Notes
XIII	763 - 775 MHz	-37.4 dBm	6.25 kHz	
XIII	793 - 805 MHz	-37.4 dBm	6.25 kHz	
XIV	769 - 775 MHz	-37.4 dBm	6.25 kHz	
XIV	799 - 805 MHz	-37.4 dBm	6.25 kHz	

The following requirement shall be applied to AAS BS operating in Bands XXVI to ensure that appropriate interference protection is provided to 800 MHz public safety operations. This requirement is also applicable at specified frequencies falling between 12.5 MHz below the first carrier frequency used and 12.5 MHz above the last carrier frequency used.

The TRP of any spurious emission shall not exceed:

Table 6.7.6.4.5.2-5: AAS BS OTA Spurious emissions limits

Operating Band	Band	Maximum Level	Measurement Bandwidth	Notes
XXVI	851 - 859 MHz	-4.4 dBm	100 kHz	Applicable for offsets > 37.5kHz from the channel edge

6.7.6.4.5.3 Single RAT E-UTRA operation

The TRP of any spurious emission shall not exceed the limits of table 6.7.6.4.5.3-1 for an AAS BS where requirements for co-existence with the system listed in the first column apply. For a *multi-band RIB*, the exclusions and conditions in the notes column of table 6.7.6.4.5.3-1 apply for each supported operating band.

Table 6.7.6.4.5.3-1: AAS BS OTA Spurious emissions limits for co-existence with systems operating in other frequency bands

System type to co-exist with	Frequency range for co-existence requirement	Maximum Level	Measurement Bandwidth	Note
GSM900	921 - 960 MHz	-45.4 dBm	100 kHz	This requirement does not apply to BS operating in band 8
	876 - 915 MHz	-49.4 dBm	100 kHz	For the frequency range 880-915 MHz, this requirement does not apply to BS operating in band 8, since it is already covered by the requirement in subclause 6.7.6.5.3.3
DCS1800 (NOTE 3)	1805 - 1880 MHz	-35.4 dBm	100 kHz	This requirement does not apply to BS operating in band 3.
	1710 - 1785 MHz	-49.4 dBm	100 kHz	This requirement does not apply to BS operating in band 3, since it is already covered by the requirement in subclause 6.7.6.5.3.3.
PCS1900	1930 - 1990 MHz	-35.4 dBm	100 kHz	This requirement does not apply to BS operating in band 2, 25, band 36 or band 70.
	1850 - 1910 MHz	-49.4 dBm	100 kHz	This requirement does not apply to BS operating in band 2 or 25, since it is already covered by the requirement in subclause 6.7.6.5.3.3. This requirement does not apply to BS operating in band 35.
GSM850 or CDMA850	869 - 894 MHz	-45.4 dBm	100 kHz	This requirement does not apply to BS operating in band 5 or 26. This requirement applies to E-UTRA BS operating in Band 27 for the frequency range 879-894 MHz.
	824 - 849 MHz	-49.4 dBm	100 kHz	This requirement does not apply to BS operating in band 5 or 26, since it is already covered by the requirement in subclause 6.7.6.5.3.3. For BS operating in Band 27, it applies 3 MHz below the Band 27 <i>downlink operating band</i> .
UTRA FDD Band I or E-UTRA Band 1 or NR band n1	2110 - 2170 MHz	-40.4 dBm	1 MHz	This requirement does not apply to BS operating in band 1 or 65,
	1920 - 1980 MHz	-37.4 dBm	1 MHz	This requirement does not apply to BS operating in band 1 or 65, since it is already covered by the requirement in subclause 6.7.6.5.3.3.
UTRA FDD Band II or E-UTRA Band 2 or NR band n2	1930 - 1990 MHz	-40.4 dBm	1 MHz	This requirement does not apply to BS operating in band 2, 25 or 70.
	1850 - 1910 MHz	-37.4 dBm	1 MHz	This requirement does not apply to BS operating in band 2 or 25, since it is already covered by the requirement in subclause 6.7.6.5.3.3
UTRA FDD Band III or E-UTRA Band 3 or NR band n3 (NOTE 3)	1805 - 1880 MHz	-40.4 dBm	1 MHz	This requirement does not apply to BS operating in band 3 or 9.
	1710 - 1785 MHz	-37.4 dBm	1 MHz	This requirement does not apply to BS operating in band 3, since it is already covered by the requirement in subclause 6.7.6.5.3.3. For BS operating in band 9, it applies for 1710 MHz to 1749.9 MHz and 1784.9 MHz to 1785 MHz, while the rest is covered in subclause 6.7.6.5.3.3.
UTRA FDD Band IV or E-UTRA Band 4	2110 - 2155 MHz	-40.4 dBm	1 MHz	This requirement does not apply to BS operating in band 4, 10 or 66
	1710 - 1755 MHz	-37.4 dBm	1 MHz	This requirement does not apply to BS operating in band 4, 10 or 66, since it is already covered by the requirement in subclause 6.7.6.5.3.3.
UTRA FDD Band V or E-UTRA Band 5 or NR band n5	869 - 894 MHz	-40.4 dBm	1 MHz	This requirement does not apply to BS operating in band 5 or 26. This requirement applies to E-UTRA BS operating in Band 27 for the frequency range 879-894 MHz.

	824 - 849 MHz	-37.4 dBm	1 MHz	This requirement does not apply to BS operating in band 5 or 26, since it is already covered by the requirement in subclause 6.7.6.5.3.3. For BS operating in Band 27, it applies 3 MHz below the Band 27 <i>downlink operating band</i> .
UTRA FDD Band VI, XIX or E-UTRA Band 6, 18, 19	860 - 890 MHz	-40.4 dBm	1 MHz	This requirement does not apply to BS operating in band 6, 18, 19
	815 - 830 MHz	-37.4 dBm	1 MHz	This requirement does not apply to BS operating in band 18 since it is already covered by the requirement in subclause 6.7.6.5.3.3.
	830 - 845 MHz	-37.4 dBm	1 MHz	This requirement does not apply to BS operating in band 6, 19, since it is already covered by the requirement in subclause 6.7.6.5.3.3.
UTRA FDD Band VII or E-UTRA Band 7 or NR band n7	2620 - 2690 MHz	-40.4 dBm	1 MHz	This requirement does not apply to BS operating in band 7.
	2500 - 2570 MHz	-37.4 dBm	1 MHz	This requirement does not apply to BS operating in band 7, since it is already covered by the requirement in subclause 6.7.6.5.3.3.
UTRA FDD Band VIII or E-UTRA Band 8 or NR band n8	925 - 960 MHz	-40.4 dBm	1 MHz	This requirement does not apply to BS operating in band 8.
	880 - 915 MHz	-37.4 dBm	1 MHz	This requirement does not apply to BS operating in band 8, since it is already covered by the requirement in subclause 6.7.6.5.3.3.
UTRA FDD Band IX or E-UTRA Band 9	1844.9 - 1879.9 MHz	-40.4 dBm	1 MHz	This requirement does not apply to BS operating in band 3 or 9.
	1749.9 - 1784.9 MHz	-37.4 dBm	1 MHz	This requirement does not apply to BS operating in band 3 or 9, since it is already covered by the requirement in subclause 6.7.6.5.3.3.
UTRA FDD Band X or E-UTRA Band 10	2110 - 2170 MHz	-40.4 dBm	1 MHz	This requirement does not apply to BS operating in band 4, 10 or 66
	1710 - 1770 MHz	-37.4 dBm	1 MHz	This requirement does not apply to BS operating in band 10 or 66, since it is already covered by the requirement in subclause 6.7.6.5.3.3. For BS operating in Band 4, it applies for 1755 MHz to 1770 MHz, while the rest is covered in subclause 6.7.6.5.3.3.
UTRA FDD Band XI or XXI or E-UTRA Band 11 or 21	1475.9 - 1510.9 MHz	-40.4 dBm	1 MHz	This requirement does not apply to BS operating in band 11, 21 or 32
	1427.9 - 1447.9 MHz	-37.4 dBm	1 MHz	This requirement does not apply to BS operating in band 11, since it is already covered by the requirement in subclause 6.7.6.5.3.3. For BS operating in Band 32, this requirement applies for carriers allocated within 1475.9MHz and 1495.9MHz.
	1447.9 - 1462.9 MHz	-37.4 dBm	1 MHz	This requirement does not apply to BS operating in band 21, since it is already covered by the requirement in subclause 6.7.6.5.3.3. For BS operating in Band 32, this requirement applies for carriers allocated within 1475.9MHz and 1495.9MHz.
UTRA FDD Band XII or E-UTRA Band 12 or NR band n12	729 - 746 MHz	-40.4 dBm	1 MHz	This requirement does not apply to BS operating in band 12 or 85.
	699 - 716 MHz	-37.4 dBm	1 MHz	This requirement does not apply to BS operating in band 12 or 85, since it is already covered by the requirement in subclause 6.7.6.5.3.3. For BS operating in Band 29, it applies 1 MHz below the Band 29 <i>downlink operating band</i> (NOTE 7)
	746 - 756 MHz	-40.4 dBm	1 MHz	This requirement does not apply to BS operating in band 13.

UTRA FDD Band XIII or E-UTRA Band 13	777 - 787 MHz	-37.4 dBm	1 MHz	This requirement does not apply to BS operating in band 13, since it is already covered by the requirement in subclause 6.7.6.5.3.3.
UTRA FDD Band XIV or E-UTRA Band 14	758 - 768 MHz	-40.4 dBm	1 MHz	This requirement does not apply to BS operating in band 14.
	788 - 798 MHz	-37.4 dBm	1 MHz	This requirement does not apply to BS operating in band 14, since it is already covered by the requirement in subclause 6.7.6.5.3.3.
E-UTRA Band 17	734 - 746 MHz	-40.4 dBm	1 MHz	This requirement does not apply to BS operating in band 17.
	704 - 716 MHz	-37.4 dBm	1 MHz	This requirement does not apply to BS operating in band 17, since it is already covered by the requirement in subclause 6.7.6.5.3.3. For BS operating in Band 29, it applies 1 MHz below the Band 29 <i>downlink operating band</i> (NOTE 7)
UTRA FDD Band XX or E-UTRA Band 20 or NR band n20	791 - 821 MHz	-40.4 dBm	1 MHz	This requirement does not apply to BS operating in band 20 or 28.
	832 - 862 MHz	-37.4 dBm	1 MHz	This requirement does not apply to BS operating in band 20, since it is already covered by the requirement in subclause 6.7.6.5.3.3.
UTRA FDD Band XXII or E-UTRA Band 22	3510 – 3590 MHz	-40.0 dBm	1 MHz	This requirement does not apply to BS operating in band 22 or 42, 48.
	3410 – 3490 MHz	-37.0 dBm	1 MHz	This requirement does not apply to BS operating in band 22, since it is already covered by the requirement in subclause 9.7.3.3. This requirement does not apply to Band 42.
E-UTRA Band 24	1525 – 1559 MHz	-40.4 dBm	1 MHz	This requirement does not apply to BS operating in band 24.
	1626.5 – 1660.5 MHz	-37.4 dBm	1 MHz	This requirement does not apply to BS operating in band 24, since it is already covered by the requirement in subclause 6.7.6.5.3.3.
UTRA FDD Band XXV or E-UTRA Band 25 or NR band n25	1930 - 1995 MHz	-40.4 dBm	1 MHz	This requirement does not apply to BS operating in band 2, 25 or 70.
	1850 - 1915 MHz	-37.4 dBm	1 MHz	This requirement does not apply to BS operating in band 25, since it is already covered by the requirement in subclause 6.7.6.5.3.3. For BS operating in Band 2, it applies for 1910 MHz to 1915 MHz, while the rest is covered in subclause 6.7.6.5.3.3.
UTRA FDD Band XXVI or E-UTRA Band 26	859 - 894 MHz	-40.4 dBm	1 MHz	This requirement does not apply to BS operating in band 5 or 26. This requirement applies to E-UTRA BS operating in Band 27 for the frequency range 879-894 MHz.
	814 - 849 MHz	-37.4 dBm	1 MHz	This requirement does not apply to BS operating in band 26, since it is already covered by the requirement in subclause 6.7.6.5.3.3. For BS operating in Band 5, it applies for 814 MHz to 824 MHz, while the rest is covered in subclause 6.7.6.5.3.3. For BS operating in Band 27, it applies 3 MHz below the Band 27 <i>downlink operating band</i> .
E-UTRA Band 27	852 – 869 MHz	-40.4 dBm	1 MHz	This requirement does not apply to BS operating in bands 5, 26 or 27.

	807 – 824 MHz	-37.4 dBm	1 MHz	This requirement does not apply to BS operating in band 27, since it is already covered by the requirement in subclause 6.7.6.5.3.3. For BS operating in Band 26, it applies for 807 MHz to 814 MHz, while the rest is covered in subclause 6.7.6.5.3.3. This requirement also applies to BS operating in Band 28, starting 4 MHz above the Band 28 <i>downlink operating band</i> (NOTE 6).
E-UTRA Band 28 or NR band n28	758 - 803 MHz	-40.4 dBm	1 MHz	This requirement does not apply to BS operating in band 20, 28, 44, 67 or 68.
	703 - 748 MHz	-37.4 dBm	1 MHz	This requirement does not apply to BS operating in band 28, since it is already covered by the requirement in subclause 6.7.6.5.3.3. This requirement does not apply to BS operating in Band 44. For BS operating in Band 67, it applies for 703-736MHz. For E-UTRA BS operating in Band 68, it applies for 728MHz to 733MHz.
E-UTRA Band 29	717 – 728 MHz	-40.4 dBm	1 MHz	This requirement does not apply to BS operating in Band 29 or 85
E-UTRA Band 30	2350 - 2360 MHz	-40.4 dBm	1 MHz	This requirement does not apply to BS operating in band 30 or 40.
	2305 - 2315 MHz	-37.4 dBm	1 MHz	This requirement does not apply to BS operating in band 30, since it is already covered by the requirement in subclause 6.7.6.5.3.3. This requirement does not apply to BS operating in Band 40.
E-UTRA Band 31	462.5 – 467.5 MHz	-40.4 dBm	1 MHz	This requirement does not apply to BS operating in band 31, 72, 73.
	452.5 – 457.5 MHz	-37.4 dBm	1 MHz	This requirement does not apply to BS operating in band 31, since it is already covered by the requirement in subclause 6.7.6.5.3.3. This requirement does not apply to E-UTRA BS operating in band 72 or 73.
UTRA FDD Band XXXII or E-UTRA Band 32	1452 - 1496 MHz	-40.4 dBm	1 MHz	This requirement does not apply to BS operating in band 11, 21 or 32.
UTRA TDD Band a) or E-UTRA Band 33	1900 - 1920 MHz	-40.4 dBm	1 MHz	This requirement does not apply to BS operating in Band 33
UTRA TDD Band a) or E-UTRA Band 34 or NR band n34	2010 - 2025 MHz	-40.4 dBm	1 MHz	This requirement does not apply to BS operating in Band 34
UTRA TDD Band b) or E-UTRA Band 35	1850 – 1910 MHz	-40.4 dBm	1 MHz	This requirement does not apply to BS operating in Band 35
UTRA TDD Band b) or E-UTRA Band 36	1930 - 1990 MHz	-40.4 dBm	1 MHz	This requirement does not apply to BS operating in Band 2, 25 or 36
UTRA TDD Band c) or E-UTRA Band 37	1910 - 1930 MHz	-40.4 dBm	1 MHz	This is not applicable to BS operating in Band 37. This unpaired band is defined in ITU-R M.1036, but is pending any future deployment.
UTRA TDD Band d) or E-UTRA Band 38 or NR band n38	2570 – 2620 MHz	-40.4 dBm	1 MHz	This requirement does not apply to BS operating in Band 38 or 69.
UTRA TDD Band f) or E-UTRA Band 39 or NR band n39	1880 – 1920MHz	-40.4 dBm	1 MHz	This is not applicable to BS operating in Band 39

UTRA TDD Band e) or E-UTRA Band 40 or NR band n40	2300 – 2400MHz	-40.4 dBm	1 MHz	This is not applicable to BS operating in Band 30 or 40
E-UTRA Band 41 or NR band n41	2496 – 2690MHz	-40.4 dBm	1 MHz	This is not applicable to BS operating in Band 41
E-UTRA Band 42	3400 – 3600 MHz	-40.0 dBm	1 MHz	This is not applicable to BS operating in Band 22, 42, 43, 48, 52.
E-UTRA Band 43	3600 – 3800 MHz	-40.0 dBm	1 MHz	This is not applicable to BS operating in Band 42, 43, 48
E-UTRA Band 44	703 - 803 MHz	-40.4 dBm	1 MHz	This is not applicable to BS operating in Band 28 or 44
E-UTRA Band 45	1447 - 1467 MHz	-40.4 dBm	1 MHz	This is not applicable to BS operating in Band 45
E-UTRA Band 46	5150 - 5925 MHz	-39.5 dBm	1 MHz	
E-UTRA Band 47	5855 - 5925 MHz	-52 dBm	1 MHz	
E-UTRA Band 48	3550 – 3700 MHz	-52 dBm	1 MHz	This is not applicable to BS operating in Band 22, 42, 43, 48
E-UTRA Band 49	3550 – 3700 MHz	-52 dBm	1 MHz	This is not applicable to BS operating in Band 22, 42, 43, 48
E-UTRA Band 50 or NR Band n50	1432 - 1517 MHz	-40.4 dBm	1 MHz	This requirement does not apply to E-UTRA BS operating in Band 11, 21, 32, 45, 50, 51, 74, 75 or 76
E-UTRA Band 51 or NR Band n51	1427 - 1432 MHz	-40.4 dBm	1 MHz	This requirement does not apply to E-UTRA BS operating in Band 50, 51, 75 or 76.
E-UTRA Band 52	3300 – 3400 MHz	-52 dBm	1 MHz	This is not applicable to E-UTRA BS operating in Band 42 or 52.
E-UTRA Band 65	2110 - 2200 MHz	-40.4 dBm	1 MHz	This requirement does not apply to BS operating in band 1 or 65,
	1920 - 2010 MHz	-37.4 dBm	1 MHz	This requirement does not apply to BS operating in band 65, since it is already covered by the requirement in subclause 6.7.6.5.3.3. For BS operating in Band 1, it applies for 1980 MHz to 2010 MHz, while the rest is covered in subclause 6.7.6.5.3.3.
E-UTRA Band 66 or NR Band n66	2110 - 2200 MHz	-40.4 dBm	1 MHz	This requirement does not apply to BS operating in band 4, 10, 23 or 66.
	1710 - 1780 MHz	-37.4 dBm	1 MHz	This requirement does not apply to BS operating in band 66, since it is already covered by the requirement in subclause 6.7.6.5.3.3. For BS operating in Band 4, it applies for 1755 MHz to 1780 MHz, while the rest is covered in subclause 6.7.6.5.3.3. For BS operating in Band 10, it applies for 1770 MHz to 1780 MHz, while the rest is covered in subclause 6.7.6.5.3.3.
E-UTRA Band 67	738 – 758 MHz	-40.4 dBm	1 MHz	This requirement does not apply to BS operating in band 28 or 67.
E-UTRA Band 68	753 - 783 MHz	-40.4 dBm	1 MHz	This requirement does not apply to E-UTRA BS operating in band 28, or 68.
	698 - 728 MHz	-37.4 dBm	1 MHz	This requirement does not apply to E-UTRA BS operating in band 68, since it is already covered by the requirement in subclause 9.7.3.3. For E-UTRA BS operating in Band 28, it applies between 698 MHz and 703 MHz, while the rest is covered in subclause 9.7.3.3.
E-UTRA Band 69	2570 - 2620 MHz	-40.4 dBm	1 MHz	This requirement does not apply to E-UTRA BS operating in Band 38 or 69.
E-UTRA Band 70 or NR Band n70	1995 - 2020 MHz	-40.4 dBm	1 MHz	This requirement does not apply to E-UTRA BS operating in band 2, 25 or 70
	1695 – 1710 MHz	-37.4 dBm	1 MHz	This requirement does not apply to E-UTRA BS operating in band 70, since it is already covered by the requirement in subclause 6.7.6.5.3.3

E-UTRA Band 71 or NR Band n71	617 - 652 MHz	-40.4 dBm	1 MHz	This requirement does not apply to BS operating in band 71.
	663 – 698 MHz	-37.4 dBm	1 MHz	This requirement does not apply to BS operating in band 71/n71, since it is already covered by the requirement in sub-clause 6.7.6.3.5.3.3
E-UTRA Band 72	461 - 466 MHz	-40.4 dBm	1 MHz	This requirement does not apply to BS operating in band 31, 72 or 73.
	451 - 456 MHz	-37.4 dBm	1 MHz	This requirement does not apply to BS operating in band 72, since it is already covered by the requirement in sub-clause 6.7.6.3.5.3.3 This requirement does not apply to BS operating in band 73.
E-UTRA Band 73	460 - 465 MHz	-40.4 dBm	1 MHz	This requirement does not apply to BS operating in band 31, 72 or 73.
	450 - 455 MHz	-37.4 dBm	1 MHz	This requirement does not apply to BS operating in band 73, since it is already covered by the requirement in sub-clause 6.7.6.3.5.3.3
E-UTRA Band 74 or NR band n74	1475 – 1518 MHz	-40.4 dBm	1 MHz	This requirement does not apply to BS operating in band 11, 21, 32, 50 74 or 75.
	1427 – 1470 MHz	-37.4 dBm	1MHz	This requirement does not apply to BS operating in Band 74, since it is already covered by the requirement in sub-clause 6.7.6.3.5.3.3 This requirement does not apply to BS operating in band 32, 45, 50, 51, 75 or 76.
E-UTRA Band 75 or NR Band n75	1432 - 1517 MHz	-40.4 dBm	1 MHz	This requirement does not apply to BS operating in Band 11, 21, 32, 45, 50, 51, 74, 75 or 76.
E-UTRA Band 76 or NR Band n76	1427 - 1432 MHz	-40.4 dBm	1 MHz	This requirement does not apply to BS operating in Band 50, 51, 75 or 76.
NR Band n77	3300 – 4200 MHz	-40.0 dBm	1 MHz	This is not applicable to BS operating in Band 42, 43, 48
NR Band n78	3300 – 3800 MHz	-40.0 dBm	1 MHz	This is not applicable to BS operating in Band 42, 43, 48
NR Band n79	4400 – 5000 MHz	-39.5 dBm	1 MHz	This requirement does not apply to BS operating in Band n79
NR Band n80	1710 - 1785 MHz	-37.4 dBm	1 MHz	This requirement does not apply to BS operating in band 3, since it is already covered by the requirement in sub-clause 6.7.6.3.5.3.3 For BS operating in band 9, it applies for 1710 MHz to 1749.9 MHz and 1784.9 MHz to 1785 MHz, while the rest is covered in sub-clause 6.7.6.3.5.3.3
NR Band n81	880 - 915 MHz	-37.4 dBm	1 MHz	This requirement does not apply to BS operating in band 8, since it is already covered by the requirement in sub-clause 6.7.6.3.5.3.3
NR Band n82	832 - 862 MHz	-37.4 dBm	1 MHz	This requirement does not apply to BS operating in band 20, since it is already covered by the requirement in subclause 6.7.6.3.5.3.3
NR Band n83	703 - 748 MHz	-37.4 dBm	1 MHz	This requirement does not apply to BS operating in band 28, since it is already covered by the requirement in sub-clause 6.7.6.3.5.3.3 This requirement does not apply to BS operating in Band 44. For BS operating in Band 67, it applies for 703-736MHz. For BS operating in Band 68, it applies for 728MHz to 733MHz.
NR Band n84	1920 - 1980 MHz	-37.4 dBm	1 MHz	This requirement does not apply to BS operating in band 1 or 65, since it is already covered by the requirement in sub-clause 6.7.6.3.5.3.3
E-UTRA Band 85	728 - 746 MHz	-40.4 dBm	1 MHz	This requirement does not apply to BS operating in band 12, 29 or 85.

	698 - 716 MHz	-37.4 dBm	1 MHz	This requirement does not apply to BS operating in band 85, since it is already covered by the requirement in sub-clause 6.7.6.3.5.3.3 For BS operating in Band 29, it applies 1 MHz below the Band 29 downlink operating band (Note 7).
NR Band n86	1710 - 1780 MHz	-37.4 dBm	1 MHz	This requirement does not apply to BS operating in band 66/n66, since it is already covered by the requirement in sub-clause 6.7.6.3.5.13.3. For BS operating in Band 4, it applies for 1755 MHz to 1780 MHz, while the rest is covered in sub-clause 6.7.6.3.5.13.3. For BS operating in Band 10, it applies for 1770 MHz to 1780 MHz, while the rest is covered in sub-clause 6.7.6.3.5.3.3

NOTE 1: As defined in the scope for spurious emissions in this subclause, except for the cases where the noted requirements apply to a BS operating in Band 25, Band 27, Band 28 or Band 29, the co-existence requirements in table 6.7.6.4.5.3-1 do not apply for the 10 MHz frequency range immediately outside the *downlink operating band* (see subclause 6.7.1). Emission limits for this excluded frequency range may be covered by local or regional requirements.

NOTE 2: Table 6.7.6.4.5.3-1 assumes that two operating bands, where the frequency ranges in subclause 4.7 would be overlapping, are not deployed in the same geographical area. For such a case of operation with overlapping frequency arrangements in the same geographical area, special co-existence requirements may apply that are not covered by the 3GPP specifications.

NOTE 3: For the protection of DCS1800, UTRA Band III or E-UTRA Band 3 in China, the frequency ranges of the downlink and uplink protection requirements are 1805 – 1850 MHz and 1710 – 1755 MHz respectively.

NOTE 4: TDD base stations deployed in the same geographical area, that are synchronized and use the same or adjacent operating bands can transmit without additional co-existence requirements. For unsynchronized base stations (except in Band 46), special co-existence requirements may apply that are not covered by the 3GPP specifications.

NOTE 6: For Band 28 BS, specific solutions may be required to fulfil the spurious emissions limits for BS for co-existence with Band 27 UL operating band.

NOTE 7: For Band 29 BS, specific solutions may be required to fulfil the spurious emissions limits for BS for co-existence with UTRA Band XII or E-UTRA Band 12 UL operating band, E-UTRA Band 17 UL operating band or E-UTRA Band 85 UL operating band.

The following requirement may be applied for the protection of PHS. This requirement is also applicable at specified frequencies falling between 10 MHz below the lowest BS transmitter frequency of the *downlink operating band* and 10 MHz above the highest BS transmitter frequency of the *downlink operating band*.

The TRP of any spurious emission shall not exceed:

Table 6.7.6.4.5.3-2: AAS BS OTA Spurious emissions limits for BS for co-existence with PHS

Frequency range	Maximum Level	Measurement Bandwidth	Notes
1884.5 - 1915.7 MHz	-32 dBm	300 kHz	Applicable for co-existence with PHS system operating in 1884.5-1915.7MHz
NOTE: The requirement is not applicable in China.			

The following requirement shall be applied to AAS BS operating in Bands 13 and 14 to ensure that appropriate interference protection is provided to 700 MHz public safety operations. This requirement is also applicable at the frequency range from 10 MHz below the lowest frequency of the BS *downlink operating band* up to 10 MHz above the highest frequency of the BS *downlink operating band*.

The TRP of any spurious emission shall not exceed:

Table 6.7.6.4.5.3-3: AAS BS OTA Spurious emissions limits for protection of 700 MHz public safety operations

Operating Band	Frequency range	Maximum Level	Measurement Bandwidth	Notes
13	763 - 775 MHz	-37 dBm	6.25 kHz	
13	793 - 805 MHz	-37 dBm	6.25 kHz	
14	769 - 775 MHz	-37 dBm	6.25 kHz	
14	799 - 805 MHz	-37 dBm	6.25 kHz	

The following requirement shall be applied to AAS BS operating in Band 26 to ensure that appropriate interference protection is provided to 800 MHz public safety operations. This requirement is also applicable at the frequency range from 10 MHz below the lowest frequency of the BS *downlink operating band* up to 10 MHz above the highest frequency of the BS *downlink operating band*.

The TRP of any spurious emission shall not exceed:

Table 6.7.6.4.5.3-4: AAS BS OTA Spurious emissions limits for protection of 800 MHz public safety operations

Operating Band	Frequency range	Maximum Level	Measurement Bandwidth	Notes
26	851 - 859 MHz	-4 dBm	100 kHz	Applicable for offsets > 37.5kHz from the channel edge

The following requirement may apply to E-UTRA AAS BS operating in Band 41 in certain regions. This requirement is also applicable at the frequency range from 10 MHz below the lowest frequency of the BS *downlink operating band* up to 10 MHz above the highest frequency of the BS *downlink operating band*.

The TRP of any spurious emission shall not exceed:

Table 6.7.6.4.5.3-5: Additional AAS BS OTA Spurious emissions limits for Band 41

Frequency range	Maximum Level	Measurement Bandwidth	Notes
2505MHz – 2535MHz	-30.4 dBm	1 MHz	
2535MHz – 2655MHz	-10.4 dBm	1 MHz	Applicable at offsets \geq 250% of <i>channel bandwidth</i> from carrier frequency
NOTE: This requirement applies for 10 or 20 MHz E-UTRA carriers allocated within 2545-2575MHz or 2595-2645MHz.			

The following requirement may apply to AAS BS operating in Band 30 in certain regions. This requirement is also applicable at the frequency range from 10 MHz below the lowest frequency of the BS *downlink operating band* up to 10 MHz above the highest frequency of the BS *downlink operating band*.

The TRP of any spurious emission shall not exceed:

Table 6.7.6.4.5.3-6: Additional AAS BS OTA Spurious emissions limits for Band 30

Frequency range	Maximum Level	Measurement Bandwidth	Notes
2200MHz – 2345MHz	-33.4 dBm	1 MHz	
2362.5MHz – 2365MHz	-13.4 dBm	1 MHz	
2365MHz – 2367.5MHz	-28.4 dBm	1 MHz	
2367.5MHz – 2370MHz	-30.4 dBm	1 MHz	
2370MHz – 2395MHz	-33.4 dBm	1 MHz	

The following requirement may apply to AAS BS operating in Band 48 in certain regions. The TRP of any spurious emission shall not exceed:

Table 6.7.6.4.5.3-7: Additional AAS BS OTA Spurious emissions limits for Band 48

Frequency range	Maximum Level	Measurement Bandwidth	Notes
3530MHz – 3720MHz	-13 dBm	1 MHz	Applicable 10MHz from the assigned channel edge
3100MHz – 3530MHz 3720MHz – 4200MHz	-28.0 dBm	1 MHz	

In addition to the requirements in subclauses 6.7.6.5.3.1, 6.7.6.5.3.2, 6.7.6.5.3.3 and above in the present subclause, the AAS BS may have to comply with the applicable emission limits established by FCC Title 47 [18], when deployed in regions where those limits are applied, and under the conditions declared by the manufacturer.

Table 6.7.6.4.5.3-8: Void

The following requirement shall be applied to AAS BS operating in Bands 13 and 14 to ensure that appropriate interference protection is provided to 700 MHz public safety operations. This requirement is also applicable at the frequency range from 10 MHz below the lowest frequency of the BS *downlink operating band* up to 10 MHz above the highest frequency of the BS *downlink operating band*.

The TRP of any spurious emission shall not exceed:

Table 6.7.6.4.5.3-9: AAS BS OTA Spurious emissions limits for protection of 700 MHz public safety operations

Operating Band	Frequency range	Maximum Level	Measurement Bandwidth	Notes
13	763 - 775 MHz	-37 dBm	6.25 kHz	
13	793 - 805 MHz	-37 dBm	6.25 kHz	
14	769 - 775 MHz	-37 dBm	6.25 kHz	
14	799 - 805 MHz	-37 dBm	6.25 kHz	

The following requirement shall be applied to AAS BS operating in Band 26 to ensure that appropriate interference protection is provided to 800 MHz public safety operations. This requirement is also applicable at the frequency range from 10 MHz below the lowest frequency of the BS *downlink operating band* up to 10 MHz above the highest frequency of the BS *downlink operating band*.

The TRP of any spurious emission shall not exceed:

Table 6.7.6.4.5.3-10: AAS BS OTA Spurious emissions limits for protection of 800 MHz public safety operations

Operating Band	Frequency range	Maximum Level	Measurement Bandwidth	Notes
26	851 - 859 MHz	-13 dBm	100 kHz	Applicable for offsets > 37.5kHz from the channel edge

6.7.6.5 Co-location with other base stations

6.7.6.5.1 Definition and applicability

6.7.6.5.2 Minimum Requirement

The minimum requirement for AAS BS in *MSR operation* is defined in TS 37.105 [6], subclause 9.7.6.2.

The minimum requirement for AAS BS in *single RAT UTRA operation* is defined in TS 37.105 [6], subclause 9.7.6.3.

The minimum requirement for AAS BS in *single RAT E-UTRA operation* is defined in TS 37.105 [6], subclause 9.7.6.4.

6.7.6.5.3 Test purpose

The test purpose of OTA spurious emission is to verify the radiated spurious emissions from the AAS BS at the *RIB* are within specified requirements.

For OTA co-location spurious emission, the test purpose is to verify that the emission is within the specified requirement limits at the CLTA conducted output(s).

6.7.6.5.4 Method of test

6.7.6.5.4.1 Initial conditions

See sub-clause 6.7.6.3.4.1.

6.7.6.5.4.2 Procedure

See sub-clause 6.7.6.3.4.2.

6.7.6.5.5 Test Requirement

6.7.6.5.5.1 MSR operation

These requirements may be applied for the protection of other BS receivers when GSM900, DCS1800, PCS1900, GSM850, CDMA850, UTRA FDD, UTRA TDD, E-UTRA and/or NR BS are co-located with a BS.

The requirements assume with base stations of the same class.

NOTE: For co-location with UTRA, the requirements are based on co-location with UTRA FDD or TDD base stations.

The requirements are co-location emission requirements are specified as the power sum of the supported polarization(s) at the CLTA conducted output(s).

The output of the CLTA of any spurious emission shall not exceed the limits of table 6.7.6.5.5.1-1 for a AAS BS where requirements for co-location with a BS type listed in the first column apply, depending on the declared Base Station class. For a *multi-band RIB*, the exclusions and conditions in the notes column of table 6.7.6.5.5.1-1 apply for each supported operating band.

Table 6.7.6.5.5.1-1: AAS BS OTA Spurious emissions E-UTRA limits for AAS BS co-located with another BS

Type of co-located BS	Frequency range for co-location requirement	Maximum Level (WA-BS)	Maximum Level (MR-BS)	Maximum Level (LA-BS)	Measurement Bandwidth	Note
GSM900	876-915 MHz	-115.9 dBm	-108.9 dBm	-105.9 dBm	100 kHz	
DCS1800	1710 - 1785 MHz	-115.9 dBm	-108.9 dBm	-105.9 dBm	100 kHz	
PCS1900	1850 - 1910 MHz	-115.9 dBm	-108.9 dBm	-105.9 dBm	100 kHz	
GSM850 or CDMA850	824 - 849 MHz	-115.9 dBm	-108.9 dBm	-105.9 dBm	100 kHz	
UTRA FDD Band I or E-UTRA Band 1 or NR Band n1	1920 - 1980 MHz	-113.9 dBm	-108.9 dBm	-105.9 dBm	100 kHz	
UTRA FDD Band II or E-UTRA Band 2 or NR Band n2	1850 - 1910 MHz	-113.9 dBm	-108.9 dBm	-105.9 dBm	100 kHz	
UTRA FDD Band III or E-UTRA Band 3 or NR Band n3	1710 - 1785 MHz	-113.9 dBm	-108.9 dBm	-105.9 dBm	100 kHz	
UTRA FDD Band IV or E-UTRA Band 4	1710 - 1755 MHz	-113.9 dBm	-108.9 dBm	-105.9 dBm	100 kHz	
UTRA FDD Band V or E-UTRA Band 5 or NR Band n5	824 - 849 MHz	-113.9 dBm	-108.9 dBm	-105.9 dBm	100 kHz	
UTRA FDD Band VI, XIX or E-UTRA Band 6, 19	830 - 845 MHz	-113.9 dBm	-108.9 dBm	-105.9 dBm	100 kHz	
UTRA FDD Band VII or E-UTRA Band 7 or NR Band n7	2500 - 2570 MHz	-113.9 dBm	-108.9 dBm	-105.9 dBm	100 kHz	
UTRA FDD Band VIII or E-UTRA Band 8 or NR Band n8	880 - 915 MHz	-113.9 dBm	-108.9 dBm	-105.9 dBm	100 kHz	
UTRA FDD Band IX or E-UTRA Band 9	1749.9 - 1784.9 MHz	-113.9 dBm	-108.9 dBm	-105.9 dBm	100 kHz	
UTRA FDD Band X or E-UTRA Band 10	1710 - 1770 MHz	-113.9 dBm	-108.9 dBm	-105.9 dBm	100 kHz	
UTRA FDD Band XI or E-UTRA Band 11	1427.9 - 1447.9 MHz	-113.9 dBm	-108.9 dBm	-105.9 dBm	100 kHz	This is not applicable to BS operating in Band 50/n50, 51/n51, 75/n75, 76/n76
UTRA FDD Band XII or E-UTRA Band 12 or NR Band n12	699 - 716 MHz	-113.9 dBm	-108.9 dBm	-105.9 dBm	100 kHz	
UTRA FDD Band XIII or E-UTRA Band 13	777 - 787 MHz	-113.9 dBm	-108.9 dBm	-105.9 dBm	100 kHz	
UTRA FDD Band XIV or E-UTRA Band 14	788 - 798 MHz	-113.9 dBm	-108.9 dBm	-105.9 dBm	100 kHz	
E-UTRA Band 17	704 - 716 MHz	-113.9 dBm	-108.9 dBm	-105.9 dBm	100 kHz	

E-UTRA Band 18	815 - 830 MHz	-113.9 dBm	-108.9 dBm	-105.9 dBm	100 kHz	
UTRA FDD Band XX or E-UTRA Band 20 or NR Band n20	832 - 862 MHz	-113.9 dBm	-108.9 dBm	-105.9 dBm	100 kHz	
UTRA FDD Band XXI or E-UTRA Band 21	1447.9 – 1462.9 MHz	-113.9 dBm	-108.9 dBm	-105.9 dBm	100 kHz	This is not applicable to BS operating in Band 32, 50/n50, 75/n75
UTRA FDD Band XXII or E-UTRA Band 22	3410 – 3490 MHz	-113.7 dBm	-108.7dBm	-105.7 dBm	100 kHz	This is not applicable to BS operating in Band 42, n77 or n78
E-UTRA Band 23	2000 - 2020 MHz	-113.9 dBm	-108.9 dBm	-105.9 dBm	100 kHz	
E-UTRA Band 24	1626.5 – 1660.5 MHz	-113.9 dBm	-108.9 dBm	-105.9 dBm	100 kHz	
UTRA FDD Band XXV or E-UTRA Band 25 or NR Band n25	1850 - 1915 MHz	-113.9 dBm	-108.9 dBm	-105.9 dBm	100 kHz	
UTRA FDD Band XXVI or E-UTRA Band 26	814 - 849 MHz	-113.9 dBm	-108.9 dBm	-105.9 dBm	100 kHz	
E-UTRA Band 27	807 - 824 MHz	-113.9 dBm	-108.9 dBm	-105.9 dBm	100 kHz	
E-UTRA Band 28 or NR Band n28	703 – 748 MHz	-113.9 dBm	-108.9 dBm	-105.9 dBm	100 kHz	This is not applicable to BS operating in Band 44
E-UTRA Band 30	2305 - 2315 MHz	-113.9 dBm	-108.9 dBm	-105.9 dBm	100 kHz	This is not applicable to BS operating in Band 40/n40
E-UTRA Band 31	452.5 – 457.5 MHz	-113.9 dBm	-108.9 dBm	-105.9 dBm	100 kHz	
UTRA TDD Band a) or E-UTRA Band 33	1900 - 1920 MHz	-113.9 dBm	-108.9 dBm	-105.9 dBm	100 kHz	This is not applicable to BS operating in Band 33
UTRA TDD Band a) or E-UTRA Band 34 or NR Band n34	2010 - 2025 MHz	-113.9 dBm	-108.9 dBm	-105.9 dBm	100 kHz	This is not applicable to BS operating in Band 34/n34
UTRA TDD Band b) or E-UTRA Band 35	1850 – 1910 MHz	-113.9 dBm	-108.9 dBm	-105.9 dBm	100 kHz	This is not applicable to BS operating in Band 35
UTRA TDD Band b) or E-UTRA Band 36	1930 - 1990 MHz	-113.9 dBm	-108.9 dBm	-105.9 dBm	100 kHz	This is not applicable to BS operating in Band 2, n2 and 36
UTRA TDD Band c) or E-UTRA Band 37	1910 - 1930 MHz	-113.9 dBm	-108.9 dBm	-105.9 dBm	100 kHz	This is not applicable to BS operating in Band 37. This unpaired band is defined in ITU-R M.1036, but is pending any future deployment.

UTRA TDD Band d) or E-UTRA Band 38 or NR Band n38	2570 – 2620 MHz	-113.9 dBm	-108.9 dBm	-105.9 dBm	100 kHz	This is not applicable to BS operating in Band 38/n38.
UTRA TDD Band f) or E-UTRA Band 39 or NR Band n39	1880 – 1920MHz	-113.9 dBm	-108.9 dBm	-105.9 dBm	100 kHz	This is not applicable to BS operating in Band 33 and 39/n39
UTRA TDD Band e) or E-UTRA Band 40 or NR Band n40	2300 – 2400MHz	-113.9 dBm	-108.9 dBm	-105.9 dBm	100 kHz	This is not applicable to BS operating in Band 30 or 40/n40
E-UTRA Band 41 or NR Band n41	2496 – 2690MHz	-113.9 dBm	-108.9 dBm	-105.9 dBm	100 kHz	This is not applicable to BS operating in Band 41/n41
E-UTRA Band 42	3400 – 3600 MHz	-113.7 dBm	-108.7 dBm	-105.7 dBm	100 kHz	This is not applicable to BS operating in Band 22, 42, 43, 48, 52, n77 or n78
E-UTRA Band 43	3600 – 3800 MHz	-113.7 dBm	-108.7 dBm	-105.7 dBm	100 kHz	This is not applicable to BS operating in Band 42, 43, 48, n77 or n78
E-UTRA Band 44	703 – 803 MHz	-113.9 dBm	-108.9 dBm	-105.9 dBm	100 kHz	This is not applicable to BS operating in Band 28/n28 or 44
E-UTRA Band 45	1447 – 1467 MHz	-113.9 dBm	-108.9 dBm	-105.9 dBm	100 kHz	This is not applicable to BS operating in Band 45
E-UTRA Band 48	3550 – 3700 MHz	-113.7 dBm	-108.7 dBm	-105.7 dBm	100 kHz	This is not applicable to BS operating in Band 42, 43, 48, n77 or n78
E-UTRA Band 49	3550 – 3700 MHz	N/A	N/A	-105.7 dBm	100 kHz	This is not applicable to BS operating in Band 42, 43, 48, n77 or n78
E-UTRA Band 50 or NR band n50	1432 – 1517 MHz	-113.9 dBm	-108.9 dBm	-105.9 dBm	100 kHz	This is not applicable to BS operating in Band 11, 21, 32, 51, n51, 74, 75/n75, 76/n76
E-UTRA Band 51 or NR Band n51	1427 – 1432 MHz	N/A	N/A	-105.9 dBm	100 kHz	This is not applicable to BS operating in Band 50/n50, 75/n75, 76/n76
E-UTRA Band 52	3300 – 3400 MHz	-113.7 dBm	-108.7 dBm	-105.7 dBm	100 kHz	This is not applicable to BS operating in Band 42 or 52
E-UTRA Band 65	1920 - 2010 MHz	-113.9 dBm	-108.9 dBm	-105.9 dBm	100 kHz	
E-UTRA Band 66 or NR Band n66	1710 – 1780 MHz	-113.9 dBm	-108.9 dBm	-105.9 dBm	100 kHz	

E-UTRA Band 68	698 – 728 MHz	-113.9 dBm	-108.9 dBm	-105.9 dBm	100 kHz	
E-UTRA Band 70 or NR Band n70 or NR band n70	1695 – 1710 MHz	-113.9 dBm	-108.9 dBm	-105.9 dBm	100 kHz	
E-UTRA Band 71 or NR Band n71	663 – 698 MHz	-113.9 dBm	-108.9 dBm	-105.9 dBm	100 kHz	
E-UTRA Band 72	451 – 456 MHz	-113.9 dBm	-108.9 dBm	-105.9 dBm	100 kHz	
E-UTRA Band 73	450 – 455 MHz	-113.9 dBm	-108.9 dBm	-105.9 dBm	100 kHz	
E-UTRA Band 74 or NR band n74	1427 – 1470 MHz	-113.9 dBm	-108.9 dBm	-105.9 dBm	100 kHz	This is not applicable to BS operating in Band 50/n50, 51/n51
NR Band n77	3300 MHz – 4200 MHz	-113.7 dBm	-108.7 dBm	-105.7 dBm	100 kHz	This is not applicable to BS operating in Band 22, 42, 43, 48, 52, n77 or n78
NR Band n78	3300 MHz – 3800 MHz	-113.7 dBm	-108.7 dBm	-105.7 dBm	100 kHz	This is not applicable to BS operating in Band 22, 42, 43, 48, 52, n77 or n78
NR band n79	4400 MHz – 5000 MHz	-113.6 dBm	-108.6 dBm	-105.6 dBm	100 kHz	
NR band n80	1710 MHz – 1785 MHz	-113.9 dBm	-108.9 dBm	-105.9 dBm	100 kHz	
NR band n81	880 MHz – 915 MHz	-113.9 dBm	-108.9 dBm	-105.9 dBm	100 kHz	
NR band n82	832 MHz – 862 MHz	-113.9 dBm	-108.9 dBm	-105.9 dBm	100 kHz	
NR band n83	703 MHz – 748 MHz	-113.9 dBm	-108.9 dBm	-105.9 dBm	100 kHz	
NR band n84	1920 MHz – 1980 MHz	-113.9 dBm	-108.9 dBm	-105.9 dBm	100 kHz	
E-UTRA Band 85	698 - 716 MHz	-113.9 dBm	-108.9 dBm	-105.9 dBm	100 kHz	
NR band n86	1710 MHz – 1780 MHz	-113.9 dBm	-108.9 dBm	-105.9 dBm	100 kHz	

NOTE 1: As defined in the scope for spurious emissions in this subclause, the co-location requirements in table 6.7.6.5.3.5-1 do not apply for the 10 MHz frequency range immediately outside the BS transmit frequency range of a *downlink operating band* (see subclause 6.7.1). The current state-of-the-art technology does not allow a single generic solution for co-location with other system on adjacent frequencies for 30 dB BS-BS minimum coupling loss. However, there are certain site-engineering solutions that can be used. These techniques are addressed in TR 25.942 [31].

NOTE 2: Table 6.7.6.5.3.5-1 assumes that two operating bands, where the corresponding BS transmit and receive frequency ranges in subclause 4.6 would be overlapping, are not deployed in the same geographical area. For such a case of operation with overlapping frequency arrangements in the same geographical area, special co-location requirements may apply that are not covered by the 3GPP specifications.

NOTE 3: Co-located TDD base stations that are synchronized and using the same or adjacent operating band can transmit without special co-locations requirements. For unsynchronized base stations, special co-location requirements may apply that are not covered by the 3GPP specifications.

6.7.6.5.5.2 Single RAT UTRA operation

These requirements may be applied for the protection of other BS receivers when GSM900, DCS1800, PCS1900, GSM850, CDMA850, UTRA FDD, UTRA TDD and/or E-UTRA BS are co-located with a BS.

The requirements assume with base stations of the same class.

NOTE: For co-location with UTRA, the requirements are based on co-location with UTRA FDD or TDD base stations.

The requirements are co-location emission requirements and specified as the power sum of the supported polarization(s) at the CLTA conducted output(s).

The power sum of any spurious emission is specified over all supported polarizations at the conducted output(s) of the CLTA and shall not exceed the limits of table 6.7.6.5.5.2-1 for a AAS BS where requirements for co-location with a BS type listed in the first column apply, depending on the declared Base Station class. For a *multi-band RIB*, the exclusions and conditions in the Notes column of table 6.7.6.5.5.2-1 apply for each supported operating band.

Table 6.7.6.5.5.2-1: UTRA AAS BS OTA Spurious emissions limits for AAS BS co-located with another BS

Type of co-located BS	Frequency range for co-location requirement	Maximum Level (WA-BS)	Maximum Level (MR-BS)	Maximum Level (LA-BS)	Measurement Band width	Notes
GSM900	876-915 MHz	-118.9 dBm	-111.9 dBm	-108.9 dBm	100 kHz	
DCS1800	1710 - 1785 MHz	-118.9 dBm	-111.9 dBm	-108.9 dBm	100 kHz	
PCS1900	1850 - 1910 MHz	-118.9 dBm	-111.9 dBm	-108.9 dBm	100 kHz	
GSM850 or CDMA850	824 - 849 MHz	-118.9 dBm	-111.9 dBm	-108.9 dBm	100 kHz	
UTRA FDD Band I or E-UTRA Band 1 or NR band n1	1920 - 1980 MHz	-116.9 dBm	-111.9 dBm	-108.9 dBm	100 kHz	
UTRA FDD Band II or E-UTRA Band 2 or NR band n2	1850 - 1910 MHz	-116.9 dBm	-111.9 dBm	-108.9 dBm	100 kHz	
UTRA FDD Band III or E-UTRA Band 3 or NR band n3	1710 - 1785 MHz	-116.9 dBm	-111.9 dBm	-108.9 dBm	100 kHz	
UTRA FDD Band IV or E-UTRA Band 4	1710 - 1755 MHz	-116.9 dBm	-111.9 dBm	-108.9 dBm	100 kHz	
UTRA FDD Band V or E-UTRA Band 5 or NR band n5	824 - 849 MHz	-116.9 dBm	-111.9 dBm	-108.9 dBm	100 kHz	
UTRA FDD Band VI, XIX or E-UTRA Band 6, 19	830 - 845 MHz	-116.9 dBm	-111.9 dBm	-108.9 dBm	100 kHz	
UTRA FDD Band VII or E-UTRA Band 7 or NR band n7	2500 - 2570 MHz	-116.9 dBm	-111.9 dBm	-108.9 dBm	100 kHz	
UTRA FDD Band VIII or E-UTRA Band 8 or NR band n8	880 - 915 MHz	-116.9 dBm	-111.9 dBm	-108.9 dBm	100 kHz	
UTRA FDD Band IX or E-UTRA Band 9	1749.9 - 1784.9 MHz	-116.9 dBm	-111.9 dBm	-108.9 dBm	100 kHz	
UTRA FDD Band X or E-UTRA Band 10	1710 - 1770 MHz	-116.9 dBm	-111.9 dBm	-108.9 dBm	100 kHz	
UTRA FDD Band XI or E-UTRA Band 11	1427.9 - 1447.9 MHz	-116.9 dBm	-111.9 dBm	-108.9 dBm	100 kHz	

UTRA FDD Band XII or E-UTRA Band 12 or NR band n12	699 - 716 MHz	-116.9 dBm	-111.9 dBm	-108.9 dBm	100 kHz	
UTRA FDD Band XIII or E-UTRA Band 13	777 - 787 MHz	-116.9 dBm	-111.9 dBm	-108.9 dBm	100 kHz	
UTRA FDD Band XIV or E-UTRA Band 14	788 - 798 MHz	-116.9 dBm	-111.9 dBm	-108.9 dBm	100 kHz	
E-UTRA Band 17	704 - 716 MHz	-116.9 dBm	-111.9 dBm	-108.9 dBm	100 kHz	
E-UTRA Band 18	815 - 830 MHz	-116.9 dBm	-111.9 dBm	-108.9 dBm	100 kHz	
UTRA FDD Band XX or E-UTRA Band 20 or NR band n20	832 - 862 MHz	-116.9 dBm	-111.9 dBm	-108.9 dBm	100 kHz	
UTRA FDD Band XXI or E-UTRA Band 21	1447.9 – 1462.9 MHz	-116.9 dBm	-111.9 dBm	-108.9 dBm	100 kHz	
UTRA FDD Band XXII or E-UTRA Band 22	3410 – 3490 MHz	-116.7 dBm	-111.7 dBm	-108.7 dBm	100 kHz	This is not applicable to BS operating in Band 42
E-UTRA Band 23	2000 - 2020 MHz	-116.9 dBm	-111.9 dBm	-108.9 dBm	100 kHz	
E-UTRA Band 24	1626.5 – 1660.5 MHz	-116.9 dBm	-111.9 dBm	-108.9 dBm	100 kHz	
UTRA FDD Band XXV or E-UTRA Band 25 or NR band n25	1850 - 1915 MHz	-116.9 dBm	-111.9 dBm	-108.9 dBm	100 kHz	
UTRA FDD Band XXVI or E-UTRA Band 26	814 - 849 MHz	-116.9 dBm	-111.9 dBm	-108.9 dBm	100 kHz	
E-UTRA Band 27	807 - 824 MHz	-116.9 dBm	-111.9 dBm	-108.9 dBm	100 kHz	
E-UTRA Band 28 or NR band n28	703 – 748 MHz	-116.9 dBm	-111.9 dBm	-108.9 dBm	100 kHz	This is not applicable to BS operating in Band 44
E-UTRA Band 30	2305 - 2315 MHz	-116.9 dBm	-111.9 dBm	-108.9 dBm	100 kHz	This is not applicable to BS operating in Band 40
E-UTRA Band 31	452.5 – 457.5 MHz	-116.9 dBm	-111.9 dBm	-108.9 dBm	100 kHz	
UTRA TDD Band a) or E-UTRA Band 33	1900 - 1920 MHz	-116.9 dBm	-111.9 dBm	-108.9 dBm	100 kHz	This is not applicable to BS operating in Band 33
UTRA TDD Band a) or E-UTRA Band 34 or NR band n34	2010 - 2025 MHz	-116.9 dBm	-111.9 dBm	-108.9 dBm	100 kHz	This is not applicable to BS operating in Band 34

UTRA TDD Band b) or E-UTRA Band 35	1850 – 1910 MHz	-116.9 dBm	-111.9 dBm	-108.9 dBm	100 kHz	This is not applicable to BS operating in Band 35
UTRA TDD Band b) or E-UTRA Band 36	1930 - 1990 MHz	-116.9 dBm	-111.9 dBm	-108.9 dBm	100 kHz	This is not applicable to BS operating in Band 2 and 36
UTRA TDD Band c) or E-UTRA Band 37	1910 - 1930 MHz	-116.9 dBm	-111.9 dBm	-108.9 dBm	100 kHz	This is not applicable to BS operating in Band 37. This unpaired band is defined in ITU-R M.1036, but is pending any future deployment.
UTRA TDD Band d) or E-UTRA Band 38 or NR band n38	2570 – 2620 MHz	-116.9 dBm	-111.9 dBm	-108.9 dBm	100 kHz	This is not applicable to BS operating in Band 38.
UTRA TDD Band f) or E-UTRA Band 39 or NR band n39	1880 – 1920MHz	-116.9 dBm	-111.9 dBm	-108.9 dBm	100 kHz	This is not applicable to BS operating in Band 33 and 39
UTRA TDD Band e) or E-UTRA Band 40 or NR band n40	2300 – 2400MHz	-116.9 dBm	-111.9 dBm	-108.9 dBm	100 kHz	This is not applicable to BS operating in Band 30 or 40
E-UTRA Band 41 or NR band n41	2496 – 2690MHz	-116.9 dBm	-111.9 dBm	-108.9 dBm	100 kHz	This is not applicable to BS operating in Band 41
E-UTRA Band 42	3400 – 3600 MHz	-116.7 dBm	-111.7 dBm	-108.7 dBm	100 kHz	This is not applicable to BS operating in Band 22, 42 or 43
E-UTRA Band 43	3600 – 3800 MHz	-116.7 dBm	-111.7 dBm	-108.7 dBm	100 kHz	This is not applicable to BS operating in Band 42 or 43
E-UTRA Band 44	703 – 803 MHz	-116.9 dBm	-111.9 dBm	-108.9 dBm	100 kHz	This is not applicable to BS operating in Band 28 or 44
E-UTRA Band 45	1447 – 1467 MHz	-116.9 dBm	-111.9 dBm	-108.9 dBm	100 kHz	This is not applicable to BS operating in Band 45
E-UTRA Band 48	3550 – 3700 MHz	-113.7 dBm	-108.7 dBm	-105.7 dBm	100 kHz	
E-UTRA Band 49	3550 – 3700 MHz	N/A	N/A	-105.7 dBm	100 kHz	
E-UTRA Band 50 or NR band n50	1432 – 1517 MHz	-113.9 dBm	-108.9 dBm	-105.9 dBm	100 kHz	This is not applicable to BS operating in Band XI
E-UTRA Band 51 or NR Band n51	1427 – 1432 MHz	N/A	N/A	-105.9 dBm	100 kHz	
E-UTRA Band 52	3300 – 3400 MHz	-113.9 dBm	-108.9 dBm	-105.9 dBm	100 kHz	
E-UTRA Band 65	1920 - 2010 MHz	-116.9 dBm	-111.9 dBm	-108.9 dBm	100 kHz	
E-UTRA Band 66 or NR band n66	1710 – 1780 MHz	-116.9 dBm	-111.9 dBm	-108.9 dBm	100 kHz	

E-UTRA Band 68	698 – 728 MHz	-116.9 dBm	-111.9 dBm	-108.9 dBm	100 kHz	
E-UTRA Band 70 or NR band n70	1695 – 1710 MHz	-116.9 dBm	-111.9 dBm	-108.9 dBm	100 kHz	
E-UTRA Band 71 or NR Band n71	663 – 698 MHz	-116.9 dBm	-108.9 dBm	-105.9 dBm	100 kHz	
E-UTRA Band 72	451 – 456 MHz	-116.9 dBm	-108.9 dBm	-105.9 dBm	100 kHz	
E-UTRA Band 73	450 – 455 MHz	-116.9 dBm	-108.9 dBm	-105.9 dBm	100 kHz	
E-UTRA Band 74 or NR band n74	1427 – 1470 MHz	-116.9 dBm	-108.9 dBm	-105.9 dBm	100 kHz	
NR Band n77	3300 MHz – 4200 MHz	-116.7 dBm	-108.7 dBm	-105.7 dBm	100 kHz	
NR Band n78	3300 MHz – 3800 MHz	-116.7 dBm	-108.7 dBm	-105.7 dBm	100 kHz	
NR band n79	4400 MHz – 5000 MHz	-116.6 dBm	-108.6 dBm	-105.6 dBm	100 kHz	
NR band n80	1710 – 1785 MHz	-116.9 dBm	-111.9 dBm	-108.9 dBm	100 kHz	
NR band n81	880 – 915 MHz	-116.9 dBm	-111.9 dBm	-108.9 dBm	100 kHz	
NR band n82	832 – 862 MHz	-116.9 dBm	-111.9 dBm	-108.9 dBm	100 kHz	
NR band n83	703 – 748 MHz	-116.9 dBm	-111.9 dBm	-108.9 dBm	100 kHz	
NR band n84	1920 – 1980 MHz	-116.9 dBm	-111.9 dBm	-108.9 dBm	100 kHz	
E-UTRA Band 85	698 - 716 MHz	-116.9 dBm	-108.9 dBm	-105.9 dBm	100 kHz	
NR band n86	1710 -1780 MHz	-116.9 dBm	-111.9 dBm	-108.9 dBm	100 kHz	

NOTE 1: As defined in the scope for spurious emissions in this subclause, the co-location requirements in table 6.7.6.5.2.5-1 do not apply for the 10 MHz frequency range immediately outside the BS transmit frequency range of a *downlink operating band* (see subclause 6.7.1). The current state-of-the-art technology does not allow a single generic solution for co-location with other system on adjacent frequencies for 30 dB BS-BS minimum coupling loss. However, there are certain site-engineering solutions that can be used. These techniques are addressed in TR 25.942 [31].

NOTE 2: Table 6.7.6.5.2.5-1 assumes that two operating bands, where the corresponding BS transmit and receive frequency ranges in subclause 4.6 would be overlapping, are not deployed in the same geographical area. For such a case of operation with overlapping frequency arrangements in the same geographical area, special co-location requirements may apply that are not covered by the 3GPP specifications.

NOTE 3: Co-located TDD base stations that are synchronized and using the same or adjacent operating band can transmit without special co-locations requirements. For unsynchronized base stations, special co-location requirements may apply that are not covered by the 3GPP specifications.

6.7.6.5.5.3 Single RAT E-UTRA operation

These requirements may be applied for the protection of other BS receivers when GSM900, DCS1800, PCS1900, GSM850, CDMA850, UTRA FDD, UTRA TDD and/or E-UTRA BS are co-located with a BS.

The requirements assume co-location with base stations of the same class.

NOTE: For co-location with UTRA, the requirements are based on co-location with UTRA FDD or TDD base stations.

The requirements are co-location emission requirements and specified as the power sum of the supported polarization(s) at the CLTA conducted output(s).

The power sum of any spurious emission is specified over all supported polarizations at the conducted output(s) of the CLTA and shall not exceed the limits of table 6.7.6.5.5.3-1 for a AAS BS where requirements for co-location with a BS type listed in the first column apply, depending on the declared Base Station class. For a *multi-band RIB*, the exclusions and conditions in the notes column of table 6.7.6.5.5.3-1 apply for each supported operating band.

Table 6.7.6.5.3-1: AAS BS OTA Spurious emissions E-UTRA limits for AAS BS co-located with another BS

Type of co-located BS	Frequency range for co-location requirement	Maximum Level (WA-BS)	Maximum Level (MR-BS)	Maximum Level (LA-BS)	Measurement Band width	Notes
GSM900	876-915 MHz	-115.9 dBm	-108.9 dBm	-105.9 dBm	100 kHz	
DCS1800	1710 - 1785 MHz	-115.9 dBm	-108.9 dBm	-105.9 dBm	100 kHz	
PCS1900	1850 - 1910 MHz	-115.9 dBm	-108.9 dBm	-105.9 dBm	100 kHz	
GSM850 or CDMA850	824 - 849 MHz	-115.9 dBm	-108.9 dBm	-105.9 dBm	100 kHz	
UTRA FDD Band I or E-UTRA Band 1 or NR band n1	1920 - 1980 MHz	-113.9 dBm	-108.9 dBm	-105.9 dBm	100 kHz	
UTRA FDD Band II or E-UTRA Band 2 or NR band n2	1850 - 1910 MHz	-113.9 dBm	-108.9 dBm	-105.9 dBm	100 kHz	
UTRA FDD Band III or E-UTRA Band 3 or NR band n3	1710 - 1785 MHz	-113.9 dBm	-108.9 dBm	-105.9 dBm	100 kHz	
UTRA FDD Band IV or E-UTRA Band 4	1710 - 1755 MHz	-113.9 dBm	-108.9 dBm	-105.9 dBm	100 kHz	
UTRA FDD Band V or E-UTRA Band 5 or NR band n5	824 - 849 MHz	-113.9 dBm	-108.9 dBm	-105.9 dBm	100 kHz	
UTRA FDD Band VI, XIX or E-UTRA Band 6, 19	830 - 845 MHz	-113.9 dBm	-108.9 dBm	-105.9 dBm	100 kHz	
UTRA FDD Band VII or E-UTRA Band 7 or NR band n7	2500 - 2570 MHz	-113.9 dBm	-108.9 dBm	-105.9 dBm	100 kHz	
UTRA FDD Band VIII or E-UTRA Band 8 or NR band n8	880 - 915 MHz	-113.9 dBm	-108.9 dBm	-105.9 dBm	100 kHz	
UTRA FDD Band IX or E-UTRA Band 9	1749.9 - 1784.9 MHz	-113.9 dBm	-108.9 dBm	-105.9 dBm	100 kHz	
UTRA FDD Band X or E-UTRA Band 10	1710 - 1770 MHz	-113.9 dBm	-108.9 dBm	-105.9 dBm	100 kHz	
UTRA FDD Band XI or E-UTRA Band 11	1427.9 - 1447.9 MHz	-113.9 dBm	-108.9 dBm	-105.9 dBm	100 kHz	

Type of co-located BS	Frequency range for co-location requirement	Maximum Level (WA-BS)	Maximum Level (MR-BS)	Maximum Level (LA-BS)	Measurement Band width	Notes
GSM900	876-915 MHz	-115.9 dBm	-108.9 dBm	-105.9 dBm	100 kHz	
UTRA FDD Band XII or E-UTRA Band 12 or NR band n12	699 - 716 MHz	-113.9 dBm	-108.9 dBm	-105.9 dBm	100 kHz	
UTRA FDD Band XIII or E-UTRA Band 13	777 - 787 MHz	-113.9 dBm	-108.9 dBm	-105.9 dBm	100 kHz	
UTRA FDD Band XIV or E-UTRA Band 14	788 - 798 MHz	-113.9 dBm	-108.9 dBm	-105.9 dBm	100 kHz	
E-UTRA Band 17	704 - 716 MHz	-113.9 dBm	-108.9 dBm	-105.9 dBm	100 kHz	
E-UTRA Band 18	815 - 830 MHz	-113.9 dBm	-108.9 dBm	-105.9 dBm	100 kHz	
UTRA FDD Band XX or E-UTRA Band 20 or NR band n20	832 - 862 MHz	-113.9 dBm	-108.9 dBm	-105.9 dBm	100 kHz	
UTRA FDD Band XXI or E-UTRA Band 21	1447.9 – 1462.9 MHz	-113.9 dBm	-108.9 dBm	-105.9 dBm	100 kHz	
UTRA FDD Band XXII or E-UTRA Band 22	3410 – 3490 MHz	-113.7 dBm	-108.7dBm	-105.7 dBm	100 kHz	This is not applicable to BS operating in Band 42
E-UTRA Band 23	2000 - 2020 MHz	-113.9 dBm	-108.9 dBm	-105.9 dBm	100 kHz	
E-UTRA Band 24	1626.5 – 1660.5 MHz	-113.9 dBm	-108.9 dBm	-105.9 dBm	100 kHz	
UTRA FDD Band XXV or E-UTRA Band 25 or NR band n25	1850 - 1915 MHz	-113.9 dBm	-108.9 dBm	-105.9 dBm	100 kHz	
UTRA FDD Band XXVI or E-UTRA Band 26	814 - 849 MHz	-113.9 dBm	-108.9 dBm	-105.9 dBm	100 kHz	
E-UTRA Band 27	807 - 824 MHz	-113.9 dBm	-108.9 dBm	-105.9 dBm	100 kHz	
E-UTRA Band 28 or NR band n28	703 – 748 MHz	-113.9 dBm	-108.9 dBm	-105.9 dBm	100 kHz	This is not applicable to BS operating in Band 44
E-UTRA Band 30	2305 - 2315 MHz	-113.9 dBm	-108.9 dBm	-105.9 dBm	100 kHz	This is not applicable to BS operating in Band 40
E-UTRA Band 31	452.5 – 457.5 MHz	-113.9 dBm	-108.9 dBm	-105.9 dBm	100 kHz	
UTRA TDD Band a) or E-UTRA Band 33	1900 - 1920 MHz	-113.9 dBm	-108.9 dBm	-105.9 dBm	100 kHz	This is not applicable to BS operating in Band 33

Type of co-located BS	Frequency range for co-location requirement	Maximum Level (WA-BS)	Maximum Level (MR-BS)	Maximum Level (LA-BS)	Measurement Band width	Notes
GSM900	876-915 MHz	-115.9 dBm	-108.9 dBm	-105.9 dBm	100 kHz	
UTRA TDD Band a) or E-UTRA Band 34 or NR band n34	2010 - 2025 MHz	-113.9 dBm	-108.9 dBm	-105.9 dBm	100 kHz	This is not applicable to BS operating in Band 34
UTRA TDD Band b) or E-UTRA Band 35	1850 – 1910 MHz	-113.9 dBm	-108.9 dBm	-105.9 dBm	100 kHz	This is not applicable to BS operating in Band 35
UTRA TDD Band b) or E-UTRA Band 36	1930 - 1990 MHz	-113.9 dBm	-108.9 dBm	-105.9 dBm	100 kHz	This is not applicable to BS operating in Band 2 and 36
UTRA TDD Band c) or E-UTRA Band 37	1910 - 1930 MHz	-113.9 dBm	-108.9 dBm	-105.9 dBm	100 kHz	This is not applicable to BS operating in Band 37. This unpaired band is defined in ITU-R M.1036, but is pending any future deployment.
UTRA TDD Band d) or E-UTRA Band 38 or NR band n38	2570 – 2620 MHz	-113.9 dBm	-108.9 dBm	-105.9 dBm	100 kHz	This is not applicable to BS operating in Band 38.
UTRA TDD Band f) or E-UTRA Band 39 or NR band n39	1880 – 1920MHz	-113.9 dBm	-108.9 dBm	-105.9 dBm	100 kHz	This is not applicable to BS operating in Band 33 and 39
UTRA TDD Band e) or E-UTRA Band 40 or NR band n40	2300 – 2400MHz	-113.9 dBm	-108.9 dBm	-105.9 dBm	100 kHz	This is not applicable to BS operating in Band 30 or 40
E-UTRA Band 41 or NR band n41	2496 – 2690MHz	-113.9 dBm	-108.9 dBm	-105.9 dBm	100 kHz	This is not applicable to BS operating in Band 41
E-UTRA Band 42	3400 – 3600 MHz	-113.7 dBm	-108.7 dBm	-105.7 dBm	100 kHz	This is not applicable to BS operating in Band 22, 42, 43, 48, 52
E-UTRA Band 43	3600 – 3800 MHz	-113.7 dBm	-108.7 dBm	-105.7 dBm	100 kHz	This is not applicable to BS operating in Band 42 or 43
E-UTRA Band 44	703 – 803 MHz	-113.9 dBm	-108.9 dBm	-105.9 dBm	100 kHz	This is not applicable to BS operating in Band 28 or 44
E-UTRA Band 45	1447 – 1467 MHz	-113.9 dBm	-108.9 dBm	-105.9 dBm	100 kHz	This is not applicable to BS operating in Band 45
E-UTRA Band 48	3550 – 3700 MHz	-113.7 dBm	-108.7 dBm	-105.7 dBm	100 kHz	This is not applicable to BS operating in Band 42, 43, 48
E-UTRA Band 49	3550 – 3700 MHz	N/A	N/A	-105.7 dBm	100 kHz	This is not applicable to BS operating in Band 42, 43, 48

Type of co-located BS	Frequency range for co-location requirement	Maximum Level (WA-BS)	Maximum Level (MR-BS)	Maximum Level (LA-BS)	Measurement Band width	Notes
GSM900	876-915 MHz	-115.9 dBm	-108.9 dBm	-105.9 dBm	100 kHz	
E-UTRA Band 50 or NR band n50	1432 – 1517 MHz	-113.9 dBm	-108.9 dBm	-105.9 dBm	100 kHz	This is not applicable to BS operating in Band 11, 21, 32, 51, n51, 74
E-UTRA Band 51 or NR Band n51	1427 – 1432 MHz	N/A	N/A	-105.9 dBm	100 kHz	This is not applicable to BS operating in Band 50
E-UTRA Band 52	3300 – 3400 MHz	-113.7 dBm	-108.7 dBm	-105.7 dBm	100 kHz	This is not applicable to BS operating in Band 42 or 52
E-UTRA Band 65	1920 - 2010 MHz	-113.9 dBm	-108.9 dBm	-105.9 dBm	100 kHz	
E-UTRA Band 66	1710 – 1780 MHz	-113.9 dBm	-108.9 dBm	-105.9 dBm	100 kHz	
E-UTRA Band 68	698 – 728 MHz	-113.9 dBm	-108.9 dBm	-105.9 dBm	100 kHz	
E-UTRA Band 70	1695 – 1710 MHz	-113.9 dBm	-108.9 dBm	-105.9 dBm	100 kHz	
E-UTRA Band 71 or NR Band n71	663 – 698 MHz	-113.9 dBm	-108.9 dBm	-105.9 dBm	100 kHz	
E-UTRA Band 72	451 – 456 MHz	-113.9 dBm	-108.9 dBm	-105.9 dBm	100 kHz	
E-UTRA Band 73	450 – 455 MHz	-113.9 dBm	-108.9 dBm	-105.9 dBm	100 kHz	
E-UTRA Band 74 or NR band n74	1427 – 1470 MHz	-113.9 dBm	-108.9 dBm	-105.9 dBm	100 kHz	This is not applicable to BS operating in Band 50, 51
NR Band n77	3300 MHz – 4200 MHz	-113.7 dBm	-108.7 dBm	-105.7 dBm	100 kHz	This is not applicable to BS operating in Band 22, 42, 43, 48, 52
NR Band n78	3300 MHz – 3800 MHz	-113.7 dBm	-108.7 dBm	-105.7 dBm	100 kHz	This is not applicable to BS operating in Band 22, 42, 43, 48, 52
NR band n79	4400 – 5000 MHz	-113.6 dBm	-108.6 dBm	-105.6 dBm	100 kHz	
NR band n80	1710 – 1785 MHz	-113.9 dBm	-108.9 dBm	-105.9 dBm	100 kHz	
NR band n81	880 – 915 MHz	-113.9 dBm	-108.9 dBm	-105.9 dBm	100 kHz	
NR band n82	832 – 862 MHz	-113.9 dBm	-108.9 dBm	-105.9 dBm	100 kHz	
NR band n83	703 – 748 MHz	-113.9 dBm	-108.9 dBm	-105.9 dBm	100 kHz	
NR band n84	1920 – 1980 MHz	-113.9 dBm	-108.9 dBm	-105.9 dBm	100 kHz	
E-UTRA Band 85	698 - 716 MHz	-113.9 dBm	-108.9 dBm	-105.9 dBm	100 kHz	
NR band n86	1710 -1780 MHz	-113.9 dBm	-108.9 dBm	-105.9 dBm	100 kHz	

NOTE 1: As defined in the scope for spurious emissions in this subclause, the co-location requirements in table 6.7.6.5.3.5-1 do not apply for the 10 MHz frequency range immediately outside the BS transmit frequency range of a *downlink operating band* (see subclause 6.7.1). The current state-of-the-art technology does not allow a single generic solution for co-location with other system on adjacent frequencies for 30 dB BS-BS minimum coupling loss. However, there are certain site-engineering solutions that can be used. These techniques are addressed in TR 25.942 [31].

NOTE 2: Table 6.7.6.5.3.5-1 assumes that two operating bands, where the corresponding BS transmit and receive frequency ranges in subclause 4.6 would be overlapping, are not deployed in the same geographical area. For such a case of operation with overlapping frequency arrangements in the same geographical area, special co-location requirements may apply that are not covered by the 3GPP specifications.

NOTE 3: Co-located TDD base stations that are synchronized and using the same or adjacent operating band can transmit without special co-locations requirements. For unsynchronized base stations, special co-location requirements may apply that are not covered by the 3GPP specifications.

6.8 OTA Transmitter intermodulation

6.8.1 Definition and applicability

The OTA transmitter intermodulation requirement is a measure of the capability of the transmitter unit to inhibit the generation of signals in its non-linear elements caused by presence of the wanted signal and an interfering signal reaching the transmitter unit via the RDN and antenna array from a co-located base station. The requirement applies during the *transmitter ON period* and the *transmitter transient period*.

The requirement applies at each RIB supporting transmission in the operating band.

The transmitter intermodulation level is the *total radiated power* of the intermodulation products when an interfering signal is injected into the CLTA.

For *OTA AAS BS*, the transmitter intermodulation requirement is captured by the co-location transmitter intermodulation scenario case, in which the interfering signal is injected into the CLTA.

6.8.2 Minimum Requirement

The minimum requirement for AAS BS in *MSR operation* is defined in TS 37.105 [6], subclause 9.8.2.

The minimum requirement for AAS BS in *single RAT UTRA operation* is defined in TS 37.105 [6], subclause 9.8.3.

The minimum requirement for AAS BS in *single RAT E-UTRA operation* is defined in TS 37.105 [6], subclause 9.8.4.

6.8.3 Test purpose

The test purpose is to verify the ability of the transmitter units associated with the *RIB* under test to restrict the generation of intermodulation products in its nonlinear elements caused by presence of the wanted signal and an interfering signal reaching the transmitter unit via the RDN and antenna array from a co-located base station to below specified levels.

6.8.4 Method of test

6.8.4.1 Initial conditions

Test environment:

- normal; see annex G.2.

RF channels to be tested for single carrier:

- M; see subclause 4.12.1.

Base Station RF Bandwidth positions to be tested for multi-carrier:

- M_{RFBW} in *single-band RIB*, see subclause 4.12.1; $B_{\text{RFBW_T'RFBW}}$ and $B'_{\text{RFBW_T'RFBW}}$ in *multi-band RIB*, see subclause 4.12.1.

In addition, for *multi-band RIB*:

- For $B_{\text{RFBW_T'RFBW}}$, emission testing above the highest operating band may be omitted.
- For $B'_{\text{RFBW_T'RFBW}}$, emission testing below the lowest operating band may be omitted.
- FFS

Directions to be tested for:

As the requirement is based on TRP the beam pattern(s) may be set up to optimise the TRP measurement procedure (see annex F) as long as the required TRP level is achieved.

6.8.4.2 Procedure

- 1) Select a CLTA according to parameters given in Table 4.15.2.2-1.
- 2) Place the CLTA according to parameters given in Table 4.15.2.3-1.
- 3) The test antenna(s) shall be dual (or single) polarized covering the same frequency range as the *AAS BS* and the emission frequencies.
- 4) Several test antennas are required to cover both the *AAS BS* and the whole emission frequency range.
- 5) Connect the test antenna and CLTA to the measurement equipment as shown in Annex D1.5, Figures D.1.5-1.
- 6) During the OTA emission measurements at the test antenna conducted output(s), both *AAS BS* and CLTA are rotated around same axis.
- 7) The OTA unwanted emissions measurement method shall be TRP, according to the procedure described in Annex F.
- 8) The measurement device (signal analyzer) characteristics shall be:
 - Detection mode: True RMS.
- 9) Set the *AAS BS* to transmit:
 - a) For MSR:
 - Set the *AAS BS* to transmit maximum power according to the applicable test configuration in clause 5 using the corresponding test models or set of physical channels in subclause 4.11.
 - b) For UTRA FDD:
 - For a *AAS BS* declared to be capable of single carrier operation only, set the *AAS BS* to transmit maximum power according to TM1, subclause 4.12.2, at the manufacturer's declared rated carrier TRP, $P_{\text{Rated,c,TRP}}$.
 - For a *AAS BS* declared to be capable of multi-carrier operation, set the *AAS BS* to transmit maximum power according to TM1 on all carriers configured using the applicable test configuration and corresponding power setting specified in subclause 4.11.
 - c) For E-UTRA:
 - For *AAS BS* declared to be capable of single carrier operation only, set the *AAS BS* to transmit maximum power according to E-TM1.1 in subclause 4.12.2, at manufacturer's declared rated carrier TRP, $P_{\text{Rated,c,TRP}}$.
 - For a *AAS BS* declared to be capable of multi-carrier and/or CA operation, set the *AAS BS* to transmit maximum power according to E-TM1.1 on all carriers configured using the applicable test configuration and corresponding power setting specified in subclause 4.11.

- 10) Generate the interfering signal via the CLTA. The CLTA shall be fed with a power level equal to declared $P_{\text{rated,t,TRP}}$, divided over all supported polarizations, from the same signal generator source:
- a) For MSR:
 - using E-TM1.1 as defined in subclause 4.12.2, with 5 MHz channel bandwidth, at a centre frequency offset according to the conditions in table 6.8.5.1.1-1, but exclude interfering frequencies that are outside of the allocated downlink operating band or interfering frequencies that are not completely within the sub-block gap or within the *Inter RF Bandwidth gap*.
 - b) For UTRA FDD:
 - in accordance to TM1, subclause 4.12.2 with a frequency offset according to the conditions of table 6.8.5.2.1-1, but exclude interfering signal frequencies that are outside of the allocated downlink operating band or interfering signal frequencies that are not completely within the sub-block gap or within the *Inter RF Bandwidth gap*.
 - c) For E-UTRA:
 - according to E-TM1.1, as defined in subclause 4.12.2, with 5 MHz channel bandwidth and a centre frequency offset according to the conditions of table 6.8.5.3.1-1, but exclude interfering frequencies that are outside of the allocated downlink operating band or interfering frequencies that are not completely within the sub-block gap or within the *Inter RF Bandwidth gap*.
- 11) Adjust the interfering signal level at the CLTA conducted input(s) as defined in:
- a) For MSR:
 - i. General co-location table 6.8.5.1.1-1.
 - ii. Additional co-location (BC1 and BC2) table 6.8.5.1.2-1.
 - iii. Additional co-location (BC3) table 6.8.5.1.3-1.
 - b) For UTRA FDD:
 - i. General co-location table 6.8.5.2.1-1 .
 - c) For E-UTRA:
 - i. General co-location table 6.8.5.3.1-1.
 - ii. Additional requirement for Band 41 table 6.8.5.3.2-1.
- 12) If the interferer signal is applicable according to clause 5, perform the unwanted emission tests specified in subclauses 6.7.3 (OTA ACLR), 6.7.4 (OTA spectrum mask) and 6.7.5 (OTA OBUE), for all third and fifth order intermodulation products which appear in the frequency ranges defined in subclauses 6.7.3, 6.7.4 and 6.7.5 (NOTE 2). The width of the intermodulation products shall be taken into account.
- 13) If the interferer signal is applicable according to clause 5, perform the transmitter spurious emissions test as specified in subclause 6.7.6 (OTA spurious emission), except OTA co-location spurious emission, for all third and fifth order intermodulation products which appear in the frequency ranges defined in subclause 6.7.6 (NOTE 2). The width of the intermodulation products shall be taken into account.
- 14) Verify that the emission level does not exceed the required level in subclause 6.8.5 (Test requirements) with the exception of interfering signal frequencies.
- 15) Repeat the test for the remaining interfering signal centre frequency offsets according to the conditions of:
- a) For MSR:
 - i. General co-location table 6.8.5.1.1-1.
 - ii. Additional co-location (BC1 and BC2) table 6.8.5.1.2-1.
 - iii. Additional co-location (BC3) table 6.8.5.1.3-1.

- b) For UTRA FDD:
 - i. General co-location table 6.8.5.2.1-1 .
- c) For E-UTRA:
 - i. General co-location table 6.8.5.3.1-1.
 - ii. Additional requirement for Band 41 table 6.8.5.3.2-1.

16) Repeat the test for the remaining interfering signals defined in clause 5 for requirements 6.7.3 (OTA ACLR), 6.7.4 (OTA spectrum mask), 6.7.5 (OTA OBUE) and 6.7.6 (OTA spurious emission), except OTA co-location spurious emission.

In addition, for *multi-band AAS BS*, the following steps shall apply:

17) For *multi-band AAS BS* and single band tests, repeat the steps above per involved band where single band test configurations and test models shall apply with no carrier activated in the other band.

NOTE 1: The third order intermodulation products are centred at $2F1 \pm F2$ and $2F2 \pm F1$. The fifth order intermodulation products are centred at $3F1 \pm 2F2$, $3F2 \pm 2F1$, $4F1 \pm F2$, and $4F2 \pm F1$ where $F1$ represents the test signal centre frequency or centre frequency of each sub-block and $F2$ represents the interfering signal centre frequency. The widths of intermodulation products are:

- $(n \cdot BW_{F1} + m \cdot BW_{F2})$ for the $nF1 \pm mF2$ products;
- $(n \cdot BW_{F2} + m \cdot BW_{F1})$ for the $nF2 \pm mF1$ products;

where BW_{F1} represents the test signal RF bandwidth or channel bandwidth in case of single carrier, or sub-block bandwidth, and BW_{F2} represents the interfering signal bandwidth.

NOTE 2: During the conformance test the interferer signal can be applied on one side of the wanted signal, while the transmitter intermodulation emission is measured only on the opposite side of the wanted signal. This applies for intermodulation products which are within the operating band or OBUE region.

6.8.5 Test Requirement

6.8.5.1 MSR test requirements

6.8.5.1.1 General test requirement

In the frequency range relevant for this test the transmitter intermodulation level shall not exceed the unwanted emission limits specified for transmitter spurious emission in subclause 6.7.6 (except co-location spurious emission), operating band unwanted emission in subclause 6.7.5 and ACLR in subclause 6.7.3 in the presence of a wanted signal and an interfering signal according to table 6.8.5.1.1-1 for an *OTA AAS BS* operating in BC1, BC2 and BC3.

The requirement is applicable outside the edges of the *Base Station RF Bandwidth*. The interfering signal offset is defined relative to the *Base Station RF Bandwidth edges* or *radio bandwidth edges*.

For *RIB* supporting operation in *non-contiguous spectrum*, the requirement is also applicable inside a *sub-block gap* for interfering signal offsets where the interfering signal falls completely within the *sub-block gap*. The interfering signal offset is defined relative to the *sub-block edges*.

For *multi-band RIBs*, the requirement applies relative to the *Base Station RF Bandwidth edges* of each operating band. In case the inter *Base Station RF Bandwidth* gap is less than 15 MHz, the requirement in the gap applies only for interfering signal offsets where the interfering signal falls completely within the inter *Base Station RF Bandwidth* gap.

Table 6.8.5.1.1-1: Interfering and wanted signals for the OTA transmitter intermodulation requirement

Parameter	Value
Wanted signal type	E-UTRA or NR signal
Interfering signal type	E-UTRA signal of <i>channel bandwidth</i> 5 MHz
Interfering signal level applied to the CLTA	Rated transmitter TRP per RIB in the operating band (corresponding to $P_{\text{Rated,t,TRP}}$)
Interfering signal centre frequency offset from <i>Base Station RF Bandwidth</i> edge or edge of <i>sub-block</i> inside a gap	± 2.5 MHz ± 7.5 MHz ± 12.5 MHz
NOTE 1: Interfering signal positions that are partially or completely outside of any <i>downlink operating band</i> of the RIB is excluded from the requirement, unless the interfering signal positions fall within the frequency range of adjacent <i>downlink operating bands</i> in the same geographical area. In case that none of the interfering signal positions fall completely within the frequency range of the <i>downlink operating band</i> , 3GPP TS 37.141 provides further guidance regarding appropriate test requirements.	
NOTE 2: In certain regions, NOTE 1 is not applied in Band 1, 3, 8, 9, 11, 18, 19, 21, 28, 32 operating within 1 475.9 MHz to 1 495.9 MHz, 34.	
NOTE 3: The $P_{\text{Rated,t,TRP}}$ is split between supported polarizations at the CLTA input ports.	

6.8.5.1.2 Additional test requirement (BC1 and BC2)

In the frequency range relevant for this test the transmitter intermodulation level shall not exceed the unwanted emission limits specified for transmitter spurious emission in subclause 6.7.6 (except co-location spurious emission), operating band unwanted emission in subclause 6.7.5 and ACLR in subclause 6.7.3 in the presence of a wanted signal and an interfering signal according to table 6.8.5.1.2-1 for an *OTA AAS BS* operating in BC2.

The requirement is applicable outside the edges of the *Base Station RF Bandwidth* for BC2. The interfering signal offset is defined relative to the *Base Station RF Bandwidth edges*.

For *RIBs* supporting operation in *non-contiguous spectrum* in BC1 or BC2, the requirement is also applicable inside a *sub-block gap* with a gap size larger than or equal to two times the interfering signal centre frequency offset. For *RIBs* supporting operation in *non-contiguous spectrum* in BC1, the requirement is not applicable inside a *sub-block gap* with a gap size equal to or larger than 5 MHz. The interfering signal offset is defined relative to the *sub-block edges*.

For *multi-band RIBs*, the requirement applies relative to the *Base Station RF Bandwidth edges* of a BC2 operating band. The requirement is also applicable for BC1 and BC2 inside an inter *Base Station RF Bandwidth gap* equal to or larger than two times the interfering signal centre frequency offset. For *RIBs* supporting operation in multiple operating bands, the requirement is not applicable for BC1 band inside an inter *Base Station RF Bandwidth gap* with a gap size equal to or larger than 5 MHz.

Table 6.8.5.1.2-1: Interfering and wanted signals for the OTA transmitter intermodulation requirement

Parameter	Value
Wanted signal type	E-UTRA and/or NR UTRA signal
Interfering signal type	CW
Interfering signal level applied to the CLTA	Rated transmitter TRP per RIB in the operating band (corresponding to $P_{\text{Rated,t,TRP}}$)
Interfering signal centre frequency offset from <i>Base Station RF Bandwidth</i> edge or edge of <i>sub-block</i> inside a gap	$> \text{abs}(800)$ kHz for CW interferer
NOTE 1: Interfering signal positions that are partially or completely outside of any <i>downlink operating band</i> of the RIB are excluded from the requirement.	
NOTE 2: The $P_{\text{Rated,t,TRP}}$ is split between polarizations at the CLTA.	

6.8.5.1.3 Additional test requirement (BC3)

In the frequency range relevant for this test, the transmitter intermodulation level shall not exceed the unwanted emission limits specified for transmitter spurious emission in subclause 6.7.6 (except co-location spurious emission),

operating band unwanted emission in subclause 6.7.5 and ACLR in subclause 6.7.3 in the presence of a wanted signal and an interfering signal according table 6.8.5.1.3-1 an *OTA AAS BS* operating in BC3.

For *multi-band RIBs*, the requirement applies relative to *the Base Station RF Bandwidth edges* of each operating band. In case the *Inter RF Bandwidth gap* is less than 3.2 MHz, the requirement in the gap applies only for interfering signal offsets where the interfering signal falls completely within the *inter Base Station RF Bandwidth gap*.

Table 6.8.5.1.3-1: Interfering and wanted signals for the OTA transmitter intermodulation requirement (BC3)

Parameter	Value
Wanted signal type	E-UTRA and/or UTRA and/or NR signal
Interfering signal type	1,28 Mcps UTRA TDD signal of <i>channel bandwidth</i> 1,6 MHz
Interfering signal level applied to the CLTA	Rated transmitter TRP per RIB in the operating band (corresponding to $P_{\text{Rated,t,TRP}}$)
Interfering signal centre frequency offset from <i>Base Station RF Bandwidth</i> edge or edge of <i>sub-block</i> inside a gap	±0,8 MHz ±1,6 MHz ±2,4 MHz
NOTE 1: Interfering signal positions that are partially or completely outside of any <i>downlink operating band</i> of the base station are excluded from the requirement.	
NOTE 2: The $P_{\text{Rated,t,TRP}}$ is split between polarizations at the CLTA.	

6.8.5.2 Single RAT UTRA operation

6.8.5.2.1 General test requirement for UTRA FDD

In the frequency range relevant for this test, the transmitter intermodulation level shall not exceed the out of band emission or the spurious emission requirements of subclause 6.7.4 (OTA spectrum mask) and subclause 6.7.6 (OTA spurious emission, except co-location spurious emission), in the presence of interfering signal according to table 6.8.5.2.1-1.

For *RIBs* supporting operation in *non-contiguous spectrum*, the requirement is also applicable inside a *sub-block gap* for interfering signal offsets where the interfering signal falls completely within the *sub-block gap*. The interfering signal offset is defined relative to the *sub-block* edges.

For *multi-band RIBs*, the requirement is also applicable inside an *Inter RF Bandwidth gap* for interfering signal offsets where the interfering signal falls completely within the *Base Station RF Bandwidth gap*.

NOTE: If the above Test Requirement differs from the Minimum Requirement then the Test Tolerance applied for this test is non-zero. The Test Tolerance for this test is defined in subclause 4.1.2 and the explanation of how the Minimum Requirement has been relaxed by the Test Tolerance is given in annex C.

Table 6.8.5.2.1-1: Interfering and wanted signal frequency offset for OTA transmitter intermodulation requirement

Parameter	Value
Wanted signal type	UTRA
Interfering signal type	UTRA
Interfering signal level applied to the CLTA	Rated transmitter TRP per RIB in the operating band (corresponding to $P_{\text{Rated,t,TRP}}$)
Interfering signal centre frequency offset from the lower (upper) edge of the wanted signal or edge of <i>sub-block</i> inside a gap	-2,5 MHz -7,5 MHz -12,5 MHz +2,5 MHz +7,5 MHz +12,5 MHz
NOTE 1: Interference frequencies that are outside of any allocated frequency band for UTRA-FDD downlink specified in subclause 4.6 are excluded from the requirement, unless the interfering signal positions fall within the frequency range of adjacent <i>downlink operating bands</i> in the same geographical area.	
NOTE 2: NOTE 1 is not applied in Band I, III, VI, VIII, IX, XI, XIX, XXI, and XXXII operating within 1 475.9 MHz to 1 495.9MHz, in certain regions.	
NOTE 3: The $P_{\text{Rated,t,TRP}}$ is split between polarizations at the CLTA.	

6.8.5.3 Single RAT E-UTRA operation

6.8.5.3.1 General test requirement

In the frequency range relevant for this test, the transmitter intermodulation level shall not exceed the unwanted emission limits in subclauses 6.7.6 (OTA spurious emission, except co-location spurious emission), 6.7.5 (OTA OBUE) and 6.7.3 (OTA ACLR) in the presence of an E-UTRA interfering signal according to according to table 6.8.5.3.1-1.

The requirement is applicable outside the *Base Station RF Bandwidth* or *radio bandwidth*. The interfering signal offset is defined relative to the *Base Station RF Bandwidth edges* or *radio bandwidth edges*.

For *RIBs* supporting operation in *non-contiguous spectrum*, the requirement is also applicable inside a *sub-block gap* for interfering signal offsets where the interfering signal falls completely within the *sub-block gap*. The interfering signal offset is defined relative to the *sub-block edges*.

For *multi-band RIBs*, the requirement applies relative to the *Base Station RF Bandwidth edges* of each supported operating band. In case the *Inter RF Bandwidth gap* is less than 15 MHz, the requirement in the gap applies only for interfering signal offsets where the interfering signal falls completely within the *inter Base Station RF Bandwidth gap*.

Table 6.8.5.3.1-1: Interfering and wanted signals for the OTA transmitter intermodulation requirement

Parameter	Value
Wanted signal	E-UTRA single carrier, or multi-carrier, or multiple intra-band contiguously or non-contiguously aggregated carriers
Interfering signal type	E-UTRA signal of <i>channel bandwidth</i> 5 MHz
Interfering signal level applied to the CLTA	Rated transmitter TRP per RIB in the operating band (corresponding to $P_{\text{Rated,t,TRP}}$)
Interfering signal centre frequency offset from the lower (upper) edge of the wanted signal or edge of <i>sub-block</i> inside a <i>sub-block gap</i>	$\pm 2,5$ MHz $\pm 7,5$ MHz $\pm 12,5$ MHz
NOTE 1: Interfering signal positions that are partially or completely outside of any <i>downlink operating band</i> of the base station are excluded from the requirement, unless the interfering signal positions fall within the frequency range of adjacent <i>downlink operating bands</i> in the same geographical area. In case that none of the interfering signal positions fall completely within the frequency range of the <i>downlink operating band</i> , 3GPP TS 36.141 provides further guidance regarding appropriate test requirements.	
NOTE 2: In certain regions, NOTE 1 is not applied in Band 1, 3, 8, 9, 11, 18, 19, 21, 28, 32 operating within 1 475.9 MHz to 1 495.9 MHz, 34.	
NOTE 3: The $P_{\text{rated,t,TRP}}$ is split between polarizations at the CLTA.	

6.8.5.3.2 Additional test requirement for Band 41

In certain regions, the following requirement may apply: For E-UTRA single RAT AAS BS operating in operating band 41 in the presence of an interfering signal according to table 6.8.5.3.2-1, the OTA transmitter intermodulation level shall not exceed the maximum levels for OTA spurious emission (except co-location spurious emission), and OTA operating band unwanted emission specified additionally for operating band 41 *single RAT E-UTRA operation*. Also, the OTA ACLR requirements for same carrier type assumed in adjacent channels shall be fulfilled in the presence of the interfering signal.

Table 6.8.5.3.2-1: Interfering and wanted signals for the additional OTA transmitter intermodulation requirement for Band 41

Parameter	Value
Wanted signal	E-UTRA single carrier (NOTE)
Interfering signal type	E-UTRA signal of the same <i>channel bandwidth</i> as the wanted signal
Interfering signal level applied to the CLTA	Rated transmitter TRP per RIB in the operating band (corresponding to $P_{\text{Rated,t,TRP}}$)
Interfering signal centre frequency offset from the centre frequency of the wanted signal	$\pm BW_{\text{Channel}}$ $\pm 2 \times BW_{\text{Channel}}$
NOTE 1: This requirement applies for 10 MHz or 20 MHz E-UTRA carriers allocated within 2 545 MHz to 2 575 MHz or 2 595 MHz to 2 645 MHz.	
NOTE 2: The $P_{\text{rated,t,TRP}}$ is split between polarizations at the CLTA.	

7 Radiated receiver characteristics

7.1 General

OTA receiver characteristics requirements apply to the AAS BS including all its functional components active unless otherwise stated in each requirement.

Unless otherwise stated the requirements in clause 7 apply during the AAS BS *receive period*.

The requirements in clause 7 shall be met for any transmitter setting.

The (E-UTRA) throughput requirements defined for the receiver characteristics in this clause do not assume HARQ retransmissions.

When the AAS BS is configured to receive multiple carriers, all the throughput requirements are applicable for each received carrier.

Any radiated receiver test requirement specified in 3GPP TS 37.105 [6] is not applicable for AAS BS operation in Band 46.

Each requirement shall be met over the RoAoA specified.

For requirements which are to be met over the *OTA REFSENS RoAoA* absolute requirement values are offset by the following term:

$$\Delta_{\text{OTAREFSENS}} = 44.1 - 10 \cdot \log_{10}(\text{Be}W_{\theta, \text{REFSENS}} \cdot \text{Be}W_{\phi, \text{REFSENS}}) \text{ (dB) for the reference direction.}$$

And

$$\Delta_{\text{OTAREFSENS}} = 41.1 - 10 \cdot \log_{10}(\text{Be}W_{\theta, \text{REFSENS}} \cdot \text{Be}W_{\phi, \text{REFSENS}}) \text{ (dB) for all other directions.}$$

For requirements which are to be met over the *minSENS RoAoA* absolute requirement values are offset by the following term:

$$\Delta_{\text{minSENS}} = \text{PREFSENS} - \text{EIS}_{\text{minSENS}} \text{ (dB)}$$

7.2 OTA sensitivity

7.2.1 Definition and applicability

The OTA sensitivity requirement is based upon the declaration of one or more *OTA sensitivity direction declarations* (OSDD), related to an *AAS BS receiver*.

The *AAS BS receiver* may optionally be capable of redirecting/changing the *receiver target* by means of adjusting BS settings resulting in multiple *sensitivity RoAoA*. The *sensitivity RoAoA* resulting from the current AAS BS settings is the active *sensitivity RoAoA*.

If the AAS BS is capable of redirecting the *receiver target* related to the OSDD then the OSDD shall include:

- The set(s) of RAT, *Channel bandwidth* and declared minimum EIS level applicable to any active *sensitivity RoAoA* inside the *receiver target redirection range* in the OSDD.
- A declared *receiver target redirection range*, describing all the angles of arrival that can be addressed for the OSDD through alternative settings in the AAS BS.
- Five declared *sensitivity RoAoA* comprising the conformance testing directions as detailed in [7].
- The *receiver target reference direction*.

NOTE 1: Some of the declared *sensitivity RoAoA* may coincide depending on the redirection capability.

NOTE 2: In addition to the declared *sensitivity RoAoA*, several *sensitivity RoAoA* may be implicitly defined by the *receiver target redirection range* without being explicitly declared in the OSDD.

NOTE 3: (Void)

If the AAS BS is not capable of redirecting the *receiver target* related to the OSDD, then the OSDD includes only:

- The set(s) of RAT, *Channel bandwidth* and declared minimum EIS level applicable to the *sensitivity RoAoA* in the OSDD.
- One declared active *sensitivity RoAoA*.
- The *receiver target reference direction*.

NOTE 4: For AAS BS without target redirection capability, the declared (fixed) *sensitivity RoAoA* is always the active *sensitivity RoAoA*.

The OTA sensitivity EIS level declaration shall apply to all supported polarizations, under the assumption of *polarization match*.

7.2.2 Minimum Requirement

The minimum requirement for MSR & NR operation is in 3GPP TS 37.105 [6], subclause 10.2.2.

For AAS BS in *single RAT UTRA operation* the minimum requirement is defined in TS 37.105 [6], subclause 10.2.3.

For AAS BS in *single RAT E-UTRA operation* the minimum requirement is defined in TS 37.105 [6], subclause 10.2.4.

7.2.3 Test Purpose

The test purpose is to verify that the AAS BS can meet the BER or throughput requirement for a specified measurement channel at the EIS level and the range of angles of arrival declared in the OSDD.

7.2.4 Method of test

7.2.4.1 Initial conditions

Test environment:

- normal: see annex G.2.

RF channels to be tested:

- M; see subclause 4.12.1.

Directions to be tested:

- *receiver target reference direction* (see table 4.10-1, D10.9),
- conformance test directions (see table 4.10-1, D10.10).

7.2.4.2 Procedure

- 1) Place the AAS BS with its manufacturer declared coordinate system reference point in the same place as calibrated point in the test system, as shown in annex D1.1.
- 2) Align the manufacturer declared coordinate system orientation of the AAS BS with the test system.
- 3) Align the BS with the test antenna in the declared direction to be tested.
- 4) Ensure the polarization is accounted for such that all the power from the test antenna is captured by the AAS BS under test.
- 5) Configure the beam peak direction of the AAS BS according to declared *reference beam direction pair* for the appropriate beam identifier.
- 6) Set the AAS BS to transmit the beam(s) of the same operational band and RAT as the OSDD being tested according to the appropriate test configuration in clause 5.
- 7) Start the signal generator for the wanted signal to transmit:
 - 12.2 kbps DPCH with reference measurement channel defined in annex A in 3GPP TS 25.141 [10] (PN-9 data sequence or longer) for UTRA FDD.
 - UL reference measurement channel (12.2 kbps) defined in annex A.2.1 in 3GPP TS 25.142 [11] for UTRA TDD 1.28Mcps operation.

- The test signal as specified in subclause 7.2.5.4 for E-UTRA.
 - The test signal as specified in subclause 7.2.5.5 for NR.
- 8) Set the test signal mean power so the calibrated radiated power at the AAS BS Antenna Array coordinate system reference point is as specified in subclause 7.2.5.
- 9) Measure:
- BER according to annex C in 3GPP TS 25.141 [10] for FDD UTRA.
 - BER according to annex F in 3GPP TS 25.142 [11] for TDD UTRA.
 - Throughput according to annex E in 3GPP TS 36.141 [12] for E-UTRA.
 - Throughput according to annex A in 3GPP TS 38.141-2 [34] for NR.
- 10) Repeat steps 3 to 9 for all OSDD(s) declared for the AAS BS (see table 4.10-1, D10.1), and supported polarizations.

For multi-band capable AAS BS and single band tests, repeat the steps above per involved band where single band test configurations and test models shall apply with no carriers activated in the other band.

7.2.5 Test Requirements

7.2.5.1 General

The minimum EIS level is a declared figure for each OSDD (see table 4.10-1, D10.6). The test requirement is calculated from the declared value offset by the EIS Test Tolerance specified in subclause 4.1.2.3.

7.2.5.2 UTRA FDD Test Requirements

The BER measurement result in step 9 of subclause 7.2.4.2 shall not be greater than the limit specified in table 7.2.5.2-1.

Table 7.2.5.2-1: EIS levels

Reference measurement channel	Reference measurement channel data rate	OTA sensitivity (dBm)		BER
		f ≤ 3.0 GHz	3.0 GHz < f ≤ 4.2 GHz	
12.2kbps DPCH with reference measurement channel defined in annex A in 3GPP TS 25.141 [10] (PN-9 data sequence or longer)	12.2 kbps	Declared minimum EIS (D10.6) + 1.3 dB	Declared minimum EIS (D10.6) + 1.4 dB	BER shall not exceed 0.001

7.2.5.3 UTRA TDD 1,28Mcp option Test Requirements

The BER measurement result in step 9 of subclause 7.2.4.2 shall not be greater than the limit specified in table 7.2.5.3-1.

Table 7.2.5.3-1: EIS levels

Reference measurement channel	Reference measurement channel data rate	OTA sensitivity (dBm)		BER
		f ≤ 3.0 GHz	3.0 GHz < f ≤ 4.2 GHz	
UL reference measurement channel (12.2 kbps) defined in annex A.2.1 in 3GPP TS 25.142 [11]	12.2 kbps	Declared minimum EIS (D10.6) + 1.3 dB	Declared minimum EIS (D10.6) + 1.4 dB	BER shall not exceed 0.001

7.2.5.4 E-UTRA Test Requirements

For each measured E-UTRA carrier, the throughput measured in step 9 of subclause 7.2.4.2 shall be $\geq 95\%$ of the maximum throughput of the reference measurement channel as specified in 3GPP TS 36.141 [12] annex A.1 with parameters specified in table 7.2.5.4-1.

Table 7.2.5.4-1: EIS levels

E-UTRA channel bandwidth (MHz)	Reference measurement channel	OTA sensitivity (dBm)	
		$f \leq 3.0$ GHz	3.0 GHz $< f \leq 4.2$ GHz
1.4	FRC A1-1 in annex A.1 [12]	Declared minimum EIS (D10.6) + 1.3 dB	Declared minimum EIS (D10.6) + 1.4 dB
3	FRC A1-2 in annex A.1 [12]		
5	FRC A1-3 in annex A.1 [12]		
10	FRC A1-3 in annex A.1 [12] (Note)		
15			
20			
NOTE: EIS is the power level of a single instance of the reference measurement channel. This requirement shall be met for each consecutive application of a single instance of FRC A1-3 in [11] mapped to disjoint frequency ranges with a width of 25 Resource Blocks each. This reference measurement channel is not applied for Band 46 nor Band 49.			

7.2.5.5 NR Test Requirements

For each measured carrier, the throughput measured in step 9 of subclause 7.2.4.2 shall be $\geq 95\%$ of the maximum throughput of the reference measurement channel as specified in TS 38.104 [33] annex A.1 with parameters specified in table 7.2.5.5-1.

Table 7.2.5.5-1: EIS levels

BS channel bandwidth [MHz]	Sub-carrier spacing [kHz]	Reference measurement channel	EIS level [dBm]		
			$f \leq 3.0$ GHz	3.0 GHz $< f \leq 4.2$ GHz	4.2 GHz $< f \leq 6.0$ GHz
5, 10, 15, 25, 30	15	G- FR1-A1-1 in clause A.1 in [33]	Declared minimum EIS + 1.3	Declared minimum EIS + 1.4	Declared minimum EIS + 1.6
5, 10, 15, 25, 30	30	G- FR1-A1-2 in clause A.1 in [33]	Declared minimum EIS + 1.3	Declared minimum EIS + 1.4	Declared minimum EIS + 1.6
10, 15, 25, 30	60	G- FR1-A1-3 in clause A.1 in [33]	Declared minimum EIS + 1.3	Declared minimum EIS + 1.4	Declared minimum EIS + 1.6
20, 40, 50, 60, 70, 80, 90, 100	15	G- FR1-A1-4 in clause A.1 in [33]	Declared minimum EIS + 1.3	Declared minimum EIS + 1.4	Declared minimum EIS + 1.6
20, 40, 50, 60, 70, 80, 90, 100	30	G- FR1-A1-5 in clause A.1 in [33]	Declared minimum EIS + 1.3	Declared minimum EIS + 1.4	Declared minimum EIS + 1.6
20, 40, 50, 60, 70, 80, 90, 100	60	G- FR1-A1-6 in clause A.1 in [33]	Declared minimum EIS + 1.3	Declared minimum EIS + 1.4	Declared minimum EIS + 1.6

7.3 OTA Reference sensitivity level

7.3.1 Definition and applicability

The OTA REFSENS requirement is intended to ensure the OTA reference sensitivity level for a declared *OTA REFSENS RoAoA*. The OTA REFSENS requirement shall apply to each supported polarization, under the assumption of *polarization match*.

The OTA reference sensitivity power level $EIS_{REFSENS}$ is the mean power received at the radiated interface at which a reference performance requirement shall be met for a specified reference measurement channel.

The OTA REFSENS EIS level declaration shall apply to all supported polarizations, under the assumption of *polarization match*.

7.3.2 Minimum Requirement

The minimum requirement for MSR & NR operation is in 3GPP TS 37.105 [6], subclause 10.3.2.

The minimum requirement for AAS BS in *single RAT UTRA operation* is defined in TS 37.105 [6], subclause 10.3.3.

The minimum requirement for AAS BS in *single RAT E-UTRA operation* is defined in TS 37.105 [6], subclause 10.3.4.

7.3.3 Test purpose

The test purpose is to verify that the AAS BS can meet the BER or throughput requirement for a specified measurement channel at the $EIS_{REFSENS}$ level and the range of angles of arrival within the OTA REFSENS RoAoA.

7.3.4 Method of test

7.3.4.1 Initial conditions

Test environment:

- normal: see annex G.2.

RF channels to be tested:

- B, M and T; see subclause 4.12.1.

Directions to be tested:

- OTA REFSENS *receiver target reference direction* (see table 4.10-2, D11.29),
- OTA REFSENS conformance test directions (see table 4.10-2, D11.31).

7.3.4.2 Procedure

- 1) Place the AAS BS with its manufacturer declared coordinate system reference point in the same place as calibrated point in the test system, as shown in annex D1.1.
- 2) Align the manufacturer declared coordinate system orientation of the AAS BS with the test system.
- 3) Align the BS with the test antenna in the declared direction to be tested.
- 4) Ensure the polarization is accounted for such that all the power from the test antenna is captured by the AAS BS under test.
- 5) Configure the beam peak direction of the AAS BS according to declared reference beam direction pair for the appropriate beam identifier.
- 6) Set the AAS BS to transmit the beam(s) of the same operational band and RAT as the OTA REFSENS RoAoA being tested according to the appropriate test configuration in clause 5.
- 7) Start the signal generator for the wanted signal to transmit:
 - 12.2 kbps DPCH with reference measurement channel defined in annex A in 3GPP TS 25.141 [10] (PN-9 data sequence or longer) for UTRA FDD.
 - The test signal as specified in subclause 7.3.5.3 for E-UTRA.
 - The test signal as specified in subclause 7.3.5.4 for NR.
- 8) Set the test signal mean power so the calibrated radiated power at the AAS BS Antenna Array coordinate system reference point is as specified in subclause 7.3.5.

9) Measure:

- BER according to annex C in 3GPP TS 25.141 [10] for FDD UTRA.
- Throughput according to annex E in 3GPP TS 36.141 [12] for E-UTRA.
- Throughput according to annex A in 3GPP TS 38.141-2 [34] for NR.

10) Repeat steps 3 to 9 for all directions to be tested, and supported polarizations.

For multi-band capable AAS BS and single band tests, repeat the steps above per involved band where single band test configurations and test models shall apply with no carriers activated in the other band.

7.3.5 Test Requirement

7.3.5.1 General

The $EIS_{REFSENS}$ level is the conducted REFSSENS requirement value offset by $\Delta_{OTAREFSSENS}$. The test requirement is calculated from the $EIS_{REFSENS}$ level offset by the $EIS_{REFSENS}$ Test Tolerance specified in subclause 4.1.2.3.

7.3.5.2 UTRA FDD Test Requirements

The BER measurement result in step 9 of subclause 7.3.4.2 shall not be greater than the limit specified in table 7.3.5.2-1.

Table 7.3.5.2-1: $EIS_{REFSENS}$ levels

Reference measurement channel	Reference measurement channel data rate	$EIS_{REFSENS}$ (dBm)		BER
		$f \leq 3.0$ GHz	3.0 GHz $< f \leq 4.2$ GHz	
12.2kbps DPCH with reference measurement channel defined in annex A in 3GPP TS 25.141 [10] (PN-9 data sequence or longer)	12.2 kbps	$-119.7 - \Delta_{OTAREFSSENS}$	$-119.6 - \Delta_{OTAREFSSENS}$	BER shall not exceed 0.001

7.3.5.3 E-UTRA Test Requirements

For each measured E-UTRA carrier, the throughput measured in step 9 of subclause 7.3.4.2 shall be ≥ 95 % of the maximum throughput of the reference measurement channel as specified in 3GPP TS 36.141 [12] annex A.1 with parameters specified in table 7.3.5.3-1.

Table 7.3.5.3-1: $EIS_{REFSENS}$ levels

E-UTRA channel bandwidth (MHz)	Reference measurement channel	$EIS_{REFSENS}$ (dBm)	
		$f \leq 3.0$ GHz	3.0 GHz $< f \leq 4.2$ GHz
1.4	FRC A1-1 in annex A.1 [12]	$-105.5 - \Delta_{OTAREFSSENS}$	$-105.4 - \Delta_{OTAREFSSENS}$
3	FRC A1-2 in annex A.1 [12]	$-101.7 - \Delta_{OTAREFSSENS}$	$-101.6 - \Delta_{OTAREFSSENS}$
5	FRC A1-3 in annex A.1 [12]	$-100.2 - \Delta_{OTAREFSSENS}$	$-100.1 - \Delta_{OTAREFSSENS}$
10	FRC A1-3 in annex A.1 [12] (Note)	$-100.2 - \Delta_{OTAREFSSENS}$	$-100.1 - \Delta_{OTAREFSSENS}$
15			
20			

NOTE: $EIS_{REFSENS}$ is the power level of a single instance of the reference measurement channel. This requirement shall be met for each consecutive application of a single instance of FRC A1-3 in [11] mapped to disjoint frequency ranges with a width of 25 Resource Blocks each.

7.3.5.4 NR Test Requirements

For each measured carrier, the throughput measured in step 9 of subclause 7.3.4.2 shall be $\geq 95\%$ of the maximum throughput of the reference measurement channel as specified in annex TS 38.104 [33] A.1 with parameters specified in tables 7.3.5.4-1 to 7.3.5.4-3.

Table 7.3.5.4-1: Wide Area BS EIS_{REFSENS} levels

BS channel bandwidth [MHz]	Sub-carrier spacing [kHz]	Reference measurement channel	EIS _{REFSENS} [dBm]		
			$f \leq 3.0$ GHz	3.0 GHz $< f \leq 4.2$ GHz	4.2 GHz $< f \leq 6.0$ GHz
5, 10, 15, 25, 30	15	G- FR1-A1-1	-100.4 – $\Delta_{OTAREFSNS}$	-100.3 – $\Delta_{OTAREFSNS}$	-100.1 – $\Delta_{OTAREFSNS}$
5, 10, 15, 25, 30	30	G- FR1-A1-2	-100.5 – $\Delta_{OTAREFSNS}$	-100.4 – $\Delta_{OTAREFSNS}$	-100.2 – $\Delta_{OTAREFSNS}$
10, 15, 25, 30	60	G- FR1-A1-3	-97.6 – $\Delta_{OTAREFSNS}$	-97.5 – $\Delta_{OTAREFSNS}$	-97.3 – $\Delta_{OTAREFSNS}$
20, 40, 50, 60, 70, 80, 90, 100	15	G- FR1-A1-4	-94 – $\Delta_{OTAREFSNS}$	-93.9 – $\Delta_{OTAREFSNS}$	-93.7 – $\Delta_{OTAREFSNS}$
20, 40, 50, 60, 70, 80, 90, 100	30	G- FR1-A1-5	-94.3 – $\Delta_{OTAREFSNS}$	-94.2 – $\Delta_{OTAREFSNS}$	-94 – $\Delta_{OTAREFSNS}$
20, 40, 50, 60, 70, 80, 90, 100	60	G- FR1-A1-6	-94.4 – $\Delta_{OTAREFSNS}$	-94.3 – $\Delta_{OTAREFSNS}$	-94.1 – $\Delta_{OTAREFSNS}$
NOTE: P _{REFSENS} is the power level of a single instance of the reference measurement channel. This requirement shall be met for each consecutive application of a single instance of the reference measurement channel mapped to disjoint frequency ranges with a width corresponding to the number of resource blocks of the reference measurement channel each, except for one instance that might overlap one other instance to cover the full BS channel bandwidth.					

Table 7.3.5.4-2: Medium Range BS EIS_{REFSENS} levels

BS channel bandwidth [MHz]	Sub-carrier spacing [kHz]	Reference measurement channel	EIS _{REFSENS} [dBm]		
			$f \leq 3.0$ GHz	3.0 GHz $< f \leq 4.2$ GHz	4.2 GHz $< f \leq 6.0$ GHz
5, 10, 15, 25, 30	15	G- FR1-A1-1	-95.4 – $\Delta_{OTAREFSNS}$	-95.3 – $\Delta_{OTAREFSNS}$	-95.1 – $\Delta_{OTAREFSNS}$
5, 10, 15, 25, 30	30	G- FR1-A1-2	-95.5 – $\Delta_{OTAREFSNS}$	-95.4 – $\Delta_{OTAREFSNS}$	-95.2 – $\Delta_{OTAREFSNS}$
10, 15, 25, 30	60	G- FR1-A1-3	-92.6 – $\Delta_{OTAREFSNS}$	-92.5 – $\Delta_{OTAREFSNS}$	-92.3 – $\Delta_{OTAREFSNS}$
20, 40, 50, 60, 70, 80, 90, 100	15	G- FR1-A1-4	-89 – $\Delta_{OTAREFSNS}$	-88.9 – $\Delta_{OTAREFSNS}$	-88.7 – $\Delta_{OTAREFSNS}$
20, 40, 50, 60, 70, 80, 90, 100	30	G- FR1-A1-5	-89.3 – $\Delta_{OTAREFSNS}$	-89.2 – $\Delta_{OTAREFSNS}$	-89 – $\Delta_{OTAREFSNS}$
20, 40, 50, 60, 70, 80, 90, 100	60	G- FR1-A1-6	-89.4 – $\Delta_{OTAREFSNS}$	-89.3 – $\Delta_{OTAREFSNS}$	-89.1 – $\Delta_{OTAREFSNS}$
NOTE: P _{REFSENS} is the power level of a single instance of the reference measurement channel. This requirement shall be met for each consecutive application of a single instance of the reference measurement channel mapped to disjoint frequency ranges with a width corresponding to the number of resource blocks of the reference measurement channel each, except for one instance that might overlap one other instance to cover the full BS channel bandwidth.					

Table 7.3.5.4-3: Local Area BS EIS_{REFSENS} levels

BS channel bandwidth [MHz]	Sub-carrier spacing [kHz]	Reference measurement channel	EIS _{REFSENS} [dBm]		
			$f \leq 3.0$ GHz	3.0 GHz $< f \leq 4.2$ GHz	4.2 GHz $< f \leq 6.0$ GHz
5, 10, 15, 25, 30	15	G- FR1-A1-1	-92.4 – $\Delta_{\text{OTAREFSSENS}}$	-92.3 – $\Delta_{\text{OTAREFSSENS}}$	-92.1 – $\Delta_{\text{OTAREFSSENS}}$
5, 10, 15, 25, 30	30	G- FR1-A1-2	-92.5 – $\Delta_{\text{OTAREFSSENS}}$	-92.4 – $\Delta_{\text{OTAREFSSENS}}$	-92.2 – $\Delta_{\text{OTAREFSSENS}}$
10, 15, 25, 30	60	G- FR1-A1-3	-89.6 – $\Delta_{\text{OTAREFSSENS}}$	-89.5 – $\Delta_{\text{OTAREFSSENS}}$	-89.3 – $\Delta_{\text{OTAREFSSENS}}$
20, 40, 50, 60, 70, 80, 90, 100	15	G- FR1-A1-4	-86 – $\Delta_{\text{OTAREFSSENS}}$	-85.9 – $\Delta_{\text{OTAREFSSENS}}$	-85.7 – $\Delta_{\text{OTAREFSSENS}}$
20, 40, 50, 60, 70, 80, 90, 100	30	G- FR1-A1-5	-86.3 – $\Delta_{\text{OTAREFSSENS}}$	-86.2 – $\Delta_{\text{OTAREFSSENS}}$	-86 – $\Delta_{\text{OTAREFSSENS}}$
20, 40, 50, 60, 70, 80, 90, 100	60	G- FR1-A1-6	-86.4 – $\Delta_{\text{OTAREFSSENS}}$	-86.3 – $\Delta_{\text{OTAREFSSENS}}$	-86.1 – $\Delta_{\text{OTAREFSSENS}}$
NOTE:	P _{REFSENS} is the power level of a single instance of the reference measurement channel. This requirement shall be met for each consecutive application of a single instance of the reference measurement channel mapped to disjoint frequency ranges with a width corresponding to the number of resource blocks of the reference measurement channel each, except for one instance that might overlap one other instance to cover the full <i>BS channel bandwidth</i> .				

7.4 OTA Dynamic range

7.4.1 Definition and applicability

The OTA dynamic range is a measure of the capability of the receiver unit to receive a wanted signal in the presence of an interfering signal inside the received *channel bandwidth* or the capability of receiving high level of wanted signal.

The requirement applies at the RIB when the AoA of the incident wave of a received signal and the interfering signal are from the same direction and are within the OTA REFSENS *RoAoA*.

The wanted and interfering signals apply to all supported polarizations, under the assumption of *polarization match*.

7.4.2 Minimum Requirement

For AAS BS in *MSR operation* the minimum requirement is defined in TS 37.105 [6], subclause 10.4.2.

For AAS BS in *single RAT UTRA operation* the minimum requirement is defined in TS 37.105 [6], subclause 10.4.3.

For AAS BS in *single RAT E-UTRA operation* the minimum requirement is defined in TS 37.105 [6], subclause 10.4.4.

7.4.3 Test purpose

To verify that at the dynamic range of the receiver shall fulfil the specified limit.

7.4.4 Method of test

7.4.4.1 Initial conditions

Test environment: normal; see annex G.2.

RF channels to be tested for single carrier: M; see subclause 4.12.1.

Directions to be tested: OTA REFSENS receiver target reference direction (see table 4.10-2, D11.30).

7.4.4.2 Procedure

- 1) Place the AAS BS with its manufacturer declared coordinate system reference point in the same place as calibrated point in the test system, as shown in Annex D2.2
- 2) Align the manufacturer declared coordinate system orientation of the AAS BS with the test system.
- 3) Align the BS with the test antenna in the declared direction to be tested.
- 4) Align the NR BS to that the wanted signal and interferer signal is *polarization matched* with the test antenna(s)..
- 5) Set the test signal mean power so the calibrated radiated power at the AAS BS Antenna Array coordinate system reference point is as specified as follows:
 - a) Set the signal generator for the wanted signal to transmit:
 - as specified in table 7.4.5.1-1 for UTRA.
 - as specified in table 7.4.5.2-3 to table 7.4.5.2-5 for E-UTRA.
 - as specified in table 7.4.5.3-3 to table 7.4.5.2-5 for NR.
 - b) Set the Signal generator for the AWGN interfering signal at the same frequency as the wanted signal to transmit:
 - as specified in table 7.4.5.1-1 for UTRA.
 - as specified in table 7.4.5.2-3 to table 7.4.5.2-5 for E-UTRA.
 - as specified in table 7.4.5.3-3 to table 7.4.5.23-5 for NR.
- 6) Measure:
 - BER according to annex C in 3GPP TS 25.141 [10] for FDD UTRA.
 - Throughput according to annex E in 3GPP TS 36.141 [12] for E-UTRA.
 - Throughput according to TS 38.141-2 [34] for NR.
- 7) Repeat for all supported polarizations.

In addition, for *multi-band RIB(s)*, the following steps shall apply:

- 8) For *multi-band RIBs* and single band tests, repeat the steps above per involved band where single band test configurations and test models shall apply with no carrier activated in the other band.

7.4.5 Test Requirement

7.4.5.1 UTRA FDD operation

The BER shall not exceed 0,001 for the parameters specified in table 7.3.5.1-1.

Table 7.4.5.1-1: Dynamic range

Parameter	Level Wide Area BS	Level Medium Range BS	Level Local Area BS	Unit
Reference measurement channel data rate	12.2	12.2	12.2	kbps
Wanted signal mean power	-90.7 - $\Delta_{OTAREFSENS}$	-80.7 - $\Delta_{OTAREFSENS}$	-76.7 - $\Delta_{OTAREFSENS}$	dBm
Interfering AWGN signal	-73 - $\Delta_{OTAREFSENS}$	-63 - $\Delta_{OTAREFSENS}$	-59 - $\Delta_{OTAREFSENS}$	dBm/3.84 MHz

NOTE: If the above Test Requirement differs from the Minimum Requirement then the Test Tolerance applied for this test is non-zero. The Test Tolerance for this test is defined in subclause 4.1.2 and the explanation of how the Minimum Requirement has been relaxed by the Test Tolerance is given in annex C.

7.4.5.2 E-UTRA operation

For each measured E-UTRA carrier, the throughput shall be $\geq 95\%$ of the *maximum throughput* of the reference measurement channel as specified in annex A in 36.141 [12] 3GPP TS 36.141 [12] with parameters specified in table 7.3.5.3-1 for an AAS BS of Wide Area BS class, in Table 7.3.5.3-2 for an AAS BS of Local Area BS class and in table 7.3.5.3-3 for AAS BS of Medium Range BS class.

Table 7.4.5.2-1: AAS BS of Wide Area BS class dynamic range

E-UTRA channel bandwidth [MHz]	Reference measurement channel	Wanted signal mean power [dBm]	Interfering signal mean power [dBm] / BW_{Config}	Type of interfering signal
1.4	FRC A2-1 in 3GPP TS 36.104 [4], annex A.2	$-76.0 - \Delta_{OTAREFSENS}$	$-88.7 - \Delta_{OTAREFSENS}$	AWGN
3	FRC A2-2 in 3GPP TS 36.104 [4], annex A.2	$-72.1 - \Delta_{OTAREFSENS}$	$-84.7 - \Delta_{OTAREFSENS}$	AWGN
5	FRC A2-3 in 3GPP TS 36.104 [4], annex A.2	$-69.9 - \Delta_{OTAREFSENS}$	$-82.5 - \Delta_{OTAREFSENS}$	AWGN
10	FRC A2-3 in 3GPP TS 36.104 [4], annex A.2 (NOTE)	$-69.9 - \Delta_{OTAREFSENS}$	$-79.5 - \Delta_{OTAREFSENS}$	AWGN
15	FRC A2-3 in 3GPP TS 36.104 [4], annex A.2 (NOTE)	$-69.9 - \Delta_{OTAREFSENS}$	$-77.7 - \Delta_{OTAREFSENS}$	AWGN
20	FRC A2-3 in 3GPP TS 36.104 [4], annex A.2 (NOTE)	$-69.9 - \Delta_{OTAREFSENS}$	$-76.4 - \Delta_{OTAREFSENS}$	AWGN
NOTE: The wanted signal mean power is the power level of a single instance of the reference measurement channel. This requirement shall be met for each consecutive application of a single instance of FRC A2-3 mapped to disjoint frequency ranges with a width of 25 resource blocks each.				

Table 7.3.5.3-2: AAS BS of Local Area BS class dynamic range

E-UTRA channel bandwidth [MHz]	Reference measurement channel	Wanted signal mean power [dBm]	Interfering signal mean power [dBm] / BW_{Config}	Type of interfering signal
1.4	FRC A2-1 in 3GPP TS 36.104 [4], annex A.2	$-68.0 - \Delta_{OTAREFSENS}$	$-80.7 - \Delta_{OTAREFSENS}$	AWGN
3	FRC A2-2 in 3GPP TS 36.104 [4], annex A.2	$-64.1 - \Delta_{OTAREFSENS}$	$-76.7 - \Delta_{OTAREFSENS}$	AWGN
5	FRC A2-3 in 3GPP TS 36.104 [4], annex A.2	$-61.9 - \Delta_{OTAREFSENS}$	$-74.5 - \Delta_{OTAREFSENS}$	AWGN
10	FRC A2-3 in 3GPP TS 36.104 [4], annex A.2 (NOTE 1)	$-61.9 - \Delta_{OTAREFSENS}$	$-71.5 - \Delta_{OTAREFSENS}$	AWGN
15	FRC A2-3 in 3GPP TS 36.104 [4], annex A.2 (NOTE 1)	$-61.9 - \Delta_{OTAREFSENS}$	$-69.7 - \Delta_{OTAREFSENS}$	AWGN
20	FRC A2-3 in 3GPP TS 36.104 [4], annex A.2 (NOTE 1)	$-61.9 - \Delta_{OTAREFSENS}$	$-68.4 - \Delta_{OTAREFSENS}$	AWGN
NOTE 1: The wanted signal mean power is the power level of a single instance of the reference measurement channel. This requirement shall be met for each consecutive application of a single instance of FRC A2-3 mapped to disjoint frequency ranges with a width of 25 resource blocks each. This reference measurement channel is not applied for Band 46 nor Band 49.				
NOTE 2: Void				

Table 7.3.5.3-3: AAS BS of Medium Range BS class dynamic range

E-UTRA channel bandwidth [MHz]	Reference measurement channel	Wanted signal mean power [dBm]	Interfering signal mean power [dBm] / BWConfig	Type of interfering signal
1.4	FRC A2-1 in 3GPP TS 36.104 [4], annex A.2	-71.0 - $\Delta_{OTAREFSENS}$	-83.7 - $\Delta_{OTAREFSENS}$	AWGN
3	FRC A2-2 in 3GPP TS 36.104 [4], annex A.2	-67.1 - $\Delta_{OTAREFSENS}$	-79.7 - $\Delta_{OTAREFSENS}$	AWGN
5	FRC A2-3 in 3GPP TS 36.104 [4], annex A.2	-64.9 - $\Delta_{OTAREFSENS}$	-77.5 - $\Delta_{OTAREFSENS}$	AWGN
10	FRC A2-3 in 3GPP TS 36.104 [4], annex A.2 (NOTE 1)	-64.9 - $\Delta_{OTAREFSENS}$	-74.5 - $\Delta_{OTAREFSENS}$	AWGN
15	FRC A2-3 in 3GPP TS 36.104 [4], Annex A.2 (NOTE 1)	-64.9 - $\Delta_{OTAREFSENS}$	-72.7 - $\Delta_{OTAREFSENS}$	AWGN
20	FRC A2-3 in 3GPP TS 36.104 [4], annex A.2 (NOTE 1)	-64.9 - $\Delta_{OTAREFSENS}$	-71.4 - $\Delta_{OTAREFSENS}$	AWGN
NOTE 1: The wanted signal mean power is the power level of a single instance of the reference measurement channel. This requirement shall be met for each consecutive application of a single instance of FRC A2-3 mapped to disjoint frequency ranges with a width of 25 resource blocks each. This reference measurement channel is not applied for Band 46.				
NOTE 2: Void.				

NOTE: If the above Test Requirement differs from the Minimum Requirement then the Test Tolerance applied for this test is non-zero. The Test Tolerance for this test is defined in subclause 4.1.2 and the explanation of how the Minimum Requirement has been relaxed by the Test Tolerance is given in annex C.

7.4.5.3 NR operation

For each measured carrier, the throughput measured in step 6 of subclause 7.4.4.2 shall be $\geq 95\%$ of the maximum throughput of the reference measurement channel as specified in TS 38.104 [33] annex A.2 with parameters specified in tables 7.4.5.3-1 to 7.4.5.3-3.

Table 7.4.5.3-1: Wide Area BS dynamic range

BS channel bandwidth [MHz]	Subcarrier spacing [kHz]	Reference measurement channel	Wanted signal mean power [dBm]			Interfering signal mean power [dBm] / BWConfig	Type of interfering signal
			$f \leq 3.0$ GHz	3.0 GHz $< f \leq 4.2$ GHz	4.2 GHz $< f \leq 6.0$ GHz		
5	15	G-FR1-A2-1	-70.4 – $\Delta_{OTAREFSENS}$	-70.4 – $\Delta_{OTAREFSENS}$	-70.4 – $\Delta_{OTAREFSENS}$	-82.5 – $\Delta_{OTAREFSENS}$	AWGN
	30	G-FR1-A2-2	-71.1 – $\Delta_{OTAREFSENS}$	-71.1 – $\Delta_{OTAREFSENS}$	-71.1 – $\Delta_{OTAREFSENS}$		
10	15	G-FR1-A2-1	-70.4 – $\Delta_{OTAREFSENS}$	-70.4 – $\Delta_{OTAREFSENS}$	-70.4 – $\Delta_{OTAREFSENS}$	-79.3 – $\Delta_{OTAREFSENS}$	AWGN
	30	G-FR1-A2-2	-71.1 – $\Delta_{OTAREFSENS}$	-71.1 – $\Delta_{OTAREFSENS}$	-71.1 – $\Delta_{OTAREFSENS}$		
	60	G-FR1-A2-3	-68.1 – $\Delta_{OTAREFSENS}$	-68.1 – $\Delta_{OTAREFSENS}$	-68.1 – $\Delta_{OTAREFSENS}$		
15	15	G-FR1-A2-1	-70.4 – $\Delta_{OTAREFSENS}$	-70.4 – $\Delta_{OTAREFSENS}$	-70.4 – $\Delta_{OTAREFSENS}$	-77.5 – $\Delta_{OTAREFSENS}$	AWGN
	30	G-FR1-A2-2	-71.1 – $\Delta_{OTAREFSENS}$	-71.1 – $\Delta_{OTAREFSENS}$	-71.1 – $\Delta_{OTAREFSENS}$		
	60	G-FR1-A2-3	-68.1 – $\Delta_{OTAREFSENS}$	-68.1 – $\Delta_{OTAREFSENS}$	-68.1 – $\Delta_{OTAREFSENS}$		
20	15	G-FR1-A2-4	-64.2 – $\Delta_{OTAREFSENS}$	-64.2 – $\Delta_{OTAREFSENS}$	-64.2 – $\Delta_{OTAREFSENS}$	-76.2 – $\Delta_{OTAREFSENS}$	AWGN
	30	G-FR1-A2-5	-64.2 – $\Delta_{OTAREFSENS}$	-64.2 – $\Delta_{OTAREFSENS}$	-64.2 – $\Delta_{OTAREFSENS}$		

	60	G- FR1-A2-6	-64.5 – $\Delta_{OTAREFSENS}$	-64.5 – $\Delta_{OTAREFSENS}$	-64.5 – $\Delta_{OTAREFSENS}$		
25	15	G- FR1-A2-4	-64.2 – $\Delta_{OTAREFSENS}$	-64.2 – $\Delta_{OTAREFSENS}$	-64.2 – $\Delta_{OTAREFSENS}$	-75.2 – $\Delta_{OTAREFSENS}$	AWGN
	30	G- FR1-A2-5	-64.2 – $\Delta_{OTAREFSENS}$	-64.2 – $\Delta_{OTAREFSENS}$	-64.2 – $\Delta_{OTAREFSENS}$		
	60	G- FR1-A2-6	-64.5 – $\Delta_{OTAREFSENS}$	-64.5 – $\Delta_{OTAREFSENS}$	-64.5 – $\Delta_{OTAREFSENS}$		
30	15	G- FR1-A2-4	-64.2 – $\Delta_{OTAREFSENS}$	-64.2 – $\Delta_{OTAREFSENS}$	-64.2 – $\Delta_{OTAREFSENS}$	-74.4 – $\Delta_{OTAREFSENS}$	AWGN
	30	G- FR1-A2-5	-64.2 – $\Delta_{OTAREFSENS}$	-64.2 – $\Delta_{OTAREFSENS}$	-64.2 – $\Delta_{OTAREFSENS}$		
	60	G- FR1-A2-6	-64.5 – $\Delta_{OTAREFSENS}$	-64.5 – $\Delta_{OTAREFSENS}$	-64.5 – $\Delta_{OTAREFSENS}$		
40	15	G- FR1-A2-4	-64.2 – $\Delta_{OTAREFSENS}$	-64.2 – $\Delta_{OTAREFSENS}$	-64.2 – $\Delta_{OTAREFSENS}$	-73.1 – $\Delta_{OTAREFSENS}$	AWGN
	30	G- FR1-A2-5	-64.2 – $\Delta_{OTAREFSENS}$	-64.2 – $\Delta_{OTAREFSENS}$	-64.2 – $\Delta_{OTAREFSENS}$		
	60	G- FR1-A2-6	-64.5 – $\Delta_{OTAREFSENS}$	-64.5 – $\Delta_{OTAREFSENS}$	-64.5 – $\Delta_{OTAREFSENS}$		
50	15	G- FR1-A2-4	-64.2 – $\Delta_{OTAREFSENS}$	-64.2 – $\Delta_{OTAREFSENS}$	-64.2 – $\Delta_{OTAREFSENS}$	-72.2 – $\Delta_{OTAREFSENS}$	AWGN
	30	G- FR1-A2-5	-64.2 – $\Delta_{OTAREFSENS}$	-64.2 – $\Delta_{OTAREFSENS}$	-64.2 – $\Delta_{OTAREFSENS}$		
	60	G- FR1-A2-6	-64.5 – $\Delta_{OTAREFSENS}$	-64.5 – $\Delta_{OTAREFSENS}$	-64.5 – $\Delta_{OTAREFSENS}$		
60	30	G- FR1-A2-5	-64.2 – $\Delta_{OTAREFSENS}$	-64.2 – $\Delta_{OTAREFSENS}$	-64.2 – $\Delta_{OTAREFSENS}$	-71.4 – $\Delta_{OTAREFSENS}$	AWGN
	60	G- FR1-A2-6	-64.5 – $\Delta_{OTAREFSENS}$	-64.5 – $\Delta_{OTAREFSENS}$	-64.5 – $\Delta_{OTAREFSENS}$		
70	30	G- FR1-A2-5	-64.2 – $\Delta_{OTAREFSENS}$	-64.2 – $\Delta_{OTAREFSENS}$	-64.2 – $\Delta_{OTAREFSENS}$	-70.8 – $\Delta_{OTAREFSENS}$	AWGN
	60	G- FR1-A2-6	-64.5 – $\Delta_{OTAREFSENS}$	-64.5 – $\Delta_{OTAREFSENS}$	-64.5 – $\Delta_{OTAREFSENS}$		
80	30	G- FR1-A2-5	-64.2 – $\Delta_{OTAREFSENS}$	-64.2 – $\Delta_{OTAREFSENS}$	-64.2 – $\Delta_{OTAREFSENS}$	-70.1 – $\Delta_{OTAREFSENS}$	AWGN
	60	G- FR1-A2-6	-64.5 – $\Delta_{OTAREFSENS}$	-64.5 – $\Delta_{OTAREFSENS}$	-64.5 – $\Delta_{OTAREFSENS}$		
90	30	G- FR1-A2-5	-64.2 – $\Delta_{OTAREFSENS}$	-64.2 – $\Delta_{OTAREFSENS}$	-64.2 – $\Delta_{OTAREFSENS}$	-69.6 – $\Delta_{OTAREFSENS}$	AWGN
	60	G- FR1-A2-6	-64.5 – $\Delta_{OTAREFSENS}$	-64.5 – $\Delta_{OTAREFSENS}$	-64.5 – $\Delta_{OTAREFSENS}$		
100	30	G- FR1-A2-5	-64.2 – $\Delta_{OTAREFSENS}$	-64.2 – $\Delta_{OTAREFSENS}$	-64.2 – $\Delta_{OTAREFSENS}$	-69.1 – $\Delta_{OTAREFSENS}$	AWGN
	60	G- FR1-A2-6	-64.5 – $\Delta_{OTAREFSENS}$	-64.5 – $\Delta_{OTAREFSENS}$	-64.5 – $\Delta_{OTAREFSENS}$		

NOTE: The wanted signal mean power is the power level of a single instance of the corresponding reference measurement channel. This requirement shall be met for each consecutive application of a single instance of the reference measurement channel mapped to disjoint frequency ranges with a width corresponding to the number of resource blocks of the reference measurement channel each, except for one instance that might overlap one other instance to cover the full *BS channel bandwidth*.

Table 7.4.5.3-2: Medium Range BS dynamic range

BS channel bandwidth [MHz]	Subcarrier spacing [kHz]	Reference measurement channel	Wanted signal mean power [dBm]			Interfering signal mean power [dBm] / BW_{Config}	Type of interfering signal
			$f \leq 3.0$ GHz	3.0 GHz < $f \leq 4.2$ GHz	4.2 GHz < $f \leq 6.0$ GHz		
5	15	G-FR1-A2-1	-65.4 – $\Delta_{OTAREFSENS}$	-65.4 – $\Delta_{OTAREFSENS}$	-65.4 – $\Delta_{OTAREFSENS}$	-77.5 – $\Delta_{OTAREFSENS}$	AWGN
	30	G- FR1-A2-2	-66.1 – $\Delta_{OTAREFSENS}$	-66.1 – $\Delta_{OTAREFSENS}$	-66.1 – $\Delta_{OTAREFSENS}$		

NOTE: The wanted signal mean power is the power level of a single instance of the corresponding reference measurement channel. This requirement shall be met for each consecutive application of a single instance of the reference measurement channel mapped to disjoint frequency ranges with a width corresponding to the number of resource blocks of the reference measurement channel each, except for one instance that might overlap one other instance to cover the full *BS channel bandwidth*.

Table 7.4.5.3-3: Local Area BS dynamic range

BS channel bandwidth [MHz]	Subcarrier spacing [kHz]	Reference measurement channel	Wanted signal mean power [dBm]			Interfering signal mean power [dBm] / BW _{Config}	Type of interfering signal
			f ≤ 3.0 GHz	3.0 GHz < f ≤ 4.2 GHz	4.2 GHz < f ≤ 6.0 GHz		
5	15	G-FR1-A2-1	-62.4 – Δ _{OTAREFSENS}	-62.4 – Δ _{OTAREFSENS}	-62.4 – Δ _{OTAREFSENS}	-74.5 – Δ _{OTAREFSENS}	AWGN
	30	G- FR1-A2-2	-63.1 – Δ _{OTAREFSENS}	-63.1 – Δ _{OTAREFSENS}	-63.1 – Δ _{OTAREFSENS}		
10	15	G-FR1-A2-1	-62.4 – Δ _{OTAREFSENS}	-62.4 – Δ _{OTAREFSENS}	-62.4 – Δ _{OTAREFSENS}	-71.3 – Δ _{OTAREFSENS}	AWGN
	30	G- FR1-A2-2	-63.1 – Δ _{OTAREFSENS}	-63.1 – Δ _{OTAREFSENS}	-63.1 – Δ _{OTAREFSENS}		
	60	G- FR1-A2-3	-60.1 – Δ _{OTAREFSENS}	-60.1 – Δ _{OTAREFSENS}	-60.1 – Δ _{OTAREFSENS}		
15	15	G-FR1-A2-1	-62.4 – Δ _{OTAREFSENS}	-62.4 – Δ _{OTAREFSENS}	-62.4 – Δ _{OTAREFSENS}	-69.5 – Δ _{OTAREFSENS}	AWGN
	30	G- FR1-A2-2	-63.1 – Δ _{OTAREFSENS}	-63.1 – Δ _{OTAREFSENS}	-63.1 – Δ _{OTAREFSENS}		
	60	G- FR1-A2-3	-60.1 – Δ _{OTAREFSENS}	-60.1 – Δ _{OTAREFSENS}	-60.1 – Δ _{OTAREFSENS}		
20	15	G- FR1-A2-4	-56.2 – Δ _{OTAREFSENS}	-56.2 – Δ _{OTAREFSENS}	-56.2 – Δ _{OTAREFSENS}	-68.2 – Δ _{OTAREFSENS}	AWGN
	30	G- FR1-A2-5	-56.2 – Δ _{OTAREFSENS}	-56.2 – Δ _{OTAREFSENS}	-56.2 – Δ _{OTAREFSENS}		
	60	G- FR1-A2-6	-56.5 – Δ _{OTAREFSENS}	-56.5 – Δ _{OTAREFSENS}	-56.5 – Δ _{OTAREFSENS}		
25	15	G- FR1-A2-4	-56.2 – Δ _{OTAREFSENS}	-56.2 – Δ _{OTAREFSENS}	-56.2 – Δ _{OTAREFSENS}	-67.2 – Δ _{OTAREFSENS}	AWGN
	30	G- FR1-A2-5	-56.2 – Δ _{OTAREFSENS}	-56.2 – Δ _{OTAREFSENS}	-56.2 – Δ _{OTAREFSENS}		
	60	G- FR1-A2-6	-56.5 – Δ _{OTAREFSENS}	-56.5 – Δ _{OTAREFSENS}	-56.5 – Δ _{OTAREFSENS}		
30	15	G- FR1-A2-4	-56.2 – Δ _{OTAREFSENS}	-56.2 – Δ _{OTAREFSENS}	-56.2 – Δ _{OTAREFSENS}	-66.4 – Δ _{OTAREFSENS}	AWGN
	30	G- FR1-A2-5	-56.2 – Δ _{OTAREFSENS}	-56.2 – Δ _{OTAREFSENS}	-56.2 – Δ _{OTAREFSENS}		
	60	G- FR1-A2-6	-56.5 – Δ _{OTAREFSENS}	-56.5 – Δ _{OTAREFSENS}	-56.5 – Δ _{OTAREFSENS}		
40	15	G- FR1-A2-4	-56.2 – Δ _{OTAREFSENS}	-56.2 – Δ _{OTAREFSENS}	-56.2 – Δ _{OTAREFSENS}	-65.1 – Δ _{OTAREFSENS}	AWGN
	30	G- FR1-A2-5	-56.2 – Δ _{OTAREFSENS}	-56.2 – Δ _{OTAREFSENS}	-56.2 – Δ _{OTAREFSENS}		
	60	G- FR1-A2-6	-56.5 – Δ _{OTAREFSENS}	-56.5 – Δ _{OTAREFSENS}	-56.5 – Δ _{OTAREFSENS}		
50	15	G- FR1-A2-4	-56.2 – Δ _{OTAREFSENS}	-56.2 – Δ _{OTAREFSENS}	-56.2 – Δ _{OTAREFSENS}	-64.2 – Δ _{OTAREFSENS}	AWGN
	30	G- FR1-A2-5	-56.2 – Δ _{OTAREFSENS}	-56.2 – Δ _{OTAREFSENS}	-56.2 – Δ _{OTAREFSENS}		
	60	G- FR1-A2-6	-56.5 – Δ _{OTAREFSENS}	-56.5 – Δ _{OTAREFSENS}	-56.5 – Δ _{OTAREFSENS}		
60	30	G- FR1-A2-5	-56.2 – Δ _{OTAREFSENS}	-56.2 – Δ _{OTAREFSENS}	-56.2 – Δ _{OTAREFSENS}	-63.4 – Δ _{OTAREFSENS}	AWGN
	60	G- FR1-A2-6	-56.5 – Δ _{OTAREFSENS}	-56.5 – Δ _{OTAREFSENS}	-56.5 – Δ _{OTAREFSENS}		

70	30	G- FR1-A2-5	-56.2 – $\Delta_{\text{OTAREFSENS}}$	-56.2 – $\Delta_{\text{OTAREFSENS}}$	-56.2 – $\Delta_{\text{OTAREFSENS}}$	-62.8 – $\Delta_{\text{OTAREFSENS}}$	AWGN
	60	G- FR1-A2-6	-56.5 – $\Delta_{\text{OTAREFSENS}}$	-56.5 – $\Delta_{\text{OTAREFSENS}}$	-56.5 – $\Delta_{\text{OTAREFSENS}}$		
80	30	G- FR1-A2-5	-56.2 – $\Delta_{\text{OTAREFSENS}}$	-56.2 – $\Delta_{\text{OTAREFSENS}}$	-56.2 – $\Delta_{\text{OTAREFSENS}}$	-62.1 – $\Delta_{\text{OTAREFSENS}}$	AWGN
	60	G- FR1-A2-6	-56.5 – $\Delta_{\text{OTAREFSENS}}$	-56.5 – $\Delta_{\text{OTAREFSENS}}$	-56.5 – $\Delta_{\text{OTAREFSENS}}$		
90	30	G- FR1-A2-5	-56.2 – $\Delta_{\text{OTAREFSENS}}$	-56.2 – $\Delta_{\text{OTAREFSENS}}$	-56.2 – $\Delta_{\text{OTAREFSENS}}$	-61.6 – $\Delta_{\text{OTAREFSENS}}$	AWGN
	60	G- FR1-A2-6	-56.5 – $\Delta_{\text{OTAREFSENS}}$	-56.5 – $\Delta_{\text{OTAREFSENS}}$	-56.5 – $\Delta_{\text{OTAREFSENS}}$		
100	30	G- FR1-A2-5	-56.2 – $\Delta_{\text{OTAREFSENS}}$	-56.2 – $\Delta_{\text{OTAREFSENS}}$	-56.2 – $\Delta_{\text{OTAREFSENS}}$	-61.1 – $\Delta_{\text{OTAREFSENS}}$	AWGN
	60	G- FR1-A2-6	-56.5 – $\Delta_{\text{OTAREFSENS}}$	-56.5 – $\Delta_{\text{OTAREFSENS}}$	-56.5 – $\Delta_{\text{OTAREFSENS}}$		

NOTE: The wanted signal mean power is the power level of a single instance of the corresponding reference measurement channel. This requirement shall be met for each consecutive application of a single instance of the reference measurement channel mapped to disjoint frequency ranges with a width corresponding to the number of resource blocks of the reference measurement channel each, except for one instance that might overlap one other instance to cover the full *BS channel bandwidth*.

7.5 OTA Adjacent channel selectivity, general blocking, and narrowband blocking

7.5.1 Definition and applicability

The adjacent channel selectivity (ACS), general blocking and narrowband blocking characteristics are measures of the receiver unit ability to receive a wanted signal at its assigned channel in the presence of an unwanted interferer inside the operating band.

The requirement applies at the RIB when the AoA of the incident wave of a received signal and the interfering signal are from the same direction, and:

- when the wanted signal is based on EIS_{REFSENS} : the AoA of the incident wave of a received signal and the interfering signal are within the OTA REFSENS *RoAoA*.
- when the wanted signal is based on EIS_{minSENS} : the AoA of the incident wave of a received signal and the interfering signal are within the *minSENS RoAoA*.

The wanted and interfering signals apply to all supported polarizations, under the assumption of *polarization match*.

NOTE: For Single RAT requirements, the in-band selectivity characteristics is referred to as "adjacent channel selectivity", whereas for the MSR requirements, the corresponding property is referred to as "general blocking" since the adjacent frequency range may not carry a channel addressable from the interfered carrier. The in-band blocking requirement applies from $F_{\text{UL_low}} - \Delta f_{\text{OOB}}$ to $F_{\text{UL_high}} + \Delta f_{\text{OOB}}$, excluding the downlink frequency range of the *operating band*. The Δf_{OOB} is defined in table 7.5-1.

Table 7.5-1: Δf_{OOB} offset for operating bands

Operating band characteristics	Δf_{OOB} [MHz]
$F_{\text{UL_high}} - F_{\text{UL_low}} < 100$ MHz	20
$100 \text{ MHz} \leq F_{\text{UL_high}} - F_{\text{UL_low}} \leq 900$ MHz	60

7.5.2 Minimum Requirement

For AAS BS in *MSR operation* the minimum requirement is defined in TS 37.105 [6], subclause 10.5.2.

For AAS BS in *single RAT UTRA operation* the minimum requirement is defined in TS 37.105 [6], subclause 10.5.3.

For AAS BS in *single RAT E-UTRA operation* the minimum requirement is defined in TS 37.105 [6], subclause 10.5.4.

7.5.3 Test purpose

The test stresses the receiver unit ability to withstand high-level interference from unwanted signals at specified frequency offsets without undue degradation of its sensitivity.

7.5.4 Method of test

7.5.4.1 Initial conditions

Test environment: normal; see annex G.2.

RF channels to be tested for single carrier: M ; see subclause 4.12.1.

Base Station RF Bandwidth positions to be tested for multi-carrier (MC): - M_{RFBW} for *single-band RIB(s)*, see subclause 4.12.1, $B_{\text{RFBW_T'RFBW}}$ and $B'_{\text{RFBW_T'RFBW}}$ for *multi-band RIB(s)*, see subclause 4.12.1.

Directions to be tested:

OTA minSENS receiver target reference direction (see table 4.10-2, D107).

OTA REFSSENS conformance test directions (see table 4.10-2, D11.31).).

7.5.4.2 Procedure

7.5.4.2.1 General procedure

The general procedure steps apply to the procedures for all the RATs.

- 1) Place the AAS BS with its manufacturer declared coordinate system reference point in the same place as calibrated point in the test system, as shown in Annex D1.1.
- 2) Align the manufacturer declared coordinate system orientation of the AAS BS with the test system.
- 3) Align the BS with the test antenna in the declared direction to be tested.
- 4) Align the NR BS to that the wanted signal and interferer signal is *polarization matched* with the test antenna(s).
- 5) Set the test signal mean power so the calibrated radiated power at the AAS BS Antenna Array coordinate system reference point is as specified as follows:
 - a) Set the signal generator for the wanted signal according to the applicable test configuration (see clause 5) using applicable reference measurement channel to transmit:
 - For E-UTRA see clause A.1 in TS 36.141 [12].
 - For UTRA FDD see clause A.2 in TS 25.141 [10].
 - For NR see clause A.1 in TS 38.141-2 [34].

7.5.4.2.2 MSR operation

7.5.4.2.2.1 Procedure for general blocking

- 1) Adjust the signal generators to the type of interfering signal, levels and the frequency offsets as specified in table 7.5.5.1.1-1.
- 2) The interfering signal shall be swept with a step size of 1 MHz starting from the minimum offset to the channel edges of the wanted signals as specified in table 7.5.5.1.1-1.

- 3) Measure the performance of the wanted signal as defined in subclause 7.5.5.1, for the relevant carriers specified by the test configuration in subclause 4.11.
- 4) Repeat for all the specified measurement directions.
- 5) Repeat for all supported polarizations.

In addition, for *multi-band RIB(s)*, the following steps shall apply:

- 6) For *multi-band RIBs* and single band tests, repeat the steps above per involved band where single band test configurations and test models shall apply with no carrier activated in the other band.

7.5.4.2.2.2 Procedure for narrowband blocking

- 1) Adjust the signal generators to the type of interfering signal, levels and the frequency offsets as specified in table 7.5.5.1.2-1.
- 2) Set-up and sweep the interfering RB centre frequency offset to the channel edge of the wanted signal according to table 7.5.5.1.2-1.
- 3) Measure the performance of the wanted signal at the receiver under test, as defined in subclause 7.5.5.1, for the relevant carriers specified by the test configuration in subclause 4.11.
- 4) Repeat for all the specified measurement directions.
- 5) Repeat for all supported polarizations.

In addition, for *multi-band RIB(s)*, the following steps shall apply:

- 6) For *multi-band RIBs* and single band tests, repeat the steps above per involved band where single band test configurations and test models shall apply with no carrier activated in the other band.

7.5.4.2.2.3 Procedure for additional BC3 blocking requirement

- 1) Adjust the signal generators to the type of interfering signal, levels and the frequency offsets as specified in table 7.5.5.1.3-1.
- 2) Measure the performance of the wanted signal at the receiver under test, as defined in subclause 7.5.5, for the relevant carriers specified by the test configuration in subclause 4.8.
- 3) Repeat for all the specified measurement directions and all supported polarizations.

7.5.4.2.3 Single RAT UTRA FDD operation

- 1) Generate the wanted signal and adjust the ATT1 to set the input level to the level specified in table 7.5.5.2-1 For a RIB supporting multi-carrier operation, generate the wanted signal according to the applicable test configuration (see clause 4.11) using applicable reference measurement channel to the RIB under test. Power settings are specified in table 7.5.5.2-1.
- 2) Set-up the interfering signal at the adjacent channel frequency and adjust the ATT2 to obtain the specified level of interfering signal at the AAS BS input defined in table 7.5.5.2-1. Note that the interfering signal shall have an ACLR of at least 63 dB in order to eliminate the impact of interfering signal adjacent channel leakage power on the ACS measurement.
- 3) Measure the BER of the wanted signal at the receiver under test.
- 4) Repeat for all the specified measurement directions and all supported polarizations.

In addition, for *multi-band RIB(s)*, the following steps shall apply:

- 5) For *multi-band RIBs* and single band tests, repeat the steps above per involved band where single band test configurations and test models shall apply with no carrier activated in the other band.

7.5.4.2.4 Single RAT E-UTRA operation

7.4.4.2.4.1 Procedure for adjacent channel selectivity

- 1) Generate the wanted signal using the applicable test configuration specified in subclause 5.3.4 and adjust the input level to the level specified in table 7.5.5.3-1 for the appropriate BS class.
- 2) Set-up the interfering signal at the adjacent channel frequency and adjust the interfering signal level to the level defined in table 7.5.5.3-1 for the appropriate BS class.
- 3) Measure the throughput according to annex E in 36.141 [12]3GPP TS 36.141 [12], for multi-carrier and/or CA operation the throughput shall be measured for relevant carriers specified by the test configuration specified in subclause 5.3.4.
- 4) Repeat for all the specified measurement directions and all supported polarizations.

In addition, for *multi-band RIB(s)*, the following steps shall apply:

- 5) For *multi-band RIBs* and single band tests, repeat the steps above per involved band where single band test configurations and test models shall apply with no carrier activated in the other band.

7.5.4.2.4.2 Procedure for narrow-band blocking

- 1) Configure the beam peak direction of the AAS BS according to declared *reference beam direction pair* for the appropriate beam identifier.
- 2) For RIB operating E-UTRA FDD declared to be capable of single carrier operation only in the operating band, set the AAS BS to transmit according to subclause 4.12.2 at manufacturers declared rated carrier TRP $P_{\text{Rated,c,TABC}}$.

For a RIB operating E-UTRA FDD declared to be capable of multi-carrier and/or CA operation in the operating band, set the ASA BS to transmit according to subclause 4.12.2 on all carriers configured using the applicable test configuration and corresponding power setting specified in subclause 5.3.4.

- 3) Generate the wanted signal using the applicable test configuration specified in subclause 5.3.4 and adjust the input level to the level specified in table 7.5.5.3-1.
- 4) Adjust the interfering signal level to the level defined in table 7.5.5.3-1. Set-up and sweep the interfering RB centre frequency offset to the channel edge of the wanted signal according to table 7.5.5.3-2.
- 5) Measure the throughput according to annex E in 36.141 [12]3GPP TS 36.141 [12], for multi-carrier and/or CA operation the throughput shall be measured for relevant carriers specified by the test configuration specified in subclause 5.3.4.
- 6) Repeat for all the specified measurement directions and all supported polarizations.

In addition, for *multi-band RIB(s)*, the following steps shall apply:

- 7) For *multi-band RIBs* and single band tests, repeat the steps above per involved band where single band test configurations and test models shall apply with no carrier activated in the other band.

7.5.5 Test Requirement

7.5.5.1 MSR operation

7.5.5.1.1 General blocking test requirement

For the general blocking requirement, the interfering signal shall be a UTRA FDD signal as specified in clause A.1 in 3GPP TS 25.141 [10] for a UTRA, E-UTRA or NR (≤ 20 MHz) wanted signal. The interfering signal shall be a 20 MHz E-UTRA signal for NR wanted signal channel bandwidth greater than 20 MHz.

For RIBs supporting operation in *non-contiguous spectrum*, the requirement applies in addition inside any *sub-block gap*, in case the *sub-block gap* size is at least 15 MHz. The interfering signal offset is defined relative to the sub-block edges inside the *sub-block gap*.

For *multi-band RIBs* the requirement applies in addition inside any *Inter RF Bandwidth gap*, in case the gap size is at least 15 MHz. The interfering signal offset is defined relative to the *Base Station RF Bandwidth edges* inside the *Inter RF Bandwidth gap*.

For the wanted and interfering signal coupled to the *RIB*, using the parameters in tables 7.5.5.1.1-1 and 7.5.5.1.1-2, the following requirements shall be met:

- For any measured E-UTRA carrier, the throughput shall be $\geq 95\%$ of the *maximum throughput* of the reference measurement channel defined in subclause 7.2.5.4.
- For any measured UTRA FDD carrier, the BER shall not exceed 0.001 for the reference measurement channel defined in subclause 7.2.5.2.
- For any measured NR carrier, the throughput shall be $\geq 95\%$ of the maximum throughput of the reference measurement channel defined in subclause 7.2 of TS 38.104 [33].

For *multi-band RIBs*, the requirement applies according to table 7.5.5.1.1-1 for the in-band blocking frequency ranges of each supported operating band.

Table 7.5.5.1.1-1: General blocking requirement

Base Station Type	Mean power of interfering signal [dBm]	Wanted Signal mean power [dBm] (NOTE 1)	Centre Frequency of Interfering Signal	Interfering signal centre frequency minimum frequency offset from the Base Station RF Bandwidth edge or edge of sub-block inside a gap [MHz]
Wide Area BS	$-40 + y - \Delta_{\text{OTAREFSSENS}}$ (NOTE 7, 9)	$\text{EIS}_{\text{REFSENS}} + x$ dB (NOTE 2, 5, 9)	$F_{\text{UL_low}} - \Delta f_{\text{OOB}}$ to $F_{\text{UL_high}} + \Delta f_{\text{OOB}}$	$(\pm 7.5+z)$ (Note 11)
	$-40 + y - \Delta_{\text{minSENS}}$ (NOTE 7, 10)	$\text{EIS}_{\text{minSENS}} + x$ dB (NOTE 2, 5, 10)		
Medium Range BS	$-35 + y - \Delta_{\text{OTAREFSSENS}}$ (NOTE 7, 9)	$\text{EIS}_{\text{REFSENS}} + x$ dB (NOTE 3, 5, 9)		
	$-35 + y - \Delta_{\text{minSENS}}$ (NOTE 7, 10)	$\text{EIS}_{\text{minSENS}} + x$ dB (NOTE 3, 5, 10)		
Local Area BS	$-30 + y - \Delta_{\text{OTAREFSSENS}}$ (NOTE 7, 9)	$\text{EIS}_{\text{REFSENS}} + x$ dB (NOTE 4, 5, 9)		
	$-30 + y - \Delta_{\text{minSENS}}$ (NOTE 7, 10)	$\text{EIS}_{\text{minSENS}} + x$ dB (NOTE 4, 5, 10)		
<p>NOTE 1: $\text{EIS}_{\text{REFSENS}}$ and $\text{EIS}_{\text{minSENS}}$ depend on the RAT, the BS class and on the <i>channel bandwidth</i>, see subclauses 7.3 and 7.2.</p> <p>NOTE 2: For WA BS that does not support NR, “x” is equal to 6 in case of E-UTRA or UTRA wanted signals and equal to 3 in case of GSM/EDGE wanted signal.</p> <p>NOTE 3: For MR BS that does not support NR, “x” is equal to 6 in case of UTRA wanted signals, 9 in case of E-UTRA wanted signal and 3 in case of GSM/EDGE wanted signal.</p> <p>NOTE 4: For LA BS that does not support NR, “x” is equal to 11 in case of E-UTRA wanted signal, 6 in case of UTRA wanted signal and equal to 3 in case of GSM/EDGE wanted signal.</p> <p>NOTE 5: For a BS that supports NR but does not support UTRA, x is equal to 6.</p> <p>NOTE 6: For a BS capable of multi-band operation, “x” in Note 2, 3, 4, 5 applies in case of interfering signals that are in the in-band blocking frequency range of the operating band where the wanted signal is present or in an adjacent or overlapping band. For other in-band blocking frequency ranges of the interfering signal for the supported operating bands, “x” is equal to 1.4 dB.</p> <p>NOTE 7: For a BS that not supporting NR, “y” is equal to zero for all BS classes. For a BS that supports NR but does not support UTRA, “y” is equal to -3 for the WA and MR BS class and -5 for the LA BS class.</p> <p>NOTE 8: The downlink frequency range of an FDD operating band is excluded from the general blocking requirement.</p> <p>NOTE 9: This test requirement is only applied in the OTA REFSSENS conformance test directions.</p> <p>NOTE 10: This test requirement is only applied in the OTA minSENS receiver target reference direction.</p> <p>NOTE 11: For NR wanted signal channel bandwidth greater than 20 MHz, $z = 22.5$ MHz. For all other cases, $z = 0$ MHz.</p>				

Table 7.5.5.1.1-2: Void

NOTE: The requirement in tables 7.5.5.1.1-1 and 7.5.5.1.1-2 assumes that two operating bands, where the *downlink operating band* (see table 4.4-1 and table 4.4-2 in 3GPP TS 37.141 [13].) of one band would be within the in-band blocking region of the other band, are not deployed in the same geographical area.

7.5.5.1.2 General narrowband blocking test requirement

For the narrowband blocking requirement, the interfering signal shall be an E-UTRA 1RB signal as specified in clause A.3 in 3GPP TS 37.141 [13].

The requirement is applicable outside the *Base Station RF Bandwidth* or *Maximum Radio Bandwidth*. The interfering signal offset is defined relative to the *Base Station RF Bandwidth edges* or *Maximum Radio Bandwidth edges*.

For RIBs supporting operation in non-contiguous spectrum, the requirement applies in addition inside any *sub-block gap*, in case the *sub-block gap* size is at least 3 MHz. The interfering signal offset is defined relative to the sub-block edges inside the *sub-block gap*.

For *multi-band RIBs*, the requirement applies in addition inside any *Inter RF Bandwidth gap* in case the gap size is at least 3 MHz. The interfering signal offset is defined relative to the *Base Station RF Bandwidth edges* inside the *Inter RF Bandwidth gap*.

For the wanted and interfering signal coupled to the RIB, using the parameters in table 7.4.5.1.2-1 the following requirements shall be met:

- For any measured E-UTRA carrier, the throughput shall be $\geq 95\%$ of the *maximum throughput* of the reference measurement channel defined in subclause 7.2.5.4.
- For any measured UTRA FDD carrier, the BER shall not exceed 0.001 for the reference measurement channel defined in subclause 7.2.5.2.
- For any NR carrier, the throughput shall be $\geq 95\%$ of the maximum throughput of the reference measurement channel defined for *BS type 1-O* in TS 38.104 [33], subclause 10.3.2

Table 7.5.5.1.2-1: Narrowband blocking requirement

Base Station Type	RAT of the carrier	Wanted signal mean power [dBm] (NOTE 1,2)	Interfering signal mean power [dBm]	Interfering RB (NOTE 3) centre frequency offset from the AAS <i>Base Station RF Bandwidth edge</i> or <i>edge of sub-block</i> inside a gap [kHz]	
Wide Area BS	E-UTRA, NR, UTRA	$EIS_{REFSENS} + x$ dB (NOTE 6)	$-49 - \Delta_{OTAREFSENS}$ (NOTE 6)	$\pm(240 + m \cdot 180)$, $m=0, 1, 2, 3, 4, 9, 14$ (Note 4)	
		$EIS_{minSENS} + x$ dB (NOTE 7)	$-49 - \Delta_{minSENS}$ (NOTE 7)		
Medium Range BS		$EIS_{REFSENS} + x$ dB (NOTE 6)	$-44 - \Delta_{OTAREFSENS}$ (NOTE 6)		
		$EIS_{minSENS} + x$ dB (NOTE 7)	$-44 - \Delta_{minSENS}$ (NOTE 7)		
Local Area BS		$EIS_{REFSENS} + x$ dB (NOTE 6)	$-41 - \Delta_{OTAREFSENS}$ (NOTE 6)		$\pm(550 + m \cdot 180)$, $m=0, 1, 2, 3, 4, 29, 54, 79, 100$ (Note 5)
		$EIS_{minSENS} + x$ dB (NOTE 7)	$-41 - \Delta_{minSENS}$ (NOTE 7)		
NOTE 1: $EIS_{REFSENS}$ and $EIS_{minSENS}$ depend on the RAT, the BS class and on the <i>channel bandwidth</i> , see subclauses 7.3 and 7.2.					
NOTE 2: "x" is equal to 6 dB in case of E-UTRA or UTRA wanted signals.					
NOTE 3: Interfering signal (E-UTRA 3 MHz) consisting of one resource block positioned at the stated offset, the <i>channel bandwidth</i> of the interfering signal is located adjacently to the AAS <i>Base Station RF Bandwidth edge</i> .					
NOTE 4: Applicable for <i>channel bandwidths</i> equal to or below 20 MHz.					
NOTE 5: Applicable for <i>channel bandwidths</i> above 20MHz.					
NOTE 6: This test requirement is only applied in the OTA REFSSENS conformance test directions.					
NOTE 7: This test requirement is only applied in the OTA minSENS receiver target reference direction.					

7.5.5.1.3 Additional BC3 blocking test requirement

The interfering signal is a 1,28Mcps UTRA TDD modulated signal as specified in clause A.2 in 3GPP TS 37.141 [13].

The requirement is applicable outside the *Base Station RF Bandwidth* or *Maximum Radio Bandwidth*. The interfering signal offset is defined relative to the *Base Station RF Bandwidth edges* or *Maximum Radio Bandwidth edges*.

For *multi-band RIBs*, the requirement applies in addition inside any *Inter RF Bandwidth gap*, in case the gap size is at least 4.8MHz. The interfering signal offset is defined relative to the *Base Station RF Bandwidth edges* inside the *Inter RF Bandwidth gap*.

For the wanted and interfering signal coupled to the RIB, using the parameters in table 7.4.5.1.3-1, the following requirements shall be met:

- For any measured E-UTRA carrier, the throughput shall be $\geq 95\%$ of the *maximum throughput* of the reference measurement channel defined in subclause 7.2.5.3.

Table 7.5.5.1.3-1: Additional blocking requirement for Band Category 3

Operating Band	Centre Frequency of Interfering Signal [MHz]	Interfering Signal mean power [dBm]	Wanted Signal mean power [dBm] (NOTE)	Interfering signal centre frequency minimum frequency offset from the Base Station RF Bandwidth edge [MHz]
33 - 40	(F _{UL_low} - 20) to (F _{UL_high} + 20)	-40 - $\Delta_{\text{OTAREFSSENS}}$ (NOTE 2)	EIS _{REFSENS} + 6 dB (NOTE 2)	$\pm 2,4$
		-40 - Δ_{minSENS} (NOTE 3)	EIS _{minSENS} + 6 dB (NOTE 3)	
NOTE 1: EIS _{REFSENS} and EIS _{minSENS} depend on the RAT, the BS class and on the <i>channel bandwidth</i> , see subclauses 7.3 and 7.2.				
NOTE 2: This test requirement is only applied in the OTA REFSENS conformance test directions.				
NOTE 3: This test requirement is only applied in the OTA minSENS receiver target reference direction.				

7.5.5.2 Single RAT UTRA FDD operation

For each measured carrier, the BER shall not exceed 0,001 for the parameters specified in table 7.5.5.2-1.

For *multi-carrier RIB* the ACS requirement is applicable outside the *Base Station RF Bandwidth* or *Maximum Radio Bandwidth*. The interfering signal offset is defined relative to the lower/upper *Base Station RF Bandwidth edges* or *Maximum Radio Bandwidth edges*.

For RIBs supporting operation in *non-contiguous spectrum* within any operating band, the requirement applies in addition inside any *sub-block gap*, in case the *sub-block gap* size is at least 5 MHz. The interfering signal offset is defined relative to the lower/upper sub-block edge inside the *sub-block gap* and is equal to -2.5 MHz/+2.5 MHz, respectively.

For a *multi-band RIBs*, the requirement applies in addition inside any *Inter RF Bandwidth gap*, in case the *Inter RF Bandwidth gap* size is at least 5 MHz. The interfering signal offset is defined relative to lower/upper *Base Station RF Bandwidth edges* inside the *Inter RF Bandwidth gap* and is equal to -2.5 MHz/+2.5 MHz, respectively.

Table 7.5.5.2-1: Adjacent channel selectivity

Parameter	Level Wide Area BS	Level Medium Range BS	Level Local Area / Home BS	Unit
Data rate	12.2	12.2	12.2	kbps
Wanted signal mean power	-115 - Δ_{minSENS}	-105 - Δ_{minSENS}	-101 - Δ_{minSENS}	dBm
Interfering signal mean power	-52 - Δ_{minSENS}	-42 - Δ_{minSENS}	-38 - Δ_{minSENS}	dBm
F _{uw} offset (Modulated)	± 5	± 5	± 5	MHz

NOTE: If the above Test Requirement differs from the Minimum Requirement then the Test Tolerance applied for this test is non-zero. The Test Tolerance for this test is defined in subclause 4.1.2 and the explanation of how the Minimum Requirement has been relaxed by the Test Tolerance is given in annex C.

7.5.5.3 Single RAT E-UTRA operation

The throughput shall be $\geq 95\%$ of the *maximum throughput* of the reference measurement channel.

For E-UTRA Wide Area BS, the wanted and the interfering signal coupled to the BS antenna input are specified in tables 7.5.5.3-1 and 7.5.5.3-2 for narrowband blocking and 7.5.5.3-3 for ACS. The reference measurement channel for

the wanted signal is identified in table 10.3.4-1 for each *channel bandwidth* and further specified in 3GPP TS 36.104 [4] Annex A.

For E-UTRA Medium Range BS, the wanted and the interfering signal coupled to the BS antenna input are specified in tables 7.5.5.3-1 and 7.5.5.3-2 for narrowband blocking and in table 7.5.5.3-5 for ACS. Narrowband blocking requirements are not applied for Band 46. The reference measurement channel for the wanted signal is identified in table 10.3.4-3 for each *channel bandwidth* and further specified in 3GPP TS 36.104 [4] Annex A.

For E-UTRA Local Area BS, the wanted and the interfering signal coupled to the BS antenna input are specified in tables 7.5.5.3-1 and 7.5.5.3-2 for narrowband blocking and 7.5.5.3-4 for ACS. Narrowband blocking requirements are not applied for Band 46. The reference measurement channel for the wanted signal is identified in table 10.3.4-2 for each *channel bandwidth* and further specified in 3GPP TS 36.104 [4] Annex A.

For narrowband blocking the OTA levels are applied referenced to 2 antenna gain offsets $\Delta_{\text{OTAREFSENS}}$ and Δ_{minSENS} .

For ACS the OTA levels are applied referenced to Δ_{minSENS} .

The ACS and narrowband blocking requirement is applicable outside the *Base Station RF Bandwidth* or *Radio Bandwidth*. The interfering signal offset is defined relative to the *Base station RF Bandwidth edges* or *Radio Bandwidth edges*.

For RIBs supporting operation in *non-contiguous spectrum* within any operating band, the ACS requirement applies in addition inside any *sub-block gap*, in case the *sub-block gap* size is at least as wide as the E-UTRA interfering signal in tables 7.5.5.3-3, 7.5.5.3-4 and 7.5.5.3-5. The interfering signal offset is defined relative to the *sub-block edges* inside the *sub-block gap*.

For *multi-band RIBs*, the ACS requirement applies in addition inside any *Inter RF Bandwidth gap* at the RIB, in case the gap size is at least as wide as the E-UTRA interfering signal in tables 7.5.5.3-3, 7.5.5.3-4 and 7.5.5.3-5. The interfering signal offset is defined relative to the *Base Station RF Bandwidth edges* inside the *Inter RF Bandwidth gap*.

For a RIBs operating in *non-contiguous spectrum* within any operating band, the narrowband blocking requirement applies in addition inside any *sub-block gap*, in case the *sub-block gap* size is at least as wide as the *channel bandwidth* of the E-UTRA interfering signal in table 7.5.5.3-2. The interfering signal offset is defined relative to the *sub-block edges* inside the *sub-block gap*.

For *multi-band RIBs*, the narrowband blocking requirement applies in addition inside any *Inter RF Bandwidth gap*, in case the *Inter RF Bandwidth gap* size is at least as wide as the E-UTRA interfering signal in table 7.5.5.3-2. The interfering signal offset is defined relative to the *Base Station RF Bandwidth edges* inside the *Inter RF Bandwidth gap*.

Table 7.5.5.3-1: Narrowband blocking requirement

	Wanted signal mean power [dBm] (NOTE)	Interfering signal mean power [dBm]	Type of interfering signal
Wide Area BS	$EIS_{\text{REFSENS}} + 6 \text{ dB}$ (NOTE 2)	$-49 - \Delta_{\text{OTAREFSENS}}$ (NOTE 2)	See table 10.5.4.2-2
	$EIS_{\text{minSENS}} + 6 \text{ dB}$ (NOTE 3)	$-49 - \Delta_{\text{minSENS}}$ (NOTE 3)	
Medium Range BS	$EIS_{\text{REFSENS}} + 6 \text{ dB}$ (NOTE 2)	$-44 - \Delta_{\text{OTAREFSENS}}$ (NOTE 2)	See table 10.5.4.2-2
	$EIS_{\text{minSENS}} + 6 \text{ dB}$ (NOTE 3)	$-44 - \Delta_{\text{minSENS}}$ (NOTE 3)	
Local Area BS	$EIS_{\text{REFSENS}} + 6 \text{ dB}$ (NOTE 2)	$-41 - \Delta_{\text{OTAREFSENS}}$ (NOTE 2)	See table 10.5.4.2-2
	$EIS_{\text{minSENS}} + 6 \text{ dB}$ (NOTE 3)	$-41 - \Delta_{\text{minSENS}}$ (NOTE 3)	
NOTE 1: EIS_{REFSENS} and EIS_{minSENS} depend on the RAT, the BS class and on the <i>channel bandwidth</i> , see subclauses 7.3 and 7.2.			
NOTE 2: This test requirement is only applied in the OTA REFSSENS conformance test directions.			
NOTE 3: This test requirement is only applied in the OTA minSENS receiver target reference direction.			

Table 7.5.5.3-2: Interfering signal for Narrowband blocking requirement

E-UTRA channel BW of the lowest/highest carrier received [MHz]	Interfering RB centre frequency offset to the lower/upper Base Station RF Bandwidth edge or sub-block edge inside a <i>sub-block gap</i> [kHz]	Type of interfering signal
1.4	$\pm(252.5+m*180)$, m=0, 1, 2, 3, 4, 5	1.4 MHz E-UTRA signal, 1 RB (NOTE)
3	$\pm(247.5+m*180)$, m=0, 1, 2, 3, 4, 7, 10, 13	3 MHz E-UTRA signal, 1 RB (NOTE)
5	$\pm(342.5+m*180)$, m=0, 1, 2, 3, 4, 9, 14, 19, 24	5 MHz E-UTRA signal, 1 RB (NOTE)
10	$\pm(347.5+m*180)$, m=0, 1, 2, 3, 4, 9, 14, 19, 24	5 MHz E-UTRA signal, 1 RB (NOTE)
15	$\pm(352.5+m*180)$, m=0, 1, 2, 3, 4, 9, 14, 19, 24	5 MHz E-UTRA signal, 1 RB (NOTE)
20	$\pm(342.5+m*180)$, m=0, 1, 2, 3, 4, 9, 14, 19, 24	5 MHz E-UTRA signal, 1 RB (NOTE)
NOTE: Interfering signal consisting of one resource block is positioned at the stated offset, the <i>channel bandwidth</i> of the interfering signal is located adjacently to the lower/upper <i>Base Station RF Bandwidth edge</i> .		

Table 7.5.5.3-3: Adjacent channel selectivity for Wide Area BS

E-UTRA channel bandwidth of the lowest/highest carrier received [MHz]	Wanted signal mean power [dBm] (NOTE)	Interfering signal mean power [dBm]	Interfering signal centre frequency offset from the lower/upper <i>Base Station RF Bandwidth edge</i> or sub-block edge inside a <i>sub-block gap</i> [MHz]	Type of interfering signal
1.4	$EIS_{\min SENS} + 11$ dB	$-52 - \Delta_{\min SENS}$	± 0.7025	1.4MHz E-UTRA signal
3	$EIS_{\min SENS} + 8$ dB	$-52 - \Delta_{\min SENS}$	± 1.5075	3MHz E-UTRA signal
5	$EIS_{\min SENS} + 6$ dB	$-52 - \Delta_{\min SENS}$	± 2.5025	5MHz E-UTRA signal
10	$EIS_{\min SENS} + 6$ dB	$-52 - \Delta_{\min SENS}$	± 2.5075	5MHz E-UTRA signal
15	$EIS_{\min SENS} + 6$ dB	$-52 - \Delta_{\min SENS}$	± 2.5125	5MHz E-UTRA signal
20	$EIS_{\min SENS} + 6$ dB	$-52 - \Delta_{\min SENS}$	± 2.5025	5MHz E-UTRA signal
NOTE: $EIS_{\min SENS}$ depends on the <i>channel bandwidth</i> as specified see subclause 7.2.				

Table 7.5.5.3-4: Adjacent channel selectivity for Local Area BS

E-UTRA channel bandwidth of the lowest/highest carrier received [MHz]	Wanted signal mean power [dBm] (NOTE 1)	Interfering signal mean power [dBm]	Interfering signal centre frequency offset from the lower/upper Base Station RF Bandwidth edge or sub-block edge inside a sub-block gap [MHz]	Type of interfering signal
1.4	$EIS_{minSENS} + 11$ dB	$-44 - \Delta_{minSENS}$	± 0.7025	1.4MHz E-UTRA signal
3	$EIS_{minSENS} + 8$ dB	$-44 - \Delta_{minSENS}$	± 1.5075	3MHz E-UTRA signal
5	$EIS_{minSENS} + 6$ dB	$-44 - \Delta_{minSENS}$	± 2.5025	5MHz E-UTRA signal
10	$EIS_{minSENS} + 6$ dB	$-44 - \Delta_{minSENS}$	± 2.5075 ± 10.0175	5MHz E-UTRA signal (NOTE 2) 20 MHz E-UTRA signal (NOTE 3)
15	$EIS_{minSENS} + 6$ dB	$-44 - \Delta_{minSENS}$	± 2.5125	5MHz E-UTRA signal
20	$EIS_{minSENS} + 6$ dB	$-44 - \Delta_{minSENS}$	± 2.5025 ± 10.0175	5MHz E-UTRA signal (NOTE 2) 20 MHz E-UTRA signal (NOTE 3)

NOTE 1: $EIS_{minSENS}$ depends on the channel bandwidth as specified see subclause 7.2.
NOTE 2: This type of interfering signal is not applied for Band 46.
NOTE 3: This type of interfering signal is only applied for Band 46.

Table 7.5.5.3-5: Adjacent channel selectivity for Medium Range BS

E-UTRA channel bandwidth of the lowest/highest carrier received [MHz]	Wanted signal mean power [dBm] (NOTE 1)	Interfering signal mean power [dBm]	Interfering signal centre frequency offset to the lower/upper Base Station RF Bandwidth edge or sub-block edge inside a sub-block gap [MHz]	Type of interfering signal
1.4	$EIS_{minSENS} + 11$ dB	$-47 - \Delta_{minSENS}$	± 0.7025	1.4MHz E-UTRA signal
3	$EIS_{minSENS} + 8$ dB	$-47 - \Delta_{minSENS}$	± 1.5075	3MHz E-UTRA signal
5	$EIS_{minSENS} + 6$ dB	$-47 - \Delta_{minSENS}$	± 2.5025	5MHz E-UTRA signal
10	$EIS_{minSENS} + 6$ dB	$-47 - \Delta_{minSENS}$	± 2.5075 ± 10.0175	5MHz E-UTRA signal (NOTE 2) 20 MHz E-UTRA signal (NOTE 3)
15	$EIS_{minSENS} + 6$ dB	$-47 - \Delta_{minSENS}$	± 2.5125	5MHz E-UTRA signal
20	$EIS_{minSENS} + 6$ dB	$-47 - \Delta_{minSENS}$	± 2.5025 ± 10.0175	5MHz E-UTRA signal (NOTE 2) 20 MHz E-UTRA signal (NOTE 3)

NOTE 1: $EIS_{minSENS}$ depends on the channel bandwidth as specified see subclause 7.2.
NOTE 2: This type of interfering signal is not applied for Band 46.
NOTE 3: This type of interfering signal is only applied for Band 46.

NOTE: If the above Test Requirement differs from the Minimum Requirement then the Test Tolerance applied for this test is non-zero. The Test Tolerance for this test is defined in subclause 4.1.2 and the explanation of how the Minimum Requirement has been relaxed by the Test Tolerance is given in annex C.

7.6 OTA Blocking

7.6.1 General

The blocking characteristics are a measure of the receiver unit ability to receive a wanted signal at the RIB at its assigned channel in the presence of an unwanted interferer.

The requirement applies at the RIB when the AoA of the incident wave of the received signal and the interfering signal are the same direction and are within the *minSENS RoAoA*

The wanted signal applies to all supported polarizations, under the assumption of *polarization match*. The interferer shall be polarization matched for in-band frequencies and the polarization maintained for out-of-band frequencies.

7.6.2 General Requirement

7.6.2.1 Definition and applicability

7.6.2.2 Minimum Requirement

The minimum requirement for AAS BS in *MSR operation* is defined in TS 37.105 [6], subclause 10.6.2.

The minimum requirement for AAS BS in *single RAT UTRA operation* is defined in TS 37.105 [6], subclause 10.6.3.

The minimum requirement for AAS BS in *single RAT E-UTRA operation* is defined in TS 37.105 [6], subclause 10.6.4.

7.6.2.3 Test purpose

The test stresses the ability of the receiver unit associated with the RIB under test to withstand high-level interference from unwanted signals at specified frequency bands, without undue degradation of its sensitivity.

7.6.2.4 Method of test

7.6.2.4.1 Initial conditions

Test environment:

- normal; see annex G.2.

RF channels to be tested for single carrier (SC):

- M; see subclause 4.12.1

Base Station RF Bandwidth positions to be tested for multi-carrier (MC):

- M_{RFBW} for *single-band RIB*, see subclause 4.12.1, $B_{\text{RFBW_T_RFBW}}$ and $B'_{\text{RFBW_T_RFBW}}$ for *multi-band RIB*, see subclause 4.12.1.

In addition, for *multi-band RIB*:

- For $B_{\text{RFBW_T_RFBW}}$, blocking testing above the highest operating band may be omitted.
- For $B'_{\text{RFBW_T_RFBW}}$, blocking testing below the lowest operating band may be omitted.

Directions to be tested:

- OTA REFSSENS receiver target reference direction (see table 4.10-2, D11.30).

7.6.2.4.2 Procedure

7.6.2.4.2.1 General procedure

- 1) Place AAS BS and the test antenna(s) according to Annex D.2.4.
- 2) Place test antenna(s) in reference direction (see table 4.10-1, D10.9) at far-field distance, aligned in all supported polarizations with the AAS BS as depicted in Annex D.2.4.
- 3) Connect test antenna(s) to the measurement equipment as shown in Annex D.2.4.
- 4) The test antenna(s) shall be dual (or single) polarized covering the same frequency ranges as the AAS BS and the blocking frequencies. If the test antenna does not cover both the wanted and interfering signal frequencies, separate test antennas for the wanted and interfering signal are required.

- 5) The OTA blocking interferer is injected into the test antenna, with the blocking interferer producing specified interferer field strength level for each supported polarization. The interferer shall be *polarization matched* in-band and the polarization maintained for out-of-band frequencies.
- 6) The AAS BS receives the wanted signal and the interferer signal for supported polarization(s), in the reference direction (see table 4.10-1, D10.9) from the test antenna(s).

7.6.2.4.2.2 MSR operation

- 1) Generate the wanted signal from the test antenna, according to the applicable test configuration (see clause 5) using applicable reference measurement channel to the *RIB* under test as follows:
 - For E-UTRA see clause A.1 in 3GPP TS 36.141 [12].
 - For UTRA FDD see clause A.2 in 3GPP TS 25.141 [10].
 - For NR see clause A.1 in 3GPP TS 38.141-2 [34].

- 2) Set the transmitter unit(s) associated with the *RIB* under test to transmit in reference direction (see table 4.10-1, D10.9) with the carrier set-up and power allocation according to the applicable test configuration(s) (see clause 5).

The transmitter unit(s) associated with the *RIB* under test may be turned off for the out-of-band blocker tests when the frequency of the blocker is such that no IM2 or IM3 products fall inside the bandwidth of the wanted signal.

- 3) Adjust the signal generators to the type of interfering signals, levels and the frequency offsets as specified for general test requirements in table 7.6.2.5.1-1 and, when applicable, for co-location test requirements in table 7.6.3.5.1-1.

The distance between the test object and test antenna injecting the interferer signal is adjusted when necessary to ensure specified interferer signal level to be received.

- 4) The CW interfering signal shall be swept with a step size of 1 MHz within the specified range.
- 5) Measure the performance of the wanted signal at the receiver unit associated with the *RIB*, as defined in the subclause 7.6.5, for the relevant carriers specified by the test configuration in subclause 4.11.
- 6) Repeat for all supported polarizations.

In addition, for *multi-band RIB*, the following steps shall apply:

- 7) For *multi-band RIB* and single band tests, repeat the steps above per involved band where single band test configurations and test models shall apply with no carrier activated in the other band.

7.6.2.4.2.3 Single RAT UTRA FDD operation

- 1) Generate the wanted signal, from the test antenna, according to the applicable test configuration (see clause 5) using applicable reference measurement channel to the *RIB* under test as shown in subclause A.2.1 in 3GPP TS 25.141 [10].
- 2) Set the transmitter unit(s) associated with the *RIB* under test to transmit in reference direction (see table 4.10-1, D10.9) with the carrier set-up and power allocation according to the applicable test configuration(s) (see clause 5).

The transmitter unit(s) associated with the *RIB* under test may be turned off for the out-of-band blocker tests when the frequency of the blocker is such that no IM2 or IM3 products fall inside the bandwidth of the wanted signal.

- 3) Adjust the signal generators to the type of interfering signals and the frequency offsets as specified in tables 7.6.2.5.2-1 to 7.6.2.5.2-2 (in-band and narrowband blocking test requirements) and 7.6.3.5.2-1 (co-location test requirements). Note that the GMSK modulated interfering signal shall have an ACLR of at least 72 dB in order to eliminate the impact of interfering signal adjacent channel leakage power on the blocking characteristics measurement. For the tests defined in tables 7.6.2.5.2-1 to 7.6.2.5.2-2, the interfering signal shall be at a frequency offset F_{uw} from the assigned channel frequency of the wanted signal which is given by:

$$F_{uw} = \pm (n \times 1 \text{ MHz}),$$

where n shall be increased in integer steps from $n = 10$ up to such a value that the centre frequency of the interfering signal covers the range from 1 MHz to 12.75 GHz.

- 4) Measure the BER of the wanted signal at the receiver unit associated with the *RIB* under test.
- 5) Repeat for all supported polarizations.

In addition, for *multi-band RIB*, the following steps shall apply:

- 6) For *multi-band RIB* and single band tests, repeat the steps above per involved band where single band test configurations and test models shall apply with no carrier activated in the other band.

7.6.2.4.2.4 Single RAT E-UTRA operation

- 1) Generate the wanted signal from the test antenna, according to the applicable test configuration (see clause 5) using applicable reference measurement channel to the *RIB* under test as shown in clause A.1 in 3GPP TS 36.141 [6].
- 2) Set the transmitter unit(s) associated with the *RIB* under test to transmit in reference direction (see table 4.10-1, D10.9) with the carrier set-up and power allocation according to the applicable test configuration(s) (see clause 5).

The transmitter unit(s) associated with the *RIB* under test may be turned off for the out-of-band blocker tests when the frequency of the blocker is such that no IM2 or IM3 products fall inside the bandwidth of the wanted signal.

- 3) Adjust the signal generators to the type of interfering signals and the frequency offsets as specified in tables 7.6.2.5.3-1 to 7.6.2.5.3-2 (in-band blocking test requirements), 7.6.3.5.3-1 (co-location test requirements).
- 4) The CW interfering signal shall be swept with a step size of 1 MHz within the specified range.
- 5) Measure the performance of the wanted signal at the receiver unit associated with the *RIB*, as defined in the subclause 7.6.5, for the relevant carriers specified by the test configuration in subclause 4.11.
- 6) Repeat for all supported polarizations.

In addition, for *multi-band RIB*, the following steps shall apply:

- 7) For *multi-band RIB* and single band tests, repeat the steps above per involved band where single band test configurations and test models shall apply with no carrier activated in the other band.

7.6.2.5 Test Requirement

7.6.2.5.1 MSR operation

The OTA interfering signal RMS field-strength shall be set to 0.36 V/m at the base station RIB per polarization.

NOTE: The RMS field-strength level in V/m is related to the interferer EIRP level at a distance described as

$$E = \frac{\sqrt{30EIRP}}{r},$$

where EIRP is in W and r is in m; for example, 0.36 V/m is equivalent to 36 dBm at fixed distance of 30 m.

For a wanted and an interfering signal specified at the RIB using the parameters in table 7.6.2.5.1-1, the following requirements shall be met:

- For any E-UTRA carrier, the throughput shall be ≥ 95 % of the *maximum throughput* of the reference measurement channel defined in 3GPP TS 36.104 [9], subclause 7.2.1.
- For any UTRA FDD carrier, the BER shall not exceed 0.001 for the reference measurement channel defined in 3GPP TS 25.104 [2], subclause 7.2.1.

- For any NR carrier, the throughput shall be $\geq 95\%$ of the *maximum throughput* of the reference measurement channel defined in 3GPP TS 38.104 [33], subclause 7.2.1.

For *multi-band RIB*, the requirement applies for each supported operating band. The in-band blocking frequency ranges of all supported operating bands according to table 7.6.2.5.1-1 shall be excluded from the requirement.

The OTA blocking requirement applies from 30 MHz to $F_{UL_low} - \Delta f_{OOB}$ and from $F_{UL_high} + \Delta f_{OOB}$ up to 12750 MHz, including the downlink frequency range of the *FDD operating band* for BS supporting FDD. Δf_{OOB} is defined in subclause 7.5.1.

Table 7.6.2.5.1-1: Blocking performance requirement

Wanted signal mean power (dBm)	Interfering signal RMS field-strength (V/m)	Type of interfering signal
$EIS_{minSENS} + 6$ dB (Note 1)	0.36 V/m	CW carrier
NOTE 1: $EIS_{minSENS}$ depends on the RAT, the BS class and the <i>channel bandwidth</i> , see TS 37.105 [6] subclause 10.2.		
NOTE 2: Void		

7.6.2.5.2 Single RAT UTRA FDD operation

In addition to the following in-band and narrowband requirements, the general minimum requirements relating to out of band blocking defined for MSR in subclause 7.6.2.5.1-1 shall also be applied for single RAT UTRA operation.

The minimum requirement for in-band blocking and narrowband blocking UTRA operation is defined below:

The requirement is applicable outside the *Base Station RF Bandwidth* or *Radio Bandwidth*. The interfering signal offset is defined relative to the *Base Station RF Bandwidth edges* or *Radio Bandwidth edges* applicable to each *RIB*.

For *RIB* supporting operation in *non-contiguous spectrum*, the requirement applies in addition inside any *sub-block gap*, in case the *sub-block gap* size is at least 15MHz. The interfering signal offset is defined relative to the *sub-block edges* inside the *sub-block gap* and is equal to -7.5MHz/+7.5MHz, respectively.

For a *RIB* supporting operation in *non-contiguous spectrum* the narrowband blocking requirement applies in addition inside any *sub-block gap*, in case the *sub-block gap* size is at least 400kHz or 600kHz, depending on the operating band. The interfering signal offset is defined relative to the *sub-block edges* inside the *sub-block gap* and is equal to -200kHz/+200kHz or -300kHz/+300kHz, respectively.

For *multi-band RIBs* the requirement in the in-band blocking frequency range applies for each supported operating band. The requirement applies in addition inside any *Inter RF Bandwidth gap*, in case *Inter RF Bandwidth gap* size is at least 15MHz. The interfering signal offset is defined relative to lower/upper *Base Station RF Bandwidth edges* inside the *Inter RF Bandwidth gap* and is equal to -7.5MHz/+7.5MHz, respectively.

For *multi-band RIBs* the narrowband blocking requirement applies in addition inside any *Inter RF Bandwidth gap*, in case the *Inter RF Bandwidth gap* size is at least 400kHz or 600kHz, depending on the operating band. The interfering signal offset is defined relative to lower/upper *Base Station RF Bandwidth edges* inside the *Inter RF Bandwidth gap* and is equal to -200kHz/+200kHz or -300kHz/+300kHz, respectively.

For the wanted and interfering signal at the *RIB*, using the parameters in tables 7.6.2.5.2-1 and 7.6.2.5.2-2, the following requirements shall be met:

- For any UTRA FDD carrier, the BER shall not exceed 0.001 for the reference measurement channel defined in 3GPP TS 25.104 [2], subclause 7.2.1.

The OTA levels are applied referenced to two antenna gain offsets $\Delta_{OTAREFSENS}$ and $\Delta_{minSENS}$.

Table 7.6.2.5.2-1: In-band blocking requirement for single RAT UTRA AAS BS

Base Station Type	Mean power of interfering signal [dBm]	Wanted Signal mean power [dBm]	Minimum Offset of Interfering Signal	Type of Interfering Signal
Wide Area BS	$-40 - \Delta_{OTAREFSENS}$	$EIS_{REFSENS} + 6 \text{ dB}$	$\pm 10 \text{ MHz}$	WCDMA signal (NOTE 1)
	$-40 - \Delta_{minSENS}$	$EIS_{minSENS} + 6 \text{ dB}$		
Medium Range BS	$-35 - \Delta_{OTAREFSENS}$	$EIS_{REFSENS} + 6 \text{ dB}$		
	$-35 - \Delta_{minSENS}$	$EIS_{minSENS} + 6 \text{ dB}$		
Local Area BS	$-30 - \Delta_{OTAREFSENS}$	$EIS_{REFSENS} + 6 \text{ dB}$		
	$-30 - \Delta_{minSENS}$	$EIS_{minSENS} + 6 \text{ dB}$		
NOTE 1: The characteristics of the W-CDMA interference signal are specified in Annex C of TS 25.104 [2].				
NOTE 2: For <i>multi-band RIBs</i> , in case of interfering signal that is not in the in-band blocking frequency range of the operating band where the wanted signal is present, and not in an adjacent or overlapping band, the wanted signal mean power is equal to $-119.6 - \Delta_{OTAREFSENS}$ dBm or $-119.6 - \Delta_{minSENS}$ dBm as appropriate.				

NOTE: Table 7.6.2.5.2-1 assumes that two operating bands, where the downlink frequencies (see subclause 4.6) of one band would be within the in-band blocking region of the other band, are not deployed in the same geographical area.

Table 7.6.2.5.2-2: Blocking performance requirement (narrowband) for single RAT UTRA AAS BS

Base Station Type	Mean power of interfering signal [dBm]	Wanted Signal mean power [dBm]	Minimum Offset of Interfering Signal	Type of Interfering Signal
Wide Area BS	$-47 - \Delta_{OTAREFSENS}$	$EIS_{REFSENS} + 6 \text{ dB}$	$\pm 2.7 \text{ MHz}$ (NOTE 2) $\pm 2.8 \text{ MHz}$ (NOTE 3)	GMSK modulated (NOTE 1)
	$-47 - \Delta_{minSENS}$	$EIS_{minSENS} + 6 \text{ dB}$		
Medium Range BS	$-42 - \Delta_{OTAREFSENS}$	$EIS_{REFSENS} + 6 \text{ dB}$		
	$-42 - \Delta_{minSENS}$	$EIS_{minSENS} + 6 \text{ dB}$		
Local Area BS	$-37 - \Delta_{OTAREFSENS}$	$EIS_{REFSENS} + 6 \text{ dB}$		
	$-37 - \Delta_{minSENS}$	$EIS_{minSENS} + 6 \text{ dB}$		
NOTE 1: GMSK modulation as defined in TS 45.004 [32].				
NOTE 2: applies for bands II,IV,V,VIII,X,XII,XIV,XXV,XXVI				
NOTE 3: applies for bands III,VIII				

7.6.2.5.3 Single RAT E-UTRA operation

In addition to the following in-band and narrowband requirements, the general minimum requirements relating to out of band blocking defined for MSR in subclause 7.6.2.5.1-1 shall also be applied for single RAT E-UTRA operation.

The minimum requirement for in-band blocking E-UTRA operation is defined below:

The requirement is applicable outside the *Base Station RF Bandwidth* or *Radio Bandwidth*. The interfering signal offset is defined relative to the *Base Station RF Bandwidth edges* or *Radio Bandwidth edges* applicable to each *RIB*.

For *RIB* supporting operation in *non-contiguous spectrum*, the requirement applies in addition inside any *sub-block gap*, in case the *sub-block gap* size is at least 15 MHz. The interfering signal offset is defined relative to the *sub-block edges* inside the *sub-block gap*.

For *multi-band RIBs*, the requirement applies in addition inside any *Inter RF Bandwidth gap*, in case the gap size is at least 15 MHz. The interfering signal offset is defined relative to the *Base Station RF Bandwidth edges* inside the *Inter RF Bandwidth gap*.

For the wanted and interfering signal at the *RIB*, using the parameters in tables 7.6.2.5.3-1 and 7.6.2.5.3-2, the following requirements shall be met:

- For any E-UTRA carrier, the throughput shall be $\geq 95\%$ of the *maximum throughput* of the reference measurement channel defined in 3GPP TS 36.104 [4], subclause 7.2.1.

The OTA levels are applied referenced to two antenna gain offsets $\Delta_{\text{OTAREFSENS}}$ and Δ_{minSENS} .

For *multi-band RIBs*, the requirement applies according to table 7.6.2.5.3-1 for the in-band blocking frequency ranges of each supported operating band.

Table 7.6.2.5.3-1: In-band blocking requirement for single RAT E-UTRA

Base Station Type	Mean power of interfering signal [dBm]	Wanted Signal mean power [dBm] (NOTE 1,2)	Type of Interfering Signal	Interfering signal centre frequency minimum frequency offset from the <i>Base Station RF Bandwidth edge or edge of sub-block inside a gap</i> [MHz]
Wide Area BS	$-43 - \Delta_{\text{OTAREFSENS}}$	$\text{EIS}_{\text{REFSENS}} + 6 \text{ dB}$	See table 7.6.2.5.3-2	See table 7.6.2.5.3-2
	$-43 - \Delta_{\text{minSENS}}$	$\text{EIS}_{\text{minSENS}} + 6 \text{ dB}$		
Medium Range BS	$-38 - \Delta_{\text{OTAREFSENS}}$	$\text{EIS}_{\text{REFSENS}} + 6 \text{ dB}$		
	$-38 - \Delta_{\text{minSENS}}$	$\text{EIS}_{\text{minSENS}} + 6 \text{ dB}$		
Local Area BS	$-35 - \Delta_{\text{OTAREFSENS}}$	$\text{EIS}_{\text{REFSENS}} + 6 \text{ dB}$		
	$-35 - \Delta_{\text{minSENS}}$	$\text{EIS}_{\text{minSENS}} + 6 \text{ dB}$		
NOTE 1: $\text{EIS}_{\text{REFSENS}}$ and $\text{EIS}_{\text{minSENS}}$ depend on the RAT, the BS class and on the <i>channel bandwidth</i> , see subclauses 10.3 and 10.2 in TS 37.105 [6].				
NOTE 2: For <i>multi-band RIBs</i> , in case of interfering signal that is not in the in-band blocking frequency range of the operating band where the wanted signal is present, and not in an adjacent or overlapping band, the wanted signal mean power is equal to $\text{EIS}_{\text{REFSENS}} + 1.4 \text{ dB}$ or $\text{EIS}_{\text{minSENS}} + 1.4 \text{ dB}$ as appropriate.				

Table 7.6.2.5.3-2: Interfering signals for single RAT E-UTRA in-band blocking performance requirement

E-UTRA channel BW of the lowest/highest carrier received [MHz]	Interfering signal centre frequency minimum offset to the lower/upper <i>Base Station RF Bandwidth edge or sub-block edge inside a sub-block gap</i> [MHz]	Type of interfering signal
1.4	± 2.1	1.4 MHz E-UTRA signal
3	± 4.5	3 MHz E-UTRA signal
5	± 7.5	5 MHz E-UTRA signal
10	± 7.5	5 MHz E-UTRA signal
15	± 7.5	5 MHz E-UTRA signal
20	± 7.5	5 MHz E-UTRA signal
20	± 30	20 MHz E-UTRA signal

7.6.3 Co-location Requirement

7.6.3.1 Definition and applicability

This additional blocking requirement may be applied for the protection of *AAS BS receivers* when E-UTRA BS, UTRA BS, NR BS, CDMA BS or GSM/EDGE BS operating in a different frequency band are co-located with an AAS BS.

The requirement is a co-location requirement. The interferer power levels are specified at the CLTA conducted input(s).

Interfering signal shall be applied to the CLTA. The interfering power is specified per polarization.

7.6.3.2 Minimum Requirement

The minimum requirement for AAS BS in *MSR operation* is defined in TS 37.105 [6], subclause 10.6.2.

The minimum requirement for AAS BS in *single RAT UTRA operation* is defined in TS 37.105 [6], subclause 10.6.3.

The minimum requirement for AAS BS in *single RAT E-UTRA operation* is defined in TS 37.105 [6], subclause 10.6.4.

7.6.3.3 Test purpose

The test stresses the ability of the receiver unit associated with the *RIB* under test to withstand high-level interference from unwanted signals at specified frequency bands, without undue degradation of its sensitivity.

7.6.3.4 Method of test

7.6.3.4.1 Initial conditions

Initial conditions according to sub-clause 7.6.2.4.1.

7.6.3.4.2 Procedure

- 1) Place *AAS BS* and CLTA as specified in sub-clause 4.15, at the distance $d=0.1\text{m}$.
- 2) Several CLTAs are required to cover the whole co-location blocking frequency ranges.
- 3) Place test antenna in reference direction (see table 4.10-1, D10.9) at far-field distance, aligned in all supported polarizations (single or dual) with the *AAS BS* as depicted in Annex D.2.4.
- 4) The test antenna shall be dual (or single) polarized, with the same frequency range as the *AAS BS*, for the co-location blocking test case.
- 5) Connect test antenna and CLTA to the measurement equipment as depicted in Annex D.2.4.
- 6) The *AAS BS* receives the wanted signal in all supported polarizations (single or dual), in the reference direction (see table 4.10-1, D10.9) from the test antenna.
- 7) The OTA co-location blocking interferer is injected into the CLTA. The CLTA is fed with the co-location blocking interferer.

7.6.3.4.2.1 MSR operation

See sub-clause 7.6.2.4.2.2.

7.6.3.4.2.2 Single RAT UTRA FDD operation

See sub-clause 7.6.2.4.2.3.

7.6.3.4.2.3 Single RAT E-UTRA operation

See sub-clause 7.6.2.4.2.4.

7.6.3.5 Test Requirement

7.6.3.5.1 MSR operation

This additional blocking requirement may be applied for the protection of *AAS BS receivers* when E-UTRA BS, UTRA BS, NR BS, CDMA BS or GSM/EDGE BS operating in a different frequency band are co-located with an *AAS BS*.

The requirement is a co-location requirement, the interferer power levels specified at the CLTA conducted input(s).

The requirement is valid over *minSENS RoAoA*.

Interfering signal shall be applied to the CLTA. The interfering power is specified per polarization.

When the wanted and an interfering signal using the parameters in table 7.6.3.5.1-1, the following requirements shall be met:

- For any E-UTRA carrier, the throughput shall be ≥ 95 % of the *maximum throughput* of the reference measurement channel defined in 3GPP TS 36.104 [9], subclause 7.2.1.
- For any UTRA FDD carrier, the BER shall not exceed 0.001 for the reference measurement channel defined in 3GPP TS 25.104 [2], subclause 7.2.1.
- For any NR carrier, the throughput shall be ≥ 95 % of the *maximum throughput* of the reference measurement channel defined in 3GPP TS 38.104 [33], subclause 7.2.1.

Table 7.6.3.5.1-1: Blocking requirement for co-location with BS in other frequency bands

Type of co-located BS	Centre Frequency of Interfering Signal [MHz]	Interfering Signal mean power for WA BS [dBm]	Interfering Signal mean power for MR BS [dBm]	Interfering Signal mean power for LA BS [dBm]	Wanted Signal mean power [dBm]	Type of Interfering Signal
GSM850 or CDMA850	869 – 894	+46	+38	+24	$EIS_{minSENS} + x$ dB (NOTE 1)	CW carrier
GSM900	921 – 960	+46	+38	+24	$EIS_{minSENS} + x$ dB (NOTE 1)	CW carrier
DCS1800	1805 - 1880 (NOTE 4)	+46	+38	+24	$EIS_{minSENS} + x$ dB (NOTE 1)	CW carrier
PCS1900	1930 – 1990	+46	+38	+24	$EIS_{minSENS} + x$ dB (NOTE 1)	CW carrier
UTRA FDD Band I or E-UTRA Band 1 or NR band n1	2110 – 2170	+46	+38	+24	$EIS_{minSENS} + x$ dB (NOTE 1)	CW carrier
UTRA FDD Band II or E-UTRA Band 2 or NR band n2	1930 – 1990	+46	+38	+24	$EIS_{minSENS} + x$ dB (NOTE 1)	CW carrier
UTRA FDD Band III or E-UTRA Band 3 or NR band n3	1805 - 1880 (NOTE 4)	+46	+38	+24	$EIS_{minSENS} + x$ dB (NOTE 1)	CW carrier
UTRA FDD Band IV or E-UTRA Band 4	2110 – 2155	+46	+38	+24	$EIS_{minSENS} + x$ dB (NOTE 1)	CW carrier
UTRA FDD Band V or E-UTRA Band 5 or NR band n5	869 – 894	+46	+38	+24	$EIS_{minSENS} + x$ dB (NOTE 1)	CW carrier
UTRA FDD Band VI or E-UTRA Band 6	875 – 885	+46	+38	+24	$EIS_{minSENS} + x$ dB (NOTE 1)	CW carrier
UTRA FDD Band VII or E-UTRA Band 7 or NR band n7	2620 – 2690	+46	+38	+24	$EIS_{minSENS} + x$ dB (NOTE 1)	CW carrier
UTRA FDD Band VIII or E-UTRA Band 8 or NR band n8	925 – 960	+46	+38	+24	$EIS_{minSENS} + x$ dB (NOTE 1)	CW carrier
UTRA FDD Band IX or E-UTRA Band 9	1844.9 - 1879.9	+46	+38	+24	$EIS_{minSENS} + x$ dB (NOTE 1)	CW carrier
UTRA FDD Band X or E-UTRA Band 10	2110 – 2170	+46	+38	+24	$EIS_{minSENS} + x$ dB (NOTE 1)	CW carrier
UTRA FDD Band XI or E-UTRA Band 11	1475.9 - 1495.9	+46	+38	+24	$EIS_{minSENS} + x$ dB (NOTE 1)	CW carrier
UTRA FDD Band XII or E-UTRA Band 12 or NR band n12	729 – 746	+46	+38	+24	$EIS_{minSENS} + x$ dB (NOTE 1)	CW carrier
UTRA FDD Band XIII or E-UTRA Band 13	746 – 756	+46	+38	+24	$EIS_{minSENS} + x$ dB (NOTE 1)	CW carrier
UTRA FDD Band XIV or E-UTRA Band 14	758 – 768	+46	+38	+24	$EIS_{minSENS} + x$ dB (NOTE 1)	CW carrier
E-UTRA Band 17	734 – 746	+46	+38	+24	$EIS_{minSENS} + x$ dB (NOTE 1)	CW carrier
E-UTRA Band 18	860 – 875	+46	+38	+24	$EIS_{minSENS} + x$ dB (NOTE 1)	CW carrier
UTRA FDD Band XIX or E-UTRA Band 19	875 – 890	+46	+38	+24	$EIS_{minSENS} + x$ dB (NOTE 1)	CW carrier
UTRA FDD Band XX or E-UTRA Band 20 or NR band n20	791 – 821	+46	+38	+24	$EIS_{minSENS} + x$ dB (NOTE 1)	CW carrier
UTRA FDD Band XXI or E-UTRA Band 21	1495.9 - 1510.9	+46	+38	+24	$EIS_{minSENS} + x$ dB (NOTE 1)	CW carrier
UTRA FDD Band XXII or E-UTRA Band 22	3510 - 3 590	+46	+38	+24	$EIS_{minSENS} + x$ dB (NOTE 1)	CW carrier
E-UTRA Band 23	2180 – 2200	+46	+38	+24	$EIS_{minSENS} + x$ dB (NOTE 1)	CW carrier
E-UTRA Band 24	1525 – 1559	+46	+38	+24	$EIS_{minSENS} + x$ dB (NOTE 1)	CW carrier

Type of co-located BS	Centre Frequency of Interfering Signal [MHz]	Interfering Signal mean power for WA BS [dBm]	Interfering Signal mean power for MR BS [dBm]	Interfering Signal mean power for LA BS [dBm]	Wanted Signal mean power [dBm]	Type of Interfering Signal
UTRA FDD Band XXV or E-UTRA Band 25 or NR band n25	1930 – 1995	+46	+38	+24	$EIS_{minSENS} + x$ dB (NOTE 1)	CW carrier
UTRA FDD Band XXVI or E-UTRA Band 26	859 – 894	+46	+38	+24	$EIS_{minSENS} + x$ dB (NOTE 1)	CW carrier
E-UTRA Band 27	852 – 869	+46	+38	+24	$EIS_{minSENS} + x$ dB (NOTE 1)	CW carrier
E-UTRA Band 28 or NR band n28	758 – 803	+46	+38	+24	$EIS_{minSENS} + x$ dB (NOTE 1)	CW carrier
E-UTRA Band 29	717 – 728	+46	+38	+24	$EIS_{minSENS} + x$ dB (NOTE 1)	CW carrier
E-UTRA Band 30	2350 – 2360	+46	+38	+24	$EIS_{minSENS} + x$ dB (NOTE 1)	CW carrier
E-UTRA Band 31	462.5 - 467.5	+46	+38	+24	$EIS_{minSENS} + x$ dB (NOTE 1)	CW carrier
UTRA FDD Band XXXII or E-UTRA Band 32	1452 - 1496 (NOTE-5)	+46	+38	+24	$EIS_{minSENS} + x$ dB (NOTE 1)	CW carrier
UTRA TDD Band a) or E-UTRA TDD Band 33	1900 – 1920	+46	+38	+24	$EIS_{minSENS} + x$ dB (NOTE 1)	CW carrier
UTRA TDD Band a) or E-UTRA TDD Band 34 or NR band n34	2010 – 2025	+46	+38	+24	$EIS_{minSENS} + x$ dB (NOTE 1)	CW carrier
UTRA TDD Band b) or E-UTRA TDD Band 35	1850 – 1910	+46	+38	+24	$EIS_{minSENS} + x$ dB (NOTE 1)	CW carrier
UTRA TDD Band b) or E-UTRA TDD Band 36	1930 – 1990	+46	+38	+24	$EIS_{minSENS} + x$ dB (NOTE 1)	CW carrier
UTRA TDD Band c) or E-UTRA TDD Band 37	1910 – 1930	+46	+38	+24	$EIS_{minSENS} + x$ dB (NOTE 1)	CW carrier
UTRA TDD Band d) or E-UTRA Band 38 or NR band n38	2570 – 2620	+46	+38	+24	$EIS_{minSENS} + x$ dB (NOTE 1)	CW carrier
UTRA TDD Band f) or E-UTRA Band 39 or NR band n39	1880 – 1920	+46	+38	+24	$EIS_{minSENS} + x$ dB (NOTE 1)	CW carrier
UTRA TDD Band e) or E-UTRA Band 40 or NR band n40	2300 – 2400	+46	+38	+24	$EIS_{minSENS} + x$ dB (NOTE 1)	CW carrier
E-UTRA Band 41 or NR band n41	2496 – 2690	+46	+38	+24	$EIS_{minSENS} + x$ dB (NOTE 1)	CW carrier
E-UTRA Band 42	3400 – 3600	+46	+38	+24	$EIS_{minSENS} + x$ dB (NOTE 1)	CW carrier
E-UTRA Band 43	3600 – 3800	+46	+38	+24	$EIS_{minSENS} + x$ dB (NOTE 1)	CW carrier
E-UTRA Band 44	703 – 803	+46	+38	+24	$EIS_{minSENS} + x$ dB (NOTE 1)	CW carrier
E-UTRA Band 45	1447 - 1467	+46	+38	+24	$EIS_{minSENS} + x$ dB (NOTE 1)	CW carrier
E-UTRA Band 46	5150 - 5925	N/A	+38	+24	$EIS_{minSENS} + x$ dB (NOTE 1)	CW carrier
E-UTRA Band 48	3550 – 3700	+46	+38	+24	$EIS_{minSENS} + x$ dB (NOTE 1)	CW carrier
E-UTRA Band 49	3550 – 3700	N/A	N/A	+24	$EIS_{minSENS} + x$ dB (NOTE 1)	CW carrier
E-UTRA Band 50 or NR band n50	1432 – 1517	+46	+38	+24	$EIS_{minSENS} + x$ dB (NOTE 1)	CW carrier

Type of co-located BS	Centre Frequency of Interfering Signal [MHz]	Interfering Signal mean power for WA BS [dBm]	Interfering Signal mean power for MR BS [dBm]	Interfering Signal mean power for LA BS [dBm]	Wanted Signal mean power [dBm]	Type of Interfering Signal
E-UTRA Band 51 or or NR band n51	1427– 1432	N/A	N/A	+24	$EIS_{minSENS} + x$ dB (NOTE 1)	CW carrier
E-UTRA Band 52	3300 - 3400	+46	+38	+24	$EIS_{minSENS} + x$ dB (NOTE 1)	CW carrier
E-UTRA Band 65	2110 – 2200	+46	+38	+24	$EIS_{minSENS} + x$ dB (NOTE 1)	CW carrier
E-UTRA Band 66 or or NR band n66	2110 – 2200	+46	+38	+24	$EIS_{minSENS} + x$ dB (NOTE 1)	CW carrier
E-UTRA Band 67	738 - 758	+46	+38	+24	$EIS_{minSENS} + x$ dB (NOTE 1)	CW carrier
E-UTRA Band 68	753 - 783	+46	+38	+24	$EIS_{minSENS} + x$ dB (NOTE 1)	CW carrier
E-UTRA Band 69	2570-2620	+46	+38	+24	$EIS_{minSENS} + x$ dB (NOTE 1)	CW carrier
E-UTRA Band 70 or or NR band n70	1995 - 2020	+46	+38	+24	$EIS_{minSENS} + x$ dB (NOTE 1)	CW carrier
E-UTRA Band 71 or or NR band n71	617 - 652	+46	+38	+24	$EIS_{minSENS} + x$ dB (NOTE 1)	CW carrier
E-UTRA Band 72	461 - 466	+46	+38	+24	$EIS_{minSENS} + x$ dB (NOTE 1)	CW carrier
E-UTRA Band 73	460 - 465	+46	+38	+24	$EIS_{minSENS} + x$ dB (NOTE 1)	CW carrier
E-UTRA Band 74 or NR band n74	1475 - 1518	+46	+38	+24	$EIS_{minSENS} + x$ dB (NOTE 1)	CW carrier
E-UTRA Band 75 or or NR band n75	1432 - 1517	+46	+38	+24	$EIS_{minSENS} + x$ dB (NOTE 1)	CW carrier
E-UTRA Band 76 or or NR band n76	1427 - 1432	N/A	N/A	+24	$EIS_{minSENS} + x$ dB (NOTE 1)	CW carrier
NR band n77	3300 - 4200	+46	+38	+24	$EIS_{minSENS} + x$ dB (NOTE 1)	CW carrier
NR band n78	3300 - 3800	+46	+38	+24	$EIS_{minSENS} + x$ dB (NOTE 1)	CW carrier
NR band n79	4400 - 5000	+46	+38	+24	$EIS_{minSENS} + x$ dB (NOTE 1)	CW carrier
E-UTRA Band 85	728 - 746	+46	+38	+24	$EIS_{minSENS} + x$ dB (NOTE 1)	CW carrier
<p>NOTE 1: $EIS_{minSENS}$ depends on the RAT, the BS class and on the <i>channel bandwidth</i>, see subclauses 10.3 and 10.2 in TS 37.105; "x" is equal to 6 dB in case of E-UTRA or UTRA wanted signals.</p> <p>NOTE 2: Except for a BS operating in Band 13, these requirements do not apply when the interfering signal falls within any of the supported <i>uplink operating band</i> or in the Δf_{OoB} immediately outside any of the supported <i>uplink operating band</i>. For a BS operating in band 13 the requirements do not apply when the interfering signal falls within the frequency range 768 - 797 MHz.</p> <p>NOTE 3: Some combinations of bands may not be possible to co-site based on the requirements above. The current state-of-the-art technology does not allow a single generic solution for co-location of UTRA TDD or E-UTRA TDD or NR TDD with E-UTRA FDD on adjacent frequencies for 30dB BS-BS minimum coupling loss. However, there are certain site-engineering solutions that can be used. These techniques are addressed in 3GPP TR 25.942 [31].</p> <p>NOTE 4: In China, the blocking requirement for co-location with DCS1800 and Band III BS is only applicable in the frequency range 1805 - 1850 MHz.</p> <p>NOTE 5: For an AAS BS operating in band 11 or 21, this requirement applies for interfering signal within the frequency range 1475.9 - 1495.9 MHz.</p>						

7.6.3.5.2 Single RAT UTRA FDD operation

This additional blocking requirement may be applied for the protection of AAS BS receivers when E-UTRA BS, UTRA BS, CDMA BS or GSM/EDGE BS operating in a different frequency band are co-located with an AAS BS.

The requirement is a co-location requirement, the interferer power levels specified at the CLTA conducted input(s).

The requirement is valid over *minSENS RoAoA*.

Interfering signal shall be applied to the CLTA. The interfering power is specified per polarization.

When the wanted and an interfering signal using the parameters in table 7.6.3.5.1-1 for co-location with UTRA or E-UTRA systems and table 7.6.3.5.2-1 for co-location with GSM systems, the following requirements shall be met:

- For any UTRA FDD carrier, the BER shall not exceed 0.001 for the reference measurement channel defined in 3GPP TS 25.104 [2], subclause 7.2.1.

Table 7.6.3.5.2-1: UTRA additional OTA blocking requirement for co-location with BS in other frequency bands

Type of co-located BS	Centre Frequency of Interfering Signal [MHz]	Interfering Signal mean power for WA BS [dBm]	Interfering Signal mean power for MR BS [dBm]	Interfering Signal mean power for LA BS [dBm]	Wanted Signal mean power [dBm]	Type of Interfering Signal
GSM850 or CDMA850	869 – 894	+46	+38	+24	$EIS_{minSENS} + x$ dB (NOTE 1)	CW carrier
GSM900	921 – 960	+46	+38	+24	$EIS_{minSENS} + x$ dB (NOTE 1)	CW carrier
DCS1800	1805 - 1880 (NOTE 4)	+46	+38	+24	$EIS_{minSENS} + x$ dB (NOTE 1)	CW carrier
PCS1900	1930 – 1990	+46	+38	+24	$EIS_{minSENS} + x$ dB (NOTE 1)	CW carrier
UTRA FDD Band I or E-UTRA Band 1 or NR band n1	2110 – 2170	+46	+38	+24	$EIS_{minSENS} + x$ dB (NOTE 1)	CW carrier
UTRA FDD Band II or E-UTRA Band 2 or NR band n2	1930 – 1990	+46	+38	+24	$EIS_{minSENS} + x$ dB (NOTE 1)	CW carrier
UTRA FDD Band III or E-UTRA Band 3 or NR band n3	1805 - 1880 (NOTE 4)	+46	+38	+24	$EIS_{minSENS} + x$ dB (NOTE 1)	CW carrier
UTRA FDD Band IV or E-UTRA Band 4	2110 – 2155	+46	+38	+24	$EIS_{minSENS} + x$ dB (NOTE 1)	CW carrier
UTRA FDD Band V or E-UTRA Band 5 or NR band n5	869 – 894	+46	+38	+24	$EIS_{minSENS} + x$ dB (NOTE 1)	CW carrier
UTRA FDD Band VI or E-UTRA Band 6	875 – 885	+46	+38	+24	$EIS_{minSENS} + x$ dB (NOTE 1)	CW carrier
UTRA FDD Band VII or E-UTRA Band 7 or NR band n7	2620 – 2690	+46	+38	+24	$EIS_{minSENS} + x$ dB (NOTE 1)	CW carrier
UTRA FDD Band VIII or E-UTRA Band 8 or NR band n8	925 – 960	+46	+38	+24	$EIS_{minSENS} + x$ dB (NOTE 1)	CW carrier
UTRA FDD Band IX or E-UTRA Band 9	1844.9 - 1879.9	+46	+38	+24	$EIS_{minSENS} + x$ dB (NOTE 1)	CW carrier
UTRA FDD Band X or E-UTRA Band 10	2110 – 2170	+46	+38	+24	$EIS_{minSENS} + x$ dB (NOTE 1)	CW carrier
UTRA FDD Band XI or E-UTRA Band 11	1475.9 - 1495.9	+46	+38	+24	$EIS_{minSENS} + x$ dB (NOTE 1)	CW carrier
UTRA FDD Band XII or E-UTRA Band 12 or NR band n12	729 – 746	+46	+38	+24	$EIS_{minSENS} + x$ dB (NOTE 1)	CW carrier
UTRA FDD Band XIII or E-UTRA Band 13	746 – 756	+46	+38	+24	$EIS_{minSENS} + x$ dB (NOTE 1)	CW carrier
UTRA FDD Band XIV or E-UTRA Band 14	758 – 768	+46	+38	+24	$EIS_{minSENS} + x$ dB (NOTE 1)	CW carrier
E-UTRA Band 17	734 – 746	+46	+38	+24	$EIS_{minSENS} + x$ dB (NOTE 1)	CW carrier
E-UTRA Band 18	860 – 875	+46	+38	+24	$EIS_{minSENS} + x$ dB (NOTE 1)	CW carrier
UTRA FDD Band XIX or E-UTRA Band 19	875 – 890	+46	+38	+24	$EIS_{minSENS} + x$ dB (NOTE 1)	CW carrier
UTRA FDD Band XX or E-UTRA Band 20 or NR band n20	791 – 821	+46	+38	+24	$EIS_{minSENS} + x$ dB (NOTE 1)	CW carrier
UTRA FDD Band XXI or E-UTRA Band 21	1495.9 - 1510.9	+46	+38	+24	$EIS_{minSENS} + x$ dB (NOTE 1)	CW carrier
UTRA FDD Band XXII or E-UTRA Band 22	3510 - 3 590	+46	+38	+24	$EIS_{minSENS} + x$ dB (NOTE 1)	CW carrier
E-UTRA Band 23	2180 – 2200	+46	+38	+24	$EIS_{minSENS} + x$ dB (NOTE 1)	CW carrier
E-UTRA Band 24	1525 – 1559	+46	+38	+24	$EIS_{minSENS} + x$ dB (NOTE 1)	CW carrier

Type of co-located BS	Centre Frequency of Interfering Signal [MHz]	Interfering Signal mean power for WA BS [dBm]	Interfering Signal mean power for MR BS [dBm]	Interfering Signal mean power for LA BS [dBm]	Wanted Signal mean power [dBm]	Type of Interfering Signal
UTRA FDD Band XXV or E-UTRA Band 25 or NR band n25	1930 – 1995	+46	+38	+24	$EIS_{minSENS} + x$ dB (NOTE 1)	CW carrier
UTRA FDD Band XXVI or E-UTRA Band 26	859 – 894	+46	+38	+24	$EIS_{minSENS} + x$ dB (NOTE 1)	CW carrier
E-UTRA Band 27	852 – 869	+46	+38	+24	$EIS_{minSENS} + x$ dB (NOTE 1)	CW carrier
E-UTRA Band 28 or NR band n28	758 – 803	+46	+38	+24	$EIS_{minSENS} + x$ dB (NOTE 1)	CW carrier
E-UTRA Band 29	717 – 728	+46	+38	+24	$EIS_{minSENS} + x$ dB (NOTE 1)	CW carrier
E-UTRA Band 30	2350 – 2360	+46	+38	+24	$EIS_{minSENS} + x$ dB (NOTE 1)	CW carrier
E-UTRA Band 31	462.5 - 467.5	+46	+38	+24	$EIS_{minSENS} + x$ dB (NOTE 1)	CW carrier
UTRA FDD Band XXXII or E-UTRA Band 32	1452 - 1496 (NOTE-5)	+46	+38	+24	$EIS_{minSENS} + x$ dB (NOTE 1)	CW carrier
UTRA TDD Band a) or E-UTRA TDD Band 33	1900 – 1920	+46	+38	+24	$EIS_{minSENS} + x$ dB (NOTE 1)	CW carrier
UTRA TDD Band a) or E-UTRA TDD Band 34 or NR band n34	2010 – 2025	+46	+38	+24	$EIS_{minSENS} + x$ dB (NOTE 1)	CW carrier
UTRA TDD Band b) or E-UTRA TDD Band 35	1850 – 1910	+46	+38	+24	$EIS_{minSENS} + x$ dB (NOTE 1)	CW carrier
UTRA TDD Band b) or E-UTRA TDD Band 36	1930 – 1990	+46	+38	+24	$EIS_{minSENS} + x$ dB (NOTE 1)	CW carrier
UTRA TDD Band c) or E-UTRA TDD Band 37	1910 – 1930	+46	+38	+24	$EIS_{minSENS} + x$ dB (NOTE 1)	CW carrier
UTRA TDD Band d) or E-UTRA Band 38 or NR band n38	2570 – 2620	+46	+38	+24	$EIS_{minSENS} + x$ dB (NOTE 1)	CW carrier
UTRA TDD Band f) or E-UTRA Band 39 or NR band n39	1880 – 1920	+46	+38	+24	$EIS_{minSENS} + x$ dB (NOTE 1)	CW carrier
UTRA TDD Band e) or E-UTRA Band 40 or NR band n40	2300 – 2400	+46	+38	+24	$EIS_{minSENS} + x$ dB (NOTE 1)	CW carrier
E-UTRA Band 41 or NR band n41	2496 – 2690	+46	+38	+24	$EIS_{minSENS} + x$ dB (NOTE 1)	CW carrier
E-UTRA Band 42	3400 – 3600	+46	+38	+24	$EIS_{minSENS} + x$ dB (NOTE 1)	CW carrier
E-UTRA Band 43	3600 – 3800	+46	+38	+24	$EIS_{minSENS} + x$ dB (NOTE 1)	CW carrier
E-UTRA Band 44	703 – 803	+46	+38	+24	$EIS_{minSENS} + x$ dB (NOTE 1)	CW carrier
E-UTRA Band 45	1447 - 1467	+46	+38	+24	$EIS_{minSENS} + x$ dB (NOTE 1)	CW carrier
E-UTRA Band 46	5150 - 5925	N/A	+38	+24	$EIS_{minSENS} + x$ dB (NOTE 1)	CW carrier
E-UTRA Band 48	3550 – 3700	+46	+38	+24	$EIS_{minSENS} + x$ dB (NOTE 1)	CW carrier
E-UTRA Band 49	3550 – 3700	N/A	N/A	+24	$EIS_{minSENS} + x$ dB (NOTE 1)	CW carrier
E-UTRA Band 50 or NR band n50	1432 – 1517	+46	+38	+24	$EIS_{minSENS} + x$ dB (NOTE 1)	CW carrier

Type of co-located BS	Centre Frequency of Interfering Signal [MHz]	Interfering Signal mean power for WA BS [dBm]	Interfering Signal mean power for MR BS [dBm]	Interfering Signal mean power for LA BS [dBm]	Wanted Signal mean power [dBm]	Type of Interfering Signal
E-UTRA Band 51 or or NR band n51	1427– 1432	N/A	N/A	+24	$EIS_{minSENS} + x$ dB (NOTE 1)	CW carrier
E-UTRA Band 52	3300 - 3400	+46	+38	+24	$EIS_{minSENS} + x$ dB (NOTE 1)	CW carrier
E-UTRA Band 65	2110 – 2200	+46	+38	+24	$EIS_{minSENS} + x$ dB (NOTE 1)	CW carrier
E-UTRA Band 66 or or NR band n66	2110 – 2200	+46	+38	+24	$EIS_{minSENS} + x$ dB (NOTE 1)	CW carrier
E-UTRA Band 67	738 - 758	+46	+38	+24	$EIS_{minSENS} + x$ dB (NOTE 1)	CW carrier
E-UTRA Band 68	753 - 783	+46	+38	+24	$EIS_{minSENS} + x$ dB (NOTE 1)	CW carrier
E-UTRA Band 69	2570-2620	+46	+38	+24	$EIS_{minSENS} + x$ dB (NOTE 1)	CW carrier
E-UTRA Band 70 or or NR band n70	1995 - 2020	+46	+38	+24	$EIS_{minSENS} + x$ dB (NOTE 1)	CW carrier
E-UTRA Band 71 or or NR band n71	617 - 652	+46	+38	+24	$EIS_{minSENS} + x$ dB (NOTE 1)	CW carrier
E-UTRA Band 72	461 - 466	+46	+38	+24	$EIS_{minSENS} + x$ dB (NOTE 1)	CW carrier
E-UTRA Band 73	460 - 465	+46	+38	+24	$EIS_{minSENS} + x$ dB (NOTE 1)	CW carrier
E-UTRA Band 74 or NR band n74	1475 - 1518	+46	+38	+24	$EIS_{minSENS} + x$ dB (NOTE 1)	CW carrier
E-UTRA Band 75 or or NR band n75	1432 - 1517	+46	+38	+24	$EIS_{minSENS} + x$ dB (NOTE 1)	CW carrier
E-UTRA Band 76 or or NR band n76	1427 - 1432	N/A	N/A	+24	$EIS_{minSENS} + x$ dB (NOTE 1)	CW carrier
NR band n77	3300 - 4200	+46	+38	+24	$EIS_{minSENS} + x$ dB (NOTE 1)	CW carrier
NR band n78	3300 - 3800	+46	+38	+24	$EIS_{minSENS} + x$ dB (NOTE 1)	CW carrier
NR band n79	4400 - 5000	+46	+38	+24	$EIS_{minSENS} + x$ dB (NOTE 1)	CW carrier
E-UTRA Band 85	728 – 746	+46	+38	+24	$EIS_{minSENS} + x$ dB (NOTE 1)	CW carrier

NOTE 1: $EIS_{minSENS}$ depends on the BS class and on the *channel bandwidth*, see subclauses 10.2 in TS 37.105; "x" is equal to 6 dB in case of UTRA wanted signals.

NOTE 2: Except for a BS operating in Band XIII, these requirements do not apply when the interfering signal falls within any of the supported *uplink operating band* or in the 10 MHz immediately outside any of the supported *uplink operating band*.
For a BS operating in band XIII the requirements do not apply when the interfering signal falls within the frequency range 768 - 797 MHz.

NOTE 3: Some combinations of bands may not be possible to co-site based on the requirements above. The current state-of-the-art technology does not allow a single generic solution for co-location of UTRA TDD on adjacent frequencies for 30dB BS-BS minimum coupling loss. However, there are certain site-engineering solutions that can be used. These techniques are addressed in 3GPP TR 25.942 [31].

NOTE 4: In China, the blocking requirement for co-location with DCS1800 and Band III BS is only applicable in the frequency range 1805 - 1850 MHz.

NOTE 5: For an AAS BS operating in band XI, this requirement applies for interfering signal within the frequency range 1475.9 - 1495.9 MHz.

7.6.3.5.3 Single RAT E-UTRA operation

This additional blocking requirement may be applied for the protection of AAS BS receivers when E-UTRA BS, UTRA BS, CDMA BS or GSM/EDGE BS operating in a different frequency band are co-located with an AAS BS.

The requirement is a co-location requirement, the interferer power levels specified at the CLTA conducted input(s).

The requirement is valid over *minSENS RoAoA*.

Interfering signal shall be applied to the CLTA. The interfering power is specified per polarization.

When the wanted and an interfering signal using the parameters in table 7.6.3.5.1-1 for co-location with UTRA or E-UTRA systems and table 7.6.3.5.3-1 for co-location with GSM systems, the following requirements shall be met:

- For any E-UTRA carrier, the throughput shall be ≥ 95 % of the *maximum throughput* of the reference measurement channel defined in 3GPP TS 36.104 [9], subclause 7.2.1.

Table 7.6.3.5.3-1: E-UTRA additional OTA blocking requirement for co-location with BS in other frequency bands

Type of co-located BS	Centre Frequency of Interfering Signal [MHz]	Interfering Signal mean power for WA BS [dBm]	Interfering Signal mean power for MR BS [dBm]	Interfering Signal mean power for LA BS [dBm]	Wanted Signal mean power [dBm]	Type of Interfering Signal
GSM850 or CDMA850	869 – 894	+46	+38	+24	$EIS_{minSENS} + x$ dB (NOTE 1)	CW carrier
GSM900	921 – 960	+46	+38	+24	$EIS_{minSENS} + x$ dB (NOTE 1)	CW carrier
DCS1800	1805 - 1880 (NOTE 4)	+46	+38	+24	$EIS_{minSENS} + x$ dB (NOTE 1)	CW carrier
PCS1900	1930 – 1990	+46	+38	+24	$EIS_{minSENS} + x$ dB (NOTE 1)	CW carrier
UTRA FDD Band I or E-UTRA Band 1 or NR band n1	2110 – 2170	+46	+38	+24	$EIS_{minSENS} + x$ dB (NOTE 1)	CW carrier
UTRA FDD Band II or E-UTRA Band 2 or NR band n2	1930 – 1990	+46	+38	+24	$EIS_{minSENS} + x$ dB (NOTE 1)	CW carrier
UTRA FDD Band III or E-UTRA Band 3 or NR band n3	1805 - 1880 (NOTE 4)	+46	+38	+24	$EIS_{minSENS} + x$ dB (NOTE 1)	CW carrier
UTRA FDD Band IV or E-UTRA Band 4	2110 – 2155	+46	+38	+24	$EIS_{minSENS} + x$ dB (NOTE 1)	CW carrier
UTRA FDD Band V or E-UTRA Band 5 or NR band n5	869 – 894	+46	+38	+24	$EIS_{minSENS} + x$ dB (NOTE 1)	CW carrier
UTRA FDD Band VI or E-UTRA Band 6	875 – 885	+46	+38	+24	$EIS_{minSENS} + x$ dB (NOTE 1)	CW carrier
UTRA FDD Band VII or E-UTRA Band 7 or NR band n7	2620 – 2690	+46	+38	+24	$EIS_{minSENS} + x$ dB (NOTE 1)	CW carrier
UTRA FDD Band VIII or E-UTRA Band 8 or NR band n8	925 – 960	+46	+38	+24	$EIS_{minSENS} + x$ dB (NOTE 1)	CW carrier
UTRA FDD Band IX or E-UTRA Band 9	1844.9 - 1879.9	+46	+38	+24	$EIS_{minSENS} + x$ dB (NOTE 1)	CW carrier
UTRA FDD Band X or E-UTRA Band 10	2110 – 2170	+46	+38	+24	$EIS_{minSENS} + x$ dB (NOTE 1)	CW carrier
UTRA FDD Band XI or E-UTRA Band 11	1475.9 - 1495.9	+46	+38	+24	$EIS_{minSENS} + x$ dB (NOTE 1)	CW carrier
UTRA FDD Band XII or E-UTRA Band 12 or NR band n12	729 – 746	+46	+38	+24	$EIS_{minSENS} + x$ dB (NOTE 1)	CW carrier
UTRA FDD Band XIII or E-UTRA Band 13	746 – 756	+46	+38	+24	$EIS_{minSENS} + x$ dB (NOTE 1)	CW carrier
UTRA FDD Band XIV or E-UTRA Band 14	758 – 768	+46	+38	+24	$EIS_{minSENS} + x$ dB (NOTE 1)	CW carrier
E-UTRA Band 17	734 – 746	+46	+38	+24	$EIS_{minSENS} + x$ dB (NOTE 1)	CW carrier
E-UTRA Band 18	860 – 875	+46	+38	+24	$EIS_{minSENS} + x$ dB (NOTE 1)	CW carrier
UTRA FDD Band XIX or E-UTRA Band 19	875 – 890	+46	+38	+24	$EIS_{minSENS} + x$ dB (NOTE 1)	CW carrier
UTRA FDD Band XX or E-UTRA Band 20 or NR band n20	791 – 821	+46	+38	+24	$EIS_{minSENS} + x$ dB (NOTE 1)	CW carrier
UTRA FDD Band XXI or E-UTRA Band 21	1495.9 - 1510.9	+46	+38	+24	$EIS_{minSENS} + x$ dB (NOTE 1)	CW carrier
UTRA FDD Band XXII or E-UTRA Band 22	3510 - 3 590	+46	+38	+24	$EIS_{minSENS} + x$ dB (NOTE 1)	CW carrier
E-UTRA Band 23	2180 – 2200	+46	+38	+24	$EIS_{minSENS} + x$ dB (NOTE 1)	CW carrier
E-UTRA Band 24	1525 – 1559	+46	+38	+24	$EIS_{minSENS} + x$ dB (NOTE 1)	CW carrier

Type of co-located BS	Centre Frequency of Interfering Signal [MHz]	Interfering Signal mean power for WA BS [dBm]	Interfering Signal mean power for MR BS [dBm]	Interfering Signal mean power for LA BS [dBm]	Wanted Signal mean power [dBm]	Type of Interfering Signal
UTRA FDD Band XXV or E-UTRA Band 25 or NR band n25	1930 – 1995	+46	+38	+24	$EIS_{minSENS} + x$ dB (NOTE 1)	CW carrier
UTRA FDD Band XXVI or E-UTRA Band 26	859 – 894	+46	+38	+24	$EIS_{minSENS} + x$ dB (NOTE 1)	CW carrier
E-UTRA Band 27	852 – 869	+46	+38	+24	$EIS_{minSENS} + x$ dB (NOTE 1)	CW carrier
E-UTRA Band 28 or NR band n28	758 – 803	+46	+38	+24	$EIS_{minSENS} + x$ dB (NOTE 1)	CW carrier
E-UTRA Band 29	717 – 728	+46	+38	+24	$EIS_{minSENS} + x$ dB (NOTE 1)	CW carrier
E-UTRA Band 30	2350 – 2360	+46	+38	+24	$EIS_{minSENS} + x$ dB (NOTE 1)	CW carrier
E-UTRA Band 31	462.5 - 467.5	+46	+38	+24	$EIS_{minSENS} + x$ dB (NOTE 1)	CW carrier
UTRA FDD Band XXXII or E-UTRA Band 32	1452 - 1496 (NOTE-5)	+46	+38	+24	$EIS_{minSENS} + x$ dB (NOTE 1)	CW carrier
UTRA TDD Band a) or E-UTRA TDD Band 33	1900 – 1920	+46	+38	+24	$EIS_{minSENS} + x$ dB (NOTE 1)	CW carrier
UTRA TDD Band a) or E-UTRA TDD Band 34 or NR band n34	2010 – 2025	+46	+38	+24	$EIS_{minSENS} + x$ dB (NOTE 1)	CW carrier
UTRA TDD Band b) or E-UTRA TDD Band 35	1850 – 1910	+46	+38	+24	$EIS_{minSENS} + x$ dB (NOTE 1)	CW carrier
UTRA TDD Band b) or E-UTRA TDD Band 36	1930 – 1990	+46	+38	+24	$EIS_{minSENS} + x$ dB (NOTE 1)	CW carrier
UTRA TDD Band c) or E-UTRA TDD Band 37	1910 – 1930	+46	+38	+24	$EIS_{minSENS} + x$ dB (NOTE 1)	CW carrier
UTRA TDD Band d) or E-UTRA Band 38 or NR band n38	2570 – 2620	+46	+38	+24	$EIS_{minSENS} + x$ dB (NOTE 1)	CW carrier
UTRA TDD Band f) or E-UTRA Band 39 or NR band n39	1880 – 1920	+46	+38	+24	$EIS_{minSENS} + x$ dB (NOTE 1)	CW carrier
UTRA TDD Band e) or E-UTRA Band 40 or NR band n40	2300 – 2400	+46	+38	+24	$EIS_{minSENS} + x$ dB (NOTE 1)	CW carrier
E-UTRA Band 41 or NR band n41	2496 – 2690	+46	+38	+24	$EIS_{minSENS} + x$ dB (NOTE 1)	CW carrier
E-UTRA Band 42	3400 – 3600	+46	+38	+24	$EIS_{minSENS} + x$ dB (NOTE 1)	CW carrier
E-UTRA Band 43	3600 – 3800	+46	+38	+24	$EIS_{minSENS} + x$ dB (NOTE 1)	CW carrier
E-UTRA Band 44	703 – 803	+46	+38	+24	$EIS_{minSENS} + x$ dB (NOTE 1)	CW carrier
E-UTRA Band 45	1447 - 1467	+46	+38	+24	$EIS_{minSENS} + x$ dB (NOTE 1)	CW carrier
E-UTRA Band 46	5150 - 5925	N/A	+38	+24	$EIS_{minSENS} + x$ dB (NOTE 1)	CW carrier
E-UTRA Band 48	3550 – 3700	+46	+38	+24	$EIS_{minSENS} + x$ dB (NOTE 1)	CW carrier
E-UTRA Band 49	3550 – 3700	N/A	N/A	+24	$EIS_{minSENS} + x$ dB (NOTE 1)	CW carrier
E-UTRA Band 50 or NR band n50	1432 – 1517	+46	+38	+24	$EIS_{minSENS} + x$ dB (NOTE 1)	CW carrier

Type of co-located BS	Centre Frequency of Interfering Signal [MHz]	Interfering Signal mean power for WA BS [dBm]	Interfering Signal mean power for MR BS [dBm]	Interfering Signal mean power for LA BS [dBm]	Wanted Signal mean power [dBm]	Type of Interfering Signal
E-UTRA Band 51 or or NR band n51	1427– 1432	N/A	N/A	+24	$EIS_{\min SENS} + x$ dB (NOTE 1)	CW carrier
E-UTRA Band 52	3300 – 3400	+46	+38	+24	$EIS_{\min SENS} + x$ dB (NOTE 1)	CW carrier
E-UTRA Band 65	2110 – 2200	+46	+38	+24	$EIS_{\min SENS} + x$ dB (NOTE 1)	CW carrier
E-UTRA Band 66 or or NR band n66	2110 – 2200	+46	+38	+24	$EIS_{\min SENS} + x$ dB (NOTE 1)	CW carrier
E-UTRA Band 67	738 - 758	+46	+38	+24	$EIS_{\min SENS} + x$ dB (NOTE 1)	CW carrier
E-UTRA Band 68	753 - 783	+46	+38	+24	$EIS_{\min SENS} + x$ dB (NOTE 1)	CW carrier
E-UTRA Band 69	2570-2620	+46	+38	+24	$EIS_{\min SENS} + x$ dB (NOTE 1)	CW carrier
E-UTRA Band 70 or or NR band n70	1995 - 2020	+46	+38	+24	$EIS_{\min SENS} + x$ dB (NOTE 1)	CW carrier
E-UTRA Band 71 or or NR band n71	617 - 652	+46	+38	+24	$EIS_{\min SENS} + x$ dB (NOTE 1)	CW carrier
E-UTRA Band 72	461 - 466	+46	+38	+24	$EIS_{\min SENS} + x$ dB (NOTE 1)	CW carrier
E-UTRA Band 73	460 - 465	+46	+38	+24	$EIS_{\min SENS} + x$ dB (NOTE 1)	CW carrier
E-UTRA Band 74 or NR band n74	1475 - 1518	+46	+38	+24	$EIS_{\min SENS} + x$ dB (NOTE 1)	CW carrier
E-UTRA Band 75 or or NR band n75	1432 - 1517	+46	+38	+24	$EIS_{\min SENS} + x$ dB (NOTE 1)	CW carrier
E-UTRA Band 76 or or NR band n76	1427 - 1432	N/A	N/A	+24	$EIS_{\min SENS} + x$ dB (NOTE 1)	CW carrier
NR band n77	3300 - 4200	+46	+38	+24	$EIS_{\min SENS} + x$ dB (NOTE 1)	CW carrier
NR band n78	3300 - 3800	+46	+38	+24	$EIS_{\min SENS} + x$ dB (NOTE 1)	CW carrier
NR band n79	4400 - 5000	+46	+38	+24	$EIS_{\min SENS} + x$ dB (NOTE 1)	CW carrier
E-UTRA Band 85	728 – 746	+46	+38	+24	$EIS_{\min SENS} + x$ dB (NOTE 1)	CW carrier

NOTE 1: $EIS_{\min SENS}$ depends on the BS class and on the *channel bandwidth*, see subclauses 10.2 in TS 37.105; "x" is equal to 6 dB in case of E-UTRA wanted signals.

NOTE 2: Except for a BS operating in Band 13, these requirements do not apply when the interfering signal falls within any of the supported *uplink operating band* or in the 10 MHz immediately outside any of the supported *uplink operating band*.
For a BS operating in band 13 the requirements do not apply when the interfering signal falls within the frequency range 768 - 797 MHz.

NOTE 3: Some combinations of bands may not be possible to co-site based on the requirements above. The current state-of-the-art technology does not allow a single generic solution for co-location of E-UTRA TDD with E-UTRA FDD on adjacent frequencies for 30dB BS-BS minimum coupling loss. However, there are certain site-engineering solutions that can be used. These techniques are addressed in 3GPP TR 25.942 [31].

NOTE 4: In China, the blocking requirement for co-location with DCS1800 and Band III BS is only applicable in the frequency range 1805 - 1850 MHz.

NOTE 5: For an AAS BS operating in band 11 or 21, this requirement applies for interfering signal within the frequency range 1475.9 - 1495.9 MHz.

7.7 OTA Receiver spurious emissions

7.7.1 Definition and applicability

The receiver spurious emission requirement is the power of the emissions radiated from the antenna array from a receiver unit. For an *OTA AAS BS* operating in FDD, OTA RX spurious emissions requirement do not apply as they are

superseded by the OTA TX spurious emissions requirement. This is due to the fact that TX and RX spurious emissions cannot be distinguished in OTA domain.

NOTE: The OTA receiver spurious emission requirement applicability for the AAS BS with the RX-only capabilities is FFS.

For an *OTA AAS BS* operating in TDD, the OTA receiver spurious emissions requirement applies during the *transmitter OFF period* only.

For RX only *multi-band RIB*, the RX spurious emissions requirements are subject to exclusion zones in each supported operating band.

7.7.2 Minimum Requirement

For an MSR AAS BS the minimum requirement is in TS 37.105 [6], subclause 10.7.2

For AAS BS in *single RAT E-UTRA operation* the minimum requirement is defined in TS 37.105 [6], subclause 10.7.4

For single RAT UTRA AAS BS the minimum requirement is in TS 37.105 [6], subclause 10.7.3

7.7.3 Test purpose

The test purpose is to verify the receiver radiated spurious emissions from the AAS BS at the RIB are within the specified requirements.

7.7.4 Method of test

7.7.4.1 Initial conditions

Test environment: normal; see annex G.2.

RF channels to be tested for single carrier: M; see subclause 4.12.1.

RF bandwidth positions to be tested in single-band operation: - M_{RFBW} , see subclause 4.12.1,

RF bandwidth positions to be tested in multi-band operation, see subclause 4.12.1.

- $B_{\text{RFBW}} \cdot T_{\text{RFBW}}$ when testing from 30 MHz to $F_{\text{DL_Blow_low}} - \Delta f_{\text{OBUE}}$
- $B'_{\text{RFBW}} \cdot T_{\text{RFBW}}$ when testing from $F_{\text{DL_Bhigh_high}} + \Delta f_{\text{OBUE}}$ to 12.75GHz (or to 5th harmonic)
- $B_{\text{RFBW}} \cdot T_{\text{RFBW}}$ and $B'_{\text{RFBW}} \cdot T_{\text{RFBW}}$ when testing from $F_{\text{DL_Blow_high}} + \Delta f_{\text{OBUE}}$ to $F_{\text{DL_Bhigh_low}} - \Delta f_{\text{OBUE}}$

Directions to be tested: Not applicable as Rx only TRP measurement.

7.7.4.2 Procedure

- 1) Place the AAS BS at the positioner.
- 2) Align the manufacturer declared coordinate system orientation (see table 4.10-1, D9.2) of the AAS BS with the test system.
- 3) Measurements shall use a measurement bandwidth in accordance to the conditions in 3GPP TS 37.104 [5] subclause 6.6.1.
- 4) The measurement device characteristics shall be:
 - Detection mode: True RMS.
- 5) Set the TDD AAS BS to receive only
- 6) Set the AAS BS in the direction of the appropriated TRP measurement grid (see annex F)
- 7) Measure the emission at the specified frequencies with specified measurement bandwidth

- 8) Repeat step 6-9 for all directions in the appropriated TRP measurement grid needed for full TRP estimation (see annex F).

Note 1: the TRP measurement grid may not be the same for all measurement frequencies.

Note 2: the frequency sweep or the TRP measurement grid sweep may be done in any order

- 9) Calculate TRP at each specified frequency using the directional measurements.

In addition, for *multi-band RIB(s)*, the following steps shall apply:

- 10) For *multi-band RIBs* and single band tests, repeat the steps above per involved band where single band test configurations and test models shall apply with no carrier activated in the other band.

NOTE: As an alternative, TRP can be measured in a reverberation chamber following step 1, 3, 4, 5, 7 and 10.

7.7.5 Test Requirement

The TRP of any spurious emission shall not exceed the levels in table 7.7.5-1:

Table 7.7.5-1: Receiver spurious emission test requirement

Frequency range	Maximum level (Note 2)	Measurement bandwidth	NOTE
30MHz - 1 GHz	-54.5 + X dBm	100 kHz	
1 GHz - 6GHz	-44.5 + X dBm	1 MHz	
6 GHz - 12.75 GHz	-42.8 + X dBm	1 MHz	
12.75 GHz - 5 th harmonic of the upper frequency edge of the UL operating band in GHz	-42.8 + X dBm	1 MHz	Applies only for Bands 22, 42, 43, 48.
NOTE: The frequency range between 2.5 * <i>channel bandwidth</i> below the first carrier frequency and 2.5 * <i>channel bandwidth</i> above the last carrier frequency transmitted by the AAS BS may be excluded from the requirement. However, frequencies that are more than 10 MHz below the lowest frequency of any of the AAS BS supported <i>downlink operating band</i> or more than 10 MHz above the highest frequency of any of the AAS BS supported <i>downlink operating band</i> shall not be excluded from the requirement. For a <i>multiband RIB</i> , the exclusion applies for all supported operating bands.			
NOTE 2: X = 9 dB, unless stated differently in regional regulation.			

In addition to the requirements in table 7.7.5-1, the power of any spurious emission shall not exceed the levels specified for Protection of the E-UTRA FDD BS receiver of own or different BS in subclause 6.7.6.3 and for Co-existence with other systems in the same geographical area in subclause 6.7.6.4. In addition, the co-existence requirements for co-located base stations specified in subclause 6.7.6.5 may also be applied.

7.8 OTA Receiver intermodulation

7.8.1 Definition and applicability

Third and higher order mixing of the two interfering RF signals can produce an interfering signal in the band of the desired channel. Intermodulation response rejection is a measure of the capability of the receiver unit to receive a wanted signal on its assigned channel frequency in the presence of two interfering signals which have a specific frequency relationship to the wanted signal.

The requirement applies at the RIB when the AoA of the incident wave of a received signal and the interfering signal are from the same direction, and:

- when the wanted signal is based on $EIS_{REFSENS}$: the AoA of the incident wave of a received signal and the interfering signal are within the OTA REFSENS $RoAoA$.
- when the wanted signal is based on $EIS_{minSENS}$: the AoA of the incident wave of a received signal and the interfering signal are within the within the $minSENS$ $RoAoA$.

The wanted and interfering signals apply to each supported polarization, under the assumption of *polarization match*.

7.8.2 Minimum Requirement

For AAS BS in *MSR operation* the minimum requirement is defined in TS 37.105 [6], subclause 10.8.2.

For AAS BS in *single RAT UTRA operation* the minimum requirement is defined in TS 37.105 [6], subclause 10.8.3.

For AAS BS in *single RAT E-UTRA operation* the minimum requirement is defined in TS 37.105 [6], subclause 10.8.4.

7.8.3 Test purpose

The test purpose is to verify the ability of the receiver to inhibit the generation of intermodulation products in its non-linear elements caused by the presence of two high-level interfering signals at frequencies with a specific relationship to the frequency of the wanted signal.

7.8.4 Method of test

7.8.4.1 Initial conditions

Test environment: normal; see annex G.2.

RF channels to be tested for single carrier: M; see subclause 4.12.1.

Base Station RF Bandwidth positions to be tested: For *single-band RIB(s)*: M_{RFBW} if ATC4 is applicable; B_{RFBW} and T_{RFBW} for other ATC, see subclause 4.12.1. For *multi-band RIB(s)*: $B_{RFBW_T_{RFBW}}$ and $B'_{RFBW_T_{RFBW}}$, see subclause 4.12.1.

Directions to be tested: OTA REFSENS receiver target reference direction (see table 4.10-20 D11.30).

7.8.4.2 Procedure

7.8.4.2.1 General procedure

The general procedure steps apply to the procedures for all the RATs.

- 1) Place the AAS BS with its manufacturer declared coordinate system reference point in the same place as calibrated point in the test system, as shown in Annex D2.6.
- 2) Align the manufacturer declared coordinate system orientation of the AAS BS with the test system.
- 3) Align the BS with the test antenna in the declared direction to be tested.
- 4) Align the NR BS to that the wanted signal and interferer signal is *polarization matched* with the test antenna(s)
- 5) Configure the beam peak direction of the AAS BS according to declared *reference beam direction pair* for the appropriate beam identifier.
- 6) Set the AAS BS to transmit the beam(s) of the same operational band and RAT as the OSDD being tested according to the appropriate test configuration in clause 5.
- 7) Set the test signal mean power so the calibrated radiated power at the AAS BS Antenna Array coordinate system reference point is as specified as follows:

Set the signal generator for the wanted signal according to the applicable test configuration (see clause 5) using applicable reference measurement channel to transmit:

- For E-UTRA see clause A.1 in TS 36.141 [12].
- For UTRA FDD see clause A.2 in TS 25.141 [10].
- For NR see clause A.1 in TS 38.141-2 [34].

7.8.4.2.2 MSR operation

7.8.4.4.2.1 Procedure for general and narrowband intermodulation

- 1) Adjust the signal generators to the type of interfering signals, levels and the frequency offsets as specified in table 7.8.5.1.1-1 and Table 7.7.5.1.1-2 for general intermodulation requirement, and Table 7.8.5.2.1-1 and Table 7.7.8.5.2.1-2 for narrowband intermodulation requirement.
- 2) Measure the performance of the wanted signal at the receiver under test, as defined in subclause 7.8.5.1.1 and 7.8.5.1.2, for the relevant carriers specified by the test configuration in clause 5.
- 3) Repeat for all supported polarizations.

In addition, for *multi-band RIB(s)*, the following steps shall apply:

- 4) For *multi-band RIBs* and single band tests, repeat the steps above per involved band where single band test configurations and test models shall apply with no carrier activated in the other band.

7.8.4.2.3 Single RAT UTRA FDD operation

- 1) Generate the wanted signal (reference signal) and adjust ATT1 to set the signal level to the level specified in table 7.8.5.2-1. For a RIB supporting multi-carrier operation, generate the wanted signal according to the applicable test configuration (see clause 4.11) using applicable reference measurement channel. Power settings are specified in table 7.8.5.2-1.
- 2) Adjust the signal generators to the type of interfering signals and the frequency offsets as specified in tables 7.8.5.2-1 and 7.8.5.2-2. Note that the GMSK modulated interfering signal shall have an ACLR of at least 72 dB in order to eliminate the impact of interfering signal adjacent channel leakage power on the intermodulation characteristics measurement.
- 3) Adjust the ATT2 and ATT3 to obtain the specified level of interfering signal at the RIB.
- 4) Measure the BER of the wanted signal. For a RIB supporting multi-carrier operation the BER shall be measured for all relevant carriers specified by the test configuration.
- 5) Repeat for all supported polarizations.

In addition, for *multi-band RIB(s)*, the following steps shall apply:

- 6) For *multi-band RIBs* and single band tests, repeat the steps above per involved band where single band test configurations and test models shall apply with no carrier activated in the other band.

7.8.4.2.4 Single RAT E-UTRA operation

- 1) Generate the wanted signal using the applicable test configuration specified in clause 5 and adjust the signal level to the level specified in table 7.8.5.3-1.
- 2) Adjust the signal generators to the type of interfering signals, levels and the frequency offsets as specified in table 7.8.5.3-2 for intermodulation requirement and Table 7.8.5.3-3, Table 7.8.5.3-4 and Table 7.8.5.3-5 for narrowband intermodulation requirement.
- 3) Adjust the signal generators to obtain the specified level of interfering signal.
- 4) Measure the throughput according to annex E of 36.141 [12] 3GPP TS 36.141 [12], for multi-carrier and/or CA operation the throughput shall be measured for relevant carriers specified by the test configuration specified in clause 5.
- 5) Repeat for all supported polarizations.

In addition, for *multi-band RIB(s)*, the following steps shall apply:

- 6) For *multi-band RIBs* and single band tests, repeat the steps above per involved band where single band test configurations and test models shall apply with no carrier activated in the other band.

7.8.5 Test Requirement

7.8.5.1 MSR operation

7.8.5.1.1 General intermodulation test requirement

Interfering signals shall be a CW signal and an E-UTRA, NR or UTRA signal as specified in 3GPP TS 37.104 [5], annex A.

The requirement is applicable outside the *Base Station RF Bandwidth* or *Radio Bandwidth*. The interfering signal offset is defined relative to the *Base Station RF Bandwidth edges* or *Radio Bandwidth edges*.

For *multi-band RIBs*, the requirement applies in addition inside any *Inter RF Bandwidth gap* at those connectors, in case the gap size is at least twice as wide as the UTRA/E-UTRA interfering signal centre frequency offset from the *Base Station RF Bandwidth edge*. The interfering signal offset is defined relative to the *Base Station RF Bandwidth edges* inside the *Inter RF Bandwidth gap*.

For the wanted signal at the assigned channel frequency and two interfering signals at the RIB, using the parameters in tables 7.8.5.1.1-1 and 7.8.5.1.1-2, the following requirements shall be met:

- For any E-UTRA carrier, the throughput shall be $\geq 95\%$ of the *maximum throughput* of the reference measurement channel defined in TS 36.104 [4], subclause 7.2.5.3.
- For any UTRA FDD carrier, the BER shall not exceed 0,001 for the reference measurement channel defined in TS 25.104 [2], subclause 7.2.5.1.
- For any NR carrier, the throughput shall be $\geq 95\%$ of the *maximum throughput* of the reference measurement channel defined in TS 38.104 [33], subclause 7.2.5.3.

The OTA levels are applied referenced to 2 antenna gain offsets $\Delta_{\text{OTAREFSENS}}$ and Δ_{minSENS} .

Table 7.8.5.1.1-1: General intermodulation requirement

Base Station Type	Mean power of interfering signals [dBm]	Wanted Signal mean power [dBm] (NOTE 1)	Type of interfering signal
Wide Area BS	$-48 + y - \Delta_{OTAREFS\text{ENS}}$ (NOTE 6)	$EIS_{REFS\text{ENS}} + x$ dB (NOTE 2, 5)	See table 7.8.5.1.1-2
	$-48 + y - \Delta_{minS\text{ENS}}$ (NOTE 6)	$EIS_{minS\text{ENS}} + x$ dB (NOTE 2, 5)	
Medium Range BS	$-44 + y - \Delta_{OTAREFS\text{ENS}}$ (NOTE 6)	$EIS_{REFS\text{ENS}} + x$ dB (NOTE 3, 5)	
	$-44 + y - \Delta_{minS\text{ENS}}$ (NOTE 6)	$EIS_{minS\text{ENS}} + x$ dB (NOTE 3, 5)	
Local Area BS	$-38 + y - \Delta_{OTAREFS\text{ENS}}$ (NOTE 6)	$EIS_{REFS\text{ENS}} + x$ dB (NOTE 4, 5)	
	$-38 + y - \Delta_{minS\text{ENS}}$ (NOTE 6)	$EIS_{minS\text{ENS}} + x$ dB (NOTE 4, 5)	
NOTE 1: $EIS_{REFS\text{ENS}}$ and $EIS_{minS\text{ENS}}$ depend on the RAT, the BS class and on the <i>channel bandwidth</i> , see subclauses 7.3 and 7.2.			
NOTE 2: For WA BS not supporting NR, "x" is equal to 6 in case of E-UTRA or UTRA or NB-IoT wanted signals and equal to 3 in case of GSM/EDGE wanted signal.			
NOTE 3: For MR BS not supporting NR, "x" is equal to 6 in case of UTRA wanted signals, 9 in case of E-UTRA or NB-IoT wanted signal and equal to 3 in case of GSM/EDGE wanted signal.			
NOTE 4: For LA BS not supporting NR, "x" is equal to 12 in case of E-UTRA or NB-IoT wanted signals, 6 in case of UTRA wanted signal and equal to 3 in case of GSM/EDGE wanted signal.			
NOTE 5: For a BS supporting NR and not supporting UTRA, x is equal to 6.			
NOTE 6: For a BS not supporting NR, "y" is equal to zero for all BS classes. For a BS that supports NR and supporting UTRA; "y" is equal to -4 for the WA BS class, -3 for the MR BS class and -6 for the LA BS class.			

Table 7.8.5.1.1-2: Interfering signals for intermodulation requirement

RAT of the carrier adjacent to the upper/lower Base Station RF Bandwidth edge	Interfering signal centre frequency offset from the Base Station RF Bandwidth edge [MHz]	Type of interfering signal
E-UTRA 1.4 MHz	$\pm 2,0$ (BC1 and BC3) / $\pm 2,1$ (BC2)	CW
	$\pm 4,9$	1,4 MHz E-UTRA signal
E-UTRA 3 MHz	$\pm 4,4$ (BC1 and BC3) / $\pm 4,5$ (BC2)	CW
	$\pm 10,5$	3 MHz E-UTRA signal
UTRA FDD and E-UTRA 5 MHz	$\pm 7,5$	CW
	$\pm 17,5$	5 MHz E-UTRA signal
E-UTRA 10 MHz	$\pm 7,375$	CW
	$\pm 17,5$	5 MHz E-UTRA signal
E-UTRA 15 MHz	$\pm 7,25$	CW
	$\pm 17,5$	5 MHz E-UTRA signal
E-UTRA 20 MHz	$\pm 7,125$	CW
	$\pm 17,5$	5 MHz E-UTRA signal
GSM/EDGE	$\pm 7,575$	CW
	$\pm 17,5$	5 MHz E-UTRA signal
1,28 Mcps UTRA TDD	$\pm 2,3$ (BC3)	CW
	$\pm 5,6$ (BC3)	1,28 Mcps UTRA TDD signal
NR 5 MHz	[$\pm 7,5$]	CW
	[$\pm 17,5$]	5MHz E-UTRA signal
NR 10 MHz	[$\pm 7,45$]	CW
	[$\pm 17,5$]	5MHz E-UTRA signal
NR 15 MHz	[$\pm 7,43$]	CW
	[$\pm 17,5$]	5MHz E-UTRA signal
NR 20 MHz	[$\pm 7,38$]	CW
	[$\pm 17,5$]	5MHz E-UTRA signal
NR 25 MHz	[$\pm 7,45$]	CW
	[± 25]	20MHz E-UTRA signal
NR 30 MHz	[$\pm 7,43$]	CW
	[± 25]	20MHz E-UTRA signal
NR 40 MHz	[$\pm 7,45$]	CW
	[± 25]	20MHz E-UTRA signal
NR 50 MHz	[$\pm 7,35$]	CW
	[± 25]	20MHz E-UTRA signal
NR 60 MHz	[$\pm 7,49$]	CW
	[± 25]	20MHz E-UTRA signal
NR 70 MHz	[$\pm 7,42$]	CW
	[± 25]	20MHz E-UTRA signal
NR 80 MHz	[$\pm 7,44$]	CW
	[± 25]	20MHz E-UTRA signal
NR 90 MHz	[± 25]	CW
	[$\pm 7,43$]	20MHz E-UTRA signal
NR 100 MHz	[$\pm 7,45$]	CW
	[± 25]	20MHz E-UTRA signal

7.8.5.1.2 General narrowband intermodulation test requirement

Interfering signals shall be a CW signal and an E-UTRA 1RB signal as specified in 3GPP TS 37.104 [5], annex A.

The requirement is applicable outside the *Base Station RF Bandwidth* or *Radio Bandwidth*. The interfering signal offset is defined relative to the *Base Station RF Bandwidth edges* or *Radio Bandwidth edges*.

For RIB supporting operation in *non-contiguous spectrum* within each supported operating band, the requirement applies in addition inside any *sub-block gap* in case the *sub-block gap* is at least as wide as the *channel bandwidth* of the E-UTRA interfering signal in table 10.8.2.2-2. The interfering signal offset is defined relative to the *sub-block edges* inside the gap.

For *multi-band RIBs*, the requirement applies in addition inside any *Inter RF Bandwidth gap*, in case the gap size is at least as wide as the E-UTRA interfering signal in table 7.8.5.1.2-2. The interfering signal offset is defined relative to the *Base Station RF Bandwidth edges* inside the *Inter RF Bandwidth gap*.

For the wanted signal at the assigned channel frequency and two interfering signals at the RIB, using the parameters in tables 7.8.5.1.2-1 and 7.8.5.1.2-2, the following requirements shall be met:

- For any E-UTRA carrier, the throughput shall be ≥ 95 % of the *maximum throughput* of the reference measurement channel defined in TS 36.104 [4], subclause 7.2.5.3.
- For any UTRA FDD carrier, the BER shall not exceed 0,001 for the reference measurement channel defined in TS 25.104 [2], subclause 7.2.5.1.
- For any NR carrier, the throughput shall be ≥ 95 % of the *maximum throughput* of the reference measurement channel defined in TS 38.104 [33], subclause 7.2.5.3.

The OTA levels are applied referenced to 2 antenna gain offsets $\Delta_{\text{OTAREFSENS}}$ and Δ_{minSENS} .

Table 7.8.5.1.2-1: General narrowband intermodulation requirement

Base Station Type	Mean power of interfering signals [dBm]	Wanted Signal mean power [dBm] (NOTE)	Type of interfering signal
Wide Area BS	$-52 - \Delta_{\text{OTAREFSENS}}$	$\text{EIS}_{\text{REFSENS}} + 6 \text{ dB}$	See table 7.8.5.1.2-2
	$-52 - \Delta_{\text{minSENS}}$	$\text{EIS}_{\text{minSENS}} + 6 \text{ dB}$	
Medium Range BS	$-47 - \Delta_{\text{OTAREFSENS}}$	$\text{EIS}_{\text{REFSENS}} + 6 \text{ dB}$	
	$-47 - \Delta_{\text{minSENS}}$	$\text{EIS}_{\text{minSENS}} + 6 \text{ dB}$	
Local Area BS	$-44 - \Delta_{\text{OTAREFSENS}}$	$\text{EIS}_{\text{REFSENS}} + 6 \text{ dB}$	
	$-44 - \Delta_{\text{minSENS}}$	$\text{EIS}_{\text{minSENS}} + 6 \text{ dB}$	
NOTE	$\text{EIS}_{\text{REFSENS}}$ and $\text{EIS}_{\text{minSENS}}$ depend on the RAT, the BS class and on the <i>channel bandwidth</i> , see subclauses 10.3 and 10.2.		

Table 7.8.5.1.2-2: Interfering signals for narrowband intermodulation requirement

RAT of the carrier adjacent to the upper/lower Base Station RF Bandwidth edge or edge of the sub-block	CW or 1RB interfering signal centre frequency offset from the Base Station RF Bandwidth edge or edge of sub-block inside a gap [kHz]	Type of interfering signal
E-UTRA 1.4 MHz	± 260 (BC1 and BC3) / ± 270 (BC2)	CW
	± 970 (BC1 and BC3) / ± 790 (BC2)	1,4 MHz E-UTRA signal, 1 RB (NOTE 1)
E-UTRA 3 MHz	± 260 (BC1 and BC3) / ± 270 (BC2)	CW
	± 960 (BC1 and BC3) / ± 780 (BC2)	3,0 MHz E-UTRA signal, 1 RB (NOTE 1)
E-UTRA 5 MHz	± 360	CW
	$\pm 1\ 060$	5 MHz E-UTRA signal, 1 RB (NOTE 1)
E-UTRA 10 MHz (NOTE 2)	± 325	CW
	$\pm 1\ 240$	5 MHz E-UTRA signal, 1 RB (NOTE 1)
E-UTRA 15 MHz (NOTE 2)	± 380	CW
	$\pm 1\ 600$	5MHz E-UTRA signal, 1 RB (NOTE 1)
E-UTRA 20 MHz (NOTE 2)	± 345	CW
	$\pm 1\ 780$	5MHz E-UTRA signal, 1 RB (NOTE 1)
UTRA FDD	± 345 (BC1 and BC2)	CW
	$\pm 1\ 780$ (BC1 and BC2)	5MHz E-UTRA signal, 1 RB (NOTE 1)
GSM/EDGE	± 340	CW
	± 880	5MHz E-UTRA signal, 1 RB (NOTE 1)
1,28 Mcps UTRA TDD	± 190 (BC3)	CW
	± 970 (BC3)	1,4 MHz E-UTRA signal, 1 RB (NOTE 1)
NR 5 MHz	[± 360]	CW
	[± 1420]	E-UTRA signal, 1 RB (NOTE 1)
NR 10 MHz	[± 325]	CW
	[± 1780]	E-UTRA signal, 1 RB (NOTE 1)
NR 15 MHz (Note 2)	[± 380]	CW
	[± 1600]	E-UTRA signal, 1 RB (NOTE 1)
NR 20 MHz (Note 2)	[± 345]	CW
	[± 1780]	E-UTRA signal, 1 RB (NOTE 1)
NR 25 MHz (Note 2)	[± 325]	CW
	[± 1990]	E-UTRA signal, 1 RB (NOTE 1)
NR 30 MHz (Note 2)	[± 320]	CW
	[± 1990]	E-UTRA signal, 1 RB (NOTE 1)
NR 40 MHz (Note 2)	[± 310]	CW
	[± 2710]	E-UTRA signal, 1 RB (NOTE 1)
NR 50 MHz (Note 2)	[± 330]	CW
	[± 3250]	E-UTRA signal, 1 RB (NOTE 1)
NR 60 MHz (Note 2)	[± 350]	CW
	[± 3790]	E-UTRA signal, 1 RB (NOTE 1)
NR 70 MHz (Note 2)	[± 400]	CW
	[± 4870]	E-UTRA signal, 1 RB (NOTE 1)
NR 80 MHz (Note 2)	[± 390]	CW
	[± 4870]	E-UTRA signal, 1 RB (NOTE 1)
NR 90 MHz (Note 2)	[± 340]	CW
	[± 5770]	E-UTRA signal, 1 RB (NOTE 1)
NR 100 MHz (Note 2)	[± 340]	CW
	[± 5770]	E-UTRA signal, 1 RB (NOTE 1)
NOTE 1: Interfering signal consisting of one resource block positioned at the stated offset, the channel bandwidth of the interfering signal is located adjacently to the Base Station RF Bandwidth edge.		
NOTE 2: This requirement shall apply only for an E-UTRA FRC A1-3 mapped to the frequency range at the channel edge adjacent to the interfering signals.		

7.8.5.2 Single RAT UTRA operation

The static reference performance as specified in subclause 10.3 and 10.2 shall be met for a Wide Area BS when the signals in table 7.8.5.2-1 and table 7.8.5.2-2 are at the RIB.

The static reference performance as specified in subclause 10.3 and 10.2 shall be met for a Medium range BS when the signals in table 7.8.5.2-3 and table 7.8.5.2-4 are at the RIB.

The static reference performance as specified in subclause 10.3 and 10.2 shall be met for a Local Area BS when the signals in table 7.8.5.2-5 and table 7.8.5.2-6 are at the RIB.

For RIB supporting operation in *non-contiguous spectrum* within each supported operating band, the requirement applies in addition inside any *sub-block gap* in case the *sub-block gap* is at least is at least 6.8MHz. The CW interfering signal offset is defined relative to the lower/upper *sub-block* edge inside the *sub-block gap* and is equal to -1MHz/+1MHz, respectively. The GMSK modulated interfering signal offset is defined relative to the lower/upper *sub-block* edge inside the *sub-block gap* and is equal to -3.4MHz/+3.4MHz, respectively.

For *multi-band RIBs*, the requirement applies in addition inside any *Inter RF Bandwidth gap*, in case the *Inter RF Bandwidth gap* size is at least 6.8MHz. The CW interfering signal offset is defined relative to lower/upper *Base Station RF Bandwidth edges* inside the *Inter RF Bandwidth gap* and is equal to -1MHz/+1MHz, respectively. The GMSK modulated interfering signal offset is defined relative to lower/upper *Base Station RF Bandwidth edges* inside the *Inter RF Bandwidth gap* and is equal to -3.4MHz/+3.4MHz, respectively.

The OTA levels are applied referenced to 2 antenna gain offsets $\Delta_{\text{OTAREFSENS}}$ and Δ_{minSENS} .

Table 7.8.5.2-1: Intermodulation performance requirement (Wide Area BS)

Operating band	Mean power of interfering signals [dBm]	Wanted Signal mean power [dBm] (NOTE)	Offset	Type of Interfering Signal
All bands	$-48 - \Delta_{\text{OTAREFSENS}}$	$-115 - \Delta_{\text{OTAREFSENS}}$	± 10 MHz	CW signal
	$-48 - \Delta_{\text{minSENS}}$	$-115 - \Delta_{\text{minSENS}}$		
	$-48 - \Delta_{\text{OTAREFSENS}}$	$-115 - \Delta_{\text{OTAREFSENS}}$	± 20 MHz	WCDMA signal (NOTE)
	$-48 - \Delta_{\text{minSENS}}$	$-115 - \Delta_{\text{minSENS}}$		

NOTE: The characteristics of the WCDMA interference signal are specified in 3GPP TS 25.104 [2] Annex C.

Table 7.8.5.2-2: Narrowband intermodulation performance requirement (Wide Area BS)

Operating band	Mean power of interfering signals [dBm]	Wanted Signal mean power [dBm] (NOTE)	Offset	Type of Interfering Signal
II, III, IV, V, VIII, X, XII, XIII, XIV, XXV, XXVI	$-47 - \Delta_{\text{OTAREFSENS}}$	$-115 - \Delta_{\text{OTAREFSENS}}$	± 3.5 MHz	CW signal
	$-47 - \Delta_{\text{minSENS}}$	$-115 - \Delta_{\text{minSENS}}$		
	$-47 - \Delta_{\text{OTAREFSENS}}$	$-115 - \Delta_{\text{OTAREFSENS}}$	± 5.9 MHz	GMSK modulated (NOTE)
	$-47 - \Delta_{\text{minSENS}}$	$-115 - \Delta_{\text{minSENS}}$		

NOTE: GMSK as defined in TS45.004 [32]

Table 7.8.5.2-3: Intermodulation performance requirement (Medium Range BS)

Operating band	Mean power of interfering signals [dBm]	Wanted Signal mean power [dBm] (NOTE)	Offset	Type of Interfering Signal
All bands	$-44 - \Delta_{\text{OTAREFSENS}}$	$-105 - \Delta_{\text{OTAREFSENS}}$	± 10 MHz	CW signal
	$-44 - \Delta_{\text{minSENS}}$	$-105 - \Delta_{\text{minSENS}}$		
	$-44 - \Delta_{\text{OTAREFSENS}}$	$-105 - \Delta_{\text{OTAREFSENS}}$	± 20 MHz	WCDMA signal (NOTE)
	$-44 - \Delta_{\text{minSENS}}$	$-105 - \Delta_{\text{minSENS}}$		

NOTE: The characteristics of the WCDMA interference signal are specified in 3GPP TS 25.104 [2] Annex C.

Table 7.8.5.2-4: Narrowband intermodulation performance requirement (Medium Range BS)

Operating band	Mean power of interfering signals [dBm]	Wanted Signal mean power [dBm] (NOTE)	Offset	Type of Interfering Signal
II, III, IV, V, VIII, X, XII, XIII, XIV, XXV, XXVI	$-43 - \Delta_{\text{OTAREFSENS}}$	$-105 - \Delta_{\text{OTAREFSENS}}$	± 3.5 MHz	CW signal
	$-43 - \Delta_{\text{minSENS}}$	$-105 - \Delta_{\text{minSENS}}$		
	$-43 - \Delta_{\text{OTAREFSENS}}$	$-105 - \Delta_{\text{OTAREFSENS}}$	± 5.9 MHz	GMSK modulated (NOTE)
	$-43 - \Delta_{\text{minSENS}}$	$-105 - \Delta_{\text{minSENS}}$		
NOTE: GMSK as defined in TS45.004 [32]				

Table 7.8.5.2-5: Intermodulation performance requirement (Local Area BS)

Operating band	Mean power of interfering signals [dBm]	Wanted Signal mean power [dBm] (NOTE)	Offset	Type of Interfering Signal
All bands	$-38 - \Delta_{\text{OTAREFSENS}}$	$-101 - \Delta_{\text{OTAREFSENS}}$	± 10 MHz	CW signal
	$-38 - \Delta_{\text{minSENS}}$	$-101 - \Delta_{\text{minSENS}}$		
	$-38 - \Delta_{\text{OTAREFSENS}}$	$-101 - \Delta_{\text{OTAREFSENS}}$	± 20 MHz	WCDMA signal (NOTE)
	$-38 - \Delta_{\text{minSENS}}$	$-101 - \Delta_{\text{minSENS}}$		
NOTE: The characteristics of the WCDMA interference signal are specified in 3GPP TS 25.104 [2] Annex C.				

Table 7.8.5.2-6: Narrowband intermodulation performance requirement (Local Area BS)

Operating band	Mean power of interfering signals [dBm]	Wanted Signal mean power [dBm] (NOTE)	Offset	Type of Interfering Signal
II, III, IV, V, VIII, X, XII, XIII, XIV, XXV, XXVI	$-38 - \Delta_{\text{OTAREFSENS}}$	$-101 - \Delta_{\text{OTAREFSENS}}$	± 3.5 MHz	CW signal
	$-38 - \Delta_{\text{minSENS}}$	$-101 - \Delta_{\text{minSENS}}$		
	$-38 - \Delta_{\text{OTAREFSENS}}$	$-101 - \Delta_{\text{OTAREFSENS}}$	± 5.9 MHz	GMSK modulated (NOTE)
	$-38 - \Delta_{\text{minSENS}}$	$-101 - \Delta_{\text{minSENS}}$		
NOTE: GMSK as defined in TS45.004 [32]				

7.8.5.3 Single RAT E- UTRA operation

For E-UTRA, the throughput shall be $\geq 95\%$ of the *maximum throughput* of the reference measurement channel, with a wanted signal at the assigned channel frequency and two interfering signals at the RIB, with the conditions specified in tables 7.8.5.3-1 and 7.8.5.3-2 for intermodulation performance and in tables 7.8.5.3-3, 7.8.5.3-4, and 7.8.5.3-5 for narrowband intermodulation performance. Narrowband intermodulation requirements are not applied for Band 46. The reference measurement channel for the wanted signal is identified in table 10.8.4-1 to 6 for each *channel bandwidth* and further specified in 3GPP TS 36.104 [4] Annex A.

The receiver intermodulation requirement is applicable outside the *Base Station RF Bandwidth* or *Radio Bandwidth edges*. The interfering signal offset is defined relative to the *Base Station RF Bandwidth edges* or *Radio Bandwidth edges*.

For RIB supporting operation in *non-contiguous spectrum* within each supported operating band, the requirement applies in addition inside any *sub-block gap* in case the *sub-block gap* is at least as wide as the *channel bandwidth* of the E-UTRA interfering signal in table 7.8.5.3-3. The interfering signal offset is defined relative to the *sub-block edges* inside the *sub-block gap*.

For *multi-band RIBs*, the intermodulation requirement applies in addition inside any *Inter RF Bandwidth gap*, in case the gap size is at least as wide as the E-UTRA interfering signal centre frequency offset from the *Base Station RF Bandwidth edge*.

For *multi-band RIBs*, the narrowband intermodulation requirement applies in addition inside any *Inter RF Bandwidth gap*, in case the gap size is at least as wide as the E-UTRA interfering signal in tables 7.8.5.3-3, 7.8.5.3-4 and 7.8.5.3-5. The interfering signal offset is defined relative to the *Base Station RF Bandwidth edges* inside the *Inter RF Bandwidth gap*.

The OTA levels are applied referenced to 2 antenna gain offsets $\Delta_{\text{OTAREFSENS}}$ and Δ_{minSENS} .

Table 7.8.5.3-1: Intermodulation performance requirement

BS type	Wanted signal mean power [dBm]	Interfering signal mean power [dBm] (NOTE)	Type of interfering signal
Wide Area BS	$EIS_{REFSENS} + 6\text{dB}$	$-52 - \Delta_{OTAREFSENS}$	See table 7.8.5.3-2
	$EIS_{minSENS} + 6\text{dB}$	$-52 - \Delta_{minSENS}$	
Medium Range BS	$EIS_{REFSENS} + 6\text{dB}$	$-47 - \Delta_{OTAREFSENS}$	
	$EIS_{minSENS} + 6\text{dB}$	$-47 - \Delta_{minSENS}$	
Local Area BS	$EIS_{REFSENS} + 6\text{dB}$	$-44 - \Delta_{OTAREFSENS}$	
	$EIS_{minSENS} + 6\text{dB}$	$-44 - \Delta_{minSENS}$	
NOTE: $EIS_{REFSENS}$ and $EIS_{minSENS}$ depend on the RAT, the BS class and on the <i>channel bandwidth</i> , see subclauses 7.3 and 7.2.			

Table 7.8.5.3-2: Interfering signal for Intermodulation performance requirement

E-UTRA <i>channel bandwidth</i> of the lowest/highest carrier received [MHz]	Interfering signal centre frequency offset from the lower/upper <i>Base Station RF Bandwidth edge</i> [MHz]	Type of interfering signal
3	± 4.5	CW
	± 10.5	3 MHz E-UTRA signal (NOTE 3)
5	± 7.5	CW
	± 17.5	5 MHz E-UTRA signal
10	± 7.375	CW
	± 17.5	5 MHz E-UTRA signal
15	± 7.25	CW
	± 17.5	5 MHz E-UTRA signal
20	± 7.125	CW
	± 17.5	5 MHz E-UTRA signal (NOTE 1)
20	± 7.125	CW
	± 24	20 MHz E-UTRA signal (NOTE 2)
NOTE 1: This type of interfering signal is not applied for Band 46.		
NOTE 2: This type of interfering signal is only applied for Band 46.		
NOTE 3: 3 MHz <i>channel bandwidth</i> is not applicable to guard band operation.		

Table 7.8.5.3-3: Narrowband intermodulation performance requirement for Wide Area BS

E-UTRA channel bandwidth of the lowest/highest carrier received [MHz]	Wanted signal mean power [dBm] (NOTE 1)	Interfering signal mean power [dBm]	Interfering RB centre frequency offset from the lower/upper Base Station RF Bandwidth edge or sub-block edge inside a sub-block gap [kHz]	Type of interfering signal
1.4	$EIS_{REFSENS} + 6\text{dB}$	$-52 - \Delta_{OTAREFSENS}$	± 270	CW
	$EIS_{minSENS} + 6\text{dB}$	$-52 - \Delta_{minSENS}$		
	$EIS_{REFSENS} + 6\text{dB}$	$-52 - \Delta_{OTAREFSENS}$	± 790	1.4 MHz E-UTRA signal, 1 RB (NOTE 2)
	$EIS_{minSENS} + 6\text{dB}$	$-52 - \Delta_{minSENS}$		
3	$EIS_{REFSENS} + 6\text{dB}$	$-52 - \Delta_{OTAREFSENS}$	± 270	CW
	$EIS_{minSENS} + 6\text{dB}$	$-52 - \Delta_{minSENS}$		
	$EIS_{REFSENS} + 6\text{dB}$	$-52 - \Delta_{OTAREFSENS}$	± 780	3.0 MHz E-UTRA signal, 1 RB (NOTE 2)
	$EIS_{minSENS} + 6\text{dB}$	$-52 - \Delta_{minSENS}$		
5	$EIS_{REFSENS} + 6\text{dB}$	$-52 - \Delta_{OTAREFSENS}$	± 360	CW
	$EIS_{minSENS} + 6\text{dB}$	$-52 - \Delta_{minSENS}$		
	$EIS_{REFSENS} + 6\text{dB}$	$-52 - \Delta_{OTAREFSENS}$	± 1060	5 MHz E-UTRA signal, 1 RB (NOTE 2)
	$EIS_{minSENS} + 6\text{dB}$	$-52 - \Delta_{minSENS}$		
10 (NOTE 3)	$EIS_{REFSENS} + 6\text{dB}$	$-52 - \Delta_{OTAREFSENS}$	± 325	CW
	$EIS_{minSENS} + 6\text{dB}$	$-52 - \Delta_{minSENS}$		
	$EIS_{REFSENS} + 6\text{dB}$	$-52 - \Delta_{OTAREFSENS}$	± 1240	5 MHz E-UTRA signal, 1 RB (NOTE 2)
	$EIS_{minSENS} + 6\text{dB}$	$-52 - \Delta_{minSENS}$		
15 (NOTE 3)	$EIS_{REFSENS} + 6\text{dB}$	$-52 - \Delta_{OTAREFSENS}$	± 380	CW
	$EIS_{minSENS} + 6\text{dB}$	$-52 - \Delta_{minSENS}$		
	$EIS_{REFSENS} + 6\text{dB}$	$-52 - \Delta_{OTAREFSENS}$	± 1600	5MHz E-UTRA signal, 1 RB (NOTE 2)
	$EIS_{minSENS} + 6\text{dB}$	$-52 - \Delta_{minSENS}$		
20 (NOTE 3)	$EIS_{REFSENS} + 6\text{dB}$	$-52 - \Delta_{OTAREFSENS}$	± 345	CW
	$EIS_{minSENS} + 6\text{dB}$	$-52 - \Delta_{minSENS}$		
	$EIS_{REFSENS} + 6\text{dB}$	$-52 - \Delta_{OTAREFSENS}$	± 1780	5MHz E-UTRA signal, 1 RB (NOTE 2)
	$EIS_{minSENS} + 6\text{dB}$	$-52 - \Delta_{minSENS}$		
NOTE 1: $EIS_{REFSENS}$ and $EIS_{minSENS}$ depend on the RAT, the BS class and on the channel bandwidth, see subclauses 7.3 and 7.2.				
NOTE 2: Interfering signal consisting of one resource block positioned at the stated offset, the channel bandwidth of the interfering signal is located adjacently to the lower/upper Base Station RF Bandwidth edge.				
NOTE 3: This requirement shall apply only for a FRC A1-3 mapped to the frequency range at the channel edge adjacent to the interfering signals				

Table 7.8.5.3-4: Narrowband intermodulation performance requirement for Local Area BS

E-UTRA channel bandwidth of the lowest/highest carrier received [MHz]	Wanted signal mean power [dBm] (NOTE 1)	Interfering signal mean power [dBm]	Interfering RB centre frequency offset from the lower/upper Base Station RF Bandwidth edge or sub-block edge inside a sub-block gap [kHz]	Type of interfering signal
1.4	$EIS_{REFSENS} + 6\text{dB}$	$-44 - \Delta_{OTAREFSENS}$	± 270	CW
	$EIS_{minSENS} + 6\text{dB}$	$-44 - \Delta_{minSENS}$		
	$EIS_{REFSENS} + 6\text{dB}$	$-44 - \Delta_{OTAREFSENS}$	± 790	1.4 MHz E-UTRA signal, 1 RB (NOTE 2)
	$EIS_{minSENS} + 6\text{dB}$	$-44 - \Delta_{minSENS}$		
3	$EIS_{REFSENS} + 6\text{dB}$	$-44 - \Delta_{OTAREFSENS}$	± 270	CW
	$EIS_{minSENS} + 6\text{dB}$	$-44 - \Delta_{minSENS}$		
	$EIS_{REFSENS} + 6\text{dB}$	$-44 - \Delta_{OTAREFSENS}$	± 780	3.0 MHz E-UTRA signal, 1 RB (NOTE 2)
	$EIS_{minSENS} + 6\text{dB}$	$-44 - \Delta_{minSENS}$		
5	$EIS_{REFSENS} + 6\text{dB}$	$-44 - \Delta_{OTAREFSENS}$	± 360	CW
	$EIS_{minSENS} + 6\text{dB}$	$-44 - \Delta_{minSENS}$		
	$EIS_{REFSENS} + 6\text{dB}$	$-44 - \Delta_{OTAREFSENS}$	± 1060	5 MHz E-UTRA signal, 1 RB (NOTE 2)
	$EIS_{minSENS} + 6\text{dB}$	$-44 - \Delta_{minSENS}$		
10 (NOTE 3)	$EIS_{REFSENS} + 6\text{dB}$	$-44 - \Delta_{OTAREFSENS}$	± 325	CW
	$EIS_{minSENS} + 6\text{dB}$	$-44 - \Delta_{minSENS}$		
	$EIS_{REFSENS} + 6\text{dB}$	$-44 - \Delta_{OTAREFSENS}$	± 1240	5 MHz E-UTRA signal, 1 RB (NOTE 2)
	$EIS_{minSENS} + 6\text{dB}$	$-44 - \Delta_{minSENS}$		
15 (NOTE 3)	$EIS_{REFSENS} + 6\text{dB}$	$-44 - \Delta_{OTAREFSENS}$	± 380	CW
	$EIS_{minSENS} + 6\text{dB}$	$-44 - \Delta_{minSENS}$		
	$EIS_{REFSENS} + 6\text{dB}$	$-44 - \Delta_{OTAREFSENS}$	± 1600	5MHz E-UTRA signal, 1 RB (NOTE 2)
	$EIS_{minSENS} + 6\text{dB}$	$-44 - \Delta_{minSENS}$		
20 (NOTE 3)	$EIS_{REFSENS} + 6\text{dB}$	$-44 - \Delta_{OTAREFSENS}$	± 345	CW
	$EIS_{minSENS} + 6\text{dB}$	$-44 - \Delta_{minSENS}$		
	$EIS_{REFSENS} + 6\text{dB}$	$-44 - \Delta_{OTAREFSENS}$	± 1780	5MHz E-UTRA signal, 1 RB (NOTE 2)
	$EIS_{minSENS} + 6\text{dB}$	$-44 - \Delta_{minSENS}$		
NOTE 1: $EIS_{REFSENS}$ and $EIS_{minSENS}$ depend on the RAT, the BS class and on the channel bandwidth, see subclauses 7.3 and 7.2.				
NOTE 2: Interfering signal consisting of one resource block positioned at the stated offset, the channel bandwidth of the interfering signal is located adjacently to the lower/upper Base Station RF Bandwidth edge.				
NOTE 3: This requirement shall apply only for a FRC A1-3 mapped to the frequency range at the channel edge adjacent to the interfering signals				

Table 7.8.5.3-5: Narrowband intermodulation performance requirement for Medium Range BS

E-UTRA channel bandwidth of the lowest/highest carrier received [MHz]	Wanted signal mean power [dBm] (NOTE 1)	Interfering signal mean power [dBm]	Interfering RB centre frequency offset from the lower/upper Base Station RF Bandwidth edge or sub-block edge inside a sub-block gap [kHz]	Type of interfering signal
1.4	$EIS_{REFSENS} + 6\text{dB}$	$-47 - \Delta_{OTAREFSENS}$	± 270	CW
	$EIS_{minSENS} + 6\text{dB}$	$-47 - \Delta_{minSENS}$		
	$EIS_{REFSENS} + 6\text{dB}$	$-47 - \Delta_{OTAREFSENS}$	± 790	1.4 MHz E-UTRA signal, 1 RB (NOTE 2)
	$EIS_{minSENS} + 6\text{dB}$	$-47 - \Delta_{minSENS}$		
3	$EIS_{REFSENS} + 6\text{dB}$	$-47 - \Delta_{OTAREFSENS}$	± 270	CW
	$EIS_{minSENS} + 6\text{dB}$	$-47 - \Delta_{minSENS}$		
	$EIS_{REFSENS} + 6\text{dB}$	$-47 - \Delta_{OTAREFSENS}$	± 780	3.0 MHz E-UTRA signal, 1 RB (NOTE 2)
	$EIS_{minSENS} + 6\text{dB}$	$-47 - \Delta_{minSENS}$		
5	$EIS_{REFSENS} + 6\text{dB}$	$-47 - \Delta_{OTAREFSENS}$	± 360	CW
	$EIS_{minSENS} + 6\text{dB}$	$-47 - \Delta_{minSENS}$		
	$EIS_{REFSENS} + 6\text{dB}$	$-47 - \Delta_{OTAREFSENS}$	± 1060	5 MHz E-UTRA signal, 1 RB (NOTE 2)
	$EIS_{minSENS} + 6\text{dB}$	$-47 - \Delta_{minSENS}$		
10 (NOTE 3)	$EIS_{REFSENS} + 6\text{dB}$	$-47 - \Delta_{OTAREFSENS}$	± 325	CW
	$EIS_{minSENS} + 6\text{dB}$	$-47 - \Delta_{minSENS}$		
	$EIS_{REFSENS} + 6\text{dB}$	$-47 - \Delta_{OTAREFSENS}$	± 1240	5 MHz E-UTRA signal, 1 RB (NOTE 2)
	$EIS_{minSENS} + 6\text{dB}$	$-47 - \Delta_{minSENS}$		
15 (NOTE 3)	$EIS_{REFSENS} + 6\text{dB}$	$-47 - \Delta_{OTAREFSENS}$	± 380	CW
	$EIS_{minSENS} + 6\text{dB}$	$-47 - \Delta_{minSENS}$		
	$EIS_{REFSENS} + 6\text{dB}$	$-47 - \Delta_{OTAREFSENS}$	± 1600	5MHz E-UTRA signal, 1 RB (NOTE 2)
	$EIS_{minSENS} + 6\text{dB}$	$-47 - \Delta_{minSENS}$		
20 (NOTE 3)	$EIS_{REFSENS} + 6\text{dB}$	$-47 - \Delta_{OTAREFSENS}$	± 345	CW
	$EIS_{minSENS} + 6\text{dB}$	$-47 - \Delta_{minSENS}$		
	$EIS_{REFSENS} + 6\text{dB}$	$-47 - \Delta_{OTAREFSENS}$	± 1780	5MHz E-UTRA signal, 1 RB (NOTE 2)
	$EIS_{minSENS} + 6\text{dB}$	$-47 - \Delta_{minSENS}$		
NOTE 1: $EIS_{REFSENS}$ and $EIS_{minSENS}$ depend on the RAT, the BS class and on the <i>channel bandwidth</i> , see subclauses 7.3 and 7.2.				
NOTE 2: Interfering signal consisting of one resource block positioned at the stated offset, the <i>channel bandwidth</i> of the interfering signal is located adjacently to the lower/upper <i>Base Station RF Bandwidth edge</i> .				
NOTE 3: This requirement shall apply only for a FRC A1-3 mapped to the frequency range at the channel edge adjacent to the interfering signals				

7.9 OTA In-channel selectivity

7.9.1 Definition and applicability

In-channel selectivity (ICS) is a measure of the receiver unit ability to receive a wanted signal at its assigned resource block locations in the presence of an interfering signal received at a larger power spectral density. In this condition a throughput requirement shall be met for a specified reference measurement channel.

The requirement applies at the RIB when the AoA of the incident wave of a received signal and the interfering signal are from the same direction and are within the *minSENS RoAoA*.

The wanted and interfering signals apply to each supported polarization, under the assumption of *polarization match*.

7.9.2 Minimum Requirement

For AAS BS in *MSR operation* the minimum requirement is defined in TS 37.105 [6], subclause 10.9.2.

For AAS BS in *single RAT UTRA operation* the minimum requirement is defined in TS 37.105 [6], subclause 10.9.3.

For AAS BS in *single RAT E-UTRA operation* the minimum requirement is defined in TS 37.105 [6], subclause 10.9.4.

7.9.3 Test purpose

The purpose of this test is to verify the ability of the receiver to suppress the IQ leakage.

7.9.4 Method of test

7.9.4.1 Initial conditions

Test environment: normal; see annex G.2

RF channels to be tested for single carrier: M; see subclause 4.12.1.

Directions to be tested: OTA REFSENS receiver target reference direction (see table 4.10-2, D11.30).

7.9.4.2 Procedure

- 1) Place the AAS BS with its manufacturer declared coordinate system reference point in the same place as calibrated point in the test system, as shown in Annex D1.1.
- 2) Align the manufacturer declared coordinate system orientation of the AAS BS with the test system.
- 3) Align the BS with the test antenna in the declared direction to be tested.
- 4) Align the NR BS so that the wanted signal and interferer signal is *polarization matched* with the test antenna(s)

For each supported E-UTRA channel BW:

- 5) Adjust the signal generator for the wanted signal as specified in table 7.9.5.1-1 for AAS BS of Wide Area BS class, in table 7.9.5.1-2 for AAS BS of Local Area BS class and in table 7.9.5.1-3 for AAS BS of Medium Range BS class on one side of the F_C .
- 6) Adjust the signal generator for the interfering signal as specified in table 7.9.5.1-1 for AAS BS of Wide Area BS class, in table 7.9.5.1-2 for AAS BS of Local Area BS class and in table 7.9.5.1-3 for AAS BS of Medium Range BS class at opposite side of the F_C and adjacent to the wanted signal.
- 7) Measure throughput according to annex E in TS 36.141 [12].
- 8) Repeat the measurement with the wanted signal on the other side of the F_C , and the interfering signal at opposite side of the F_C and adjacent to the wanted signal.
- 9) Repeat for all supported polarizations. 10

For each supported NR channel BW:

- 2) Adjust the signal generator for the wanted signal as specified in table 7.9.5.2-1 for AAS BS of Wide Area BS class, in table 7.9.5.2-2 for AAS BS of Local Area BS class and in table 7.9.5.2-3 for AAS BS of Medium Range BS class on one side of the F_C .
- 3) Adjust the signal generator for the interfering signal as specified in table 7.9.5.2-1 for AAS BS of Wide Area BS class, in table 7.9.5.2-2 for AAS BS of Local Area BS class and in table 7.9.5.2-3 for AAS BS of Medium Range BS class at opposite side of the F_C and adjacent to the wanted signal.
- 4) Measure throughput according to annex A in TS 38.141-2 [34].
- 5) Repeat the measurement with the wanted signal on the other side of the F_C , and the interfering signal at opposite side of the F_C and adjacent to the wanted signal.

In addition, for *multi-band RIB(s)*, the following steps shall apply:

- 10) For *multi-band RIBs* and single band tests, repeat the steps above per involved band where single band test configurations and test models shall apply with no carrier activated in the other band.

7.9.5 Test Requirement

7.9.5.1 E-UTRA test requirement

For E-UTRA, the throughput shall be $\geq 95\%$ of the *maximum throughput* of the reference measurement channel as specified in 3GPP 36.104 [4] Annex A with parameters specified in table 10.9.4-1 for Wide Area BS, in table 10.9.4-2 for Local Area BS and in table 10.9.4-3 for Medium Range BS.

The OTA levels are applied referenced to $\Delta_{\min\text{SENS}}$.

Table 7.9.5-1 Wide Area BS in-channel selectivity for E-UTRA

E-UTRA channel bandwidth [MHz]	Reference measurement channel	Wanted signal mean power [dBm]		Interfering signal mean power [dBm]	Type of interfering signal
		$f \leq 3.0$ GHz	$3.0 \text{ GHz} < f \leq 4.2$ GHz		
1.4	A1-4 in 3GPP 36.104 [4] Annex A.1	$-105.2 - \Delta_{\min\text{SENS}}$	$-104.8 - \Delta_{\min\text{SENS}}$	$-87 - \Delta_{\min\text{SENS}}$	1.4 MHz E-UTRA signal, 3 RBs
3	A1-5 in 3GPP 36.104 [4] Annex A.1	$-100.4 - \Delta_{\min\text{SENS}}$	$-100.0 - \Delta_{\min\text{SENS}}$	$-84 - \Delta_{\min\text{SENS}}$	3 MHz E-UTRA signal, 6 RBs
5	A1-2 in 3GPP 36.104 [4] Annex A.1	$-98.3 - \Delta_{\min\text{SENS}}$	$-97.9 - \Delta_{\min\text{SENS}}$	$-81 - \Delta_{\min\text{SENS}}$	5 MHz E-UTRA signal, 10 RBs
10	A1-3 in 3GPP 36.104 [4] Annex A.1	$-96.8 - \Delta_{\min\text{SENS}}$	$-96.4 - \Delta_{\min\text{SENS}}$	$-77 - \Delta_{\min\text{SENS}}$	10 MHz E-UTRA signal, 25 RBs
15	A1-3 in 3GPP 36.104 [4] Annex A.1 (NOTE)	$-96.8 - \Delta_{\min\text{SENS}}$	$-96.4 - \Delta_{\min\text{SENS}}$	$-77 - \Delta_{\min\text{SENS}}$	15 MHz E-UTRA signal, 25 RBs (NOTE)
20	A1-3 in 3GPP 36.104 [4] Annex A.1 (NOTE)	$-96.8 - \Delta_{\min\text{SENS}}$	$-96.4 - \Delta_{\min\text{SENS}}$	$-77 - \Delta_{\min\text{SENS}}$	20 MHz E-UTRA signal, 25 RBs (NOTE)

NOTE: Wanted and interfering signal are placed adjacently around F_c

Table 7.9.5-2 Local Area BS in-channel selectivity for E-UTRA

E-UTRA channel bandwidth [MHz]	Reference measurement channel	Wanted signal mean power [dBm]		Interfering signal mean power [dBm]	Type of interfering signal
		$f \leq 3.0$ GHz	$3.0 \text{ GHz} < f \leq 4.2$ GHz		
1.4	A1-4 in 3GPP 36.104 [4] Annex A.1	$-97.2 - \Delta_{\min\text{SENS}}$	$-96.8 - \Delta_{\min\text{SENS}}$	$-79 - \Delta_{\min\text{SENS}}$	1.4 MHz E-UTRA signal, 3 RBs
3	A1-5 in 3GPP 36.104 [4] Annex A.1	$-92.4 - \Delta_{\min\text{SENS}}$	$-92.0 - \Delta_{\min\text{SENS}}$	$-76 - \Delta_{\min\text{SENS}}$	3 MHz E-UTRA signal, 6 RBs
5	A1-2 in 3GPP 36.104 [4] Annex A.1	$-90.3 - \Delta_{\min\text{SENS}}$	$-89.9 - \Delta_{\min\text{SENS}}$	$-73 - \Delta_{\min\text{SENS}}$	5 MHz E-UTRA signal, 10 RBs
10	A1-3 in 3GPP 36.104 [4] Annex A.1 (NOTE 3)	$-88.8 - \Delta_{\min\text{SENS}}$	$-88.4 - \Delta_{\min\text{SENS}}$	$-69 - \Delta_{\min\text{SENS}}$	10 MHz E-UTRA signal, 25 RBs (NOTE 3)
15	A1-3 in 3GPP 36.104 [4] Annex A.1 (NOTE 1)	$-88.8 - \Delta_{\min\text{SENS}}$	$-88.4 - \Delta_{\min\text{SENS}}$	$-69 - \Delta_{\min\text{SENS}}$	15 MHz E-UTRA signal, 25 RBs (NOTE 1)
20	A1-3 in 3GPP 36.104 [4] Annex A.1 (NOTE 1)	$-88.8 - \Delta_{\min\text{SENS}}$	$-88.4 - \Delta_{\min\text{SENS}}$	$-69 - \Delta_{\min\text{SENS}}$	20 MHz E-UTRA signal, 25 RBs (NOTE 1)

NOTE 1: Wanted and interfering signal are placed adjacently around F_c , this reference measurement channel and interfering signal are not applied for Band 46 nor Band 49.
NOTE 2: Void
NOTE 3: This reference measurement channel and interfering signal are not applied for Band 46 nor Band 49.

Table 7.9.5-3 Medium Range BS in-channel selectivity for E-UTRA

E-UTRA channel bandwidth [MHz]	Reference measurement channel	Wanted signal mean power [dBm]		Interfering signal mean power [dBm]	Type of interfering signal
		$f \leq 3.0$ GHz	3.0 GHz $< f \leq 4.2$ GHz		
1.4	A1-4 in 3GPP 36.104 [4] Annex A.1	$-100.2 - \Delta_{\min\text{SENS}}$	$-99.8 - \Delta_{\min\text{SENS}}$	$-82 - \Delta_{\min\text{SENS}}$	1.4 MHz E-UTRA signal, 3 RBs
3	A1-5 in 3GPP 36.104 [4] Annex A.1	$-95.4 - \Delta_{\min\text{SENS}}$	$-95.0 - \Delta_{\min\text{SENS}}$	$-79 - \Delta_{\min\text{SENS}}$	3 MHz E-UTRA signal, 6 RBs
5	A1-2 in 3GPP 36.104 [4] Annex A.1	$-93.3 - \Delta_{\min\text{SENS}}$	$-92.9 - \Delta_{\min\text{SENS}}$	$-76 - \Delta_{\min\text{SENS}}$	5 MHz E-UTRA signal, 10 RBs
10	A1-3 in 3GPP 36.104 [4] Annex A.1 (NOTE 3)	$-91.8 - \Delta_{\min\text{SENS}}$	$-91.4 - \Delta_{\min\text{SENS}}$	$-72 - \Delta_{\min\text{SENS}}$	10 MHz E-UTRA signal, 25 RBs (NOTE 3)
15	A1-3 in 3GPP 36.104 [4] Annex A.1 (NOTE 1)	$-91.8 - \Delta_{\min\text{SENS}}$	$-91.4 - \Delta_{\min\text{SENS}}$	$-72 - \Delta_{\min\text{SENS}}$	15 MHz E-UTRA signal, 25 RBs (NOTE 1)
20	A1-3 in 3GPP 36.104 [4] Annex A.1 (NOTE 1)	$-91.8 - \Delta_{\min\text{SENS}}$	$-91.4 - \Delta_{\min\text{SENS}}$	$-72 - \Delta_{\min\text{SENS}}$	20 MHz E-UTRA signal, 25 RBs (NOTE 1)

NOTE 1: Wanted and interfering signal are placed adjacently around F_c , this reference measurement channel and interfering signal are not applied for Band 46.
 NOTE 2: Void
 NOTE 3: This reference measurement channel and interfering signal are not applied for Band 46.

7.9.5.2 NR test requirement

The requirement shall apply at the RIB when the AoA of the incident wave of the received signal and the interfering signal are the same direction and are within the *minSENS RoAoA*

The wanted and interfering signals applies to all supported polarizations, under the assumption of *polarization matching*.

Details of the reference measurement channels can be found in TS 38.141-2 [34] annex A.

Table 7.9.5.2-1: Wide Area BS in-channel selectivity

BS channel bandwidth [MHz]	Subcarrier spacing [KHz]	Reference measurement channel	Wanted signal mean power [dBm]			Interfering signal mean power [dBm]	Type of interfering signal
			$f \leq 3.0$ GHz	3.0 GHz $< f \leq 4.2$ GHz	4.2 GHz $< f \leq 6.0$ GHz		

5	15	G-FR1-A1-7	-98.9- $\Delta_{\min\text{SENS}}$	-98.5- $\Delta_{\min\text{SENS}}$	-98.2- $\Delta_{\min\text{SENS}}$	-81.4 - $\Delta_{\min\text{SENS}}$	DFT-s-OFDM NR signal, SCS 15 kHz, 10 PRB
10, 15, 20, 25, 30	15	G-FR1-A1-1	-97- $\Delta_{\min\text{SENS}}$	-96.6- $\Delta_{\min\text{SENS}}$	-96.3- $\Delta_{\min\text{SENS}}$	-77.4 - $\Delta_{\min\text{SEN}}$	DFT-s-OFDM NR signal, SCS 15 kHz, 25 PRB
40, 50	15	G-FR1-A1-4	-90.6- $\Delta_{\min\text{SENS}}$	-90.2- $\Delta_{\min\text{SENS}}$	-89.9- $\Delta_{\min\text{SENS}}$	-71.4 - $\Delta_{\min\text{SEN}}$	DFT-s-OFDM NR signal, SCS 15 kHz, 100 PRB
5	30	G-FR1-A1-8	-99.6- $\Delta_{\min\text{SENS}}$	-99.2- $\Delta_{\min\text{SENS}}$	-98.9- $\Delta_{\min\text{SENS}}$	-81.4 - $\Delta_{\min\text{SEN}}$	DFT-s-OFDM NR signal, SCS 30 kHz, 5 PRB
10, 15, 20, 25, 30	30	G-FR1-A1-2	-97.1- $\Delta_{\min\text{SENS}}$	-96.7- $\Delta_{\min\text{SENS}}$	-96.4- $\Delta_{\min\text{SENS}}$	-78.4 - $\Delta_{\min\text{SEN}}$	DFT-s-OFDM NR signal, SCS 30 kHz, 10 PRB
40, 50, 60, 70, 80, 90, 100	30	G-FR1-A1-5	-90.9- $\Delta_{\min\text{SENS}}$	-90.5- $\Delta_{\min\text{SENS}}$	-90.2- $\Delta_{\min\text{SENS}}$	-71.4 - $\Delta_{\min\text{SEN}}$	DFT-s-OFDM NR signal, SCS 30 kHz, 50 PRB
10, 15, 20, 25, 30	60	G-FR1-A1-9	-96.5- $\Delta_{\min\text{SENS}}$	-96.1- $\Delta_{\min\text{SENS}}$	-95.8- $\Delta_{\min\text{SENS}}$	-78.4 - $\Delta_{\min\text{SEN}}$	DFT-s-OFDM NR signal, SCS 60 kHz, 5 PRB
40, 50, 60, 70, 80, 90, 100	60	G-FR1-A1-6	-91- $\Delta_{\min\text{SENS}}$	-90.6- $\Delta_{\min\text{SENS}}$	-90.3- $\Delta_{\min\text{SENS}}$	-71.6 - $\Delta_{\min\text{SEN}}$	DFT-s-OFDM NR signal, SCS 60 kHz, 24 PRB
NOTE: Wanted and interfering signal are placed adjacently around F_c , where the F_c is defined for <i>BS channel bandwidth</i> of the wanted signal according to the table 5.4.2.2-1 and located in the interfering signal.							

Table 7.9.5.2-2: Medium Range BS in-channel selectivity

BS channel bandwidth [MHz]	Subcarrier spacing [KHz]	Reference measurement channel	Wanted signal mean power [dBm]			Interfering signal mean power [dBm]	Type of interfering signal
			$f \leq 3.0$ GHz	3.0 GHz < $f \leq 4.2$ GHz	4.2 GHz < $f \leq 6.0$ GHz		

5	15	G-FR1-A1-7	-93.9- Δ_{minSENS}	-93.5- Δ_{minSENS}	-93.2- Δ_{minSENS}	-76.4 - Δ_{minSENS}	DFT-s-OFDM NR signal, SCS 15 kHz, 10 PRB
10, 15, 20, 25, 30	15	G-FR1-A1-1	-92- Δ_{minSENS}	-91.6- Δ_{minSENS}	-91.3- Δ_{minSENS}	-72.4 - Δ_{minSENS}	DFT-s-OFDM NR signal, SCS 15 kHz, 25 PRB
40, 50	15	G-FR1-A1-4	-85.6- Δ_{minSENS}	-85.2- Δ_{minSENS}	-84.9- Δ_{minSENS}	-66.4 - Δ_{minSENS}	DFT-s-OFDM NR signal, SCS 15 kHz, 100 PRB
5	30	G-FR1-A1-8	-94.6- Δ_{minSENS}	-94.2- Δ_{minSENS}	-93.9- Δ_{minSENS}	-76.4 - Δ_{minSENS}	DFT-s-OFDM NR signal, SCS 30 kHz, 5 PRB
10, 15, 20, 25, 30	30	G-FR1-A1-2	-92.1- Δ_{minSENS}	-91.7- Δ_{minSENS}	-91.4- Δ_{minSENS}	-73.4 - Δ_{minSENS}	DFT-s-OFDM NR signal, SCS 30 kHz, 10 PRB
40, 50, 60, 70, 80, 90, 100	30	G-FR1-A1-5	-85.9- Δ_{minSENS}	-85.5- Δ_{minSENS}	-85.2- Δ_{minSENS}	-66.4 - Δ_{minSENS}	DFT-s-OFDM NR signal, SCS 30 kHz, 50 PRB
10, 15, 20, 25, 30	60	G-FR1-A1-9	-91.5- Δ_{minSENS}	-91.1- Δ_{minSENS}	-90.8- Δ_{minSENS}	-73.4 - Δ_{minSENS}	DFT-s-OFDM NR signal, SCS 60 kHz, 5 PRB
40, 50, 60, 70, 80, 90, 100	60	G-FR1-A1-6	-86- Δ_{minSENS}	-85.6- Δ_{minSENS}	-85.3- Δ_{minSENS}	-66.6 - Δ_{minSENS}	DFT-s-OFDM NR signal, SCS 60 kHz, 24 PRB
NOTE: Wanted and interfering signal are placed adjacently around F_c , where the F_c is defined for <i>BS channel bandwidth</i> of the wanted signal according to the table 5.4.2.2-1 and located in the interfering signal.							

Table 7.9.5.2-3: Local area BS in-channel selectivity

BS channel bandwidth [MHz]	Subcarrier spacing [KHz]	Reference measurement channel	Wanted signal mean power [dBm]			Interfering signal mean power [dBm]	Type of interfering signal
			$f \leq 3.0$ GHz	3.0 GHz < $f \leq 4.2$ GHz	4.2 GHz < $f \leq 6.0$ GHz		

5	15	G-FR1-A1-7	-90.9- Δ_{minSENS}	-90.5- Δ_{minSENS}	-90.2- Δ_{minSENS}	-73.4 - Δ_{minSENS}	DFT-s-OFDM NR signal, SCS 15 kHz, 10 PRB
10, 15, 20, 25, 30	15	G-FR1-A1-1	-89- Δ_{minSENS}	-88.6- Δ_{minSENS}	-88.3- Δ_{minSENS}	-69.4 - Δ_{minSENS}	DFT-s-OFDM NR signal, SCS 15 kHz, 25 PRB
40, 50	15	G-FR1-A1-4	-82.6- Δ_{minSENS}	-82.2- Δ_{minSENS}	-81.9- Δ_{minSENS}	-63.4 - Δ_{minSENS}	DFT-s-OFDM NR signal, SCS 15 kHz, 100 PRB
5	30	G-FR1-A1-8	-91.6- Δ_{minSENS}	-91.2- Δ_{minSENS}	-90.9- Δ_{minSENS}	-73.4 - Δ_{minSENS}	DFT-s-OFDM NR signal, SCS 30 kHz, 5 PRB
10, 15, 20, 25, 30	30	G-FR1-A1-2	-89.1- Δ_{minSENS}	-88.7- Δ_{minSENS}	-88.4- Δ_{minSENS}	-70.4 - Δ_{minSENS}	DFT-s-OFDM NR signal, SCS 30 kHz, 10 PRB
40, 50, 60, 70, 80, 90, 100	30	G-FR1-A1-5	-82.9- Δ_{minSENS}	-82.5- Δ_{minSENS}	-82.2- Δ_{minSENS}	-63.4 - Δ_{minSENS}	DFT-s-OFDM NR signal, SCS 30 kHz, 50 PRB
10, 15, 20, 25, 30	60	G-FR1-A1-9	-88.5- Δ_{minSENS}	-88.1- Δ_{minSENS}	-87.8- Δ_{minSENS}	-70.4 - Δ_{minSENS}	DFT-s-OFDM NR signal, SCS 60 kHz, 5 PRB
40, 50, 60, 70, 80, 90, 100	60	G-FR1-A1-6	-83- Δ_{minSENS}	-82.6- Δ_{minSENS}	-82.3- Δ_{minSENS}	-63.6 - Δ_{minSENS}	DFT-s-OFDM NR signal, SCS 60 kHz, 24 PRB
NOTE: Wanted and interfering signal are placed adjacently around F_c , where the F_c is defined for <i>BS channel bandwidth</i> of the wanted signal according to the table 5.4.2.2-1 and located in the interfering signal.							

8 Radiated performance requirements

8.1 General

Radiated performance requirements specify the ability of the OTA AAS BS to correctly demodulate radiated signals in various propagation conditions and configurations.

The demodulation requirements for an OTA AAS BS are limited to two OTA *demodulation branches* as described in subclause 8.1.1, and are the same as non-AAS BS demodulation requirements specified for:

- *Single RAT UTRA operation* in 3GPP TS 25.104 [2] clause 8 for FDD operation,
- *Single RAT E-UTRA operation* in 3GPP TS 36.104 [4], subclauses 8.2 – 8.4 (for PUSCH, PUCCH and PRACH) and 8.6 – 8.7 (for subslot-PUSCH and SPUCCH),
- *MSR operation* in 3GPP TS 37.105 [6], based on references to the single RAT requirements in 3GPP TS 25.104 [2] and 3GPP TS 36.104 [4].

8.1.1 OTA demodulation branches

OTA performance requirements are only specified for up to 2 *demodulation branches*.

If the OTA AAS BS uses polarization diversity and has the ability to maintain isolation between the signals for each of the *demodulation branches*, then OTA performance requirements can be tested for up to two *demodulation branches* (i.e. 1TX-1RX or 1TX-2RX test setup). When tested for two *demodulation branches*, each demodulation branch maps to one polarization.

If the OTA AAS BS does not use polarization diversity then OTA performance requirements can only be tested for a single *demodulation branch* (i.e. 1TX-1RX test setup).

8.2 Radiated performance requirements for MSR

For OTA AAS BS in *single RAT UTRA operation*, minimum requirements for radiated demodulation performance are specified in subclause 8.3.

For OTA AAS BS in *single RAT E-UTRA operation*, minimum requirements for radiated demodulation performance are specified in subclause 8.4.

For OTA AAS BS in NR operation, minimum requirements for radiated demodulation performance are specified in subclause 8.5.

NOTE: Radiated performance requirements for MSR BS are applicable to the multi-RAT of single RAT operation, but tested only in single RAT configuration.

8.3 Radiated performance requirements for UTRA FDD

8.3.1 General

Radiated performance requirements for *single RAT UTRA operation* in FDD are specified for the fixed reference channels (FRC) and propagation conditions defined in TS 25.104 [2] annex A and annex B, respectively. The requirements only apply to those FRCs that are supported by the OTA AAS BS.

Unless stated otherwise, radiated performance requirements apply for a single carrier only. Performance requirements for a BS supporting DC-HSUPA or DB-DC-HSUPA are defined in terms of single carrier requirements. The requirements in subclause 8.3 shall be met with the transmitter(s) ON.

NOTE: In normal operating conditions the *transceiver units* are configured to transmit and receive at the same time. The transmitter unit(s) associated with the RIB may be OFF for some of the tests in clause 8.

In the referenced conducted test requirements from TS 25.141 [10] the method to test describes connection to one or a number of BS antenna connectors. When applying these methods to the OTA AAS BS, connection shall be made to the RIB, based on one or two OTA *demodulation branches*.

In the referred UTRA specifications and in this section, the term “BS with RX diversity” refers to performance requirements for two *demodulation branches*, and the term “BS without RX diversity” refers to performance requirements for one *demodulation branch*. For “BS with RX diversity”, only the BS performance requirements with Rx diversity apply, otherwise only the BS performance requirements without Rx diversity apply.

For testing purposes, there is one *demodulation branch* per active polarization assumed. In tests performed with signal generators a synchronization signal may be provided, from the BS to the signal generator, to enable correct timing of the wanted signal.

The E_b/N_0 used is defined as:

$$E_b / N_o = \frac{E_c}{N_o} \cdot \frac{L_{chip}}{L_{inf}}$$

Where:

E_c is the received total energy of DPDCH, DPCCH, S-DPCCH, HS-DPCCH, E-DPDCH, S-E-DPDCH, E-DPCCH and S-E-DPCCH per PN chip per *demodulation branch* from all branches

N_o is the total one-sided noise power spectral density due to all noise sources

L_{chip} is the number of chips per frame

L_{inf} is the number of information bits in DTCH excluding CRC bits per frame

All Bit Error Ratio (BER) and Block Error ratio (BLER) measurements shall be carried out according to the general rules for statistical testing defined in ITU-T Recommendation O.153 [30] and TS 25.141 [10], annex C.

If external BLER measurement is not used then the internal BLER calculation shall be used instead. When internal BLER calculation is used, the requirements of the verification test according to TS 25.141 [10] subclause 8.6 shall be met in advance.

Table 8.3.1-1: Summary of AAS BS performance targets for *single RAT UTRA operation* in FDD

Physical channel	Measurement channel	Static	Multi-path Case 1	Multi-path Case 2	Multi-path Case 3	Moving	Birth / Death	High Speed Train (Note)
		Performance metric						
DCH	12.2 kbps	BLER<10 ⁻²	BLER<10 ⁻²	BLER<10 ⁻²	BLER<10 ⁻²	BLER <10 ⁻²	BLER <10 ⁻²	BLER <10 ⁻²
	64 kbps	BLER<10 ⁻¹ ,10 ⁻²	BLER<10 ⁻¹ , 10 ⁻²	BLER<10 ⁻¹ ,10 ⁻²	BLER <10 ⁻¹ , 10 ⁻² ,10 ⁻³	BLER <10 ⁻¹ ,10 ⁻²	BLER <10 ⁻¹ ,10 ⁻²	-
	144 kbps	BLER<10 ⁻¹ ,10 ⁻²	BLER<10 ⁻¹ ,10 ⁻²	BLER<10 ⁻¹ ,10 ⁻²	BLER <10 ⁻¹ , 10 ⁻² ,10 ⁻³	-	-	-
	384 kbps	BLER<10 ⁻¹ ,10 ⁻²	BLER<10 ⁻¹ ,10 ⁻²	BLER<10 ⁻¹ ,10 ⁻²	BLER <10 ⁻¹ , 10 ⁻² ,10 ⁻³	-	-	-

NOTE: Optional condition, not applicable for all BSs.

8.3.2 Definitions and applicability

Definitions of radiated performance requirements in *single RAT UTRA operation* in FDD and their applicability are the same as defined in TS 25.141 [10], in requirement's specific "Definition and applicability" subclauses within 8.2 - 8.13 subclauses.

The following limitation apply for the radiated performance requirements in *single RAT UTRA operation* in FDD:

- All the radiated performance requirements referred from TS 25.141 [10] are subject to 2Rx limitation in the OTA test setup, as captured in subclause 8.1.1.
- If the OTA AAS BS does not use polarisation diversity then performance requirements only apply to a single *demodulation branch* (i.e. 1TX-1RX test setup).
- If the OTA AAS BS uses polarisation diversity and has the ability to maintain isolation between the performance requirements signals for each of the *demodulation branches*, then performance requirements can be applied to up to two *demodulation branches* (i.e. 1TX-2RX test setups).

NOTE: for the list of BS demodulation requirements which were found to be feasible in OTA test setup with the above 2Rx limitation, refer to TR 37.843 [29], subclause 7.8.

- For FRC8 in TS 25.104 [2] the non E-DPCCH boosting and E-DPCCH boosting requirement only apply for the option supported by the OTA AAS BS.
- Performance of signalling detection for 4C-HSDPA HS-DPCCH test shall be performed only for the BS supporting 4C-HSDPA.
- Performance of signalling detection for 8C-HSDPA HS-DPCCH test shall be performed only for the BS supporting 8C-HSDPA.
- The performance requirements for the high speed train scenarios defined in TS 25.104 [2] are optional.

8.3.3 Minimum requirements

Minimum requirements for radiated performance requirements in *single RAT UTRA operation* in FDD are the same as defined in TS 25.104 [2], in requirement's specific "Minimum requirement" subclauses within 8.2 - 8.12 subclauses, subject to limitations listed in subclause 8.3.2.

8.3.4 Test purposes

Test purposes for the radiated performance requirements in *single RAT UTRA operation* in FDD are the same as defined in TS 25.141 [10], in requirement's specific "Test purpose" subclauses within subclauses 8.2 - 8.13.

The radiated test shall verify the OTA AAS BS receiver's ability to achieve requirement's specific performance metric under defined propagation conditions emulated in OTA test chamber, for a given E_b/N_0 (or E_c/N_0).

8.3.5 Method of test

8.3.5.1 Initial conditions

Initial conditions of radiated performance requirements in *single RAT UTRA operation* in FDD are the same as defined in TS 25.141 [10], in requirement's specific "Initial conditions" subclauses within 8.2 - 8.13 subclauses, with the exception, that instead of connecting the BS tester(s) directly to antenna connector(s), either a single or two polarizations should be transmitted via test antenna(s) in the OTA chamber, where each polarization represents a *demodulation branch*.

The initial conditions for the radiated performance requirements in *single RAT UTRA operation* in FDD are generalized as follows:

Test environment: normal, see annex G.2.

RF channels to be tested: B, M and T; see TS 25.141 [10], subclause 4.8.

Direction to be tested: receiver target reference direction (see table 4.10-1, D10.9).

8.3.5.2 Procedure

- 1) Place the OTA AAS BS with its manufacturer declared coordinate system reference point in the same place as calibrated point in the test system, as shown in annex D.3.
- 2) Align the manufacturer declared coordinate system orientation of the OTA AAS BS with the test system.
- 3) Set the OTA AAS BS in the declared direction to be tested.
- 4) Connect the BS tester generating the wanted signal, multipath fading simulators and/or AWGN generators (depending on the required OTA test procedure) to a test antenna via a combining network in OTA test setup, as shown in annex D.3.
- 5) Apply the conducted performance test procedure appropriate to the requirement as described in subclause 8 of TS 25.141 [10]. Instead of connection via an antenna connector, one of the RX antenna signals should be transmitted on each polarization of the test antenna(s).
- 6) The characteristics of the wanted signal shall be configured according to the corresponding UL reference measurement channel defined in annex A in TS 25.141 [10], and according to additional test parameters listed in respective conducted performance test procedure in TS 25.141 [10].
 - a. For RACH requirements: configure test signal generator to send a preamble according to the test signal pattern defined for RACH in TS 25.141 [10].
- 7) The multipath fading emulators shall be configured according to the corresponding channel model defined in TS 25.141 [10], annex D.
- 8) Adjust the test signal mean power so the calibrated radiated signal level at the BS receiver is as specified in requirement's specific subclause 8 of TS 25.141 [10].
 - a. For DCH requirements: Adjust the test signal mean power so the calibrated radiated E_b/N_0 value at the BS receiver is as specified in requirement's specific subclause 8 of TS 25.141 [10]. To achieve the specified E_b/N_0 , the ratio of the wanted signal level relative to the AWGN signal should be adjusted to: $10 * \text{Log}_{10}(R_b / 3.84 * 10^6) + E_b/N_0$ [dB].

- b. For RACH requirements: Adjust the test signal mean power so the calibrated radiated E_b/N_0 (or E_c/N_0) value at the BS receiver is as specified in requirement's specific subclause 8 of TS 25.141 [10].
- i. For RACH preamble detection in static propagation, multipath fading case 3, or in high speed train conditions: To achieve the specified E_c/N_0 , the ratio of the wanted signal level (of the preamble part) relative to the AWGN signal at the BS receiver should be adjusted to: E_c/N_0 [dB].
- ii. For Demodulation of RACH message in static propagation conditions, multipath fading case 3, or in high speed train conditions: To achieve the specified E_c/N_0 , the ratio of the wanted signal level (of the message part) relative to the AWGN signal at the BS receiver should be adjusted to: $10 * \text{Log}_{10}(\text{TB} / (\text{TTI} * 3.84 * 10^6)) + E_b/N_0$ [dB].
- c. For HS-DPCCH: Adjust the test signal mean power so the calibrated radiated E_c/N_0 value at the BS receiver is as specified in requirement's specific subclause 8 of TS 25.141 [10]. To achieve the specified E_c/N_0 , the ratio of the wanted signal level relative to the AWGN signal at the BS input should be adjusted to: E_c/N_0 [dB].

The power level for the transmission may be set such that the AWGN level at the RIB is equal to the AWGN level quoted in the test procedure of TS 25.141 [10] minus $\Delta_{\text{OTAREFSENS}}$. Example of the AWGN levels for the UTRA FDD requirements, with the $\Delta_{\text{OTAREFSENS}}$ correction are presented in table 8.4.5.2-1.

Table 8.3.5.2-1: AWGN power level at the BS input for UTRA FDD requirements

BS class	AWGN power level
Wide Area	- 84 - $\Delta_{\text{OTAREFSENS}}$ [dBm] / 3.84 MHz
Medium Range	- 74 - $\Delta_{\text{OTAREFSENS}}$ [dBm] / 3.84 MHz
Local Area	- 70 - $\Delta_{\text{OTAREFSENS}}$ [dBm] / 3.84 MHz

While signal power adjustment, reassure that the E_b/N_0 (or E_c/N_0) at the BS receiver is not impacted by the noise floor.

- 9) If RX diversity is not supported, ensure the *polarisation match* is achieved among test antenna(s) and the OTA AAS BS under test, in order to maximize the power at the BS receiver.

- 10) For reference channels applicable to the BS, measure the appropriate performance metric for the requirement as described in clause 8 of TS 25.141 [10].

8.3.6 Test requirements

Test requirements of radiated performance requirements in *single RAT UTRA operation* in FDD are the same as defined in TS 25.141 [10], in requirement's specific "Test requirement" subclauses within 8.2 - 8.13 subclauses, with the exception that shall be derived based on the OTA test procedure, as in subclause 8.3.5.2.

Applicability of radiated test requirements is subject to limitations listed in subclause 8.3.2.

In the referenced test requirements in this section, the term "number of RX antennas" should be replaced by one if a single polarization is transmitted or by two if two polarizations are transmitted.

NOTE: If the above Test Requirement differs from the Minimum Requirement then the Test Tolerance applied for this test is non-zero. The Test Tolerance for this test and the explanation of how the Minimum Requirement has been relaxed by the Test Tolerance is given in annex C.

8.4 Radiated performance requirements for E-UTRA

8.4.1 General

Radiated performance requirements for *single RAT E-UTRA operation* are specified for the fixed reference channels (FRC) and propagation conditions defined in TS 36.104 [4] annex A and annex B, respectively. The requirements only apply to those FRCs that are supported by the OTA AAS BS.

Unless stated otherwise, radiated performance requirements apply for a single carrier only. Radiated performance requirements for an OTA AAS BS in E-UTRA operation supporting *carrier aggregation* are defined in terms of single carrier requirements.

In the referred E-UTRA specification TS 36.104 [4], the term "RX antennas" refers to *demodulation branches* (and not physical antennas).

Conformance requirements can only be tested for 1 or 2 *demodulation branches* depending on the number of polarizations supported by the BS, with the required SNR /SINR (in case of E-UTRA demodulation requirements), or required E_b/N_0 (in case of UTRA FDD demodulation requirements) applied separately per polarization.

Only 2RX BS performance requirements apply when OTA AAS BS supports and is tested with dual polarizations, except where requirements are defined with 1RX only (e.g. HST) where the requirements shall be tested with single polarization.

NOTE: OTA AAS BS can support more than 2 *demodulation branches*, however OTA conformance testing can only be performed for 1 or 2 *demodulation branches*.

For tests in subclause 8.4 the transmitters may be OFF.

The performance requirements for High Speed Train conditions are optional.

The performance requirements for UL timing adjustment scenario 2 are optional.

In tests performed with signal generators a synchronization signal may be provided, from the BS to the signal generator, to enable correct timing of the wanted signal.

For E-UTRA performance requirements the SNR used in this clause is specified based on a single carrier and defined as:

$$\text{SNR} = S / N$$

Where:

S is the total signal energy in the subframe.

N is the noise energy in a bandwidth corresponding to the *transmission bandwidth* over the duration of a subframe.

For enhanced E-UTRA performance requirements type A, the SINR used in this clause is specified based on a single carrier and defined as:

$$\text{SINR} = S / N'$$

Where:

S is the total signal energy in the subframe.

N' is the summation of the received energy of the strongest interferers explicitly defined in a test procedure plus the white noise energy N , in a bandwidth corresponding to the *transmission bandwidth* over the duration of a subframe. The respective energy of each interferer relative to N' is defined by its associated DIP value.

In the referenced conducted test requirements from TS 36.141 [12] the method to test describes connection to one or a number of BS antenna connectors. When applying these methods to the OTA AAS BS, connection shall be made to the RIB, based on one or two OTA *demodulation branches*.

8.4.2 Definitions and applicability

Definitions of radiated performance requirements in *single RAT E-UTRA operation* and their applicability are the same as defined in TS 36.141 [12], in requirement's specific "Definition and applicability" subclauses within 8.2 - 8.4 subclauses.

The following limitation apply for the radiated performance requirements in *single RAT E-UTRA operation*:

- All the radiated performance requirements referred from TS 36.141 [12] are subject to 2Rx limitation in the OTA test setup, as captured in subclause 8.1.1.

- If the OTA AAS BS does not use polarisation diversity then performance requirements only apply to a single *demodulation branch* (i.e. 1TX-1RX test setup).
- If the OTA AAS BS uses polarisation diversity and has the ability to maintain isolation between the performance requirements signals for each of the *demodulation branches*, then performance requirements can be applied to up to two *demodulation branches* (i.e. 1TX-2RX test setups).

NOTE: for the list of BS demodulation requirements which were found to be feasible in OTA test setup with the above 2Rx limitation, refer to TR 37.843 [29], subclause 7.8.

- A test for a specific channel bandwidth is only applicable if the BS supports it. For a BS supporting multiple channel bandwidths only the tests for the lowest and the highest channel bandwidths supported by the BS are applicable.
- The performance requirements for High Speed Train conditions are optional.
- The performance requirements for UL timing adjustment scenario 2 are optional.
- Performance requirements for coverage enhancements are applicable only to the AAS BS supporting coverage enhancement configured with CEModeA. This applies to the following requirements:
 - Requirements for PUSCH supporting coverage enhancement
 - Requirements for PUSCH supporting Cat-M1 UEs
 - PUCCH performance requirements for supporting Cat-M1 UEs
 - PRACH missed detection, Cat-M1 mode
- The enhanced performance requirements apply to AAS BS supporting the enhanced performance requirements type A and/or type B.
- Performance requirements for NB-IoT are not applicable to AAS BS.

For PUSCH performance requirements, the FRCs for the throughput performance metric derivation are listed in TS 36.141 [12], annex A.

8.4.3 Minimum requirements

Minimum requirements for radiated performance requirements in *single RAT E-UTRA operation* are the same as defined in TS 36.104 [4], in requirement's specific "Minimum requirement" subclauses within 8.2 - 8.4 (for PUSCH, PUCCH and PRACH) and 8.6 - 8.7 (for subslot-PUSCH and SPUCCH), subject to limitations listed in subclause 8.4.2.

8.4.4 Test purposes

Test purposes for the radiated performance requirements in *single RAT E-UTRA operation* are the same as defined in TS 36.141 [12], in requirement's specific "Test purpose" subclauses within subclauses 8.2 - 8.4 (for PUSCH, PUCCH and PRACH) and 8.6 - 8.7 (for subslot-PUSCH and SPUCCH).

The radiated test shall verify the OTA AAS BS receiver's ability to achieve requirement's specific performance metric under defined propagation conditions emulated in OTA test chamber, for a given SNR (or SINR).

8.4.5 Method of test

8.4.5.1 Initial conditions

Initial conditions of radiated performance requirements in *single RAT E-UTRA operation* are the same as defined in TS 36.141 [12], in requirement's specific "Initial conditions" subclauses within 8.2 - 8.4 and 8.6 - 8.7, with the exception, that instead of connecting the BS tester(s) directly to antenna connector(s), either a single or two polarizations should be transmitted via test antenna(s) in the OTA chamber, where each polarization represents a *demodulation branch*.

The initial conditions for the radiated performance requirements in *single RAT E-UTRA operation* are generalized as follows:

Test environment: normal, annex G.2.

RF channels to be tested: M; see TS 36.141 [12], subclause 4.7.

Direction to be tested: receiver target reference direction (see table 4.10-1, D10.9).

8.4.5.2 Procedure

- 1) Place the OTA AAS BS with its manufacturer declared coordinate system reference point in the same place as calibrated point in the test system, as shown in annex D.3.
- 2) Align the manufacturer declared coordinate system orientation of the OTA AAS BS with the test system.
- 3) Set the OTA AAS BS in the declared direction to be tested.
- 4) Connect the BS tester generating the wanted signal, interference signal(s), multipath fading simulators and/or AWGN generators (depending on the required OTA test procedure) to a test antenna via a combining network in OTA test setup, as shown in annex D.3.
 - a. For enhanced performance requirements and for ACK missed detection for multi user PUCCH format 1a: Interconnect attenuators for relative power setting purposes for all transmitting branches (wanted signal and all interferers, separately).
- 5) Apply the conducted performance test procedure appropriate to the requirement as described in subclause 8 of TS 36.141 [12]. Instead of connection via an antenna connector, one of the RX antenna signals should be transmitted on each polarization of the test antenna(s).
- 6) The characteristics of the wanted/interfering signal shall be configured according to the corresponding UL reference measurement channel defined in annex A in TS 36.141 [12], and according to additional test parameters listed in respective conducted performance test procedure in TS 36.141 [12]. In case of PUCCH requirements, the characteristics of the wanted signal shall be configured according to TS 36.211 [28].
- 7) The multipath fading emulators shall be configured according to the corresponding channel model defined in TS 36.141 [12], annex B.
- 8) Adjust the test signal mean power so the calibrated radiated SNR (or SINR) value at the BS receiver is as specified in requirement's specific subclause 8 of TS 36.141 [12], and that the SNR (or SINR) at the BS receiver is not impacted by the noise floor.

The power level for the transmission may be set such that the AWGN level at the RIB is equal to the AWGN level quoted in the test procedure of TS 36.141 [12] minus $\Delta_{\text{OTAREFSENS}}$. Examples of the AWGN levels for the E-UTRA PUSCH as well as for the PUCCH and PRACH requirements, with the $\Delta_{\text{OTAREFSENS}}$ correction are presented in table 8.4.5.2-1 and table 8.4.5.2-2, respectively.

Table 8.4.5.2-1: AWGN power level at the BS input for PUSCH requirements

Channel bandwidth [MHz]	AWGN power level
1.4	$-92.7 - \Delta_{\text{OTAREFSENS}}$ [dBm] / 1.08 MHz
3	$-88.7 - \Delta_{\text{OTAREFSENS}}$ [dBm] / 2.7 MHz
5	$-86.5 - \Delta_{\text{OTAREFSENS}}$ [dBm] / 4.5 MHz
10	$-83.5 - \Delta_{\text{OTAREFSENS}}$ [dBm] / 9 MHz
15	$-81.7 - \Delta_{\text{OTAREFSENS}}$ [dBm] / 13.5 MHz
20	$-80.4 - \Delta_{\text{OTAREFSENS}}$ [dBm] / 18 MHz

Table 8.4.5.2-2: AWGN power level at the BS input for PUCCH and PRACH requirements

Channel bandwidth [MHz]	AWGN power level
1.4	$-89.7 - \Delta_{\text{OTAREFSENS}}$ [dBm] / 1.08 MHz
3	$-85.7 - \Delta_{\text{OTAREFSENS}}$ [dBm] / 2.7 MHz
5	$-83.5 - \Delta_{\text{OTAREFSENS}}$ [dBm] / 4.5 MHz
10	$-80.5 - \Delta_{\text{OTAREFSENS}}$ [dBm] / 9 MHz
15	$-78.7 - \Delta_{\text{OTAREFSENS}}$ [dBm] / 13.5 MHz
20	$-77.4 - \Delta_{\text{OTAREFSENS}}$ [dBm] / 18 MHz

- 9) If RX diversity is not supported, ensure the *polarisation match* is achieved among test antenna(s) and the OTA AAS BS under test, in order to maximize the power at the BS receiver.
- 10) For reference channels applicable to the BS, measure the appropriate performance metric for the requirement as described in clause 8 of TS 36.141 [12].

8.4.6 Test requirements

Test requirements of radiated performance requirements in *single RAT E-UTRA operation* are the same as defined in TS 36.141 [12], in requirement's specific "Test requirement" subclauses within 8.2 - 8.4 and 8.6 – 8.7, with the exception that shall be derived based on the OTA test procedure, as in subclause 8.4.5.2.

Applicability of radiated test requirements is subject to limitations listed in subclause 8.4.2.

In the referenced test requirements in this section, the term "number of RX antennas" should be replaced by one if a single polarization is transmitted or by two if two polarizations are transmitted.

NOTE: If the above Test Requirement differs from the Minimum Requirement then the Test Tolerance applied for this test is non-zero. The Test Tolerance for this test and the explanation of how the Minimum Requirement has been relaxed by the Test Tolerance is given in annex C.

8.5 Radiated performance requirements for NR

8.5.1 General

Radiated performance requirements specify the ability of the *BS type 1-O* or *BS type 2-O* to correctly demodulate radiated signals in various conditions and configurations. Radiated performance requirements are specified at the RIB.

Radiated performance requirements for NR operation are specified for the fixed reference channels (FRC) and propagation conditions defined in TS 38.104 [36] annex A and annex G, respectively. The requirements only apply to those FRCs that are supported by the OTA AAS BS.

The radiated performance requirements for *BS type 1-O* and for the *BS type 2-O* are limited to two OTA *demodulation branches* as described in subclause 8.1.1. Conformance requirements can only be tested for 1 or 2 *demodulation branches* depending on the number of polarizations supported by the BS, with the required SNR applied separately per polarization.

NOTE 1: The BS can support more than 2 *demodulation branches*, however OTA conformance testing can only be performed for 1 or 2 *demodulation branches*.

Unless stated otherwise, radiated performance requirements apply for a single carrier only. Radiated performance requirements for NR operation supporting *carrier aggregation* are defined in terms of single carrier requirements.

For *BS type 1-O* in FDD operation the requirements in clause 8 shall be met with the transmitter units associated with the RIB in the *operating band* turned ON.

NOTE 2: In normal operating conditions, transceivers in FDD operation are configured to transmit and receive at the same time. The associated transmitter unit(s) may be OFF for some of the tests as specified in TS 38.141-2 [34].

In tests performed with signal generators a synchronization signal may be provided, from the BS to the signal generator, to enable correct timing of the wanted signal.

Conformance requirements can only be tested for 1 or 2 *demodulation branches* depending on the number of polarizations supported by the BS, with the required SNR applied separately per polarization.

Only 2RX BS performance requirements apply when OTA AAS BS supports and is tested with dual polarizations.

NOTE 3: OTA AAS BS can support more than 2 *demodulation branches*, however OTA conformance testing can only be performed for 1 or 2 *demodulation branches*.

The SNR used in this clause is specified based on a single carrier and defined as:

$$\text{SNR} = S / N$$

Where:

S is the total signal energy in a slot on a RIB.

N is the noise energy in a bandwidth corresponding to the transmission bandwidth over the duration of a slot on a RIB.

8.5.2 Definitions and applicability

Definitions of radiated performance requirements in NR operation and their applicability are the same as defined in TS 38.141-2 [34], in requirement's specific "Definition and applicability" subclauses within 8.2 - 8.4.

The following limitation apply for the radiated performance requirements in NR operation:

- All the radiated performance requirements referred from TS 38.141-2 [34] are subject to 2RX limitation in the OTA test setup, as captured in subclause 8.1.1.
- If the OTA AAS BS does not use polarisation diversity then performance requirements only apply to a single *demodulation branch* (i.e. 1TX-1RX test setup).
- If the OTA AAS BS uses polarisation diversity and has the ability to maintain isolation between the performance requirements signals for each of the *demodulation branches*, then performance requirements can be applied to up to two *demodulation branches* (i.e. 1TX-2RX test setups).
- A test for a specific channel bandwidth is only applicable if the BS supports it. For a BS supporting multiple channel bandwidths only the tests for the lowest and the highest channel bandwidths supported by the BS are applicable.

For PUSCH performance requirements, the FRCs for the throughput performance metric derivation are listed in TS 38.141-2 [34], annex A.

8.5.3 Minimum requirements

Minimum requirements for radiated performance requirements in NR operation are the same as defined in TS 38.104 [36], in requirement's specific "Minimum requirement" subclauses within 8.2 - 8.4, subject to limitations listed in subclause 8.5.2.

8.5.4 Test purposes

Test purposes for the radiated performance requirements in NR operation are the same as defined in TS 38.141-2 [34], in requirement's specific "Test purpose" subclauses within 8.2 - 8.4.

The radiated test shall verify the OTA AAS BS receiver's ability to achieve requirement's specific performance metric under defined propagation conditions emulated in OTA test chamber, for a given SNR.

8.5.5 Method of test

8.5.5.1 Initial conditions

Initial conditions of radiated performance requirements in NR operation are the same as defined in TS 38.141-2 [34], in requirement's specific "Initial conditions" subclauses within 8.2 - 8.4.

A single or two polarizations should be transmitted via test antenna(s) in the OTA chamber, where each polarization represents a *demodulation branch*.

The initial conditions for the radiated performance requirements in NR operation are generalized as follows:

Test environment: normal, annex G.2.

RF channels to be tested: M; see TS 38.141-2 [34], subclause 4.9.

Direction to be tested:

- For BS type 1-O, receiver target reference direction.
- For BS type 2-O, OTA REFSENS receiver target reference direction.

8.5.5.2 Procedure

- 1) Place the OTA AAS BS with its manufacturer declared coordinate system reference point in the same place as calibrated point in the test system, as shown in annex D.3.
- 2) Align the manufacturer declared coordinate system orientation of the OTA AAS BS with the test system.
- 3) Set the OTA AAS BS in the declared direction to be tested.
- 4) Connect the BS tester generating the wanted signal, interference signal(s), multipath fading simulators and/or AWGN generators (depending on the required OTA test procedure) to a test antenna via a combining network in OTA test setup, as shown in annex D.3.
- 5) Apply the performance test procedure appropriate to the requirement as described in subclause 8 of TS 38.141-2 [34]. One of the RX antenna signals should be transmitted on each polarization of the test antenna(s).
- 6) The characteristics of the wanted/interfering signal shall be configured according to the corresponding UL reference measurement channel defined in annex A in TS 38.141-2 [34], and according to additional test parameters listed in respective performance test procedures. In case of PUCCH requirements, the characteristics of the wanted signal shall be configured according to TS 38.211 [36].
- 7) The multipath fading emulators shall be configured according to the corresponding channel model defined in TS 38.141-2 [34], annex J.
- 8) Adjust the test signal mean power so the calibrated radiated SNR value at the BS receiver is as specified in requirement's specific subclause 8 of TS 38.141-2 [34], and that the SNR at the BS receiver is not impacted by the noise floor.

[The power level for the transmission may be set such that the AWGN level at the RIB is equal to the AWGN level quoted in the test procedure of TS 38.141-2 [34] minus $\Delta_{\text{OTAREFSENS}}$.]

Table 8.2.1.4.2-2: AWGN power level at the BS input

TBD

- 9) If RX diversity is not supported, ensure the *polarisation match* is achieved among test antenna(s) and the OTA AAS BS under test, in order to maximize the power at the BS receiver.
- 10) For reference channels applicable to the BS, measure the appropriate performance metric for the requirement as described in clause 8 of TS 38.141-2 [34].

8.5.6 Test requirements

Test requirements of radiated performance requirements in NR operation are the same as defined in TS 38.141-2 [34], in requirement's specific "Test requirement" subclauses within 8.2 - 8.4.

Applicability of radiated test requirements is subject to limitations listed in subclause 8.5.2.

NOTE: If the above Test Requirement differs from the Minimum Requirement then the Test Tolerance applied for this test is non-zero. The Test Tolerance for this test and the explanation of how the Minimum Requirement has been relaxed by the Test Tolerance is given in annex C.

Annex A (normative): Test system characterization

The radiated measurement methods for AAS BS conformance testing were described in 3GPP TR 37.842 [7], including descriptions of their limitations and testing applicability.

Annex B (normative): Calibration

The radiated measurement methods for AAS BS conformance testing were described in 3GPP TR 37.842 [7]. Calibration stage description was covered for each of the identified Test Systems in the measurement's procedure description, which covered two distinct stages: calibration stage and measurement stage. This has been separately covered for transmitter and for receiver requirements.

Annex C (informative): Test tolerances and derivation of test requirements

C.1 General

The test requirements explicitly defined in this specification have been calculated by relaxing the minimum requirements of the core specification using the Test Tolerances defined here. When the Test Tolerance is non-zero, the test requirements will differ from the minimum requirements, and the formula used for this relaxation is given in the following tables.

The Test Tolerances are derived from Test System uncertainties.

The Test Tolerances should not be modified for any reason e.g. to take account of commonly known test system errors (such as mismatch, cable loss, etc.).

Note that a formula for applying Test Tolerances is provided for all tests.

NOTE: OTA test requirements for AAS BS are specified for Normal conditions, only.

C.2 Measurement of transmitter (OTA)

Table C.2-1: Derivation of Test Requirements (OTA transmitter tests)

Test	Minimum Requirement in 3GPP TS 37.105 [6]	Test Tolerance (TT)	Test Requirement in the present document
6.2 Radiated transmit power	See 3GPP TS 37.105 [6], subclause 9.2	1.1 dB, $f \leq 3.0$ GHz 1.3 dB, $3.0 \text{ GHz} < f \leq 4.2 \text{ GHz}$	Formula: Upper limit + TT, Lower limit – TT
6.2 Radiated transmit power (extreme conditions)	See 3GPP TS 37.105 [6], subclause 9.2	2.5 dB, $f \leq 3.0$ GHz 2.6 dB, $3.0 \text{ GHz} < f \leq 4.2 \text{ GHz}$	Formula: Upper limit + TT, Lower limit – TT
6.3.2 OTA Maximum output power	See 3GPP TS 37.105 [6], subclause 9.3.2	1.4 dB, $f \leq 3.0$ GHz 1.5 dB, $3.0 \text{ GHz} < f \leq 4.2$	Formula: Upper limit + TT, Lower limit – TT
6.3.3 OTA E-UTRA DL RS power	See 3GPP TS 37.105 [6], subclause 9.3.3	1.3 dB, $f \leq 3.0$ GHz 1.5 dB, $3.0 \text{ GHz} < f \leq 4.2 \text{ GHz}$	Formula: Upper limit + TT, Lower limit – TT
6.4.2 OTA UTRA Inner loop power control in the downlink	See 3GPP TS 37.105 [6], subclause 9.4.2	0.1 dB	Formula: Upper limit + TT, Lower limit – TT
6.4.3 OTA Power control dynamic range	See 3GPP TS 37.105 [6], subclause 9.4.3	1.1 dB	Formula: Upper limit - TT, Lower limit + TT
6.4.4 OTA Total power dynamic range	See 3GPP TS 37.105 [6], subclause 9.4.4	0.3 dB UTRA 0.4 dB E-UTRA & NR	Formula: limit - TT
6.4.5 OTA IPDL time mask	See 3GPP TS 37.105 [6], subclause 9.4.5	0.7 dB	Formula: limit - TT
6.5 OTA Transmit ON/OFF power	See 3GPP TS 37.105 [6], subclause 9.5	3.4 dB, $f \leq 3.0$ GHz 3.6 dB, $3.0 \text{ GHz} < f \leq 4.2 \text{ GHz}$	Formula: limit - TT
6.6.2 OTA Frequency Error	See 3GPP TS 37.105 [6] subclause 9.6.2	12 Hz	Limit + TT
6.6.3 OTA Time alignment error	See 3GPP TS 37.105 [6], subclause 9.6.3	25 ns	Limit + TT
6.6.4 OTA Modulation quality	See 3GPP TS 37.105 [6], subclause 9.6.3	1 %	Limit + TT
6.7.2 OTA occupied bandwidth	See 3GPP TS 37.105 [6], subclause 9.7.2	0 Hz	Limit
6.7.3 OTA Adjacent Channel Leakage power Ratio	See 3GPP TS 37.105 [6], subclause 9.7.3	ACLR / CACLR 1.0 dB, $f \leq 3.0$ GHz 1.2 dB, $3.0 \text{ GHz} < f \leq 4.2$ Absolute limit 0 dB	Limit + TT
6.7.4 OTA Spectrum emission mask	See 3GPP TS 37.105 [6], subclause 9.6.3	1.8 dB, $f \leq 3.0\text{GHz}$ 2.0 dB, $3.0\text{GHz} < f \leq 4.2\text{GHz}$ FFS	Limit + TT
6.7.5 OTA Operating band unwanted emission	See 3GPP TS 37.105 [6], subclause 9.6.3	close to carrier (<10MHz) 1.8 dB, $f \leq 3.0\text{GHz}$ 2.0 dB, $3.0\text{GHz} < f \leq 4.2\text{GHz}$ far from carrier ($\geq 10\text{MHz}$) 0dB	Limit + TT
6.7.6.2 OTA Transmitter spurious emissions, Mandatory Requirements	See 3GPP TS 37.105 [6], subclause 9.7.6.2.1, 9.7.6.3.1 and 9.7.6.4.1	0dB	FFS
6.7.6.3 Transmitter spurious emissions, Protection of BS receiver	See 3GPP TS 37.105 [6], subclause 9.7.6.2.2, 9.7.6.3.2 and 9.7.6.4.2	3.1 dB, $f \leq 3.0\text{GHz}$ 3.3 dB, $3.0\text{GHz} < f \leq 4.2\text{GHz}$	Limit + TT
6.7.6.4 Transmitter spurious emissions, Additional spurious emission requirements	See 3GPP TS 37.105 [6], subclause 9.7.6.2.3, 9.7.6.3.3 and 9.7.6.4.3	2.6 dB, $f \leq 3.0\text{GHz}$ 3.0 dB, $3.0\text{GHz} < f \leq 4.2\text{GHz}$ 3.5 dB, $4.2 \text{ GHz} < f \leq 6.0 \text{ GHz}$ For co-existence with PHS and public safety bands. 0 dB	Limit + TT
6.7.6.5 Transmitter spurious emissions, Co-location	See 3GPP TS 37.105 [6], subclause 9.7.6.2.4, 9.7.6.3.4 and 9.7.6.4.4	3.1 dB, $f \leq 3.0\text{GHz}$ 3.3 dB, $3.0\text{GHz} < f \leq 4.2\text{GHz}$ 3.4 dB, $4.2\text{GHz} < f \leq 6.0 \text{ GHz}$	Limit + TT
6.8 OTA Transmitter intermodulation	See 3GPP TS 37.105 [6]	0dB	

C.3 Measurement of receiver (OTA)

Table C.2-1: Derivation of Test Requirements (OTA receiver tests)

Test	Minimum Requirement in 3GPP TS 37.105 [6]	Test Tolerance	Test Requirement in the present document
7.2 OTA sensitivity	See 3GPP TS 37.105 [6], subclause 10.2	1.3 dB, $f \leq 3.0$ GHz 1.4 dB, $3.0 \text{ GHz} < f \leq 4.2 \text{ GHz}$	Formula: Declared Minimum EIS + TT
7.3 OTA Reference Sensitivity	See 3GPP TS 37.105 [6], subclause 10.3	1.3 dB, $f \leq 3.0$ GHz 1.4 dB, $3.0 \text{ GHz} < f \leq 4.2 \text{ GHz}$	Formula: EISREFSENS + TT
7.4 OTA Dynamic range	See 3GPP TS 37.105 [6], subclause 10.4	0.3 dB	Formula: Wanted signal power + TT. Interferer signal power unchanged.
7.5 OTA Adjacent channel selectivity, general blocking, and narrowband blocking	See 3GPP TS 37.105 [6], subclause 10.5	0 dB	Formula: Wanted signal power + TT. Interferer signal power unchanged.
7.6 OTA Blocking - in-band	See 3GPP TS 37.105 [6], subclause 10.6	0 dB	Formula: Wanted signal power + TT. Interferer signal power unchanged.
7.6 OTA Blocking - out of band	See 3GPP TS 37.105 [6], subclause 10.6	0 dB	
7.6 OTA blocking – co-location	See 3GPP TS 37.105 [6], subclause 10.6	0 dB	Formula: Wanted signal power unchanged Interferer signal power - TT.
7.7 Receiver spurious emissions	See 3GPP TS 37.105 [6], subclause 10.7	2.5 dB, $30\text{MHz} < f \leq 6 \text{ GHz}$ 4.2 dB, $6 \text{ GHz} < f \leq 19 \text{ GHz}$	Formula: Wanted signal power + TT.
7.8 OTA Receiver intermodulation	See 3GPP TS 37.105 [6], subclause 10.8	0 dB	Formula: Wanted signal power + TT. Interferer signal power unchanged.
7.9 OTA In-channel selectivity	See 3GPP TS 37.105 [6], subclause 10.9	1.7 dB, $f \leq 3.0 \text{ GHz}$ 2.1 dB, $3.0 \text{ GHz} < f \leq 4.2 \text{ GHz}$	Formula: Wanted signal power + TT. Interferer signal power unchanged.

Annex D (informative): Test system set-up

D.1 Transmitter

D.1.1 Radiated Transmit Power, OTA E-UTRA DL RS power, output power dynamics and Transmitter signal quality

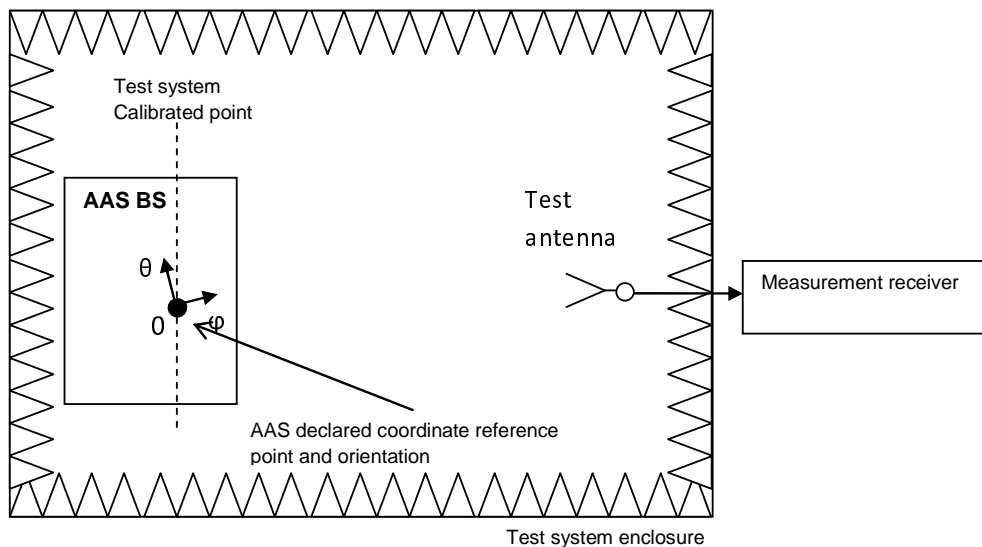

Figure D.1.1-1: Measurement set up for Radiated Transmit Power, OTA E-UTRA DL RS power, output power dynamics, Transmitter signal quality

The OTA chamber shown in figure D.1.1-1 is intended to be generic and can be replaced with any suitable OTA chamber (Far field anechoic chamber, CATR, Near field chamber, etc..).

D.1.2 OTA Base Station output power, ACLR, OTA spectrum emissions mask, OTA operating band unwanted emissions

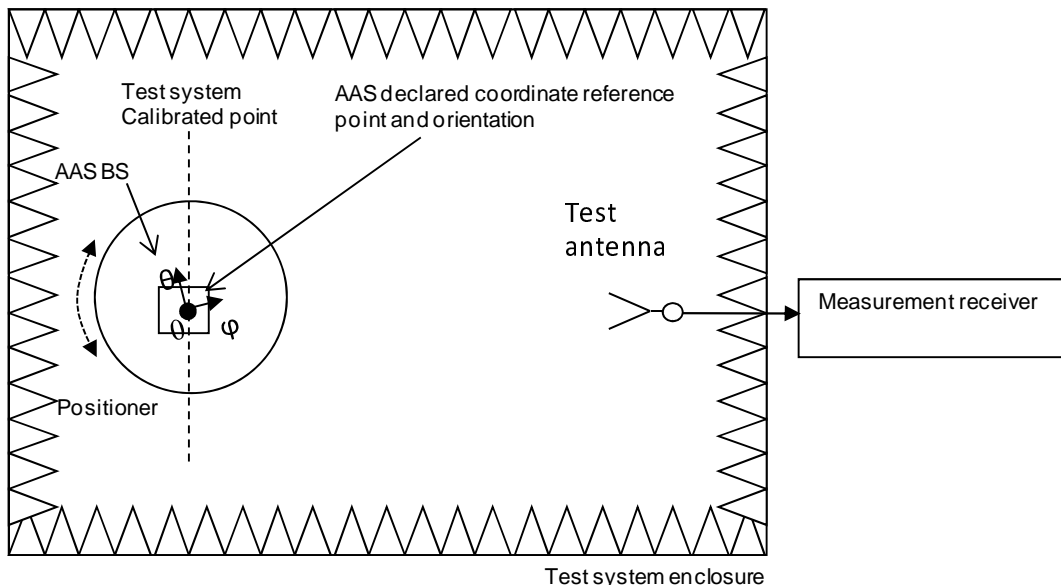

Figure D.1.2-1: Measurement set up for OTA Base Station output power, ACLR, OTA spectrum emissions mask, OTA operating band unwanted emissions

D.1.3 OTA spurious emissions

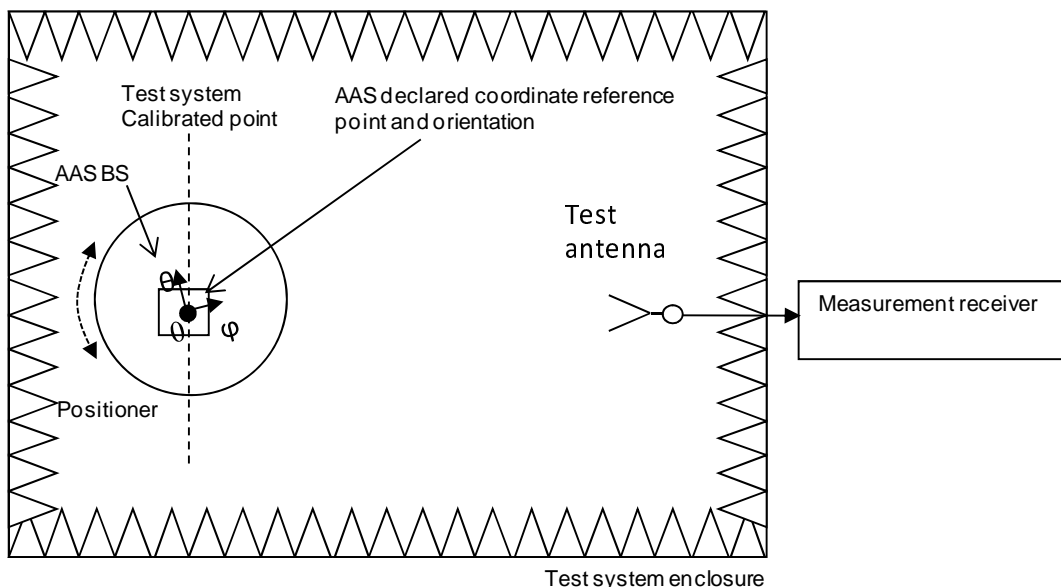

Figure D.1.3-1: Measurement set up for OTA spurious emissions

D.1.4 OTA Co-location emissions, TX OFF power

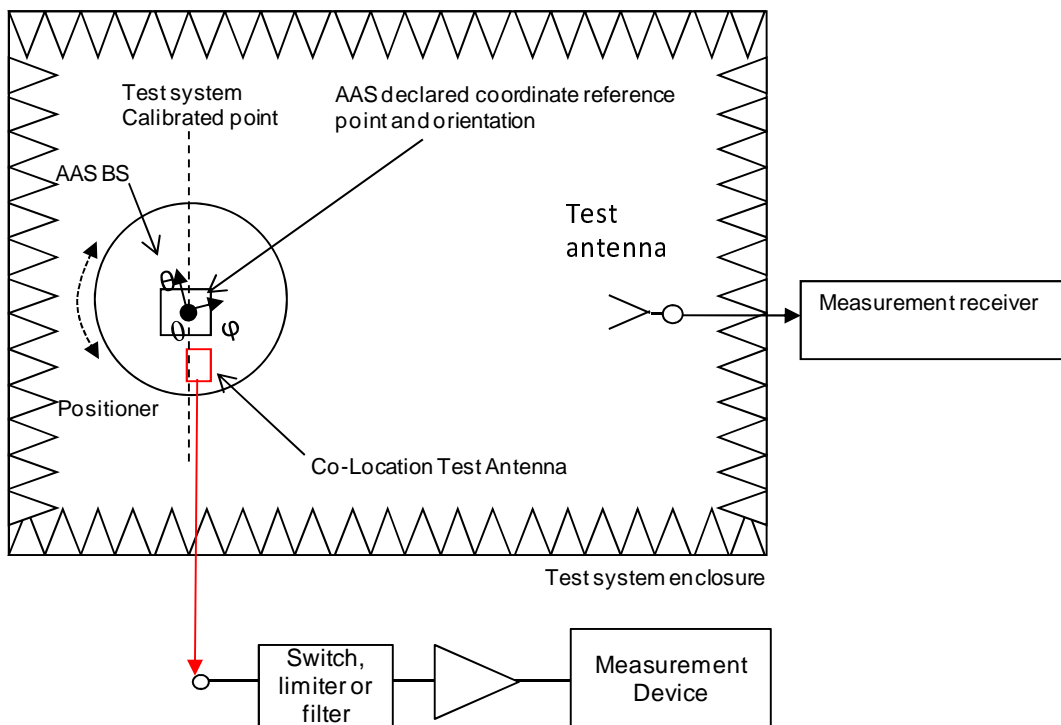

Figure D.1.4-1: Measurement set up for OTA Co-location emissions, TX OFF power

D.1.5 OTA Transmitter Intermodulation

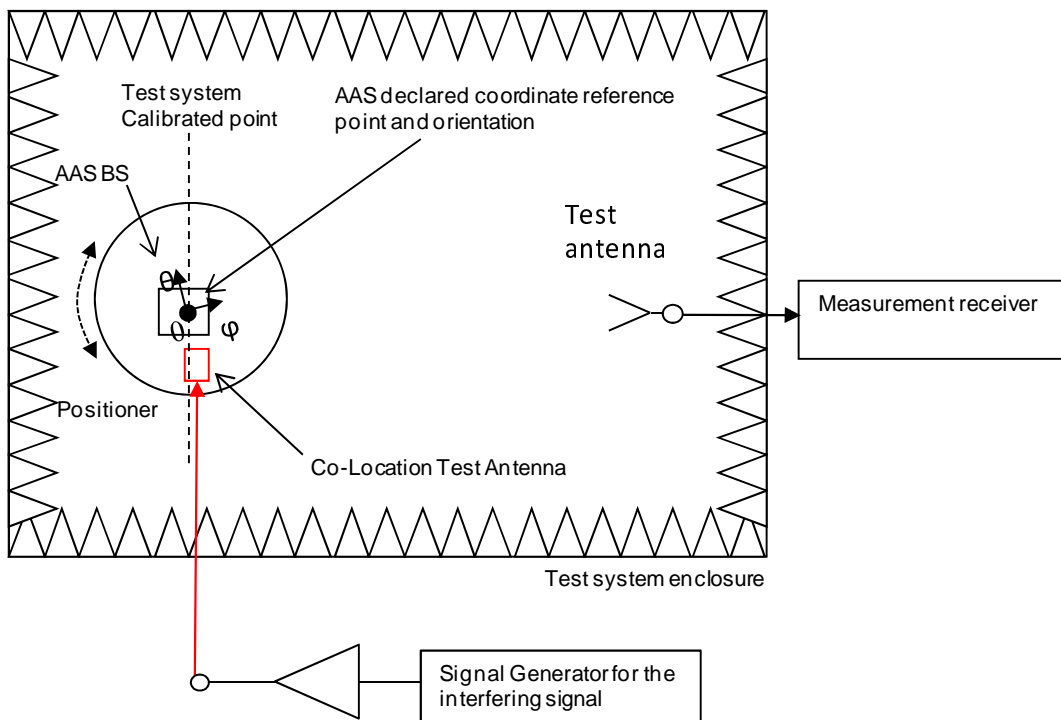

Figure D.1.5-1: Measurement set up for OTA Transmitter intermodulation

D.2 Receiver

D.2.1 OTA sensitivity and OTA Reference sensitivity

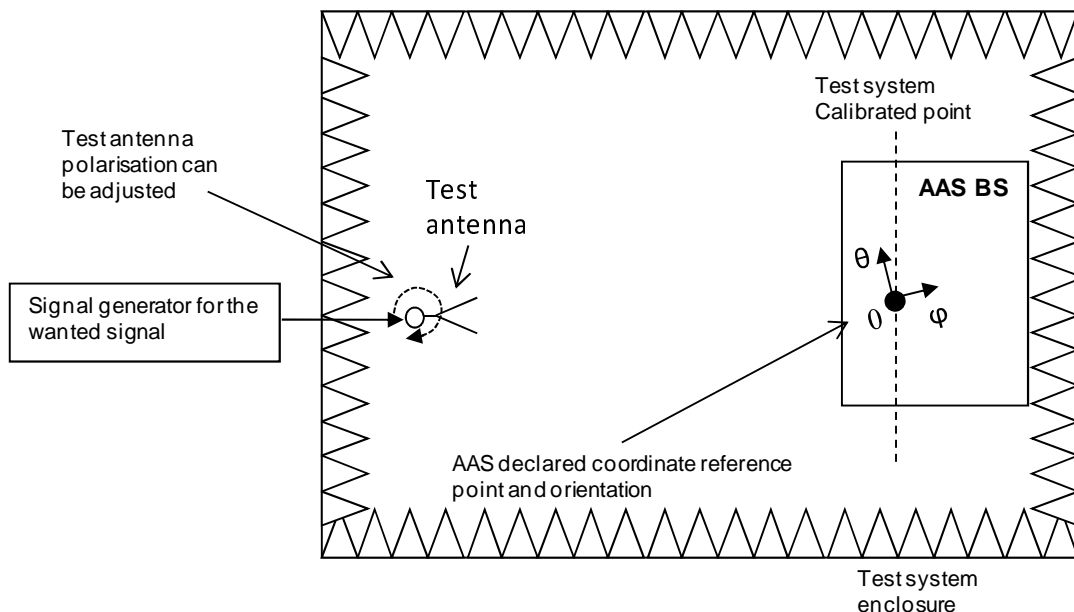

Figure D.2.1-1: Measurement set up for OTA sensitivity and OTA reference sensitivity

The OTA chamber shown in figure D.2.1-1 is intended to be generic and can be replaced with any suitable OTA chamber (Far field anechoic chamber, CATR, etc..).

D.2.2 OTA Dynamic range

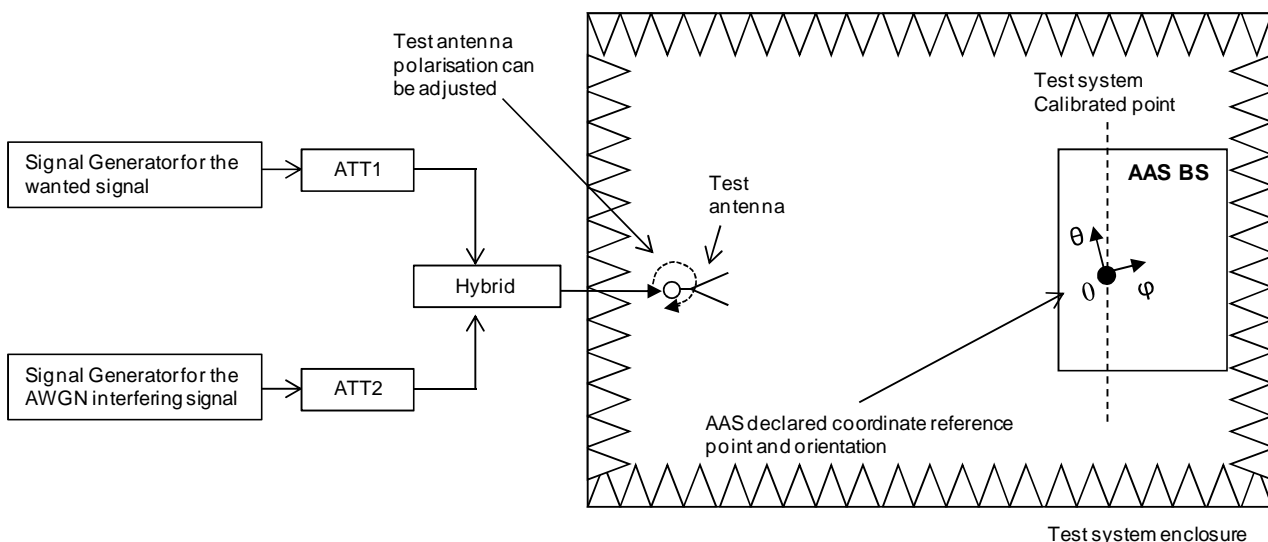

Figure D.2.2-1: Measurement set up for OTA Dynamic range

The OTA chamber shown in figure D.2.2-1 is intended to be generic and can be replaced with any suitable OTA chamber (Far field anechoic chamber, CATR, etc..).

D.2.3 OTA Adjacent channel selectivity, general blocking, and narrowband blocking

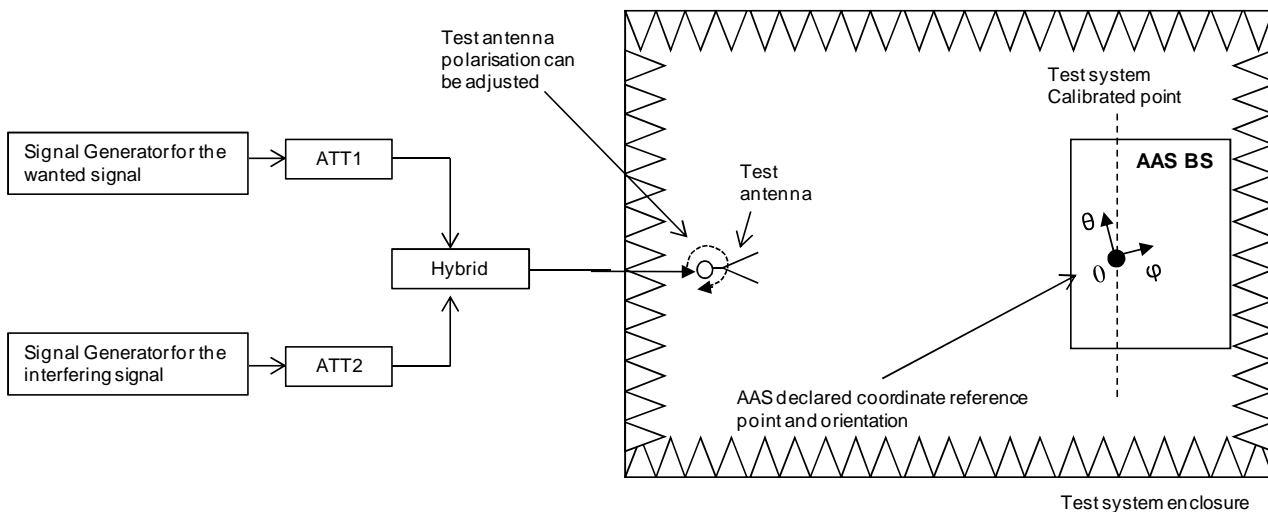

Figure D.2.3-1: Measurement set up for OTA ACS and narrowband blocking

Test

The OTA chamber shown in figure D.2.3-1 is intended to be generic and can be replaced with any suitable OTA chamber (Far field anechoic chamber, CATR, etc..).

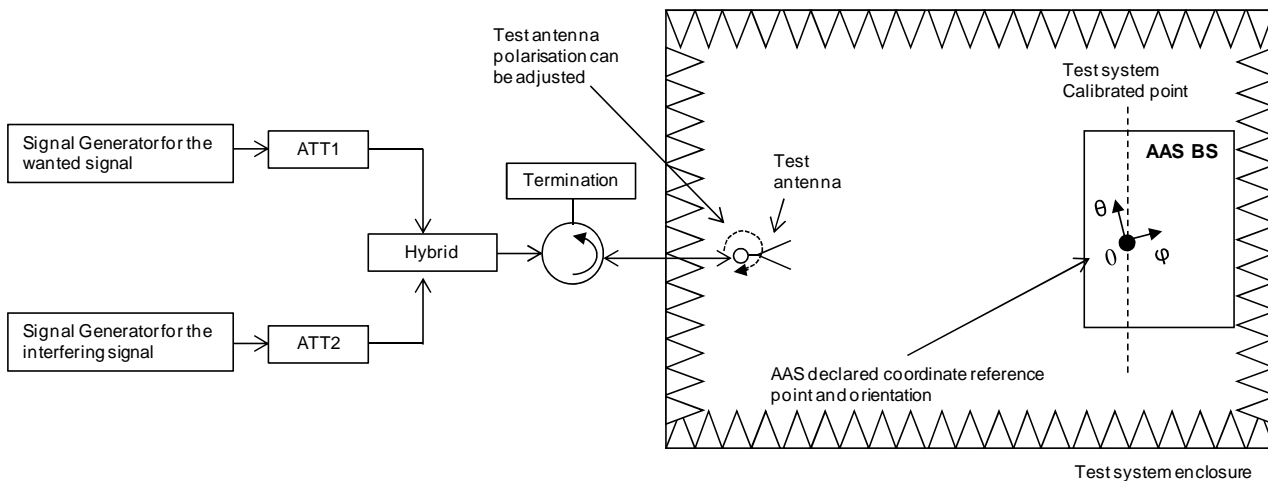

Figure D.2.3-2: Measurement set up for OTA general blocking

The OTA chamber shown in figure D.2.3-2 is intended to be generic and can be replaced with any suitable OTA chamber (Far field anechoic chamber, CATR, etc..).

D.2.4 OTA Blocking

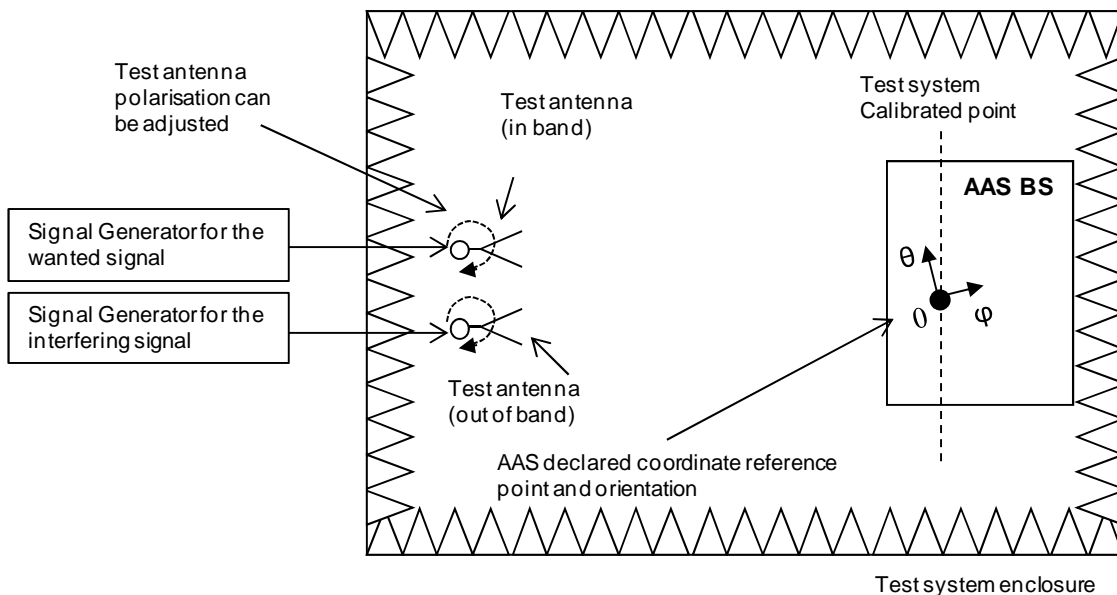

Figure D.2.4-1: Measurement set up for OTA Blocking

The OTA chamber shown in figure D.2.4-1 is intended to be generic and can be replaced with any suitable OTA chamber (Far field anechoic chamber, CATR, etc..).

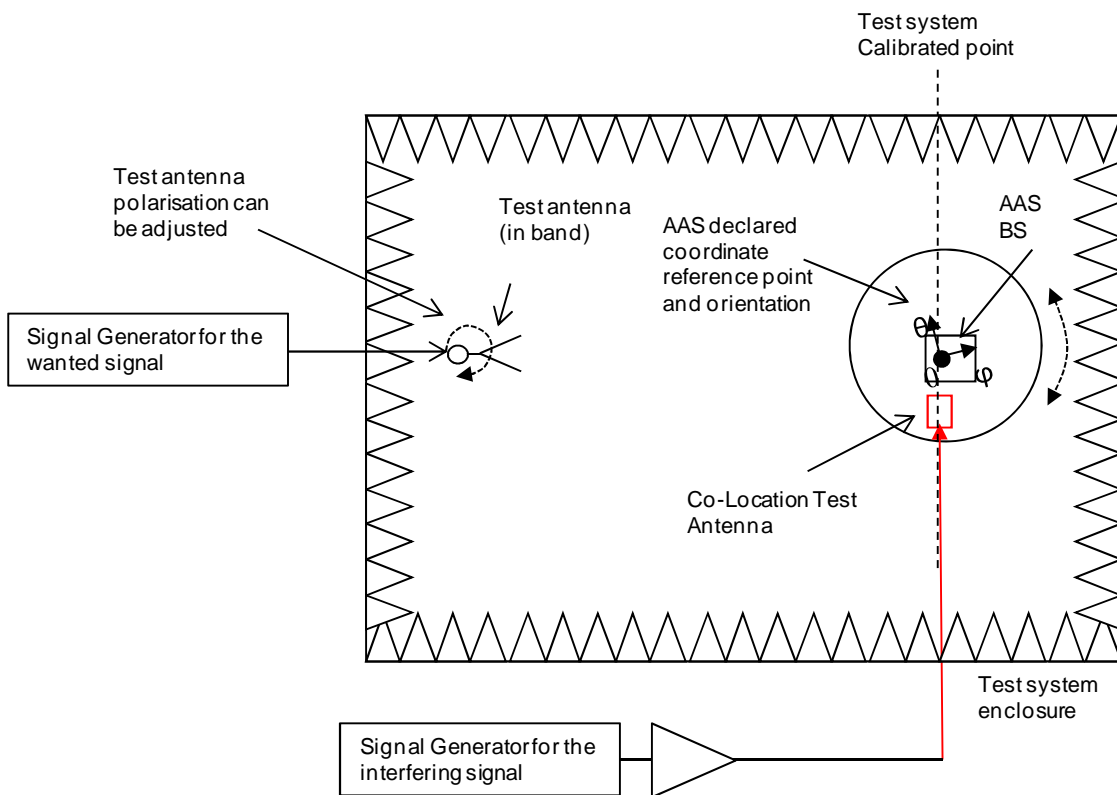

Figure D.2.4-2: Measurement set up for OTA co-location blocking

D.2.5 OTA Receiver spurious emissions

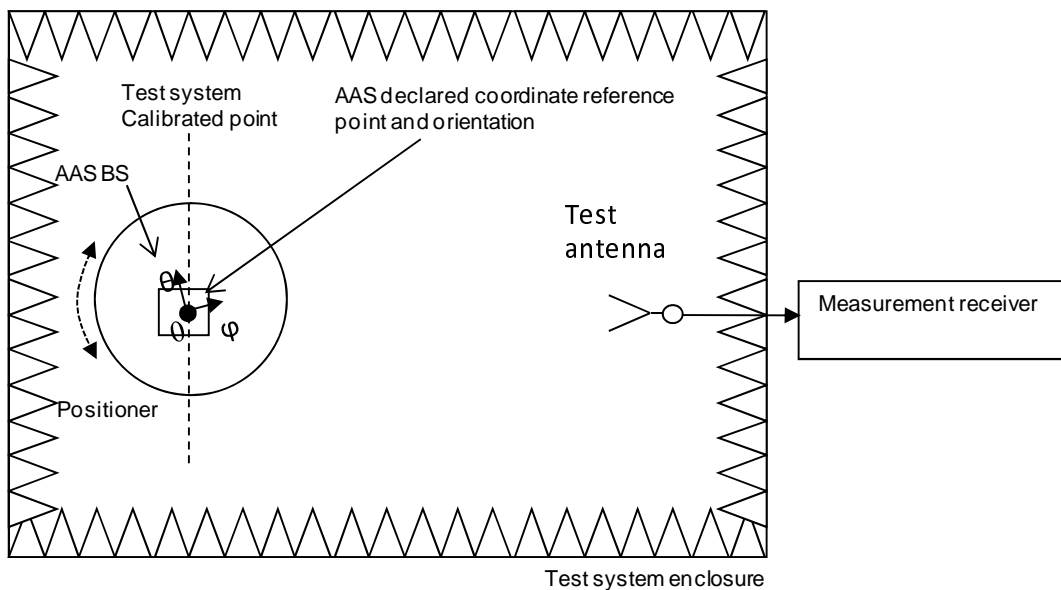

Figure D.2.5-1: Measurement set up for OTA receiver spurious emissions

D.2.6 OTA Receiver intermodulation

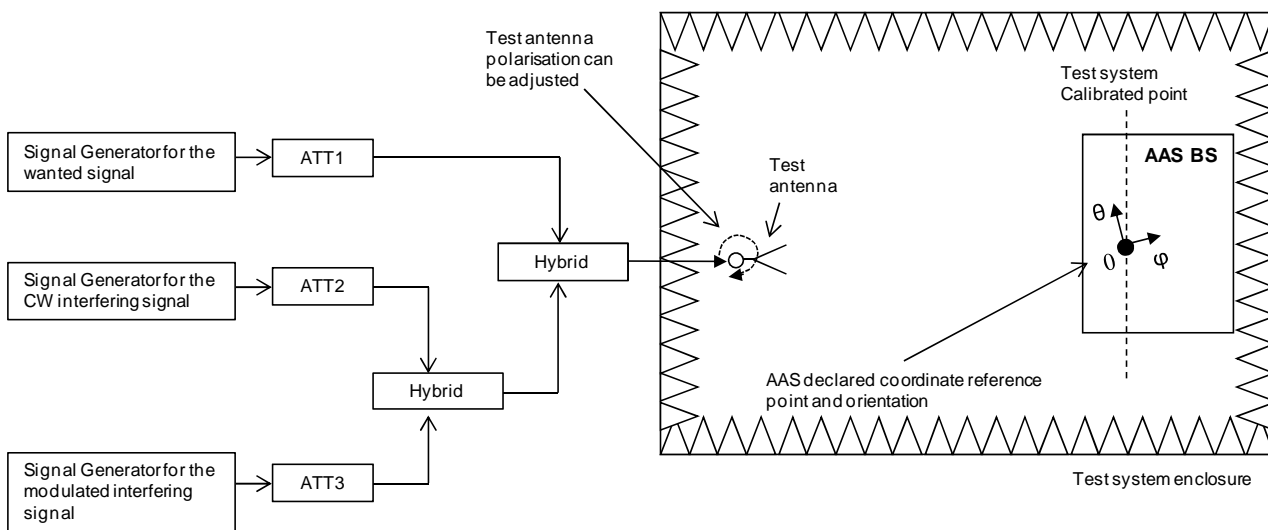

Figure D.2.6-1: Measurement set up for OTA receiver intermodulation

The OTA chamber shown in figure D.2.6-1 is intended to be generic and can be replaced with any suitable OTA chamber (Far field anechoic chamber, CATR, etc..).

D.2.7 OTA In-channel selectivity

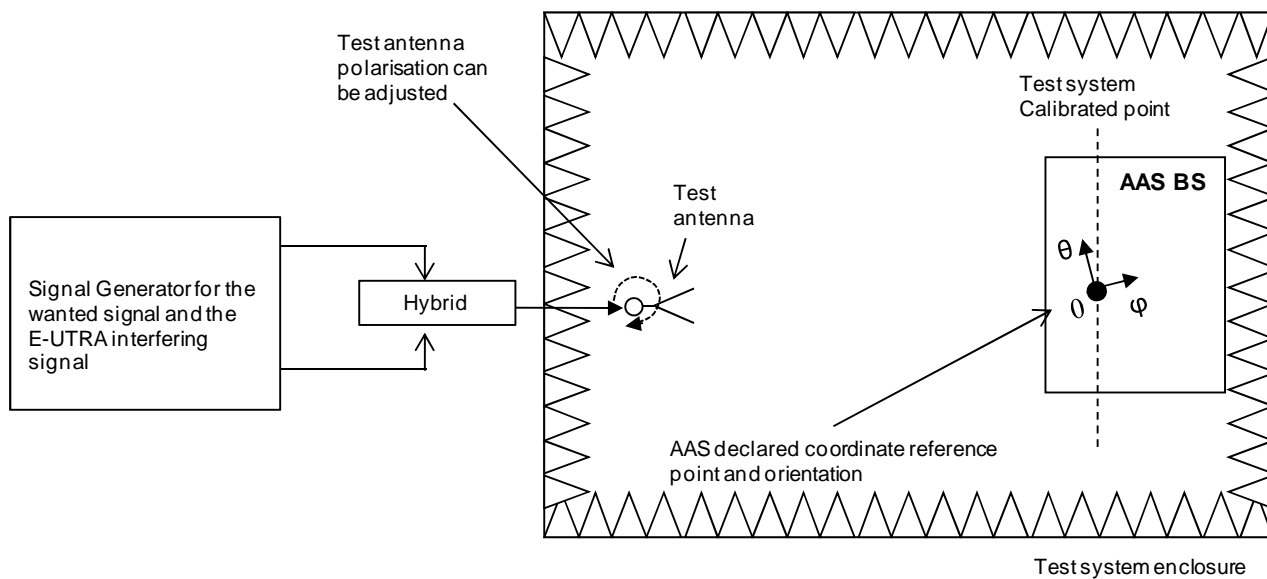

Figure D.2.7-1: Measurement set up for OTA In-channel selectivity

The OTA chamber shown in figure D.2.7-1 is intended to be generic and can be replaced with any suitable OTA chamber (Far field anechoic chamber, CATR, etc..).

D.3 Performance requirements

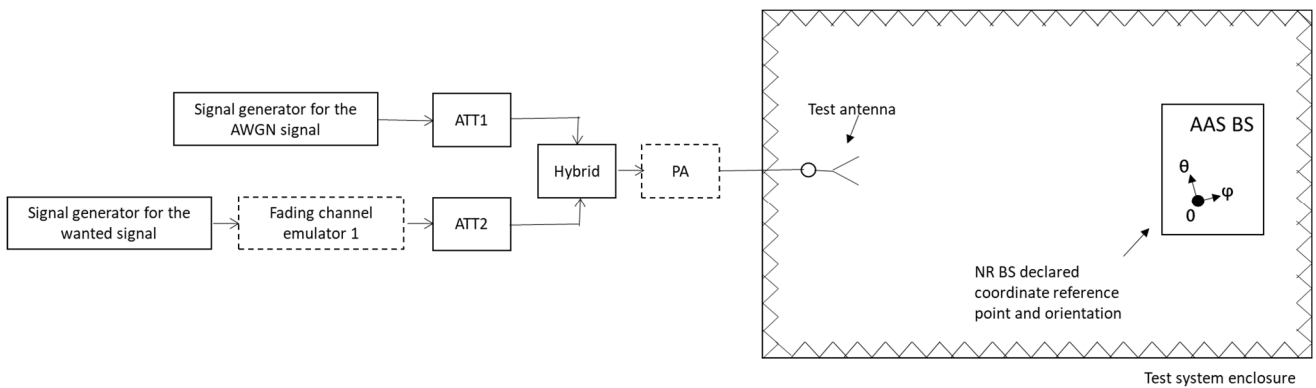

Figure D.3-1: Measurement set up for single TX, single demodulation branch radiated performance requirements

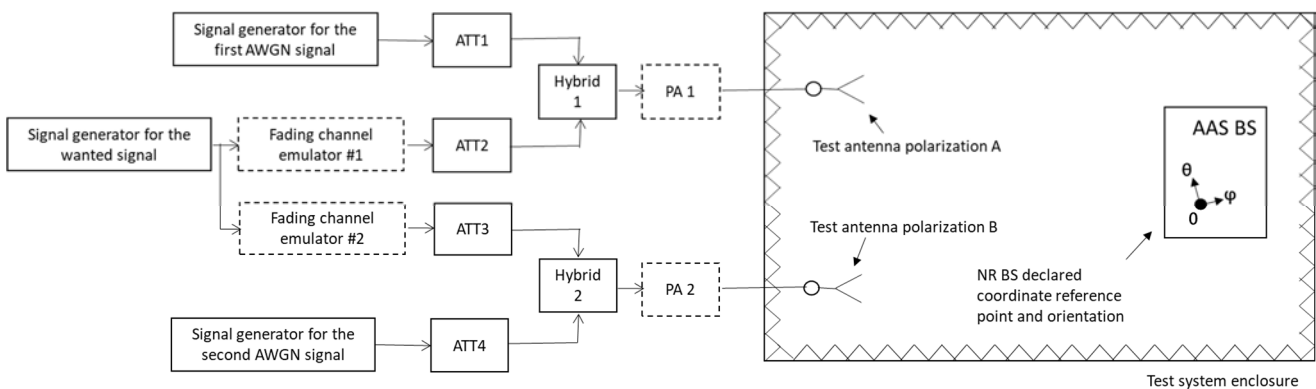

Figure D.3-2: Measurement set up for single TX, dual polarization radiated performance requirements

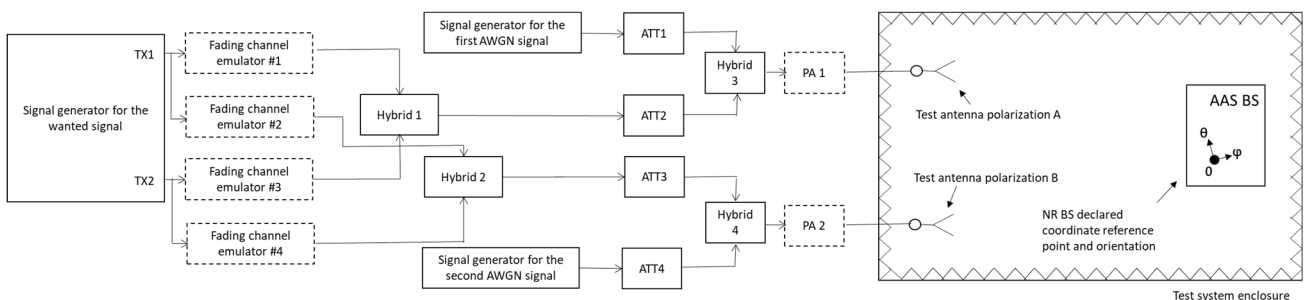

Figure D.3-3: Measurement set up for dual TX, dual polarization radiated performance requirements

The OTA chambers shown in figures D.3-1, D.3-2 and D.3-3 are intended to be generic and can be replaced with any suitable OTA chamber (e.g. far field anechoic chamber, CATR, etc.). The PA depicted in figures D.3-1, D.3-2 and D.3-3 is optional. Fading channel emulators are included when needed according to the requirement description.

Annex E (normative): Estimation of Measurement Uncertainty

E.1 General

Common measurement uncertainty budget calculation principle, was described in 3GPP TR 37.842 [7].

E.2 Measurement methodology descriptions

The AAS BS radiated measurement method descriptions, including description of the calibration stage, and the measurement stage, are described separately for each of the OTA tests, i.e. for radiated transmit power and for OTA sensitivity test in 3GPP TR 37.842 [7].

E.3 Measurement uncertainty budget format

Each test methodology is characterized by different uncertainty contributors. Moreover, within single test methodology, certain uncertainty contributors will need to be modified, depending on the transmitter, or receiver test. Therefore, separate uncertainty budget format were collected for all considered Test Systems in 3GPP TR 37.842 [7], specifying uncertainty contributors for calibration stage, as well as measurement stage.

E.4 Measurement uncertainty budgets

Descriptions of uncertainty assessment for radiated transmit power and for OTA sensitivity test were described separately for each of the considered Tests Systems as in 3GPP TR 37.842 [7].

E.5 Measurement error contribution descriptions

Detailed descriptions of the uncertainty contributors for the radiated transmit power and OTA sensitivity test were described separately for each of the considered Tests Systems as in 3GPP TR 37.842 [7].

Annex F (normative): TRP measurement grids

F.1 General

The annex describes various procedures for BS OTA TRP measurements. These procedures can provide either an accurate or an over-estimate of TRP values. The procedures for an accurate estimate can be applied to all TRP requirements. However, if a TRP requirement does not need accurate TRP estimate then the procedures for over-estimate of TRP may be used in order to have a reasonable OTA test time. Pre-scan does not provide an accurate TRP estimate or over-estimate of TRP. Pre-scan is a fast but coarse method that is used to identify the spurious emission frequencies with emission power as described in annex F.13. A sequential measurement is then made at the emission frequencies, to assess the TRP as described in annex F.2 to annex F.9.

F.2 Spherical equal angle grid

F.2.1 General

$TRP_{Estimate}$ is defined as:

$$TRP_{Estimate} = \frac{\pi}{2NM} \sum_{n=0}^{N-1} \sum_{m=0}^{M-1} EIRP(\theta_n, \phi_m) \sin \theta_n$$

when EIRP measurements is used or as:

$$TRP_{Estimate} = 4\pi d^2 \frac{\pi}{2NM} \sum_{n=1}^{N-1} \sum_{m=0}^{M-1} P_D(\theta_n, \phi_m) \sin \theta_n$$

when power density measurements are used, and d is the test distance. N and M are the number of samples in the θ and ϕ angles. Each (θ_n, ϕ_m) is a sampling point. The sampling angular intervals for θ and ϕ angles are $\Delta\theta = \frac{\pi}{N}$ and $\Delta\phi = \frac{2\pi}{M}$. The sampling intervals $\Delta\theta$ and $\Delta\phi$ are described in F.2.2.

F.2.2 Reference angular step criteria

The reference angular steps $\Delta\phi$ and $\Delta\theta$, in degrees, are defined as:

$$\Delta\theta_{ref} = \min\left(\frac{180^\circ \lambda}{\pi D}, 15^\circ\right)$$

$$\Delta\phi_{ref} = \min\left(\frac{180^\circ \lambda}{\pi D_{cyl}}, 15^\circ\right)$$

The upper limit for these reference angular steps of 15° ensures a low Summation Error (SE) when λ is large compared to the DUT dimensions.

D_{cyl} and D are calculated as:

$$D_{cyl} = \sqrt{d^2 + w^2}$$

$$D = \sqrt{d^2 + w^2 + h^2}$$

The definition of d , w and h is shown in Figure F.2.2-1. The radiation source can be EUT antenna array or the whole of EUT.

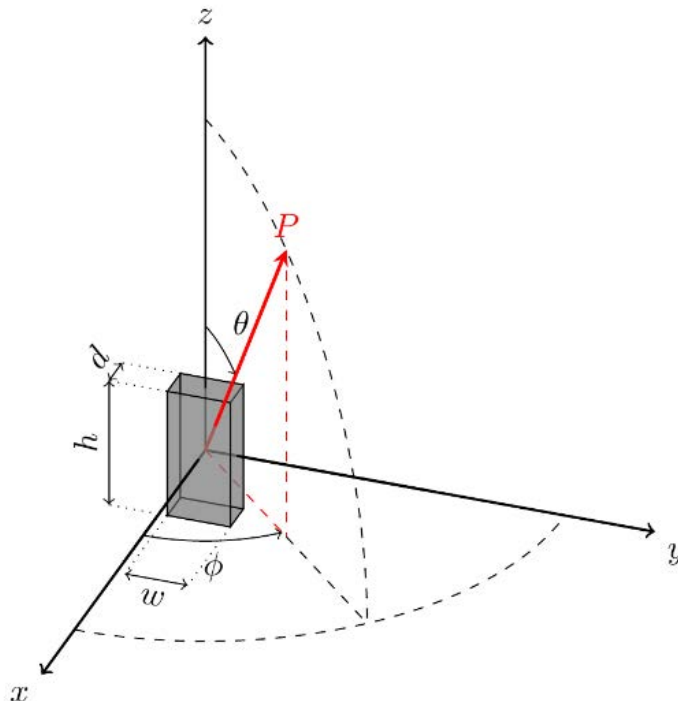

Figure F.2.2-1: Dimensions of a radiation source: depth (d), width (w) and height (h)

Optionally, in the case of a Uniform Linear Array (ULA), when d is negligible ($d \approx 0$) and when the EUT is mounted along the yz plane as shown in figure F.2.2-2, the reference angular step, in degrees, can be determined by

$$\Delta\theta_{ref} = \arcsin(\lambda/D_z)$$

$$\Delta\phi_{ref} = \arcsin\left(\frac{\lambda}{D_y}\right)$$

Where D_y is the length of radiating parts of EUT along y-axis, D_z is the length of radiating parts of EUT along the z-axis and λ is wavelength for the measured frequency.

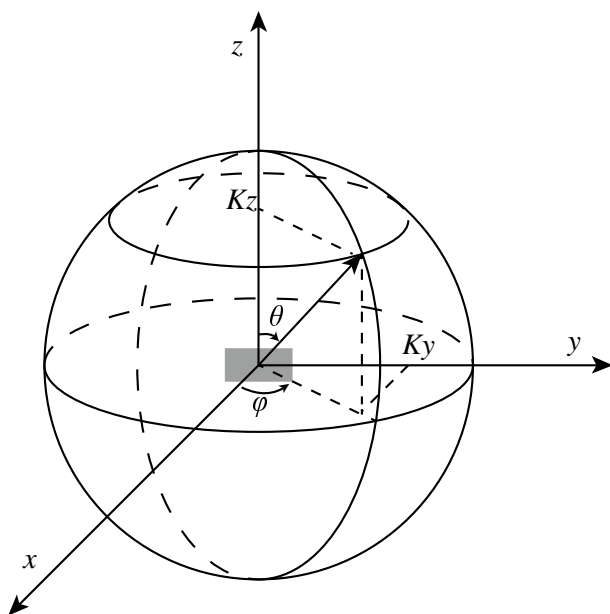

Figure F.2.2-2. Spherical coordinate for OTA conformance testing of EUT

Where due to practical reasons such as time constraints or turn-table precision, measurement with the reference steps is not practical, sparser grids can be used. Use of sparse grids can lead to errors in TRP assessment. In order to characterize these errors, the SF (sparsity factor) of the grid is defined as:

$$SF = \max\left(\frac{\Delta\theta_{grid}}{\Delta\theta_{ref}}, \frac{\Delta\phi_{grid}}{\Delta\phi_{ref}}\right)$$

Where $\Delta\theta$ and $\Delta\phi$ are the actual angular steps used in the measurement.

Alternatively, when the EUT radiating dimensions are not known. For each frequency within the *downlink operating band* including Δf_{OBUE} , the reference angular steps can be specified in terms of the *beamwidth* of the wanted signal as

$$\Delta\phi_{ref} = \frac{\lambda}{\lambda_0} BeW_\phi$$

$$\Delta\theta_{ref} = \frac{\lambda}{\lambda_0} BeW_\theta$$

where λ_0 is the wavelength of the wanted signal, and BeW_ϕ and BeW_θ are the *beamwidth* of the wanted signal in the ϕ -axis and θ -axis, respectively.

BeW_ϕ and BeW_θ may be set to *beamwidth* declared for the *OTA AAS BS* radiated transmit power requirement provided the same *beam* is applied to test in-band TRP requirements.

NOTE: *Beamwidth* is approximately equal to half the first-null beam width.

F.3 Spherical equal area grid

$TRP_{Estimate}$ is defined as:

$$TRP_{Estimate} = \frac{1}{N} \sum_{n=1}^N EIRP(\theta_n, \phi_n)$$

N is the total number of samples and specified as:

$$N \geq \frac{4\pi}{\Delta\theta_{ref}\Delta\phi_{ref}}$$

The sampling intervals $\Delta\theta_{ref}$ and $\Delta\phi_{ref}$ are described in F.2.2. Each (θ_n, ϕ_n) is a sampling point.

F.4 Spherical Fibonacci grid

$TRP_{Estimate}$ is defined as:

$$TRP_{Estimate} = \frac{1}{N} \sum_{n=0}^{N-1} EIRP(\theta_n, \phi_n)$$

N is the total number of samples and specified as:

$$N \geq \frac{4\pi}{\Delta\theta_{ref}\Delta\phi_{ref}}$$

The sampling intervals $\Delta\theta_{ref}$ and $\Delta\phi_{ref}$ are described in F.2.2. Each (θ_n, ϕ_n) is a sampling point, where θ_n and ϕ_n , in degrees, are defined as:

$$\theta_n = \cos^{-1}\left(1 - \frac{2n+1}{N}\right)$$

$$\phi_n = \frac{360^\circ n}{\Psi}, \quad \Psi = \frac{1+\sqrt{5}}{2}$$

F.5 Orthogonal cut grid

Here, at least two cuts (default) shall be used, an optional third cut can be used. The alignment of the cuts must be along the symmetry planes of the antenna array. No alignment is required for spurious emissions.

When alignment is required:

1. The first mandatory cut is a horizontal cut passing through the peak direction of the main beam.
2. The second mandatory is a vertical cut passing through the peak direction of the main beam. Using the data from these two mandatory cuts, a conditional pattern multiplication can be used.
3. The third optional cut is a vertical cut orthogonal to the first and the second cut.

When alignment is not required, the cuts can be aligned arbitrarily.

Once the number and the orientation of the cuts are decided, the total EIRP is measured on the orthogonal cuts and the TRP is then calculated as follows: First the contributions from each cut is calculated as:

$$EIRP_{av,cut-n} = \frac{1}{P} \sum_{j=1}^P EIRP(j)$$

where P is the number of sampling points in the cut. The final contribution for all cuts is calculated as:

$$TRP_{Estimate} = \frac{1}{N} \sum_{n=1}^N EIRP_{av,cut-n}$$

where N is the number of cuts. Note that when orthogonal cuts are measured, the intersection points are measured multiple times and the repeated values can be removed from the samples before averaging.

When two cuts measurements are used, a conditional pattern multiplication can be applied. The following are the conditions for applying pattern multiplication:

- i. The vertical cut (and the main beam) is in the xz -plane
- ii. The frequency of the emission is within the downlink operating band.
- iii. The bandwidth of the emission is the same as the bandwidth of the in-band modulated signal
- iv. The emission appears/disappears when the Tx power is turned on/off.
- v. The antenna arrays of the EUT
 1. Have rectangular grids of antenna element positions
 2. Have symmetry planes that are vertical and horizontal.
 3. Have parallel antenna planes

The antenna array is here assumed to be placed in the yz -plane. The pattern multiplication is performed in uv -coordinates and the data in the two cuts are denoted $EIRP_{cut1}(\phi)$ at $\theta = \theta_H$ and a vertical cut with data $EIRP_{cut2}(\theta)$ at $\phi = 0$. The data is split in two parts corresponding to the forward and backward hemispheres. The uv -coordinates are the projections of the angular directions onto the antenna plane, here the yz -plane. Using the spherical coordinates as depicted in figure F.2.2.-1 the u and v coordinates are defined as:

$$\begin{cases} u = \sin \theta \sin \phi \\ v = \cos \theta \end{cases}$$

Note that only the data on the cuts are measured.

Calculate power density/EIRP values outside the two cardinal cuts as

$$EIRP(u, v) = \frac{EIRP_{cut1}(u)EIRP_{cut2}(v)}{EIRP(0, \theta_H)}$$

The pattern multiplication is applied separately for the forward (fwd) and backward (bwd) hemisphere. The TRP is then calculated as:

$$\text{TRP} = \frac{1}{4\pi} \left[\iint_{\text{fwd}} \text{EIRP}_{\text{fwd}}(u, v) \frac{dudv}{\sqrt{1-u^2-v^2}} + \iint_{\text{bwd}} \text{EIRP}_{\text{bwd}}(u, v) \frac{dudv}{\sqrt{1-u^2-v^2}} \right]$$

NOTE: the numerical singularity at $u^2 + v^2 = 1$ must be treated with care, e.g. by change of variables.

F.6 Wave vector space grid

If EUT is mounted along the yz plane as shown in figure F.2.2-1, the reference step in wave vector space can be determined by:

$$\Delta u_{\text{ref}} = \frac{\lambda}{D_y}$$

$$\Delta v_{\text{ref}} = \frac{\lambda}{D_z}$$

where D_y is the length of radiating parts of EUT along y-axis, D_z is the length of radiating parts of EUT along the z-axis.

According to the relationship between the normalized wave vector and spherical coordinate, the wave vector can be represented as following:

$$u = \sin(\theta) \sin(\phi), v = \cos(\theta)$$

The total radiated power (TRP) in the wave vector space is determined by:

$$\text{TRP} = \frac{\Delta u \Delta v}{4\pi} \left(\sum_{\substack{u^2+v^2 < 1 \\ \cos\phi > 0}} \frac{\text{EIRP}(\theta_n, \phi_{m,n})}{\sin\theta_n |\cos\phi_{m,n}|} + \sum_{\substack{u^2+v^2 < 1 \\ \cos\phi < 0}} \frac{\text{EIRP}(\theta_n, \phi_{m,n})}{\sin\theta_n |\cos\phi_{m,n}|} \right)$$

Where due to practical reasons such as time constraints or turn-table precision, measurement with the reference steps is not practical, sparser grids can be used. Use of sparse grids can lead to errors in TRP assessment. In order to characterize these errors, the SF (sparsity factor) of the grid is defined as:

$$SF = \max\left(\frac{\Delta u_{\text{grid}}}{\Delta u_{\text{ref}}}, \frac{\Delta v_{\text{grid}}}{\Delta v_{\text{ref}}}\right)$$

Where Δu_{grid} and Δv_{grid} are the actual steps used in the wave vector space in the measurement and the upper bound of their value is 15 degrees.

F.7 Orthogonal 2 cuts with pattern multiplication

This method can be used when the antenna symmetries are compatible with pattern multiplication, see Subclause F.1.2.4. The procedure is as follows:

1. Calculate the reference angular steps as described in Subclause F.1.2.
2. Align the EUT to allow for proper pattern multiplication. See Subclause F.5. Measure EIRP on two orthogonal cuts with steps smaller or equal to the reference steps according to step 1.
3. Apply pattern multiplication according to Subclause F.5 to extrapolate the two cuts data to full-sphere.
4. Apply numerical integration to obtain the TRP estimate as described in Subclause F.5.

F.8 Orthogonal 2 or 3 cut with dense sampling

F.8.1 Operating band unwanted emissions

The procedure is as follows:

- 1) Follow steps described in annex F.5 for the first two mandatory cuts and calculate the TRP estimate.
- 2) Compare the TRP estimate to the limit.
- 3) If the TRP estimate is above the limit, perform the measurement on an additional third cut and repeat steps 1 to 2.

Table F.8-1: Void

NOTE: Table F.8-1 is moved to subclause F.8.2 as Table F.8.2-1.

F.8.2 Spurious unwanted emissions

The procedure is as follows:

- 1) Follow steps described in annex F.5 for two cuts and calculate the TRP estimate.
- 2) Add the appropriate correction factor ΔTRP according to table F.8.2-1 to ensure overestimation with 95% confidence.
- 3) Compare the TRP estimate + ΔTRP to the limit.
- 4) If the TRP estimate + ΔTRP is above the limit, perform the measurement on an additional third cut and repeat steps 1 to 3.

Table F.8.2-1: The correction factor for two or three cuts dense sampling

	Three cuts	Two cuts
Correction factor ΔTRP (dB)	2.0	2.5

F.9 Full sphere with sparse sampling

The procedure is as follows:

1. Set the angular grid:
 - a. Non-harmonic frequencies: choose the angular steps $\Delta\phi$ and $\Delta\theta$ smaller than or equal to 15 degrees. Calculate the sparsity factor (SF) as

$$\text{SF} = \max\left(\frac{\Delta\phi}{\Delta\phi_{\text{ref}}}, \frac{\Delta\theta}{\Delta\theta_{\text{ref}}}\right)$$

and the correction factor as:

$$\Delta\text{TRP} = \frac{\text{SF}-1}{\text{SF}_{\text{max}}-1} \cdot 1.0 \text{ dB},$$

where SF_{max} corresponds to 15 degrees angular step. If the sparsity factor is smaller than 1, the correction factor ΔTRP is 0 dB.

- b. Harmonic frequencies with fixed beam test signal: choose the angular steps smaller than or equal to the reference angular steps $\Delta\phi_{\text{ref}}$ and $\Delta\theta_{\text{ref}}$. Correction factor ΔTRP is 0 dB.

- c. Harmonic frequencies with beam sweeping test signal: set the angular steps to 15 degrees. Correction factor is ΔTRP 0 dB.
2. Apply a suitable numerical integration to calculate the TRP estimate.
3. Add the appropriate correction factor ΔTRP according to step 1 to ensure an overestimation with 95% confidence.
4. Compare the (TRP estimate + ΔTRP) with the limit. If the (TRP estimate + ΔTRP) is above the limit, choose a smaller angular step and repeat steps 2-4. If the sparsity factor is less than one, no significant improvement of accuracy is expected.

F.10 Beam-based directions

Beam-based direction can be used in the base station operating band if the directivity of the EUT antenna is known for the base station *operating band*. $\text{TRP}_{\text{Estimate}}$ is defined as:

$$\text{TRP}_{\text{Estimate}} = \frac{\text{EIRP}_{\text{peak}}}{D_{\text{EUT}}},$$

where $\text{EIRP}_{\text{peak}}$ is the maximum EIRP in the *beam peak direction* within a particular *beam direction pair* and D_{EUT} is directivity of the EUT antenna.

F.11 Peak method

The peak method can be used when frequencies with unwanted peak emissions are identified during pre-scan. The method does not provide an estimate of TRP.

For each peak emission frequency identified during pre-scan, measure peak EIRP or power density as follows:

1. Move EUT and test antenna to the same position where the peak emission is recorded during the pre-scan.
2. Move the EUT around the position and test antenna orientation to find the final peak EIRP or power density.
3. The measured peak power density or EIRP shall be used to demonstrate conformance.

NOTE: Peak EIRP is the linear sum of two orthogonal polarised components.

F.12 Equal sector with peak average

Equal sector with peak average can be performed on frequencies with unwanted peak emission, which are considered by the peak method for further measurements.

The spherical angle ϕ is divided into K equal sectors. If the largest dimension of EUT is less than 60 cm, then each sector is a half quadrant of 45°.

For each peak emission frequency, measure peak EIRP of beams belonging to different sectors of the sphere as follows:

1. Move EUT and test antenna to the same position where the emission peak is recorded during the pre-scan.
2. Move EUT around the position and test antenna orientation to find the final peak EIRP.
3. Repeat Steps 1 to 2 until all sectors are covered.
4. Calculate $\text{TRP}_{\text{Estimate}}$ as:

$$\text{TRP}_{\text{Estimate}} = \frac{1}{K} \sum_{k=1}^K \text{EIRP}_k,$$

where EIRP_k is the peak EIRP in the kth sector.

NOTE: Peak EIRP is the linear sum of two orthogonal polarised components.

F.13 Pre-scan

Pre-scan is used to identify frequencies with unwanted emission power levels above a certain threshold. The pre-scan does not provide an estimate of TRP.

The procedure for pre-scan is as follows:

1. Scan the entire surface around EUT.
2. Rotate test antenna to cover all possible polarisations of emissions to detect maximum emissions.
3. Record the list of frequencies and corresponding unwanted emission power levels, EUT spatial positions, and test antenna polarization for which the maximum emission levels occur.
4. Emissions which are 20 dB or more below the specified limit shall not require further measurements.

Annex G (normative): Environmental requirements for the BS equipment

G.1 General

For each test in the present document, the environmental conditions under which the AAS BS is to be tested are defined. The environmental conditions and class shall be from the relevant IEC specifications or the corresponding ETSI specifications.

For OTA requirements where it is not possible to environmentally control the entire calibrated OTA chamber either localised control of the AAS BS hardware or alternative OTA measurements which are then related to the original specification are acceptable.

G.2 Normal test environment

When a normal test environment is specified for a test, the test should be performed within the minimum and maximum limits of the conditions stated in table G.2-1.

Table G.2-1: Limits of conditions for Normal Test Environment

Condition	Minimum	Maximum
Barometric pressure	86 kPa	106 kPa
Temperature	15°C	30°C
Relative Humidity	20 %	85 %
Power supply	Nominal, as declared by the manufacturer	
Vibration	Negligible	

The ranges of barometric pressure, temperature and humidity represent the maximum variation expected in the uncontrolled environment of a test laboratory. If it is not possible to maintain these parameters within the specified limits, the actual values shall be recorded in the test report.

G.3 Extreme test environment

G.3.1 General

The manufacturer shall declare one of the following:

- 1) the equipment class for the equipment under test, as defined in the IEC 60721-3-3 [21] or ETSI EN 300 019-1-3 [23] ("Stationary use at weather protected locations");
- 2) the equipment class for the equipment under test, as defined in the IEC 60721-3-4 [22] or ETSI EN 300 019-1-4 [24] ("Stationary use at non weather protected locations");
- 3) the equipment that does not comply to the mentioned classes, the relevant classes from IEC 60721 [20] documentation for Temperature, Humidity and Vibration shall be declared.

NOTE: Reduced functionality for conditions that fall outside of the standard operational conditions are not tested in the present document. These may be stated and tested separately.

G.3.2 Extreme temperature

When an extreme temperature test environment is specified for a test, the test shall be performed at the standard minimum and maximum operating temperatures defined by the manufacturer's declaration for the equipment under test.

Minimum temperature:

The test shall be performed with the environment test equipment and methods including the required environmental phenomena into the equipment, conforming to the test procedure of IEC 60068-2-1 [25].

Maximum temperature:

The test shall be performed with the environmental test equipment and methods including the required environmental phenomena into the equipment, conforming to the test procedure of IEC 60068-2-2 [26].

NOTE: It is recommended that the equipment is made fully operational prior to the equipment being taken to its lower operating temperature.

G.4 Vibration

When vibration conditions are specified for a test, the test shall be performed while the equipment is subjected to a vibration sequence as defined by the manufacturer's declaration for the equipment under test. This shall use the environmental test equipment and methods of inducing the required environmental phenomena in to the equipment, conforming to the test procedure of IEC 60068-2-6 [27]. Other environmental conditions shall be within the ranges specified in annex G.2.

NOTE: The higher levels of vibration may induce undue physical stress in to equipment after a prolonged series of tests. The testing body should only vibrate the equipment during the RF measurement process.

G.5 Power supply

When extreme power supply conditions are specified for a test, the test shall be performed at the standard upper and lower limits of operating voltage defined by manufacturer's declaration for the equipment under test.

Upper voltage limit:

The equipment shall be supplied with a voltage equal to the upper limit declared by the manufacturer (as measured at the input terminals to the equipment). The tests shall be carried out at the steady state minimum and maximum temperature limits declared by the manufacturer for the equipment, to the methods described in IEC 60068-2-1 [25] Test Ab/Ad and IEC 60068-2-2 [26] Test Bb/Bd: Dry Heat.

Lower voltage limit:

The equipment shall be supplied with a voltage equal to the lower limit declared by the manufacturer (as measured at the input terminals to the equipment). The tests shall be carried out at the steady state minimum and maximum temperature limits declared by the manufacturer for the equipment, to the methods described in IEC 60068-2-1 [25] Test Ab/Ad and IEC 60068-2-2 [26] Test Bb/Bd: Dry Heat.

G.6 Measurement of test environments

The measurement accuracy of the BS test environments shall be:

Pressure:	±5 kPa.
Temperature:	±2 degrees.
Relative Humidity:	±5 %.
DC Voltage:	±1,0 %.
AC Voltage:	±1,5 %.
Vibration:	10 %.
Vibration frequency:	0,1 Hz.

The above values shall apply unless the test environment is otherwise controlled and the specification for the control of the test environment specifies the uncertainty for the parameter.

G.7 OTA extreme test methods

G.7.1 Direct far field method

The AAS BS under test is placed inside a sealed RF transparent environmental enclosure, as showed in Figure G.7.1-1. This is connected to an environment control system which regulates the temperature inside the enclosure. The remaining equipment inside the OTA chamber (any suitable antenna test range chamber type is acceptable) is outside the environmental control and is at nominal temperature. Positioners, test antennas and all other OTA test equipment do not need to be specified over the extreme temperature range.

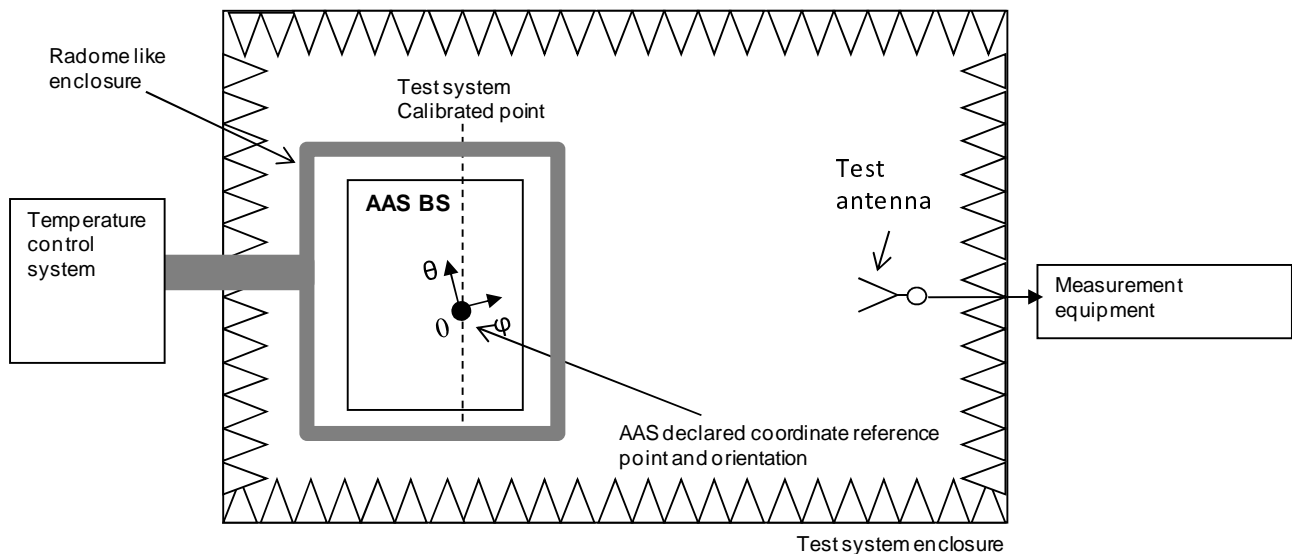

Figure G.7.1-1: Measurement set up for Extreme conditions for EIRP accuracy using direct far field method

The presence of the environmental chamber inside the OTA chamber may affect the measurement accuracy due to additional reflections and refractions, also the loss through the environmental enclosure may not be consistent with direction as the path through the radome may vary with angle. Hence the system should be calibrated in all tested directions.

NOTE. Currently only a single direction is specified for extreme testing so a single calibration direction is sufficient.

Conformance may be demonstrated by measuring the difference between the nominal measurement and the extreme measurement (Δ_{sample}) or by measuring $P_{\text{max,c,EIRP, extreme}}$ directly.

As the measurement is done in the far field (or measure in near field transformed to far field)

- a) If the test facility only supports single polarization, then measure EIRP with the test facility's test antenna/probe polarization matched to the AAS BS.
- b) If the test facility supports dual polarization then measure total EIRP for two orthogonal polarizations (denoted p_1 and p_2) and calculate total radiated transmit power for particular *beam direction pair* as $\text{EIRP} = \text{EIRP}_{p_1} + \text{EIRP}_{p_2}$.

G.7.2 Relative method

The AAS BS under test is placed inside a small (compared to a far field chamber) anechoic chamber which is both RF a screened and suitable for environmental conditioning. The RF conditionals inside the chamber are absorptive and capable of dissipating the power the the AAS BS when radiating. A sample antenna or RF probe are placed in a location which gives a sample of the main beam EIRP but does not have to accurately measure the EIRP directly, instead the

near-field response is measured. For this method test components are exposed to the full temperature range for example the test antenna/probe, cables, absorbers etc. may change as a function of temperature.

Using the relative method it is also necessary to measure the EIRP under nominal conditions using an appropriately calibrated far field (or near field) test range to obtain $P_{\max,c,EIRP}$.

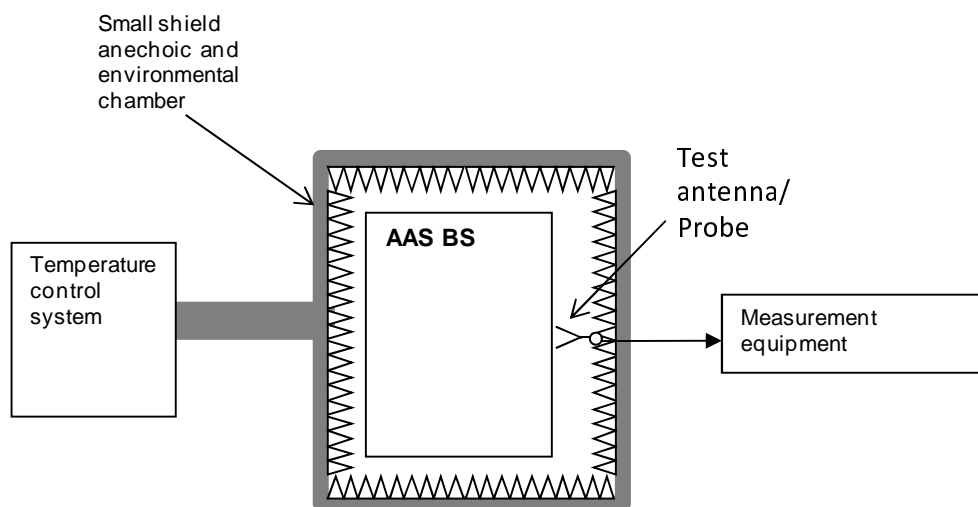

Figure F.7.2-1: Measurement set up for Extreme conditions for EIRP accuracy using difference method

Measurements from the test antenna/ probe are taken under nominal conditions and extreme conditions to calculate (Δ_{sample}). The difference between the nominal and extreme conditions (Δ_{sample}) is then used along with the nominal EIRP measurement ($P_{\max,c,EIRP}$) made in the appropriate far field or near field chamber and compared against the extreme requirement. As follows:

$$P_{\max,c,EIRP, \text{ extreme}} = P_{\max,c,EIRP} + \Delta_{\text{sample}}$$

To conserve test time it is beneficial to measure two orthogonal polarizations and add the result together. Otherwise, each polarization must be measured separately including a polarization matching procedure.

Annex H (informative): Measuring noise close to noise-floor

As the emission level seen by the measurement receiver (P_{UEM}) for co-location requirements are very low, it is suggested to measure relative noise change instead of absolute noise level. The relations between measured noise change δ_1 , noise floor N_0 and the relation to P_{UEM} with respect to the noise floor denoted δ_2 is visualized in Figure H-1.

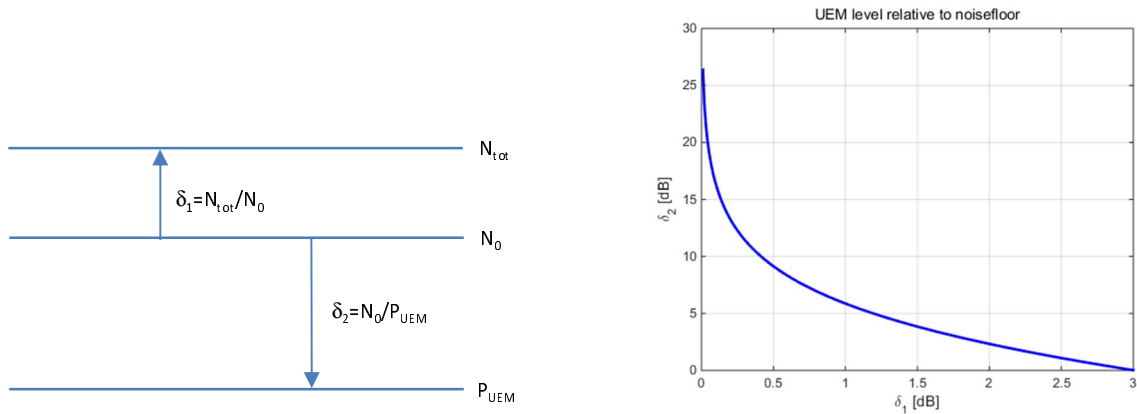

Figure H-1: Relative noise measurement

The absolute emission level in decibel scale is calculated as:

$P_{UEM} = N_0 - \delta_2$, where N_0 is the noise floor of the measurement receiver and δ_2 is plotted as a function of δ_1 in Figure H-1. The absolute noise floor of the measurement receiver, including probe antenna, cables, filter and LNA is determined by a calibration procedure. The calibration will determine the absolute emission level (N_0) accuracy of measuring out-of-band unwanted emission close to the thermal noise floor.

Annex I (informative): Change history

Change history							
Date	Meeting	TDoc	CR	Rev	Cat	Subject/Comment	New version
2016-02	RAN4#78	R4-161118				Specification structure	0.1.0
2016-04	RAN4#78 bis	R4-162524				R4-161370 - TP for TS 37.145-2: Adding Annex for relations between core and conformance requirements	0.2.0
2016-05	RAN4#79	R4-164927				R4-164717 - TP to TS 37.145 (part 2) sections 1-5 R4-164718 - TP for TS 37.145-2: Addition of radiated transmit power conformance test requirement in clause 6 R4-164719 - TP to TS 37.145 (part 2) section 7 - Radiated receiver characteristics	0.3.0
2016-08	RAN4#80	R4-167179				R4-166422 - TP to 3GPP TS 37.145-2 - clean up R4-166218 - TP for TS 37.145-2: Editorial correction on table numbers R4-166567 - TP to TS 37.145-2: Manufacturer declarations consistency improvements R4-166938 - TP for TS 37.145-2: Improvements of text in subclause 4.8 R4-166940 TP for TS 37.145-2: Improvements on text relating to the reference coordinate system R4-166939 TP to TR 37.145-2: Test Requirements derivation: Annexes A, B, C, E R4-166929 TP to TS 37.145-2: Measurement uncertainties and TT values R4-166931 TP for TS 37.145-2 - On OTA RX sensitivity requirements for AAS R4-167191 TP to TR 37.145-2: definition and test procedure clarifications for EIRP and EIS	0.4.0
2016-09	RP-73	RP-161450				Editorial corrections after review by ETSI editHelp	1.0.0
2016-09	RP-73					TS was approved by RAN plenary	13.0.0
2016-12	RP-74	RP-162422	0003	-	A	Correction of Manufacturer declaration description list in TS 37.145-2	13.1.0
2017-03	RP-75	RP-170586	0005	1	F	TS 37.145-2: Clarification of test procedure for radiated transmit power	13.2.0
2017-03	RP-75	RP-170586	0006	1	F	TS 37.145-2: Corrections	13.2.0
2017-03	RP-75	-	-	-	-	Update to Rel-14 version (MCC)	14.0.0
2017-06	RP-76	RP-171306	0011		A	CR to TS 37.145-2: Isolation of Band 46 from the AAS BS specification	14.1.0
2017-09	RP-77	RP-171968	0013		A	CR to TS 37.145-2: Editorial corrections, Rel-14	14.2.0
2017-12	RAN#78	RP-172608	0015	1	A	Correction of maximum steering directions declarations	14.3.0
2018-03	RAN#79	RP-180280	0017		A	CR to TS 37.145-2: corrections to the EIS test requirements (7.2) Rel-14	14.4.0
2018-06	RAN#80	RP-181109	0019		A	CR to TR 37.145-2: Clarifications on OTA sensitivity requirement (7.2.1)	14.5.0
2018-06	SA#80					Update to Rel-15 version (MCC)	15.0.0
2018-09	RAN#81	RP-181907	0034		B	CR to TS 37.145-2	15.1.0
2018-12	RAN#82	RP-182387	0035	1	F	CR to TS 37.145-2 Correction on OTA test requirements	15.2.0
2018-12	RAN#82	RP-182387	0040	1	F	CR to TS 37.145-2: CLTA definition	15.2.0
2018-12	RAN#82	RP-182387	0041	1	F	CR to TS 37.145-2: Clarification on CLTA related MU	15.2.0
2018-12	RAN#82	RP-182387	0042	2	F	CR to TS 37.145-2: Corrections on OTA Transmit ON/OFF power	15.2.0
2018-12	RAN#82	RP-182380	0046		A	CR to TS 37.145-2: corrections of declarations for the Radiated Transmit Power, Rel-15	15.2.0
2018-12	RAN#82	RP-182387	0047		F	CR to TS 37.145-2: correction of the "EIRP accuracy directions set" into "OTA peak directions set"	15.2.0
2018-12	RAN#82	RP-182387	0052		F	CR to TS 37.145-2: terminology corrections for "Minimum requirements", Rel-15	15.2.0
2018-12	RAN#82	RP-182387	0054	1	F	CR to TS 37.145-2: Clarification on demodulation requirements (8.1)	15.2.0
2018-12	RAN#82	RP-182387	0055	1	F	CR to TS 37.145-2: OTA Adjacent Channel Leakage Ratio (6.7.3) and OTA Operating band unwanted emissions (6.7.5) - corrections to text and tables	15.2.0
2018-12	RAN#82	RP-182387	0056	1	F	CR to TS 37.145-2: adding TRP measurement procedures in Annex F.	15.2.0
2018-12	RAN#82	RP-182387	0060	1	F	CR to 37.145-2: MU clarifications	15.2.0
2018-12	RAN#82	RP-182387	0061	1	F	CR to 37.145-2: Corrections to co-location requirements	15.2.0
2018-12	RAN#82	RP-182387	0063		F	CR to TS 37.145-2: UTRA TDD removal	15.2.0
2018-12	RAN#82	RP-182387	0064	1	F	CR to TS 37.145-2: fix for the EUTRA demodulation requirements	15.2.0

2018-12	RAN#82	RP-182387	0065	1	F	Cleanup to OTA requirements text	15.2.0
2018-12	RAN#82	RP-182387	0066	1	F	Correction to RX receiver test directions	15.2.0
2018-12	RAN#82	RP-182362	0067	1	B	Introduction of NR to 37.145-2	15.2.0
2018-12	RAN#82	RP-182387	0068	2	F	CR to TS 37.145-2 - polarisation wording improvements for OTA reference sensitivity	15.2.0
2018-12	RAN#82	RP-182387	0070		F	CR to TS 37.145-2 Removal of referencing error for in-band blocking	15.2.0
2019-03	RAN#83	RP-190419	0071	2	F	CR to TS37.145-2 Correction on OTA test requirements	15.3.0
2019-03	RAN#83	RP-190418	0073	1	F	Correction to definition of OTA reference sensitivity	15.3.0
2019-03	RAN#83	RP-190419	0074	1	F	Addition of measurement system setup for radiated performance requirements	15.3.0
2019-03	RAN#83	RP-190419	0075	1	F	Correction to TDD OFF power requirement	15.3.0
2019-03	RAN#83	RP-190418	0076		F	CR to TS 37.145-2: Corrections on blocking requirements	15.3.0
2019-03	RAN#83	RP-190419	0077	1	F	CR to TS 37.145-2: Intermodulation product bandwidth in Tx IMD test (Rel-15)	15.3.0
2019-03	RAN#83	RP-190419	0078	1	F	CR to TS 37.145-2: Corrections to acceptable uncertainty of test system (4.1.2)	15.3.0
2019-03	RAN#83	RP-190419	0080	3	D	TS 37.145-2: Editorial corrections	15.3.0
2019-03	RAN#83	RP-190418	0082		F	CR to TS 37.145-2: additional reference angular step criteria in Annex F.2.2	15.3.0
2019-03	RAN#83	RP-190419	0083	1	F	CR to TS 37.145-2 on Correction of unwanted emissions scaling	15.3.0
2019-03	RAN#83	RP-190418	0084	1	F	CR to TS 37.145-2: Implementation of 1024QAM for E-UTRA, Rel-15	15.3.0
2019-03	RAN#83	RP-190418	0085		F	CR to TS 37.145-2: Implementation of sTTI for E-UTRA, Rel-15	15.3.0
2019-03	RAN#83	RP-190418	0086		F	CR to TS 37.145-2: BS Spurious emissions limits for protection of the BS receiver for B28 in Europe, Rel-15	15.3.0
2019-03	RAN#83	RP-190419	0087	2	F	CR to TS 37.145-2: new Rel-15 bands and isolation of band 49, Tx, Rel-15	15.3.0
2019-03	RAN#83	RP-190419	0088	3	F	CR to TS 37.145-2: new Rel-15 bands and isolation of band 49, Rx, Rel-15	15.3.0
2019-06	RAN#84	RP-191263	0090	1	F	CR to TS 37.145-2: Corrections on out-of-band blocking requirement	15.4.0
2019-06	RAN#84	RP-191263	0091	1	F	CR to TS 37.145-2: clarification on CSA and RCSA relations for hybrid AAS BS, Rel-15	15.4.0
2019-06	RAN#84	RP-191236	0093	1	F	CR to TS 37.145-2: updates to Tx spur and Tx co-location	15.4.0
2019-06	RAN#84	RP-191236	0094	1	F	CR to TS 37.145-2: Corrections related to TRP measurements in Annex F	15.4.0
2019-06	RAN#84	RP-191263	0095	1	F	CR to TS37.145-2 Correction on OTA test requirements for spurious emissions	15.4.0
2019-06	RAN#84	RP-191236	0096		D	CR to TS 37.145-2: Adding reference in subclause 6.4.1	15.4.0
2019-06	RAN#84	RP-191262	0097	1	F	Clarification on polarisations to be tested	15.4.0
2019-06	RAN#84	RP-191236	0104	1	F	CR to TS 37.145-2: Corrections related to TRP measurements in Annex F	15.4.0
2019-06	RAN#84	RP-191263	0105		F	Corrections to operation in Band 46 and 49	15.4.0
2019-06	RAN#84	RP-191263	0107	1	F	Correction on Δf_{OOB} for 37.145-2	15.4.0
2019-06	RAN#84	RP-191262	0108	1	F	Addition of power backoff for 256QAM and 1024QAM	15.4.0
2019-06	RAN#84	RP-191262	0109	1	F	Blocking requirement for MSR/NR operation	15.4.0
2019-06	RAN#84	RP-191263	0110	1	F	Correction of applicable RATs for OOB blocking requirement	15.4.0
2019-06	RAN#84	RP-191236	0111		F	CR to TS 37.145-2: Correction on multi-band test configurations	15.4.0
2019-06	RAN#84	RP-191263	0112		F	CR to TS 37.145-2: Addition of RC test method for spurious emissions in subclause 6.7.6 and 7.7.4	15.4.0
2019-06	RAN#84	RP-191263	0114	2	F	CR to TS 37.145-2: Clarification on beam identifier declaration in subclause 4.10	15.4.0
2019-06	RAN#84	RP-191262	0115	2	F	CR to TS 37.145-2. Clarification of TRP methods applicability in Annex F	15.4.0
2019-06	RAN#84	RP-191262	0118	1	D	CR to TS 37.145-2: Correction to reference to Annex	15.4.0
2019-06	RAN#84	RP-191263	0123	1	F	CR to TS 37.145-2: Correction to Total Radiated Power definition and Single-band RIB	15.4.0
2019-06	RAN#84	RP-191262	0124	1	F	CR to TS 37.145-2: Correction on usage of terms TRP and EIRP	15.4.0
2019-06	RAN#84	RP-191262	0125		F	CR to TS 37.145-2: Correction of Radiated Interface Boundary (RIB) definition	15.4.0
2019-06	RAN#84	RP-191236	0127	1	F	CR to TR 37.145-2 removal of Tx Diversity for TAE testing	15.4.0
2019-06	RAN#84	RP-191236	0130		F	CR to TS 37.145-2: adding further details to spherical Fibonacci grids (F.4)	15.4.0
2019-06	RAN#84	RP-191258	0133		F	CR to TS 37.145-2: mirror of operating band and frequency range declaration from NR, Rel-15	15.4.0
2019-06	RAN#84	RP-191263	0134	1	B	CR to TS37.145-2: BS demodulation requirements for NR	15.4.0
2019-06	RAN#84	RP-191263	0135		F	Non-AAS CRs mirroring to the AAS specification	15.4.0

History

Document history		
V15.1.0	October 2018	Publication
V15.2.0	April 2019	Publication
V15.3.0	May 2019	Publication
V15.4.0	July 2019	Publication