

ETSI TS 137 340 V15.7.0 (2019-10)



Universal Mobile Telecommunications System (UMTS);

LTE;

5G;

NR;

Multi-connectivity;

Overall description;

Stage-2

(3GPP TS 37.340 version 15.7.0 Release 15)



Reference

RTS/TSGR-0237340vf70

Keywords

5G,LTE,UMTS

ETSI

650 Route des Lucioles
F-06921 Sophia Antipolis Cedex - FRANCE

Tel.: +33 4 92 94 42 00 Fax: +33 4 93 65 47 16

Siret N° 348 623 562 00017 - NAF 742 C
Association à but non lucratif enregistrée à la
Sous-Préfecture de Grasse (06) N° 7803/88

Important notice

The present document can be downloaded from:

<http://www.etsi.org/standards-search>

The present document may be made available in electronic versions and/or in print. The content of any electronic and/or print versions of the present document shall not be modified without the prior written authorization of ETSI. In case of any existing or perceived difference in contents between such versions and/or in print, the prevailing version of an ETSI deliverable is the one made publicly available in PDF format at www.etsi.org/deliver.

Users of the present document should be aware that the document may be subject to revision or change of status.

Information on the current status of this and other ETSI documents is available at

<https://portal.etsi.org/TB/ETSIDeliverableStatus.aspx>

If you find errors in the present document, please send your comment to one of the following services:

<https://portal.etsi.org/People/CommiteeSupportStaff.aspx>

Copyright Notification

No part may be reproduced or utilized in any form or by any means, electronic or mechanical, including photocopying and microfilm except as authorized by written permission of ETSI.

The content of the PDF version shall not be modified without the written authorization of ETSI.

The copyright and the foregoing restriction extend to reproduction in all media.

© ETSI 2019.

All rights reserved.

DECT™, **PLUGTESTS™**, **UMTS™** and the ETSI logo are trademarks of ETSI registered for the benefit of its Members.

3GPP™ and **LTE™** are trademarks of ETSI registered for the benefit of its Members and of the 3GPP Organizational Partners.

oneM2M™ logo is a trademark of ETSI registered for the benefit of its Members and of the oneM2M Partners.

GSM® and the GSM logo are trademarks registered and owned by the GSM Association.

Intellectual Property Rights

Essential patents

IPRs essential or potentially essential to normative deliverables may have been declared to ETSI. The information pertaining to these essential IPRs, if any, is publicly available for **ETSI members and non-members**, and can be found in ETSI SR 000 314: "*Intellectual Property Rights (IPRs); Essential, or potentially Essential, IPRs notified to ETSI in respect of ETSI standards*", which is available from the ETSI Secretariat. Latest updates are available on the ETSI Web server (<https://ipr.etsi.org/>).

Pursuant to the ETSI IPR Policy, no investigation, including IPR searches, has been carried out by ETSI. No guarantee can be given as to the existence of other IPRs not referenced in ETSI SR 000 314 (or the updates on the ETSI Web server) which are, or may be, or may become, essential to the present document.

Trademarks

The present document may include trademarks and/or tradenames which are asserted and/or registered by their owners. ETSI claims no ownership of these except for any which are indicated as being the property of ETSI, and conveys no right to use or reproduce any trademark and/or tradename. Mention of those trademarks in the present document does not constitute an endorsement by ETSI of products, services or organizations associated with those trademarks.

Legal Notice

This Technical Specification (TS) has been produced by ETSI 3rd Generation Partnership Project (3GPP).

The present document may refer to technical specifications or reports using their 3GPP identities. These shall be interpreted as being references to the corresponding ETSI deliverables.

The cross reference between 3GPP and ETSI identities can be found under <http://webapp.etsi.org/key/queryform.asp>.

Modal verbs terminology

In the present document "**shall**", "**shall not**", "**should**", "**should not**", "**may**", "**need not**", "**will**", "**will not**", "**can**" and "**cannot**" are to be interpreted as described in clause 3.2 of the [ETSI Drafting Rules](#) (Verbal forms for the expression of provisions).

"**must**" and "**must not**" are **NOT** allowed in ETSI deliverables except when used in direct citation.

Contents

Intellectual Property Rights	2
Legal Notice	2
Modal verbs terminology.....	2
Foreword.....	5
1 Scope	6
2 References	6
3 Definitions, symbols and abbreviations	7
3.1 Definitions	7
3.2 Abbreviations	8
4 Multi-Radio Dual Connectivity.....	8
4.1 General	8
4.1.1 Common MR-DC principles.....	8
4.1.2 MR-DC with the EPC.....	8
4.1.3 MR-DC with the 5GC.....	9
4.1.3.1 E-UTRA-NR Dual Connectivity	9
4.1.3.2 NR-E-UTRA Dual Connectivity	9
4.1.3.3 NR-NR Dual Connectivity	9
4.2 Radio Protocol Architecture	9
4.2.1 Control Plane	9
4.2.2 User Plane.....	10
4.3 Network interfaces	12
4.3.1 Control Plane	12
4.3.1.1 Common MR-DC principles	12
4.3.1.2 MR-DC with EPC	13
4.3.1.3 MR-DC with 5GC.....	13
4.3.2 User Plane.....	13
4.3.2.1 Common MR-DC principles	13
4.3.2.2 MR-DC with EPC	14
4.3.2.3 MR-DC with 5GC.....	14
5 Layer 1 related aspects	14
6 Layer 2 related aspects	14
6.1 MAC Sublayer.....	14
6.2 RLC Sublayer.....	15
6.3 PDCP Sublayer.....	15
6.4 SDAP Sublayer	15
7 RRC related aspects.....	15
7.1 System information handling	15
7.2 Measurements.....	15
7.3 UE capability coordination.....	17
7.4 Handling of combined MN/SN RRC messages.....	17
7.5 SRB3	17
7.6 Split SRB.....	18
7.7 SCG/MCG failure handling.....	18
7.8 UE identities	19
7.9 Inter-node Resource Coordination	19
8 Bearer handling aspects.....	19
8.1 QoS aspects	19
8.2 Bearer type selection	20
8.3 Bearer type change	21
8.4 User data forwarding.....	21
9 Security related aspects	22

10	Multi-Connectivity operation related aspects.....	22
10.1	General	22
10.2	Secondary Node Addition	22
10.2.1	EN-DC	22
10.2.2	MR-DC with 5GC.....	24
10.3	Secondary Node Modification (MN/SN initiated)	26
10.3.1	EN-DC	26
10.3.2	MR-DC with 5GC.....	30
10.4	Secondary Node Release (MN/SN initiated).....	34
10.4.1	EN-DC	34
10.4.2	MR-DC with 5GC.....	36
10.5	Secondary Node Change (MN/SN initiated)	37
10.5.1	EN-DC	37
10.5.2	MR-DC with 5GC.....	40
10.6	PSCell change	43
10.7	Inter-Master Node handover with/without Secondary Node change.....	43
10.7.1	EN-DC	43
10.7.2	MR-DC with 5GC.....	45
10.8	Master Node to eNB/gNB Change	47
10.8.1	EN-DC	47
10.8.2	MR-DC with 5GC.....	49
10.9	eNB/gNB to Master Node change.....	50
10.9.1	EN-DC	50
10.9.2	MR-DC with 5GC.....	51
10.10	RRC Transfer	52
10.10.1	EN-DC	52
10.10.2	MR-DC with 5GC.....	53
10.11	Secondary RAT data volume reporting	55
10.11.1	EN-DC	55
10.11.2	MR-DC with 5GC.....	56
10.12	Activity Notification.....	56
10.12.1	EN-DC	56
10.12.2	MR-DC with 5GC.....	57
10.13	Notification Control Indication	59
10.13.1	EN-DC	59
10.13.2	MR-DC with 5GC.....	59
10.14	PDU Session Split at UPF	59
10.14.1	PDU Session Split at UPF during PDU session resource setup.....	59
10.14.2	PDU Session Split at UPF during PDU session resource modify (5GC initiated).....	60
10.14.3	PDU Session Split at UPF (RAN initiated QoS flows offloading from MN to SN).....	61
11	Service related aspects.....	64
11.1	Roaming and Access Restrictions	64
11.2	Support of Network Sharing.....	64
12	X2/Xn Interface related aspects	64
13	Other aspects	64
13.1	Interference avoidance for in-device coexistence.....	64
Annex A (informative):	Layer 2 handling for bearer type change	65
Annex B (informative):	Supported MR-DC Handover Scenarios	67
Annex C (informative):	Change history	68
History		71

Foreword

This Technical Specification has been produced by the 3rd Generation Partnership Project (3GPP).

The contents of the present document are subject to continuing work within the TSG and may change following formal TSG approval. Should the TSG modify the contents of the present document, it will be re-released by the TSG with an identifying change of release date and an increase in version number as follows:

Version x.y.z

where:

x the first digit:

- 1 presented to TSG for information;
- 2 presented to TSG for approval;
- 3 or greater indicates TSG approved document under change control.

Y the second digit is incremented for all changes of substance, i.e. technical enhancements, corrections, updates, etc.

Z the third digit is incremented when editorial only changes have been incorporated in the document.

1 Scope

The present document provides an overview of the multi-connectivity operation using E-UTRA and NR radio access technologies. Details of the network and radio interface protocols are specified in companion specifications of the 36 and 38 series.

2 References

The following documents contain provisions which, through reference in this text, constitute provisions of the present document.

- References are either specific (identified by date of publication, edition number, version number, etc.) or non-specific.
- For a specific reference, subsequent revisions do not apply.
- For a non-specific reference, the latest version applies. In the case of a reference to a 3GPP document (including a GSM document), a non-specific reference implicitly refers to the latest version of that document *in the same Release as the present document*.

- [1] 3GPP TR 21.905: "Vocabulary for 3GPP Specifications".
- [2] 3GPP TS 36.300: "Evolved Universal Terrestrial Radio Access (E-UTRA) and Evolved Universal Terrestrial Radio Access Network (E-UTRAN); Overall description; Stage 2".
- [3] 3GPP TS 38.300: "NR; NR and NG-RAN Overall description; Stage 2".
- [4] 3GPP TS 38.331: "NR; Radio Resource Control (RRC) protocol specification".
- [5] 3GPP TS 38.423: "NG-RAN; Xn application protocol (XnAP)".
- [6] 3GPP TS 38.425: "NG-RAN; NR user plane protocol".
- [7] 3GPP TS 38.401: "NG-RAN; Architecture description".
- [8] 3GPP TS 38.133: "NG-RAN; Requirements for support of radio resource management".
- [9] 3GPP TS 36.423: "Evolved Universal Terrestrial Radio Access Network (E-UTRAN); X2 Application Protocol (X2AP)".
- [10] 3GPP TS 36.331: "Evolved Universal Terrestrial Radio Access (E-UTRA); Radio Resource Control (RRC); Protocol specification".
- [11] 3GPP TS 23.501: "System Architecture for the 5G System; Stage 2".
- [12] 3GPP TS 38.101-1: "User Equipment (UE) radio transmission and reception; Part 1: Range 1 Standalone".
- [13] 3GPP TS 38.101-2: "User Equipment (UE) radio transmission and reception; Part 2: Range 2 Standalone".
- [14] 3GPP TS 38.101-3: "User Equipment (UE) radio transmission and reception; Part 3: Range 1 and Range 2 Interworking operation with other radios".
- [15] 3GPP TS 36.323: "Evolved Universal Terrestrial Radio Access (E-UTRA); Packet Data Convergence Protocol (PDCP) specification".
- [16] 3GPP TS 38.323: "NR; Packet Data Convergence Protocol (PDCP) specification".

3 Definitions, symbols and abbreviations

3.1 Definitions

For the purposes of the present document, the terms and definitions given in TR 21.905 [1] and the following apply. A term defined in the present document takes precedence over the definition of the same term, if any, in TR 21.905 [1] and TS 36.300 [2].

En-gNB: node providing NR user plane and control plane protocol terminations towards the UE, and acting as Secondary Node in EN-DC.

Master Cell Group: in MR-DC, a group of serving cells associated with the Master Node, comprising of the SpCell (PCell) and optionally one or more SCells.

Master node: in MR-DC, the radio access node that provides the control plane connection to the core network. It may be a Master eNB (in EN-DC), a Master ng-eNB (in NGEN-DC) or a Master gNB (in NR-DC and NE-DC).

MCG bearer: in MR-DC, a radio bearer with an RLC bearer (or two RLC bearers, in case of CA packet duplication) only in the MCG.

MN terminated bearer: in MR-DC, a radio bearer for which PDCP is located in the MN.

MCG SRB: in MR-DC, a direct SRB between the MN and the UE.

Multi-Radio Dual Connectivity: Dual Connectivity between E-UTRA and NR nodes, or between two NR nodes.

Ng-eNB: as defined in TS 38.300 [3].

PCell: SpCell of a master cell group.

PSCell: SpCell of a secondary cell group.

RLC bearer: RLC and MAC logical channel configuration of a radio bearer in one cell group.

Secondary Cell Group: in MR-DC, a group of serving cells associated with the Secondary Node, comprising of the SpCell (PSCell) and optionally one or more SCells.

Secondary node: in MR-DC, the radio access node, with no control plane connection to the core network, providing additional resources to the UE. It may be an en-gNB (in EN-DC), a Secondary ng-eNB (in NE-DC) or a Secondary gNB (in NR-DC and NGEN-DC).

SCG bearer: in MR-DC, a radio bearer with an RLC bearer (or two RLC bearers, in case of CA packet duplication) only in the SCG.

SN terminated bearer: in MR-DC, a radio bearer for which PDCP is located in the SN.

SpCell: primary cell of a master or secondary cell group.

SRB3: in EN-DC, NGEN-DC and NR-DC, a direct SRB between the SN and the UE.

Split bearer: in MR-DC, a radio bearer with RLC bearers both in MCG and SCG.

Split PDU Session (or PDU Session split): a PDU Session whose QoS Flows are served by more than one SDAP entities in the NG-RAN.

Split SRB: in MR-DC, a SRB between the MN and the UE with RLC bearers both in MCG and SCG.

User plane resource configuration: in MR-DC with 5GC, encompasses radio network resources and radio access resources related to either one or more PDU sessions, one or more QoS flows, one or more DRBs, or any combination thereof.

3.2 Abbreviations

For the purposes of the present document, the abbreviations given in TR 21.905 [1] and the following apply. An abbreviation defined in the present document takes precedence over the definition of the same abbreviation, if any, in TR 21.905 [1] and TS 36.300 [2].

DC	Intra-E-UTRA Dual Connectivity
EN-DC	E-UTRA-NR Dual Connectivity
MCG	Master Cell Group
MN	Master Node
MR-DC	Multi-Radio Dual Connectivity
NE-DC	NR-E-UTRA Dual Connectivity
NGEN-DC	NG-RAN E-UTRA-NR Dual Connectivity
NR-DC	NR-NR Dual Connectivity
SCG	Secondary Cell Group
SN	Secondary Node

4 Multi-Radio Dual Connectivity

4.1 General

4.1.1 Common MR-DC principles

Multi-Radio Dual Connectivity (MR-DC) is a generalization of the Intra-E-UTRA Dual Connectivity (DC) described in TS 36.300 [2], where a multiple Rx/Tx capable UE may be configured to utilise resources provided by two different nodes connected via non-ideal backhaul, one providing NR access and the other one providing either E-UTRA or NR access. One node acts as the MN and the other as the SN. The MN and SN are connected via a network interface and at least the MN is connected to the core network.

NOTE 1: MR-DC is designed based on the assumption of non-ideal backhaul between the different nodes but can also be used in case of ideal backhaul.

NOTE 2: All MR-DC normative text and procedures in this version of the specification show the aggregated node case. The details about non-aggregated node for MR-DC operation are described in TS 38.401 [7].

4.1.2 MR-DC with the EPC

E-UTRAN supports MR-DC via E-UTRA-NR Dual Connectivity (EN-DC), in which a UE is connected to one eNB that acts as a MN and one en-gNB that acts as a SN. The eNB is connected to the EPC via the S1 interface and to the en-gNB via the X2 interface. The en-gNB might also be connected to the EPC via the S1-U interface and other en-gNBs via the X2-U interface.

The EN-DC architecture is illustrated in Figure 4.1.2-1 below.

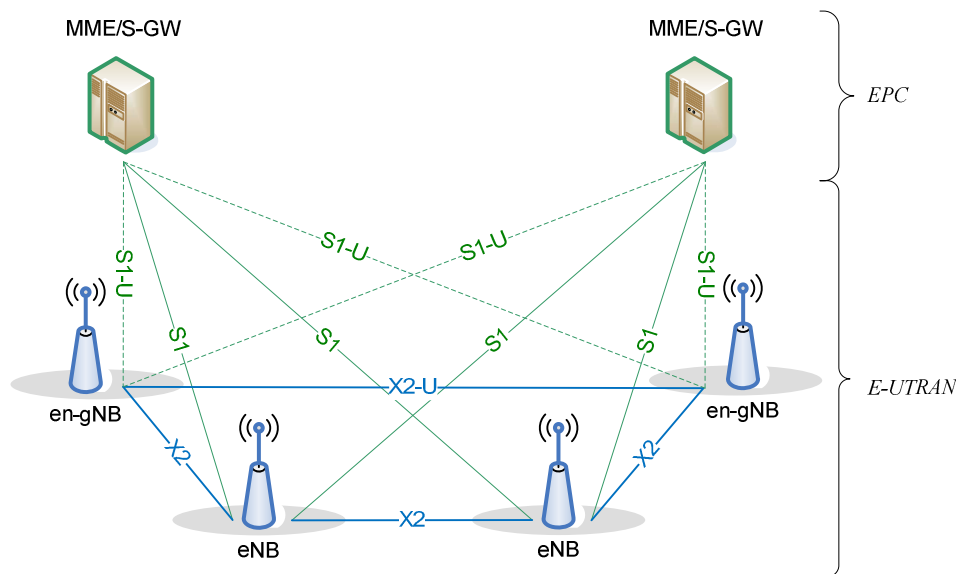

Figure 4.1.2-1: EN-DC Overall Architecture

4.1.3 MR-DC with the 5GC

4.1.3.1 E-UTRA-NR Dual Connectivity

NG-RAN supports NG-RAN E-UTRA-NR Dual Connectivity (NGEN-DC), in which a UE is connected to one ng-eNB that acts as a MN and one gNB that acts as a SN. The ng-eNB is connected to the 5GC and the gNB is connected to the ng-eNB via the Xn interface.

4.1.3.2 NR-E-UTRA Dual Connectivity

NG-RAN supports NR-E-UTRA Dual Connectivity (NE-DC), in which a UE is connected to one gNB that acts as a MN and one ng-eNB that acts as a SN. The gNB is connected to 5GC and the ng-eNB is connected to the gNB via the Xn interface.

4.1.3.3 NR-NR Dual Connectivity

NG-RAN supports NR-NR Dual Connectivity (NR-DC), in which a UE is connected to one gNB that acts as a MN and another gNB that acts as a SN. The master gNB is connected to the 5GC via the NG interface and to the secondary gNB via the Xn interface. The secondary gNB might also be connected to the 5GC via the NG-U interface. In addition, NR-DC can also be used when a UE is connected to two gNB-DUs, one serving the MCG and the other serving the SCG, connected to the same gNB-CU, acting both as a MN and as a SN.

4.2 Radio Protocol Architecture

4.2.1 Control Plane

In MR-DC, the UE has a single RRC state, based on the MN RRC and a single C-plane connection towards the Core Network. Figure 4.2.1-1 illustrates the Control plane architecture for MR-DC. Each radio node has its own RRC entity (E-UTRA version if the node is an eNB or NR version if the node is a gNB) which can generate RRC PDUs to be sent to the UE.

RRC PDUs generated by the SN can be transported via the MN to the UE. The MN always sends the initial SN RRC configuration via MCG SRB (SRB1), but subsequent reconfigurations may be transported via MN or SN. When transporting RRC PDU from the SN, the MN does not modify the UE configuration provided by the SN.

In E-UTRA connected to EPC, at initial connection establishment SRB1 uses E-UTRA PDCP. If the UE supports EN-DC, regardless whether EN-DC is configured or not, after initial connection establishment, MCG SRBs (SRB1 and

SRB2) can be configured by the network to use either E-UTRA PDCP or NR PDCP (either SRB1 and SRB2 are both configured with E-UTRA PDCP, or they are both configured with NR PDCP). Change from E-UTRA PDCP to NR PDCP (or vice-versa) is supported via a handover procedure (reconfiguration with mobility) or, for the initial change of SRB1 from E-UTRA PDCP to NR PDCP, with a reconfiguration without mobility before the initial security activation.

If the SN is a gNB (i.e. for EN-DC, NGEN-DC and NR-DC), the UE can be configured to establish a SRB with the SN (SRB3) to enable RRC PDUs for the SN to be sent directly between the UE and the SN. RRC PDUs for the SN can only be transported directly to the UE for SN RRC reconfiguration not requiring any coordination with the MN.

Measurement reporting for mobility within the SN can be done directly from the UE to the SN if SRB3 is configured.

Split SRB is supported for all MR-DC options, allowing duplication of RRC PDUs generated by the MN, via the direct path and via the SN. Split SRB uses NR PDCP. This version of the specification does not support the duplication of RRC PDUs generated by the SN via the MN and SN paths.

In EN-DC, the SCG configuration is kept in the UE during suspension. The UE releases the SCG configuration (but not the radio bearer configuration) during resumption initiation.

In MR-DC with 5GC, the UE stores the PDCP/SDAP configuration when moving to RRC Inactive but it releases the SCG configuration.

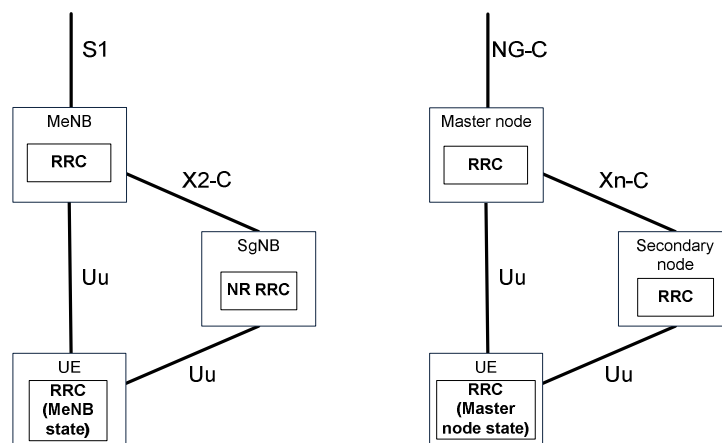

Figure 4.2.1-1: Control plane architecture for EN-DC (left) and MR-DC with 5GC (right).

4.2.2 User Plane

In MR-DC, from a UE perspective, three bearer types exist: MCG bearer, SCG bearer and split bearer. These three bearer types are depicted in Figure 4.2.2-1 for MR-DC with EPC (EN-DC) and in Figure 4.2.2-2 for MR-DC with 5GC (NGEN-DC, NE-DC and NR-DC).

For EN-DC, the network can configure either E-UTRA PDCP or NR PDCP for MN terminated MCG bearers while NR PDCP is always used for all other bearers.

In MR-DC with 5GC, NR PDCP is always used for all bearer types. In NGEN-DC, E-UTRA RLC/MAC is used in the MN while NR RLC/MAC is used in the SN. In NE-DC, NR RLC/MAC is used in the MN while E-UTRA RLC/MAC is used in the SN. In NR-DC, NR RLC/MAC is used in both MN and SN.

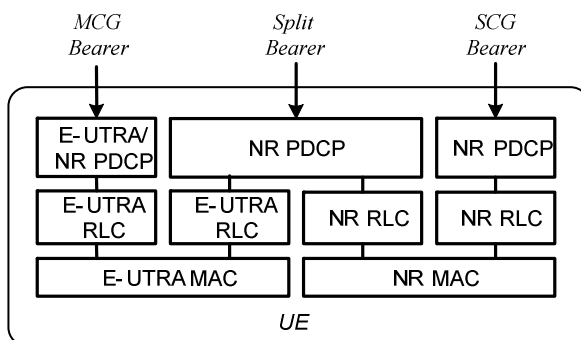

Figure 4.2.2-1: Radio Protocol Architecture for MCG, SCG and split bearers from a UE perspective in MR-DC with EPC (EN-DC)

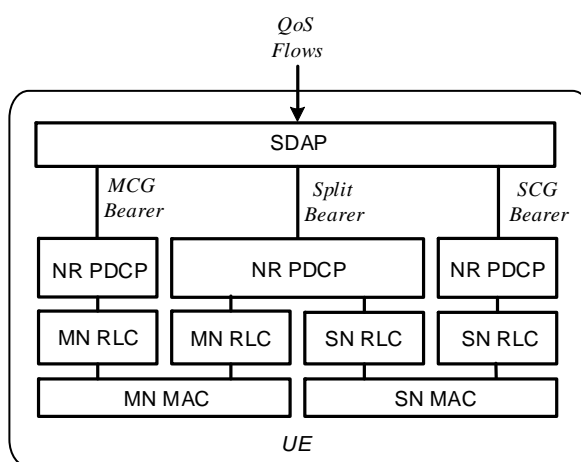

Figure 4.2.2-2: Radio Protocol Architecture for MCG, SCG and split bearers from a UE perspective in MR-DC with 5GC (NGEN-DC, NE-DC and NR-DC).

From a network perspective, each bearer (MCG, SCG and split bearer) can be terminated either in MN or in SN. Network side protocol termination options are shown in Figure 4.2.2-3 for MR-DC with EPC (EN-DC) and in Figure 4.2.2-4 for MR-DC with 5GC (NGEN-DC, NE-DC and NR-DC).

NOTE 1: Even if only SCG bearers are configured for a UE, for SRB1 and SRB2 the logical channels are always configured at least in the MCG, i.e. this is still an MR-DC configuration and a PCell always exists.

NOTE 2: If only MCG bearers are configured for a UE, i.e. there is no SCG, this is still considered an MR-DC configuration, as long as at least one of the bearers is terminated in the SN.

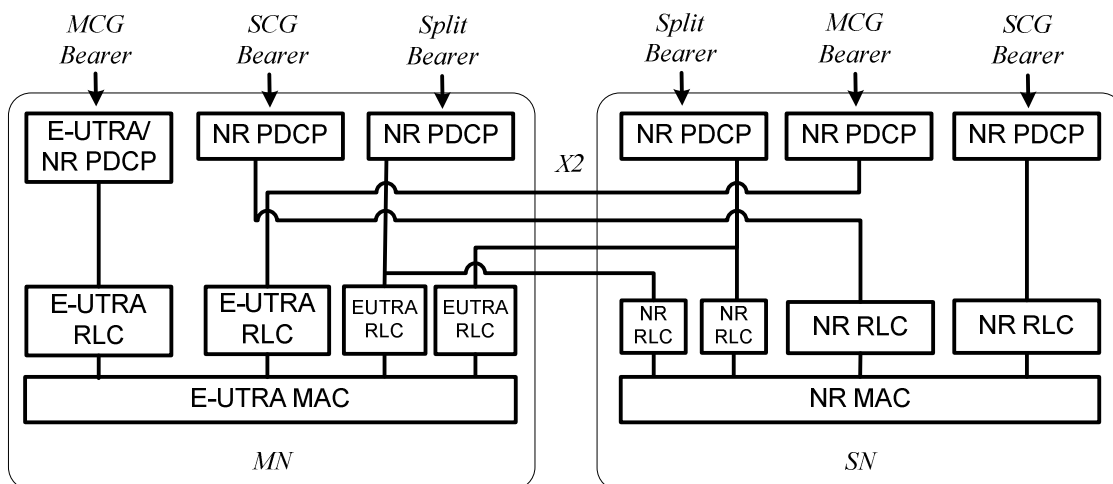

Figure 4.2.2-3: Network side protocol termination options for MCG, SCG and split bearers in MR-DC with EPC (EN-DC).

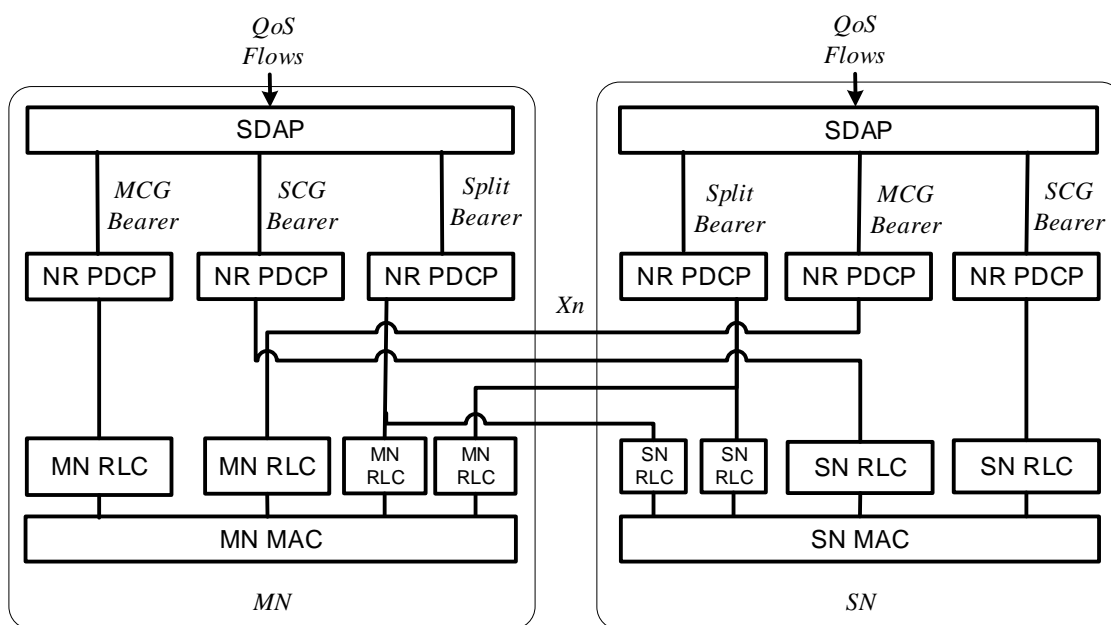

Figure 4.2.2-4: Network side protocol termination options for MCG, SCG and split bearers in MR-DC with 5GC (NGEN-DC, NE-DC and NR-DC).

4.3 Network interfaces

4.3.1 Control Plane

4.3.1.1 Common MR-DC principles

In MR-DC, there is an interface between the MN and the SN for control plane signalling and coordination. For each MR-DC UE, there is also one control plane connection between the MN and a corresponding CN entity. The MN and

the SN involved in MR-DC for a certain UE control their radio resources and are primarily responsible for allocating radio resources of their cells.

Figure 4.3.1.1-1 shows C-plane connectivity of MN and SN involved in MR-DC for a certain UE.

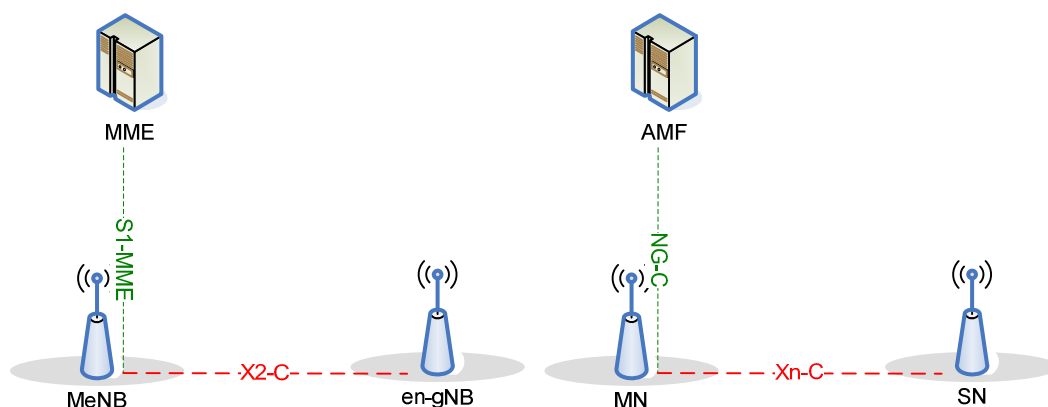

Figure 4.3.1.1-1: C-Plane connectivity for EN-DC (left) and MR-DC with 5GC (right).

4.3.1.2 MR-DC with EPC

In MR-DC with EPC (EN-DC), the involved core network entity is the MME. S1-MME is terminated in MN and the MN and the SN are interconnected via X2-C.

4.3.1.3 MR-DC with 5GC

In MR-DC with 5GC (NGEN-DC, NE-DC and NR-DC), the involved core network entity is the AMF. NG-C is terminated in the MN and the MN and the SN are interconnected via Xn-C.

4.3.2 User Plane

4.3.2.1 Common MR-DC principles

There are different U-plane connectivity options of the MN and SN involved in MR-DC for a certain UE, as shown in Figure 4.3.2.1-1. The U-plane connectivity depends on the bearer option configured:

- For *MN terminated bearers*, the user plane connection to the CN entity is terminated in the MN;
- For *SN terminated bearers*, the user plane connection to the CN entity is terminated in the SN;
- The transport of user plane data over the Uu either involves MCG or SCG radio resources or both:
 - For *MCG bearers*, only MCG radio resources are involved;
 - For *SCG bearers*, only SCG radio resources are involved;
 - For *split bearers*, both MCG and SCG radio resources are involved.
- For split bearers, *MN terminated SCG bearers* and *SN terminated MCG bearers*, PDCP data is transferred between the MN and the SN via the MN-SN user plane interface.

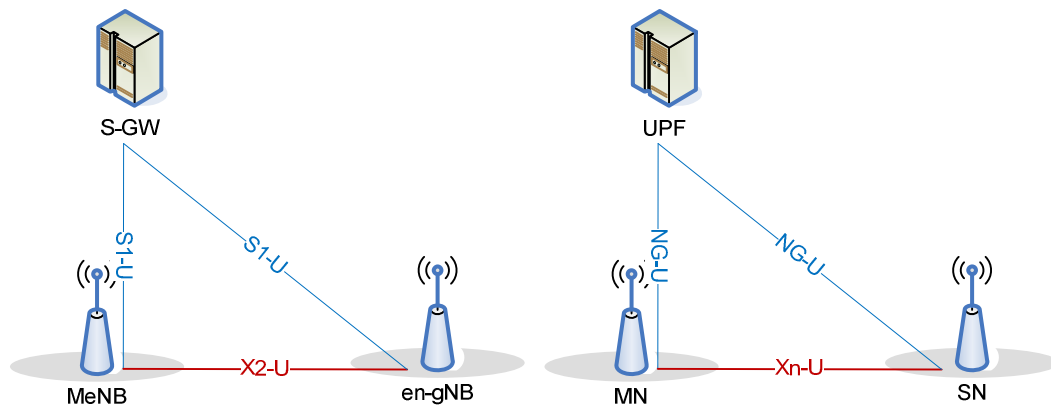

Figure 4.3.2.1-1: U-Plane connectivity for EN-DC (left) and MR-DC with 5GC (right).

4.3.2.2 MR-DC with EPC

For MR-DC with EPC (EN-DC), X2-U interface is the user plane interface between MN and SN, and S1-U is the user plane interface between the MN, the SN or both and the S-GW.

4.3.2.3 MR-DC with 5GC

For MR-DC with 5GC (NGEN-DC, NE-DC and inter-gNB NR-DC), Xn-U interface is the user plane interface between MN and SN, and NG-U is the user plane interface between the MN, the SN or both and the UPF.

5 Layer 1 related aspects

In MR-DC, two or more Component Carriers (CCs) may be aggregated over two cell groups. A UE may simultaneously receive or transmit on multiple CCs depending on its capabilities. The maximum number of configured CCs for a UE is 32 for DL and UL. Depending on UE's capabilities, up to 31 CCs can be configured for an E-UTRA cell group when the NR cell group is configured. For the NR cell group, the maximum number of configured CCs for a UE is 16 for DL and 16 for UL.

A gNB may configure the same Physical Cell ID (PCI) to more than one NR cell it serves. To avoid PCI confusion for MR-DC, NR PCIs should be allocated in a way that an NR cell is uniquely identifiable by a PCell identifier. This PCell is in the coverage area of an NR cell included in the MR-DC operation. In addition, NR PCIs should only be re-used in NR cells on the same SSB frequency sufficiently distant from each other. X2-C/Xn-C signalling supports disambiguation of NR PCIs by including the CGI of the PCell in respective X2AP/XnAP messages (e.g. SGNB ADDITION REQUEST/S-NODE ADDITION REQUEST) and by providing neighbour cell relationship via non-UE associated signaling (e.g. via the Xn Setup procedure or the NG-RAN node Configuration Update procedure).

6 Layer 2 related aspects

6.1 MAC Sublayer

In MR-DC, the UE is configured with two MAC entities: one MAC entity for the MCG and one MAC entity for the SCG. The serving cells of the MCG other than the PCell can only be activated/deactivated by the MAC Control Element received on MCG, and the serving cells of the SCG other than PSCell can only be activated/deactivated by the MAC Control Element received on SCG. The MAC entity applies the bitmap for the associated cells of either MCG or SCG. PSCell in SCG is always activated like the PCell (i.e. deactivation timer is not applied to PSCell). With the exception of PUCCH SCell, one deactivation timer is configured per SCell by RRC.

In MR-DC, semi-persistent scheduling (SPS) resources can be configured on both PCell and PSCell.

In MR-DC, the BSR configuration, triggering and reporting are independently performed per cell group. For split bearers, the PDCP data is considered in BSR in the cell group(s) configured by RRC.

In MR-DC, separate DRX configurations are provided for MCG and SCG.

6.2 RLC Sublayer

Both RLC AM and UM can be configured for MR-DC, for all bearer types (MCG, SCG and split bearers).

6.3 PDCP Sublayer

In EN-DC, CA duplication (see [3]) can be applied in the MN and in the SN, but MCG bearer CA duplication can be configured only in combination with E-UTRAN PDCP and MCG bearer CA duplication can be configured only if DC duplication is not configured for any split bearer.

In NGEN-DC, CA duplication can only be configured for SCG bearer. In NE-DC, CA duplication can only be configured for MCG bearer. In NR-DC, CA duplication can be configured for both MCG and SCG bearers.

In MR-DC, RoHC (as described in TS 36.323 [15] and TS 38.323 [16]) can be configured for all the bearer types.

6.4 SDAP Sublayer

In MR-DC with 5GC, the network may host up to two SDAP protocol entities for each individual PDU session, one for MN and another one for SN (see clause 8.1). The UE is configured with one SDAP protocol entity per PDU session.

7 RRC related aspects

7.1 System information handling

In MR-DC, the SN is not required to broadcast system information other than for radio frame timing and SFN. System information for initial configuration is provided to the UE by dedicated RRC signalling via the MN. The UE acquires, at least, radio frame timing and SFN of SCG from the PSS/SSS and MIB (if the SN is an eNB) / NR-PSS/SSS and PBCH (if the SN is a gNB) of the PSCell.

Additionally, upon change of the relevant system information of a configured SCell, the network releases and subsequently adds the concerned SCell (with updated system information), via one or more *RRC reconfiguration* messages sent on SRB1 or SRB3, if configured.

7.2 Measurements

If the measurement is configured to the UE in preparation for the Secondary Node Addition procedure described in clause 10.2, the Master node should configure the measurement to the UE.

In case of the intra-secondary node mobility described in clause 10.3, the SN should configure the measurement to the UE in coordination with the MN, if required.

The Secondary Node Change procedure described in clause 10.5 can be triggered by both the MN (only for inter-frequency secondary node change) and the SN. For secondary node changes triggered by the SN, the RRM measurement configuration is maintained by the SN which also processes the measurement reporting, without providing the measurement results to the MN.

Measurements can be configured independently by the MN and by the SN (intra-RAT measurements on serving and non-serving frequencies). The MN indicates the maximum number of frequency layers and measurement identities that can be used in the SN to ensure that UE capabilities are not exceeded. If MN and SN both configure measurements on the same carrier frequency then the configurations need to be consistent (if the network wants to ensure these are considered as a single measurement layer). Each node (MN and SN) can configure independently a threshold for the

SpCell quality. In (NG)EN-DC scenario, when the PCell quality is above the threshold configured by the MN, the UE is still required to perform inter-RAT measurements configured by the MN on the SN RAT (while it's not required to perform intra-RAT measurements); when the PCell quality is above the threshold configured by the SN, the UE is not required to perform measurements configured by the SN. In NR-DC or NE-DC scenario, when the PCell quality is above the threshold configured by the MN, the UE is not required to perform measurements configured by the MN; when the PCell quality is above the threshold configured by the SN, the UE is not required to perform measurements configured by the SN.

NOTE: The SN cannot renegotiate the number of frequency layers allocated by the MN in this version of the protocol.

In MR-DC, both the MN and the SN can configure CGI reporting. The MN can configure CGI reporting for intra-RAT and inter-RAT cells but the SN can only configure CGI reporting of intra-RAT cells. At any point in time, the UE can be configured with at most one CGI reporting configuration. For CGI reporting coordination, the SN sends the CGI measurement request and the embedded CGI reporting configuration to the MN. Optionally, the SN sends the unknown cell information to the MN. If there is no ongoing CGI reporting measurement on UE side, the MN forwards the SN CGI measurement configuration to UE. Otherwise the MN rejects the request by sending X2/Xn reject message. In case the SN indicates the unknown cell information, and the CGI information of the requested cell is already available in the MN, the MN can also reject the request, and sends the CGI information of the requested cell to the SN. The SN cannot configure the CGI measurement using the SRB3.

When SRB3 is not configured, reports for measurements configured by the SN are sent on SRB1. When SRB3 is configured, reports for measurements configured by the SN are sent on SRB3.

Measurement results related to the target SN can be provided by MN to target SN at MN initiated SN change procedure. Measurement results of target SN can be forwarded from source SN to target SN via MN at SN initiated SN change procedure. Measurement results related to the target SN can be provided by source MN to target MN at Inter-MN handover with/without SN change procedure.

Measurement results according to measurement configuration from the MN are encoded according to SN RRC when they are provided by MN to SN in *SgNB Addition Request* message / *SN Addition Request* message. During SN initiated SN change procedure, measurement results according to measurement configuration from SN are encoded according to SN RRC when they are provided by MN to SN in *SgNB Addition Request* message / *SN Addition Request* message.

Per-UE or per-FR measurement gaps can be configured, depending on UE capability to support independent FR measurement and network preference. Per-UE gap applies to both FR1 (E-UTRA and NR) and FR2 (NR) frequencies. For per-FR gap, two independent gap patterns (i.e. FR1 gap and FR2 gap) are configured for FR1 and FR2 respectively. The UE may also be configured with a per-UE gap sharing configuration (applying to per-UE gap) or with two separate gap sharing configurations (applying to FR1 and FR2 measurement gaps respectively) [8].

A measurement gap configuration is always provided:

- In EN-DC, NGEN-DC and NE-DC, for UEs configured with E-UTRA inter-frequency measurements as described in table 9.1.2-2 in TS 38.133 [8];
- In EN-DC and NGEN-DC, for UEs configured with UTRAN and GERAN measurements as described in table 9.1.2-2 in TS 38.133 [8];
- In NR-DC, for UEs configured with E-UTRAN measurements as described in table 9.1.2-3 in TS 38.133 [8];
- In MR-DC, for UEs that support either per-UE or per-FR gaps, when the conditions to measure SSB based inter-frequency measurement or SSB based intra-frequency measurement as described in clause 9.2.4 in TS 38.300 [3] are met;

If per-UE gap is used, the MN decides the gap pattern and the related gap sharing configuration. If per-FR gap is used, in EN-DC and NGEN-DC, the MN decides the FR1 gap pattern and the related gap sharing configuration for FR1, while the SN decides the FR2 gap pattern and the related gap sharing configuration for FR2; in NE-DC and NR-DC, the MN decides both the FR1 and FR2 gap patterns and the related gap sharing configurations.

In EN-DC and NGEN-DC, the measurement gap configuration from the MN to the UE indicates if the configuration from the MN is a per-UE gap or an FR1 gap configuration. The MN also indicates the configured per-UE or FR1 measurement gap pattern and the gap purpose (per-UE or per-FR1) to the SN. Measurement gap configuration assistance information can be exchanged between the MN and the SN. For the case of per-UE gap, the SN indicates to the MN the list of SN configured frequencies in FR1 and FR2 measured by the UE. For the per-FR gap case, the SN

indicates to the MN the list of SN configured frequencies in FR1 measured by the UE and the MN indicates to the SN the list of MN configured frequencies in FR2 measured by the UE.

In NE-DC, the MN indicates the configured per-UE or FR1 measurement gap pattern to the SN. The SN can provide a gap request to the MN, without indicating any list of frequencies.

In NR-DC, the MN indicates the configured per-UE, FR1 or FR2 measurement gap pattern and the gap purpose to the SN. The SN can indicate to the MN the list of SN configured frequencies in FR1 and FR2 measured by the UE.

7.3 UE capability coordination

In (NG)EN-DC and NE-DC, the capabilities of a UE supporting MR-DC are carried by different capability containers. Some MR-DC related capabilities are in the MR-DC container e.g. MR-DC band combinations, while other MR-DC related capabilities are contained in the E-UTRA and NR capability containers e.g. feature sets. The MR-DC capabilities in the MR-DC container need to be visible to both MN and SN, while the capabilities in the E-UTRA and NR containers only need to be visible to the node of the concerned RAT.

In NR-DC, all NR-DC related capabilities are in the NR capability container and are visible to both MN and SN.

When retrieving MR-DC related capabilities, the MN shall provide an MR-DC filter that affects the MR-DC related capabilities in MR-DC, E-UTRA and NR capability containers. When using different *UE capability enquiry* messages to retrieve the different containers, the MN shall employ the same MR-DC filter in all enquiry messages. In the E-UTRA RRC UE capability enquiry, the MR-DC filter is also used for retrieval of NR capabilities i.e. there is in fact one MR-DC/NR filter (while there is a separate filter for E-UTRA capabilities). Furthermore, the MN stores the retrieved capabilities and the corresponding filter, used to retrieve those capabilities, in the core network for later use.

For the UE capabilities requiring coordination between E-UTRA and NR (i.e. band combinations, baseband processing capabilities and the maximum power for FR1 the UE can use in SCG) or between NR MN and NR SN (i.e. band combinations, baseband processing capabilities), it is up to the MN to decide on how to resolve the dependency between MN and SN configurations. The MN then provides the resulting UE capabilities usable for SCG configuration to the SN, including the list of allowed MR-DC band combinations and feature sets, and the SN indicates the selected band combination and feature set to the MN. When subsequently reconfiguring the SCG, the SN should inform the MN whenever the band combination and/or feature set selected for the SCG changes (i.e. even if the selection concerns a band combination and feature set that is allowed). As part of an SN initiated SN modification, the SN may also indicate the desired UE capabilities usable for SCG configuration (e.g. a band combination and a feature set) outside those allowed by the MN (i.e. it may re-negotiate the UE capabilities for SCG configuration), and it is up to the MN to make the final decision whether to accept or reject the request.

7.4 Handling of combined MN/SN RRC messages

When both MCG and SCG reconfiguration is required due to the need for coordination with the MN, the *SN RRC reconfiguration* message is encapsulated in an MN RRC message that also carries the corresponding MCG reconfiguration that ensures that the combined configuration can be jointly processed by the UE. If the MN terminates a bearer using NR PDCP, the NR PDCP configuration is generated by the MN itself. If the SN terminates the bearer, the SN generates the NR PDCP configuration and sends it to the MN as a separate container.

The UE uses a joint success/failure procedure for messages in an encapsulating MN RRC message. A failure of the MN RRC messages, including one encapsulated SN RRC message with or without any MCG reconfiguration fields, triggers a re-establishment procedure. Each *SN RRC reconfiguration* message should have its own RRC response message even when the SN RRC message is encapsulated in an MN RRC message. The SN RRC response message is forwarded over X2/Xn to the SN. If a *SN RRC reconfiguration* message is contained in a MN RRC message, the UE sends a MN RRC response message that encapsulates the SN RRC response message.

NOTE: If the MN RRC message does not encapsulate an *SN RRC reconfiguration* message (i.e. an SCG configuration) but only information elements generated by the SN (e.g. the PDCP configuration for an SN terminated bearer), the UE will not send an SN RRC response message.

7.5 SRB3

SRB3 is supported in EN-DC, NGEN-DC and NR-DC, but not in NE-DC.

The decision to establish SRB3 is taken by the SN, which provides the SRB3 configuration using an SN RRC message. SRB3 establishment and release can be done at Secondary Node Addition and Secondary Node Change. SRB3 reconfiguration can be done at Secondary Node Modification procedure.

SRB3 may be used to send *SN RRC Reconfiguration*, *SN RRC Reconfiguration Complete* and *SN Measurement Report* messages, only in procedures where the MN is not involved. *SN RRC Reconfiguration Complete* messages are mapped to the same SRB as the message initiating the procedure. *SN Measurement Report* messages are mapped to SRB3, if configured, regardless of whether the configuration is received directly from the SN or via the MN. No MN RRC messages are mapped to SRB3.

SRB3 is modelled as one of the SRBs defined in TS 38.331 [4] and uses the NR-DCCH logical channel type. RRC PDUs on SRB3 are ciphered and integrity protected using NR PDCP, with security keys derived from $S-K_{gNB}$. The SN selects ciphering and integrity protection algorithms for the SRB3 and provides them to the MN within the SCG Configuration for transmission to the UE.

NOTE: A NR SCG RRC message sent via E-UTRA MCG SRB is protected by E-UTRA MCG SRB security (NR security is not used in this case).

SRB3 is of higher scheduling priority than all DRBs. The default scheduling priorities of split SRB1 and SRB3 are the same.

There is no requirement on the UE to perform any reordering of RRC messages between SRB1 and SRB3.

When SCG is released, SRB3 is released.

7.6 Split SRB

Split SRB is supported for both SRB1 and SRB2 (split SRB is not supported for SRB0 and SRB3) in all MR-DC cases. RRC PDUs on split SRB are ciphered and integrity protected using NR PDCP.

Split SRB can be configured by the MN in Secondary Node Addition and/or Modification procedure, with SN configuration part provided by the SN. A UE can be configured with both split SRB and SRB3 simultaneously. SRB3 and the SCG leg of split SRB can be independently configured.

For the split SRB, the selection of transmission path in downlink depends on network implementation. For uplink, the UE is configured via MN RRC signalling whether to use MCG path or duplicate the transmission on both MCG and SCG.

7.7 SCG/MCG failure handling

RLF is declared separately for the MCG and for the SCG.

If radio link failure is detected for MCG, the UE initiates the RRC connection re-establishment procedure.

The following SCG failure cases are supported:

- SCG RLF;
- SN change failure;
- For EN-DC, NGEN-DC and NR-DC, SCG configuration failure (only for messages on SRB3);
- For EN-DC, NGEN-DC and NR-DC, SCG RRC integrity check failure (on SRB3).

Upon SCG failure the UE suspends SCG transmissions for all radio bearers and reports the SCG Failure Information to the MN, instead of triggering re-establishment.

In all SCG failure cases, the UE maintains the current measurement configurations from both the MN and the SN and the UE continues measurements based on configuration from the MN and the SN if possible. The SN measurements configured to be routed via the MN will continue to be reported after the SCG failure.

NOTE: UE may not continue measurements based on configuration from the SN after SCG failure in certain cases (e.g. UE cannot maintain the timing of PSCell).

The UE includes in the *SCG Failure Information* message the measurement results available according to current measurement configuration of both the MN and the SN. The MN handles the *SCG Failure Information* message and may decide to keep, change, or release the SN/SCG. In all the cases, the measurement results according to the SN configuration and the SCG failure type may be forwarded to the old SN and/or to the new SN.

7.8 UE identities

In MR-DC, two C-RNTIs are independently allocated to the UE: one for MCG, and one for SCG.

7.9 Inter-node Resource Coordination

For MR-DC operations, MN and SN may coordinate their UL and DL radio resources in semi-static manner via UE associated signalling.

8 Bearer handling aspects

8.1 QoS aspects

In EN-DC, the E-UTRAN QoS framework defined in TS 36.300 [2] applies:

- An S1-U bearer is established between the EPC and the SN for SN terminated bearers;
- An X2-U bearer is established between the MN and the SN for split bearers, MN terminated SCG bearers and SN terminated MCG bearers;
- MN terminated and SN terminated bearers may have either MCG or SCG radio resources or both, MCG and SCG radio resources, established;

In MR-DC with 5GC:

- The NG-RAN QoS framework defined in TS 38.300 [3] applies;
- QoS flows belonging to the same PDU session may be mapped to different bearer types (see clause 4.2.2) and as a result there may be two different SDAP entities for the same PDU session: one at the MN and another one at the SN, in which case the MN decides which QoS flows are assigned to the SDAP entity in the SN. If the SN decides that its SDAP entity cannot host a given QoS flow any longer, the SN informs the MN and the MN cannot reject the request. If the MN decides that its SDAP entity can host a given QoS flow which has already been relocated to SN, the MN informs the SN;
- The MN or SN node that hosts the SDAP entity for a given QoS flow decides how to map the QoS flow to DRBs;
- If the SDAP entity for a given QoS flow is hosted by the MN and the MN decides that SCG resources are to be configured it provides to the SN
 - DRB QoS flow level QoS parameters, which the SN may reject, and
 - QoS flow to DRB mapping information and the respective per QoS flow information;
- If the SDAP entity for a given QoS flow is hosted by the SN and the SN configures MCG resources, based on offered MCG resource information from the MN, the SN provides to the MN
 - DRB QoS flow level QoS parameters, which the MN may reject, and
 - QoS flow to DRB mapping information and the respective per QoS flow information.
- If the SDAP entity for a given QoS flow is hosted by the SN, the MN provides sufficient QoS related information to enable the SN to configure appropriate SCG resources and to request the configuration of appropriate MCG resources. The MN may offer MCG resources to the SN and may indicate for GBR QoS flows

the amount offered to the SN on a per QoS flow level. The SN may request the MN to release QoS flows from the SDAP entity hosted by the SN that the MN cannot reject.

- MN decides the DL PDU session AMBR and UL PDU session AMBR limits to be assigned to the SN, and indicates these to the SN:
 - The PDCP entity at the SN applies the received DL PDU session AMBR limit to the set of all bearers for which the SN hosts PDCP for the UE;
 - The MAC entity at the SN applies the received UL PDU session AMBR limit to the scheduled uplink radio traffic at the SN for the UE.

In all MR-DC cases:

- The MN decides the DL UE AMBR and UL UE AMBR limits to be assigned to the SN, and indicates these to the SN:
 - The PDCP entity at the SN applies the received DL UE AMBR limit to the set of all bearers for which the SN hosts PDCP for the UE;
 - The MAC entity at the SN applies the received UL UE AMBR limit to the scheduled uplink radio traffic at the SN for the UE.

To support PDU sessions mapped to different bearer types, MR-DC with 5GC provides the possibility for the MN to request the 5GC:

- For some PDU sessions of a UE: Direct the User Plane traffic of the whole PDU session either to the MN or to the SN. In that case, there is a single NG-U tunnel termination at the NG-RAN for such PDU session.
 - The MN may request to change this assignment during the life time of the PDU session.
- For some other PDU sessions of a UE: Direct the User Plane traffic of a subset of the QoS flows of the PDU session to the SN (respectively MN) while the rest of the QoS flows of the PDU session is directed to the MN (respectively SN). In that case, there are two NG-U tunnel terminations at the NG-RAN for such PDU session.
 - The MN may request to change this assignment during the life time of the PDU session.

To support notification control indication for GBR QoS flows along the QoS framework specified in 38.300 [3] for MR-DC with 5GC, SN and MN may mutually indicate whenever QoS requirements for GBR QoS flows cannot be fulfilled anymore or can be fulfilled again.

8.2 Bearer type selection

In EN-DC, for each radio bearer the MN decides the location of the PDCP entity and in which cell group(s) radio resources are to be configured. Once an SN terminated split bearer is established, e.g. by means of the Secondary Node Addition procedure or MN initiated Secondary Node Modification procedure, the SN may remove SCG resources for the respective E-RAB, as long as the QoS for the respective E-RAB is guaranteed. In case an SN terminated bearer is released (or reconfigured to an MN terminated bearer), only the MN generates the corresponding release configuration.

In MR-DC with 5GC, the following principles apply:

- The MN decides per PDU session the location of the SDAP entity, i.e. whether it shall be hosted by the MN or the SN or by both (split PDU session);
- If the MN decides to host an SDAP entity it may decide some of the related QoS flows to be realized as MCG bearer, some as SCG bearer, and others to be realized as split bearer;
- If the MN decides that an SDAP entity shall be hosted in the SN, some of the related QoS flows may be realized as SCG bearer, some as MCG bearer, while others may be realized as split bearer. The SN is responsible to assign the corresponding DRB IDs, based on the DRB IDs indicated by the MN. The SN may remove or add SCG resources for the respective QoS flows, as long as the QoS for the respective QoS flow is guaranteed
- For each PDU session, including split PDU sessions, at most one default DRB may be configured (see [3]). The MN decides whether the SN is allowed to setup the default DRB or not.

8.3 Bearer type change

In MR-DC, all the possible bearer type change options are supported:

- MCG bearer to/from split bearer;
- MCG bearer to/from SCG bearer;
- SCG bearer to/from split bearer.

Bearer termination point change is supported for all bearer types, and can be performed with or without bearer type change:

- MN terminated bearer to/from SN terminated bearer.

For MR-DC:

- when the security key is changed for a bearer, the associated PDCP and RLC entities are re-established, while MAC behavior might depend on the solution selected by the network, e.g. MAC reset, change of LCID, etc. (see Annex A);
- for MCG bearer, split bearer and SCG bearer, during MN security key change the MCG/SCG PDCP and RLC are re-established and MCG/SCG MAC is reset;
- if a bearer type change happens together with MN security key change then for MCG bearer, split bearer and SCG bearer, the MCG/SCG PDCP and RLC are re-established and MCG/SCG MAC is reset;
- if a bearer type change happens through SN change procedure, then SN terminated PDCP and SCG RLC are re-established and SCG MAC is reset. MCG RLC/MAC behavior depends on the solution selected by the network, see Annex A;
- one step (direct) bearer type change between MN terminated bearer types without using the handover procedure is supported;
- one step (direct) bearer type change between SN terminated bearer types without using the handover or SN change procedure is supported;
- one step (direct) bearer type change from/to MN terminated bearer to/from SN terminated bearer without using the handover procedure is supported;
- PDCP version change for DRB (only applicable for EN-DC) or PDCP SN length change for an AM DRB or RLC mode change for DRB is performed using a release and add of the DRBs (in a single message) or full configuration;
- One step (direct) bearer type change with PDCP version change (only applicable for EN-DC) is supported.

NOTE 1: In this clause the term "handover" refers to an E-UTRA handover or to an NR synchronous reconfiguration not necessarily implying a P(S)Cell change with or without security key change.

NOTE 2: L2 handling for bearer type change in MR-DC is also summarized in Annex A (the table does not consider the cases that PDCP SN length is changed and avoiding reuse of COUNT).

8.4 User data forwarding

Upon EN-DC specific activities, user data forwarding may be performed for E-RABs for which the bearer type change from/to MN terminated bearer to/from SN terminated bearer is performed. The behaviour of the node from which data is forwarded is the same as specified for the "source eNB" for handover, the behaviour of the node to which data is forwarded is the same as specified for the "target eNB" for handover.

For MR-DC with 5GC, user data forwarding may be performed between NG-RAN nodes whenever the logical node hosting the PDCP entity changes. The behaviour of the node from which data is forwarded is the same as specified for the "source NG-RAN node" for handover, the behaviour of the node to which data is forwarded is the same as specified for the "target NG-RAN node" for handover.

For mobility scenarios which involve more than two RAN nodes, either direct or indirect data forwarding may be applied.

9 Security related aspects

MR-DC can only be configured after security activation in the MN.

In EN-DC and NGEN-DC, for bearers terminated in the MN the network configures the UE with K_{eNB} ; for bearers terminated in the SN the network configures the UE with $S-K_{gNB}$. In NE-DC, for bearers terminated in the MN the network configures the UE with K_{gNB} ; for bearers terminated in the SN the network configures the UE with $S-K_{eNB}$. In NR-DC, for bearers terminated in the MN the network configures the UE with K_{gNB} ; for bearers terminated in the SN the network configures the UE with $S-K_{gNB}$.

In NE-DC and NR-DC, a PCell change without K_{gNB} change does not require a $S-K_{eNB}$ change (NE-DC case) or a $S-K_{gNB}$ change (NR-DC case).

In EN-DC, NGEN-DC and NR-DC, for a PSCell change that does not require a K_{eNB} change (i.e. no simultaneous PCell handover in EN-DC and NGEN-DC) or a K_{gNB} change (in NR-DC), $S-K_{gNB}$ key refresh is not required if the PDCP termination point of the SN is not changed. In NE-DC, a PSCell change always requires a $S-K_{eNB}$ change.

In EN-DC, the UE supports the NR security algorithms corresponding to the E-UTRA security algorithms signalled at NAS level and the UE NR AS Security capability is not signalled to the MN over RRC. Mapping from E-UTRA security algorithms to the corresponding NR security algorithms, where necessary, is performed at the MN.

For MR-DC with 5GC, UP integrity protection can be configured on a per radio bearer basis. All DRBs which belong to the same PDU session always have the same UP integrity protection activation, i.e., either on or off:

- For NR-DC: MN and/or SN terminated DRBs of a PDU session can have UP integrity protection activation either on or off.
- For NE-DC: MN terminated DRBs of a PDU session can have UP integrity protection activation on; however, in this case, the MN will not at any point offload any DRB of such PDU session to the SN. SN terminated DRBs of a PDU session always have UP integrity protection activation off.
- For NGEN-DC: Both MN terminated and SN terminated DRBs of a PDU session always have UP integrity protection activation off.

10 Multi-Connectivity operation related aspects

10.1 General

Similar procedures as defined under clause 10.1.2.8 (Dual Connectivity operation) in TS 36.300 [2] apply for MR-DC.

10.2 Secondary Node Addition

10.2.1 EN-DC

The Secondary Node Addition procedure is initiated by the MN and is used to establish a UE context at the SN to provide resources from the SN to the UE. For bearers requiring SCG radio resources, this procedure is used to add at least the first cell of the SCG. This procedure can also be used to configure an SN terminated MCG bearer (where no SCG configuration is needed). Figure 10.2.1-1 shows the Secondary Node Addition procedure.

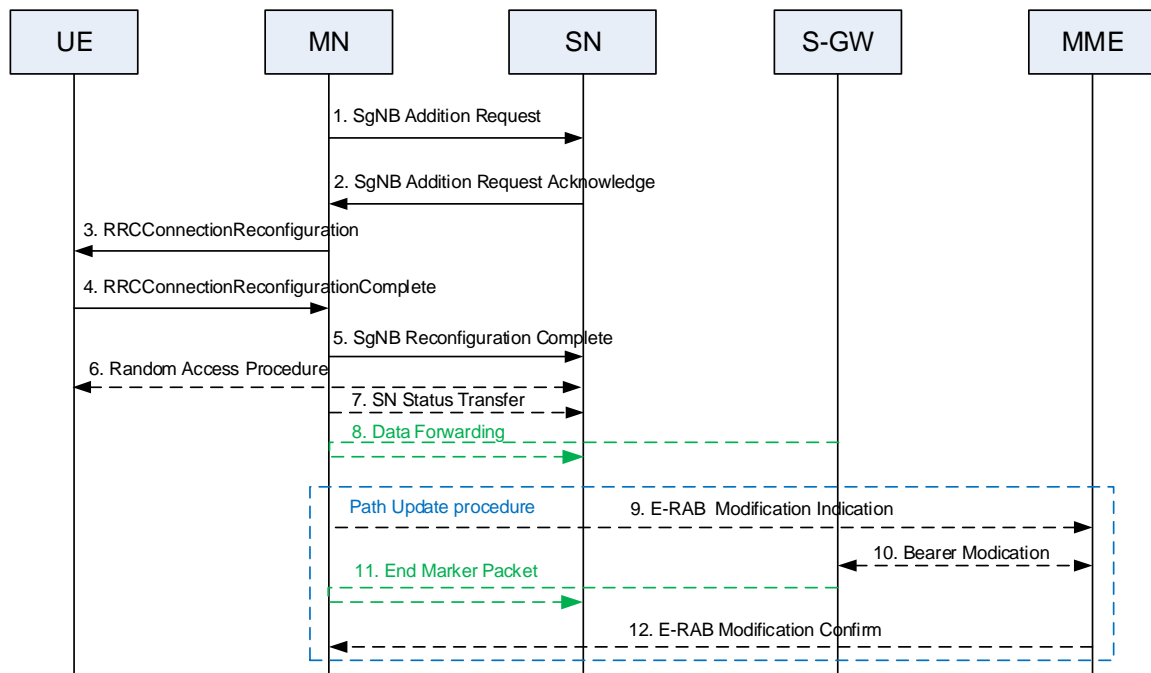

Figure 10.2.1-1: Secondary Node Addition procedure

1. The MN decides to request the SN to allocate resources for a specific E-RAB, indicating E-RAB characteristics (E-RAB parameters, TNL address information corresponding to bearer type). In addition, for bearers requiring SCG radio resources, MN indicates the requested SCG configuration information, including the entire UE capabilities and the UE capability coordination result. In this case, the MN also provides the latest measurement results for SN to choose and configure the SCG cell(s). The MN may request the SN to allocate radio resources for split SRB operation. The MN always provides all the needed security information to the SN (even if no SN terminated bearers are setup) to enable SRB3 to be setup based on SN decision. In case of bearer options that require X2-U resources between the MN and the SN, the MN provides X2-U TNL address information for the respective E-RAB, X2-U DL TNL address information for SN terminated bearers, X2-U UL TNL address information for MN terminated bearers. In case of SN terminated split bearers the MN provides the maximum QoS level that it can support. The SN may reject the request.

NOTE 1: For split bearers, MCG and SCG resources may be requested of such an amount, that the QoS for the respective E-RAB is guaranteed by the exact sum of resources provided by the MCG and the SCG together, or even more. For MN terminated split bearers, the MN's decision is reflected in step 1 by the E-RAB parameters signalled to the SN, which may differ from E-RAB parameters received over S1.

NOTE 2: For a specific E-RAB, the MN may request the direct establishment of an SCG or a split bearer, i.e., without first having to establish an MCG bearer. It is also allowed that all E-RABs can be configured as SN terminated bearers, i.e. there is no E-RAB established as an MN terminated bearer.

2. If the RRM entity in the SN is able to admit the resource request, it allocates respective radio resources and, dependent on the bearer option, respective transport network resources. For bearers requiring SCG radio resources, the SN triggers Random Access so that synchronisation of the SN radio resource configuration can be performed. The SN decides the PSCell and other SCG SCells and provides the new SCG radio resource configuration to the MN in a *NR RRC configuration* message contained in the *SgNB Addition Request Acknowledge* message. In case of bearer options that require X2-U resources between the MN and the SN, the SN provides X2-U TNL address information for the respective E-RAB, X2-U UL TNL address information for SN terminated bearers, X2-U DL TNL address information for MN terminated bearers. For SN terminated bearers, the SN provides the S1-U DL TNL address information for the respective E-RAB and security algorithm. If SCG radio resources have been requested, the SCG radio resource configuration is provided.

NOTE 3: For the SN terminated split bearer option, the SN may either decide to request resources from the MN of such an amount, that the QoS for the respective E-RAB is guaranteed by the exact sum of resources provided by the MN and the SN together, or even more. The SN's decision is reflected in step 2 by the E-RAB parameters signalled to the MN, which may differ from E-RAB parameters received in step 1. The QoS level requested from the MN shall not exceed the level that the MN offered when setting up the split bearer in step 1.

NOTE 4: In case of MN terminated bearers, transmission of user plane data may take place after step 2.

NOTE 5: In case of SN terminated bearers, data forwarding and the SN Status Transfer may take place after step 2.

3. The MN sends to the UE the *RRCConnectionReconfiguration* message including the NR RRC configuration message, without modifying it.
4. The UE applies the new configuration and replies to MN with *RRCConnectionReconfigurationComplete* message, including a NR RRC response message, if needed. In case the UE is unable to comply with (part of) the configuration included in the *RRCConnectionReconfiguration* message, it performs the reconfiguration failure procedure.
5. The MN informs the SN that the UE has completed the reconfiguration procedure successfully via *SgNB ReconfigurationComplete* message, including the encoded NR RRC response message, if received from the UE.
6. If configured with bearers requiring SCG radio resources, the UE performs synchronisation towards the PSCell of the SN. The order the UE sends the *RRCConnectionReconfigurationComplete* message and performs the Random Access procedure towards the SCG is not defined. The successful RA procedure towards the SCG is not required for a successful completion of the RRC Connection Reconfiguration procedure.
7. In case of SN terminated bearers using RLC AM, the MN sends SN Status Transfer.
8. In case of SN terminated bearers using RLC AM, and dependent on the bearer characteristics of the respective E-RAB, the MN may take actions to minimise service interruption due to activation of EN-DC (Data forwarding).
- 9-12. For SN terminated bearers, the update of the UP path towards the EPC is performed.

10.2.2 MR-DC with 5GC

The Secondary Node (SN) Addition procedure is initiated by the MN and is used to establish a UE context at the SN in order to provide resources from the SN to the UE. For bearers requiring SCG radio resources, this procedure is used to add at least the initial SCG serving cell of the SCG. This procedure can also be used to configure an SN terminated MCG bearer (where no SCG configuration is needed). Figure 10.2.2-1 shows the SN Addition procedure.

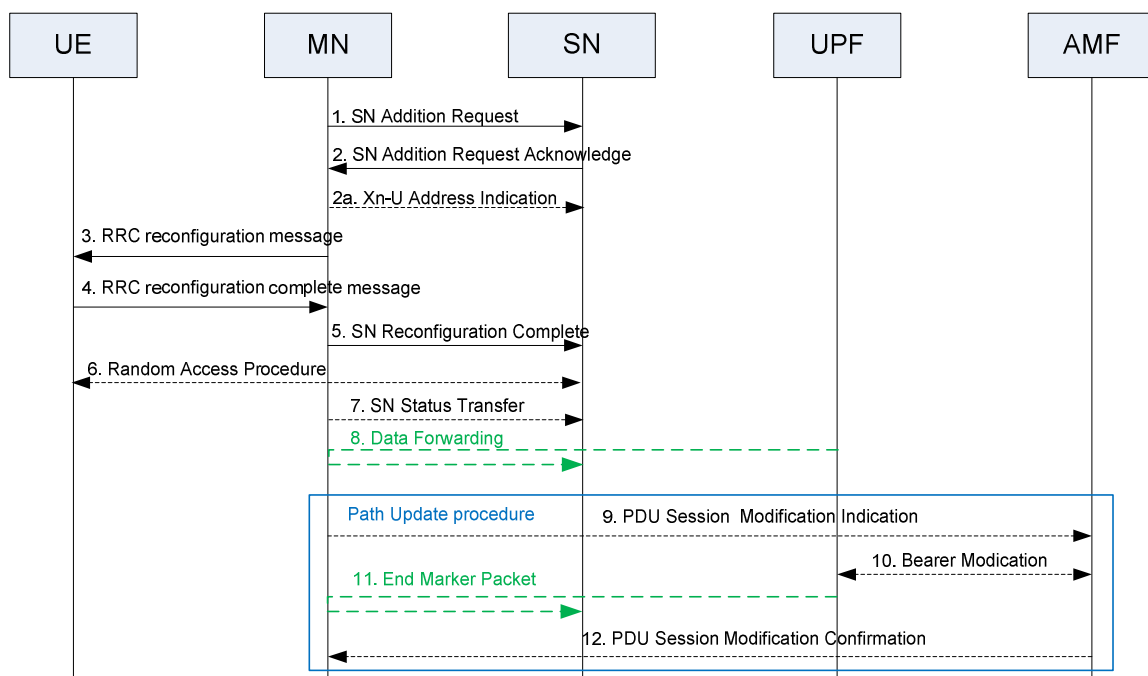

Figure 10.2.2-1: SN Addition procedure

1. The MN decides to request the target SN to allocate resources for one or more specific PDU Sessions/QoS Flows, indicating QoS Flows characteristics (QoS Flow Level QoS parameters, PDU session level TNL address information, and PDU session level Network Slice info). In addition, for bearers requiring SCG radio resources, MN indicates the requested SCG configuration information, including the entire UE capabilities and the UE

capability coordination result. In this case, the MN also provides the latest measurement results for SN to choose and configure the SCG cell(s). The MN may request the SN to allocate radio resources for split SRB operation. In NGEN-DC and NR-DC, the MN always provides all the needed security information to the SN (even if no SN terminated bearers are setup) to enable SRB3 to be setup based on SN decision.

For MN terminated bearer options that require Xn-U resources between the MN and the SN, the MN provides Xn-U UL TNL address information. For SN terminated bearers, the MN provides a list of available DRB IDs. The S-NG-RAN node shall store this information and use it when establishing SN terminated bearers. The SN may reject the request.

For SN terminated bearer options that require Xn-U resources between the MN and the SN, the MN provides in step 1 a list of QoS flows per PDU Sessions for which SCG resources are requested to be setup upon which the SN decides how to map QoS flows to DRB.

NOTE 1: For split bearers, MCG and SCG resources may be requested of such an amount, that the QoS for the respective QoS Flow is guaranteed by the exact sum of resources provided by the MCG and the SCG together, or even more. For MN terminated split bearers, the MN decision is reflected in step 1 by the QoS Flow parameters signalled to the SN, which may differ from QoS Flow parameters received over NG.

NOTE 2: For a specific QoS flow, the MN may request the direct establishment of SCG and/or split bearers, i.e. without first having to establish MCG bearers. It is also allowed that all QoS flows can be mapped to SN terminated bearers, i.e. there is no QoS flow mapped to an MN terminated bearer.

2. If the RRM entity in the SN is able to admit the resource request, it allocates respective radio resources and, dependent on the bearer type options, respective transport network resources. For bearers requiring SCG radio resources the SN triggers UE Random Access so that synchronisation of the SN radio resource configuration can be performed. The SN decides for the PSCell and other SCG SCells and provides the new SCG radio resource configuration to the MN within an SN RRC configuration message contained in the *SN Addition Request Acknowledge* message. In case of bearer options that require Xn-U resources between the MN and the SN, the SN provides Xn-U TNL address information for the respective DRB, Xn-U UL TNL address information for SN terminated bearers, Xn-U DL TNL address information for MN terminated bearers. For SN terminated bearers, the SN provides the NG-U DL TNL address information for the respective PDU Session and security algorithm. If SCG radio resources have been requested, the SCG radio resource configuration is provided.

NOTE 3: In case of MN terminated bearers, transmission of user plane data may take place after step 2.

NOTE 4: In case of SN terminated bearers, data forwarding and the SN Status Transfer may take place after step 2.

NOTE 5: For MN terminated NR SCG bearers for which PDCP duplication with CA is configured the MN allocates 2 separate Xn-U bearers.

For SN terminated NR MCG bearers for which PDCP duplication with CA is configured the SN allocates 2 separate Xn-U bearers.

2a. For SN terminated bearers using MCG resources, the MN provides Xn-U DL TNL address information in the *Xn-U Address Indication* message.

3. The MN sends the *MN RRC reconfiguration* message to the UE including the SN RRC configuration message, without modifying it.

4. The UE applies the new configuration and replies to MN with *MN RRC reconfiguration complete* message, including an SN RRC response message for SN, if needed. In case the UE is unable to comply with (part of) the configuration included in the *MN RRC reconfiguration* message, it performs the reconfiguration failure procedure.

5. The MN informs the SN that the UE has completed the reconfiguration procedure successfully via *SN Reconfiguration Complete* message, including the SN RRC response message, if received from the UE.

6. If configured with bearers requiring SCG radio resources, the UE performs synchronisation towards the PSCell configured by the SN. The order the UE sends the *MN RRC reconfiguration complete* message and performs the Random Access procedure towards the SCG is not defined. The successful RA procedure towards the SCG is not required for a successful completion of the RRC Connection Reconfiguration procedure.

7. In case of SN terminated bearers using RLC AM, the MN sends SN Status Transfer.

8. In case of SN terminated bearers using RLC AM, and dependent on the bearer characteristics of the respective QoS Flows, the MN may take actions to minimise service interruption due to activation of MR-DC (Data forwarding).
- 9-12. For SN terminated bearers, the update of the UP path towards the 5GC is performed via PDU Session Path Update procedure.

10.3 Secondary Node Modification (MN/SN initiated)

10.3.1 EN-DC

The Secondary Node Modification procedure may be initiated either by the MN or by the SN and be used to modify, establish or release bearer contexts, to transfer bearer contexts to and from the SN or to modify other properties of the UE context within the same SN. It may also be used to transfer an NR RRC message from the SN to the UE via the MN and the response from the UE via MN to the SN (e.g. when SRB3 is not used).

The Secondary Node modification procedure does not necessarily need to involve signalling towards the UE.

MN initiated SN Modification

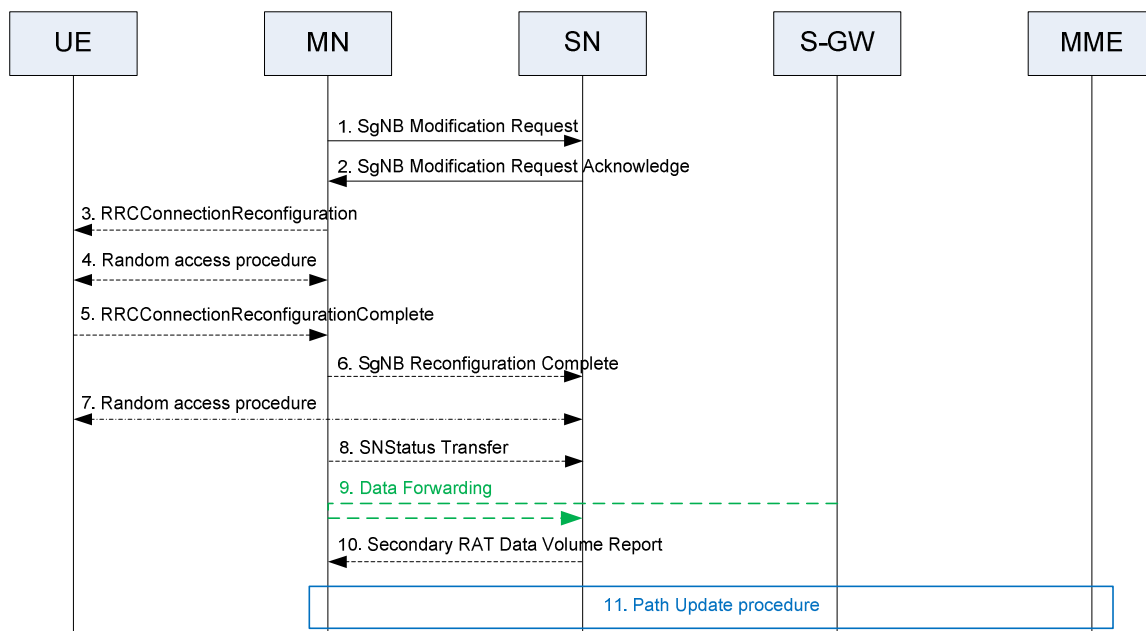

Figure 10.3.1-1: SN Modification procedure - MN initiated

The MN uses the procedure to initiate configuration changes of the SCG within the same SN, e.g. the addition, modification or release of SCG bearer(s) and the SCG RLC bearer of split bearer(s), as well as configuration changes for SN terminated MCG bearers. Bearer termination point change is realized by adding the new bearer configuration and releasing the old bearer configuration within a single MN initiated SN Modification procedure for the respective E-RAB. The MN uses this procedure to perform handover within the same MN while keeping the SN. The MN also uses the procedure to query the current SCG configuration, e.g. when delta configuration is applied in an MN initiated SN change. The MN also uses the procedure to provide the S-RLF related information to the SN. The MN may not use the procedure to initiate the addition, modification or release of SCG SCells. The SN may reject the request, except if it concerns the release of SN terminated bearer(s) or the SCG RLC bearer of MN terminated bearer(s), or if it is used to perform handover within the same MN while keeping the SN. Figure 10.3.1-1 shows an example signalling flow for an MN initiated SN Modification procedure.

1. The MN sends the *SgNB Modification Request* message, which may contain bearer context related or other UE context related information, data forwarding address information (if applicable) and the requested SCG configuration information, including the UE capability coordination result to be used as basis for the reconfiguration by the SN. In case a security key update in the SN is required, a new *SgNB Security Key* is included. In case of SCG RLC re-establishment for E-RABs configured with an MN terminated bearer with an

SCG RLC bearer for which no bearer type change is performed, the MN provides a new UL GTP tunnel endpoint to the SN. The SN shall continue sending UL PDCP PDUs to the MN with the previous UL GTP tunnel endpoint until it re-establishes the RLC and use the new UL GTP tunnel endpoint after re-establishment. In case of PDCP re-establishment for E-RABs configured with an SN terminated bearer with an MCG RLC bearer for which no bearer type change is performed, the MN provides a new DL GTP tunnel endpoint to the SN. The SN shall continue sending DL PDCP PDUs to the MN with the previous DL GTP tunnel endpoint until it performs PDCP re-establishment and use the new DL GTP tunnel endpoint starting with the PDCP re-establishment.

2. The SN responds with the *SgNB Modification Request Acknowledge* message, which may contain SCG radio resource configuration information within a NR RRC configuration message and data forwarding address information (if applicable). In case of a security key update (with or without PSCell change), for E-RABs configured with the MN terminated bearer option that require X2-U resources between the MN and the SN, for which no bearer type change is performed, the SN provides a new DL GTP tunnel endpoint to the MN. The MN shall continue sending DL PDCP PDUs to the SN with the previous DL GTP tunnel endpoint until it performs PDCP re-establishment or PDCP data recovery, and use the new DL GTP tunnel endpoint starting with the PDCP re-establishment or data recovery. In case of a security key update (with or without PSCell change), for E-RABs configured with the SN terminated bearer option that require X2-U resources between the MN and the SN, for which no bearer type change is performed, the SN provides a new UL GTP tunnel endpoint to the MN. The MN shall continue sending UL PDCP PDUs to the SN with the previous UL GTP tunnel endpoint until it re-establishes the RLC and use the new UL GTP tunnel endpoint after re-establishment.
- 3-5. The MN initiates the RRC connection reconfiguration procedure, including the NR RRC configuration message. The UE applies the new configuration, synchronizes to the MN (if instructed, in case of intra-MN handover) and replies with *RRCConnectionReconfigurationComplete*, including a NR RRC response message, if needed. In case the UE is unable to comply with (part of) the configuration included in the *RRCConnectionReconfiguration* message, it performs the reconfiguration failure procedure.
6. Upon successful completion of the reconfiguration, the success of the procedure is indicated in the *SgNB Reconfiguration Complete* message.
7. If instructed, the UE performs synchronisation towards the PSCell of the SN as described in SgNB addition procedure. Otherwise, the UE may perform UL transmission after having applied the new configuration.
8. If PDCP termination point is changed for bearers using RLC AM, and when RRC full configuration is not used, the MN sends the SN Status transfer.
9. If applicable, data forwarding between MN and the SN takes place (Figure 10.3.1-1 depicts the case where a bearer context is transferred from the MN to the SN).
10. The SN sends the *Secondary RAT Data Usage Report* message to the MN and includes the data volumes delivered to and received from the UE over the NR radio for the E-RABs to be released and for the E-RABs for which the S1 UL GTP Tunnel endpoint was requested to be modified.

NOTE 1: The order the SN sends the *Secondary RAT Data Usage Report* message and performs data forwarding with MN is not defined. The SN may send the report when the transmission of the related bearer is stopped.

11. If applicable, a path update is performed.

SN initiated SN Modification with MN involvement

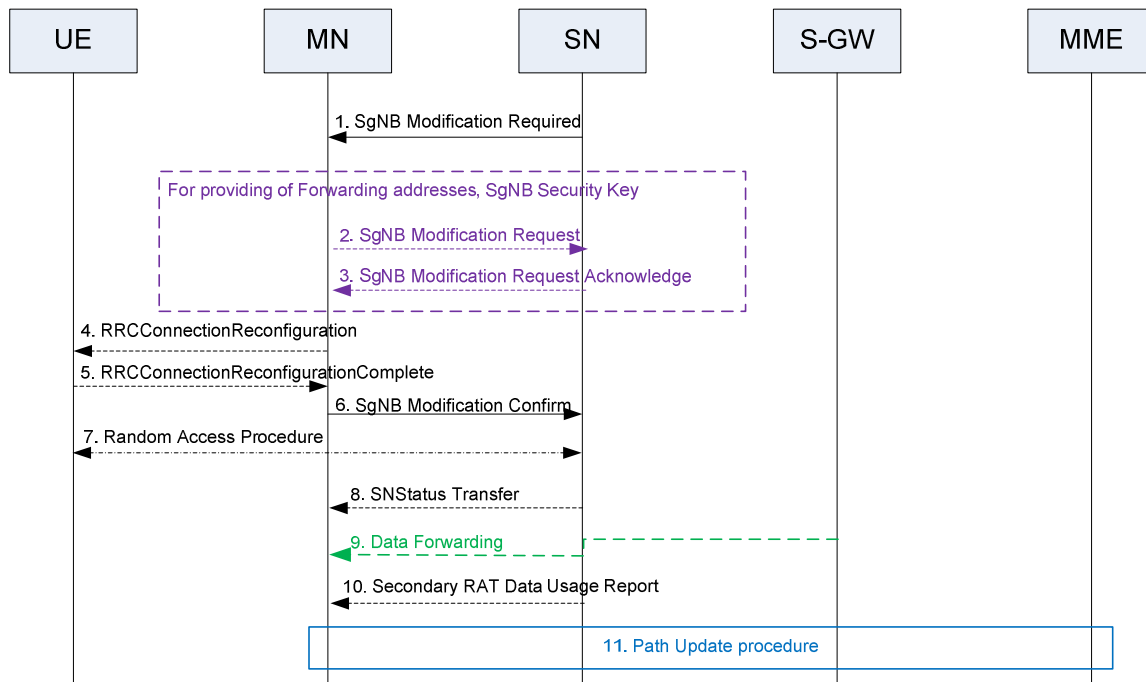

Figure 10.3.1-2: SN Modification procedure - SN initiated with MN involvement

The SN uses the procedure to perform configuration changes of the SCG within the same SN, e.g. to trigger the release of SCG bearer(s) and the SCG RLC bearer of split bearer(s) (upon which the MN may release the bearer or maintain current bearer type or reconfigure it to an MCG bearer, either MN terminated or SN terminated), and to trigger PSCell change (e.g. when a new security key is required or when the MN needs to perform PDCP data recovery). The MN cannot reject the release request of SCG bearer and the SCG RLC bearer of a split bearer. Figure 10.3.1-2 shows an example signalling flow for an SN initiated SgNB Modification procedure, with MN involvement.

1. The SN sends the *SgNB Modification Required* message including a NR RRC configuration message, which may contain bearer context related, other UE context related information and the new SCG radio resource configuration. For bearer release or modification, a corresponding E-RAB list is included in the *SgNB Modification Required* message. In case of change of security key, the *PDCP Change Indication* indicates that a $S\text{-}K_{\text{SgNB}}$ update is required. In case the MN needs to perform PDCP data recovery, the *PDCP Change Indication* indicates that PDCP data recovery is required.

The SN can decide whether the change of security key is required.

- 2/3. The MN initiated SN Modification procedure may be triggered by the *SN Modification Required* message (e.g. to provide information such as data forwarding addresses, new SN security key, measurement gap, etc...)

NOTE 2: If only SN security key is provided in step 2, the MN does not need to wait for the reception of step 3 to initiate the RRC connection reconfiguration procedure.

4. The MN sends the *RRCConnectionReconfiguration* message including a NR RRC configuration message to the UE including the new SCG radio resource configuration.
5. The UE applies the new configuration and sends the *RRCConnectionReconfigurationComplete* message, including an encoded NR RRC response message, if needed. In case the UE is unable to comply with (part of) the configuration included in the *RRCConnectionReconfiguration* message, it performs the reconfiguration failure procedure.
6. Upon successful completion of the reconfiguration, the success of the procedure is indicated in the *SgNB Modification Confirm* message containing the encoded NR RRC response message, if received from the UE.

7. If instructed, the UE performs synchronisation towards the PSCell of the SN as described in SN addition procedure. Otherwise, the UE may perform UL transmission after having applied the new configuration.
8. If PDCP termination point is changed for bearers using RLC AM, and when RRC full configuration is not used, the SN sends the MN Status transfer.
9. If applicable, data forwarding between MN and the SN takes place (Figure 10.3.1-2 depicts the case where a bearer context is transferred from the SN to the MN).
10. The SN sends the *Secondary RAT Data Usage Report* message to the MN and includes the data volumes delivered to and received from the UE over the NR radio for the E-RABs to be released.

NOTE 3: The order the SN sends the *Secondary RAT Data Usage Report* message and performs data forwarding with MN is not defined. The SN may send the report when the transmission of the related bearer is stopped.

11. If applicable, a path update is performed.

SN initiated SN Modification without MN involvement

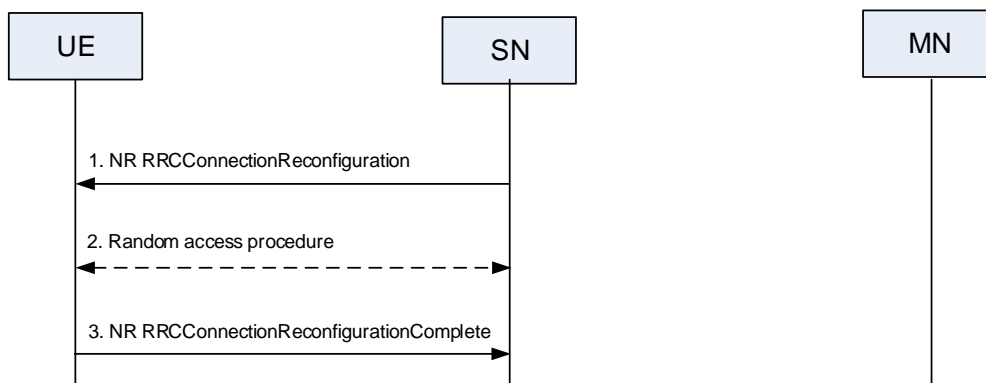

Figure 10.3.1-3: SN modification - SN initiated without MN involvement

The SN initiated modification without MN involved procedure is used to modify the configuration within SN in case no coordination with MN is required, including the addition/modification/release of SCG SCell and PSCell change (e.g. when the security key does not need to be changed and the MN does not need to be involved in PDCP recovery). Figure 10.3.1-3 shows an example signalling flow for SN initiated SN modification procedure, without MN involvement. The SN can decide whether the Random Access procedure is required.

1. The SN sends the *RRCConnectionReconfiguration* message to the UE through SRB3. The UE applies the new configuration. In case the UE is unable to comply with (part of) the configuration included in the *RRCConnectionReconfiguration* message, it performs the reconfiguration failure procedure.
2. If instructed, the UE performs synchronisation towards the PSCell of the SN.
3. The UE replies with the *RRCConnectionReconfigurationComplete* message.

Transfer of an NR RRC message to/from the UE (when SRB3 is not used)

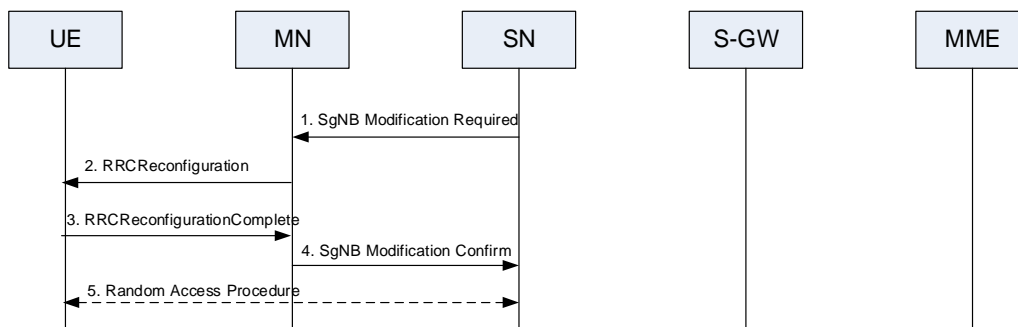

Figure 10.3.1-4: Transfer of an NR RRC message to/from the UE

The SN initiates the procedure when it needs to transfer an NR RRC message to the UE and SRB3 is not used.

1. The SN initiates the procedure by sending the *SgNB Modification Required* to the MN.
2. The MN forwards the NR RRC message to the UE in the *RRCConnectionReconfiguration* message.
3. The UE applies the new configuration and replies with the *RRCConnectionReconfigurationComplete* message.
4. The MN forwards the NR RRC response message, if received from the UE, to the SN in the *SgNB Modification Confirm* message.
5. If instructed, the UE performs synchronisation towards the PSCell of the SN as described in *SgNB Addition* procedure. Otherwise the UE may perform UL transmission after having applied the new configuration.

10.3.2 MR-DC with 5GC

The SN Modification procedure may be initiated either by the MN or by the SN and be used to modify the current user plane resource configuration (e.g. related to PDU session, QoS flow or DRB) or to modify other properties of the UE context within the same SN. It may also be used to transfer an RRC message from the SN to the UE via the MN and the response from the UE via MN to the SN (e.g. when SRB3 is not used). In NGEN-DC and NR-DC, the RRC message is an NR message (i.e., *RRCReconfiguration*) whereas in NE-DC it is an E-UTRA message (i.e., *RRCConnectionReconfiguration*).

The SN modification procedure does not necessarily need to involve signalling towards the UE.

MN initiated SN Modification

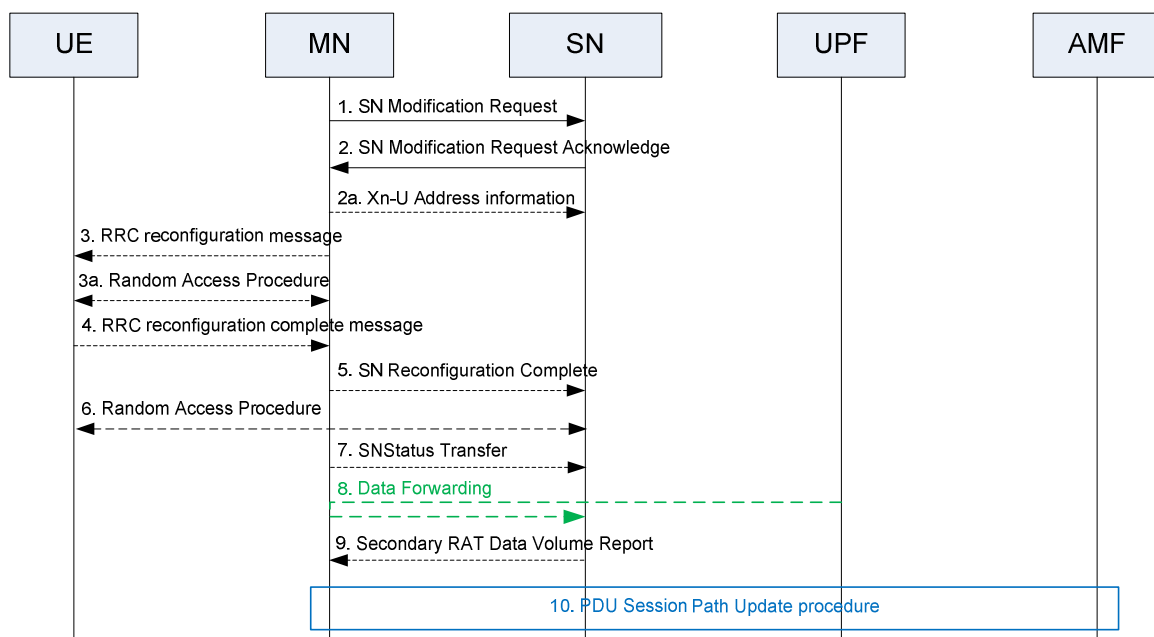

Figure 10.3.2-1: SN Modification procedure - MN initiated

The MN uses the procedure to initiate configuration changes of the SCG within the same SN, including addition, modification or release of the user plane resource configuration. The MN uses this procedure to perform handover within the same MN while keeping the SN, when the SN needs to be involved (i.e. in NGEN-DC). The MN also uses the procedure to query the current SCG configuration, e.g. when delta configuration is applied in an MN initiated SN change. The MN also uses the procedure to provide the S-RLF related information to the SN or to provide additional available DRB IDs to be used for SN terminated bearers. The MN may not use the procedure to initiate the addition, modification or release of SCG SCells. The SN may reject the request, except if it concerns the release of the user plane resource configuration, or if it is used to perform handover within the same MN while keeping the SN. Figure 10.3.2-1 shows an example signalling flow for an MN initiated SN Modification procedure.

1. The MN sends the *SN Modification Request* message, which may contain user plane resource configuration related or other UE context related information, data forwarding address information (if applicable), PDU session level Network Slice info and the requested SCG configuration information, including the UE capabilities

coordination result to be used as basis for the reconfiguration by the SN. In case a security key update in the SN is required, a new *SN Security Key* is included.

2. The SN responds with the *SN Modification Request Acknowledge* message, which may contain new SCG radio configuration information within an SN RRC reconfiguration message, and data forwarding address information (if applicable).

NOTE 1: For MN terminated NR SCG bearers to be setup for which PDCP duplication with CA is configured the MN allocates 2 separate Xn-U bearers

For SN terminated NR MCG bearers to be setup for which PDCP duplication with CA is configured the SN allocates 2 separate Xn-U bearers.

- 2a. For SN terminated MCG bearers, the MN provides Xn-U DL TNL address information in the *Xn-U Address Indication* message.
- 3/4. The MN initiates the RRC reconfiguration procedure, including an *SN RRC reconfiguration* message. The UE applies the new configuration, synchronizes to the MN (if instructed, in case of intra-MN handover) and replies with *MN RRC reconfiguration complete* message, including an SN RRC response message, if needed. In case the UE is unable to comply with (part of) the configuration included in the *MN RRC reconfiguration* message, it performs the reconfiguration failure procedure.
5. Upon successful completion of the reconfiguration, the success of the procedure is indicated in the *SN Reconfiguration Complete* message.
6. If instructed, the UE performs synchronisation towards the PSCell of the SN as described in SN addition procedure. Otherwise, the UE may perform UL transmission after having applied the new configuration.
7. If PDCP termination point is changed for bearers using RLC AM, and when RRC full configuration is not used, the MN sends the SN Status transfer.
8. If applicable, data forwarding between MN and the SN takes place (Figure 10.3.2-1 depicts the case where a user plane resource configuration related context is transferred from the MN to the SN).
9. The SN sends the *Secondary RAT Data Usage Report* message to the MN and includes the data volumes delivered to and received from the UE as described in clause 10.11.2.

NOTE 2: The order the SN sends the *Secondary RAT Data Usage Report* message and performs data forwarding with MN is not defined. The SN may send the report when the transmission of the related QoS flow is stopped.

10. If applicable, a PDU Session path update procedure is performed.

SN initiated SN Modification with MN involvement

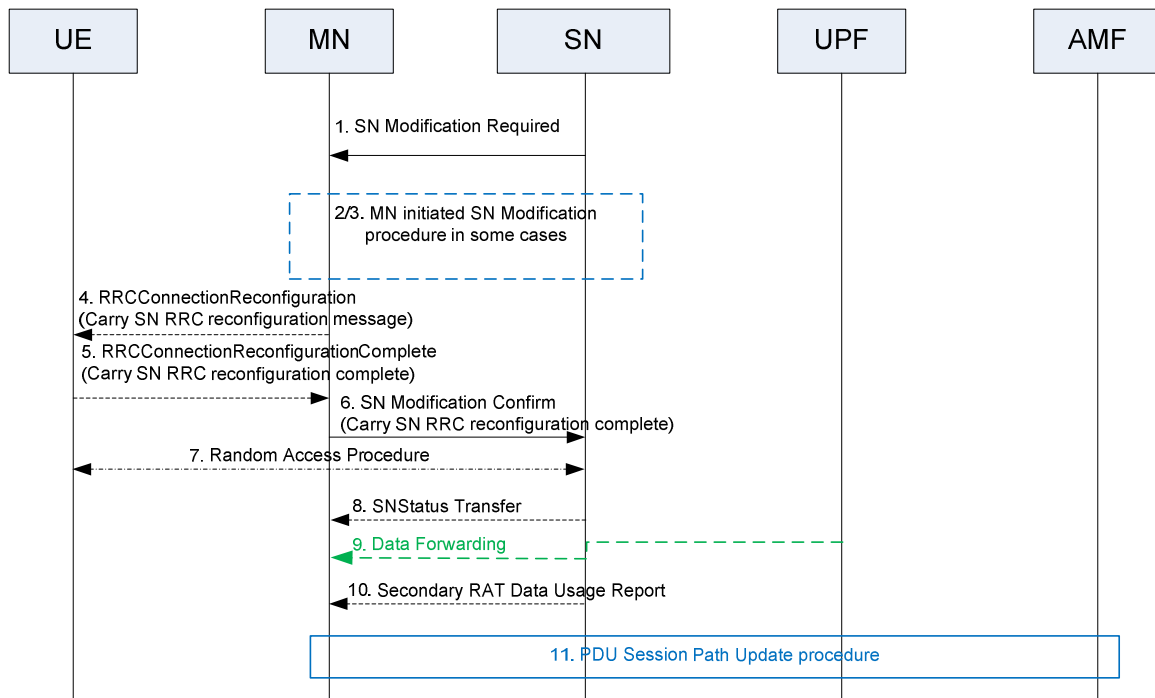

Figure 10.3.2-2: SN Modification procedure - SN initiated with MN involvement

The SN uses the procedure to perform configuration changes of the SCG within the same SN, e.g. to trigger the modification/release of the user plane resource configuration and to trigger PSCell changes (e.g. when a new security key is required or when the MN needs to perform PDCP data recovery). The MN cannot reject the release request of PDU session/QoS flows. The SN also uses the procedure to request the MN to provide more DRB IDs to be used for SN terminated bearers or to return DRB IDs used for SN terminated bearers that are not needed any longer. Figure 10.3.2-2 shows an example signalling flow for SN initiated SN Modification procedure.

1. The SN sends the *SN Modification Required* message including an SN RRC reconfiguration message, which may contain user plane resource configuration related context, other UE context related information and the new radio resource configuration of SCG. In case of change of security key, the *PDCP Change Indication* indicates that an SN security key update is required. In case the MN needs to perform PDCP data recovery, the *PDCP Change Indication* indicates that PDCP data recovery is required.

The SN can decide whether the change of security key is required.

- 2/3. The MN initiated SN Modification procedure may be triggered by *SN Modification Required* message, e.g. when an SN security key change needs to be applied.

NOTE 3: For SN terminated NR MCG bearers to be setup for which PDCP duplication with CA is configured the SN allocates 2 separate Xn-U bearers.

4. The MN sends the *MN RRC reconfiguration* message to the UE including the SN RRC reconfiguration message with the new SCG radio resource configuration.
5. The UE applies the new configuration and sends the *MN RRC reconfiguration complete* message, including an SN RRC response message, if needed. In case the UE is unable to comply with (part of) the configuration included in the *MN RRC reconfiguration* message, it performs the reconfiguration failure procedure.
6. Upon successful completion of the reconfiguration, the success of the procedure is indicated in the *SN Modification Confirm* message including the SN RRC response message, if received from the UE.
7. If instructed, the UE performs synchronisation towards the PSCell configured by the SN as described in SN Addition procedure. Otherwise, the UE may perform UL transmission directly after having applied the new configuration.
8. If PDCP termination point is changed for bearers using RLC AM, and when RRC full configuration is not used, the SN sends the MN Status transfer.

- 9. If applicable, data forwarding between MN and the SN takes place (Figure 10.3.2-2 depicts the case where a user plane resource configuration related context is transferred from the SN to the MN).
 - 10. The SN sends the *Secondary RAT Data Usage Report* message to the MN and includes the data volumes delivered to and received from the UE as described in clause 10.11.2.
- NOTE 4: The order the SN sends the *Secondary RAT Data Usage Report* message and performs data forwarding with MN is not defined. The SN may send the report when the transmission of the related QoS flow is stopped.
- 11. If applicable, a PDU Session path update procedure is performed.

SN initiated SN Modification without MN involvement

This procedure is not supported for NE-DC.

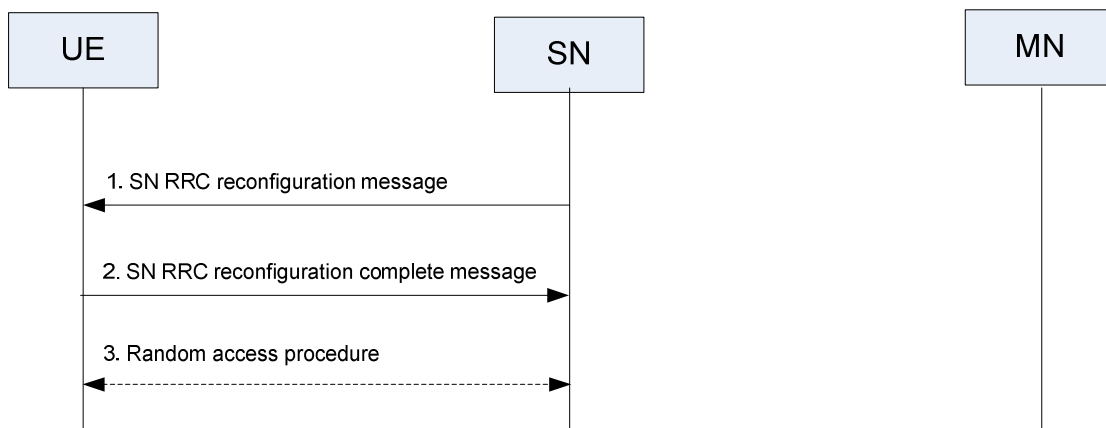

Figure 10.3.2-3: SN Modification – SN initiated without MN involvement

The SN initiated SN modification procedure without MN involvement is used to modify the configuration within SN in case no coordination with MN is required, including the addition/modification/release of SCG SCell and PSCell change (e.g. when the security key does not need to be changed and the MN does not need to be involved in PDCP recovery). Figure 10.3.2-3 shows an example signalling flow for SN initiated SN modification procedure without MN involvement. The SN can decide whether the Random Access procedure is required.

- 1. The SN sends the *SN RRC reconfiguration* message to the UE through SRB3.
- 2. The UE applies the new configuration and replies with the *SN RRC reconfiguration complete* message. In case the UE is unable to comply with (part of) the configuration included in the *SN RRC reconfiguration* message, it performs the reconfiguration failure procedure.
- 3. If instructed, the UE performs synchronisation towards the PSCell of the SN as described in SN Addition procedure. Otherwise the UE may perform UL transmission after having applied the new configuration.

Transfer of an NR RRC message to/from the UE (when SRB3 is not used)

This procedure is supported for all the MR-DC options.

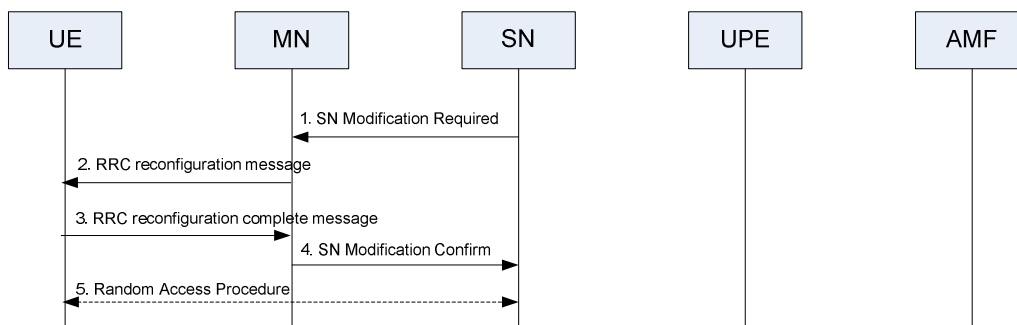

Figure 10.3.2-4: Transfer of an NR RRC message to/from the UE

The SN initiates the procedure when it needs to transfer an NR RRC message to the UE and SRB3 is not used.

1. The SN initiates the procedure by sending the *SN Modification Required* to the MN including the SN RRC reconfiguration message.
2. The MN forwards the SN RRC reconfiguration message to the UE including it in the *RRC reconfiguration* message.
3. The UE applies the new configuration and replies with the *RRC reconfiguration complete* message by including the SN RRC reconfiguration complete message.
4. The MN forwards the SN RRC response message, if received from the UE, to the SN by including it in the *SN Modification Confirm* message.
5. If instructed, the UE performs synchronisation towards the PSCell of the SN as described in SN Addition procedure. Otherwise the UE may perform UL transmission after having applied the new configuration.

10.4 Secondary Node Release (MN/SN initiated)

10.4.1 EN-DC

The Secondary Node Release procedure may be initiated either by the MN or by the SN and is used to initiate the release of the UE context at the SN. The recipient node of this request can reject it, e.g., if a SN change procedure is triggered by the SN.

It does not necessarily need to involve signalling towards the UE, e.g., in case of the RRC connection re-establishment due to Radio Link Failure in MN.

MN initiated SN Release

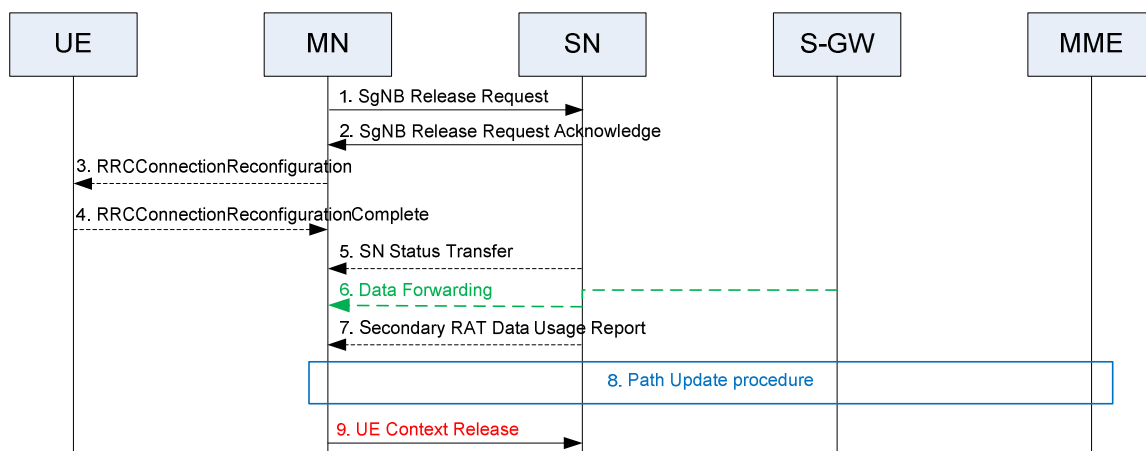

Figure 10.4.1-1: SN Release procedure – MN initiated

Figure 10.4.1-1 shows an example signalling flow for the MN initiated Secondary Node Release procedure when SN Release is confirmed by SN.

1. The MN initiates the procedure by sending the *SgNB Release Request* message. If data forwarding is requested, the MN provides data forwarding addresses to the SN.
2. The SN confirms SN Release by sending the *SgNB Release Request Acknowledge* message. If appropriate, the SN may reject SN Release, e.g. if the SN change procedure is triggered by the SN.
- 3/4. If required, the MN indicates in the *RRCConnectionReconfiguration* message towards the UE that the UE shall release the entire SCG configuration. In case the UE is unable to comply with (part of) the configuration included in the *RRCConnectionReconfiguration* message, it performs the reconfiguration failure procedure.

NOTE 1: If data forwarding is applied, timely coordination between steps 1 and 2 may minimize gaps in service provision, this is however regarded to be an implementation matter.

5. If the released bearers use RLC AM, the SN sends the SN Status transfer.
6. Data forwarding from the SN to the MN may start.
7. The SN sends the *Secondary RAT Data Usage Report* message to the MN and includes the data volumes delivered to and received from the UE over the NR radio for the related E-RABs.

NOTE 2: If data forwarding is applied, the order the SN sends the *Secondary RAT Data Usage Report* message and starts data forwarding with MN is not defined i.e., step 7 can take place before step 6. The SN does not need to wait for the end of data forwarding to send the *Secondary RAT Data Usage Report* message.

8. If applicable, the path update procedure is initiated.
9. Upon reception of the *UE Context Release* message, the SN can release radio and C-plane related resource associated to the UE context. Any ongoing data forwarding may continue.

SN initiated SN Release

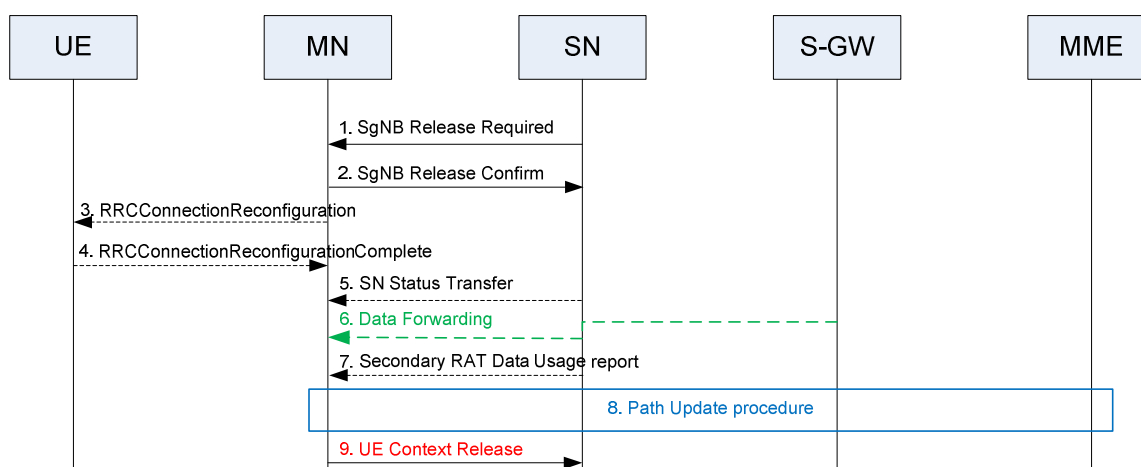

Figure 10.4.1-2: SN Release procedure – SN initiated

Figure 10.4.1-2 shows an example signalling flow for the SN initiated Secondary Node Release procedure.

1. The SN initiates the procedure by sending the *SgNB Release Required* message which does not contain inter-node message.
2. If data forwarding is requested, the MN provides data forwarding addresses to the SN in the *SgNB Release Confirm* message. The SN may start data forwarding and stop providing user data to the UE as early as it receives the *SgNB Release Confirm* message.
- 3/4. If required, the MN indicates in the *RRCConnectionReconfiguration* message towards the UE that the UE shall release the entire SCG configuration. In case the UE is unable to comply with (part of) the configuration included in the *RRCConnectionReconfiguration* message, it performs the reconfiguration failure procedure.

NOTE 3: If data forwarding is applied, timely coordination between steps 2 and 3 may minimize gaps in service provision. This is however regarded to be an implementation matter.

5. If the released bearers use RLC AM, the SN sends the SN Status transfer.
6. Data forwarding from the SN to the MN may start.
7. The SN sends the *Secondary RAT Data Usage Report* message to the MN and includes the data volumes delivered to and received from the UE over the NR radio for the related E-RABs.

NOTE 4: If data forwarding is applied, the order the SN sends the *Secondary RAT Data Usage Report* message and starts data forwarding with MN is not defined i.e., step 7 can take place before step 6. The SN does not need to wait for the end of data forwarding to send the *Secondary RAT Data Usage Report* message.

8. If applicable, the path update procedure is initiated.

9. Upon reception of the *UE Context Release* message, the SN can release radio and C-plane related resource associated to the UE context. Any ongoing data forwarding may continue.

10.4.2 MR-DC with 5GC

The SN Release procedure may be initiated either by the MN or by the SN and is used to initiate the release of the UE context and relevant resources at the SN. The recipient node of this request can reject it, e.g., if an SN change procedure is triggered by the SN.

MN initiated SN Release

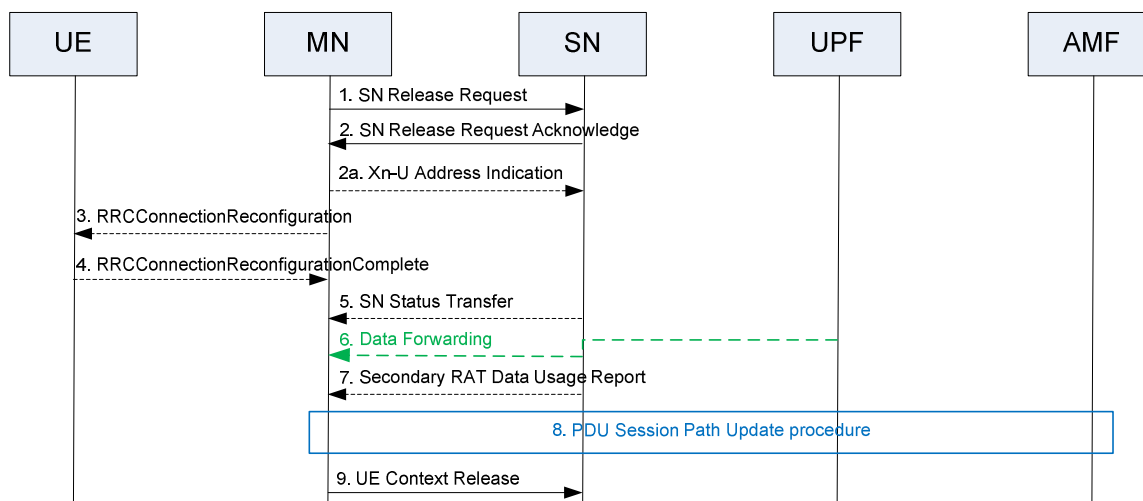

Figure 10.4.2-1: SN release procedure - MN initiated

Figure 10.4.2-1 shows an example signalling flow for the MN initiated SN Release procedure.

1. The MN initiates the procedure by sending the *SN Release Request* message.
2. The SN confirms SN Release by sending the *SN Release Request Acknowledge* message. If appropriate, the SN may reject SN Release, e.g., if the SN change procedure is triggered by the SN.
- 2a. When applicable, the MN provides forwarding address information to the SN.

NOTE 0: The MN may send the *Data Forwarding Address Indication* message to provide forwarding address information before step 2.

- 3/4. If required, the MN indicates in the *MN RRC reconfiguration* message towards the UE that the UE shall release the entire SCG configuration. In case the UE is unable to comply with (part of) the configuration included in the *MN RRC reconfiguration* message, it performs the reconfiguration failure procedure.

NOTE 1: If data forwarding is applied, timely coordination between steps 1 and 2 may minimize gaps in service provision, this is however regarded to be an implementation matter.

5. If the released bearers use RLC AM, the SN sends the *SN Status transfer*.
6. Data forwarding from the SN to the MN may start.
7. The SN sends the *Secondary RAT Data Usage Report* message to the MN and includes the data volumes delivered to and received from the UE as described in clause 10.11.2.

NOTE 1a: If data forwarding is applied, the order the SN sends the *Secondary RAT Data Usage Report* message and starts data forwarding with MN is not defined i.e., step 7 can take place before step 6. The SN does not need to wait for the end of data forwarding to send the *Secondary RAT Data Usage Report* message.

8. If applicable, the PDU Session path update procedure is initiated.
9. Upon reception of the *UE Context Release* message, the SN can release radio and C-plane related resource associated to the UE context. Any ongoing data forwarding may continue.

SN initiated SN Release

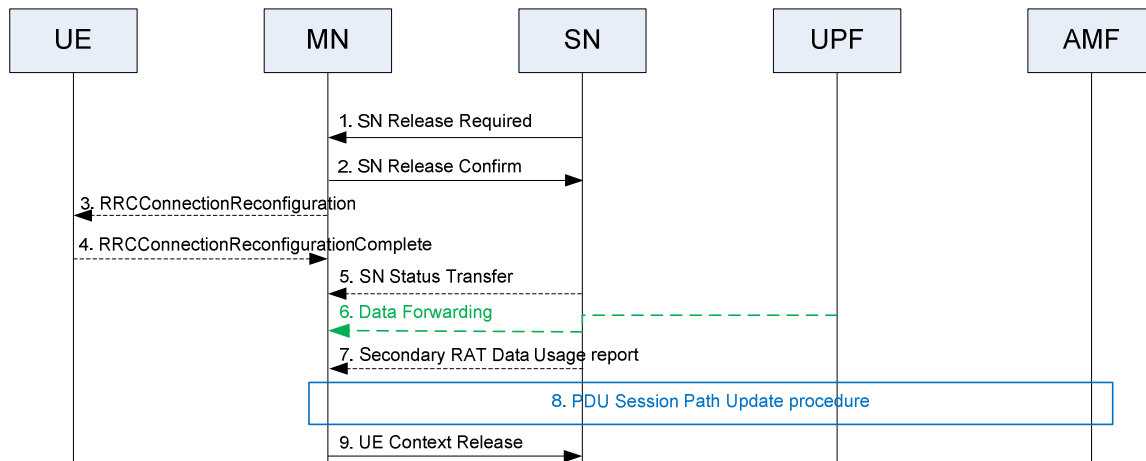

Figure 10.4.2-2: SN release procedure - SN initiated

Figure 10.4.2-2 shows an example signalling flow for the SN initiated SN Release procedure.

1. The SN initiates the procedure by sending the *SN Release Required* message which does not contain any inter-node message.
2. If data forwarding is requested, the MN provides data forwarding addresses to the SN in the *SN Release Confirm* message. The SN may start data forwarding and stop providing user data to the UE as early as it receives the *SN Release Confirm* message.
- 3/4. If required, the MN indicates in the *MN RRC reconfiguration* message towards the UE that the UE shall release the entire SCG configuration. In case the UE is unable to comply with (part of) the configuration included in the *MN RRC reconfiguration* message, it performs the reconfiguration failure procedure.

NOTE 2: If data forwarding is applied, timely coordination between steps 2 and 3 may minimize gaps in service provision. This is however regarded to be an implementation matter.

5. If the released bearers use RLC AM, the SN sends the *SN Status transfer*.
6. Data forwarding from the SN to the MN may start.
7. The SN sends the *Secondary RAT Data Usage Report* message to the MN and includes the data volumes delivered to and received from the UE as described in clause 10.11.2.

NOTE 3: If data forwarding is applied, the order the SN sends the *Secondary RAT Data Usage Report* message and starts data forwarding with MN is not defined i.e., step 7 can take place before step 6. The SN does not need to wait for the end of data forwarding to send the *Secondary RAT Data Usage Report* message.

8. If applicable, the PDU Session path update procedure is initiated.
9. Upon reception of the *UE Context Release* message, the SN can release radio and C-plane related resource associated to the UE context. Any ongoing data forwarding may continue.

10.5 Secondary Node Change (MN/SN initiated)

10.5.1 EN-DC

The Secondary Node Change procedure is initiated either by MN or SN and used to transfer a UE context from a source SN to a target SN and to change the SCG configuration in UE from one SN to another.

NOTE 1: Inter-RAT SN change procedure with single RRC reconfiguration is not supported in this version of the protocol (i.e. no transition from EN-DC to DC).

The Secondary Node Change procedure always involves signalling over MCG SRB towards the UE.

MN initiated SN Change

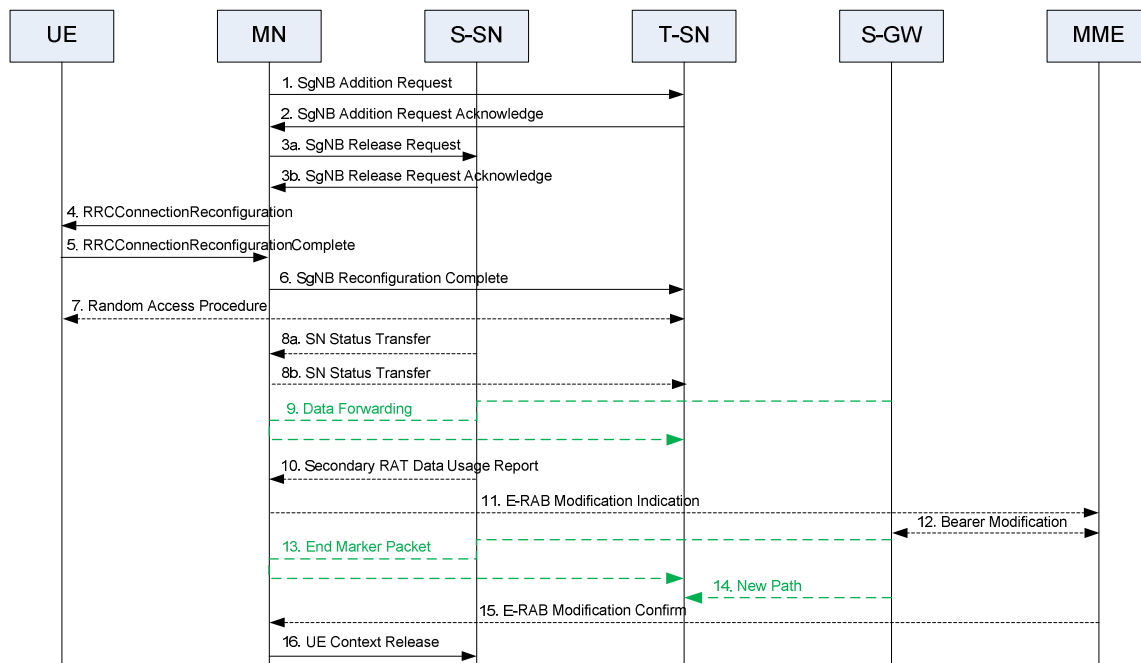

Figure 10.5.1-1: SN Change – MN initiated

Figure 10.5.1-1 shows an example signalling flow for the MN initiated Secondary Node Change:

- 1/2. The MN initiates the SN change by requesting the target SN to allocate resources for the UE by means of the SgNB Addition procedure. The MN may include measurement results related to the target SN. If forwarding is needed, the target SN provides forwarding addresses to the MN. The target SN includes the indication of the full or delta RRC configuration.

NOTE 2: The MN may send the *SgNB Modification Request* message (to the source SN) to request the current SCG configuration before step 1.

3. If the allocation of target SN resources was successful, the MN initiates the release of the source SN resources including a Cause indicating SCG mobility. The Source SN may reject the release. If data forwarding is needed the MN provides data forwarding addresses to the source SN. If direct data forwarding is used for SN terminated bearers, the MN provides data forwarding addresses as received from the target SN to source SN. Reception of the *SgNB Release Request* message triggers the source SN to stop providing user data to the UE and, if applicable, to start data forwarding.
- 4/5. The MN triggers the UE to apply the new configuration. The MN indicates to the UE the new configuration in the *RRCConnectionReconfiguration* message including the NR RRC configuration message generated by the target SN. The UE applies the new configuration and sends the *RRCConnectionReconfigurationComplete* message, including the encoded NR RRC response message for the target SN, if needed. In case the UE is unable to comply with (part of) the configuration included in the *RRCConnectionReconfiguration* message, it performs the reconfiguration failure procedure.
6. If the RRC connection reconfiguration procedure was successful, the MN informs the target SN via *SgNBReconfigurationComplete* message with the encoded NR RRC response message for the target SN, if received from the UE.
7. If configured with bearers requiring SCG radio resources, the UE synchronizes to the target SN.
8. For SN terminated bearers using RLC AM, the source SN sends the SN Status transfer, which the MN sends then to the target SN.
9. If applicable, data forwarding from the source SN takes place. It may be initiated as early as the source SN receives the *SgNB Release Request* message from the MN.

10. The source SN sends the *Secondary RAT Data Usage Report* message to the MN and includes the data volumes delivered to and received from the UE over the NR radio for the related E-RABs.

NOTE 3: The order the SN sends the *Secondary RAT Data Usage Report* message and performs data forwarding with MN is not defined. The SN may send the report when the transmission of the related bearer is stopped.

11-15. If one of the bearer was terminated at the source SN, path update is triggered by the MN.

16. Upon reception of the *UE Context Release* message, the source SN can release radio and C-plane related resource associated to the UE context. Any ongoing data forwarding may continue.

SN initiated SN Change

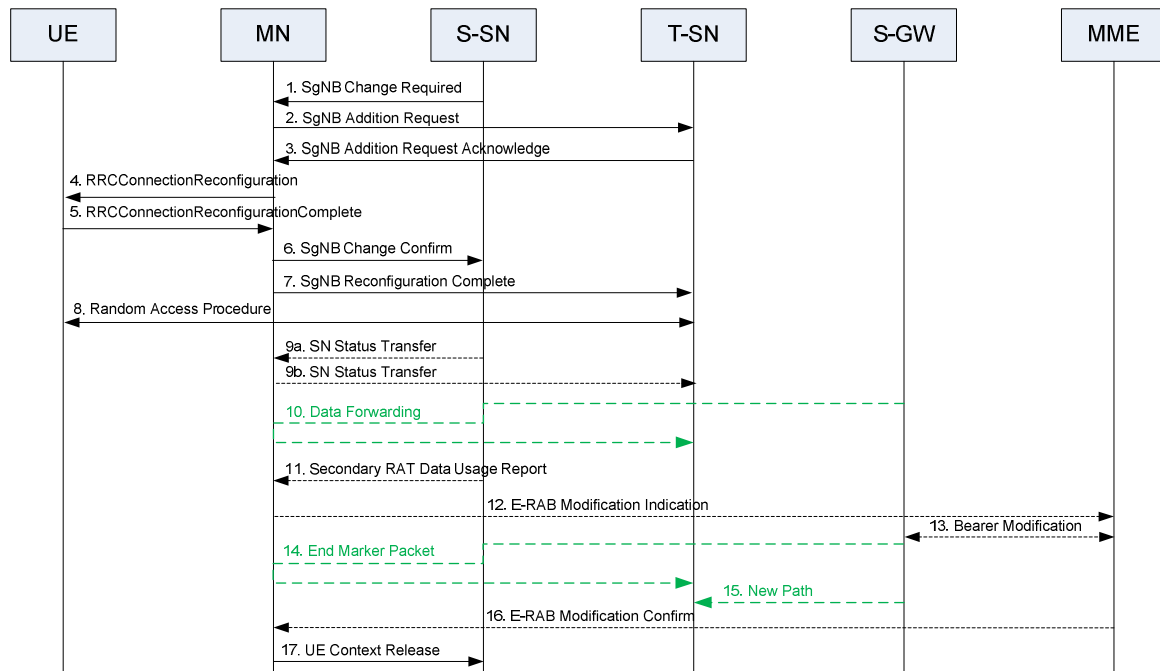

Figure 10.5.1-2: SN Change – SN initiated

Figure 10.5.1-2 shows an example signalling flow for the Secondary Node Change initiated by the SN:

1. The source SN initiates the SN change procedure by sending *SgNB Change Required* message which contains target SN ID information and may include the SCG configuration (to support delta configuration) and measurement results related to the target SN.
- 2/3. The MN requests the target SN to allocate resources for the UE by means of the SgNB Addition procedure, including the measurement results related to the target SN received from the source SN. If forwarding is needed, the target SN provides forwarding addresses to the MN. The target SN includes the indication of the full or delta RRC configuration.
- 4/5. The MN triggers the UE to apply the new configuration. The MN indicates the new configuration to the UE in the *RRCConnectionReconfiguration* message including the NR RRC configuration message generated by the target SN. The UE applies the new configuration and sends the *RRCConnectionReconfigurationComplete* message, including the encoded NR RRC response message for the target SN, if needed. In case the UE is unable to comply with (part of) the configuration included in the *RRCConnectionReconfiguration* message, it performs the reconfiguration failure procedure.
6. If the allocation of target SN resources was successful, the MN confirms the release of the source SN resources. If data forwarding is needed the MN provides data forwarding addresses to the source SN. If direct data forwarding is used for SN terminated bearers, the MN provides data forwarding addresses as received from the target SN to source SN. Reception of the *SgNB Change Confirm* message triggers the source SN to stop providing user data to the UE and, if applicable, to start data forwarding.

7. If the RRC connection reconfiguration procedure was successful, the MN informs the target SN via *SgNB Reconfiguration Complete* message with the encoded NR RRC response message for the target SN, if received from the UE.
 8. The UE synchronizes to the target SN.
 9. For SN terminated bearers using RLC AM, the source SN sends the SN Status transfer, which the MN sends then to the target SN.
 10. If applicable, data forwarding from the source SN takes place. It may be initiated as early as the source SN receives the *SgNB Change Confirm* message from the MN.
 11. The source SN sends the *Secondary RAT Data Usage Report* message to the MN and includes the data volumes delivered to and received from the UE over the NR radio for the related E-RABs.
- NOTE 4: The order the source SN sends the *Secondary RAT Data Usage Report* message and performs data forwarding with MN/target SN is not defined. The SgNB may send the report when the transmission of the related bearer is stopped.
- 12-16. If one of the bearer was terminated at the source SN, path update is triggered by the MN.
 17. Upon reception of the *UE Context Release* message, the source SN can release radio and C-plane related resource associated to the UE context. Any ongoing data forwarding may continue.

10.5.2 MR-DC with 5GC

MN initiated SN Change

The MN initiated SN change procedure is used to transfer a UE context from the source SN to a target SN and to change the SCG configuration in UE from one SN to another.

The Secondary Node Change procedure always involves signalling over MCG SRB towards the UE.

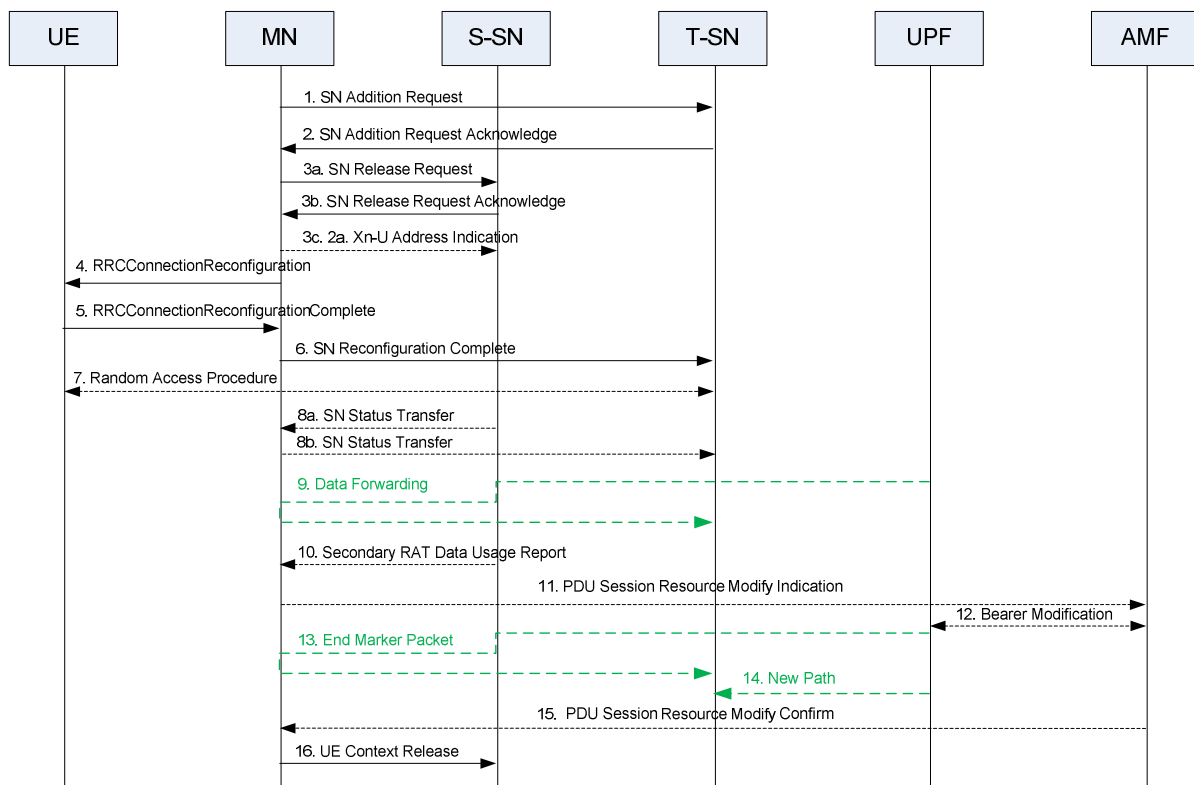

Figure 10.5.2-1: SN change procedure - MN initiated

Figure 10.5.2-1 shows an example signalling flow for the SN Change initiated by the MN:

1/2. The MN initiates the SN change by requesting the target SN to allocate resources for the UE by means of the SN Addition procedure. The MN may include measurement results related to the target SN. If data forwarding is needed, the target SN provides data forwarding addresses to the MN. The target SN includes the indication of the full or delta RRC configuration.

NOTE 1: The MN may send the *SN Modification Request* message (to the source SN) to request the current SCG configuration and allow provision of data forwarding related information before step 1.

3. If the allocation of target SN resources was successful, the MN initiates the release of the source SN resources including a Cause indicating SCG mobility. The Source SN may reject the release. If data forwarding is needed the MN provides data forwarding addresses to the source SN. If direct data forwarding is used for SN terminated bearers, the MN provides data forwarding addresses as received from the target SN to source SN. Reception of the *SN Release Request* message triggers the source SN to stop providing user data to the UE.

4/5. The MN triggers the UE to apply the new configuration. The MN indicates the new configuration to the UE in the *MN RRC reconfiguration message* including the target SN RRC reconfiguration message. The UE applies the new configuration and sends the *MN RRC reconfiguration complete* message, including the SN RRC response message for the target SN, if needed. In case the UE is unable to comply with (part of) the configuration included in the *MN RRC reconfiguration message*, it performs the reconfiguration failure procedure.

6. If the RRC connection reconfiguration procedure was successful, the MN informs the target SN via *SN Reconfiguration Complete* message with the included SN RRC response message for the target SN, if received from the UE.

7. If configured with bearers requiring SCG radio resources the UE synchronizes to the target SN.

8. For SN terminated bearers using RLC AM, the source SN sends the SN Status transfer, which the MN sends then to the target SN.

9. If applicable, data forwarding from the source SN takes place. It may be initiated as early as the source SN receives the *SN Release Request* message from the MN.

10. The source SN sends the *Secondary RAT Data Usage Report* message to the MN and includes the data volumes delivered to and received from the UE as described in clause 10.11.2.

NOTE 2: The order the SN sends the *Secondary RAT Data Usage Report* message and performs data forwarding with MN is not defined. The SN may send the report when the transmission of the related QoS flow is stopped.

11-15. If the user plane resource configuration was terminated at the source SN, path update procedure is triggered by the MN.

16. Upon reception of the *UE Context Release* message, the source SN can release radio and C-plane related resource associated to the UE context. Any ongoing data forwarding may continue

SN initiated SN Change

The SN initiated SN change procedure is used to transfer a UE context from the source SN to a target SN and to change the SCG configuration in UE from one SN to another.

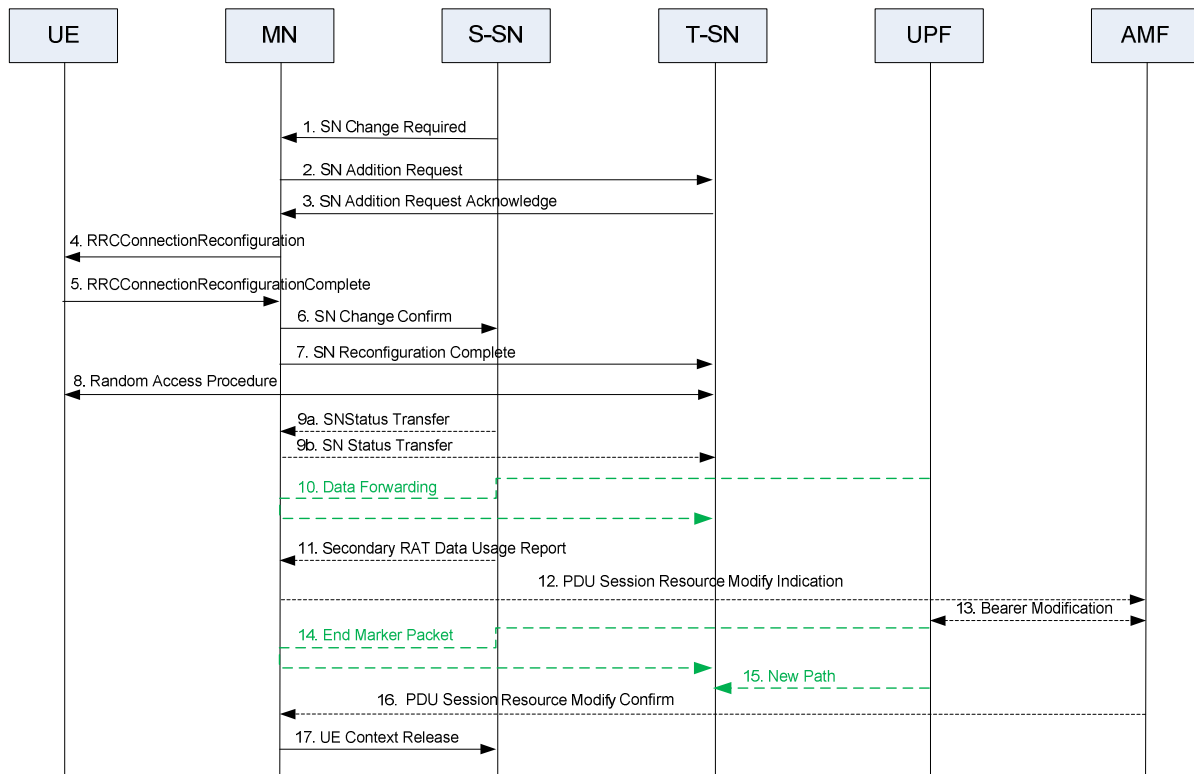

Figure 10.5.2-2: SN change procedure - SN initiated

Figure 10.5.2-2 shows an example signalling flow for the SN Change initiated by the SN:

1. The source SN initiates the SN change procedure by sending the *SN Change Required* message, which contains a candidate target node ID and may include the SCG configuration (to support delta configuration) and measurement results related to the target SN.
- 2/3. The MN requests the target SN to allocate resources for the UE by means of the SN Addition procedure, including the measurement results related to the target SN received from the source SN. If data forwarding is needed, the target SN provides data forwarding addresses to the MN. The target SN includes the indication of the full or delta RRC configuration.
- 4/5. The MN triggers the UE to apply the new configuration. The MN indicates the new configuration to the UE in the *MN RRC reconfiguration* message including the SN RRC reconfiguration message generated by the target SN. The UE applies the new configuration and sends the *MN RRC reconfiguration complete* message, including the SN RRC response message for the target SN, if needed. In case the UE is unable to comply with (part of) the configuration included in the *MN RRC reconfiguration* message, it performs the reconfiguration failure procedure.
6. If the allocation of target SN resources was successful, the MN confirms the change of the source SN. If data forwarding is needed the MN provides data forwarding addresses to the source SN. If direct data forwarding is used for SN terminated bearers, the MN provides data forwarding addresses as received from the target SN to source SN. Reception of the *SN Change Confirm* message triggers the source SN to stop providing user data to the UE and, if applicable, to start data forwarding.
7. If the RRC connection reconfiguration procedure was successful, the MN informs the target SN via *SN Reconfiguration Complete* message with the included SN RRC response message for the target SN, if received from the UE.
8. The UE synchronizes to the target SN.
9. For SN terminated bearers using RLC AM, the source SN sends the SN Status transfer, which the MN sends then to the target SN.
10. If applicable, data forwarding from the source SN takes place. It may be initiated as early as the source SN receives the *SN Change Confirm* message from the MN.

11. The source SN sends the *Secondary RAT Data Usage Report* message to the MN and includes the data volumes delivered to and received from the UE as described in clause 10.11.2.

NOTE 3: The order the SN sends the *Secondary RAT Data Usage Report* message and performs data forwarding with MN/target SN is not defined. The SN may send the report when the transmission of the related QoS flow is stopped.

12-16. If the user plane resource configuration was terminated at the source SN, path update procedure is triggered by the MN.

17. Upon reception of the *UE Context Release* message, the source SN can release radio and C-plane related resource associated to the UE context. Any ongoing data forwarding may continue.

10.6 PSCell change

In MR-DC, a PSCell change does not always require a security key change.

If a security key change is required, this is performed through a synchronous SCG reconfiguration procedure towards the UE involving random access on PSCell and a security key change, during which the MAC entity configured for SCG is reset and RLC configured for SCG is re-established regardless of the bearer type(s) established on SCG. For SN terminated bearers, PDCP is re-established. In all MR-DC options, to perform this procedure within the same SN, the SN Modification procedure as described in clause 10.3 is used, setting the *PDCP Change Indication* to indicate that a $S-K_{gNB}$ (for EN-DC, NGEN-DC and NR-DC) or $S-K_{eNB}$ (for NE-DC) update is required when the procedure is initiated by the SN or including the *SgNB Security Key / SN Security Key* when the procedure is initiated by the MN. In all MR-DC options, to perform a PSCell change between different SN nodes, the SN Change procedure as described in clause 10.5 is used.

If a security key change is not required (only possible in EN-DC, NGEN-DC and NR-DC), this is performed through a synchronous SCG reconfiguration procedure without security key change towards the UE involving random access on PSCell, during which the MAC entity configured for SCG is reset and RLC configured for SCG is re-established regardless of the bearer type(s) established on SCG. For bearers using RLC AM mode PDCP data recovery applies, for bearers using RLC UM no action is performed in PDCP while for SRBs PDCP discards all stored SDUs and PDUs. Unless MN terminated SCG or split bearers are configured, this does not require MN involvement. In this case, if location information was requested for the UE, the SN informs the MN about the PSCell change (as part of location information) using the SN initiated SN modification procedure independently from the reconfiguration of the UE. In case of MN terminated SCG or split bearers, the SN initiated SN Modification procedure as described in clause 10.3 is used, setting the *PDCP Change Indication* to indicate that a PDCP data recovery is required.

10.7 Inter-Master Node handover with/without Secondary Node change

10.7.1 EN-DC

Inter-Master Node handover with/without MN initiated Secondary Node change is used to transfer context data from a source MN to a target MN while the context at the SN is kept or moved to another SN. During an Inter-Master Node handover, the target MN decides whether to keep or change the SN (or release the SN, as described in clause 10.8).

NOTE 1: Inter-system Inter-Master node handover with/without SN change is not supported in this version of the protocol (e.g. no transition from EN-DC to NGEN-DC or NR-DC).

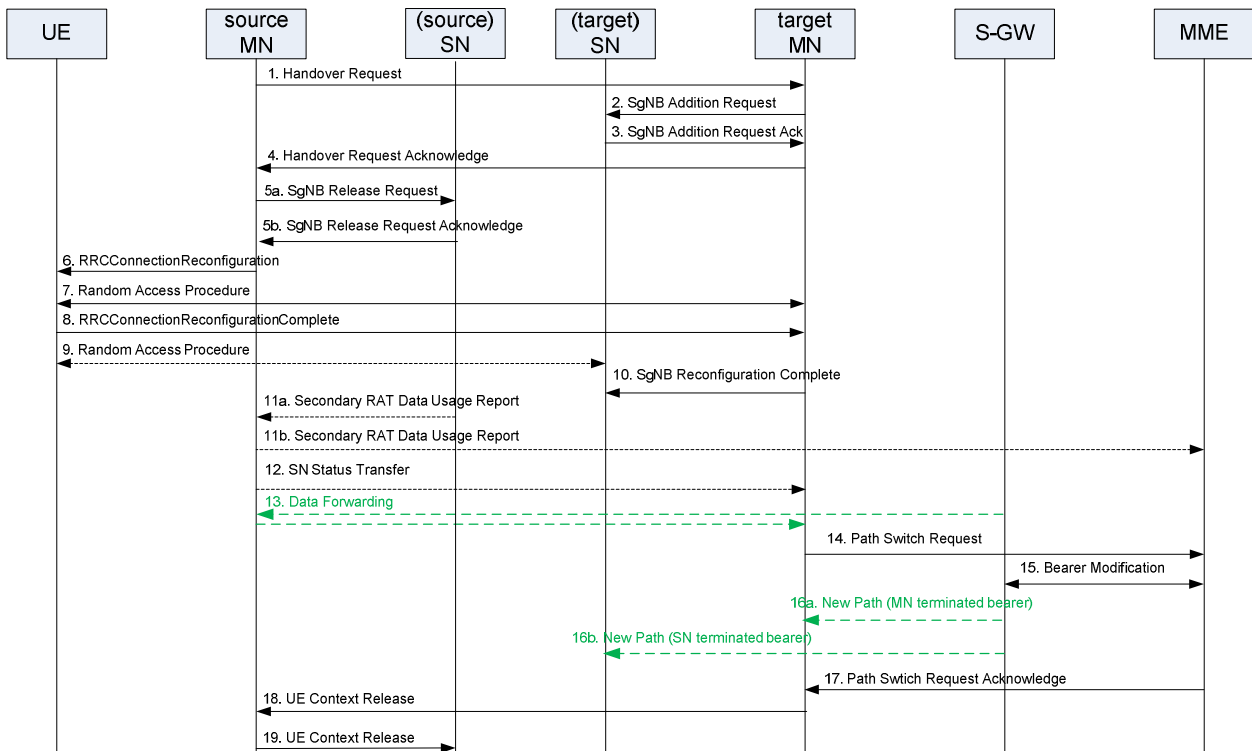

Figure 10.7.1-1: Inter-MN handover with/without MN initiated SN change

Figure 10.7.1-1 shows an example signaling flow for inter-Master Node handover with or without MN initiated Secondary Node change:

NOTE 2: For an inter-Master Node handover without Secondary Node change, the source SN and the target SN shown in Figure 10.7.1-1 are the same node.

1. The source MN starts the handover procedure by initiating the X2 Handover Preparation procedure including both MCG and SCG configuration. The source MN includes the (source) SN UE X2AP ID, SN ID and the UE context in the (source) SN in the *Handover Request* message.

NOTE 3: The source MN may send the *SgNB Modification Request* message (to the source SN) to request the current SCG configuration before step 1.

2. If the target MN decides to keep the SN, the target MN sends *SN Addition Request* to the SN including the SN UE X2AP ID as a reference to the UE context in the SN that was established by the source MN. If the target MN decides to change the SN, the target MN sends the *SgNB Addition Request* to the target SN including the UE context in the source SN that was established by the source MN.
3. The (target) SN replies with *SN Addition Request Acknowledge*. The (target) SN may include the indication of the full or delta RRC configuration.
4. The target MN includes within the *Handover Request Acknowledge* message a transparent container to be sent to the UE as an RRC message to perform the handover, and may also provide forwarding addresses to the source MN. The target MN indicates to the source MN that the UE context in the SN is kept if the target MN and the SN decided to keep the UE context in the SN in step 2 and step 3.
5. The source MN sends *SN Release Request* to the (source) SN including a Cause indicating MCG mobility. The (source) SN acknowledges the release request. The source MN indicates to the (source) SN that the UE context in SN is kept, if it receives the indication from the target MN. If the indication as the UE context kept in SN is included, the SN keeps the UE context.
6. The source MN triggers the UE to apply the new configuration.
- 7/8. The UE synchronizes to the target MN and replies with *RRCConnectionReconfigurationComplete* message.

9. If configured with bearers requiring SCG radio resources, the UE synchronizes to the (target) SN.
 10. If the RRC connection reconfiguration procedure was successful, the target MN informs the (target) SN via *SgNB Reconfiguration Complete* message.
 - 11a. The SN sends the *Secondary RAT Data Usage Report* message to the source MN and includes the data volumes delivered to and received from the UE over the NR radio for the related E-RABs.
- NOTE 4: The order the source SN sends the *Secondary RAT Data Usage Report* message and performs data forwarding with MN/target SN is not defined. The SgNB may send the report when the transmission of the related bearer is stopped.
- 11b. The source MN sends the *Secondary RAT Report* message to MME to provide information on the used NR resource.
 12. For bearers using RLC AM, the source MN sends the SN Status transfer to the target MN.
 13. Data forwarding from the source MN takes place. If the SN is kept, data forwarding may be omitted for SCG bearers and SCG split bearers.
 - 14-17. The target MN initiates the S1 Path Switch procedure.
- NOTE 5: If new UL TEIDs of the S-GW are included, the target MN performs MN initiated SN Modification procedure to provide them to the SN.
18. The target MN initiates the UE Context Release procedure towards the source MN.
 19. Upon reception of the *UE Context Release* message, the (source) SN can release C-plane related resource associated to the UE context towards the source MN. Any ongoing data forwarding may continue. The SN shall not release the UE context associated with the target MN if the indication was included in the SN Release Request in step 5.

10.7.2 MR-DC with 5GC

Inter-MN handover with/without MN initiated SN change is used to transfer UE context data from a source MN to a target MN while the UE context at the SN is kept or moved to another SN. During an Inter-Master Node handover, the target MN decides whether to keep or change the SN (or release the SN, as described in clause 10.8). Only intra-RAT Inter-Master node handover with/without SN change is supported (e.g. no transition from NGEN-DC to NR-DC).

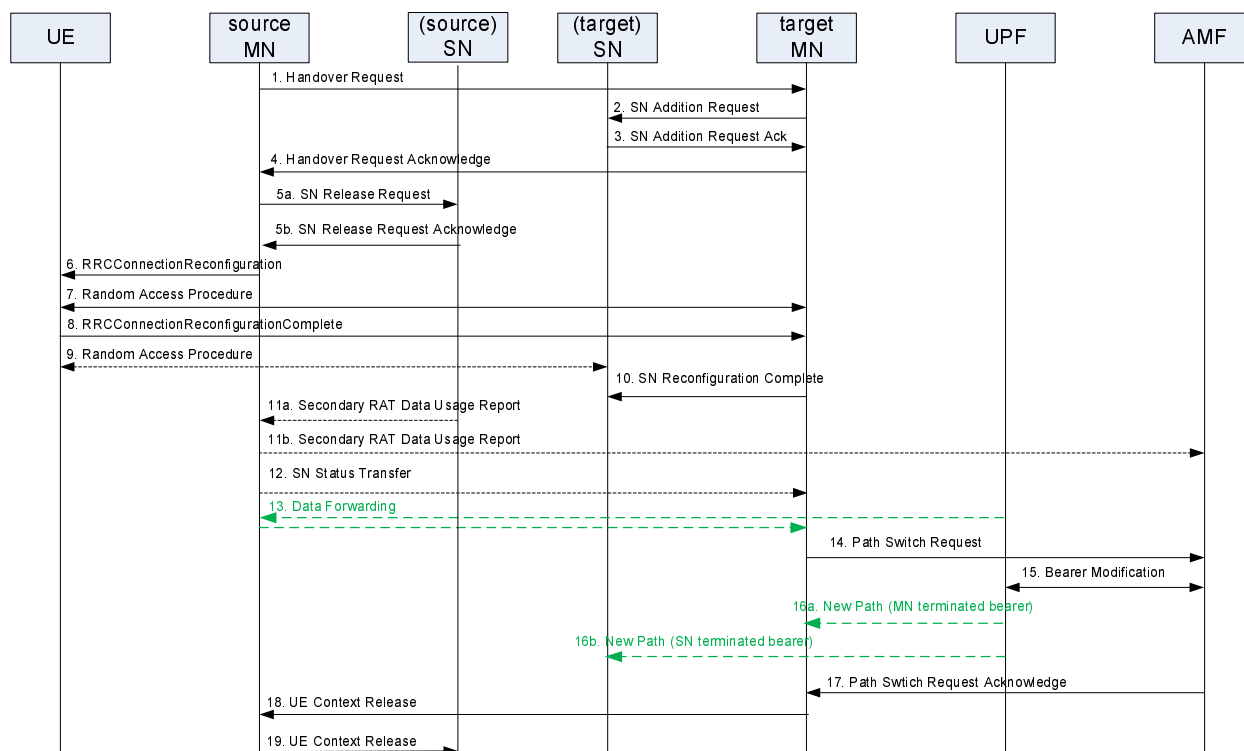

Figure 10.7.2-1: Inter-MN handover with/without MN initiated SN change procedure

Figure 10.7.2-1 shows an example signalling flow for inter-MN handover with or without MN initiated SN change:

NOTE 1: For an Inter-Master Node handover without Secondary Node change, the source SN and the target SN shown in Figure 10.7.2-1 are the same node.

1. The source MN starts the handover procedure by initiating the Xn Handover Preparation procedure including both MCG and SCG configuration. The source MN includes the source SN UE XnAP ID, SN ID and the UE context in the source SN in the *Handover Request* message.

NOTE 2: The source MN may send the *SN Modification Request* message (to the source SN) to request the current SCG configuration and allow provision of data forwarding related information before step 1.

2. If the target MN decides to keep the source SN, the target MN sends *SN Addition Request* to the SN including the SN UE XnAP ID as a reference to the UE context in the SN that was established by the source MN. If the target MN decides to change the SN, the target MN sends the *SN Addition Request* to the target SN including the UE context in the source SN that was established by the source MN.
 3. The (target) SN replies with *SN Addition Request Acknowledge*. The (target) SN may include the indication of the full or delta RRC configuration.
 4. The target MN includes within the *Handover Request Acknowledge* message the MN RRC reconfiguration message to be sent to the UE in order to perform the handover, and may also provide forwarding addresses to the source MN. If PDU session split is performed in the target MN node during handover procedure, more than one data forwarding addresses corresponding to each node should be included in *Handover Request Acknowledge* message. The target MN indicates to the source MN that the UE context in the SN is kept if the target MN and the SN decided to keep the UE context in the SN in step 2 and step 3.
- 5a/5b. The source MN sends *SN Release Request* message to the (source) SN including a Cause indicating MCG mobility. The (source) SN acknowledges the release request. The source MN indicates to the (source) SN that the UE context in SN is kept, if it receives the indication from the target MN. If the indication as the UE context kept in SN is included, the SN keeps the UE context.

- 5c. The source MN sends XN-U Address Indication message to the (source) SN to transfer data forwarding information. More than one data forwarding addresses may be provided if the PDU session is split in the target node.
 6. The source MN triggers the UE to perform handover and apply the new configuration.
 - 7/8. The UE synchronizes to the target MN and replies with *MN RRC reconfiguration complete* message.
 9. If configured with bearers requiring SCG radio resources, the UE synchronizes to the (target) SN.
 10. If the RRC connection reconfiguration procedure was successful, the target MN informs the (target) SN via *SN Reconfiguration Complete* message.
 - 11a. The source SN sends the *Secondary RAT Data Usage Report* message to the source MN and includes the data volumes delivered to and received from the UE over the NR/E-UTRA radio as described in clause 10.11.2.
- NOTE 2a: The order the source SN sends the *Secondary RAT Data Usage Report* message and performs data forwarding with MN/target SN is not defined. The SN may send the report when the transmission of the related QoS is stopped.
- 11b. The source MN sends the *Secondary RAT Report* message to AMF to provide information on the used NR/E-UTRA resource.
 12. For bearers using RLC AM, *SN Status transfer* message may be transferred from source SN to source MN, from source MN to target MN and from target MN to target SN.
 13. Data forwarding from the source node takes place. If the SN is kept, data forwarding may be omitted for SCG bearers and SCG split bearers.
 - 14-17. The target MN initiates the Path Switch procedure. If the target MN includes multiple DL TEIDs for one PDU session in the *Path Switch Request* message, multiple UL TEID of the UPF for the PDU session should be included in the *Path Switch Ack* message in case there is TEID update in UPF.
- NOTE 3: If new UL TEIDs of the UPF for SN are included, the target MN performs MN initiated SN Modification procedure to provide them to the SN.
18. The target MN initiates the UE Context Release procedure towards the source MN.
 19. Upon reception of the *UE Context Release* message from source MN, the (source) SN can release C-plane related resource associated to the UE context towards the source MN. Any ongoing data forwarding may continue. The SN shall not release the UE context associated with the target MN if the indication was included in the *SN Release Request* message in step 5.

10.8 Master Node to eNB/gNB Change

10.8.1 EN-DC

The Master Node to eNB Change procedure is used to transfer context data from a source MN/SN to a target eNB.

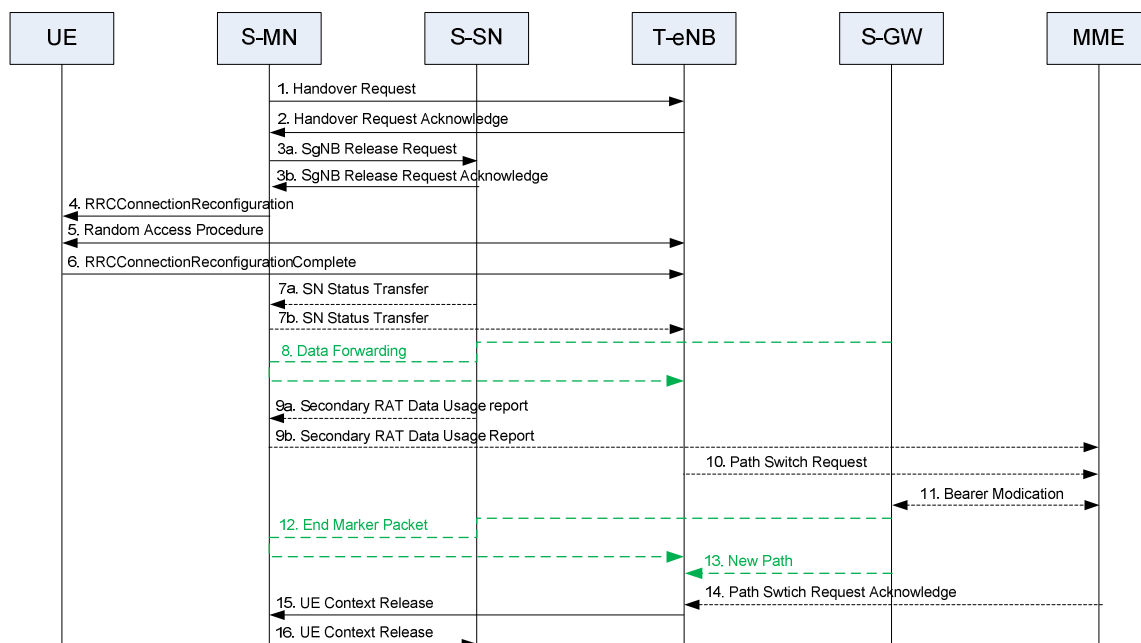

Figure 10.8.1-1: Master Node to eNB Change procedure

Figure 10.8.1-1 shows an example signalling flow for the Master Node to eNB Change procedure:

1. The source MN starts the MN to eNB Change procedure by initiating the X2 Handover Preparation procedure, including both MCG and SCG configuration.

NOTE 1: The source MN may send the *SgNB Modification Request* message (to the source SN) to request the current SCG configuration before step 1.

2. The target eNB includes the field in HO command which releases SCG configuration, and may also provide forwarding addresses to the source MN.
3. If the allocation of target eNB resources was successful, the MN initiates the release of the source SN resources towards the source SN including a Cause indicating MCG mobility. The SN acknowledges the release request. If data forwarding is needed, the MN provides data forwarding addresses to the source SN. Reception of the *SgNB Release Request* message triggers the source SN to stop providing user data to the UE and, if applicable, to start data forwarding.
4. The MN triggers the UE to apply the new configuration. Upon receiving the new configuration, the UE releases the entire SCG configuration.
- 5/6. The UE synchronizes to the target eNB.
7. For SN terminated bearers using RLC AM, the SN sends the SN Status transfer, which the source MN sends then to the target eNB.
8. If applicable, data forwarding from the source SN takes place. It may start as early as the source SN receives the *SgNB Release Request* message from the MN.
- 9a. The source SN sends the *Secondary RAT Data Usage Report* message to the source MN and includes the data volumes delivered to and received from the UE over the NR radio for the related E-RABs.

NOTE 2: The order the SN sends the *Secondary RAT Data Usage Report* message and performs data forwarding with MN is not defined. The SN may send the report when the transmission of the related bearer is stopped.

- 9b. The source MN sends the *Secondary RAT Report* message to MME to provide information on the used NR resource.

10-14. The target eNB initiates the S1 Path Switch procedure.

15. The target eNB initiates the UE Context Release procedure towards the source MN.

16. Upon reception of the *UE Context Release* message, the S-SN can release radio and C-plane related resource associated to the UE context. Any ongoing data forwarding may continue.

NOTE 3: Inter-system HO from E-UTRA with EN-DC configuration to NR or to E-UTRA connected to 5GC is also supported.

10.8.2 MR-DC with 5GC

The MN to ng-eNB/gNB Change procedure is used to transfer UE context data from a source MN/SN to a target ng-eNB/gNB. Both the cases where the source MN and the target node belong to the same RAT (i.e. they are both ng-eNBs or both gNBs) and the cases where the source MN and the target node belong to different RATs are supported.

NOTE 0: Inter-system HO from ng-eNB/gNB MN to eNB is also supported.

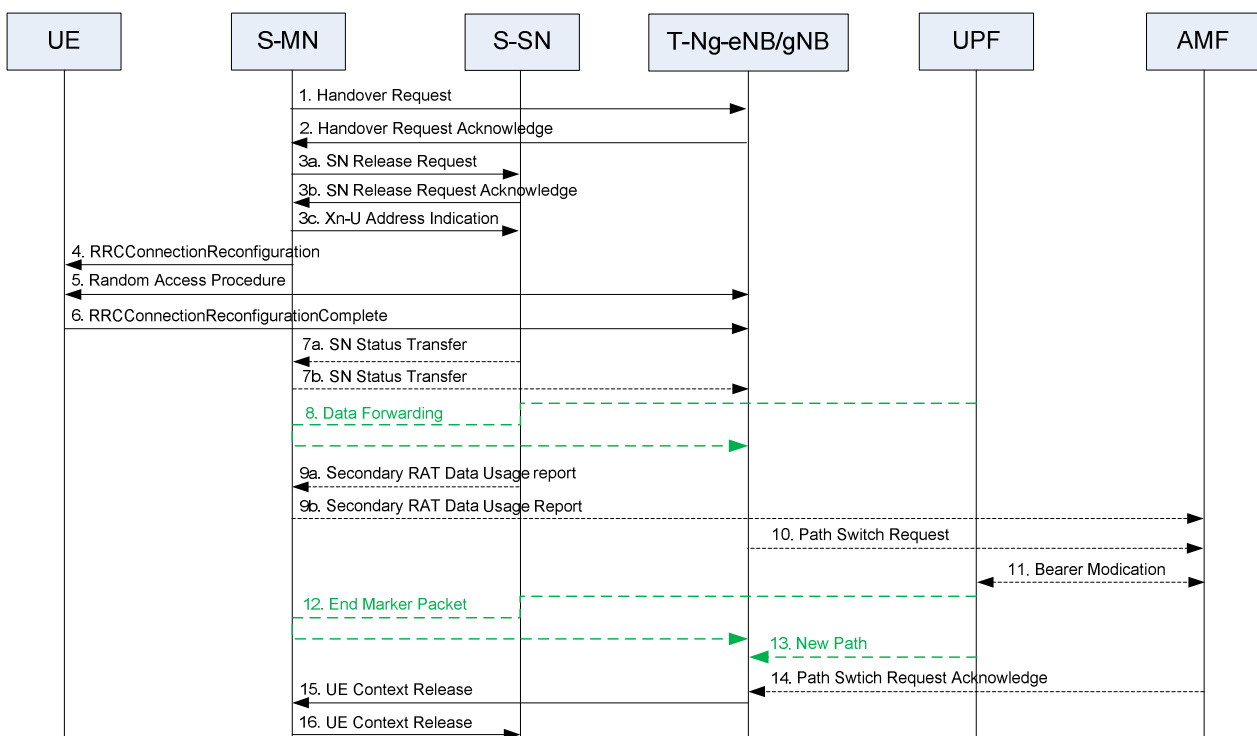

Figure 10.8.2-1: MN to ng-eNB/gNB Change procedure

Figure 10.8.2-1 shows an example signalling flow for the MN to ng-eNB/gNB Change procedure:

1. The source MN starts the MN to ng-eNB/gNB Change procedure by initiating the Xn Handover Preparation procedure, including both MCG and SCG configuration.

NOTE 1: The source MN may send the *SN Modification Request* message (to the source SN) to request the current SCG configuration and allow provision of data forwarding related information before step 1.

2. The target ng-eNB/gNB includes the field in HO command which releases the SCG configuration, and may also provide forwarding addresses to the source MN.
3. If the resource allocation of target ng-eNB/gNB was successful, the MN initiates the release of the source SN resources towards the source SN including a Cause indicating MCG mobility. The SN acknowledges the release request. If data forwarding is needed, the MN provides data forwarding addresses to the source SN. Reception of the *SN Release Request* message triggers the source SN to stop providing user data to the UE.
4. The MN triggers the UE to perform HO and apply the new configuration. Upon receiving the new configuration, the UE releases the entire SCG configuration.
- 5/6. The UE synchronizes to the target ng-eNB/gNB.

7. For SN terminated bearers using RLC AM, the SN sends the SN Status transfer, which the source MN sends then to the target ng-eNB/gNB.
 8. If applicable, data forwarding from the source SN takes place. It may start as early as the source SN receives the *SN Release Request* message from the MN.
 - 9a. The source SN sends the *Secondary RAT Data Usage Report* message to the source MN and includes the data volumes delivered to and received from the UE as described in clause 10.11.2.
- NOTE 2: The order the SN sends the *Secondary RAT Data Usage Report* message and performs data forwarding with MN is not defined. The SN may send the report when the transmission of the related QoS flow is stopped.
- 9b. The source MN sends the *Secondary RAT Report* message to AMF to provide information on the used NR/E-UTRA resource.
 - 10-14. The target ng-eNB/gNB initiates the Path Switch procedure.
 15. The target ng-eNB/gNB initiates the UE Context Release procedure towards the source MN.
 16. Upon reception of the *UE Context Release* message from MN, the source SN can release radio and C-plane related resource associated to the UE context. Any ongoing data forwarding may continue.

10.9 eNB/gNB to Master Node change

10.9.1 EN-DC

The eNB to Master Node change procedure is used to transfer context data from a source eNB to a target MN that adds an SN during the handover.

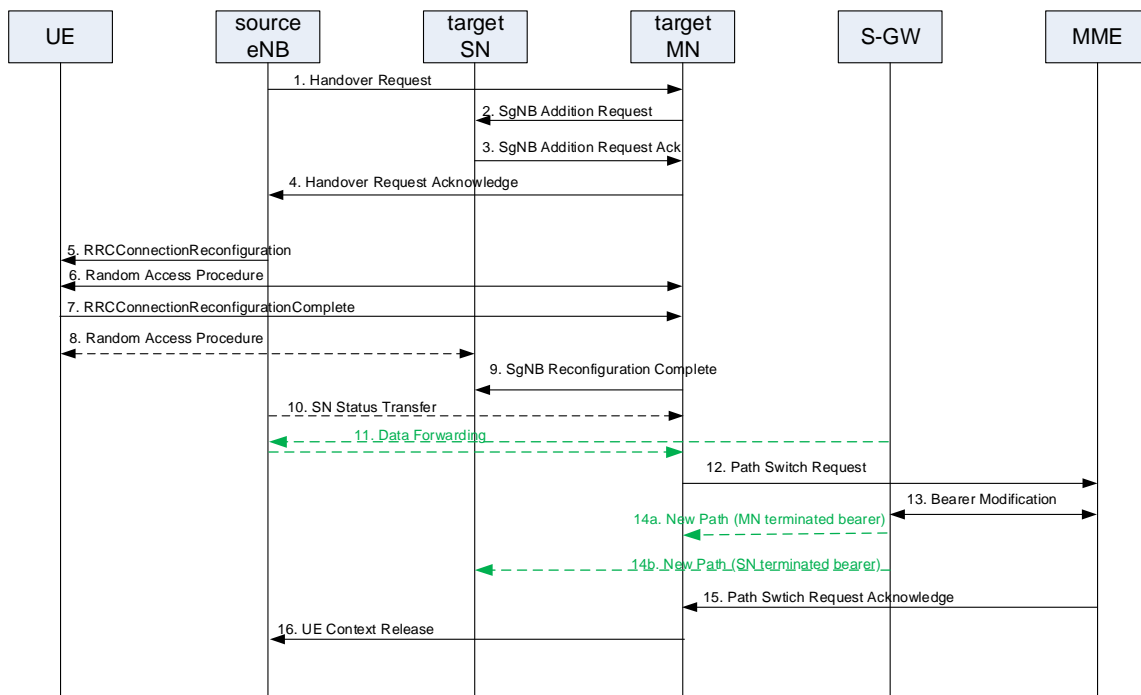

Figure 10.9.1-1: eNB to Master Node change

Figure 10.9.1-1 shows an example signaling flow for eNB to Master Node change:

1. The source eNB starts the handover procedure by initiating the X2 Handover Preparation procedure.
2. The target MN sends *SgNB Addition Request* to the target SN.

3. The target SN replies with *SgNB Addition Request Acknowledge*. If data forwarding is needed, the target SN provides forwarding addresses to the target MN.
4. The target MN includes within the *Handover Request Acknowledge* message a transparent container to be sent to the UE as an E-UTRA RRC message, including a NR RRC configuration message which also includes the SCG configuration, to perform the handover, and may also provide forwarding addresses to the source eNB.
5. The source eNB triggers the UE to apply the new configuration.
- 6/7. The UE synchronizes to the target MN and replies with *RRCConnectionReconfigurationComplete* message.
8. If configured with bearers requiring SCG radio resources, the UE synchronizes to the target SN.
9. If the RRC connection reconfiguration procedure was successful, the target MN informs the target SN.
10. For bearers using RLC AM, the source eNB sends the SN Status transfer to the target MN.
11. Data forwarding from the source eNB takes place.
- 12-15. The target MN initiates the S1 Path Switch procedure.

NOTE 1: If new UL TEIDs of the S-GW are included, the target MN performs MN initiated SN Modification procedure to provide them to the target SN.

16. The target MN initiates the *UE Context Release* procedure towards the source eNB.

NOTE 2: Inter-system HO from NR or from E-UTRA connected to 5GC to E-UTRA with EN-DC configuration is not supported. Inter-system HO from E-UTRA with EPC to MR-DC with 5GC is also not supported.

10.9.2 MR-DC with 5GC

The ng-eNB/gNB to MN change procedure is used to transfer UE context data from a source ng-eNB/gNB to a target MN that adds an SN during the handover. Only the cases where the source node and the target MN belong to the same RAT (i.e. they are both ng-eNBs or both gNBs) are supported.

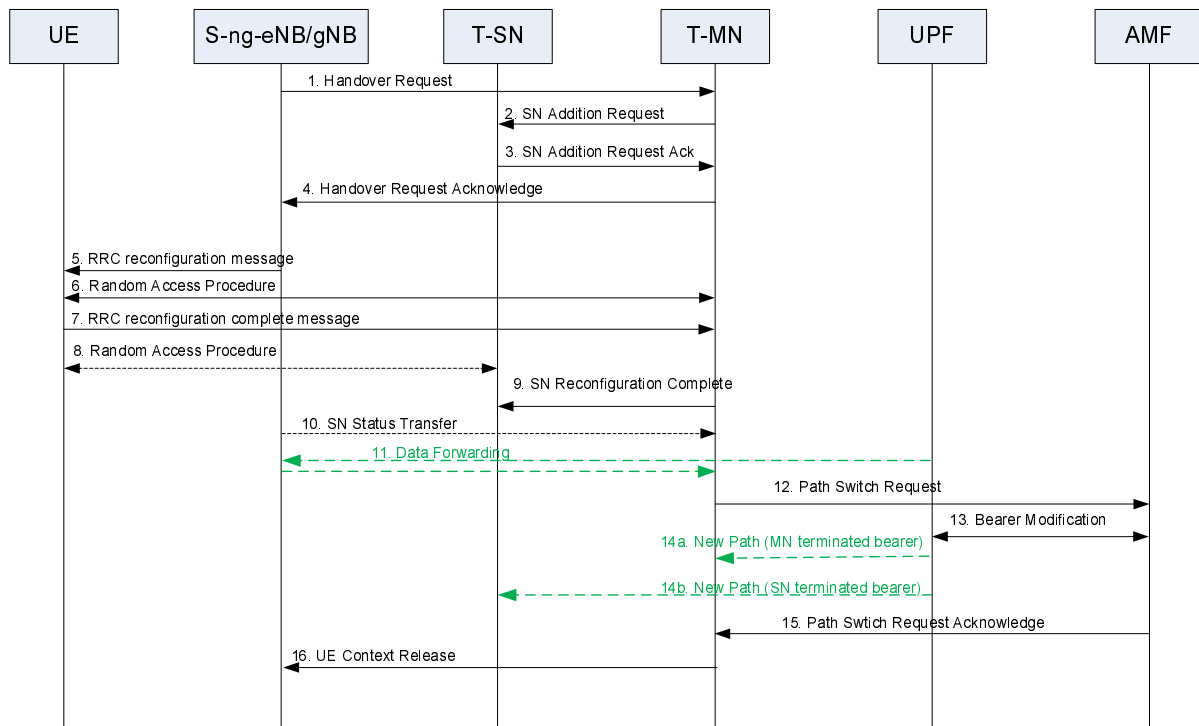

Figure 10.9.2-1: ng-eNB/gNB to MN change procedure

Figure 10.9.2-1 shows an example signalling flow for ng-eNB/gNB to MN change:

1. The source ng-eNB/gNB starts the handover procedure by initiating the Xn Handover Preparation procedure.
 2. The target MN sends *SN Addition Request* to the target SN.
 3. The target SN replies with *SN Addition Request Acknowledge*. If data forwarding is needed, the target SN provides forwarding addresses to the target MN.
 4. The target MN includes within the *Handover Request Acknowledge* message the SN RRC reconfiguration message to be sent to the UE that includes the SCG configuration to perform the handover, and may also provide forwarding addresses to the source ng-eNB/gNB.
 5. The source ng-eNB/gNB triggers the UE to perform handover and apply the new configuration.
 - 6/7. The UE synchronizes to the target MN and replies with *MN RRC reconfiguration complete* message including the SN RRC reconfiguration complete message.
 8. If configured with bearers requiring SCG radio resources, the UE synchronizes to the target SN.
 9. If the RRC connection reconfiguration procedure was successful, the target MN informs the target SN via *SN Reconfiguration Complete* message.
 10. For bearers using RLC AM, the source ng-eNB/gNB sends the SN Status transfer to the target MN.
 11. Data forwarding from the source ng-eNB/gNB takes place.
 - 12-15. The target MN initiates the PDU Session Path Switch procedure.
- NOTE: If new UL TEIDs of the UPF are included, the target MN performs MN initiated SN Modification procedure to provide them to the target SN.
16. The target MN initiates the *UE Context Release* procedure towards the source ng-eNB/gNB.

10.10 RRC Transfer

10.10.1 EN-DC

The RRC Transfer procedure is used to deliver an RRC message, encapsulated in a PDCP PDU between the MN and the SN (and vice versa) so that it may be forwarded to/from the UE using split SRB. The RRC transfer procedure is also used for providing a NR measurement report or NR failure information from the UE to the SN via the MN. Additional details of the RRC transfer procedure are defined in TS 36.423 [9].

Split SRB:

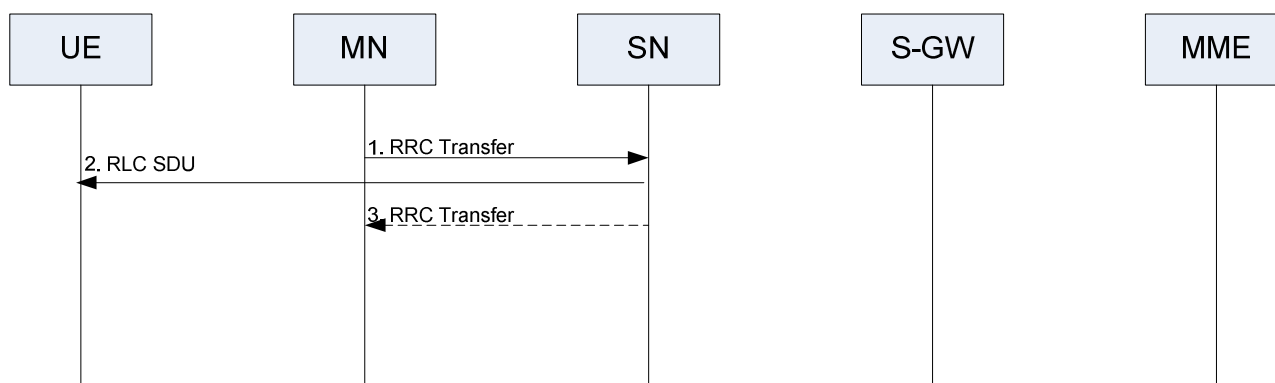

Figure 10.10.1-1: RRC Transfer procedure for the split SRB (DL operation)

Figure 10.10.1-1 shows an example signaling flow for the DL RRC Transfer in case of the split SRB:

1. The MN, when it decides to use the split SRBs, starts the procedure by initiating the RRC Transfer procedure. The MN encapsulates the RRC message in a PDCP-C PDU and ciphers with own keys.

NOTE: The usage of the split SRBs shall be indicated in the Secondary Node Addition procedure or Modification procedure.

2. The SN forwards the RRC message to the UE.
3. The SN may send PDCP delivery acknowledgement of the RRC message forwarded in step 2.

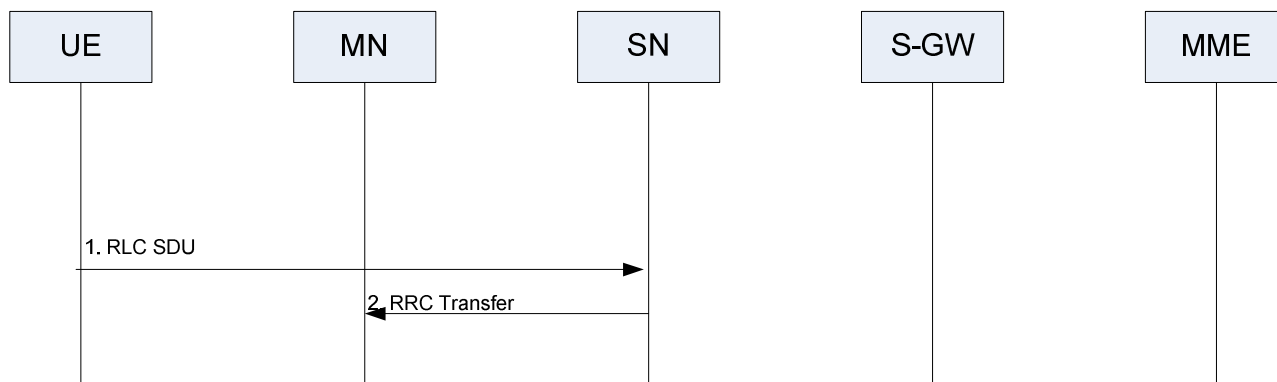

Figure 10.10.1-2: RRC Transfer procedure for the split SRB (UL operation)

Figure 10.10.1-2 shows an example signaling flow for the UL RRC Transfer in case of the split SRB:

1. When the UE provides response to the RRC message, it sends it to the SN.
2. The SN initiates the RRC Transfer procedure, in which it transfers the received PDCP-C PDU with encapsulated RRC message.

NR measurement report or NR failure information:

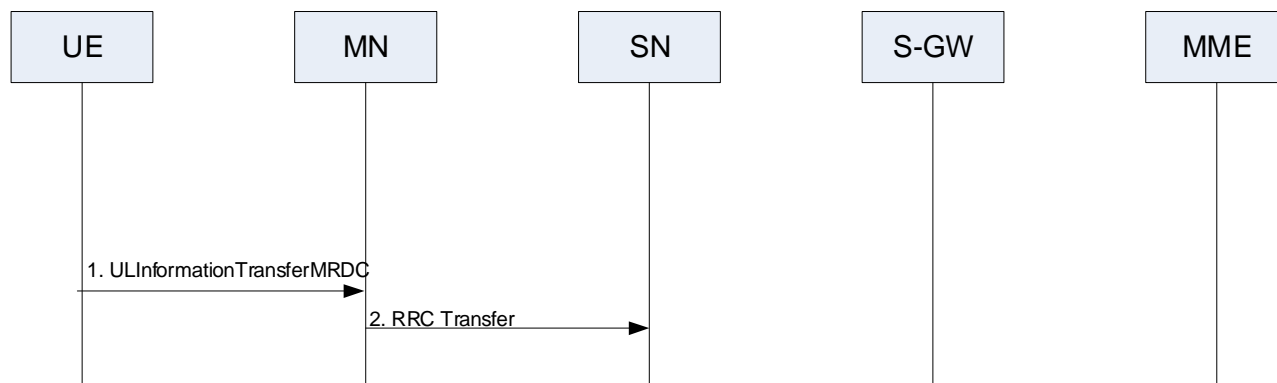

Figure 10.10.1-3: RRC Transfer procedure for NR measurement report or NR failure information

Figure 10.10.1-3 shows an example signaling flow for RRC Transfer in case of the forwarding of the NR measurement report or NR failure information from the UE:

1. When the UE sends a measurement report or NR failure information, it sends it to the MN in a container called *ULInformationTransferMRDC* as specified in TS 36.331 [10].
2. The MN initiates the RRC Transfer procedure, in which it transfers the received NR measurement report or NR failure information as an octet string.

10.10.2 MR-DC with 5GC

The RRC Transfer procedure is used to exchange RRC messages, encapsulated in a PDCP PDU, between the MN and the UE via the SN (split SRB) and to provide SN measurement reports or failure information report from the UE to the SN. Additional details of the RRC transfer procedure are defined in TS 38.423 [5].

Split SRB:

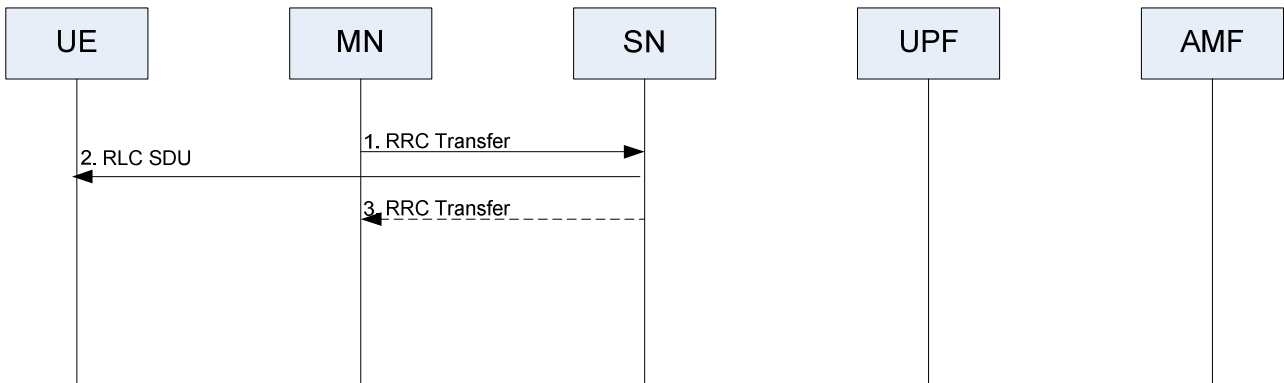

Figure 10.10.2-1: RRC Transfer procedure for split SRB (DL operation)

Figure 10.10.2-1 shows an example signaling flow for DL RRC Transfer in case of the split SRB:

1. The MN, when it decides to use the split SRBs, starts the procedure by initiating the RRC Transfer procedure. The MN encapsulates the RRC message in a PDCP PDU and ciphers with own keys.

NOTE: The usage of the split SRBs shall be indicated in the Secondary Node Addition procedure or Modification procedure.

2. The SN forwards the RRC message to the UE.
3. The SN may send PDCP delivery acknowledgement of the RRC message forwarded in step 2.

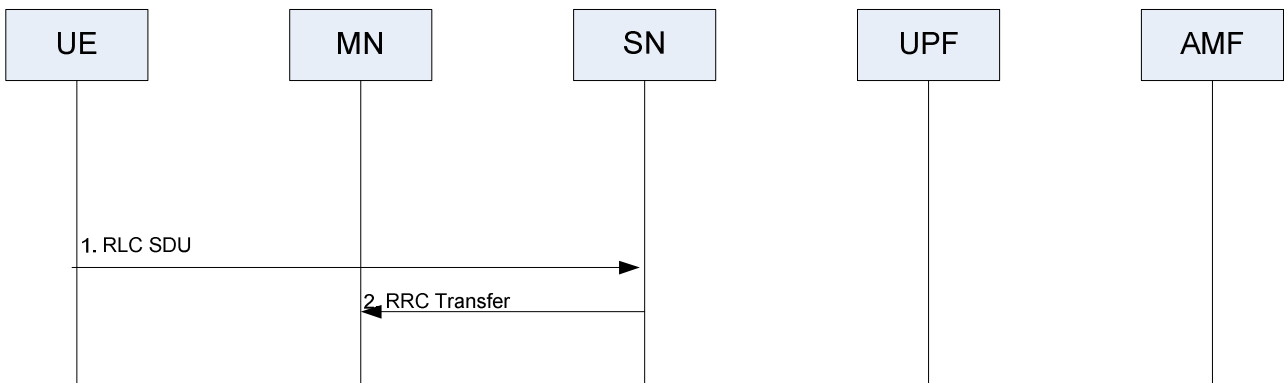

Figure 10.10.2-2: RRC Transfer procedure for split SRB (UL operation)

Figure 10.10.2-2 shows an example signaling flow for UL RRC Transfer in case of the split SRB:

1. When the UE provides response to the RRC message, it sends it to the SN.
2. The SN initiates the RRC Transfer procedure, in which it transfers the received PDCP PDU with encapsulated RRC message.

SN measurement report or failure information report:

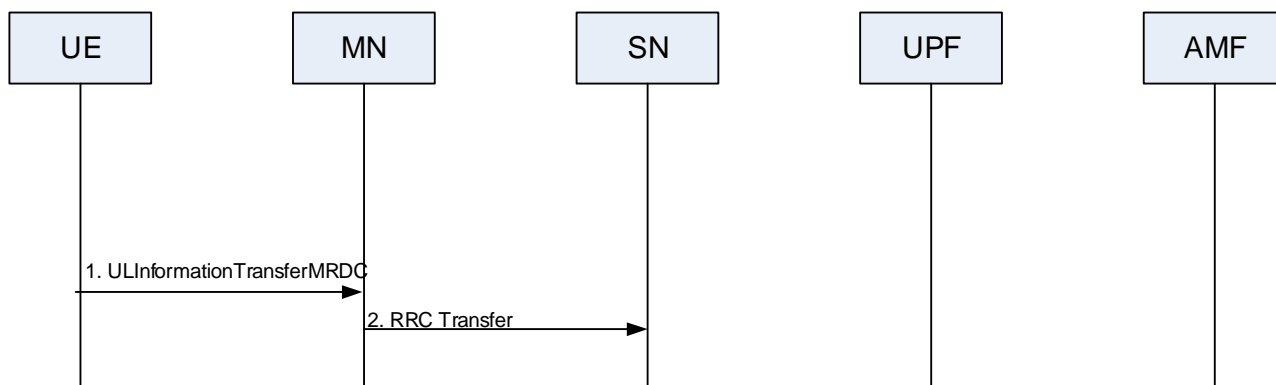

Figure 10.10.2-3: RRC Transfer procedure for SN measurement report or failure information report

Figure 10.10.2-3 shows an example signalling flow for RRC Transfer in case of the forwarding of the SN measurement report or failure information report from the UE:

1. When the UE sends an SN measurement report or failure information report, it sends it to the MN in a container called *ULInformationTransferMRDC* as specified in TS 38.331 [4].
2. The MN initiates the RRC Transfer procedure, in which it transfers the received SN measurement report or failure information as an octet string.

10.11 Secondary RAT data volume reporting

10.11.1 EN-DC

The secondary RAT data volume reporting function is used to report the data volume of secondary RAT to CN. In EN-DC, if configured, the MN reports the uplink and downlink data volumes of used NR resources to the EPC on a per EPS bearer basis as specified in TS 36.300 [2]. Periodic reporting is performed by periodically sending the *Secondary RAT Data Usage Report* messages to the MME.

The data volume is counted by the node hosting PDCP. Downlink data volume is counted in bytes of PDCP SDUs successfully delivered to the UE over NR (for RLC AM) or transmitted to the UE over NR (for RLC UM). Uplink data volume is counted in bytes of PDCP SDUs received by the node hosting PDCP over NR. Forwarded packets shall not be counted when PDCP entity is relocated. When PDCP duplication is activated, packets shall be counted only once.

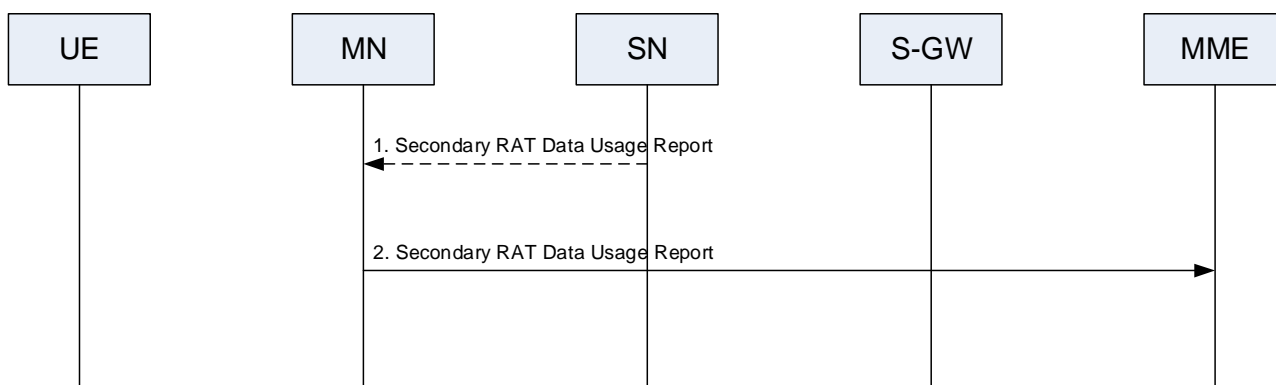

Figure 10.11.1-1: Secondary RAT data volume periodic reporting - EN-DC

Figure 10.11.1-1 shows an example signalling flow for secondary RAT data volume periodic reporting:

1. If the periodic reporting is configured, then the SN periodically sends the *Secondary RAT Data Usage Report* message to the MN and includes the data volumes of used NR radio resources for the related SN-terminated E-RABs.

- The MN sends the *Secondary RAT Data Usage Report* message to MME to provide information on the used NR resource.

NOTE: The *Secondary RAT Data Usage Report* message sent by the MN may also include secondary RAT report information of MN-terminated bearers.

10.11.2 MR-DC with 5GC

The secondary RAT data volume reporting function is used to report the data volume of secondary RAT to the 5GC. In MR-DC with 5GC, if configured, the MN reports the uplink and downlink data volumes of used secondary RAT resources to the 5GC as specified in TS 23.501 [11]. Configuration for reporting of secondary RAT data volume may happen separately for NR and E-UTRA. Secondary RAT data volume reporting indicates the secondary RAT type. For each PDU session, it contains data volumes consumed for the whole PDU Session, or for selected QoS flow, or both. Periodic reporting is performed by periodically sending the *Secondary RAT Data Usage Report* messages to the 5GC.

The data volume is counted by the node hosting PDCP. Downlink data volume is counted in bytes of SDAP SDUs successfully delivered to the UE (for RLC AM) or transmitted to the UE (for RLC UM). Uplink data volume is counted in bytes of SDAP SDUs received by the node hosting PDCP. Forwarded packets shall not be counted when PDCP entity is relocated. When PDCP duplication is activated, packets shall be counted only once.

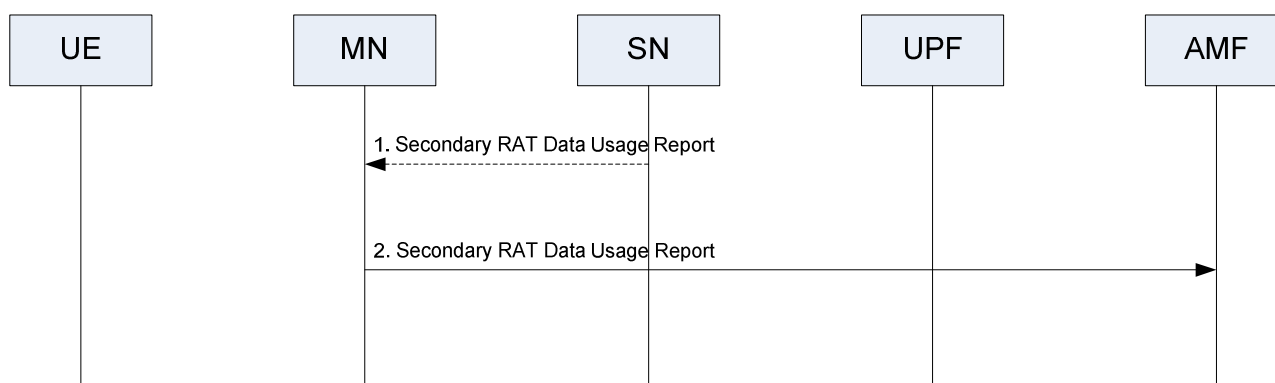

Figure 10.11.2-1: Secondary RAT data volume periodic reporting - MR-DC with 5GC

Figure 10.11.2-1 shows an example signalling flow for secondary RAT data volume periodic reporting:

- For SN terminated bearers, the SN sends the *Secondary RAT Data Usage Report* message to the MN and includes the data volumes of used secondary RAT resources for PDU Sessions or selected QoS flows or both mapped to SN-terminated bearers. If periodic reporting is configured, then the SN periodically sends the *Secondary RAT Data Usage Report* message to the MN and includes the data volumes of used radio resources.
- The MN sends the *Secondary RAT Data Usage Report* message to the 5GC to provide information on the used radio resources.

NOTE: The *Secondary RAT Data Usage Report* message sent by the MN may also include secondary RAT data volumes of used secondary RAT resources for MN terminated bearers.

10.12 Activity Notification

10.12.1 EN-DC

The Activity Notification function is used to report user plane activity within SN resources. It can either report inactivity or resumption of activity after inactivity was reported. In EN-DC the Activity Reporting is provided from the SN only. The MN may take further actions.

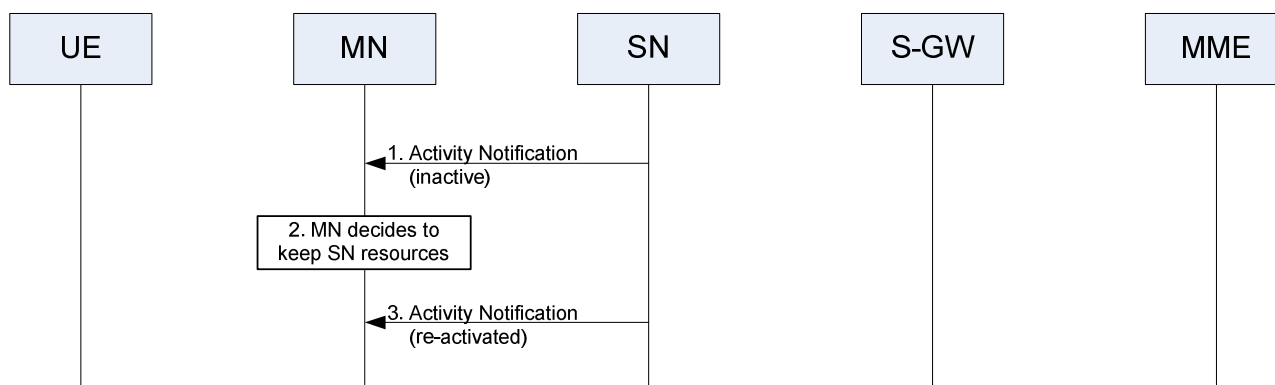

Figure 10.12.1-1: Support of Activity Notification in EN-DC

Support of Activity Notification in EN-DC is used to keep the MN informed about user traffic activity in resources owned by the SN. The MN may take appropriate action upon receiving such notification.

1. The SN informs the MN about user data inactivity of resources owned by the SN.
2. The MN decides to keep SN resources.
3. After a while the SN reports resumption of user plane activity.

10.12.2 MR-DC with 5GC

The Activity Notification function is used to report user plane activity within SN resources or to report a RAN Paging Failure event to the SN. It can either report inactivity or resumption of activity after inactivity was reported. In MR-DC with 5GC the Activity Reporting is provided from the SN only. The MN may take further actions. RAN Paging Failure Reporting is provided from the MN only.

MR-DC with 5GC Activity Notification

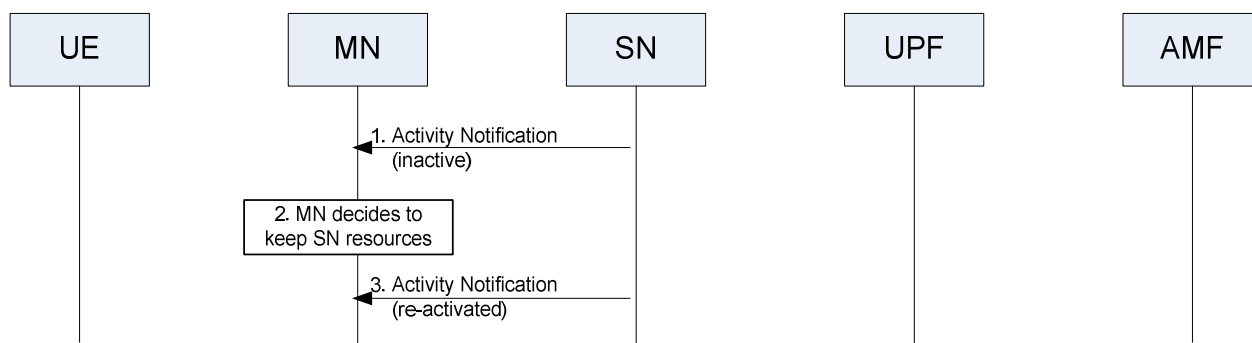

Figure 10.12.2-1: Support of Activity Notification in MR-DC with 5GC

1. The SN notifies the MN about user data inactivity.
2. The MN decides further actions that impact SN resources (e.g. send UE to RRC_INACTIVE, bearer reconfiguration). In the case shown, MN takes no action.
3. The SN notifies the MN that the (UE or PDU Session or QoS flow) is no longer inactive.

MR-DC with 5GC with RRC_INACTIVE

The Activity Notification function may be used to enable MR-DC with 5GC with RRC_INACTIVE operation. The MN node may decide, after inactivity is reported from the SN and also MN resources show no activity, to send the UE to

RRC_INACTIVE. Resumption to RRC_CONNECTED may take place after activity is reported from the SN for SN terminated bearers.

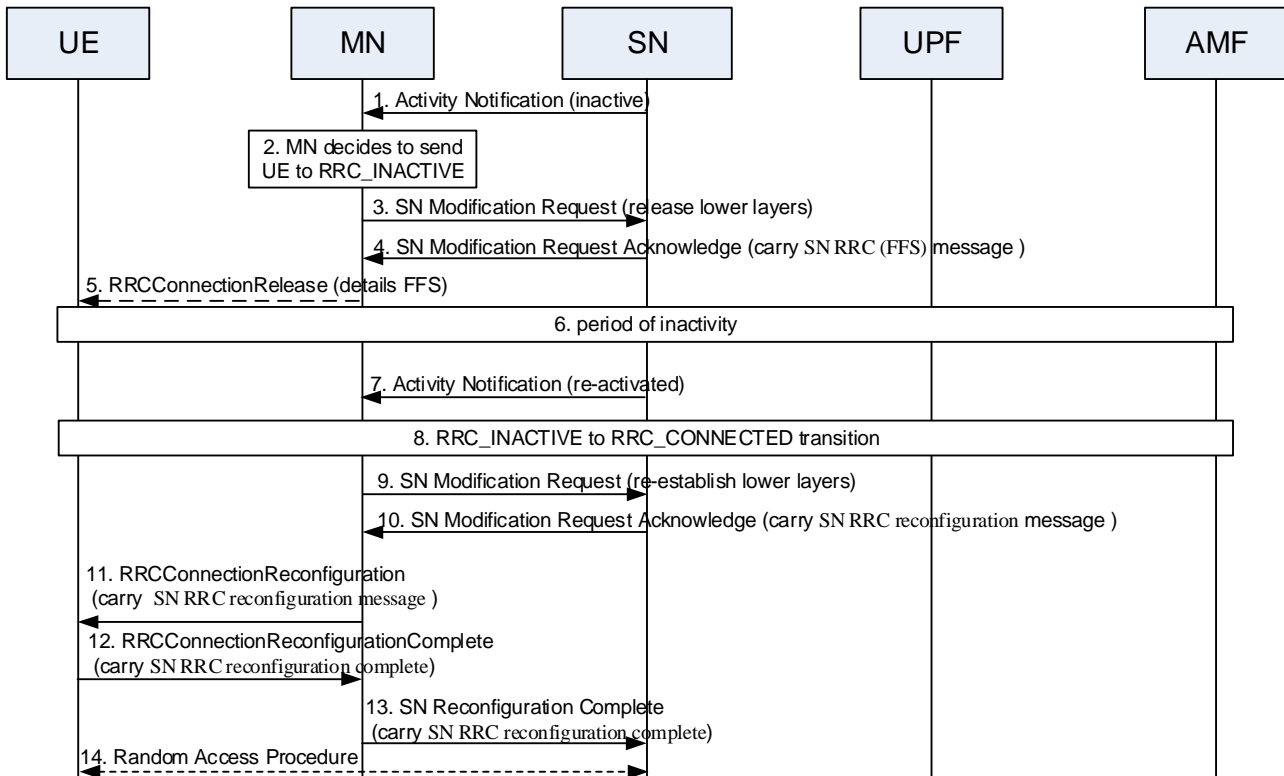

Figure 10.12.2-2: Support of Activity Notification in MR-DC with 5GC with RRC_Inactive

Figure 10.12.2-2 shows how Activity Notification function interacts with NG-RAN functions for RRC_INACTIVE and SN Modification procedures in order to keep the higher layer MR-DC configuration established for UEs in RRC_INACTIVE, including NG and Xn interface C-plane, U-plane and bearer contexts established while lower layer MCG and SCG resources are released. When the UE transits successfully back to RRC_CONNECTED, lower layer MCG and SCG resources are established afterwards by means of RRC Connection Reconfiguration.

Editors Note: RRC related details are FFS.

Editors Note: Figure 10.12.2-2 depicts the case where the UE when coming back to RRC_CONNECTED consumes radio resources from the same SN and MN as before it was sent to RRC_INACTIVE. Whether further scenarios need to be depicted needs further discussions.

1. The SN notifies the MN about user data inactivity for SN terminated bearers.
2. The MN decides to send the UE to RRC_INACTIVE.
- 3/4. The MN triggers the MN initiated SN Modification procedure, requesting the SN to release lower layers.
5. The UE is sent to RRC_INACTIVE.
- 6-8. After a period of inactivity, upon activity notification from the SN, the UE returns to RRC_CONNECTED.
- 9/10. The MN triggers the MN initiated SN Modification procedure to re-establish lower layers. The SN provides configuration data within an *SN RRC configuration* message.
- 11-14. The RRCConnectionReconfiguration procedure commences.

10.13 Notification Control Indication

10.13.1 EN-DC

Notification Control Indication procedure is not supported in EN-DC.

10.13.2 MR-DC with 5GC

The Notification Control Indication procedure may be initiated either by the MN or by the SN and is used to indicate that GBR for one or several QoS flows cannot be fulfilled any more or can be fulfilled again by the reporting node.

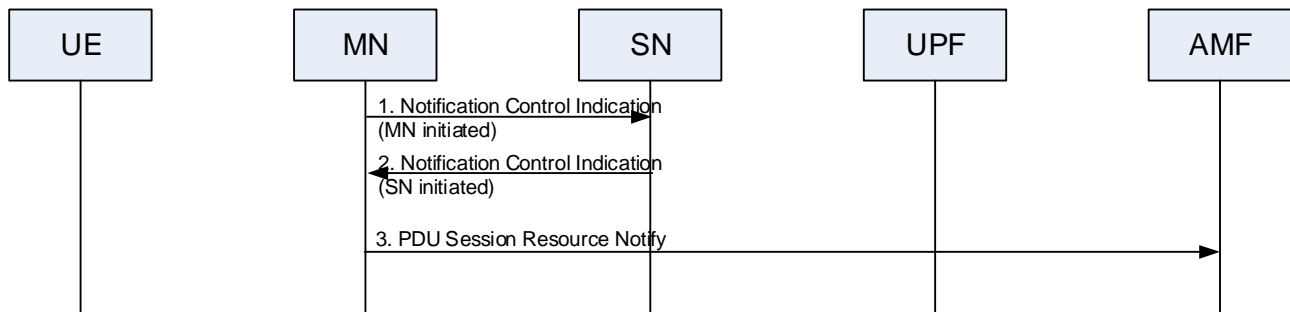

Figure 10.13.2-1: Notification Control Indication procedure

Figure 10.13.2-1 shows an example signalling flow for the Notification Control Indication procedure.

1. The MN may, for an SN terminated bearer, indicate, that the GBR requested from the MN cannot be fulfilled anymore.
In case the SN terminated bearer is configured as a split bearer, the SN may decide to increase the share provided by the SN or it may decide to notify the MN that resources requested for the SN terminated bearer cannot fulfill the GBR any more.
2. Continuing the example message flow from step 1, the SN informs the MN that the GBR for an SN terminated bearer cannot be fulfilled any more.
3. The MN decides to inform the 5GC that NG-RAN cannot fulfill the GBR for a GBR QoS flow any more.

10.14 PDU Session Split at UPF

10.14.1 PDU Session Split at UPF during PDU session resource setup

When a new PDU session needs to be established, the 5GC may provide two UL TEID addresses during PDU Session Resource Setup in order to allow for PDU session split. If the MN decides to split the PDU session, the MN provides two DL TEID addresses and also the QoS flows associated with the tunnel.

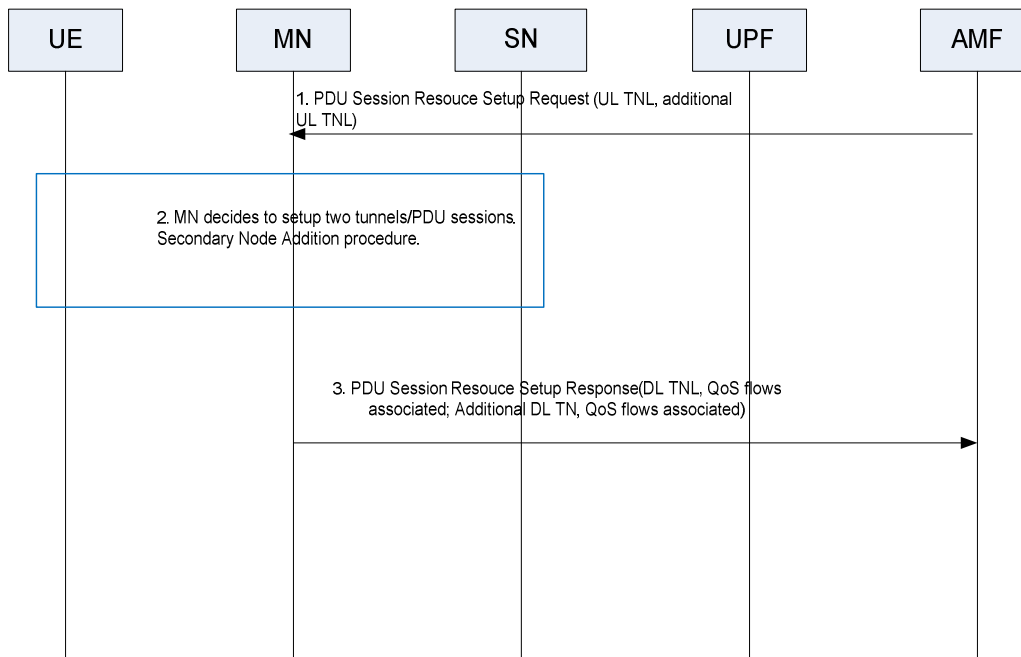

Figure 10.14.1-1: PDU Session Split at UPF during PDU session resource setup

1. The 5GC provides two UL TEID addresses during PDU Session Resource Setup, to be applied as the first UL tunnel on the NG-U interface and the additional NG-U tunnel in case the MN decides to split the PDU session.
2. The MN decides to setup two tunnels. MN uses the SN Addition procedure as described in 10.2.2 up to step 6 or SN Modification procedure as described in 10.3.2 up to step 8.
3. The MN provides a DL TEID address to be applied as the first and an additional DL tunnel address on the NG-U interface. MN also provides which QoS flows are associated with which tunnel.

10.14.2 PDU Session Split at UPF during PDU session resource modify (5GC initiated)

When 5GC uses the PDU sessions resource modify procedure, the 5GC may provide an additional UL TEID address during PDU Session Resource Modify Request in order to allow the MN to split the PDU session. The MN may perform the SN Addition or SN modification procedure. If the MN decides to use PDU session split, the MN provides a DL TEID address to be applied as the additional DL tunnel address and the QoS flows associated to the tunnel.

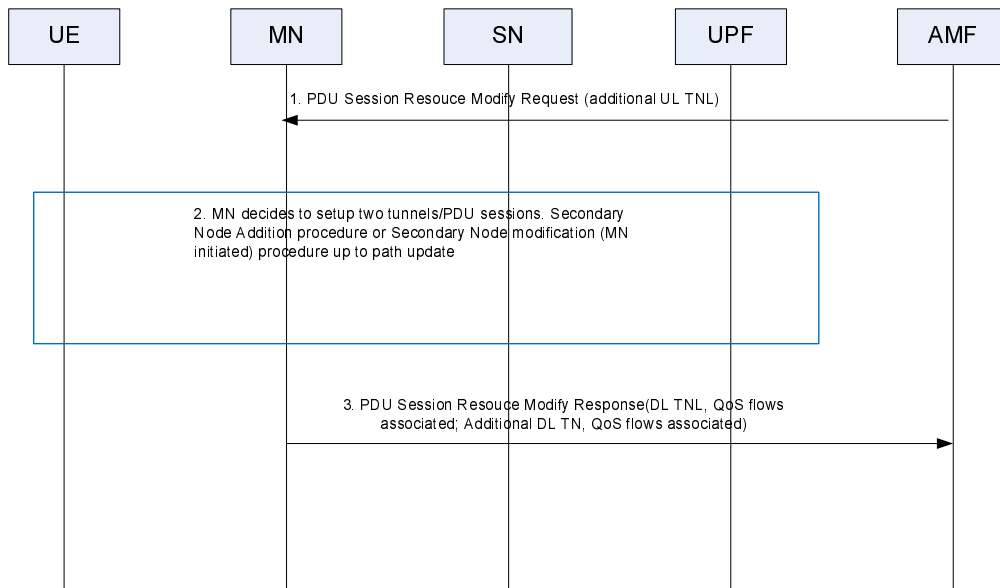

Figure 10.14.2-1: PDU Session Split at UPF during PDU session resource modify

1. The 5GC provides an additional UL TEID address during PDU Session Resource Modify Request, to be applied as the additional NG-U tunnel in case the MN decides to split the PDU session.
2. The MN decides to setup two tunnels. If the new tunnel is to be setup at SN, the MN may perform SN Addition as described in 10.2.2 up to step 6 or the MN performs SN modification as described in 10.3.2 up to step 8.
3. The MN provides a DL TEID address to be applied as the additional DL tunnel address on the NG-U interface and the QoS flows associated with it.

10.14.3 PDU Session Split at UPF (RAN initiated QoS flows offloading from MN to SN)

When the MN decides to split the PDU session into more than one NG-U tunnels, the MN sends the *SN Addition/Modification Request* message including UPF UL TEID address used at MN. Later on, if the MN receives a new UL TEID in the *PDU Session Resource Modify Confirm* message, the MN may provide the new UL TEID to SN.

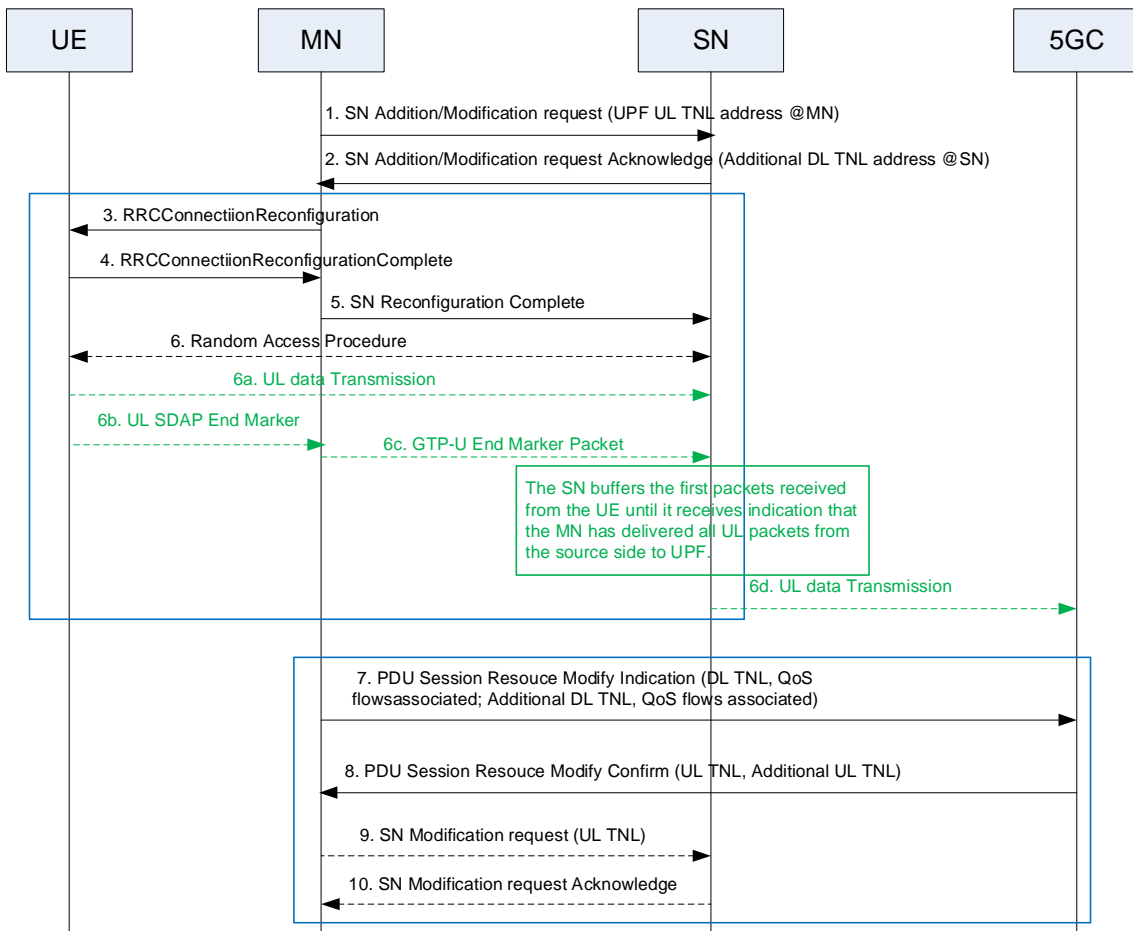

Figure 10.14.3-1: PDU Session Split at UPF during RAN initiated PDU session resource modify (QoS flows offloading from MN to SN)

- 1-2. The MN decides to split the PDU session, it uses the SN Addition procedure or SN modification procedure, including current UPF UL NG-U tunnel used at the MN. If in-order delivery is required for some of the QoS flows, UL forwarding tunnels may be setup at this stage.
- 3-6d. If in-order delivery is required, the SN buffers the first packets received from the UE for a certain QoS flow until it receives GTP-U end marker packets over the UL forwarding tunnel indicating that the MN has delivered all UL packets from the source side to UPF for that QoS flow. Then SN starts delivering UL packets to UPF for that QoS flow using the UPF UL TEID address used at the MN received at step 1.
- 7-8. The MN uses the *PDU Session Resource Modify Indication* to inform the 5GC that the PDU session is split into two tunnels and indicate which QoS flows are associated with which DL tunnel. The 5GC confirms with *PDU Session Resource Modify Confirm* and allocates corresponding uplink tunnels.
- 9-10. If the MN receives a new UL TEID in the *PDU Session Modify Confirm* message for itself, the MN will use it. If the MN receives a new UL TEID for the SN then the step 9 and step 10 (i.e., SN Modification procedure) are used to provide the new UL TEID to the SN in a subsequent *SN Modification Request* message and then the SN switches to use the new UL TEID to deliver UL packets.

10.14.4 PDU Session Split at UPF (RAN initiates QoS flows offloading from SN to MN)

When some QoS flows are offloaded from the SN to the MN, the MN may decide to split the PDU session into more than one NG-U tunnels. If the MN requests to offload, the MN sends *SN Modification Request* message to the SN. In case the SN requests to offload, the SN sends the *SN Modification Required* message to the MN.

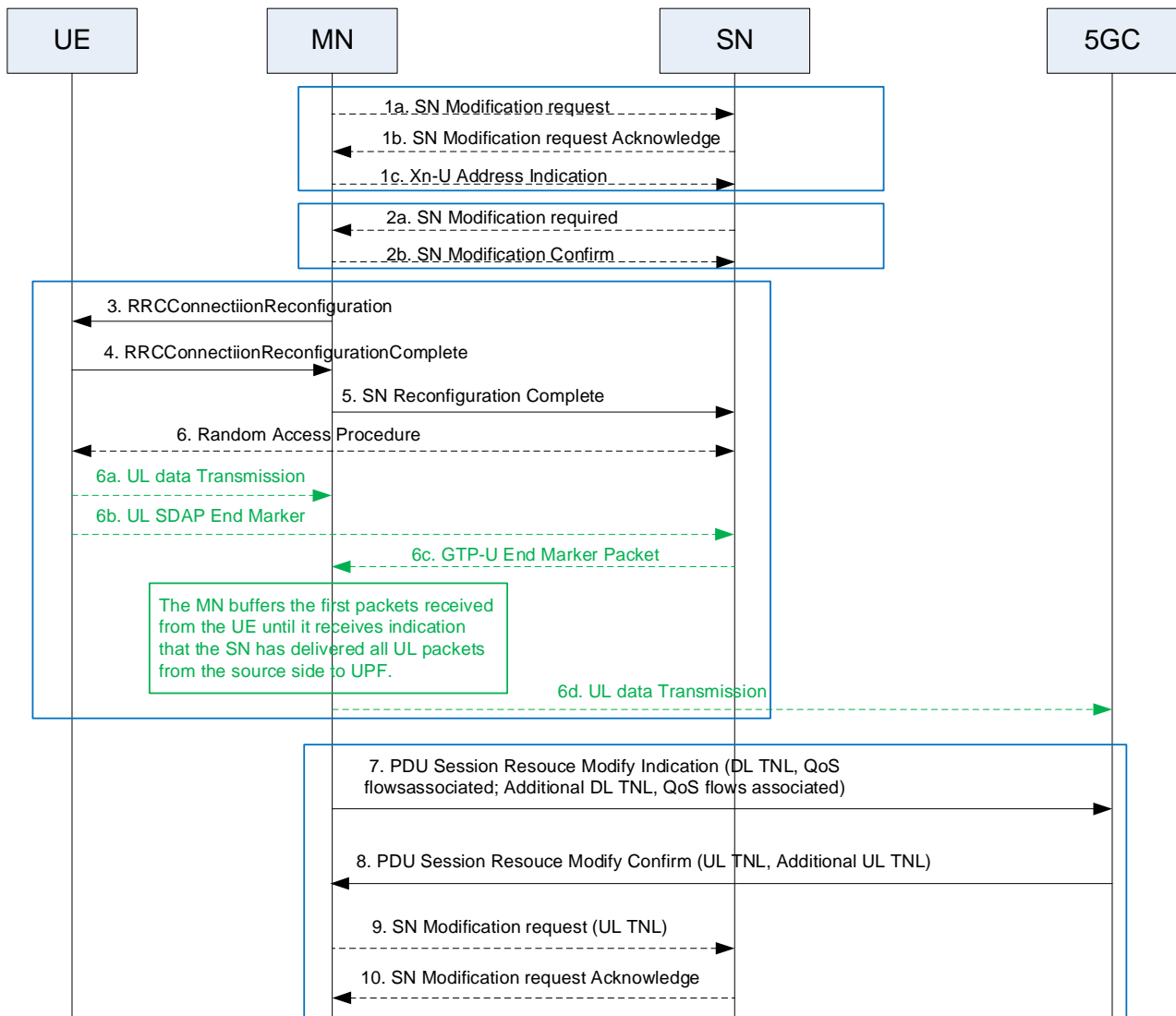

Figure 10.14.4-1: PDU Session Split at UPF during RAN initiated PDU session resource modify (QoS flows offloading from SN to MN)

- 1a-1c. When the MN requests to offload QoS flows from the SN to the MN and decides to split the PDU session into more than one NG-U tunnels, it sends the *SN Modification Request* message. If in-order delivery is required for some of the QoS flows, UL forwarding tunnels may be setup at this stage and the MN provides UL forwarding tunnels address information in the *Xn-U Address Indication* message.
- 2a-2b. When the SN requests to offload QoS flows from SN to MN, the SN sends the *SN Modification Required* message. If in-order delivery is required for some of the QoS flows, UL forwarding tunnels may be setup at this stage and the MN provides the UL forwarding tunnels address information in the *SN Modification Confirm* message.
- 3-6d. If in-order delivery is required, the MN buffers the first packets received from the UE for a certain QoS flow until it receives GTP-U end marker packets over the UL forwarding tunnel indicating that the SN has delivered all UL packets from the source side to UPF for that QoS flows.
- 7-8. The MN uses the *PDU Session Resource Modify Indication* to inform the 5GC that the PDU session is split into two tunnels and indicate which QoS flows are associated with which DL tunnel. The 5GC confirms with *PDU Session Resource Modify Confirm* and allocates corresponding uplink tunnels.
- 9-10. If the MN receives a new UL TEID in the *PDU Session Modify Confirm* message for itself, the MN will use it to deliver UL packets to UPF. If the MN receives a new UL TEID for the SN then the step 9 and step 10 (i.e., SN Modification procedure) are used to provide the new UL TEID to the SN in a subsequent *SN Modification Request* message and then the SN switches to use the new UL TEID to deliver UL packets.

11 Service related aspects

11.1 Roaming and Access Restrictions

The principles for conveying roaming and access restriction info for EN-DC are described in TS 36.300 [2].

For MR-DC with 5GC, SCG (re)selection at the SN is based on roaming and access restriction information in SN. If roaming and access restriction information is not available at the SN, the SN shall consider that there is no restriction for SCG (re)selection. Therefore, MN needs to convey the up-to-date roaming and access restriction information to SN via XnAP messages.

11.2 Support of Network Sharing

E-UTRAN and NG-RAN aspects of network sharing are specified in TS 36.300 [2] and TS 38.300 [3].

12 X2/Xn Interface related aspects

Stage 2 specification for X2-C procedures for EN-DC is contained in TS 36.300 [2].

Xn-C procedures for MR-DC with 5GC are specified in TS 38.423 [5].

X2-U procedures for EN-DC and Xn-U procedures for MR-DC with 5GC are specified in TS 38.425 [6].

13 Other aspects

13.1 Interference avoidance for in-device coexistence

In-Device Coexistence (IDC) solution as described in TS 36.300 [2] is extended to address EN-DC operation. Only FDM solution, where the list of NR carriers suffering from IDC problems is signalled in IDC indication, is supported in this version of the specifications. The requirement on RRM/RLM/CSI measurements in different phases of IDC interference defined in TS 36.300 [2] is applicable except that for NR serving cell, the requirements in TS 38.133 [8] and TS 38.101-1 [12], TS 38.101-2 [13], TS 38.101-3 [14] apply.

Annex A (informative): Layer 2 handling for bearer type change

This clause provides for information an overview on L2 handling for bearer type change in MR-DC, with and without security key change, i.e. with and without a change of the termination point.

Table A-1: L2 handling for bearer type change with and without security key change

Bearer type change from row to col	MCG		Split		SCG	
	no key change	with key change (change of termination point)	no key change	with key change (change of termination point)	no key change	with key change (change of termination point)
MCG	N/A	PDCP: Re-establish MCG RLC: See Note 1 MCG MAC: See Note 1 SCG RLC: No action SCG MAC: No action	PDCP: Reconfigure MCG RLC: No action MCG MAC: No action SCG RLC: Establish SCG MAC: Reconfigure	PDCP: Re-establish MCG RLC: See Note 1 MCG MAC: See Note 1 SCG RLC: Establish SCG MAC: Reconfigure	PDCP: Recovery MCG RLC: See Note 3 MCG MAC: Reconfigure SCG RLC: Establish SCG MAC: Reconfigure	PDCP: Re-establish MCG RLC: See Note 3 MCG MAC: Reconfigure SCG RLC: Establish SCG MAC: Reconfigure
Split	PDCP: Recovery MCG RLC: No action MCG MAC: No action SCG RLC: See Note 4 SCG MAC: Reconfigure	PDCP: Re-establish MCG RLC: See Note 1 MCG MAC: See Note 1 SCG RLC: See Note 4 SCG MAC: Reconfigure	N/A	PDCP: Re-establish MCG RLC: See Note 1 MCG MAC: See Note 1 SCG RLC: See Note 1 SCG MAC: See Note 1	PDCP: Recovery MCG RLC: See Note 3 MCG MAC: Reconfigure SCG RLC: No action SCG MAC: No action	PDCP: Re-establish MCG RLC: See Note 3 MCG MAC: Reconfigure SCG RLC: See Note 1 SCG MAC: See Note 1
SCG	PDCP: Recovery MCG RLC: Establish MCG MAC: Reconfigure SCG RLC: See Note 4 SCG MAC: Reconfigure	PDCP: Re-establish MCG RLC: Establish MCG MAC: Reconfigure SCG RLC: See Note 4 SCG MAC: Reconfigure	PDCP: Reconfigure MCG RLC: Establish MCG MAC: Reconfigure SCG RLC: No action SCG MAC: No action	PDCP: Re-establish MCG RLC: Establish MCG MAC: Reconfigure SCG RLC: See Note 1 SCG MAC: See Note 1	N/A	PDCP: Re-establish MCG RLC: No action MCG MAC: No action SCG RLC: See Note 1 SCG MAC: See Note 1

NOTE 1: For EN-DC and NGEN-DC MCG, NE-DC SCG: the MAC/RLC behaviour depends on the solution selected by the network. It can be PCell handover (for EN-DC and NGEN-DC) or PSCell change (for NE-DC), which triggers MAC reset and RLC re-establishment. Alternatively, the logical channel identity can be changed, either via RLC bearer release and add for the same DRB (including RLC re-establishment), or via reconfiguration of the RLC bearer with RLC-re-establishment.

For EN-DC and NGEN-DC SCG, NE-DC MCG, NR-DC MCG and SCG: the MAC/RLC behaviour depends on the solution selected by the network. It can be reconfiguration with sync, with MAC reset and RLC re-establishment. Alternatively, the logical channel identity can be changed via RLC bearer release and add.

NOTE 2: Void

NOTE 3: For EN-DC and NGEN-DC: Re-establishment and release. For NE-DC and NR-DC: Release.

NOTE 4: For NE-DC: Re-establishment and release. For EN-DC, NGEN-DC and NR-DC: Release.

Annex B (informative): Supported MR-DC Handover Scenarios

Table B-1 summarizes the supported handover scenarios involving MR-DC configurations.

Table B-1: Supported MR-DC handover scenarios.

To (column) HO from (row)	E-UTRA with EPC	E-UTRA with 5GC	NR	GERAN or UTRAN	EN-DC	NGEN-DC	NE-DC	NR-DC
E-UTRA with EPC	YES	YES	YES	YES	YES	NO	NO	NO
E-UTRA with 5GC	YES	YES	YES	NO	NO	YES	NO	NO
NR	YES	YES	YES	NO	NO	NO	YES	YES
GERAN or UTRAN	YES	NO	NO	YES	NO	NO	NO	NO
EN-DC	YES	YES	YES	YES	YES	NO	NO	NO
NGEN-DC	YES	YES	YES	NO	NO	YES	NO	NO
NE-DC	YES	YES	YES	NO	NO	NO	YES	NO
NR-DC	YES	YES	YES	NO	NO	NO	NO	YES

Annex C (informative): Change history

Change history							
Date	Meeting	Tdoc	CR	Rev	Cat	Subject/Comment	New version
2017.04	RAN2#9 7bis	R2-1703828	-	-	-	Draft Skeleton	0.0.1
2017.04	RAN2#9 7bis	R2-1703923	-	-	-	Endorsed Skeleton	0.0.2
2017.05	RAN2#9 8	R2-1704898	-	-	-	Initial version, including: Agreements from TR38.912 Agreements from RAN2#97bis on: - System information handling - Measurements - UE capability coordination - Handling of combined MN/SN RRC messages - SCG SRB - MCG split SRB - SN/MN Failure handling - QoS aspects - Bearer type configuration - Security aspects	0.1.0
2017.06	RAN2 NR AdHoc2	R2-1706418	-	-	-	Agreements from RAN3#96 on: - Network interfaces - Initial EN-DC operation related aspects - UP related aspects Agreements from RAN2#98 on: - Measurement coordination - UE capability coordination - SCG SRB Further RAN2 agreements on EN-DC operation related aspects	0.1.1
2017.06	RAN2 NR AdHoc2	R2-1707467	-	-	-	Endorsed version at RAN2 NR AH2, also including: Initial description of procedures for MR-DC with 5GC Correction to SN initiated SN change procedure for EN-DC	0.2.0
2017.08	RAN2#9 9	R2-1708080	-	-	-	Agreements from RAN3 NR AH2 on: - Data forwarding for SCG split bearer - Path Update procedure Agreements from RAN2 NR AH2 on: - Bearer type harmonization / bearer type change - UE capability coordination - SRB3 (SCG SRB) - MCG Split SRB - SN failure handling - Security handling - SN Addition procedure - MN initiated SN Modification/Release procedures Miscellaneous corrections	0.2.1
2017.08	RAN2#9 9	R2-1709831	-	-	-	Endorsed version at RAN2#99	0.3.0
2017.08	RAN2#9 9	R2-1709939	-	-	-	Agreements from RAN2#99 on: - Bearer type harmonization / bearer type change - SN failure handling - Measurement result exchange - Security aspects - Embedded RRC transport - Other MR-DC procedures related aspects RAN3 endorsed TPs on miscellaneous corrections to MR-DC procedures (in R3-173187, R3-173380, R3-173381, R3-173384, R3-173386, R3-173388 and R3-173390),	0.4.0
2017.09	RAN#77	RP-171872	-	-	-	Provided for information to RAN	1.0.0
2017.09	RAN#77	RP-172036	-	-	-	Correction of some auto-formatting issues	1.0.1
2017.09	RAN2#9 9bis	R2-1711526	-	-	-	Alignment to the agreed terminology for the different nodes: - introduction of the en-gNB term - replacement of MeNB and SgNB with MN and SN Clarification on UE capabilities coordination Clarification in Figure 4.2.2-2 that there is one SDAP entity per cell group	1.0.2
2017.10	RAN2#9 9bis	R2-1711937	-	-	-	Endorsed version at RAN2#99bis	1.1.0
2017.10	RAN2#9	R2-1712072	-	-	-	Agreements from RAN2#99bis on:	1.1.1

	9bis					<ul style="list-style-type: none"> - Bearer type harmonization / bearer type change - SCG change and Pscell change - MN/SN measurement coordination - UE capabilities coordination - MR-DC procedures related aspects - Security aspects Agreed Text Proposals in: <ul style="list-style-type: none"> - R2-1711929 TP on SN modification without MN involvement - R2-1711942 TP on inter-MN HO with SN change Agreements from RAN3#97bis in R3-174254, collecting changes from: <ul style="list-style-type: none"> - R3-174214 Text Proposal for QoS Handling in 5GC DC - R3-174132 Completion of the RRC tunnelling in MR-DC - R3-174136 Stage 2 TP on bearer type change without MAC reset - R3-174221 TP for Supporting MN Initiate SN Change - R3-174194 UE-AMBR enforcement - R3-174234 Secondary RAT data volume reporting - R3-174160 MN and SN role for QoS flow to DRB mapping - R3-174101 Clean-up of 37.340 RAN3 Related Part 	
2017.11	RAN2#100	R2-1712301	-	-	-	Clean version	1.2.0
2017.11	RAN2#100	R2-1712302	-	-	-	MR-DC related agreements moved from TS 38.300: <ul style="list-style-type: none"> - on two C-RNTIs independently allocated at the UE - on RLF declared separately for the MCG and for the SCG - on roaming and access restrictions for MR-DC with 5GC - on SPS and BSR configuration, triggering and reporting Addition of a note on support of ideal backhaul. Clarification on use of SRB3. Clarification on security key handling. Editorial corrections in various Figures Removal of FFSs for MR-DC with 5GC (moved to a separate list)	1.2.1
2017.12	RAN2#100	R2-1714080	-	-	-	Agreed Text Proposals in: <ul style="list-style-type: none"> - R2-1713141 TP on 37.340 - R2-1713838 Bearer type change with PDPC version change - R2-1714176 PSCell change clarification and SCG Change removal - R2-1714183 Stage 2 TP to update bearer type description - R2-1714237 Clarification for the MR-DC QoS framework - R3-174308 Cleanup of reference/definitions for 37.340 - R3-174565 TP for SCG Change related to Bearer Type Change - R3-174661 TP for querying SCGconfig for MN to eNB/gNB Change - R3-174763 TP for a unified 5G User Plane protocol - R3-174876 Further Clean-up of TS37.340 RAN3 Related Part - R3-174913 Clarifications on Inter-MN handover with SN change - R3-174916 Clarification on the interface between gNB for Option 3 - R3-174917 Tunnel ID switching in case of reconfiguration - R3-174921 Introducing bearer harmonization – RAN3 parts - R3-174923 On security related IE in MN initiated SN modification - R3-174928 TP on UE-AMBR for EN-DC - R3-174930 Stage 2 for secondary RAT data volume reporting - R3-175009 Removing data forwarding from corresponding node - R3-175048 Stage 2 TP for bearer type change - R3-174975 Race conditions in case of SN release Other miscellaneous agreements from RAN2#100	1.2.2
2017.12	RAN2#100	R2-1714251	-	-	-	RAN2 agreed version	1.3.0
2017.12	RP-78	RP-172464	-	-	-	Provided for approval to RAN	2.0.0
2017/12	RP-78					Upgraded to Rel-15	15.0.0
2018/03	RP-79	RP-180440	0004	1	F	Miscellaneous corrections	15.1.0
	RP-79	RP-180440	0008	1	F	Baseline CR for TS 37.340 (RAN3 part) covering agreements of RAN3 #NR adhoc 1801 and RAN3 #99	15.1.0
2018/06	RP-80	RP-181214	0012	2	F	Further miscellaneous corrections	15.2.0
	RP-80	RP-181214	0014	1	F	CR on EN-DC bearer type changes in TS 37.340	15.2.0
	RP-80	RP-181214	0015	1	F	CR on EN-DC reconfiguration procedure via SRB3 in TS 37.340	15.2.0
	RP-80	RP-181214	0017	-	F	Radio Protocol Architecture figure clarification with SDAP	15.2.0
	RP-80	RP-181215	0018	1	F	Stage 2 CR on combined bearer type and termination point change	15.2.0
	RP-80	RP-181215	0021	1	F	Correction to TS 37.340 on PDPC version for SRB	15.2.0
	RP-80	RP-181215	0024	1	F	L2 handling for bearer type change when PDPC SN length changed	15.2.0
	RP-80	RP-181215	0025	1	F	Correction on SN configured NR measurements after SCG failure	15.2.0
	RP-80	RP-181215	0026	1	F	Clarification of the usage of SN Status Transfer	15.2.0
	RP-80	RP-181215	0027	-	F	Addition of the full config indicator in SN Change	15.2.0
	RP-80	RP-181216	0028	2	F	Coordination of Inactivity for EN-DC	15.2.0
	RP-80	RP-181216	0029	-	F	CR on maintaining the bearer type on wrap-around for TS37.340	15.2.0
	RP-80	RP-181216	0030	2	F	Enabling re-use of NR PCIs in cells served by the same SN in EN-DC	15.2.0
2018/09	RP-81	RP-181939	0037	2	F	Clarification on number of CC for NR CA	15.3.0
	RP-81	RP-181942	0039	2	F	CR for 37.340 for CA duplication of LTE bearer	15.3.0
	RP-81	RP-181942	0042	-	F	Capturing the agreement related to Count wrap around handling for	15.3.0

						split bearer type	
	RP-81	RP-181941	0043	1	F	Miscellaneous clarifications	15.3.0
	RP-81	RP-181941	0044	1	F	Inclusion of measurement gap related agreements	15.3.0
	RP-81	RP-181942	0046	2	F	Small correction about bear type change	15.3.0
	RP-81	RP-181942	0047	3	F	CR to 37.340 on the Layer 2 handling for bearer type change	15.3.0
	RP-81	RP-181939	0048	-	F	CR on the support of RLC mode reconfiguration	15.3.0
	RP-81	RP-181939	0051	-	F	Corrections on 37.340 for bearer type change support	15.3.0
	RP-81	RP-181941	0054	1	F	NR Corrections (37.340 Baseline CR covering RAN3-101 agreements)	15.3.0
2018/12	RP-82	RP-182650	0067	1	F	Split SRB UL configuration	15.4.0
	RP-82	RP-182656	0071	1	F	Miscellaneous clarifications	15.4.0
	RP-82	RP-182669	0073	4	B	Agreements for MR-DC	15.4.0
	RP-82	RP-182651	0079	-	F	Correction for SN terminated MCG bearer	15.4.0
	RP-82	RP-182667	0082	3	F	Updates to UE capability coordination for MR-DC	15.4.0
	RP-82	RP-182664	0084	2	F	Corrections on RRC transfer procedure in EN-DC	15.4.0
	RP-82	RP-182666	0085	3	F	Correction of SN Initiated SN Modification procedure for Measurement Gap	15.4.0
	RP-82	RP-182660	0086	1	F	Stage 2 CR on Measurement gap configuration scenarios	15.4.0
	RP-82	RP-182669	0092	1	B	Baseline CR for TS37.340	15.4.0
2019/03	RP-83	RP-190543	0090	3	F	Corrections for MR-DC procedures	15.5.0
	RP-83	RP-190543	0096	2	F	QoS flow offloading for MR-DC	15.5.0
	RP-83	RP-190540	0098	1	F	Introduction of IDC mechanism for EN-DC operation	15.5.0
	RP-83	RP-190543	0104	1	F	Correction on UP integrity protection in late drop	15.5.0
	RP-83	RP-190543	0106	1	F	Corrections to SN Modification Request in MR-DC	15.5.0
	RP-83	RP-190553	0107	-	F	PSCell information for LI purposes	15.5.0
	RP-83	RP-190544	0108	-	F	Correction of EN DC data volume reporting and relocation	15.5.0
	RP-83	RP-190544	0110	-	F	Data volume reporting for MR-DC with 5GC	15.5.0
	RP-83	RP-190544	0111	-	F	Correction of RAN triggered PDU session split	15.5.0
	RP-83	RP-190544	0112	-	F	Correction of PDU session split at handover	15.5.0
	RP-83	RP-190544	0113	-	F	TEID change in case of key change	15.5.0
	RP-83	RP-190545	0114	1	F	Support of PDU session split during inter-MN handover for MR-DC with 5GC	15.5.0
2019/06	RP-84	RP-191375	0116	1	F	MN-SN coordination for ANR in MR-DC	15.6.0
	RP-84	RP-191378	0118	3	F	CR on 37.340 for s-Measure in NR-DC and NE-DC	15.6.0
	RP-84	RP-191374	0120	-	F	Clarification on RLC bearer release and add	15.6.0
	RP-84	RP-191374	0122	-	F	Activation/deactivation of SCells in MR-DC	15.6.0
	RP-84	RP-191374	0123	-	F	Corrections on MN and SN inter-node resource coordination	15.6.0
	RP-84	RP-191376	0124	1	F	Measurement gap coordination in MR-DC	15.6.0
	RP-84	RP-191379	0125	2	F	Inter-RAT HO support	15.6.0
	RP-84	RP-191376	0126	1	F	Editorial clean-up	15.6.0
	RP-84	RP-191379	0133	-	F	Various Clean-ups for TS37.340	15.6.0
	RP-84	RP-191380	0134	-	F	Correction of RAN triggered PDU session split	15.6.0
	RP-84	RP-191381	0135	1	F	Allow MN to retrieve forwarding proposal from the source SN	15.6.0
	RP-84	RP-191380	0136	-	F	RAN paging failure handling in SN	15.6.0
	RP-84	RP-191380	0137	-	F	Rapporteur Clean-ups of Secondary RAT Data Volume Report	15.6.0
	RP-84	RP-191380	0138	-	F	Correction of the references to the GTP tunnel endpoint information	15.6.0
	RP-84	RP-191380	0139	-	F	In-order delivery when QoS flows offloaded from SN	15.6.0
	RP-84	RP-191380	0140	-	F	RAN sharing with multiple Cell ID broadcast	15.6.0
2019/09	RP-85	RP-192191	0141	1	F	PDCP configuration generation	15.7.0
	RP-85	RP-192190	0142	1	F	Clarification on selectedBandCombination	15.7.0
	RP-85	RP-192194	0143	3	F	Clarification about PSCell change between different SN nodes	15.7.0
	RP-85	RP-192193	0144	2	F	Clarification of handover terminology	15.7.0
	RP-85	RP-192191	0145	1	F	Default DRB handling	15.7.0
	RP-85	RP-192192	0148	1	F	Capability report and coordination in NR-DC	15.7.0
	RP-85	RP-192191	0151	1	F	LTE to NR-DC Inter-RAT HO support	15.7.0
	RP-85	RP-192190	0153	-	F	Correction of E-RAB Modification Indication	15.7.0
	RP-85	RP-192191	0154	1	F	TS37.340 Rapporteur Cleanups	15.7.0

History

Document history		
V15.2.0	September 2018	Publication
V15.3.0	September 2018	Publication
V15.4.0	April 2019	Publication
V15.5.0	May 2019	Publication
V15.6.0	July 2019	Publication
V15.7.0	October 2019	Publication