

ETSI TS 137 544 V16.0.0 (2020-09)



**Universal Mobile Telecommunications System (UMTS);
LTE;
Universal Terrestrial Radio Access (UTRA)
and Evolved UTRA (E-UTRA);
User Equipment (UE) Over The Air (OTA) performance;
Conformance testing
(3GPP TS 37.544 version 16.0.0 Release 16)**



Reference

RTS/TSGR-0537544vg00

Keywords

LTE,UMTS

ETSI

650 Route des Lucioles
F-06921 Sophia Antipolis Cedex - FRANCE

Tel.: +33 4 92 94 42 00 Fax: +33 4 93 65 47 16

Siret N° 348 623 562 00017 - NAF 742 C
Association à but non lucratif enregistrée à la
Sous-Préfecture de Grasse (06) N° 7803/88

Important notice

The present document can be downloaded from:

<http://www.etsi.org/standards-search>

The present document may be made available in electronic versions and/or in print. The content of any electronic and/or print versions of the present document shall not be modified without the prior written authorization of ETSI. In case of any existing or perceived difference in contents between such versions and/or in print, the prevailing version of an ETSI deliverable is the one made publicly available in PDF format at www.etsi.org/deliver.

Users of the present document should be aware that the document may be subject to revision or change of status.

Information on the current status of this and other ETSI documents is available at

<https://portal.etsi.org/TB/ETSIDeliverableStatus.aspx>

If you find errors in the present document, please send your comment to one of the following services:

<https://portal.etsi.org/People/CommiteeSupportStaff.aspx>

Copyright Notification

No part may be reproduced or utilized in any form or by any means, electronic or mechanical, including photocopying and microfilm except as authorized by written permission of ETSI.

The content of the PDF version shall not be modified without the written authorization of ETSI.

The copyright and the foregoing restriction extend to reproduction in all media.

© ETSI 2020.

All rights reserved.

DECT™, **PLUGTESTS™**, **UMTS™** and the ETSI logo are trademarks of ETSI registered for the benefit of its Members.

3GPP™ and **LTE™** are trademarks of ETSI registered for the benefit of its Members and of the 3GPP Organizational Partners.

oneM2M™ logo is a trademark of ETSI registered for the benefit of its Members and of the oneM2M Partners.

GSM® and the GSM logo are trademarks registered and owned by the GSM Association.

Intellectual Property Rights

Essential patents

IPRs essential or potentially essential to normative deliverables may have been declared to ETSI. The information pertaining to these essential IPRs, if any, is publicly available for **ETSI members and non-members**, and can be found in ETSI SR 000 314: "*Intellectual Property Rights (IPRs); Essential, or potentially Essential, IPRs notified to ETSI in respect of ETSI standards*", which is available from the ETSI Secretariat. Latest updates are available on the ETSI Web server (<https://ipr.etsi.org/>).

Pursuant to the ETSI IPR Policy, no investigation, including IPR searches, has been carried out by ETSI. No guarantee can be given as to the existence of other IPRs not referenced in ETSI SR 000 314 (or the updates on the ETSI Web server) which are, or may be, or may become, essential to the present document.

Trademarks

The present document may include trademarks and/or tradenames which are asserted and/or registered by their owners. ETSI claims no ownership of these except for any which are indicated as being the property of ETSI, and conveys no right to use or reproduce any trademark and/or tradename. Mention of those trademarks in the present document does not constitute an endorsement by ETSI of products, services or organizations associated with those trademarks.

Legal Notice

This Technical Specification (TS) has been produced by ETSI 3rd Generation Partnership Project (3GPP).

The present document may refer to technical specifications or reports using their 3GPP identities. These shall be interpreted as being references to the corresponding ETSI deliverables.

The cross reference between 3GPP and ETSI identities can be found under <http://webapp.etsi.org/key/queryform.asp>.

Modal verbs terminology

In the present document "**shall**", "**shall not**", "**should**", "**should not**", "**may**", "**need not**", "**will**", "**will not**", "**can**" and "**cannot**" are to be interpreted as described in clause 3.2 of the [ETSI Drafting Rules](#) (Verbal forms for the expression of provisions).

"**must**" and "**must not**" are **NOT** allowed in ETSI deliverables except when used in direct citation.

Contents

Intellectual Property Rights	2
Legal Notice	2
Modal verbs terminology.....	2
Foreword.....	14
1 Scope	15
2 References	15
3 Definitions, symbols and abbreviations	17
3.1 Definitions	17
3.2 Symbols.....	17
3.3 Abbreviations	18
4 General	19
4.1 Terminal classes	20
4.1.1 Mechanical modes	20
4.2 UTRA chip rates.....	20
4.3 DUT positioning.....	20
4.3.1 DUT positioning for Speech Mode with beside the Head Phantom	20
4.3.2 DUT positioning for LMEs on Laptop Ground Plane Phantom	21
4.3.3 DUT positioning for Speech Mode with beside the Head and Hand Phantom	21
4.3.3.1 General	21
4.3.3.2 Mono-blocks and closed sliders	22
4.3.3.3 Folds and open-slides	23
4.3.3.4 PDA.....	23
4.3.4 DUT positioning for Browsing Mode with Hand Phantom	24
4.3.4.1 General	24
4.3.4.2 Narrow DUT	24
4.3.4.3 PDA.....	25
4.3.5 DUT positioning for devices with embedded modules.....	25
4.3.6 DUT positioning for total radiated multi-antenna sensitivity	25
4.3.6.1 Handheld UE – Free Space	25
4.3.6.1.1 MPAC Positioning Guidelines	25
4.3.6.1.2 RTS Positioning Guidelines	26
4.4 Sampling grid	26
4.5 Number of independent samples (for reverberation chamber procedure)	26
5 Measurement frequencies.....	26
5.1 UTRA FDD frequency bands and measurement channels	26
5.2 UTRA TDD frequency bands and measurement channels.....	27
5.3 E-UTRA FDD frequency bands and measurement frequencies allocations.....	28
5.4 E-UTRA TDD frequency bands and measurement frequencies allocations.....	35
5.5 E-UTRA FDD operating bands and measurement frequency allocations for receiver total radiated multi-antenna sensitivity	37
5.6 E-UTRA TDD operating bands and measurement frequency allocations for receiver total radiated multi-antenna sensitivity	39
6 Transmitter Performance	40
6.1 Performance for handheld UE	40
6.1.1 Total Radiated Power (TRP) for UTRA FDD in Speech Mode with beside the Head Phantom	40
6.1.1.1 Definition and applicability.....	40
6.1.1.2 Minimum Requirements.....	41
6.1.1.3 Test purpose	41
6.1.1.4 Method of test	41
6.1.1.4.1 Initial conditions	41
6.1.1.4.2 Procedure	42
6.1.1.4.3 Procedure, reverberation chamber method.....	42

6.1.1.5	Test requirements	43
6.1.2	Total Radiated Power (TRP) for UTRA LCR TDD in Speech Mode with beside the Head Phantom	43
6.1.2.1	Definition and applicability	44
6.1.2.2	Minimum Requirements	44
6.1.2.3	Test purpose	45
6.1.2.4	Method of test	45
6.1.2.4.1	Initial conditions	45
6.1.2.4.2	Procedure	46
6.1.2.4.3	Procedure, reverberation chamber method.....	46
6.1.2.5	Test requirements	46
6.1.3	Total Radiated Power (TRP) for UTRA FDD in Speech Mode with beside the Head and Hand Phantom	47
6.1.3.1	Definition and applicability.....	47
6.1.3.2	Minimum Requirements.....	48
6.1.3.3	Test purpose	49
6.1.3.4	Method of test	49
6.1.3.4.1	Initial conditions	49
6.1.3.4.2	Procedure	49
6.1.3.4.3	Procedure, reverberation chamber method.....	50
6.1.3.5	Test requirements	50
6.1.4	Total Radiated Power (TRP) for UTRA LCR TDD in Speech Mode with beside the Head and Hand Phantom	51
6.1.4.1	Definition and applicability.....	51
6.1.4.2	Minimum Requirements.....	52
6.1.4.3	Test purpose	53
6.1.4.4	Method of test	53
6.1.4.4.1	Initial conditions	53
6.1.4.4.2	Procedure	53
6.1.4.4.3	Procedure, reverberation chamber method.....	54
6.1.4.5	Test requirements	54
6.1.5	Total Radiated Power (TRP) for E-UTRA FDD in Speech Mode with beside the Head and Hand Phantom	55
6.1.5.1	Definition and applicability.....	55
6.1.5.2	Minimum Requirements.....	57
6.1.5.3	Test purpose	57
6.1.5.4	Method of test	57
6.1.5.4.1	Initial conditions	57
6.1.5.4.2	Procedure	58
6.1.5.4.3	Procedure, reverberation chamber method.....	58
6.1.5.5	Test requirements	58
6.1.6	Total Radiated Power (TRP) for E-UTRA TDD in Speech Mode with beside the Head and Hand Phantom	58
6.1.6.1	Definition and applicability.....	59
6.1.6.2	Minimum Requirements.....	60
6.1.6.3	Test purpose	60
6.1.6.4	Method of test	60
6.1.6.4.1	Initial conditions	60
6.1.6.4.2	Procedure	61
6.1.6.4.3	Procedure, reverberation chamber method.....	61
6.1.6.5	Test requirements	61
6.1.7	Total Radiated Power (TRP) for UTRA FDD in Browsing Mode with Hand Phantom.....	62
6.1.7.1	Definition and applicability.....	62
6.1.7.2	Minimum Requirements.....	63
6.1.7.3	Test purpose	63
6.1.7.4	Method of test	64
6.1.7.4.1	Initial conditions	64
6.1.7.4.2	Procedure	64
6.1.7.4.3	Procedure, reverberation chamber method.....	65
6.1.7.5	Test requirements	65
6.1.8	Total Radiated Power (TRP) for UTRA LCR TDD in Browsing Mode with Hand Phantom.....	65
6.1.8.1	Definition and applicability.....	66
6.1.8.2	Minimum Requirements.....	66

6.1.8.3	Test purpose	67
6.1.8.4	Method of test	67
6.1.8.4.1	Initial conditions	67
6.1.8.4.2	Procedure	68
6.1.8.4.3	Procedure, reverberation chamber method.....	68
6.1.8.5	Test requirements.....	68
6.1.9	Total Radiated Power (TRP) for E-UTRA FDD in Browsing Mode with Hand Phantom	69
6.1.9.1	Definition and applicability.....	69
6.1.9.2	Minimum Requirements.....	70
6.1.9.3	Test purpose	70
6.1.9.4	Method of test	70
6.1.9.4.1	Initial conditions	70
6.1.9.4.2	Procedure	71
6.1.9.4.3	Procedure, reverberation chamber method.....	71
6.1.9.5	Test requirements.....	71
6.1.10	Total Radiated Power (TRP) for E-UTRA TDD in Browsing Mode with Hand Phantom.....	72
6.1.10.1	Definition and applicability.....	72
6.1.10.2	Minimum Requirements.....	73
6.1.10.3	Test purpose	73
6.1.10.4	Method of test	73
6.1.10.4.1	Initial conditions	73
6.1.10.4.2	Procedure	73
6.1.10.4.3	Procedure, reverberation chamber method.....	74
6.1.10.5	Test requirements	74
6.2	Performance for LME	74
6.2.1	Total Radiated Power (TRP) for UTRA FDD LME	74
6.2.1.1	Definition and applicability.....	74
6.2.1.2	Minimum Requirements.....	75
6.2.1.3	Test purpose	76
6.2.1.4	Method of test	76
6.2.1.4.1	Initial conditions	76
6.2.1.4.2	Procedure.....	76
6.2.1.4.3	Procedure, reverberation chamber method	77
6.2.1.5	Test requirements.....	77
6.2.2	Total Radiated Power (TRP) for UTRA LCR TDD LME	78
6.2.2.1	Definition and applicability.....	78
6.2.2.2	Minimum Requirements.....	79
6.2.2.3	Test purpose	80
6.2.2.4	Method of test	80
6.2.2.4.1	Initial conditions	80
6.2.2.4.2	Procedure.....	81
6.2.2.4.3	Procedure, reverberation chamber method	81
6.2.2.5	Test requirements.....	82
6.2.3	Total Radiated Power (TRP) for E-UTRA FDD LME.....	82
6.2.3.1	Definition and applicability.....	82
6.2.3.2	Minimum Requirements.....	83
6.2.3.3	Test purpose	84
6.2.3.4	Method of test	84
6.2.3.4.1	Initial conditions	84
6.2.3.4.2	Procedure.....	84
6.2.3.4.3	Procedure, reverberation chamber method	84
6.2.3.5	Test requirements.....	84
6.2.4	Total Radiated Power (TRP) for E-UTRA TDD LME	85
6.2.4.1	Definition and applicability.....	85
6.2.4.2	Minimum Requirements.....	86
6.2.4.3	Test purpose	86
6.2.4.4	Method of test	86
6.2.4.4.1	Initial conditions	86
6.2.4.4.2	Procedure.....	87
6.2.4.4.3	Procedure, reverberation chamber method	87
6.2.4.5	Test requirements.....	87
6.3	Performance for LEE.....	87

6.3.1	Total Radiated Power (TRP) for UTRA FDD LEE	87
6.3.1.1	Definition and applicability.....	88
6.3.1.2	Minimum Requirements.....	88
6.3.1.3	Test purpose	89
6.3.1.4	Method of test	90
6.3.1.4.1	Initial conditions	90
6.3.1.4.2	Procedure	90
6.3.1.4.3	Procedure, reverberation chamber method.....	91
6.3.1.5	Test requirements.....	91
6.3.2	Total Radiated Power (TRP) for UTRA LCR TDD LEE	93
6.3.2.1	Definition and applicability.....	93
6.3.2.2	Minimum Requirements.....	94
6.3.2.3	Test purpose	94
6.3.2.4	Method of test	95
6.3.2.4.1	Initial conditions	95
6.3.2.4.2	Procedure	95
6.3.2.4.3	Procedure, reverberation chamber method.....	96
6.3.2.5	Test requirements.....	96
6.3.3	Total Radiated Power (TRP) for E-UTRA FDD LEE	97
6.3.3.1	Definition and applicability.....	98
6.3.3.2	Minimum Requirements.....	99
6.3.3.3	Test purpose	100
6.3.3.4	Method of test	100
6.3.3.4.1	Initial conditions.....	100
6.3.3.4.2	Procedure.....	101
6.3.3.4.3	Procedure, reverberation chamber method	101
6.3.3.5	Test requirements.....	101
6.3.4	Total Radiated Power (TRP) for E-UTRA TDD LEE	102
6.3.4.1	Definition and applicability.....	102
6.3.4.2	Minimum Requirements.....	103
6.3.4.3	Test purpose	104
6.3.4.4	Method of test	104
6.3.4.4.1	Initial conditions.....	104
6.3.4.4.2	Procedure.....	105
6.3.4.4.3	Procedure, reverberation chamber method	105
6.3.4.5	Test requirements.....	105
7	Receiver Performance	106
7.1	Performance for handheld UE	106
7.1.1	Total Radiated Sensitivity (TRS) for UTRA FDD in Speech Mode with beside the Head Phantom	106
7.1.1.1	Definition and applicability.....	106
7.1.1.2	Minimum requirements.....	106
7.1.1.3	Test Purpose	107
7.1.1.4	Method of test	107
7.1.1.4.1	Initial conditions	107
7.1.1.4.2	Test procedure.....	108
7.1.1.4.3	Test procedure, reverberation chamber method	108
7.1.1.5	Test requirements.....	108
7.1.2	Total Radiated Sensitivity (TRS) for UTRA LCR TDD in Speech Mode with beside the Head Phantom	109
7.1.2.1	Definition and applicability.....	109
7.1.2.2	Minimum Requirements.....	110
7.1.2.3	Test purpose	110
7.1.2.4	Method of test	110
7.1.2.4.1	Initial conditions	110
7.1.2.4.2	Procedure	111
7.1.2.4.3	Procedure, reverberation chamber method.....	112
7.1.2.5	Test requirements.....	112
7.1.3	Total Radiated Sensitivity (TRS) for UTRA FDD in Speech Mode with beside the Head and Hand Phantom	112
7.1.3.1	Definition and applicability.....	112
7.1.3.2	Minimum Requirements.....	113

7.1.3.3	Test purpose	114
7.1.3.4	Method of test	114
7.1.3.4.1	Initial conditions	114
7.1.3.4.2	Procedure	115
7.1.3.4.3	Procedure, reverberation chamber method.....	115
7.1.3.5	Test requirements.....	116
7.1.4	Total Radiated Sensitivity (TRS) for UTRA LCR TDD in Speech Mode with beside the Head and Hand Phantom	117
7.1.4.1	Definition and applicability.....	117
7.1.4.2	Minimum Requirements.....	118
7.1.4.3	Test purpose	119
7.1.5.4	Method of test	119
7.1.4.4.1	Initial conditions	119
7.1.4.4.2	Procedure	120
7.1.4.4.3	Procedure, reverberation chamber method.....	120
7.1.4.5	Test requirements.....	121
7.1.5	Total Radiated Sensitivity (TRS) for E-UTRA FDD in Speech Mode with beside the Head and Hand Phantom	121
7.1.5.1	Definition and applicability.....	121
7.1.5.2	Minimum Requirements.....	122
7.1.5.3	Test purpose	123
7.1.5.4	Method of test	123
7.1.5.4.1	Initial conditions	123
7.1.5.4.2	Procedure	123
7.1.5.4.3	Procedure, reverberation chamber method.....	124
7.1.5.5	Test requirements.....	124
7.1.6	Total Radiated Sensitivity (TRS) for E-UTRA TDD in Speech Mode with beside the Head and Hand Phantom	124
7.1.6.1	Definition and applicability.....	124
7.1.6.2	Minimum Requirements.....	125
7.1.6.3	Test purpose	126
7.1.6.4	Method of test	126
7.1.6.4.1	Initial conditions	126
7.1.6.4.2	Procedure	126
7.1.6.4.3	Procedure, reverberation chamber method.....	126
7.1.6.5	Test requirements.....	127
7.1.7	Total Radiated Sensitivity (TRS) for UTRA FDD in Browsing Mode with Hand Phantom.....	127
7.1.7.1	Definition and applicability.....	127
7.1.7.2	Minimum Requirements.....	128
7.1.7.3	Test purpose	128
7.1.7.4	Method of test	129
7.1.7.4.1	Initial conditions	129
7.1.7.4.2	Procedure	129
7.1.7.4.3	Procedure, reverberation chamber method.....	130
7.1.7.5	Test requirements.....	130
7.1.8	Total Radiated Sensitivity (TRS) for UTRA LCR TDD in Browsing Mode with Hand Phantom.....	131
7.1.8.1	Definition and applicability.....	131
7.1.8.2	Minimum Requirements.....	131
7.1.8.3	Test purpose	132
7.1.8.4	Method of test	132
7.1.8.4.1	Initial conditions	132
7.1.8.4.2	Procedure	133
7.1.8.4.3	Procedure, reverberation chamber method.....	133
7.1.8.5	Test requirements.....	133
7.1.9	Total Radiated Sensitivity (TRS) for E-UTRA FDD in Browsing Mode with Hand Phantom.....	134
7.1.9.1	Definition and applicability.....	134
7.1.9.2	Minimum Requirements.....	135
7.1.9.3	Test purpose	135
7.1.9.4	Method of test	135
7.1.9.4.1	Initial conditions	135
7.1.9.4.2	Procedure	135
7.1.9.4.3	Procedure, reverberation chamber method.....	136

7.1.9.5	Test requirements	136
7.1.10	Total Radiated Sensitivity (TRS) for E-UTRA TDD in Browsing Mode with Hand Phantom	136
7.1.10.1	Definition and applicability	136
7.1.10.2	Minimum Requirements	137
7.1.10.3	Test purpose	137
7.1.10.4	Method of test	137
7.1.10.4.1	Initial conditions	137
7.1.10.4.2	Procedure	138
7.1.10.4.3	Procedure, reverberation chamber method	138
7.1.10.5	Test requirements	138
7.2	Performance for LME	138
7.2.1	Total Radiated Sensitivity (TRS) for UTRA FDD LME	138
7.2.1.1	Definition and applicability	139
7.2.1.2	Minimum Requirements	139
7.2.1.3	Test purpose	140
7.2.1.4	Method of test	140
7.2.1.4.1	Initial conditions	140
7.2.1.4.2	Procedure	141
7.2.1.4.3	Test procedure, reverberation chamber method	141
7.2.1.5	Test requirements	141
7.2.2	Total Radiated Sensitivity (TRS) for UTRA LCR TDD LME	142
7.2.2.1	Definition and applicability	142
7.2.2.2	Minimum Requirements	143
7.2.2.3	Test purpose	143
7.2.2.4	Method of test	143
7.2.2.4.1	Initial conditions	143
7.2.2.4.2	Procedure	144
7.2.2.4.3	Test procedure, reverberation chamber method	145
7.2.2.5	Test requirements	145
7.2.3	Total Radiated Sensitivity (TRS) for E-UTRA FDD LME	145
7.2.3.1	Definition and applicability	145
7.2.3.2	Minimum Requirements	146
7.2.3.3	Test purpose	146
7.2.3.4	Method of test	146
7.2.3.4.1	Initial conditions	146
7.2.3.4.2	Procedure	147
7.2.3.4.3	Procedure, reverberation chamber method	147
7.2.3.5	Test requirements	147
7.2.4	Total Radiated Sensitivity (TRS) for E-UTRA TDD LME	147
7.2.4.1	Definition and applicability	148
7.2.4.2	Minimum Requirements	148
7.2.4.3	Test purpose	148
7.2.4.4	Method of test	149
7.2.4.4.1	Initial conditions	149
7.2.4.4.2	Procedure	149
7.2.4.4.3	Procedure, reverberation chamber method	149
7.2.4.5	Test requirements	149
7.3	Performance for LEE	150
7.3.1	Total Radiated Sensitivity (TRS) for UTRA FDD LEE	150
7.3.1.1	Definition and applicability	150
7.3.1.2	Minimum Requirements	151
7.3.1.3	Test purpose	152
7.3.1.4	Method of test	152
7.3.1.4.1	Initial conditions	152
7.3.1.4.2	Procedure	153
7.3.1.4.3	Procedure, reverberation chamber method	153
7.3.1.5	Test requirements	154
7.3.2	Total Radiated Sensitivity (TRS) for UTRA LCR TDD LEE	155
7.3.2.1	Definition and applicability	155
7.3.2.2	Minimum Requirements	156
7.3.2.3	Test purpose	157
7.3.2.4	Method of test	157

7.3.2.4.1	Initial conditions	157
7.3.2.4.2	Procedure	158
7.3.2.4.3	Procedure, reverberation chamber method.....	158
7.3.2.5	Test requirements.....	159
7.3.3	Total Radiated Sensitivity (TRS) for E-UTRA FDD LEE	160
7.3.3.1	Definition and applicability.....	160
7.3.3.2	Minimum Requirements.....	161
7.3.3.3	Test purpose	162
7.3.3.4	Method of test	162
7.3.3.4.1	Initial conditions	162
7.3.3.4.2	Procedure	163
7.3.3.4.3	Procedure, reverberation chamber method.....	163
7.3.3.5	Test requirements.....	163
7.3.4	Total Radiated Sensitivity (TRS) for E-UTRA TDD LEE	164
7.3.4.1	Definition and applicability.....	164
7.3.4.2	Minimum Requirements.....	165
7.3.4.3	Test purpose	165
7.3.5.4	Method of test	166
7.3.4.4.1	Initial conditions	166
7.3.4.4.2	Procedure	166
7.3.4.4.3	Procedure, reverberation chamber method.....	166
7.3.4.5	Test requirements.....	166
7.4	Radiated Performance of Multiple-antenna Receivers in the UE.....	167
7.4.1	Total Radiated Multi-antenna Sensitivity (TRMS) for E-UTRA FDD for Handheld UE in Free Space.....	167
7.4.1.1	Definition and applicability.....	167
7.4.1.2	Minimum requirements.....	168
7.4.1.3	Test Purpose	168
7.4.1.4	Method of test for Multi-probe Anechoic Chamber.....	168
7.4.1.4.1	Initial conditions	168
7.4.1.4.2	Procedure	169
7.4.1.4A	Method of test for Radiated Two-Stage	169
7.4.1.4A.1	Initial conditions.....	170
7.4.1.4A.2	Procedure.....	170
7.4.1.5	Test requirements.....	171
7.4.2	Total Radiated Multi-antenna Sensitivity (TRMS) for E-UTRA TDD for Handheld UE in Free Space.....	171
7.4.2.1	Definition and applicability.....	171
7.4.2.2	Minimum requirements.....	172
7.4.2.3	Test Purpose	172
7.4.2.4	Method of test for Multi-probe Anechoic Chamber.....	172
7.4.2.4.1	Initial conditions	172
7.4.2.4.2	Procedure.....	173
7.4.2.4A	Method of test for Radiated Two-Stage	174
7.4.2.4A.1	Initial conditions.....	174
7.4.2.4A.2	Procedure.....	174
7.4.2.5	Test requirements.....	175
Annex A (normative): Test system characterization and environmental requirements.....		176
A.1	General	176
A.2	Phantom specifications.....	176
A.2.1	Head phantom	176
A.2.2	Hand phantom	176
A.2.2.1	General.....	176
A.2.2.2	Dimensions	176
A.2.2.3	Dielectric properties	178
A.2.2.4	Hand phantom grips.....	178
A.2.2.5	Mechanical Requirements of Hand Phantoms	180
A.2.3	Laptop Ground Plane Phantom	181
A.2.4	Parameters for embedded devices	183
A.2.4.1	General.....	183

A.2.4.2	Notebook	183
A.2.4.3	Tablet	184
A.3	Anechoic chamber constraints.....	184
A.3.1	General	184
A.3.2	Quiet zone dimension	187
A.3.3	Minimum distance between the DUT and the measurement antenna.....	187
A.3.4	Reflectivity of the quiet zone	187
A.3.5	Shielding effectiveness of the chamber	187
A.4	Reverberation chamber constraints	187
A.4.1	General	187
A.4.2	Positioning and mode stirring facilities	188
A.4.3	Polarization imbalance and receiving antennas	188
A.4.4	Measurement antennas	189
A.4.5	Chamber size and characteristics.....	189
A.4.6	Shielding effectiveness of the chamber	189
A.5	Anechoic chamber constraints for Radiated Performance of Multiple-antenna Receivers	189
A.5.1	General	189
A.5.1.1	Multi-probe Anechoic Chamber	190
A.5.1.1.1	Concept and configuration	191
A.5.1.2	Radiated Two-Stage	192
A.5.1.2.1	Concept and configuration.....	193
A.5.2	Testing environment conditions	194
A.5.2.1	MPAC Positioning Guidelines.....	201
A.5.2.2	RTS Positioning Guidelines and test zone dimensions	205
Annex B (normative):	Calibration.....	206
B.1	General	206
B.2.1	Calibration procedure for Anechoic chamber method.....	206
B.2.2	Calibration procedure for Reverberation chamber method	207
B.2.2.1	Measurement of S-parameters through the chamber for a complete stirring sequence.....	208
B.2.2.2	Calculation of the chamber reference transfer function	209
B.2.2.3	Cable calibration.....	209
B.2.3	Calibration procedure for Anechoic chamber method with Multiprobe configuration	210
B.2.3.1	Example Calibration Procedure	210
B.2.4	Calibration procedure for RTS method	212
Annex C (informative):	Measurement test report.....	214
C.1	General	214
Annex D (normative):	Maximum uncertainty of test system and test tolerance.....	215
D.1	Maximum uncertainty of test system	215
D.2	Test tolerances.....	218
Annex E (informative):	Estimation of measurement uncertainty.....	222
E.1	General	222
E.2	Mismatch uncertainty between measurement receiver and the probe antenna.....	227
E.2.1	Total combined mismatch uncertainty calculations.....	227
E.2.1.1	Mismatch uncertainty through the connector between two elements	227
E.2.1.2	Mismatch uncertainty due to the interaction of several elements	228
E.2.2	Total combined mismatch uncertainty	229
E.3	Mismatch uncertainty of the RF relay	229
E.3.1	First part: RF Relay switched on the co-polarized signal	230
E.3.1.1	The mismatch through the connector between two elements	230
E.3.1.2	Mismatch due to the interaction between two elements or more	230
E.3.2	Second part: RF relay switched on the cross-polarized signal	231
E.3.2.1	The mismatch through the connector between two elements	231

E.3.2.2	Mismatch due to the interaction between two elements or more	231
E.3.3	Total combined mismatch uncertainty	232
E.4	Insertion loss of the probe antenna cable	232
E.5	Insertion loss of the probe antenna attenuator (if used)	232
E.6	Insertion loss of the RF relays (if used).....	232
E.7	Influence of the antenna cable.....	233
E.7.1	Probe antenna cable.....	233
E.7.2	Calibration antenna cable	233
E.8	Absolute gain of the probe antenna.....	233
E.9	Measurement receiver: uncertainty of absolute level.....	233
E.10	Measurement distance	233
E.10.1	Offset of DUT phase centre from axis(es) of rotation	233
E.10.2	Mutual coupling	234
E.10.3	Phase curvature	234
E.11	Quality of quiet zone	234
E.12	Tx-power drift of DUT.....	234
E.13	Uncertainty related to the use of phantoms	235
E.13.1	Uncertainty from using different types of SAM phantom	235
E.13.2	Simulated tissue liquid uncertainty	235
E.13.3	Uncertainty of dielectric properties and shape of the hand phantom	235
E.13.4	Uncertainty from using different types of Laptop Ground Plane phantom.....	237
E.14	Coarse sampling grid.....	237
E.15	Random uncertainty	238
E.16	Uncertainty of network analyzer	239
E.17	Uncertainty of the gain/efficiency of the calibration antenna.....	239
E.18	Base station simulator: uncertainty of the absolute level	239
E.19	BER measurement: output level step resolution.....	239
E.20	Statistical uncertainty of the BER measurement	239
E.21	BER data rate normalization uncertainty.....	240
E.22	DUT sensitivity drift	240
E.23	Cable loss measurement uncertainty	240
E.24	Signal generator: uncertainty of the absolute output level	241
E.25	Signal generator: output level stability.....	241
E.26	Insertion loss: calibration antenna feed cable.....	241
E.27	Insertion loss: calibration antenna attenuator (if used).....	241
E.28	Chamber Statistical Ripple and Repeatability	241
E.29	Additional Power Loss in EUT Chassis	241
Annex F (informative):	Suggested recipes of liquid to be used inside SAM phantom.....	256
F.1	General	256
Annex G (informative):	Anechoic chamber specification and validation method.....	257
G.1	Shielded anechoic chamber specifications	257
G.2	Quiet zone reflectivity level validation	257
G.2.1	Description of a practical method for Quiet Zone characterization	257
G.3	Standard deviation of electric field.....	258
Annex H (informative):	Reverberation chamber specifications and validation method.....	260
H.1	Shielded reverberation chamber specifications	260
H.2	Reverberation chamber statistical ripple and repeatability validation	260
Annex I (informative):	Recommended performance for Handheld UE.....	262
I.1	General	262
I.2	Total Radiated Power	262
I.2.1	Beside the head phantom position.....	262
I.2.1.1	UTRA FDD	262
I.2.1.2	UTRA LCR TDD	263

I.2.2	Beside the head and hand phantoms position	263
I.2.2.1	UTRA FDD	263
I.2.2.2	UTRA LCR TDD	263
I.2.2.3	E-UTRA FDD.....	264
I.2.2.4	E-UTRA TDD	264
I.2.3	Hand phantom browsing mode position.....	264
I.2.3.1	UTRA FDD	264
I.2.3.2	UTRA LCR TDD	264
I.2.3.3	E-UTRA FDD.....	265
I.2.3.4	E-UTRA TDD	265
I.3	Total Radiated Sensitivity	265
I.3.1	Beside the head phantom position.....	265
I.3.1.1	UTRA FDD	265
I.3.1.2	UTRA LCR TDD	266
I.3.2	Beside the head and hand phantoms position	266
I.3.2.1	UTRA FDD	266
I.3.2.2	UTRA LCR TDD	266
I.3.2.3	E-UTRA FDD.....	267
I.3.2.4	E-UTRA TDD	267
I.3.3	Hand phantom browsing mode position.....	267
I.3.3.1	UTRA FDD	267
I.3.3.2	UTRA LCR TDD	268
I.3.3.3	E-UTRA FDD.....	268
I.3.3.4	E-UTRA TDD	268
Annex J (informative): Recommended performance for LME.....		269
J.1	General	269
J.2	Total Radiated Power	269
J.2.1	UTRA FDD	269
J.2.2	UTRA LCR TDD	269
J.2.3	E-UTRA FDD.....	270
J.2.4	E-UTRA TDD	270
J.3	Total Radiated Sensitivity	270
J.3.1	UTRA FDD	270
J.3.2	UTRA LCR TDD	270
J.3.3	E-UTRA FDD.....	271
J.3.4	E-UTRA TDD	271
Annex K (informative): Recommended performance for LEE.....		272
K.1	General	272
K.2	Total Radiated Power	272
K.2.1	UTRA FDD	272
K.2.2	UTRA LCR TDD	273
K.2.3	E-UTRA FDD.....	273
K.2.4	E-UTRA TDD	273
K.3	Total Radiated Sensitivity	274
K.3.1	UTRA FDD	274
K.3.2	UTRA LCR TDD	275
K.3.3	E-UTRA FDD.....	275
K.3.4	E-UTRA TDD	275
Annex L (informative): Multi-Probe Anechoic Chamber Specification and Validation Method.....		276
L.1	Multi-probe anechoic chamber specifications	276
L.2	Multi-probe anechoic chamber minimum distance between the DUT and the measurement antenna	276
L.3	Multi-probe anechoic chamber quiet zone reflectivity level validation	276
L.4	Multi-probe anechoic chamber channel model verification	276
Annex M (normative): Channel Model emulation of the Base Station antenna pattern configuration for Radiated Performance of Multiple-antenna Receivers.....		277

M.1	Channel Model(s).....	277
M.2	Base Station antenna pattern configuration.....	278
Annex N (informative):	Estimation of measurement uncertainty for Multiple-antenna receivers	279
N.1	General	279
N.2	Fading channel emulator output uncertainty	283
N.3	External Amplifiers Uncertainty Terms	284
N.3.1	Stability	284
N.3.2	Linearity	284
N.3.3	Noise Figure	284
N.3.4	Mismatch.....	284
N.3.5	Gain	284
Annex O (normative):	Environmental conditions	285
O.1	General	285
O.2	Environmental requirements	285
O.2.1	Temperature	285
O.2.2	Voltage	285
Annex P (normative):	Base Station (BS) configuration for Radiated Performance of Multiple-antenna Receivers	286
P.1	eNodeB emulator settings	286
Annex Q (informative):	RTS Anechoic Chamber Specification and Validation Method	289
Q.1	RTS anechoic chamber specifications	289
Q.2	RTS anechoic chamber minimum distance between the DUT and the measurement antenna	289
Q.3	RTS anechoic chamber quiet zone reflectivity level validation	289
Q.4	RTS anechoic chamber channel model verification	289
Annex R:	UE ATF Requirements.....	290
R.1	RSAP.....	290
R.2	RSARP	290
Annex S:	Change history	291
History		292

Foreword

This Technical Specification has been produced by the 3rd Generation Partnership Project (3GPP).

The contents of the present document are subject to continuing work within the TSG and may change following formal TSG approval. Should the TSG modify the contents of the present document, it will be re-released by the TSG with an identifying change of release date and an increase in version number as follows:

Version x.y.z

where:

- x the first digit:
 - 1 presented to TSG for information;
 - 2 presented to TSG for approval;
 - 3 or greater indicates TSG approved document under change control.
- y the second digit is incremented for all changes of substance, i.e. technical enhancements, corrections, updates, etc.
- z the third digit is incremented when editorial only changes have been incorporated in the document.

1 Scope

The present document describes the test procedure for the radiated performances measurements of the user equipment (UE).

The handheld UE measurement procedures explained in this document are defined for roaming bands for the speech mode position (beside the head and beside the head and hand) and hand phantom browsing mode position. Laptop mounted equipment (LME) measurement procedures are defined for roaming bands for the data mode transfer position (laptop ground plane phantom). Laptop embedded equipment (LEE) measurement procedures are defined for roaming bands for the data mode transfer position (free space).

The browsing mode position explained in this document applies when the UE is held in hand, but not pressed against ear (such as web browsing and navigation).

The data mode transfer position (free space) explained in this document applies when the UE is used away from the user's head. Free space measurements are applicable to devices used in the data mode transfer position that consist of the laptop mounted equipment (LME) plug-in UEs and laptop embedded equipment (LEE) UEs.

All bands are potential roaming bands, and the requirements for roaming bands shall therefore be fulfilled for all bands supported by a UE.

Radiated performance of multiple-antenna receivers for handheld UE is defined for roaming bands in free space configuration.

Recommended performance values for operating bands (Annex I) are however included in this specification for information. It should be recognised that the ability to meet the recommended performance values depends on the number of frequency bands supported by the UE.

The radiated radio tests considered here are:

1. The measurement of the Total Radiated Power (TRP)
2. The measurement of the Total Radiated Sensitivity (TRS)
3. The measurement of Total Radiated Multi-antenna Sensitivity (TRMS)

The test procedure described in this document measures the performance of the transmitter and the receiver, including the antenna and also the effects of the user.

2 References

The following documents contain provisions which, through reference in this text, constitute provisions of the present document.

- References are either specific (identified by date of publication, edition number, version number, etc.) or non-specific.
- For a specific reference, subsequent revisions do not apply.
- For a non-specific reference, the latest version applies. In the case of a reference to a 3GPP document (including a GSM document), a non-specific reference implicitly refers to the latest version of that document *in the same Release as the present document*.

- [1] 3GPP TR 21.905: "Vocabulary for 3GPP Specifications".
- [2] 3GPP TS 25.101: "User Equipment (UE) radio transmission and reception (FDD)".
- [3] 3GPP TR 25.914: "Measurements of radio performances for UMTS terminals in speech mode".
- [4] 3GPP TS 34.108: "Common Test Environments for User Equipment (UE) Conformance Testing".
- [5] 3GPP TS 34.109: "Terminal logical test interface; Special conformance testing functions"

- [6] 3GPP TS 34.114: "User Equipment (UE) / Mobile Station (MS) Over The Air (OTA) antenna performance; Conformance testing".
- [7] 3GPP TS 34.121-1: 3rd Generation Partnership Project; Technical Specification Group Terminals; Terminal conformance specification; Radio transmission and reception (FDD)
- [8] 3GPP TS 34.122: "Terminal conformance specification; Radio transmission and reception (TDD)"
- [9] 3GPP TS 36 101: "E-UTRA UE radio transmission and reception".
- [10] 3GPP TS 36.508: "Common test environments for User Equipment (UE)".
- [11] 3GPP TS 36.521-1: "Evolved Universal Terrestrial Radio Access (E-UTRA); User Equipment (UE) conformance specification; Radio transmission and reception; Part 1: conformance testing".
- [12] 3GPP TS 37.144: "User Equipment (UE) and Mobile Station (MS) GSM, UTRA, and E-UTRA over the air performance requirements".
- [13] 3GPP TR 37.844: "User Equipment (UE) GSM, UTRA and E-UTRA over the air performance requirements".
- [14] 3GPP TR 37.902: "Measurements of User Equipment (UE) radio performances for LTE/UMTS terminals; Total Radiated Power (TRP) and Total Radiated Sensitivity (TRS) test methodology (Release 12)"
- [15] IEEE standard P1528; "Recommended Practice for Determining the Peak Spatial-Average Specific Absorption Rate (SAR) in the Human Head from Wireless Communications Devices: Experimental Techniques", April, 2003.
- [16] CENELEC Standard ENS 50361: "Basic Standard for the measurement of Specific Absorption Rate related to human exposure to electromagnetic fields from mobile phones (300 MHz-3 GHz)", Brussels, Belgium, CENELEC, July 2001, 51 p.
- [17] H. Knoess, M. Christensen, S. Svendsen, T. Hiegler, A. Friederich, "Investigation of Different Phantom Head Models Including Holder", COST 273 TD(04) 068, Gothenburg, June 2004, 6 p.
- [18] ETSI ETR 273: "Electromagnetic compatibility and Radio spectrum Matters (ERM); Improvement of radiated methods of measurement (using test sites) and evaluation of the corresponding measurement uncertainties; Part 1: Uncertainties in the measurement of mobile radio equipment characteristics; Sub-part 2: Examples and annexes".
- [19] M.Y. Kanda, M. Ballen, C.K. Chou. "Formulation and characterization of tissue simulating liquids used for SAR measurement (500-2000 MHz)" Asia-Pacific Radio Science Conference, Tokyo, Japan, August 1-4, 2001, p. 274.
- [20] V. Vigneras, "Elaboration and characterization of biological tissues equivalent liquids in the frequency range 0.9 - 3 GHz", Final report, PIOM Laboratory, University of Bordeaux, France, November 2001.
- [21] Dr. Michael D. Foegelle, ETS-Lindgren, Kevin Li, Nokia Corp., Andrew Pavacic and Paul Moller, Motorola, Inc. "Developing a Standard Hand Phantom for Wireless Testing" Part 1, Wireless design and Development
- [22] Gabriel, C., "Tissue Equivalent Material for Hand Phantoms," Physics in Medicine and Biology, 52 (2007), pp. 4205 - 4210,
- [23] Dr. Michael D. Foegelle, ETS-Lindgren, Kevin Li, Nokia Corp., Andrew Pavacic and Paul Moller, Motorola, Inc. Wireless Design & Development, The Development of a Standard Hand Phantom for Wireless Performance Testing: Part 2
- [24] T. Laitinen, J. Ollikainen, P. Vainikainen, C. Icheln, "Rapid Spherical 3-D Field Measurement System for Mobile Terminal Antennas", COST273 TD(03)134
- [25] ETSI TR 100 028: "ElectroMagnetic Compatibility and Radio Spectrum Matters (ERM); Uncertainties in the measurement of mobile radio equipment characteristics Part 1".

- [26] ETSI TR 102 273-1-1: "Electromagnetic compatibility and Radio spectrum Matters (ERM); Improvement on Radiated Methods of Measurement (using test site) and evaluation of the corresponding measurement uncertainties; Part 1: Uncertainties in the measurement of mobile radio equipment characteristics; Sub-part 1: Introduction".
- [27] ETSI TR 102 273-1-2: "Electromagnetic compatibility and Radio spectrum Matters (ERM); Improvement on Radiated Methods of Measurement (using test site) and evaluation of the corresponding measurement uncertainties; Part 1: Uncertainties in the measurement of mobile radio equipment characteristics; Sub-part 2: Examples and annexes".
- [28] IEEE standard P1528; "Recommended Practice for Determining the Peak Spatial-Average Specific Absorption Rate (SAR) in the Human Head from Wireless Communications Devices: Experimental Techniques", April, 2003
- [29] 3GPP TR 37.977: "Verification of radiated multi-antenna reception performance of User Equipment (UE)"
- [30] IEEE.149-1979.R2008: "IEEE Standard Test Procedures for Antennas," IEEE, October 2003.
- [31] Yanakiev, Boyan Radkov; Nielsen, Jesper Ødum; Christensen, Morten; Pedersen, Gert F, "Antennas In Real Environments", 2011 Proceedings of the Fifth European Conference on Antennas and Propagation (EuCAP). IEEE, 2011. p. 2766-2770.
- [32] CTIA: "Test Plan for Wireless Device Over-the-Air Performance"
- [33] TD(09) 742, COST 2100 SWG 2.2, Braunschweig, Germany, February 2009, J. Takada: "Handset MIMO Antenna Testing Using a RF-controlled Spatial Fading Emulator".
- [34] 3GPP TS 36.509: "Special conformance testing functions for User Equipment (UE)"

3 Definitions, symbols and abbreviations

3.1 Definitions

For the purposes of the present document, the terms and definitions given in TR 21.905 [1] and the following apply. A term defined in the present document takes precedence over the definition of the same term, if any, in TR 21.905 [1].

Browsing mode position: UE is held in hand, but not pressed against ear (such as web browsing and navigation).

Data mode transfer position: UE used away from the user's head, applicable for LME and LEE devices.

FS: UE used in a free space configuration.

Intended use position: UE is attached to the SAM phantom intended for use in the check position.

LEE: Laptop embedded equipment (such as embedded module card embedded in notebooks).

LME: Laptop mounted equipment (such as plug-in devices like USB dongles).

Primary mechanical mode: The mode that is most often used during a call beside the head. Other mechanical modes are secondary. Every terminal has at least one primary mechanical mode.

Speech mode position: UE is placed into a hand phantom, which is holding the UE against the SAM head phantom.

3.2 Symbols

For the purposes of the present document, the following symbols apply:

θ	Zenith angle in the spherical co-ordinate system
ϕ	Azimuth angle in the spherical co-ordinate system
Ω	Solid angle defined at the phase centre of the DUT

$G_{\psi}(\theta, \phi, f)$	Antenna gain pattern in the ψ -polarization as function of the spherical co-ordinates and the carrier frequency
F	Carrier frequency
P_{tr}	Transmitted power
$Q_{\psi}(\theta, \phi, f)$	Angular power distribution in the ψ -polarization as function of the spherical co-ordinates and the carrier frequency
dB	decibel
dBm	dB referenced to one milliwatt
m	meter
mm	millimeter
kbps	kilobit per second
ms	millisecond
MHz	megahertz
$TRMS_{average, 70}$	Average TRMS quantity calculated from sensitivity measurements at 70% throughput
$TRMS_{average, 95}$	Average TRMS quantity calculated from sensitivity measurements at 95% throughput
$TRP_{average}$	the average measured total radiated power of low, mid and high channel
TRP_{min}	the lowest measured total radiated power of each channel within an operating band
$TRS_{average}$	the average measured total radiated sensitivity of low, mid and high channel
TRS_{max}	the highest measured total radiated sensitivity of each channel within an operating band
P_d	Direct signal
$P_{meas\ n}$	Measured power received by field-probe at position n
$P_{MODE, x, i}$	Measured sensitivity value when $MODE$ is one of $\{FS_DMP, FS_DML, FS_DMSU\}$, x is one of $\{70, 95\}$ at azimuth position i
P_r	Reflected signal
$P_{RS-EPRE-MAX}$	Maximum downlink RS-EPRE
R_{level}	Reflectivity level

3.3 Abbreviations

For the purposes of the present document, the abbreviations given in TR 21.905 [1] and the following apply. An abbreviation defined in the present document takes precedence over the definition of the same abbreviation, if any, in TR 21.905 [1].

3G	3 rd Generation
3GPP	3G Partnership Project
3-D	Three Dimensional
AAU	Aalborg University
APD	Angular Power Distribution
ARFCN	Absolute Radio Frequency Channel Number
ATF	Antenna Test Function
BER	Bit Error Ratio
BS	Base Station
BT	Bluetooth
BTS	Base Transceiver Station
CAD	Computer Aided Design
CN	Core Network
CPICH RSCP	Common Pilot Channel Received Signal Code Power
CRC	Cyclic Redundancy Check
DCH	Dedicated Channel
DL	Downlink
DML	Data Mode Landscape
DMP	Data Mode Portrait
DMSU	Data Mode Screen Up
DPCH	Dedicated Physical Channel
DPDCH	Dedicated Physical Data Channel
DPCCH	Physical Control Channel
DTCH	Dedicated Traffic Channel
DUT	Device Under Test
EIRP	Effective Isotropic Radiated Power
EIS	Effective Isotropic Sensitivity
ETSI	European Telecommunications Standards Institute
EUT	Equipment Under Test

E-UTRA	Evolved UMTS Terrestrial Radio Access
E-UTRAN	Evolved UMTS Terrestrial Radio Access Network
FDD	Frequency Division Duplex
FS	Free Space
FS DML	Free Space Data Mode Landscape
FS DMP	Free Space Data Mode Portrait
FS DMSU	Free Space Data Mode Screen Up
GPS	Global Positioning System
HUT	Helsinki University of Technology
LCD	Liquid Crystal Display
LEE	Laptop Embedded Equipment (e.g. embedded module card embedded in notebooks)
LME	Laptop Mounted Equipment (e.g., plug-in devices like USB dongles)
LTE	Long Term Evolution
MPAC	Multi-Probe Anechoic Chamber
NB	Node B
NSA	Normalised Site Attenuation
OTA	Over The Air
PDA	Personal Digital Assistant
QoS	Quality of Service
QPSK	Quadrature Phase Shift Keying (modulation)
RAB	Radio Access Bearer
RB	Radio Bearer
RAN	Radio Access Network
RBW	Resolution Bandwidth
RF	Radio Frequency
RMS	Root Mean Square
RS-EPRE	Reference Signal-Energy Per Resource Element
Rx	Receiver
SAM	Specific Anthropomorphic Mannequin
SAR	Specific Absorption Rate
SS	System Simulator
TDD	Time Division Duplex
TFCI	Transport Format Combination Indicator
Tx	Transmitter
TRMS	Total Radiated Multi-antenna Sensitivity
TRP	Total Radiated Power
TRS	Total Radiated Sensitivity
UDP	User Datagram Protocol
UE	User Equipment
UL	Uplink
UMTS	Universal Mobile Telecommunications System
USB	Universal Serial Bus
UTRA	UMTS Terrestrial Radio Access
VBW	Video Bandwidth
VNA	Vector Network Analyzer
VSWR	Voltage Standing Wave Ratio
WLAN	Wireless Local Area Network
WWAN	Wireless Wide Area Network
XPD	Cross-Polar Discrimination of the antenna
XPR	Cross-Polarization ratio of the channel

4 General

The device under test (DUT) presented in this clause is based on a device that is tested to determine performance as defined in the present release of specifications.

4.1 Terminal classes

4.1.1 Mechanical modes

The mechanical modes of a DUT are declared by the manufacturer. A DUT shall have at least one mechanical mode. If only one mode is supported, then this is defined as the primary.

4.2 UTRA chip rates

The requirements defined in this specification for UTRA are based on a chip rate of 3.84 Mcps (FDD) and 1.28 Mcps (TDD).

NOTE: Other chip rates may be considered in future releases.

4.3 DUT positioning

4.3.1 DUT positioning for Speech Mode with beside the Head Phantom

The positioning specified in this clause is used for the tests cases titled as tests for Speech Mode with beside the Head Phantom. The characteristics of the Specific Anthropomorphic Mannequin (SAM) phantom are specified in Annex A.2.1.

The DUT is attached to the SAM phantom in "cheek" position as defined both by IEEE [28] and CELENEC [16] standards. The DUT performance is measured on both left and right side of the head.

Three points as shown in Figure 4.3.1-1 define the reference plane: centre of the right ear piece (RE), centre of the left ear piece (LE) and centre of mouth (M).

At first, set the DUT ready for operation.

Definition of the 'Cheek' position:

1. Align the ear piece of the phone (see Figure 4.3.1-1) at the line RE-LE. Then, position the DUT beside the phantom so that the vertical line (see Figure 4.3.1-3) is parallel to the reference plane in Figure 4.3.1-2 and is aligned with the line M-RE on the reference plane (see Figure 4.3.1-3).
2. Position the DUT so that the ear piece of the DUT touches the ear piece of the phantom head on the line RE-LE. Tilt the DUT chassis towards the cheek of the phantom having the vertical line aligned with the reference plane until any point on the front side of the DUT is in contact with the cheek or until the contact with the ear is lost.

NOTE: A holder fixture made of e.g. plastic may be used to position the handset against the phantom. An experimental study presented in [17] shows that some plastic holders might introduce an unexpectedly large effect to the measurement results. Therefore, special care must be seen when selecting such fixtures for radiated measurements.

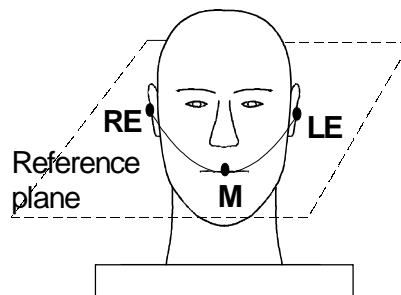

Figure 4.3.1-1: Reference plane on head phantom, front view

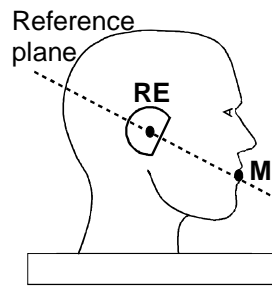

Figure 4.3.1-2: Reference plane on head phantom, side view

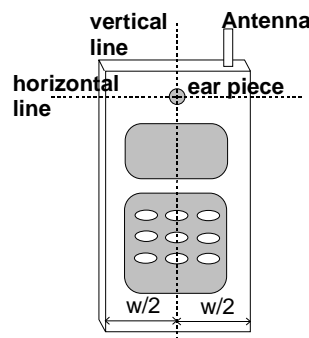

Figure 4.3.1-3: Reference lines at a DUT

NOTE: W is the width of the chassis [28].

The characteristics of DUT positioning on head phantom in "cheek" position are specified in Table 4.3.1-1.

Table 4.3.1-1: Characteristics of DUT positioning on head phantom in "cheek" position

ID	Cheek position on phantom head	DUT chassis tilt	DUT chassis position
0	Low	Shift Down	Up
1	Medium	No Shift	Aligned
2	High	Shift Up	Down

4.3.2 DUT positioning for LMEs on Laptop Ground Plane Phantom

The DUT positioning on Laptop Ground Plane Phantom means that a laptop ground plane phantom is used for radiated performance measurements in case of plug-in DUT like USB dongles that is used away from the user's head. This includes all tests cases for LME devices. The characteristics of the laptop ground plane phantom are specified in Annex A.2.3. The objective of the laptop ground plane phantom is to reproduce the effects of the ground plane for the antenna of the DUT while avoiding the variation of the measurements introduced by a real laptop.

The DUT should be plugged into the USB connector and positioned in accordance with the manufacturer recommended primary mechanical mode. In the absence of such a recommendation the DUT with either rotary USB porter or non-rotary USB porter should be horizontally plugged into the horizontal USB connector, as shown in Figure A.2.3-1.

4.3.3 DUT positioning for Speech Mode with beside the Head and Hand Phantom

4.3.3.1 General

The positioning specified in this clause is used for the tests cases titled as tests for Speech Mode with beside the Head and Hand Phantom. The characteristics of the Head and Hand Phantoms are specified in Annexes A.2.1 and A.2.2.

Speech mode is simulation of a voice call user case. DUT is placed in to a hand phantom, which is holding the DUT against the SAM head phantom. Positioning of the DUT in the hand phantom varies with the grip being used. Positioning of the DUT against the head phantom is identical to Subclause 4.3.2 with the exception that 6° tilt angle from the cheek is being used instead of having direct contact between the cheek and DUT. A mask may be used to help configuration of cheek + 6° tilt angle. The mask is a 32 mm wide conformal strip, created by sweeping the surface of the head phantom through a 6° rotation about the ear. Direct DUT contact against the mask thus establishes the required 6° spacing away from the cheek, regardless of DUT form factor. The material for the head phantom mask spacer shall have dielectric constant of less than 1.3 and a loss tangent of less than 0.003. Material additions can be used to help fixing of the mask spacer onto the head phantom.

4.3.3.2 Mono-blocks and closed sliders

This procedure applies to mounting mono-block DUTs and closed-slide DUTs, when the DUT is less than 56 mm wide. For consistent, repeatable positioning that conforms to the grip studies, an alignment tool with evenly spaced rulings is first used to measure the DUT. Alignment Tool A in Figure 4.3.3.2-1, features a 120° interior corner to ensure that the ring fingertip lands in the desired position at the bottom of the DUT. The DUT is then positioned in accordance with ruled markings on a conformal palm spacer regardless of any curvature in the DUT corners. DUTs with rounded corners will sit lower in the tool than DUTs having square corners, and thus give a different reading.

1. Place the DUT face-up in Alignment Tool A with its side along the side ruler, and slide it down until it makes contact at the 120° corner. Record the bottom location of the DUT by reading off the bottom ruler of Tool A.
2. Observe the top of the DUT against the side ruler of the tool. If the top of the DUT extends past the 120 mm marking on the side ruler, then the additional length beyond 120 mm shall be added to the reading from Step 1.
3. Place the DUT on the right-handed or left-handed hand phantom spacer between the fingers. The bottom location of the DUT on the spacer should be aligned with the reading recorded in Steps 1 and 2. Vertical centreline of the DUT should be centred with the spacer. Make sure index finger is in contact with DUT.
4. While keeping the DUT in the hand phantom in the position defined in previous steps, place the DUT and the hand phantom against the head phantom in such way that the DUT is in 6° tilt angle as described in Subclause 4.3.3.

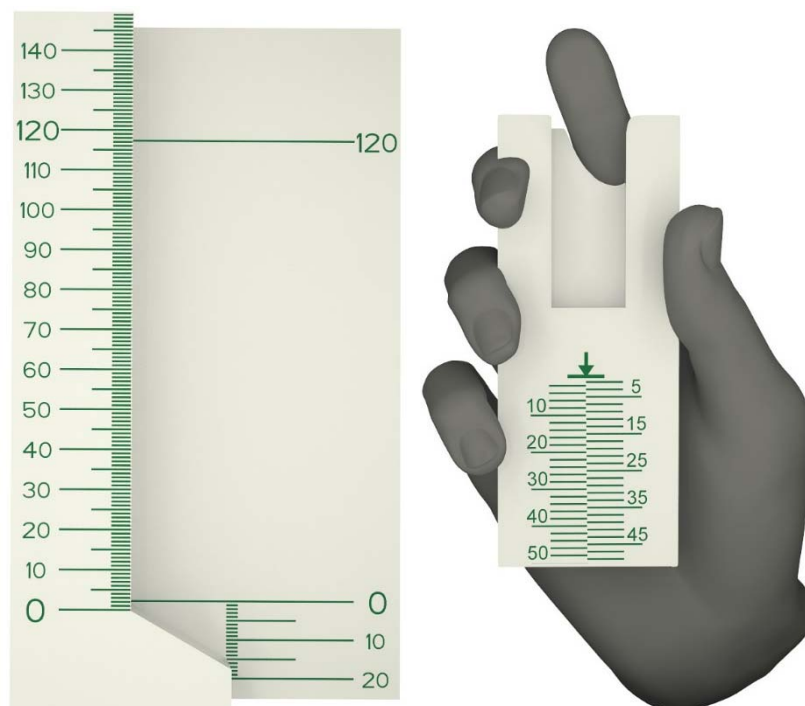

Figure 4.3.3.2-1: Alignment Tool A and right-handed mono-block hand phantom with a spacer

NOTE: The Alignment tool is used to determine DUT bottom location on spacer. Use left-handed (mirror-imaged) spacers with left-handed phantoms.

4.3.3.3 Folds and open-slides

This procedure applies to fold and open-slide DUTs, when the DUT is less than 56 mm wide. To help maintain a consistent, repeatable positioning that conforms to the grip studies, an alignment tool with evenly spaced rulings is first used to measure the DUT. The DUT is then positioned in accordance with ruled markings on a phantom spacer. Alignment Tool B in Figure 4.3.3.3-1 features two rounded humps upon which the DUT is suspended. One hump represents the index fingertip of the hand phantom, while the other represents the palm spacer. This design helps ensure that the index finger remains in contact with the flip for any fold DUT geometry.

1. Open the DUT and place it face-up on the alignment Tool B with its hinge suspended between the two humps. The side of the DUT shall be aligned against the side wall of the tool. The base of the DUT shall rest on the wide hump with ruled markings, and the flip of the DUT shall rest on the narrow hump.
2. Tool B has an engraved line on the side wall. Align axis of a fold hinge to this marking. An open slider should be slide longitudinally until the base part of the DUT touches the narrow hump of the Tool B. Record the correct longitudinal position of the bottom of the DUT by reading off the ruler of Tool B. Visually align the two halves of the split-level ruler to minimize parallax reading error.
3. Position the DUT in the right-handed or left-handed Fold Hand Phantom. It should be resting on the index fingertip and palm spacer, with the bottom of the DUT aligned to the ruling on the right-handed or left-handed palm spacer that corresponds to the reading from Step 2. Ensure that all fingertips are in contact with the DUT.
4. While keeping the DUT in the hand phantom in the position defined in previous steps, place the DUT and the hand phantom against the head phantom in such way that the DUT is in 6° tilt angle as described in Subclause 4.3.3.

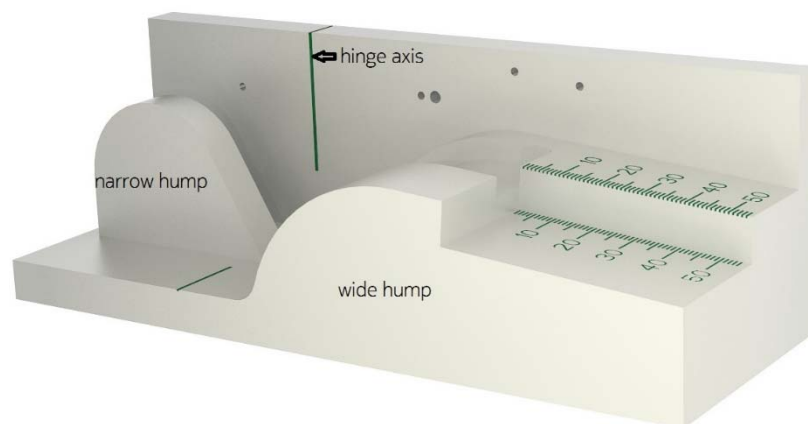

Figure 4.3.3.3-1: Alignment Tool B and right-handed fold hand phantom with a spacer

NOTE: Use left-handed (mirror-imaged) spacers with left-handed phantoms.

4.3.3.4 PDA

This procedure applies to DUTs that are from 56 to 72 mm wide. To help achieve a consistent positioning, the DUT is aligned to a PDA palm spacer. No alignment tool is required. The PDA spacer features side and bottom walls to ensure consistent alignment of DUTs of various sizes.

1. Place the DUT on the PDA spacer between the fingers and align the DUT to the side wall of the PDA.
2. If the DUT is shorter than 135 mm, then align the top of the DUT with the top of the PDA spacer. Otherwise, align the bottom of the DUT with the bottom wall of the PDA spacer.

3. While keeping the DUT in the hand phantom in the position defined in previous steps, place the DUT and the hand phantom against the head phantom in such way that the DUT is in 6° tilt angle as described in Subclause 4.3.3.

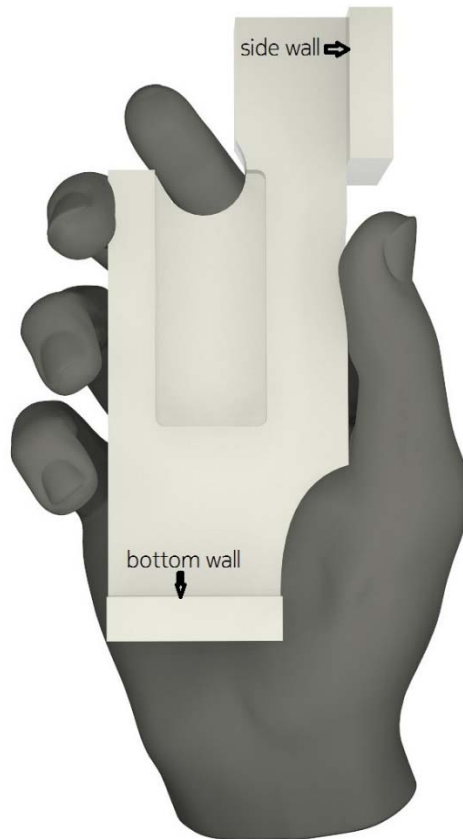

Figure 4.3.3.4-1: Right-handed PDA hand phantom with a spacer

NOTE: Use left-handed (mirror-imaged) spacers with left-handed phantoms.

4.3.4 DUT positioning for Browsing Mode with Hand Phantom

4.3.4.1 General

The positioning specified in this clause is used for the test cases titles as tests for Browsing Mode with Hand Phantom. The characteristics of the Hand Phantom are specified in Annex A.2.2. Browsing mode is used to simulate user cases where the DUT is held in hand, but not pressed against ear e.g. web browsing and navigation. The DUT shall be mounted in a suitable hand phantom and oriented such that the DUT's main display is tilted 45 degrees from vertical. Devices with a cover piece are tested cover open.

4.3.4.2 Narrow DUT

This procedure is suitable for use with all DUTs narrower than 56 mm. The alignment Tool A in Figure 4.3.4.2-1 is first used to measure the distance between the bottom of the DUT and the centre of its navigation key. The DUT is then positioned in accordance with ruled markings on a palm spacer to data mode hand phantom.

1. Place the DUT on the DUT alignment Tool A. Record the chin length from the scale at the bottom of the alignment tool.
2. Record the location of the navigation key (or the "2" key, if no navigation key is present) on the side ruler of the DUT alignment tool A. The key's centre is used as the reference.

3. Add the two readings from Step 2 and 3 together. If the sum is less than 30 mm, then use 30 mm location on spacer instead.
4. Place the DUT on the right-hand or left-hand narrow data palm spacer and align the side of the DUT with the side wall of the spacer. The bottom edge of the DUT shall be placed on the narrow data palm spacer at the ruling corresponding to the value obtained in Step 4.

Make sure that the index finger is in contact with the back of the DUT. If the device is very narrow and/or thin, it may occur that the middle finger does not curl tightly enough to contact the DUT. In such case, in order to ensure consistent test results, no attempt should be made to force the fingertip to contact the DUT. Touch fastener material may be used to maintain the DUT in the desired position.



Figure 4.3.4.2-1: Right-handed data hand phantom with a spacer

NOTE: Use left-handed (mirror-imaged) spacers with left-handed phantoms.

4.3.4.3 PDA

This procedure is suitable for use with DUTs of width 56-72 mm. The positioning of the DUT in the PDA hand for data mode is identical to that for speech mode described in Subclause 4.3.3.4.

4.3.5 DUT positioning for devices with embedded modules

The DUT positioning in a free space configuration without head and hand phantoms, as specified in Annex A.2.4, is used for radiated performance measurements in case of an embedded module card, which is used away from the user's head. This positioning covers all tests cases for LEE devices. Parameters required for Notebooks are specified in Annex A.2.4.2 and those for Tablets are specified in Annex A.2.4.3.

4.3.6 DUT positioning for total radiated multi-antenna sensitivity

4.3.6.1 Handheld UE – Free Space

The DUT positioning for Handheld UE is done using free space configuration.

4.3.6.1.1 MPAC Positioning Guidelines

The MPAC positioning guidelines of the handheld UE in data mode in the MPAC system shall follow the requirements in Annex A.5.2.1.

4.3.6.1.2 RTS Positioning Guidelines

The RTS positioning guidelines of the handheld UE in data mode in the RTS system shall follow the requirements in Annex A.5.2.2.

4.4 Sampling grid

For the anechoic chamber based measurement procedures the measurement of TRP is basically based on the measurement of the spherical radiation pattern of the DUT. The power radiated by the DUT is sampled in far field in a group of points located on a spherical surface enclosing the DUT. Generally it can be said that since the radiating object has a limited size the gain pattern cannot change arbitrarily versus angle, and therefore only a limited number of samples are required to represent the gain pattern to a given accuracy. The samples of TRP are taken using a constant sample step of 15° both in theta (θ) and phi (ϕ) directions.

The measurement of TRS is based on the measurement of the spherical sensitivity pattern of the DUT. The sensitivity values of the DUT at a predefined BLER level are sampled in far field in a group of points located on a spherical surface enclosing the DUT. The samples of TRS are taken using a constant sample step of 30° both in theta (θ) and phi (ϕ) directions.

All the samples are taken with two orthogonal linear polarizations, θ - and ϕ -polarisations. It is also possible to measure some other polarisation components, if it is possible to recover θ - and ϕ -polarisations from the measured data by some technique.

Alternatively, different sampling patterns may be used if they are able to ensure same or greater accuracy and provided appropriate measurement uncertainty terms are applied. The TRP can be calculated by interpolating the values to points on the regular grid. If an alternative sampling pattern is used number of measurement points should be greater than in the regular sampling grid.

For the multi-probe anechoic chambers procedures the measurement of TRMS are taken using sample steps of 30° in phi (ϕ), i.e. with 12 different UE azimuth rotations. For more details, see Annex A.5.

4.5 Number of independent samples (for reverberation chamber procedure)

When measuring TRP and TRS in an isotropic Rayleigh fading environment, 100 independent samples can be considered sufficient for ensuring an expanded accuracy better than 0.5 dB. Observe that it might be necessary to collect more samples than this during a measurement sequence in order to ensure a sufficient number of independent samples, since all collected samples might not be independent. The number of samples to be collected during a measurement sequence for each chamber should be chosen so that the overall measurement uncertainty is within the specified limits.

5 Measurement frequencies

5.1 UTRA FDD frequency bands and measurement channels

Table 5.1-1 provides the list of UTRA FDD frequency bands.

Table 5.1-1: UTRA FDD frequency bands

Operating Band	UL Frequencies UE transmit, Node B receive	DL frequencies UE receive, Node B transmit
I	1920 – 1980 MHz	2110 –2170 MHz
II	1850 –1910 MHz	1930 –1990 MHz
III	1710-1785 MHz	1805-1880 MHz
IV	1710-1755 MHz	2110-2155 MHz
V	824 – 849 MHz	869-894 MHz
VI	830-840 MHz	875-885 MHz
VII	2500-2570 MHz	2620-2690 MHz
VIII	880 – 915 MHz	925 – 960 MHz
IX	1749.9-1784.9 MHz	1844.9-1879.9 MHz
X	1710 – 1770 MHz	2110 – 2170 MHz
XIX	830 – 845MHz	875 – 890 MHz

Table 5.1-2: specifies the measurement channels for UTRA FDD

TBD

Table 5.1-2: UTRA FDD measurement channels

Operating Band	UL Channels			DL Channels		
	Low	Mid	High	Low	Mid	High
I	9612	9750	9888	10562	10700	10838
II	9262	9400	9538	9662	9800	9938
III	937	1113	1288	1162	1338	1513
IV	1312	1413	1513	1537	1638	1738
V	4132	4183	4233	4357	4408	4458
VI	4162	4175	4188	4387	4400	4413
VII	2012	2175	2338	2237	2400	2563
VIII	2712	2788	2863	2937	3013	3088
IX	8762	8837	8912	9237	9312	9387
X	2888	3025	3162	3113	3250	3387
XIX	387	412	437	787	812	837

5.2 UTRA TDD frequency bands and measurement channels

Table 5.2-1 provides the UTRA TDD frequency bands.

Table 5.2-1: UTRA TDD frequency bands

Operating Band	Frequencies
a	1900-1920 MHz 2010-2025 MHz
b*	1850-1910 MHz 1930-1990 MHz
c*	1910-1930 MHz
d**	2570-2620 MHz
e	2300-2400 MHz
f	1880-1920 MHz

NOTE: Deployment in other frequency bands is not precluded.

* Used in ITU Region 2

** Used in ITU Region 1

Table 5.2-2: specifies the measurement channels for UTRA TDD

TBD

Table 5.2-3: UTRA TDD measurement channels

Operating Band	Channels		
	Low	Mid	High
a 1900-1920 MHz 2010-2025 MHz	9504 10054	9550 10087	9596 10121
b 1850-1910 MHz 1930-1990 MHz	9254 9654	9400 9800	9546 9946
c 1910-1930 MHz	9554	9600	9646
d 2570-2620 MHz	12854	12975	13096
e 2300-2400 MHz	11504	11750	11996
f 1880-1920 MHz	9404	9500	9596

5.3 E-UTRA FDD frequency bands and measurement frequencies allocations

Editor's notes: This Subclause is incomplete. The following item is missing or incomplete:

- TBDs in Tables 5.3-1 (TRP) and 5.3.3 (TRS)

- Some E-UTRA bands are not included and are FFS

This section specifies the LTE-FDD TRP and TRS frequency bands and measurement frequencies allocations. Table 5.3-0 lists the operating bands. Table 5.3-1 specifies the measurement frequency allocations for TRP and Table 5.3-2 specifies the measurement frequency allocations for TRS.

Table 5.3-0 E-UTRA FDD operating bands for TRP and TRS

E-UTRA Operating Band	Uplink (UL) operating band BS receive UE transmit	Downlink (DL) operating band BS transmit UE receive	Duplex Mode
	$F_{UL_low} - F_{UL_high}$	$F_{DL_low} - F_{DL_high}$	
1	1920 MHz – 1980 MHz	2110 MHz – 2170 MHz	FDD
2	1850 MHz – 1910 MHz	1930 MHz – 1990 MHz	FDD
3	1710 MHz – 1785 MHz	1805 MHz – 1880 MHz	FDD
4	1710 MHz – 1755 MHz	2110 MHz – 2155 MHz	FDD
5	824 MHz – 849 MHz	869 MHz – 894 MHz	FDD
7	2500 MHz – 2570 MHz	2620 MHz – 2690 MHz	FDD
8	880 MHz – 915 MHz	925 MHz – 960 MHz	FDD
12	699 MHz – 716 MHz	729 MHz – 746 MHz	FDD
13	777 MHz – 787 MHz	746 MHz – 756 MHz	FDD
14	788 MHz – 798 MHz	758 MHz – 768 MHz	FDD
17	704 MHz – 716 MHz	734 MHz – 746 MHz	FDD
19	830 MHz – 845 MHz	875 MHz – 890 MHz	FDD
20	832 MHz – 862 MHz	791 MHz – 821 MHz	FDD
21	1447.9 MHz – 1462.9 MHz	1495.9 MHz – 1510.9 MHz	FDD
22	3410 MHz – 3490 MHz	3510 MHz – 3590 MHz	FDD
23	2000 MHz – 2020 MHz	2180 MHz – 2200 MHz	FDD
24	1626.5 MHz – 1660.5 MHz	1525 MHz – 1559 MHz	FDD
25	1850 MHz – 1915 MHz	1930 MHz – 1995 MHz	FDD
26	814 MHz – 849 MHz	859 MHz – 894 MHz	FDD
27	807 MHz – 824 MHz	852 MHz – 869 MHz	FDD
28	703 MHz – 748 MHz	758 MHz – 803 MHz	FDD

Table 5.3-1: Measurement frequency allocations for TRP (FDD)

DL EARFCN	UL EARFCN	Channel BW	DL Carrier Frequency	UL Carrier frequency	DL C _{LRB}	DL RB _{Start}	UL C _{LRB}	UL RB _{Start}
Band 1								
50	18050	10	2115	1925	Note 1	Note 1	12	0
300	18300	10	2140	1950	Note 1	Note 1	12	19
550	18550	10	2165	1975	Note 1	Note 1	12	38
Band 2								
650	18650	10	1935	1855	Note 1	Note 1	12	0
900	18900	10	1960	1880	Note 1	Note 1	12	19
1150	19150	10	1985	1905	Note 1	Note 1	12	38
Band 3								
1250	19250	10	1810	1715	Note 1	Note 1	12	0
1575	19575	10	1842,5	1747,5	Note 1	Note 1	12	19
1900	19900	10	1875	1780	Note 1	Note 1	12	38
Band 4								
2000	20000	10	2115	1715	Note 1	Note 1	12	0
2175	20175	10	2132,5	1732,5	Note 1	Note 1	12	19
2350	20350	10	2150	1750	Note 1	Note 1	12	38
Band 5								
2450	20450	10	874	829	Note 1	Note 1	12	0
2525	20525	10	881,5	836,5	Note 1	Note 1	12	19
2600	20600	10	889	844	Note 1	Note 1	12	38
Band 7								
2800	20800	10	2625	2505	Note 1	Note 1	12	0
3100	21100	10	2655	2535	Note 1	Note 1	12	19
3400	21400	10	2685	2565	Note 1	Note 1	12	38
Band 8								
3500	21500	10	930	885	Note 1	Note 1	12	0
3625	21625	10	942,5	897,5	Note 1	Note 1	12	19
3750	21750	10	955	910	Note 1	Note 1	12	38
Band 12								
5060	23060	10	734	704	Note 1	Note 1	12	0
5095	23095	10	737,5	707,5	Note 1	Note 1	12	19
5130	23130	10	741	711	Note 1	Note 1	12	38
Band 13								
5230	23230	10	751	782	Note 1	Note 1	12	0
5230	23230	10	751	782	Note 1	Note 1	12	19
5230	23230	10	751	782	Note 1	Note 1	12	38
Band 14								
5330	23330	10	763	793	Note 1	Note 1	12	0
5330	23330	10	763	793	Note 1	Note 1	12	19
5330	23330	10	763	793	Note 1	Note 1	12	38
Band 17								
5780	23780	10	739	709	Note 1	Note 1	12	0
5790	23790	10	740	710	Note 1	Note 1	12	19
5800	23800	10	741	711	Note 1	Note 1	12	38
Band 19								
6050	24050	10	880	835	Note 1	Note 1	12	0
6075	24075	10	882,5	837,5	Note 1	Note 1	12	19
6100	24100	10	885	840	Note 1	Note 1	12	38
Band 20								
6200	24200	10	796	837	Note 1	Note 1	12	0
6300	24300	10	806	847	Note 1	Note 1	12	19
6400	24400	10	816	857	Note 1	Note 1	12	38
Band 21								
6525	24525	15	1503.4	1455.4	Note 1	Note 1	16	0
6525	24525	15	1503.4	1455.4	Note 1	Note 1	16	29
6525	24525	15	1503.4	1455.4	Note 1	Note 1	16	59
Band 22								
TBD	TBD	TBD	TBD	TBD	TBD	TBD	TBD	TBD
TBD	TBD	TBD	TBD	TBD	TBD	TBD	TBD	TBD
TBD	TBD	TBD	TBD	TBD	TBD	TBD	TBD	TBD
Band 23								
TBD	TBD	TBD	TBD	TBD	TBD	TBD	TBD	TBD
TBD	TBD	TBD	TBD	TBD	TBD	TBD	TBD	TBD

TBD	TBD	TBD	TBD	TBD	TBD	TBD	TBD	TBD
Band 24								
TBD	TBD	TBD	TBD	TBD	TBD	TBD	TBD	TBD
TBD	TBD	TBD	TBD	TBD	TBD	TBD	TBD	TBD
TBD	TBD	TBD	TBD	TBD	TBD	TBD	TBD	TBD
Band 25								
8065	26065	5	1932.5	1852.5	Note 1	Note 1	8	0
8365	26365	5	1962.5	1882.5	Note 1	Note 1	8	8
8665	26665	5	1992.5	1912.5	Note 1	Note 1	8	17
Band 26								
TBD	TBD	TBD	TBD	TBD	TBD	TBD	TBD	TBD
TBD	TBD	TBD	TBD	TBD	TBD	TBD	TBD	TBD
TBD	TBD	TBD	TBD	TBD	TBD	TBD	TBD	TBD
Band 27								
TBD	TBD	TBD	TBD	TBD	TBD	TBD	TBD	TBD
TBD	TBD	TBD	TBD	TBD	TBD	TBD	TBD	TBD
TBD	TBD	TBD	TBD	TBD	TBD	TBD	TBD	TBD
Band 28								
9260	27260	10	763	708	Note 1	Note 1	12	0
9410	27410	10	778	723	Note 1	Note 1	12	19
9610	27610	10	798	743	Note 1	Note 1	12	38
Note 1: As per 3GPP TS 36.521-1 [11], Section 6.2 (UE Maximum Output Power), and Section A.3.2.A (Downlink Reference measurement channel for TX characteristics).								
Note 2: Network signalling value NS_01 shall be used in TRP test								

Table 5.3-2: Measurement frequency allocations for TRS (FDD)

DL EARFCN	UL EARFCN	Channel BW	DL Carrier Frequency	UL Carrier frequency	DL C _{LRB}	DL RB _{Start}	UL C _{LRB}	UL RB _{Start}
Band 1								
50	18050	10	2115	1925	50	0	50	0
300	18300	10	2140	1950	50	0	50	0
550	18550	10	2165	1975	50	0	50	0
Band 2								
650	18650	10	1935	1855	50	0	50	0
900	18900	10	1960	1880	50	0	50	0
1150	19150	10	1985	1905	50	0	50	0
Band 3								
1250	19250	10	1810	1715	50	0	50	0
1575	19575	10	1842,5	1747,5	50	0	50	0
1900	19900	10	1875	1780	50	0	50	0
Band 4								
2000	20000	10	2115	1715	50	0	50	0
2175	20175	10	2132,5	1732,5	50	0	50	0
2350	20350	10	2150	1750	50	0	50	0
Band 5								
2450	20450	10	874	829	50	0	25	25
2525	20525	10	881,5	836,5	50	0	25	25
2600	20600	10	889	844	50	0	25	25
Band 7								
2800	20800	10	2625	2505	50	0	50	0
3100	21100	10	2655	2535	50	0	50	0
3400	21400	10	2685	2565	50	0	50	0
Band 8								
3500	21500	10	930	885	50	0	25	25
3625	21625	10	942,5	897,5	50	0	25	25
3750	21750	10	955	910	50	0	25	25
Band 12								
5060	23060	10	734	704	50	0	20	30
5095	23095	10	737,5	707,5	50	0	20	30
5130	23130	10	741	711	50	0	20	30
Band 13								
5230	23230	10	751	782	50	0	15	0
5230	23230	10	751	782	50	0	15	0
5230	23230	10	751	782	50	0	15	0
Band 14								
5330	23330	10	763	793	50	0	20	0
5330	23330	10	763	793	50	0	20	0
5330	23330	10	763	793	50	0	20	0
Band 17								
5780	23780	10	739	709	50	0	20	30
5790	23790	10	740	710	50	0	20	30
5800	23800	10	741	711	50	0	20	30
Band 19								
6050	24050	10	880	835	50	0	25	0
6075	24075	10	882,5	837,5	50	0	25	0
6100	24100	10	885	840	50	0	25	0
Band 20								
6200	24200	10	796	837	50	0	20	30
6300	24300	10	806	847	50	0	20	30
6400	24400	10	816	857	50	0	20	30
Band 21								
6525	24525	15	1503.4	1455.4	75	0	25	0
6525	24525	15	1503.4	1455.4	75	0	25	0
6525	24525	15	1503.4	1455.4	75	0	25	0
Band 22								
TBD	TBD	TBD	TBD	TBD	TBD	TBD	TBD	TBD
TBD	TBD	TBD	TBD	TBD	TBD	TBD	TBD	TBD
TBD	TBD	TBD	TBD	TBD	TBD	TBD	TBD	TBD
Band 23								
TBD	TBD	TBD	TBD	TBD	TBD	TBD	TBD	TBD
TBD	TBD	TBD	TBD	TBD	TBD	TBD	TBD	TBD

TBD	TBD	TBD	TBD	TBD	TBD	TBD	TBD	TBD
Band 24								
TBD	TBD	TBD	TBD	TBD	TBD	TBD	TBD	TBD
TBD	TBD	TBD	TBD	TBD	TBD	TBD	TBD	TBD
TBD	TBD	TBD	TBD	TBD	TBD	TBD	TBD	TBD
Band 25								
8065	26065	5	1932.5	1852.5	25	0	25	0
8365	26365	5	1962.5	1882.5	25	0	25	0
8665	26665	5	1992.5	1912.5	25	0	25	0
Band 26								
TBD	TBD	TBD	TBD	TBD	TBD	TBD	TBD	TBD
TBD	TBD	TBD	TBD	TBD	TBD	TBD	TBD	TBD
TBD	TBD	TBD	TBD	TBD	TBD	TBD	TBD	TBD
Band 27								
TBD	TBD	TBD	TBD	TBD	TBD	TBD	TBD	TBD
TBD	TBD	TBD	TBD	TBD	TBD	TBD	TBD	TBD
TBD	TBD	TBD	TBD	TBD	TBD	TBD	TBD	TBD
Band 28								
9260	27260	10	763	708	50	0	25	0
9410	27410	10	778	723	50	0	25	0
9610	27610	10	798	743	50	0	25	0
Note 1:	Refer to TS 36.521-1-1 [11], Table A.3.2-1 (Fixed Reference Channel for Receiver Requirements (FDD)), 10MHz configuration							
Note 2:	Network signalling value NS_01 shall be used in TRS tests unless explicitly specified							
Note 3:	Network signalling value NS_03 shall be used for Bands 2, 4, and 23							
Note 4:	Network signalling value NS_06 shall be used for Bands 12, 13, 14, and 17							
Note 5:	Network signalling value NS_08 shall be used for Band 19							
Note 6:	Network signalling value NS_09 shall be used for Band 21							

5.4 E-UTRA TDD frequency bands and measurement frequencies allocations

Editor's notes: This Subclause is incomplete. The following item is missing or incomplete:

- TBDs in Tables 5.4-1 (TRP) and 5.4.3 (TRS)

This section specifies the LTE-TDD TRP and TRS frequency bands and measurement frequencies allocations. Table 5.4-0 lists the operating bands. Table 5.4-1 specifies the measurement frequency allocations for TRP and Table 5.4-2 specifies the measurement frequency allocations for TRS.

Table 5.4-0 E-UTRA TDD operating bands for TRP and TRS

E-UTRA Operating Band	Uplink (UL) operating band BS receive UE transmit		Downlink (DL) operating band BS transmit UE receive		Duplex Mode
	F _{UL_low} – F _{UL_high}		F _{DL_low} – F _{DL_high}		
33	1900 MHz	– 1920 MHz	1900 MHz	– 1920 MHz	TDD
34	2010 MHz	– 2025 MHz	2010 MHz	– 2025 MHz	TDD
35	1850 MHz	– 1910 MHz	1850 MHz	– 1910 MHz	TDD
36	1930 MHz	– 1990 MHz	1930 MHz	– 1990 MHz	TDD
37	1910 MHz	– 1930 MHz	1910 MHz	– 1930 MHz	TDD
38	2570 MHz	– 2620 MHz	2570 MHz	– 2620 MHz	TDD
39	1880 MHz	– 1920 MHz	1880 MHz	– 1920 MHz	TDD
40	2300 MHz	– 2400 MHz	2300 MHz	– 2400 MHz	TDD
41	2496 MHz	– 2690 MHz	2496 MHz	– 2690 MHz	TDD
42	3400 MHz	– 3600 MHz	3400 MHz	– 3600 MHz	TDD
43	3600 MHz	– 3800 MHz	3600 MHz	– 3800 MHz	TDD
44	703 MHz	– 803 MHz	703 MHz	– 803 MHz	TDD

Table 5.4-1: Measurement frequency allocations for TRP (TDD)

DL EARFCN	UL EARFCN	Channel BW	DL Carrier Frequency	UL Carrier frequency	DL C _{LRB}	DL RB _{Start}	UL C _{LRB}	UL RB _{Start}
Band 33								
36100	36100	20	1910	1910	Note 1	Note 1	18	41
Band 34								
TBD	TBD	TBD	TBD	TBD	TBD	TBD	TBD	TBD
Band 35								
36450	36450	20	1860	1860	Note 1	Note 1	18	0
36650	36650	20	1880	1880	Note 1	Note 1	18	41
36850	36850	20	1900	1900	Note 1	Note 1	18	82
Band 36								
37050	37050	20	1940	1940	Note 1	Note 1	18	0
37250	37250	20	1960	1960	Note 1	Note 1	18	41
37450	37450	20	1980	1980	Note 1	Note 1	18	82
Band 37								
37650	37650	20	1920	1920	Note 1	Note 1	18	41
Band 38								
37850	37850	20	2580	2580	Note 1	Note 1	18	0
38000	38000	20	2595	2595	Note 1	Note 1	18	41
38150	38150	20	2610	2610	Note 1	Note 1	18	82
Band 39								
38350	38350	20	1890	1890	Note 1	Note 1	18	0
38450	38450	20	1900	1900	Note 1	Note 1	18	41
38550	38550	20	1910	1910	Note 1	Note 1	18	82
Band 40								
38750	38750	20	2310	2310	Note 1	Note 1	18	0
39150	39150	20	2350	2350	Note 1	Note 1	18	41
39550	39550	20	2390	2390	Note 1	Note 1	18	82
Band 41								
39750	39750	20	2506	2506	Note 1	Note 1	18	0
40620	40620	20	2593	2593	Note 1	Note 1	18	41
41490	41490	20	2680	2680	Note 1	Note 1	18	82
Band 42								
41690	41690	20	3410	3410	Note 1	Note 1	18	0
42590	42590	20	3500	3500	Note 1	Note 1	18	41
43490	43490	20	3590	3590	Note 1	Note 1	18	82
Band 43								
43690	43690	20	3610	3610	Note 1	Note 1	18	0
44590	44590	20	3700	3700	Note 1	Note 1	18	41
45490	45490	20	3790	3790	Note 1	Note 1	18	82
Band 44								
TBD	TBD	TBD	TBD	TBD	TBD	TBD	TBD	TBD
Note 1: As per 3GPP TS 36.521-1 [11], Section 6.2 (UE Maximum Output Power), and Section A.3.2.A (Downlink Reference measurement channel for TX characteristics).								
Note 2: Network signalling value NS_01 shall be used in TRP tests.								

Table 5.4-2: Measurement frequency allocations for TRS (TDD)

DL EARFCN	UL EARFCN	Channel BW	DL Carrier Frequency	UL Carrier frequency	DL C _{LRB}	DL RB _{Start}	UL C _{LRB}	UL RB _{Start}
Band 33								
36100	36100	20	1910	1910	100	0	100	0
Band 34								
TBD	TBD	TBD	TBD	TBD	TBD	TBD	TBD	TBD
Band 35								
36450	36450	20	1860	1860	100	0	100	0
36650	36650	20	1880	1880	100	0	100	0
36850	36850	20	1900	1900	100	0	100	0
Band 36								
37050	37050	20	1940	1940	100	0	100	0
37250	37250	20	1960	1960	100	0	100	0
37450	37450	20	1980	1980	100	0	100	0
Band 37								
37650	37650	20	1920	1920	100	0	100	0
Band 38								
37850	37850	20	2580	2580	100	0	100	0
38000	38000	20	2595	2595	100	0	100	0
38150	38150	20	2610	2610	100	0	100	0
Band 39								
38350	38350	20	1890	1890	100	0	100	0
38450	38450	20	1900	1900	100	0	100	0
38550	38550	20	1910	1910	100	0	100	0
Band 40								
38750	38750	20	2310	2310	100	0	100	0
39150	39150	20	2350	2350	100	0	100	0
39550	39550	20	2390	2390	100	0	100	0
Band 41								
39750	39750	20	2506	2506	100	0	100	0
40620	40620	20	2593	2593	100	0	100	0
41490	41490	20	2680	2680	100	0	100	0
Band 42								
41690	41690	20	3410	3410	100	0	100	0
42590	42590	20	3500	3500	100	0	100	0
43490	43490	20	3590	3590	100	0	100	0
Band 43								
43690	43690	20	3610	3610	100	0	100	0
44590	44590	20	3700	3700	100	0	100	0
45490	45490	20	3790	3790	100	0	100	0
Band 44								
TBD	TBD	TBD	TBD	TBD	TBD	TBD	TBD	TBD
Note 1: Refer to TS 36.521-1 [7], Table A.3.2-2 (Fixed Reference Channel for Receiver Requirements (TDD)), 20MHz configuration								
Note 2: Network signalling value NS_01 shall be used in TRS tests								

5.5 E-UTRA FDD operating bands and measurement frequency allocations for receiver total radiated multi-antenna sensitivity

This section specifies the E-UTRA FDD operating bands and measurement frequency allocations for TRMS. Table 5.5-1 lists the operating bands and Table 5.5-2 specifies the measurement frequency allocations for TRMS.

Table 5.5-1 E-UTRA FDD operating bands for receiver total radiated multi-antenna sensitivity requirements

E-UTRA Operating Band	Uplink (UL) operating band BS receive UE transmit		Downlink (DL) operating band BS transmit UE receive		Duplex Mode
	F _{UL_low} – F _{UL_high}		F _{DL_low} – F _{DL_high}		
1	1920 MHz	– 1980 MHz	2110 MHz	– 2170 MHz	FDD
2	1850 MHz	– 1910 MHz	1930 MHz	– 1990 MHz	FDD
3	1710 MHz	– 1785 MHz	1805 MHz	– 1880 MHz	FDD
4	1710 MHz	– 1755 MHz	2110 MHz	– 2155 MHz	FDD
5	824 MHz	– 849 MHz	869 MHz	– 894 MHz	FDD
7	2500 MHz	– 2570 MHz	2620 MHz	– 2690 MHz	FDD
8	880 MHz	– 915 MHz	925 MHz	– 960 MHz	FDD
12	699 MHz	– 716 MHz	729 MHz	– 746 MHz	FDD
13	777 MHz	– 787 MHz	746 MHz	– 756 MHz	FDD
19	830 MHz	– 845 MHz	875 MHz	– 890 MHz	FDD
20	832 MHz	– 862 MHz	791 MHz	– 821 MHz	FDD
28	703 MHz	– 748 MHz	758 MHz	– 803 MHz	FDD
32	N/A		1452 MHz	– 1496 MHz	FDD ¹

NOTE 1: Restricted to E-UTRA operation when carrier aggregation is configured. The downlink operating band is paired with the uplink operating band (external) of the carrier aggregation configuration that is supporting the configured Pcell.

Deployment in other frequency bands is not precluded.

Table 5.5-2: Measurement frequency allocations for TRMS (FDD)

DL EARFCN	UL EARFCN	Channel BW	DL Carrier Frequency	UL Carrier frequency	DL C _{LRB}	DL RB _{Start}	UL C _{LRB}	UL RB _{Start}
Band 1								
300	18300	10	2140	1950	50	0	50	0
Band 2								
900	18900	10	1960	1880	50	0	50	0
Band 3								
1575	19575	10	1842,5	1747,5	50	0	50	0
Band 4								
2175	20175	10	2132,5	1732,5	50	0	50	0
Band 5								
2525	20525	10	881,5	836,5	50	0	50	0
Band 7								
3100	21100	10	2655	2535	50	0	50	0
Band 8								
3625	21625	10	942,5	897,5	50	0	50	0
Band 12								
5095	23095	10	737,5	707,5	50	0	50	0
Band 13								
5230	23230	10	751	782	50	0	50	0
Band 19								
6075	24075	10	882,5	837,5	50	0	50	0
Band 20								
6300	24300	10	806	847	50	0	50	0
Band 28								
9410	27410	10	778	723	50	0	50	0
Band 32								
10140	N/A	10	1474	N/A	50	0	N/A	N/A

5.6 E-UTRA TDD operating bands and measurement frequency allocations for receiver total radiated multi-antenna sensitivity

This section specifies the E-UTRA TDD operating bands and measurement frequency allocations for TRMS. Table 5.6-1 lists the operating bands and Table 5.6-2 specifies the measurement frequency allocations for TRMS.

Table 5.6-1 E-UTRA TDD operating bands for receiver total radiated multi-antenna sensitivity requirements

E-UTRA Operating Band	Uplink (UL) operating band BS receive UE transmit	Downlink (DL) operating band BS transmit UE receive	Duplex Mode
	$F_{UL_low} - F_{UL_high}$	$F_{DL_low} - F_{DL_high}$	
38	2570 MHz – 2620 MHz	2570 MHz – 2620 MHz	TDD
39	1880 MHz – 1920 MHz	1880 MHz – 1920 MHz	TDD
40	2300 MHz – 2400 MHz	2300 MHz – 2400 MHz	TDD
41	2496 MHz – 2690 MHz	2496 MHz – 2690 MHz	TDD
42	3400 MHz – 3600 MHz	3400 MHz – 3600 MHz	TDD
46	5150 MHz – 5925 MHz	5150 MHz – 5925 MHz	TDD ^{1,2}
NOTE 1: This band is an unlicensed band restricted to licensed-assisted operation using Frame Structure Type 3.			
NOTE 2: In this version of the specification, restricted to E-UTRA DL operation when carrier aggregation is configured.			

Deployment in other frequency bands is not precluded.

Table 5.6-2: Measurement frequency allocations for TRMS (TDD)

DL EARFCN	UL EARFCN	Channel BW	DL Carrier Frequency	UL Carrier frequency	DL C_{LRB}	DL RB_{Start}	UL C_{LRB}	UL RB_{Start}
Band 38								
38000	38000	20	2595	2595	100	0	100	0
Band 39								
38450	38450	20	1900	1900	100	0	100	0
Band 40								
39150	39150	20	2350	2350	100	0	100	0
Band 41								
40620	40620	20	2593	2593	100	0	100	0
Band 42								
42590	42590	20	3500	3500	100	0	100	0
Band 46								
50665	50665	20	5537,5	5537,5	100	0	100	0

6 Transmitter Performance

6.1 Performance for handheld UE

6.1.1 Total Radiated Power (TRP) for UTRA FDD in Speech Mode with beside the Head Phantom

6.1.1.1 Definition and applicability

The Total Radiated Power (TRP) is a measure of how much power the DUT actually radiates. The TRP is defined as the integral of the power transmitted in different directions over the entire radiation sphere:

$$TRP = \frac{1}{4\pi} \oint (EIRP_{\theta}(\Omega; f) + EIRP_{\varphi}(\Omega; f)) d\Omega$$

Where Ω is the solid angle describing the direction, f is frequency. θ and φ are the orthogonal polarizations. $EIRP_{\theta}$ and $EIRP_{\varphi}$ are the actually transmitted power-levels in corresponding polarizations.

Thus

$$TRP \approx \frac{\pi}{2NM} \sum_{n=0}^{N-1} \sum_{m=0}^{M-1} [EIRP_{\theta}(\theta_n, \varphi_m; f) + EIRP_{\varphi}(\theta_n, \varphi_m; f)] \sin(\theta_n)$$

In these formulas N and M are the number of sampling intervals for theta and phi. θ_n and φ_m are the measurement angles. The sampling intervals are discussed further in Subclause 4.4.

The TRP can also be calculated from Rayleigh faded samples of the total power transmitted from the UE. The measurement of transmitter performance in an isotropic Rayleigh fading environment is based on sampling the radiated power of the UE for a discrete number of field combinations in the chamber. The average value of these statistically distributed samples is proportional to the TRP and by calibrating the average power transfer function, an absolute value of the TRP can be obtained. Thus

$$TRP \approx \frac{\sum_{n=1}^N \left(\frac{P_n}{C_n (1 - R_n)} \right)}{\sum_{n=1}^N P_{ref,n}}$$

where $P_{ref,n}$ is the reference power transfer function for fixed measurement antenna n , R_n is the reflection coefficient for fixed measurement antenna n and C_n is the path loss in the cables connecting the measurement receiver to fixed measurement antenna n . These parameters are calculated from the calibration measurement and are further discussed in Annex B.2. P_n is the average power measured by fixed measurement antenna n and can be calculated using the following expression:

$$P_n = \frac{\sum_{m=1}^M |S_{21,n,m}|^2}{M}$$

where $S_{21,n,m}$ is sample number m of the complex transfer function measured with fixed measurement antenna n and M is the total number of samples measured for each fixed measurement antenna.

Note that all averaging must be performed using linear power values (e.g. measurements in Watts).

The requirements and this test apply to all types of UTRA for the FDD UE for Release 7 and later releases.

6.1.1.2 Minimum Requirements

The average TRP of low, mid and high channel in beside head position shall be higher than minimum performance requirements for roaming bands shown in Table 6.1.1.2-1. The averaging shall be done in linear scale for the TRP results of both right and left side of the phantom head.

$$TRP_{average} = 10 \log \left[\frac{10^{P_{left_low}/10} + 10^{P_{left_mid}/10} + 10^{P_{left_high}/10} + 10^{P_{right_low}/10} + 10^{P_{right_mid}/10} + 10^{P_{right_high}/10}}{6} \right]$$

In addition the minimum TRP of each measured channel in beside head position shall be higher than minimum performance requirements shown in the columns "Min".

$$TRP_{min} = \min [P_{left_low}, P_{left_mid}, P_{left_high}, P_{right_low}, P_{right_mid}, P_{right_high}]$$

Table 6.1.1.2-1: TRP minimum performance requirement for FDD roaming bands in the speech position and the primary mechanical mode

Operating band	Power Class 1	Power Class 2	Power Class 3		Power Class 3bis		Power Class 4	
	Power (dBm)	Power (dBm)	Power (dBm)		Power (dBm)		Power (dBm)	
			Average	Min	Average	Min	Average	Min
I	-	-	+15	+13	+15	+13	+13	+11
II	-	-	+15	+13	+15	+13	+13	+11
III	-	-	+15	+13	+15	+13	+13	+11
IV	-	-	+15	+13	+15	+13	+13	+11
V	-	-	+11	+9	+11	+9	+9	+7
VI	-	-	+11	+9	+11	+9	+9	+7
VII	-	-	+15	+13	+15	+13	+13	+11
VIII	-	-	+12	+10	+12	+10	+10	+8
IX	-	-	+15	+13	+15	+13	+13	+11
XIX	-	-	+11.5	+9.5	+11.5	+9.5	+9.5	+7.5

NOTE: Applicable for dual-mode GSM/UMTS.

The normative reference for this Subclause is TS 37.144 Subclause 6.1.1.2.

6.1.1.3 Test purpose

The purpose of this test is to verify that $TRP_{average}$ and TRP_{min} of the UE is not below specified values. A lower $TRP_{average}$ and TRP_{min} decrease the coverage area.

6.1.1.4 Method of test

6.1.1.4.1 Initial conditions

The output power is a measure of the maximum power the UE can transmit in a bandwidth of at least $(1 + \alpha)$ times the chip rate of the radio access mode, for more information see 3GPP TS 34.121-1 [7] chapter 5.2. The period of measurement shall be at least one timeslot. Also care should be taken that the noise floor of the measurement receiver is not disturbing the power measurement.

Test environment: normal; see TS34.121-1 [7] Annex G.2.1.

Frequencies to be tested: low range, mid range, high range; see Table 5.1-2.

- 1) Set the SS downlink physical channels according to settings in Table 6.1.1.4.1-1. Set the DPCH power such that there will not be transmission gaps due to too low signal strength throughout the measurement.

- 2) Power on the UE.
- 3) A call is set up according to the Generic call setup procedure. The power control algorithm shall be set to Power Control Algorithm 2. Compressed mode shall be set to OFF.
- 4) Enter the UE into loopback test mode 2 and start the loopback test.

See TS 34.108 [4] and TS 34.109 [5] for details regarding generic call setup procedure and loopback test.

Table 6.1.1.4.1-1: Downlink Physical Channels transmitted during a connection

Physical Channel	Power
CPICH	CPICH_Ec / DPCH_Ec = 7 dB
P-CCPCH	P-CCPCH_Ec / DPCH_Ec = 5 dB
SCH	SCH_Ec / DPCH_Ec = 5 dB
PICH	PICH_Ec / DPCH_Ec = 2 dB
DPCH	Test dependent power

6.1.1.4.2 Procedure

- 1) Send continuously Up power control commands to the UE.
- 2) As the UE reaches maximum power, start sending PN15 data pattern.
- 3) Position the UE against the SAM phantom
- 4) Measure the $EIRP_{\theta}$ and $EIRP_{\phi}$ with a sample step of 15° in theta (θ) and phi (ϕ) directions using a test system having characteristics as described in Annex A.
- 5) Calculate TRP using equations from Subclause 6.1.1.1

NOTE 1: The measurement procedure is based on the measurement of the spherical radiation pattern of the DUT. The power radiated by the DUT is sampled in far field in a group of points located on a spherical surface enclosing the DUT. The EIRP samples are taken using a constant sample step of 15° both in theta (θ) and phi (ϕ) directions. In some cases a different sampling grid may be used to speed up the measurements (See Subclause 4.4). All the EIRP samples are taken with two orthogonal polarizations, θ - and ϕ - polarisations.

NOTE 2: The noise floor of the measurement receiver shall not disturb the power measurement.

NOTE 3: Non Standard settings: To speed up sensitivity measurements, power measurements may be done with non standard modulation. However to obtain TRP result the measured EIRP figures shall be normalized by

$$\overline{\Delta EIRP} = \frac{1}{n} \sum_{i=1}^n (EIRP_{std_i} - EIRP_{nstd_i})$$

where $EIRP_{std_i}$ is power measurement done with standard setting. $EIRP_{nstd_i}$ is power measurement done with non standard modulation. n is amount of reference measurement points.

To ensure accuracy of TRP, the amount of reference points measured should be at least 4. It is recommended to spread the reference measurements equally during the measurement time.

6.1.1.4.3 Procedure, reverberation chamber method

- 1) Send continuously Up power control commands to the UE.
- 2) As the UE reaches maximum power, start sending PN15 data pattern.
- 3) Position the UE against the SAM phantom

- 4) Measure a sufficient number of independent samples (see Subclause 4.5) of $S_{21,n,m}$ using a test system having characteristics as described in Annex A.
- 5) Calculate TRP using equations from Subclause 6.1.1.1.

NOTE 1: The measurement procedure is based on the measurement of the total power radiated from the UE to a full 3 dimensional isotropic environment with uniform elevation and azimuth field distribution. The power transmitted by the DUT is undergoing Rayleigh fading and is sampled by the fixed measurement antennas. Moreover, it is important that the samples collected are independent, in order to get sufficient accuracy of the estimated TRP value.

NOTE 2: The noise floor of the measurement receiver shall not disturb the power measurement.

6.1.1.5 Test requirements

The average TRP of low, mid and high channel in beside head position shall be higher than test performance requirements for roaming bands shown in Table 6.1.1.5-1. The averaging shall be done in linear scale for the TRP results of both right and left side of the phantom head.

$$TRP_{average} = 10 \log \left[\frac{10^{P_{left_low}/10} + 10^{P_{left_mid}/10} + 10^{P_{left_high}/10} + 10^{P_{right_low}/10} + 10^{P_{right_mid}/10} + 10^{P_{right_high}/10}}{6} \right]$$

In addition the minimum TRP of each measured channel in beside head position shall be higher than minimum performance requirements shown in the columns “Min”.

$$TRP_{min} = \min \left[P_{left_low}, P_{left_mid}, P_{left_high}, P_{right_low}, P_{right_mid}, P_{right_high} \right]$$

Table 6.1.1.5-1: TRP test requirement for FDD roaming bands in the speech position and the primary mechanical mode

Operating band	Power Class 1	Power Class 2	Power Class 3		Power Class 3bis		Power Class 4	
	Power (dBm)	Power (dBm)	Power (dBm)		Power (dBm)		Power (dBm)	
			Average	Min	Average	Min	Average	Min
I	-	-	+14.3	+12.0	+14.3	+12.0	+12.3	+10.0
II	-	-	+14.3	+12.0	+14.3	+12.0	+12.3	+10.0
III	-	-	+14.3	+12.0	+14.3	+12.0	+12.3	+10.0
IV	-	-	+14.3	+12.0	+14.3	+12.0	+12.3	+10.0
V	-	-	+10.3	+8.0	+10.3	+8.0	+8.3	+6
VI	-	-	+10.3	+8.0	+10.3	+8.0	+8.3	+6
VII	-	-	+14.3	+12.0	+14.3	+12.0	+12.3	+10.0
VIII	-	-	+11.3	+9.0	+11.3	+9.0	+9.3	+7
IX	-	-	+14.3	+12.0	+14.3	+12.0	+12.3	+10.0
XIX	-	-	+11.5+TT	+9.0+TT	+11.5+T T	+9.0+TT	+9.5+TT	+7.5+TT

NOTE: Applicable for dual-mode GSM/UMTS.

NOTE: If the above Test Requirement differs from the Minimum Requirement then the Test Tolerance applied for this test is non-zero. The Test Tolerance for this test is defined and the explanation of how the Minimum Requirement has been relaxed by the Test Tolerance is given in Annex D.

6.1.2 Total Radiated Power (TRP) for UTRA LCR TDD in Speech Mode with beside the Head Phantom

Editor’s note: This test case is incomplete. The following aspects are either missing or not yet determined:

- The TRP Minimum Performance Requirement for operating bands b, c, d of this test is undefined
- The Test Requirements and related Test Tolerances applicable for operating bands b, c, d of this test are undefined

6.1.2.1 Definition and applicability

The Total Radiated Power (TRP) is a measure of how much power the DUT actually radiates. The TRP is defined as the integral of the power transmitted in different directions over the entire radiation sphere:

$$TRP = \frac{1}{4\pi} \oint (EIRP_{\theta}(\Omega; f) + EIRP_{\varphi}(\Omega; f)) d\Omega$$

Where Ω is the solid angle describing the direction, f is frequency. θ and φ are the orthogonal polarizations.

$EIRP_{\theta}$ and $EIRP_{\varphi}$ are the actually transmitted power-levels in corresponding polarizations.

Thus,

$$TRP \approx \frac{\pi}{2NM} \sum_{n=0}^{N-1} \sum_{m=0}^{M-1} [EIRP_{\theta}(\theta_n, \varphi_m; f) + EIRP_{\varphi}(\theta_n, \varphi_m; f)] \sin(\theta_n)$$

In these formulas N and M are the number of sampling intervals for theta and phi. θ_n and φ_m are the measurement angles. The sampling intervals are discussed further in Section 4.4.

The TRP can also be calculated from Rayleigh faded samples of the total power transmitted from the UE/MS. The measurement of transmitter performance in an isotropic Rayleigh fading environment is based on sampling the radiated power of the UE/MS for a discrete number of field combinations in the chamber. The average value of these statistically distributed samples is proportional to the TRP and by calibrating the average power transfer function, an absolute value of the TRP can be obtained. Thus,

$$TRP \approx \frac{\sum_{n=1}^N \left(\frac{P_n}{C_n (1 - R_n)} \right)}{\sum_{n=1}^N P_{ref,n}}$$

where $P_{ref,n}$ is the reference power transfer function for fixed measurement antenna n , R_n is the reflection coefficient for fixed measurement antenna n and C_n is the path loss in the cables connecting the measurement receiver to fixed measurement antenna n . These parameters are calculated from the calibration measurement and are further discussed in Annex B.2. P_n is the average power measured by fixed measurement antenna n and can be calculated using the following expression:

$$P_n = \frac{\sum_{m=1}^M |S_{21,n,m}|^2}{M}$$

where $S_{21,n,m}$ is sample number m of the complex transfer function measured with fixed measurement antenna n and M is the total number of samples measured for each fixed measurement antenna.

The requirements and this test apply to all types of UTRA for the TDD UE for Release 8 and later releases.

6.1.2.2 Minimum Requirements

The average TRP of low, mid and high channel in beside head position shall be higher than minimum performance requirements for roaming bands shown in Table 6.1.2.2-1. The averaging shall be done in linear scale for the TRP results of both right and left side of the phantom head.

$$TRP_{average} = 10 \log \left[\frac{10^{P_{left_low}/10} + 10^{P_{left_mid}/10} + 10^{P_{left_high}/10} + 10^{P_{right_low}/10} + 10^{P_{right_mid}/10} + 10^{P_{right_high}/10}}{6} \right]$$

In addition the minimum TRP of each measured channel in beside head position shall be higher than minimum performance requirements shown in the columns “Min”.

$$TRP_{\min} = \min \left[P_{\text{left_low}}, P_{\text{left_mid}}, P_{\text{left_high}}, P_{\text{right_low}}, P_{\text{right_mid}}, P_{\text{right_high}} \right]$$

Table 6.1.2.2-1: TRP minimum performance requirement for UTRA LCR TDD using Head Phantom

Operating band	Power Class 1		Power Class 2		Power Class 3		Power Class 4	
	Power (dBm)		Power (dBm)		Power (dBm)		Power (dBm)	
	Average	Min	Average	Min	Average	Min	Average	Min
a	–	–	+15	+13	–	–	–	–
b	–	–	TBD	TBD	–	–	–	–
c	–	–	TBD	TBD	–	–	–	–
d	–	–	TBD	TBD	–	–	–	–
e	–	–	+15	+13	–	–	–	–
f	–	–	+15	+13	–	–	–	–

Note: Applicable for dual-mode GSM/UTRA LCR TDD.

The normative reference for this clause is TS37.144 section 6.1.1.3.

6.1.2.3 Test purpose

The purpose of this test is to verify that TRP_{average} and TRP_{\min} of the UE are not below specified values. A lower TRP_{average} and TRP_{\min} decrease the coverage area.

6.1.2.4 Method of test

6.1.2.4.1 Initial conditions

The output power is a measure of the maximum power the UE can transmit in a bandwidth of at least $(1 + \alpha)$ times the chip rate of the radio access mode, for more information see 3GPP TS 34.122 chapter 5.2. The period of measurement shall be at least one timeslot. Also, care should be taken that the noise floor of the measurement receiver is not disturbing the power measurement. Normally, the receiving device should be set accordingly so that the receiving signal will be at least 30dB higher than the system noise floor.

Test environment: normal; see 3GPP TS34.122-1 [8] clause G.2.1.

Frequencies to be tested: low range, mid range, high range; see Table 5.2-2.

- 1) Set the SS downlink physical channels parameters. Set the DPCH power such that there will not be transmission gaps due to too low signal strength throughout the measurement.
- 2) Power on the UE.
- 3) A call is set up according to the Generic call setup procedure. The power control algorithm shall be set to Power Control Algorithm 2.
- 4) Enter the UE into loopback test mode and start the loopback test.
- 5) The measurement receiver shall be set to: zero span, video trigger and RMS detector. The RBW shall be at least $(1 + \alpha)$ times the chip rate of the radio access mode and the VBW at least 3 times bigger than the RBW. For 1.28Mcps TDD UE, the RBW shall be set to 3MHz, and VBW shall be set to 10MHz.

See TS 34.108 [4] and TS 34.109 [5] for details regarding generic call setup procedure and loopback test.

6.1.2.4.2 Procedure

- 1) Send continuously Up power control commands to the UE.
- 2) As the UE reaches maximum power, start sending PN15 data pattern.
- 3) Position the UE against the SAM phantom.
- 4) Measure the $EIRP_{\theta}$ and $EIRP_{\phi}$ with a sample step of 15° in theta (θ) and phi (ϕ) directions using a test system having characteristics as described in Annex A.
- 5) Calculate TRP using equations from chapter 6.1.2.1.

NOTE 1: The measurement procedure is based on the measurement of the spherical radiation pattern of the DUT. The power radiated by the DUT is sampled in far field in a group of points located on a spherical surface enclosing the DUT. The EIRP samples are taken using a constant sample step of 15° both in theta (θ) and phi (ϕ) directions. In some cases a different sampling grid may be used to speed up the measurements (See Section 4.4). All the EIRP samples are taken with two orthogonal polarizations, θ - and ϕ - polarizations.

NOTE 2: The noise floor of the measurement receiver shall not disturb the power measurement.

NOTE 3: Non Standard settings: To speed up sensitivity measurements, power measurements may be done with non standard modulation. However to obtain TRP result the measured EIRP figures shall be normalized by

$$\overline{\Delta EIRP} = \frac{1}{n} \sum_{i=1}^n (EIRP_{std_i} - EIRP_{nstd_i})$$

where $i EIRP_{std_i}$ is power measurement done with standard setting. $EIRP_{nstd_i}$ is power measurement done with non standard modulation. n is amount of reference measurement points.

To ensure accuracy of TRP, the amount of reference points measured should be at least 4. It is recommended to spread the reference measurements equally during the measurement time.

6.1.2.4.3 Procedure, reverberation chamber method

- 1) Send continuously Up power control commands to the UE.
- 2) As the UE reaches maximum power, start sending PN15 data pattern.
- 3) Position the UE against the SAM phantom
- 4) Measure a sufficient number of independent samples (see section 4.5) of $S_{21,n,m}$ using a test system having the characteristics described in Annex A.
- 5) Calculate TRP using equations from section 6.1.2.1.

NOTE 1: The measurement procedure is based on the measurement of the total power radiated from the UE/MS to a full 3 dimensional isotropic environment with uniform elevation and azimuth field distribution. The power transmitted by the DUT is undergoing Rayleigh fading and is sampled by the fixed measurement antennas. Moreover, it is important that the samples collected are independent, in order to get sufficient accuracy of the estimated TRP value.

NOTE 2: The noise floor of the measurement receiver shall not disturb the power measurement.

6.1.2.5 Test requirements

The average TRP of low, mid and high channel in beside head position shall be higher than test performance requirements for roaming bands shown in Table 6.1.2.5-1. The averaging shall be done in linear scale for the TRP results of both right and left side of the phantom head.

$$TRP_{average} = 10 \log \left[\frac{10^{P_{left_low}/10} + 10^{P_{left_mid}/10} + 10^{P_{left_high}/10} + 10^{P_{right_low}/10} + 10^{P_{right_mid}/10} + 10^{P_{right_high}/10}}{6} \right]$$

In addition the minimum TRP of each measured channel in beside head position shall be higher than minimum performance requirements shown in the columns “Min”.

$$TRP_{min} = \min [P_{left_low}, P_{left_mid}, P_{left_high}, P_{right_low}, P_{right_mid}, P_{right_high}]$$

Table 6.1.2.5-1: TRP test performance requirement for UTRA LCR TDD using Head Phantom

Operating band	Power Class 1		Power Class 2		Power Class 3		Power Class 4	
	Power (dBm)		Power (dBm)		Power (dBm)		Power (dBm)	
	Average	Min	Average	Min	Average	Min	Average	Min
a	–	–	+14.3	+12	–	–	–	–
b	–	–	TBD+TT	TBD+TT	–	–	–	–
c	–	–	TBD+TT	TBD+TT	–	–	–	–
d	–	–	TBD+TT	TBD+TT	–	–	–	–
e	–	–	+14.3	+12	–	–	–	–
f	–	–	+14.3	+12	–	–	–	–

Note: Applicable for dual-mode GSM/UTRA LCR TDD.

NOTE: If the above Test Requirement differs from the Minimum Requirement then the Test Tolerance applied for this test is non-zero. The Test Tolerance for this test is defined and the explanation of how the Minimum Requirement has been relaxed by the Test Tolerance is given in Annex D.

6.1.3 Total Radiated Power (TRP) for UTRA FDD in Speech Mode with beside the Head and Hand Phantom

Editor’s notes: This Subclause is incomplete. The following items are missing or incomplete:

- TBDs in Table 6.1.3.2-1 and 6.1.3.5-1 as they are not specified in TS 37.144 yet

6.1.3.1 Definition and applicability

The Total Radiated Power (TRP) is a measure of how much power the DUT actually radiates. The TRP is defined as the integral of the power transmitted in different directions over the entire radiation sphere:

$$TRP = \frac{1}{4\pi} \oint (EIRP_{\theta}(\Omega; f) + EIRP_{\varphi}(\Omega; f)) d\Omega$$

Where Ω is the solid angle describing the direction, f is frequency. θ and φ are the orthogonal polarizations.

$EIRP_{\theta}$ and $EIRP_{\varphi}$ are the actually transmitted power-levels in corresponding polarizations.

Thus

$$TRP \approx \frac{\pi}{2NM} \sum_{n=0}^{N-1} \sum_{m=0}^{M-1} [EIRP_{\theta}(\theta_n, \varphi_m; f) + EIRP_{\varphi}(\theta_n, \varphi_m; f)] \sin(\theta_n)$$

In these formulas N and M are the number of sampling intervals for theta and phi. θ_n and φ_m are the measurement angles. The sampling intervals are discussed further in Subclause 4.4.

The TRP can also be calculated from Rayleigh faded samples of the total power transmitted from the UE. The measurement of transmitter performance in an isotropic Rayleigh fading environment is based on sampling the radiated power of the UE for a discrete number of field combinations in the chamber. The average value of these statistically distributed samples is proportional to the TRP and by calibrating the average power transfer function, an absolute value of the TRP can be obtained. Thus

$$TRP \approx \frac{\sum_{n=1}^N \left(\frac{P_n}{C_n (1 - R_n)} \right)}{\sum_{n=1}^N P_{ref,n}}$$

where $P_{ref,n}$ is the reference power transfer function for fixed measurement antenna n , R_n is the reflection coefficient for fixed measurement antenna n and C_n is the path loss in the cables connecting the measurement receiver to fixed measurement antenna n . These parameters are calculated from the calibration measurement and are further discussed in Annex B.2. P_n is the average power measured by fixed measurement antenna n and can be calculated using the following expression:

$$P_n = \frac{\sum_{m=1}^M |S_{21,n,m}|^2}{M}$$

where $S_{21,n,m}$ is sample number m of the complex transfer function measured with fixed measurement antenna n and M is the total number of samples measured for each fixed measurement antenna.

Note that all averaging must be performed using linear power values (e.g. measurements in Watts).

The requirements and this test apply to all types of UTRA for the FDD UE for Release 7 and later releases.

6.1.3.2 Minimum Requirements

The average TRP of low, mid and high channel in beside head position shall be higher than minimum performance requirements for roaming bands shown in Table 6.1.3.2-1. The averaging shall be done in linear scale for the TRP results of both right and left side of the phantom head.

$$TRP_{average} = 10 \log \left[\frac{10^{P_{left_low}/10} + 10^{P_{left_mid}/10} + 10^{P_{left_high}/10} + 10^{P_{right_low}/10} + 10^{P_{right_mid}/10} + 10^{P_{right_high}/10}}{6} \right]$$

In addition the minimum TRP of each measured channel in beside head position shall be higher than minimum performance requirements shown in the columns "Min".

$$TRP_{min} = \min [P_{left_low}, P_{left_mid}, P_{left_high}, P_{right_low}, P_{right_mid}, P_{right_high}]$$

Table 6.1.3.2-1: TRP minimum performance requirement for UTRA FDD roaming bands in the speech mode and the primary mechanical mode

Operating band	Power Class 1	Power Class 2	Power Class 3		Power Class 3bis		Power Class 4	
	Power (dBm)	Power (dBm)	Power (dBm)		Power (dBm)		Power (dBm)	
			Average	Min	Average	Min	Average	Min

I	-	-	13.25	TBD	TBD	TBD	TBD	TBD
II	-	-	13.25	TBD	TBD	TBD	TBD	TBD
III	-	-	TBD	TBD	TBD	TBD	TBD	TBD
IV	-	-	TBD	TBD	TBD	TBD	TBD	TBD
V	-	-	9.40	TBD	TBD	TBD	TBD	TBD
VI	-	-	9.4	TBD	TBD	TBD	TBD	TBD
VII	-	-	TBD	TBD	TBD	TBD	TBD	TBD
VIII	-	-	9.40	TBD	TBD	TBD	TBD	TBD
IX	-	-	TBD	TBD	TBD	TBD	TBD	TBD
XIX	-	-	9.4	TBD	TBD	TBD	TBD	TBD
NOTE 1: Applicable for dual-mode GSM/UMTS. NOTE 2: Applicable for devices narrower than 72mm as defined in TR 25.914. NOTE 3: Not applicable for devices supporting CDMA or carrier aggregation.								

The normative reference for this clause is TS37.144 [12] Subclause 6.1.2.1.

6.1.3.3 Test purpose

The purpose of this test is to verify that $TRP_{average}$ and TRP_{min} of the UE is not below specified values. A lower $TRP_{average}$ and TRP_{min} decrease the coverage area.

6.1.3.4 Method of test

6.1.3.4.1 Initial conditions

The output power is a measure of the maximum power the UE can transmit in a bandwidth of at least $(1 + \alpha)$ times the chip rate of the radio access mode, for more information see 3GPP TS 34.121-1 [7] Subclause 5.2. The period of measurement shall be at least one timeslot. Also care should be taken that the noise floor of the measurement receiver is not disturbing the power measurement.

Test environment: normal; see TS 34.121-1 [7] Subclause G.2.1.

Frequencies to be tested: low range, mid range, high range; see Table 5.1-2.

- 1) Set the SS downlink physical channels according to settings in Table 6.1.3.4.1-1. Set the DPCH power such that there will not be transmission gaps due to too low signal strength throughout the measurement.
- 2) Power on the UE.
- 3) A call is set up according to the Generic call setup procedure. The power control algorithm shall be set to Power Control Algorithm 2. Compressed mode shall be set to OFF.
- 4) Enter the UE into loopback test mode 2 and start the loopback test.

See TS 34.108 [4] and TS 34.109 [5] for details regarding generic call setup procedure and loopback test.

Table 6.1.3.4.1-1: Downlink Physical Channels transmitted during a connection

Physical Channel	Power
CPICH	CPICH_Ec / DPCH_Ec = 7 dB
P-CCPCH	P-CCPCH_Ec / DPCH_Ec = 5 dB
SCH	SCH_Ec / DPCH_Ec = 5 dB
PICH	PICH_Ec / DPCH_Ec = 2 dB
DPCH	Test dependent power

6.1.3.4.2 Procedure

- 1) Send continuously Up power control commands to the UE.
- 2) As the UE reaches maximum power, start sending PN15 data pattern.

- 3) Position the UE according to the DUT positioning for speech mode specified in Subclause 4.3.3.
- 4) Measure the $EIRP_{\theta}$ and $EIRP_{\phi}$ with a sample step of 15° in theta (θ) and phi (ϕ) directions using a test system having characteristics as described in Annex A.
- 5) Calculate TRP using equations from Subclause 6.1.3.1.

NOTE 1: The measurement procedure is based on the measurement of the spherical radiation pattern of the DUT. The power radiated by the DUT is sampled in far field in a group of points located on a spherical surface enclosing the DUT. The EIRP samples are taken using a constant sample step of 15° both in theta (θ) and phi (ϕ) directions. In some cases a different sampling grid may be used to speed up the measurements (See Subclause 4.4). All the EIRP samples are taken with two orthogonal polarizations, θ - and ϕ - polarisations.

NOTE 2: The noise floor of the measurement receiver shall not disturb the power measurement.

NOTE 3: Non Standard settings: To speed up sensitivity measurements, power measurements may be done with non standard modulation. However to obtain TRP result the measured EIRP figures shall be normalized by

$$\overline{\Delta EIRP} = \frac{1}{n} \sum_{i=1}^n (EIRP_{std_i} - EIRP_{nstd_i})$$

where $EIRP_{std_i}$ is power measurement done with standard setting, $EIRP_{nstd_i}$ is power measurement done with non standard modulation. n is amount of reference measurement points.

To ensure accuracy of TRP, the amount of reference points measured should be at least 4. It is recommended to spread the reference measurements equally during the measurement time.

6.1.3.4.3 Procedure, reverberation chamber method

- 1) Send continuously Up power control commands to the UE.
- 2) As the UE reaches maximum power, start sending PN15 data pattern.
- 3) Position the UE according to the DUT positioning for speech mode specified in Subclause 4.3.3.
- 4) Measure a sufficient number of independent samples (see Subclause 4.5) of $S_{21,n,m}$ using a test system having characteristics as described in Annex A.
- 5) Calculate TRP using equations from Subclause 6.1.3.1.

NOTE 1: The measurement procedure is based on the measurement of the total power radiated from the UE to a full 3 dimensional isotropic environment with uniform elevation and azimuth field distribution. The power transmitted by the DUT is undergoing Rayleigh fading and is sampled by the fixed measurement antennas. Moreover, it is important that the samples collected are independent, in order to get sufficient accuracy of the estimated TRP value.

NOTE 2: The noise floor of the measurement receiver shall not disturb the power measurement.

6.1.3.5 Test requirements

The average TRP of low, mid and high channel in beside head position shall be higher than test performance requirements for roaming bands shown in Table 6.1.3.5-1. The averaging shall be done in linear scale for the TRP results of both right and left side of the phantom head.

$$TRP_{average} = 10 \log \left[\frac{10^{P_{left_low}/10} + 10^{P_{left_mid}/10} + 10^{P_{left_high}/10} + 10^{P_{right_low}/10} + 10^{P_{right_mid}/10} + 10^{P_{right_high}/10}}{6} \right]$$

In addition the minimum TRP of each measured channel in beside head position shall be higher than minimum performance requirements shown in the columns “Min”.

$$TRP_{\min} = \min[P_{\text{left_low}}, P_{\text{left_mid}}, P_{\text{left_high}}, P_{\text{right_low}}, P_{\text{right_mid}}, P_{\text{right_high}}]$$

Table 6.1.3.5-1: TRP test requirement for UTRA FDD roaming bands in the speech position and the primary mechanical mode

Operating band	Power Class 1	Power Class 2	Power Class 3		Power Class 3bis		Power Class 4	
	Power (dBm)	Power (dBm)	Power (dBm)		Power (dBm)		Power (dBm)	
			Average	Min	Average	Min	Average	Min
I	-	-	12.55	TBD+TT	TBD+TT	TBD+TT	TBD+TT	TBD+TT
II	-	-	12.55	TBD+TT	TBD+TT	TBD+TT	TBD+TT	TBD+TT
III	-	-	TBD+TT	TBD+TT	TBD+TT	TBD+TT	TBD+TT	TBD+TT
IV	-	-	TBD+TT	TBD+TT	TBD+TT	TBD+TT	TBD+TT	TBD+TT
V	-	-	8.70	TBD+TT	TBD+TT	TBD+TT	TBD+TT	TBD+TT
VI	-	-	8.70	TBD+TT	TBD+TT	TBD+TT	TBD+TT	TBD+TT
VII	-	-	TBD+TT	TBD+TT	TBD+TT	TBD+TT	TBD+TT	TBD+TT
VIII	-	-	8.70	TBD+TT	TBD+TT	TBD+TT	TBD+TT	TBD+TT
IX	-	-	TBD+TT	TBD+TT	TBD+TT	TBD+TT	TBD+TT	TBD+TT
XIX	-	-	8.70	TBD+TT	TBD+TT	TBD+TT	TBD+TT	TBD+TT

NOTE 1: Applicable for dual-mode GSM/UMTS.
NOTE 2: Applicable for devices narrower than 72mm as defined in TR 25.914.
NOTE 3: Not applicable for devices supporting CDMA or carrier aggregation.

NOTE: If the above Test Requirement differs from the Minimum Requirement then the Test Tolerance applied for this test is non-zero. The Test Tolerance for this test is defined and the explanation of how the Minimum Requirement has been relaxed by the Test Tolerance is given in Annex D.

6.1.4 Total Radiated Power (TRP) for UTRA LCR TDD in Speech Mode with beside the Head and Hand Phantom

Editor’s notes: This Subclause is incomplete. The following items are missing or incomplete:

- TBDs in Tables 6.1.4.2-1 and 6.1.4.5-2 as they are not specified in TS 37.144 yet

6.1.4.1 Definition and applicability

The Total Radiated Power (TRP) is a measure of how much power the DUT actually radiates. The TRP is defined as the integral of the power transmitted in different directions over the entire radiation sphere:

$$TRP = \frac{1}{4\pi} \oint (EIRP_{\theta}(\Omega; f) + EIRP_{\varphi}(\Omega; f)) d\Omega$$

Where Ω is the solid angle describing the direction, f is frequency. θ and φ are the orthogonal polarizations.

$EIRP_{\theta}$ and $EIRP_{\varphi}$ are the actually transmitted power-levels in corresponding polarizations.

Thus

$$TRP \approx \frac{\pi}{2NM} \sum_{n=0}^{N-1} \sum_{m=0}^{M-1} [EIRP_{\theta}(\theta_n, \varphi_m; f) + EIRP_{\varphi}(\theta_n, \varphi_m; f)] \sin(\theta_n)$$

In these formulas N and M are the number of sampling intervals for theta and phi. θ_n and φ_m are the measurement angles. The sampling intervals are discussed further in Subclause 4.4.

The TRP can also be calculated from Rayleigh faded samples of the total power transmitted from the UE. The measurement of transmitter performance in an isotropic Rayleigh fading environment is based on sampling the radiated

power of the UE for a discrete number of field combinations in the chamber. The average value of these statistically distributed samples is proportional to the TRP and by calibrating the average power transfer function, an absolute value of the TRP can be obtained. Thus

$$TRP \approx \frac{\sum_{n=1}^N \left(\frac{P_n}{C_n(1-R_n)} \right)}{\sum_{n=1}^N P_{ref,n}}$$

where $P_{ref,n}$ is the reference power transfer function for fixed measurement antenna n , R_n is the reflection coefficient for fixed measurement antenna n and C_n is the path loss in the cables connecting the measurement receiver to fixed measurement antenna n . These parameters are calculated from the calibration measurement and are further discussed in Annex B.2. P_n is the average power measured by fixed measurement antenna n and can be calculated using the following expression:

$$P_n = \frac{\sum_{m=1}^M |S_{21,n,m}|^2}{M}$$

where $S_{21,n,m}$ is sample number m of the complex transfer function measured with fixed measurement antenna n and M is the total number of samples measured for each fixed measurement antenna.

Note that all averaging must be performed using linear power values (e.g. measurements in Watts).

The requirements and this test apply to all types of UTRA for the TDD UE for Release 8 and later releases.

6.1.4.2 Minimum Requirements

The average TRP of low, mid and high channel in beside head position shall be higher than minimum performance requirements for roaming bands shown in Table 6.1.4.2-1. The averaging shall be done in linear scale for the TRP results of both right and left side of the phantom head.

$$TRP_{average} = 10 \log \left[\frac{10^{P_{left_low}/10} + 10^{P_{left_mid}/10} + 10^{P_{left_high}/10} + 10^{P_{right_low}/10} + 10^{P_{right_mid}/10} + 10^{P_{right_high}/10}}{6} \right]$$

In addition the minimum TRP of each measured channel in beside head position shall be higher than minimum performance requirements shown in the columns "Min".

$$TRP_{min} = \min [P_{left_low}, P_{left_mid}, P_{left_high}, P_{right_low}, P_{right_mid}, P_{right_high}]$$

Table 6.1.4.2-1: TRP minimum performance requirement for UTRA LCR TDD roaming bands in the speech mode and the primary mechanical mode

Operating band	Power Class 1		Power Class 2		Power Class 3		Power Class 4	
	Power (dBm)		Power (dBm)		Power (dBm)		Power (dBm)	
	Average	Min	Average	Min	Average	Min	Average	Min
a	–	–	TBD	TBD	–	–	–	–
b	–	–	TBD	TBD	–	–	–	–
c	–	–	TBD	TBD	–	–	–	–
d	–	–	TBD	TBD	–	–	–	–
e	–	–	TBD	TBD	–	–	–	–
f	–	–	TBD	TBD	–	–	–	–

Note: Applicable for dual-mode GSM/UTRA LCR TDD.

The normative reference for this clause is TS37.144 [12] Subclause 6.1.2.2.

6.1.4.3 Test purpose

The purpose of this test is to verify that $TRP_{average}$ and TRP_{min} of the UE is not below specified values. A lower $TRP_{average}$ and TRP_{min} decrease the coverage area.

6.1.4.4 Method of test

6.1.4.4.1 Initial conditions

The output power is a measure of the maximum power the UE can transmit in a bandwidth of at least $(1 + \alpha)$ times the chip rate of the radio access mode, for more information see 3GPP TS 34.122 [8] Subclause 5.2. The period of measurement shall be at least one timeslot. Also care should be taken that the noise floor of the measurement receiver is not disturbing the power measurement. Normally, the receiving device should be set accordingly so that the receiving signal will be at least 30dB higher than the system noise floor.

Test environment: normal; see 3GPP TS34.122-1 [8] Subclause G.2.1.

Frequencies to be tested: low range, mid range, high range; see Table 5.2-2.

- 1) Set the SS downlink physical channels parameters. Set the DPCH power such that there will not be transmission gaps due to too low signal strength throughout the measurement.
- 2) Power on the UE.
- 3) A call is set up according to the Generic call setup procedure. The power control algorithm shall be set to Power Control Algorithm 2.
- 4) Enter the UE into loopback test mode and start the loopback test.
- 5) The measurement receiver shall be set to: zero span, video trigger and RMS detector. The RBW shall be at least $(1 + \alpha)$ times the chip rate of the radio access mode and the VBW at least 3 times bigger than the RBW. For 1.28Mcps TDD UE, the RBW shall be set to 3MHz, and VBW shall be set to 10MHz.

See TS 34.108 [4] and TS 34.109 [5] for details regarding generic call setup procedure and loopback test.

6.1.4.4.2 Procedure

- 1) Send continuously Up power control commands to the UE.
- 2) As the UE reaches maximum power, start sending PN15 data pattern.

- 3) Position the UE according to the DUT positioning for speech mode specified in Subclause 4.3.3.
- 4) Measure the $EIRP_{\theta}$ and $EIRP_{\phi}$ with a sample step of 15° in theta (θ) and phi (ϕ) directions using a test system having characteristics as described in Annex A.
- 5) Calculate TRP using equations from Subclause 6.1.4.1.

NOTE 1: The measurement procedure is based on the measurement of the spherical radiation pattern of the DUT. The power radiated by the DUT is sampled in far field in a group of points located on a spherical surface enclosing the DUT. The EIRP samples are taken using a constant sample step of 15° both in theta (θ) and phi (ϕ) directions. In some cases a different sampling grid may be used to speed up the measurements (See Subclause 4.4). All the EIRP samples are taken with two orthogonal polarizations, θ - and ϕ - polarizations.

NOTE 2: The noise floor of the measurement receiver shall not disturb the power measurement.

NOTE 3: Non Standard settings: To speed up sensitivity measurements, power measurements may be done with non standard modulation. However to obtain TRP result the measured EIRP figures shall be normalized by

$$\overline{\Delta EIRP} = \frac{1}{n} \sum_{i=1}^n (EIRP_{std_i} - EIRP_{nstd_i})$$

where $EIRP_{std_i}$ is power measurement done with standard setting. $EIRP_{nstd_i}$ is power measurement done with non standard modulation. n is amount of reference measurement points.

To ensure accuracy of TRP, the amount of reference points measured should be at least 4. It is recommended to spread the reference measurements equally during the measurement time.

6.1.4.4.3 Procedure, reverberation chamber method

- 1) Send continuously Up power control commands to the UE.
- 2) As the UE reaches maximum power, start sending PN15 data pattern.
- 3) Position the UE according to the DUT positioning for speech mode specified in Subclause 4.3.3.
- 4) Measure a sufficient number of independent samples (see Subclause 4.5) of $S_{21,n,m}$ using a test system having characteristics as described in Annex A.
- 5) Calculate TRP using equations from Subclause 6.1.4.1.

NOTE 1: The measurement procedure is based on the measurement of the total power radiated from the UE to a full 3 dimensional isotropic environment with uniform elevation and azimuth field distribution. The power transmitted by the DUT is undergoing Rayleigh fading and is sampled by the fixed measurement antennas. Moreover, it is important that the samples collected are independent, in order to get sufficient accuracy of the estimated TRP value.

NOTE 2: The noise floor of the measurement receiver shall not disturb the power measurement.

6.1.4.5 Test requirements

The average TRP of low, mid and high channel in beside head position shall be higher than test performance requirements for roaming bands shown in Table 6.1.4.5-1. The averaging shall be done in linear scale for the TRP results of both right and left side of the phantom head.

$$TRP_{average} = 10 \log \left[\frac{10^{P_{left_low}/10} + 10^{P_{left_mid}/10} + 10^{P_{left_high}/10} + 10^{P_{right_low}/10} + 10^{P_{right_mid}/10} + 10^{P_{right_high}/10}}{6} \right]$$

In addition the minimum TRP of each measured channel in beside head position shall be higher than minimum performance requirements shown in the columns "Min".

$$TRP_{\min} = \min[P_{\text{left_low}}, P_{\text{left_mid}}, P_{\text{left_high}}, P_{\text{right_low}}, P_{\text{right_mid}}, P_{\text{right_high}}]$$

Table 6.1.4.5-1: TRP test requirement for UTRA LCR TDD roaming bands in the speech position and the primary mechanical mode

Operating band	Power Class 1		Power Class 2		Power Class 3		Power Class 4	
	Power (dBm)		Power (dBm)		Power (dBm)		Power (dBm)	
	Average	Min	Average	Min	Average	Min	Average	Min
a	–	–	TBD+TT	TBD+TT	–	–	–	–
b	–	–	TBD+TT	TBD+TT	–	–	–	–
c	–	–	TBD+TT	TBD+TT	–	–	–	–
d	–	–	TBD+TT	TBD+TT	–	–	–	–
e	–	–	TBD+TT	TBD+TT	–	–	–	–
f	–	–	TBD+TT	TBD+TT	–	–	–	–
Note: Applicable for dual-mode GSM/UTRA LCR TDD.								

NOTE: If the above Test Requirement differs from the Minimum Requirement then the Test Tolerance applied for this test is non-zero. The Test Tolerance for this test is defined and the explanation of how the Minimum Requirement has been relaxed by the Test Tolerance is given in Annex D.

6.1.5 Total Radiated Power (TRP) for E-UTRA FDD in Speech Mode with beside the Head and Hand Phantom

Editor's notes: This subclause is incomplete. The following items are missing or incomplete:

- Table 6.1.5.2-1 and 6.1.5.5-1 as they are not specified in TS 37.144 yet

6.1.5.1 Definition and applicability

The Total Radiated Power (TRP) is a measure of how much power the antenna actually radiates, when non-idealities such as mismatch and losses in the antenna are taken into account. The TRP is defined as the integral of the power transmitted in different directions over the entire radiation sphere:

$$P_{TRP} = \frac{1}{4\pi} \oint (P_{tx} G_{\theta}(\Omega; f) + P_{tx} G_{\varphi}(\Omega; f)) d\Omega$$

Using ψ to denote either θ or φ , $G_{\psi}(\Omega; f)$ is the ψ -polarization component of the gain pattern for the handset antenna measured at the frequency f , where Ω is the solid angle describing the direction. P_{tx} is the transmit power level of the handset so that $P_{tx} G_{\psi}(\Omega; f)$ is the actually transmitted power-level, also known as EIRP, in the ψ -polarization and in the direction Ω for frequency f .

The above equation may be written in "gain" form, that is, the TRP given by P_{TRP} is normalized to the transmitted power P_{tx} . This is the total radiation efficiency, which can also be denoted as Total Radiated Power Gain, TRPG,

$$\Gamma_{TRP} = \frac{1}{4\pi} \oint (G_{\theta}(\Omega; f) + G_{\varphi}(\Omega; f)) d\Omega$$

In practice discrete samples of $P_{tx}G_{\psi}(\Omega; f)$ are measured and used to approximate the integral so that the TRP is computed as

$$P_{TRP} \approx \frac{\Delta_{\theta}\Delta_{\varphi}}{4\pi} \sum_{n=0}^{N-1} \sum_{m=0}^{M-1} [P_{tx}G_{\theta}(\theta_n, \varphi_m; f) + P_{tx}G_{\varphi}(\theta_n, \varphi_m; f)] \sin(\theta_n)$$

Or, by using the relation $EIRP = P_{tx}G$:

$$P_{TRP}(f) \approx \frac{\Delta_{\theta}\Delta_{\varphi}}{4\pi} \sum_{n=0}^{N-1} \sum_{m=0}^{M-1} [EIRP_{\theta}(\theta_n, \varphi_m; f) + EIRP_{\varphi}(\theta_n, \varphi_m; f)] \sin(\theta_n)$$

In gain form the TRP can be expressed as:

$$\Gamma_{TRP} \approx \frac{\Delta_{\theta}\Delta_{\varphi}}{4\pi} \sum_{n=0}^{N-1} \sum_{m=0}^{M-1} [G_{\theta}(\theta_n, \varphi_m; f) + G_{\varphi}(\theta_n, \varphi_m; f)] \sin(\theta_n)$$

In these formulas $\Delta_{\theta} = \pi/(N)$ and $\Delta_{\varphi} = 2\pi/M$ are the sampling intervals for the θ - and φ -angles, respectively, and the number of samples in the θ - and φ -angles are given by N and M , respectively. The sampling points of the sphere are given by $\theta_n = n\Delta_{\theta}$ and $\varphi_m = m\Delta_{\varphi}$. The sampling intervals are discussed further in Section 4.4.

When measuring power radiated by active devices, expressing the data in terms of EIRP is more appropriate. The upper form of the TRP formulas (which includes EIRP terms) will be used in the data processing.

The TRP can also be calculated from Rayleigh faded samples of the total power transmitted from the UE. The measurement of transmitter performance in an isotropic Rayleigh fading environment is based on sampling the radiated power of the UE for a discrete number of field combinations in the chamber. The average value of these statistically distributed samples is proportional to the TRP and by calibrating the average power transfer function, an absolute value of the TRP can be obtained. Thus

$$TRP \approx \frac{\sum_{n=1}^N \left(\frac{P_n}{C_n(1-R_n)} \right)}{\sum_{n=1}^N P_{ref,n}}$$

where $P_{ref,n}$ is the reference power transfer function for fixed measurement antenna n, R_n is the reflection coefficient for fixed measurement antenna n and C_n is the path loss in the cables connecting the measurement receiver to fixed measurement antenna n. These parameters are calculated from the calibration measurement and are further discussed in Annex B.2. P_n is the average power measured by fixed measurement antenna n and can be calculated using the following expression:

$$P_n = \frac{\sum_{m=1}^M |S_{21,n,m}|^2}{M}$$

where $S_{21,n,m}$ is sample number m of the complex transfer function measured with fixed measurement antenna n and M is the total number of samples measured for each fixed measurement antenna.

Note that all averaging must be performed using linear power values (e.g. measurements in Watts).

The requirements and this test apply to all types of LTE UEs independent of release.

6.1.5.2 Minimum Requirements

The average TRP of low, mid and high channel in beside head position shall be higher than minimum performance requirements for roaming bands shown in Table 6.1.5.2-1. The averaging shall be done in linear scale for the TRP results of both right and left side of the phantom head.

$$TRP_{average} = 10 \log \left[\frac{10^{P_{left_low}/10} + 10^{P_{left_mid}/10} + 10^{P_{left_high}/10} + 10^{P_{right_low}/10} + 10^{P_{right_mid}/10} + 10^{P_{right_high}/10}}{6} \right]$$

In addition the minimum TRP of each measured channel in beside head position shall be higher than minimum performance requirements shown in the columns "Min".

$$TRP_{min} = \min \left[P_{left_low}, P_{left_mid}, P_{left_high}, P_{right_low}, P_{right_mid}, P_{right_high} \right]$$

Table 6.1.5.2-1: TRP minimum performance requirement for E-UTRA FDD roaming mode in beside the head and hand phantom position and the primary mechanical mode

TBD

The normative reference for this clause is TS37.144 [12] Subclause 6.1.2.3.

6.1.5.3 Test purpose

The purpose of this test is to verify that $TRP_{average}$ and TRP_{min} of the UE is not below specified values. A lower $TRP_{average}$ and TRP_{min} decrease the coverage area.

6.1.5.4 Method of test

6.1.5.4.1 Initial conditions

A radio communications tester or a corresponding device is used as a NB simulator to setup calls to the DUT. The NB/BS simulator may also measure the radiated power samples. Alternatively, a measurement receiver or spectrum analyzer may be used for that purpose.

The maximum output power for different UE power classes are defined in 3GPP TS 36.521-1 [11] Subclause 6.2.2 for any transmission bandwidth within the channel bandwidth. Also care should be taken that the noise floor of the measurement receiver is not disturbing the power measurement.

Chamber environment constraints and coordinate system shall be the same as described in Subclause A.3.

Phantom Specifications shall be the same as described in Subclause A.2.1 and A.2.2.

Test environment: normal; see TS36.508 [10] Subclause 4.1.1.

Frequencies to be tested: low range, mid range, high range; see Table 5.3-1.

Positioning Requirements shall be the same as described in Subclause 4.3.

- 1) Position the UE according to the DUT positioning for speech mode specified in Subclause 4.3.3.
- 2) Power on the UE.
- 3) Set the initial conditions as per Subclause 6.2.2 of 3GPP TS 36.521-1 [11], with the following exception: set the carrier frequency, channel bandwidth, RB length and RB location as per Table 5.3-1 for FDD mode.

6.1.5.4.2 Procedure

- 1) Follow Steps 1 and 2 in section 6.2.2.4.2 of 3GPP TS 36.521-1 [11] and ensure that the DUT transmits with its maximum power.
- 2) For the anechoic chamber based methodologies, measure the spherical effective isotropic radiated power (EIRP) pattern following the sampling grid specified in Subclause 4.4. Calculate the TRP using the EIRP pattern data as per Subclause 6.1.5.1.
- 3) Repeat the measurement of the DUT on the left and right ears of the head phantom using the left and right hand phantom for low, mid and high channels.
- 4) Calculate the average and minimum TRP as per Subclause 6.1.5.2.

6.1.5.4.3 Procedure, reverberation chamber method

- 1) Follow Steps 1 and 2 in section 6.2.2.4.2 of 3GPP TS 36.521-1 [11] and ensure that the DUT transmits with its maximum power.
- 2) Measure a sufficient number of independent samples (see Subclause 4.5) of $S_{21,n,m}$ using a test system having characteristics as described in Annex A. Calculate TRP using equations from Subclause 6.1.5.1.
- 3) Repeat the measurement of the DUT on the left and right ears of the head phantom using the left and right hand phantom for low, mid and high channels.
- 4) Calculate the average and minimum TRP as per Subclause 6.1.5.2.

6.1.5.5 Test requirements

The average TRP of low, mid and high channel in beside head position shall be higher than test performance requirements for roaming bands shown in Table 6.1.5.5-1. The averaging shall be done in linear scale for the TRP results of both right and left side of the phantom head.

$$TRP_{average} = 10 \log \left[\frac{10^{P_{left_low}/10} + 10^{P_{left_mid}/10} + 10^{P_{left_high}/10} + 10^{P_{right_low}/10} + 10^{P_{right_mid}/10} + 10^{P_{right_high}/10}}{6} \right]$$

In addition the minimum TRP of each measured channel in beside head position shall be higher than minimum performance requirements shown in the columns “Min”.

$$TRP_{min} = \min \left[P_{left_low}, P_{left_mid}, P_{left_high}, P_{right_low}, P_{right_mid}, P_{right_high} \right]$$

Table 6.1.5.5-1: TRP test requirement for E-UTRA FDD roaming bands in the speech position and the primary mechanical mode

TBD

NOTE: If the above Test Requirement differs from the Minimum Requirement then the Test Tolerance applied for this test is non-zero. The Test Tolerance for this test is defined and the explanation of how the Minimum Requirement has been relaxed by the Test Tolerance is given in Annex D.

6.1.6 Total Radiated Power (TRP) for E-UTRA TDD in Speech Mode with beside the Head and Hand Phantom

Editor’s notes: This subclause is incomplete. The following items are missing or incomplete:

- Table 6.1.6.2-1 and 6.1.6.5-1 as they are not specified in TS 37.144 yet

6.1.6.1 Definition and applicability

The Total Radiated Power (TRP) is a measure of how much power the antenna actually radiates, when non-idealities such as mismatch and losses in the antenna are taken into account. The TRP is defined as the integral of the power transmitted in different directions over the entire radiation sphere:

$$P_{TRP} = \frac{1}{4\pi} \oint (P_{tx} G_{\theta}(\Omega; f) + P_{tx} G_{\varphi}(\Omega; f)) d\Omega$$

Using ψ to denote either θ or φ , $G_{\psi}(\Omega; f)$ is the ψ -polarization component of the gain pattern for the handset antenna measured at the frequency f , where Ω is the solid angle describing the direction. P_{tx} is the transmit power level of the handset so that $P_{tx} G_{\psi}(\Omega; f)$ is the actually transmitted power-level, also known as EIRP, in the ψ -polarization and in the direction Ω for frequency f .

The above equation may be written in "gain" form, that is, the TRP given by P_{TRP} is normalized to the transmitted power P_{tx} . This is the total radiation efficiency, which can also be denoted as Total Radiated Power Gain, TRPG,

$$\Gamma_{TRP} = \frac{1}{4\pi} \oint (G_{\theta}(\Omega; f) + G_{\varphi}(\Omega; f)) d\Omega$$

In practice discrete samples of $P_{tx} G_{\psi}(\Omega; f)$ are measured and used to approximate the integral so that the TRP is computed as

$$P_{TRP} \approx \frac{\Delta_{\theta} \Delta_{\varphi}}{4\pi} \sum_{n=0}^{N-1} \sum_{m=0}^{M-1} [P_{tx} G_{\theta}(\theta_n, \varphi_m; f) + P_{tx} G_{\varphi}(\theta_n, \varphi_m; f)] \sin(\theta_n)$$

Or, by using the relation $EIRP = P_{tx} G$:

$$P_{TRP}(f) \approx \frac{\Delta_{\theta} \Delta_{\varphi}}{4\pi} \sum_{n=0}^{N-1} \sum_{m=0}^{M-1} [EIRP_{\theta}(\theta_n, \varphi_m; f) + EIRP_{\varphi}(\theta_n, \varphi_m; f)] \sin(\theta_n)$$

In gain form the TRP can be expressed as:

$$\Gamma_{TRP} \approx \frac{\Delta_{\theta} \Delta_{\varphi}}{4\pi} \sum_{n=0}^{N-1} \sum_{m=0}^{M-1} [G_{\theta}(\theta_n, \varphi_m; f) + G_{\varphi}(\theta_n, \varphi_m; f)] \sin(\theta_n)$$

In these formulas $\Delta_{\theta} = \pi/(N)$ and $\Delta_{\varphi} = 2\pi/M$ are the sampling intervals for the θ - and φ -angles, respectively, and the number of samples in the θ - and φ -angles are given by N and M , respectively. The sampling points of the sphere are given by $\theta_n = n\Delta_{\theta}$ and $\varphi_m = m\Delta_{\varphi}$. The sampling intervals are discussed further in Section 4.4.

When measuring power radiated by active devices, expressing the data in terms of EIRP is more appropriate. The upper form of the TRP formulas (which includes EIRP terms) will be used in the data processing.

The TRP can also be calculated from Rayleigh faded samples of the total power transmitted from the UE. The measurement of transmitter performance in an isotropic Rayleigh fading environment is based on sampling the radiated power of the UE for a discrete number of field combinations in the chamber. The average value of these statistically distributed samples is proportional to the TRP and by calibrating the average power transfer function, an absolute value of the TRP can be obtained. Thus

$$TRP \approx \frac{\sum_{n=1}^N \left(\frac{P_n}{C_n (1 - R_n)} \right)}{\sum_{n=1}^N P_{ref,n}}$$

where $P_{ref,n}$ is the reference power transfer function for fixed measurement antenna n, R_n is the reflection coefficient for fixed measurement antenna n and C_n is the path loss in the cables connecting the measurement receiver to fixed measurement antenna n. These parameters are calculated from the calibration measurement and are further discussed in Annex B.2. P_n is the average power measured by fixed measurement antenna n and can be calculated using the following expression:

$$P_n = \frac{\sum_{m=1}^M |S_{21,n,m}|^2}{M}$$

where $S_{21,n,m}$ is sample number m of the complex transfer function measured with fixed measurement antenna n and M is the total number of samples measured for each fixed measurement antenna.

Note that all averaging must be performed using linear power values (e.g. measurements in Watts).

The requirements and this test apply to all types of LTE UEs independent of release.

6.1.6.2 Minimum Requirements

The average TRP of low, mid and high channel in beside head position shall be higher than minimum performance requirements for roaming bands shown in Table 6.1.6.2-1. The averaging shall be done in linear scale for the TRP results of both right and left side of the phantom head.

$$TRP_{average} = 10 \log \left[\frac{10^{P_{left_low}/10} + 10^{P_{left_mid}/10} + 10^{P_{left_high}/10} + 10^{P_{right_low}/10} + 10^{P_{right_mid}/10} + 10^{P_{right_high}/10}}{6} \right]$$

In addition the minimum TRP of each measured channel in beside head position shall be higher than minimum performance requirements shown in the columns "Min".

$$TRP_{min} = \min [P_{left_low}, P_{left_mid}, P_{left_high}, P_{right_low}, P_{right_mid}, P_{right_high}]$$

Table 6.1.6.2-1: TRP minimum performance requirement for E-UTRA TDD roaming mode in beside the head and hand phantom position and the primary mechanical mode

TBD

The normative reference for this clause is TS37.144 [12] Subclause 6.1.2.4.

6.1.6.3 Test purpose

The purpose of this test is to verify that $TRP_{average}$ and TRP_{min} of the UE is not below specified values. A lower $TRP_{average}$ and TRP_{min} decrease the coverage area.

6.1.6.4 Method of test

6.1.6.4.1 Initial conditions

A radio communications tester or a corresponding device is used as a NB simulator to setup calls to the DUT. The NB/BS simulator may also measure the radiated power samples. Alternatively, a measurement receiver or spectrum analyzer may be used for that purpose.

The maximum output power for different UE power classes are defined in 3GPP TS 36.521-1 [11] Subclause 6.2.2 for any transmission bandwidth within the channel bandwidth. Also care should be taken that the noise floor of the measurement receiver is not disturbing the power measurement.

Chamber environment constraints and coordinate system shall be the same as described in Subclause A.3.

Phantom Specifications shall be the same as described in Subclause A.2.1 and A.2.2.

Test environment: normal; see TS36.508 [10] Subclause 4.1.1.

Frequencies to be tested: low range, mid range, high range; see Table 5.4-2.

Positioning Requirements shall be the same as described in Subclause 4.3.

- 1) Position the UE according to the DUT positioning for speech mode specified in Subclause 4.3.3.
- 2) Power on the UE.
- 3) Set the initial conditions as per Subclause 6.2.2 of 3GPP TS 36.521-1 [11], with the following exception: set the carrier frequency, channel bandwidth, RB length and RB location as per Table 5.4-1 for TDD mode.

6.1.6.4.2 Procedure

- 1) Follow Steps 1 and 2 in section 6.2.2.4.2 of 3GPP TS 36.521-1 [11] and ensure that the DUT transmits with its maximum power.
- 2) For the anechoic chamber based methodologies, measure the spherical effective isotropic radiated power (EIRP) pattern following the sampling grid specified in Subclause 4.4. Slots with transient periods are not under test. The uplink downlink configuration and the special subframe configuration in TDD is set as per Table 8.2.2-1 of 3GPP TS 36.521-1 [11]. Calculate the TRP using the EIRP pattern data as per Subclause 6.1.6.1.
- 3) Repeat the measurement of the DUT on the left and right ears of the head phantom using the left and right hand phantom for low, mid and high channels.
- 4) Calculate the average and minimum TRP as per Subclause 6.1.6.2.

6.1.6.4.3 Procedure, reverberation chamber method

- 1) Follow Steps 1 and 2 in section 6.2.2.4.2 of 3GPP TS 36.521-1 [11] and ensure that the DUT transmits with its maximum power.
- 2) Measure a sufficient number of independent samples (see Subclause 4.5) of $S_{21,n,m}$ using a test system having characteristics as described in Annex A. Calculate TRP using equations from Subclause 6.1.6.1.
- 3) Repeat the measurement of the DUT on the left and right ears of the head phantom using the left and right hand phantom for low, mid and high channels.
- 4) Calculate the average and minimum TRP as per Subclause 6.1.6.2.

6.1.6.5 Test requirements

The average TRP of low, mid and high channel in beside head position shall be higher than test performance requirements for roaming bands shown in Table 6.1.6.5-1. The averaging shall be done in linear scale for the TRP results of both right and left side of the phantom head.

$$TRP_{average} = 10 \log \left[\frac{10^{P_{left_low}/10} + 10^{P_{left_mid}/10} + 10^{P_{left_high}/10} + 10^{P_{right_low}/10} + 10^{P_{right_mid}/10} + 10^{P_{right_high}/10}}{6} \right]$$

In addition the minimum TRP of each measured channel in beside head position shall be higher than minimum performance requirements shown in the columns "Min".

$$TRP_{\min} = \min \left[P_{\text{left_low}}, P_{\text{left_mid}}, P_{\text{left_high}}, P_{\text{right_low}}, P_{\text{right_mid}}, P_{\text{right_high}} \right]$$

Table 6.1.6.5-1: TRP test requirement for E-UTRA TDD roaming bands in the speech position and the primary mechanical mode

TBD

NOTE: If the above Test Requirement differs from the Minimum Requirement then the Test Tolerance applied for this test is non-zero. The Test Tolerance for this test is defined and the explanation of how the Minimum Requirement has been relaxed by the Test Tolerance is given in Annex D.

6.1.7 Total Radiated Power (TRP) for UTRA FDD in Browsing Mode with Hand Phantom

Editor's notes: This subclause is incomplete. The following items are missing or incomplete:

- Minimum requirements are not specified in TS 37.144 yet
- Text for Procedure, reverberation chamber method

6.1.7.1 Definition and applicability

The Total Radiated Power (TRP) is a measure of how much power the DUT actually radiates. The TRP is defined as the integral of the power transmitted in different directions over the entire radiation sphere:

$$TRP = \frac{1}{4\pi} \oint \left(EIRP_{\theta}(\Omega; f) + EIRP_{\varphi}(\Omega; f) \right) d\Omega$$

Where Ω is the solid angle describing the direction, f is frequency. θ and φ are the orthogonal polarizations. $EIRP_{\theta}$ and $EIRP_{\varphi}$ are the actually transmitted power-levels in corresponding polarizations.

Thus,

$$TRP \approx \frac{\pi}{2NM} \sum_{n=0}^{N-1} \sum_{m=0}^{M-1} \left[EIRP_{\theta}(\theta_n, \varphi_m; f) + EIRP_{\varphi}(\theta_n, \varphi_m; f) \right] \sin(\theta_n)$$

In these formulas N and M are the number of sampling intervals for theta and phi. θ_n and φ_m are the measurement angles. The sampling intervals are discussed further in Subclause 4.4.

The TRP can also be calculated from Rayleigh faded samples of the total power transmitted from the UE. The measurement of transmitter performance in an isotropic Rayleigh fading environment is based on sampling the radiated power of the UE for a discrete number of field combinations in the chamber. The average value of these statistically distributed samples is proportional to the TRP and by calibrating the average power transfer function, an absolute value of the TRP can be obtained. Thus,

$$TRP \approx \frac{\sum_{n=1}^N \left(\frac{P_n}{C_n (1 - R_n)} \right)}{\sum_{n=1}^N P_{ref,n}}$$

where $P_{ref,n}$ is the reference power transfer function for fixed measurement antenna n , R_n is the reflection coefficient for fixed measurement antenna n and C_n is the path loss in the cables connecting the measurement receiver to fixed measurement antenna n . These parameters are calculated from the calibration measurement and are further discussed in Annex B.2. P_n is the average power measured by fixed measurement antenna n and can be calculated using the following expression:

$$P_n = \frac{\sum_{m=1}^M |S_{21,n,m}|^2}{M}$$

where $S_{21,n,m}$ is sample number m of the complex transfer function measured with fixed measurement antenna n and M is the total number of samples measured for each fixed measurement antenna.

Note that all averaging must be performed using linear power values (e.g. measurements in Watts).

The requirements and this test apply to all types of UTRA for the FDD UE for Release 7 and later releases.

6.1.7.2 Minimum Requirements

The average TRP of low, mid and high channel in hand phantom browsing mode position shall be higher than minimum performance requirements for roaming bands shown in Table 6.1.7.2-1. The averaging shall be done in linear scale for the TRP results of both right and left hand phantom measurements.

$$TRP_{average} = 10 \log \left[\frac{10^{P_{left_low}/10} + 10^{P_{left_mid}/10} + 10^{P_{left_high}/10} + 10^{P_{right_low}/10} + 10^{P_{right_mid}/10} + 10^{P_{right_high}/10}}{6} \right]$$

In addition the minimum TRP of each measured channel in hand phantom browsing mode position shall be higher than minimum performance requirements shown in the columns “Min”.

$$TRP_{min} = \min \left[P_{left_low}, P_{left_mid}, P_{left_high}, P_{right_low}, P_{right_mid}, P_{right_high} \right]$$

Table 6.1.7.2-1: TRP minimum performance requirement for UTRA FDD roaming bands in hand phantom browsing mode position

Operating band	Power Class 1	Power Class 2	Power Class 3		Power Class 3bis		Power Class 4	
	Power (dBm)	Power (dBm)	Power (dBm)		Power (dBm)		Power (dBm)	
			Average	Min	Average	Min	Average	Min
I	-	-	TBD	TBD	TBD	TBD	TBD	TBD
II	-	-	TBD	TBD	TBD	TBD	TBD	TBD
III	-	-	TBD	TBD	TBD	TBD	TBD	TBD
IV	-	-	TBD	TBD	TBD	TBD	TBD	TBD
V	-	-	TBD	TBD	TBD	TBD	TBD	TBD
VI	-	-	TBD	TBD	TBD	TBD	TBD	TBD
VII	-	-	TBD	TBD	TBD	TBD	TBD	TBD
VIII	-	-	TBD	TBD	TBD	TBD	TBD	TBD
IX	-	-	TBD	TBD	TBD	TBD	TBD	TBD
XIX	-	-	TBD	TBD	TBD	TBD	TBD	TBD

NOTE: Applicable for dual-mode GSM/UMTS.

The normative reference for this clause is TS37.144 [12] Subclause 6.1.3.1.

6.1.7.3 Test purpose

The purpose of this test is to verify that $TRP_{average}$ and TRP_{min} of the UE is not below specified values. A lower $TRP_{average}$ and TRP_{min} decrease the coverage area.

6.1.7.4 Method of test

6.1.7.4.1 Initial conditions

The output power is a measure of the maximum power the UE can transmit in a bandwidth of at least $(1 + \alpha)$ times the chip rate of the radio access mode, for more information see 3GPP TS 34.121-1 [7] Subclause 5.2. The period of measurement shall be at least one timeslot. Also, care should be taken that the noise floor of the measurement receiver is not disturbing the power measurement.

Test environment: normal; see TS34.121-1 [7] Subclause G.2.1.

Frequencies to be tested: low range, mid range, high range; see Table 5.1-2.

- 1) Set the SS downlink physical channels according to settings in Table 6.1.7.4.1-1. Set the DPCH power such that there will not be transmission gaps due to too low signal strength throughout the measurement.
- 2) Power on the UE.
- 3) A call is set up according to the Generic call setup procedure. The power control algorithm shall be set to Power Control Algorithm 2. Compressed mode shall be set to OFF.
- 4) Enter the UE into loopback test mode 2 and start the loopback test.

See TS 34.108 [4] and TS 34.109 [5] for details regarding generic call setup procedure and loopback test.

Table 6.1.7.4.1-1: Downlink Physical Channels transmitted during a connection

Physical Channel		Power
CPICH	CPICH_Ec / DPCH_Ec	7 dB
P-CCPCH	P-CCPCH_Ec / DPCH_Ec	5 dB
SCH	SCH_Ec / DPCH_Ec	5 dB
PICH	PICH_Ec / DPCH_Ec	2 dB
DPCH	Test dependent power	-

6.1.7.4.2 Procedure

- 1) Send continuously Up power control commands to the UE.
- 2) As the UE reaches maximum power, start sending PN15 data pattern.
- 3) Position the UE according to the DUT positioning for browsing mode specified in Subclause 4.3.4.
- 4) Measure the $EIRP_{\theta}$ and $EIRP_{\phi}$ with a sample step of 15° in theta (θ) and phi (ϕ) directions using a test system having characteristics as described in Annex A.
- 5) Calculate TRP using equations from Subclause 6.1.7.1.

NOTE 1: The measurement procedure is based on the measurement of the spherical radiation pattern of the DUT. The power radiated by the DUT is sampled in far field in a group of points located on a spherical surface enclosing the DUT. The EIRP samples are taken using a constant sample step of 15° both in theta (θ) and phi (ϕ) directions. In some cases a different sampling grid may be used to speed up the measurements (See Subclause 4.4). All the EIRP samples are taken with two orthogonal polarizations, θ - and ϕ - polarisations.

NOTE 2: The noise floor of the measurement receiver shall not disturb the power measurement.

NOTE 3: Non Standard settings: To speed up sensitivity measurements, power measurements may be done with non standard modulation. However to obtain TRP result the measured EIRP figures shall be normalized by

$$\overline{\Delta EIRP} = \frac{1}{n} \sum_{i=1}^n (EIRPstd_i - EIRPnstd_i)$$

where $EIRPstd_i$ is power measurement done with standard setting. $EIRPnstd_i$ is power measurement done with non standard modulation. n is amount of reference measurement points.

To ensure accuracy of TRP, the amount of reference points measured should be at least 4. It is recommended to spread the reference measurements equally during the measurement time.

6.1.7.4.3 Procedure, reverberation chamber method

TBD

6.1.7.5 Test requirements

The average TRP of low, mid and high channel in hand phantom browsing mode position shall be higher than test performance requirements for roaming bands shown in Table 6.1.7.5-1. The averaging shall be done in linear scale for the TRP results of both right and left hand phantom measurements.

$$TRP_{average} = 10 \log \left[\frac{10^{P_{left_low}/10} + 10^{P_{left_mid}/10} + 10^{P_{left_high}/10} + 10^{P_{right_low}/10} + 10^{P_{right_mid}/10} + 10^{P_{right_high}/10}}{6} \right]$$

In addition the minimum TRP of each measured channel in hand phantom browsing mode position shall be higher than minimum performance requirements shown in the columns “Min”.

$$TRP_{min} = \min [P_{left_low}, P_{left_mid}, P_{left_high}, P_{right_low}, P_{right_mid}, P_{right_high}]$$

Table 6.1.7.5-1: TRP test requirement for UTRA FDD roaming bands in hand phantom browsing mode position

Operating band	Power Class 1	Power Class 2	Power Class 3		Power Class 3bis		Power Class 4	
	Power (dBm)	Power (dBm)	Power (dBm)		Power (dBm)		Power (dBm)	
			Average	Min	Average	Min	Average	Min
I	-	-	TBD+TT	TBD+TT	TBD+TT	TBD+TT	TBD+TT	TBD+TT
II	-	-	TBD+TT	TBD+TT	TBD+TT	TBD+TT	TBD+TT	TBD+TT
III	-	-	TBD+TT	TBD+TT	TBD+TT	TBD+TT	TBD+TT	TBD+TT
IV	-	-	TBD+TT	TBD+TT	TBD+TT	TBD+TT	TBD+TT	TBD+TT
V	-	-	TBD+TT	TBD+TT	TBD+TT	TBD+TT	TBD+TT	TBD+TT
VI	-	-	TBD+TT	TBD+TT	TBD+TT	TBD+TT	TBD+TT	TBD+TT
VII	-	-	TBD+TT	TBD+TT	TBD+TT	TBD+TT	TBD+TT	TBD+TT
VIII	-	-	TBD+TT	TBD+TT	TBD+TT	TBD+TT	TBD+TT	TBD+TT
IX	-	-	TBD+TT	TBD+TT	TBD+TT	TBD+TT	TBD+TT	TBD+TT
XIX	-	-	TBD+TT	TBD+TT	TBD+TT	TBD+TT	TBD+TT	TBD+TT

NOTE: Applicable for dual-mode GSM/UMTS.

NOTE: If the above Test Requirement differs from the Minimum Requirement then the Test Tolerance applied for this test is non-zero. The Test Tolerance for this test is defined and the explanation of how the Minimum Requirement has been relaxed by the Test Tolerance is given in Annex D.

6.1.8 Total Radiated Power (TRP) for UTRA LCR TDD in Browsing Mode with Hand Phantom

Editor's notes: This subclause is incomplete. The following items are missing or incomplete:

- Minimum requirements are not specified in TS 37.144 yet

- Text for Subclause Procedure, reverberation chamber method

6.1.8.1 Definition and applicability

The Total Radiated Power (TRP) is a measure of how much power the DUT actually radiates. The TRP is defined as the integral of the power transmitted in different directions over the entire radiation sphere:

$$TRP = \frac{1}{4\pi} \oint (EIRP_{\theta}(\Omega; f) + EIRP_{\varphi}(\Omega; f)) d\Omega$$

Where Ω is the solid angle describing the direction, f is frequency. θ and φ are the orthogonal polarizations.

$EIRP_{\theta}$ and $EIRP_{\varphi}$ are the actually transmitted power-levels in corresponding polarizations.

Thus,

$$TRP \approx \frac{\pi}{2NM} \sum_{n=0}^{N-1} \sum_{m=0}^{M-1} [EIRP_{\theta}(\theta_n, \varphi_m; f) + EIRP_{\varphi}(\theta_n, \varphi_m; f)] \sin(\theta_n)$$

In these formulas N and M are the number of sampling intervals for theta and phi. θ_n and φ_m are the measurement angles. The sampling intervals are discussed further in Subclause 4.4.

The TRP can also be calculated from Rayleigh faded samples of the total power transmitted from the UE. The measurement of transmitter performance in an isotropic Rayleigh fading environment is based on sampling the radiated power of the UE for a discrete number of field combinations in the chamber. The average value of these statistically distributed samples is proportional to the TRP and by calibrating the average power transfer function, an absolute value of the TRP can be obtained. Thus,

$$TRP \approx \frac{\sum_{n=1}^N \left(\frac{P_n}{C_n (1 - R_n)} \right)}{\sum_{n=1}^N P_{ref,n}}$$

where $P_{ref,n}$ is the reference power transfer function for fixed measurement antenna n, R_n is the reflection coefficient for fixed measurement antenna n and C_n is the path loss in the cables connecting the measurement receiver to fixed measurement antenna n. These parameters are calculated from the calibration measurement and are further discussed in Annex B.2. P_n is the average power measured by fixed measurement antenna n and can be calculated using the following expression:

$$P_n = \frac{\sum_{m=1}^M |S_{21,n,m}|^2}{M}$$

where $S_{21,n,m}$ is sample number m of the complex transfer function measured with fixed measurement antenna n and M is the total number of samples measured for each fixed measurement antenna.

Note that all averaging must be performed using linear power values (e.g. measurements in Watts).

The requirements and this test apply to all types of UTRA for the TDD UE for Release 8 and later releases.

6.1.8.2 Minimum Requirements

The average TRP of low, mid and high channel in hand phantom browsing mode position shall be higher than minimum performance requirements for roaming bands shown in Table 6.1.8.2-1. The averaging shall be done in linear scale for the TRP results of both right and left hand phantom measurements.

$$TRP_{average} = 10 \log \left[\frac{10^{P_{left_low}/10} + 10^{P_{left_mid}/10} + 10^{P_{left_high}/10} + 10^{P_{right_low}/10} + 10^{P_{right_mid}/10} + 10^{P_{right_high}/10}}{6} \right]$$

In addition the minimum TRP of each measured channel in hand phantom browsing mode position shall be higher than minimum performance requirements shown in the columns “Min”.

$$TRP_{min} = \min \left[P_{left_low}, P_{left_mid}, P_{left_high}, P_{right_low}, P_{right_mid}, P_{right_high} \right]$$

Table 6.1.8.2-1: TRP minimum performance requirement for UTRA LCR TDD roaming bands in hand phantom browsing mode position

Operating band	Power Class 1		Power Class 2		Power Class 3		Power Class 4	
	Power (dBm)		Power (dBm)		Power (dBm)		Power (dBm)	
	Average	Min	Average	Min	Average	Min	Average	Min
a	–	–	TBD	TBD	–	–	–	–
b	–	–	TBD	TBD	–	–	–	–
c	–	–	TBD	TBD	–	–	–	–
d	–	–	TBD	TBD	–	–	–	–
e	–	–	TBD	TBD	–	–	–	–
f	–	–	TBD	TBD	–	–	–	–
Note: Applicable for dual-mode GSM/UTRA LCR TDD.								

The normative reference for this clause is TS37.144 [12] Subclause 6.1.3.2.

6.1.8.3 Test purpose

The purpose of this test is to verify that $TRP_{average}$ and TRP_{min} of the UE is not below specified values. A lower $TRP_{average}$ and TRP_{min} decrease the coverage area.

6.1.8.4 Method of test

6.1.8.4.1 Initial conditions

The output power is a measure of the maximum power the UE can transmit in a bandwidth of at least $(1 + \alpha)$ times the chip rate of the radio access mode, for more information see 3GPP TS 34.122 [8] Subclause 5.2. The period of measurement shall be at least one timeslot. Also, care should be taken that the noise floor of the measurement receiver is not disturbing the power measurement. Normally, the receiving device should be set accordingly so that the receiving signal will be at least 30dB higher than the system noise floor.

Test environment: normal; see 3GPP TS34.122-1 [8] Subclause G.2.1.

Frequencies to be tested: low range, mid range, high range; see Table 5.2-2.

- 1) Set the SS downlink physical channels parameters. Set the DPCH power such that there will not be transmission gaps due to too low signal strength throughout the measurement.
- 2) Power on the UE.
- 3) A call is set up according to the Generic call setup procedure. The power control algorithm shall be set to Power Control Algorithm 2.
- 4) Enter the UE into loopback test mode and start the loopback test.

- 5) The measurement receiver shall be set to: zero span, video trigger and RMS detector. The RBW shall be at least $(1 + \alpha)$ times the chip rate of the radio access mode and the VBW at least 3 times bigger than the RBW. For 1.28Mcps TDD UE, the RBW shall be set to 3MHz, and VBW shall be set to 10MHz.

See TS 34.108 [4] and TS 34.109 [5] for details regarding generic call setup procedure and loopback test.

6.1.8.4.2 Procedure

- 1) Send continuously Up power control commands to the UE.
- 2) As the UE reaches maximum power, start sending PN15 data pattern.
- 3) Position the UE according to the DUT positioning for browsing mode specified in Subclause 4.3.4.
- 4) Measure the $EIRP_{\theta}$ and $EIRP_{\phi}$ with a sample step of 15° in theta (θ) and phi (ϕ) directions using a test system having characteristics as described in Annex A.
- 5) Calculate TRP using equations from Subclause 6.1.8.1.

NOTE 1: The measurement procedure is based on the measurement of the spherical radiation pattern of the DUT. The power radiated by the DUT is sampled in far field in a group of points located on a spherical surface enclosing the DUT. The EIRP samples are taken using a constant sample step of 15° both in theta (θ) and phi (ϕ) directions. In some cases a different sampling grid may be used to speed up the measurements (See Subclause 4.4). All the EIRP samples are taken with two orthogonal polarizations, θ - and ϕ - polarizations.

NOTE 2: The noise floor of the measurement receiver shall not disturb the power measurement.

NOTE 3: Non Standard settings: To speed up sensitivity measurements, power measurements may be done with non standard modulation. However to obtain TRP result the measured EIRP figures shall be normalized by

$$\Delta \overline{EIRP} = \frac{1}{n} \sum_{i=1}^n (EIRP_{std_i} - EIRP_{nstd_i})$$

where $i EIRP_{std_i}$ is power measurement done with standard setting. $EIRP_{nstd_i}$ is power measurement done with non standard modulation. n is amount of reference measurement points.

To ensure accuracy of TRP, the amount of reference points measured should be at least 4. It is recommended to spread the reference measurements equally during the measurement time.

6.1.8.4.3 Procedure, reverberation chamber method

TBD

6.1.8.5 Test requirements

The average TRP of low, mid and high channel in hand phantom browsing mode position shall be higher than test performance requirements for roaming bands shown in Table 6.1.8.5-1. The averaging shall be done in linear scale for the TRP results of both right and left side hand phantom measurements.

$$TRP_{average} = 10 \log \left[\frac{10^{P_{left_low}/10} + 10^{P_{left_mid}/10} + 10^{P_{left_high}/10} + 10^{P_{right_low}/10} + 10^{P_{right_mid}/10} + 10^{P_{right_high}/10}}{6} \right]$$

In addition the minimum TRP of each measured channel in hand phantom browsing mode position shall be higher than minimum performance requirements shown in the columns "Min".

$$TRP_{min} = \min [P_{left_low}, P_{left_mid}, P_{left_high}, P_{right_low}, P_{right_mid}, P_{right_high}]$$

Table 6.1.8.5-1: TRP test requirement for UTRA LCR TDD roaming bands in hand phantom browsing mode position

Operating band	Power Class 1		Power Class 2		Power Class 3		Power Class 4	
	Power (dBm)		Power (dBm)		Power (dBm)		Power (dBm)	
	Average	Min	Average	Min	Average	Min	Average	Min
a	–	–	TBD+TT	TBD+TT	–	–	–	–
b	–	–	TBD+TT	TBD+TT	–	–	–	–
c	–	–	TBD+TT	TBD+TT	–	–	–	–
d	–	–	TBD+TT	TBD+TT	–	–	–	–
e	–	–	TBD+TT	TBD+TT	–	–	–	–
f	–	–	TBD+TT	TBD+TT	–	–	–	–

Note: Applicable for dual-mode GSM/UTRA LCR TDD.

NOTE: If the above Test Requirement differs from the Minimum Requirement then the Test Tolerance applied for this test is non-zero. The Test Tolerance for this test is defined and the explanation of how the Minimum Requirement has been relaxed by the Test Tolerance is given in Annex D.

6.1.9 Total Radiated Power (TRP) for E-UTRA FDD in Browsing Mode with Hand Phantom

Editor's notes: This subclause is incomplete. The following items are missing or incomplete:

- Minimum requirements are not specified in TS 37.144 yet
- Text for Subclause Procedure, reverberation chamber method
- Test requirements are to be determined

6.1.9.1 Definition and applicability

The Total Radiated Power (TRP) is a measure of how much power the antenna actually radiates, when non-idealities such as mismatch and losses in the antenna are taken into account. The TRP is defined as the integral of the power transmitted in different directions over the entire radiation sphere:

$$P_{TRP} = \frac{1}{4\pi} \oint (P_{tx} G_{\theta}(\Omega; f) + P_{tx} G_{\varphi}(\Omega; f)) d\Omega$$

Using ψ to denote either θ or φ , $G_{\psi}(\Omega; f)$ is the ψ -polarization component of the gain pattern for the handset antenna measured at the frequency f , where Ω is the solid angle describing the direction. P_{tx} is the transmit power level of the handset so that $P_{tx} G_{\psi}(\Omega; f)$ is the actually transmitted power-level, also known as EIRP, in the ψ -polarization and in the direction Ω for frequency f .

The above equation may be written in "gain" form, that is, the TRP given by P_{TRP} is normalized to the transmitted power P_{tx} . This is the total radiation efficiency, which can also be denoted as Total Radiated Power Gain, TRPG,

$$\Gamma_{TRP} = \frac{1}{4\pi} \oint (G_{\theta}(\Omega; f) + G_{\varphi}(\Omega; f)) d\Omega$$

In practice discrete samples of $P_{tx} G_{\psi}(\Omega; f)$ are measured and used to approximate the integral so that the TRP is computed as

$$P_{TRP} \approx \frac{\Delta_\theta \Delta_\varphi}{4\pi} \sum_{n=0}^{N-1} \sum_{m=0}^{M-1} [P_{tx} G_\theta(\theta_n, \varphi_m; f) + P_{tx} G_\varphi(\theta_n, \varphi_m; f)] \sin(\theta_n)$$

Or, by using the relation $EIRP = P_{tx} G$:

$$P_{TRP}(f) \approx \frac{\Delta_\theta \Delta_\varphi}{4\pi} \sum_{n=0}^{N-1} \sum_{m=0}^{M-1} [EIRP_\theta(\theta_n, \varphi_m; f) + EIRP_\varphi(\theta_n, \varphi_m; f)] \sin(\theta_n)$$

In gain form the TRP can be expressed as:

$$\Gamma_{TRP} \approx \frac{\Delta_\theta \Delta_\varphi}{4\pi} \sum_{n=0}^{N-1} \sum_{m=0}^{M-1} [G_\theta(\theta_n, \varphi_m; f) + G_\varphi(\theta_n, \varphi_m; f)] \sin(\theta_n)$$

In these formulas $\Delta_\theta = \pi/(N)$ and $\Delta_\varphi = 2\pi/M$ are the sampling intervals for the θ - and φ -angles, respectively, and the number of samples in the θ - and φ -angles are given by N and M , respectively. The sampling points of the sphere are given by $\theta_n = n\Delta_\theta$ and $\varphi_m = m\Delta_\varphi$. The sampling intervals are discussed further in Section 4.4.

When measuring power radiated by active devices, expressing the data in terms of EIRP is more appropriate. The upper form of the TRP formulas (which includes EIRP terms) will be used in the data processing.

The requirements and this test apply to all types of LTE UEs independent of release.

6.1.9.2 Minimum Requirements

The average TRP of low, mid and high channel in hand phantom browsing mode position shall be higher than minimum performance requirements for roaming bands shown in Table 6.1.9.2-1. The averaging shall be done in linear scale for the TRP results of both right and left hand phantom measurements.

$$TRP_{average} = 10 \log \left[\frac{10^{P_{left_low}/10} + 10^{P_{left_mid}/10} + 10^{P_{left_high}/10} + 10^{P_{right_low}/10} + 10^{P_{right_mid}/10} + 10^{P_{right_high}/10}}{6} \right]$$

In addition the minimum TRP of each measured channel in hand phantom browsing mode position shall be higher than minimum performance requirements shown in the columns "Min".

$$TRP_{min} = \min [P_{left_low}, P_{left_mid}, P_{left_high}, P_{right_low}, P_{right_mid}, P_{right_high}]$$

Table 6.1.9.2-1: TRP minimum performance requirement for E-UTRA FDD roaming bands in hand phantom browsing mode position

TBD

The normative reference for this clause is TS37.144 [12] Subclause 6.1.3.3.

6.1.9.3 Test purpose

The purpose of this test is to verify that $TRP_{average}$ and TRP_{min} of the UE is not below specified values. A lower $TRP_{average}$ and TRP_{min} decrease the coverage area.

6.1.9.4 Method of test

6.1.9.4.1 Initial conditions

A radio communications tester or a corresponding device is used as a NB simulator to setup calls to the DUT. The NB/BS simulator may also measure the radiated power samples. Alternatively, a measurement receiver or spectrum analyzer may be used for that purpose.

The maximum output power for different UE power classes are defined in 3GPP TS 36.521-1 [11] Subclause 6.2.2 for any transmission bandwidth within the channel bandwidth. Also care should be taken that the noise floor of the measurement receiver is not disturbing the power measurement.

Chamber environment constraints and coordinate system shall be the same as described in Subclause A.3.

Phantom Specifications shall be the same as described in Subclause A.2.2.

Test environment: normal; see TS36.508 [10] Subclause 4.1.1.

Frequencies to be tested: low range, mid range, high range; see Table 5.3-1.

Positioning Requirements shall be the same as described in Subclause 4.3.

- 1) Position the UE according to the DUT positioning for hand phantom browsing mode specified in Subclause 4.3.4.
- 2) Power on the UE.
- 3) Set the initial conditions as per Subclause 6.2.2 of 3GPP TS 36.521-1 [11], with the following exception: set the carrier frequency, channel bandwidth, RB length and RB location as per Table 5.3-1 for FDD mode.

6.1.9.4.2 Procedure

- 1) Follow Steps 1 and 2 in section 6.2.2.4.2 of 3GPP TS 36.521-1 [11] and ensure that the DUT transmits with its maximum power.
- 2) For the anechoic chamber based methodologies, measure the spherical effective isotropic radiated power (EIRP) pattern following the sampling grid specified in Subclause 4.4. Calculate the TRP using the EIRP pattern data as per Subclause 6.1.9.1.
- 3) Repeat the measurement of the DUT using the left and right hand phantom for low, mid and high channels.
- 4) Calculate the average and minimum TRP as per Subclause 6.1.9.2.

6.1.9.4.3 Procedure, reverberation chamber method

TBD

6.1.9.5 Test requirements

The average TRP of low, mid and high channel in hand phantom browsing mode position shall be higher than test performance requirements for roaming bands shown in Table 6.1.9.5-1. The averaging shall be done in linear scale for the TRP results of both right and left hand phantom measurements.

$$TRP_{average} = 10 \log \left[\frac{10^{P_{left_low}/10} + 10^{P_{left_mid}/10} + 10^{P_{left_high}/10} + 10^{P_{right_low}/10} + 10^{P_{right_mid}/10} + 10^{P_{right_high}/10}}{6} \right]$$

In addition the minimum TRP of each measured channel in hand phantom browsing mode position shall be higher than minimum performance requirements shown in the columns "Min".

$$TRP_{min} = \min \left[P_{left_low}, P_{left_mid}, P_{left_high}, P_{right_low}, P_{right_mid}, P_{right_high} \right]$$

Table 6.1.9.5-1: TRP test requirement for E-UTRA FDD roaming bands in hand phantom browsing mode position

TBD

NOTE: If the above Test Requirement differs from the Minimum Requirement then the Test Tolerance applied for this test is non-zero. The Test Tolerance for this test is defined and the explanation of how the Minimum Requirement has been relaxed by the Test Tolerance is given in Annex D.

6.1.10 Total Radiated Power (TRP) for E-UTRA TDD in Browsing Mode with Hand Phantom

Editor's notes: This subclause is incomplete. The following items are missing or incomplete:

- Minimum requirements are not specified in TS 37.144 yet
- Text for Subclause Procedure, reverberation chamber method
- Test requirements are to be determined

6.1.10.1 Definition and applicability

The Total Radiated Power (TRP) is a measure of how much power the antenna actually radiates, when non-idealities such as mismatch and losses in the antenna are taken into account. The TRP is defined as the integral of the power transmitted in different directions over the entire radiation sphere:

$$P_{TRP} = \frac{1}{4\pi} \oint (P_{tx} G_{\theta}(\Omega; f) + P_{tx} G_{\varphi}(\Omega; f)) d\Omega$$

Using ψ to denote either θ or φ , $G_{\psi}(\Omega; f)$ is the ψ -polarization component of the gain pattern for the handset antenna measured at the frequency f , where Ω is the solid angle describing the direction. P_{tx} is the transmit power level of the handset so that $P_{tx} G_{\psi}(\Omega; f)$ is the actually transmitted power-level, also known as EIRP, in the ψ -polarization and in the direction Ω for frequency f .

The above equation may be written in "gain" form, that is, the TRP given by P_{TRP} is normalized to the transmitted power P_{tx} . This is the total radiation efficiency, which can also be denoted as Total Radiated Power Gain, TRPG,

$$\Gamma_{TRP} = \frac{1}{4\pi} \oint (G_{\theta}(\Omega; f) + G_{\varphi}(\Omega; f)) d\Omega$$

In practice discrete samples of $P_{tx} G_{\psi}(\Omega; f)$ are measured and used to approximate the integral so that the TRP is computed as

$$P_{TRP} \approx \frac{\Delta_{\theta} \Delta_{\varphi}}{4\pi} \sum_{n=0}^{N-1} \sum_{m=0}^{M-1} [P_{tx} G_{\theta}(\theta_n, \varphi_m; f) + P_{tx} G_{\varphi}(\theta_n, \varphi_m; f)] \sin(\theta_n)$$

Or, by using the relation $EIRP = P_{tx} G$:

$$P_{TRP}(f) \approx \frac{\Delta_{\theta} \Delta_{\varphi}}{4\pi} \sum_{n=0}^{N-1} \sum_{m=0}^{M-1} [EIRP_{\theta}(\theta_n, \varphi_m; f) + EIRP_{\varphi}(\theta_n, \varphi_m; f)] \sin(\theta_n)$$

In gain form the TRP can be expressed as:

$$\Gamma_{TRP} \approx \frac{\Delta_{\theta} \Delta_{\varphi}}{4\pi} \sum_{n=0}^{N-1} \sum_{m=0}^{M-1} [G_{\theta}(\theta_n, \varphi_m; f) + G_{\varphi}(\theta_n, \varphi_m; f)] \sin(\theta_n)$$

In these formulas $\Delta_{\theta} = \pi/(N)$ and $\Delta_{\varphi} = 2\pi/M$ are the sampling intervals for the θ - and φ -angles, respectively, and the number of samples in the θ - and φ -angles are given by N and M , respectively. The sampling points of the sphere are given by $\theta_n = n\Delta_{\theta}$ and $\varphi_m = m\Delta_{\varphi}$. The sampling intervals are discussed further in Section 4.4.

When measuring power radiated by active devices, expressing the data in terms of EIRP is more appropriate. The upper form of the TRP formulas (which includes EIRP terms) will be used in the data processing.

The requirements and this test apply to all types of LTE UEs independent of release.

6.1.10.2 Minimum Requirements

The average TRP of low, mid and high channel in hand phantom browsing mode position shall be higher than minimum performance requirements for roaming bands shown in Table 6.1.10.2-1. The averaging shall be done in linear scale for the TRP results of both right and left hand phantom measurements.

$$TRP_{average} = 10 \log \left[\frac{10^{P_{left_low}/10} + 10^{P_{left_mid}/10} + 10^{P_{left_high}/10} + 10^{P_{right_low}/10} + 10^{P_{right_mid}/10} + 10^{P_{right_high}/10}}{6} \right]$$

In addition the minimum TRP of each measured channel in beside head position shall be higher than minimum performance requirements shown in the columns "Min".

$$TRP_{min} = \min \left[P_{left_low}, P_{left_mid}, P_{left_high}, P_{right_low}, P_{right_mid}, P_{right_high} \right]$$

Table 6.1.10.2-1: TRP minimum performance requirement for E-UTRA TDD roaming bands in hand phantom browsing mode position

TBD

The normative reference for this clause is TS37.144 [12] Subclause 6.1.3.4.

6.1.10.3 Test purpose

The purpose of this test is to verify that $TRP_{average}$ and TRP_{min} of the UE is not below specified values. A lower $TRP_{average}$ and TRP_{min} decrease the coverage area.

6.1.10.4 Method of test

6.1.10.4.1 Initial conditions

A radio communications tester or a corresponding device is used as a NB simulator to setup calls to the DUT. The NB/BS simulator may also measure the radiated power samples. Alternatively, a measurement receiver or spectrum analyzer may be used for that purpose.

The maximum output power for different UE power classes are defined in 3GPP TS 36.521-1 [11] Subclause 6.2.2 for any transmission bandwidth within the channel bandwidth. Also care should be taken that the noise floor of the measurement receiver is not disturbing the power measurement.

Chamber environment constraints and coordinate system shall be the same as described in Subclause A.3.

Phantom Specifications shall be the same as described in Subclause A.2.2.

Test environment: normal; see TS36.508 [10] Subclause 4.1.1.

Frequencies to be tested: low range, mid range, high range; see Table 5.4-2.

Positioning Requirements shall be the same as described in Subclause 4.3.

- 1) Position the UE according to the DUT positioning for hand phantom browsing mode specified in Subclause 4.3.4.
- 2) Power on the UE.
- 3) Set the initial conditions as per Subclause 6.2.2 of 3GPP TS 36.521-1 [11], with the following exception: set the carrier frequency, channel bandwidth, RB length and RB location as per Table 5.4-1 for TDD mode.

6.1.10.4.2 Procedure

- 1) Follow Steps 1 and 2 in section 6.2.2.4.2 of 3GPP TS 36.521-1 [11] and ensure that the DUT transmits with its maximum power.

- 2) For the anechoic chamber based methodologies, measure the spherical effective isotropic radiated power (EIRP) pattern following the sampling grid specified in Subclause 4.4. Slots with transient periods are not under test. The uplink downlink configuration and the special subframe configuration in TDD are set as per Table 8.2.2-1 of 3GPP TS 36.521-1 [11]. Calculate the TRP using the EIRP pattern data as per Subclause 6.1.10.1.
- 3) Repeat the measurement of the DUT using the left and right hand phantom for low, mid and high channels.
- 4) Calculate the average and minimum TRP as per Subclause 6.1.10.2.

6.1.10.4.3 Procedure, reverberation chamber method

TBD

6.1.10.5 Test requirements

The average TRP of low, mid and high channel in hand phantom browsing mode position shall be higher than test performance requirements for roaming bands shown in Table 6.1.10.5-1. The averaging shall be done in linear scale for the TRP results of both right and left hand phantom measurements.

$$TRP_{average} = 10 \log \left[\frac{10^{P_{left_low}/10} + 10^{P_{left_mid}/10} + 10^{P_{left_high}/10} + 10^{P_{right_low}/10} + 10^{P_{right_mid}/10} + 10^{P_{right_high}/10}}{6} \right]$$

In addition the minimum TRP of each measured channel in beside head position shall be higher than minimum performance requirements shown in the columns "Min".

$$TRP_{min} = \min [P_{left_low}, P_{left_mid}, P_{left_high}, P_{right_low}, P_{right_mid}, P_{right_high}]$$

Table 6.1.10.5-1: TRP test requirement for E-UTRA TDD roaming bands in hand phantom browsing mode position

TBD

NOTE: If the above Test Requirement differs from the Minimum Requirement then the Test Tolerance applied for this test is non-zero. The Test Tolerance for this test is defined and the explanation of how the Minimum Requirement has been relaxed by the Test Tolerance is given in Annex D.

6.2 Performance for LME

6.2.1 Total Radiated Power (TRP) for UTRA FDD LME

Editor's note: This test case is incomplete. The following aspects are either missing or not yet determined:

- *The TRP Minimum Performance Requirement for this test is undefined*
- *The Test Requirements and related Test Tolerances applicable for this test are undefined*

6.2.1.1 Definition and applicability

The Total Radiated Power (TRP) is a measure of how much power the DUT actually radiates. The TRP is defined as the integral of the power transmitted in different directions over the entire radiation sphere:

$$TRP = \frac{1}{4\pi} \oint (EIRP_{\theta}(\Omega; f) + EIRP_{\varphi}(\Omega; f)) d\Omega$$

Where Ω is the solid angle describing the direction, f is frequency. θ and φ are the orthogonal polarizations. $EIRP_{\theta}$ and $EIRP_{\varphi}$ are the actually transmitted power-levels in corresponding polarizations.

Thus

$$TRP \approx \frac{\pi}{2NM} \sum_{n=0}^{N-1} \sum_{m=0}^{M-1} [EIRP_{\theta}(\theta_n, \varphi_m; f) + EIRP_{\varphi}(\theta_n, \varphi_m; f)] \sin(\theta_n)$$

In these formulas N and M are the number of sampling intervals for theta and phi. θ_n and φ_m are the measurement angles. The sampling intervals are discussed further in Section 4.4.

The TRP can also be calculated from Rayleigh faded samples of the total power transmitted from the LME. The measurement of transmitter performance in an isotropic Rayleigh fading environment is based on sampling the radiated power of the LME for a discrete number of field combinations in the chamber. The average value of these statistically distributed samples is proportional to the TRP and by calibrating the average power transfer function, an absolute value of the TRP can be obtained. Thus

$$TRP \approx \frac{\sum_{n=1}^N \left(\frac{P_n}{C_n (1 - R_n)} \right)}{\sum_{n=1}^N P_{ref,n}}$$

where $P_{ref,n}$ is the reference power transfer function for fixed measurement antenna n, R_n is the reflection coefficient for fixed measurement antenna n and C_n is the path loss in the cables connecting the measurement receiver to fixed measurement antenna n. These parameters are calculated from the calibration measurement and are further discussed in Annex B.2. P_n is the average power measured by fixed measurement antenna n and can be calculated using the following expression:

$$P_n = \frac{\sum_{m=1}^M |S_{21,n,m}|^2}{M}$$

where $S_{21,n,m}$ is sample number m of the complex transfer function measured with fixed measurement antenna n and M is the total number of samples measured for each fixed measurement antenna.

The requirements and this test apply to all types of UTRA for the FDD UE for Release 11 and later releases that support LME.

NOTE: This test case can be optionally executed for Release 7 and onward UE's supporting LME feature.

6.2.1.2 Minimum Requirements

The average TRP of low, mid and high channel shall be higher than minimum performance requirements for roaming bands shown in Table 6.1.2.2-1. The averaging shall be done in linear scale for the TRP results.

$$TRP_{average} = 10 \log \left[\frac{10^{P_{low}/10} + 10^{P_{mid}/10} + 10^{P_{high}/10}}{3} \right]$$

In addition the minimum TRP of each measured channel shall be higher than minimum performance requirements shown in the columns "Min".

$$TRP_{min} = 10 \log \left[\min \left(10^{P_{low}/10}, 10^{P_{mid}/10}, 10^{P_{high}/10} \right) \right]$$

Table 6.1.2.2-1: TRP minimum performance requirement for UTRA FDD using LME

Operating band	Power Class 1	Power Class 2	Power Class 3		Power Class 3bis		Power Class 4	
	Power (dBm)	Power (dBm)	Power (dBm)		Power (dBm)		Power (dBm)	
			Average	Min	Average	Min	Average	Min

I	-	-	TBD	TBD	TBD	TBD	TBD	TBD
II	-	-	TBD	TBD	TBD	TBD	TBD	TBD
III	-	-	TBD	TBD	TBD	TBD	TBD	TBD
IV	-	-	TBD	TBD	TBD	TBD	TBD	TBD
V	-	-	TBD	TBD	TBD	TBD	TBD	TBD
VI	-	-	TBD	TBD	TBD	TBD	TBD	TBD
VII	-	-	TBD	TBD	TBD	TBD	TBD	TBD
VIII	-	-	TBD	TBD	TBD	TBD	TBD	TBD
IX	-	-	TBD	TBD	TBD	TBD	TBD	TBD
XIX	-	-	TBD	TBD	TBD	TBD	TBD	TBD

NOTE 1: Applicable for dual-mode GSM/UMTS.
NOTE 2: Applicable for USB plug-in devices.

The normative reference for this clause is TS37.144 [12] Subclause 6.2.2.

6.2.1.3 Test purpose

The purpose of this test is to verify that $TRP_{average}$ and TRP_{min} of the UE is not below specified values. A lower $TRP_{average}$ and TRP_{min} decrease the coverage area.

6.2.1.4 Method of test

6.2.1.4.1 Initial conditions

The output power is a measure of the maximum power the UE can transmit in a bandwidth of at least $(1 + \alpha)$ times the chip rate of the radio access mode, for more information see TS 34.121-1 [7] clause 5.2. The period of measurement shall be at least one timeslot. Also, care should be taken that the noise floor of the measurement receiver is not disturbing the power measurement.

Test environment: normal; see TS 34.121-1 [7] clause G.2.1.

Frequencies to be tested: low range, mid range, high range; see Table 5.1-2.

- 1) Set the SS downlink physical channels according to settings in Table 6.2.1.4.1-1. Set the DPCH power such that there will not be transmission gaps due to too low signal strength throughout the measurement.
- 2) Connect the plug-in UE to a laptop ground plane phantom. Power on the plug-in UE. The real functional laptop supplies power to the plug-in UE.
- 3) A call is set up according to the Generic call setup procedure. The power control algorithm shall be set to Power Control Algorithm 2. Compressed mode shall be set to OFF.
- 4) Enter the UE into loopback test mode 2 and start the loopback test.

See TS 34.108 [4] and TS 34.109 [5] for details regarding generic call setup procedure and loopback test.

Table 6.2.1.4.1-1: Downlink Physical Channels transmitted during a connection

Physical Channel		Power
CPICH	CPICH_Ec / DPCH_Ec	7 dB
P-CCPCH	P-CCPCH_Ec / DPCH_Ec	5 dB
SCH	SCH_Ec / DPCH_Ec	5 dB
PICH	PICH_Ec / DPCH_Ec	2 dB
DPCH	Test dependent power	-

6.2.1.4.2 Procedure

- 1) Send continuously Up power control commands to the plug-in UE.
- 2) As the plug-in UE reaches maximum power, start sending PN15 data pattern.

- 3) Position the plug-in UE into the USB connector in accordance with the manufacturer recommended primary mechanical mode. In the absence of such a recommendation position the plug-in UE so that it is horizontally plugged into the horizontal USB connector.
- 4) Measure the $EIRP_{\theta}$ and $EIRP_{\phi}$ with a sample step of 15° in theta (θ) and phi (ϕ) directions using a test system having characteristics as described in Annex A.
- 5) Calculate TRP using equations from clause 6.2.1.2.

NOTE 1: The measurement procedure is based on the measurement of the spherical radiation pattern of the DUT. The power radiated by the DUT is sampled in far field in a group of points located on a spherical surface enclosing the DUT. The EIRP samples are taken using a constant sample step of 15° both in theta (θ) and phi (ϕ) directions. In some cases a different sampling grid may be used to speed up the measurements (See Section 4.4). All the EIRP samples are taken with two orthogonal polarizations, θ - and ϕ - polarisations.

NOTE 2: The noise floor of the measurement receiver shall not disturb the power measurement.

NOTE 3: Non Standard settings: To speed up sensitivity measurements, power measurements may be done with non standard modulation. However to obtain TRP result the measured EIRP figures shall be normalized by

$$\overline{\Delta EIRP} = \frac{1}{n} \sum_{i=1}^n (EIRPstd_i - EIRPnstd_i)$$

where $EIRPstd_i$ is power measurement done with standard setting. $EIRPnstd_i$ is power measurement done with non standard modulation. n is amount of reference measurement points.

To ensure accuracy of TRP, the amount of reference points measured should be at least 4. It is recommended to spread the reference measurements equally during the measurement time.

6.2.1.4.3 Procedure, reverberation chamber method

- 1) Send continuously Up power control commands to the plug-in UE.
- 2) As the plug-in UE reaches maximum power, start sending PN15 data pattern.
- 3) Position the plug-in UE into the USB connector in accordance with the manufacturer recommended primary mechanical mode. In the absence of such a recommendation position the plug-in UE so that it is horizontally plugged into the horizontal USB connector.
- 4) Measure a sufficient number of independent samples (see section 4.5) of $S_{21,n,m}$ using a test system having characteristics as described in Annex A.
- 5) Calculate TRP using equations from clause 6.2.1.2.

NOTE 1: The measurement procedure is based on the measurement of the total power radiated from the UE/MS to a full 3 dimensional isotropic environment with uniform elevation and azimuth field distribution. The power transmitted by the DUT is undergoing Rayleigh fading and is sampled by the fixed measurement antennas. Moreover, it is important that the samples collected are independent, in order to get sufficient accuracy of the estimated TRP value.

NOTE 2: The noise floor of the measurement receiver shall not disturb the power measurement.

6.2.1.5 Test requirements

The average TRP of low, mid and high channel shall be higher than test performance requirements for roaming bands shown in Table 6.2.1.5-1. The averaging shall be done in linear scale for the TRP.

$$TRP_{average} = 10 \log \left[\frac{10^{P_{low}/10} + 10^{P_{mid}/10} + 10^{P_{high}/10}}{3} \right]$$

In addition the minimum TRP of each measured channel shall be higher than minimum performance requirements shown in the columns “Min”.

$$TRP_{min} = 10 \log \left[\min \left(10^{P_{low}/10}, 10^{P_{mid}/10}, 10^{P_{high}/10} \right) \right]$$

Table 6.2.1.5-1: TRP test requirement for UTRA FDD using LME

Operating band	Power Class 1	Power Class 2	Power Class 3		Power Class 3bis		Power Class 4	
	Power (dBm)	Power (dBm)	Power (dBm)		Power (dBm)		Power (dBm)	
			Average	Min	Average	Min	Average	Min
I	-	-	TBD +TT	TBD +TT	TBD +TT	TBD +TT	TBD +TT	TBD +TT
II	-	-	TBD +TT	TBD +TT	TBD +TT	TBD +TT	TBD +TT	TBD +TT
III	-	-	TBD +TT	TBD +TT	TBD +TT	TBD +TT	TBD +TT	TBD +TT
IV	-	-	TBD +TT	TBD +TT	TBD +TT	TBD +TT	TBD +TT	TBD +TT
V	-	-	TBD +TT	TBD +TT	TBD +TT	TBD +TT	TBD +TT	TBD +TT
VI	-	-	TBD +TT	TBD +TT	TBD +TT	TBD +TT	TBD +TT	TBD +TT
VII	-	-	TBD +TT	TBD +TT	TBD +TT	TBD +TT	TBD +TT	TBD +TT
VIII	-	-	TBD +TT	TBD +TT	TBD +TT	TBD +TT	TBD +TT	TBD +TT
IX	-	-	TBD +TT	TBD +TT	TBD +TT	TBD +TT	TBD +TT	TBD +TT
XIX	-	-	TBD +TT	TBD +TT	TBD +TT	TBD +TT	TBD +TT	TBD +TT

NOTE 1: Applicable for dual-mode GSM/UMTS.
NOTE 2: Applicable for USB plug-in devices.

NOTE: If the above Test Requirement differs from the Minimum Requirement then the Test Tolerance applied for this test is non-zero. The Test Tolerance for this test is defined and the explanation of how the Minimum Requirement has been relaxed by the Test Tolerance is given in Annex D.

6.2.2 Total Radiated Power (TRP) for UTRA LCR TDD LME

Editor’s note: This test case is incomplete. The following aspects are either missing or not yet determined:

- The TRP Minimum Performance Requirement for this test is undefined
- The Test Requirements and related Test Tolerances applicable for this test are undefined

6.2.2.1 Definition and applicability

The Total Radiated Power (TRP) is a measure of how much power the DUT actually radiates. The TRP is defined as the integral of the power transmitted in different directions over the entire radiation sphere:

$$TRP = \frac{1}{4\pi} \oint \left(EIRP_{\theta}(\Omega; f) + EIRP_{\varphi}(\Omega; f) \right) d\Omega$$

Where Ω is the solid angle describing the direction, f is frequency. θ and φ are the orthogonal polarizations.

$EIRP_{\theta}$ and $EIRP_{\varphi}$ are the actually transmitted power-levels in corresponding polarizations.

Thus

$$TRP \approx \frac{\pi}{2NM} \sum_{n=0}^{N-1} \sum_{m=0}^{M-1} [EIRP_{\theta}(\theta_n, \varphi_m; f) + EIRP_{\varphi}(\theta_n, \varphi_m; f)] \sin(\theta_n)$$

In these formulas N and M are the number of sampling intervals for theta and phi. θ_n and φ_m are the measurement angles. The sampling intervals are discussed further in Section 4.4.

The TRP can also be calculated from Rayleigh faded samples of the total power transmitted from the LME. The measurement of transmitter performance in an isotropic Rayleigh fading environment is based on sampling the radiated power of the LME for a discrete number of field combinations in the chamber. The average value of these statistically distributed samples is proportional to the TRP and by calibrating the average power transfer function, an absolute value of the TRP can be obtained. Thus

$$TRP \approx \frac{\sum_{n=1}^N \left(\frac{P_n}{C_n(1-R_n)} \right)}{\sum_{n=1}^N P_{ref,n}}$$

where $P_{ref,n}$ is the reference power transfer function for fixed measurement antenna n , R_n is the reflection coefficient for fixed measurement antenna n and C_n is the path loss in the cables connecting the measurement receiver to fixed measurement antenna n . These parameters are calculated from the calibration measurement and are further discussed in Annex B.2. P_n is the average power measured by fixed measurement antenna n and can be calculated using the following expression:

$$P_n = \frac{\sum_{m=1}^M |S_{21,n,m}|^2}{M}$$

where $S_{21,n,m}$ is sample number m of the complex transfer function measured with fixed measurement antenna n and M is the total number of samples measured for each fixed measurement antenna.

The requirements and this test apply to all types of UTRA for the TDD UE for Release 11 and later releases that support LME.

NOTE: This test case can be optionally executed for Release 8 and onward UE's supporting LME feature.

6.2.2.2 Minimum Requirements

The average TRP of low, mid and high channel shall be higher than minimum performance requirements for roaming bands shown in Table 6.2.2.2-1. The averaging shall be done in linear scale for the TRP results.

$$TRP_{average} = 10 \log \left[\frac{10^{P_{low}/10} + 10^{P_{mid}/10} + 10^{P_{high}/10}}{3} \right]$$

In addition the minimum TRP of each measured channel shall be higher than minimum performance requirements shown in the columns "Min".

$$TRP_{min} = 10 \log \left[\min \left(10^{P_{low}/10}, 10^{P_{mid}/10}, 10^{P_{high}/10} \right) \right]$$

Table 6.2.2.2-1: TRP minimum performance requirement for UTRA LCR TDD using LME

Operating band	Power Class 1		Power Class 2		Power Class 3		Power Class 4	
	Power (dBm)		Power (dBm)		Power (dBm)		Power (dBm)	
	Average	Min	Average	Min	Average	Min	Average	Min

a	–	–	TBD	TBD	–	–	–	–
b	–	–	TBD	TBD	–	–	–	–
c	–	–	TBD	TBD	–	–	–	–
d	–	–	TBD	TBD	–	–	–	–
e	–	–	TBD	TBD	–	–	–	–
f	–	–	TBD	TBD	–	–	–	–
NOTE 1: Applicable for dual-mode GSM/UTRA LCR TDD. NOTE 2: Applicable for USB plug-in devices.								

The normative reference for this clause is TS37.144 [12] Subclause 6.2.3.

6.2.2.3 Test purpose

The purpose of this test is to verify that $TRP_{average}$ and TRP_{min} of the UE is not below specified values. A lower $TRP_{average}$ and TRP_{min} decrease the coverage area.

6.2.2.4 Method of test

6.2.2.4.1 Initial conditions

The output power is a measure of the maximum power the UE can transmit in a bandwidth of at least $(1 + \alpha)$ times the chip rate of the radio access mode, for more information see TS 34.122 [8] clause 5.2. The period of measurement shall be at least one timeslot. Also, care should be taken that the noise floor of the measurement receiver is not disturbing the power measurement. Normally, the receiving device should be set accordingly so that the receiving signal will be at least 30 dB higher than the system noise floor.

Test environment: normal; see TS 34.122 [8] clause G.2.1.

Frequencies to be tested: low range, mid range, high range; see TS 34.122 [8] clause G.2.4.

- 1) Set the SS downlink physical channels according to settings in Table 6.2.2.4.1-1. Set the DPCH power such that there will not be transmission gaps due to too low signal strength throughout the measurement.
- 2) Connect the plug-in UE to a laptop ground plane phantom. Power on the plug-in UE. The real functional laptop supplies power to the plug-in UE.
- 3) A call is set up according to the Generic call setup procedure. The power control algorithm shall be set to Power Control Algorithm 2.
- 4) Enter the UE into loopback test mode and start the loopback test.
- 5) The measurement receiver shall be set to: zero span, video trigger and RMS detector. The RBW shall be at least $(1 + \alpha)$ times the chip rate of the radio access mode and the VBW at least 3 times bigger than the RBW. For 1.28Mcps TDD UE, the RBW shall be set to 3MHz, and VBW shall be set to 10MHz.

See TS 34.108 [4] and TS 34.109 [5] for details regarding generic call setup procedure and loopback test.

Table 6.2.2.4.1-1: Downlink Physical Channels transmitted during a connection

Physical Channel		Power
lor	-75 dBm	-
DwPCH	DwPCH_Ec / lor	0 dB
PCCPCH	\sum P-CCPCH_Ec / lor	-3 dB
SCCPCH	\sum S-CCPCH_Ec / lor	-6 dB
PICH	\sum PICH_Ec / lor	-6 dB
FPACH	FPACH_Ec / lor	-6 dB
DL DPCH	\sum DPCH_Ec / lor	0 dB

6.2.2.4.2 Procedure

- 1) Send continuously Up power control commands to the plug-in UE.
- 2) As the plug-in UE reaches maximum power, start sending PN15 data pattern.
- 3) Position the plug-in UE into the USB connector in accordance with the manufacturer recommended primary mechanical mode. In the absence of such a recommendation position the plug-in UE so that it is horizontally plugged into the horizontal USB connector.
- 4) Measure the $EIRP_{\theta}$ and $EIRP_{\phi}$ with a sample step of 15° in theta (θ) and phi (ϕ) directions using a test system having characteristics as described in Annex A.
- 5) Calculate TRP using equations from clause 6.2.2.2.

NOTE 1: The measurement procedure is based on the measurement of the spherical radiation pattern of the DUT. The power radiated by the DUT is sampled in far field in a group of points located on a spherical surface enclosing the DUT. The EIRP samples are taken using a constant sample step of 15° both in theta (θ) and phi (ϕ) directions. In some cases a different sampling grid may be used to speed up the measurements (See Section 4.4). All the EIRP samples are taken with two orthogonal polarizations, θ - and ϕ - polarisations.

NOTE 2: The noise floor of the measurement receiver shall not disturb the power measurement.

NOTE 3: Non Standard settings: To speed up sensitivity measurements, power measurements may be done with non standard modulation. However to obtain TRP result the measured EIRP figures shall be normalized by

$$\overline{\Delta EIRP} = \frac{1}{n} \sum_{i=1}^n (EIRPstd_i - EIRPnstd_i)$$

where $EIRPstd_i$ is power measurement done with standard setting. $EIRPnstd_i$ is power measurement done with non standard modulation. n is amount of reference measurement points.

To ensure accuracy of TRP, the amount of reference points measured should be at least 4. It is recommended to spread the reference measurements equally during the measurement time.

6.2.2.4.3 Procedure, reverberation chamber method

- 1) Send continuously Up power control commands to the plug-in UE.
- 2) As the plug-in UE reaches maximum power, start sending PN15 data pattern.
- 3) Position the plug-in UE into the USB connector in accordance with the manufacturer recommended primary mechanical mode. In the absence of such a recommendation position the plug-in UE so that it is horizontally plugged into the horizontal USB connector.
- 4) Measure a sufficient number of independent samples (see section 4.5) of $S_{21,n,m}$ using a test system having characteristics as described in Annex A.
- 5) Calculate TRP using equations from clause 6.2.2.2.

NOTE 1: The measurement procedure is based on the measurement of the total power radiated from the UE/MS to a full 3 dimensional isotropic environment with uniform elevation and azimuth field distribution. The power transmitted by the DUT is undergoing Rayleigh fading and is sampled by the fixed measurement antennas. Moreover, it is important that the samples collected are independent, in order to get sufficient accuracy of the estimated TRP value.

NOTE 2: The noise floor of the measurement receiver shall not disturb the power measurement.

6.2.2.5 Test requirements

The average TRP of low, mid and high channel shall be higher than test performance requirements for roaming bands shown in Table 6.2.2.5-1. The averaging shall be done in linear scale for the TRP.

$$TRP_{average} = 10 \log \left[\frac{10^{P_{low}/10} + 10^{P_{mid}/10} + 10^{P_{high}/10}}{3} \right]$$

In addition the minimum TRP of each measured channel shall be higher than minimum performance requirements shown in the columns "Min".

$$TRP_{min} = 10 \log \left[\min \left(10^{P_{low}/10}, 10^{P_{mid}/10}, 10^{P_{high}/10} \right) \right]$$

Table 6.2.2.5-1: TRP test requirement for UTRA LCR TDD using LME

Operating band	Power Class 1		Power Class 2		Power Class 3		Power Class 4	
	Power (dBm)		Power (dBm)		Power (dBm)		Power (dBm)	
	Average	Min	Average	Min	Average	Min	Average	Min
a	–	–	TBD + TT	TBD + TT	–	–	–	–
b	–	–	TBD + TT	TBD + TT	–	–	–	–
c	–	–	TBD + TT	TBD + TT	–	–	–	–
d	–	–	TBD + TT	TBD + TT	–	–	–	–
e	–	–	TBD + TT	TBD + TT	–	–	–	–
f	–	–	TBD + TT	TBD + TT	–	–	–	–

NOTE 1: Applicable for dual-mode GSM/UTRA LCR TDD.
NOTE 2: Applicable for USB plug-in devices.

NOTE: If the above Test Requirement differs from the Minimum Requirement then the Test Tolerance applied for this test is non-zero. The Test Tolerance for this test is defined and the explanation of how the Minimum Requirement has been relaxed by the Test Tolerance is given in Annex D.

6.2.3 Total Radiated Power (TRP) for E-UTRA FDD LME

Editor's notes: This subclause is incomplete. The following items are missing or incomplete:

- The requirements are not defined in RAN4 yet
- Applicability
- Procedure, reverberation chamber method to be determined
- Test requirements are to be determined

6.2.3.1 Definition and applicability

The Total Radiated Power (TRP) is a measure of how much power the antenna actually radiates, when non-idealities such as mismatch and losses in the antenna are taken into account. The TRP is defined as the integral of the power transmitted in different directions over the entire radiation sphere:

$$P_{TRP} = \frac{1}{4\pi} \oint (P_{\alpha} G_{\theta}(\Omega; f) + P_{\alpha} G_{\phi}(\Omega; f)) d\Omega$$

Using ψ to denote either θ or φ , $G_\psi(\Omega; f)$ is the ψ -polarization component of the gain pattern for the handset antenna measured at the frequency f , where Ω is the solid angle describing the direction. P_{tx} is the transmit power level of the handset so that $P_{tx}G_\psi(\Omega; f)$ is the actually transmitted power-level, also known as EIRP, in the ψ -polarization and in the direction Ω for frequency f .

The above equation may be written in "gain" form, that is, the TRP given by P_{TRP} is normalized to the transmitted power P_{tx} . This is the total radiation efficiency, which can also be denoted as Total Radiated Power Gain, TRPG,

$$\Gamma_{TRP} = \frac{1}{4\pi} \oint (G_\theta(\Omega; f) + G_\varphi(\Omega; f)) d\Omega$$

In practice discrete samples of $P_{tx}G_\psi(\Omega; f)$ are measured and used to approximate the integral so that the TRP is computed as

$$P_{TRP} \approx \frac{\Delta_\theta \Delta_\varphi}{4\pi} \sum_{n=0}^{N-1} \sum_{m=0}^{M-1} [P_{tx}G_\theta(\theta_n, \varphi_m; f) + P_{tx}G_\varphi(\theta_n, \varphi_m; f)] \sin(\theta_n)$$

Or, by using the relation $EIRP = P_{tx}G$:

$$P_{TRP}(f) \approx \frac{\Delta_\theta \Delta_\varphi}{4\pi} \sum_{n=0}^{N-1} \sum_{m=0}^{M-1} [EIRP_\theta(\theta_n, \varphi_m; f) + EIRP_\varphi(\theta_n, \varphi_m; f)] \sin(\theta_n)$$

In gain form the TRP can be expressed as:

$$\Gamma_{TRP} \approx \frac{\Delta_\theta \Delta_\varphi}{4\pi} \sum_{n=0}^{N-1} \sum_{m=0}^{M-1} [G_\theta(\theta_n, \varphi_m; f) + G_\varphi(\theta_n, \varphi_m; f)] \sin(\theta_n)$$

In these formulas $\Delta_\theta = \pi/(N)$ and $\Delta_\varphi = 2\pi/M$ are the sampling intervals for the θ - and φ -angles, respectively, and the number of samples in the θ - and φ -angles are given by N and M , respectively. The sampling points of the sphere are given by $\theta_n = n\Delta_\theta$ and $\varphi_m = m\Delta_\varphi$. The sampling intervals are discussed further in Section 4.4.

When measuring power radiated by active devices, expressing the data in terms of EIRP is more appropriate. The upper form of the TRP formulas (which includes EIRP terms) will be used in the data processing.

[Applicability is TBD]

6.2.3.2 Minimum Requirements

The average TRP of low, mid and high channel shall be higher than minimum performance requirements for roaming bands shown in Table 6.2.3.2-1. The averaging shall be done in linear scale for the TRP results.

$$TRP_{average} = 10 \log \left[\frac{10^{P_{low}/10} + 10^{P_{mid}/10} + 10^{P_{high}/10}}{3} \right]$$

In addition the minimum TRP of each measured channel shall be higher than minimum performance requirements shown in the columns "Min".

$$TRP_{min} = 10 \log \left[\min \left(10^{P_{low}/10}, 10^{P_{mid}/10}, 10^{P_{high}/10} \right) \right]$$

Table 6.2.3.2-1: TRP minimum performance requirement for E-UTRA FDD using LME

TBD

The normative reference for this clause is TS37.144 [12] Subclause 6.2.3.

6.2.3.3 Test purpose

The purpose of this test is to verify that $TRP_{average}$ and TRP_{min} of the UE is not below specified values. A lower $TRP_{average}$ and TRP_{min} decrease the coverage area.

6.2.3.4 Method of test

6.2.3.4.1 Initial conditions

A radio communications tester or a corresponding device is used as a NB simulator to setup calls to the DUT. The NB/BS simulator may also measure the radiated power samples. Alternatively, a measurement receiver or spectrum analyzer may be used for that purpose.

The maximum output power for different UE power classes are defined in 3GPP TS 36.521-1 [11] Subclause 6.2.2 for any transmission bandwidth within the channel bandwidth. Also, care should be taken that the noise floor of the measurement receiver is not disturbing the power measurement.

Chamber environment constraints and coordinate system shall be the same as described in Subclause A.3.

Phantom Specifications shall be the same as described in Subclause A.2.3. Parameters required for laptop ground plane phantom are specified in Annex A.2.3.

Test environment: normal; see TS36.508 [10] Subclause 4.1.1.

Frequencies to be tested: low range, mid range, high range; see Table 5.3-1.

Positioning Requirements shall be the same as described in Subclause 4.3.

- 1) Position the UE according to the DUT positioning on laptop ground plane phantom specified in Subclause 4.3.2.
- 2) Power on the UE.
- 3) Set the initial conditions as per Subclause 6.2.2 of 3GPP TS 36.521-1 [11], with the following exception: set the carrier frequency, channel bandwidth, RB length and RB location as per Table 5.3-1 for FDD mode.

6.2.3.4.2 Procedure

- 1) Follow Steps 1 and 2 in section 6.2.2.4.2 of 3GPP TS 36.521-1 [11] and ensure that the DUT transmits with its maximum power.
- 2) For the anechoic chamber based methodologies, measure the spherical effective isotropic radiated power (EIRP) pattern following the sampling grid specified in Subclause 4.4. Calculate the TRP using the EIRP pattern data as per Subclause 6.2.3.1.
- 3) Repeat the measurement of the DUT for low, mid and high channels.
- 4) Calculate the average and minimum TRP as per Subclause 6.2.3.2.
- ...

6.2.3.4.3 Procedure, reverberation chamber method

TBD

6.2.3.5 Test requirements

The average TRP of low, mid and high channel shall be higher than test performance requirements for roaming bands shown in Table 6.2.3.5-1. The averaging shall be done in linear scale for the TRP.

$$TRP_{average} = 10 \log \left[\frac{10^{P_{low}/10} + 10^{P_{mid}/10} + 10^{P_{high}/10}}{3} \right]$$

In addition the minimum TRP of each measured channel shall be higher than minimum performance requirements shown in the columns "Min".

$$TRP_{\min} = 10 \log \left[\min \left(10^{P_{\text{low}}/10}, 10^{P_{\text{mid}}/10}, 10^{P_{\text{high}}/10} \right) \right]$$

Table 6.2.3.5-1: TRP test requirement for E-UTRA FDD using LME

TBD

NOTE: If the above Test Requirement differs from the Minimum Requirement then the Test Tolerance applied for this test is non-zero. The Test Tolerance for this test is defined and the explanation of how the Minimum Requirement has been relaxed by the Test Tolerance is given in Annex D.

6.2.4 Total Radiated Power (TRP) for E-UTRA TDD LME

Editor's notes: This subclause is incomplete. The following items are missing or incomplete:

- The requirements are not defined in RAN4 yet
- Applicability
- Procedure, reverberation chamber method to be determined
- Test requirements are to be determined

6.2.4.1 Definition and applicability

The Total Radiated Power (TRP) is a measure of how much power the antenna actually radiates, when non-idealities such as mismatch and losses in the antenna are taken into account. The TRP is defined as the integral of the power transmitted in different directions over the entire radiation sphere:

$$P_{TRP} = \frac{1}{4\pi} \oint (P_{tx} G_{\theta}(\Omega; f) + P_{tx} G_{\varphi}(\Omega; f)) d\Omega$$

Using ψ to denote either θ or φ , $G_{\psi}(\Omega; f)$ is the ψ -polarization component of the gain pattern for the handset antenna measured at the frequency f , where Ω is the solid angle describing the direction. P_{tx} is the transmit power level of the handset so that $P_{tx} G_{\psi}(\Omega; f)$ is the actually transmitted power-level, also known as EIRP, in the ψ -polarization and in the direction Ω for frequency f .

The above equation may be written in "gain" form, that is, the TRP given by P_{TRP} is normalized to the transmitted power P_{tx} . This is the total radiation efficiency, which can also be denoted as Total Radiated Power Gain, TRPG,

$$\Gamma_{TRP} = \frac{1}{4\pi} \oint (G_{\theta}(\Omega; f) + G_{\varphi}(\Omega; f)) d\Omega$$

In practice discrete samples of $P_{tx} G_{\psi}(\Omega; f)$ are measured and used to approximate the integral so that the TRP is computed as

$$P_{TRP} \approx \frac{\Delta_{\theta} \Delta_{\varphi}}{4\pi} \sum_{n=0}^{N-1} \sum_{m=0}^{M-1} [P_{tx} G_{\theta}(\theta_n, \varphi_m; f) + P_{tx} G_{\varphi}(\theta_n, \varphi_m; f)] \sin(\theta_n)$$

Or, by using the relation $EIRP = P_{tx} G$:

$$P_{TRP}(f) \approx \frac{\Delta_{\theta} \Delta_{\varphi}}{4\pi} \sum_{n=0}^{N-1} \sum_{m=0}^{M-1} [EIRP_{\theta}(\theta_n, \varphi_m; f) + EIRP_{\varphi}(\theta_n, \varphi_m; f)] \sin(\theta_n)$$

In gain form the TRP can be expressed as:

$$\Gamma_{TRP} \approx \frac{\Delta_{\theta} \Delta_{\varphi}}{4\pi} \sum_{n=0}^{N-1} \sum_{m=0}^{M-1} [G_{\theta}(\theta_n, \varphi_m; f) + G_{\varphi}(\theta_n, \varphi_m; f)] \sin(\theta_n)$$

In these formulas $\Delta_{\theta} = \pi/(N)$ and $\Delta_{\varphi} = 2\pi/M$ are the sampling intervals for the θ - and φ -angles, respectively, and the number of samples in the θ - and φ -angles are given by N and M , respectively. The sampling points of the sphere are given by $\theta_n = n\Delta_{\theta}$ and $\varphi_m = m\Delta_{\varphi}$. The sampling intervals are discussed further in Section 4.4.

When measuring power radiated by active devices, expressing the data in terms of EIRP is more appropriate. The upper form of the TRP formulas (which includes EIRP terms) will be used in the data processing.

[Applicability is TBD]

6.2.4.2 Minimum Requirements

The average TRP of low, mid and high channel shall be higher than minimum performance requirements for roaming bands shown in Table 6.2.4.2-1. The averaging shall be done in linear scale for the TRP results.

$$TRP_{average} = 10 \log \left[\frac{10^{P_{low}/10} + 10^{P_{mid}/10} + 10^{P_{high}/10}}{3} \right]$$

In addition the minimum TRP of each measured channel shall be higher than minimum performance requirements shown in the columns "Min".

$$TRP_{min} = 10 \log \left[\min \left(10^{P_{low}/10}, 10^{P_{mid}/10}, 10^{P_{high}/10} \right) \right]$$

Table 6.2.4.2-1: TRP minimum performance requirement for E-UTRA TDD using LME

TBD

The normative reference for this clause is TS37.144 [12] Subclause 6.2.4.

6.2.4.3 Test purpose

The purpose of this test is to verify that $TRP_{average}$ and TRP_{min} of the UE is not below specified values. A lower $TRP_{average}$ and TRP_{min} decrease the coverage area.

6.2.4.4 Method of test

6.2.4.4.1 Initial conditions

A radio communications tester or a corresponding device is used as a NB simulator to setup calls to the DUT. The NB/BS simulator may also measure the radiated power samples. Alternatively, a measurement receiver or spectrum analyzer may be used for that purpose.

The maximum output power for different UE power classes are defined in 3GPP TS 36.521-1 [11] Subclause 6.2.2 for any transmission bandwidth within the channel bandwidth. Also, care should be taken that the noise floor of the measurement receiver is not disturbing the power measurement.

Chamber environment constraints and coordinate system shall be the same as described in Subclause A.3.

Phantom Specifications shall be the same as described in Subclause A.2.3. Parameters required for laptop ground plane phantom are specified in Annex A.2.3.

Test environment: normal; see TS36.508 [10] Subclause 4.1.1.

Frequencies to be tested: low range, mid range, high range; see Table 5.4-1.

Positioning Requirements shall be the same as described in Subclause 4.3.

- 1) Position the UE according to the DUT positioning on laptop ground plane phantom specified in Subclause 4.3.2.
- 2) Power on the UE.
- 3) Set the initial conditions as per Subclause 6.2.2 of 3GPP TS 36.521-1 [11], with the following exception: set the carrier frequency, channel bandwidth, RB length and RB location as per Table 5.4-1 for TDD mode.

6.2.4.4.2 Procedure

- 1) Follow Steps 1 and 2 in section 6.2.2.4.2 of 3GPP TS 36.521-1 [11] and ensure that the DUT transmits with its maximum power.
- 2) For the anechoic chamber based methodologies, measure the spherical effective isotropic radiated power (EIRP) pattern following the sampling grid specified in Subclause 4.4. Slots with transient periods are not under test. The uplink downlink configuration and the special subframe configuration in TDD are set as per Table 8.2.2-1 of 3GPP TS 36.521-1 [11]. Calculate the TRP using the EIRP pattern data as per Subclause 6.2.4.1.
- 3) Repeat the measurement of the DUT for low, mid and high channels.
- 4) Calculate the average and minimum TRP as per Subclause 6.2.4.2.

6.2.4.4.3 Procedure, reverberation chamber method

TBD

6.2.4.5 Test requirements

The average TRP of low, mid and high channel shall be higher than test performance requirements for roaming bands shown in Table 6.2.4.5-1. The averaging shall be done in linear scale for the TRP.

$$TRP_{average} = 10 \log \left[\frac{10^{P_{low}/10} + 10^{P_{mid}/10} + 10^{P_{high}/10}}{3} \right]$$

In addition the minimum TRP of each measured channel shall be higher than minimum performance requirements shown in the columns "Min".

$$TRP_{min} = 10 \log \left[\min \left(10^{P_{low}/10}, 10^{P_{mid}/10}, 10^{P_{high}/10} \right) \right]$$

Table 6.2.4.5-1: TRP test requirement for E-UTRA TDD using LME

TBD

NOTE: If the above Test Requirement differs from the Minimum Requirement then the Test Tolerance applied for this test is non-zero. The Test Tolerance for this test is defined and the explanation of how the Minimum Requirement has been relaxed by the Test Tolerance is given in Annex D.

6.3 Performance for LEE

6.3.1 Total Radiated Power (TRP) for UTRA FDD LEE

Editor's notes: This Subclause is incomplete. The following items are missing or incomplete:

- TBDs in Tables 6.3.1.2-1 and 6.3.1.5-2 as they are not specified in TS 37.144 yet

6.3.1.1 Definition and applicability

The Total Radiated Power (TRP) is a measure of how much power the DUT actually radiates. The TRP is defined as the integral of the power transmitted in different directions over the entire radiation sphere:

$$TRP = \frac{1}{4\pi} \oint (EIRP_{\theta}(\Omega; f) + EIRP_{\phi}(\Omega; f)) d\Omega$$

Where Ω is the solid angle describing the direction, f is frequency. θ and ϕ are the orthogonal polarizations. $EIRP_{\theta}$ and $EIRP_{\phi}$ are the actually transmitted power-levels in corresponding polarizations.

Thus

$$TRP \approx \frac{\pi}{2NM} \sum_{n=0}^{N-1} \sum_{m=0}^{M-1} [EIRP_{\theta}(\theta_n, \phi_m; f) + EIRP_{\phi}(\theta_n, \phi_m; f)] \sin(\theta_n)$$

In these formulas N and M are the number of sampling intervals for theta and phi. θ_n and ϕ_m are the measurement angles. The sampling intervals are discussed further in Subclause 4.4.

The TRP can also be calculated from Rayleigh faded samples of the total power transmitted from the LEE. The measurement of transmitter performance in an isotropic Rayleigh fading environment is based on sampling the radiated power of the LEE for a discrete number of field combinations in the chamber. The average value of these statistically distributed samples is proportional to the TRP and by calibrating the average power transfer function, an absolute value of the TRP can be obtained. Thus

$$TRP \approx \frac{\sum_{n=1}^N \left(\frac{P_n}{C_n (1 - R_n)} \right)}{\sum_{n=1}^N P_{ref,n}}$$

where $P_{ref,n}$ is the reference power transfer function for fixed measurement antenna n , R_n is the reflection coefficient for fixed measurement antenna n and C_n is the path loss in the cables connecting the measurement receiver to fixed measurement antenna n . These parameters are calculated from the calibration measurement and are further discussed in Annex B.2. P_n is the average power measured by fixed measurement antenna n and can be calculated using the following expression:

$$P_n = \frac{\sum_{m=1}^M |S_{21,n,m}|^2}{M}$$

where $S_{21,n,m}$ is sample number m of the complex transfer function measured with fixed measurement antenna n and M is the total number of samples measured for each fixed measurement antenna.

Note that all averaging must be performed using linear power values (e.g. measurements in Watts).

The requirements and this test apply to all types of UTRA for the FDD UE for Release 11 and later releases that support LEE.

NOTE: This test case can be optionally executed for Release 7 and onward UE's supporting LEE feature.

6.3.1.2 Minimum Requirements

The average TRP of low, mid and high channel of the LEE in the data transfers position shall be higher than minimum performance requirements for roaming bands shown in Table 6.3.1.2-1 for notebook devices and in 6.3.1.2-2 for tablet devices. The averaging shall be done in linear scale for the TRP results.

$$TRP_{average} = 10 \log \left[\frac{10^{P_{low}/10} + 10^{P_{mid}/10} + 10^{P_{high}/10}}{3} \right]$$

In addition the minimum TRP of each measured channel in the data transfers position shall be higher than minimum performance requirements shown in the columns “Min”.

$$TRP_{min} = \min [P_{low}, P_{mid}, P_{high}]$$

Table 6.3.1.2-1: TRP minimum performance requirement for UTRA FDD notebook devices in the data transfers position

Operating band	Power Class 1	Power Class 2	Power Class 3		Power Class 3bis		Power Class 4	
	Power (dBm)	Power (dBm)	Power (dBm)		Power (dBm)		Power (dBm)	
			Average	Min	Average	Min	Average	Min
I	-	-	19.0	17.5	TBD	TBD	TBD	TBD
II	-	-	TBD	TBD	TBD	TBD	TBD	TBD
III	-	-	TBD	TBD	TBD	TBD	TBD	TBD
IV	-	-	TBD	TBD	TBD	TBD	TBD	TBD
V	-	-	TBD	TBD	TBD	TBD	TBD	TBD
VI	-	-	18.5	16.5	TBD	TBD	TBD	TBD
VII	-	-	TBD	TBD	TBD	TBD	TBD	TBD
VIII	-	-	18.5	16.5	TBD	TBD	TBD	TBD
IX	-	-	TBD	TBD	TBD	TBD	TBD	TBD
XIX	-	-	18.5	16.5	TBD	TBD	TBD	TBD

NOTE 1: Applicable for dual-mode GSM/UMTS.
NOTE 2: Applicable for notebook devices.

NOTE: TRP minimum performance requirements in Table 6.3.1.2-1 apply to HSPA and LTE UEs supporting only single carrier operation. Their applicability to multi-carrier operation is FFS. This is because it has not been verified whether the UEs measured to derive the requirements supported carrier aggregation or not.

Table 6.3.1.2-2: TRP minimum performance requirement for UTRA FDD tablet devices in the data transfers position

Operating band	Power Class 1	Power Class 2	Power Class 3		Power Class 3bis		Power Class 4	
	Power (dBm)	Power (dBm)	Power (dBm)		Power (dBm)		Power (dBm)	
			Average	Min	Average	Min	Average	Min
I	-	-	19.0	17.5	TBD	TBD	TBD	TBD
II	-	-	TBD	TBD	TBD	TBD	TBD	TBD
III	-	-	TBD	TBD	TBD	TBD	TBD	TBD
IV	-	-	TBD	TBD	TBD	TBD	TBD	TBD
V	-	-	17.0	15.0	TBD	TBD	TBD	TBD
VI	-	-	TBD	TBD	TBD	TBD	TBD	TBD
VII	-	-	TBD	TBD	TBD	TBD	TBD	TBD
VIII	-	-	TBD	TBD	TBD	TBD	TBD	TBD
IX	-	-	TBD	TBD	TBD	TBD	TBD	TBD
XIX	-	-	17.0	15.0	TBD	TBD	TBD	TBD

NOTE 1: Applicable for dual-mode GSM/UMTS.
NOTE 2: Applicable for tablet devices with two antennas.

The normative reference for this clause is TS37.144 [12] Subclause 6.3.2.

6.3.1.3 Test purpose

The purpose of this test is to verify that $TRP_{average}$ and TRP_{min} of the UE is not below specified values. A lower $TRP_{average}$ and TRP_{min} decrease the coverage area.

6.3.1.4 Method of test

6.3.1.4.1 Initial conditions

The output power is a measure of the maximum power the UE can transmit in a bandwidth of at least $(1 + \alpha)$ times the chip rate of the radio access mode, for more information see 3GPP TS 34.121-1 [7] Subclause 5.2. The period of measurement shall be at least one timeslot. Also care should be taken that the noise floor of the measurement receiver is not disturbing the power measurement.

The LEE shall be tested according to DUT positioning described in Subclause 4.3.5.

Test environment: normal; see TS34.121-1 [7] Subclause G.2.1.

Frequencies to be tested: low range, mid range, high range; see Table 5.1-2.

- 1) Set the SS downlink physical channels according to settings in Table 6.3.1.4.1-1. Set the DPCH power such that there will not be transmission gaps due to too low signal strength throughout the measurement.
- 2) Power on the UE.
- 3) A call is set up according to the Generic call setup procedure. The power control algorithm shall be set to Power Control Algorithm 2. Compressed mode shall be set to OFF.
- 4) Enter the UE into loopback test mode 2 and start the loopback test.

See TS 34.108 [4] and TS 34.109 [5] for details regarding generic call setup procedure and loopback test.

Table 6.3.1.4.1-1: Downlink Physical Channels transmitted during a connection

Physical Channel	Power
CPICH	CPICH_Ec / DPCH_Ec = 7 dB
P-CCPCH	P-CCPCH_Ec / DPCH_Ec = 5 dB
SCH	SCH_Ec / DPCH_Ec = 5 dB
PICH	PICH_Ec / DPCH_Ec = 2 dB
DPCH	Test dependent power

6.3.1.4.2 Procedure

- 1) Send continuously Up power control commands to the UE.
- 2) As the UE reaches maximum power, start sending PN15 data pattern.
- 3) Position and configure the LEE according to Subclause 4.3.5.
- 4) Measure the $EIRP_{\theta}$ and $EIRP_{\phi}$ with a sample step of 15° in theta (θ) and phi (ϕ) directions using a test system having characteristics as described in Annex A.
- 5) Calculate TRP using equations from Subclause 6.3.1.2.

NOTE 1: The measurement procedure is based on the measurement of the spherical radiation pattern of the DUT. The power radiated by the DUT is sampled in far field in a group of points located on a spherical surface enclosing the DUT. The EIRP samples are taken using a constant sample step of 15° both in theta (θ) and phi (ϕ) directions. In some cases a different sampling grid may be used to speed up the measurements (See Subclause 4.4). All the EIRP samples are taken with two orthogonal polarizations, θ - and ϕ -polarisations.

NOTE 2: The noise floor of the measurement receiver shall not disturb the power measurement.

NOTE 3: Non Standard settings: To speed up sensitivity measurements, power measurements may be done with non standard modulation. However to obtain TRP result the measured EIRP figures shall be normalized by

$$\overline{\Delta EIRP} = \frac{1}{n} \sum_{i=1}^n (EIRPstd_i - EIRPnstd_i)$$

where $EIRPstd_i$ is power measurement done with standard setting. $EIRPnstd_i$ is power measurement done with non standard modulation. n is amount of reference measurement points.

To ensure accuracy of TRP, the amount of reference points measured should be at least 4. It is recommended to spread the reference measurements equally during the measurement time.

6.3.1.4.3 Procedure, reverberation chamber method

- 1) Send continuously Up power control commands to the UE.
- 2) As the UE reaches maximum power, start sending PN15 data pattern.
- 3) Position and configure the LEE according to Subclause 4.3.5.
- 4) Measure a sufficient number of independent samples (see Subclause 4.5) of $S_{21,n,m}$ using a test system having characteristics as described in Annex A.
- 5) Calculate TRP using equations from Subclause 6.3.1.1.

NOTE 1: The measurement procedure is based on the measurement of the total power radiated from the UE to a full 3 dimensional isotropic environment with uniform elevation and azimuth field distribution. The power transmitted by the DUT is undergoing Rayleigh fading and is sampled by the fixed measurement antennas. Moreover, it is important that the samples collected are independent, in order to get sufficient accuracy of the estimated TRP value.

NOTE 2: The noise floor of the measurement receiver shall not disturb the power measurement.

6.3.1.5 Test requirements

The average TRP of low, mid and high channel in the data transfers position shall be higher than test performance requirements for roaming bands shown in Table 6.3.1.5-1 for notebook devices and in Table 6.3.1.5-2 for tablet devices. The averaging shall be done in linear scale for the TRP results.

$$TRP_{average} = 10 \log \left[\frac{10^{P_{low}/10} + 10^{P_{mid}/10} + 10^{P_{high}/10}}{3} \right]$$

In addition the minimum TRP of each measured channel in the data transfers position shall be higher than minimum performance requirements shown in the columns "Min".

$$TRP_{min} = \min [P_{low}, P_{mid}, P_{high}]$$

Table 6.3.1.5-1: TRP test requirement for UTRA FDD notebook devices in the data transfers position

Operating band	Power Class 1	Power Class 2	Power Class 3		Power Class 3bis		Power Class 4	
	Power (dBm)	Power (dBm)	Power (dBm)		Power (dBm)		Power (dBm)	
			Average	Min	Average	Min	Average	Min
I	-	-	18.3	16.5	TBD+TT	TBD+T T	TBD+TT	TBD+T T
II	-	-	TBD+TT	TBD+T T	TBD+TT	TBD+T T	TBD+TT	TBD+T T
III	-	-	TBD+TT	TBD+T T	TBD+TT	TBD+T T	TBD+TT	TBD+T T
IV	-	-	TBD+TT	TBD+T T	TBD+TT	TBD+T T	TBD+TT	TBD+T T
V	-	-	TBD+TT	TBD+T T	TBD+TT	TBD+T T	TBD+TT	TBD+T T
VI	-	-	17.8	15.5	TBD+TT	TBD+T T	TBD+TT	TBD+T T
VII	-	-	TBD+TT	TBD+T T	TBD+TT	TBD+T T	TBD+TT	TBD+T T
VIII	-	-	17.8	15.5	TBD+TT	TBD+T T	TBD+TT	TBD+T T
IX	-	-	TBD+TT	TBD+T T	TBD+TT	TBD+T T	TBD+TT	TBD+T T
XIX	-	-	18.5+TT	16.5+T T	TBD+TT	TBD+T T	TBD+TT	TBD+T T

NOTE 1: Applicable for dual-mode GSM/UMTS.
NOTE 2: Applicable for notebook devices.

NOTE: If the above Test Requirement differs from the Minimum Requirement then the Test Tolerance applied for this test is non-zero. The Test Tolerance for this test is defined and the explanation of how the Minimum Requirement has been relaxed by the Test Tolerance is given in Annex D.

Table 6.3.1.5-2: TRP test requirement for UTRA FDD tablet devices in the data transfers position

Operating band	Power Class 1	Power Class 2	Power Class 3		Power Class 3bis		Power Class 4	
	Power (dBm)	Power (dBm)	Power (dBm)		Power (dBm)		Power (dBm)	
			Average	Min	Average	Min	Average	Min
I	-	-	18.3	16.5	TBD+TT	TBD+T T	TBD+TT	TBD+T T
II	-	-	TBD+TT	TBD+T T	TBD+TT	TBD+T T	TBD+TT	TBD+T T
III	-	-	TBD+TT	TBD+T T	TBD+TT	TBD+T T	TBD+TT	TBD+T T
IV	-	-	TBD+TT	TBD+T T	TBD+TT	TBD+T T	TBD+TT	TBD+T T
V	-	-	16.3	14.0	TBD+TT	TBD+T T	TBD+TT	TBD+T T
VI	-	-	TBD+TT	TBD+T T	TBD+TT	TBD+T T	TBD+TT	TBD+T T
VII	-	-	TBD+TT	TBD+T T	TBD+TT	TBD+T T	TBD+TT	TBD+T T
VIII	-	-	TBD+TT	TBD+T T	TBD+TT	TBD+T T	TBD+TT	TBD+T T
IX	-	-	TBD+TT	TBD+T T	TBD+TT	TBD+T T	TBD+TT	TBD+T T
XIX	-	-	17.0+TT	15.0+T T	TBD+TT	TBD+T T	TBD+TT	TBD+T T

NOTE 1: Applicable for dual-mode GSM/UMTS.
NOTE 2: Applicable for tablet devices with two antennas.

NOTE: If the above Test Requirement differs from the Minimum Requirement then the Test Tolerance applied for this test is non-zero. The Test Tolerance for this test is defined and the explanation of how the Minimum Requirement has been relaxed by the Test Tolerance is given in Annex D.

6.3.2 Total Radiated Power (TRP) for UTRA LCR TDD LEE

Editor's notes: This Subclause is incomplete. The following items are missing or incomplete:

- TBDs in Tables 6.3.2.2-1 and 6.3.2.5-2 as they are not specified in TS 37.144 yet

6.3.2.1 Definition and applicability

The Total Radiated Power (TRP) is a measure of how much power the DUT actually radiates. The TRP is defined as the integral of the power transmitted in different directions over the entire radiation sphere:

$$TRP = \frac{1}{4\pi} \oint (EIRP_{\theta}(\Omega; f) + EIRP_{\varphi}(\Omega; f)) d\Omega$$

Where Ω is the solid angle describing the direction, f is frequency. θ and φ are the orthogonal polarizations. $EIRP_{\theta}$ and $EIRP_{\varphi}$ are the actually transmitted power-levels in corresponding polarizations.

Thus

$$TRP \approx \frac{\pi}{2NM} \sum_{n=0}^{N-1} \sum_{m=0}^{M-1} [EIRP_{\theta}(\theta_n, \varphi_m; f) + EIRP_{\varphi}(\theta_n, \varphi_m; f)] \sin(\theta_n)$$

In these formulas N and M are the number of sampling intervals for theta and phi. θ_n and φ_m are the measurement angles. The sampling intervals are discussed further in Subclause 4.4.

The TRP can also be calculated from Rayleigh faded samples of the total power transmitted from the LEE. The measurement of transmitter performance in an isotropic Rayleigh fading environment is based on sampling the radiated power of the LEE for a discrete number of field combinations in the chamber. The average value of these statistically distributed samples is proportional to the TRP and by calibrating the average power transfer function, an absolute value of the TRP can be obtained. Thus

$$TRP \approx \frac{\sum_{n=1}^N \left(\frac{P_n}{C_n (1 - R_n)} \right)}{\sum_{n=1}^N P_{ref,n}}$$

where $P_{ref,n}$ is the reference power transfer function for fixed measurement antenna n, R_n is the reflection coefficient for fixed measurement antenna n and C_n is the path loss in the cables connecting the measurement receiver to fixed measurement antenna n. These parameters are calculated from the calibration measurement and are further discussed in Annex B.2. P_n is the average power measured by fixed measurement antenna n and can be calculated using the following expression:

$$P_n = \frac{\sum_{m=1}^M |S_{21,n,m}|^2}{M}$$

where $S_{21,n,m}$ is sample number m of the complex transfer function measured with fixed measurement antenna n and M is the total number of samples measured for each fixed measurement antenna.

Note that all averaging must be performed using linear power values (e.g. measurements in Watts).

The requirements and this test apply to all types of UTRA for the TDD UE for Release 11 and later releases that support LEE.

Note: This test case can be optionally executed for Release 8 and onward UE's supporting LEE feature.

6.3.2.2 Minimum Requirements

The average TRP of low, mid and high channel shall be higher than minimum performance requirements for roaming bands shown in Table 6.3.2.2-1 for notebook devices and in Table 6.3.2.2-2 for tablet devices. The averaging shall be done in linear scale for the TRP results.

$$TRP_{average} = 10 \log \left[\frac{10^{P_{low}/10} + 10^{P_{mid}/10} + 10^{P_{high}/10}}{3} \right]$$

In addition the minimum TRP of each measured channel shall be higher than minimum performance requirements shown in the columns "Min".

$$TRP_{min} = 10 \log \left[\min \left(10^{P_{low}/10}, 10^{P_{mid}/10}, 10^{P_{high}/10} \right) \right]$$

Table 6.3.2.2-1: TRP minimum performance requirement for UTRA TDD notebook devices in the data transfers position

Operating band	Power Class 1		Power Class 2		Power Class 3		Power Class 4	
	Power (dBm)		Power (dBm)		Power (dBm)		Power (dBm)	
	Average	Min	Average	Min	Average	Min	Average	Min
a	-	-	TBD	TBD	-	-	-	-
b	-	-	TBD	TBD	-	-	-	-
c	-	-	TBD	TBD	-	-	-	-
d	-	-	TBD	TBD	-	-	-	-
e	-	-	TBD	TBD	-	-	-	-
f	-	-	TBD	TBD	-	-	-	-

NOTE 1: Applicable for dual-mode GSM/UTRA LCR TDD.
NOTE 2: Applicable for notebook devices.

Table 6.3.2.2-2: TRP minimum performance requirement for UTRA TDD tablet devices in the data transfers position

Operating band	Power Class 1		Power Class 2		Power Class 3		Power Class 4	
	Power (dBm)		Power (dBm)		Power (dBm)		Power (dBm)	
	Average	Min	Average	Min	Average	Min	Average	Min
a	-	-	TBD	TBD	-	-	-	-
b	-	-	TBD	TBD	-	-	-	-
c	-	-	TBD	TBD	-	-	-	-
d	-	-	TBD	TBD	-	-	-	-
e	-	-	TBD	TBD	-	-	-	-
f	-	-	TBD	TBD	-	-	-	-

NOTE 1: Applicable for dual-mode GSM/UTRA LCR TDD.
NOTE 2: Applicable for tablet devices.

The normative reference for this clause is TS37.144 [12] Subclause 6.3.3.

6.3.2.3 Test purpose

The purpose of this test is to verify that $TRP_{average}$ and TRP_{min} of the UE is not below specified values. A lower $TRP_{average}$ and TRP_{min} decrease the coverage area.

6.3.2.4 Method of test

6.3.2.4.1 Initial conditions

The output power is a measure of the maximum power the UE can transmit in a bandwidth of at least $(1 + \alpha)$ times the chip rate of the radio access mode, for more information see TS 34.122 [8] Subclause 5.2. The period of measurement shall be at least one timeslot. Also care should be taken that the noise floor of the measurement receiver is not disturbing the power measurement. Normally, the receiving device should be set accordingly so that the receiving signal will be at least 30 dB higher than the system noise floor.

The LEE shall be tested according to DUT positioning described in Subclause 4.3.5.

Test environment: normal; see TS 34.122 [8] Subclause G.2.1.

Frequencies to be tested: low range, mid range, high range; see Table 5.2-2.

- 1) Set the SS downlink physical channels according to settings in Table 6.3.2.4.1-1. Set the DPCH power such that there will not be transmission gaps due to too low signal strength throughout the measurement.
- 2) Power on the LEE UE
- 3) A call is set up according to the Generic call setup procedure. The power control algorithm shall be set to Power Control Algorithm 2.
- 4) Enter the UE into loopback test mode and start the loopback test.
- 5) The measurement receiver shall be set to: zero span, video trigger and RMS detector. The RBW shall be at least $(1 + \alpha)$ times the chip rate of the radio access mode and the VBW at least 3 times bigger than the RBW. For 1.28Mcps TDD UE, the RBW shall be set to 3MHz, and VBW shall be set to 10MHz.

See TS 34.108 [4] and TS 34.109 [5] for details regarding generic call setup procedure and loopback test.

Table 6.3.2.4.1-1: Downlink Physical Channels transmitted during a connection

Physical Channel		Power
lor	-75 dBm	-
DwPCH	DwPCH_Ec / lor	0 dB
PCCPCH	$\sum P\text{-CCPCH_Ec} / \text{lor}$	-3 dB
SCCPCH	$\sum S\text{-CCPCH_Ec} / \text{lor}$	-6 dB
PICH	$\sum PICH_Ec / \text{lor}$	-6 dB
FPACH	FPACH_Ec / lor	-6 dB
DL DPCH	$\sum DPCH_Ec / \text{lor}$	0 dB

6.3.2.4.2 Procedure

- 1) Send continuously Up power control commands to the LEE UE.
- 2) As the LEE UE reaches maximum power, start sending PN15 data pattern.
- 3) Position and configure the LEE according to Subclause 4.3.5.
- 4) Measure the $EIRP_{\theta}$ and $EIRP_{\phi}$ with a sample step of 15° in theta (θ) and phi (ϕ) directions using a test system having characteristics as described in Annex A.
- 5) Calculate TRP using equations from Subclause 6.3.2.2.

NOTE 1: The measurement procedure is based on the measurement of the spherical radiation pattern of the DUT. The power radiated by the DUT is sampled in far field in a group of points located on a spherical surface enclosing the DUT. The EIRP samples are taken using a constant sample step of 15° both in theta (θ) and phi (ϕ) directions. In some cases a different sampling grid may be used to speed up the measurements (See Subclause 4.4). All the EIRP samples are taken with two orthogonal polarizations, θ - and ϕ -polarisations.

NOTE 2: The noise floor of the measurement receiver shall not disturb the power measurement.

NOTE 3: Non Standard settings: To speed up sensitivity measurements, power measurements may be done with non standard modulation. However to obtain TRP result the measured EIRP figures shall be normalized by

$$\overline{\Delta EIRP} = \frac{1}{n} \sum_{i=1}^n (EIRP_{std_i} - EIRP_{nstd_i})$$

where $EIRP_{std_i}$ is power measurement done with standard setting. $EIRP_{nstd_i}$ is power measurement done with non standard modulation. n is amount of reference measurement points.

To ensure accuracy of TRP, the amount of reference points measured should be at least 4. It is recommended to spread the reference measurements equally during the measurement time.

6.3.2.4.3 Procedure, reverberation chamber method

- 1) Send continuously Up power control commands to the LEE UE.
- 2) As the LEE UE reaches maximum power, start sending PN15 data pattern.
- 3) Position and configure the LEE according to Subclause 4.3.5.
- 4) Measure a sufficient number of independent samples (see Subclause 4.5) of $S_{21,n,m}$ using a test system having characteristics as described in Annex A.
- 5) Calculate TRP using equations from Subclause 6.3.2.1.

NOTE 1: The measurement procedure is based on the measurement of the total power radiated from the UE to a full 3 dimensional isotropic environment with uniform elevation and azimuth field distribution. The power transmitted by the DUT is undergoing Rayleigh fading and is sampled by the fixed measurement antennas. Moreover, it is important that the samples collected are independent, in order to get sufficient accuracy of the estimated TRP value.

NOTE 2: The noise floor of the measurement receiver shall not disturb the power measurement.

6.3.2.5 Test requirements

The average TRP of low, mid and high channel shall be higher than test performance requirements for roaming bands shown in Table 6.3.2.5-1 for notebook devices and in Table 6.3.2.5-2 for tablet devices. The averaging shall be done in linear scale for the TRP.

$$TRP_{average} = 10 \log \left[\frac{10^{P_{low}/10} + 10^{P_{mid}/10} + 10^{P_{high}/10}}{3} \right]$$

In addition the minimum TRP of each measured channel shall be higher than minimum performance requirements shown in the columns "Min".

$$TRP_{min} = 10 \log \left[\min \left(10^{P_{low}/10}, 10^{P_{mid}/10}, 10^{P_{high}/10} \right) \right]$$

Table 6.3.2.5-1: TRP test requirement for UTRA TDD notebook devices in the data transfers position

Operating band	Power Class 1		Power Class 2		Power Class 3		Power Class 4	
	Power (dBm)		Power (dBm)		Power (dBm)		Power (dBm)	
	Average	Min	Average	Min	Average	Min	Average	Min
a	-	-	TBD +TT	TBD +TT	-	-	-	-
b	-	-	TBD +TT	TBD +TT	-	-	-	-
c	-	-	TBD +TT	TBD +TT	-	-	-	-
d	-	-	TBD +TT	TBD +TT	-	-	-	-
e	-	-	TBD +TT	TBD +TT +TT	-	-	-	-
f	-	-	TBD +TT	TBD +TT	-	-	-	-

NOTE 1: Applicable for dual-mode GSM/UTRA LCR TDD.
NOTE 2: Applicable for notebook devices.

NOTE: If the above Test Requirement differs from the Minimum Requirement then the Test Tolerance applied for this test is non-zero. The Test Tolerance for this test is defined and the explanation of how the Minimum Requirement has been relaxed by the Test Tolerance is given in Annex D.

Table 6.3.2.5-2: TRP test requirement for UTRA TDD tablet devices in the data transfers position

Operating band	Power Class 1		Power Class 2		Power Class 3		Power Class 4	
	Power (dBm)		Power (dBm)		Power (dBm)		Power (dBm)	
	Average	Min	Average	Min	Average	Min	Average	Min
a	-	-	TBD +TT	TBD +TT	-	-	-	-
b	-	-	TBD +TT	TBD +TT	-	-	-	-
c	-	-	TBD +TT	TBD +TT	-	-	-	-
d	-	-	TBD +TT	TBD +TT	-	-	-	-
e	-	-	TBD +TT	TBD +TT +TT	-	-	-	-
f	-	-	TBD +TT	TBD +TT	-	-	-	-

NOTE 1: Applicable for dual-mode GSM/UTRA LCR TDD.
NOTE 2: Applicable for tablet devices.

NOTE: If the above Test Requirement differs from the Minimum Requirement then the Test Tolerance applied for this test is non-zero. The Test Tolerance for this test is defined and the explanation of how the Minimum Requirement has been relaxed by the Test Tolerance is given in Annex D.

6.3.3 Total Radiated Power (TRP) for E-UTRA FDD LEE

Editor's notes: This subclause is incomplete. The following items are missing or incomplete:

- Table 6.3.3.2-1 and 6.3.3.5-1 as they are not specified in TS 37.144 yet
- Applicability

6.3.3.1 Definition and applicability

The Total Radiated Power (TRP) is a measure of how much power the antenna actually radiates, when non-idealities such as mismatch and losses in the antenna are taken into account. The TRP is defined as the integral of the power transmitted in different directions over the entire radiation sphere:

$$P_{TRP} = \frac{1}{4\pi} \oint (P_{tx} G_{\theta}(\Omega; f) + P_{tx} G_{\varphi}(\Omega; f)) d\Omega$$

Using ψ to denote either θ or φ , $G_{\psi}(\Omega; f)$ is the ψ -polarization component of the gain pattern for the handset antenna measured at the frequency f , where Ω is the solid angle describing the direction. P_{tx} is the transmit power level of the handset so that $P_{tx} G_{\psi}(\Omega; f)$ is the actually transmitted power-level, also known as EIRP, in the ψ -polarization and in the direction Ω for frequency f .

The above equation may be written in "gain" form, that is, the TRP given by P_{TRP} is normalized to the transmitted power P_{tx} . This is the total radiation efficiency, which can also be denoted as Total Radiated Power Gain, TRPG,

$$\Gamma_{TRP} = \frac{1}{4\pi} \oint (G_{\theta}(\Omega; f) + G_{\varphi}(\Omega; f)) d\Omega$$

In practice discrete samples of $P_{tx} G_{\psi}(\Omega; f)$ are measured and used to approximate the integral so that the TRP is computed as

$$P_{TRP} \approx \frac{\Delta_{\theta} \Delta_{\varphi}}{4\pi} \sum_{n=0}^{N-1} \sum_{m=0}^{M-1} [P_{tx} G_{\theta}(\theta_n, \varphi_m; f) + P_{tx} G_{\varphi}(\theta_n, \varphi_m; f)] \sin(\theta_n)$$

Or, by using the relation $EIRP = P_{tx} G$:

$$P_{TRP}(f) \approx \frac{\Delta_{\theta} \Delta_{\varphi}}{4\pi} \sum_{n=0}^{N-1} \sum_{m=0}^{M-1} [EIRP_{\theta}(\theta_n, \varphi_m; f) + EIRP_{\varphi}(\theta_n, \varphi_m; f)] \sin(\theta_n)$$

In gain form the TRP can be expressed as:

$$\Gamma_{TRP} \approx \frac{\Delta_{\theta} \Delta_{\varphi}}{4\pi} \sum_{n=0}^{N-1} \sum_{m=0}^{M-1} [G_{\theta}(\theta_n, \varphi_m; f) + G_{\varphi}(\theta_n, \varphi_m; f)] \sin(\theta_n)$$

In these formulas $\Delta_{\theta} = \pi/(N)$ and $\Delta_{\varphi} = 2\pi/M$ are the sampling intervals for the θ - and φ -angles, respectively, and the number of samples in the θ - and φ -angles are given by N and M , respectively. The sampling points of the sphere are given by $\theta_n = n\Delta_{\theta}$ and $\varphi_m = m\Delta_{\varphi}$. The sampling intervals are discussed further in Section 4.4.

When measuring power radiated by active devices, expressing the data in terms of EIRP is more appropriate. The upper form of the TRP formulas (which includes EIRP terms) will be used in the data processing.

The TRP can also be calculated from Rayleigh faded samples of the total power transmitted from the UE. The measurement of transmitter performance in an isotropic Rayleigh fading environment is based on sampling the radiated power of the UE for a discrete number of field combinations in the chamber. The average value of these statistically distributed samples is proportional to the TRP and by calibrating the average power transfer function, an absolute value of the TRP can be obtained. Thus

$$TRP \approx \frac{\sum_{n=1}^N \left(\frac{P_n}{C_n (1 - R_n)} \right)}{\sum_{n=1}^N P_{ref,n}}$$

where $P_{ref,n}$ is the reference power transfer function for fixed measurement antenna n, R_n is the reflection coefficient for fixed measurement antenna n and C_n is the path loss in the cables connecting the measurement receiver to fixed measurement antenna n. These parameters are calculated from the calibration measurement and are further discussed in Annex B.2. P_n is the average power measured by fixed measurement antenna n and can be calculated using the following expression:

$$P_n = \frac{\sum_{m=1}^M |S_{21,n,m}|^2}{M}$$

where $S_{21,n,m}$ is sample number m of the complex transfer function measured with fixed measurement antenna n and M is the total number of samples measured for each fixed measurement antenna.

Note that all averaging must be performed using linear power values (e.g. measurements in Watts).

6.3.3.2 Minimum Requirements

The average measured TRP of low, mid and high channel for laptop embedded equipment shall be higher than the average TRP requirement specified in Table 6.3.3.2-1 for notebook devices and in Table 6.3.3.2-2 for tablet devices. The averaging shall be done in linear scale for the TRP results. Average TRP requirement is shown in the column “Average” on the requirement tables.

$$TRP_{average} = 10 \log \left[\frac{10^{P_{low}/10} + 10^{P_{mid}/10} + 10^{P_{high}/10}}{3} \right]$$

In addition the lowest TRP of each measured channel shall be higher than minimum TRP requirement specified in the column “Min” on the requirement tables.

$$TRP_{min} = 10 \log \left[\min \left(10^{P_{low}/10}, 10^{P_{mid}/10}, 10^{P_{high}/10} \right) \right]$$

Table 6.3.3.2-1: TRP minimum performance requirement for E-UTRA FDD roaming mode for notebook devices in the data transfers position and the primary mechanical mode

TBD

Table 6.3.3.2-2: TRP minimum performance requirement for E-UTRA FDD roaming mode for tablet devices in the data transfers position and the primary mechanical mode

Operating band	Power Class 1	Power Class 2	Power Class 3		Power Class 4
	Power (dBm)	Power (dBm)	Power (dBm)		Power (dBm)
			Average	Min	
1			18.5	17.0	
2					
3			18.5	17.0	
4					
5					
7			18.0	16.5	
8					
12					
13					
19			17.5	15.5	
20			17.5	15.5	
21			17.5	16.0	
28					

NOTE 1: Applicable for multi-mode GSM/UMTS/LTE.
NOTE 2: Applicability for devices supporting CDMA or aggregated carriers (e.g. multi-carrier HSPA, LTE Carrier Aggregation) is FFS.

The normative reference for this clause is TS37.144 [12] Subclause 6.3.4.

6.3.3.3 Test purpose

The purpose of this test is to verify that $TRP_{average}$ and TRP_{min} of the UE is not below specified values. A lower $TRP_{average}$ and TRP_{min} decrease the coverage area.

6.3.3.4 Method of test

6.3.3.4.1 Initial conditions

A radio communications tester or a corresponding device is used as a NB simulator to setup calls to the DUT. The NB/BS simulator may also measure the radiated power samples. Alternatively, a measurement receiver or spectrum analyzer may be used for that purpose.

The maximum output power for different UE power classes are defined in 3GPP TS 36.521-1 [11] Subclause 6.2.2 for any transmission bandwidth within the channel bandwidth. Also care should be taken that the noise floor of the measurement receiver is not disturbing the power measurement.

Chamber environment constraints and coordinate system shall be the same as described in Subclause A.3.

Phantom Specifications shall be the same as described in Subclause A.2.4. Parameters required for Notebooks are specified in Annex A.2.4.2 and those for Tablets are specified in Annex A.2.4.3.

Test environment: normal; see TS36.508 [10] Subclause 4.1.1.

Frequencies to be tested: low range, mid range, high range; see Table 5.3-1.

Positioning Requirements shall be the same as described in Subclause 4.3.

- 1) Position the UE according to the DUT positioning for devices with embedded modules specified in Subclause 4.3.5.
- 2) Power on the UE.
- 3) Set the initial conditions as per Subclause 6.2.2 of 3GPP TS 36.521-1 [11], with the following exception: set the carrier frequency, channel bandwidth, RB length and RB location as per Table 5.3-1 for FDD mode.

6.3.3.4.2 Procedure

- 1) Follow Steps 1 and 2 in section 6.2.2.4.2 of 3GPP TS 36.521-1 [11] and ensure that the DUT transmits with its maximum power.
- 2) For the anechoic chamber based methodologies, measure the spherical effective isotropic radiated power (EIRP) pattern following the sampling grid specified in Subclause 4.4. Calculate the TRP using the EIRP pattern data as per Subclause 6.3.3.1.
- 3) Repeat the measurement of the DUT for low, mid and high channels.
- 4) Calculate the average and minimum TRP as per Subclause 6.3.3.2.

6.3.3.4.3 Procedure, reverberation chamber method

- 1) Follow Steps 1 and 2 in section 6.2.2.4.2 of 3GPP TS 36.521-1 [11] and ensure that the DUT transmits with its maximum power.
- 2) Measure a sufficient number of independent samples (see Subclause 4.5) of $S_{21,n,m}$ using a test system having characteristics as described in Annex A. Calculate TRP using equations from Subclause 6.3.3.1.
- 3) Repeat the measurement of the DUT for low, mid and high channels.
- 4) Calculate the average and minimum TRP as per Subclause 6.3.3.2.

6.3.3.5 Test requirements

The average measured TRP of low, mid and high channel for laptop embedded equipment shall be higher than the average TRP requirement specified in Table 6.3.3.5-1 for notebook devices and in Table 6.3.3.5-2 for tablet devices. The averaging shall be done in linear scale for the TRP results. Average TRP requirement is shown in the column "Average" on the requirement tables.

$$TRP_{average} = 10 \log \left[\frac{10^{P_{low}/10} + 10^{P_{mid}/10} + 10^{P_{high}/10}}{3} \right]$$

In addition the lowest TRP of each measured channel shall be higher than minimum TRP requirement specified in the column "Min" on the requirement tables.

$$TRP_{min} = 10 \log \left[\min \left(10^{P_{low}/10}, 10^{P_{mid}/10}, 10^{P_{high}/10} \right) \right]$$

Table 6.3.3.5-1: TRP test requirement for E-UTRA FDD roaming bands for notebook devices in the data transfers position and the primary mechanical mode

TBD

NOTE: If the above Test Requirement differs from the Minimum Requirement then the Test Tolerance applied for this test is non-zero. The Test Tolerance for this test is defined and the explanation of how the Minimum Requirement has been relaxed by the Test Tolerance is given in Annex D.

Table 6.3.3.5-2: TRP test requirement for E-UTRA FDD roaming bands for tablet devices in the data transfers position and the primary mechanical mode

Operating band	Power Class 1	Power Class 2	Power Class 3		Power Class 4
	Power (dBm)	Power (dBm)	Power (dBm)		Power (dBm)
			Average	Min	
1			17.8	16.0	
2					
3			17.8	16.0	
4					
5					
7			17.3	15.5	
8					
12					
13					
19			16.8	14.5	
20			16.8	14.5	
21			16.8	15.0	
28					

NOTE 1: Applicable for multi-mode GSM/UMTS/LTE.
NOTE 2: Applicability for devices supporting CDMA or aggregated carriers (e.g. multi-carrier HSPA, LTE Carrier Aggregation) is FFS.

NOTE: If the above Test Requirement differs from the Minimum Requirement then the Test Tolerance applied for this test is non-zero. The Test Tolerance for this test is defined and the explanation of how the Minimum Requirement has been relaxed by the Test Tolerance is given in Annex D.

6.3.4 Total Radiated Power (TRP) for E-UTRA TDD LEE

Editor's notes: This subclause is incomplete. The following items are missing or incomplete:

- Table 6.3.4.2-1 and 6.3.4.5-1 as they are not specified in TS 37.144 yet
- Applicability

6.3.4.1 Definition and applicability

The Total Radiated Power (TRP) is a measure of how much power the antenna actually radiates, when non-idealities such as mismatch and losses in the antenna are taken into account. The TRP is defined as the integral of the power transmitted in different directions over the entire radiation sphere:

$$P_{TRP} = \frac{1}{4\pi} \oint (P_{tx} G_{\theta}(\Omega; f) + P_{tx} G_{\varphi}(\Omega; f)) d\Omega$$

Using ψ to denote either θ or φ , $G_{\psi}(\Omega; f)$ is the ψ -polarization component of the gain pattern for the handset antenna measured at the frequency f , where Ω is the solid angle describing the direction. P_{tx} is the transmit power level of the handset so that $P_{tx} G_{\psi}(\Omega; f)$ is the actually transmitted power-level, also known as EIRP, in the ψ -polarization and in the direction Ω for frequency f .

The above equation may be written in "gain" form, that is, the TRP given by P_{TRP} is normalized to the transmitted power P_{tx} . This is the total radiation efficiency, which can also be denoted as Total Radiated Power Gain, TRPG,

$$\Gamma_{TRP} = \frac{1}{4\pi} \oint (G_{\theta}(\Omega; f) + G_{\varphi}(\Omega; f)) d\Omega$$

In practice discrete samples of $P_{tx} G_{\psi}(\Omega; f)$ are measured and used to approximate the integral so that the TRP is computed as

$$P_{TRP} \approx \frac{\Delta_\theta \Delta_\varphi}{4\pi} \sum_{n=0}^{N-1} \sum_{m=0}^{M-1} [P_{tx} G_\theta(\theta_n, \varphi_m; f) + P_{tx} G_\varphi(\theta_n, \varphi_m; f)] \sin(\theta_n)$$

Or, by using the relation $EIRP = P_{tx} G$:

$$P_{TRP}(f) \approx \frac{\Delta_\theta \Delta_\varphi}{4\pi} \sum_{n=0}^{N-1} \sum_{m=0}^{M-1} [EIRP_\theta(\theta_n, \varphi_m; f) + EIRP_\varphi(\theta_n, \varphi_m; f)] \sin(\theta_n)$$

In gain form the TRP can be expressed as:

$$\Gamma_{TRP} \approx \frac{\Delta_\theta \Delta_\varphi}{4\pi} \sum_{n=0}^{N-1} \sum_{m=0}^{M-1} [G_\theta(\theta_n, \varphi_m; f) + G_\varphi(\theta_n, \varphi_m; f)] \sin(\theta_n)$$

In these formulas $\Delta_\theta = \pi/(N)$ and $\Delta_\varphi = 2\pi/M$ are the sampling intervals for the θ - and φ -angles, respectively, and the number of samples in the θ - and φ -angles are given by N and M , respectively. The sampling points of the sphere are given by $\theta_n = n\Delta_\theta$ and $\varphi_m = m\Delta_\varphi$. The sampling intervals are discussed further in Section 4.4.

When measuring power radiated by active devices, expressing the data in terms of EIRP is more appropriate. The upper form of the TRP formulas (which includes EIRP terms) will be used in the data processing.

The TRP can also be calculated from Rayleigh faded samples of the total power transmitted from the UE. The measurement of transmitter performance in an isotropic Rayleigh fading environment is based on sampling the radiated power of the UE for a discrete number of field combinations in the chamber. The average value of these statistically distributed samples is proportional to the TRP and by calibrating the average power transfer function, an absolute value of the TRP can be obtained. Thus

$$TRP \approx \frac{\sum_{n=1}^N \left(\frac{P_n}{C_n (1 - R_n)} \right)}{\sum_{n=1}^N P_{ref,n}}$$

where $P_{ref,n}$ is the reference power transfer function for fixed measurement antenna n, R_n is the reflection coefficient for fixed measurement antenna n and C_n is the path loss in the cables connecting the measurement receiver to fixed measurement antenna n. These parameters are calculated from the calibration measurement and are further discussed in Annex B.2. P_n is the average power measured by fixed measurement antenna n and can be calculated using the following expression:

$$P_n = \frac{\sum_{m=1}^M |S_{21,n,m}|^2}{M}$$

where $S_{21,n,m}$ is sample number m of the complex transfer function measured with fixed measurement antenna n and M is the total number of samples measured for each fixed measurement antenna.

Note that all averaging must be performed using linear power values (e.g. measurements in Watts).

[Applicability is TBD]

6.3.4.2 Minimum Requirements

The average measured TRP of low, mid and high channel for laptop embedded equipment shall be higher than the average TRP requirement specified in Table 6.3.4.2-1 for notebook devices and in Table 6.3.4.2-2 for tablet devices. The averaging shall be done in linear scale for the TRP results. Average TRP requirement is shown in the column "Average" on the requirement tables.

$$TRP_{average} = 10 \log \left[\frac{10^{P_{low}/10} + 10^{P_{mid}/10} + 10^{P_{high}/10}}{3} \right]$$

In addition the lowest TRP of each measured channel shall be higher than minimum TRP requirement specified in the column “Min” on the requirement tables.

$$TRP_{min} = 10 \log \left[\min \left(10^{P_{low}/10}, 10^{P_{mid}/10}, 10^{P_{high}/10} \right) \right]$$

Table 6.3.4.2-1: TRP minimum performance requirement for E-UTRA TDD roaming mode for notebook devices in the data transfers position and the primary mechanical mode

TBD

Table 6.3.4.2-2: TRP minimum performance requirement for E-UTRA TDD roaming mode for tablet devices in the data transfers position and the primary mechanical mode

TBD

The normative reference for this clause is TS37.144 [12] Subclause 6.3.5.

6.3.4.3 Test purpose

The purpose of this test is to verify that $TRP_{average}$ and TRP_{min} of the UE is not below specified values. A lower $TRP_{average}$ and TRP_{min} decrease the coverage area.

6.3.4.4 Method of test

6.3.4.4.1 Initial conditions

A radio communications tester or a corresponding device is used as a NB simulator to setup calls to the DUT. The NB/BS simulator may also measure the radiated power samples. Alternatively, a measurement receiver or spectrum analyzer may be used for that purpose.

The maximum output power for different UE power classes are defined in 3GPP TS 36.521-1 [11] Subclause 6.2.2 for any transmission bandwidth within the channel bandwidth. Also care should be taken that the noise floor of the measurement receiver is not disturbing the power measurement.

Chamber environment constraints and coordinate system shall be the same as described in Subclause A.3.

Phantom Specifications shall be the same as described in Subclause A.2.4. Parameters required for Notebooks are specified in Annex A.2.4.2 and those for Tablets are specified in Annex A.2.4.3.

Test environment: normal; see TS36.508 [10] Subclause 4.1.1.

Frequencies to be tested: low range, mid range, high range; see Table 5.4-1.

Positioning Requirements shall be the same as described in Subclause 4.3.

- 1) Position the UE according to the DUT positioning for devices with embedded modules specified in Subclause 4.3.5.
- 2) Power on the UE.
- 3) Set the initial conditions as per Subclause 6.2.2 of 3GPP TS 36.521-1 [11], with the following exception: set the carrier frequency, channel bandwidth, RB length and RB location as per Table 5.4-1 for TDD mode.

6.3.4.4.2 Procedure

- 1) Follow Steps 1 and 2 in section 6.2.2.4.2 of 3GPP TS 36.521-1 [11] and ensure that the DUT transmits with its maximum power.
- 2) For the anechoic chamber based methodologies, measure the spherical effective isotropic radiated power (EIRP) pattern following the sampling grid specified in Subclause 4.4. Slots with transient periods are not under test. The uplink downlink configuration and the special subframe configuration in TDD are set as per Table 8.2.2-1 of 3GPP TS 36.521-1 [11]. Calculate the TRP using the EIRP pattern data as per Subclause 6.3.4.1.
- 3) Repeat the measurement of the DUT for low, mid and high channels.
- 4) Calculate the average and minimum TRP as per Subclause 6.3.4.2.

6.3.4.4.3 Procedure, reverberation chamber method

- 1) Follow Steps 1 and 2 in section 6.2.2.4.2 of 3GPP TS 36.521-1 [11] and ensure that the DUT transmits with its maximum power.
- 2) Measure a sufficient number of independent samples (see Subclause 4.5) of $S_{21,n,m}$ using a test system having characteristics as described in Annex A. Calculate TRP using equations from Subclause 6.3.4.1.
- 3) Repeat the measurement of the DUT for low, mid and high channels.
- 4) Calculate the average and minimum TRP as per Subclause 6.3.4.2.

6.3.4.5 Test requirements

The average measured TRP of low, mid and high channel for laptop embedded equipment shall be higher than the average TRP requirement specified in Table 6.3.4.5-1 for notebook devices and in Table 6.3.5.5-2 for tablet devices. The averaging shall be done in linear scale for the TRP results. Average TRP requirement is shown in the column "Average" on the requirement tables.

$$TRP_{average} = 10 \log \left[\frac{10^{P_{low}/10} + 10^{P_{mid}/10} + 10^{P_{high}/10}}{3} \right]$$

In addition the lowest TRP of each measured channel shall be higher than minimum TRP requirement specified in the column "Min" on the requirement tables.

$$TRP_{min} = 10 \log \left[\min \left(10^{P_{low}/10}, 10^{P_{mid}/10}, 10^{P_{high}/10} \right) \right]$$

Table 6.3.4.5-1: TRP test requirement for E-UTRA TDD roaming bands for notebook devices in the data transfers position and the primary mechanical mode

TBD

NOTE: If the above Test Requirement differs from the Minimum Requirement then the Test Tolerance applied for this test is non-zero. The Test Tolerance for this test is defined and the explanation of how the Minimum Requirement has been relaxed by the Test Tolerance is given in Annex D.

Table 6.3.4.5-2: TRP test requirement for E-UTRA TDD roaming bands for tablet devices in the data transfers position and the primary mechanical mode

TBD

NOTE: If the above Test Requirement differs from the Minimum Requirement then the Test Tolerance applied for this test is non-zero. The Test Tolerance for this test is defined and the explanation of how the Minimum Requirement has been relaxed by the Test Tolerance is given in Annex D.

7 Receiver Performance

7.1 Performance for handheld UE

7.1.1 Total Radiated Sensitivity (TRS) for UTRA FDD in Speech Mode with beside the Head Phantom

Editor's notes: This subclause is incomplete. The following item is missing or incomplete:

- Text for Subclause 7.1.1.4.3 Procedure, reverberation chamber method

7.1.1.1 Definition and applicability

The Total Radiated Sensitivity is defined as:

$$TRS = \frac{4\pi}{\oint \left[\frac{1}{EIS_{\theta}(\Omega; f)} + \frac{1}{EIS_{\varphi}(\Omega; f)} \right] d\Omega}$$

Where the effective isotropic sensitivity (*EIS*) is defined as the power available at the antenna output such as the sensitivity threshold is achieved for each polarization. Ω is the solid angle describing the direction, f is frequency. θ and φ are the orthogonal polarizations.

$$TRS \approx \frac{2NM}{\pi \sum_{n=0}^{N-1} \sum_{m=0}^{M-1} \left[\frac{1}{EIS_{\theta}(\theta_n, \varphi_m; f)} + \frac{1}{EIS_{\varphi}(\theta_n, \varphi_m; f)} \right] \sin(\theta_n)}$$

In these formulas N and M are the number of sampling intervals for theta and phi. θ_n and φ_m are the measurement angles. The sampling intervals are discussed further in Subclause 4.4.

The requirements and this test apply to all types of UTRA for the FDD UE for Release 7 and later releases.

7.1.1.2 Minimum requirements

The average measured total radiated sensitivity (TRS) of low, mid and high channel for handheld UE shall be lower than the average TRS requirement specified in Table 7.1.1.2-1. The averaging shall be done in linear scale for the TRS results of both right and left side of the phantom head. Average TRS requirement is shown in the column "Average" on the requirement tables.

$$TRS_{average} = 10 \log \left[6 / \left(\frac{1}{10^{P_{left_low}/10}} + \frac{1}{10^{P_{left_mid}/10}} + \frac{1}{10^{P_{left_high}/10}} + \frac{1}{10^{P_{right_low}/10}} + \frac{1}{10^{P_{right_mid}/10}} + \frac{1}{10^{P_{right_high}/10}} \right) \right]$$

In addition the maximum TRS of each measured channel in beside head position shall be better than minimum performance requirements for roaming bands shown in the columns "Max" on the requirement tables.

$$TRS_{max} = 10 \log \left[\max \left(10^{P_{left_low}/10}, 10^{P_{left_mid}/10}, 10^{P_{left_high}/10}, 10^{P_{right_low}/10}, 10^{P_{right_mid}/10}, 10^{P_{right_high}/10} \right) \right]$$

Table 7.1.1.2-1: TRS minimum requirements for UTRA FDD roaming bands in the speech position for the primary mechanical mode

Operating band	Unit	<REF _{or} >	
		Average	Max
I	dBm/3.84 MHz	-101	-98
II	dBm/3.84 MHz	-99	-96
III	dBm/3.84 MHz	-98	-95
IV	dBm/3.84 MHz	-101	-98
V	dBm/3.84 MHz	-96	-93
VI	dBm/3.84 MHz	-96	-93
VII	dBm/3.84 MHz	-99	-96
VIII	dBm/3.84 MHz	-96	-93
IX	dBm/3.84 MHz	-100	-97
XIX	dBm/3.84 MHz	-96	-93

NOTE 1: For Power class 3, 3bis and 4 this shall be achieved at the maximum output power.

NOTE 2: For the UE which supports both Band III and Band IX operating frequencies, the reference level of TDB dBm TRS <REF_{or}> [average and min] shall apply for Band IX.

NOTE 3: Applicable for dual-mode GSM/UMTS.

NOTE 4: For the UE which supports DB-DC-HSDPA configuration 2, average <REF_{or}> level of -98 dBm/3.84 MHz and max <REF_{or}> level of -95 dBm/3.84 MHz shall apply for Band II.

NOTE 5: For the UE which supports DB-DC-HSDPA configuration 2, average <REF_{or}> level of -100 dBm/3.84 MHz and max <REF_{or}> level of -97 dBm/3.84 MHz shall apply for Band IV.

The normative reference for this clause is TS 37.144 [12] Subclause 7.1.1.2.

7.1.1.3 Test Purpose

The purpose of this test is to ensure that $TRS_{average}$ and TRS_{max} of the UE is above specified limit. The lack of the reception sensitivity decreases the coverage area at the far side from Node B.

7.1.1.4 Method of test

7.1.1.4.1 Initial conditions

A radio communications tester or a corresponding device is used as a NB/BS simulator to setup calls to the DUT. The NB/BS simulator is also used to send test signals to the UE and measure the BER levels of the radio link and the information on the dedicated channel needed to extract the DUT receiver performances.

Chamber environment constraints and coordinate system shall be the same as described in Subclause A.3.

Phantom Specifications shall be the same as described in Subclause A.2.1.

Test environment: normal; see TS 36.508 [10] Subclause 4.1.1.

Frequencies to be tested: low range, mid range, high range; see Table 5.1-2.

Positioning Requirements shall be the same as described in Subclause 4.3.

- 1) Position the UE according to the DUT positioning for speech mode specified in Subclause 4.3.3.
- 2) Set the SS downlink physical channels according to settings in Table 7.1.1.4.1-1.
- 3) Power on the UE.
- 4) A call is set up according to the Generic call setup procedure. The power control algorithm shall be set to Power Control Algorithm 2. Compressed mode shall be set to OFF.
- 5) Enter the UE into loopback test mode 2 and start the loopback test.

See TS 34.108 [4] and TS 34.109 [5] for details regarding generic call setup procedure and loopback test.

Table 7.1.1.4.1-1: Downlink Physical Channels transmitted during a connection

Physical Channel	Power
CPICH	CPICH_Ec / DPCH_Ec = 7 dB
P-CCPCH	P-CCPCH_Ec / DPCH_Ec = 5 dB
SCH	SCH_Ec / DPCH_Ec = 5 dB
PICH	PICH_Ec / DPCH_Ec = 2 dB
DPCH	Test dependent power

7.1.1.4.2 Test procedure

- 1) Send continuously Up power control commands to the UE.
- 2) As the UE reaches maximum power, start sending PN15 data pattern.
- 3) Position the UE against the SAM phantom
- 4) Measure EIS from one measurement point. EIS is the power transmitted from one specific direction to the UE causing BER value of 1% ± 0.2% using 20000 or more bits, see Annex E.20.

NOTE: To meet BER value target DL power level can be changed using user's freely selectable algorithm.

- 5) Measure the EIS for every direction of selected sampling grid using two orthogonal polarizations to obtain TRS.
- 6) Calculate TRS using equations from chapter 7.1.1.1

NOTE: To speed up sensitivity measurements non standard setting (i.e. data speed, PCL, BER target) can be used in the measurements. However to obtain TRS result the measured EIS figures shall be normalized by

$$\overline{\Delta EIS} = \frac{1}{n} \sum_{i=1}^n (EISstd_i - EISnstd_i)$$

Where $EISstd_i$ is sensitivity measurement done with standard setting. $EISnstd_i$ is sensitivity measurement done with non standard settings. n is amount of reference measurement points.

To ensure accuracy of TRS, the amount of reference points measured should be at least 4. It is recommended to spread the reference measurements equally during the measurement time.

The measurement procedure is based on the measurement of the spherical sensitivity pattern of the DUT. The sensitivity values of the DUT at a predefined BER level are sampled in far field in a group of points located on a spherical surface enclosing the DUT. The EIS samples are taken using a constant sample step of 30° both in theta (θ) and phi (ϕ) directions. All the EIS samples are taken with two orthogonal polarizations, θ - and ϕ -polarisations (See Subclause 4.4).

The Total Radiated Sensitivity is calculated from the measured data by equation in Subclause 7.1.1.2.

7.1.1.4.3 Test procedure, reverberation chamber method

TBD

7.1.1.5 Test requirements

The average measured total radiated sensitivity (TRS) of low, mid and high channel for handheld UE shall be lower than the average TRS requirement specified in Table 7.1.1.5-1. The averaging shall be done in linear scale for the TRS results of both right and left side of the phantom head. Average TRS requirement is shown in the column "Average" on the requirement tables.

$$TRS_{average} = 10 \log \left[6 / \left(\frac{1}{10^{P_{left_low}/10}} + \frac{1}{10^{P_{left_mid}/10}} + \frac{1}{10^{P_{left_high}/10}} + \frac{1}{10^{P_{right_low}/10}} + \frac{1}{10^{P_{right_mid}/10}} + \frac{1}{10^{P_{right_high}/10}} \right) \right]$$

In addition the highest TRS of each measured channel shall be lower than maximum TRS requirement specified in Table 7.1.1.5-1. Maximum TRS requirement is shown in the column “Max” on the requirement tables.

$$TRS_{max} = 10 \log \left[\max \left(10^{P_{left_low}/10}, 10^{P_{left_mid}/10}, 10^{P_{left_high}/10}, 10^{P_{right_low}/10}, 10^{P_{right_mid}/10}, 10^{P_{right_high}/10} \right) \right]$$

Table 7.1.1.5-1: TRS test requirements for UTRA FDD roaming bands in the speech position for the primary mechanical mode

Operating band	Unit	<REF _{or} >	
		Average	Max
I	dBm/3.84 MHz	-100.1	-96.8
II	dBm/3.84 MHz	-98.1	-94.8
III	dBm/3.84 MHz	-97.1	-93.8
IV	dBm/3.84 MHz	-100.1	-96.8
V	dBm/3.84 MHz	-95.1	-91.8
VI	dBm/3.84 MHz	-95.1	-91.8
VII	dBm/3.84 MHz	-98.1	-94.8
VIII	dBm/3.84 MHz	-95.1	-91.8
IX	dBm/3.84 MHz	-99.1	-95.8
XIX	dBm/3.84 MHz	-96+TT	-93+TT

NOTE 1: For Power class 3, 3bis and 4 this shall be achieved at the maximum output power.
NOTE 2: For the UE which supports both Band III and Band IX operating frequencies, the reference level of TDB dBm TRS <REF_{or}> [average and min] shall apply for Band IX.
NOTE 3: Applicable for dual-mode GSM/UMTS.
NOTE 4: For the UE which supports DB-DC-HSDPA configuration 2, average <REF_{or}> level of -97.1 dBm/3.84 MHz and max <REF_{or}> level of -93.8 dBm/3.84 MHz shall apply for Band II.
NOTE 5: For the UE which supports DB-DC-HSDPA configuration 2, average <REF_{or}> level of -99.1 dBm/3.84 MHz and max <REF_{or}> level of -95.8 dBm/3.84 MHz shall apply for Band IV.

NOTE: If the above Test Requirement differs from the Minimum Requirement then the Test Tolerance applied for this test is non-zero. The Test Tolerance for this test is defined and the explanation of how the Minimum Requirement has been relaxed by the Test Tolerance is given in Annex D.2.

7.1.2 Total Radiated Sensitivity (TRS) for UTRA LCR TDD in Speech Mode with beside the Head Phantom

Editor’s notes: This subclause is incomplete. The following items are missing or incomplete:

- Table 7.1.2.2-1 and 7.1.2.5-1 as they are not completed in TS 37.144 yet
- Text for Subclause 7.1.2.4.3 Procedure, reverberation chamber method

7.1.2.1 Definition and applicability

The Total Radiated Sensitivity is defined as:

$$TRS = \frac{4\pi}{\oint \left[\frac{1}{EIS_{\theta}(\Omega; f)} + \frac{1}{EIS_{\varphi}(\Omega; f)} \right] d\Omega}$$

Where the effective isotropic sensitivity (*EIS*) is defined as the power available at the antenna output such as the sensitivity threshold is achieved for each polarization. Ω is the solid angle describing the direction, f is frequency. θ and φ are the orthogonal polarizations.

$$TRS \approx \frac{2NM}{\pi \sum_{n=0}^{N-1} \sum_{m=0}^{M-1} \left[\frac{1}{EIS_{\theta}(\theta_n, \varphi_m; f)} + \frac{1}{EIS_{\varphi}(\theta_n, \varphi_m; f)} \right] \sin(\theta_n)}$$

In these formulas N and M are the number of sampling intervals for theta and phi. θ_n and φ_m are the measurement angles. The sampling intervals are discussed further in Subclause 4.4.

The requirements and this test apply to all types of UTRA for the TDD UE for Release 8 and later releases.

7.1.2.2 Minimum Requirements

The average measured total radiated sensitivity (TRS) of low, mid and high channel for handheld UE shall be lower than the average TRS requirement specified in Table 7.1.2.2-1. The averaging shall be done in linear scale for the TRS results of both right and left side of the phantom head. Average TRS requirement is shown in the column “Average” on the requirement tables.

$$TRS_{average} = 10 \log \left[6 / \left(\frac{1}{10^{P_{left_low}/10}} + \frac{1}{10^{P_{left_mid}/10}} + \frac{1}{10^{P_{left_high}/10}} + \frac{1}{10^{P_{right_low}/10}} + \frac{1}{10^{P_{right_mid}/10}} + \frac{1}{10^{P_{right_high}/10}} \right) \right]$$

In addition the highest TRS of each measured channel shall be lower than maximum TRS requirement specified in Table 7.1.2.2-1. Maximum TRS requirement is shown in the column “Max” on the requirement tables.

$$TRS_{max} = 10 \log \left[\max \left(10^{P_{left_low}/10}, 10^{P_{left_mid}/10}, 10^{P_{left_high}/10}, 10^{P_{right_low}/10}, 10^{P_{right_mid}/10}, 10^{P_{right_high}/10} \right) \right]$$

Table 7.1.2.2-1: TRS minimum requirements for UTRA LCR TDD roaming bands in the speech position for the primary mechanical mode

Operating Band	Unit	<REF _{or} >	
		Average	Max
a	dBm/1.28 MHz	-101	-100
b	dBm/1.28 MHz	TBD	TBD
c	dBm/1.28 MHz	TBD	TBD
d	dBm/1.28 MHz	TBD	TBD
e	dBm/1.28 MHz	-101	-100
f	dBm/1.28 MHz	-101	-100

NOTE Applicable for dual-mode GSM/UTRA LCR TDD.

The normative reference for this clause is TS 37.144 [12] Subclause 7.1.1.3.

7.1.2.3 Test purpose

The purpose of this test is to ensure that $TRS_{average}$ and TRS_{max} of the UE is above specified limit. The lack of the reception sensitivity decreases the coverage area at the far side from Node B.

7.1.2.4 Method of test

7.1.2.4.1 Initial conditions

A radio communications tester or a corresponding device is used as a NB simulator to setup calls to the DUT. The NB/BS simulator is also used to send test signals to the UE and measure the BER levels of the radio link and the information on the dedicated channel needed to extract the DUT receiver performances.

Chamber environment constraints and coordinate system shall be the same as described in Subclause A.3.

Phantom Specifications shall be the same as described in Subclause A.2.1.

Test environment: normal; see TS36.508 [10] Subclause 4.1.1.

Frequencies to be tested: low range, mid range, high range; see Table 5.2-2.

Positioning Requirements shall be the same as described in Subclause 4.3.

- 1) Position the UE according to the DUT positioning for speech mode specified in Subclause 4.3.3.
- 2) Set the SS downlink physical channels according to settings in Table 7.1.2.4.1-1. The DL power level should be set to ensure 0% BER at 12.2kbps data rate at the whole 3D initial scan.
- 3) Power on the UE.
- 4) A call is set up according to the Generic call setup procedure. The power control algorithm shall be set to Power Control Algorithm 2.
- 5) Enter the UE into loopback test mode and start the loopback test.

See TS 34.108 [4] and TS 34.109 [5] and Annex C of TS 34.122 [8] for details regarding generic call setup procedure and loopback test.

Table 7.1.2.4.1-1: Downlink Physical Channels transmitted during a connection

Physical Channel		Power
lor	-75 dBm	-
DwPCH	DwPCH_Ec / lor	0 dB
PCCPCH	\sum P-CCPCH_Ec / lor	-3 dB
SCCPCH	\sum S-CCPCH_Ec / lor	-6 dB
PICH	\sum PICH_Ec / lor	-6 dB
FPACH	FPACH_Ec / lor	-6 dB
DL DPCH	\sum DPCH_Ec / lor	0 dB

7.1.2.4.2 Procedure

- 1) Send continuously Up power control commands to the UE.
- 2) As the UE reaches maximum power, start sending PN15 data pattern.
- 3) Measure EIS from one measurement point. EIS is the power transmitted from one specific direction to the UE causing BER value of $1\% \pm 0.2\%$ using 40000 or more bits; see Annex E.20. The DL power step size shall be no bigger than 0.5dB when the RF level is near the TDD UE sensitivity level.

NOTE: To meet BER value target DL power level can be changed using user's freely selectable algorithm.

- 4) Measure the EIS for every direction of selected sampling grid using two orthogonal polarizations to obtain TRS.
- 5) Calculate TRS using equations from Subclause 7.1.2.1.

NOTE: To speed up sensitivity measurements non standard setting (i.e. data speed, PCL, BER target) can be used in the measurements. However to obtain TRS result the measured EIS figures shall be normalized by

$$\overline{\Delta EIS} = \frac{1}{n} \sum_{i=1}^n (EISstd_i - EISnst_i)$$

Where $EISstd_i$ is sensitivity measurement done with standard setting, $EISnst_i$ is sensitivity measurement done with non standard settings. n is amount of reference measurement points.

To ensure accuracy of TRS, the amount of reference points measured should be at least 4. It is recommended to spread the reference measurements equally during the measurement time.

The measurement procedure is based on the measurement of the spherical sensitivity pattern of the DUT. The sensitivity values of the DUT at a predefined BER level are sampled in far field in a group of points located on a spherical surface enclosing the DUT. The EIS samples are taken using a constant sample step of 30° both in theta (θ) and phi (ϕ) directions. All the EIS samples are taken with two orthogonal polarizations, θ - and ϕ -polarisations (See Subclause 4.4).

The Total Radiated Sensitivity is calculated from the measured data by equation in Subclause 7.1.2.2.

7.1.2.4.3 Procedure, reverberation chamber method

TBD

7.1.2.5 Test requirements

The average measured total radiated sensitivity (TRS) of low, mid and high channel for handheld UE shall be lower than the average TRS requirement specified in Table 7.1.2.5-1. The averaging shall be done in linear scale for the TRS results of both right and left side of the phantom head. Average TRS requirement is shown in the column “Average” on the requirement tables.

$$TRS_{average} = 10 \log \left[6 \left/ \left(\frac{1}{10^{P_{left_low}/10}} + \frac{1}{10^{P_{left_mid}/10}} + \frac{1}{10^{P_{left_high}/10}} + \frac{1}{10^{P_{right_low}/10}} + \frac{1}{10^{P_{right_mid}/10}} + \frac{1}{10^{P_{right_high}/10}} \right) \right] \right]$$

In addition the highest TRS of each measured channel shall be lower than maximum TRS requirement specified in Table 7.1.2.5-1. Maximum TRS requirement is shown in the column “Max” on the requirement tables.

$$TRS_{max} = 10 \log \left[\max \left(10^{P_{left_low}/10}, 10^{P_{left_mid}/10}, 10^{P_{left_high}/10}, 10^{P_{right_low}/10}, 10^{P_{right_mid}/10}, 10^{P_{right_high}/10} \right) \right]$$

Table 7.1.2.5-1: TRS minimum requirement for UTRA LCR TDD roaming bands in the speech position and the primary mechanical mode

Operating Band	Unit	<REF _{or} >	
		Average	Max
a	dBm/1.28 MHz	-100.1	-98.8
b	dBm/1.28 MHz	TBD + TT	TBD + TT
c	dBm/1.28 MHz	TBD + TT	TBD + TT
d	dBm/1.28 MHz	TBD + TT	TBD + TT
e	dBm/1.28 MHz	-100.1	-98.8
f	dBm/1.28 MHz	-100.1	-98.8

NOTE Applicable for dual-mode GSM/UTRA LCR TDD.

NOTE: If the above Test Requirement differs from the Minimum Requirement then the Test Tolerance applied for this test is non-zero. The Test Tolerance for this test is defined and the explanation of how the Minimum Requirement has been relaxed by the Test Tolerance is given in Annex D.2.

7.1.3 Total Radiated Sensitivity (TRS) for UTRA FDD in Speech Mode with beside the Head and Hand Phantom

Editor’s notes: This subclause is incomplete. The following items are missing or incomplete:

- Table 7.1.3.2-1 and 7.1.3.5-1 as they are not specified in TS 37.144 yet

7.1.3.1 Definition and applicability

The Total Radiated Sensitivity is defined as:

$$TRS = \frac{4\pi}{\oint \left[\frac{1}{EIS_{\theta}(\Omega; f)} + \frac{1}{EIS_{\varphi}(\Omega; f)} \right] d\Omega}$$

Where the effective isotropic sensitivity (*EIS*) is defined as the power available at the antenna output such as the sensitivity threshold is achieved for each polarization. Ω is the solid angle describing the direction, f is frequency. θ and φ are the orthogonal polarizations.

$$TRS \approx \frac{2NM}{\pi \sum_{n=0}^{N-1} \sum_{m=0}^{M-1} \left[\frac{1}{EIS_{\theta}(\theta_n, \varphi_m; f)} + \frac{1}{EIS_{\varphi}(\theta_n, \varphi_m; f)} \right] \sin(\theta_n)}$$

In these formulas N and M are the number of sampling intervals for theta and phi. θ_n and φ_m are the measurement angles. The sampling intervals are discussed further in Subclause 4.4.

The TRS can also be calculated from measurements in a Rayleigh fading 3 dimensional isotropic environment with in average uniform elevation and azimuth distribution. The calculation of the TRS is in this case based on searching for the lowest power received by the UE/MS for a discrete number of field combinations in the chamber that gives a BER that is better than the specified target BER level. By calibrating the average power transfer function, an absolute value of the TRS can be obtained. The following expression can be used to find the TRS.

$$TRS \approx 2N \frac{\left(\sum_{n=1}^N (C_n (1 - R_n) P_{thres,n}) \right)^{-1}}{\sum_{n=1}^N P_{ref,n}}$$

where $P_{ref,n}$ is the reference power transfer function for fixed measurement antenna n , R_n is the reflection coefficient for fixed measurement antenna n and C_n is the path loss in the cables connecting the measurement receiver to fixed measurement antenna n . These parameters are calculated from the calibration measurement and are further discussed in Annex B.2. $P_{thres,n}$ is calculated by using the following equation:

$$P_{thres,n} = \frac{\sum_{m=1}^M \frac{1}{|S_{21,n,m}^{thres}|^2}}{M}$$

where $S_{21,n,m}^{thres}$ is the m :th value of the transfer function for fixed measurement antenna n , which gives the BER threshold. M is the total number of values of the BER threshold power measured for each fixed measurement antenna.

The requirements and this test apply to all types of UTRA for the FDD UE for Release 7 and later releases.

7.1.3.2 Minimum Requirements

The average measured total radiated sensitivity (TRS) of low, mid and high channel for handheld UE shall be lower than the average TRS requirement specified in Table 7.1.3.2-1. The averaging shall be done in linear scale for the TRS results of both right and left side of the phantom head. Average TRS requirement is shown in the column ‘‘Average’’ on the requirement tables.

$$TRS_{average} = 10 \log \left[6 / \left(\frac{1}{10^{P_{left_low}/10}} + \frac{1}{10^{P_{left_mid}/10}} + \frac{1}{10^{P_{left_high}/10}} + \frac{1}{10^{P_{right_low}/10}} + \frac{1}{10^{P_{right_mid}/10}} + \frac{1}{10^{P_{right_high}/10}} \right) \right]$$

In addition the highest TRS of each measured channel shall be lower than maximum TRS requirement specified in Table 7.1.3.2-1. Maximum TRS requirement is shown in the column “Max” on the requirement tables.

$$TRS_{\max} = 10 \log \left[\max \left(10^{P_{\text{left_low}}/10}, 10^{P_{\text{left_mid}}/10}, 10^{P_{\text{left_high}}/10}, 10^{P_{\text{right_low}}/10}, 10^{P_{\text{right_mid}}/10}, 10^{P_{\text{right_high}}/10} \right) \right]$$

Table 7.1.3.2-1: TRS minimum requirements for UTRA FDD roaming bands in the speech position for the primary mechanical mode

Operating band	Unit	<REF _{or} >	
		Average	Max
I	dBm/3.84 MHz	-101.10	TBD
II	dBm/3.84 MHz	-99.0	TBD
III	dBm/3.84 MHz	TBD	TBD
IV	dBm/3.84 MHz	TBD	TBD
V	dBm/3.84 MHz	-96.75	TBD
VI	dBm/3.84 MHz	-96.75	TBD
VII	dBm/3.84 MHz	TBD	TBD
VIII	dBm/3.84 MHz	-96.75	TBD
IX	dBm/3.84 MHz	TBD	TBD
XIX	dBm/3.84 MHz	-96.75	TBD

NOTE 1: For power class 3, 3bis and 4 this shall be achieved at the maximum output power.

NOTE 2: For the UE which supports both Band III and Band IX operating frequencies, the reference level of TDB dBm TRS <REF_{or}> [average and min] shall apply for Band IX.

NOTE 3: Applicable for dual-mode GSM/UMTS.

NOTE 4: For the UE which supports DB-DC-HSDPA configuration 2, average <REF_{or}> level of -98 dBm/3.84 MHz and max <REF_{or}> level of -95 dBm/3.84 MHz shall apply for Band II.

NOTE 5: For the UE which supports DB-DC-HSDPA configuration 2, average <REF_{or}> level of -100 dBm/3.84 MHz and max <REF_{or}> level of -97 dBm/3.84 MHz shall apply for Band IV.

NOTE 6: Applicable for devices narrower than 72mm as defined in TR 25.914.

NOTE 7: Not applicable for devices supporting CDMA or carrier aggregation.

The normative reference for this clause is TS 37.144 [12] Subclause 7.1.2.1.

7.1.3.3 Test purpose

The purpose of this test is to ensure that TRS_{average} and TRS_{max} of the UE is above specified limit. The lack of the reception sensitivity decreases the coverage area at the far side from Node B.

7.1.3.4 Method of test

7.1.3.4.1 Initial conditions

A radio communications tester or a corresponding device is used as a NB simulator to setup calls to the DUT. The NB/BS simulator is also used to send test signals to the UE and measure the BER levels of the radio link and the information on the dedicated channel needed to extract the DUT receiver performances.

Chamber environment constraints and coordinate system shall be the same as described in Subclause A.3.

Phantom Specifications shall be the same as described in Subclause A.2.1 and A.2.2.

Test environment: normal; see TS36.508 [10] Subclause 4.1.1.

Frequencies to be tested: low range, mid range, high range; see Table 5.1-2.

Positioning Requirements shall be the same as described in Subclause 4.3.

- 1) Position the UE according to the DUT positioning for speech mode specified in Subclause 4.3.3.
- 2) Set the SS downlink physical channels according to settings in Table 7.1.3.4.1-1.
- 3) Power on the UE.
- 4) A call is set up according to the Generic call setup procedure. The power control algorithm shall be set to Power Control Algorithm 2. Compressed mode shall be set to OFF.
- 5) Enter the UE into loopback test mode 2 and start the loopback test.

See TS 34.108 [4] and TS 34.109 [5] for details regarding generic call setup procedure and loopback test.

Table 7.1.3.4.1-1: Downlink Physical Channels transmitted during a connection

Physical Channel	Power
CPICH	CPICH_Ec / DPCH_Ec = 7 dB
P-CCPCH	P-CCPCH_Ec / DPCH_Ec = 5 dB
SCH	SCH_Ec / DPCH_Ec = 5 dB
PICH	PICH_Ec / DPCH_Ec = 2 dB
DPCH	Test dependent power

7.1.3.4.2 Procedure

- 1) Send continuously Up power control commands to the UE.
- 2) As the UE reaches maximum power, start sending PN15 data pattern.
- 3) Measure EIS from one measurement point. EIS is the power transmitted from one specific direction to the UE causing BER value of $1\% \pm 0.2\%$ using 20000 or more bits; see Annex E.20.

NOTE: To meet BER value target DL power level can be changed using user's freely selectable algorithm.

- 4) Measure the EIS for every direction of selected sampling grid using two orthogonal polarizations to obtain TRS.
- 5) Calculate TRS using equations from Subclause 7.1.3.1.

NOTE: To speed up sensitivity measurements non standard setting (i.e. data speed, PCL, BER target) can be used in the measurements. However to obtain TRS result the measured EIS figures shall be normalized by

$$\Delta \overline{EIS} = \frac{1}{n} \sum_{i=1}^n (EISstd_i - EISnstd_i)$$

Where $EISstd_i$ is sensitivity measurement done with standard setting, $EISnstd_i$ is sensitivity measurement done with non standard settings. n is amount of reference measurement points.

To ensure accuracy of TRS, the amount of reference points measured should be at least 4. It is recommended to spread the reference measurements equally during the measurement time.

The measurement procedure is based on the measurement of the spherical sensitivity pattern of the DUT. The sensitivity values of the DUT at a predefined BER level are sampled in far field in a group of points located on a spherical surface enclosing the DUT. The EIS samples are taken using a constant sample step of 30° both in theta (θ) and phi (ϕ) directions. All the EIS samples are taken with two orthogonal polarizations, θ - and ϕ -polarisations (See Subclause 4.4).

The Total Radiated Sensitivity is calculated from the measured data by equation in Subclause 7.1.3.2.

7.1.3.4.3 Procedure, reverberation chamber method

- 1) Send continuously Up power control commands to the UE.
- 2) As the UE reaches maximum power, start sending PN15 data pattern.

- 3) Set the base station simulator to a specific output power and perform a BER measurement.
- 4) Increase or decrease the base station output power as needed, and repeat step 4 until the lowest output power is found that gives a BER value of $1\% \pm 0.2\%$ using 20000 or more bits, see Annex E.20. This corresponds to

$$\left| S_{21,n,m}^{thres} \right|^2.$$

NOTE: To meet BER value target DL power level can be changed using user's freely selectable algorithm.

- 5) Repeat step 3 and 4 until a sufficient number of independent samples (see section 4.5) of $\left| S_{21,n,m}^{thres} \right|^2$ has been measured.
- 7) Calculate TRS using equations from chapter 7.1.3.1.

NOTE 1: The measurement procedure is based on samples of the received signal power at the UE/MS from a full 3 dimensional isotropic environment with uniform elevation and azimuth field distribution. The power received by the DUT is undergoing Rayleigh fading and is transmitted by the fixed measurement antennas. Moreover, it is important that the samples collected are independent, in order to get sufficient accuracy of the estimated TRS value.

The Total Radiated Sensitivity is calculated from the measured data by equation in Subclause 7.1.3.2.

7.1.3.5 Test requirements

The average measured total radiated sensitivity (TRS) of low, mid and high channel for handheld UE shall be lower than the average TRS requirement specified in Table 7.1.3.5-1. The averaging shall be done in linear scale for the TRS results of both right and left side of the phantom head. Average TRS requirement is shown in the column "Average" on the requirement tables.

$$TRS_{average} = 10 \log \left[6 / \left(\frac{1}{10^{P_{left_low}/10}} + \frac{1}{10^{P_{left_mid}/10}} + \frac{1}{10^{P_{left_high}/10}} + \frac{1}{10^{P_{right_low}/10}} + \frac{1}{10^{P_{right_mid}/10}} + \frac{1}{10^{P_{right_high}/10}} \right) \right]$$

In addition the highest TRS of each measured channel shall be lower than maximum TRS requirement specified in Table 7.1.3.5-1. Maximum TRS requirement is shown in the column "Max" on the requirement tables.

$$TRS_{max} = 10 \log \left[\max \left(10^{P_{left_low}/10}, 10^{P_{left_mid}/10}, 10^{P_{left_high}/10}, 10^{P_{right_low}/10}, 10^{P_{right_mid}/10}, 10^{P_{right_high}/10} \right) \right]$$

Table 7.1.3.5-1: TRS minimum requirement for UTRA FDD roaming bands in the speech position and the primary mechanical mode

Operating band	Unit	<REF _{or} >	
		Average	Max
I	dBm/3.84 MHz	-100.1	TBD+TT
II	dBm/3.84 MHz	-98.1	TBD+TT
III	dBm/3.84 MHz	TBD+TT	TBD+TT
IV	dBm/3.84 MHz	TBD+TT	TBD+TT
V	dBm/3.84 MHz	-95.85	TBD+TT
VI	dBm/3.84 MHz	-95.85	TBD+TT
VII	dBm/3.84 MHz	TBD+TT	TBD+TT
VIII	dBm/3.84 MHz	-95.85	TBD+TT
IX	dBm/3.84 MHz	TBD+TT	TBD+TT
XIX	dBm/3.84 MHz	-95.85	TBD+TT

NOTE 1: For power class 3, 3bis and 4 this shall be achieved at the maximum output power.

NOTE 2: For the UE which supports both Band III and Band IX operating frequencies, the reference level of TDB dBm TRS <REF_{or}> [average and min] shall apply for Band IX.

NOTE 3: Applicable for dual-mode GSM/UMTS.

NOTE 4: For the UE which supports DB-DC-HSDPA configuration 2, average <REF_{or}> level of -98 dBm/3.84 MHz and max <REF_{or}> level of -95 dBm/3.84 MHz shall apply for Band II.

NOTE 5: For the UE which supports DB-DC-HSDPA configuration 2, average <REF_{or}> level of -100 dBm/3.84 MHz and max <REF_{or}> level of -97 dBm/3.84 MHz shall apply for Band IV.

NOTE 6: Applicable for devices narrower than 72mm as defined in TR 25.914.

NOTE 7: Not applicable for devices supporting CDMA or carrier aggregation.

NOTE: If the above Test Requirement differs from the Minimum Requirement then the Test Tolerance applied for this test is non-zero. The Test Tolerance for this test is defined and the explanation of how the Minimum Requirement has been relaxed by the Test Tolerance is given in Annex D.

7.1.4 Total Radiated Sensitivity (TRS) for UTRA LCR TDD in Speech Mode with beside the Head and Hand Phantom

Editor's notes: This subclause is incomplete. The following items are missing or incomplete:

- Table 7.1.4.2-1 and 7.1.5.4-1 as they are not specified in TS 37.144 yet

7.1.4.1 Definition and applicability

The Total Radiated Sensitivity is defined as:

$$TRS = \frac{4\pi}{\oint \left[\frac{1}{EIS_{\theta}(\Omega; f)} + \frac{1}{EIS_{\varphi}(\Omega; f)} \right] d\Omega}$$

Where the effective isotropic sensitivity (*EIS*) is defined as the power available at the antenna output such as the sensitivity threshold is achieved for each polarization. Ω is the solid angle describing the direction, f is frequency. θ and φ are the orthogonal polarizations.

$$TRS \approx \frac{2NM}{\pi \sum_{n=0}^{N-1} \sum_{m=0}^{M-1} \left[\frac{1}{EIS_{\theta}(\theta_n, \varphi_m; f)} + \frac{1}{EIS_{\varphi}(\theta_n, \varphi_m; f)} \right]} \sin(\theta_n)$$

In these formulas N and M are the number of sampling intervals for theta and phi. θ_n and φ_m are the measurement angles. The sampling intervals are discussed further in Subclause 4.4.

The TRS can also be calculated from measurements in a Rayleigh fading 3 dimensional isotropic environment with in average uniform elevation and azimuth distribution. The calculation of the TRS is in this case based on searching for the lowest power received by the UE/MS for a discrete number of field combinations in the chamber that gives a BER that is better than the specified target BER level. By calibrating the average power transfer function, an absolute value of the TRS can be obtained. The following expression can be used to find the TRS.

$$TRS \approx 2N \frac{\left(\sum_{n=1}^N (C_n (1 - R_n) P_{thres,n}) \right)^{-1}}{\sum_{n=1}^N P_{ref,n}}$$

where $P_{ref,n}$ is the reference power transfer function for fixed measurement antenna n , R_n is the reflection coefficient for fixed measurement antenna n and C_n is the path loss in the cables connecting the measurement receiver to fixed measurement antenna n . These parameters are calculated from the calibration measurement and are further discussed in Annex B.2. $P_{thres,n}$ is calculated by using the following equation:

$$P_{thres,n} = \frac{\sum_{m=1}^M \frac{1}{|S_{21,n,m}^{thres}|^2}}{M}$$

where $S_{21,n,m}^{thres}$ is the m :th value of the transfer function for fixed measurement antenna n , which gives the BER threshold. M is the total number of values of the BER threshold power measured for each fixed measurement antenna.

The requirements and this test apply to all types of UTRA for the TDD UE for Release 8 and later releases.

7.1.4.2 Minimum Requirements

The average measured total radiated sensitivity (TRS) of low, mid and high channel for handheld UE shall be lower than the average TRS requirement specified in Table 7.1.4.2-1. The averaging shall be done in linear scale for the TRS results of both right and left side of the phantom head. Average TRS requirement is shown in the column “Average” on the requirement tables.

$$TRS_{average} = 10 \log \left[6 / \left(\frac{1}{10^{P_{left_low}/10}} + \frac{1}{10^{P_{left_mid}/10}} + \frac{1}{10^{P_{left_high}/10}} + \frac{1}{10^{P_{right_low}/10}} + \frac{1}{10^{P_{right_mid}/10}} + \frac{1}{10^{P_{right_high}/10}} \right) \right]$$

In addition the highest TRS of each measured channel shall be lower than maximum TRS requirement specified in Table 7.1.5.2-1. Maximum TRS requirement is shown in the column “Max” on the requirement tables.

$$TRS_{max} = 10 \log \left[\max \left(10^{P_{left_low}/10}, 10^{P_{left_mid}/10}, 10^{P_{left_high}/10}, 10^{P_{right_low}/10}, 10^{P_{right_mid}/10}, 10^{P_{right_high}/10} \right) \right]$$

Table 7.1.4.2-1: TRS minimum requirements for UTRA LCR TDD roaming bands in the speech position for the primary mechanical mode

Operating band	Unit	<REFlor>	
		Average	Max
a	dBm/1.28 MHz	TBD	TBD
b	dBm/1.28 MHz	TBD	TBD
c	dBm/1.28 MHz	TBD	TBD
d	dBm/1.28 MHz	TBD	TBD
e	dBm/1.28 MHz	TBD	TBD
f	dBm/1.28 MHz	TBD	TBD
Note: Applicable for dual-mode GSM/UTRA LCR TDD.			

The normative reference for this clause is TS 37.144 [12] Subclause 7.1.2.2.

7.1.4.3 Test purpose

The purpose of this test is to ensure that $TRS_{average}$ and TRS_{max} of the UE is above specified limit. The lack of the reception sensitivity decreases the coverage area at the far side from Node B.

7.1.5.4 Method of test

7.1.4.4.1 Initial conditions

A radio communications tester or a corresponding device is used as a NB simulator to setup calls to the DUT. The NB/BS simulator is also used to send test signals to the UE and measure the BER levels of the radio link and the information on the dedicated channel needed to extract the DUT receiver performances.

Chamber environment constraints and coordinate system shall be the same as described in Subclause A.3.

Phantom Specifications shall be the same as described in Subclause A.2.1 and A.2.2.

Test environment: normal; see TS36.508 [10] Subclause 4.1.1.

Frequencies to be tested: low range, mid range, high range; see Table 5.2-2.

Positioning Requirements shall be the same as described in Subclause 4.3.

- 1) Position the UE according to the DUT positioning for speech mode specified in Subclause 4.3.3.
- 2) Set the SS downlink physical channels according to settings in Table 7.1.4.4.1-1. The DL power level should be set to ensure 0% BER at 12.2kbps data rate at the whole 3D initial scan.
- 3) Power on the UE.
- 4) A call is set up according to the Generic call setup procedure. The power control algorithm shall be set to Power Control Algorithm 2.
- 5) Enter the UE into loopback test mode and start the loopback test.

See TS 34.108 [4] and TS 34.109 [5] and Annex C of TS 34.122 [8] for details regarding generic call setup procedure and loopback test.

Table 7.1.4.4.1-1: Downlink Physical Channels transmitted during a connection

Physical Channel		Power
lor	-75 dBm	
DwPCH	DwPCH_Ec / lor	0 dB
PCCPCH	\sum P-CCPCH_Ec / lor	-3 dB
SCCPCH	\sum S-CCPCH_Ec / lor	-6 dB
PICH	\sum PICH_Ec / lor	-6 dB
FPACH	FPACH_Ec / lor	-6 dB
DL DPCH	\sum DPCH_Ec / lor	0 dB

7.1.4.4.2 Procedure

- 1) Send continuously Up power control commands to the UE.
- 2) As the UE reaches maximum power, start sending PN15 data pattern.
- 3) Measure EIS from one measurement point. EIS is the power transmitted from one specific direction to the UE causing BER value of $1\% \pm 0.2\%$ using 40000 or more bits; see Annex E.20. The DL power step size shall be no bigger than 0.5dB when the RF level is near the TDD UE sensitivity level.

NOTE: To meet BER value target DL power level can be changed using user's freely selectable algorithm.

- 4) Measure the EIS for every direction of selected sampling grid using two orthogonal polarizations to obtain TRS.
- 5) Calculate TRS using equations from Subclause 7.1.4.1.

NOTE: To speed up sensitivity measurements non standard setting (i.e. data speed, PCL, BER target) can be used in the measurements. However to obtain TRS result the measured EIS figures shall be normalized by

$$\Delta \overline{EIS} = \frac{1}{n} \sum_{i=1}^n (EISstd_i - EISnstd_i)$$

Where $EISstd_i$ is sensitivity measurement done with standard setting, $EISnstd_i$ is sensitivity measurement done with non standard settings. n is amount of reference measurement points.

To ensure accuracy of TRS, the amount of reference points measured should be at least 4. It is recommended to spread the reference measurements equally during the measurement time.

The measurement procedure is based on the measurement of the spherical sensitivity pattern of the DUT. The sensitivity values of the DUT at a predefined BER level are sampled in far field in a group of points located on a spherical surface enclosing the DUT. The EIS samples are taken using a constant sample step of 30° both in theta (θ) and phi (ϕ) directions. All the EIS samples are taken with two orthogonal polarizations, θ - and ϕ -polarisations (See Subclause 4.4).

The Total Radiated Sensitivity is calculated from the measured data by equation in Subclause 7.1.5.2.

7.1.4.4.3 Procedure, reverberation chamber method

- 1) Send continuously Up power control commands to the UE.
- 2) As the UE reaches maximum power, start sending PN15 data pattern.
- 3) Set the base station simulator to a specific output power and perform a BER measurement.
- 4) Increase or decrease the base station output power as needed, and repeat step 4 until the lowest output power is found that gives a BER value of $1\% \pm 0.2\%$ using 20000 or more bits, see Annex E.20. This corresponds to

$$\left| S_{21,n,m}^{thres} \right|^2$$

NOTE: To meet BER value target DL power level can be changed using user's freely selectable algorithm.

- 5) Repeat step 3 and 4 until a sufficient number of independent samples (see section 4.5) of $|S_{21,n,m}^{thres}|^2$ has been measured.
- 7) Calculate TRS using equations from chapter 7.1.4.1.

NOTE 1: The measurement procedure is based on samples of the received signal power at the UE/MS from a full 3 dimensional isotropic environment with uniform elevation and azimuth field distribution. The power received by the DUT is undergoing Rayleigh fading and is transmitted by the fixed measurement antennas. Moreover, it is important that the samples collected are independent, in order to get sufficient accuracy of the estimated TRS value.

The Total Radiated Sensitivity is calculated from the measured data by equation in Subclause 7.1.4.2.

7.1.4.5 Test requirements

The average measured total radiated sensitivity (TRS) of low, mid and high channel for handheld UE shall be lower than the average TRS requirement specified in Table 7.1.4.5-1. The averaging shall be done in linear scale for the TRS results of both right and left side of the phantom head. Average TRS requirement is shown in the column “Average” on the requirement tables.

$$TRS_{average} = 10 \log \left[6 / \left(\frac{1}{10^{P_{left_low}/10}} + \frac{1}{10^{P_{left_mid}/10}} + \frac{1}{10^{P_{left_high}/10}} + \frac{1}{10^{P_{right_low}/10}} + \frac{1}{10^{P_{right_mid}/10}} + \frac{1}{10^{P_{right_high}/10}} \right) \right]$$

In addition the highest TRS of each measured channel shall be lower than maximum TRS requirement specified in Table 7.1.4.5-1. Maximum TRS requirement is shown in the column “Max” on the requirement tables.

$$TRS_{max} = 10 \log \left[\max \left(10^{P_{left_low}/10}, 10^{P_{left_mid}/10}, 10^{P_{left_high}/10}, 10^{P_{right_low}/10}, 10^{P_{right_mid}/10}, 10^{P_{right_high}/10} \right) \right]$$

Table 7.1.4.5-1: TRS minimum requirement for UTRA LCR TDD roaming bands in the speech position and the primary mechanical mode

Operating band	Unit	<REFFior>	
		Average	Max
a	dBm/1.28 MHz	TBD+TT	TBD+TT
b	dBm/1.28 MHz	TBD+TT	TBD+TT
c	dBm/1.28 MHz	TBD+TT	TBD+TT
d	dBm/1.28 MHz	TBD+TT	TBD+TT
e	dBm/1.28 MHz	TBD+TT	TBD+TT
f	dBm/1.28 MHz	TBD+TT	TBD+TT
Note: Applicable for dual-mode GSM/UTRA LCR TDD.			

NOTE: If the above Test Requirement differs from the Minimum Requirement then the Test Tolerance applied for this test is non-zero. The Test Tolerance for this test is defined and the explanation of how the Minimum Requirement has been relaxed by the Test Tolerance is given in Annex D.

7.1.5 Total Radiated Sensitivity (TRS) for E-UTRA FDD in Speech Mode with beside the Head and Hand Phantom

Editor’s notes: This subclause is incomplete. The following items are missing or incomplete:

- Table 7.1.5.2-1 and 7.1.5.5-1 as they are not specified in TS 37.144 yet

7.1.5.1 Definition and applicability

The Total Radiated Sensitivity is defined as:

$$TRS = \frac{4\pi}{\oint \left[\frac{1}{EIS_{\theta}(\Omega; f)} + \frac{1}{EIS_{\varphi}(\Omega; f)} \right] d\Omega}$$

Where the effective isotropic sensitivity (*EIS*) is defined as the power available at the antenna output such as the sensitivity threshold is achieved for each polarization. Ω is the solid angle describing the direction, f is frequency. θ and φ are the orthogonal polarizations.

$$TRS \approx \frac{2NM}{\pi \sum_{n=0}^{N-1} \sum_{m=0}^{M-1} \left[\frac{1}{EIS_{\theta}(\theta_n, \varphi_m; f)} + \frac{1}{EIS_{\varphi}(\theta_n, \varphi_m; f)} \right] \sin(\theta_n)}$$

In these formulas N and M are the number of sampling intervals for theta and phi. θ_n and φ_m are the measurement angles. The sampling intervals are discussed further in Subclause 4.4.

The TRS can also be calculated from measurements in a Rayleigh fading 3 dimensional isotropic environment with in average uniform elevation and azimuth distribution. The calculation of the TRS is in this case based on searching for the lowest power received by the UE/MS for a discrete number of field combinations in the chamber that gives a BER that is better than the specified target BER level. By calibrating the average power transfer function, an absolute value of the TRS can be obtained. The following expression can be used to find the TRS.

$$TRS \approx 2N \frac{\left(\sum_{n=1}^N (C_n (1 - R_n) P_{thres,n}) \right)^{-1}}{\sum_{n=1}^N P_{ref,n}}$$

where $P_{ref,n}$ is the reference power transfer function for fixed measurement antenna n , R_n is the reflection coefficient for fixed measurement antenna n and C_n is the path loss in the cables connecting the measurement receiver to fixed measurement antenna n . These parameters are calculated from the calibration measurement and are further discussed in Annex B.2. $P_{thres,n}$ is calculated by using the following equation:

$$P_{thres,n} = \frac{\sum_{m=1}^M \frac{1}{|S_{21,n,m}^{thres}|^2}}{M}$$

where $S_{21,n,m}^{thres}$ is the m :th value of the transfer function for fixed measurement antenna n , which gives the BER threshold. M is the total number of values of the BER threshold power measured for each fixed measurement antenna.

The requirements and this test apply to all types of LTE UEs independent of release.

7.1.5.2 Minimum Requirements

The average measured total radiated sensitivity (TRS) of low, mid and high channel for handheld UE shall be lower than the average TRS requirement specified in Table 7.1.5.2-1. The averaging shall be done in linear scale for the TRS results of both right and left side of the phantom head. Average TRS requirement is shown in the column ‘‘Average’’ on the requirement tables.

$$TRS_{average} = 10 \log \left[6 / \left(\frac{1}{10^{P_{left_low}/10}} + \frac{1}{10^{P_{left_mid}/10}} + \frac{1}{10^{P_{left_high}/10}} + \frac{1}{10^{P_{right_low}/10}} + \frac{1}{10^{P_{right_mid}/10}} + \frac{1}{10^{P_{right_high}/10}} \right) \right]$$

In addition the highest TRS of each measured channel shall be lower than maximum TRS requirement specified in Table 7.1.5.2-1. Maximum TRS requirement is shown in the column “Max” on the requirement tables.

$$TRS_{\max} = 10 \log \left[\max \left(10^{P_{\text{left_low}}/10}, 10^{P_{\text{left_mid}}/10}, 10^{P_{\text{left_high}}/10}, 10^{P_{\text{right_low}}/10}, 10^{P_{\text{right_mid}}/10}, 10^{P_{\text{right_high}}/10} \right) \right]$$

Table 7.1.5.2-1: TRS minimum requirements for E-UTRA FDD roaming bands in the speech position for the primary mechanical mode

TBD

The normative reference for this clause is TS 37.144 [12] Subclause 7.1.2.3.

7.1.5.3 Test purpose

The purpose of this test is to ensure that TRS_{average} and TRS_{\max} of the UE is above specified limit. The lack of the reception sensitivity decreases the coverage area at the far side from Node B.

7.1.5.4 Method of test

7.1.5.4.1 Initial conditions

A radio communications tester or a corresponding device is used as a NB simulator to setup calls to the DUT. The NB/BS simulator is also used to send test signals to the UE and measure the BER levels of the radio link and the information on the dedicated channel needed to extract the DUT receiver performances.

Chamber environment constraints and coordinate system shall be the same as described in Subclause A.3.

Phantom Specifications shall be the same as described in Subclause A.2.1 and A.2.2.

Test environment: normal; see TS36.508 [10] Subclause 4.1.1.

Frequencies to be tested: low range, mid range, high range; see Table 5.3-2.

Positioning Requirements shall be the same as described in Subclause 4.3.

- 1) Position the UE according to the DUT positioning for speech mode specified in Subclause 4.3.3.
- 2) Power on the UE.
- 3) Set the initial conditions as per Subclause 7.3 of 3GPP TS 36.521-1 [11], with the following exception: set the carrier frequency, channel bandwidth, RB length and RB location as per Table 5.3-2 for FDD mode. For DUTs with more than one receiver port, all the tests should be performed using both (all) antenna ports simultaneously.

7.1.5.4.2 Procedure

- 1) Follow Steps 1 through 4 in Subclause 7.3.4.2 of 3GPP TS 36.521-1 [11], with the following exception: measure the receiver sensitivity by adjusting the downlink signal level to 95 % throughput of the maximum throughput of the reference channel (maximum throughput is per Annex A of 3GPP TS 36.521-1 [11]).
- 2) For the anechoic chamber based methodologies, repeat Step 1) with 3-D sampling grid specified in Subclause 4.4. The minimum RF power level resulting in a data throughput greater than or equal to 95 % throughput of the maximum throughput for each test shall be recorded for integration pursuant to Subclause 7.1.5.1 to calculate TRS.
- 3) Repeat the measurement of the DUT on the left and right ears of the head phantom using the left and right hand phantom for low, mid and high channels.
- 4) Calculate the average and minimum TRS as per Subclause 7.1.5.2.

7.1.5.4.3 Procedure, reverberation chamber method

- 1) Follow Steps 1 through 4 in Subclause 7.3.4.2 of 3GPP TS 36.521-1 [11], with the following exception: measure the receiver sensitivity by adjusting the downlink signal level to 95 % throughput of the maximum throughput of the reference channel (maximum throughput is per Annex A of 3GPP TS 36.521-1 [11]).
- 2) Repeat Step 1) until a sufficient number of independent samples (see section 4.5) of $|S_{21,n,m}^{thres}|^2$ has been measured. The minimum RF power level resulting in a data throughput greater than or equal to 95 % throughput of the maximum throughput for each sample shall be recorded for calculating the TRS according to Subclause 7.1.5.1.
- 3) Repeat the measurement of the DUT on the left and right ears of the head phantom using the left and right hand phantom for low, mid and high channels.
- 4) Calculate the average and minimum TRS as per Subclause 7.1.5.2.

7.1.5.5 Test requirements

The average measured total radiated sensitivity (TRS) of low, mid and high channel for handheld UE shall be lower than the average TRS requirement specified in Table 7.1.5.5-1. The averaging shall be done in linear scale for the TRS results of both right and left side of the phantom head. Average TRS requirement is shown in the column “Average” on the requirement tables.

$$TRS_{average} = 10 \log \left[6 \left/ \left(\frac{1}{10^{P_{left_low}/10}} + \frac{1}{10^{P_{left_mid}/10}} + \frac{1}{10^{P_{left_high}/10}} + \frac{1}{10^{P_{right_low}/10}} + \frac{1}{10^{P_{right_mid}/10}} + \frac{1}{10^{P_{right_high}/10}} \right) \right] \right]$$

In addition the highest TRS of each measured channel shall be lower than maximum TRS requirement specified in Table 7.1.5.5-1. Maximum TRS requirement is shown in the column “Max” on the requirement tables.

$$TRS_{max} = 10 \log \left[\max \left(10^{P_{left_low}/10}, 10^{P_{left_mid}/10}, 10^{P_{left_high}/10}, 10^{P_{right_low}/10}, 10^{P_{right_mid}/10}, 10^{P_{right_high}/10} \right) \right]$$

Table 7.1.5.5-1: TRS minimum requirement for E-UTRA FDD roaming bands in the speech position and the primary mechanical mode

TBD

NOTE: If the above Test Requirement differs from the Minimum Requirement then the Test Tolerance applied for this test is non-zero. The Test Tolerance for this test is defined and the explanation of how the Minimum Requirement has been relaxed by the Test Tolerance is given in Annex D.

7.1.6 Total Radiated Sensitivity (TRS) for E-UTRA TDD in Speech Mode with beside the Head and Hand Phantom

Editor’s notes: This subclause is incomplete. The following items are missing or incomplete:

- Table 7.1.6.2-1 and 7.1.6.5-1 as they are not specified in TS 37.144 yet

7.1.6.1 Definition and applicability

The Total Radiated Sensitivity is defined as:

$$TRS = \frac{4\pi}{\oint \left[\frac{1}{EIS_{\theta}(\Omega; f)} + \frac{1}{EIS_{\varphi}(\Omega; f)} \right] d\Omega}$$

Where the effective isotropic sensitivity (*EIS*) is defined as the power available at the antenna output such as the sensitivity threshold is achieved for each polarization. Ω is the solid angle describing the direction, f is frequency. θ and φ are the orthogonal polarizations.

$$TRS \approx \frac{2NM}{\pi \sum_{n=0}^{N-1} \sum_{m=0}^{M-1} \left[\frac{1}{EIS_{\theta}(\theta_n, \varphi_m; f)} + \frac{1}{EIS_{\varphi}(\theta_n, \varphi_m; f)} \right] \sin(\theta_n)}$$

In these formulas N and M are the number of sampling intervals for theta and phi. θ_n and φ_m are the measurement angles. The sampling intervals are discussed further in Subclause 4.4.

The TRS can also be calculated from measurements in a Rayleigh fading 3 dimensional isotropic environment with in average uniform elevation and azimuth distribution. The calculation of the TRS is in this case based on searching for the lowest power received by the UE/MS for a discrete number of field combinations in the chamber that gives a BER that is better than the specified target BER level. By calibrating the average power transfer function, an absolute value of the TRS can be obtained. The following expression can be used to find the TRS.

$$TRS \approx 2N \frac{\left(\sum_{n=1}^N (C_n (1 - R_n) P_{thres,n}) \right)^{-1}}{\sum_{n=1}^N P_{ref,n}}$$

where $P_{ref,n}$ is the reference power transfer function for fixed measurement antenna n , R_n is the reflection coefficient for fixed measurement antenna n and C_n is the path loss in the cables connecting the measurement receiver to fixed measurement antenna n . These parameters are calculated from the calibration measurement and are further discussed in Annex B.2. $P_{thres,n}$ is calculated by using the following equation:

$$P_{thres,n} = \frac{\sum_{m=1}^M \frac{1}{|S_{21,n,m}^{thres}|^2}}{M}$$

where $S_{21,n,m}^{thres}$ is the m :th value of the transfer function for fixed measurement antenna n , which gives the BER threshold. M is the total number of values of the BER threshold power measured for each fixed measurement antenna.

The requirements and this test apply to all types of LTE UEs independent of release.

7.1.6.2 Minimum Requirements

The average measured total radiated sensitivity (TRS) of low, mid and high channel for handheld UE shall be lower than the average TRS requirement specified in Table 7.1.6.2-1. The averaging shall be done in linear scale for the TRS results of both right and left side of the phantom head. Average TRS requirement is shown in the column ‘‘Average’’ on the requirement tables.

$$TRS_{average} = 10 \log \left[6 / \left(\frac{1}{10^{P_{left_low}/10}} + \frac{1}{10^{P_{left_mid}/10}} + \frac{1}{10^{P_{left_high}/10}} + \frac{1}{10^{P_{right_low}/10}} + \frac{1}{10^{P_{right_mid}/10}} + \frac{1}{10^{P_{right_high}/10}} \right) \right]$$

In addition the highest TRS of each measured channel shall be lower than maximum TRS requirement specified in Table 7.1.6.2-1. Maximum TRS requirement is shown in the column ‘‘Max’’ on the requirement tables.

$$TRS_{max} = 10 \log \left[\max \left(10^{P_{left_low}/10}, 10^{P_{left_mid}/10}, 10^{P_{left_high}/10}, 10^{P_{right_low}/10}, 10^{P_{right_mid}/10}, 10^{P_{right_high}/10} \right) \right]$$

Table 7.1.6.2-1: TRS minimum requirements for E-UTRA TDD roaming bands in the speech position for the primary mechanical mode

TBD

The normative reference for this clause is TS 37.144 [12] Subclause 7.1.2.4.

7.1.6.3 Test purpose

The purpose of this test is to ensure that $TRS_{average}$ and TRS_{max} of the UE is above specified limit. The lack of the reception sensitivity decreases the coverage area at the far side from Node B.

7.1.6.4 Method of test

7.1.6.4.1 Initial conditions

A radio communications tester or a corresponding device is used as a NB simulator to setup calls to the DUT. The NB/BS simulator is also used to send test signals to the UE and measure the BER levels of the radio link and the information on the dedicated channel needed to extract the DUT receiver performances.

Chamber environment constraints and coordinate system shall be the same as described in Subclause A.3.

Phantom Specifications shall be the same as described in Subclause A.2.1 and A.2.2.

Test environment: normal; see TS36.508 [10] Subclause 4.1.1.

Frequencies to be tested: low range, mid range, high range; see Table 5.4-2.

Positioning Requirements shall be the same as described in Subclause 4.3.

- 1) Position the UE according to the DUT positioning for speech mode specified in Subclause 4.3.3.
- 2) Power on the UE.
- 3) Set the initial conditions as per Subclause 7.3 of 3GPP TS 36.521-1 [11], with the following exception: set the carrier frequency, channel bandwidth, RB length and RB location as per Table 5.4-2 for TDD mode. For DUTs with more than one receiver port, all the tests should be performed using both (all) antenna ports simultaneously.

7.1.6.4.2 Procedure

- 1) Follow Steps 1 through 4 in Subclause 7.3.4.2 of 3GPP TS 36.521-1 [11], with the following exception: measure the receiver sensitivity by adjusting the downlink signal level to 95 % throughput of the maximum throughput of the reference channel (maximum throughput is per Annex A of 3GPP TS 36.521-1 [11]).
- 2) For the anechoic chamber based methodologies, repeat Step 1) with 3-D sampling grid specified in Subclause 4.4. The minimum RF power level resulting in a data throughput greater than or equal to 95 % throughput of the maximum throughput for each test shall be recorded for integration pursuant to Subclause 7.1.6.1 to calculate TRS.
- 3) Repeat the measurement of the DUT on the left and right ears of the head phantom using the left and right hand phantom for low, mid and high channels.
- 4) Calculate the average and minimum TRS as per Subclause 7.1.6.2.

7.1.6.4.3 Procedure, reverberation chamber method

- 1) Follow Steps 1 through 4 in Subclause 7.3.4.2 of 3GPP TS 36.521-1 [11], with the following exception: measure the receiver sensitivity by adjusting the downlink signal level to 95 % throughput of the maximum throughput of the reference channel (maximum throughput is per Annex A of 3GPP TS 36.521-1 [11]).

- 2) Repeat Step 1) until a sufficient number of independent samples (see section 4.5) of $|S_{21,n,m}^{thres}|^2$ has been measured. The minimum RF power level resulting in a data throughput greater than or equal to 95 % throughput of the maximum throughput for each sample shall be recorded for calculating the TRS according to Subclause 7.1.6.1.
- 3) Repeat the measurement of the DUT on the left and right ears of the head phantom using the left and right hand phantom for low, mid and high channels.
- 4) Calculate the average and minimum TRS as per Subclause 7.1.6.2.

7.1.6.5 Test requirements

The average measured total radiated sensitivity (TRS) of low, mid and high channel for handheld UE shall be lower than the average TRS requirement specified in Table 7.1.6.5-1. The averaging shall be done in linear scale for the TRS results of both right and left side of the phantom head. Average TRS requirement is shown in the column “Average” on the requirement tables.

$$TRS_{average} = 10 \log \left[6 / \left(\frac{1}{10^{P_{left_low}/10}} + \frac{1}{10^{P_{left_mid}/10}} + \frac{1}{10^{P_{left_high}/10}} + \frac{1}{10^{P_{right_low}/10}} + \frac{1}{10^{P_{right_mid}/10}} + \frac{1}{10^{P_{right_high}/10}} \right) \right]$$

In addition the highest TRS of each measured channel shall be lower than maximum TRS requirement specified in Table 7.1.6.5-1. Maximum TRS requirement is shown in the column “Max” on the requirement tables.

$$TRS_{max} = 10 \log \left[\max \left(10^{P_{left_low}/10}, 10^{P_{left_mid}/10}, 10^{P_{left_high}/10}, 10^{P_{right_low}/10}, 10^{P_{right_mid}/10}, 10^{P_{right_high}/10} \right) \right]$$

Table 7.1.6.5-1: TRS minimum requirement for E-UTRA TDD roaming bands in the speech position and the primary mechanical mode

TBD

NOTE: If the above Test Requirement differs from the Minimum Requirement then the Test Tolerance applied for this test is non-zero. The Test Tolerance for this test is defined and the explanation of how the Minimum Requirement has been relaxed by the Test Tolerance is given in Annex D.

7.1.7 Total Radiated Sensitivity (TRS) for UTRA FDD in Browsing Mode with Hand Phantom

Editor’s notes: This subclause is incomplete. The following items is missing or incomplete:

- Table 7.1.7.2-1 and 7.1.7.5-1 as they are not specified in TS 37.144 yet
- Text for Subclause 7.1.7.4.3 Procedure, reverberation chamber method

7.1.7.1 Definition and applicability

The Total Radiated Sensitivity is defined as:

$$TRS = \frac{4\pi}{\oint \left[\frac{1}{EIS_{\theta}(\Omega; f)} + \frac{1}{EIS_{\varphi}(\Omega; f)} \right] d\Omega}$$

Where the effective isotropic sensitivity (*EIS*) is defined as the power available at the antenna output such as the sensitivity threshold is achieved for each polarization. Ω is the solid angle describing the direction, f is frequency. θ and φ are the orthogonal polarizations.

$$TRS \approx \frac{2NM}{\pi \sum_{n=0}^{N-1} \sum_{m=0}^{M-1} \left[\frac{1}{EIS_{\theta}(\theta_n, \varphi_m; f)} + \frac{1}{EIS_{\varphi}(\theta_n, \varphi_m; f)} \right]} \sin(\theta_n)$$

In these formulas N and M are the number of sampling intervals for theta and phi. θ_n and φ_m are the measurement angles. The sampling intervals are discussed further in Subclause 4.4.

The requirements and this test apply to all types of UTRA for the FDD UE for Release 7 and later releases.

7.1.7.2 Minimum Requirements

The average measured total radiated sensitivity (TRS) of low, mid and high channel for handheld UE shall be lower than the average TRS requirement specified in Table 7.1.7.2-1. For the hand phantom browsing mode position the averaging shall be done in linear scale for the TRS results of both right and left hand phantom measurements. Average TRS requirement is shown in the column “Average” on the requirement tables.

$$TRS_{average} = 10 \log \left[6 / \left(\frac{1}{10^{P_{left_low}/10}} + \frac{1}{10^{P_{left_mid}/10}} + \frac{1}{10^{P_{left_high}/10}} + \frac{1}{10^{P_{right_low}/10}} + \frac{1}{10^{P_{right_mid}/10}} + \frac{1}{10^{P_{right_high}/10}} \right) \right]$$

In addition the highest TRS of each measured channel shall be lower than maximum TRS requirement specified in Table 7.1.7.2-1. Maximum TRS requirement is shown in the column “Max” on the requirement tables.

$$TRS_{max} = 10 \log \left[\max \left(10^{P_{left_low}/10}, 10^{P_{left_mid}/10}, 10^{P_{left_high}/10}, 10^{P_{right_low}/10}, 10^{P_{right_mid}/10}, 10^{P_{right_high}/10} \right) \right]$$

Table 7.1.7.2-1: Handheld UE TRS minimum requirements for UTRA FDD roaming bands in hand phantom browsing mode position

Operating band	Unit	<REF _{or} >	
		Average	Max
I	dBm/3.84 MHz	TBD	TBD
II	dBm/3.84 MHz	TBD	TBD
III	dBm/3.84 MHz	TBD	TBD
IV	dBm/3.84 MHz	TBD	TBD
V	dBm/3.84 MHz	TBD	TBD
VI	dBm/3.84 MHz	TBD	TBD
VII	dBm/3.84 MHz	TBD	TBD
VIII	dBm/3.84 MHz	TBD	TBD
IX	dBm/3.84 MHz	TBD	TBD
XIX	dBm/3.84 MHz	TBD	TBD

NOTE 1: For power class 3, 3bis and 4 this shall be achieved at the maximum output power.

NOTE 2: For the UE which supports both Band III and Band IX operating frequencies, the reference level of TDB dBm TRS <REF_{or}> [average and min] shall apply for Band IX.

NOTE 3: Applicable for dual-mode GSM/UMTS.

NOTE 4: For the UE which supports DB-DC-HSDPA configuration 2, average <REF_{or}> level of -98 dBm/3.84 MHz and max <REF_{or}> level of -95 dBm/3.84 MHz shall apply for Band II.

NOTE 5: For the UE which supports DB-DC-HSDPA configuration 2, average <REF_{or}> level of -100 dBm/3.84 MHz and max <REF_{or}> level of -97 dBm/3.84 MHz shall apply for Band IV.

The normative reference for this clause is TS 37.144 [12] Subclause 7.1.3.1.

7.1.7.3 Test purpose

The purpose of this test is to ensure that $TRS_{average}$ and TRS_{max} of the UE is above specified limit. The lack of the reception sensitivity decreases the coverage area at the far side from Node B.

7.1.7.4 Method of test

7.1.7.4.1 Initial conditions

A radio communications tester or a corresponding device is used as a NB/BS simulator to setup calls to the DUT. The NB/BS simulator is also used to send test signals to the UE and measure the BER levels of the radio link and the information on the dedicated channel needed to extract the DUT receiver performances.

Chamber environment constraints and coordinate system shall be the same as described in Subclause A.3.

Phantom Specifications shall be the same as described in Subclause A.2.2.

Test environment: normal; see TS36.508 [10] Subclause 4.1.1.

Frequencies to be tested: low range, mid range, high range; see Table 5.2-2.

Positioning Requirements shall be the same as described in Subclause 4.3.

- 1) Position the UE according to the DUT positioning for browsing mode specified in Subclause 4.3.4.
- 2) Set the SS downlink physical channels according to settings in Table 7.1.7.4.1-1.
- 3) Power on the UE.
- 4) A call is set up according to the Generic call setup procedure. The power control algorithm shall be set to Power Control Algorithm 2. Compressed mode shall be set to OFF.
- 5) Enter the UE into loopback test mode 2 and start the loopback test.

See TS 34.108 [4] and TS 34.109 [5] for details regarding generic call setup procedure and loopback test.

Table 7.1.7.4.1-1: Downlink Physical Channels transmitted during a connection

Physical Channel	Power
CPICH	CPICH_Ec / DPCH_Ec = 7 dB
P-CCPCH	P-CCPCH_Ec / DPCH_Ec = 5 dB
SCH	SCH_Ec / DPCH_Ec = 5 dB
PICH	PICH_Ec / DPCH_Ec = 2 dB
DPCH	Test dependent power

7.1.7.4.2 Procedure

- 1) Send continuously Up power control commands to the UE.
- 2) As the UE reaches maximum power, start sending PN15 data pattern.
- 3) Measure EIS from one measurement point. EIS is the power transmitted from one specific direction to the UE causing BER value of 1% ± 0.2% using 20000 or more bits, see Annex E.20.

NOTE: To meet BER value target DL power level can be changed using user's freely selectable algorithm.

- 4) Measure the EIS for every direction of selected sampling grid using two orthogonal polarizations to obtain TRS.
- 5) Calculate TRS using equations from Subclause 7.1.7.1.

NOTE: To speed up sensitivity measurements non standard setting (i.e. data speed, PCL, BER target) can be used in the measurements. However to obtain TRS result the measured EIS figures shall be normalized by

$$\overline{\Delta EIS} = \frac{1}{n} \sum_{i=1}^n (EISstd_i - EISnstd_i)$$

Where $EISstd_i$ is sensitivity measurement done with standard setting. $EISnstd_i$ is sensitivity measurement done with non standard settings. n is amount of reference measurement points.

To ensure accuracy of TRS, the amount of reference points measured should be at least 4. It is recommended to spread the reference measurements equally during the measurement time.

The measurement procedure is based on the measurement of the spherical sensitivity pattern of the DUT. The sensitivity values of the DUT at a predefined BER level are sampled in far field in a group of points located on a spherical surface enclosing the DUT. The EIS samples are taken using a constant sample step of 30° both in theta (θ) and phi (ϕ) directions. All the EIS samples are taken with two orthogonal polarizations, θ - and ϕ -polarisations (See Subclause 4.4).

The Total Radiated Sensitivity is calculated from the measured data by equation in Subclause 7.1.7.2.

7.1.7.4.3 Procedure, reverberation chamber method

TBD

7.1.7.5 Test requirements

The average measured total radiated sensitivity (TRS) of low, mid and high channel for handheld UE shall be lower than the average TRS requirement specified in Table 7.1.7.5-1. For the hand phantom browsing mode position the averaging shall be done in linear scale for the TRS results of both right and left hand phantom measurements. Average TRS requirement is shown in the column “Average” on the requirement tables.

$$TRS_{average} = 10 \log \left[6 / \left(\frac{1}{10^{P_{left_low}/10}} + \frac{1}{10^{P_{left_mid}/10}} + \frac{1}{10^{P_{left_high}/10}} + \frac{1}{10^{P_{right_low}/10}} + \frac{1}{10^{P_{right_mid}/10}} + \frac{1}{10^{P_{right_high}/10}} \right) \right]$$

In addition the highest TRS of each measured channel shall be lower than maximum TRS requirement specified in Table 7.1.7.5-1. Maximum TRS requirement is shown in the column “Max” on the requirement tables.

$$TRS_{max} = 10 \log \left[\max \left(10^{P_{left_low}/10}, 10^{P_{left_mid}/10}, 10^{P_{left_high}/10}, 10^{P_{right_low}/10}, 10^{P_{right_mid}/10}, 10^{P_{right_high}/10} \right) \right]$$

Table 7.1.7.5-1: TRS minimum requirement for UTRA FDD roaming bands in hand phantom browsing mode position

Operating band	Unit	<REF _{or} >	
		Average	Max
I	dBm/3.84 MHz	TBD+TT	TBD+TT
II	dBm/3.84 MHz	TBD+TT	TBD+TT
III	dBm/3.84 MHz	TBD+TT	TBD+TT
IV	dBm/3.84 MHz	TBD+TT	TBD+TT
V	dBm/3.84 MHz	TBD+TT	TBD+TT
VI	dBm/3.84 MHz	TBD+TT	TBD+TT
VII	dBm/3.84 MHz	TBD+TT	TBD+TT
VIII	dBm/3.84 MHz	TBD+TT	TBD+TT
IX	dBm/3.84 MHz	TBD+TT	TBD+TT
XIX	dBm/3.84 MHz	TBD+TT	TBD+TT

NOTE 1: For power class 3, 3bis and 4 this shall be achieved at the maximum output power.

NOTE 2: For the UE which supports both Band III and Band IX operating frequencies, the reference level of TDB dBm TRS <REF_{or}> [average and min] shall apply for Band IX.

NOTE 3: Applicable for dual-mode GSM/UMTS.

NOTE 4: For the UE which supports DB-DC-HSDPA configuration 2, average <REF_{or}> level of -98 dBm/3.84 MHz and max <REF_{or}> level of -95 dBm/3.84 MHz shall apply for Band II.

NOTE 5: For the UE which supports DB-DC-HSDPA configuration 2, average <REF_{or}> level of -100 dBm/3.84 MHz and max <REF_{or}> level of -97 dBm/3.84 MHz shall apply for Band IV.

NOTE: If the above Test Requirement differs from the Minimum Requirement then the Test Tolerance applied for this test is non-zero. The Test Tolerance for this test is defined and the explanation of how the Minimum Requirement has been relaxed by the Test Tolerance is given in Annex D.

7.1.8 Total Radiated Sensitivity (TRS) for UTRA LCR TDD in Browsing Mode with Hand Phantom

Editor's notes: This subclause is incomplete. The following items is missing or incomplete:

- Table 7.1.8.2-1 and 7.1.8.5-1 as they are not specified in TS 37.144 yet
- Text for Subclause 7.1.8.4.3 Procedure, reverberation chamber method

7.1.8.1 Definition and applicability

The Total Radiated Sensitivity is defined as:

$$TRS = \frac{4\pi}{\oint \left[\frac{1}{EIS_{\theta}(\Omega; f)} + \frac{1}{EIS_{\varphi}(\Omega; f)} \right] d\Omega}$$

Where the effective isotropic sensitivity (*EIS*) is defined as the power available at the antenna output such as the sensitivity threshold is achieved for each polarization. Ω is the solid angle describing the direction, f is frequency. θ and φ are the orthogonal polarizations.

$$TRS \approx \frac{2NM}{\pi \sum_{n=0}^{N-1} \sum_{m=0}^{M-1} \left[\frac{1}{EIS_{\theta}(\theta_n, \varphi_m; f)} + \frac{1}{EIS_{\varphi}(\theta_n, \varphi_m; f)} \right] \sin(\theta_n)}$$

In these formulas N and M are the number of sampling intervals for theta and phi. θ_n and φ_m are the measurement angles. The sampling intervals are discussed further in Subclause 4.4.

The requirements and this test apply to all types of UTRA for the TDD UE for Release 8 and later releases.

7.1.8.2 Minimum Requirements

The average measured total radiated sensitivity (TRS) of low, mid and high channel for handheld UE shall be lower than the average TRS requirement specified in Table 7.1.5.2-1. For the hand phantom browsing mode position the averaging shall be done in linear scale for the TRS results of both right and left hand phantom measurements. Average TRS requirement is shown in the column "Average" on the requirement tables.

$$TRS_{average} = 10 \log \left[6 / \left(\frac{1}{10^{P_{left_low}/10}} + \frac{1}{10^{P_{left_mid}/10}} + \frac{1}{10^{P_{left_high}/10}} + \frac{1}{10^{P_{right_low}/10}} + \frac{1}{10^{P_{right_mid}/10}} + \frac{1}{10^{P_{right_high}/10}} \right) \right]$$

In addition the highest TRS of each measured channel shall be lower than maximum TRS requirement specified in Table 7.1.8.2-1. Maximum TRS requirement is shown in the column "Max" on the requirement tables.

$$TRS_{max} = 10 \log \left[\max \left(10^{P_{left_low}/10}, 10^{P_{left_mid}/10}, 10^{P_{left_high}/10}, 10^{P_{right_low}/10}, 10^{P_{right_mid}/10}, 10^{P_{right_high}/10} \right) \right]$$

Table 7.1.8.2-1: Handheld UE TRS minimum requirement for UTRA LCR TDD roaming bands in hand phantom browsing mode position

Operating band	Unit	<REFlor>	
		Average	Max
a	dBm/1.28 MHz	TBD	TBD
b	dBm/1.28 MHz	TBD	TBD
c	dBm/1.28 MHz	TBD	TBD
d	dBm/1.28 MHz	TBD	TBD
e	dBm/1.28 MHz	TBD	TBD
f	dBm/1.28 MHz	TBD	TBD
Note: Applicable for dual-mode GSM/UTRA LCR TDD.			

The normative reference for this clause is TS 37.144 [12] Subclause 7.1.3.2.

7.1.8.3 Test purpose

The purpose of this test is to ensure that $TRS_{average}$ and TRS_{max} of the UE is above specified limit. The lack of the reception sensitivity decreases the coverage area at the far side from Node B.

7.1.8.4 Method of test

7.1.8.4.1 Initial conditions

A radio communications tester or a corresponding device is used as a NB/BS simulator to setup calls to the DUT. The NB/BS simulator is also used to send test signals to the UE and measure the BER levels of the radio link and the information on the dedicated channel needed to extract the DUT receiver performances.

Chamber environment constraints and coordinate system shall be the same as described in Subclause A.3.

Phantom Specifications shall be the same as described in Subclause A.2.2.

Test environment: normal; see TS36.508 [10] Subclause 4.1.1.

Frequencies to be tested: low range, mid range, high range; see Table 5.3-2.

Positioning Requirements shall be the same as described in Subclause 4.3.

- 1) Position the UE according to the DUT positioning for speech mode specified in Subclause 4.3.4.
- 2) Set the SS downlink physical channels according to settings in Table 7.1.8.4.1-1. The DL power level should be set to ensure 0% BER at 12.2kbps data rate at the whole 3D initial scan.
- 3) Power on the UE.
- 4) A call is set up according to the Generic call setup procedure. The power control algorithm shall be set to Power Control Algorithm 2.
- 5) Enter the UE into loopback test mode and start the loopback test.

See TS 34.108 [4] and TS 34.109 [5] and Annex C of TS 34.122 [8] for details regarding generic call setup procedure and loopback test.

Table 7.1.8.4.1-1: Downlink Physical Channels transmitted during a connection

Physical Channel		Power
lor	-75 dBm	-
DwPCH	DwPCH_Ec / lor	0 dB
PCCPCH	\sum P-CCPCH_Ec / lor	-3 dB
SCCPCH	\sum S-CCPCH_Ec / lor	-6 dB
PICH	\sum PICH_Ec / lor	-6 dB
FPACH	FPACH_Ec / lor	-6 dB
DL DPCH	\sum DPCH_Ec / lor	0 dB

7.1.8.4.2 Procedure

- 1) Send continuously Up power control commands to the UE.
- 2) As the UE reaches maximum power, start sending PN15 data pattern.
- 3) Measure EIS from one measurement point. EIS is the power transmitted from one specific direction to the UE causing BER value of 1% \pm 0.2% using 40000 or more bits, see Annex E.20. The DL power step size shall be no bigger than 0.5dB when the RF level is near the TDD UE sensitivity level.

NOTE: To meet BER value target DL power level can be changed using user's freely selectable algorithm.

- 4) Measure the EIS for every direction of selected sampling grid using two orthogonal polarizations to obtain TRS.
- 5) Calculate TRS using equations from Subclause 7.1.8.1.

NOTE: To speed up sensitivity measurements non standard setting (i.e. data speed, PCL, BER target) can be used in the measurements. However to obtain TRS result the measured EIS figures shall be normalized by

$$\Delta \overline{EIS} = \frac{1}{n} \sum_{i=1}^n (EIS_{std_i} - EIS_{nstd_i})$$

Where EIS_{std_i} is sensitivity measurement done with standard setting. EIS_{nstd_i} is sensitivity measurement done with non standard settings. n is amount of reference measurement points.

To ensure accuracy of TRS, the amount of reference points measured should be at least 4. It is recommended to spread the reference measurements equally during the measurement time.

The measurement procedure is based on the measurement of the spherical sensitivity pattern of the DUT. The sensitivity values of the DUT at a predefined BER level are sampled in far field in a group of points located on a spherical surface enclosing the DUT. The EIS samples are taken using a constant sample step of 30° both in theta (θ) and phi (ϕ) directions. All the EIS samples are taken with two orthogonal polarizations, θ - and ϕ -polarisations (See Subclause 4.4).

The Total Radiated Sensitivity is calculated from the measured data by equation in Subclause 7.1.8.2.

7.1.8.4.3 Procedure, reverberation chamber method

TBD

7.1.8.5 Test requirements

The average measured total radiated sensitivity (TRS) of low, mid and high channel for handheld UE shall be lower than the average TRS requirement specified in Table 7.1.8.5-1. For the hand phantom browsing mode position the averaging shall be done in linear scale for the TRS results of both right and left hand phantom measurements. Average TRS requirement is shown in the column "Average" on the requirement tables.

$$TRS_{average} = 10 \log \left[6 / \left(\frac{1}{10^{P_{left_low}/10}} + \frac{1}{10^{P_{left_mid}/10}} + \frac{1}{10^{P_{left_high}/10}} + \frac{1}{10^{P_{right_low}/10}} + \frac{1}{10^{P_{right_mid}/10}} + \frac{1}{10^{P_{right_high}/10}} \right) \right]$$

In addition the highest TRS of each measured channel shall be lower than maximum TRS requirement specified in Table 7.1.8.5-1. Maximum TRS requirement is shown in the column “Max” on the requirement tables.

$$TRS_{\max} = 10 \log \left[\max \left(10^{P_{\text{left_low}}/10}, 10^{P_{\text{left_mid}}/10}, 10^{P_{\text{left_high}}/10}, 10^{P_{\text{right_low}}/10}, 10^{P_{\text{right_mid}}/10}, 10^{P_{\text{right_high}}/10} \right) \right]$$

Table 7.1.8.5-1: TRS minimum requirement for UTRA LCR TDD roaming bands in hand phantom browsing mode position

Operating band	Unit	<REFlor>	
		Average	Max
a	dBm/1.28 MHz	TBD+TT	TBD+TT
b	dBm/1.28 MHz	TBD+TT	TBD+TT
c	dBm/1.28 MHz	TBD+TT	TBD+TT
d	dBm/1.28 MHz	TBD+TT	TBD+TT
e	dBm/1.28 MHz	TBD+TT	TBD+TT
f	dBm/1.28 MHz	TBD+TT	TBD+TT
Note: Applicable for dual-mode GSM/UTRA LCR TDD			

NOTE: If the above Test Requirement differs from the Minimum Requirement then the Test Tolerance applied for this test is non-zero. The Test Tolerance for this test is defined and the explanation of how the Minimum Requirement has been relaxed by the Test Tolerance is given in Annex D.

7.1.9 Total Radiated Sensitivity (TRS) for E-UTRA FDD in Browsing Mode with Hand Phantom

Editor’s notes: This subclause is incomplete. The following items is missing or incomplete:

- Table 7.1.9.2-1 and 7.1.9.5-1 as they are not specified in TS 37.144 yet
- Text for Subclause 7.1.9.4.3 Procedure, reverberation chamber method

7.1.9.1 Definition and applicability

The Total Radiated Sensitivity is defined as:

$$TRS = \frac{4\pi}{\oint \left[\frac{1}{EIS_{\theta}(\Omega; f)} + \frac{1}{EIS_{\varphi}(\Omega; f)} \right] d\Omega}$$

Where the effective isotropic sensitivity (*EIS*) is defined as the power available at the antenna output such as the sensitivity threshold is achieved for each polarization. Ω is the solid angle describing the direction, f is frequency. θ and φ are the orthogonal polarizations.

$$TRS \approx \frac{2NM}{\pi \sum_{n=0}^{N-1} \sum_{m=0}^{M-1} \left[\frac{1}{EIS_{\theta}(\theta_n, \varphi_m; f)} + \frac{1}{EIS_{\varphi}(\theta_n, \varphi_m; f)} \right] \sin(\theta_n)}$$

In these formulas N and M are the number of sampling intervals for theta and phi. θ_n and φ_m are the measurement angles. The sampling intervals are discussed further in Subclause 4.4.

The requirements and this test apply to all types of LTE UEs independent of release.

7.1.9.2 Minimum Requirements

The average measured total radiated sensitivity (TRS) of low, mid and high channel for handheld UE shall be lower than the average TRS requirement specified in Table 7.1.9.2-1. For the hand phantom browsing mode position the averaging shall be done in linear scale for the TRS results of both right and left hand phantom measurements. Average TRS requirement is shown in the column “Average” on the requirement tables.

$$TRS_{average} = 10 \log \left[6 / \left(\frac{1}{10^{P_{left_low}/10}} + \frac{1}{10^{P_{left_mid}/10}} + \frac{1}{10^{P_{left_high}/10}} + \frac{1}{10^{P_{right_low}/10}} + \frac{1}{10^{P_{right_mid}/10}} + \frac{1}{10^{P_{right_high}/10}} \right) \right]$$

In addition the highest TRS of each measured channel shall be lower than maximum TRS requirement specified in Table 7.1.9.2-1. Maximum TRS requirement is shown in the column “Max” on the requirement tables.

$$TRS_{max} = 10 \log \left[\max \left(10^{P_{left_low}/10}, 10^{P_{left_mid}/10}, 10^{P_{left_high}/10}, 10^{P_{right_low}/10}, 10^{P_{right_mid}/10}, 10^{P_{right_high}/10} \right) \right]$$

Table 7.1.9.2-1: TRS minimum requirements for E-UTRA FDD roaming bands in hand phantom browsing mode position

TBD

The normative reference for this clause is TS 37.144 [12] Subclause 7.1.3.3.

7.1.9.3 Test purpose

The purpose of this test is to ensure that $TRS_{average}$ and TRS_{max} of the UE is above specified limit. The lack of the reception sensitivity decreases the coverage area at the far side from Node B.

7.1.9.4 Method of test

7.1.9.4.1 Initial conditions

A radio communications tester or a corresponding device is used as a NB/BS simulator to setup calls to the DUT. The NB/BS simulator is also used to send test signals to the UE and measure the BER levels of the radio link and the information on the dedicated channel needed to extract the DUT receiver performances.

Chamber environment constraints and coordinate system shall be the same as described in Subclause A.3.

Phantom Specifications shall be the same as described in Subclause A.2.2.

Test environment: normal; see TS36.508 [10] Subclause 4.1.1.

Frequencies to be tested: low range, mid range, high range; see Table 5.4-2.

Positioning Requirements shall be the same as described in Subclause 4.3.

- 1) Position the UE according to the DUT positioning for speech mode specified in Subclause 4.3.4.
- 2) Power on the UE.
- 3) Set the initial conditions as per Subclause 7.3 of 3GPP TS 36.521-1 [11], with the following exception: set the carrier frequency, channel bandwidth, RB length and RB location as per Table 5.4-2 for FDD mode. For DUTs with more than one receiver port, all the tests should be performed using both (all) antenna ports simultaneously.

7.1.9.4.2 Procedure

- 1) Follow Steps 1 through 4 in Subclause 7.3.4.2 of 3GPP TS 36.521-1 [11], with the following exception: measure the receiver sensitivity by adjusting the downlink signal level to 95 % throughput of the maximum throughput of the reference channel (maximum throughput is per Annex A of 3GPP TS 36.521-1 [11]).
- 2) For the anechoic chamber based methodologies, repeat Step 1) with 3-D sampling grid specified in Subclause 4.4. The minimum RF power level resulting in a data throughput greater than or equal to 95 % throughput of the

maximum throughput for each test shall be recorded for integration pursuant to Subclause 7.1.9.1 to calculate TRS.

- 3) Repeat the measurement of the DUT on the left and right ears of the head phantom using the left and right hand phantom for low, mid and high channels.
- 4) Calculate the average and minimum TRS as per Subclause 7.1.9.2.

7.1.9.4.3 Procedure, reverberation chamber method

TBD

7.1.9.5 Test requirements

The average measured total radiated sensitivity (TRS) of low, mid and high channel for handheld UE shall be lower than the average TRS requirement specified in Table 7.1.9.5-1. For the hand phantom browsing mode position the averaging shall be done in linear scale for the TRS results of both right and left hand phantom measurements. Average TRS requirement is shown in the column “Average” on the requirement tables.

$$TRS_{average} = 10 \log \left[6 / \left(\frac{1}{10^{P_{left_low}/10}} + \frac{1}{10^{P_{left_mid}/10}} + \frac{1}{10^{P_{left_high}/10}} + \frac{1}{10^{P_{right_low}/10}} + \frac{1}{10^{P_{right_mid}/10}} + \frac{1}{10^{P_{right_high}/10}} \right) \right]$$

In addition the highest TRS of each measured channel shall be lower than maximum TRS requirement specified in Table 7.1.9.5-1. Maximum TRS requirement is shown in the column “Max” on the requirement tables.

$$TRS_{max} = 10 \log \left[\max \left(10^{P_{left_low}/10}, 10^{P_{left_mid}/10}, 10^{P_{left_high}/10}, 10^{P_{right_low}/10}, 10^{P_{right_mid}/10}, 10^{P_{right_high}/10} \right) \right]$$

Table 7.1.9.5-1: TRS minimum requirement for E-UTRA FDD roaming bands in hand phantom browsing mode position

TBD

NOTE: If the above Test Requirement differs from the Minimum Requirement then the Test Tolerance applied for this test is non-zero. The Test Tolerance for this test is defined and the explanation of how the Minimum Requirement has been relaxed by the Test Tolerance is given in Annex D.

7.1.10 Total Radiated Sensitivity (TRS) for E-UTRA TDD in Browsing Mode with Hand Phantom

Editor’s notes: This subclause is incomplete. The following items is missing or incomplete:

- Table 7.1.10.2-1 and 7.1.10.5-1 as they are not specified in TS 37.144 yet
- Text for Subclause 7.1.10.4.3 Procedure, reverberation chamber method

7.1.10.1 Definition and applicability

The Total Radiated Sensitivity is defined as:

$$TRS = \frac{4\pi}{\oint \left[\frac{1}{EIS_{\theta}(\Omega; f)} + \frac{1}{EIS_{\varphi}(\Omega; f)} \right] d\Omega}$$

Where the effective isotropic sensitivity (*EIS*) is defined as the power available at the antenna output such as the sensitivity threshold is achieved for each polarization. Ω is the solid angle describing the direction, f is frequency. θ and φ are the orthogonal polarizations.

$$TRS \approx \frac{2NM}{\pi \sum_{n=0}^{N-1} \sum_{m=0}^{M-1} \left[\frac{1}{EIS_{\theta}(\theta_n, \varphi_m; f)} + \frac{1}{EIS_{\varphi}(\theta_n, \varphi_m; f)} \right]} \sin(\theta_n)$$

In these formulas N and M are the number of sampling intervals for theta and phi. θ_n and φ_m are the measurement angles. The sampling intervals are discussed further in Subclause 4.4.

The requirements and this test apply to all types of LTE UEs independent of release.

7.1.10.2 Minimum Requirements

The average measured total radiated sensitivity (TRS) of low, mid and high channel for handheld UE shall be lower than the average TRS requirement specified in Table 7.1.10.2-1. For the hand phantom browsing mode position the averaging shall be done in linear scale for the TRS results of both right and left hand phantom measurements. Average TRS requirement is shown in the column “Average” on the requirement tables.

$$TRS_{average} = 10 \log \left[6 / \left(\frac{1}{10^{P_{left_low}/10}} + \frac{1}{10^{P_{left_mid}/10}} + \frac{1}{10^{P_{left_high}/10}} + \frac{1}{10^{P_{right_low}/10}} + \frac{1}{10^{P_{right_mid}/10}} + \frac{1}{10^{P_{right_high}/10}} \right) \right]$$

In addition the highest TRS of each measured channel shall be lower than maximum TRS requirement specified in Table 7.1.10.2-1. Maximum TRS requirement is shown in the column “Max” on the requirement tables.

$$TRS_{max} = 10 \log \left[\max \left(10^{P_{left_low}/10}, 10^{P_{left_mid}/10}, 10^{P_{left_high}/10}, 10^{P_{right_low}/10}, 10^{P_{right_mid}/10}, 10^{P_{right_high}/10} \right) \right]$$

Table 7.1.10.2-1: TRS minimum requirements for E-UTRA TDD roaming bands in hand phantom browsing mode position

TBD

The normative reference for this clause is TS 37.144 [12] Subclause 7.1.3.4.

7.1.10.3 Test purpose

The purpose of this test is to ensure that $TRS_{average}$ and TRS_{max} of the UE is above specified limit. The lack of the reception sensitivity decreases the coverage area at the far side from Node B.

7.1.10.4 Method of test

7.1.10.4.1 Initial conditions

A radio communications tester or a corresponding device is used as a NB/BS simulator to setup calls to the DUT. The NB/BS simulator is also used to send test signals to the UE and measure the BER levels of the radio link and the information on the dedicated channel needed to extract the DUT receiver performances.

Chamber environment constraints and coordinate system shall be the same as described in Subclause A.3.

Phantom Specifications shall be the same as described in Subclause A.2.2.

Test environment: normal; see TS36.508 [10] Subclause 4.1.1.

Frequencies to be tested: low range, mid range, high range; see Table 5.5-2.

Positioning Requirements shall be the same as described in Subclause 4.3.

- 1) Position the UE according to the DUT positioning for speech mode specified in Subclause 4.3.4.
- 2) Power on the UE.

- 3) Set the initial conditions as per Subclause 7.3 of 3GPP TS 36.521-1 [11], with the following exception: set the carrier frequency, channel bandwidth, RB length and RB location as per Table 5.5-2 for TDD mode. For DUTs with more than one receiver port, all the tests should be performed using both (all) antenna ports simultaneously.

7.1.10.4.2 Procedure

- 1) Follow Steps 1 through 4 in Subclause 7.3.4.2 of 3GPP TS 36.521-1 [11], with the following exception: measure the receiver sensitivity by adjusting the downlink signal level to 95 % throughput of the maximum throughput of the reference channel (maximum throughput is per Annex A of 3GPP TS 36.521-1 [11]).
- 2) For the anechoic chamber based methodologies, repeat Step 1) with 3-D sampling grid specified in Subclause 4.4. The minimum RF power level resulting in a data throughput greater than or equal to 95 % throughput of the maximum throughput for each test shall be recorded for integration pursuant to Subclause 7.1.10.1 to calculate TRS.
- 3) Repeat the measurement of the DUT on the left and right ears of the head phantom using the left and right hand phantom for low, mid and high channels.
- 4) Calculate the average and minimum TRS as per Subclause 7.1.10.2.

7.1.10.4.3 Procedure, reverberation chamber method

TBD

7.1.10.5 Test requirements

The average measured total radiated sensitivity (TRS) of low, mid and high channel for handheld UE shall be lower than the average TRS requirement specified in Table 7.1.10.5-1. For the hand phantom browsing mode position the averaging shall be done in linear scale for the TRS results of both right and left hand phantom measurements. Average TRS requirement is shown in the column “Average” on the requirement tables.

$$TRS_{average} = 10 \log \left[6 / \left(\frac{1}{10^{P_{left_low}/10}} + \frac{1}{10^{P_{left_mid}/10}} + \frac{1}{10^{P_{left_high}/10}} + \frac{1}{10^{P_{right_low}/10}} + \frac{1}{10^{P_{right_mid}/10}} + \frac{1}{10^{P_{right_high}/10}} \right) \right]$$

In addition the highest TRS of each measured channel shall be lower than maximum TRS requirement specified in Table 7.1.10.5-1. Maximum TRS requirement is shown in the column “Max” on the requirement tables.

$$TRS_{max} = 10 \log \left[\max \left(10^{P_{left_low}/10}, 10^{P_{left_mid}/10}, 10^{P_{left_high}/10}, 10^{P_{right_low}/10}, 10^{P_{right_mid}/10}, 10^{P_{right_high}/10} \right) \right]$$

Table 7.1.10.5-1: TRS minimum requirement for E-UTRA TDD roaming bands in hand phantom browsing mode position

TBD

NOTE: If the above Test Requirement differs from the Minimum Requirement then the Test Tolerance applied for this test is non-zero. The Test Tolerance for this test is defined and the explanation of how the Minimum Requirement has been relaxed by the Test Tolerance is given in Annex D.

7.2 Performance for LME

7.2.1 Total Radiated Sensitivity (TRS) for UTRA FDD LME

Editor’s notes: This subclause is incomplete. The following items are missing or incomplete:

- Table 7.2.1.2-1 and 7.2.1.5-1 as they are not specified in TS 37.144 yet
- Text for Subclause 7.2.1.4.3 Procedure, reverberation chamber method

7.2.1.1 Definition and applicability

The Total Radiated Sensitivity is defined as:

$$TRS = \frac{4\pi}{\oint \left[\frac{1}{EIS_{\theta}(\Omega; f)} + \frac{1}{EIS_{\varphi}(\Omega; f)} \right] d\Omega}$$

Where the effective isotropic sensitivity (*EIS*) is defined as the power available at the antenna output such as the sensitivity threshold is achieved for each polarization. Ω is the solid angle describing the direction, f is frequency. θ and φ are the orthogonal polarizations.

$$TRS \approx \frac{2NM}{\pi \sum_{n=0}^{N-1} \sum_{m=0}^{M-1} \left[\frac{1}{EIS_{\theta}(\theta_n, \varphi_m; f)} + \frac{1}{EIS_{\varphi}(\theta_n, \varphi_m; f)} \right] \sin(\theta_n)}$$

In these formulas N and M are the number of sampling intervals for theta and phi. θ_n and φ_m are the measurement angles. The sampling intervals are discussed further in Subclause 4.4.

The requirements and this test apply to all types of UTRA for the FDD UE for Release 11 and later releases that support LME.

NOTE: This test case can be optionally executed for Release 7 and onward UE's supporting LME feature.

7.2.1.2 Minimum Requirements

The average TRS of low, mid and high channel for 1% BER with 12.2kbps DL reference channel as defined in Annex C.3 of TS 25.101 [2] shall be lower than minimum performance requirements for roaming bands shown in Table 7.2.1.2-1. The averaging shall be done in linear scale for the TRS results.

$$TRS_{average} = 10 \log \left[3 / \left(\frac{1}{10^{P_{low}/10}} + \frac{1}{10^{P_{mid}/10}} + \frac{1}{10^{P_{high}/10}} \right) \right]$$

In addition the maximum TRS of each measured channel shall be better than minimum performance requirements for roaming bands shown in the columns "Max" on the requirement tables.

$$TRS_{max} = 10 \log \left[\max \left(10^{P_{low}/10}, 10^{P_{mid}/10}, 10^{P_{high}/10} \right) \right]$$

Table 7.2.1.2-1: TRS minimum requirements for UTRA FDD roaming mode for LME devices in the data transfers position and the primary mechanical mode

Operating Band	Unit	<REF _{or} >	
		Average	Max
I	dBm/3.84 MHz	TBD	TBD
II	dBm/3.84 MHz	TBD	TBD
III	dBm/3.84 MHz	TBD	TBD
IV	dBm/3.84 MHz	TBD	TBD
V	dBm/3.84 MHz	TBD	TBD
VI	dBm/3.84 MHz	TBD	TBD
VII	dBm/3.84 MHz	TBD	TBD
VIII	dBm/3.84 MHz	TBD	TBD
IX	dBm/3.84 MHz	TBD	TBD
IX	dBm/3.84 MHz	TBD	TBD

NOTE 1 For Power Class 3, 3bis and 4 this shall be achieved at the maximum output power.
NOTE 2 Applicable for dual-mode GSM/UMTS.
NOTE 3 Applicable for USB plug-in devices.

The normative reference for this clause is TS 37.144 [12] Subclause 7.2.2.

7.2.1.3 Test purpose

The purpose of this test is to ensure that $TRS_{average}$ and TRS_{max} of the UE is above specified limit. The lack of the reception sensitivity decreases the coverage area at the far side from Node B.

7.2.1.4 Method of test

7.2.1.4.1 Initial conditions

A radio communications tester or a corresponding device is used as a NB simulator to setup calls to the DUT. The NB simulator is also used to send test signals to the UE and measure the BER levels of the radio link and the information on the dedicated channel needed to extract the DUT receiver performances.

Chamber environment constraints and coordinate system shall be the same as described in Subclause A.3.

Phantom Specifications shall be the same as described in Subclause A.2.3.

Test environment: normal; see TS 36.508 [10] Subclause 4.1.1.

Frequencies to be tested: low range, mid range, high range; see Table 5.1-2.

Positioning Requirements shall be the same as described in Subclause 4.3.

- 1) Position the plug-in UE according to the DUT positioning on laptop ground plane phantom specified in Subclause 4.3.2.
- 2) Set the SS downlink physical channels according to settings in Table 7.2.1.4.1-1.
- 3) Power on the plug-in UE. The real functional laptop supplies power to the plug-in UE.
- 4) A call is set up according to the Generic call setup procedure. The power control algorithm shall be set to Power Control Algorithm 2. Compressed mode shall be set to OFF.
- 5) Enter the UE into loopback test mode 2 and start the loopback test.

See TS 34.108 [4] and TS 34.109 [5] for details regarding generic call setup procedure and loopback test.

Table 7.2.1.4.1-1: Downlink Physical Channels transmitted during a connection

Physical Channel		Power
CPICH	CPICH_Ec / DPCH_Ec	7 dB
P-CCPCH	P-CCPCH_Ec/ DPCH_Ec	5 dB
SCH	SCH_Ec / DPCH_Ec	5 dB
PICH	PICH_Ec / DPCH_Ec	2 dB
DPCH	Test dependent power	-

7.2.1.4.2 Procedure

- 1) Send continuously Up power control commands to the plug-in UE.
- 2) As the plug-in UE reaches maximum power, start sending PN15 data pattern.
- 3) Position the plug-in UE into the USB connector in accordance with the manufacturer recommended primary mechanical mode. In the absence of such a recommendation position the plug-in UE so that it is horizontally plugged into the horizontal USB connector.
- 4) Measure EIS from one measurement point. EIS is the power transmitted from one specific direction to the plug-in UE causing BER value of $1\% \pm 0.2\%$ using 20000 or more bits; see Annex E.20.

NOTE: To meet BER value target DL power level can be changed using user's freely selectable algorithm.

- 5) Measure the EIS for every direction of selected sampling grid using two orthogonal polarizations to obtain TRS.
- 6) Calculate TRS using equations from clause 7.2.1.1

NOTE: To speed up sensitivity measurements non standard setting (i.e. data speed, PCL, BER target) can be used in the measurements. However to obtain TRS result the measured EIS figures shall be normalized by

$$\overline{\Delta EIS} = \frac{1}{n} \sum_{i=1}^n (EIS_{std_i} - EIS_{nstd_i})$$

Where EIS_{std_i} is sensitivity measurement done with standard setting. EIS_{nstd_i} is sensitivity measurement done with non standard settings. n is amount of reference measurement points.

To ensure accuracy of TRS, the amount of reference points measured should be at least 4. It is recommended to spread the reference measurements equally during the measurement time.

The measurement procedure is based on the measurement of the spherical sensitivity pattern of the DUT. The sensitivity values of the DUT at a predefined BER level are sampled in far field in a group of points located on a spherical surface enclosing the DUT. The EIS samples are taken using a constant sample step of 30° both in theta (θ) and phi (ϕ) directions. All the EIS samples are taken with two orthogonal polarizations, θ - and ϕ -polarisations (See Subclause 4.4).

The Total Radiated Sensitivity is calculated from the measured data by equation in Subclause 7.2.1.2.

7.2.1.4.3 Test procedure, reverberation chamber method

TBD

7.2.1.5 Test requirements

The average TRS of low, mid and high channel for 1% BER with 12.2kbps DL reference channel as defined in Annex C.3 of TS 25.101 [2] shall be lower than test requirements for roaming bands shown in Table 7.2.1.5-1. The averaging shall be done in linear scale for the TRS results.

$$TRS_{average} = 10 \log \left[3 / \left(\frac{1}{10^{P_{low}/10}} + \frac{1}{10^{P_{mid}/10}} + \frac{1}{10^{P_{high}/10}} \right) \right]$$

In addition the maximum TRS of each measured channel shall be better than minimum performance requirements for roaming bands shown in the columns “Max” on the requirement tables.

$$TRS_{\max} = 10 \log \left[\max \left(10^{P_{\text{low}}/10}, 10^{P_{\text{mid}}/10}, 10^{P_{\text{high}}/10} \right) \right]$$

Table 7.2.1.5-1: TRS test requirements for UTRA FDD roaming mode for LME devices in the data transfers position and the primary mechanical mode

Operating Band	Unit	<REF> _{or}	
		Average	Max
I	dBm/3.84 MHz	TBD + TT	TBD + TT
II	dBm/3.84 MHz	TBD + TT	TBD + TT
III	dBm/3.84 MHz	TBD + TT	TBD + TT
IV	dBm/3.84 MHz	TBD + TT	TBD + TT
V	dBm/3.84 MHz	TBD + TT	TBD + TT
VI	dBm/3.84 MHz	TBD + TT	TBD + TT
VII	dBm/3.84 MHz	TBD + TT	TBD + TT
VIII	dBm/3.84 MHz	TBD + TT	TBD + TT
IX	dBm/3.84 MHz	TBD + TT	TBD + TT
XIX	dBm/3.84 MHz	TBD + TT	TBD + TT

NOTE 1 For Power Class 3, 3bis and 4 this shall be achieved at the maximum output power.
NOTE 2 Applicable for dual-mode GSM/UMTS.
NOTE 3 Applicable for USB plug-in devices.

NOTE: If the above Test Requirement differs from the Minimum Requirement then the Test Tolerance applied for this test is non-zero. The Test Tolerance for this test is defined and the explanation of how the Minimum Requirement has been relaxed by the Test Tolerance is given in Annex D.2.

7.2.2 Total Radiated Sensitivity (TRS) for UTRA LCR TDD LME

Editor’s notes: This subclause is incomplete. The following items are missing or incomplete:

- Table 7.2.2.2-1 and 7.2.2.5-1 as they are not specified in TS 37.144 yet
- Text for Subclause 7.2.2.4.3 Procedure, reverberation chamber method

7.2.2.1 Definition and applicability

The Total Radiated Sensitivity is defined as:

$$TRS = \frac{4\pi}{\oint \left[\frac{1}{EIS_{\theta}(\Omega; f)} + \frac{1}{EIS_{\varphi}(\Omega; f)} \right] d\Omega}$$

Where the effective isotropic sensitivity (*EIS*) is defined as the power available at the antenna output such as the sensitivity threshold is achieved for each polarization. Ω is the solid angle describing the direction, f is frequency. θ and φ are the orthogonal polarizations.

$$TRS \approx \frac{2NM}{\pi \sum_{n=0}^{N-1} \sum_{m=0}^{M-1} \left[\frac{1}{EIS_{\theta}(\theta_n, \varphi_m; f)} + \frac{1}{EIS_{\varphi}(\theta_n, \varphi_m; f)} \right] \sin(\theta_n)}$$

In these formulas N and M are the number of sampling intervals for theta and phi. θ_n and φ_m are the measurement angles. The sampling intervals are discussed further in Subclause 4.4.

The requirements and this test apply to all types of UTRA for the TDD UE for Release 11 and later releases that support LME.

NOTE: This test case can be optionally executed for Release 7 and onward UE's supporting LME feature.

7.2.2.2 Minimum Requirements

The average TRS of low, mid and high channel for 1% BER with 12.2kbps DL reference channel as defined in Annex C.3 of TS 34.122 [8] shall be lower than minimum performance requirements for roaming bands shown in Table 7.2.2.2-1. The averaging shall be done in linear scale for the TRS results.

$$TRS_{average} = 10 \log \left[3 / \left(\frac{1}{10^{P_{low}/10}} + \frac{1}{10^{P_{mid}/10}} + \frac{1}{10^{P_{high}/10}} \right) \right]$$

In addition the maximum TRS of each measured channel shall be better than minimum performance requirements for roaming bands shown in the columns "Max" on the requirement tables.

$$TRS_{max} = 10 \log \left[\max \left(10^{P_{low}/10}, 10^{P_{mid}/10}, 10^{P_{high}/10} \right) \right]$$

Table 7.2.2.2-1: TRS minimum requirements for UTRA LCR TDD roaming mode for LME devices in the data transfers position and the primary mechanical mode

Operating Band	Unit	<REFior>	
		Average	Max
-	-		
a	dBm/1.28 MHz	TBD	TBD
b	dBm/1.28 MHz	TBD	TBD
c	dBm/1.28 MHz	TBD	TBD
d	dBm/1.28 MHz	TBD	TBD
e	dBm/1.28 MHz	TBD	TBD
f	dBm/1.28 MHz	TBD	TBD
NOTE 1: Applicable for dual-mode GSM/UTRA LCR TDD.			
NOTE 2: Applicable for USB plug-in devices.			

The normative reference for this clause is TS 37.144 [12] section 7.2.3.

7.2.2.3 Test purpose

The purpose of this test is to ensure that $TRS_{average}$ and TRS_{max} of the UE is above specified limit. The lack of the reception sensitivity decreases the coverage area at the far side from Node B.

7.2.2.4 Method of test

7.2.2.4.1 Initial conditions

A radio communications tester or a corresponding device is used as a NB simulator to setup calls to the DUT. The NB simulator is also used to send test signals to the UE and measure the BER levels of the radio link and the information on the dedicated channel needed to extract the DUT receiver performances.

Chamber environment constraints and coordinate system shall be the same as described in Subclause A.3.

Phantom Specifications shall be the same as described in Subclause A.2.3.

Test environment: normal; see TS36.508 [10] Subclause 4.1.1.

Frequencies to be tested: low range, mid range, high range; see Table 5.2-2.

Positioning Requirements shall be the same as described in Subclause 4.3.

- 1) Position the plug-in UE according to the DUT positioning on laptop ground plane phantom specified in Subclause 4.3.2.
- 2) Set the SS downlink physical channels according to settings in Table 7.2.2.4.1-1.
- 3) Power on the plug-in UE. The real functional laptop supplies power to the plug-in UE.
- 4) A call is set up according to the Generic call setup procedure. The power control algorithm shall be set to Power Control Algorithm 2. Compressed mode shall be set to OFF.
- 5) Enter the UE into loopback test mode 2 and start the loopback test.

See TS 34.108 [4] and TS 34.109 [5] and Annex C of TS 34.122 [8] for details regarding generic call setup procedure and loopback test.

Table 6.7.2: Downlink Physical Channels transmitted during a connection

Physical Channel		Power
lor	-75 dBm	-
DwPCH	DwPCH_Ec / lor	0 dB
PCCPCH	$\sum P\text{-CCPCH_Ec} / \text{lor}$	-3 dB
SCCPCH	$\sum S\text{-CCPCH_Ec} / \text{lor}$	-6 dB
PICH	$\sum PICH_Ec / \text{lor}$	-6 dB
FPACH	FPACH_Ec / lor	-6 dB
DL DPCH	$\sum DPCH_Ec / \text{lor}$	0 dB

7.2.2.4.2 Procedure

- 1) Send continuously Up power control commands to the plug-in UE.
- 2) As the plug-in UE reaches maximum power, start sending PN15 data pattern.
- 3) Position the plug-in UE into the USB connector in accordance with the manufacturer recommended primary mechanical mode. In the absence of such a recommendation position the plug-in UE so that it is horizontally plugged into the horizontal USB connector.
- 4) Measure EIS from one measurement point. EIS is the power transmitted from one specific direction to the UE causing BER value of $1\% \pm 0.2\%$ using 40000 or more bits; see Annex E.20. The DL power step size shall be no bigger than 0.5dB when the RF level is near the TDD UE sensitivity level.

NOTE: To meet BER value target DL power level can be changed using user's freely selectable algorithm.

- 5) Measure the EIS for every direction of selected sampling grid using two orthogonal polarizations to obtain TRS.
- 6) Calculate TRS using equations from Subclause 7.2.2.1.

NOTE: To speed up sensitivity measurements non standard setting (i.e. data speed, PCL, BER target) can be used in the measurements. However to obtain TRS result the measured EIS figures shall be normalized by

$$\overline{\Delta EIS} = \frac{1}{n} \sum_{i=1}^n (EISstd_i - EISnstd_i)$$

Where $EISstd_i$ is sensitivity measurement done with standard setting. $EISnstd_i$ is sensitivity measurement done with non standard settings. n is amount of reference measurement points.

To ensure accuracy of TRS, the amount of reference points measured should be at least 4. It is recommended to spread the reference measurements equally during the measurement time.

The measurement procedure is based on the measurement of the spherical sensitivity pattern of the DUT. The sensitivity values of the DUT at a predefined BER level are sampled in far field in a group of points located on a spherical surface enclosing the DUT. The EIS samples are taken using a constant sample step of 30° both in theta (θ)

and phi (ϕ) directions. All the EIS samples are taken with two orthogonal polarizations, θ - and ϕ -polarisations (See Subclause 4.4).

The Total Radiated Sensitivity is calculated from the measured data by equation in Subclause 7.2.2.2.

7.2.2.4.3 Test procedure, reverberation chamber method

TBD

7.2.2.5 Test requirements

The average TRS of low, mid and high channel for 1% BER with 12.2kbps DL reference channel as defined in Annex C.3 of TS 34.122 [8] shall be lower than test requirements for roaming bands shown in Table 7.2.2.5-1. The averaging shall be done in linear scale for the TRS results.

$$TRS_{average} = 10 \log \left[3 / \left(\frac{1}{10^{P_{low}/10}} + \frac{1}{10^{P_{mid}/10}} + \frac{1}{10^{P_{high}/10}} \right) \right]$$

In addition the maximum TRS of each measured channel shall be better than minimum performance requirements for roaming bands shown in the columns "Max" on the requirement tables.

$$TRS_{max} = 10 \log \left[\max \left(10^{P_{low}/10}, 10^{P_{mid}/10}, 10^{P_{high}/10} \right) \right]$$

Table 7.2.2.5-1: TRS test requirements for UTRA LCR TDD roaming mode for LME devices in the data transfers position and the primary mechanical mode

Operating Band	Unit	<REFlor>	
		Average	Max
-	-		
a	dBm/1.28 MHz	TBD + TT	TBD + TT
b	dBm/1.28 MHz	TBD + TT	TBD + TT
c	dBm/1.28 MHz	TBD + TT	TBD + TT
d	dBm/1.28 MHz	TBD + TT	TBD + TT
e	dBm/1.28 MHz	TBD + TT	TBD + TT
f	dBm/1.28 MHz	TBD + TT	TBD + TT
NOTE 1: Applicable for dual-mode GSM/UTRA LCR TDD.			
NOTE 2: Applicable for USB plug-in devices.			

NOTE: If the above Test Requirement differs from the Minimum Requirement then the Test Tolerance applied for this test is non-zero. The Test Tolerance for this test is defined and the explanation of how the Minimum Requirement has been relaxed by the Test Tolerance is given in Annex D.2.

7.2.3 Total Radiated Sensitivity (TRS) for E-UTRA FDD LME

Editor's notes: This subclause is incomplete. The following items are missing or incomplete:

- Table 7.2.3.2-1 and 7.2.3.5-1 as they are not specified in TS 37.144 yet
- Text for Subclause 7.2.3.4.3 Procedure, reverberation chamber method
- Applicability

7.2.3.1 Definition and applicability

The Total Radiated Sensitivity is defined as:

$$TRS = \frac{4\pi}{\oint \left[\frac{1}{EIS_{\theta}(\Omega; f)} + \frac{1}{EIS_{\varphi}(\Omega; f)} \right] d\Omega}$$

Where the effective isotropic sensitivity (*EIS*) is defined as the power available at the antenna output such as the sensitivity threshold is achieved for each polarization. Ω is the solid angle describing the direction, f is frequency. θ and φ are the orthogonal polarizations.

$$TRS \approx \frac{2NM}{\pi \sum_{n=0}^{N-1} \sum_{m=0}^{M-1} \left[\frac{1}{EIS_{\theta}(\theta_n, \varphi_m; f)} + \frac{1}{EIS_{\varphi}(\theta_n, \varphi_m; f)} \right] \sin(\theta_n)}$$

In these formulas N and M are the number of sampling intervals for theta and phi. θ_n and φ_m are the measurement angles. The sampling intervals are discussed further in Subclause 4.4.

[Applicability is TBD]

7.2.3.2 Minimum Requirements

The average measured total radiated sensitivity (TRS) of low, mid and high channel for handheld UE shall be lower than the average TRS requirement specified in Table 7.2.3.2-1. The averaging shall be done in linear scale for the TRS results. Average TRS requirement is shown in the column “Average” on the requirement tables.

$$TRS_{average} = 10 \log \left[6 / \left(\frac{1}{10^{P_{left_low}/10}} + \frac{1}{10^{P_{left_mid}/10}} + \frac{1}{10^{P_{left_high}/10}} + \frac{1}{10^{P_{right_low}/10}} + \frac{1}{10^{P_{right_mid}/10}} + \frac{1}{10^{P_{right_high}/10}} \right) \right]$$

In addition the highest TRS of each measured channel shall be lower than maximum TRS requirement specified in Table 7.2.3.2-1. Maximum TRS requirement is shown in the column “Max” on the requirement tables.

$$TRS_{max} = 10 \log \left[\max \left(10^{P_{left_low}/10}, 10^{P_{left_mid}/10}, 10^{P_{left_high}/10}, 10^{P_{right_low}/10}, 10^{P_{right_mid}/10}, 10^{P_{right_high}/10} \right) \right]$$

Table 7.2.3.2-1: TRS minimum performance requirement for E-UTRA FDD roaming mode for LME devices in the data transfers position and the primary mechanical mode

TBD

The normative reference for this clause is TS 37.144 [12] Subclause 7.2.4.

7.2.3.3 Test purpose

The purpose of this test is to ensure that $TRS_{average}$ and TRS_{max} of the UE is above specified limit. The lack of the reception sensitivity decreases the coverage area at the far side from Node B.

7.2.3.4 Method of test

7.2.3.4.1 Initial conditions

A radio communications tester or a corresponding device is used as a NB simulator to setup calls to the DUT. The NB simulator is also used to send test signals to the UE and measure the BER levels of the radio link and the information on the dedicated channel needed to extract the DUT receiver performances.

Chamber environment constraints and coordinate system shall be the same as described in Subclause A.3.

Phantom Specifications shall be the same as described in Subclause A.2.3.

Test environment: normal; see TS36.508 [10] Subclause 4.1.1.

Frequencies to be tested: low range, mid range, high range; see Table 5.3-2.

Positioning Requirements shall be the same as described in Subclause 4.3.

- 1) Position the plug-in UE according to the DUT positioning on laptop ground plane phantom specified in Subclause 4.3.2.
- 2) Power on the plug-in UE. The real functional laptop supplies power to the plug-in UE.
- 3) Set the initial conditions as per Subclause 7.3 of 3GPP TS 36.521-1 [11], with the following exception: set the carrier frequency, channel bandwidth, RB length and RB location as per Table 5.3-2 for FDD mode. For DUTs with more than one receiver port, all the tests should be performed using both (all) antenna ports simultaneously.

7.2.3.4.2 Procedure

- 1) Follow Steps 1 through 4 in Subclause 7.3.4.2 of 3GPP TS 36.521-1 [11], with the following exception: measure the receiver sensitivity by adjusting the downlink signal level to 95 % throughput of the maximum throughput of the reference channel (maximum throughput is per Annex A of 3GPP TS 36.521-1 [11]).
- 2) For the anechoic chamber based methodologies, repeat Step 1) with 3-D sampling grid specified in Subclause 4.4. The minimum RF power level resulting in a data throughput greater than or equal to 95 % throughput of the maximum throughput for each test shall be recorded for integration pursuant to Subclause 7.2.3.1 to calculate TRS.
- 3) Repeat the measurement of the DUT for low, mid and high channels.
- 4) Calculate the average and minimum TRS as per Subclause 7.2.3.2.

7.2.3.4.3 Procedure, reverberation chamber method

TBD

7.2.3.5 Test requirements

The average measured total radiated sensitivity (TRS) of low, mid and high channel for handheld UE shall be lower than the average TRS requirement specified in Table 7.2.3.5-1. The averaging shall be done in linear scale for the TRS results. Average TRS requirement is shown in the column “Average” on the requirement tables.

$$TRS_{average} = 10 \log \left[6 / \left(\frac{1}{10^{P_{left_low}/10}} + \frac{1}{10^{P_{left_mid}/10}} + \frac{1}{10^{P_{left_high}/10}} + \frac{1}{10^{P_{right_low}/10}} + \frac{1}{10^{P_{right_mid}/10}} + \frac{1}{10^{P_{right_high}/10}} \right) \right]$$

In addition the highest TRS of each measured channel shall be lower than maximum TRS requirement specified in Table 7.2.3.5-1. Maximum TRS requirement is shown in the column “Max” on the requirement tables.

$$TRS_{max} = 10 \log \left[\max \left(10^{P_{left_low}/10}, 10^{P_{left_mid}/10}, 10^{P_{left_high}/10}, 10^{P_{right_low}/10}, 10^{P_{right_mid}/10}, 10^{P_{right_high}/10} \right) \right]$$

Table 7.2.3.5-1: TRS minimum requirement for E-UTRA FDD roaming mode for LME devices in the data transfers position and the primary mechanical mode

TBD

NOTE: If the above Test Requirement differs from the Minimum Requirement then the Test Tolerance applied for this test is non-zero. The Test Tolerance for this test is defined and the explanation of how the Minimum Requirement has been relaxed by the Test Tolerance is given in Annex D.2.

7.2.4 Total Radiated Sensitivity (TRS) for E-UTRA TDD LME

Editor's notes: This subclause is incomplete. The following items are missing or incomplete:

- Table 7.2.4.2-1 and 7.2.4.5-1 as they are not specified in TS 37.144 yet
- Text for Subclause 7.2.4.4.3 Procedure, reverberation chamber method
- Applicability

7.2.4.1 Definition and applicability

The Total Radiated Sensitivity is defined as:

$$TRS = \frac{4\pi}{\oint \left[\frac{1}{EIS_{\theta}(\Omega; f)} + \frac{1}{EIS_{\varphi}(\Omega; f)} \right] d\Omega}$$

Where the effective isotropic sensitivity (*EIS*) is defined as the power available at the antenna output such as the sensitivity threshold is achieved for each polarization. Ω is the solid angle describing the direction, f is frequency. θ and φ are the orthogonal polarizations.

$$TRS \approx \frac{2NM}{\pi \sum_{n=0}^{N-1} \sum_{m=0}^{M-1} \left[\frac{1}{EIS_{\theta}(\theta_n, \varphi_m; f)} + \frac{1}{EIS_{\varphi}(\theta_n, \varphi_m; f)} \right] \sin(\theta_n)}$$

In these formulas N and M are the number of sampling intervals for theta and phi. θ_n and φ_m are the measurement angles. The sampling intervals are discussed further in Subclause 4.4.

[Applicability is TBD]

7.2.4.2 Minimum Requirements

The average measured total radiated sensitivity (TRS) of low, mid and high channel for handheld UE shall be lower than the average TRS requirement specified in Table 7.2.4.2-1. The averaging shall be done in linear scale for the TRS results. Average TRS requirement is shown in the column "Average" on the requirement tables.

$$TRS_{average} = 10 \log \left[6 / \left(\frac{1}{10^{P_{left_low}/10}} + \frac{1}{10^{P_{left_mid}/10}} + \frac{1}{10^{P_{left_high}/10}} + \frac{1}{10^{P_{right_low}/10}} + \frac{1}{10^{P_{right_mid}/10}} + \frac{1}{10^{P_{right_high}/10}} \right) \right]$$

In addition the highest TRS of each measured channel shall be lower than maximum TRS requirement specified in Table 7.2.4.2-1. Maximum TRS requirement is shown in the column "Max" on the requirement tables.

$$TRS_{max} = 10 \log \left[\max \left(10^{P_{left_low}/10}, 10^{P_{left_mid}/10}, 10^{P_{left_high}/10}, 10^{P_{right_low}/10}, 10^{P_{right_mid}/10}, 10^{P_{right_high}/10} \right) \right]$$

Table 7.2.4.2-1: TRS minimum performance requirement for E-UTRA TDD roaming mode for LME devices in the data transfers position and the primary mechanical mode

TBD

The normative reference for this clause is TS 37.144 [12] Subclause 7.2.5.

7.2.4.3 Test purpose

The purpose of this test is to ensure that $TRS_{average}$ and TRS_{max} of the UE is above specified limit. The lack of the reception sensitivity decreases the coverage area at the far side from Node B.

7.2.4.4 Method of test

7.2.4.4.1 Initial conditions

A radio communications tester or a corresponding device is used as a NB simulator to setup calls to the DUT. The NB simulator is also used to send test signals to the UE and measure the BER levels of the radio link and the information on the dedicated channel needed to extract the DUT receiver performances.

Chamber environment constraints and coordinate system shall be the same as described in Subclause A.3.

Phantom Specifications shall be the same as described in Subclause A.2.3.

Test environment: normal; see TS36.508 [10] Subclause 4.1.1.

Frequencies to be tested: low range, mid range, high range; see Table 5.4-2.

Positioning Requirements shall be the same as described in Subclause 4.3.

- 1) Position the plug-in UE according to the DUT positioning on laptop ground plane phantom specified in Subclause 4.3.2.
- 2) Power on the plug-in UE. The real functional laptop supplies power to the plug-in UE.
- 3) Set the initial conditions as per Subclause 7.3 of 3GPP TS 36.521-1 [11], with the following exception: set the carrier frequency, channel bandwidth, RB length and RB location as per Table 5.5-2 for TDD mode. For DUTs with more than one receiver port, all the tests should be performed using both (all) antenna ports simultaneously.

7.2.4.4.2 Procedure

- 1) Follow Steps 1 through 4 in Subclause 7.3.4.2 of 3GPP TS 36.521-1 [11], with the following exception: measure the receiver sensitivity by adjusting the downlink signal level to 95 % throughput of the maximum throughput of the reference channel (maximum throughput is per Annex A of 3GPP TS 36.521-1 [11]).
- 2) For the anechoic chamber based methodologies, repeat Step 1) with 3-D sampling grid specified in Subclause 4.4. The minimum RF power level resulting in a data throughput greater than or equal to 95 % throughput of the maximum throughput for each test shall be recorded for integration pursuant to Subclause 7.2.4.1 to calculate TRS.
- 3) Repeat the measurement of the DUT for low, mid and high channels.
- 4) Calculate the average and minimum TRS as per Subclause 7.2.4.2.

7.2.4.4.3 Procedure, reverberation chamber method

TBD

7.2.4.5 Test requirements

The average measured total radiated sensitivity (TRS) of low, mid and high channel for handheld UE shall be lower than the average TRS requirement specified in Table 7.2.4.5-1. The averaging shall be done in linear scale for the TRS results. Average TRS requirement is shown in the column "Average" on the requirement tables.

$$TRS_{average} = 10 \log \left[6 \left/ \left(\frac{1}{10^{P_{left_low}/10}} + \frac{1}{10^{P_{left_mid}/10}} + \frac{1}{10^{P_{left_high}/10}} + \frac{1}{10^{P_{right_low}/10}} + \frac{1}{10^{P_{right_mid}/10}} + \frac{1}{10^{P_{right_high}/10}} \right) \right] \right]$$

In addition the highest TRS of each measured channel shall be lower than maximum TRS requirement specified in Table 7.2.4.5-1. Maximum TRS requirement is shown in the column “Max” on the requirement tables.

$$TRS_{\max} = 10 \log \left[\max \left(10^{P_{\text{left_low}}/10}, 10^{P_{\text{left_mid}}/10}, 10^{P_{\text{left_high}}/10}, 10^{P_{\text{right_low}}/10}, 10^{P_{\text{right_mid}}/10}, 10^{P_{\text{right_high}}/10} \right) \right]$$

Table 7.2.4.5-1: TRS minimum requirement for E-UTRA TDD roaming mode for LME devices in the data transfers position and the primary mechanical mode

TBD

NOTE: If the above Test Requirement differs from the Minimum Requirement then the Test Tolerance applied for this test is non-zero. The Test Tolerance for this test is defined and the explanation of how the Minimum Requirement has been relaxed by the Test Tolerance is given in Annex D.2.

7.3 Performance for LEE

7.3.1 Total Radiated Sensitivity (TRS) for UTRA FDD LEE

Editor’s notes: This subclause is incomplete. The following items are missing or incomplete:

- Table 7.3.1.2-1 and 7.3.1.5-1 as they are not specified in TS 37.144 yet
- Applicability

7.3.1.1 Definition and applicability

The Total Radiated Sensitivity is defined as:

$$TRS = \frac{4\pi}{\oint \left[\frac{1}{EIS_{\theta}(\Omega; f)} + \frac{1}{EIS_{\varphi}(\Omega; f)} \right] d\Omega}$$

Where the effective isotropic sensitivity (*EIS*) is defined as the power available at the antenna output such as the sensitivity threshold is achieved for each polarization. Ω is the solid angle describing the direction, f is frequency. θ and φ are the orthogonal polarizations.

$$TRS \approx \frac{2NM}{\pi \sum_{n=0}^{N-1} \sum_{m=0}^{M-1} \left[\frac{1}{EIS_{\theta}(\theta_n, \varphi_m; f)} + \frac{1}{EIS_{\varphi}(\theta_n, \varphi_m; f)} \right] \sin(\theta_n)}$$

In these formulas N and M are the number of sampling intervals for theta and phi. θ_n and φ_m are the measurement angles. The sampling intervals are discussed further in Subclause 4.4.

The TRS can also be calculated from measurements in a Rayleigh fading 3 dimensional isotropic environment with in average uniform elevation and azimuth distribution. The calculation of the TRS is in this case based on searching for the lowest power received by the UE/MS for a discrete number of field combinations in the chamber that gives a BER that is better than the specified target BER level. By calibrating the average power transfer function, an absolute value of the TRS can be obtained. The following expression can be used to find the TRS.

$$TRS \approx 2N \frac{\left(\sum_{n=1}^N (C_n (1 - R_n) P_{\text{thres},n}) \right)^{-1}}{\sum_{n=1}^N P_{\text{ref},n}}$$

where $P_{ref,n}$ is the reference power transfer function for fixed measurement antenna n, R_n is the reflection coefficient for fixed measurement antenna n and C_n is the path loss in the cables connecting the measurement receiver to fixed measurement antenna n. These parameters are calculated from the calibration measurement and are further discussed in Annex B.2. $P_{thres,n}$ is calculated by using the following equation:

$$P_{thres,n} = \frac{\sum_{m=1}^M \frac{1}{|S_{21,n,m}^{thres}|^2}}{M}$$

where $S_{21,n,m}^{thres}$ is the m:th value of the transfer function for fixed measurement antenna n, which gives the BER threshold. M is the total number of values of the BER threshold power measured for each fixed measurement antenna.

[Applicability is TBD]

7.3.1.2 Minimum Requirements

The average TRS of low, mid and high channel of the LEE in the data transfers position for 1% BER with 12.2kbps DL reference channel as defined in Annex C.3 of TS25.101 [2] shall be lower than minimum performance requirements for roaming bands shown in Table 7.3.1.2-1 for notebook devices and in Table 7.3.1.2-2 for tablet devices. The averaging shall be done in linear scale for the TRS results.

$$TRS_{average} = 10 \log \left[3 / \left(\frac{1}{10^{P_{low}/10}} + \frac{1}{10^{P_{mid}/10}} + \frac{1}{10^{P_{high}/10}} \right) \right]$$

In addition the maximum TRS of each measured channel in the data transfers position shall be better than minimum performance requirements for roaming bands shown in the columns "Max".

$$TRS_{max} = 10 \log \left[\max \left(10^{P_{low}/10}, 10^{P_{mid}/10}, 10^{P_{high}/10} \right) \right]$$

Table 7.3.1.2-1: TRS minimum requirements for UTRA FDD roaming mode for notebook devices in the data transfers position and the primary mechanical mode

Operating band	Unit	<REF>	
		Average	Max
I	dBm/3.84 MHz	-103.5	-102.0
II	dBm/3.84 MHz	TBD	TBD
III	dBm/3.84 MHz	TBD	TBD
IV	dBm/3.84 MHz	TBD	TBD
V	dBm/3.84 MHz	TBD	TBD
VI	dBm/3.84 MHz	-101.5	-99.5
VII	dBm/3.84 MHz	TBD	TBD
VIII	dBm/3.84 MHz	-101.5	-99.5
IX	dBm/3.84 MHz	TBD	TBD
XIX	dBm/3.84 MHz	-101.5	-99.5

NOTE 1: For power class 3, 3bis and 4 this shall be achieved at the maximum output power.
NOTE 2: Applicable for dual-mode GSM/UMTS.
NOTE 3: Applicable for notebook devices.

NOTE: TRS minimum performance requirements in Table 7.3.1.2-1 apply to HSPA and LTE UEs supporting only single carrier operation. Their applicability to multi-carrier operation is FFS. This is because it has not been verified whether the UEs measured to derive the requirements supported carrier aggregation or not.

Table 7.3.1.2-2: TRS minimum requirements for UTRA FDD roaming mode for tablet devices in the data transfers position and the primary mechanical mode

Operating band	Unit	<REF _{or} >	
		Average	Max
I	dBm/3.84 MHz	-105.75	104.25
II	dBm/3.84 MHz	TBD	TBD
III	dBm/3.84 MHz	TBD	TBD
IV	dBm/3.84 MHz	TBD	TBD
V	dBm/3.84 MHz	-103.0	101.0
VI	dBm/3.84 MHz	TBD	TBD
VII	dBm/3.84 MHz	TBD	TBD
VIII	dBm/3.84 MHz	TBD	TBD
IX	dBm/3.84 MHz	TBD	TBD
XIX	dBm/3.84 MHz	-103.0	101.0

NOTE 1: For power class 3, 3bis and 4 this shall be achieved at the maximum output power.
NOTE 2: Applicable for dual-mode GSM/UMTS.
NOTE 3: Applicable for tablet devices with two antennas.

The normative reference for this clause is TS 37.144 [12] Subclause 7.3.2.

7.3.1.3 Test purpose

The purpose of this test is to ensure that $TRS_{average}$ and TRS_{max} of the UE is above specified limit. The lack of the reception sensitivity decreases the coverage area at the far side from Node B.

7.3.1.4 Method of test

7.3.1.4.1 Initial conditions

A radio communications tester or a corresponding device is used as a NB simulator to setup calls to the DUT. The NB simulator is also used to send test signals to the UE and measure the BER levels of the radio link and the information on the dedicated channel needed to extract the DUT receiver performances.

Chamber environment constraints and coordinate system shall be the same as described in Subclause A.3.

Phantom Specifications shall be the same as described in Subclause A.2.4. Parameters required for Notebooks are specified in Annex A.2.4.2 and those for Tablets are specified in Annex A.2.4.3.

Test environment: normal; see TS36.508 [10] Subclause 4.1.1.

Frequencies to be tested: low range, mid range, high range; see Table 5.1-2.

Positioning Requirements shall be the same as described in Subclause 4.3.

- 1) Position the UE according to the DUT positioning for devices with embedded modules specified in Subclause 4.3.5.
- 2) Set the SS downlink physical channels according to settings in Table 7.3.1.4.1-1.
- 3) Power on the UE.
- 4) A call is set up according to the Generic call setup procedure. The power control algorithm shall be set to Power Control Algorithm 2. Compressed mode shall be set to OFF.
- 5) Enter the UE into loopback test mode 2 and start the loopback test.

See TS 34.108 [4] and TS 34.109 [5] for details regarding generic call setup procedure and loopback test.

Table 7.3.1.4.1-1: Downlink Physical Channels transmitted during a connection

Physical Channel	Power
CPICH	CPICH_Ec / DPCH_Ec = 7 dB
P-CCPCH	P-CCPCH_Ec / DPCH_Ec = 5 dB
SCH	SCH_Ec / DPCH_Ec = 5 dB
PICH	PICH_Ec / DPCH_Ec = 2 dB
DPCH	Test dependent power

7.3.1.4.2 Procedure

- 1) Send continuously Up power control commands to the UE.
- 2) As the UE reaches maximum power, start sending PN15 data pattern.
- 3) Measure EIS from one measurement point. EIS is the power transmitted from one specific direction to the UE causing BER value of $1\% \pm 0.2\%$ using 20000 or more bits; see Annex E.20.

NOTE: To meet BER value target DL power level can be changed using user's freely selectable algorithm.

- 4) Measure the EIS for every direction of selected sampling grid using two orthogonal polarizations to obtain TRS.
- 5) Calculate TRS using equations from Subclause 7.3.1.1.

NOTE: To speed up sensitivity measurements non standard setting (i.e. data speed, PCL, BER target) can be used in the measurements. However to obtain TRS result the measured EIS figures shall be normalized by

$$\Delta \overline{EIS} = \frac{1}{n} \sum_{i=1}^n (EISstd_i - EISnstd_i)$$

Where $EISstd_i$ is sensitivity measurement done with standard setting, $EISnstd_i$ is sensitivity measurement done with non standard settings. n is amount of reference measurement points.

To ensure accuracy of TRS, the amount of reference points measured should be at least 4. It is recommended to spread the reference measurements equally during the measurement time.

The measurement procedure is based on the measurement of the spherical sensitivity pattern of the DUT. The sensitivity values of the DUT at a predefined BER level are sampled in far field in a group of points located on a spherical surface enclosing the DUT. The EIS samples are taken using a constant sample step of 30° both in theta (θ) and phi (ϕ) directions. All the EIS samples are taken with two orthogonal polarizations, θ - and ϕ -polarisations (See Subclause 4.4).

The Total Radiated Sensitivity is calculated from the measured data by equation in Subclause 7.3.1.2.

7.3.1.4.3 Procedure, reverberation chamber method

- 1) Send continuously Up power control commands to the UE.
- 2) As the UE reaches maximum power, start sending PN15 data pattern.
- 3) Set the base station simulator to a specific output power and perform a BER measurement.
- 4) Increase or decrease the base station output power as needed, and repeat step 4 until the lowest output power is found that gives a BER value of $1\% \pm 0.2\%$ using 20000 or more bits, see Annex E.20. This corresponds to

$$\left| S_{21,n,m}^{thres} \right|^2.$$

NOTE: To meet BER value target DL power level can be changed using user's freely selectable algorithm.

- 5) Repeat step 3 and 4 until a sufficient number of independent samples (see section 4.5) of $\left| S_{21,n,m}^{thres} \right|^2$ has been measured.

7) Calculate TRS using equations from chapter 7.3.1.1.

NOTE 1: The measurement procedure is based on samples of the received signal power at the UE/MS from a full 3 dimensional isotropic environment with uniform elevation and azimuth field distribution. The power received by the DUT is undergoing Rayleigh fading and is transmitted by the fixed measurement antennas. Moreover, it is important that the samples collected are independent, in order to get sufficient accuracy of the estimated TRS value.

The Total Radiated Sensitivity is calculated from the measured data by equation in Subclause 7.3.1.2.

7.3.1.5 Test requirements

The average TRS of low, mid and high channel in the data transfers position for 1% BER with 12.2kbps DL reference channel as defined in Annex C.3 of TS 25.101 [2] shall be lower than test requirements for roaming bands shown in Table 7.3.1.5-1 for notebook devices and in Table 7.3.1.5-2 for tablet devices. The averaging shall be done in linear scale for the TRS results.

$$TRS_{average} = 10 \log \left[3 / \left(\frac{1}{10^{P_{low}/10}} + \frac{1}{10^{P_{mid}/10}} + \frac{1}{10^{P_{high}/10}} \right) \right]$$

In addition the maximum TRS of each measured channel in the data transfers position shall be better than minimum performance requirements for roaming bands shown in the columns "Max".

$$TRS_{max} = 10 \log \left[\max \left(10^{P_{low}/10}, 10^{P_{mid}/10}, 10^{P_{high}/10} \right) \right]$$

Table 7.3.1.5-1: TRS test requirements for UTRA FDD roaming mode for notebook devices in the data transfers position and the primary mechanical mode

Operating band	Unit	<REF _{or} >	
		Average	Max
I	dBm/3.84 MHz	-103.5+TT	TBD+TT
II	dBm/3.84 MHz	TBD+TT	TBD+TT
III	dBm/3.84 MHz	TBD+TT	TBD+TT
IV	dBm/3.84 MHz	TBD+TT	TBD+TT
V	dBm/3.84 MHz	TBD+TT	TBD+TT
VI	dBm/3.84 MHz	-101.5+TT	TBD+TT
VII	dBm/3.84 MHz	TBD+TT	TBD+TT
VIII	dBm/3.84 MHz	-101.5+TT	TBD+TT
IX	dBm/3.84 MHz	TBD+TT	TBD+TT
XIX	dBm/3.84 MHz	-101.5+TT	TBD+TT
NOTE 1: For power class 3, 3bis and 4 this shall be achieved at the maximum output power.			
NOTE 2: Applicable for dual-mode GSM/UMTS.			
NOTE 3: Applicable for notebook devices.			

NOTE: If the above Test Requirement differs from the Minimum Requirement then the Test Tolerance applied for this test is non-zero. The Test Tolerance for this test is defined and the explanation of how the Minimum Requirement has been relaxed by the Test Tolerance is given in Annex D.

Table 7.3.1.5-2: TRS test requirements for UTRA FDD roaming mode for tablet devices in the data transfers position and the primary mechanical mode

Operating band	Unit	<REF> _{or}	
		Average	Max
I	dBm/3.84 MHz	-105.75+TT	104.25+TT
II	dBm/3.84 MHz	TBD+TT	TBD+TT
III	dBm/3.84 MHz	TBD+TT	TBD+TT
IV	dBm/3.84 MHz	TBD+TT	TBD+TT
V	dBm/3.84 MHz	-103.0+TT	101.0+TT
VI	dBm/3.84 MHz	TBD+TT	TBD+TT
VII	dBm/3.84 MHz	TBD+TT	TBD+TT
VIII	dBm/3.84 MHz	TBD+TT	TBD+TT
IX	dBm/3.84 MHz	TBD+TT	TBD+TT
XIX	dBm/3.84 MHz	-103.0+TT	101.0+TT

NOTE 1: For power class 3, 3bis and 4 this shall be achieved at the maximum output power.
NOTE 2: Applicable for dual-mode GSM/UMTS.
NOTE 3: Applicable for tablet devices with two antennas.

NOTE: If the above Test Requirement differs from the Minimum Requirement then the Test Tolerance applied for this test is non-zero. The Test Tolerance for this test is defined and the explanation of how the Minimum Requirement has been relaxed by the Test Tolerance is given in Annex D.

7.3.2 Total Radiated Sensitivity (TRS) for UTRA LCR TDD LEE

Editor's notes: This subclause is incomplete. The following items are missing or incomplete:

- Table 7.3.2.2-1 and 7.3.2.5-1 as they are not specified in TS 37.144 yet
- Text for Subclause 7.3.2.4.3 Procedure, reverberation chamber method
- Applicability

7.3.2.1 Definition and applicability

The Total Radiated Sensitivity is defined as:

$$TRS = \frac{4\pi}{\oint \left[\frac{1}{EIS_{\theta}(\Omega; f)} + \frac{1}{EIS_{\varphi}(\Omega; f)} \right] d\Omega}$$

Where the effective isotropic sensitivity (EIS) is defined as the power available at the antenna output such as the sensitivity threshold is achieved for each polarization. Ω is the solid angle describing the direction, f is frequency. θ and φ are the orthogonal polarizations.

$$TRS \approx \frac{2NM}{\pi \sum_{n=0}^{N-1} \sum_{m=0}^{M-1} \left[\frac{1}{EIS_{\theta}(\theta_n, \varphi_m; f)} + \frac{1}{EIS_{\varphi}(\theta_n, \varphi_m; f)} \right] \sin(\theta_n)}$$

In these formulas N and M are the number of sampling intervals for theta and phi. θ_n and φ_m are the measurement angles. The sampling intervals are discussed further in Subclause 4.4.

The TRS can also be calculated from measurements in a Rayleigh fading 3 dimensional isotropic environment with in average uniform elevation and azimuth distribution. The calculation of the TRS is in this case based on searching for the lowest power received by the UE/MS for a discrete number of field combinations in the chamber that gives a BER that is better than the specified target BER level. By calibrating the average power transfer function, an absolute value of the TRS can be obtained. The following expression can be used to find the TRS.

$$TRS \approx 2N \frac{\left(\sum_{n=1}^N (C_n (1 - R_n) P_{thres,n}) \right)^{-1}}{\sum_{n=1}^N P_{ref,n}}$$

where $P_{ref,n}$ is the reference power transfer function for fixed measurement antenna n, R_n is the reflection coefficient for fixed measurement antenna n and C_n is the path loss in the cables connecting the measurement receiver to fixed measurement antenna n. These parameters are calculated from the calibration measurement and are further discussed in Annex B.2. $P_{thres,n}$ is calculated by using the following equation:

$$P_{thres,n} = \frac{\sum_{m=1}^M \frac{1}{|S_{21,n,m}^{thres}|^2}}{M}$$

where $S_{21,n,m}^{thres}$ is the m:th value of the transfer function for fixed measurement antenna n, which gives the BER threshold. M is the total number of values of the BER threshold power measured for each fixed measurement antenna.

[Applicability is TBD]

7.3.2.2 Minimum Requirements

The average TRS of low, mid and high channel of the LEE in the data transfers position for 1% BER with 12.2kbps DL reference channel as defined in Annex C.3 of TS34.122 [8] shall be lower than minimum performance requirements for roaming bands shown in Table 7.3.2.2-1 for notebook devices and in Table 7.3.2.2-2 for tablet devices. The averaging shall be done in linear scale for the TRS results.

$$TRS_{average} = 10 \log \left[3 / \left(\frac{1}{10^{P_{low}/10}} + \frac{1}{10^{P_{mid}/10}} + \frac{1}{10^{P_{high}/10}} \right) \right]$$

In addition the maximum TRS of each measured channel in the data transfers position shall be better than minimum performance requirements for roaming bands shown in the columns "Max".

$$TRS_{max} = 10 \log \left[\max \left(10^{P_{low}/10}, 10^{P_{mid}/10}, 10^{P_{high}/10} \right) \right]$$

Table 7.3.2.2-1: TRS minimum requirements for UTRA LCR TDD roaming mode for notebook devices in the data transfers position and the primary mechanical mode

Operating Band	Unit	<REFlor>	
		Average	Max
-	-		
a	dBm/1.28 MHz	TBD	TBD
b	dBm/1.28 MHz	TBD	TBD
c	dBm/1.28 MHz	TBD	TBD
d	dBm/1.28 MHz	TBD	TBD
e	dBm/1.28 MHz	TBD	TBD
f	dBm/1.28 MHz	TBD	TBD

NOTE 1: Applicable for dual-mode GSM/UTRA LCR TDD.
NOTE 2: Applicable for notebook devices.

Table 7.3.2.2-1: TRS minimum requirements for UTRA LCR TDD roaming mode for tablet devices in the data transfers position and the primary mechanical mode

Operating Band	Unit	<REFFor>	
		Average	Max
-	-		
a	dBm/1.28 MHz	TBD	TBD
b	dBm/1.28 MHz	TBD	TBD
c	dBm/1.28 MHz	TBD	TBD
d	dBm/1.28 MHz	TBD	TBD
e	dBm/1.28 MHz	TBD	TBD
f	dBm/1.28 MHz	TBD	TBD
NOTE 1: Applicable for dual-mode GSM/UTRA LCR TDD.			
NOTE 2: Applicable for notebook devices.			

The normative reference for this clause is TS 37.144 [12] Subclause 7.3.3.

7.3.2.3 Test purpose

The purpose of this test is to ensure that $TRS_{average}$ and TRS_{max} of the UE is above specified limit. The lack of the reception sensitivity decreases the coverage area at the far side from Node B.

7.3.2.4 Method of test

7.3.2.4.1 Initial conditions

A radio communications tester or a corresponding device is used as a NB simulator to setup calls to the DUT. The NB simulator is also used to send test signals to the UE and measure the BER levels of the radio link and the information on the dedicated channel needed to extract the DUT receiver performances.

Chamber environment constraints and coordinate system shall be the same as described in Subclause A.3.

Phantom Specifications shall be the same as described in Subclause A.2.4. Parameters required for Notebooks are specified in Annex A.2.4.2 and those for Tablets are specified in Annex A.2.4.3.

Test environment: normal; see TS36.508 [10] Subclause 4.1.1.

Frequencies to be tested: low range, mid range, high range; see Table 5.2-2.

Positioning Requirements shall be the same as described in Subclause 4.3.

- 1) Position the UE according to the DUT positioning for devices with embedded modules specified in Subclause 4.3.5.
- 2) Set the SS downlink physical channels according to settings in Table 7.3.2.4.1-1.
- 3) Power on the UE.
- 4) A call is set up according to the Generic call setup procedure. The power control algorithm shall be set to Power Control Algorithm 2. Compressed mode shall be set to OFF.
- 5) Enter the UE into loopback test mode 2 and start the loopback test.

See TS 34.108 [4] and TS 34.109 [5] and Annex C of TS 34.122 [8] for details regarding generic call setup procedure and loopback test.

Table 7.3.2.4.1-1: Downlink Physical Channels transmitted during a connection

Physical Channel		Power
lor	-75 dBm	-
DwPCH	DwPCH_Ec / lor	0 dB
PCCPCH	$\sum P\text{-CCPCH_Ec} / \text{lor}$	-3 dB
SCCPCH	$\sum S\text{-CCPCH_Ec} / \text{lor}$	-6 dB
PICH	$\sum PICH_Ec / \text{lor}$	-6 dB
FPACH	FPACH_Ec / lor	-6 dB
DL DPCH	$\sum DPCH_Ec / \text{lor}$	0 dB

7.3.2.4.2 Procedure

- 1) Send continuously Up power control commands to the UE.
- 2) As the UE reaches maximum power, start sending PN15 data pattern.
- 3) Measure EIS from one measurement point. EIS is the power transmitted from one specific direction to the UE causing BER value of $1\% \pm 0.2\%$ using 40000 or more bits; see Annex E.20. The DL power step size shall be no bigger than 0.5dB when the RF level is near the TDD UE sensitivity level.

NOTE 1: To meet BER value target DL power level can be changed using user's freely selectable algorithm.

- 4) Measure the EIS for every direction of selected sampling grid using two orthogonal polarizations to obtain TRS.
- 5) Calculate TRS using equations from Subclause 7.3.2.1.

NOTE 2: To speed up sensitivity measurements non standard setting (i.e. data speed, PCL, BER target) can be used in the measurements. However to obtain TRS result the measured EIS figures shall be normalized by

$$\Delta \overline{EIS} = \frac{1}{n} \sum_{i=1}^n (EISstd_i - EISnstd_i)$$

Where $EISstd_i$ is sensitivity measurement done with standard setting, $EISnstd_i$ is sensitivity measurement done with non standard settings. n is amount of reference measurement points.

To ensure accuracy of TRS, the amount of reference points measured should be at least 4. It is recommended to spread the reference measurements equally during the measurement time.

The measurement procedure is based on the measurement of the spherical sensitivity pattern of the DUT. The sensitivity values of the DUT at a predefined BER level are sampled in far field in a group of points located on a spherical surface enclosing the DUT. The EIS samples are taken using a constant sample step of 30° both in theta (θ) and phi (ϕ) directions. All the EIS samples are taken with two orthogonal polarizations, θ - and ϕ -polarisations (See Subclause 4.4).

The Total Radiated Sensitivity is calculated from the measured data by equation in Subclause 7.3.2.2.

7.3.2.4.3 Procedure, reverberation chamber method

- 1) Send continuously Up power control commands to the UE.
- 2) As the UE reaches maximum power, start sending PN15 data pattern.
- 3) Set the base station simulator to a specific output power and perform a BER measurement.
- 4) Increase or decrease the base station output power as needed, and repeat step 4 until the lowest output power is found that gives a BER value of $1\% \pm 0.2\%$ using 20000 or more bits, see Annex E.20. This corresponds to

$$\left| S_{21,n,m}^{thres} \right|^2.$$

NOTE 1: To meet BER value target DL power level can be changed using user's freely selectable algorithm.

- 5) Repeat step 3 and 4 until a sufficient number of independent samples (see section 4.5) of $|S_{21,n,m}^{thres}|^2$ has been measured.
- 6)
- 7) Calculate TRS using equations from chapter 7.3.2.1.

NOTE 2: The measurement procedure is based on samples of the received signal power at the UE/MS from a full 3 dimensional isotropic environment with uniform elevation and azimuth field distribution. The power received by the DUT is undergoing Rayleigh fading and is transmitted by the fixed measurement antennas. Moreover, it is important that the samples collected are independent, in order to get sufficient accuracy of the estimated TRS value.

The Total Radiated Sensitivity is calculated from the measured data by equation in Subclause 7.3.2.2.

...

7.3.2.5 Test requirements

The average TRS of low, mid and high channel for 1% BER with 12.2kbps DL reference channel as defined in Annex C.3 of TS 34.122 [8] shall be lower than test requirements for roaming bands shown in Table 7.3.2.5-1 for notebook devices and Table 7.3.2.5-2 for tablet devices. The averaging shall be done in linear scale for the TRS results.

$$TRS_{average} = 10 \log \left[3 / \left(\frac{1}{10^{P_{low}/10}} + \frac{1}{10^{P_{mid}/10}} + \frac{1}{10^{P_{high}/10}} \right) \right]$$

In addition the maximum TRS of each measured channel shall be better than minimum performance requirements for roaming bands shown in the columns "Max".

$$TRS_{max} = 10 \log \left[\max \left(10^{P_{low}/10}, 10^{P_{mid}/10}, 10^{P_{high}/10} \right) \right]$$

Table 7.3.2.5-1: TRS test requirements for UTRA LCR TDD roaming mode for notebook devices in the data transfers position and the primary mechanical mode

Operating Band	Unit	<REFlor>	
		Average	Max
a	dBm/1.28 MHz	TBD +TT	TBD +TT
b	dBm/1.28 MHz	TBD +TT	TBD +TT
c	dBm/1.28 MHz	TBD +TT	TBD +TT
d	dBm/1.28 MHz	TBD +TT	TBD +TT
e	dBm/1.28 MHz	TBD +TT	TBD +TT
f	dBm/1.28 MHz	TBD +TT	TBD +TT
NOTE 1: Applicable for dual-mode GSM/UTRA LCR TDD.			
NOTE 2: Applicable for notebook devices.			

NOTE 1: If the above Test Requirement differs from the Minimum Requirement then the Test Tolerance applied for this test is non-zero. The Test Tolerance for this test is defined and the explanation of how the Minimum Requirement has been relaxed by the Test Tolerance is given in Annex D.

Table 7.3.2.5-2: TRS test requirements for UTRA LCR TDD roaming mode for tablet devices in the data transfers position and the primary mechanical mode

Operating Band	Unit	<REFlor>	
		Average	Max
a	dBm/1.28 MHz	TBD +TT	TBD +TT
b	dBm/1.28 MHz	TBD +TT	TBD +TT
c	dBm/1.28 MHz	TBD +TT	TBD +TT
d	dBm/1.28 MHz	TBD +TT	TBD +TT
e	dBm/1.28 MHz	TBD +TT	TBD +TT
f	dBm/1.28 MHz	TBD +TT	TBD +TT

NOTE 1: Applicable for dual-mode GSM/UTRA LCR TDD.
NOTE 2: Applicable for notebook devices.

NOTE 2: If the above Test Requirement differs from the Minimum Requirement then the Test Tolerance applied for this test is non-zero. The Test Tolerance for this test is defined and the explanation of how the Minimum Requirement has been relaxed by the Test Tolerance is given in Annex D.

7.3.3 Total Radiated Sensitivity (TRS) for E-UTRA FDD LEE

Editor's notes: This subclause is incomplete. The following items are missing or incomplete:

- Table 7.3.3.2-1 and 7.3.3.5-1 as they are not specified in TS 37.144 yet
- Applicability

7.3.3.1 Definition and applicability

The Total Radiated Sensitivity is defined as:

$$TRS = \frac{4\pi}{\oint \left[\frac{1}{EIS_{\theta}(\Omega; f)} + \frac{1}{EIS_{\varphi}(\Omega; f)} \right] d\Omega}$$

Where the effective isotropic sensitivity (*EIS*) is defined as the power available at the antenna output such as the sensitivity threshold is achieved for each polarization. Ω is the solid angle describing the direction, f is frequency. θ and φ are the orthogonal polarizations.

$$TRS \approx \frac{2NM}{\pi \sum_{n=0}^{N-1} \sum_{m=0}^{M-1} \left[\frac{1}{EIS_{\theta}(\theta_n, \varphi_m; f)} + \frac{1}{EIS_{\varphi}(\theta_n, \varphi_m; f)} \right] \sin(\theta_n)}$$

In these formulas N and M are the number of sampling intervals for theta and phi. θ_n and φ_m are the measurement angles. The sampling intervals are discussed further in Subclause 4.4.

The TRS can also be calculated from measurements in a Rayleigh fading 3 dimensional isotropic environment with in average uniform elevation and azimuth distribution. The calculation of the TRS is in this case based on searching for the lowest power received by the UE/MS for a discrete number of field combinations in the chamber that gives a BER that is better than the specified target BER level. By calibrating the average power transfer function, an absolute value of the TRS can be obtained. The following expression can be used to find the TRS.

$$TRS \approx 2N \frac{\left(\sum_{n=1}^N (C_n (1 - R_n) P_{thres,n}) \right)^{-1}}{\sum_{n=1}^N P_{ref,n}}$$

where $P_{ref,n}$ is the reference power transfer function for fixed measurement antenna n , R_n is the reflection coefficient for fixed measurement antenna n and C_n is the path loss in the cables connecting the measurement receiver to fixed measurement antenna n . These parameters are calculated from the calibration measurement and are further discussed in Annex B.2. $P_{thres,n}$ is calculated by using the following equation:

$$P_{thres,n} = \frac{\sum_{m=1}^M \frac{1}{|S_{21,n,m}^{thres}|^2}}{M}$$

where $S_{21,n,m}^{thres}$ is the m :th value of the transfer function for fixed measurement antenna n , which gives the BER threshold. M is the total number of values of the BER threshold power measured for each fixed measurement antenna.

[Applicability is TBD]

7.3.3.2 Minimum Requirements

The average measured total radiated sensitivity (TRS) of low, mid and high channel for handheld UE shall be lower than the average TRS requirement specified in Table 7.3.3.2-1 for notebook devices and in Table 7.3.3.2-2 for tablet devices. The averaging shall be done in linear scale for the TRS results of both right and left side of the phantom head. Average TRS requirement is shown in the column “Average” on the requirement tables.

$$TRS_{average} = 10 \log \left[6 / \left(\frac{1}{10^{P_{left_low}/10}} + \frac{1}{10^{P_{left_mid}/10}} + \frac{1}{10^{P_{left_high}/10}} + \frac{1}{10^{P_{right_low}/10}} + \frac{1}{10^{P_{right_mid}/10}} + \frac{1}{10^{P_{right_high}/10}} \right) \right]$$

In addition the highest TRS of each measured channel shall be lower than maximum TRS requirement specified in Table 7.3.3.2-1 for notebook devices and in Table 7.3.3.2-2 for tablet devices. Maximum TRS requirement is shown in the column “Max” on the requirement tables.

$$TRS_{max} = 10 \log \left[\max \left(10^{P_{left_low}/10}, 10^{P_{left_mid}/10}, 10^{P_{left_high}/10}, 10^{P_{right_low}/10}, 10^{P_{right_mid}/10}, 10^{P_{right_high}/10} \right) \right]$$

Table 7.3.3.2-1: TRS minimum performance requirement for E-UTRA FDD roaming mode for notebook devices in the data transfers position and the primary mechanical mode

TBD

LEE TRS minimum performance requirements for E-UTRA FDD in data transfer position mode for throughput $\geq 95\%$ of the maximum throughput of the reference measurement channels as specified in section 7.3 of [11] and Annex A of [11] are defined in Table 7.3.3.2-2 for Tablet devices.

Table 7.3.3.2-2: TRS minimum performance requirement for E-UTRA FDD roaming mode for tablet devices in the data transfers position and the primary mechanical mode

Operating band	Channel bandwidth	Sensitivity (dBm)	
		Average	Max
1	10 MHz	-93.75	-92.25
2	10 MHz		
3	10 MHz	-95.0	-93.5
4	10 MHz		
5	10 MHz		
7	10 MHz	-93.5	-92.0
8	10 MHz		
12	10 MHz		
13	10 MHz		
19	10 MHz	-91.5	-89.5
20	10 MHz	-92.5	-90.5
21	15 MHz	-90.0	-88.5
28	10 MHz		
32	10 MHz		

NOTE 1: Applicable for multi-mode GSM/UMTS/LTE.
NOTE 2: Applicability for devices supporting CDMA or aggregated carriers (e.g. multi-carrier HSPA, LTE Carrier Aggregation) is FFS.

The normative reference for this clause is TS 37.144 [12] Subclause 7.3.4.

7.3.3.3 Test purpose

The purpose of this test is to ensure that $TRS_{average}$ and TRS_{max} of the UE is above specified limit. The lack of the reception sensitivity decreases the coverage area at the far side from Node B.

7.3.3.4 Method of test

7.3.3.4.1 Initial conditions

A radio communications tester or a corresponding device is used as a NB simulator to setup calls to the DUT. The NB simulator is also used to send test signals to the UE and measure the BER levels of the radio link and the information on the dedicated channel needed to extract the DUT receiver performances.

Chamber environment constraints and coordinate system shall be the same as described in Subclause A.3.

Phantom Specifications shall be the same as described in Subclause A.2.4. Parameters required for Notebooks are specified in Annex A.2.4.2 and those for Tablets are specified in Annex A.2.4.3.

Test environment: normal; see TS36.508 [10] Subclause 4.1.1.

Frequencies to be tested: low range, mid range, high range; see Table 5.3-2.

Positioning Requirements shall be the same as described in Subclause 4.3.

- 1) Position the UE according to the DUT positioning for devices with embedded modules specified in Subclause 4.3.5.
- 2) Power on the UE.
- 3) Set the initial conditions as per Subclause 7.3 of 3GPP TS 36.521-1 [11], with the following exception: set the carrier frequency, channel bandwidth, RB length and RB location as per Table 5.3-2 for FDD mode. For DUTs with more than one receiver port, all the tests should be performed using both (all) antenna ports simultaneously.

7.3.3.4.2 Procedure

- 1) Follow Steps 1 through 4 in Subclause 7.3.4.2 of 3GPP TS 36.521-1 [11], with the following exception: measure the receiver sensitivity by adjusting the downlink signal level to 95 % throughput of the maximum throughput of the reference channel (maximum throughput is per Annex A of 3GPP TS 36.521-1 [11]).
- 2) For the anechoic chamber based methodologies, repeat Step 1) with 3-D sampling grid specified in Subclause 4.4. The minimum RF power level resulting in a data throughput greater than or equal to 95 % throughput of the maximum throughput for each test shall be recorded for integration pursuant to Subclause 7.3.3.1 to calculate TRS.
- 3) Repeat the measurement of the DUT for low, mid and high channels.
- 4) Calculate the average and minimum TRS as per Subclause 7.3.3.2.

7.3.3.4.3 Procedure, reverberation chamber method

- 1) Follow Steps 1 through 4 in Subclause 7.3.4.2 of 3GPP TS 36.521-1 [11], with the following exception: measure the receiver sensitivity by adjusting the downlink signal level to 95 % throughput of the maximum throughput of the reference channel (maximum throughput is per Annex A of 3GPP TS 36.521-1 [11]).
- 2) Repeat Step 1) until a sufficient number of independent samples (see section 4.5) of $|S_{21,n,m}^{thres}|^2$ has been measured. The minimum RF power level resulting in a data throughput greater than or equal to 95 % throughput of the maximum throughput for each sample shall be recorded for calculating the TRS according to Subclause 7.3.3.1.
- 3) Repeat the measurement of the DUT for low, mid and high channels.
- 4) Calculate the average and minimum TRS as per Subclause 7.3.3.2.

7.3.3.5 Test requirements

The average measured total radiated sensitivity (TRS) of low, mid and high channel for handheld UE shall be lower than the average TRS requirement specified in Table 7.3.3.5-1 for notebook devices and in Table 7.3.3.5-2 for tablet devices. The averaging shall be done in linear scale for the TRS results of both right and left side of the phantom head. Average TRS requirement is shown in the column “Average” on the requirement tables.

$$TRS_{average} = 10 \log \left[6 / \left(\frac{1}{10^{P_{left_low}/10}} + \frac{1}{10^{P_{left_mid}/10}} + \frac{1}{10^{P_{left_high}/10}} + \frac{1}{10^{P_{right_low}/10}} + \frac{1}{10^{P_{right_mid}/10}} + \frac{1}{10^{P_{right_high}/10}} \right) \right]$$

In addition the highest TRS of each measured channel shall be lower than maximum TRS requirement specified in Table 7.3.3.5-1 for notebook devices and in Table 7.3.3.5-2 for tablet devices. Maximum TRS requirement is shown in the column “Max” on the requirement tables.

$$TRS_{max} = 10 \log \left[\max \left(10^{P_{left_low}/10}, 10^{P_{left_mid}/10}, 10^{P_{left_high}/10}, 10^{P_{right_low}/10}, 10^{P_{right_mid}/10}, 10^{P_{right_high}/10} \right) \right]$$

Table 7.3.3.5-1: TRS minimum requirement for E-UTRA FDD roaming mode for notebook devices in the data transfers position and the primary mechanical mode

TBD

Table 7.3.3.5-2: TRS minimum requirement for E-UTRA FDD roaming mode for tablet devices in the data transfers position and the primary mechanical mode

Operating band	Channel bandwidth	Sensitivity (dBm)	
		Average	Max
1	10 MHz	-92.85	-91.05
2	10 MHz		
3	10 MHz	-94.1	-92.3
4	10 MHz		
5	10 MHz		
7	10 MHz	-92.6	-90.8
8	10 MHz		
12	10 MHz		
13	10 MHz		
19	10 MHz	-90.6	-88.3
20	10 MHz	-91.6	-89.3
21	15 MHz	-89.1	-87.3
28	10 MHz		
32	10 MHz		

NOTE 1: Applicable for multi-mode GSM/UMTS/LTE.
NOTE 2: Applicability for devices supporting CDMA or aggregated carriers (e.g. multi-carrier HSPA, LTE Carrier Aggregation) is FFS.

7.3.4 Total Radiated Sensitivity (TRS) for E-UTRA TDD LEE

Editor's notes: This subclause is incomplete. The following items are missing or incomplete:

- Table 7.3.4.2-1 and 7.3.4.5-1 as they are not specified in TS 37.144 yet
- Applicability

7.3.4.1 Definition and applicability

The Total Radiated Sensitivity is defined as:

$$TRS = \frac{4\pi}{\oint \left[\frac{1}{EIS_{\theta}(\Omega; f)} + \frac{1}{EIS_{\varphi}(\Omega; f)} \right] d\Omega}$$

Where the effective isotropic sensitivity (*EIS*) is defined as the power available at the antenna output such as the sensitivity threshold is achieved for each polarization. Ω is the solid angle describing the direction, f is frequency. θ and φ are the orthogonal polarizations.

$$TRS \approx \frac{2NM}{\pi \sum_{n=0}^{N-1} \sum_{m=0}^{M-1} \left[\frac{1}{EIS_{\theta}(\theta_n, \varphi_m; f)} + \frac{1}{EIS_{\varphi}(\theta_n, \varphi_m; f)} \right] \sin(\theta_n)}$$

In these formulas N and M are the number of sampling intervals for theta and phi. θ_n and φ_m are the measurement angles. The sampling intervals are discussed further in Subclause 4.4.

The TRS can also be calculated from measurements in a Rayleigh fading 3 dimensional isotropic environment with in average uniform elevation and azimuth distribution. The calculation of the TRS is in this case based on searching for the lowest power received by the UE/MS for a discrete number of field combinations in the chamber that gives a BER

that is better than the specified target BER level. By calibrating the average power transfer function, an absolute value of the TRS can be obtained. The following expression can be used to find the TRS.

$$TRS \approx 2N \frac{\left(\sum_{n=1}^N (C_n (1 - R_n) P_{thres,n}) \right)^{-1}}{\sum_{n=1}^N P_{ref,n}}$$

where $P_{ref,n}$ is the reference power transfer function for fixed measurement antenna n , R_n is the reflection coefficient for fixed measurement antenna n and C_n is the path loss in the cables connecting the measurement receiver to fixed measurement antenna n . These parameters are calculated from the calibration measurement and are further discussed in Annex B.2. $P_{thres,n}$ is calculated by using the following equation:

$$P_{thres,n} = \frac{\sum_{m=1}^M \frac{1}{|S_{21,n,m}^{thres}|^2}}{M}$$

where $S_{21,n,m}^{thres}$ is the m :th value of the transfer function for fixed measurement antenna n , which gives the BER threshold. M is the total number of values of the BER threshold power measured for each fixed measurement antenna.

[Applicability is TBD]

7.3.4.2 Minimum Requirements

The average measured total radiated sensitivity (TRS) of low, mid and high channel for handheld UE shall be lower than the average TRS requirement specified in Table 7.3.4.2-1 for notebook devices and in Table 7.3.4.2-2 for tablet devices. The averaging shall be done in linear scale for the TRS results of both right and left side of the phantom head. Average TRS requirement is shown in the column “Average” on the requirement tables.

$$TRS_{average} = 10 \log \left[6 / \left(\frac{1}{10^{P_{left_low}/10}} + \frac{1}{10^{P_{left_mid}/10}} + \frac{1}{10^{P_{left_high}/10}} + \frac{1}{10^{P_{right_low}/10}} + \frac{1}{10^{P_{right_mid}/10}} + \frac{1}{10^{P_{right_high}/10}} \right) \right]$$

In addition the highest TRS of each measured channel shall be lower than maximum TRS requirement specified in Table 7.3.4.2-1 for notebook devices and in Table 7.3.4.2-2 for tablet devices. Maximum TRS requirement is shown in the column “Max” on the requirement tables.

$$TRS_{max} = 10 \log \left[\max \left(10^{P_{left_low}/10}, 10^{P_{left_mid}/10}, 10^{P_{left_high}/10}, 10^{P_{right_low}/10}, 10^{P_{right_mid}/10}, 10^{P_{right_high}/10} \right) \right]$$

Table 7.3.4.2-1: TRS minimum performance requirement for E-UTRA TDD roaming mode for notebook devices in the data transfers position and the primary mechanical mode

TBD

Table 7.3.4.2-2: TRS minimum performance requirement for E-UTRA TDD roaming mode for tablet devices in the data transfers position and the primary mechanical mode

TBD

The normative reference for this clause is TS 37.144 [12] Subclause 7.3.5.

7.3.4.3 Test purpose

The purpose of this test is to ensure that $TRS_{average}$ and TRS_{max} of the UE is above specified limit. The lack of the reception sensitivity decreases the coverage area at the far side from Node B.

7.3.5.4 Method of test

7.3.4.4.1 Initial conditions

A radio communications tester or a corresponding device is used as a NB simulator to setup calls to the DUT. The NB simulator is also used to send test signals to the UE and measure the BER levels of the radio link and the information on the dedicated channel needed to extract the DUT receiver performances.

Chamber environment constraints and coordinate system shall be the same as described in Subclause A.3.

Phantom Specifications shall be the same as described in Subclause A.2.4. Parameters required for Notebooks are specified in Annex A.2.4.2 and those for Tablets are specified in Annex A.2.4.3.

Test environment: normal; see TS36.508 [10] Subclause 4.1.1.

Frequencies to be tested: low range, mid range, high range; see Table 5.4-2.

Positioning Requirements shall be the same as described in Subclause 4.3.

- 1) Position the UE according to the DUT positioning for devices with embedded modules specified in Subclause 4.3.5.
- 2) Power on the UE.
- 3) Set the initial conditions as per Subclause 7.3 of 3GPP TS 36.521-1 [11], with the following exception: set the carrier frequency, channel bandwidth, RB length and RB location as per Table 5.5-2 for TDD mode. For DUTs with more than one receiver port, all the tests should be performed using both (all) antenna ports simultaneously.

7.3.4.4.2 Procedure

- 1) Follow Steps 1 through 4 in Subclause 7.3.4.2 of 3GPP TS 36.521-1 [11], with the following exception: measure the receiver sensitivity by adjusting the downlink signal level to 95 % throughput of the maximum throughput of the reference channel (maximum throughput is per Annex A of 3GPP TS 36.521-1 [11]).
- 2) For the anechoic chamber based methodologies, repeat Step 1) with 3-D sampling grid specified in Subclause 4.4. The minimum RF power level resulting in a data throughput greater than or equal to 95 % throughput of the maximum throughput for each test shall be recorded for integration pursuant to Subclause 7.3.4.1 to calculate TRS.
- 3) Repeat the measurement of the DUT for low, mid and high channels.
- 4) Calculate the average and minimum TRS as per Subclause 7.3.4.2.

7.3.4.4.3 Procedure, reverberation chamber method

- 1) Follow Steps 1 through 4 in Subclause 7.3.4.2 of 3GPP TS 36.521-1 [11], with the following exception: measure the receiver sensitivity by adjusting the downlink signal level to 95 % throughput of the maximum throughput of the reference channel (maximum throughput is per Annex A of 3GPP TS 36.521-1 [11]).
- 2) Repeat Step 1) until a sufficient number of independent samples (see section 4.5) of $|S_{21,n,m}^{thres}|^2$ has been measured. The minimum RF power level resulting in a data throughput greater than or equal to 95 % throughput of the maximum throughput for each sample shall be recorded for calculating the TRS according to Subclause 7.3.4.1.
- 3) Repeat the measurement of the DUT for low, mid and high channels.
- 4) Calculate the average and minimum TRS as per Subclause 7.3.4.2.

7.3.4.5 Test requirements

The average measured total radiated sensitivity (TRS) of low, mid and high channel for handheld UE shall be lower than the average TRS requirement specified in Table 7.3.4.5-1 for notebook devices and in Table 7.3.4.5-2 for tablet devices.

The averaging shall be done in linear scale for the TRS results of both right and left side of the phantom head. Average TRS requirement is shown in the column “Average” on the requirement tables.

$$TRS_{average} = 10\log \left[6 / \left(\frac{1}{10^{P_{left_low}/10}} + \frac{1}{10^{P_{left_mid}/10}} + \frac{1}{10^{P_{left_high}/10}} + \frac{1}{10^{P_{right_low}/10}} + \frac{1}{10^{P_{right_mid}/10}} + \frac{1}{10^{P_{right_high}/10}} \right) \right]$$

In addition the highest TRS of each measured channel shall be lower than maximum TRS requirement specified in Table 7.3.4.5-1 for notebook devices and in Table 7.3.4.5-2 for tablet devices. Maximum TRS requirement is shown in the column “Max” on the requirement tables.

$$TRS_{max} = 10\log \left[\max \left(10^{P_{left_low}/10}, 10^{P_{left_mid}/10}, 10^{P_{left_high}/10}, 10^{P_{right_low}/10}, 10^{P_{right_mid}/10}, 10^{P_{right_high}/10} \right) \right]$$

Table 7.3.4.5-1: TRS minimum requirement for E-UTRA TDD roaming mode for notebook devices in the data transfers position and the primary mechanical mode

TBD

Table 7.3.4.5-2: TRS minimum requirement for E-UTRA TDD roaming mode for tablet devices in the data transfers position and the primary mechanical mode

TBD

7.4 Radiated Performance of Multiple-antenna Receivers in the UE

7.4.1 Total Radiated Multi-antenna Sensitivity (TRMS) for E-UTRA FDD for Handheld UE in Free Space

Editor’s notes: This subclause is incomplete. The following items are missing or incomplete:

- Statistical significance

7.4.1.1 Definition and applicability

Requirements in this section are stated for the free space configuration and are applicable to handheld devices, and are not applicable to wrist-worn devices.

For the MPAC methodology and the harmonized RTS methodology, the average TRMS of free space data mode portrait (FS DMP), free space data mode landscape (FSDML), and free space data mode screen up (FS DMSU), as defined in Annex E of TR 37.977 [29], when measured at the mid channel shall be lower than the average TRMS requirements specified in subclauses 7.4.1.2. The averaging shall be done in linear scale for the TRMS results at these DUT positions. Two average TRMS quantities are calculated from sensitivity measurements at 70% and 95% throughput, respectively. Average TRMS requirement are shown in the column “Average, 70” and “Average, 95” on the requirement tables.

$$TRMS_{average,70} = 10\log \left[3 / \left(\frac{1}{10^{S_{FS_DMP,70}/10}} + \frac{1}{10^{S_{FS_DML,70}/10}} + \frac{1}{10^{S_{FS_DMSU,70}/10}} \right) \right]$$

$$TRMS_{average,95} = 10\log \left[3 / \left(\frac{1}{10^{S_{FS_DMP,95}/10}} + \frac{1}{10^{S_{FS_DML,95}/10}} + \frac{1}{10^{S_{FS_DMSU,95}/10}} \right) \right]$$

Where

$$S_{MODE,x} = 10\log \left[12 / \left(\frac{1}{10^{P_{MODE,x,0}/10}} + \frac{1}{10^{P_{MODE,x,1}/10}} + \dots + \frac{1}{10^{P_{MODE,x,11}/10}} \right) \right]$$

Such that *MODE* is one of {*FS_DMP*, *FS_DML*, *FS_DMSU*}, *x* is one of {70, 95}, and {*P_{MODE,x,0}*, ..., *P_{MODE,x,11}*} are the measured sensitivity values at each azimuth position.

For the MPAC methodology and the harmonized RTS methodology, if 1 azimuth position does not result in a defined measured sensitivity at 70% or 95% throughput, $S_{MODE,70}$ or $S_{MODE,95}$ are calculated using the 11 measured sensitivities and the maximum downlink RS-EPRE $P_{RS-EPRE-MAX}$ (substitution approach) for the one missing result. If 2 azimuth positions do not result in a defined measured sensitivity at 95% throughput, $S_{MODE,95}$ is calculated using the 10 measured sensitivities and $P_{RS-EPRE-MAX}$ for the two missing results. If more azimuth positions result in undefined values for measured sensitivity at the 70% and/or 95% throughput, then the TRMS requirement for the corresponding throughput levels has not been met by such a device. $P_{RS-EPRE-MAX}$ is defined as -80 dBm/15 kHz and is the maximum downlink RS-EPRE supported by the test system.

The requirements and this test apply to all types of E-UTRA FDD UE for Release 14 and forward.

7.4.1.2 Minimum requirements

Handheld UE TRMS minimum performance requirements for E-UTRA FDD in free space and the primary mechanical mode for 70% and 95% DL throughput with the reference measurement channel defined in Clause 7 of TR 37.977 [29] are defined in Table 7.4.1.2-1.

Table 7.4.1.2-1: Handheld UE TRMS minimum requirements for E-UTRA FDD roaming bands in free space and the primary mechanical mode

Channel Model as defined in Annex M.1		Test 1	
		SCME urban micro-cell	
Operating band	Unit	<REF _{or} >	
		Average, 70	Average, 95
1	dBm/15 kHz	-94.75	-92.75
3	dBm/15 kHz	-93.75	-91.75
5	dBm/15 kHz	-91.5	-89.5
7	dBm/15 kHz	-92.5	-90.5
13	dBm/15 kHz	TBD	TBD
19	dBm/15 kHz	-91.5	-89.5

NOTE: Applicability for devices supporting 4-receiver architectures is not confirmed.

The normative reference for this clause is TS 37.144 [12] Subclause 8.1.1.1.

7.4.1.3 Test Purpose

The purpose of this test is to ensure that the UE meets the TRMS minimum performance requirements for E-UTRA FDD specified in Subclause 7.4.1.2.

7.4.1.4 Method of test for Multi-probe Anechoic Chamber

7.4.1.4.1 Initial conditions

A radio communications tester or a corresponding device is used as a NB/BS simulator to setup calls to the DUT according to Annex P.1.

Channel model shall be set according to Annex M.1 and the emulated antenna array configuration shall be set according to Annex M.2.

Chamber environment constraints and coordinate system shall be the same as described in Annex A.5.1.

Test environment according to Annex O.

The positioning of the device under test within the test volume shall be set as defined in Annex A.5.2.

The calibration procedure is specified in Annex B.2.3.

Positioning Requirements shall be according to Annex A.5.2.

Initial conditions are a set of test configurations the UE shall be tested in and the steps for the SS to take with the UE to reach the correct measurement state for each test case.

- 1) Ensure environmental requirements of Annex O are met.
- 2) Configure the test system according to Annex P.1 for the applicable test case.
- 3) Verify the implementation of the channel model as specified in Annex M.

NOTE: The verification of the channel model implementation can be part of the laboratory accreditation process i.e. performed once for each channel model, and will remain valid as long as the setup and instruments remain unchanged. Otherwise the channel model validation may need to be performed prior to starting each throughput test.

- 4) Position the UE in the chamber according to Annex A.5.2.
- 5) Power on the UE.
- 6) Set up the connection.

7.4.1.4.2 Procedure

- 1) Follow Steps 1 and 2 in Subclause 7.3.4.2 of 3GPP TS 36.521-1 [11].
- 2) Set the Downlink signal level to the appropriate REFSENS value defined in Table 7.1.9.5-1 for 95 % throughput of the maximum throughput of the reference channel (maximum throughput is per Annex A of 3GPP TS 36.521-1 [11]) for azimuth position 0. Send continuously uplink power control "up" commands in the uplink scheduling information to the UE to ensure the UE transmits P_{UMAX} level for at least the duration of the Throughput measurement. Measure the average throughput for a duration sufficient to achieve statistical significance TBD.

NOTE 1: The downlink power step size shall be no more than 0.5 dB when RF power level is near the LTE MIMO sensitivity level.

NOTE 2: The initial RS EPRE can be set to the user's freely selectable level. Recommended initial RS EPRE is found in Tables P.1-1 and P.1-2.

NOTE 3: The throughput value target DL power level can be changed using user's freely selectable algorithm.

NOTE 4: For devices that do not reach target throughput, the highest RS EPRE at which throughput is measured shall be -80 dBm/15 kHz. The starting RS EPRE level of the LTE MIMO sensitivity level search does not need to be specified (NOTE 2)

NOTE 5: For devices that exhibit non-linear throughput behaviour and that achieve target throughput at multiple RF power levels, LTE MIMO sensitivity level is chosen to be lowest measured DL power level which crosses the target throughput level

- 3) Repeat Steps 2 for all azimuth positions: Rotate the UE around vertical axis of the test system by 30 degrees and repeat from Step 2 until one complete rotation has been measured i.e. 12 different UE azimuth rotations. A list of orientations is given in Annex A.5.2.
- 4) Repeat Steps 2 & 3 for all MODEs as specified in Clause 7.4.1.1.
- 5) Repeat Steps 2, 3 & 4 for 70% throughput as specified in Clause 7.4.1.1.
- 6) Use post processing and averaging method specified in Clause 7.4.1.1 and calculate average TRMS for 70% and 95% throughput levels.

7.4.1.4A Method of test for Radiated Two-Stage

Use of the RTS method for conformance test depends on the specification of the UE antenna test function which is defined in TR 36.978 [34].

7.4.1.4A.1 Initial conditions

A radio communications tester or a corresponding device is used as a NB/BS simulator to setup calls to the DUT according to Clause P.1.

Channel model shall be set according to Clause M.1 and the emulated antenna array configuration shall be set according to Clause M.2 and Annex C of TR 37.977 [29].

Chamber environment constraints and coordinate system shall be the same as described in Annex A.5.1.2.

Test environment according to Annex O.

The positioning of the device under test within the test volume shall be set as defined in Annex A.5.2.

The calibration procedure is specified in Annex B.2.4.

Positioning Requirements shall be according to Annex A.5.2.

Initial conditions are a set of test configurations the UE shall be tested in and the steps for the SS to take with the UE to reach the correct measurement state for each test case.

- 1) Ensure environmental requirements of Annex O are met.
- 2) Configure the test system according to P.1 for the applicable test case.
- 3) Verify the implementation of the channel model as specified in Annex M.

NOTE: The verification of the channel model implementation can be part of the laboratory accreditation process i.e. performed once for each channel model, and will remain valid as long as the setup and instruments remain unchanged. Otherwise the channel model validation may need to be performed prior to starting each throughput test.

- 4) Position the UE in the chamber according to Annex A.5.2.
- 5) Power on the UE.
- 6) Set up the connection.

7.4.1.4A.2 Procedure

The following steps shall be followed in order to evaluate MIMO OTA performance of the DUT:

- 1) Measure the DUT complex antenna pattern at a nominal -60 dBm downlink power as described in Annex A.5.1.2.1 first stage
- 2) Select an appropriate orientation from the measured antenna pattern and establish a radiated MIMO connection to the DUT using the V and H probes as described in Annex A.5.1.2.1 second stage. Measure the transmission matrix in the chamber and apply the inverse matrix to the MIMO signal. The DUT orientation at which this is done is selected to optimize the achievable isolation. The unknown gain of the DUT antennas represented by the absolute accuracy of the RSAP measurement is then de-embedded from the measured antenna pattern. This is done by comparing the RSAP measurement from the first stage at the orientation being used in the second stage, to a second RSAP measurement made in the second stage using a nominal signal of -60 dBm adjusted by the uncorrected antenna gain for that orientation. The difference in the RSAP measurements represents the true antenna gain for that orientation.
- 3) With the desired channel model applied, measure the isolation in dB between each stream as seen by the DUT receiver and ensure it is at least 15 dB averaged over at least 200 RSAP measurements.
- 4) Using the calibrated radiated connection validate monotonicity of the DUT RSAP and RSARP measurements over the range and step size defined in Annex R.
- 5) Once monotonicity has been validated, check the linearity of RSAP at the orientation of the peak antenna gain over the range -60 dBm to -80 dBm is < 1 dB. Check the linearity of RSARP over the range +/- 180 degrees is < 5 degrees. If the uncorrected RSAP or RSARP results do not meet the linearity requirements, calculate and apply a transfer function to the measured patterns to ensure the necessary linearity; if the linearity fails, it must be re-validated after a transfer function has been applied.

- 6) Convolve the antenna patterns from stage 1, linearized if necessary, with the channel model in the channel emulator and perform the throughput test.
- 7) Record the throughput for each DUT orientation controlled by the channel emulator and each RS EPRE level.
- 8) Identify and report the RS EPRE level achieving 70% throughput for averaged throughput.

NOTE 1: The initial RS EPRE can be set to the user's freely selectable level.
Recommended initial RS EPRE is found in Tables P.1-1 and P.1-2.

NOTE 2: To meet the throughput value target DL RS EPRE level can be changed using user's freely selectable algorithm.

7.4.1.5 Test requirements

For Handheld UE TRMS minimum performance test requirements for E-UTRA FDD in free space and the primary mechanical mode for 70% and 95% DL throughput with the reference measurement channel defined in Clause 7 of TR 37.977 [29] are specified in Table 7.4.1.6-1.

Table 7.4.1.6-1: Handheld UE TRMS minimum test requirements for E-UTRA FDD roaming bands in free space and the primary mechanical mode

		Test 1	
Channel Model as defined in Annex M.1		SCME urban micro-cell	
Operating band	Unit	<REF _{or} >	
		Average, 70	Average, 95
1	dBm/15 kHz	-93.75	-91.75
3	dBm/15 kHz	-92.75	-90.75
5	dBm/15 kHz	-90.50	-88.50
7	dBm/15 kHz	-91.50	-89.50
13	dBm/15 kHz	TBD	TBD
19	dBm/15 kHz	-90.50	-88.50
NOTE: Applicability for devices supporting 4-receiver architectures is not confirmed.			

7.4.2 Total Radiated Multi-antenna Sensitivity (TRMS) for E-UTRA TDD for Handheld UE in Free Space

Editor's note: This subclause is incomplete. The following items are missing or incomplete:

- Statistical significance

7.4.2.1 Definition and applicability

Requirements in this section are stated for the free space configuration and are applicable to handheld devices, and are not applicable to wrist-worn devices.

For the reference MPAC methodology and the harmonized RTS methodology, the average TRMS of free space data mode portrait (FS DMP), free space data mode landscape (FSDML), and free space data mode screen up (FS DMSU), as defined in Annex E of TR 37.977 [29], when measured at the mid channel shall be lower than the average TRMS requirements specified in subclauses 7.4.2.2. The averaging shall be done in linear scale for the TRMS results at these DUT positions. Two average TRMS quantities are calculated from sensitivity measurements at 70% and 95% throughput, respectively. Average TRMS requirement are shown in the column "Average, 70" and "Average, 95" on the requirement tables.

$$TRMS_{average,70} = 10\log \left[3 / \left(\frac{1}{10^{S_{FS,DMP,70}/10}} + \frac{1}{10^{S_{FS,DML,70}/10}} + \frac{1}{10^{S_{FS,DMSU,70}/10}} \right) \right]$$

$$TRMS_{average,95} = 10\log \left[3 / \left(\frac{1}{10^{S_{FS,DMP,95}/10}} + \frac{1}{10^{S_{FS,DML,95}/10}} + \frac{1}{10^{S_{FS,DMSU,95}/10}} \right) \right]$$

Where

$$S_{MODE,x} = 10 \log \left[12 / \left(\frac{1}{10^{P_{MODE,x,0}/10}} + \frac{1}{10^{P_{MODE,x,1}/10}} + \dots + \frac{1}{10^{P_{MODE,x,11}/10}} \right) \right]$$

Such that *MODE* is one of {*FS_DMP*, *FS_DML*, *FS_DMSU*}, *x* is one of {70, 95}, and {*P_{MODE,x,0}*, ..., *P_{MODE,x,11}*} are the measured sensitivity values at each azimuth position.

For the reference MPAC methodology and the harmonized RTS methodology, if 1 azimuth position does not result in a defined measured sensitivity at 70% or 95% throughput, *S_{MODE,70}* or *S_{MODE,95}* are calculated using the 11 measured sensitivities and the maximum downlink RS-EPRE *P_{RS-EPRE-MAX}* (substitution approach) for the one missing result. If 2 azimuth positions do not result in a defined measured sensitivity at 95% throughput, *S_{MODE,95}* is calculated using the 10 measured sensitivities and *P_{RS-EPRE-MAX}* for the two missing results. If more azimuth positions result in undefined values for measured sensitivity at the 70% and/or 95% throughput, then the TRMS requirement for the corresponding throughput levels has not been met by such a device. *P_{RS-EPRE-MAX}* is defined as -80 dBm/15 kHz and is the maximum downlink RS-EPRE supported by the test system.

The requirements and this test apply to all types of E-UTRA TDD UE for Release 14 and forward. Use of the TDD RTS test method requires the device supports the ATF defined in Annex R, uses only two Rx antennas for the tested band and the antenna pattern shall not change in response to the radio environment.

7.4.2.2 Minimum requirements

Handheld UE TRMS minimum performance requirements for E-UTRA TDD in free space and the primary mechanical mode for 70% and 95% DL throughput with the reference measurement channel defined in Clause 7 of TR 37.977 [29] are defined in Table 7.4.2.2-1.

Table 7.4.2.2-1: Handheld UE TRMS minimum requirements for E-UTRA TDD roaming bands in free space and the primary mechanical mode

		Test 1	
Channel Model as defined in Annex M.1		SCME urban micro-cell	
Operating band	Unit	<REF _{or} >	
		Average, 70	Average, 95
38	dBm/15 kHz	-95.5	-93.5
41	dBm/15 kHz	-95.5	-93.5
NOTE 1: In this version of the specification, restricted to E-UTRA DL operation when carrier aggregation is configured.			
NOTE 2: Applicability for devices supporting 4-receiver architectures is not confirmed.			

The normative reference for this clause is TS 37.144 [12] Subclause 8.1.1.2.

7.4.2.3 Test Purpose

The purpose of this test is to ensure that the UE meets the TRMS minimum performance requirements for E-UTRA TDD specified in Subclause 7.4.2.2.

7.4.2.4 Method of test for Multi-probe Anechoic Chamber

7.4.2.4.1 Initial conditions

A radio communications tester or a corresponding device is used as a NB/BS simulator to setup calls to the DUT according to Annex P.1.

Channel model shall be set according to Annex M.1 and the emulated antenna array configuration shall be set according to Annex M.2.

Chamber environment constraints and coordinate system shall be the same as described in Annex A.5.1.

Test environment according to Annex O.

The positioning of the device under test within the test volume shall be set as defined in Annex A.5.2.

The calibration procedure is specified in Annex B.2.3.

Positioning Requirements shall be according to Annex A5.2.

Initial conditions are a set of test configurations the UE shall be tested in and the steps for the SS to take with the UE to reach the correct measurement state for each test case.

- 1) Ensure environmental requirements of Annex O are met.
- 2) Configure the test system according to Annex P.1 for the applicable test case.
- 3) Verify the implementation of the channel model as specified in Annex M.

NOTE: The verification of the channel model implementation can be part of the laboratory accreditation process i.e. performed once for each channel model, and will remain valid as long as the setup and instruments remain unchanged. Otherwise the channel model validation may need to be performed prior to starting each throughput test.

- 4) Position the UE in the chamber according to Annex A.5.2.
- 5) Power on the UE.
- 6) Set up the connection.

7.4.2.4.2 Procedure

- 1) Follow Steps 1 and 2 in Subclause 7.3.4.2 of 3GPP TS 36.521-1 [11].
- 2) Set the Downlink signal level to the appropriate REFSENS value defined in Table 7.1.9.5-1 for 95 % throughput of the maximum throughput of the reference channel (maximum throughput is per Annex A of 3GPP TS 36.521-1 [11]) for azimuth position 0. Send continuously uplink power control "up" commands in the uplink scheduling information to the UE to ensure the UE transmits P_{UMAX} level for at least the duration of the Throughput measurement. Measure the average throughput for a duration sufficient to achieve statistical significance TBD.

NOTE 1: The downlink power step size shall be no more than 0.5 dB when RF power level is near the LTE MIMO sensitivity level.

NOTE 2: The initial RS EPRE can be set to the user's freely selectable level. Recommended initial RS EPRE is found in Tables P.1-1 and P.1-2.

NOTE 3: The throughput value target DL power level can be changed using user's freely selectable algorithm.

NOTE 4: For devices that do not reach target throughput, the highest RS EPRE at which throughput is measured shall be -80 dBm/15 kHz. The starting RS EPRE level of the LTE MIMO sensitivity level search does not need to be specified (NOTE 2)

NOTE 5: For devices that exhibit non-linear throughput behaviour and that achieve target throughput at multiple RF power levels, LTE MIMO sensitivity level is chosen to be lowest measured DL power level which crosses the target throughput level

- 3) Repeat Steps 2 for all azimuth positions: Rotate the UE around vertical axis of the test system by 30 degrees and repeat from Step 2 until one complete rotation has been measured i.e. 12 different UE azimuth rotations. A list of orientations is given in Annex A.5.2.
- 4) Repeat Steps 2 & 3 for all MODEs as specified in Clause 7.4.2.1.
- 5) Repeat Steps 2, 3 & 4 for 70% throughput as specified in Clause 7.4.2.1.
- 6) Use post processing and averaging method specified in Clause 7.4.2.1 and calculate average TRMS for 70% and 95% throughput levels.

7.4.2.4A Method of test for Radiated Two-Stage

Use of the RTS method for conformance test depends on the specification of the UE antenna test function which is defined in TR 36.978 [34].

7.4.2.4A.1 Initial conditions

A radio communications tester or a corresponding device is used as a NB/BS simulator to setup calls to the DUT according to Clause P.1.

Channel model shall be set according to Clause M.1 and the emulated antenna array configuration shall be set according to Clause M.2 and Annex C of TR 37.977 [29].

Chamber environment constraints and coordinate system shall be the same as described in Annex A.5.1.2.

Test environment according to Annex O.

The positioning of the device under test within the test volume shall be set as defined in Annex A.5.2.

The calibration procedure is specified in Annex B.2.4.

Positioning Requirements shall be according to Annex A.5.2.

Initial conditions are a set of test configurations the UE shall be tested in and the steps for the SS to take with the UE to reach the correct measurement state for each test case.

- 1) Ensure environmental requirements of Annex O are met.
- 2) Configure the test system according to P.1 for the applicable test case.
- 3) Verify the implementation of the channel model as specified in Annex M.

NOTE: The verification of the channel model implementation can be part of the laboratory accreditation process i.e. performed once for each channel model, and will remain valid as long as the setup and instruments remain unchanged. Otherwise the channel model validation may need to be performed prior to starting each throughput test.

- 4) Position the UE in the chamber according to Annex A.5.2.
- 5) Power on the UE.
- 6) Set up the connection.

7.4.2.4A.2 Procedure

The following steps shall be followed in order to evaluate MIMO OTA performance of the DUT:

- 1) Measure the DUT complex antenna pattern at a nominal -60 dBm downlink power as described in Annex A.5.1.2.1 first stage
- 2) Select an appropriate orientation from the measured antenna pattern and establish a radiated MIMO connection to the DUT using the V and H probes as described in Annex A.5.1.2.1 second stage. Measure the transmission matrix in the chamber and apply the inverse matrix to the MIMO signal. The DUT orientation at which this is done is selected to optimize the achievable isolation. The unknown gain of the DUT antennas represented by the absolute accuracy of the RSAP measurement is then de-embedded from the measured antenna pattern. This is done by comparing the RSAP measurement from the first stage at the orientation being used in the second stage, to a second RSAP measurement made in the second stage using a nominal signal of -60 dBm adjusted by the uncorrected antenna gain for that orientation. The difference in the RSAP measurements represents the true antenna gain for that orientation.
- 3) With the desired channel model applied, measure the isolation in dB between each stream as seen by the DUT receiver and ensure it is at least 15 dB averaged over at least 200 RSAP measurements.
- 4) Using the calibrated radiated connection validate monotonicity of the DUT RSAP and RSARP measurements over the range and step size defined in Annex R.

- 5) Once monotonicity has been validated, check the linearity of RSAP at the orientation of the peak antenna gain over the range -60 dBm to -80 dBm is < 1 dB. Check the linearity of RSARP over the range +/- 180 degrees is < 5 degrees. If the uncorrected RSAP or RSARP results do not meet the linearity requirements, calculate and apply a transfer function to the measured patterns to ensure the necessary linearity; if the linearity fails, it must be re-validated after a transfer function has been applied.
- 6) Convolve the antenna patterns from stage 1, linearized if necessary, with the channel model in the channel emulator and perform the throughput test.
- 7) Record the throughput for each DUT orientation controlled by the channel emulator and each RS EPRE level.
- 8) Identify and report the RS EPRE level achieving 70% throughput for averaged throughput.

NOTE 1: The initial RS EPRE can be set to the user's freely selectable level.
Recommended initial RS EPRE is found in Tables P.1-1 and P.1-2.

NOTE 2: To meet the throughput value target DL RS EPRE level can be changed using user's freely selectable algorithm.

7.4.2.5 Test requirements

For Handheld UE TRMS minimum performance test requirements for E-UTRA TDD in free space and the primary mechanical mode for 70% and 95% DL throughput with the reference measurement channel defined in Clause 7 of TR 37.977 [29] are specified in Table 7.4.2.5-1.

Table 7.4.2.5-1: Handheld UE TRMS minimum test requirements for E-UTRA TDD roaming bands in free space and the primary mechanical mode

		Test 1	
Channel Model as defined in Annex M.1		SCME urban micro-cell	
Operating band	Unit	<REF _{or} >	
		Average, 70	Average, 95
38	dBm/15 kHz	-94.5	-92.5
41	dBm/15 kHz	-94.5	-92.5
NOTE 1: In this version of the specification, restricted to E-UTRA DL operation when carrier aggregation is configured.			
NOTE 2: Applicability for devices supporting 4-receiver architectures is not confirmed.			

Annex A (normative): Test system characterization and environmental requirements

A.1 General

The main objective of this section is to specify basic parameters of simulated user (phantom) and anechoic and reverberation chamber suited for the Tx and Rx measurement.

A.2 Phantom specifications

A.2.1 Head phantom

The Specific Anthropomorphic Mannequin (SAM) is used for radiated performance measurements. The phantom shape is derived from the size and dimensions of the 90-th percentile large adult male reported in an anthropometric study. It has also been adapted to represent the flattened ear of a wireless device user.

For DUT radiated performance measurements in "intended use" position SAM head phantom without a shoulder section will be used.

The shell of the SAM phantom should be made of low-loss material (loss tangent less than 0.05) with low permittivity (less than 5). The thickness has to be 2.0 ± 0.2 mm in the areas close to the handset in "intended use" position.

The phantom has to be filled with tissue simulating liquid. It is recommended to use one of the typical SAR tissue simulating liquids and Annex B gives four example recipes of such liquids. It is also recommended to verify the RF properties of the liquid with suitable equipment. The values should be maintained within 15% of the values relative permittivity 40 ($\pm 15\%$) and sigma 1.4 ($\pm 15\%$) at 1900 MHz. If the difference is more than $\pm 15\%$, it should be taken in to account in the uncertainty budget. Dielectric properties measurement methods can be found e.g. in [16] [17].

Alternatively, a dry SAM phantom made of plastic material with corresponding electrical parameters can be used.

NOTE: Measurements for the radiated performance of a UE can be influenced by the hand presence. However, it is very difficult to develop a standardized hand phantom, which could allow pertinent and reproducible measurements. Therefore, a phantom hand is not included in this test procedure.

A.2.2 Hand phantom

A.2.2.1 General

Users hand can have a great impact on radiated performance of a UE. The impact goes beyond blocking or absorbing a portion of the radiation, since the impedance of the antenna itself may be changed due to the material in near field. Thus, a standardized hand phantom has been developed for radiated testing to reflect real world user scenarios [18].

A.2.2.2 Dimensions

Dimensions of the hand phantom are based on 50th percentile of the men's hand and women's hand dimensions averaged together in order to produce a standard hand phantom that lies in the middle of the expected range of users. Figure A.2.2.2-1 illustrates the segments of the human hand and Table A.2.2.2-1 summarizes the various dimensions for an open hand phantom [18].

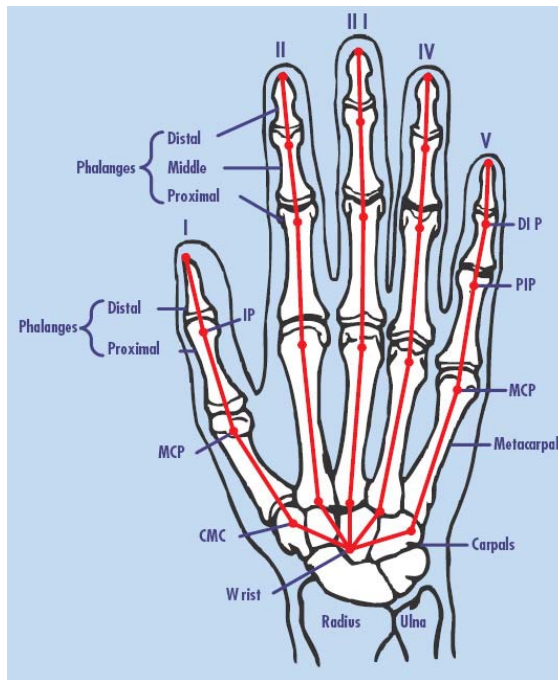

Figure A.2.2.2-1: Segments and dimension points of the human hand

Table A.2.2.2-1: Hand phantom dimensions

Dimension Description	Dim. (mm)	Dimension Description	Dim. (mm)
Major Hand and Wrist Dimensions		Digit III Dimensions	
Wrist Width	61.4	Distal Phalanx Length ²	20.1
Wrist Circumference	162.9	Middle Phalanx Length ²	31.7
Hand Length, Center of Wrist to Tip of Digit III	186.5	Proximal Phalanx Length ²	49.6
Hand Circumference	200.2	Metacarpal Length ³	66.2
Palm Length, Middle to Distal Palm Creases	105.7	Carpal Length ³	17.4
Hand Width	85.0	DIP Width	18.5
Interdigital Crotch Dimensions		PIP Width	
Between Digit II & III Crotch to Tip of Digit II	72.5	DIP Circumference	54.4
Between Digit II & III Crotch to Tip of Digit III	80.5	PIP Circumference	65.5
Between Digit III & IV Crotch to Tip of Digit IV	75.7	Digit IV Dimensions	
Between Digit IV & V Crotch to Tip of Digit V	61.5	Distal Phalanx Length ²	20.0
Between Digit I & II Crotch to Tip of Digit I ¹	56.5	Middle Phalanx Length ²	30.8
Digit I Dimensions		Proximal Phalanx Length ²	
Distal Phalanx Length ²	29.4	Metacarpal Length ³	60.4
Proximal Phalanx Length ²	36.5	Carpal Length ³	19.4
Metacarpal Length ²	46.8	DIP Width	17.2
Carpal Length ²	22.0	PIP Width	19.9
DIP Width	22.3	DIP Circumference	50.3
DIP Circumference	67.7	PIP Circumference	61.2
Digit II Dimensions		Digit V Dimensions	
Distal Phalanx Length ²	18.1	Distal Phalanx Length ²	17.3
Middle Phalanx Length ²	26.7	Middle Phalanx Length ²	21.8
Proximal Phalanx Length ²	45.7	Proximal Phalanx Length ²	38.0
Metacarpal Length ³	67.4	Metacarpal Length ³	56.6
Carpal Length ³	20.6	Carpal Length ³	24.3
DIP Width	18.7	DIP Width	16.1
PIP Width	21.5	PIP Width	17.9
DIP Circumference	54.1	DIP Circumference	45.9
PIP Circumference	64.8	PIP Circumference	54.2

A.2.2.3 Dielectric properties

Dielectric properties of dry palm human tissue are set as the target dielectric parameters for hand phantoms [19]. The properties are presented in Table A.2.2.3-1. It's important that the hand phantom has equivalent electrical properties to real human hand to ensure that the same near field effects are seen with the hand phantom as would be seen with real hand. Relative permittivity of hand phantoms shall be within $\pm 15\%$ of the values listed in Table A.2.2.3-1. Conductivity of hand phantoms shall be within $\pm 25\%$ of the values listed in Table A.2.2.3-1. Methods for measuring dielectric properties can be found e.g. in [22] [23].

Table A.2.2.3-1: Target dielectric properties of a hand phantom

Frequency (MHz)	Er	σ (S/m)
300,00	37,1	0,36
450,00	33,9	0,43
835,00	30,3	0,59
900,00	30	0,62
1450,00	27,9	0,85
1575,00	27,5	0,9
1800,00	27	0,99
1900,00	26,7	1,04
1950,00	26,6	1,07
2000,00	26,5	1,09
2100,00	26,3	1,14
2450,00	25,7	1,32
3000,00	24,8	1,61
4000,00	23,5	2,18
5000,00	22,2	2,84
5200,00	22	2,98
5400,00	21,7	3,11
5600,00	21,4	3,25
5800,00	21,2	3,38
6000,00	20,9	3,52

A.2.2.4 Hand phantom grips

Hand phantom grips are based on human factor studies that were done to record how a phone of certain form factor was gripped by a large sample of people. Based on the grip study findings, three grip designs are chosen for 40- to 56-mm wide devices: one for mono-block devices used in a voice call, another for fold devices in a voice call, and a third for "data mode" grip, simulating for example web browsing, Figure A.2.2.4-1 shows mono-block and fold grips [20]. Grip studies showed that devices wider than 56 mm (generally PDA and touch screen devices) could be conveniently accommodated by a single grip to cover primary use cases, voice calls and data browsing [20].

Each grip is used with a spacer that is designed for repeatable positioning of terminals to the grips. The material for the monoblock palm spacer shall be hollow with a wall thickness less than 2 mm and a dielectric constant of less than 5.0 and a loss tangent of less than 0.05 or it shall be solid with a dielectric constant of less than 1.3 and a loss tangent of less than 0.003. Touch fastener material may be used to affix the DUT to the palm spacer.

Figures A.2.2.4-1 and A.2.2.4-2 below illustrate the right-handed and left-handed mono-block and fold grips, respectively.

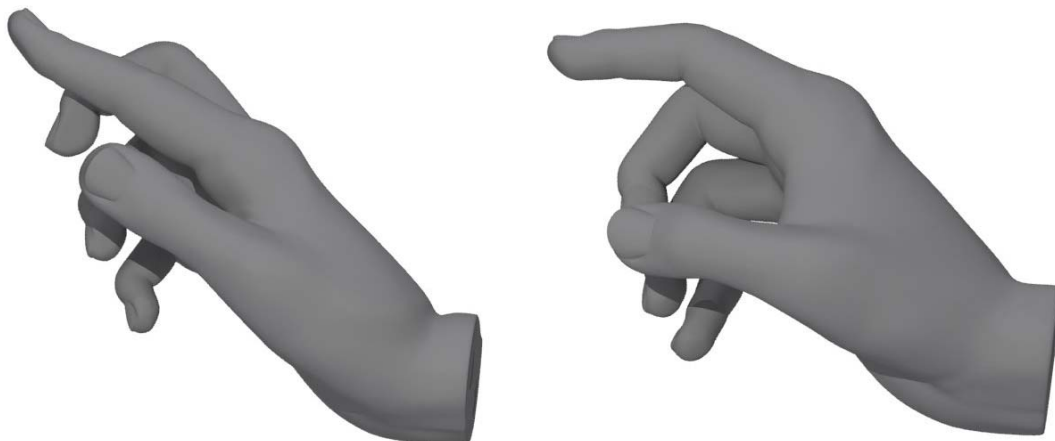

Figure A.2.2.4-1: Right-handed grips defined to hold mono-block and fold UEs during voice calls

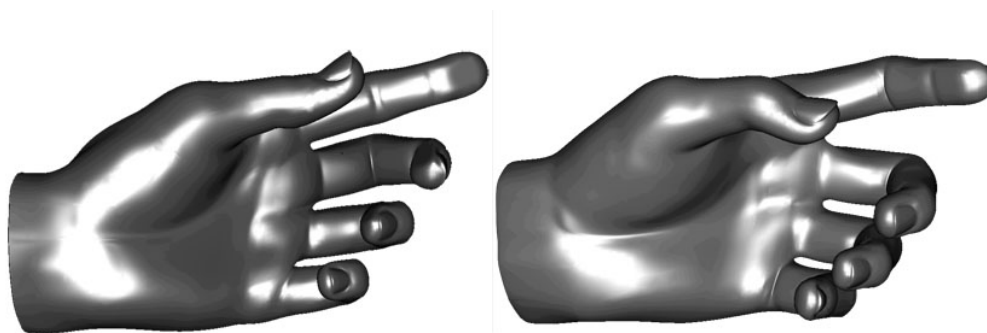

Figure A.2.2.4-2: Left-handed grips defined to hold mono-block and fold UEs during voice calls

Figures A.2.2.4-3 and A.2.2.4-4 below illustrate the right-handed and left-handed data browsing with narrow UEs and PDA grips, respectively.

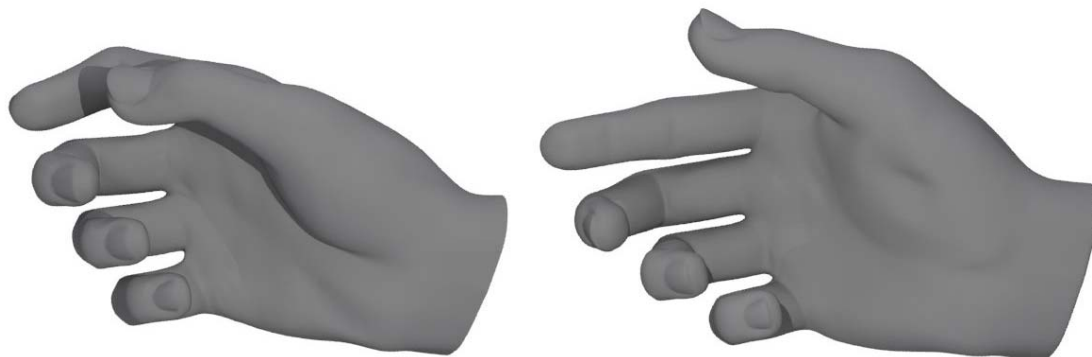

Figure A.2.2.4-3: Right-handed grip defined for data browsing with narrow UEs and grip for holding PDA type of devices

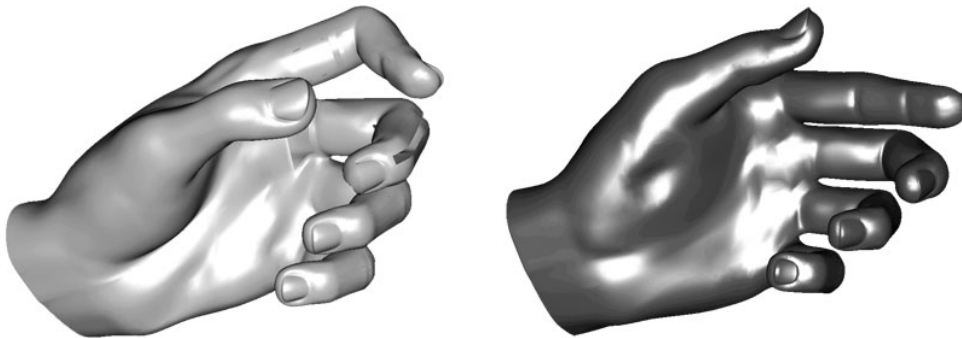

Figure A.2.2.4-4: Left-handed grip defined for data browsing with narrow UEs and grip for holding PDA type of devices

CAD models in Table A.2.2.4-1 define exact finger locations and spacers for the specified grips. The files are available in a subfolder of the archive area for this specification.

Table A.2.2.4-1: CAD models for specified hand phantom grips and spacers

Hand phantom grip	Grip CAD file name	Grip spacer file name
Right Mono-block grip	25914-b10_CAD_hand1.zip	25914-b10_CAD_spacer1.zip
Right Fold grip	25914-b10_CAD_hand2.zip	25914-b10_CAD_spacer2.zip
Right Narrow data browsing grip	25914-b10_CAD_hand3.zip	25914-b10_CAD_spacer3.zip
Right PDA grip	25914-b10_CAD_hand4.zip	25914-b10_CAD_spacer4.zip
Left Mono-block grip	25914-b10_CAD_hand5.zip	25914-b10_CAD_spacer5.zip
Left Fold grip	25914-b10_CAD_hand6.zip	25914-b10_CAD_spacer6.zip
Left Narrow data browsing grip	25914-b10_CAD_hand7.zip	25914-b10_CAD_spacer7.zip
Left PDA grip	25914-b10_CAD_hand8.zip	25914-b10_CAD_spacer8.zip

A.2.2.5 Mechanical Requirements of Hand Phantoms

The hand phantoms shall be constructed of a material that is sufficiently flexible to accommodate the range of devices specified in A.2.2.4. The material shall also be made sufficiently stiff that the hand grip remains constant under rotation.

Adequate material stiffness of the hand phantom is necessary to maintain high repeatability of OTA measurements. The stiffness of the hand material shall be verified by measuring the deflection of the index finger of a moulded monoblock hand phantom under a given weight. Test procedure is following;

1. Position the hand phantom such that the index finger is horizontal.
2. Apply an indicator needle that extends horizontally 55 mm \pm 1 mm beyond the tip of the index finger.
3. Record the position of the indicator needle on a vertical scale.
4. Apply 20 g \pm 0.2 g of weight centred 6 mm \pm 0.5 mm from the tip of the index finger towards the hand.
5. Record the new position of the indicator needle on a vertical scale.

The deflection of the index finger of the hand phantom shall be between 2 and 5 mm. Deflection less than 2 mm per 20 g weight indicates a material that is too rigid. Deflection greater than 5 mm per 20 g weight indicates a material that is too soft.

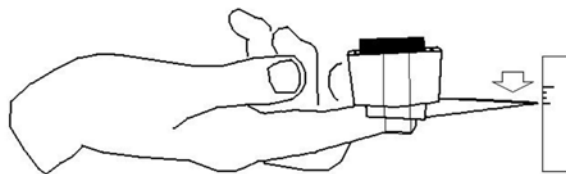

Figure A.2.2.5-1: Hand phantom stiffness test

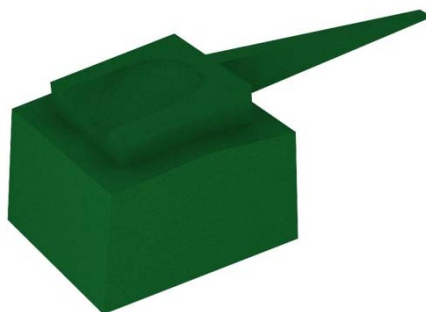

Figure A.2.2.5-2: A weight container designed for a hand phantom stiffness test

A weight container presented in Figure A.2.2.5-2 may be used in the stiffness test. It is assumed that other grips will have similar stiffness as the monoblock hand from the same material. Therefore, a stiffness test of the monoblock hand alone is considered sufficient.

The characteristics of position of the hand phantom such that the index finger is horizontal are specified in Table A.2.2.5-1.

Table A.2.2.5-1: Characteristics of position of the hand phantom

ID	Hand Grip Placement	Characteristic
0	Low	Shift Up
1	Medium	No Shift
2	High	Shift Down

The characteristics of deflection of the index finger of the hand phantom are specified in Table A.2.2.5-2.

Table A.2.2.5-2: Characteristics of deflection of the index finger of the hand phantom

ID	Deflection of Index Finger (df) Placement	Characteristic Type
0	$df \geq 2 \text{ mm per } 20\text{g}$	Rigid
1	$2\text{mm} < df \leq 5\text{mm per } 20\text{g}$	Stable
2	$df > 5\text{mm per } 20\text{g}$	Soft

A.2.3 Laptop Ground Plane Phantom

Laptop ground plane phantom is used for radiated performance measurements in case of plug-in DUT like USB dongles. The objective of the laptop ground plane phantom is to reproduce the effects of the ground plane for the antenna of the DUT while avoiding the variation of the measurements introduced by a real laptop.

The laptop ground plane phantom, as showed in Figure A.2.3-1, is composed by the following parts:

- A rectangular plane covered by a conductive film on the upper side with thickness of 4mm to emulate the keyboard and main body of the laptop;

- A rectangular plane covered by the same conductive film on the upper side with thickness of 4mm to emulate the screen of laptop;
- The conductive film on the two planes is connected. The angle between the two planes is 110 degrees. The material is FR-4 copper-clad sheet and the length and width of these two planes are 345mm and 238mm respectively;
- A horizontal USB connector placed along the short end of the plane; the location of the port is at the right back corner, the distance between the central axis of the USB connector and the rear edge of plane is 45mm, the ground of the USB connector is welded on the conductive film of the plane. The detailed description of the structure is presented in Figure A.2.3-2;
- A USB cable crossing the ground plane and connecting the USB connector to a real functional laptop; the USB cable should be equipped with a shielded metal film, and the portion of the cable that is hung in the air shall be covered with absorbing material or treated with quarter wave chokes. The part of the USB cable lying on the plane is covered by a conductive adhesive strip used for fixing the cable on the plane and for guarantying at the same time the superficial continuity of the conductive plane. The shielded conductive film of this part of the USB cable is connected to the conductive film of the plane and the covered strip to well ground the antenna. The length of the USB cable should be no more than 3 meters.

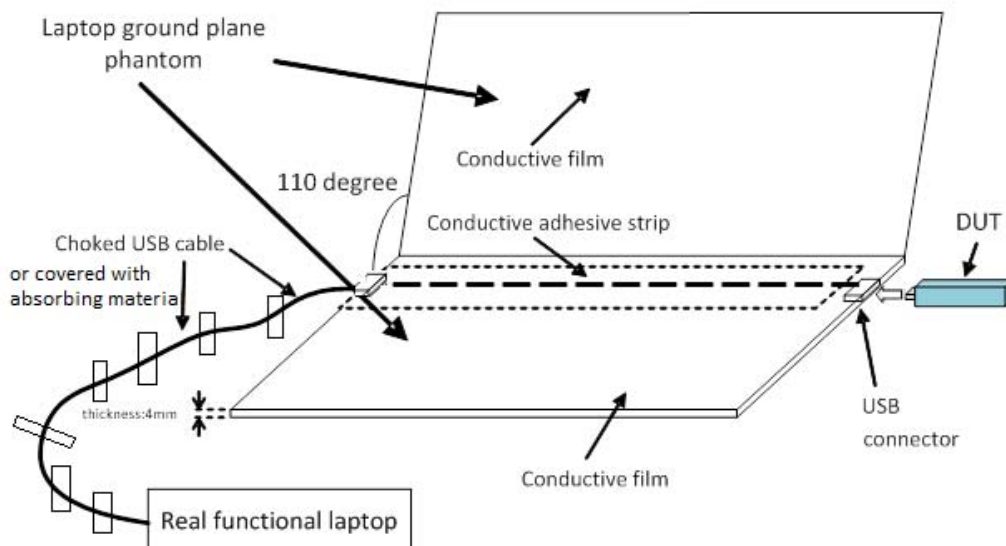

Figure A.2.3-1: The laptop ground plane phantom, the DUT and the real functional laptop

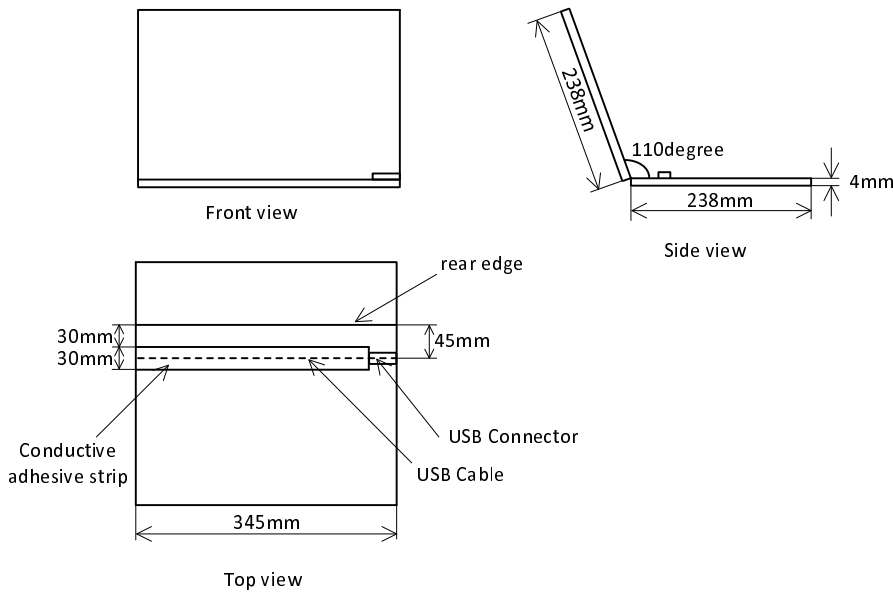

Figure A.2.3-2: The structure and dimension of the laptop ground phantom

The real functional laptop is laid on the floor of the anechoic chamber, supplies power to the DUT and controls the state of the DUT. Both the USB cable and the real functional laptop are properly setup in order to have a negligible impact on the measurements: the real functional laptop is fully wrapped up with anechoic absorbers.

A.2.4 Parameters for embedded devices

A.2.4.1 General

The main objectives of this section are to define basic parameters required when performing TRP and TRS measurements on notebooks and tablets.

A.2.4.2 Notebook

A notebook PC is a portable personal computer combining the computer, keyboard and display in one form factor. Typically the keyboard is built into the base and the display is hinged along the back edge of the base. The largest single dimension for a notebook is limited to 0.42 m.

As notebooks are not body worn equipment nor recommended for use placed directly on the lap, the notebook shall be tested in a free space configuration without head and hand phantoms.

When the notebook is placed in a measurement chamber the display shall be configured according to Table A.2.4.2-1.

Table A.2.4.2-1: Display Settings

Parameter	Value	Note
Display lid angle	110 +/- 5 degrees	The lid angle is defined as the angle between the front of the display to the levelled base.
LCD Backlight	50%	
Ambient sensor	Disabled	

A typical notebook PC is equipped with several radio access technologies. During the measurement the DUT shall be configured according to Table A.2.4.2-2.

Table A.2.4.2-2: Embedded radio transmitters

Parameter	Value	Note
WWAN	Enabled	This is the DUT transceiver
Other transceivers	Disabled	UWB, WLAN, Bluetooth™

The notebook power management shall be configured according to Table A.2.4.2-3.

Table A.2.4.2-3: Power management

Parameter	Value	Note
Screensaver	Disabled	
Turn OFF display	Never	
Turn OFF Hard drive	Never	
System Hibernate	Never	
System Standby	Never	
Dynamic control of clock frequencies	Disabled	
Power source	Standard battery	

If the notebook is equipped with retractable antennas the device shall be tested with the antennas in a configuration recommended by the manufactures.

A.2.4.3 Tablet

A tablet is a portable personal computer combining the computer and display in a single form factor. User input is accomplished via touch screen or a pen. The largest single dimension (i.e., length, width, height) for a tablet is limited to 0.42 m. Tablet devices may have different primary mechanical modes.

Tablet shall be tested in a free space configuration without head and hand phantoms. If hand phantom grips become available for tablets, the testing configuration for tablets may be revisited. The centre of rotation shall be the three-dimensional geometric centre of the EUT, display facing free space.

When a tablet is placed in a measurement chamber the display shall be configured according to Table A.2.4.3-1.

Table A.2.4.3-1: Display Settings

Parameter	Value	Note
LCD Backlight	50%	
Ambient light sensor	Disabled	

A typical tablet is equipped with several radio access technologies. During the measurement the EUT shall be configured according to Table A.2.4.2-2.

EUT shall be powered by battery and power management settings in Table A.2.4.2-3 shall be used.

If a fixture is required to mount the EUT to the positioning system, the EUT holding fixture shall be made of a material with a dielectric constant of less than 5.0, and loss tangent less than 0.05. The fixture shall not extend beyond the footprint of the EUT by more than 20 mm and shall be no more than 20 mm in thickness. It is recommended, but not required, that a Styrofoam spacer would be used between the holding fixture and the EUT.

A.3 Anechoic chamber constraints

A.3.1 General

The main objective of this section is to define basic parameters of the anechoic chamber suited for the Tx and Rx measurement of UMTS and E-UTRA UEs.

The chamber should be equipped with an antenna positioner making possible to perform full 3-D measurements for both Tx and Rx radiated performance. Two main measurement set-ups are presented for this purpose:

- a) A so-called spherical scanner system implies that the DUT is placed on a positioner that rotates in a horizontal plane. The probe antenna is rotated physically in the vertical plane. Alternatively, multiple probe antennas can be placed along an arch in vertical plane and electronically switched in order to get the full 3-D radiation/sensitivity pattern (see Figure A.3.1-1). Alternatively a multiple probe system, which has a set of probes located on the full spherical surface may be used [21]. In this case the DUT does not have to be rotated.
- b) A dual axis system implies that the DUT is placed on a positioner that is able to rotate around two different axes. The signal is transmitted/received by a fixed probe (see Figure A.3.1-2). It is noted that many conventional two-axis systems (i.e. many commercially available systems built for a more general use) are built for the support of rather heavy test objects (with narrow antenna beam), which by their mechanical size may disturb the measurement of nearly omnidirectional antennas. Note that such systems are equipped with a positioner that may disturb the measurement of nearly omnidirectional antennas.

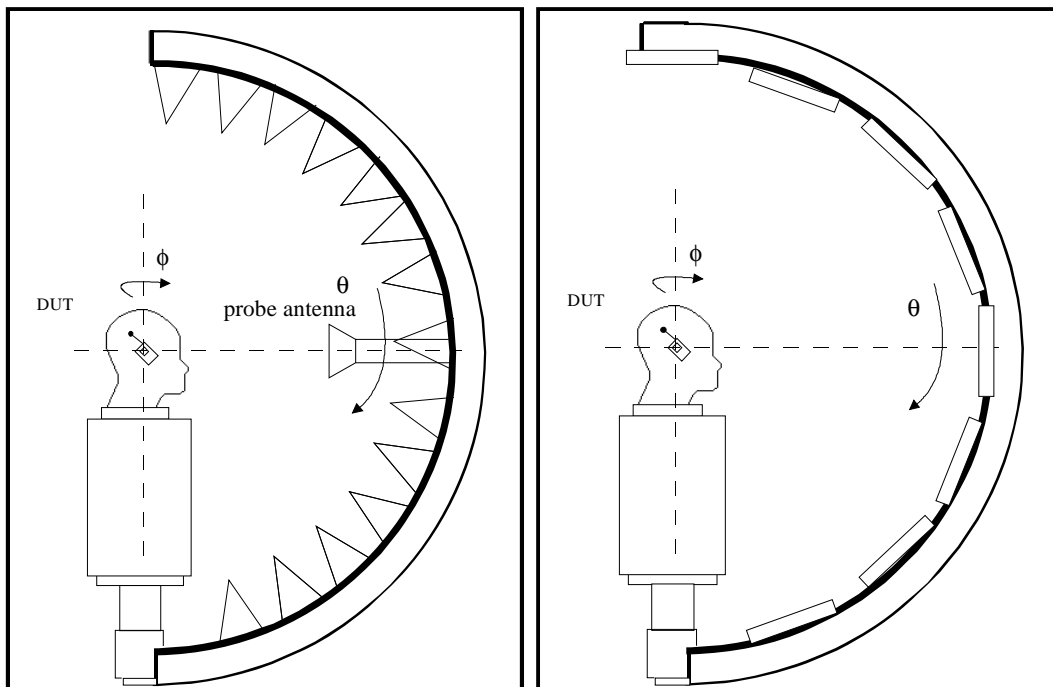

Figure A.3.1-1: Example of a spherical positioner system with a moving probe antenna (left), and with multiple probe antennas (right)

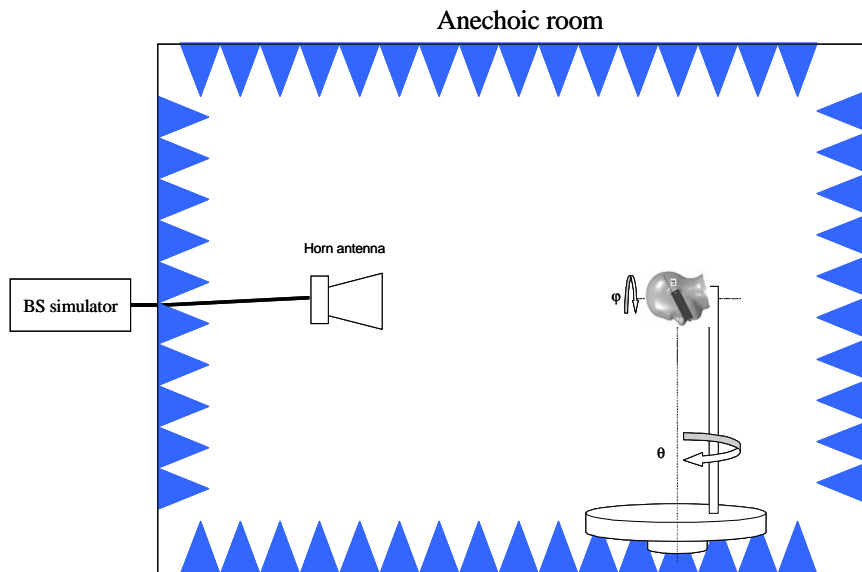

Figure A.3.2-2: Example of a dual axis (roll-over-azimuth) positioner system

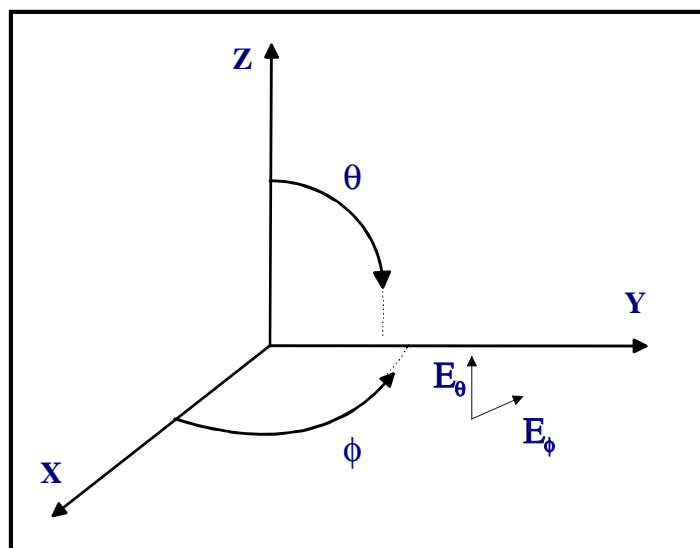

Figure A.3.3-3: The coordinate system used in the measurements

In both cases the measurement antenna should be able to measure two orthogonal linear polarizations (typically theta (θ) and phi (ϕ) polarizations).

Note that for an anechoic chamber, horn antennas are usually used as probe antennas. There are two kinds of horn antennas: single-polarized and dual-polarized. The dual-polarized horn antenna has advantages of a major importance in comparison with the single-polarized. In fact, it is possible to measure two orthogonal polarizations without any movement of the probe, and this will:

- a) Reduce the cable antenna uncertainty contribution
- b) Improve the measurement stability
- c) Reduce the time delay between the acquisitions of each polarized signal due to the electrical RF relay.

If using single-polarized probe antenna, it is possible to perform the measurements by turning one linear polarized antenna by 90° for every measurement point. However, this technique has a major drawback: the cable of this antenna is subjected to numerous bendings and rotations, which brings some measurement instabilities. The various positions of

the cable have an effect on the repeatability of measurements, and the stress applied to the cable can reduce its performance. The use of a "stress cable", or a rotary joint, connected to the main low-loss cable that is connected to the BTS simulator is recommended if using a single-polarized probe.

A.3.2 Quiet zone dimension

Quiet zone has to be large enough to contain DUT attached to a phantom head and shoulders. The dimensions have to be slightly larger than the phantom dimension due to the fact that the rotation axes are not passing through the symmetry plane of the phantom, but through the phase centre of the DUT. Thus minimum radius of the quiet zone has to be 150mm, which is the approximate distance from a UE to the edge of the head and shoulders phantom while the phone is placed in an "intended use" position.

A.3.3 Minimum distance between the DUT and the measurement antenna

For far-field measurements, the distance r between the DUT and the measurement antenna should be calculated by the following equation.

$$r > \max\left(\frac{2D^2}{\lambda}, 3D, 3\lambda\right)$$

where λ is the largest wavelength within the frequency band of interest and D the maximum extension of the radiating structure. Then the phase and amplitude uncertainty limits and the reactive near field limit are not exceeded. The influence of measurement distance is discussed in Annex E.

A.3.4 Reflectivity of the quiet zone

Reflectivity of the quiet zone must be measured for frequencies used with method described in Annex G. Measured reflectivity level is used in uncertainty calculations.

A.3.5 Shielding effectiveness of the chamber

In order to be able to measure sensitivity all external radiation has to be eliminated. Depending on the conditions at the test site in question, different values of shielding effectiveness of the measurement chamber might be required. The only general requirement on the shielding effectiveness of the chamber is that the measured level of external signals at the frequency of interest (UMTS, E-UTRA frequency band) has to be 10dB below sensitivity level of the UE. See Annex G for more details on shielding effectiveness validation.

When specified in a test, the manufacturer shall declare the nominal value of a parameter, or whether an option is supported.

A.4 Reverberation chamber constraints

A.4.1 General

The main objective of this section is to define basic parameters of the reverberation chambers suited for the Tx and Rx measurement of UMTS, and E-UTRA UEs.

The reverberation chambers have for a couple of decades been used for some types of EMC measurements. A reverberation chamber is a metal cavity that is sufficiently large to support many resonant modes, and it is provided with means to stir the modes. The measurements in the reverberation chamber are fast and repeatable, provided the chambers utilize efficient stirring methods. The following sections describe how the reverberation chamber can be used for measurements of TRP and TRS.

A.4.2 Positioning and mode stirring facilities

The reverberation chamber shall be equipped with mode-stirring facilities in such a way that enough number of independent power samples can be achieved for the accuracy requirement stated in this standard to be fulfilled. Possible mode-stirring methods include platform stirring, polarization stirring and mechanical stirring with fan-type stirrers, irregular shaped rotational stirrers, or plate-type stirrers. Also, frequency stirring is possible if the type of measurement allows for a frequency-averaged value, but this is not necessary if the chamber is sufficiently large and well stirred.

For the DUT positioning on head phantom or for the DUT positioning on laptop ground plane phantom, the DUT should be placed in such a way that a sufficient number of independent samples are obtained to fulfil the uncertainty requirements. For example, for chambers utilizing platform stirring the DUT should be placed on the edge of the turntable in order to maximize rotation of the DUT. In addition, the DUT must not be closer than 0.5 wavelengths to other electromagnetic reflective objects inside the chamber and 0.7 wavelengths to absorbing objects.

For the DUT positioning on laptop ground plane phantom the real functional laptop is laid on the floor of the chamber, supplies power to the DUT and controls the state of the DUT. Both the USB cable and the real functional laptop are properly setup in order to have a negligible impact on the measurements: the real functional laptop is fully wrapped up with anechoic absorbers. The real functional laptop can be placed outside the chamber if the connection to the DUT can be maintained and if the communication interface between DUT and real functional laptop has negligible impact on the measurements.

A schematic picture of the measurement setup is provided in Figure A.4.2-1.

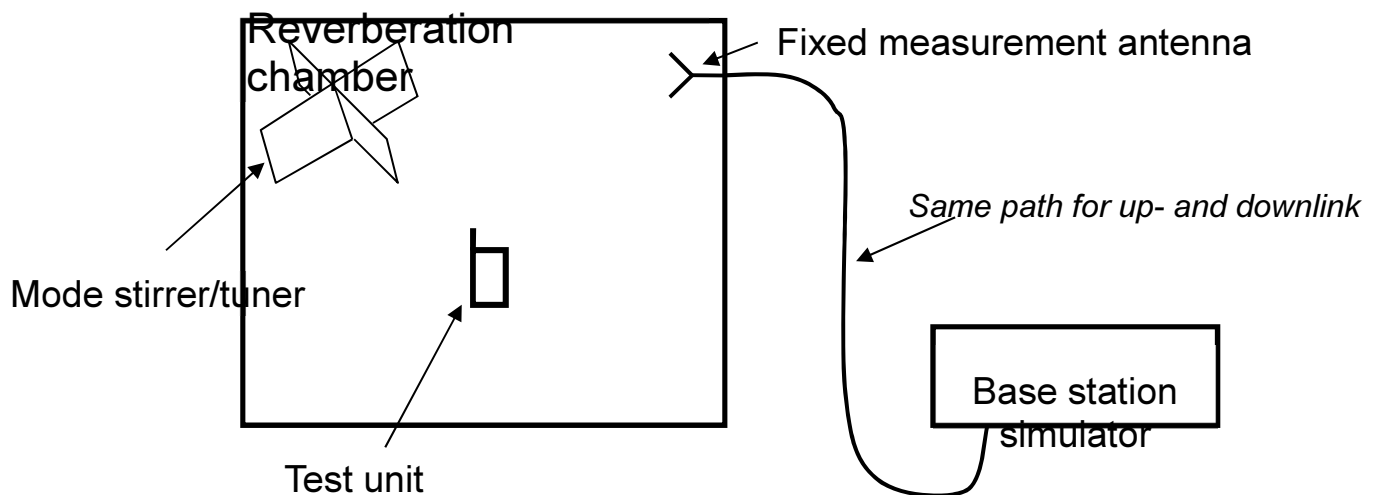

Figure A.4.2-1: A schematic picture of the reverberation chamber measurement setup

A.4.3 Polarization imbalance and receiving antennas

It is important that the statistical distribution of waves in the chamber corresponds to the chosen test environment. Present knowledge about reverberation chambers limits this to isotropic environments, i.e. the TRP and TRS parameters can be measured. Since the probability of each polarization is equal in the isotropic environment, a check of the polarization imbalance in the reverberation chamber must be done.

The polarization imbalance can be obtained during the calibration measurement by measuring both when the calibration antenna is oriented for vertical polarization and when it is oriented for horizontal polarization. These two values shall differ by less than the specification in Table A.4.3-1. In order to obtain values for comparison with the results in the table, the reference levels shall be measured for both orientations of the calibration dipole at 8 different positions of the dipole inside the chamber. The average, standard deviation and maximum deviation shall be evaluated by comparing results for both polarizations over the whole set of 8 measurements. Alternatively, the levels for the two polarizations of the calibration antenna at 1 MHz intervals between 1900 MHz and 2200 MHz can be measured, and thereafter the average, standard deviation and maximum of the difference between the two sets of values over these frequency ranges are calculated.

An effective way of avoiding polarization imbalance is to use polarization stirring, i.e. using three orthogonal linearly polarized receiving antennas. These three receiving antennas may be monopoles connected orthogonally to three different and orthogonal walls (including ceiling/floor) of the chamber. The three antennas are below referred to as the three fixed wall mounted antennas.

Table A.4.3-1: Specifications of differences of measured reference levels in each frequency band between using vertically and horizontally polarized calibration dipoles

	Maximum tolerable value
Average	0.2 dB
Standard deviation	0.5 dB
Maximum	1.0 dB

A.4.4 Measurement antennas

It is important that the measurement antennas are configured in such a way that the statistical distribution of waves in the chamber in average corresponds to an isotropic environment.

A.4.5 Chamber size and characteristics

The reverberation chamber shall have a volume large enough to support the number of modes needed for the stated accuracy at the lowest operating frequency. If the UE is moved around in the chamber during the measurement, the volume of the reverberation chamber can be reduced. Also, frequency stirring can be used to improve the accuracy. However, this will reduce the resolution of the results correspondingly.

The reverberation chamber can be loaded with lossy objects in order to control the power delay profile in the chamber to some extent. However the reverberation chamber should not be loaded to such an extent that the mode statistics in the chamber are destroyed. It is important to keep the same amount of lossy objects in the chamber during calibration measurement and test measurement, in order not to change the average power transfer function between these two cases. Examples of lossy object are head and hand phantoms.

Furthermore, the DUT must not be closer than 0.5 wavelengths to other electromagnetic reflective objects inside the chamber and 0.7 wavelengths to absorbing objects.

A.4.6 Shielding effectiveness of the chamber

The shielding effectiveness of the chamber shall be as large as needed for the interference from other sources not to influence the measured parameters. This means that the requirements of the shielding is specific to each test site and may vary accordingly.

The recommended level of the shielding effectiveness is -100 dB from 800 MHz to 4 GHz. See Annex H for more details on shielding effectiveness validation.

A.5 Anechoic chamber constraints for Radiated Performance of Multiple-antenna Receivers

A.5.1 General

An OTA method based on the use of an Anechoic RF Chamber is described consisting of a number of test antenna probes located in the chamber transmitting signals with temporal and spatial characteristics for testing multiple antenna devices.

This clause describes the methodologies based on Anechoic RF Chamber, where a number of test antennas are located in different positions of the chamber, and the Device Under Test (DUT) is located at centre position. The DUT is tested over the air without RF cables.

A.5.1.1 Multi-probe Anechoic Chamber

An OTA method based on the use of an Anechoic RF Chamber is described consisting of a number of test antennas located in the chamber transmitting signals with temporal and spatial characteristics for testing multiple antenna devices. The method consists of a number of test antennas located in different positions of the chamber, and the device under test (DUT) is located at the centre position. The DUT is tested over the air without RF cables.

The Anechoic chamber techniques creates a realistic geometric based spatio-temporal-polarimetric radio channel for testing MIMO performance using Geometric based stochastic channel models as defined in Annex M.1.

The components of the solution include:

- Anechoic Chamber
- System Simulator (SS)
- N channel RF emulator, with OTA Channel Generation Features
- N linearly polarized antenna elements configured V, H or co-located V&H or slant X polarizations
- K azimuthally separated antenna positions with predefined angles at radius R
- Channel model definition for each test case

An illustration of an anechoic chamber is shown in Figure A.5.1.1-1 below.

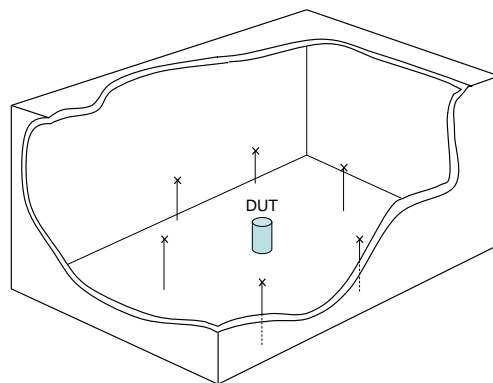

Figure A.5.1.1-1: N-element Anechoic Chamber approach (Absorbing tiles and cabling not shown)

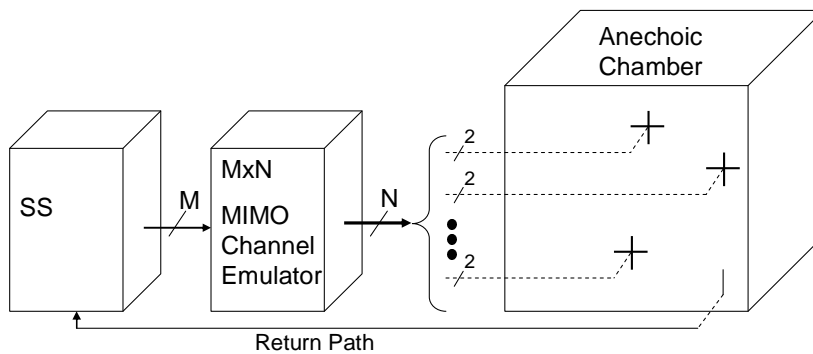

Figure A.5.1.1-2: OTA system level block diagram

A system level block diagram is shown in Figure A.5.1.1-2, which includes the SS to generate the M branch MIMO signal, and an RF Channel Emulator with an OTA Channel Generation Feature to properly correlate, fade, scale, delay, and distribute the signal to each test probe in the chamber. For the selected environmental conditions modelled by the SCME UMa and UMi channel models, the minimum setup configuration can be described as below:

Table A.5.1.1-1: Example of a minimum setup for Boundary Array implementations using the Anechoic Chamber Methodology

	Full Ring	Single Cluster
Minimum number of antenna positions	8	3
Antenna spacing	45°	Determined on the setup
Applicable channel model	SCME UMa/SCME UMi	Single Cluster UMa and Single Cluster UMi

The full SCME or Multi-Cluster channel models are defined in Annex M.1. The Single-Cluster model, which is not part of the set of channel models validated in clause 8, would be based on the channel models defined in Annex M.1 with a set of dithered AoAs around zero degrees.

A.5.1.1.1 Concept and configuration

For MIMO OTA modelling the geometric channel models are mapped into the fading emulator, converting the geometric channel models into the emulator tap coefficients. This process is illustrated in Figure A.5.1.1.1-1.

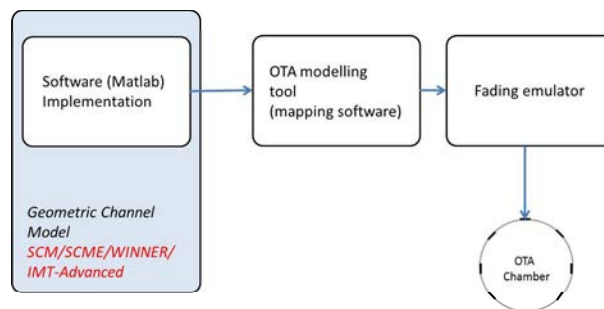

Figure A.5.1.1.1-1: Modelling process

The setup of OTA chamber antennas with eight antenna positions is depicted in Figure A.5.1.1.1-2. The DUT is at the centre, and the antennas are in a circle around the DUT with uniform spacing (e.g. 45° with 16 elements arranged in 8 positions, where each position contains a vertically and horizontally polarized antenna pair). Denoting directions of K OTA antennas with $\theta_k, k = 1 \dots K$, and antenna spacing in the angle domain with $\Delta\theta$. Each antenna is connected to a single fading emulator output port. In the figure, for example, antenna A_{1V} denotes the first OTA antenna position and Vertically (V) polarized element, A_{8H} denotes the eight OTA antenna position and horizontally (H) polarized element, etc.

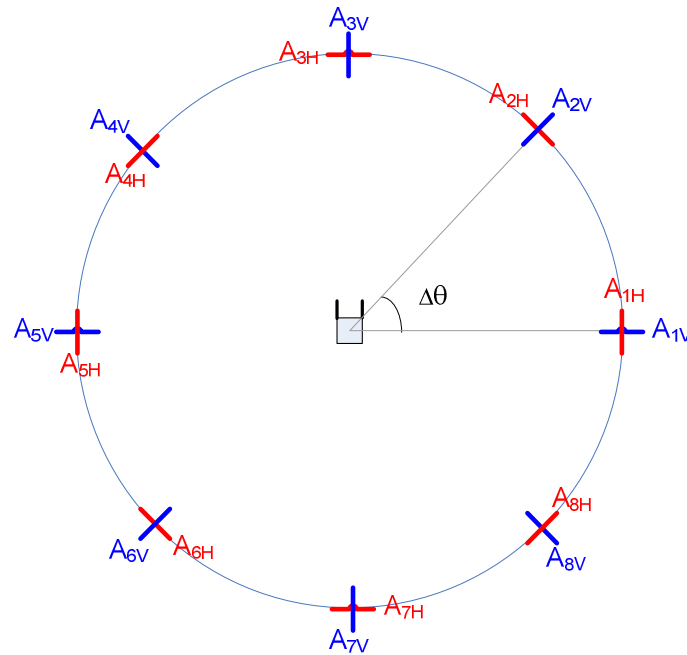

Figure A.5.1.1.1-2: OTA chamber antenna setup with eight uniformly spaced dual polarized chamber antennas

NOTE: In the drawing the V-polarized elements are actually orthogonal to the paper (azimuth plane)

A.5.1.2 Radiated Two-Stage

The principle of two-stage MIMO OTA method is based on the assumption that the DUT far-field antenna radiation pattern will contain all the necessary information for evaluation of the DUT's antenna's performance like radiation power, efficiency and correlation and that with channel model approaches, the influence of antenna radiation pattern can be correctly incorporated into the channel model. Thus the method will first measure the DUT's MIMO antenna patterns and then convolve the measured antenna patterns with the chosen MIMO OTA channel models for real-time emulation. The resulting test signal generated by the channel emulator and coupled back into the DUT receivers represents the signal that the DUT receivers would have seen if the DUT had been placed in the desired radiated field. Thus an ideal implementation of the two-stage method provides the same results as an ideal implementation of the boundary antenna array method.

The two-stage method can be used to measure the following figures of merit:

- 1) Throughput
- 2) TRP and TRS
- 3) CQI, BLER
- 4) Antenna efficiency and MEG
- 5) Antenna correlation, MIMO channel capacity.

In order to accurately measure the antenna pattern of the intact device, the DUT chipset needs to support received amplitude and relative phase measurements of the antennas. The validity of antenna pattern measurement is predicated on the assumption that for the frequency being tested, the DUT antenna pattern is static. Devices that can alter their antenna pattern in real time as a function of the radiated environment is not supported. The method of coupling the base station emulator and DUT uses a specially calibrated radiated connection (radiated two-stage or RTS method) to do the test on throughput, etc., to test how the MIMO antennas will influence the performance. The conducted method of coupling is straightforward but does not capture the impact of radiated leakage from the DUT transmit antennas to the DUT receive antennas, thus in its current form without additional interference estimation the conducted method of coupling in the second stage is not proposed for use in conformance testing. Its description is included for historical

completeness of the development of the two-stage method. The radiated method of coupling in the second stage does fully capture radiated leakage and is the method defined for conformance testing.

A.5.1.2.1 Concept and configuration

The assumption of the two-stage MIMO OTA method is that the measured far field antenna pattern of the DUT's multiple antennas can fully capture the mutual coupling of the multiple antenna arrays and their influence on radiated performance.

Thus to do the two-stage MIMO OTA test, the antenna patterns of the antenna array needs to be measured accurately in the first stage. In order to accurately measure the antenna pattern of the intact device, the chipset needs to support amplitude and relative phase measurements of the antennas. To achieve this, two new UE measurements have been defined called Reference Signal Antenna Power (RSAP) and Reference Signal Relative Antenna Phase (RSARP). These measurements are defined in TS 36.509 [34].

Stage 1: The measurement of the DUT's multiple antennas takes place in a traditional anechoic chamber set up as described in Annex A.3, where the DUT is put into the chamber and each antenna element's complex far zone pattern is measured using the RSAP and RSARP measurements defined in TR 36.509 [34]. The influence of human body loss can also be measured by attaching the DUT to a SAM head and or hand phantom when doing the antenna pattern measurements. The characteristics of the SAM phantom are specified in Annex A.2. The chamber is equipped with a positioner, that makes it possible to perform full 3-D far zone pattern measurements for both Tx and Rx radiated performance. As specified in A.3, the measurement antenna shall be able to measure two orthogonal polarizations (typically linear theta (θ) and phi (ϕ) polarizations as shown in Figure A.5.1.2.1-1).

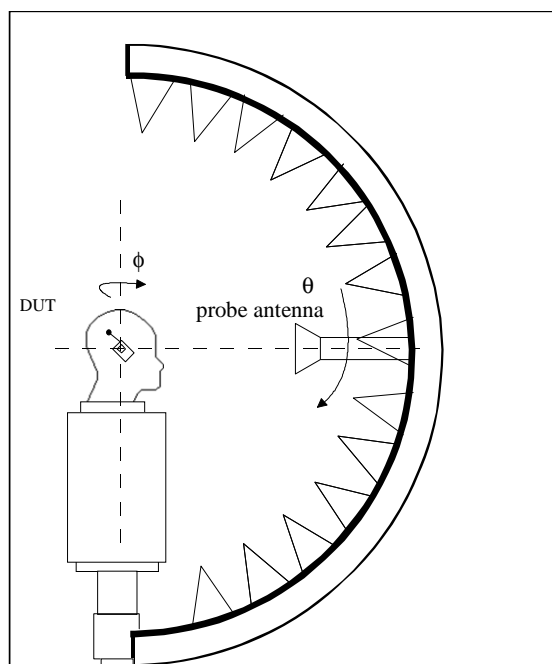

Figure A.5.1.2.1-1: The coordinate system used in the measurements

Stage 2: Convolve the antenna patterns measured in stage 1 with the chosen MIMO channel model, using a channel emulator and then use the resulting signal to perform the OTA throughput test. The signal is coupled into the DUT using a radiated connection.

The radiated two-stage (RTS) method is illustrated in Figure A.5.1.2.1-2. The BS emulator is connected to the MIMO channel emulator and then to the DUT using a calibrated radiated connection in an anechoic environment. This coupling technique exploits the Eigen modes of the transmission channel in the anechoic chamber to provide isolated radiated connections between the probe antennas and each DUT receiver after the DUT antenna.

To convolve the DUT antenna patterns with MIMO channel model.

- a) Apply antenna patterns to correlation-based channel models. With a correlation matrix calculation method for arbitrary antenna patterns under multipath channel conditions, the correlation matrix and the antenna imbalance can be calculated and then emulated by the channel emulator.

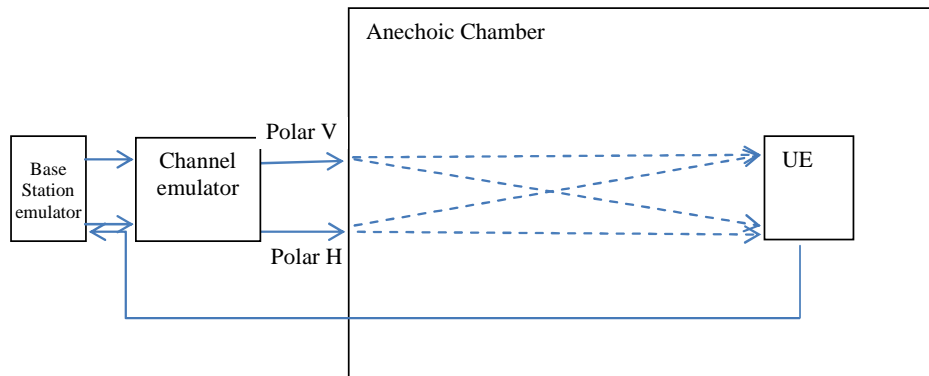

Figure A.5.1.2.1-2: Radiated two-stage (RTS) test methodology for MIMO OTA test

Figure A.5.1.2.1-2 shows the radiated coupling method for the second stage. Two probe antennas with polarization V and H are co-located in the anechoic chamber. Note, unlike in the first stage where the V and H probes are used at different times, in the second stage both V and H probes are used simultaneously. An example implementation of this would be the dual polarized configuration described in Annex A.3. Due to the propagation channel in the chamber, signals transmitted from each probe antenna are received by both DUT antennas. However, by precoding the transmitted signals using spatial multiplexing techniques it is possible by calculating the radiated channel matrix and by applying its inverse to the transmitted signals, to create an identity matrix allowing the transmitted signals to be received independently at each DUT receiver after the DUT antenna.

The establishment of the radiated connection is explained as follows. Assume x_1 and x_2 are the transmitted signals from the base station emulator, after applying the desired channel model and convolution with the complex antenna pattern we get:

$$f(x_1) \text{ and } f(x_2).$$

The radiated channel matrix between the probe antennas and the DUT antennas is $= \begin{pmatrix} h_{11} & h_{12} \\ h_{21} & h_{22} \end{pmatrix}$.

If the channel emulator applies the inverse of the radiated channel matrix $H^{-1} = \begin{pmatrix} \alpha & \beta \\ \gamma & \delta \end{pmatrix}$ to $f(x_1)$ and $f(x_2)$, the signal received after the DUT antennas is same as if the channel emulator were directly connected to equivalent antenna connectors:

$$\begin{pmatrix} y_1 \\ y_2 \end{pmatrix} = \begin{pmatrix} h_{11} & h_{12} \\ h_{21} & h_{22} \end{pmatrix} \begin{pmatrix} \alpha & \beta \\ \gamma & \delta \end{pmatrix} \begin{pmatrix} f(x_1) \\ f(x_2) \end{pmatrix} = \begin{pmatrix} 1 & 0 \\ 0 & 1 \end{pmatrix} \begin{pmatrix} f(x_1) \\ f(x_2) \end{pmatrix} = \begin{pmatrix} f(x_1) \\ f(x_2) \end{pmatrix}$$

The above example of RTS using two probe antennas is applicable to UE with two Rx antennas. For UE with > 2 Rx antennas, the RTS method is FFS.

A.5.2 Testing environment conditions

This annex lists the testing environment conditions for all DUT types relevant to testing of radiated performance of multiple-antenna receivers. The use cases (positioning) discussed here are applicable for all methodologies, however the orientation and rotations described may be applicable for some methodologies only, and not for some other methodologies.

Table A.5.2-1 below lists the testing environment conditions along with a diagram and applicable references. The reference coordinate system and orientation of devices in that coordinate system is shown in Figure A.5.2-1 below that includes the mechanical alignment of a phone. For tablets the home button, charging connector and similar components can be used to define top and bottom. For laptops the definitions specified in 3GPP TR 25.914 [3] (and repeated here in Table A.5.2-1) are used. In the case of methodologies utilizing a spatial channel model in Figure A.5.2-1, the X axis

points towards the channel model reference. For example in the case of an anechoic chamber utilizing 2D antenna array in the azimuth plane (XY plane from Figure A.5.2-1) this is the direction of the first probe at 0 degrees.

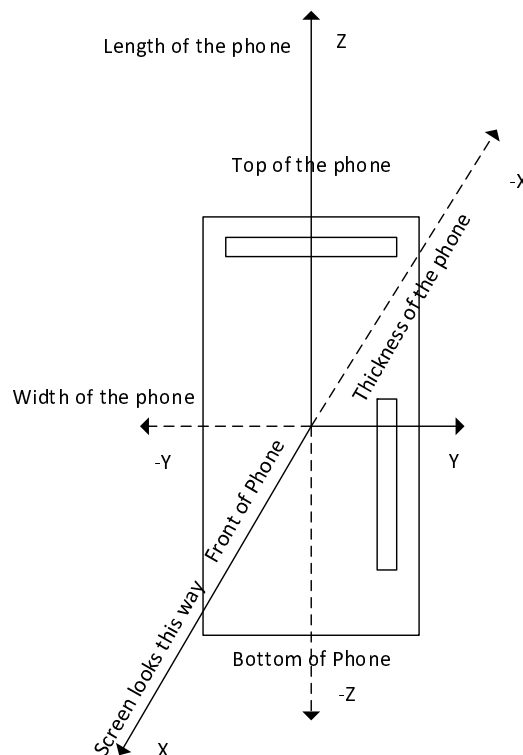

Figure A.5.2-1: Reference coordinate system and reference device orientation

First the terminology used below is defined here. Where possible consistency with [3], [30], [31] and [32] is sought.

Use Case (Position): the use case (position) indicates how the DUT is related to its environment. This includes the following example use cases: free space, beside head, beside head and hand, hand only, etc. Note that formerly this has been referred to as position in [6] as well as in [32]. Since to date only isotropic metrics have been used (TRP/TRS) the definition of positioning the device for a certain use case has been equivalent to orienting it relative to the environment. With the introduction of spatial channel models, the positioning for a specific use case has to be separated from the actual orientation relative to the spatial incoming signals. For some methodologies not utilizing spatial channel models this distinction might not be necessary.

Orientation: The orientation of the device in three dimensional space is defined using the three Euler angles – Ψ -yaw; Θ -pitch; Φ -roll as defined in [30] and [31] and linked to the reference coordinate systems and reference orientation from Figure A.5.2-1. Note that for most use cases practical considerations of how to position the DUT together with the phantom may determine the DUT orientation.

Rotation: Once positioned for a specific use case and oriented within the reference coordinate system, the DUT and phantom are rotated within the test zone to measure the performance under various spatial channel illuminations. The rotation is defined with the same Euler angles but expressed as vectors of equal size. An example is given below:

EXAMPLE: Consider a DUT measured in an anechoic chamber [29].
To measure the free space use case in the YZ plane (see Table A.5.2-1) for example at every 30 degrees the rotation vectors would be as follows:

$\Psi = [0\ 0\ 0\ 0\ 0\ 0\ 0\ 0\ 0\ 0\ 0\ 0]$ - a vector of 12 zeros indicating no rotation from the reference position for any phi value below

$\Theta = [-90\ -90\ -90\ -90\ -90\ -90\ -90\ -90\ -90\ -90\ -90\ -90]$ – a vector of 12 values equal to -90 indicating a constant pitch of -90 degrees for all phi values below

$\Phi = [0\ 30\ 60\ 90\ 120\ 150\ 180\ 210\ 240\ 270\ 300\ 330]$ – a vector of 12 distinct rotations from the reference position representing a rotation along the azimuth plane with a step of 30 degrees.

These vectors unambiguously define that the DUT is to be oriented with the screen up and rotated in azimuth every 30 degrees. The principal antenna pattern cuts (XY plane, XZ plane, and YZ plane) are defined in [30]. The XY plane cut corresponds to the absolute throughput testing condition applied to the CTIA reference antennas for the inter-lab inter-technique activity. The XZ plane and YZ plane cuts are shown for completeness and are not required for the absolute data throughput framework. The YZ plane cut corresponds to a device positioned with its screen up in a USB/WLAN tethering scenario and may be a useful testing point for handset devices expected to achieve performance metrics under such usage conditions.

Table A.5.2-1: Summary of possible testing environment conditions for devices supporting DL MIMO data reception

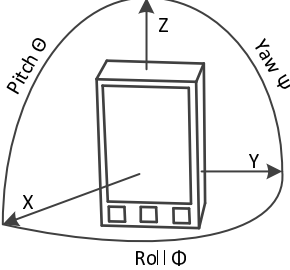
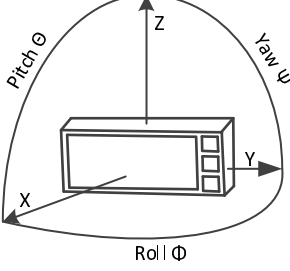
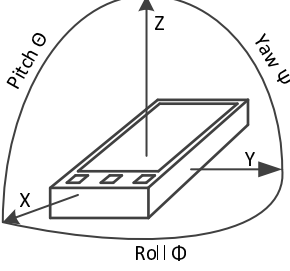
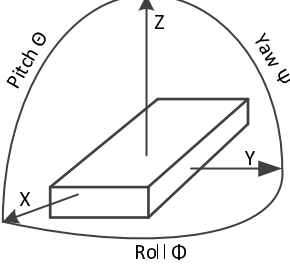
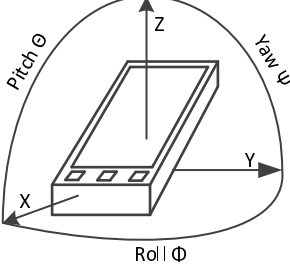
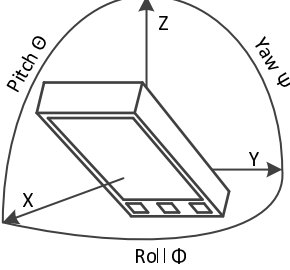
DUT type and dimensions	Testing condition	DUT orientation angles	Diagram
Handset, tablet, CTIA reference antennas	XY plane or P0	$\Psi=0;$ $\Theta=0;$ $\Phi=0$	
Handset, tablet, CTIA reference antennas	XZ plane or L0	$\Psi=90;$ $\Theta=0;$ $\Phi=0$	
Handset, tablet, CTIA reference antennas	Free space data mode screen up (FS DMSU) or YZ plane or Face Up	$\Psi=0;$ $\Theta=-90;$ $\Phi=0$	
Handset, tablet	Face Down	$\Psi=0;$ $\Theta=-90;$ $\Phi=0$	
Handset, tablet	Free space data mode portrait (FS DMP)	$\Psi=0;$ $\Theta=-45;$ $\Phi=0$	
Handset, tablet	Free space portrait tilt down	$\Psi=0;$ $\Theta=45;$ $\Phi=0$	

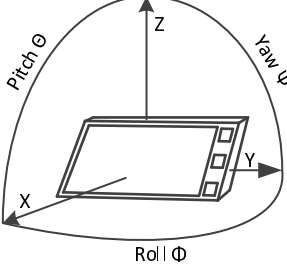
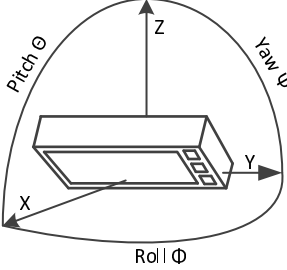
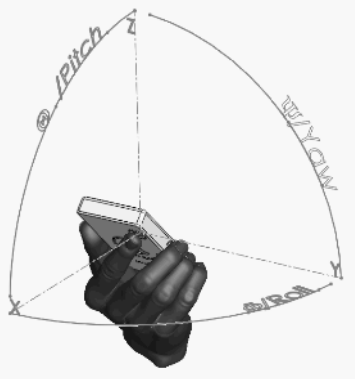
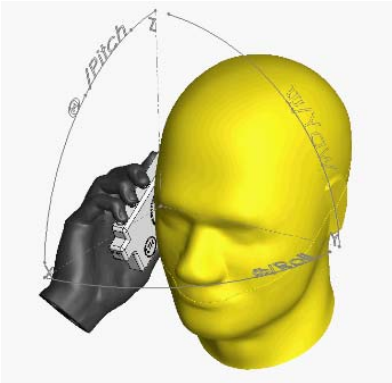
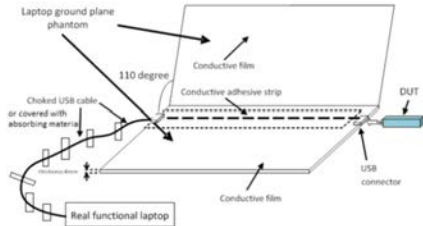
<p>Handset, tablet</p>	<p>Free space data mode landscape (FS DML)</p>	<p>$\Psi=90;$ $\Theta=-45;$ $\Phi=0$ – left tilt</p>	
<p>Handset, tablet</p>	<p>Free space landscape tilt down</p>	<p>$\Psi=90;$ $\Theta=45;$ $\Phi=0$ – left tilt</p>	
<p>Handset, width < 56mm</p>	<p>Left/right hand narrow phantom data mode portrait (LH/RH DMP)</p>	<p>$\Psi=0;$ $\Theta=-45;$ $\Phi=0$</p>	
<p>Handset, 56 mm < width < 72 mm</p>	<p>Left/right hand PDA phantom data mode portrait (LH/RH DMP)</p>	<p>$\Psi=0;$ $\Theta=-45;$ $\Phi=0$</p>	
<p>Handset width < 56 mm</p>	<p>Beside head and hand right/left (BHHR/BHHL)</p>	<p>$\Psi=60;$ $\Theta=6;$ $\Phi=-90$ – right side $\Psi=-60;$ $\Theta=-6;$ $\Phi=90$ – left side</p>	
<p>Handset 56 < width < 72 mm</p>	<p>Beside head and hand right/left (BHHR/BHHL)</p>	<p>$\Psi=60;$ $\Theta=6;$ $\Phi=-90$ – right side $\Psi=-60;$ $\Theta=-6;$ $\Phi=90$ – left side</p>	
<p>LME</p>	<p>Laptop ground plane phantom</p>	<p>$\Psi=0;$ $\Theta=0;$ $\Phi=0$</p>	

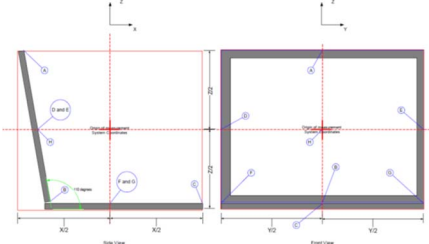
LEE	XY plane	$\Psi=0;$ $\Theta=0;$ $\Phi=0$	
<p>NOTE 1: The orientation angles given in the table define a set of use cases and orientations relative to the spatial channel model. The rotation angles to be used for measurements are FFS. Methodologies not utilizing spatial channel models might not need to define any rotations but are expected to measure for the given use cases.</p> <p>NOTE 2: The CTIA reference antennas have been defined for inter-lab inter-technique testing for the purposes of comparing MIMO OTA methodologies.</p> <p>NOTE 3: For DMP, other pitch positions can be considered FFS.</p> <p>NOTE 4: The absolute throughput usage mode is defined only within the framework of the CTIA reference antennas and is used for comparison of results within/across MIMO OTA methodologies.</p> <p>NOTE 5: Screen up flat positioning reference corresponds to a possible USB/WLAN tethering case, details of implementing this DUT orientation condition such as additional cabling, etc., are FFS.</p> <p>NOTE 6: Left/right/both hand phantoms for the DML usage scenario are not currently defined in 3GPP; until these phantom designs become available, it is possible to only define a DML usage scenario in free space.</p> <p>NOTE 7: For a symmetric 2D coverage of testing points in azimuth, DML left and right tilts are expected to produce identical results in free space. Once phantom designs become available, we expect the interaction of the phantom with the antennas to be dependent on the tilt.</p> <p>NOTE 8: The 110 degree angle of the notebook screen opening is a standard reference for all measurements of antennas embedded in notebooks; as a result, the LEE measurement in free space is the principal XY plane cut with respect to this reference.</p> <p>NOTE 9: The orientation angles for the talk mode position are only approximate. The phone positioning is defined as in [3] and in [32] relative to the SAM phantom.</p>			

The Data Mode Portrait (DMP) conditions are defined in TR 25.914 [3], and are included in this table for completeness. The Data Mode Landscape (DML) testing conditions are not currently defined in any standard testing methodology but benefit from a thorough treatment in academic literature [31]. This testing condition considers free space for all handset sizes until a DML phantom design becomes available, at which time the testing condition will be revisited.

The Laptop Mounted Equipment (LME) and Laptop Embedded Equipment (LEE) testing conditions are well defined in TR 25.914 [3] and constitute an XY plane cut measurement, given the proper orientation of the lid of the laptop ground plane phantom (in the case of LME) or of the laptop itself (in the case of LEE).

Given a 2D ring of symmetrically distributed probes [29]:

- The XZ plane is similar to the DML mode except for the additional 45 degrees pitch in the DML
- For the phantom case the tilt of the DML case is very relevant since the interaction of the phantoms with the antennas will depend on it – see Figure A.5.2-2.

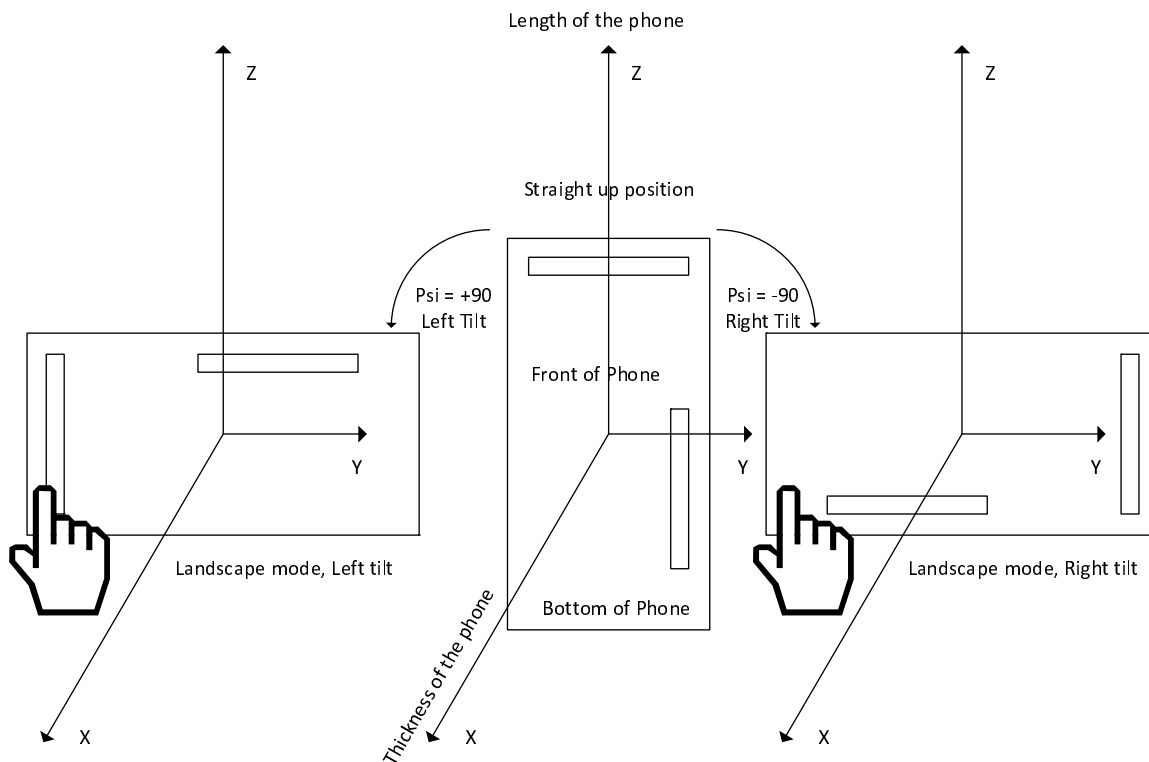

Figure A.5.2-2: Left and Right tilts for landscape mode with left hand phantom shown to interact differently with the antennas depending on the tilt

A.5.2.1 MPAC Positioning Guidelines

In order for the anechoic chamber multi probe system to emulate the intended propagation statistics within the region of space incident on the DUT antennas, two concepts determine the associated antenna spacing and positioning guidelines. The maximum antenna spacing in the DUT must be within the limit determined by the anechoic chamber multi probe system’s ability to emulate the spatial correlation function, and the power stability of the field incident on the DUT antennas must be verified.

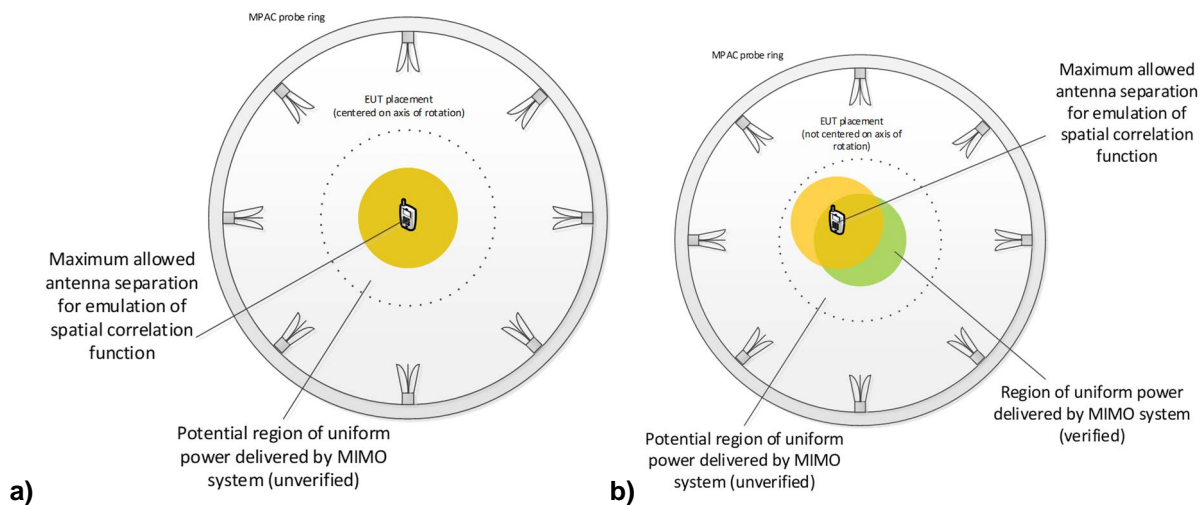

Figure A.5.2.1-1: Illustration of DUT antenna spacing and positioning guidelines; a) guideline in this specification, b) example with DUT meeting the maximum allowed antenna separation but not within the verified power stability region

As the channel model validation procedures for spatial correlation as defined in [29] are to be performed at the downlink centre frequency in 3GPP TS 36.508 [10], the maximum antenna spacing in the DUT shall be defined by the wavelength per operating band centre frequency of the middle channel of the downlink at the band under test. A verification of power stability can be derived from the spatial correlation verification results in [29]. Given that this verification spans a region with a diameter of 1 wavelength centered on the axis of rotation in the chamber and that the performance demonstrated by multiple 8 dual-polarized probe MPAC implementations in [29] has shown good alignment up to 0.85λ for SCME UMi, the region where DUT antennas shall be placed (the MIMO OTA test zone) shall be defined in the same way (see Figure A.5.2.1-1a above) but further confined by the 0.85λ antenna separation limit for SCME UMi. Figure A.5.2.1-1b above provides an example of a DUT meeting the maximum allowed antenna separation but not within the verified power stability region; this placement of a DUT shall not be used. The optimization of the maximum allowed antenna spacing of the DUT and the verification of the test zone, as well as SCME UMa considerations, are expected as part of future work.

The region of uniform power delivered by the MIMO system (unverified) as shown in Figure A.5.2.1-1 is an indication of the region where the wave front may maintain its uniformity. Therefore, it may be used to extend the test volume but is not allowed at this time. It is considered unverified because the validation of spatial correlation provides a verification that spans a region of 1 wavelength. Any further extension of the verified test volume would require an update to the spatial correlation validation in [29].

The DUT maximum antenna spacing and placement within the test zone shall be defined by the following two-tier methodology due to the primary radiation modes below 1 GHz and above 1 GHz and how they relate to the device and/or antenna size.

When operating in frequency bands lower than 1GHz, the physical centre of the DUT shall be placed in the chamber centre, the DUT shall be completely contained within the volume defined by the respective operating band equivalent to a sphere with a radius equal to 0.425λ as defined in Tables A.5.2.1-1 and Tables A.5.2.1-2 for SCME UMi.

When operating in frequency bands higher than 1 GHz the equidistant physical point between the DUT MIMO antenna system shall be placed in the chamber centre following guidance defined in Figure A.5.2.1-2 and the DUT MIMO antenna system (further physical dimension or both antennas' maximum E-field regions) shall be completely contained within the volume defined by the respective operating band equivalent to a sphere with a radius equal to 0.425λ defined in Tables A.5.2.1-1 and Tables A.5.2.1-2 for SCME UMi. The definition of the equidistant point between the DUT MIMO antennas shall be provided through manufacturer declaration for all operating bands where the maximum antenna separation requirement has been met. The location of the equidistant point(s) for each operating band shall be identified by the manufacturer by either marking the device utilized for MIMO OTA testing or by providing clear instructions to the test operator as to the physical location(s).

The two-tier approach is needed to be technically correct when defining the MPAC test volume. While the geometric centre can be used in frequencies lower than 1GHz, the same methodology will add unnecessary limitations for test applicability in frequencies above 1GHz. In this case, manufacturers will need to provide further information to enable the proper definition of the test volume. Ideally, the same approach adopted in frequencies above 1 GHz could be used for all frequencies. However, the extra positioning work and need to identify the equidistant point between the DUT MIMO antennas isn't necessary for frequencies under 1GHz since the wavelength dimension is large enough for all handsets, phablets, and most tablets and laptops.

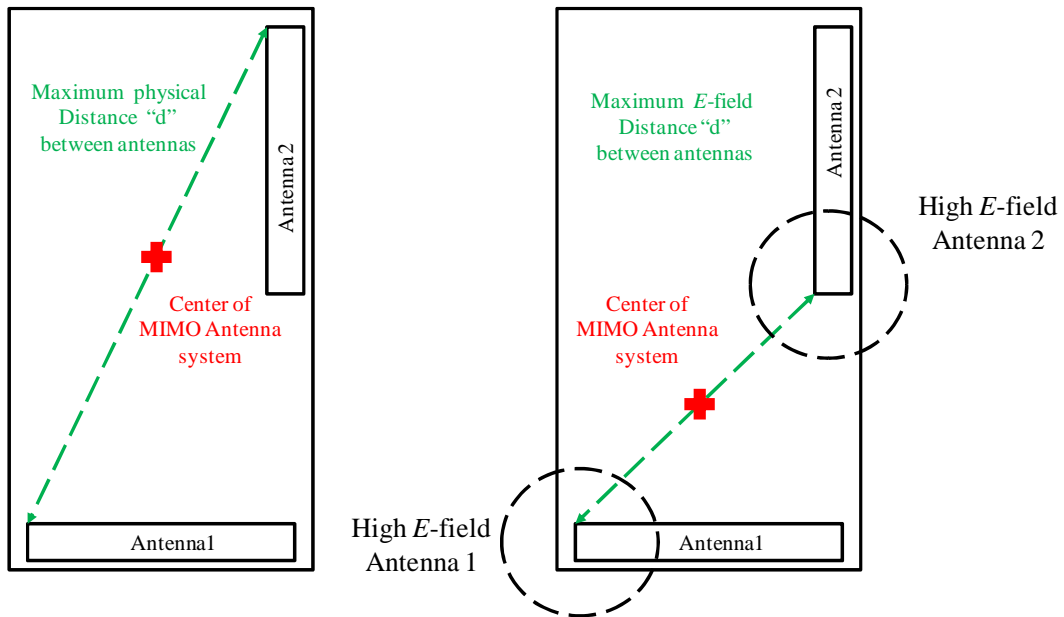

Figure A.5.2.1-2: Definition of distance between MIMO antennas and DUT centre, maximum physical separation, or E-field maximum separation defined by manufacturer

Table A.5.2.1-1: Test zone dimension definition vs. FDD band of operation

Band	DL middle channel frequency (MHz)	0.85*Wavelength (m) middle channel	Test volume sphere radius (m)
1	2140	0.119	0.060
2	1960	0.130	0.065
3	1842.5	0.138	0.069
4	2132.5	0.119	0.060
5	881.5	0.289	0.145
6	880	0.290	0.145
7	2655	0.096	0.048
8	942.5	0.270	0.135
9	1862.4	0.137	0.068
10	2140	0.119	0.060
11	1485.9	0.171	0.086
12	737.5	0.346	0.173
13	751	0.339	0.170
14	763	0.334	0.167
17	740	0.344	0.172
18	867.5	0.294	0.147
19	882.5	0.289	0.144
20	806	0.316	0.158
21	1503.4	0.169	0.085
22	3550	0.072	0.036
23	2190	0.116	0.058
24	1542	0.165	0.083
25	1962.5	0.130	0.065
26	876.5	0.291	0.145
27	860.5	0.296	0.148
28	780.5	0.326	0.163
29	722.5	0.353	0.176
30	2355	0.108	0.054
31	465	0.548	0.274
32	1474	0.173	0.086

Table A.5.2.1-2: Test zone dimension definition vs. TDD band of operation

Band	DL middle channel frequency (MHz)	0.85*Wavelength (m) middle channel	Test Volume Sphere Radius (m)
34	2017.5	0.126	0.063
35	1880	0.136	0.068
36	1960	0.130	0.065
37	1920	0.133	0.066
38	2595	0.098	0.049
39	1900	0.134	0.067
40	2350	0.108	0.054
41	2593	0.098	0.049
42	3500	0.073	0.036
43	3700	0.069	0.034
44	753	0.338	0.169

The positioning of the device under test within the test volume shall be set as defined above and in [29].

The environmental requirements for the device under test shall be set as defined in Annex M.

A.5.2.2 RTS Positioning Guidelines and test zone dimensions

For the RTS system, it can be seen from earlier analysis in the MU budget in TR 37.977 Annex B.2 [29] that the MU elements related to device size are linked to uncertainties in the field uniformity of the anechoic chamber used for the first stage antenna pattern measurement. The RTS MU budget was calculated with the assumption that the device size was within the limits defined by the chamber quiet zone defined in TS 34.114 Annex A2.3 [6], TS 34.114 E.10 [6] and as measured in TS 34.114 Annex G.2 [6]. The applicable device size for RTS is therefore the same as used for SISO TRS in the same chamber.

The second stage of the RTS method which involves a cable replacement radiated connection, is assumed in the MU budget to take place in the same anechoic chamber as was used for the first stage antenna pattern measurement, and there are no additional test zone considerations required. The use of a different chamber for the second stage is not precluded, but would require a recalculation of the impact of any difference between the anechoic chambers.

For device positioning within the test zone for the first stage the normal positioning accuracy assumed in TR 37.977 Table B.2-1 [29] of 1 degree is considered insignificant compared to the raster used for the antenna measurement.

For the second stage positioning impact, and with the assumption the chamber is the same as used in the first stage, the issue is the repeatability of the position used from the first stage. This is likely to be less than the 1 degree absolute positioning error so is again assumed to be negligible.

Annex B (normative): Calibration

B.1 General

The relative power values of the measurement points will be transformed to absolute radiated power values (in dBm) by performing a calibration measurement. The calibration measurement is done by using a reference antenna with known efficiency or gain values. In the calibration measurement the reference antenna is measured in the same place as the DUT, and the attenuation of the complete transmission path (L_{total}) from the DUT to the measurement receiver/NB/BS simulator is calibrated out.

The gain and/or radiation efficiency of the reference antenna shall be known at the frequency bands in which the calibrations are performed. Recommended calibration antennas are monopole antennas or sleeve dipoles tuned for the each frequency band of interest. Alternatively, other methods may be used if they ensure an equal or greater level of accuracy. A network analyzer is recommended to be used to perform the calibration measurement. Also other devices can be used to measure attenuation.

The principle is based on the use of calibration/substitution antennas presenting an efficiency known with a sufficient accuracy in the measurement bandwidths. Such a calibration antenna is placed on the DUT positioner at the exact UE location used for TRP and TRS measurement. It is possible to use a mechanical piece to place the calibration antenna on the positioner. This mechanical piece should not present any electromagnetic properties, which could influence the frequency response and the radiation properties of the calibration antenna.

B.2 Calibration procedure

B.2.1 Calibration procedure for Anechoic chamber method

For the anechoic chamber method, the calibration is performed individually for the both orthogonal polarizations, all the transmission paths and all frequencies used in the testing. An illustration of the substitution configuration is shown in Figure B.2.1-1.

L_{total} is the attenuation between P and B, see Figure B.2.1-1.

$$L_{total} = (L_{AB} - L_{AC} + E_{cal})$$

Where L_{AC} is cable loss from A to C. The cable AC connecting the substitution antenna should be such that its influence upon radiation pattern measurements is minimal. L_{AB} is the attenuation between points A and B. In TRP and TRS measurements point B is connected to the calibrated input/output port of measurement receiver.

E_{cal} is the efficiency or gain of the calibration antenna at the frequency of interest.

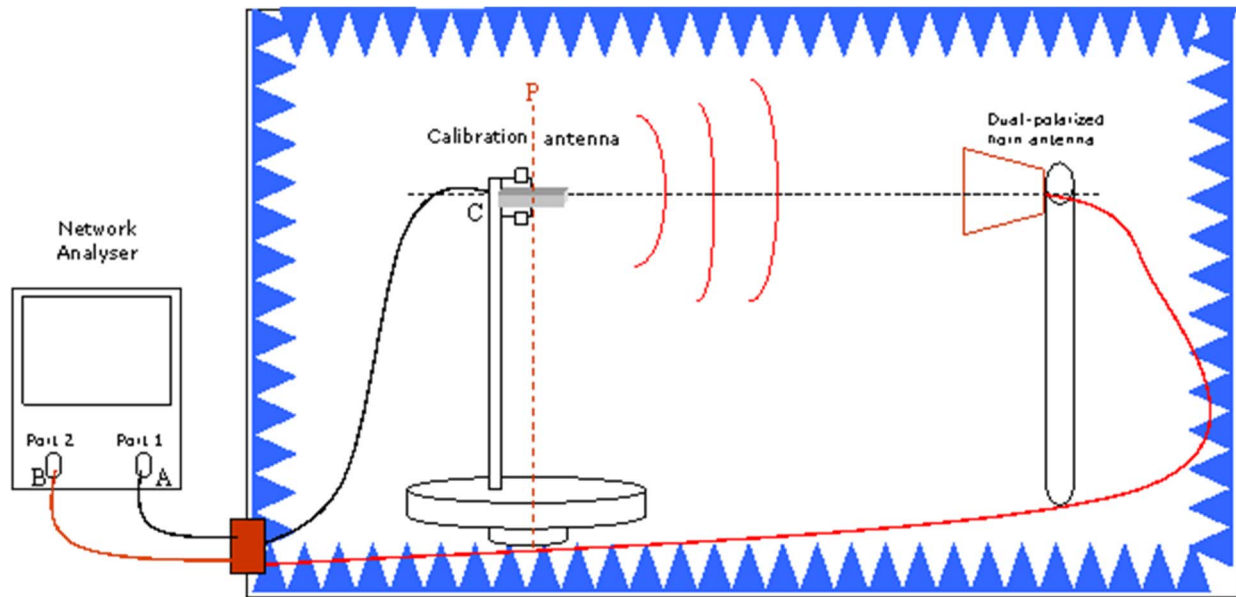

Figure B.2.1-1: Calibration/substitution procedures using a vector network analyzer

If the calibration is based on known efficiency of the calibration antenna, a full spherical scanning is performed to determine L_{AB} . Unless otherwise specified in the calibration antenna documentation, TRP sampling grid in clause 4.4 and equation for TRP in clause 6 should be used for head and hand phantom and TRP sampling grid in clause 4.4 and equation for TRP in clause 6 should be used for laptop ground plane phantom and embedded devices.

This procedure has to be done at each frequency of interest.

To achieve measurements with an uncertainty as low as possible, it is absolutely necessary to exactly keep the same P to B configuration (cables, dual-polarized antenna).

B.2.2 Calibration procedure for Reverberation chamber method

For the reverberation chamber method, all polarizations and transmission paths are included in one calibration measurement. The calibration antenna can be placed in an arbitrarily position, as long as it is placed 0.5 wavelengths from other metallic objects and 0.7 wavelengths from absorbing objects. An illustration of the measurement setup for this procedure is shown in Figure B.2.2-1.

The purpose of the calibration measurement is to determine the average power transfer function in the chamber, mismatch of fixed measurement antennas and path losses in cables connecting the power sampling instrument and the fixed measurement antennas. Preferably a network analyzer is used for these measurements. Recommended calibration antennas are dipoles tuned to the frequency band of interest.

In general, the calibration of a reverberation chamber is performed in three steps:

1. Measurement of S-parameters through the reverberation chamber for a complete stirring sequence
2. Calculation of the chamber reference transfer function
3. Measurement of connecting cable insertion loss

If several setups are used (e.g. empty chamber, chamber with head or hand phantom, etc.), steps 1 and 2 must be repeated for each configuration. The calibration measurement setup is shown in Figure B.2.2-1.

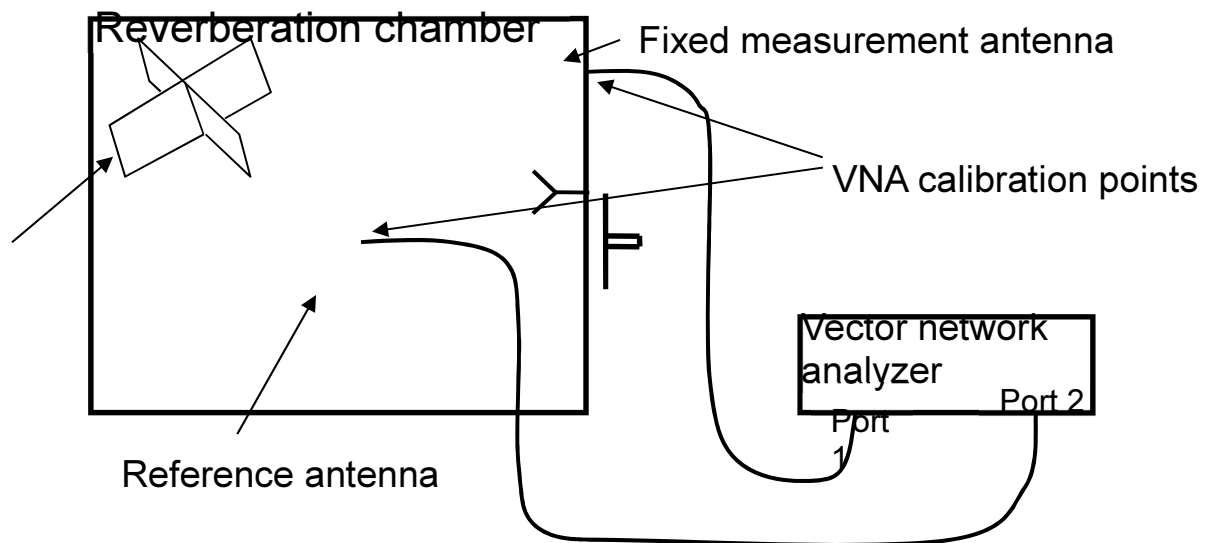

Figure B.2.2-1: Calibration measurement setup in the reverberation chamber, using a vector network analyzer

B.2.2.1 Measurement of S-parameters through the chamber for a complete stirring sequence

This step will measure S-parameters through the reverberation chamber through a complete stirring sequence. This information is required to determine the chamber's reference transfer function. The procedure must be performed separately for each measurement setup of which the loading of the chamber has been changed. The calibration procedure must be repeated for each frequency as defined above. Therefore, it is advantageous if the network analyzer can be set to a frequency sweep covering the defined frequencies, so that all frequencies of interest can be measured with a minimal number of measurement runs.

- i. Place all objects into the RC which will be used during TRP or TRS measurements, including a head phantom, hand phantom and fixture for the EUT. This ensures that the loss in the chamber, which determines the average power transfer level, is the same during both calibration and test measurements. Also, if the EUT is large or contains many antennas, it may represent a noticeable loading of the chamber. It should then be present in the chamber and turned on during the calibration.
- ii. Place the calibration antenna inside the chamber. The calibration antenna is preferably mounted on a low-loss dielectric fixture, to avoid effects from the fixture itself which may affect the EUT's radiation efficiency and mismatch factor. The calibration antenna must be placed in the chamber in such a way that it is far enough from any walls, mode-stirrers, head phantom, hand phantom, or other object, such that the environment for the calibration antenna (taken over the complete stirring sequence) resembles a free space environment. "Far enough away" depends on the type of calibration antenna used. For low gain nearly omni-directional antennas like dipoles, it is normally sufficient to ensure that this spacing is larger than 0.5 wavelengths. More directive calibration antennas should be situated towards the centre of the chamber. The calibration antenna should be present in the chamber during the TRP/TRS measurements.
- iii. Calibrate the network analyzer with a full 2-port calibration in such a way that the vector S-parameters between the ports of the fixed measurement antenna and the calibration antenna can be accurately measured. Preferably, the network analyzer is set to perform a frequency sweep at each stirrer position. This will enable calibration of several frequency points during the same stirring sequence, thereby reducing calibration time. This will also enable frequency stirring, i.e., averaging the measured power transfer function over a small frequency bandwidth around each measured frequency point (moving frequency window). This will increase accuracy at the expense of frequency resolution.
- iv. Connect the antennas and measure the S-parameters for each stirrer position and each fixed measurement antenna.

The number of stirrer positions in the chosen stirring sequence, i.e. the number of S-parameter samples at each frequency point, should be chosen in such a way that it is large enough to yield an acceptable statistical contribution to the total measurement uncertainty. As a guideline it should be larger than 100, preferable 200 or 400 to ensure that the number of independent samples is not severely limited by the total number of samples measured. The number of independent samples, which is a subset of all samples, determines the statistical contribution to the expanded accuracy (which is two times the standard deviation). This should be not less than 100 to ensure an expanded accuracy better than 0.5 dB. The number of independent samples depends on the operating frequency, volume of the chamber, efficacy of the chamber's stirrers, the level of loading by absorbing objects, and whether or not frequency stirring is used.

The sequence of moving the stirrers to different positions may be either step-wise (stopping stirrer for each sample) or continuous (sampling on-the-fly). With continuous stirring it may not be possible to characterize the chamber over a wide frequency band at the same time.

B.2.2.2 Calculation of the chamber reference transfer function

From the S-parameters obtained in the calibration measurement, the chamber reference transfer function for fixed antenna n can be calculated. The reflection coefficient for fixed antenna n can be calculated by the following equation,

$$R_n = \left| \frac{1}{M} \sum_{m=1}^M S_{11,n,m} \right|^2 = \left| \overline{S_{11,n}} \right|^2$$

Thus, the chamber reference transfer function can be calculated by the following equation,

$$P_{ref,n} = \frac{1}{M} \sum_{m=1}^M \frac{|S_{21,n,m}|^2}{(1 - R_n)(1 - |\overline{S_{22}}|^2)} \cdot \frac{1}{e_{ref}}$$

where M is the total number of samples of the transfer function measured for each fixed measurement antenna and $S_{21,n,m}$ is sample number m of the transfer function for measurement antenna n . Moreover, $\overline{S_{22}}$ is the complex average of the calibration antenna reflection coefficient. Finally, e_{ref} is the radiation efficiency of the calibration antenna.

NOTE: The radiation efficiency of the fixed antenna is not corrected for because it will be the same both during calibration and measurements. Therefore, the fixed antenna's radiation efficiency will not affect the final results. The same can be said about the mismatch factor of the fixed measurement antennas, but it is still advantageous to correct for this factor if frequency stirring is applied to improve accuracy.

B.2.2.3 Cable calibration

This measurement step will calibrate the power loss of the cable needed to connect the instrument used to measure the received power at the fixed measurement antenna during TRP measurements, and to generate the power radiated by the fixed antenna during TRS measurements.

- i. Disconnect the cables between the VNA and the chamber.
- ii. Connect the cables one-by-one between the two ports of the network analyzer. The VNA must be calibrated at its own two ports.
- iii. Measure the frequency response of the transmission S-parameter (S_{21} or S_{12}) of the cable.
- iv. Save the power transfer values ($|S_{21}|^2$) of the frequency response curve for the test frequencies and cables positions, etc).

Calibration shall be performed yearly or if any equipment in the measurement system is changed.

B.2.3 Calibration procedure for Anechoic chamber method with Multiprobe configuration

The system needs to be calibrated in two steps in order to ensure that the absolute power is correct. The first calibration steps ensures the accurate generation of the channel model in the centre of the chamber as required by Annex L.4. The second step validates the total power as would be seen by the DUT and allows for that power to be scaled up or down if necessary.

Considering the complexity of the system various way to calibrate are possible. The end goals are however the same no matter the exact procedure. The two steps must achieve the following:

Step 1: This step is used to equalize the power in the centre coming from the different probes. This being a relative measurement is very robust and with minimal uncertainty. It is sufficient to use instruments calibrated according to the manufacturer's specifications and the measurements require no additional calibration. This step is done for both vertical and horizontal polarizations. The relative differences between probe path losses are recorded and used (typically in the fading emulator) to adjust the generated fading signals for each probe. Example measurement set-up is shown in Figure B.2.3.1-1.

NOTE 1: If Step 1 is performed as an absolute measurement accounting for the cable and reference antenna gains Step 2 can be omitted.

Step 2: This step is used to measure the total absolute power of at least one polarization in the centre of the ring. Then assuming that validation of the channel models has been done, the total power available to the DUT in the centre of the chamber can be computed. If necessary the power can be scaled up or down to achieve the desired power level. Since this is an absolute power measurement, the measurement cable and reference antenna gains have to be accounted for.

NOTE 2: To minimize measurement uncertainty the passive and active components of the system may be calibrated independently as well as at different intervals.

NOTE 3: Step 2 of the calibration should be performed with the channel model loaded and LTE signalling active. Sufficient amount of time averaging is required because of the fading nature of the models used.

NOTE 4: Various ways of performing the two steps may exist depending on the equipment used. The lab is responsible for providing a comprehensive calibration procedure.

NOTE 5: Steps one and two may be combined with the channel verification procedure.

NOTE 6: The calibration must be performed for all frequencies of interest.

B.2.3.1 Example Calibration Procedure

The calibration procedure outlined below is only one possibility based on a concrete measurement set-up. Improvements can be made to minimize measurement uncertainty.

Step 1 (see Figure B.2.3.1-1)

1. Place a vertical reference dipole in the centre of the chamber, connected to a VNA port, with the other VNA port connected to the input of the channel emulator unit.
2. Configure the channel emulator for bypass mode (NOTE this might not be available in all instruments)
3. Measure the response of each path from each vertical polarization probe to the reference antenna in the centre.
4. Adjust the power on all vertical polarization branches of the channel emulator so that the powers received at the centre are equal.
5. Repeat the steps 1 to 4 with the magnetic loop and horizontally polarized probes instead, and adjust the horizontal polarization branches of the channel emulator.

NOTE: At this stage all vertical polarization paths have equalized gains, and so do all horizontal polarization paths. The two polarizations however do not necessarily produce the same signal strength in the centre of the chamber – this most commonly happens if two physically different channel emulators are used for the two polarizations. The resulting power imbalance can be accounted for either at this step or adjusted at point 7 of step 2.

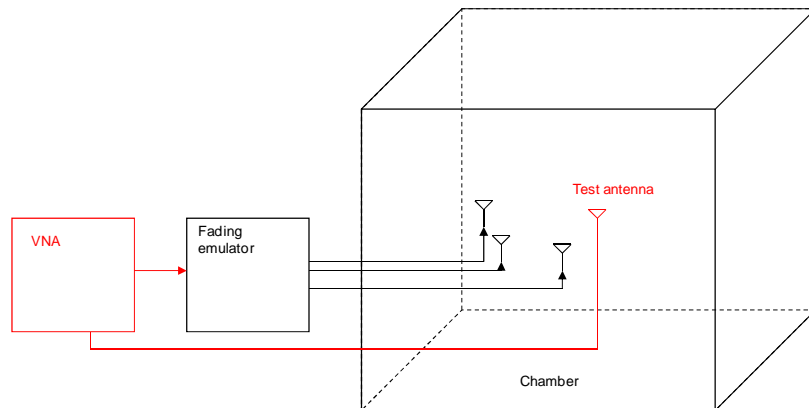

Figure B.2.3.1-1: Setup for VNA measurements

Step 2 (see Figure B.2.3.1-2)

1. Place a vertical reference dipole in the centre of the chamber connected to a spectrum analyzer via an RF cable.
NOTE: A power meter can also be used.
2. Record the cable and reference dipole gains.
3. Load the target channel model
4. Start the LTE signalling in the base station emulator with the required parameter identical to the measurements conditions (some special instrument options might be necessary).
5. Average the power received by the spectrum analyzer for a sufficient amount of time to account for the fading channel – one full channel simulation might be unnecessary.
6. Repeat steps 1 to 4 with a magnetic loop for the horizontal polarization (NOTE: this way no prior validation of the channel model is required)
7. Calculate the total power received at the test area as the sum of the power in the two polarizations.
8. Adjust the power in the two polarizations if necessary. The power adjustment can be a simple scaling of the power up or down or adjustment of the XPR due to slight differences in the fading unit's branches. Depending on the adjustment needed, it can be done at the base station emulator or the channel emulator or both.

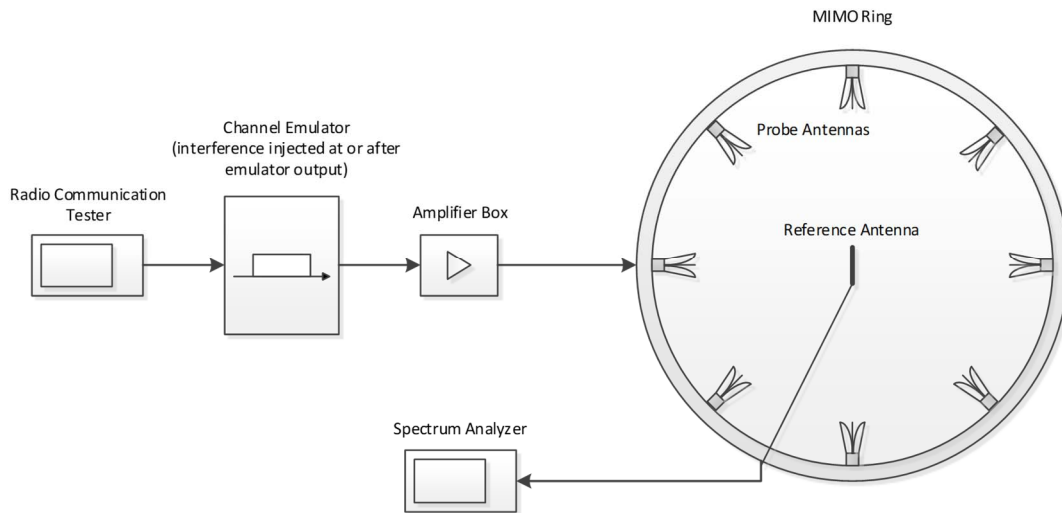

Figure B.2.3.1-2: Example setup for step 2 of the calibration

B.2.4 Calibration procedure for RTS method

For the RTS method, only the DUT reporting RSAP calibration is to perform. The RTS method depends on reported RSAP to do the antenna pattern measurement, and the power calibration for radiated second-stage throughput test. Since these reported readings do not come from a calibrated measurement instrument, their accuracies are often subject to questioning. Below procedure provides method for proper calibration to validate the reported RSAP accuracy.

- DUT reporting RSAP calibration:

With proper spherical coordinate definition of mobile terminal setup, the receive antenna pattern at any coordinate (θ_i, ϕ_i) can be expressed as:

$$P(\theta_i, \phi_i) = RS_i \quad (1)$$

The test point (θ_i, ϕ_i) can be at any point on the 4π solid angle of the coordinate. More precisely, the reported RS of the UE can be expressed as:

$$RS_i(x) = m(x) \cdot x + c \quad (2)$$

where $m(x_i)$ and c is a function of signal strength independent of testing point angular coordinates. x is the actual incident field power density that can be derived from the signal power and test range loss. The above equation (2) assumes that the signal variables in both sides of the equation are expressed in decibels or dB. When $m(x)=1$ and $c=g_0$, where g_0 is the received antenna gain at the test point, we would have declared that the RS report is a true reading of the signal strength. But in reality, $m(x)$ can be biased by either the signal level relative to the receiver's detector operating condition, or by application software programming errors. Meanwhile, the offset constant c can also be biased by either the noise floor of the receiver and/or other artificial factors in the UE RS reporting. Therefore, a Taylor's series can be introduced to have a better representation of the RS report value:

$$RS_i(x) = c + ax + bx^2 + dx^3 + ex^4 + \dots \quad (3)$$

In theory, equation (3) may require many terms to represent the RS report accurately. However, since the reported RS reading in the receive antenna pattern in (1) has a limited signal dynamic range, the following three term expression is enough to correct for the reporting errors:

$$RS_i(x) = c + ax + bx^2 + o(x^3) \quad (4)$$

The third order term $o(x^3)$ is ignored since it is not significant for limited signal dynamic range.

The RS pattern in (1) will need to be calibrated for its possible reporting errors. One practical method is to introduce signal correction terms in equation (4) to enhance the accuracy. This process is also referred to as the linearization. The following steps describe what is needed to linearize the RS report and the RS antenna pattern in (1):

1. Find the maximum RS reading in the pattern obtained in (1) from all angular test points, and at all polarizations. Set this point as the reference point and record signal generator power P_0 and let $x_0 = P_0 - \text{Test Range Path Loss}$ (in dB), and note the maximum RS reading as r_0 .
2. At the reference test point, decrease the signal generator's output power P_i , and let $x_i = P_i - \text{Test Range Path Loss}$ (in dB), starting from P_0 with a step size (1.0 dB by default) to a power range so as to obtain the full RS reading range while searching from the reference point r_0 when the test system dynamic range allows, or to 20 dB by default when the system dynamic range is known to be limited, whichever is lower in range. Record the corresponding RS reading of the UE as r_i . Repeat this process until all angular test points are completed as required.
3. Use those pairs of data obtained in Step 2) (r_i, x_i) as the input of the quadratic fitting curve in (4) to formulate the Algorithm LSF (Least Square Fit) to calculate the three coefficients (a,b, and c) in:

$$\text{Err}(a,b,c) = \sum (c + ax_i + bx_i - r_i)^2 \quad (5)$$

Please note that the power range of the linearization can be limited to 20 dB as stated in Step 2) since the lower RS readings than the processed range do not contribute to the overall receive antenna pattern as much.

Once the three coefficients (a,b, and c) are obtained in LSF of (5), the use of the inverse function of Equation (4) to convert RS pattern in (1) into the normalized incident power pattern. This process completes the error correction for both constant biased and the non-linearity in the RS report from the UE within the limited signal dynamic range as tested in (1) and Step 1. Similar steps can be applied for error corrections if multiple receiver RS are involved in the testing.

Of course, the reference test point can also be further tested for the threshold of the receiver sensitivity and/or throughput knee-point for the required calibrated reference power level.

Annex C (informative): Measurement test report

C.1 General

Operational mode, model and serial number of the DUT shall be documented to the test report. Whether the DUT is positioned against the phantom head with a specific device holder or by other means it should be described in the test report. When the DUT is positioned on the hand phantom it should be described in the test report. When the DUT is positioned on the laptop ground plane phantom it should be described in the test report. A photograph of the test setup is recommended.

Test equipment list should be included in the test report.

\overline{TRP} [dBm] and \overline{TRS} [dBm] values shall be reported for each tested channel and for each side of the head and a frequency band average shall be calculated by using the following equations when the phantom head is used.

$$\overline{TRP} = 10 \log \left[\frac{10^{\frac{TRP_{low_right}}{10}} + 10^{\frac{TRP_{mid_right}}{10}} + 10^{\frac{TRP_{high_right}}{10}} + 10^{\frac{TRP_{low_left}}{10}} + 10^{\frac{TRP_{mid_left}}{10}} + 10^{\frac{TRP_{high_left}}{10}}}{6} \right]$$

$$\overline{TRS} = 10 \log \left[\frac{6}{10^{-\frac{TRS_{low_right}}{10}} + 10^{-\frac{TRS_{mid_right}}{10}} + 10^{-\frac{TRS_{high_right}}{10}} + 10^{-\frac{TRS_{low_left}}{10}} + 10^{-\frac{TRS_{mid_left}}{10}} + 10^{-\frac{TRS_{high_left}}{10}}} \right]$$

\overline{TRP} [dBm] and \overline{TRS} [dBm] values shall be reported for each tested channel and for each hand and a frequency band average shall be calculated by using the following equations when the hand phantom is used.

$$\overline{TRP} = 10 \log \left[\frac{10^{\frac{TRP_{low_right}}{10}} + 10^{\frac{TRP_{mid_right}}{10}} + 10^{\frac{TRP_{high_right}}{10}} + 10^{\frac{TRP_{low_left}}{10}} + 10^{\frac{TRP_{mid_left}}{10}} + 10^{\frac{TRP_{high_left}}{10}}}{6} \right]$$

$$\overline{TRS} = 10 \log \left[\frac{6}{10^{-\frac{TRS_{low_right}}{10}} + 10^{-\frac{TRS_{mid_right}}{10}} + 10^{-\frac{TRS_{high_right}}{10}} + 10^{-\frac{TRS_{low_left}}{10}} + 10^{-\frac{TRS_{mid_left}}{10}} + 10^{-\frac{TRS_{high_left}}{10}}} \right]$$

\overline{TRP} [dBm] and \overline{TRS} [dBm] values shall be reported for each tested channel and a frequency band average shall be calculated by using the following equations when the laptop ground plane phantom is used and when the embedded devices are tested.

$$\overline{TRP} = 10 \log \left[\frac{10^{\frac{TRP_{low}/10}} + 10^{\frac{TRP_{mid}/10}} + 10^{\frac{TRP_{high}/10}}}{3} \right]$$

$$\overline{TRS} = 10 \log \left[3 / \left(\frac{1}{10^{\frac{TRS_{low}/10}} + \frac{1}{10^{\frac{TRS_{mid}/10}} + \frac{1}{10^{\frac{TRS_{high}/10}}}} \right) \right]$$

The expanded measurement uncertainty, assessed according Annex E, shall be documented next to the corresponding TRP and TRS results. The uncertainty calculation shall be made available.

Annex D (normative): Maximum uncertainty of test system and test tolerance

D.1 Maximum uncertainty of test system

The maximum acceptable uncertainty of the Test System is specified in Table D.1-1 for each test, where appropriate. The Test System shall enable each test to be measured with an uncertainty not exceeding the specified values. All ranges and uncertainties are absolute values and are valid for a confidence level of 95 %.

In Annex E, the estimation of measurement uncertainty is defined.

Table D.1-1: Maximum Test System uncertainties for OTA tests

Clause	Maximum Test System Uncertainty	Derivation of Test System Uncertainty
6.1.1 TRP for UTRA FDD in Speech Mode with beside the Head Phantom	Bands I,II,III,IV,V,VI,VII,VIII,IX ±1.9 dB for single measurement	Refer to Annex E
6.1.2 TRP for UTRA TDD in Speech Mode with beside the Head Phantom	Bands a,e,f ±1.9 dB for single measurement	Refer to Annex E
6.1.3 TRP for UTRA FDD in Speech Mode with beside the Head and Hand Phantom	±1.9 dB for single measurement	[TBD]
6.1.4 TRP for UTRA TDD in Speech Mode with beside the Head and Hand Phantom	±1.9 dB for single measurement	[TBD]
6.1.5 TRP for E-UTRA FDD in Speech Mode with beside the Head and Hand Phantom	[TBD]	[TBD]
6.1.6 TRP for E-UTRA TDD in Speech Mode with beside the Head and Hand Phantom	[TBD]	[TBD]
6.1.7 TRP for UTRA FDD in Browsing Mode with Hand Phantom	[TBD]	[TBD]
6.1.8 TRP for UTRA TDD in Browsing Mode with Hand Phantom	[TBD]	[TBD]
6.1.9 TRP for E-UTRA FDD in Browsing Mode with Hand Phantom	[TBD]	[TBD]
6.1.10 TRP for E-UTRA TDD in Browsing Mode with Hand Phantom	[TBD]	[TBD]
6.2.1 TRP for UTRA FDD LME	Bands I,II,III,IV,V,VI,VII,VIII,IX ±1.9 dB for single measurement	Refer to Annex E
6.2.2 TRP for UTRA TDD LME	Bands a,e,f ±1.9 dB for single measurement	Refer to Annex E
6.2.3 TRP for E-UTRA FDD LME	[TBD]	[TBD]
6.2.4 TRP for E-UTRA TDD LME	[TBD]	[TBD]
6.3.1 TRP for UTRA FDD LEE	Bands I,II,III,IV,V,VI,VII,VIII,IX ±1.9 dB for single measurement	Refer to Annex E
6.3.2 TRP for UTRA TDD LEE	Bands a,e,f ±1.9 dB for single measurement	Refer to Annex E
6.3.3 TRP for E-UTRA FDD LEE	±1.9 dB for single measurement	[TBD]
6.3.4 TRP for E-UTRA TDD LEE	±1.9 dB for single measurement	[TBD]
7.1.1 TRS for UTRA FDD in Speech Mode with beside the Head Phantom	Bands I,II,III,IV,V,VI,VII,VIII,IX ±2.3 dB for single measurement	Refer to Annex E
7.1.2 TRS for UTRA TDD in Speech Mode with beside the Head Phantom	Bands a,e,f ±2.3 dB for single measurement	Refer to Annex E
7.1.3 TRS for UTRA FDD in Speech Mode with Head and Hand Phantom	±2.3 dB for single measurement	[TBD]
7.1.4 TRS for UTRA TDD in Speech Mode with beside the Head and Hand Phantom	±2.3 dB for single measurement	[TBD]
7.1.5 TRS for E-UTRA FDD in Speech Mode with beside the Head and Hand Phantom	[TBD]	[TBD]
7.1.6 TRS for E-UTRA TDD in Speech Mode with beside the Head and Hand Phantom	[TBD]	[TBD]
7.1.7 TRS for UTRA FDD in Browsing Mode with Hand Phantom	[TBD]	[TBD]
7.1.8 TRS for UTRA TDD in Browsing Mode with Hand Phantom	[TBD]	[TBD]
7.1.9 TRS for E-UTRA FDD in Browsing Mode with Hand Phantom	[TBD]	[TBD]
7.1.10 TRS for E-UTRA TDD in Browsing Mode with Hand Phantom	[TBD]	[TBD]
7.2.1 TRS for UTRA FDD LME	Bands I,II,III,IV,V,VI,VII,VIII,IX ±2.3 dB for single measurement	Refer to Annex E

7.2.2 TRS for UTRA TDD LME	Bands a,e,f ±2.3 dB for single measurement	Refer to Annex E
7.2.3 TRS for E-UTRA FDD LME	[TBD]	[TBD]
7.2.4 TRS for E-UTRA TDD LME	[TBD]	[TBD]
7.3.1 TRS for UTRA FDD LEE	Bands I,II,III,IV,V,VI,VII,VIII,IX ±2.3 dB for single measurement	Refer to Annex E
7.3.2 TRS for UTRA TDD LEE	Bands a,e,f ±2.3 dB for single measurement	Refer to Annex E
7.3.3 TRS for E-UTRA FDD LEE	±2.3 dB for single measurement	[TBD]
7.3.4 TRS for E-UTRA TDD LEE	±2.3 dB for single measurement	[TBD]
7.4.1 Radiated Performance of Multiple-antenna Receivers FDD	±2.65 dB for MPAC	Refer to Annex N
7.4.2 Radiated Performance of Multiple-antenna Receivers TDD	±2.65 dB for MPAC	Refer to Annex N

D.2 Test tolerances

Test tolerances in Table D.2-1 are used to relax the Minimum Requirements in the present document and to derive the Test Requirements.

Table D.2-1: Test Tolerances for OTA tests

Clause	Test Tolerance
6.1.1 TRP for UTRA FDD in Speech Mode with beside the Head Phantom	Bands I,II,III,IV,V,VI,VII,VIII,IX 1.0 dB for minimum requirement 0.7 dB for average requirement
6.1.2 TRP for UTRA TDD in Speech Mode with beside the Head Phantom	Bands a,e,f 1.0 dB for minimum requirement 0.7 dB for average requirement
6.1.3 TRP for UTRA FDD in Speech Mode with beside the Head and Hand Phantom	1.0 dB for minimum requirement 0.7 dB for average requirement
6.1.4 TRP for UTRA TDD in Speech Mode with beside the Head and Hand Phantom	1.0 dB for minimum requirement 0.7 dB for average requirement
6.1.5 TRP for E-UTRA FDD UE in Speech Mode with beside the Head and Hand Phantom	[TBD]
6.1.6 TRP for E-UTRA TDD UE in Speech Mode with beside the Head and Hand Phantom	[TBD]
6.1.7 TRP for UTRA FDD UE in Browsing Mode with Hand Phantom	[TBD]
6.1.8 TRP for UTRA TDD UE in Browsing Mode with Hand Phantom	[TBD]
6.1.9 TRP for E-UTRA FDD UE in Browsing Mode with Hand Phantom	[TBD]
6.1.10 TRP for E-UTRA TDD UE in Browsing Mode with Hand Phantom	[TBD]
6.2.1 TRP for UTRA FDD LME	Bands I,II,III,IV,V,VI,VII,VIII,IX 1.0 dB for minimum requirement 0.7 dB for average requirement
6.2.2 TRP for UTRA TDD LME	Bands a,e,f 1.0 dB for minimum requirement 0.7 dB for average requirement
6.2.3 TRP for E-UTRA FDD LME	[TBD]
6.2.4 TRP for E-UTRA TDD LME	[TBD]
6.3.1 TRP for UTRA FDD LEE	Bands I,II,III,IV,V,VI,VII,VIII,IX 1.0 dB for minimum requirement 0.7 dB for average requirement
6.3.2 TRP for UTRA TDD LEE	Bands a,e,f 1.0 dB for minimum requirement 0.7 dB for average requirement
6.3.3 TRP for E-UTRA FDD LEE	1.0 dB for minimum requirement 0.7 dB for average requirement
6.3.4 TRP for E-UTRA TDD LEE	1.0 dB for minimum requirement 0.7 dB for average requirement
7.1.1 TRS for UTRA FDD in Speech Mode with beside the Head Phantom	Bands I,II,III,IV,V,VI,VII,VIII,IX 1.2 dB for maximum requirement 0.9 dB for average requirement
7.1.2 TRS for UTRA TDD in Speech Mode with beside the Head Phantom	Bands a,e,f 1.2 dB for minimum requirement 0.9 dB for average requirement
7.1.3 TRS for UTRA FDD in Speech Mode with beside the Head and Hand Phantom	1.2 dB for maximum requirement 0.9 dB for average requirement
7.1.4 TRS for UTRA TDD in Speech Mode with beside the Head and Hand Phantom	1.2 dB for maximum requirement 0.9 dB for average requirement
7.1.5 TRS for E-UTRA FDD in Speech Mode with beside the Head and Hand Phantom	[TBD]
7.1.6 TRS for E-UTRA TDD in Speech Mode with beside the Head and Hand Phantom	[TBD]
7.1.7 TRS for UTRA FDD in Browsing Mode with Hand Phantom	[TBD]
7.1.8 TRS for UTRA TDD in Browsing Mode with Hand Phantom	[TBD]
7.1.9 TRS for E-UTRA FDD in Browsing Mode with Hand Phantom	[TBD]
7.1.10 TRS for E-UTRA TDD in Browsing Mode with Hand Phantom	[TBD]

7.2.1 TRS for UTRA FDD LME	Bands I,II,III,IV,V,VI,VII,VIII,IX 1.2 dB for maximum requirement 0.9 dB for average requirement
7.2.2 TRS for UTRA TDD LME	Bands a,e,f 1.2 dB for minimum requirement 0.9 dB for average requirement
7.2.3 TRS for E-UTRA FDD LME	[TBD]
7.2.4 TRS for E-UTRA TDD LME	[TBD]
7.3.1 TRS for UTRA FDD LEE	Bands I,II,III,IV,V,VI,VII,VIII,IX 1.2 dB for maximum requirement 0.9 dB for average requirement
7.3.2 TRS for UTRA TDD LEE	Bands a,e,f 1.2 dB for minimum requirement 0.9 dB for average requirement
7.3.3 TRS for E-UTRA FDD LEE	1.2 dB for maximum requirement 0.9 dB for average requirement
7.3.4 TRS for E-UTRA TDD LEE	1.2 dB for maximum requirement 0.9 dB for average requirement
7.4.1 Radiated Performance of Multiple-antenna Receivers FDD	1 dB
7.4.2 Radiated Performance of Multiple-antenna Receivers TDD	1 dB

Annex E (informative): Estimation of measurement uncertainty

E.1 General

Individual uncertainty contributions in the TRP and TRS measurements are discussed and evaluated in this Annex. A technique for calculating the total measurement uncertainty is also presented.

An important part of a standard measurement procedure is the identification of uncertainty sources and the evaluation of the overall measurement uncertainty. There are various individual uncertainty sources in the measurement procedure that introduce a certain uncertainty contribution to the final measurement result. The approach in this standard test procedure is that the test laboratories are not limited to using some specific instruments and antenna positioners, for example. However, a limit is set for the maximum overall measurement uncertainty.

The TRP/TRS measurement procedure can be considered to include two stages. In Stage 1 the actual measurement of the 3-D pattern of the Device Under Test (DUT) is performed. In Stage 2 the calibration of the absolute level of the DUT measurement results is performed by means of using a calibration antenna whose absolute gain/radiation efficiency is known at the frequencies of interest. The uncertainty contributions related to TRP are listed in Tables E.1-1 and E.1-2 and the contributions related to TRS are in Tables E.1-3 and E.1-4. The uncertainty contributions are analyzed in the following paragraphs.

The calculation of the uncertainty contribution is based on the ISO Guide to the expression of uncertainty in measurement. Each individual uncertainty is expressed by its Standard Deviation (termed here as 'standard uncertainty') and represented by symbol U . The uncertainty contributions can be classified to two categories: Type-A uncertainties, which are statistically determined e.g. by repeated measurements, and Type-B uncertainties, which are derived from existing data e.g. data sheets. Several individual uncertainties are common in Stage 1 and Stage 2 and therefore cancel.

The procedure of forming the uncertainty budget in TRP measurement is:

- 1) Compile lists of individual uncertainty contributions for TRP measurement in both Stage 1 and Stage 2.
- 2) Determine the standard uncertainty of each contribution by
 - a) Determining the distribution of the uncertainty (Gaussian, U-shaped, rectangular, etc.)
 - b) Determining the maximum value of each uncertainty (unless the distributions is Gaussian)
 - c) Calculating the standard uncertainty by dividing the uncertainty by $\sqrt{2}$ if the distribution is U-shaped, and by $\sqrt{3}$ if the distribution is rectangular.
- 3) Convert the units into decibel, if necessary.
- 4) Combine all the standard uncertainties by the Root of the Sum of the Squares (RSS) method.
- 5) Combine the total uncertainties in Stage 1 and Stage 2 also by the RSS method:

$$u_c = \sqrt{u_{c,DUT\ measurement}^2 + u_{c,calibration\ measurement}^2}$$
- 6) Multiply the result by an expansion factor of 1.96 to derive expanded uncertainty at 95% confidence level:

$$1.96 * u_c$$

Example uncertainty budgets are presented in Tables E.29-1, E.29-2, E.29-3, E.29-4, E.29-5, E.29-6, E.29-7, E.29-8, E.29.9, and E.29-10.

Table E.1-1: Uncertainty contributions in TRP measurement for anechoic chamber method

Description of uncertainty contribution	Details in paragraph
Stage 1, DUT measurement	
1) Mismatch of receiver chain (i.e. between probe antenna and measurement receiver)	E.2-E.3
2) Insertion loss of receiver chain	E.4-E.6
3) Influence of the probe antenna cable	E.7
4) Uncertainty of the absolute antenna gain of the probe antenna	E.8
5) Measurement Receiver: uncertainty of the absolute level	E.9
6) Measurement distance: a) offset of DUT phase centre from axis(es) of rotation b) mutual coupling between the DUT and the probe antenna c) phase curvature across the DUT	E.10
7) Quality of quiet zone	E.11
8) DUT Tx-power drift	E.12
9) Uncertainty related to the use of phantoms: (applicable when a phantom is used): If SAM head phantom is used: a) uncertainty from using different types of SAM phantom b) simulated tissue liquid uncertainty If SAM head and hand phantoms are used: a) uncertainty from using different types of SAM phantom b) simulated tissue liquid uncertainty c) uncertainty of dielectric properties and shape of the hand phantom If a hand phantom is used: a) uncertainty of dielectric properties and shape of the hand phantom If a laptop ground plane phantom is used: a) Uncertainty related to the use of the Laptop Ground Plane phantom	E.13
10) Coarse sampling grid	E.14
11) Random uncertainty (repeatability, including positioning uncertainty of the DUT against the SAM phantom or DUT plugged into the Laptop Ground Plane phantom)	E.15
Stage 2, Calibration measurement, network analyzer method, figure B.2.1-1	
13) Uncertainty of network analyzer	E.16
14) Mismatch of receiver chain	E.2-E.3
15) Insertion loss of receiver chain	E.4-E.6
16) Mismatch in the connection of calibration antenna	E.2
17) Influence of the calibration antenna feed cable	E.7
18) Influence of the probe antenna cable	E.7
19) Uncertainty of the absolute gain of the probe antenna	E.8
20) Uncertainty of the absolute gain/ radiation efficiency of the calibration antenna	E.17
21) Measurement distance: a) Offset of calibration antenna's phase centre from axis(es) of rotation b) Mutual coupling between the calibration antenna and the probe antenna c) Phase curvature across the calibration antenna	E.10
22) Quality of quiet zone	E.11

Table E.1-2: Uncertainty contributions in Uncertainty contributions in TRP measurement for reverberation chamber method

Description of uncertainty contribution	Details in paragraph
Stage 1, DUT measurement	
1) Mismatch of receiver chain (i.e. between fixed measurement antenna and measurement receiver)	E.2-E.3
2) Insertion loss of receiver chain	E.4-E.6
3) Influence of the fixed measurement antenna cable	E.7
4) Uncertainty of the absolute antenna gain of the fixed measurement antenna	E.8
5) Measurement Receiver: uncertainty of the absolute level	E.9
6) Chamber statistical ripple and repeatability	E.28
7) Additional power loss in EUT chassis	E.29
8) DUT Tx-power drift	E12
9) Uncertainty related to the use of phantoms: (applicable when a phantom is used): If SAM head phantom is used: a) uncertainty from using different types of SAM phantom b) simulated tissue liquid uncertainty If SAM head and hand phantoms are used: a) uncertainty from using different types of SAM phantom b) simulated tissue liquid uncertainty c) uncertainty of dielectric properties and shape of the hand phantom If a hand phantom is used: a) uncertainty of dielectric properties and shape of the hand phantom If a laptop ground plane phantom is used: a) Uncertainty related to the use of the Laptop Ground Plane phantom	E.13
10) Independent samples	E.14
11) Random uncertainty (repeatability, including positioning uncertainty of the DUT against the SAM phantom or DUT plugged into the Laptop Ground Plane phantom)	E.15
Stage 2 , Calibration measurement, network analyzer method, figure B.2.2-1	
12) Uncertainty of network analyzer	E.16
13) Mismatch of receiver chain	E.2-E.3
14) Insertion loss of receiver chain	E.4-E.6
15) Mismatch in the connection of calibration antenna	E.2
16) Influence of the calibration antenna feed cable	E.7
17) Influence of the fixed measurement antenna cable	E.7
18) Uncertainty of the absolute gain of the fixed measurement antenna	E.8
19) Uncertainty of the absolute gain/ radiation efficiency of the calibration antenna	E.17
20) Chamber statistical ripple and repeatability	E.28

Table E.1-3: Uncertainty contributions in TRS measurement for anechoic chamber method

Description of uncertainty contribution	Details in paragraph
Stage 1, DUT measurement	
1) Mismatch of transmitter chain (i.e. between probe antenna and base station simulator)	E.2-E.3
2) Insertion loss of transmitter chain	E.4-E.6
3) Influence of the probe antenna cable	E.7
4) Uncertainty of the absolute antenna gain of the probe antenna	E.8
5) Base station simulator: uncertainty of the absolute output level	E.18
6) BER measurement: output level step resolution	E.19
7) Statistical uncertainty of BER measurement	E.20
8) BER data rate normalization	E.21
9) Measurement distance: a) offset of DUT phase centre from axis(es) of rotation b) mutual coupling between the DUT and the probe antenna c) phase curvature across the DUT	E.10
10) Quality of quiet zone	E.11
11) DUT sensitivity drift	E.22
12) Uncertainty related to the use of phantoms: (applicable when a phantom is used): If SAM head phantom is used: a) uncertainty from using different types of SAM phantom b) simulated tissue liquid uncertainty If SAM head and hand phantoms are used: a) uncertainty from using different types of SAM phantom b) simulated tissue liquid uncertainty c) uncertainty of dielectric properties and shape of the hand phantom If a hand phantom is used: a) uncertainty of dielectric properties and shape of the hand phantom If a laptop ground plane phantom is used: a) Uncertainty related to the use of the Laptop Ground Plane phantom	E.13
13) Coarse sampling grid	E.14
14) Random uncertainty (repeatability) -positioning uncertainty of the DUT against the SAM or DUT plugged into the Laptop Ground Plane phantom	E.15
Stage 2, Calibration measurement, network analyzer method, figure B.2.1-1	
16) Uncertainty of network analyzer	E.16
17) Mismatch in the connection of transmitter chain (i.e. between probe antenna and NA)	E.2-E.3
18) Insertion loss of transmitter chain	E.4-E.6
19) Mismatch in the connection of calibration antenna	E.2
20) Influence of the calibration antenna feed cable	E.7
21) Influence of the probe antenna cable	E.7
22) Uncertainty of the absolute gain of the probe antenna	E.8
23) Uncertainty of the absolute gain/radiation efficiency of the calibration antenna	E.17
24) Measurement distance: a) Offset of calibration antenna's phase centre from axis(es) of rotation b) Mutual coupling between the calibration antenna and the probe antenna c) Phase curvature across the calibration antenna	E.10
25) Quality of quiet zone	E.11

Table E.1-4: Uncertainty contributions in Uncertainty contributions in TRS measurement for reverberation chamber method

Description of uncertainty contribution	Details in paragraph
Stage 1, DUT measurement	
1) Mismatch of transmitter chain (i.e. between fixed measurement antenna and base station simulator)	E.2-E.3
2) Insertion loss of transmitter chain	E.4-E.6
3) Influence of the fixed measurement antenna cable	E.7
4) Uncertainty of the absolute antenna gain of the fixed measurement antenna	E.8
5) Base station simulator: uncertainty of the absolute output level	E.18
6) BER measurement: output level step resolution	E.19
7) Statistical uncertainty of BER measurement	E.20
8) BER data rate normalization	E.21
9) Chamber statistical ripple and repeatability	E.28
10) Additional power loss in EUT chassis	E.29
11) DUT sensitivity drift	E.22
12) Uncertainty related to the use of phantoms: (applicable when a phantom is used): If SAM head phantom is used: a) uncertainty from using different types of SAM phantom b) simulated tissue liquid uncertainty If SAM head and hand phantoms are used: a) uncertainty from using different types of SAM phantom b) simulated tissue liquid uncertainty c) uncertainty of dielectric properties and shape of the hand phantom If a hand phantom is used: a) uncertainty of dielectric properties and shape of the hand phantom If a laptop ground plane phantom is used: a) Uncertainty related to the use of the Laptop Ground Plane phantom	E.13
14) Independent samples	E.14
13) Random uncertainty (repeatability) - positioning uncertainty of the DUT against the SAM or DUT plugged into the Laptop Ground Plane phantom	E.15
Stage 2 , Calibration measurement, network analyzer method, figure B.2.2-1	
15) Uncertainty of network analyzer	E.16
16) Mismatch of receiver chain	E.2-E.3
17) Insertion loss of receiver chain	E.4-E.6
18) Mismatch in the connection of calibration antenna	E.2
19) Influence of the calibration antenna feed cable	E.7
20) Influence of the fixed measurement antenna cable	E.7
21) Uncertainty of the absolute gain of the fixed measurement antenna	E.8
22) Uncertainty of the absolute gain/ radiation efficiency of the calibration antenna	E.17
23) Chamber statistical ripple and repeatability	E.28

E.2 Mismatch uncertainty between measurement receiver and the probe antenna

If the same chain configuration (including the measurement receiver; the probe antenna and other elements) is used in both stages, the uncertainty is considered systematic and constant → 0.00dB value.

If it is not the case, this uncertainty contribution has to be taken into account and determined by the following method.

In a measurement configuration, when two elements (devices, networks...) are connected, if the matching is not ideal, there is an uncertainty in the RF level signal passing through the connection. The magnitude of the uncertainty depends on the VSWR at the junction of the two connectors. In practical measurement system there are probably several connections in a test set-up, they will all interact and contribute to the combined mismatch uncertainty.

The total combined mismatch uncertainty is composed of 2 parts:

- 1) The mismatch through the connector between two elements
- 2) The mismatch due to the interaction between two elements

E.2.1 Total combined mismatch uncertainty calculations

E.2.1.1 Mismatch uncertainty through the connector between two elements

Hereunder, a measurement configuration:

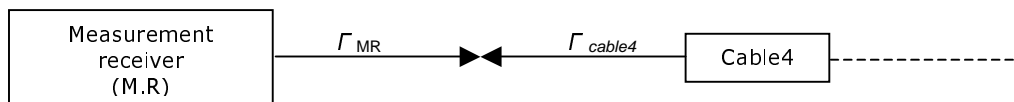

Figure E.2.1.1-1: Mismatch uncertainty through the connector

Γ_{MR} is the complex reflection coefficient of the Measurement Receiver

Γ_{cable4} is the complex reflection coefficient of the cable4

S_{21} is the forward gain in the network between the two reflection coefficients of interest

S_{12} is the backward gain in the network between the two reflection coefficients of interest

Note that S_{21} and S_{12} are set to 1 if the two parts are directly connected.

The uncertainty limits of the mismatch are calculated by means of the following formula table 1 of [26]:

$$\text{Mismatch limits(\% voltage)} = |\Gamma_{MR}| \times |\Gamma_{cable4}| \times |S_{21}| \times |S_{12}| \times 100$$

These mismatch limits are divided by $\sqrt{2}$ because of the U-shaped (table 1 of) [26] distribution of the mismatch uncertainty and give the following standard uncertainty:

$$U_{\text{mismatch}} (\% \text{ voltage}) = \frac{|\Gamma_{MR}| \times |\Gamma_{cable4}| \times |S_{21}| \times |S_{12}| \times 100}{\sqrt{2}}$$

To convert this standard uncertainty in dB, we divide it by the standard uncertainty conversion factor (table 1 of) [26]:

$$U_{\text{mismatch}}(\text{dB}) = \frac{|\Gamma_{MR}| \times |\Gamma_{cable4}| \times |S_{21}| \times |S_{12}| \times 100}{\sqrt{2} \times 11.5}$$

E.2.1.2 Mismatch uncertainty due to the interaction of several elements

Previously, we presented how to determine the mismatch uncertainty between two elements through the junction (connector). Now, we introduce the other type of mismatch uncertainty, which is a result of the interaction between several elements.

Hereunder, a measurement configuration:

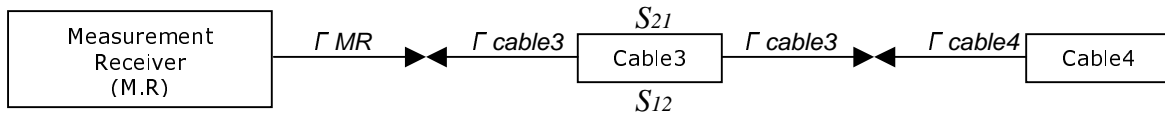

Figure E.2.1.2-1: Mismatch uncertainty due to the interaction of several elements

Firstly, we determine the mismatch uncertainty between junctions of the elements:

Between the MR and the cable3:

$$U_{mismatch1}(dB) = \frac{|\Gamma_{MR}| \times |\Gamma_{cable3}| \times |S_{21}| \times |S_{12}| \times 100}{\sqrt{2} \times 11.5}$$

Between the cable3 and the cable4:

$$U_{mismatch2}(dB) = \frac{|\Gamma_{cable3}| \times |\Gamma_{cable4}| \times |S_{21}| \times |S_{12}| \times 100}{\sqrt{2} \times 11.5}$$

$|S_{21}|$ and $|S_{12}|$ are set to 1 because there is no element between cable3 and cable 4.

$$U_{mismatch1}(dB) = \frac{|\Gamma_{MR}| \times |\Gamma_{cable3}| \times 100}{\sqrt{2} \times 11.5}$$

$$U_{mismatch2}(dB) = \frac{|\Gamma_{cable3}| \times |\Gamma_{cable4}| \times 100}{\sqrt{2} \times 11.5}$$

Each mismatch uncertainty due to the interaction between the measurement receiver and the cable4 is determined by means of the following formula (table 1 of) [26]:

$$U_{mismatch_interaction1}(dB) = \frac{|\Gamma_{MR}| \times |\Gamma_{cable4}| \times |S_{21Cable3}| \times |S_{12Cable3}| \times 100}{\sqrt{2} \times 11.5}$$

$|S_{21}|$ and $|S_{12}|$ are equal and correspond to the cable3 attenuation.

$$U_{mismatch_interaction1}(dB) = \frac{|\Gamma_{MR}| \times |\Gamma_{cable4}| \times |S_{21Cable3}|^2 \times 100}{\sqrt{2} \times 11.5}$$

We consider in the general case, the following measurement configuration:



Figure E.2.1.2-2: Mismatch uncertainty measurement configuration

In the general case, this uncertainty contribution can be calculated by:

$$U_{\text{mismatch_interaction_N}}(\text{dB}) = \frac{|\Gamma_{MR}| \times |\Gamma_{\text{antenna}}| \times |S_{21\text{cable1}}| \times |S_{12\text{cable1}}| \times \dots \times |S_{21\text{cableN}}| \times |S_{12\text{cableN}}| \times 100}{\sqrt{2} \times 11.5}$$

$|S_{21}| = |S_{12}|$ for passive elements (cables...)

$$U_{\text{mismatch_interaction_N}}(\text{dB}) = \frac{|\Gamma_{MR}| \times |\Gamma_{\text{antenna}}| \times |S_{21\text{cable1}}|^2 \times \dots \times |S_{21\text{cableN}}|^2 \times 100}{\sqrt{2} \times 11.5}$$

E.2.2 Total combined mismatch uncertainty

The two kinds of mismatch uncertainty contributions are combined by the root-sum-squares (RSS) method to derive the total combined mismatch uncertainty.

The total combined mismatch uncertainty is equal to:

$$\sqrt{U_{\text{mismatch1}}(\text{dB}) + \dots + U_{\text{mismatchN}}(\text{dB}) + U_{\text{mismatch_interaction1}}(\text{dB}) + \dots + U_{\text{mismatch_interactionN}}(\text{dB})}$$

This formula shows that the uncertainty is frequency dependent by the way of the forward and the backward gains in the network between the two components. The uncertainty upon $|S_{21}|$ and $|S_{12}|$ increases with frequency. One can therefore expect for the UMTS band a higher mismatch uncertainty value than in the GSM and DCS bands.

Note that for an anechoic chamber, horn antennas are usually used as probe antennas. There are two kinds of horn antennas: single-polarized and dual-polarized. With the second one, it is possible to measure the co-polarized and cross-polarized signals without any movement of the probe, which reduces the cable antenna uncertainty contribution and improves the measurement stability.

To conduct the signals to the measurement receiver, the measurement system configuration using a dual-polarized horn antenna has to be completed with an RF Relay. This device will include new mismatch uncertainty contributions, which have to be determined with the previously presented calculation methods, completed by the RF relay parameters contributions, and described in the following.

E.3 Mismatch uncertainty of the RF relay

If the same receiver chain configuration (including the measurement receiver; the probe antenna and other elements) is used in both stages, the uncertainty is considered systematic and constant → 0.00dB value.

If it is not the case, this uncertainty contribution has to be taken into account and determined by the following method.

The following figure describes the RF Relay with its 'S' parameters and the complex reflection coefficient of the inputs and output:

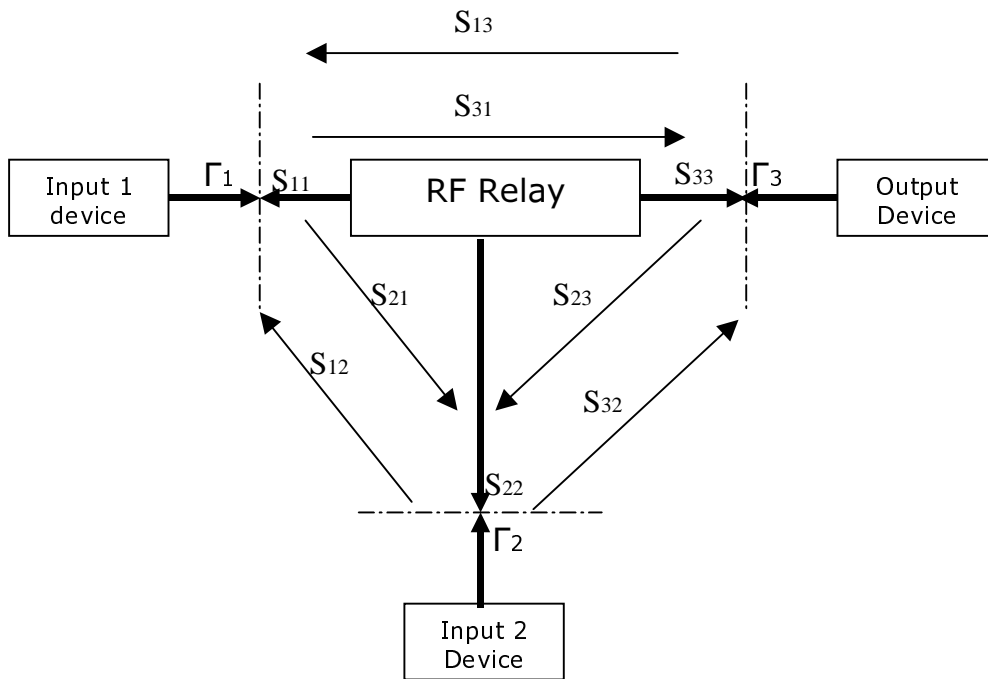

Figure E.3-1: Mismatch uncertainty of the RF relay

The RF relay is used to switchover the cross and direct polarization signals from the probe antenna. To determine RF Relay mismatch uncertainty contributions, reflection coefficients for each port and the cross talk attenuation have to be known.

The total combined mismatch uncertainty is composed of two parts:

- 1) The mismatch uncertainty contributions when the RF Relay switches on the direct polarization signal
- 2) The mismatch uncertainty contributions when the RF Relay switches on the cross polarization signal

Each part is composed of two types of uncertainties introduced in the previous paragraph: the mismatch through the connector between two elements and the mismatch due to the interaction between several elements.

E.3.1 First part: RF Relay switched on the co-polarized signal

E.3.1.1 The mismatch through the connector between two elements

Between the Input1 and the port1:

$$U_{\text{mismatch1}}(\text{dB}) = \frac{|\Gamma_1| \times |S_{11}| \times 100}{\sqrt{2} \times 11.5}$$

Between the port3 and the Output:

$$U_{\text{mismatch2}}(\text{dB}) = \frac{|\Gamma_3| \times |S_{33}| \times 100}{\sqrt{2} \times 11.5}$$

Between the Input2 and the port2:

The RF Relay switchovers on the direct polarization signal. As a result, there is no mismatch uncertainty contribution.

E.3.1.2 Mismatch due to the interaction between two elements or more

Between the Input1 and the Output:

$$U_{\text{interaction1}}(\text{dB}) = \frac{|\Gamma_1| \times |\Gamma_3| \times |S_{31}| \times |S_{13}| \times 100}{\sqrt{2} \times 11.5}$$

Between the Input1 and the Input2:

$$U_{\text{interaction2}}(\text{dB}) = \frac{|\Gamma_1| \times |\Gamma_2| \times |S_{21}| \times |S_{12}| \times 100}{\sqrt{2} \times 11.5}$$

The RF Relay switchovers on the cross polarization signal. As a result; this uncertainty contribution is usually disregarded because of the high crosstalk attenuation which is characterized by $|S_{21}|$ and $|S_{12}|$ 'S' parameters. If the crosstalk attenuation is low, this uncertainty contribution has to be considered.

Between the Input2 and the Output:

$$U_{\text{interaction3}}(\text{dB}) = \frac{|\Gamma_2| \times |\Gamma_3| \times |S_{23}| \times |S_{32}| \times 100}{\sqrt{2} \times 11.5}$$

The RF Relay switchovers on the cross polarization signal. As a result; this uncertainty contribution is usually disregarded because of the high cross-talk attenuation, which is characterized by $|S_{23}|$ and $|S_{32}|$ 'S' parameters. If the crosstalk attenuation is low, this uncertainty contribution has to be considered.

E.3.2 Second part: RF relay switched on the cross-polarized signal

E.3.2.1 The mismatch through the connector between two elements

Between the Input1 and the port1:

The RF Relay switchovers on the direct polarization signal. As a result, there is no mismatch uncertainty contribution.

Between the port3 and the Output:

$$U_{\text{mismatch3}}(\text{dB}) = \frac{|\Gamma_3| \times |S_{33}| \times 100}{\sqrt{2} \times 11.5}$$

Between the Input2 and the port2:

$$U_{\text{mismatch4}}(\text{dB}) = \frac{|\Gamma_2| \times |S_{22}| \times 100}{\sqrt{2} \times 11.5}$$

E.3.2.2 Mismatch due to the interaction between two elements or more

Between the Input1 and the Output:

$$U_{\text{interaction4}}(\text{dB}) = \frac{|\Gamma_1| \times |\Gamma_3| \times |S_{31}| \times |S_{13}| \times 100}{\sqrt{2} \times 11.5}$$

The RF Relay switchovers on the cross polarization signal. As a result; this uncertainty contribution is usually disregarded because of the high crosstalk attenuation which is characterized by $|S_{31}|$ and $|S_{13}|$ 'S' parameters. If the crosstalk attenuation is low, this uncertainty contribution has to be considered.

Between the Input1 and the Input2:

$$U_{\text{interaction5}}(\text{dB}) = \frac{|\Gamma_1| \times |\Gamma_2| \times |S_{21}| \times |S_{12}| \times 100}{\sqrt{2} \times 11.5}$$

The RF Relay switchovers on the cross polarization signal. As a result; this uncertainty contribution is usually disregarded because of the high crosstalk attenuation which is characterized by $|S_{21}|$ and $|S_{12}|$ 'S' parameters. If the crosstalk attenuation is low, this uncertainty contribution has to be considered.

Between the Input2 and the Output:

$$U_{\text{interaction6}}(\text{dB}) = \frac{|\Gamma_2| \times |\Gamma_3| \times |S_{23}| \times |S_{32}| \times 100}{\sqrt{2} \times 11.5}$$

E.3.3 Total combined mismatch uncertainty

Each non-zero mismatch uncertainty contribution from both parts (RF Relay switched on the cross and direct polarization signal) are combined by the root-sum-squares (RSS) method to derive the total combined mismatch uncertainty.

The total combined mismatch uncertainty is equal to:

$$\sqrt{U_{\text{mismatch1}}(\text{dB}) + \dots + U_{\text{mismatchN}}(\text{dB}) + U_{\text{mismatch_interaction1}}(\text{dB}) + \dots + U_{\text{mismatch_interactionN}}(\text{dB})}$$

If a RF Relay is used to drive the cross and direct polarization signals from the dual-polarized antenna, this total combined mismatch uncertainty has to be added with all the uncertainty measurement contributions for the total combined measurement uncertainty.

E.4 Insertion loss of the probe antenna cable

If the probe antenna cable does not move between the calibration and the DUT measurement stage, the uncertainty due to the insertion loss of the cable is assumed to be systematic. Moreover, this uncertainty is common and constant in both stages and that is why this leads to 0.00dB value.

If a different cable is used in the calibration measurement and in the DUT measurement, and the difference of the insertion loss is used in the calculations, then the overall combined standard uncertainty of the insertion loss measurement should be used in the uncertainty budget. The distribution of this uncertainty is assumed to be rectangular, in which case the standard uncertainty can be calculated as the maximum value/ $\sqrt{3}$.

E.5 Insertion loss of the probe antenna attenuator (if used)

See Insertion loss of the probe antenna cable

If the probe antenna attenuator is used in both stages, the uncertainty is considered systematic and constant → 0.00dB value.

E.6 Insertion loss of the RF relays (if used)

See Insertion loss of the probe antenna cable.

If the RF relay is used in both stages, the uncertainty is considered systematic and constant → 0.00dB value.

E.7 Influence of the antenna cable

E.7.1 Probe antenna cable

If the probe antenna is directional (i.e. peak gain >+5dBi e.g. horn, LPDA, etc.) and the same probe antenna cable configuration is used for both stages, the uncertainty is considered systematic and constant → 0.00dB value.

In other cases a technical study should be done.

An ETSI technical report [25] (clause D.1.3.6) gives a discussion on the results obtained by testing a vertically polarized biconical antenna over a ground plane with differing RF cable configurations.

E.7.2 Calibration antenna cable

If an efficiency calibration is performed, influence of the calibration antenna feed cable can be assumed to be negligible, due to data averaging.

In the case of gain calibration, the influence of the calibration antenna feed cable must be assessed by measurements. A gain calibration measurement is repeated with a reasonably differing routing of the feed cable. Largest difference between the results is entered to the uncertainty budget with a rectangular distribution.

E.8 Absolute gain of the probe antenna

The uncertainty appears in the both stages and it is thus considered systematic and constant 0.00dB value.

E.9 Measurement receiver: uncertainty of absolute level

The receiving device is used to measure the received signal level in TRP tests either as an absolute level or as a relative level. Receiving device used is typically a Base Station Simulator (BSS), spectrum analyzer (SA), or power meter (PM). Generally there occurs an uncertainty contribution from limited absolute level accuracy and non-linearity.

E.10 Measurement distance

The uncertainty contribution from a finite measurement distance is estimated in three parts.

E.10.1 Offset of DUT phase centre from axis(es) of rotation

In all the measurements defined in this test procedure the DUT and phantom combination is rotated about the ear reference point of SAM phantom, which is also assumed to be the location of the phase centre in both angular directions of the measurements.

For some turntables this may be practically impossible in which case a measurement uncertainty contribution can arise because the phase centre will rotate on a non-zero radius about the centre of rotation, thereby giving a variable measurement distance. Data averaging process may lead to a partial self-cancel of this uncertainty.

The following formula is used to estimate this uncertainty contribution in stage 1:

$$U_{\text{phase_center_limits}} \text{ (dB)} = 10\log(d \pm \Delta d)^2 + 10\log(d)^2$$

If a gain calibration is performed in Stage 2, the uncertainty contribution of calibration antenna's displacement is estimated with the previous formula. Misalignment can be estimated with following formula,

$$U_{\text{misalignment}} \text{ (dB)} = 20\log(\cos \theta) ,$$

where θ is the misalignment angle between the calibration antenna and the probe antenna. The contribution shall be added to displacement error:

$$U_{\text{cal}} \text{ (dB)} = \sqrt{U_{\text{phase_center_}\Delta}^2 + U_{\text{misalignment}}^2}$$

For an efficiency calibration with an omnidirectional calibration antenna, the U_{cal} is calculated similarly as for gain calibration but the uncertainty may be divided by factor 2. This is due to correcting impact of data averaging in this type of calibration.

E.10.2 Mutual coupling

In measurement of radio performances of UMTS mobile phones in speech mode, the mutual coupling uncertainty for this frequency band is a 0.00dB value (see annex A-2 in [27]).

The 0.00dB value can be extended for the GSM, DCS and PCS band frequencies.

E.10.3 Phase curvature

This uncertainty originates from the finite far-field measurement distance, which causes phase curvature across the DUT. If the measurement distance is $> 10\lambda$, this error is assumed to be negligible. At 2 GHz λ is 0.15 m, thus 10λ is 1.5 m.

E.11 Quality of quiet zone

The uncertainty contribution of the reflectivity level of the anechoic chamber is determined from the average standard deviation of the electric field in the quiet zone. By repeating a free space VSWR measurement in 15-degree grid in elevation and azimuth, 264 standard deviation values in both polarizations are determined. From these values average standard deviation of electric field in the quiet zone can be calculated from the equation:

$$\overline{S_{\text{freq}}} = \frac{\frac{\pi}{2NM} \sum_{n=1}^N \sum_{m=1}^M s_{n,m,hor} \sin(\theta_n) + \frac{\pi}{2NM} \sum_{n=1}^N \sum_{m=1}^M s_{n,m,ver} \sin(\theta_n)}{2}$$

Where

N is number of angular intervals in elevation,

M is number of angular intervals in azimuth and

θ_n is elevation of single measurement $s_{n,m,pol}$.

If an efficiency calibration with omnidirectional calibration antenna is performed, the effect of reflectivity level

decreases in Stage 2 and $\overline{S_{\text{freq}}}$ may be divided by factor 2. This is due to correcting impact of data averaging in this type of calibration. Efficiency calibration done with sampling step $\leq 15^\circ$, can be considered to have at least four independent samples.

It's likely that asymmetry of the field probe will have a very small impact on this measurement uncertainty contributor; however, an upper bound to probe symmetry should be considered.

E.12 Tx-power drift of DUT

A single point power reference measurement in the beginning and at the end of the measurement procedure is recommended to monitor the power drift of the DUT. Based on TX-power drift measurements for typical 3G UE, an

uncertainty of 0.2 dB shall be entered to uncertainty budget with a rectangular distribution. If the drift measurement indicates larger drift, the actual drift shall be included to uncertainty.

In order to minimize Tx-power drift error it's recommended to interleave sensitivity and power measurement of multiple channels. This spreads the measurements over a longer period, which helps to average the drift of the TX-power.

Typical TX-power drifts of 3G UE, measured in a single angular point, DUT placed against phantom head are shown in Figure E.12-1.

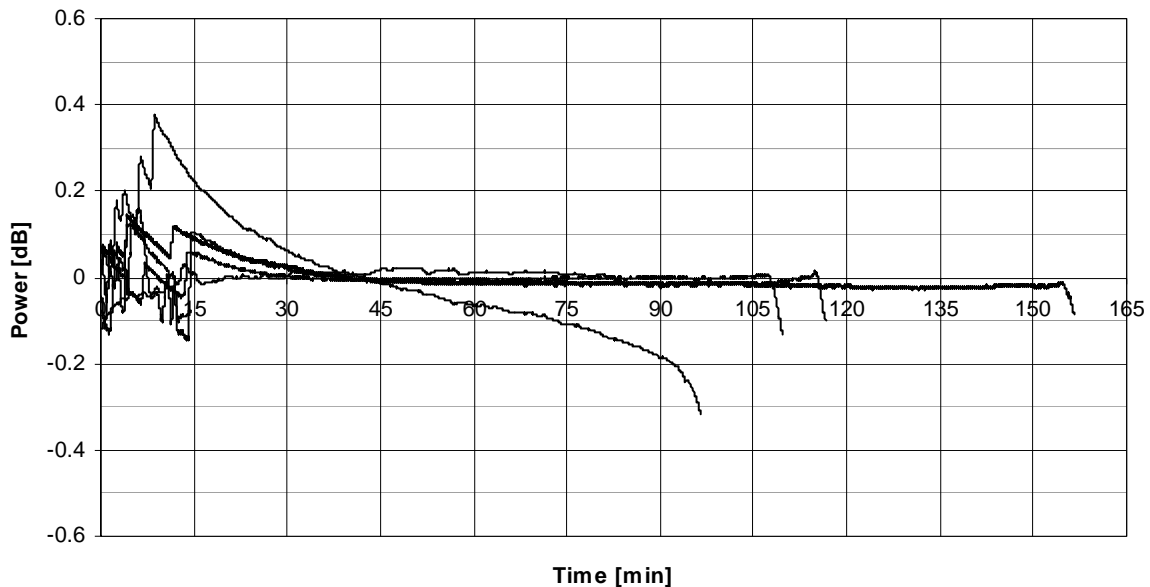

Figure E.12-1: Output power variation of typical 3G UE during battery life

E.13 Uncertainty related to the use of phantoms

E.13.1 Uncertainty from using different types of SAM phantom

This uncertainty contribution originates from the fact that different laboratories may use the two different versions of SAM head: the SAM head phantom or the SAM phantom including the head and the shoulders. The standard SAM head is the specified phantom. However, the use of the other type of SAM is also allowed with the requirement that the resulting uncertainty contribution is taken into account in the uncertainty budget.

E.13.2 Simulated tissue liquid uncertainty

This uncertainty will occur, if the laboratory uses a liquid which has dielectric parameters deviating more than $\pm 15\%$ of the target parameters.

E.13.3 Uncertainty of dielectric properties and shape of the hand phantom

The hand phantom makes a contribution to OTA measurement uncertainty due to the manufacturing tolerances of its dielectric properties and shape. The dielectric properties on the surface of the hand may differ from those of its interior, so both are included in the evaluation. The moulded exterior surface of the hand shall be measured directly with an open-ended coaxial probe. The interior hand material is evaluated indirectly, by substituting a cube-shaped sample moulded from the same material and having some exterior surfaces removed. Following procedure will be used to evaluate the dielectric properties of the hand phantom;

1. Each hand shall be manufactured together with a reference cube of the same material. The sides of the reference cube shall be not less than 40 mm in length.
2. The moulded surface on three orthogonal sides of the cube shall be sliced away to a depth of at least 3 mm, in order to expose interior material for evaluation. The remaining three sides of the cube shall be left untreated.
3. Relative permittivity and conductivity shall be measured at ten different points on each of the three cut, exposed surfaces of the reference cube, and the combined interior averages ($\varepsilon_{int\,avg}$, $\sigma_{int\,avg}$, 30 points) and standard deviations ($\varepsilon_{int\,std}$, $\sigma_{int\,std}$, 30 points) shall be calculated. Individual interior averages for each of these three sides ($\varepsilon_{int\,i}$, $\sigma_{int\,i}$, 10 points) shall also be calculated.
4. Relative permittivity and conductivity shall be measured at ten points on the hand phantom exterior. A measurement point shall be located to each fingertip or as close to the tip as applicable. One measurement point shall be located to the back of the hand and one to the inner surface of wrist area. The exterior averages ($\varepsilon_{ext\,avg}$, $\sigma_{ext\,avg}$, 10 points) and standard deviations ($\varepsilon_{ext\,std}$, $\sigma_{ext\,std}$, 10 points) calculated accordingly.
5. The total averages (ε_{avg} , σ_{avg}) shall be calculated as the average of exterior and interior values by either evaluating all data points or using equations : $\varepsilon_{avg} = \frac{\varepsilon_{ext\,avg} + 3 * \varepsilon_{int\,avg}}{4}$, $\sigma_{avg} = \frac{\sigma_{ext\,avg} + 3 * \sigma_{int\,avg}}{4}$
6. The total standard deviations (ε_{std} , σ_{std}) shall be calculated as the statistical combination of exterior and interior values by either evaluating all data points or using equations: $\varepsilon_{std} = \sqrt{\frac{1}{4}(\varepsilon_{ext\,std}^2 + \varepsilon_{ext\,avg}^2 + 3 * (\varepsilon_{int\,std}^2 + \varepsilon_{int\,avg}^2))} - \varepsilon_{avg}^2$, $\sigma_{std} = \sqrt{\frac{1}{4}(\sigma_{ext\,std}^2 + \sigma_{ext\,avg}^2 + 3 * (\sigma_{int\,std}^2 + \sigma_{int\,avg}^2))} - \sigma_{avg}^2$
7. The hands are acceptable for radiated performance testing, i.e., meet the minimal requirements, if
 - a. ε_{avg} deviate by less than 15% from the target values
 - b. σ_{avg} deviate by less than 25% from the target values
 - c. the difference between the averaged permittivity of each 10-point interior surface $\varepsilon_{int\,avg}$ deviates by less than 10% and $\varepsilon_{ext\,avg}$ by less than 20% from the total average ε_{avg}
 - d. the difference between the averaged conductivity of each 10-point interior surface $\delta_{int\,avg}$ deviates by less than 20% and $\sigma_{ext\,avg}$ by less than 30% from the total average σ_{avg}
 - e. the standard deviation of the combined measurements (30 interior points and 10 exterior points) is less than 20% for permittivity ε_{std} and less than 40% for conductivity σ_{std}
8. For the hands meeting the minimal requirements of step 7, the following approximations shall be used to determine the hand uncertainty due to dielectric properties.

$$U_{\varepsilon} [dB] = c_1 * \left[10 * \log_{10} \left(1 + \left| \frac{\sqrt{\Delta\varepsilon_{avg}^2 + \varepsilon_{unc}^2 + (a_1 \varepsilon_{std})^2}}{\varepsilon} \right| \right) \right]$$

$$U_{\sigma} [dB] = c_2 * \left[10 * \log_{10} \left(1 + \left| \frac{\sqrt{\Delta\sigma_{avg}^2 + \sigma_{unc}^2 + (a_1 \sigma_{std})^2}}{\varepsilon} \right| \right) \right]$$

$\Delta\varepsilon_{avg}$, $\Delta\sigma_{avg}$, ε_{std} , σ_{std} are the values determined as defined above, ε_{unc} and σ_{unc} are expanded measurement uncertainties ($k = 2$) of the dielectric parameter measurement method. The cube will be provided together with the hand such that the user can evaluate if the interior (cube) properties of the hand has degenerated over time by performing the test above. Coefficient $c_1 = 0.78$, $c_2 = 0.39$ and $a_1 = 0.50$ were determined by numeric simulations.

In case the hand phantoms are manufactured within CAD models, the tolerance is 2% and therefore the effects shape errors are negligible. If the tolerance is larger, a numerical study must be conducted.

E.13.4 Uncertainty from using different types of Laptop Ground Plane phantom

This uncertainty contribution originates from the fact that different laboratories may use different variations of Laptop Ground Plane phantom. The standard Laptop Ground Plane is the specified phantom.

E.14 Coarse sampling grid

Degreasing of sampling density to finite amount of samples affects the measurement uncertainty by two different errors. First is due to inadequate number of samples and second is a systematic discrimination approximation error in TRP and TRS equations.

Figure E.14-1 shows simulated sampling grid errors for typical 3G UE. Approximation error is not included. Simulations are based on thin plate surface interpolation of real radiation patterns, measured beside a phantom head.

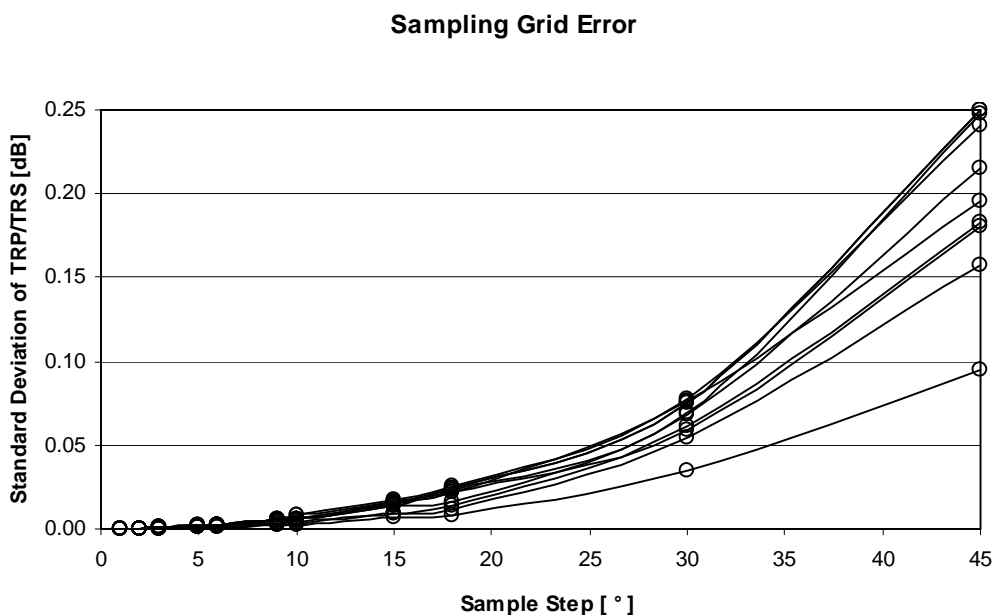

Figure E.14-1: Simulated TPR/TRS error as a function of sampling grid

The offset of systematic approximation error can be expressed by using formula

$$Offset = 10 \cdot \log_{10} \left(\frac{\pi}{2N} \sum_{n=1}^N \sin(\theta_n) \right).$$

where

N is number of angular intervals in elevation,

θ_n is elevation.

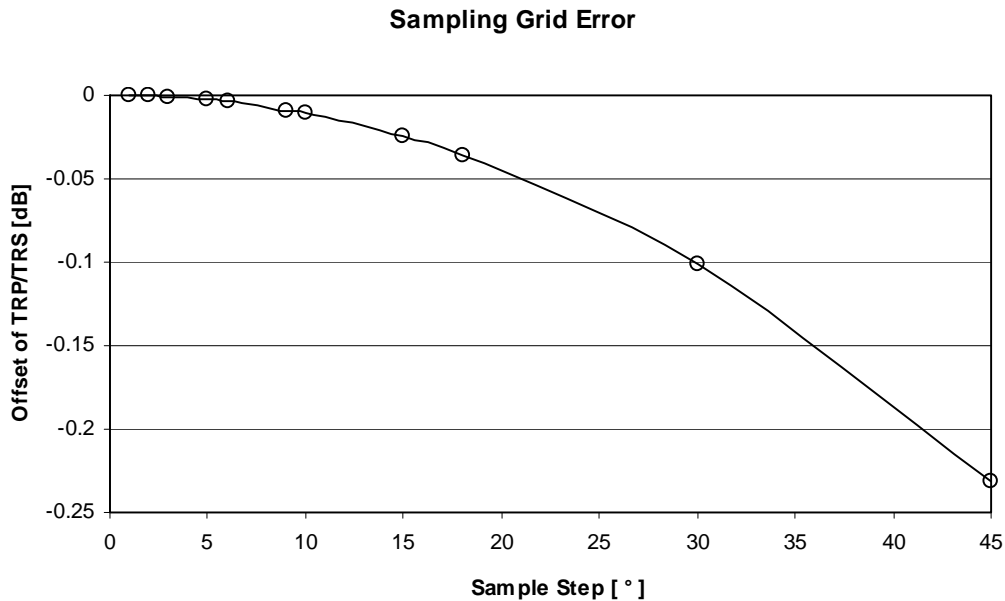

Figure E.14-2: Approximation error of TRP/TRS

The 10° or 15° sampling grid used in TRP measurements has been shown to introduce only very small differences as compared to the results obtained with denser grids, so with that sampling grid the uncertainty contribution can be assumed negligible.

When using a sample step size of 15° - 30°, a standard uncertainty of 0.15 dB can be assumed to cover errors. If a step size >30° is used, a larger uncertainty should be considered.

NOTE: the simulation results presented here are not usable for irregular sampling grids or in the case of MEG/MERS.

E.15 Random uncertainty

The random uncertainty characterizes the undefined and miscellaneous effects which cannot be forecasted. One can estimate this type of uncertainty with a repeatability test by making a series of repeated measurements with a reference DUT without changing anything in the measurement set-up.

The random uncertainty differs from one laboratory to another. Moreover, each DUT has its own electromagnetic behaviour and random uncertainty. Some uncertainty also occurs from the positioning of the DUT against the SAM phantom, as the DUT cannot be attached exactly in the same way every time. This uncertainty depends on how much the DUT's positioning against the SAM phantom and hand phantoms varies from the specified testing positions. It is noted that the uncertainty of the phone positioning depends on the phone holder and the measurement operator and is in fact difficult to distinguish from random uncertainty. Some uncertainty also occurs from the positioning of the DUT plugged into the Laptop Ground Plane phantom, as the DUT may not be plugged into the USB connector and positioned exactly in the same way every time. This uncertainty depends on how much the DUT's position plugged into the Laptop Ground Plane phantom varies from the specified plug-in position. Therefore, the positioning uncertainty is included in random uncertainty.

To estimate this uncertainty for the SAM phantom, it is suggested to perform at least five evaluations of TRP/TRS whereby the device shall be dismounted and newly positioned with a fully charged battery before each test. This measurement set has to be carried out in the mid channel of the lowest and highest frequency bands utilized by the testing lab, for at least three phones with different types of mechanical design. The values have to be normalized by the mean for each measurement set. As a result, the uncertainty contribution entered to the uncertainty budget is the difference between the maximum and minimum normalized values.

With head and hand phantoms, random uncertainty evaluation may be done separately for each measurement configuration i.e. head only, browsing mode or speech mode. A speech mode random uncertainty evaluation, where both

head and hand phantoms are used, can reasonably be considered to be the worst-case scenario and thus random uncertainties in other configurations to be less.

To estimate this uncertainty for the Laptop Ground Plane phantom, it is suggested to perform at least five evaluations of TRP/TRS for the plug-in position whereby the device shall be dismounted and newly positioned before each tests. This measurement set has to be carried out in mid channel of lowest and highest frequency bands utilized by the testing lab, for at least three USBs with different type of mechanical design. The values have to be normalized by the mean for each measurement set. As a result the uncertainty contribution entered to uncertainty budget is the difference between the maximum and minimum normalized value.

E.16 Uncertainty of network analyzer

This uncertainty includes the all uncertainties involved in the S21 measurement with a network analyzer, and will be calculated from the manufacturer's data in logs with a rectangular distribution, unless otherwise informed, (see clause 5.1.2 in [26]).

E.17 Uncertainty of the gain/efficiency of the calibration antenna

The calibration antenna only appears in Stage 2. Therefore, the gain/efficiency uncertainty has to be taken into account.

This uncertainty will be calculated from the manufacturer's data in logs with a rectangular distribution, unless otherwise informed (see clause 5.1.2 in [26]).

If the manufacturer's data do not give the information, the value has to be checked, see annex A-12 in [27].

E.18 Base station simulator: uncertainty of the absolute level

The transmitter device (typically a BS Simulator) is used to drive a signal to the horn antenna in sensitivity tests either as an absolute level or as a relative level. Receiving device used is typically a UE/MS. Generally there occurs uncertainty contribution from limited absolute level accuracy and non-linearity of the BS Simulator.

For practical reasons, the calibration measurement (Stage 2) should be only performed with the probe antenna as a receiver. Hence, the uncertainty on the absolute level of the transmitter device cannot be assumed as systematic. This uncertainty should be calculated from the manufacturer's data in logs with a rectangular distribution, unless otherwise informed (see clause 5.1.2 in [26]). Furthermore, the uncertainty of the non-linearity of the device is included in the absolute level uncertainty.

E.19 BER measurement: output level step resolution

When output power of the BS simulator is swept to reach the BER target, used power step resolution creates this uncertainty. Output power step used in the BER measurement is divided by factor 2 to obtain the uncertainty with rectangular distribution.

E.20 Statistical uncertainty of the BER measurement

To study statistical uncertainty of BER measurement, see ETSI document TR 100 028-1, section 6.6 [25]. For a BER target of $1\% \pm 0.2\%$ using 20000 bits, uncertainty of 0.19 dB for a single measurement can be used. Using a BER target of $10\% \pm 2\%$ with 20000 tested bits will lead to uncertainty of 0.46dB/single measurement.

For a full TRS measurement with a regular sampling grid, the statistical uncertainty can be approximated by using the following formula:

$$U_{fullTRS} = \frac{U_{SingleTRS}}{\sqrt{N/4}},$$

Where

$U_{SingleTRS}$ is the statistical uncertainty of single measurement,

N is the number of measurements.

E.21 BER data rate normalization uncertainty

This uncertainty occurs only when a higher data rate than 12.2kbps is used to speed up TRS measurement. It can be calculated using following formula:

$$U_{norm} = \frac{\sqrt{\left(\frac{U_{SingleTRSref}}{2}\right)^2 + \left(\frac{U_{SingleTRSfast}}{2}\right)^2}}{\sqrt{N_{ref}}},$$

Where

$U_{SingleTRSref}$ is the statistical uncertainty of the used reference measurement,

$U_{SingleTRSfast}$ is the statistical uncertainty of the higher data rate measurement,

N_{ref} Is the number of measured reference points.

E.22 DUT sensitivity drift

Due to statistical uncertainty of BER measurement, drift in the TRS cannot be monitored similarly to TRP. An uncertainty value of 0.2dB can be used, or the TRS drift should be measured, with a setup corresponding to the actual TRS measurement.

E.23 Cable loss measurement uncertainty

Before performing the calibration, cable losses have to be measured. This measurement includes a standard uncertainty, which is composed of the mismatch, and the insertion loss uncertainties. In the calibration measurement, the transmitter part is composed with the calibration antenna, cables, and signal generator. The receiver part is composed with the probe antenna, cables, and measurement device.

The cable loss of transmitter and receiver parts should be measured separately. By this way, the cable losses will be compliant with the cable routing of the calibration stage. On the opposite, if the cable losses were measured together at the same time, the measured values would include errors from miscellaneous mismatch contributions, which do not appear in the cable routing of the calibration stage.

The cable loss measurement uncertainty is the result of the RSS of the uncertainty contributions listed in Table E.23-1.

Table E.23-1: Uncertainty contributions in the cable loss measurement

Description of uncertainty contribution	Standard Uncertainty (dB)
Mismatch uncertainty of cable(s) receiver part	
Insertion loss of the cable(s) receiver part	
Measurement device: absolute level uncertainty	
Measurement device: linearity	
Mismatch uncertainty of cable(s) transmitter part	
Insertion loss of the cable(s) transmitter part	
Signal generator: absolute output level uncertainty	
Signal generator: output level stability uncertainty	
Cable loss measurement uncertainty (RSS)	

E.24 Signal generator: uncertainty of the absolute output level

The signal generator is only used at this stage. It substitutes the DUT by feeding the calibration antenna with a known power level. The use of this signal generator introduces an uncertainty on the absolute output level.

This uncertainty will be calculated from the manufacturer's data in logs with a rectangular distribution (see clause 5.1.2 in [26]).

E.25 Signal generator: output level stability

The uncertainty on the output level stability has to be taken into account only when the uncertainty of the absolute level is not considered.

This uncertainty will be calculated from the manufacturer's data in logs with a rectangular distribution (see clause 5.1.2 in [26]).

E.26 Insertion loss: calibration antenna feed cable

The feed cable of the calibration antenna only appears in Stage 2. As a result, this uncertainty has to be taken into account.

This uncertainty will be measured or calculated from the manufacturer's data in logs with a rectangular distribution (see clause 5.1.2 in [26]).

E.27 Insertion loss: calibration antenna attenuator (if used)

If a calibration antenna attenuator is used, it only appears in Stage 2. As a result, this uncertainty has to be taken into account.

This uncertainty will be calculated from the manufacturer's data in logs with a rectangular distribution (see clause 5.1.2 in [26]).

E.28 Chamber Statistical Ripple and Repeatability

The uncertainty due to chamber statistics is determined by repeated calibration measurements as described in Annex G. This uncertainty contribution is a composite value consisting of most of the specific reverberation chamber contributions, such as limited number of modes and mode-stirring techniques.

The uncertainty contribution value shall be determined by measurements as described in Annex G and be assumed to have a normal distribution.

E.29 Additional Power Loss in EUT Chassis

When the EUT is small and do not add noticeable loss to the chamber, the calibration procedure outlined in clause x.x, is performed without the EUT present in the chamber. The possible difference in average chamber transmission level between the EUT measurement and the reference measurement must in this case be considered in the uncertainty evaluation.

The uncertainty value for this contribution can be tested empirically by choosing a unit within a set of samples which is considered to incur the highest amount of loss (normally the largest unit), and measure the average transmission loss in the chamber with and without the test unit present in the chamber. The difference between the two cases shall be used in the uncertainty calculation and the distribution should be assumed to be rectangular.

Alternatively, a fixed value of 0.2 dB with a rectangular distribution can be used in the uncertainty calculations.

Table E.29-1: Example of uncertainty budget for head only TRP measurement for anechoic chamber method

Uncertainty Source	Comment	Uncertainty Value [dB]	Prob Distr	Div	ci	Standard Uncertainty [dB]
STAGE 1 (DUT measurement)						
1) Mismatch of receiver chain	$\Gamma_{\text{power meter}} < 0.05$ $\Gamma_{\text{probe antenna connection}} < 0.16$	0.05	N	1	1	0.05
2) Insertion loss of receiver chain	Systematic with Stage 2 (=> cancels)	0	R	$\sqrt{2}$	1	0
3) Influence of the probe antenna cable	Systematic with Stage 2 (=> cancels)	0	R	$\sqrt{3}$	1	0
4) Absolute antenna gain of the probe antenna	Systematic with Stage 2 (=> cancels)	0	R	$\sqrt{3}$	1	0
5) Measurement Receiver: uncertainty of the absolute level	Power Meter	0.06	R	$\sqrt{3}$	1	0.03
6) Measurement distance a) Offset of DUT phase centre	$\Delta d = 0.05\text{m}$	0.14	R	$\sqrt{3}$	1	0.08
7) Quality of quiet zone	Standard deviation of E-field in QZ measurement	0.5	N	1	1	0.5
8) DUT Tx-power drift	Drift	0.2	R	$\sqrt{3}$	1	0.12
9) Uncertainty related to the use of SAM phantom	Standard SAM head with standard tissue simulant	0	R	$\sqrt{3}$	1	0
10) Coarse sampling grid	Negligible, used $\Delta_{\theta} = 15^{\circ}$ and $\Delta_{\varphi} = 15^{\circ}$.	0	N	1	1	0
11) Repeatability	Monoblock, clamshell, slide design	0.4	R	$\sqrt{3}$	1	0.23
STAGE 2 (Calibration)						
13) Uncertainty of network analyzer	Manufacturer's uncertainty calculator, covers whole NA setup	0.5	R	$\sqrt{3}$	1	0.29
14) Mismatch of receiver chain	Taken in to account in NA setup uncertainty	0	U	$\sqrt{2}$	1	0
15) Insertion loss of receiver chain	Systematic with Stage 1 (=> cancels)	0	R	$\sqrt{3}$	1	0
16) Mismatch in the connection of calibration antenna	Taken in to account in NA setup uncertainty	0	U	$\sqrt{2}$	1	0
17) Influence of the feed cable of the calibration antenna	Gain calibration with a dipole	0.3	R	$\sqrt{3}$	1	0.17
18) Influence of the probe antenna cable	Systematic with Stage 1 (=> cancels)	0	R	$\sqrt{3}$	1	0
19) Uncertainty of the absolute gain of the probe antenna	Systematic with Stage 1 (=> cancels)	0	R	$\sqrt{3}$	1	0
20) Uncertainty of the absolute gain of the calibration antenna	Calibration certificate	0.5	R	$\sqrt{3}$	1	0.29
21) Measurement distance: Calibration antenna's displacement and misalignment	$d=3\text{m}$, $\Delta d=0.05\text{m}$, $\theta=2^{\circ}$	0.29	R	$\sqrt{3}$	1	0.17
22) Quality of quiet zone	Standard deviation of e-field in QZ measurement, Gain calibration	0.5	N	1	1	0.5
Combined standard uncertainty	$u_c = \sqrt{\sum_{i=1}^m c_i^2 \cdot u_i^2}$					0.89
Expanded uncertainty (Confidence interval of 95 %)			$u_e = 1.96 u_c$			1.75

Table E.29-2: Example of uncertainty budget for TRP head+hand (speech mode) measurement for anechoic chamber method

Uncertainty Source	Comment	Uncertainty Value [dB]	Prob Distr	Div	ci	Standard Uncertainty [dB]
STAGE 1 (DUT measurement)						
1) Mismatch of receiver chain	$\Gamma_{\text{power meter}} < 0.05$ $\Gamma_{\text{probe antenna connection}} < 0.16$	0.05	N	1	1	0.05
2) Insertion loss of receiver chain	Systematic with Stage 2 (=> cancels)	0	R	$\sqrt{2}$	1	0
3) Influence of the probe antenna cable	Systematic with Stage 2 (=> cancels)	0	R	$\sqrt{3}$	1	0
4) Absolute antenna gain of the probe antenna	Systematic with Stage 2 (=> cancels)	0	R	$\sqrt{3}$	1	0
5) Measurement Receiver: uncertainty of the absolute level	Power Meter	0.06	R	$\sqrt{3}$	1	0.03
6) Measurement distance a) Offset of DUT phase centre	$\Delta d = 0.05\text{m}$	0.14	R	$\sqrt{3}$	1	0.08
7) Quality of quiet zone	Standard deviation of E-field in QZ measurement	0.5	N	1	1	0.5
8) DUT Tx-power drift	Drift	0.2	R	$\sqrt{3}$	1	0.12
9) Uncertainty related to the use of the SAM head and hand phantoms: a) uncertainty from using different types of SAM phantom b) simulated tissue liquid uncertainty c) uncertainty of dielectric properties and shape of the hand phantom	Standard SAM head with standard tissue simulant $U_{\varepsilon}[\text{dB}] = 0.20$ $U_{\sigma}[\text{dB}] = 0.15$	0.32	R	$\sqrt{3}$	1	0.19
10) Coarse sampling grid	Negligible, used $\Delta_{\theta} = 15^{\circ}$ and $\Delta_{\phi} = 15^{\circ}$.	0	N	1	1	0
11) Repeatability of speech mode	Monoblock, clamshell and PDA design used for testing	1.04	R	$\sqrt{3}$	1	0.6
STAGE 2 (Calibration)						
12) Uncertainty of network analyzer	Manufacturer's uncertainty calculator, covers whole NA setup	0.5	R	$\sqrt{3}$	1	0.29
13) Mismatch of receiver chain	Taken in to account in NA setup uncertainty	0	U	$\sqrt{2}$	1	0
14) Insertion loss of receiver chain	Systematic with Stage 1 (=> cancels)	0	R	$\sqrt{3}$	1	0
15) Mismatch in the connection of calibration antenna	Taken in to account in NA setup uncertainty	0	U	$\sqrt{2}$	1	0
16) Influence of the feed cable of the calibration antenna	Gain calibration with a dipole	0.3	R	$\sqrt{3}$	1	0.17
17) Influence of the probe antenna cable	Systematic with Stage 1 (=> cancels)	0	R	$\sqrt{3}$	1	0
18) Uncertainty of the absolute gain of the probe antenna	Systematic with Stage 1 (=> cancels)	0	R	$\sqrt{3}$	1	0
19) Uncertainty of the absolute gain of the calibration antenna	Calibration certificate	0.5	R	$\sqrt{3}$	1	0.29
20) Measurement distance: Calibration antenna's displacement and misalignment	$d=3\text{m}$, $\Delta d=0.05\text{m}$, $\theta=2^{\circ}$	0.29	R	$\sqrt{3}$	1	0.17
21) Quality of quiet zone	Standard deviation of e-field in QZ measurement, Gain calibration	0.5	N	1	1	0.5
Combined standard uncertainty	$u_c = \sqrt{\sum_{i=1}^m c_i^2 \cdot u_i^2}$					1.07
Expanded uncertainty (Confidence interval of 95 %)			$u_e = 1,96 u_c$			2.10

Table E.29-3: Example of uncertainty budget for TRP hand only (browsing mode) measurement for anechoic chamber method

Uncertainty Source	Comment	Uncertainty Value [dB]	Prob Distr	Div	ci	Standard Uncertainty [dB]
STAGE 1 (DUT measurement)						
1) Mismatch of receiver chain	$\Gamma_{\text{power meter}} < 0.05$ $\Gamma_{\text{probe antenna connection}} < 0.16$	0.05	N	1	1	0.05
2) Insertion loss of receiver chain	Systematic with Stage 2 (=> cancels)	0	R	$\sqrt{2}$	1	0
3) Influence of the probe antenna cable	Systematic with Stage 2 (=> cancels)	0	R	$\sqrt{3}$	1	0
4) Absolute antenna gain of the probe antenna	Systematic with Stage 2 (=> cancels)	0	R	$\sqrt{3}$	1	0
5) Measurement Receiver: uncertainty of the absolute level	Power Meter	0.06	R	$\sqrt{3}$	1	0.03
6) Measurement distance a) Offset of DUT phase centre	$\Delta d = 0.05\text{m}$	0.14	R	$\sqrt{3}$	1	0.08
7) Quality of quiet zone	Standard deviation of E-field in QZ measurement	0.5	N	1	1	0.5
8) DUT Tx-power drift	Drift	0.2	R	$\sqrt{3}$	1	0.12
9) Uncertainty related to the use of hand phantom: Uncertainty of dielectric properties and shape of the hand phantom.	$U_{\epsilon} [\text{dB}] = 0.20$ $U_{\sigma} [\text{dB}] = 0.15$	0.32	R	$\sqrt{3}$	1	0.19
10) Coarse sampling grid	Negligible, used $\Delta_{\theta} = 15^{\circ}$ and $\Delta_{\phi} = 15^{\circ}$.	0	N	1	1	0
11) Repeatability of browsing mode	Monoblock, clamshell and PDA design used for testing	0.81	R	$\sqrt{3}$	1	0.22
STAGE 2 (Calibration)						
12) Uncertainty of network analyzer	Manufacturer's uncertainty calculator, covers whole NA setup	0.5	R	$\sqrt{3}$	1	0.29
13) Mismatch of receiver chain	Taken in to account in NA setup uncertainty	0	U	$\sqrt{2}$	1	0
14) Insertion loss of receiver chain	Systematic with Stage 1 (=> cancels)	0	R	$\sqrt{3}$	1	0
15) Mismatch in the connection of calibration antenna	Taken in to account in NA setup uncertainty	0	U	$\sqrt{2}$	1	0
16) Influence of the feed cable of the calibration antenna	Gain calibration with a dipole	0.3	R	$\sqrt{3}$	1	0.17
17) Influence of the probe antenna cable	Systematic with Stage 1 (=> cancels)	0	R	$\sqrt{3}$	1	0
18) Uncertainty of the absolute gain of the probe antenna	Systematic with Stage 1 (=> cancels)	0	R	$\sqrt{3}$	1	0
19) Uncertainty of the absolute gain of the calibration antenna	Calibration certificate	0.5	R	$\sqrt{3}$	1	0.29
20) Measurement distance: Calibration antenna's displacement and misalignment	$d=3\text{m}$, $\Delta d=0.05\text{m}$, $\theta=2^{\circ}$	0.29	R	$\sqrt{3}$	1	0.17
21) Quality of quiet zone	Standard deviation of e-field in QZ measurement, Gain calibration	0.5	N	1	1	0.5
Combined standard uncertainty	$u_c = \sqrt{\sum_{i=1}^m c_i^2 \cdot u_i^2}$					1.0
Expanded uncertainty (Confidence interval of 95 %)			$u_e = 1,96 u_c$			1.96

Table E.29-4: Example of uncertainty budget for TRP measurement with laptop ground plane phantom

Uncertainty Source	Comment	Uncertainty Value [dB]	Prob Distr	Div	ci	Standard Uncertainty [dB]
STAGE 1 (DUT measurement)						
1) Mismatch of receiver chain	$\Gamma_{\text{power meter}} < 0.05$ $\Gamma_{\text{probe antenna connection}} < 0.16$	0.05	N	1	1	0.05
2) Insertion loss of receiver chain	Systematic with Stage 2 (=> cancels)	0	R	$\sqrt{2}$	1	0
3) Influence of the probe antenna cable	Systematic with Stage 2 (=> cancels)	0	R	$\sqrt{3}$	1	0
4) Absolute antenna gain of the probe antenna	Systematic with Stage 2 (=> cancels)	0	R	$\sqrt{3}$	1	0
5) Measurement Receiver: uncertainty of the absolute level	Power Meter	0.06	R	$\sqrt{3}$	1	0.03
6) Measurement distance a) Offset of DUT phase centre	$\Delta d = 0.05\text{m}$	0.14	R	$\sqrt{3}$	1	0.08
7) Quality of quiet zone	Standard deviation of E-field in QZ measurement	0.5	N	1	1	0.5
8) DUT Tx-power drift	Drift	0.2	R	$\sqrt{3}$	1	0.12
9) Uncertainty related to the use of laptop ground plane phantom:	Standard laptop phantom	0	R	$\sqrt{3}$	1	0
10) Coarse sampling grid	Negligible, used $\Delta_{\theta} = 15^{\circ}$ and $\Delta_{\varphi} = 15^{\circ}$.	0	N	1	1	0
11) Repeatability	horizontal USB design, rotary USB porter, and non-rotary USB porter used for testing	0.4	R	$\sqrt{3}$	1	0.23
STAGE 2 (Calibration)						
13) Uncertainty of network analyzer	Manufacturer's uncertainty calculator, covers whole NA setup	0.5	R	$\sqrt{3}$	1	0.29
14) Mismatch of receiver chain	Taken in to account in NA setup uncertainty	0	U	$\sqrt{2}$	1	0
15) Insertion loss of receiver chain	Systematic with Stage 1 (=> cancels)	0	R	$\sqrt{3}$	1	0
16) Mismatch in the connection of calibration antenna	Taken in to account in NA setup uncertainty	0	U	$\sqrt{2}$	1	0
17) Influence of the feed cable of the calibration antenna	Gain calibration with a dipole	0.3	R	$\sqrt{3}$	1	0.17
18) Influence of the probe antenna cable	Systematic with Stage 1 (=> cancels)	0	R	$\sqrt{3}$	1	0
19) Uncertainty of the absolute gain of the probe antenna	Systematic with Stage 1 (=> cancels)	0	R	$\sqrt{3}$	1	0
20) Uncertainty of the absolute gain of the calibration antenna	Calibration certificate	0.5	R	$\sqrt{3}$	1	0.29
21) Measurement distance: Calibration antenna's displacement and misalignment	$d=3\text{m}$, $\Delta d=0.05\text{m}$, $\theta=2^{\circ}$	0.29	R	$\sqrt{3}$	1	0.17
22) Quality of quiet zone	Standard deviation of e-field in QZ measurement, Gain calibration	0.5	N	1	1	0.5
Combined standard uncertainty	$u_c = \sqrt{\sum_{i=1}^m c_i^2 \cdot u_i^2}$					0.89
Expanded uncertainty (Confidence interval of 95 %)			$u_e = 1,96 u_c$			1.75

Table E.29-5: Example of uncertainty budget for TRS head only measurement for anechoic chamber method

Uncertainty Source	Comment	Uncertainty Value [dB]	Prob Distr	Div	ci	Standard Uncertainty [dB]
STAGE 1 (DUT measurement)						
1) Mismatch of transmitter chain	$\Gamma_{\text{BSS}} < 0.13$ $\Gamma_{\text{antenna connection}} < 0.03$	0.02	N	1	1	0.02
2) Insertion loss of transmitter chain	Systematic with Stage 1 (=> cancels)	0	R	$\sqrt{3}$	1	0
3) Influence of the probe antenna cable	Systematic with Stage 2 (=> cancels)	0	R	$\sqrt{3}$	1	0
4) Absolute antenna gain of the probe antenna	Systematic with Stage 2 (=> cancels)	0	R	$\sqrt{3}$	1	0
5) Base station simulator: uncertainty of the absolute level		1	R	$\sqrt{3}$	1	0.58
6) BER measurement: output level step resolution	Step 0.1dB	0.05	R	$\sqrt{3}$	1	0.03
7) Statistical uncertainty of the BER measurement	BER target 10%±2% , 20000 tested bits , N=60	0.12	N	1	1	0.12
8) TRS data rate normalization	4 reference points measured	0.12	N	1	1	0.12
9) Measurement distance a) Offset of DUT phase centre	$\Delta d = 0.05\text{m}$	0.14	R	$\sqrt{3}$	1	0.08
10) Quality of quiet zone	Standard deviation of E-field in QZ measurement	0.5	N	1	1	0.5
11) DUT sensitivity drift	Drift measurement	0.2	R	$\sqrt{3}$	1	0.12
12) Uncertainty related to the use of SAM phantom:	Standard SAM with standard tissue simulant	0	R	$\sqrt{3}$	1	0
13) Coarse sampling grid	$\Delta_\theta = 30^\circ$ and $\Delta_\phi = 30^\circ$.	0.15	N	N	1	0.15
14) Repeatability	Monoblock, clamshell, slide design	0.5	R	$\sqrt{3}$	1	0.29
STAGE 2 (Calibration)						
16) Uncertainty of network analyzer	Manufacturer's uncertainty calculator, covers NA setup	0.5	R	$\sqrt{3}$	1	0.29
17) Mismatch of transmitter chain	Taken in to account in NA setup uncertainty	0	U	$\sqrt{2}$	1	0
18) Insertion loss of transmitter chain	Systematic with Stage 1 (=> cancels)	0	R	$\sqrt{3}$	1	0
19) Mismatch in the connection of calibration antenna	Taken in to account in NA setup uncertainty	0	R	$\sqrt{3}$	1	0
20) Influence of the feed cable of the calibration antenna	Gain calibration with dipole	0.3	R	$\sqrt{3}$	1	0.17
21) Influence of the probe antenna cable	Systematic with Stage 1 (=> cancels)	0	R	$\sqrt{3}$	1	0
22) Uncertainty of the absolute gain of the probe antenna	Systematic with Stage 1 (=> cancels)	0	R	$\sqrt{3}$	1	0
23) Uncertainty of the absolute gain of the calibration antenna	Calibration certificate	0.5	R	$\sqrt{3}$	1	0.29
24) Measurement distance: Calibration antenna's displacement and misalignment	$d=3\text{m}$, $\Delta d=0.05\text{m}$, $\theta=2^\circ$	0.29	R	$\sqrt{3}$	1	0.17
25) Quality of quiet zone	Standard deviation of E-field in QZ measurement	0.5	N	1	1	0.5
Combined standard uncertainty	$u_c = \sqrt{\sum_{i=1}^m c_i^2 \cdot u_i^2}$					1.1
Expanded uncertainty (Confidence interval of 95 %)			$u_e = 1,96 u_c$			2.16

Table E.29-6: Example of uncertainty budget for TRS head+hand (speech mode) measurement for anechoic chamber method

Uncertainty Source	Comment	Uncertainty Value [dB]	Prob Distr	Div	ci	Standard Uncertainty [dB]
STAGE 1 (DUT measurement)						
1) Mismatch of transmitter chain	$\Gamma_{\text{BSS}} < 0.13$ $\Gamma_{\text{antenna connection}} < 0.03$	0.02	N	1	1	0.02
2) Insertion loss of transmitter chain	Systematic with Stage 1 (=> cancels)	0	R	$\sqrt{3}$	1	0
3) Influence of the probe antenna cable	Systematic with Stage 2 (=> cancels)	0	R	$\sqrt{3}$	1	0
4) Absolute antenna gain of the probe antenna	Systematic with Stage 2 (=> cancels)	0	R	$\sqrt{3}$	1	0
5) Base station simulator: uncertainty of the absolute level		1	R	$\sqrt{3}$	1	0.58
6) BER measurement: output level step resolution	Step 0.1dB	0.05	R	$\sqrt{3}$	1	0.03
7) Statistical uncertainty of the BER measurement	BER target 10%±2% , 20000 tested bits , N=60	0.12	N	1	1	0.12
8) TRS data rate normalization	4 reference points measured	0.12	N	1	1	0.12
9) Measurement distance a) Offset of DUT phase centre	$\Delta d = 0.05\text{m}$	0.14	R	$\sqrt{3}$	1	0.08
10) Quality of quiet zone	Standard deviation of E-field in QZ measurement	0.5	N	1	1	0.5
11) DUT sensitivity drift	Drift measurement	0.2	R	$\sqrt{3}$	1	0.12
12) Uncertainty related to the use of the SAM head and hand phantoms: a) uncertainty from using different types of SAM phantom b) simulated tissue liquid uncertainty c) uncertainty of dielectric properties and shape of the hand phantom:	Standard SAM head with standard tissue simulant $U_{\epsilon} [\text{dB}] = 0.12$ $U_{\sigma} [\text{dB}] = 0.15$	0.32	R	$\sqrt{3}$	1	0.19
13) Coarse sampling grid	$\Delta_{\theta} = 30^{\circ}$ and $\Delta_{\phi} = 30^{\circ}$.	0.15	N	N	1	0.15
14) Repeatability of speech mode	Monoblock, clamshell and PDA used for testing	1.4	R	$\sqrt{3}$	1	0.81
STAGE 2 (Calibration)						
15) Uncertainty of network analyzer	Manufacturer's uncertainty calculator, covers NA setup	0.5	R	$\sqrt{3}$	1	0.29
16) Mismatch of transmitter chain	Taken in to account in NA setup uncertainty	0	U	$\sqrt{2}$	1	0
17) Insertion loss of transmitter chain	Systematic with Stage 1 (=> cancels)	0	R	$\sqrt{3}$	1	0
18) Mismatch in the connection of calibration antenna	Taken in to account in NA setup uncertainty	0	R	$\sqrt{3}$	1	0
19) Influence of the feed cable of the calibration antenna	Gain calibration with dipole	0.3	R	$\sqrt{3}$	1	0.17
20) Influence of the probe antenna cable	Systematic with Stage 1 (=> cancels)	0	R	$\sqrt{3}$	1	0
21) Uncertainty of the absolute gain of the probe antenna	Systematic with Stage 1 (=> cancels)	0	R	$\sqrt{3}$	1	0
22) Uncertainty of the absolute gain of the calibration antenna	Calibration certificate	0.5	R	$\sqrt{3}$	1	0.29
23) Measurement distance: Calibration antenna's displacement and misalignment	$d = 3\text{m}$, $\Delta d = 0.05\text{m}$, $\theta = 2^{\circ}$	0.29	R	$\sqrt{3}$	1	0.17
24) Quality of quiet zone	Standard deviation of E-field in QZ measurement	0.5	N	1	1	0.5
Combined standard uncertainty	$u_c = \sqrt{\sum_{i=1}^m c_i^2 \cdot u_i^2}$					1.35
Expanded uncertainty (Confidence interval of 95 %)			$u_e = 1,96 u_c$			2.64

Table E.29-7: Example of uncertainty budget for TRS hand only (browsing mode) measurement for anechoic chamber method

Uncertainty Source	Comment	Uncertainty Value [dB]	Prob Distr	Div	ci	Standard Uncertainty [dB]
STAGE 1 (DUT measurement)						
1) Mismatch of transmitter chain	$\Gamma_{\text{BSS}} < 0.13$ $\Gamma_{\text{antenna connection}} < 0.03$	0.02	N	1	1	0.02
2) Insertion loss of transmitter chain	Systematic with Stage 1 (=> cancels)	0	R	$\sqrt{3}$	1	0
3) Influence of the probe antenna cable	Systematic with Stage 2 (=> cancels)	0	R	$\sqrt{3}$	1	0
4) Absolute antenna gain of the probe antenna	Systematic with Stage 2 (=> cancels)	0	R	$\sqrt{3}$	1	0
5) Base station simulator: uncertainty of the absolute level		1	R	$\sqrt{3}$	1	0.58
6) BER measurement: output level step resolution	Step 0.1dB	0.05	R	$\sqrt{3}$	1	0.03
7) Statistical uncertainty of the BER measurement	BER target 10%±2% , 20000 tested bits , N=60	0.12	N	1	1	0.12
8) TRS data rate normalization	4 reference points measured	0.12	N	1	1	0.12
9) Measurement distance a) Offset of DUT phase centre	$\Delta d = 0.05\text{m}$	0.14	R	$\sqrt{3}$	1	0.08
10) Quality of quiet zone	Standard deviation of E-field in QZ measurement	0.5	N	1	1	0.5
11) DUT sensitivity drift	Drift measurement	0.2	R	$\sqrt{3}$	1	0.12
12) Uncertainty related to the use of hand phantom: Uncertainty of dielectric properties and shape of the hand phantom.	$U_{\epsilon} [\text{dB}] = 0.12$ $U_{\sigma} [\text{dB}] = 0.15$	0.32	R	$\sqrt{3}$	1	0.19
13) Coarse sampling grid	$\Delta_{\theta} = 30^{\circ}$ and $\Delta_{\phi} = 30^{\circ}$.	0.15	N	N	1	0.15
14) Repeatability of browsing mode	Monoblock, clamshell and PDA used for testing	0.91	R	$\sqrt{3}$	1	0.28
STAGE 2 (Calibration)						
15) Uncertainty of network analyzer	Manufacturer's uncertainty calculator, covers NA setup	0.5	R	$\sqrt{3}$	1	0.29
16) Mismatch of transmitter chain	Taken in to account in NA setup uncertainty	0	U	$\sqrt{2}$	1	0
17) Insertion loss of transmitter chain	Systematic with Stage 1 (=> cancels)	0	R	$\sqrt{3}$	1	0
18) Mismatch in the connection of calibration antenna	Taken in to account in NA setup uncertainty	0	R	$\sqrt{3}$	1	0
19) Influence of the feed cable of the calibration antenna	Gain calibration with dipole	0.3	R	$\sqrt{3}$	1	0.17
20) Influence of the probe antenna cable	Systematic with Stage 1 (=> cancels)	0	R	$\sqrt{3}$	1	0
21) Uncertainty of the absolute gain of the probe antenna	Systematic with Stage 1 (=> cancels)	0	R	$\sqrt{3}$	1	0
22) Uncertainty of the absolute gain of the calibration antenna	Calibration certificate	0.5	R	$\sqrt{3}$	1	0.29
23) Measurement distance: Calibration antenna's displacement and misalignment	$d=3\text{m}$, $\Delta d=0.05\text{m}$, $\theta=2^{\circ}$	0.29	R	$\sqrt{3}$	1	0.17
24) Quality of quiet zone	Standard deviation of E-field in QZ measurement	0.5	N	1	1	0.5
Combined standard uncertainty	$u_c = \sqrt{\sum_{i=1}^m c_i^2 \cdot u_i^2}$					1.2
Expanded uncertainty (Confidence interval of 95 %)			$u_e = 1,96 u_c$			2.35

Table E.29-8: Example of uncertainty budget for TRS measurement with laptop ground plane phantom

Uncertainty Source	Comment	Uncertainty Value [dB]	Prob Distr	Div	ci	Standard Uncertainty [dB]
STAGE 1 (DUT measurement)						
1) Mismatch of transmitter chain	$\Gamma_{\text{BSS}} < 0.13$ $\Gamma_{\text{antenna connection}} < 0.03$	0.02	N	1	1	0.02
2) Insertion loss of transmitter chain	Systematic with Stage 1 (=> cancels)	0	R	$\sqrt{3}$	1	0
3) Influence of the probe antenna cable	Systematic with Stage 2 (=> cancels)	0	R	$\sqrt{3}$	1	0
4) Absolute antenna gain of the probe antenna	Systematic with Stage 2 (=> cancels)	0	R	$\sqrt{3}$	1	0
5) Base station simulator: uncertainty of the absolute level		1	R	$\sqrt{3}$	1	0.58
6) BER measurement: output level step resolution	Step 0.1dB	0.05	R	$\sqrt{3}$	1	0.03
7) Statistical uncertainty of the BER measurement	BER target 10%±2% , 20000 tested bits , N=60	0.12	N	1	1	0.12
8) TRS data rate normalization	4 reference points measured	0.12	N	1	1	0.12
9) Measurement distance a) Offset of DUT phase centre	$\Delta d = 0.05\text{m}$	0.14	R	$\sqrt{3}$	1	0.08
10) Quality of quiet zone	Standard deviation of E-field in QZ measurement	0.5	N	1	1	0.5
11) DUT sensitivity drift	Drift measurement	0.2	R	$\sqrt{3}$	1	0.12
9) Uncertainty related to the use of laptop ground plane phantom	Standard laptop phantom	0	R	$\sqrt{3}$	1	0
13) Coarse sampling grid	$\Delta_\theta = 30^\circ$ and $\Delta_\phi = 30^\circ$.	0.15	N	N	1	0.15
14) Repeatability	horizontal USB design, rotary USB porter, and non-rotary USB porter used for testing	0.5	R	$\sqrt{3}$	1	0.29
STAGE 2 (Calibration)						
15) Uncertainty of network analyzer	Manufacturer's uncertainty calculator, covers NA setup	0.5	R	$\sqrt{3}$	1	0.29
16) Mismatch of transmitter chain	Taken in to account in NA setup uncertainty	0	U	$\sqrt{2}$	1	0
17) Insertion loss of transmitter chain	Systematic with Stage 1 (=> cancels)	0	R	$\sqrt{3}$	1	0
18) Mismatch in the connection of calibration antenna	Taken in to account in NA setup uncertainty	0	R	$\sqrt{3}$	1	0
19) Influence of the feed cable of the calibration antenna	Gain calibration with dipole	0.3	R	$\sqrt{3}$	1	0.17
20) Influence of the probe antenna cable	Systematic with Stage 1 (=> cancels)	0	R	$\sqrt{3}$	1	0
21) Uncertainty of the absolute gain of the probe antenna	Systematic with Stage 1 (=> cancels)	0	R	$\sqrt{3}$	1	0
22) Uncertainty of the absolute gain of the calibration antenna	Calibration certificate	0.5	R	$\sqrt{3}$	1	0.29
23) Measurement distance: Calibration antenna's displacement and misalignment	$d=3\text{m}$, $\Delta d=0.05\text{m}$, $\theta=2^\circ$	0.29	R	$\sqrt{3}$	1	0.17
24) Quality of quiet zone	Standard deviation of E-field in QZ measurement	0.5	N	1	1	0.5
Combined standard uncertainty	$u_c = \sqrt{\sum_{i=1}^m c_i^2 \cdot u_i^2}$					1.1
Expanded uncertainty (Confidence interval of 95 %)			$u_e = 1,96 u_c$			2.16

Table E.29-9: Example of uncertainty budget for TRP measurement for reverberation chamber method

Uncertainty Source	Comment	Uncertainty Value [dB]	Prob Distr	Div	ci	Standard Uncertainty [dB]
STAGE 1 (DUT measurement)						
1) Mismatch of receiver chain	$\Gamma_{\text{power meter}} < 0.05$ $\Gamma_{\text{fixed measurement antenna connection}} < 0.16$	0.05	U	$\sqrt{2}$	1	0.04
2) Insertion loss of receiver chain	Systematic with Stage 2 (=> cancels)	0	R	$\sqrt{3}$	1	0
3) Influence of the fixed measurement antenna cable	Systematic with Stage 2 (=> cancels)	0	R	$\sqrt{3}$	1	0
4) Absolute antenna gain of the fixed measurement antenna	Systematic with Stage 2 (=> cancels)	0	R	$\sqrt{3}$	1	0
5) Measurement Receiver: uncertainty of the absolute level	Power Meter	0.06	R	$\sqrt{3}$	1	0.03
6) Chamber statistical ripple and repeatability	Statistics of chamber	0.4	N	1	1	0.4
7) Additional power loss in EUT chassis	The EUT not present in the chamber during calibration measurement	0.1	R	$\sqrt{3}$	1	0.06
8) DUT Tx-power drift	Drift	0.2	R	$\sqrt{3}$	1	0.12
9) a) Uncertainty related to the use of SAM phantom:	Standard SAM head with standard tissue simulant	0	R	$\sqrt{3}$	1	0
b) Simulated tissue liquid uncertainty	Maximum allowed error	0.5	R	$\sqrt{3}$	1	0.29
c) Effect of DUT holder	Fixed value	0.2	R	$\sqrt{3}$	1	0.12
10) Repeatability	Using the same setup and stirring sequence	0.4	R	$\sqrt{3}$	1	0.23
11) Uncertainty related to the use of Laptop Ground Plane phantom	Standard Laptop Ground Plane phantom	[0]	R	$\sqrt{3}$	1	[0]
STAGE 2 (Calibration)						
12) Uncertainty of network analyzer	Manufacturer's uncertainty calculator, covers whole NA setup	0.5	R	$\sqrt{3}$	1	0.29
13) Mismatch of receiver chain	Taken in to account in NA setup uncertainty	0	U	$\sqrt{2}$	1	0
14) Insertion loss of receiver chain	Systematic with Stage 1 (=> cancels)	0	R	$\sqrt{3}$	1	0
15) Mismatch in the connection of calibration antenna	Taken in to account in NA setup uncertainty	0	U	$\sqrt{2}$	1	0
16) Influence of the feed cable of the calibration antenna	Gain calibration with a dipole antenna	0.3	R	$\sqrt{3}$	1	0.17
17) Influence of the fixed measurement antenna cable	Systematic with Stage 1 (=> cancels)	0	R	$\sqrt{3}$	1	0
18) Uncertainty of the absolute gain of the fixed measurement antenna	Systematic with Stage 1 (=> cancels)	0	R	$\sqrt{3}$	1	0
19) Uncertainty of the absolute gain of the calibration antenna	Calibration certificate	0.5	R	$\sqrt{3}$	1	0.29
20) Chamber statistical ripple and repeatability	Statistics of chamber	0.5	N	1	1	0.5
Combined standard uncertainty	$u_c = \sqrt{\sum_{i=1}^m c_i^2 \cdot u_i^2}$					0.88

Expanded uncertainty (Confidence interval of 95 %)			$u_e = 1,96 u_c$		1.73
--	--	--	------------------	--	------

Table E.29-10: Example of uncertainty budget for TRS measurement for reverberation chamber method

Uncertainty Source	Comment	Uncertainty Value [dB]	Prob Distr	Div	ci	Standard Uncertainty [dB]
STAGE 1 (DUT measurement)						
1) Mismatch of transmitter chain	$\Gamma_{\text{BSS}} < 0.13$ $\Gamma_{\text{antenna connection}} < 0.03$	0.02	N	1	1	0.02
2) Insertion loss of transmitter chain	Systematic with Stage 1 (=> cancels)	0	R	$\sqrt{3}$	1	0
3) Influence of the fixed measurement antenna cable	Systematic with Stage 2 (=> cancels)	0	R	$\sqrt{3}$	1	0
4) Absolute antenna gain of the fixed measurement antenna	Systematic with Stage 2 (=> cancels)	0	R	$\sqrt{3}$	1	0
5) Base station simulator: uncertainty of the absolute level		1	R	$\sqrt{3}$	1	0.58
6) BER measurement: output level step resolution	Step 0.1dB	0.05	R	$\sqrt{3}$	1	0.03
7) Statistical uncertainty of the BER measurement	BER target 10%±2% , 20000 tested bits , N=60	0.12	N	1	1	0.12
8) TRS data rate normalization	4 reference points measured	0.12	N	1	1	0.12
9) Chamber statistical ripple and repeatability	Statistics of chamber	0.4	N	1	1	0.4
10) Additional power loss in EUT chassis	The EUT not present in the chamber during calibration measurement	0.1	R	$\sqrt{3}$	1	0.06
11) DUT sensitivity drift	Drift measurement	0.2	R	$\sqrt{3}$	1	0.12
12) a) Uncertainty related to the use of SAM phantom:	Standard SAM with standard tissue simulant	0	R	$\sqrt{3}$	1	0
b) Simulated tissue liquid uncertainty	Maximum allowed error	0.5	R	$\sqrt{3}$	1	0.29
c) Effect of DUT holder	Fixed value	0.2	R	$\sqrt{3}$	1	0.12
13) Repeatability	Using the same setup and stirring sequence	0.4	R	$\sqrt{3}$	1	0.23
14) Uncertainty related to the use of Laptop Ground Plane phantom	Standard Laptop Ground Plane phantom	[0]	R	$\sqrt{3}$	1	[0]
STAGE 2 (Calibration)						
15) Uncertainty of network analyzer	Manufacturer's uncertainty calculator, covers NA setup	0.5	R	$\sqrt{3}$	1	0.29
16) Mismatch of transmitter chain	Taken in to account in NA setup uncertainty	0	U	$\sqrt{2}$	1	0
17) Insertion loss of transmitter chain	Systematic with Stage 1 (=> cancels)	0	R	$\sqrt{3}$	1	0
18) Mismatch in the connection of calibration antenna	Taken in to account in NA setup uncertainty	0	R	$\sqrt{3}$	1	0
19) Influence of the feed cable of the calibration antenna	Gain calibration with dipole antenna	0.3	R	$\sqrt{3}$	1	0.17
20) Influence of the fixed measurement antenna cable	Systematic with Stage 1 (=> cancels)	0	R	$\sqrt{3}$	1	0
21) Uncertainty of the absolute gain of the fixed measurement antenna	Systematic with Stage 1 (=> cancels)	0	R	$\sqrt{3}$	1	0
22) Uncertainty of the absolute gain of the calibration antenna	Calibration certificate	0.5	R	$\sqrt{3}$	1	0.29

23) Chamber statistical ripple and repeatability	Statistics of chamber	0.5	N	1	1	0.5
Combined standard uncertainty	$u_c = \sqrt{\sum_{i=1}^m c_i^2 \cdot u_i^2}$					1.07
Expanded uncertainty (Confidence interval of 95 %)			$u_e = 1,96 u_c$			2.09

Annex F (informative): Suggested recipes of liquid to be used inside SAM phantom

F.1 General

The Specific Anthropomorphic Mannequin (SAM) is used for radiated performance measurements. The absorption of electromagnetic energy by the human muscle or brain tissue is simulated by measuring the electrical field inside a SAM phantom filled with a liquid having the same electrical properties as human tissue. Tables F.1-1 and F.1-2 are proposals for two different recipes of the liquid to be used inside the SAM phantom.

Table F.1-1: Liquid recipe proposal 1

Component	Mass %
De-ionized Water	57.12
Tween 20	42.30
NaCl	0.58

Table F.1-2: Liquid recipe proposal 2

Component	Mass %
De-ionized Water	54.9 %
Diethylene Glycol Butyl Ether (DGBE) (> 99 % pure)	44.92 %
NaCl	0.18 %

Annex G (informative): Anechoic chamber specification and validation method

G.1 Shielded anechoic chamber specifications

To avoid environmental perturbations the measurements shall be performed in a shielded enclosure, preserved from electromagnetic disturbances coming from electromagnetic environment (Radio and TV broadcast, cellular, ISM equipment, etc...). The shielding effectiveness shall be tested according to the EN 50 147-1 standard in the frequency range of 800 MHz up to 4 GHz.

The recommended level of the shielding effectiveness is -100 dB from 800 MHz to 4 GHz.

Testing of the shielding effectiveness can be performed either before or after the installation of absorbers.

G.2 Quiet zone reflectivity level validation

The performance of anechoic chamber is typically evaluated from reflectivity level R_{level} in the quiet zone. The reflectivity level is defined as power ratio of all summed reflected signals P_r to direct signal P_d from antenna:

$$R_{level} = 10 \log \frac{P_r}{P_d} .$$

To evaluate the quiet zone reflectivity level, the contribution of absorbing materials, the antenna positioning system and other constructions in the anechoic chamber should be measured.

To measure accurately quality of the quiet zone in anechoic chamber an omni-directional antenna shall be used. Near omni-directional three axes field-probes are available with fibre optic connection thus minimizing cable effects. Because sensitivity of field probe is limited it shall be carefully checked that the field probe is operated at least 6dB above the noise floor of the probe.

NOTE: The quiet zone evaluation should be performed with the antenna positioning system in its place, in order to include its effect on the reflectivity level.

G.2.1 Description of a practical method for Quiet Zone characterization

A practical version of the Free Space VSWR method is presented.

In the Free Space VSWR method the quality of quiet zone is measured from amplitude ripple caused by reflections inside the anechoic chamber. Phase variation of the direct signal and the reflected signals is obtained by moving a field-probe in the quiet zone. Amplitude ripple in the quiet zone is caused by this phase variation of reflected signals and the direct signal from antenna. Figure 2 below shows seven measuring positions.

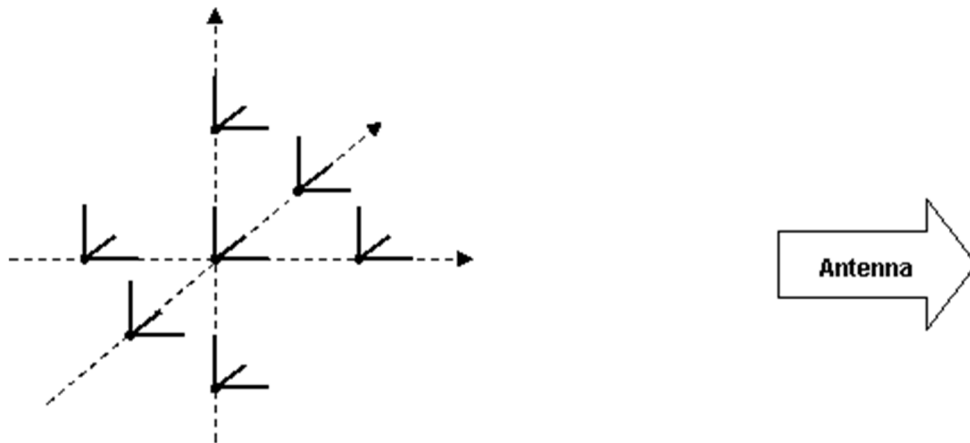

Figure G.2.1-1: Measurement positions with 150mm separation

In each of the seven-measurement position amplitude of power received by field-probe P_{meas_n} [dBm] is measured where n is index of measuring position. Variance of measurement distance to the antenna from field-probe in different measurement positions can be compensated by following equation:

$$P_n = P_{meas_n} + 20 \log\left(\frac{d_n}{l}\right)$$

where,

d_n is distance to point n from the antenna,

l is distance to centre of quiet zone from the antenna

P_{meas_n} is uncorrected measurement value from point n .

The sample standard deviation of the electric field in the quiet zone can be calculated from these distance corrected values or directly from the measured values with the following equation:

$$s = \sqrt{\frac{1}{N-1} \sum_{i=1}^N (P_i - \bar{P})^2}$$

where,

N is number of measurements positions

\bar{P} is dB average of all P_n

P_i is P_n or P_{meas_n}

G.3 Standard deviation of electric field

To obtain a more accurate picture of quality of quiet zone, the measurement described in G.2.1 can be done from multiple directions and polarizations. Doing free space VSWR measurement from different directions in 15-degree separation for elevation and azimuth, results in 264 standard deviation values in both polarizations ($S_{\theta, \Phi, pol}$). From these values average sample standard deviation in electric field in quiet zone can be calculated from equation:

$$\overline{S}_{freq} = \frac{\frac{\pi}{2IJ} \sum_{i=1}^I \sum_{j=1}^J s_{i,j,hor} \sin(\Theta_i) + \frac{\pi}{2IJ} \sum_{i=1}^I \sum_{j=1}^J s_{i,j,ver} \sin(\Theta_i)}{2}$$

where,

I is number of angular intervals in elevation,

J is number of angular intervals in azimuth and

Θ_i is elevation of measurement $s_{i,j,pol}$.

This quiet zone quality measurement should be done at all the frequencies used in measurements. It can also be sufficient on all the centre frequencies in the measurement bands but also in this case the Tx and Rx shall be measured separately.

Annex H (informative): Reverberation chamber specifications and validation method

H.1 Shielded reverberation chamber specifications

Before measuring the test site characteristics in terms of stirring effectiveness, the shielding effectiveness of the metallic enclosure must be measured.

To avoid environmental perturbations, the measurements shall be performed in a shielded enclosure, preserved from electromagnetic disturbances coming from electromagnetic environment such as: TV broadcast, radio, cellular, ISM equipment, to name a few. The shielding effectiveness recommended to be tested according to the EN 50 147-1 standard in the frequency range of 800 MHz up to 4 GHz.

The recommended level of the shielding effectiveness is -100 dB from 800 MHz to 4 GHz.

H.2 Reverberation chamber statistical ripple and repeatability validation

The reverberation chamber is typically evaluated according to its isotropy level and ability to produce independent samples. The uncertainty due to chamber statistics is determined by repeated calibration measurements as described in Annex B.2.2. This uncertainty contribution is a composite value consisting of most of the specific reverberation chamber contributions, such as limited number of modes, polarization imbalance and mode-stirring techniques.

The uncertainty contribution value shall be determined by repeated calibration measurements for nine different positions and orientations of the calibration antenna in order to determine the statistical variation as a function of frequency, or at least at the frequencies where the chamber shall be used. This uncertainty contribution value can be assumed to have a normal distribution.

The uncertainty will depend on chamber size, frequency, stirrer sequence, stirrer types and shapes, polarization stirring (if any), and the degree of chamber loading. All these factors must remain the same for all of the nine calibration measurements. The uncertainty will also depend on frequency stirring bandwidth (if any), but the effects of different amounts of frequency stirring can be studied with the same sets of calibration data as when no frequency stirring is applied.

The nine net average power transfer functions of all or some of the nine calibration configurations for each loading case shall be averaged to provide a good reference level. Frequency stirring can only be applied to improve the reference level. Therefore, the uncertainty shall be found by computing the average and standard deviation of the net average power transfer function of each of the nine reference (antenna) positions and orientations (without frequency stirring) around the reference level (which can be frequency stirred if it gives better overall accuracy).

The data obtained during these reference measurements can be used for analysis of the chamber's systematic and deterministic contribution to S21. Such analysis can help determine possible uncertainty sources in chambers where the "chamber statistics" portion of the uncertainty analysis is too high to fulfil the total uncertainty criterion. The normalized standard deviation is calculated using the following expression:

$$\Sigma_{measured} = \frac{\sqrt{\sigma^2}}{P_{ref}^{mean}}$$

where,

$$\sigma^2 = \frac{1}{T} \sum_{t=1}^T (P_{ref,t} - P_{ref}^{mean})^2$$

is the standard deviation of the power transfer function over T different calibration antenna positions. $P_{ref,t}$ is the reference power transfer function for position t of the calibration antenna. The power transfer function for every

calibration antenna position is further the average over the power transfer function $P_{ref,t,n}$ for each fixed measurement antenna in the chamber defined in Annex B.2.2. Thus,

$$P_{ref,t} = \frac{1}{N} \sum_{n=1}^N P_{ref,t,n}$$

where,

N is the total number of fixed measurement antennas. Moreover,

$$P_{ref}^{mean} = \frac{1}{T} \sum_{t=1}^T P_{ref,t}$$

is the average power transfer function over the T calibration antenna positions.

Annex I (informative): Recommended performance for Handheld UE

Editor's notes: This annex is incomplete. The following items are missing or incomplete:

- Table I.2.1.2-1, I.2.2.1-1, I.2.2.2-1, I.2.3.1-1, I.2.3.2-1, I.3.1.2-1, I.3.2.1-1, I.3.2.2-1, I.3.3.1-1 and I.3.3.2-1 as they are not complete in TS 37.144 yet
- Table I.2.2.3-1, I.2.2.4-1, I.2.3.3-1, I.2.3.4-1, I.3.2.3-1, I.3.2.4-1, I.3.3.3-1 and I.3.3.4 as they are not specified in TS 37.144 yet

I.1 General

This annex introduces the concept of recommended OTA performance for operating bands for handheld UE's. This requirement is not mandatory but is recommended.

The concept of recommended performance is to ensure that UE OTA performance is maximised in order to improve user experience and network performance. It is recognised that the ability to meet the recommended performance depends on the number of frequency bands supported by the UE.

I.2 Total Radiated Power

The OTA TRP performance for UTRA and E-UTRA should be greater or equal than the recommended values in this clause.

I.2.1 Beside the head phantom position

Beside the head phantom test method is defined in subclause 4.3.1.

I.2.1.1 UTRA FDD

Table I.2.1.1-1: Handheld UE TRP recommended performance for UTRA FDD in beside the head phantom position and the primary mechanical mode

Operating band	Power class 1	Power class 2	Power class 3	Power class 3bis	Power class 4
	Power (dBm)	Power (dBm)	Power (dBm)	Power (dBm)	Power (dBm)
	Average	Average	Average	Average	Average
I	-	-	+18	+18	+16
II	-	-	+18	+18	+16
III	-	-	+18	+18	+16
IV	-	-	+18	+18	+16
V	-	-	+14	+14	+12
VI	-	-	+14.5	+14.5	+12.5
VII	-	-	+18	+18	+16
VIII	-	-	+15	+15	+13
IX	-	-	+18	+18	+16
XIX	-	-	+14.5	+14.5	+12.5

NOTE: Applicable for dual-mode GSM/UMTS.

I.2.1.2 UTRA LCR TDD

Table I.2.1.2-1: Handheld UE TRP recommended performance for UTRA LCR TDD in beside the head phantom position and the primary mechanical mode

Operating band	Power class 1	Power class 2	Power class 3	Power class 3bis	Power class 4
	Power (dBm)	Power (dBm)	Power (dBm)	Power (dBm)	Power (dBm)
	Average	Average	Average	Average	Average
a	-	+18	-	-	-
b	-	TBD	-	-	-
c	-	TBD	-	-	-
d	-	TBD	-	-	-
e	-	+18	-	-	-
f	-	+18	-	-	-

Note: Applicable for dual-mode GSM/UTRA LCR TDD.

I.2.2 Beside the head and hand phantoms position

Beside the head and hand phantoms test method is defined in subclauses 4.3.3.

I.2.2.1 UTRA FDD

Table I.2.2.1-1: Handheld UE TRP recommended performance for UTRA FDD beside the head and hand phantoms position and the primary mechanical mode

Operating band	Power class 1	Power class 2	Power class 3	Power class 3bis	Power class 4
	Power (dBm)	Power (dBm)	Power (dBm)	Power (dBm)	Power (dBm)
			Average	Average	Average
I	-	-	16.25	TBD	TBD
II	-	-	16.25	TBD	TBD
III	-	-	TBD	TBD	TBD
IV	-	-	TBD	TBD	TBD
V	-	-	12.40	TBD	TBD
VI	-	-	12.40	TBD	TBD
VII	-	-	TBD	TBD	TBD
VIII	-	-	12.40	TBD	TBD
IX	-	-	TBD	TBD	TBD
XIX	-	-	12.40	TBD	TBD

NOTE 1: Applicable for dual-mode GSM/UMTS.
NOTE 2: Applicable for devices narrower than 72mm as defined in TR 25.914.
NOTE 3: Not applicable for devices supporting CDMA or carrier aggregation.

I.2.2.2 UTRA LCR TDD

Table I.2.2.2-1: Handheld UE TRP recommended performance for UTRA LCR TDD in beside the head and hand phantoms position and the primary mechanical mode

Operating band	Power class 1	Power class 2	Power class 3	Power class 3bis	Power class 4
	Power (dBm)	Power (dBm)	Power (dBm)	Power (dBm)	Power (dBm)
		Average			
a	-	TBD	-	-	-
b	-	TBD	-	-	-
c	-	TBD	-	-	-
d	-	TBD	-	-	-
e	-	TBD	-	-	-
f	-	TBD	-	-	-

Note: Applicable for dual-mode GSM/UTRA LCR TDD.

I.2.2.3 E-UTRA FDD

Table I.2.2.3-1: TBD

I.2.2.4 E-UTRA TDD

Table I.2.2.4-1: TBD

I.2.3 Hand phantom browsing mode position

Hand phantom browsing mode test method is defined in subclauses 4.3.4.

I.2.3.1 UTRA FDD

Table I.2.3.1-1: Handheld UE TRP recommended performance for UTRA FDD in the hand phantom browsing mode position

Operating band	Power class 1	Power class 2	Power class 3	Power class 3bis	Power class 4
	Power (dBm)	Power (dBm)	Power (dBm)	Power (dBm)	Power (dBm)
			Average	Average	Average
I	-	-	TBD	TBD	TBD
II	-	-	TBD	TBD	TBD
III	-	-	TBD	TBD	TBD
IV	-	-	TBD	TBD	TBD
V	-	-	TBD	TBD	TBD
VI	-	-	TBD	TBD	TBD
VII	-	-	TBD	TBD	TBD
VIII	-	-	TBD	TBD	TBD
IX	-	-	TBD	TBD	TBD
XIX	-	-	TBD	TBD	TBD

NOTE: Applicable for dual-mode GSM/UMTS.

I.2.3.2 UTRA LCR TDD

Table I.2.3.2-1: Handheld UE TRP recommended performance for UTRA LCR TDD in the hand phantom browsing mode position

Operating band	Power class 1	Power class 2	Power class 3	Power class 3bis	Power class 4
	Power (dBm)	Power (dBm)	Power (dBm)	Power (dBm)	Power (dBm)
		Average			
a	-	TBD	-	-	-
b	-	TBD	-	-	-
c	-	TBD	-	-	-
d	-	TBD	-	-	-
e	-	TBD	-	-	-
f	-	TBD	-	-	-

Note: Applicable for dual-mode GSM/UTRA LCR TDD.

I.2.3.3 E-UTRA FDD

Table I.2.3.3-1: Tablet TRP recommended performance for E-UTRA FDD in the data transfer position

Operating band	Power Class 1	Power Class 2	Power Class 3	Power Class 4
	Power (dBm)	Power (dBm)	Power (dBm)	Power (dBm)
			Average	
1			21.0	
2				
3			20.5	
4				
5				
7			20.0	
8				
12				
13				
19			20.0	
20			19.5	
21			20.0	
28				

NOTE 1: Applicable for multi-mode GSM/UMTS/LTE.
NOTE 2: Applicability for devices supporting CDMA or aggregated carriers (e.g. multi-carrier HSPA, LTE Carrier Aggregation) is FFS.

I.2.3.4 E-UTRA TDD

Table I.2.3.4-1: TBD

I.3 Total Radiated Sensitivity

The OTA TRS performance for UTRA and E-UTRA should be lower or equal than the recommended values shown in this clause.

I.3.1 Beside the head phantom position

Beside the head phantom test method is defined in subclause 4.3.1.

I.3.1.1 UTRA FDD

Table I.3.1.1-1: Handheld UE TRS recommended performance for FDD in beside the head phantom position for the primary mechanical mode

Operating band	Unit	<REF _{lor} >
I	dBm/3.84 MHz	-104
II	dBm/3.84 MHz	-102
III	dBm/3.84 MHz	-101
IV	dBm/3.84 MHz	-104
V	dBm/3.84 MHz	-99.5
VI	dBm/3.84 MHz	-101
VII	dBm/3.84 MHz	-102
VIII	dBm/3.84 MHz	-100
IX	dBm/3.84 MHz	-103
XIX	dBm/3.84 MHz	-101

NOTE 1: For the UE which supports DB-DC-HSDPA configuration 2, average <REF_{lor}> level of -101 dBm/3.84 shall apply for Band II.
NOTE 2: For the UE which supports DB-DC-HSDPA configuration 2, average <REF_{lor}> level of -103 dBm/3.84 MHz shall apply for Band IV.

I.3.1.2 UTRA LCR TDD

Table I.3.1.2-1: Handheld UE TRS recommended performance for UTRA LCR TDD in beside the head phantom position and the primary mechanical mode.

Operating band	Unit	<REF _{lor} > Average
a	dBm/1.28 MHz	-105
b	dBm/1.28 MHz	TBD
c	dBm/1.28 MHz	TBD
d	dBm/1.28 MHz	TBD
e	dBm/1.28 MHz	-105
f	dBm/1.28 MHz	-105

NOTE: Applicable for dual-mode GSM/UTRA LCR TDD.

I.3.2 Beside the head and hand phantoms position

Beside the head and hand phantoms test method is defined in subclauses 4.3.3.

I.3.2.1 UTRA FDD

Table I.3.2.1-1: TRS recommended performance for UTRA FDD in the beside the head and hand phantoms position for the primary mechanical mode

Operating band	Unit	<REF _{lor} > Average
I	dBm/3.84 MHz	-104.0
II	dBm/3.84 MHz	-102.0
III	dBm/3.84 MHz	TBD
IV	dBm/3.84 MHz	TBD
V	dBm/3.84 MHz	-99.75
VI	dBm/3.84 MHz	-99.75
VII	dBm/3.84 MHz	TBD
VIII	dBm/3.84 MHz	-99.75
IX	dBm/3.84 MHz	TBD
XIX	dBm/3.84 MHz	-99.75

NOTE 1: For the UE which supports DB-DC-HSDPA configuration 2, average <REF_{lor}> level of -101 dBm/3.84 shall apply for Band II.
NOTE 2: For the UE which supports DB-DC-HSDPA configuration 2, average <REF_{lor}> level of -103 dBm/3.84 MHz shall apply for Band IV.
NOTE 3: Applicable for devices narrower than 72mm as defined in TR 25.914
NOTE 4: Not applicable for devices supporting CDMA or carrier aggregation

I.3.2.2 UTRA LCR TDD

Table I.3.2.2-1: TRS recommended performance for UTRA LCR TDD in the beside the head and hand phantoms position and the primary mechanical mode

Operating band	Unit	<REF _{lor} > Average
a	dBm/1.28 MHz	TBD
b	dBm/1.28 MHz	TBD
c	dBm/1.28 MHz	TBD
d	dBm/1.28 MHz	TBD
e	dBm/1.28 MHz	TBD
f	dBm/1.28 MHz	TBD

NOTE: Applicable for dual-mode GSM/UTRA LCR TDD.

I.3.2.3 E-UTRA FDD

Table I.3.2.3-1: Tablet TRS recommended performance for E-UTRA FDD in data transfer position

Operating band	Channel bandwidth	Sensitivity (dBm)
		Average
1	10 MHz	-96.0
2	10 MHz	
3	10 MHz	-97.0
4	10 MHz	
5	10 MHz	
7	10 MHz	-95.75
8	10 MHz	
12	10 MHz	
13	10 MHz	
19	10 MHz	-94.5
20	10 MHz	-94.5
21	15 MHz	-93.0
28	10 MHz	
32	10 MHz	

NOTE 1: Applicable for multi-mode GSM/UMTS/LTE.
 NOTE 2: Applicability for devices supporting CDMA or aggregated carriers (e.g. multi-carrier HSPA, LTE Carrier Aggregation) is FFS.

I.3.2.4 E-UTRA TDD

Table I.3.2.4-1: TBD

I.3.3 Hand phantom browsing mode position

Hand phantom browsing mode test method is defined in subclauses 4.3.4.

I.3.3.1 UTRA FDD

Table I.3.3.1-1: TRS recommended performance for UTRA FDD in hand phantom browsing mode position

Operating band	Unit	<REF _{or} > Average
I	dBm/3.84 MHz	TBD
II	dBm/3.84 MHz	TBD
III	dBm/3.84 MHz	TBD
IV	dBm/3.84 MHz	TBD
V	dBm/3.84 MHz	TBD
VI	dBm/3.84 MHz	TBD
VII	dBm/3.84 MHz	TBD
VIII	dBm/3.84 MHz	TBD
IX	dBm/3.84 MHz	TBD
XIX	dBm/3.84 MHz	TBD

NOTE 1: For the UE which supports DB-DC-HSDPA configuration 2, average <REF_{or}> level of -101 dBm/3.84 shall apply for Band II.
 NOTE 2: For the UE which supports DB-DC-HSDPA configuration 2, average <REF_{or}> level of -103 dBm/3.84 MHz shall apply for Band IV.

I.3.3.2 UTRA LCR TDD

Table I.3.3.2-1: TRS recommended performance for UTRA LCR TDD in hand phantom browsing mode position

Operating band	Unit	<REFlor> Average
a	dBm/1.28 MHz	TBD
b	dBm/1.28 MHz	TBD
c	dBm/1.28 MHz	TBD
d	dBm/1.28 MHz	TBD
e	dBm/1.28 MHz	TBD
f	dBm/1.28 MHz	TBD
NOTE: Applicable for dual-mode GSM/UTRA LCR TDD.		

I.3.3.3 E-UTRA FDD

Table I.3.3.3-1 TBD

I.3.3.4 E-UTRA TDD

Table I.3.3.4-1 TBD

Annex J (informative): Recommended performance for LME

Editor's notes: This annex is incomplete. The following items are missing or incomplete:

- Table J.2.1-1, J.2.2-1, J.3.1-1 and J.3.2-1 as they are not complete in TS 37.144 yet
- Table J.2.3-1, J.2.4-1, J.3.3-1 and J.3.4-1 as they are not specified in TS 37.144 yet

J.1 General

This annex introduces the concept of recommended OTA performance for operating bands for UE's supporting LME feature. This requirement is not mandatory but is recommended.

The concept of recommended performance is to ensure that UE OTA performance is maximised in order to improve user experience and network performance. It is recognised that the ability to meet the recommended performance depends on the number of frequency bands supported by the UE.

J.2 Total Radiated Power

The OTA TRP performance for UTRA and E-UTRA should be greater or equal than the recommended values in this clause.

Laptop ground plane phantom test method is defined in subclauses 4.3.2.

J.2.1 UTRA FDD

Table J.2.1-1: LME TRP recommended performance for UTRA FDD in data transfer position

Operating band	Power class 1	Power class 2	Power class 3	Power class 3bis	Power class 4
	Power (dBm)	Power (dBm)	Power (dBm)	Power (dBm)	Power (dBm)
	Average	Average	Average	Average	Average
I	-	-	TBD	TBD	TBD
II	-	-	TBD	TBD	TBD
III	-	-	TBD	TBD	TBD
IV	-	-	TBD	TBD	TBD
V	-	-	TBD	TBD	TBD
VI	-	-	TBD	TBD	TBD
VII	-	-	TBD	TBD	TBD
VIII	-	-	TBD	TBD	TBD
IX	-	-	TBD	TBD	TBD
XIX	-	-	TBD	TBD	TBD

NOTE 1: Applicable for dual-mode GSM/UMTS.
NOTE 2: Applicable for USB plug-in devices.

J.2.2 UTRA LCR TDD

Table J.2.2-1: LME TRP recommended performance for UTRA LCR TDD in data transfer position

Operating band	Power class 1	Power class 2	Power class 3	Power class 3bis	Power class 4
	Power (dBm)	Power (dBm)	Power (dBm)	Power (dBm)	Power (dBm)
	Average	Average	Average	Average	Average

a	-	TBD	-	-	-
b	-	TBD	-	-	-
c	-	TBD	-	-	-
d	-	TBD	-	-	-
e	-	TBD	-	-	-
f	-	TBD	-	-	-
NOTE 1: Applicable for dual-mode GSM/UTRA LCR TDD. NOTE 2: Applicable for USB plug-in devices.					

J.2.3 E-UTRA FDD

Table J.2.3-1: TBD

J.2.4 E-UTRA TDD

Table J.2.4-1: TBD

J.3 Total Radiated Sensitivity

The OTA TRS performance for UTRA and E-UTRA should be lower or equal than the recommended values shown in this clause.

Laptop ground plane phantom test method is defined in subclauses 4.3.2.

J.3.1 UTRA FDD

Table J.3.1-1: LME TRS recommended performance for UTRA FDD in the data transfer position

Operating band	Unit	<REF _{lor} > Average
I	dBm/3.84 MHz	TBD
II	dBm/3.84 MHz	TBD
III	dBm/3.84 MHz	TBD
IV	dBm/3.84 MHz	TBD
V	dBm/3.84 MHz	TBD
VI	dBm/3.84 MHz	TBD
VII	dBm/3.84 MHz	TBD
VIII	dBm/3.84 MHz	TBD
IX	dBm/3.84 MHz	TBD
XIX	dBm/3.84 MHz	TBD
NOTE: Applicable for USB plug-in devices.		

J.3.2 UTRA LCR TDD

Table J.3.2-1: LME TRS recommended performance for UTRA LCR TDD in the data transfer position

Operating band	Unit	<REF _{lor} > Average
a	dBm/1.28 MHz	TBD
b	dBm/1.28 MHz	TBD
c	dBm/1.28 MHz	TBD
d	dBm/1.28 MHz	TBD
e	dBm/1.28 MHz	TBD
f	dBm/1.28 MHz	TBD
NOTE 1: Applicable for dual-mode GSM/UTRA LCR TDD. NOTE 2: Applicable for USB plug-in devices.		

J.3.3 E-UTRA FDD

Table J.3.3-1: TBD

J.3.4 E-UTRA TDD

Table J.3.4-1: TBD

Annex K (informative): Recommended performance for LEE

Editor's notes: This annex is incomplete. The following items are missing or incomplete:

- Table K.2.1-1, K.2.1-2, K.2.2-1, K.2.2-2, K.3.1-1, K.3.1-2, K.3.2-1 and K.3.2-2 as they are not complete in TS 37.144 yet
- Table K.2.3-1, K.2.3-2, K.2.4-1, K.2.4-2, K.3.3-1, K.3.3-2, K.3.4-1 and K.3.4-2 as they are not specified in TS 37.144 yet

K.1 General

This annex introduces the concept of recommended OTA performance for operating bands for UE's supporting LEE feature. This requirement is not mandatory but is recommended.

The concept of recommended performance is to ensure that UE OTA performance is maximised in order to improve user experience and network performance. It is recognised that the ability to meet the recommended performance depends on the number of frequency bands supported by the UE.

K.2 Total Radiated Power

The OTA TRP performance for UTRA and E-UTRA should be greater or equal than the recommended values in this clause.

Test method for devices with embedded modules is defined in subclauses 4.3.5.

K.2.1 UTRA FDD

Table K.2.1-1: Notebook TRP recommended performance for UTRA FDD in data transfer position

Operating band	Power class 1	Power class 2	Power class 3	Power class 3bis	Power class 4
	Power (dBm)	Power (dBm)	Power (dBm)	Power (dBm)	Power (dBm)
	Average	Average	Average	Average	Average
I	-	-	21.5	TBD	TBD
II	-	-	TBD	TBD	TBD
III	-	-	TBD	TBD	TBD
IV	-	-	TBD	TBD	TBD
V	-	-	TBD	TBD	TBD
VI	-	-	21.0	TBD	TBD
VII	-	-	TBD	TBD	TBD
VIII	-	-	21.0	TBD	TBD
IX	-	-	TBD	TBD	TBD
XIX	-	-	21.0	TBD	TBD

NOTE 1: Applicable for multi-mode GSM/UMTS/LTE.
NOTE 2: Applicable for notebook devices.

NOTE: TRP minimum performance requirements in Table K.2.1-1 apply to HSPA and LTE UEs supporting only single carrier operation. Their applicability to multi-carrier operation is FFS. This is because it has not been verified whether the UEs measured to derive the requirements supported carrier aggregation or not.

Table K.2.1-2: Tablet TRP recommended performance for UTRA FDD in data transfer position

Operating band	Power class 1	Power class 2	Power class 3	Power class 3bis	Power class 4
	Power (dBm)	Power (dBm)	Power (dBm)	Power (dBm)	Power (dBm)
	Average	Average	Average	Average	Average
I	-	-	21.5	TBD	TBD
II	-	-	TBD	TBD	TBD
III	-	-	TBD	TBD	TBD
IV	-	-	TBD	TBD	TBD
V	-	-	19.5	TBD	TBD
VI	-	-	TBD	TBD	TBD
VII	-	-	TBD	TBD	TBD
VIII	-	-	TBD	TBD	TBD
IX	-	-	TBD	TBD	TBD
XIX	-	-	19.5	TBD	TBD

NOTE 1: Applicable for dual-mode GSM/UMTS.
NOTE 2: Applicable for tablet devices with two antennas.

K.2.2 UTRA LCR TDD

Table K.2.2-1: Notebook TRP recommended performance for UTRA LCR TDD in data transfer position

Operating band	Power class 1	Power class 2	Power class 3	Power class 3bis	Power class 4
	Power (dBm)	Power (dBm)	Power (dBm)	Power (dBm)	Power (dBm)
	Average	Average	Average	Average	Average
a	-	TBD	-	-	-
b	-	TBD	-	-	-
c	-	TBD	-	-	-
d	-	TBD	-	-	-
e	-	TBD	-	-	-
f	-	TBD	-	-	-

NOTE 1: Applicable for dual-mode GSM/UTRA LCR TDD.
NOTE 2: Applicable for notebook devices.

Table K.2.2-2: Tablet TRP recommended performance for UTRA LCR TDD in data transfer position

Operating band	Power class 1	Power class 2	Power class 3	Power class 3bis	Power class 4
	Power (dBm)	Power (dBm)	Power (dBm)	Power (dBm)	Power (dBm)
	Average	Average	Average	Average	Average
a	-	TBD	-	-	-
b	-	TBD	-	-	-
c	-	TBD	-	-	-
d	-	TBD	-	-	-
e	-	TBD	-	-	-
f	-	TBD	-	-	-

NOTE 1: Applicable for dual-mode GSM/UTRA LCR TDD.
NOTE 2: Applicable for tablet devices.

K.2.3 E-UTRA FDD

[Table K.2.3-1 and K.2.3-2 TBD]

K.2.4 E-UTRA TDD

[Table K.2.4-1 and K.2.4-2 TBD]

K.3 Total Radiated Sensitivity

The OTA TRS performance for UTRA and E-UTRA should be lower or equal than the recommended values shown in this clause.

Test method for devices with embedded modules is defined in subclauses 4.3.5.

K.3.1 UTRA FDD

Table K.3.1-1: Notebook TRS recommended performance for UTRA FDD in the data transfer position

Operating band	Unit	<REF _{or} > Average
I	dBm/3.84 MHz	-106.5
II	dBm/3.84 MHz	TBD
III	dBm/3.84 MHz	TBD
IV	dBm/3.84 MHz	TBD
V	dBm/3.84 MHz	TBD
VI	dBm/3.84 MHz	-104.5
VII	dBm/3.84 MHz	TBD
VIII	dBm/3.84 MHz	-104.5
IX	dBm/3.84 MHz	TBD
XIX	dBm/3.84 MHz	-104.5
NOTE 1: Applicable for multi-mode GSM/UMTS/LTE.		
NOTE 2: Applicable for notebook devices.		

NOTE: TRS minimum performance requirements in Table K.3.1-1 apply to HSPA and LTE UEs supporting only single carrier operation. Their applicability to multi-carrier operation is FFS. This is because it has not been verified whether the UEs measured to derive the requirements supported carrier aggregation or not.

Table K.3.1-2: Tablet TRS recommended performance for UTRA FDD in the data transfer position

Operating band	Unit	<REF _{or} > Average
I	dBm/3.84 MHz	108.75
II	dBm/3.84 MHz	TBD
III	dBm/3.84 MHz	TBD
IV	dBm/3.84 MHz	TBD
V	dBm/3.84 MHz	106.0
VI	dBm/3.84 MHz	TBD
VII	dBm/3.84 MHz	TBD
VIII	dBm/3.84 MHz	TBD
IX	dBm/3.84 MHz	TBD
XIX	dBm/3.84 MHz	106.0
NOTE: Applicable for tablet devices with two antennas.		

K.3.2 UTRA LCR TDD

Table K.3.2-1: Notebook TRS recommended performance for UTRA LCR TDD in the data transfer position

Operating band	Unit	<REFlor> Average
a	dBm/1.28 MHz	TBD
b	dBm/1.28 MHz	TBD
c	dBm/1.28 MHz	TBD
d	dBm/1.28 MHz	TBD
e	dBm/1.28 MHz	TBD
f	dBm/1.28 MHz	TBD
NOTE 1: Applicable for dual-mode GSM/UTRA LCR TDD. NOTE 2: Applicable for notebook devices.		

Table K.3.2-2: Tablet TRS recommended performance for UTRA LCR TDD in the data transfer position

Operating band	Unit	<REFlor> Average
a	dBm/1.28 MHz	TBD
b	dBm/1.28 MHz	TBD
c	dBm/1.28 MHz	TBD
d	dBm/1.28 MHz	TBD
e	dBm/1.28 MHz	TBD
f	dBm/1.28 MHz	TBD
NOTE 1: Applicable for dual-mode GSM/UTRA LCR TDD. NOTE 2: Applicable for tablet devices.		

K.3.3 E-UTRA FDD

[Table K.3.3-1 and K.3.3-2 TBD]

K.3.4 E-UTRA TDD

[Table K.3.4-1 and K.3.4-2 TBD]

Annex L (informative): Multi-Probe Anechoic Chamber Specification and Validation Method

L.1 Multi-probe anechoic chamber specifications

The Multi-Probe Anechoic Chamber implementation is based on the full SCME implementation described in TR 37.977 [29] clause 6.3.1.1 and would be evaluated for shielding effectiveness in accordance with Annex G.1 and would follow the recommendations in Annex A.3.5.

L.2 Multi-probe anechoic chamber minimum distance between the DUT and the measurement antenna

The multi-probe anechoic chamber minimum distance between the DUT and the measurement antenna would follow the recommendations in Annex A.3.3.

L.3 Multi-probe anechoic chamber quiet zone reflectivity level validation

The multi-probe anechoic chamber quiet zone reflectivity level validation is performed in accordance with Annex G.2 and Annex G.3 and would follow the recommendations in Annex A.3.2 and Annex A.3.4.

L.4 Multi-probe anechoic chamber channel model verification

The multi-probe anechoic chamber channel model verification is performed in accordance with TR 37.977 [29] clause 8.3 for the channel model defined in clause 7.4.1.2 at the downlink centre frequency of the mid-channel defined in TS 36.508 [10] for the operating bands defined in clause 7.4.1.2. The results are expected to meet the recommended limits in TR 37.977 [29] clause 8.3.3.

Annex M (normative): Channel Model emulation of the Base Station antenna pattern configuration for Radiated Performance of Multiple-antenna Receivers

M.1 Channel Model(s)

The following channel models are used in evaluation of MIMO OTA methodologies.

The generic models are

- SCME Urban micro-cell, and

In addition, the BS antenna assumptions defined in Annex M.2 also apply when emulating the channel models.

In the following we define the cross polarization power ratio a propagation channel as $XPR = XPR_V = XPR_H$, where

$$XPR_V = \frac{S_{VV}}{S_{HV}} \text{ and } XPR_H = \frac{S_{HH}}{S_{VH}}$$

and

- S_{VV} is the coefficient for scattered/reflected power on V-polarization and incident power on V-polarization;
- S_{VH} is the coefficient for scattered/reflected power on V-polarization and incident power on H-polarization;
- S_{HV} is the coefficient for scattered/reflected power on H-polarization and incident power on V-polarization;
- S_{HH} is the coefficient for scattered/reflected power on H-polarization and incident power on H-polarization.

NOTE: For Vertical only measurements, the powers per delay are used without regard to the specified XPR values.

The following SCME Urban Micro-cell is unchanged from the original SCME paper, with added XPR values, Direction of Travel, and Velocity.

Table M.1-1: SCME urban micro-cell channel model

SCME Urban micro-cell								
Cluster #	Delay [ns]			Power [dB]			AoD [°]	AoA [°]
1	0	5	10	-3.0	-5.2	-7.0	6.6	0.7
2	285	290	295	-4.3	-6.5	-8.3	14.1	-13.2
3	205	210	215	-5.7	-7.9	-9.7	50.8	146.1
4	660	665	670	-7.3	-9.5	-11.3	38.4	-30.5
5	805	810	815	-9.0	-11.2	-13.0	6.7	-11.4
6	925	930	935	-11.4	-13.6	-15.4	40.3	-1.1
Delay spread [ns]								294
Cluster AS AoD / AS AoA [°]								5 / 35
Cluster PAS shape								Laplacian
Total AS AoD / AS AoA [°]								18.2 / 67.8
Mobile speed [km/h] / Direction of travel [°]								3, 30 / 120
XPR (NOTE: V & H components based on assumed BS antennas)								9 dB
Mid-paths Share Cluster parameter values for:								AoD, AoA, AS, XPR

The parameters of the channel models are the expected parameters for the MIMO OTA channel models. However, the final channel model achieved for different methods could be a combined effect of the chamber and the channel emulator.

The Rayleigh fading may be implementation specific. However, the fading can be considered to be appropriate as long as the statistics of the generated Rayleigh fading are within standard requirement on Rayleigh fading statistics.

M.2 Base Station antenna pattern configuration

The emulated BS antennas to be used for all emulation of the channel models defined in Annex M.1 shall be assumed to be dual polarized equal power elements with a fixed 0λ separation, 45 degrees slanted.

The slant 45 degree antenna is an "X" configuration and is modelled as an ideal dipole with isotropic gain and subject to a foreshortening of the slanted radiating element, which is observed to vary as a function of the path angle of departure. This foreshortening with AoD is a typical slanted dipole behaviour and is a source of power variation in the channel model. The effective antenna pattern for this antenna is illustrated in Figure M.2-1.

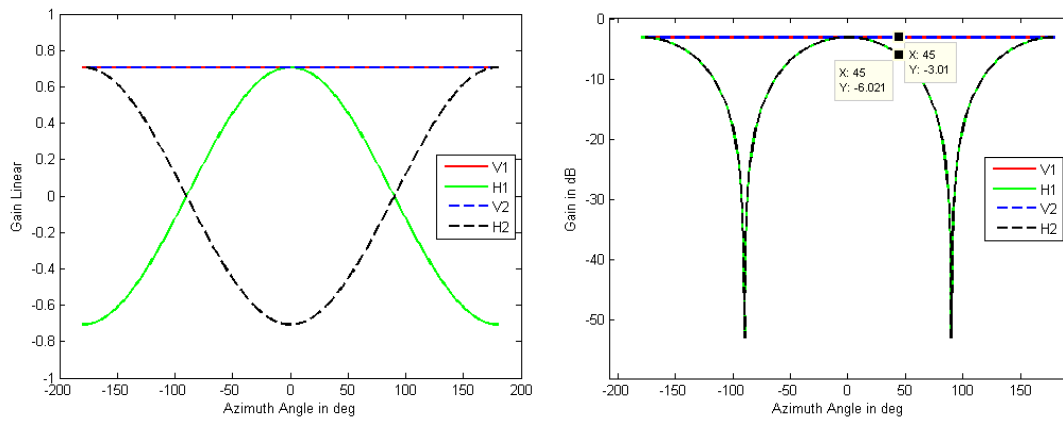

Figure M.2-1: X antenna gain assumption (a) Linear gain (b) dB gain

Annex N (informative): Estimation of measurement uncertainty for Multiple-antenna receivers

N.1 General

Editor's notes: Table N.1-1 is based on a similar table in RAN4 TR 37.977. There are a number of inconsistencies (examples are listed below) and errors in the source table that are still remaining in Table N.1-1. They should be fixed once RAN4 fixes the corresponding table in TR 37.977.

- NOTES 1, 3 & 4 are not relevant to MPAC; the NOTES should be removed.
- Item 19 is not relevant to MPAC and should be removed.
- Items 9 and 10 seem to be related to SIR that is out of scope of the WI; these may be removed from the table.

Individual uncertainty contributions in the TRMS measurements are discussed and evaluated in this Annex. A technique for calculating the total measurement uncertainty is also presented.

An important part of a standard measurement procedure is the identification of uncertainty sources and the evaluation of the overall measurement uncertainty. There are various individual uncertainty sources in the measurement procedure that introduce a certain uncertainty contribution to the final measurement result. The approach in this standard test procedure is that the test laboratories are not limited to using some specific instruments and antenna positioners, for example. However, a limit is set for the maximum overall measurement uncertainty.

The TRMS measurement procedure can be considered to include two stages. In Stage 1 the actual measurement of the MIMO OTA throughput of the Device Under Test (DUT) is performed. In Stage 2 the calibration of the absolute level of the DUT measurement results is performed.

The uncertainty contributions related to TRMS are listed in Tables N.1-1. The uncertainty contributions are analysed in the following paragraphs.

The calculation of the uncertainty contribution is based on the ISO Guide to the expression of uncertainty in measurement. Each individual uncertainty is expressed by its Standard Deviation (termed here as 'standard uncertainty') and represented by symbol U . The uncertainty contributions can be classified to two categories: Type-A uncertainties, which are statistically determined e.g. by repeated measurements, and Type-B uncertainties, which are derived from existing data e.g. data sheets. Several individual uncertainties are common in Stage 1 and Stage 2 and therefore cancel.

The procedure of forming the uncertainty budget in measurement is:

- 1) Compile lists of individual uncertainty contributions for measurements in both Stage 1 and Stage 2.
- 2) Determine the standard uncertainty of each contribution by
 - a) Determining the distribution of the uncertainty (Gaussian, U-shaped, rectangular, etc.)
 - b) Determining the maximum value of each uncertainty (unless the distributions is Gaussian)
 - c) Calculating the standard uncertainty by dividing the uncertainty by $\sqrt{2}$ if the distribution is U-shaped, and by $\sqrt{3}$ if the distribution is rectangular.
- 3) Convert the units into decibel, if necessary.
- 4) Combine all the standard uncertainties by the Root of the Sum of the Squares (RSS) method.
- 5) Combine the total uncertainties in Stage 1 and Stage 2 also by the RSS method:

$$U_c = \sqrt{U_{c,DUT\ measurement}^2 + U_{c,calibration\ measurement}^2}$$

- 6) Multiply the result by an expansion factor of 1.96 to derive expanded uncertainty at 95% confidence level:
 $1.96 * U_c$.

Table N.1-1: Measurement uncertainty budget for Multiprobe Anechoic method

#	Description of uncertainty contribution	Details in	MPAC		
			Example Value [dB]	Prob Distr	Std Uncertainty [dB]
	Stage 1-DUT measurement				
1	Mismatch of transmitter chain (i.e. between fixed measurement antenna and base station simulator)	TS 34.114, E.1-E.2	0.00	u-shape	0.00
2	Insertion loss of transmitter chain	TS 34.114, E.3-E.5	0.00	rect	0.00
3	Influence of the fixed measurement antenna cable	TS 34.114, E.6	0.00	rect	0.00
4	Uncertainty of the absolute antenna gain of the fixed measurement antenna	TS 34.114, E.7	0.00	rect	0.00
5	Base station simulator: uncertainty of the absolute output level	TS 34.114, E.17 [TS 36.521-1 F.1.3]	1.00	rect	0.58
6	Throughput measurement: output level step resolution	TS 34.114, E.18	0.25	rect	0.14
7	Statistical uncertainty of throughput measurement	TS34.114, E.19	FFS (negligible and partially included in repeatability)		
8	Fading channel emulator output uncertainty (if used) - absolute output power - output signal stability - output stability with temperature	N.2	1.5dB 0.5dB 0.4dB	normal (output power) rect (stability)	0.84
9	AWGN flatness within LTE band	TBD (NOTE 4)			FFS
10	Signal-to noise ratio uncertainty, averaged over downlink transmission Bandwidth	TBD (NOTE 4)			FFS
11	Channel model implementation (NOTE 2)	TBD	FFS		FFS
12	Chamber statistical ripple and repeatability	TS 34.114, E.26.A	N/A		0.00
13	Additional power loss in EUT chassis	TS 34.114, E.26.B	N/A		0.00
14	Quality of the quiet zone	TS 34.114, E.10	0.50	std	0.50
15	Measurement Distance - VSWR - Chamber Standing Wave	TS 34.114, E.9	0.00		0.00
16	DUT sensitivity drift	TS 34.114, E.21	0.20	rect	0.12
17	Uncertainty related to the use of the phantoms:				0.00
	a) Uncertainty of dielectric properties and shape of the hand phantom	TR 25.914, A.12.3			0.00
	b) Uncertainty related to the use of laptop ground plane phantom	TR 25.914, A.12.4			0.00
18	Random uncertainty (repeatability)	TS 34.114, E.14	0.20	rect	0.12
19	Uncertainty associated with the stirring method and number of subframes (NOTE 3)		N/A		0.00
	Stage 2-Calibration measurement				0.00
20	Uncertainty of network analyzer - Receiver and Source VNA - Receiver VNA Calibration prior to measurement	TS 34.114, E.15	0.50	rect	0.29
21	Mismatch of transmitter chain	TS 34.114, E.1-E.2	0.20	u-shape	0.14
22	Insertion loss of transmitter chain	TS 34.114, E.3-E.5	0.00		0.00
23	Mismatch in the connection of calibration antenna	TS 34.114, E.1	0.00	rect	0.00

24	Influence of the calibration antenna feed cable	TS 34.114, E.6			0.00
25	Influence of the transmitter antennas/probes cables	TS 34.114, E.6	0.00	rect	0.00
26	Uncertainty of the absolute gain of the transmitter antennas/probes	TS 34.114, E.7	0.00	rect	0.00
27	Uncertainty of the absolute gain/radiation efficiency of the calibration antenna	TS 34.114, E.16	0.50	std	0.50
28	Chamber statistical ripple and repeatability	TS 34.114, E.26.A			0.00
29	Phase Centre Offset (when using horn to calibrate)	TS 34.114, E.9	0.00	rect	0.00
30	Quality of the quiet zone (Range Ref. Antenna)	TS 34.114, E.10	0.50	rect	0.29
	External Amplifiers				0.00
31	Stability	N.3.1	0.30	rect	0.17
32	Linearity	N.3.2	0.10	rect	0.06
33	Noise Figure	N.3.3	0.30	rect	0.17
34	Mismatch	N.3.4	0.00	rect	0.00
35	Gain	N.3.5	0.00	rect	0.00

NOTE 1: 0dB if fading for RTS is done in baseband; same as RC&CE and MPAC if fading is not in baseband

NOTE 2: assumption is that MU set to 0dB with channel model validation pass/fail limits (FFS) that have negligible impact on TP FOM; MU for channel model validation is FFS

NOTE 3: Analysis of the element associated with stirring method and number of subframes is based on existing harmonization test campaign data and can be further augmented by additional measurements. The following combinations of stirring modes and number of subframes have been identified as common use cases with the following standard uncertainties (different combinations require separate validation):

A: stepped stirring mode with 20k SF per stirring state: 0dB

B: stepped stirring mode with 400 SF per stirring state: 0.22dB

C: continuous stirring mode with 20k SF per sample: FFS

D: continuous stirring mode with 400 SF per sample: FFS

Until MU elements for continuous stirring modes have been defined, the test plan shall only consider stepped stirring approach

NOTE 4: As the applicability of SIR to MIMO OTA performance evaluation is FFS, the measurement uncertainty treatment for SIR related items will remain FFS. When the applicability of SIR is confirmed, the measurement uncertainty treatment defined in 3GPP TS 36.521-1 [11] Table F.1.4-1 for line item 8.2.1.3.1 should be considered along with the related test system constraints. Any adjustments to the test system limits or uncertainty definitions necessary for MIMO OTA performance testing should be applied.

N.2 Fading channel emulator output uncertainty

In the case where a fading channel emulator is used, the outputs of the fading channel emulator are used to drive signals through the amplifiers, if necessary, to the probe antennas in the MIMO OTA tests either as an absolute level or as a relative level. The receiving device used is a UE. Generally, an uncertainty contribution comes from the absolute level accuracy, non-linearity, and output signal stability of the fading channel emulator. All of the contributions should be considered. However, the applicability of each contribution is contingent on the specific measurement implementation and calibration procedure.

This uncertainty should be determined from the manufacturer's data sheet expressed in dB with a rectangular distribution, unless otherwise informed (see clause 5.1.2 in [33]). Furthermore, the uncertainty of the non-linearity and the output signal stability of the device may be included in the absolute level uncertainty. If not, the non-linearity, output signal stability and output signal stability versus temperature should be determined from the manufacturer's data

sheet. Once determined, the non-linearity uncertainty and the output signal stability uncertainties should be combined with the output uncertainty using the RSS method.

N.3 External Amplifiers Uncertainty Terms

Any components in the setup can potentially introduce measurement uncertainty. It is then needed to determine the uncertainty contributors associated with the use of such components. For the case of external amplifiers, the following uncertainties should be considered but the applicability is contingent to the measurement implementation and calibration procedure.

N.3.1 Stability

An uncertainty contribution comes from the output level stability of the amplifier. Even if the amplifier is part of the system for both measurement and calibration, the uncertainty due to the stability shall be considered. This uncertainty can be either measured or determined by the manufacturers' data sheet for the operating conditions in which the system will be required to operate.

N.3.2 Linearity

An uncertainty contribution comes from the linearity of the amplifier since in most cases calibration and measurements are performed at two different input/output power levels. This uncertainty can be either measured or determined by the manufacturers' data sheet.

N.3.3 Noise Figure

When the signal goes into an amplifier, noise is added so that the SNR at the output is reduced with regard to the SNR of the signal at the input. This added noise introduces error on the signal which affects the Error Rate of the receiver thus the EVM (Error Vector Magnitude). An uncertainty can be calculated through the following formula:

$$\varepsilon_{EVM} = 20 \cdot \log \left(1 + 10^{\frac{-SNR}{20}} \right)$$

where SNR is the signal to noise ratio in dB at the signal level used during the sensitivity measurement.

N.3.4 Mismatch

If the external amplifier is used for both stages, measurement and calibration the uncertainty contribution associated with it can be considered systematic and constant -> 0dB. If it is not the case, the mismatch uncertainty at its input and output shall be either measured or determined by the method described in [3].

N.3.5 Gain

If the external amplifier is used for both stages, measurement and calibration the uncertainty contribution associated with it can be considered systematic and constant -> 0dB. If it is not the case, this uncertainty shall be considered.

Annex O (normative): Environmental conditions

O.1 General

This normative annex specifies the environmental requirements of the UE. Within these limits the requirements of the present documents shall be fulfilled.

O.2 Environmental requirements

The requirements in this clause apply to all types of UE(s) and MS(s).

O.2.1 Temperature

All the OTA requirements are applicable in room temperature e.g. 25°C.

O.2.2 Voltage

The UE or MS shall be equipped with a real battery that is fully charged (in the beginning of the Test).

Annex P (normative): Base Station (BS) configuration for Radiated Performance of Multiple-antenna Receivers

P.1 eNodeB emulator settings

The eNodeB emulator parameters shall be set according to Table P.1-1 for FDD and Table P.1-2 for TDD. The settings for DL stream 1 and stream 2 are the same.

Table P.1-1: Settings for FDD eNodeB emulator

eNodeB settings (Note 1)	Unit	Value
Physical channel		
Connection mode of UE		Connection established
DL MIMO mode		2 x 2 open loop spatial multiplexing
Duplex mode		FDD
Operating band (UL channel, DL channel)		Band 7 (21100, 3100) Band 20 (24300, 6300)
Schedule type		Reference Measurement Channel (RMC)
Reference Channel		R.35 (Note 2)
Bandwidth DL	MHz	10
Number of RBs DL		50
Start RB DL		0
Modulation DL		64QAM
Maximum Theoretical Throughput	Mbps	35.424
TBS Idx DL		18 (RMC defined, Note 2)
Bandwidth UL	MHz	10
Number of RBs UL		50
Start RB UL		0
Modulation UL		QPSK
TBS Idx UL		6 (RMC defined)
Transmit power control	dBm	-10/10 MHz, open loop (Note 3)
PDSCH power offset relative to RS EPRE	dB	$\rho_A = -3$ $\rho_B = -3$
Number of HARQ transmissions		1 (no HARQ re-transmissions)
AWGN		OFF
DL power level (RS EPRE)	dBm / 15 kHz	Set at eNodeB simulator with correction from calibration
Number of subframes for FOM measurement		2000 minimum for static channel 20000 minimum for faded channel (Note 4)
NOTE 1: This set of parameters is aligned with R&S CMW500, Anritsu MTC8820C, AT4 S3110B, and Agilent E6621A (to be confirmed).		
NOTE 2: This RMC is defined in 3GPP TS 36.521-1 [12], Table A.3.3.2.1-1. R.35 subframes 1-4 and 6-9 utilize DL TBS 18, while R.35 subframe 0 utilizes TBS 17 (See Table A.3.3.2.1-1 Fixed Reference Channel two antenna ports in 3GPP TS 36.521-1 [12]).		
NOTE 3: No uplink power control.		
NOTE 4: These values might need to be increased for frequency and mobile speed reasons.		

Table P.1-2: Settings for TDD eNodeB emulator

eNodeB settings	Unit	Value
Physical channel		
Connection mode of UE		Connection established
DL MIMO mode		2 x 2 open loop spatial multiplexing
Duplex mode		TDD
Operating band (UL / DL channel)		Band 38 (38000) Band 39 (38450) Band 40 (39150) Band 41 (40620)
Schedule type		Reference Measurement Channel (RMC)
Reference Channel		Table P.1-3
Up/Downlink Frame Configuration		1
Special Frame configuration		7
Bandwidth DL	MHz	20
Number of RBs DL		100
Start RB DL		0
Modulation DL		64QAM
TBS Idx DL		16 (RMC defined, NOTE 1)
Bandwidth UL	MHz	20
Number of RBs UL		100
Start RB UL		0
Modulation UL		QPSK
TBS Idx UL		6
Transmit power control	dBm	-10/20 MHz, open loop (NOTE 2)
PDSCH power offset relative to RS EPRE	dB	$\rho_A = -3$ $\rho_B = -3$
Number of HARQ transmissions		1 (no HARQ re-transmissions)
AWGN		OFF
DL power level (RS EPRE)	dBm / 15 kHz	Set at eNodeB simulator with correction from calibration
Number of subframes for FOM measurement		2000 minimum for static channel 20000 minimum for faded channel (NOTE 3)
NOTE 1: This RMC is defined in Table P.1-3. Subframes 0, 1, 4, 6 and 9 utilize DL TBS 16, subframe 5 is unused for DL data transmission and other subframes are for UL.		
NOTE 2: No uplink power control.		
NOTE 3: These values might need to be increased for frequency and mobile speed reasons.		

Table P.1-3: Fixed Reference Channel two antenna ports for 20MHz TD-LTE

Parameter	Unit	Value
Channel bandwidth	MHz	20
Allocated resource blocks (Note 3)		100
Uplink-Downlink Configuration (Note 1)		1
Allocated subframes per Radio Frame (D+S)		4+2
Modulation		64QAM
Target Coding Rate		0.4
Information Bit Payload (Note 3)		
For Sub-Frames 4,9	Bits	32856
For Sub-Frames 1,6		24496
For Sub-Frame 5	Bits	N/A
For Sub-Frame 0	Bits	32856
Number of Code Blocks (Notes 2 and 3)		
For Sub-Frames 4,9		5
For Sub-Frames 1,6		4
For Sub-Frame 5		N/A
For Sub-Frame 0		5
Binary Channel Bits (Note 3)		
For Sub-Frames 4,9	Bits	82800
For Sub-Frames 1,6		67968
For Sub-Frame 5	Bits	N/A
For Sub-Frame 0	Bits	80712
Max. Throughput averaged over 1 frame (Note 3)	Mbps	14.756
UE Category		≥ 1
NOTE 1: As per Table 4.2-2 in TS 36.211 [33].		
NOTE 2: If more than one Code Block is present, an additional CRC sequence of L = 24 Bits is attached to each Code Block (otherwise L = 0 Bit).		
NOTE 3: Given per component carrier per codeword		

Annex Q (informative): RTS Anechoic Chamber Specification and Validation Method

Q.1 RTS anechoic chamber specifications

The RTS Anechoic Chamber implementation is based on the full SCME implementation described in TR 37.977 [29] clause 6.3.1.3 and would be evaluated for shielding effectiveness in accordance with Annex G.1 and would follow the recommendations in Annex A.3.5.

Q.2 RTS anechoic chamber minimum distance between the DUT and the measurement antenna

The RTS anechoic chamber minimum distance between the DUT and the measurement antenna would follow the recommendations in Annex A.3.3.

Q.3 RTS anechoic chamber quiet zone reflectivity level validation

The RTS anechoic chamber quiet zone relectivity level validation is performed in accordance with Annex G.2 and Annex G.3 and would follow the recommendations in Annex A.3.2 and Annex A.3.4.

Q.4 RTS anechoic chamber channel model verification

The RTS anechoic chamber channel model verification is performed in accordance with TR 37.977 [29] clause 8.3 for the channel model defined in clause 7.4.1.2 at the downlink centre frequency of the mid-channel defined in TS 36.508 [10] for the operating bands defined in clause 7.4.1.2. The results are expected to meet the recommended limits in TR 37.977 [29] clause 8.3.3.

Annex R: UE ATF Requirements

This annex defines the accuracy requirements for the RSAP and RSARP measurements, these requirements are normative for devices using the RTS method as defined in section 7.4.

It should be noted that the two-stage test method includes RSAP and RSARP validation and if necessary linearization of the results prior to calibration of the results against known radiated metrology standards, therefore the requirement for RSAP and RSARP is that they are monotonic over a given range and resolution. As a consequence their absolute accuracies are not relevant. However, due to the similarity with RSRP, in order to guide RSAP implementation, an upper bound limit on accuracy is defined for RSAP. Since RSAP is measured in much easier conditions than RSRP, the RSRP absolute requirement will not increase the demands on existing receiver designs.

R.1 RSAP

The requirements for RSAP accuracy are given in Table R-1.

Table R-1: Reference Signal Antenna Power requirements

Parameter	Value
Absolute accuracy	± 6 dB
Range	RSAP absolute accuracy and monotonicity to be maintained over the range -60 dBm to -80 dBm incident power measured at the orientation of the DUT's maximum antenna gain.
Monotonicity	Monotonicity over a 1 dB interval. This is necessary to enable linearization of the UE RSAP response as part of the accuracy requirements for the derived complex antenna pattern.

R.2 RSARP

The requirements for RSARP accuracy are given in Table R-2.

Table R-2: Reference Signal Antenna Relative Phase requirements

Parameter	Value
Range	RSARP monotonicity to be maintained over the range -60 dBm to -80 dBm incident power measured at the orientation of the DUT's maximum antenna gain.
Monotonicity	Monotonicity over a 5 degree interval. This is necessary to enable linearization of the UE RSARP response as part of the accuracy requirements for the derived complex antenna pattern.

Annex S: Change history

Change history							
Date	TSG #	TSG Doc.	CR	Rev	Subject/Comment	Old	New
2014-08	RAN5#64	R5-14xxxx	-	-	TS 37.544 Skeleton proposed for RAN5#64	-	0.0.1
2014-09	RAN5#64	R5-144940	-	-	TS 37.544 v0.1.0	0.0.1	0.1.0
2014-11	RAN5#65	R5-145473	-	-	TS 37.544 v0.2.0	0.1.0	0.2.0
2015-02	RAN5#66	R5150208	-	-	TS 37.544 v0.3.0	0.2.0	0.3.0
2015-05	RAN5#67	R5-151230	-	-	TS 37.544 v0.4.0	0.3.0	0.4.0
2015-08	RAN5#68	R5-153129	-	-	TS 37.544 v0.5.0	0.4.0	0.5.0
2015-11	RAN5#69	R5-155372	-	-	TS 37.544 v0.6.0	0.5.0	0.6.0
2015-12	RAN#70	-	-	-	editorial cleanup by MCC according to 3GPP formatting rules	0.6.0	0.6.1
2016-05	RAN5#71	R5-162124	-	-	TS 37.544 v0.7.0	0.6.1	0.7.0
2016-08	RAN5#72	R5-162123	-	-	TS 37.544 v1.0.0	0.7.0	1.0.0
2016-09	RAN#73	-	-	-	TS 37.544 v2.0.0	1.0.0	2.0.0
2016-09	RAN#73	-	-	-	TS 37.544 v2.1.0	2.0.0	2.1.0
2016-09	RAN#73	-	-	-	upgraded to v14.0.0 with editorial changes	2.1.0	14.0.0
2017-03	RAN#75	R5-171303	0008	-	Corrections to Test Requirements	14.0.0	14.1.0
2017-03	RAN#75	R5-171908	0001	1	Radiated Performance of Multiple-antenna Receivers - Scope	14.0.0	14.1.0
2017-03	RAN#75	R5-171909	0002	1	Radiated Performance of Multiple-antenna Receivers - References	14.0.0	14.1.0
2017-03	RAN#75	R5-171910	0004	1	Radiated Performance of Multiple-antenna Receivers - DUT Positioning for total radiated multi-antenna sensitivity (TRMS)	14.0.0	14.1.0
2017-03	RAN#75	R5-171911	0003	1	Radiated Performance of Multiple-antenna Receivers - E-UTRA FDD and TDD frequencies	14.0.0	14.1.0
2017-03	RAN#75	R5-171912	0005	1	Radiated Performance of Multiple-antenna Receivers - Sampling Grid	14.0.0	14.1.0
2017-03	RAN#75	R5-171913	0006	1	Radiated Performance of Multiple-antenna Receivers - Receiver TRMS for E-UTRA FDD & TDD in Free Space	14.0.0	14.1.0
2017-03	RAN#75	R5-171914	0007	1	E-UTRA FDD and TDD Frequency Bands	14.0.0	14.1.0
2017-06	RAN#76	R5-173366	0009	1	Introduction of Multi-Probe Anechoic Chamber Specification and Validation Method	14.1.0	14.2.0
2017-06	RAN#76	R5-173368	0010	1	Updated minimum requirements for LTE Tablet and UTRA TRP/TRS	14.1.0	14.2.0
2017-09	RAN#77	R5-175048	0011	1	Updates to TRMS Minimum Requirements for TC 7.4.1 & 7.4.2	14.2.0	14.3.0
2017-09	RAN#77	R5-175049	0012	1	Updates on maximum RS-EPRE level	14.2.0	14.3.0
2017-09	RAN#77	R5-175174	0013	1	Calibration procedure for Multi-probe Anechoic chamber (MPAC) method	14.2.0	14.3.0
2017-12	RAN#78	R5-177099	0017	2	MIMO OTA Maximum uncertainty of test system and test tolerance	14.3.0	14.4.0
2017-12	RAN#78	R5-177100	0018	2	MIMO OTA TRMS requirements for PS1	14.3.0	14.4.0
2017-12	RAN#78	R5-177101	0023	2	Estimation of measurement uncertainty	14.3.0	14.4.0
2017-12	RAN#78	R5-177386	0015	1	MIMO OTA Definitions, symbols and abbreviations	14.3.0	14.4.0
2017-12	RAN#78	R5-177387	0016	1	MIMO OTA Environmental Requirements	14.3.0	14.4.0
2018-03	RAN#79	R5-180882	0025	-	Introduction of RTS Anechoic Chamber Specification and Validation Method in TS 37.544	14.4.0	14.5.0
2018-03	RAN#79	R5-181660	0024	1	Addition of Radiated Two-Stage (RTS) in TS 37.544	14.4.0	14.5.0
2018-03	RAN#79	R5-181661	0026	1	Addition of UE ATF requirements in TS 37.544	14.4.0	14.5.0
2018-06	RAN#80	R5-183852	0028	1	Addition RTS applicability for FDD bands	14.5.0	14.6.0
2018-09	RAN#81	R5-186894	0029	-	Update on RTS Linearization	14.6.0	14.7.0
2020-06	SA#88	-	-	-	Upgraded to Rel-15 with no change	14.7.0	15.0.0
2020-06	SA#88	-	-	-	Upgraded to Rel-16 with no change	15.0.0	16.0.0

History

Document history		
V16.0.0	September 2020	Publication